

# G.9807 10-Gigabit Symmetric Passive Optical Networks

- G-PON compatibility via a wavelength plan, blocking filters, loss budget for coexistence on a common ODN, and a combo OLT
- Support for single-sided and mid-span reach extension, with reach up to 60 km
- Full-service support with symmetric rate – including voice, TDM, Ethernet (up to Gigabit rates), xDSL, wireless haul
- Powerful OAM&P capabilities providing a feature rich service management system
- Advanced security features including authentication, rogue detection, and information privacy
- Power saving features on top of the already considerable low power nature of fibre access

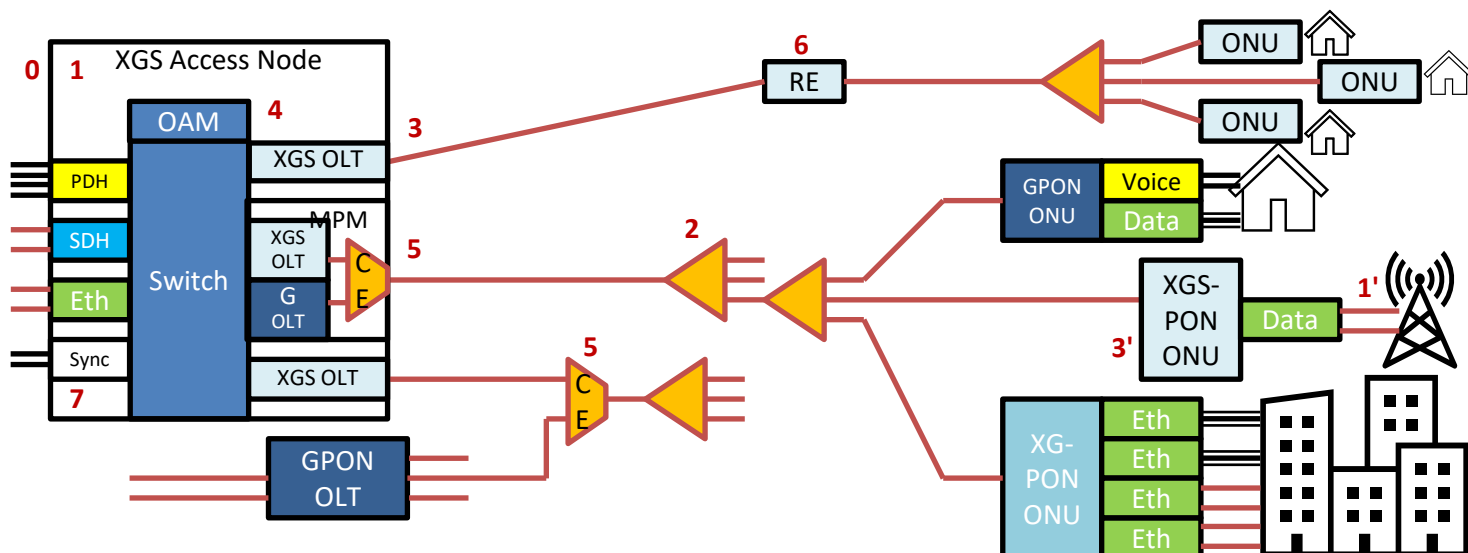

## 0. ITU-T G.9807.1, Clauses 3-5 – 10-Gigabit-capable symmetric passive optical network (XGS-PON), definitions/acronyms/conventions

Establish the common terms and acronyms used in the series, and delineate the various optical access topologies.

### 1. ITU-T G.9807.1, Annex A – General requirements of XGS-PON

Provides examples of services, User Network Interfaces (UNI) and Service Node Interfaces (SNI) that are required by network operators. In addition, it shows the principal deployment configuration. The most important requirement is the backward compatibility with existing Optical Distribution Networks (ODN) that comply with ITU-T G.984.x, ITU-T G.987.x and ITU-T G.989.x series of Recommendations.

#### 1'. ONU applications and services

The XGS-PON system is intended to be a full-service access network. A key part of that is the extreme diversity of optical network unit (ONU) types and form factors. In addition to all the applications described for G-PON, the higher capacity of XGS-PON opens new possibilities. Examples of these are serving 4G cell sites and various enterprises. Existing G-PON ONUs can remain in service alongside the XGS-PON ONUs, allowing for easier system upgrades.

### 2. ITU-T G.9807.1, Annex B – Physical media dependent (PMD) layer specifications of XGS-PON

Specifies the physical layer requirements and specifications for the PMD layer. This Recommendation covers systems with nominal line rates of 9953.28 Mbit/s in both the downstream and upstream directions. The PMD is designed to operate bidirectionally over a single strand of single mode optical fibre (ITU-T G.652). The basic wavelength plan specifies downstream wavelength band as 1575 to 1580

nm, and upstream wavelength band as 1260 to 1280 nm. This wavelength plan allows wavelength division multiplex (WDM) coexistence with G-PON and NG-PON2, and time division multiplex (TDM) coexistence with XG-PON and XGS-PON ONUs. The optional wavelength plan contains downstream wavelength band of 1480 to 1500 nm, and upstream wavelength band of 1300 to 1320 nm which allows WDM coexistence with XGS-PON and NG-PON2.

### 3. ITU-T G.9807.1, Annex C – Transmission convergence layer specification of XGS-PON

Defines the frame format and media access control method, which are largely based upon the XG-PON system with small adjustments for 10G symmetry. It describes the ranging and activation processes, dynamic bandwidth allocation (DBA), and the physical layer management (PLOAM) functionality that supports them. Security, power saving, protection, and rogue ONU mitigation are described.

#### 3'. ONU behaviour

The approach taken in ITU-T G.9807.1, Annex C is to describe in detail the behaviour of the ONU, leaving the detailed behaviour of the optical line terminal (OLT) to the implementer. The approach makes it possible to test for ONU conformance to the specifications. This makes the interoperability of different vendor's ONUs on a single PON possible. There are conformance and interoperability testing programs organized by the Broadband Forum (BBF).

### 4. ITU-T G.988 – ONU management and control interface (OMCI) specification

Defines the managed entities of a protocol-independent Management Information Base (MIB) that models the exchange of information between the Optical Line Termination OLT and the ONU, not only for XGS-PON, but all PON

systems. The MIB implicitly describes in detail the wide range of UNIs that an ONU may support. It covers the ONT management and control channel, protocol and detailed messages.

### 5. ITU-T G.984.5 – Gigabit-capable passive optical networks (G-PON): Enhancement band

Defines wavelength ranges reserved for additional service signals to be overlaid via wavelength-division multiplexing (WDM) in future PONs for maximizing the value of ODNs. The details of both the coexistence element (CE) and the blocking filter at the ONU are described. As new PON systems are standardized, this standard is updated to account for them.

### 6. ITU-T G.9807.2 – 10 Gigabit-capable passive optical networks (XG(S)-PON): Reach extension

Outlines the architecture and interface parameters for XGS-PON systems with extended reach using a physical layer reach extension device, including regenerators or optical amplifiers. Wavelength converting, continuous mode, 1:N and combination type reach extenders (REs) are also described. The maximum reach is up to 60 km with loss budgets in excess of 28.5 dB being achievable in both spans. This new capability will allow operators to provide optical access service to areas that were previously out of reach, and also explore new network designs for greater central office consolidation.

**7. Synchronization** and timing are supported as part of the XGS-PON system. G.9807.1 Annex C describes methods for transferring precision timing information over the PON system. This is important for various wireless applications.