

SOA Based Next Generation E/E Architecture

Innovation of Automotive Network : **Automotive Ethernet & IP**

- Faster & Unicast/Multicast/Broadcast Support
- Logical & Dynamic Configuration

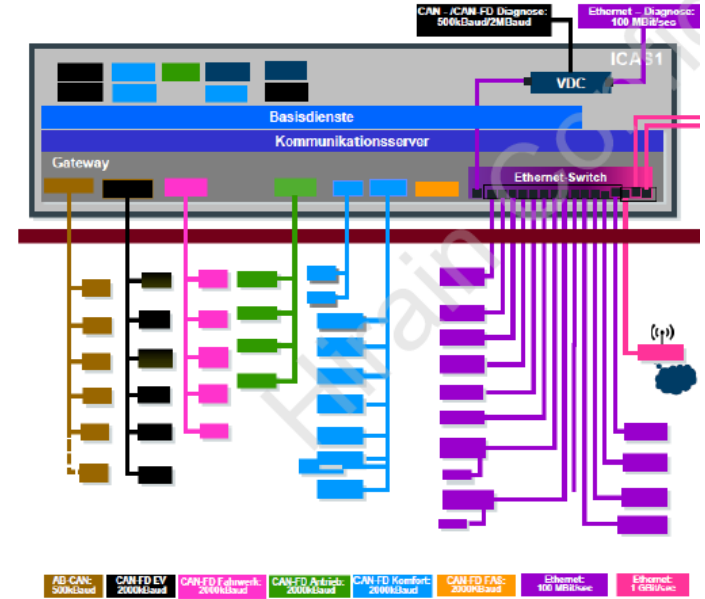

Hardware Architecture

Innovation in System/Software area :

- Service-Oriented Architecture (SoA)“Services” : reusable, remotely accessible, independently maintainable
- An application can consume services regardless of service location.
- Services provided through SoA Middleware running on top of Automotive Ethernet & IP.

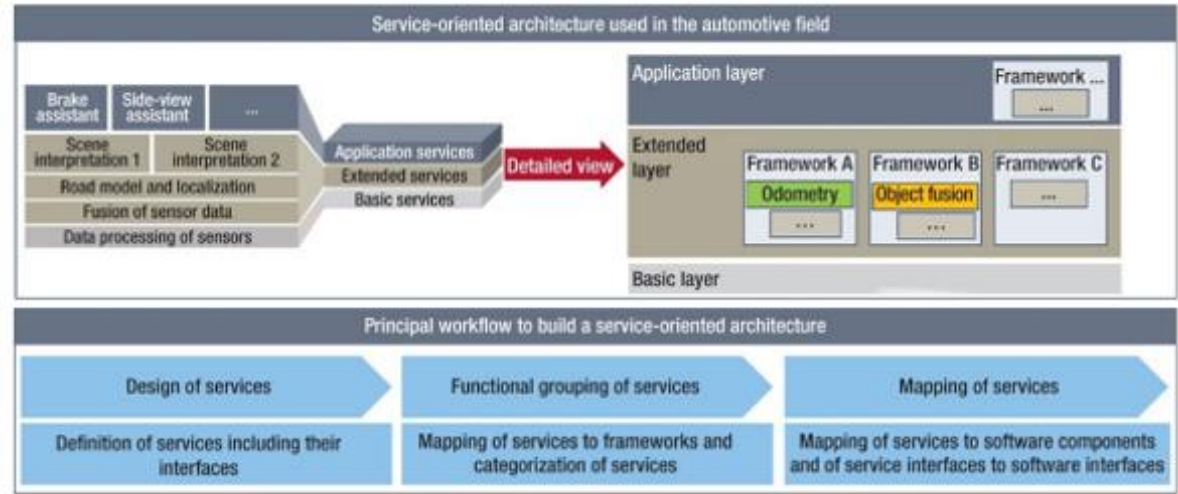

Software Architecture

Case study

Send command (from external device) to vehicle legacy system

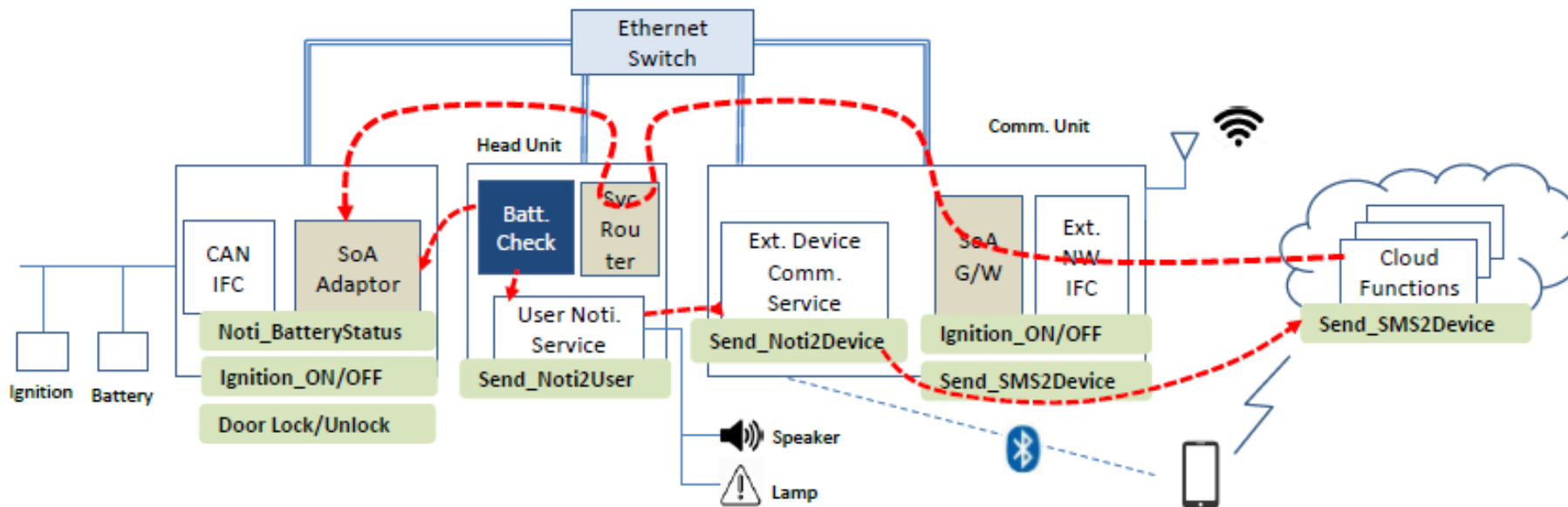

Cloud Function—Gets user's ignition-on command to re-charge
Remotely turn on ignition : invoking "Ignition ON" (provided by SoA Adaptor through SoA G/W)