

Recommendation

ITU-T G.8272.2 (2024) Amd. 1 (05/2025)

SERIES G: Transmission systems and media, digital systems and networks

Packet over Transport aspects – Synchronization, quality and availability targets

Timing characteristics of coherent network primary reference time clocks

Amendment 1



ITU-T G-SERIES RECOMMENDATIONS

Transmission systems and media, digital systems and networks

INTERNATIONAL TELEPHONE CONNECTIONS AND CIRCUITS	G.100-G.199
GENERAL CHARACTERISTICS COMMON TO ALL ANALOGUE CARRIER-TRANSMISSION SYSTEMS	G.200-G.299
INDIVIDUAL CHARACTERISTICS OF INTERNATIONAL CARRIER TELEPHONE SYSTEMS ON METALLIC LINES	G.300-G.399
GENERAL CHARACTERISTICS OF INTERNATIONAL CARRIER TELEPHONE SYSTEMS ON RADIO-RELAY OR SATELLITE LINKS AND INTERCONNECTION WITH METALLIC LINES	G.400-G.449
COORDINATION OF RADIOTELEPHONY AND LINE TELEPHONY	G.450-G.499
TRANSMISSION MEDIA AND OPTICAL SYSTEMS CHARACTERISTICS	G.600-G.699
DIGITAL TERMINAL EQUIPMENTS	G.700-G.799
DIGITAL NETWORKS	G.800-G.899
DIGITAL SECTIONS AND DIGITAL LINE SYSTEM	G.900-G.999
MULTIMEDIA QUALITY OF SERVICE AND PERFORMANCE – GENERIC AND USER-RELATED ASPECTS	G.1000-G.1999
TRANSMISSION MEDIA CHARACTERISTICS	G.6000-G.6999
DATA OVER TRANSPORT – GENERIC ASPECTS	G.7000-G.7999
PACKET OVER TRANSPORT ASPECTS	G.8000-G.8999
Ethernet over Transport aspects	G.8000-G.8099
MPLS over Transport aspects	G.8100-G.8199
Synchronization, quality and availability targets	G.8200-G.8299
Mobile network transport aspects	G.8300-G.8399
Service Management	G.8600-G.8699
ACCESS NETWORKS	G.9000-G.9999

For further details, please refer to the list of ITU-T Recommendations.

Recommendation ITU-T G.8272.2

Timing characteristics of coherent network primary reference time clocks

Amendment 1

Summary

Recommendation ITU-T G.8272.2 specifies requirements for coherent network primary reference time clocks suitable for time, phase and frequency synchronization in networks. These requirements apply under the normal environmental conditions specified for the equipment.

Amendment 1 provides the following updates:

- Adds material to the scope on cnPRTC clocks and cnPRTC groups of clocks.
- Adds material to clause 10 Coherency.
- Changes "time standard" to "time scale" and clarifies the use of UTC.
- Replaces the term "calibration" with the more appropriate term "compensation".
- Adds material on "UTC time signal source" to clause 5, Conventions.

Adds new Appendix IV, cnPRTC coherency requirement assumptions (GNSS example).

History*

Edition	Recommendation	Approval	Study Group	Unique ID
1.0	ITU-T G.8272.2	2024-01-13	15	11.1002/1000/15826
1.1	ITU-T G.8272.2 (2024) Amd. 1	2025-05-14	15	11.1002/1000/16358

Keywords

cnPRTC, ePRTC, PRTC, synchronization, time error, wander.

* To access the Recommendation, type the URL <https://handle.itu.int/> in the address field of your web browser, followed by the Recommendation's unique ID.

FOREWORD

The International Telecommunication Union (ITU) is the United Nations specialized agency in the field of telecommunications, and information and communication technologies (ICTs). The ITU Telecommunication Standardization Sector (ITU-T) is a permanent organ of ITU. ITU-T is responsible for studying technical, operating and tariff questions and issuing Recommendations on them with a view to standardizing telecommunications on a worldwide basis.

The World Telecommunication Standardization Assembly (WTSA), which meets every four years, establishes the topics for study by the ITU-T study groups which, in turn, produce Recommendations on these topics.

The approval of ITU-T Recommendations is covered by the procedure laid down in WTSA Resolution 1.

In some areas of information technology which fall within ITU-T's purview, the necessary standards are prepared on a collaborative basis with ISO and IEC.

NOTE

In this Recommendation, the expression "Administration" is used for conciseness to indicate both a telecommunication administration and a recognized operating agency.

Compliance with this Recommendation is voluntary. However, the Recommendation may contain certain mandatory provisions (to ensure, e.g., interoperability or applicability) and compliance with the Recommendation is achieved when all of these mandatory provisions are met. The words "shall" or some other obligatory language such as "must" and the negative equivalents are used to express requirements. The use of such words does not suggest that compliance with the Recommendation is required of any party.

INTELLECTUAL PROPERTY RIGHTS

ITU draws attention to the possibility that the practice or implementation of this Recommendation may involve the use of a claimed Intellectual Property Right. ITU takes no position concerning the evidence, validity or applicability of claimed Intellectual Property Rights, whether asserted by ITU members or others outside of the Recommendation development process.

As of the date of approval of this Recommendation, ITU had received notice of intellectual property, protected by patents/software copyrights, which may be required to implement this Recommendation. However, implementers are cautioned that this may not represent the latest information and are therefore strongly urged to consult the appropriate ITU-T databases available via the ITU-T website at <https://www.itu.int/ITU-T/ipr/>.

© ITU 2025

All rights reserved. No part of this publication may be reproduced, by any means whatsoever, without the prior written permission of ITU.

Table of Contents

	Page
1 Scope.....	1
2 References.....	1
3 Definitions	2
4 Abbreviations and acronyms	2
5 Conventions	3
6 Time error, wander and jitter in locked mode	3
6.1 Time error in locked mode	3
6.2 Wander in locked mode	4
6.3 Jitter	6
7 Phase discontinuity	6
8 Transient response and holdover performance	6
9 Interfaces.....	6
10 Coherency	7
10.1 Coherency requirement level 1	7
10.2 Coherency requirement level 2.....	7
Annex A – UTC(<i>k</i>) usage for cnPRTC (optional)	8
Appendix I – cnPRTC functional architecture.....	10
I.1 Introduction	10
I.2 cnPRTC functional architecture	10
Appendix II – cnPRTC deployment scenarios.....	14
Appendix III – Flexible synchronization network based on cnPRTC	15
Appendix IV – cnPRTC coherency requirement assumptions (GNSS example).....	16
Bibliography.....	17

Recommendation ITU-T G.8272.2

Timing characteristics of coherent network primary reference time clocks

Amendment 1

Editorial note: This is a complete-text publication. Modifications introduced by this amendment are shown in revision marks relative to Recommendation ITU-T G.8272.2 (2024).

1 Scope

This Recommendation specifies requirements for coherent network primary reference time clocks (cnPRTCs) suitable for time, phase and frequency synchronization in networks. These requirements apply under normal environmental conditions specified for the equipment.

A cnPRTC provides a reference time signal traceable to a recognized time [standardscale](#) and a frequency reference. The cnPRTC is subject to stringent output performance requirements utilizing sources referenced to a coordinated universal time (UTC) realization such as the global navigation satellite system (GNSS), frequency inputs from autonomous primary reference clocks, and connections to other cnPRTC clocks for further resilience and enhanced performance.

NOTE – Mobile communication networks in time division duplex (TDD) mode need to be synchronized to the same time scale for the case that the TDD area is not isolated. For details, see Appendix VI of [ITU-T G.8271]. UTC is an appropriate solution, and is available and accessible worldwide. For details, see [b-WRC-23 Res. 655] and [b-ITU-R TF.486-2].

A cnPRTC provides the reference signal for time, phase and frequency synchronization for clocks within an entire or section of a network. In particular, the cnPRTC can also provide the reference signal to the telecom grandmaster (T-GM) within the network node where the cnPRTC is located.

This Recommendation specifies cnPRTC output requirements, including those for a cnPRTC integrated with a T-GM clock.

~~In addition to an individual, is a group of cnPRTC clocks deployed in a network, a cnPRTC ensemble, is also important. There are performance requirements associated with a cnPRTC ensemble, one of which is that for coherency. This is the relative time accuracy required between deployed cnPRTC clocks. This coherency requirement is in addition to the accuracy to a recognized time standard referred to in the second paragraph. This is for further study.~~

This Recommendation also covers aspects of a group of cnPRTC clocks, in addition to an individual cnPRTC clock. This group of cnPRTC clocks deployed in a network, which acts as a distributed clock comprising a timescale, is referred to as a cnPRTC ensemble. There are performance requirements associated with a cnPRTC ensemble, one of which is that of coherency. This is the relative time accuracy required between deployed cnPRTC clocks. This coherency requirement is in addition to the accuracy to a recognized time standard as referred to above.

2 References

The following ITU-T Recommendations and other references contain provisions which, through reference in this text, constitute provisions of this Recommendation. At the time of publication, the editions indicated were valid. All Recommendations and other references are subject to revision; users of this Recommendation are therefore encouraged to investigate the possibility of applying the most recent edition of the Recommendations and other references listed below. A list of the currently valid ITU-T Recommendations is regularly published. The reference to a document within this Recommendation does not give it, as a stand-alone document, the status of a Recommendation.

- [ITU-T G.703] Recommendation ITU-T G.703 (2016), *Physical/electrical characteristics of hierarchical digital interfaces*.
- [ITU-T G.810] Recommendation ITU-T G.810 (1996), *Definitions and terminology for synchronization networks*.
- [ITU-T G.811] Recommendation ITU-T G.811 (1997), *Timing characteristics of primary reference clocks*.
- [ITU-T G.811.1] Recommendation ITU-T G.811.1 (2017), *Timing characteristics of enhanced primary reference clock*.
- [ITU-T G.8260] Recommendation ITU-T G.8260 (2022), *Definitions and terminology for synchronization in packet networks*.
- [ITU-T G.8271] Recommendation ITU-T G.8271/Y.1366 (2020), *Time and phase synchronization aspects of telecommunication networks*.
- [ITU-T G.8271.1] Recommendation ITU-T G.8271.1/Y.1366.1 (2022), *Network limits for time synchronization in packet networks with full timing support from the network*.
- [\[ITU-T G.8272\]](#) [Recommendation ITU-T G.8272 \(2025\), Timing characteristics of primary reference time clocks.](#)
- [ITU-T G.8272.1] Recommendation ITU-T G.8272.1/~~Y.1367.1~~ (2024), *Timing characteristics of enhanced primary reference time clocks*.
- [ITU-T G.8275] Recommendation ITU-T G.8275/~~Y.1369~~ (2024), *Architecture and requirements for packet-based time and phase distribution*.

3 Definitions

Terms related to synchronization are defined in [ITU-T G.810] and [ITU-T G.8260].

4 Abbreviations and acronyms

This Recommendation uses the following abbreviations and acronyms:

24/7 24 h/day, 7 days/week

[BIPM](#) [International Bureau of Weights and Measures](#)

cnPRTC coherent network Primary Reference Time Clock

CV Common View

ePRC enhanced Primary Reference Clock

ePRTC enhanced Primary Reference Time Clock

GNSS Global Navigation Satellite System

MTIE Maximum Time Interval Error

PPS Pulse Per Second

PRTC Primary Reference Time Clock

PTP Precision Time Protocol

TDEV Time Deviation

ToD Time of Day

T-GM Telecom Grandmaster

UTC Coordinated Universal Time

UTC(k) Reference time scale realized in timing institutes (metrology and research institutes) which approximates UTC (see [ITU-T G.8260])

5 Conventions

~~None.~~

Within this Recommendation, the following convention is used: the term "UTC time signal source" refers to the term defined in clause 5 of [ITU-T G.8272].

6 Time error, wander and jitter in locked mode

Time error noise generation of a cnPRTC is characterized by two main aspects:

- 1) the constant time error (time offset) at output compared to ~~the applicable primary time standard (e.g., UTC)~~ a UTC time signal source;
- 2) the amount of phase error (wander and jitter) produced at output.

For characterization of phase error (2)) the calculation of the maximum time interval error (MTIE) and the time deviation (TDEV) is useful.

Clause 6.1 describes the time error requirements applicable at output of the cnPRTC, which correspond to the combination of constant time error and phase error. No requirement is set for the constant time error component taken alone, only when it is combined with phase error.

Clauses 6.2 and 6.3 describe the wander and jitter requirements applicable at output of the cnPRTC, which correspond to the phase error.

The performance specified in clauses 6.1 and 6.2 also applies to the output of the combined cnPRTC and T-GM function when integrated into a single piece of equipment. Therefore, there is no additional allowance for the inclusion of the T-GM function.

NOTE – Optimization of the noise inside equipment is possible by combining the two functions. Therefore, the total noise of equipment that integrates the cnPRTC and T-GM can be the same as equipment that only contains the cnPRTC.

6.1 Time error in locked mode

Under normal, locked operating conditions, the time output of the cnPRTC, or the combined cnPRTC and T-GM function, should be accurate to within 30 ns or better when verified against the applicable ~~primary time standard (e.g., UTC)~~ UTC time signal source. For the cnPRTC this value includes all noise components, i.e., the constant time error (time offset) and the phase error (wander and jitter) of the cnPRTC.

For the combined cnPRTC and T-GM function, the time error samples are measured through a moving-average low-pass filter of at least 100 consecutive time error samples. This filter is applied by the test equipment to remove errors caused by timestamp quantization, or any quantization of packet position in the test equipment, before calculating the maximum time error. Normal, locked operating conditions mean that:

- The cnPRTC is fully locked to the incoming reference time signal, and is not warming up;
- There are no failures or facility errors in the reference path, including but not limited to antenna failures;
- The environmental conditions are within the operating limits specified for the equipment;
- The equipment is properly commissioned and calibrated/compensated for fixed offsets such as antenna cable length, cable amplifiers and receiver delays;

- The reference time signal (e.g., GNSS signal) is operating within limits, as determined by the relevant operating authorities;
- If the reference time signal is operated over a radio system such as GNSS, multipath reflections and interference from other local transmissions, such as jamming, must be minimized to an acceptable level;
- There are no extreme propagation anomalies, such as severe thunderstorms or solar flares;
- There may be GNSS constellation switching events, which need to be accommodated if this is required to meet the target performance.

6.2 Wander in locked mode

The wander requirements apply to all interfaces listed in clause 9.

When the cnPRTC is in the normal, locked mode of operation, the wander, expressed in MTIE, measured using a similar configuration to the synchronized clock configuration specified in Figure 1-a of [ITU-T G.810] (with the use of a standard based on time reference instead of a frequency reference), should have the limits listed in Table 1:

Table 1 – Wander generation (MTIE)

MTIE limit (ns)	Observation interval τ (s)
4	$0.1 < \tau \leq 1$
$0.111\ 14\tau + 3.89$	$1 < \tau \leq 100$
$0.037\ 5 \times 10^{-3}\tau + 15$	$100 < \tau \leq 400\ 000$
30	$\tau > 400\ 000$

The resultant requirements are shown in Figure 1.

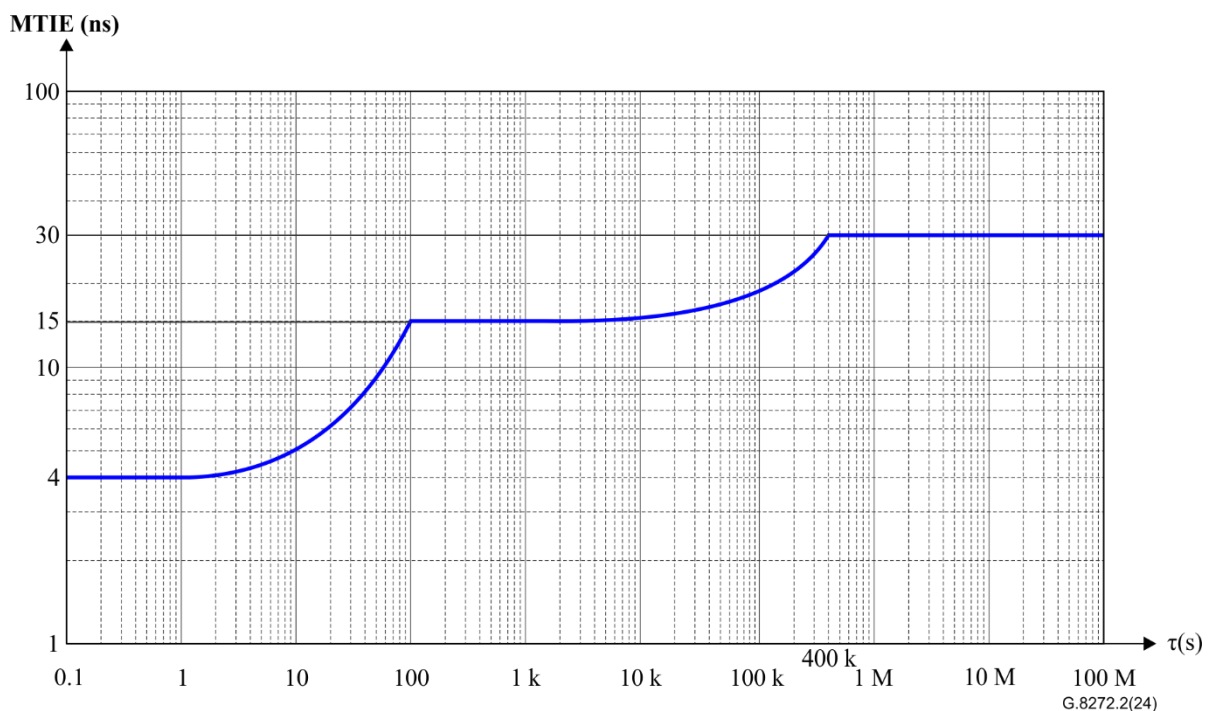

Figure 1 – MTIE as a function of an observation (integration) interval τ

NOTE 1 – For the 1 pulse per second (PPS) output interface, the MTIE mask is applicable for observation intervals ≥ 1 s.

When the cnPRTC is in the normal, locked mode of operation, the wander, expressed in TDEV, measured using a similar configuration to the synchronized clock configuration shown in Figure 1-a of [ITU-T G.810] (with the use of a [standard based on time reference](#) instead of frequency [reference](#)), should have the limits listed in Table 2:

Table 2 – Wander generation (TDEV)

TDEV limit (ns)	Observation interval τ (s)
1	$0.1 < \tau \leq 30\ 000$
$3.333\ 33 \times 10^{-5} \tau$	$30\ 000 < \tau \leq 300\ 000$
10	$300\ 000 < \tau < 1\ 000\ 000$

The resultant requirements are shown in Figure 2.

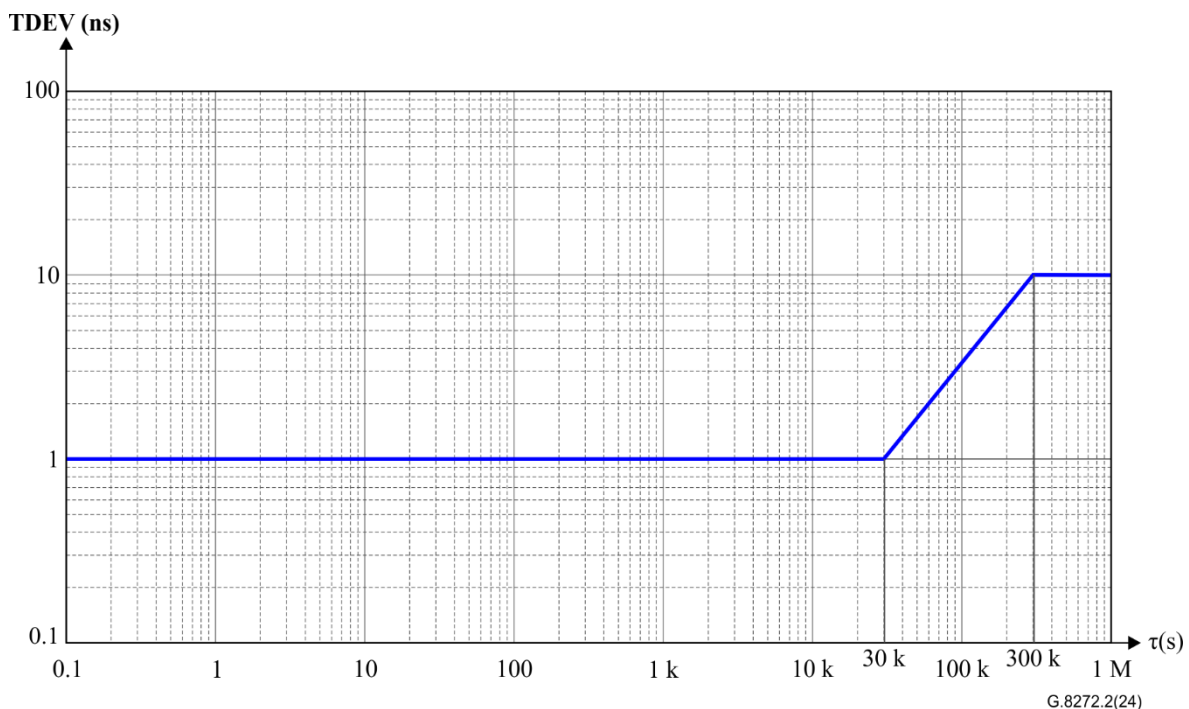

Figure 2 – TDEV as a function of an observation (integration) interval τ

NOTE 2 – For the 1 PPS output interface, the TDEV mask is applicable for observation intervals ≥ 1 s.

The applicable MTIE and TDEV requirements for the 1 PPS output interfaces are based on the time interval error of the 1 PPS signal taken at 1 sample/s and without any low-pass filtering.

The applicable MTIE and TDEV requirements for synchronous Ethernet, 2 048 kHz, 2 048 kbit/s and 1 544 kbit/s output interfaces are measured through an equivalent 10 Hz, first-order, low-pass measurement filter, at a maximum sampling time τ_0 of 1/30 s.

The applicable MTIE and TDEV requirements for an Ethernet interface carrying precision time protocol (PTP) messages are measured through a moving-average low-pass filter of at least 100 consecutive time error samples. This filter is applied by the test equipment to remove errors caused by timestamp quantization, or any quantization of packet position in the test equipment, before calculating the MTIE and TDEV.

The minimum measurement period for TDEV is 12 times the integration period ($T = 12\tau$).

NOTE 3 – In the case of PTP, a sample is a single estimate of two-way time error, calculated by combining the packets in forward and reverse directions. It is calculated by test equipment measuring the difference between the time from the primary reference time clock (PRTC) and the reference time. As an example,

according to [b-ITU-T G.8275.1] the PTP message rate is 16 packets/s in each direction; therefore, there are 16 samples/s, calculated by combining a pair of packets in each direction.

6.3 Jitter

6.3.1 Output port jitter

While most specifications in this Recommendation are independent of the output interface at which they are measured, this is not the case for jitter generation. Jitter generation specifications must utilize existing specifications that are currently specified differently for different interfaces. These requirements are stated separately for some of the interfaces identified in clause 9.

The applicable jitter requirements for 2 048 kHz, 2 048 kbit/s, 1 544 kbit/s and 10 MHz output interfaces are specified in [ITU-T G.811].

The intrinsic jitter for the other interfaces identified in clause 9 is for further study.

6.3.2 Input port jitter tolerance

The 10 MHz input interface should tolerate jitter as specified by [ITU-T G.811] for the 10 MHz output interface.

The jitter tolerance for the other interfaces identified in clause 9 is for further study.

7 Phase discontinuity

The phase discontinuity of a cnPRTC is for further study.

8 Transient response and holdover performance

If all network connections to the neighbouring cnPRTC clock combiner are completely lost, the cnPRTC seamlessly transitions to the enhanced primary reference time clock (ePRTC) function, and [ITU-T G.8272.1] compliance is maintained.

NOTE – If inputs coming from remote cnPRTC clock combiners to a cnPRTC clock combiner change, the transient response of the cnPRTC is subject to the time error requirement specified in clause 6.1 for locked mode.

9 Interfaces

All interface requirements specified in [ITU-T G.8272.1] are valid; if a cnPRTC clock combiner loses all its connections from remote cnPRTC clock combiners, the system has to act as an ePRTC.

A cnPRTC has additional phase and time input interfaces if the optional UTC(*k*) insertion is supported:

- 1 PPS 50 Ω phase-synchronization input interface to be used for UTC(*k*) insertion, as specified in [ITU-T G.703] and [ITU-T G.8271].

Note that a 1 PPS 50 Ω phase-synchronization input interface is the typical interface [for 1 PPS](#) provided by UTC(*k*) time laboratories. As a 1 PPS signal provides phase synchronization information only, time of day (ToD) needs to be provided by an additional interface.

- ITU-T V.11-based time/phase interface, as specified in [ITU-T G.703] and [ITU-T G.8271]. The ITU-T V.11-based time/phase interface has embedded 1 PPS information.

For both of these 1 PPS interface types, the cable delay has to be compensated for. The cable delay compensation accuracy tolerance is ±2 ns.

[See Appendix III of \[ITU-T G.8272\] concerning information exchanged over time interfaces.](#)

10 Coherency

Coherency performance for a cnPRTC is for further study.

The coherency requirements are network requirements that specify the maximum relative time error between different local combiners deployed at the highest level of timing and synchronization network, as specified for the cnPRTC architecture.

The coherency requirements have been derived based on deployment scenario examples. For details on the deployment scenarios, refer to Appendix VII of [ITU-T G.8275].

See Appendix IV for a description of cnPRTC coherency requirement assumptions.

Figure 3 shows an example to clarify the coherency specification concept with $\max TE_R$ specification.

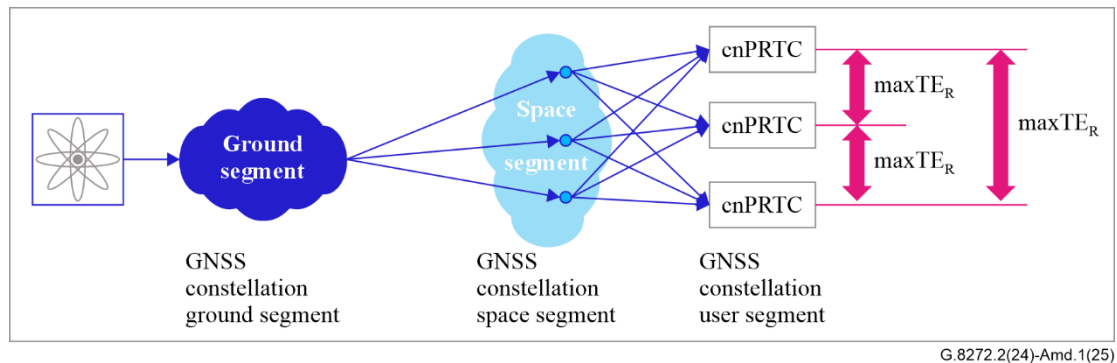

Figure 3 – cnPRTC coherency concept example, based on GNSS

10.1 Coherency requirement level 1

When the systems are operating in normal, locked mode, the maximum relative time error shall not exceed 40 ns.

NOTE – As an example of the coherency performance for level 1, it could be applicable to a cnPRTC in deployment scenarios 1 and 2 (as described in Appendix VII of [ITU-T G.8275]).

10.2 Coherency requirement level 2

The coherency performance level 2 is for further study.

Annex A

UTC(k) usage for cnPRTC (optional)

(This annex forms an integral part of this Recommendation.)

This annex is optional but, if implemented, it is necessary for the equipment to conform to requirements contained herein.

The cnPRTC architecture is a highly resilient system. It uses local primary clocks for frequency as specified in [ITU-T G.811.1] for ePRC, PRTCs as specified in [ITU-T G.8272.1] for ePRTC and a clock combiner specified in this Recommendation.

High-accuracy time transfer links fulfilling the performance specification of [ITU-T G.8271.1] are used to build up the meshed network between cnPRTC locations.

The main purpose of the cnPRTC mesh is high resilience, which is attainable after initial synchronization. After initialization, the system can overcome PRTC loss (e.g., due to GNSS loss) for several months utilizing ePRCs (e.g., based on caesium clocks).

About UTC(k)

UTC(k) designates the real-time [approximate](#) realization of UTC, which itself is not available as a physical signal. Supervision and monitoring of this external UTC(k) is the responsibility of UTC(k) ~~time-laboratories, see [ITU-T G.8260] for details according to metrology conventions, the latter lying outside the scope of ITU-T Recommendations.~~

Network operators may have temporary or permanent direct or remote access with known uncertainty to a UTC(k) from a trusted cnPRTC external source.

Purpose of UTC(k) for the cnPRTC architecture

UTC(k) from a cnPRTC external source can be used to:

- initialize a cnPRTC mesh when a PRTC source is unavailable (e.g., GNSS inaccessible);
- having one or more fixed UTC cornerstones for the cnPRTC mesh to have the cnPRTC mesh timing close to UTC with known uncertainty;
- having a disaster recovery network-reconfiguration option, using UTC(k) in case of network-wide PRTC unavailability (e.g., GNSS outage) or other problems.

Details for using UTC(k) in a cnPRTC mesh

Most UTC(k) time laboratories do not guarantee 24 h/day, 7 days/week (24/7) UTC(k) availability, though network operators need 24/7 timing and synchronization, e.g., for their mobile networks. If the UTC(k) is not owned by the network operator, an agreement (e.g., a service level agreement) with the UTC(k) operator is needed along with appropriate methods for informing or warning the network operator in the event of UTC(k) problems.

One or more UTC(k) sources can be used for cnPRTC UTC insertion. Only one or a very few cnPRTC clock combiners in the cnPRTC mesh are intended to use the UTC insertion function. UTC(k) insertion could be a basis for disaster management, where parts of the network or the PRTC sources (e.g., GNSS) are, in general, not available and an optional flexible synchronization network structure, based on the cnPRTC as described in this Recommendation and [ITU-T G.8275] is available.

cnPRTC functional block diagram with UTC(k) insertion

With UTC(k) insertion, the cnPRTC clock combiner uses UTC(k) as long as the signal is available. In the case of active UTC(k) insertion function usage, the local system can be seen as a UTC distribution and measurement system. The UTC(k) signal bypasses the measurement function and is

internally used as an active reference for all output signals. $UTC(k)$ is distributed to all connected cnPRTC clock combiners.

Figure A.1 shows $UTC(k)$ insertion in a cnPRTC clock combiner functional block diagram, based on the functional block diagram in Appendix I.

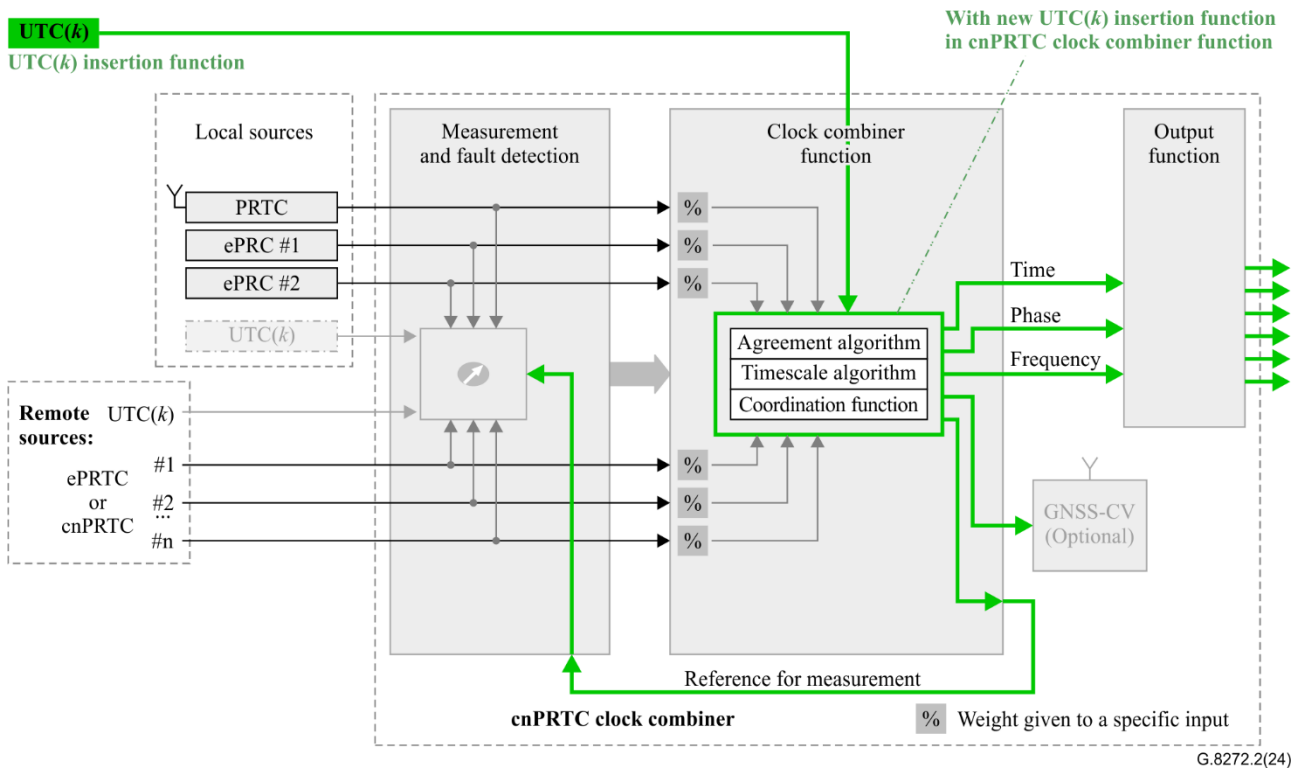

Figure A.1 – $UTC(k)$ insertion to the cnPRTC clock combiner shown in modified functional block diagram

The $UTC(k)$ interfaces in the "remote sources" and "local sources" blocks are inputs to the measurement functions and are intended to be part of the clock combiner algorithm. The optional $UTC(k)$ insertion function is intended to work differently. If the $UTC(k)$ insertion function, highlighted in green in Figure A.1, is used, the clock combiner algorithm is superseded, and the $UTC(k)$ insertion function is used directly. Therefore, it is drawn differently, rather than using the optional "remote" or "local" $UTC(k)$ interfaces of the measurement and fault detection function.

$UTC(k)$ interface options

Several $UTC(k)$ interface options in different combinations suitable for time, phase, and frequency are possible. Typical interfaces in $UTC(k)$ time laboratories are: 1 PPS together with 10 MHz according to [ITU-T G.703], along with ToD. ToD alone would be another option.

Appendix I

cnPRTC functional architecture

(This appendix does not form an integral part of this Recommendation.)

I.1 Introduction

The coherent network PRTC connects primary reference clocks at the highest core or regional network level, which provides the ability to maintain network-wide ePRTC time accuracy, even during periods of regional or network-wide GNSS loss. Comparative measurements between clocks is a central component of the cnPRTC system, thus monitoring of the clocks is also provided by the cnPRTC system.

I.2 cnPRTC functional architecture

A central aspect to working with a group of clocks is the algorithm for combining them, which is known as a timescale algorithm. These algorithms are important to national laboratories, GNSS control segments, and indeed to the establishment of UTC at the Bureau International des Poids et Mesures (International Bureau of Weights and Measures, BIPM). Other aspects important to combining clocks in a network are also discussed in this clause. Two examples of cnPRTC clock groups are shown in Figure I.1, one with six clocks, which could be suitable to a central core, and another with three clocks, which could be suitable for a smaller regional area.

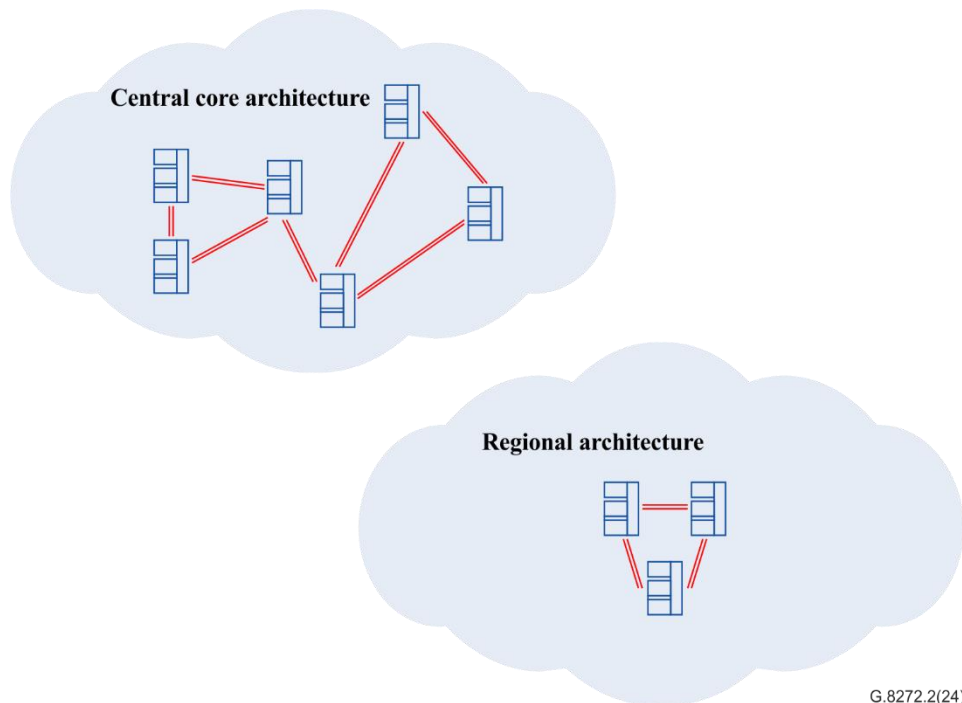

Figure I.1 – Coherent network PRTC architecture examples

What distinguishes these examples from a standalone PRTC or ePRTC is the connection and interaction between the clocks. Note in the central core example that the clocks are not completely meshed. Nevertheless, given the connections that are there, any clock can be compared to any other clock through a direct connection or indirectly through one or more intermediary connections. References are made in Figure I.2 to common-view and all-in-view; further details are in [b-NIST] and [b-Weiss]. The optional UTC(*k*) insertion function is not shown in Figure I.2. See Annex A for further details.

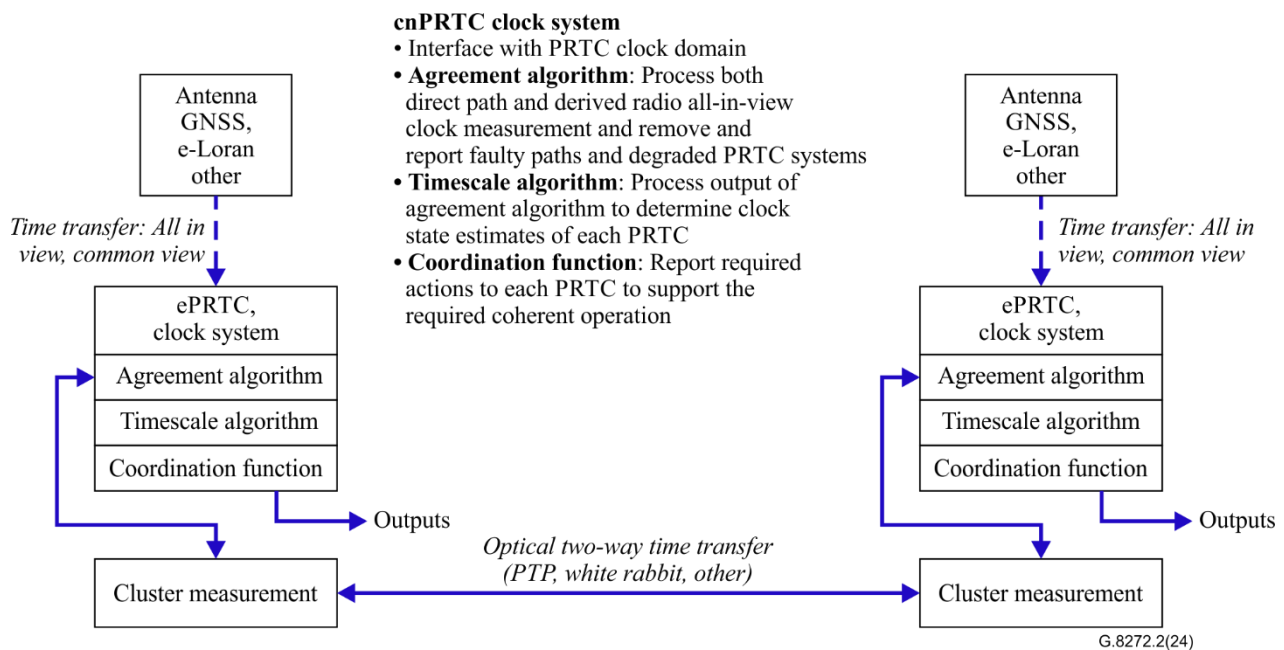

Figure I.2 – Coherent network PRTC functional architecture

Figure I.2 shows that there are three components to the ensembling function: 1) agreement algorithm; 2) timescale algorithm; and 3) coordination function. These are discussed in this clause. As noted in the first paragraph, the timescale algorithm is at the heart of the ensembling function, though important aspects are also contained within the agreement algorithm and coordination function.

NOTE – Performance requirements of high-accuracy time transfer over optical links ("Optical two-way time transfer" in Figure I.2) are covered in [ITU-T G.8271.1].

Agreement algorithm

The agreement algorithm provides a mechanism for weighting, de-weighting or potentially eliminating clocks. It is important to determine the group of clocks considered worthy of inclusion in the coherency. The agreement algorithm refers to a methodology for networking clocks that has been in use for a number of decades. It is of critical importance in a real-world application of distributed networks with distributed timescales. A prominent example of this is the network time protocol intersection algorithm.

Timescale algorithm

The timescale algorithm is central to the ensembling function of the cnPRTC and more generally to the ensembling function of any group of clocks. If the agreement algorithm has established a valid group of clocks, then pairwise measurements can be used to evolve the timescale. An example of a timescale algorithm among the many in use in time and frequency metrology is the international atomic time algorithm (see [b-Panfilo] for more details). A timescale algorithm looks at the pairwise measurements and determines the state estimates for the phase, frequency and drift that need to be applied to any of those clocks to set them on the ensemble average.

Coordination function

The coordination function applies corrections determined by the timescale algorithm. It uses knowledge gained from the timescale algorithm, the state estimates, and goes out to all distributed clocks with instructions for actions to take. It is important to note that the result of the action taken, because of errors in the system, does not perfectly match the desired action. Without further action, there would be a small accumulation of time error, with clocks eventually drifting apart. Thus, continual measurement needs also to be part of the coordination function, given that coherency is the goal. The coordination function includes two things: instructions that are issued to the individual

ePRTC or PRTC clocks to set them at the right time; and feedback to ensure that any errors are accounted for and corrected.

Summary: Agreement, timescale and coordination

In summary, three functions – the agreement algorithm, timescale algorithm and coordination function – are combined for cnPRTC clock ensembling. The timescale algorithm, which is at the heart of the combined function, looks at all contributing members of the timescale grouping, determining what each of them needs to do. It is preceded by an agreement algorithm, which validates the sources, and is followed by a coordination function, which generates a coordinated timescale throughout a distributed set of systems.

The agreement algorithm, timescale algorithm and coordination function described in this clause need to be implemented at each cnPRTC node, as indicated in Figure I.2. The functional entity responsible is termed the cnPRTC clock combiner and is shown in Figure I.3. In addition to the agreement algorithm, timescale algorithm and coordination function (described as the clock combiner function), additional functions are needed for measurement, fault detection and output. All combined, these functions form the cnPRTC clock combiner.

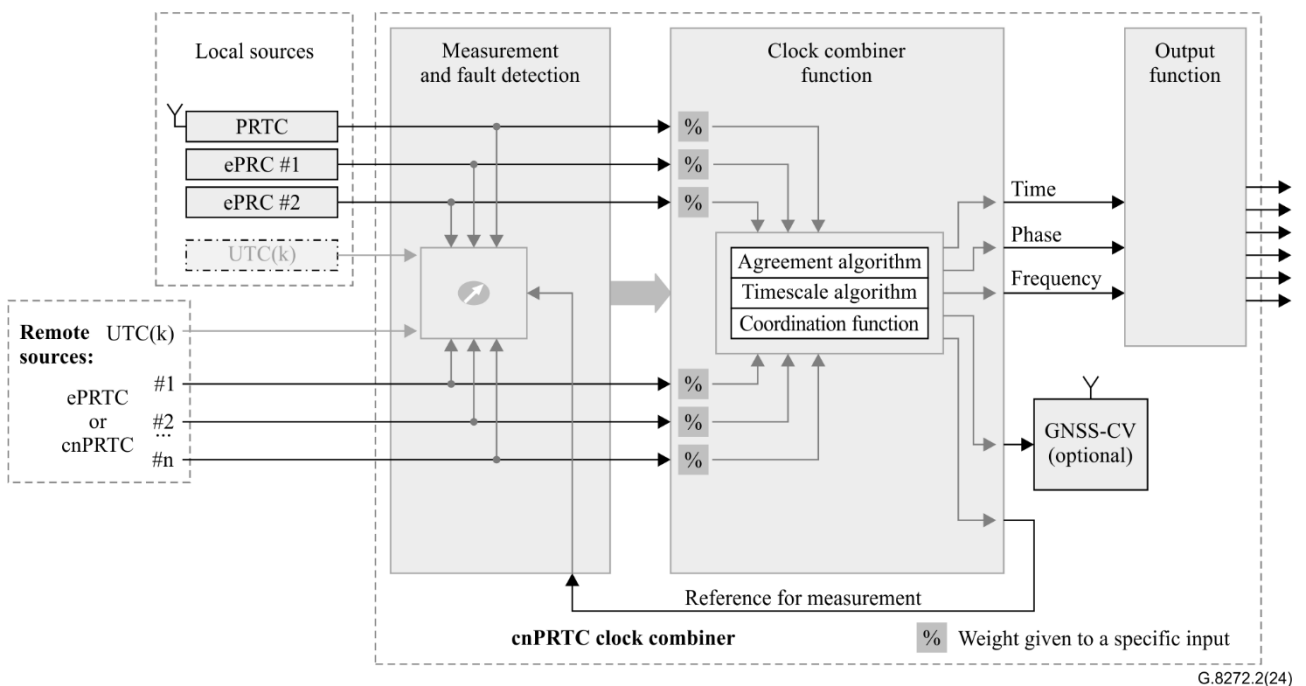

Figure I.3 – Coherent network PRTC functional block diagram

NOTE 1 – The clock combiner need not combine physical data, it could be based on measurement data only.

NOTE 2 – Depending on implementation, the cnPRTC function could be fully based on software (only). This functional block diagram shows the logical view.

NOTE 3 – Clock combiner algorithms are implementation specific.

NOTE 4 – Usage of UTC(k) is for further study.

Input sources can include both local and remote sources. Local sources can be PRTC, atomic clock (e.g., ePRC) or a local UTC time laboratory.

Remote sources are delivered via a high-accuracy time-transfer from neighbouring cnPRTC nodes or UTC(k) sources.

The measurement and fault detection function are needed to compare and validate input sources against the output of the local clock combiner function. As indicated in Figure I.3, this measurement and fault information is conveyed to the clock combiner function. The fault detection function

identifies missing or corrupted signals. It does not consider the validity of information carried by the signals.

If the measurement and fault detection block determine that a signal is missing or corrupted, it sends that information to the clock combiner block, which is part of the information indicated by the thick grey arrow. However, the failed input signal is still input to the clock combiner block, which uses the information it receives from the measurement and fault detection block to decide whether to include the signal.

The clock combiner function, with its agreement algorithm, timescale algorithm and coordination function, makes use of multiple available sources. A weighting function is applied to the individual inputs. For example, local sources may be given a higher weighting as compared to remote sources, or the weighting of a specific input may be adjusted or even squelched in the case of problems observed on the input.

A specific weight range is given to a specific input. The weight range of local sources is higher than that of remote sources by configuration. Due to specific measurement results, weight can be automatically adjusted within the configured range as determined by the agreement algorithm in the clock combiner function block. In case of problems, the specific input can be squelched based on the agreement algorithm. Except possibly for initialization, the weights are determined by the agreement algorithm.

The output function takes the time, frequency and phase output from the clock combiner function and generates the necessary signals for local (e.g., 10 MHz, 1 PPS and ToD) and remote (e.g., PTP + synchronous Ethernet) use. Multiple outputs of the same type may be required, principally for remote distribution. Outputs are for local usage, e.g., via a T-GM, or for providing a source for high-accuracy time transfer towards neighbour locations.

An additional optional output to provide input to GNSS common view (CV) is also shown. The results of these measurements can then be used for additional steering of individual cnPRTC clock combiner functions (e.g., as a remote input). GNSS CV measurement results may be used to compare a cnPRTC to other cnPRTCs. An algorithm similar to that of BIPM can optionally be used.

Remote sources are delivered via high-accuracy time transfer. This could be from neighbouring cnPRTC functions or optionally from a UTC(*k*) time laboratory.

Appendix II

cnPRTC deployment scenarios

(This appendix does not form an integral part of this Recommendation.)

The cnPRTC deployment scenarios material is provided in Appendix VII of [ITU-T G.8275].

Appendix III

Flexible synchronization network based on cnPRTC

(This appendix does not form an integral part of this Recommendation.)

Material on the flexible synchronization network based on the cnPRTC is provided in Appendix X of [ITU-T G.8275].

Appendix IV

cnPRTC coherency requirement assumptions (GNSS example)

(This appendix does not form an integral part of this Recommendation.)

The cnPRTC architecture may be based on the example of GNSS usage. To meet the **coherent** requirements for this case, the following assumptions regarding GNSS usage are considered valid:

- All GNSS receivers are configured in the same way, with the same combination of GNSS systems (e.g., GPS together with Galileo).
- The same GNSS frequency bands are used.
- Multi-frequency band receivers are used to mitigate ionospheric effects.
- The same elevation mask is configured.
- Any satellite-system specific configuration parameters, such as the GGTO (GPS – Galileo Timing Offset), are configured in the same way.
- All systems are at a position-hold mode, with the position calculated during a one day or longer initial measurement window.
- All systems are under normal locked operation conditions, specified in [ITU-T G.8272.1].
- All systems are operated under the normal environmental conditions specified for the equipment in this Recommendation.

Bibliography

- [b-ITU-T G.8275.1] Recommendation ITU-T G.8275.1/Y.1369.1 (2022), *Precision time protocol telecom profile for phase/time synchronization with full timing support from the network*.
- [b-ITU-T V.11] Recommendation ITU-T V.11 (1996), *Electrical characteristics for balanced double-current interchange circuits operating at data signalling rates up to 10 Mbit/s*.
- [\[b-ITU-R TF.486-2\]](#) [Recommendation ITU-R TF.486-2 \(1998\), *Use of UTC frequency as reference in standard frequency and time signal emissions*](#).
- [\[b-WRC-23-Res. 655\]](#) [Resolution 655 \(Rev.WRC-23\) World Radiocommunication Conference \(Dubai, 2023\), *Definition of time scale and dissemination of time signals via radiocommunication systems*](#).
- [b-NIST] Time realization and distribution group (2023), *Common view GNSS time transfer*. Gaithersberg, MD: National Institute of Standards and Technology. Available [viewed 2024-02-14] at: <https://www.nist.gov/pml/time-and-frequency-division/atomic-standards/common-view-gps-time-transfer>
- [b-Panfilo] Panfilo, G. (2009), Algorithms for TAI. *2009 IEEE International Frequency Control Symposium Joint with the 22nd European Frequency and Time forum*, Besancon, France, pp. xviii-xix, doi: 10.1109/FREQ.2009.5168124.
- [b-Weiss] Weiss, M.A., Petit, G., Jiang Z. (2005), A comparison of GPS common-view time transfer to all-in-view. *Proc. 2005 IEEE International Frequency Control Symposium and Exposition, 2005*, Vancouver, BC, Canada, pp. 324-8.
Available [viewed 2024-02-14] at: https://ws680.nist.gov/publication/get_pdf.cfm?pub_id=50214

SERIES OF ITU-T RECOMMENDATIONS

Series A	Organization of the work of ITU-T
Series D	Tariff and accounting principles and international telecommunication/ICT economic and policy issues
Series E	Overall network operation, telephone service, service operation and human factors
Series F	Non-telephone telecommunication services
Series G	Transmission systems and media, digital systems and networks
Series H	Audiovisual and multimedia systems
Series I	Integrated services digital network
Series J	Cable networks and transmission of television, sound programme and other multimedia signals
Series K	Protection against interference
Series L	Environment and ICTs, climate change, e-waste, energy efficiency; construction, installation and protection of cables and other elements of outside plant
Series M	Telecommunication management, including TMN and network maintenance
Series N	Maintenance: international sound programme and television transmission circuits
Series O	Specifications of measuring equipment
Series P	Telephone transmission quality, telephone installations, local line networks
Series Q	Switching and signalling, and associated measurements and tests
Series R	Telegraph transmission
Series S	Telegraph services terminal equipment
Series T	Terminals for telematic services
Series U	Telegraph switching
Series V	Data communication over the telephone network
Series X	Data networks, open system communications and security
Series Y	Global information infrastructure, Internet protocol aspects, next-generation networks, Internet of Things and smart cities
Series Z	Languages and general software aspects for telecommunication systems