

Recommendation

ITU-T G.8152.1/Y.1375.1 (2021) Amd. 3 (06/2025)

SERIES G: Transmission systems and media, digital systems and networks

Packet over Transport aspects – MPLS over Transport aspects

SERIES Y: Global information infrastructure, Internet protocol aspects, next-generation networks, Internet of Things and smart cities

Internet protocol aspects – Transport

Operation, administration, maintenance (OAM) management information and data models for the MPLS-TP network element

Amendment 3



ITU-T G-SERIES RECOMMENDATIONS

Transmission systems and media, digital systems and networks

INTERNATIONAL TELEPHONE CONNECTIONS AND CIRCUITS	G.100-G.199
GENERAL CHARACTERISTICS COMMON TO ALL ANALOGUE CARRIER-TRANSMISSION SYSTEMS	G.200-G.299
INDIVIDUAL CHARACTERISTICS OF INTERNATIONAL CARRIER TELEPHONE SYSTEMS ON METALLIC LINES	G.300-G.399
GENERAL CHARACTERISTICS OF INTERNATIONAL CARRIER TELEPHONE SYSTEMS ON RADIO-RELAY OR SATELLITE LINKS AND INTERCONNECTION WITH METALLIC LINES	G.400-G.449
COORDINATION OF RADIOTELEPHONY AND LINE TELEPHONY	G.450-G.499
TRANSMISSION MEDIA AND OPTICAL SYSTEMS CHARACTERISTICS	G.600-G.699
DIGITAL TERMINAL EQUIPMENTS	G.700-G.799
DIGITAL NETWORKS	G.800-G.899
DIGITAL SECTIONS AND DIGITAL LINE SYSTEM	G.900-G.999
MULTIMEDIA QUALITY OF SERVICE AND PERFORMANCE – GENERIC AND USER-RELATED ASPECTS	G.1000-G.1999
TRANSMISSION MEDIA CHARACTERISTICS	G.6000-G.6999
DATA OVER TRANSPORT – GENERIC ASPECTS	G.7000-G.7999
PACKET OVER TRANSPORT ASPECTS	G.8000-G.8999
Ethernet over Transport aspects	G.8000-G.8099
MPLS over Transport aspects	G.8100-G.8199
Synchronization, quality and availability targets	G.8200-G.8299
Mobile network transport aspects	G.8300-G.8399
Service Management	G.8600-G.8699
ACCESS NETWORKS	G.9000-G.9999

For further details, please refer to the list of ITU-T Recommendations.

Recommendation ITU-T G.8152.1/Y.1375.1

Operation, administration, maintenance (OAM) management information and data models for the MPLS-TP network element

Amendment 3

Summary

Recommendation ITU-T G.8152.1/Y.1375.1 specifies the operation, administration, maintenance (OAM) information model and data models for multi-protocol label switching – transport profile (MPLS-TP) transport network element (NE) to support specific interface protocols and specific management and control functions. The information model is interface protocol neutral and derived from the ITU-T G.8152/Y.1375 foundation MPLS-TP NE information model. The data models are interface protocol specific and translated from the information model with the assistance of an automated translation tool. The specific data models considered in this Recommendation include, but are not limited to, yet another new generation (YANG) data models. The specific management and control functions covered by this Recommendation are the ITU-T G.8113.1/Y.1372.1 specific OAM functions. The YANG modules of this Recommendation are intended to be compatible with the relevant base generic YANG modules from the IETF for the ITU-T G.8113.1/Y.1372.1 OAM functionality.

Amendment 1 of this Recommendation enhances the MPLS-TP OAM information/data model specification to specify the on-demand UML and YANG models. The OAM models, including the version 1.0 specified proactive OAM, are also aligned with the pattern of the Ethernet OAM model defined in Recommendation ITU-T G.8052.1/Y.1346.1.

Amendment 1 also adds Appendix III to demonstrate how to use the IETF MPLS static lsp model with MPLS-TP co-oam models, and Appendix IV to demonstrate IETF MPLS static UML re-engineered from MPLS Static YANG.

Amendment 2 updates the UML model to advance the preliminary UML artifacts to maturity, including the measurement jobs. The text of clause 4, clause 7.2.1, clause 7.2.2.1 to clause 7.2.2.4, clause 7.2.3.1 to clause 7.2.3.4 and Appendix II are also updated.

Amendment 3 updates the copyright notice in the YANG file.

History*

Edition	Recommendation	Approval	Study Group	Unique ID
1.0	ITU-T G.8152.1/Y.1375.1	2021-01-13	15	11.1002/1000/14559
1.1	ITU-T G.8152.1/Y.1375.1 (2021) Amd. 1	2023-02-06	15	11.1002/1000/15211
1.2	ITU-T G.8152.1/Y.1375.1 (2021) Amd. 2	2024-08-29	15	11.1002/1000/16089
1.3	ITU-T G.8152.1/Y.1375.1 (2025) Amd. 3	2025-06-13	15	11.1002/1000/16402

Keywords

Data model, information model, MPLS-TP, OAM, protocol-neutral, transport resource, UML, YANG.

* To access the Recommendation, type the URL <https://handle.itu.int/> in the address field of your web browser, followed by the Recommendation's unique ID.

FOREWORD

The International Telecommunication Union (ITU) is the United Nations specialized agency in the field of telecommunications, and information and communication technologies (ICTs). The ITU Telecommunication Standardization Sector (ITU-T) is a permanent organ of ITU. ITU-T is responsible for studying technical, operating and tariff questions and issuing Recommendations on them with a view to standardizing telecommunications on a worldwide basis.

The World Telecommunication Standardization Assembly (WTSA), which meets every four years, establishes the topics for study by the ITU-T study groups which, in turn, produce Recommendations on these topics.

The approval of ITU-T Recommendations is covered by the procedure laid down in WTSA Resolution 1.

In some areas of information technology which fall within ITU-T's purview, the necessary standards are prepared on a collaborative basis with ISO and IEC.

NOTE

In this Recommendation, the expression "Administration" is used for conciseness to indicate both a telecommunication administration and a recognized operating agency.

Compliance with this Recommendation is voluntary. However, the Recommendation may contain certain mandatory provisions (to ensure, e.g., interoperability or applicability) and compliance with the Recommendation is achieved when all of these mandatory provisions are met. The words "shall" or some other obligatory language such as "must" and the negative equivalents are used to express requirements. The use of such words does not suggest that compliance with the Recommendation is required of any party.

INTELLECTUAL PROPERTY RIGHTS

ITU draws attention to the possibility that the practice or implementation of this Recommendation may involve the use of a claimed Intellectual Property Right. ITU takes no position concerning the evidence, validity or applicability of claimed Intellectual Property Rights, whether asserted by ITU members or others outside of the Recommendation development process.

As of the date of approval of this Recommendation, ITU had not received notice of intellectual property, protected by patents/software copyrights, which may be required to implement this Recommendation. However, implementers are cautioned that this may not represent the latest information and are therefore strongly urged to consult the appropriate ITU-T databases available via the ITU-T website at <https://www.itu.int/ITU-T/ipr/>.

© ITU 2025

All rights reserved. No part of this publication may be reproduced, by any means whatsoever, without the prior written permission of ITU.

Table of Contents

	Page
1 Scope.....	1
2 References.....	1
3 Definitions	2
3.1 Terms defined elsewhere	2
3.2 Terms defined in this Recommendation.....	2
4 Abbreviations and acronyms	2
5 Conventions	4
5.1 Information modelling conventions	4
5.2 Equipment function conventions	4
5.3 Colour code conventions	4
6 Functions of MPLS-TP OAM	5
6.1 Proactive OAM for performance measurement	7
6.2 On-demand for performance measurement	8
6.3 Proactive fault management	8
6.4 On-demand fault management	9
7 Information model of MPLS-TP OAM	10
7.1 IETF CO-OAM UML Re-engineered from CO-OAM YANG.....	10
7.2 MPLS-TP OAM UML	10
7.3 UML model files	21
8 Data models of MPLS-TP OAM	22
8.1 MPLS-TP YANG data models.....	22
Appendix I – Overview of the MPLS-TP OAM model configuration cases.....	24
I.1 MEP and MIP configuration	24
I.2 OAM Pac configuration	25
Appendix II – Analysis of ITU-T G.8152 attributes and operations for ITU-T G.8152.1	26
Appendix III – Examples of using the IETF MPLS static lsp model with MPLS-TP co- oam models.....	42
III.1 MPLS-TP trail monitoring examples	42
III.2 MPLS-TP tandem connection monitoring (TCM) examples	44
Appendix IV – IETF MPLS static UML re-engineered from MPLS static YANG	48
Bibliography.....	49

Recommendation ITU-T G.8152.1/Y.1375.1

Operation, administration, maintenance (OAM) management information and data models for the MPLS-TP network element

Amendment 3

Editorial note: This is a complete-text publication. Modifications introduced by this amendment are shown in revision marks relative to Recommendation ITU-T G.8152.1/Y.1375.1 (2021) and its Amendments 1 and 2.

1 Scope

This Recommendation specifies the operation, administration, maintenance (OAM) information model and data models for multi-protocol label switching – transport profile (MPLS-TP) transport network element (NE) to support specific interface protocols and specific management and control functions. The information model is interface protocol neutral and derived from the [ITU-T G.8152] foundation MPLS-TP NE information model. The data models are interface protocol specific and translated from the information model with the assistance of an automated translation tool. The specific data models considered in this Recommendation include, but are not limited to, yet another new generation (YANG) data models. The specific management and control functions covered by this Recommendation are the [ITU-T G.8113.1] specific OAM functions.

The YANG modules of this Recommendation are aimed to be compatible with the relevant base generic YANG modules from the IETF for the [ITU-T G.8113.1] OAM functionality.

2 References

The following ITU-T Recommendations and other references contain provisions which, through reference in this text, constitute provisions of this Recommendation. At the time of publication, the editions indicated were valid. All Recommendations and other references are subject to revision; users of this Recommendation are therefore encouraged to investigate the possibility of applying the most recent edition of the Recommendations and other references listed below. A list of the currently valid ITU-T Recommendations is regularly published. The reference to a document within this Recommendation does not give it, as a stand-alone document, the status of a Recommendation.

- [ITU-T G.7711] Recommendation ITU-T G.7711/Y.1702 (2022), *Generic protocol-neutral information model for transport resources.*
- [ITU-T G.8013] Recommendation ITU-T G.8013/Y.1731 (2015), *Operation, administration and maintenance (OAM) functions and mechanisms for Ethernet-based networks.*
- [ITU-T G.8113.1] Recommendation ITU-T G.8113.1/Y.1372.1 (2016), *Operations, administration and maintenance mechanisms for MPLS-TP in packet transport networks.*
- [ITU-T G.8121] Recommendation ITU-T G.8121/Y.1381 (2018), *Characteristics of MPLS-TP equipment functional blocks.*
- [ITU-T G.8121.1] Recommendation ITU-T G.8121.1/Y.1381.1 (2018), *Characteristics of MPLS-TP equipment functional blocks supporting ITU-T G.8113.1/Y.1372.1 OAM mechanisms.*
- [ITU-T G.8151] Recommendation ITU-T G.8151/Y.1374 (2024), *Management aspects of the MPLS-TP network element.*

- [ITU-T G.8152] Recommendation ITU-T G.8152/Y.1735 (2018), *Protocol-neutral management information model for the MPLS-TP network element*.
- [IETF RFC 6371] IETF RFC 6371 (2011), *Operations, Administration, and Maintenance Framework For MPLS-Based Transport Networks*.
- [IETF RFC 6991] IETF RFC 6691 (2013), *Common YANG Data Types*.
- [IETF RFC 7950] IETF RFC 7950 (2016), *The YANG 1.1 Data Modeling Language*.
- [IETF RFC 8340] IETF RFC 8340 (2018), *YANG Tree Diagrams*.
- [IETF RFC 8342] IETF RFC 8342 (2018), *Network Management Datastore Architecture (NMDA)*.
- [IETF RFC 8531] IETF RFC 8531 (2019), *Generic YANG Data Model for Connection-Oriented Operations, Administration, and Maintenance (OAM) Protocols*.

3 Definitions

3.1 Terms defined elsewhere

This Recommendation uses the following terms defined elsewhere:

- 3.1.1 maintenance entity (ME)** [ITU-T G.8013]
- 3.1.2 maintenance entity group (MEG)** [ITU-T G.8013]
- 3.1.3 MEG end point (MEP)** [ITU-T G.8013]
- 3.1.4 MEG intermediate point (MIP)** [ITU-T G.8013]
- 3.1.5 on-demand monitoring** [ITU-T G.8013]
- 3.1.6 proactive monitoring** [ITU-T G.8013]
- 3.1.7 maintenance domain (MD)** [IETF RFC 8531]
- 3.1.8 maintenance association (MA)** [IETF RFC 8531]
- 3.1.9 session** [IETF RFC 8531]

3.2 Terms defined in this Recommendation

None.

4 Abbreviations and acronyms

This Recommendation uses the following abbreviations and acronyms:

1DM	One-way Delay Measurement
1TH	One-way Throughput Test
AIS	Alarm Indication Signal
APS	Automatic Protection Switching
CCM	Continuity Check Message
CTP	Connection Termination Point
DM	Delay Measurement
DMM	Delay Measurement Message
DMR	Delay Measurement Reply

DT	Diagnostic Test
LCK	Locked
LM	Loss Measurement
LMM	Loss Measurement Message
LMR	Loss Measurement Reply
LOC	Loss of Continuity
LSP	Label Switched Path
MCC	Management Communication Channel
ME	Maintenance Entity
MEG	Maintenance Entity Group
MEP	Maintenance entity group End Point
MD	Maintenance Domain
MA	Maintenance Association
MI	Management Information
MIP	Maintenance entity group Intermediate Point
MPLS	Multi-Protocol Label Switching
MPLS-TP	Multi-Protocol Label Switching – Transport Profile
NCM	Network Connection Monitoring
NE	Network Element
OAM	Operation, Administration and Maintenance
PDU	Protocol Data Unit
PM	Performance Monitoring
PW	Pseudowire
RDI	Remote Defect Indication
RT	Route Trace
SCC	Signalling Communication Channel
Sk	Sink
SLA	Service Level Agreement
SL	Synthetic Loss Measurement
SLp	Proactive Synthetic Loss Measurement
SLo	On-demand Synthetic Loss Measurement
SNC	Sub-Network Connection
So	Source
TCM	Tandem Connection Monitoring
TH	Throughput
TST	Test
TP	Termination Point

TTL	Time-To-Live
TTP	Trail Termination Point
UML	Unified Modelling Language
YANG	Yet Another New Generation

5 Conventions

5.1 Information modelling conventions

See clause 5.1 of [ITU-T G.7711].

5.1.1 UML modelling conventions

See clause 5.1 of [ITU-T G.7711].

5.1.2 Model artefact lifecycle stereotypes conventions

See clause 5.2 of [ITU-T G.7711].

5.1.3 Forwarding entity terminology conventions

See clause 5.3 of [ITU-T G.7711].

5.1.4 Conditional package conventions

See clause 5.4 of [ITU-T G.7711].

5.1.5 Pictorial diagram conventions

See clause 5.5 of [ITU-T G.7711].

5.2 Equipment function conventions

5.2.1 Maintenance entity group end point (MEP) [ITU-T G.8121]

See clause 5.2.1 of [ITU-T G.8152].

5.2.2 Maintenance entity group intermediate point (MIP) [ITU-T G.8121]

See clause 5.2.2 of [ITU-T G.8152].

5.2.3 MEPs and MIPs along a maintenance entity

See clause 5.2.3 of [ITU-T G.8152].

5.3 Colour code conventions

The following "colour code" is used in this Recommendation:

Table 5-1 – Colour code convention

"colour code"	ITU-T G.8152.1 object class
	Object classes imported from [ITU-T G.8152]
	Object classes reverse-engineered from IETF
	Preliminary or experimental object classes in this Recommendation
	Object classes in this Recommendation
	Abstract object classes in this Recommendation

6 Functions of MPLS-TP OAM

The specific functions covered by this Recommendation are OAM functions of [ITU-T G.8121], [ITU-T G.8121.1] and [ITU-T G.8113.1]. The OAM capability support is listed in Table 6-1. The right-most column is used to describe the involved object instances of the OAM functions.

Table 6-1 – OAM capability support

Consolidation of Tables 7-1 of [ITU-T G.8152] and 7-1 of [ITU-T G.8113.1]

OAM function [ITU-T G.8113.1]		OAM mechanism [ITU-T G.8121] and [ITU-T G.8121.1]		Involved object instances
Proactive performance measuremen t (PM)	Loss measurement (LM)	Direct near-end loss	CCM (Dual-ended) 8.8.4 of [ITU-T G.8121] 8.8.1 of [ITU-T G.8121.1] 8.2.1 of [ITU-T G.8113.1]	Both the A-end MEP and Z-end MEP
		Direct near-end loss & far-end loss	LM (Single-ended) 8.8.4 of [ITU-T G.8121] 8.8.4 of [ITU-T G.8121.1] 8.2.6 of [ITU-T G.8113.1]	Single MEP
		Synthetic near- end loss	Both the A-end MEP and Z-end MEP	
		Synthetic near- end loss & far- end loss	Single MEP	
	Delay measurement (DM)	1-way near-end delay	1DM (dual-ended) 8.8.6 of [ITU-T G.8121] 8.8.6 of [ITU-T G.8121.1] 8.2.7 of [ITU-T G.8113.1]	Both the A-end MEP and Z-end MEP
		• 2-way delay, • 1-way near- end delay • 1-way far-end delay	DM (single-ended) 8.8.6 of [ITU-T G.8121] 8.8.6 of [ITU-T G.8121.1] 8.2.8 of [ITU-T G.8113.1]	Single MEP
On-demand performance measuremen t (PM)	Loss measurement (LM)	Direct near-end loss & far-end loss	LM (single-ended) 8.8.5 of [ITU-T G.8121] 8.8.5 of [ITU-T G.8121.1] 8.2.6 of [ITU-T G.8113.1]	Single MEP
		Synthetic near- end loss	Both the A-end MEP and Z-end MEP	
		Synthetic near-end loss & far-end loss	Single MEP	
	Delay measurement (DM)	1-way near-end delay	1DM (dual-ended) 8.8.7 of [ITU-T G.8121] 8.8.7 of [ITU-T G.8121.1] 8.2.7 of [ITU-T G.8113.1]	Both the A-end MEP and Z-end MEP
		• way near-end delay • way far-end delay • 2-way delay	DM (single-ended) 8.8.7 of [ITU-T G.8121] 8.8.7 of [ITU-T G.8121.1] 8.2.8 of [ITU-T G.8113.1]	Single MEP

Table 6-1 – OAM capability support

Consolidation of Tables 7-1 of [ITU-T G.8152] and 7-1 of [ITU-T G.8113.1]

OAM function [ITU-T G.8113.1]		OAM mechanism [ITU-T G.8121] and [ITU-T G.8121.1]	Involved object instances
	Throughput 1-way throughput test (1TH)	TST (dual-ended) 8.8.8 of [ITU-T G.8121] 8.8.8 of [ITU-T G.8121.1] 8.2.5 of [ITU-T G.8113.1]	Both the A-end MEP and Z-end MEP
Proactive fault management (FM)	Continuity check and connectivity verification (CC of ITU-T CV)	CCM 8.8.1 of [ITU-T G.8121.1] 8.2.1 of [ITU-T G.8113.1]	Gen: A-end MEP of the LSP (or PW or TCM or Section) to Z-end MEP Rec: Z-end MEP
	Remote defect indication (RDI)	RDI bit of CCM 8.8.2 of [ITU-T G.8121.1] 8.2.1 of [ITU-T G.8113.1]	Gen: Z-end MEP of the LSP (or PW or TCM or Section) to A-end MEP Rec: A-end MEP
	Alarm indication signal (AIS)	AIS 8.6.2 and 8.8.10 of [ITU-T G.8121] 8.6.2 and 8.8.10 of [ITU-T G.8121.1] 8.2.3 of [ITU-T G.8113.1]	Gen: Intermediate TP of the LSP (or PW or TCM) to downstream Rec: Downstream MEP
	Locked signal (lock report) (LCK)	LCK 8.6.3 and 8.8.10 of [ITU-T G.8121] 8.6.3 and 8.8.10 of [ITU-T G.8121.1] 8.2.4 of [ITU-T G.8113.1]	Gen: Intermediate TP of the LSP (or PW or TCM) to both up/ef ITU-T down-stream Rec: Downstream MEP Rec: Upstream MEP
	Client signal failure (CSF)	CSF 8.7.3 of [ITU-T G.8121] 8.7.3 of [ITU-T G.8121.1] 8.2.9 of [ITU-T G.8113.1]	Gen: A-end MEP to Z-end MEP Rec: Z-end MEP
On-demand fault management (FM)	Connectivity verification (CV)	LB 8.8.3 of [ITU-T G.8121] 8.8.3 of [ITU-T G.8121.1] 8.2.2 of [ITU-T G.8113.1]	Gen: A-end MEP of the LSP (or PW or TCM or Section) to Z-end MEP Rec: Z-end MEP or Intermediate MIP
	Lock instruction (LKI) – Out of scope of this Recommendation		–
	Route tracing (RT) – For further study	RT 8.8.9 of [ITU-T G.8121] 8.8.9 of [ITU-T G.8121.1] 7.2.1.3 of [ITU-T G.8113.1]	For further study

Table 6-1 – OAM capability support

Consolidation of Tables 7-1 of [ITU-T G.8152] and 7-1 of [ITU-T G.8113.1]

OAM function [ITU-T G.8113.1]		OAM mechanism [ITU-T G.8121] and [ITU-T G.8121.1]	Involved object instances
	Diagnostic test (DT)	LB (bidirectional) 8.8.3 of [ITU-T G.8121.1] 8.2.2 of [ITU-T G.8113.1] TST (unidirectional) 8.8.8 of [ITU-T G.8121.1] 8.2.5 of [ITU-T G.8113.1]	Gen: A-end MEP of the LSP (or PW or TCM or Section) to Z-end MEP Rec: Z-end MEP and Respond back to A-end MEP
OAM for other applications	Automatic protection switching (APS) – Out of scope of this Recommendation		–
	Management communication channel (MCC)of ITU-T signalling communication channel (SCC) – Out of scope of this Recommendation		–

In Table 6-1, there are five types of MPLS-TP OAM, include proactive OAM for performance measurement, on-demand OAM for performance measurement, proactive OAM for fault management and on-demand OAM for fault management and OAM for other applications. The functions of OAM for other applications are out of the scope of this Recommendation. All these MPLS-TP OAM functions are applicable to MPLS-TP sections, label switched paths (LSPs) and pseudowires (PWs).

6.1 Proactive OAM for performance measurement

The proactive OAM for performance measurement is used for performance monitoring purposes. There are two types of functions in Table 6-1: proactive loss measurement and proactive delay measurement.

6.1.1 Proactive loss measurement (LM)

The proactive loss measurement (LM) function is used to measure packet loss on a connection for performance-monitoring purposes. It is performed continuously, and its result is used to verify the performance of the connection against the service level agreement (SLA). This function can be performed by two methods: dual-ended proactive LM by continuity check message (CCM) and single-ended proactive LM by loss measurement message/loss measurement reply (LMM/LMR). The CCM process for dual-ended proactive LM is defined in clauses 8.8.4 of [ITU-T G.8121] and 8.8.1 of [ITU-T G.8121.1]. This process calculates the number of transmitted and lost packets per second. The LMM/LMR process for single-ended LM is defined in clause 8.8.4 of [ITU-T G.8121.1]. This process counts the number of transmitted and received packets.

6.1.2 Proactive delay measurement

The proactive delay measurement is used to measure packet delay (PD) and packet delay variation (PDV) on a connection for performance-monitoring purposes. It is performed continuously, and its result is used to verify the performance of the connection against the service level agreement (SLA). This function can be performed by two methods: single-ended DM by delay measurement message/delay measurement reply (DMM/DMR) and dual-ended DM by one-way delay measurement (1DM). The DMM/DMR process for single-ended proactive DM is defined in clauses 8.8.6.3-8.8.6.6 of [ITU-T G.8121.1]. A source maintenance entity group end point (MEP) sends frames with delay measurement message (DMM) to its peer sink MEP and receives frames

with DM reply (DMR) information from its peer sink MEP to carry out two-way frame delay and two-way frame delay variation measurements. The 1DM process for dual-ended proactive DM is defined in clauses 8.8.6 of [ITU-T G.8121] and 8.8.6.7-8.8.6.10 of [ITU-T G.8121.1]. A source MEP sends frames with 1DM packet to its peer sink MEP and sink MEP enables 1DM to calculate one-way frame delay and one-way frame delay variation. This method needs the clocks between the two MEPs should be synchronized.

6.2 On-demand for performance measurement

The on-demand OAM for performance measurement is used for maintenance purposes. It is performed during a configured specific time interval and its result can be used for diagnosis and analysis. There are three types of functions in Table 6-1: on-demand loss measurement, on-demand delay measurement and throughput measurement.

6.2.1 On-demand loss measurement

The on-demand loss measurement is used to measure packet loss for direct near-end and far-end. This function commonly be performed by the method of single-ended on demand LM with LMM/LMR. The LMM/LMR process for single-ended LM is defined in clause 8.8.5 of [ITU-T G.8121] and [ITU-T G.8121.1] and OAM protocol data unit (PDU) formats are defined in clause 8.2.6 of [ITU-T G.8113.1].

6.2.2 On-demand delay measurement

The on-demand delay measurement is used to measure packet delay for near-end and far-end. This function can be performed by two methods: single-ended DM by DMM/DMR and dual-ended DM by 1DM. The DMM/DMR process for single-ended proactive DM is defined in clauses 8.8.7.3-8.8.7.6 of [ITU-T G.8121.1] and OAM PDU format is defined in clause 8.2.8 of [ITU-T G.8113.1]. A source MEP sends frames with delay measurement message (DMM) to its peer sink MEP and receives frames with DM reply (DMR) information from its peer sink MEP to carry out two-way frame delay and two-way frame delay variation measurements. The 1DM process for dual-ended proactive DM is defined in clauses 8.8.7 of [ITU-T G.8121] and 8.8.7.7-8.8.7.10 of [ITU-T G.8121.1] and OAM PDU format is defined in clause 8.2.7 of [ITU-T G.8113.1]. A source MEP sends frames with 1DM packet to its peer sink MEP and sink MEP enables 1DM to calculate one-way frame delay and one-way frame delay variation. This method needs the clocks between the two MEPs should be synchronized.

6.2.3 Throughput measurement

Throughput measurement is a test function for measuring the rate of receiving packet percentage at sink MEP when source MEP sends OAM test packets at an increasing rate. This function can be performed by two methods: single-ended throughput and dual-ended throughput. This function commonly is performed by the method of dual-ended throughput test (TST) 1-way throughput test (1TH). The TST (1TH) process for dual-ended throughput is defined in clauses 8.8.8 of [ITU-T G.8121] and 8.8.8.2-8.8.8.5 of [ITU-T G.8121.1] and OAM PDU format is defined in clause 8.2.5 of [ITU-T G.8113.1].

6.3 Proactive fault management

The proactive OAM for fault measurement is used for fault management for monitoring purposes. In Table 6-1, there are five types of functions: continuity check and connectivity verification (CC/CV), remote defect indication (RDI), alarm indication signal (AIS), locked signal (LCK) and client signal failure (CSF).

6.3.1 Continuity check and connectivity verification (CC/CV)

The proactive continuity check and connectivity verification (CC/CV) function is used for fault monitoring. The source (So) MEP sends continuity check/connectivity verification (CC/CV) OAM packets periodically at the configured rate. Then the sink (Sk) MEP monitors the arrival of these CC/CV OAM packets at the configured rate and detects the defect of loss of continuity (LOC). The CC/CV function is defined in clause 7.2.1.1.1 of [ITU-T G.8113.1] and OAM PDU format is defined in clause 8.2.1 of [ITU-T G.8113.1]. The CCM process is defined in clauses 8.8.1.2-8.8.1.3 of [ITU-T G.8121.1].

6.3.2 Remote defect indication (RDI)

The proactive remote defect indication (RDI) is an indicator which can be used by a MEP to communicate to its peer MEPs. When a MEP detects a signal fail condition, it sends an RDI to its peer MEPs. An RDI is used only when proactive CC/CV bidirectional transmission is enabled. The RDI function is defined in clause 7.2.1.1.2 of [ITU-T G.8113.1] and OAM PDU format is defined in clause 8.2.1 of [ITU-T G.8113.1]. The CCM process for RDI is defined in clauses 8.8.1.2 and 8.8.1.3 of [ITU-T G.8121.1].

6.3.3 Alarm indication signal (AIS)

The proactive alarm indication signal (AIS) function is used to suppress alarms from a server MEP to the downstream sink client MEP. The AIS function is defined in clause 7.2.1.1.3 of [ITU-T G.8113.1] and OAM PDU format is defined in clause 8.2.3 of [ITU-T G.8113.1]. The AIS process is defined in clauses 8.6.2 and 8.8.10 of [ITU-T G.8121] and [ITU-T G.8121.1].

6.3.4 Locked signal (Lock report) (LCK)

The proactive locked signal (LCK) function is used to communicate to the client (sub-)layer MEPs the administrative locking of a server (sub-)layer MEP and consequential interruption of data traffic forwarding in the client (sub-)layer. The LCK function is defined in clause 7.2.1.1.4 of [ITU-T G.8113.1] and OAM PDU format is defined in clause 8.2.4 of [ITU-T G.8113.1]. The LCK process is defined in clauses 8.6.3 and 8.8.10 of [ITU-T G.8121] and [ITU-T G.8121.1].

6.3.5 Client signal failure (CSF)

The proactive client signal fail (CSF) function is used to process client defects and propagate a client signal defect to the associated remote MEPs using OAM packets. This function is usually used when the client of the MPLS-TP trail does not support a native defect/alarm indication mechanism. The CSF function is defined in clause 7.2.1.1.5 of [ITU-T G.8113.1] and OAM PDU format is defined in clause 8.2.9 of [ITU-T G.8113.1]. The CSF process is defined in clause 8.7.3 of [ITU-T G.8121] and [ITU-T G.8121.1].

6.4 On-demand fault management

The on-demand OAM for fault measurement is used in fault management for maintenance purposes. In Table 6-1, there are six types of functions: CV, LKI, RT, DT. LKI is out of the scope this Recommendation.

6.4.1 Connectivity verification (CV)

On-demand connectivity verification (CV) function is used to detect failures in the path for troubleshooting purposes. It can be used to check in end-to-end MEG or just between an MEP and a specific MIP. This function is defined in clause 7.2.1.2.1 of [ITU-T G.8113.1] and OAM PDU format is defined in clause 8.2.1 of [ITU-T G.8113.1]. The CVM/CVR process is defined in clause 8.8.3 of [ITU-T G.8121] and [ITU-T G.8121.1].

6.4.2 Diagnostic test (DT)

The on-demand DT function is used to estimate fault location by sending OAM DT packets on one direction of the MEG, such as packet loss and bit errors estimation. DT can be performed by two methods: bidirectional loopback (LB) and unidirectional TST. LB procedure for DT is defined in clause 9.1.2 of [ITU-T G.8113.1] and its OAM PDU format is defined in clause 8.2.2 of [ITU-T G.8113.1]. TST process is defined in clause 8.8.8 of [ITU-T G.8121.1] and its OAM PDU format is defined in clause 8.2.5 of [ITU-T G.8113.1].

7 Information model of MPLS-TP OAM

This clause contains the UML information model of the MPLS-TP OAM functions identified in clause 6. This information model is derived from the Recommendation [ITU-T G.8152] foundation MPLS-TP NE information model.

7.1 IETF CO-OAM UML Re-engineered from CO-OAM YANG

IETF has developed the ietf-connection-oriented-oam YANG model, defined in [IETF RFC 8531], which is the generic YANG model for OAM intended to be used as the basis for technology-specific (e.g., MPLS-TP OAM) augmentations. Therefore, the first step to model the ITU-T G.8152.1 information model is to reverse-engineer the UML model from [IETF RFC 8531] YANG model. Figure 7-1 shows object classes reverse-engineered from the [IETF RFC 8531] YANG model.

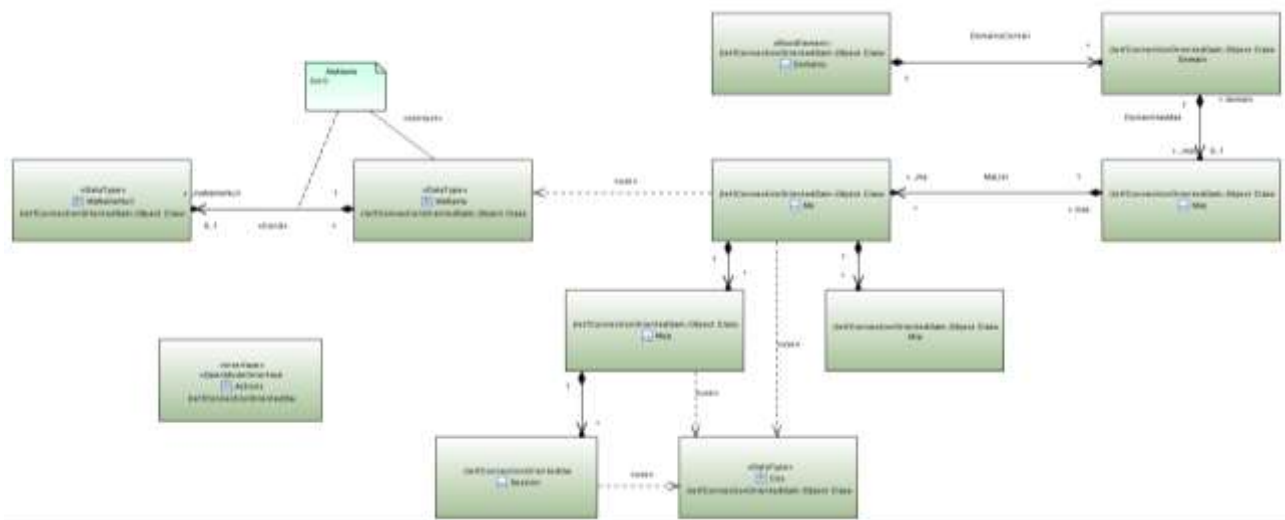

Figure 7-1 – Object classes reverse-engineered from the IETF RFC 8531 YANG model

7.2 MPLS-TP OAM UML

7.2.1 G.8152 based object classes considered

To manage the carrier MPLS-TP OAM functions identified in clause 6, the following ITU-T G.8152 object classes are considered to meet the needs of this Recommendation:

- MT_TrailTerminationPoint/Bidirectional/Sink/Source and the subordinate Pacs
- MT_ConnectionTerminationPoint/Bidirectional/Sink/Source and the subordinate Pacs
- Mep/Bidirectional/Sink/Source
- Mip/Bidirectional/Sink/Source
- OnDemandMeasurementJobControl
- OnDemandSingleEndedMeasurementJobControl
- OnDemandSingleEndedMeasurementJobControlSource

- OnDemandDualEndedMeasurementJobControlSink
- ProactiveDualEndedMeasurementJobControlSink
- ProactiveDualEndedMeasurementJobControlSource
- ProactiveSingleEndedMeasurementJobControlSink
- ProactiveSingleEndedMeasurementJobControlSource
- ProactiveSingleEndedMeasurementJobControlSinkG8113Dot1
- ProactiveSingleEndedMeasurementJobControlSourceG8113Dot1
- MT_CurrentData
- ProactiveDmCurrent/HistoryData
- ProactiveLmCurrentData/HistoryData
- Proactive1LmCurrentData/HistoryData
- Proactive1DmCurrentData/HistoryData
- ThresholdProfile

Besides the above identified ITU-T G.8152 object classes, additional object classes and interface classes are defined in this Recommendation specifically for augmenting the IETF CO-OAM base model.

The object classes and interface classes of the UML model of this Recommendation are organized in two modules as follows.

- The itut-mpls-tp-oam module
 - This module consists of object classes and interface classes for MPLS-TP OAM and performance monitoring, including pro-active monitoring and on-demand monitoring, and maintenance operations.
 - It has the following object classes¹
 - MtMepOamSpec
 - SessionSpec
 - MtProActiveDualEndedMeaJob
 - ProActiveDualEndedMeaJobControlTarget
 - DualEndedCurrentData
 - DualEndedHistoryData
 - ProActiveDualEndedMeaJobControlInitiator
 - MtProActiveSingleEndedMeaJob
 - ProActiveSingleEndedMeaJobControl
 - SingleEndedCurrentData
 - SingleEndedHistoryData
 - MtOnDemandDualEndedMeaJob
 - OnDemandDualEndedMeaJobControlTarget
 - OdDeMjAction
 - OnDemandDualEndedMeaJobControlInitiator

¹ Indentation in the listing reflects subordination hierarchy.

- MtOnDemandSingleEndedMeaJob
 - OnDemandSingleEndedMeaJobControl
 - OdSeMjAction
 - ThresholdProfile
 - It has the following interface classes
 - MtMaintenanceAction
- The itut-mpls-tp-oam-static-lsp module
 - This module consists of object classes for binding the MPLS-TP OAM with the forwarding plane (IETF MPLS static LSP YANG model).
 - It consists of the following three object classes
 - *MaBidirStaticLspSpec*: It references the BidirStaticLsp and augments the Ma
 - *MepInterfaceSpec*: It references the Interface and augments the MEP
 - See Appendix IV for additional information.

7.2.2 Augmentation to the IETF re-engineered UML

The YANG model described in this Recommendation aims to augment the IETF CO-OAM YANG for the MPLS-TP OAM functionality. In UML form, the ITU-T G.8152.1 UML model aims to augment the IETF CO-OAM UML.

Figure 7-2 provides an overview of the augmentation relationship between the IETF CO-OAM classes and those defined in this Recommendation. It illustrates, at high level, that:

- MaSpec augments IETF Ma for the MPLS-TP OAM
- MtMepOamSpec augments IETF Mep for the MPLS-TP MEP (see Figure 7-4 for details)
- MtMipSpec augments IETF Mip for the MPLS-TP MIP (see Figure 7-9)
- MtMaintenanceAction augments IETF Actions for the MPLS-TP OAM operations (see Figure 7-10)
- SessionSpec augments IETF Session for the MPLS-TP proactive and on-demand measurement job.

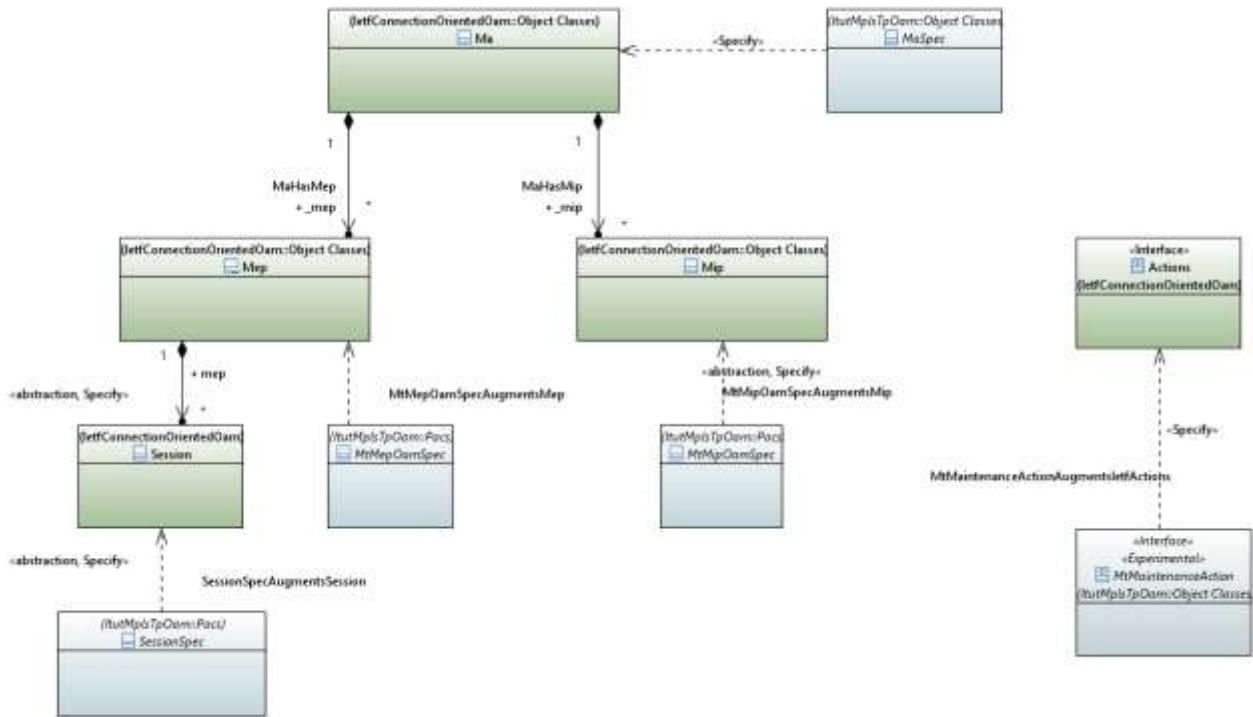

Figure 7-2 – IETF and ITU-T OAM augmentation relationship

7.2.2.1 Maintenance association name choice

Figure 7-3 depicts the maintenance association name choice. The concepts ME, MEG, MEP and MIP are described in both of [ITU-T G.8113.1] and [IETF RFC 6371]. The MEP object class has the attribute megId, which identifies the MEG that the MEP belongs to.

NOTE – The MEG is modelled in [IETF RFC 8531] as a MD with a single MA in [IETF RFC 8531]. The MD name is null and the MA name provides the MEG-ID, which augments the MA name choice.

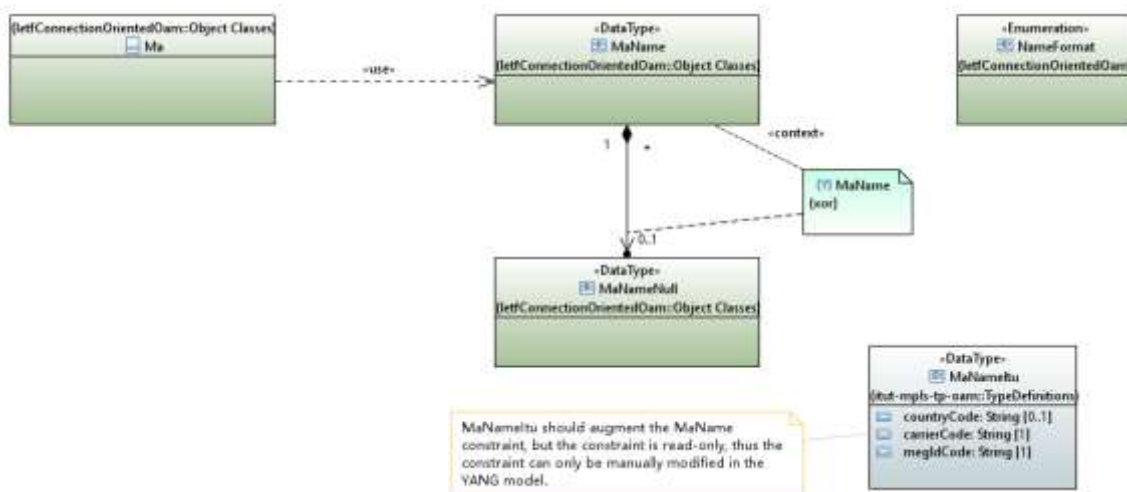

Figure 7-3 – Maintenance association name choice

7.2.2.2 MEP and measurement jobs

The Mep object class and the session object class of the reverse-engineered IETF CO-OAM UML are the touch points for the MPLS-TP OAM augmentation. The IETF Mep UML class and Session UML class are augmented with the MtMepOamSpec class and SessionSpec class of this Recommendation respectively. Figure 7-4 shows the MEP OAM augmentation structure, which is organized according to the MEP OAM functions. This organization is preferred over the alternative way, which organizes according to MEP Bi/Sink/Source.

The MtMepOamSpec object class of this Recommendation contains the following OAM attributes:

- mepType
- tcmMep
- mtLck
- mtAis
- mtTst
- mtCsf
- mtOnDemandCv

These OAM attributes are defined through pruning/refactoring from the ITU-T G.8152 TTP, CTP, Mep, MepSink, MepSource and MepBidirectional classes, as shown in Table II.2.

The measurement jobs are contained in the SessionSpec object class of this Recommendation. The SessionSpec contains an instance of measurement job according to the measurement purpose (i.e., application) and the control mechanism as shown in Table 7-2.1.

Table 7-2.1 – MPLS-TP measurement job and control

Purpose (application)	Control	Measurement job class	Needed control classes
<i>Performance monitoring</i>	<i>Dual ended</i>	MtProActiveDualEndedMeaJob	ProActiveDualEndedMeaJobControlInitiator <i>at the initiating MEP</i>
			ProActiveDualEndedMeaJobControlTarget <i>at the responding MEP</i>
	<i>Single ended</i>	MtProActiveSingleEndedMeaJob	ProActiveSingleEndedMeaJobControl <i>at the initiating MEP</i>
<i>Maintenance</i>	<i>Dual ended</i>	MtOnDemandDualEndedMeaJob	OnDemandDualEndedMeaJobControlInitiator <i>or at the initiating MEP</i>
			OnDemandDualEndedMeaJobControlTarget <i>at the responding MEP</i>
	<i>Single ended</i>	MtOnDemandSingleEndedMeaJob	OnDemandSingleEndedMeaJobControl <i>at the initiating MEP</i>

Note that the above four measurement jobs cannot be enabled at the same time, so there is an 'xor' constraint on them.

Also, for a dual ended measurement job, when the measurement session is establishing, one end of the session can and only can be configured as source, and another end of the session can and only can be configured as sink. So, there is an 'xor' constraint on the initiator and target measurement job control classes.

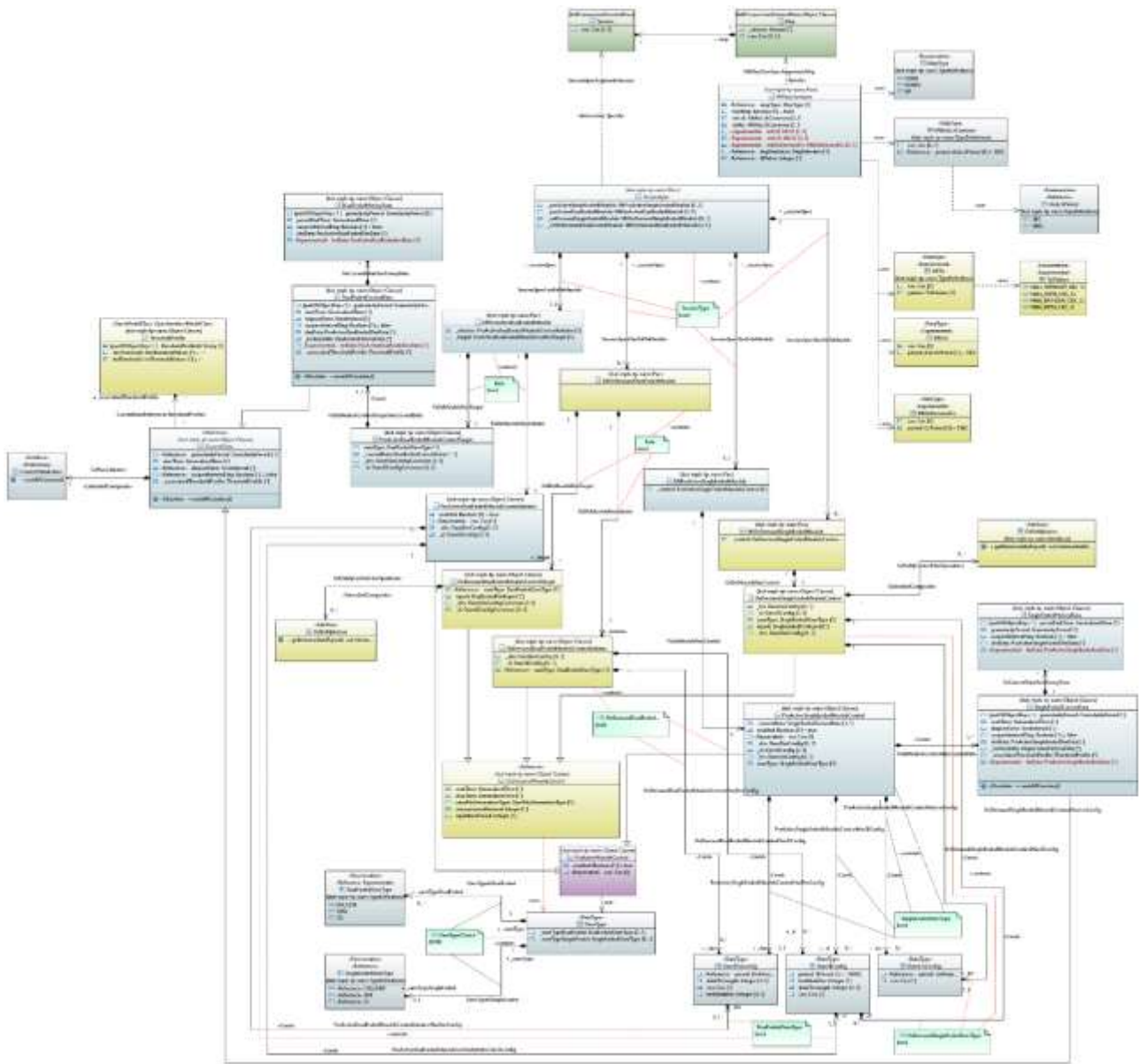

Figure 7-4 – MPLS-TP MEP augmentation with IETF MEP OAM

The measurement job control classes and measurement current/history data classes are pruned and refactored from the corresponding classes defined in [ITU-T G.8152].

Figure 7-5 shows the pruning and refactoring relationship.

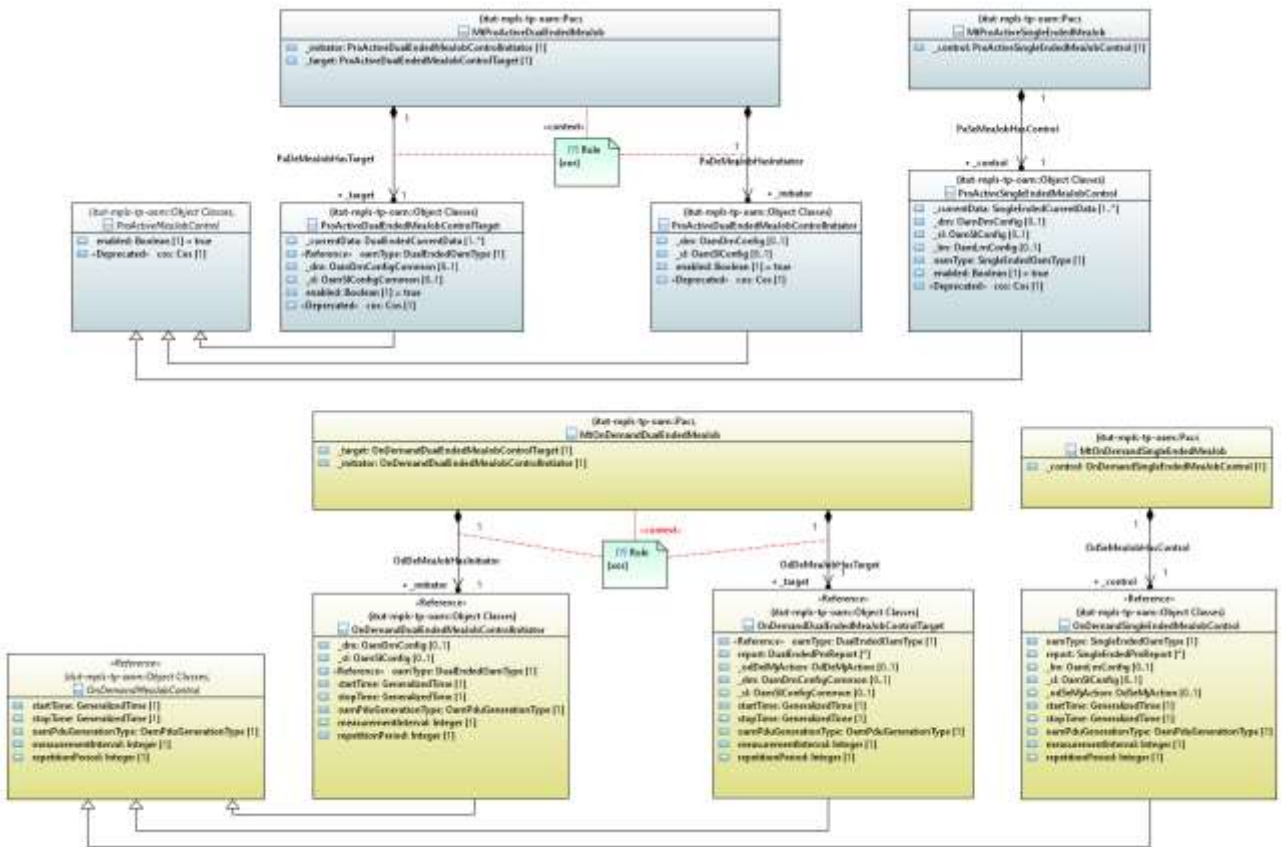

Figure 7-6 – Measurement job control

Figure 7-7 shows the MPLS-TP CurrentData and ThresholdProfile object classes for MPLS-TP performance monitoring measurement thresholding.

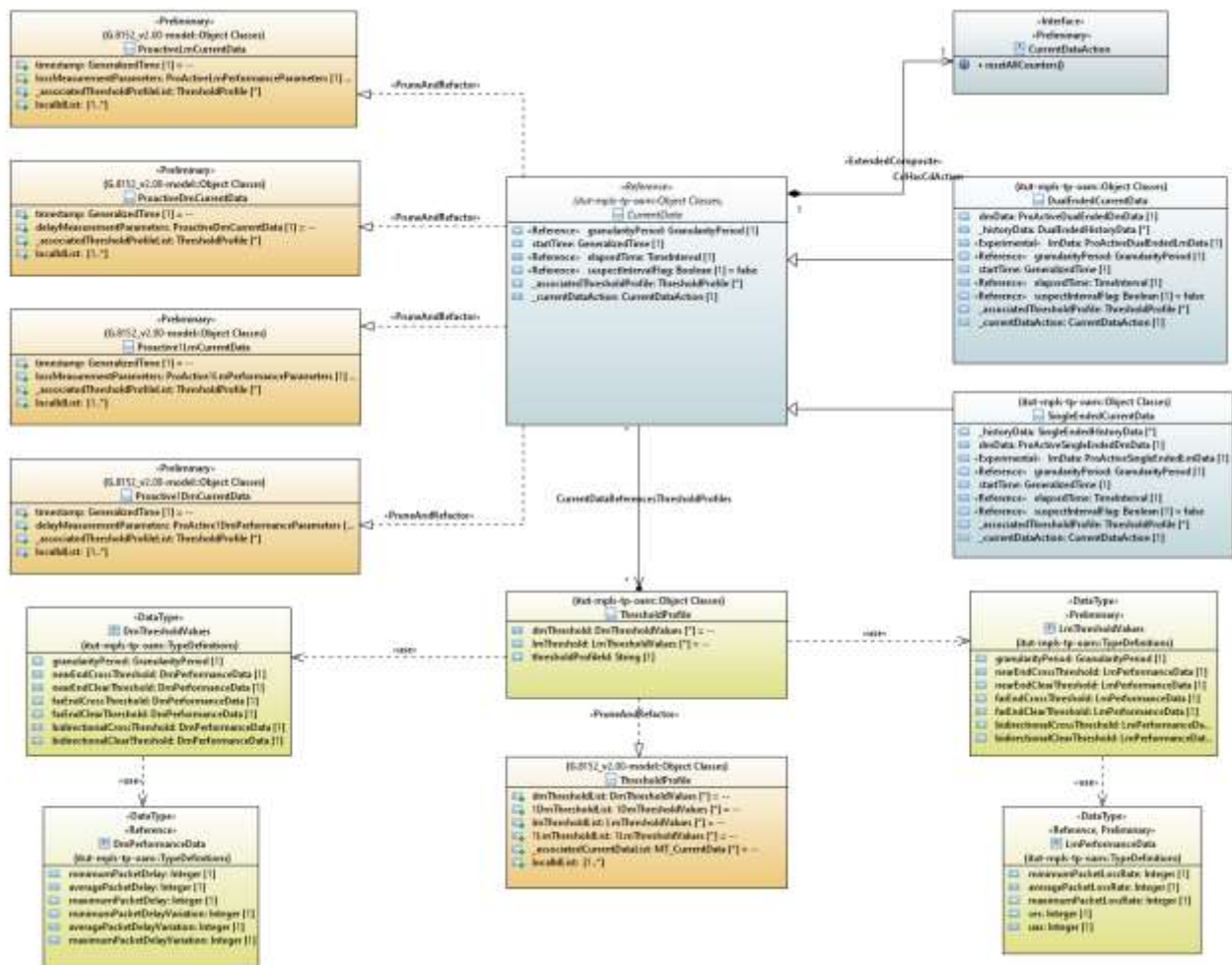

Figure 7-7 – MPLS-TP PM current data and thresholding

Figure 7-8 shows the pruning and refactoring of the ITU-T G.8152 HistoryData to derive the MPLS-TP HistoryData and subclasses.

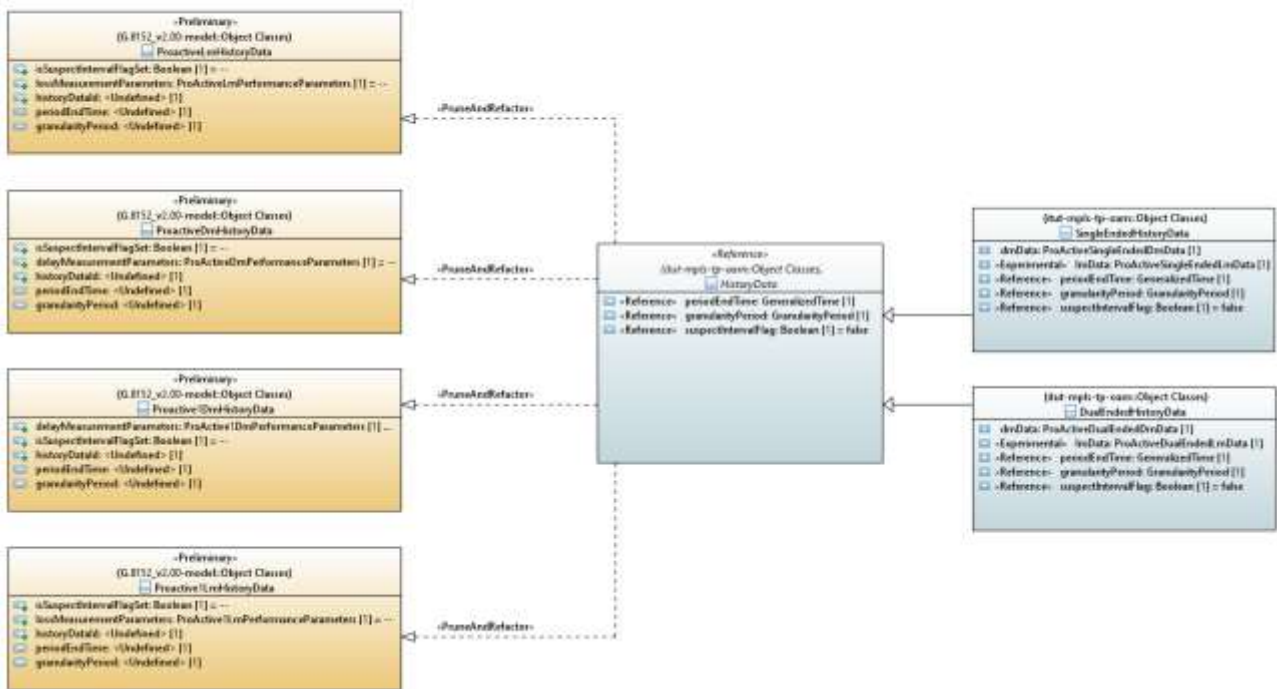

Figure 7-8 – MPLS-TP PM history data

7.2.2.3 MIP

Figure 7-9 shows the MtMipOamSpec object class augmenting the IETF RFC8531 MIP. The MtMipOamSpec is pruned from ITU-T G.8152 MipBirectional object class.

Table II.3 contains the analysis of pruning/refactoring the attributes of the ITU-T G.8152 MIP object classes for this Recommendation.

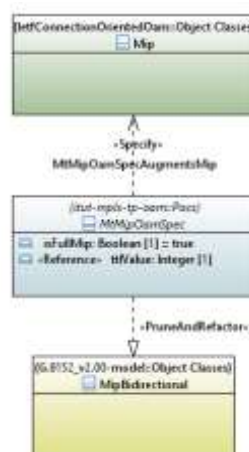

Figure 7-9 – MPLS-TP MIP augmentation and pruning/refactoring

7.2.2.4 Operations

The reverse-engineered IETF RFC8531 OAM UML Actions interface class is the touch point for MPLS-TP OAM operation augmentation. This Action interface class contains the IETF RFC8531 OAM ContinuityCheck, ContinuityVerification and Traceroute operations. It is augmented with the ITU-T G.8152 MtMaintenanceAction interface class for the MPLS-TP OAM maintenance operations.

Figure 7-10 shows the operation augmentation structure. The MtMaintenanceAction interface is designed to contain all the operations that are pruned and refactored from the ITU-T G.8152 MepSource, MepSink, MepBidirectional, MepSourceDot1 and MepSinkDot1.

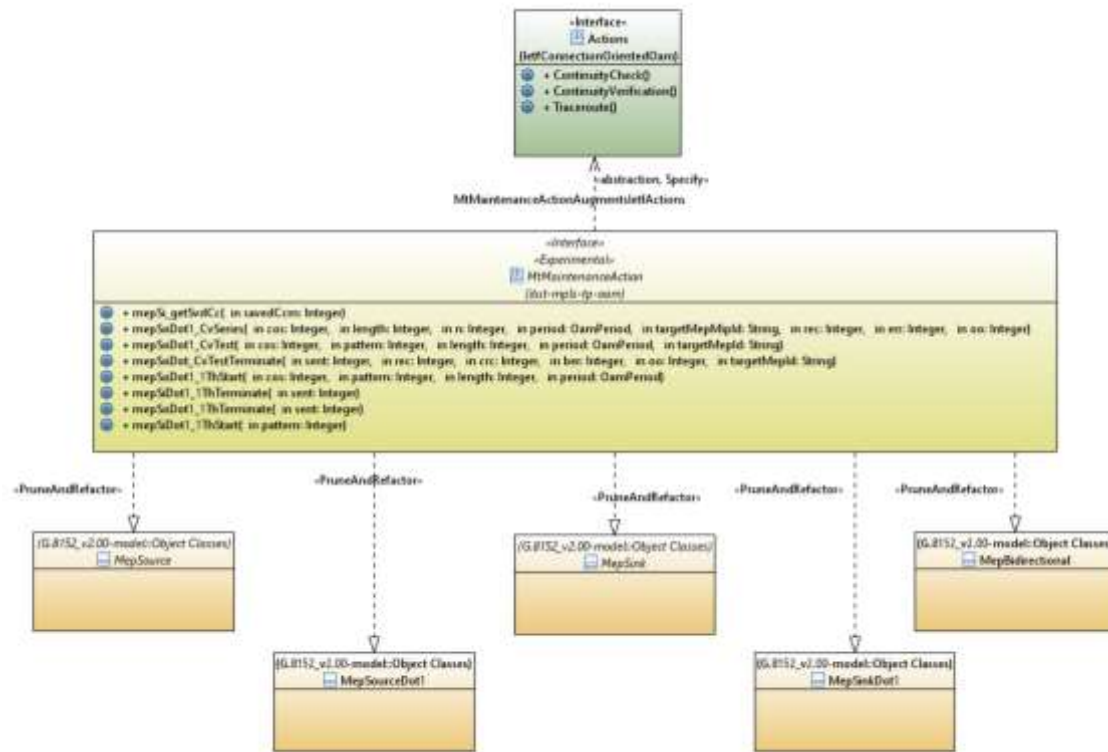

Figure 7-10 – Operations pruning/refactoring augmentation structure

The pruning/refactoring attributes of ITU-T G.8152 MPLS-TP OAM operations for this Recommendation is listed in the Table II.4.

7.2.3 OAM functions modelling

7.2.3.1 Proactive OAM for performance measurement

The proactive OAM for performance measurement functions mainly use two object classes: MtProActiveDualEndedMeaJob and MtProActiveSingleEndedMeaJob. They are pruned and refactored from ProactiveDualEndedMeasurementJobControlSource, ProactiveDualEndedMeasurementJobControlSink, ProactiveSingleEndedMeasurementJobControlSource and ProactiveSingleEndedMeasurementJobControlSink object classes of [ITU-T G.8152].

7.2.3.1.1 Proactive loss measurement (LM)

The dual-ended proactive LM by CCM uses MtProActiveDualEndedMeaJob and single-ended proactive LM by LMM/LMR uses MtProActiveSingleEndedMeaJob.

7.2.3.1.2 Proactive delay measurement (DM)

The single-ended DM by DMM/DMR uses MtProActiveSingleEndedMeaJob and dual-ended DM by IDM uses MtProActiveDualEndedMeaJob.

7.2.3.2 On-demand OAM for performance measurement

The functions of on-demand OAM for performance measurement mainly use two object classes: MtOnDemandDualEndedMeaJob and MtOnDemandSingleEndedMeaJob. They are pruned and refactored from OnDemandSingleEndedMeasurementJobControl, OnDemandSingleEndedMeasurementJobControlSource and OnDemandDualEndedMeasurementJobSink object classes of [ITU-T G.8152].

7.2.3.2.1 On-demand loss measurement

This function is commonly performed by the method of single-ended on demand LM with LMM/LMR, only MtOnDemandSingleEndedMeaJob is used.

7.2.3.2.2 On-demand delay measurement

The single-ended DM by DMM/DMR uses MtOnDemandSingleEndedMeaJob and dual-ended DM by 1DM uses MtOnDemandDualEndedMeaJob.

7.2.3.2.3 Throughput measurement

The single-ended throughput function uses MtOnDemandSingleEndedMeaJob and the dual-ended throughput function uses MtOnDemandDualEndedMeaJob.

7.2.3.3 Proactive fault management

The attributes of this function are in the MtMepOamSpec object class.

7.2.3.3.1 Continuity check and connectivity verification (CC/CV)

The proactive CC/CV related attributes are all pruned from [ITU-T G.8152], as they are already in the MEP object class of [IETF RFC 8531].

7.2.3.3.3 Alarm indication signal (AIS)

This function uses MtMepOamSpec object class. It is pruned and refactored from the [ITU-T G.8152] MT_ConnectionTerminationPointSink object class.

7.2.3.3.4 Locked signal (Lock report)

This function uses MtMepOamSpec object class. It is pruned and refactored from the [ITU-T G.8152] MT_ConnectionTerminationPointSink object class.

7.2.3.3.5 Client signal failure (CSF)

This function uses MtMepOamSpec object class.

7.2.3.4 On-demand fault management

7.2.3.4.1 Connectivity verification (CV)

The on-demand CV related attributes are in the MtMepOamSpec object class, operations are in the MtMaintenanceAction interface object class of [ITU-T G.8152.1].

7.3 UML model files

The UML model for this Recommendation, developed using the Papyrus open-source modelling tool can be found at:

https://www.itu.int/ITU-T/formal-language/itu-t/g/g8152.1/2024/g8152.1_v1.2_uml.zip

The zip file includes the following folders:

- The *G.8152.1_v1.2* folder, which includes the following files:
 - The papyrus project file

- .project
- The .di, .notation, and .uml files of the itut-mpls-tp-oam module
 - itut-mpls-tp-oam.di
 - itut-mpls-tp-oam.notation
 - itut-mpls-tp-oam.uml
- The .di, .notation, and .uml files of the itut-mpls-tp-oam-static-lsp module. This module is still preliminary and is needed to link the MPLS-TP OAM with the Static LSP. Note that the Static LSP Yang model [b-draft-ietf-mpls-static-yang] is still under development in IETF.
 - itut-mpls-tp-oam-static-lsp.di
 - itut-mpls-tp-oam-static-lsp.notation
 - itut-mpls-tp-oam-static-lsp.uml
- The *UmlProfiles* folder, which defines the properties of the UML artefacts:
 - The *OpenModelProfile* folder, which contains the .di, .notation, and uml of the open model profile
 - The *OpenInterfaceModelProfile* folder, which contains the .di, .notation, and uml of the open model interface profile
 - The *ProfileLifecycleProfile* folder, which contains the .di, .notation, and uml of the profile lifecycle profile
 - The *ClassDiagramStyleSheet.css* style sheet
- The *diagrams* folder, which contains the PNG images of all the class diagrams.
- The *doc* folder, which contains the data dictionary form of the ITU-T G.8152.1 UML model
 - The *template* subfolder, which contains the Gendoc template file that is used to generate the data dictionary.
- The G.8152_v2.00 folder, which contains the ITU-T G.8152 base MPLS-TP UML information model that is needed (i.e., imported) by the ITU-T G.8152.1 UML model
- The G.7711_v4.0 folder, which contains the ITU-T G.7711 Core information model that is needed (i.e., imported) by the ITU-T G.8152.1 UML model
- The IetfModels_v1.2 folder, which contains the IETF model that is needed (i.e., imported) by the ITU-T G.8152.1 UML model.

8 Data models of MPLS-TP OAM

This clause contains the interface-protocol-specific data models of the MPLS-TP OAM functions identified in clause 6. These data models are translated from the interface-protocol-neutral UML information specified in clause 7.

8.1 MPLS-TP YANG data models

This clause contains the ITU-T G.8152.1 YANG data model.

The YANG data models defined in this version of the Recommendation uses the YANG 1.1 language defined in [IETF RFC 7950]. The tree format defined in [IETF RFC 8340] is used for the YANG data model tree representation. The YANG data model(s) defined in this Recommendation conforms to the network management datastore architecture in [IETF RFC 8342].

The ITU-T G.8152.1 YANG model is translated from the UML information provided in clause 7.3. The translation is done with the assistance of the Open Source translation tooling xmi2yang, which is developed according to the [b-ONF TR-531] mapping guidelines.

At the time of publication of this Recommendation, the xmi2yang mapping tool is still a work in progress. Therefore, manual modifications on the tool-generated YANG are necessary.

The YANG schema and YANG tree files of the ITU-T G.8152.1 YANG data model can be found at:

https://www.itu.int/ITU-T/formal-language/itu-t/g/g8152.1/2024/g8152.1_v1.2_yang.zip

https://www.itu.int/ITU-T/formal-language/itu-t/g/g8152.1/2025/G.8152.1_v1.3_yang.zip

Appendix I

Overview of the MPLS-TP OAM model configuration cases

(This appendix does not form an integral part of this Recommendation.)

The information model of this Recommendation contains ME, MEG, MEP, MIP, and several OAM function Pacs. In a specific case of OAM configuration, it is necessary to describe how these object classes are used.

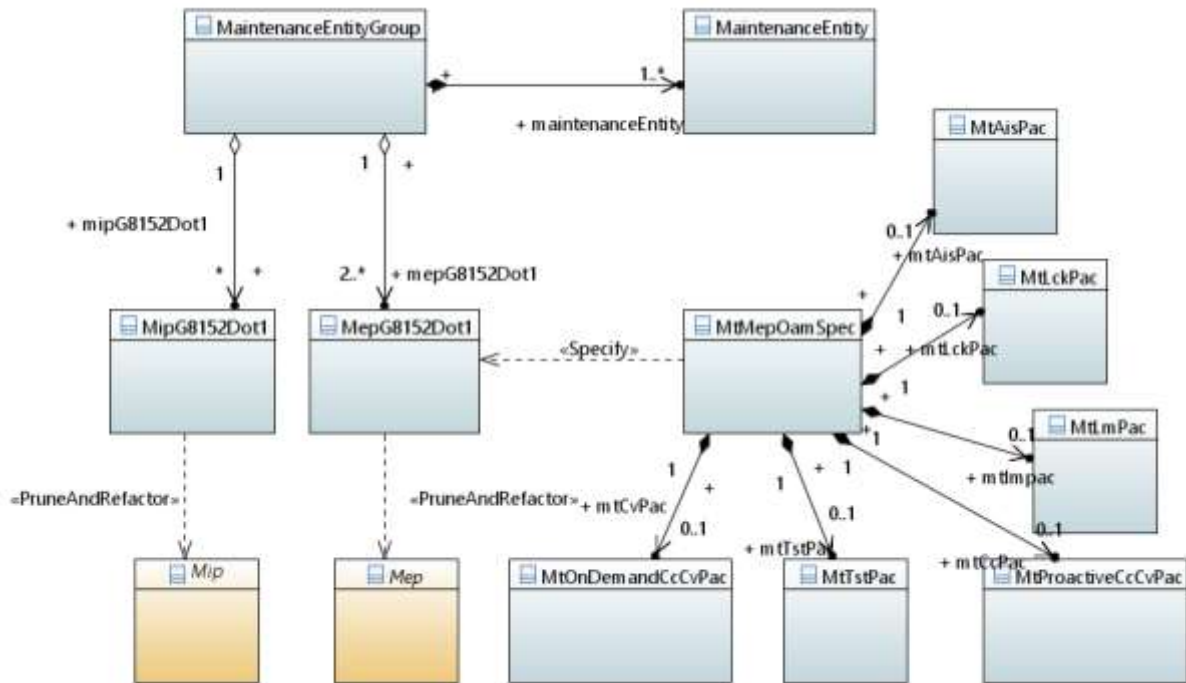

Figure I.1 – OAM configuration

From the Figure I.1, some constraints need to be considered:

- In case of an unidirectional ME, it uses a MepSource at the head-end and MepSink at the tail-end, the MepBidirectional is not used.
- In case of a bidirectional ME, it uses a MepBidirectional at the head-end and the tail-end, the MepSource and MepSink are not used.
- In case of point-to-multipoint MEG, several MEs could share MepSource at root end.

I.1 MEP and MIP configuration

[IETF RFC 6371] provided four types of ME and the [ITU-T G.8110.1] provided point-to-point and point-to-multipoint MEGs, the Table I.1 concludes all configuration cases.

Table I.1 – MEP and MIP configuration

Case	ME and MEG	MEP	MIP
A unidirectional point-to-point transport path	A single unidirectional ME in the point-to-point MEG	A pair of MepSource and MepSink (the MepSource is at the head-end of the path and the MepSink is at the tail-end of the path).	Zero or several pairs of MipSink and MipSource
Associated bidirectional point-to-point transport paths	Two independent unidirectional MEs in the point-to-point MEG	A pair of MepSource and MepSink for each direction of the path (the MepSource is at the head-end of the path and the MepSink is at the tail-end of the path).	Zero or several pairs of MipSink and MipSource
Co-routed bidirectional point-to-point transport paths	A single bidirectional ME in the point-to-point MEG	A pair of MepBidirectional	Zero or several MepBidirectional
Unidirectional point-to-multipoint transport path	A single unidirectional ME for each leaf in point-to-multipoint MEG	A pair of MepSource and MepSink for the path of each of the leaves (the MepSource is at the root and the MepSink is at the leaf. Can use/share a common MepSource at the root.).	Zero or several pairs of MipSink and MipSource

NOTE — The OAM mechanism in [ITU-T G.8113.1] only supports co-routed bidirectional point-to-point MPLS-TP connections.

I.2 OAM Pac configuration

All OAM function attributes are pruned and refactored from the [ITU-T G.8152] model to form MtCc/Cv/Lck/AisPacs in this Recommendation, and anchor to the MtMepOamSpec class. When configuring a specific OAM function on a transport path, Mep could be enhanced by using one or more Pacs of MtMepOamSpec.

Appendix II

Analysis of ITU-T G.8152 attributes and operations for ITU-T G.8152.1

(This appendix does not form an integral part of this Recommendation.)

Table II.1 summarizes the analysis and disposition of the attributes and operations of the base ITU-T G.8152 model on whether they should be retained, refactored or pruned for this Recommendation, and the rationale of doing so.

Table II.1 – MT TTP and CTP pruning/refactoring

Source artefact	To be pruned or moved to	Rationale
Inherited by MT_ConnectionTerminationPoint/Sink/Source/Bidirectional		
Address::address	Pruned	Not needed. It can be inherited from LTP.
G8152LocalClass::localIdList	Pruned	Not needed. It can be inherited from LTP.
LocalClass::localId	Pruned	Not needed. It can be inherited from LTP.
G8152LayerProtocol::layerProtocolName	Pruned	Not needed.
G8152LayerProtocol::_lpSpec	Pruned	No Spec is needed so far.
G8152LayerProtocol::configuredClientCapacity	Pruned	Not needed. This attribute is from the core model LayerProtocol. The client LTP association should provide all necessary detail hence this attribute is questionable, even in the core model.
G8152LayerProtocol::lpDirection	Pruned	Not needed. Already have explicit Bi/Sink/Source object class instances (although in most case is Bidirectional), so no need for the attribute lpDirection (which is Bi/Si/So/UndefinedOrUnknown).
G8152LayerProtocol::terminationState	Pruned	Indicates whether the layer is terminated and if so how. For MT CTP, it is not terminated.
State_Pac::lifecycleState	Pruned	It can be inherited from the LTP.
State_Pac::administrativeState	Pruned	It can be inherited from the LTP.
State_Pac::administrativeControl	Pruned	It can be inherited from the LTP.
State_Pac::operationalState	Pruned	It can be inherited from the LTP.
Extension::extension	Pruned	Not needed. It can be inherited from LTP.
Label::label	Pruned	Not needed. It can be inherited from LTP.
Name::name	Pruned	Not needed. It can be inherited from LTP.

Table II.1 – MT TTP and CTP pruning/refactoring

Source artefact	To be pruned or moved to	Rationale
ClientLayerSpecificAdaptationMi_Pac::clientlayerspecificadaptationmi_pac	Pruned	Not needed. Not complete in [ITU-T G.8152] model.
AdminState::adminState	Pruned	Refactored from Mep::adminState of [ITU-T G.8152].
MT_ConnectionTerminationPointSink		
tc2PhbMapping	Pruned	Qos is out of scope of ITU-T G.8152.1. Used in TC/Label process defined in clause 8.2 of [ITU-T G.8121] to support E-LSP and L-LSP.
qosDecodingMode	Pruned	Qos is out of scope of ITU-T G.8152.1. Used in TC/Label process defined in clause 8.2 of [ITU-T G.8121] to support E-LSP and L-LSP.
lckOamTool:OamTool	Pruned	The mechanism defined in [ITU-T G.8113.1] is used.
lckPeriod::LckAisPeriod	Refactored	Moved (re-factored) to the datatype MtAisLckCommon
lckCos::Integer	Refactored	Moved (re-factored) to the datatype MtAisLckCommon
aisOamTool:OamTool	Pruned	The mechanism defined in [ITU-T G.8113.1] is used.
aisPeriod:LckAisPeriod	Refactored	Moved (re-factored) to the datatype MtAisLckCommon
aisCos:Integer	Refactored	Moved (re-factored) to the datatype MtAisLckCommon
MT_ConnectionTerminationPointSource		
tc2PhbMapping	Pruned	Qos is out of scope of ITU-T G.8152.1.
qosDecodingMode	Pruned	Qos is out of scope of ITU-T G.8152.1.
apsOamCos	Pruned	APS is out of scope of ITU-T G.8152.1.
MT_ConnectionTerminationPointBidirectional		
_mepBidirectional	Retained & Refactored	In ITU-T G.8152.1 model, MtMepOamSpec is used instead of [ITU-T G.8152] class MepBidirectional.

Table II.1 – MT TTP and CTP pruning/refactoring

Source artefact	To be pruned or moved to	Rationale
_mipBidirectional	Retained & Refactored	In ITU-T G.8152.1 model, MtMepOamSpec is used instead of [ITU-T G.8152] class MipBidirectional.
Inherited by MT_TrailTerminationPoint/Sink/Source/Bidirectional		
G8152LocalClass::localId	Pruned	Not needed. It can be inherited from LTP.
G8152GlobalClass::localIdList	Pruned	Not needed. It can be inherited from LTP.
G8152LocalClass::localIdList	Pruned	Not needed. It can be inherited from LTP.
G8152GlobalClass::uuid	Pruned	Not needed. It can be inherited from LTP.
G8152LayerProtocol::layerProtocolName	Pruned	The object class already indicates it is MT TTP. Not needed. It can be inherited from LTP.
G8152LayerProtocol::_lpSpec	Pruned	No Spec is needed so far. Not needed. It can be inherited from LTP.
G8152LayerProtocol::configuredClientCapacity	Pruned	Not needed. This attribute is from the core model LayerProtocol. The client LTP association should provide all necessary detail hence this attribute is questionable, even in the core model.
G8152LayerProtocol::lpDirection	Pruned	Not needed. Already have explicit Bi/Sink/Source object class instances (although in most case is Bidirectional), so no need for the attribute lpDirection (which is Bi/Si/So/UndefinedOrUnknown).
G8152LayerProtocol::terminationState	Pruned	Not needed. MT TTP is terminated. Not needed. It can be inherited from LTP.
Pacs::Tp_Pac::alarmStatus	Pruned	In [ITU-T G.8152] v2.00, Tp_Pac is incomplete.
Pacs::Tp_Pac::crossConnectionObjectPointer	Pruned	In [ITU-T G.8152] v2.00, Tp_Pac is incomplete.
Pacs::Tp_Pac::currentProblemList	Pruned	In [ITU-T G.8152] v2.00, Tp_Pac is incomplete.
Pacs::Tp_Pac::alarmSeverityAssignmentProfilePointer	Pruned	In [ITU-T G.8152] v2.00, Tp_Pac is incomplete.

Table II.1 – MT TTP and CTP pruning/refactoring

Source artefact	To be pruned or moved to	Rationale
Serverlayerspecificadaptationmi_pac	Pruned	In [ITU-T G.8152] v2.00, Tp_Pac is incomplete.
mt_connectionterminationpoint	Pruned	Not needed.
MT_TrailTerminationPointSink		
lmTfMin:Boolean	Refactored	These four attributes are defined in clause 6.1.3.3 of [ITU-T G.8121] for Degrade signal defect (dDEG) to monitor connectivity of a MT trail. According to Figure 9-6 of [ITU-T G.8121.1], these attributes are used for defect generation after a proactive oam sink control process. Moved to MtMepOamSpec.
lmDegm:Integer	Refactored	
lmM:Integer	Refactored	
lmDegThr:Integer	Refactored	
currentProblemList	Pruned	Not needed.
MT_TrailTerminationPointSource		
ttlValue	Pruned	Refactored from MepSource::ttlvalue of [ITU-T G.8152].
MT_TrailTerminationPointBidirectional		
_sccTp	Pruned	Assume not in the scope of ITU-T G.8152.1.
_mccCtp	Pruned	Assume not in the scope of ITU-T G.8152.1.
_mepBidirectional	Retained & Refactored	In ITU-T G.8152.1 model, a class MtMepOamSpec is used instead of [ITU-T G.8152] class MepBidirectional.
_ethConnectionTerminationPoint	Pruned	Not needed.

Table II.2 – MT MEP classes pruning/refactoring

Source artefact	To be pruned or moved to	Rationale
G8152LocalClass::localId	Pruned	Not needed. It can be inherited from LTP.
MEP		
Mep::adminState	Retained	Used in Selector process defined in clause 8.6.1 of [ITU-T G.8121].
Mep::mepMac	Pruned	It does not exist in [ITU-T G.8152] model.

Table II.2 – MT MEP classes pruning/refactoring

Source artefact	To be pruned or moved to	Rationale
Mep::mel	Pruned	It does not exist in [ITU-T G.8152] model.
G8152LocalClass::localIdList	Pruned	Not needed. It can be inherited from LTP.
Mep::megId	Refactored	This attribute identifies the MEG instance that the subject MEP belongs to. Move to G.8152.1::MaNameItu::megIdCode
Mep::mepId	Pruned	Available in IETF::Mep::mepId
Mep::cvOamTool	Pruned	The mechanism defined in [ITU-T G.8113.1] is used.
Mep::cvpEnable	Pruned	MI_CVp_Enable defined in [ITU-T G.8121] is automatically configured true by setting MI_CC_Enable true.
Mep::ccEnable	Pruned	Available in IETF::Mep::ccEnable
Mep::ccPeriod	Pruned	Available in IETF::ContinuityCheck::ccTransmit Interval
Mep::ccCos	Pruned	Available in IETF::Mep::cosid
Mep::ccOamTool	Pruned	The mechanism defined in [ITU-T G.8113.1] is used.
Mep::dpLoopbackEnable	Pruned	dpLoopback is for [ITU-T G.8113.2], is out of scope of [ITU-T G.8113.1].
Mep::rdiOamTool	Pruned	The mechanism defined in [ITU-T G.8113.1] is used.
Mep::lThOamTool	Pruned	The mechanism defined in [ITU-T G.8113.1] is used.
MEP Sink		
MepSink::peerMepIdentifier	Pruned	MepId and peerMepIdentifier can identify a ME. Available in IETF::Mep::Session::destinationMep
MepSink::aisOamTool	Pruned	The mechanism defined in [ITU-T G.8113.1] is used.
MepSink::lckOamTool	Pruned	The mechanism defined in [ITU-T G.8113.1] is used.
MepSink::remoteLockRequest	Pruned	As Table 6-1 of ITU-T G.8152.1 shows that, LKI is out of scope of ITU-T G.8152.1. The remoteLockRequest models for MI_Admin_State_Request defined

Table II.2 – MT MEP classes pruning/refactoring

Source artefact	To be pruned or moved to	Rationale
		in clause 8.8.11 of [ITU-T G.8121] for Lock Instruct process.
MEP Source		
MepSource::ttlValue	Retained	From source Mep to Mip, and from Mip to sink Mep, "Time To Live" value is inserted in the outer shim header's TTL field within the MT_AI traffic unit. Moved to G.8152.1::MtMepOamSpe::ttlvalue
MepSource::lockInstructEnable	Pruned	As Table 6-1 of ITU-T G.8152.1 shows that, LKI is out of scope of ITU-T G.8152.1. The remoteLockRequest models for MI_Admin_State_Request defined in clause 8.8.11 of [ITU-T G.8121] for Lock Instruct process.
MepSource::adminState	Pruned	Retained from G.8152::Mep::adminState
MEP Bidirectional		

Table II.3 summarises MT MIP classes pruning/refactoring.

Table II.3 – MT MIP Classes Pruning/Refactoring

Source artefact	To be pruned or moved to	Rationale
G8152LocalClass::localId	Pruned	It can be inherited from LTP.
MIP		
G8152LocalClass::localIdList	Pruned	It can be inherited from LTP.
Mip::mipId	Pruned	For identify a Mip instance. Available in IETF::Mip::name
Mip::ttlValue	Retained	From source Mep to Mip, and from Mip to sink Mep, "Time To Live" value is inserted in the outer shim header's TTL field within the MT_AI traffic unit. Moved to G.8152.1::MtMipOamSpe::ttlvalue
Mip::cvOamTool	Pruned	The mechanism defined in [ITU-T G.8113.1] is used.
Mip::dpLoopbackEnable	Pruned	It is defined in [ITU-T G.8113.2], is out of scope of [ITU-T G.8113.1].

Table II.3 – MT MIP Classes Pruning/Refactoring

Source artefact	To be pruned or moved to	Rationale
MIP Sink		
MIP Source		
MIP Bidirectional		
Mip::isFullMip	Retained	Moved to MtMipOamSpec object class.

Table II.4 summarises pruning/refactoring of MEP/MIP operations.

Table II.4 – Pruning/refactoring of MEP/MIP operations

Source artefact	To be pruned or moved to	Rationale
MtMepInterface		
mepSi_establishOnDemandDualEndedMeasurementJobSink	Pruned	Achieved via object creation of an instance of MtOnDemandDualEndedMeasurementJob and a subtending OnDemandDualEndedMeasurementJobControlTarget instance.
mepSi_establishProactiveDualEndedMeasurementJobSink	Pruned	Achieved via object creation of an instance of MtProActiveDualEndedMeasurementJob and a subtending ProActiveDualEndedMeasurementJobControlTarget instance.
mepSi_getSvdCc	Retained	Cc is a Proactive FM function using CCM which is an ITU-T OAM mechanism. Moved to MtMaintenanceAction::mepSi_getSvdCc
mepSo_establishOnDemandDualEndedMeasurementJobSource	Pruned	Achieved via object creation of an instance of MtOnDemandDualEndedMeasurementJob and a subtending OnDemandDualEndedMeasurementJobControlInitiator instance.
mepSo_establishProactiveDualEndedMeasurementJobSource	Pruned	Achieved via object creation of an instance of MtProActiveDualEndedMeasurementJob and a subtending ProActiveDualEndedMeasurementJobControlInitiator instance.

Table II.4 – Pruning/refactoring of MEP/MIP operations

Source artefact	To be pruned or moved to	Rationale
mepSo_CvSeries	Pruned	Achieved via mepSoDot1_CvSeries.
mepBi_establishOnDemandDualEndedMeasurementJob	Pruned	Achieved via object creation of an instance of MtOnDemandDualEndedMeaJob and subtending OnDemandDualEndedMeaJobControlInitiator, OnDemandDualEndedMeaJobControlTarget instances.
mepBi_establishProactiveDualEndedMeasurementJob	Pruned	Achieved via object creation of an instance of MtProActiveDualEndedMeaJob and subtending ProActiveDualEndedMeaJobControlInitiator, ProActiveDualEndedMeaJobControlTarget instances.
mepSoDot1_1ThStart	Retained	1Th is an On-demand PM function using TST which is an ITU-T OAM mechanism. Moved to MtMaintenanceAction::mepSoDot1_1ThStart.
mepSoDot1_1ThTerminate	Retained	1Th is an On-demand PM function using TST which is an ITU-T OAM mechanism. Moved to MtMaintenanceAction::mepSoDot1_1ThTerminate.
mepSoDot1_CvSeries	Retained	Cv is a Proactive FM function using CCM or an On-demand FM function using LB which both are ITU-T OAM mechanisms. Moved to MtMaintenanceAction::mepSoDot1_CvSeries.
mepSoDot1_CvTest	Retained	Cv is a Proactive FM function using CCM or an On-demand FM function using LB which both are ITU-T OAM mechanisms. Moved to MtMaintenanceAction::mepSoDot1_CvTest.
mepSoDot1_CvTestTerminate	Retained	Cv is a Proactive FM function using CCM or an On-demand

Table II.4 – Pruning/refactoring of MEP/MIP operations

Source artefact	To be pruned or moved to	Rationale
		FM function using LB which both are ITU-T OAM mechanisms. Moved to MtMaintenanceAction:: mepSoDot1_CvTestTerminate.
mepSiDot1_1ThStart	Retained	1Th is an On-demand PM function using TST which is an ITU-T OAM mechanism. Moved to MtMaintenanceAction:: mepSiDot1_1ThStart.
mepSiDot1_1ThTerminate	Retained	1Th is an On-demand PM function using TST which is an ITU-T OAM mechanism. Moved to MtMaintenanceAction:: mepSiDot1_1ThTerminate.
mepControl_createMep	Pruned	Achieved via object creation of an instance of Mep.
mepControl_deleteMep	Pruned	Achieved via object deletion of an instance of Mep.
mepControl_getAllContainedMeps	Pruned	Achieved via retrieval of all object instances of Mep.
mepControl_modifyMep	Pruned	Achieved via object modification of an instance of Mep.
onDemandDualEndedMeaJobControlSink_getIntermediateReport	Retained	This is an ITU-T measurement job. Moved to OdDeMjAction.
onDemandSingleEndedMeaJobControl_getIntermediateReport	Retained	This is an ITU-T measurement job. Moved to OdSeMjAction
MtMipInterface		
mipControl_createMip	Pruned	Achieved via object creation of an instance of Mip.
mipControl_modifyMip	Pruned	Achieved via object modification of an instance of Mip.
mipControl_deleteMip	Pruned	Achieved via object deletion of an instance of Mip.
mipControl_getAllContainedMips	Pruned	Achieved via retrieval of all contained instances of Mip.

Table II.5 summarises MT measurement job classes pruning/refactoring.

Table II.5 – MT measurement job classes pruning/refactoring

Source artefact	To be pruned or moved to	Rationale
Inherited by ProactiveSingleEndedMeasurementJobControlSource/Sink/SourcG8113Dot1/SinkG8113Dot1		
G8152LocalClass::localIdList	Pruned	Not needed.
State_Pac::lifecycleState	Pruned	It can be inherited from the LTP.
State_Pac::administrativeState	Pruned	It can be inherited from the LTP.
State_Pac::administrativeControl	Pruned	It can be inherited from the LTP.
State_Pac::operationalState	Pruned	It can be inherited from the LTP.
Extension::extension	Pruned	Not needed.
Label::label	Pruned	Not needed.
Name::name	Pruned	Not needed.
ProactiveSingleEndedMeasurementJobControlSource		
ProactiveSingleEndedMeasurementJobControlSource::oamType	Refactored:	ProactiveSingleEndedMeaJ ob is used for 2-way measurement. Moved (re-factored) to ProActiveSingleEndedMea JobControl::oamType
ProactiveSingleEndedMeasurementJobControlSource::isEnabled	Refactored:	Moved (re-factored) to ProActiveSingleEndedMea JobControl::enabled
ProactiveSingleEndedMeasurementJobControlSource::period	Refactored	Move to ProActiveSingleEndedMea JobControl::dm::period, ProActiveSingleEndedMea JobControl::sl::period, ProActiveSingleEndedMea JobControl::lm::period
ProactiveSingleEndedMeasurementJobControlSource::classOfService	Refactored	This attribute contains the priority value on which the MEP performs the measurement. When the measurement is enabled, the MEP should use this value to encode the priority of generated measurement frames. Move to ProActiveSingleEndedMea JobControl::dm::cos, ProActiveSingleEndedMea JobControl::lm::cos,

Table II.5 – MT measurement job classes pruning/refactoring

Source artefact	To be pruned or moved to	Rationale
		ProActiveSingleEndedMeaJobControl::sl::cos
ProactiveSingleEndedMeasurementJobControlSource::testIdentifier	Refactored	Move to ProActiveSingleEndedMeaJobControl::dm::testIdentifier, ProActiveSingleEndedMeaJobControl::sl::testIdentifier
ProactiveSingleEndedMeasurementJobControlSource::dataTlvLength	Refactored	Move to ProActiveSingleEndedMeaJobControl::dm::dataTlvLength, ProActiveSingleEndedMeaJobControl::sl::dataTlvLength
ProactiveSingleEndedMeasurementJobControlSink		
ProactiveSingleEndedMeasurementJobControlSink::oamType	Refactored	ProactiveSingleEndedMeaJob is used for 2-way measurement. Moved (re-factored) to ProActiveSingleEndedMeaJobControl::oamType
ProactiveSingleEndedMeasurementJobControlSink::isEnabled	Refactored	Moved (re-factored) to ProActiveSingleEndedMeaJobControl::enabled
ProactiveSingleEndedMeasurementJobControlSink::classOfService	Refactored	Refactored to ProActiveSingleEndedMeaJobControl::dm::cos, ProActiveSingleEndedMeaJobControl::sl::cos, ProActiveSingleEndedMeaJobControl::lm::cos
ProactiveSingleEndedMeasurementJobControlSourceG8113Dot1/SinkG8113Dot1		
Inherited by ProactiveDualEndedMeasurementJobSource/Sink		
G8152LocalClass::localIdList	Pruned	Not needed.
State_Pac::lifecycleState	Pruned	It can be inherited from the LTP.
State_Pac::administrativeState	Pruned	It can be inherited from the LTP.
State_Pac::administrativeControl	Pruned	It can be inherited from the LTP.
State_Pac::operationalState	Pruned	It can be inherited from the LTP.
Extension::extension	Pruned	Not needed.

Table II.5 – MT measurement job classes pruning/refactoring

Source artefact	To be pruned or moved to	Rationale
Label::label	Pruned	Not needed.
Name::name	Pruned	Not needed.
G8152LocalClass::localIdList	Pruned	Not needed.
State_Pac::lifecycleState	Pruned	It can be inherited from the LTP.
State_Pac::administrativeState	Pruned	It can be inherited from the LTP.
State_Pac::administrativeControl	Pruned	It can be inherited from the LTP.
State_Pac::operationalState	Pruned	It can be inherited from the LTP.
Extension::extension	Pruned	Not needed.
ProactiveDualEndedMeasurementJobControlSource		
ProactiveDualEndedMeasurementJobControlSource::oamType	Refactored	MtProActiveDualEndedMeaJob is used for 1-way measurement. Moved to ProActiveDualEndedMeaJobControlInitiator::oamType
ProactiveDualEndedMeasurementJobControlSource::oamTool	Pruned	The mechanism defined in [ITU-T G.8113.1] is used.
ProactiveDualEndedMeasurementJobControlSource::isEnabled	Refactored	Moved (re-factored) to ProActiveDualEndedMeaJobControlInitiator::enabled
ProactiveDualEndedMeasurementJobControlSource::period	Refactored	Moved to ProActiveDualEndedMeaJobControlInitiator::dm::period, ProActiveDualEndedMeaJobControlInitiator::sl::period
ProactiveDualEndedMeasurementJobControlSource::classOfService	Refactored	Moved to ProActiveDualEndedMeaJobControlInitiator::dm::cos, ProActiveDualEndedMeaJobControlInitiator::sl::cos
ProactiveDualEndedMeasurementJobControlSource::testIdentifier	Refactored	Moved to ProActiveDualEndedMeaJobControlInitiator::dm::testIdentifier, ProActiveDualEndedMeaJobControlInitiator::sl::testIdentifier

Table II.5 – MT measurement job classes pruning/refactoring

Source artefact	To be pruned or moved to	Rationale
ProactiveDualEndedMeasurementJobControlSink		
ProactiveDualEndedMeasurementJobControlSink::oamType	Refactored	MtProActiveDualEndedMeaJob is used for 1-way measurement. Moved (re-factored) to ProActiveDualEndedMeaJobControlTarget::oamType
ProactiveDualEndedMeasurementJobControlSink::isEnabled	Refactored	Moved (re-factored) to ProActiveDualEndedMeaJobControlTarget::enabled
ProactiveDualEndedMeasurementJobControlSink::period	Refactored	ProActiveDualEndedMeaJobControlTarget::dm::period, ProActiveDualEndedMeaJobControlTarget::sl::period
ProactiveDualEndedMeasurementJobControlSink::testIdentifier	Refactored	ProActiveDualEndedMeaJobControlTarget::dm::testIdentifier, ProActiveDualEndedMeaJobControlTarget::sl::testIdentifier
Inherited by OnDemandSingleEndedMeasurementJobControl		
OnDemandSingleEndedMeasurementJobControl::oamType	Refactored	MtOnDemandDualEndedMeaJob is used for 2-way measurement. Moved to OnDemandSingleEndedMeaJobControl::oamType
OnDemandSingleEndedMeasurementJobControl::startTime	Refactored	Moved to OnDemandSingleEndedMeaJobControl::startTime
OnDemandSingleEndedMeasurementJobControl::stopTime	Refactored	Moved to OnDemandSingleEndedMeaJobControl::stopTime
OnDemandSingleEndedMeasurementJobControl::oamPduGenerationType	Refactored	Moved to OnDemandSingleEndedMeaJobControl::oamPduGenerationType
OnDemandSingleEndedMeasurementJobControl::classOfService	Refactored	Moved to OnDemandSingleEndedMeaJobControl::sl::cos, OnDemandSingleEndedMeaJobControl::lm::cos, OnDemandSingleEndedMeaJobControl::dm::cos
OnDemandSingleEndedMeasurementJobControl::testIdentifier	Refactored	Moved to

Table II.5 – MT measurement job classes pruning/refactoring

Source artefact	To be pruned or moved to	Rationale
		OnDemandSingleEndedMeasurementJobControl::sl::testIdentifier, OnDemandSingleEndedMeasurementJobControl::dm::testIdentifier
OnDemandSingleEndedMeasurementJobControl::measurementInterval	Refactored	Moved to OnDemandSingleEndedMeasurementJobControl::measurementInterval
OnDemandSingleEndedMeasurementJobControl::messagePeriod	Refactored	Refactored to OnDemandSingleEndedMeasurementJobControl::sl::period, OnDemandSingleEndedMeasurementJobControl::lm::period, OnDemandSingleEndedMeasurementJobControl::dm::period
OnDemandSingleEndedMeasurementJobControl::dataTlvLength	Refactored	Moved to OnDemandSingleEndedMeasurementJobControl::sl::dataTlvLength, OnDemandSingleEndedMeasurementJobControl::dm::dataTlvLength
OnDemandSingleEndedMeasurementJobControl::repetitionPeriod	Refactored	Moved to OnDemandSingleEndedMeasurementJobControl::repetitionPeriod
OnDemandSingleEndedMeasurementJobControl::onDemandPerformanceData	Pruned	Not needed.
Inherited by OnDemandSingleEndedMeasurementJobControlSource		
OnDemandSingleEndedMeasurementJobControlSource::oamType	Refactored	MtOnDemandDualEndedMeasurementJob is used for 1-way measurement. Moved to OnDemandSingleEndedMeasurementJobControl::oamType
OnDemandSingleEndedMeasurementJobControlSource::startTime	Refactored	Moved to OnDemandSingleEndedMeasurementJobControl::startTime
OnDemandSingleEndedMeasurementJobControlSource::stopTime	Refactored	Moved to OnDemandSingleEndedMeasurementJobControl::stopTime
OnDemandSingleEndedMeasurementJobControlSource::oamPduGenerationType	Refactored	Moved to OnDemandSingleEndedMeasurementJobControl::oamPduGenerationType

Table II.5 – MT measurement job classes pruning/refactoring

Source artefact	To be pruned or moved to	Rationale
OnDemandSingleEndedMeasurementJobControlSource::classOfService	Refactored	Refactored to OnDemandSingleEndedMeasurementJobControl::sl::cos, OnDemandSingleEndedMeasurementJobControl::lm::cos, OnDemandSingleEndedMeasurementJobControl::dm::cos
OnDemandSingleEndedMeasurementJobControlSource::testIdentifier	Refactored	Moved to OnDemandSingleEndedMeasurementJobControl::sl::testIdentifier, OnDemandSingleEndedMeasurementJobControl::dm::testIdentifier
OnDemandSingleEndedMeasurementJobControlSource::measurementInterval	Refactored	Moved to OnDemandSingleEndedMeasurementJobControl::measurementInterval
OnDemandSingleEndedMeasurementJobControlSource::messagePeriod	Refactored	Refactored to OnDemandSingleEndedMeasurementJobControl::sl::period, OnDemandSingleEndedMeasurementJobControl::lm::period, OnDemandSingleEndedMeasurementJobControl::dm::period
OnDemandSingleEndedMeasurementJobControlSource::dataTlvLength	Refactored	Moved to OnDemandSingleEndedMeasurementJobControl::sl::dataTlvLength, OnDemandSingleEndedMeasurementJobControl::dm::dataTlvLength
OnDemandSingleEndedMeasurementJobControlSource::repetitionPeriod	Refactored	Moved to OnDemandSingleEndedMeasurementJobControl::repetitionPeriod
OnDemandSingleEndedMeasurementJobControlSource::onDemandPerformanceData	Refactored	Moved to OnDemandSingleEndedMeasurementJobControl::OamLmConfig, OnDemandSingleEndedMeasurementJobControl::OamSlConfig

Table II.5 – MT measurement job classes pruning/refactoring

Source artefact	To be pruned or moved to	Rationale
Inherited by OnDemandDualEndedMeasurementJobControlSink		
OnDemandDualEndedMeasurementJobControlSink::oamType	Refactored	MtOnDemandDualEndedMeasurementJob is used for 1-way measurement. Moved to OnDemandDualEndedMeasurementJobControlTarget::oamType
OnDemandDualEndedMeasurementJobControlSink::startTime	Refactored	Moved to OnDemandDualEndedMeasurementJobControlTarget::startTime
OnDemandDualEndedMeasurementJobControlSink::stopTime	Refactored	Moved to OnDemandDualEndedMeasurementJobControlTarget::stopTime
OnDemandDualEndedMeasurementJobControlSink::onDemandPerformanceData	Pruned	Not needed.
OnDemandDualEndedMeasurementJobControlSink::testIdentifier	Refactored	Moved to OnDemandDualEndedMeasurementJobControlTarget::dm::testIdentifier, OnDemandDualEndedMeasurementJobControlTarget::sl::testIdentifier

Appendix III

Examples of using the IETF MPLS static lsp model with MPLS-TP co-oam models

(This appendix does not form an integral part of this Recommendation.)

The following JSON codes are provided as examples of instances of the configuration and operational data stores of the YANG models defined in this Recommendation, together with the MPLS static LSP YANG model and under definition in [b-draft-ietf-mpls-static-yang], MPLS-TP OAM YANG model, to support the different operational scenarios.

The examples can be downloaded from [this repository](#).

III.1 MPLS-TP trail monitoring examples

Figure III.1 describes the reference network used to analyse the examples for MPLS-TP trail monitoring:

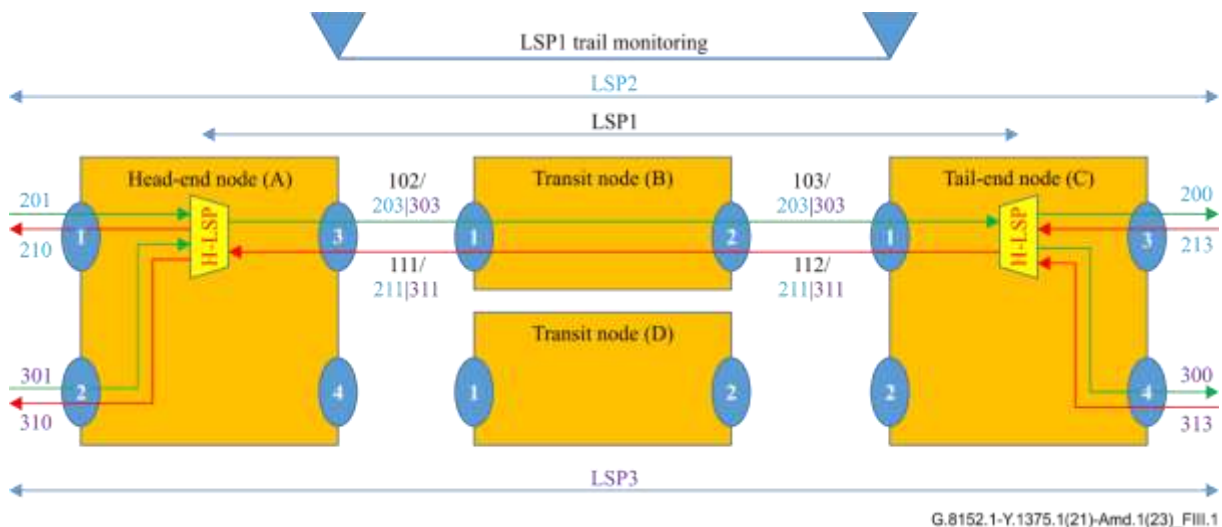

Figure III.1 – Example reference network for MPLS-TP trail monitoring

In this example, an MPLS-TP trail (i.e., LSP1) has been set up, with trail monitoring, between nodes A and C to be used as a server MPLS-TP sub-layer to carry two client MPLS-TP sub-network connections (i.e., LSP2 and LSP3).

The label values marked in black (e.g., 102) represent the label assigned to LSP1 on different links; the label values marked in cyan (e.g., 201) represent the label values assigned to LSP2 on different links, and the label values marked in magenta (e.g., 301) represent the label values assigned to LSP3 on different links. The convention 102/203|303 is used to represent the case where packets are transmitted on the link with a label stack having at the top of the stack label a label assigned to LSP1 (e.g., 102) and at the second position in the stack a label assigned to an LSP being carried over LSP1 (e.g., 102/203 for LSP2 over LSP1 packets and 102/303 for LSP3 over LSP1 packets).

It is worth noting that transit nodes for LSP1 (e.g., node B) forwards packets only based on the label at the top of the stack (used for LSP1): the second label in the stack is only used by the trail-end node (e.g., node C) to decide how to forward the packet after the label at the top of the stack has been terminated.

III.1.1 Set-up of an MPLS-TP trail with trail monitoring

In this scenario, trail monitoring is configured during the set-up of the MPLS-TP trail (e.g., LSP1 in Figure III.1).

The `start-up-state-node-a.json`, `start-up-state-node-b.json` and `start-up-state-node-c.json` JSON codes show the initial applied configuration of the MPLS-TP node A, B and C within the reference network of Figure III.1.

The `static-lsp`, the OAM domain and the `mpls-tp-linear-protection` lists are not shown in the `start-up-state-node-a.json`, `start-up-state-node-b.json` and `start-up-state-node-c.json` JSON codes since there are no static LSPs, MEGs or linear protection groups shown in Figure III.1. However, other static LSPs, MPLS-TP MEGs or linear protection groups, which are outside the scope of this example, may be present, but not shown in the `start-up-state-node-a.json`, `start-up-state-node-b.json` and `start-up-state-node-c.json` JSON codes.

In this scenario, the MCS should perform the following configuration on the head-end node A, middle node B and tail-end node C:

- Configure the MPLS-TP MD and MA used to monitor LSP1;
- Configure static LSP1:
 - Configure bidirectional static LSP1;
 - Configure reverse static LSP1;
 - Configure forward static LSP1.

This configuration can be provided as a single protocol transaction or a sequence of atomic protocol operations or also as a sequence of protocol transactions when the MCS implements a network-wide process e.g., to coordinate the label assignment in the two directions.

The `trail-oam-config-node-a.json`, `trail-oam-config-node-b.json` and `trail-oam-config-node-c.json` JSON codes show the complete configuration that the MCS should provide on the MPLS-TP node A, B and C within the reference network of Figure III.1, to set up the MPLS-TP trail LSP1, with trail monitoring, together with its client MPLS-TP sub-network connections LSP2 and LSP3.

The location of the down NCM MEP of LSP1 on node A and C can be inferred from the LSP1 forwarding configuration, and therefore its configuration is optional. The examples in `trail-oam-config-node-a.json` and `trail-oam-config-node-c.json` JSON codes describe the case where the MCS does not explicitly configure this information.

The location of the in/out MIPs of LSP1 on node B shall be configured by the MCS and this configuration shall be consistent with the LSP1 forwarding configuration.

The `trail-oam-state-node-a.json`, `trail-oam-state-node-b.json` and `trail-oam-state-node-c.json` JSON codes show the corresponding applied configuration. It is worth noting that the location of the down NCM MEP of LSP1 is reported in the operational datastore, as required by the NMDA architecture in [RFC8342].

III.1.2 Add trail monitoring on existing MPLS-TP trail

In this scenario, trail monitoring is added after the MPLS-TP trail (e.g., LSP1 in Figure III.1) has been set up.

The `trail-setup-state-node-a.json`, `trail-oam-state-node-b.json` and `trail-oam-state-node-c.json` JSON codes show the initial applied configuration of the MPLS-TP node A within the reference network of Figure III.1. In this configuration, MPLS-TP trail LSP1 has been set up without trail monitoring together with its client MPLS-TP sub-network connections LSP2 and LSP3.

In this scenario, the MCS should perform the following configuration on the head-end node A, middle node B and tail-end node C:

- Configure the MPLS-TP MD and MA used to monitor LSP1.

It is worth noting that adding MPLS-TP trail monitoring to an existing MPLS-TP trail (e.g., LSP1) has no impact on its forwarding configuration nor on the configuration of its client MPLS-TP SNCs (e.g., LSP2 and LSP3).

The `trail-oam-config-node-a.json`, `trail-oam-config-node-b.json` and `trail-oam-config-node-c.json` JSON code shows the configuration that the MCS should provide on the MPLS-TP node A, B and C within the reference network of Figure 1 to add MPLS-TP trail monitoring to the existing MPLS-TP trail LSP1.

The `trail-oam-state-node-a.json`, `trail-oam-state-node-b.json` and `trail-oam-state-node-c.json` JSON codes show the corresponding applied configuration.

As discussed in clause III.1.1, this example describes the case where the MSC does not explicitly configure the location of the down NCM MEP of LSP1.

III.1.3 Remove trail monitoring keeping MPLS-TP trail

In this scenario, trail monitoring is removed but the MPLS-TP trail (e.g., LSP1 in Figure III.1) is not removed.

The `trail-oam-state-node-a.json`, `trail-oam-state-node-b.json` and `trail-oam-state-node-c.json` JSON code shows the initial applied configuration of the MPLS-TP node A, B and C within the reference network of Figure III.1. In this configuration, MPLS-TP trail LSP1 has been set up with trail monitoring together with its client MPLS-TP sub-network connections LPS2 and LSP3.

In this scenario, the MCS should perform the following configuration on the head-end node A, middle node B and tail-end node C:

- Remove the MPLS-TP MD and MA used to monitor LSP1

It is worth noting that removing MPLS-TP trail monitoring from an MPLS-TP trail (e.g., LSP1) has no impact on its forwarding configuration nor on the configuration of its client MPLS-TP SNCs (e.g., LSP2 and LSP3).

The `trail-setup-config-node-a.json`, `trail-setup-config-node-b.json` and `trail-setup-config-node-c.json` JSON codes show the configuration that the MCS should provide on the MPLS-TP node A within the reference network of Figure III.1 to remove MPLS-TP trail monitoring from MPLS-TP trail LSP1.

The `trail-setup-state-node-a.json`, `trail-setup-state-node-b.json` and `trail-setup-state-node-c.json` JSON codes show the corresponding applied configuration.

III.2 MPLS-TP tandem connection monitoring (TCM) examples

Figure III.2 describes the reference network used to analyse the examples for MPLS-TP tandem connection monitoring (TCM):

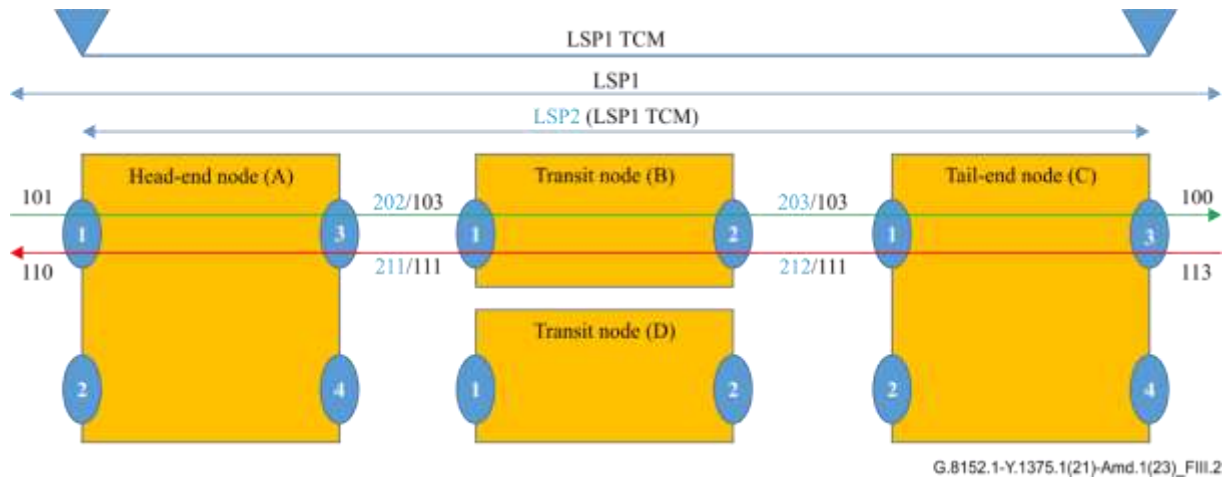

Figure III.2 – Example reference network for LSP TCM

As described in [IETF RFC 6371] and in [ITU-T G.8113.1], in order to set up MPLS-TP TCM, a hierarchical LSP (e.g., LSP2 in Figure III.2) needs to be set up between the TCM end-points.

III.2.1 Set-up of an MPLS-TP SNC with TCM

In this scenario, TCM is configured during the set-up of the MPLS-TP SNC (e.g., LSP1 in Figure III.2).

The `start-up-state-node-a.json`, `start-up-state-node-b.json` and `start-up-state-node-c.json` JSON codes show the initial applied configuration of the MPLS-TP node A, B and C within the reference network of Figure III.2.

As discussed in clause III.1.1, other static LSPs, MEGs or linear protection groups, which are outside the scope of this example, may be present but not show in the `start-up-state-node-a.json`, `start-up-state-node-b.json` and `start-up-state-node-c.json` JSON codes.

In this scenario, the MCS should perform the following configuration on the head-end node A, middle node B and tail-end node C:

- Configure the MPLS-TP MD and MA used to monitor LSP2;
- Configure static LSP2:
 - Configure bidirectional static LSP2;
 - Configure reverse static LSP2;
 - Configure forward static LSP2;
- Configure static LSP1:
 - Configure forward and reverse static LSPs
 - Configure bidirectional static LSPs.

The MA at the head-end node A contains an Up MEP on interface 1 and a per-interface MIP on interface 3.

The MA at the middle node B contains a per-interface MIP on interface 1 and a per-interface MIP on interface 2.

The MA at the tail-end node C contains an Up MEP on interface 3 and a per-interface MIP on interface 1.

As discussed in clause III.1.1, this configuration can be provided as a single protocol transaction or a sequence of atomic protocol operations or also as a sequence of protocol transactions.

The `tcm-oam-config-node-a.json`, `tcm-oam-config-node-b.json` and `tcm-oam-config-node-c.json` JSON codes show the complete configuration that the MCS should provide on the MPLS-TP node A, B and C within the reference network of Figure III.2 to set up MPLS-TP SNC LSP1 with TCM LSP2.

The location of the up TCM MEP and, as described in clause 3.4 of [IETF RFC 6371], also of the per-interface MIP, can be inferred from the LSP1 forwarding configuration and therefore its configuration is optional. The examples in `tcm-oam-config-node-a.json` and `tcm-oam-config-node-c.json` JSON code describes the case where the MSC does not explicitly configure this information.

The location of the in/out MIPs of LSP1 on node B shall be configured by the MCS and this configuration shall be consistent with the LSP2 forwarding configuration. The examples in `tcm-oam-config-node-b.json` JSON code describes the case where the MSC configures this information.

The `tcm-oam-state-node-a.json`, `tcm-oam-state-node-b.json` and `tcm-oam-state-node-c.json` JSON codes show the corresponding applied configuration. It is worth noting that the location of the up TCM MEP and of the per-interface MIP of LSP2 is reported in the operational datastore, as required by the NMDA architecture in [IETF RFC 8342].

III.2.2 Add TCM on existing MPLS-TP SNC

In this scenario, TCM is added after the MPLS-TP SNC (e.g., LSP1 in Figure III.2) has been set up.

The `snc-setup-state-node-a.json`, `snc-setup-state-node-b.json` and `snc-setup-state-node-c.json` JSON code shows the initial applied configuration of the MPLS-TP node A, B and C within the reference network of Figure III.2. In this configuration, MPLS-TP SNC LSP1 is set up without TCM and therefore also without the hierarchical LSP used for TCM OAM (e.g., LSP2), as shown in Figure III.3.

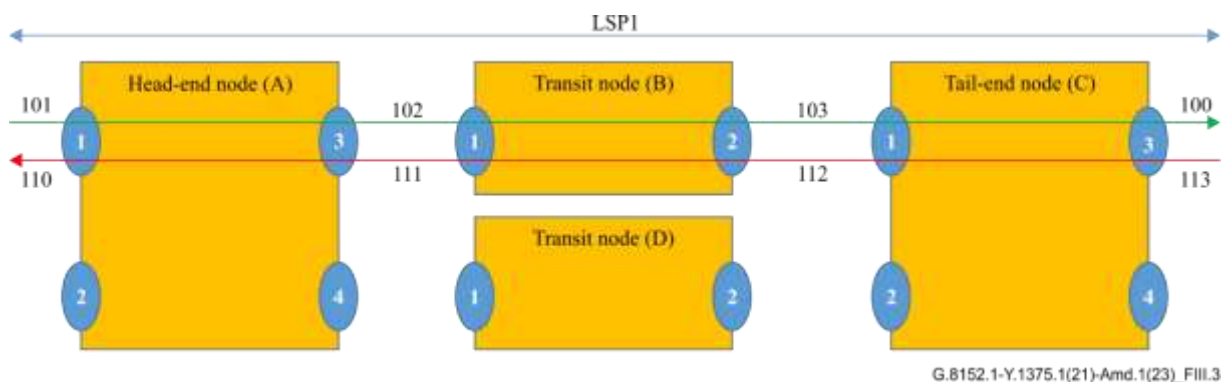

Figure III.3 – Example reference network for MPLS-TP SNC without TCM

In this scenario, the MCS should perform the following configuration on the head-end node A, middle node B and tail-end node C:

- Configure the MPLS-TP MD and MA used to monitor LSP2;
- Configure static LSP2:
 - Configure bidirectional static LSP2;

- Configure reverse static LSP2;
- Configure forward static LSP2;
- Re-configure forward static LSP1 to use LSP2 hierarchical LSP.

It is worth noting that adding MPLS-TP TCM to an existing MPLS-TP SCN (e.g., LSP1) requires changing its forwarding configuration.

As discussed in clause III.1.1, this configuration can be provided as a single protocol transaction or a sequence of atomic protocol operations or also as a sequence of protocol transactions. For example, the reconfiguration of LSP1 forwarding could be performed after the LSP2 has been setup through the network (make-before-break).

The `tcm-oam-config-node-a.json`, `tcm-oam-config-node-b.json` and `tcm-oam-config-node-c.json` JSON code shows the complete configuration that the MCS should provide on the MPLS-TP node A within the reference network of Figure III.2, to add MPLS-TP TCM LSP2 to the existing MPLS-TP SNC LSP1.

The `tcm-oam-state-node-a.json`, `tcm-oam-state-node-b.json` and `tcm-oam-state-node-c.json` JSON code shows the corresponding applied configuration.

As discussed in clause III.2.1, this example describes the case where the MSC does not explicitly configure the location of the up TCM MEP and of the per-interface MIP of LSP2.

III.2.3 Remove TCM keeping MPLS-TP SNC

In this scenario, the TCM is removed but the MPLS-TP SNC (e.g., LSP1 in Figure III.2) is not removed.

The `tcm-oam-state-node-a.json`, `tcm-oam-state-node-b.json` and `tcm-oam-state-node-c.json` JSON code shows the initial applied configuration of the MPLS-TP node A, B and C within the reference network of Figure III.2. In this configuration, MPLS-TP SNC LSP1 is set up with TCM.

In this scenario, the MCS should perform the following configuration on the head-end node A, middle node B and tail-end C:

- Re-configure forward static LSP1 not to use LSP2 hierarchical LSP;
- Remove static LSP2:
 - Remove forward static LSP2;
 - Remove reverse static LSP2;
 - Remove bidirectional static LSP2;
- Remove the MPLS-TP MD and MA used to monitor LSP2.

It is worth noting that removing MPLS-TP TCM from an MPLS-TP SCN (e.g., LSP1) requires changing its forwarding configuration.

As discussed in clause III.1.1, this configuration can be provided as a single protocol transaction or a sequence of atomic protocol operations or also as a sequence of protocol transactions.

The `snc-setup-config-node-a.json`, `snc-setup-config-node-b.json` and `snc-setup-config-node-c.json` JSON code shows the complete configuration that the MCS should provide on the MPLS-TP node A within the reference network of Figure III.2, to remove the MPLS-TP TCM LSP2 from the MPLS-TP SNC LSP1, as shown in Figure III.3.

The `snc-setup-state-node-a.json`, `snc-setup-state-node-b.json` and `snc-setup-state-node-c.json` JSON codes show the corresponding applied configuration.

Bibliography

- [b-draft-ietf-mpls-static-yang] draft-ietf-mpls-static-yang-13 A YANG Data Model for MPLS Static LSPs.
<https://datatracker.ietf.org/doc/pdf/draft-ietf-mpls-static-yang-13>
- [b-ONF TR-531] ONF TR-531_UML-YANG Mapping Guidelines.
https://opennetworking.org/wp-content/uploads/2018/08/TR-531_UML-YANG_Mapping_Gdls_v1.1-1-1.pdf

ITU-T Y-SERIES RECOMMENDATIONS

Global information infrastructure, Internet protocol aspects, next-generation networks, Internet of Things and smart cities

GLOBAL INFORMATION INFRASTRUCTURE	Y.100-Y.999
INTERNET PROTOCOL ASPECTS	Y.1000-Y.1999
General	Y.1000-Y.1099
Services and applications	Y.1100-Y.1199
Architecture, access, network capabilities and resource management	Y.1200-Y.1299
Transport	Y.1300-Y.1399
Interworking	Y.1400-Y.1499
Quality of service and network performance	Y.1500-Y.1599
Signalling	Y.1600-Y.1699
Operation, administration and maintenance	Y.1700-Y.1799
Charging	Y.1800-Y.1899
IPTV over NGN	Y.1900-Y.1999
NEXT GENERATION NETWORKS	Y.2000-Y.2999
FUTURE NETWORKS	Y.3000-Y.3499
CLOUD COMPUTING	Y.3500-Y.3599
BIG DATA	Y.3600-Y.3799
QUANTUM KEY DISTRIBUTION NETWORKS	Y.3800-Y.3999
INTERNET OF THINGS AND SMART CITIES AND COMMUNITIES	Y.4000-Y.4999

For further details, please refer to the list of ITU-T Recommendations.

SERIES OF ITU-T RECOMMENDATIONS

Series A	Organization of the work of ITU-T
Series D	Tariff and accounting principles and international telecommunication/ICT economic and policy issues
Series E	Overall network operation, telephone service, service operation and human factors
Series F	Non-telephone telecommunication services
Series G	Transmission systems and media, digital systems and networks
Series H	Audiovisual and multimedia systems
Series I	Integrated services digital network
Series J	Cable networks and transmission of television, sound programme and other multimedia signals
Series K	Protection against interference
Series L	Environment and ICTs, climate change, e-waste, energy efficiency; construction, installation and protection of cables and other elements of outside plant
Series M	Telecommunication management, including TMN and network maintenance
Series N	Maintenance: international sound programme and television transmission circuits
Series O	Specifications of measuring equipment
Series P	Telephone transmission quality, telephone installations, local line networks
Series Q	Switching and signalling, and associated measurements and tests
Series R	Telegraph transmission
Series S	Telegraph services terminal equipment
Series T	Terminals for telematic services
Series U	Telegraph switching
Series V	Data communication over the telephone network
Series X	Data networks, open system communications and security
Series Y	Global information infrastructure, Internet protocol aspects, next-generation networks, Internet of Things and smart cities
Series Z	Languages and general software aspects for telecommunication systems