



INTERNATIONAL TELECOMMUNICATION UNION

ITU-T

TELECOMMUNICATION
STANDARDIZATION SECTOR
OF ITU

X.28

(12/97)

SERIES X: DATA NETWORKS AND OPEN SYSTEM
COMMUNICATIONS

Public data networks – Interfaces

**DTE/DCE interface for a start-stop mode data
terminal equipment accessing the Packet
Assembly/Disassembly facility (PAD) in a public
data network situated in the same country**

ITU-T Recommendation X.28

(Previously CCITT Recommendation)

ITU-T X-SERIES RECOMMENDATIONS
DATA NETWORKS AND OPEN SYSTEM COMMUNICATIONS

PUBLIC DATA NETWORKS	
Services and facilities	X.1–X.19
Interfaces	X.20–X.49
Transmission, signalling and switching	X.50–X.89
Network aspects	X.90–X.149
Maintenance	X.150–X.179
Administrative arrangements	X.180–X.199
OPEN SYSTEM INTERCONNECTION	
Model and notation	X.200–X.209
Service definitions	X.210–X.219
Connection-mode protocol specifications	X.220–X.229
Connectionless-mode protocol specifications	X.230–X.239
PICS proformas	X.240–X.259
Protocol Identification	X.260–X.269
Security Protocols	X.270–X.279
Layer Managed Objects	X.280–X.289
Conformance testing	X.290–X.299
INTERWORKING BETWEEN NETWORKS	
General	X.300–X.349
Satellite data transmission systems	X.350–X.399
MESSAGE HANDLING SYSTEMS	X.400–X.499
DIRECTORY	X.500–X.599
OSI NETWORKING AND SYSTEM ASPECTS	
Networking	X.600–X.629
Efficiency	X.630–X.639
Quality of service	X.640–X.649
Naming, Addressing and Registration	X.650–X.679
Abstract Syntax Notation One (ASN.1)	X.680–X.699
OSI MANAGEMENT	
Systems Management framework and architecture	X.700–X.709
Management Communication Service and Protocol	X.710–X.719
Structure of Management Information	X.720–X.729
Management functions and ODMA functions	X.730–X.799
SECURITY	X.800–X.849
OSI APPLICATIONS	
Commitment, Concurrency and Recovery	X.850–X.859
Transaction processing	X.860–X.879
Remote operations	X.880–X.899
OPEN DISTRIBUTED PROCESSING	X.900–X.999

For further details, please refer to ITU-T List of Recommendations.

ITU-T RECOMMENDATION X.28

DTE/DCE INTERFACE FOR A START-STOP MODE DATA TERMINAL EQUIPMENT ACCESSING THE PACKET ASSEMBLY/DISASSEMBLY FACILITY (PAD) IN A PUBLIC DATA NETWORK SITUATED IN THE SAME COUNTRY

Summary

This Recommendation provides the DTE/DCE interface to facilitate access to the public data network from the public telephone network, circuit-switched public data networks and leased circuits.

Source

ITU-T Recommendation X.28 was revised by ITU-T Study Group 7 (1997-2000) and was approved under the WTSC Resolution No. 1 procedure on the 12th of December 1997.

FOREWORD

ITU (International Telecommunication Union) is the United Nations Specialized Agency in the field of telecommunications. The ITU Telecommunication Standardization Sector (ITU-T) is a permanent organ of the ITU. The ITU-T is responsible for studying technical, operating and tariff questions and issuing Recommendations on them with a view to standardizing telecommunications on a worldwide basis.

The World Telecommunication Standardization Conference (WTSC), which meets every four years, establishes the topics for study by the ITU-T Study Groups which, in their turn, produce Recommendations on these topics.

The approval of Recommendations by the Members of the ITU-T is covered by the procedure laid down in WTSC Resolution No. 1.

In some areas of information technology which fall within ITU-T's purview, the necessary standards are prepared on a collaborative basis with ISO and IEC.

NOTE

In this Recommendation, the expression "Administration" is used for conciseness to indicate both a telecommunication administration and a recognized operating agency.

INTELLECTUAL PROPERTY RIGHTS

The ITU draws attention to the possibility that the practice or implementation of this Recommendation may involve the use of a claimed Intellectual Property Right. The ITU takes no position concerning the evidence, validity or applicability of claimed Intellectual Property Rights, whether asserted by ITU members or others outside of the Recommendation development process.

As of the date of approval of this Recommendation, the ITU had not received notice of intellectual property, protected by patents, which may be required to implement this Recommendation. However, implementors are cautioned that this may not represent the latest information and are therefore strongly urged to consult the TSB patent database.

© ITU 1998

All rights reserved. No part of this publication may be reproduced or utilized in any form or by any means, electronic or mechanical, including photocopying and microfilm, without permission in writing from the ITU.

CONTENTS

	<i>Page</i>	
1	Procedures for the establishment of a national access information path between a start-stop mode DTE and a PAD.....	2
1.1	Access via a public switched telephone network or leased lines with V-Series interfaces.....	2
1.2	Access via a public switched data network or via leased lines with X-Series interfaces.....	3
2	Procedures for character interchange and service initialization between a start-stop mode DTE and a PAD	4
2.1	Format of characters used in the exchange of control information between start-stop mode DTE and a PAD.....	4
2.2	Procedures for initialization.....	5
3	Procedures for the exchange of control information between a start-stop mode DTE and a PAD.....	11
3.1	General.....	11
3.2	Procedures for virtual call control.....	12
3.3	Procedures for setting or changing the values of PAD parameters.....	16
3.4	Procedures for reading the values of one or several parameters by the start-stop mode DTE.....	18
3.5	Formats of PAD command signals and PAD service signals.....	18
3.6	Editing functions in the PAD.....	31
3.7	Procedure for request of status of the virtual call.....	33
4	Procedures for the exchange of user data between a start-stop mode DTE and a PAD.....	33
4.1	Data transfer state.....	33
4.2	Data from the start-stop mode DTE received by the PAD.....	34
4.3	Delivery of user data to the start-stop mode DTE.....	34
4.4	Data forwarding conditions.....	34
4.5	Procedure for the PAD to indicate to the start-stop mode DTE, by means of a PAD service signal, a temporary inability to accept additional information.....	34
4.6	Procedures for transmission of X-ON and X-OFF by the PAD.....	35
4.7	Procedures for reset.....	35
4.8	Procedure for indication of break.....	35
4.9	Escape from the data transfer state.....	36
4.10	Echo.....	37
4.11	Selection of the procedure on receipt of the break signal from the start-stop mode DTE.....	37
4.12	Selection of padding characters to be inserted after the character 0/13 (CR).....	38
4.13	Selection of line folding.....	38
4.14	Procedure for the start-stop mode DTE to indicate to the PAD a temporary inability to accept additional information.....	38
4.15	Selection of linefeed insertion after carriage return.....	39
4.16	Selection of padding characters to be inserted after the character 0/10 (LF).....	39
4.17	Editing of user data.....	39
4.18	Page wait.....	39
4.19	Interleaving of echo and output.....	40
4.20	Display interrupt.....	41
5	Formats of additional PAD command signals and PAD service signals available in the extended dialogue mode.....	41
5.1	Format of the break PAD command signal.....	42
5.2	Format of the NUI ON and NUI OFF PAD command signals.....	42
5.3	Format of the language PAD command signal.....	43
5.4	Format of the help PAD command signal.....	43
5.5	Standard format of the help PAD service signal.....	43

	<i>Page</i>
6 Multi-Aspect PAD (MAP) operation in accordance with Recommendation X.8.....	44
6.1 Procedures required to support MAP	44
6.2 Formats of <i>MAP command</i> signals	45
6.3 Format of <i>MAP service</i> signals	46
6.4 Error conditions.....	47
6.5 Format of additional <i>MAP command</i> signals and <i>MAP service</i> signals available in the extended dialogue mode	47
Annex A – PAD command signals and PAD service signals	48
Annex B – PAD Time-outs.....	50
Annex C – PAD service signals for extended dialogue mode	52
C.1 Possible <i>PAD service</i> signals text in Spanish for extended dialogue mode	52
C.2 Possible <i>PAD service</i> signals text in French for extended dialogue mode.....	54

Recommendation X.28

DTE/DCE INTERFACE FOR A START-STOP MODE DATA TERMINAL EQUIPMENT ACCESSING THE PACKET ASSEMBLY/DISASSEMBLY FACILITY (PAD) IN A PUBLIC DATA NETWORK SITUATED IN THE SAME COUNTRY

*(Provisional, Geneva, 1977;
amended, Geneva, 1980, Málaga-Torremolinos, 1984,
Melbourne, 1988, Helsinki, 1993;
revised in 1997)*

Preface

The establishment in various countries of public data networks providing packet-switched data transmission services creates a need to produce standards to facilitate access from the public telephone network, circuit-switched public data networks and leased circuits.

The ITU-T,

considering

- a) that Recommendations X.1 and X.2 define user classes of service and user facilities provided by a public data network, and Recommendation X.96 defines call progress signals;
- b) that Recommendation X.29 defines procedures for a packet mode DTE to control the PAD and for interworking between PADs;
- c) that Recommendation X.3 defines the Packet Assembly/Disassembly (PAD) facility in a public data network;
- d) that the logical control links for packet-switched data transmission services are defined in Recommendation X.92;
- e) the need for defining an international Recommendation for the exchange of control information between a start-stop mode DTE and a PAD;
- f) that DTEs operating in the start-stop mode will send and receive network call control information and user information in the form of characters according to Recommendation T.50 or the *break* signal;
- g) that the necessary elements for an interface Recommendation should be defined independently as:
 - 1) procedures for the establishment of a national access information path between a start-stop mode DTE and a PAD,
 - 2) procedures for character interchange and service initialization between a start-stop mode DTE and a PAD,
 - 3) procedures for the exchange of control information between a start-stop mode DTE and a PAD,
 - 4) procedures for the exchange of user data between a start-stop mode DTE and a PAD;
- h) that the Recommendation X.8 defines the Multi-Aspect PAD (MAP) framework and service definition,

unanimously declares

that start-stop mode DTE accessing the PAD should operate in accordance with this Recommendation.

1 Procedures for the establishment of a national access information path between a start-stop mode DTE and a PAD

1.1 Access via a public switched telephone network or leased lines with V-Series interfaces

1.1.1 DTE/DCE interface

The access information path will be provided by the use of modems standardized for use in the public switched telephone network or leased line operating:

- a) at rates up to 300 bit/s in accordance with Recommendation V.21; or
- b) at the rate of 1200 bit/s in accordance with Recommendation V.22 alternative B, mode b) or V.22 *bis* mode 4, and at the rates of 2400 bit/s in accordance with Recommendation V.22 *bis* mode 2, on the public switched telephone network or 2-wire leased circuit, or at the rates up to 1200 bit/s in accordance with Recommendation V.23 without backward channel on 4-wire leased circuits; or
- c) at the rate of 75/1200 bit/s (for the signal received by the DTE and 75 bit/s for the signal sent by the DTE on the backward channel) in accordance with Recommendation V.23.

The particular interchange circuits provided, and their operation, shall be in accordance with the relevant modem Recommendations, and clamping of circuit 104 shall be implemented in accordance with 4.3/V.24.

At rates of up to 300 bit/s or at 1200 bit/s or 2400 bit/s:

- d) on the telephone network, the modem shall be set up for channel operation in accordance with Recommendation V.21, or with Recommendation V.22, or with Recommendation V.22 *bis*; or
- e) on leased lines (2-wire), the channel operation will be determined by the same rule, the modem at the DTE side being considered as the one making the telephone call.

At the rate of 75/1200 bit/s: the modem shall be set up for channel operation in accordance with Recommendation V.23.

NOTE 1 – The interface requirements for other data signalling rates are for further study.

NOTE 2 – In some networks, references to modem characteristics do not apply (e.g. for leased lines).

1.1.2 Electrical characteristics

The electrical characteristics of the DTE/DCE interface shall be in accordance with this Recommendation.

1.1.3 Procedure for setting up and disconnecting the access information path

1.1.3.1 Setting up the access information path by the DTE

The access information path shall be established in accordance with Recommendation V.25 for a manual data station calling an automatic answering station.

The mechanism for echo suppressor disablement may not be implemented in some national networks where the access information path does not include echo suppressors.

Subsequent to the completion of the above, both the DTE and DCE shall transmit binary 1 on circuits 103 and 104.

1.1.3.2 Disconnecting the access information path by the DTE

The access information path shall be disconnected by:

- a) reversion of the data circuit to the voice mode, or
- b) the DTE turning circuit 108/1 or 108/2 OFF for a period greater than Z. The value of Z is for further study.

1.1.3.3 Setting up the access information path by the PAD

The procedure for the PAD to establish an access information path shall be in accordance with Recommendation V.25 as far as it is perceived by the DTE.

1.1.3.4 Disconnecting the access information path by the PAD

Disconnection by the PAD will be indicated by the DCE turning circuits 106 and 109 OFF, while circuit 108 is ON.

NOTE – Access information path clear indication to the DTE is not signalled by circuit 107 OFF. Not all DTEs allow circuit 107 to be turned OFF if circuit 108 has not been turned OFF previously.

1.2 Access via a public switched data network or via leased lines with X-Series interfaces

1.2.1 DTE/DCE interface designed for start-stop transmission services on public data networks (Recommendation X.20)

1.2.1.1 Physical characteristics

The physical characteristics of the DTE/DCE interface are defined in 2/X.20.

1.2.1.2 Procedures for setting up and disconnecting the access information path (call control)

The procedures and formats for call control of the public circuit-switched data network are described in 3/X.20 and 4/X.20. The procedures for setting up a virtual call in a packet-switched network are those given in clauses 2, 3 and 4. The use of Recommendation X.20 procedures to establish a virtual call via a PAD is for further study.

1.2.2 DTE/DCE interface designed for operation on telephone type networks (Recommendation X.20 bis)

In the case of DTEs with interfaces designed for operation on telephone type networks (V-Series interfaces), the access information path will be established by the use of DCEs standardized for start-stop transmission services on public data networks according to Recommendation X.20 *bis*.

1.2.2.1 Characteristics of interchange circuits

The characteristics of the interchange circuits are described in 2/X.20 *bis*.

1.2.2.2 Operational requirements

The requirements for the operation of the interchange circuits 106, 107, 108, 109 and 125 are described in 3/X.20 *bis*.

1.2.2.3 Operational requirements for disconnecting the access information path by the DTE

The access information path shall be disconnected either:

- *manually* by depressing the clearing key of the DCE, or
- *automatically* by the DTE turning OFF circuit 108/1 or 108/2 for a period longer than 210 ms.

1.2.2.4 Indication of disconnection by the PAD

Disconnection by the PAD, i.e. DCE clearing, will be indicated by the DCE by turning OFF circuits 106 and 109. The DTE should then perform clear confirmation by turning OFF circuit 108.

1.2.2.5 Setting up the access information path by the PAD

The procedure for the PAD to establish an access information path is for further study.

1.2.2.6 Operational constraints for maintaining the access information path during information transfer

The transmission of a break signal longer than 200 ms may cause clearing in a public switched data network. Therefore, the transmission of a *break* signal in either direction should either be avoided or the timer of the circuit generating a *break* signal should be adjusted to generate a signal length considerably shorter than 200 ms (see also 3.1.2).

2 Procedures for character interchange and service initialization between a start-stop mode DTE and a PAD

2.1 Format of characters used in the exchange of control information between start-stop mode DTE and a PAD

2.1.1 The start-stop mode DTE shall generate and be capable of receiving characters in accordance with International Alphabet No. 5 as described in Recommendation T.50. The general structure of characters shall be in accordance with Recommendation X.4 except that the transmitted stop bits shall be as specified in 2.1.2. The character format specified below applies to the procedures described in clauses 2 and 3.

2.1.2 The PAD will transmit and expect to receive 8-bit characters.

When the value of parameter 21 is set to 0, whenever the PAD has to transfer a data character or has to interpret a received character for a specific action different from or additional to the transfer of this data character to the remote DTE, it will only inspect the first seven bits and will not take account of the eighth bit (the last bit preceding the stop element).

When the value of parameter 21 is set to 1, the PAD will treat the 8th bit of the characters received from the start-stop DTE as a parity bit and check this bit against the type of parity [even, odd, space ("0") or mark ("1")] used between the PAD and the start-stop mode DTE.

When the value of parameter 21 is set to 2, the PAD will replace the 8th bit of the characters to be sent to the start-stop mode DTE with the bit that corresponds to the type of parity used between the PAD and the start-stop mode DTE.

When the value of parameter 21 is set to 3, the PAD will both check the parity bit for characters received from the start-stop mode DTE and generate the parity bit for characters to be sent to the start-stop mode DTE, as described for values 1 and 2.

When the value of parameter 21 is set to 4, the PAD will transparently pass the 8th bit whenever the PAD has to transfer a data character or has to interpret a received character.

Whenever the PAD generates characters (e.g. *PAD service* signals), they will be transmitted by the PAD with even parity if parameter 21 is set to 0, and with the type of parity (even, odd, space or mark) used between the PAD and the start-stop mode DTE if parameter 21 is set to 1, 2 or 3 or with space parity if set to 4. Additionally, when parameter 21 equals 0 and the parity is determined by an alternate means (e.g. detected by the PAD with the *service request* signal according to 2.2.2) the PAD may transmit the service signals with the type of parity thereby determined.

When the value of parameter 21 is set to 1 or 3, if the PAD detects a parity error in the characters received from the start-stop mode DTE, the PAD will:

- if parameter 2 is set to 0 (no echo), and parameter 6 is set to 0 (no service signals), reset the virtual circuit;
- if parameter 2 is set to 1 (echo) and parameter 6 is set to 0 (no service signals), discard and not echo the character in error and transmit the character 0/7 (BEL) to the start-stop mode DTE;
- if parameter 2 is set to 1 (echo) and parameter 6 is set to 1 or greater (service signals) discard and not echo the character in error and transmit the character 0/7 (BEL) to the start-stop mode DTE; the PAD may also transmit the parity error *PAD service* signal. The action of the PAD when parameter 2 is set to 0 (no echo) and parameter 6 is set to 1 or greater (service signal) is for further study.

The PAD will accept characters which have a single stop element and will transmit characters with at least two stop elements if the start-stop mode DTE is operating at 110 bit/s. If the PAD is operating at any other speed, the PAD will transmit and accept characters with a single stop element.

2.2 Procedures for initialization

The references to states in the following procedures correspond to the state diagrams (Figures 1, 2 and 3).

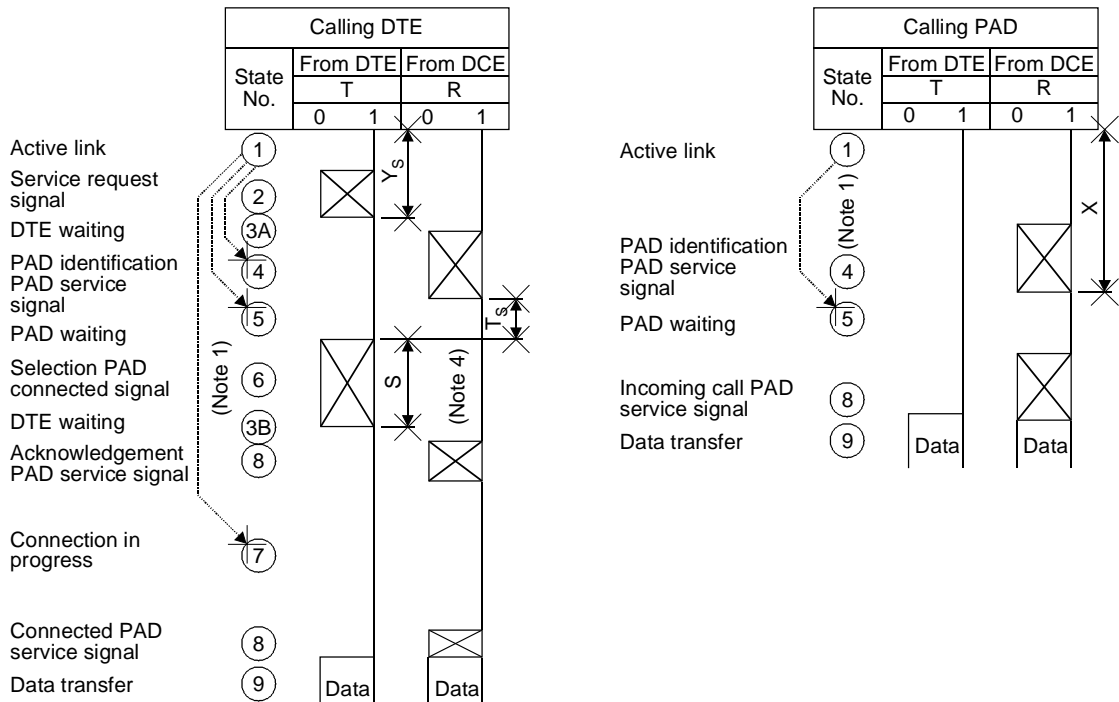

a) Sequence of events at the interface: call establishment

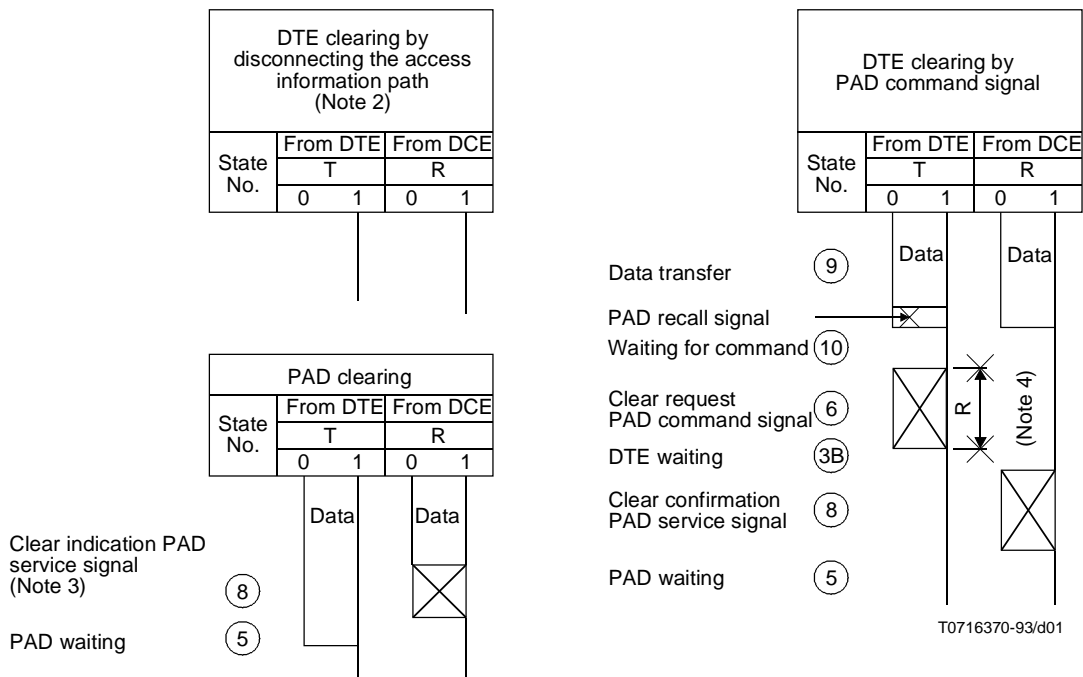

b) Sequence of events at the interface: call clearing

NOTE 1 – Some networks may allow a direct state transition from state 1 to either state 4, 5 or 7.

NOTE 2 – The *DTE clear* may be performed by disconnecting the access information path (see clause 1). The response from the DCE is *PAD clearing* which also disconnects the access information path.

NOTE 3 – *PAD clearing* may also be performed by disconnecting the access information path (see clause 1).

NOTE 4 – The time-outs S and R are not less than 60 s.

Figure 1/X.28

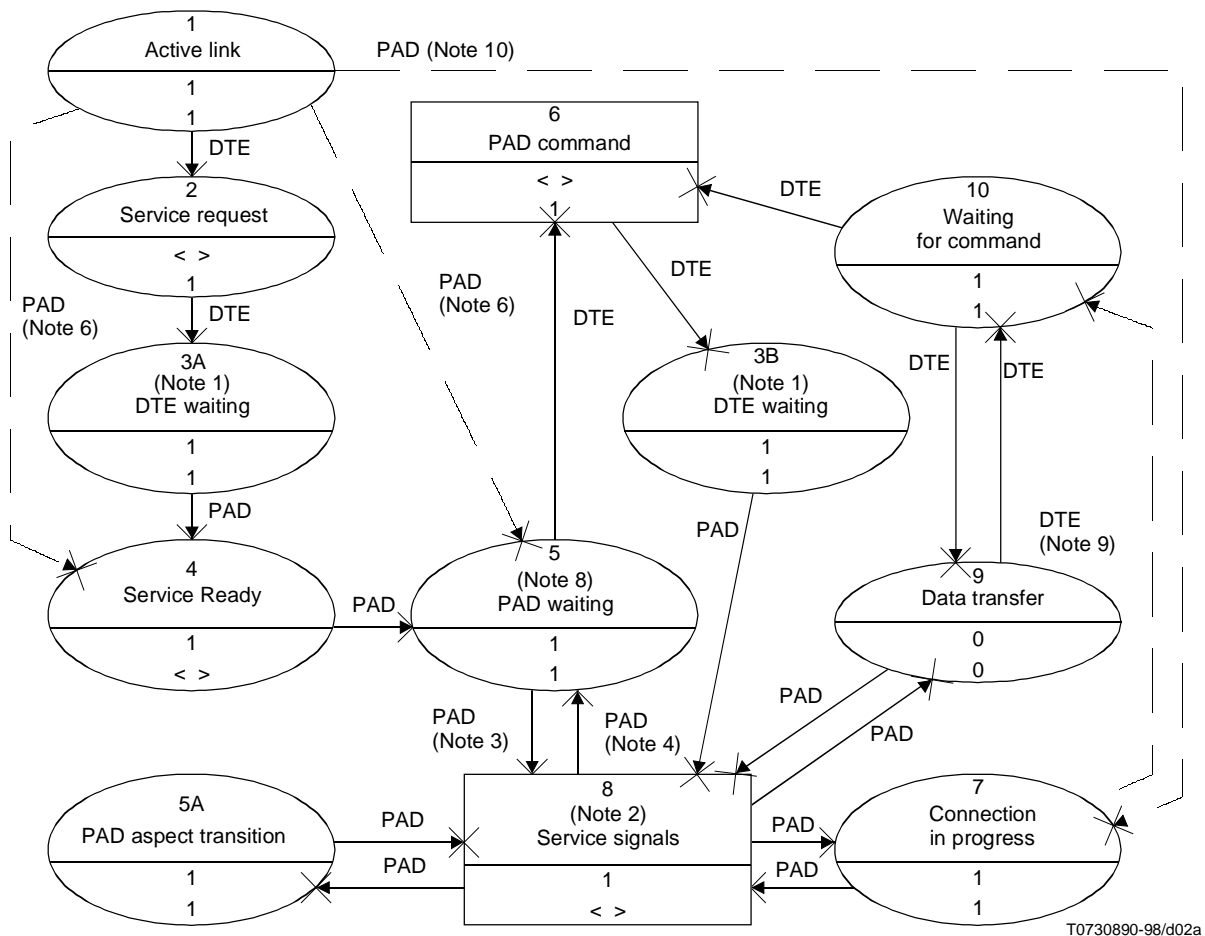

T0730890-98/d02a

a) DTE/PAD states when parameter 6 is set to 1

- NOTE 1 – States 3A and 3B are represented in Figure 2a) for convenience. They are functionally equivalent.
- NOTE 2 – State 8 is used to represent a state during which all *PAD service* signals are transmitted (except for the *editing PAD service*).
- NOTE 3 – The transition from state 5 to state 8 occurs only when the PAD receives a call destined for the start-stop mode DTE.
- NOTE 4 – The PAD may permit entry to the *PAD waiting state* N times before performing PAD disconnection (see 3.2.3.1.2).
- NOTE 5 – Under certain circumstances *DTE clearing* is performed by disconnecting the access information path (see clause 1).
- NOTE 6 – Some networks may allow a direct state transition from state 1 to either state 4 or 5.
- NOTE 7 – See Figure 3 for the symbol definitions of the state diagram.
- NOTE 8 – The condition of the interchange circuit 103 (Recommendations X.20 *bis* and V.21) or the T interchange circuit (Recommendation X.20) shown in state 5 is the preferred condition. It is recognized that the DTE may not have sufficient information to maintain this condition under all circumstances and consequently may transmit characters.
- NOTE 9 – Some networks allow the transition from state 7 to state 10 for the purpose of accepting *PAD command* signals (e.g. *clear request PAD command* signal) as described in 3.2.1.5.
- NOTE 10 – In some networks, the transition from state 1 to state 7 occurs when the PAD establishes a virtual call without receiving the *service request* signal and *selection PAD command* signal. It is network dependent how the PAD knows the start-stop mode DTE characteristics relevant to the virtual call.

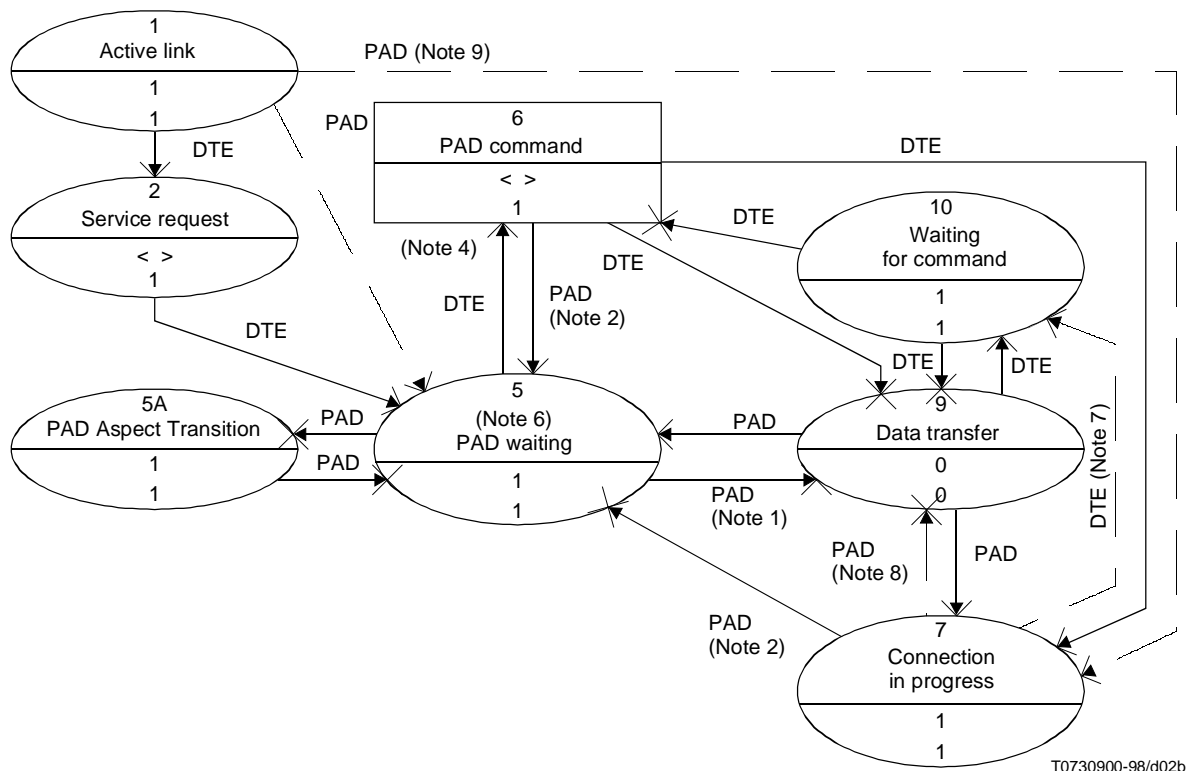

b) DTE/PAD states when parameter 6 is set to 0

NOTE 1 – The transition from state 5 to state 9 occurs only when the PAD receives a call destined for the start-stop mode DTE.

NOTE 2 – The PAD will permit entry to the *PAD waiting state* N times before performing PAD disconnection (see 3.2.3.1.2).

NOTE 3 – Under certain circumstances *DTE clearing* is performed by disconnecting the access information path (see clause 1).

NOTE 4 – Some networks may allow a direct state transition from state 1 to state 5.

NOTE 5 – See Figure 3 for the symbol definitions of the state diagram.

NOTE 6 – The condition of the interchange circuit 103 (Recommendations X.20 *bis* and V.21) or the T interchange circuit (Recommendation X.20) shown in state 5 is the preferred condition. It is recognized that the DTE may not have sufficient information to maintain this condition under all circumstances and consequently may transmit characters.

NOTE 7 – Some networks allow the transition from state 7 to state 10 for the purpose of accepting *PAD command* signals (e.g. *clear request PAD command* signal) as described in 3.2.1.5.

NOTE 8 – Some networks allow the transition from state 9 to state 7 for the purpose of performing DTE reselection.

NOTE 9 – In some networks, the transition from state 1 to state 7 occurs when the PAD establishes a virtual call without receiving the *service request* signal and *selection PAD command* signal. It is network dependent how the PAD knows the start-stop mode DTE characteristics relevant to the virtual call.

Figure 2/X.28

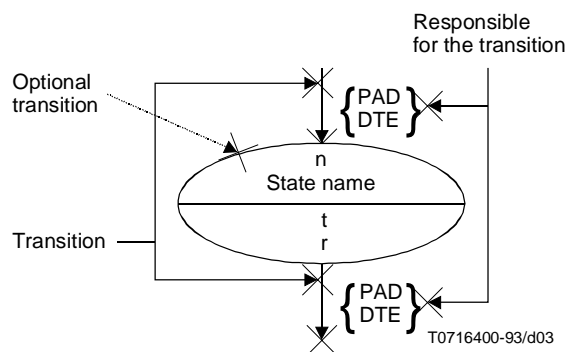

- n State number
- t Value on interchange circuit 103 when access is via X.20 *bis* or V.21; or on T interchange circuit when access is via X.20
- r Value on interchange circuit 104 when access is via X.20 *bis* or V.21; or on R interchange circuit when access is via X.20
- DTE to DTE data signal
- 0 and 1 Steady binary conditions
- < > An International Alphabet No. 5 character sequence

Figure 3/X.28 – Symbol definitions of the state diagrams

2.2.1 Active link (state 1)

After the access information path has been established, the start-stop mode DTE and the PAD exchange binary 1 across the start-stop mode DTE/DCE interface and the interface is in the *active link* state.

2.2.2 Service request (state 2)

If the interface is in the *active link* state, the DTE shall transmit a sequence of characters to indicate *service request* and to initialize the PAD. The *service request* signal enables the PAD to detect the data rate, the code and, optionally, the parity used by the DTE and to select the *initial profile* of the PAD. The parameters of ITU-T *standard profiles* are summarized in Table 1.

The format of the *service request* signal to be transmitted by the DTE is given in 3.5.16.

Some networks may allow state 2 to be bypassed. In case the start-stop mode DTE is connected to the PAD by a leased line or if the access information path is set up by the PAD, the PAD either knows the speed, code, and initial profile, required for the start-stop mode DTE or uses a default value. The default value is network dependent. In case the access information path is set up by the start-stop mode DTE, the access method chosen may be uniquely dedicated to a single combination of speed, code and initial profile.

2.2.3 DTE waiting (state 3A)

Following the transmission of the *service request* signal, the DTE shall transmit binary 1 and the interface will be in the *DTE waiting* state.

When the value of parameter 6 is set to 0, the interface will directly enter the *PAD waiting* state following receipt of a valid *service request* signal.

2.2.4 Service ready (state 4)

When parameter 6 is not set to 0, the interface will enter the *service ready* state when the PAD transmits a *PAD identification PAD service* signal after receiving a *service request* signal. If the *PAD identification PAD service* signal is not received within V seconds, the DTE should retransmit the *service request* signal. Following transmission of the *service request* signal W times, the user should report a fault to the appropriate point. The values of V and W are for further study.

The standard format of the *PAD identification PAD service* signal is given in 3.5.18.

Table 1/X.28 – PAD parameter settings

[The parameter references and values relate to Recommendation X.3 (Note 1)]

Parameter reference number (Note 3)	Parameter description	Parameter setting for ITU-T standard profile (Note 2)	
		Transparent standard profile (Note 4)	Simple standard profile (Note 4)
1	PAD recall using a character	Set to <i>not possible</i> (value 0)	Set to <i>possible</i> (value 1)
2	Echo	Set to <i>no echo</i> (value 0)	Set to <i>echo</i> (value 1)
3	Selection of <i>data forwarding</i> signal	Set to <i>no data forwarding signal</i> (value 0)	Set to <i>all characters in columns 0 and 1 and character 7/15 (DEL) of International Alphabet No. 5</i> (value 126)
4	Selection of <i>idle timer delay</i>	Set to <i>one second</i> (value 20)	Set to <i>no time-out</i> (value 0)
5	Ancillary device control	Set to <i>no use of X-ON and X-OFF</i> . (value 0)	Set to <i>use of X-ON and X-OFF</i> (value 1)
6	Control of <i>PAD service</i> signals and <i>PAD command</i> signals	Set to <i>no service signals sent to the start-stop mode DTE</i> (value 0)	Set to <i>service signals are sent</i> (value 1)
7	Selection of operation of PAD on receipt of <i>break</i> signal from the start-stop mode DTE	Set to <i>reset</i> (value 2)	Set to <i>reset</i> (value 2)
8	Discard output	Set to <i>normal data delivery</i> (value 0)	Set to <i>normal data delivery</i> (value 0)
9	Padding after carriage return (CR)	Set to <i>no padding after CR</i> (value 0) (Note 5)	Set to <i>no padding after CR</i> (value 0) (Note 5)
10	Line folding	Set to <i>no line folding</i> (value 0)	Set to <i>no line folding</i> (value 0)
11 (read only)	Binary speed of start-stop mode DTE	Indicate speed of DTE	Indicate speed of DTE
12	Flow control of the PAD by the start-stop mode DTE	Set to <i>no use of X-ON and X-OFF</i> (value 0)	Set to <i>use of X-ON and X-OFF</i> (value 1)
13 (Note 6)	Linefeed insertion after carriage return	Set to <i>no linefeed insertion</i> (value 0)	Set to <i>no linefeed insertion</i> (value 0)
14 (Note 6)	Linefeed padding	Set to <i>no linefeed after LF</i> (value 0)	Set to <i>no linefeed after LF</i> (value 0)
15 (Notes 6 and 7)	Editing	Set to <i>no editing in data transfer state</i> (value 0)	Set to <i>no editing in data transfer state</i> (value 0)
16 (Note 6)	Character delete	Set to character 7/15 (DEL) (value 127)	Set to character 7/15 (DEL) (value 127)
17 (Note 6)	Line delete	Set to character 1/8 (CAN) (value 24)	Set to character 1/8 (CAN) (value 24)
18 (Note 6)	Line display	Set to character 1/2 (DC2) (value 18)	Set to character 1/2 (DC2) (value 18)
19 (Notes 6 and 7)	Editing <i>PAD service</i> signals	Set to <i>editing PAD service signals for printing terminals</i> (value 1)	Set to <i>editing PAD service signals for printing terminals</i> (value 1)
20 (Notes 6 and 8)	Echo mask	Set to <i>echo all characters</i> (value 0)	Set to <i>echo all characters</i> (value 0)
21 (Notes 6 and 9)	Parity treatment	Set to <i>no parity detection or generation</i> (value 0)	Set to <i>no parity detection or generation</i> (value 0)

Table 1/X.28 – PAD parameter settings (concluded)

[The parameter references and values relate to Recommendation X.3 (Note 1)]

Parameter reference number (Note 3)	Parameter description	Parameter setting for ITU-T standard profile (Note 2)	
		Transparent standard profile (Note 4)	Simple standard profile (Note 4)
22 (Note 6)	Page Wait	Set to page wait disabled (value 0)	Set to page wait disabled (value 0)
23 (Note 6)	Size of input field	Set to undefined size (value 0)	Set to undefined size (value 0)
24 (Note 6)	End-of-frame signals	Set to no end-of-frame signal (value 0)	Set to no end-of-frame signal (value 0)
25 (Note 6)	Extended data forwarding signals	Set to no extended data forwarding signal (value 0)	Set to no extended data forwarding signal (value 0)
26 (Note 6)	Display interrupt	Set to no display interrupt (value 0)	Set to no display interrupt (value 0)
27 (Note 6)	Display interrupt confirmation	Set to no display interrupt confirmation (value 0)	Set to no display interrupt confirmation (value 0)
28 (Note 6)	Diacritic character coding	Set to basic coding (value 0)	Set to basic coding (value 0)
29 (Note 6)	Extended echo mask	Set to no extended echo mask (value 0)	Set to no extended echo mask (value 0)

NOTE 1 – All parameters standardized by ITU-T are listed in Table 1/X.3 including those which provide additional user facilities listed in Recommendation X.2.

NOTE 2 – In the case of a leased circuit access, the appropriate profile parameter values are specified at subscription time. In the case of access from public telephone networks or circuit switched public data networks, the definition of other ITU-T standard profiles is for further study.

NOTE 3 – Parameter reference 0 is not used to define a PAD parameter. Specific use of the decimal value 0 in PAD messages to permit the existence of parameters not defined by ITU-T is provided in Recommendation X.29. A similar use of this value in this Recommendation is for further study.

NOTE 4 – The procedures for selecting *transparent standard profile* or *simple standard profile* by the start-stop mode DTE are currently defined by using the *service request* signal or *standard profile selection PAD command* signal.

NOTE 5 – There will be no padding except that *PAD service* signals will obtain a number of padding characters according to the data transmission rate of the start-stop mode DTE.

NOTE 6 – Parameter which provides additional user facilities available in some countries for international and national services (see Recommendation X.3). The implementation of this parameter in a PAD is a matter for national determination. When implemented, the values appropriate when a *standard profile* is selected are given in this table.

NOTE 7 – Editing functions apply during the *PAD command* state irrespective of the value of parameter 15. The default values of selectable values of parameters 16, 17, 18 and 19 apply for the functions.

NOTE 8 – This parameter does not apply if parameter 2 is set to 0.

NOTE 9 – Characters generated by the PAD itself (e.g. *PAD service* signals) have even parity when parameter 21 is set to zero unless the parity is determined by an alternate means as stated in 2.1.2.

2.2.5 Fault condition

If a valid *service request* signal is not received by the PAD within Y seconds after the transmission of binary 1, it will perform PAD clearing by disconnecting the access information path.

The value of Y is for further study.

NOTE – Some networks may allow states 2 to 4 to be bypassed. In this case the condition described under 2.2.4 does not apply.

3 Procedures for the exchange of control information between a start-stop mode DTE and a PAD

3.1 General

3.1.1 PAD command signals and PAD service signals

The operation of the PAD depends on the current values of internal PAD variables which are known as PAD parameters. Initially, PAD parameter values depend on the initial standard profile applicable at the time of sending a service request signal or by previous arrangement with the Administration. The parameter values for the transparent and simple standard profile are given in Table 1.

PAD command signals (direction DTE to PAD) are provided for:

- a) the establishment and clearing of a virtual call (see 3.2);
- b) the selection of a set of preset values of PAD parameters known as a *standard* profile, either ITU-T or network defined (see 3.3.1);
- c) the selection of individual PAD parameter values (see 3.3.2);
- d) requesting the current values of PAD parameters to be transmitted by the PAD to the DTE (see 3.4);
- e) sending of an interrupt;
- f) requesting the status of the circuit (see 3.7);
- g) resetting the virtual call.

PAD service signals (direction PAD to DTE) are provided to:

- a) transmit *call progress* signals to the calling DTE;
- b) acknowledge *PAD command* signals;
- c) transmit information regarding the operation of the PAD to the start-stop mode DTE.

The formats of *PAD command* signals and the standard formats of *PAD service* signals are given in 3.5. Some networks may also support the extended dialogue mode for *PAD command* signals and *PAD service* signals as defined in 3.5 and clause 5. Some networks may also support additional *PAD command* signals and *PAD service* signals as defined in clause 5.

The information content of *PAD command* signals and *PAD service* signals are summarized in Annex A.

3.1.2 Break signal

The *break* signal is provided to allow the start-stop mode DTE to signal to the PAD without loss of character transparency. The *break* signal can also be transmitted by the PAD to the start-stop mode DTE.

The *break* signal is defined as the transmission of binary 0 for more than 135 ms. The maximum permitted duration shall depend upon the type of access information path used (see, for example, 1.2.2.6).

A *break* signal shall be separated from any following start-stop character or other *break* signal by the transmission of binary 1 for more than 100 ms.

3.1.3 Prompt PAD service signal

If parameter 6 is set to 5 on entering the *PAD waiting* state or *waiting for command* state, the PAD will indicate its readiness to receive a *PAD command* signal by transmitting the *prompt PAD service* signal.

If the value of parameter 6 is set to 0 or 1, the PAD will not transmit the *prompt PAD service* signal to the start-stop mode DTE.

If the value of parameter 6 is set to 5, a *PAD command* signal transmitted before the *prompt PAD service* signal has been received from the PAD will be ignored.

If the value of parameter 6 is set to any of the values 8-15, the availability and format of a *prompt PAD service* signal is network dependent.

The standard format of the *prompt PAD service* signal is given in 3.5.23.

3.2 Procedures for virtual call control

Figure 1 (Sequence of events at the interface) shows the procedures at the DTE/DCE interface during call establishment, data transfer and call clearing. Figure 2 shows the state diagram.

For details on the action expected of the start-stop mode DTE following receipt of a *PAD service* signal, refer to Recommendation X.96.

3.2.1 Call establishment

3.2.1.1 PAD waiting (state 5)

Following the transmission of a *PAD service* signal, the interface will be in the *PAD waiting* state unless a virtual call is established or is being established. During the *PAD waiting* state, the PAD will transmit binary 1.

If parameter 2 is set to 1, all characters are echoed.

NOTE – In some networks the *active link* state will either lead directly to the *PAD waiting* state, the *service ready* state or the *connection in progress* state.

3.2.1.2 Network User Identification (NUI)

When required for security, billing and/or network management purposes, the network user shall transmit a *network user identification* signal. Some Administrations may not implement a *network user identification* signal. When implemented, the *network user identification* signal will be defined in the *facility request* block of a *selection PAD command* signal.

The format of the *facility request* block is defined in 3.5.15.1.

The information content of the *network user identification* signal is network dependent.

When *network user identification* is not used and the calling DTE is not identified by other means, the *reverse charging* facility will be used.

3.2.1.3 PAD command (state 6)

The DTE may transmit a *PAD command* signal when the interface is in the *PAD waiting* state (state 5) and enters the *PAD command* state at the start of a *PAD command* signal.

The DTE may also transmit *PAD command* signals after escaping from the *data transfer* state or the *connection in progress* state (see 4.9.1).

If parameter 2 is set to 1, characters in *PAD command* signals are echoed, except the characters following the character P in a *selection PAD command* signal, which are not echoed. If parameter 20 is implemented, the set of characters to be echoed is determined by the value of parameter 20.

If parameter 6 is not set to 0, the PAD will ignore all characters received from the DTE following the receipt of a *PAD command* signal until the associated *PAD service* signal or sequence of *PAD service* signals has been transmitted to the DTE by the PAD.

If parameter 6 is set to 0, the PAD will not transmit a *PAD service* signal. Therefore it is for the user to define the way in which information regarding the completion of the connection is signalled to the start-stop mode DTE.

The DTE may request the establishment of a virtual call by transmitting a *selection PAD command* signal.

The DTE may edit *PAD command* signals before they are actioned by the PAD by using the procedures in 3.6.

The formats of *PAD command* signals are given in 3.5. A summary of *PAD command* signals is given in Table 2.

Table 2/X.28 – Summary of PAD command signals

PAD command signals	Valid before virtual call set-up	Valid after escaping from data transfer state	Valid after escaping from connection in progress
Selection (3.2.1.3)	X		
Profile selection (3.3.1 and 4.9.2.5)	X	X	
Set (3.3.2 and 4.9.2.5)	X	X	
Set and read (3.3.2 and 4.9.2.5)	X	X	
Read (3.4 and 4.9.2.5)	X	X	
Clear request [3.2.1.5, 3.2.2.1.1 a) and 4.9.2.1]		X	X
Status (3.7 and 4.9.2.2)	X	X	
Reset (4.9.2.3)		X	
Interrupt (4.9.2.4)		X	
Remote set and read (3.3.4)		X	
Remote read (3.4.2)		X	
Invitation to clear (3.2.2)		X	
<i>Extended dialogue mode</i>			
Break (5.1)		X	
Help (5.4)	X	X	
Language (5.3)	X	X	
NUI on (5.2)	X		
NUI off (5.2)	X		
Modify MAP (6.2.1)	X	X	X
Change MAP (6.2.2)	X		
Confirm change MAP	X		

3.2.1.4 DTE waiting (state 3B)

Following the transmission of a *PAD command* signal, the DTE will transmit binary 1 and the interface will be in the *DTE waiting* state.

3.2.1.5 Connection in progress (state 7)

If parameter 6 is not set to 0, on receipt of a valid *selection PAD command* signal the PAD will transmit an *acknowledgement PAD service* signal followed by binary 1 and the interface will enter the *connection in progress* state. The interface will enter the *PAD service signals* state as necessary and the PAD will transmit the *connected PAD service* signal or a *clear indication PAD service* signal to the DTE. During this period the PAD will not accept any *PAD command* signals. Characters are not echoed.

If the value of parameter 6 is 0, the PAD will not transmit *PAD service* signals to the start-stop mode DTE. Following the receipt of a valid *selection PAD command* signal, the interface shall remain in the *connection in progress* state until the virtual call has been established.

In some networks, during the *connection in progress* state, the start-stop mode DTE may escape from that state by transmitting a *PAD recall* signal to the PAD. On detection of the *PAD recall* signal, the interface will enter the *waiting for command* state.

If parameter 1 is set to 1, the PAD will recognize the character 1/0 (DLE) as the *PAD recall* signal from the start-stop mode DTE.

If parameter 1 is set to a decimal value from 32 to 126, the PAD will recognize the binary representation of the decimal value as the *PAD recall* signal from the start-stop mode DTE.

If parameter 7 is set to 8, the *break* signal may be used as the *PAD recall* signal from the *connection in progress* state, allowing for escape from the *connection in progress* state without loss of character transparency.

If parameter 6 is set to 5, the *prompt PAD service* will be transmitted by the PAD. At this time, the PAD may accept the *clear request PAD command* signal or another suitable command to be determined by further study.

On receipt of the next character from the start-stop mode DTE, the PAD will act in accordance with one of the following conditions:

- a) If the character received is the *PAD recall* character or the *PAD command* signal delimiter [characters 2/11 (+) or 0/13 (CR)] the interface will return to the *connection in progress* state and no action will be taken with the character.
- b) If the character received is in columns 2 to 7 of International Alphabet No. 5, excluding the characters 2/0 (SP), 2/11 (+) [see 3.2.1.5], 7/15 (DEL) and the *PAD recall* character, the interface will enter the *PAD command* state, and the character will be placed in the editing buffer. Characters 2/0 (SP) and 7/15 (DEL) will be ignored.
- c) If the character is not covered above, for example editing characters in columns 2 to 7 and characters in columns 0 and 1 of IA5, the action by the PAD is for further study.

If the first character of a *PAD command* signal is not received within P seconds of the interface entering the *waiting for command* state from the *connection in progress* state, the PAD will transmit an *error PAD service* signal, when parameter 6 is not set to 0. The interface will then enter the *connection in progress* state, irrespective of the value of parameter 6. The value of P is for further study but will not be less than 60 s.

If the *PAD command* signal delimiter is not received within Q seconds of the interface entering the *PAD command* state from the *connection in progress* state, or an invalid *PAD command* signal is received, the PAD will transmit an *error PAD service* signal, when parameter 6 is not set to 0, indicating that an error has occurred. The interface will then enter the *connection in progress* state, irrespective of the value of parameter 6. The value of Q is for further study but will not be less than 60 s.

If a valid *clear request PAD command* signal is received, the procedure will be as described in 3.2.2.1.1 a).

3.2.1.6 PAD service signals (state 8)

Following receipt by the DTE of a *PAD service* signal or a sequence of *PAD service* signals (in the case of call set-up) in response to a previously transmitted *PAD command* signal, the interface will be in either:

- a) a *PAD waiting* state (state 5) if no virtual call is in progress, or
- b) a *data transfer* state (state 9) if a virtual call is in progress.

Any *PAD service* signal arising from events within the packet network will not be transmitted until any *PAD service* signal outstanding from a previously received *PAD command* signal has been transmitted.

PAD service signals will not be transmitted if the value of parameter 6 is set to 0 and the *PAD service* signals state will be bypassed.

The standard format of *PAD service* signals is defined in 3.5.

A summary of *PAD service* signals is given in Annex A.

3.2.1.7 Incoming calls

The PAD will indicate *incoming call* to the start-stop mode DTE only if the DTE/DCE interface is in the *PAD waiting* state (state 5). In any other case the PAD will only indicate incoming call if:

- a) the PAD knows the speed and code of the start-stop mode DTE by previous agreement, or a default value is applicable;
- b) the PAD waiting state (state 5) is reached by the setting up of an access information path within X seconds.

The value of X is for further study, but should not exceed 120 s.

The PAD will transmit to the start-stop mode DTE an *incoming call PAD service* signal.

The PAD will not expect a response to the *incoming call PAD service* signal from the start-stop mode DTE and will consider the interface to enter at once the *data transfer* state (state 9).

The standard format of the *incoming call PAD service* signal is given in 3.5.22.

3.2.2 Clearing

3.2.2.1 Clearing by the start-stop mode DTE

3.2.2.1.1 Clearing by the local PAD

DTE clearing of the PAD to which the DTE is connected shall be indicated by either:

- a) transmitting a *clear request PAD command* signal after escaping from the *data transfer* state during a virtual call (see 4.9). The format of a *clear request PAD command* signal is given in 3.5.8. The PAD will transmit a *clear confirmation PAD service* signal within B seconds. The value of B is for further study. The standard format of the *clear confirmation PAD service* signal is given in 3.5.9. The interface will enter the *PAD waiting* state and the DTE will be allowed to make a follow-on call; or
- b) disconnecting the access information path.

3.2.2.1.2 Clearing of the remote PAD

NOTE – This is an optional function which will not be supported on all PADs.

DTE clearing of a remote PAD shall be indicated by transmitting an *invitation to clear PAD command* signal after escaping from the data transfer state during a virtual call (see 4.9). The format of an *invitation to clear PAD command* signal is given in 3.5.8. The PAD to which the DTE issuing the invitation to clear is connected will transmit a *clear indication PAD service* signal to that DTE once indication of clearing has been received from the remote PAD. The format of the *clear indication PAD service* signal is given in 3.5.17. The interface will enter the *PAD waiting* state and the DTE will be allowed to make a follow-on call or disconnect the access information path.

3.2.2.2 PAD clearing

- a) When parameter 6 is not set to 0, PAD clearing may be indicated by:
 - 1) transmitting a *clear indication PAD service* signal. The standard format of a *clear indication PAD service* signal is given in 3.5.17. After transmitting a *clear indication PAD service* signal, the interface will be in the *PAD waiting* state. The DTE shall stop sending data on receipt of a *clear indication PAD service* signal and shall transmit binary 1; or
 - 2) disconnecting the access information path.
- b) When parameter 6 is set to 0, PAD clearing may be performed by:
 - 1) not disconnecting the access information path and the interface will enter the *PAD waiting* state (State 5); or
 - 2) disconnecting the access information path.

3.2.3 Unsuccessful calls

If a call is unsuccessful for any reason, the PAD will indicate the reason to the start-stop mode DTE by means of a *clear indication PAD service* signal. If parameter 6 is set to 0, a *PAD service* signal is not transmitted.

After transmission of the *clear indication PAD service* signal, the PAD will be in the *PAD waiting* state.

3.2.3.1 Fault conditions

3.2.3.1.1 Failure to receive a PAD command signal

If the first character of a *PAD command* signal is not received within T seconds of the interface entering the *PAD waiting* state, the PAD will perform PAD clearing in accordance with 3.2.2.2. The value of T is for further study.

This restriction does not apply to a DTE which accesses the PAD by a leased line.

If following the first character of a *PAD command* signal a *PAD command* signal delimiter is not received within S seconds, the PAD will transmit an *error PAD service* signal, if parameter 6 is not set to 0, indicating that an error has occurred (see 3.5.19) and the interface will return to the *PAD waiting* state. The value of S is for further study but will not be less than 60 s.

If the PAD receives an unrecognized *PAD command* signal it will transmit an *error PAD service* signal, if parameter 6 is not set to 0, indicating that an error has occurred and the interface will return to the *PAD waiting* state.

The operation of the PAD when parameter 6 is set to 0 is for further study.

3.2.3.1.2 Failure to establish a virtual call

If the interface enters the *PAD waiting* state more than N times after setting up the access information path without a virtual call being established, the PAD will disconnect the access information path. This restriction does not apply to DTEs which access the PAD by leased lines.

The value of N is for further study.

3.2.3.1.3 Invalid clear request PAD command signal

If the PAD receives a *clear request PAD command* signal while the interface is in the *PAD waiting* state, the PAD will transmit a *clear indication PAD service* signal (local procedure error) if parameter 6 is not set to 0 and the interface will return to the *PAD waiting* state. The standard format of the relevant *clear indication PAD service* signal is given in 3.5.17.

3.2.3.1.4 Invalid facility request

If the PAD receives an invalid facility request code the PAD will perform PAD clearing in accordance with 3.2.2.2.

3.2.3.2 Failure of the access information path

If the access information path is disconnected for any reason, the call attempt or virtual call will be cleared by the PAD.

3.2.4 Data transfer

The procedures for data transfer are given in clause 4.

3.2.5 Called DTE reselection

The called DTE reselection is provided as default condition by the PAD. The start-stop mode DTE is able to prevent the called DTE reselection by including the *called DTE reselection prevention facility* in the *selection PAD command* signal.

On receipt of a *reselection PAD* message the PAD will, if parameter 6 is not set to 0 and the *called DTE reselection prevention facility* has not been requested in the *selection PAD command* signal, send a *reselection PAD service* signal to the start-stop mode DTE.

The standard format of the *reselection PAD service* signal is given in 3.5.29. The interface will enter *connection in progress* state, and the PAD will act as described in 3.2.1.5.

NOTE – Some networks may not implement this procedure.

3.3 Procedures for setting or changing the values of PAD parameters

The procedures described in 3.3.1 and 3.3.2 give details for setting or changing the values of PAD parameters by the start-stop mode DTE connected to that PAD. These procedures may be used before the *selection PAD command* signal is sent and also after escaping from the *data transfer* state.

The procedures described in 3.3.3 refer to the PAD behaviour about the current values of PAD parameters in the case of call clearing.

The procedures described in 3.3.4 give details for setting or changing the values of remote PAD parameters by a start-stop mode DTE. These procedures may only be used after escaping the *data transfer* state.

NOTE – The procedure for setting or changing parameters in a remote PAD is optional and may not be supported by many PADs.

3.3.1 Selection of a standard profile by the start-stop mode DTE

The start-stop mode DTE may select a set of defined values of PAD parameters known as a *standard profile* [see 3.1.1 b)] by sending the *profile selection PAD command* signal which includes a profile identifier. This procedure is additional to the selecting of an *initial standard profile* by transmitting the *service request* signal. The start-stop mode DTE may select a set of parameter values as an initial profile at subscription time by agreement with the Administration.

The format of the *profile selection PAD command* signal is given in 3.5.5.

A list of the parameter values associated with the *transparent* and *simple standard profiles* is given in Table 1. Other ITU-T *standard profiles*, all corresponding parameter values and their identifiers are subjects for further study.

When parameter 6 is not set to 0, the PAD will acknowledge the *profile selection PAD command* signal by sending an *acknowledgement PAD service* signal to the start-stop mode DTE.

The standard format of the *acknowledgement PAD service* signal is defined in 3.5.3.

3.3.2 Procedures for setting or changing one or several parameters by the start-stop mode DTE

The start-stop mode DTE may change the values of one or several parameters by sending a *set* or *set and read PAD command* signal including the parameter reference(s) and value(s). The format of *PAD command* signals is defined in 3.5.

When parameter 6 is not set to 0, the PAD will respond to a valid *set and read PAD command* signal by transmitting a *parameter value PAD service* signal, showing the newly set parameter values. The PAD will respond to a valid *set PAD command* signal by transmitting an *acknowledgement PAD service* signal. If at least one of the requested PAD parameters is invalid, the PAD will send a *parameter value PAD service* signal to the start-stop mode DTE to identify the invalid parameters. In this case the valid parameters will be accepted and invoked. Valid parameter references and values are given in Table 1/X.3.

The format of the *parameter value PAD service* signal is defined in 3.5.14.

When parameter 6 is set to 0, the PAD will accept and invoke valid parameters without advising the start-stop mode DTE of any invalid parameters or parameter values.

If the function of a character is duplicated by the selection of parameter values by use of the *set* or *set and read PAD command* signal, the PAD will consider these parameter changes as valid, and will respond as described above. After these changes are invoked, when the PAD receives from the start-stop mode DTE the character with the duplicated function, the PAD will perform the function of the character that has the highest priority among the functions that are duplicated. The priority assignment of the functions is as follows:

- | | | |
|-----------|----|---|
| (Highest) | 1) | PAD recall character (parameter 1) |
| | 2) | PAD command signal delimiter |
| | 3) | X-ON, X-OFF (parameters 12 and 22) |
| | 4) | Line display (parameter 18) |
| | 5) | Character delete (parameter 16) |
| | 6) | Line delete (parameter 17) |
| (Lowest) | 7) | Data forwarding character (parameter 31). |

3.3.3 PAD procedures regarding the current values of PAD parameters

The following situations are considered:

1) *Call establishment phase*

In any case if a *clear* condition, without disconnecting the access information path, occurs prior to the virtual call being set up, the current values of PAD parameters are left as they are.

2) *Clear after call set up*

In the case where a *clear* condition, without disconnecting the access information path, occurs after set-up of the virtual call, the PAD will reset the parameters to the values specified in the *initial profile*.

3.3.4 Procedures for setting or changing one or several parameters of a remote PAD by the start-stop mode DTE

NOTE – The function of being able to set or change parameters in the remote PAD is optional and may not be supported by many PADs.

The start-stop mode DTE may change the values of one or several parameters in a remote PAD by sending a remote *set and read PAD command* signal including the parameter reference(s) and value(s). The format of *PAD command* signals is defined in 3.5.

When parameter 6 is not set to 0, the PAD will, in response to a valid remote *set and read PAD command* signal from the local DTE and following receipt of a *parameter indication PAD* message from the remote PAD, transmit a remote parameter value PAD service signal to the local DTE showing the newly set parameter values in the remote PAD. In this case, the remote set and read PAD command signal and the remote parameter value PAD service signal and the procedure may only be used after escaping from the data transfer state.

3.4 Procedures for reading the values of one or several parameters by the start-stop mode DTE

This procedure may be used when parameter 6 is not set to 0. The PAD will ignore a *read PAD command* signal or a *remote read PAD command signal* if parameter 6 is set to 0.

3.4.1 To read local PAD parameter values

The start-stop mode DTE may enquire about the current values of one or several PAD parameters by sending the *read PAD command* signal and the references of the required parameters before the *selection PAD command* signal is sent and also after escaping from the *data transfer* state. The format of the *read PAD command* signal is defined in 3.5.4.

The PAD will respond by sending a *parameter value PAD service* signal containing the requested parameter values. The standard format of the *parameter value PAD service* signal is defined in 3.5.14.

3.4.2 To read remote PAD parameter values

The procedures used by the start-stop mode DTE to enquire about the current values of the remote PAD are similar to those in 3.4.1. In this case the remote *read PAD command* signal and *remote parameter value PAD* signal are used, and the procedure may only be used after escaping from the *data transfer* state.

3.5 Formats of PAD command signals and PAD service signals

All characters in columns 2 to 7 of International Alphabet No. 5, excluding the characters 2/0 (SP), 7/15 (DEL), 2/11 (+) and the characters assigned to perform editing functions will be recognized by the PAD as forming part of a *PAD command* signal. The PAD will always recognize the characters 0/13 (CR) and 2/11 (+) as the *PAD command signal delimiter*. The *PAD command signal delimiter* is not part of the command. Characters 2/0 (SP) and 7/15 (DEL) are not considered as part of a *PAD command* signal and those characters will be ignored by the PAD if no other function is assigned to these characters. Characters from columns 0 to 7 may be assigned to perform editing functions and in this case the PAD will operate in accordance with 3.6. Unassigned characters in columns 0 and 1 will be ignored by the PAD.

PAD command signals are defined in upper case characters in this Recommendation; however, in addition, lower case characters are acceptable. For an interim period, some networks may consider *PAD command* signals containing lower case characters as invalid.

All *PAD command* signals shall be terminated with the *PAD command signal delimiter*.

If the low order 4 bits or parameter 6 are set to a value of 1 or 5, *PAD service* signals will be sent in the standard format, as described below. If the low order 4 bits of parameter 6 are set to one of the values 8 to 15 *PAD service* signals are sent in a network dependent format.

If the high order 4 bits of parameter 6 are not all zero, the PAD will operate in the extended dialogue mode. The extended dialogue mode provides additional natural language text in *PAD service* signals. It provides a *help PAD command* signal for requesting explanatory information on *PAD command* signals, PAD parameters, standard profiles, etc. In the following definitions of standard formats for *PAD service* signals, the extended text, where shown, is to be sent only when the PAD is in the extended dialogue mode. In some networks the extended dialogue mode information may be provided in different languages. Additional *PAD command* signals may be provided as defined in clause 5. Some networks may also provide the additional *PAD command* signals while the PAD is not in extended dialogue mode.

NOTE – The text for service signals in languages other than English is for further study. See Annex C.

Some networks may not permit the free use of character 2/0 (SP) anywhere in the command when operating in the extended dialogue mode. In particular this character may not be permitted within keywords. In addition, at least one such character may be required as a separator between keywords or between keywords and numeric values.

PAD service signals, other than the *acknowledgement*, *prompt*, *character deleted*, *line deleted* and *page wait* *PAD service* signals (see 3.5.2, 3.5.23, 3.5.24, 3.5.25 and 3.5.26) will commence with and be followed by the *format effector*.

3.5.1 Format of the PAD command signal delimiter

The character 0/13 (CR) or character 2/11 (+) may be sent as a delimiter.

3.5.2 Format of the format effector

The characters 0/13 (CR) 0/10 (LF) will be sent by the PAD followed by, when parameter 9 is set to 0, two padding characters if the start-stop mode DTE operates at a data rate of 110 bit/s and four padding characters if the start-stop mode DTE operates at 200 bit/s, 300 bit/s, 1200 bit/s, 75/1200 bit/s or 2400 bit/s.

If parameter 9 is not set to 0, then the number of padding characters transmitted after the character 0/10 (LF) will be equal to the current value of that parameter.

The format of the padding characters is given in 3.5.20.

NOTE – The term "format effector" is used here slightly differently from that in Recommendation T.50.

3.5.3 Standard format of the acknowledgement PAD service signal

The *format effector* will be sent.

3.5.4 Format of read PAD command signal

3.5.4.1 To read parameters of the local PAD to which the requesting DTE is connected, the characters 5/0 (P) 4/1 (A) 5/2 (R) 3/15 (?) shall be sent followed by the decimal reference of the parameter to be read.

Characters of International Alphabet No. 5 will be sent to represent both the parameter reference and parameter value, e.g. decimal value 12 would be sent as characters 3/1 (1) and 3/2 (2).

If no parameter reference number is indicated in the *read PAD command* signal then it applies implicitly to all parameters.

When more than one parameter is required to be read by sending the *read PAD command* signal, the character 2/12 (.) shall be sent between the decimal references of the parameters.

Example: PAR? 1, 3, 5

The format required to read national parameters is for further study.

3.5.4.2 If reading of remote PAD parameters is supported by the local PAD, the characters 5/2 (R) 5/0 (P) 4/1 (A) 5/2 (R) 3/15 (?) shall be sent followed by the reference of the parameter to be read.

Characters of International Alphabet No. 5 will be sent to represent both the parameter reference and parameter value, e.g. decimal value 12 would be sent as characters 3/1 (1) and 3/2 (2).

If no parameter reference number is indicated in the *remote read PAD command* signal, then it applies implicitly to all parameters.

When more than one parameter is required to be read by sending the *remote read PAD command* signal, the character 2/12 (,) shall be sent between the decimal references of the parameters.

Example: RPAR? 1, 3, 5

3.5.5 Format of profile selection PAD command signal

The characters 5/0 (P) 5/2 (R) 4/15 (O) 4/6 (F) shall be sent followed by a profile identifier. A profile identifier will consist of one or more alphanumeric characters. The profile identifiers 90-99 are reserved for ITU-T defined profiles as defined in Table 3. In addition, some networks may also assign other profile identifiers to ITU-T defined profiles.

Table 3/X.28 – ITU-T standard profile identifiers

Profile identifier	ITU-T standard profile
90	Simple standard profile
91	Transparent standard profile
92 to 99	Reserved for future use

3.5.6 Format of set PAD command signal and the set and read PAD command signal

3.5.6.1 To set or set and read parameters in the local PAD to which the DTE is connected.

The set PAD command signal will consist of the characters 5/3 (S) 4/5 (E) 5/4 (T) followed by the decimal reference of the parameter to be set, followed by character 3/10 (:) and the parameter value required.

The set and read PAD command signal will consist of the characters 5/3 (S) 4/5 (E) 5/4 (T) 3/15 (?) followed by the decimal reference of the parameter to be set and read, followed by the character 3/10 (:) and the parameter value required.

If more than one parameter is to be set or set and read by the *set and read PAD command* signal, the character 2/12 (,) shall be sent between a parameter value and the next parameter reference.

Example: SET 2:0, 3:2, 9:4

The format required to set national parameters is for further study.

3.5.6.2 To set and read parameter in the remote PAD

The local PAD may optionally support the setting and reading of the remote PAD parameters.

The *remote set and read PAD command* signal will consist of the characters 5/2 (R) 5/3 (S) 4/5 (E) 5/4 (T) 3/15 (?) followed by the decimal reference of the parameter to set and read, followed by the character 3/10 (:) and the parameter value required.

If more than one parameter is to be set and read by the *remote set and read PAD command* signal, the character 2/12 (,) shall be sent between a parameter value and the next parameter reference.

Example: RSET 2:0, 3:2, 9:4

3.5.7 Standard format of the reset PAD service signal

The *reset PAD service* signal consists of the following elements:

<reset PAD service signal> ::= <RESET> <cause> <diagnostic> <text>

where:

<RESET> ::= 5/2 (R) 4/5 (E) 5/3 (S) 4/5 (E) 5/4 (T) 2/0 (SP)

<cause> ::= as shown in Table 5

<diagnostic> ::= 1, 2 or 3 characters which represent the decimal value of the diagnostic code, as specified in Recommendation X.25

NOTE – The inclusion of the <diagnostic> field is optional.

<text> ::= 2/0 (SP) 2/13 (–) 2/0 (SP) followed by extended dialogue mode text as specified in Table 5

3.5.8 Format of the clear request PAD command signal and invitation to clear PAD command signal

3.5.8.1 Standard format of the clear request PAD command signal

The *clear request PAD command* signal will, in the following order, consist of the following elements:

- One mandatory field:

The characters 4/3 (C) 4/12 (L) 5/2 (R) shall be sent to cause the local PAD to clear the call, followed by <Formatting character>.

- One optional field (only present in conjunction with the fast select facility):

Up to 128 characters of clear user data that may only be present in conjunction with the fast select facility.

NOTE – The characters 0/13 (CR) and 2/11 (+) should not be included in the *clear user data* field because they will be treated as a *PAD command* signal delimiter and not transmitted to the remote packet mode DTE. The editing functions should not be included in the *clear user data* field as they will be treated as providing the editing function.

3.5.8.2 Invitation to clear PAD command signal

The local PAD may support the capability to generate an *invitation to clear* PAD message to the remote PAD to request the remote PAD to clear the call when all remaining data has been transmitted to the remote DTE.

The characters 4/9 (I) 4/3 (C) 4/12 (L) 5/2 (R) shall be sent to cause the local PAD to send an invitation to clear to the remote PAD.

3.5.9 Standard format of the clear confirmation PAD service signal

The *clear confirmation PAD service* signal consists of the following elements:

<clear confirmation> ::= <CLR> <CONF> <text> <format effector> <optional facility block>

where:

<CLR> ::= 4/3 (C) 4/12 (L) 5/2 (R) 2/0 (SP)

<CONF> ::= characters as specified in Table 7

<text> ::= 2/0 (SP) 2/13 (–) 2/0 (SP) followed by extended dialogue mode text as specified in Table 7.

<format effector> ::= see 3.5.2

<optional facility block> ::= see 3.5.17.3

If subscribed to or requested in the *selection PAD command* signal (see Table 4), the optional facility block will contain the charging information and will be transmitted by the PAD to the start-stop mode DTE. The format of the charging information is network dependent.

3.5.10 Format of the status PAD command signal

The characters 5/3 (S) 5/4 (T) 4/1 (A) 5/4 (T) shall be sent.

3.5.11 Standard format of the status engaged and status free PAD service signals

The *status engaged PAD service* signal consists of the following elements:

<status engaged> ::= <ENGAGED> <text> <MAP status block>

where:

<ENGAGED> ::= 4/5 (E) 4/14 (N) 4/7 (G) 4/1 (A) 4/7 (G) 4/5 (E) 4/4 (D)

<text> ::= 2/0 (SP) 2/13 (–) 2/0 (SP) followed by the extended dialogue mode text "Call Established"

<MAP status block> ::= see 6.3.1

NOTE – The inclusion of additional information (e.g. destination address) is for further study.

Table 4/X.28 – Facility request/indication codes

Facility request/indication code	Facility	Remarks
4/2 (B)	Bilateral closed user group	Note 2
4/3 (C)	Charging information	Note 1
4/4 (D)	Throughput class negotiation	Note 2
4/5 (E) Address Extension String	Called Address extension	Note 1
4/6 (F)	Fast select with no restriction on response	Note 1
4/7 (G) CUG String	Closed user group	Note 1
4/13 (M)	Called line address modified notification	Note 1
4/14 (N) NUI String	Network user identification	Note 1
4/15 (O) CUG String	Closed user group with outgoing access	Note 1
5/0 (P)	Packet size negotiation	Note 2
5/1 (Q)	Fast select with restriction on response	Note 1
5/2 (R)	Reverse charging	Note 1
5/3 (S)	Called DTE reselection prevention	Note 1
5/4 (T) ROA string	ROA transit network selection	Note 1
5/5 (U)	Call redirection and deflection notification	Note 1
5/7 (W)	Window size negotiation	Note 2
CUG Closed User Group NUI Network User Identification NOTE 1 – These codes may currently be in use. NOTE 2 – These codes are reserved for possible future use.		

Table 5/X.28 – Extended dialogue mode text for reset PAD service signal

<Cause>	<Text>
4/4 (D) 5/4 (T) 4/5 (E)	Reset by remote device, data may be lost
4/5 (E) 5/2 (R) 5/2 (R)	Reset by network, local procedure error, data may be lost
4/15 (N) 4/3 (C)	Reset due to temporary network problem, data may be lost
5/2 (R) 5/0 (P) 4/5 (E)	Reset by network, remote procedure error, data may be lost

The *status free PAD service signal* consists of the following elements:

<status free> ::= <FREE> <text> <MAP status block>

where:

<FREE> ::= 4/6 (F) 5/2 (R) 4/5 (E) 4/5 (E)

<text> ::= 2/0 (SP) 2/13 (–) 2/0 (SP) followed by the extended dialogue mode text

"No Call Established"

<MAP status block> ::= see 6.3.1

NOTE – The inclusion of additional information (e.g. see 3.5.18) is for further study.

3.5.12 Format of the reset PAD command signal

The characters 5/2 (R) 4/5 (E) 5/3 (S) 4/5 (E) 5/4 (T) shall be sent.

3.5.13 Format of the interrupt PAD command signal

The characters 4/9 (I) 4/14 (N) 5/4 (T) shall be sent.

3.5.14 Standard format of parameter value PAD service signals

The *parameter value PAD service* signal consists of the following elements:

<parameter value PAD service signal> ::= <PAR> <parameter list>

where:

<PAR> ::= 5/0 (P) 4/1 (A) 5/2 (R) 2/0 (SP)

(Response from the local PAD to a request for parameter values)

5/2 (R) 5/0 (P) 4/1 (A) 5/2 (R) 2/0 (SP)

(Response from the remote PAD to a request for parameter values)

<parameter list> ::= one or more of <parameter>

<parameter> ::= <parameter reference> <parameter value> <text>

<parameter reference> ::= decimal reference of the parameter followed by the character 3/10 (:)

<parameter value> ::= decimal value of the parameter

<text> ::= 2/0 (SP) 2/13 (–) 2/0 (SP) followed by the extended dialogue mode text as specified in Table 8.

If the requested parameter reference or value is invalid, the characters 4/9 (I) 4/14 (N) 5/6 (V) will be sent in place of the appropriate parameter value.

If more than one parameter value is contained in the *parameter value PAD service* signal, the characters 2/12 (,) 2/0 (SP) will be sent before the next parameter reference.

In extended dialogue mode, if the length of the next parameter reference, value and text would cause the line length to exceed the value of PAD parameter 10 (if it is non-zero), then the character 2/12 (,) followed by the format effector may be used.

3.5.15 Format of the selection PAD command signal

A *selection PAD command* signal shall, in the following order, consist of a *facility request* block, or an *address* block, or both, optionally followed by *call user data* field.

3.5.15.1 Format of facility request block

Characters representing the facility request code shall be sent as defined in Table 4. When more than one *facility request* code is to be sent, the character 2/12 (,) shall be sent to separate the *facility request* codes. The character 2/13 (–) shall be sent at the end of the *facility request* block.

3.5.15.1.1 The format of the NUI facility request signal is as follows:

<facility request> ::= <N> <NUI string>

<N> ::= IA5 character 4/14 (N)

<NUI string> ::= one or more characters in columns 2 to 7 of International Alphabet No. 5 (IA5), except 2/0 (SP) 7/15 (DEL), 2/13 (–), 2/12 (,) and 2/11 (+).

NOTE 1 – The recognition by the PAD of the presence of the *facility request* signal should turn off the echo (irrespective of its parameter value) for the duration of the NUI *facility request*.

NOTE 2 – The length of the NUI string is network dependent.

NOTE 3 – Characters in columns 0 and 1, except 0/13 (CR), and characters 7/15 (DEL), and 2/0 (SP) may be included during the transmission of the NUI string but will not form part of the NUI string and will be discarded.

3.5.15.1.1.1 Format of the NUI facility request signal with extended format

The format for the NUI facility request signal with extended format is as follows:

<facility request> ::= <X> <formatted NUI string>
[</> <verifying entity> [</> <transmit NUI to remote DTE>]]

NOTE 1 – The extended NUI format may not be supported by all networks.

<X> ::= IA5 character 5/8

<formatted NUI string> ::= <O> <=> <NUI field> | <S> <=> <subfield string> | <I> <=> <ISO/ITU-T string>

<O> ::= IA5 character 4/15

NOTE 2 – <O> is used to indicate that there are no constraints on the following NUI field.

<NUI field> ::= one or more characters in columns 2 to 7 of International Alphabet No. 5, except 2/0 (SP), 7/15 (DEL), 2/6 (&), 3/10 (:), 2/15 (/), 2/13 (–), 2/12 (,) and 2/11 (+).

<S> ::= IA5 character 5/3

NOTE 3 – <S> is used to indicate subfield format(s) with no constraints.

<subfield string> ::= <subfield information> [<&> <subfield string>]

<subfield information> ::= [<A> <:> <IA5 data>] | [<:> <BCD data>]

<A> ::= IA5 character 4/1

 ::= IA5 character 4/2

<:> ::= IA5 character 3/10

<&> ::= IA5 character 2/6

NOTE 4 – The contents of <NUI field> and <IA5 data> shall consist of one or more characters in columns 2 to 7 of International Alphabet No. 5 (IA5), except 2/0 (SP), 7/15 (DEL), 2/13 (–), 2/11 (+), 2/6 (&), 3/10 (:), and 2/15 (/). Characters in columns 0 and 1, except 0/13 (CR), and characters 7/15 (DEL) and 2/0 (SP) may be included during the transmission of <NUI field> or <IA5 data> but will not form part of <NUI field> or <IA5 data> and will be discarded.

<I> ::= IA5 character 4/9

<ISO/ITU-T string> ::= <subfield string>

<verifying entity> ::= <O> | <T> | <D>

NOTE 5 – <O> is used to indicate the originating network is the verifying entity;

<T> is used to indicate the first transit network is the verifying entity;

<D> is used to indicate the destination network is the verifying entity.

<T> ::= IA5 character 5/4

<D> ::= IA5 character 4/4

<transmit NUI to remote DTE> ::= <R> | <U>

NOTE 6 – <R> is used to indicate the remote DTE is restricted from access to the NUI field information;

<U> is used to indicate the remote DTE is unrestricted from access to NUI field information.

NOTE 7 – The use of R and U parameter field are for further study.

<R> ::= IA5 character 5/2

<U> ::= IA5 character 5/5

3.5.15.1.2 The format of the ROA (transit network) selection *facility request* signal is as follows:

<ROA facility request> ::= <T> <ROA string>

<ROA string> ::= The DNIC of the requested ROA. In addition, some networks may also support graphic representations of the DNIC which may be used.

<T> ::= IA5 character 5/4 (T).

3.5.15.1.3 The format of the reverse charging facility request signal is as follows:

<reverse charging facility request> ::= <R>

<R> ::= IA5 character 5/2 (R)

3.5.15.1.4 Formats for Closed User Group Signals

When the user has subscribed to Closed User Groups (CUG), a preferential CUG must be chosen. In this case, only the *CUG facility request* signal may be used by the user.

When the user has subscribed to CUG and has outgoing access (CUG/OA) and/or incoming access (CUG/IA), the user may choose whether or not to have a preferential CUG. If a preferential has not been chosen, the user may signal the *CUG facility request* or the *CUG/OA facility request* in a particular *PAD selection command* signal. When the user has chosen a preferential CUG, only the *CUG facility request* signal may be used.

The *CUG facility request* and the *CUG/OA facility request* shall not be used in the same *PAD selection command* signal.

3.5.15.1.4.1 The format of the closed user group facility request signal is as follows:

<CUG facility request> ::= <G> <Optional index>

<G> ::= IA5 character 4/7 (G)

<Optional index> ::= one or two decimal digits

The PAD shall treat the absence of the index as an implicit request for the preferential CUG.

The PAD shall treat the absence of a *CUG facility request* as an implicit preferential CUG request if the user has subscribed to the CUG, CUG/OA and/or CUG/IA facility and has chosen a preferential.

3.5.15.1.4.2 The format of the closed user group with outgoing access facility is as follows:

<CUG with outgoing access facility request> ::= <O> <Optional index>

<O> ::= IA5 character 4/15 (O)

<Optional index> ::= one or two decimal digits

3.5.15.1.5 The format of the charging information facility request signal is as follows:

<charging information facility request> ::= <C>

<C> ::= IA5 character 4/3 (C).

3.5.15.1.6 The format of the called address extension *facility request* signal is as follows:

CAE facility request:

<CAE facility request> ::= <E> <CAE string>

<E> ::= IA5 character 4/5 (E)

<CAE string> ::= The called address extension is a string of up to 40 characters from the set 3/0-3/9. Further, other representations of the called address extension are for further study.

The means to indicate the type of address present in the called address extension facility is for further study.

3.5.15.1.7 The format of the fast select with no restriction on response *facility request* signal is as follows:

<fast select with no restriction on response facility request> ::= <F>

<F> ::= IA5 character 4/6 (F)

3.5.15.1.8 The format of the called DTE reselection prevention *facility request* signal is as follows:

<called DTE reselection prevention facility request> ::= <S>

<S> ::= IA5 character 5/3 (S)

3.5.15.1.9 The format of the fast select with restriction on response *facility request* signal is as follows:

<fast select with restriction on response facility request> ::= <Q>

<Q> ::= IA5 character 5/1 (Q)

The formats of other *facility request* codes are for further study.

3.5.15.2 Format of address block

Characters representing a full address or an abbreviated address shall be sent. When an abbreviated address is sent, it shall be prefixed by character 2/14 (.). When more than one address, either full address or abbreviated address, is sent, the character 2/12 (,) is sent as a separator. When an abbreviated address is used, the call user data field shall be separated from the *abbreviated address* signal by the character 2/10 (*).

3.5.15.2.1 The format of the full address is as follows:

<full address> ::= one or more numeric characters of the International Alphabet No. 5 (IA5).

NOTE – The numeric characters are those in the ranges 3/0 to 3/9.

3.5.15.2.2 The format of the abbreviated address is as follows:

<abbreviated address> ::= one or more characters in columns 2 to 7 of the International Alphabet No. 5, except 2/10 (*), 2/11 (+) 2/12 (,) and 7/15 (DEL).

NOTE 1 – The PAD shall translate the string into a full address.

NOTE 2 – Recommendations for the translation of the character string to a full address are for further study.

NOTE 3 – This facility is optional.

3.5.15.3 Format of call user data field

The format of the call user data field will be as given in 3.5.15.3.1 for non-transparent working and in 3.5.15.3.2 for transparent working.

3.5.15.3.1 Format of call user data field for normal non-transparent working

The character 5/0 (P) or the character 4/4 (D) shall be sent, followed by up to 12 characters of user data or up to 124 characters of user data in conjunction with the fast select facility. Some networks may not make this field available to the user.

NOTE – The characters 0/13 (CR) and 2/11 (+) should not be included in the user data field because they will be treated as a *PAD command signal delimiter* and not transmitted to the remote packet mode DTE. The editing characters should not be included in the user data field as they will be treated as providing the editing function.

3.5.15.3.2 Format of call user data field for transparent working

The character 4/8 (H) shall be sent, followed by up to 12 character pairs of user data or up to 124 character pairs of user data in conjunction with the fast select facility. Each character of each character pair shall only be from the set 3/0 ... 3/9, 4/1 ... 4/6 (0 ... 9, A ... F). Each character pair shall be understood by the PAD to represent the hexadecimal value of one octet to be included in the corresponding position of the user data field of the call request packet.

In the event of the PAD receiving only one character of a character pair, then it will transmit an *error PAD service* signal, if parameter 6 is not set to 0, indicating that an error has occurred and the interface will return to the PAD waiting state.

3.5.16 Format of service request signal

The format is for further study.

3.5.17 Standard format of clear indication PAD service signal

The *clear indication PAD service* signal will, in the following order, consist of the following elements:

– *one mandatory field:*

<a sequence of alphabetic characters indicating the clear indication (see 3.5.17.1)> <formatting character>

– *the following optional fields:*

<called DTE address block (see 3.5.17.2)> <formatting character>

<optional facility block (see 3.5.17.3)> <formatting character>

<optional clear user data block (see 3.5.17.4)> <formatting character>

3.5.17.1 Standard format of the mandatory field

The mandatory field consists of the following elements:

<Mandatory field> ::= <CLEAR> <cause> <cause code> <diagnostic> <text>

<CLEAR> ::= 4/3 (C) 4/12 (L) 5/2 (R) 2/0 (SP)

<cause> ::= one of the causes shown in Table 6

<cause code> ::= 2/0 (SP) 4/3 (C) 3/10 (:) followed by 1, 2 or 3 characters which represent the decimal value of the cause code, as specified in Recommendation X.25

<diagnostic> ::= 2/0 (SP) 4/4 (D) 3/10 (:) followed by 1, 2 or 3 characters which represent the decimal value of the diagnostic code, as specified in Recommendation X.25

<text> ::= 2/0 (SP) 2/13 (–) 2/0 (SP) followed by extended dialogue mode text as specified for the corresponding <cause> in Table 6.

NOTE – The use of the <cause code> and <diagnostic> field is optional.

Table 6/X.28 – Cause and extended dialogue mode text for clear PAD service signal

<Cause>	<Text>
4/15 (O) 4/3 (C) 4/3 (C)	Call cleared, number busy
4/14 (N) 4/3 (C)	Call cleared, temporary network problem
4/9 (I) 4/14 (N) 5/6 (V)	Call cleared, invalid facility requested
4/14 (N) 4/1 (A)	Call cleared, access to this number is barred
4/5 (E) 5/2 (R) 5/2 (R)	Call cleared, network detected local procedure error
5/2 (R) 5/0 (P) 4/5 (E)	Call cleared, network detected remote procedure error
4/14 (N) 5/0 (P)	Call cleared, number not assigned
4/4 (D) 4/5 (E) 5/2 (R)	Call cleared, number out of order
5/0 (P) 4/1 (A) 4/4 (D)	Call cleared, remote request
4/4 (D) 5/4 (T) 4/5 (E)	Call cleared, by remote device, data may be lost
5/2 (R) 4/14 (N) 4/1 (A)	Call cleared, reverse charging refused
4/9 (I) 4/4 (D)	Call cleared, incompatible destination
5/3 (S) 4/1 (A)	Call cleared, ship cannot be contacted
4/6 (F) 4/14 (N) 4/1 (A)	Call cleared, fast select refused
5/2 (R) 4/15 (O) 4/15 (O)	Call cleared, cannot be routed as requested
NOTE – For details, see Recommendation X.96.	

Table 7/X.28 – Extended dialogue mode text for clear confirmation PAD service signal

<CONF>	<Text>
4/3 (C) 4/15 (O) 4/14 (N) 4/6 (F)	Call cleared, confirmed

Table 8/X.28 – PAD parameter names for extended dialogue mode

Parameter reference number	Abbreviated parameter name (Note 1)	Parameter description (Note 2)
1	esc(ape)	PAD recall using a character
2	ech(o)	Echo
3	for(ward)	Selection of data forwarding characters
4	idl(e)	Selection of idle timer delay
5	dev(ice)	Ancillary device control
6	sig(nals)	Control of PAD service signals
7	bre(ak)	Operation on receipt of break signal
8	dis(card)	Discard output
9	CRp(ad)	Padding after carriage return
10	fol(ding)	Line folding
11	spe(ed)	Binary speed of start-stop mode DTE
12	flo(w)	Flow control of the PAD
13	LFi(nsert)	Linefeed insertion after carriage return
14	LFp(ad)	Padding after linefeed
15	Edi(t)	Editing
16	Cdel(ete)	Character delete
17	Ldel(ete)	Line delete
18	Ldis(play)	Line display
19	Esig(nals)	Editing PAD service signals
20	Mas(k)	Echo mask
21	par(ity)	Parity treatment
22	pag(e)	Page wait
23	inp(ut)	Size of input field
24	fra(me)	End-of-frame signal
25	Xfor(ward)	Extended forwarding signals
26	Dint(errupt)	Display interrupt character
27	Dcon(firmation)	Display interrupt confirmation
28	Cod(ing)	Diacritic character coding scheme
29	Xech(o)	Extended echo mask

NOTE 1 – These names are provisional. This name should appear in the *parameter value PAD service* signals. The name or abbreviation should be accepted in the *read, set, or set and read PAD command* signals.

NOTE 2 – In some networks this parameter description may appear in the *parameter value PAD service* signals. Alternative parameter descriptions are for further study.

3.5.17.2 Format of the called DTE address block

The need and the format of the called DTE address block is for further study.

3.5.17.3 Format of the optional facility block

If subscribed to, or requested in the *selection PAD command* signal (see Table 4), the optional facility block will contain the charging information and/or the CLAMN facility indication signal with the appropriate reason specified in the code index field and will be transmitted by the PAD to the start-stop mode DTE. The format of the charging information is network dependent.

3.5.17.3.1 Format of the Called Line Address Modified Notification Facility indication signal

<CLAMN facility> ::= <M> <code index> [<diagnostic code>] (see Note)

<M> ::= IA5 character 4/13

<code index> ::= (one of the following)

- CHG (4/3, 4/8, 4/7) – Call distribution within a Hunt Group
- CRO (4/3, 5/2, 4/15) – Call Redirection, originally called DTE is Out-Of-Order
- CRB (4/3, 5/2, 4/2) – Call Redirection Busy
- PRO (5/0, 5/2, 4/15) – Call redirection due to a Prior Request from the Originally called DTE
- CDO (4/3, 4/4, 4/15) – Called DTE Originated
- OCD (4/15, 4/3, 4/4) – Call deflection by Originally Called DTE

<diagnostic code> ::= The decimal value of the diagnostic transmitted by the originally called DTE.

NOTE – <Diagnostic code> is present when the code index is CDO.

3.5.17.4 Format of the clear user data block

The 128 or less characters from the clear user data field received from the remote DTE shall be sent. The clear user data field is only allowed in conjunction with the fast select facility.

3.5.18 Standard format of the PAD identification PAD service signal

The characters that will comprise this *PAD service* signal will be network dependent, but would probably indicate the PAD identity and port identity.

3.5.19 Standard format of the error PAD service signal

The characters 4/5 (E) 5/2 (R) 5/2 (R) will be sent, followed by other characters which are for further study.

3.5.20 Format of padding characters

The padding character will be 0/0 (NUL) or the equivalent duration of binary 1 according to the particular network.

3.5.21 Standard format of the connected PAD service signal

The *connected PAD service* signal will, in the following order, consist of the following elements:

- <optional called DTE address block> <formatting characters>
- <optional facility block> <formatting characters>
- <optional called user data field (see 3.5.21.1)> <formatting characters>
- <characters 4/3 (C) 4/15 (O) 4/13 (M)> <formatting characters>

The called DTE address block will consist of numeric characters from IA5. The optional facility block will be as given in 3.5.22.2 below. It is for further study if the formatting characters will be 2/0 (SP) or the format effector.

If subscribed to, or requested in the selection PAD command signal (see Table 4), the optional facility block will contain the charging information and/or the CLAMN facility indication signal with the appropriate reason specified in the code index field and will be transmitted by the PAD to the start-stop mode DTE. The format of the charging information is network dependent. The format for the CLAMN facility indication signal is given in 3.5.17.3.1.

3.5.21.1 Standard format of the called user data field

The 124 or less characters from the called user data field received from the remote DTE shall be sent. The called user data field is only allowed in conjunction with the fast select facility.

3.5.22 Standard format of the incoming call PAD service signal

The standard format of the *incoming call PAD service* signal will, in the following order, consist of the following elements:

- <calling DTE address block> <formatting characters>
- <optional facility block> <formatting character>

- <call data block> <formatting characters>
- <characters 4/3 (C) 4/15 (O) 4/13 (M)>

The calling DTE address block will consist of numeric characters from IA5. The optional facility block will be as given in 3.5.22.2. The call data block will be as given in 3.5.22.3. It is for further study whether these fields will be separated by a 2/0 (SP) character or the format effector. In some networks an alternative *incoming call PAD service* signal may be transmitted.

3.5.22.1 Standard format of the calling DTE address block

The standard format of the calling DTE address block is for further study.

3.5.22.2 Standard format of the optional facility block

The standard format of the facility block is as follows:

<facility block> ::= <FAC:> <facility string>

<FAC:> ::= <IA5 characters 4/6 (F), 4/1 (A), 4/3 (C), 3/10 (:), 2/0 (SP)>

<facility string> ::= One or more facility indication codes separated by character 2/12 (,). For facility indication codes, see Table 4 and 3.5.15.1, 3.5.17.3 and 3.5.22.2.1.

The facility block is suppressed if no facilities are present in the incoming call.

3.5.22.2.1 Standard format of the Call Redirection/Deflection Notification facility indication signal

<Call Redir./Defle. Facility> ::= <U> <code index> [<diagnostic code>] (see Note)

<U> ::= IA5 character 5/5

<code index> ::= (one of the following)

CRO (4/3, 5/2, 4/15) – Call Redirection, originally called DTE is Out-Of-Order

CRB (4/3, 5/2, 4/2) – Call Redirection Busy

PRO (5/0, 5/2, 4/15) – Call redirection due to a Prior Request from the Originally called DTE

CDO (4/3, 4/4, 4/15) – Called DTE Originated

OCD (4/15, 4/3, 4/4) – Call deflection by Originally Called DTE

<diagnostic code> ::= The decimal value of the diagnostic transmitted by the originally called DTE.

NOTE – <Diagnostic code> is present when the code index is CDO.

3.5.22.3 Standard format of the call data block

The 12 or less characters, or 124 or less characters in conjunction with the fast select facility, from the call data field received from the remote DTE shall be sent.

3.5.23 Standard format of the prompt PAD service signal

The standard format of the *prompt PAD service* signal is the character 2/10 (*) following a *format effector*.

NOTE – For an interim period, other characters are permitted.

3.5.24 Standard format of the character deleted PAD service signal

Depending on the value of parameter 19, the following will apply:

Value 0: no *PAD service* signal will be sent;

Value 1: the character 5/12 (\) will be sent; see Note;

Value 2: the characters 0/8 (BS) 2/0 (SP) 0/8 (BS) will be sent;

Value 8, 32-126: one character from International Alphabet No. 5 will be sent.

NOTE – Alternatively the character 2/15 (/) may be used by some networks.

3.5.25 Standard format of the line deleted PAD service signal

Depending on the value of parameter 19, the following will apply:

- Value 0: no *PAD service* signal will be sent;
- Value 1, 8, 32-126: the characters 5/8 (X), 5/8 (X), 5/8 (X) will be sent followed by the format effector;
- Value 2: the characters 0/8 (BS), 2/0 (SP), 0/8 (BS) will be sent the number of times equal to the number of graphic characters being deleted from the buffer.

3.5.26 Standard format of the parity error PAD service signal

The standard format is for further study.

3.5.27 Standard format of the page wait PAD service signal

The characters 0/13 (CR) 5/0 (P) 4/1 (A) 4/7 (G) 4/5 (E) will be sent.

3.5.28 Format of the page wait cancellation character

The character X-ON will be sent.

3.5.29 Standard format of the reselection PAD service signal

The standard format of the *reselection PAD service* signal will, in the following order, consist of the following element:

- <characters 5/4 (T) 5/2 (R) 4/1 (A) 4/14 (N) 5/3 (S) 4/9 (F) 4/5 (E) 5/2 (R) 2/0 (SP) 5/4 (T) 4/15 (O) 3/10 (:)>
<formatting character>
- <reselected DTE address block> <formatting character>
- <optional facility block> <character> <note>

NOTE 1 – The optional facility block contains the facilities included by the PAD in the *Call Request Packet* sent to the reselected DTE. The format of the optional facility block is identical to the one of the *incoming call PAD service* signal.

NOTE 2 – If requested in the *selection PAD command* signal for the original call or in the *reselection PAD service* signal for the reselected call(s), the PAD will send the charging information before transmitting the *reselection PAD service* signal (see 3.6. iii)/X.29).

NOTE 3 – The format of charging information is network dependent (see 3.5.17.2).

3.6 Editing functions in the PAD

The PAD provides functions for the start-stop mode DTE to edit characters input to the PAD in *PAD command* signals before being processed by the PAD. The functions provided are:

- a) character delete,
- b) line delete,
- c) line display.

Optionally available in some PADs are identical functions for use by the start-stop mode DTE during the *data transfer* state. When the value of parameter 15 is set to 0, no editing is available during the *data transfer* state.

When the value of parameter 15 is set to 1, editing is provided during the *data transfer* state (see 4.17).

The user may also have the ability in some PAD implementations to select the character used to effect each of the above functions by setting the value of parameters 16, 17 and 18 and to choose if and in what format the PAD will respond to the editing characters by setting the value of parameter 19 appropriately.

The procedures for editing described in this subclause apply to both *PAD command* and *data transfer* state (when provided).

3.6.1 Editing buffer

To perform the functions of editing, the PAD provides temporary storage of characters in an editing buffer.

3.6.1.1 Editing buffer size in PAD command state

In the *PAD command* state, the size of the editing buffer will be sufficient to contain the longest mandatory *PAD command* signal permissible in this Recommendation.

3.6.1.2 Editing buffer size in data transfer state

In the *data transfer* state, the size of the editing buffer is network dependent but will not be smaller than the full packet size and will not be smaller than the value of parameter 10 plus one. It should be noted however, that in some networks the size of the editing buffer may be limited to a maximum of 128 octets.

3.6.1.2.1 Impact of Videotex parameter reference 23 "Size of input field" in data transfer state

If parameter reference 23 is implemented and set to a non-zero value, the editing buffer size is network dependent but will not be smaller than the value of parameter reference 23.

3.6.1.3 Impact of editing on data forwarding conditions

In the *data transfer* state, characters entered into the editing buffer will be forwarded in a complete packet sequence when any of the data forwarding conditions described in 4.4 and in 2.1/X.29 occurs, except that:

- a) the PAD will not take account of the value of the idle time delay defined by the value of parameter 4;
- b) data forwarding on full packet will be suspended.

Whenever more than enough data has been received to fill the editing buffer, one full packet will be forwarded. The remaining characters will be placed in the beginning of the editing buffer and editing of these characters remains possible.

Once a packet has been forwarded, characters included in it can no longer be edited by the start-stop mode DTE by use of the PAD editing functions.

To take into account editing of diacritic characters, whenever more than enough data has been received to fill the editing buffer and the sequence of a composite coded character is located across a packet boundary, a non-full packet will be forwarded, the last character of this packet being the one preceding the first byte of the composite coded character. The sequence of the composite coded character will be placed in the beginning of the editing buffer and editing of this diacritic character remains possible.

NOTE 1 – It should be noted that the forwarding of the non full packet will prevent the recombination of the complete packet sequence (see Recommendation X.25, *More Data mark*).

NOTE 2 – The videotex diacritic character coding is indicated by parameter reference 28. It is the responsibility of the X.25 DTE to ensure that the start-stop mode DTE and the PAD use the same diacritic character coding in order to allow a correct editing of these characters.

3.6.1.3.1 Impact of Videotex parameter reference 23 on data forwarding condition

When parameter reference 23 is implemented and set to a non-zero value and when the editing buffer is filled, one full packet is not forwarded. Instead, a complete packet sequence containing all the data of the editing buffer is forwarded. Characters included in the complete packet sequence can no longer be edited by the start-stop mode DTE.

3.6.2 Procedures for editing

The procedures for editing *PAD command* signals and user data (when this facility is provided) use PAD parameters as defined in Recommendation X.3.

3.6.2.1 Procedure for character delete editing function

The character delete editing function is performed when the PAD receives a *character delete* character or a series of *character delete* characters from the start-stop mode DTE. The receipt of each *character delete* character causes the last character currently in the editing buffer to be deleted.

Subsequently, if the value of parameter 6 is not set to 0, if the value of parameter 19 is set to 2 or 8 and a graphic character is removed from the editing buffer, or, if the value of parameter 19 is set to 1 or 32 to 126, and a character is removed from the editing buffer, the *character deleted PAD service* signal will be sent by the PAD. The standard format of the *character deleted PAD service* signal is given in 3.5.24.

The *character delete* character when user selectable is determined by the value of parameter 16. The default value of parameter 16 or the *character delete* character when not user selectable is the character 7/15 (DEL).

3.6.2.2 Procedure for line delete editing function

The line delete editing function is performed when the PAD receives a *line delete* character from the start-stop mode DTE. The receipt of the *line delete* character causes the deletion of the current contents of the editing buffer.

The PAD will transmit, if parameter 6 and parameter 19 are not set to 0 and the editing buffer is not empty, a *line deleted PAD service* signal.

The *line delete* character when user selectable is determined by the value of parameter 17. The default value of parameter 17 or the *line delete* character when not user selectable is the character 1/8 (CAN).

3.6.2.3 Procedure for line display editing function

The line display editing function is performed when the PAD receives a *line display* character from the start-stop mode DTE.

The receipt of the *line display* character causes the PAD to transmit to the start-stop mode DTE a format effector followed by the characters currently stored in the editing buffer.

The *line display* character when user selectable is determined by the value of parameter 18. The default value of parameter 18 or the *line display* character when not user suitable is the character 1/2 (DC2).

3.7 Procedure for request of status of the virtual call

The start-stop mode DTE may, if parameter 6 is not set to 0, enquire whether a virtual call exists by sending the *status PAD command* signal to the PAD. The PAD will respond by sending the *status engaged* or *status free PAD service* signal to the DTE. The format of the PAD command signal and the standard format of the PAD service signals is given in 3.5.10 and 3.5.11 respectively.

4 Procedures for the exchange of user data between a start-stop mode DTE and a PAD

The procedures described apply during the *data transfer* state of the interface to a start-stop mode DTE.

4.1 Data transfer state

After receipt of the *connected* or *incoming call PAD service* signal, the interface shall be in the *data transfer* state and will remain in that state, unless it escapes as described in 4.9, until the virtual call is cleared by the PAD or by the start-stop mode DTE as described in 3.2.2.

If parameters 1, 12, 15 and 22 when implemented are set to 0, during the *data transfer* state any character sequence may be transmitted by the start-stop mode DTE for delivery to the remote DTE. If parameter 1 is not set to 0, the PAD recall character selected by the value of parameter 1 can only be transferred by following the procedure described in 4.9.1.

If parameter 12 is set to 1, characters 1/1 (DC1) and 1/3 (DC3) are unable to be transferred to the remote DTE; if parameter 15 is set to 1 the characters assigned for editing functions are unable to be transferred to the remote DTE; and if parameter 22 when implemented is not set to 0, the character 1/1 (DC1) is unable to be transferred to the remote DTE.

The values of other parameters may affect the characters which may be transferred during the *data transfer* state.

4.2 Data from the start-stop mode DTE received by the PAD

Characters received from the start-stop mode DTE are defined as consisting of all the bits received between, but not including, the start and stop bits. The action of the PAD with respect to the parity bit (bit 8) of all characters received is described in 2.1.

4.3 Delivery of user data to the start-stop mode DTE

Data received by the PAD for delivery to the start-stop mode DTE will be treated as contiguous octets. Each octet will be transmitted to the start-stop mode DTE at the data signalling rate appropriate to the start-stop mode DTE. The action of the PAD with respect to bit 8 (parity) of all characters transmitted is described in 2.1.

Start and stop bits will be added to the characters in accordance with Recommendation X.4, except that the number of stop bits will be as follows. If the PAD is operating at 110 bit/s, two stop bits will be transmitted. At any other speed, one stop bit will be transmitted.

The data will be transmitted to the start-stop mode DTE at the earliest opportunity permitted by the interleaving rules (see 4.19).

4.4 Data forwarding conditions

A packet will be forwarded subject to flow control, whenever more than enough data has been received from the start-stop mode DTE to fill a packet after the last packet was forwarded if the value of parameter 15 is set to 0. A packet will also be forwarded when the maximum assembly timer delay period, which starts upon receipt by the PAD of the first character to be assembled into a packet, elapses. The value of the time-out, when implemented, is network dependent and will be greater than or equal to 15 minutes.

In addition, the start-stop mode DTE may indicate to the PAD that a packet should be forwarded, subject to flow control, whenever it performs any one, or more, of the following:

- a) Allows the idle time delay period (see parameter 4 in Table 1/X.3), after the transmission of the previous character to the PAD, to elapse without sending a character. If, due to flow control constraints, the packet cannot be forwarded, characters from the start-stop mode DTE will continue to be added to the packet until flow control permits the packet to be forwarded or the packet becomes full. The start-stop mode DTE may be advised (see 4.5 and 4.6 below) if this latter condition occurs. This forwarding condition does not apply if the value of parameter 15 is set to 1.
- b) Transmits one of the data forwarding character (see parameter 3 in Table 1/X.3). The character will be included in the data field of the packet it delimits before the packet is forwarded. In case the forwarding character is the character 0/13 (CR) and the value of parameter 13 is set to 6 or 7, the character 0/10 (LF) will be included in the same complete packet sequence as the character 0/13 (CR) and will delimit it.
- c) Transmits the *break* signal when parameter 7 is set to any value except 0.
- d) Transmits the first character of a *PAD command* signal after the interface has entered a *waiting for command* state as described in 4.9.1.
- e) If the value of parameter 15 is set to 1, data forwarding will take place as described in 3.6.1.3.

4.5 Procedure for the PAD to indicate to the start-stop mode DTE, by means of a PAD service signal, a temporary inability to accept additional information

The procedure to enable the PAD to indicate a temporary inability to receive additional characters and to subsequently indicate that characters will be accepted, using PAD service signals, is for further study.

This procedure will not operate if parameter 6 is set to 0.

4.6 Procedures for transmission of X-ON and X-OFF by the PAD

4.6.1 If parameter 5 is set to 1, the following ancillary device control procedure applies:

- The PAD will send the X-ON character to the DTE as soon as the interface enters the *data transfer* state. The character 1/1 (DC1) will be transmitted by the PAD as the X-ON character.
- The PAD will send the X-OFF character to the start-stop mode DTE when it is incapable of receiving more than M characters from the ancillary device at the start-stop mode DTE and another character is received from the DTE. The PAD will also send the X-OFF character before the interface leaves the *data transfer* state. The character 1/3(DC3) will be transmitted by the PAD as the X-OFF character.
- When the PAD is again able to receive at least M + 1 characters from the start-stop mode DTE, it will send the X-ON character to that DTE.

4.6.2 If parameter 5 is set to 2, the following flow control procedure applies:

- The PAD will send the X-ON character to DTE as soon as the interface enters the *PAD waiting* state (state 5), after link initialization.
- The PAD will send the X-OFF character to the start-stop mode DTE, when it is incapable of receiving more than M characters from the start-stop mode DTE and another character is received from the DTE, in either state 5, 6, 7, 9 or 10.
- When the PAD is again able to receive at least M + 1 characters from the start-stop mode DTE, it will send the X-ON character to that DTE.
- The PAD will not send the X-OFF character to the start-stop mode DTE other than as specified in the above paragraph.

NOTE – Some networks may send the X-ON character to the start-stop mode DTE when the interface enters either state 5, 6, 7, 9 or 10 from any other state.

4.6.3 The value of M is for further study.

4.7 Procedures for reset

4.7.1 Reset by the DTE

The start-stop mode DTE shall send a *reset PAD command* signal to the PAD when it wishes to reset the virtual call.

- a) The *break* signal (see 3.1.2) will be recognized by the PAD as a *reset PAD command* signal if parameter 7 is set to 2.
- b) Alternatively the start-stop mode DTE may request reset by escaping from the *data transfer* state and sending a *reset PAD command* signal according to the procedure of 4.9.2.3.

4.7.2 Indication of reset by the PAD

If the virtual call is reset by the packet mode DTE, by the remote start-stop mode DTE connected via a PAD or by the network, the PAD will send a *reset PAD service* signal, if the value of parameter 6 is not set to 0, to the start-stop mode DTE. The *PAD service* signal will indicate the cause of the reset.

The following reset causes will be indicated to the start-stop mode DTE:

- a) The remote DTE has reset the virtual call; the standard format is given in 3.5.7.
- b) A local procedure error has occurred; the standard format is given in 3.5.7.
- c) Network congestion has occurred; the standard format is given in 3.5.7.
- d) A remote procedure error has occurred; the standard format is given in 3.5.7.

When parameter 6 is set to 0, the PAD is unable to indicate to the start-stop mode DTE that a reset has occurred.

4.8 Procedure for indication of break

The PAD will inform the start-stop mode DTE that an incoming *indication of break PAD message* has been received by the PAD (see Recommendation X.29) by sending the *break* signal (see 3.1.2).

4.9 Escape from the data transfer state

4.9.1 During the *data transfer* state, the start-stop mode DTE may escape from that state by transmitting a *PAD recall* signal to the PAD. On detection of the *PAD recall* signal, the interface will enter the *waiting for command* state. On entering the *waiting for command* state, delivery of any data characters to the start-stop mode DTE will be delayed until the interface returns to the *data transfer* state.

If parameter 1 is set to 1, the PAD will recognize the character 1/0 (DLE) as the *PAD recall* signal from the start-stop mode DTE.

If parameter 1 is set to a decimal value from 32 to 126, the PAD will recognize the binary representation of the decimal value as the *PAD recall* signal from the start-stop mode DTE.

If parameter 7 is set to 8, the *break* signal may be used as the *PAD recall* signal from the *data transfer* state, allowing for escape from the *data transfer* state without loss of character transparency.

If parameter 6 is set to 5, the *prompt PAD service* signal will be transmitted by the PAD.

On receipt of the next character from the start-stop mode DTE, the PAD will act in accordance with one of the following conditions:

- a) If the character is the *PAD recall* character, the interface will immediately return to the *data transfer* state. This character will be treated as user data.
- b) If the character received is the *PAD command signal delimiter* [characters 2/11 (+) or 0/13 (CR)], the PAD will not transfer it and the interface will return to the *data transfer* state.
- c) If the character received is in columns 2 to 7 of International Alphabet No. 5, excluding the characters 2/0 (SP), 2/11 (+) [see 4.9.1 b)], 7/15 (DEL) and the *PAD recall* character, the interface will enter the *PAD command* state. Characters 2/0 (SP) and 7/15 (DEL) will be ignored. Entering the *PAD command* state is a data forwarding condition and data will be sent to the packet mode DTE as described in 4.4 .
- d) If the character is not covered above, the action by the PAD is for further study.

If the *PAD command* signal delimiter is not received within R seconds of the interface entering the *PAD command* state, or an invalid *PAD command* signal is received, the PAD will transmit an *error PAD service* signal, when parameter 6 is not set to 0, indicating that an error has occurred. Following transmission of the *error PAD service* signal, the interface will be in the *data transfer* state. The value of R is for further study but will not be less than 60 s.

If a valid *PAD command* signal is received the interface will, if parameter 6 is not set to 0, subsequently enter the *PAD service* signal state, and on transmission of the last character of the *PAD service* signal, will enter the *PAD waiting* state or the *data transfer* state as appropriate. If parameter 6 is set to 0, the interface will enter the *PAD waiting* state or the *data transfer* state, as appropriate, following the transmission of a *PAD command* signal or following the time-out condition specified above.

4.9.2 The ability to escape from the *data transfer* state allows a start-stop mode DTE to use the following *PAD command* signals and procedures.

4.9.2.1 Clearing

The procedure for clearing of the virtual call by the start-stop mode DTE sending a *clear request PAD command* signal is described in 3.2.2.1.1 a).

4.9.2.2 Request for status of the virtual call

The procedure for requesting the status of the virtual call by the start-stop mode DTE sending a *status PAD command* signal, is described in 3.7.

4.9.2.3 Reset

The start-stop mode DTE may request a resetting of the virtual call by sending a *reset PAD command* signal to the PAD. The format of the *reset PAD command* signal is given in 3.5.12.

The PAD will acknowledge the *reset PAD command* signal, if parameter 6 is not set to 0, by transmitting the *acknowledgement PAD service* signal.

4.9.2.4 Interrupt

The start-stop mode DTE may request that an *interrupt* packet (with the interrupt user data field appropriately coded, see Recommendation X.29) is sent by the PAD by sending an *interrupt PAD command* signal to the PAD. The format of the *interrupt PAD command signal* is given in 3.5.13.

The PAD will acknowledge the *PAD command* signal, if parameter 6 is not set to 0, by transmitting the *acknowledgement PAD service* signal.

4.9.2.5 Setting, setting and reading, and reading PAD parameter values after having entered the data transfer state

The start-stop mode DTE shall be able to send the following *PAD command* signals to set, set and read, and read PAD parameter values:

- a) *profile selection PAD command* signal;
- b) *set PAD command* signal;
- c) *set and read PAD command* signal;
- d) *read PAD command* signal.

As an option, a PAD may enable the start-stop mode DTE to send the following *PAD command* signals to read or set and read the remote PAD parameter values:

- 1) *read remote PAD command* signal;
- 2) *set and read remote PAD command* signal.

The procedures for sending the above *PAD command* signals are described in 3.3 and 3.4.

4.9.2.6 Procedure when parameter 6 is set to 0

In all cases of the procedures given, when parameter 6 is set to 0, the *PAD service* signal state (state 8) is bypassed and the interface will enter *PAD waiting* state or the *data transfer* state as appropriate.

4.10 Echo

If parameter 2 is set to 1, the following procedures will apply:

- Received characters not masked by parameter 20 will be echoed to the start-stop mode DTE at the earliest opportunity permitted by the interleaving rules (see 4.19).
- In the case where the PAD cannot handle and ignores a data character coming from the start-stop mode DTE, e.g. because of flow control constraints, the PAD will not echo the characters.
- Echoing of editing characters will not be masked if editing is not enabled.

4.11 Selection of the procedure on receipt of the break signal from the start-stop mode DTE

The start-stop mode DTE, by means of parameter 7, will be able to select the state of the interface and which procedure the PAD will perform when the PAD receives the *break* signal from the start-stop mode DTE. The start-stop mode DTE may select any one of the following:

- a) If parameter 7 is set to 0, the state of the interface remains the same and no action is taken by the PAD.
- b) If parameter 7 is set to 1, the state of the interface remains the same and the PAD causes an *interrupt* packet, (with the interrupt user data field appropriately coded) to be transmitted by the PAD (see Recommendation X.29).
- c) If parameter 7 is set to 2, the state of the interface remains the same and the PAD causes the virtual call to be reset (see Recommendation X.29).
- d) If parameter 7 is set to 21, the state of the interface remains the same, the PAD discards all data received for delivery to the start-stop mode DTE, and the PAD sends an *interrupt* packet (with the interrupt user data field appropriately coded) followed by an *indication of break PAD message* (see Recommendation X.29).

- e) If parameter 7 is set to 8, the interface will escape from the *data transfer* state and will enter the *waiting for command* state.
- f) If parameter 7 is set to 5, the state of the interface remains the same, the PAD sends an *interrupt* packet (with the interrupt user data field appropriately coded), followed by an *indication of break PAD* message.

Other procedures which may be selected by the start-stop mode DTE are for further study.

NOTE 1 – The receipt by the PAD of a *break* signal is a packet forwarding condition except when parameter 7 is set to 0.

NOTE 2 – The receipt of a *break* signal by the PAD when there is no virtual call established is ignored and the PAD takes no action.

4.12 Selection of padding characters to be inserted after the character 0/13 (CR)

The start-stop mode DTE, by means of parameter 9, will be able to select the number of padding characters that will be inserted after each character 0/13 (CR) transmitted or echoed to it. The value selected will also apply to the number of padding characters transmitted after the character 0/10 (LF) of the *format effector* as described in 3.5.2 above.

Other padding sequences and other padding rules are for further study.

4.13 Selection of line folding

The start-stop mode DTE, by means of parameter 10, will be able to select line folding and specify the maximum number (L) of graphic characters that the PAD may send as a single line to the start-stop mode DTE.

When line folding is requested, the PAD will maintain a count (C) which is incremented by 1 subsequent to the transmission of a graphic character including echoed characters, to the start-stop mode DTE.

The graphic characters are those shown in columns 2 to 7 of International Alphabet No. 5, excluding the character 7/15 (DEL).

If the value of C is equal to the value of L, and the next character to be transmitted to the start-stop mode DTE is a graphic character, the PAD will transmit to the start-stop mode DTE a *format effector* (see 3.5.2) and set the value of C to 0.

The PAD will set the value of C to 0 when the PAD transmits the character 0/13 (CR) to the start-stop mode DTE.

The actions of the PAD after the transmission of the character 0/8 (BS) is for further study.

Line folding also applies to *PAD service* signals and the echo of *PAD command* signals.

4.14 Procedure for the start-stop mode DTE to indicate to the PAD a temporary inability to accept additional information

The start-stop mode DTE, by means of parameter 12, will be able to select the use of X-ON and X-OFF characters to flow control the PAD.

If the value of parameter 12 is set to 1 and the interface is in the *data transfer* state, the following procedure applies.

The start-stop mode DTE may indicate a temporary inability to receive additional characters from the PAD by transmitting the X-OFF character 1/3 (DC3).

Following transmission of the character 1/3 (DC3), the X-OFF condition will exist until the start-stop mode DTE indicates the ability to receive additional characters from the PAD by transmitting the X-ON character 1/1 (DC1).

While the X-OFF condition exists, the PAD will not transmit characters to the start-stop mode DTE.

The X-OFF condition is cancelled when the interface leaves the *data transfer* state, and does not exist when the interface enters the *data transfer* state.

The X-ON and X-OFF characters will not be echoed regardless of the value of parameters 2 and 20.

4.15 Selection of linefeed insertion after carriage return

The start-stop mode DTE, by means of parameter 13, will be able to select which procedure the PAD will perform during the *data transfer* state when it receives the character 0/13 (CR) to be transmitted to the start-stop mode DTE.

If parameter 13 is set to 0, the PAD takes no action.

If parameter 13 is set to 1, 5 or 7, the PAD will insert the character 0/10 (LF) after every character 0/13 (CR) in the data stream *to* the start-stop mode DTE.

If parameter 13 is set to 6 or 7, the PAD will insert the character 0/10 (LF) after every character 0/13 (CR) in the data stream *from* the start-stop mode DTE.

If parameter 13 is set to 4, 5, 6 or 7 (and parameter 2 is set to 1), the PAD will insert the character 0/10 (LF) after the echo of a character 0/13 (CR) to the start-stop mode DTE.

When this parameter includes the value 2, in combination with other optional values, then the LF inserted after CR in the data stream from the start-stop mode DTE will be placed in the editing buffer and may subsequently be edited, if parameter 15 is set to 1.

4.16 Selection of padding characters to be inserted after the character 0/10 (LF)

The start-stop mode DTE, by means of parameter 14, will be able to select the number of padding characters that will be inserted after each character 0/10 (LF) transmitted or echoed to it during the *data transfer* state. The value selected will not apply to the number of padding characters transmitted after the character 0/10 (LF) of the *format effector* as described in 3.5.2 and 4.12.

4.17 Editing of user data

The editing functions described in 3.6 above may also apply during the *data transfer* state. The start-stop mode DTE by means of parameter 15 may select whether or not to use the editing functions. The start-stop mode DTE may select, by using parameters 16, 17 and 18, the character used for each editing function provided by the PAD and by use of parameter 19, select the response of the PAD to the editing characters (see Recommendation X.3).

4.18 Page wait

4.18.1 General

The start-stop mode DTE will be able to suspend the transmission of additional characters to the start-stop mode DTE after a specified number of linefeeds have been transmitted by the PAD as determined by the value of parameter 22 when the page wait condition occurs. The PAD will, if parameter 6 is not set to 0, send to the start-stop mode DTE a *page wait PAD service* signal. No further data will be sent until the page wait condition is cancelled. The standard format of the *page wait PAD service* signal is described in 3.5.27.

4.18.2 Page wait cancellation

The PAD will cancel the page wait condition and after transmitting a format effector resume normal transmission when any of the following occur:

- on receipt of any condition that resets the count of linefeeds as described in 4.18.3;
- on receipt of the page wait cancellation character (X-ON); or
- on resetting parameter 22 to zero.

4.18.3 Page wait linefeed count reset

The count of linefeed will be reset to zero by the PAD when any of the following occur:

- after the format effector following the page wait cancellation character;
- on receipt of all data forwarding conditions;
- on echoing linefeed in user input;

- after the *line deleted PAD service* signal (with all associated linefeeds) has been sent; or
- on leaving the *PAD command* state (state 6) after all associated linefeeds.

Other conditions for resetting the linefeed count are for further study.

4.19 Interleaving of echo and output

Character sent to start-stop DTE by the PAD are classified into *echo characters* and *output characters*. The *echo characters* are all characters contained in the following:

- a) echoed received characters, either of a *PAD command* signal or of user input;
- b) any line feed inserted after the echo of a carriage return, when parameter 13 has value 4, 5, 6 or 7 (see 4.15);
- c) the *character deleted*, *line deleted* and *parity error PAD service* signals;
- d) a *format effector* inserted as a result of line folding initiated by some other echoed character (see 4.13);
- e) all characters generated in response to the *line display* character (see 3.6.2.3).

All other characters sent to the start-stop DTE by the PAD are *output characters*.

Echo and *output characters* shall be sent to the start-stop DTE by the PAD in accordance with either the *basic interleaving rules*, see 4.19.1, or the *extended interleaving rules*, see 4.19.2. The choice between rules is network dependent.

4.19.1 Basic interleaving rules

If any *echo character* is waiting to be sent to the start-stop DTE by the PAD, it shall be sent immediately.

If any *output character* is waiting to be sent to the start-stop DTE by the PAD, and if no *echo character* is waiting, the *output character* shall be sent immediately.

4.19.2 Extended interleaving rules

Characters sent to the start-stop DTE by the PAD are grouped into *interleaving units*. An *interleaving unit* either consists entirely of *echo characters* or consists entirely of *output characters*.

An interleaving unit of *echo characters* is terminated by any data forwarding condition, or by a *PAD command signal delimiter*.

A *PAD service* signal (which is not classified as echo), or a series of *PAD service* signals generated in response to a single PAD command, is an *interleaving unit*.

Each complete packet sequence sent from the Packet mode DTE is whole number of *interleaving units*. How a complete packet sequence is divided into one or more *interleaving units* is network dependent.

NOTE 1 – A preferred division rule is that any line feed or form feed should terminate an *interleaving unit* including any line feed inserted if the value of parameter 13 is odd.

NOTE 2 – If only part of an *interleaving unit* (output or echo) is sent to the start-stop mode DTE, characters of the other category (echo or output) may be delayed indefinitely. This may be avoided by the use of timers; details are for further study.

4.19.3 Videotex interleaving rules

To prevent the intermixing of echo data with output data, a data buffer will be used to store echo data at the PAD while output data is being presented to the start-stop mode DTE. This buffer will be called the type-ahead buffer. Parameter reference 24 will control the interleaving rules.

4.19.3.1 Echo data to the start-stop mode DTE

If parameter reference 24 is > 0 and parameter reference 2 is 1 or 32 to 126, then echo data ready for transmission to the start-stop mode DTE will be stored in the type-ahead buffer when output data is being sent to the start-stop mode DTE.

The size of the type-ahead buffer is recommended to be at least 256 characters.

If the type-ahead buffer is full, the echo data (that is in excess of the type-ahead buffer) will be discarded.

4.19.3.2 Output data to the start-stop mode DTE

- a) If parameter reference 24 is 1 to 31 and parameter reference 2 is 1 or 32 to 126, then output data will be transmitted to the start-stop mode DTE until the end-of-frame signal is detected.
- b) If parameter reference 24 is 32 and parameter reference 2 is 1 or 32 to 126, then output data will be transmitted to the start-stop mode DTE until the end of a complete packet sequence is detected.
- c) If parameter reference 24 is 64 and parameter reference 2 is 1 or 32 to 126, then output data will be transmitted to the start-stop mode DTE until the end-of-frame timer has expired.

Upon fulfilling the criteria as defined by parameter reference 24, the PAD will suspend the output data and, then, echo data stored in the type-ahead buffer will be transmitted to the start-stop mode DTE. The end-of-frame timer is reset (if parameter reference 24 is greater or equal to 64) and the next output data will be transmitted to the start-stop mode DTE.

NOTE – When combining values of parameter reference 24, the end-of-frame timer has priority over the other two.

4.20 Display interrupt

In order to cancel output data transmission instantaneously without using the break signal, parameter reference 26 will be used in conjunction with parameter reference 8.

If parameter reference 26 is greater than 0, on receipt of the character equal to the value of parameter reference 26, the PAD will do the following :

- a) set parameter reference 8 to 1;
- b) clear any data waiting for transmission to the start-stop mode DTE;
- c) transmit the character defined by parameter reference 27 (if > 0) to the start-stop mode DTE;
- d) transmit the display interrupt character to the X.25 DTE.

NOTE – Either the X.25 DTE (via the X.29 *set PAD* message) or the start-stop mode DTE (via the *set PAD command* signal) must reset the parameter reference 8 to 0 in order to resume the communication.

5 Formats of additional PAD command signals and PAD service signals available in the extended dialogue mode

In addition to the *PAD command* signals and *PAD service* signals defined above (see 3.1.1 and 3.5), some networks may support additional capabilities in the extended dialogue mode. Additional PAD command signal keywords, which are provisionally defined in Table 9, can be used instead of the corresponding standard keywords. Some networks may provide these keywords when the PAD is not in the extended dialogue mode.

Additional *PAD command* signals may be provided for:

- a) requesting the action associated with the break signal (see 5.1);
- b) indicating a network user identifier prior to establishing calls, or terminating the use of a NUI (see 5.2);
- c) selecting a language for *PAD service* signals (see 5.3);
- d) requesting explanatory information on *PAD command* signals, PAD parameters, standard profiles, etc.

NOTE – This function must be provided if extended dialogue mode is supported (see 5.4).

Additional *PAD service* signals may be provided for:

- a) explanatory information as described above (see 5.5);
- b) prompting for additional information for certain *PAD command* signals. The formats and procedures are for further study.

When the PAD is in the extended dialogue mode, the parameter reference number of a PAD parameter in the *read*, *set*, *set and read*, *remote read* or *remote set and read PAD command* signals may be replaced by the abbreviated name shown in Table 8. The possible use of names to represent PAD parameter value is for further study.

Table 9/X.28 – PAD command signal keywords for extended dialogue mode

Standard keyword	Extended dialogue mode keyword(s)	PAD command signal name
None	CALL	Selection
CLR	CLEAR	Clear request
INT	INTERRUPT	Interrupt
PROF	PROFILE	Profile selection
PAR?	PAR PARAMETER READ	Read
RESET	Reset
SET	Set
SET?	SETREAD	Set and read
STAT	STATUS	Status
....	BREAK	Break
....	HELP	Help
....	LANG LANGUAGE	Language
....	NUI	NUI
RPAR?	RREAD	Remote read
ICLR	ICLEAR	Invitation to clear
RSET?	RSETREAD	Remote set and read
MOD	MODIFY	Modify PAD Aspect
CHA	CHANGE	Change PAD Aspect
Y	YES	Confirm Change

5.1 Format of the break PAD command signal

The *break PAD command* signal consists of the following elements:

<break PAD command signal> ::= <BREAK>

where:

<BREAK> ::= 4/2 (B) 5/2 (R) 4/5 (E) 4/1 (A) 4/11 (K)

The *break PAD command* signal requests the PAD to act as if it had received the break signal from the start-stop mode DTE. The action depends on the value of PAD parameter 7, as defined in 4.11. However, the interface will enter the *PAD waiting* state or *data transfer* state as appropriate unless parameter 7 has the value 8 set, in which case the interface will reenter the *waiting for command* state.

NOTE – Escape from data transfer state is not possible by using this command.

5.2 Format of the NUI ON and NUI OFF PAD command signals

The NUI ON command signal consists of the following elements:

<command signal> ::= <ID> <NUI string>

where:

<ID> ::= 4/9 (I) 4/4 (D)

<NUI string> is optional but if present is as defined in 3.5.15.1.1.

NOTE 1 – The characters that follow the characters <ID> (i.e. the <NUI string>) should not be echoed.

NOTE 2 – The character sequence <OFF> is not permitted as the NUI string.

The *NUI ON PAD command* signal identifies an individual terminal user to the PAD. This identification will apply for all subsequent calls until either the access path is disconnected or a *NUI OFF PAD command* signal is received by the PAD.

If the prompting facility is provided, then the PAD may request additional user input if required when the <NUI string> is omitted.

The NUI OFF PAD command signal consists of the following elements:

<NUI OFF PAD command signal> ::= <IDOFF>

where:

<IDOFF> ::= 4/9 (I) 4/4 (D) 4/15 (O) 4/6 (F) 4/6 (F)

The *NUI OFF PAD command* signal indicates the termination of the use of the NUI.

5.3 Format of the language PAD command signal

The *language PAD command* signal consists of the following elements:

<language PAD command signal> ::= <LANG> <language string>

where:

<LANG> ::= 4/12 (L) 4/1 (A) 4/14 (N) 4/7 (G)

<language string> ::= an appropriate identifier for a language or mode supported by the network for use in service signals.

The *language PAD command* may be provided to give a simpler way to set parameter 6 for a choice of language or mode.

If <language string> refers to a language which the network provides in extended dialogue mode, then the value of parameter 6 is set to the appropriate value (16 or greater). If <language string> refers to a language which the network provides in network dependent service signal formats, then the value of parameter 6 may be set to the appropriate value from 8 to 15.

The format of <language string> and the availability of more than one language is network dependent.

The need for selection of different languages for *PAD command* signals is for further study.

NOTE – If a network provides a language choice independent of extended dialogue mode, the format of <language string> should provide for identifying the mode and the language.

5.4 Format of the help PAD command signal

The *help PAD command* signal consists of the following elements:

<help PAD command signal> ::= <HELP> <help subject>

where:

<HELP> ::= 4/8 (H) 4/5 (E) 4/12 (L) 5/0 (P)

<help subject> ::= identifier for the type of explanatory information requested, as defined in Table 10.

5.5 Standard format of the help PAD service signal

The *help PAD service* signal consists of the following elements:

<help PAD service signal> ::= <text>

where:

<text> is network dependent and corresponds to the <help subject> requested in the *help PAD command* signal, as defined in Table 10.

Table 10/X.28 – Help PAD command signal operands and results

<help subject> (Note 2)	Service signal contents (Note 1)
None or HELP	Description of help PAD command
LIST	List of available help subjects
COMMAND	List of PAD command signals
PARAMETER	List of PAD parameters
PARAMETER <reference>	Description of referenced PAD parameter
PROFILES	List of available standard profiles
Any PAD command	Description of specified PAD command signal
PROFILE <reference>	Name and parameter values of referenced standard profile
MAP	List of supported and available PAD Aspects for use (See 6)
NOTE 1 – The actual contents of the help <i>PAD service</i> signal and the amount of detail presented are network dependent.	
NOTE 2 – Some networks may provide help for additional subjects to those listed.	

6 Multi-Aspect PAD (MAP) operation in accordance with Recommendation X.8

Any and all PAD Aspects offered by the ITU-T may be supported in conjunction with a PAD operating in accordance with this Recommendation. Current ITU-T PAD Aspects are defined in Recommendation X.8. Listed in Table 11 are the PAD Codes to be used when operating in accordance with this Recommendation, along with their referenced Recommendations. In addition, a PAD code is provided for support of non-ITU-T Aspects.

Table 11/X.28 – ITU Defined PAD Aspects

PAD Aspect selections	X.28 PAD Aspect codes	Recommendations
Facsimile PAD	4/6 (F), 5/0 (P), 4/1 (A), 4/4 (D)	X.38/X.39
Start-stop (or character) PAD	4/3 (C), 5/0 (P), 4/1 (A), 4/4 (D)	X.28/X.29
Generalized polling PAD	4/7 (G), 5/0 (P), 4/1 (A), 4/4 (D)	X.42
Telex	5/4 (T), 5/0 (P), 4/1 (A), 4/4 (D)	X.340
Non-ITU-T network specific	4/13 (N), 5/3 (S) (Note 1)	–
NOTE 1 – The IA5 Code 4/13 (N) 5/3 (S) followed by a network specific code(s) applies to those PAD Aspects that are not defined in ITU-T Recommendations.		
NOTE 2 – Additional columns of Aspect-specific PAD codes will be added as PAD Aspects are defined in the ITU-T.		

6.1 Procedures required to support MAP

6.1.1 Procedures for MAP status inquiry

The DTE may inquire about the status of the current Aspect, available Aspects and the default Aspect by sending the *status PAD command* signal to the PAD. The PAD will respond by sending the *status engaged or status free PAD service* signal, including the MAP status block, to the DTE. The format of the *PAD command* signal and the standard format of the *PAD service* signals is given in 3.5.10 and 3.5.11 respectively.

6.1.2 Procedures to temporarily modify the PAD Aspect

The *Modify MAP command* signal procedures operates in accordance with 6.2/X.8. The format for the *Modify MAP command* signal is specified in 6.2.1. The format for the *Confirm Modify MAP service* signal is specified in 6.3.2.

Upon entry into the start-stop PAD from another PAD Aspect the PAD shall issue an *Aspect Entry MAP service* signal to indicate successful transition to the start-stop PAD instance (see 6.3.3).

The *Modify MAP PAD command* signal is entered to cause the PAD to change Aspects normally for one complete call sequence (i.e. call request through clear indication). The command is entered from the PAD Waiting state. All PAD parameter settings and values set previous to the *Modify MAP PAD command* signal remain as set. No changes to any values take place due to the new Aspect. The command is valid both when a virtual call is in progress, and when it is not. If a virtual call was in progress at the time of the *Modify MAP PAD command* signal, the PAD will remain in the modified Aspect until that virtual call has cleared or as indicated by the duration parameter value. If the virtual call was not in progress, then the PAD will remain in the modified Aspect as specified by the duration parameter value.

6.1.3 Procedures to permanently change the PAD Aspect

The DTE may permanently change the PAD Aspect as defined in 7.1/X.8. The DTE will issue the *Change MAP command* signal and the PAD will respond with the *Change MAP service* signal. Formats for these signals may be found in 6.2.2 and 6.3.4 respectively.

6.1.4 Procedures for entering a CPAD from another aspect

Upon entering the CPAD Aspect, the *PAD identification PAD service* signal defined in 3.5.18 is sent.

6.1.5 Procedures for the provision of multi-session

The procedures for the provision of multi-session are for further study.

6.1.6 Procedures for the provision of remote MAP control

The procedures for the provision of remote MAP control are for further study.

6.1.7 PAD Aspect Transition – Exit and Entry State 5A

PAD Aspect Transition state is introduced for the MAP support. This state is entered directly from PAD Waiting state (if no *PAD Service* signals are utilized) or from State 8 (if *PAD Service* signals are enabled). The purpose of the *PAD Aspect Transition state* is to provide a finite state for the PAD to transition from one PAD Aspect to another Aspect. State 5A also provides the re-entry point for entering into the PAD Aspect from a different Aspect. The impact to the state diagrams can be found in the specific Recommendations associated with the originating PAD Aspect. State diagrams can be found in Figures 2 a) and 2 b).

6.2 Formats of MAP command signals

6.2.1 Format of the Modify MAP command signal

The *Modify MAP command* signal consists of the following elements:

<modify> ::= <MOD-> <new aspect> <duration> <additional information>

<MOD-> ::= 4/13 (M) 4/15 (O) 4/4 (D) 2/3 (-)

<new aspect> ::= the IA5 PAD code for the aspect requested. See Table 11 PAD Aspect codes.

<duration> ::= 2/12 (,) followed by one of the following elements <VC> <idle time> <AIP>

<VC> ::= 56 (V) 4/3 (C)

<idle time> ::= a decimal number 1-255 representing the length of time in seconds before the Aspect will revert to the default.

<AIP> ::= 4/1 (A) 4/9 (I) 5/0 (P) is used to revert to the default Aspect after the access information path is disconnected.

<additional information> ::= the format and contents of this element are for further study.

NOTE – The <duration> and <additional information> are optional. The omission of <duration>, the setting of the <idle time> to zero, or the inclusion of <VC> indicate that the duration is for one complete call sequence.

6.2.2 Format of the *change MAP command signal*

The *change MAP command* signal consists of the following elements:

<change> ::= <CHA> <new aspect> <additional information>

<CHA> ::= 4/3 (C) 4/8 (H) 4/1 (A)

<new aspect> ::= the IA5 PAD code for the Aspect requested. See Table 11 PAD Aspect codes.

<additional information> ::= information that may be defined for entering a new Aspect

6.2.3 Standard format of the *confirm change MAP command signal*

The IA5 character 5/9 (Y) is sent.

6.2.4 Format for the *multi-session MAP command signals*

The format of the *MAP command* signals for the provision of multi-session, including New Instance Establishment, Switch Instance, and Close Instance, are for further study.

6.2.5 Format for the *remote MAP control command signals*

The format *MAP command* signals for the provision of remote MAP control, including Remote Inquiry, Remote Modify, and Remote Synchronize, are for further study.

6.3 Format of *MAP service signals*

6.3.1 Standard format of the *MAP status block*

The MAP status block has the following format:

<MAP status block> ::= <format effector>

<MAP text> <format effector>

<current aspect> <format effector>

<available aspects> <format effector>

<default aspect>

<format effector> ::= see 3.5.2

MAP text> ::= 4/13 (M) 4/1 (A) 5/0 (P) 2/0 (SP) 4/1 (A) 5/3 (S) 5/0 (P) 4/5 (E) 4/3 (C) 5/4 (T) 5/3 (S)

<current aspect> ::= <CUR> <current value>

<CUR> ::= 4/3 (C) 5/5 (U) 5/2 (R) 2/0 (SP)

<current value> ::= 4/3 (C) 5/0 (P) 4/1 (A) 4/4 (D)

<available aspects> ::= <AVA> <available values>

<AVA> ::= 4/1 (A) 5/6 (V) 4/1 (A) 2/0 (SP)

<available values> ::= list of codes for Aspects available on this MAP. If more than one Aspect value is contained in this list, then the characters 2/12 (,) 2/0 (SP) are sent before the next Aspect code.

<default aspect> ::= <DEF> <default value>

<DEF> ::= 4/4 (D) 4/5 (E) 4/6 (F) 2/0 (SP)

<default value> ::= code for default Aspect value

Example: Free – No Call Established

MAP ASPECTS

CUR CPAD

AVA CPAD, FPAD, GPAD

DEF CPAD

6.3.2 Standard format of the *confirm modify MAP service signal*

The characters 4/13 (M) 4/15 (O) 4/4 (D) 2/0 (SP) 4/3 (C) 4/15 (O) 4/14 (N) 4/6 (F) are sent.

6.3.3 Standard format of the Aspect entry *MAP service* signal

The PAD identification *PAD service* signal defined in 3.5.18 is sent.

6.3.4 Change confirm signals

The *change confirm MAP service* signal is a dialogue to verify the change is intentional.

6.3.4.1 Standard format of the *verify change MAP service* signal

The *verify change MAP service* signal has the following format:

<verify change> ::= <CHANGE PORT TO> <new aspect> 3/15 (?)

<CHANGE PORT TO> ::= 4/3 (C) 4/8 (H) 4/1 (A) 4/14 (N) 4/7 (G) 4/5 (E) 2/0 (SP) 5/0 (P) 4/15 (O) 5/2 (R) 5/4 (T) 2/0 (SP) 5/4 (T) 4/15 (O) 2/0 (SP)

<new aspect> ::= the IA5 PAD code for the Aspect requested. See Table 11 PAD Aspect codes.

6.3.4.2 Standard format of the *confirm change MAP service* signal

The characters 4/3 (C) 4/8 (H) 4/1 (A) 2/0 (SP) 4/3 (C) 4/15 (O) 4/14 (N) 4/6 (F) are sent.

6.3.5 Format for the *multi-session MAP service* signals

The format of the *MAP service* signals for the provision of multi-session, including New Instance Establishment, Switch Instance, and Close Instance, are for further study.

6.3.6 Format for the *remote MAP control service* signals

The format *MAP service* signals for the provision of remote MAP control, including Remote Inquiry, Remote Modify, and Remote Synchronize, are for further study.

6.4 Error conditions

The error PAD service signal defined in 3.5.19 is used when an invalid *MAP command* signal is sent.

6.5 Format of additional *MAP command* signals and *MAP service* signals available in the extended dialogue mode

In addition to the *MAP command* signals and *MAP service* signals defined above (see 6.2 and 6.3), some networks may support additional capabilities in the extended dialogue mode. Additional *MAP command* signal keywords, which are defined in Table 9, can be used instead of the corresponding standard keywords. Some networks may provide these keywords when the MAP is not in the extended dialogue mode.

Annex A

PAD command signals and PAD service signals

Table A.1/X.28 – PAD command signals

PAD command signal format	Function	PAD service signal sent in response (see Note)
STAT	To request status information regarding a virtual call connected to the DTE and MAP status	FREE [MAP status] or ENGAGED [MAP status]
CLR	To clear down a virtual call	CLR CONF or CLR ERR (in the case of local procedure error)
PAR? List of parameter references	To request the current values of specified parameters	PAR (list of parameter with their current values or INV)
SET? List of parameter references and corresponding values	To request changing or setting of the current values of the specified parameters and to request the current values of specified parameters	PAR (list of parameter with their current values or INV)
PROF (identifier)	To give to PAD parameters a standard set of values	Acknowledgement
RESET	To reset the virtual call	Acknowledgement
INT	To transmit an <i>interrupt</i> packet	Acknowledgement
SET List of parameters with requested values	To set or change parameter values	Acknowledgement or PAR (list of invalid parameter reference followed by INV)
<i>Selection PAD command signal</i>	To set up a virtual call	Acknowledgement
ICLR	To invite remote PAD to clear down a virtual call	CLR PAD
RPAR? List of parameter references	To request the current values of specified parameters in remote PAD	RPAR (list of parameter references with their current values or INV)
RSET? List of parameter references	To request changing or setting of the current values of the specified parameter(s) and to request the current value of specified parameters at the remote PAD	RPAR (list of parameter references with their current values or INV)
MOD PAD Aspect, duration applicable, and additional information	To modify the PAD Aspect, indicate the duration that the modify applies, and to include additional call set-up information	MOD CONF
CHA PAD Aspect and additional information	To change the default PAD Aspect and specify additional information	CHANGE PORT TO (new PAD Aspect)?
Y	To verify the PAD Aspect default value is correct	CHA CONF
NOTE – PAD service signals are not sent when parameter 6 is set to 0.		

Table A.2/X.28 – PAD service signals

Standard format of the PAD service signal		Explanation
RESET	DTE 1, 2 or 3 characters which represent the decimal value of the diagnostic code ERR NC (Note 1) RPE	Indication that the remote DTE has reset the virtual call Indication of a reset of a virtual call due to local procedure error Indication of a reset of a virtual call due to network congestion Indication of a reset of a virtual call due to remote procedure error
CLR	Table 6	Indication of clearing
CLR	CONF	Confirmation of clearing
Note 7	–	Indication of call connected
	The characters to be sent are network dependent	PAD identification PAD service signal
ERR		Indication that a <i>PAD command</i> signal is in error
Note 2		Indication of incoming call
XXX		Indication of line delete function completed for printing terminals (Notes 3 and 4)
	Note 8	Indication of character delete function completed for printing terminals
PAGE		Indication that a page wait condition has occurred
BS SP BS		Indication of character delete function completed for video terminals (Note 4)
ENGAGED	[MAP status]	Response to <i>status PAD command</i> signal when a call has been established
FREE	[MAP status]	Response to <i>status PAD command</i> signal when a call is not established
PAR	Decimal value of parameter: Parameter value, INV, or list of invalid parameters	Response to <i>set and read PAD command</i> signal and to <i>set PAD command</i> signal if at least one parameter is invalid
MOD	CONF	Confirmation of MAP Aspect modification. Sent in response to <i>modify MAP command</i> signal
CHANGE PORT TO	[New Aspect]?	Response to <i>change MAP command</i> signal
CHA	CONF	Confirmation of MAP Aspect change. Sent in response to <i>confirm change MAP command</i> signal
*		<i>Prompt PAD service</i> signal
Format effector		<i>Acknowledgement PAD service</i> signal
TRANSFER TO	DTE address and facilities (Notes 5 and 6)	Indication that a called DTE reselection by the PAD is in progress
RPAR	Decimal value of parameter: parameter value, INV, or list of invalid parameters	Responses to <i>remote set and read PAD command</i> signal

Table A.2/X.28 – PAD service signals (concluded)

NOTE 1 – The diagnostic codes are specified in Recommendation X.25. Some networks may not provide these characters.
 NOTE 2 – The standard format of the *incoming call PAD service* signal is given in 3.5.22.
 NOTE 3 – If echoing is required, the *line delete* character is echoed before the *line deleted PAD service* signal is transmitted.
 NOTE 4 – The standard format of the indication of line delete function completed for video terminals is a repetition of the BS SP BS sequence.
 NOTE 5 – The mentioned DTE address is the address of the DTE towards which the call is being transferred by the PAD.
 NOTE 6 – The format of the facilities is identical to the one of the *incoming call PAD service* signal.
 NOTE 7 – The standard format of the *connected PAD service* signal is given in 3.5.21.
 NOTE 8 – Alternatively the character 2/15 (/) may be used by some networks.

Annex B

PAD Time-outs

Table B.1/X.28 – PAD time-outs

Time-out value	Time-out number	Interface state	Started by	Normally terminated	Action to be taken when time-out expires	Remarks
Y	T10	State 1	Binary 1 is transmitted on both T and R	The PAD has received a valid <i>service request</i> signal	The PAD will disconnect the <i>information path</i>	
T = 60 s	T11	State 5	The PAD enters the <i>PAD waiting</i> state	The PAD has received the first character of a <i>PAD command</i> signal	The PAD clears in accordance with 3.2.2.2	4 possible methods may be used. This time-out is not applicable in case of leased line access.
S > 60 s	T12	State 6	The PAD has received the first character of a <i>PAD command</i> signal	The PAD has received a complete <i>PAD command</i> signal	The PAD will transmit an <i>error PAD service</i> signal (when parameter 6 is not set to 0) and will return to the <i>PAD waiting</i> state, or its action is for further study (when parameter 6 is set to 0)	The PAD will permit entry into the <i>PAD waiting</i> state N times before disconnecting the access information paths: this time-out is not applicable in case of leased line access.
R > 60 s	T13	State 6	The PAD receives a graphic character other than 2/0, 2/11 or 7/15 after the DTE escapes from the <i>data transfer</i> state	Reception of a complete <i>PAD command</i> signal	The PAD will transmit an <i>error PAD service</i> signal and will return to the <i>data transfer</i> state (when parameter 6 is not set to 0) or the <i>PAD waiting</i> state of <i>data transfer</i> state as appropriate (when parameter 6 is set to 0)	This time-out is not applicable in the case of leased line access

Table B.1/X.28 – PAD time-outs (concluded)

Time-out value	Time-out number	Interface state	Started by	Normally terminated	Action to be taken when time-out expires	Remarks
V	T20	State 4	DTE transmits the <i>service request</i> signal	DTE has received a <i>PAD identification service</i> signal	DTE should retransmit the <i>service request</i> signal	When this time-out expires W times a fault should be reported
B	T21	State 6	DTE transmits a <i>clear request PAD command</i> signal	The PAD has transmitted <i>clear confirmation PAD service</i> signal (when parameter 6 is not set to 0) or has disconnected the access information path (when parameter 6 is set to 0)	The DTE will disconnect the access information path (indeterminate result)	
X = 120 s	T30	–	Incoming call	PAD waiting state	The PAD will clear the virtual call	See 3.2.1.7
Z	T31	–	Circuit 108/1 or 108/2 OFF	Circuit 108 ON	The access information path is disconnected	See 1.1.3.2
P > 60 s	T14	State 10	The PAD is recalled from the connection in progress state	The PAD has received the first character of a <i>PAD command</i> signal	The PAD will transmit an error <i>PAD service</i> signal (when parameter 6 is not set to 0) and will return to connection in progress state	
Q > 60 s	T15	State 6	The PAD receives a graphic character other than 2/0, 2/11 or 7/15 after the DTE escape from the connection in progress state	Reception of a complete <i>PAD command</i> signal	(As for P above)	

Annex C

PAD service signals for extended dialogue mode

C.1 Possible *PAD* service signals text in Spanish for extended dialogue mode

- 1 ENGAGED: Comunicación establecida (3.5.11)
- 2 FREE: Comunicación no establecida (3.5.11)
- 3 *Reset PAD service* signal (Table 5)
 - DTE – Reiniciación por el dispositivo en el extremo distante, pueden perderse datos
 - ERR – Reiniciación por la red, error de procedimiento local, pueden perderse datos
 - NC – Reiniciación por problema en la red, pueden perderse datos
 - RPE – Reiniciación por la red, error de procedimiento en el extremo distante, pueden perderse datos
- 4 *Clear PAD service* signal (Table 6)
 - OCC – Liberación de la llamada, número ocupado
 - NC – Liberación de la llamada, problema temporal en la red
 - INV – Liberación de la llamada, petición de facilidad no válida
 - NA – Liberación de la llamada, acceso prohibido a este número
 - ERR – Liberación de la llamada, error de procedimiento local, identificado por la red
 - RPE – Liberación de la llamada, error de procedimiento en el extremo distante, identificado por la red
 - NP – Liberación de la llamada, número no asignado
 - DER – Liberación de la llamada, número fuera de servicio
 - PAD – Liberación de la llamada, petición distante
 - DTE – Liberación de la llamada, por el dispositivo en el extremo distante, pueden perderse datos
 - RNA – Liberación de la llamada, cobro revertido rechazado
 - ID – Liberación de la llamada, destino incompatible
 - SA – Liberación de la llamada, barco ausente
 - FNA – Liberación de la llamada, selección rápida rechazada
 - ROO – Liberación de la llamada, no se puede encaminar según se ha pedido
- 5 *Clear confirmation PAD service* signal (Table 7)
 - CONF – Liberación de llamada, confirmación
- 6 PAD parameter names (Table 8)

Parameter reference number	Parameter description
1	– Rellamada al PAD utilizando un carácter
2	– Eco
3	– Elección de la señal de envío de datos
4	– Elección de la duración de la temporización de reposo
5	– Control de dispositivo auxiliar
6	– Control de señales de servicio de PAD
7	– Operación al recibir una señal de corte
8	– Descartar salida
9	– Relleno después del retroceso del carro
10	– Delimitación de la línea
11	– Velocidad binaria del DTE arrítmico
12	– Control de flujo del PAD
13	– Inserción de cambio de renglón después del retroceso del carro
14	– Relleno después del cambio de renglón
15	– Edición
16	– Supresión de carácter
17	– Supresión de línea
18	– Visualización de línea
19	– Señales de servicio de PAD de edición
20	– Máscara de eco
21	– Tratamiento de la paridad
22	– Espera de página
23	– Longitud del campo de entrada
24	– Señal de final de trama
25	– Señales adicionales de envío de datos
26	– Carácter de interrupción de visualización
27	– Confirmación de la interrupción de visualización
28	– Esquema de codificación de los caracteres diacríticos
29	– Máscara de eco ampliada

C.2 Possible *PAD* service signals text in French for extended dialogue mode

- 1 ENGAGED: Etat occupé (3.5.11)
- 2 FREE: Etat libre (3.5.11)
- 3 *Reset PAD service* signal (Table 5)
 - ETTD – Réinitialisation par l'équipement distant, perte de données possible
 - ERR – Réinitialisation par le réseau, erreur de procédure locale, perte de données possible
 - NC – Réinitialisation en raison d'un dérangement momentané du réseau, perte de données possible
 - RPE – Réinitialisation par le réseau, erreur de procédure distante, perte de données possible
- 4 *Clear PAD service* signal (Table 6)
 - OCC – Communication libérée, numéro occupé
 - NC – Communication libérée, encombrement momentané du réseau
 - INV – Communication libérée, demande de service complémentaire non valable
 - NA – Communication libérée, interdiction d'accès au numéro
 - ERR – Communication libérée, erreur de procédure locale décelée par le réseau
 - RPE – Communication libérée, erreur de procédure distante décelée par le réseau
 - NP – Communication libérée, numéro non attribué
 - DER – Communication libérée, numéro en dérangement
 - PAD – Communication libérée, demande distante
 - ETTD – Communication libérée, par un équipement distant
 - RNA – Communication libérée, taxation à l'arrivée refusée
 - ID – Communication libérée, destination incompatible
 - SA – Communication libérée, le navire ne peut être atteint
 - FNA – Communication libérée, sélection rapide refusée
 - POO – Communication libérée, acheminement demandé impossible
- 5 *Clear confirmation PAD service* signal (Table 7)
 - CONF – Communication libérée, confirmation
- 6 *PAD* parameter names (Table 8)

Parameter reference number	Parameter description
1	– Rappel du PAD au moyen d'un caractère
2	– Renvoi en écho
3	– Choix des caractères d'envoi de données
4	– Choix du délai de temporisation de repos
5	– Commande de dispositifs auxiliaires
6	– Commande de signaux de service de PAD
7	– Fonctionnement à la réception du signal de coupure
8	– Mise au rebut des données de sortie
9	– Remplissage après retour du chariot
10	– Retour à la ligne
11	– Débit binaire de l'ETTD arythmique
12	– Contrôle de flux du PAD
13	– Insertion d'interligne après retour du chariot
14	– Remplissage après interligne
15	– Edition
16	– Effacement de caractère
17	– Effacement de ligne
18	– Affichage de ligne
19	– Signaux de service de PAD d'édition
20	– Gabarit d'écho
21	– Traitement de parité
22	– Attente de page
23	– Longueur du champ de saisie
24	– Signaux de fin de page
25	– Choix supplémentaire de caractères d'envoi de données
26	– Interruption d'affichage
27	– Confirmation d'interruption d'affichage
28	– Codage des caractères diacritiques
29	– Gabarit d'écho supplémentaire

ITU-T RECOMMENDATIONS SERIES

Series A	Organization of the work of the ITU-T
Series B	Means of expression: definitions, symbols, classification
Series C	General telecommunication statistics
Series D	General tariff principles
Series E	Overall network operation, telephone service, service operation and human factors
Series F	Non-telephone telecommunication services
Series G	Transmission systems and media, digital systems and networks
Series H	Audiovisual and multimedia systems
Series I	Integrated services digital network
Series J	Transmission of television, sound programme and other multimedia signals
Series K	Protection against interference
Series L	Construction, installation and protection of cables and other elements of outside plant
Series M	TMN and network maintenance: international transmission systems, telephone circuits, telegraphy, facsimile and leased circuits
Series N	Maintenance: international sound programme and television transmission circuits
Series O	Specifications of measuring equipment
Series P	Telephone transmission quality, telephone installations, local line networks
Series Q	Switching and signalling
Series R	Telegraph transmission
Series S	Telegraph services terminal equipment
Series T	Terminals for telematic services
Series U	Telegraph switching
Series V	Data communication over the telephone network
Series X	Data networks and open system communications
Series Y	Global information infrastructure
Series Z	Programming languages