



INTERNATIONAL TELECOMMUNICATION UNION

CCITT

THE INTERNATIONAL
TELEGRAPH AND TELEPHONE
CONSULTATIVE COMMITTEE

V.110

(09/92)

**DATA COMMUNICATION
OVER THE TELEPHONE NETWORK**

**SUPPORT OF DATA TERMINAL EQUIPMENTS
WITH V-SERIES TYPE INTERFACES BY AN
INTEGRATED SERVICES DIGITAL NETWORK**



Recommendation V.110

FOREWORD

The CCITT (the International Telegraph and Telephone Consultative Committee) is a permanent organ of the International Telecommunication Union (ITU). CCITT is responsible for studying technical, operating and tariff questions and issuing Recommendations on them with a view to standardizing telecommunications on a worldwide basis.

The Plenary Assembly of CCITT which meets every four years, establishes the topics for study and approves Recommendations prepared by its Study Groups. The approval of Recommendations by the members of CCITT between Plenary Assemblies is covered by the procedure laid down in CCITT Resolution No. 2 (Melbourne, 1988).

Recommendation V.110 was revised by Study Group XVII and was approved under the Resolution No. 2 procedure on the 18th of September 1992.

CCITT NOTES

- 1) In this Recommendation, the expression "Administration" is used for conciseness to indicate both a telecommunication Administration and a recognized private operating agency.
- 2) A list of abbreviations used in this Recommendation can be found in Annex B.

© ITU 1993

All rights reserved. No part of this publication may be reproduced or utilized in any form or by any means, electronic or mechanical, including photocopying and microfilm, without permission in writing from the ITU.

Recommendation V.110¹⁾

SUPPORT OF DATA TERMINAL EQUIPMENTS WITH V-SERIES TYPE INTERFACES BY AN INTEGRATED SERVICES DIGITAL NETWORK

(Malaga-Torremolinos, 1984; amended at Melbourne, 1988, revised 1992)

The CCITT,

considering

- (a) that the ISDN will offer the universal interfaces to connect subscriber terminals according to the reference configuration described in Recommendation I.411;
- (b) that during the evolution of ISDN, however, there will exist for a considerable period data terminal equipment (DTEs) with V-Series type interfaces which have to be connected to the ISDN;
- (c) that bearer services supported by an ISDN are described in Recommendation I.211;
- (d) that the D-channel signalling protocol is described in Recommendations I.430, I.441/Q.921 and I.451/Q.931;

unanimously declares the view

- (1) that the scope of this Recommendation shall cover the connection of terminals with interfaces for modems conforming to current V-Series Recommendations on the ISDN operating in accordance with circuit switched or leased circuit services;
 - (2) that the following circuit switched service capabilities shall be supported:
 - data transmission; (or)
 - alternate speech/data transmission; (and/or)
 - automatic calling and/or automatic answering;
 - (3) that the reference configurations of § 1 shall apply;
 - (4) that the support of interworking of terminal equipments (TEs) on an ISDN with DTEs on other types of networks, e.g. public switched telephone network (PSTN), is described in the Recommendations I.500-Series;
 - (5) that the terminal adaptor (TA) functions necessary to support the connection of DTEs with V-Series type interfaces on an ISDN, shall include the following:
 - conversion of electrical and mechanical interface characteristics;
 - bit rate adaptation;
 - end-to-end synchronization of entry to and exit from the data transfer phase;
 - call establishment and disestablishment based on either manual or automatic calling and/or automatic answering.

1 Reference configurations

1.1 Terminal adaptor reference model

The terminal adaptor functions have been defined in the context of a simple reference model. Annex A describes the reference model in further detail, and defines a basic terminal adaptor TA-A, and an auto-calling/autoanswering terminal adaptor TA-B.

¹⁾ This Recommendation is also included in the Recommendations of the I-Series under the number I.463.

1.2 Connection types

The terminal adaptor functions described in this Recommendation take into account interworking between TAs of different types, e.g. V-Series TE2 with X.21 TE2, and end-to-end connections of different types. These are described in further detail in Annex A.

2 Line signals at S and T reference points

The TA signals at ISDN reference points S or T shall be in conformance with the characteristics of an ISDN's "Basic user/network interface" as described in Recommendation I.430 (layer 1 specification), I.441/Q.921 (layer 2 specification) and I.451/Q.931 (layer 3 specification).

2.1 Bit rate adaptation of synchronous data signalling rates up to 19.2 kbit/s

2.1.1 General approach

The bit rate adaptation functions within the TA are shown in Figure 1/V.110. The functions RA1 converts the user data signalling rate to an appropriate intermediate rate expressed by $2^k \times 8$ kbit/s (where $k = 0, 1$ or 2). RA2 performs the second conversion from the intermediate rates to 64 kbit/s. The data signalling rates of 48 and 56 kbit/s are converted directly into the 64 kbit/s B-channel rate.

2.1.2 Adaptation of V-Series data signalling rates to the intermediate rates

The intermediate rate used with each of the V-Series data signalling rates are shown in Table 1/V.110.

Note – The specific V-Series data signalling rate(s) to be supported by an ISDN are for further study.

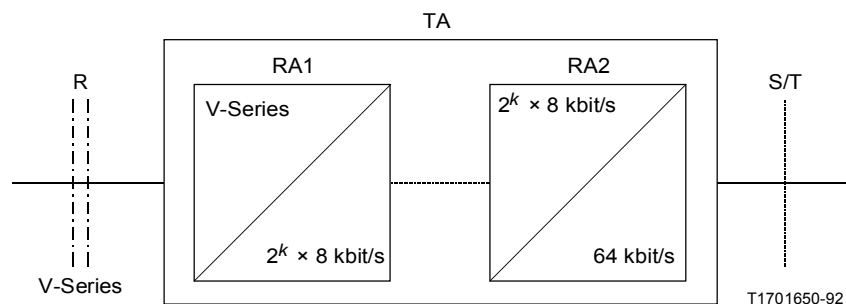

FIGURE 1/V.110

Two step bit rate adaptation

TABLE 1/V.110

First step rate adaptation

Data signalling rate (bit/s)	Intermediate rate		
	8 kbit/s	16 kbit/s	32 kbit/s
600	X		
1 200	X		
2 400	X		
4 800	X		
7 200		X	
9 600		X	
12 000			X
14 400			X
19 200			X

2.1.2.1 *Frame structure*

The frame structure is shown in Table 2/V.110 and is described in the following paragraphs.

As shown in Table 2/V.110, the conversion of the V-Series rates to the intermediate rates uses an 80-bit frame. The octet zero contains all binary 0, whilst octet 5 consists of a binary 1 followed by seven E bits (see § 2.1.2.4). Octets 1-4 and 6-9 contain a binary 1 in bit number one, a status bit (S- or X-bit) in bit number 8 and six data bits (D-bits) in bit positions 2-7. The order of bit transmission is from left to right and top to bottom.

TABLE 2/V.110

Frame structure

Octet number	Bit number							
	1	2	3	4	5	6	7	8
0	0	0	0	0	0	0	0	0
1	1	D1	D2	D3	D4	D5	D6	S1
2	1	D7	D8	D9	D10	D11	D12	X
3	1	D13	D14	D15	D16	D17	D18	S3
4	1	D19	D20	D21	D22	D23	D24	S4
5	1	E1	E2	E3	E4	E5	E6	E7
6	1	D25	D26	D27	D28	D29	D30	S6
7	1	D31	D32	D33	D34	D35	D36	X
8	1	D37	D38	D39	D40	D41	D42	S8
9	1	D43	D44	D45	D46	D47	D48	S9

2.1.2.2 *Frame synchronization*

The 17-bit frame alignment pattern consists of all 8 bits (set to binary 0) of octet zero and bit one (set to binary 1) of the following nine octets (see also § 2.1.3).

2.1.2.3 *Status bits (S1, S3, S4, S6, S8, S9 and X)*

The bits S and X are used to convey channel control information associated with the data bits in the data transfer state, as shown in Table 3/V.110. The S-bits are put into two groups SA and SB, to carry the condition of two interchange circuits. The X-bit is used to carry the condition of circuit 106, and in addition, signals the state of frame synchronization between TAs. The X-bit can also be used optionally to carry flow control information between TAs supporting asynchronous terminal equipment. This usage is specified in § 2.4.2.

The use of S- and X-bits for synchronization of entry to and exit from the data transfer state is specified in § 4.

The mechanism for proper assignment of the control information from the transmitting signal rate adapter interface via these bits to the receiving signal rate adapter interface is shown in Table 3/V.110 and described in § 4.

For the S- and X-bits, a ZERO corresponds with the ON condition, a ONE with the OFF condition.

Control information, conveyed by the S-bits, and user data, conveyed by the D-bits, should not have different transmission delays. The S-bits should therefore transmit control information sampled simultaneously with the D-bits in the positions specified in Table 4/V.110 and as presented in Figure 2/V.110.

The X-bit should be presented upon arrival to control circuit 106. Circuit 106 shall respond as defined in § 3.3 (X = ZERO, 106 = ON).

TABLE 3/V.110

General mapping scheme

108 -----	S1, S3, S6, S8 = SA	----- 107
105 -----	S4, S9 = SB	----- 109
Frame synch and 106/IWF -----	X	----- 106

TABLE 4/V.110

Coordination between S-bits and D-bits

S-bit	D-bit	
	Octet No.	Bit No.
S1	2	3 (D8)
S3	3	5 (D16)
S4	4	7 (D24)
S6	7	3 (D32)
S8	8	5 (D40)
S9	9	7 (D48)

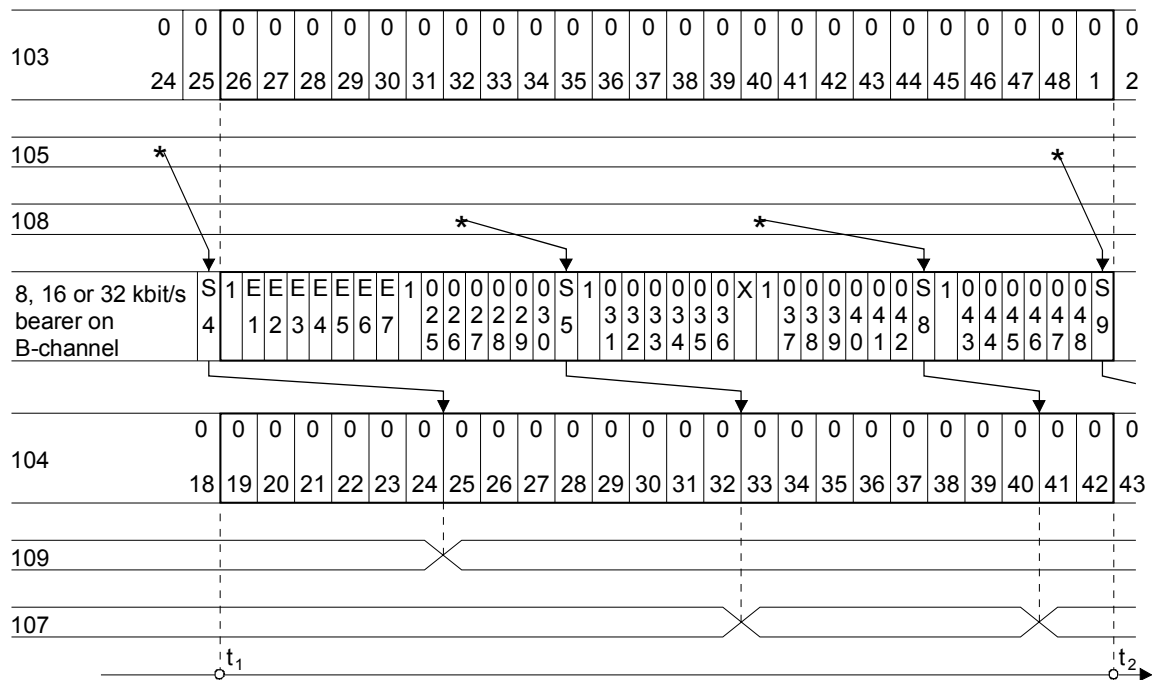
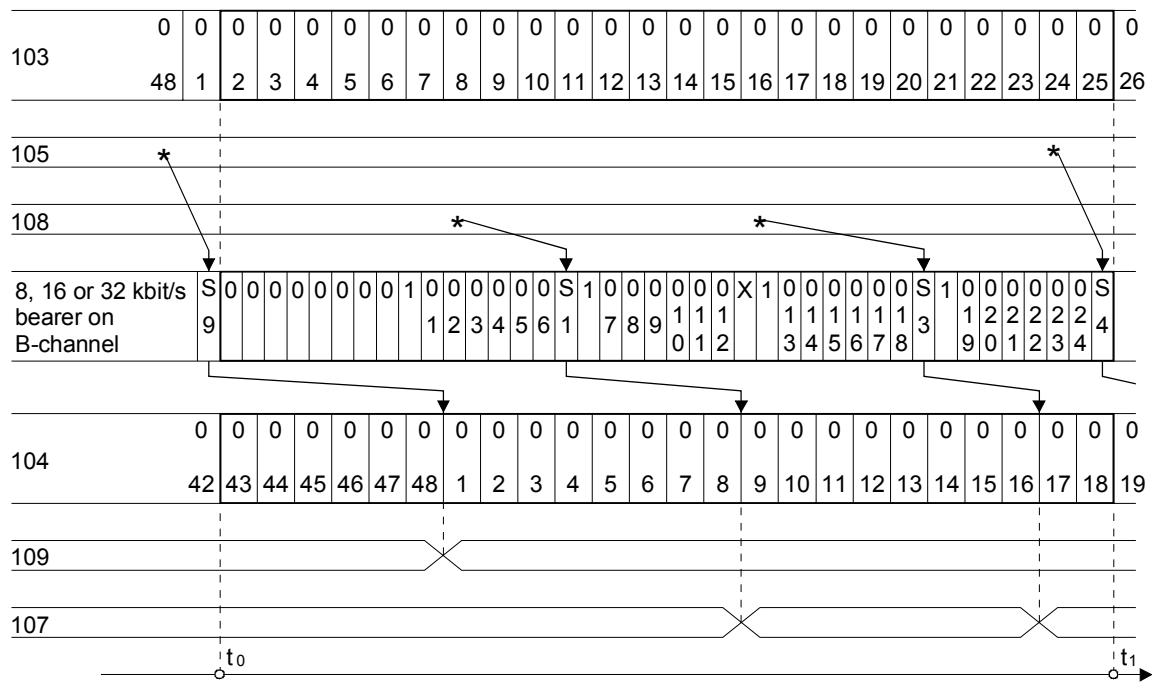

* Indicates the sampling point for circuit 105 and 108
 X Indicates the change point for circuits 107 and 109

T1701660-92

Note 1 – In order to maintain conformity with the bit rate adaptation of X.1 user classes of service described in Recommendation X.30 (I.461), the bits S1 and S6, S3 and S8, S4 and S9 are used to convey channel status information associated with the P-, Q- and R-bit groups respectively.

Refer to § 2.1.1.2.3 of Recommendation X.30 (I.461) for detailed information concerning the mapping of the information on circuit C of the X.21 interface to the S-bits and to the I-bits of the distant interface.

Note 2 – The coordination between S- and D-bits described in Table 4/V.110 and Figure 2/V.110 is intended to provide for compatibility with Recommendation X.30 (I.461). Whether this coordination is strictly necessary in the context of Recommendation V.110 is for further study.

FIGURE 2/V.110
 Coordination between S-bits and D-bits

2.1.2.4 E-bit usage

The E-bits are used to carry the following information:

- a) *Rate repetition information:* Bits E1, E2 and E3, in conjunction with the intermediate rate (see Table 2/V.110), provide the user data signalling rate (synchronous) identification. The coding of these bits shall be as shown in Table 5/V.110.
- b) *Network independent clock information:* Bits E4, E5 and E6 are used as specified in § 5 to carry network independent clock phase information.
- c) *Multiframe information:* Bit E7 is used as indicated in Table 5/V.110.

TABLE 5/V.110

E-bit usage
(Note 1)

Intermediate rates kbit/s			E1	E2	E3	E4	R5	E6	E7
8	16	32	(Note 4)			(Note 3)			
bit/s 600	bit/s	bit/s	1	0	0	C	C	C	1 ou 0 (Note 2)
1200			0	1	0	C	C	C	1
2400			1	1	0	C	C	C	1
		12 000	0	0	1	C	C	C	1
	7200	14 400	1	0	1	C	C	C	1
4800	9600	19 200	0	1	1	C	C	C	1

Note 1 — The data signalling rates of 600, 2400, 4800 and 9600 bit/s are also Recommendation X.1 user classes of service (see also Recommendation X.30/I.461).

Note 2 — In order to maintain compatibility with Recommendation X.30 (I.461), the 600 bit/s user rate E7 is coded to enable the 4×80 bit multiframe synchronization. To this end, E7 in the fourth 80-bit frame is set to binary 0 (see § 2.1.2.7 and Table 6a/V.110).

Note 3 — C indicates the use of E4, E5 and E6 for the Transport of Network Independent blocking information (see § 5). These bits shall be set to ONE when unused.

Note 4 — Synchronous rate information is carried by bits E1, E2 and E3 as indicated. Asynchronous rate information must be provided with out-of-band signalling (layer 3 messages in the D-channel) or with In-band parameter exchange as described in Appendix I.

2.1.2.5 Rate negotiation

Negotiation of the synchronous rate may be appropriate in interworking situations involving interconnections with modems on the PSTN where the remote modem/DTE has the capability of operating at different rates depending upon the conditions. It may also be appropriate in interconnections for asynchronous transmission specified in § 2.3 and accommodate split rate operation. The need for rate negotiation and the method is for further study.

2.1.2.6 Data bits

Data are conveyed in D-bits, i.e. up to 48 bits per 80-bit frame. In this Recommendation the octet boundaries of the user's data stream are not defined.

2.1.2.7 *Bit assignment*

The adaptation of 600, 1200 and 2400 bit/s rates to the 8 kbit/s intermediate rate are shown in Tables 6a/V.110, 6b/V.110 and 6c/V.110, respectively.

The adaptation of 7200 and 14 400 bit/s rates to the 16 and 32 kbit/s intermediate rate, respectively, use the data bit assignments shown in Table 6d/V.110.

The adaptation of 4800, 9600 and 19 200 bit/s rates to the 8, 16 and 32 kbit/s intermediate rate, respectively, use the data bit assignments shown in Table 6e/V.110.

The adaptation of 12 000 bit/s user rate to 32 kbit/s intermediate rate use the data bit assignments shown in Table 6f/V.110.

2.1.3 *Frame synchronization and additional signalling capacity*

2.1.3.1 *Search for frame synchronization*

The following 17-bit alignment pattern is used to achieve frame synchronization:

```
00000000  1XXXXXXX  1XXXXXXX  1XXXXXXX  1XXXXXXX
1XXXXXXX 1XXXXXXX  1XXXXXXX  1XXXXXXX  1XXXXXXX
```

To ensure a reliable synchronization, it is suggested that at least two 17-bit alignment patterns in consecutive frames be detected.

Once frame synchronization is achieved, it is suggested that a persistence check be made of the S = X = OFF condition of § 4.1.2 prior to proceeding to transparent data transfer with the S = X = ON condition, as shown in Figure 3/V.110.

2.1.3.2 *Frame synchronization monitoring and recovery*

Monitoring of the frame synchronization shall be a continuous process using the same procedures as for initial detection.

Loss of frame synchronization shall not be assumed unless at least three consecutive frames, each with at least one framing bit error, are detected.

Following loss of frame synchronization, the TA shall enter a recovery state as discussed in § 4.1.5. If recovery is not successful, further maintenance procedures may be used.

2.1.4 *Adaptation of intermediate rates to 64 kbit/s*

Since rate adaptation of a single intermediate rate (e.g. 8, 16, or 32 kbit/s) to the 64 kbit/s B channel rate and the possible multiplexing of several intermediate rate streams²⁾ to the 64 kbit/s B-channel rate must be compatible to enable interworking, a common approach is needed for the second step rate adaptation and, possibly, for intermediate rate multiplexing. This second step rate adaptation method is described in Recommendation I.460.

2.2 *Rate adaptation of 48 and 56 kbit/s user rates to 64 kbit/s*

The 48 and 56 kbit/s user data signalling rates are adapted to the 64 kbit/s B-channel rate in one step as indicated in Tables 7a/V.110 and 7b/V.110 or 7c/V.110 respectively.

²⁾ Multiplying of several intermediate rate streams is for further study.

TABLE 6a/V.110

**Adaptation of 600 bit/s user rate
to 8 kbit/s intermediate rates**

0	0	0	0	0	0	0	0
1	D1	D1	D1	D1	D1	D1	S1
1	D1	D1	D2	D2	D2	D2	X
1	D2	D2	D2	D2	D3	D3	S3
1	D3	D3	D3	D3	D3	D3	S4
1	1	0	0	E4	E5	E6	E7 ^{a)}
1	D4	D4	D4	D4	D4	D4	S6
1	D4	D4	D5	D5	D5	D5	X
1	D5	D5	D5	D5	D6	D6	S8
1	D6	D6	D6	D6	D6	D6	S9

a) See Note 2 to Table 5/V.110.

TABLE 6b/V.110

**Adaptation of 1200 bit/s user rate
to 8 kbit/s intermediate rate**

0	0	0	0	0	0	0	0
1	D1	D1	D1	D1	D2	D2	S1
1	D2	D2	D3	D3	D3	D3	X
1	D4	D4	D4	D4	D5	D5	S3
1	D5	D5	D6	D6	D6	D6	S4
1	0	1	0	E4	E5	E6	E7
1	D7	D7	D7	D7	D8	D8	S6
1	D8	D8	D9	D9	D9	D9	X
1	D10	D10	D10	D10	D11	D11	S8
1	D11	D11	D12	D12	D12	D12	S9

TABLE 6c/V.110

**Adaptation of 2400 bit/s user rate
to 8 kbit/s intermediate rate**

0	0	0	0	0	0	0	0
1	D1	D1	D2	D2	D3	D3	S1
1	D4	D4	D5	D5	D6	D6	X
1	D7	D7	D8	D8	D9	D9	S3
1	D10	D10	D11	D11	D12	D12	S4
1	1	1	0	E4	E5	E6	E7
1	D13	D13	D14	D14	D15	D15	S6
1	D16	D16	D17	D17	D18	D18	X
1	D19	D19	D20	D20	D21	D21	S8
1	D22	D22	D23	D23	D24	D24	S9

TABLE 6d/V.110

**Adaptation of $N^a) \times 3600$ bit/s user rate
to the intermediate rate**

0	0	0	0	0	0	0	0
1	D1	D2	D3	D4	D5	D6	S1
1	D7	D8	D9	D10	F	F	X
1	D11	D12	F	F	D13	D14	S3
1	F	F	D15	D16	D17	D18	S4
1	1	0	1	E4	E5	E6	E7
1	D19	D20	D21	D22	D23	D24	S6
1	D25	D26	D27	D28	F	F	X
1	D29	D30	F	F	D31	D32	S8
1	F	F	D33	D34	D35	D36	S9

F = Fill bit

a) $N = 2$ or 4 only.

TABLE 6e/V.110

**Adaptation of $N^a) \times 4800$ bit/s user rate
to the intermediate rate**

0	0	0	0	0	0	0	0
1	D1	D2	D3	D4	D5	D6	S1
1	D7	D8	D9	D10	D11	D12	X
1	D13	D14	D15	D16	D17	D18	S3
1	D19	D20	D21	D22	D23	D24	S4
1	0	1	1	E4	E5	E6	E7
1	D25	D26	D27	D28	D29	D30	S6
1	D31	D32	D33	D34	D35	D36	X
1	D37	D38	D39	D40	D41	D42	S8
1	D43	D44	D45	D46	D47	D48	S9

a) $N = 1, 2$ or 4 only.

TABLE 6f/V.110

**Adaptation of 12 000 bit/s user rate
to 32 kbit/s intermediate rate**

0	0	0	0	0	0	0	0
1	D1	D2	D3	D4	D5	D6	S1
1	D7	D8	D9	D10	F	F	X
1	D11	D12	F	F	D13	D14	S3
1	F	F	D15	F	F	F	S4
1	0	0	1	E4	E5	E6	E7
1	D16	D17	D18	D19	D20	D21	S6
1	D22	D23	D24	D25	F	F	X
1	D26	D27	F	F	D28	D29	S8
1	F	F	D30	F	F	F	S9

F = Fill

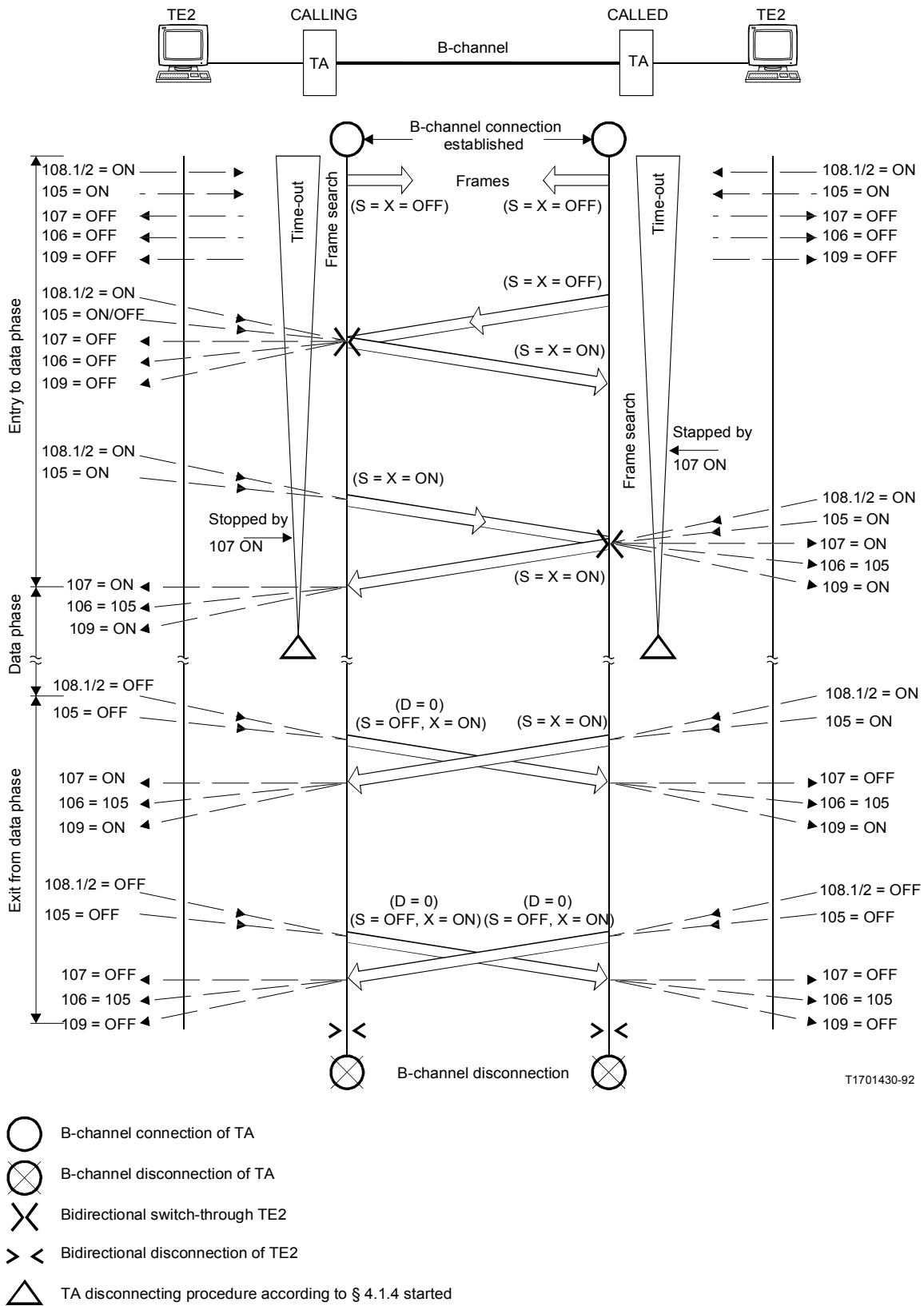

FIGURE 3/V.110
TA synchronization of entry to and exit from data transfer phase

TABLE 7a/V.110

Adaptation of 48 kbit/s user rate to 64 kbit/s

Octet number	Bit number							
	1	2	3	4	5	6	7	8
1	1	D1	D2	D3	D4	D5	D6	S1
2	0	D7	D8	D9	D10	D11	D12	X
3	1	D13	D14	D15	D16	D17	D18	S3
4	1	D19	D20	D21	D22	D23	D24	S4

Note 1 – 48 kbit/s is also a Recommendation X.1 user class of service (see also Recommendation X.30/L.461, § 2.2.1).

Note 2 – Refer to § 2.1.2.3 for the use of status bits and bit X; however for international operation over restricted 64 kbit/s bearer capabilities, bit X must be set to binary 1.

TABLE 7b/V.110

Adaptation of 56 kbit/s user rate to 64 kbit/s

Octet number	Bit number							
	1	2	3	4	5	6	7	8
1	D1	D2	D3	D4	D5	D6	D7	1
2	D8	D9	D10	D11	D12	D13	D14	1
3	D15	D16	D17	D18	D19	D20	D21	1
4	D22	D23	D24	D25	D26	D27	D28	1
5	D29	D30	D31	D32	D33	D34	D35	1
6	D36	D37	D38	D39	D40	D41	D42	1
7	D43	D44	D45	D46	D47	D48	D49	1
8	D50	D51	D52	D53	D54	D55	D56	1

TABLE 7c/V.110

**Alternative frame structure for the adaptation of 56 kbit/s
user rate to 64 kbit/s**

Octet number	Bit number							
	1	2	3	4	5	6	7	8
1	D1	D2	D3	D4	D5	D6	D7	0
2	D8	D9	D10	D11	D12	D13	D14	X
3	D15	D16	D17	D18	D19	D20	D21	S3
4	D22	D23	D24	D25	D26	D27	D28	S4
5	D29	D30	D31	D32	D33	D34	D35	1
6	D36	D37	D38	D39	D40	D41	D42	1
7	D43	D44	D45	D46	D47	D48	D49	1
8	D50	D51	D52	D53	D54	D55	D56	1

Note 1 – Refer to § 2.1.2.3 for the use status bits and bit X.

Note 2 – Table 7c/V.110 is a permitted option to provide for signalling to enter and to leave the data phase. However, the recommended approach shall be as in Table 7b/V.110 and the responsibility shall be on the user of Table 7c/V.110 to insure that interworking can be achieved.

2.2.1 Frame synchronization

At the user data signalling rate of 48 kbit/s, the frame alignment pattern consists of 1011 in bit 1 of consecutive octets of one frame. To ensure reliable synchronization, it is suggested that at least five 4-bit alignment patterns in consecutive frames be detected.

At the user data signalling rate of 56 kbit/s with the alternative frame structure according to Table 7c/V.110 the frame alignment pattern consists of OYY1111 in bit 8 of consecutive octets of one frame. Bits marked with Y may be either “0” or “1”. To ensure a reliable synchronization, it is suggested that at least four 5-bit (01111) alignment patterns in the 8 bit sequence of OYYYY1111 in consecutive octets be detected.

Frame synchronization monitoring and recovery is described in § 2.1.3.2.

2.3 Adaptation for asynchronous rates of up to 19 200 bit/s

2.3.1 General approach

The bit rate adaptation functions within the TA are shown in Figure 4/V.110. A three-step method is employed with the functional blocks RA0, RA1, and RA2. The RA0 function is an asynchronous-to-synchronous conversion step, for support of the rates specified in Table 8/V.110, using the same technique as defined in Recommendation V.14. It produces a synchronous bit stream defined by $2^n \times 600$ bits (where $n = 0$ to 5). The functions RA1 and RA2 are the same as specified in § 2.1. Function RA1 adapts the user rate to the next higher rate expressed by $2^k \times 8$ bit/s (where $k = 0, 1$ or 2). RA2 performs the second conversion to 64 kbit/s.

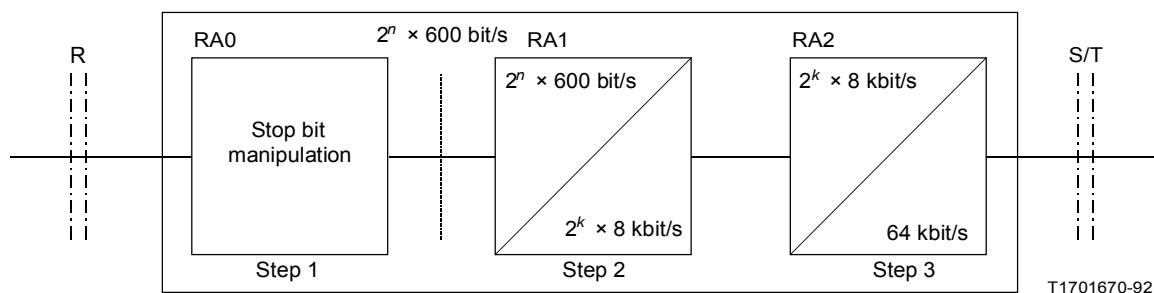

FIGURE 4/V.110

Three step rate adaption bit

2.3.2 *Supported asynchronous user rates*

The asynchronous user rates to be supported, mandatory and optional, are specified in Table 8/V.110.

TABLE 8/V.110

Asynchronous user rates

Data rate (bit/s)	Rate tolerance (%)	Number of data units	Number of stop elements	RA0/RA1 rate (bit/s)	RA1 rate (kbit/s)
50	± 2.5	5	1,5	600	8
75	± 2.5	5.7 or 8	1:1.5:2	600	8
110	± 2.5	7 or 8	1 or 2	600	8
150	± 2.5	7 or 8	1 or 2	600	8
200	± 2.5	7 or 8	1 or 2	600	8
300 *	± 2.5	7 or 8	1 or 2	600	8
600 *	+ 1 – 2.5	7 or 8	1 or 2	600	8
1 200 *	+ 1 – 2.5	7 or 8	1 or 2	1 200	8
2 400 *	+ 1 – 2.5	7 or 8	1 or 2	2 400	8
3 600	+ 1 – 2.5	7 or 8	1 or 2	4 800	8
4 800 *	+ 1 – 2.5	7 or 8	1 or 2	4 800	8
7 200	+ 1 – 2.5	7 or 8	1 or 2	9 600	16
9 600 *	+ 1 – 2.5	7 or 8	1 or 2	9 600	16
12 000	+ 1 – 2.5	7 or 8	1 or 2	19 200	32
14 400	+ 1 – 2.5	7 or 8	1 or 2	19 200	32
19 200	+ 1 – 2.5	7 or 8	1 or 2	19 200	32

Note 1 – * indicates rate whose support is mandatory for universal TA.

Note 2 – Number of data bits includes possible parity bits.

2.3.3 *Asynchronous-to-synchronous conversion (RA0)*

The RA0 function is only used with asynchronous V-Series interfaces. Incoming asynchronous data is padded by the addition of stop elements to fit the nearest channel rate defined by $2^n \times 600$ bit/s. Thus, a 7200 bit/s user data signalling rate shall be adapted to a synchronous 9600 bit/s stream and a 110 bit/s user data

signalling rate shall be adapted to synchronous 600 bit/s stream. The resultant synchronous stream is fed to RA1. Padding with stop elements is inhibited during the transmission of the break signal as described in § 2.3.5.

2.3.4 *Overspeed/underspeed*

A terminal adaptor shall insert additional stop elements when its associated terminal is transmitting with a lower than nominal character rate. If the terminal is transmitting characters with an overspeed of up to 1% (or 2.5% in the case of nominal speeds lower than 600 bit/s), the asynchronous-to-synchronous converter may delete stop elements as often as is necessary to a maximum of one every eight characters at 1% overspeed. The converter on the receiving side shall detect deleted stop elements and re-insert them in the received data stream (circuit 104).

The nominal length of the start elements and data units shall be the same for all characters. The length of the stop element may be reduced as much as 12.5% by the receiving converter for nominal speeds exceeding 300 bit/s to allow for overspeed in the transmitting terminal. For nominal speeds less than or equal to 300 bit/s, a 25% reduction in stop element is allowed.

2.3.5 *Break signal*

The terminal adaptor shall detect and transmit the break signal as follows:

If the converter detects M to $2M + 3$ bits, all of start polarity, where M is the number of bits per character in the selected format including start and stop elements, the converter shall transmit $2M + 3$ bits of start polarity.

If the converter detects more than $2M + 3$ bits, all of start polarity, the converter shall transmit all these bits as start polarity.

For the cases where the asynchronous rate is lower than the synchronous rate for the converter, the following rules shall apply:

- the converter shall transmit start polarity (to RA1) for a time period equal to $2M + 3$ bits at the asynchronous rate if the converter has detected M to $2M + 3$ bits of start polarity;
- the converter shall transmit (to RA1) start polarity for a time period as long as the received break condition if the converter has detected more than $2M + 3$ bits of start polarity;
- the $2M + 3$ or more bits of start polarity received from the transmitting side shall be output to the receiving DTE;
- the DTE must transmit on circuit 103 at least $2M$ bits of stop polarity after the start polarity break signal before sending further data characters. The converter shall then regain character synchronism from the following stop to start transition.

2.3.6 *Parity bits*

Possible parity bits included in the user data are considered as data bits by the RA0 function.

2.4 *Flow control*

A flow control option, for use with TAs supporting asynchronous DTEs, is described in this section. Flow control allows the connection of asynchronous DTEs operating at different user data rates by reducing the character output of the faster to that of the slower. Support of flow control will require the use of end-to-end (TA-to-TA) protocol defined in § 2.4.2 and an incoming line (from network) buffer in addition to a selected local protocol (see § 2.4.1). Depending upon the local flow control protocol employed, there will also be a requirement for character buffering from the DTE interface. The size of this buffer is not defined in this Recommendation because it is dependent upon implementation.

Local flow control of the DTE interface is required where the DTE operates at a rate higher than the synchronous rate established between TAs. End-to-end flow control is required where the synchronous rate established between TAs is consistent with the operating rate of one DTE (or interworking unit) and higher than the synchronous rate consistent with the operating rate of the other DTE (or interworking unit). Both local and end-to-end flow control could be required in some applications.

2.4.1 *Local flow control: TA to DTE*

Connection may be made between TAs connected to asynchronous DTEs operating at two different speeds. It is the responsibility of the TA connected to the faster DTE to execute a local flow control protocol to reduce the character rate to that of the slower DTE. This operation will require some buffer storage in the TA. A TA may support several different local flow control protocols, although only one will be selected at any one time. There are a number of such protocols in use, some of which are detailed in the following text.

2.4.1.1 *105/106 operation*

This is an out-of-band flow control mechanism, utilizing two of the interchange circuits specified in Recommendation V.24. If a DTE requires to transmit a character, it turns ON circuit 105 (request to send). The DTE can only begin transmission when it receives in return circuit 106 ON (ready for sending). If, during transmission of a block of characters circuit 106 goes OFF, the DTE must cease transmission (after completing the transmission of any character of which transmission has started) until circuit 106 turns ON again.

2.4.1.2 *XON/XOFF operation*

This is an in-band flow control mechanism using two characters of the International Alphabet No. 5 (IA5) set for XON and XOFF operation. If a DTE receives an XOFF character, it must cease transmission. When it receives an XON character, it may resume transmission. The characters typically used for XON and XOFF are device control one (DC1) and device control three (DC3) (bit combination 1/1 and 1/3 in Recommendation T.50) respectively, although alternative bit-combinations can be used.

2.4.1.3 *Other methods*

Alternative and non-standard methods of asynchronous flow control are in use, and these may be mapped onto the TA flow control protocol.

2.4.2 *End-to-end (TA to TA) flow control*

Matching (by reduction) of the transmitted character rate of the DTE to the rate of the TA is not sufficient in all cases to guarantee correct operation, and end-to-end flow control may be required.

The X-bit is used to carry flow control information. A TA will buffer incoming characters. When the number of buffered characters exceeds a threshold TH1, depending upon implementation, the TA will set the X-bit of its outgoing frames to OFF.

Upon receipt of a frame containing an X-bit set to OFF, a TA will execute its selected local flow control procedure indicating that the attached DTE must stop sending characters, and cease the transmission of data after completion of the character in progress by setting the data bits in the outgoing frames to ONE.

When the buffer contents of a TA which has initiated an end-to-end flow control drops below threshold TH2, the TA will reset the outgoing X-bit to ON.

When the far-end TA receives a frame with the X-bit set to ON, it will recommence data transmission, and, by use of the local flow control procedure, indicate to the attached DTE that it may continue.

Note – There may be a delay between initiation of the end-to-end flow control protocol and termination of the incoming character stream. The characters arriving during this time must be buffered, and the total buffer size will depend upon the character rate, round trip delay and the buffer threshold.

2.4.3 *Use of channel capacity*

Upon accepting a call from a TA supporting flow control and operating at a different user rate and/or intermediate rate, the called TA will adopt the identical intermediate rate and bit repetition factor. This will override the parameters normally selected. In such cases, the TA connected to the faster DTE will execute a local flow control procedure to reduce the character rate to that of the slower DTE.

Thus, if a faster DTE calls a slower DTE, the faster intermediate channel rate and bit repetition factor will be adopted by the TAs on both ends. To reduce the character rate received by the slower DTE, its TA will exercise end-to-end flow control and cause the TA on the calling side to utilize local flow control.

If a slower DTE calls a faster DTE, the slower intermediate channel rate and bit repetition factor will be adopted by the TAs on both ends. To reduce the character rate transmitted by the faster DTE, its TA will exercise local flow control.

If the called TA does not implement the intermediate rate and bit repetition factor used by the calling TA, the call shall be rejected.

2.4.4 *Requirements of a TA supporting flow control*

The following are general requirements for a TA supporting flow control:

- i) A TA supporting flow control shall be capable of operating with an intermediate rate and bit repetition factor that is independent of the asynchronous speed used at its DTE interface.
- ii) A TA supporting flow control shall, if possible, adapt to the intermediate rate and bit repetition factor required for an incoming call. User rate information will be obtained from signalling.
- iii) A TA supporting flow control shall be capable of executing a local flow control protocol to reduce the character rate to that of the far-end DTE.
- iv) A TA supporting flow control will support the use of end-to-end (TA to TA) flow control using the X-bit, and will contain a character buffer.

3 Interchange circuits

3.1 *Essential and optional interchange circuits*

The essential and optional interchange circuits are listed in Table 9/V.110 below.

3.2 *Timing arrangement*

The TA shall derive ISDN timing from the received bit stream of the ISDN's basic user/network interface (see §§ 5 and 8 of Recommendation I.430). This network timing shall be used by the TA to provide the DTE with transmitter signal element timing on circuit 114 and receiver signal element timing on circuit 115.

3.3 *Circuit 106*

After the start-up and retrain synchronization sequences, the ON state of circuit 106 shall be delayed relative to the ON state of circuit 105 (where implemented) by an interval of at least N bits (a value of N equal to 24 has been proposed, but the value is for further study). ON to OFF state transitions of circuit 106 shall follow ON to OFF state transitions of circuit 105 (when implemented) by less than 2 ms. Where circuit 105 is not implemented, the initial circuit 106 transition to the ON state shall be delayed by an interval greater than or equal to N bits relative to the corresponding transition in the state of circuit 109. Subsequent transitions in the state of circuit 106 should occur solely in accordance with the operating sequences defined in § 4, or when used for the optional flow control in § 2.4.

3.4 *Circuit 109*

OFF to ON and ON to OFF transitions of circuit 109 should occur solely in accordance with the operating sequence defined in § 4.

TABLE 9/V.110

Interchange circuit		Notes
Number	Description	
102	Signal ground or common return	
102a	DTE common return	2
102b	DCE common return	2
103	Transmitted data	
104	Received data	
105	Request for sending	3
106	Ready for sending	
107	Data set ready	
108/1	Connect data set to line	4
108/2	Data terminal ready	4
109	Data channel received line signal detector	
111	Data signalling rate selector (DTE source)	5
112	Data signalling rate selector (DCE source)	5
113	Transmitter signal element timing (DTE source)	6
114	Transmitter signal element timing (DC source)	
115	Receiver signal element timing (DCE source)	
125	Calling indicator	7
140	Loopback/maintenance test	8
141	Local loopback	8
142	Test indicator	8

Note 1 — All essential circuits and any others which are provided shall comply with the functional and operational requirements of Recommendation V.24. All interchange circuits provided shall be properly terminated in the data terminal equipment and in the data circuit-terminating equipment in accordance with the appropriate Recommendation for electrical characteristics (see § 3.5).

Note 2 — Interchange circuits 102a and 102b are required where the electrical characteristics defined in Recommendation V.10 are used at data signalling rates above 20 kbit/s.

Note 3 — Not required for DTEs that operate with DCEs in the continuous carrier mode.

Note 4 — This circuit shall be capable of operating as circuit 108/1 or 108/2, depending on its use (by the associated TE).

Note 5 — The use of this circuit is for further study.

Note 6 — The use of circuit 113 is for further study, since its application is restricted by the synchronous nature of ISDN.

Note 7 — This circuit is used with the automatic answering terminal adaptor function.

Note 8 — The use for loopback testing is for further study.

3.5 *Electrical/mechanical characteristics of interchange circuits*

3.5.1 *Basic ISDN user/network interface*

The electrical and mechanical characteristics of the basic ISDN user/network interface are described in §§ 8 and 10 of Recommendation I.430.

3.5.2 *TE2/TA (DTE/DCE) interface*

3.5.2.1 *Rates less than or equal to 19.2 kbit/s*

Use of electrical characteristics conforming to Recommendation V.28, is recommended together with the connector and pin assignment plan specified by ISO 2110.

Note — Manufacturers may wish to note that the long-term objective is to replace electrical characteristics specified in Recommendation V.28, and that Study Group XVII has agreed that the work shall proceed to develop a

more efficient, all-balanced, interface for the V-Series application which minimizes the number of interchange circuits (Recommendation V.230).

3.5.2.2 *Rates greater than 19.2 kbit/s*

Use of electrical characteristics conforming to Recommendation V.10 and/or V.11 is recommended together with the use of the connector and pin assignment plan specified by ISO 4902.

- i) Concerning circuits 103, 104, 113, 114 and 115, both the generators and the receivers shall be in accordance with Recommendation V.11.
- ii) In the case of circuits 105, 106, 107 and 109, generators shall comply with Recommendation V.10 or alternatively Recommendation V.11. The receivers shall comply with Recommendation V.10, category 1, or Recommendation V.11 without termination.
- iii) In the case of all other circuits, Recommendation V.10 applies, with receivers configured as specified by Recommendation V.10 for category 2.

Alternatively, the interface defined in Appendix II to Recommendation V.35 together with connector and pin assignment plan specified by ISO 2593 may be used.

3.6 *Fault condition on interchange circuits*

(See § 7 of Recommendation V.28 for association of the receiver failure detection types).

3.6.1 The DTE should interpret a fault condition on circuit 107 as an OFF condition using failure detection type 1.

3.6.2 The data circuit-terminating equipment (DCE) should interpret a fault condition on circuits 105 and 108 as an OFF condition using failure detection type 1.

3.6.3 All other circuits not referred to above may use failure detection types 0 or 1.

4 **Operating sequence**

4.1 *TA duplex operation*

When using the TA to provide data transmission service within ISDN, the call is established over a 64 kbit/s connection using the procedures applicable to the particular network and/or terminal configuration.

The internal arrangement of the TA functional parts and the DTE (with a V-Series type interface) is not within the scope of this Recommendation. It is assumed that means are provided to control the entry to and the exit from the data transfer mode. For example, it is assumed that the means are provided to control circuits 108/1 (Connect data set to line) or 108/2 (Data terminal ready) internally, that is within the station at the customer premises. However, for the purpose of this Recommendation circuit 108/2, as defined in Recommendation V.24, is assumed.

4.1.1 *Idle (or ready) state*

4.1.1.1 During the idle (or ready) state the TA (DCE) will be receiving the following from the DTE:

Circuit 103 = Continuous binary 1

Circuit 105 = See Note

Circuit 108/1 = OFF; circuit 108/2 = ON

Note – In many duplex DTEs circuit 105 is either permanently in the ON condition or it is not present. If not present, the function must be set in an ON condition in the TA. See § 4.1.2.4 for the case where a duplex DTE can operate circuit 105.

4.1.1.2 During the idle (or ready) state the TA will transmit continuous binary 1s into the B- and D-channels (i.e. all bits of Table 2/V.110 = binary 1).

4.1.1.3 During the idle (or ready) state the TA (DCE) will transmit the following toward the DTE:

Circuit 104 = Continuous binary 1

Circuit 107 = OFF

Circuit 106 = OFF

Circuit 109 = OFF

4.1.2 *Connect TA to line state*

4.1.2.1 When the TA is to be switched to the data mode, circuit 108 must be ON. Switching to the data mode causes the TA to transmit the following towards the ISDN (refer to Table 2/V.110):

- a) frame synchronization pattern as described in §§ 2.1.3.1 and 2.2.1;
- b) data bits = binary 1;
- c) status bits S = OFF and X = OFF (ON = binary 0/OFF = binary 1).

Note 1 – At this time' circuit 103 is not connected to the data channel (e.g. the binary 1 condition of the data bits is generated within the TA).

Note 2 – In the following description only the inter-operation between TE2/TA (DTE/DCE) interface and the intermediate rate frames (see Tables 6a/V.110 to 6f/V.110) and the 64 kbit/s frame of Tables 7a/V.110 and 7c/V.110 are discussed. The second step of rate adaptation encoding and decoding and the multiplexing and demultiplexing of the ISDN basic user/network interface are discussed in Recommendations I.460 and I.430, respectively.

4.1.2.2 At this time (i.e. switching to data mode) the receiver in the TA will begin to search for the frame synchronization pattern in the received bit stream (see §§ 2.1.3.1 and 2.2.1).

4.1.2.3 When the receiver recognizes the frame synchronization pattern, it causes the S- and X-bits in the transmitted frames to be turned ON (provided that circuit 108 is ON).

4.1.2.4 When the receiver recognizes that the status of bits S and X are in the ON condition, it will perform the following functions:

- a) Turn ON circuit 107 toward the DTE and stop timer T1.

Note – A duplex DTE that implements and is able to operate circuit 105 may be expected to turn this circuit ON at any time. However, if not previously turned ON, it must be turned ON in response to the ON condition on circuit 107.

- b) Then, circuit 103 may be connected to the data bits in the frame; however, the DTE must maintain a binary 1 condition until circuit 106 is turned ON in the next portion of the sequence.
- c) Turn ON circuit 109 and connect the data bits to circuit 104.

Note – Binary 1 is being received on circuit 104 at this time.

- d) After an interval of *N* bits (see § 3.3), it will turn ON circuit 106.
- e) Circuit 106 transitioning from OFF to ON will cause the transmitted data to transition from binary 1 to the data mode.

If circuit 107 has not been turned ON, after expiring of timer T1 the TA shall be disconnected according to the procedures given in § 4.1.4.

4.1.3 *Data transfer state*

4.1.3.1 While in the data transfer state, the following circuit conditions exist:

- a) circuits 105 (when implemented), 106, 107, 108/1 or 108/2 and 109 are in the ON condition;
- b) data is being transmitted on circuit 103 and received on circuit 104.

4.1.4 *Disconnect mode*

4.1.4.1 At the completion of the data transfer phase, the local DTE will indicate a disconnect request by turning OFF circuit 108. This will cause the following to occur:

- a) the status bits S in the frame toward ISDN will turn OFF, status bits X are kept ON;
- b) circuit 106 will be turned OFF;
- c) the data bits in the frame will be set to binary 0.

4.1.4.2 If circuit 108 is still ON at the remote TA, this TA will recognize the transition of the status bits from ON to OFF and the data bits from data to binary 0 as a disconnected signal and it will turn OFF circuits 107 and 109. This DTE should respond by turning OFF circuit 108 and transferring to disconnected mode. The disconnection will be signalled via the ISDN D-channel signalling protocol. At this time, the DTE/DCE interface should be placed in the idle (or ready) state.

4.1.4.3 The TA at the station that originated the disconnect request will recognize reception of S = OFF or the loss of framing signals as a disconnect acknowledgement and turn OFF circuits 107 and 109 and transfer to disconnected mode. The disconnection will be signalled via the ISDN D-channel signalling protocol. At this time, the DTE/DCE interface should be placed in the idle (or ready) state.

4.1.5 *Loss of frame synchronization*

In the event of loss of frame synchronization, the TA should attempt to resynchronize as follows:

- a) Place circuit 104 in binary 1 condition (passes from the data mode).
- b) Turn OFF status bit X in the transmitted frame.
- c) The remote TA upon recognition of status bit X OFF will turn OFF circuit 106 which will cause the remote DTE to place circuit 103 in a binary 1 condition.
- d) The local TA should attempt to resynchronize on the incoming signal.
- e) If after an interval of three seconds the local TA cannot attain synchronization, it should send a disconnect request by turning OFF all of the status bits for several (at least three) frames with data bits set to binary 0 and then disconnect by turning OFF circuit 107 and transferring to the disconnected mode as discussed in § 4.1.4.2 above.

Note – The values of three seconds and three frames are provisional and should be confirmed or amended after further study.

- f) If resynchronization is achieved, the TA should turn ON status bit X toward the distant station.
- g) If resynchronization is achieved, the TA (which has turned OFF circuit 106) should, after an interval of *N* bits (see § 3.3), turn ON circuit 106. This will cause circuit 103 to change from binary 1 to the data mode.

Note – During a resynchronization attempt, circuits 107 and 109 should remain ON.

4.2 *TA half-duplex operation*

The data call establishment for the interworking of half-duplex DTEs equipped with V-Series type interfaces is the same as discussed in § 4.1 above. The only difference between half-duplex operation is in the control of the circuits 105, 106, and 109, as follows.

Note – This is a unique application; therefore, TA arranged for half-duplex operation will not be able to interwork with either a V-Series or an X-Series duplex DTE (TE2).

4.2.1 In a TA arranged to accommodate half-duplex DTEs, circuit 109 will be under the control of the status bits SB in the incoming frame, as follows:

- a) If at the local interface circuit 109 is OFF and circuit 104 is in the binary 1 state, the DTE may “**request to send**” by turning ON circuit 105.

- b) The TA will then turn ON status bits SB in the transmitted frame which will turn ON circuit 109 in the remote interface and connect circuit 104 to the data bit stream of the incoming frame.
- c) After an N bit interval (see § 3.3) the local TA will turn ON circuit 106, which will allow the local DTE to transmit data on circuit 103.
- d) Upon completion of the transmission the local DTE will turn OFF circuit 105. This will in turn:
 - turn OFF circuit 106 in the local interface and circuit 103 will revert to the binary 1 state;
 - turn OFF status bits SB which will in turn at the remote TA turn OFF circuit 109 and place circuit 104 in a binary 1 condition.
- e) At this time the remote DTE is able to reverse the sequence by turning ON circuit 105.

4.3 *Automatic calling*

The mapping of V.25 and/or V.25 *bis* automatic calling and/or automatic answering procedures to the ISDN D-channel signalling protocols is for further study.

5 **Network independent clocks**

In cases where synchronous data signals at user rates up to and including 19.2 kbit/s are received from outside the ISDN (e.g. through an interworking unit from a DTE/modem on the PSTN), the data may not be synchronized to the ISDN. The following method shall be used to enable transfer of those data signals and the corresponding bit timing information via the 80-bit frame to the receiving TA. Such a situation would exist where the signals are received through an interworking unit from voice-band data modems on the analogue PSTN where the transmit data from the remote modem is synchronized to the modem clock (normal case for such applications). The frequency tolerance of such modems is 100 ppm.

5.1 *Measurement of phase differences*

The phase difference between the following two frequencies will be measured:

- i) $R1 = 0.6 \times$ the nominal intermediate rate (except where Fill bits are used; see Note), synchronized with the ISDN;
- ii) $R2 = 0.6 \times$ the nominal intermediate rate (except where Fill bits are used; see Note), derived from and synchronized with the bit timing received from the remote synchronous source, e.g. modem.

Note – Clocks R1 and R2 are nominally either 4800, 9600 or 19200 Hz at 8 kbit/s, 16 kbit/s and 32 kbit/s intermediate rate, respectively.

Where Fill bits are used, in the cases of 7200 and 14400 bit/s R1 and R2 will have the same nominal rate as the user bit rate.

Compensation will affect one, one-half, one-quarter or one-eighth of a user data bit, dependent upon the bit repetition factor.

A state diagram for the transmitting TA showing the phase of R2 relative to R1 appears in Figure 5/V.110. Table 10/V.110 shows the related bit coding.

Comparison of R1 and R2 will give a phase difference relative to R1 which will be encoded as shown in Table 10/V.110. The resultant 3-bit code will be transmitted in bit positions E4, E5 and E6, and used for clock control at the receiving TA.

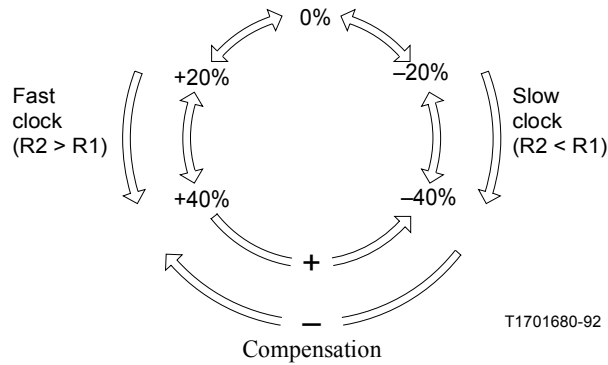

Note 1 – Phase measurements are given relative to R1 by the formula: Phase = phase(R2) – phase(R1).

Note 2 – Receipt of a bit combination requiring an illegal move of more than one state will cause a legal move of one state in the appropriate direction.

Note 3 – The initial state of both the receiving and transmitting sides of the TA will be 0%.

FIGURE 5/V.110
Network-independent clocking state diagram

TABLE 10/V.110
Coding of E-bits for network-independent clocking

Displacement (in % of nominal R1 clock period at $n \times 4800$ bit/s, $n = 1, 2$ or 4)	Coding in the 80-bit frame		
	E4	E5	E6
Nominally 0	1	1	1
+ 20	0	0	0
+ 40	0	0	1
- 40	0	1	0
- 20	0	1	1
Compensation control			
Positive compensation of a one	1	0	1
Positive compensation of a zero	1	0	0
Negative compensation	1	1	0

To avoid continuous jitter between neighbouring displacement positions, hysteresis shall be applied, as follows:

The displacement code shall be changed only when the measured phase difference between R1 and R2 is 15% (of the R1 clock period) more or less than the difference indicated by the existing displacement code.

Example – Bit combination 000 indicates a phase difference of nominally 20%. This bit combination will be changed into 001 when the measured phase difference is 35% or more, and into 111 when the measured phase difference is 5% or less.

5.2 *Positive/negative compensation*

On transition from the +40% state to the -40% state, an extra user D-bit has to be transmitted in the 80-bit frame, using bit E6 (positive compensation). At the receiving TA, this extra bit will be inserted between D24 and D25 as shown in Table 2/V.110, immediately following the E-bits.

On transition from the -40% state to the +40% state, a bit combination is transmitted in the 80-bit frame (E4, E5 and E6 = 1, 1, 0, respectively), indicating to the receiving TA that bit D25 of the 80-bit frame, being set to ONE, does not contain user data and should be removed (negative compensation).

5.3 *Encoding*

The encoding of the measured phase difference for clock control and the positive/negative compensation control overrides and replaces the clock control coding.

6 **Inband parameter exchange state**

The capabilities provided and operation in an optional inband parameter exchange state are described in Appendix I to this Recommendation.

7 **Testing facilities**

The provision of maintenance test loops is for further study, taking in consideration Recommendations I.603 and V.54.

ANNEX A

(to Recommendation V.110)

Reference configurations

A.1 *Introduction*

Figures A-1/V.110 and A-2/V.110 show the two basic reference models used in the development of this Recommendation, and provide valuable examples of the way in which the terminal adaptor may be used. These are provided simply as an aid to the interpretation of this Recommendation and should not be seen as restrictive in any way.

A.2 *V.110 terminal adaptor reference model*

Figure A-1/V.110 shows the basic reference model for a V.110 terminal adaptor.

The elements (1), (2), (3) and (4) shown in Figure A-1/V.110 represent the functionality required of a terminal adaptor. The elements are not intended to correspond to separate physical units. However, a terminal adaptor need not necessarily constitute a single physical unit. The functions of these elements are:

- 1) Provision of layer 1, in accordance with Recommendations V.24 and V.28 or other applicable Recommendations and ISO 2110 or other applicable standards, of the interface at reference point R.
- 2) Specific TA functions, including the adaption of the TE2 data (rate and format) for transmission over an ISDN B-channel and provision of R-interface lead control information. This Recommendation covers primarily these functions.
- 3) Network control signalling functions, including the mapping of call control signals (in accordance with Recommendation V.25 *bis* or other applicable standard) at the R-interface into signals (according to Recommendation Q.931) for transmission on the D-channel across the S/T interface.
- 4) Provision of layer 1, in accordance with Recommendation I.430 of the interface at reference points S or T.

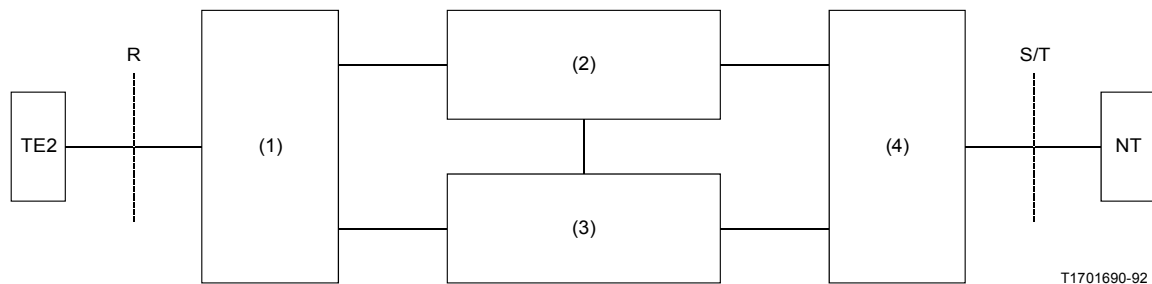

- NT Network termination
 TE2 Data terminal equipment (DTE) with an interface complying to Recommendation V.24.
 (1) R interface functions (according to Recommendations V.24, V.28, etc.).
 (2) Specific TA functions (e.g. data rate adaption).
 (3) Control access signalling function (e.g. signalling in accordance with Recommendations Q.921 and Q.931, auto calling in accordance with Recommendation V.25 bis).
 (4) S/T interface layer 1 functions (according to Recommendation I.430).

FIGURE A-1/V.110
Terminal adaptor reference model

A.3 Terminal adaption type

A.3.1 Terminal adaptor – Type A (TA-A)

The TA-A provides manual call control functions and the functions necessary for data transfer. The following data transfer functions are included:

- a) Conversion of electrical, mechanical, functional and procedural characteristics of the V-Series type interface(s) to those required by an ISDN at reference points S and/or T, as discussed in § 3.5.
- b) Bit rate adaption of the V-Series data signalling rates to the 64 kbit/s B-channel rate as described in §§ 2.1, 2.2 and 2.3.
- c) End-to-end synchronization of entry to and exit from the data transfer phase, as described in § 4.

Terminal adaptor TA-A may be implemented using a physically separate TE1 for providing the network control signalling function, unit (3) in Figure A-1/V.110, or the function may be part of an integrated implementation. The function provides for data connection establishment when using the circuit-mode 64 kbit/s unrestricted bearer service. The function includes provisions for speech and data connection establishment when using for speech, either circuit-mode 64 kbit/s bearer service usable for 3.1 kHz audio information transfer, and, for data, the circuit-mode 64 kbit/s unrestricted bearer service concurrently on two B-channels.

A.3.2 Terminal adaptor – Type B (TA-B)

The TA-B includes, in addition to those functions provided by a TA-A, the mapping functions necessary to convert the automatic calling and/or automatic answering procedures of Recommendations V.25 and V.25 bis to the ISDN D-channel signalling protocol. This additional functionality is in functional unit (3) in Figure A-1/V.110. Terminal adaptor type B is to be used with the 64 kbit/s unrestricted bearer service.

The need for provisions covering functional unit (3) in Figure A-1/V.110 for the implementation of a type B-terminal adaptor is for further study.

Note – Reference to the use of the term “unrestricted bearer”. During an interim period, some networks may only support restricted 64 kbit/s signal digital information transfer capability, i.e. information transfer capability solely restricted by the requirement that the all-zero octet is not allowed. Such networks may offer bearer services with restricted transport capabilities.

A.4 *Types of end-to-end connection*

The terminal adaptor functions described in this Recommendation take into account the end-to-end connection types shown in Figure A-2/V.110. The Figure shows the interoperational cases considered in this Recommendation, as follows:

V-Series TE2 with V-Series TE2

V-Series TE2 with X.21 TE2

V-Series TE2 with TE1

V-Series TE2 with V-Series DTE on the PSTN through an interworking function (IWF)

Note – The adaption of terminals by the connection of modem-equipped TE2s to the analogue side of a CODEC to provide for the use of 3.1 kHz bearer capabilities is not addressed in this Recommendation.

Interworking with PSTNs may be provided on the basis of a trunk interconnection using interworking functions (IWFs) (see Note 1 of Figure A-2/V.110). The reference connections illustrated in Figure A-2/V.110 do not envisage a direct connection between an ISDN in one country and a public switched telephone network (PSTN) in another country via a network-provided interworking function in the first country. However, access to non-ISDN countries could be through the normal PSTN international connections.

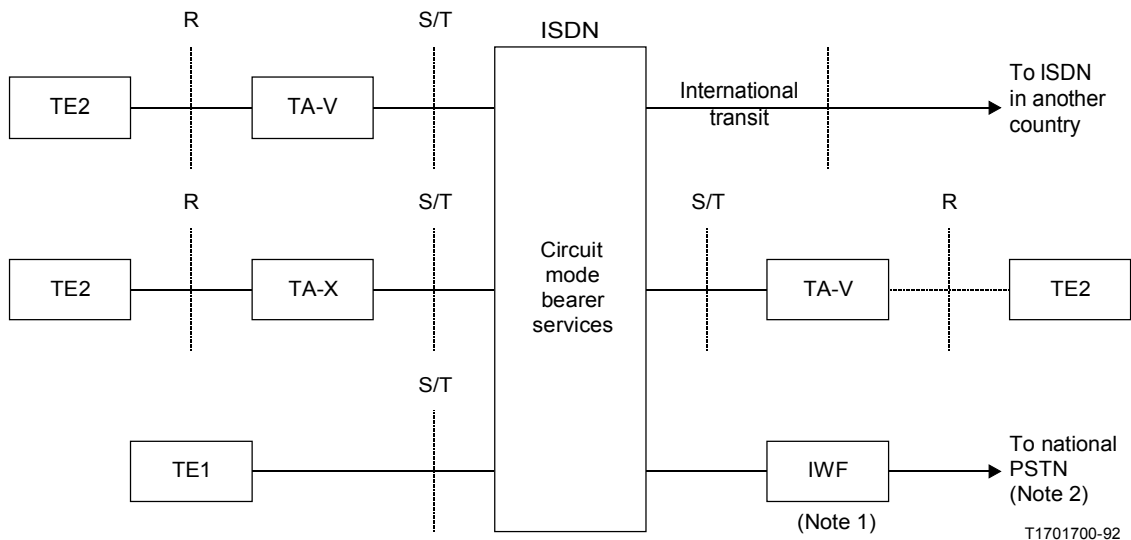

- IWF Interworking function
- TA-V Terminal adaptor function – (DTEs with V-Series interfaces)
- TA-X Terminal adaptor function – (DTEs with X.21 or X.21bis interfaces). See Recommendations X.30/I.461

Note 1 – The location of this interworking function is discussed in Recommendation I.510 and general requirements are given in Recommendations I.515 and I.530. The need for a Recommendation covering detailed requirements for such an IWF is for further study.

Note 2 – For access to national non-ISDN terminals or international access to PSTNs of non-ISDN countries.

FIGURE A-2/V.110
Network reference connections

ANNEX B
(to Recommendation V.110)

**Alphabetical list of abbreviations
used in this Recommendation**

CFI	Call failure indication
CRI	Call request with identification
CRN	Call request with number
DC1	Device control one
DC3	Device control three
DCE	Data circuit-terminating equipment
DTE	Data terminal equipment
DTR	Data terminal ready
IA5	International Alphabet No. 5
IDN	Integrated digital network
IPE	In-band parameter exchange
ISDN	Integrated services digital network
IWF	Interworking function
Mm	Modem
MNT	Maintenance
NIC	Network independent clock
NT	Network termination
PARAM-X	Parameter X (X = 0, 1, 2, 3, 4)
PSTN	Public switched telephone network
RA	Rate adaption
RD	Received data
TA	Terminal adaptor
TD	Transmitted data
TE	Terminal equipment
TE1	Terminal equipment type 1
TE2	Terminal equipment type 2
TH	Threshold
Tn	Timer n (n = 1, 2, 3)

APPENDIX I

(to Recommendation V.110)

In-band parameter exchange

I.1 *Introduction*

During the evolution of ISDN there will exist for a considerable period:

- DTEs with V-Series type interfaces which are to be connected to an ISDN by terminal adaptors, and
- requirements for interoperation between DTEs/TAs connected to ISDNs, that are interconnected with facilities which do not provide for the full ISDN out-of-band signalling capability necessary to support parameter exchange between terminal adaptors.

Considering that Recommendation I.530 defines interworking between an ISDN and a PSTN in general, that Recommendation I.515 describes the parameter exchange for interworking between ISDNs and existing networks, the specific procedure to be used for in-band parameter exchange (IPE) within the context of terminal adaptors following this Recommendation is as described in this appendix. This procedure is consistent with Recommendations I.530 and I.515.

It enhances the capability of V.110 TA in order to support:

- the transfer of the end-to-end information required for the compatibility checking of data calls;
- an exchange of terminal adaptor parameter information; and
- an exchange of information related to maintenance operations.

I.2 *Definitions*

For the IPE, which is described in this appendix, the following definitions apply. These definitions are ordered logically to minimize forward referencing.

I.2.1 **TA**

A terminal adaptor.

I.2.2 **calling TA**

The TA requesting the connection to be established.

I.2.3 **called TA**

The TA accepting the connection.

I.2.4 **originating TA**

The TA which is responsible for initiating the next exchange of parameter information. Initially, the calling TA takes on the role of the originating TA.

I.2.5 **answering TA**

The TA which is not responsible for initiating the next exchange of parameter information. Initially, the called TA takes on the role of the answering TA.

I.2.6 **parameter information**

Terminal adaptation protocol information, TA parameters, and (optionally) maintenance information.

I.2.7 **parameter block**

The complete set of parameter information structured into message groups which are transferred by each TA towards the other during each parameter exchange.

I.2.8 **message group**

The arrangement of octets based on a repeated sequence of command octets followed by a series of three LOW-HIGH data octet pairs. Each message group transfers one octet of the parameter information.

I.2.9 **sequence of command octets**

The repeated transmission of at least 32 command octets transmitted without interval for 64 kbit/s unrestricted and restricted channels. In the case of asynchronous IPE the sequence may be interrupted, within the limits of the procedures.

I.2.10 **series of LOW-HIGH data octet pairs**

The transmission of six octets grouped into three pairs of LOW-HIGH data octets, the LOW data octet being transmitted in each pair before the HIGH data octet. The six octets are transmitted without interval for 64 kbit/s unrestricted and restricted channels. In the case of asynchronous IPE, the transmission of the six octets may be interrupted, within the limits of the procedures.

I.2.11 **verification**

Establishment of the validity of a piece of data according to the specified error handling procedures.

I.3 *Overview*

The in-band parameter exchange (IPE) described in this appendix is based on the transfer of parameter information within the user data stream of an established connection. Specific IPE rates have been selected to cover the application of IPE to connections based on 64 kbit/s unrestricted channels, 64 kbit/s restricted channels and intermediate rate channels. For IPE at rates other than 64 kbit/s, rate adaption according to this Recommendation is applied to the user data stream containing the parameter information.

In the case of IPE within intermediate rate channels, it is first necessary to achieve frame synchronization according to this Recommendation before the exchange can commence. The parameter information is transferred in a parameter block during one or more exchanges between the two TAs. The block structure is based on message groups, containing a sequence of command octets which identify the information carried in the message group, and a series of general purpose LOW-HIGH data octet pairs which carry the information. The command octets are always transmitted in a repeated sequence of at least 32 octets to allow persistency error handling techniques to be employed. The LOW-HIGH data octet pairs are always transmitted in a series of three to enable majority voting error recovery techniques to be used.

After the first exchange of parameters, the called TA determines whether the parameter exchange has been successful. If it is, both TAs proceed to the data transfer state directly unless the agreed data transfer rate first requires re-synchronization to a new intermediate rate according to this Recommendation. After the first exchange, and each subsequent exchange, the responsibility for determining the success of the exchange is transferred, to allow the negotiation of parameters to progress evenly. Status information is also transferred during the IPE to enable both TAs to monitor the progression of the exchange. If at any time either TA concludes that a successful exchange of parameters cannot be achieved, the TA should clear the connection.

Interworking with TAs not supporting IPE is specified.

I.4 *Reference configuration*

Figure I-1/V.110 gives an example of a scenario for an IPE procedure. It illustrates the connection of ISDNs using the connectivity of existing networks. As the evolution towards a ubiquitous international ISDN capability proceeds, the connection of ISDN islands will often use existing network capabilities. Two alternatives are indicated in Figure I-1/V.110. Either arrangement indicated may exist though the use of "digital connectivity" based on the existing integrated digital network (IDN) has many advantages including the avoidance of the need for layer 1

interworking functions. The IDN, however, does not have the ISDN signalling capability and this leads to the need for an IPE procedure. The IPE capability is required to enable communicating TAs to exchange parameters as well as to perform other operations such as maintenance functions. Even where the ISDN signalling capability is available, the IPE capability may be used to provide enhanced parameter exchange.

I.5 Procedures

I.5.1 General

Described in § I.5 are the procedures which permit a TA to exchange parameter and maintenance information in-band by using messages within the user data stream.

Once the call has been established, the IPE is initiated at one of four user data rates as per Table I-1/V.110. It is recommended that, where possible, the IPE is performed using the unrestricted/restricted 64 kbit/s rate. If the TA is not capable of starting at this rate, then the appropriate default intermediate rate is used. Default intermediate-rate channels are selected according to the Recommendation for single stream operation described in Recommendation I.460. Substrate multiplexing cannot be supported until the IPE is complete.

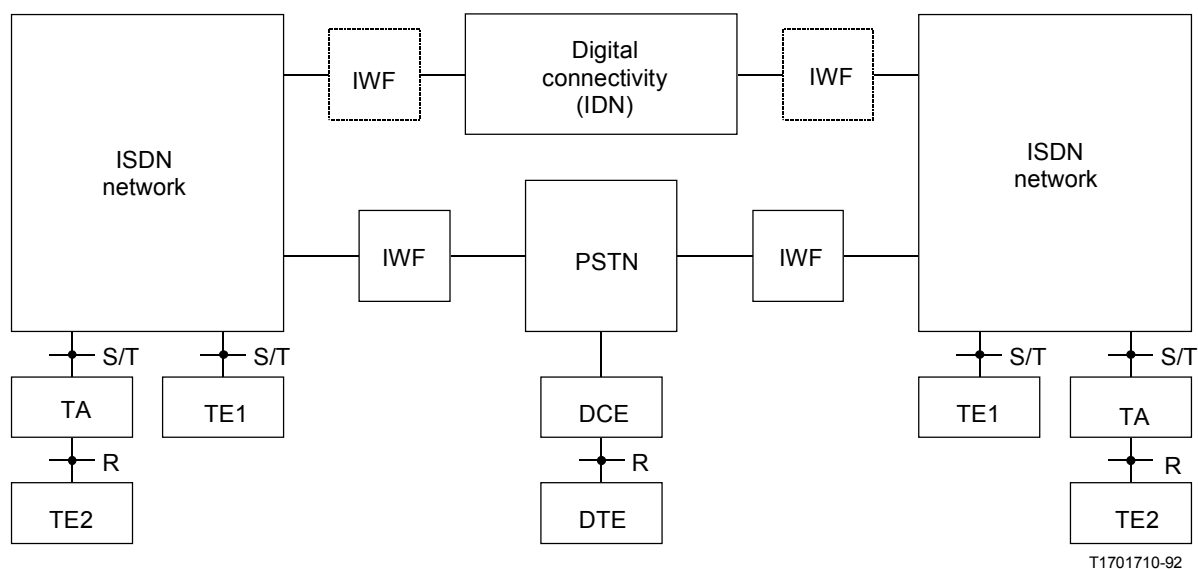

FIGURE I-1/V.110

Reference configuration

The final rate of data transfer is not restricted by the choice of IPE user rate. It is therefore possible for an IPE at 4.8 kbit/s async, for example, to agree on the use of 64 kbit/s unrestricted during the data transfer state. For IPE at rates other than 64 kbit/s, rate adaption according to this Recommendation is applied to the user data stream containing the IPE information. In order to prevent unintended disconnection when rate adaption according to this Recommendation is used, it is necessary to avoid the condition S = OFF, X = ON and all the data bits set to ZERO. This is achieved by the use of asynchronous characters with one stop bit and the permanent setting of bit 8 in all octets to ONE.

Section I.5.2 describes how IPE is initiated, with the procedures for IPE itself described in § I.5.3. If the parameter exchange results in the selection of a data rate based on a different intermediate rate to that used for IPE, re-synchronization is required. The procedures for re-synchronization and data transfer are given in §§ I.5.4 and I.5.5

respectively. In § I.5.6, the procedures for interworking with a TA not supporting IPE are given. In § I.5.7 the procedures associated with maintenance are described. Paragraph I.5.8 defines re-entry to IPE from the data transfer state, and § I.5.9 provides the procedures for error protection and handling. Message codings are given in § I.6, timer values in § I.7 and state transition diagrams in § I.8.

TABLE I-1/V.110

Selection of IPE user rate

IPE intermediate rate	IPE data rate
Unrestricted/restricted (64 kbit/s)	56 kbit/s
32 kbit/s intermediate-rate channel	19.2 kbit/s async
16 kbit/s intermediate-rate channel	9.6 kbit/s async
8 kbit/s intermediate-rate channel	4.8 kbit/s async

I.5.2 Initiating the exchange

An IPE TA requires a local memory flag (the re-entry flag) to control the re-entry into IPE from the data transfer state.

During the inactive state, the TA shall transmit continuous ONES into the B-channel (see § I.8). Once a connection has been established, both TAs will initiate the parameter exchange at the selected user rate and set the re-entry flag to ZERO. Before beginning the parameter exchange, both TAs start Timer T2 and may send repeated IDLE status octets (see § I.6.5).

In the case where the TAs operate on a different IPE user rate, the following procedure shall be applied:

- during the first half of period T2, the called TA only tries to adapt to the IPE rate of the calling TA before transmitting its initial exchange of information;
- during the second half of period T2, the calling TA only tries to adapt to the called TA, and retransmits the initial exchange of information at the called TA user rate.

If Timer T2 expires before a complete parameter block has been received, both TAs shall begin data transfer using their default parameters.

In the case of user rates of 4.8, 9.6 or 19.2 kbit/s, the TA first completes the frame synchronization procedure described in this Recommendation, with the changes detailed below:

- a) The transmitter sends frames towards its peer with status information S = OFF and X = OFF and enters the Awaiting Synchronization-Parameter Exchange state (state 6).
- b) When the TA recognizes the frame synchronization pattern in the awaiting synchronization-parameter exchange state (state 6), it verifies the status information received and then enters the appropriate state, in a coordinated manner, as follows:
 - Data Transfer (state 4), upon receipt of S = ON and X = ON (see § I.5.6);
 - IPE Default Exchange (state 5), upon receipt of S = OFF and X = OFF;
 - Parameter Exchange (state 7), upon receipt of S = OFF and X = ON (see § I.5.3).
- c) When the TA is in the IPE Default Exchange state (state 5), it shall transmit frames with status information S = OFF and X = ON and verify the status information received and then enter the appropriate state, in a coordinated manner, as follows:
 - Data Transfer (state 4), upon receipt of S = ON and X = ON (see § I.5.6);
 - Parameter Exchange (state 7), upon receipt of S = OFF and X = ON (see § I.5.3).

In the case of user rates of 56 or 64 kbit/s there is no frame synchronization requirement.

I.5.3 *Parameter exchange*

I.5.3.1 *Octet alignment*

In the case of user rates of 4.8, 9.6 or 19.2 kbit/s, each octet of the parameter exchange message is carried as a single start-stop character (see § I.6.1). In the case of user rates of 56 or 64 kbit/s, network-provided octet alignment shall be used.

I.5.3.2 *Transfer of parameters*

The correct interpretation of this section requires careful adherence to the definitions made in § I.2, particularly for the meaning of a “sequence of command octets” (§ I.2.9) and a “series of LOW-HIGH data octet pairs” (§ I.2.10). Further detailed information is given in § I.5.9 and § I.6.

After the connection has been established, the calling TA takes on the role of the originating TA and the called TA the role of the answering TA.

The originating TA begins by starting Timer T1 and transmitting a sequence of XSTART command octets (see § I.6.3). After verifying the receipt of the XSTART command octets, the answering TA starts Timer T1 and begins parameter transfer as described below. Once the originating TA has verified the receipt of the RA VERSION command octet (at the start of the parameter transfer) from the answering TA, the originating TA also begins parameter transfer in the same manner. Figure I-2/V.110 portrays the normal sequence of events during the parameter exchange.

The parameter transfer commences with the transmission of a sequence of RA VERSION command octets followed by a series of LOW-HIGH data octet pairs containing the rate adaption identifier (see § I.6.2). Directly following the transmission of the rate adaption identifier, the transfer continues with the parameters themselves in five groups: PARAM-0 to PARAM-4 (see § I.6.4), transmitted in ascending order. Each group begins with the transmission of a sequence of the appropriate PARAM command octet followed by a series of LOW-HIGH data octet pairs which carry the parameters. At the completion of the parameter information transfer, both TAs send repeated FILL status octets until the next stage of the parameter exchange. Transmission of the complete parameter block shall be made within the period T2.

After receiving and processing the rate adaption and parameter information, the answering TA determines whether the parameters exchanged in both directions are compatible, or whether it can adapt to the parameters of the originating TA. In either case, the exchange has been successful and the procedures described in § I.5.3.3 are followed. If the parameters were not compatible and the answering TA decides to continue, it now takes on the role of the originating TA and recommences the parameter exchange with the transmission of a sequence of XSTART command octets. The parameter transfer procedures therefore continue as described above, but with the roles of originating and answering carried out by the opposing TAs. In the first exchange, the called TA should attempt to adapt to the parameters of the calling TA. When continuing the exchange the new originating TA should attempt, as far as possible, to move the values of its next transmitted parameters towards the values of those previously received. If either TA determines that there is no point in continuing the parameter exchange, the procedures described in § I.5.3.4 are followed.

Parameter information continues to be exchanged in this manner, with alternate reversal of the roles of originating and answering TA until the outcome is successful, unsuccessful, or Timer T1 expires.

In order that the service offered is not degraded from that provided without IPE, a TA should connect using its default parameters upon expiry of Timer T1. This does not prohibit either TA initiating disconnection at any time.

I.5.3.3 *Successful exchange*

A parameter exchange is considered successful when the last set of TA parameters transferred in both directions are compatible, or when the answering TA can adapt to the parameters of the originating TA. The answering TA shall notify the originating TA of a successful exchange before proceeding; this notification is provided by the transmission of a sequence of READY status octets. Both TAs shall set the re-entry flag to ONE. In any case, both TAs will proceed into the data transfer state (see § I.5.5.1) unless re-synchronization to a new intermediate rate is required (see § I.5.4).

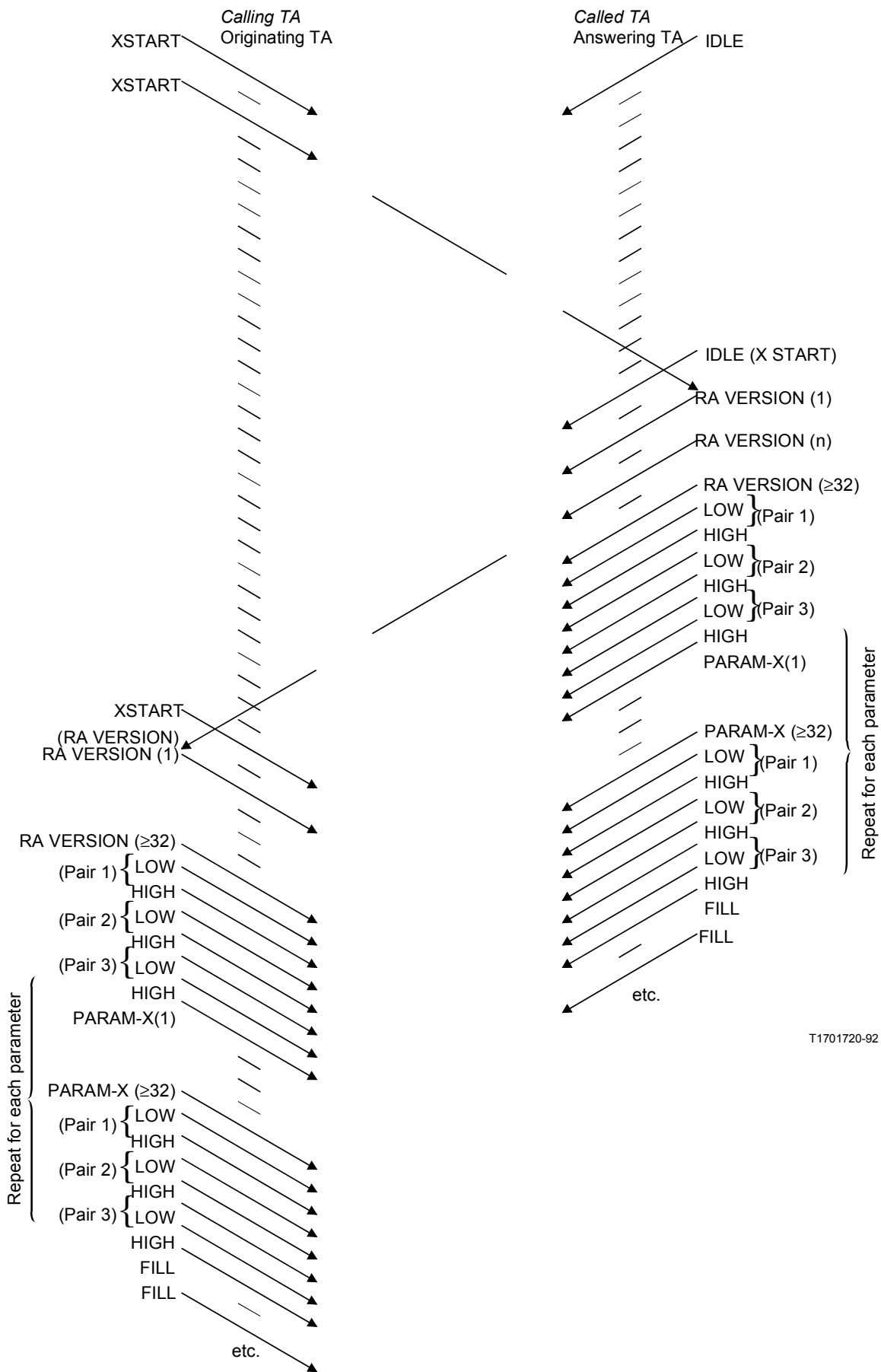

T1701720-92

FIGURE I-2/V.110

Initial sequence of events during a parameter exchange

I.5.3.4 *Unsuccessful exchange*

If at any time during the exchange either TA concludes that a successful exchange of parameters cannot be achieved or that the rate adaption protocols are not compatible, the TA should clear the connection.

I.5.4 *Re-synchronization to a new intermediate rate*

If the outcome of the IPE is the selection of a user data rate requiring a new intermediate rate, re-synchronization will be necessary, and the TA enters the Awaiting Re-synchronization state (state 8). Whilst in this state the transmitter of the TA will send frames with S = OFF and X = OFF towards the peer TA in the new intermediate rate channel agreed. The default intermediate-rate channel positions correspond to those recommended for single stream operation in Recommendation I.460.

At the same time, the receiver of the TA will commence searching for the frame synchronization pattern in the selected sub-rate channel. When the TA recognizes the frame synchronization pattern, it shall verify the status information received and enter the appropriate state, in a coordinated manner, as follows:

- Data Transfer (state 4), upon receipt of S = ON and X = ON (see § I.5.6.);
- No Exchange (state 9), upon receipt of S = OFF and X = OFF.

When the TA is in the No Exchange state (state 9), it shall transmit frames with status information S = ON and X = ON and enter the data transfer state (state 4) upon receipt of S = ON and X = ON.

I.5.5 *Data transfer*

I.5.5.1 *Transition into the data transfer state*

Entry into the Data Transfer state should be carried out in a coordinated manner, as described by this Recommendation by both TAs after sufficient time has been given to enable the processing of the parameter information.

I.5.5.2 *The data transfer state*

The procedures on entering the Data Transfer state (state 4) and the values of S and X status information in the case of data rates less than 56 kbit/s are described in this Recommendation.

I.5.6 *Interworking with a TA not supporting IPE*

A TA may choose to by-pass IPE; for example, when it is used in a pre-configured arrangement, or when the parameter exchange can be effected by out-of-band signalling. In this situation a TA supporting IPE may receive S = ON and X = ON verified status information, causing the TA to directly enter the Data Transfer state. See § I.8.

A TA not supporting IPE can receive frames containing the status information S = OFF and X = ON from its peer. In this situation the non-IPE TA may either continue to transmit the status information S = OFF and X = OFF, or change to the Data Transfer state and transmit the status information S = ON and X = ON. Both cases will lead to entry into the Data Transfer state without IPE. See § I.8.

In the case of IPE at 64 kbit/s unrestricted or restricted, or in the case of a TA continuing to transmit the status information S = OFF and X = OFF, Timer T2 ensures that service is not degraded from that provided without IPE. See § I.8.

I.5.7 *Maintenance*

A TA maintenance (MNT) call is made by indicating in PARAM-0 that the calling TA requires MNT support and by directly following the parameter transfer with a MAINTENANCE message group identifying the function required (see § I.6.6). A TA which supports MNT shall indicate in PARAM-0 that MNT support is available. When an MNT function is requested by a calling TA, the called TA capable of supporting MNT shall acknowledge the request by initiating a subsequent parameter exchange including at the end the identical MAINTENANCE message group, before continuing directly to invoke the required MNT function.

A successful MNT call with no timer required is terminated by either TA clearing the call. A successful MNT call with timer required returns the called TA to the inactive state upon expiry of Timer T3, or to the Null state upon disconnection.

A TA which does not support MNT shall indicate in PARAM-0 of the initial exchange that no MNT support is provided, and should clear the connection after the initial parameter exchange when an MNT call is received.

I.5.8 *Re-entering IPE from the data transfer state*

Test loopbacks in this Recommendation refer to the I.600-Series. The major application of this facility is to provide a mechanism to allow a remote loopback to be established for maintenance purposes without disconnecting the equipment in the established path. This mechanism may also be used generally to re-enter IPE.

This mechanism is not applicable to unrestricted 64 kbit/s or restricted 64 kbit/s connection types, or when the rate during data transfer is 64 kbit/s, 56 kbit/s or 48 kbit/s.

If re-entry to IPE is required and the re-entry flag has the value ONE, then the initiating TA enters the Awaiting Re-entry to IPE state (state 10) and transmits S = OFF, X = ON and D = IDLE. Re-entry to IPE in order to set a test loop 4 shall only be initiated by a calling TA.

Receipt of S = OFF, X = ON and D = IDLE shall cause a TA in state 4 to re-enter the Parameter Exchange state (state 7) at the IPE user rate defined in § I.5.1 which is of the same intermediate rate as that used for data transfer.

Receipt of S = OFF, X = ON and D = IDLE shall cause the initiating TA to re-enter the Parameter Exchange state (state 7) at the IPE user rate defined in § I.5.1 which is of the same intermediate rate as that used for data transfer.

I.5.9 *Error protection and handling*

Error protection and handling are required to overcome the possibility of data corruption. In addition, error recovery procedures are required, for example in the case of loss of frame synchronization.

To protect against data corruption, IPE commands shall be sent in a repeated sequence of at least 32 octets. Verification of the correct receipt of a command octet can then be carried out based on persistence checking techniques. Once a verified command octet has been received, it can be identified by the codings given in § I.6. Any command octet not recognized shall be ignored. To protect against data corruption, LOW-HIGH data message pairs shall be sent in groups of three pairs. This enables majority voting techniques to be employed by the receiving TA.

Upon the detection of irrecoverable data corruption during the parameter exchange, loss of frame synchronization or other situations requiring the exchange to be restarted, the TA shall complete the current message flow and initiate error recovery by transmitting a sequence of XSTART command octets and assuming the role of the originating TA. Upon receipt of a sequence of XSTART commands octets, a TA will recommence the parameter exchange as described in § I.5.3.2. In this case of a collision of XSTART octets, the original originating and answering roles are assumed by the TAs.

I.6 *Coding*

I.6.1 *General*

Information transfer during IPE is based on a group of messages. These messages are used to carry out a variety of tasks. The messages associated with rate adaption identification are described in § I.6.2, whilst those associated with the actual parameter transfer are given in § I.6.4. The messages associated with the control of the IPE are described in § I.6.3, and § I.6.5 covers those used to indicate status. Finally, § I.6.6 covers the coding of the maintenance message.

The messages are all based on octets structured as shown in Figure I-4/V.110.

In the case of a user rate of 64 kbit/s, the octets are transmitted to line in bit sequence from bit 1 to bit 8. Network-provided octet alignment shall be used.

In the case of a user rate of 56 kbit/s, the data is transmitted to line in bit sequence from bit 1 to bit 7 followed by an 8th bit set to ONE — according to this Recommendation, rate adaptation (in total this is the equivalent data stream to 64 kbit/s). Network-provided octet alignment shall be used.

In the case of user rates of 4.8, 9.6 or 19.2 kbit/s, the octets are packaged as single start-stop characters, using the following format:

- 1 start bit;
- 8 data bits (in order of transmission shown in Figure I-3/V.110);
- No parity; and
- 1 stop bit.

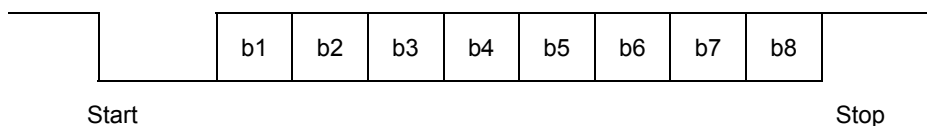
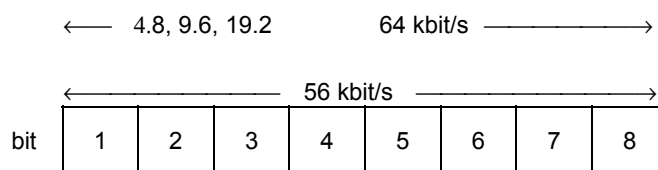

FIGURE I-3/V.110
Asynchronous character format



bit 8: Set to ONE (and ignored on receipt)

Note – Equivalent data stream to that for 64 kbit/s is created with 56 kbit/s when rate adaptation according to this Recommendation is used.

bit 7: Set to ZERO for IPE data
Set to ONE for IPE signal

For IPE data

bit 6: Set to ONE
(Set to ZERO: message reserved for private use and ignored if not implemented)

bit 5: Set to ZERO when carrying data bits d0-d3
Set to ONE when carrying data bits d4-d7

bits 1-4: Carrying data bits (d0-d3) or (d4-d7)

For IPE signal

bit 6: Set to ONE
(Set to ZERO: message reserved for private use and ignored if not implemented)

bit 5: Set to ZERO for command messages
Set to One for status messages

bits 1-4: The signal code

FIGURE I-4/V.110
Octet structure of the IPE coding

Figure I-5/V.110 provides a complete set of octet codings for use in IPE.

		Message	← 4.8, 9.6, 19.2 and 64 kbit/s →							
			← 56 kbit/s →							
			b1	b2	b3	b4	b5	b6	b7	b8
I P E s i g n a l s	C o m m a n d	PARAM-0	0	0	0	0	0	1	1	1
		PARAM-1	0	0	0	1	0	1	1	1
		PARAM-2	0	0	1	0	0	1	1	1
		PARAM-3	0	0	1	1	0	1	1	1
		PARAM-4	0	1	0	0	0	1	1	1
		RA VERSION	0	1	0	1	0	1	1	1
		XSTART	0	1	1	0	0	1	1	1
		MAINTENANCE	0	1	1	1	0	1	1	1
		Status	READY	0	1	0	1	1	1	1
	IDLE		0	1	1	1	1	1	1	1
	FILL		1	1	0	1	1	1	1	1
	INACTIVE		1	1	1	1	1	1	1	1
IPE data		LOW	d0	d1	d2	d3	0	1	0	1
		HIGH	d4	d5	d6	d7	1	1	0	1

Note – All spare codings are reserved (unless indicated for private use). Any octet received, and verified, which is not recognized shall be ignored.

FIGURE I-5/V.110

IPE octet codings

I.6.2 Rate adaption version identification

Transfer of the rate adaption identifier is achieved by a message group based on three octets and transferred according to the procedures described in §§ I.5.3.2 and I.5.9. The message consists of a sequence of RA VERSION command octets followed by a series of LOW-HIGH data octet pairs, the LOW data octet being transmitted in the pair before the HIGH data octet. Figure I-6/V.110 shows the message codings for rate adaption identification.

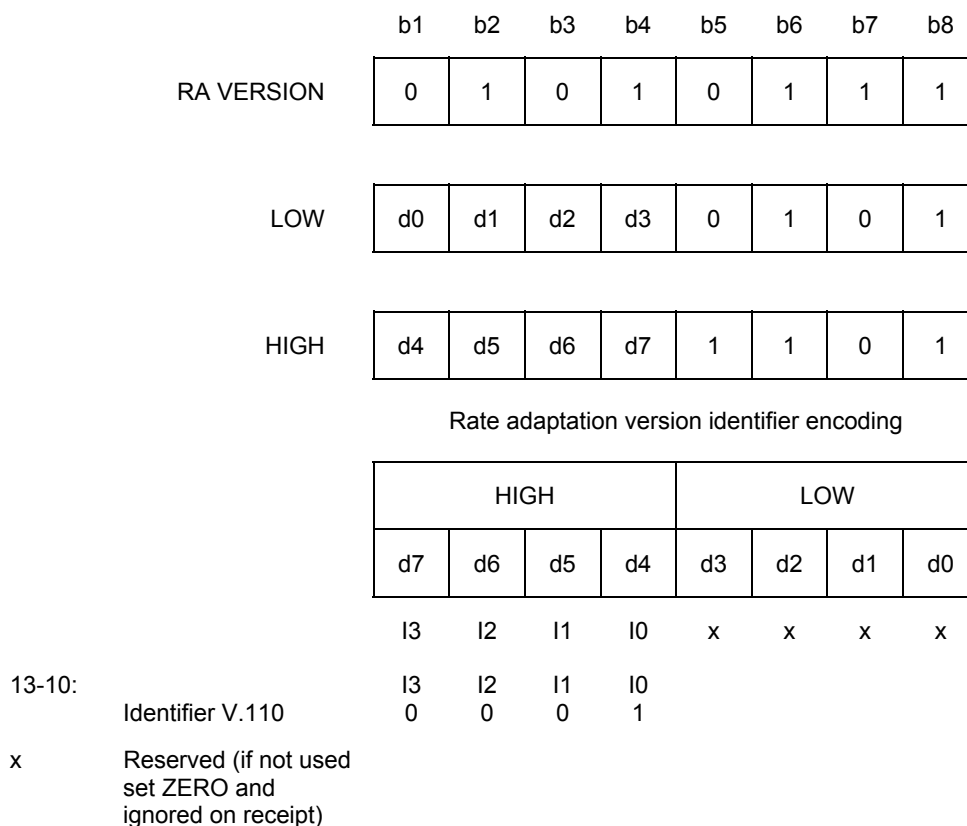

Note – All other codings are reserved.

FIGURE I-6/V.110

Rate adaptation version identifier

I.6.3 Control

Before each transfer of TA parameter information can begin, a sequence of XSTART command octets is transmitted by the originating TA towards the answering TA as described in §§ I.5.3.2 and I.5.9. Figure I-7/V.110 shows the coding for the XSTART command octet.

	b1	b2	b3	b4	b5	b6	b7	b8
XSTART	0	1	1	0	0	1	1	1

FIGURE I-7/V.110

XSTART coding

I.6.4 *Parameters*

Transfer of the TA parameters is achieved in a series of five message groups each based on three octets and transferred according to the procedures described in §§ I.5.3.2 and I.5.9. Each message group consists of a sequence of cPARAM-X command octets (PARAM-0 to PARAM-4) followed by a series of LOW-HIGH data octet pairs, the LOW data octet being transmitted in the pair before the HIGH data octet. Figure I-8/V.110 shows the command octet codings and Figures I-9/V.110 to I-13/V.110 show the data octet codings for parameter transfer.

	b1	b2	b3	b4	b5	b6	b7	b8
PARAM-X	0	x2	x1	x0	0	1	1	1
		x2	x1	x0				
PARAM-0		0	0	0				
PARAM-1		0	0	1				
PARAM-2		0	1	0				
PARAM-3		0	1	1				
PARAM-4		1	0	0				
LOW	d0	d1	d2	d3	0	1	0	1
HIGH	d4	d5	d6	d7	1	1	0	1

FIGURE I-8/V.110

Format of parameter message group

HIGH				LOW			
d7	d6	d5	d4	d3	d2	d1	d0
Sp	Sp	Ms	Mr	x	x	x	Ex

SP (Spare): Set to ZERO on transmission, ignored on reception.

Ms (Maintenance supported):
Maintenance not supported 0
Maintenance supported 1

Mr (Maintenance required):
Maintenance not required 0
Maintenance required 1

Ex (Extension):
If TA does not require octet alignment according to Rec. X.30. 0
If TA does require octet alignment according to Rec. X.30. 1

x Reserved
(if not used set to ZERO and ignored on receipt)

FIGURE I-9/V.110

Parameter 0 encoding

		HIGH				LOW			
		d7	d6	d5	d4	d3	d2	d1	d0
		P2	P1	P0	Mo	x	x	x	Ch
P2-P0	Parity	P2	P1	P0					
	Odd	0	0	0					
	Even	0	1	0					
	None	0	1	1					
	Forced to ZERO	1	0	0					
	Forced to ONE	1	0	1					
Mo (Mode)	Asynchronous				0				
	Synchronous				1				
Ch (Check)	DTE Parity check made when required								0
	No DTE parity check made when required								1
x	Reserved (if not used set to ZERO and ignored on receipt)								

FIGURE I-10/V.110

Parameter 1 encoding

		HIGH				LOW			
		d7	d6	d5	d4	d3	d2	d1	d0
		S1	S0	C1	C0	x	x	x	Cx
S1-S0	Stop bits	S1	S0						
	Not used	0	0						
	1	0	1						
	1.5	1	0						
	2	1	1						
C1-C0	Character length			C1	C0				
	Not used			0	0				
	5			0	1				
	7			1	0				
	8			1	1				
Cx	(Character length extension): Standard C1-C0 codings used								0
	9-bits character length used								1
x	Reserved (if not used set to ZERO and ignored on receipt)								

Note – Character length includes parity.

FIGURE I-11/V.110

Parameter 2 coding

HIGH				LOW			
d7	d6	d5	d4	d3	d2	d1	d0
Sp	R6	R5	R4	R3	R2	R1	R0

Sp(d7) Set to ZERO on transmission,
ignored on reception

R6-R0	Rates	R6	R5	R4	R3	R2	R1	R0
	Reserved	0	0	0	0	0	0	0
	600	0	0	0	0	0	0	1
	1200	0	0	0	0	0	1	0
	2400	0	0	0	0	0	1	1
	3600	0	0	0	0	1	0	0
	4800	0	0	0	0	1	0	1
	7200	0	0	0	0	1	1	0
	Reserved	0	0	0	0	1	1	1
	9600	0	0	0	1	0	0	0
	14 400	0	0	0	1	0	0	1
	Reserved	0	0	0	1	0	1	0
	19 200	0	0	0	1	0	1	1
	Reserved	0	0	0	1	1	0	0
	Reserved	0	0	0	1	1	0	1
	48 000	0	0	0	1	1	1	0
	56 000	0	0	0	1	1	1	1
	Reserved	0	0	1	0	0	0	0
	50	0	0	1	0	0	0	1
	75	0	0	1	0	0	1	0
	110	0	0	1	0	0	1	1
	150	0	0	1	0	1	0	0
	200	0	0	1	0	1	0	1
	300	0	0	1	0	1	1	0
	12 000	0	0	1	0	1	1	1
	Reserved	0	0	1	1	0	0	0
					to			
	Reserved	1	1	1	1	1	1	0
	64 000	1	1	1	1	1	1	1

FIGURE I-12/V.110

Parameter 3 encoding

HIGH				LOW			
d7	d6	d5	d4	d3	d2	d1	d0
Sp	Fc	TNIC	RNIC	x	x	x	Mm

NIC	Network independent clock (see § 5)						
Sp	(Spare): Set to ZERO on transmission; ignored on reception						
Fc	(Flow control): No end-to-end flow control supported	0					
	End-to-end flow control supported	1					
TNIC	If TA need not use NIC	0					
	If TA needs to use NIC	1					
RNIC	If TA cannot accept NIC		0				
	If TA can accept NIC		1				
Mm	(Modem): TA not connected to a modem						0
	TA connected to a modem						1
x	Reserved (if not used set to ZERO and ignored on receipt)						

FIGURE I-13/V.110

Parameter 4 encoding

I.6.5 *Status*

To inform the peer TA that a parameter exchange has been successful, a sequence of READY status octets shall be transmitted towards the peer according to the procedures in § I.5. Figure I-14/V.110 shows the coding for the READY status octet.

To inform the peer TA that it is in an idle condition prior to parameter exchange, a sequence of IDLE status octets are transmitted towards the peer according to the procedures in § I.5. Figure I-15/V.110 shows the message coding for the IDLE status octet.

The FILL status octet is used as a fill between parameter transfers, according to the procedures in § I.5. Figure I-16/V.110 shows the coding for the FILL status octet.

To inform the peer TA that the channel is currently inactive, a sequence of INACTIVE status octets are transmitted towards the peer according to the procedures in § I.5. Figure I-17/V.110 shows the coding for the INACTIVE status octet.

	b1	b2	b3	b4	b5	b6	b7	b8
READY	0	1	0	1	1	1	1	1

FIGURE I-14/V.110

READY octet coding

	b1	b2	b3	b4	b5	b6	b7	b8
IDLE	0	1	1	1	1	1	1	1

FIGURE I-15/V.110

IDLE octet coding

	b1	b2	b3	b4	b5	b6	b7	b8
FILL	1	1	0	1	1	1	1	1

FIGURE I-16/V.110

FILL octet coding

	b1	b2	b3	b4	b5	b6	b7	b8
INACTIVE	1	1	1	1	1	1	1	1

FIGURE I-17/V.110

INACTIVE octet coding

I.6.6 *Maintenance*

This message group based on three octets is used to carry information in association with maintenance operations. The message group consists of a sequence of MAINTENANCE command octets followed by a series of LOW-HIGH data octet pairs, the LOW data octet being transmitted in the pair before the HIGH data octet. Figure I-18/V.110 shows the message codings.

I.7 *Timer values*

I.7.1 *Timer values for parameter exchange*

Timer T1 shall be at least 8 seconds but less than Timer T1 in § 4.1.2.2.

Timer T2 shall be 3 seconds.

I.7.2 *Timer values for maintenance*

Timer T3 shall be 60 seconds.

I.8 *State transition diagrams*

I.8.1 *General*

In this section, state transition diagrams are provided to show the states of a terminal adaptor in the following situations:

- terminal adaptor not supporting the exchange of parameter information (Figure I-19/V.110);
- terminal adaptor interworking with a terminal adaptor not supporting the exchange of parameter information (Figure I-20/V.110);
- terminal adaptor capable of supporting the exchange of parameter information (Figure I-21/V.110);
- terminal adaptor capable of supporting a maintenance test loop 4 (Figure I-22/V.110).

Following is a summary of the basic states involved:

State 0 Null

State 1 Inactive

State 2 Awaiting synchronization — Data transfer

State 3 Default exchange

State 4 Data transfer

State 5 IPE default exchange

State 6 Awaiting synchronization — Parameter exchange

State 7 Parameter exchange

State 8 Awaiting re-synchronization

State 9 No exchange

State 10 Awaiting re-entry to IPE

State 11 Maintenance loop 4 loopback

	b1	b2	b3	b4	b5	b6	b7	b8
MAINTENANCE	0	1	1	1	0	1	1	1
LOW	d0	d1	d2	d3	0	1	0	1
HIGH	d4	d5	d6	d7	1	1	0	1

Maintenance encoding

HIGH				LOW			
d7	d6	d5	d4	d3	d2	d1	d0
Sp	Rt	L1	L0	x	x	x	R1

Sp(d7) SET to ZERO on transmission, ignored on reception

Rt (Request for timer T3 — § 1.5.7):
 No timer required 0
 Timer required 1

L1-L0 (Loop required):
 No loopback L1 L0
 0 0
 Test loop 4 0 1
 (I.600-series Recommendations)
 Reserved 1 0
 Reserved 1 1

R1 (d0 test loop 5):
 (I.600-series Recommendations)
 Test loop 5 not required R1 0
 Test loop 5 required R1 1

x Reserved
 (if not used set to ZERO and ignored on receipt)

Note 1 — Test loop 5 is applied as near to the interface at the R reference point as practicable, and is outside the scope of this Recommendation.

Note 2 — Loop definitions 4 and 5 are defined in the I.600-series Recommendations.

Note 3 — Definitions are for the direction of calling TA to called TA. In the reverse direction they represent confirmation of the maintenance function.

FIGURE I-18/V.110

Coding of MAINTENANCE message group

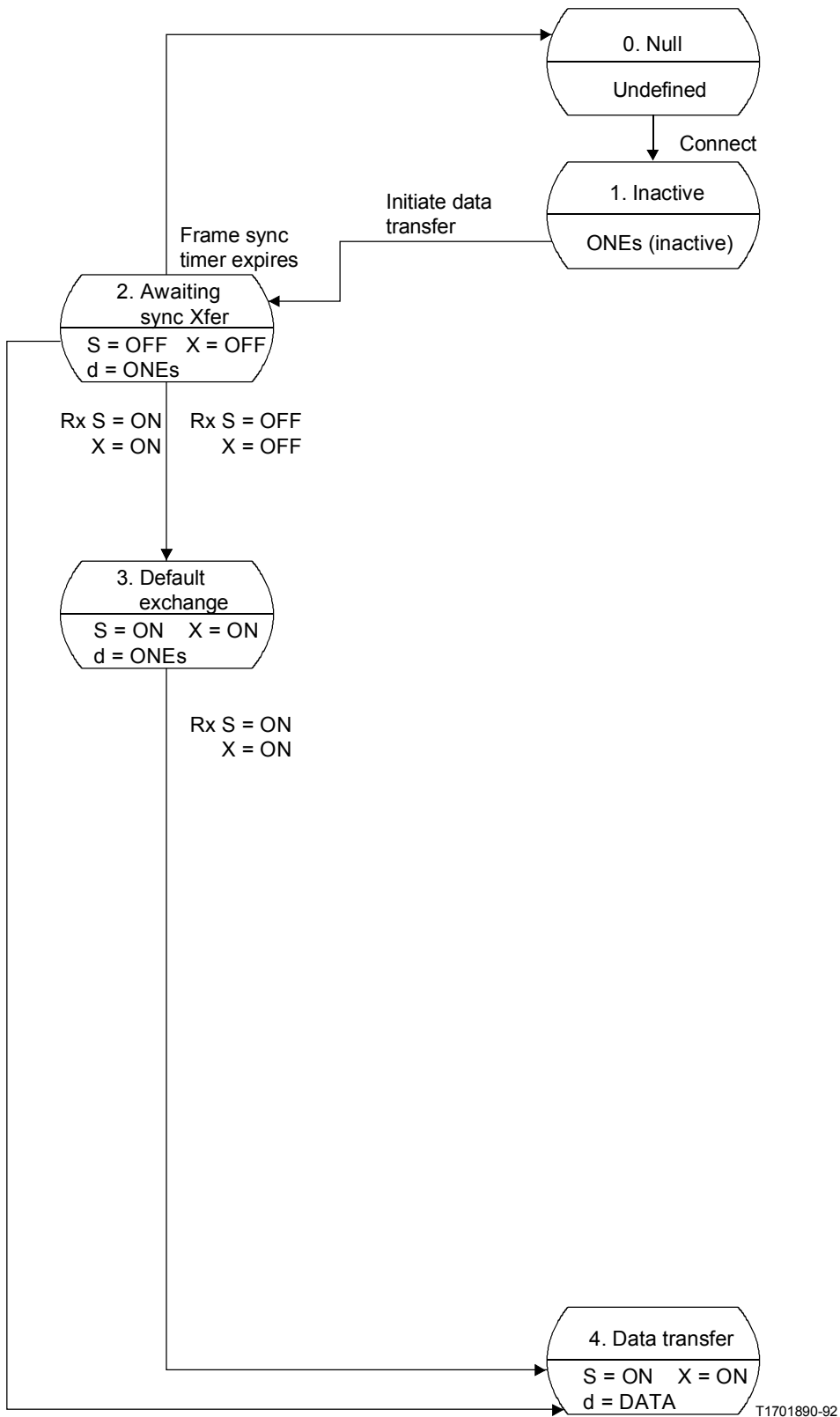

Note – Release sequences not shown.

FIGURE I-19/V.110
State diagram: TA not supporting IPE

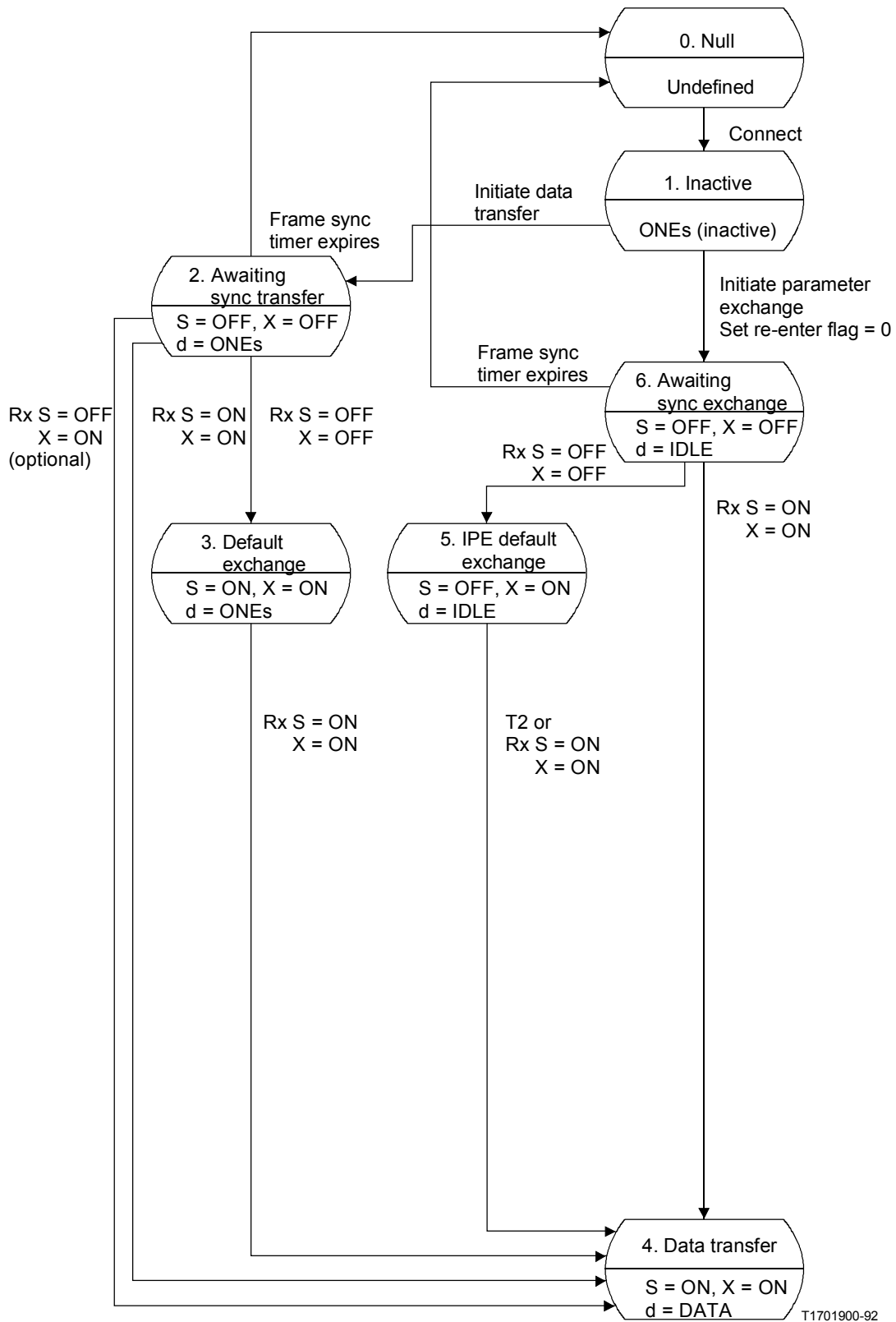

Note – Release sequences not shown.

FIGURE I-20/V.110

State diagram: Interworking with a TA not supporting IPE

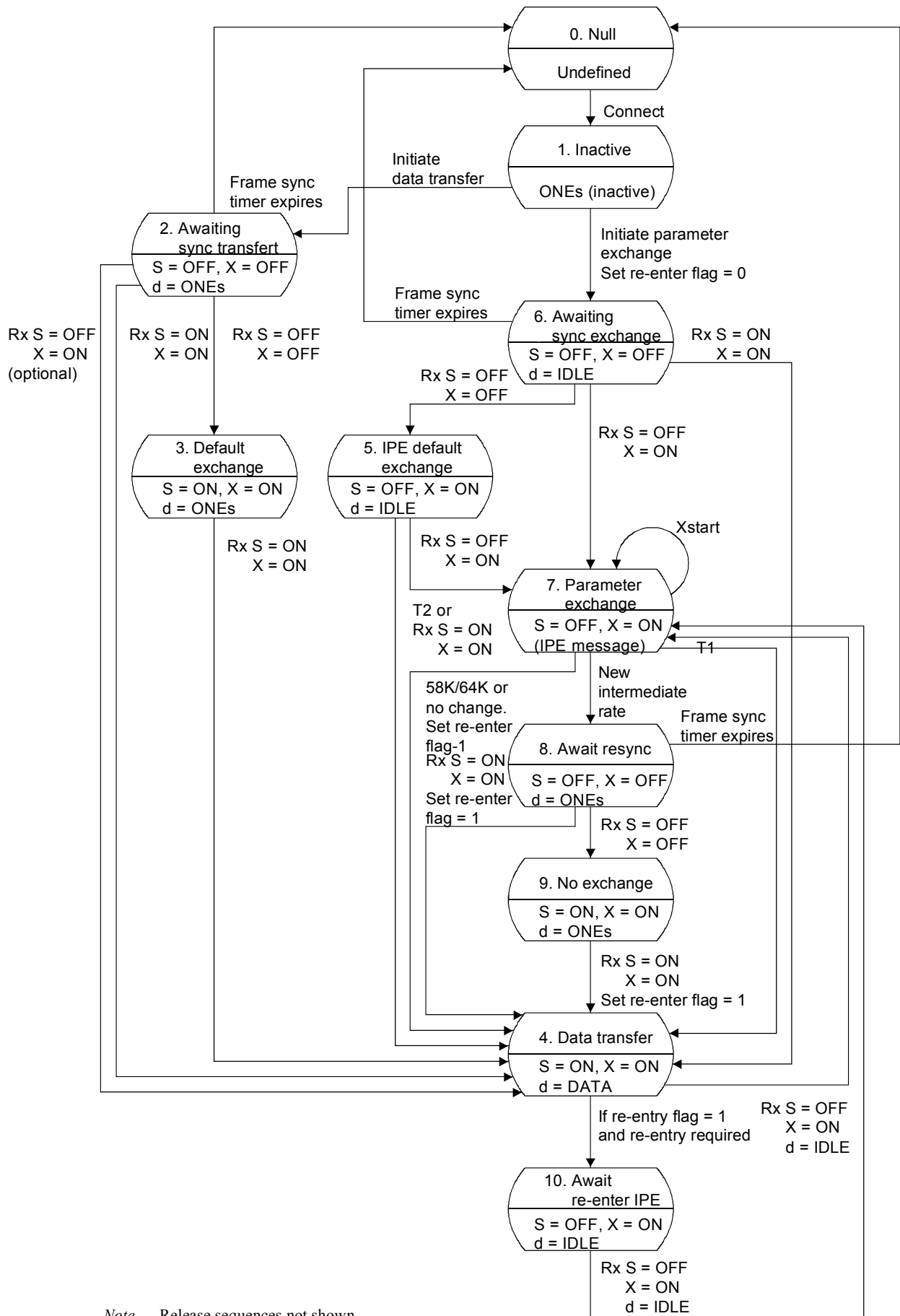

T1701910-92

FIGURE I-21/V.110
State diagram: TA supporting IPE

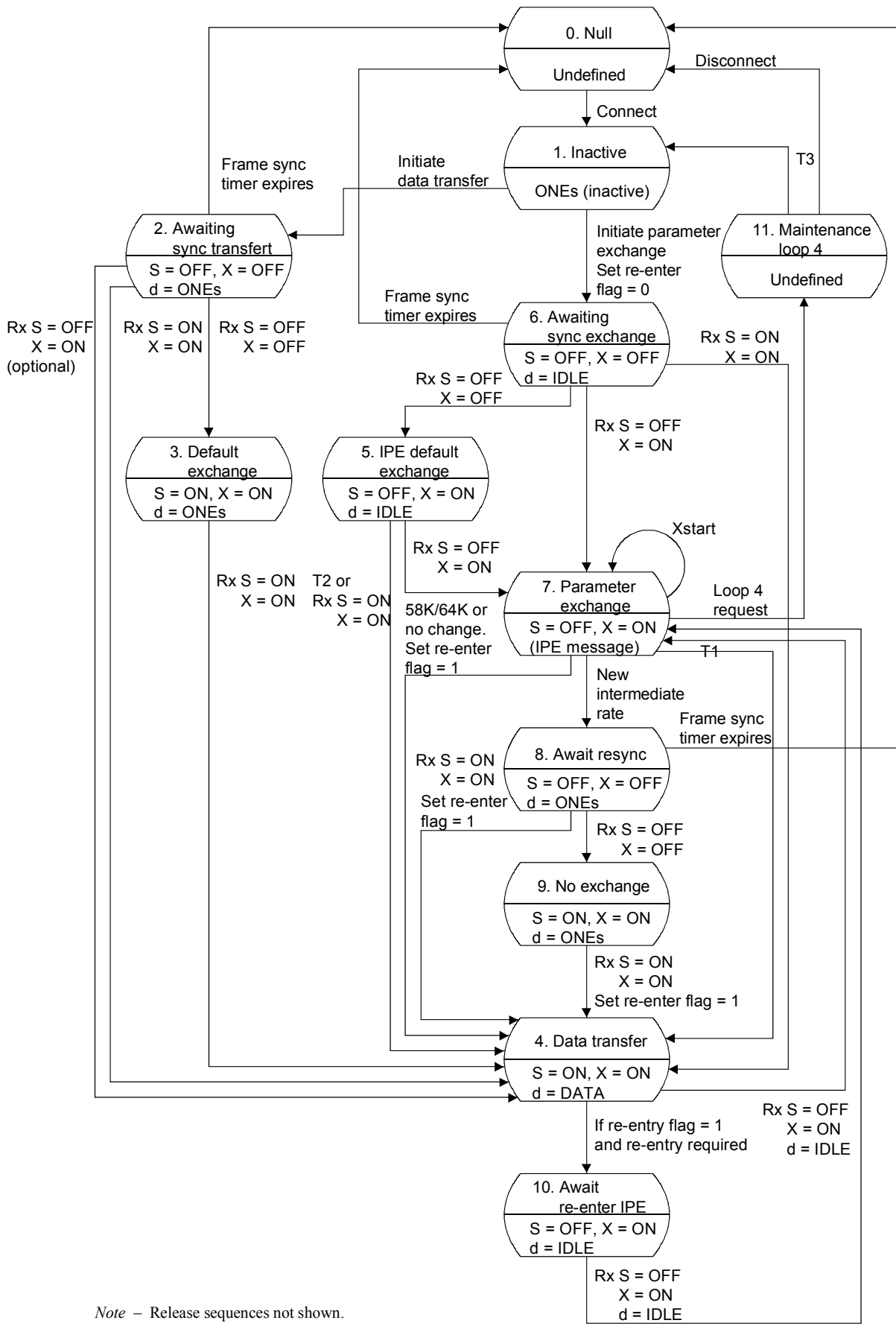

Note – Release sequences not shown.

T1701920-92

FIGURE I-22/V.110

State diagram: Maintenance loop 4

APPENDIX II

(to Recommendation V.110)

V.25 bis to Q.931 protocol mapping

II.1 *General*

The D-channel signalling capabilities of the ISDN customer-access are as defined in Recommendation Q.931. The mapping of the V.25 bis interface signalling procedures to the Q.931 protocol at the S/T reference point are described below.

The logical representation of this mapping function is shown in Figure II-1/V.110.

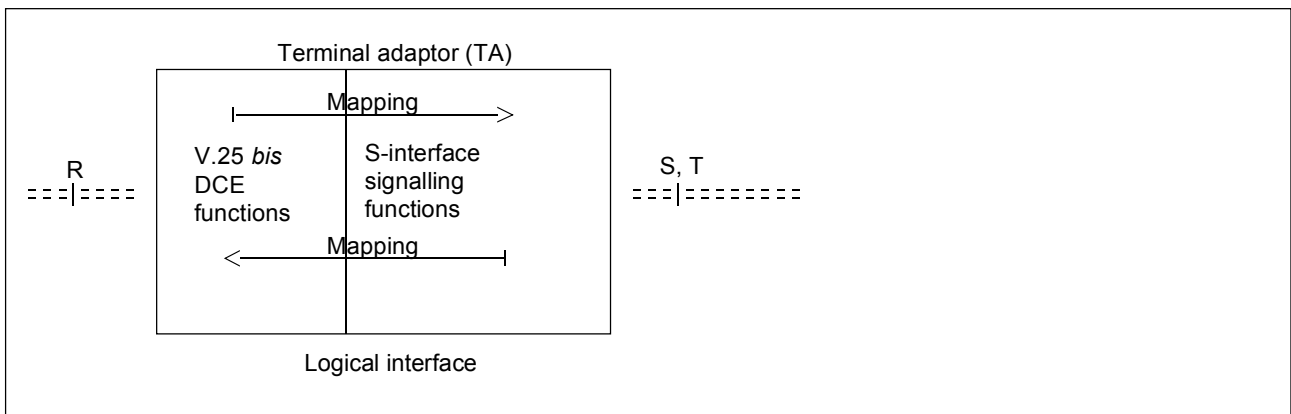

T1701370-91

FIGURE II-1/V.110
Terminal adaptor V.25 bis mapping

The D-channel signalling capabilities provided to V.25 bis based terminals shall comprise the signalling messages as defined in Recommendation Q.931.

The following description and figures depict examples of V.25 bis mapping to the ISDN call control procedures. It is recognized that other possibilities and user options exist. But this section is intended to provide general guidelines for a satisfactory means of V.25 bis support. Only the normal call establishment and clearing procedures are shown. The following sections are titled with the terms of signalling messages at the S-interface.

Recall of the circuit list involved in the V.25 bis call set-up:

- Ready for sending (106)
- Data set ready (107)
- Data terminal ready (108/2)
- Transmit data (103)
- Receive data (104)
- Calling indicator (125).

This appendix deals with call establishment and clearing. Any specific use of V.24 interchange circuits herein described only applies during these phases. The management of interchange circuits during the data transmission phase is not part of this appendix.

The state of other interchange circuits is not part of this appendix. However, to ensure maximum compatibility with existing equipment, the other interchange circuits provided should retain their normal function as defined in Recommendation V.24 during the automatic call procedure.

Particularly to ensure correct operation of the DTE, the condition of circuit 109 should follow the condition of circuit 106.

The DTE may choose to hold circuit 105 ON during the automatic calling procedure, but the TA is not required to recognize this condition.

II.2 *Call origination*

II.2.1 *Call set-up*

II.2.1.1 *From TA*

In the DTE ready state (see Recommendation V.25 *bis*), the present circuit 108/2 ON and 103 = '1'. The TA presents 106 = OFF, 107 = OFF, 125 = OFF and 104 = '1' (state 2 of the V.25 *bis* state diagram).

In response to detecting circuit 108/2 ON, the TA presents 106 ON which is equivalent to a Proceed to Select indication (X-Series Recommendations), and the DTE enters the DTE-DCE dialogue by presenting Call Request Command call request with identification (CRI) or call request with number (CRN). In response to 108/2 ON, the TA will have initiated the interface at the S/T reference point layer 1 activation as in Recommendation I.430.

The layer 2 at the interface at the S/T reference point shall be established on request of layer 3 when the set-up message is to be sent, according to Recommendation Q.931.

When the end of the valid command is received at the R-Interface, the TA transmits a set-up message via the D-channel requesting the unrestricted 64 kbit/s bearer capability, for a transfer in circuit mode.

The user may also specify the layer 1 terminal adaptation in the low layer compatibility information element of the call SETUP message. (See Recommendation Q.931, Annex L, entitled *Low layer information coding principles*.)

The called party address information element shall be encoded *en-bloc* with the complete address of the called party as received from the V.25 *bis* interface.

II.2.1.2 *SETUP acknowledge/call proceeding (from exchange)*

The network reaction on the SETUP message received from the TA can be either:

- sending of a CALL PROCEEDING

When the call proceeding message is received on the D-channel of the interface at the S/T reference point, the B-channel will be allocated and the TA connects to the B-channel;

- sending a SETUP Acknowledge

When the SETUP Acknowledge message to the TA is received on the D-channel at the interface at the S/T reference point, the B-channel will be allocated to the TA.

II.2.1.3 *CONNECT (from exchange)*

When a CONNECT is received on the D-channel at the interface at the S/T reference point, the TA transmits any DCE response to the calling DTE and enters state 5 Answer Tone Detected by turning 106 OFF.

The TA proceeds to the Connect to Line state as described in § 4.1.2 completing the V.25 *bis* control phase with circuit 107 ON.

II.2.2 *Call received from remote DTE/TA*

II.2.2.1 *Call SETUP (from exchange)*

The TA should accept a SETUP message regardless of the V.25 *bis* interface state 1 or state 2. When a SETUP message is received on the D-channel at the S interface, the TA shall follow the procedures for determining compatibility checking (data signalling rate) found in Recommendation Q.931. If the TA determines that it can respond to the incoming call, it follows the procedures of Recommendation Q.931.

The TA indicates an incoming call via the V.25 *bis* interface by setting 125 = ON, 104 = '1' and 107 = OFF; thereby entering state 8 Incoming Call.

If the DTE does not present 108/2 = ON within a timer time T', the TA rejects the call with a CALL REJECT indicating no answer from DTE.

II.2.2.2 *CONNECT (from TA)*

When state 9 Incoming Call Recognized is presented by the DTE turning circuit 108/2 ON (note that this may be immediate if the DTE presents 108/2 permanent ON) to accept the incoming call, the TA transmits a CONNECT message via the D-channel of the interface at the S/T reference point.

II.2.2.3 *CONNECT Acknowledge (from exchange)*

When a CONNECT Acknowledge message is received on the D-channel at the interface at the S/T reference point, the TA, selected by this message, signals Line Seized (state 13) by presenting circuit 125 = OFF to the DTE after presenting positive responses if any.

The TA proceeds to the Connect to Line state as described in § 4.1.2 completing the V.25 *bis* call control phase with circuit 107 = ON.

II.3 *Call clearing (Figure II-2/V.110 and Figure II-3/V.110)*

II.3.1 *DISCONNECT (from TA)*

A clearing by the DTE (state 7) 103 = '1' 108/2 = OFF is transmitted by the TA via the B-channel to the remote DTE.

The TA at the clearing DTE on recognizing state 7 at the V.25 *bis* interface, disconnects the circuits 103, 104 and 108/2 from the B-channel. The TA causes the status and data bits on the B-channel to correspond to circuit 108/2 OFF and 103 = '1' and awaits for Clearing Acknowledge from remote DTE (108/2 = OFF, 103 = '1') for a timer time of 10 seconds. The TA then transmits DCE Clear Confirmation by turning OFF 107 to the clearing DTE (no corresponding state of the V.25 *bis* interface). It also transmits a DISCONNECT message via the D-channel at the interface at the S/T reference point.

After reception of the RELEASE message on the D-channel, the TA sends RELEASE COMPLETE to the exchange, and the DTE enters DTE Ready or DTE Not Ready states.

II.3.2 *DISCONNECT (from exchange)*

In the case of the clearing by the network, the local exchange transmits the DISCONNECT message via the D-channel to the TA to be cleared. After reception of the DISCONNECT message in the TA, the TA transmits a RELEASE message on the D-channel to the exchange.

If the V.25 *bis* interface is in the call establishment phase and has not yet reached state 5, 6 or 12, and if the DISCONNECT contains the reason for clearing, the TA moves to DTE-DCE dialogue state 3 and transmits the corresponding Call Failure Indication to the DTE prior to Call Clearing.

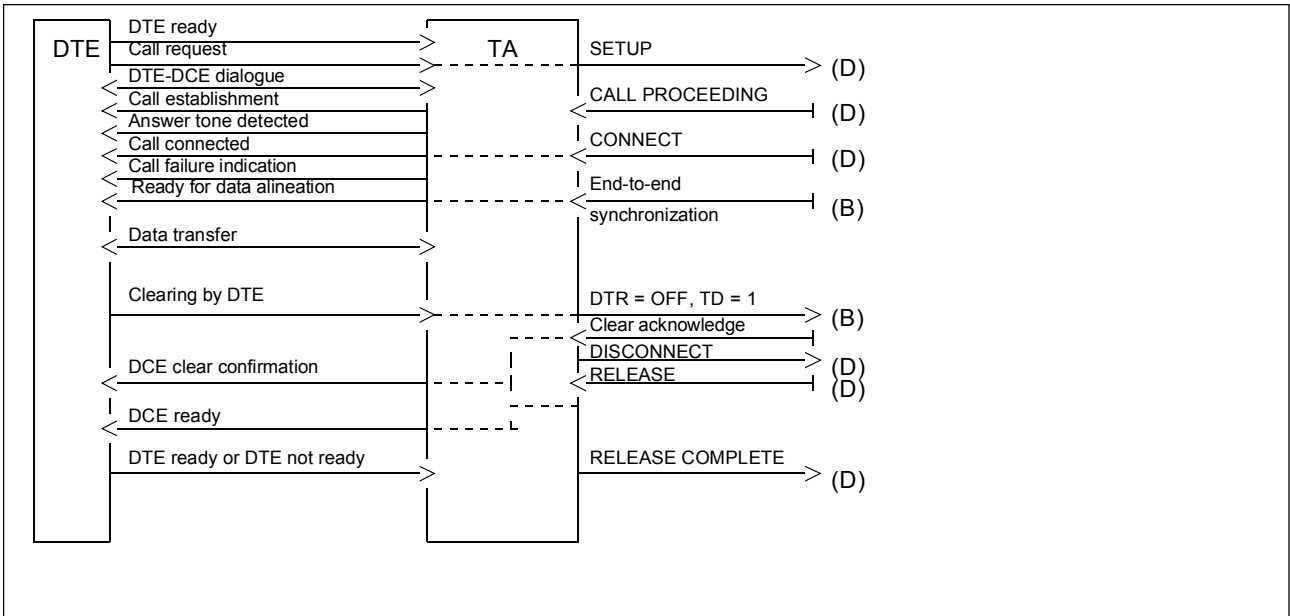

T1701380-91

DTR Data terminal ready
TD Transmitted data

FIGURE II-2/V.110
V.25 bis – Example of DTE call establishment and call clearing

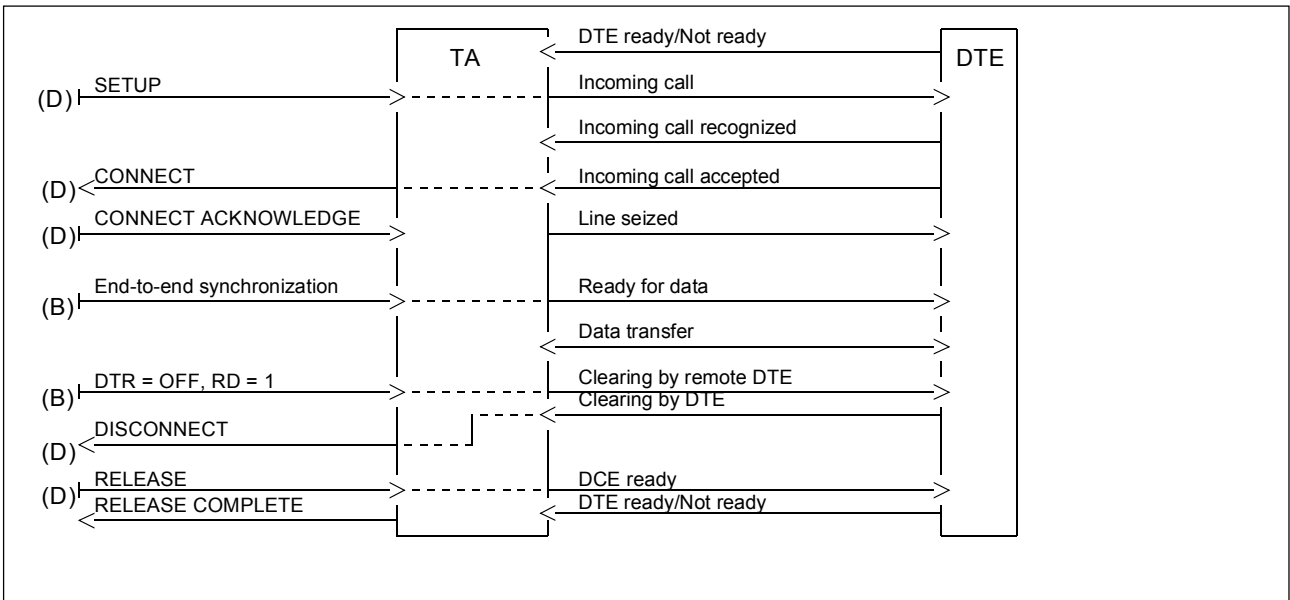

T1701380-91

RD Received data

FIGURE II-3/V.110
V.25 bis – Example of DCE call establishment and call clearing

Otherwise the TA transmits the DCE clear indication (107 = OFF, 103 = '1'), via the V.25 *bis* interface to the DTE, which sends back to the TA the DTE Clear Confirmation which is identical to Clearing by DTE 108/2 = OFF, 104 = '1' as described in Recommendation V.24, § 4.3.3 (no V.25 *bis* interface states). If the DTE does not present 108/2 = OFF within a timer "T", the TA sends DISCONNECT to the D-channel at the expiration of the timer.

II.3.3 DISCONNECT (In-band between TAs)

When the DTE initiates the Clearing by DTE, this status is transmitted in slot within the B-channel and received as DCE clear indication equivalent to a PSTN disconnect in the DTE 107 = OFF.

The TA recognizes the clear request received in-band via the B-channel at the interface at the S/T reference point, separates the 103 108/2 leads from the B-channel and transmits to the DTE the DCE Clear Indication, 104 = OFF, 107 = OFF.

After the DTE to be cleared has received DTE Clear Confirmation, (108/2 = OFF, 104 = '1') from the clearing DTE, it transmits a DISCONNECT message via the D-channel, and clears the B-channel.

After reception of a release message on the D-channel, the TA releases the call reference, sends a RELEASE COMPLETE message to the exchange, and the V.25 *bis* interface enters the state DTE Not Ready or DTE Ready depending on the state of 108/2.

II.3.4 RELEASE COMPLETE

When the RELEASE COMPLETE is received via the D-channel at the interface at the S/T reference point of the TA of the cleared DTE, the V.25 *bis* interface enters DTE Ready or DTE Not Ready depending on the state of circuit 108/2.

II.3.5 Negative response to an incoming call

RELEASE COMPLETE message including the appropriate case code, is sent by a TA supporting a terminal which is compatible with information contained in the SETUP message, to indicate that the call cannot be accepted at this time for the following reason: busy condition of the called terminal (see Figure II-4/V.110).

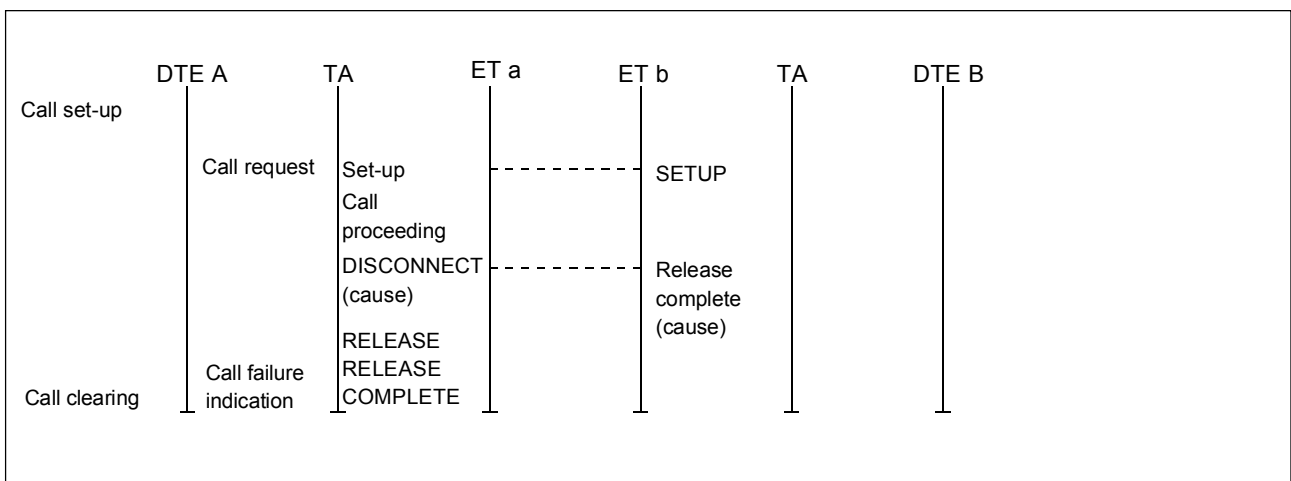

T1701400-91

FIGURE II-4/V.110

Negative response to an incoming call

II.4 *Direct call*

II.4.1 *Direct call DTE call set-up and clearing*

The process is best described in Figure II-5/V.110.

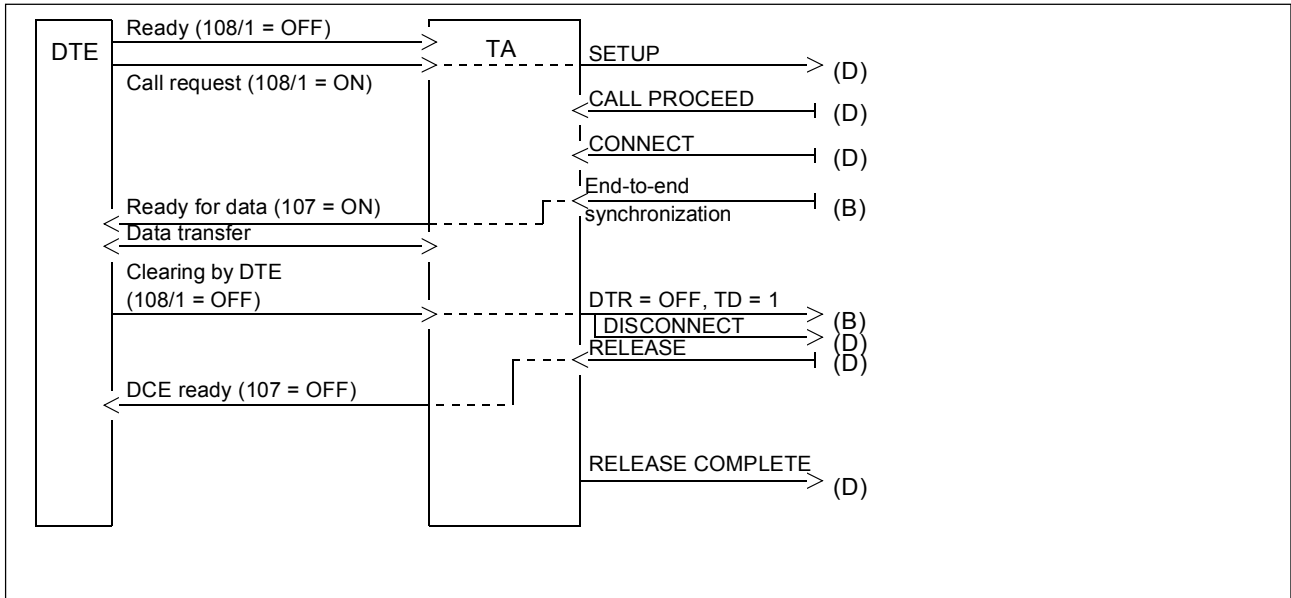

T1701410-91

FIGURE II-5/V.110

V.25 bis – Direct DTE call establishment and call clearing

II.4.2 *Direct call DCE call set-up and clearing*

The process is best described in Figure II-6/V.110.

II.5 *Mapping of Q.931 causes to V.25 bis call failure indications and responses*

In several cases, it will be necessary to map causes from Recommendations Q.931 to V.25 bis indications. The TA shall use Table II-1/V.110 to map the causes from Q.931 messages to V.25 bis Call Failure Indication or Call Progress Signals. The cause codes are provided by the ISDN to the TA.

Handling of the Call Failure Indication (CFI) by the DTE may be a national matter. CFI(AB) is to be taken by the DTE as no use for the DTE to call again, some changes need to be done within the DTE before the call can be successful; CFI(ET) is to be taken by the DTE as a transient condition, the DTE may retry the call without changes; CFI(NT) indicates a serious failure of the call and the DTE should wait before retrying the call. CFI(INV) is reserved for local invalid commands and is not a mapping of an ISDN cause code.

Not all Q.931 causes will be reported to the R interface. The general principles kept in Table II-1/V.110 is to distinguish between normal events (in a call) causes 0 to 31, resource unavailable causes 32 to 47, service not available causes 48 to 63, service not implemented causes 64 to 79, invalid message causes 80 to 95, protocol error causes 96 to 111, interworking causes 112 to 127.

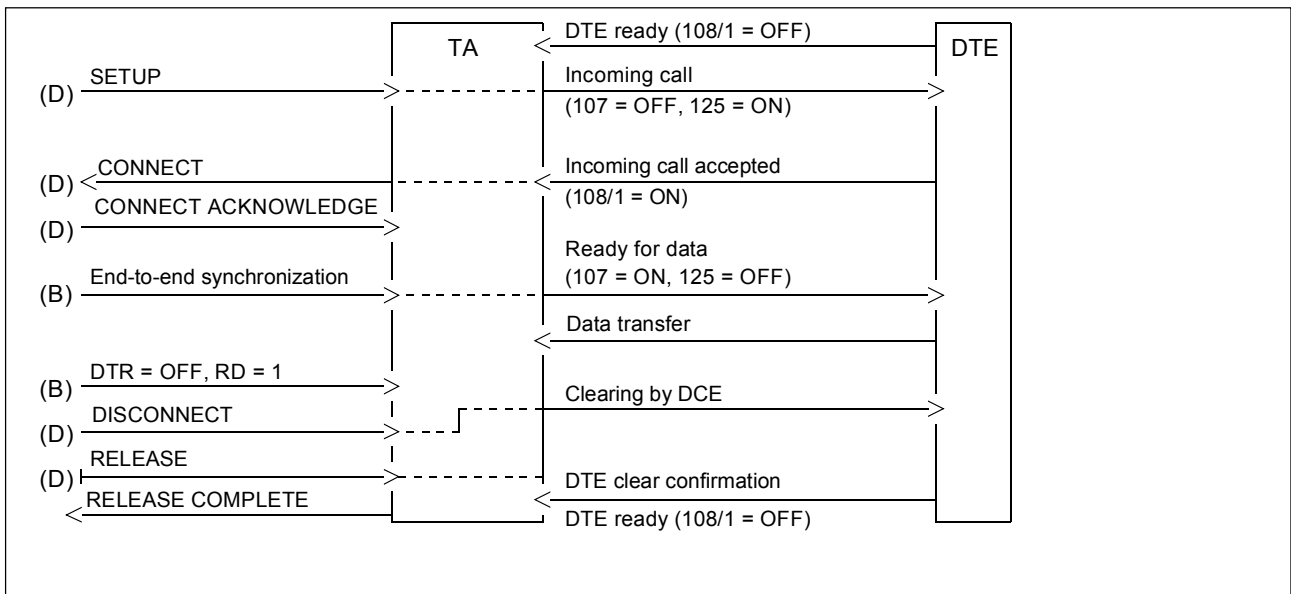

T1701420-91

FIGURE II-6/V.110
V.25 bis – Direct DCE call establishment and call clearing

II.6 Additional information for handling of exception situations

When the call is cleared prematurely or a call failure occurs, the rules of Recommendations Q.931 and of V.25 bis apply. The following procedures are derived for the mutual mapping between the R and the S reference points.

II.6.1 Call collision

Incoming call from the exchange has priority on outgoing call to the exchange (for V.25 bis DTE which is normally attached to PSTN).

II.6.1.1 Call collision at the V.25 bis interface

The TA shall accept an incoming SETUP message. When at the V.25 bis interface a call collision is detected (TA presents incoming call indication, V.25 bis DTE presents call request), the TA will delay the outgoing call to monitor for incoming calls and will accept the incoming call and not process the outgoing call.

II.6.1.2 Call collision at the interface at the S/T reference point

The procedures defined in Recommendation Q.931 will apply.

II.6.2 No channel available

If no channel including no B-channel at the interface at the S/T reference point is available for connection establishment, an outgoing SETUP message is answered from the exchange by a RELEASE COMPLETE message with the cause 34 = no channel available. This is mapped at the V.25 bis interface in the call failure indication ET (Engaged Tone).

TABLE II-1/V.110

Item	Q.931 cause	ISDN code	V.25 bis call response	V.25 bis code
1	Unassigned or unallocated number	1	Not obtainable	AB
2	No route to specified network	2	Not obtainable	NT
3	No route to destination	3	Not obtainable	AB
4	Channel unacceptable	6	Not obtainable	ET
5	Calling established channel	7		AB
6	Normal clearing	16	Not applicable	None
7	User busy	17	Number busy	ET
8	Timer expire	18	No connection	NT
9	No answer	19	No connection	NT
10	Call rejected	21	No connection	NT
11	Number changed	22	Changed number	AB
12	Non selected user clearing	26	No connection	AB
13	Destination out of order	27	No connection	NT
14	Invalid number format	28	Selection signals error	AB
15	Facility requested not provided	29		AB
16	Respond to state enquiry	30		AB
17	Normal, unspecified	31		AB
18	No circuit available	34	No connection	ET
19	Network out of order	38	No connection	NT
20	Temporary failure	41	Out of order	NT
21	Switched equipment congestion	42	Network congestion	NT
22	Access, information discarded	43	No connection	NT
23	Requested circuit not available	44	No connection	ET
24	Resource not available	47	Network congestion	NT
25	QOS unavailable	49		AB
26	Invalid facility request	50		AB
27	Bearer capability not authorized	57	Incompatible user class	AB
28	Bearer capability not available	58	Network congestion	ET
29	Service not available	63	No connection	AB
30	Bearer service not implemented	65	Invalid facility request	AB
31	Channel type not implemented	66	Invalid facility request	AB

TABLE II-1/V.110 (cont.)

Item	Q.931 cause	ISDN code	V.25 bis call response	V.25 bis code
32	Requested facility not implemented	69	Invalid facility request	AB
33	Restricted digital bearer only available	70	Invalid facility request	AB
34	Service not implemented	79	Invalid facility request	AB
35	Invalid call reference value	81		NT
36	Identified channel not existing	82	No report	
37	Call identification not existing	83	No report	
38	Call identification in use	84	No report	
39	No call suspended	85	No report	
40	Call with identification cleared	86	No report	
41	Incompatible destination	88		AB
42	Invalid transit network selection	91	No report	
43	Invalid message	95	No report	
44	Mandatory information element missing	96	No report	
45	Message type non-existent	97	Protocol error, no report	
46	Uncompatible message	98	Protocol error, no report	
47	Information element non-existent	99	Protocol error, no report	
48	Invalid information element content	100	Protocol error, no report	
49	Message not compatible	101	Protocol error, no report	
50	Recuperation on timer expiration	102	No report	
51	Protocol error unspecified	111	Protocol error, no report	
52	Interworking unspecified	127	Not applicable	

Note – New call failure indication to report ISDN related situations at the V.25 bis interface is for further study.

II.6.3 Premature call clearing

II.6.3.1 No answer to outgoing SETUP

If an outgoing SETUP is not answered by the exchange, the DTE will after a time out which is fixed by the national Administrations T2 timer, initiate the clearing by DTE by dropping 108/2 = OFF. The TA on its S reference point, will send a RELEASE COMPLETE message (cause code 31: normal, unspecified). The V.25 bis interface will go back to DTE Ready or DTE Not Ready.

On the other end if a TA is provided with the optional timer T303 (see Recommendation Q.931) it may start the clearing procedure at the interface at the S/T reference point interface as above by transmitting RELEASE COMPLETE (cause code 102: recovery on timer expiry). At the V.25 bis interface, the TA sends the call failure indication No Tone.

