



INTERNATIONAL TELECOMMUNICATION UNION

CCITT

THE INTERNATIONAL
TELEGRAPH AND TELEPHONE
CONSULTATIVE COMMITTEE

Q.920

(11/1988)

SERIES Q: DIGITAL SUBSCRIBER SIGNALLING
SYSTEM No. 1 (DSS 1), DATA LINK LAYER

**ISDN USER-NETWORK INTERFACE DATA LINK
LAYER – GENERAL ASPECTS**

Reedition of CCITT Recommendation Q.920 published in
the Blue Book, Fascicle VI.10 (1988)

NOTES

- 1 CCITT Recommendation Q.920 was published in Fascicle VI.10 of the *Blue Book*. This file is an extract from the *Blue Book*. While the presentation and layout of the text might be slightly different from the *Blue Book* version, the contents of the file are identical to the *Blue Book* version and copyright conditions remain unchanged (see below).
- 2 In this Recommendation, the expression “Administration” is used for conciseness to indicate both a telecommunication administration and a recognized operating agency.

Recommendation Q.920¹⁾

ISDN USER-NETWORK INTERFACE DATA LINK LAYER – GENERAL ASPECTS

1 General

This Recommendation describes in general terms the Link Access Procedure on the D-channel, LAPD. The application of this protocol to other channel types is for further study. Details are provided in Recommendation Q.921(I.441) [1].

The purpose of LAPD is to convey information between layer 3 entities across the ISDN user-network interface using the D-channel.

The definition of LAPD takes into consideration the principles and terminology of:

- Recommendations X.200 [2] and X.210 [3] – the reference model and layer service conventions for Open Systems Interconnection (OSI);
- Recommendation X.25 [4] – LAPB user-network interface for packet mode terminals; and
- ISO 3309 [5] and ISO 4335 [6] – High-level Data Link Control (HDLC) standards for frame structure and elements of procedures.

LAPD is a protocol that operates at the data link layer of the OSI architecture. The relationship between the data link layer and other protocol layers is defined in Recommendation I.320 [7].

Note 1 – The physical layer is currently defined in Recommendations I.430 [8] and I.431 [9] and layer 3 is defined in Recommendations Q.930(I.450) [10], Q.931(I.451) [11], and X.25 [4]. References should be made to these Recommendations for the complete definition of the protocols and procedures across the ISDN user-network interface.

Note 2 – The term “data link layer” is used in the main text of this Recommendation. However, mainly in figures and tables, the terms “layer 2” and “L2” are used as abbreviations. Furthermore, in accordance with Recommendations Q.930(I.450) [10] and Q.931(I.451) [11], the term “layer 3” is used to indicate the layer above the data link layer.

LAPD is independent of transmission bit rate. It requires a duplex, bit transparent D-channel.

The characteristics of the D-channel are defined in Recommendation I.412 [12].

§ 2 below describes basic concepts used in this Recommendation and Recommendation Q.921.

§ 3 gives an overview description of LAPD functions and procedures.

§ 4 summarizes the services that the data link layer provides to layer 3 and the services that the data link layer requires from the physical layer.

§ 5 provides an overview of the data link layer structure.

2 Concepts and terminology

The basic structuring technique in the OSI reference model is layering. According to this technique, communication among application processes is viewed as being logically partitioned into an ordered set of layers represented in a vertical sequence as shown in Figure 1/Q.920.

A data link layer Service Access Point (SAP) is the point at which the data link layer provides services to layer 3. Associated with each data link layer SAP is one or more data link connection endpoint(s). See Figure 2/Q.920. A data link connection endpoint is identified by a data link connection endpoint identifier as seen from layer 3 and by a Data Link Connection Identifier (DLCI) as seen from the data link layer.

Entities exist in each layer. Entities in the same layer, but in different systems which must exchange information to achieve a common objective are called “peer entities”. Entities in adjacent layers interact through their common boundary. The services provided by the data link layer are the combination of the services and functions provided by both the data link layer and the physical layer.

¹⁾ This Recommendation will be included in the series I Recommendations of the CCITT *Blue Book* (1988) under the number I.440.

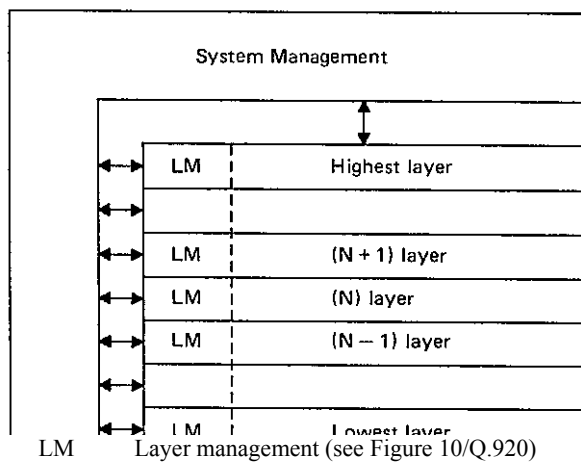

FIGURE 1/Q.920
Layering

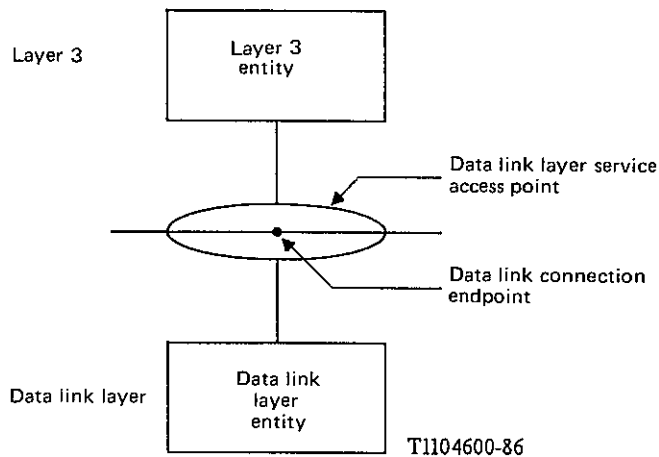

FIGURE 2/Q.920
Entities, service access points and endpoints

Cooperation between data link layer entities is governed by a peer-to-peer protocol specific to the layer. In order for information to be exchanged between two or more layer 3 entities, an association must be established between the layer 3 entities in the data link layer using a data link layer protocol. This association is called a data link connection. Data link connections are provided by the data link layer between two or more SAPs (see Figure 3/Q.920).

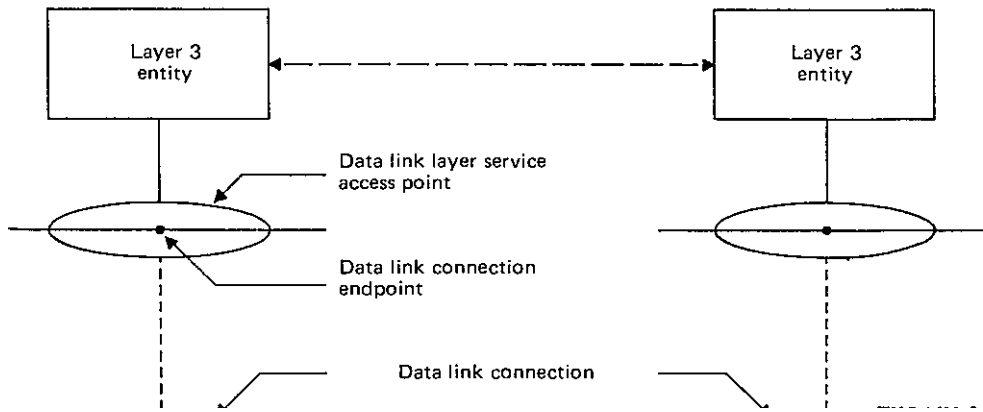

FIGURE 3/Q.920
Peer-to-peer relationship

Data link layer message units are conveyed between data link layer entities by means of a physical connection.

Layer 3 requests services from the data link layer via service primitives. The same applies for the interaction between the data link layer and the physical layer. The primitives represent, in an abstract way, the logical exchange of information and control between the data link layer and adjacent layers. They do not specify or constrain implementation.

The primitives that are exchanged between the data link layer and adjacent layers are of the following four types (see also Figure 4/Q.920):

- a) REQUEST;
- b) INDICATION;
- c) RESPONSE; and
- d) CONFIRM.

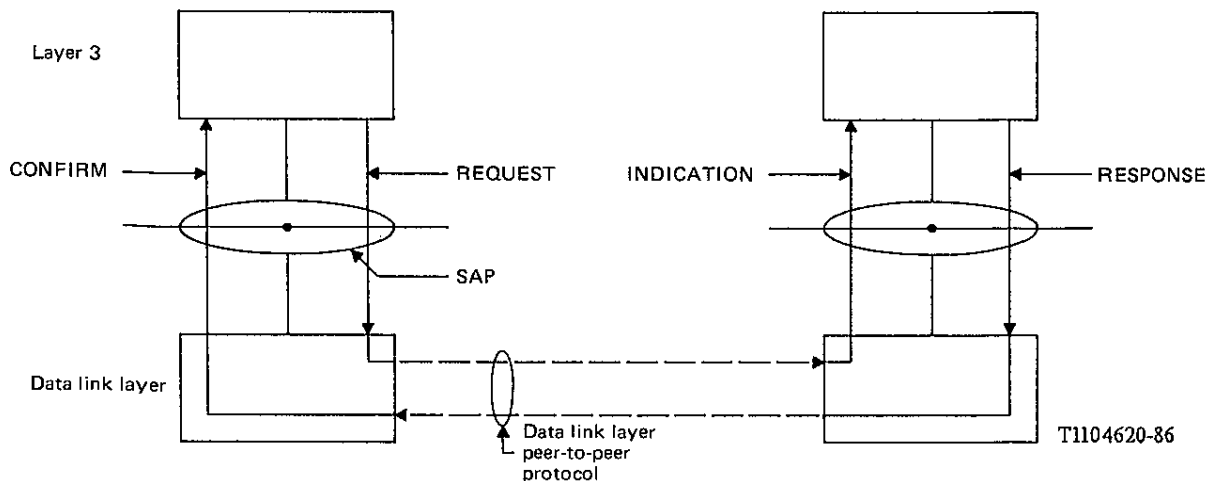

Note – The same principle applies for data link layer-physical interactions.

FIGURE 4/Q.920
Primitive action sequence

The REQUEST primitive type is used when a higher layer is requesting a service from the next lower layer.

The INDICATION primitive type is used by a layer providing a service to notify the next higher layer of any specific activity which is service related. The INDICATION primitive may be the result of an activity of the lower layer related to the primitive type REQUEST at the peer entity.

The RESPONSE primitive type is used by a layer to acknowledge receipt, from a lower layer, of the primitive type INDICATION.

The CONFIRM primitive type is used by the layer providing the requested service to confirm that the activity has been completed.

Layer-to-layer interactions are specified in Recommendation Q.921.

Information is transferred, in various types of message units, between peer entities and between entities in adjacent layers that are attached to a specific SAP. The message units are of two types:

- message units of a peer-to-peer protocol; and
- message units that contain layer-to-layer information concerning status and specialized service requests.

The message units of the layer 3 peer-to-peer protocol are carried by the data link connection. The message units containing layer-to-layer information concerning status and specialized service requests are never conveyed over a data link connection or a physical connection.

This Recommendation specifies (see also Figure 5/Q.920):

- a) the peer-to-peer protocol for the transfer of information and control between any pair of data link layer service access points; and
- b) the interactions between the data link layer and layer 3, and between the data link layer and the physical layer.

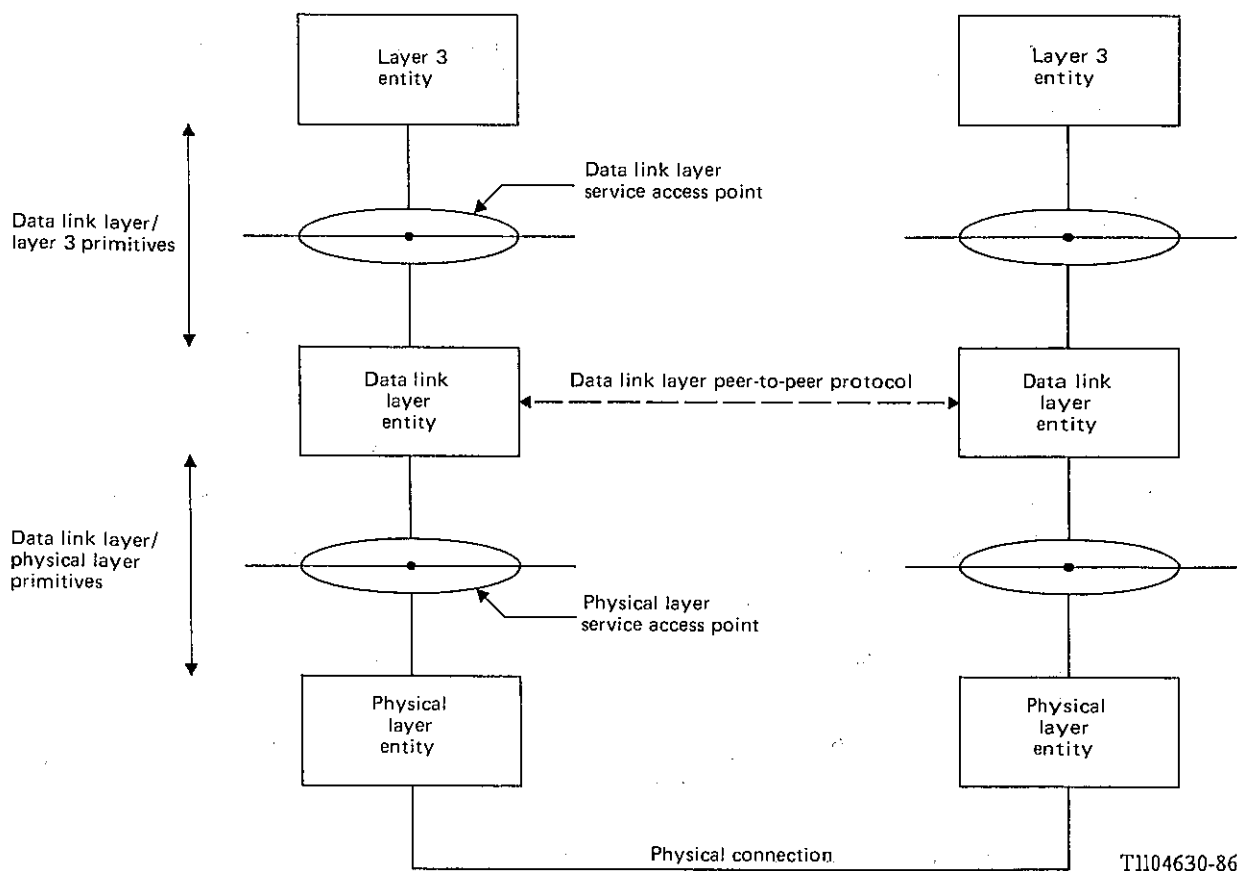

FIGURE 5/Q.920
Data link layer reference model

3 Overview description of LAPD functions and procedures

3.1 *General*

The purpose of LAPD is to convey information between layer 3 entities across the ISDN user-network interface using the D-channel. Specifically LAPD will support:

- multiple terminal installations at the user-network interface;
- multiple layer 3 entities.

All data link layer messages are transmitted in frames which are delimited by flags. (A flag is a unique bit pattern.) The frame structure is defined in Recommendation Q.921(I.441).

LAPD includes functions for:

- a) the provision of one or more data link connections on a D-channel. Discrimination between the data link connections is by means of a data link connection identifier (DLCI) contained in each frame;
- b) frame delimiting, alignment and transparency, allowing recognition of a sequence of bits transmitted over a D-channel as a frame;
- c) sequence control, to maintain the sequential order of frames across a data link connection;
- d) detection of transmission, format and operational errors on a data link connection;
- e) recovery from detected transmission, format, and operational errors;
- f) notification to the management entity of unrecoverable errors; and
- g) flow control.

Data link layer functions provide the means for information transfer between multiple combinations of data link connection endpoints. The information transfer may be via point-to-point data link connections or via broadcast data link connections. In the case of point-to-point information transfer, a frame is directed to a single endpoint, while in the case of broadcast information transfer, a frame is directed to one or more endpoints.

Figure 6/Q.920 shows three examples of point-to-point information transfer. Figure 7/Q.920 shows an example of broadcast information transfer.

Two types of operation of the data link layer are defined for layer 3 information transfer: unacknowledged and acknowledged. They may coexist on a single D-channel.

3.2 *Unacknowledged operation*

With this type of operation layer 3 information is transmitted in Unnumbered Information (UI) frames.

At the data link layer the UI frames are not acknowledged. Even if transmission and format errors are detected, no error recovery mechanism is defined. Flow control mechanisms are not defined.

Unacknowledged operation is applicable for point-to-point and broadcast information transfer; that is, a UI frame may be sent to a specific endpoint or broadcast to multiple endpoints associated with a specific Service Access Point Identifier (SAPI).

3.3 *Acknowledged operation*

With this type of operation, layer 3 information is transmitted in frames that are acknowledged at the data link layer.

Error recovery procedures based on retransmission of unacknowledged frames are specified. In the case of errors which cannot be corrected by the data link layer, a report to the management entity is made. Flow control procedures are also defined.

Acknowledged operation is applicable for point-to-point information transfer.

One form of acknowledged information transfer is defined, multiple frame operation.

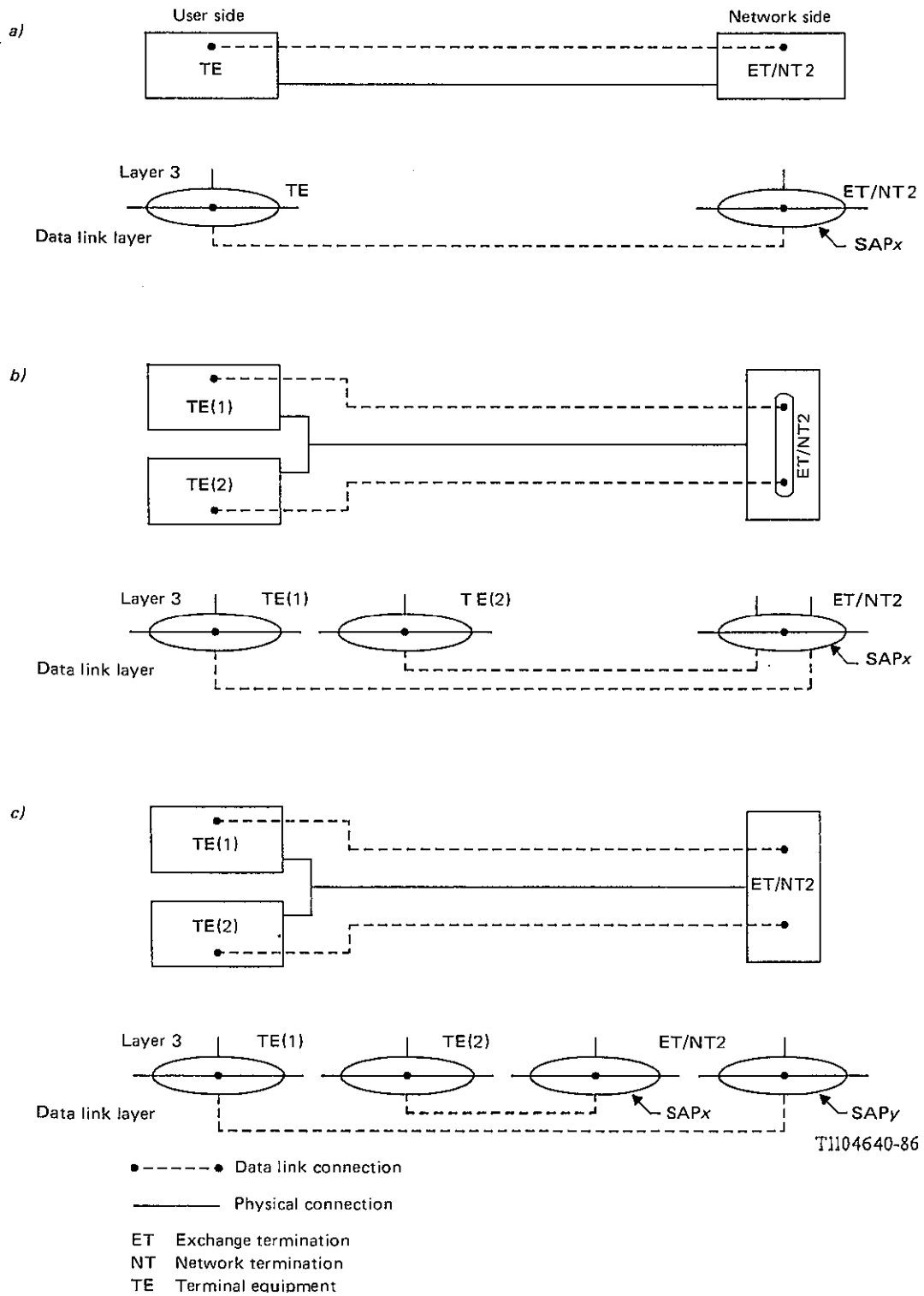

FIGURE 6/Q.920
 Point-to-point data link connections

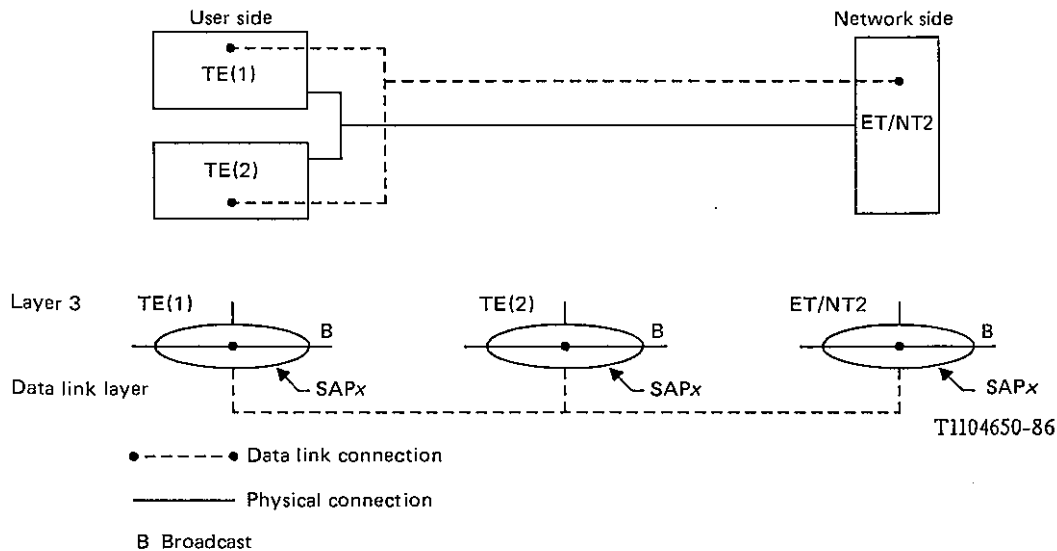

FIGURE 7/Q.920
Broadcast data link connection

Layer 3 information is sent in numbered Information (I) frames. A number of I frames may be outstanding at the same time. Multiple frame operation is initiated by a multiple frame establishment procedure using a Set Asynchronous Balanced Mode Extended (SABME) command.

3.4 Establishment of information transfer modes

3.4.1 Data link connection identification

A data link connection is identified by a Data Link Connection Identifier (DLCI) carried in the address field of each frame.

The data link connection identifier is associated with a connection endpoint identifier at the two ends of the data link connection (see Figure 8/Q.920).

The connection endpoint identifier is used to identify message units passed between the data link layer and layer 3. It consists of the SAPI and the Connection Endpoint Suffix (CES).

The DLCI consists of two elements: the SAPI and the Terminal Endpoint Identifier (TEI).

The SAPI is used to identify the service access point on the network side or the user side of the user-network interface.

The TEI is used to identify a specific connection endpoint within a service access point.

The TEI is assigned by the network, if the user equipment is of the automatic TEI assignment category or it is entered into the user equipment, for example, by the user or the manufacturer, if the user equipment is of the nonautomatic TEI assignment category (see § 3.4.3).

The DLCI is a pure data link layer concept. It is used internally by the data link layer entity and is not known by the layer 3 entity or management entity. In these latter entities, the concept of Connection Endpoint Identifier (CEI) will be used instead.

The CEI is composed of the SAPI information and a reference value named CES. The CES is a value selected by the layer 3 or management entity to address the data link layer entity. When the relevant TEI is known by this entity, it will internally associate the DLCI to the CEI. The layer 3 and management entities will use this CEI to address its peer entity.

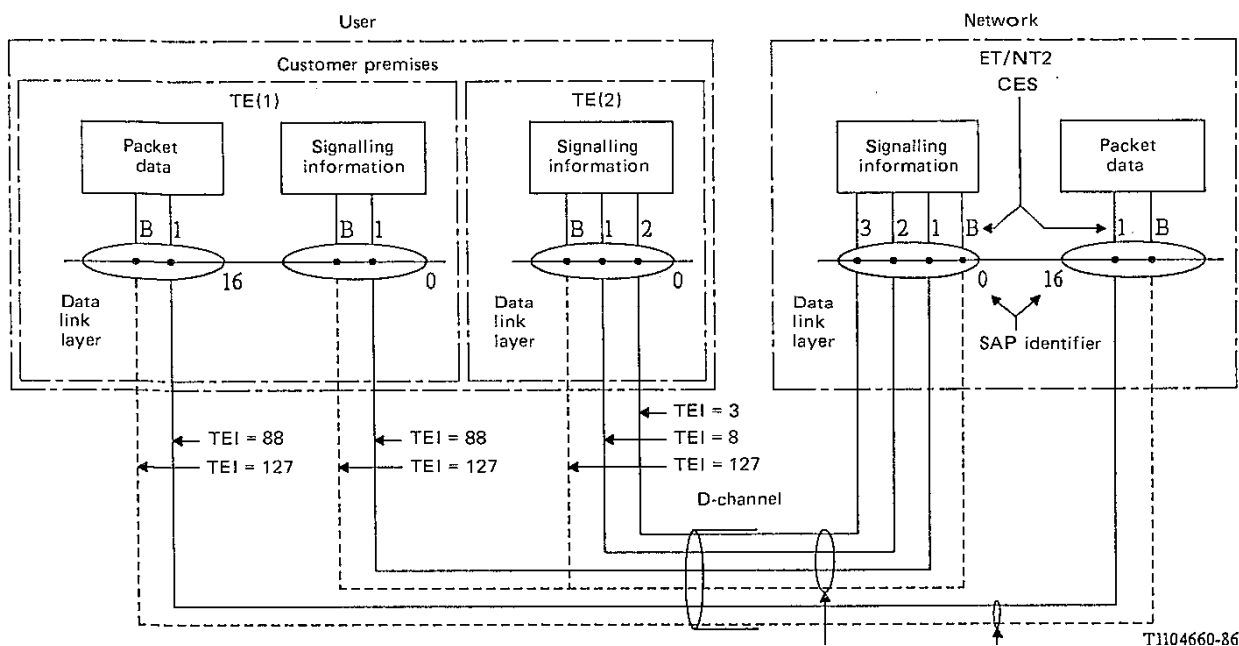

T1104660-86

- Broadcast data link connection (B)
- _____ Point-to-point data link connection
- DLCI = SAPI + TEI
- CEI = SAPI + CES

Note 1 – The management entity is not shown in this figure.

Note 2 – The selection of the SAPI and TEI values is based on Recommendation Q.921, §§ 3.3.3 and 3.3.4.2, respectively.

FIGURE 8/Q.920
Overview description of the relationship between SAPI, TEI and DLCI

3.4.2 Data link states

A point-to-point data link entity may be in one of three basic states:

- a) TEI-unassigned state. In this state a TEI has not been assigned. No layer 3 information transfer is possible; or
- b) TEI-assigned state. In this state a TEI has been assigned by means of the TEI assignment procedure. Unacknowledged information transfer is possible; or
- c) multi-frame-established state. This state is established by means of a multiple frame establishment procedure. Acknowledged and unacknowledged information transfer are possible.

Note – For the detailed description of procedures in Recommendation Q.921(I.441), an expansion of the basic set of states listed above is required.

A broadcast data link entity is always in an information transfer state capable of only unacknowledged information transfer (that is, TEI-assigned state).

3.4.3 TEI administration

The purpose of the TEI assignment procedure is to allow a user equipment to obtain a TEI value that the data link layer entities within the user equipment will use in subsequent communications over the data link connections.

The assigned TEI value is typically common to all SAPs (if more than one) in a user equipment. The procedure is conceptually located in the management entity.

When a TEI has been assigned, the user equipment establishes an association between the TEI and a CES in each SAP (that is, the DLCI is associated with a CEI). In the network, the corresponding association is made upon reception of the first frame containing the assigned TEI, or at the time of TEI assignment.

At that point in time, a data link layer peer-to-peer association has been formed.

The association between the DLCI and CEI will be removed by the TEI removal procedures on request from the management entity when recognizing that the TEI value is no longer valid.

When in the TEI-assigned state or the multiple-frame-established state, the TEI check procedure may be used by the network to check the status of a TEI (for example, to determine if a user equipment has been disconnected from an installation). Optionally, the user equipment may request the network to initiate the TEI check procedure.

Examples of criteria for initiation of the TEI assignment procedure, the TEI check procedure, and the TEI removal procedures are described in Recommendation Q.921(I.441).

Note – This section is not intended to provide a complete specification of possible criteria for establishing and removing an association between the DLCI and CEI.

3.4.4 *Establishment of multiple frame operation*

Before point-to-point acknowledged information transfer can start, an exchange of a SABME frame and an Unnumbered Acknowledgement (UA) frame must take place.

The multiple frame establishment procedure is specified in detail in Recommendation Q.921.

4 **Service characteristics**

4.1 *General*

The data link layer provides services to layer 3 and to the layer 2 management entity and utilizes the services provided by the physical layer and layer management. A formal description of the data link layer service provided to layer 3 and layer management is given in § 4.2 and § 4.3, respectively. The layer management service provided to the data link layer is given in § 4.4.

Note – Communication between different layers in the OSI reference model makes use of primitives which are passed across the layer boundaries. The data link layer primitives defined in this Recommendation represent, in an abstract way, the logical exchange of information and control between the data link layer and adjacent layers. They do not specify nor constrain implementations.

4.2 *Services provided to layer 3*

The specification of the interactions with layer 3, (primitives) provides a description of the services that the data link layer, plus the physical layer, offer to layer 3, as viewed from layer 3.

Two forms of information transfer service are associated with layer 3. The first is based on unacknowledged information transfer at the data link layer while the second service is based on acknowledged information transfer at the data link layer.

Layer 3 message units are handled according to their respective layer 2 priority (see § 5.2).

4.2.1 *Unacknowledged information transfer service*

Note – In this case the information transfer is not acknowledged at the data link layer. Acknowledgement procedures may be provided at higher layers.

The information transfer is via broadcast or point-to-point data link connections.

The characteristics of the unacknowledged information transfer service are summarized in the following:

- a) provision of a data link connection between layer 3 entities for unacknowledged information transfer of layer 3 message units;
- b) identification of data link connection endpoints; and
- c) no verification of message arrival within the peer data link layer entity.

The primitives associated with the unacknowledged information transfer service are:

DL-UNIT DATA-REQUEST/INDICATION

The DL-UNIT DATA-REQUEST primitive is used to request that a message unit be sent using the procedures for unacknowledged information transfer service. The DL-UNIT DATA-INDICATION primitive indicates the arrival of a message unit received by means of an unacknowledged information transfer service.

4.2.2 *Acknowledged information transfer service*

One mode of operation is defined, multiple frame.

The characteristics of the acknowledged information transfer service are summarized in the following:

- a) provision of a data link connection between layer 3 entities for acknowledged information transfer of layer 3 message units;
- b) identification of data link connection endpoints;
- c) sequence integrity of data link layer message units in the absence of malfunctions;
- d) notification to the peer entity in the case of errors, for example, loss of sequence;
- e) notification to the management entity of unrecoverable errors detected by the data link layer; and
- f) flow control.

The primitives associated with the acknowledged information transfer services are:

i) *Data transfer*

DL-DATA-REQUEST/INDICATION

The DL-DATA-REQUEST primitive is used to request that a message unit be sent using the procedures for the acknowledged information transfer service. The DL-DATA-INDICATION primitive indicates the arrival of a message unit received by means of the acknowledged information transfer service.

ii) *Establishment of multiple frame operation*

DL-ESTABLISH-REQUEST/INDICATION/CONFIRM

These primitives are used, respectively, to request, indicate and confirm the establishment of multiple frame operation between two service access points.

iii) *Termination of multiple frame operation*

DL-RELEASE-REQUEST/INDICATION/CONFIRM

These primitives are used, respectively, to request, indicate and confirm an attempt to terminate multiple frame operation between two service access points.

4.3 *Services provided to layer management*

Only the unacknowledged information transfer service is provided to layer management in order that the data link layer management can communicate with its peer layer management.

Note – In this case the information transfer is not acknowledged at the data link layer. Acknowledgement procedures may be provided by layer management.

The information transfer is via broadcast connections, but in principle information transfer can also be via point-to-point connections [no application for data transfer via point-to-point connections has been identified or included in Recommendation Q.921(I.441)].

The characteristics of the unacknowledged information transfer service are summarized in the following:

- a) provision of a data link connection between layer management entities for unacknowledged information transfer of data units;
- b) identification of data link connection endpoints; and
- c) no verification of message arrival within the peer data link layer entity.

The primitives associated with the unacknowledged information transfer service provided for layer management are:

MDL-UNIT DATA-REQUEST/INDICATION

The MDL-UNIT DATA-REQUEST primitive is used to request that a message unit be sent using the procedure for unacknowledged information transfer service for layer management. The MDL-UNIT DATA-INDICATION primitive indicates the arrival of a message unit received by means of the unacknowledged information transfer service to layer management.

4.4 *Administrative services*

The characteristics of the administrative services currently recognized are summarized in the following:

- a) assignment, checking, and removal of TEI values; and

- b) data link connection parameter passing (an optional service performed on a per connection basis).

These services are considered to be conceptually provided by layer management either on the user side or the network side. The method of describing these administrative functions uses service primitives.

The primitives associated with these services are:

- i) *Assignment of TEI value*

MDL-ASSIGN-REQUEST/INDICATION

The MDL-ASSIGN-INDICATION primitive is used to indicate to layer management the need for a TEI value. The MDL-ASSIGN-REQUEST primitive is used to pass the TEI value from layer management to the data link layer in order that the user data link layer entities can begin to communicate with the network data link layer entities.

- ii) *Removal of TEI value*

MDL-REMOVE-REQUEST

This primitive is used to convey a layer management function request for removal of a TEI value that has been previously assigned via the MDL-ASSIGN primitives.

- iii) *Notification of error*

MDL-ERROR-INDICATION/RESPONSE

These primitives are used to report error situations between layer management and the data link layer entities.

4.5 Model of the data link service

4.5.1 General

The ability of the data link layer to execute a service request by layer 3 depends on the internal state of the data link layer. For the layer 3 entity, the internal state of the data link layer is represented by the state of that data link connection endpoint within a data link service access point which is used by this layer 3 entity to invoke a service.

Consequently, the data link service may be defined by means of data link connection endpoint states, whereby the capabilities provided by the data link layer and the service primitives may be related to these states.

In order to allow a data link service user to invoke a service by making use of primitives, the DL-primitives defined in Recommendation Q.921(I.441) have to be related to: point-to-point data link connections (acknowledged or unacknowledged transfer of information) and/or broadcast data link connections (unacknowledged transfer of information) (see Table 1/Q.920).

An unconfirmed service is defined as a service which does not result in an explicit confirmation. A confirmed service is defined as a service which results in an explicit confirmation from the service-provider. There is not necessarily any relationship to a response from the peer service-user.

TABLE 1/Q.920

Applicability of DL-Primitives to information transfer modes

Generic name of the DL- primitive	POINT-TO-POINT INFORMATION TRANSFER MODE		BROADCAST INFORMATION TRANSFER MODE
	ACKNOWLEDGED	UNACKNOWLEDGED	
ESTABLISH	CONFIRMED SERVICE		
RELEASE	CONFIRMED SERVICE		
DATA	UNCONFIRMED SERVICE		
UNIT DATA		UNCONFIRMED SERVICE	UNCONFIRMED SERVICE

4.5.2 *Data link layer representation as seen by layer 3*

4.5.2.1 *Data link connection endpoint states*

The states of a data link connection endpoint may be derived from the internal states of the data link layer entity supporting this type of a data link connection.

4.5.2.2 *Broadcast data link layer connection services*

A broadcast data link connection provides an unacknowledged information transfer service.

The broadcast data link connection endpoint is always in the information transfer state.

4.5.2.3 *Point-to-point data link connection endpoint services*

A point-to-point data link connection provides both an unacknowledged and acknowledged information transfer service. Within each data link service access point, one or more than one data link connection endpoint may be present, each identified by a CES.

The acknowledged information transfer service, in addition, implies the presence of the link establishment, link re-establishment and link release services.

The point-to-point data link connection endpoint states are:

- *link connection released* state;
- *awaiting establish* state;
- *awaiting release* state;
- *link connection established* state.

4.5.2.4 *Sequences of primitives at one point-to-point data link connection endpoint*

The primitives provide the procedural means to specify conceptually how a data link service user can invoke a service.

This section defines the constraints on the sequence in which the primitives may occur. The sequences are related to the states at one point-to-point data link connection endpoint.

The possible overall sequences of primitives at a point-to-point data link connection endpoint are defined in the state transition diagram, Figure 9/Q.920. The *link connection released* and *link connection established* states are stable states whilst the *awaiting establish* and *awaiting release* are transition states.

4.6 *Services required from the physical layer*

The services provided by the physical layer are described in detail in Recommendation I.430 [8] or I.431 [9]. They are summarized in the following:

- a) physical layer connection for the transparent transmission of bits in the same order in which they are submitted to the physical layer;
- b) indication of the physical status of the D-channel; and
- c) transmission of data link layer message units according to their respective data link layer priority.

Some of the above services may be implemented in the management entity on the user side or network side. The method of describing these services is by means of service primitives. The primitives between the data link layer and the physical layer are:

- i) PH-DATA-REQUEST/INDICATION

These primitives are used to request that a message unit be sent and to indicate the arrival of a message unit.

- ii) *Activation*

PH-ACTIVATE-REQUEST/INDICATION

These primitives are used to request activation of the physical layer connection, and to indicate that the physical layer connection has been activated.

- iii) *Deactivation*

PH-DEACTIVATE-REQUEST/INDICATION

This primitive is used to indicate that the physical layer connection has been deactivated.

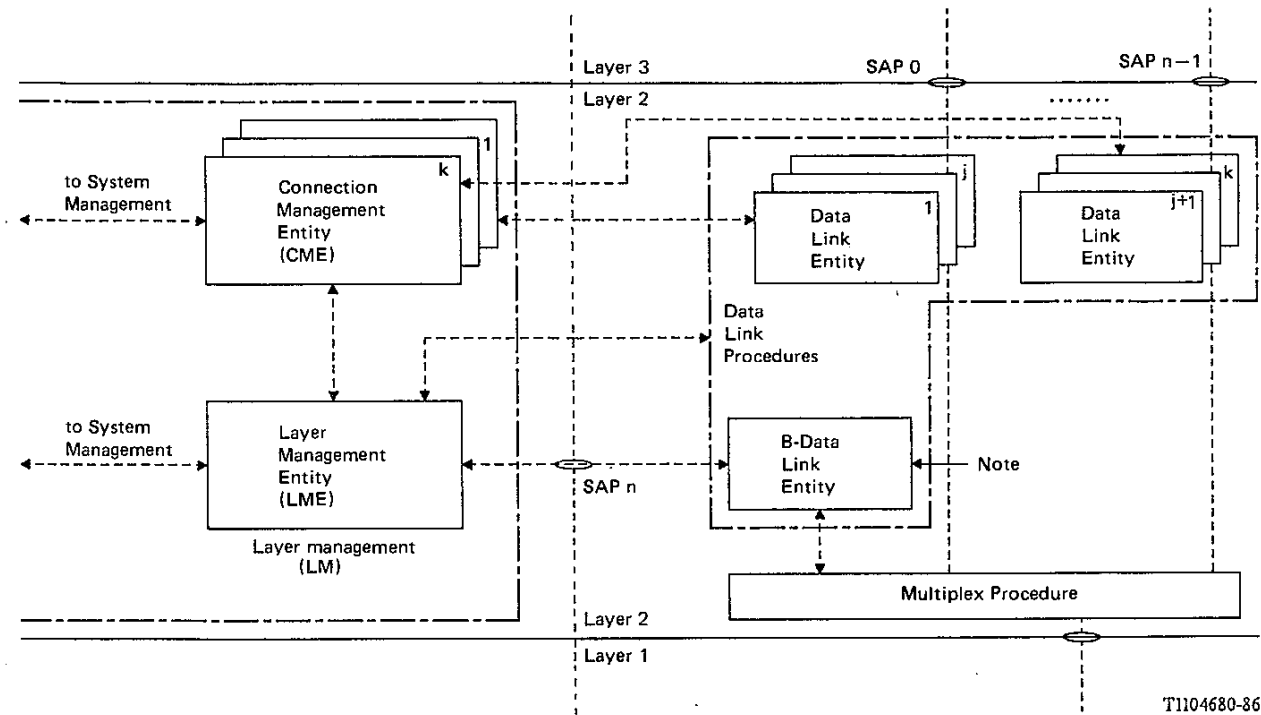

T1104680-86

B Broadcast

Note – The broadcast links for SAPs other than SAP 63 are not shown.

FIGURE 10/Q.920
Functional Model of the data link layer – Management

5.1 Data link procedure

This procedure analyzes the control field of the received frame [see Recommendation Q.921(I.441)] and provides appropriate peer-to-peer responses and layer-to-layer indications. In addition, it analyzes the data link layer service primitives and transmits the appropriate peer-to-peer commands and responses.

5.2 Multiplex procedure

This procedure analyzes the flag, □Frame Check Sequence (FCS), and address octets of a received frame. If the frame is correct, it distributes the frame to the appropriate data link procedures block based on the DLCI [see Recommendation Q.921(I.441)].

On frame transmission, this procedure may provide data link layer contention resolution between the various data link procedure blocks. The contention resolution is based on the SAPI value, giving priority to SAPI = 0 information.

5.3 Structure of the data link procedure

The functional model of the data link procedure is shown in Figure 11/Q.920. The model consists of several functional blocks for point-to-point and broadcast connections.

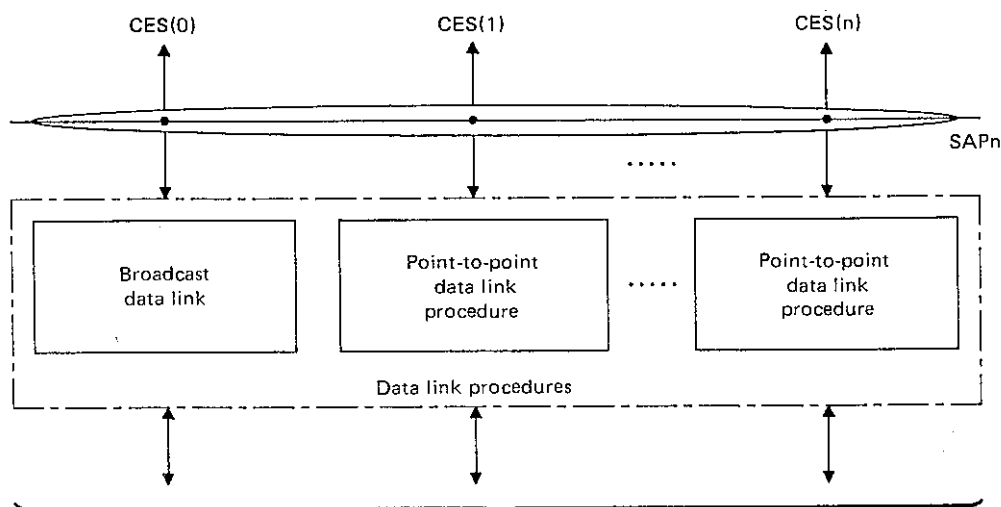

FIGURE 11/Q.920
Data link procedure structure

References

- [1] CCITT Recommendation Q.921(I.441) *ISDN user-network interface data link layer specification*.
- [2] CCITT Recommendation X.200 *Reference model of open systems interconnection for CCITT applications*.
- [3] CCITT Recommendation X.210 *OSI layer service conventions*.
- [4] CCITT Recommendation X.25 *Interface between data terminal equipment (DTE) and data circuit-terminating equipment (DCE) for terminals operating in the packet mode and connected to public data networks by dedicated circuit*.
- [5] ISO 3309 *Data communication – High-level data link control procedures – Frame structure*.
- [6] ISO 4335 *Data communication – High-level data link control procedures – Consolidation of elements of procedures*.
- [7] CCITT Recommendation I.320 *ISDN protocol reference model*.
- [8] CCITT Recommendation I.430 *Basic user-network interface layer 1 specification*.
- [9] CCITT Recommendation I.431 *Primary rate user-network interface layer 1 specification*.
- [10] CCITT Recommendation Q.930(I.450) *ISDN user-network interface layer 3 – general aspects*.
- [11] CCITT Recommendation Q.931(I.451) *ISDN user-network interface layer 3 specification*.
- [12] CCITT Recommendation I.412 *ISDN user-network interfaces interface structure and access capabilities*.

ITU-T RECOMMENDATIONS SERIES

Series A	Organization of the work of the ITU-T
Series B	Means of expression: definitions, symbols, classification
Series C	General telecommunication statistics
Series D	General tariff principles
Series E	Overall network operation, telephone service, service operation and human factors
Series F	Non-telephone telecommunication services
Series G	Transmission systems and media, digital systems and networks
Series H	Audiovisual and multimedia systems
Series I	Integrated services digital network
Series J	Transmission of television, sound programme and other multimedia signals
Series K	Protection against interference
Series L	Construction, installation and protection of cables and other elements of outside plant
Series M	TMN and network maintenance: international transmission systems, telephone circuits, telegraphy, facsimile and leased circuits
Series N	Maintenance: international sound programme and television transmission circuits
Series O	Specifications of measuring equipment
Series P	Telephone transmission quality, telephone installations, local line networks
Series Q	Switching and signalling
Series R	Telegraph transmission
Series S	Telegraph services terminal equipment
Series T	Terminals for telematic services
Series U	Telegraph switching
Series V	Data communication over the telephone network
Series X	Data networks and open system communications
Series Y	Global information infrastructure and Internet protocol aspects
Series Z	Languages and general software aspects for telecommunication systems