



INTERNATIONAL TELECOMMUNICATION UNION

CCITT

THE INTERNATIONAL
TELEGRAPH AND TELEPHONE
CONSULTATIVE COMMITTEE

Q.705

(11/1988)

SERIES Q: SWITCHING AND SIGNALLING

Specifications of Signalling System No. 7 – Message
transfer part (MTP)

SIGNALLING NETWORK STRUCTURE

Reedition of CCITT Recommendation Q.705 published in
the Blue Book, Fascicle VI.7 (1988)

NOTES

- 1 CCITT Recommendation Q.705 was published in Fascicle VI.7 of the *Blue Book*. This file is an extract from the *Blue Book*. While the presentation and layout of the text might be slightly different from the *Blue Book* version, the contents of the file are identical to the *Blue Book* version and copyright conditions remain unchanged (see below).
- 2 In this Recommendation, the expression “Administration” is used for conciseness to indicate both a telecommunication administration and a recognized operating agency.

Recommendation Q.705

SIGNALLING NETWORK STRUCTURE

1 Introduction

This Recommendation describes aspects which are pertinent to and should be considered in the design of international signalling networks. Some or all of these aspects may also be relevant to the design of national networks. Some aspects are dealt with for both international and national networks (e.g. availability), others are discussed in the context of the international network only (e.g. number of *signalling transfer points* in a signalling relation). A number of aspects require further study for national networks. This Recommendation also gives in Annex A examples of how the signalling network procedures may be applied to the mesh network representation.

The national and international networks are considered to be structurally independent and, although a particular *signalling point* may belong to both networks, signalling points are allocated *signalling point codes* according to the rules of each network.

The signalling network procedures are provided in order to effectively operate a signalling network having different degrees of complexity. They provide for reliable message transfer across the network and for reconfiguration of the network in the case of failures.

The most elementary signalling network consists of *originating and destination signalling points* connected by a single *signalling link*. To meet availability requirements this may be supplemented by additional links in parallel which may share the signalling load between them. If, for all signalling relations, the originating and destination signalling points are directly connected in this way in a network then the network operates in the *associated mode*.

For technical or economic reasons a simple associated network may not be suitable and a *quasi-associated network* may be implemented in which the information between originating and destination signalling points may be transferred via a number of signalling transfer points. Such a network may be represented by a *mesh network* such as that given in Annex A, as other networks are either a subset of the mesh network or are structured using this network or its subsets as components.

2 Network components

2.1 Signalling links

Signalling links are basic components in a signalling network connecting together signalling points. The signalling links encompass the *level 2* functions which provide for message error control (detection and subsequent correction). In addition, provision for maintaining the correct message sequence is provided (see Recommendation Q.703).

2.2 Signalling points

Signalling links connect signalling points at which signalling network functions such as message routing are provided at *level 3* and at which the user functions may be provided at *level 4* if it is also an originating or destination point (see Recommendation Q.704, § 2.4).

A signalling point that only transfers messages from one signalling link to another at level 3 serves as a signalling transfer point (STP).

The signalling links, signalling transfer points, and signalling (originating or destination) points may be combined in many different ways to form a *signalling network*.

3 Structural independence of international and national signalling networks

The worldwide signalling network is structured into two functionally independent levels, namely the international and national levels, as illustrated in Figure 1/Q.705. This structure makes possible a clear division of responsibility for signalling network management and allows numbering plans of signalling points of the international network and the different national networks to be independent of one another.

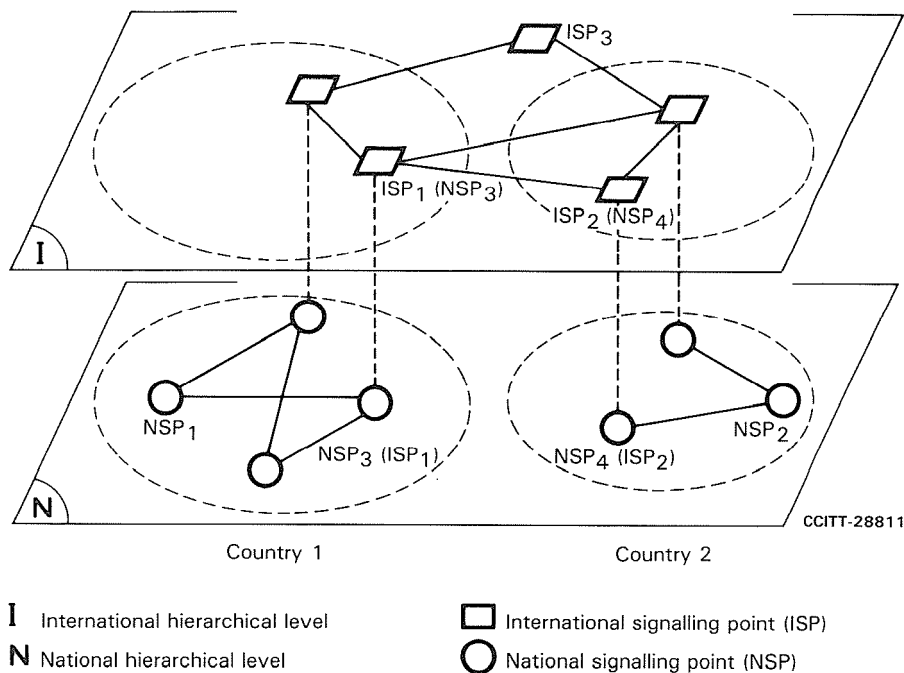

FIGURE 1/Q.705

International and national signalling networks

A signalling point (SP), including a signalling transfer point (STP), may be assigned to one of three categories:

- national signalling point (NSP) (signalling transfer point) which belongs to the national signalling network only (e.g. NSP₁) and is identified by a signalling point code (OPC or DPC) according to the national numbering plan of signalling points;
- international signalling point (ISP) (signalling transfer point) which belongs to the international signalling network only (e.g. ISP₃) and is identified by a signalling point code (OPC or DPC) according to the international numbering plan of signalling points;
- a node that functions both as an international signalling point (signalling transfer point) and a national signalling point (signalling transfer point) and therefore belongs to both the international signalling network and a national signalling network and accordingly is identified by a specific signalling point code (OPC or DPC) in each of the signalling networks.

If a discrimination between international and national signalling point codes is necessary at a signalling point, the network indicator is used (see Recommendation Q.704, § 14.2).

4 Considerations common to both international and national signalling networks

4.1 Availability of the network

The signalling network structure must be selected to meet the most stringent availability requirements of any User Part served by a specific network. The availability of the individual components of the network signalling links, (signalling points, and signalling transfer points) must be considered in determining the network structure (see Recommendation Q.709).

4.2 Message transfer delay

In order to take account of signalling message delay considerations, regard should be given, in the structuring of a particular signalling network, to the overall number of signalling links (where there are a number of signalling relations in tandem) related to a particular user transaction (e.g., to a specific call in the telephone application) (see Recommendation Q.709).

4.3 *Message sequence control*

For all messages for the same transaction (e.g. a telephone call) the Message Transfer Part will maintain the same routing provided that the same *signalling link selection* code is used in the absence of failure. However, a transaction does not necessarily have to use the same signalling route for both forward and backward messages.

4.4 *Number of signalling links used in load sharing*

The number of signalling links used to share the load of a given flow of signalling traffic typically depends on:

- the total traffic load,
- the availability of the links,
- the required availability of the path between the two signalling points concerned, and
- the bit rate of the signalling links.

Load sharing requires at least two signalling links for all bit rates, but more may be needed at lower bit rates.

When two links are used, each of them should be able to carry the total signalling traffic in case of failure of the other link. When more than two links are used, sufficient reserve link capacity should exist to satisfy the availability requirements specified in Recommendation Q.706.

4.5 *Satellite working*

Due to the considerable increase in overall signalling delay, the use of satellites in Signalling System No. 7 connections requires consideration, and further study is required.

In international operation, when the network served by the signalling network is routed on terrestrial circuits, only in exceptional circumstances should a satellite circuit be employed for the supporting signalling connection.

5 International signalling network

5.1 *General*

The international signalling network will use the procedures to be defined in the Signalling System No. 7 Recommendations. The international network structure to be defined can also serve as a model for the structure of national networks.

5.2 *Number of signalling transfer points in signalling relations*

In the international signalling network the number of signalling transfer points between an originating and a destination signalling point should not exceed two in a normal situation. In failure situations, this number may become three or even four for a short period of time. This constraint is intended to limit the complexity of the administration of the international signalling network.

5.3 *Numbering of signalling points*

A 14-bit code is used for the identification of signalling points. The allocation scheme of international signalling point codes is defined in Recommendation Q.708.

5.4 *Routing rules*

5.4.1 In order to ensure full flexibility for the routing of signalling in the System No. 7 international signalling network it appears desirable that at least one signalling point in each country should provide means for the international STP function. Such an approach should ease the use of Signalling System No. 7 on small traffic routes.

5.4.2 *Other routing rules*

(For further study.)

5.5 *Structures*

(Requires further study.)

5.6 *Procedures*

(Requires further study.)

6 Signalling network for cross-border traffic

6.1 *General*

For cross-border traffic between signalling points, the need for a special signalling network configuration is identified, because their common interests are such as to generate a considerable volume of traffic between them.

Two alternative arrangements of the signalling network for cross-border traffic are provided so that Administrations may adopt either alternative upon a bilateral agreement.

6.2 *Use of international hierarchical level*

6.2.1 This arrangement could be applied in the case that there are only a relatively small number of signalling points in a country which serve for cross-border traffic.

6.2.2 The signalling points and the signalling transfer points which are involved in a signalling of cross-border traffic should belong to the international hierarchical level described in § 3. When those signalling points or signalling transfer points are also involved in signalling of national traffic, they should belong to their national hierarchical level as well. Therefore the double numbering of signalling point codes based on both the international and national numbering schemes should be required.

6.2.3 A discrimination between international and national point codes is made by the network indicator in the service information octet (see Recommendation Q.704, § 14.2).

6.2.4 Signalling network management procedures in this network arrangement require further study.

6.3 *Integrated numbering of national signalling networks*

6.3.1 By this arrangement the signalling points, which serve cross-border traffic, should be identified by common national signalling point codes.

6.3.2 Common block of national signalling point codes is provided by bilateral agreement (further study is required).

6.4 *Interworking of national signalling networks*

At the cross-border signalling network interface, the international specification of Signalling System No. 7 should be preferred without exclusion of bilateral agreements.

7 National signalling network

Any specific structures for national signalling networks are not required to be included in the Recommendation, however, Administrations should cater for requirements imposed on a national network for the protection of international services in terms of network related user requirements such as availability and performance of the network perceived by users, (see Recommendation Q.709).

8 Procedures to prevent unauthorized use of an STP (Optional)

8.1 *General*

Administrations may make bilateral agreements to operate SS7 between their networks. These agreements may place restrictions on the SS7 messages authorized for one administration to send to the other. Restrictions could be made, for example, in the interest of network security or as a result of service restrictions. Unauthorized signalling traffic may be, for example, STP traffic for calls set up via networks other than that containing the STP, which has not been agreed bilaterally.

An Administration making an agreement with restrictions may wish to identify and provide special treatment to unauthorized SS7 messages.

The measurements in Table 6/Q.791 provide some capability to identify unauthorized SS7 messages. The procedures in this section for identifying and responding to unauthorized traffic are additional options for use at an STP with signalling links to other networks.

8.2 *Identifying unauthorized SS7 messages*

In addition to the normal signalling message handling, procedures specified in Recommendation Q.704, it shall be possible to inhibit/allow messages destined for another signalling point (SP) based on any one or combination of the following options:

- i) to inhibit/allow STP access by a combination of designated incoming link sets to designated DPCs;
This combination of DPC/incoming link set shall effectively operate in the form of a single matrix. This matrix shall consist of a maximum of 128 DPCs and a maximum of 64 incoming link sets. (These values are for guidance and may be adjusted to satisfy the requirements of the concerned Operator/Administration.)
- ii) To inhibit/allow STP access by a combination of designated outgoing link sets to designated DPCs.
This combination of DPC/outgoing link set shall effectively operate in the form of a single matrix. This matrix shall consist of a maximum of 128 DPCs and a maximum of 64 outgoing link sets. (These values are for guidance and may be adjusted to satisfy the requirements of the concerned Operator/Administration.)
- iii) to inhibit/allow STP access by examination of OPC and DPC combination in the incoming STP message.
This combination of DPC/OPC shall effectively operate in the form of a single matrix. This matrix shall consist of a maximum of 128 DPCs and a maximum of 128 OPCs. (These values are for guidance and may be adjusted to satisfy the requirements of the concerned Operator/Administration.)

8.3 *Treatment of unauthorized SS7 messages*

An STP identifying unauthorized SS7 messages should be able, on a per link set or per signalling point code basis, to:

- i) provide all unauthorized SS7 messages with the same handling as authorized traffic, or
- ii) discard all unauthorized SS7 messages.

In addition, an STP should be able to:

- i) allow all STP messages outside the designated ranges as given in § 8.2,
- ii) bar (discard) all STP messages outside the designated ranges as given in § 8.2.

8.4 *Measurements*

An STP identifying unauthorized SS7 messages incoming from another network should be able to count and record details of the unauthorized messages on a per link set and/or signalling point code basis.

8.5 *Notification to unauthorized user*

An STP identifying unauthorized SS7 messages from another network may wish to notify the Administration originating the unauthorized message(s).

This notification should be undertaken by administrative means and not involve any mechanism in Signalling System No. 7.

In addition, a violation fault report shall be issued giving the unauthorized message content. It shall be possible to selectively restrict the number of violation reports on a per link set and/or signalling point code basis.

It shall also be possible to inhibit the violation reporting mechanism on a point code/link set basis, nodally, or on a message direction, i.e. if an inhibited message is destined for an RPOA then it shall be possible to suppress the violation reports whilst allowing violation reports on inhibited messages from the RPOA.

ANNEX A
(to Recommendation Q.705)
Mesh signalling network examples

A.1 *General*

This Annex is provided to demonstrate the procedures defined in Recommendation Q.704. While the example uses a specific *mesh* network to demonstrate the procedures, it is not the intent of this annex to recommend either implicitly or explicitly the network described.

The *mesh* network is used to demonstrate the Message Transfer Part level 3 procedures because it is thought to be a possible international network implementation as shown on it, or subsets of it, may be used to construct other network structures.

A.2 *Basic network structures (example)*

Figure A-1/Q.705 shows the basic mesh network structure, while three simplified versions derived from this basic network structure are shown in Figure A-2/Q.705. More complex signalling networks can be built, using these as building components.

In the following, the basic mesh network Figure A-1/Q.705 is taken as an example to explain the procedures defined in Recommendation Q.704.

In this network, each signalling point with level 4 functions is connected by two link sets to two signalling transfer points. Each pair of signalling transfer points is connected to each other pair by four link sets. Moreover, there is a link set between the two signalling transfer points of each pair.

The simplified versions a), b) and c) of the basic signalling network are obtained by deleting respectively:

- a) two out of four intersignalling transfer point link sets;
- b) link sets between signalling transfer points of the same pair; and
- c) a) and b) together.

It should be noted that for a given signalling link availability, the more signalling link sets removed from the basic signalling network [e.g. in going from Figure A-1/Q.705 to Figure A-2c)/Q.705], the lower the availability of the signalling network. However, an increase in the availability of the simplified signalling networks may be attained by adding one or more parallel signalling links to each of the remaining signalling link sets.

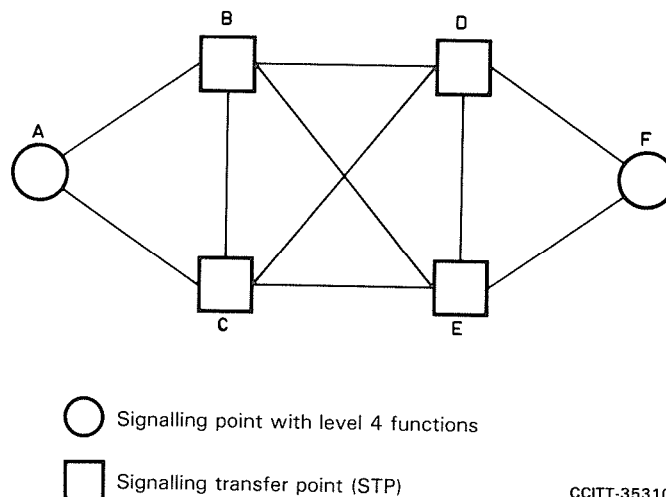
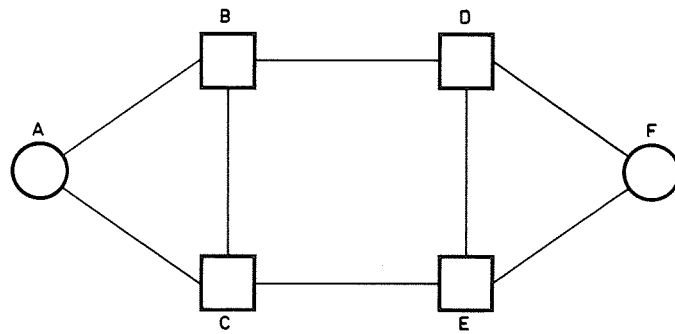
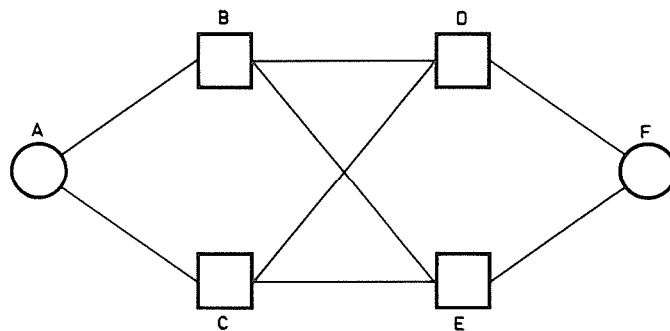

FIGURE A-1/Q.705
Basic mesh network



a) Two out of four inter-STP link sets deleted



b) Link sets between STPs of the same pair deleted

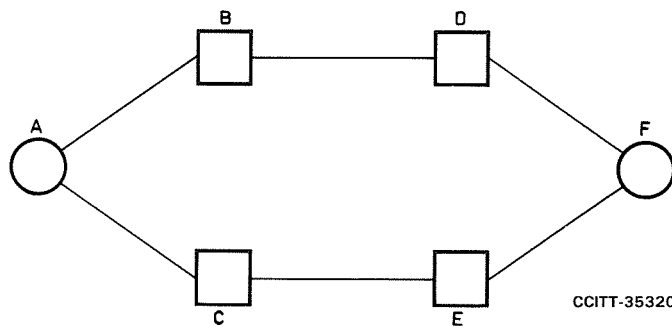

c) Two out of four inter-STP link sets and link sets between STPs of the same pair deleted

FIGURE A-2/Q.705

Simplified versions of the basic mesh network

A.3 Routing

A.3.1 General

This section gives some routing examples in the basic mesh network in Figure A-1/Q.705. Routing actions required to change message routes under failure conditions are described in § A.4. The following routing principles are assumed for the examples in § A.3:

- Message routes should pass through a minimum number of intermediate signalling transfer points.
- Routing at each signalling point will not be affected by message routes used up to the concerned signalling transfer points.

- When more than one message route is available, signalling traffic should be load–shared by such message routes.
- Messages relating to a given user transaction and sent in a given direction will be routed over the same message route to ensure correct message sequence.

A.3.2 Routing in the absence of failures

Figure A–3/Q.705 illustrates an example of routing in the absence of failures for messages from signalling point A to signalling point F.

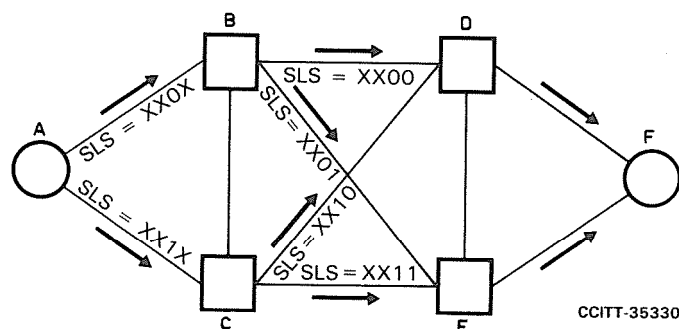

- Normal message routes from A to F
- A → B → D → F (SLS = XX00)
 - A → C → D → F (SLS = XX10)
 - A → B → E → F (SLS = XX01)
 - A → C → E → F (SLS = XX11)

FIGURE A-3/Q.705

An example of routing in the absence of failures

The following points are worthy of note:

- In distributing traffic for load–sharing at the originating signalling point and intermediate signalling transfer points, care should be taken in the use of signalling link selection (SLS) codes so that traffic will be distributed over four available routes evenly. In the example, originating signalling point A uses the second least significant bit of the signalling link selection code, and signalling transfer points B and C the least significant bit.
- Other than that described above, the choice of a particular link for a given signalling link selection code can be made at each signalling point independently. As a result, message routes for a given user transaction (e.g. SLS = 0010) in two directions may take different paths (e.g. A → C → D → F and F → E → B → A).
- Links BC and DE are not used in the absence of failures. They will be used in certain failure situations described in § A.4.
- When the number of links in a link set is not a power of 2 (i.e. 1, 2, 4, 8), SLS load sharing does not achieve even distribution of traffic across the individual links.

A.3.3 Routing under failure conditions

A.3.3.1 Alternative routing information

In order to cope with failure conditions that may arise, each signalling point has alternative routing information which specifies, for each normal link set, alternative link set(s) to be used when the former become(s) unavailable (see Recommendation Q.704, § 4.2).

Table A–1/Q.705 gives, as an example, a list of alternative link sets for all normal link sets at signalling point A and at signalling transfer point B. In the basic mesh network, all link sets except those between signalling transfer points of the same pair are normal links which carry signalling traffic in the absence of failures. In case a normal link set becomes unavailable, signalling traffic formerly carried by that link set should be diverted to the alternative link set with priority 1. Alternative link sets with priority 2 (i.e. link sets between signalling transfer points of the same pair) will be used only when both the normal link set and alternative link set(s) with priority 1 become unavailable.

Paragraphs A.3.3.2 to A.3.3.5 present some typical examples of the consequences of faults in signalling links and signalling points on the routing of signalling traffic. For the sake of simplicity, link sets are supposed to consist of only one link each.

TABLE A-1/Q.705

List of alternative link sets at signalling points A and B

	Normal link set	Alternative link set	Priority ^{a)}	
Signalling point A	AB	AC	1	
	AC	AB	1	
Signalling transfer point B	BA	BC	2	
	BC	None		
	BE	BD	1	
	BD	BC	BC	2
		BE	BE	1
	BC	BC	2	

^{a)} Priority 1 – used with normal link set on load-sharing basis in the absence of failures.
 Priority 2 – used only when all the link sets with priority 1 become unavailable.

A.3.3.2 Single link failure examples

Example 1: Failure of a link between a signalling point and a signalling transfer point (e.g. link AB) (see Figure A-4/Q.705).

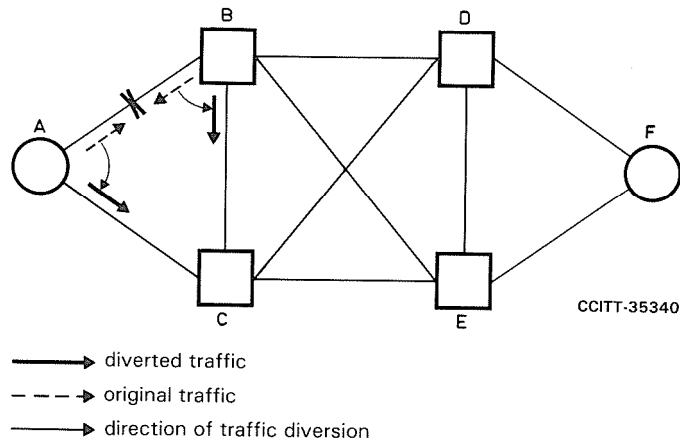

FIGURE A-4/Q.705

Failure of link AB

As indicated in Table A-1/Q.705, A diverts traffic formerly carried by link AB to link AC, while B diverts such traffic to link BC. It should be noted that the number of signalling transfer points traversed by signalling messages from F to A which passes through B is increased by one and becomes three in this case.

The principle to minimize the number of intermediate signalling transfer points in § A.3.1 is applied in this case at signalling transfer point B to get around the failure. In fact, the procedures defined in Recommendation Q.704 assume that traffic is diverted at a signalling point only in the case of a signalling link being unavailable on the route outgoing from that signalling point. Therefore, the procedures do not provide for sending an indication that traffic routed via signalling transfer point B will traverse a further signalling transfer point.

Example 2: Failure of an intersignalling transfer points link (e.g. link BD) (see Figure A-5/Q.705).

As indicated in Table A-1/Q.705, B diverts traffic carried by link BD to link BE. In the same sense, D diverts traffic carried by link DB to link DC.

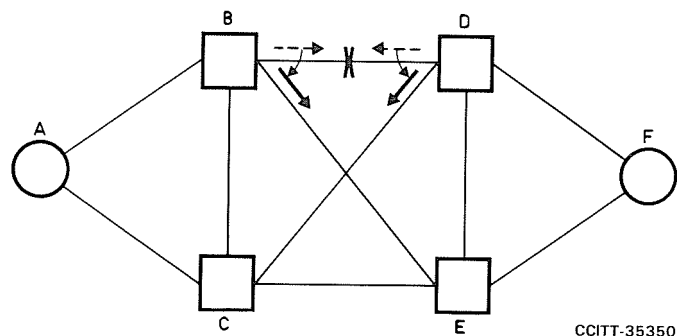

FIGURE A-5/Q.705

Failure of link BD

Example 3: Failure of a link between signalling transfer points of the same pair (e.g. link BC) (see Figure A-6/Q.705).

No routing change is required as a result of this kind of failure. Only B and C take note that the link BC has become unavailable.

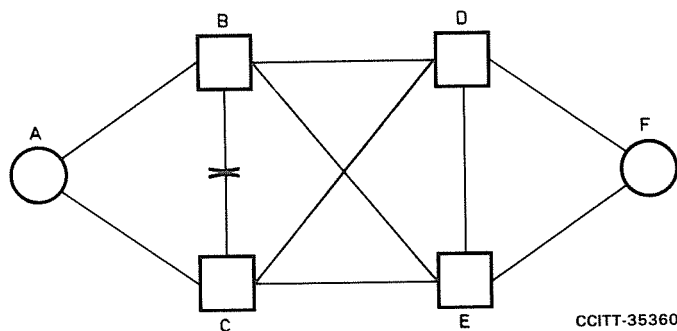

FIGURE A-6/Q.705

Failure of link BC

A.3.3.3 Multiple link failure examples

As there are a variety of cases in which more than one link set becomes unavailable, only some typical cases are given as examples in the following.

Example 1: Failure of a link between a signalling point and a signalling transfer point, and of the link between that signalling transfer point and that of the same pair (e.g. links DF, DE) (see Figure A-7/Q.705).

B diverts traffic destined to F from link BD to link BE, because destination F becomes inaccessible via D. It should be noted that only the traffic destined to F is diverted from link BD to link BE, and not all the traffic on link BD. The same applies to C, which diverts traffic destined to F from link CD to link CE. F diverts all the traffic formerly carried by link FD to link FE in the same way as the single link failure example in § A.3.3.2.

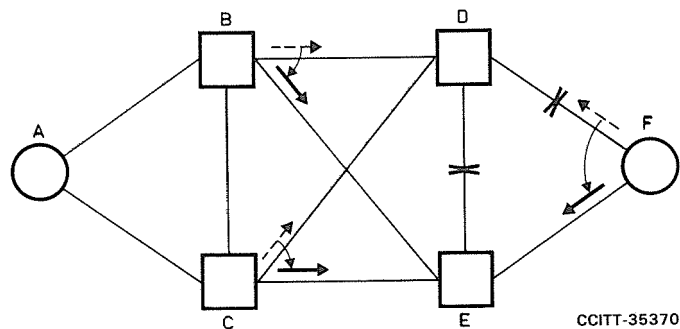

FIGURE A-7/Q.705

Failure of links DE and DF

Example 2: Failure of two intersignalling transfer point links (e.g. links BD, BE) (see Figure A-8/Q.705).

B diverts traffic formerly carried by link BD to link BC, because its alternative link set with priority 1, i.e. link BE, is also unavailable. The same applies to traffic formerly carried by link BE, and B diverts it to link BC. D and E divert traffic formerly carried by links DB and EB respectively to links DC and EC in the same way as the single link failure example in § A.3.3.2.

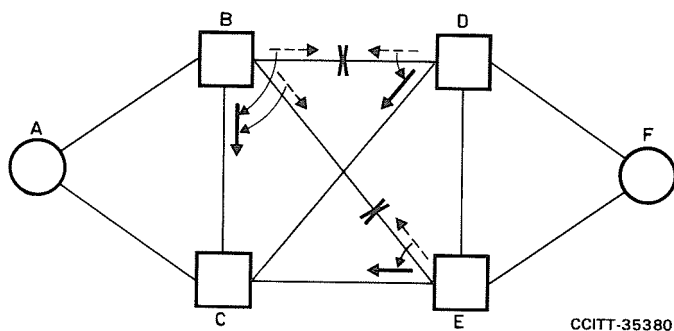

FIGURE A-8/Q.705

Failure of links BD and BE

Example 3: Failure of a link between a signalling point and a signalling transfer point, and of an intersignalling transfer point link (e.g. links DF and BD) (see Figure A-9/Q.705).

This example is a combination of Examples 1 and 2 in § A.3.3.2. D diverts traffic formerly carried by link DF to link DE, while F diverts it to link FE. Moreover D diverts traffic formerly carried by link DB to link DC (this traffic will be that generated by signalling points other than F connected to D). In the same sense, B diverts traffic carried by link BD to link BE.

It should be noted that in this case only the portion of traffic sent by C to F via D traverses three signalling transfer points (C, D and E), while all the other portions continue to traverse two.

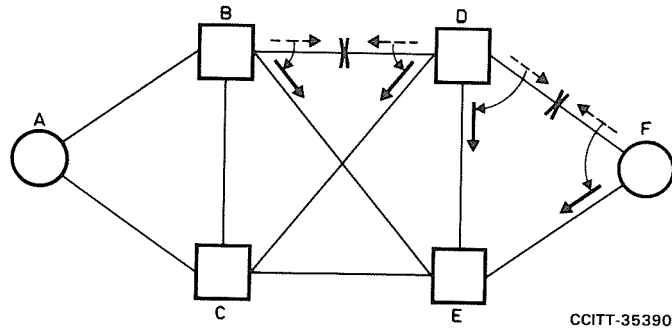

CCITT-35390

FIGURE A-9/Q.705

Failure of links BD and DF

Example 4: Failure of the two links between a signalling point and its signalling transfer points (e.g. DF and EF) (see Figure A-10/Q.705).

In this case the signalling relations between F and any other signalling point of the network are blocked. Therefore F stops all outgoing signalling traffic, while A stops only traffic destined to F.

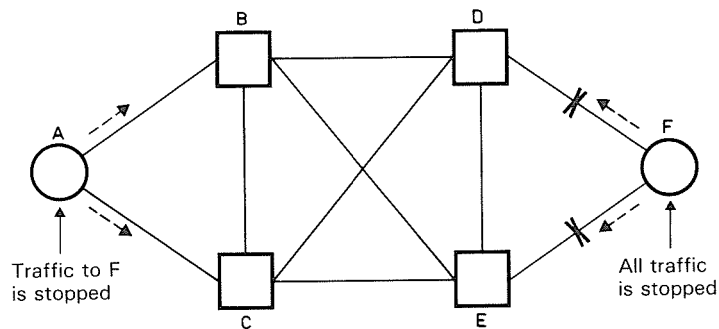

CCITT-35400

FIGURE A-10/Q.705

Failure of links DF and EF

A.3.3.4 *Single signalling point failure examples*

Example 1: Failure of a signalling transfer point (e.g. D) (see Figure A-11/Q.705).

B diverts all the traffic formerly carried by link BD to link BE. The same applies to C which diverts all the traffic carried by link CD to link CE. Originating point F diverts all the traffic carried by link FD to link FE as in the case of the link FD failure (see Example 1 in § A.3.3.2).

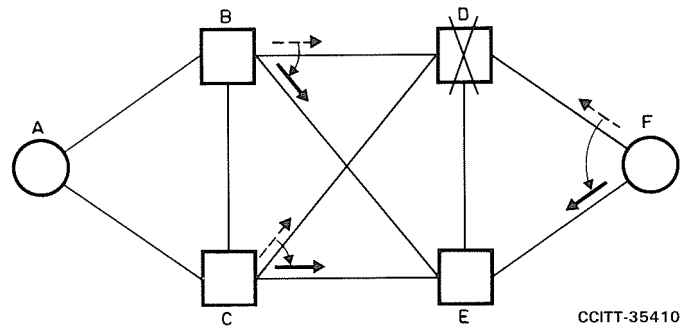

FIGURE A-11/Q.705

Failure of signalling transfer point D

Attention is drawn to the difference to Example 1 in § A.3.3.3 where only a part of the traffic previously carried by links BD and CD was diverted.

Example 2: Failure of a destination point (e.g. F) (see Figure A-12/Q.705).

In this case A stops all the traffic to F formerly carried on links AB and AC.

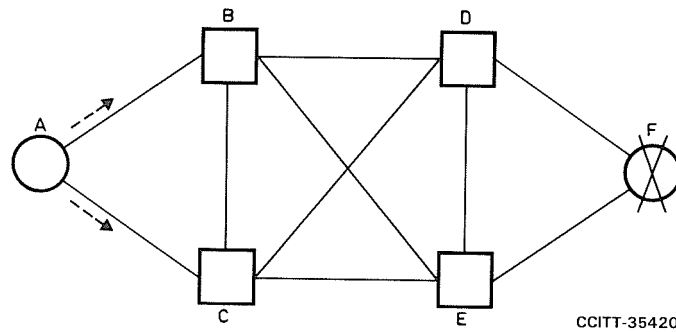

FIGURE A-12/Q.705

Failure of signalling point F

A.3.3.5 Multiple signalling transfer point failure examples

Two typical cases of two signalling transfer points failing together are presented in the following examples.

Example 1: Failure of two signalling transfer points not pertaining to the same pair (e.g. B and D) (see Figure A-13/Q.705).

As a result of the failure of B, A diverts traffic formerly carried by link AB to link AC, while E diverts traffic formerly carried by link EB to link EC. Similarly as a result of the failure of D, F diverts traffic formerly carried by link FD to link FE, while C diverts traffic formerly carried by link CD to link CE.

It should be noted that, in this example, all the traffic between A and F is concentrated on only one intersignalling transfer point link, since failure of a signalling transfer point has an effect similar to a simultaneous failure of all the signalling links connected to it.

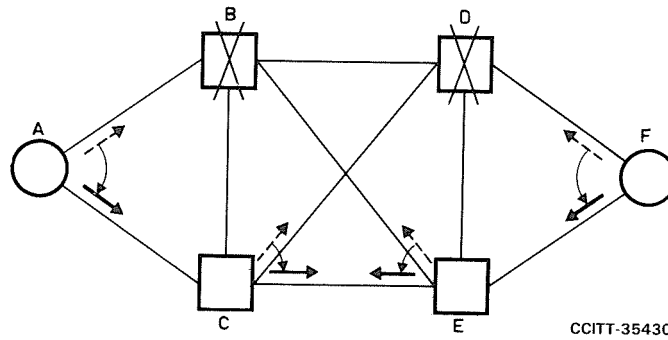

FIGURE A-13/Q.705

Failure of signalling transfer points B and D

Example 2: Failure of two signalling transfer points pertaining to the same pairs (e.g. D and E) (see Figure A-14/Q.705).

This example is equivalent to Example 4 in § A.3.3.3 as far as the inaccessibility of F is concerned, but in this case any other signalling point connected by its links to D and E also becomes inaccessible. In this case A stops signalling traffic destined to F, while F stops all outgoing signalling traffic.

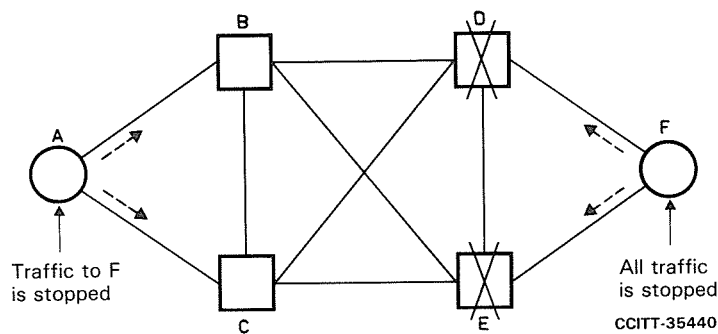

FIGURE A-14/Q.705

Failure of signalling transfer points D and E

A.4 Actions relating to failure conditions

In the following, four typical examples of the application of signalling network management procedures to the failure cases illustrated in § A.3.3 are shown. In the case of multiple failures, an arbitrary failure (and restoration) sequence is assumed for illustrative purpose.

A.4.1 Example 1: Failure of a link between a signalling point and a signalling transfer point (e.g. link AB) (see Figure A-15/Q.705)

(Same as § A.3.3.2, Example 1.)

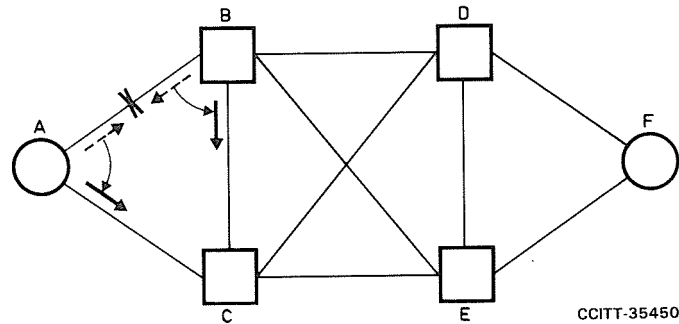

FIGURE A-15/Q.705

Failure of link AB

A.4.1.1 *Failure of link AB*

- a) When the failure of link AB is detected in A and in B, they initiate the changeover procedure, by exchanging changeover messages via C. Once buffer updating is completed, A restarts the traffic originally carried by the failed link on link AC; similarly, B restarts traffic destined to A on link BC.
- b) In addition, B sends a transfer-prohibited message to C referred to destination A (according to the criterion indicated in Recommendation Q.704, § 13.2.2).
- c) On the reception of the transfer-prohibited message, C starts the periodic sending of signalling-route-set-test messages, referred to A, to B (see Recommendation Q.704, § 13.5.2).

A.4.1.2 *Restoration of link AB*

When the restoration of link AB is completed, the following applies:

- a) B initiates the changeback procedure, by sending a changeback declaration to A via C. Once it has received the changeback acknowledgement, it restarts traffic on the restored link. Moreover, it sends to C a transfer-allowed message, referred to destination A (see Recommendation Q.704, § 13.3.2). When C receives the transfer-allowed message, it stops sending signalling-route-set-test messages to B.
- b) A initiates the changeback procedure, by sending a changeback declaration to B via C; once it has received the changeback acknowledgement, it restarts traffic on the normal link. The only traffic to be diverted is that for which link AB is the normal link set according to the load sharing rule (see § A.3.3.1). It must be pointed out, however, that if there is load sharing on parallel links between B and C, there is the possibility of missequencing. Concerning b), for example, the changeback declaration sent from A to B via C might overrun messages still buffered at signalling point C (due to e.g. retransmissions on the parallel link CB).

A.4.2 *Example 2: Failure of signalling transfer point D (see Figure A-16/Q.705)*

(Same as § A.3.3.4, Example 1.)

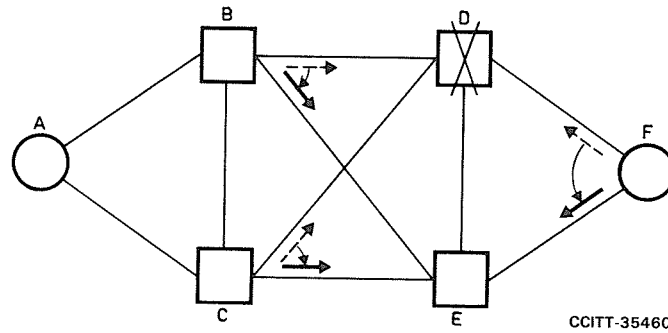

FIGURE A-16/Q.705

Failure of signalling transfer point D

A.4.2.1 *Failure of signalling transfer point D*

- a) Changeover is initiated at signalling points B, C and F from blocked links BD, CD and FD to the first priority alternative links BE, CE and FE respectively. Due to the failure of D, the concerned signalling points will receive no changeover acknowledgement message in response, and therefore they will restart traffic on alternative links at the expiry of the time T2 (see Recommendation Q.704, § 5.7.2). In addition E will send to B, C and F transfer-prohibited messages referred to destination D. These signalling points (B, C and F) will thus start periodic sending to E of signalling-route-set-test messages referred to D.
- b) When B receives a transfer-prohibited message from E referred to D, it updates its routing information so that traffic to D will be diverted to C, thus sending a transfer-prohibited message to C referred to D. The same applies to C, and C sends a transfer-prohibited message to B.
- c) So, when B receives a transfer-prohibited message from C, it finds that destination D has become inaccessible and sends a transfer-prohibited message to A. The same applies to C and thus C also sends a transfer-prohibited message to A. Having received transfer-prohibited messages from both B and C, A recognizes that D has become inaccessible and stops traffic to D.
- d) In the same manner, i.e. link-by-link transmission of transfer-prohibited messages referred to D, other signalling points B, C, E and F will finally recognize that destination D has become inaccessible. Each signalling point will, therefore, start periodic sending of signalling-route-set-test messages referred to D to their respective adjacent signalling points.

A.4.2.2 *Recovery of signalling transfer point D*

- a) Signalling points B, C, E send traffic restart allowed messages to signalling point D, as soon as signalling point D becomes accessible.
- b) Signalling transfer point D broadcasts traffic restart allowed messages, after T20 (see Recommendation Q.704, § 16.8) has stopped or expired, to all adjacent SPs.
- c) Changeback at signalling points B, C and F from the alternative to their normal links is performed. In all the three cases changeback includes the time-controlled diversion procedure (see Recommendation Q.704, § 6.4), since D is still inaccessible via E at B, C and F (as a result of previous reception of transfer-prohibited message from E).
- d) E sends to B, C and F transfer-allowed messages referred to destination D. These signalling points will thus send transfer allowed messages to their respective adjacent signalling points. Thus, the link-by-link transmission of transfer-allowed messages will declare to all signalling points that destination D has become accessible.
- e) On reception of a transfer-allowed message, each signalling point stops periodic sending of signaling-route-set-test messages to their respective adjacent signalling points.
- f) On recovery of the previously unavailable links BD, CD and FD, signalling points B, C and F will restart all the traffic normally routed via signalling transfer point D after T21 (see Recommendation Q.704, § 16.8) has stopped or expired. (They would restart any traffic terminating at D, if D had an endpoint function as well as being an STP, immediately D becomes accessible, that is after successful signalling link tests to D.)

A.4.3 *Example 3: Failure of link between a signalling point and a signalling transfer point, and of the link between that signalling transfer point and that of the same pair (e.g. links DF, DE) (see Figure A-17/Q.705)*

(Same as § A.3.3.3, Example 1.)

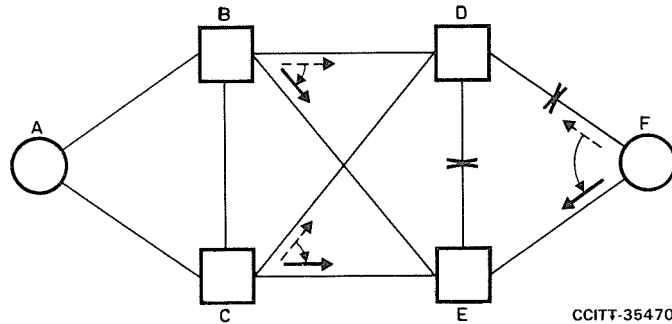

FIGURE A-17/Q.705

Failure of links DE and DF

A.4.3.1 *Failure of link DE*

On failure of link DE, this link is marked unavailable at both signalling transfer points D and E. Since in the absence of failures, link DE does not carry signalling traffic, no change in message routing takes place at this time.

However, D and E send to signalling points B, C and F transfer-prohibited messages referred to destination E or D respectively. These signalling points will thus start periodic sending of signalling-route-set-test messages, referred to D or E, to E and D respectively.

A.4.3.2 *Failure of link DF in the presence of failure of link DE*

- a) On failure of link DF the following actions occur:
 - i) Signalling point D which no longer has access to signalling point F indicates this condition to signalling transfer points B and C by sending transfer-prohibited messages. B and C will thus start the periodic sending of signalling-route-set-test messages referred to F, to D.
 - ii) Emergency changeover from link FD to link FE is initiated at signalling point F, since D becomes inaccessible to F due also to the previous failure.
- b) On receiving the transfer-prohibited messages forced rerouting is initiated at points B and C. This causes traffic destined to F to be diverted from links terminating on D to links terminating on E. Forced rerouting thus permits recovery from a failure condition caused by a fault in a remote part of the network.

A.4.3.3 *Restoration of link FD in the presence of failure of link DE*

- a) On recovery of link FD the following actions occur:
 - i) Signalling point D sends a transfer-allowed message to B and C to indicate that D once again has access to F. B and C will thus stop the sending of signalling-route-set-test messages referred to F to D.
 - ii) F initiates changeback with time controlled diversion from link FE to link FD. This procedure permits changeback to be executed at one end of a link, when it is impossible to notify the other end of the link (in this example, because link DE is unavailable). Traffic in this case is not diverted from the alternative link until a time interval has elapsed, in order to minimize the danger of mis-sequencing of messages (see Recommendation Q.704, § 6.4).
- b) On receiving the transfer-allowed message, controlled rerouting of traffic from the alternative routes (BEF, CEF) to the normal routes (BDF, CDF) is initiated at points B and C. Controlled rerouting involves diversion of traffic to a route which has become available after a time interval (see Recommendation Q.704, § 8.2.1), provisionally set at one second to minimize the danger of mis-sequencing messages.

A.4.3.4 Restoration of link DE

On recovery of link DE it is marked available at signalling transfer points D and E. Signalling points D and E send to B, C and F transfer-allowed messages referred to destination E or D respectively. These signalling transfer points will thus stop sending of signalling-route-set-test messages.

A.4.4 Example 4: Failure of links DF and EF (see Figure A-18/Q.705)

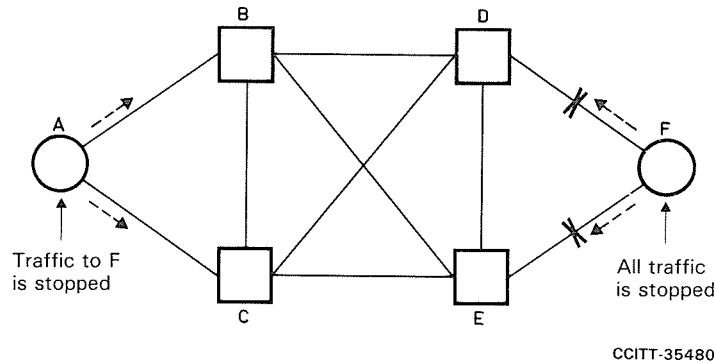

FIGURE A-18/Q.705

Failure of links DF and EF

A.4.4.1 Failure of link DF

When the failure of link DF is detected, D and F perform the changeover procedure; D diverts traffic, destined to F, to link DE, while F concentrates all the outgoing traffic on link FE.

In addition, D sends to E a transfer-prohibited message, referred to destination F; E will thus start sending of signalling-route-set-test messages, referred to F, towards D (see also § A.4.1.1).

A.4.4.2 Failure of link EF in the presence of failure of link DF

- a) When the failure of link EF is detected, the following applies:
 - i) Since all destinations become inaccessible F stops sending all signalling traffic.
 - ii) E sends to B, C and D a transfer-prohibited message, referred to destination F. B, C and D start periodic sending of signalling-route-set-test messages referred to F to E.
- b) When D receives the transfer-prohibited message, it sends to B and C a transfer-prohibited message, referred to destination F (see Recommendation Q.704, § 13.2.2 ii)). B and C start periodic sending of test messages referred to F to D.
- c) When B receives the transfer-prohibited messages from D and E, it sends a transfer-prohibited message to C; the same applies for C (it sends the message to B). As soon as B and C have received the transfer-prohibited messages from all the three possible routes (BD, BE and BC, or CD, CE and CB respectively), they send a transfer-prohibited message to A.

Note – Depending on the sequence of reception of transfer-prohibited messages at B or C, they may start a forced rerouting procedure on a route not yet declared to be unavailable; such procedure is then aborted as soon as a transfer-prohibited message is received also from that route.

- d) As soon as A receives the transfer-prohibited messages from B and C, it declares destination F inaccessible and stops sending traffic towards it. Moreover, it starts the periodic sending of signalling-route-set-test messages, referred to F, to B and C.

A.4.4.3 Restoration of link EF in the presence of failure on link DF

- a) When restoration of link EF is completed, the following applies:
 - i) Signalling point F restarts traffic on link EF.
 - ii) E sends a transfer-allowed message, referred to destination F, to B, C and D; moreover it restarts traffic on the restored link.
- b) When B and C receive the transfer-allowed message, they send a transfer-allowed message to A and C or A and B, respectively and they stop sending signalling-route-set-test messages to E; moreover, they restart the concerned traffic on link BE or CE respectively.

- c) When D receives the transfer-allowed message from E, it sends transfer-allowed messages to B and C and stops sending signalling-route-set-test messages to E; moreover, it starts the concerned traffic on link DE. On receipt of the transfer-allowed message, B and C will divert to links BD and CD, by means of a controlled rerouting procedure, traffic carried by links BE and CE for which they are the normal links (see § A.3.3). Moreover, they will stop sending signalling-route-set-test messages to D.

Note – According to the rules stated in Recommendation Q.704, § 13.3.2, on receipt of transfer-allowed messages from E [phase b) above], B and C should send transfer-allowed messages also to D and E. However, this is not appropriate in the network configurations such as the one here considered, taking into account that:

- there is no route, for example, from D (or E) to F via B (or C) and therefore the transfer-allowed messages would be ignored by D and E;
 - on restarting traffic to F on links BD, BE, CD and CE it would anyway be necessary that B and C send transfer-prohibited messages to D and E, which would contradict the previous transfer-allowed messages.
- d) As soon as A receives a transfer-allowed message from B or C, it restarts signalling traffic to B and C. If traffic has already been restarted on one link when the transfer-allowed message is received on the other link, a changeback procedure is performed to establish the normal routing situation on both links (i.e. to divert part of the traffic on the latter link).

A.4.4.4 *Restoration of link DF*

When the restoration of link DF is completed, the following applies:

- a) D initiates the changeback procedure to link DF; moreover, it sends to E a transfer-allowed message, referred to destination F,
- b) F sends signalling-route-set-test message to D referred to the destination points it normally accesses via D. It initiates the changeback procedure to link DF; this procedure refers only to the traffic for which link DF is the normal one, according to the routing rules.

A.5 *Explanatory note from the implementors forum for clarification of load sharing*

A.5.1 In general, to improve the distribution of traffic, load sharing at a particular signalling point (amongst link sets to a given destination) will be on the basis of a part of the signalling link selection field which is different than that part used for load sharing amongst signalling links within a selected link set. In the example represented in Figure 5/Q.704, if link set DF contains more than one signalling link, then the least significant bit of the signalling link selection field is not used in sharing traffic within link set DF amongst the signalling links. Similar considerations can apply to link set DE.

A.5.2 At an originating signalling point it is assumed that for a given signalling relation, signalling link selection field values are evenly distributed and traffic is shared over the appropriate link sets and signalling links within each link set on this basis. In general, to achieve this a different load sharing rule is needed for each number of link sets, and each number of signalling links within a link set, over which traffic is to be shared. The intention is to attain, for a given signalling relation, as even as possible a traffic balance over the link sets and the signalling links within each link set, based on the signalling link selection field and the numbers of link sets and signalling links within each link set; such an even traffic balance may result if the fixed part of the signalling link selection field is not excluded from consideration by the load sharing rules.

A.5.3 At a signalling transfer point, for a given signalling relation, signalling link selection field values may not be evenly distributed (see Figure 5/Q.704, signalling transfer point E). A different set of load sharing rules to those for originating signalling points may be provided to deal with this possibility. These are again based on the signalling link selection field and the numbers of link sets and signalling links within each link set, but assume that a particular part of the signalling link selection field is fixed. The fixed part of the signalling link selection field may be different at different signalling transfer points. Where signalling messages for different signalling relations arriving at a particular signalling transfer point do not have the same part of the signalling link selection field fixed, an uneven sharing of traffic for a particular signalling relation amongst the relevant link sets and signalling links within each link set may result.

ITU-T RECOMMENDATIONS SERIES

Series A	Organization of the work of the ITU-T
Series B	Means of expression: definitions, symbols, classification
Series C	General telecommunication statistics
Series D	General tariff principles
Series E	Overall network operation, telephone service, service operation and human factors
Series F	Non-telephone telecommunication services
Series G	Transmission systems and media, digital systems and networks
Series H	Audiovisual and multimedia systems
Series I	Integrated services digital network
Series J	Transmission of television, sound programme and other multimedia signals
Series K	Protection against interference
Series L	Construction, installation and protection of cables and other elements of outside plant
Series M	TMN and network maintenance: international transmission systems, telephone circuits, telegraphy, facsimile and leased circuits
Series N	Maintenance: international sound programme and television transmission circuits
Series O	Specifications of measuring equipment
Series P	Telephone transmission quality, telephone installations, local line networks
Series Q	Switching and signalling
Series R	Telegraph transmission
Series S	Telegraph services terminal equipment
Series T	Terminals for telematic services
Series U	Telegraph switching
Series V	Data communication over the telephone network
Series X	Data networks and open system communications
Series Y	Global information infrastructure and Internet protocol aspects
Series Z	Languages and general software aspects for telecommunication systems