



INTERNATIONAL TELECOMMUNICATION UNION

**ITU-T**

TELECOMMUNICATION  
STANDARDIZATION SECTOR  
OF ITU

**P.342**

(08/96)

SERIES P: TELEPHONE TRANSMISSION QUALITY

Subscribers' lines and sets

---

**Transmission characteristics for telephone  
band (300 - 3400 Hz) digital loudspeaking and  
hands-free telephony terminals**

ITU-T Recommendation P.342

(Previously CCITT Recommendation)

---

ITU-T P-SERIES RECOMMENDATIONS  
TELEPHONE TRANSMISSION QUALITY

Vocabulary and effects of transmission parameters on customer opinion of transmission quality	Series P.10
<b>Subscribers' lines and sets</b>	<b>Series P.30 P.300</b>
Transmission standards	Series P.40
Objective measuring apparatus	Series P.50 P.500
Objective electro-acoustical measurements	Series P.60
Measurements related to speech loudness	Series P.70
Methods for objective and subjective assessment of quality	Series P.80 P.800
Audiovisual quality in multimedia services	Series P.900

*For further details, please refer to ITU-T List of Recommendations.*

## **ITU-T RECOMMENDATION P.342**

### **TRANSMISSION CHARACTERISTICS FOR TELEPHONE BAND (300 - 3400 HZ) DIGITAL LOUDSPEAKING AND HANDS-FREE TELEPHONY TERMINALS**

#### **Summary**

This Recommendation provides audio performance requirements for loudspeaking and hands-free telephony terminals using, in the telephone band (300-3400 Hz), the waveform encoding according to Recommendations G.711 [3] (PCM at both 64 kbit/s and 56 kbit/s) and G.726 [12] (ADPCM 32 kbit/s).

It gives recommended values or masks for the following parameters: loudness ratings, sensitivity frequency response, harmonic distortion, out-of-band signals, terminal coupling loss, stability loss and delay.

Annex A proposes recommended test methods, including the test conditions.

The electrical interface specifications are referred to Recommendation P.310.

#### **Source**

ITU-T Recommendation P.342 was revised by ITU-T Study Group 12 (1993-1996) and was approved under the WTSC Resolution N°. 1 procedure on the 30th of August 1996.

## FOREWORD

ITU (International Telecommunication Union) is the United Nations Specialized Agency in the field of telecommunications. The ITU Telecommunication Standardization Sector (ITU-T) is a permanent organ of the ITU. The ITU-T is responsible for studying technical, operating and tariff questions and issuing Recommendations on them with a view to standardizing telecommunications on a worldwide basis.

The World Telecommunication Standardization Conference (WTSC), which meets every four years, establishes the topics for study by the ITU-T Study Groups which, in their turn, produce Recommendations on these topics.

The approval of Recommendations by the Members of the ITU-T is covered by the procedure laid down in WTSC Resolution No. 1 (Helsinki, March 1-12, 1993).

In some areas of information technology which fall within ITU-T's purview, the necessary standards are prepared on a collaborative basis with ISO and IEC.

## NOTE

In this Recommendation, the expression "Administration" is used for conciseness to indicate both a telecommunication administration and a recognized operating agency.

© ITU 1996

All rights reserved. No part of this publication may be reproduced or utilized in any form or by any means, electronic or mechanical, including photocopying and microfilm, without permission in writing from the ITU.

## CONTENTS

	<b>Page</b>
1	Scope..... 1
2	Normative references..... 1
3	Definitions and abbreviations..... 2
4	Sending characteristics..... 2
4.1	Sending loudness rating..... 2
4.2	Sensitivity frequency response..... 3
4.3	Noise..... 3
4.4	Harmonic distortion..... 3
4.5	Out-of-band signals..... 4
5	Receiving characteristics..... 4
5.1	Receiving loudness rating..... 4
5.2	Sensitivity frequency response..... 4
5.3	Noise..... 5
5.3.1	A-weighted..... 5
5.3.2	Third-octave band spectrum..... 5
5.4	Harmonic distortion..... 5
5.5	Out-of-band signals..... 6
6	Echo path loss characteristics..... 6
6.1	Terminal coupling loss..... 6
6.1.1	Hands-free function..... 6
6.1.2	Loudspeaking function..... 7
6.2	Stability loss..... 7
7	Delay..... 7
Annex A	- Test methods..... 7
A.1	Electrical interface specifications..... 7
A.2	Test conditions..... 7
A.2.1	Test rooms..... 7
A.2.2	Test arrangement..... 10
A.2.3	Electroacoustic equipment..... 11
A.2.4	Test signals..... 12
A.2.5	Test signal levels..... 12
A.2.6	Accuracy of calibrations..... 13

	<b>Page</b>
A.3 Transmission requirements testing .....	13
A.3.1 Sensitivity frequency response .....	13
A.3.2 Loudness ratings .....	14
A.3.3 Terminal coupling loss .....	14
A.3.4 Stability loss .....	15
A.3.5 Harmonic distortion.....	15
A.3.6 Out-of-band signals .....	15
A.3.7 Noise.....	16
A.3.8 Delay.....	16

## Recommendation P.342

### TRANSMISSION CHARACTERISTICS FOR TELEPHONE BAND (300 - 3400 Hz) DIGITAL LOUDSPEAKING AND HANDS-FREE TELEPHONY TERMINALS

(Geneva, 1996)

#### 1 Scope

This Recommendation provides audio performance requirements for loudspeaking and hands-free telephony terminals using, in the telephone band (300 - 3400 Hz), the waveform encoding according to Recommendations G.711 [3] (PCM at both 64 kbit/s and 56 kbit/s) and G.726 [12] (ADPCM 32 kbit/s).

The test methods are described in Annex A.

The use of digital telephones using G.728 [13] (LD-CELP, 16 kbit/s) is under study.

The requirements listed in this Recommendation should also be used as a basis of requirements for other waveform encoding schemes.

#### 2 Normative references

The following Recommendations and other references contain provisions which, through reference in this text, constitute provisions of this Recommendation. At the time of publication, the editions indicated were valid. All Recommendations and other references are subject to revision: all users of this Recommendation are therefore encouraged to investigate the possibility of applying the most recent edition of the Recommendations and other references listed below. A list of the currently valid ITU-T Recommendations is regularly published.

- [1] ITU-T Recommendation P.310 (1996), *Transmission characteristics for telephone band (300 - 3400 Hz) digital telephones.*
- [2] ITU-T Recommendation G.122 (1993), *Influence of national systems on stability, talker echo, in international connections.*
- [3] CCITT Recommendation G.711 (1988), *Pulse Code Modulation (PCM) of voice frequencies.*
- [4] ITU-T Recommendation P.340 (1996), *Transmission characteristics of hands-free telephones.*
- [5] ITU-T Recommendation P.51 (1996), *Artificial mouth.*
- [6] ITU-T Recommendation P.79 (1993), *Calculation of loudness ratings for telephone sets.*
- [7] ISO Publication 266: 1975, *Acoustics – Preferred frequencies for measurements.*
- [8] IEC 1260: 1995, *Electroacoustics – Octave-band and fractional octave-band filters.*
- [9] IEC 651: 1979, *sound level metres.*
- [10] CCITT Recommendation G.223 (1984), *Assumptions for the calculation of noise on hypothetical reference circuits for telephony.*
- [11] ITU-T Recommendation O.41 (1994), *Psophometer for use on telephone-type circuits.*
- [12] CCITT Recommendation G.726 (1990), *40, 32, 24, 16 kbit/s Adaptive Differential Pulse Code Modulation (ADPCM).*

- [13] CCITT Recommendation G.728 (1992), *Coding of speech at 16 kbit/s using low-delay code excited linear prediction.*
- [14] CCITT Recommendation G.131 (1988), *Stability and echo.*
- [15] ITU-T Recommendation P.501 (1996), *Test signals for use in telephony.*

### 3 Definitions and abbreviations

For the purposes of this Recommendation, the following definitions are used.

- 3.1 acoustic reference level (ARL):** Is defined as the acoustic level which gives  $-10$  dBm<sub>0</sub> at the digital interface.
- 3.2 hands-free reference point (HFRP):** A point located on the axis of the artificial mouth, at 50 cm from the lip ring, where the level calibration is made, in free field. It corresponds to the measurement point 11, as defined in Recommendation P.51 [5].
- 3.3 hands-free (telephone) (HFT) set:** A telephone set using a loudspeaker associated with an amplifier as a telephone receiver and which may be used without a handset.
- 3.4 loudspeaking (telephone) (LST) set:** A handset telephone using a loudspeaker associated with an amplifier as a telephone receiver.
- 3.5 single talk:** An operation mode, where only one user is speaking.
- 3.6 double talk:** An operation mode, where two users are speaking simultaneously.

For the purposes of this Recommendation, the following abbreviations are used.

AEC	Acoustic Echo Controller
AGC	Automatic Gain Control
CSS	Composite Source Signal
HATS	Head And Torso Simulator
LRGP	Loudness Rating Guard-ring Position
MRP	Mouth Reference Point
RLR	Receiving Loudness Rating
SLR	Sending Loudness Rating
TCL	Terminal Coupling Loss
TCL <sub>w</sub>	Weighted Terminal Coupling Loss

### 4 Sending characteristics

#### 4.1 Sending loudness rating

The nominal value of SLR is +13 dB.

This value is derived from Recommendation P.310 [1]. According to Recommendation P.340 [4], the SLR of a hands-free telephone should be about 5 dB (higher) than the SLR of the corresponding handset telephone.



## 4.2 Sensitivity frequency response

The sending sensitivity frequency response, from Mouth Reference Point (MRP) to digital interface, shall be within the mask drawn on Figure 1.

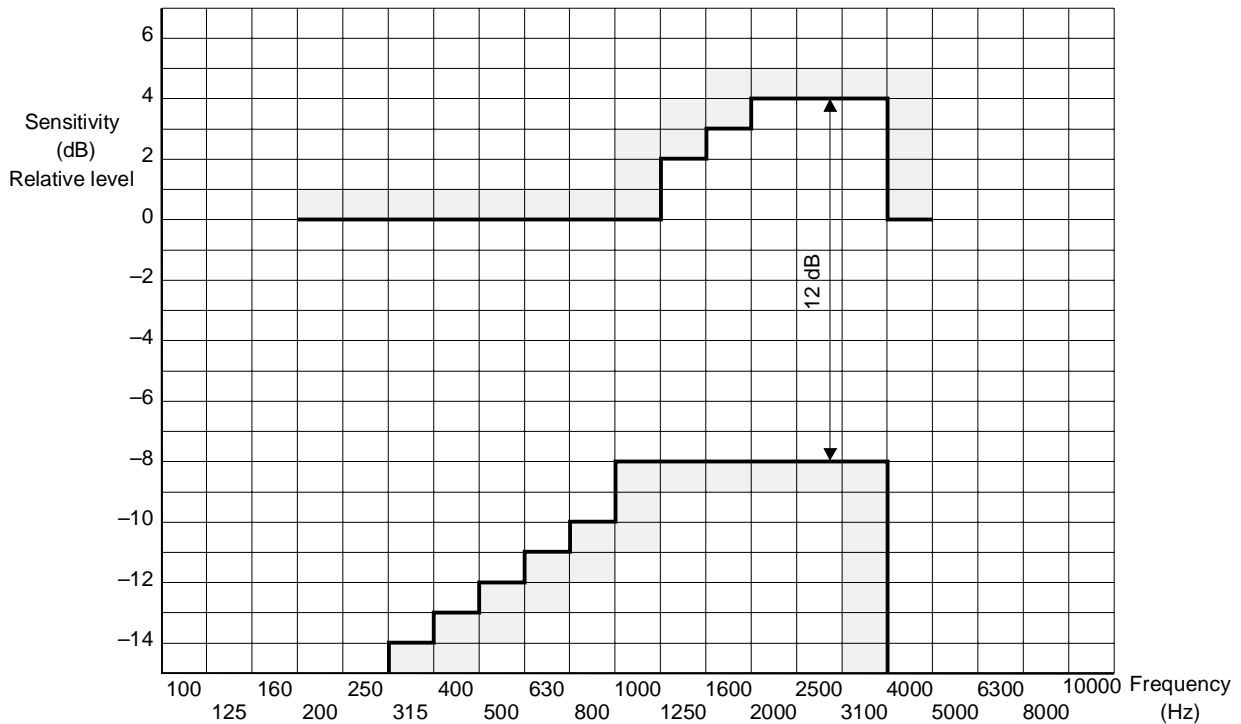

T1207400-95

FIGURE 1/P.342

### Sending sensitivity frequency mask for HFT

All sensitivity values are dB on an arbitrary scale.

Useful information on optimum frequency response can be found in Recommendation P.340 [4].

## 4.3 Noise

The noise produced by the set in the sending path shall not exceed  $-64$  dBm0p.

## 4.4 Harmonic distortion

The ratio of signal to harmonic distortion shall be above the mask defined in Table 1.

TABLE 1/P.342

Frequency	Ratio
315 Hz	26 dB
400 Hz	30.5 dB
1 kHz	30.5 dB

Limits at intermediate frequencies lie on a straight line drawn between the given values on a linear (dB ratio) - logarithmic (frequency) scale.

#### **4.5 Out-of-band signals**

With any signal above 4.6 kHz and up to 8 kHz the level of any image frequency produced at the digital interface shall be below the level obtained for the reference signal, by at least the amount (in dB) specified in Table 2.

TABLE 2/P.342

Frequency	Limit (minimum)
4.6 kHz	30 dB
8 kHz	40 dB

Limits at intermediate frequencies lie on a straight line drawn between the given values on a linear (dB ratio) - logarithmic (frequency) scale.

### **5 Receiving characteristics**

#### **5.1 Receiving loudness rating**

The nominal value of RLR is +2 dB.

The RLR value shall be met for at least one setting of the volume control (when manually operated).

This value is derived from Recommendation P.310 [1]. According to Recommendation P.340 [4], the volume control range should span the value of the receiving loudness rating which is equal to that of the corresponding handset telephone, as well as an RLR value about 10 dB lower.

#### **5.2 Sensitivity frequency response**

The receiving sensitivity frequency responses, from the digital interface to the measuring point C, shall be within the masks drawn in Figure 2.

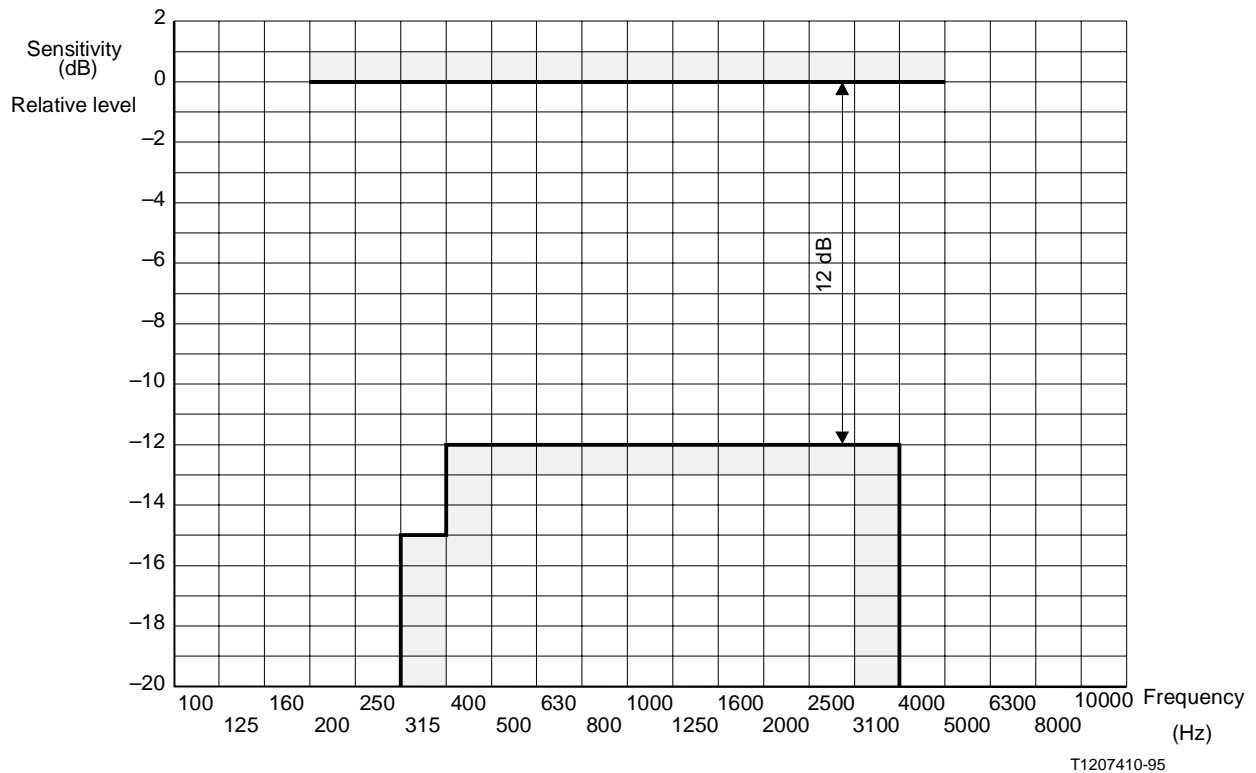

FIGURE 2/P.342

**Receiving sensitivity frequency mask for HFT**

All sensitivities are dB on an arbitrary scale.

The frequency response should be flat in the frequency range of 300 - 3400Hz.

**5.3 Noise**

**5.3.1 A-weighted**

With the volume control set to the maximum, the noise level shall not exceed  $-49$  dBPa(A).

**5.3.2 Third-octave band spectrum**

With the volume control set to the maximum, the level in any third-octave band, between 100 Hz and 10 kHz, shall not exceed a value of  $-59$  dBPa.

**5.4 Harmonic distortion**

The ratio of signal to harmonic distortion shall be above the mask defined in Table 3.

TABLE 3/P.342

**Signal to harmonic distortion ratio, receiving**

Frequency	Hands-free function	Loudspeaking function
315 Hz	26 dB	20 dB
400 Hz	26 dB	26 dB
500 Hz	30.5 dB	30.5 dB
1 kHz	30.5 dB	30.5 dB

Limits at intermediate frequencies lie on a straight line drawn between the given values on a linear (dB ratio) - logarithmic (frequency) scale.

**5.5 Out-of-band signals**

Any spurious out-of-band image signals in the frequency range from 4.6 to 8 kHz measured selectively at the point C shall be lower than the in-band level measured with a reference signal. The minimum level difference between the reference signal level and the out-of-band image signal level shall be as given in Table 4.

TABLE 4/P.342

Frequency	Limit (minimum)
4.6 kHz	35 dB
8 kHz	45 dB

The limit at intermediate frequencies lie on a straight line drawn between the given values on a linear (dB) - logarithmic (frequency) scale.

**6 Echo path loss characteristics**

**6.1 Terminal coupling loss**

**6.1.1 Hands-free function**

The weighted Terminal Coupling Loss (TCLw), in single talk operation, shall be greater than 40 dB with SLR + RLR normalized to OLR = +15 dB.

NOTE – This normalization is referred to the nominal setting of the receiving volume control.

It is assumed that this requirement is met if TCL and TCLw, respectively, meet the values of Table 5 with the receive volume control in its maximum setting.

TABLE 5/P.342

TCL (Third-octave band)	TCLw
>25 dB	>35 dB
NOTE – These values assume no other echo control in the connection.	

If information is available in the terminal about the one-way transmission time of the connection, and if the terminal operates in double talk, then the limits defined in Table 6 may apply. X is under study.

The values in Table 6 are derived from those defined in Table 5. Values in brackets are under study.

TABLE 6/P.342

	One-way transmission time	TCL (Third-octave band)	TCLw
Single talk	$\leq 25$ ms	$>(18)$ dB	$>(24)$ dB
Double talk	$>25$ ms	$>(25 - X)$ dB	$>(35 - X)$ dB
	$\leq 25$ ms	$>(12 - X)$ dB	$>(18 - X)$ dB

However, in order to meet G.131 [14] talker echo objective requirements, a weighted terminal coupling loss greater than 45 dB is desirable and should be striven for.

### 6.1.2 Loudspeaking function

TCL shall be greater than 25 dB and TCLw shall be greater than 35 dB.

When one-way transmission time is less than (25) ms, the TCL shall be greater than (18) dB and TCLw shall be greater than (24) dB.

If there is a voice switching device for the enhancement of the TCLw, it shall be assumed that, in double talk, the sending path of the associated handset gets priority over the loudspeaking path.

### 6.2 Stability loss

The attenuation from the digital input to the digital output shall be, at any time, at least 6 dB, for all frequencies in the range of 200 Hz to 4 kHz.

## 7 Delay

The total delay shall be less than 8 ms (5 ms for the telephone set to allow digital signal processing and 3 ms for the air path) for the digital telephones using G.711 [3] coding, and 8.75 ms for G.726 encoding.

Measurements shall be performed on the two paths separately. The total delay is the summation of these two values.

NOTE – An extra delay could result from the AEC processing in the processing unit. For end-to-end digital communications, the delay shall be no more than (16) ms in each direction of speech transmission.

## Annex A

### Test methods

(This annex forms an integral part of this Recommendation)

#### A.1 Electrical interface specifications

Subclauses B.2 to B.5/P.310 [1] shall apply in this Recommendation.

#### A.2 Test conditions

##### A.2.1 Test rooms

1 For the repeatability of the tests, the environment for most of the measurements shall be free field (anechoic) down to the lowest frequency of the third-octave band centred on 200 Hz.

Satisfactory free field conditions exist where errors, due to the departure from ideal conditions, do not exceed the values defined in Table A.1, inside a sphere centred on point B (see Figure 3/P.340 [4]), with one metre radius, in absence of the table.

TABLE A.1/P.342

Third-octave band centre frequency (Hz)	Allowable departure (dB)
<630	±1.5
800 to 5000	±1
>6300	±1.5

The test signal level for verification of the free field is -20 dBPa.

Measurements are made along the seven axes which are numbered (1) to (7) in Figure A.1, with the sound source placed at positions equivalent to B or C, as appropriate. Measurement points along each axis, taken from the front plan of the artificial mouth lip-ring, are at the distances of 315 mm, 400 mm, 500 mm, 630 mm, 800 mm and 1000 mm.

2 The broadband noise level shall not exceed -70 dBPa(A). The octave band noise level shall not exceed the values specified in Table A.2.

TABLE A.2/P.342

**Noise level**

Centre frequency (Hz)	Octave band pressure level (dBPa)
63	-45
125	-60
250	-65
500	-65
1 k	-65
2 k	-65
4 k	-65
8 k	-65

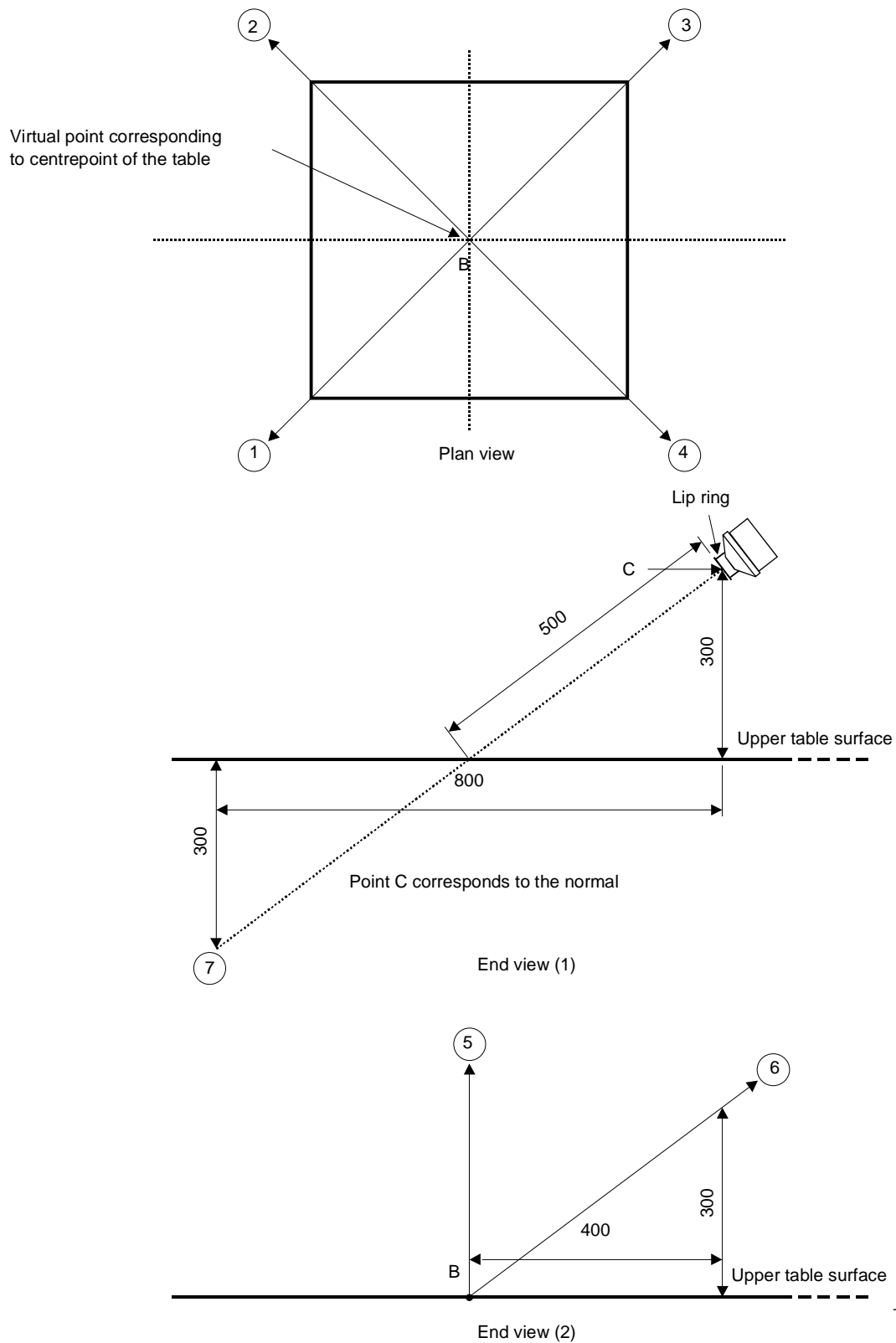

Dimensions in millimetres  
 Points 1, 2, 3 and 4 are in the horizontal plane normally occupied by the table surface  
 Measurements of free field sound pressure are made in absence of the table  
 Axes used in the determination of free field conditions for 1 m radius sphere

FIGURE A.1/P.342

**Axes used in the determination of free field conditions for 1 m radius sphere**

NOTE (informative) – A room including the test arrangement fulfilling the following requirements probably meets the satisfactory conditions.

Dimensions of the room: height  $\geq 2.2$  m; volume  $V \geq 30$  m<sup>3</sup>.

The table should be placed horizontally in the centre of the test room and there should be an inclination of  $\sim 30^\circ$  between the table and the ceiling.

The reverberation time  $T$ , measured at points B and C, should satisfy the following inequality:

$$T(s) \leq 0.0033 V \text{ (m}^3\text{)}; \text{ which is based on a calculation with the radius of 50 cm.}$$

## A.2.2 Test arrangement

### A.2.2.1 Hands-free terminal

The HFT is placed on a the table according to Recommendation P.340 [4] (subclause 6.1/P.340: Test table; subclause 6.2/P.340: Test arrangements and Figure 3/P.340 [4]).

The artificial mouth axis and the microphone axis are coincident with the straight line drawn between point C and point B (see Figure A.2).

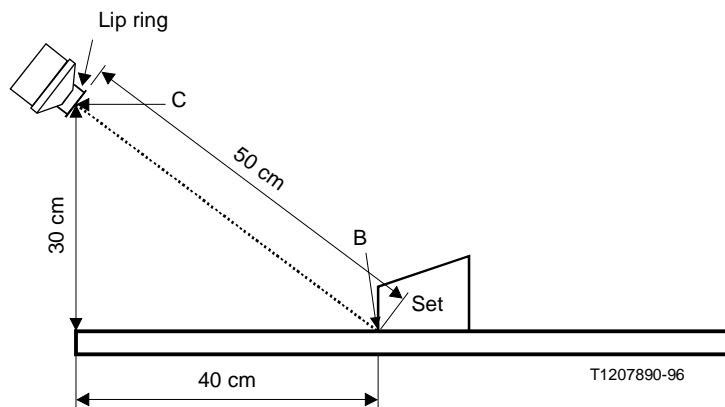

FIGURE A.2/P.342  
Measurement configuration

For stability control, the different pieces of the HFT (if the HFT is built in two or more pieces) shall be placed as close as possible to each other, but without modifying the normal using of the HFT.

NOTE – If HFT is implemented in two or more pieces, care should be taken to ensure that the test arrangement does not modify the normal use of the HFT. The case of special terminals (multifunctions, etc.) including the hands-free function is for further study.

### A.2.2.2 Loudspeaking function

The set is placed on the table according to Recommendation P.340 [4] (subclause 6.1/P.340: Test table; subclause 6.2/P.340: Test arrangements).

For TCL measurements, the handset earphone "centre" shall be placed at point C with the microphone vertical below the earphone. The meaning of "centre" is the centre of the surface of the handset earphone which is placed normally against the ear. This surface is set at 90 degrees relative to the loudspeaker.



For stability measurements, the handset shall be placed as defined in clause 11/P.310 (stability loss) [1]. The set shall be placed symmetrically to the axis of the handset. The front side of the terminal is directed towards the corner formed by the three surfaces with its front edge at a distance of 1 m from this corner.

For the test of all characteristics except TCL and stability loss, the handset shall be placed in the LRGP on the test head. The centre of the artificial mouth lip-ring shall be placed at point D, as shown on Figure A.3.

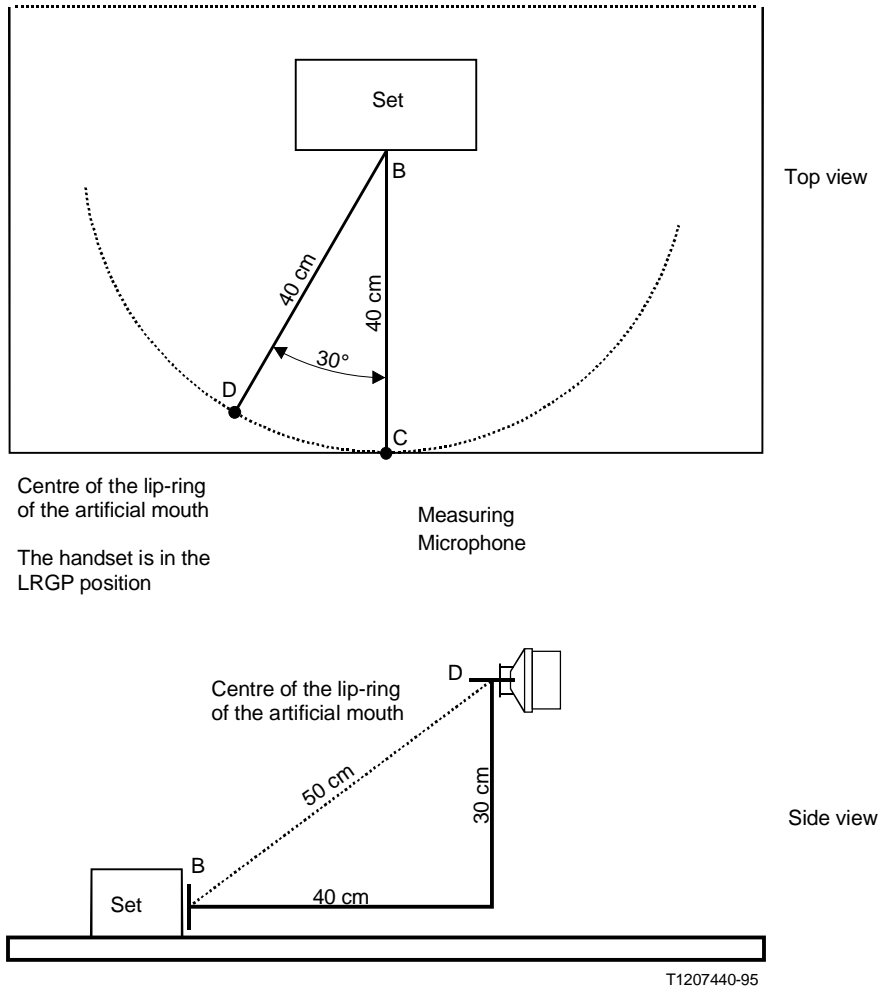

FIGURE A.3/P.342  
Measurement position, LST

### A.2.3 Electroacoustic equipment

The artificial mouth shall conform to Recommendation P.51 [5].

Sound level measurement equipment shall conform to IEC 651 [9].

#### **A.2.4 Test signals**

The test signal levels specified in this annex are referred to the active part of the signal.

In order to ensure that the test is representative of the normal operation, the test signal has two functions:

- terminal activation; and
- providing the measurement stimulus without adversely affecting the activation.

It shall be checked that both functions are correctly achieved.

Appropriate types of test signal are:

- Switched ON/OFF signals, as defined in A.2.4.1 and A.2.4.2, at a rate of 250 ms ( $\pm 5$  ms) ON and 150 ms ( $\pm 5$  ms) OFF.
- A complex signal as defined in Recommendation P.501 [15] (e.g. CSS).

For HFT incorporating adaptative AGC, AEC or other non-linear functions, the results may differ with the two signals.

A complex signal shall be used for equipment incorporating Adaptative Acoustic Echo Control functions and may be used when the switched signals do not activate properly the terminal for all tests described in this annex.

##### **A.2.4.1 Broadband signal**

One possible broadband signal shall be a gaussian pink noise, with a crest factor of 11 dB  $\pm 1$  dB.

The bandwidth of the broadband signal shall correspond to the 14 third-octave bands from 200 Hz to 4 kHz.

The third-octave spectrum of electrically generated pink noise shall be equalized within  $\pm 1$  dB, while the acoustically generated shall be equalized at the MRP within  $\pm 3$  dB.

The slope outside the bandwidth shall be at least 8 dB/third-octave.

Broadband signals are used for testing sensitivity/frequency response, loudness ratings, TCL, TCLw and stability.

##### **A.2.4.2 Sinusoidal and narrow-band signals**

- Sinusoidal signals are used for testing harmonic distortion and delay.
- Narrow-band noise signals (100 Hz bandwidth) are used for testing out-of-band signals.

#### **A.2.5 Test signal levels**

##### **A.2.5.1 Sending**

Unless specified otherwise, the test signal level shall be  $-4.7$  dBPa at the MRP. The characteristics of the artificial mouth shall be according to Recommendation P.51 [5].

The input signal from the artificial mouth is calibrated under free field conditions at the MRP, such that the spectrum corresponds to A.2.4 and the total level in the frequency range corresponding to the third-octave bands from 200 Hz to 4000 Hz is  $-4.7$  dBPa.

The spectrum at the MRP is then recorded and the level is adjusted to  $-28.7$  dBPa at the HFRP.

The spectrum at the MRP and the actual level at the MRP (measured in third-octaves) is used as reference for calculating SLR and response characteristics.

### A.2.5.2 Receiving

Unless specified otherwise, the applied test signal level at the digital input shall be  $-30$  dBm<sub>0</sub>, as far as the user-controlled receiving volume control is set at its maximum.

For measurements with the volume control at its minimum position, a test signal level of  $-15$  dBm<sub>0</sub> shall be used.

### A.2.6 Accuracy of calibrations

Unless specified otherwise, the accuracy of measurements made by test equipment shall be better than:

Item	Accuracy
Electrical signal power	$\pm 0.2$ dB for levels $\geq -50$ dBm
Electrical signal power	$\pm 0.4$ dB for levels $\leq -50$ dBm
Sound pressure	$\pm 0.7$ dB
Time	$\pm 5\%$
Frequency	$\pm 0.2\%$

Unless specified otherwise, the accuracy of the signals generated by the test equipment shall be better than:

Quantity	Accuracy
Sound pressure level at the MRP	$\pm 1$ dB
Electrical excitation level	$\pm 0.4$ dB
Frequency generation	$\pm 2\%$ (Note)
The measurement results shall be corrected for the measured deviations from the nominal level. NOTE – At 4 kHz a tolerance of $-2\%$ may be used.	

## A.3 Transmission requirements testing

Unless stated otherwise, the tests are performed with the volume control at its maximum.

### A.3.1 Sensitivity frequency response

The test signal is specified in A.2.4 and the test level is adjusted according to A.2.5.

Measurements are made of the third-octave band levels as defined by the R10-series of preferred numbers in ISO Publication 266 [7] for frequency bands from 200 Hz to 4 kHz inclusive.

The set is placed according to A.2.2 test arrangement.

#### A.3.1.1 Sending

The sensitivity for each third-octave band is expressed as dB relative to 1 V (digital interface)/Pa (MRP). The sensitivity as a function of the third-octave band is then plotted.

The sending sensitivity for each third-octave band is defined as:

$$S_{mJ} = 20 \log V_s - 20 \log P_{MRP} + \text{Corr} - 24 \text{ dB}$$

where:

$V_s$  is the measured voltage across the line termination;

$P_{MRP}$  is the applied sound pressure at the MRP;  
Corr is  $20 \log (P_{MRP}/P_{HFRP})$  of the used artificial mouth.

NOTE – The value of Corr is the value given in the calibration chart of the artificial mouth (24.0 dB is the ideal value).

### **A.3.1.2 Receiving**

The sensitivity for each third-octave band is expressed as dB relative to 1 Pa (measuring microphone position)/V (digital interface).

The sensitivity as a function of the third-octave band is then plotted.

To check the manual volume control range (if provided), the measurement is repeated at the minimum and at the maximum positions of the volume control, changing the input level accordingly.

In case of devices not provided with manual volume control, the measurement is repeated for excitation levels of  $-30$  dBm0 and  $-15$  dBm0.

### **A.3.2 Loudness ratings**

#### **A.3.2.1 Sending Loudness Rating (SLR)**

The sending sensitivity shall be measured at each of the 14 frequency bands given in Table 1/P.79 [6], bands 4 - 17 (200 Hz - 4000 Hz).

The sensitivity is expressed in terms of dB V/Pa and the SLR shall be calculated according to the formula (2-1) of Recommendation P.79 [6], using the sending weighting factors from Table 1/P.79 and according to clause 3/P.79 [6].

#### **A.3.2.2 Receiving Loudness Rating (RLR)**

The receiving sensitivity shall be measured at each of the 14 frequency bands given in Table 1/P.79 [6], bands 4 to 17 (200 Hz - 4000 Hz).

The sensitivity is expressed in terms of dB Pa/V and the RLR(cal) shall be calculated according to the formula (2-1) of Recommendation P.79 [6], using the receiving weighting factors from Table 1/P.79 and according to clause 3/P.79 [6].

The RLR shall then be computed as RLR(cal)  $-14$  dB (according to Recommendation P.340 [4]), and without the  $L_E$  factor.

For the volume control range, an additional test level of  $-15$  dBm0 shall be used.

### **A.3.3 Terminal coupling loss**

The set is placed according to A.2.2 test arrangement.

The test signal is specified in A.2.4.

The test signal level shall be  $-15$  dBm0.

TCL shall be measured as attenuation from the digital input to the digital output, by the 14 third-octave bands between 200 Hz and 4 kHz.

The TCLw (before correction) shall be calculated from Recommendation G.122 [2], with the following formula:

$$TCLw = -10 \log_{10} \left( \frac{1}{14} \sum_{i=1}^{14} A_i \right)$$

where  $A_i$  is the output/input power ratio at the  $i$ -th third-octave band.

### **A.3.4 Stability loss**

The test signal is specified in A.2.4.

The test signal level shall be  $-15$  dBm0.

Stability loss shall be measured as attenuation from the digital input to the digital output by a selective analyser with a bandwidth of  $80\text{ Hz} \pm 10\text{ Hz}$ , between  $200\text{ Hz}$  and  $4\text{ kHz}$ .

### **A.3.5 Harmonic distortion**

The set is placed according to A.2.2 test arrangement.

The signal to harmonic distortion ratio is measured on each third-octave centre frequency from  $315\text{ Hz}$  to  $1\text{ kHz}$ .

The test signal is a sinusoidal frequency (corresponding to the third-octave frequencies between  $315\text{ Hz}$  and  $1\text{ kHz}$ ) modulated ON/OFF at a rate defined in A.2.1.

The sinusoidal signal shall be switched ON/OFF at the zero crossing.

The harmonics are measured selectively up to  $3.15\text{ kHz}$ .

#### **A.3.5.1 Sending**

The sinusoidal signal level, calibrated at Hands-Free Reference Point (HFRP), shall be  $-20$  dBPa.

#### **A.3.5.2 Receiving**

The sinusoidal signal level is calibrated to  $-20$  dBm0.

The signal frequencies are limited at  $1\text{ kHz}$ . Limits above  $1\text{ kHz}$  are for further study.

### **A.3.6 Out-of-band signals**

The set is placed according to A.2.2 test arrangement.

The activation signal level shall be the same as the reference signal level. The bandwidth of the test signal shall be  $100\text{ Hz}$ .

#### **A.3.6.1 Sending**

For a correct activation of the HFT, the test signal according to A.2.4 shall be used as the reference signal with a level according to A.2.5. For the test, an out-of-band signal shall be provided as a frequency band signal centred on  $4.65\text{ kHz}$ ,  $5\text{ kHz}$ ,  $6\text{ kHz}$ ,  $6.5\text{ kHz}$ ,  $7\text{ kHz}$  and  $7.5\text{ kHz}$ , respectively. The level of any image frequencies at the digital interface shall be measured.

The levels of these signals shall be as specified in A.2.5.

The complete test signal is constituted by  $t_1$  ms of in-band signal,  $t_2$  ms of out-of-band signal and another time  $t_1$  ms of in-band signal.

The observation of the output signal on the first and second in-band signals permits to control if the set is correctly activated during the out-of-band measurement. This measurement is done during  $t_2$  period.

- $t_1$  may be  $250\text{ ms}$ .
- $t_2$  depends on the integration time of the analyser, less than  $150\text{ ms}$ .

### A.3.6.2 Receiving

For input narrow-band signals centred on 500 Hz, 1000 Hz, 2000 Hz and 3150 Hz, applied at the level of  $-30$  dBm0, the level of any out-of-band signals at frequencies up to 8 kHz shall be measured selectively at point C.

### A.3.7 Noise

To ensure that the set is correctly stated for the sending direction and the receiving direction respectively, the test signal specified in A.2.4 shall be applied with a level as specified in A.2.5 for activation.

The set is placed according to A.2.2 test arrangement.

#### A.3.7.1 Sending

The noise level shall be measured in a quiet environment [ambient noise less than  $-64$  dBPa(A)] at the digital output with a measurement equipment including psophometric weighting according to Table 4/G.223 [10], and according to Recommendation O.41 [11] regarding dynamic requirements.

The idle mode noise shall be measured 500 ms after interrupting the activation signal.

#### A.3.7.2 Receiving

The noise shall be measured 500 ms after interrupting the activation signal.

A weighting is specified in IEC 651 [9].

### A.3.8 Delay

The following method is defined in Recommendation P.310 [1].

The test arrangement is shown in Figure A.4.

The audio group delay (D) in the send and receive direction shall be measured separately from MRP to digital interface ( $D_s$ ) and from digital interface to measurement microphone ( $D_r$ ).

Measurements shall be made with pairs of sine wave signals.

The nominal frequencies are 500 Hz, 630 Hz, 800 Hz, 1 kHz, 1.25 kHz, 1.6 kHz, 2 kHz and 2.5 kHz.

The audio group delay is derived from the measurement of the phase shift between the sending signal on channel 1 (CH1) of the measurement equipment and the receiving signal on channel 2 (CH2) of this equipment. For each of the frequencies  $f_0$  the phase shift is measured at the frequencies  $f_1$  and  $f_2$ .  $f_1$  and  $f_2$  yield as follows:  $f_1 = f_0 - 50$  Hz and  $f_2 = f_0 + 50$  Hz.

NOTE 1 – If the phase shift of  $f_2$  and  $f_1$  is greater than 180 degrees, then the frequency step should be reduced (e.g. 10 Hz).

The measurements are executed in the following steps:

- 1) output the sine wave test signal with the frequency  $f_1$  on CH1;
- 2) measure the phase shift in degrees between CH1 and CH2 ( $p_1$ );
- 3) output the sine wave test signal with the frequency  $f_2$  on CH1;
- 4) measure the phase shift in degrees between CH1 and CH2 ( $p_2$ );
- 5) compute the audio group delay in milliseconds from the following formula:

$$D(f_0) = \frac{-1000 \times (p_2 - p_1)}{360 \times (f_2 - f_1)}$$

All the steps 2 and 4 negative values of  $p_1$  and  $p_2$  correspond to a lagging of CH2 relative to CH1. Care shall be taken that no errors occur, when the phase shift  $p$  passes  $360^\circ$  when switching from  $f_1$  to  $f_2$ .

Finally the average  $D$  of all values  $D(f_0)$  for the different frequencies  $f_0$  is calculated.

The audio group delay introduced by the artificial mouth shall be measured by mounting a microphone at the MRP. The audio group delay of all additional test equipment between the interface provided for the connection to a digital network and the digital input (CH2), respectively output (CH1), of the test equipment shall be determined. The values of these audio group delays are needed for the correction of the measurement results.

The audio group delay of the item under test is deduced from the formula:

$$D = D_s + D_r = D_{sm} + D_{rm} - D_e$$

where:

$D_e$  is the audio group delay of the test equipment;

$D_{sm}$  is the measurement audio group delay in the sending direction;

$D_{rm}$  is the measurement audio group delay in the receiving direction.

NOTE 2 – A new methodology for testing delay is under study.

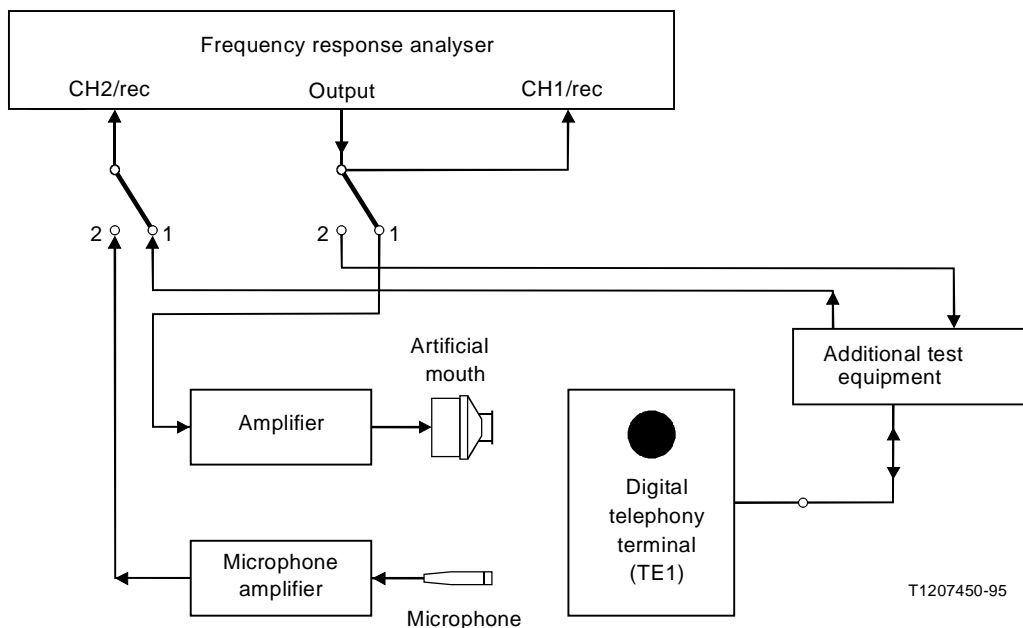

FIGURE A.4/P.342

**Configuration for delay measurements**





## ITU-T RECOMMENDATIONS SERIES

- Series A Organization of the work of the ITU-T
- Series B Means of expression
- Series C General telecommunication statistics
- Series D General tariff principles
- Series E Telephone network and ISDN
- Series F Non-telephone telecommunication services
- Series G Transmission systems and media
- Series H Transmission of non-telephone signals
- Series I Integrated services digital network
- Series J Transmission of sound-programme and television signals
- Series K Protection against interference
- Series L Construction, installation and protection of cables and other elements of outside plant
- Series M Maintenance: international transmission systems, telephone circuits, telegraphy, facsimile and leased circuits
- Series N Maintenance: international sound-programme and television transmission circuits
- Series O Specifications of measuring equipment
- Series P Telephone transmission quality**
- Series Q Switching and signalling
- Series R Telegraph transmission
- Series S Telegraph services terminal equipment
- Series T Terminal equipment and protocols for telematic services
- Series U Telegraph switching
- Series V Data communication over the telephone network
- Series X Data networks and open system communication
- Series Z Programming languages