

I n t e r n a t i o n a l T e l e c o m m u n i c a t i o n U n i o n

ITU-T

TELECOMMUNICATION
STANDARDIZATION SECTOR
OF ITU

G.976

(07/2007)

SERIES G: TRANSMISSION SYSTEMS AND MEDIA,
DIGITAL SYSTEMS AND NETWORKS

Digital sections and digital line system – Optical fibre
submarine cable systems

**Test methods applicable to optical fibre
submarine cable systems**

ITU-T Recommendation G.976



ITU-T G-SERIES RECOMMENDATIONS
TRANSMISSION SYSTEMS AND MEDIA, DIGITAL SYSTEMS AND NETWORKS

INTERNATIONAL TELEPHONE CONNECTIONS AND CIRCUITS	G.100–G.199
GENERAL CHARACTERISTICS COMMON TO ALL ANALOGUE CARRIER-TRANSMISSION SYSTEMS	G.200–G.299
INDIVIDUAL CHARACTERISTICS OF INTERNATIONAL CARRIER TELEPHONE SYSTEMS ON METALLIC LINES	G.300–G.399
GENERAL CHARACTERISTICS OF INTERNATIONAL CARRIER TELEPHONE SYSTEMS ON RADIO-RELAY OR SATELLITE LINKS AND INTERCONNECTION WITH METALLIC LINES	G.400–G.449
COORDINATION OF RADIOTELEPHONY AND LINE TELEPHONY	G.450–G.499
TRANSMISSION MEDIA AND OPTICAL SYSTEMS CHARACTERISTICS	G.600–G.699
DIGITAL TERMINAL EQUIPMENTS	G.700–G.799
DIGITAL NETWORKS	G.800–G.899
DIGITAL SECTIONS AND DIGITAL LINE SYSTEM	G.900–G.999
General	G.900–G.909
Parameters for optical fibre cable systems	G.910–G.919
Digital sections at hierarchical bit rates based on a bit rate of 2048 kbit/s	G.920–G.929
Digital line transmission systems on cable at non-hierarchical bit rates	G.930–G.939
Digital line systems provided by FDM transmission bearers	G.940–G.949
Digital line systems	G.950–G.959
Digital section and digital transmission systems for customer access to ISDN	G.960–G.969
Optical fibre submarine cable systems	G.970–G.979
Optical line systems for local and access networks	G.980–G.989
Access networks	G.990–G.999
QUALITY OF SERVICE AND PERFORMANCE – GENERIC AND USER-RELATED ASPECTS	G.1000–G.1999
TRANSMISSION MEDIA CHARACTERISTICS	G.6000–G.6999
DATA OVER TRANSPORT – GENERIC ASPECTS	G.7000–G.7999
PACKET OVER TRANSPORT ASPECTS	G.8000–G.8999
ACCESS NETWORKS	G.9000–G.9999

For further details, please refer to the list of ITU-T Recommendations.

ITU-T Recommendation G.976

Test methods applicable to optical fibre submarine cable systems

Summary

It is to be recognized that numerous test methods are specific to particular optical fibre submarine cable system designs and are, therefore, proprietary information of the system designer/supplier. However, a common understanding needs to be met between the system designer/supplier and the system purchaser/operator about the general purpose of testing and the meaning of the results.

The purpose of this Recommendation is to highlight the purpose of testing in optical fibre submarine cable systems and to list the main test methods applicable to these systems. Specific test methods are described.

Source

ITU-T Recommendation G.976 was approved on 29 July 2007 by ITU-T Study Group 15 (2005-2008) under the ITU-T Recommendation A.8 procedure.

FOREWORD

The International Telecommunication Union (ITU) is the United Nations specialized agency in the field of telecommunications. The ITU Telecommunication Standardization Sector (ITU-T) is a permanent organ of ITU. ITU-T is responsible for studying technical, operating and tariff questions and issuing Recommendations on them with a view to standardizing telecommunications on a worldwide basis.

The World Telecommunication Standardization Assembly (WTSA), which meets every four years, establishes the topics for study by the ITU-T study groups which, in turn, produce Recommendations on these topics.

The approval of ITU-T Recommendations is covered by the procedure laid down in WTSA Resolution 1.

In some areas of information technology which fall within ITU-T's purview, the necessary standards are prepared on a collaborative basis with ISO and IEC.

NOTE

In this Recommendation, the expression "Administration" is used for conciseness to indicate both a telecommunication administration and a recognized operating agency.

Compliance with this Recommendation is voluntary. However, the Recommendation may contain certain mandatory provisions (to ensure e.g. interoperability or applicability) and compliance with the Recommendation is achieved when all of these mandatory provisions are met. The words "shall" or some other obligatory language such as "must" and the negative equivalents are used to express requirements. The use of such words does not suggest that compliance with the Recommendation is required of any party.

INTELLECTUAL PROPERTY RIGHTS

ITU draws attention to the possibility that the practice or implementation of this Recommendation may involve the use of a claimed Intellectual Property Right. ITU takes no position concerning the evidence, validity or applicability of claimed Intellectual Property Rights, whether asserted by ITU members or others outside of the Recommendation development process.

As of the date of approval of this Recommendation, ITU had not received notice of intellectual property, protected by patents, which may be required to implement this Recommendation. However, implementers are cautioned that this may not represent the latest information and are therefore strongly urged to consult the TSB patent database at <http://www.itu.int/ITU-T/ipr/>.

© ITU 2008

All rights reserved. No part of this publication may be reproduced, by any means whatsoever, without the prior written permission of ITU.

CONTENTS

	Page
1 Scope	1
2 References.....	1
3 Definitions	2
3.1 Terms defined elsewhere.....	2
4 Abbreviations and acronyms	2
5 Conventions.....	4
6 Purpose of testing in optical fibre submarine cable systems	4
6.1 Qualification tests.....	4
6.2 Quality assurance tests	5
6.3 Installation tests.....	6
6.4 Cable system commissioning tests	7
6.5 Maintenance tests	8
7 List of tests to be made on optical fibre submarine cable systems and applicable test methods	9
7.1 Tests on the optical fibres of the optical fibre submarine cable.....	9
7.2 Tests on the optical fibre submarine cable	11
7.3 Tests on optical fibre amplifiers of OSR.....	13
7.4 Tests on the terminal transmission equipment	14
7.5 Tests on the power feeding equipment.....	14
7.6 Tests on the link.....	14
8 Description of specific test methods applicable to optical fibre submarine cable systems.....	16
8.1 Tests on the optical fibres of the optical fibre submarine cable.....	16
8.2 Tests on the optical fibre submarine cable	17
8.3 Tests on optical fibre amplifiers of OSR.....	26
8.4 Tests on the terminal transmission equipment	27
8.5 Tests on the power feeding equipment.....	27
8.6 Tests on the link.....	27
Annex A – Definition of terms relevant to the tests on optical fibre submarine cables	29
A.1 Q factor.....	29
Appendix I – Detailed definitions relevant to optical fibre submarine cable systems.....	30
I.1 Cable safety margin.....	30
I.2 Nominal permanent tensile strength (NPTS)	30
I.3 Nominal operating tensile strength (NOTS).....	30
I.4 Nominal transient tensile strength (NTTS)	31
Bibliography.....	32

ITU-T Recommendation G.976

Test methods applicable to optical fibre submarine cable systems

1 Scope

Testing is of high importance for optical fibre submarine cable systems since, together with a proper design and a careful definition of technologies, it is the only way to guarantee that the quality, lifetime and reliability performance of an optical fibre submarine cable system shall be met.

It is to be recognized that numerous test methods are specific to particular system designs and are therefore proprietary information of the system designer/supplier. However, a common understanding needs to be met between the system designer/supplier and the system purchaser/operator about the general purpose of testing and the meaning of the results.

Insofar as they are applicable to optical fibre submarine cable systems, general test methods recommended by the ITU-T should be applied. It should be recognized that these methods may need adaptation to the specific characteristics of optical fibre submarine systems. It should also be recognized that some test methods are specific to optical fibre submarine cable systems and of little or no use elsewhere.

The purpose of this Recommendation is to highlight the testing of optical fibre submarine cable systems by listing the main tests applicable to these systems and by describing test methods specific to these systems.

2 References

The following ITU-T Recommendations and other references contain provisions which, through reference in this text, constitute provisions of this Recommendation. At the time of publication, the editions indicated were valid. All Recommendations and other references are subject to revision; users of this Recommendation are therefore encouraged to investigate the possibility of applying the most recent edition of the Recommendations and other references listed below. A list of the currently valid ITU-T Recommendations is regularly published. The reference to a document within this Recommendation does not give it, as a stand-alone document, the status of a Recommendation.

- [ITU-T G.650.1] ITU-T Recommendation G.650.1 (2004), *Definitions and test methods for linear, deterministic attributes of single-mode fibre and cable.*
- [ITU-T G.650.2] ITU-T Recommendation G.650.2 (2007), *Definitions and test methods for statistical and non-linear related attributes of single-mode fibre and cable.*
- [ITU-T G.661] ITU-T Recommendation G.661 (2007), *Definition and test methods for the relevant generic parameters of optical amplifier devices and subsystems.*
- [ITU-T G.671] ITU-T Recommendation G.671 (2005), *Transmission characteristics of optical components and subsystems.*
- [ITU-T G.783] ITU-T Recommendation G.783 (2006), *Characteristics of synchronous digital hierarchy (SDH) equipment functional blocks.*
- [ITU-T G.810] ITU-T Recommendation G.810 (1996), *Definitions and terminology for synchronization networks.*
- [ITU-T G.821] ITU-T Recommendation G.821 (2002), *Error performance of an international digital connection operating at a bit rate below the primary rate and forming part of an Integrated Services Digital Network.*

- [ITU-T G.823] ITU-T Recommendation G.823 (2000), *The control of jitter and wander within digital networks which are based on the 2048 kbit/s hierarchy.*
- [ITU-T G.826] ITU-T Recommendation G.826 (2002), *End-to-end error performance parameters and objectives for international, constant bit-rate digital paths and connections.*
- [ITU-T G.828] ITU-T Recommendation G.828 (2000), *Error performance parameters and objectives for international, constant bit-rate synchronous digital paths.*
- [ITU-T G.972] ITU-T Recommendation G.972 (2004), *Definition of terms relevant to optical fibre submarine cable systems.*
- [ITU-T L.12] ITU-T Recommendation L.12 (2000), *Optical fibre joints.*
- [IEC 61290] IEC 61290, *Optical fibre amplifiers – Basic specification.*
- [IEC/TR 62284] IEC/TR 62284 (2003), *Effective area measurements of single-mode optical fibres – Guidance.*
- [IEC/TR 62285] IEC/TR 62285 (2005), *Application guide for non-linear coefficient measuring methods.*
- [IEC/TR 62324] IEC/TR 62324 (2007), *Single-mode optical fibres – Raman gain efficiency measurement using continuous wave method – Guidance.*

3 Definitions

3.1 Terms defined elsewhere

This Recommendation uses the following terms defined elsewhere:

3.1.1 optical fibre amplifier (OFA): See [ITU-T G.661].

3.1.2 plesiochronous digital hierarchy (PDH): See ITU-T G.8040/Y.1340.

3.1.3 synchronous digital hierarchy (SDH): See ITU-T G.707/Y.1322.

Other terms used in this Recommendation are defined in [ITU-T G.972].

4 Abbreviations and acronyms

This Recommendation uses the following abbreviations and acronyms:

ATM	Alternative Test Method
BBER	Background Block Error Ratio
BER	Bit Error Ratio
CBL	Cable Breaking Load
CF	Compression Factor
DC	Direct Current
DOHB	Draw Off/Hold Back
ESR	Errored Second Ratio
FA	Fixed Analyser
FWM	Four-Wave Mixing
GF	Gain Flatness

LW	Lightweight
LWP	Lightweight Protected
MFD	Mode Field Diameter
MTC	Marinized Terrestrial Cable
NF	Noise Figure
NG	Nominal Gain
NOTS	Nominal Operating Tensile Strength
NPTS	Nominal Permanent Tensile Strength
NSIP	Nominal Signal Input Power
NSOP	Nominal Signal Output Power
NTTS	Nominal Transient Tensile Strength
OA	Optical Amplifier
OFA	Optical Fibre Amplifier
OR	Optical Receiver
OSR	Optical Submarine Repeaters
OTDR	Optical Time Domain Reflectometry
PDG	Polarization Dependent Gain
PDH	Plesiochronous Digital Hierarchy
PDL	Polarization Dependent Loss
PFE	Power Feeding Equipment
PHB	Polarization Hole Burning
PMD	Polarization Mode Dispersion
RTM	Recommended Test Method
SCI	Self-Compensated Interferometric
SDH	Synchronous Digital Hierarchy
SESR	Severely Errored Second Ratio
SNR	Signal-to-Noise Ratio
SOA	Semiconductor Optical Amplifier
SOP	State Of Polarization
SPM	Self-Phase Modulation
SSG	Small Signal Gain
STE	System Terminal Equipment
TM	Test Method
TTE	Terminal Transmission Equipment
UV	Ultra Violet
XPM	Cross-Phase Modulation

5 Conventions

This clause is intentionally left blank.

6 Purpose of testing in optical fibre submarine cable systems

Testing is to be made at different periods in a system's life; during development, manufacturing and operation, for different purposes. A large amount of testing is of interest for the system designer and supplier only and is not relevant to this Recommendation. However, testing is also of concern for a system purchaser and operator. The latter includes qualification tests, quality assurance tests, installation tests, commissioning tests, and maintenance tests.

6.1 Qualification tests

Qualification tests are made as part of the development programme so as to choose proper designs and technologies and, once they are chosen, to demonstrate that they adequately satisfy the performance, reliability and lifetime requirement of the system. They are made on every component, material, subassembly, piece of equipment, and on the system itself. Tests conducted by the manufacturer supplying components or materials are often adequate and, therefore, used. The testing programme is defined for each item, taking into account its own characteristics and the experience already gained on similar items. Qualification tests generally include appropriate performance characterization, technology characterization and qualification, and life tests.

6.1.1 Performance characterization tests

Performance characterization is intended to demonstrate that the item satisfies the transmission requirement within the whole range of specified environmental conditions.

6.1.2 Technology characterization tests

Technology characterization is intended to evaluate the ruggedness of the technology, to identify the potential failure mechanisms (with a potential feedback on the design or technology so as to avoid dangerous mechanisms), and to establish models which permit prediction of the behaviour of devices. These tests may provide the conditions of use for the various items, and permit the establishment of screening and selection procedures, so as to eliminate devices which would exhibit early failure, or not satisfy the lifetime requirement. Some tests are made with the item operating, others in storage condition. High stress (such as severe temperature, mechanical, electrical or optical conditions), sometimes with an increased level of stress, and with a fast or slow time variation may be applied.

6.1.3 Technology qualification tests

Technology qualification is intended to confirm the quality of the technology and the adequacy of the selection procedure. The test conditions are chosen taking into account the results of the characterization tests. For example, tests can be made at several temperatures which permit the evaluation of an activation energy and/or an acceleration factor.

6.1.4 Life tests

Ageing tests are intended to evaluate the lifetime and reliability of a system with reference to end-of-life criteria chosen, taking into account the characteristics of the system's operation. Acceleration by temperature or other means, using an established or derived model, may be used. Part of the life tests may be made in conditions similar to the operating conditions of the system.

6.1.5 Testing programmes

The testing programmes for these different tests should indicate the number of devices to be tested, the description of the test conditions, and the methodology of the tests.

However, most testing programmes are the proprietary information of suppliers.

6.2 Quality assurance tests

Reference to ISO standards may be required.

Quality assurance tests are made during manufacture so as to demonstrate that the manufacturing process shall maintain the inherent quality and reliability provided by the design. It includes manufacturing control tests, component selection or acceptance tests, subassembly, subunit or equipment acceptance tests.

6.2.1 Manufacturing control tests

Manufacturing control tests are made during the manufacturing programme, including manufacture of components, subassemblies, equipment, optical fibres and cable, so as to ensure that the manufacturing operation is compatible with the required quality. Manufacturing control tests include part or all of the following:

- manufacturing process qualification tests which consist of manufacturing an industrial prototype according to the defined manufacturing procedure, prior to the start of manufacture, to finalize the manufacturing process and to verify its adequacy;
- manufacturing tools qualification tests which are periodically made, after tool recalibration during manufacture, to ensure that the performance of the manufacturing tools are in accordance with the manufacturing specification; these tests may consist of manufacturing devices which are submitted to tests which may be destructive;
- operator qualification tests, made initially after training and periodically during manufacturing, to ensure the ability of an operator to accomplish tasks according to the specification; these tests may consist of manufacturing devices which are submitted to tests which may be destructive;
- visual inspection, made at identified stages of the manufacturing process, on each production item to visually check the result of an operation or a sequence of operations; these tests are non-destructive and may be made using inspection tools such as optical microscopy, radioscopy, etc.

6.2.2 Component selection tests

Each component (e.g., electronic, optoelectronic or optical component, including the optical fibre, and raw material) to be used in an optical fibre submarine cable system is individually tested so as to ensure that it will present the required performance during the system design life. The testing procedure is defined during the qualification, taking into account the results of the technology characterization tests. Depending on the nature of the component, the selection or acceptance tests may include part or all of the following:

- batch qualification tests, which are high-stress destructive tests made on a few samples from the batch, and which are intended to ensure that the general ruggedness of the batch is satisfactory, so as to be able to eliminate unsatisfactory batches;
- stabilization tests, which are high-stress tests applied to all the components, and which result in the stabilization of the characteristics;
- screen tests, made on all the components of selected batches, to identify weaker devices which would present early failure and to eliminate them; the level of stress should be such that it will not significantly reduce the component reliability or lifetime;
- long duration tests, applied during a sufficiently long period to a few samples, or to all the components if necessary, with conditions close to the condition of operation in the system, to monitor the evolution of their characteristics and to eliminate components which would present an insufficient lifetime.

6.2.3 Subassembly, subunit or equipment factory tests

Tests are made in the factory on each subassembly (e.g., printed circuit board), subunit (e.g., repeater electronic unit, or PFE power converter) and piece of equipment (e.g., cable length, repeater or terminal equipment). It consists of testing the equipment performance (e.g., transmission performance, functional performance) in the nominal environmental conditions specified for the item.

6.3 Installation tests

These tests take place during a portion of the assembly (or on the completely submerged plant), during subsequent loading on the cable ship, during laying of the submerged plant, during and after installation of the terminal station equipment. Their purpose is to verify that, at each important period of the system installation, the functionality and the performance of the installed equipment meets the specifications necessary to ensure the successful completion of the whole cable system.

6.3.1 Tests during submarine portion assembly

General

At each jointing operation (cable-to-cable, cable to repeater/amplifier ...), tests on mechanical and electrical (if applicable) quality of the joint are performed.

Regenerated systems

The performances tests, including transmission quality assessment, supervisory and functional tests (for example, loop-back, transmitter change-over ...) are done on each individual repeater, and after connection to the assembled sections. The results should ascertain that the transmission quality is met with the specified margins on each section of regeneration, that the supervisory system meets its requirements, and that the repeater's functionality works correctly. Comparison with tests results obtained in the repeater factory are made.

Prior to the loading of the fully assembled submerged portion, transmission quality tests (including end-to-end bit-error ratio, individual error count in each repeater, jitter ...), and supervisory and repeater functional tests are used to demonstrate that the required specifications are met.

Amplified systems

Since the transmission quality measured on an amplified section does not represent the whole link, or portion thereof, these tests make use of measurements and techniques proven to be adequate during the development process. It is recognized that, environmental conditions being different from those on the sea bottom, these tests are not fully representative of the system performances. They may include tests on individual optical amplifiers (noise figure, gain and peak gain wavelength ... supervisory), and individual cabled fibre section (loss, chromatic dispersion, polarization mode dispersion ...). As a minimum, optical signal transmission, supervisory, and functional (for example, loop-back, pump laser change-over ..., if applicable) tests are performed while jointing each optical amplifier or on assembled portions to ensure they function in accordance with the system design.

At the end of the portion assembly, it is verified that the interface specifications with the other portions are met (this can be done via measurement or calculation of the Q factor, optical signal-to-noise ratio, optical spectrum, cumulated chromatic dispersion, cumulated polarization mode dispersion ... or any other parameter measurement or calculation representative of transmission quality). If applicable, all the functionalities implemented in the amplifiers are also checked through the supervisory system. It is preferred, particularly when the whole submerged plant is to be laid at once, that performance measurements also be made with the possible use of temporary compensation techniques (for example, on chromatic dispersion) to account for environmental conditions different from those on the sea bottom.

It must be recognized that since the amplified technology is new and in continuous progress, the nature of the tests to be performed may change significantly.

Repeaterless systems

These tests are mainly related to the optical characteristics of the cabled fibres in order to ascertain that the optical power budget and propagation impairments, when applicable, will provide the transmission quality with sufficient margins. When techniques such as remote pumping of in-line amplifying fibre are used, other tests such as pump signal transmission may be necessary.

6.3.2 Testing during submarine portion loading and laying

Regenerated and amplified systems

During the loading of the submarine portion on the cable ship, the system may be powered in order to check that the submarine portion is free from damage. After loading completion, the portion will be powered and tests will be carried out in order to check the stability of the portion performances over a sufficient time period.

During the laying operations, the system should be powered to the greatest extent possible, consistent with personal safety, in order to test the system and to verify that no fault or significant degradation which may jeopardize final performance has occurred. At the end of the complete installation of a submerged portion, the necessary interface performance will be checked in order to ensure that subsequent jointing with the other portions will provide the required performances. These interface tests are particularly important if the cable system is provided on a multisupplier basis since different portions may use different designs.

Repeaterless systems

As a minimum, the transmission quality of the fibres is continuously or periodically monitored during the laying operations. If techniques like remote pumping of submerged amplifying fibres are used, specific tests will be performed in complement.

6.3.3 Tests after terminal equipment installation

After completion of the equipment installation in each cable station, functional (including alarms), performance and safety tests should be carried out in order to verify that the specifications are met in the environmental conditions of each terminal station. These tests should verify the performances, functionalities and maintenance facilities of each equipment and their interworking performances. The following conditions should be considered as a minimum:

- power feed equipment working on a dummy load (except for repeaterless systems);
- terminal transmission equipment in a loop-back configuration;
- computerized maintenance controller connected to the TTE and to the PFE.

6.4 Cable system commissioning tests

These tests take place after the terminal equipment installation test in each station and after the laying of the submerged plant. They will verify that the as-installed system is compliant with the technical specifications, including a verification of the margins required at the beginning of life to warrant transmission performances, maintenance and repair operations during the specified design life. The following tests should be considered:

End-to-end performance and functionality tests

These tests are performed between the input/output ports of the cable system in order to verify that the technical specifications are met for transmission quality and functionality of the cable system as a whole.

Submerged plant performance and functional tests

Functional and transmission quality tests on the repeaters/amplifiers are performed to ensure that sufficient margins exist at the installation of the system. Tests of the supervisory system and of fault localization are also performed. Tests parameters may vary with the system design and the transmission technique (see clause 6.3.1). Transmission and margins demonstration tests use the installed terminal transmission equipment and supervisory system. For amplified systems, indirect parameters such as the Q factor, optical signal-to-noise ratio and optical spectrum may also be used. The commissioning tests include a stability period over which all the relevant parameters of the installed cable system are recorded. These results provide a baseline or reference data as necessary for future operation, maintenance or repair of the system.

Terminal station equipment tests

These performance and functional tests are performed on this equipment (TTE, PFE, maintenance controller) in their operational configuration, together with the submerged plant.

6.5 Maintenance tests

These tests are done throughout the operational life of the system during normal and maintenance operations. They are used to periodically check the performances of the system for preventive maintenance, for fault localization and to evaluate the possible margin degradations due to repairs.

6.5.1 Routine tests

These tests are performed on the submerged plant from the terminal stations with the help of the supervisory system. They are done in service, either automatically or on operator request. Their results are used for comparison with previous baseline data. They must not degrade the transmission quality below the specified levels. These tests are not applicable to repeaterless systems.

Similar routine tests are also performed on the terminal equipment.

6.5.2 Tests used for fault location on the submerged plant

These tests may be performed out-of-service from the terminal station using the supervisory system or with the help of external means (e.g., OTDR, coherent OTDR, resistance or capacitance measurements on the conductor ...). They are used to locate and to identify the fault with the maximum precision. Generally, an OTDR is employed for this purpose, especially a COTDR has good potential in long distance OFA systems fault location because of its higher sensitivity and higher frequency selectivity.

From the cable ship, before recovery of the faulty piece of cable or submerged equipment, tests for cable location can be used, for example, by electroding when applicable.

6.5.3 Tests made during and after a repair on the submerged plant

After recovery of the cable near the fault location, tests are carried out in order to more accurately determine the location and the nature of the fault. They can include optical time domain reflectometry and insulation measurements.

After a repair, tests are performed to check the mechanical, electrical and transmission quality of this repair prior to laying. For regenerated systems, the power margins on the repaired section are measured using the information on transmission quality given by the supervisory system. For amplified systems, methods similar to those used during system installation and commissioning tests may be used.

7 List of tests to be made on optical fibre submarine cable systems and applicable test methods

This clause contains references to test methods specific to submarine systems, and references to general test methods studied under other questions and which are directly applicable to optical fibre submarine cable systems.

7.1 Tests on the optical fibres of the optical fibre submarine cable

7.1.1 General

This clause lists and describes tests on the optical fibres of the optical fibre submarine cable. General descriptions of tests of single-mode optical fibres are found in [ITU-T G.650.1] and [ITU-T G.650.2]. The aim of this clause is to list the tests on the optical fibres of the optical fibre submarine cable. The tests listed here are closely related to the transmission characteristics of optical fibre submarine cable systems. All the test items, relevant Recommendations, applicable fibre types, and relevant systems are summarized in Table 1.

Table 1 – Lists of typical tests on the optical fibres of the optical fibre submarine cable

Tests	Defined in	Described in	Applicable to	Relevant systems
Mode field diameter (MFD)	3.3.2/G.650.1	5.1/G.650.1	F	All systems
Cladding diameter	3.4.3/G.650.1	5.2/G.650.1	F	All systems
Core concentricity error	3.4.8/G.650.1	5.2/G.650.1	F	All systems
Cladding non-circularity	3.4.6/G.650.1	5.2/G.650.1	F	All systems
Effective area (A_{eff})	Appendix II.2/ G.650.2	Appendix III/ G.650.2 IEC/TR 62284	F	Optically amplified long-haul systems
Non-linear coefficient (n_2/A_{eff})	Appendix II.4/ G.650.2	8.1.2.2/G.976	F	Optically amplified long-haul systems
Attenuation	3.6.2/G.650.1	5.4/G.650.1	F, C	All systems
Fibre cut-off wavelength (λ_c)	3.6.1/G.650.1	5.3/G.650.1	F	All systems
Chromatic dispersion	3.5.1/G.650.1	5.5/G.650.1	F, C	All systems
Chromatic dispersion uniformity	Under study	Appendix II/ G.650.1	F, C	All systems
Polarization mode dispersion (PMD)	3.1.1/G.650.2	5.1/G.650.1	F, C	All systems
Proof-test	3.2.3/G.650.1	5.6/G.650.1	F	All systems
Raman Gain efficiency	IEC/TR 62324	IEC/TR 62324	F, C	Optically amplified long-haul systems using Raman amplification
F Independent fibre C Fibre in the cable				

7.1.2 Tests on optogeometric characteristics

This clause lists optogeometric characteristics of the optical fibres of the optical fibre submarine cable that need to be tested.

7.1.2.1 Mode field diameter (MFD)

Mode Field Diameter (MFD) is a parameter that is related to the fundamental mode (LP₀₁) field distribution in the optical fibre. MFD is becoming increasingly important recently since it is closely related to the degree of optical non-linearities that will affect the transmission quality of the optical fibre submarine cable systems, especially in long-haul optically amplified systems.

7.1.2.2 Cladding diameter, core concentricity error, and cladding non-circularity

Cladding diameter, core concentricity error, and cladding non-circularity are the parameters that show optogeometric characteristics of the optical fibre.

7.1.2.3 Effective area (A_{eff})

Effective area (A_{eff}) is a parameter that is closely related to optical fibre non-linearities that will affect the transmission quality of the optical fibre submarine cable systems, especially in long-haul optically amplified systems.

7.1.2.4 Non-linear coefficient (n_2/A_{eff})

Non-linear coefficient (n_2/A_{eff}) is a parameter that expresses the optical fibre non-linearities. Optical fibre non-linearities will affect the transmission quality of the optical fibre submarine cable systems, especially in long-haul optically amplified systems.

7.1.2.5 Raman gain efficiency (g_R/A_{eff})

Raman gain efficiency is a parameter that expresses the ability of the optical fibre to amplify the signal power per unit fibre length and pump power.

The Raman gain efficiency becomes important in an optical submarine system that utilizes a distributed Raman amplifier.

7.1.3 Tests on transmission characteristics

This clause lists transmission characteristics of the optical fibres of the optical fibre submarine cable that need to be tested.

7.1.3.1 Attenuation

Attenuation comes from the loss of the optical fibres of the optical fibre submarine cable, and from the splicing of them. Attenuation is closely related to the maximum transmission distance of the optical fibre submarine cable systems.

7.1.3.2 Fibre cut-off wavelength (λ_c)

Fibre cut-off wavelength (λ_c) is the shortest wavelength representing single-mode operation.

7.1.3.3 Chromatic dispersion

Chromatic dispersion of the optical fibres of the optical fibre submarine cable is important since the characteristics induce waveform distortion of the transmitted data streams especially in long-haul and/or high data-rate systems.

Chromatic dispersion of the optical fibres is expressed by the following parameters:

- chromatic dispersion coefficient;
- zero-dispersion slope;
- zero-dispersion wavelength.

7.1.3.4 Chromatic dispersion uniformity

Under study.

7.1.3.5 Polarization mode dispersion (PMD)

If the optical fibres of the optical fibre submarine cable have a large amount of PMD, this will cause waveform distortion of the transmitted data streams, resulting in transmission characteristics degradation of the optical fibre submarine cable systems.

7.1.4 Tests on mechanical characteristics

For evaluation of mechanical characteristics of the optical fibres of the optical fibre submarine cable, the fibre proof-test is performed.

Fibre splices should be similarly proof tested. It is very important to establish a defined level of mechanical strength for the splice that is related to its expected lifetime. As performed for optical fibres just after manufacturing, the splice is subjected to a tensile proof-test for a short period of time. Some splicing machines perform this test with the spliced fibres in the splice chucks and some perform it after placing the spliced fibres in the holders for heat shrink protector application. Splices which have their strength below the proof-test level will be eliminated.

The splicing machine shall be able to perform the proof-test automatically or manually. The unloading time shall be short in order to minimize the strength reduction during the unloading.

Information relevant to this issue is found in [ITU-T L.12].

7.1.5 Manufacture, installation and environmental considerations

The optical fibres of the optical fibre submarine cable should be tested well before their actual installation. Some of the parameters of the optical fibres might be changed due to the cabling processes. Hence, some tests on the optical fibres of the optical fibre submarine cable may need to be repeated after the cabling processes.

Moreover, environmental conditions (such as pressure, tension and temperature of the optical fibre submarine cables) are different before and after cable laying. Such differences might induce changes in the parameters of the optical fibres of the optical fibre submarine cable. The effect of the environment on the cabled fibres should, therefore, be assessed appropriately.

7.2 Tests on the optical fibre submarine cable

In this clause, tests relevant to submarine cables, both for repeatered and repeaterless system use, are described and listed in Table 2.

The list of tests is based on typical test programmes and is, therefore, not exclusive or exhaustive. Some of the tests are inappropriate for production test purposes as they are either unsuited for online use or are of a destructive nature, some being used to determine limits of capability. Supplementary tests, or specific test conditions, should be implemented, if necessary, to ensure that the cable type offered is fit for the purpose intended.

Table 2 – Typical tests on optical fibre submarine cables

Reference	Test item	Sample history	Rep.	Replless.
8.2.1	Transmission			
8.2.1.1	Manufactured loss	C	x	x
8.2.1.2	Cabled fibre strain	C	x	x
8.2.1.3	Temperature	C, J	x	x
8.2.1.4	Pressure	C, J	x	x

Table 2 – Typical tests on optical fibre submarine cables

Reference	Test item	Sample history	Rep.	Replless.
8.2.2	Mechanical			
8.2.2.1	Tensile (fixed)	C, J	x	x
8.2.2.2	Tensile (free)	C, J	x	x
8.2.2.3	Tensile (break)	C, J	x	x
8.2.2.4	Fatigue	C	x	x
8.2.2.5	Sheave	C, J	x	x
8.2.3	Handling			
8.2.3.1	Crush	C	x	x
8.2.3.2	Impact	C	x	x
8.2.3.3	Flexure resistance	C	x	x
8.2.4	Reliability			
8.2.4.1	Water ingress	C	x	x
8.2.4.2	Corrosion	C, J	x	x
8.2.4.3	High voltage	C, J	x	x
8.2.4.4	Insulation integrity	C, J	x	x
8.2.5	Operational			
8.2.5.1	Adhesion	C	x	x
8.2.5.2	Stopper	C	x	x
8.2.5.3	Installation equipment	C, J	x	x
C	Cable samples that have previously been coiled and uncoiled.			
J	Cable samples that include joints or terminations.			
Rep.	Applicable to repeatered optical fibre submarine cables.			
Replless.	Applicable to repeaterless optical fibre submarine cables.			
x	Shows qualification stage to be tested.			
NOTE	– Where justified for ease of testing, the length of cable sample attached to joints or terminations can be shortened.			

7.2.1 Transmission performance

Tests are performed on the submarine cable to quantify its optical and electrical (if appropriate) transmission performance with regard to the mechanical strains, temperature ranges and external pressures arising during cable manufacture and operation.

7.2.2 Mechanical performance

Tests are performed on the submarine cable to quantify its mechanical performance with regard to shipboard laying, recovery and repair, and to establish a known degree of safety.

7.2.3 Handling performance

Tests are performed on the submarine cable to quantify its handling performance during transfer and storage over a wide temperature range, taking into account potential bumps and impact.

7.2.4 Reliability performance

Tests are performed on the submarine cable to quantify its reliability performance with regard to long-term exposure to sea water and in-service electric field gradients, with regard to potential corrosion, electrode toning (if appropriate) and water ingress in the event of a cable break.

7.2.5 Operational performance

Tests are performed on the submarine cable to quantify its performance with regard to being externally gripped, for example, with regard to the use of stoppers under the worst weather conditions and to the use of conventional installation equipment.

7.3 Tests on optical fibre amplifiers of OSR

7.3.1 General

This clause lists and describes tests on the optical amplifiers of OSR. General descriptions of tests of the optical amplifiers are found in [ITU-T G.661]. The aim of this clause is to list the tests on the optical amplifiers of the OSR. The tests listed here are summarized in Table 3.

Table 3 – Lists of typical tests on the optical amplifiers of the OSR

Tests	Defined in	Described in
Small signal gain (SSG)	5.1.2/G.661	6/G.661
Nominal gain (NG)	7.3.2.2/G.976	6/G.661
Gain flatness (GF)	7.3.2.3/G.976	6/G.661
Compression factor (CF)	7.3.2.4/G.976	6/G.661
Noise figure (NF)	5.1.17/G.661	6/G.661
Nominal signal output power (NSOP)	5.1.13/G.661	6/G.661
Nominal signal input power (NSIP)	Under study	6/G.661
Polarization-dependent gain (PDG)	5.1.11/G.661	Under study
Polarization-dependent loss (PDL)	3.2.23/G.671	5/G.671
Polarization hole burning (PHB)	Under study	II.4.3/G.663
Polarization mode dispersion (PMD)	5.1.33/G.661	IEC 61290-11-1
NOTE – Optically amplified long-haul systems are the only relevant systems.		

7.3.2 Tests on optical fibre amplifier characteristics of OSR

This clause lists characteristics of the optical fibres amplifier of OSR that need to be tested.

7.3.2.1 Small signal gain (SSG)

The gain of the amplifier, when operated in linear regime, where it is quite independent of the input signal optical power, at given signal wavelength and pump optical power level, for OFAs.

7.3.2.2 Nominal gain (NG)

In an OFA which is externally connected to an input jumper fibre, the increase of signal optical power from the output end of the jumper fibre to the OA output port, expressed in dB.

7.3.2.3 Gain flatness (GF)

Gain flatness is the flatness of the OFA gain versus signal wavelength at the nominal operating point. The accumulative gain flatness along a SDLS should be compliant with the pre-emphasis capability of the TTE at the transmitter side, and to the corresponding impairment allocated in the power budget table.

7.3.2.4 Compression factor (CF)

Compression factor is the difference expressed in dB between the small signal gain and the nominal gain. An in-line OFA working in a compression status will be more able to compensate for slow input power fluctuations or for some dumped in-line loss increases.

7.3.2.5 Noise figure (NF)

The decrease of the signal-to-noise ratio (SNR), at the output of an optical detector with unitary quantum efficiency, due to the propagation of a shot-noise-limited signal through the OA, expressed in dB.

7.3.2.6 Nominal signal output power (NSOP)

The minimum output signal optical power for a specified input signal optical power under nominal operating conditions.

7.3.2.7 Nominal signal input power (NSIP)

Under study.

7.3.2.8 Polarization dependent gain (PDG)

The maximum variation of gain due to a variation of the state of polarization of the input signal at nominal operating conditions.

7.3.2.9 Polarization dependent loss (PDL)

Maximum variation of insertion loss due to a variation of the state of polarization over all states of polarization.

7.3.2.10 Polarization hole burning (PHB)

Under study.

7.3.2.11 Polarization mode dispersion (PMD)

The maximum group delay difference between any polarization states on propagation through the OA.

7.4 Tests on the terminal transmission equipment

Under study.

7.5 Tests on the power feeding equipment

Tests should be made in order to ensure the safety of personnel.

7.6 Tests on the link

7.6.1 General

In this clause, the information on the tests on the link of the optical fibre submarine cable systems is provided. The aim of this clause is to provide a table which includes the information on where the performance parameters, their definitions, and their objectives are described in relevant Recommendations.

The tests on the link of the optical fibre submarine cable systems are performed on the basis of overall error performance, jitter performance and margin monitoring.

The performance parameters, relevant Recommendations and relevant systems are summarized in Table 4. It must be noted that all the Recommendations do not take into account the bit rate increase due to the FEC implementation.

Table 4 – List of performance parameters of the optical fibre submarine cable systems

Performance description	Performance parameters	Described in	Performance objective in	Relevant systems
Overall error performance	Errored second ratio (ESR)	4.2.2.1/G.821	5/G.821	PDH (below the primary rate)
	Errored second ratio (ESR)	3.2.5.1/G.828 4.7.1/G.826	6.1/G.828 7.1/G.826	SDH, PDH (at and above the primary rate)
	Severely errored second ratio (SESR)	4.2.2.2/G.821	5/G.821	PDH (below the primary rate)
	Severely errored second ratio (SESR)	3.2.5.2/G.828 4.7.2/G.826	6.1/G.828 7.1/G.826	SDH, PDH (at and above the primary rate)
	Background block error ratio (BBER)	3.2.5.3/G.828 4.7.3/G.826	6.1/G.828 7.1/G.826	SDH, PDH (at and above the primary rate)
Jitter performance (Note 1)	Maximum permissible jitter	7.1/G.810	5.1/G.823	PDH
	Jitter tolerance	15.1/G.783	15.1/G.783	SDH
Margin monitoring (Note 2)	Q factor	8.6/G.976		PDH, SDH
NOTE 1 – Applicable to regenerative systems only.				
NOTE 2 – System margin can be evaluated from the overall performance, and the Q factor is an additional parameter for margin monitoring especially in optically amplified systems. Hence, the measurement of a Q factor is not compulsory.				

7.6.2 Overall error performance

The error performance of an optical fibre submarine cable system should conform to the relevant Recommendations for the design life of the system, i.e., [ITU-T G.821] for PDH systems and [ITU-T G.826] and [ITU-T G.828] for SDH systems.

7.6.3 Jitter performance

The jitter performance of an optical fibre submarine cable system should follow [ITU-T G.823] for PDH systems, and [ITU-T G.783] for SDH systems for the system design life.

7.6.4 Margin monitoring

The Q factor at an optical receiver is related to the error performance of an optical fibre submarine cable system. Hence, the information on a Q factor at an optical receiver gives an indication of the margin of the system.

8 Description of specific test methods applicable to optical fibre submarine cable systems

This clause contains descriptions of test methods specific to submarine systems, and of general test methods studied under other questions, but which need specific adaptation to meet with submarine systems requirements.

8.1 Tests on the optical fibres of the optical fibre submarine cable

8.1.1 General

This clause describes test methods that are specific to the optical fibres of the optical fibre submarine cable.

8.1.2 Test methods on optogeometric characteristics

This clause describes specific test methods on optogeometric characteristics of the optical fibres of the optical fibre submarine cable.

8.1.2.1 Effective area (A_{eff})

Several methods have been proposed for measurement of effective area, described in Appendix III of [ITU-T G.650.2]. Further study is necessary for determining RTM and ATMs.

NOTE – [IEC/TR 62284] also describes the measurement methods of Effective area.

8.1.2.2 Non-linear coefficient (n_2/A_{eff})

Several methods have been proposed for measurement of non-linear coefficient, including:

- Self-phase modulation (SPM) method;
- Cross-phase modulation (XPM) method;
- Self-compensated interferometric (SCI) method;
- Four-wave mixing (FWM) method.

However, test methods for non-linear coefficient have not been determined yet. Further study is necessary for determining RTM and ATMs.

NOTE – The SPM method is described in [IEC/TR 62285].

8.1.2.3 Raman gain efficiency

The measurement method of Raman gain efficiency is given in [IEC/TR 62324].

8.1.3 Test methods on transmission characteristics

This clause describes specific test methods on transmission characteristics of the optical fibres of the optical fibre submarine cable.

8.1.3.1 Polarization mode dispersion (PMD)

There are several methods to measure PMD of the fibres of the optical fibre submarine cable.

Some of the measurement methods belong to the measurement in time domains such as:

RTM

- The Stokes parameter evaluation technique.

ATM

- Fixed analyser (FA) method;
- State-of-polarization (SOP) method;
- Interferometric methods (air path reference type, reference fibre type).

The Stokes parameter evaluation technique is a single reference test method (RTM) for PMD. Others are ATMs.

8.2 Tests on the optical fibre submarine cable

The purpose of the tests is to quantify the performance of a specified design of submarine cable under typical installation, service and recovery conditions.

The history and make-up of samples prior to testing must be representative of the cable state expected in practice; for example, the samples must:

- have undergone coiling and uncoiling several times, taking into account the minimum specified coiling diameter of the cable design;
- include fibre splices as appropriate;
- contain joints, terminations etc.

The tests described are intended primarily for qualification purposes although some tests may form part of standard production quality assurance procedures. Typical test programme structures, for repeated and unrepeated cables, are provided in clause 7.2; these include the recommended test sample make-up.

The successful installation/repair of a cable system can be taken to qualify the system components *only* to the level of the conditions prevailing during installation/repair; worst-case conditions may not have been encountered in such instances. Supplementary tests or specific test conditions should be implemented, if necessary, to assure that the cable system offered is fit for the purpose intended.

Test acceptance

The acceptance criterion for a test is governed by the planned system specification.

Safe working practice

This Recommendation quantifies the typical performance of a cable and its accessories. Compliance to this Recommendation does not in itself guarantee safe working practice during cable installation/repair; this is under the sole control of the installer. This Recommendation can, however, be used to identify the cable safety margin, as indicated in Appendix I.

Interpretation of terms

The definition of the terms "cable safety margin", "NTTS" and other terms relevant to this Recommendation, are given in [ITU-T G.972]. Further details for interpretation are provided in Appendix I.

8.2.1 Transmission performance

8.2.1.1 Manufactured cable loss

Objective

- To prove that the cable attenuation of an assembled cable section can satisfy system margin requirements.

Transmission tests can be performed on manufactured cable subsections; attenuation measurements are systematically performed during production stages. Excess loss due to repairs and ageing (from hydrogen, nuclear radiation, etc.) must be separately evaluated as part of the system margin analysis.

Test method

Fibre attenuation can be measured using appropriate commercially available equipment. Fibre attenuation is preferably measured in accordance with [ITU-T G.650.1].

Test conditions

Measurements are preferably carried out within a specified temperature range in accordance with [ITU-T G.650.1].

8.2.1.2 Cabled fibre strain

Objective

- To prove that the level of residual fibre underlength (strain) or overlength (excess) falls within required cable design limits.

Fibre length measurement forms part of the design qualification process. Supplementary factory measurements may be carried out for quality assurance purposes.

Test method

Fibre length (strain) can be measured using appropriate commercially available equipment. Fibre underlength or overlength can be determined by comparison with equivalent cable length measurements.

Test conditions

Measurements are preferably carried out within a specified temperature range in accordance with the cable temperature specification.

8.2.1.3 Temperature stability

Objectives

- To prove that the optical characteristics of the cable are not modified by transportation, service or storage temperature ranges.
- To determine any specific transportation or storage requirements necessary to ensure the above.

Test method

The cable sample is cycled between specified temperatures considering the conditions of both sea sections and land sections, as installed and stored, (typically between -20°C and $+50^{\circ}\text{C}$). The following characteristics are evaluated with regard to the specified cable design:

- the level of any optical attenuation increase;
- the appearance of the tested cable sample(s) structure.

Test conditions

Optical attenuation and kingwire (or composite conductor) resistance, if applicable, are monitored throughout the test.

8.2.1.4 Hydraulic pressure resistance

Objective

- To prove that the cable can withstand, both optically and electrically, the maximum seabed pressure.

Test method

A length of cable is placed inside a pressure enclosure. Pressure terminations that allow the optical fibre package to exit are used to seal the sample ends. The pressure inside the enclosure is increased to a level simulating maximum seabed pressure. Optical attenuation is monitored throughout the test. The following characteristics are evaluated with regard to the specified cable design:

- the level of any optical attenuation increase;

- the appearance of the tested cable sample(s) structure;
- the absence of water ingress in the test sample.

The integrity of the sample(s) after the pressure test may be confirmed by appropriate voltage testing.

Test conditions

The cable sample length should be based on the accuracy of the test equipment. Minimum test duration is typically 30 minutes or more; the test should be extended to 24 hours should any evidence of creep, or added loss, be detected. Clauses 8.2.4.3 and 8.2.4.4 describe appropriate voltage tests.

8.2.2 Mechanical performance

8.2.2.1 Tensile test with twist restrained

Objectives

- To prove that the cable can withstand the maximum expected tensile load during laying and recovery with a known degree of safety.
- To prove that the optical fibres are not subjected to excessive strain either during load or after unload.
- To determine whether the performance of the cable under load would permit its reuse after a cable recovery operation.

Test method

Cable samples are terminated at each end with an anchoring device and installed onto a tensile rig. The fibre ends should be fixed around the anchoring devices in a manner that allows fibre strain to be exactly measured and end effects detected. The length of test cable should be sufficient to make end effects negligible and provide accuracy in measurement; multiple optical fibres may be joined together to increase the path length. The optical attenuation and fibre strain are continuously evaluated throughout the test. The tensile load and cable elongation are continuously measured during the test. The following characteristics are evaluated with regard to the specified cable design:

- the level of any optical attenuation increase;
- the appearance of the tested cable sample(s) structure;
- the elongation stability of the cable under maximum load;
- the load versus torque characteristics.

Test conditions

The cable is fixed in such a way that the cable will not twist during elongation. The cable is loaded to its Nominal Transient Tensile Strength (NTTS) and held for a short time, typically for a minimum of an hour. The test may be repeated several times to check for hysteresis effects. Separate tests may be carried for cable samples with and without joints.

8.2.2.2 Tensile test with torque minimized

Objectives

- To prove that the cable can withstand the maximum expected tensile load during laying and recovery with a known degree of safety.
- To prove that the optical fibres are not subjected to excessive strain either during loading or after unloading.

Test method

Cable samples are terminated at each end with an anchoring device and installed onto a tensile rig. The fibre ends should be fixed around the anchoring devices in a manner that allows fibre strain to be exactly measured and end effects detected. The length of test cable should be sufficient to make end effects negligible and provide accuracy in measurement; multiple optical fibres may be joined together to increase the path length. The optical attenuation and fibre strain are continuously monitored throughout the test. The tensile load, cable elongation and cable twist are continuously measured during the test. The following characteristics are evaluated with regard to the specified cable design:

- the level of any optical attenuation increase;
- the appearance of the tested cable sample(s) structure;
- the elongation stability of the cable under maximum load;
- the level of cable twist and cable/fibre strain under load and after unloading.

Test conditions

The cable is fixed in such a way that one end of the cable is free to twist. The cable is loaded to at least its design depth deployment tension and held for a short time, typically for a minimum of an hour. The test may be repeated several times to check for hysteresis effects. Separate tests may be carried out for cable samples with and without joints.

8.2.2.3 Tensile test with load to failure

Objectives

- To prove that the cable can withstand the maximum expected tensile load during laying and recovery with a known degree of safety.
- To prove that the cable does not fail at a load below its rated tensile strength.

Test method

Cable samples are terminated at each end with an anchoring device and installed onto a tensile rig. The length of test sample may be minimized on safety considerations, provided it is sufficient for accuracy in measurement. The tensile load and elongation of the cable are continuously measured during the test. The optical attenuation and fibre strain are monitored, as far as possible, during the test.

Test conditions

The cable is normally fixed in such a way that the cable will not twist during elongation. The cable is loaded up until failure occurs in any tensile member, leading to avalanche failure; this corresponds to the cable breaking load.

Cable safety margin

The cable safety margin is the difference in tensile load between the measured load at failure and the maximum installation/recovery load proposed by the installer. The cable safety margin may typically be expressed as a percentage of measured load at failure. Appendix I provides further details.

8.2.2.4 Mechanical fatigue test

Objective

- To prove that the cable can withstand a periodic load equivalent to that typically experienced in a shipboard cable repair.

Test method

Cable samples are terminated at each end with an anchoring device and installed onto a tensile rig, which preferably includes a sheave. The cable load is cycled between low load and high load, simulating the effect of cables movement (due to wave motion) on the suspended cable at its maximum design depth under worst weather conditions. Optical attenuation and tensile load are monitored throughout the test. Simulated design depth and weather conditions are recorded. The following characteristics are evaluated with regard to the specified cable design:

- the level of any optical attenuation increase;
- the appearance and inter-layer adhesion level of the tested cable sample(s) structure.

Test conditions

The length of test cable should be sufficient to make end effects negligible and provide accuracy in measurement; multiple optical fibres may be joined together to increase the path length. The number of cycles should simulate the expected shipboard repair time and the expected sea wave cycle time, which should be stated.

8.2.2.5 Sheave tests

Objective

- To prove that the cable can withstand normal bending around the sheave under the maximum expected tensile load during laying, holding and recovery.

Test method

Both ends of the cable sample are terminated, and the sample is placed in a tensile rig such that it contacts at least a quadrant of one (or more) sheaves. The cable terminations are not allowed to rotate. The length of test cable should be sufficient to make end effects negligible and provide accuracy in measurement; multiple optical fibres may be joined together to increase the path length. The optical attenuation and tensile load are continuously measured during the test. The following characteristics are evaluated with regard to the specified cable design:

- the level of any optical attenuation increase;
- the appearance and inter-layer adhesion level of the tested cable sample(s) structure.

Test conditions

The cable is cycled relative to the sheave(s) at a constant speed and constant load for 30-50 cable traverses at a low load corresponding to the cable's maximum deployment load. The load is then raised to a high load, equivalent to the recovery tension on the cable at its maximum design depth under worst weather conditions; it is then subjected to at least three additional cable traverses. The diameter of the sheave, typically 2.5 m-3.0 m, should be stated.

8.2.3 Handling performance

8.2.3.1 Crush resistance

Objective

- To prove that the cable can withstand asymmetric pressure resulting from storage in a holding tank, or from shipboard equipment, e.g., Draw Off/Hold Back (DOHB) engine.

Test method

A short cable sample, typically 5 m, is held in a horizontal press fixture which subjects it to load for a limited period. The load is applied over a cable length of at least 0.1 m and is recorded. Optical attenuation and press fixture displacement are monitored throughout the test. The following characteristics are evaluated with regard to the specified cable design:

- the level of any optical attenuation increase;
- the appearance and inter-layer adhesion level of the tested cable sample(s) structure; the integrity of the sample(s) may be confirmed by hydraulic pressure resistance testing and/or appropriate voltage testing. Note that testing should be performed if any significant permanent mechanical damage has been observed.

Test conditions

A load simulating the maximum force per unit length acting on the cable is applied to the test portion for at least one hour and is then released. The maximum force is that provided by the weight of a full cablesheep tank, typically a 10 m depth, acting on the bottom layer of cable, or that provided by shipboard machinery, whichever is greater.

8.2.3.2 Impact resistance

Objective

- To prove that the cable can withstand bump and impact during the manufacturing or laying operation.

Test method

A short cable sample, typically 5 m, is laid on a smooth, flat steel plate. A steel cylinder is dropped on the sample from an adequate height. A low friction tube may be used for guiding the cylinder. Optical attenuation is monitored throughout the test. The following characteristics are evaluated with regard to the specified cable design:

- the level of any optical attenuation increase;
- the appearance and inter-layer adhesion level of the tested cable sample(s) structure; the integrity of the sample(s) may be confirmed by hydraulic pressure resistance testing and/or appropriate voltage testing. Note that testing should be performed if any significant permanent mechanical damage has been observed.

Test conditions

An X mm diameter cylinder of Y kg weight is dropped from a height of Z m to impact at different points and orientations along the cable. For "lightweight" cables, the typical values of X, Y and Z are 50, 2 and 1 respectively; for armoured cables, the typical values of X, Y and Z are A, B and C respectively. The test should be repeated several times to ensure consistency.

8.2.3.3 Flexure resistance

Objective

- To prove that the cable can withstand the handling from factory-to-ship, tank-to-tank or ship-to-shore over its designed temperature range.

Test method

The cable sample is alternately bent between two test fixtures representing at least a quadrant of a sheave of typically 2-m diameter. Optical attenuation is evaluated throughout the test. The ambient temperature is recorded. The following characteristics are evaluated with regard to the specified cable design:

- the level of any optical attenuation increase;
- the appearance and inter-layer adhesion level of the tested cable sample(s) structure.

Test conditions

The cable sample undergoes 50 flexures at room temperature. The sample is then subjected to 50 flexures at both a low temperature and a high temperature, corresponding to the designed

temperature range of the cable. At extreme temperatures, outside the design range, the cable's flexure performance can sometimes be determined through appropriate temperature tests on components.

8.2.4 Reliability performance

8.2.4.1 Water ingress limitation

Objectives

- To quantify the water ingress limitation along the cable in the event of a cable break on the seabed.
- To prove that the maximum water ingress length is compliant with the design specification.

Test method

The maximum water ingress length is usually evaluated by one of two test methods, detailed below. If other conditions are used, e.g., shorter sample lengths or lower pressure levels, the test data should be extrapolated, with an appropriate explanation about extrapolation, so as to show that the cable is compliant with the design specification.

Test method 1

One end of the cable sample is sealed and the other end shielded from exposure to pressure through the use of special fixturing or a calibrated breaking disc. The cable sample is placed inside a large pressure enclosure which is then filled with water and pressurized. The cable sample is removed after a number of days and inspected internally along its length for signs of water; such inspection may be facilitated if fluorescent dye has previously been added to the pressure vessel water as the dye is simply revealed by UV light.

Test method 2

The cable sample is placed inside a long pressure enclosure with the far end open to water; the near cable end exits the enclosure via a special gland so that it is open to atmosphere. Hydraulic pressure is applied to the enclosure as quickly as possible; the time taken for water to pass through the sample to atmosphere is measured, the presence of water being detected electrically.

Test conditions

The cable sample is preferably 100 m or more in length. Pressure corresponding to the maximum laying depth of the cable is introduced to the open face of the sample; the pressure is maintained for the number of days required to prove the specified water ingress limitation, typically 14 days. Should other test levels corresponding to specific system requirements be used, they should be recorded.

8.2.4.2 Corrosion test

Objectives

- To prove that the submersible plant can withstand long-term exposure to sea water.
- To prove that any corrosion present will not impair the mechanical, optical and electrical function of the plant.

The scope of the submersible plant includes cables, joints and terminations.

Test method

The submersible plant is immersed in sea water at an elevated temperature for a period of time. The plant is then inspected to determine the degree of corrosion and, if applicable, the build-up of hydrogen gas. A provision must be made for suitably sealing the cable ends prior to the test. If artificial sea water is used, its specification is to be stated.

Test conditions

Test conditions appropriate to accelerated ageing are under study; one proposal under consideration is to immerse test samples in aerated sea water at 50°C for 18 months.

8.2.4.3 High-voltage test

Objective

- To prove that a cable designed to allow power feed of repeaters or regenerators can withstand in-service electric field gradients over its lifetime.

Test method

A long cable is placed in a pool filled with conductive water at ground potential. A positive DC voltage is applied between the metallic conductor of the cable and water. No voltage breakdown must occur before the requirements of the reliability model are met.

Test conditions

The voltage applied follows the formula VT^k , where V is the service voltage, T is the test duration and k is a constant. The values of V and T selected for the test are based on the reliability model for cable and joints, taking into account the electrical loading that they will need to endure during their design lifetime. The acceleration factor k is empirically determined, and is specific to the insulation material used.

8.2.4.4 Insulation integrity test

Objectives

- To prove that the cable insulation is continuous to prevent internal crevice corrosion.
- To prove that the cable insulation will allow cable location through low tone electroding for cables designed with this feature.

Test method

A long cable is placed in a pool filled with water at ground potential. A positive DC voltage is applied between the metallic conductor of the cable and water. No voltage breakdown must be observed during the test.

Test conditions

The voltage applied and its duration are based on the level of insulation resistance that the cable will need during its lifetime.

8.2.5 Operational tests

8.2.5.1 Cable inter-layer adhesion test

Objective

- To prove that the cable elements have sufficient inter-layer adhesion to allow external gripping without damage.

Test method

The most appropriate cables for inter-layer adhesion tests are the deep water cables, i.e., lightweight (LW) and lightweight protected (LWP) cables. A nominal 150-250 mm cable sample is prepared in a manner that allows a length of insulation to be tested, typically 25 mm, after pre-exposing the strength member for gripping. The force required to initiate inter-layer movement between adjacent cable elements is evaluated with regard to the cable requirements.

Test conditions

The sample is placed on a tensile rig in such a manner that the strength member can be gripped and pulled whilst specific elements are prevented from movement. The pull force is increased until inter-layer movement occurs between the cable elements under test.

8.2.5.2 Cable stopper tests

Objective

- To prove that the cable can be gripped by stoppers under the worst weather conditions in which they would be used.

Test method

The cable samples are terminated at one end with an anchoring device and at the other end with a stopper positioned approximately 10 m from the opposite end. The sample is installed on a tensile rig. The load on the sample is then increased to a high load equivalent to the tension on the cable at its maximum design depth under worst weather conditions. Optical attenuation is monitored throughout the test; the simulated design depth and weather conditions are recorded. The type of cable stopper used in the test is to be described, e.g., make, size, etc. The following characteristics are evaluated with regard to the specified cable design:

- the level of any optical attenuation increase;
- the displacement of the stopper on the cable;
- the appearance and inter-layer adhesion level of the tested cable sample(s) structure;
- cable rotation at stopper, if applicable.

Test conditions

The test duration is typically a minimum of 90 minutes.

8.2.5.3 Tests with installation equipment

Objectives

- To prove that the cable and joints can be handled by conventional installation equipment.
- To show that the cable can be deployed through the installation equipment without slippage occurring between the cable and equipment, and without discernible evidence of cable damage.

Test method

The test samples are prepared with an anchoring device at one end to allow the jointed cable to be pulled against the installation equipment. The type of installation equipment used in the test is to be described, e.g., make, type of grip, etc.

Test conditions

The sample is pulled against the installation equipment at tensions simulating the maximum deployment load under the worst weather conditions. The load required to pull the cable through a static grip in the installation equipment should also be established for both wet and dry cable conditions.

NOTE – It is not usually necessary to carry out comprehensive tests with conventional installation equipment once initial cable compatibility has been established; other means may be more appropriate should further reassurance be required.

8.3 Tests on optical fibre amplifiers of OSR

8.3.1 General

This clause describes test methods that are specific to the optical amplifiers of OSR.

The guidelines to be followed for the measurement of most of the parameters defined in clause 7.3 are generally given in the IEC "Basic Specification for OFA test methods" 61290 series. Table 5 indicates the recommended test methods, collecting the test parameters in homogeneous groups and quoting for each group the relevant IEC Basic Specification number(s).

NOTE 1 – The comparative evaluation of the Test Methods given in the IEC Basic Specifications is currently under development. When they become available, the chosen Reference Test Methods and possible Alternative Test Methods for each relevant parameter defined in this Recommendation will be indicated.

NOTE 2 – The test methods given in the IEC Basic Specifications have been prepared for OFAs only. The extrapolation of these methods to SOAs is under study.

8.3.1.1 Gain parameters

Gain parameters are related to the gain of the amplifier, which contain SSG, NG, GF, CF, PDG and so on.

8.3.1.2 Noise parameters

Noise parameters are related to the noise of the amplifier, which contain NF and so on.

8.3.1.3 Optical power parameters

Optical power parameters are related to the optical power of the amplifier, which contain NSOP, NSIP, PDL and so on.

8.3.2 Test methods on optical power parameters of optical fibre amplifiers of OSR

Table 5 – Recommended test methods for parameters defined in clause 7.3

Group of test parameters	Parameters defined in clause 7.3	Test method (TM) – IEC basic specification number
Gain parameters	Small signal gain (SSG) Nominal gain (NG) Gain flatness (GF) Compression factor (CF) Polarization dependent gain (PDG)	61290-1-1: Optical spectrum analyzer TM 61290-1-2: Electrical spectrum analyzer TM 61290-1-3: Optical power meter TM
Noise parameters	Noise figure (NF)	61290-3-1: Optical spectrum analyzer TM 61290-3-2: Electrical spectrum analyzer TM 61290-3-3: Pulse optical TM (under study)
Optical power parameters	Nominal signal output power (NSOP) Nominal signal input power (NSIP) Polarization dependent loss (PDL)	61290-2-1: Optical spectrum analyzer TM 61290-2-2: Electrical spectrum analyzer TM 61290-2-3: Optical power meter TM

8.4 Tests on the terminal transmission equipment

8.4.1 Transmission tests

(To be studied in relation to the general test set-up provided as an example in Figure 1.)

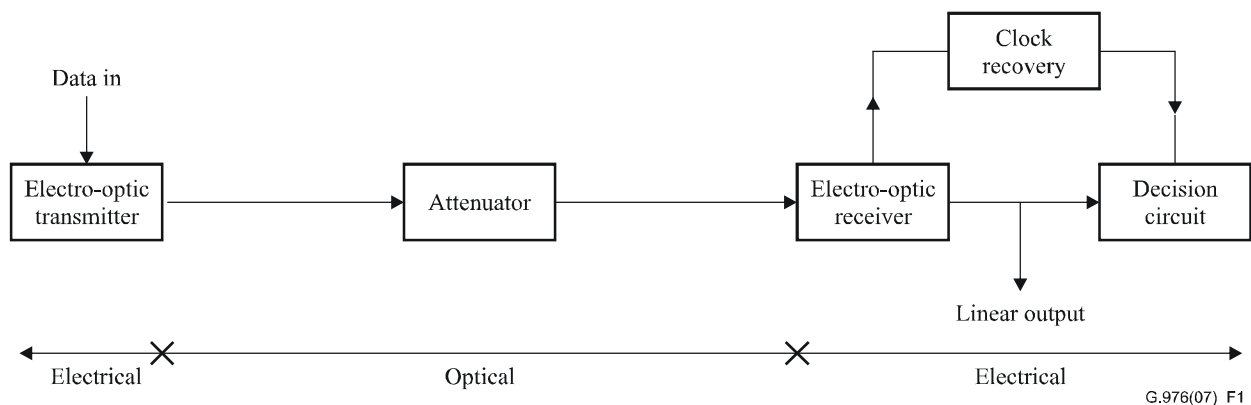

Figure 1 – Possible position of linear output for terminal equipment test

8.5 Tests on the power feeding equipment

These tests are specific to the design of the PFEs and to the configuration of the link.

8.6 Tests on the link

8.6.1 Transmission tests

8.6.1.1 Measurement of the Q factor

Objectives

- To evaluate the Q factor of the end-to-end link. The Q factor evaluates the propagation impairments caused by optical amplification noise, non-linear effects, polarization effects and chromatic dispersion, but also impairments caused by optical transmitter and receiver analogic functions. The Q factor is representative of the margins of the amplified submarine system.
- To deduce a theoretical bit-error ratio (BER) of the system associated to the measurement time period.

Test method

The Q factor is determined by analyzing the linear received electrical signal prior to regeneration, in order to measure the distortion and noise caused by the propagation, as well as the optical emitter and receiver analogic functions (Figure 2). In other words, the quality of the received signal is to be analyzed from a non-regenerated point of view.

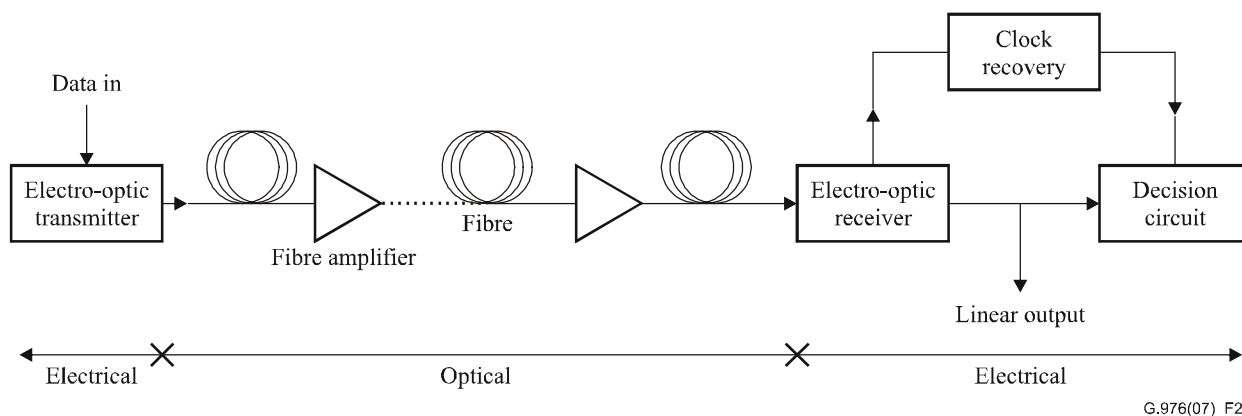

G.976(07)_F2

Figure 2 – Possible position of linear output for link test

One method of analysing the linear signal is presented in Figure 3. The output of the two decision circuits, one set with the optimal decision threshold and the other set with a variable one, are compared through an exclusive OR gate. BER is plotted against threshold. Interpolation of the measured BER curves assuming Gaussian statistics gives the $\mu_{1,0}$ and $\sigma_{1,0}$ values. The theoretical minimum attainable BER is given by Equation A-2 of the definition provided in Annex A. Other implementations are possible.

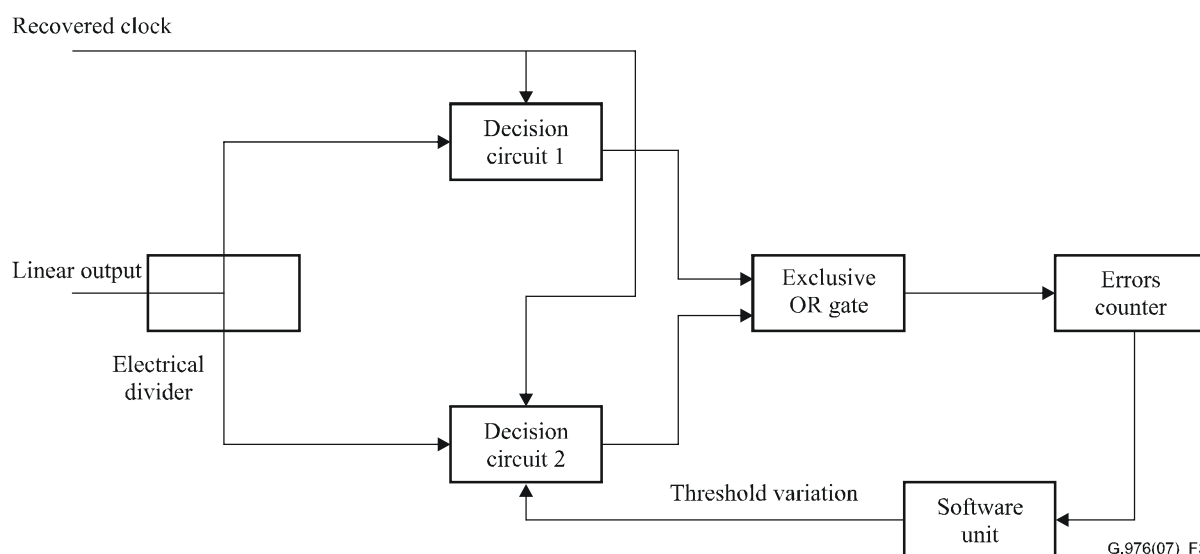

G.976(07)_F3

Figure 3 – Schematic of an implementation of Q measurement equipment

As polarization effects cause time-varying effects, the measurement results must also include some kind of statistic evaluation. As an example, if the probability density of the Q statistic is Gaussian, a value of the mean measurement Q_{mean} minus five times its standard deviation ($Q_{\text{mean}} - 5\sigma$) will guarantee that the system will get under this value only with a probability of 10^{-7} .

Test conditions

The Q factor is measured at the nominal input optical power at the receiver end. A set of measurements on a significant timespan will give an idea of the mean value (Q_{mean}) and the standard deviation (σ) of the Q factor. In case of a simultaneous transmission at several wavelengths on the same fibre, this measurement needs to be performed on each wavelength.

Annex A

Definition of terms relevant to the tests on optical fibre submarine cables

(This annex forms an integral part of this Recommendation)

This annex defines several terms relevant to the tests on the optical fibres used in optical fibre submarine cables, and does so because definitions of these terms are not at present found in ITU-T Recommendations.

A.1 Q factor

The Q factor is the signal-to-noise ratio at the decision circuit in voltage or current units, and is typically expressed by:

$$Q = \frac{(\mu_1 - \mu_0)}{(\sigma_1 + \sigma_0)} \quad (\text{A-1})$$

where $\mu_{1,0}$, is the mean value of the marks/spaces voltages or currents, and $\sigma_{1,0}$ is the standard deviation.

The mathematic relations to BER when the threshold is set to the optimum value are:

$$BER = \frac{1}{2} \operatorname{erfc}\left(\frac{Q}{\sqrt{2}}\right) \cong \frac{1}{Q\sqrt{2\pi}} e^{-\frac{Q^2}{2}} \quad (\text{A-2})$$

with:

$$\operatorname{erfc}(x) = \frac{1}{\sqrt{2\pi}} \int_x^{\infty} e^{-\frac{\beta^2}{2}} d\beta \quad (\text{A-3})$$

The Q factor can be written in terms of decibels rather than in linear values:

$$Q (\text{decibels}) = 20 \times \operatorname{Log}_{10} Q (\text{linear}) \quad (\text{A-4})$$

Details are provided in [b-Bergano].

Appendix I

Detailed definitions relevant to optical fibre submarine cable systems

(This appendix does not form an integral part of this Recommendation)

The purpose of this appendix is to provide more detailed definitions, taking into account the condition of applicability of terms defined in [ITU-T G.972].

I.1 Cable safety margin

The cable safety margin is the difference in tensile load between the measured load at failure and the maximum installation/recovery load proposed by the installer. The cable safety margin may typically be expressed as a percentage of measured load at failure.

In some cases, the minimum safety margin to which installers will operate may be dictated by specific legislation in force in their parent country, e.g., safe working load for wire ropes.

In other cases, the safety margin may be based on the nominal transient tensile strength. However, this should be handled with care as the value ascribed to NTTS depends on the cable design, i.e., its structure and materials.

I.2 Nominal permanent tensile strength (NPTS)

The maximum permanent cable tension that does not significantly reduce the system performance, lifetime and reliability.

NPTS represents the maximum residual load, which may be permanently applied to the cable on the seabed after installation.

The determined value of NPTS should reference the following:

- test condition used, i.e., whether the cable ends were free to rotate or not;
- the fibre survival probability (indicating cable length and accommodated number of fibres) and fibre proof-test level;
- fibre and cable elongation at NPTS.

NOTE – Any residual elongation resulting from NTTS should be compatible with the stated value of NOTS and NPTS.

I.3 Nominal operating tensile strength (NOTS)

The maximum average operational tension which the cable can support for the period required for marine operations (typically 48 hours) without significantly reducing the system performance, lifetime and reliability.

NOTS represents the maximum average operational tension during installation, recovery or repair.

The determined value of NOTS should reference the following:

- test condition used, i.e., whether the cable ends were free to rotate or not;
- the fibre survival probability (indicating cable length and accommodated number of fibres) and fibre proof-test level;
- fibre and cable elongation at NOTS.

NOTE – Any residual elongation resulting from NTTS should be compatible with the stated value of NOTS and NPTS.

I.4 Nominal transient tensile strength (NTTS)

The maximum short-term tension that can be applied to the cable during an at-sea recovery operation over a cumulative period of approximately one hour without significantly reducing the system performance, lifetime and reliability.

NTTS represents the maximum transient or unexpected load that may be applied to the cable, and is normally limited to a percentage of the CBL from a mechanical safety point of view.

The determined value of NTTS should reference the following:

- test condition used, i.e., whether the cable ends were free to rotate or not;
- the fibre survival probability (indicating cable length and accommodated number of fibres) and fibre proof-test level;
- fibre and cable elongation at NTTS.

NOTE – Any residual elongation resulting from NTTS should be compatible with the stated value of NOTS and NPTS.

The value ascribed to NTTS depends upon many considerations, including:

- system reliability;
- required lifetime;
- residual fibre strain after laying;
- recovery tension;
- shipboard repair time;
- fibre proof-test;
- fibre intrinsic strength;
- fibre reliability model;
- mechanical stability of cable;
- mechanical design of cable ("loose" versus "tight").

For system and personnel safety, the NTTS value ascribed must take fibre reliability, mechanical stability and wire fatigue considerations into account, including tolerances.

Bibliography

- [b-Bergano] BERGANO *et al*: Margin measurements in optical amplifier systems *IEEE Photonics Technology Letters*, Vol. 5, No. 3, pp. 304-306, March 1993.

SERIES OF ITU-T RECOMMENDATIONS

Series A	Organization of the work of ITU-T
Series D	General tariff principles
Series E	Overall network operation, telephone service, service operation and human factors
Series F	Non-telephone telecommunication services
Series G	Transmission systems and media, digital systems and networks
Series H	Audiovisual and multimedia systems
Series I	Integrated services digital network
Series J	Cable networks and transmission of television, sound programme and other multimedia signals
Series K	Protection against interference
Series L	Construction, installation and protection of cables and other elements of outside plant
Series M	Telecommunication management, including TMN and network maintenance
Series N	Maintenance: international sound programme and television transmission circuits
Series O	Specifications of measuring equipment
Series P	Telephone transmission quality, telephone installations, local line networks
Series Q	Switching and signalling
Series R	Telegraph transmission
Series S	Telegraph services terminal equipment
Series T	Terminals for telematic services
Series U	Telegraph switching
Series V	Data communication over the telephone network
Series X	Data networks, open system communications and security
Series Y	Global information infrastructure, Internet protocol aspects and next-generation networks
Series Z	Languages and general software aspects for telecommunication systems