

International Telecommunication Union

ITU-T

TELECOMMUNICATION
STANDARDIZATION SECTOR
OF ITU

G.798

(10/2010)

SERIES G: TRANSMISSION SYSTEMS AND MEDIA,
DIGITAL SYSTEMS AND NETWORKS

Digital terminal equipments – Other terminal equipment

**Characteristics of optical transport network
hierarchy equipment functional blocks**

Recommendation ITU-T G.798



ITU-T G-SERIES RECOMMENDATIONS
TRANSMISSION SYSTEMS AND MEDIA, DIGITAL SYSTEMS AND NETWORKS

INTERNATIONAL TELEPHONE CONNECTIONS AND CIRCUITS	G.100–G.199
GENERAL CHARACTERISTICS COMMON TO ALL ANALOGUE CARRIER-TRANSMISSION SYSTEMS	G.200–G.299
INDIVIDUAL CHARACTERISTICS OF INTERNATIONAL CARRIER TELEPHONE SYSTEMS ON METALLIC LINES	G.300–G.399
GENERAL CHARACTERISTICS OF INTERNATIONAL CARRIER TELEPHONE SYSTEMS ON RADIO-RELAY OR SATELLITE LINKS AND INTERCONNECTION WITH METALLIC LINES	G.400–G.449
COORDINATION OF RADIOTELEPHONY AND LINE TELEPHONY	G.450–G.499
TRANSMISSION MEDIA AND OPTICAL SYSTEMS CHARACTERISTICS	G.600–G.699
DIGITAL TERMINAL EQUIPMENTS	G.700–G.799
General	G.700–G.709
Coding of voice and audio signals	G.710–G.729
Principal characteristics of primary multiplex equipment	G.730–G.739
Principal characteristics of second order multiplex equipment	G.740–G.749
Principal characteristics of higher order multiplex equipment	G.750–G.759
Principal characteristics of transcoder and digital multiplication equipment	G.760–G.769
Operations, administration and maintenance features of transmission equipment	G.770–G.779
Principal characteristics of multiplexing equipment for the synchronous digital hierarchy	G.780–G.789
Other terminal equipment	G.790–G.799
DIGITAL NETWORKS	G.800–G.899
DIGITAL SECTIONS AND DIGITAL LINE SYSTEM	G.900–G.999
MULTIMEDIA QUALITY OF SERVICE AND PERFORMANCE – GENERIC AND USER-RELATED ASPECTS	G.1000–G.1999
TRANSMISSION MEDIA CHARACTERISTICS	G.6000–G.6999
DATA OVER TRANSPORT – GENERIC ASPECTS	G.7000–G.7999
PACKET OVER TRANSPORT ASPECTS	G.8000–G.8999
ACCESS NETWORKS	G.9000–G.9999

For further details, please refer to the list of ITU-T Recommendations.

Recommendation ITU-T G.798

Characteristics of optical transport network hierarchy equipment functional blocks

Summary

Recommendation ITU-T G.798 specifies both the components and the methodology that should be used in order to specify optical transport network functionality of network elements; it does not specify individual optical transport network equipment as such. The components in this revision support ODU and client signal and server bit rates up to 100 Gbit/s. This includes support of mapping and demapping of a multitude of client signals into carrier signals of various bit rates from STM1 as SDH transport rate and 1GE for data client rate up to the transport of 100 Gbit/s Ethernet LAN signal rate.

History

Edition	Recommendation	Approval	Study Group
1.0	ITU-T G.798	2002-01-06	15
1.1	ITU-T G.798 (2002) Amend. 1	2002-06-13	15
2.0	ITU-T G.798	2004-06-13	15
3.0	ITU-T G.798	2006-12-14	15
3.1	ITU-T G.798 (2006) Amend. 1	2008-12-12	15
3.2	ITU-T G.798 (2006) Cor.1	2009-01-13	15
4.0	ITU-T G.798	2010-10-22	15

FOREWORD

The International Telecommunication Union (ITU) is the United Nations specialized agency in the field of telecommunications, information and communication technologies (ICTs). The ITU Telecommunication Standardization Sector (ITU-T) is a permanent organ of ITU. ITU-T is responsible for studying technical, operating and tariff questions and issuing Recommendations on them with a view to standardizing telecommunications on a worldwide basis.

The World Telecommunication Standardization Assembly (WTSA), which meets every four years, establishes the topics for study by the ITU-T study groups which, in turn, produce Recommendations on these topics.

The approval of ITU-T Recommendations is covered by the procedure laid down in WTSA Resolution 1.

In some areas of information technology which fall within ITU-T's purview, the necessary standards are prepared on a collaborative basis with ISO and IEC.

NOTE

In this Recommendation, the expression "Administration" is used for conciseness to indicate both a telecommunication administration and a recognized operating agency.

Compliance with this Recommendation is voluntary. However, the Recommendation may contain certain mandatory provisions (to ensure, e.g., interoperability or applicability) and compliance with the Recommendation is achieved when all of these mandatory provisions are met. The words "shall" or some other obligatory language such as "must" and the negative equivalents are used to express requirements. The use of such words does not suggest that compliance with the Recommendation is required of any party.

INTELLECTUAL PROPERTY RIGHTS

ITU draws attention to the possibility that the practice or implementation of this Recommendation may involve the use of a claimed Intellectual Property Right. ITU takes no position concerning the evidence, validity or applicability of claimed Intellectual Property Rights, whether asserted by ITU members or others outside of the Recommendation development process.

As of the date of approval of this Recommendation, ITU had received notice of intellectual property, protected by patents, which may be required to implement this Recommendation. However, implementers are cautioned that this may not represent the latest information and are therefore strongly urged to consult the TSB patent database at <http://www.itu.int/ITU-T/ipr/>.

© ITU 2012

All rights reserved. No part of this publication may be reproduced, by any means whatsoever, without the prior written permission of ITU.

Table of Contents

	Page
1	Scope 1
2	References..... 3
3	Definitions 5
3.1	Terms defined elsewhere..... 5
3.2	Terms defined in this Recommendation..... 8
4	Abbreviations and acronyms 8
5	Methodology..... 15
6	Supervision 15
6.1	Alarm reporting control..... 15
6.2	Defects..... 15
6.3	Consequent actions..... 25
6.4	Defect correlations..... 25
6.5	Performance filters 25
7	Information flow across reference points 27
8	Generic processes 27
8.1	Scrambling processes 27
8.2	Alignment processes..... 27
8.3	Signal quality supervision 31
8.4	BIP correction..... 32
8.5	OTUk forward error correction (FEC) processing 32
8.6	Trail trace identifier (TTI) processing 32
8.7	Payload structure indication (PSI) acceptance processes 32
8.8	Status information (STAT) acceptance process 33
8.9	Generic AIS generation and detection..... 33
8.10	Generic layer fault processing 34
8.11	Optical signal processing..... 37
9	Optical transmission section (OTS) layer functions..... 38
9.1	Connection functions..... 39
9.2	Termination functions 39
9.3	Adaptation functions 46
10	Optical multiplex section (OMS) layer functions..... 49
10.1	Connection functions..... 51
10.2	Termination functions 51
10.3	Adaptation functions 56
10.4	Sub-layer functions..... 60
11	Optical physical section (OPS) layer functions..... 67
11.1	Connection functions..... 68

	Page
11.2	Termination functions 68
11.3	Adaptation functions 78
12	OCh (layer) functions 90
12.1	Connection functions 92
12.2	Termination functions 96
12.3	Adaptation functions 105
12.4	Layer functions 125
13	OTU (layer) functions 125
13.1	Connection functions 126
13.2	Termination functions 126
13.3	Adaptation functions 137
13.4	Sub-layer functions 150
14	ODU (layer) functions 151
14.1	Connection functions 153
14.2	Termination functions 161
14.3	Adaptation functions 167
14.4	COMMS functions 239
14.5	Sub-layer functions 248
14.6	Virtual concatenation functions 268
Annex A	– Optical section (OSx) and constant bit rate (CBRx) layer functions 308
A.1	Connection functions 309
A.2	Termination functions 309
A.3	Adaptation functions 312
Appendix I	– Applications and functional diagrams 316
I.1	Transparent CBRx tributary interface port with optional SDH RS non-intrusive monitor on OTN equipment 316
I.2	OTM-0.m tributary interface port on OTN equipment 317
I.3	Selectable CBRx/OTM-0.m tributary interface port on OTN equipment 319
I.4	OTM-0.m interface ports on non-OTN equipment 321
I.5	OTM-n.m interface port with 3-R regeneration functionality for an ODUk connection function 323
Appendix II	– TCM applications 325
Appendix III	– Performance of processes 327
III.1	Introduction 327
III.2	OTUk frame alignment process 327
III.3	STAT acceptance process and related defect detection (ODUkP/TdAIS, ODUkP/TdOCI, ODUkP/TdLCK, ODUkTdLTC, ODUkTdIAE) 329
III.4	OTUkdIAE, OTUkdBDI, ODUkP/TdBDI detection 330
III.5	PT acceptance process and ODUkPdPLM detection 331
III.6	Generic AIS and OTUk AIS detection 332

	Page
III.7 OTUkdBIAE and ODUkTdBIAE detection process.....	333
Appendix IV – TTI processing examples	335
IV.1 Example 1	335
IV.2 Example 2	337
Appendix V – Client services of sub ODU1 rate mapping into OTN using higher order virtual container mapping	340
V.1 Description of the application	340
V.2 ODUk/Sn compound function	342
V.3 Migration from SDH towards OTN networking	343
Bibliography.....	345

Introduction

This Recommendation forms part of a suite of Recommendations covering the full functionality of network equipment (e.g., [ITU-T G.783], [ITU-T G.705], [ITU-T G.781], and [ITU-T G.784]) and follows the principals defined in [ITU-T G.806].

This Recommendation specifies a library of basic building blocks and a set of rules by which they may be combined in order to describe equipment used in an optical transport network. The library comprises the functional building blocks needed to specify completely the generic functional structure of the optical transport network. In order to be compliant with this Recommendation, the OTN functionality of any equipment which processes at least one of the OTN layers needs to be describable as an interconnection of a subset of the functional blocks contained within this Recommendation. The interconnections of these blocks should obey the combination rules given.

The specification method is based on the functional decomposition of the equipment into atomic and compound functions. The equipment is then described by its equipment functional specification (EFS) which lists the constituent atomic and compound functions, their interconnection and any overall performance objectives (e.g., transfer delay, availability, etc.).

Recommendation ITU-T G.798

Characteristics of optical transport network hierarchy equipment functional blocks

1 Scope

This Recommendation covers the functional requirements of optical transport network functionality within equipment. Some examples of the functionality are:

- optical transmission section termination and line amplification functionality;
- optical multiplex section termination functionality;
- optical channel termination functionality;
- optical channel cross-connect functionality.

This Recommendation uses the specification methodology defined in [ITU-T G.806], in general, for transport network equipment, and is based on the architecture of optical transport networks defined in [ITU-T G.872] and the interfaces for optical transport networks defined in [ITU-T G.709]. The description is generic and no particular physical partitioning of functions is implied. The input/output information flows associated with the functional blocks serve for defining the functions of the blocks and are considered to be conceptual, not physical.

The OCh layer, as defined in [ITU-T G.872], is divided into an OCh layer, an OTU layer and an ODU layer with tandem connection sub-layers as defined in [ITU-T G.709].

The functionality defined in this Recommendation can be applied at user-to-network interfaces (UNIs) and network-node-interfaces (NNIs) of the optical transport network. It is recognized that for interfaces used within optical subnetworks, aspects of the interface are optical technology dependent and subject to change as technology progresses. Therefore, optical-technology dependent aspects (for transverse compatibility) are not defined for functional blocks used for these interfaces to allow for technology changes. The overhead processing functionality necessary for operations and management of optical subnetworks is defined.

Not every functional block defined in this Recommendation is required for every application. Different subsets of functional blocks from this Recommendation and others (e.g., [ITU-T G.783]) may be assembled in different ways according to the combination rules given in these Recommendations to provide a variety of different capabilities. Network operators and equipment suppliers may choose which functions must be implemented for each application.

The internal structure of the implementation of this functionality (equipment design) need not be identical to the structure of the functional model, as long as all the details of the externally observable behaviour comply with the equipment functional specification (EFS).

Equipment developed prior to the production of this Recommendation may not comply in all details with this Recommendation.

Equipment which is normally stated to be compliant with this Recommendation may not fulfil all the requirements in the case that it is interworking with old equipment that is not compliant with this Recommendation.

Figures 1-1, 1-2 and 1-3 present the set of atomic functions associated with the traffic signal transport. The functions for the processing of communication channels (COMMS) are not shown in these figures in order to reduce the complexity of the figures. For the COMMS functions, refer to the specific layer network descriptions.

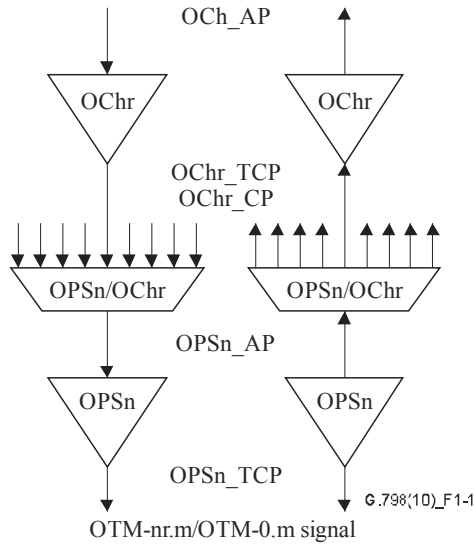
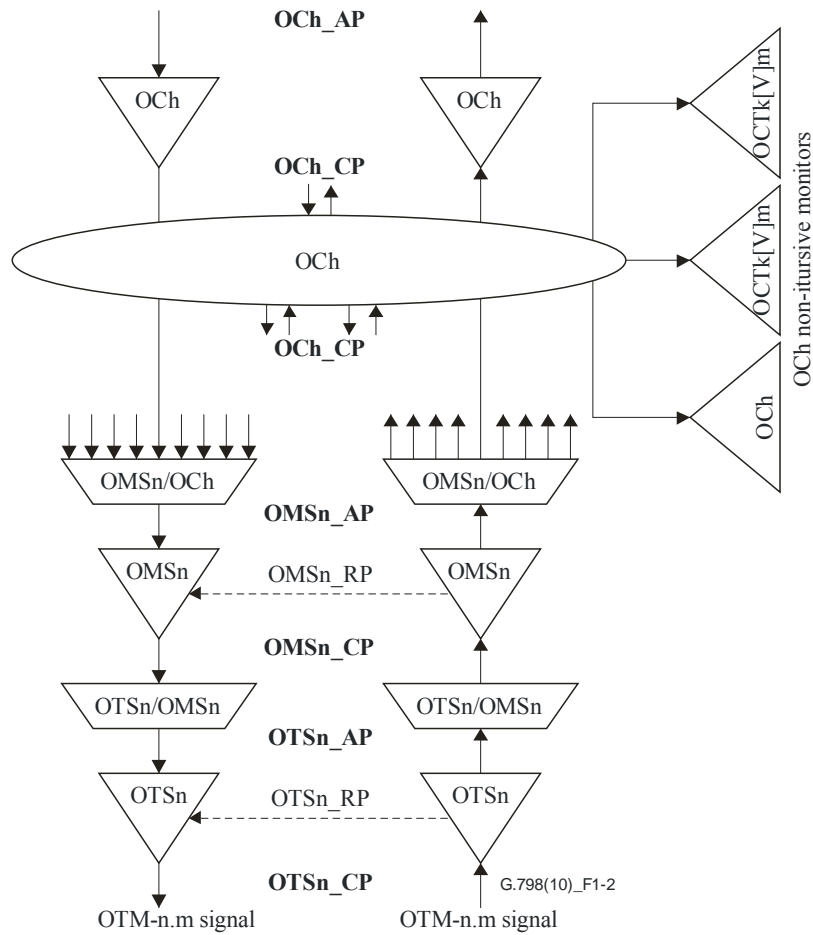

Figure 1-1 – OTN atomic functions specific for the reduced functionality OTM-nr.m/OTM-0.m interface



NOTE – OMS trail protection sub-layer functions are not shown.

Figure 1-2 – OTN atomic functions specific for the full functionality OTM-n.m interface

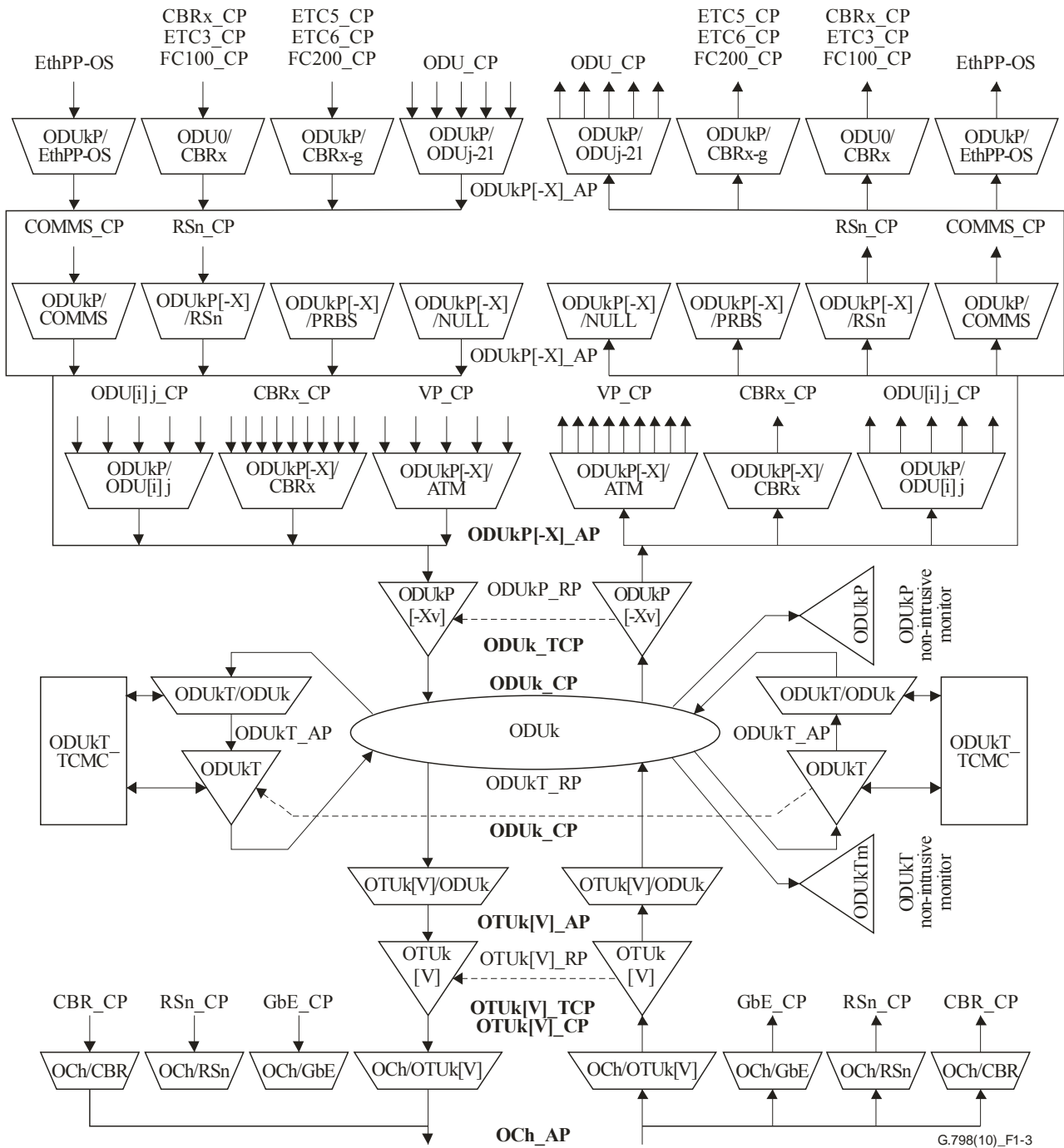

Figure 1-3 – OTN common atomic functions

2 References

The following ITU-T Recommendations and other references contain provisions which, through reference in this text, constitute provisions of this Recommendation. At the time of publication, the editions indicated were valid. All Recommendations and other references are subject to revision; users of this Recommendation are therefore encouraged to investigate the possibility of applying the most recent edition of the Recommendations and other references listed below. A list of the currently valid ITU-T Recommendations is regularly published. The reference to a document within this Recommendation does not give it, as a stand-alone document, the status of a Recommendation.

[ITU-T G.664] Recommendation ITU-T G.664 (2006), *Optical safety procedures and requirements for optical transport systems*.

- [ITU-T G.691] Recommendation ITU-T G.691 (2006), *Optical interfaces for single channel STM-64 and other SDH systems with optical amplifiers.*
- [ITU-T G.705] Recommendation ITU-T G.705 (2000), *Characteristics of plesiochronous digital hierarchy (PDH) equipment functional blocks.*
- [ITU-T G.707] Recommendation ITU-T G.707/Y.1322 (2007), *Network node interface for the synchronous digital hierarchy (SDH).*
- [ITU-T G.709] Recommendation ITU-T G.709/Y.1331 (2009), *Interfaces for the Optical Transport Network (OTN).*
- [ITU-T G.780] Recommendation ITU-T G.780/Y.1351 (2010), *Terms and definitions for synchronous digital hierarchy (SDN) networks.*
- [ITU-T G.781] Recommendation ITU-T G.781 (2008), *Synchronization layer functions.*
- [ITU-T G.783] Recommendation ITU-T G.783 (2006), *Characteristics of synchronous digital hierarchy (SDH) equipment functional blocks.*
- [ITU-T G.784] Recommendation ITU-T G.784 (1999), *Synchronous digital hierarchy (SDH) management.*
- [ITU-T G.805] Recommendation ITU-T G.805 (2000), *Generic functional architecture of transport networks.*
- [ITU-T G.806] Recommendation ITU-T G.806 (2009), *Characteristics of transport equipment – Description methodology and generic functionality.*
- [ITU-T G.808.1] Recommendation ITU-T G.808.1 (2010), *Generic protection switching – Linear trail and subnetwork protection.*
- [ITU-T G.825] Recommendation ITU-T G.825 (2000), *The control of jitter and wander within digital networks which are based on the synchronous digital hierarchy (SDH).*
- [ITU-T G.831] Recommendation ITU-T G.831 (2000), *Management capabilities of transport networks based on the synchronous digital hierarchy (SDH).*
- [ITU-T G.841] Recommendation ITU-T G.841 (1998), *Types and characteristics of SDH network protection architectures.*
- [ITU-T G.870] Recommendation ITU-T G.870/Y.1352 (2008), *Terms and definitions for optical transport networks (OTN).*
- [ITU-T G.872] Recommendation ITU-T G.872 (2001), *Architecture of optical transport networks.*
- [ITU-T G.873.1] Recommendation ITU-T G.873.1 (2006), *Optical Transport Network (OTN): Linear protection.*
- [ITU-T G.874] Recommendation ITU-T G.874 (2008), *Management aspects of optical transport network elements.*
- [ITU-T G.957] Recommendation ITU-T G.957 (2006), *Optical interfaces for equipments and systems relating to the synchronous digital hierarchy.*
- [ITU-T G.959.1] Recommendation ITU-T G.959.1 (2009), *Optical transport network physical layer interfaces.*
- [ITU-T G.7042] Recommendation ITU-T G.7042/Y.1305 (2006), *Link capacity adjustment scheme (LCAS) for virtual concatenated signals.*
- [ITU-T G.8021] Recommendation ITU-T G.8021/Y.1341 (2010), *Characteristics of Ethernet transport network equipment functional blocks.*

- [ITU-T G.8251] Recommendation ITU-T G.8251 (2010), *The control of jitter and wander within the optical transport network (OTN)*.
- [ITU-T I.150] Recommendation ITU-T I.150 (1999), *B-ISDN asynchronous transfer mode functional characteristics*.
- [ITU-T I.321] Recommendation ITU-T I.321 (1991), *B-ISDN protocol reference model and its application*.
- [ITU-T I.361] Recommendation ITU-T I.361 (1999), *B-ISDN ATM layer specification*.
- [ITU-T I.371] Recommendation ITU-T I.371 (2004), *Traffic control and congestion control in B-ISDN*.
- [ITU-T I.432.1] Recommendation ITU-T I.432.1 (1999), *B-ISDN user-network interface – Physical layer specification: General characteristics*.
- [ITU-T I.610] Recommendation ITU-T I.610 (1999), *B-ISDN operation and maintenance principles and functions*.
- [ITU-T I.732] Recommendation ITU-T I.732 (2000), *Functional characteristics of ATM equipment*.
- [ITU-T O.150] Recommendation ITU-T O.150 (1996), *General requirements for instrumentation for performance measurements on digital transmission equipment*.
- [ITU-T O.151] Recommendation ITU-T O.151 (1992), *Error performance measuring equipment operating at the primary rate and above*.
- [IEC 60825-1] IEC 60825-1 (2001), *Safety of laser products – Part 1: Equipment classification and requirements*.
- [IEC 60825-2] IEC 60825-2 (2007), *Safety of laser products – Part 2: Safety of optical fibre communication systems (OFCS)*.
- [IEEE 802.3] IEEE Std. 802.3-2008, *IEEE Standard for Information technology – Telecommunications and information exchange between systems – Local and metropolitan area networks – Specific requirements – Part 3: Carrier Sense Multiple Access with Collision Detection (CSMA/CD) Access Method and Physical Layer Specifications*.
- [IEEE 802.3ba] IEEE Std. 802.3ba-2010, *IEEE Standard for Information technology – Telecommunications and information exchange between systems – Local and metropolitan area networks – Specific requirements – Part 3: Carrier Sense Multiple Access with Collision Detection (CSMA/CD) Access Method and Physical Layer Specifications – Amendment 4: Media Access Control Parameters, Physical Layers, and Management Parameters for 40 Gb/s and 100 Gb/s Operation*.

3 Definitions

3.1 Terms defined elsewhere

This Recommendation uses the following terms defined elsewhere:

- 3.1.1 access function (AC):** [ITU-T G.870].
- 3.1.2 access point (AP):** [ITU-T G.805].
- 3.1.3 access point identifier (API):** [ITU-T G.831].

- 3.1.4 **adaptation function (A)**: [ITU-T G.806].
- 3.1.5 **adapted information (AI)**: [ITU-T G.805].
- 3.1.6 **APS channel**: [ITU-T G.870].
- 3.1.7 **APS protocol**: [ITU-T G.870].
- 3.1.8 **architecture**
 - 3.1.8.1 **1:n (protection) architecture**: [ITU-T G.870].
 - 3.1.8.2 **1+1 (protection) architecture**: [ITU-T G.870].
- 3.1.9 **automatic power reduction (APR)**: [ITU-T G.664].
- 3.1.10 **BIP-X**: [ITU-T G.780].
- 3.1.11 **CBR2G5**: [ITU-T G.870].
- 3.1.12 **CBR10G**: [ITU-T G.870].
- 3.1.13 **CBR40G**: [ITU-T G.870].
- 3.1.14 **CBRx**: [ITU-T G.870].
- 3.1.15 **characteristic information (CI)**: [ITU-T G.805].
- 3.1.16 **completely standardized OTUk (OTUk)**: [ITU-T G.870].
- 3.1.17 **component**
 - 3.1.17.1 **bridge**: [ITU-T G.870].
 - 3.1.17.1.1 **broadcast bridge**: [ITU-T G.870].
 - 3.1.17.1.2 **permanent bridge**: [ITU-T G.870].
 - 3.1.17.2 **selector**: [ITU-T G.870].
 - 3.1.17.2.1 **selective selector**: [ITU-T G.870].
- 3.1.18 **compound function**: [ITU-T G.806].
- 3.1.19 **connection function (C)**: [ITU-T G.806].
- 3.1.20 **connection matrix (CM)**: [ITU-T G.806].
- 3.1.21 **connection monitoring end point (CMEP)**: [ITU-T G.870].
- 3.1.22 **connection point (CP)**: [ITU-T G.805].
- 3.1.23 **defect**: [ITU-T G.806].
- 3.1.24 **fault cause**: [ITU-T G.806].
- 3.1.25 **function**: [ITU-T G.806].
- 3.1.26 **functionally standardized OTUk (OTUkV)**: [ITU-T G.870].
- 3.1.27 **management information (MI)**: [ITU-T G.806].
- 3.1.28 **management point (MP)**: [ITU-T G.806].
- 3.1.29 **member**: [ITU-T G.7042].
- 3.1.30 **MST_Range**: [ITU-T G.806].
- 3.1.31 **network**: [ITU-T G.805].
- 3.1.32 **ODUk path (ODUkP)**: [ITU-T G.870].
- 3.1.33 **ODUk TCM (ODUkT)**: [ITU-T G.870].

- 3.1.34 **operation**
- 3.1.34.1 **non-revertive (protection) operation:** [ITU-T G.870].
- 3.1.34.2 **revertive (protection) operation:** [ITU-T G.870].
- 3.1.35 **optical channel (OCh[r]):** [ITU-T G.870].
- 3.1.36 **optical channel data unit (ODUk):** [ITU-T G.870].
- 3.1.37 **optical channel payload unit (OPUk):** [ITU-T G.870].
- 3.1.38 **optical channel transport unit (OTUk[V]):** [ITU-T G.870].
- 3.1.39 **optical channel with full functionality (OCh):** [ITU-T G.870].
- 3.1.40 **optical channel with reduced functionality (OChr):** [ITU-T G.870].
- 3.1.41 **optical multiplex section (OMS):** [ITU-T G.872].
- 3.1.42 **optical physical section of order n (OPSn):** [ITU-T G.870].
- 3.1.43 **optical supervisory channel (OSC):** [ITU-T G.870].
- 3.1.44 **optical transmission section (OTS):** [ITU-T G.872].
- 3.1.45 **optical transport hierarchy (OTH):** [ITU-T G.870].
- 3.1.46 **optical transport module (OTM-n[r].m):** [ITU-T G.870].
- 3.1.47 **optical transport network (OTN):** [ITU-T G.870].
- 3.1.48 **OTM overhead signal (OOS):** [ITU-T G.870].
- 3.1.49 **OTM with full functionality (OTM-n.m):** [ITU-T G.870].
- 3.1.50 **OTM with reduced functionality (OTM-0.m, OTM-nr.m):** [ITU-T G.870].
- 3.1.51 **process:** [ITU-T G.806].
- 3.1.52 **protection**
- 3.1.52.1 **protection class:** [ITU-T G.870].
- 3.1.52.1.1 **sub-network connection protection:** [ITU-T G.870].
- 3.1.52.1.2 **inherent monitored (/I):** [ITU-T G.870].
- 3.1.52.1.3 **non-intrusive monitored (/N):** [ITU-T G.870].
- 3.1.53 **sublayer monitored (/S):** [ITU-T G.870].
- 3.1.54 **protection group:** [ITU-T G.870].
- 3.1.55 **remote information (RI):** [ITU-T G.806].
- 3.1.56 **remote point (RP):** [ITU-T G.806].
- 3.1.57 **server signal degrade (SSD):** [ITU-T G.806].
- 3.1.58 **server signal fail (SSF):** [ITU-T G.806].
- 3.1.59 **signal**
- 3.1.59.1 **extra traffic signal:** [ITU-T G.870].
- 3.1.59.2 **normal traffic signal:** [ITU-T G.870].
- 3.1.59.3 **null signal:** [ITU-T G.870].
- 3.1.59.4 **traffic signal:** [ITU-T G.870].
- 3.1.60 **subnetwork:** [ITU-T G.805].

- 3.1.61 subnetwork connection (SNC):** [ITU-T G.805].
- 3.1.62 switching**
- 3.1.62.1 bidirectional (protection) switching:** [ITU-T G.780].
- 3.1.62.2 unidirectional (protection) switching:** [ITU-T G.780].
- 3.1.63 TCM control function (TCMC):** [ITU-T G.870].
- 3.1.64 TCM control information (TCMCI):** [ITU-T G.870].
- 3.1.65 TCM control point (TCMCP):** [ITU-T G.870].
- 3.1.66 termination connection point (TCP):** [ITU-T G.806].
- 3.1.67 trail signal degrade (TSD):** [ITU-T G.806].
- 3.1.68 trail signal fail (TSF):** [ITU-T G.806].
- 3.1.69 trail termination function (TT):** [ITU-T G.806].
- 3.1.70 x:** (Clause 5 – "Conventions") of [ITU-T G.870].

3.2 Terms defined in this Recommendation

This Recommendation does not define any terms.

4 Abbreviations and acronyms

This Recommendation uses the following abbreviations and acronyms:

1second	one second pulse
1+1u	1+1 unidirectional protection
A	Adaptation function
AcMSI	Accepted Multiplex Structure Identifier
AcPT	Accepted Payload Type
AcPTI	Accepted Payload Type Indicator
AcSTAT	Accepted Status Field
AcTI	Accepted Trail Trace Identifier
AcVcPT	Accepted Virtual concatenation Payload Type
AC	Access function
ACT	Activation (for ODUk TCM trail)
ACTEn	Activation enabled
ACTRx	Received Activation
ACTTx	Transmitted Activation
AdminState	Administrative State
AI	Adapted Information
AIS	Alarm Indication Signal
AMP	Asynchronous Mapping Procedure
AP	Access Point
API	Access Point Identifier

APR	Automatic Power Reduction
APRCntrl	Automatic Power Reduction Control
APS	Automatic Protection Switching
ARC	Alarm Reporting Control
ATM	Asynchronous Transfer Mode
AUX	Auxiliary channel
BDI	Backward Defect Indication
BDI-O	Backward Defect Indication Overhead
BDI-P	Backward Defect Indication Payload
BEI	Backward Error Indicator
BIAE	Backward Incoming Alignment Error
BIP	Bit Interleaved Parity
C	Connection function
CBR	Constant Bit Rate signal
CBRx	Constant Bit Rate signal of bit rate [range] x
CI	Characteristic Information
CK	Clock
CLP	Cell Loss Priority
COMMS	Communications channel
CP	Connection Point
CPn	Connection Point normal
CPp	Connection Point protection
CPw	Connection Point working
CRC	Cyclic Redundancy Check
CSF	Client Signal Fail
D	Data
d	defect
DAa	Amplifier-aided Dispersion Accommodation
DAC	Channel Dispersion Accommodation
DAPI	Destination Access Point Identifier
DCC	Data Communication Channel
DEG	Degraded defect
DEGM	Degraded defect consecutive one-second Monitoring intervals
DEGThr	Degraded defect one-second errored block count Threshold
DMod	Demodulation
DMp	Delay Measurement of ODUk path monitoring
DMti	Delay Measurement of ODUk tandem connection monitoring instance (i)

DS	Defect Second
DS-O	Defect Second Overhead
DS-P	Defect Second Payload
EBC	Errored Block Count
EFCI	Explicit Forward Congestion Indication
EFS	Equipment Functional Specification
EMF	Equipment Management Function
ETC	Ethernet Coding
ETC3	Ethernet Coding 1000BASE-X
ETC5	Ethernet Coding 40GBASE-R
ETC6	Ethernet Coding 100GBASE-R
EthPP-OS	Ethernet Preamble and Ordered Set
ExDAPI	Expected Destination Access Point Identifier
ExMSI	Expected Multiplex Structure Identifier
ExSAPI	Expected Source Access Point Identifier
ExtCMD	External Command
F	Far-end
FAS	Frame Alignment Signal
FC	Fibre Channel
FDI	Forward Defect Indication
FDI-O	Forward Defect Indicator Overhead
FDI-P	Forward Defect Indicator Payload
FEC	Forward Error Correction
FECCorrErr	Forward Error Correction Corrected Errors
FECEn	Forward Error Correction Enabled
FM	Fault Management
FOP	Failure Of Protocol
FOP-PM	Failure Of Protocol Provisioning Mismatch
FOP-NR	Failure Of Protocol No Response
FS	Frame Start
F_DS	Far-end Defect Second
F_EBC	Far-end Errored Block Count
GFC	Generic Flow Control
GCC	Generic Communication Channel
GCCAccess	Generic Communication Channel Access
GCCCont	Generic Communication Channel Continue
GMP	Generic Mapping Procedure

HEC	Header Error Control
HoTime	Hold-off Time
IAE	Incoming Alignment Error
IF	In-Frame
ILA	In-Lane-Alignment
IM	In-Multiframe
IR	In Recovery
LCAS	Link Capacity Adjustment Scheme
LCK	Locked defect
LLM	Logical Lane Marker
LOA	Loss Of Alignment
LOF	Loss Of Frame
LOFLOM	Loss Of Frame and Loss Of Multiframe
LOFLANE	Loss of Frame of logical Lane
LOL	Loss of Lane alignment
LOM	Loss of Multiframe
LOR	Loss of Recovery
LOS	Loss Of Signal
LOS-O	Loss Of Signal Overhead
LOS-P	Loss Of Signal Payload
LSB	Least Significant Bit
LSS	Loss of pseudo-random bit sequence lock
LTC	Loss of Tandem Connection
m	non-intrusive monitor
MFAS	MultiFrame Alignment Signal
MFI	MultiFrame Indicator
MFS	MultiFrame Start
MI	Management Information
Mod	Modulation
MP	Management Point
MSI	Multiplex Structure Identifier
MSIM	Multiplex Structure Identifier Mismatch
MST	Member Status (signal)
n	normal
N	Near-end
N/A	Not Applicable
NC	Network Connection

NNI	Network Node Interface
N_DS	Near-end Defect Second
N_EBC	Near-end Errored Block Count
NJO	Negative Justification Opportunity byte
OA	Optical Amplification
OAM	Operation, Administration, Maintenance
OCD	Out of Cell Delineation
OCh	Optical Channel
OCI	Open Connection Indication
OChr	Optical Channel with reduced functionality
OCTk[V]m	OCh and OTU non-intrusive monitor
OCTDk[V]m	OCh and OTU and ODU Tandem Connection Monitoring Compound function
ODcx	ODUk clock of type "x", where "x" is "a", "b", "r", or "p"
ODM	Optical DeMultiplexing
ODU	Optical Data Unit
ODUi	Optical Data Unit of level i
ODU[i]j	Optical Data Unit of level j and i (i is optional; i < j)
ODUj	Optical Data Unit of level j
ODUj[/i]	Optical Data Unit of level j or i (i is optional; i < j)
ODUk	Optical Data Unit of level k
ODUkP	Optical Data Unit of level k, Path
ODUkT	Optical Data Unit of level k, Tandem connection sub-layer
OH	OverHead
OHDM	OverHead DeMultiplexing
OHM	OverHead Multiplexing
OLA	Out-of-Alignment
OM	Optical Multiplexing
OMFI	OPU MultiFrame Identifier
OMS	Optical Multiplex Section
OMSn	Optical Multiplex Section of level n
OMSnP	Optical Multiplex Section Protection sub-layer of level n
OOF	Out-Of-Frame
OOM	Out-Of-Multiframe
OOR	Out-Of-Recovery
OOS	Optical transmission module Overhead Signal
OperType	Operation Type
OPS	Optical Physical Section

OPSn	Optical Physical Section of level n
OPSM	Optical Physical Section Multilane
OPSMnk	OPS Multilane, k = 3, 4; n = 4
OPU	Optical Payload Unit
OPU4MFS	OPU4 MultiFrame Start
OPUk	Optical Payload Unit of level k
OPUk-Xv	Virtually concatenated Optical Payload Unit of level k
OS	Optical Section
OSC	Optical Supervisory Channel
OSn	Optical Section of order n
OSx	Optical Section of bit rate [range] x
OTL	Optical channel Transport Lane
OTLk.n.	Optical Transport Lane of OTUk lane number n
OTM	Optical Transmission Module
OTN	Optical Transport Network
OTS	Optical Transmission Section
OTSn	Optical Transmission Section of level n
OTU	Optical Transmission Unit
OTUk	Optical Transmission Unit of level k
OTUkV	Optical Transmission Unit of level k, functionally standardized
p	protection; performance data
PCS	Physical Coding Sub-layer
PCSL	Physical Coding Sub-layer of Lane
PJO	Positive Justification Opportunity byte
PLD	Payload
PLM	PayLoad Mismatch
PM	Performance Management
PMDC	Polarization Mode Dispersion Compensation
PMI	Payload Missing Indication
PMOH	Path Monitoring OverHead
ppm	parts per million
ProtType	Protection Type
PRBS	Pseudo-Random Bit Sequence
PSI	Payload Structure Indication
PT	Payload Type
PTI	Payload Type Identifier
RES	Reserved overhead

RI	Remote Information
RP	Remote Point
RS	Regenerator Section
RSn	Regenerator Section of level n
SAPI	Source Access Point Identifier
SDH	Synchronous Digital Hierarchy
SF	Signal Fail
Sk	Sink
SMOH	Section Monitoring OverHead
SNC	SubNetwork Connection
SNC/I	SubNetwork Connection with Inherent monitoring
SNC/N	SubNetwork Connection with Non-intrusive monitoring
SNC/S	SubNetwork Connection with Sub-layer monitoring
So	Source
SQM	Sequence indicator Mismatch
SSD	Server Signal Degraded
SSF	Server Signal Fail
SSF-O	SSF Overhead
SSF-P	SSF Payload
STAT	Status field
STM	Synchronous Transport Module
TCM	Tandem Connection Monitoring
TCMC	Tandem Connection Monitoring Control function
TCMCI	Tandem Connection Monitoring Control Information
TCMCP	Tandem Connection Monitoring Control Point
TCMOH	Tandem Connection Monitoring Overhead
TCP	Termination Connection Point
TIM	Trail trace Identifier Mismatch
TIMActDis	Trail trace Identifier Mismatch consequent Actions Disabled
TIMDetMo	Trail trace Identifier Mismatch Detection Mode
TSD	Trail Signal Degraded
TSE	Test Sequence Error
TSF	Trail Signal Fail
TSF-O	Trail Signal Fail Overhead
TSF-P	Trail Signal Fail Payload
TT	Trail Termination function
TTI	Trail Trace Identifier

TxMSI	Transmitted Multiplex Structure Identifier
TxTI	Transmitted Trail Identifier
UNI	User Network Interface
VCAT	Virtual Concatenation
VCLOM	Virtual Concatenation Loss Of Multiframe
VCMF	Virtual Concatenation MultiFrame
VCOH	Virtual Concatenation OverHead
vcPT	virtual concatenation Payload Type
VcPLM	Virtual concatenation PayLoad Mismatch
VLI	Virtual concatenation/Link capacity adjustment scheme Information
VP	Virtual Path
VPI	Virtual Path Identifier
w	working
WA	Wavelength Assignment
WS	Wavelength Selection
WTR	Wait To Restore

5 Methodology

For the basic methodology to describe transport network functionality of network elements, refer to clause 5 of [ITU-T G.806].

NOTE – The management interfaces connecting the various atomic functions defined in this Recommendation are not restricted to the use of management systems only but are available also for example control plane functions.

6 Supervision

The generic supervision functions are defined in clause 6 of [ITU-T G.806]. Specific supervision functions for the OTN are defined in this clause.

6.1 Alarm reporting control

Trail termination point mode and port modes are not supported by OTN equipment; instead alarm reporting control (ARC) is used. Refer to [ITU-T G.874] for the OTN ARC functionality.

6.2 Defects

6.2.1 Continuity supervision (loss of continuity defect)

Continuity supervision refers to the set of processes for monitoring the integrity of the continuity of a trail. Generic continuity supervision defects are described in clause 6.2.1 of [ITU-T G.806]. OTN-specific continuity supervision defects are described here. The continuity supervision requirements for the OTN are defined in [ITU-T G.872].

6.2.1.1 Loss of signal payload defect (dLOS-P)

Loss of signal payload (LOS-P) defect is monitored at the OTS, OMS and OCh layers of an OTM-n.m and at OPS and OChr layers of an OTM-nr.m/OTM-0.m signal.

At the OTS layer LOS-P shall correspond to the loss of the OTS payload in the OTM-n.m signal. At the OMS layer, LOS-P shall correspond to the loss of the OMS payload in the OTM-n.m signal. At the OCh layer, LOS-P shall correspond to the loss of an OCh payload in the OTM-n.m signal. See Figure 6-2 of [ITU-T G.709] for an illustration of OTS, OMS and OCh payload information within an OTM-n.m signal.

At the OPS layer, LOS shall correspond to the loss of the OTM-nr.m/OTM-0.m signal. At the OChr layer, LOS shall correspond to loss of an OCh payload of the OTM-nr.m/OTM-0.m signal. See Figure 6-3 of [ITU-T G.709] for an illustration of OPS and OChr information within an OTM-0.m signal. See Figure 6-4 of [ITU-T G.709] for an illustration of OPS and OChr information within an OTM-nr.m signal.

dLOS-P should take on the value "incoming payload signal absent" when the incoming power level of the payload signal at the receiver has dropped to a level that corresponds to a high error condition. The purpose of monitoring this parameter is to indicate either:

- i) transmitter failure at the OCh or OChr layer; or
- ii) optical path break at the OCh, OMS, OTS or OPS layer.

The specific detection process, including the detection time, is for further study.

An additional hold-off time is defined for the dLOS-P activation at the OTSn_TT_Sk and OMSn_TT_Sk. This time is introduced in order to avoid false dLOS-P activation in case the payload signal is already missing at the related trail termination source. The PMI signal is used to signal this information from the trail termination source to the sink (see clauses 6.2.6.7 and 8.10). The hold-off time has to cover the propagation, processing and detection delay of the PMI signal between the source and the sink. The hold-off time is not configurable, it depends on the specific implementation of the PMI signalling and LOS-P detection. Its value is for further study.

6.2.1.2 Loss of signal overhead defect (dLOS-O)

Loss of signal overhead defect is monitored at the OTS layer. LOS-O shall correspond to loss of the optical supervisory channel (OSC) signal. dLOS-P should take on the value "incoming overhead signal absent" when the incoming power level of the OSC at the receiver has dropped to a level that corresponds to a high error condition. The purpose of monitoring this parameter is to indicate either:

- i) OSC transmitter failure at the OTS layer; or
- ii) OSC optical path break at the OTS layer.

The specific detection process, including the detection time, is for further study.

6.2.1.3 Open connection indication defect (dOCI)

See clause 6.2.6.8.

6.2.1.4 Loss of tandem connection defect (dLTC)

6.2.1.4.1 dLTC at the ODUkT layer

dLTC shall be declared if the accepted STAT information (AcSTAT) is "000". dLTC shall be cleared if the accepted STAT information is not equal to "000". For the STAT information acceptance process, see clause 8.8.

During signal fail conditions of the data signal, dLTC shall be set to false. For details on the signal fail conditions, see the specific atomic functions.

6.2.2 Connectivity supervision/trail trace identifier mismatch defect (dTIM)

For the generic connectivity supervision requirements of the OTN, refer to [ITU-T G.872].

6.2.2.1 dTIM at the OTS, OTUk, ODUkT and ODUkP layer

The TTI mismatch process reports the trail trace identifier mismatch defect (dTIM). The process is based on the comparison of expected APIs (i.e., SAPI and DAPI) with the APIs in the incoming signal. The APIs are part of the 64-byte TTI as defined in [ITU-T G.709].

Depending on the topology, only the SAPI, the DAPI or both are taken into account for the mismatch detection. These topologies are:

Point-to-point

In a point-to-point topology, either unidirectional or bidirectional, only the SAPI is taken into account for the comparison at the trail termination sink as shown in Figure 6-1.

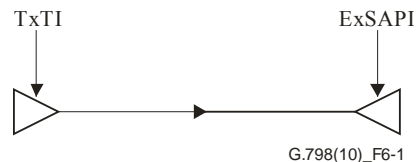

Figure 6-1 – Point-to-point configuration

Point-to-multipoint

In a point-to-multipoint topology, only the SAPI is taken into account for the comparison at the trail termination sink as shown in Figure 6-2.

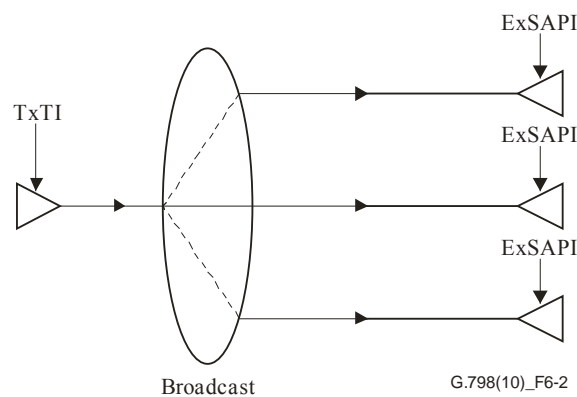

Figure 6-2 – Point-to-multipoint configuration

Multipoint-to-point

In a multipoint-to-point topology, only the DAPI is taken into account for the comparison at the trail termination sink as shown in Figure 6-3.

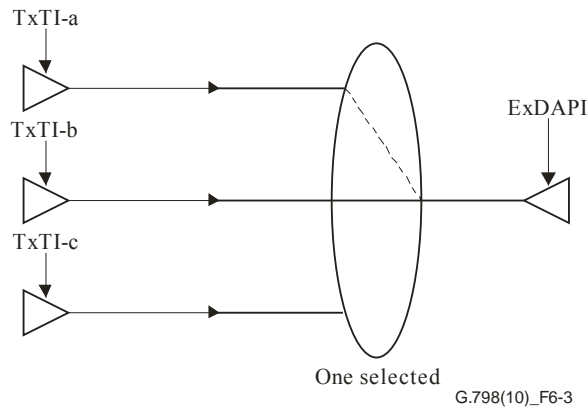

Figure 6-3 – Multipoint-to-point configuration

In addition, the mismatch detection can be disabled.

A functional decomposition of the TTI mismatch detection process is given in Figure 6-4.

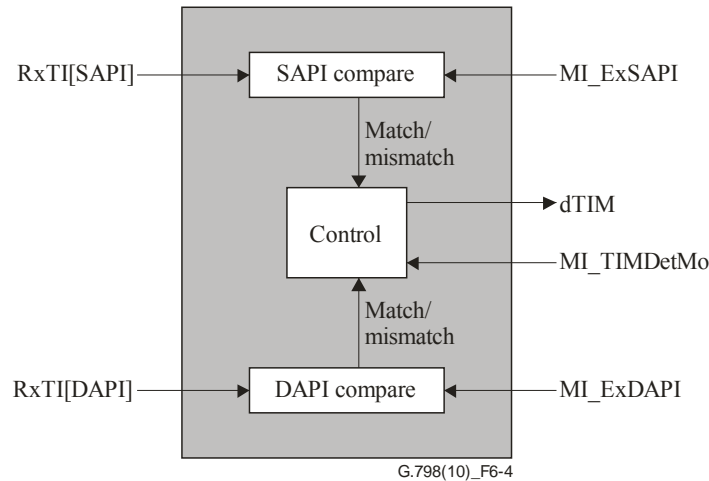

Figure 6-4 – TTI mismatch detection process

The SAPI/DAPI compare process compares the SAPI/DAPI part of the TTI in the incoming signal (RxTI) (see clause 15.2 of [ITU-T G.709]) with the equivalent expected SAPI/DAPI values set via the MP (MI_ExSAPI/DAPI). The comparison result is "match" if all 16 bytes are equal, and "mismatch" if one or more bytes are unequal. "match/mismatch" conditions shall be detected within 100 ms of changes to the RxTI, ExSAPI or ExDAPI in the absence of bit errors. A persistence check shall be used in order to prevent wrong/toggling dTIM information during bit errors.

Based on the TIM detection mode set via the MP (MI_TIMDetMo) the defect dTIM is generated as listed in Table 6-1 in the control process.

During signal fail conditions of the data/overhead signal, dTIM shall be set to false. For details on the signal fail conditions, see the specific atomic functions.

Table 6-1 – dTIM generation

MI_TIMDetMo	SAPI compare	DAPI compare	dTIM
Off	Don't care	Don't care	Clear
SAPI	Match	Don't care	Clear
SAPI	Mismatch	Don't care	Raise
DAPI	Don't care	Match	Clear
DAPI	Don't care	Mismatch	Raise
SAPI + DAPI	Match	Match	Clear
SAPI + DAPI	Match	Mismatch	Raise
SAPI + DAPI	Mismatch	Match	Raise
SAPI + DAPI	Mismatch	Mismatch	Raise

6.2.3 Signal quality supervision

6.2.3.1 OTS signal quality supervision

Specific requirements for OTS signal quality supervision are for further study. The specific implementation for signal quality supervision is outside the scope of this Recommendation.

6.2.3.2 OMS signal quality supervision

For further study.

6.2.3.3 OCh signal quality supervision

For further study.

6.2.3.4 OTUk, ODUkT signal degrade defect (dDEG) detection

The algorithm for the OTUk and ODUkT dDEG detection is defined in clause 6.2.3.1.2 of [ITU-T G.806] with the addition that the current and previous errored second count is discarded (assumed as 0 errored blocks) if the defect dIAE was active once during the second.

Bursty distribution of errors is assumed and only the degraded signal defect (dDEG) is supported.

For the errored block definition and the number of blocks per one-second interval, see Table 6-2.

6.2.3.5 ODUkP signal degrade defect (dDEG) detection

The algorithm for the ODUkP dDEG detection is defined in clause 6.2.3.1.2 of [ITU-T G.806]. Bursty distribution of errors is assumed and only the degraded signal defect (dDEG) is supported.

For the errored block definition and the number of blocks per one-second interval, see Table 6-2.

6.2.4 Payload mismatch supervision (dPLM)

6.2.4.1 dPLM at the ODUkP layer

dPLM shall be declared if the accepted payload type (AcPT) is not equal to the expected payload type(s) as defined by the specific adaptation function. dPLM shall be cleared if the accepted payload type is equal to the expected payload type(s), as defined by the specific adaptation function.

NOTE – An adaptation function may support more than one payload type.

For the payload type acceptance process, see clause 8.7.1.

6.2.4.2 dVcPLM at the ODUkP layer

dVcPLM shall be declared if the accepted virtual concatenation payload type (AcVcPT) is not equal to the expected payload type(s) as defined by the specific adaptation function. dVcPLM shall be cleared if the accepted virtual concatenation payload type is equal to the expected payload type(s) as defined by the specific adaptation function.

NOTE – An adaptation function may support more than one payload type.

For the virtual concatenation payload type acceptance process, see clause 8.7.3.

6.2.5 Alignment supervision

6.2.5.1 OTUk loss of frame defect (dLOF)

OTUk dLOF is generated based on the state of the frame alignment process defined in clause 8.2.1.

If the frame alignment process is in the out-of-frame (OOF) state for 3 ms, dLOF shall be declared. To provide for the case of intermittent OOFs, the integrating timer shall not be reset to zero until an in-frame (IF) condition persists continuously for 3 ms. dLOF shall be cleared when the IF state persists continuously for 3 ms.

6.2.5.2 OTUk loss of multiframe defect (dLOM)

OTUk dLOM is generated based on the state of the multiframe alignment process defined in clause 8.2.2.

If the multiframe alignment process is persistently in the out-of-multiframe (OOM) state for 3 ms, dLOM shall be declared. dLOM shall be cleared immediately when the multiframe alignment process is in the in-multiframe (IM) state.

6.2.5.3 ODU_j[/i] loss of frame and multiframe defect (dLOFLOM)

ODU_j[/i] dLOFLOM is generated based on the state of the frame and multiframe alignment process defined in clause 8.2.3.

If the process is in the out-of-frame (OOF) state for 3 ms, dLOFLOM shall be declared. To provide for the case of intermittent OOFs, the integrating timer shall not be reset to zero until an in-frame (IF) condition persists continuously for 3 ms. dLOFLOM shall be cleared when the IF state persists continuously for 3 ms.

6.2.5.4 ODUk virtual concatenation loss of multiframe defect (dVCLOM)

ODUkd VCLOM is generated based on the state of the virtual concatenation multiframe alignment process defined in clause 8.2.4.

If the multiframe alignment process is persistently in the out-of-multiframe (OOM) state for 500 ms, dLOM shall be declared. dLOM shall be cleared immediately when the multiframe alignment process is in the in-multiframe (IM) state.

6.2.5.5 Loss of lane alignment defect (dLOL)

dLOL is generated for multilane interfaces of type OPSMnk based on the state of the lane alignment process of the multilane signals defined in clause 8.2.6.

If the multilane alignment process is in the out-of-alignment (OLA) state, dLOL shall be declared. dLOL shall be cleared when the multilane alignment process is in the ILA state.

6.2.5.6 Loss of frame defect of logical lane (dLOFLANE)

The loss of frame defect of lane on a multilane signal dLOFLANE is generated based on the state of the frame alignment process defined in clause 8.2.5.

If the frame alignment process is in the out-of-frame (OOF) state for 3 ms, dLOFLANE shall be declared. To provide for the case of intermittent OOFs, the integrating timer shall not be reset to zero until an in-frame (IF) condition persists continuously for 3 ms. dLOFLANE shall be cleared when the IF state persists continuously for 3 ms.

6.2.6 Maintenance signal supervision

6.2.6.1 Forward defect indication payload defect (dFDI-P)

6.2.6.1.1 dFDI-P at the OMS and OCh layer

Forward defect indication payload (FDI-P) defect is monitored at the OMS and OCh layers. The purpose of monitoring this parameter is to suppress downstream alarms at the client layer caused by upstream defects detected by the server layer, which interrupt the client payload signal.

FDI-P defect (dFDI-P) shall be declared at the trail termination sink function within X ms of detecting the upstream defect causing the insertion of FDI-P into the OOS.

FDI-P defect (dFDI-P) shall be cleared at the trail termination sink function within Y ms of detecting that the upstream defect, which caused the insertion of FDI-P into the OOS, has cleared.

X and Y are for further study.

6.2.6.2 Forward defect indication overhead defect (dFDI-O)

6.2.6.2.1 dFDI-O at the OMS and OCh layer

Forward defect indication overhead (FDI-O) defect is monitored at the OMS and OCh layers. The purpose of monitoring this parameter is to suppress downstream alarms at the client layer caused by upstream defects detected by the server layer which interrupt the OTM overhead signal (OOS).

FDI-O defect (dFDI-O) shall be declared at the trail termination sink function within X ms of detecting the upstream defect causing the insertion of FDI-O into the OOS.

FDI-O defect (dFDI-O) shall be cleared at the trail termination sink function within Y ms of detecting that the upstream defect, which caused the insertion of FDI-O into the OOS, has cleared.

X and Y are for further study.

6.2.6.3 Alarm indication signal defect (dAIS)

6.2.6.3.1 dAIS at OTUk layer (generic AIS)

The OTUk dAIS defect detection is identical to the CBR client signal dAIS detection defined in clause 6.2.6.3.3.

6.2.6.3.2 dAIS at ODUkT and ODUkP layer

dAIS shall be declared if the accepted STAT information (AcSTAT) is "111". dAIS shall be cleared if the accepted STAT information is not equal to "111". For the STAT information acceptance process, see clause 8.8.

6.2.6.3.3 dAIS for CBR client signals (generic AIS)

For the CBR dAIS detection, the reverse PN-11 process is applied to the data signal, as shown in Figure 6-5. At the output of this process (OUT), an all-ZEROs pattern will occur if the input data (IN) is the PN-11 generic AIS sequence. Note that an all-ZEROs output pattern will also occur in case of an all-ZEROs input pattern. Both the output (OUT) and input (IN) signals are constantly checked over an 8192-bit interval for the number of non ZERO bits (= ONE bits). If the number of ONE bits per interval at OUT is less than 256 and the number of ONE bits per interval at IN is above or equal to 256 in three consecutive intervals, dAIS is raised. If the number of ONE bits at

OUT is above or equal to 256 or the number of ONE bits at IN is below 256 in three consecutive intervals, dAIS is cleared.

NOTE – Generic AIS forwarded to SDH interfaces will lead to LOF in OSn/RSn_A_Sk functions not capable of detecting this AIS signal. In the case where an SDH input interface is connected to an STM-N output signal of a network-element terminating the OTN transport where this AIS signal is inserted, a dLOF defect could be interpreted as an AIS indication.

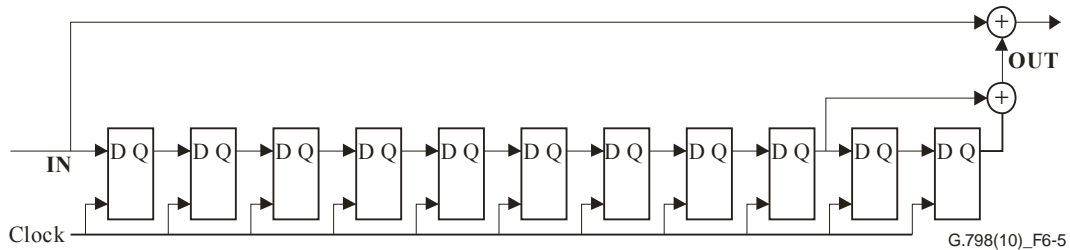

Figure 6-5 – Inverse PN-11 process for generic AIS detection

6.2.6.4 Backward defect indication payload defect (dBDI-P)

6.2.6.4.1 dBDI-P at OTS and OMS layer

Backward defect indication payload defect (dBDI-P) is monitored at the OTS and OMS layers. The purpose of monitoring this parameter is to allow for single-ended supervision of the trail.

BDI-P defect (dBDI-P) shall be declared at the trail termination sink function within X ms of detecting the far-end defect causing the insertion of BDI-P into the OOS.

BDI-P defect (dBDI-P) shall be cleared at the trail termination sink function within Y ms of detecting that the far-end defect, which caused the insertion of BDI-P into the OOS, has cleared.

X and Y are for further study.

During signal fail conditions of the overhead signal, dBDI-P shall be set to false. For details on the signal fail conditions, see the specific atomic functions.

6.2.6.5 Backward defect indication overhead defect (dBDI-O)

6.2.6.5.1 dBDI-O at OTS and OMS layer

Backward defect indication overhead defect (dBDI-O) is monitored at the OTS and OMS layers. The purpose of monitoring this parameter is to allow for single-ended supervision of the trail.

BDI-O defect (dBDI-O) shall be declared at the trail termination sink function within X ms of detecting the far-end defect causing the insertion of BDI-O into the OOS.

BDI-O defect (dBDI-O) shall be cleared at the trail termination sink function within Y ms of detecting that the far-end defect, which caused the insertion of BDI-O into the OOS, has cleared.

X and Y are for further study.

During signal fail conditions of the overhead signal, dBDI-O shall be set to false. For details on the signal fail conditions, see the specific atomic functions.

6.2.6.6 Backward defect indication defect (dBDI)

6.2.6.6.1 dBDI at OTUk, ODUkT and ODUkP layer

dBDI shall be declared if the BDI bit in the SM/TCMi/PM overhead field (byte 3, bit 5) is "1" for X consecutive frames. dBDI shall be cleared if the BDI bit in the SM/TCMi/PM overhead field is "0" for X consecutive frames. X shall be 5.

During signal fail conditions of the data signal, dBDI shall be set to false. For details on the signal fail conditions, see the specific atomic functions.

6.2.6.7 Payload missing indication defect (dPMI)

6.2.6.7.1 dPMI at the OTS and OMS layer

Payload missing indication (PMI) defect is monitored at the OTS and OMS layers. The purpose of monitoring this parameter is to suppress downstream loss of signal alarms at the trail termination sink due to upstream defects causing missing payload at the start of the trail.

PMI defect (dPMI) shall be declared at the trail termination sink function within X ms of detecting the missing payload condition causing the insertion of PMI into the OOS.

PMI defect (dPMI) shall be cleared at the trail termination sink function within Y ms of detecting that the missing payload condition, which caused the insertion of PMI into the OOS, has cleared.

X and Y are for further study. Values in the range of a few milliseconds are proposed, as PMI has to suppress the payload defect at the sink immediately.

During signal fail conditions of the overhead signal, dPMI shall be set to false. For details on the signal fail conditions, see the specific atomic functions.

NOTE – The defect PMI will not result in a fault cause. It is used to suppress LOS-P defects-related consequent actions, defect correlations and performance monitoring data at the OTS and OMS trail termination sink in case of an already missing payload at the trail termination source (see clauses 6.2.1.1 and 8.10).

6.2.6.8 Open connection indication defect (dOCI)

Open connection indication defect (dOCI) is monitored at the OCh and ODUk layers. The purpose of monitoring this parameter is to qualify a downstream loss of signal defect by indicating that the loss of signal defect is due to an output connection point not connected to an input connection point.

6.2.6.8.1 dOCI at the OCh layer

OCI defect (dOCI) shall be declared at the OCh trail termination sink function within X ms of the OCh connection function having received the command via the MP to disconnect the output OCh_CP from an input OCh_CP.

OCI defect (dOCI) shall be cleared at the OCh trail termination sink function within Y ms of the OCh connection function detecting that the output OCh_CP, which the OCI corresponded to, is connected to an input OCh_CP.

X and Y are for further study.

During signal fail conditions of the overhead signal, dOCI shall be set to false. For details on the signal fail conditions, see the specific atomic functions.

6.2.6.8.2 dOCI at the ODUkP and ODUkT layer

dOCI shall be declared if the accepted STAT information (AcSTAT) is "110". dOCI shall be cleared if the accepted STAT information is not equal to "110". For the STAT information acceptance process, see clause 8.8.

During signal fail conditions of the data signal, dOCI shall be set to false. For details on the signal fail conditions, see the specific atomic functions.

6.2.6.9 Locked defect (dLCK)

6.2.6.9.1 dLCK at the ODUkP and ODUkT layer

dLCK shall be declared if the accepted STAT information (AcSTAT) is "101". dLCK shall be cleared if the accepted STAT information is not equal to "101". For the STAT information acceptance process, see clause 8.8.

During signal fail conditions of the data signal, dLCK shall be set to false. For details on the signal fail conditions, see the specific atomic functions.

6.2.6.10 Incoming alignment error defect (dIAE)

NOTE – The defect IAE will not result in a fault cause. It is used to suppress wrong PM data (EBC and DS) at the OTUk and ODUkT trail termination sink in case of an incoming frame slip to the trail (see clause 8.10).

6.2.6.10.1 dIAE at the OTUk layer

dIAE shall be declared if the IAE bit in the SM overhead field (byte 3, bit 6) is "1" for X consecutive frames. dIAE shall be cleared if the IAE bit in the SM overhead field is "0" for X consecutive frames. X shall be 5.

During signal fail conditions of the data signal, dIAE shall be set to false. For details on the signal fail conditions, see the specific atomic functions.

6.2.6.10.2 dIAE at the ODUkT layer

dIAE shall be declared if the accepted STAT information (AcSTAT) is "010". dIAE shall be cleared if the accepted STAT information is not equal to "010". For the STAT information acceptance process, see clause 8.8.

During signal fail conditions of the data signal, dIAE shall be set to false. For details on the signal fail conditions, see the specific atomic functions.

6.2.6.11 Backward incoming alignment error defect (dBIAE)

NOTE – The defect BIAE will not result in a fault cause. It is used to suppress wrong far-end PM data (EBC and DS) at the OTUk and ODUkT trail termination sink in case of an incoming frame slip to the trail (see clause 8.10).

6.2.6.11.1 dBIAE at the OTUk and ODUkT layer

dBIAE shall be declared if the BEI/BIAE bits in the SM/TCM overhead field (byte 3, bits 1 to 4) are "1011" for X consecutive frames. dBIAE shall be cleared if the BEI/BIAE bits in the SM/TCM overhead field are not equal to "1011" for X consecutive frames. X shall be 3.

During signal fail conditions of the data signal, dBIAE shall be set to false. For details on the signal fail conditions, see the specific atomic functions.

6.2.7 Protocol supervision

6.2.7.1 Protection protocol supervision

6.2.7.1.1 ODU linear protection failure of protocol provisioning mismatch (dFOP-PM)

ODUk dFOP-PM shall be declared when the B bit of the transmitted and accepted APS protocol do not match.

ODUk dFOP-PM shall be cleared when the B bit of the transmitted and accepted APS protocols do match.

For a description of the APS protocol, see [ITU-T G.873.1].

6.2.7.1.2 ODU linear protection failure of protocol no response defect (dFOP-NR)

ODUk dFOP-NR shall be declared when the requested signal and the bridge signal in the APS protocol do not match within 1 s.

NOTE – The time after which a response on a bridge request is received depends on the transmission delay between the protection switching nodes (and the processing delay in the nodes).

ODUk dFOP-NR shall be cleared when the requested signal and the bridge signal in the APS protocol match.

For a description of the APS protocol, see [ITU-T G.873.1].

6.2.8 OTM overhead signal (OOS) related defects

As the specific format of the OOS is outside the scope of [ITU-T G.709], no specific defects, except for dLOS-P (see clause 6.2.1.1), are defined in this Recommendation either. However, depending on the specific OOS format, additional defect detection (e.g., loss of alignment) is required. These defects will contribute to the TSF-P, SSF-P, FDI-P and BDI-P consequent actions.

6.2.9 Multiplex structure identifier mismatch supervision defect (dMSIM)

6.2.9.1 dMSIM[i] at the ODU layer

Refer to clause 8.7.2 for a description of AcMSI[i] and ExMSI[i].

The defect dMSIM[i] shall be declared for the ODU tributary port #i if the AcMSI[i] is not equal to the ExMSI[i]. dMSIM[i] shall be cleared if the AcMSI[i] is equal to the ExMSI[i].

ExMSI[i] is either a fixed value or configured via the management interface. For details, see clauses 14.3.9.2 and 14.3.10.2 (ODUkP/ODU[i]j_A_Sk and ODUkP/ODUj-21_A_Sk function).

For the AcMSI[i] acceptance process, see clause 8.7.2.

6.2.10 Client signal fail defect (dCSF)

dCSF shall be declared if the CSF bit in the OPuK PSI overhead (bit 1 of the PSI[2] byte) is "1" for X consecutive 256-frame multiframes. dCSF shall be cleared if the CSF bit is "0" for X consecutive 256-frame multiframes. X shall be 3.

6.3 Consequent actions

For consequent actions, see [ITU-T G.806] and the specific atomic functions.

6.4 Defect correlations

For the defect correlations, see the specific atomic functions.

6.5 Performance filters

6.5.1 One-second performance monitoring filters associated with counts

6.5.1.1 Errored block count (EBC)

The one-second performance monitoring filters pN_EBC and pF_EBC are defined in clause 6.5 of [ITU-T G.806]. For the application of these filters, see the specific atomic functions.

The OTN errored block definitions are given in Tables 6-2 and 6-3.

During signal fail conditions of the data signal, no errored blocks shall be counted. For details on the signal fail conditions, see the specific atomic functions.

Table 6-2 – OTN near-end errored blocks definition

Layer	Errored block definition	Number of blocks per second (Note 4)
OTUk (Notes 1 and 3)	One or more errors detected by the OTUk BIP8	OTU1: 20421 OTU2: 82026 OTU3: 329492 OTU4: 856388
ODUkT/P (Notes 2 and 3)	One or more errors detected by the ODUkT/P BIP8	ODU0 10168 ODU1: 20421 ODU2: 82026 ODU2e 84986 ODU3: 329492 ODU4: 856388 CBR ODUflex: clientrate/121856 GFP-F ODUflex: clientrate/122368
<p>NOTE 1 – The block size for OTUk, k = 1, 2, 3, 4 is equal to the OTUk frame size, which is $4 \times 4080 \times 8 = 130\,560$ bits.</p> <p>NOTE 2 – The block size for ODUk, k = 0, 1, 2, 2e, 3, 4 is equal to the ODUk frame size, which is $4 \times 3824 \times 8 = 122\,368$ bits.</p> <p>NOTE 3 – The EDC is BIP8, and is computed over the OPUk payload ($4 \times 3808 \times 8$ bits) plus OPUk overhead ($4 \times 2 \times 8$ bits), for a total of $4 \times 3810 \times 8 = 121\,920$ bits. The EDC usage is $1 \times$ BIP8.</p> <p>NOTE 4 – These values are rounded to the next larger integer value.</p>		

Table 6-3 – OTN far-end errored blocks definition

Layer	Errored block definition	Number of blocks per second (Note)
OTUk	One or more errors indicated by BEI in the OTUk frame	OTU1: 20421 OTU2: 82026 OTU3: 329492 OTU4: 856388
ODUkT/P	One or more errors indicated by BEI in the ODUkT/P frame	ODU0 10168 ODU1: 20421 ODU2: 82026 ODU2e: 84986 ODU3: 329492 ODU4: 856388 CBR ODUflex: clientrate/121856 GFP-F ODUflex: clientrate/122368
<p>NOTE – These values are rounded to the next larger integer value.</p>		

6.5.1.2 Defect second (DS)

The one-second performance monitoring filters pN_DS and pF_DS are defined in clause 6.5 of [ITU-T G.806]. For the application of these filters, see the specific atomic functions.

6.5.1.3 FEC corrected errors (FECcorrErr)

The number of bits corrected by the FEC (see clause 8.5) are counted over one second and reported to the MI at the end of the second. For the application of this filter, see the specific atomic functions.

During signal fail conditions of the data signal, no corrected bits shall be counted. For details on the signal fail conditions, see the specific atomic functions.

6.5.2 Performance monitoring filters associated with gauges

For further study.

7 Information flow across reference points

See clause 7 of [ITU-T G.806] for a generic description of information flow. For the OTN-specific information flow, see the description of the functions in clause 9.

8 Generic processes

Generic processes are defined in clause 8 of [ITU-T G.806]. This clause defines the specific process for the OTN.

8.1 Scrambling processes

Scrambling is required for the OTUk signal. The OTUk scrambler is defined in clause 11.2 of [ITU-T G.709].

8.2 Alignment processes

8.2.1 OTUk frame alignment

The OTUk frame alignment shall be found by searching for the OA1, OA2 FAS bytes (see [ITU-T G.709]) contained in the OTUk frame.

The process has two states, out-of-frame (OOF) and in-frame (IF).

In the OOF state, the framing pattern searched for shall be a 4-byte subset of the OA1 and OA2 bytes. The IF state shall be entered if this subset is found and confirmed one frame period later.

In the IF state, the frame signal shall be continuously checked with the presumed frame start position for correct alignment. The framing pattern checked for shall be the OA1OA2OA2 pattern (bytes 3, 4 and 5 of the first row of the OTUk frame). The OOF state shall be entered if this subset is not found at the correct position in five consecutive frames.

The frame start shall be maintained during the OOF state.

8.2.2 OTUk multiframe alignment

The OTUk multiframe alignment shall be found based on the MFAS byte (see [ITU-T G.709]) contained in the OTUk frame.

The process has two states, out-of-multiframe (OOM) and in-multiframe (IM).

In the IM state, OOM shall be assumed when the received MFAS does not match with the expected multiframe number in five consecutive OTUk frames.

In the OOM state, multiframe alignment shall be assumed to be recovered, the multiframe counter shall be set to the new MFAS, and the IM state shall be entered, when a valid MFAS sequence is found in two consecutive OTUk frames. The MFAS sequence is valid if the MFAS of the second frame is the increment of the MFAS of the first frame.

The multiframe start shall be maintained during the OOM state.

8.2.3 ODU_j[/i] frame and multiframe alignment

The ODU_j[/i] frame and multiframe alignment shall be found by searching for the framing pattern (OA1, OA2 FAS bytes) and checking the multiframe sequence (MFAS byte) (see [ITU-T G.709]) contained in the ODU_j[/i] frame.

The process has two states, out-of-frame (OOF) and in-frame (IF).

In the OOF state, the framing pattern searched for shall be the full set of the OA1 and OA2 bytes. The IF state shall be entered if this set is found and confirmed one frame period later and an error free multiframe sequence is found in the MFAS bytes of the two frames.

In the IF state, the frame alignment signal shall be continuously checked with the presumed frame start position and the expected multiframe sequence. The framing pattern checked for shall be the OA1OA2 pattern (bytes 3 and 4 of the first row of the ODU_j[/i] frame). The OOF state shall be entered if this subset is not found at the correct position within five consecutive frames, or the received MFAS does not match the expected multiframe number within five consecutive frames.

The frame and multiframe start shall be maintained during the OOF state.

8.2.4 ODU_k virtual concatenation multiframe alignment

The ODU_k virtual concatenation multiframe (VCMF) is used on top of the ODU_k MFAS multiframe. It uses the MFI1 and MFI2 bytes of the VCOH overhead as defined in clause 18.1.2.2.2.1 of [ITU-T G.709].

The process has two states, out-of-multiframe (OOM) and in-multiframe (IM).

In the IM state, OOM shall be assumed when the received VCMF number in the MFI1 and MFI2 bytes of the VCOH does not match with the expected multiframe number in three consecutive ODU_k MFAS multiframe.

In the OOM state, multiframe alignment shall be assumed to be recovered, the multiframe counter shall be set to the received VCMF number, and the IM state shall be entered, when a valid VCMF sequence is found in two consecutive ODU_k MFAS multiframe. The VCMF sequence is valid if the received VCMF number of the second MFAS multiframe is the increment of the received VCMF number of the first frame.

NOTE – The MFI1 and MFI2 bytes are transmitted eight times per MFAS multiframe, containing the same VCMF number. For the VCMF alignment process, only the first occurrence of the MFI1 and MFI2 bytes in the MFAS multiframe (MFAS multiframe numbers 0 and 1) shall be used.

The multiframe start shall be maintained during the OOM state.

8.2.5 Logical lane frame alignment

Logical lane frame alignment shall be found by searching for the OA1, OA2 FAS bytes within the logical lane as specified in Annex C of [ITU-T G.709].

The process has two states, out-of-frame (OOF) and in-frame (IF).

In the OOF state, the framing pattern searched for shall be a 4-byte subset of 3 OA1 followed by N OA2 bytes present periodically after every 16320 bytes. The IF state shall be entered if this subset is found and confirmed a period of 16320 bytes later. N = 3 for the four-logical-lane (OTU3) interface and N = 2 for the 20-logical-lane (OTU4) interface.

In the IF state, the frame signal shall be continuously checked with the presumed frame start position for correct alignment. The framing pattern checked for shall be the OA1OA2OA2 pattern (bytes 3, 4 and 5 of the first row of the logical lane frame). The OOF state shall be entered if this subset is not found at the correct position in five consecutive periods of 16320 bytes.

The frame start shall be maintained during the OOF state.

NOTE – This process is identical to the OTUk frame alignment process.

8.2.6 Logical lane alignment

The logical lane alignment process is used to establish alignment of the lanes of the OTUk multilane interface.

The bytes of the OTUk signals ($k = 3, 4$) are distributed to the logical lanes in 16-byte increments as specified in Annex C of [ITU-T G.709].

For the OTU3 with four logical lanes, the MFAS is reused as logical lane marker information. The MFAS sequence 00000000, 00000001, .. , 11111111 (i.e., 0 to 255) is inserted before distribution of the OTU3 bytes over the four logical lanes. After distribution of the OTU3 16-byte increments over the four logical lanes, each lane will carry a subset of the MFAS values of which the two least significant bits are constant (either 00, 01, 10, or 11) and identifies the logical lane number.

- Logical lane 0 will carry the following MFAS values: 00000000 – 00000100 – 00001000 – 00001100 – 00010000 – 00010100 – ... – 11111100.
- Logical lane 1 will carry the following MFAS values: 00000001 – 00000101 – 00001001 – 00001101 – 00010001 – 00010101 – ... – 11111101.
- Logical lane 2 will carry the following MFAS values: 00000010 – 00000110 – 00001010 – 00001110 – 00010010 – 00010110 – ... – 11111110.
- Logical lane 3 will carry the following MFAS values: 00000011 – 00000111 – 00001011 – 00001111 – 00010011 – 00010111 – ... – 11111111.

For the OTU4 with twenty logical lanes the LLM carries the logical lane marker information. The LLM sequence 00000000, 00000001, .. , 11101111 (i.e., 0 to 239) is inserted before the distribution of the OTU4 bytes over the twenty logical lanes. After the distribution of the OTU4 16-byte increments over the twenty logical lanes, each logical lane will carry a subset of the LLM values of which the modulo 20 value is constant and identifies the logical lane number.

- Logical lane 0 will carry the following LLM values (0, 20, 40, 60, ..., 200, 220): 00000000 – 00010100 – ... – 11011100.
- Logical lane 1 will carry the following LLM values (1, 21, 41, 61, ..., 201, 221): 00000001 – 00010101 – ... – 11011101.
- ...
- Logical lane 18 will carry the following LLM values (18, 38, 58, 78, ..., 218, 238): 00010010 – 00100110 – ... – 11101110.
- Logical lane 19 will carry the following LLM values (19, 39, 59, 79, ..., 219, 239): 00010011 – 00100111 – ... – 11101111.

8.2.6.1 OTU3 multilane alignment

The process has two sub-processes:

- logical lane marker recovery (per lane);
- multilane alignment (composite signal).

The logical lane marker signal is located in bits 7 and 8 of the MFAS byte of the logical lane frame. These bits are scrambled with the scrambler given in clause 11.2 of [ITU-T G.709].

A logical lane marker recovery process is present per logical lane to recover the logical lane marker value. A new value of the logical lane marker is accepted when in five consecutive 16320-byte periods the same value is present in bits 7 and 8 of the MFAS byte, and the recovery process will enter the in-recovery (IR) state. In the IR state, recovery will be lost and the out-of-recovery (OOR) state will be entered, when in each of five consecutive 16320-byte periods a value is received that is

not the same as the accepted logical lane marker value. During an OOR period, the last accepted LLM value has to be maintained as a lane marker value.

If the logical lane marker recovery process is in the out-of-recovery (OOR) state for 3 ms, LOR state shall be entered. LOR shall be left when the IR state persists continuously for 3 ms.

The value of the logical lane marker is available after descrambling.

Each of the four lanes shall have recovered a unique logical lane marker value in the range 0 to 3.

If all four logical lanes have different values, the bytes of each logical lane shall be written into an elastic store with the indication of the start of the logical lane 16320-byte period boundary in line with the logical lane marker.

If the bytes of the lane signals can be written consistently into the elastic store in the presence of a differential delay in line with the particular adaptation function without exceeding the buffering time, the in-multilane-alignment (ILA) state shall be entered. In this case, the differential delay can be compensated.

If two or more logical lanes have the same logical lane marker value, or if one or more logical lane marker recovery processes are in the LOR state, or if the differential delay between two logical lanes exceeds the maximum delay that can be compensated in accordance to the related sink function, multilane alignment is not possible and the out-of-multilane-alignment (OLA) state is entered.

8.2.6.2 OTU4 multilane alignment

The process has two sub-processes:

- logical lane marker recovery (per lane);
- multilane alignment (composite signal).

The logical lane marker signal is located in the LLM byte of the logical lane frame.

A logical lane marker recovery process is present per logical lane to recover the logical lane marker value. A new value of the logical lane marker is accepted when in five consecutive 16320-byte periods the same value is present after modulo 20 operation of the LLM byte value, and the recovery process will enter the in-recovery (IR) state. In the IR state, recovery will be lost and the out-of-recovery (OOR) state be entered, when in each of five consecutive 16320-byte periods a value is received that is not the same as the accepted logical lane marker value. During an OOR period, the last accepted LLM value has to be maintained as lane marker value.

If the logical lane marker recovery process is in the out-of-recovery (OOR) state for 3 ms, LOR state shall be entered. LOR shall be left when the IR state persists continuously for 3 ms.

Each of the twenty logical lanes shall have recovered a unique logical lane marker value in the range 0 to 19.

The process shall in addition decode the MFAS signal as coded in the 7th byte following the lane identification byte and identify the position of the virtual lane data in relation to the OTU4 multiframe. This position needs to be descrambled according to the scrambler defined in clause 11.2 of [ITU-T G.709].

If the lane identification and MFA identification for all lanes is detected consistently in line with the modulo 20 operation of the LLM byte position together with the MFA value, the data shall be written into the elastic store for realignment with the indication of the start of the logical lane 16320-byte period boundary in line with the logical lane marker.

If the bytes of the logical lane signals can be written consistently into the elastic store in the presence of a differential delay in line with the particular adaptation function without exceeding the buffering time, the ILA state shall be entered. In this case the differential delay can be compensated.

If two or more logical lanes have the same logical lane marker value, or if one or more logical lane marker recovery processes are in the LOR state, or if the differential delay between two logical lanes exceeds the maximum delay that can be compensated in accordance to the related sink function, multilane alignment is not possible and the out-of-multilane-alignment (OLA) state is entered.

8.3 Signal quality supervision

8.3.1 OTS signal quality supervision

For further study.

8.3.2 OMS signal quality supervision

For further study.

8.3.3 OCh signal quality supervision

For further study.

8.3.4 OTUk, ODUkT and ODUkP signal quality supervision

A BIP8 is used for each of these layers as defined in clause 15 of [ITU-T G.709].

8.3.4.1 BIP8 source processing

The BIP8 shall be computed over the OPUk frame (columns 15 to 3824). The computed BIP8 is inserted in the BIP8 byte position of the relevant overhead field of the 2nd following frame as shown in Figure 8-1.

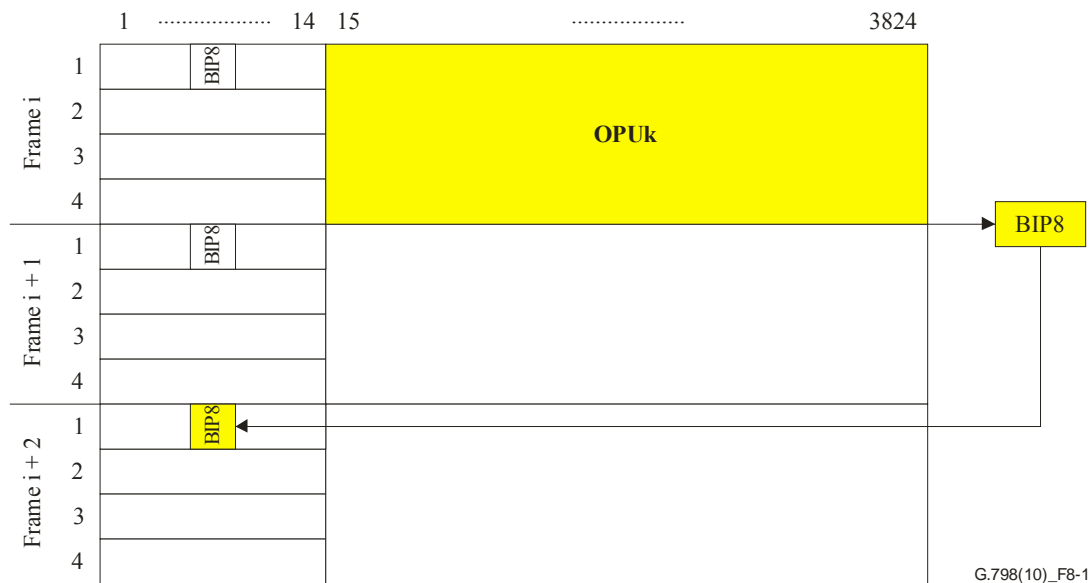

Figure 8-1 – BIP8 source processing (SMOH used as example)

8.3.4.2 BIP8 sink processing

The BIP8 is computed over the OPUk (columns 15 to 3824 of the frame). The BIP8 value generated by the TT_So shall be extracted from the BIP8 byte position of the relevant overhead field. The computed BIP8 value of the 2nd preceding frame is compared with the BIP8 value extracted from the current frame, as shown in Figure 8-2. If there is a mismatch between the two values, a near-end errored block (nN_B) is detected and the number of BIP violations (nBIPV) is forwarded to the companion TT_So function.

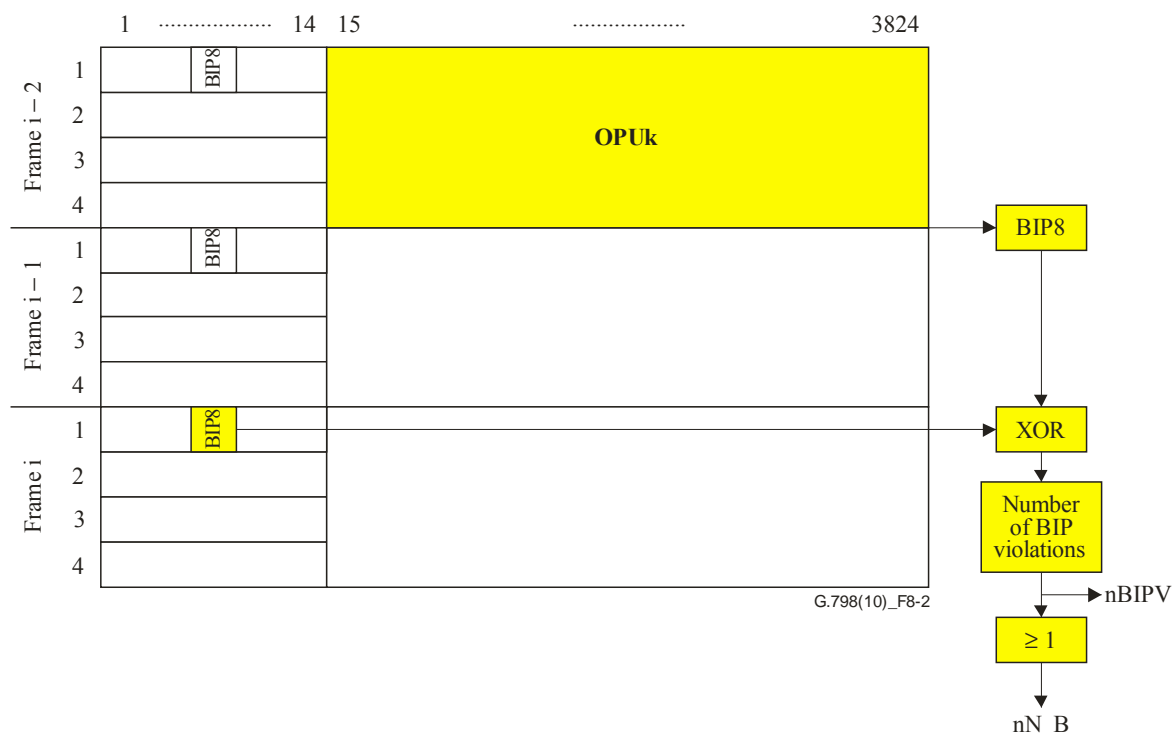

Figure 8-2 – BIP8 sink processing (SMOH used as example)

8.4 BIP correction

BIP correction is not required as the OTUk, ODUkT and ODUkP BIP8 is only calculated over the OPU and the relevant overhead is excluded. Modifications within the OTUk, ODUkT and ODUkP overhead have therefore no influence on the BIP8.

8.5 OTUk forward error correction (FEC) processing

For the FEC algorithm, see Annex A of [ITU-T G.709].

The FEC decoder shall report the number of corrected bits (nFECcorrErr). For further processing, see clause 6.5.1.3.

8.6 Trail trace identifier (TTI) processing

On request via the management interface (MI_GetAcTI), the TTI shall be reported within 100 ms. It shall be an accepted TTI (AcTI) instead of the received TTI (RxTI). The acceptance process shall include a persistency check in order to avoid wrong/toggling TTI values during bit error conditions.

For the TIM defect detection process, see clause 6.2.2.1.

8.7 Payload structure indication (PSI) acceptance processes

8.7.1 Payload type (PT) acceptance process

A new payload type is accepted (AcPT) if a new consistent value is received in the PSI[0] byte in X consecutive multiframes. X shall be 3.

8.7.2 Multiplex structure identifier (MSI) acceptance process

The multiplex structure identifier (MSI) consists of 2, 4, 8, 16, 32 or 80 bytes, which are located in the multiframed PSI overhead as illustrated in Table 8-1. The MSI contains one byte per tributary slot.

The MSI describes the allocation of tributary slots to ODTUs that contain the client ODTUs. Each ODTU is identified by means of either a 2-tuple <ODTU type, tributary port number> (k = 1, 2, 3), or <tributary slot occupation, tributary port number> (k = 4).

An ODTU is carried in one or more tributary slots a, b, ..., n. The MSI byte(s) associated with this/those tributary slot(s) is/are configured with a common 2-tuple value in the adaptation source function. The value of these 2-tuples is the same for every MSI byte in this set.

The adaptation sink function gets its ODTU to tributary slot allocation configured via the 2-, 4-, 8-, 16-, 32- or 80- byte expected MSI (ExMSI). The ExMSI bytes with the same 2-tuple value specify in which tributary slots an ODTU is expected to be carried; e.g., A, B, ..., N (A<B<...<N).

The Received MSI bytes associated with tributary slots A, B, ..., N are accepted (AcMSI[i]) if a new consistent value is received in these MSI bytes in X consecutive multiframes. X shall be 3.

NOTE – The minimum number of AcMSI[i] instances is 1 and the maximum number of AcMSI[i] instances is the number of tributary slots.

Table 8-1 – MSI bytes within PSI multiframe

ODUk type	Payload type of tributary	Tributary slots	MSI bytes in PSI position range
ODU1	20	TS[1,2]	PSI[2,3]
ODU2	20	TS[1..4]	PSI[2..5]
ODU2	21	TS[1..8]	PSI[2..9]
ODU3	20	TS[1..16]	PSI[2..17]
ODU3	21	TS[1..32]	PSI[2..33]
ODU4	21	TS[1..80]	PSI[2..81]

For details of the MSI values, please refer to clause 19.4 of [ITU-T G.709].

8.7.3 Virtual concatenation payload type (vcPT) acceptance process

The virtual concatenation payload type (vcPT) is always extracted from the first OPUk of the virtual concatenated OPUk-Xv. The vcPT information in the other OPUks is ignored.

A new vcPT (AcVcPT) is accepted if a new consistent value is received in the PSI[1] byte in X consecutive multiframes. X shall be 3.

8.8 Status information (STAT) acceptance process

A new STAT value (AcSTAT) is accepted if a new consistent value is received in the PM/TCM overhead, byte 3, bits 6 to 8, in X consecutive frames. X shall be 3.

8.9 Generic AIS generation and detection

Generic AIS including OTUk AIS is a PN-11 pseudo-random pattern as defined in [ITU-T G.709]. The pattern is generated by a pseudo-random generator. For the detection of generic AIS, the reverse process as shown in Figure 8-3 is used. As the flip-flops of the detector circuit are fed with the same data as the flip-flops of the generator circuit, data at point D1 is the same as data at G1 with a delay of 11 clock cycles. As the G1 data appears at the output of the generator (G_{out}) and as such also at the input of the detector (D_{in}) with a delay of 11 clock cycles, D1 and D_{in} data is the same for each clock cycle. A PN-11 generic AIS pattern at the input of the detector (D_{in}) should therefore result in an all-ZEROs pattern at point D2. The only other input pattern that will result in an all-ZEROs pattern at D2 is an all-ZEROs input pattern.

The detection of an all-ZEROs pattern at D2 and a non-all-ZEROs pattern at D_{in} is a criterion for the generic AIS defect. For the specific detection process, see clause 6.2.6.3.3.

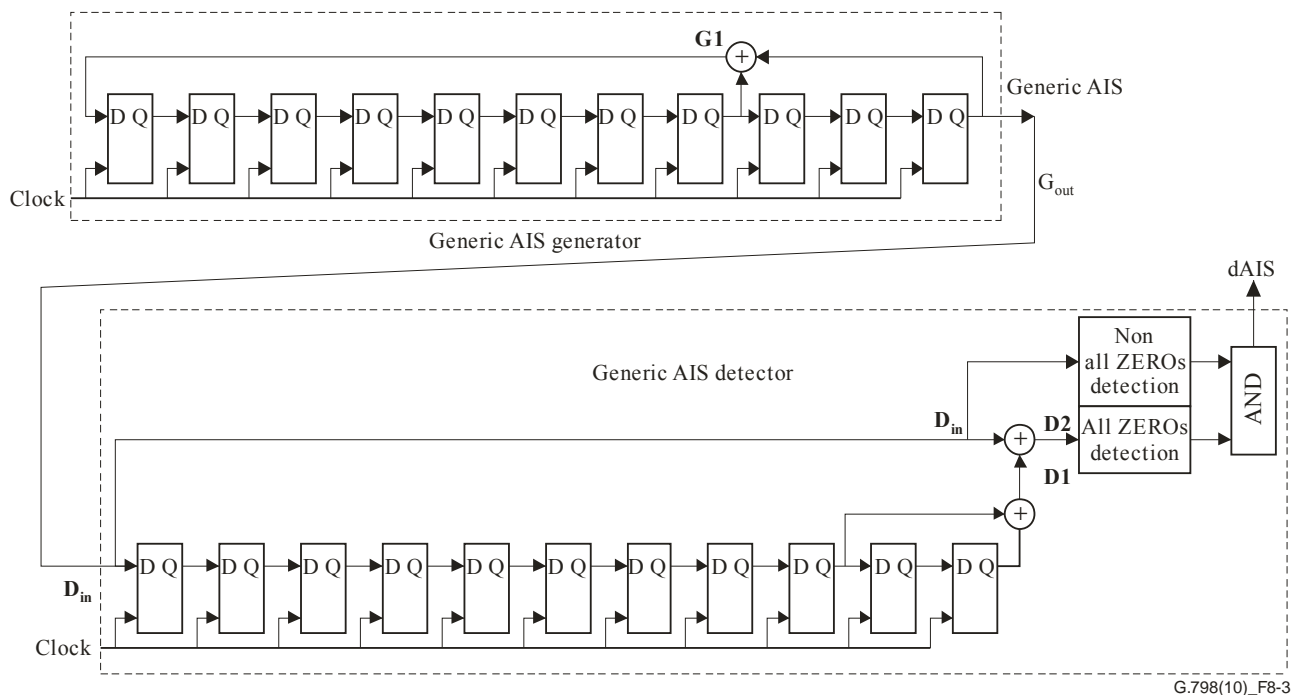

Figure 8-3 – Generic AIS generation and detection

8.10 Generic layer fault processing

Layer fault processing is concerned with the detection of failures within a layer network, the generation of consequent actions (for suppression of unwanted downstream alarms and remote information for upstream single-ended maintenance), and the report of probable fault causes to the management system.

Figure 8-4 illustrates in general the atomic functions connection, trail termination and adaptation of a layer which perform their specific fault-processing tasks. The connection function, if present, can interconnect the adaptation and trail termination functions according to the signal flow shown. Note that not all features are supported by all layers. For the specific fault processing, see the layer-specific functions.

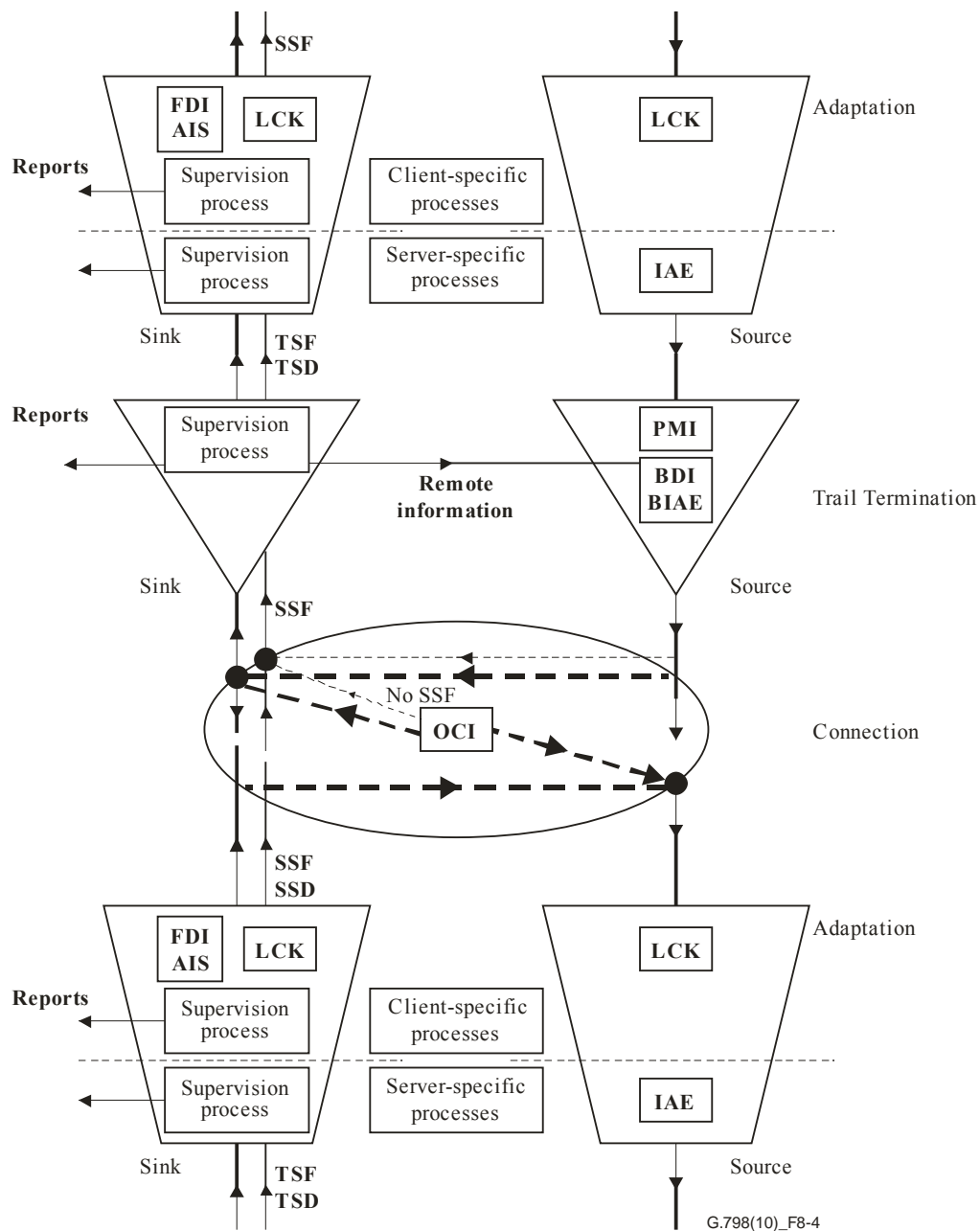

Figure 8-4 – Generic layer fault processing

In the sink direction, every layer receives a server signal fail indication (SSF) from its server layer, performs supervision of parameters pertaining to the layer, and generates a server signal fail indication to its client layer. Reports of probable fault causes are made to the management system. The signal fail state of the layer is forwarded/indicated via a forward defect indication (FDI) or an alarm indication signal (AIS). AIS is the term used when the signal is in the digital domain (ODU and OTU layer). FDI is the term used when the signal is in the optical domain; FDI is transported as a non-associated overhead in the OOS.

The LCK maintenance signal is generated on the operator request in order to lock the signal from user access while the operator is, for example, performing set-up tests. In this case, the client signal is replaced by fixed data indicated as locked (LCK). It can be generated by the server layer adaptation sink and source functions.

An open connection of a connection function generates the OCI maintenance signal in conjunction with a no SSF indication.

The trail termination source function of the OTS and OMS layer monitors the optical payload signal to determine when the incoming signal is absent. Upon detecting that the incoming payload signal is absent (see Figure 8-5), the function inserts the payload missing indication (PMI) into the OOS. At the trail termination sink, it is used to suppress the loss of payload signal defect-related actions (consequent actions, fault cause, PM data).

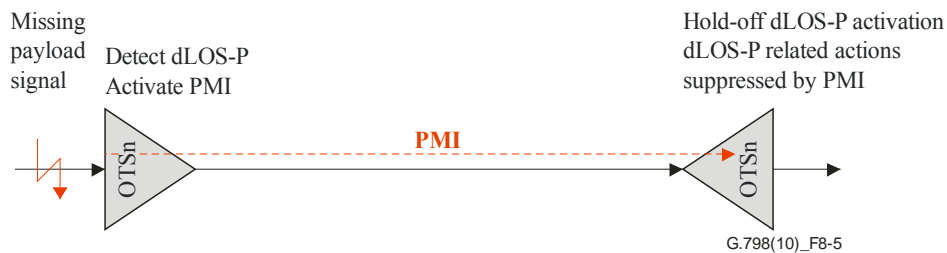

Figure 8-5 – PMI processing

NOTE 1 – A hold-off time has to be used at the trail termination sink functions for the activation of the payload missing indication. The hold-off time has to cover the propagation, processing and detection delay of the PMI signal between the source and sink.

In digital layers (ODUk, OTUk), the maintenance signals (AIS, LCK, and OCI) provide a replacement of the layer characteristic information except some OH as defined in [ITU-T G.709]. As for the optical layers (OCh, OMS, OTS), it is too expensive to generate a replacement for the optical payload, the maintenance signals FDI and OCI consist only of overhead transported as non-associated overhead in the OOS.

The trail termination sink function detects trail-specific defects (continuity, connectivity and maintenance signals). It correlates the defects and incoming SSF in order to determine the probable cause in failure reports. It activates trail signal fail (TSF) and trail signal degraded (TSD) indication towards the layer adaptation sink function on these defects and triggers the insertion of backward defect indications (BDI) at the trail termination source of upstream direction. Similarly, the adaptation sink function combines the result of its measurements with the TSF indication to generate the SSF indication, forwards TSD as SSD, and presents appropriate failure reports to the layer manager. These processes aim to present only probable causes pertaining to maintenance actions required at that layer, i.e., to perform suitable alarm suppression.

The adaptation function is split into server (common) and client-specific supervision processes. The common supervision applies to the compound signal and checks for the correct payload structure on ODUkP. The client-specific supervision performs alignment supervision. Note that several client signals may be transported by the same server signal.

The adaptation source function of the OTU layer and ODU TCM sub-layers generates an incoming alignment error (IAE), if it detects a frame slip (see Figure 8-6). At the trail termination sink function, the IAE information is detected and is used to suppress near-end and far-end performance monitoring data (DS and EBC) and DEG defect data. Furthermore, the collocated trail termination source will insert in upstream the BIAE in order to suppress the far-end performance monitoring data (DS and EBC) at the remote end.

NOTE 2 – Suppression of the performance monitoring data is performed in the equipment management function.

Within the OTS, OMS and OCh layers the data (optical payload) and overhead streams are processed independently. This independence results in the need for separate SSF, TSF, FDI and BDI signals for each such stream.

NOTE 3 – If a SSF input is not connected to any output, it is considered as a no SSF.

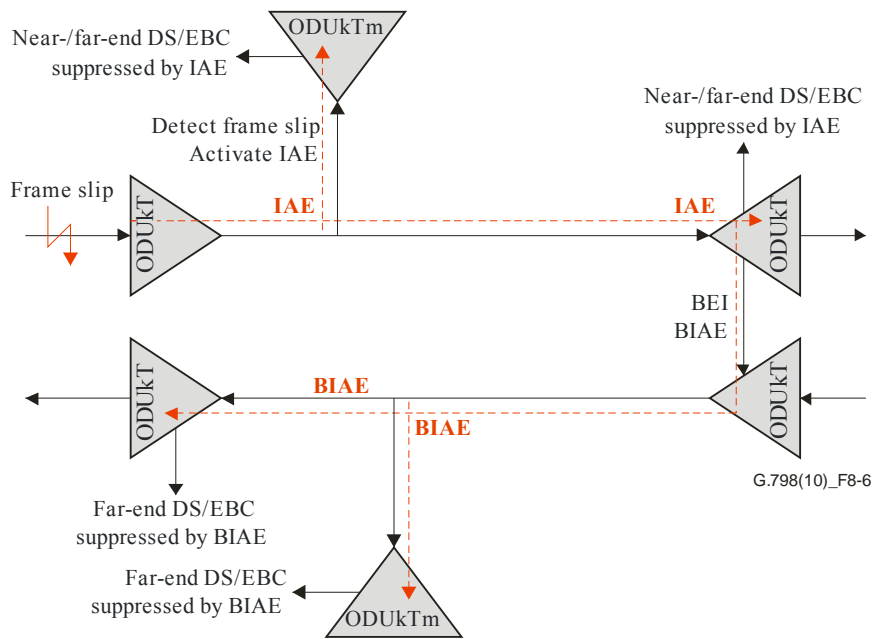

Figure 8-6 – IAE processing

8.11 Optical signal processing

This clause defines generic processes for the processing of the optical signal. These processes refer to the generation and termination of optical signals, wavelength division multiplexing, pre-conditioning of the optical signal before transmission over an optical media (e.g., fibre) and post-conditioning of the optical signal after transmission over an optical media. Some of these processes are mandatory for certain atomic functions, while others depend on the specific optical interface. With the advance of optical technology, additional processes might be introduced.

8.11.1 Optical modulation and wavelength multiplexing processes

The processes listed below are mandatory when they are listed in atomic functions. Specific parameters of these processes depend on the interface type. Refer to [ITU-T G.959.1] for the currently standardized OTN interfaces.

Optical carrier modulation (Mod): This process performs modulation of an optical carrier with the payload signal (PLD) by means of a defined modulation scheme. The modulation scheme and optical parameters (e.g., operating wavelength) depend on the specific interface type. This process is used for the generation of a non-coloured optical signal.

Optical carrier modulation and wavelength assignment (Mod/WA): This process performs modulation of an optical carrier of a specific wavelength with the payload (PLD) signal by means of a defined modulation scheme. The modulation scheme and optical parameters for the individual channels (e.g., central frequency) depend on the specific interface type. This process is used for the generation of a coloured optical signal.

Optical carrier demodulation (DMod): This process demodulates the payload signal (PLD) from the optical carrier. The modulation scheme depends on the specific interface type. This process is used for the termination of coloured and non-coloured optical signal.

Optical multiplexing (OM): This process performs optical channel multiplexing to form an optical multiplex signal.

Optical demultiplexing and wavelength selection (ODM/WS): This process performs the optical channel demultiplexing and provides access to the individual wavelength signals. The physical parameters (e.g., channel spacing) depend on the specific interface type.

8.11.2 Optical signal pre- and post-conditioning processes

The processes defined below are optional when they are listed in atomic functions. Their use and specific parameters depend on the interface type. Refer to [ITU-T G.959.1] for the currently standardized OTN interfaces.

Optical amplification (OA): This process performs optical amplification of the signal. It can be performed on multi- and single-wavelength signals. It can be used as a pre- and post-conditioning process.

Channel dispersion accommodation (DAc): This process performs the active chromatic fibre dispersion accommodation of a single-wavelength signal. It can be used as a pre- and post-conditioning process.

Amplifier-aided dispersion accommodation (DAa): This process performs the passive chromatic fibre dispersion accommodation multi- or single-wavelength signals. It can be used as a pre- and post-conditioning process.

DAa and DAc processes are independent and can be operated together.

Polarization mode dispersion compensation (PMDC): This process performs the polarization mode dispersion compensation of multi- or single-wavelength signals. Details are for further study.

9 Optical transmission section (OTS) layer functions

Figure 9-1 illustrates the OTS layer network and client layer adaptation functions. The information crossing the OTSn termination connection point (OTSn_TCP) is referred to as the OTSn characteristic information (OTSn_CI). The information crossing the OTSn access point (OTSn_AP) is referred to as the OTSn adapted information (OTSn_AI).

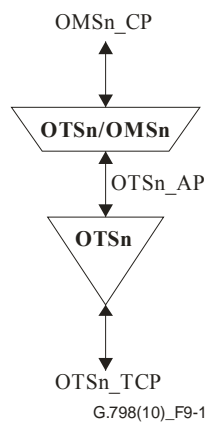

Figure 9-1 – OTS layer network and client layer adaptation functions

The OTSn characteristic information (OTSn_CI) is a physical optical signal consisting of the n multiplexed traffic wavelengths and the optical supervisory channel (OSC). The physical characteristics of the OTSn_CI signal are outside the scope of this Recommendation. The OSC wavelength transports the OTM overhead signal (OOS), which is a logical signal that contains the OTS, OMS and OCh overhead logical information elements. The OOS may also contain general management communications. Figure 9-2 illustrates the overhead information elements that shall be supported by the OOS across the OTSn_CP.

The specific OOS format is outside the scope of this Recommendation. In addition, vendor-specific overhead might be supported via the OOS. This is outside the scope of this Recommendation.

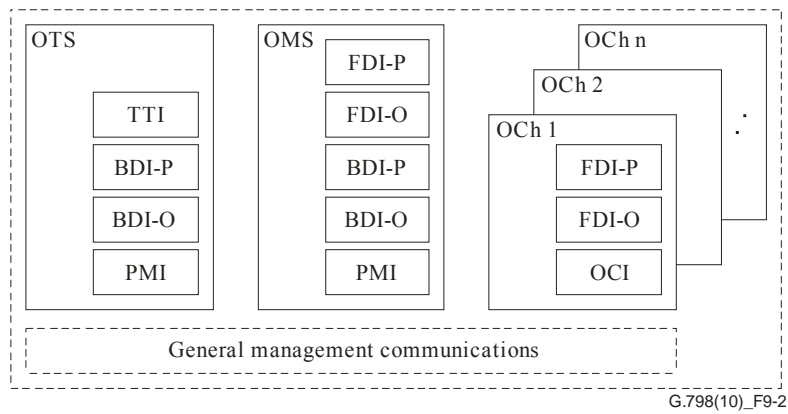

Figure 9-2 – OOS information elements at OTSn_TCP

The OTSn adapted information (OTSn_AI) consists of the OTSn adapted information payload (OTSn_AI_PLD), which is the multiplexed traffic wavelengths, and OTSn adapted information overhead (OTSn_AI_OH), which is the OMS, and OCh overhead information supported across the OTSn_AP. The OOS may also contain general management communications. Figure 9-3 illustrates the overhead information elements that shall be supported by the OOS across the OTSn_AP.

The specific OOS format is outside the scope of this Recommendation. In addition, vendor-specific overhead might be supported via the OOS. This is outside the scope of this Recommendation.

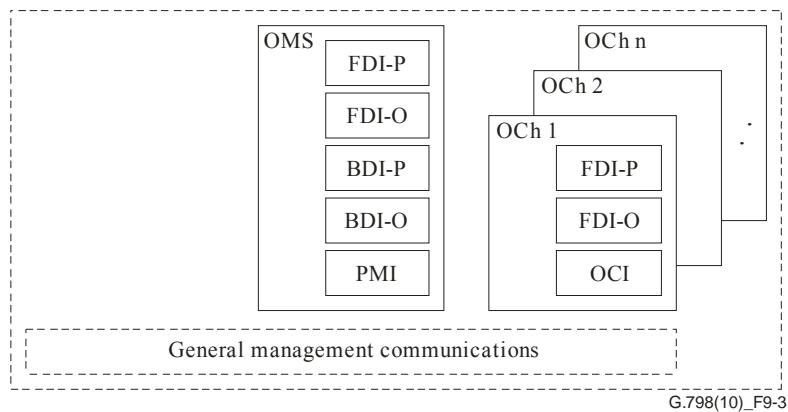

Figure 9-3 – OOS information elements at OTSn_AP

9.1 Connection functions

Not applicable.

9.2 Termination functions

9.2.1 OTS trail termination function (OTSn_TT)

The OTSn_TT functions are responsible for the end-to-end supervision of the OTSn trail. Figure 9-4 shows the combination of the unidirectional sink and source functions to form a bidirectional function.

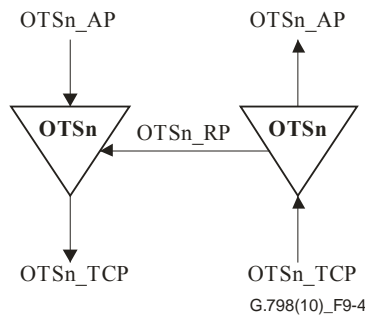

Figure 9-4 – OTSn_TT

9.2.1.1 OTS trail termination source function (OTSn_TT_So)

The OTSn_TT_So function adds OTS layer overhead into the OTM overhead signal (OOS) – including OTS TTI, PMI and BDI-P/O. The OTSn_TT_So function also maps the logical OOS into the OSC, and combines the OSC and the OTS payload signal to form the OTSn characteristic information (OTSn_CI).

The information flow and processing of the OTSn_TT_So functions is defined with reference to Figures 9-5 and 9-6.

Symbol

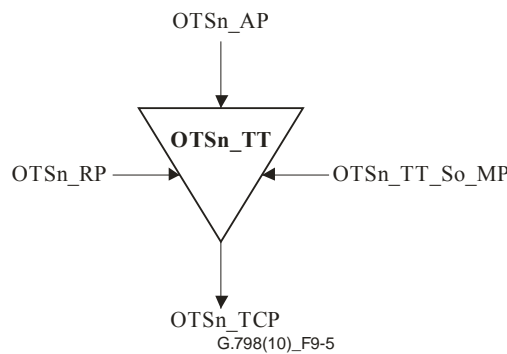

Figure 9-5 – OTSn_TT_So function

Interfaces

Table 9-1 – OTSn_TT_So inputs and outputs

Input(s)	Output(s)
OTSn_AP: OTSn_AI_PLD OTSn_AI_OH OTSn_RP: OTSn_RI_BDI-P OTSn_RI_BDI-O OTSn_RI_APR (Note 1) OTSn_TT_So_MP: OTSn_TT_So_MI_TxTI OTSn_TT_So_MI_APRCntrl (Notes 1 and 2)	OTSn_TCP: OTSn_CI
NOTE 1 – If APR is required. NOTE 2 – The APRCntrl commands depend on the specific APR process.	

Processes

The processes associated with the OTSn_TT_So function are as depicted in Figure 9-6.

TTI: The trail trace identifier information (OTS-TTI) is inserted into the OTS overhead of the OOS. Its value is derived from reference point OTSn_TT_So_MP. The trail trace format is described in clause 15.2 of [ITU-T G.709]. The specific TTI information structure within the OOS is outside the scope of this Recommendation.

BDI-P: The BDI-P information (OTS-BDI-P) is inserted into the OTS overhead of the OOS. Its value is derived from reference point OTSn_RP. Upon the declaration/clearing of aBDI-P at the termination sink function, the trail termination source function shall have inserted/removed the BDI-P indication within 50 ms. The specific BDI-P information structure within the OOS is outside the scope of this Recommendation.

BDI-O: The BDI-O information (OTS-BDI-O) is inserted into the OTS overhead of the OOS. Its value is derived from reference point OTSn_RP. Upon the declaration/clearing of aBDI-O at the termination sink function, the trail termination source function shall have inserted/removed the BDI-O indication within 50 ms. The specific BDI-O information structure within the OOS is outside the scope of this Recommendation.

OSC and PLD: The OTSn_TT_So function maps the logical OOS into the OSC information structure, and combines the OSC with the OTS payload signal to form the OTSn characteristic information (OTSn_CI). The specific OSC implementation is outside the scope of this Recommendation.

PMI: The PMI information is inserted into the OTS overhead of the OOS. Upon the declaration/clearing of aPMI, the function shall have inserted/removed the PMI indication. The specific PMI information structure within the OOS is outside the scope of this Recommendation.

Automatic power reduction (APR): For eye safety considerations, according to [IEC 60825-1] and [IEC 60825-2], it may be necessary to provide a capability for automatic (optical) power reduction (APR) in case of loss of the optical input signal at the sink function. The OTSn_TT_So performs, in this case, the power reduction for the outgoing OTM-n signal based on the trigger criteria from the sink (RI_APR) and control information (MI_APRCtrl). The specific APR procedures and trigger criteria are outside the scope of this Recommendation. Clause 6.2 of [ITU-T G.664] provides basic requirements for APR.

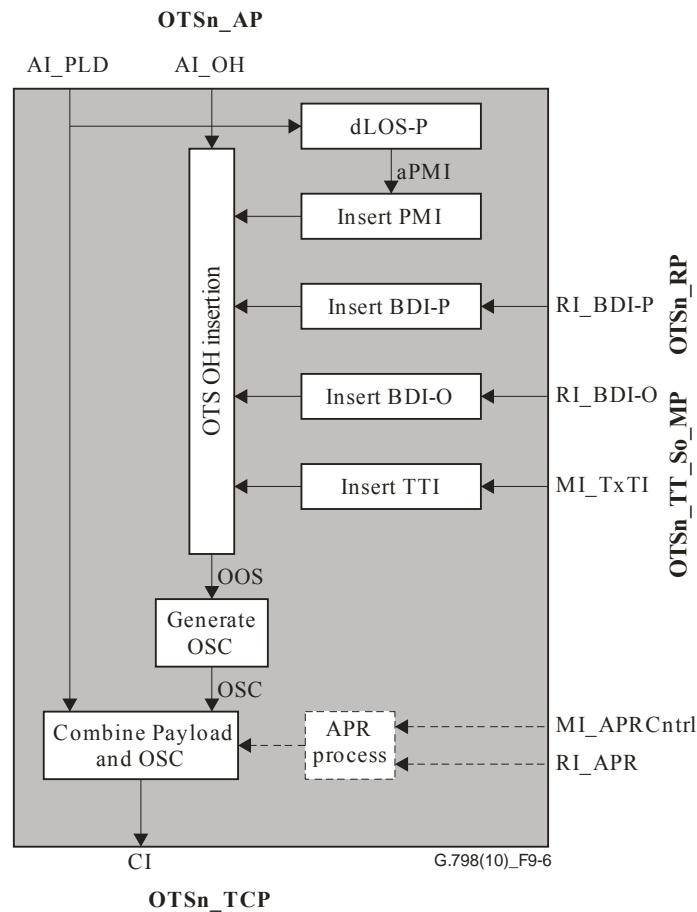

Figure 9-6 – OTSn_TT_So processes

Defects

dLOS-P: See clause 6.2.1.1.

Consequent actions

aPMI ← dLOS-P

Defect correlations: None.

NOTE – dLOS-P is not reported as fault cause, as it is not a failure condition of the trail itself. It is an incoming failure condition to the trail. It is used to generate PMI to the trail termination sink function (see clause 8.10).

Performance monitoring: None.

9.2.1.2 OTS trail termination sink function (OTSn_TT_Sk)

The OTSn_TT_Sk reports the state of the OTSn trail. The OTSn_TT_Sk function filters out the OSC from the incoming optical signal on the OTM-n.m interface and recovers the OOS from the OSC. It extracts OTSn monitoring overhead, including TTI, BDI and PMI. It detects dLOS-P, dLOS-O, dTIM, dPMI, dBDI-P and dBDI-O defects, counts during one-second periods defects to feed performance monitoring when connected, makes the TTI available to network management, and forwards the defect information as backward defect indications to the companion OTSn_TT_So function.

The information flow and processing of the OTSn_TT_Sk function is defined with reference to Figures 9-7 and 9-8.

Symbol

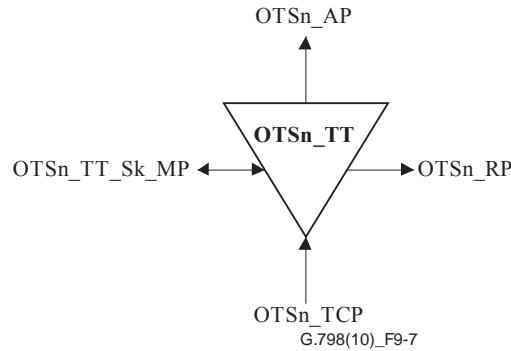

Figure 9-7 – OTSn_TT_Sk function

Interfaces

Table 9-2 – OTSn_TT_Sk inputs and outputs

Input(s)	Output(s)
OTSn_TCP: OTSn_CI OTSn_TT_Sk_MP: OTSn_TT_Sk_MI_ExSAPI OTSn_TT_Sk_MI_ExDAPI OTSn_TT_Sk_MI_GetAcTI OTSn_TT_Sk_MI_TIMDetMo OTSn_TT_Sk_MI_TIMActDis OTSn_TT_Sk_MI_1second	OTSn_AP: OTSn_AI_PLD OTSn_AI_OH OTSn_AI_TSF-P OTSn_AI_TSF-O OTSn_RP: OTSn_RI_BDI-P OTSn_RI_BDI-O OTSn_RI_APR (Note) OTSn_TT_Sk_MP: OTSn_TT_Sk_MI_AcTI OTSn_TT_Sk_MI_cTIM OTSn_TT_Sk_MI_cBDI OTSn_TT_Sk_MI_cBDI-P OTSn_TT_Sk_MI_cBDI-O OTSn_TT_Sk_MI_cLOS-P OTSn_TT_Sk_MI_cLOS-O OTSn_TT_Sk_MI_cLOS OTSn_TT_Sk_MI_pN_DS-P OTSn_TT_Sk_MI_pN_DS-O OTSn_TT_Sk_MI_pF_DS-P OTSn_TT_Sk_MI_pF_DS-O
NOTE – If APR is required.	

Processes

The processes associated with the OTSn_TT_Sk function are as depicted in Figure 9-8.

OSC and PLD: The OTSn_TT_Sk function separates the OSC and the OTS payload signal which form the OTSn characteristic information (OTSn_CI). The logical OOS is extracted from the OSC information structure. The specific OSC implementation is outside the scope of this Recommendation.

TTI: The trail trace identifier information (OTS-TTI) shall be recovered from the OTS overhead of the OOS and processed as specified in clause 8.6. The accepted value of the TTI is available at the MP. The trail trace format is described in clause 15.2 of [ITU-T G.709]. The specific TTI information structure within the OOS is outside the scope of this Recommendation.

BDI-P: The BDI-P information (OTS-BDI-P) shall be extracted from the OTS overhead of the OOS. It shall be used for BDI-P defect detection. The specific implementation for extracting BDI-P from the OOS and detecting its value is outside the scope of this Recommendation.

BDI-O: The BDI-O information (OTS-BDI-O) shall be extracted from the OTS overhead of the OOS. It shall be used for BDI-O defect detection. The specific implementation for extracting BDI-O from the OOS and detecting its value is outside the scope of this Recommendation.

PMI: The PMI information (OTS-PMI) shall be extracted from the OTS overhead of the OOS. It shall be used for PMI defect detection. The specific implementation for extracting PMI from the OOS and detecting its value is outside the scope of this Recommendation.

Signal quality supervision: For further study.

Automatic power reduction (APR): For eye safety considerations, according to [IEC 60825-1] and [IEC 60825-2], it may be necessary to provide a capability for automatic (optical) power reduction (APR) in case of loss of the optical input signal at the sink function. The OTSn_TT_Sk generates, in this case, the APR trigger criteria based on the incoming OTM-n signal (OTSn_CI) and forwards it to the OTSn_TT_So (RI_APR). The specific APR procedures and trigger criteria are outside the scope of this Recommendation. Clause 6.2 of [ITU-T G.664] provides basic requirements for APR.

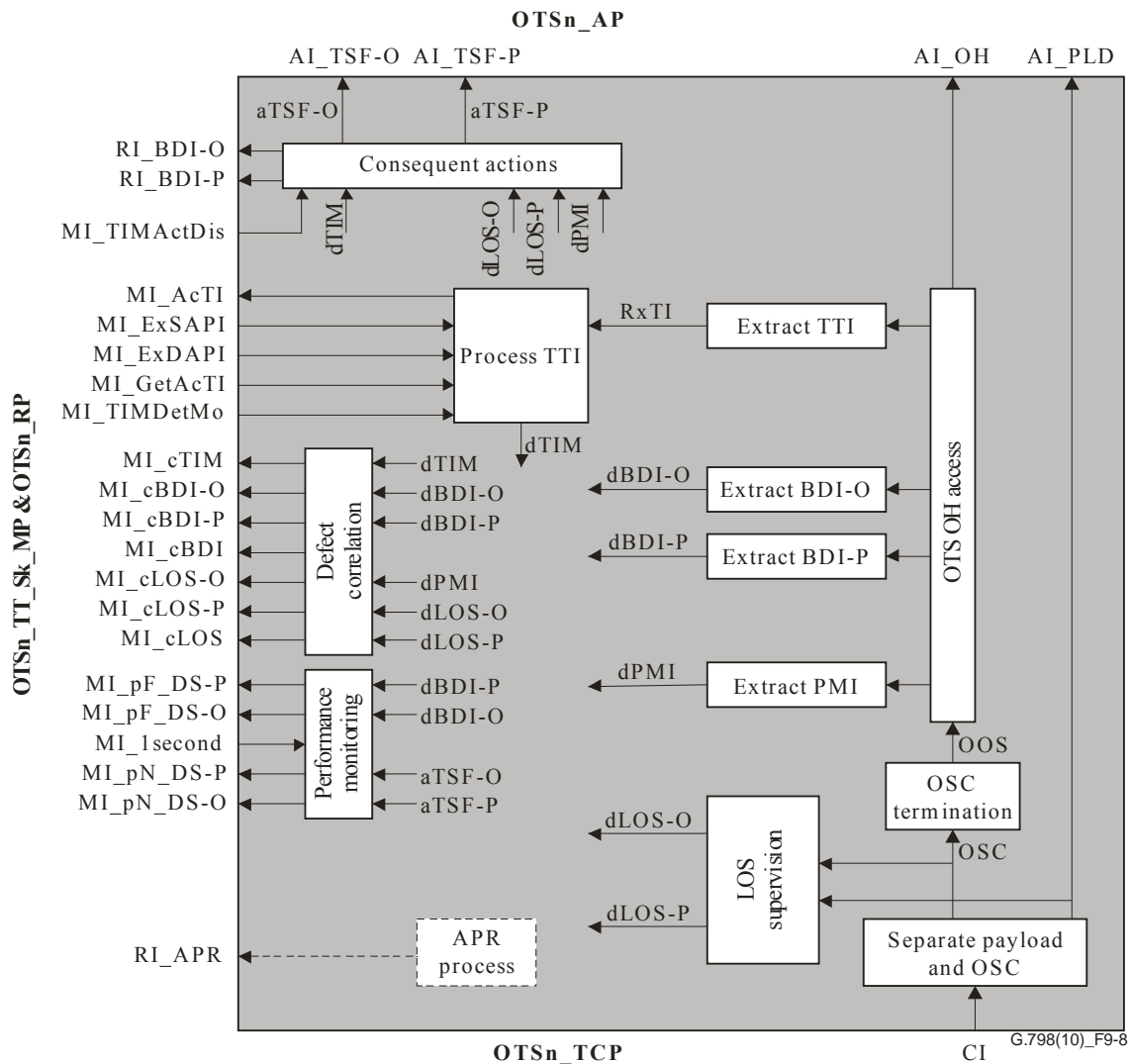

Figure 9-8 – OTSn_TT_Sk processes

Defects

The OTSn_TT_Sk function shall detect for dLOS-P, dLOS-O, dTIM, dBDI-P, dBDI-O and dPMI defects.

NOTE 1 – Detection of additional OOS-related defects might be required (see clause 6.2.8). This depends on the specific OOS format and is outside the scope of this Recommendation.

dLOS-P: See clause 6.2.1.1.

NOTE 2 – A hold-off time has to be used for the activation of LOS-P. The hold-off time has to cover the propagation, processing and detection delay of the PMI signal between the source and sink.

dLOS-O: See clause 6.2.1.2.

dTIM: See clause 6.2.2.1; dTIM shall be set to false during dLOS-O.

dBDI-P: See clause 6.2.6.4.1; dBDI-P shall be set to false during dLOS-O.

dBDI-O: See clause 6.2.6.5.1; dBDI-O shall be set to false during dLOS-O.

dPMI: See clause 6.2.6.7.1; dPMI shall be set to false during dLOS-O.

NOTE 3 – Other additional OOS-related defects will also set the above defects to false (dTIM, dBDI-P, dBDI-O, dPMI). This depends on the specific defects (e.g., loss of alignment).

Consequent actions

The OTSn_TT_Sk function shall perform the following consequent actions.

aTSF-P	←	(dLOS-P and (not dPMI)) or (dTIM and (not TIMActDis))
aTSF-O	←	dLOS-O or (dTIM and (not TIMActDis))
aBDI-P	←	(dLOS-P and (not dPMI)) or dTIM
aBDI-O	←	dLOS-O or dTIM

Defect correlations

The OTSn_TT_Sk function shall perform the following defect correlations.

cBDI	←	dBDI-P and dBDI-O and (not dLOS-O) and (not dTIM)
cBDI-P	←	dBDI-P and (not dLOS-O) and (not (dTIM and (not TIMActDis))) and (not dBDI-O)
cBDI-O	←	dBDI-O and (not dLOS-O) and (not (dTIM and (not TIMActDis))) and (not dBDI-P)
cTIM	←	dTIM and (not dLOS-O)
cLOS-P	←	dLOS-P and (not dPMI) and (not cLOS)
cLOS-O	←	dLOS-O and (not cLOS)
cLOS	←	(dLOS-P and (not dPMI)) and dLOS-O

Performance monitoring

The OTSn_TT_Sk function shall perform the following performance monitoring primitives. The performance monitoring primitives shall be reported to the EMF.

pN_DS-P	←	(dLOS-P and (not dPMI)) or dTIM
pN_DS-O	←	dLOS-O or dTIM
pF_DS-P	←	dBDI-P
pF_DS-O	←	dBDI-O

NOTE 4 – Performance monitoring primitives based on signal quality monitoring are for further study. Specific implementations are outside the scope of this Recommendation.

9.3 Adaptation functions

The OTS is server for the following clients:

- optical multiplex section (OMS);
- general management communications (COMMS).

9.3.1 OTS to OMS adaptation function (OTSn/OMSn_A)

The OTS to OMS adaptation functions perform the adaptation between the OTS layer adapted information and the OMS layer characteristic information.

9.3.1.1 OTS to OMS adaptation source function (OTSn/OMSn_A_So)

The information flow and processing of the OTSn/OMSn_A_So function is defined with reference to Figures 9-9 and 9-10. The OTSn/OMSn_A_So function monitors the OMSn_CI_PLD signal received at its OMSn_CP for missing payload.

Symbol

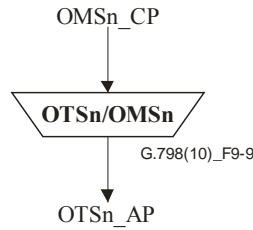

Figure 9-9 – OTSn/OMSn_A_So function

Interfaces

Table 9-3 – OTSn/OMSn_A_So inputs and outputs

Input(s)	Output(s)
OMSn_CP: OMSn_CI_PLD OMSn_CI_OH	OTSn_AP: OTSn_AI_PLD OTSn_AI_OH

Processes

The processes associated with the OTSn/OMSn_A_So function are as depicted in Figure 9-10.

Optical signal pre-conditioning: Pre-conditioning of the optical signal might be required. The specific conditioning processes depend on the OTM-n interface type and are outside the scope of this Recommendation. The processes OA and DAa, as defined in clause 8.11.2, are possible.

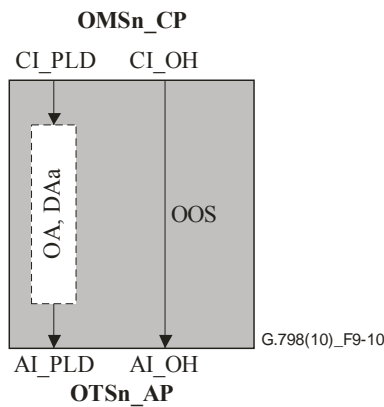

Figure 9-10 – OTSn/OMSn_A_So processes

Defects: None.

Consequent actions: None.

Defect correlations: None.

Performance monitoring: None.

9.3.1.2 OTS to OMS adaptation sink function (OTSn/OMSn_A_Sk)

The information flow and processing of the OTSn/OMSn_A_Sk function is defined with reference to Figures 9-11 and 9-12.

Symbol

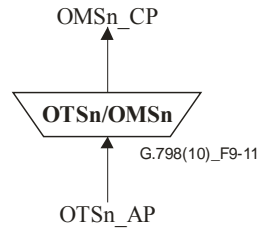

Figure 9-11 – OTSn/OMSn_A_Sk function

Interfaces

Table 9-4 – OTSn/OMSn_A_Sk inputs and outputs

Input(s)	Output(s)
OTSn_AP: OTSn_AI_PLD OTSn_AI_OH OTSn_AI_TSF-P OTSn_AI_TSF-O	OMSn_CP: OMSn_CI_PLD OMSn_CI_OH OMSn_CI_SSF-P OMSn_CI_SSF-O

Processes

The processes associated with the OTSn/OMSn_A_Sk function are as depicted in Figure 9-12.

FDI-O: On declaration of aFDI-O, the function shall insert the FDI-O information (OMS-FDI-O) into the OMS overhead of the OOS. Otherwise, the incoming OMS-FDI-O information is passed through. The specific FDI-O information structure within the OOS is outside the scope of this Recommendation.

FDI-P: On declaration of aFDI-P, the function shall insert the FDI-P information (OMS-FDI-P) into the OMS overhead of the OOS. Otherwise, the incoming OMS-FDI-P information is passed through. The specific FDI_P information structure within the OOS is outside the scope of this Recommendation.

Optical signal post-conditioning: Post-conditioning of the optical signal might be required. The specific conditioning processes depend on the OTM-n interface type and are outside the scope of this Recommendation. The processes OA, DAa and PMDC, as defined in clause 8.11.2, are possible.

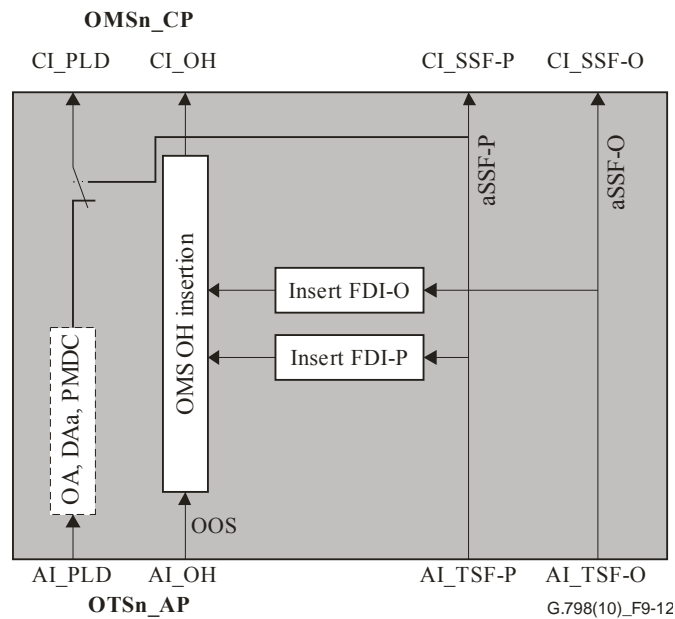

Figure 9-12 – OTSn/OMSn_A_Sk processes

Defects: None.

NOTE 1 – Detection of OOS-related defects might be required (see clause 6.2.8). This depends on the specific OOS format and is outside the scope of this Recommendation.

Consequent actions

The OTSn/OMSn_A_Sk function performs the following consequent actions.

aSSF-P ← AI_TSF-P

aFDI-P ← AI_TSF-P

NOTE 2 – If a FDI-P is active, forwarding of the downstream payload information (PLD) is discontinued (the payload signal is switched off).

aSSF-O ← AI_TSF-O

aFDI-O ← AI_TSF-O

Defect correlations: None.

Performance monitoring: None.

9.3.2 OTS to COMMS adaptation function (OTS/COMMS_A)

For further study.

10 Optical multiplex section (OMS) layer functions

Figure 10-1 illustrates the OMS layer network and client layer adaptation functions. For the trail protection sub-layer functions, see Figure 10-13. The information crossing the OMSn (termination) connection point (OMSn_CP/TCP) is referred to as the OMSn characteristic information (OMSn_CI). The information crossing the OMSn access point (OMSn_AP) is referred to as the OMSn adapted information (OMSn_AI).

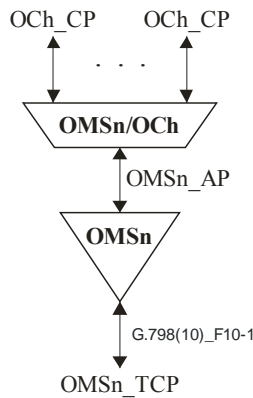

Figure 10-1 – OMS layer network and client layer adaptation functions

The OMSn characteristic information (OMSn_CI) consists of the OMSn characteristic information payload (OMSn_CI_PLD), which is the n multiplexed traffic wavelengths, and OMSn characteristic information overhead (OMSn_CI_OH), which is the OMS and OCh overhead information supported across the OMSn_CP. The OOS may also contain general management communications. Figure 10-2 illustrates the overhead information elements that shall be supported by the OOS across the OMSn_CP.

The specific OOS format is outside the scope of this Recommendation. In addition vendor-specific overhead might be supported via the OOS. This is outside the scope of this Recommendation.

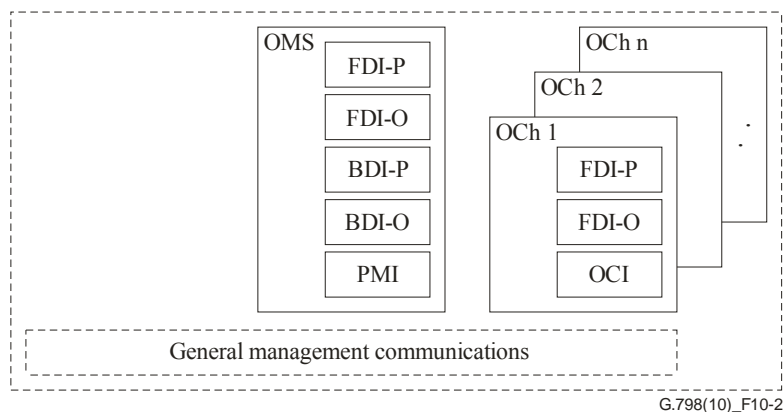

Figure 10-2 – OOS information elements at OMSn_CP/TCP

The OMSn adapted information (OMSn_AI) consists of the OMSn adapted information payload (OMSn_AI_PLD), which is the n multiplexed traffic wavelengths, and OMSn adapted information overhead (OMSn_AI_OH), which is the OCh overhead information supported across the OMSn_AP. The OOS may also contain general management communications. Figure 10-3 illustrates the overhead information elements that shall be supported by the OOS across OMSn_AP.

The specific OOS format is outside the scope of this Recommendation. In addition, vendor-specific overhead might be supported via the OOS. This is outside the scope of this Recommendation.

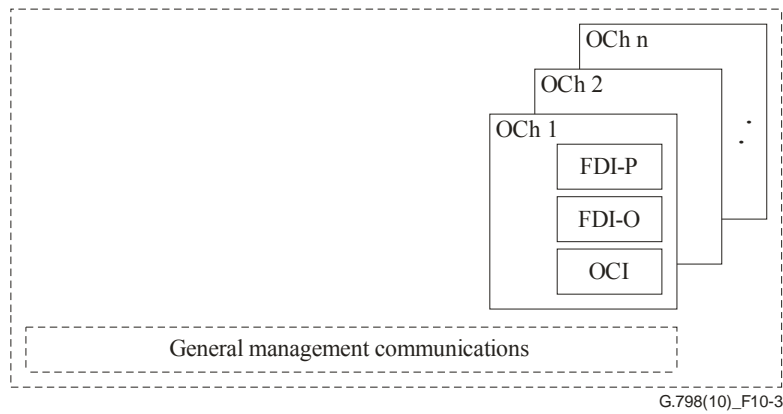

Figure 10-3 – OOS information elements at OMSn_AP

10.1 Connection functions

Not applicable.

10.2 Termination functions

10.2.1 OMS trail termination function (OMSn_TT)

The OMSn_TT functions are responsible for the end-to-end supervision of the OMSn trail. Figure 10-4 shows the combination of the unidirectional sink and source functions to form a bidirectional function.

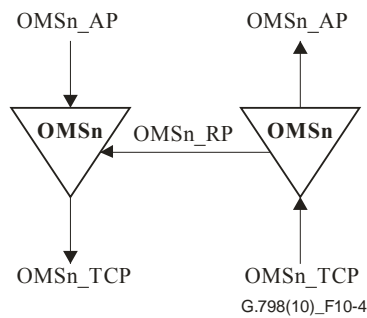

Figure 10-4 – OMSn_TT

10.2.1.1 OMS trail termination source function (OMSn_TT_So)

The OMSn_TT_So function adds OMS layer overhead into the OTM overhead signal (OOS) – including OMS BDI-P/O and PMI.

The information flow and processing of the OMSn_TT_So function is defined with reference to Figures 10-5 and 10-6.

Symbol

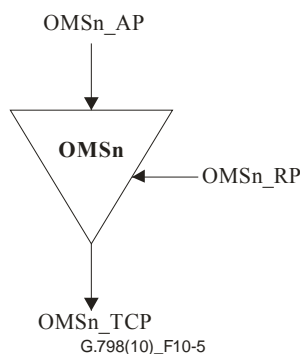

Figure 10-5 – OMSn_TT_So function

Interfaces

Table 10-1 – OMSn_TT_So inputs and outputs

Input(s)	Output(s)
OMSn_AP: OMSn_AI_PLD OMSn_AI_OH OMSn_RP: OMSn_RI_BDI-P OMSn_RI_BDI-O	OMSn_TCP: OMSn_CI_PLD OMSn_CI_OH

Processes

The processes associated with the OMSn_TT_So function are as depicted in Figure 10-6.

BDI-P: The BDI-P information is inserted into the OMS overhead of the OOS. Its value is derived from reference point OMSn_RP. Upon the declaration/clearing of aBDI-P at the termination sink function, the trail termination source function shall have inserted/removed the BDI-P indication within 50 ms. The specific BDI-P information structure within the OOS is outside the scope of this Recommendation.

BDI-O: The BDI-O information is inserted into the OMS overhead of the OOS. Its value is derived from reference point OMSn_RP. Upon the declaration/clearing of aBDI-O at the termination sink function, the trail termination source function shall have inserted/removed the BDI-O indication within 50 ms. The specific BDI-O information structure within the OOS is outside the scope of this Recommendation.

PMI: The PMI information is inserted into the OTS overhead of the OOS. Upon the declaration/clearing of aPMI, the function shall have inserted/removed the PMI indication. The specific PMI information structure within the OOS is outside the scope of this Recommendation.

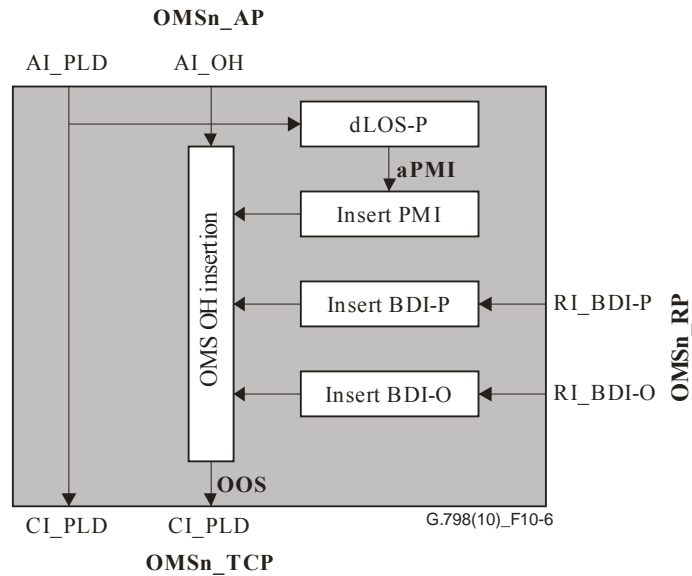

Figure 10-6 – OMSn_TT_So processes

Defects

dLOS-P: See clause 6.2.1.1.

Consequent actions

aPMI ← dLOS-P

Defect correlations: None.

NOTE – dLOS-P is not reported as fault cause, as it is not a failure condition of the trail itself. It is an incoming failure condition to the trail. It is used to generate PMI to the trail termination sink function (see clause 8.10).

Performance monitoring: None.

10.2.1.2 OMS trail termination sink function (OMSn_TT_Sk)

The OMSn_TT_Sk reports the state of the OMSn trail. The OMSn_TT_Sk function extracts OMSn monitoring overhead – including BDI, FDI-P, FDI-O and PMI. It detects dLOS-P, dPMI, dFDI-P, dFDI-O, dBDI-P and dBDI-O defects, counts during one-second periods defects to feed performance monitoring when connected, and forwards the defect information as backward defect indications to the companion OMSn_TT_So function.

The information flow and processing of the OMSn_TT_Sk function is defined with reference to Figures 10-7 and 10-8.

Symbol

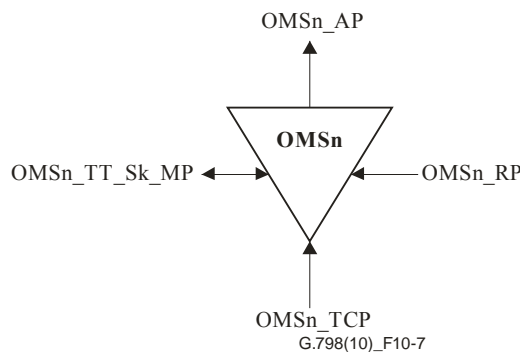

Figure 10-7 – OMSn_TT_Sk function

Interfaces

Table 10-2 – OMSn_TT_Sk inputs and outputs

Input(s)	Output(s)
<p>OMSn_TCP: OMSn_CI_PLD OMSn_CI_OH OMSn_CI_SSF-P OMSn_CI_SSF-O OMSn_TT_Sk_MP: OMSn_TT_Sk_MI_1second</p>	<p>OMSn_AP: OMSn_AI_PLD OMSn_AI_OH OMSn_AI_TSF-P OMSn_AI_TSF-O OMSn_RP: OMSn_RI_BDI-P OMSn_RI_BDI-O OMSn_TT_Sk_MP: OMSn_TT_Sk_MI_cSSF-P OMSn_TT_Sk_MI_cSSF-O OMSn_TT_Sk_MI_cSSF OMSn_TT_Sk_MI_cBDI OMSn_TT_Sk_MI_cBDI-P OMSn_TT_Sk_MI_cBDI-O OMSn_TT_Sk_MI_cLOS-P OMSn_TT_Sk_MI_pN_DS-P OMSn_TT_Sk_MI_pN_DS-O OMSn_TT_Sk_MI_pF_DS-P OMSn_TT_Sk_MI_pF_DS-O</p>

Processes

The processes associated with the OMSn_TT_Sk function are depicted in Figure 10-8.

FDI-P: The FDI-P information (OMS-FDI-P) shall be extracted from the OMS overhead of the OOS. It shall be used for FDI-P defect detection. The specific implementation for extracting FDI-P from the OOS and detecting its value is outside the scope of this Recommendation.

FDI-O: The FDI-O information (OMS-FDI-O) shall be extracted from the OMS overhead of the OOS. It shall be used for FDI-O defect detection. The specific implementation for extracting FDI-O from the OOS and detecting its value is outside the scope of this Recommendation.

BDI-P: The BDI-P information (OMS-BDI-P) shall be extracted from the OMS overhead of the OOS. It shall be used for BDI-P defect detection. The specific implementation for extracting BDI-P from the OOS and detecting its value is outside the scope of this Recommendation.

BDI-O: The BDI-O information (OMS-BDI-O) shall be extracted from the OMS overhead of the OOS. It shall be used for BDI-O defect detection. The specific implementation for extracting BDI-O from the OOS and detecting its value is outside the scope of this Recommendation.

PMI: The PMI information (OMS-PMI) shall be extracted from the OMS overhead of the OOS. It shall be used for PMI defect detection. The specific implementation for extracting PMI from the OOS and detecting its value is outside the scope of this Recommendation.

Signal quality supervision: For further study.

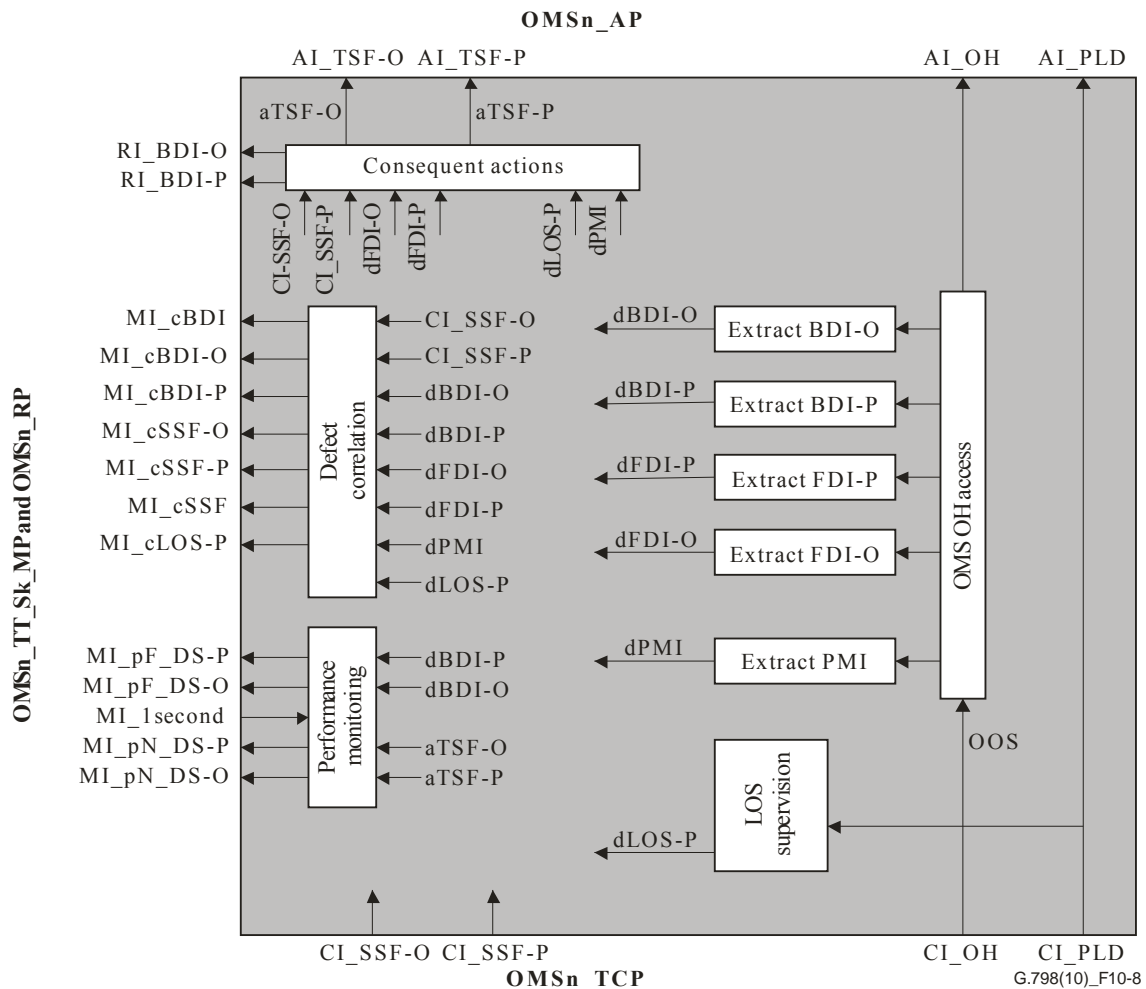

Figure 10-8 – OMSn_TT_Sk processes

Defects

The OMSn_TT_Sk function shall detect for dLOS-P, dFDI-P, dFDI-O, dBDI-P, dBDI-O and dPMI defects.

NOTE 1 – Detection of additional OOS-related defects might be required (see clause 6.2.8). This depends on the specific OOS format and is outside the scope of this Recommendation.

dLOS-P: See clause 6.2.1.1.

NOTE 2 – A hold-off time has to be used for the activation of LOS-P. The hold-off time has to cover the propagation, processing and detection delay of the PMI signal between the source and sink.

dFDI-P: See clause 6.2.6.1.1.

dFDI-O: See clause 6.2.6.2.1.

dBDI-P: See clause 6.2.6.4.1; dBDI-P shall be set to false during CI_SSF-O and dFDI-O.

dBDI-O: See clause 6.2.6.5.1; dBDI-O shall be set to false during CI_SSF-O and dFDI-O.

dPMI: See clause 6.2.6.7.1; dPMI shall be set to false during CI_SSF-O and dFDI-O.

Consequent actions

The OMSn_TT_Sk function shall perform the following consequent actions.

aTSF-P ← (dLOS-P and (not dPMI)) or dFDI-P or CI_SSF-P

aTSF-O ← dFDI-O or CI_SSF-O

aBDI-P ← (dLOS-P and (not dPMI)) or dFDI-P or CI_SSF-P
aBDI-O ← dFDI-O or CI_SSF-O

Defect correlations

The OMSn_TT_Sk function shall perform the following defect correlations.

cSSF ← (CI_SSF-P or dFDI-P) and (CI_SSF-O or dFDI-O)
cSSF-P ← (CI_SSF-P or dFDI-P) and (not cSSF)
cSSF-O ← (CI_SSF-O or dFDI-O) and (not cSSF)
cBDI ← (dBDI-P and (not dFDI-O)) and (dBDI-O and (not dFDI-O))
cBDI-P ← (dBDI-P and (not dFDI-O)) and (not cBDI)
cBDI-O ← (dBDI-O and (not dFDI-O)) and (not cBDI)
cLOS-P ← dLOS-P and (not dPMI) and (not dFDI-P) and (not CI_SSF-P)

Performance monitoring

The OMSn_TT_Sk function shall perform the following performance monitoring primitives. The performance monitoring primitives shall be reported to the EMF.

pN_DS-P ← aTSF-P
pN_DS-O ← aTSF-O
pF_DS-P ← dBDI-P
pF_DS-O ← dBDI-O

NOTE 3 – Performance monitoring primitives based on signal quality monitoring are for further study.

10.2.2 OMS non-intrusive monitoring function

Not applicable.

10.3 Adaptation functions

The OMS is server for the following clients:

- Optical channel (OCh).

10.3.1 OMS to OCh adaptation function (OMSn/OCh_A)

The OMS to OCh adaptation functions perform the adaptation between the OMS layer adapted information and the characteristic information of n OCh layer signals. This includes the optical payload and the overhead.

10.3.1.1 OMS to OCh adaptation source function (OMSn/OCh_A_So)

The OMSn/OCh_A_So function multiplexes the individual OCh_CIs to the OMSn_AI. The information flow and processing of the OMSn/OCh_A_So function is defined with reference to Figures 10-9 and 10-10.

Symbol

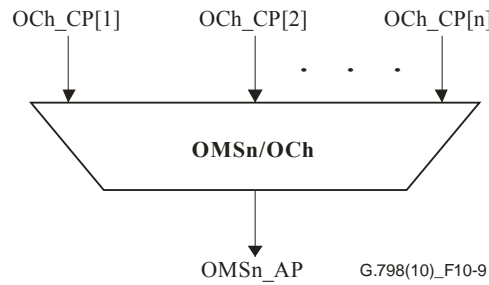

Figure 10-9 – OMSn/OCh_A_So function

Interfaces

Table 10-3 – OMSn/OCh_A_So inputs and outputs

Input(s)	Output(s)
per OCh_CP: OCh_CI_PLD OCh_CI_OH	OMSn_AP: OMSn_AI_PLD OMSn_AI_OH

Processes

The processes associated with the OMSn/OCh_A_So function are specific processes for each OCh_CI, and common processes for the compound (multiplexed) signal as depicted in Figure 10-10.

Specific processes

Optical carrier modulation and wavelength assignment (Mod/WA): See clause 8.11.1.

Optical signal pre-conditioning: Pre-conditioning of the single wavelength optical signal might be required. The specific conditioning processes depend on the OTM-n interface type and are outside the scope of this Recommendation. The processes OA, DAc, DAa and PMDC, as defined in clause 8.11.2, are possible.

Common processes

Optical multiplexing (OM): See clause 8.11.1. The parameters are outside the scope of this Recommendation.

Optical signal pre-conditioning: Pre-conditioning of the multi-wavelength optical signal might be required. The specific conditioning processes depend on the OTM-n interface type and are outside the scope of this Recommendation. The processes OA and DAa, as defined in clause 8.11.2, are possible.

Overhead multiplexing (OHM): This process performs overhead multiplexing of the OH of the individual OCh signals. The specific multiplex function is outside the scope of this Recommendation.

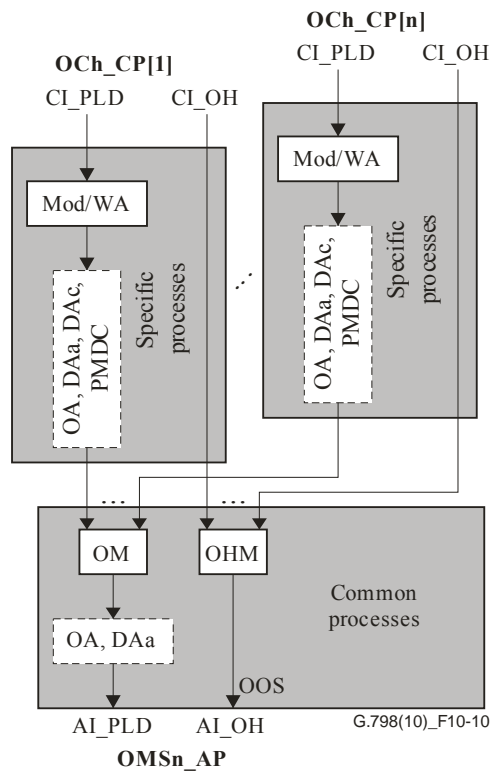

Figure 10-10 – OMSn/OCh_A_So processes

Defects: None.

Consequent actions: None.

Defect correlations: None.

Performance monitoring: None.

10.3.1.2 OMS to OCh adaptation sink function (OMSn/OCh_A_Sk)

The OMSn/OCh_A_Sk function demultiplexes the OMSn_AI into the individual OCh_CIs. Upon signal fail conditions, it generates FDI for the individual channels.

The information flow and processing of the OMSn/OCh_A_Sk function is defined with reference to Figures 10-11 and 10-12.

Symbol

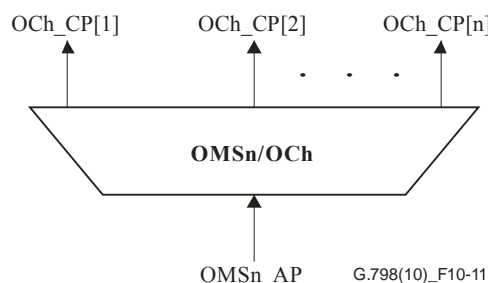

Figure 10-11 – OMSn/OCh_A_Sk function

Interfaces

Table 10-4 – OMSn/OCh_A_Sk inputs and outputs

Input(s)	Output(s)
OMSn_AP: OMSn_AI_PLD OMSn_AI_OH OMSn_AI_TSF-P OMSn_AI_TSF-O	per OCh_CP: OCh_CI_PLD OCh_CI_OH OCh_CI_SSF-P OCh_CI_SSF-O

Processes

The processes associated with the OMSn/OCh_A_Sk function are specific processes for each OCh signal and common processes for the compound (multiplexed) signal as depicted in Figure 10-12.

Common processes

Optical demultiplexing and wavelength selection (ODM/WS): See clause 8.11.1. The parameters are outside the scope of this Recommendation.

Optical signal post-conditioning: Post-conditioning of the multi-wavelength signal might be required. The specific conditioning processes depend on the OTM-n interface type and are outside the scope of this Recommendation. The processes OA, DAa and PMDC, as defined in clause 8.11.2, are possible.

Overhead demultiplexing (OHDM): This process performs the overhead demultiplexing and provides access to the OH of the individual OCh signals. The specific multiplex function is outside the scope of this Recommendation.

Specific processes

Optical carrier demodulation (DMod): See clause 8.11.1.

Optical signal post-conditioning: Post-conditioning of the single wavelength signal might be required. The specific conditioning processes depend on the OTM-n interface type and are outside the scope of this Recommendation. The processes OA, DAC, DAa and PMDC, as defined in clause 8.11.2, are possible.

FDI-O: On declaration of aFDI-O, the function shall insert the FDI-O information (OCh-FDI-O) into the OCh overhead of the OOS of each OCh. Otherwise, the incoming OCh-FDI-O information is passed through. The specific FDI-O information structure within the OOS is outside the scope of this Recommendation.

FDI-P: On declaration of aFDI-P, the function shall insert the FDI-P information (OCh-FDI-P) into the OCh overhead of the OOS of each OCh. Otherwise, the incoming OCh-FDI-P information is passed through. The specific FDI_P information structure within the OOS is outside the scope of this Recommendation.

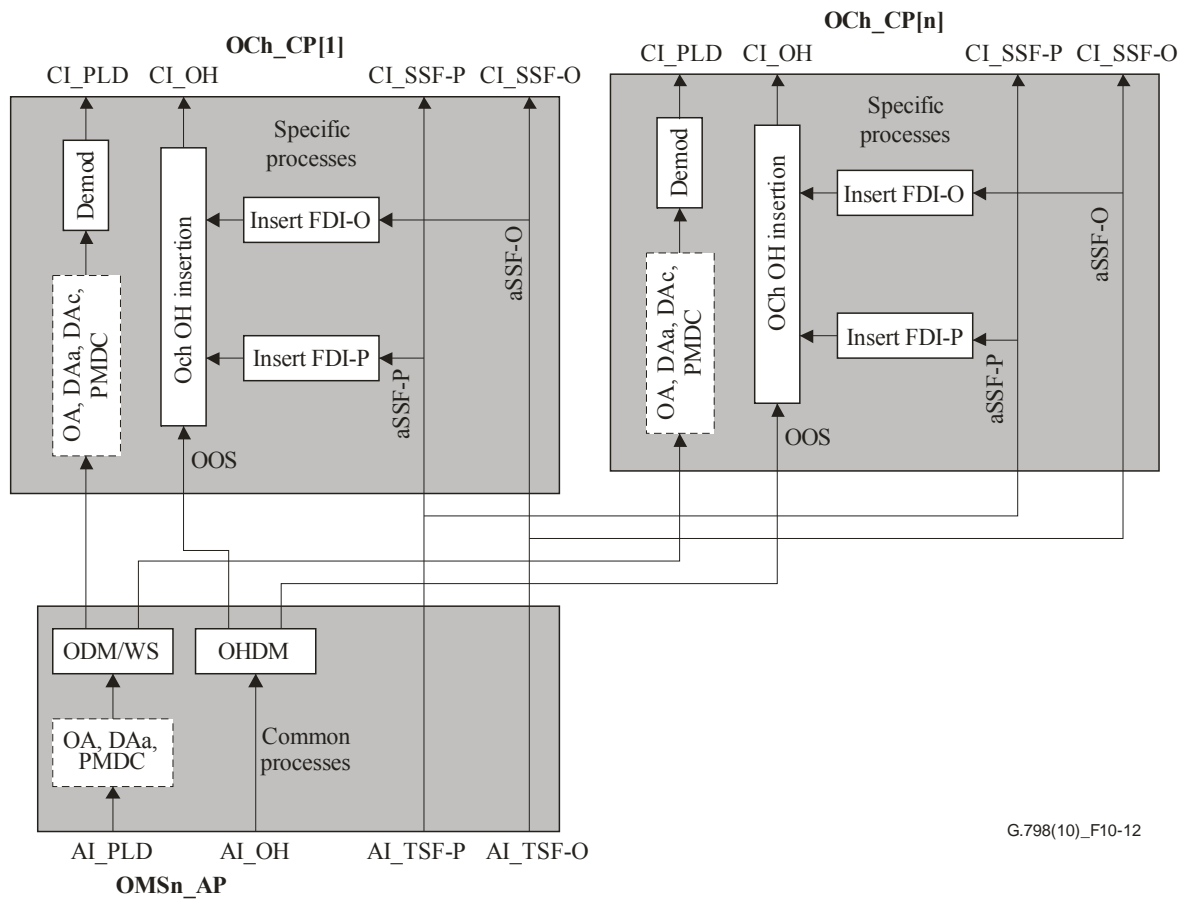

Figure 10-12 – OMSn/OCh_A_Sk processes

Defects: None.

NOTE – Detection of OOS-related defects might be required (see clause 6.2.8). This depends on the specific OOS format and is outside the scope of this Recommendation.

Consequent actions

The OMSn/OCh_A_Sk function performs the following consequent actions.

- aSSF-P ← AI_TSF-P
- aFDI-P ← AI_TSF-P
- aSSF-O ← AI_TSF-O
- aFDI-O ← AI_TSF-O

Defect correlations: None.

Performance monitoring: None.

10.3.2 OMS to COMMS adaptation function (OMS/COMMS_A)

For further study.

10.4 Sub-layer functions

10.4.1 OMS trail protection sub-layer functions

The OMS trail protection sub-layer (OMSnP) is generated by expanding the OMS trail termination. Figure 10-13 shows the OMS trail protection functions and the location between the OMS_TT and the OMS to client layer adaptation.

The following trail protection schemes are supported:

- 1+1 unidirectional.

Other protection schemes are for further study.

The basic trail protection mechanism is identical to the SDH trail connection process described in [ITU-T G.841].

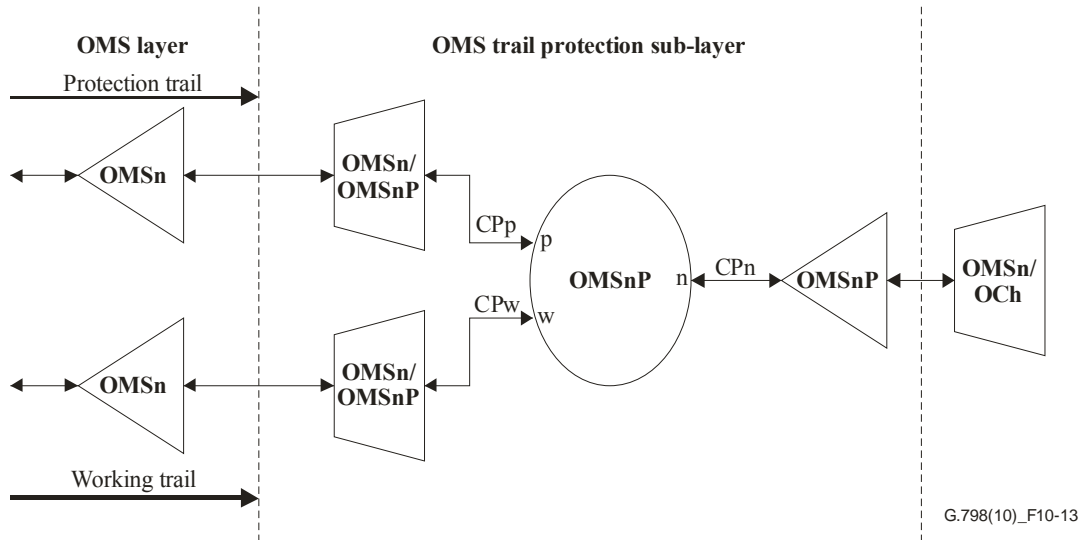

Figure 10-13 – OMS trail protection sub-layer functions

10.4.1.1 OMSP 1+1 unidirectional trail protection connection function (OMSnP1+1u_C)

The OMSnP1+1u_C provide 1+1 unidirectional trail protection at the OMS layer.

10.4.1.1.1 OMSP 1+1 unidirectional trail protection connection source function (OMSnP1+1u_C_So)

The information flow and processing of the OMSnP1+1u_C_So function is defined with reference to Figure 10-14.

Symbol

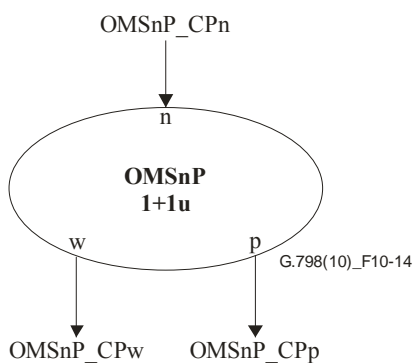

Figure 10-14 – OMSnP1+1u_C_So function

Interfaces

Table 10-5 – OMSnP1+1u_C_So inputs and outputs

Input(s)	Output(s)
OMSnP_CPn: OMSnP_CI_PLD OMSnP_CI_OH	OMSnP_CPw and OMSnP_Cpp: OMSnP_CI_PLD OMSnP_CI_OH

Processes

The function performs the bridge for the 1+1 unidirectional trail protection.

For 1+1 architecture, the CI coming from the normal (protected) OMSnP_CP is bridged permanently to both the working and protection OMSnP_CP.

Defects: None.

Consequent actions: None.

Defect correlations: None.

Performance monitoring: None.

10.4.1.1.2 OMSP 1+1 unidirectional trail protection connection sink function (OMSnP1+1u_C_Sk)

The information flow and processing of the OMSnP1+1u_C_Sk function is defined with reference to Figure 10-15.

Symbol

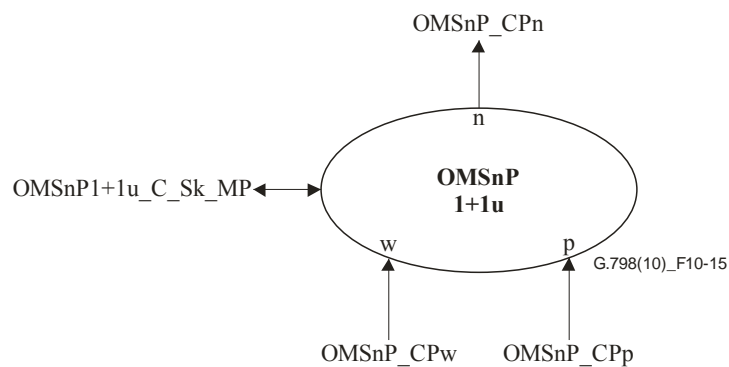

Figure 10-15 – OMSnP1+1u_C_Sk function

Interfaces

Table 10-6 – OMSnP1+1u_C_Sk inputs and outputs

Input(s)	Output(s)
OMSnP_CPw and OMSnP_CPp: OMSnP_CI_PLD OMSnP_CI_OH OMSnP_CI_SSF-P OMSnP_CI_SSF-O OMSnP1+1u_C_Sk_MP: OMSnP_C_MI_OperType OMSnP_C_MI_WTR OMSnP_C_MI_HoTime OMSnP_C_MI_ExtCMD OMSnP_C_MI_TSF-ODis	OMSnP_CPn: OMSnP_CI_PLD OMSnP_CI_OH OMSnP_CI_SSF-P OMSnP_CI_SSF-O OMSnP1+1u_C_Sk_MP: For further study

Processes

For a 1+1 architecture, the CI from either the working or protection OMSnP_CP is switched to the normal (protected) OMSnP_CP. A switch-over from working to protection OMSnP_CP or vice versa is initiated by the switch initiation criteria defined below.

Switch initiation criteria

Automatic protection switching is based on the defect conditions of the working and protection trail. These condition(s) are server signal fail payload (SSF-P) and server signal fail overhead (SSF-O). The use of SSF-O as protection switching criteria can be disabled (MI_SSF-ODis). The priority of SSF-P shall be equal to signal fail as defined in [ITU-T G.841]. The priority of SSF-O shall be equal to signal degrade as defined in [ITU-T G.841].

In order to allow interworking between nested protection schemes, a hold-off timer is provided. The hold-off timer delays switch initiation in case of signal fail in order to allow a nested protection to react and clear the fault condition. The hold-off timer is started by the activation of signal fail and runs for the hold-off time. Protection switching is only initiated if signal fail is still present at the end of the hold-off time. The hold-off time shall be provisionable between 0 and 10 s in steps of 100 ms.

Protection switching can also be initiated by external switch commands received via the MP.

Depending on the mode of operation, internal states (e.g., wait to restore) may also initiate a switch-over.

See the switch initiation criteria described in [ITU-T G.841].

Switching time

Refer to [ITU-T G.841].

Switch restoration

In the revertive mode of operation, the protected signal shall be switched back from the protection trail to the working trail when the working trail has recovered from the fault.

To prevent frequent operation of the protection switch due to an intermittent fault, a failed working trail must become fault-free for a certain period of time before it is used again. This period, called the wait to restore (WTR) period should be of the order of 5-12 minutes and should be capable of being set.

In the non-revertive mode of operation, no switchback to the working trail is performed when it has recovered from the fault.

Protection switching notifications to the MP are for further study.

Defects: None.

Consequent actions: None.

Defect correlations: None.

Performance monitoring: None.

10.4.1.2 OMSP trail termination function (OMSnP_TT)

10.4.1.2.1 OMSP trail termination source function (OMSnP_TT_So)

The information flow and processing of the OMSnP_TT_So function is defined with reference to Figure 10-16.

Symbol

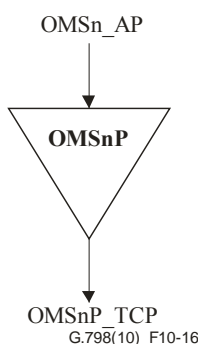

Figure 10-16 – OMSnP_TT_So function

Interfaces

Table 10-7 – OMSnP_TT_So inputs and outputs

Input(s)	Output(s)
OMSnP_AP: OMSnP_AI_PLD OMSnP_AI_OH	OMSnP_TCP: OMSnP_CI_PLD OMSnP_CI_OH

Processes

No information processing is required in the OMSnP_TT_So, the OMSnP_CI at its output being identical to the OMSnP_AI at its input.

Defects: None.

Consequent actions: None.

Defect correlations: None.

Performance monitoring: None.

10.4.1.2.2 OMSP trail termination sink function (OMSnP_TT_Sk)

The information flow and processing of the OMSnP_TT_Sk function is defined with reference to Figure 10-17.

Symbol

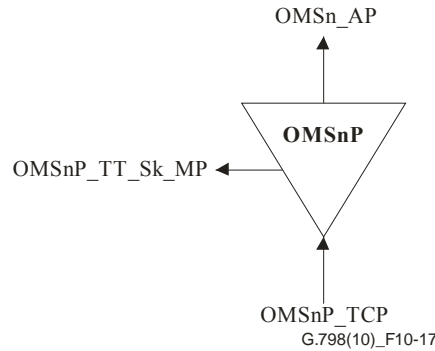

Figure 10-17 – OMSnP_TT_Sk function

Interfaces

Table 10-8 – OMSnP_TT_Sk inputs and outputs

Input(s)	Output(s)
OMSnP_TCP: OMSnP_CI_PLD OMSnP_CI_OH OMSnP_CI_SSF-P OMSnP_CI_SSF-O	OMSnP_AP: OMSnP_AI_PLD OMSnP_AI_OH OMSnP_AI_TSF-P OMSnP_AI_TSF-O OMSnP_TT_Sk_MP: OMSnP_TT_Sk_MI_cSSF-P OMSnP_TT_Sk_MI_cSSF-O OMSnP_TT_Sk_MI_cSSF

Processes

The OMSnP_TT_Sk function reports the state of the protected OMSnP trail.

No additional information processing is required in the OMSnP_TT_Sk, the OMSnP_AI at its output being identical to the OMSnP_CI at its input.

Defects: None.

Consequent actions

The OMSnP_TT_Sk function performs the following consequent actions.

aTSF-P ← CI_SSF-P

aTSF-O ← CI_SSF-O

Defect correlations

The OMSnP_TT_Sk function shall perform the following defect correlations.

cSSF ← CI_SSF-P and CI_SSF-O

cSSF-P ← CI_SSF-P and (not CI_SSF-O)

cSSF-O ← CI_SSF-O and (not CI_SSF_P)

Performance monitoring: None.

10.4.1.3 OMS to OMSP adaptation function (OMSn/OMSnP_A)

10.4.1.3.1 OMS to OMSP adaptation source function (OMSn/OMSnP_A_So)

The information flow and processing of the OMSn/OMSnP_A_So functions is defined with reference to Figure 10-18.

Symbol

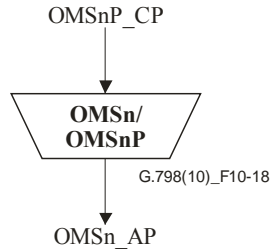

Figure 10-18 – OMSn/OMSnP_A_So function

Interfaces

Table 10-9 – OMSn/OMSnP_A_So inputs and outputs

Input(s)	Output(s)
OMSnP_CP: OMSnP_CI_PLD OMSnP_CI_OH	OMSnP_AP: OMSnP_AI_PLD OMSnP_AI_OH

Processes

No information processing is required in the OMSn/OMSnP_A_So, the OMSnP_AI at its output being identical to the OMSnP_CI at its input.

Defects: None.

Consequent actions: None.

Defect correlations: None.

Performance monitoring: None.

10.4.1.3.2 OMS to OMSP adaptation sink function (OMSn/OMSnP_A_Sk)

The information flow and processing of the OMSn/OMSnP_A_Sk function is defined with reference to Figure 10-19.

Symbol

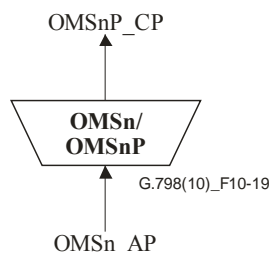

Figure 10-19 – OMSn/OMSnP_A_Sk function

Interfaces

Table 10-10 – OMSn/OMSnP_A_Sk inputs and outputs

Input(s)	Output(s)
OMSn_AP: OMSn_AI_PLD OMSn_AI_OH OMSn_AI_TSF-P OMSn_AI_TSF-O	OMSnP_CP: OMSnP_CI_PLD OMSnP_CI_OH OMSnP_CI_SSF-P OMSnP_CI_SSF-O

Processes

No information processing is required in the OMSn/OMSnP_A_Sk, the OMSnP_CI at its output being identical to the OMSn_AI at its input.

Defects: None.

Consequent actions

aSSF-P ← AI_TSF-P

aSSF-O ← AI_TSF-O

Defect correlations: None.

Performance monitoring: None.

11 Optical physical section (OPS) layer functions

Figure 11-1 illustrates the OPS layer network and client layer adaptation functions. The information crossing the OPSn termination connection point (OPSn_TCP) is referred to as the OPSn characteristic information (OPSn_CI). The information crossing the OPSn access point (OPSn_AP) is referred to as the OPSn adapted information (OPSn_AI).

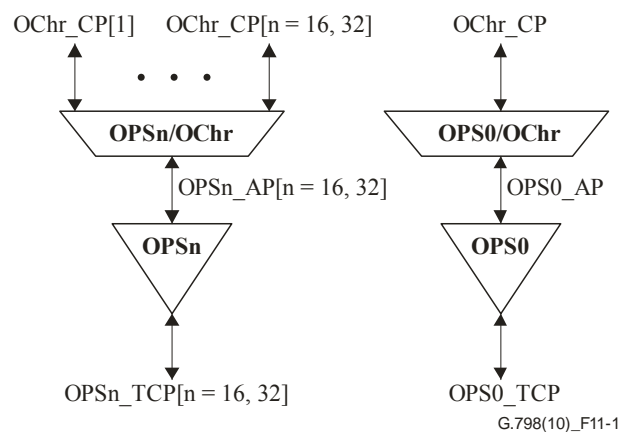

Figure 11-1 – OPSn layer network and client layer adaptation functions

The OPSn characteristic information (OPSn_CI) is a physical optical signal consisting of the n multiplexed traffic wavelengths for $n \geq 1$ and a single optical signal for $n = 0$.

The OPSn adapted information (OPSn_AI) consists of the OPSn adapted information payload (OTSn_AI_PLD), which are the n multiplexed traffic wavelengths for $n \geq 1$ and a single optical signal for $n = 0$.

11.1 Connection functions

Not applicable.

11.2 Termination functions

11.2.1 OPSn trail termination function (OPSn_TT); n = 0, 16, 32

The OPSn_TT functions are responsible for the end-to-end supervision of the OPSn trail. Figure 11-2 shows the combination of the unidirectional sink and source functions to form a bidirectional function.

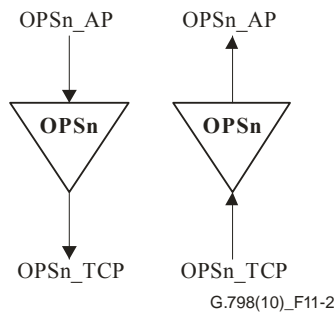

Figure 11-2 – OPSn_TT

11.2.1.1 OPS trail termination source function (OPSn_TT_So); n = 0, 16, 32

The information flow and processing of the OPSn_TT_So function is defined with reference to Figure 11-3. The OPSn_TT_So generates the OTM-nr.m signal within the physical specifications of [ITU-T G.959.1].

Symbol

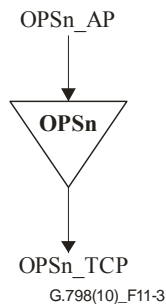

Figure 11-3 – OPSn_TT_So function

Interfaces

Table 11-1 – OPSn_TT_So inputs and outputs

Input(s)	Output(s)
OPSn_AP: OPSn_AI_PLD	OPSn_TCP: OPSn_CI

Processes

NOTE – For the optical power levels of the OTN interface specified in the current version of [ITU-T G.959.1], automatic power reduction (APR) is not necessary according to [ITU-T G.664], [IEC 60825-1] and [IEC 60825-2]. Future versions of [ITU-T G.959.1] may, however, contain power levels exceeding the safe levels. In this case, APR procedures have to be defined.

Defects: None.

Consequent actions: None.

Defect correlations: None.

Performance monitoring: None.

11.2.1.2 OPSn trail termination sink function (OPSn_TT_Sk); n = 0, 16, 32

The information flow and processing of the OPSn_TT_Sk function is defined with reference to Figures 11-4 and 11-5. The OPSn_TT_Sk reports the state of the OPSn trail. The OPSn_TT_Sk accepts an OTM-nr.m signal with physical parameters, according to clause 7 of [ITU-T G.959.1], after transport over an optical path as defined in [ITU-T G.959.1].

Symbol

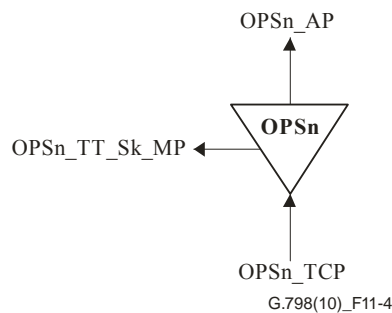

Figure 11-4 – OPSn_TT_Sk function

Interfaces

Table 11-2 – OPSn_TT_Sk inputs and outputs

Input(s)	Output(s)
OPSn_TCP: OPSn_CI	OPSn_AP: OPSn_AI_PLD OPSn_AI_TSF-P OPSn_TT_Sk_MP: OPSn_TT_Sk_MI_cLOS-P OPSn_TT_Sk_MI_pN_DS-P

Processes

The processes associated with the OPSn_TT_Sk function are depicted in Figure 11-5.

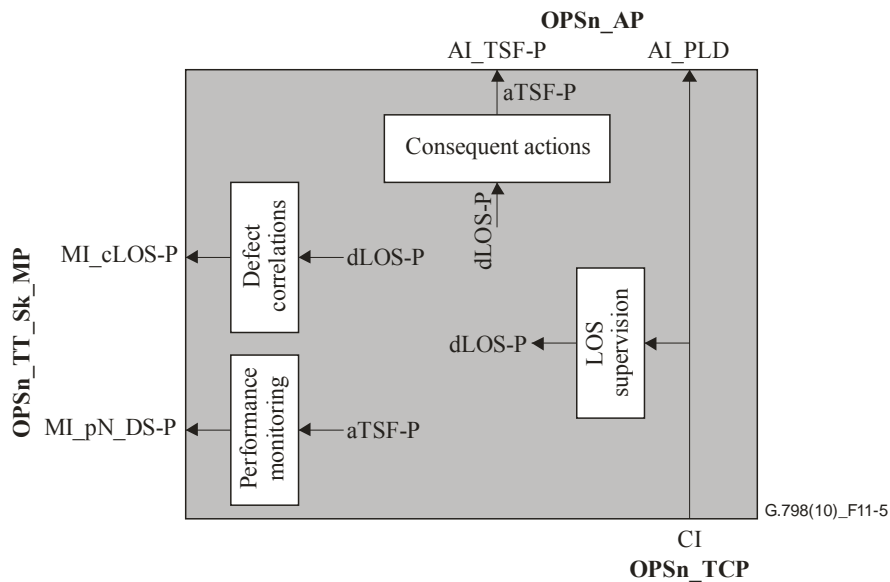

Figure 11-5 – OPSn_TT_Sk processes

Defects

The OPSn_TT_Sk function shall detect for dLOS-P defect.

dLOS-P: See clause 6.2.1.1.

Consequent actions

The OPSn_TT_Sk function shall perform the following consequent actions.

aTSF-P ← dLOS-P

Defect correlations

The OPSn_TT_Sk function shall perform the following defect correlations.

cLOS-P ← dLOS-P

Performance monitoring

The OPSn_TT_Sk function shall perform the following performance monitoring primitives. The performance monitoring primitives shall be reported to the EMF.

pN_DS-P ← aTSF-P

11.2.2 OPSMnk_TT trail termination function; k = 3, 4; n = 4

The OPSMnk_TT functions are responsible for the end-to-end supervision of the OPSMnk trail.

Figure 11-6 shows the combination of the unidirectional sink and source functions to form a bidirectional function.

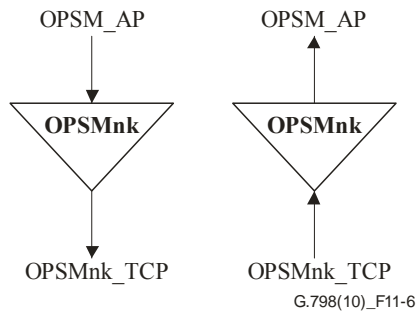

Figure 11-6 – OPSMnk_TT

11.2.2.1 OPSMnk_TT trail termination source function; k = 3, 4; n = 4

The information flow and processing of the OPSMnk_TT_So function is defined with reference to Figure 11-7. The OPSMnk_TT_So function conditions the data for transmission over the optical medium using the multilane format. For this, the OPSMnk_TT_So generates the OPSMnk signal within the physical specifications of [ITU-T G.959.1].

Symbol

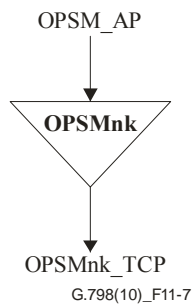

Figure 11-7 – OPSMnk_TT_So function

Interfaces

Table 11-3 – OPSMnk_TT_So inputs and outputs

Input(s)	Output(s)
OPSM_AP: OPSM_AI_D OPSM_AI_CK OPSM_AI_FS	OPSMnk_TCP: OPSMnk_CI

Processes

NOTE 1 – For the optical power levels of the OTN interface specified in [ITU-T G.959.1], automatic power reduction (APR) is not necessary according to [ITU-T G.664], [IEC 60825-1] and [IEC 60825-2].

The processes associated with the OPSMnk_TT function are specific processes for each lane signal of the OPSMnk, and common processes for the compound signal as depicted in Figure 11-8.

Common processes

16-byte block distributor and rotator: The function shall distribute each 16-byte block of the OTU3/OTU4 signal in round-robin way to the related lane structure (n = 20 logical lanes for OTU4 and n = 4 lanes for OTU3), as defined in Annex C of [ITU-T G.709]. The distribution is aligned to the OTUk frame and for OTU3 to the LSB positions of the multiframe. After every 16320th byte the mapping to the lanes shall be rotated forward by one lane, so that the OTUk FAS position will

be located in the n+1 lane as specified in Annex C of [ITU-T G.709] (see Figures C.2 and C.3 of [ITU-T G.709]).

Lane specific processes

Multilane identifier insertion: The function shall insert the multilane identifier as defined in Annex C of [ITU-T G.709] for OTU4. The multilane identifier replaces the 3rd OA2 byte position of the OTU4 FAS signal. In the case that no OTU4 frame is present (no FS indication), no identifier shall be inserted.

NOTE 2 – No multilane identifier insertion for OTU3 is required as this function is performed by the MFAS LSB positions of the OTU3 frame.

Bit multiplexing of OTU4 logical lanes: The process bit multiplexes groups of five logical lanes of the 20 logical lanes of the OTU4 Signal to four physical optical lane signals (OTLk.n [n = 1, ..., 4]) according to Annex C of [ITU-T G.709].

Optical carrier modulation and wavelength assignment (Mod/WA): See clause 8.11.1. For the parameters on the optical lanes (OTLk.n), see [ITU-T G.959.1].

Optical signal pre-conditioning: Pre-conditioning of the single wavelength optical signal might be required. The specific conditioning processes depend on the OPSMnk interface type (see [ITU-T G.959.1]). The processes OA, DAa and PMDC, as defined in clause 8.11.2, are possible.

Common processes

Optical multiplexing (OM): See clause 8.11.1.

Optical signal pre-conditioning: Pre-conditioning of the multi-wavelength optical signal might be required. The specific conditioning processes depend on the OPSMnk_TT interface type, see [ITU-T G.959.1]). The processes OA and DAa, as defined in clause 8.11.2, are possible.

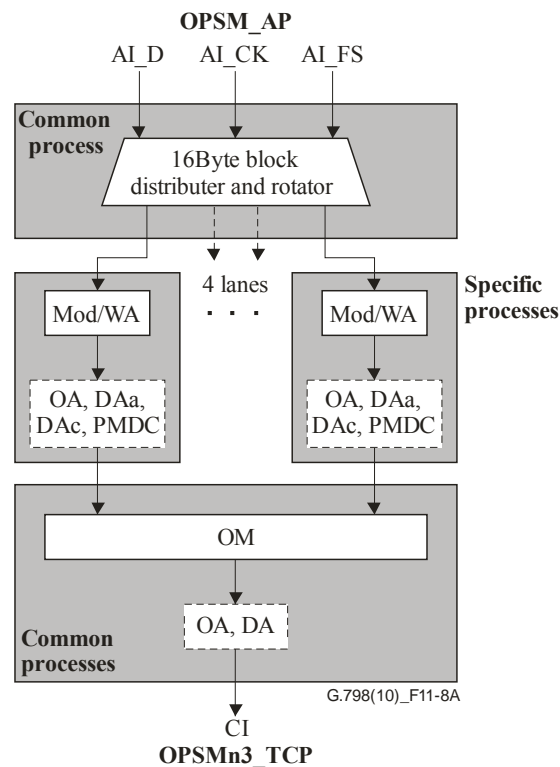

Figure 11-8A – OPSMn3_TT_So processes; n = 4

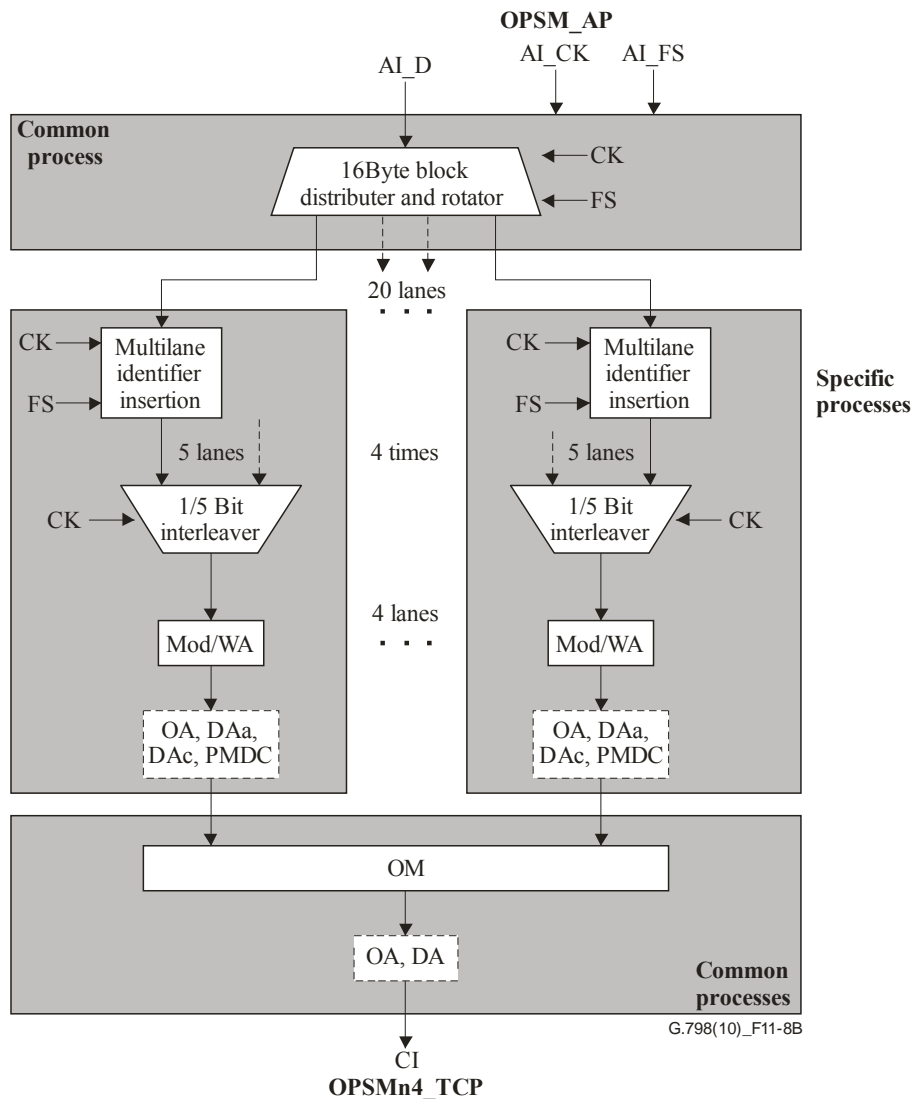

Figure 11-8B – _ OP SMn4_TT_So processes; n = 4

Consequent actions: None.

Defect correlations: None.

Performance monitoring: None.

11.2.2.2 OP SMnk_TT trail termination sink function (OP SMnk_TT_Sk); k = 3, 4; n = 4

The information flow of the OP SMnk_TT_Sk function is defined with reference to Figures 11-9, 11-10A and 11-10B. The OP SMnk_TT_Sk terminates the OP SMnk_trail. The OP SMnk_TT_Sk accepts an OP SMnk_signal with physical parameters, according to [ITU-T G.959.1], after transport over an optical path as defined in [ITU-T G.959.1].

Symbol

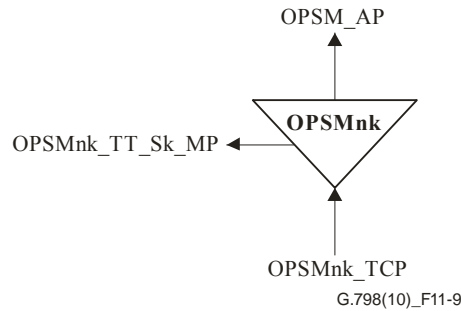

Figure 11-9 – OPSMn_TT_Sk function

Interfaces

Table 11-4 – OPSMnk_TT_Sk inputs and outputs

Input(s)	Output(s)
OPSMnk_TCP: OPSMnk_CI	OPSM_AP: OPSM_AI_D OPSM_AI_CK OPSM_AI_TSF OPSMnk_TT_Sk_MP: OPSMnk_TT_Sk_MI_cLOS OPSMnk_TT_Sk_MI_cLOL

Processes

The processes associated with the OPSMnk_TT_Sk function are specific processes for each OTLk.n signal and common processes for the compound signal as depicted in Figure 11-10.

Common processes

Optical signal post-conditioning: Post-conditioning of the multi-wavelength signal might be required. The specific conditioning processes depend on the OPSMnk interface type (see [ITU-T G.959.1]). The processes OA, DAa and PMDC, as defined in clause 8.11.2, are possible.

Optical demultiplexing and wavelength selection (ODM/WS): See clause 8.11.1. For the parameters, see [ITU-T G.959.1].

Specific processes

Optical signal post-conditioning: Post-conditioning of the single wavelength signal might be required. The specific conditioning processes depend on the OTM0k-vx interface type (see [ITU-T G.959.1]). The processes OA, DAC, DAa and PMDC, as defined in clause 8.11.2, are possible.

Optical carrier demodulation (DMod): See clause 8.11.1.

Optical lane reception process: This process recovers the OTLk.n [n = 1, .., 4] payload signal and reports the state of the OTLk.n [n = 1, .., 4] signal. It detects LOS of the payload signal.

Payload recovery: This function shall recover the OTLk.n [n = 1, .., 4] payload signals. The physical characteristics of the signals are defined in [ITU-T G.959.1].

OTL Clock recovery: The process shall recover the clock of the OTL signals from the incoming data. The function shall introduce no errors in case of jitter and wander, as defined in [ITU-T G.8251].

1/5 Bit- dis-interleaver (OTU4): The process shall bit de-multiplex the bitstream of the OTL into five logical lanes as defined in Annex C of [ITU-T G.709].

Lane frame alignment: The process shall recover the OTLk frame start, as described in clause 8.2.5.

Lane alignment recovery: The process shall recover the lane alignment signal of the logical lane, as described in clause 8.2.6.

Marker removal and OTU4 FAS re-creation: The process shall re-establish the OTU4-FAS OA2 byte pattern in the 6th byte position of the individual logical lane stream.

Lane deskew: The lane deskew consists of 4 or 20 elastic store processes, and the lane marker and delay process. The process shall establish the delay compensation, compensating the differential delay between the logical lane signals as given in Annex C of [ITU-T G.709] for OTU3 and OTU4. The compensation between the data lanes is achieved by an elastic store per lane, writing the lane data under control of the marker processing at the correct time into the 16-byte data block multiplexer. Each elastic store shall be capable of compensating at least 180 ns of absolute differential delay between the lanes in line with [IEEE 802.3].

NOTE – [IEEE 802.3] considers the differential delay to be split into a static and variable part where the variable part of the differential delay may be up to 4 ns of variation.

OTU clock generator: The process shall generate the OTUk clock from the incoming lane clock.

16-byte block mux: The process shall interleave the 4 or 20 logical lane signals in 16-byte increments to restore the original OTUk, as given in Annex C of [ITU-T G.709], Figures C.2 and C.3.

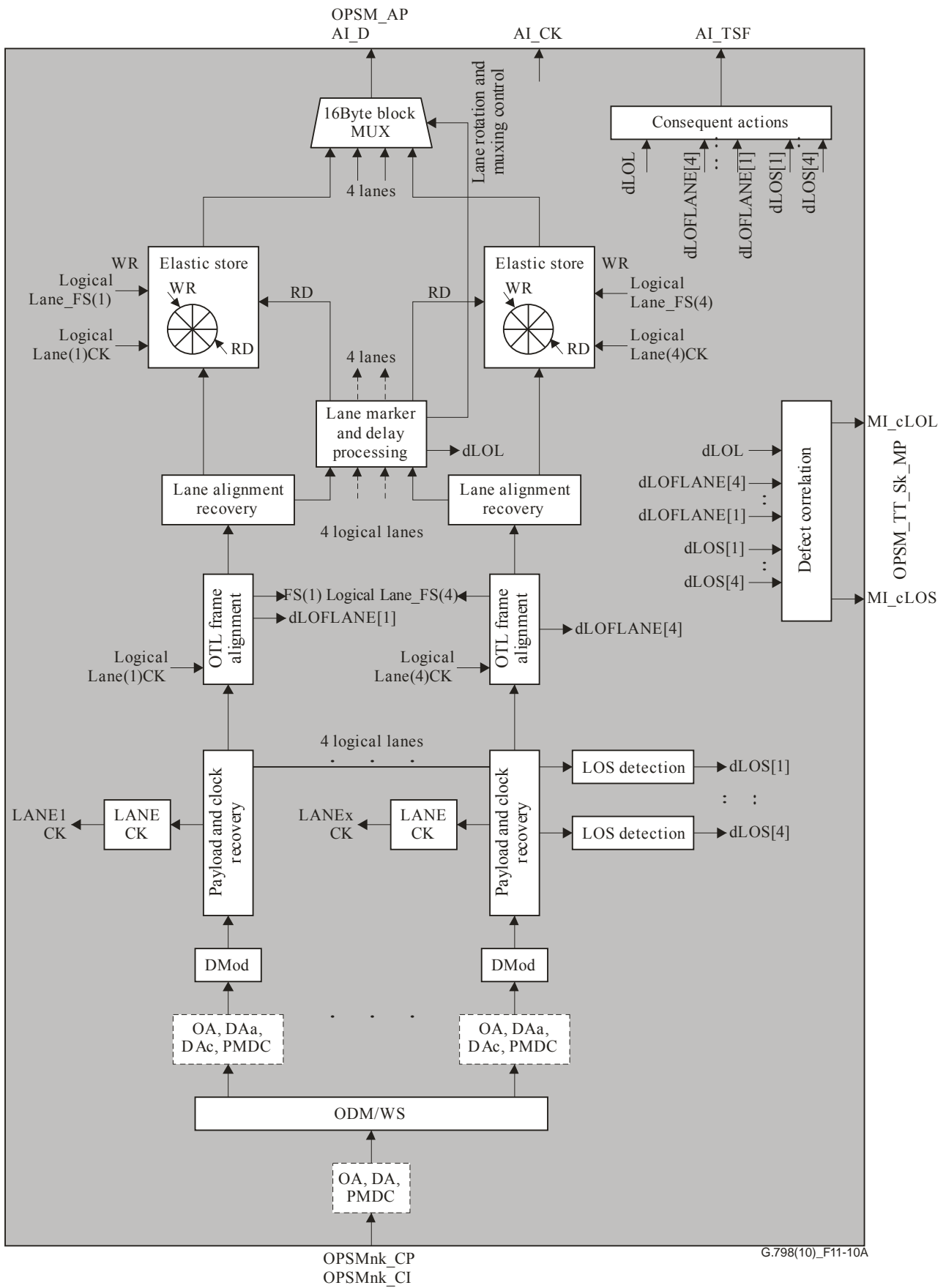
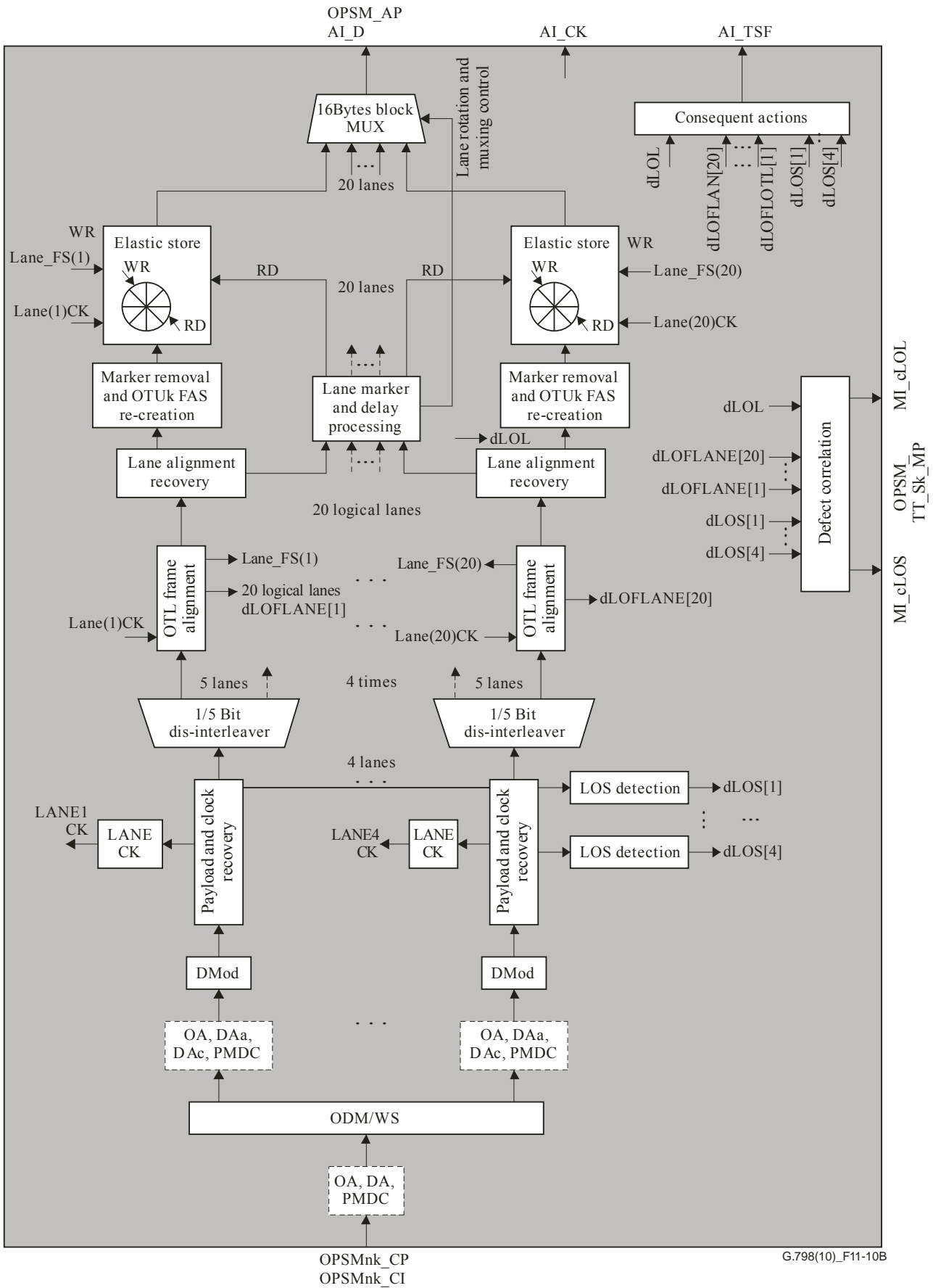

Figure 11-10A – OPSMn3_TT_Sk processes; n = 4



G.798(10)_F11-10B

Figure 11-10B – OPStMn4_TT_Sk processes; n = 4

Defects

The function shall detect for dLOS-P[1...4], dLOFLANE[1...y] and dLOL.

For OTU3, y = 4; for OTU4, y = 20.

dLOS-P[i]: See clause 6.2.1.1.

dLOL: See clause 6.2.5.5.

dLOFLANE[i]: See clause 6.2.5.6.

Consequent actions

The function shall perform the following consequent actions:

aTSF $\leftarrow \sum \text{dLOS-P}[i] \text{ or dLOL or } \sum \text{dLOFLANE}[i]$

Defect correlations

The function shall perform the following defect correlations to determine the most probable fault cause:

cLOS $\leftarrow \sum \text{dLOS-P}[i]$

cLOL $\leftarrow (\text{dLOL or } \sum \text{dLOFLANE}[i]) \text{ and (not } \sum \text{dLOS-P}[i])$

Performance monitoring

For further study.

11.3 Adaptation functions

The OPS is server for the following clients:

- OChr optical channel with reduced functionality (e.g., without non-associated overhead).

11.3.1 OPS0 to OChr adaptation function (OPS0/OChr_A)

The OPS0 to OChr adaptation functions perform the adaptation between the OPS0 layer adapted information and the characteristic information of an OChr layer signal.

11.3.1.1 OPS0 to OChr adaptation source function (OPS0/OChr_A_So)

The information flow and processing of the OPS0/OChr_A_So function is defined with reference to Figures 11-11 and 11-12.

Symbol

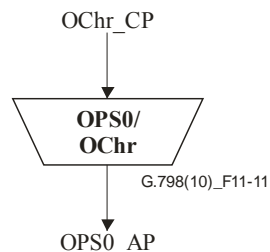

Figure 11-11 – OPS0/OChr_A_So function

Interfaces

Table 11-5 – OPS0/OChr_A_So inputs and outputs

Input(s)	Output(s)
OChr_CP: OChr_CI_PLD	OPS0_AP: OPS0_AI_PLD

Processes

The processes associated with the OPS0/OChr_A_So function are depicted in Figure 11-12.

Optical carrier modulation (Mod): See clause 8.11.1. For the parameters, see [ITU-T G.959.1].

Optical signal pre-conditioning: Pre-conditioning of the single wavelength optical signal might be required. The specific conditioning processes depend on the OTM-0 interface type (see [ITU-T G.959.1]). The processes OA, DAa, DAc and PMDC, as defined in clause 8.11.2, are possible.

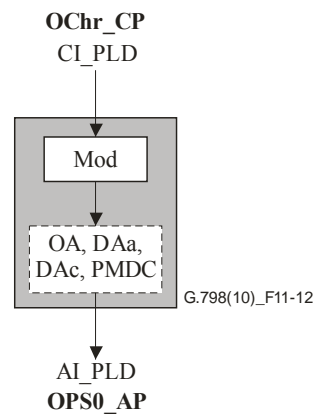

Figure 11-12 – OPS0/OChr_A_So processes

Defects: None.

Consequent actions: None.

Defect correlations: None.

Performance monitoring: None.

11.3.1.2 OPS0 to OChr adaptation sink function (OPS0/OChr_A_Sk)

The information flow and processing of the OPS0/OChr_A_Sk function is defined with reference to Figures 11-13 and 11-14.

Symbol

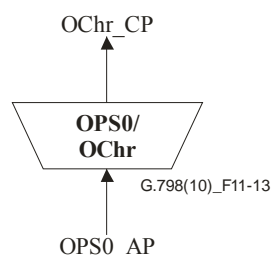

Figure 11-13 – OPS0/OChr_A_Sk function

Interfaces

Table 11-6 – OPS0/OChr_A_Sk inputs and outputs

Input(s)	Output(s)
OPS0_AP: OPS0_AI_PLD OPS0_AI_TSF-P	OChr_CP: OChr_CI_PLD OChr_CI_SSF-P

Processes

The processes associated with the OPS0/OChr_A_Sk function are depicted in Figure 11-14.

Optical signal post-conditioning: Post-conditioning of the single wavelength signal might be required. The specific conditioning processes depend on the OTM-0 interface type (see [ITU-T G.959.1]). The processes OA, DAa, DAc and PMDC, as defined in clause 8.11.2, are possible.

Optical carrier demodulation (DMod): See clause 8.11.1. For the parameters, see [ITU-T G.959.1].

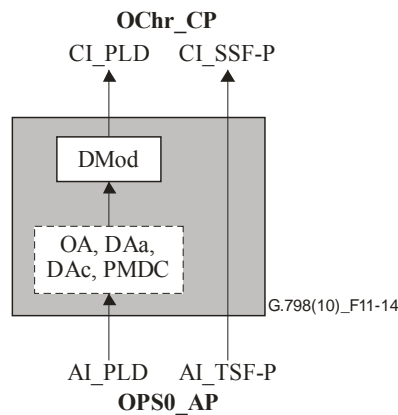

Figure 11-14 – OPS0/OChr_A_Sk processes

Defects: None.

Consequent actions

The OPS0/OChr_A_Sk function performs the following consequent actions.

aSSF-P ← AI_TSF-P

Defect correlations: None.

Performance monitoring: None.

11.3.2 OPS[n] to OChr adaptation function (OPS[n]/OChr_A) for [n = 16, 32]

The OPS[n] to OChr adaptation functions perform the adaptation between the OPS[n] layer adapted information and the characteristic information of [n] OChr layer signals for [n = 16, 32].

11.3.2.1 OPS[n] to OChr adaptation source function (OPS[n]/OChr_A_So) for [n = 16, 32]

The information flow and processing of the OPS[n]/OChr_A_So function for [n = 16, 32] is defined with reference to Figures 11-15 and 11-16.

Symbol

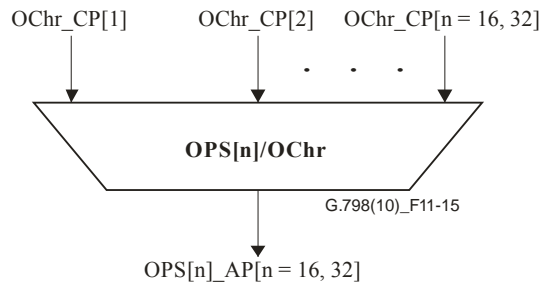

Figure 11-15 – OPS[n]/OChr_A_So function for [n = 16, 32]

Interfaces

Table 11-7 – OPS[n]/OChr_A_So inputs and outputs for [n = 16, 32]

Input(s)	Output(s)
per OChr_CP: OChr_CI_PLD	OPS[n]_AP: OPS[n]_AI_PLD

Processes

The processes associated with the OPS_n/OChr_A_So function are specific processes for each OChr_CI, and common processes for the compound signal as depicted in Figure 11-16.

Specific processes

Optical carrier modulation and wavelength assignment (Mod/WA): See clause 8.11.1. For the parameters, see [ITU-T G.959.1].

Optical signal pre-conditioning: Pre-conditioning of the single wavelength optical signal might be required. The specific conditioning processes depend on the OTM-nr interface type (see [ITU-T G.959.1]). The processes OA, DAC, DAa and PMDC, as defined in clause 8.11.2, are possible.

Common processes

Optical multiplexing (OM): See clause 8.11.1.

Optical signal pre-conditioning: Pre-conditioning of the multi-wavelength optical signal might be required. The specific conditioning processes depend on the OTM-nr interface type (see [ITU-T G.959.1]). The processes OA and DAa, as defined in clause 8.11.2, are possible.

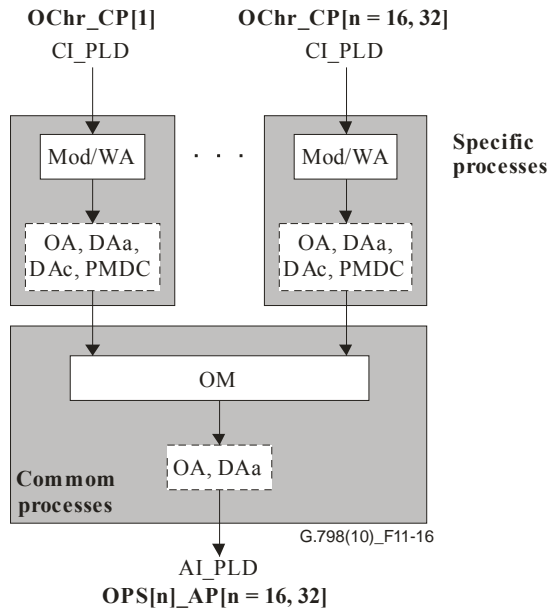

Figure 11-16 – OPS[n]/OChr_A_So processes for [n = 16, 32]

Defects: None.

Consequent actions: None.

Defect correlations: None.

Performance monitoring: None.

11.3.3 OPS[n] to OChr adaptation sink function (OPS[n]/OChr_A_Sk) for [n = 16, 32]

The information flow and processing of the OPS[n]/OChr_A_Sk function for [n = 16, 32] is defined with reference to Figures 11-17 and 11-18.

Symbol

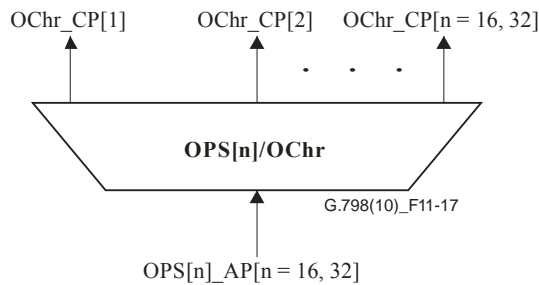

Figure 11-17 – OPS[n]/OChr_A_Sk function for [n = 16, 32]

Interfaces

Table 11-8 – OPS[n]/OChr_A_Sk inputs and outputs for [n = 16, 32]

Input(s)	Output(s)
OPS[n]_AP: OPS[n]_AI_PLD OPS[n]_AI_TSF-P	per OChr_CP: OChr_CI_PLD OChr_CI_SSF-P

Processes

The processes associated with the OPS[n]/OChr_A_Sk function for [n = 16, 32] are specific processes for each OChr signal, and common processes for the compound signal as depicted in Figure 11-18.

Common processes

Optical signal post-conditioning: Post-conditioning of the multi-wavelength signal might be required. The specific conditioning processes depend on the OTM-nr interface type (see [ITU-T G.959.1]). The processes OA, DAa and PMDC, as defined in clause 8.11.2, are possible.

Optical demultiplexing and wavelength selection (ODM/WS): See clause 8.11.1. For the parameters, see [ITU-T G.959.1].

Specific processes

Optical signal post-conditioning: Post-conditioning of the single wavelength signal might be required. The specific conditioning processes depend on the OTM-nr interface type (see [ITU-T G.959.1]). The processes OA, DAa, DAc and PMDC, as defined in clause 8.11.2, are possible.

Optical carrier demodulation (DMod): See clause 8.11.1.

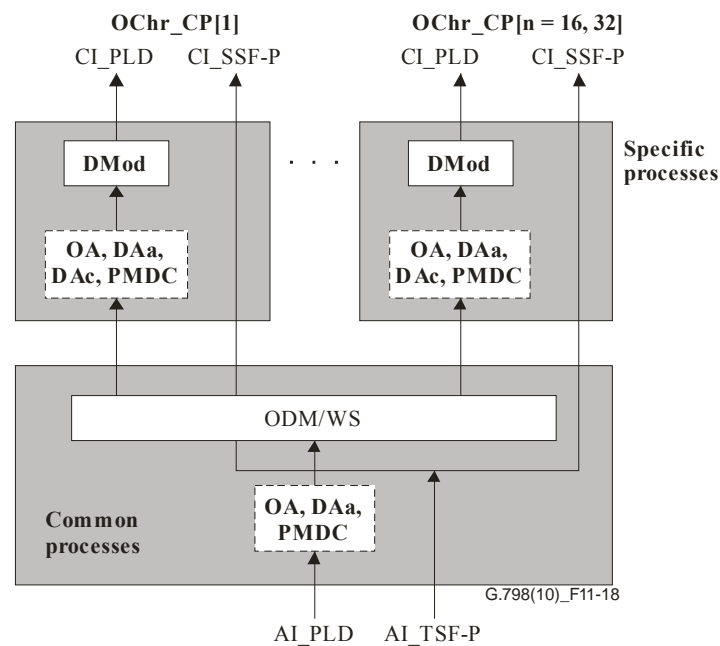

Figure 11-18 – OPS[n]/OChr_A_Sk processes for [n = 16, 32]

Defects: None.

Consequent actions

The OPS[n]/OChr_A_Sk function for [n = 16, 32] performs the following consequent actions.

aSSF-P[1..[n]] ← AI_TSF-P

Defect correlations: None.

Performance monitoring: None.

11.3.4 OPSM to OTUk adaptation function (OPSM/OTUk-a_A)

The OPSM to OTUk adaptation functions perform the adaptation between the OPSM layer adapted information and the characteristic information of the OTUk layer signal. Two types of functions are defined: one that supports forward error correction (FEC) and one that does not support FEC.

11.3.4.1 OPSM to OTUk adaptation source function with FEC (OPSM/OTUk-a_A_So)

The OPSM to OTUk adaptation source function with FEC is defined for OTU3 and OTU4.

The information flow and processing of the OPSM/OTUk-a_A_So function is defined with reference to Figures 11-19 and 11-20.

Symbol

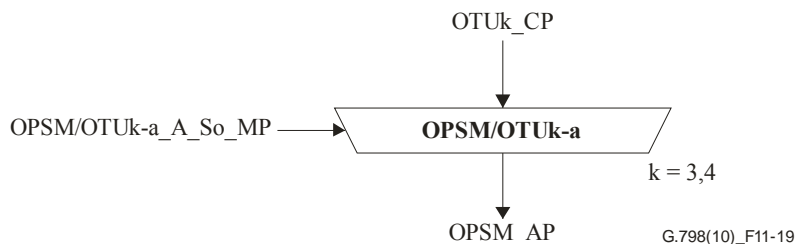

Figure 11-19 – OPSM/OTUk-a_A_So function

Interfaces

Table 11-9 – OPSM/OTUk-a_A_So inputs and outputs

Input(s)	Output(s)
OTUk_CP: OTUk_CI_CK OTUk_CI_D OTUk_CI_FS OTUk_CI_MFS OPSM/OTUk-a_A_So_MP: OPSM/OTUk-a_A_So_MI_Active	OPSM_AP: OPSM_AI_D OPSM_AI_CK OPSM_AI_FS

Processes

The processes associated with the OPSM/OTUk-a_A_So function are as depicted in Figure 11-20 .

Activation

- The OPSM/OTUk-a_A_So function shall access the access point when it is activated (MI_Active is true). Otherwise, it shall not access the access point.

FAS/MFAS insertion: The function shall insert the FAS and MFAS into the OTUk OH area as described in [ITU-T G.709].

FEC encoder: The function shall generate the RS(255,239) FEC for OTU3 and OTU4 code as defined in Annex A of [ITU-T G.709] and insert it into the OTUk FEC area.

Scrambler: The function shall scramble the signal as defined in clause 11.2 of [ITU-T G.709].

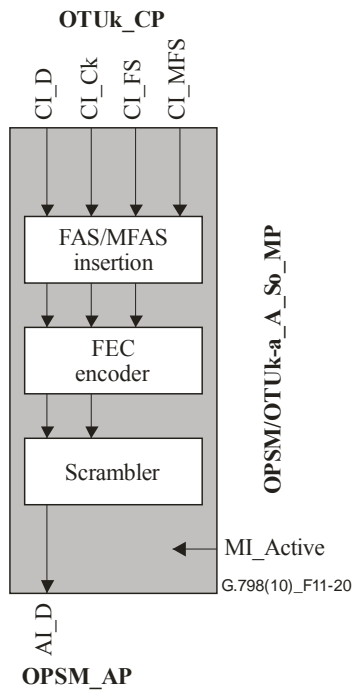

Figure 11-20 – OPSPM/OTUk-a_A_So processes

Defects: None.

Consequent actions: None.

Defect correlations: None.

Performance monitoring: None.

11.3.4.2 OPSPM to OTUk adaptation source function without FEC (OPSPM/OTUk-b_A_So)

The OPSPM to OTUk adaptation source function without FEC is defined for OTU3.

The information flow and processing of the OPSPM/OTUk-b_A_So function is defined with reference to Figures 11-21 and 11-22.

Symbol

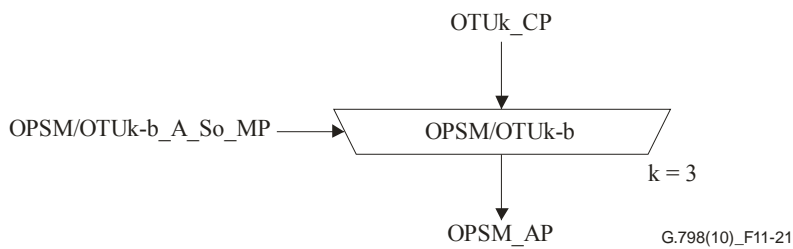

Figure 11-21 – OPSPM/OTUk-b_A_So function

Interfaces

Table 11-10 – OPSM/OTUk-b_A_So inputs and outputs

Input(s)	Output(s)
OTUk_CP: OTUk_CI_CK OTUk_CI_D OTUk_CI_FS OTUk_CI_MFS OPSM/OTUk-b_A_So_MP: OPSM/OTUk-b_A_So_MI_Active	OPSM_AP: OPSM_AI_D OPSM_AI_CK OPSM_AI_FS

Processes

The processes associated with the OPSM/OTUk-b_A_So function are as depicted in Figure 11-22.

Activation

- The OPSM/OTUk-b_A_So function shall access the access point when it is activated (MI_Active is true). Otherwise, it shall not access the access point.

FAS/MFAS insertion: The function shall insert the FAS and MFAS into the OTUk OH area as described in [ITU-T G.709].

Scrambler: The function shall scramble the signal as defined in clause 11.2 of [ITU-T G.709].

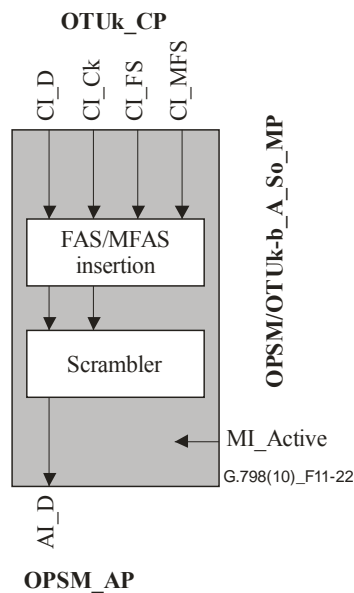

Figure 11-22 – OPSM/OTUk-b_A_So processes

Defects: None.

Consequent actions: None.

Defect correlations: None.

Performance monitoring: None.

11.3.4.3 OPSM to OTUk adaptation sink function with FEC (OPSM/OTUk-a_A_Sk)

The OPSM to OTUk adaptation sink function with FEC is defined for OTU3 and OTU4.

The information flow and processing of the OPSM/OTUk-a_A_Sk function is defined with reference to Figures 11-23 and 11-24.

Symbol

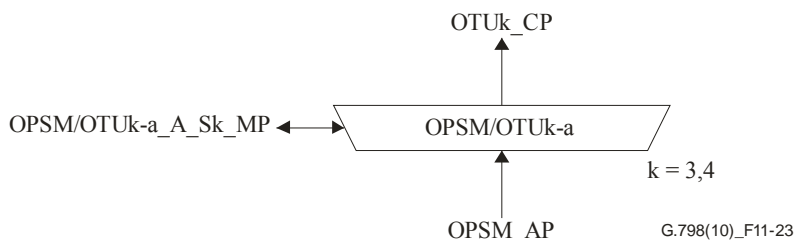

Figure 11-23 – OPSM/OTUk-a_A_Sk function

Interfaces

Table 11-11 – OPSM/OTUk-a_A_Sk inputs and outputs

Input(s)	Output(s)
OPSM_AP: OPSM_AI_D OPSM_AI_CK OPSM_AI_TSF OPSM/OTUk-a_A_Sk_MP: OPSM/OTUk-a_A_Sk_MI_FECEn (Note) OPSM/OTUk-a_A_Sk_MI_Active OPSM/OTUk-a_A_Sk_MI_1second	OTUk_CP: OTUk_CI_CK OTUk_CI_D OTUk_CI_FS OTUk_CI_MFS OTUk_CI_SSF OPSM/OTUk-a_A_Sk_MP: OPSM/OTUk-a_A_Sk_MI_cLOF OPSM/OTUk-a_A_Sk_MI_cLOM OPSM/OTUk-a_A_Sk_MI_pFECcorrErr
NOTE – This input does not exist for OTU4.	

Processes

The processes associated with the OPSM/OTUk-a_A_Sk function are as depicted in Figure 11-24.

Activation

- The OPSM/OTUk-a_A_Sk function shall access the access point and perform the common and specific processes operation specified below when it is activated (MI_Active is true). Otherwise, it shall activate the SSF signals at its output (CP) and not report its status via the management point.

Frame alignment: The function shall recover the OTUk frame start as described in clause 8.2.1.

Descrambler: The function shall perform descrambling as defined in clause 11.2 of [ITU-T G.709].

FEC decoder:

- for OTU3: If FEC processing is enabled (MI_FECEn is true), the function shall extract the RS(255,239) FEC data from the OTUk FEC area and perform error correction, as defined in Annex A of [ITU-T G.709]. The number of corrected bits shall be reported (nFECcorrErr). Otherwise, the FEC data is ignored and no error correction is performed.
- for OTU4: FEC processing is always enabled (MI_FECEn is true), the function shall extract the FEC data from the OTUk FEC area and perform error correction, as defined in Annex A of [ITU-T G.709]. The number of corrected bits shall be reported (nFECcorrErr).

Multiframe alignment: The function shall recover the OTUk multiframe start as described in clause 8.2.2.

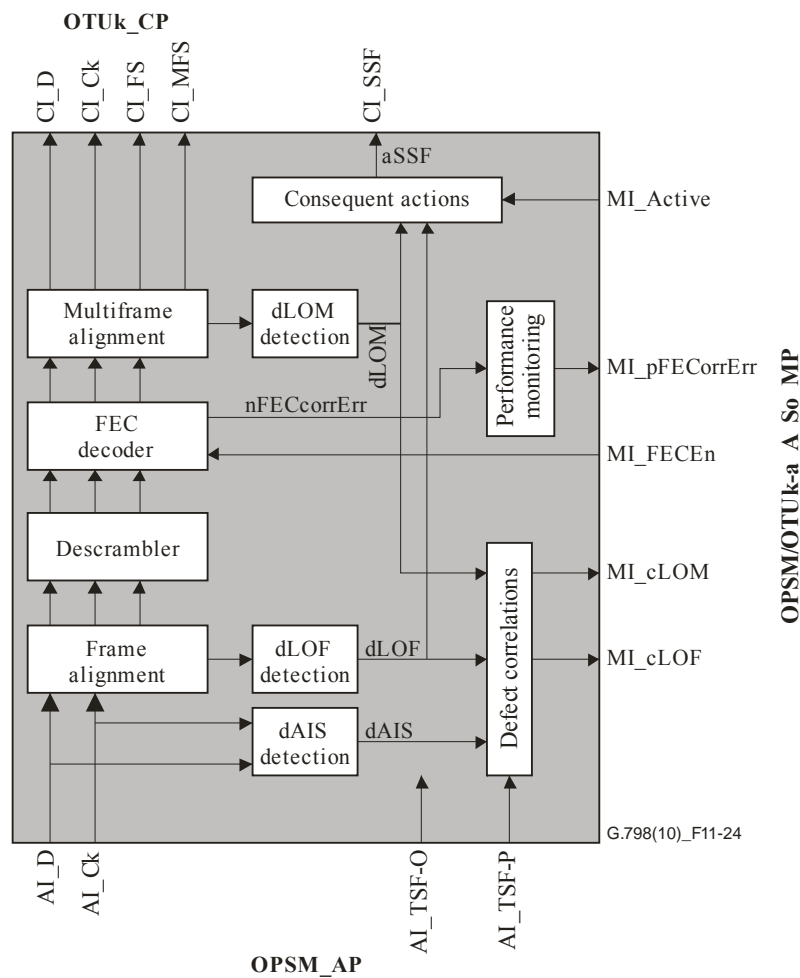

Figure 11-24 – OPSM/OTUk-a_A_Sk processes

Defects

The function shall detect for dLOF, dAIS and dLOM.

dAIS: See clause 6.2.6.3.1.

dLOF: See clause 6.2.5.1.

dLOM: See clause 6.2.5.2.

Consequent actions

aSSF ← dAIS or dLOF or dLOM or AI_TSFP or (not MI_Active)

Defect correlations

cLOF ← dLOF and (not dAIS) and (not AI_TSFP)

cLOM ← dLOM and (not dLOF) and (not dAIS) and (not AI_TSFP)

NOTE 1 – dAIS is not reported as fault cause as it is a secondary alarm and will result in aSSF, which is reported as cSSF fault cause in the OTUk_TT_Sk that directly follows this function.

Performance monitoring

The function shall perform the following performance monitoring primitives processing. The performance monitoring primitives shall be reported to the equipment management function (EMF).

$$pFECcorrErr \leftarrow \sum nFECcorrErr$$

NOTE 2 – During AI_TSF-P, dAIS, dLOF and dLOM, no corrected bits shall be counted.

11.3.4.4 OPSM to OTUk adaptation sink function without FEC (OPSM/OTUk-b_A_Sk)

The OPSM to OTUk adaptation sink function without FEC is defined for OTU3.

The information flow and processing of the OPSM/OTUk-b_A_Sk function is defined with reference to Figures 11-25 and 11-26.

Symbol

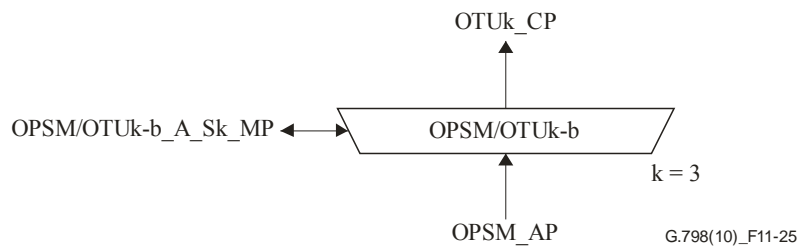

Figure 11-25 – OPSM/OTUk-b_A_Sk function

Interfaces

Table 11-12 – OPSM/OTUk-b_A_Sk inputs and outputs

Input(s)	Output(s)
OPSM_AP: OPSM_AI_D OPSM_AI_CK OPSM_AI_TSF OPSM/OTUk-b_A_Sk_MP: OPSM/OTUk-b_A_Sk_MI_Active	OTUk_CP: OTUk_CI_CK OTUk_CI_D OTUk_CI_FS OTUk_CI_MFS OTUk_CI_SSF OPSM/OTUk-b_A_Sk_MP: OPSM/OTUk-b_A_Sk_MI_cLOF OPSM/OTUk-b_A_Sk_MI_cLOM

Processes

The processes associated with the OPSM/OTUk-b_A_Sk function are as depicted in Figure 11-26.

Activation

- The OPSM/OTUk-b_A_Sk function shall access the access point and perform the common and specific processes operation specified below when it is activated (MI_Active is true). Otherwise, it shall activate the SSF signals at its output (CP) and not report its status via the management point.

Frame alignment: The function shall recover the OTUk frame start as described in clause 8.2.1.

Descrambler: The function shall perform descrambling as defined in clause 11.2 of [ITU-T G.709].

Multiframe alignment: The function shall recover the OTUk multiframe start as described in clause 8.2.2.

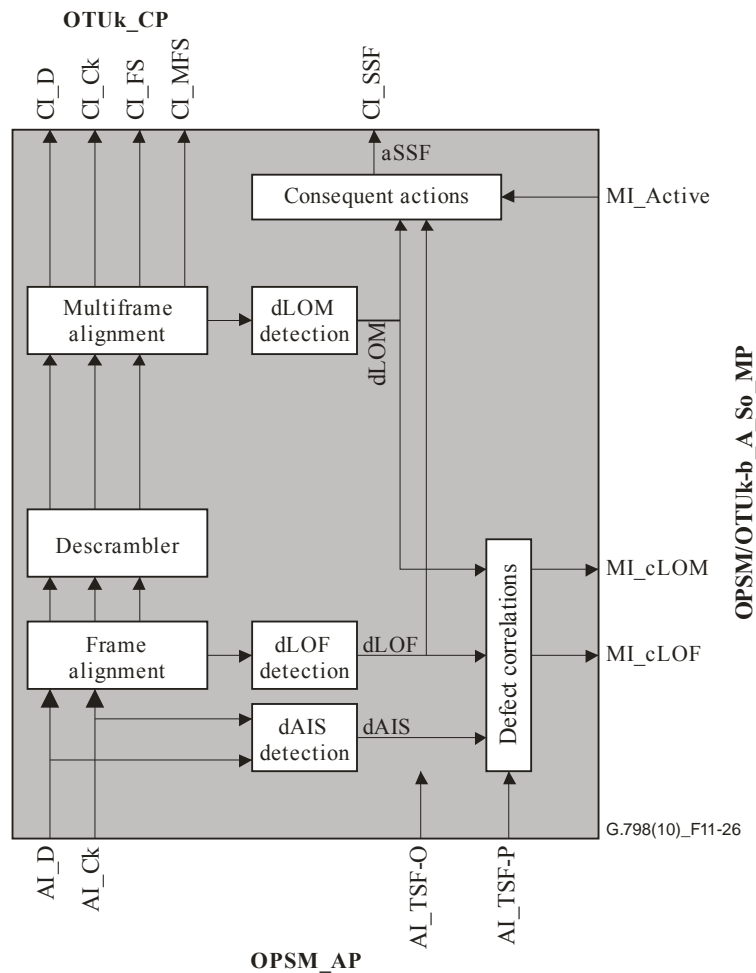

Figure 11-26 – OPSPM/OTUk-b_A_Sk processes

Defects

The function shall detect for dAIS, dLOF and dLOM.

dAIS See clause 6.2.6.3.1.

dLOF: See clause 6.2.5.1.

dLOM: See clause 6.2.5.2.

Consequent actions

aSSF ← dAIS or dLOF or dLOM or AI_TSF-P or (not MI_Active)

NOTE – dAIS is not reported as fault cause as it is a secondary alarm and will result in aSSF, which is reported as cSSF fault cause in the OTUk_TT_Sk that directly follows this function.

Defect correlations

cLOF ← dLOF and (not dAIS) and (not AI_TSF-P)

cLOM ← dLOM and (not dLOF) and (not dAIS) and (not AI_TSF-P)

Performance monitoring: None.

12 OCh (layer) functions

Two distinct flavours of the OCh layer and related functionality exist as shown in Figure 12-1: the OCh layer with full functionality using non-associated overhead, and the OChr layer with reduced functionality and without non-associated overhead. Each layer has its distinct trail termination

functions, while the adaptation functions are used by both. The connection function is only defined for the OCh layer and not for the OChr layer.

The information crossing the OCh (trail) connection point (OCh_CP/TCP) is referred to as the OCh characteristic information (OCh_CI). The information crossing the OChr connection point (OChr_CP) is referred to as the OChr characteristic information (OChr_CI). The information crossing the OCh access point (OCh_AP) is referred to as the OCh adapted information (OCh_AI).

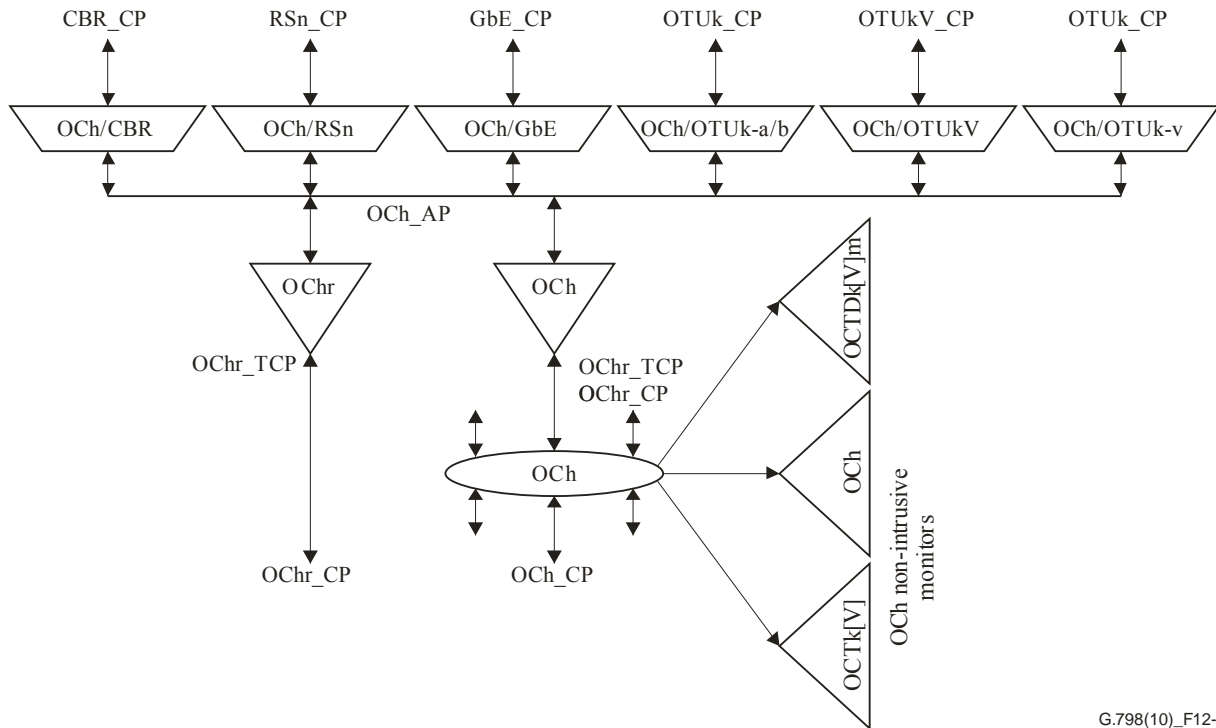

G.798(10)_F12-1

Figure 12-1 – OCh/OChr layer network and client layer adaptation functions

The OCh characteristic information (OCh_CI) consists of the OCh characteristic information payload (OCh_CI_PLD), which is a single traffic signal, and OCh characteristic information overhead (OCh_CI_OH), which is the OCh overhead information supported across the OCh_CP. The OOS may also contain general management communications. Figure 12-2 illustrates the overhead information elements that shall be supported by the OOS across the OCh_CP.

The specific OOS format is outside the scope of this Recommendation. In addition, vendor-specific overhead might be supported via the OOS. This is outside the scope of this Recommendation.

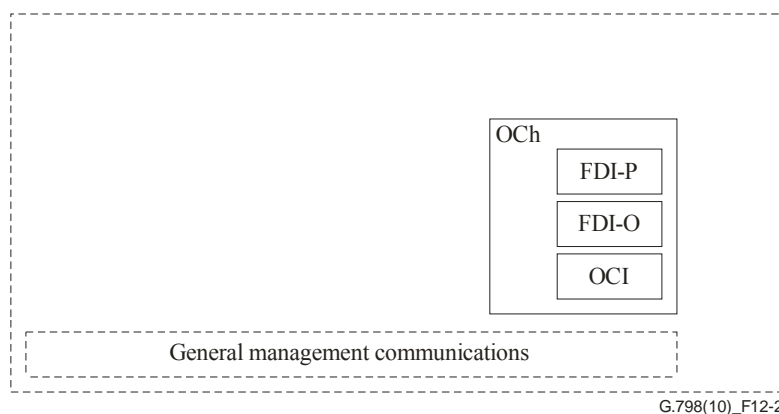

G.798(10)_F12-2

Figure 12-2 – OOS information elements at OCh_CP/TCP

The OChr characteristic information (OChr_CI) consists of the OChr characteristic information payload (OChr_CI_PLD), which is a single traffic signal.

The OCh adapted information (OCh_AI) consists of the single OCh data signal (OCh_AI_D). In case of an OTUk client signal, it is the OTUk signal as defined in [ITU-T G.709].

12.1 Connection functions

12.1.1 OCh connection function (OCh_C)

The information flow and processing of the OCh_C function is defined with reference to Figures 12-3 and 12-4. The OCh_C function connects OCh characteristic information from its input ports to its output ports. As the process does not affect the nature of characteristic information, the reference points on either side of the OCh_C function are the same as illustrated in Figure 12-3.

The connection process is unidirectional and, as such, no differentiation in sink and source is required.

In addition, the OCh_C function supports the following subnetwork connection protection scheme:

- 1+1 unidirectional SNC/N.

Other protection schemes are for further study.

NOTE 1 – The protection processes have a dedicated sink and source behaviour.

Symbol

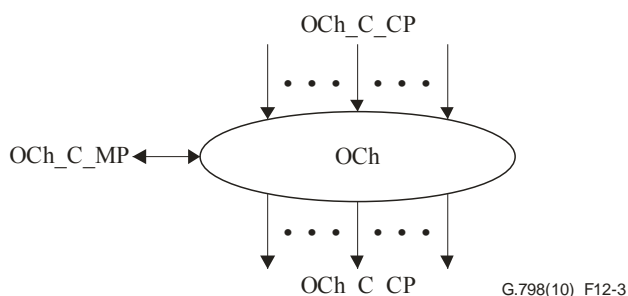

Figure 12-3 – OCh_C function

Interfaces

Table 12-1 – OCh_C function inputs and outputs

Input(s)	Output(s)
Per OCh_CP: OCh_CI_PLD OCh_CI_OH OCh_CI_SSF-P OCh_CI_SSF-O OCh_CI_TSF-P (Note) OCh_C_MP: MI_MatrixControl Per protection group: OCh_C_MI_OperType OCh_C_MI_WTR OCh_C_MI_HoTime OCh_C_MI_ExtCMD OCh_C_MI_TSF-ODis	Per OCh_CP: OCh_CI_PLD OCh_CI_OH OCh_CI_SSF-P OCh_CI_SSF-O OCh_C_MP: For further study
NOTE – In case of SNC/N protection.	

Processes

The processes associated with the OCh_C function are as depicted in Figure 12-4.

OCh_CI is routed between input and output connection points by means of a matrix connection. Connection points may be allocated within a protection group.

NOTE 2 – Neither the number of input/output signals to the connection function, nor the connectivity, is specified in this Recommendation. That is a property of individual network elements. Examples of connectivity are given in Appendix I of [ITU-T G.806].

Routing: The function shall be able to connect a specific input with a specific output by means of establishing a matrix connection between the specified input and output, and it shall be able to remove an established matrix connection as defined by MI_MatrixControl.

Each (matrix) connection in the OCh_C function should be characterized by the:

- type of connection: unprotected, 1+1 unidirectional protected;
- traffic direction: unidirectional, bidirectional;
- input and output connection points: set of connection points.

NOTE 3 – Broadcast connections are handled as separate connections to the same CP.

NOTE 4 – For the case a network element supports 1+1 protected matrix connections in its OCh_C function, this function may contain at any moment in time either all unprotected matrix connections, or all 1+1 protected matrix connections, or a mixture of unprotected and 1+1 protected matrix connections. The actual set of matrix connections and associated connection types and directions are operational parameters controlled by network management.

Provided no protection switching action is activated/required, the following changes to (the configuration of) a connection shall be possible without disturbing the CI passing the connection:

- addition and removal of protection;
- addition and removal of connections to/from a broadcast connection;
- change of WTR time;
- change of operation type;
- change of hold-off time.

Open connection indication (OCI): If an output of the connection function is not connected to an input, the OCI maintenance signal is generated for the overhead of the outgoing signal (CI_OH). No optical payload CI_PLD is available. CI_SSF-P and CI_SSF-O are false.

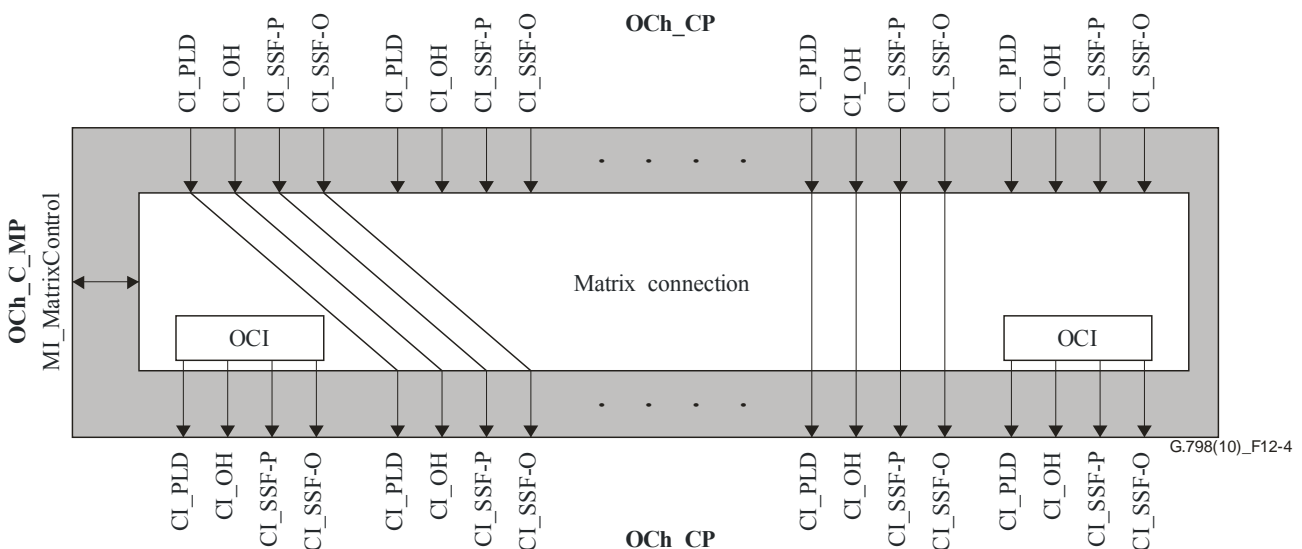

Figure 12-4 – OCh_C function processes

Defects: None.

Consequent actions: None.

Defect correlations: None.

Performance monitoring: None.

12.1.1.1 Subnetwork connection protection process

NOTE – This process is active in the OCh_C function as many times as there are 1+1 protected matrix connections.

The basic subnetwork connection protection mechanism is identical to the SDH subnetwork connection process described in [ITU-T G.841].

SNC protection with non-intrusive monitoring (SNC/N) is supported.

Figure 12-5 gives the atomic functions involved in SNC/N protection. The working and protection OCh_CI coming from an OMSn/OCh_A function are monitored by an OCh non-intrusive monitor, which provides the TSF-P protection switching criteria.

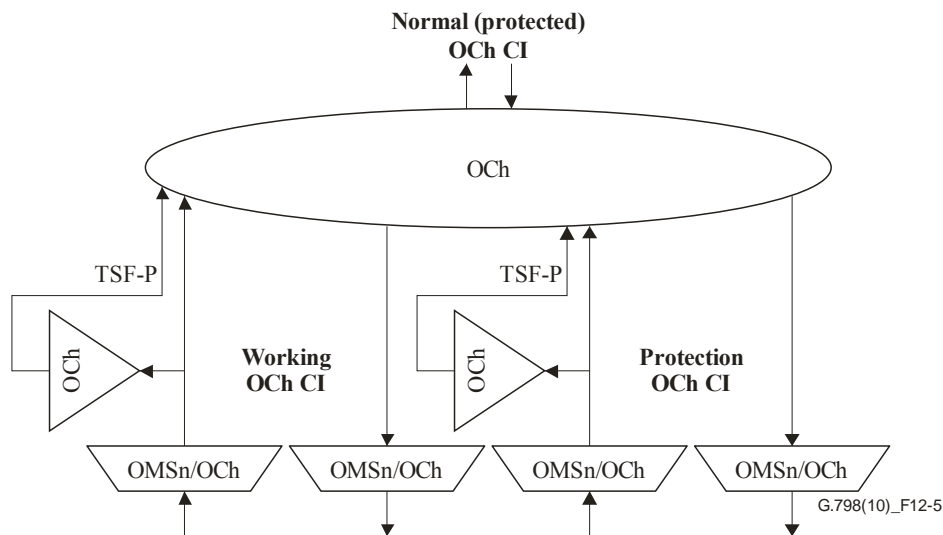

Figure 12-5 – SNC/N protection atomic functions

The protection functions at both ends operate the same way, by monitoring working and protection subnetwork connections for defects, evaluating the system status taking into consideration the priorities of defect conditions and of external switch requests, and switching the appropriate channel to the protected (sub)network connection.

The signal flow associated with the OCh_C SNC protection process is described with reference to Figure 12-6. The protection process receives control parameters and external switch requests at the MP reference point. The report of status information at the MP reference point is for further study.

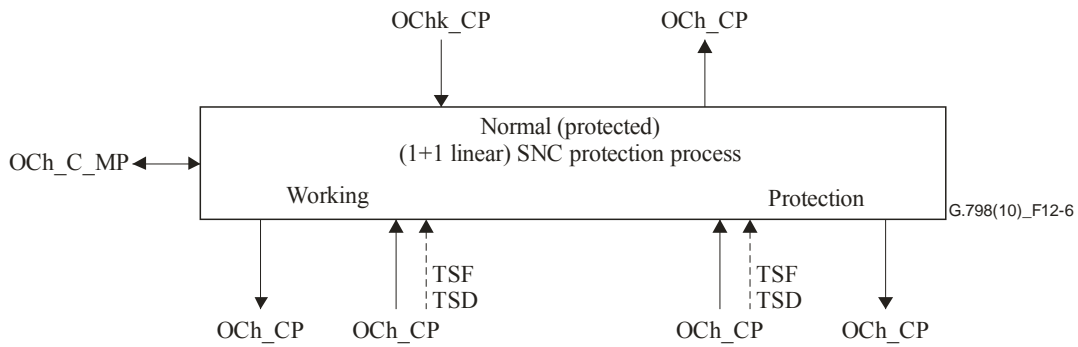

Figure 12-6 – SNC/N protection process

Source direction

For 1+1 architecture, the CI coming from the normal (protected) OCh_CP is bridged permanently to both the working and protection OCh_CP.

Sink direction

For a 1+1 architecture, the CI coming either from the working or protection OCh_CP is switched to the normal (protected) OCh_CP. A switchover from working to protection OCh_CP, or vice versa, is initiated by the switch initiation criteria defined below.

Switch initiation criteria

Automatic protection switching is based on the defect conditions of the working and protection (sub)network connections. These condition(s) are for SNC/N trail signal fail payload (TSF-P) and trail signal fail overhead (TSF-O). The use of TSF-O as protection switching criteria can be disabled (MI_TSF-ODis). The priority of TSF-P shall be equal to signal fail as defined in [ITU-T G.841]. The priority of TSF-O shall be equal to signal degrade as defined in [ITU-T G.841].

In order to allow interworking between nested protection schemes, a hold-off timer is provided. The hold-off timer delays switch initiation in case of signal fail in order to allow a nested protection to react and clear the fault condition. The hold-off timer is started by the activation of signal fail and runs for the hold-off time. Protection switching is only initiated if signal fail is still present at the end of the hold-off time. The hold-off time shall be provisionable between 0 and 10 s in steps of 100 ms.

Protection switching can also be initiated by external switch commands received via the MP.

Depending on the mode of operation, internal states (e.g., wait to restore) may also initiate a switch over.

See the switch initiation criteria described in [ITU-T G.841].

Switching time

Refer to [ITU-T G.841].

Switch restoration

In the revertive mode of operation, the protected signal shall be switched back from the protection (sub)network connection to the working (sub)network connection when the working (sub)network connection has recovered from the fault.

To prevent frequent operation of the protection switch due to an intermittent fault, a failed working (sub)network connection must become fault-free for a certain period of time before it is used again. This period, called wait to restore (WTR) period should be of the order of 5-12 minutes and should be capable of being set.

In the non-revertive mode of operation, no switchback to the working (sub)network connection is performed when it has recovered from the fault.

Protection switching notifications to the MP are for further study.

12.2 Termination functions

12.2.1 OCh trail termination function (OCh_TT)

The OCh_TT functions are responsible for the end-to-end supervision of the OCh trail. They provide full functionality based on the non-associated overhead information. Figure 12-7 shows the combination of the unidirectional sink and source functions to form a bidirectional function.

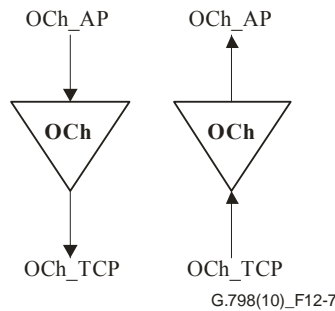

Figure 12-7 – OCh_TT

12.2.1.1 OCh trail termination source function (OCh_TT_So)

The OCh_TT_So function conditions the data for transmission over the optical medium and presents it at the OCh_TCP. The information flow and processing of the OCh_TT_So function is defined with reference to Figures 12-8 and 12-9.

Symbol

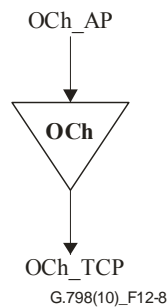

Figure 12-8 – OCh_TT_So function

Interfaces

Table 12-2 – OCh_TT_So inputs and outputs

Input(s)	Output(s)
OCh_AP: OCh_AI_D	OCh_TCP: OCh_CI_PLD

Processes

The processes associated with the OCh_TT_So function are as depicted in Figure 12-9.

Payload generation: The function shall generate the OCh payload signal (baseband signal). The physical specifications of the signal are outside the scope of this Recommendation.

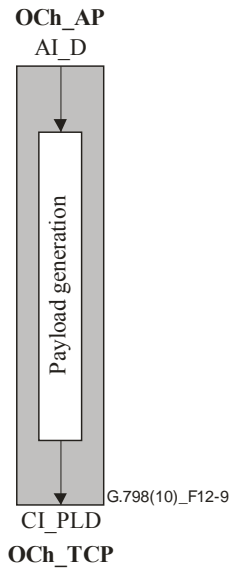

Figure 12-9 – OCh_TT_So processes

Defects: None.

Consequent actions: None.

Defect correlations: None.

Performance monitoring: None.

12.2.1.2 OCh trail termination sink function (OCh_TT_Sk)

The OCh_TT_Sk function recovers the OCh payload signal and reports the state of the OCh trail. It extracts the OCh overhead – including the FDI-P, FDI-O and OCI signals – from the OCh signal at its OCh_TCP, detects for LOS, OCI, FDI-P and FDI-O defects.

Symbol

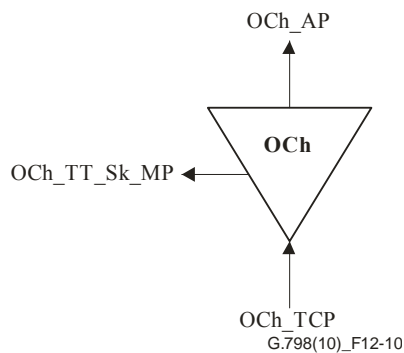

Figure 12-10 – OCh_TT_Sk function

Interfaces

Table 12-3 – OCh_TT_Sk inputs and outputs

Input(s)	Output(s)
OCh_TCP: OCh_CI_PLD OCh_CI_OH OCh_CI_SSF-P OCh_CI_SSF-O	OCh_AP: OCh_AI_D OCh_AI_TSF-P OCh_AI_TSF-O OCh_TT_Sk_MP: OCh_TT_Sk_MI_cLOS-P OCh_TT_Sk_MI_cOCI OCh_TT_Sk_MI_cSSF OCh_TT_Sk_MI_cSSF-P OCh_TT_Sk_MI_cSSF-O

Processes

The processes associated with the OCh_TT_Sk function are as depicted in Figure 12-11.

Payload recovery: This function shall recover the OCh payload signal. The physical specifications of the signal are outside the scope of this Recommendation.

FDI-P: The FDI-P information (OCh-FDI-P) shall be extracted from the OCh overhead of the OOS. It shall be used for FDI-P defect detection. The specific implementation for extracting FDI-P from the OOS and detecting its value is outside the scope of this Recommendation.

FDI-O: The FDI-O information (OCh-FDI-O) shall be extracted from the OCh overhead of the OOS. It shall be used for FDI-O defect detection. The specific implementation for extracting FDI-O from the OOS and detecting its value is outside the scope of this Recommendation.

OCI: The OCI information (OCh-OCI) shall be extracted from the OCh overhead of the OOS. It shall be used for OCI defect detection. The specific implementation for extracting OCI from the OOS and detecting its value is outside the scope of this Recommendation.

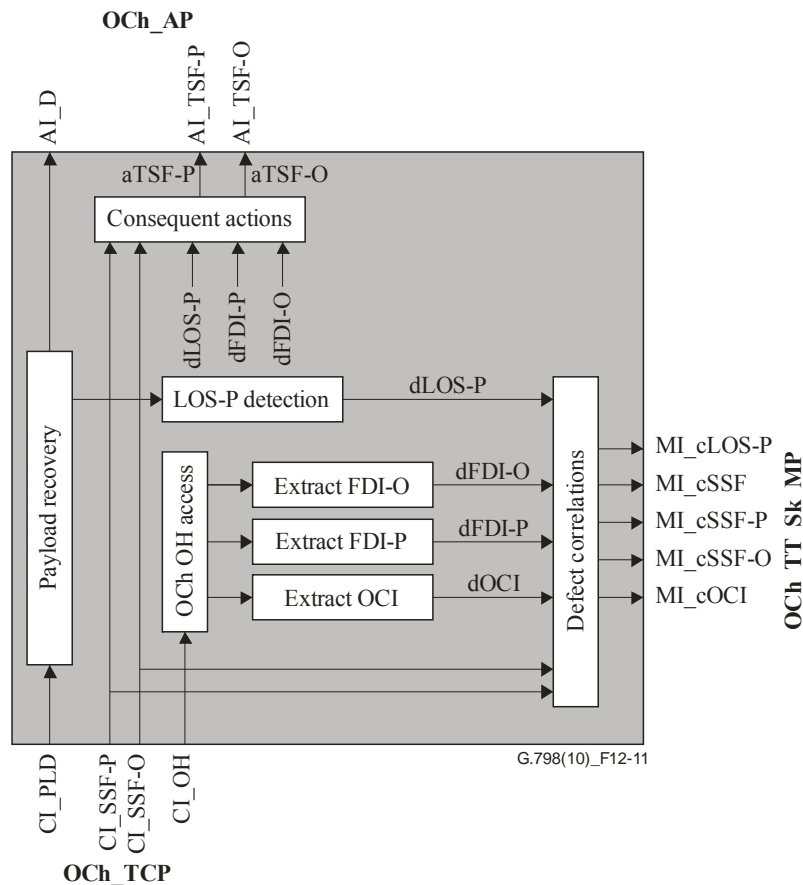

Figure 12-11 – OCh_TT_Sk processes

Defects

The function shall detect for dLOS-P, dFDI-P, dFDI-O and dOCI.

NOTE – Detection of additional OOS-related defects might be required (see clause 6.2.8). This depends on the specific OOS format and is outside the scope of this Recommendation.

dLOS-P: See clause 6.2.1.1.

dFDI-P: See clause 6.2.6.1.1.

dFDI-O: See clause 6.2.6.2.1.

dOCI: See clause 6.2.6.8.1; dOCI shall be set to false during CI_SSF-O and dFDI-O.

Consequent actions

The function shall perform the following consequent actions:

aTSF-P ← CI_SSF-P or dLOS-P or dOCI or dFDI-P

aTSF-O ← CI_SSF-O or dFDI-O

Defect correlations

The function shall perform the following defect correlations to determine the most probable fault cause. This fault cause shall be reported to the EMF.

cLOS-P ← dLOS-P and (not dOCI) and (not FDI-P) and (not CI_SSF-P)

cOCI ← dOCI and (not CI_SSF-P) and (not CI_SSF-O) and (not FDI-O) and (not FDI-P)

cSSF ← (CI_SSF-P or dFDI-P) and (CI_SSF-O or dFDI-O)

cSSF-P ← (CI_SSF-P or dFDI-P) and (not cSSF)

cSSF-O ← (CI_SSF-O or dFDI-O) and (not cSSF)

Performance monitoring

For further study.

12.2.2 OChr trail termination function (OChr_TT)

The OChr_TT functions are responsible for the end-to-end supervision of the OChr trail. They provide only reduced functionality as no non-associated overhead information is available. Figure 12-12 shows the combination of the unidirectional sink and source functions to form a bidirectional function.

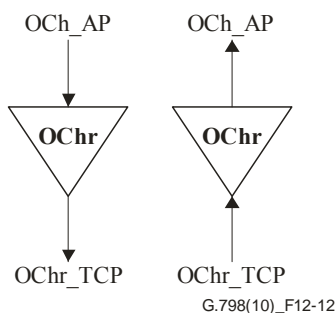

Figure 12-12 – OChr_TT

12.2.2.1 OChr trail termination source function (OChr_TT_So)

The OChr_TT_So function conditions the data for transmission over the optical medium and presents it at the OChr_TCP.

The information flow and processing of the OChr_TT_So function is defined with reference to Figures 12-13 and 12-14.

Symbol

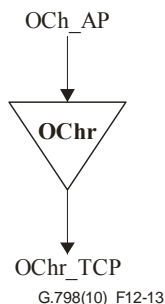

Figure 12-13 – OChr_TT_So function

Interfaces

Table 12-4 – OChr_TT_So inputs and outputs

Input(s)	Output(s)
OCh_AP: OCh_AI_D	OChr_TCP: OChr_CI_PLD

Processes

The processes associated with the OChr_TT_So function are as depicted in Figure 12-14.

Payload generation: The function shall generate the OCh payload signal (baseband signal). The physical specifications of the signal are defined in [ITU-T G.959.1].

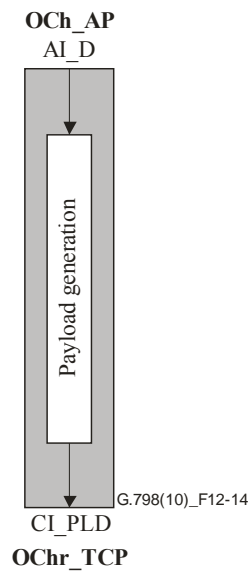

Figure 12-14 – OChr_TT_So processes

Defects: None.

Consequent actions: None.

Defect correlations: None.

Performance monitoring: None.

12.2.2.2 OChr trail termination sink function (OChr_TT_Sk)

The OChr_TT_Sk function recovers the OCh payload signal and reports the state of the OChr trail. It detects for LOS of the payload signal.

The information flow and processing of the OChr_TT_Sk function is defined with reference to Figures 12-15 and 12-16.

Symbol

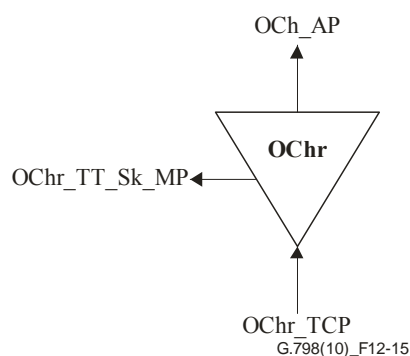

Figure 12-15 – OChr_TT_Sk function

Interfaces

Table 12-5 – OChr_TT_Sk inputs and outputs

Input(s)	Output(s)
OChr_TCP: OChr_CI_PLD OChr_CI_SSF-P	OCh_AP: OCh_AI_D OCh_AI_TSF-P OChr_TT_Sk_MP: OChr_TT_Sk_MI_cLOS OChr_TT_Sk_MI_cSSF-P

Processes

The processes associated with the OChr_TT_Sk function are as depicted in Figure 12-16.

Payload recovery: This function shall recover the OChr payload signal. The physical characteristics of the signal are defined in [ITU-T G.959.1].

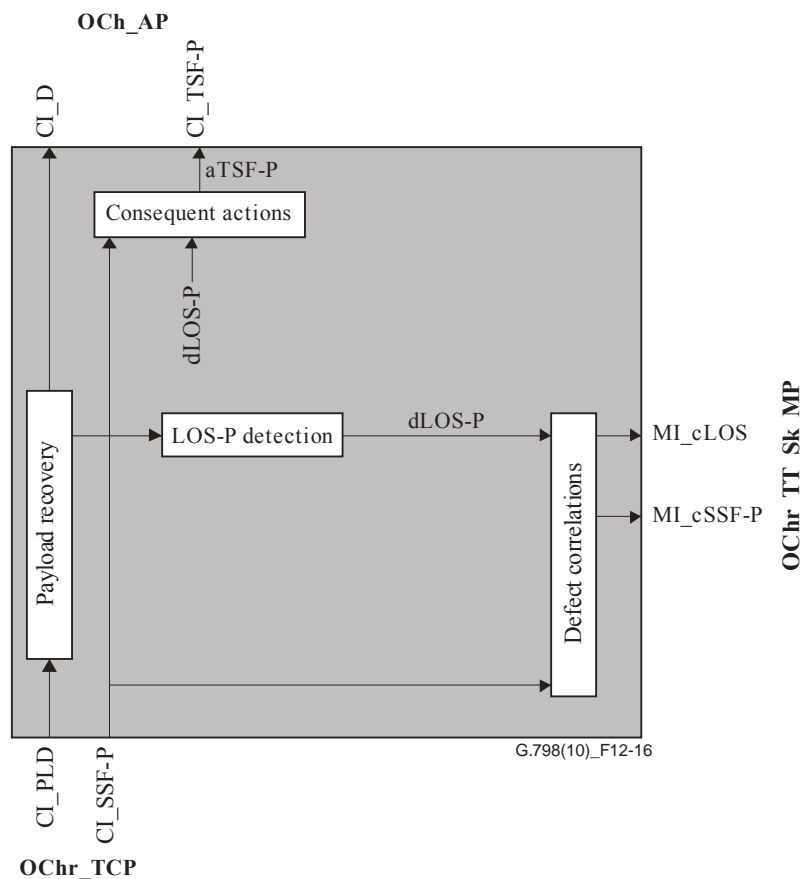

Figure 12-16 – OChr_TT_Sk processes

Defects

The function shall detect for dLOS-P.

dLOS-P: See clause 6.2.1.1.

Consequent actions

The function shall perform the following consequent actions:

aTSF-P ← CI_SSF-P or dLOS-P

Defect correlations

The function shall perform the following defect correlations to determine the most probable fault cause:

cLOS ← dLOS and (not CI_SSF-P)

cSSF-P ← CI_SSF-P

Performance monitoring

For further study.

12.2.3 OCh non-intrusive monitor function

As the functionality of the OCh non-intrusive monitor function is identical to the OCh_TT_Sk function (see clause 12.2.1.2), no dedicated OCh non-intrusive monitoring function OChm_TT_Sk is defined. For OCh non-intrusive monitoring, the OCh_TT_Sk function can be connected to the OCh_CP as shown in Figure 12-17. The OCh_TT_Sk function can be connected to any OCh_CP in this manner.

The TSF and TSD outputs can be connected to an OCh_C connection function and used as protection switching trigger criteria for SNC/N protection.

The unused outputs (e.g., OCh_AI_D) are left open.

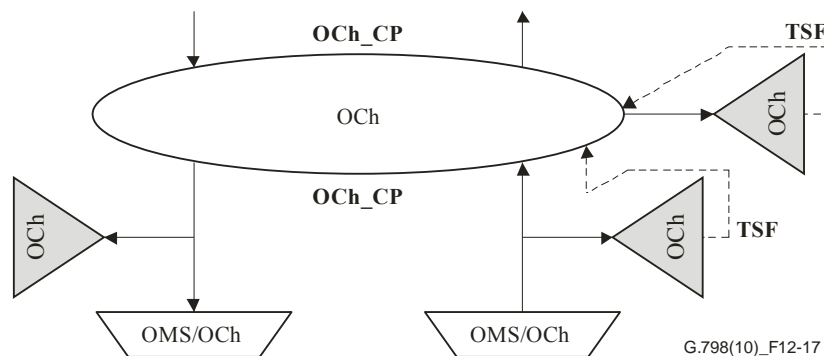

Figure 12-17 – Connection of OCh_TT_Sk function as non-intrusive monitor

12.2.4 Combined OCh and OTUk[V] non-intrusive monitor function (OCTk[V]m)

As the OCh and OTUk[V] termination are always collocated in an OTN network, a combined OCh and OTUk[V] non-intrusive monitor is defined as a compound function OCTk[V]m. The OCTk[V]m compound function is the combination of a OCh_TT_Sk (see clause 12.2.1.2), OCh/OTUk[V]_A_Sk (see clauses 12.3.1 and 12.3.2.2) and OTUk[V]_TT_Sk (see clauses 13.2.1.2 and 13.2.2.2) as shown in Figure 12-18. For the OCh/OTUk_A, either an OCh/OTUk-a_A_Sk with FEC (see clause 12.3.1.3) or an OCh/OTUk-b_A_Sk without FEC (see clause 12.3.1.4) can be used. This depends on the specific application and OTUk signal.

For non-intrusive monitoring, the OCTk[V]m function can be connected to the OCh_CP as shown in Figure 12-19. The OCTk[V]m function can be connected to any OCh_CP in this manner.

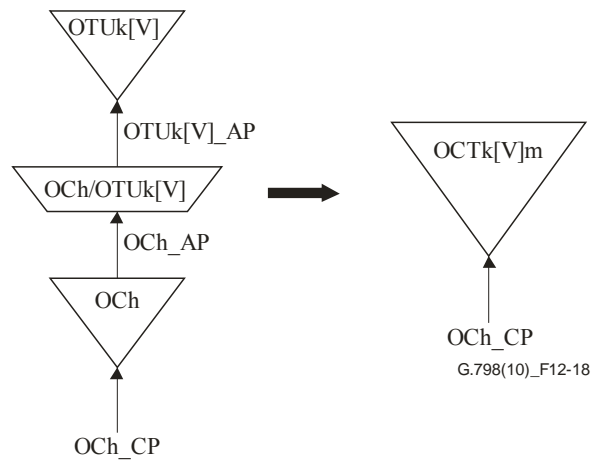

Figure 12-18 – OCTk[V]m compound function

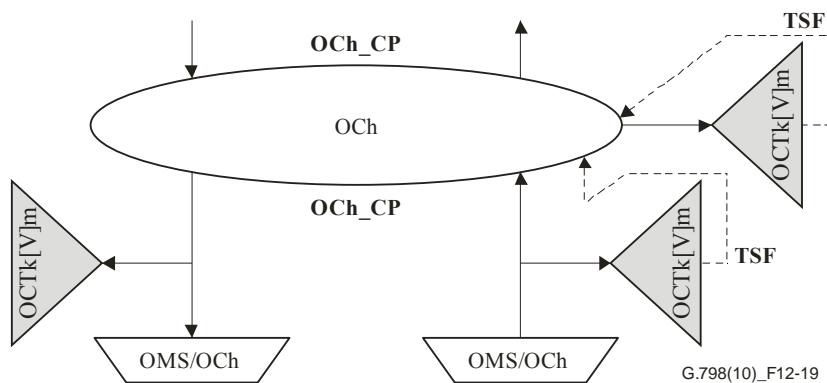

Figure 12-19 – Connection OCTk[V]m compound function (non-intrusive monitor)

12.2.5 Combined OCh, OTUk[V] and ODUkT non-intrusive monitor function (OCTDk[V]m)

To support detection of bit errors in a serial compound ODUk link connection carried through an OCh domain with 3R regeneration, it is necessary to deploy ODUk tandem connection monitoring between the ODUk connection points at the endpoints of the ODUk serial compound link connection. For this purpose, a combined OCh, OTUk[V] and ODUkT non-intrusive monitor is defined as a compound function OCTDk[V]m. The OCTDk[V]m compound function is the combination of OCh_TT_Sk (see clause 12.2.1.2), OCh/OTUk[V]_A_Sk (see clauses 12.3.1 and 12.3.2.2), OTUk[V]_TT_Sk (see clauses 13.2.1.2 and 13.2.2.2), OTUk[V]/ODUk_A (see clauses 13.3.1 and 13.3.2) and ODUkT_TT (see clause 14.5.1.1) as shown in Figure 12-20. For the OCh/OTUk_A, either an OCh/OTUk-a_A_Sk with FEC (see clause 12.3.1.3) or an OCh/OTUk-b_A_Sk without FEC (see clause 12.3.1.4) can be used. This depends on the specific application and of the OTUk signal.

For non-intrusive monitoring, the OCTDk[V]m function can be connected to the OCh_CP as shown in Figure 12-21. The OCTDk[V]m function can be connected to any OCh_CP in this manner.

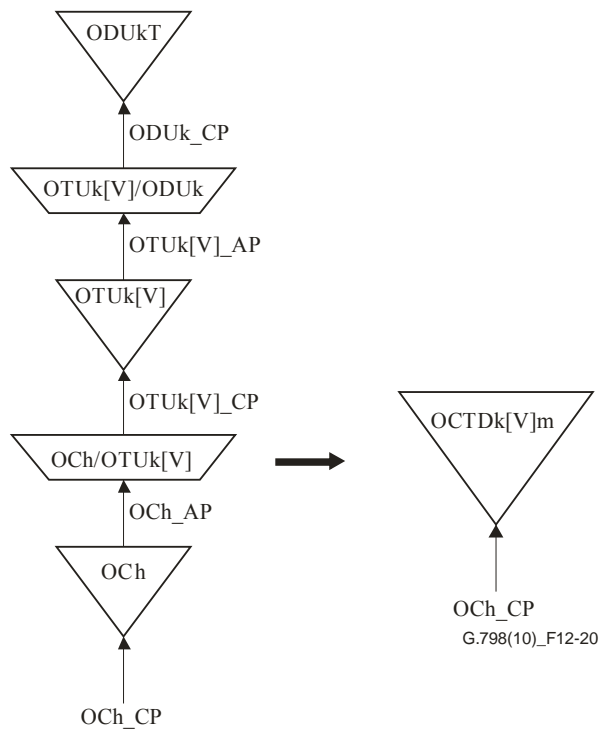

Figure 12-20 – OCTDk[V]m compound function

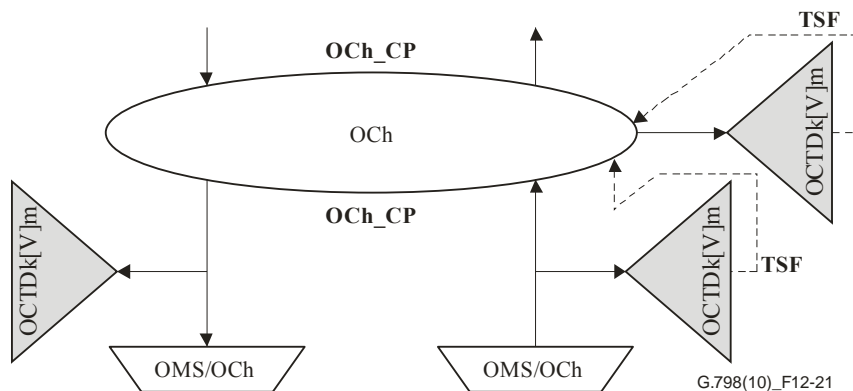

Figure 12-21 – Connection OCTDk[V]m compound function (non-intrusive monitor)

12.3 Adaptation functions

12.3.1 OCh to OTUk adaptation function (OCh/OTUk_A)

The OCh to OTUk adaptation functions perform the adaptation between the OCh layer adapted information and the characteristic information of the completely standardized OTUk layer signal. Three types of functions are defined: one that supports the standardized forward error correction (FEC), one that does not support FEC, and one that supports vendor-specific FEC.

12.3.1.1 OCh to OTUk adaptation source function with FEC (OCh/OTUk-a_A_So)

The information flow and processing of the OCh/OTUk-a_A_So function is defined with reference to Figures 12-22 and 12-23.

Symbol

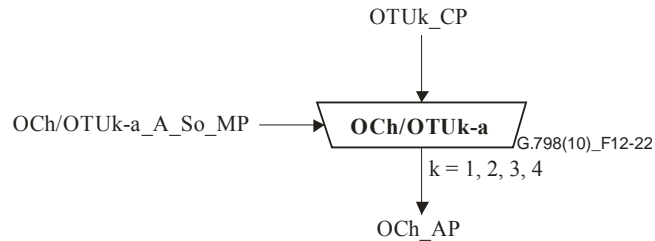

Figure 12-22 – OCh/OTUk-a_A_So function

Interfaces

Table 12-6 – OCh/OTUk-a_A_So inputs and outputs

Input(s)	Output(s)
OTUk_CP: OTUk_CI_CK OTUk_CI_D OTUk_CI_FS OTUk_CI_MFS OCh/OTUk-a_A_So_MP: OCh/OTUk-a_A_So_MI_Active	OCh_AP: OCh_AI_D

Processes

The processes associated with the OCh/OTUk-a_A_So function are as depicted in Figure 12-23.

Activation

- The OCh/OTUk-a_A_So function shall access the access point when it is activated (MI_Active is true). Otherwise, it shall not access the access point.

FAS/MFAS insertion: The function shall insert the FAS and MFAS into the OTUk OH area as described in [ITU-T G.709].

FEC encoder: The function shall generate the RS(255,239) FEC code as defined in Annex A of [ITU-T G.709] and insert it into the OTUk FEC area.

Scrambler: The function shall scramble the signal as defined in clause 11.2 of [ITU-T G.709].

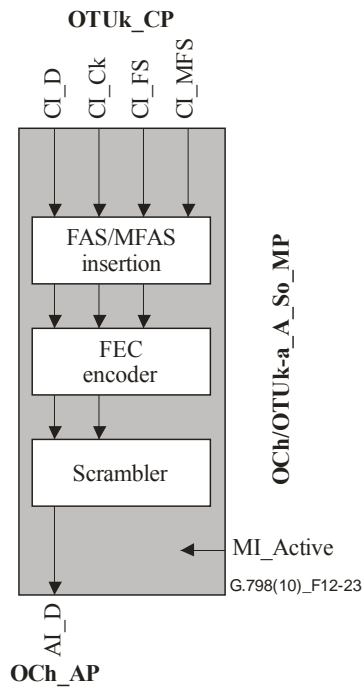

Figure 12-23 – OCh/OTUk-a_A_So processes

Defects: None.

Consequent actions: None.

Defect correlations: None.

Performance monitoring: None.

12.3.1.2 OCh to OTUk adaptation source function without FEC (OCh/OTUk-b_A_So)

The information flow and processing of the OCh/OTUk-b_A_So function is defined with reference to Figures 12-24 and 12-25.

Symbol

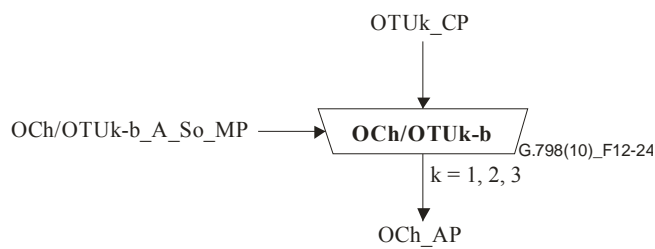

Figure 12-24 – OCh/OTUk-b_A_So function

Interfaces

Table 12-7 – OCh/OTUk-b_A_So inputs and outputs

Input(s)	Output(s)
OTUk_CP: OTUk_CI_CK OTUk_CI_D OTUk_CI_FS OTUk_CI_MFS OCh/OTUk-b_A_So_MP: OCh/OTUk-b_A_So_MI_Active	OCh_AP: OCh_AI_D

Processes

The processes associated with the OCh/OTUk-b_A_So function are as depicted in Figure 12-25.

Activation

- The OCh/OTUk-b_A_So function shall access the access point when it is activated (MI_Active is true). Otherwise, it shall not access the access point.

FAS/MFAS insertion: The function shall insert the FAS and MFAS into the OTUk OH area, as described in [ITU-T G.709].

Scrambler: The function shall scramble the signal as defined in clause 11.2 of [ITU-T G.709].

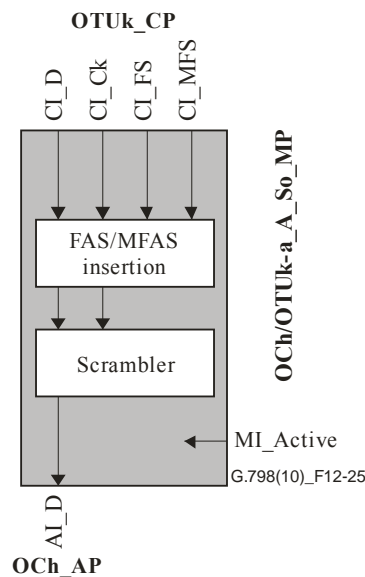

Figure 12-25 – OCh/OTUk-b_A_So processes

Defects: None.

Consequent actions: None.

Defect correlations: None.

Performance monitoring: None.

12.3.1.3 OCh to OTUk adaptation sink function with FEC (OCh/OTUk-a_A_Sk)

The information flow and processing of the OCh/OTUk-a_A_Sk function is defined with reference to Figures 12-26 and 12-27.

Symbol

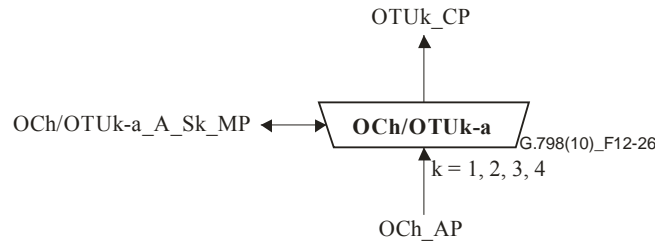

Figure 12-26 – OCh/OTUk-a_A_Sk function

Interfaces

Table 12-8 – OCh/OTUk-a_A_Sk inputs and outputs

Input(s)	Output(s)
OCh_AP: OCh_AI_D OCh_AI_TSF OCh/OTUk-a_A_Sk_MP: OCh/OTUk-a_A_Sk_MI_FECEn OCh/OTUk-a_A_Sk_MI_Active OCh/OTUk-a_A_Sk_MI_1second	OTUk_CP: OTUk_CI_CK OTUk_CI_D OTUk_CI_FS OTUk_CI_MFS OTUk_CI_SSF OCh/OTUk-a_A_Sk_MP: OCh/OTUk-a_A_Sk_MI_cLOF OCh/OTUk-a_A_Sk_MI_cLOM OCh/OTUk-a_A_Sk_MI_pFECcorrErr

Processes

The processes associated with the OCh/OTUk-a_A_Sk function are as depicted in Figure 12-27.

Activation

- The OCh/OTUk-a_A_Sk function shall access the access point and perform the common and specific processes operation specified below when it is activated (MI_Active is true). Otherwise, it shall activate the SSF signals at its output (CP) and not report its status via the management point.

Clock recovery: The function shall recover the OTUk clock signal from the incoming data. The function shall introduce no errors in case of jitter and wander as defined in clause 6 of [ITU-T G.8251].

Frame alignment: The function shall recover the OTUk frame start as described in clause 8.2.1.

Descrambler: The function shall perform descrambling as defined in clause 11.2 of [ITU-T G.709].

FEC decoder: If FEC processing is enabled (MI_FECEn is true), the function shall extract the RS(255,239) FEC data from the OTUk FEC area and perform error correction as defined in Annex A of [ITU-T G.709]. The number of corrected bits shall be reported (nFECcorrErr). Otherwise, the FEC data is ignored and no error correction is performed.

Multiframe alignment: The function shall recover the OTUk multiframe start as described in clause 8.2.2.

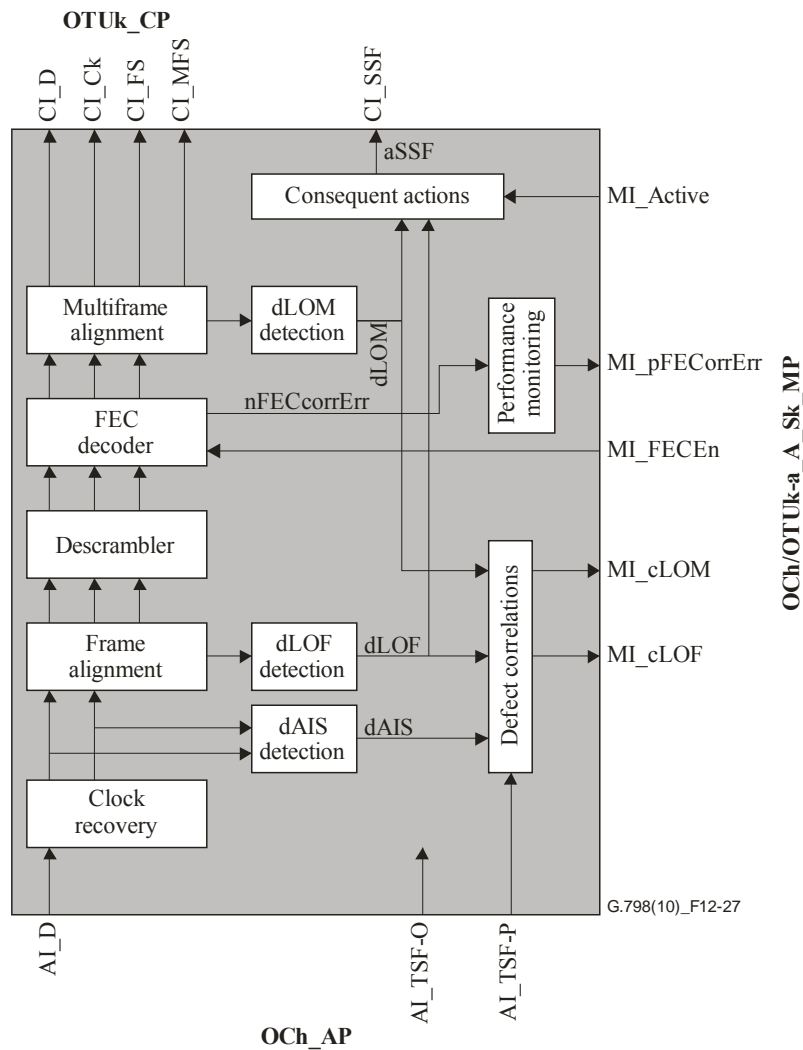

Figure 12-27 – OCh/OTUk-a_A_Sk processes

Defects

The function shall detect for dAIS, dLOF and dLOM.

dAIS: See clause 6.2.6.3.1.

dLOF: See clause 6.2.5.1.

dLOM: See clause 6.2.5.2.

Consequent actions

aSSF ← dAIS or dLOF or dLOM or AI_TSFP or (not MI_Active)

Defect correlations

cLOF ← dLOF and (not dAIS) and (not AI_TSFP)

cLOM ← dLOM and (not dLOF) and (not dAIS) and (not AI_TSFP)

NOTE 1 – dAIS is not reported as fault cause as it is a secondary alarm and will result in aSSF, which is reported as cSSF fault cause in the OTUk_TT_Sk that directly follows this function.

Performance monitoring

The function shall perform the following performance monitoring primitives processing. The performance monitoring primitives shall be reported to the EMF.

$$pFECcorrErr \leftarrow \sum nFECcorrErr$$

NOTE 2 – During AI_TSF-P, dAIS, dLOF and dLOM, no corrected bits shall be counted.

12.3.1.4 OCh to OTUk adaptation sink function without FEC (OCh/OTUk-b_A_Sk)

The information flow and processing of the OCh/OTUk-b_A_Sk function is defined with reference to Figures 12-28 and 12-29.

Symbol

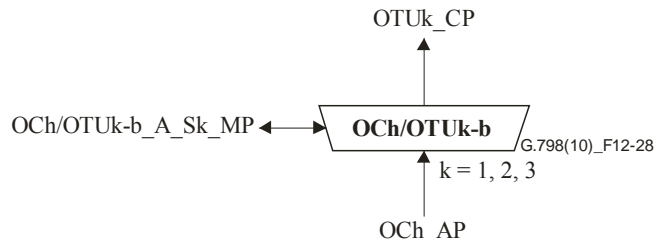

Figure 12-28 – OCh/OTUk-b_A_Sk function

Interfaces

Table 12-9 – OCh/OTUk-b_A_Sk inputs and outputs

Input(s)	Output(s)
OCh_AP: OCh_AI_D OCh_AI_TSF OCh/OTUk-b_A_Sk_MP: OCh/OTUk-b_A_Sk_MI_Active	OTUk_CP: OTUk_CI_CK OTUk_CI_D OTUk_CI_FS OTUk_CI_MFS OTUk_CI_SSF OCh/OTUk-b_A_Sk_MP: OCh/OTUk-b_A_Sk_MI_cLOF OCh/OTUk-b_A_Sk_MI_cLOM

Processes

The processes associated with the OCh/OTUk-b_A_Sk function are as depicted in Figure 12-29.

Activation

- The OCh/OTUk-b_A_Sk function shall access the access point and perform the common and specific processes operation specified below when it is activated (MI_Active is true). Otherwise, it shall activate the SSF signals at its output (CP) and not report its status via the management point.

Clock recovery: The function shall recover the OTUk clock signal from the incoming data. The function shall introduce no errors in case of jitter and wander as defined in clause 6 of [ITU-T G.8251].

Frame alignment: The function shall recover the OTUk frame start as described in clause 8.2.1.

Descrambler: The function shall perform descrambling as defined in clause 11.2 of [ITU-T G.709].

Multiframe alignment: The function shall recover the OTUk multiframe start as described in clause 8.2.2.

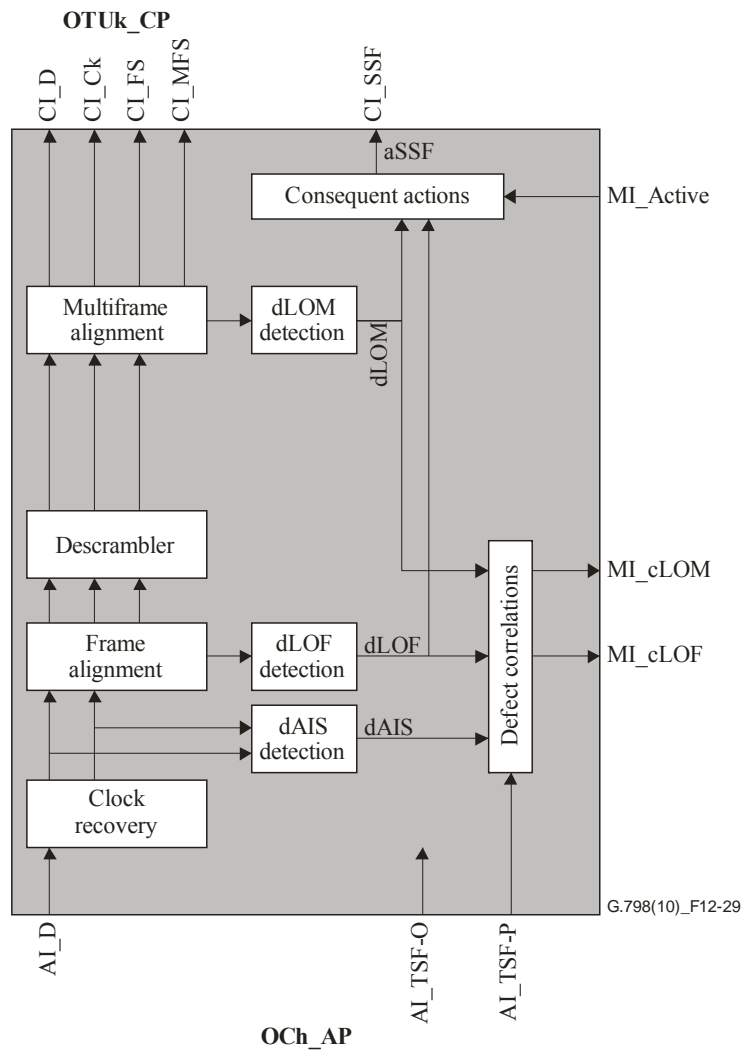

Figure 12-29 – OCh/OTUk-b_A_Sk processes

Defects

The function shall detect for dAIS, dLOF and dLOM.

dAIS: See clause 6.2.6.3.1.

dLOF: See clause 6.2.5.1.

dLOM: See clause 6.2.5.2.

Consequent actions

aSSF ← dAIS or dLOF or dLOM or AI_TSF-P or (not MI_Active)

NOTE – dAIS is not reported as fault cause as it is a secondary alarm and will result in aSSF, which is reported as cSSF fault cause in the OTUk_TT_Sk that directly follows this function.

Defect correlations

cLOF ← dLOF and (not dAIS) and (not AI_TSF-P)

cLOM ← dLOM and (not dLOF) and (not dAIS) and (not AI_TSF-P)

Performance monitoring: None.

12.3.1.5 OCh to OTUk adaptation source function with vendor-specific FEC (OCh/OTUk-v_A_So)

The information flow and processing of the OCh/OTUk-v_A_So function is defined with reference to Figures 12-30 and 12-31.

Symbol

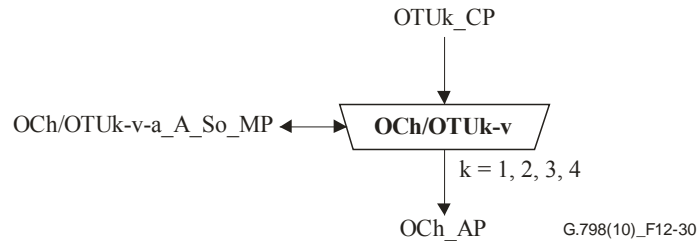

Figure 12-30 – OCh/OTUk-v_A_So function

Interfaces

Table 12-10 – OCh/OTUk-v_A_So inputs and outputs

Input(s)	Output(s)
OTUk_CP: OTUk_CI_CK OTUk_CI_D OTUk_CI_FS OTUk_CI_MFS OCh/OTUk-v_A_So_MP: OCh/OTUk-v_A_So_MI_Active	OCh_AP: OCh_AI_D

Processes

The processes associated with the OCh/OTUk-v_A_So function are as depicted in Figure 12-31.

Activation

- The OCh/OTUk-v_A_So function shall access the access point when it is activated (MI_Active is true). Otherwise, it shall not access the access point.

FAS/MFAS insertion: The function shall insert the FAS and MFAS into the OTUk OH area, as described in [ITU-T G.709].

FEC encoder: The function shall generate the vendor-specific FEC code and insert it into the OTUk FEC area.

Scrambler: The function shall scramble the signal as defined in clause 11.2 of [ITU-T G.709].

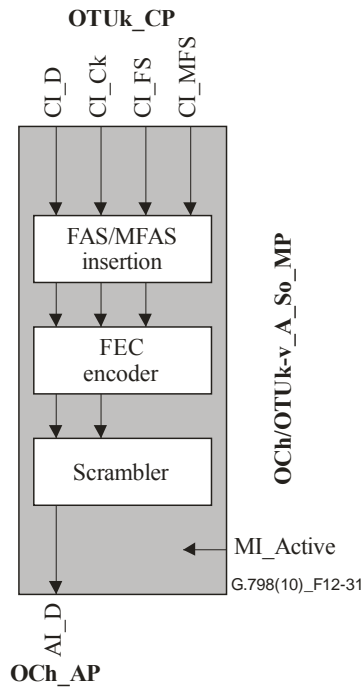

Figure 12-31 – OCh/OTUk-v_A_So processes

Defects: None.

Consequent actions: None.

Defect correlations: None.

Performance monitoring: None.

12.3.1.6 OCh to OTUk adaptation sink function with with vendor-specific FEC (OCh/OTUk-v_A_Sk)

The information flow and processing of the OCh/OTUk-v_A_Sk function is defined with reference to Figures 12-32 and 12-33.

Symbol

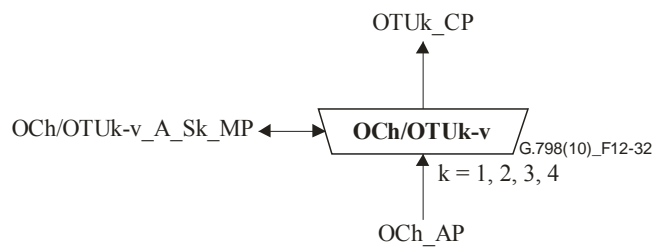

Figure 12-32 – OCh/OTUk-v_A_Sk function

Interfaces

Table 12-11 – OCh/OTUk-v_A_Sk inputs and outputs

Input(s)	Output(s)
OCh_AP: OCh_AI_D OCh_AI_TSF OCh/OTUk-v_A_Sk_MP: OCh/OTUk-v_A_Sk_MI_FECEn OCh/OTUk-v_A_Sk_MI_Active OCh/OTUk-v_A_Sk_MI_1second	OTUk_CP: OTUk_CI_CK OTUk_CI_D OTUk_CI_FS OTUk_CI_MFS OTUk_CI_SSF OCh/OTUk-v_A_Sk_MP: OCh/OTUk-v_A_Sk_MI_cLOF OCh/OTUk-v_A_Sk_MI_cLOM OCh/OTUk-v_A_Sk_MI_pFECcorrErr

Processes

The processes associated with the OCh/OTUk-v_A_Sk function are as depicted in Figure 12-33.

Activation

- The OCh/OTUk-v_A_Sk function shall access the access point and perform the common and specific processes operation specified below when it is activated (MI_Active is true). Otherwise, it shall activate the SSF signals at its output (CP) and not report its status via the management point.

Clock recovery: The function shall recover the OTUk clock signal from the incoming data. The function shall introduce no errors in case of jitter and wander as defined in clause 6 of [ITU-T G.8251].

Frame alignment: The function shall recover the OTUk frame start as described in clause 8.2.1.

Descrambler: The function shall perform descrambling as defined in clause 11.2 of [ITU-T G.709].

FEC decoder: If FEC processing is enabled (MI_FECEn is true), the function shall extract the vendor-specific FEC data from the OTUk FEC area and perform error correction. The number of corrected bits shall be reported (nFECcorrErr). Otherwise, the FEC data is ignored and no error correction is performed.

Multiframe alignment: The function shall recover the OTUk multiframe start as described in clause 8.2.2.

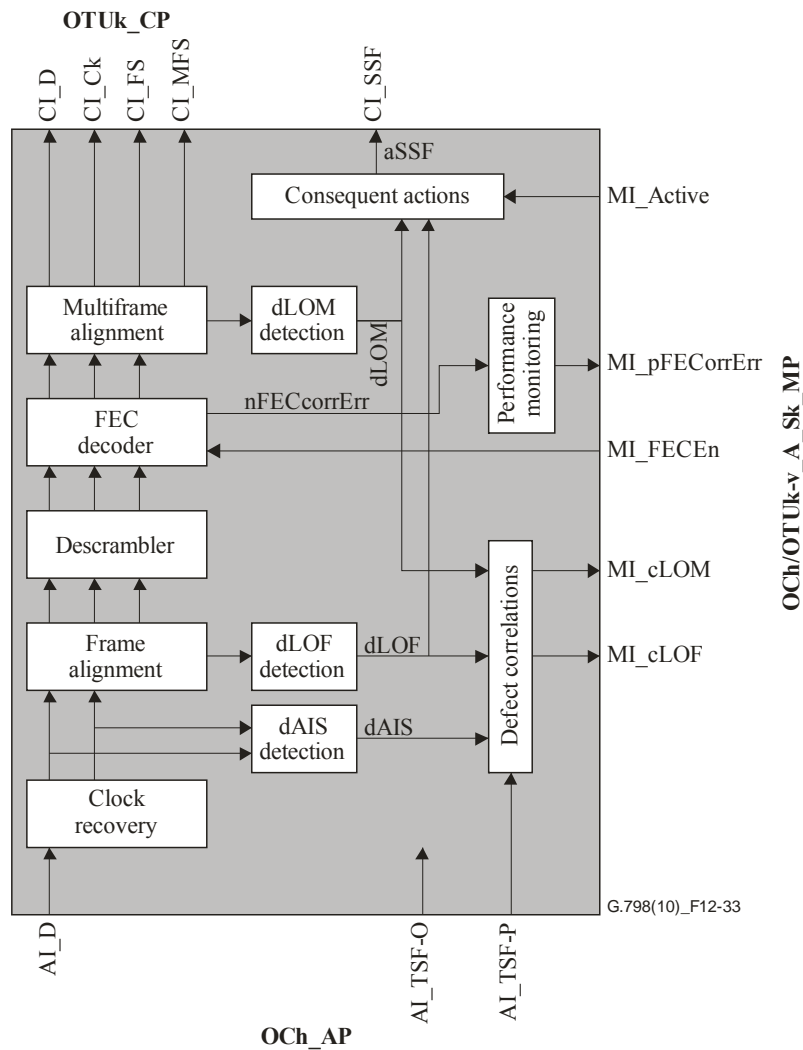

Figure 12-33 – OCh/OTUk-v_A_Sk processes

Defects

The function shall detect for dAIS, dLOF and dLOM.

dAIS: See clause 6.2.6.3.1.

dLOF: See clause 6.2.5.1.

dLOM: See clause 6.2.5.2.

Consequent actions

aSSF ← dAIS or dLOF or dLOM or AI_TSF-P or (not MI_Active)

Defect correlations

cLOF ← dLOF and (not dAIS) and (not AI_TSF-P)

cLOM ← dLOM and (not dLOF) and (not dAIS) and (not AI_TSF-P)

NOTE 1 – dAIS is not reported as fault cause as it is a secondary alarm and will result in aSSF, which is reported as cSSF fault cause in the OTUk_TT_Sk that directly follows this function.

Performance monitoring

The function shall perform the following performance monitoring primitives processing. The performance monitoring primitives shall be reported to the EMF.

$$pFECcorrErr \leftarrow \sum nFECcorrErr$$

NOTE 2 – During AI_TSF-P, dAIS, dLOF and dLOM, no corrected bits shall be counted.

12.3.2 OCh to OTUkV adaptation function (OCh/OTUkV_A)

The OCh to OTUkV adaptation functions perform the adaptation between the OCh layer adapted information and the characteristic information of functionally standardized OTUkV layer signal.

12.3.2.1 OCh to OTUkV adaptation source function (OCh/OTUkV_A_So)

The information flow and processing of the OCh/OTUkV_A_So function is defined with reference to Figure 12-34.

Symbol

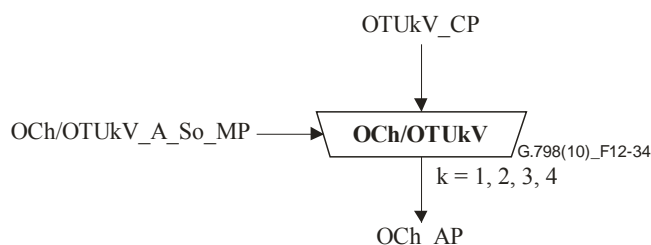

Figure 12-34 – OCh/OTUkV_A_So function

Interfaces

Table 12-12 – OCh/OTUkV_A_So inputs and outputs

Input(s)	Output(s)
OTUkV_CP: OTUkV_CI_CK OTUkV_CI_D OTUkV_CI_FS OTUkV_VI_MFS (Note) OCh/OTUkV_A_So_MP: OCh/OTUkV_A_So_MI_Active	OCh_AP: OCh_AI_D
NOTE – If OTUkV has a multiframe.	

Processes

Activation

- The OCh/OTUkV_A_So function shall access the access point when it is activated (MI_Active is true). Otherwise, it shall not access the access point.

The OCh/OTUkV_A_So function provides all processes necessary for the adaptation to the OCh layer, which includes processes that ensure clock and frame recovery at the adaptation sink and optional forward error correction coding.

The specific processes are outside the scope of this Recommendation.

Defects: None.

Consequent actions: None.

Defect correlations: None.

Performance monitoring: None.

12.3.2.2 OCh to OTUkV adaptation sink function (OCh/OTUkV_A_Sk)

The information flow and processing of the OCh/OTUkV_A_Sk function is defined with reference to Figure 12-35.

Symbol

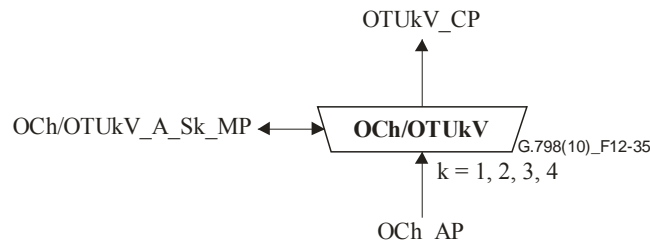

Figure 12-35 – OCh/OTUkV_A_Sk function

Interfaces

Table 12-13 – OCh/OTUkV_A_Sk inputs and outputs

Input(s)	Output(s)
OCh_AP: OCh_AI_D OCh_AI_TSF OCh/OTUkV_A_Sk_MP: OCh/OTUkV_A_Sk_MI_Active OCh/OTUkV_A_Sk_MI_1second (Note 2)	OTUkV_CP: OTUkV_CI_CK OTUkV_CI_D OTUkV_CI_FS OTUkV_CI_MFS (Note 1) OTUk_CI_SSF OCh/OTUkV_A_Sk_MP: OCh/OTUkV_A_Sk_MI_cLOF OCh/OTUkV_A_Sk_MI_cLOM (Note 1) OCh/OTUkV_A_Sk_MI_pFECcorrErr (Note 2)
NOTE 1 – If OTUkV has a multiframe. NOTE 2 – If the function performs FEC.	

Processes

Activation

- The OCh/OTUkV_A_Sk function shall access the access point and perform the common and specific processes operation specified below when it is activated (MI_Active is true). Otherwise, it shall activate the SSF signals at its output (CP) and not report its status via the management point.

The OCh/OTUkV_A_Sk function provides all processes necessary for the adaptation from the OCh layer, which includes processes for clock and frame start recovery and optional forward error correction decoding.

The specific processes are outside the scope of this Recommendation.

Defects

The function shall detect for dAIS and dLOF. If the OTUkV includes a multiframe, it shall in addition detect dLOM.

dAIS: See clause 6.2.6.3.1.

dLOF: The dLOF detection depends on the specific frame structure and is outside the scope of this Recommendation.

dLOM: The dLOM detection is only required if the OTUkV has a multiframe, the detection depends on the specific multiframe structure and is outside the scope of this Recommendation.

Consequent actions:

aSSF ← dAIS or dLOF or AI_TSF-P or dLOM or (not MI_Active)

NOTE 1 – dLOM is only included if the OTUkV has a multiframe.

Defect correlations

cLOF ← dLOF and (not dAIS) and (not AI_TSF-P)

cLOM ← dLOM and (not dLOF) and (not dAIS) and (not AI_TSF-P)

NOTE 2 – cLOM is only defined if the OTUkV has a multiframe.

NOTE 3 – dAIS is not reported as fault cause as it is a secondary alarm and will result in aSSF, which is reported as cSSF fault cause in the ODUk_TT_Sk that directly follows this function.

Performance monitoring

The function shall perform the following performance monitoring primitives processing if it includes FEC processing. The performance monitoring primitives shall be reported to the EMF.

pFECcorrErr ← \sum nFECcorrErr

NOTE 4 – During AI_TSF-P, dAIS, dLOF and dLOM no corrected bits shall be counted.

12.3.3 OCh to CBRx adaptation (OCh/CBRx_A)

The OCh to CBRx adaptation functions perform the adaptation between the OCh layer adapted information and the characteristic information of a CBRx layer signal.

The parameter x defines the supported bit rate or bit-rate range. The values x = 2G5, 10G and 40G are defined for client signals that comply to the SDH bit rates as defined in Table 12-14. Support for other bit rates and bit-rate ranges is for further study.

Table 12-14 – Defined values for x

x	Bit rate	Clock range
2G5	2 488 320 kbit/s ± 20 ppm	2 488 320 kHz ± 20 ppm
10G	9 953 280 kbit/s ± 20 ppm	9 953 280 kHz ± 20 ppm
40G	39 813 120 kbit/s ± 20 ppm	39 813 120 kHz ± 20 ppm

12.3.3.1 OCh to CBRx adaptation source function (OCh/CBRx_A_So); x = 2G5, 10G, 40G

The information flow and processing of the OCh/CBRx_A_So function is defined with reference to Figure 12-36.

Symbol

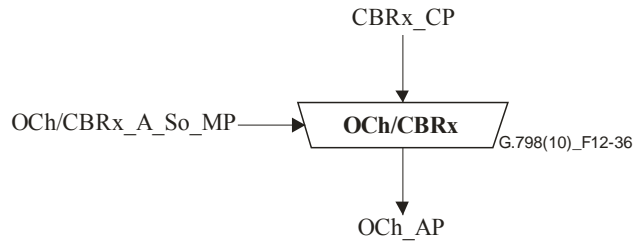

Figure 12-36 – OCh/CBRx_A_So function

Interfaces

Table 12-15 – OCh/CBRx_A_So inputs and outputs

Input(s)	Output(s)
CBRx_CP: CBRx_CI_D CBRx_CI_CK OCh/CBRx_A_So_MP: OCh/CBRx_A_So_MI_Active	OCh_AP: OCh_AI_D

Processes

The function generates the OCh_AI signal from the CBRx_CI.

Activation

- The OCh/CBRx_A_So function shall access the access point when it is activated (MI_Active is true). Otherwise, it shall not access the access point.

For the defined values of x, the jitter and wander requirements, as defined in clause 9.3.1.1 of [ITU-T G.783], apply.

Defects: None.

Consequent actions: None.

Defect correlations: None.

Performance monitoring: None.

12.3.3.2 OCh to CBRx adaptation sink function (OCh/CBRx_A_Sk); x = 2G5, 10G, 40G

The information flow and processing of the OCh/CBRx_A_Sk function is defined with reference to Figures 12-37 and 12-38.

Symbol

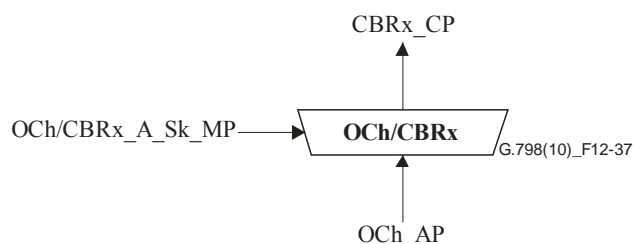

Figure 12-37 – OCh/CBRx_A_Sk function

Interfaces

Table 12-16 – OCh/CBRx_A_Sk inputs and outputs

Input(s)	Output(s)
OCh_AP: OCh_AI_D OCh_AI_TSF OCh/CBRx_A_Sk_MP: OCh/CBRx_A_Sk_MI_Active	CBRx_CP: CBRx_CI_D CBRx_CI_CK CBRx_CI_SSF

Processes

The processes associated with the OCh/CBRx_A_Sk function are depicted in Figure 12-38.

Activation

- The OCh/CBRx_A_Sk function shall access the access point and perform the common and specific processes operation specified below when it is activated (MI_Active is true). Otherwise, it shall activate the SSF signals and generate a generic AIS at its output (CP).

Clock recovery: The function shall recover the clock signal from the incoming data. For the defined values of x, the input clock ranges are defined in Table 12-14 and the jitter and wander requirements, as defined in clause 9.3.1.2 of [ITU-T G.783], apply.

To ensure adequate immunity against the presence of consecutive identical digits (CID) in the signal, the function shall comply with the specification in clause 15.1.4 of [ITU-T G.783].

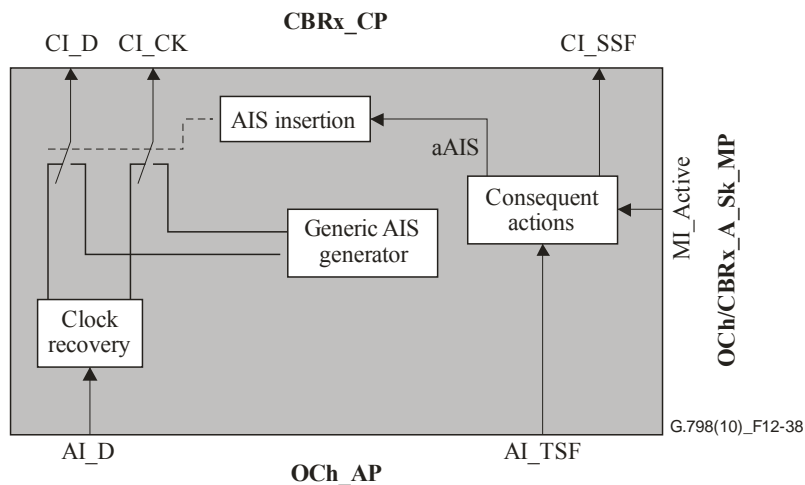

Figure 12-38 – OCh/CBRx_A_Sk processes

Defects: None.

Consequent actions

The OCh/CBRx_A_Sk function performs the following consequent actions:

- aSSF ← AI_TSF or (not MI_Active)
- aAIS ← AI_TSF or (not MI_Active)

On declaration of aAIS, the function shall output a GenericAIS pattern/signal as defined in clause 16.6 of [ITU-T G.709] within X ms. On clearing of aAIS, the GenericAIS pattern/signal shall be removed within Y ms, with normal data being output. The values for X and Y are for further study.

The GenericAIS clock start shall be independent from the incoming clock. The GenericAIS clock has to be within the range defined in Table 12-14.

Defect correlations: None.

Performance monitoring: None.

12.3.4 OCh to GbE adaptation function (OCh/GbE_A)

For further study.

12.3.5 OCh to RSn adaptation (OCh/RSn_A)

The OCh to RSn adaptation functions perform the adaptation between the OCh layer adapted information and the characteristic information of a RSn layer signal.

NOTE – The source function is identical to the OCh/CBRx adaptation source functions except for the different CI at the CP (CBRx_CI replaced by RSn_CI). In the sink direction, the function provides framing on the SDH signal and GenericAIS supervision. In the OCh/CBR_A_Sk function, no such functionality is available.

12.3.5.1 OCh to RSn adaptation source function (OCh/RSn_A_So)

The information flow and processing of the OCh/RSn_A_So function is defined with reference to Figure 12-39.

Symbol

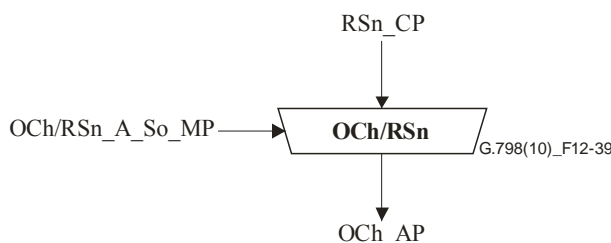

Figure 12-39 – OCh/RSn_A_So function

Interfaces

Table 12-17 – OCh/RSn_A_So inputs and outputs

Input(s)	Output(s)
RSn_CP: RSn_CI_D RSn_CI_CK OCh/RSn_A_So_MP: OCh/RSn_A_So_MI_Active	OCh_AP: OCh_AI_D

Processes

The function generates the OCh_AI signal from the RSn_CI.

Activation

- The OCh/RSn_A_So function shall access the access point when it is activated (MI_Active is true). Otherwise, it shall not access the access point.

The jitter and wander requirements, as defined in clause 9.3.1.1 of [ITU-T G.783], apply.

Defects: None.

Consequent actions: None.

Defect correlations: None.

Performance monitoring: None.

12.3.5.2 OCh to RSn adaptation sink function (OCh/RSn_A_Sk)

The information flow and processing of the OCh/RSn_A_Sk function is defined with reference to Figures 12-40 and 12-41.

Symbol

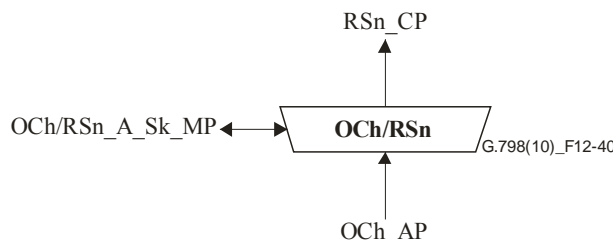

Figure 12-40 – OCh/RSn_A_Sk function

Interfaces

Table 12-18 – OCh/RSn_A_Sk inputs and outputs

Input(s)	Output(s)
OCh_AP: OCh_AI_D OCh_AI_TSF OCh/RSn_A_Sk_MP: OCh/RSn_A_Sk_MI_Active	RSn_CP: RSn_CI_D RSn_CI_CK RSn_CI_FS RSn_CI_SSF OCh/RSn_A_Sk_MP: OCh/RSn_A_Sk_MI_cLOF

Processes

The processes associated with the OCh/RSn_A_Sk function are depicted in Figure 12-41.

Activation

- The OCh/RSn_A_Sk function shall access the access point and perform the common and specific processes operation specified below when it is activated (MI_Active is true). Otherwise, it shall activate the SSF signals and generate AIS at its output (CP) and not report its status via the management point.

Clock recovery: The function shall recover the RSn clock signal from the incoming data. The supported input clock range is $N \times 155\,520 \text{ kbit/s} \pm 20 \text{ ppm}$.

To ensure adequate immunity against the presence of consecutive identical digits (CID) in the STM-N signal, the function shall comply with the specification in clause 15.1.4 of [ITU-T G.783].

The function shall process the signal such that in the absence of input jitter, the intrinsic jitter at the STM-N output interface shall not exceed the values specified in clause 15.1.2 of [ITU-T G.783].

The function shall process the signal such that the jitter transfer shall be as specified in clause 15.1.3 of [ITU-T G.783].

Frame alignment: The function shall perform frame alignment on the STM-N frame as described in clause 8.2.1 of [ITU-T G.783].

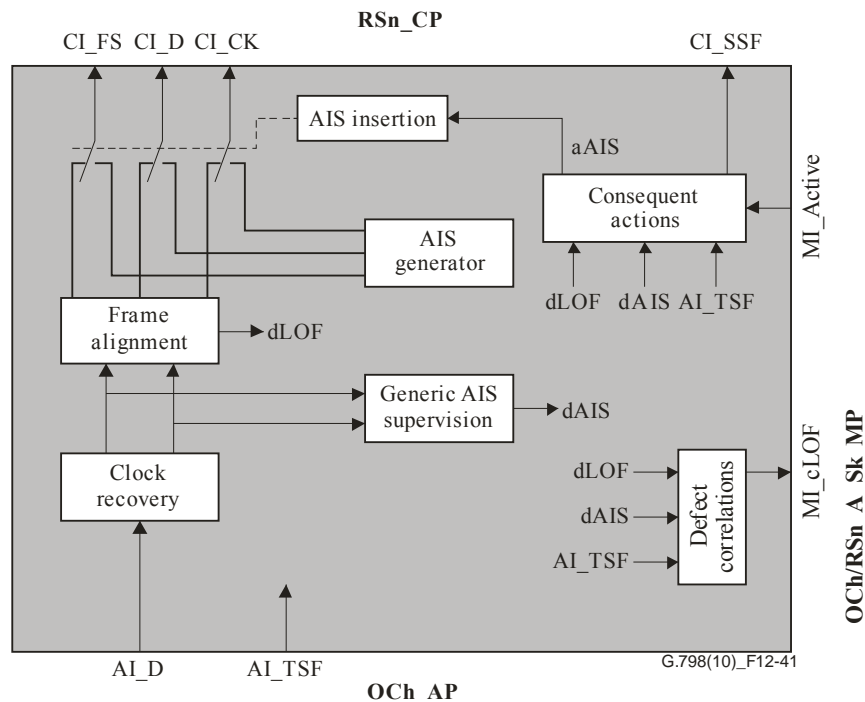

Figure 12-41 – OCh/RSn_A_Sk processes

Defects

The function shall detect for the dAIS and dLOF.

dAIS: See clause 6.2.6.3.3.

dLOF: See clause 6.2.5.1 of [ITU-T G.783].

Consequent actions

aSSF ← AI_TSF or dAIS or dLOF or (not MI_Active)

aAIS ← AI_TSF or dAIS or dLOF or (not MI_Active)

On declaration of aAIS, the function shall output a logical all-ONES (AIS) signal within two STM-N frames. On clearing of aAIS, the logical all-ONES (AIS) signal shall be removed within two STM-N frames, with normal data being output. The AIS clock start shall be independent from the incoming clock. The AIS clock has to be within $N \times 155\,520\text{ kbit/s} \pm 20\text{ ppm}$. Jitter and wander requirements are for further study.

Defect correlations

cLOF ← LOF and (not dAIS) and (not AI_TSF)

NOTE – dAIS is not reported as fault cause as it is a secondary alarm and will result in aSSF, which is reported as cSSF fault cause in the RSn_TT_Sk that directly follows this function.

Performance monitoring: None.

12.3.6 COMMS adaptation function (OCh/COMMS_A)

For further study.

12.4 Layer functions

Not applicable.

13 OTU (layer) functions

A completely standardized OTUk and functionally standardized OTUkV are defined. Figure 13-1 illustrates the OTUk[V] layer network and client layer adaptation functions. The information crossing the OTUk[V] (trail) connection point (OTUk[V]_CP/TCP) is referred to as the OTUk[V] characteristic information (OTUk[V]_CI). The information crossing the OTUk[V] access point (OTUk[V]_AP) is referred to as the OTUk[V] adapted information (OTUk[V]_AI).

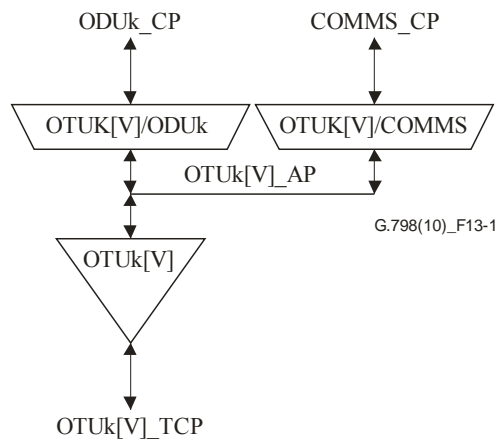

Figure 13-1 – OTUk[V] layer network and client layer adaptation functions

The OTUk characteristic information (OTUk_CI) is the unscrambled OTUk frame without FEC code and the defined SM, GCC0 and RES overhead as shown in Figure 13-2, together with a frame and multiframe start. The GCC0 overhead is optional and set to all-ZEROS if not used. The RES overhead is set to all-ZEROS.

		Column#																
		1	2	3	4	5	6	7	8	9	10	11	12	13	14	15	16	
Row #	1								SM		GCC0		RES		OPUk overhead			
	2	ODUk overhead																
	3																	
	4																	

G.798(10)_F13-2

Figure 13-2 – OTUk overhead at the OTUk_CP/TCP

The OTUkV characteristic information (OTUkV_CI) is the OTUkV frame with valid SM and GCC0 overhead. The OTUkV frame format is outside the scope of this Recommendation.

The OTUk adapted information (OTUk_AI) consists of the ODUk_CI adapted to the OTUk frame, together with a frame and multiframe start. In case of COMMS access at the OTUk_AP, it includes also the OTUk GCC overhead (GCC0).

The OTUkV adapted information (OTUkV_AI) consists of the ODUk_CI adapted to the OTUkV frame. The OTUkV frame format and the ODUk_CI mapping are outside the scope of this Recommendation. In case of COMMS access at the OTUkV_AP, it includes also the OTUkV GCC overhead.

13.1 Connection functions

Not applicable.

13.2 Termination functions

13.2.1 OTUk trail termination function (OTUk_TT)

The OTUk_TT function terminates the section monitoring (SM) overhead of the OTUk overhead to determine the status of the OTUk trail. Figure 13-3 shows the combination of the unidirectional sink and source functions to form a bidirectional function.

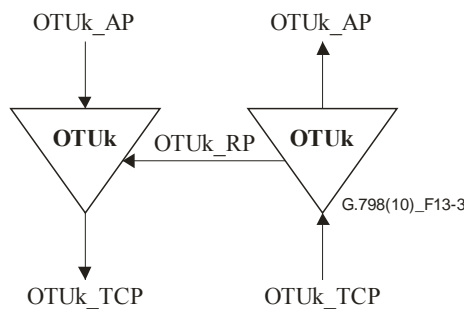

Figure 13-3 – OTUk_TT

13.2.1.1 OTUk trail termination source function (OTUk_TT_So)

The OTUk_TT_So function computes the BIP8 and adds section monitoring overhead (SMOH) – including the TTI, BIP8, BDI, BEI and IAE signals – in the SM overhead field to the OTUk signal at its OTUk_AP.

The information flow and processing of the OTUk_TT_So function is defined with reference to Figures 13-4 and 13-5.

Symbol

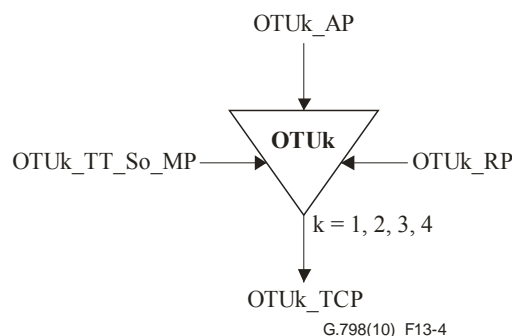

Figure 13-4 – OTUk_TT_So function

Interfaces

Table 13-1 – OTUk_TT_So inputs and outputs

Input(s)	Output(s)
OTUk_AP: OTUk_AI_CK OTUk_AI_D OTUk_AI_FS OTUk_AI_MFS OTUk_AI_IAE OTUk_RP: OTUk_RI_BDI OTUk_RI_BEI OTUk_RI_BIAE OTUk_TT_So_MP: OTUk_TT_So_MI_TxTI	OTUk_TCP: OTUk_CI_CK OTUk_CI_D OTUk_CI_FS OTUk_CI_MFS

Processes

The processes associated with the OTUk_TT_So function are as depicted in Figure 13-5.

SMOH-TTI: The trail trace identifier is inserted in the TTI byte position of the SM field. Its value is derived from reference point OTUk_TT_So_MP. The trail trace format is described in clause 15.2 of [ITU-T G.709].

SMOH-BDI: The backward defect indication is inserted in the BDI bit position of the SM field. Its value is derived from reference point OTUk_RP. Upon the declaration/clearing of aBDI at the termination sink function, the trail termination source function shall have inserted/removed the BDI indication within 50 ms.

SMOH-BEI/BIAE: If RI_BIAE is true, the value "1011" is inserted into the BEI/BIAE bits of the SM field. If RI_BIAE is false, the number of errors indicated in RI_BEI is encoded in the BEI/BIAE bits of the SM field. Upon the detection of incoming alignment error or a number of errors at the termination sink function, the trail termination source function shall have inserted the value in the BEI/BIAE bits within 50 ms.

SMOH-BIP8: See clause 8.3.4.1. The calculated BIP8 is inserted into the BIP8 byte of the SM field.

SMOH-IAE: The incoming alignment error information AI_IAE is inserted into the IAE bit position of the SM field. Upon the declaration of AI_IAE, the function shall insert the IAE indication for the next 16 multiframes (16 × 256 frames). Each new declaration of AI_IAE restarts the 16 multiframe insertion time.

SMOH-RES: The RES field is reserved for future international standardization. The value shall be fixed to 00.

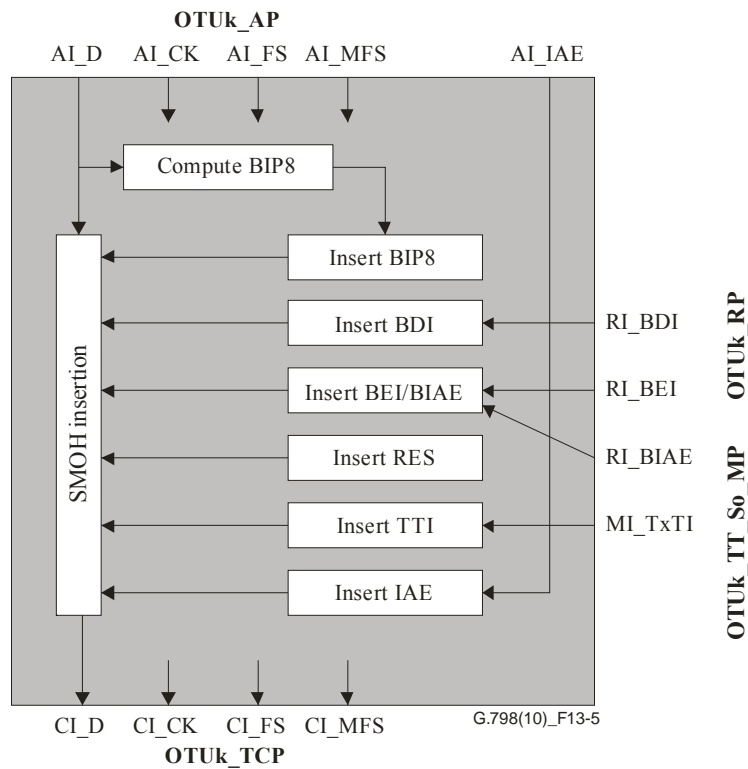

Figure 13-5 – OTUk_TT_So processes

Defects: None.

Consequent actions: None.

Defect correlations: None.

Performance monitoring: None.

13.2.1.2 OTUk trail termination sink function (OTUk_TT_Sk)

The OTUk_TT_Sk function reports the state of the OTUk trail. It computes the BIP8, extracts section monitoring overhead (SMOH) – including the TTI, BIP8, IAE, BDI and BEI signals – in the SM overhead field from the OTUk signal at its OTUk_TCP, detects for TIM, DEG and BDI defects, counts during one-second periods errors (detected via the BIP8) and defects to feed PM when connected, makes the TTI available to network management, and forwards the error and defect information as backward indications to the companion OTUk_TT_So function.

The information flow and processing of the OTUk_TT_Sk function is defined with reference to Figures 13-6 and 13-7.

Symbol

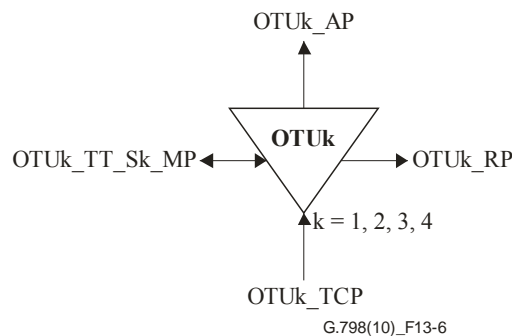

Figure 13-6 – OTUk_TT_Sk function

Interfaces

Table 13-2 – OTUk_TT_Sk inputs and outputs

Input(s)	Output(s)
OTUk_TCP: OTUk_CI_CK OTUk_CI_D OTUk_CI_FS OTUk_CI_MFS OTUk_CI_SSF OTUk_TT_Sk_MP: OTUk_TT_Sk_MI_ExSAPI OTUk_TT_Sk_MI_ExDAPI OTUk_TT_Sk_MI_GetAcTI OTUk_TT_Sk_MI_TIMDetMo OTUk_TT_Sk_MI_TIMActDis OTUk_TT_Sk_MI_DEGThr OTUk_TT_Sk_MI_DEGM OTUk_TT_Sk_MI_1second	OTUk_AP: OTUk_AI_CK OTUk_AI_D OTUk_AI_FS OTUk_AI_MFS OTUk_AI_TSF OTUk_AI_TSD OTUk_RP: OTUk_RI_BDI OTUk_RI_BEI OTUk_RI_BIAE OTUk_TT_Sk_MP: OTUk_TT_Sk_MI_AcTI OTUk_TT_Sk_MI_cTIM OTUk_TT_Sk_MI_cDEG OTUk_TT_Sk_MI_cBDI OTUk_TT_Sk_MI_cSSF OTUk_TT_Sk_MI_pN_EBC OTUk_TT_Sk_MI_pN_DS OTUk_TT_Sk_MI_pF_EBC OTUk_TT_Sk_MI_pF_DS OTUk_TT_Sk_MI_pBIAE OTUk_TT_Sk_MI_pIAE

Processes

The processes associated with the OTUk_TT_Sk function are as depicted in Figure 13-7.

SMOH-BIP8: See clause 8.3.4.2. The BIP8 is extracted from the BIP8 byte of the SM field.

SMOH-TTI: The trail trace identifier shall be recovered from the TTI byte position of the SM field as defined in clause 8.6. The accepted value of the TTI is available at the MP (MI_AcTI).

SMOH-BDI: The backward defect indication shall be recovered from the BDI bit position of the SM field. It shall be used for BDI defect detection.

SMOH-BEI/BIAE: The BEI shall be recovered from the BEI/BIAE bits in the SM field. It shall be used to determine if a far-end errored block (nF_B) has occurred. A nF_B has occurred if the BEI/BIAE value is between 1 [0001] and 8 [1000]; otherwise, no nF_B has occurred.

SMOH-IAE: The incoming alignment error information shall be recovered from IAE bit position of the SM field. It shall be used for IAE defect detection.

SMOH-RES: RES in the SM field in the OTUk signal at the OTUk_TCP is reserved for future international standardization. For this version of this Recommendation, its value shall be ignored.

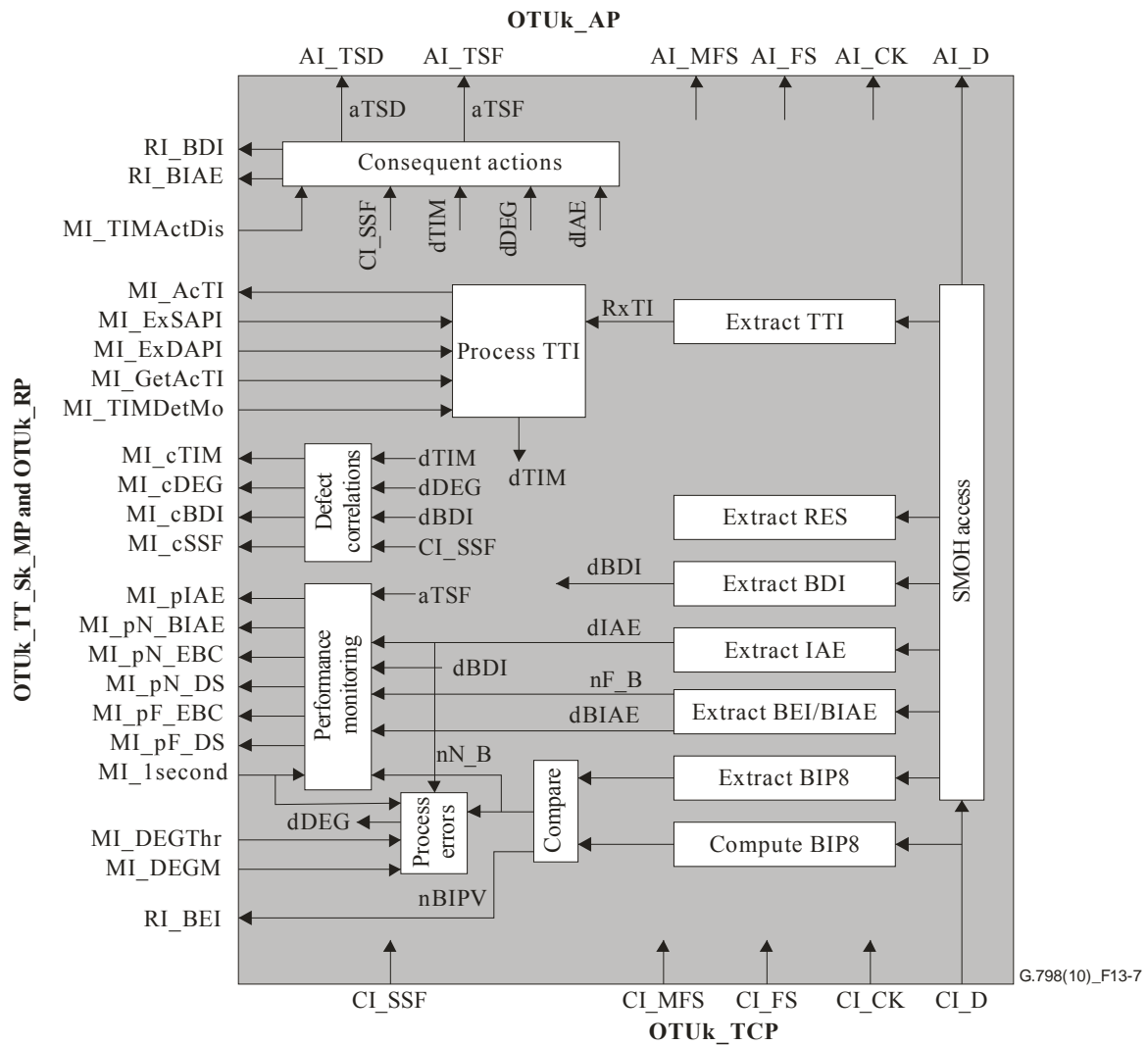

Figure 13-7 – OTUk_TT_Sk processes

Defects

The function shall detect for dTIM, dDEG, dBDI, dBIAE and dIAE defects.

dTIM: See clause 6.2.2.1; dTIM shall be set to false during CI_SSF.

dDEG: See clause 6.2.3.4.

NOTE 1 – IAE suppresses the one-second near-end errored block count, which is the input for the dDEG detection. This avoids wrong dDEG declaration due to alignment errors already incoming in an OTUk trail.

dBDI: See clause 6.2.6.6.1; dBDI shall be set to false during CI_SSF.

dIAE: See clause 6.2.6.10.1; dIAE shall be set to false during CI_SSF and dTIM.

dBIAE: See clause 6.2.6.11.1; dBIAE shall be set to false during CI_SSF and dTIM.

Consequent actions

The function shall perform the following consequent actions:

- aBDI ← CI_SSF or dTIM
- aBEI ← nBIPV
- aBIAE ← dIAE
- aTSF ← CI_SSF or (dTIM and (not TIMActDis))

aTSD ← dDEG

Defect correlations

The function shall perform the following defect correlations to determine the most probable fault cause. This fault cause shall be reported to the EMF.

cTIM ← dTIM and (not CI_SSF)

cDEG ← dDEG and (not CI_SSF) and (not (dTIM and (not TIMActDis)))

cBDI ← dBDI and (not CI_SSF) and (not (dTIM and (not TIMActDis)))

cSSF ← CI_SSF

Performance monitoring

The function shall perform the following performance monitoring primitives processing. The performance monitoring primitives shall be reported to the EMF.

pN_DS ← CI_SSF or dTIM

pF_DS ← dBDI

pN_EBC ← \sum nN_B

NOTE 2 – During CI_SSF, no errored blocks shall be counted.

pF_EBC ← \sum nF_B

NOTE 3 – During CI_SSF, no errored blocks shall be counted.

pBIAE ← dBIAE

NOTE 4 – pBIAE is activated at the end of a second if dBIAE was active once during the second.

pIAE ← dIAE

NOTE 5 – pIAE is activated at the end of a second if dIAE was active once during the second.

NOTE 6 – pIAE and pBIAE are used for the suppression of the PM data in the equipment management functions (see [ITU-T G.874]). If pBIAE is active, the F_DS and F_EBC values of the previous and current second have to be discarded (EBC = 0 and DS = false). If pIAE is active, the N/F_DS and N/F_EBC values of the previous and current second have to be discarded (EBC = 0 and DS = false). The previous second has to be included due to the delay of the IAE information coming from the remote source.

13.2.2 OTUkV trail termination function (OTUkV_TT)

The OTUkV_TT function terminates the section monitoring (SM) overhead of the OTUkV overhead to determine the status of the OTUkV trail. Figure 13-8 shows the combination of the unidirectional sink and source functions to form a bidirectional function.

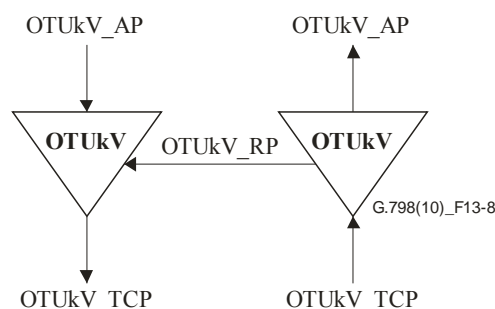

Figure 13-8 – OTUkV_TT

13.2.2.1 OTUkV trail termination source function (OTUkV_TT_So)

The OTUkV_TT_So function computes the signal quality supervision code and adds section monitoring overhead (SMOH) – including the TTI, signal quality supervision code, BDI, BEI signals – in the SM overhead to the OTUkV signal at its OTUkV_AP. In case of frame synchronous mapping of the ODUk client signal, an IAE signal has to be added to the SM overhead.

The information flow and processing of the OTUkV_TT_So function is defined with reference to Figures 13-9 and 13-10.

Symbol

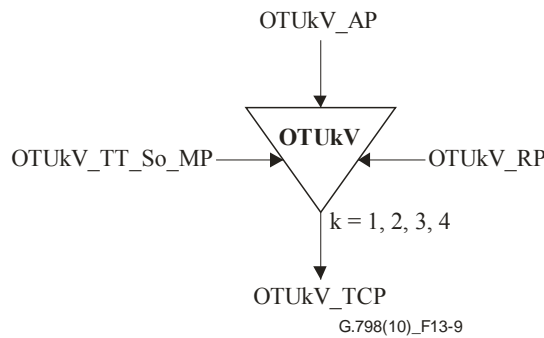

Figure 13-9 – OTUkV_TT_So function

Interfaces

Table 13-3 – OTUkV_TT_So inputs and outputs

Input(s)	Output(s)
OTUkV_AP: OTUkV_AI_CK OTUkV_AI_D OTUkV_AI_FS OTUkV_AI_MFS (Note 1) OTUkV_AI_IAE (Note 2) OTUkV_RP: OTUkV_RI_BDI OTUkV_RI_BEI OTUkV_RI_BIAE (Note 2) OTUkV_TT_So_MP: OTUkV_TT_So_MI_TxTI	OTUkV_TCP: OTUkV_CI_CK OTUkV_CI_D OTUkV_CI_FS OTUkV_CI_MFS (Note 1)
NOTE 1 – If OTUkV has a multiframe. NOTE 2 – In case of frame synchronous mapping of ODUk client signal.	

Processes

The processes associated with the OTUkV_TT_So function are as depicted in Figure 13-10.

SMOH-TTI: The trail trace identifier is inserted in the TTI byte position of the SM field. Its value is derived from reference point OTUkV_TT_So_MP. The trail trace format is described in clause 15.2 of [ITU-T G.709].

SMOH-BDI: The backward defect indication is inserted in the BDI field of the SMOH. Its value is derived from reference point OTUkV_RP. Upon the declaration/clearing of aBDI at the termination sink function, the trail termination source function shall have inserted/removed the BDI indication within 50 ms. The BDI coding is outside the scope of this Recommendation.

SMOH-BEI: The number of errors indicated in RI_BEI is encoded in the BEI field of the SMOH. Upon the detection of a number of errors at the termination sink function, the trail termination source function shall have inserted that value in the BEI bits within 50 ms. The BEI coding is outside the scope of this Recommendation.

SMOH-signal quality supervision: The calculated signal quality supervision code is inserted into the signal quality supervision field of the SMOH. The signal supervision code is outside the scope of this Recommendation.

SMOH-IAE: If a frame synchronous mapping for the ODUk is used, the incoming alignment error information AI_IAE is inserted into the IAE field of the SMOH. Upon the declaration of AI_IAE, the function shall insert the IAE indication for the next 16 multiframes. Each new declaration of AI_IAE restarts the 16 multiframe insertion time. The IAE coding is outside the scope of this Recommendation.

SMOH-BIAE: If a frame synchronous mapping for the ODUk is used, the backward incoming error information RI_BIAE is inserted into the BIAE field of the SMOH. Upon the detection of the incoming alignment error at the termination sink function, the trail termination source function shall have inserted that value in the BIAE fields within 50 ms. The BIAE coding is outside the scope of this Recommendation.

The format of the OTUkV frame and overhead is outside the scope of this Recommendation.

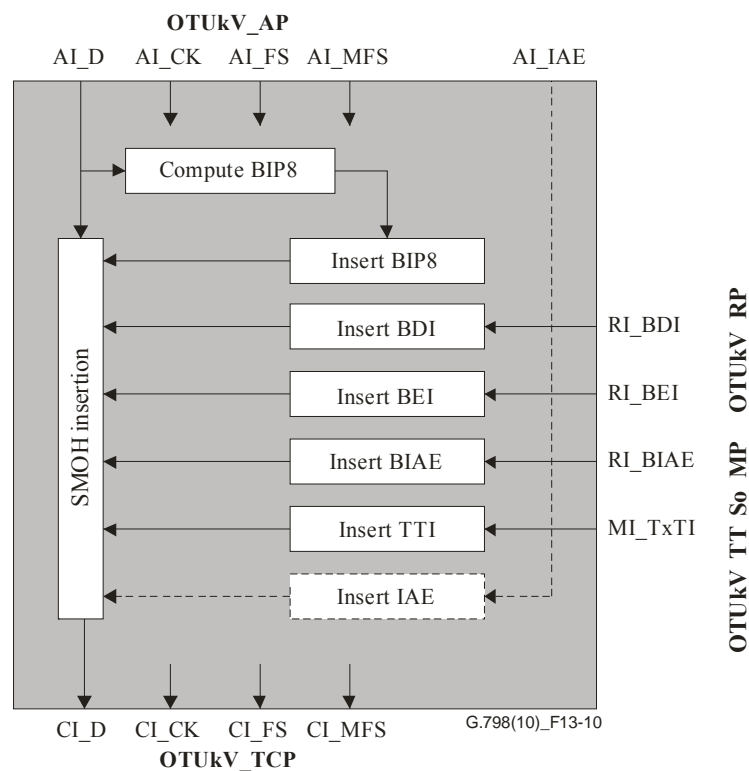

Figure 13-10 – OTUkV_TT_So processes

Defects: None.

Consequent actions: None.

Defect correlations: None.

Performance monitoring: None.

13.2.2.2 OTUkV trail termination sink function (OTUkV_TT_Sk)

The OTUkV_TT_Sk function reports the state of the OTUkV trail. It computes the signal quality supervision code, extracts section monitoring overhead (SMOH) – including the TTI, signal quality supervision, BDI and BEI signals – in the SM overhead field from the OTUkV signal at its OTUkV_TCP, detects for TIM, DEG and BDI defects, counts during one-second periods errors (detected via the signal quality supervision) and defects to feed PM when connected, makes the TTI available to network management, and forwards the error and defect information as backward indications to the companion OTUkV_TT_So function. In case of frame synchronous mapping of the ODUk client signal, an IAE signal has to be extracted from the SM overhead.

The information flow and processing of the OTUkV_TT_Sk function is defined with reference to Figures 13-11 and 13-12.

Symbol

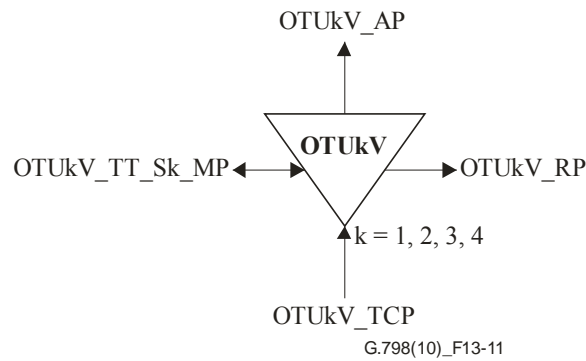

Figure 13-11 – OTUkV_TT_Sk function

Interfaces

Table 13-4 – OTUkV_TT_Sk inputs and outputs

Input(s)	Output(s)
OTUkV_TCP: OTUkV_CI_CK OTUkV_CI_D OTUkV_CI_FS OTUkV_CI_MFS (Note 1) OTUkV_CI_SSF OTUkV_TT_Sk_MP: OTUkV_TT_Sk_MI_ExSAPI OTUkV_TT_Sk_MI_ExDAPI OTUkV_TT_Sk_MI_GetAcTI OTUkV_TT_Sk_MI_TIMDetMo OTUkV_TT_Sk_MI_TIMActDis OTUkV_TT_Sk_MI_DEGThr OTUkV_TT_Sk_MI_DEGM OTUkV_TT_Sk_MI_1second	OTUkV_AP: OTUkV_AI_CK OTUkV_AI_D OTUkV_AI_FS OTUkV_AI_MFS (Note 1) OTUkV_AI_TSF OTUkV_AI_TSD OTUkV_RP: OTUkV_RI_BDI OTUkV_RI_BEI OTUkV_RI_BIAE (Note 2) OTUkV_TT_Sk_MP: OTUkV_TT_Sk_MI_AcTI OTUkV_TT_Sk_MI_cTIM OTUkV_TT_Sk_MI_cDEG OTUkV_TT_Sk_MI_cBDI OTUkV_TT_Sk_MI_cSSF OTUkV_TT_Sk_MI_pN_EBC OTUkV_TT_Sk_MI_pN_DS OTUkV_TT_Sk_MI_pF_EBC OTUkV_TT_Sk_MI_pF_DS OTUkV_TT_Sk_MI_pBIAE (Note 2) OTUkV_TT_Sk_MI_pIAE (Note 2)
NOTE 1 – If OTUkV has a multiframe.	
NOTE 2 – In case of frame synchronous mapping of ODUk client signal.	

Processes

The processes associated with the OTUkV_TT_Sk function are as depicted in Figure 13-12.

SMOH-signal quality supervision: The signal quality supervision code is extracted from the signal quality field of the SMOH. The signal supervision code is outside the scope of this Recommendation.

SMOH-TTI: The trail trace identifier shall be recovered from TTI field of the SMOH as defined in clause 8.6. The accepted value of the TTI is available at the MP (MI_AcTI).

SMOH-BDI: The backward defect indication shall be recovered from BDI field of the SMOH. It shall be used for BDI defect detection. The BDI code is outside the scope of this Recommendation.

SMOH-BEI: The BEI shall be recovered from the BEI field in the SMOH. It shall be used to determine if a far-end errored block (nF_B) has occurred. The BEI code is outside the scope of this Recommendation.

SMOH-IAE: If a frame synchronous mapping for the ODUk client layer is used, the incoming alignment error information shall be recovered from the IAE field of the SMOH. It shall be used for IAE defect detection. The IAE code is outside the scope of this Recommendation.

The format of the OTUkV frame and overhead is outside the scope of this Recommendation.

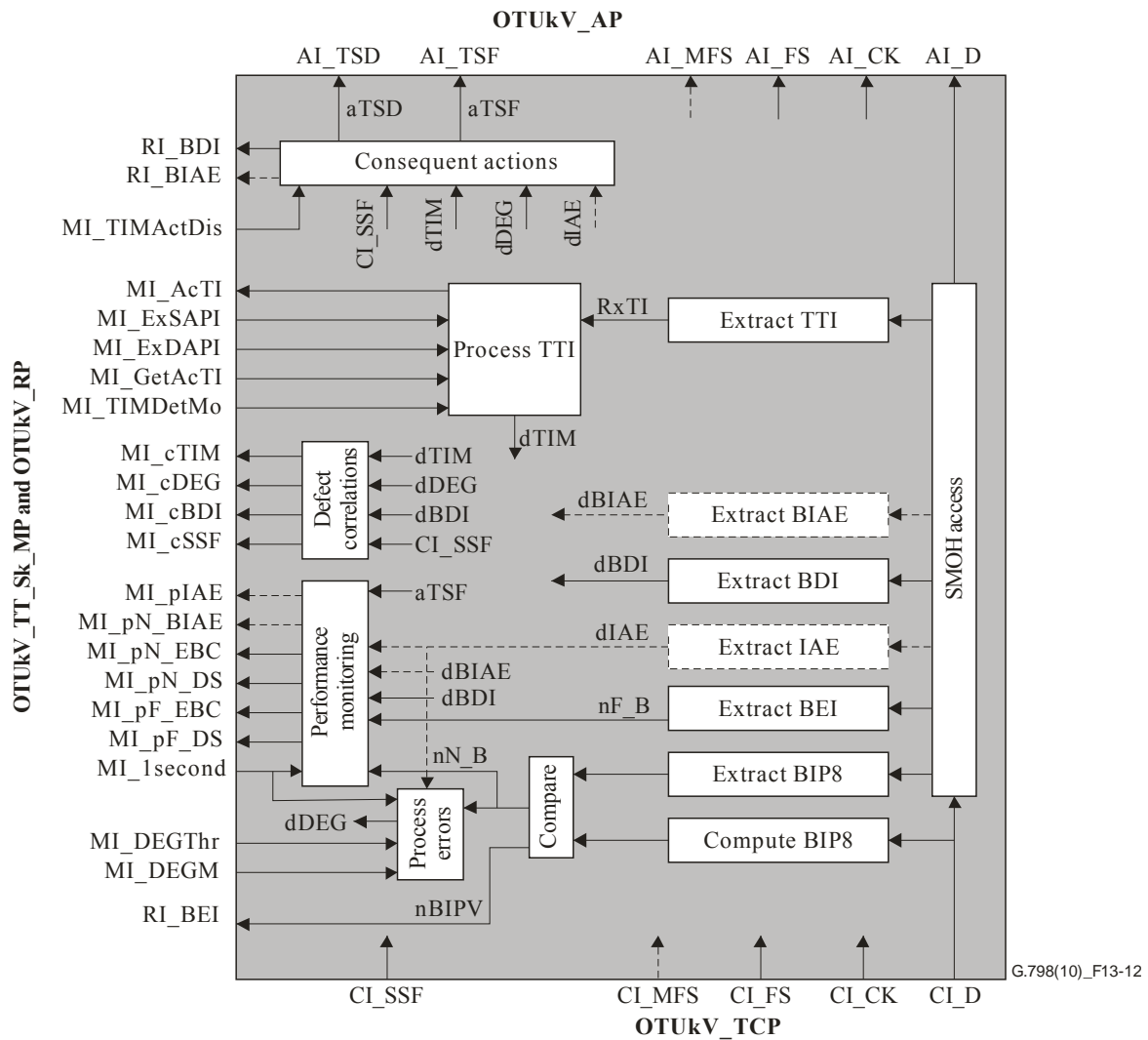

Figure 13-12 – OTUkV_TT_Sk processes

Defects

The function shall detect for dTIM, dDEG, dBDI and, if a frame synchronous mapping for the ODUk client layer is used, it shall detect for dIAE defects.

dTIM: See clause 6.2.2.1; dTIM shall be set to false during CI_SSF.

dDEG: See clause 6.2.3.4.

NOTE 1 – IAE (if supported) suppresses the one-second near-end errored block count, which is the input for the dDEG detection. This avoids wrong dDEG declaration due to alignment errors already incoming in an OTUkV trail.

dBDI: The dBDI detection depends on the specific frame structure and is outside the scope of this Recommendation; dBDI shall be set to false during CI_SSF.

dIAE: The dIAE detection depends on the specific frame structure and is outside the scope of this Recommendation; dIAE shall be set to false during CI_SSF and dTIM.

dBIAE: The dBIAE detection depends on the specific frame structure and is outside the scope of this Recommendation; dTIM shall be set to false during CI_SSF and dTIM.

NOTE 2 – IAE and BIAE are only required in case of frame synchronous mapping of the ODUk into the OTUkV.

Consequent actions

The function shall perform the following consequent actions:

aBDI	←	CI_SSF or dTIM
aBEI	←	nBIPV
aBIAE	←	dIAE
aTSF	←	CI_SSF or (dTIM and (not TIMActDis))
aTSD	←	dDEG

Defect correlations

The function shall perform the following defect correlations to determine the most probable fault cause. This fault cause shall be reported to the EMF.

cTIM	←	dTIM and (not CI_SSF)
cDEG	←	dDEG and (not CI_SSF) and (not (dTIM and (not TIMActDis)))
cBDI	←	dBIDI and (not CI_SSF) and (not (dTIM and (not TIMActDis)))
cSSF	←	CI_SSF

Performance monitoring

The function shall perform the following performance monitoring primitives processing. The performance monitoring primitives shall be reported to the EMF.

pN_DS	←	CI_SSF or dTI
pF_DS	←	dBIDI
pN_EBC	←	$\sum nN_B$

NOTE 3 – During CI_SSF, no errored blocks shall be counted.

pF_EBC	←	$\sum nF_B$
--------	---	--------------

NOTE 4 – During CI_SSF, no errored blocks shall be counted.

pBIAE	←	dBIAE
-------	---	-------

NOTE 5 – pBIAE is activated at the end of a second if dBIAE was active once during the second.

pIAE	←	dIAE
------	---	------

NOTE 6 – pIAE is activated at the end of a second if dIAE was active once during the second.

NOTE 7 – pBIAE and pIAE are only defined in case of frame synchronous mapping of the ODUk into the OTUkV.

NOTE 8 – pIAE and pBIAE are used for the suppression of the PM data in the equipment management functions (see [ITU-T G.874]). If pBIAE is active, the F_DS and F_EBC values of the previous and current second have to be discarded (EBC = 0 and DS = false). If pIAE is active, the N/F_DS and N/F_EBC values of the previous and current second have to be discarded (EBC = 0 and DS = false). The previous second has to be included due to the delay of the IAE information coming from the remote source.

13.3 Adaptation functions

13.3.1 OTUk to ODUk adaptation function (OTUk/ODUk_A)

The OTUk to ODUk adaptation functions perform the adaptation between the OTUk layer adapted information and the characteristic information of an ODUk layer signal.

13.3.1.1 OTUk to ODUk adaptation source function (OTUk/ODUk_A_So)

The OTUk/ODUk_A_So function creates the OTUk signal and maps the ODUk signal frame synchronous into this OTUk signal as defined in [ITU-T G.709].

The information flow and processing of the OTUk/ODUk_A_So functions is defined with reference to Figures 13-13 and 13-14.

Symbol

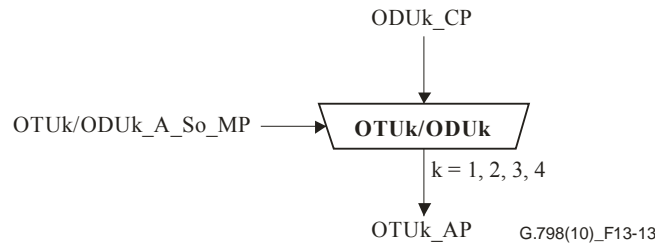

Figure 13-13 – OTUk/ODUk_A_So function

Interfaces

Table 13-5 – OTUk/ODUk_A_So inputs and outputs

Input(s)	Output(s)
ODUk_CP: ODUk_CI_CK ODUk_CI_D ODUk_CI_FS ODUk_CI_MFS OTUk/ODUk_A_So_MP: OTUk/ODUk_A_So_MI_AdminState	OTUk_AP: OTUk_AI_CK OTUk_AI_D OTUk_AI_FS OTUk_AI_MFS OTUk_AI_IAE

Processes

The processes associated with the OTUk/ODUk_A_So function are as depicted in Figure 13-14.

ODUk-LCK: The function shall generate the ODUk-LCK signal as defined in clause 16.5 of [ITU-T G.709]. The clock, frame start and multiframe start are defined by the incoming ODUk signal.

Selector: The normal signal may be replaced by the ODUk-LCK signal. ODUk-LCK signal is selected if the MI_AdminState is LOCKED.

OTUk signal generation: The function shall generate the OTUk clock (AI_CK) by multiplying the incoming ODUk clock (CI_CK) to the OTUk frequency as listed in Table 13-6.

Table 13-6 – OTU frequencies

OTU type	OTU nominal bit rate	OTU bit-rate tolerance
OTU1	2 666 057 kHz	±20 ppm
OTU2	10 709 225 kHz	
OTU3	43 018 413 kHz	
OTU4	111 809 973 kHz	
NOTE – The OTUk (k = 1, 2, 3) clock is $255/(239 - k) \times 4^{(k-1)} \times 2\,488\,320$ kHz ± 20 ppm. The OTU4 clock is $255/227 \times 40 \times 2\,488\,320$ kHz ± 20 ppm.		

For the case that an ODU signal is not terminated in the network element (e.g., it is through connected from an OTM input to an OTM output), the clock parameters and jitter and wander requirements, as defined in Annex A of [ITU-T G.8251] (ODCr clock), apply. Otherwise, the clock requirements are defined in the ODUkP/client adaptation functions.

NOTE – The OTUk/ODUk_A_Sk and So clocks are concentrated in a single ODCr clock in [ITU-T G.8251].

The function shall generate the OTUk frame start reference signals (AI_FS), which is derived from the incoming ODUk frame start (CI_FS).

The function shall generate the OTUk multiframe start reference signals (AI_MFS), which is derived from the incoming ODUk multiframe start (CI_MFS).

Incoming alignment error (IAE): If the incoming ODUk frame start (CI_FS) position is not at the expected frame start position, the incoming alignment error IAE shall be activated. IAE shall be deactivated if the incoming ODUk frame start (CI_FS) position is at the expected frame start position. The expected frame start position is based on the previous incoming ODUk frame start.

Mapping: The function shall map the incoming ODUk frame (CI_D) into the OTUk frame (AI_D) as defined in clause 11.1 of [ITU-T G.709].

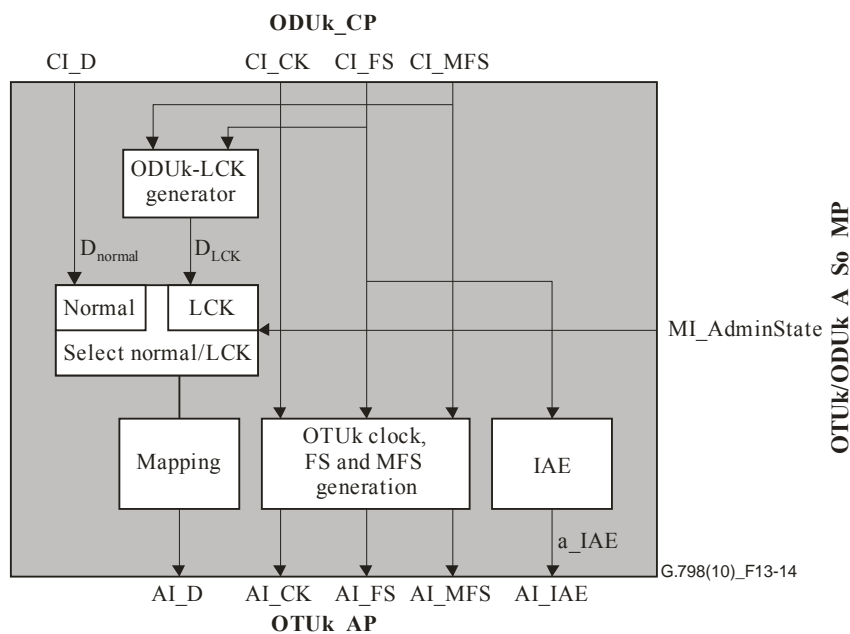

Figure 13-14 – OTUk/ODUk_A_So processes

Defects: None.

Consequent actions

The function shall perform the following consequent actions:

aIAE ← IAE

Defect Correlations: None.

Performance monitoring: None.

13.3.1.2 OTUk to ODUk adaptation sink function (OTUk/ODUk_A_Sk)

The ODUk/ODUk_A_Sk extracts the ODUk signal from the OTUk. It may insert ODUk-AIS under signal fail conditions.

The information flow and processing of the OTUk/ODUk_A_Sk functions is defined with reference to Figures 13-15 and 13-16.

Symbol

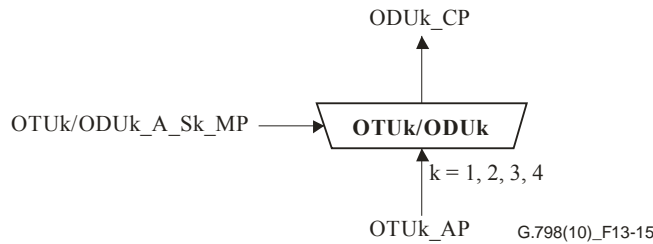

Figure 13-15 – OTUk/ODUk_A_Sk function

Interfaces

Table 13-7 – OTUk/ODUk_A_Sk inputs and outputs

Input(s)	Output(s)
OTUk_AP: OTUk_AI_CK OTUk_AI_D OTUk_AI_FS OTUk_AI_MFS OTUk_AI_TSF OTUk_AI_TSD OTUk/ODUk_A_Sk_MP: OTUk/ODUk_A_Sk_MI_AdminState	ODUk_CP: ODUk_CI_CK ODUk_CI_D ODUk_CI_FS ODUk_CI_MFS ODUk_CI_SSF ODUk_CI_SSD

Processes

The processes associated with the OTUk/ODUk_A_Sk function are as depicted in Figure 13-16.

ODUk clock, FS and MFS signal generation: The function shall generate the ODUk clock (CI_CK) by dividing the incoming OTUk clock (AI_CK) down to the particular ODUk clock as listed in Table 13-8.

Table 13-8 – ODUk frequencies

ODU type	ODU nominal bit rate	ODU bit-rate tolerance
ODU1	2 498 775 kHz	±20 ppm
ODU2	10 037 274 kHz	
ODU3	40 319 219 kHz	
ODU4	104 794 446 kHz	
NOTE – The ODUk (k = 1, 2, 3) clock is " $239/(239 - k) \times 4^{(k-1)} \times 2\,488\,320\text{ kHz} \pm 20\text{ ppm}$ ". The ODU4 clock is " $239/227 \times 40 \times 2\,488\,320\text{ kHz} \pm 20\text{ ppm}$ ".		

For the case that an ODU signal is not terminated in the network element (e.g., it is through connected from an OTM input to an OTM output), the clock parameters and jitter and wander requirements, as defined in Annex A of [ITU-T G.8251] (ODCr clock), apply. Otherwise, the clock requirements are defined in the ODUkP/client adaptation functions.

NOTE – The OTUk/ODUk_A_Sk and So clocks are concentrated in a single ODCr clock in [ITU-T G.8251].

The function shall generate the ODUk frame start reference signals (CI_FS), which is derived from the incoming OTUk frame start (AI_FS).

The function shall generate the ODUk multiframe start reference signals (CI_MFS), which is derived from the incoming OTUk multiframe start (AI_MFS).

Extract ODUk from OTUk: The function shall extract the ODUk frame (CI_D) from the incoming OTUk frame (AI_D) as defined in clause 11.1 of [ITU-T G.709].

ODUk-LCK, ODUk-AIS: The function shall generate the ODUk-LCK and ODUk-AIS signals as defined in [ITU-T G.709]. The clock, frame start and multiframes start shall be independent from the incoming clock. The clock has to be within the frequency range as given in Table 13-8. Jitter and wander requirements, as defined in Annex A of [ITU-T G.8251] (ODCa clock), apply.

Selector: The normal signal may be replaced by either the ODUk-AIS or the ODUk-LCK signal. ODUk-LCK signal is selected if the MI_AdminState is LOCKED. ODUk-AIS is selected if MI_AdminState is not LOCKED and aAIS is true.

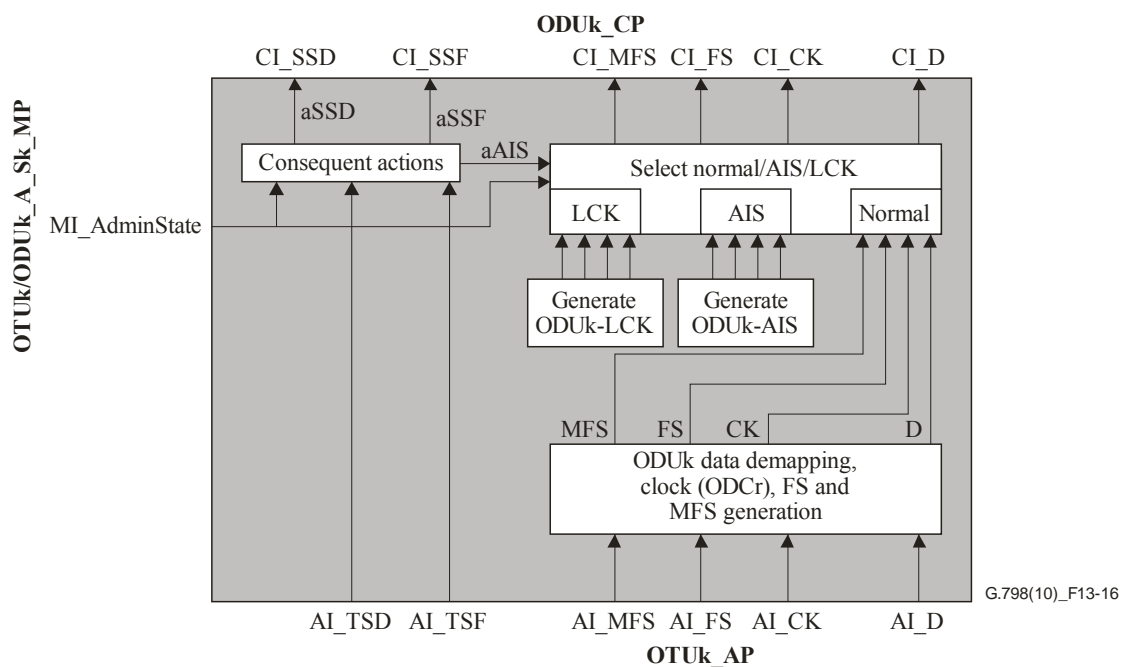

Figure 13-16 – OTUk/ODUk_A_Sk processes

Defects: None.

Consequent actions

The function shall perform the following consequent actions:

- aSSF ← AI_TSF and (not MI_AdminState = LOCKED)
- aAIS ← AI_TSF and (not MI_AdminState = LOCKED)
- aSSD ← AI_TSD and (not MI_AdminState = LOCKED)

On declaration of aAIS, the function shall output an all-ONES pattern/signal within two frames. On clearing of aAIS the all-ONES pattern/signal shall be removed within two frames, with normal data being output. The AIS clock, frame start and multiframe start shall be independent from the incoming clock, frame start and multiframe start. The AIS clock has to be the frequency range as

given in Table 13-8. Jitter and wander requirements, as defined in Annex A of [ITU-T G.8251] (ODCa clock), apply.

Defect correlations: None.

Performance monitoring: None.

13.3.2 OTUkV to ODUk adaptation function (OTUkV/ODUk_A)

The OTUkV to ODUk adaptation functions perform the adaptation between the OTUkV layer adapted information and the characteristic information of an ODUk layer signal.

13.3.2.1 OTUkV to ODUk adaptation source function (OTUkV/ODUk_A_So)

The OTUkV/ODUk_A_So function creates the OTUkV signal and maps the ODUk signal into this OTUkV.

The information flow and processing of the OTUkV/ODUk_A_So functions is defined with reference to Figures 13-17 and 13-18.

Symbol

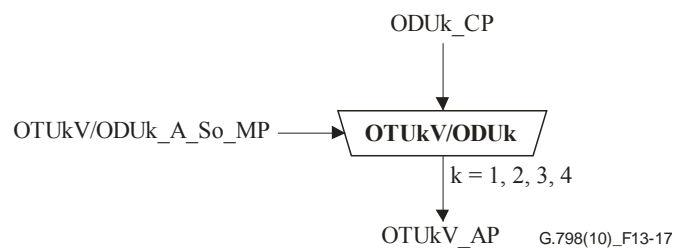

Figure 13-17 – OTUkV/ODUk_A_So function

Interfaces

Table 13-9 – OTUkV/ODUk_A_So inputs and outputs

Input(s)	Output(s)
ODUk_CP: ODUk_CI_CK ODUk_CI_D ODUk_CI_FS ODUk_CI_MFS OTUkV/ODUk_A_So_MP: OTUkV/ODUk_A_So_MI_AdminState	OTUkV_AP: OTUkV_AI_CK OTUkV_AI_D OTUkV_AI_FS OTUkV_AI_MFS (Note 1) OTUkV_AI_IAE (Note 2)
NOTE 1 – If the OTUkV has a multiframe.	
NOTE 2 – In case of frame synchronous mapping of ODUk client signal.	

Processes

The processes associated with the OTUkV/ODUk_A_So function are as depicted in Figure 13-18.

ODUk-LCK: The function shall generate the ODUk-LCK signal as defined in clause 16.5 of [ITU-T G.709]. The clock, frame start and multiframe start are defined by the incoming ODUk signal.

Selector: The normal signal may be replaced by the ODUk-LCK signal. ODUk-LCK signal is selected if the MI_AdminState is LOCKED.

OTUkV signal generation: The function shall generate the OTUkV clock and frame start. The specific generation processes are outside the scope of this Recommendation.

Incoming alignment error: In case of a frame synchronous mapping of the ODUk in the OTUkV, IAE has to be generated. If the incoming ODUk frame start (CI_FS) position is not at the expected frame start position, incoming alignment error (IAE) shall be activated. IAE shall be deactivated if the incoming ODUk frame start (CI_FS) position is at the expected frame start position. The expected frame start position is based on the previous incoming ODUk frame start.

Mapping: The function shall map the incoming ODUk frame (CI_D) into the OTUkV frame (AI_D). The specific mapping process is outside the scope of this Recommendation.

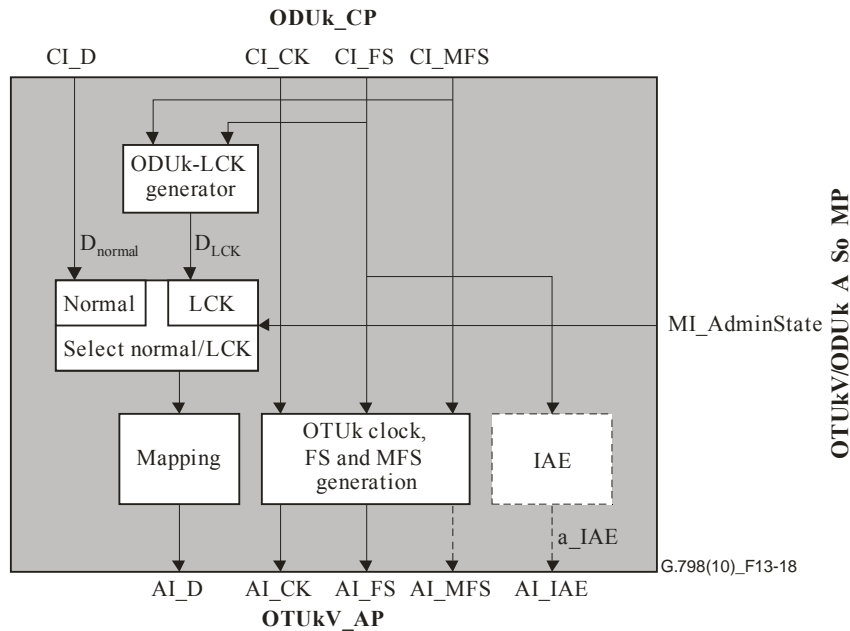

Figure 13-18 – OTUkV/ODUk_A_So processes

Defects: None.

Consequent actions

The function shall perform the following consequent actions:

$$aIAE \leftarrow IAE$$

NOTE – aIAE is only required in case of frame synchronous mapping of the ODUk client signal.

Defect correlations: None.

Performance monitoring: None.

13.3.2.2 OTUkV to ODUk adaptation sink function (OTUkV/ODUk_A_Sk)

The OTUkV/ODUk_A_Sk extracts the ODUk signal from the OTUkV. It may insert ODUk-AIS under signal fail conditions.

The information flow and processing of the OTUkV/ODUk_A_Sk functions is defined with reference to Figures 13-19 and 13-20.

Symbol

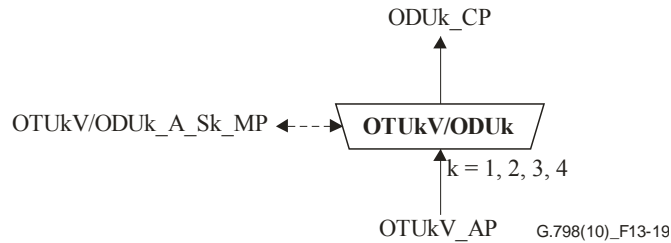

Figure 13-19 – OTUkV/ODUk_A_Sk function

Interfaces

Table 13-10 – OTUkV/ODUk_A_Sk inputs and outputs

Input(s)	Output(s)
OTUkV_AP: OTUkV_AI_CK OTUkV_AI_D OTUkV_AI_FS OTUkV_AI_MFS (Note 1) OTUkV_AI_TSF OTUkV_AI_TSD OTUkV/ODUk_A_Sk_MP: OTUkV/ODUk_A_Sk_MI_AdminState	ODUk_CP: ODUk_CI_CK ODUk_CI_D ODUk_CI_FS ODUk_CI_MFS ODUk_CI_SSF ODUk_CI_SSD OTUkV/ODUk_A_Sk_MP: OTUkV/ODUk_A_Sk_MI_cLOA (Note 2)
NOTE 1 – If the OTUkV has a multiframe.	
NOTE 2 – If loss of alignment supervision is performed.	

Processes

The processes associated with the OTUkV/ODUk_A_Sk function are as depicted in Figure 13-20.

Demapping: The function shall extract the ODUk signal, including clock, frame start, multiframe start and data from the OTUkV. The specific demapping processes are outside the scope of this Recommendation.

ODUk-LCK, ODUk-AIS: The function shall generate the ODUk-LCK and ODUk-AIS signals as defined in [ITU-T G.709]. The clock, frame start and multiframe start shall be independent from the incoming clock. The clock has to be within the frequency range as given in Table 13-8. Jitter and wander requirements, as defined in Annex A of [ITU-T G.8251] (ODCa clock), apply.

Selector: The normal signal may be replaced by either the ODUk-AIS or the ODUk-LCK signal. ODUk-LCK signal is selected if the MI_AdminState is LOCKED. ODUk-AIS is selected if MI_AdminState is not LOCKED and aAIS is true.

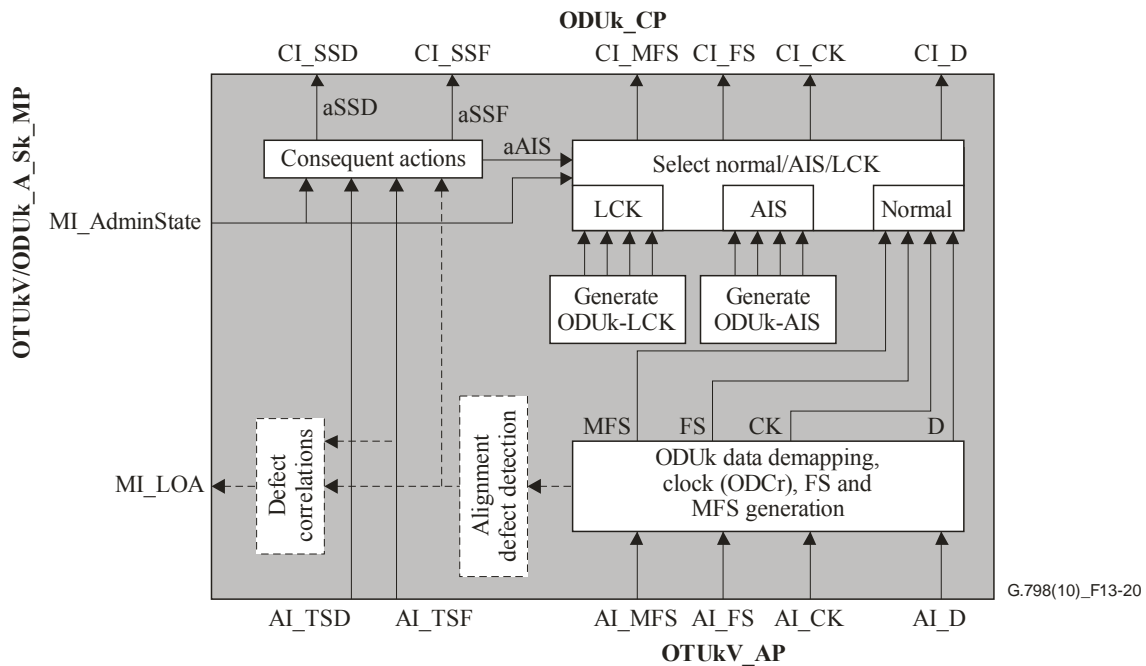

Figure 13-20 – OTUkV/ODUk_A_Sk processes

Defects

Depending on the ODUk mapping defect, detection might be necessary (e.g., loss of alignment).

Consequent actions

The function shall perform the following consequent actions:

- aSSF ← AI_TSF and (not MI_AdminState = LOCKED)
- aAIS ← AI_TSF and (not MI_AdminState = LOCKED)
- aSSD ← AI_TSD and (not MI_AdminState = LOCKED)

Depending on the ODUk mapping, additional defects might contribute to aSSF and aAIS (e.g., loss of alignment).

On declaration of aAIS, the function shall output an all-ONEs pattern/signal within two frames. On clearing of aAIS the all-ONEs pattern/signal shall be removed within two frames, with normal data being output. The AIS clock, frame start and multiframe start shall be independent from the incoming clock, frame start and multiframe start. The AIS clock has to be within the frequency range as given in Table 13-8. Jitter and wander requirements, as defined in Annex A of [ITU-T G.8251] (ODCa clock), apply.

Defect correlations

Depending on the ODUk mapping, defect correlations might be necessary (e.g., loss of alignment).

Performance monitoring: None.

13.3.3 OTUk to COMMS adaptation function (OTUk/COMMS_A)

The OTUk to COMMS adaptation functions provide access to the GCC0 overhead in the OTUk for generic data communication.

13.3.3.1 OTUk to COMMS adaptation source function (OTUk/COMMS_A_So)

The OTUk/COMMS_A_So function maps the generic communication channel data into the OTUk GCC0 overhead.

The information flow and processing of the OTUk/COMMS_A_So functions is defined with reference to Figures 13-21 and 13-22.

Symbol

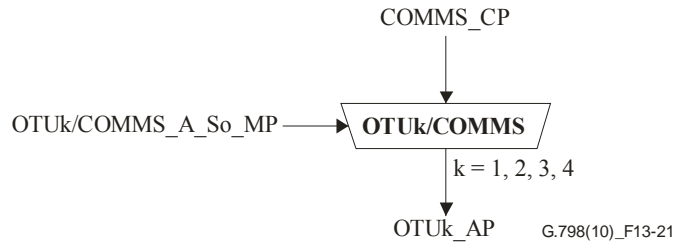

Figure 13-21 – OTUk/COMMS_A_So function

Interfaces

Table 13-11 – OTUk/COMMS_A_So inputs and outputs

Input(s)	Output(s)
COMMS_CP: COMMS_CI_D OTUk_AP: OTUk_AI_CK OTUk_AI_FS OTUk/COMMS_A_So_MP: OTUk/COMMS_A_So_MI_Active	COMMS_CP: COMMS_CI_CK OTUk_AP: OTUk_AI_D

Processes

Activation

- The OTUk/COMMS_A_So function shall access the access point when it is activated (MI_Active is true). Otherwise, it shall not access the access point.

The processes associated with the OTUk/COMMS_A_So function are as depicted in Figure 13-22.

COMMS clock generation: The function shall generate the COMMS clock (CI_CK) by dividing the incoming OTUk clock (AI_CK) by a factor of 8160.

Mapping: The function shall map the incoming COMMS data (CI_D) into the GCC0 overhead of the OTUk frame (AI_D). The bit rate of the COMMS data is defined by the outgoing COMMS clock (CI_CK) and is in the range given in Table 13-12.

Table 13-12 – COMMS channel frequencies

OTU type	COMMS channel frequency	COMMS channel bit-rate tolerance
OTU1	326 kHz	±20 ppm
OTU2	1312 kHz	
OTU3	5271 kHz	
OTU4	13702 kHz	

NOTE – The OTUk COMMS clock is in the range of $(255/(239 - k) \times 4^{(k-1)}) / 8160 \times 2\,488\,320$ kHz ± 20 ppm (k = 1, 2, 3) and $(255/227 \times 40/8160 \times 2\,488\,320)$ kHz ± 20 ppm (k = 4).

The insertion of the COMMS data follows the transmission order of the GCC bits and bytes.

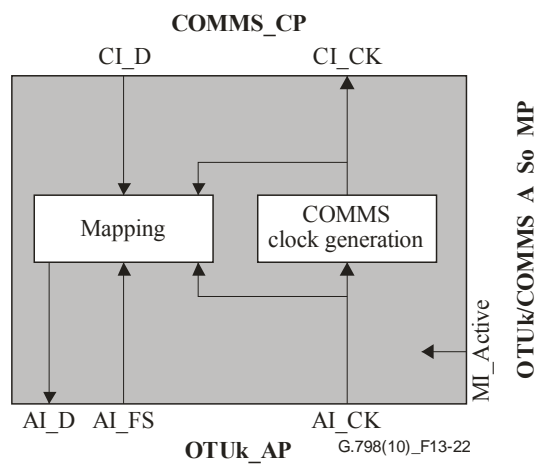

Figure 13-22 – OTUk/COMMS_A_So processes

Defects: None.

Consequent actions: None.

Defect correlations: None.

Performance monitoring: None.

13.3.3.2 OTUk to COMMS adaptation sink function (OTUk/COMMS_A_Sk)

The OTUk/COMMS_A_Sk extracts the COMMS data from the OTUk GCC0 overhead.

The information flow and processing of the OTUk/COMMS_A_Sk functions is defined with reference to Figures 13-23 and 13-24.

Symbol

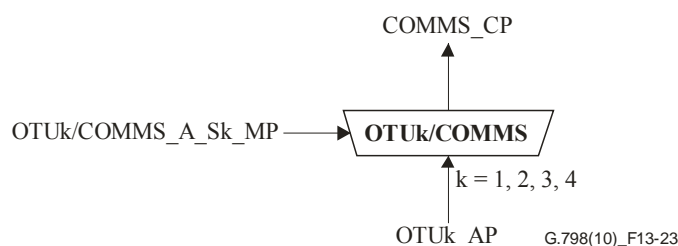

Figure 13-23 – OTUk/COMMS_A_Sk function

Interfaces

Table 13-13 – OTUk/COMMS_A_Sk inputs and outputs

Input(s)	Output(s)
OTUk_AP: OTUk_AI_CK OTUk_AI_D OTUk_AI_FS OTUk_AI_TSF OTUk/COMMS_A_Sk_MP: OTUk/COMMS_A_Sk_MI_Active	COMMS_CP: COMMS_CI_CK COMMS_CI_D COMMS_CI_SSF

Processes

Activation

- The OTUk/COMMS_A_Sk function shall access the access point and perform the common and specific processes operation specified below when it is activated (MI_Active is true). Otherwise, it shall activate the SSF signals at its output (CI_SSF).

The processes associated with the OTUk/COMMS_A_Sk function are as depicted in Figure 13-24.

COMMS clock generation: The function shall generate the COMMS clock (CI_CK) by dividing the incoming OTUk clock (AI_CK) by a factor of 8160.

Demapping: The function shall extract the COMMS data (CI_D) from the GCC0 overhead of the OTUk frame (AI_D). The bit rate of the COMMS data is defined by the outgoing COMMS clock (CI_CK) and is in the range given in Table 13-12.

The extraction of the COMMS data follows the transmission order of the GCC bits and bytes.

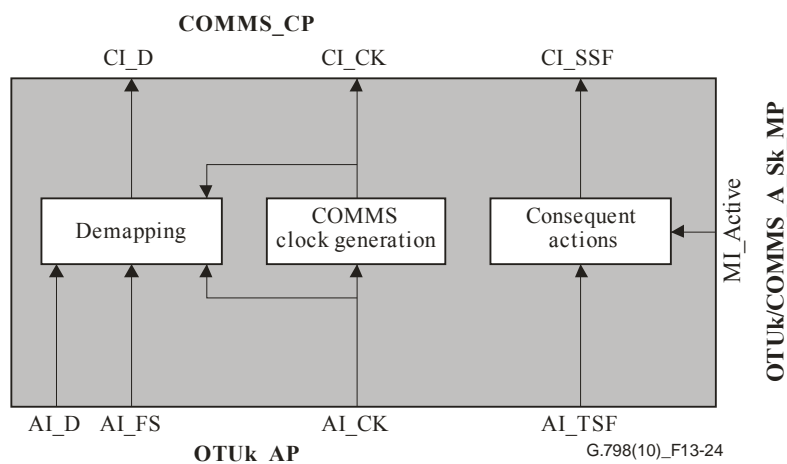

Figure 13-24 – OTUk/COMMS_A_Sk processes

Defects: None.

Consequent actions

The function shall perform the following consequent actions:

aSSF ← AI_TSF or (not MI_Active)

Defect correlations: None.

Performance monitoring: None.

13.3.4 OTUkV to COMMS adaptation function (OTUkV/COMMS_A)

The OTUkV to COMMS adaptation functions provide access to the GCC overhead in the OTUkV for generic data communication. The format of the OTUkV GCC overhead is outside the scope of this Recommendation.

13.3.4.1 OTUkV to COMMS adaptation source function (OTUkV/COMMS_A_So)

The OTUkV/COMMS_A_So function maps the generic communication channel data into the OTUkV GCC overhead.

The information flow and processing of the OTUkV/COMMS_A_So functions is defined with reference to Figure 13-25.

Symbol

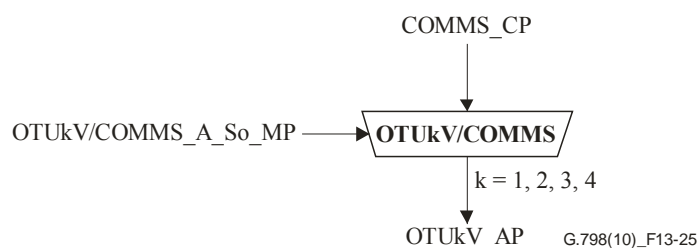

Figure 13-25 – OTUkV/COMMS_A_So function

Interfaces

Table 13-14 – OTUkV/COMMS_A_So inputs and outputs

Input(s)	Output(s)
COMMS_CP: COMMS_CI_D OTUkV_AP: OTUkV_AI_CK OTUkV_AI_FS OTUkV/COMMS_A_So_MP: OTUkV/COMMS_A_So_MI_Active	COMMS_CP: COMMS_CI_CK OTUkV_AP: OTUkV_AI_D

Processes

Activation

- The OTUkV/COMMS_A_So function shall access the access point when it is activated (MI_Active is true). Otherwise, it shall not access the access point.

The function shall insert the COMMS data into the OTUkV GCC overhead. The specific processes are outside the scope of this Recommendation.

Defects: None.

Consequent actions: None.

Defect correlations: None.

Performance monitoring: None.

13.3.4.2 OTUkV to COMMS adaptation sink function (OTUkV/COMMS_A_Sk)

The OTUkV/COMMS_A_Sk extracts the COMMS data from the OTUkV GCC overhead.

The information flow and processing of the OTUkV/COMMS_A_Sk functions is defined with reference to Figure 13-26.

Symbol

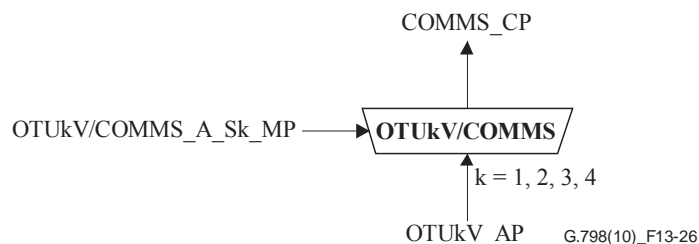

Figure 13-26 – OTUkV/COMMS_A_Sk function

Interfaces

Table 13-15 – OTUkV/COMMS_A_Sk inputs and outputs

Input(s)	Output(s)
OTUkV_AP: OTUkV_AI_CK OTUkV_AI_D OTUkV_AI_FS OTUkV_AI_TSF OTUkV/COMMS_A_Sk_MP: OTUkV/COMMS_A_Sk_MI_Active	COMMS_CP: COMMS_CI_CK COMMS_CI_D COMMS_CI_SSF

Processes

Activation

- The OTUkV/COMMS_A_Sk function shall access the access point and perform the common and specific processes operation specified below when it is activated (MI_Active is true). Otherwise, it shall activate the SSF signals at its output (CI_SSF).

The function shall extract the COMMS data from the OTUkV GCC overhead. The specific processes are outside the scope of this Recommendation.

Defects: None.

Consequent actions

The function shall perform the following consequent actions:

aSSF ← AI_TSF or (not MI_Active)

Defect correlations: None.

Performance monitoring: None.

13.4 Sub-layer functions

Not applicable.

14 ODU (layer) functions

Figure 14-1 illustrates the ODUk layer network and client layer adaptation functions. The information crossing the ODUk connection point (ODUk_CP) is referred to as the ODUk characteristic information (ODUk_CI). The information crossing the ODUkP access point (ODUkP_AP) is referred to as the ODUkP adapted information (ODUkP_AI).

The tandem connection monitoring (TCM) sub-layer ODUkT and the related functions (ODUkT_TT, ODUkT/ODUk_A and ODUkTm) are optional. Up to six TCM sub-layers can be terminated within one NE. The figure shows a generic example for the connection of the ODUkT functions. They can be connected to any ODUk_CP. It is not required to connect them via an ODUk_C function; they can be directly inserted without a connection function.

The COMMS access functions (ODUk/COMMS_AC and ODUkP/COMMS_A) are optional. The figure shows a generic example for the connection of the ODUk/COMMS_AC functions. They can be inserted into any ODUk_CP (including TCPs) independent of sink or source processing. It is not required to connect them via an ODUk_C function; they can be directly inserted without a connection function.

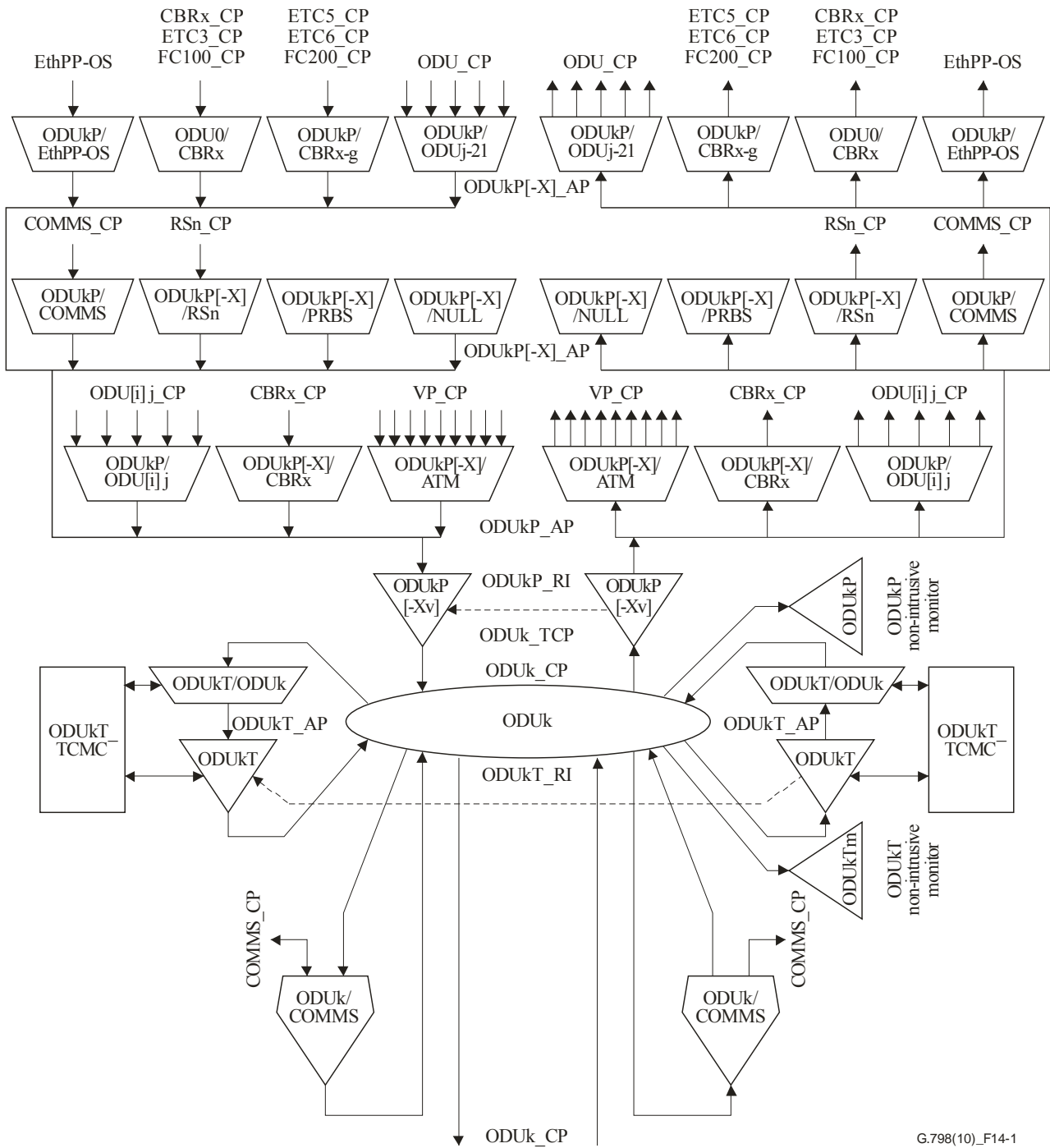

Figure 14-1 – ODUk layer network and client layer adaptation functions

The ODUk characteristic information (ODUk_CI) is the ODUk frame as defined in [ITU-T G.709] with valid ODUk overhead as shown in Figure 14-2, together with a frame and multiframe start. TCM1..6 overhead is only used if one or more ODUkT trails cross the CP; otherwise, it is set to all-ZEROS. APS/PCC overhead is only used in case of an ODUk protection scheme with APS support; otherwise, it is set to all-ZEROS. GCC1, GCC2 and EXP overhead are optional. If they are not used, they are set to all-ZEROS. FTLF and TCM ACT overhead are for further study, they are set to all-ZEROS. The RES overhead is set to all-ZEROS. PM and TCM overheads are for delay measurement of ODU path (DMp) and TCM (DMti) sections.

		Column#															
		1	2	3	4	5	6	7	8	9	10	11	12	13	14	15	16
Row#	1															OPUk overhead	
	2	RES		PM and TCM	TCM ACT	TCM6			TCM5			TCM4			FTFL		
	3	TCM3			TCM2			TCM1			PM		EXP				
	4	GCC1		GCC2		ASP/PCC				RES							

G.798(10)_F14-2

Figure 14-2 – ODUk overhead at ODUk_CP

The ODUkP adapted information (ODUkP_AI) consists of the client layer CI adapted to the OPUk frame as defined in [ITU-T G.709] and the OPUk overhead as shown in Figure 14-3, together with a frame and multiframe start. The mapping-specific overhead depends on the client mapping scheme. In case of COMMS access at the ODUkP_AP, it includes also ODUk GCC overhead (GCC1/2).

		Column#															
		1	2	3	4	5	6	7	8	9	10	11	12	13	14	15	16
Row#	1															Mapping-specific overhead	
	2																
	3																
	4	GCC1		GCC2													

G.798(10)_F14-3

Figure 14-3 – OPUk overhead at ODUk_AP

14.1 Connection functions

14.1.1 ODUk connection function (ODU_C)

The information flow and processing of the ODU_C function is defined with reference to Figures 14-4 and 14-5. The ODU_C function connects ODUk characteristic information from its input ports to its output ports. As the process does not affect the nature of characteristic information, the reference points on either side of the ODU_C function are the same as illustrated in Figure 14-4.

The connection process is unidirectional and as such no differentiation in sink and source is required.

In addition, the ODU_C function supports the following subnetwork connection protection schemes:

- 1+1 unidirectional SNC/N, SNC/I and SNC/S protection without an APS protocol.
- 1+1 unidirectional SNC/N, SNC/I and SNC/S protection with an APS protocol.
- 1+1 bidirectional SNC/N, SNC/I and SNC/S protection with an APS protocol.
- 1:n unidirectional SNC/I and SNC/S protection with an APS protocol.
- 1:n bidirectional SNC/I and SNC/S protection with an APS protocol.

The protection functionality is described in clause 14.1.1.1.

NOTE 1 – The protection processes have a dedicated sink and source behaviour.

Symbol

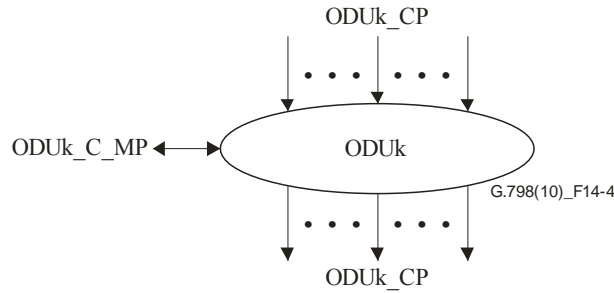

Figure 14-4 – ODU_C function

Interfaces

Table 14-1 – ODU_C function inputs and outputs

Input(s)	Output(s)
<p>per ODUk_CP: ODUk_CI_D ODUk_CI_CK ODUk_CI_FS ODUk_CI_MFS ODUk_CI_SSF ODUk_CI_SSD (for SNC/S and SNC/I protection) ODUk_CI_TSF (for SNC/N protection) ODUk_CI_TSD (for SNC/N protection)</p> <p>ODUk_C_MP: ODUk_C_MI_MatrixControl</p> <p>per protection group (for SNC protection): ODUk_C_MI_ProtType ODUk_C_MI_OperType ODUk_C_MI_WTR ODUk_C_MI_HoTime ODUk_C_MI_ExtCMD ODUk_C_MI_APSSchannel (for SNC protection with APS protocol) ODUk_C_MI_SDEnable</p>	<p>per ODUk_CP: ODUk_CI_D ODUk_CI_CK ODUk_CI_FS ODUk_CI_MFS ODUk_CI_SSF</p> <p>ODUk_C_MP: per protection group (for SNC protection with APS protocol): ODUk_C_MI_cFOP-PM ODUk_C_MI_cFOP-NR</p>

Processes

The processes associated with the ODU_C function are as depicted in Figure 14-5.

ODU_CI is routed between input and output connection points by means of a matrix connection. Connection points may be allocated within a protection group.

NOTE 2 – Neither the number of input/output signals to the connection function, nor the connectivity, is specified in this Recommendation. That is a property of individual network elements.

Routing: The function shall be able to connect a specific input with a specific output by means of establishing a matrix connection between the specified input and output. It shall be able to remove an established matrix connection.

Each (matrix) connection in the ODU_C function should be characterized by the:

- Type of connection: unprotected.

- Traffic direction: unidirectional, bidirectional.
- Input and output connection points: set of connection points.

NOTE 3 – Broadcast connections are handled as separate connections to the same CP.

The following changes to (the configuration of) a connection shall be possible without disturbing the CI passing the connection:

- addition and removal of protection;
- addition and removal of connections to/from a broadcast connection;
- change of WTR time;
- change of operation type;
- change of hold-off time;
- change of APS channel.

Open connection indication (OCI): If an output of the connection function is not connected to an input, an ODU-OCI signal as defined in clause 16.5 of [ITU-T G.709] is generated for this output. The clock of the OCI signal has to be within the minimum and maximum clock frequencies specified for the ODU signals that are given in Table 14-2. The jitter and wander requirements as defined in Annex A of [ITU-T G.8251] (ODCa clock) apply. CI_SSF is false.

Table 14-2 – ODU types and frequency

ODU type	ODU frequency	ODU frequency tolerance
ODU0	1 244 160 kHz	±20 ppm
ODU1	2 498 775 kHz	
ODU2	10 037 274 kHz	
ODU3	40 319 219 kHz	
ODU4	104 794 446 kHz	
ODU2e	10 399 525 kHz	±100 ppm
ODUflex (CBR)	$239/238 \times$ client signal clock frequency	Client signal clock frequency tolerance, with a maximum of ±100 ppm
ODUflex (GFP)	Frequency configured according to clause 12.2.5 of [ITU-T G.709]	±20 ppm
NOTE – The nominal ODU _k clock frequencies are approximately: $239/(239 - k) * 4^{(k-1)} * 2\,488\,320$ kHz ± 20 ppm for ODU _k (k = 1, 2, 3), 1 244 160 kHz ± 20 ppm for ODU0 and $(239/238 \times$ client bit rate ± client tolerance (k = flex), 104 794 445.815 kHz (ODU4) and 10 399 525.316 kHz (ODU2e). See Table 7-2 of [ITU-T G.709].		

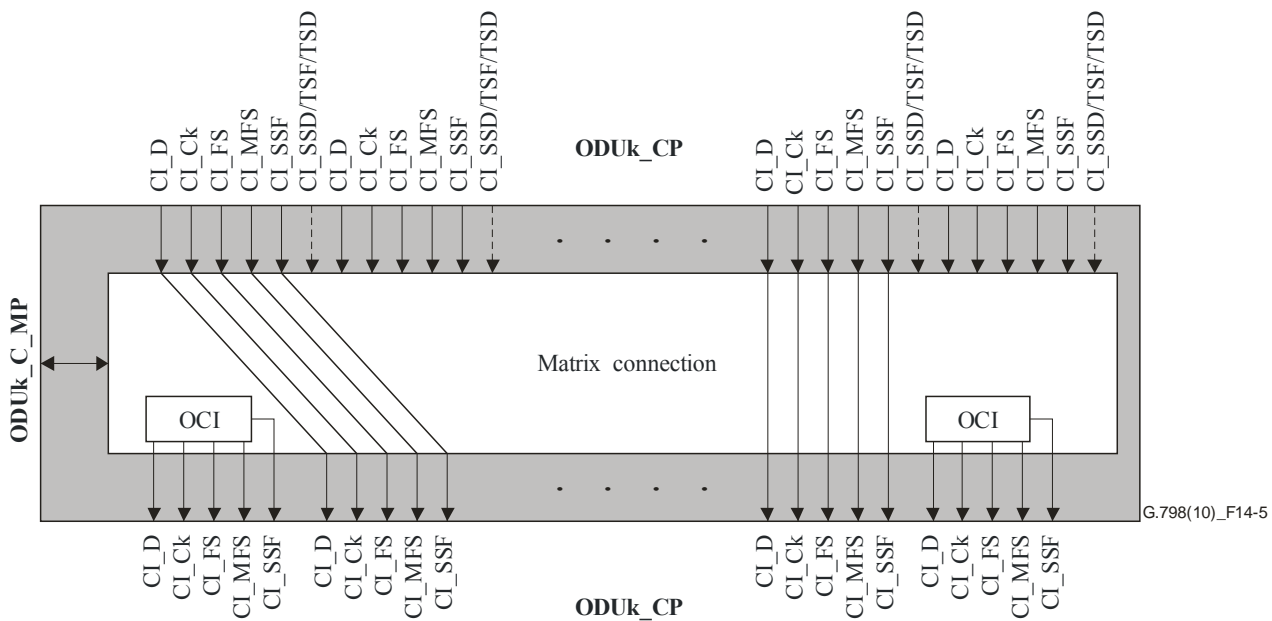

Figure 14-5 – ODU_C function processes

Defects: See clause 14.1.1.1 for protection-specific defects.

Consequent actions: None.

Defect correlations: See clause 14.1.1.1 for protection-specific defect correlations.

Performance monitoring: None.

14.1.1.1 Subnetwork connection protection process

NOTE 1 – This process is active in the ODU_C function as many times as there are 1+1 and 1:N protected matrix connections.

The generic subnetwork connection protection mechanism is defined in [ITU-T G.808.1] with OTN-specific extensions in [ITU-T G.873.1].

SNC protection with non-intrusive monitoring (SNC/N), with inherent monitoring (SNC/I) and with sub-layer monitoring based on TCM (SNC/S), are supported. SNC/I is limited to a single OTUk[V] or HO ODUk server layer trail for the working and protection subnetwork connection between the source and sink protection switch (e.g., no intermediate OTUk termination/3R regeneration or HO ODUk termination is allowed).

NOTE 2 – The limitation to a single server layer trail for SNC/I protection is given by the use of signal degrade (SD) as protection switching criteria. SD is only available from the OTUk[V] or HO ODUk trail that is locally terminated and not from further upstream OTUk[V] or HO ODUk trails. Furthermore, FDI/AIS, which provides information about defects in upstream OTUk[V] or HO ODUk trails, is not detected in the OTUk[V]/ODUk_A_Sk, ODUkP/ODU[i]j_A_Sk or the ODUkP/ODUj-21_A_Sk.

Figure 14-6 gives the atomic functions involved in SNC/N protection. The working and protection ODU_CI coming from either an OTUk[V]/ODUk_A or ODUkT/ODUk_A function are monitored by a ODUkP or ODUkT non-intrusive monitor, which provide the TSF and TSD protection switching criteria.

Figure 14-7 gives the atomic functions involved in SNC/I protection. The trail termination sink of an OTUk[V] or ODUkP server layer provides the TSF and TSD protection switching criteria via the OTUk[V]/ODUk_A or ODUkP/ODU[i]j_A functions (SSF and SSD).

Figure 14-8 gives the atomic functions involved in SNC/S protection. The trail termination sink of an ODUkT TCM sub-layer provides the TSF and TSD protection switching criteria via the ODUkT/ODUk_A function (SSF and SSD).

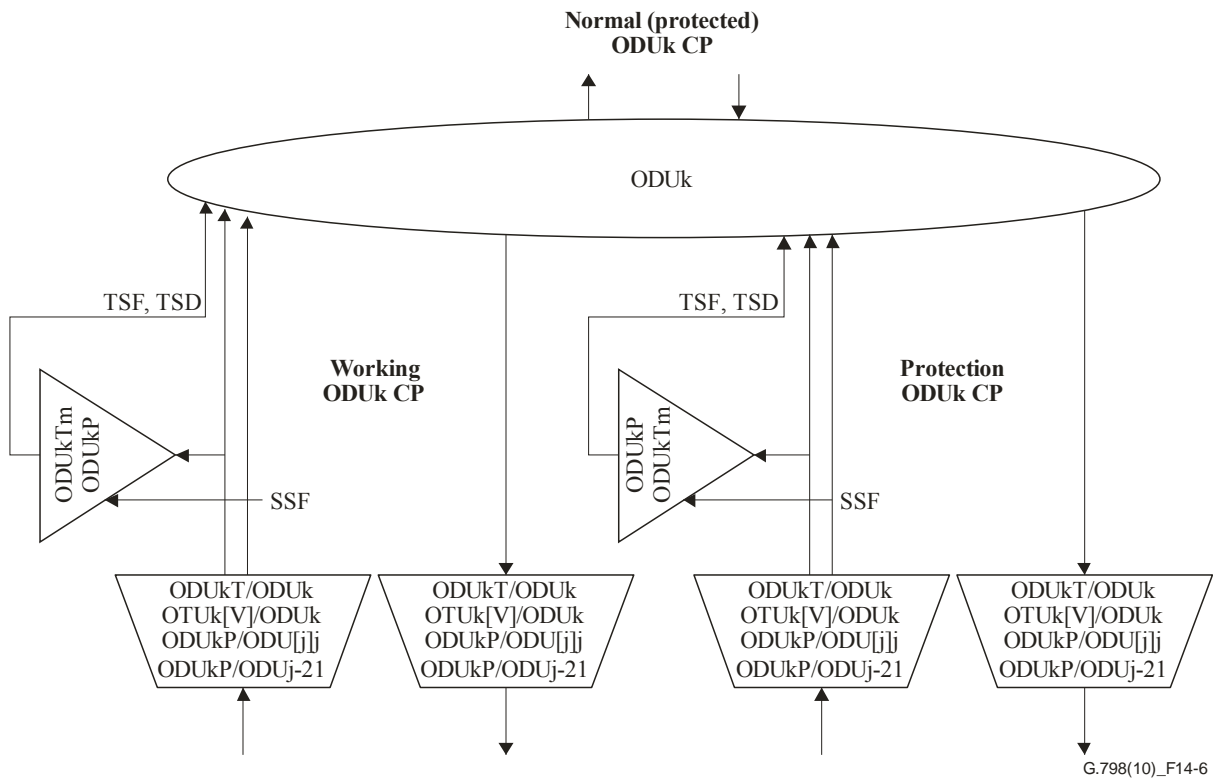

G.798(10)_F14-6

Figure 14-6 – SNC/N protection atomic functions

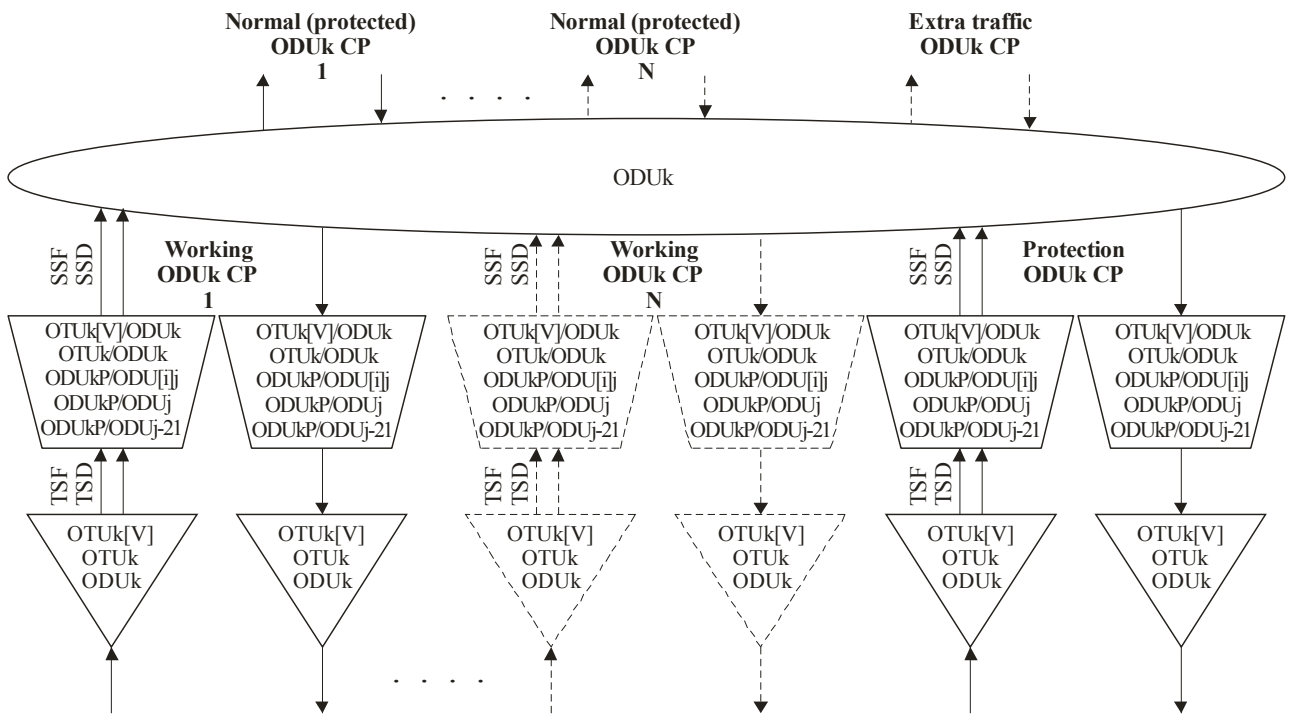

G.798(10)_F14-7

Figure 14-7 – SNC/I protection atomic functions

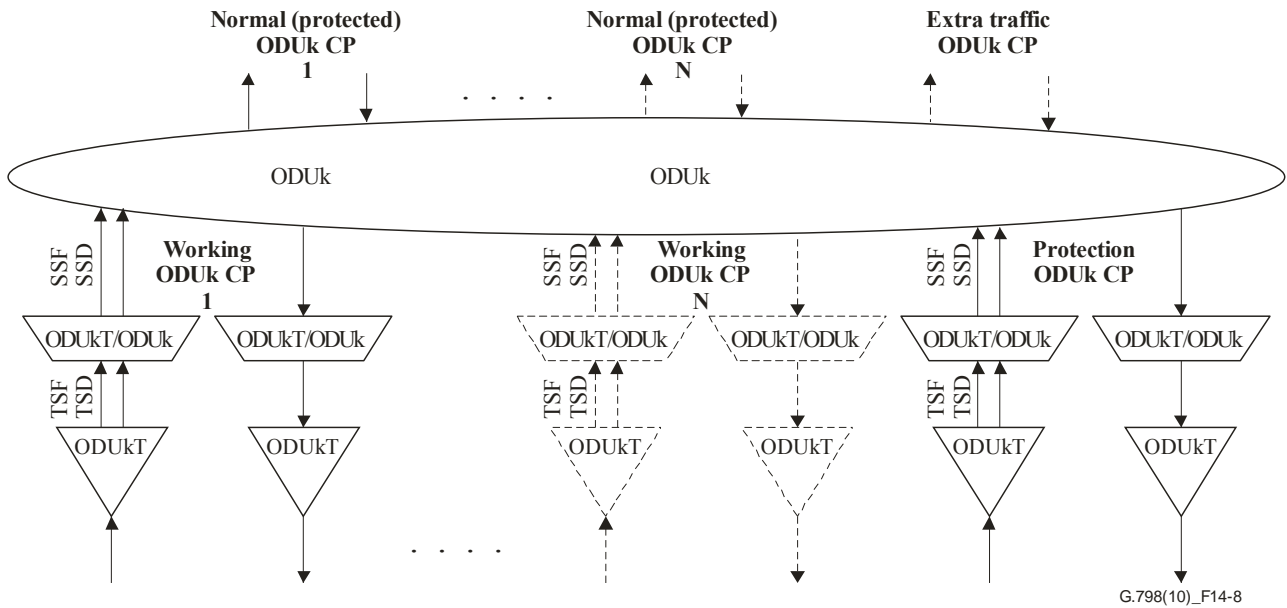

Figure 14-8 – SNC/S protection atomic functions

The signal flow associated with the ODU_C SNC protection process is described with reference to Figures 14-9 to 14-13. The protection process receives control parameters and external switch requests at the MP reference point. The report of status information at the MP reference point is for further study.

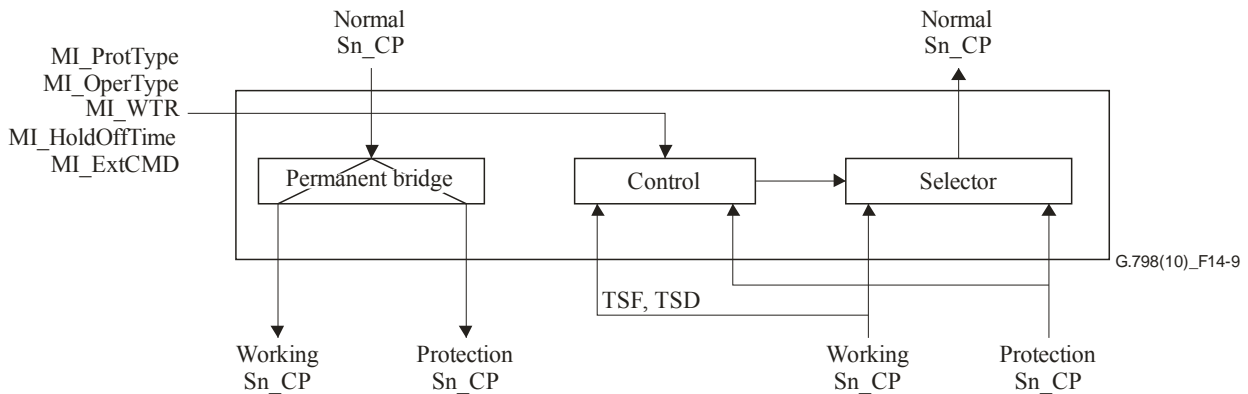

Figure 14-9 – 1+1 unidirectional SNC/N protection process without APS protocol

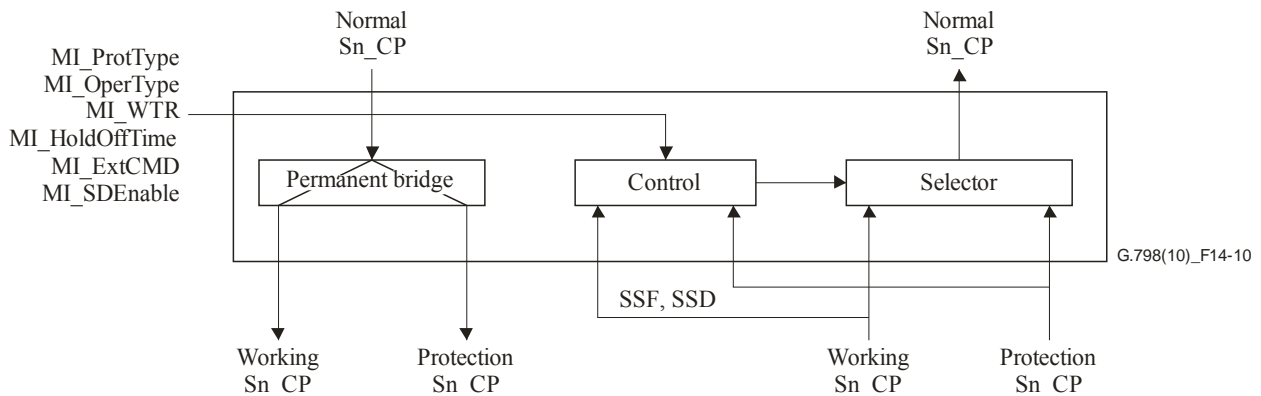

Figure 14-10 – 1+1 unidirectional SNC/S and SNC/I protection process without APS protocol

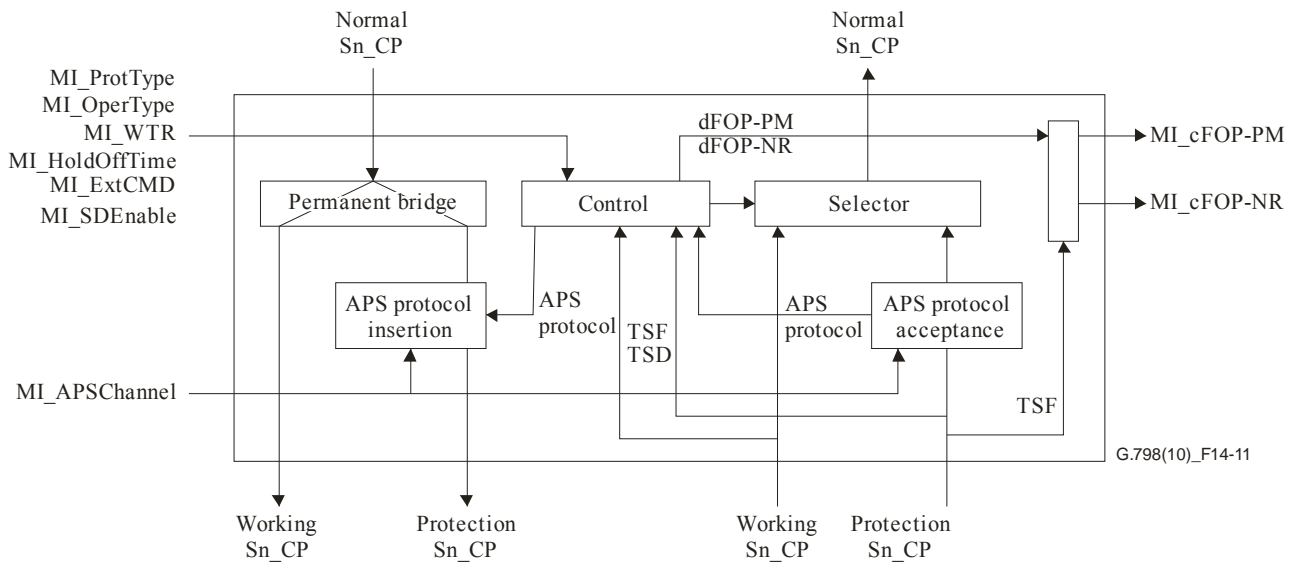

Figure 14-11 – 1+1 SNC/N protection process with APS protocol

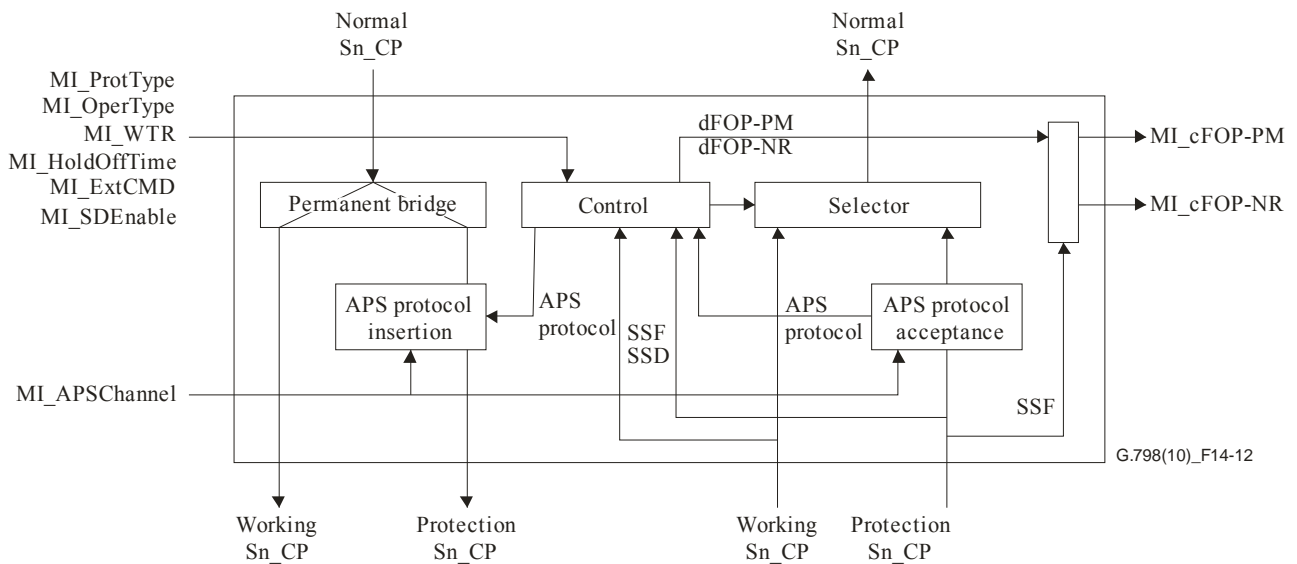

Figure 14-12 – 1+1 SNC/S and SNC/I protection process with APS protocol

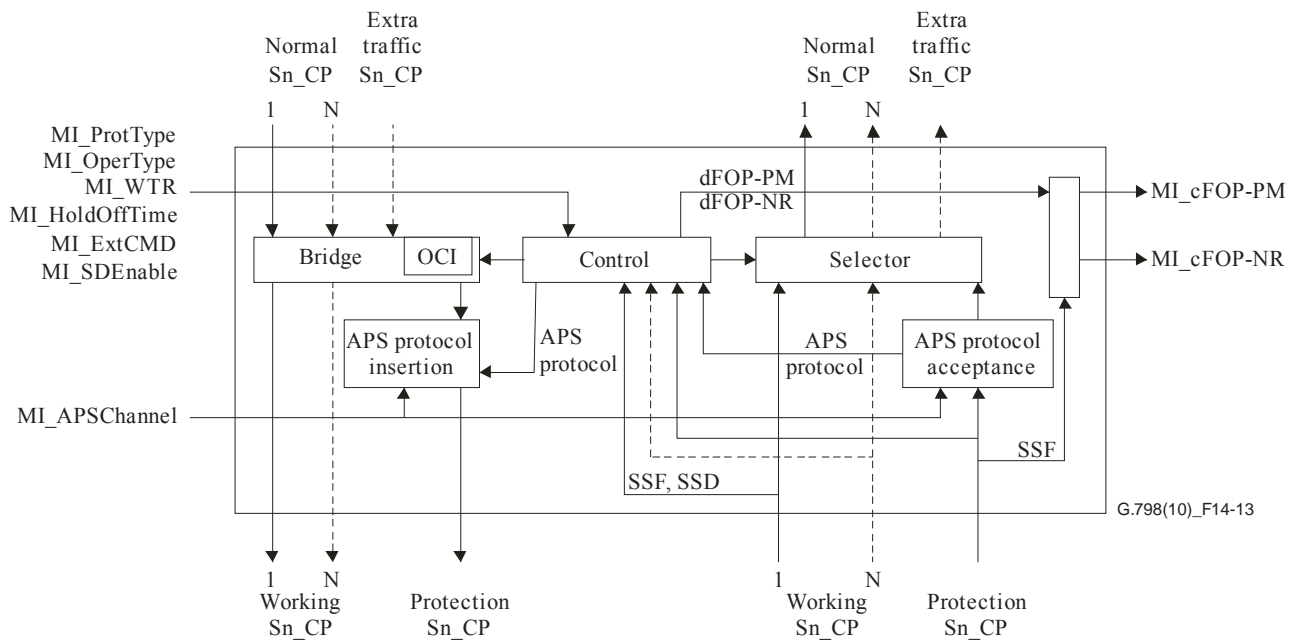

Figure 14-13 – 1:N SNC/S and SNC/I protection process with APS protocol

For the description of the protection processes including bridge and selector control, APS acceptance and transmission, see [ITU-T G.873.1].

A permanent bridge, as defined in [ITU-T G.808.1], shall be used for the 1+1 protection. A broadcast bridge, as defined in [ITU-T G.808.1], shall be used for the 1:N protection. It permanently connects the normal traffic signal to the working transport entity. In case no normal or extra traffic signal is connected to the protection transport entity, an ODUk-OCI signal, as defined in clause 16.5 of [ITU-T G.709], is generated for the protection transport entity. The clock of the OCI signal has to be within the minimum and maximum frequencies of the specified ODU signal in Table 14-2. The jitter and wander requirements, as defined in Annex A of [ITU-T G.8251] (ODCa clock), apply. CI_SSF is false.

A selective selector, as defined in [ITU-T G.808.1], shall be used.

MI_ProtType configures the protection type as defined in clause 8.4 of [ITU-T G.873.1].

NOTE 3 – Only a subset or a single protection type can be supported. In the latter case, the configuration is not needed.

MI_OperType configures between revertive and non-revertive operation as defined in clause 7.3 of [ITU-T G.873.1].

NOTE 4 – Only a single operation type can be supported. In this case, the configuration is not needed.

MI_HoTime configures the hold-off time as defined in clause 8.12 of [ITU-T G.873.1].

MI_WTR configures the wait to restore (WTR) time as defined in clause 15 of [ITU-T G.808.1].

MI_ExtCMD configures the protection group commands as defined in clause 6 of [ITU-T G.873.1].

MI_APSCchannel configures the APS channel (see clause 15.8.2.4 of [ITU-T G.709]) in case an APS protocol is used.

If MI_SDEnable is true, the SSD/TSD signal is used as trigger for the protection. If it is false, SSD/TSD is not used as trigger for the protection. It applies to all working and the protection signals in common.

Protection switching performance

The transfer Time T_t , as defined in clause 13 of [ITU-T G.808.1], shall not exceed 50 ms for a protection span length that does not exceed 1200 km.

Defects

The function shall detect for dFOP-PM and dFOP-NR defects in case the APS protocol is used.

dFOP-PM: See clause 6.2.7.1.1.

dFOP-NR: See clause 6.2.7.1.2.

Consequent actions: None.

Defect correlations

cFOP-PM ← dFOP-PM and (not CI_SSF/TSF)

cFOP-NR ← dFOP-NR and (not CI_SSF/TSF)

In case of SNC/S and SNC/I, CI_SSF of the protection signal is used. In case of SNC/N, CI_TSF of the protection signal is used.

Performance monitoring: None.

14.1.1.2 Compound link subnetwork connection group protection process

For further study.

14.2 Termination functions

14.2.1 ODUkP trail termination function (ODUkP_TT)

The ODUkP_TT function terminates the path monitoring (PM) overhead of the ODUk overhead to determine the status of the ODUk trail. Figure 14-14 shows the combination of the unidirectional sink and source functions to form a bidirectional function.

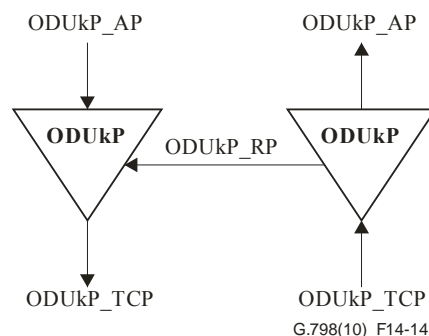

Figure 14-14 – ODUkP_TT

14.2.1.1 ODUkP trail termination source function (ODUkP_TT_So)

The ODUkP_TT_So function computes the BIP8 and adds path monitoring overhead (PMOH) – including the TTI, BIP8, DMp, BDI and BEI signals – in the PM overhead field to the ODUk signal at its ODUkP_AP.

The information flow and processing of the ODUkP_TT_So function is defined with reference to Figures 14-15 and 14-16.

Symbol

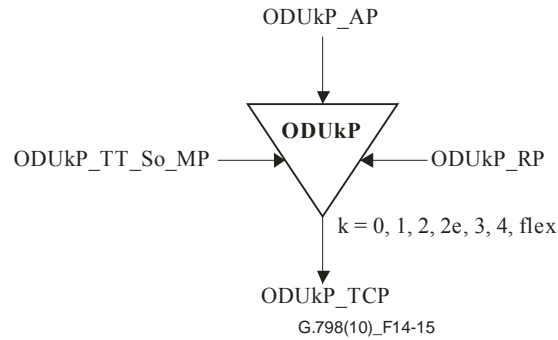

Figure 14-15 – ODUkP_TT_So function

Interfaces

Table 14-3 – ODUkP_TT_So inputs and outputs

Input(s)	Output(s)
ODUkP_AP: ODUkP_AI_CK ODUkP_AI_D ODUkP_AI_FS ODUkP_AI_MFS ODUkP_RP: ODUkP_RI_BDI ODUkP_RI_BEI ODUkP_RI_DM ODUkP_TT_So_MP: ODUkP_TT_So_MI_TxTI ODUkP_TT_So_MI_DM_Source ODUkP_TT_So_MI_DMValue	ODUk_TCP: ODUk_CI_CK ODUk_CI_D ODUk_CI_FS ODUk_CI_MFS

Processes

The processes associated with the ODUkP_TT_So function are as depicted in Figure 14-16.

PMOH-TTI: The trail trace identifier is inserted in the TTI byte position of the PM field. Its value is derived from reference point ODUkP_TT_So_MP. The trail trace format is described in clause 15.2 of [ITU-T G.709].

PMOH-BDI: The backward defect indication is inserted in the BDI bit position of the PM field. Its value is derived from reference point ODUkP_RP. Upon the declaration/clearing of aBDI at the termination sink function, the trail termination source function shall have inserted/removed the BDI indication within 50 ms.

PMOH-BEI: The number of errors indicated in RI_BEI is encoded in the BEI bits of the PM field. Upon the detection of a number of errors at the termination sink function, the trail termination source function shall have inserted that value in the BEI bits within 50 ms.

PMOH-BIP8: See clause 8.3.4.1. The calculated BIP8 is inserted into the BIP8 byte of the PM field.

PMOH-DMp: If MI_DM_Source is false, then the value of the DMp bit is determined by the RI_DM. If MI_DM_Source is true, then the value of the DMp bit is set to MI_DMValue.

NOTE – Equipment developed prior to the 2010 version of this Recommendation will not support the DMp processing.

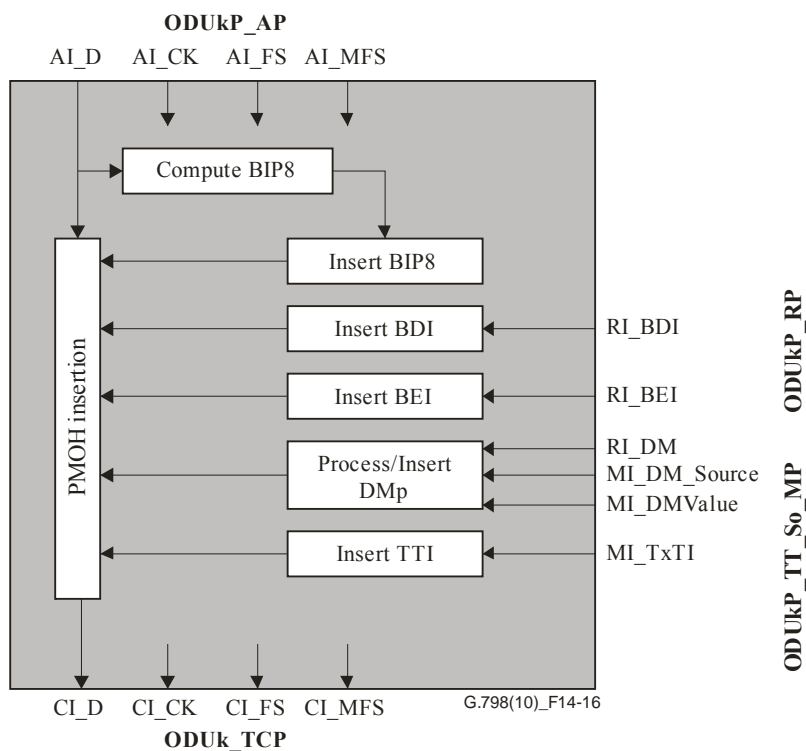

Figure 14-16 – ODUkP_TT_So processes

Defects: None.

Consequent actions: None.

Defect correlations: None.

Performance monitoring: None.

14.2.1.2 ODUkP trail termination sink function (ODUkP_TT_Sk)

The ODUkP_TT_Sk function reports the state of the ODUk trail (path). It computes the BIP8, extracts path monitoring overhead (PMOH) – including the TTI, BIP8, BDI, BEI, DMp and STAT signals – in the PM overhead field from the ODUk signal at its ODUk_TCP, detects for AIS, OCI, LCK, TIM, DEG and BDI defects, counts during one-second periods errors (detected via the BIP8), counts number of frames for delay measurement and defects to feed performance monitoring when connected, makes the TTI available to network management, and forwards the error and defect information as backward indications to the companion ODUkP_TT_So function.

NOTE 1 – The ODUkP_TT_Sk function extracts and processes the PM overhead irrespective of the presence of one or more levels of tandem connection overhead in the TCM fields.

The information flow and processing of the ODUkP_TT_Sk function is defined with reference to Figures 14-17 and 14-18.

Symbol

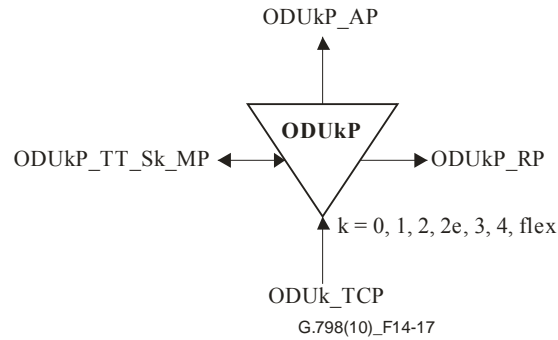

Figure 14-17 – ODUkP_TT_Sk function

Interfaces

Table 14-4 – ODUkP_TT_Sk inputs and outputs

Input(s)	Output(s)
ODUk_TCP: ODUk_CI_CK ODUk_CI_D ODUk_CI_FS ODUk_CI_MFS ODUk_CI_SSF ODUkP_TT_Sk_MP: ODUkP_TT_Sk_MI_ExSAPI ODUkP_TT_Sk_MI_ExDAPI ODUkP_TT_Sk_MI_GetAcTI ODUkP_TT_Sk_MI_TIMDetMo ODUkP_TT_Sk_MI_TIMActDis OTUk_TT_Sk_MI_DEGThr OTUk_TT_Sk_MI_DEGM OTUk_TT_Sk_MI_1second ODUkP_TT_Sk_MI_DM_Source ODUkP_TT_Sk_MI_DMValue	ODUkP_AP: ODUkP_AI_CK ODUkP_AI_D ODUkP_AI_FS ODUkP_AI_MFS ODUkP_AI_TSF ODUkP_AI_TSD ODUkP_RP: ODUkP_RI_BDI ODUkP_RI_BEI ODUkP_RI_DM ODUkP_TT_Sk_MP: ODUkP_TT_Sk_MI_AcTI ODUkP_TT_Sk_MI_cOCI ODUkP_TT_Sk_MI_cLCK ODUkP_TT_Sk_MI_cTIM ODUkP_TT_Sk_MI_cDEG ODUkP_TT_Sk_MI_cBDI ODUkP_TT_Sk_MI_cSSF ODUkP_TT_Sk_MI_pN_EBC ODUkP_TT_Sk_MI_pN_DS ODUkP_TT_Sk_MI_pF_EBC ODUkP_TT_Sk_MI_pF_DS ODUkP_TT_Sk_MI_pN_delay

Processes

The processes associated with the ODUkP_TT_Sk function are as depicted in Figure 14-18.

PMOH-BIP8: See clause 8.3.4.2. The BIP8 is extracted from the BIP8 byte of the PM field.

PMOH-TTI: The trail trace identifier shall be recovered from the TTI byte position of the PM field in the ODUk signal at the ODUk_TCP and processed as specified in clause 8.6. The accepted value of the TTI is available at the MP (MI_AcTI).

PMOH-BDI: The backward defect indication shall be recovered from the BDI bit position of the PM field in the ODUk signal at the ODUk_TCP. It shall be used for BDI defect detection.

PMOH-BEI: The BEI shall be recovered from the BEI bits in the PM field in the ODUk signal at the ODUk_TCP. It shall be used to determine if a far-end errored block (nF_B) has occurred. A nF_B has occurred if the BEI value is between 1 [0001] and 8 [1000]; otherwise, no nF_B has occurred.

PMOH-DMp: If MI_DM_Source is false, then the value of the DMp bit is output to RI_DM. If MI_DM_Source is true and MI_DMValue toggles, then a count of CI_FS transitions is started and the incoming DMp value is monitored. A change of value of DMp, from (NOT MI_DMValue) to MI_DMValue, validated by a 3-frame persistency check, stops the counting. The delay is represented by the count minus the persistency check and is output as MI_pN_delay.

NOTE 2 – Equipment developed prior to the 2010 version of this Recommendation will not support the DMp processing.

PMOH-STAT: The status information shall be recovered from the STAT bits in the PM field in the ODUk signal at the ODUk_TCP as defined in clause 8.8. It shall be used for AIS, OCI and LCK defect detection.

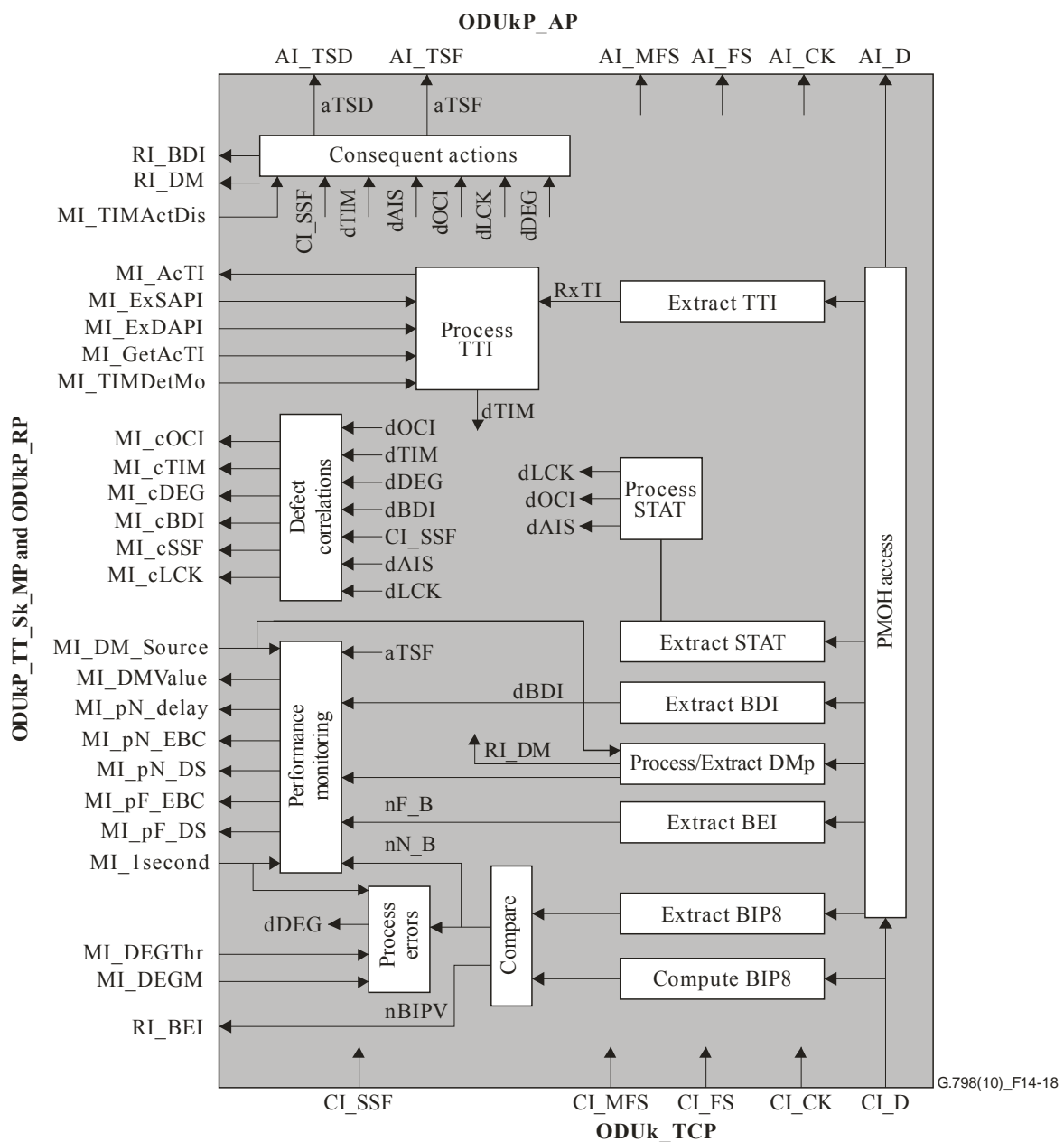

Figure 14-18 – ODUkP_TT_Sk processes

Defects

The function shall detect for dAIS, dOCI, dLCK, dTIM, dDEG and dBDI defects.

dAIS: See clause 6.2.6.3.2.

dOCI: See clause 6.2.6.8.2; dOCI shall be set to false during CI_SSF.

dLCK: See clause 6.2.6.9.1; dLCK shall be set to false during CI_SSF.

dTIM: See clause 6.2.2.1; dTIM shall be set to false during CI_SSF.

dDEG: See clause 6.2.3.5.

dBDI: See clause 6.2.6.6.1; dBDI shall be set to false during CI_SSF.

Consequent actions

The function shall perform the following consequent actions:

aBDI ← CI_SSF or dAIS or dOCI or dLCK or dTIM

aBEI ← NBIPV

aTSF ← CI_SSF or dAIS or dOCI or dLCK or (dTIM and (not TIMActDis))

aTSD ← dDEG

Defect correlations

The function shall perform the following defect correlations to determine the most probable fault cause (see clause 6.4 of [ITU-T G.806]). This fault cause shall be reported to the EMF.

cOCI ← dOCI and (not CI_SSF)

cLCK ← dLCK and (not CI_SSF)

cTIM ← dTIM and (not CI_SSF) and (not dAIS) and (not dOCI) and (not dLCK)

cDEG ← dDEG and (not CI_SSF) and (not dAIS) and (not dOCI) and (not dLCK) and (not (dTIM and (not TIMActDis)))

cBDI ← dBDI and (not CI_SSF) and (not dAIS) and (not dOCI) and (not dLCK) and (not (dTIM and (not TIMActDis)))

cSSF ← CI_SSF or dAIS

Performance monitoring

The function shall perform the following performance monitoring primitives processing (see clause 6.5 of [ITU-T G.806]). The performance monitoring primitives shall be reported to the EMF.

pN_DS ← CI_SSF or dAIS or dOCI or dLCK or dTIM

pF_DS ← dBDI

pN_EBC ← $\sum nN_B$

NOTE 3 – During CI_SSF, dAIS, dLCK and dOCI, no errored blocks shall be counted.

pF_EBC ← $\sum nF_B$

NOTE 4 – During CI_SSF, dAIS, dLCK and dOCI, no errored blocks shall be counted.

pN_delay ← \sum number of frames since DMValue toggle event

NOTE 5 – This count is triggered by the ODUkP_TT_So_MI_DMValue toggle event.

NOTE 6 – This value is a snapshot value.

Table 14-5A – Defined values for x for bit synchronous mapping

x	Bit rate	Clock range
2G5	2 488 320 kbit/s ± 20 ppm	2 488 320 kHz ± 20 ppm
10G	9 953 280 kbit/s ± 20 ppm	9 953 280 kHz ± 20 ppm
10G3	10 312 500 kbit/s ± 100 ppm	10 312 500 kHz ± 100 ppm
40G	39 813 120 kbit/s ± 20 ppm	39 813 120 kHz ± 20 ppm
Any other rate above 2G5	Client rate with a tolerance up to a maximum of ± 100 ppm	Client frequency with a tolerance up to a maximum of ± 100 ppm

Table 14-5B – Defined values for x for asynchronous mapping

x	Bit rate	Clock range
2G5	2 488 320 kbit/s ± 20 ppm	2 488 320 kHz ± 20 ppm
2G5 (Note)	2 488 320 kbit/s ± 32 ppm	2 488 320 kHz ± 32 ppm
10G	9 953 280 kbit/s ± 20 ppm	9 953 280 kHz ± 20 ppm
40G	39 813 120 kbit/s ± 20 ppm	39 813 120 kHz ± 20 ppm

NOTE – The 2G5 signal with 32 ppm tolerance represents the CM-GPON signal.

Two different source functions are defined. The ODUkP/CBRx-a_A_So provides asynchronous mapping, while the ODUkP/CBRx-b_A_So provides bit synchronous mapping. In the sink direction, the ODUkP/CBRx_A_Sk can handle both (bit synchronous and asynchronous) mappings.

14.3.1.1 ODUkP to CBRx asynchronous mapping adaptation source function (ODUkP/CBRx-a_A_So) (x = 2G5, 10G, 40G)

The ODUkP/CBRx-a_A_So function creates the ODUk signal from a free-running clock. It asynchronously maps the $4^{(k-1)} * 2\,488\,320$ kbit/s constant bit-rate client signal from the CBRx_CP into the payload of the OPUk (k = 1, 2, 3), adds OPUk overhead (RES, PT, JC) and default ODUk overhead.

The information flow and processing of the ODUkP/CBRx-a_A_So function are defined with reference to Figures 14-20 and 14-21.

Symbol

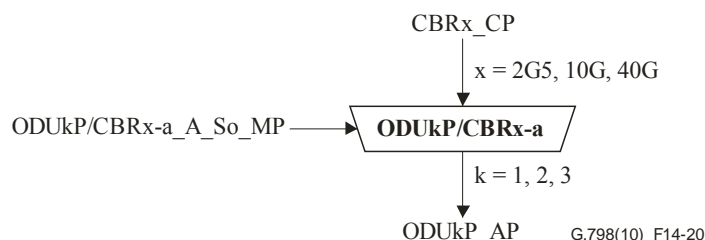

Figure 14-20 – ODUkP/CBRx-a_A_So function

Interfaces

Table 14-6 – ODUkP/CBRx-a_A_So inputs and outputs

Input(s)	Output(s)
CBRx_CP: CBRx_CI_CK CBRx_CI_D CBRx_CI_SSF ODUkP/CBRx-a_A_So_MP: ODUkP/CBRx-a_A_So_MI_Active	ODUkP_AP: ODUkP_AI_CK ODUkP_AI_D ODUkP_AI_FS ODUkP_AI_MFS

Processes

Activation: The ODUkP/CBRx-a_A_So function shall access the access point when it is activated (MI_Active is true). Otherwise, it shall not access the access point.

- **Clock and (multi)frame start signal generation:** The function shall generate a local ODUk clock (ODUkP_AI_CK) of " $(239/(239 - k)) * 4^{(k-1)} * 2\,488\,320\text{ kHz} \pm 20\text{ ppm}$ " from a free-running oscillator. The clock parameters, including jitter and wander requirements, as defined in Annex A of [ITU-T G.8251] (ODCa clock), apply.

The function shall generate the (multi)frame start reference signals AI_FS and AI_MFS for the ODUk signal. The AI_FS signal shall be active once per 122 368 clock cycles. AI_MFS shall be active once every 256 frames.

- **Mapping, frequency justification and bit rate adaptation:** The function shall provide an elastic store (buffer) process. The data signal CBRx_CI shall be written into the buffer under control of the associated input clock. The data shall be read out of the buffer and written onto the D and N/PJO bytes in the OPUk frame under control of the ODUk clock and justification decisions as defined in clause 17.1 of [ITU-T G.709].

A justification decision shall be performed each frame. Each justification decision results in a corresponding positive, negative or no justification action. Upon a positive justification action, the reading of one data byte out of the buffer shall be cancelled once. No CBRx data shall be written onto the PJO and NJO byte. Upon a negative justification action, one extra data byte shall be read once out of the buffer. CBRx data shall be written onto the PJO and NJO byte. If neither a positive nor a negative justification action is to be performed, CBRx data shall be written onto the PJO byte and no CBRx data shall be written onto the NJO byte.

The justification decisions determine the phase error introduced by the function.

Buffer size: In the presence of jitter as specified by [ITU-T G.825] and a frequency within the range $4^{(k-1)} * 2\,488\,320\text{ kHz} \pm 20\text{ ppm}$, this mapping process shall not introduce any errors. The maximum buffer hysteresis, and therefore the maximum phase error introduced, shall be as listed in Table 14-7.

Table 14-7 – Maximum buffer hysteresis

Mapping	Maximum buffer hysteresis
2G5 → ODU1	2 bytes
10G → ODU2	8 bytes
40G → ODU3	32 bytes

- **JC bits:** The function shall generate the justification control (JC) bits based on the justification decision performed in the current frame according to the specification in clause 17.1 of [ITU-T G.709]. It shall insert the justification control bits in the appropriate JC bit positions in the JC bytes of the current frame.
- **PT:** The function shall insert code "0000 0010" into the PT byte position of the PSI overhead as defined in clause 15.9.2.1 of [ITU-T G.709].
 - **RES:** The function shall insert all-0s into the RES bytes and reserved bits within the JC bytes.
 - **CSF:** The function shall signal the failure of the client signal to the far end by use of Bit 1 of the PSI[2] byte of the payload structure identifier as defined in clause 17.1 of [ITU-T G.709].

All other bits of the ODUk overhead should be sourced as "0"s, except the ODUk-PM STAT field which should be set to the value "normal path signal" (001).

NOTE – Equipment developed prior to the 2010 version of this Recommendation will not support the CSF processing.

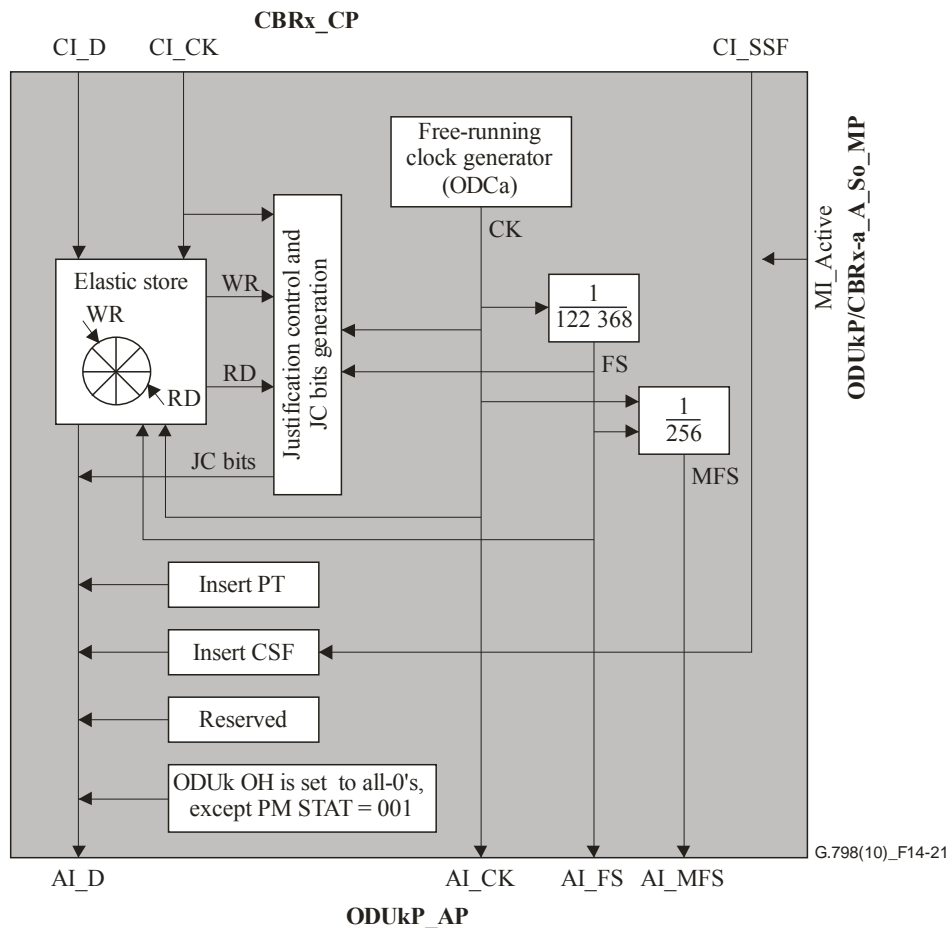

Figure 14-21 – ODUkP/CBRx-a_A_So processes

Defects: None.

Consequent actions: None.

Defect correlations: None.

Performance monitoring: None.

14.3.1.2 ODUkP to CBRx bit synchronous mapping adaptation source function (ODUkP/CDRx-b_A_So)

The ODUkP/CDRx-b_A_So function creates the ODUk signal from a clock, derived from the incoming CBRx_CI clock. It bit synchronously maps the $4^{(k-1)} * 2\,488\,320$ kbit/s ± 20 ppm ($k = 1, 2, 3$) or $10\,312\,500$ kbit/s ± 100 ppm ($k = 2e$) or other CBR signals greater than $2\,488\,320$ kbit/s ± 100 ppm ($k = flex$) constant bit-rate client signal from the CBRx_CP into the payload of the OPUk ($k = 1, 2, 2e, 3, flex$), adds OPUk overhead (PT, JC, RES) and default ODUk overhead.

The information flow and processing of the ODUkP/CDRx-b_A_So function are defined with reference to Figures 14-22 and 14-23.

Symbol

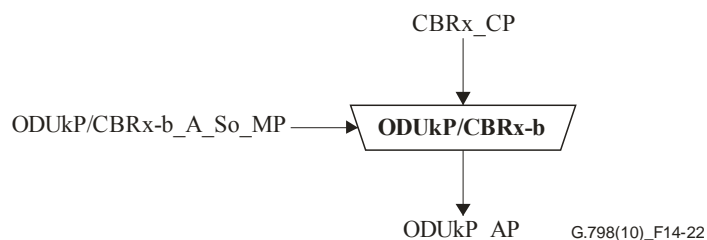

Figure 14-22 – ODUkP/CDRx-b_A_So function

Interfaces

Table 14-8 – ODUkP/CDRx-b_A_So inputs and outputs

Input(s)	Output(s)
CDRx_CP: CDRx_CI_CK CDRx_CI_D CDRx_CI_SSF ODUkP/CDRx-b_A_So_MP: ODUkP/CDRx-b_A_So_MI_Active	ODUkP_AP: ODUkP_AI_CK ODUkP_AI_D ODUkP_AI_FS ODUkP_AI_MFS

Processes

Activation: The ODUkP/CDRx-b_A_So function shall access the access point when it is activated (MI_Active is true). Otherwise, it shall not access the access point.

- **Clock and (multi)frame start signal generation:** The function shall generate the ODUk (AI_CK) clock by multiplying the incoming CDRx clock (CI_CK) by factor as specified in Table 14-9 below. The clock parameters, including jitter and wander requirements, as defined in Annex A of [ITU-T G.8251] (ODCb clock), apply.

Table 14-9 – Bit synchronous mapping parameters

ODUk	Multiplication factor	CBR clock frequency	CBR client jitter specification in
ODU1	239/238	2 488 320 kHz \pm 20 ppm	[ITU-T G.825]
ODU2	239/237	9 953 280 kHz \pm 20 ppm	[ITU-T G.825]
ODU2e	239/237	10 312 500 kHz \pm 100 ppm	[IEEE 802.3]
ODU3	239/236	39 813 120 kHz \pm 20 ppm	[ITU-T G.825]
ODUflex	239/238	Client frequency with a tolerance up to a maximum of \pm 100 ppm	Client specific

During failure conditions of the incoming CBR clock signal (CI_CK), the ODUk clock shall stay within its limits as defined in [ITU-T G.8251] and no frame phase discontinuity shall be introduced.

The function shall generate the (multi)frame start reference signals AI_FS and AI_MFS for the ODUk signal. The AI_FS signal shall be active once per 122 368 clock cycles. AI_MFS shall be active once every 256 frames.

- **Mapping, frequency justification and bit-rate adaptation:** The function shall provide an elastic store (buffer) process. The data signal CBRx_CI shall be written into the buffer under control of the associated input clock. The data shall be read out of the buffer and written onto the D and PJO bytes in the OPUk frame under control of the ODUk clock as defined in clause 17.2 of [ITU-T G.709] (k = 1, 2, 2e, 3) and clause 17.9 of [ITU-T G.709] (k = flex).

Neither negative nor positive justification is to be performed. No data shall be written onto the NJO byte and data shall always be written onto the PJO byte.

Buffer size: In the presence of jitter as specified by the relevant standard as listed in Table 14-9, this mapping process shall not introduce any errors.

Following a step in frequency of the CI_CK signal (for example, due to removal of AIS (generic AIS or Local Fault)), there will be a maximum recovery time of X seconds after which this process shall not generate any bit errors. The value of X is for further study; a value of 1 second has been proposed.

- **JC bits:** The function shall generate the fixed justification control (JC) bits "00" according to clause 17.2 of [ITU-T G.709]. It shall insert the justification control bits in the appropriate JC bit positions in the JC bytes.
- **RES:** The function shall insert all-0s into the RES bytes and Reserved bits within the JC bytes.
 - **PT:** The function shall insert code "0000 0011" into the PT byte position of the PSI overhead as defined in clause 15.9.2.1 of [ITU-T G.709].
 - **Client signal fail:** The function shall insert client signal fail indication CSF under control of CBR_CI_SSF into Bit 1 of the PSI[2] byte of the payload structure identifier, as defined in clause 17.1 of [ITU-T G.709].

All other bits of the ODUk overhead should be sourced as "0"s, except the ODUk-PM STAT field which should be set to the value "normal path signal" (001).

NOTE – Equipment developed prior to the 2010 version of this Recommendation will not support the CSF processing.

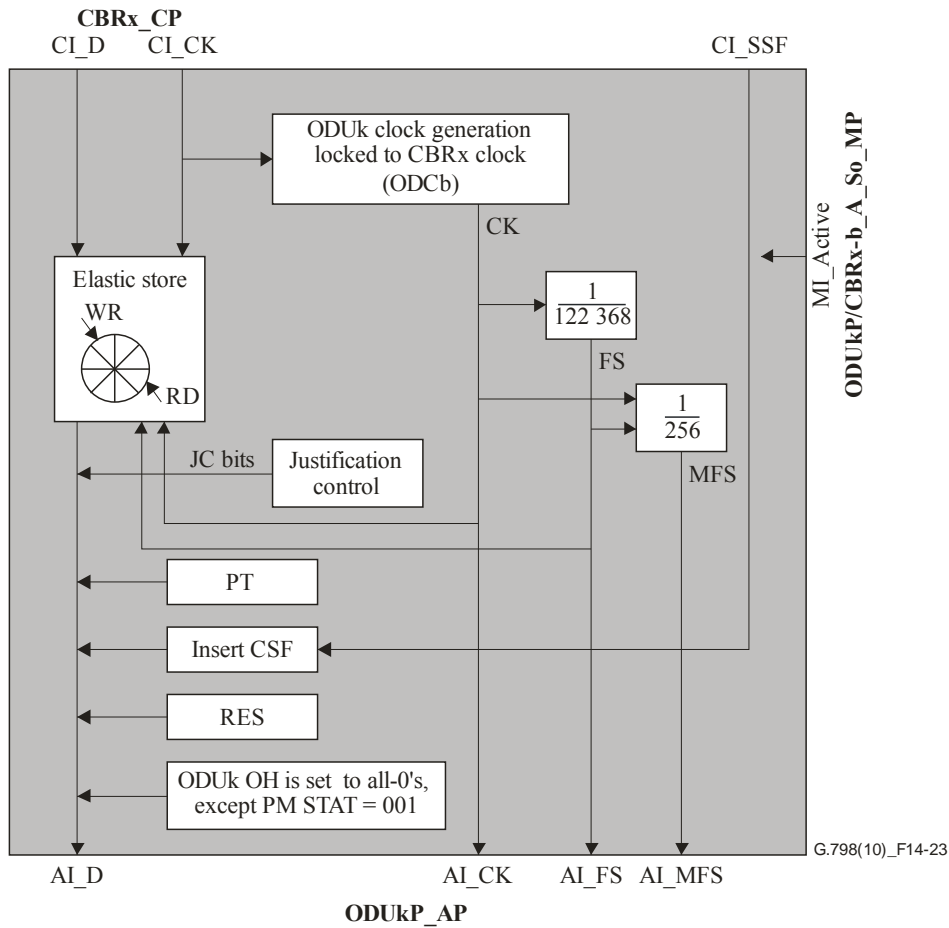

Figure 14-23 – ODUkP/CDRx-b_A_So processes

Defects: None.

Consequent actions: None.

Defect correlations: None.

Performance monitoring: None.

14.3.1.3 ODUkP to CDRx adaptation sink function (ODUkP/CDRx_A_Sk)

The ODUkP/CDRx_A_Sk recovers the constant bit-rate client signal from the OPUk payload using the justification control information (JC overhead) to determine if a data or stuff byte is present within the NJO and PJO bytes. It extracts the OPUk overhead (PT, JC, and RES) and monitors the reception of the correct payload type. Under signal fail condition, generic-AIS shall be generated.

The information flow and processing of the ODUkP/CDRx_A_Sk function are defined with reference to Figures 14-24 and 14-25.

Symbol

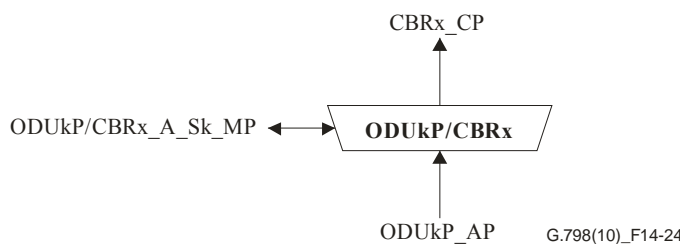

Figure 14-24 – ODUkP/CDRx_A_Sk function

Interfaces

Table 14-10 – ODUkP/CBRx_A_Sk inputs and outputs

Input(s)	Output(s)
ODUkP_AP: ODUkP_AI_CK ODUkP_AI_D ODUkP_AI_FS ODUkP_AI_TSF ODUkP/CBRx_A_Sk_MP: ODUkP/CBRx_A_Sk_MI_Active	CBRx_CP: CBRx_CI_CK CBRx_CI_D CBRx_CI_SSF ODUkP/CBRx_A_Sk_MP: ODUkP/CBRx_A_Sk_MI_cPLM ODUkP/CBRx_A_Sk_MI_cCSF ODUkP/CBRx_A_Sk_MI_AcPT

Processes

Activation: The ODUkP/CBRx_A_Sk function shall access the access point and perform the common and specific processes operation specified below when it is activated (MI_Active is true). Otherwise, it shall activate the SSF signals and generate generic AIS at its output (CP) and not report its status via the management point.

- **PT:** The function shall extract the PT byte from the PSI overhead as defined in clause 8.7.1. The accepted PT value is available at the MP (MI_AcPT) and is used for PLM defect detection.
- **RES:** The value in the RES bytes shall be ignored.
- **JC:** The function shall interpret the justification control information in the JC byte as defined in clauses 17.2 and 17.9 of [ITU-T G.709] in order to determine the justification action (positive, negative, none) for the current frame. RES bits in the JC shall be ignored.
- **Demapping, CBR clock generation:** The function shall provide an elastic store (buffer) process. The CBR data shall be written into the buffer from the D, PJO and NJO byte in the OPUk frame. The information extraction of the PJO and NJO bytes shall be under control of the justification control information. The CBRx data (CI_D) shall be read out of the buffer under control of the CBRx clock (CI_CK).

Upon a positive justification action, the writing of one data byte into the buffer shall be cancelled once. No CBRx data shall be read from the PJO and NJO byte. Upon a negative justification action, one extra data byte shall be written into the buffer once. CBRx data shall be read from the PJO and NJO byte. If neither a positive nor a negative justification action is to be performed, CBRx data shall be read from the PJO byte and no CBRx data shall be read from the NJO byte.

Client signal fail: The function shall extract the CSF signal indicating the failure of the client signal out of the Bit 1 of the PSI[2] byte of the payload structure identifier, as defined in clause 17.1 of [ITU-T G.709].

Smoothing and jitter limiting process: The function shall provide for a clock smoothing and elastic store (buffer) process. The data signal shall be written into the buffer under control of the associated (gapped) input clock. The data signal shall be read out of the buffer under control of a smoothed (equally spaced) clock. The rate is determined by the signal at the input of the remote ODUkP/CBRx_A_So.

The clock parameters, including jitter and wander requirements, as defined in Annex A of [ITU-T G.8251] (ODCp clock), apply.

Buffer size: In the presence of jitter as specified by the relevant standard as listed in Table 14-9, this justification process shall not introduce any errors.

Following a step in frequency of the signal transported by the ODUkP_AI (for example due to reception of CBRx_CI from a new RSn_TT_So at the far end or removal of generic-AIS signal with a frequency offset), there will be a maximum recovery time of X seconds after which this process shall not generate any bit errors. The value of X is for further study; a value of 1 second has been proposed.

NOTE – Equipment developed prior to the 2010 version of this Recommendation will not support the CSF processing.

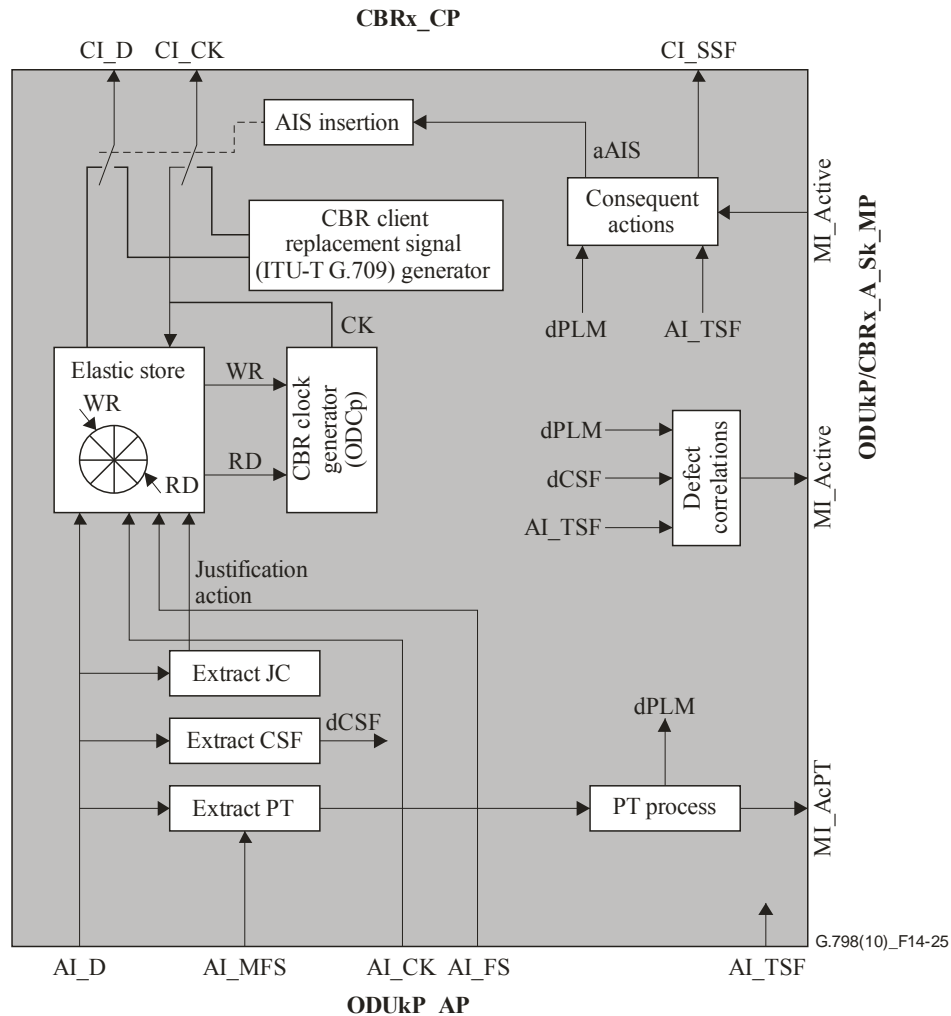

Figure 14-25 – ODUkP/CDRx_A_Sk processes

Defects

The function shall detect for dPLM.

- **dPLM**: See clause 6.2.4.1. The expected payload types are "0000 0010" (asynchronous CBRx mapping) and "0000 0011" (bit synchronous CBRx mapping), as defined in [ITU-T G.709].
- **dCSF**: See clause 6.2.10.

Consequent actions

aSSF ← AI_TSF or dPLM or (not MI_Active)

aAIS ← AI_TSF or dPLM or (not MI_Active)

On declaration of aAIS, the function shall output a replacement signal as defined in clauses 17.2 and 17.9 of [ITU T G.709] within two frames. On clearing of aAIS the replacement pattern/signal

shall be removed within two frames and normal data being output. The replacement signal clock shall be independent from the incoming clock. The replacement signal clock has to be within the range specified by Table 14-9. Jitter and wander requirements, as defined in Annex A of [ITU-T G.8251] (ODCp clock), apply.

Defect correlations

- cPLM ← dPLM and (not AI_TSF)
- cCSF ← dCSF and (not dPLM) and (not AI_TSF)

Performance monitoring: None.

14.3.2 ODUkP to ATM VP adaptation function (ODUkP/VP_A)

NOTE – The specification of this adaptation function is derived from equivalent adaptation functions defined in Annex D of [ITU-T I.732].

14.3.2.1 ODUkP to ATM VP adaptation source function (ODUkP/VP_A_So)

Symbol

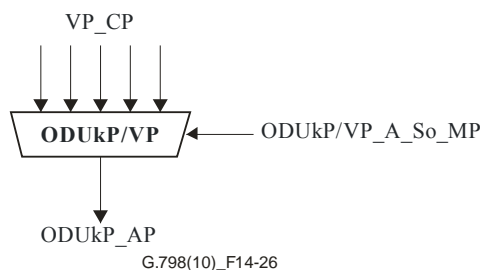

Figure 14-26 – ODUkP/VP_A_So symbol

Interfaces

Table 14-11 – ODUkP/VP_A_So input and output signals

Input(s)	Output(s)
<p>per VP_CP, for each VP configured:</p> <p>VP_CI_D VP_CI_ACS VP_CI_SSF</p> <p>ODUkP/VP_A_So_MP:</p> <p>ODUkP/VP_A_So_MI_Active ODUkP/VP_A_So_MI_CellDiscardActive ODUkP/VP_A_So_MI_TPushActive ODUkP/VP_A_So_MI_GFCActive ODUkP/VP_A_So_MI_VPI-KActive</p>	<p>ODUkP_AP:</p> <p>ODUkP_AI_CK ODUkP_AI_D ODUkP_AI_FS ODUkP_AI_MFS</p>

Processes

The ODUkP/VP_A_So function provides adaptation from the ATM virtual path layer to the ODUk path. This is performed by a grouping of specific processes and common processes as shown in Figure 14-27.

Activation

- The ODUkP/VP_A_So function shall access the access point when it is activated (MI_Active is true). Otherwise, it shall not access the access point.

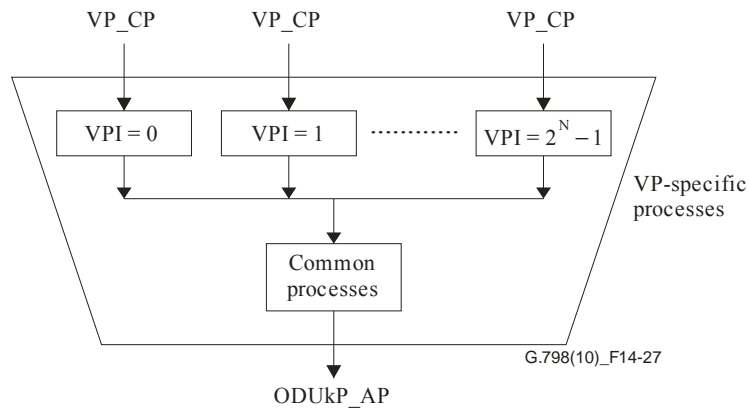

Figure 14-27 – ODUkP/VP_A_So atomic function decomposed into specific and common processes parts

NOTE 1 – The sequential order of the processes within the atomic functions is important. For the correct order, refer to the ordering of the processes given below.

Clock and (multi)frame start signal generation: The function shall generate a local ODUk ($k = 1, 2, 3$) clock (ODUkP_AI_CK) of " $239/(239 - k) \times 4^{(k-1)} \times 2\,488\,320$ kHz ± 20 ppm". The jitter and wander requirements, as defined in Annex A of [ITU-T G.8251] (ODCa clock), apply.

The function shall generate the (multi)frame start reference signals ODUkP_AI_FS and ODUkP_AI_MFS for the ODUk signal. The ODUkP_AI_FS signal shall be active once per 122 368 clock cycles. ODUkP_AI_MFS shall be active once every 256 frames.

VP-specific processes

These processes include VPI setting as well as VP asynchronous multiplexing. Each of these specific processes is characterized by the virtual path identifier number K , where $0 \leq K \leq 2^N - 1$.

NOTE 2 – The value of N represents the number of bits in the VPI field and is an integer number. Its maximum value is equal to 12 for the ATM NNI. Its maximum value is equal to 8 for the ATM UNI.

VPI-K activation

- Layer management function: The specific processes perform the operation specified below when it is activated (MI_VPI-KActive is true).

The format of the characteristic information (VP_CI) is given in Figure 14-28.

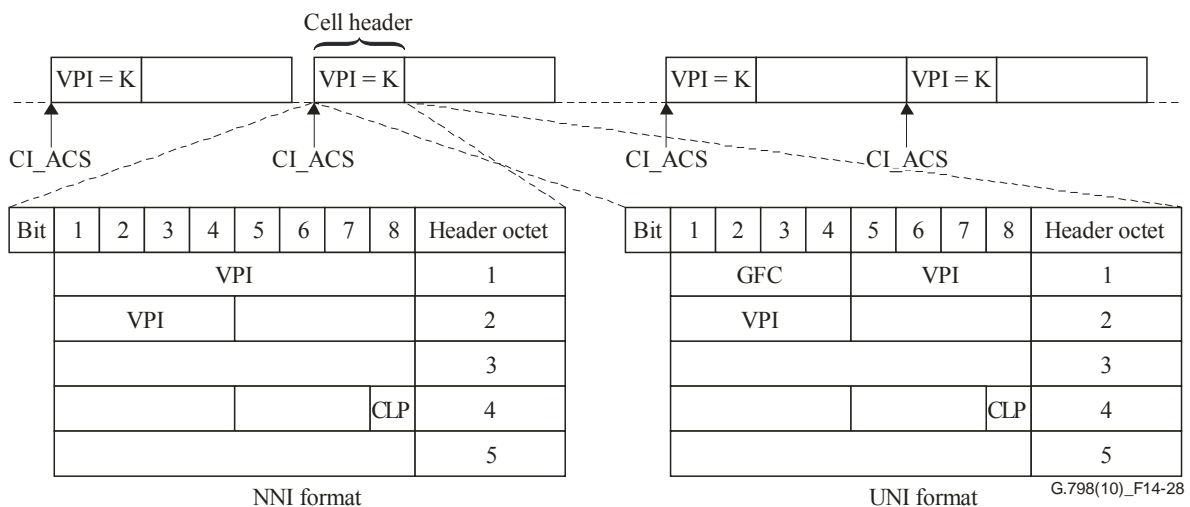

Figure 14-28 – VP_CI

VPI setting

- Transfer function: VPI setting inserts the value of "K" as VPI for each active specific function.
- Layer management function: VPI setting is based on the activation of the specific function by MI_VPI-KActive.

VP multiplexing

- Transfer function: Asynchronous multiplexing is performed for each active specific function.

Common processes

The common processes include: congestion control (selective cell discard (CLP based)), GFC processing, TP usage measurement, cell rate decoupling, HEC processing, cell information field scrambling, cell stream mapping, and processing of the payload-specific bytes PT and RES, to the OPUk OH. The logical ordering of the processes from input to output must be maintained.

Bit	1	2	3	4	5	6	7	8	Header octet
	GFC			VPI					1
	VPI								2
									3
									4
	HEC								5

UNI format

Bit	1	2	3	4	5	6	7	8	Header octet
	VPI								1
	VPI								2
									3
									4
	HEC								5

NNI format

G.798(10)_F14-29

Figure 14-29 – Cell header information processed in ODUkP/VP_A_So

Congestion control

- Transfer function: If enabled by MI_CellDiscard = Active, this process shall perform selective cell discard according to CLP value. In the event of congestion, cells with CLP = 1 are subject to be discarded prior to cells with CLP = 0. See [ITU-T I.371] for further details about the use of the CLP. In the event of congestion, the EFCI marking in the PTI field is set according to [ITU-T I.361].

GFC processing

- Transfer function: The support of the GFC protocol applies to the UNI and in point-to-point configuration only and is an option. This process sets the GFC field. The GFC field processing is defined in [ITU-T I.150] and [ITU-T I.361].
- Layer management function: The GFC function uses assigned and unassigned cells. Two modes of operation are available: uncontrolled transmission (MI_GFCActive is false) and controlled transmission (MI_GFCActive is true). In uncontrolled transmission mode, neither the controlling nor the controlled NE performs the GFC procedure. If enabled by MI_GFCActive = true, this process shall insert the GFC protocol in the GFC field. If the GFC function is not supported or the GFC function is disabled by MI_GFCActive = false, the binary contents of the GFC field shall be set to "0000".

TP usage measurement

- Transfer function: Cell transmission is indicated to layer management.
- Layer management function: The process shall count the transmitted cells for cell measurement purposes. This cell counting shall be activated/deactivated by MI_TPusgActive.

Cell rate decoupling

- Transfer function: This process takes the ATM cell stream present at its input and inserts it into the OPUk payload having a capacity of 4×3808 bytes adding fixed stuff idle cells. The idle cells format is specified in [ITU-T I.361]. The cell rate decoupling process makes use of the ODUk local timing clock, frame position and idle cell generator.

HEC processing

- Transfer function: The HEC value for each cell is calculated and inserted into the HEC field. The method of HEC value calculation shall be according to [ITU-T I.432.1].

Cell information field scrambling

- Transfer function: The self-synchronizing scrambler polynomial $x^{43} + 1$ has been identified for the SDH-based transmission paths and minimizes the error multiplication introduced by the self-synchronizing scrambling process. It is also used here for the mapping into ODUks. It scrambles the information field bits only. The operation of the scrambler shall be according to clause 7.3.4.1 of [ITU-T I.432.1].

Cell stream mapping

- Transfer function: The octet structure of ATM cells shall be aligned with the octet structure of the OPUk payload area as defined in clause 17.3 of [ITU-T G.709].

Processing of the payload-specific bytes

RES: This payload-dependent set of bytes is not used for the mapping of ATM cells into OPUk. The contents of this byte shall be 00Hex.

PT: In this byte, the process shall insert code "0000 0100" (ATM mapping) as defined in [ITU-T G.709].

All other bits of the ODUk overhead should be sourced as "0"s, except the ODUk-PM STAT field which should be set to the value "normal path signal" (001).

Defects: None.

Consequent actions: None.

Defect correlations: None.

Performance monitoring

The use of the performance monitoring parameters is for further study. The parameters for the following processes need to be defined:

- TP usage measurement;
- count of discarded cells from congestion control.

14.3.2.2 ODUkP to ATM VP adaptation sink function (ODUkP/VP_A_Sk)

Symbol

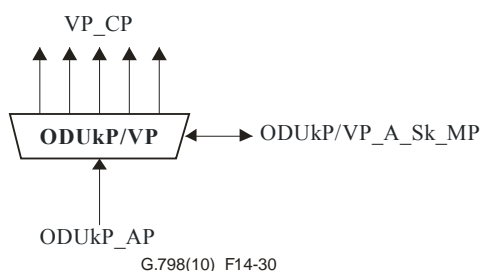

Figure 14-30 – ODUkP/VP_A_Sk symbol

Interfaces

Table 14-12 – ODUkP/VP_A_Sk input and output signals

Input(s)	Output(s)
ODUkP_AP: ODUkP_AI_CK ODUkP_AI_D ODUkP_AI_FS ODUkP_AI_TSF ODUkP_AI_TSD ODUkP/VP_A_Sk_MP: ODUkP/VP_A_Sk_MI_Active ODUkP/VP_A_Sk_MI_CellDiscardActive ODUkP/VP_A_Sk_MI_TPushActive ODUkP/VP_A_Sk_MI_VPIrange ODUkP/VP_A_Sk_MI_HECActive ODUkP/VP_A_Sk_MI_GFCActive ODUkP/VP_A_Sk_MI_DTDLuseEnabled ODUkP/VP_A_Sk_MI_VPI-KActive ODUkP/VP_A_Sk_MI_VPI-K_SAISActive	per VP_CP, for each VP configured: VP_CI_D VP_CI_ACS VP_CI_SSF VP_CI_CNGI ODUkP/VP_A_Sk_MP: ODUkP/VP_A_Sk_MI_cPLM ODUkP/VP_A_Sk_MI_cLCD ODUkP/VP_A_Sk_MI_AcPT

Processes

The ODUkP/VP_A_Sk function provides adaptation from the ODUk to the ATM virtual path. This is performed by a grouping of specific processes and common processes as shown in Figure 14-31.

Activation

- The ODUkP/VP_A_Sk function shall access the access point and perform the common and specific processes operation specified below when it is activated (MI_Active is true). Otherwise, it shall activate the SSF signals and generate AIS at its output (CP) and not report its status via the management point.

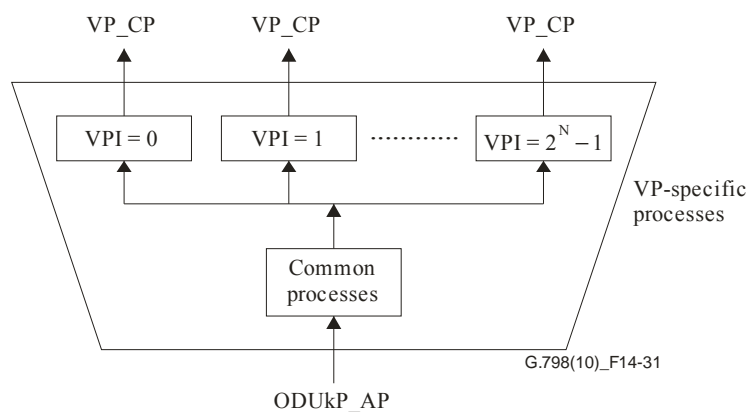

Figure 14-31 – ODUkP/VP_A_Sk atomic function decomposed into specific and common processes parts

NOTE 1 – The sequential order of the processes within the atomic functions is important. For the correct order, refer to the ordering of the processes given below.

Common processes

These common processes include: handling of the payload-specific bytes (PT, PSI and RES), demapping, cell delineation, cell information field descrambling, HEC processing, cell rate decoupling, TP usage measurement, header verification, GFC processing, VPI verification, and

congestion control (selective cell discard (CLP-based)). The logical ordering of these processes from input to output must be maintained.

Handling of payload-specific bytes

PT: The process shall extract the payload type as defined in clause 8.7.1. The accepted PT value is available at the MP (MI_AcPT) and is used for PLM defect detection.

RES: This payload-dependent byte is not used for this mapping and the receiver shall ignore its contents.

Demapping

- Transfer function: The cell stream shall be extracted from the OPUk payload in the ODUkP_AI in accordance with [ITU-T G.709].

Cell delineation

- Transfer function: Cell delineation is performed on the continuous cell stream. The cell delineation algorithm should be in accordance with [ITU-T I.432.1]. The OCD events are indicated to the layer management function.
- Layer management function: loss of cell delineation defect (dLCD) shall be declared as in the defect section below.

Cell information field descrambling

- Transfer function: The self-synchronizing descrambler polynomial $x^{43} + 1$ has been identified for the SDH-based transmission paths and minimizes the error multiplication introduced by the self-synchronizing scrambling process (factor 2). It is also used here for the mapping into ODUks. It descrambles the information field bits only. The operation of the descrambler in relation to the HEC cell delineation state diagram shall be according to clause 7.3.4.1 of [ITU-T I.432.1].

HEC processing

- Transfer function: HEC verification and correction shall be according to [ITU-T I.432.1]. Cells determined to have an invalid and uncorrectible HEC pattern shall be discarded.
- Layer management function: A count of invalid HEC events and a count of invalid HEC cell discard events are maintained with threshold crossings checked. HEC correction mode may be activated/deactivated by MI_HECActive. The HEC correction mode should be activated by default.

Cell rate decoupling

- Transfer function: The process shall extract the idle cells used as fixed stuff in the far-end ODUkP/VP adaptation source function.

TP usage measurement

- Transfer function: The cell reception is indicated to the layer management function.
- Layer management function: The process shall count the received cells for cell measurement purposes. This cell counting shall be activated/deactivated by MI_TPUsGActive.

Header verification

- Transfer function: The receiving function shall verify that the first four octets of the ATM cell header are recognizable as being a valid header pattern. Cells with unrecognized header patterns shall be discarded. An indication of an invalid header cell discard event is provided to layer management.

- Invalid header patterns from paths based on OTN transmission systems are as follows (except idle cell) (x = any value):

UNI	GFC xxxx	VPI all 0's	VCI all 0's	PTI xxx	CLP 1
NNI	VPI all 0's		VCI all 0's	PTI xxx	CLP 1

- Layer management function: The process shall count the invalid header cell discard event.

GFC processing

- Transfer function: The support of the GFC protocol applies to the UNI and in point-to-point configuration only and is an option. This process extracts the GFC field. The GFC field processing is defined in [ITU-T I.150] and [ITU-T I.361].
- Layer management function: The GFC function uses assigned and unassigned cells. Two modes of operation are available: uncontrolled transmission (MI_GFCActive is false) and controlled transmission (MI_GFCActive is true). In uncontrolled transmission mode, neither the controlling nor the controlled NE performs the GFC procedure. If enabled by MI_GFCActive = true, this process shall extract the GFC protocol from the GFC field.

NOTE 2 – According to the protocol reference model ([ITU-T I.321]), the unassigned cells should be processed in the ATM layer. Some of the ATM layer processes are adaptation processes belonging to the adaptation function between the TP and the VP layer network. The unassigned cells, as well as idle cells, are per physical connection (VPI = 0, VCI = 0). For this reason, the idle and unassigned cells' processing is allocated to the same atomic function.

VPI verification

- Transfer function: The process shall verify that the received cell VPI is valid. If the VPI is determined to be invalid (i.e., out-of-range VPI or not assigned), the cell shall be discarded. An indication of the invalid VPI cell discard events is provided to the layer management function.
- Layer management function: The range of valid VPIs is given by MI_VPIrange. The invalid VPI cell discard events are counted.

Congestion control

- Transfer function: In the event of congestion, cells with CLP = 1 are subject to be discarded prior to cells with CLP = 0. See [ITU-T I.371] for further details about the use of the CLP. In the event of congestion, the indication VP_CI_CNGI is set for the traffic management function VPTM_TT_So to insert EFCI on all VPs.
- Layer management function: If enabled by MI_CellDiscardActive, this process shall perform selective cell discard according to CLP value.

VP-specific processes

The function performs end-to-end VP-AIS insertion, segment VP-AIS insertion and demultiplexing on a per-VP basis.

VPI-K activation

- Layer management function: The specific processes perform the operation specified below when it is activated (MI_VPI-KActive is true). Otherwise, it shall send no cells and SSF = false.

End-to-end VP-AIS insertion

- Transfer function: This process inserts end-to-end VP-AIS cells from the layer management function for each active specific function.
- Layer management function: End-to-end VP-AIS cells (Figure 14-32) shall be generated according to the consequent actions section of the coordination function below for each active specific function.

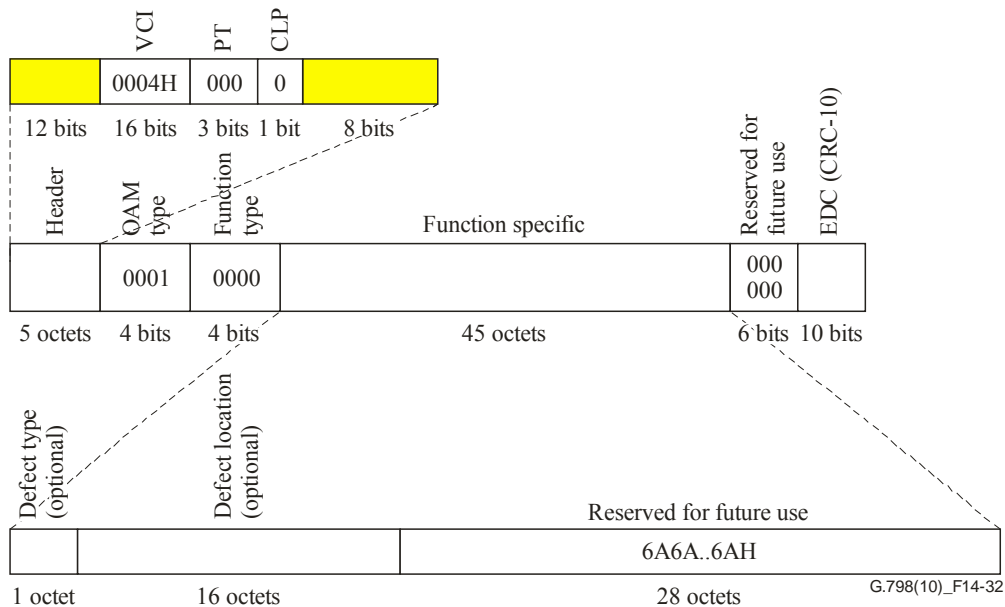

Figure 14-32 – End-to-end VP-AIS OAM cell as part of the VP_CI

Segment VP-AIS insertion

- Transfer function: This process inserts segment VP-AIS cells from the layer management function for each active specific function.
- Layer management function: Segment VP-AIS cells (Figure 14-33) shall be generated according to the consequent actions section of the coordination function below for each active specific function and the segment VP-AIS cells insertion is also activated (MI_VPI-K_SAISActive is true).

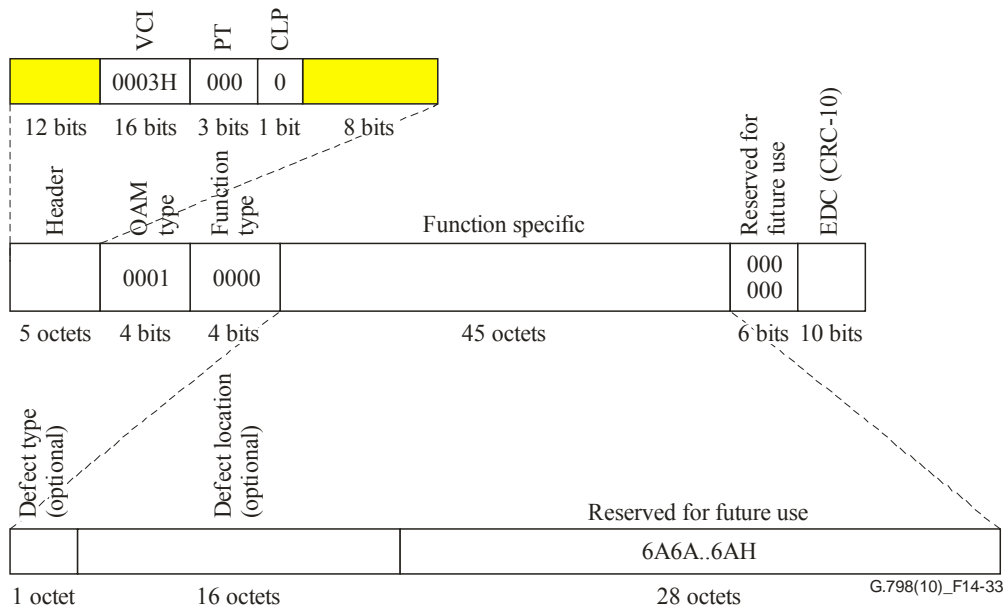

Figure 14-33 – Segment VP-AIS OAM cell as part of the VP_CI

VP demultiplexing

- Transfer function: The adaptation sink function has access to a specific VP identified by the number K ($0 \leq K \leq 2^N - 1$). For each active specific function, only the cells of that specific VPI-K are passed in the client direction.

NOTE 3 – The value of N represents the number of bits in the VPI field and is an integer number. Its maximum value is equal to 12 for the ATM NNI. Its maximum value is equal to 8 for the ATM UNI.

Defects

The function shall detect for the dPLM and dLCD defects.

dPLM: See clause 6.2.4.1. The expected payload type is "000 0100" (ATM mapping).

dLCD: See [ITU-T I.432.1].

Consequent actions

- aCNGI ← "Event of congestion" and CellDiscardActive
- aSSF ← dPLM or dLCD or AI_TSF or (not MI_Active)
- aAIS ← dPLM or dLCD or AI_TSF or (not MI_Active)

On declaration of aAIS, the function shall output end-to-end VP-AIS cells (Figure 14-32) on all active VPCs and segment VP-AIS cells (Figure 14-33) on all active VPCs for which MI_SAISactive is true, according to clause 9.2.1.1.1.1 of [ITU-T I.610]. On clearing of aAIS, the generation of end-to-end and segment VP-AIS cells shall be stopped. If either the function does not support the defect type and defect location (DTDLD) option, or the function supports the DTDLD option and the MI_DTDLDuseEnabled is false, the binary contents of the defect type and defect location fields of the end-to-end and segment VP-AIS cell shall be coded as 6AH. If the function supports the DTDLD option and if the MI_DTDLDuseEnabled is true, the defect type and defect location values shall be inserted in the information field of the end-to-end and segment VP-AIS cells.

NOTE 4 – As long as the coding scheme of defect type and defect location fields is not defined, the fields shall be encoded as 6AH.

The consequent action aSSF is conveyed by CI_SSF through the VP_CI.

Defect correlations

cPLM ← dPLM and (not AI_TSF)
cLCD ← dLCD and (not dPLM) and (not AI_TSF)

Performance monitoring

The use of the performance monitoring parameters is for further study. The parameters for the following functions need to be defined:

- TP usage measurement;
- count of discarded cells from congestion control;
- count of invalid HEC events;
- count of invalid HEC discard events;
- count of invalid header discard events (one common counter for invalid header/invalid VPI/invalid VCI is maintained);
- OCD event.

14.3.3 ODU2P to Ethernet PP-OS adaptation function (ODU2P/EthPP-OS_A)

The ODU2P to Ethernet PP-OS adaptation function for supporting the transport of the preamble and ordered set information of the 10GBASE-R signals over extended OPU2 payload area (clause 17.4.1 of [ITU-T G.709]) is given in clause 11.5.3 of [ITU-T G.8021].

14.3.4 ODUkP to NULL adaptation function (ODUkP/NULL_A)

The ODUkP to NULL adaptation functions perform the adaptation of a NULL test signal as defined in clause 17.5.1 of [ITU-T G.709] into the ODUkP ($k = 0, 1, 2, 2e, 3, 4, \text{flex}$). The NULL signal is an all-ZEROs pattern.

14.3.4.1 ODUkP to NULL adaptation source function (ODUkP/NULL_A_So)

The ODUkP/NULL_A_So function creates the ODUk signal from a free-running clock. It maps the NULL signal into the payload of the OPUk ($k = 0, 1, 2, 2e, 3, 4, \text{flex}$), adds OPUk overhead (RES, PT) and default ODUk overhead.

The information flow and processing of the ODUkP/NULL_A_So function is defined with reference to Figures 14-34 and 14-35.

Symbol

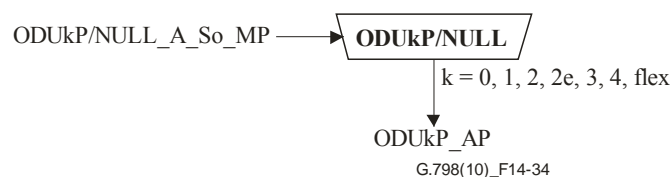

Figure 14-34 – ODUkP/NULL_A_So function

Interfaces

Table 14-13 – ODUkP/NULL_A_So inputs and outputs

Input(s)	Output(s)
ODUkP/NULL_A_So_MP: ODUkP/NULL_A_So_MI_Active ODUkP/NULL_A_So_MI_Nominal_Bitrate_and_Tolerance	ODUkP_AP: ODUkP_AI_CK ODUkP_AI_D ODUkP_AI_FS ODUkP_AI_MFS

Processes

Activation

- The ODUkP/NULL_A_So function shall access the access point when it is activated (MI_Active is true). Otherwise, it shall not access the access point.

Clock and (multi)frame start signal generation: The function shall generate a local ODUk clock (ODUkP_AI_CK) with a clock frequency within the minimum to maximum values of the specified ODU signal as given in Table 14-2 and provisioned by the MI_Nominal_Bitrate_and_Tolerance from a free-running oscillator. The jitter and wander requirements, as defined in Annex A of [ITU-T G.8251] (ODCa clock), apply.

The function shall generate the (multi)frame start reference signals AI_FS and AI_MFS for the ODUk signal. The AI_FS signal shall be active once per 122 368 clock cycles. AI_MFS shall be active once every 256 frames.

Insert NULL signal: The function shall insert an all-ZEROs pattern into the OPuK payload area as defined in clause 17.5.1 of [ITU-T G.709].

PT: The function shall insert code "1111 1101" into the PT byte position of the PSI overhead as defined in clause 15.9.2.1 of [ITU-T G.709].

RES: The function shall insert all-ZEROs into the RES bytes.

All other bits of the ODUk overhead should be sourced as "0"s, except the ODUk-PM STAT field which should be set to the value "normal path signal" (001).

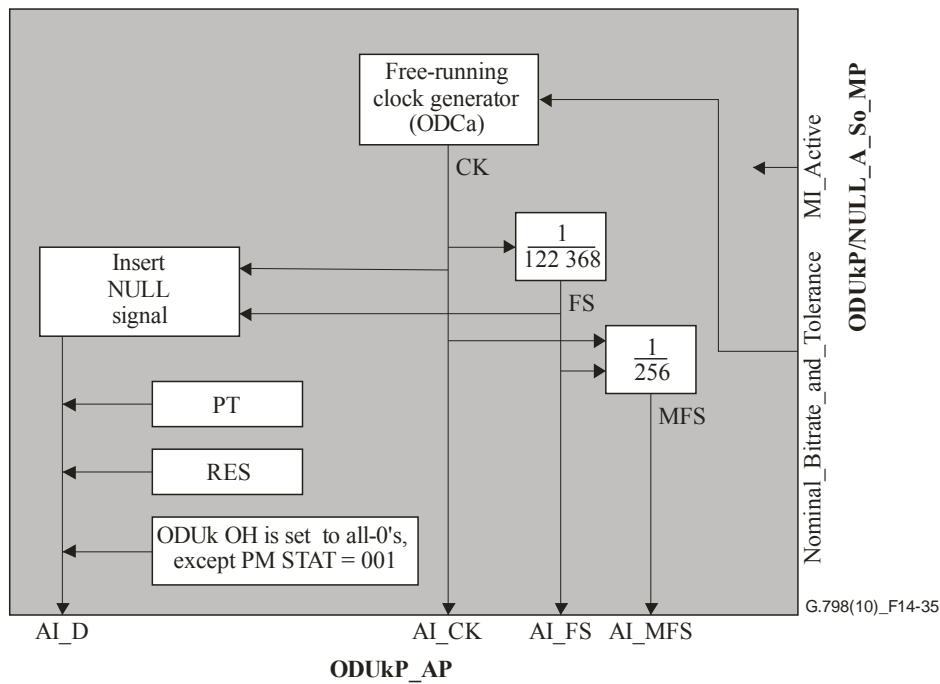

Figure 14-35 – ODUkP/NULL_A_So processes

Defects: None.

Consequent actions: None.

Defect correlations: None.

Performance monitoring: None.

14.3.4.2 ODUkP to NULL adaptation sink function (ODUkP/NULL_A_Sk)

The ODUkP/NULL_A_Sk extracts the OPUk overhead (PT and RES) and monitors the reception of the correct payload type.

The information flow and processing of the ODUkP/NULL_A_Sk function is defined with reference to Figures 14-36 and 14-37.

Symbol

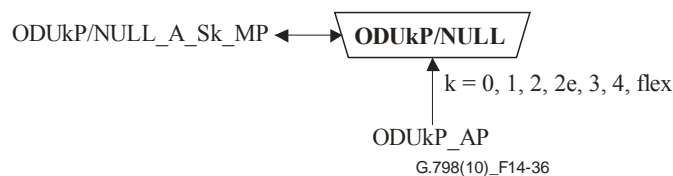

Figure 14-36 – ODUkP/NULL_A_Sk function

Interfaces

Table 14-14 – ODUkP/NULL_A_Sk inputs and outputs

Input(s)	Output(s)
ODUkP_AP: ODUkP_AI_CK ODUkP_AI_D ODUkP_AI_FS ODUkP_AI_MFS ODUkP_AI_TSF ODUkP/NULL_A_Sk_MP: ODUkP/NULL_A_Sk_MI_Active	ODUkP/NULL_A_Sk_MP: ODUkP/NULL_A_Sk_MI_cPLM ODUkP/NULL_A_Sk_MI_AcPT

Processes

Activation

- The ODUkP/NULL_A_Sk function shall access the access point and perform the common and specific processes operation specified below when it is activated (MI_Active is true). Otherwise, it shall not report its status via the management point.

PT: The function shall extract the PT byte from the PSI overhead as defined in clause 8.7.1. The accepted PT value is available at the MP (MI_AcPT) and is used for PLM defect detection.

RES: The value in the RES bytes shall be ignored.

Payload: The value in the OPUk payload area shall be ignored.

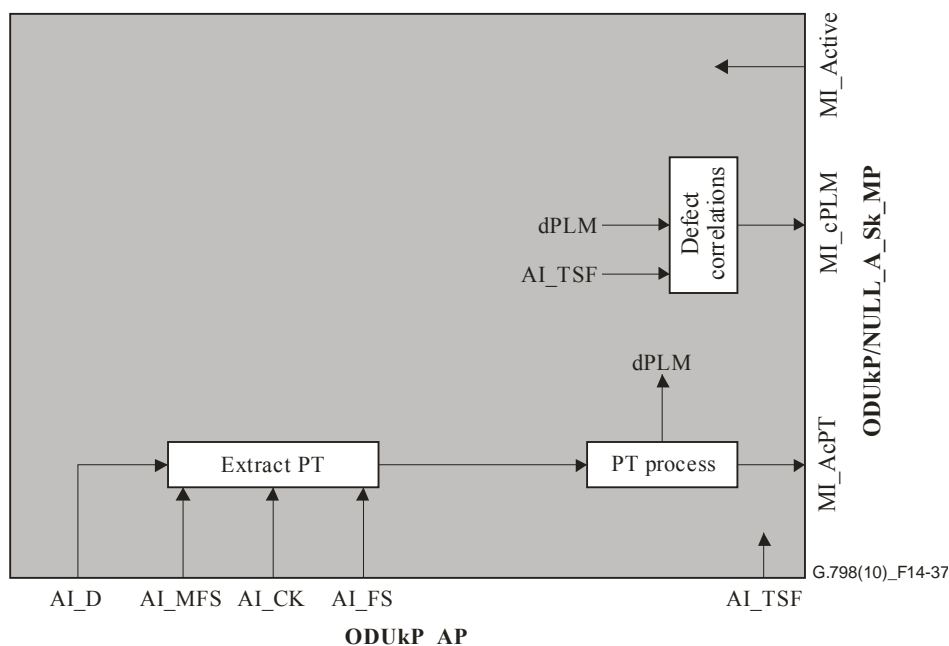

Figure 14-37 – ODUkP/NULL_A_Sk processes

Defects

The function shall detect for dPLM.

dPLM: See clause 6.2.4.1. The expected payload type is "1111 1101" (NULL test signal mapping) as defined in [ITU-T G.709].

Consequent actions: None.

Defect correlations

cPLM ← dPLM and (not AI_TSF)

Performance monitoring: None.

14.3.5 ODUkP to PRBS adaptation function (ODUkP/PRBS_A)

The ODUkP to PRBS adaptation functions perform the adaptation of a PRBS test signal as defined in clause 17.5.2 of [ITU-T G.709] into the ODUkP ($k = 0, 1, 2, 2e, 3, 4, \text{flex}$). The PRBS signal is a 2 147 483 647-bit pseudo-random test sequence ($2^{31} - 1$) as specified in clause 5.8 of [ITU-T O.150].

14.3.5.1 ODUkP to PRBS adaptation source function (ODUkP/PRBS_A_So)

The ODUkP/PRBS_A_So function creates the ODUk signal from a free-running clock. It maps the PRBS signal into the payload of the OPUk ($k = 0, 1, 2, 2e, 3, 4, \text{flex}$), adds OPUk overhead (RES, PT) and default ODUk overhead.

The information flow and processing of the ODUkP/PRBS_A_So function is defined with reference to Figures 14-38 and 14-39.

Symbol

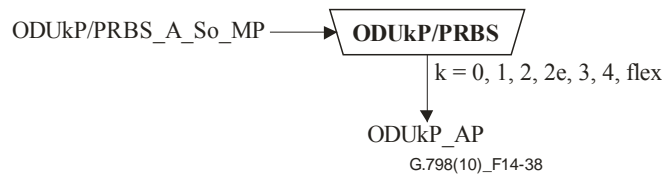

Figure 14-38 – ODUkP/PRBS_A_So function

Interfaces

Table 14-15 – ODUkP/PRBS_A_So inputs and outputs

Input(s)	Output(s)
ODUkP/PRBS_A_So_MP: ODUkP/PRBS_A_So_MI_Active ODUkP/PRBS_A_So_MI_Nominal_Bitrate_and_Tolerance	ODUkP_AP: ODUkP_AI_CK ODUkP_AI_D ODUkP_AI_FS ODUkP_AI_MFS

Processes

Activation

- The ODUkP/PRBS_A_So function shall access the access point when it is activated (MI_Active is true). Otherwise, it shall not access the access point.

Clock and (multi)frame start signal generation: The function shall generate a local ODUk clock with a clock frequency within the minimum to maximum values of the specified ODU signal as given in Table 14-2 provisioned by the MI_Nominal_Bitrate_and_Tolerance from a free-running oscillator. The jitter and wander requirements, as defined in Annex A of [ITU-T G.8251] (ODCa clock), apply.

The function shall generate the (multi)frame start reference signals AI_FS and AI_MFS for the ODUk signal. The AI_FS signal shall be active once per 122 368 clock cycles. AI_MFS shall be active once every 256 frames.

Generate and insert PRBS signal: The function shall generate the PRBS signal and insert it into the OPUk payload area as defined in clause 17.5.2 of [ITU-T G.709].

PT: The function shall insert code "1111 1110" into the PT byte position of the PSI overhead as defined in clause 15.9.2.1 of [ITU-T G.709].

RES: The function shall insert all-ZEROs into the RES bytes.

All other bits of the ODUk overhead should be sourced as "0"s, except the ODUk-PM STAT field which should be set to the value "normal path signal" (001).

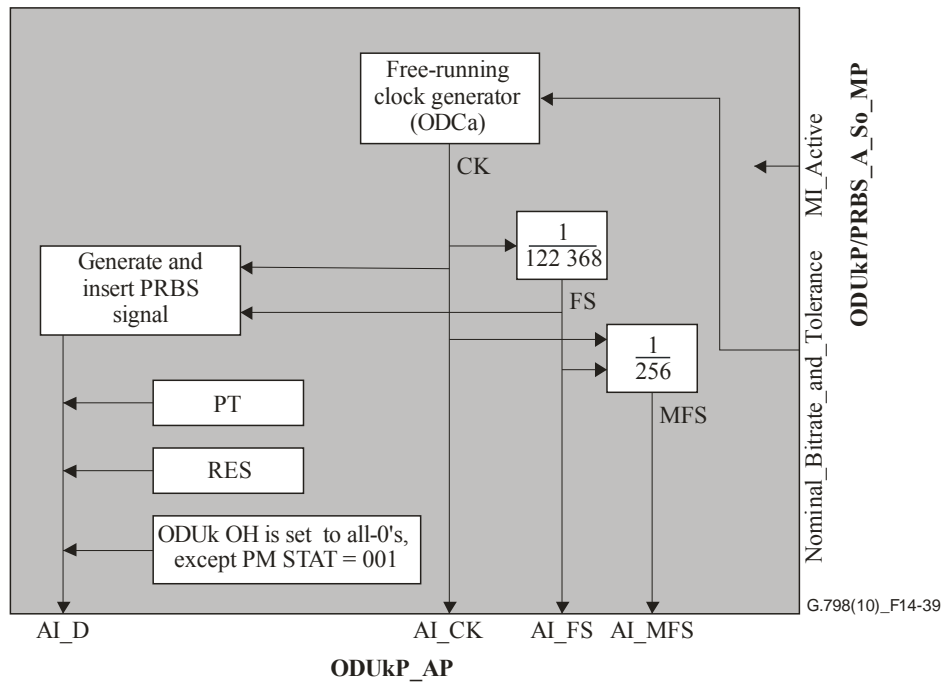

Figure 14-39 – ODUkP/PRBS_A_So processes

Defects: None.

Consequent actions: None.

Defect correlations: None.

Performance monitoring: None.

14.3.5.2 ODUkP to PRBS adaptation sink function (ODUkP/PRBS_A_Sk)

The ODUkP/PRBS_A_Sk recovers the PRBS test signal from the OPUk payload area and monitors test sequence errors (TSEs) in the PRBS sequence. It extracts the OPUk overhead (PT and RES) and monitors the reception of the correct payload type.

The information flow and processing of the ODUkP/PRBS_A_Sk function is defined with reference to Figures 14-40 and 14-41.

Symbol

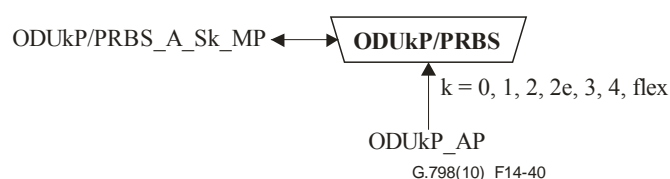

Figure 14-40 – ODUkP/PRBS_A_Sk function

Interfaces

Table 14-16 – ODUkP/PRBS_A_Sk inputs and outputs

Input(s)	Output(s)
ODUkP_AP: ODUkP_AI_CK ODUkP_AI_D ODUkP_AI_FS ODUkP_AI_TSF ODUkP/PRBS_A_Sk_MP: ODUkP/PRBS_A_Sk_MI_Active	ODUkP/PRBS_A_Sk_MP: ODUkP/PRBS_A_Sk_MI_cPLM ODUkP/PRBS_A_Sk_MI_AcPT ODUkP/PRBS_A_Sk_MI_cLSS ODUkP/PRBS_A_Sk_MI_pN_TSE

Processes

Activation

- The ODUkP/PRBS_A_Sk function shall access the access point and perform the common and specific processes operation specified below when it is activated (MI_Active is true). Otherwise, it shall not report its status via the management point.

PT: The function shall extract the PT byte from the PSI overhead as defined in clause 8.7.1. The accepted PT value is available at the MP (MI_AcPT) and is used for PLM defect detection.

RES: The value in the RES bytes shall be ignored.

TSE check: Test sequence errors (TSEs) are bit errors in the PRBS data stream extracted from the OPUk payload area and shall be detected whenever the PRBS detector is in lock and the received data bit does not match the expected value.

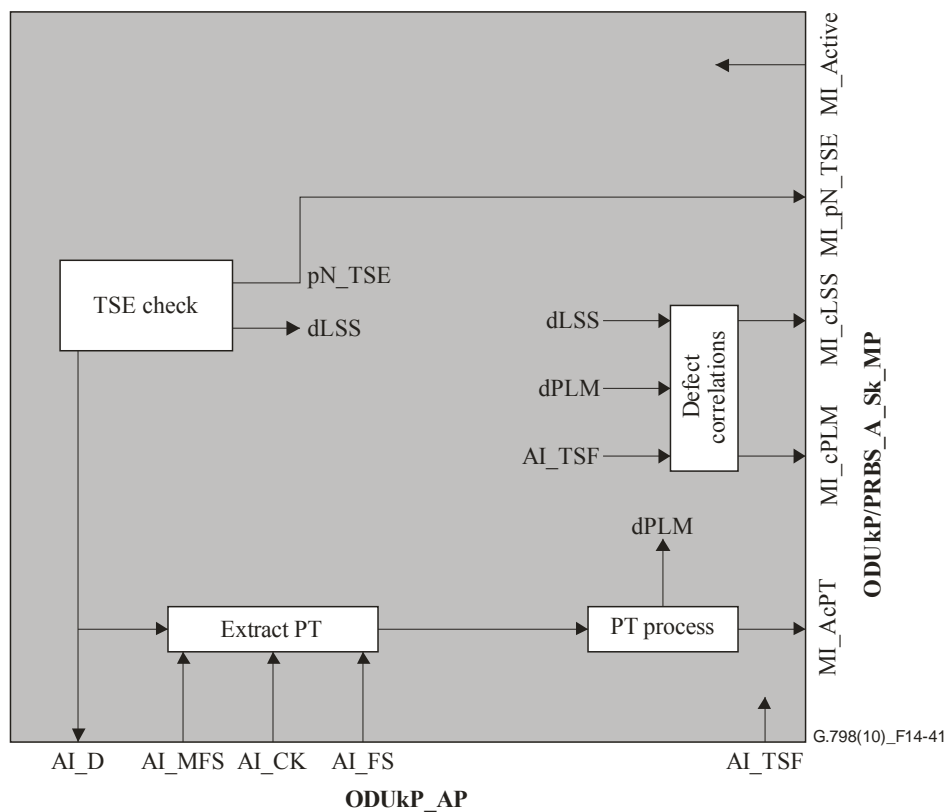

Figure 14-41 – ODUkP/PRBS_A_Sk processes

Defects

The function shall detect for dPLM and dLSS.

dPLM: See clause 6.2.4.1. The expected payload type is "1111 1110" (PRBS test signal mapping) as defined in [ITU-T G.709].

dLSS: The function shall detect for loss of PRBS lock (dLSS) according to the criteria defined in clause 2.6 of [ITU-T O.151].

Consequent actions: None.

Defect correlations

cPLM ← dPLM and (not AI_TSF)

cLSS ← dLSS and (not AI_TSF) and (not dPLM)

Performance monitoring

pN_TSE ← Sum of test sequence errors (TSEs) within one second period.

14.3.6 ODUkP to RSn adaptation function (ODUkP/RSn_A)

The ODUkP to RSn adaptation functions perform the adaptation between the ODUkP ($k = 1, 2, 3$) layer adapted information and the characteristic information of a RSn signal ($n = 16, 64, 256$).

Two different source functions are defined. The ODUkP/RSn-a_A_So provides asynchronous mapping, while the ODUkP/RSn-b_A_So provides bit synchronous mapping. In the sink direction, the ODUkP/RSn_A_Sk can handle both (bit synchronous and asynchronous) mappings.

NOTE 1 – The source functions are identical with the ODUkP/CBRx adaptation source functions, except for the different CI at the CP (CBRx_CI replaced by RSn_CI). In the sink direction, the function provides framing on the SDH signal and GenericAIS supervision. In the ODUkP/CBR_A_Sk function, no such functionality is available.

NOTE 2 – The ODUkP/RSn_A functions are only intended to be used together with RSn_TT functions (see [ITU-T G.783]). The direct interconnection of ODUkP/RSn_A functions with any other (server layer)/RS_A functions at the RSn_CP is not intended. The ODUkP/RSn functions are only used if further SDH processing is performed (e.g., RS termination). For example, Figure I.1 shows the ODUkP/RSn_A_Sk together with a RS_TT_Sk for non-intrusive monitoring, and Figure I.4 shows the use of the ODUkP/RSn_A functions at OTN interfaces on SDH equipment. For transparent mapping of constant bit-rate signals, the ODUkP/CBRx_A functions shall be used as shown in Figure I.1.

14.3.6.1 ODUkP to RSn asynchronous mapping adaptation source function (ODUkP/RSn-a_A_So)

The ODUkP/RSn-a_A_So function creates the ODUk signal from a free-running clock. It asynchronously maps the STM-N ($N = 4^{(k+1)}$) client signal from the RSn_CP into the payload of the OPUk ($k = 1, 2, 3$), adds OPUk overhead (RES, PT, JC) and default ODUk overhead.

The information flow and processing of the ODUkP/RSn-a_A_So function is defined with reference to Figures 14-42 and 14-43.

Symbol

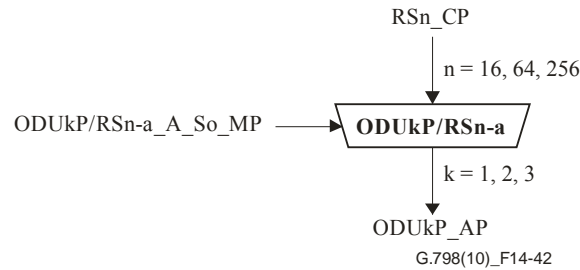

Figure 14-42 – ODUkP/RSn-a_A_So function

Interfaces

Table 14-17 – ODUkP/RSn-a_A_So inputs and outputs

Input(s)	Output(s)
RSn_CP: RSn_CI_CK RSn_CI_D ODUkP/RSn-a_A_So_MP: ODUkP/RSn-a_A_So_MI_Active	ODUkP_AP: ODUkP_AI_CK ODUkP_AI_D ODUkP_AI_FS ODUkP_AI_MFS

Processes

Activation

- The ODUkP/RSn-a_A_So function shall access the access point when it is activated (MI_Active is true). Otherwise, it shall not access the access point.

Clock and (multi)frame start signal generation: The function shall generate a local ODUk clock (ODUkP_AI_CK) of " $239/(239 - k) \times 4^{(k-1)} \times 2\,488\,320$ kHz \pm 20 ppm" from a free-running oscillator. The clock parameters, including jitter and wander requirements, as defined in Annex A of [ITU-T G.8251] (ODCa clock), apply.

The function shall generate the (multi)frame start reference signals AI_FS and AI_MFS for the ODUk signal. The AI_FS signal shall be active once per 122 368 clock cycles. AI_MFS shall be active once every 256 frames.

Mapping, frequency justification and bit-rate adaptation: The function shall provide an elastic store (buffer) process. The data signal RSn_CI shall be written into the buffer under control of the associated input clock. The data shall be read out of the buffer and written onto the D and N/PJO bytes in the OPUk frame under control of the ODUk clock and justification decisions as defined in clause 17.2 of [ITU-T G.709].

A justification decision shall be performed each frame. Each justification decision results in a corresponding positive, negative or no justification action. Upon a positive justification action, the reading of one data byte out of the buffer shall be cancelled once. No RSn data shall be written onto the PJO and NJO bytes. Upon a negative justification action, one extra data byte shall be read once out of the buffer. RSn data shall be written onto the PJO and NJO bytes. If neither a positive nor a negative justification action is to be performed, RSn data shall be written onto the PJO byte and no RSn data shall be written onto the NJO byte.

The justification decisions determine the phase error introduced by the function.

Buffer size: In the presence of jitter as specified by [ITU-T G.825] and a frequency within the range $4^{(k-1)} \times 2\,488\,320\text{ kHz} \pm 20\text{ ppm}$, this mapping process shall not introduce any errors. The maximum buffer hysteresis, and therefore the maximum phase error introduced, shall be as listed in Table 14-7.

JC bits: The function shall generate the justification control (JC) bits based on the justification decision performed in the current frame according to the specification in clause 17.2 of [ITU-T G.709]. It shall insert the justification control bits in the appropriate JC bit positions in the JC bytes of the current frame.

PT: The function shall insert code "0000 0010" into the PT byte position of the PSI overhead as defined in clause 15.9.2.1 of [ITU-T G.709].

RES: The function shall insert all-ZEROs into the RES bytes and reserved bits within the JC bytes.

All other bits of the ODUk overhead should be sourced as "0"s, except the ODUk-PM STAT field which should be set to the value "normal path signal" (001).

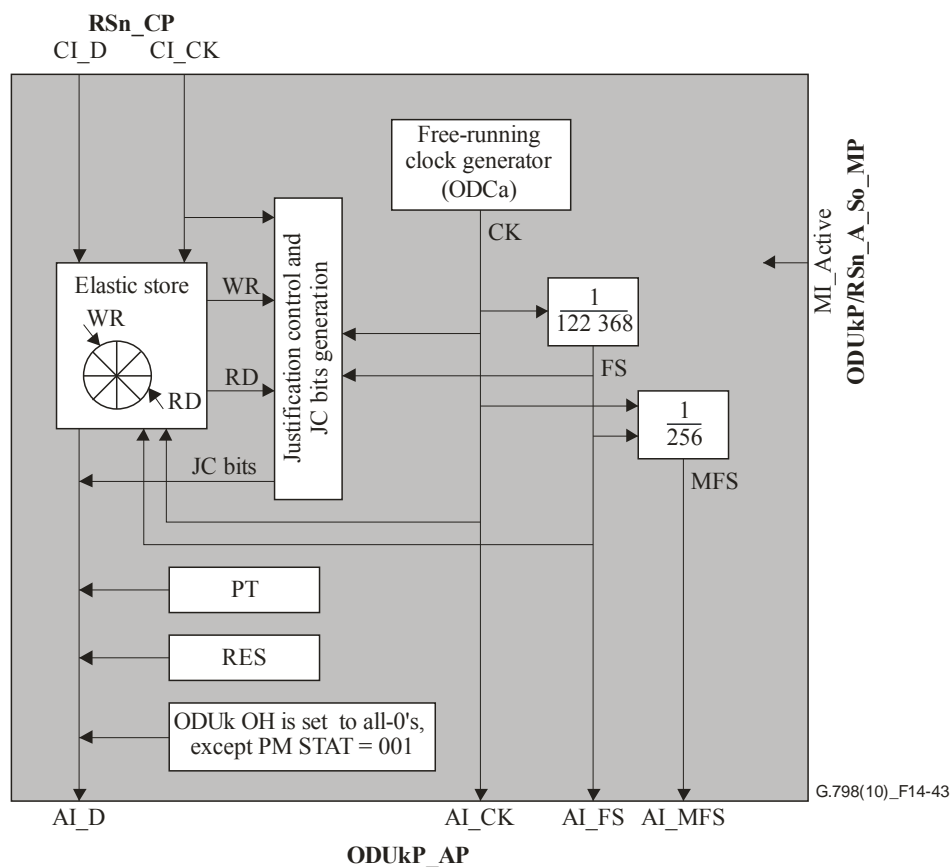

Figure 14-43 – ODUkP/RSn-a_A_So processes

Defects: None.

Consequent actions: None

Defect correlations: None.

Performance monitoring: None.

14.3.6.2 ODUkP to RSn bit synchronous mapping adaptation source function (ODUkP/RSn-b_A_So)

The ODUkP/RSn-b_A_So function creates the ODUk signal from a clock, derived from the incoming RSn_CI clock. It bit synchronously maps the STM-N ($N = 4^{(k+1)}$) client signal from the

RSn_CP into the payload of the OPUk, adds OPUk overhead (PT, JC, RES) and default ODUk overhead.

The information flow and processing of the ODUkP/RSn-b_A_So function is defined with reference to Figures 14-44 and 14-45.

Symbol

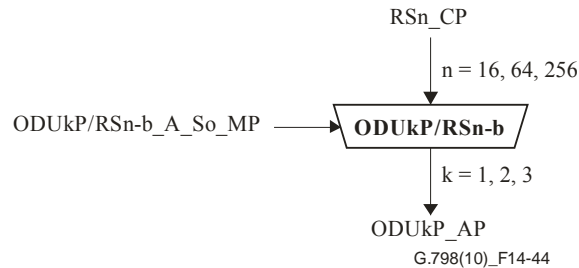

Figure 14-44 – ODUkP/RSn-b_A_So function

Interfaces

Table 14-18 – ODUkP/RSn-b_A_So inputs and outputs

Input(s)	Output(s)
RSn_CP: RSn_CI_CK RSn_CI_D ODUkP/RSn-b_A_So_MP: ODUkP/RSn-b_A_So_MI_Active	ODUkP_AP: ODUkP_AI_CK ODUkP_AI_D ODUkP_AI_FS ODUkP_AI_MFS

Processes

Activation

- The ODUkP/RSn-b_A_So function shall access the access point when it is activated (MI_Active is true). Otherwise, it shall not access the access point.

Clock and (multi)frame start signal generation: The function shall generate the ODUk (AI_CK) clock by multiplying the incoming RSn clock (CI_CK) by a factor of $239/(239 - k)$. The clock parameters, including jitter and wander requirements, as defined in Annex A of [ITU-T G.8251] (ODCb clock), apply.

NOTE 1 – The ODUk clock is " $239/(239 - k) \times 4^{(k-1)} \times 2\,488\,320\text{ kHz} \pm 20\text{ ppm}$ ".

NOTE 2 – The incoming RSn CK (CI_CK) signal has to be within the range of $4^{(k-1)} \times 2\,488\,320\text{ kHz} \pm 20\text{ ppm}$.

During failure conditions of the incoming RS clock signal (CI_CK), the ODUk clock shall stay within its limits as defined in [ITU-T G.8251] and no frame phase discontinuity shall be introduced.

The function shall generate the (multi)frame start reference signals AI_FS and AI_MFS for the ODUk signal. The AI_FS signal shall be active once per 122 368 clock cycles. AI_MFS shall be active once every 256 frames.

Mapping, frequency justification and bit-rate adaptation: The function shall provide an elastic store (buffer) process. The data signal RSn_CI shall be written into the buffer under control of the associated input clock. The data shall be read out of the buffer and written onto the D and PJO bytes in the OPUk frame under control of the ODUk clock, as defined in clause 17.2 of [ITU-T G.709].

Neither negative nor positive justification is to be performed. No data shall be written onto the NJO byte and data shall always be written onto the PJO byte.

Buffer size: In the presence of jitter as specified by [ITU-T G.825] and a frequency within the range $4^{(k-1)} \times 2\,488\,320\text{ kHz} \pm 20\text{ ppm}$, this mapping process shall not introduce any errors.

Following a step in frequency of the $4^{(k-1)} \times 2\,488\,320\text{ kbit/s}$ CI_CK signal (for example, due to the removal of AIS (RS-AIS)), there will be a maximum recovery time of X seconds after which this process shall not generate any bit errors. The value of X is for further study; a value of one second has been proposed.

JC bits: The function shall generate the fixed justification control (JC) bits "00" according to clause 17.2 of [ITU-T G.709]. It shall insert the justification control bits in the appropriate JC bit positions in the JC bytes.

RES: The function shall insert all-ZEROs into the RES bytes and reserved bits within the JC bytes.

PT: The function shall insert code "0000 0011" into the PT byte position of the PSI overhead as defined in clause 15.9.2.1 of [ITU-T G.709].

All other bits of the ODUk overhead should be sourced as "0"s, except the ODUk-PM STAT field which should be set to the value "normal path signal" (001).

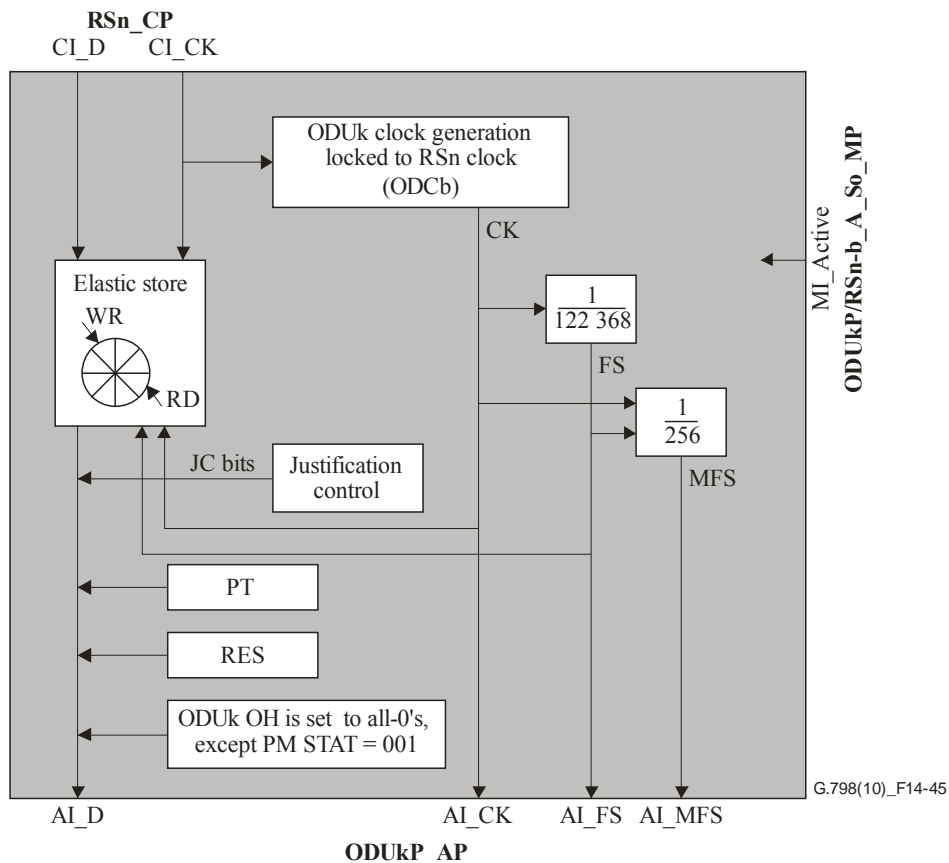

Figure 14-45 – ODUkP/RSn-b_A_So processes

Defects: None.

Consequent actions: None.

Defect correlations: None.

Performance monitoring: None.

14.3.6.3 ODUkP to RSn adaptation sink function (ODUkP/RSn_A_Sk)

The ODUkP/RSn_A_Sk recovers the STM-N ($N = 4^{(k+1)}$) client signal from the OPUk payload using the justification control information (JC overhead) to determine if a data or stuff byte is present within the NJO and PJO bytes. It extracts the OPUk overhead (PT, JC, RES) and monitors the reception of the correct payload type. It detects GenericAIS and recovers the frame start of the STM-N signal. Under signal fail condition, a logical all-ONEs (AIS) signal shall be generated.

The information flow and processing of the ODUkP/RSn_A_Sk function is defined with reference to Figures 14-46 and 14-47.

Symbol

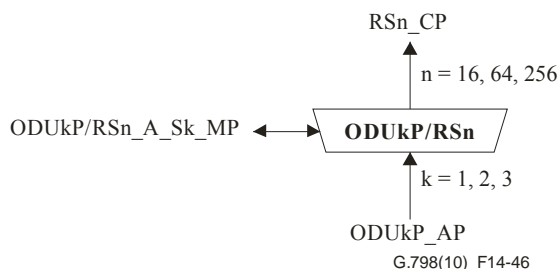

Figure 14-46 – ODUkP/RSn_A_Sk function

Interfaces

Table 14-19 – ODUkP/RSn_A_Sk inputs and outputs

Input(s)	Output(s)
ODUkP_AP: ODUkP_AI_CK ODUkP_AI_D ODUkP_AI_FS ODUkP_AI_MFS ODUkP_AI_TSF ODUkP/RSn_A_Sk_MP: ODUkP/RSn_A_Sk_MI_Active	RSn_CP: RSn_CI_CK RSn_CI_D RSn_CI_FS RSn_CI_SSF ODUkP/RSn_A_Sk_MP: ODUkP/RSn_A_Sk_MI_cPLM ODUkP/RSn_A_Sk_MI_AcPT ODUkP/RSn_A_Sk_MI_cLOF

Processes

Activation

- The ODUkP/RSn_A_Sk function shall access the access point and perform the common and specific processes operation specified below when it is activated (MI_Active is true). Otherwise, it shall activate the SSF signals and generate AIS at its output (CP) and not report its status via the management point.

PT: The function shall extract the PT byte from the PSI overhead as defined in clause 8.7.1. The accepted PT value is available at the MP (MI_AcPT) and is used for PLM defect detection.

RES: The value in the RES bytes shall be ignored.

JC: The function shall interpret the justification control information in the JC byte as defined in clause 17.2 of [ITU-T G.709] in order to determine the justification action (positive, negative, none) for the current frame. RES bits in the JC shall be ignored.

Demapping, CBR clock generation: The function shall provide an elastic store (buffer) process. The CBR data shall be written into the buffer from the D, PJO and NJO bytes in the OPUk frame. The information extraction of the PJO and NJO bytes shall be under control of the justification control information. The RSn data (CI_D) shall be read out of the buffer under control of the RSn clock (CI_CK).

Upon a positive justification action, the writing of one data byte into the buffer shall be cancelled once. No RSn data shall be read from the PJO and NJO bytes. Upon a negative justification action, one extra data byte shall be written into the buffer once. RSn data shall be read from the PJO and NJO bytes. If neither a positive nor a negative justification action is to be performed, RSn data shall be read from the PJO byte and no RSn data shall be read from the NJO byte.

Smoothing and jitter limiting process: The function shall provide for a clock smoothing and elastic store (buffer) process. The $4^{(k-1)} \times 2\,488\,320$ kbit/s ($k = 1, 2, 3$) data signal shall be written into the buffer under control of the associated (gapped) input clock (with a frequency accuracy within ± 20 ppm). The data signal shall be read out of the buffer under control of a smoothed (equally spaced) $4^{(k-1)} \times 2\,488\,320$ kbit/s ± 20 ppm clock (the rate is determined by the 2.5 Gbit/s, 10 Gbit/s, 40 Gbit/s signal at the input of the remote ODUkP/RSn_A_So).

The clock parameters, including jitter and wander requirements, as defined in Annex A of [ITU-T G.8251] (ODCp clock), apply.

Buffer size: In the presence of jitter as specified by [ITU-T G.825] and a frequency within the range $4^{(k-1)} \times 2\,488\,320$ kbit/s ± 20 ppm, this justification process shall not introduce any errors.

Following a step in frequency of the $4^{(k-1)} \times 2\,488\,320$ kbit/s signal transported by the ODUkP_AI (for example, due to reception of RSn_CI from a new RSn_TT_So at the far end or removal of generic-AIS signal with a frequency offset), there will be a maximum recovery time of X seconds after which this process shall not generate any bit errors. The value of X is for further study; a value of one second has been proposed.

Frame alignment: The function shall perform frame alignment on the STM-N frame as described in clause 8.2.1 of [ITU-T G.783].

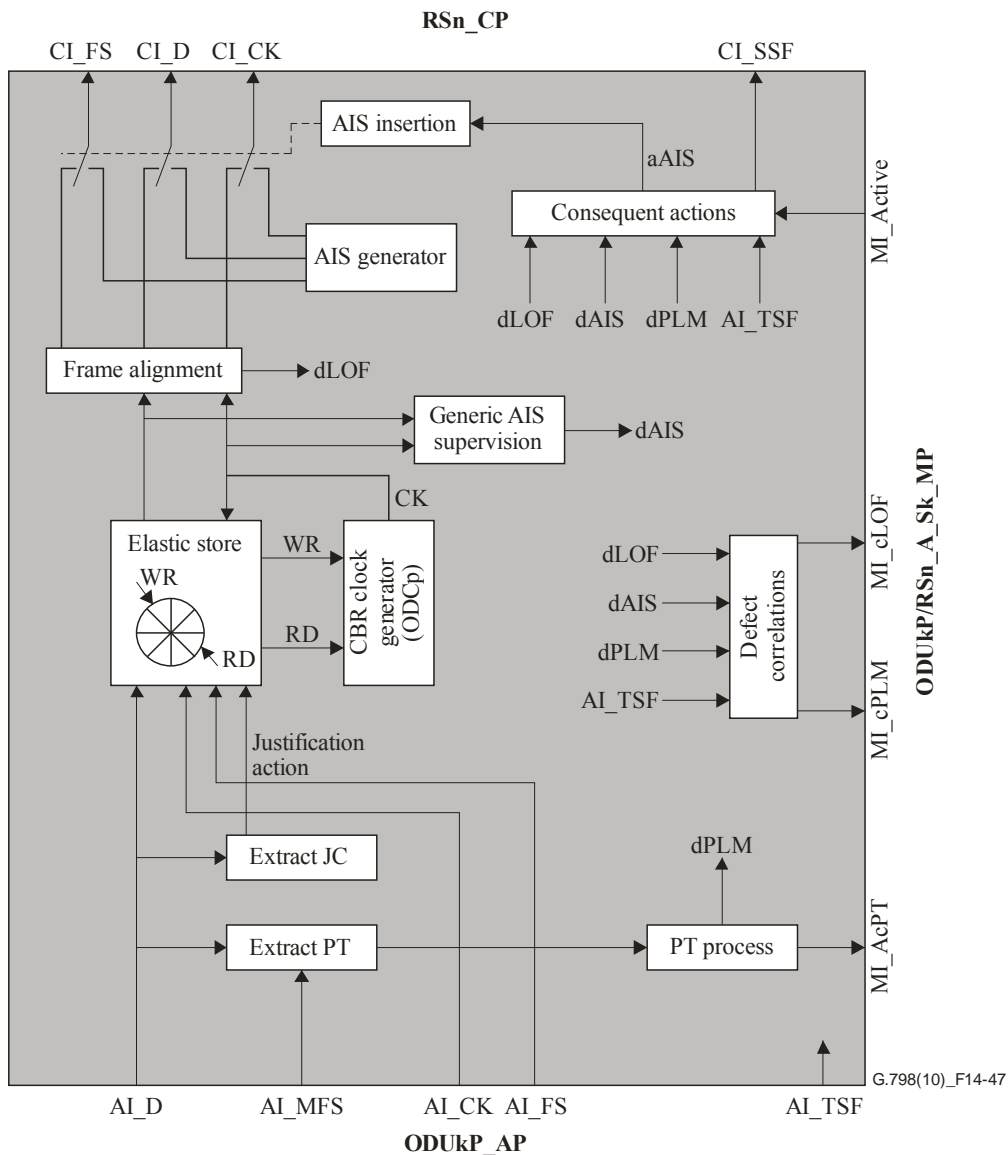

Figure 14-47 – ODUkP/RSn_A_Sk processes

Defects

The function shall detect for dPLM, dAIS and dLOF.

dPLM: See clause 6.2.4.1. The expected payload types are "0000 0010" (asynchronous CBRx mapping) and "0000 0011" (bit synchronous CBRx mapping) as defined in [ITU-T G.709].

dAIS: See clause 6.2.6.3.3.

dLOF: See clause 6.2.5.1 of [ITU-T G.783].

Consequent actions

aSSF ← AI_TSF or dPLM or dAIS or dLOF or (not MI_Active)

aAIS ← AI_TSF or dPLM or dAIS or dLOF or (not MI_Active)

On declaration of aAIS, the function shall output a logical all-ONES (AIS) signal within two STM-N frames. On clearing of aAIS, the logical all-ONES (AIS) signal shall be removed within two STM-N frames, with normal data being output. The AIS clock shall be independent from the incoming clock. The AIS clock has to be within $4^{(k-1)} \times 2\,488\,320\text{ kHz} \pm 20\text{ ppm}$. The jitter and wander requirements, as defined in Annex A of [ITU-T G.8251] (ODCp clock), apply.

Defect correlations

cPLM ← dPLM and (not AI_TSF)

cLOF ← dLOF and (not dAIS) and (not dPLM) and (not AI_TSF)

NOTE – dAIS is not reported as fault cause as it is a secondary alarm and will result in aSSF, which is reported as cSSF fault cause in the RSn_TT_Sk that directly follows this function.

Performance monitoring: None.

14.3.7 ODU0P to client adaptation function (ODU0P/CBRx_A) ($0 \leq x \leq 1.25G$)

The ODU0P to CBRx adaptation functions perform the adaptation between the ODU0P layer adapted information and the characteristic information of a CBRx signal.

Parameter x defines the bit rate or bit-rate range of the CBR signal. The value of x can range between 0 kbit/s and the OPU0 payload rate of 1 238 954 kbit/s (± 20 ppm). In the case of the 1.25 Gbit/s 1000BASE-X Ethernet signal, as described in clause 17.7.1 of [ITU-T G.709], a timing transparent adaptation into GFP-T is used to produce a CBR signal with a rate of approximately 1 171 875 kbit/s that is mapped into the OPU0. The values for which x is defined are listed in Table 14-20.

Table 14-20 – Defined values for x for ODU0 clients

x	PTI	Maximum buffer hysteresis	Bit rate	Clock range
155M	Hex code 0A	1 byte	155 520 kbit/s ± 20 ppm	155 520 kHz ± 20 ppm
622M	Hex code 0B	1 byte	622 080 kbit/s ± 20 ppm	622 080 kHz ± 20 ppm
1G25 (Note) ETC3	Hex code 07	1 byte	1 171 875 kbit/s ± 100 ppm	1 171 875 kHz ± 100 ppm
FC100	Hex code 0C	1 byte	1 062 500 kbit/s ± 100 ppm	1 062 500 kHz ± 100 ppm

NOTE – The original bit rate and clock range of the associated 1000BASE-X Ethernet client signal is 1 250 000 kbit/s ± 100 ppm. The bit rate and clock range in this table are for the CBR stream that is produced after mapping the client signal into a GFP-T.

The ODU0P/CBRx_A source function always provides asynchronous mapping.

14.3.7.1 ODU0P to CBRx mapping adaptation source function (ODU0P/CBRx_A_So) ($0 \leq x \leq 1.25G$)

The ODU0P/CBRx_A_So function creates the ODU0 signal from a free-running clock. It asynchronously maps the constant bit-rate client signal from the CBRx_CP into the payload area of the OPU0 using a sigma-delta based justification distribution as defined in [ITU-T G.709], and adds OPU0 overhead (RES, PT, JC) and default ODU0 overhead.

The information flow of the ODU0P/CBRx_A_So function is defined with reference to Figure 14-48 and the processing of the ODU0P/CBRx_A_So function is defined with reference to Figures 14-49 and 14-50.

Symbol

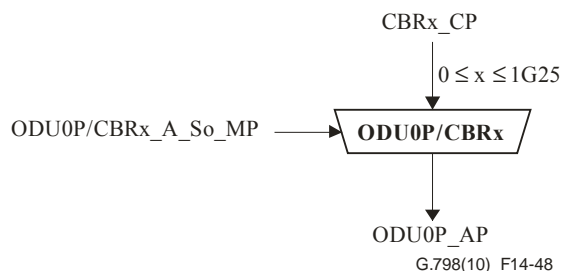

Figure 14-48 – ODU0P/Client_A_So function

Interfaces

Table 14-21 – ODU0P/Client_A_So inputs and outputs

Input(s)	Output(s)
CBRx_CP: CBRx_CI_CK CBRx_CI_D CBRx_CI_SF ODU0P/Client_A_So_MP: ODU0P/Client_A_So_MI_Active	ODU0P_AP: ODU0P_AI_CK ODU0P_AI_D ODU0P_AI_FS ODU0P_AI_MFS

Processes

Activation

- The ODU0P/Client_A_So function shall access the access point when it is activated (MI_Active is true). Otherwise, it shall not access the access point.

Clock and (multi)frame start signal generation: The function shall generate a local ODU0 clock (ODU0P_AI_CK) of "1 244 160 kHz ± 20 ppm" from a free-running oscillator. The clock parameters, including jitter and wander requirements, as defined in Annex A of [ITU-T G.8251] (ODCa clock), apply.

The function shall generate the (multi)frame start reference signals AI_FS and AI_MFS for the ODUk signal. The AI_FS signal shall be active once per 122 368 clock cycles. AI_MFS shall be active once every 256 frames.

Mapping, frequency justification and bit-rate adaptation: The function shall provide an elastic store (buffer) process. The data signal shall be written into the buffer under control of the associated input clock. The data shall be read out of the buffer and written onto the D bytes in the OPU0 frame under control of the sigma/delta based data/stuff distribution algorithm as defined in Annex D of [ITU-T G.709].

As per Annex D of [ITU-T G.709], the amount of data, in n-bit words, to be transmitted in the subsequent frame is determined. The $C_m(t)$ value encoded in JC1/2/3 represents the number of m-bit words that are mapped into the subsequent frame and the $\sum C_{nD}(t)$ value encoded in the JC4/5/6 represents in, n-bit words, the accumulated remainder that could not be transmitted.

For 1GE clients, the data signal shall be synchronously transcoded into a GFP-T signal in which each GFP-T frame contains one superblock and in which the 65B_PAD character and GFP Idle frames are not used, under control of the associated input clock, and then the synchronous GFP-T like signal shall be written into the buffer under a synchronous input clock. This sub-process is depicted in Figure 14-50.

Buffer size: In the presence of jitter as described for each client in [ITU-T G.8251], this mapping process shall not introduce any errors. The maximum buffer hysteresis, and therefore the maximum phase error introduced, shall be as listed in Table 14-20.

JC bytes: The function shall insert the justification control (JC) bytes. As specified in clause 17.7.1 of [ITU-T G.709] and Annex D of [ITU-T G.709], $C_m(t)$ and $\sum C_{nD}(t)$ values are determined every frame and inserted into the JC1/2/3 and JC4/5/6 OPU overhead locations respectively. The following clients require $\sum C_{nD}(t)$ with $n = 1 : STM-1, STM-4$.

PT: The function shall insert the appropriate payload type code into the PT byte position of the PSI overhead as defined in clause 15.9.2.1 of [ITU-T G.709].

Client signal fail: The function shall signal the failure of the client signal to the far end by use of the Bit 1 of the PSI[2] byte of the payload structure identifier, as defined in clause 17.1 of [ITU-T G.709].

RES: The function shall insert all-0's into the RES bytes and reserved bits within the JC bytes.

All other bits of the ODU0 overhead should be sourced as "0"s, except the ODU0-PM STAT field which should be set to the value "normal path signal" (001).

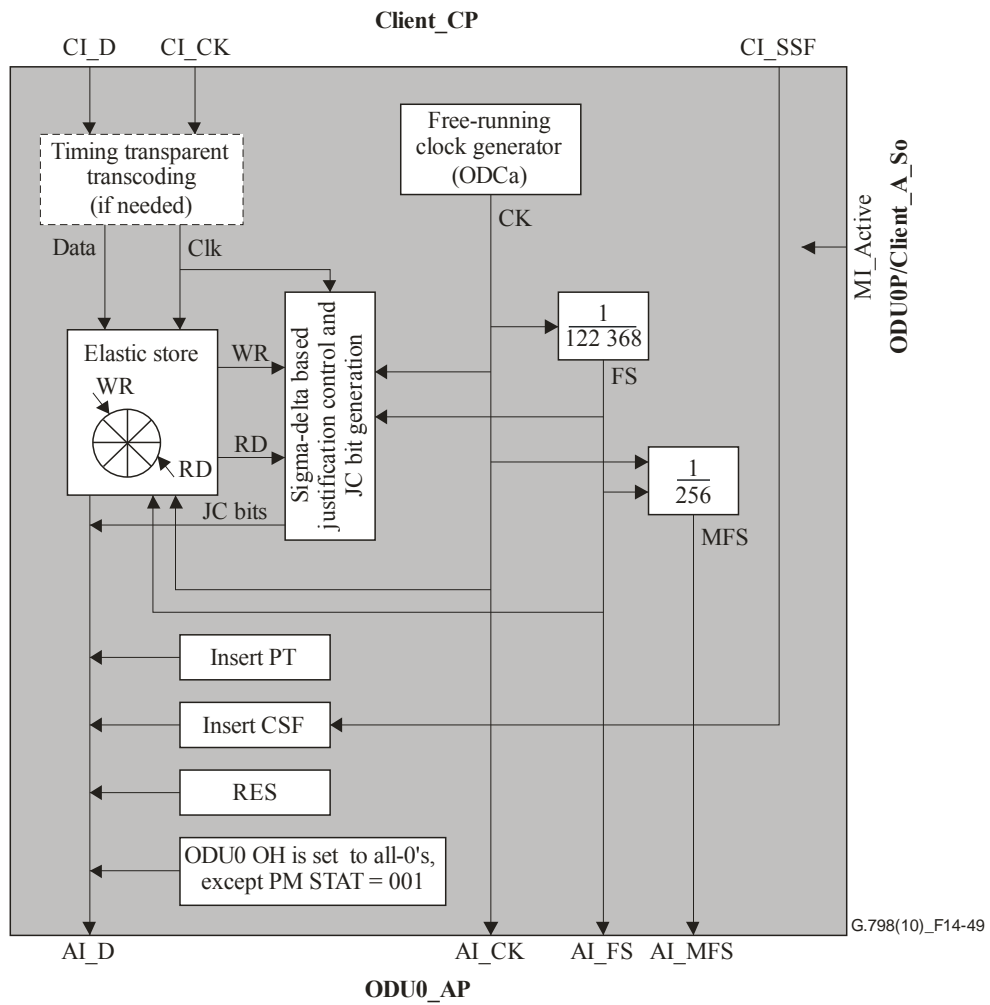

Figure 14-49 – ODU0P/Client_A_So function

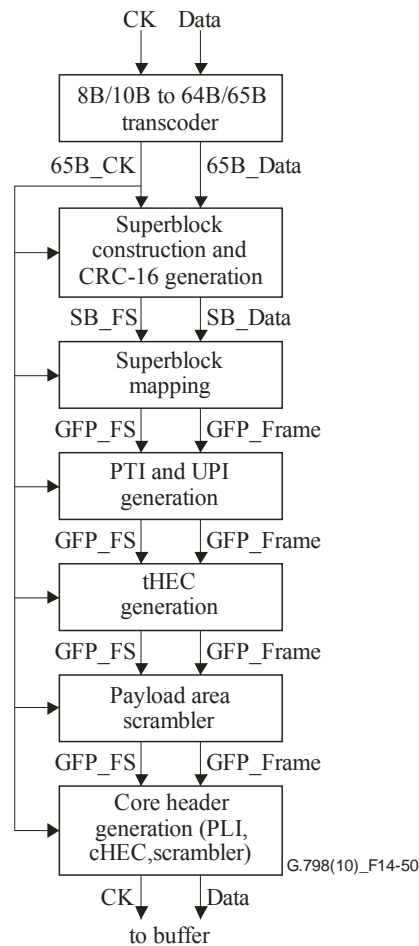

Figure 14-50 – Timing transparent transcoding process for 1000BASE-X clients

Defects: None.

Consequent actions: None.

Defect correlations: None.

Performance monitoring: None.

14.3.7.2 ODU0P to CBRx adaptation sink function (ODU0P/CBRx_A_Sk) (0 ≤ x ≤ 1.25G)

The ODU0P/CBRx_A_Sk recovers the constant bit-rate client signal from the OPU0 payload using the justification control information (JC overhead) of the previous frame to determine the number client data bytes that were sent during the current frame, and the location of these data bytes within the payload area from the sigma-delta justification. It extracts the OPU0 overhead (PT, JC, and RES) and monitors the reception of the correct payload type. Under signal fail condition, generic replacement signals as given in Table 14-22 shall be inserted.

Table 14-22 – Defined replacement signals and jitter specification references for ODU0 clients

Client	PTI	Replacement signal	Bit rate	Jitter standard
155M CBR	Hex code 0A	Generic-AIS	155 520 kbit/s ± 20 ppm	[ITU-T G.825]
622M CBR	Hex code 0B	Generic-AIS	622 080 kbit/s ± 20 ppm	[ITU-T G.825]

Table 14-22 – Defined replacement signals and jitter specification references for ODU0 clients

Client	PTI	Replacement signal	Bit rate	Jitter standard
1G25 ETC3	Hex code 07	Link fault	1 250 000 kbit/s ± 100 ppm	[IEEE 802.3]
FC100	Hex code 0C	Link fault	1 062 500 kbit/s ± 100 ppm	[b-ANSI INCITS 352]

The information flow and processing of the ODU0P/CBR_x_A_Sk function is defined with reference to Figures 14-51, 14-52, and 14-53.

Symbol

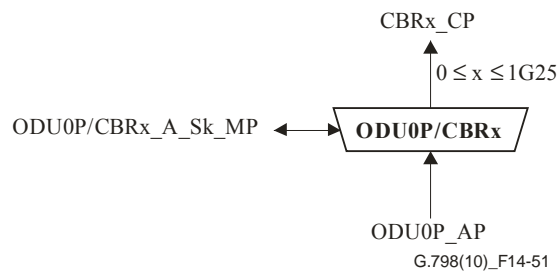

Figure 14-51 – ODU0P/Client_A_Sk function

Interfaces

Table 14-23 – ODU0P/Client_A_Sk inputs and outputs

Input(s)	Output(s)
ODU0P_AP: ODU0P_AI_CK ODU0P_AI_D ODU0P_AI_FS ODU0P_AI_MFS ODU0P_AI_TSF ODU0P/CBR_x_A_Sk_MP: ODU0P/CBR _x _A_Sk_MI_Active	CBRx_CP: CBR _x _CI_CK CBR _x _CI_D CBR _x _CI_SSF ODU0P/CBR_x_A_Sk_MP: ODU0P/CBR _x _A_Sk_MI_cPLM ODU0P/CBR _x _A_Sk_MI_AcPT

Processes

Activation

- The ODU0P/CBR_x_A_Sk function shall access the access point and perform the common and specific processes operation specified below when it is activated (MI_Active is true). Otherwise, it shall activate the SSF signals and generate generic AIS at its output (CP) and not report its status via the management point.

PT: The function shall extract the PT byte from the PSI overhead as defined in clause 8.7.1. The accepted PT value is available at the MP (MI_AcPT) and is used for PLM defect detection.

RES: The value in the RES bytes shall be ignored.

JC: The function shall interpret the justification control information in the JC bytes, as defined in clause 17.7.1 of [ITU-T G.709], from the current frame in order to determine the number of payload

bytes for the following frame. RES bits in the JC shall be ignored. The function shall extract the $\sum C_{nD}(t)$ with $n = 1$ for the following clients: STM-1, STM-4.

Client signal fail: The function shall extract the CSF signal indicating the failure of the client signal out of Bit 1 of the PSI[2] byte of the payload structure identifier, as defined in clause 17.1 of [ITU-T G.709].

Demapping, CBR clock generation: The function shall provide an elastic store (buffer) process. The CBR data shall be written into the buffer from the data-bearing D bytes in the OPU0 frame. The information extraction of the payload area shall be under the control of the sigma-delta based justification. For 1GE clients, the function shall also provide a GFP-T extraction process. This synchronous transcoding sub-process is depicted in Figure 14-53. The CBRx data (CI_D) shall be read out of the buffer under control of the CBRx clock (CI_CK).

The locations of the data and stuff bytes are determined based on the count value sent in the JC bytes of the immediately preceding frame and the sigma/delta mapping algorithm, as defined in Annex D of [ITU-T G.709]. When a stuff byte is encountered in the payload area, the writing of one data byte into the buffer shall be cancelled once.

Smoothing and jitter limiting process: The function shall provide for a clock smoothing and elastic store (buffer) process. The data bytes shall be written into the buffer under control of the associated (gapped) input clock. The data signal shall be read out of the buffer under control of a smoothed (equally spaced) clock at a rate and frequency accuracy determined by the client signal rate at the input of the remote ODU0P/CBRx_a_So. According to specification of [ITU-T G.8251] for STM1 (CBR155M) and STM4 (CBR622M), the clock generation process shall use the $\sum C_{nD}(t)$ phase information with $n = 1$ for reading the data out of the buffer.

The clock parameters, including jitter and wander requirements, as defined in Annex A of [ITU-T G.8251] (ODCp clock), apply.

Buffer size: In the presence of jitter as specified by the relevant standard as listed in Table 14-22 and an ODU0 frequency within the range $1\ 244\ 160\ \text{kbit/s} \pm 20\ \text{ppm}$, this justification process shall not introduce any errors.

Following a step in frequency of the signal transported by the ODU0P_AI (for example, due to reception of CBRx_CI from a new CBR_TT_So at the far end or removal of generic-AIS signal with a frequency offset), there will be a maximum recovery time of X seconds after which this process shall not generate any bit errors. The value of X is for further study; a value of 1 second has been proposed.

NOTE 1 – Equipment developed prior to the 2010 version of this Recommendation will not support the CSF processing.

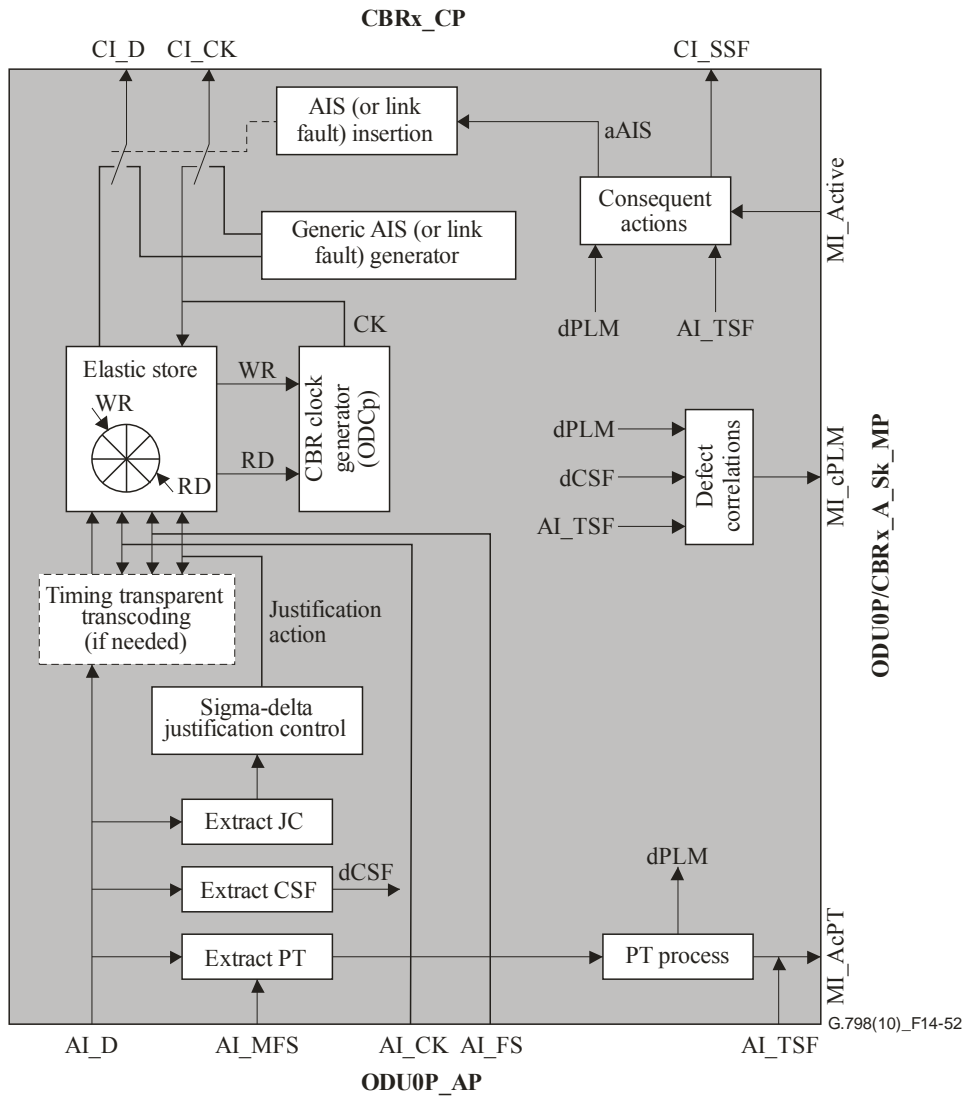

Figure 14-52 – ODU0P/Client_A_Sk processes

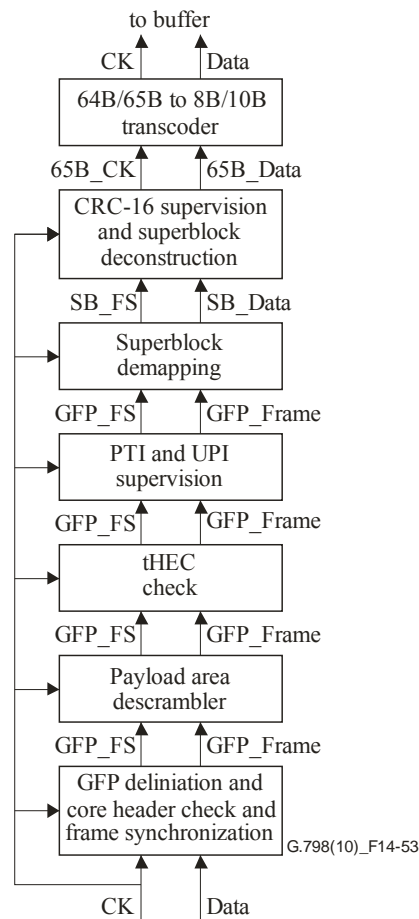

Figure 14-53 – Timing transparent transcoding process for 1000BASE-X clients

NOTE 2 – No detection and alarming as well as PM of the GFP related defects and indicators is required as the GFP process is used as mapping only and due to the 1/1 relation to the ODU0 all errors are visible on the ODU layer already. This means a detection of the related GFP defined indicators does not add any additional information about the cause of degradation.

Defects

The function shall detect for dPLM.

dPLM: See clause 6.2.4.1. The expected payload types are defined in clause 15.9.2.1 of [ITU-T G.709].

dCSF: See clause 6.2.10.

Consequent actions

aSSF ← AI_TSF or dPLM or (not MI_Active)

aAIS ← AI_TSF or dPLM or (not MI_Active)

NOTE 3 – The state of the determination process of the C_m and its contribution to AIS consequent action is for further study.

For 1GE clients, on declaration of aAIS the function shall output a link fault pattern/signal as defined in clause 17.7.1 of [ITU-T G.709] within two frames. For other clients, on declaration of aAIS the function shall output a GenericAIS pattern/signal as defined in clause 16.6 of [ITU-T G.709] within two frames. On clearing of aAIS the GenericAIS pattern/signal shall be removed within two frames and normal data being output. The link fault or GenericAIS clock start

shall be independent from the incoming clock. The link fault or GenericAIS clock has to be within the frequency, jitter, and wander tolerance specifications of the associated client signal.

Defect correlations

cPLM ← dPLM and (not AI_TSF)

cCSF ← dCSF and (not dPLM) and (not AI_TSF)

Performance monitoring: None.

14.3.8 ODUkP to CBRx adaptation function using GMP (ODUkP/CBRx-g_A)

The ODUkP/CBRx-g_A performs the adaptation between the ODUkP layer adapted information and the characteristic information of the indicated client signals transported as constant bit-rate streams.

Parameter x defines the bit rate or bit-rate range of the CBR signal. The values of x are given in Table 14-24 as described in clause 17.7 of [ITU-T G.709].

Table 14-24 – Defined values for x for ODUk clients

x	PTI	Maximum buffer hysteresis	Bit rate	Clock tolerance	ODUk type
ETC5	Hex code 07	32 bytes	40 117 188 (kbit/s)	± 100	3
ETC6	Hex code 07	80 bytes	103 125 000 (kbit/s)	± 100	4
FC-200	Hex code 0D	2 bytes	2 125 000 (kbit/s)	± 100	1

The ODUkP/CBRx-g_A source function always provides GMP mapping.

14.3.8.1 ODUkP to CBRx adaptation source function using GMP (ODUkP/CBRx-g_A_So)

The ODUkP/CBRx-g_A_So function creates the ODUk signal from a free-running clock. It asynchronously maps the constant bit-rate client signal from the CBRx_CP into the payload area of the OPUk using a sigma-delta based data and stuff distribution as defined in Annex D of [ITU-T G.709], and adds OPUk overhead (RES, PT, JC) and default ODUk overhead.

The information flow of the ODUkP/CBRx-g_A_So function is defined with reference to Figure 14-54 and the processing of the ODUkP/CBRx-g_A_So function is defined with reference to Figures 14-54 and 14-55.

Symbol

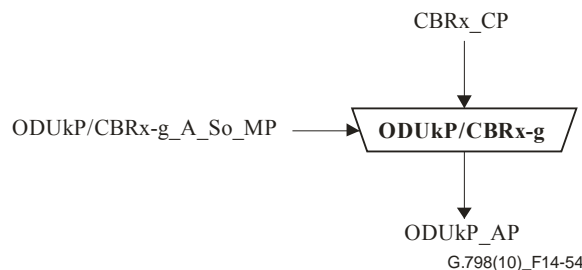

Figure 14-54 – ODUkP/CBRx-g_A_So function

Interfaces

Table 14-25 – ODUkP/CBRx-g_A_So inputs and outputs

Input(s)	Output(s)
CBRx_CP: CBRx_CI_CK CBRx_CI_D CBRx_CI_SSF CBRx_CI_Blockstart CBRx_CI_Lanestart ODUkP/CBRx-g_A_So_MP: ODUkP/CBRx-g_A_So_MI_Active	ODUkP_AP: ODUkP_AI_CK ODUkP_AI_D ODUkP_AI_FS ODUkP_AI_MFS

Processes

Activation

- The ODUkP/CBRx-g_A_So function shall access the access point when it is activated (MI_Active is true). Otherwise, it shall not access the access point.

Clock and (multi)frame start signal generation: The function shall generate a local ODUk clock (ODUkP_AI_CK) as given in Table 14-2 from a free-running oscillator. The clock parameters, including jitter and wander requirements, as defined in Annex A of [ITU-T G.8251] (ODCa clock), apply.

The function shall generate the (multi)frame start reference signals AI_FS and AI_MFS for the ODUk signal. The AI_FS signal shall be active once per 122 368 clock cycles. AI_MFS shall be active once every 256 frames.

Mapping, frequency justification and bit-rate adaptation: The function shall provide an elastic store (buffer) process. The data signal shall be written into the buffer under control of the associated input clock. The data shall be read out of the buffer and written onto the D bytes in the OPUk frame under control of the sigma/delta based data/stuff distribution algorithm as defined in Annex D of [ITU-T G.709].

As per Annex D of [ITU-T G.709], the amount of data, in n-bit words, to be transmitted in the subsequent frame is determined. The $C_m(t)$ value encoded in JC1/2/3 represents the number of m-bit words that are mapped into the subsequent frame and the $\sum C_{nD}(t)$ value encoded in the JC4/5/6 represents in, n-bit words, the accumulated remainder that could not be transmitted.

For 40GE clients, the data signal 40GE_CI_D shall be synchronous transcoded under control of the associated input clock, and then the synchronous transcoded signal shall be written into the buffer under a synchronous input clock as defined in clause 17.7.4.1 of [ITU-T G.709].

Buffer size: In the presence of jitter as described for each client in [ITU-T G.8251], this mapping process shall not introduce any errors. The maximum buffer hysteresis, and therefore the maximum phase error introduced, shall be as listed in Table 14-24.

Lane processing: For multilane Ethernet interfaces, lane reordering is needed. The process is depicted in Figure 14-56 and described in clauses 17.7.4.1 and 17.7.5.1 of [ITU-T G.709].

Incoming PCS BIP monitoring and mask insertion and OTN section BIP generation

- For 40 gigabit Ethernet multilane interfaces an error mask is to be calculated over the PCSL BIP of the incoming signal. For the OTN section a BIP has to be calculated on the descrambled datastream. The "OTN BIP" and the error mask will be transmitted together in the transcoded lane marker. See Annex E of [ITU-T G.709] and Figure 14-56.

- For 100 gigabit Ethernet multilane interfaces, the incoming PCSL BIP will be transparently transmitted. See Annex E of [ITU-T G.709] and Figure 14-56.

JC bits: The function shall insert the justification control (JC) bytes. As specified in clause 17.7 of [ITU-T G.709], $C_m(t)$ and $\sum C_{nD}(t)$ values are determined every frame as specified in Annex D of [ITU-T G.709] and inserted into the JC1/2/3 and JC4/5/6 OPU overhead locations respectively.

PT: The function shall insert the appropriate payload type code into the PT byte position of the PSI overhead, as defined in clause 15.9.2.1 of [ITU-T G.709].

Client signal fail: The function shall signal the failure of the client signal to the far end by use of the Bit 1 of the PSI[2] byte of the payload structure identifier, as defined in clause 17.1 of [ITU-T G.709].

RES: The function shall insert all-0's into the RES bytes and reserved bits within the JC bytes.

All other bits of the ODUk overhead should be sourced as "0"s, except the ODUk-PM STAT field which should be set to the value "normal path signal" (001).

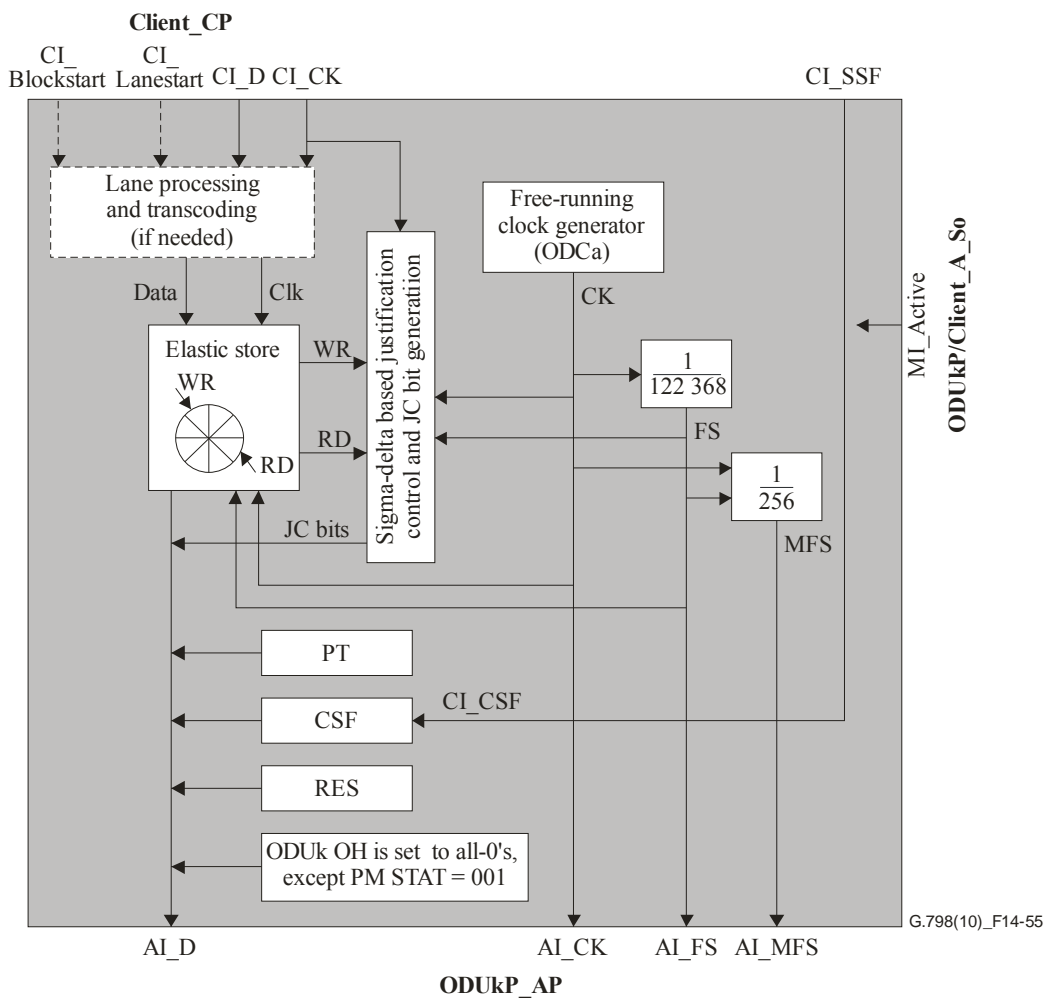

Figure 14-55 – ODUkP/CBRx-g_A_So function

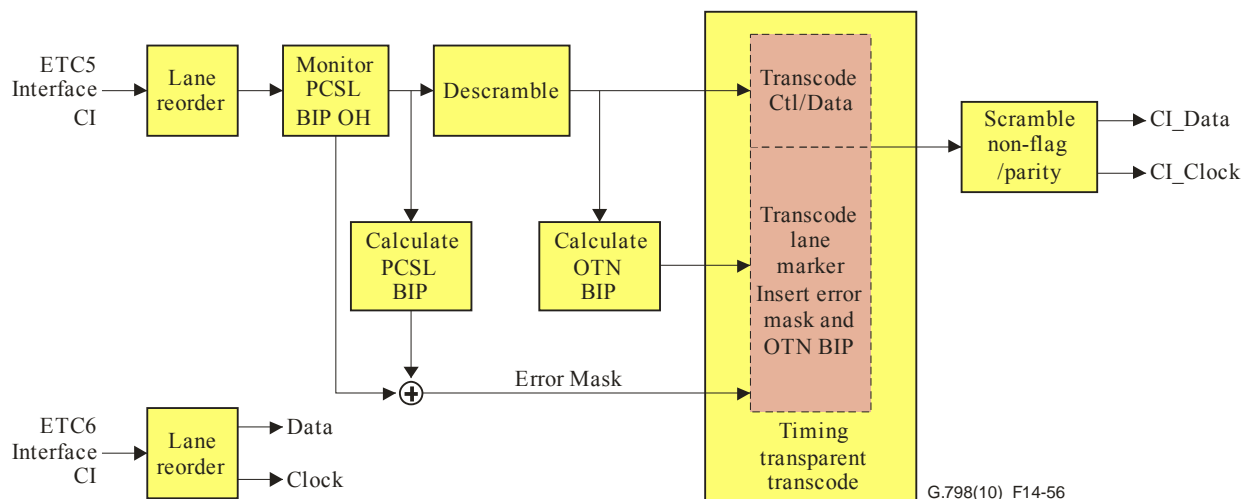

Figure 14-56 – Lane processing and timing transparent process of the ODUkP/CBRx-g_A_So function for ETC5 and ETC6 clients

Defects: None.

Consequent actions: None.

Defect correlations: None.

Performance monitoring: None.

14.3.8.2 ODUkP to CBRx adaptation sink function using GMP (ODUkP/CBRx-g_A_Sk)

The ODUkP/CBRx-g_A_Sk recovers the constant bit-rate client signal from the OPUk payload using the justification control information (JC overhead) of the previous frame to determine the number of client data byte blocks that were sent during the current frame, and the location of these data byte blocks within the payload area from the sigma-delta justification. It extracts the OPUk overhead (PT, JC, and RES) and monitors the reception of the correct payload type. Under signal fail condition, generic replacement signals, as given in Table 14-26, shall be inserted.

Table 14-26 – Defined replacement signals for ODUk clients

Client	PTI	Replacement signal	Bit rate	Jitter standard
ETC5	Hex code 07	Link fault	40 117 188 (kbit/s) ± 100	[IEEE 802.3ba]
ETC6	Hex code 07	Link fault	103 125 000 (kbit/s) ± 100	[IEEE 802.3ba]
FC-200	Hex code 0D	Link fault	2 125 000 (kbit/s) ± 100	[b-ANSI INCITS 352]

The information flow and processing of the ODUkP/CBRx-g_A_Sk function is defined with reference to Figures 14-57, 14-58, and 14-59.

Symbol

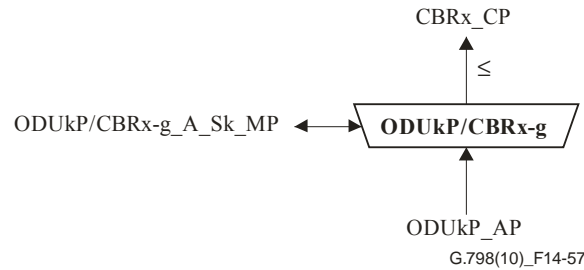

Figure 14-57 – ODUkP/ CBRx-g_A_Sk function

Interfaces

Table 14-27 – ODUkP/ CBRx-g_A_Sk inputs and outputs

Input(s)	Output(s)
ODUkP_AP: ODUkP_AI_CK ODUkP_AI_D ODUkP_AI_FS ODUkP_AI_MFS ODUkP_AI_TSF ODUkP/ CBRx-g_A_Sk_MP: ODUkP/ CBRx-g_A_Sk_MI_Active ODUkP/ CBRx-g_A_Sk_MI_Enable_PCSL_Section_Mon	CBRx_CP: CBRx_CI_CK CBRx_CI_D CBRx_CI_SSF ODUkP/ CBRx-g_A_Sk_MP: ODUkP/ CBRx-g_A_Sk_MI_cPLM ODUkP/ CBRx-g_A_Sk_MI_AcPT ODUkP/ CBRx-g_A_Sk_MI_cCSF

Processes

Activation

The ODUkP/ CBRx-g_A_Sk function shall access the access point and perform the common and specific processes operation specified below when it is activated (MI_Active is true). Otherwise, it shall activate the SSF signals and generate generic AIS at its output (CP) and not report its status via the management point.

PT: The function shall extract the PT byte from the PSI overhead as defined in clause 8.7.1. The accepted PT value is available at the MP (MI_AcPT) and is used for PLM defect detection.

RES: The value in the RES bytes shall be ignored.

JC: The function shall interpret the justification control information in the JC bytes, as defined in clause 17.7.1 of [ITU-T G.709], from the current multiframe in order to determine the number of payload bytes for the following multiframe. RES bits in the JC shall be ignored.

Lane processing and transcoding: For multilane Ethernet interfaces, lane processing and transcoding (transcoding for ETC5) is needed. The process is depicted in Figure 14-59 and described in clauses 17.7.4.1 and 17.7.5.1 of [ITU-T G.709].

BIP correction: When MI_Enable_PCSL_Section_Mon is True for multilane Ethernet interfaces, a new PCSL BIP is calculated and inserted.

When MI_Enable_PCSL_Section_Mon is false, the following processes are to be performed:

- For 40Gigabit Ethernet multilane interfaces, the PCSL BIP error mask is to be extracted and an OTN BIP error mask is calculated before scrambling. Both error masks are used for calculating an adjusted PCSL BIP which will be inserted. See Annex E of [ITU-T G.709] and Figure 14-59.
- For 100Gigabit Ethernet multilane interfaces, the incoming PCSL BIP will be transparently transmitted. See Annex E of [ITU-T G.709] and Figure 14-59.

Client signal fail: The function shall extract the CSF signal indicating the failure of the client signal out of Bit 1 of the PSI[2] byte of the payload structure identifier, as defined in clause 17.1 of [ITU-T G.709].

Demapping, CBR clock generation: The function shall provide an elastic store (buffer) process. The CBR data shall be written into the buffer from the data-bearing D bytes in the OPUk frames. The information extraction of the payload area shall be under control of the sigma-delta based data/stuff distribution. The CBRx data (CI_D) shall be read out of the buffer under control of the CBRx clock (CI_CK).

The locations of the data and stuff bytes are determined based on the count value sent in the JC bytes of the immediately preceding frame, as defined in clause 17.7 of [ITU-T G.709]. When a stuff m-bit block is encountered in the payload area, the writing of one m-bit block into the buffer shall be cancelled once. For the GMP justification process, refer to Annex D of [ITU-T G.709].

Smoothing and jitter limiting process: The function shall provide for a clock smoothing and elastic store (buffer) process. The data signal shall be written into the buffer under control of the associated (gapped) input clock. The data signal shall be read out of the buffer under control of a smoothed (equally spaced) clock at a rate and frequency accuracy determined by the client signal rate at the input of the remote ODUkP/CBRx_a_So. The clock generation process for reading the data out of the buffer shall use the $\sum C_{nD}$ justification information with $n = 8$, as per clause 17.7 of [ITU-T G.709].

The clock parameters, including jitter and wander requirements, as defined in Annex A of [ITU-T G.8251] (ODCp clock), apply.

Buffer size: In the presence of jitter as specified for client signals in the standards given in Table 14-26, this justification process shall not introduce any errors.

Following a step in frequency of the signal transported by the ODUkP_AI (for example, due to reception of CBRx_CI from a new CBR_TT_So at the far end or removal of generic-AIS signal with a frequency offset), there will be a maximum recovery time of X seconds after which this process shall not generate any bit errors. The value of X is for further study; a value of 1 second has been proposed.

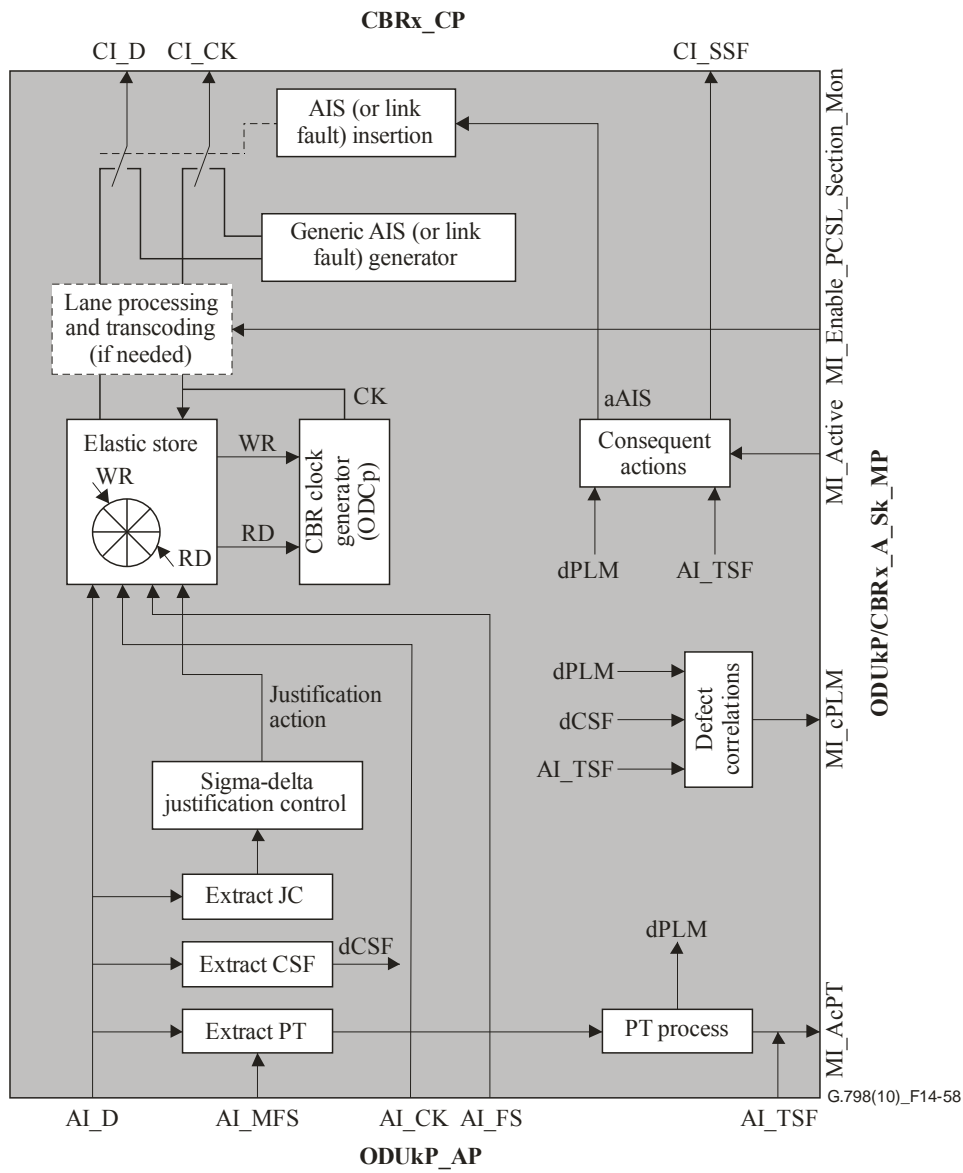
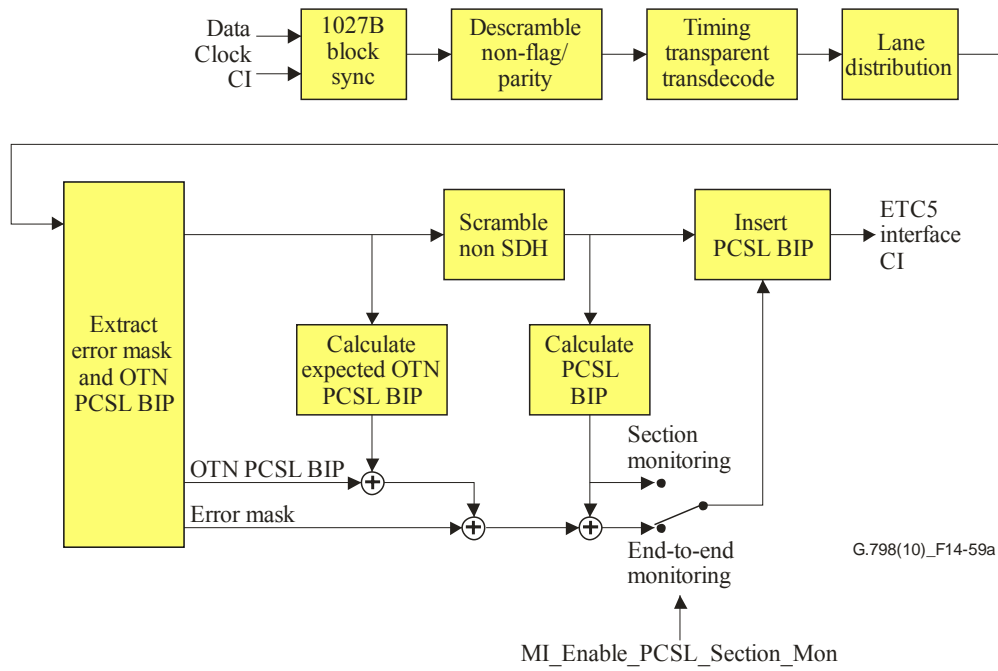
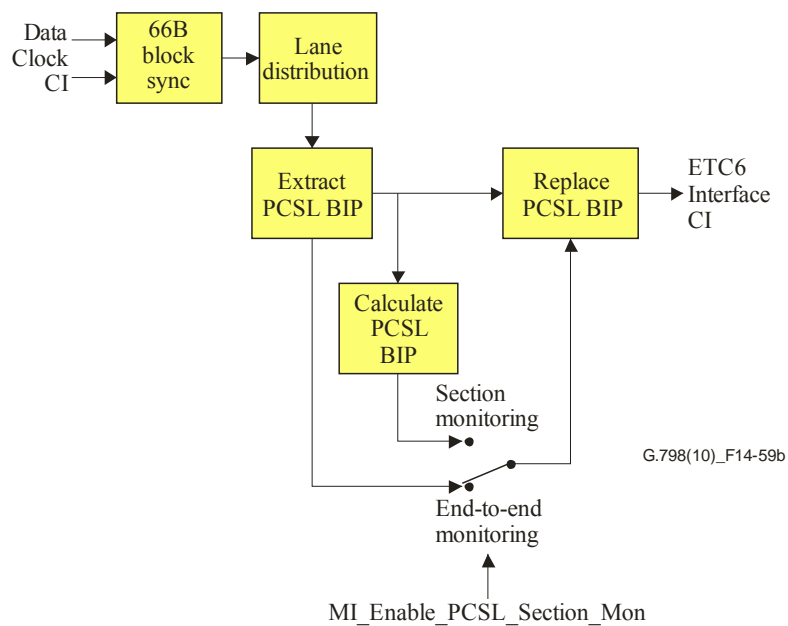

Figure 14-58 – ODUkP/CBRx-g_A_Sk processes



a) ETC5 client



b) ETC6 client

Figure 14-59 – Lane processing and timing transparent process of the ODUkP/CBRx-g_A_Sk function for ETC5 and ETC6 clients

Defects

The function shall detect for dPLM.

dPLM: See clause 6.2.4.1. The expected payload types are defined in clause 15.9.2.1 of [ITU-T G.709].

dCSF: See clause 6.2.10.

Consequent actions

aSSF ← AI_TSF or dPLM or (not MI_Active)

aAIS ← AI_TSF or dPLM or (not MI_Active)

NOTE – The state of the determination process of the C_m and its contribution to AIS consequent action is for further study.

For Ethernet clients, on declaration of aAIS the function shall output a link fault pattern/signal as defined in clause 17.7.1 of [ITU-T G.709] within two frames. On clearing of aAIS, the link fault pattern/signal shall be removed within two frames and normal data being output. The link fault or GenericAIS clock start shall be independent from the incoming clock. The link fault or GenericAIS clock has to be within the frequency, jitter, and wander tolerance specifications of the associated client signal.

Defect correlations

cPLM ← dPLM and (not AI_TSF)

cCSF ← dCSF and (not dPLM) and (not AI_TSF)

14.3.9 ODU_kP to ODU_{[i]j} adaptation function (ODU_kP/ODU_{[i]j}_A)

The ODU_kP to ODU_{[i]j} adaptation functions perform the adaptation between the ODU_kP ($k = 1, 2, 3$) layer adapted information and the characteristic information of ODU_j ($j = 0, 1, 2; j < k$) [and ODU_i ($i = 1; i < j$)] signals.

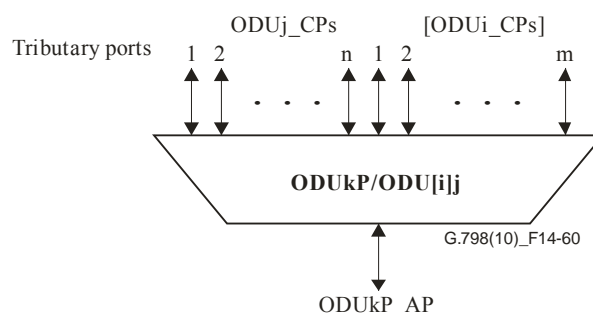

Figure 14-60 – ODU_kP/ODU_{[i]j}_A function

Five different types of functions are possible:

- the ODU₁P/ODU₀_A performs multiplexing/demultiplexing of 2 ODU₀ into an ODU₁;
- the ODU₂P/ODU₁_A performs multiplexing/demultiplexing of 4 ODU₁ into an ODU₂;
- the ODU₃P/ODU₁_A performs multiplexing/demultiplexing of 16 ODU₁ into an ODU₃;
- the ODU₃P/ODU₂_A performs multiplexing/demultiplexing of 4 ODU₂ into an ODU₃;
- the ODU₃P/ODU₁₂_A performs multiplexing/demultiplexing of ODU₁ and ODU₂ into an ODU₃.

The maximum number of tributary ports depends on the specific function type as listed in Table 14-28. Note that for the ODU₃P/ODU₁₂_A function, only a subset of the tributary signals can be active and transported via the ODU₃ at one time. The number of active ODU₁ ports plus four times the number of active ODU₂ ports is limited to 16. The multiplex structure identifier (MSI) defines the configuration in this case.

Note that the ODU₃P/ODU₁₂_A function can interwork with the ODU₂P/ODU₁_A, ODU₃P/ODU₁_A and ODU₃P/ODU₂_A functions as it supports all related multiplex structures.

Table 14-28 – ODUkP/ODU[i]j_A tributary ports

Function type	n ports	m ports
ODU1P/ODU0_A	2 ODU0	–
ODU2P/ODU1_A	4 ODU1	–
ODU3P/ODU1_A	16 ODU1	–
ODU3P/ODU2_A	4 ODU2	–
ODU3P/ODU12_A	16 ODU1	4 ODU2

14.3.9.1 ODUkP to ODU[i]j adaptation source function (ODUkP/ODU[i]j_A_So)

The ODUkP/ODU[i]j_A_So function creates the ODUk signal from a free-running clock. It asynchronously maps the ODUj [and ODUi] client signal from the ODUj_ [and ODUi] CPs into ODTUjk[/ik] including justification control (JC) information. The ODTUjk[/ik] are multiplexed into the payload area of the OPUk. It adds OPUk overhead (RES, PT, MSI) and default ODUk overhead. It provides access to ODUk PM APS overhead.

The information flow and processing of the ODUkP/ODU[i]j_A_So function is defined with reference to Figures 14-61 and 14-62.

Symbol

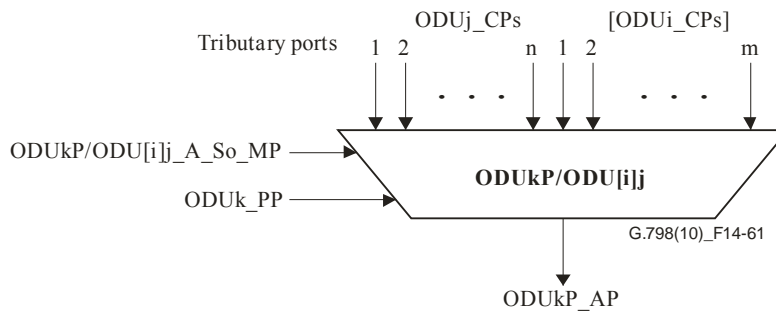

Figure 14-61 – ODUkP/ODU[i]j_A_So function

Interfaces

Table 14-29 – ODUkP/ODU[i]j_A_So inputs and outputs

Input(s)	Output(s)
<p>n × ODUj_CP: ODUj_CI_CK ODUj_CI_D ODUj_CI_FS ODUj_CI_MFS m × ODUi_CP: (Note) ODUi_CI_CK ODUi_CI_D ODUi_CI_FS ODUi_CI_MFS ODUk_PP: ODUk_PI_APS ODUkP/ODU[i]j_A_So_MP: ODUkP/ODU[i]j_A_So_MI_Active ODU3P/ODU12_A_So_MI_TxMSI (Note) ODUkP/ODU[i]j_A_So_MI_AdminState[n+m]</p>	<p>ODUkP_AP: ODUkP_AI_CK ODUkP_AI_D ODUkP_AI_FS ODUkP_AI_MFS</p>
<p>NOTE – For ODU3P/ODU12_A_So only.</p>	

Processes

Activation

The ODUkP/ODU[i]j_A_So function shall access the access point when it is activated (MI_Active is true). Otherwise, it shall not access the access point.

The processes associated with the ODUkP/ODU[i]j_A_So function are specific processes for each ODUj[i/]_CP and common processes for the compound (multiplexed) signal as depicted in Figure 14-62.

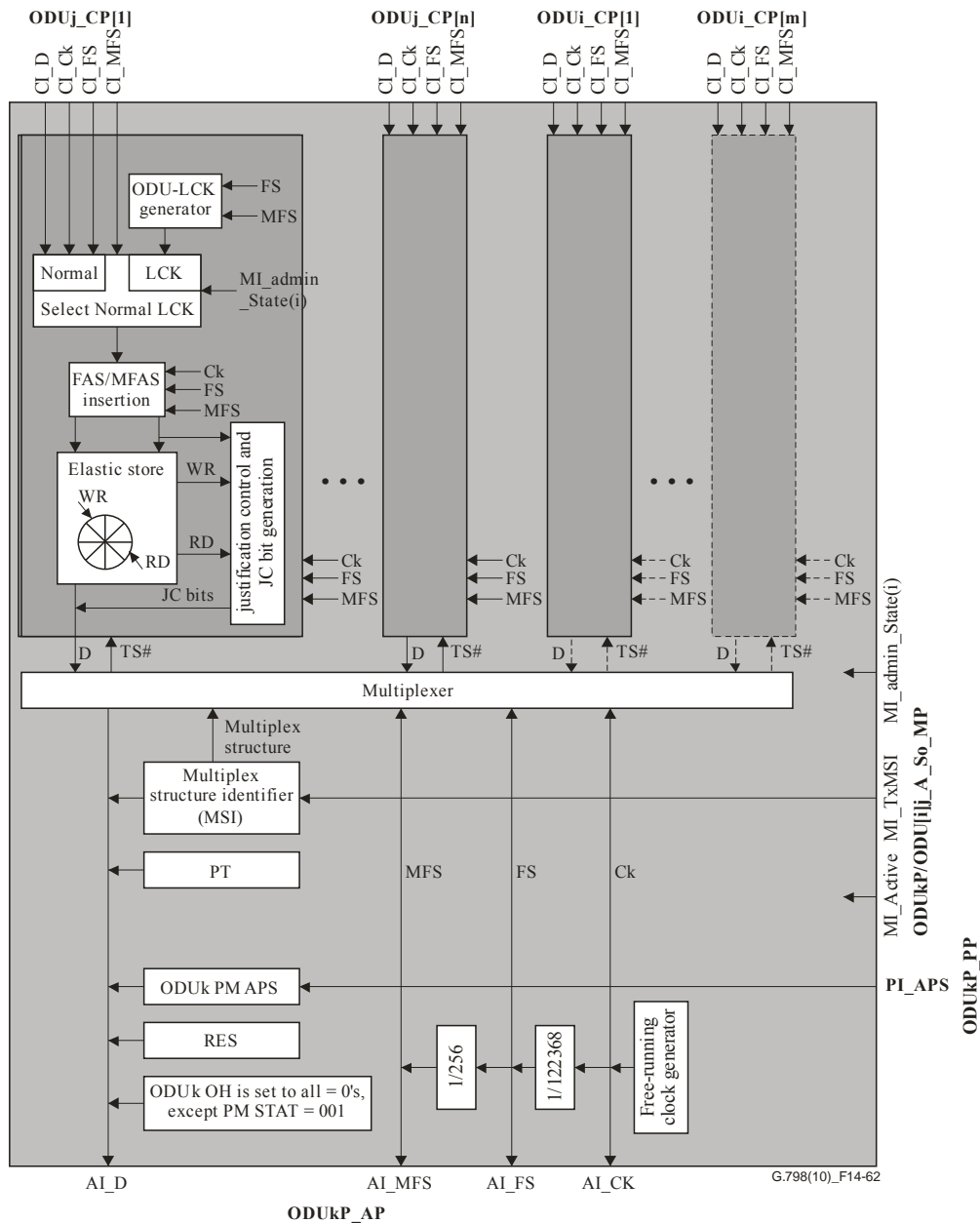

Figure 14-62 – ODUkP/ODU[i]j_A_So processes

Specific processes

The specific processes are performed independently for each ODUj [and ODUi] client signal that is multiplexed into the ODUk. The specific processes perform the mapping of the ODUj[i] into an ODTUjk[ik].

FAS/MFAS insertion: The function shall extend the ODUj[i] with the frame alignment overhead (FAS and MFAS) in row one, bytes 1 to 7, as described in clause 15.6.2 of [ITU-T G.709]. Bytes 8 to 14 of row one are set to all-ZEROS.

Mapping, frequency justification and bit-rate adaptation: The function shall provide an elastic store (buffer) process for the ODUj[i] client signal. The data signal ODUj[i]_CI shall be written into the buffer under control of the associated input clock. The data shall be read out of the buffer and written onto the D, NJO, PJO1 and PJO2 bytes of the selected ODTUjk[ik] frame under control of the ODUk clock and justification decisions, as defined in clause 19.5 of [ITU-T G.709].

A justification decision shall be performed every second frame for the ODTU01, every fourth frame for the ODTU12, every sixteenth frame for the ODTU13 and four times every sixteen frames for

the ODTU23. Each justification decision results in a corresponding double positive, positive, negative or no justification action. Upon a double positive justification action, the reading of two data bytes out of the buffer shall be cancelled once. No ODUj[i] data shall be written onto the PJO2, PJO1 or NJO bytes. Upon a positive justification action, the reading of one data byte out of the buffer shall be cancelled once. No ODUj[i] data shall be written onto the PJO1 or NJO bytes and data shall be written onto the PJO2 byte. Upon a negative justification action, one extra data byte shall be read once out of the buffer. ODUj[i] data shall be written onto the PJO2, PJO1 and NJO bytes. If no justification action is to be performed, ODUj[i] data shall be written onto the PJO2 and PJO1 bytes and no ODUj[i] data shall be written onto the NJO byte. The ODUk frame that contains the PJO2, PJO1 and NJO bytes depends on the time slot(s) of the ODTUjk[ik].

The justification decisions determine the phase error introduced by the function.

Buffer size: In the presence of jitter as specified by [ITU-T G.8251] and a frequency within the range $239/(239 - j[i]) \times 4^{(i-1)} \times 2\,488\,320\text{ kHz} \pm 20\text{ ppm}$ ($j = 1, 2; i = 1$) and $1\,244\,160\text{ kHz} \pm 20\text{ ppm}$ ($j = 0$), this mapping process shall not introduce any errors. The maximum buffer hysteresis, and therefore the maximum phase error introduced, shall be as listed in Table 14-30.

Table 14-30 – Maximum buffer hysteresis

Mapping	Maximum buffer hysteresis
ODU0 → ODU1	1 byte
ODU1 → ODU2 or ODU3	2 bytes
ODU2 → ODU3	8 bytes

JC: The function shall generate the justification control bits based on the justification decision (double positive, positive, negative, none) according to the specification in clause 19.5 of [ITU-T G.709]. It shall insert the justification control bits in bit 7 and 8 of all three JC bytes of the frame in which the justification is performed. The remaining (RES) bits of the JC byte shall be set to all-ZEROs. The ODUk frame that contains the JC bytes depends on the time slot(s) of the ODTUjk[ik].

ODUk-LCK: The function shall generate the ODUk-LCK signal as defined in clause 16.5 of [ITU-T G.709]. The clock, frame start and multiframe start are defined by the incoming ODUk signal.

Selector: The normal signal may be replaced by the ODUk-LCK signal. ODUk-LCK signal is selected if the MI_AdminState is LOCKED.

Common processes

Clock and (multi)frame start signal generation: The function shall generate a local ODUk clock (ODUkP_AI_CK) of " $239/(239 - k) \times 4^{(k-1)} \times 2\,488\,320\text{ kHz} \pm 20\text{ ppm}$ " from a free-running oscillator. The clock parameters, including jitter and wander requirements, as defined in Annex A of [ITU-T G.8251] (ODCa clock), apply.

The function shall generate the (multi)frame start reference signals AI_FS and AI_MFS for the ODUk signal. The AI_FS signal shall be active once per 122 368 clock cycles. AI_MFS shall be active once every 256 frames.

Multiplexing: The function assigns the individual ODTUjk[ik] to specific time slots of the OPUk payload area as defined by the multiplex structure (see clauses 19.3 and 19.4.1 of [ITU-T G.709]).

MSI: The function shall insert the TxMSI into the MSI byte positions of the PSI overhead as defined in clause 19.4 of [ITU-T G.709]. The TxMSI value, and as such the multiplex structure, is either fixed or configurable via MI_TxMSI as shown in Table 14-31.

PT: The function shall insert code "0010 0000" (ODU multiplex structure) into the PT byte position of the PSI overhead as defined in clause 15.9.2.1 of [ITU-T G.709].

ODUk PM APS: The function shall insert the PI_APS value into the ODUk path APS/PCC field, which is available once per 8 ODUk frames when MFAS bits 6, 7, 8 are 000.

RES: The function shall insert all-ZEROs into the RES bytes.

All other bits of the ODUk overhead should be sourced as "0"s, except the ODUk-PM STAT field which should be set to the value "normal path signal" (001).

Table 14-31 – Multiplex structure configuration and TxMSI values

Function	Multiplex structure	TxMSI value for fixed multiplex structure
ODU1P/ODU0_A	Fixed 2 ODU0 → ODU1	11 000000 11 000001
ODU2P/ODU1_A	Fixed 4 ODU1 → ODU2	00 000000 00 000001 00 000010 00 000011
ODU3P/ODU1_A	Fixed 16 ODU1 → ODU3	00 000000 00 000001 00 000010 00 000011 00 000100 00 000101 00 000110 00 000111 00 001000 00 001001 00 001010 00 001011 00 001100 00 001101 00 001110 00 001111

Table 14-31 – Multiplex structure configuration and TxMSI values

Function	Multiplex structure	TxMSI value for fixed multiplex structure
ODU3P/ODU2_A	Fixed 4 ODU2 → ODU3	01 000000 01 000001 01 000010 01 000011 01 000000 01 000001 01 000010 01 000011 01 000000 01 000001 01 000010 01 000011 01 000000 01 000001 01 000010 01 000011
ODU3P/ODU12_A	Configured via MI_TxMSI	–

Defects: None.

Consequent actions: None.

Defect correlations: None.

Performance monitoring: None.

14.3.9.2 ODUkP to ODU[i]j adaptation sink function (ODUkP/ODU[i]j_A_Sk)

The ODUkP/ODU[i]j_A_Sk function extracts the OPUk overhead (PT, MSI, RES) and monitors the reception of the correct payload type. It demultiplexes the individual ODTUjk[/ik] from the payload area of the OPUk and recovers the ODUj[/i] signals using the justification control information (JC overhead). It determines the frame and multiframe structure of the ODUj[/i]. It provides access to ODUk PM APS overhead.

The information flow and processing of the ODUkP/ODU[i]j_A_Sk function is defined with reference to Figures 14-63 and 14-64.

Symbol

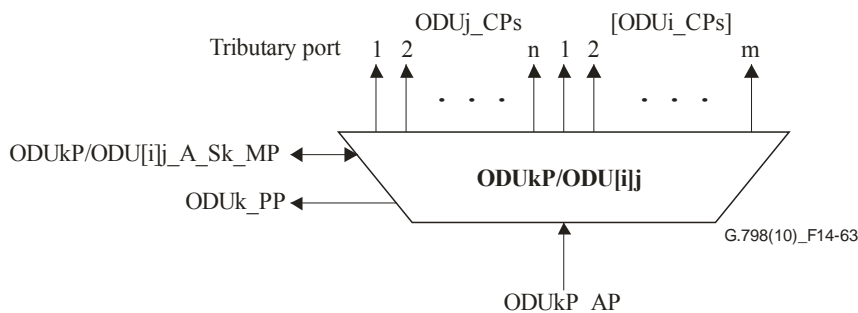

Figure 14-63 – ODUkP/ODU[i]j_A_Sk function

Interfaces

Table 14-32 – ODUkP/ODU[i]j_A_Sk inputs and outputs

Input(s)	Output(s)
<p>ODUkP_AP: ODUkP_AI_CK ODUkP_AI_D ODUkP_AI_FS ODUkP_AI_MFS ODUkP_AI_TSF ODUkP_AI_TSD</p> <p>ODUkP/ODU[i]j_A_Sk_MP: ODUkP/ODU[i]j_A_Sk_MI_Active ODU3P/ODU12_A_Sk_MI_ExMSI[n+m] (Note) ODUkP/ODU[i]j_A_Sk_MI_AdminState[n+m]</p>	<p>n × ODUj_CP: ODUj_CI_CK ODUj_CI_D ODUj_CI_FS ODUj_CI_MFS ODUj_CI_SSF ODUj_CI_SSD</p> <p>m × ODUi_CP: (Note) ODUi_CI_CK ODUi_CI_D ODUi_CI_FS ODUi_CI_MFS ODUi_CI_SSF ODUj_CI_SSD</p> <p>ODUk_PP: ODUk_PI_APS ODUk_PI_TSF ODUk_PI_TSD</p> <p>ODUkP/ODU[i]j_A_Sk_MP: ODUkP/ODU[i]j_A_Sk_MI_cPLM ODUkP/ODU[i]j_A_Sk_MI_cMSIM[1..maxTS] ODUkP/ODU[i]j_A_Sk_MI_AcPT ODUkP/ODU[i]j_A_Sk_MI_AcMSI[1..maxTS] n × ODUkP/ODUj_A_Sk_MI_cLOFLOM m × ODUkP/ODUi_A_Sk_MI_cLOFLOM (Note)</p>
<p>NOTE – For ODU3P/ODU12_A_Sk only.</p>	

Processes

Activation

The ODUkP/ODU[i]j_A_Sk function shall access the access point when it is activated (MI_Active is true). Otherwise, it shall not access the access point.

The processes associated with the ODUkP/ODU[i]j_A_Sk function are specific processes for each ODUj[i/]_CP and common processes for the compound (multiplexed) signal as depicted in Figure 14-64.

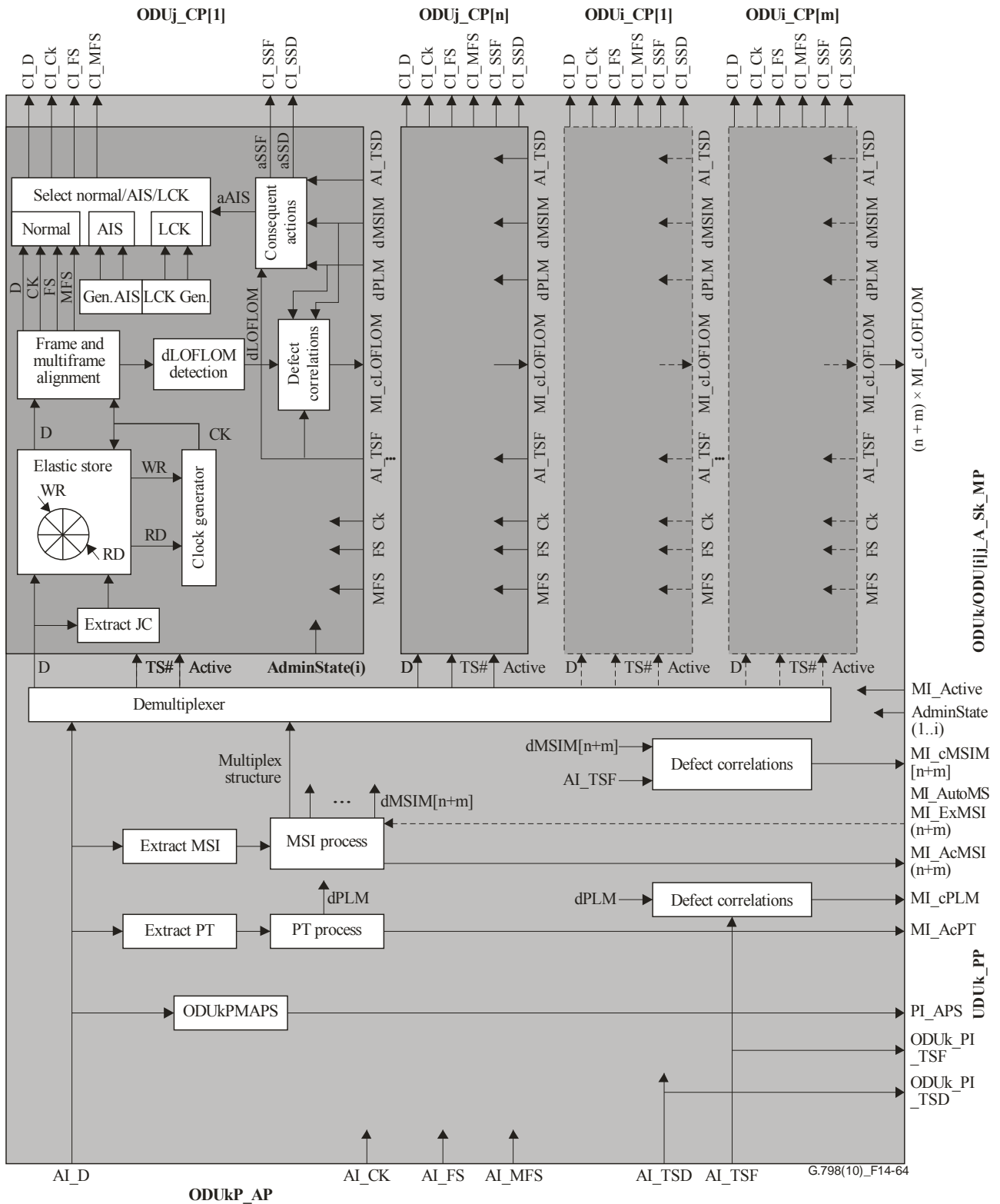

Figure 14-64 – ODUkP/ODU[i]j_A_Sk processes

Common processes

PT: The function shall extract the PT byte from the PSI overhead as defined in clause 8.7.1. The accepted PT value is available at the MP (MI_AcPT) and is used for PLM defect detection.

MSI: The function shall extract the MSI from the PSI overhead per configured tributary signal as defined in clause 8.7.2. The accepted MSI for a tributary signal #i (AcMSI[i]) is available at the MP (MI_AcMSI[i]). The multiplex structure is defined by ExMSI, which is either fixed or is configurable via MI_ExMSI as shown in Table 14-33.

RES: The value in the RES bytes shall be ignored.

ODUk PM APS: The function shall extract the information from the ODUk path APS/PCC field, which is available once per 8 ODUk frames when MFAS bits 6, 7, 8 are 000 and apply this to the PI_APS.

Demultiplexing: The function activates the ODTUjk[/ik] and assigns the time slots of the ODUk payload area to the individual ODTUjk[/ik] as defined by the multiplex structure (see clauses 19.3 and 19.4.1 of [ITU-T G.709]).

Table 14-33 – Multiplex structure configuration and ExMSI values

Function	Multiplex structure	ExMSI value for fixed multiplex structure
ODU1P/ODU0_A	Fixed 2 ODU0 → ODU1	11 000000 11 000001
ODU2P/ODU1_A	Fixed 4 ODU1 → ODU2	00 000000 00 000001 00 000010 00 000011
ODU3P/ODU1_A	Fixed 16 ODU1 → ODU3	00 000000 00 000001 00 000010 00 000011 00 000100 00 000101 00 000110 00 000111 00 001000 00 001001 00 001010 00 001011 00 001100 00 001101 00 001110 00 001111
ODU3P/ODU2_A	Fixed 4 ODU2 → ODU3	01 000000 01 000001 01 000010 01 000011 01 000000 01 000001 01 000010 01 000011 01 000000 01 000001 01 000010 01 000011 01 000000 01 000001 01 000010 01 000011
ODU3P/ODU12_A	Configured via MI_	–

Specific processes

The specific processes are performed independently for each ODU_j [and ODU_i] client signal that is multiplexed into the ODU_k. The specific processes recover the ODU_j[/i] from the ODTU_{jk}[/ik].

JC: The function shall interpret the justification control information in bits 7 and 8 of the JC bytes as defined in clause 19.5 of [ITU-T G.709] in order to determine the justification action (double positive, positive, negative, none) for the current frame. A two out of three majority decision is used. RES bits in the JC bytes shall be ignored. The ODU_k frame that contains the JC bytes depends on the time slot(s) of the ODTU_{jk}[/ik].

Demapping, CBR clock generation: The function shall provide an elastic store (buffer) process. The ODU_j[/i] data shall be written into the buffer from the D, NJO, PJO1 and PJO2 bytes in the ODTU_{jk}[/ik] frame. The information extraction of the PJO2, PJO1 and NJO bytes shall be under control of the justification control information. The ODU_j[/i] data (CI_D) shall be read out of the buffer under control of the ODU_j[/i] clock (CI_CK).

Upon a double positive justification action, the writing of two data bytes into the buffer shall be cancelled once. No ODU_j[/i] data shall be read from the PJO2, PJO1 or NJO bytes. Upon a positive justification action, the writing of one data byte into the buffer shall be cancelled once. No ODU_j[/i] data shall be read from the PJO1 or NJO bytes and data shall be read from the PJO2 byte. Upon a negative justification action, one extra data byte shall be written into the buffer once. ODU_j[/i] data shall be read from the PJO2, PJO1 and NJO bytes. If no justification action is to be performed, ODU_j[/i] data shall be read from the PJO2 and PJO1 bytes and no ODU_j[/i] data shall be read from the NJO bytes. The ODU_k frame that contains the PJO2, PJO1 and NJO bytes depends on the time slot(s) of the ODTU_{jk}[/ik].

Smoothing and jitter limiting process: The function shall provide for a clock smoothing and elastic store (buffer) process. The $239/(239 - j[i]) \times 4^{(i-1)} \times 2\,488\,320$ kbit/s ($j = 1, 2; i = 1$) and $1\,244\,160$ kHz ± 20 ppm ($j = 0$) data signal shall be written into the buffer under control of the associated (gapped) input clock (with a frequency accuracy within ± 20 ppm). The data signal shall be read out of the buffer under control of a smoothed (equally spaced) $239/(239 - j[i]) \times 4^{(i-1)} \times 2\,488\,320$ kbit/s ± 20 ppm ($j = 1, 2; i = 1$) and $1\,244\,160$ kHz ± 20 ppm ($j = 0$) clock (the rate is determined by the ODU_j[/i] signal at the input of the remote ODU_kP/ODU_iJ_A_So).

The clock parameters, including jitter and wander requirements, as defined in Annex A of [ITU-T G.8251] (ODCp clock), apply.

Buffer size: In the presence of jitter as specified by [ITU-T G.8251] and a frequency within the range $239/(239 - j[i]) \times 4^{(i-1)} \times 2\,488\,320$ kbit/s ± 20 ppm ($j = 1, 2; i = 1$) and $1\,244\,160$ kHz ± 20 ppm ($j = 0$), this justification process shall not introduce any errors.

Following a step in frequency of the $239/(239 - j[i]) \times 4^{(i-1)} \times 2\,488\,320$ kbit/s ($j = 1, 2; i = 1$) and $1\,244\,160$ kHz ± 20 ppm ($j = 0$) signal transported (for example, due to reception of ODU_j[/i]_CI from a new ODU_j[/i]_TT_So at the far end or removal of a ODU AIS signal with a frequency offset), there will be a maximum recovery time of X seconds after which this process shall not generate any bit errors. The value of X is for further study; a value of one second has been proposed.

Frame and multiframe alignment: The function shall perform frame and multiframe alignment as described in clause 8.2.3.

ODU_j[/i]-LCK, ODU_j[/i]-AIS: The function shall generate the ODU_j[/i]-LCK and ODU_j[/i]-AIS signals as defined in [ITU-T G.709]. The clock, frame start and multiframes start shall be independent from the incoming clock. The clock has to be within $239/(239 - j[i]) \times 4^{(i-1)} \times 2\,488\,320$ kHz ± 20 ppm ($j = 1, 2; i = 1$) and $1\,244\,160$ kHz ± 20 ppm ($j = 0$). Jitter and wander requirements, as defined in Annex A of [ITU-T G.8251] (ODCa clock), apply.

Selector: The normal signal may be replaced by either the ODU_j[/i]-AIS or ODU_j[/i]-LCK signal. ODU_j[/i]-LCK is selected if the corresponding MI_AdminState[n+m] signal is LOCKED. ODU_j[/i]-AIS is selected if the corresponding MI_AdminState[n+m] signal is not LOCKED and aAIS is true.

Defects

The function shall detect for dPLM, dMSIM and dLOFLOM.

dPLM: See clause 6.2.4.1. The expected payload type is "0010 0000" (ODU multiplex structure) as defined in [ITU-T G.709].

dMSIM: See clause 6.2.9.1. dMSIM is detected per active ODU_j[/i].

dLOFLOM: See clause 6.2.5.3. dLOFLOM is detected per active ODU_j[/i].

Consequent actions

PI_TSF ← AI_TSF

PI_TSD ← AI_TSD

For each ODU_j[/i]:

aSSF ← ((AI_TSF or dPLM or dMSIM or dLOFLOM) and (not MI_AdminState = LOCKED)) or (not Active)

For each ODU_j[/i]:

aSSD ← AI_TSD and (not MI_AdminState = LOCKED)

For each ODU_j[/i]:

aAIS ← ((AI_TSF or dPLM or dMSIM or dLOFLOM) and (not MI_AdminState = LOCKED)) or (not Active)

On declaration of aAIS, the function shall output an all-ONEs pattern/signal within two frames. On clearing of aAIS the all-ONEs pattern/signal shall be removed within two frames, with normal data being output. The AIS clock, frame start and multiframe start shall be independent from the incoming clock, frame start and multiframe start. The AIS clock has to be within $239/(239 - j [/i]) \times 4^{(j/i-1)} \times 2\,488\,320 \text{ kHz} \pm 20 \text{ ppm}$ ($j = 1, 2; i = 1$) and $1\,244\,160 \text{ kHz} \pm 20 \text{ ppm}$ ($j = 0$). Jitter and wander requirements, as defined in Annex A of [ITU-T G.8251] (ODCa clock), apply.

Defect correlations

cPLM ← dPLM and (not AI_TSF)

For each ODU_j[/i]

cMSIM ← dMSIM and (not dPLM) and (not AI_TSF)

For each ODU_j[/i]:

cLOFLOM ← dLOFLOM and (not MSIM) and (not dPLM) and (not AI_TSF) and (Active)

Performance monitoring: None.

14.3.10 ODU_kP to ODU_j payload type 21 adaptation function (ODU_kP/ODU_j-21_A)

The ODU_kP to ODU_j payload type 21 adaptation functions perform the adaptation between the ODU_kP ($k = 2, 3, 4$) layer adapted information and the characteristic information of ODU_j ($j = 0, 1, 2, 2e, 3, flex$) signals.

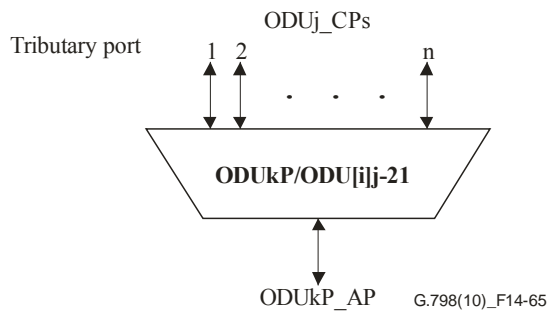

Figure 14-65 – ODUkP/ODUj-21_A function

Three different types of functions are possible:

- the ODU2P/ODUj-21_A performs multiplexing/demultiplexing of any LO ODU with a bit rate less than the OPU2 payload bit rate into an OPU2;
- the ODU3P/ODUj-21_A performs multiplexing/demultiplexing of any LO ODU with a bit rate less than the OPU3 payload bit rate into an OPU3;
- the ODU4P/ODUj-21_A performs multiplexing/demultiplexing of any LO ODU with a bit rate less than the OPU4 payload bit rate into an OPU4.

Tributary ports are dynamically created and deleted under control of management. Each tributary port is associated with one ODUj connection point on one hand, and M OPUk tributary slots on the other hand. The multiplex structure identifier (MSI) carries the configuration of tributary ports to tributary slots.

14.3.10.1 ODUkP to ODUj payload type 21 adaptation source function (ODUkP/ODUj-21_A_So)

The ODUkP/ODUj-21_A_So function creates the ODUk signal from a free-running clock. It asynchronously maps the ODUj client signal from the ODUj CPs into ODTUjk or ODTUk.M including justification control (JC) information. The ODTUjk and ODTUk.M are multiplexed into the tributary slots of the OPUk. It adds OPUk overhead (RES, PT, MSI, OMFI) and default ODUk overhead. It provides access to ODUk PM APS overhead.

The information flow and processing of the ODUkP/ODUj-21_A_So function is defined with reference to Figures 14-66 and 14-67.

Symbol

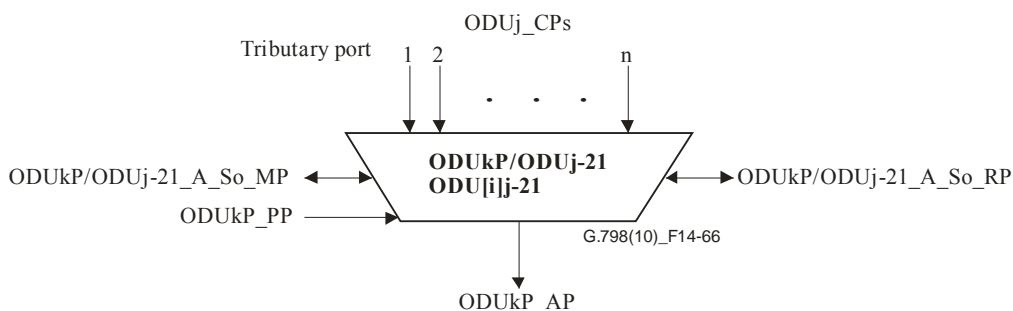

Figure 14-66 – ODUkP/ODUj-21_A_So function

Interfaces

Table 14-34 – ODUkP/ODUj-21_A_So inputs and outputs

Input(s)	Output(s)
<p>n × ODUj_CP: ODUj_CI_CK ODUj_CI_D ODUj_CI_FS ODUj_CI_MFS ODUk_PP: ODUk_PI_APS ODUkP/ODUj-21_A_So_MP: ODUkP/ODUj-21_A_So_MI_Active ODUkP/ODUj-21_A_So_MI_TxMSI ODUkP/ODUj-21_A_So_MI_AUTOpayloadtype ODUkP/ODUj_A_So_MI_AdminState[n] ODUkP/ODUj-21_A_So_RP: ODUkP/ODUj-21_A_So_RI_AcPT</p>	<p>ODUkP_AP: ODUkP_AI_CK ODUkP_AI_D ODUkP_AI_FS ODUkP_AI_MFS ODUkP/ODUj-21_A_So_RP: ODUkP/ODUj-21_A_So_RI_TrPT ODUkP/ODUj-21_A_So_MP: ODUkP/ODUj-21_A_So_MI_TrPT</p>

Processes

Activation

The ODUkP/ODUj-21_A_So function shall access the access point when it is activated (MI_Active is true). Otherwise, it shall not access the access point.

The processes associated with the ODUkP/ODUj-21_A_So function are specific processes for each ODUj_CP and common processes for the compound (multiplexed) signal as depicted in Figure 14-67.

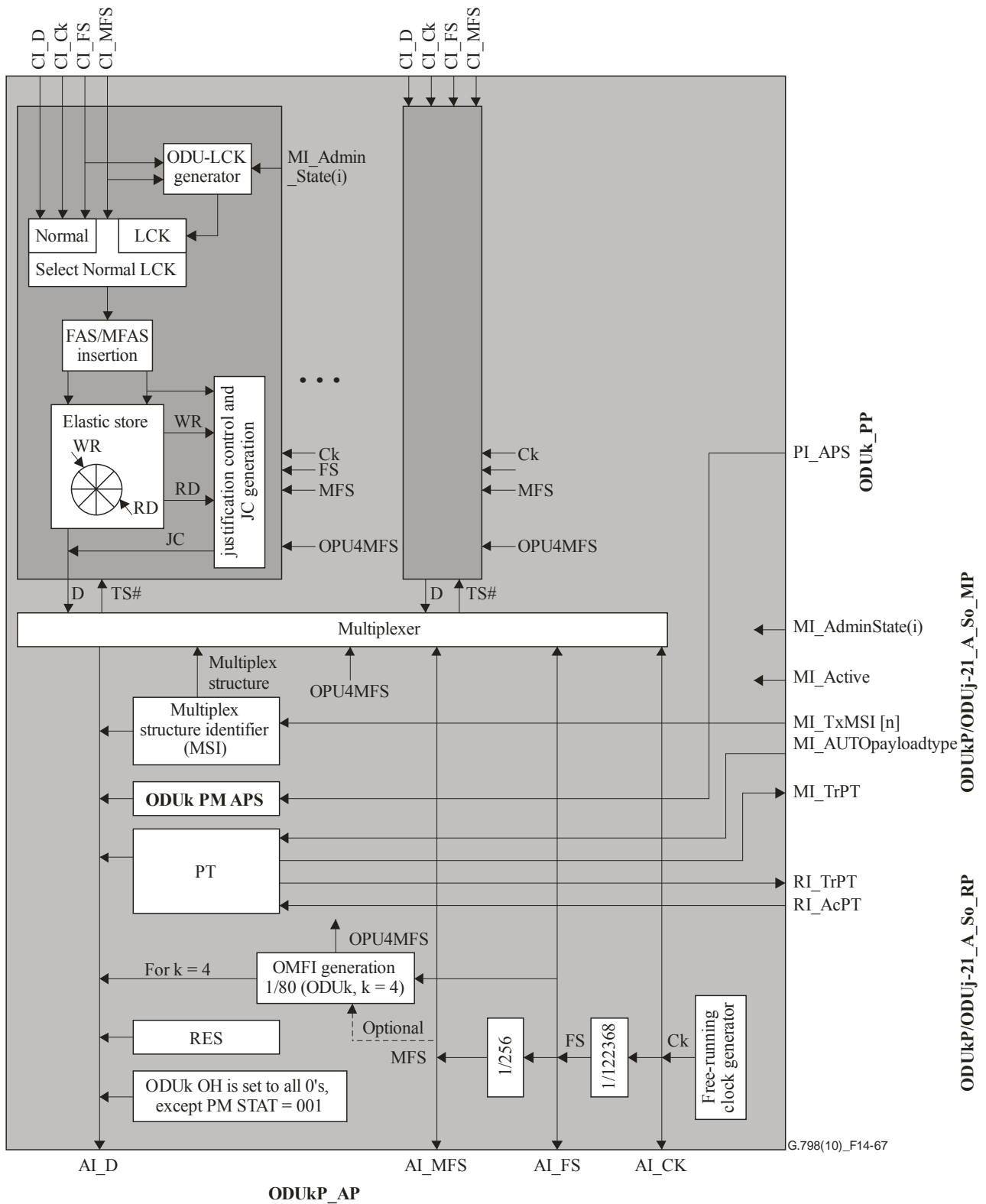

Figure 14-67 – ODUkP/ODUj-21_A_So processes

Specific processes

The specific processes are performed independently for each ODUj client signal that is multiplexed into the OPUk. The specific processes perform the mapping of the ODUj into an ODTUjk or ODTUk.M.

FAS/MFAS insertion: The function shall extend the ODU_j with the frame alignment overhead (FAS and MFAS) in row one bytes 1 to 7 as described in clause 15.6.2 of [ITU-T G.709]. Bytes 8 to 14 of row one are set to all-ZEROS.

Mapping, frequency justification and bit-rate adaptation: The function shall provide an elastic store (buffer) process for the ODU_j client signal. The data signal ODU_j_CI shall be written into the buffer under control of the associated input clock. Two justification methods, as described below, are provided, AMP (*ODTU_{jk}*) and GMP (*ODTUK.M*).

ODTU_{jk}: The data shall be read out of the buffer and written onto the D, NJO, PJO1 and PJO2 bytes of the selected ODTU_{jk} frame under control of the ODU_k clock and the asynchronous mapping procedure (AMP) justification decisions as defined in clause 19.5 of [ITU-T G.709].

A justification decision shall be performed two times per OPU_k multiframe (*jk* = 12, 13) and eight times per OPU_k multiframe (*jk* = 23). Justification decisions are taken at the beginning of the OPU_k frame carrying an instance of the ODTU_{jk} justification overhead. Each justification decision results in a corresponding double positive, positive, negative or no justification action in this OPU_k frame. Upon a double positive justification action, the reading of two data bytes out of the buffer shall be cancelled once. No ODU_j data shall be written onto the PJO2, PJO1 or NJO bytes. Upon a positive justification action, the reading of one data byte out of the buffer shall be cancelled once. No ODU_j data shall be written onto the PJO1 or NJO bytes and data shall be written onto the PJO2 byte. Upon a negative justification action, one extra data byte shall be read once out of the buffer. ODU_j data shall be written onto the PJO2, PJO1 and NJO bytes. If no justification action is to be performed, ODU_j data shall be written onto the PJO2 and PJO1 bytes and no ODU_j data shall be written onto the NJO byte. The OPU_k frame that contains the PJO2, PJO1 and NJO bytes depends on the tributary slots occupied by the ODTU_{jk}.

The justification decisions determine the phase error introduced by the function.

ODTUK.M: The data shall be read out of the buffer and written onto groups of *M* successive bytes of the ODTU_k.*M* payload area under control of the ODU_k clock and the GMP data/stuff control mechanism as defined in clause 19.6 of [ITU-T G.709].

Buffer size: In the presence of jitter as specified by [ITU-T G.8251] and a frequency within the range specified in Table 14-2, this mapping process shall not introduce any errors. The maximum buffer hysteresis, and therefore the maximum phase error introduced, shall be as listed in Table 14-35.

Table 14-35 – Maximum buffer hysteresis

Mapping	Maximum buffer hysteresis
ODU _j → ODTU _k . <i>M</i>	<i>M</i> bytes
ODU _j → ODTU _{jk}	2 bytes (<i>j</i> = 1) 8 bytes (<i>j</i> = 2)

ODTU_{jk} JC: The function shall generate the justification control bits based on the justification decision according to the specification in clause 19.5 of [ITU-T G.709]. It shall insert the justification control bits in bit 7 and 8 of all three JC bytes of the frame in which the justification is performed. The remaining (RES) bits of the JC byte shall be set to all-ZEROS. The ODU_k frame that contains the JC bytes depends on the time slot(s) of the ODTU_{jk}.

ODTUK.M JC1/JC2/JC3, JC4/JC5/JC6: The function shall generate the GMP *C_m* and GMP ΣC_{nD} information and insert this into the JC1/JC2/JC3 and JC4/JC5/JC6 bytes, respectively, according to the specification in clause 19.6 and Annex D of [ITU-T G.709].

ODUk-LCK: The function shall generate the ODUk-LCK signal as defined in clause 16.5 of [ITU-T G.709]. The clock, frame start and multiframe start are defined by the incoming ODUk signal.

Selector: The normal signal may be replaced by the ODUk-LCK signal. The ODUk-LCK signal is selected if the MI_AdminState is LOCKED.

Common processes

Clock and (multi)frame start signal generation: The function shall generate a local ODUk clock (ODUkP_AI_CK) of " $239/(239 - k) \times 4^{(k-1)} \times 2\,488\,320\text{ kHz} \pm 20\text{ ppm}$ " ($k = 2, 3$) or " $239/227 \times 40 \times 2\,488\,320\text{ kHz} \pm 20\text{ ppm}$ " ($k = 4$) from a free-running oscillator. The clock parameters, including jitter and wander requirements, as defined in Annex A of [ITU-T G.8251] (ODCa clock), apply.

The function shall generate the (multi)frame start reference signals AI_FS and AI_MFS for the ODUk signal. The AI_FS signal shall be active once per 122 368 clock cycles. AI_MFS shall be active once every 256 frames.

OPU multiframe (OMFI) start signal generation for OPUk with $k = 4$: For OPU4 in addition to MFAS, a dedicated 80-frame OPU multiframe indicator is used for the multiplexing of LO ODUs into the OPU4. This multiframe structure is locked to bits 2, 3, 4, 5, 6, 7 and 8 of the OMFI byte, as shown in Table 19-4 of [ITU-T G.709], and to be inserted into the OPU overhead. The function shall generate OPU4 multiframe and the related start signal (OPU4MFS) dividing the frame signal sequence by 80. The OMFI start signal may optionally be phase aligned to the ODU multiframe signal. In this case, the OMFI = 0 position is aligned with MFAS = 0 position every 1280 frame periods. See clause 19.4.4 of [ITU-T G.709].

Multiplexing: The function assigns the individual ODTUjk or ODTUk.M to specific time slots of the OPUk payload area as defined by the multiplex structure (see clauses 19.3 and 19.4.1 of [ITU-T G.709]).

MSI: The function shall insert the TxMSI into the MSI byte positions of the PSI overhead as defined in clauses 19.4.1.4, 19.4.1.5, 19.4.1.6 of [ITU-T G.709]. The TxMSI value, and as such the multiplex structure, is configurable via MI_TxMSI.

PT: The function shall insert code "0010 0001" (ODU multiplex structure supporting ODTUk.ts or ODTUk.ts and ODTUjk) into the PT byte position of the PSI overhead as defined in clause 15.9.2.1 of [ITU-T G.709] for $k = 4$.

For $k = 2, 3$ the inserted PT code shall default to code "0010 0001". This code may be replaced by code "0010 0000" under control of the PT = 21-to-PT = 20 interworking process described hereafter. When MI_AUTOpayloadtype is activated, the function shall adapt a PT21 supporting port to a PT20 structure.

If the corresponding adaptation sink provides the information of a PT = 20 at the RI_AcPT, the function shall fall back to PT = 20 under the following conditions: The MI_AUTOpayloadtype is true and the HO ODU source is either not provisioned for any traffic signal structure, or the HO ODU2 source configured for one or more ODU1 signals to be mapped into TS1/TS5 and/or TS2/TS6 and/or TS3/TS7 and/or TS4/TS8, or the HO ODU3 source is configured to support one or more ODU1 signals mapped into TS1/TS17, TS2/TS18, TSi/TS16+I and/or one or more ODU2 signals mapped into TSa/TS16+a/TSb/TS16+b/TSc/TS16+c/Tsd/TS16+16 and no other ODU type signals. In this case, the function shall insert PT20 into the PSI positions.

In the case the ODU2 or ODU3 adaptation source is configured for either ODU0, or an ODUflex, or an ODU2e, or for an ODU1 in TSi/TSj with $j > 4 + i$ (for ODU2) or $j > 16 + i$ (for ODU3) then PT21 is to be inserted. The inserted PT shall be reported at the ODUkP/ODUj-21_A_So_RI_TrPT to the corresponding adaptation sink function and the ODUkP/ODUj-21_A_So_MI_TrPT.

RES: The function shall insert all-ZEROs into the RES bytes.

ODUk PM APS: The function shall insert the PI_APS value into the ODUk path APS/PCC field, which is available once per 8 ODUk frames when MFAS bits 6, 7, 8 are 000.

All other bits of the ODUk overhead should be sourced as "0"s, except the ODUk-PM STAT field which should be set to the value "normal path signal" (001).

Defects: None.

Consequent actions: None.

Defect correlations: None.

Performance monitoring: None.

14.3.10.2 ODUkP to ODUj payload type 21 adaptation sink function (ODUkP/ODUj-21_A_Sk)

The ODUkP/ODUj-21_A_Sk function extracts the OPUk overhead (PT, MSI, RES and OMFI) and monitors the reception of the correct payload type. It demultiplexes the individual ODTUjk and ODTUk.M from the payload area of the OPUk and recovers the ODUj signals using the justification control information (JC, JC1/2/3/4/5/6 overhead). It determines the frame and multiframe structure of the ODUj. It provides access to ODUk PM APS overhead.

The information flow and processing of the ODUkP/ODUj-21_A_Sk function is defined with reference to Figures 14-68 and 14-69.

Symbol

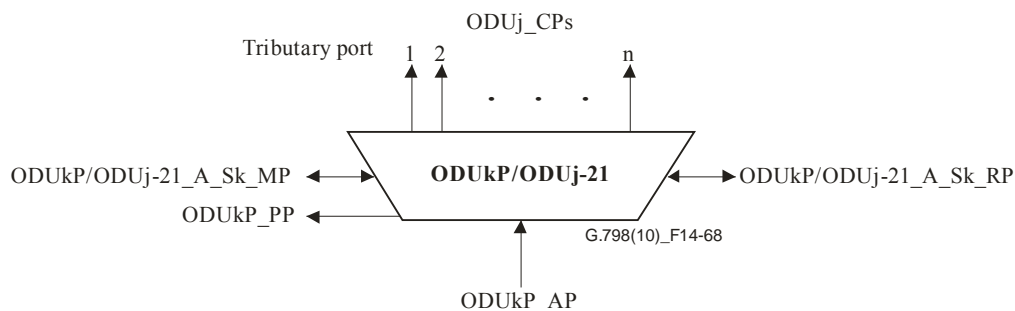

Figure 14-68 – ODUkP/ODUj-21_A_Sk function

Interfaces

Table 14-36 – ODUkP/ODUj-21_A_Sk inputs and outputs

Input(s)	Output(s)
<p>ODUkP_AP: ODUkP_AI_CK ODUkP_AI_D ODUkP_AI_FS ODUkP_AI_MFS ODUkP_AI_TSF ODUkP_AI_TSD</p> <p>ODUkP/ODUj21_A_Sk_MP: ODUkP/ODUj21_A_Sk_MI_Active ODU3P/ODUj21_A_Sk_MI_ExMSI ODUkP/ODUj-21_A_Sk_MI_AdminState[n] ODUkP/ODUj-21_A_Sk_MI_Nominal_Bitrate_and_Tolerance[i]</p> <p>ODUkP/ODUj-21_A_Sk_RP: ODUkP/ODUj-21_A_Sk_RI_TrPT</p>	<p>n × ODUj_CP: ODUj_CI_CK ODUj_CI_D ODUj_CI_FS ODUj_CI_MFS ODUj_CI_SSF ODUj_CI_SSD</p> <p>ODUk_PP: ODUk_PI_APS ODUk_PI_TSF ODUk_PI_TSD</p> <p>ODUkP/ODU[i]j_A_Sk_MP: ODUkP/ODUj-21_A_Sk_MI_cPLM ODUkP/ODUj-21_A_Sk_MI_cLOOMFI ODUkP/ODUj-21_A_Sk_MI_cMSIM ODUkP/ODUj-21_A_Sk_MI_AcPT ODUkP/ODUj-21_A_Sk_MI_AcMSI[i] ODUkP/ODUj-21_A_Sk_MI_cLOFLOM[i]</p> <p>ODUkP/ODUj-21_A_Sk_RP: ODUkP/ODUj-21_A_Sk_RI_AcPT</p>

Processes

Activation

The ODUkP/ODUj-21_A_Sk function shall access the access point when it is activated (MI_Active is true). Otherwise, it shall not access the access point.

The processes associated with the ODUkP/ODUj-21_A_Sk function are specific processes for each ODUj_CP and common processes for the compound (multiplexed) signal as depicted in Figure 14-69.

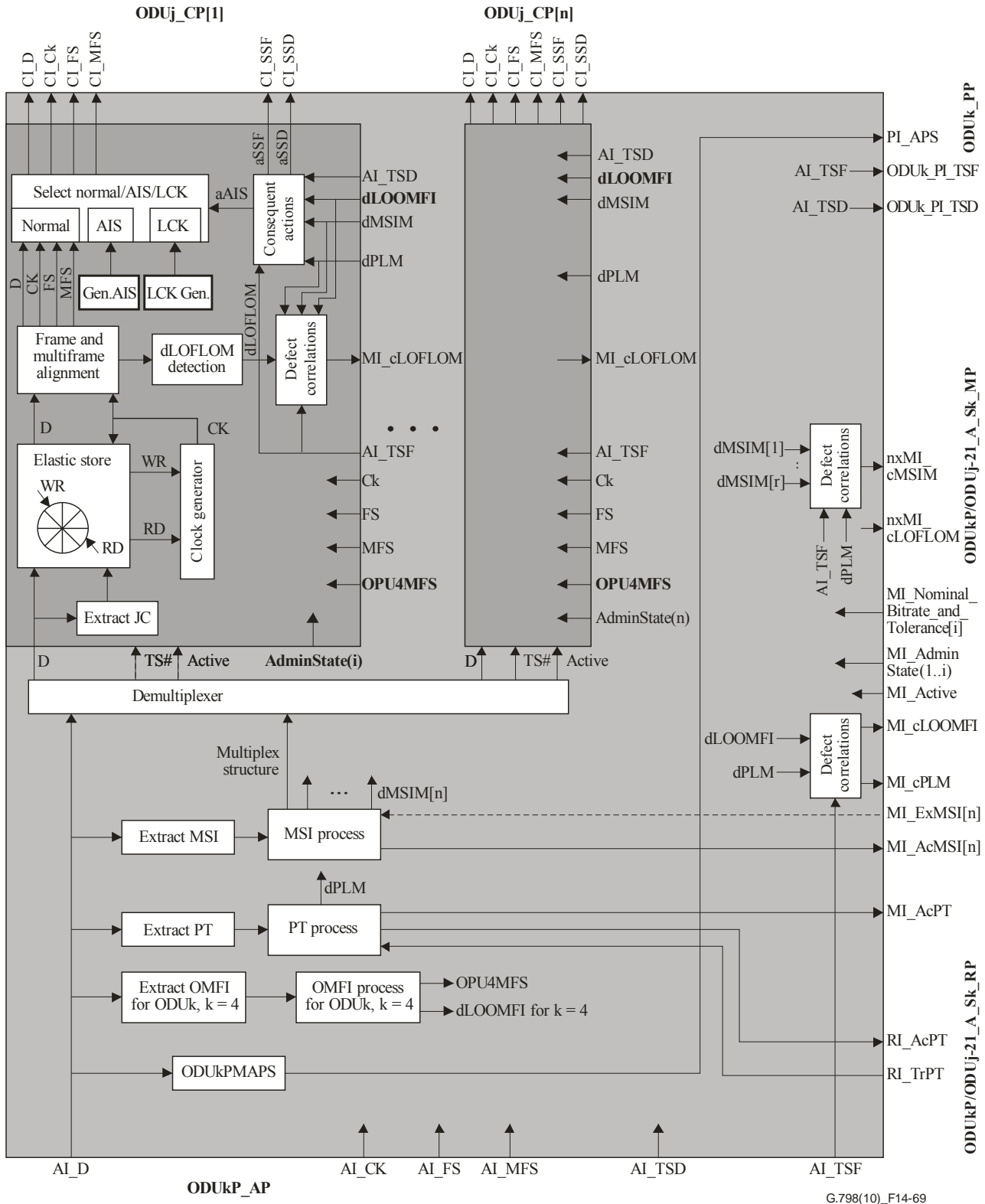

Figure 14-69 – ODUkP/ODUj-21_A_Sk processes

Common processes

OPU multiframe (OMFI) reception for OPuk with k = 4: For OPU4 in addition to MFAS, a dedicated 80-frame OPU multiframe indicator is used for the multiplexing of LO ODUs into the OPU4. This multiframe structure is locked to bits 2, 3, 4, 5, 6, 7 and 8 of the OMFI byte, as shown in Table 19-4 of [ITU-T G.709]. The function shall detect OPU multiframe by searching for the

framing pattern in the bits indicated above. The process has two states, out-of-multiframe (OOM) and in-multiframe (IM). The IM state shall be entered if this set is found and confirmed one frame period later and an error-free multiframe sequence is found in the byte positions of the two frames. In the IM state, the frame alignment signal shall be continuously checked with the presumed OMFI frame start position and the expected multiframe sequence. The OOM state shall be entered if this subset is not found at the correct position in five consecutive frames or the received OMFI does not match with the expected multiframe number in five consecutive frames. The OPU4 multiframe start (OPU4MFS) shall be maintained during the OOM state of the OMFI detection process. The defect dLOOMFI shall be generated based on the state of the OMFI alignment process.

If the OMFI alignment process is persistently in the out-of-multiframe (OOM) state for 3 ms, dLOOMFI shall be declared. dLOOMFI shall be cleared immediately when the OMFI alignment process is in the in-multiframe (IM) state

PT: The function shall extract the PT byte from the PSI overhead as defined in clause 8.7.1. The accepted PT value is available at the MP (MI_AcPT) and is used for PLM defect detection. The accepted PT is provisioned to the RP (RI_AcPT) for automatic PT adaptation. The PLM detection shall be based on the comparison of the accepted PT with the provided PT on the RP at the RI_TrPT input.

MSI: The function shall extract the MSI from the PSI overhead as defined in clause 8.7.2. The accepted MSI for a tributary signal #i (AcMSI[i]) is available at the MP (MI_AcMSI[i]). The multiplex structure is defined by ExMSI, which is either fixed or is configurable via MI_ExMSI.

RES: The value in the RES bytes shall be ignored.

ODUk PM APS: The function shall extract the information from the ODUk path APS/PCC field, which is available once per 8 ODUk frames when MFAS bits 6, 7, 8 are 000 and apply this to the PI_APS.

Demultiplexing: The function activates the ODTUjk or ODTUk.M and assigns the time slots of the ODUk payload area to the individual ODTUjk or ODTUk.M as defined by the multiplex structure (see clauses 19.3 and 19.4.1 of [ITU-T G.709]).

Specific processes

The specific processes are performed independently for each ODUj client signal that is multiplexed into the OPUk. The specific processes recover the ODUj from the ODTUjk or ODTUk.M.

Two justification methods as described below are provided, AMP (*ODTUjk*) and GMP (*ODTUk.M*).

ODTUjk JC: The function shall interpret the justification control information in bits 7 and 8 of the JC bytes as defined in clause 19.5 of [ITU-T G.709] in order to determine the justification action (double positive, positive, negative, none) for the current frame. A two out of three majority decision is used. RES bits in the JC bytes shall be ignored. The ODUk frame that contains the JC bytes depends on the time slot(s) of the ODTUjk.

ODTUk.ts JC1/2/3 and JC4/5/6: The function shall interpret the GMP overhead information in the JC1/2/3 and JC4/5/6 bytes as defined in clause 19.6 of [ITU-T G.709] in order to determine the number of M-byte ODUj entities in the next ODTUk.M multiframe. The OPUk frame that contains the JC1/2/3 and JC4/5/6 bytes depends on the last tributary slot that is occupied by the ODTUk.M.

Demapping, CBR clock generation: The function shall provide an elastic store (buffer) process.

ODTUjk: The ODUj data shall be written into the buffer from the D, NJO, PJO1 and PJO2 bytes in the ODTUjk frame. The information extraction of the PJO2, PJO1 and NJO bytes shall be under control of the justification control information.

Upon a double positive justification action, the writing of two data bytes into the buffer shall be cancelled once. No ODU_j data shall be read from the PJO2, PJO1 or NJO bytes. Upon a positive justification action, the writing of one data byte into the buffer shall be cancelled once. No ODU_j data shall be read from the PJO1 or NJO bytes and data shall be read from the PJO2 byte. Upon a negative justification action, one extra data byte shall be written into the buffer once. ODU_j data shall be read from the PJO2, PJO1 and NJO bytes. If no justification action is to be performed, ODU_j data shall be read from the PJO2 and PJO1 bytes and no ODU_j data shall be read from the NJO bytes. The OPU_k frame that contains the PJO2, PJO1 and NJO bytes depends on the tributary slots occupied by the ODTU_{jk}.

ODTUK.M: The ODU_j data shall be extracted from the groups of M successive bytes of the ODTU_{k.M} payload area under control of the GMP data/stuff control mechanism as defined in clause 19.6 of [ITU-T G.709] and be written into the buffer. The C_n information associated with the ODU_j is computed from the GMP C_m and ΣC_{nd} parameters carried within the JC1/2/3 and JC 4/5/6 overhead of the ODTU_{k.M} as specified in clause 19.6 of [ITU-T G.709]. For the GMP data/stuff control mechanism, refer to Annex D of [ITU-T G.709].

The ODU_j data (CI_D) shall be read out of the buffer under control of the ODU_j clock (CI_{CK}).

Smoothing and jitter limiting process: The function shall provide for a clock smoothing and elastic store (buffer) process. The ODU_j data signal shall be written into the buffer under control of the associated (gapped) OPU_k input clock (with a frequency accuracy within ± 20 ppm). The data signal shall be read out of the buffer under control of a smoothed (equally spaced) ODU_j clock (the rate is determined by the ODU_j signal at the input of the remote ODU_{kP}/ODU_{j-21_A_So}).

The clock parameters, including jitter and wander requirements, as defined in Annex A of [ITU-T G.8251] (ODC_p clock), apply.

Buffer size: In the presence of jitter as specified by [ITU-T G.8251] and a frequency within the tolerance range specified for the ODU_j signal in Table 14-2, this justification process shall not introduce any errors.

Following a step in frequency of the ODU_j signal transported (for example, due to reception of ODU_j_CI from a new ODU_j_TT_So at the far end or removal of a ODU_j-AIS signal with a frequency offset), there will be a maximum recovery time of X seconds after which this process shall not generate any bit errors. The value of X is for further study; a value of one second has been proposed.

Frame and multiframe alignment: The function shall perform frame and multiframe alignment as described in clause 8.2.3.

ODU_j-LCK, ODU_j-AIS: The function shall generate the ODU_j-LCK and ODU_j-AIS signals as defined in [ITU-T G.709]. The clock, frame start and multiframes start shall be independent from the incoming clock. The clock has to be within the ODU_j frequency tolerance range as specified in Table 14-2 provisioned by the MI_Nominal_Bitrate_and_Tolerance from a free-running oscillator. Jitter and wander requirements, as defined in Annex A of [ITU-T G.8251] (ODC_a clock), apply.

Selector: The normal signal may be replaced by the ODU_j-AIS. ODU_j-AIS is selected if aAIS is true.

Defects

The function shall detect for dPLM, dMSIM, dLOOMFI and dLOFLOM.

dPLM: See clause 6.2.4.1. The expected payload type is "0010 0001" (ODU multiplex structure supporting ODTU_{k.ts} or ODTU_{k.ts} and ODTU_{jk}) as defined in [ITU-T G.709].

dLOOMFI: dLOOMFI is detected per OPU_k with k = 4. See the OPU multiframe (OMFI) detection process for OPU_k with k = 4.

dMSIM[i]: See clause 6.2.9.1. dMSIM is detected per active ODU_j.

dLOFLOM[i]: See clause 6.2.5.3. dLOFLOM is detected per active ODU_j.

Consequent actions

PI_TSF ← AI_TSF

PI_TSD ← AI_TSD

For each ODU_j:

aSSF[i] ← ((AI_TSF or dPLM or dLOOMFI or dMSIM[i] or dLOFLOM[i]) and (not MI_AdminState = LOCKED)) or (not Active)

For each ODU_j:

aSSD[i] ← AI_TSD and (not MI_AdminState = LOCKED)

For each ODU_j:

aAIS[i] ← ((AI_TSF or dPLM or dLOOMFI or dMSIM[i] or dLOFLOM[i]) and (not MI_AdminState = LOCKED)) or (not Active)

NOTE – The state of the determination process of the C_m and its contribution to AIS consequent action is for further study.

On declaration of aAIS, the function shall output a replacement signal as defined in clauses 17.2 and 17.9 of [ITU-T G.709] within two frames. On clearing of aAIS, the replacement pattern/signal shall be removed within two frames and normal data being output. The replacement signal clock shall be independent from the incoming clock. The replacement signal clock has to be within the range specified by Table 14-9. Jitter and wander requirements, as defined in Annex A of [ITU-T G.8251] (ODCp clock), apply.

Defect correlations

cPLM ← dPLM and (not AI_TSF)

For ODU_k with k = 4:

cLOOMFI ← dLOOMFI and (not AI_TSF)

For each ODU_j:

cMSIM[i] ← dMSIM[i] and (not dPLM) and (not dLOOMFI) and (not AI_TSF)

For each ODU_j:

cLOFLOM[i] ← dLOFLOM[i] and (not MSIM) and (not dLOOMFI) and (not dPLM) and (not AI_TSF) and (Active)

14.4 COMMS functions

Two types of COMMS functions are defined for the ODU_k: the ODU_kP/COMMS adaptation function (ODU_kP/COMMS_A) that provides access to the ODU_k GCC1/2 overhead at the ODU_kP access point (ODU_kP_AP), and the ODU_k/COMMS access function (ODU_k/COMMS_AC) that provides access to the ODU_k GCC1/2 at ODU_k (termination) connection points (ODU_k_CP/TCPs), as shown in Figure 14-70. The ODU_kP/COMMS_A function supports transport of the COMMS data over an ODU_kP trail including the trail supervision, while the ODU_k/COMMS_AC function supports transport of COMMS data over a ODU_k subnetwork connection.

NOTE – COMMS subnetwork connections are independent of TCM subnetwork connections.

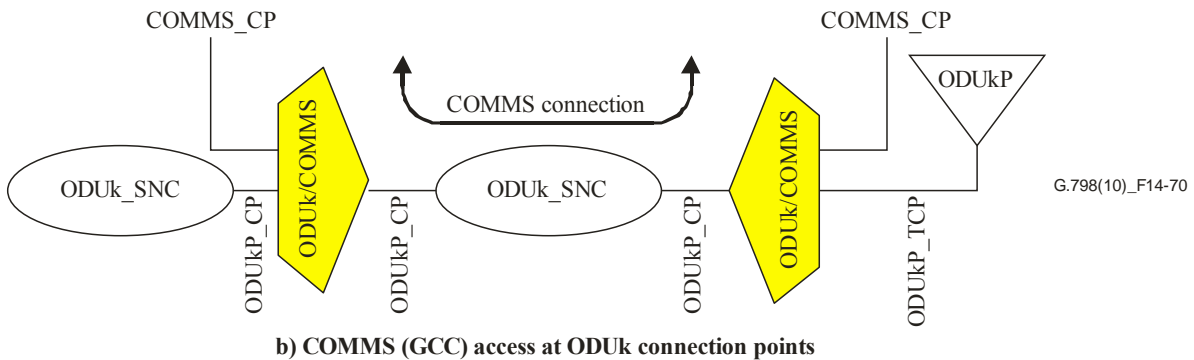
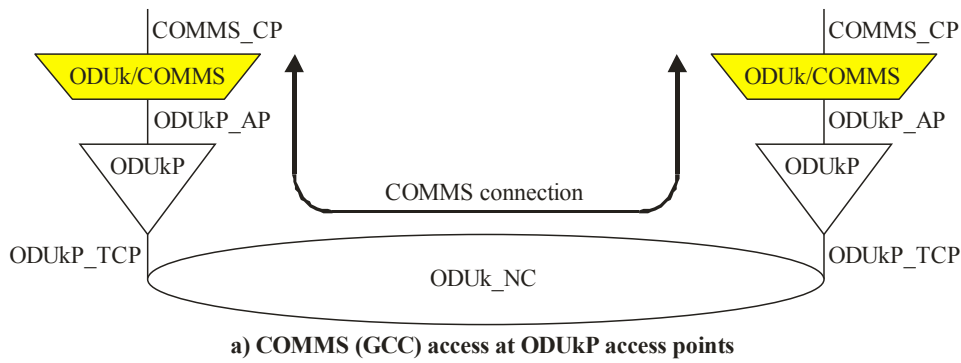

Figure 14-70 – ODUk GCC access

14.4.1 ODUkP to COMMS adaptation function (ODUkP/COMMS_A)

The ODUkP to COMMS adaptation functions provide access to the GCC1/2 overhead in the ODUk for generic data communication.

14.4.1.1 ODUkP to COMMS adaptation source function (ODUkP/COMMS_A_So)

The ODUkP/COMMS_A_So function maps the generic communication channel data into the ODUk GCC1/2 overhead.

The information flow and processing of the ODUkP/COMMS_A_So functions is defined with reference to Figures 14-71 and 14-72.

Symbol

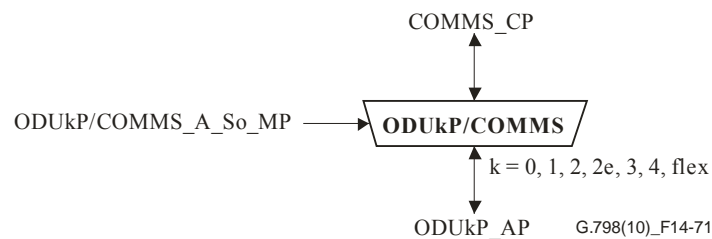

Figure 14-71 – ODUkP/COMMS_A_So function

Interfaces

Table 14-37 – ODUkP/COMMS_A_So inputs and outputs

Input(s)	Output(s)
COMMS_CP: COMMS_CI_D ODUkP_AP: ODUkP_AI_CK ODUkP_AI_FS ODUkP/COMMS_A_So_MP: ODUkP/COMMS_A_So_MI_Active ODUkP/COMMS_A_So_MI_GCCAccess	COMMS_CP: COMMS_CI_CK ODUkP_AP: ODUkP_AI_D

Processes

Activation

- The ODUkP/COMMS_A_So function shall access the access point when it is activated (MI_Active is true). Otherwise, it shall not access the access point.

The processes associated with the ODUkP/COMMS_A_So function are as depicted in Figure 14-72.

COMMS clock generation: The function shall generate the COMMS clock (CI_CK) by dividing the incoming ODUkP clock (AI_CK) by a factor of 7648 if one GCC overhead is accessed, or by a factor of 3824 if both GCC overheads are accessed.

Mapping: Depending on the MI_GCCAccess configuration, the function shall map the incoming COMMS (CI_D) data only into GCC1 (MI_GCCAccess = "GCC1") or only into GCC2 (MI_GCCAccess = "GCC2") or into both GCC1 and GCC2 overhead (MI_GCCAccess = "GCC1+GCC2") of the ODUk frame. The bit rate of the COMMS data is defined by the outgoing COMMS clock (CI_CK) and is in the range as given in Table 14-38.

Table 14-38 – COMMS channel frequencies

OTU type	COMMS channel frequency for 1 GCC	COMMS channel frequency for 2 GCC	COMMS channel bit-rate tolerance
ODU0	162 kHz	325 kHz	±20 ppm
ODU1	326 kHz	653 kHz	±20 ppm
ODU2	1312 kHz	2624 kHz	±20 ppm
ODU2e	1359 kHz	2719 kHz	±100 ppm
ODU3	5271 kHz	10543 kHz	±20 ppm
ODU4	13702 kHz	27404 kHz	±20 ppm
ODU flex (packet) of n timeslots	ODUflex rate/7648 kHz	2 × ODUflex rate/7648 kHz	±20 ppm

Table 14-38 – COMMS channel frequencies

OTU type	COMMS channel frequency for 1 GCC	COMMS channel frequency for 2 GCC	COMMS channel bit-rate tolerance
ODU flex (CBR)	$(239/238)/7648 \times \text{client bit rate}$	$(239/238)/3824 \times \text{client bit rate}$	Client signal bit-rate tolerance, with a maximum of ± 100 ppm
<p>NOTE – The ODU COMMS clock is in the range of $(239/(239 - k) \times 4^{(k-1)})/7648 \times 2\,488\,320 \text{ kHz} \pm 20 \text{ ppm}$ ($k = 1, 2, 3$), of $(239/237)/7648 \times 10\,312\,500 \text{ kHz} \pm 100 \text{ ppm}$ ($k = 2e$), of $(2\,488\,320 \text{ kHz} \times 0.5)/7648 \pm 20 \text{ ppm}$ ($k = 0$), of $(239/227 \times 40)/7648 \times 2\,488\,320 \text{ kHz} \pm 20 \text{ ppm}$ ($k = 4$), of $(239/238)/7648 \times \text{client bit rate} \pm \text{client tolerance}$ ($k = \text{flex}$) if one GCC overhead is accessed or in the range of $(239/(239 - k) \times 4^{(k-1)})/3824 \times 2\,488\,320 \text{ kHz} \pm 20 \text{ ppm}$ ($k = 1, 2, 3$), of $(239/237)/3824 \times 10\,312\,500 \text{ kHz} \pm 100 \text{ ppm}$ ($k = 2e$), of $(2\,488\,320 \text{ kHz} \times 0.5)/3824 \pm 20 \text{ ppm}$ ($k = 0$), of $(239/227 \times 40)/3824 \times 2\,488\,320 \text{ kHz} \pm 20 \text{ ppm}$ ($k = 4$), of $(239/238)/3824 \times \text{client bit rate} \pm \text{client tolerance}$ ($k = \text{flex}$) if both GCC1 and GCC2 overhead are accessed.</p>			

The insertion of the COMMS data follows the transmission order of the GCC bits and bytes.

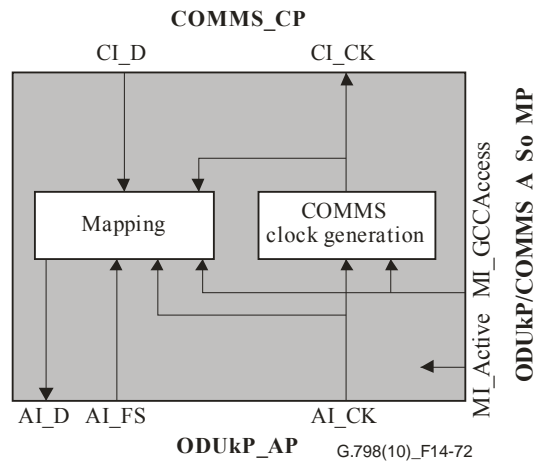

Figure 14-72 – ODUkP/COMMS_A_So processes

Defects: None.

Consequent actions: None.

Defect correlations: None.

Performance monitoring: None.

14.4.1.2 ODUkP to COMMS adaptation sink function (ODUkP/COMMS_A_Sk)

The ODUkP/COMMS_A_Sk extracts the COMMS data from the ODUk GCC overhead.

Symbol

The information flow and processing of the ODUkP/COMMS_A_Sk functions is defined with reference to Figures 14-73 and 14-74.

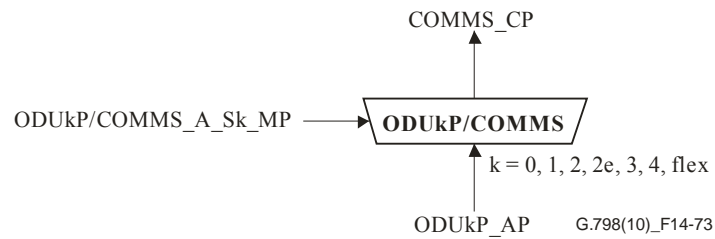

Figure 14-73 – ODUkP/COMMS_A_Sk function

Interfaces

Table 14-39 – ODUkP/COMMS_A_Sk inputs and outputs

Input(s)	Output(s)
ODUkP_AP: ODUkP_AI_CK ODUkP_AI_D ODUkP_AI_FS ODUkP_AI_TSF ODUkP/COMMS_A_Sk_MP: ODUkP/COMMS_A_Sk_MI_Active ODUkP/COMMS_A_Sk_MI_GCCAccess	COMMS_CP: COMMS_CI_CK COMMS_CI_D COMMS_CI_SSF

Processes

Activation

- The ODUkP/COMMS_A_Sk function shall access the access point and perform the common and specific processes operation specified below when it is activated (MI_Active is true). Otherwise, it shall activate the SSF signals at its output (CP).

The processes associated with the ODUkP/COMMS_A_Sk function are as depicted in Figure 14-74.

COMMS clock generation: The function shall generate the COMMS clock (CI_CK) by dividing the incoming ODUkP clock (AI_CK) by a factor of 7648 if one GCC overhead is accessed, or by a factor of 3824 if both GCC overheads are accessed.

Demapping: Depending on the MI_GCCAccess configuration, the function shall extract the COMMS (CI_D) data only from GCC1 (MI_GCCAccess = "GCC1") or only from GCC2 (MI_GCCAccess = "GCC2") or from both GCC1 and GCC2 overhead (MI_GCCAccess = "GCC1+GCC2") of the ODUk frame. The bit rate of the COMMS data is defined by the outgoing COMMS clock (CI_CK) and is in the range as given in Table 14-38.

The extraction of the COMMS data follows the transmission order of the GCC bits and bytes.

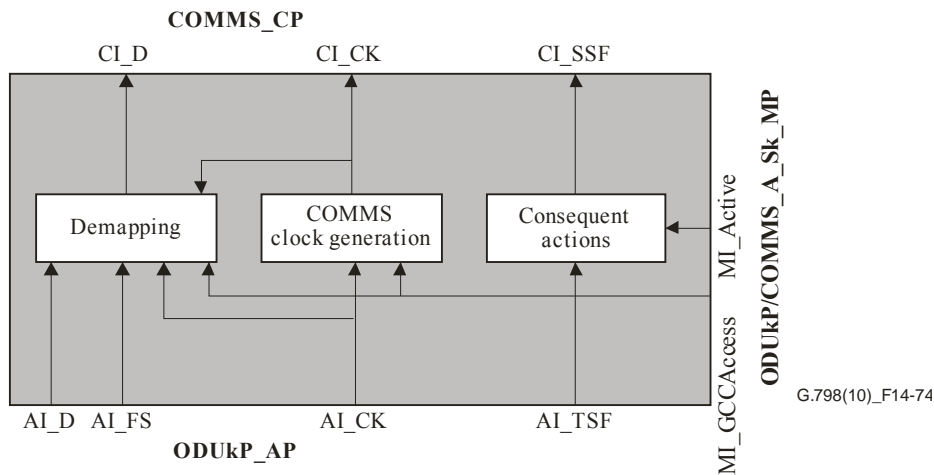

Figure 14-74 – ODUkP/COMMS_A_Sk processes

Defects: None.

Consequent actions

The function shall perform the following consequent action:

$$aSSF \leftarrow AI_TSF \text{ or (not } MI_Active)$$

Defect correlations: None.

Performance monitoring: None.

14.4.2 ODUk to COMMS access function (ODUk/COMMS_AC)

The ODUk to COMMS access functions provide access to the GCC1/2 overhead in the ODUk for generic data communication at ODUk_CP (including TCPs). As the functions act on the ODUk signal that passes through the CP, they are inserted into an expanded ODUk_CP as shown in Figure 14-75. They can be inserted into any ODUk_CP, independently of sink or source processing. A ODUk/COMMS_AC_Sk and So function can be used at the same CP for extraction of the COMMS data from the GCC and insertion of new COMMS data.

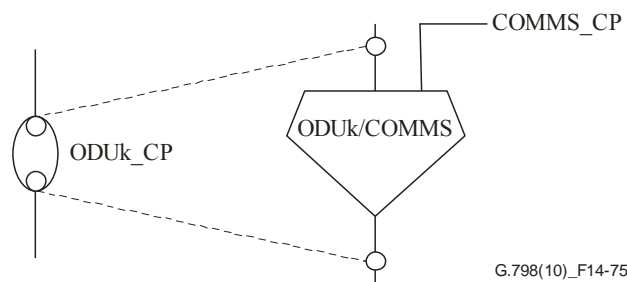

Figure 14-75 – ODUk_CP expansion for COMMS access

14.4.2.1 ODUk to COMMS access source function (ODUk/COMMS_AC_So)

The ODUk/COMMS_AC_So function maps the generic communication channel data into the GCC1/2 overhead of the ODUk signal that passes through the function.

The information flow and processing of the ODUk/COMMS_AC_So functions is defined with reference to Figures 14-76 and 14-77.

Symbol

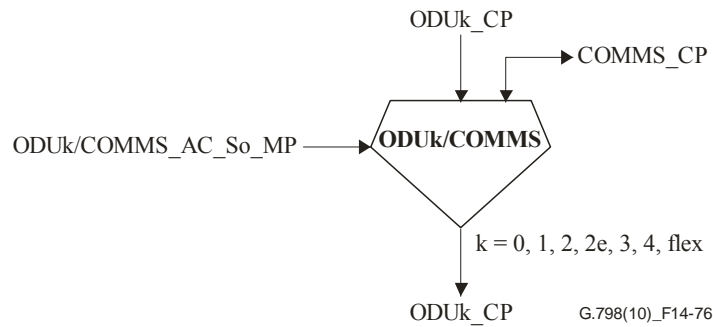

Figure 14-76 – ODUk/COMMS_AC_So function

Interfaces

Table 14-40 – ODUk/COMMS_AC_So inputs and outputs

Input(s)	Output(s)
COMMS_CP: COMMS_CI_D ODUk_CP: ODUk_CI_D ODUk_CI_CK ODUk_CI_FS ODUk_CI_MFS ODUk_CI_SSF ODUk/COMMS_AC_So_MP: ODUk/COMMS_AC_So_MI_Active ODUk/COMMS_AC_So_MI_GCCAccess	COMMS_CP: COMMS_CI_CK ODUk_CP: ODUk_CI_D ODUk_CI_CK ODUk_CI_FS ODUk_CI_MFS ODUk_CI_SSF

Processes

Activation

- The ODUk/COMMS_AC_So function shall perform the processes defined below when it is activated (MI_Active is true). Otherwise, it shall pass through the ODUk_CI between the input and output ODUk_CP unmodified.

The processes associated with the ODUk/COMMS_AC_So function are as depicted in Figure 14-77.

COMMS clock generation: The function shall generate the COMMS clock (COMMS_CI_CK) by dividing the incoming ODUk clock (ODUk_CI_CK) by a factor of 7648 if one GCC overhead is accessed, or by a factor of 3824 if both GCC overheads are accessed.

Mapping: Depending on the MI_GCCAccess configuration, the function shall map the incoming COMMS (CI_D) data only into GCC1 (MI_GCCAccess = "GCC1") or only into GCC2 (MI_GCCAccess = "GCC2") or into both GCC1 and GCC2 overhead (MI_GCCAccess = "GCC1+GCC2") of the ODUk frame. The bit rate of the COMMS data is defined by the outgoing COMMS clock (CI_CK) and is in the range as given in Table 14-38.

The insertion of the COMMS data follows the transmission order of the GCC bits and bytes.

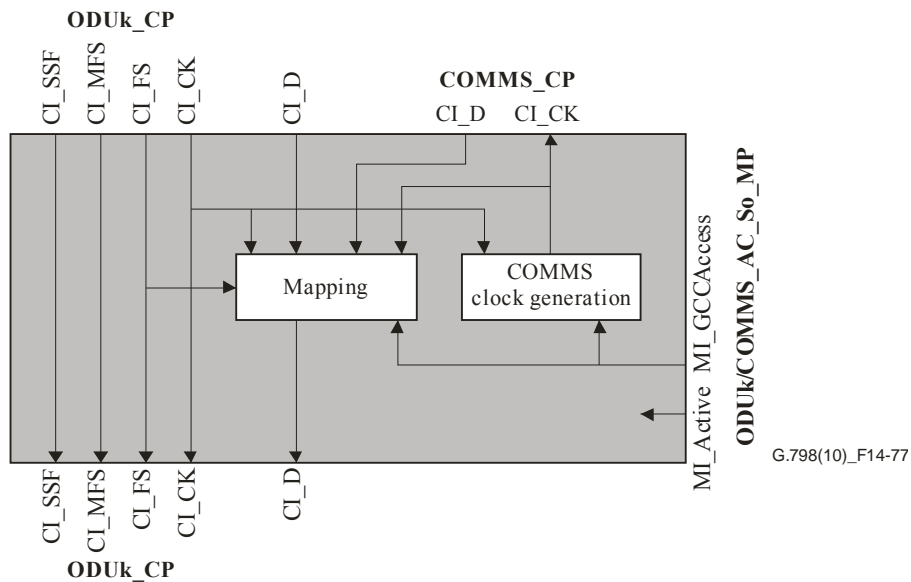

Figure 14-77 – ODUk/COMMS_AC_So processes

Defects: None.

Consequent actions: None.

Defect correlations: None.

Performance monitoring: None.

14.4.2.2 ODUk to COMMS access sink function (ODUk/COMMS_AC_Sk)

The ODUk/COMMS_AC_Sk extracts the COMMS data from the ODUk GCC overhead.

The information flow and processing of the ODUk/COMMS_AC_Sk functions is defined with reference to Figures 14-78 and 14-79.

Symbol

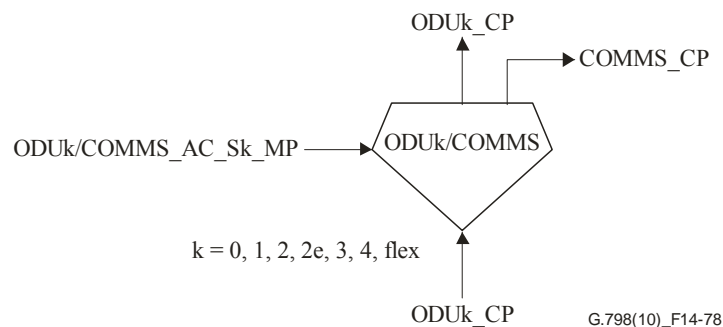

Figure 14-78 – ODUk/COMMS_AC_Sk function

Interfaces

Table 14-41 – ODUk/COMMS_AC_Sk inputs and outputs

Input(s)	Output(s)
ODUk_CP: ODUk_CI_CK ODUk_CI_D ODUk_CI_FS ODUk_CI_MFS ODUk_CI_SSF ODUk/COMMS_AC_Sk_MP: ODUk/COMMS_AC_Sk_MI_Active ODUk/COMMS_AC_Sk_MI_GCCAccess ODUk/COMMS_AC_Sk_MI_GCCCont	COMMS_CP: COMMS_CI_CK COMMS_CI_D COMMS_CI_SSF ODUk_CP: ODUk_CI_CK ODUk_CI_D ODUk_CI_FS ODUk_CI_MFS ODUk_CI_SSF

Processes

Activation

- The ODUk/COMMS_AC_Sk function shall perform the processes defined below when it is activated (MI_Active is true). Otherwise, it shall pass through the ODUk_CI between the input and output ODUk CP unmodified and it shall activate the SSF signals at its COMMS output (COMMS CP).

The processes associated with the ODUk/COMMS_AC_Sk function are as depicted in Figure 14-79.

COMMS clock generation: The function shall generate the COMMS clock (COMMS_CI_CK) by dividing the incoming ODUk clock (ODUk_CI_CK) by a factor of 7648 if one GCC overhead is accessed, or by a factor of 3824 if both GCC overheads are accessed.

Demapping: Depending on the MI_GCCAccess configuration, the function shall extract the COMMS (CI_D) data only from GCC1 (MI_GCCAccess = "GCC1") or only from GCC2 (MI_GCCAccess = "GCC2") or from both GCC1 and GCC2 overhead (MI_GCCAccess = "GCC1+GCC2") of the ODUk frame. The bit rate of the COMMS data is defined by the outgoing COMMS clock (CI_CK) and is in the range as given in Table 14-38.

The extraction of the COMMS data follows the transmission order of the GCC bits and bytes.

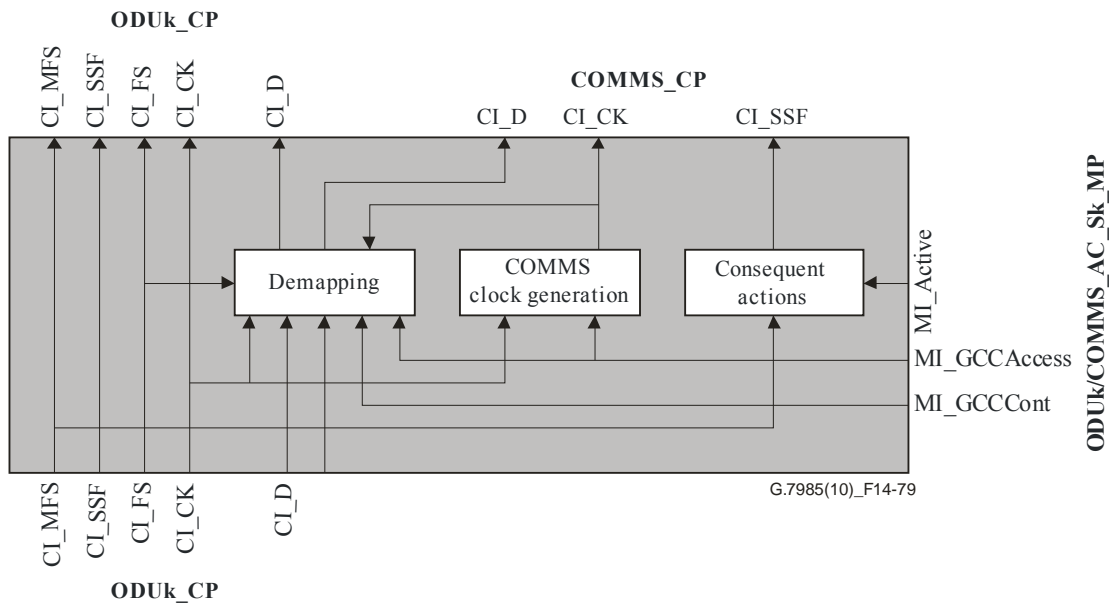

Figure 14-79 – ODUk/COMMS_AC_Sk processes

Defects: None.

Consequent actions

The function shall perform the following consequent action:

COMMSaSSF ← ODUk_CI_SSF or (not MI_Active)

Defect correlations: None.

Performance monitoring: None.

14.5 Sub-layer functions

14.5.1 ODU tandem connection sub-layer (ODUkT) functions

Up to six independent ODUkT sub-layers can pass through or can be terminated at an ODUk_CP as defined in [ITU-T G.709]. For an ODUkT sub-layer termination, the ODUk-CP is expanded as defined in [ITU-T G.805].

The ODUkT_TT, ODUkT/ODUk_A and ODUkT_TCMC functions are always combined together and can be located at any ODUk_CP as shown in Figure 14-80. For the location of the ODUkTm_TT function, see Figure 14-86.

NOTE – In accordance with [ITU-T G.709], nesting and cascading are the default operational configurations. Overlapping is an additional configuration for testing purposes only. Overlapped monitored connections must be operated in a non-intrusive mode in which the maintenance signals ODUk-AIS and ODUk-LCK are not generated. For the case where one of the endpoints in an overlapping monitored connection is located inside a SNC protected domain while the other endpoint is located outside the protected domain, the SNC protection should be forced to working when the endpoint of the overlapping monitored connection is located on the working connection, and forced to protection when the endpoint is located on the protection connection.

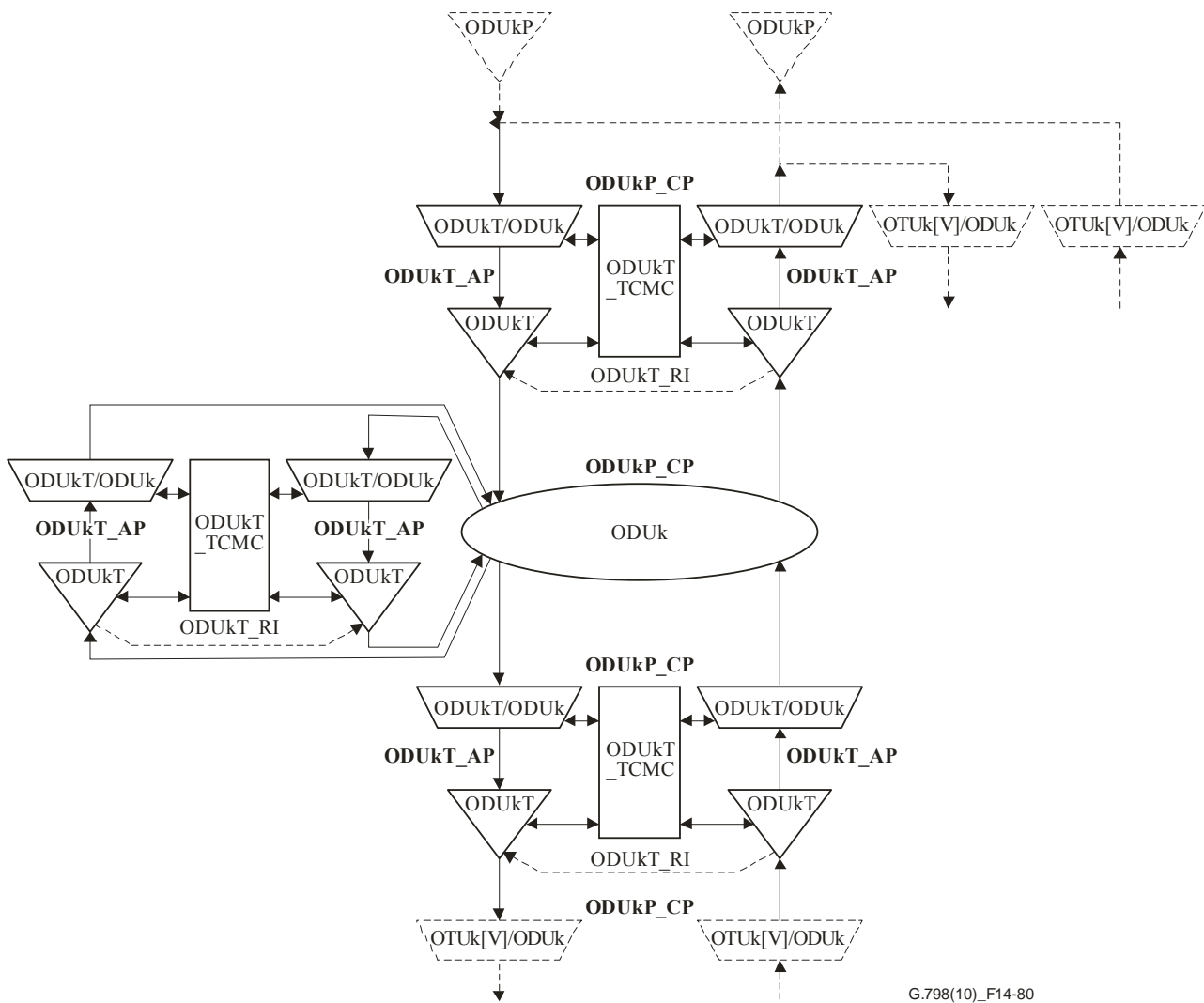

Figure 14-80 – Location of ODUkT_TT, ODUkT/ODUk_A and ODUkT_TCMC functions

14.5.1.1 ODUkT trail termination function (ODUkT_TT)

The ODUkT_TT function terminates a level of tandem connection monitoring (TCM) overhead of the ODUk overhead to determine the status of an ODUk TCM sub-layer trail.

Furthermore, the ODUkT_TT function provides read/write access to the TCM ACT signal in the ODUk overhead over the TCM control point (TCMCP) for the tandem connection monitor control (TCMC) function that can be connected to an ODUkT_TT.

Figure 14-81 shows the combination of the unidirectional sink and source functions to form a bidirectional function.

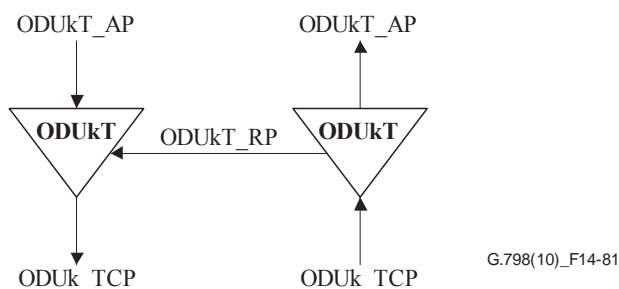

Figure 14-81 – ODUkT_TT

14.5.1.1.1 ODUkT trail termination source function (ODUkT_TT_So)

The ODUkT_TT_So function computes the BIP8 and adds tandem connection monitoring overhead (TCMOH) – including the TTI, BIP8, DMti, $i = 1$ to 6 bits, BDI and BEI signals – in a selected TCMOH field to the ODUk signal at its ODUkT_AP if it is OPERATIONAL; otherwise, in TRANSPARENT mode, the TCMOH field signal is passed through transparently.

The information flow and processing of the ODUkT_TT_So function is defined with reference to Figures 14-82 and 14-83.

Symbol

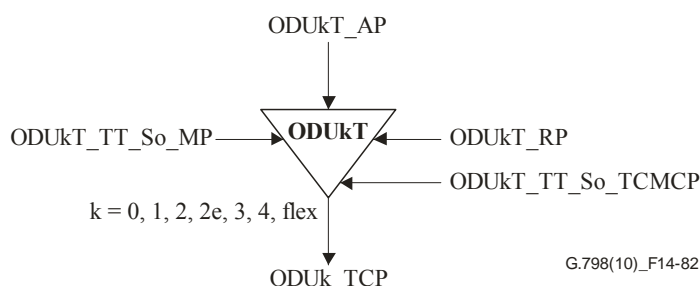

Figure 14-82 – ODUkT_TT_So function

Interfaces

Table 14-42 – ODUkT_TT_So inputs and outputs

Input(s)	Output(s)
ODUkT_AP: ODUkT_AI_CK ODUkT_AI_D ODUkT_AI_FS ODUkT_AI_MFS ODUkT_RP: ODUkT_RI_BDI ODUkT_RI_BEI ODUkT_RI_BIAE ODUkT_RI_DM ODUkT_TT_So_MP: ODUkT_TT_So_MI_TxTI ODUkT_TT_So_MI_DM_Source ODUkT_TT_So_MI_DMValue ODUkT_TT_So_TCMCP: ODUkT_TT_So_TCMCI_Mode ODUkT_TT_So_TCMCI_Level	ODUk_TCP: ODUk_CI_CK ODUk_CI_D ODUk_CI_FS ODUk_CI_MFS

Processes

The processes associated with the ODUkT_TT_So function are as depicted in Figure 14-83.

Mode: If the TCMCI_Mode has the value OPERATIONAL, the following processes shall be performed. If the TCMCI_Mode has the value TRANSPARENT, all information shall be passed through transparently and the following processes shall not be performed.

TCMOH-TTI: If TCMCI_Mode is OPERATIONAL, the trail trace identifier is inserted in the TTI byte position of the TCM[TCMCI_Level] field. Its value is derived from reference point ODUkT_TT_So_MP. The trail trace format is described in clause 15.2 of [ITU-T G.709].

TCMOH-BDI: If TCMCI_Mode is OPERATIONAL, the backward defect indication is inserted in the BDI bit position of the TCM[TCMCI_Level] field. Its value is derived from reference point ODUkT_RP. Upon the declaration/clearing of aBDI at the termination sink function, the trail termination source function shall have inserted/removed the BDI indication within 50 ms.

TCMOH-BEI/BIAE: If TCMCI_Mode is OPERATIONAL, if RI_BIAE is true the value "1011" is inserted into the BEI/BIAE bits of the TCM[TCMCI_Level] field. If RI_BIAE is false, the number of errors indicated in RI_BEI is encoded in the BEI/IBAE bits of the TCM[TCMCI_Level] field. Upon the detection of incoming alignment error or a number of errors at the termination sink function, the trail termination source function shall have inserted the values in the BEI/BIAE bits within 50 ms.

TCMOH-BIP8: If TCMCI_Mode is OPERATIONAL, the calculated BIP8 is inserted into the BIP8 byte of the TCM[TCMCI_Level] field. For the BIP8 calculation, see clause 8.3.4.1.

PMOH-DMti: If TCMCI_Mode is OPERATIONAL and if MI_DM_Source is false, then the value of the DMti bit is determined by the RI_DM. If MI_DM_Source is True, then the value of the DMti bit is set to MI_DMValue.

NOTE – Equipment developed prior to the 2010 version of this Recommendation will not support the DMti processing.

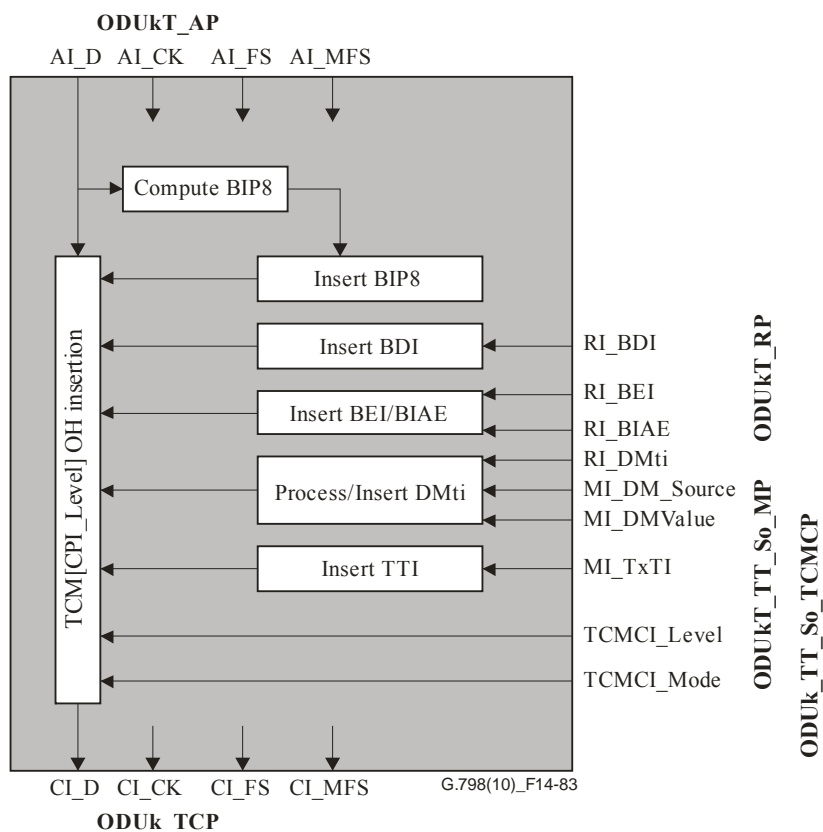

Figure 14-83 – ODUkT_TT_So processes

Defects: None.

Consequent actions: None.

Defect correlations: None.

Performance monitoring: None.

14.5.1.1.2 ODUkT trail termination sink function (ODUkT_TT_Sk)

The ODUkT_TT_Sk function reports the state of the ODUk monitored tandem connection. It computes the BIP8, extracts tandem connection monitoring overhead (TCMOH) – including the TTI, BIP8, DMti, BDI and BEI signals – in a selected TCMOH field from the ODUk signal at its ODUk_TCP, detects for AIS, OCI, LCK, TIM, DEG and BDI defects, counts during one-second periods errors (detected via the BIP8), counts numbers of frames for delay measurement and defects to feed PM when it is OPERATIONAL or MONITOR.

The information flow and processing of the ODUkT_TT_Sk function is defined with reference to Figures 14-84 and 14-85.

Symbol

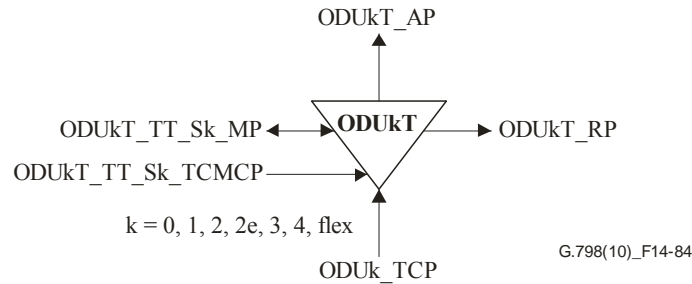

Figure 14-84 – ODUkT_TT_Sk function

Interfaces

Table 14-43 – ODUkT_TT_Sk inputs and outputs

Input(s)	Output(s)
ODUk_TCP: ODUk_CI_CK ODUk_CI_D ODUk_CI_FS ODUk_CI_MFS ODUk_CI_SSF ODUKT_TT_Sk_MP: ODUKT_TT_Sk_MI_ExSAPI ODUKT_TT_Sk_MI_ExDAPI ODUKT_TT_Sk_MI_GetAcTI ODUKT_TT_Sk_MI_TIMDetMo ODUKT_TT_Sk_MI_TIMActDis ODUKT_TT_Sk_MI_DEGThr ODUKT_TT_Sk_MI_DEGM ODUKT_TT_Sk_MI_1second ODUKT_TT_Sk_MI_DM_Source ODUKT_TT_Sk_MI_DMValue ODUKT_TT_Sk_TCMCP: ODUKT_TT_Sk_TCMCI_Mode ODUKT_TT_Sk_TCMCI_Level	ODUKT_AP: ODUKT_AI_CK ODUKT_AI_D ODUKT_AI_FS ODUKT_AI_MFS ODUKT_AI_TSF ODUKT_AI_TSD ODUKT_AI_AIS ODUKT_RP: ODUKT_RI_BDI ODUKT_RI_BEI ODUKT_RI_BIAE ODUKT_RI_DM ODUKT_TT_Sk_MP: ODUKT_TT_Sk_MI_AcTI ODUKT_TT_Sk_MI_cOCI ODUKT_TT_Sk_MI_cLCK ODUKT_TT_Sk_MI_cLTC ODUKT_TT_Sk_MI_cTIM ODUKT_TT_Sk_MI_cDEG ODUKT_TT_Sk_MI_cBDI ODUKT_TT_Sk_MI_cSSF ODUKT_TT_Sk_MI_pN_EBC ODUKT_TT_Sk_MI_pN_DS ODUKT_TT_Sk_MI_pF_EBC ODUKT_TT_Sk_MI_pF_DS ODUKT_TT_Sk_MI_pBIAE ODUKT_TT_Sk_MI_pIAE ODUKT_TT_Sk_MI_pN_delay

Processes

The processes associated with the ODUkT_TT_Sk function are as depicted in Figure 14-85.

Mode: If the TCMCI_Mode has the value OPERATIONAL or MONITOR, the following processes shall be performed. TCMCI_Mode OPERATIONAL initiates the consequent actions aAIS, aTSF and aTSD in case of defects. TCMCI_Mode MONITOR does not initiate the consequent actions aAIS, aTSF and aTSD in case of defects. If the TCMCI_Mode has the value TRANSPARENT, all information shall be passed through transparently and the following processes shall not be performed.

TCMOH-BIP8: If the TCMCI_Mode has the value OPERATIONAL or MONITOR, the BIP8 shall be processed as defined in clause 8.3.4.2. The BIP8 is extracted from the BIP8 byte of the TCM[TCMCI_Level] field.

TCMOH-TTI: If the TCMCI_Mode has the value OPERATIONAL or MONITOR, the trail trace identifier shall be recovered from the TTI byte position of the TCM[TCMCI_Level] field in the ODUk signal at the ODUk_TCP as specified in clause 8.6. The accepted value of the TTI is available at the MP (MI_AcTI).

TCMOH-BDI: If the TCMCI_Mode has the value OPERATIONAL or MONITOR, the backward defect indication shall be recovered from the BDI bit position of the TCM[TCMCI_Level] field in the ODUk signal at the ODUk_TCP. It shall be used for BDI defect detection.

TCMOH-BEI/BIAE: If the TCMCI_Mode has the value OPERATIONAL or MONITOR, the BEI shall be recovered from the BEI/BIAE bits in the TCM[TCMCI_Level] field in the ODUk signal at the ODUk_TCP. It shall be used to determine if a far-end errored block (nF_B) has occurred. A nF_B has occurred if the BEI/BIAE value is between 1 [0001] and 8 [1000]; otherwise, no nF_B has occurred.

TCMOH-STAT: If the TCMCI_Mode has the value OPERATIONAL or MONITOR, the status information shall be recovered from the STAT bits in the TCM[TCMCI_Level] field in the ODUk signal at the ODUk_TCP as defined in clause 8.8 (→ AcSTAT). It shall be used for AIS, OCI, LCK, LTC and IAE defect detection.

TCMOH-DMti: If the TCMCI_Mode has the value OPERATIONAL and if MI_DM_Source is false, then the value of the DMti bit is output to RI_DM. If MI_DM_Source is true and MI_DMValue toggles, then a count of CI_FS transitions is started and the incoming DMti value is monitored. A change of value of DMti, from (NOT MI_DMValue) to MI_DMValue, validated by a three-frame persistency check, stops the counting. The delay is represented by the count minus the persistency check and is output as MI_pN_delay.

NOTE – Equipment developed prior to the 2010 version of this Recommendation will not support the DMti processing.

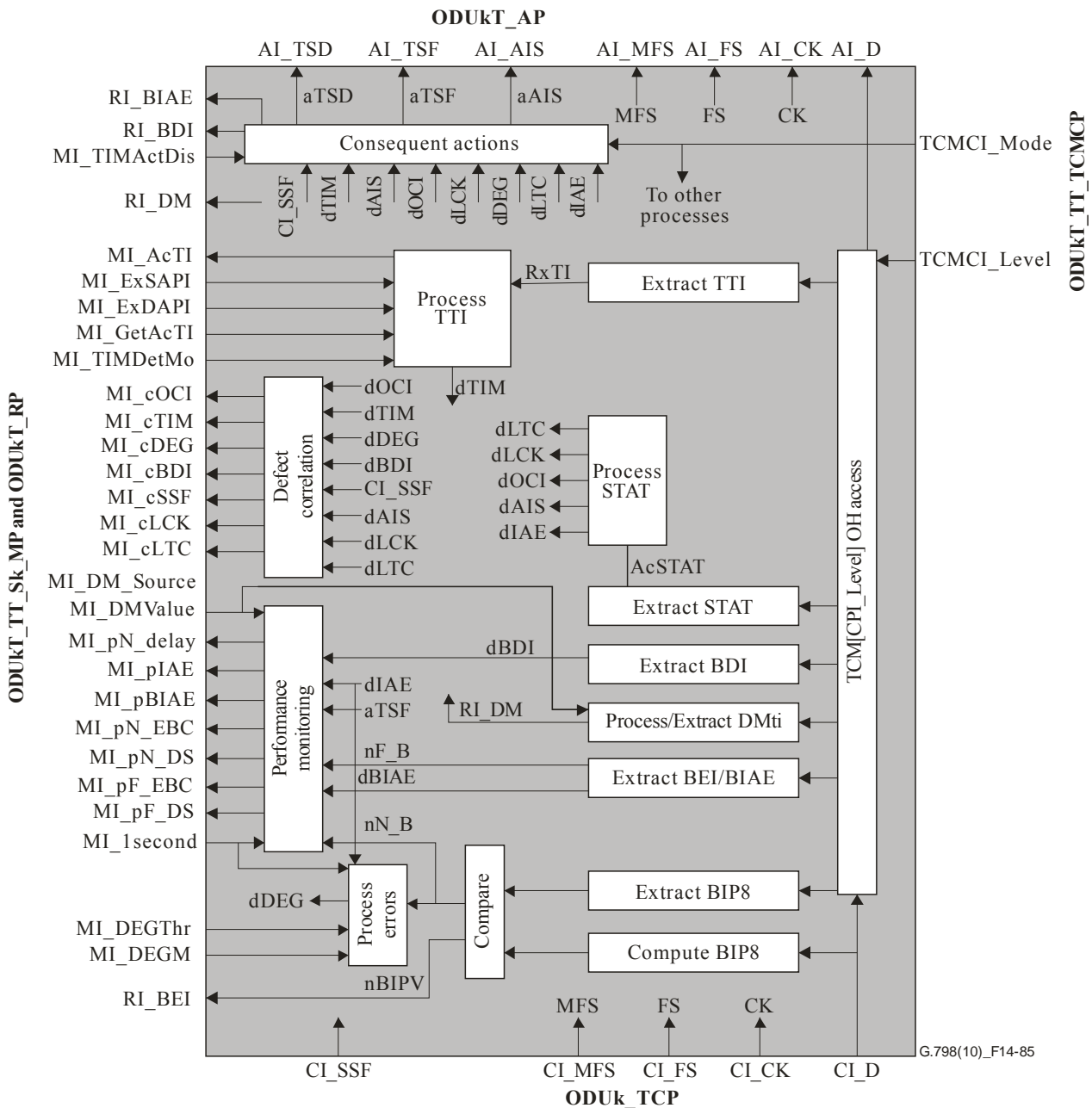

Figure 14-85 – ODUkT_TT_Sk processes

Defects

If the TCMCI_Mode has the value OPERATIONAL or MONITOR, the function shall detect for dLTC, dAIS, dOCI, dLCK, dTIM, dDEG, dIAE, dBIAE and dBDI defects. If the TCMCI_Mode is TRANSPARENT, all defects are cleared.

dLTC: See clause 6.2.1.4; dLTC shall be set to false during CI_SSF and dAIS.

dAIS: See clause 6.2.6.3.2.

dOCI: See clause 6.2.6.8.2; dOCI shall be set to false during CI_SSF and dAIS.

dLCK: See clause 6.2.6.9.1; dLCK shall be set to false during CI_SSF and dAIS.

dTIM: See clause 6.2.2.1; dTIM shall be set to false during CI_SSF and dAIS.

dDEG: See clause 6.2.3.4.

NOTE – IAE suppresses the one-second near-end errored block count, which is the input for the dDEG detection. This avoids wrong dDEG declaration due to alignment errors already incoming in an OTUk trail.

dBDI: See clause 6.2.6.6.1; dBDI shall be set to false during CI_SSF and dAIS.

dIAE: See clause 6.2.6.10.2; dIAE shall be set to false during CI_SSF, dAIS and dTIM.

dBIAE: See clause 6.2.6.11.1; dBIAE shall be set to false during CI_SSF, dAIS and dTIM.

Consequent actions

The function shall perform the following consequent actions (see clause 6.3 of [ITU-T G.806]):

aBDI	←	(CI_SSF or dAIS or dLTC or dOCI or dLCK or dTIM) and TCMCI_Mode ≠ TRANSPARENT
aBEI	←	"nBIPV" and TCMCI_Mode ≠ TRANSPARENT
aBIAE	←	dIAE and TCMCI_Mode ≠ TRANSPARENT
aTSF	←	CI_SSF or ((dAIS or dLTC or dOCI or dLCK or (dTIM and (not TIMActDis))) and TCMCI_Mode == OPERATIONAL)
aTSD	←	dDEG and TCMCI_Mode == OPERATIONAL
aAIS	←	(dOCI or dLCK or (dTIM and (not TIMActDis))) and TCMCI_Mode == OPERATIONAL

Defect correlations

The function shall perform the following defect correlations to determine the most probable fault cause (see clause 6.4 of [ITU-T G.806]). This fault cause shall be reported to the EMF.

cSSF	←	CI_SSF or dAIS
cLTC	←	dLTC and (not CI_SSF)
cOCI	←	dOCI and (not CI_SSF)
cLCK	←	dLCK and (not CI_SSF)
cTIM	←	dTIM and (not CI_SSF) and (not dAIS) and (not dLTC) and (not dOCI) and (not dLCK)
cDEG	←	dDEG and (not CI_SSF) and (not dAIS) and (not dLTC) and (not dOCI) and (not dLCK) and (not (dTIM and (not TIMActDis)))
cBDI	←	dBDI and (not CI_SSF) and (not dAIS) and (not dLTC) and (not dOCI) and (not dLCK) and (not (dTIM and (not TIMActDis)))

Performance monitoring

If the TCMCI_Mode has the value OPERATIONAL or MONITOR, the function shall perform the following performance monitoring primitives processing (see clause 6.5 of [ITU-T G.806]). The performance monitoring primitives shall be reported to the EMF.

pN_DS	←	CI_SSF or dAIS or dLTC or dOCI or dLCK or dTIM
pF_DS	←	dBDI
pN_EBC	←	$\sum nN_B$

NOTE 1 – During CI_SSF, dAIS, dLTC, dLCK and dOCI, no errored blocks shall be counted.

pF_EBC	←	$\sum nF_B$
--------	---	--------------

NOTE 2 – During CI_SSF, dAIS, dLTC, dLCK and dOCI, no errored blocks shall be counted.

pBIAE	←	dBIAE
-------	---	-------

NOTE 3 – pBIAE is activated at the end of a second if dBIAE was active once during the second.

pIAE ← dIAE

NOTE 4 – pIAE is activated at the end of a second if dIAE was active once during the second.

NOTE 5 – pIAE and pBIAE are used for the suppression of the PM data in the equipment management functions (see [ITU-T G.874]). If pBIAE is active, the F_DS and F_EBC values of the previous and current second have to be discarded (EBC = 0 and DS = false). If pIAE is active, the N/F_DS and N/F_EBC values of the previous and current second have to be discarded (EBC = 0 and DS = false). The previous second has to be included due to the delay of the IAE information coming from the remote source.

pN_delay ← Σ number of frames since DMValue toggle event

NOTE 6 – This count is triggered by the ODUkP_TT_So_MI_DMValue toggle event.

NOTE 7 – This value is a snapshot value.

14.5.1.1.3 ODUkT non-intrusive monitoring function (ODUkTm_TT_Sk)

The ODUkTm_TT_Sk function reports the state of the ODUk monitored tandem connection. It computes the BIP8, extracts tandem connection monitoring overhead (TCMOH) – including the TTI, BIP8, BDI and BEI signals – in a selected TCMOH field from the ODUk signal at its ODUk_TCP, detects for AIS, OCI, LCK, TIM, DEG and BDI defects, counts during one-second periods errors (detected via the BIP8) and defects to feed PM.

For ODUkT non-intrusive monitoring, the ODUkTm_TT_Sk function can be connected to the ODUk_CPs as shown in Figure 14-86. The ODUkTm_TT_Sk function can be connected to any ODUk_CP in this manner, either directly or via a connection function.

The TSF and TSD outputs can be connected to an ODUk_C connection function and used as protection switching trigger criteria for SNC/N protection.

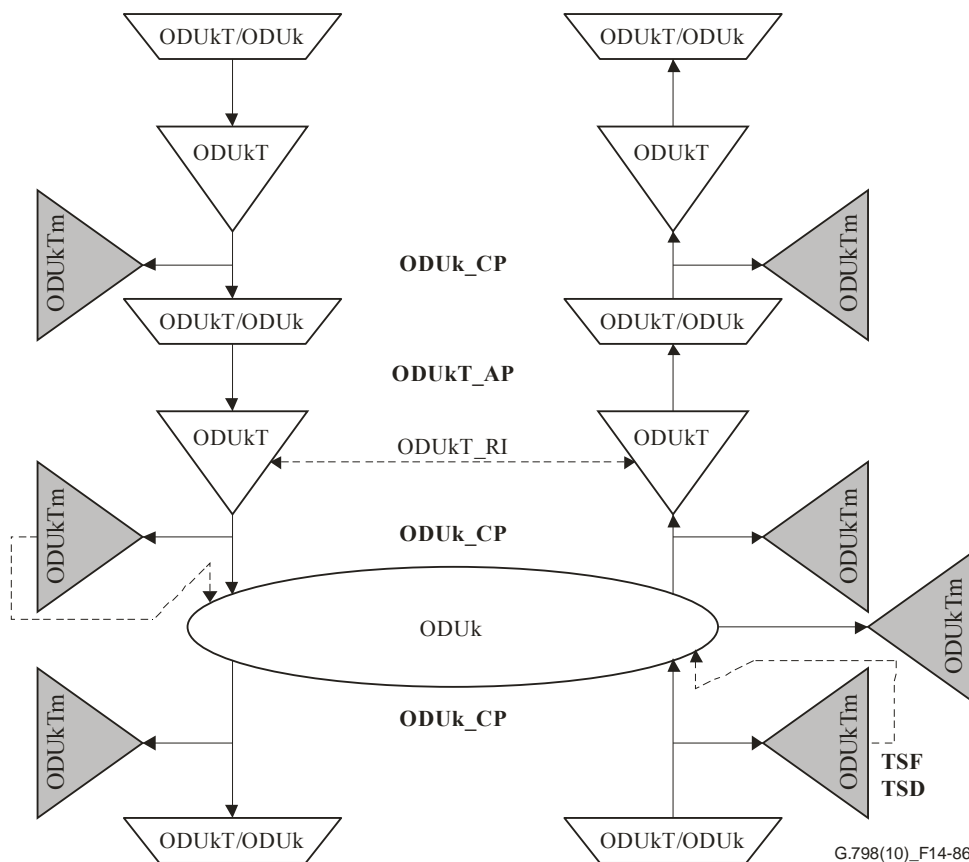

Figure 14-86 – Connection of ODUkTm_TT_Sk function (non-intrusive monitor)

The information flow and processing of the ODUkTm_TT_Sk function is defined with reference to Figures 14-87 and 14-88.

Symbol

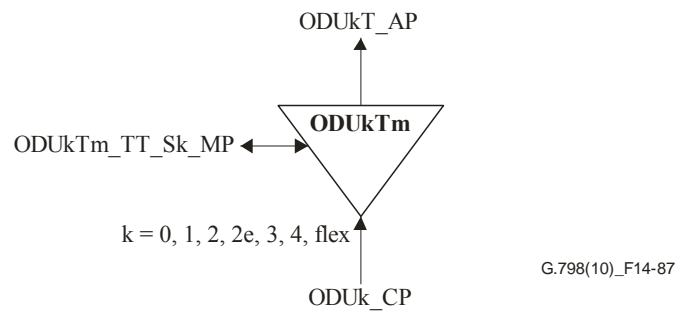

Figure 14-87 – ODUkTm_TT_Sk function

Interfaces

Table 14-44 – ODUkTm_TT_Sk inputs and outputs

Input(s)	Output(s)
ODUk_CP: ODUk_CI_CK ODUk_CI_D ODUk_CI_FS ODUk_CI_MFS ODUk_CI_SSF ODUkTm_TT_Sk_MP: ODUkTm_TT_Sk_MI_Level ODUkTm_TT_Sk_MI_ExSAPI ODUkTm_TT_Sk_MI_ExDAPI ODUkTm_TT_Sk_MI_GetAcTI ODUkTm_TT_Sk_MI_TIMDetMo ODUkTm_TT_Sk_MI_TIMActDis ODUkTm_TT_Sk_MI_DEGThr ODUkTm_TT_Sk_MI_DEGM ODUkTm_TT_Sk_MI_1second	ODUKT_AP: ODUKT_AI_TSF ODUKT_AI_TSD ODUkTm_TT_Sk_MP: ODUkTm_TT_Sk_MI_AcTI ODUkTm_TT_Sk_MI_cOCI ODUkTm_TT_Sk_MI_cLCK ODUkTm_TT_Sk_MI_cLTC ODUkTm_TT_Sk_MI_cTIM ODUkTm_TT_Sk_MI_cDEG ODUkTm_TT_Sk_MI_cBDI ODUkTm_TT_Sk_MI_cSSF ODUkTm_TT_Sk_MI_pN_EBC ODUkTm_TT_Sk_MI_pN_DS ODUkTm_TT_Sk_MI_pF_EBC ODUkTm_TT_Sk_MI_pF_DS ODUkTm_TT_Sk_MI_pBIAE ODUkTm_TT_Sk_MI_pIAE

Processes

The processes associated with the ODUkTm_TT_Sk function are as depicted in Figure 14-88.

TCMOH-BIP8: The BIP8 shall be processed as defined in clause 8.3.4. The BIP8 is extracted from the BIP8 byte of the TCM[MI_Level] field.

TCMOH-TTI: The trail trace identifier shall be recovered from the TTI byte position of the TCM[MI_Level] field in the ODUk signal at the ODUk_TCP as specified in clause 8.6. The accepted value of the TTI is available at the MP (MI_AcTI).

TCMOH-BDI: The backward defect indication shall be recovered from the BDI bit position of the TCM[MI_Level] field in the ODUk signal at the ODUk_TCP. It shall be used for BDI defect detection.

TCMOH-BEI/BIAE: The BEI shall be recovered from the BEI/BIAE bits in the TCM[MI_Level] field in the ODUk signal at the ODUk_TCP. It shall be used to determine if a far-end errored block (nF_B) has occurred. A nF_B has occurred if the BEI/BIAE value is between 1 [0001] and 8 [1000]; otherwise, no nF_B has occurred. The BEI/BIAE information is also used for BIAE defect detection.

TCMOH-STAT: The status information shall be recovered from the STAT bits in the TCM[MI_Level] field in the ODUk signal at the ODUk_TCP as defined in clause 8.8 (→ AcSTAT). It shall be used for AIS, OCI, LCK, LTC and IAE defect detection.

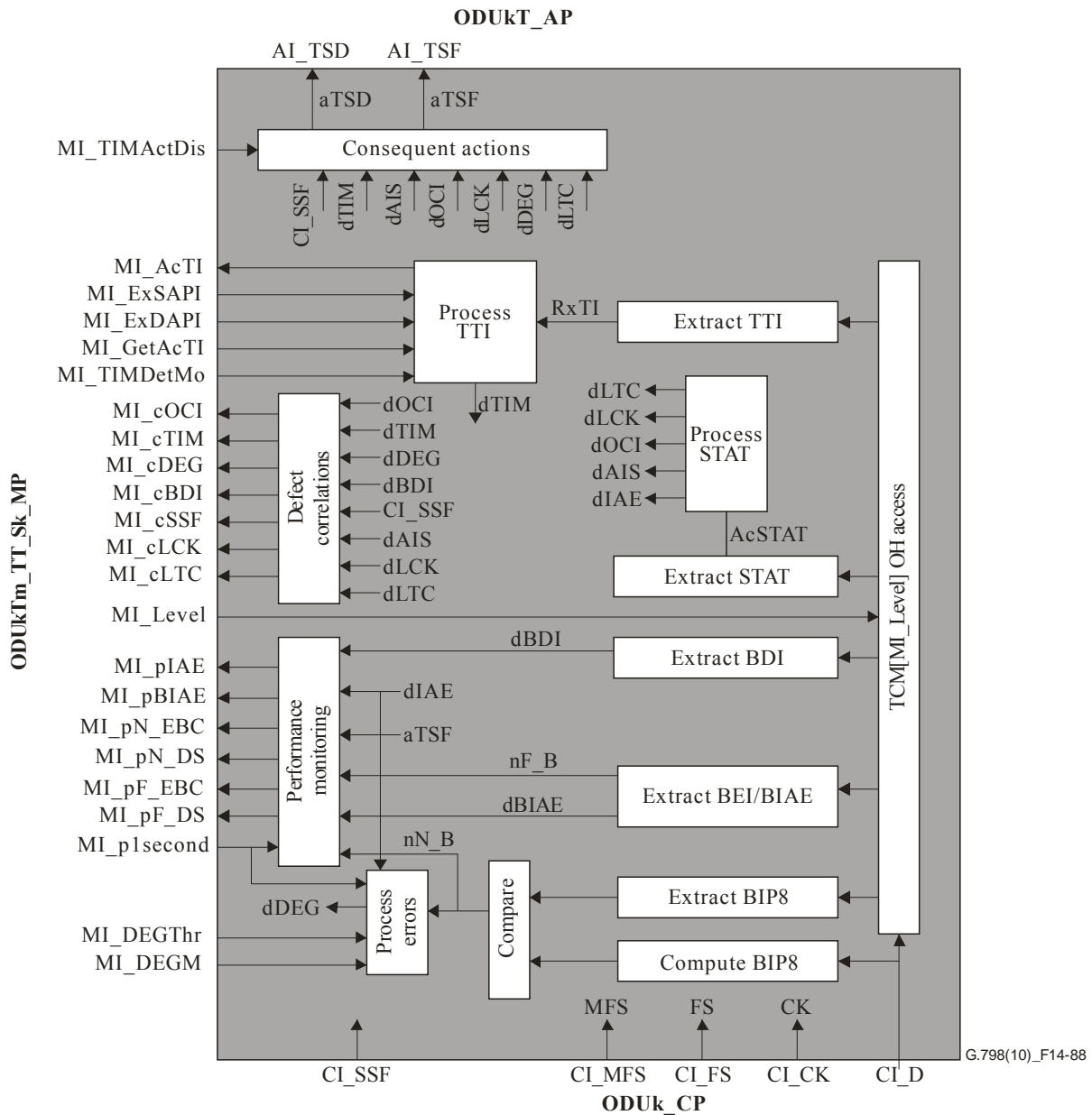

Figure 14-88 – ODUkTm_TT_Sk processes

Defects

The function shall detect for dLTC, dAIS, dOCI, dLCK, dTIM, dDEG, dIAE, dBIAE and dBDI defects.

dLTC: See clause 6.2.1.4.1; dLTC shall be set to false during CI_SSF and dAIS.

dAIS: See clause 6.2.6.3.2.

dOCI: See clause 6.2.6.8.2; dOCI shall be set to false during CI_SSF and dAIS.

dLCK: See clause 6.2.6.9.1; dLCK shall be set to false during CI_SSF and dAIS.

dTIM: See clause 6.2.2.1; dTIM shall be set to false during CI_SSF and dAIS.

dDEG: See clause 6.2.3.4.

NOTE 1 – IAE suppresses the one-second near-end errored block count, which is the input for the dDEG detection. This avoids wrong dDEG declaration due to alignment errors already incoming in an OTUk trail.

dBBDI: See clause 6.2.6.6.1; dBBDI shall be set to false during CI_SSF and dAIS.

dIAE: See clause 6.2.6.10.2; dIAE shall be set to false during CI_SSF, dAIS and dTIM.

dBIAE: See clause 6.2.6.11.1; dBIAE shall be set to false during CI_SSF, dAIS and dTIM.

Consequent actions

The function shall perform the following consequent actions (see clause 6.3 of [ITU-T G.806]):

aTSF ← CI_SSF or (dAIS or dLTC or dOCI or dLCK or (dTIM and (not TIMActDis)))

aTSD ← dDEG

Defect correlations

The function shall perform the following defect correlations to determine the most probable fault cause (see clause 6.4 of [ITU-T G.806]). This fault cause shall be reported to the EMF.

cSSF ← CI_SSF or dAIS

cLTC ← dLTC and (not CI_SSF)

cOCI ← dOCI and (not CI_SSF)

cLCK ← dLCK and (not CI_SSF)

cTIM ← dTIM and (not CI_SSF) and (not dAIS) and (not dLTC) and (not dOCI) and (not dLCK)

cDEG ← dDEG and (not CI_SSF) and (not dAIS) and (not dLTC) and (not dOCI) and (not dLCK) and (not (dTIM and (not TIMActDis)))

cBBDI ← dBBDI and (not CI_SSF) and (not dAIS) and (not dLTC) and (not dOCI) and (not dLCK) and (not (dTIM and (not TIMActDis)))

Performance monitoring

The function shall perform the following performance monitoring primitives processing (see clause 6.5 of [ITU-T G.806]). The performance monitoring primitives shall be reported to the EMF.

pN_DS ← CI_SSF or (dAIS or dLTC or dOCI or dLCK or dTIM)

pF_DS ← dBBDI

pN_EBC ← $\sum nN_B$

NOTE 2 – During CI_SSF, dAIS, dLTC, dLCK and dOCI, no errored blocks shall be counted.

pF_EBC ← $\sum nF_B$

NOTE 3 – During CI_SSF, dAIS, dLTC, dLCK and dOCI, no errored blocks shall be counted.

pBIAE ← dBIAE

NOTE 4 – pBIAE is activated at the end of the second if dBIAE was active once during the second.

pIAE ← dIAE

NOTE 5 – pIAE is activated at the end of the second if dIAE was active once during the second.

NOTE 6 – pIAE and pBIAE are used for the suppression of the PM data in the equipment management functions (see [ITU-T G.874]). If pBIAE is active, the F_DS and F_EBC values of the previous and current second have to be discarded (EBC = 0 and DS = false). If pIAE is active, the N/F_DS and N/F_EBC values of the previous and current second have to be discarded (EBC = 0 and DS = false). The previous second has to be included due to the delay of the IAE information coming from the remote source.

14.5.1.2 ODUkT to ODUk adaptation function (ODUkT/ODUk_A)

The ODUkT/ODUk_A function starts and ends a selected TCM level if it is OPERATIONAL.

Furthermore, the ODUkT/ODUk_A function provides access to the TCM ACT signal and the TCM status information in the ODUk overhead over the TCM control point (TCMCP) for the tandem connection monitor control (TCMC) function that can be connected to an ODUkT/ODUk_A.

14.5.1.2.1 ODUkT to ODUk adaptation source function (ODUkT/ODUk_A_So)

The ODUkT/ODUk_A_So function starts a selected TCM level and can initiate maintenance signals (LCK) if it is OPERATIONAL.

Furthermore, the ODUkT/ODUk_A_So function provides access to the TCM ACT signal and the TCM status information in the ODUk overhead over the TCMCP for the TCMC function that can be connected to an ODUkT/ODUk_A. It provides access to ODUk PM APS overhead.

The information flow and processing of the ODUkT/ODUk_A_So function is defined with reference to Figures 14-89 and 14-90.

Symbol

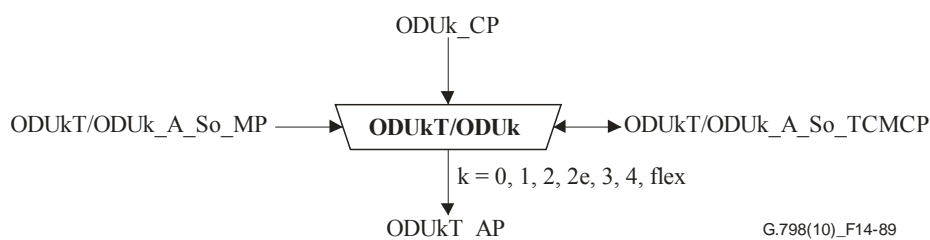

Figure 14-89 – ODUkT/ODUk_A_So function

Interfaces

Table 14-45 – ODUkT/ODUk_A_So inputs and outputs

Input(s)	Output(s)
ODUk_CP: ODUk_CI_CK ODUk_CI_D ODUk_CI_FS ODUk_CI_MFS ODUkT_PP: ODUk_PI_APS ODUkT/ODUk_A_So_MP: ODUkT/ODUk_A_So_MI_AdminState ODUkT/ODUk_A_So_TCMCP: ODUkT/ODUk_A_So_TCMCI_Mode ODUkT/ODUk_A_So_TCMCI_Level ODUkT/ODUk_A_So_TCMCI_ACTTx ODUkT/ODUk_A_So_TCMCI_ACTEn	ODUkT_AP: ODUkT_AI_CK ODUkT_AI_D ODUkT_AI_FS ODUkT_AI_MFS ODUkT/ODUk_A_So_TCMCP: ODUkT/ODUk_A_So_TCMCI_AcSTAT[1..6] ODUkT/ODUk_A_So_TCMCI_ACTRx

Processes

The processes associated with the ODUkT/ODUk_A_So function are as depicted in Figure 14-90.

TCMOH-STAT Rx: The status of all six TCM levels is recovered from the TCM OH [1..6] STAT field and provided to the TCM control function via TCMCI_STAT[1..6]. For the STAT acceptance process, see clause 8.8.

TCM ACT: The TCM ACT overhead byte is made available to the control plane via TCMCI_ACTRx. The byte is taken directly from the overhead without any acceptance process. If TCMCI_ACTEn is true, the ACT value received via TCMCI_ACTRx from the TCM control function is inserted into the TCM ACT byte. Otherwise, the byte is passed through transparently.

NOTE – An acceptance process might be performed for the received ACT information in the control plane.

ODUk-LCK: The function shall generate the ODUk-LCK signal as defined in clause 16.5 of [ITU-T G.709]. The clock, frame start and multiframe start are defined by the incoming ODUk signal.

Mode: If the CPI_Mode has the value OPERATIONAL, the following processes shall be performed. If the TCMCI_Mode has the value TRANSPARENT, all information shall be passed through transparently and the following processes shall not be performed.

IAE: If the incoming ODUk frame start (CI_FS) position is not at the expected frame start position, incoming alignment error (IAE) shall be activated. IAE shall be deactivated if the incoming ODUk frame start (CI_FS) position is at the expected frame start position. The expected frame start position is based on the previous incoming ODUk frame start.

Selector: If TCMCI_Mode is OPERATIONAL, the normal signal may be replaced by the ODUk-LCK signal. ODUk-LCK signal is selected if the MI_AdminState is LOCKED.

ODUk TCM APS: If TCMCI_Mode is OPERATIONAL, the function shall insert the PI_APS value into the ODUk TCM APS/PCC[TCMCI_Level] field, which is available once per eight ODUk frames as specified in Table 15-6 of [ITU-T G.709].

TCMOH-STAT Tx: If TCMCI_Mode is OPERATIONAL, the TC status is inserted into the STAT bit positions of TCM OH[TCMCI_Level] based on the incoming alignment error (IAE) information. Normally, the code "in use without IAE" (001) is inserted. Upon the declaration of

IAE at this function, the function shall insert the code "in use with IAE" (010) in the STAT field for the next 16 multiframes. Each new declaration of aIAE restarts the 16-multiframe insertion time.

TCMOH-Others: If TCMCI_Mode is OPERATIONAL, all other TCM OH[TCMCI_Level] bits are set to "0".

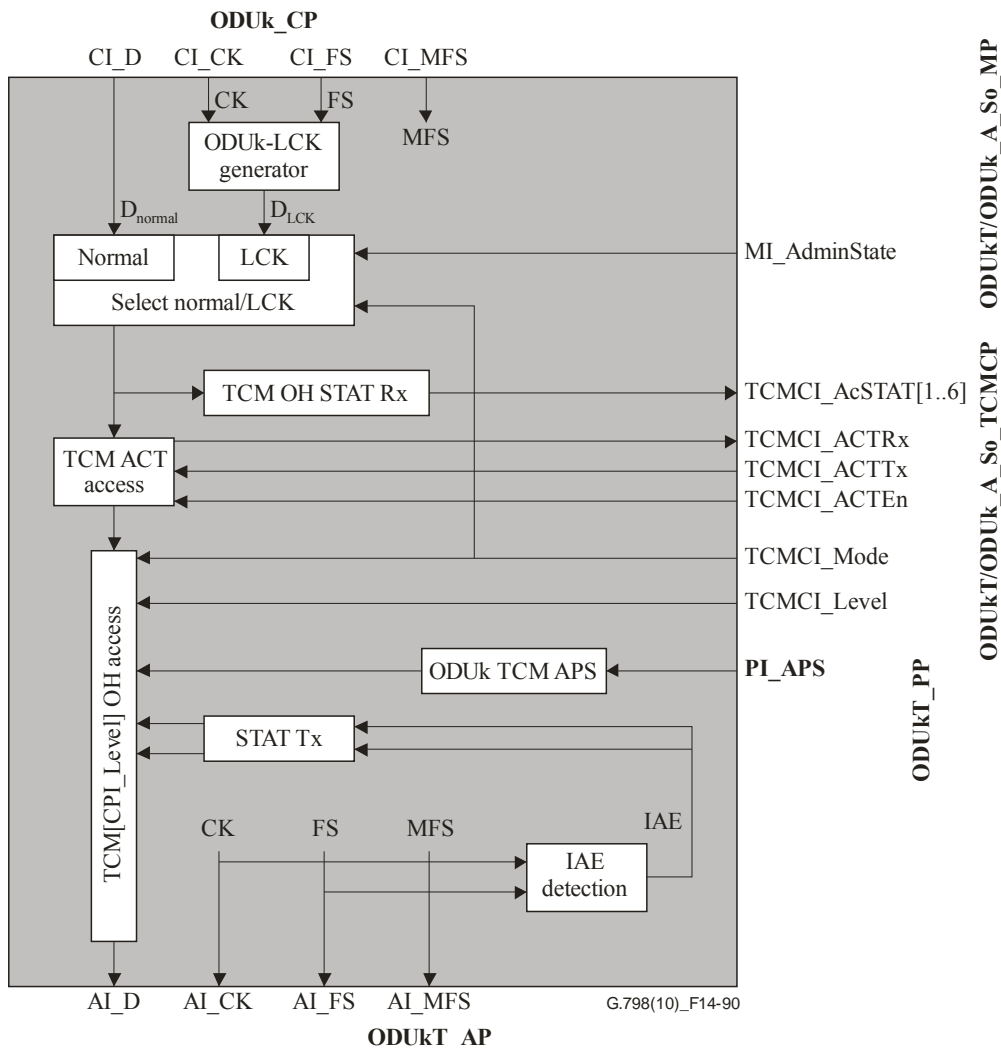

Figure 14-90 – ODUkT/ODUk_A_So processes

Defects: None.

Consequent actions: None.

Defect correlations: None.

Performance monitoring: None.

14.5.1.2.2 ODUkT to ODUk adaptation sink function (ODUkT/ODUk_A_Sk)

The ODUkT/ODUk_A_Sk function ends a selected TCM level and can initiate maintenance signals (ODUk AIS, LCK) if it is OPERATIONAL.

Furthermore, the ODUkT/ODUk_A_Sk function provides access to the TCM ACT signal and the TCM status information in the ODUk overhead over the TCMCP for the TCMC function that can be connected to an ODUkT/ODUk_A. It provides access to ODUk PM APS overhead.

The information flow and processing of the ODUkT/ODUk_A_Sk function is defined with reference to Figures 14-91 and 14-92.

Symbol

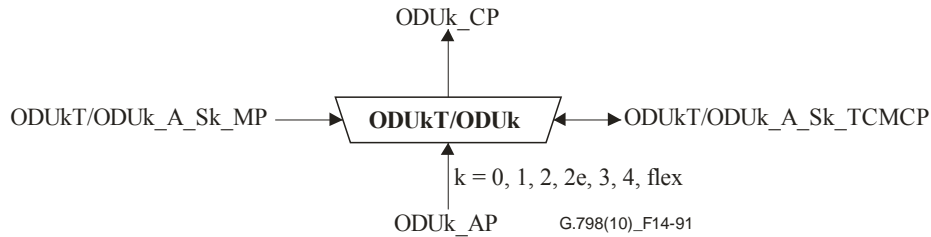

Figure 14-91 – ODUkT/ODUk_A_Sk function

Interfaces

Table 14-46 – ODUkT/ODUk_A_Sk inputs and outputs

Input(s)	Output(s)
ODUkT_AP: ODUkT_AI_CK ODUkT_AI_D ODUkT_AI_FS ODUkT_AI_MFS ODUkT_AI_TSF ODUkT_AI_TSD ODUkT_AI_AIS ODUkT/ODUk_A_Sk_MP: ODUkT/ODUk_A_Sk_MI_AdminState ODUkT/ODUk_A_Sk_TCMCP: ODUkT/ODUk_A_Sk_TCMCI_Mode ODUkT/ODUk_A_Sk_TCMCI_Level ODUkT/ODUk_A_Sk_TCMCI_ACTTx ODUkT/ODUk_A_Sk_TCMCI_ACTEn	ODUk_CP: ODUk_CI_CK ODUk_CI_D ODUk_CI_FS ODUk_CI_MFS ODUk_CI_SSF ODUk_CI_SSD ODUkT_PP: ODUkT_PI_APS ODUkT_PI_TSF ODUkT_PI_TSD ODUkT/ODUk_A_Sk_TCMCP: ODUkT/ODUk_A_Sk_TCMCI_AcSTAT[1..6] ODUkT/ODUk_A_Sk_TCMCI_ACTRx

Processes

The processes associated with the ODUkT/ODUk_A_Sk function are as depicted in Figure 14-92.

ODUk TCM APS: If the TCMCI_Mode has the value OPERATIONAL, the function shall extract the information from the ODUk TCM APS/PCC[TCMCI_Level] field, which is available once per eight ODUk frames as specified in Table 15-6 of [ITU-T G.709] and apply this to the PI_APS.

TCMOH-STAT Rx: The status of all six TCM levels is recovered from the TCM OH [1..6] STAT field and provided to the control function via TCMCI_AcSTAT[1..6]. For the STAT acceptance process, see clause 8.8.

TCM ACT: The TCM ACT overhead byte is made available to the control function via TCMCI_ACTRx. The byte is taken directly from the overhead without any acceptance process. If TCMCI_ACTEn is true, the ACT value received via TCMCI_ACTRx from the control plane is inserted into the TCM ACT byte. Otherwise, the byte is passed through transparently.

NOTE – An acceptance process might be performed for the received ACT information in the control function.

ODUk-LCK, ODUk-AIS: The function shall generate the ODUk-LCK and ODUk-AIS signals as defined in [ITU-T G.709]. The clock, frame start and multiframe start are defined by the incoming ODUk signal.

Mode: If the TCMCI_Mode has the value OPERATIONAL, the following processes shall be performed. If the TCMCI_Mode has the values MONITOR or TRANSPARENT, all information shall be passed through transparently and the following processes shall not be performed.

Selector: If TCMCI_Mode is OPERATIONAL, the normal signal may be replaced by either the ODUk-AIS or the ODUk-LCK signal. ODUk-LCK signal is selected if the MI_AdminState is LOCKED. ODUk-AIS is selected if MI_AdminState is not LOCKED and aAIS is true. If TCMCI_Mode has the values MONITOR or TRANSPARENT, the normal signal is always selected.

Remove TCMOH: If the TCMCI_Mode has the value OPERATIONAL, an all-ZEROs pattern shall be inserted in the TCMOH and TCM APS/PCC at location TCMCI_Level. If the TCMCI_Mode has the values TRANSPARENT or MONITOR, the information shall be passed through transparently.

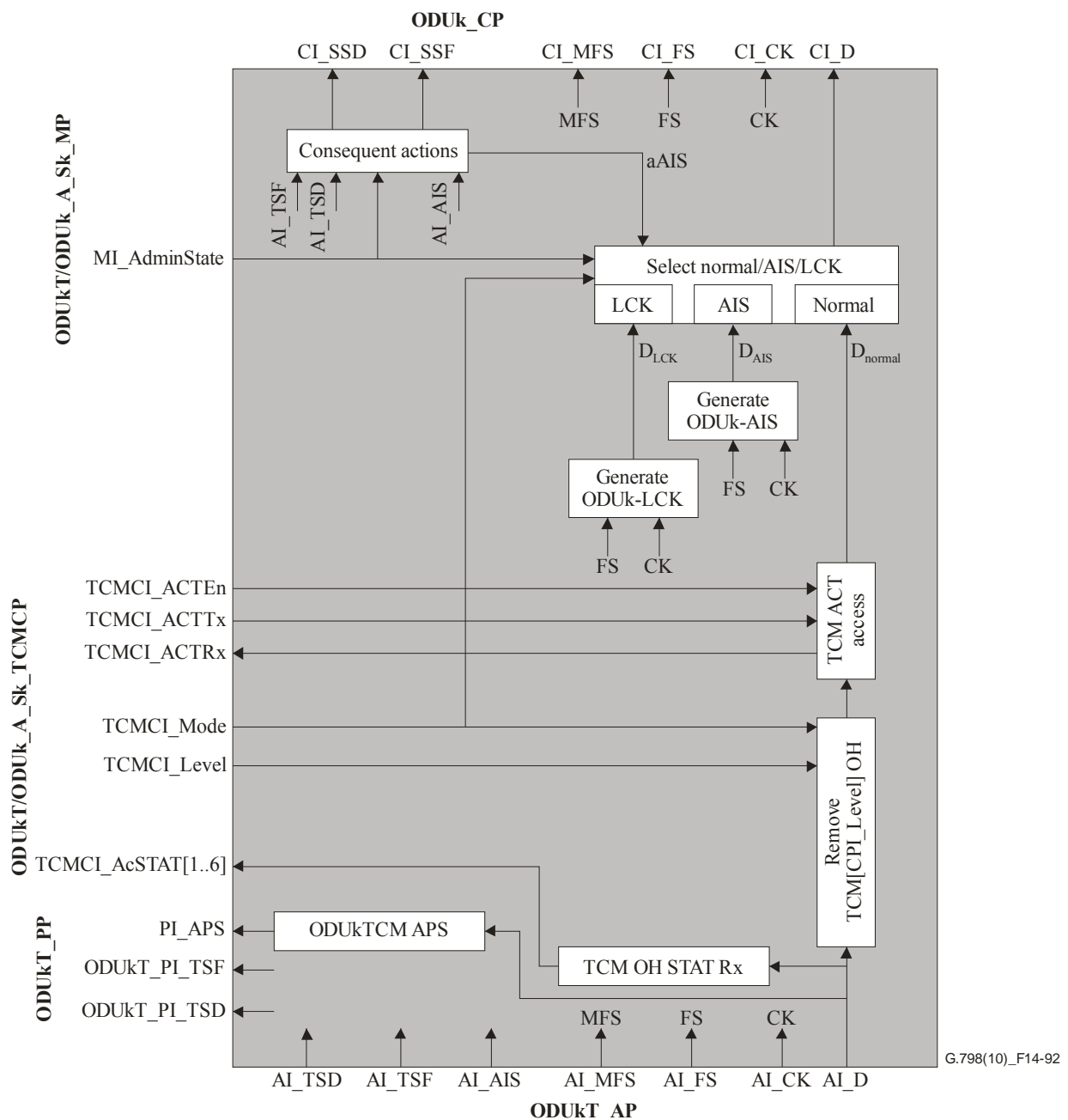

Figure 14-92 – ODUkT/ODUk_A_Sk processes

Defects: None.

Consequent actions

aAIS ← AI_AIS and (TCMCI_Mode = OPERATIONAL) and (not MI_AdminState = LOCKED)

aSSF ← AI_TSF and (not MI_AdminState = LOCKED)

aSSD ← AI_TSD and (not MI_AdminState = LOCKED)

On declaration of aAIS, the function shall output an ODUk-AIS signal within two frames. On clearing of aAIS, the ODUk-AIS signal shall be removed within two frames with normal data being output.

Defect correlations: None.

Performance monitoring: None.

14.5.1.3 ODUkT TCM control functions (ODUkT_TCMC)

The ODUkT_TCMC functions are responsible for the activation/deactivation of a TCM trail. An ODUkT_TCMC function is connected to the ODUkT_TT and ODUkT/ODUk_A functions at the TCM control points (TCMCP) as shown in Figure 14-93.

Currently only an ODUkT_TCMC function for manual activation/deactivation via the management interface is defined. ODUkT_TCMC functions for automatic activation are for further study.

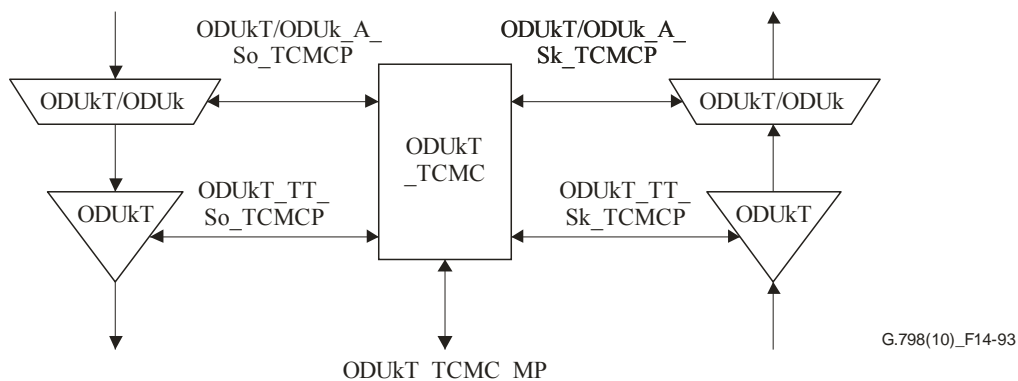

Figure 14-93 – ODUkT_TCMC connections

14.5.1.3.1 ODUkT control function for manual activation (ODUkT_TCMCm)

The ODUkT_TCMCm function performs manual activation/deactivation of a TCM trail via the management interface.

The TCM ACT channel is not used. The TCM status of the sink and source is provided to the management interface. The TCM level and the mode of the sink and source functions is selected by the management interface.

The information flow and processing of the ODUkT_TCMCm function is defined with reference to Figures 14-94 and 14-95.

Symbol

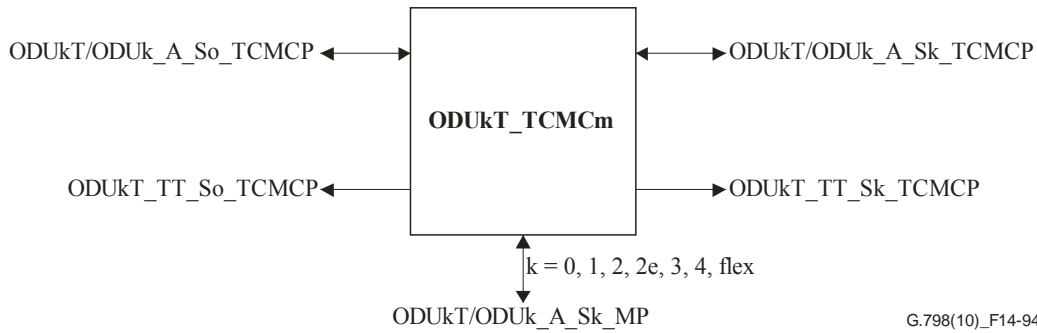

Figure 14-94 – ODUkT_TCMCm function

Interfaces

Table 14-47 – ODUkT_TCMCm inputs and outputs

Input(s)	Output(s)
ODUkT_TCMCm_MP: ODUkT_TCMCm_MI_Level ODUkT_TCMCm_MI_ModeSo ODUkT_TCMCm_MI_ModeSk ODUkT/ODUk_A_So_TCMCP: ODUkT/ODUk_A_So_TCMCI_AcSTAT[1..6] ODUkT/ODUk_A_Sk_TCMCP: ODUkT/ODUk_A_Sk_TCMCI_AcSTAT[1..6]	ODUkT_TCMCm_MP: ODUkT_TCMCm_MI_AcSTATSo[1..6] ODUkT_TCMCm_MI_AcSTATSk[1..6] ODUkT/ODUk_A_So_TCMCP: ODUkT/ODUk_A_So_TCMCI_Mode ODUkT/ODUk_A_So_TCMCI_Level ODUkT/ODUk_A_So_TCMCI_ACTEn ODUkT/ODUk_A_Sk_TCMCP: ODUkT/ODUk_A_Sk_TCMCI_Mode ODUkT/ODUk_A_Sk_TCMCI_Level ODUkT/ODUk_A_Sk_TCMCI_ACTEn ODUkT_TT_So_TCMCP: ODUkT_TT_So_TCMCI_Mode ODUkT_TT_So_TCMCI_Level ODUkT_TT_Sk_TCMCP: ODUkT_TT_Sk_TCMCI_Mode ODUkT_TT_Sk_TCMCI_Level

Processes

The processes associated with the ODUkT_TCMCm function are as depicted in Figure 14-95.

As the TCM ACT bytes are not used, TCMCI_ACTEn for sink and source is fixed set to "false".

The TCM level is provided by the management via MI_Level and distributed to sink and source termination and adaptation functions.

The mode is provided independently for sink and source by the management (MI_ModeSo and MI_ModeSk).

The sink and source TCM status of all six levels is provided to the management (MI_AcSTATSo[1..6] and MI_AcSTATSk[1..6]).

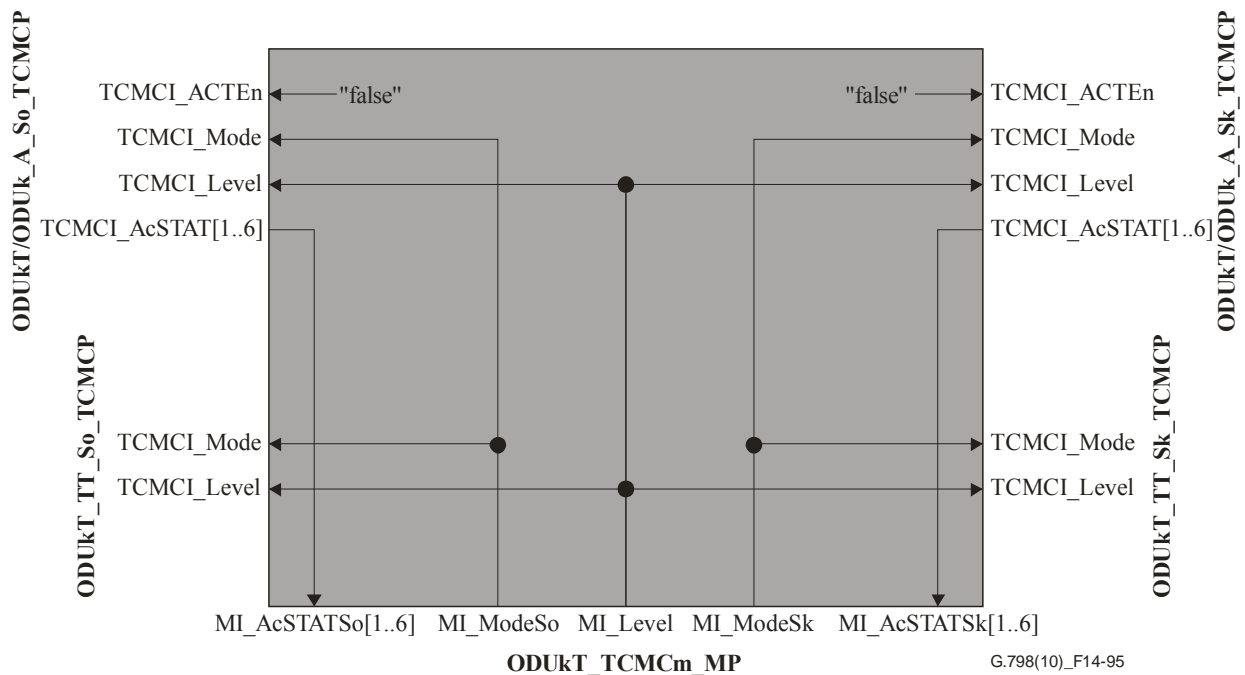

Figure 14-95 – ODUkT_TCMcM processes

Defects: None.

Consequent actions: None.

Defect correlations: None.

Performance monitoring: None.

14.6 Virtual concatenation functions

NOTE – Only LCAS-capable virtual concatenation functions are defined. In case the LCAS functionality is not needed (e.g., support of a CBR client), it can be disabled. If only a fixed-bandwidth ODUkP-Xv-L-to-client (e.g., ODUkP-Xv-L/CBRx_A) adaptation function is supported by the ODUkP-Xv-L termination, only the functionality for the LCAS-disabled mode is required to be implemented.

14.6.1 LCAS-capable virtual concatenated ODUkP layer functions ODUkP-Xv-L (k = 1, 2, 3; X ≥ 1)

The LCAS-capable virtual concatenated ODUkP layer functions (ODUkP-Xv-L, k = 1, 2, 3) are instantiations of the generic functions defined in clause 10.1 of [ITU-T G.806] (P-Xv-L), particularized with some technology-specific aspects.

The definitions in this clause provide references to the appropriate generic function definitions in clause 10.1 of [ITU-T G.806] and specify the technology-specific particularizations where necessary.

14.6.1.1 ODUkP-Xv-L trail termination function (ODUkP-Xv-L_TT)

The ODUkP-Xv-L_TT function is further decomposed as defined in clause 10.1.1 of [ITU-T G.806] and shown in Figure 14-96.

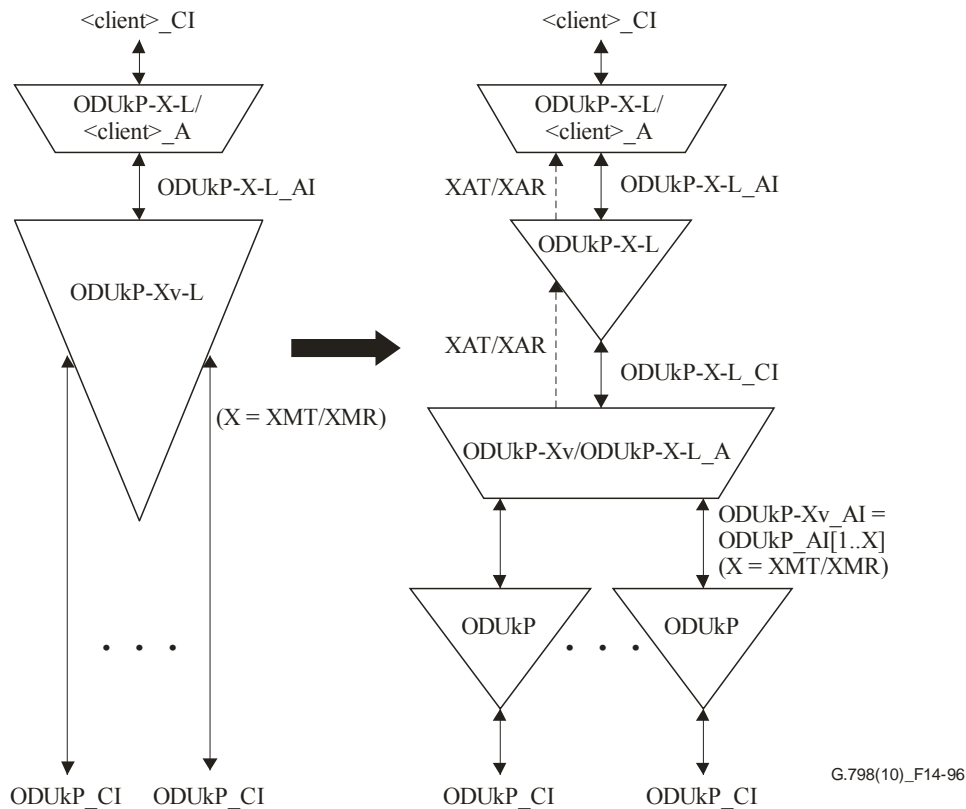

Figure 14-96 – Decomposition of the ODUkP-Xv-L_TT function

The decomposition for this function is the same as for the corresponding generic function P-Xv-L_TT as defined in clause 10.1.1 of [ITU-T G.806], with the following technology-specific particularizations:

- The path-layer "P-" is the ODUkP layer.
- The ODUkP_TT functions are the normal ODUkP trail termination functions as defined in clause 14.2.1.
- $X_{MT}, X_{MR} \leq 256$, according to the definitions in clause 18.1 of [ITU-T G.709].

14.6.1.2 ODUkP-Xv/ODUkP-X-L adaptation source function (ODUkP-Xv/ODUkP-X-L_A_So)

Symbol

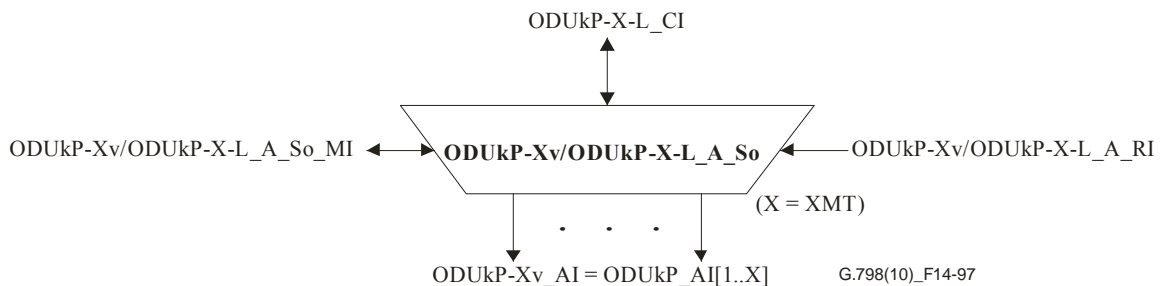

Figure 14-97 – ODUkP-Xv/ODUkP-X-L_A_So symbol

Interfaces

The interfaces for this function are the same as for the corresponding generic function P-Xv/P-X-L_A_So as defined in clause 10.1.1.1 of [ITU-T G.806], with the following technology-specific particularizations:

- The path-layer "P-" is the ODUkP layer.
- MST_Range = 255 (corresponding to the range as defined in clause 18.1 of [ITU-T G.709]).

In addition to those in clause 10.1.1.1 of [ITU-T G.806], this function shall have the following interfaces (see Table 14-48):

Table 14-48 – ODUkP-Xv/ODUkP-X-L_A_So additional inputs and outputs

Input(s)	Output(s)
ODUkP-X-L_CP: ODUkP-X-L_CI_MFS ODUkP-Xv/ODUkP-X-L_A_So_MP: ODUkP-Xv/ODUkP-X-L_A_So_MI_Active	ODUkP_AP: ODUkP_AI_MFS

Processes

The process definitions for this function are the same as for the corresponding generic function P-Xv/P-X-L_A_So as defined in clause 10.1.1.1 of [ITU-T G.806], with the following technology-specific particularizations:

Clock, frame start and multiframe start: The clock for each of the ODUkP signals (ODUkP_AI_Ck) is generated by dividing the ODUkP-X-L clock (ODUkP-X-L_CI_CK) by X_{AT} .

The multiframe start signal (MFS) is transported from the ODUkP-X-L_CP to each of the ODUkP_AP points through the processes along with the frame start (FS) signal.

The virtual concatenation multiframe is generated by the function.

OH Extract: The extracted overhead information _CI_OH consists of the null signal (i.e., this process does not perform any function for the ODUkP virtual concatenation case).

Deinterleave (distribution process): The distribution process shall be as follows:

Starting from column $14X + 1$, the ODUkP-X-L_CI_D signal shall be distributed to the X_{AT} ODUkP as defined in Table 14-49 below.

Table 14-49 – ODUkP-X distribution mapping

ODUkP-X-L_CI_D column	Deinterleave output number	Deinterleave output column
$14X + 1$	1	15
...
$15X_{AT}$	X_{AT}	15
$15X_{AT} + 1$	1	16
...
$16X_{AT}$	X_{AT}	16
$16X_{AT} + 1$	1	17
...
$3824 \times X_{AT}$	X_{AT}	3824

NOTE – This mapping is uniform throughout the OPUk overhead and payload columns. This mapping is illustrated in Figure 18-1 of [ITU-T G.709].

For the outputs $X_{AT} + 1, X_{AT} + 2, \dots, X_{MT}$, this block inserts an all-ZEROS signal with the rate and format of an ODUkP signal.

"Switch 1" (assignment of sequence numbers): For all non-payload-carrying outputs ($_PC[s]=0$) this process inserts an all-ZEROs signal with the rate and format of an ODUkP signal.

VLI insertion: The VLI information consists of the value of the VCOH bytes, and has the coding defined in clause 18.1 of [ITU-T G.709] for those overhead bytes.

VLI assemble and CRC: The VLI information consists of the value of the VCOH bytes, and has the coding defined in clause 18.1 of [ITU-T G.709] for those overhead bytes. The CRC code used is the CRC-8 defined in clause 18.1 of [ITU-T G.709].

Irrespective of the value of MI_LCASEnable, all unused fields in the VCOH multiframe structure shall be sourced as zeros.

OH insert: The function shall insert code "0000 0110" into the PT byte position of the PSI overhead as defined in clause 15.9.2 of [ITU-T G.709].

All bits of the X times ODUk overhead should be sourced as "0"s, except the ODUk-PM STAT field which should be set to the value "normal path signal" (001).

Defects: See clause 10.1.1.1 of [ITU-T G.806].

Consequent actions: See clause 10.1.1.1 of [ITU-T G.806].

Defect correlations: See clause 10.1.1.1 of [ITU-T G.806].

Performance monitoring: See clause 10.1.1.1 of [ITU-T G.806].

14.6.1.3 LCAS-capable ODUkP-Xv/ODUkP-X-L adaptation sink function (ODUkP-Xv/ODUkP-X-L_A_Sk)

Symbol

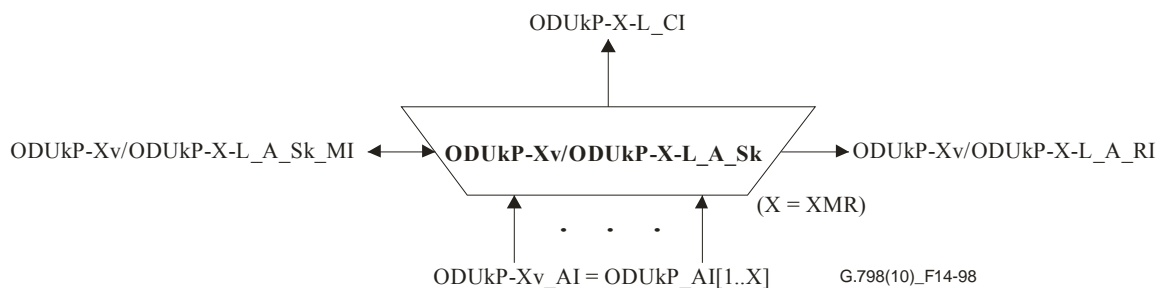

Figure 14-98 – ODUkP-Xv/ODUkP-X-L_A_Sk symbol

Interfaces

The interfaces for this function are the same as for the corresponding generic function P-Xv/P-X-L_A_Sk as defined in clause 10.1.1.2 of [ITU-T G.806], with the following technology-specific particularizations:

- The path-layer "P-" is the ODUkP layer.
- MST_Range = 255 (corresponding to the range as defined in clause 18.1 of [ITU-T G.709]).

In addition to those in clause 10.1.1.2 of [ITU-T G.806], this function shall have the following interfaces (see Table 14-50):

Table 14-50 – ODUkP-Xv/ODUkP-X-L_A_Sk additional inputs and outputs

Input(s)	Output(s)
ODUkP_AP: ODUkP_AI_MFS	ODUkP-X-L_CP: ODUkP-X-L_CI_MFS ODUkP-Xv/ODUkP-X-L_A_Sk_MP: ODUkP-Xv/ODUkP-X-L_A_Sk_MI_cPLM[1..XMR] ODUkP-Xv/ODUkP-X-L_A_Sk_MI_AcPT[1..XMR] ODUkP-Xv/ODUkP-X-L_A_Sk_MI_Active

Processes

The process definitions for this function are the same as for the corresponding generic function P-Xv/P-X-L_A_Sk as defined in clause 10.1.1.2 of [ITU-T G.806], with the following technology-specific particularizations:

The function shall extract the PT byte from the PSI overhead as defined in clause 8.7.1. The accepted PT value is available at the MP (MI_AcPT[1..X_{MR}]) and is used for PLM defect detection. This processing is done individually for each of the ODUkP_AI input signals.

MI_AcPT acceptance and PLM defect detection are performed at each ODUkP_AI input of the function before any further processing. A dPLM[i] detected for a member is treated equivalently to an active ODUkP_AI_TSF[i] indication by all subsequent processes.

Clock, frame start and multiframe start: The clock for the ODUkP-X-L signal (ODUkP-X-L_CI_CK) is generated by selecting the ODUkP clock (ODUkP_AI_CK) of one of the active members and multiplying it by X_{AR}. The clock parameters, including jitter and wander requirements, as defined in Annex A of [ITU-T G.8251] (ODCr clock), apply.

The frame start and multiframe start signals for the ODUkP-X-L signal (ODUkP-X-L_FS/MFS) are generated based on the frame and multiframe at the output of the delay process.

MFI extract: The multiframe alignment process shall be according to clause 8.2.4. The _MFI[i] output consists of a 24-bit word with the value of the MFI contained in the MFI-1, MFI-2 and MFAS positions (from MSB to LSB) in AI_D[i]. If AI_TSF[i] = true, then the _MFI[i] output of this process shall be an all-ONES 24-bit word. The dLOM[i] detection for each member shall be as described in defects below.

VLI, TSx extract: The VLI information consists of the value of the VCOH bytes, and has the coding defined in clause 18.1 of [ITU-T G.709] for those overhead bytes. If _TSF[i] is false and dMND[i] is false, then the _VLI[i] output of this process is the value of the VCOH byte positions at the input of this process. If _TSF[i] is true or dMND[i] is true, then the _VLI[i] output of this process shall be an all-ONES signal.

VLI disassemble and CRC: The VLI information consists of the value of the VCOH bytes, and has the coding defined in clause 18.1 of [ITU-T G.709] for those overhead bytes. The CRC code used is the CRC-8 defined in clause 18.1 of [ITU-T G.709].

"Interleave process": The recovery process shall be as follows:

Starting from column 15, the ODUkP-Xc signal shall be recovered from the X_{AR} ODUkP, as defined in Table 14-51 below.

Table 14-51 – ODUkP-X-L recovery mapping

Interleave input number	Interleave input column	ODUkP-X-L_CI column
1	15	14 XAR + 1
...
XAR	15	15 XAR
1	16	15 XAR + 1
...
XAR	16	16 XAR
1	17	16 XAR + 1
...
XAR	3824	3824 × XAR

NOTE – This mapping is uniform throughout the OPUk overhead and payload columns.

Defects

Payload mismatch (dPLM): The function shall detect payload mismatch (dPLM[i]) for each of its ODUkP_AI[i] input signals. The processing is as per clause 6.2.4.1. The expected payload type is "0000 0110" (virtual concatenated signal) as defined in [ITU-T G.709].

Loss of multiframe defect (dLOM): See clause 6.2.5.2.

Loss of sequence defect (dSQM): See clause 10.1.1.2 of [ITU-T G.806].

Member not deskewable (dMND): See clause 10.1.1.2 of [ITU-T G.806].

Loss of alignment (dLOA): See clause 10.1.1.2 of [ITU-T G.806].

Consequent actions

See clause 10.1.1.2 of [ITU-T G.806], taking the following definitions of mMSU and mMSU_L:

mMSU[i] ← MI_ProvM[i] and (AI_TSF[i] or dPLM[i] or dLOM[i] or dLOA or dSQM[i])

mMSU_L[i] ← MI_ProvM[i] and (AI_TSF[i] or dPLM[i] or dMND[i] or AI_TSD[n] or dLOM[i])

On declaration of aAIS, the function shall output a generic AIS signal within two frames; on clearing of aAIS, the function shall output normal data within two frames. The bit rate of this generic AIS signal shall be consistent with the value of $_X_{AR}$ as calculated by the processes involved.

Defect correlations

cPLM[i] ← dPLM[i] and (not AI_TSF[i])

cLOM[i] ← MI_ProvM[i] and dLOM[i] and (not dPLM[i]) and (not AI_TSF[i])

cMND[i] ← MI_ProvM[i] and dMND[i] and (not dPLM[i]) and (not dLOM[i]) and (not AI_TSF[i])

cSQM[i] ← MI_ProvM[i] and dSQM[i] and (not dPLM[i]) and (not dLOM[i]) and (not dLOA) and (not AI_TSF[i])

cLOA: As per clause 10.1.1.2 of [ITU-T G.806].

cPLCR: As per clause 10.1.1.2 of [ITU-T G.806].

cTLCR: As per clause 10.1.1.2 of [ITU-T G.806].

Performance monitoring: See clause 10.1.1.2 of [ITU-T G.806].

14.6.1.4 LCAS-capable ODUkP-X-L trail termination source function (ODUkP-X-L_TT_So)

Symbol

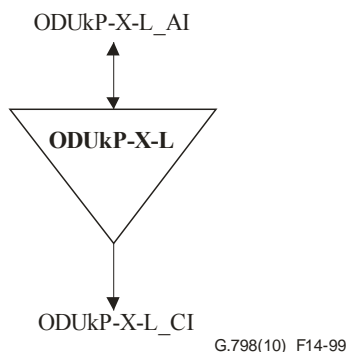

Figure 14-99 – ODUkP-X-L_TT_So symbol

Interfaces

The interfaces for this function are the same as for the corresponding generic function P-Xv/P-X-L_TT_So as defined in clause 10.1.1.3 of [ITU-T G.806], with the following technology-specific particularization:

- The path-layer "P-" is the ODUkP layer.

In addition to those in clause 10.1.1.3 of [ITU-T G.806], this function shall have the following interfaces (see Table 14-52):

Table 14-52 – ODUkP-X-L_TT_So additional inputs and outputs

Input(s)	Output(s)
ODUkP-X-L_AP: ODUkP-X-L_AI_MFS	ODUkP-X-L_CP: ODUkP-X-L_CI_MFS

Processes: See clause 10.1.1.3 of [ITU-T G.806].

In addition, the multiframe start signal (MFS) is transported from the ODUkP-X-L_AP to the ODUkP-X-L_CP point along with the frame start (FS) signal.

Defects: See clause 10.1.1.3 of [ITU-T G.806].

Consequent actions: See clause 10.1.1.3 of [ITU-T G.806].

Defect correlations: See clause 10.1.1.3 of [ITU-T G.806].

Performance monitoring: See clause 10.1.1.3 of [ITU-T G.806].

14.6.1.5 LCAS-capable ODUkP-X-L trail termination sink function (ODUkP-X-L_TT_Sk)

Symbol

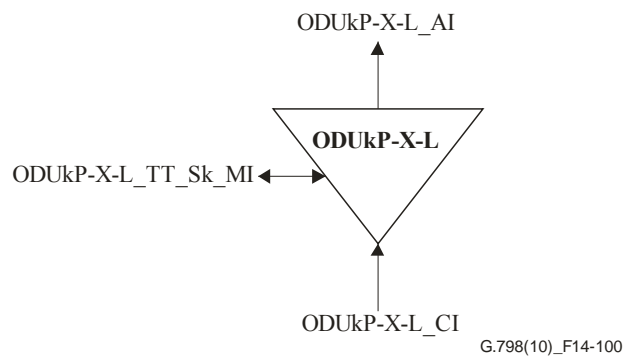

Figure 14-100 – ODUkP-X-L_TT_Sk symbol

Interfaces

The interfaces for this function are the same as for the corresponding generic function P-Xv/P-X-L_TT_Sk as defined in clause 10.1.1.4 of [ITU-T G.806], with the following technology-specific particularization:

- The path-layer "P-" is the ODUkP layer.

In addition to those in clause 10.1.1.4 of [ITU-T G.806], this function shall have the following interfaces (see Table 14-53):

Table 14-53 – ODUkP-X-L_TT_Sk additional inputs and outputs

Input(s)	Output(s)
ODUkP-X-L_CP: ODUkP-X-L_CI_MFS	ODUkP-X-L_AP: ODUkP-X-L_AI_MFS

Processes: See clause 10.1.1.4 of [ITU-T G.806].

In addition, the multiframe start signal (MFS) is transported from the ODUkP-X-L_CP to the ODUkP-X-L_AP point along with the frame start (FS) signal.

Defects: See clause 10.1.1.4 of [ITU-T G.806].

Consequent actions: See clause 10.1.1.4 of [ITU-T G.806].

Defect correlations: See clause 10.1.1.4 of [ITU-T G.806].

Performance monitoring: See clause 10.1.1.4 of [ITU-T G.806].

14.6.2 Virtual concatenated ODUkP to client adaptation functions

14.6.2.1 ODUkP-X-L to CBRx adaptation function (ODUkP-X-L/CBRx_A) (x = 10G, 40G)

The ODUkP-X-L to CBRx adaptation functions perform the adaptation between the ODUkP-X-L (k = 1, 2; X = 4, 16) layer adapted information and the characteristic information of a CBRx signal.

The parameter x defines the bit rate or bit-rate range of the CBR signal. The values x = 10G and 40G are defined for client signals that comply to the SDH bit rates as defined in Table 14-54. Support for other bit rates and bit-rate ranges is for further study.

Table 14-54 – Defined values for x

x	Bit rate	Clock range	Supporting ODUkP-X-L
10G	9 953 280 kbit/s ± 20 ppm	9 953 280 kHz ± 20 ppm	ODU1P-4-L
40G	39 813 120 kbit/s ± 20 ppm	39 813 120 kHz ± 20 ppm	ODU1P-16-L ODU2P-4-L

Two different source functions are defined. The ODUkP-X-L/CBRx-a_A_So provides asynchronous mapping, while the ODUkP-X-L/CBRx-b_A_So provides bit synchronous mapping. In the sink direction the ODUkP-X-L/CBRx_A_Sk can handle both (bit synchronous and asynchronous) mappings.

NOTE – The ODUkP-X-L/CBRx_A functions require that the LCAS functionality is disabled, as a fixed number of virtual concatenated ODUs is required for the transport of the client signal.

14.6.2.1.1 ODUkP-X-L to CBRx asynchronous mapping adaptation source function (ODUkP-X-L/CBRx-a_A_So) (x = 10G, 40G)

The ODUkP-X-L/CBRx-a_A_So function creates the ODUk signal from a free-running clock. It asynchronously maps the $X \times 4^{(k-1)} \times 2\,488\,320$ kbit/s constant bit rate client signal from the CBRx_CP into the payload of the OPUk-Xv (k = 1, 2; X = 4, 16) and adds OPUk-Xv overhead (RES, vcPT, JC).

The information flow and processing of the ODUkP-X-L/CBRx-a_A_So function is defined with reference to Figures 14-101 and 14-102.

Symbol

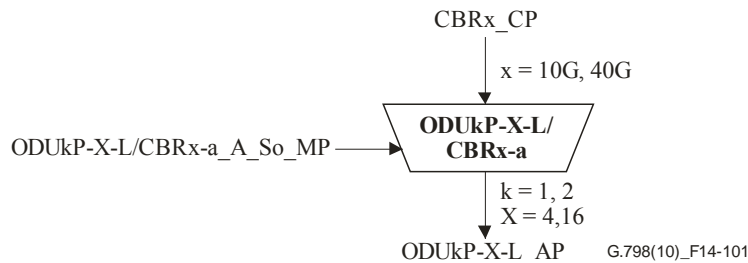

Figure 14-101 – ODUkP-X-L/CBRx-a_A_So function

Interfaces

Table 14-55 – ODUkP-X-L/CBRx-a_A_So inputs and outputs

Input(s)	Output(s)
CBRx_CP: CBRx_CI_CK CBRx_CI_D ODUkP-X-L/CBRx-a_A_So_MP: ODUkP-X-L/CBRx-a_A_So_MI_Active	ODUkP-X-L_AP: ODUkP-X-L_AI_CK ODUkP-X-L_AI_D ODUkP-X-L_AI_FS ODUkP-X-L_AI_MFS

Processes

Activation

- The ODUkP-X-L/CBRx-a_A_So function shall access the access point when it is activated (MI_Active is true). Otherwise, it shall not access the access point.

Clock and (multi)frame start signal generation: The function shall generate a local ODUk-X-L clock (ODUkP-X-L_AI_CK) of " $X \times 239 / (239 - k) \times 4^{(k-1)} \times 2\,488\,320 \text{ kHz} \pm 20 \text{ ppm}$ " from a free-running oscillator. The clock parameters, including jitter and wander requirements, as defined in Annex A of [ITU-T G.8251] (ODCa clock), apply.

The function shall generate the (multi)frame start reference signals AI_FS and AI_MFS for the ODUk-X-L signal. The AI_FS signal shall be active once per $X \times 122\,368$ clock cycles. AI_MFS shall be active once every 256 frames.

Mapping, frequency justification and bit-rate adaptation: The function shall provide an elastic store (buffer) process. The data signal CBRx_CI shall be written into the buffer under control of the associated input clock. The data shall be read out of the buffer and written onto the D and N/PJO bytes in the OPUk-Xv frame under control of the ODUk-X-L clock and justification decisions as defined in clause 18.2.1 of [ITU-T G.709] for OPUk-4v and in clause 18.2.2 of [ITU-T G.709] for OPUk-16v.

A justification decision shall be performed each row for OPUk-4v and four times per row for OPUk-16v. Each justification decision results in a corresponding positive, negative or no justification action. Upon a positive justification action, the reading of one data byte out of the buffer shall be cancelled once. No CBRx data shall be written onto the PJO and NJO bytes. Upon a negative justification action, one extra data byte shall be read once out of the buffer. CBRx data shall be written onto the PJO and NJO bytes. If neither a positive nor a negative justification action is to be performed, CBRx data shall be written onto the PJO byte and no CBRx data shall be written onto the NJO byte.

The justification decisions determine the phase error introduced by the function.

Buffer size: In the presence of jitter as specified by [ITU-T G.825] and a frequency within the range $4^{(k-1)} \times 2\,488\,320 \text{ kHz} \pm 20 \text{ ppm}$, this mapping process shall not introduce any errors. The maximum buffer hysteresis, and therefore the maximum phase error introduced, shall be as listed in Table 14-56.

Table 14-56 – Maximum buffer hysteresis

Mapping	Maximum buffer hysteresis
10G → ODU1-4v	8 bytes
40G → ODU2-4v, ODU1-16v	32 bytes

JC bits: The function shall generate the justification control (JC) bits based on the justification decision performed in the current frame according to the specification in clause 18.2.1 of [ITU-T G.709] for OPUk-4v and in clause 18.2.2 of [ITU-T G.709] for OPUk-16v. It shall insert the justification control bits in the appropriate JC bit positions in the JC bytes of the current frame.

vcPT: The function shall insert code "0000 0010" into the vcPT byte position of the PSI overhead as defined in clause 18.1.2.2 of [ITU-T G.709].

RES: The function shall insert all-ZEROs into the RES bytes and reserved bits within the JC bytes.

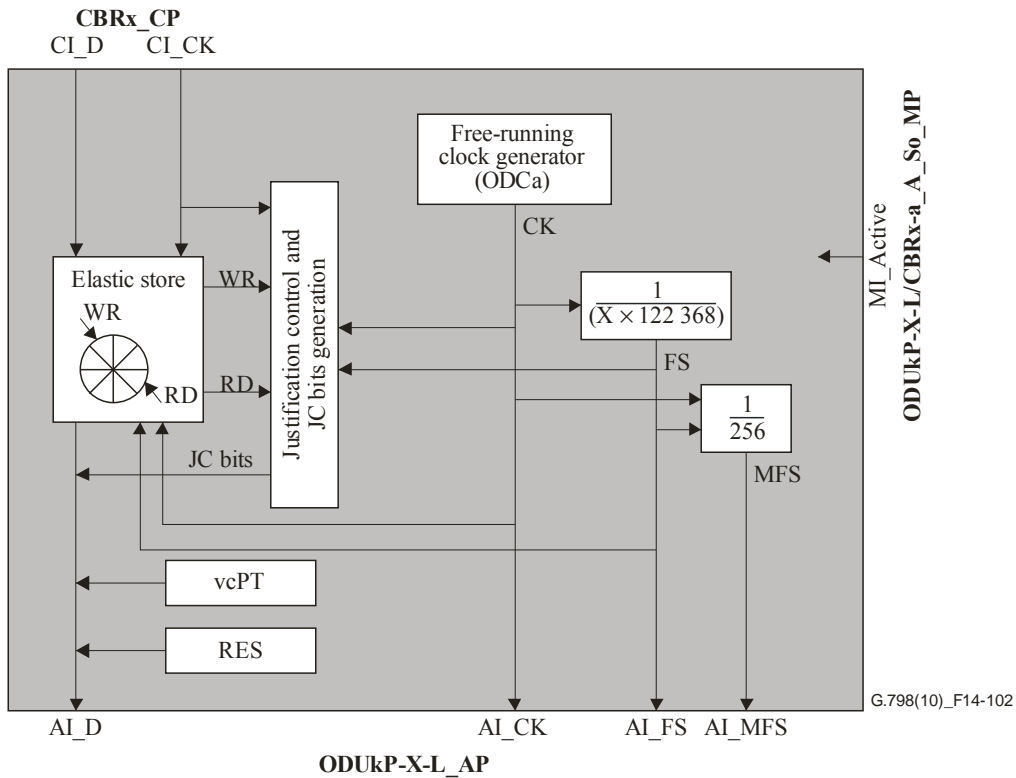

Figure 14-102 – ODUkP-X-L/CDRx-a_A_So processes

Defects: None.

Consequent actions: None.

Defect correlations: None.

Performance monitoring: None.

14.6.2.1.2 ODUkP-X-L to CDRx bit synchronous mapping adaptation source function (ODUkP-X-L/CDRx-b_A_So) (x = 10G, 40G)

The ODUkP-X-L/CDRx-b_A_So function creates the ODUk signal from a clock, derived from the incoming CDRx_CI clock. It bit synchronously maps the $X \times 4^{(k-1)} \times 2\,488\,320$ kbit/s ± 20 ppm constant bit-rate client signal from the CDRx_CP into the payload of the OPUk-Xv (k = 1, 2; X = 4, 16) and adds OPUk-Xv overhead (vcPT, JC, RES).

The information flow and processing of the ODUkP-X-L/CDRx-b_A_So function is defined with reference to Figures 14-103 and 14-104.

Symbol

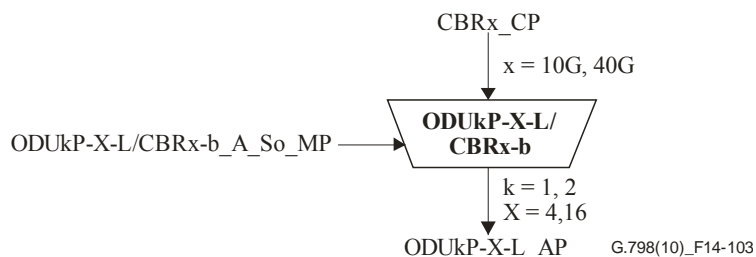

Figure 14-103 – ODUkP-X-L/CDRx-b_A_So function

Interfaces

Table 14-57 – ODUkP-X-L/CBRx-b_A_So inputs and outputs

Input(s)	Output(s)
CBRx_CP: CBRx_CI_CK CBRx_CI_D ODUkP-X-L/CBRx-b_A_So_MP: ODUkP-X-L/CBRx-b_A_So_MI_Active	ODUkP-X-L_AP: ODUkP-X-L_AI_CK ODUkP-X-L_AI_D ODUkP-X-L_AI_FS ODUkP-X-L_AI_MFS

Processes

Activation

- The ODUkP-X-L/CBRx-b_A_So function shall access the access point when it is activated (MI_Active is true). Otherwise, it shall not access the access point.

Clock and (multi)frame start signal generation: The function shall generate the ODUk-X-L (AI_CK) clock by multiplying the incoming CBRx clock (CI_CK) by a factor of $239/(239 - k)$. The clock parameters, including jitter and wander requirements, as defined in Annex A of [ITU-T G.8251] (ODCb clock), apply.

NOTE 1 – The ODUkP-X-L clock is " $X \times 239/(239 - k) \times 4^{(k-1)} \times 2\,488\,320\text{ kHz} \pm 20\text{ ppm}$ ".

NOTE 2 – The incoming CBRx CK (CI_CK) signal has to be within the range of $X \times 4^{(k-1)} \times 2\,488\,320\text{ kHz} \pm 20\text{ ppm}$.

During failure conditions of the incoming CBR clock signal (CI_CK), the ODUk-X-L clock shall stay within its limits as defined in [ITU-T G.8251] and no frame phase discontinuity shall be introduced.

The function shall generate the (multi)frame start reference signals AI_FS and AI_MFS for the ODUk-X-L signal. The AI_FS signal shall be active once per $X \times 122\,368$ clock cycles. AI_MFS shall be active once every 256 frames.

Mapping, frequency justification and bit-rate adaptation: The function shall provide an elastic store (buffer) process. The data signal CBRx_CI shall be written into the buffer under control of the associated input clock. The data shall be read out of the buffer and written onto the D and PJO bytes in the OPUk-Xv frame under control of the ODUk-X-L clock as defined in clause 18.2.1 of [ITU-T G.709] for OPUk-4v and in clause 18.2.2 of [ITU-T G.709] for OPUk-16v.

Neither negative nor positive justification is to be performed. No data shall be written onto the NJO byte and data shall always be written onto the PJO byte.

Buffer size: In the presence of jitter as specified by [ITU-T G.825] and a frequency within the range $X \times 4^{(k-1)} \times 2\,488\,320\text{ kHz} \pm 20\text{ ppm}$, this mapping process shall not introduce any errors.

Following a step in frequency of the $X \times 4^{(k-1)} \times 2\,488\,320\text{ kbit/s}$ CI_CK signal (for example, due to the removal of AIS (generic AIS)), there will be a maximum recovery time of Y seconds after which this process shall not generate any bit errors. The value of Y is for further study; a value of one second has been proposed.

JC bits: The function shall generate the fixed justification control (JC) bits "00" according to clause 18.2.1 of [ITU-T G.709] for OPUk-4v and clause 18.2.2 of [ITU-T G.709] for OPUk-16v. It shall insert the justification control bits in the appropriate JC bit positions in the JC bytes.

RES: The function shall insert all-ZEROs into the RES bytes and reserved bits within the JC bytes.

vcPT: The function shall insert code "0000 0010" into the vcPT byte position of the PSI overhead as defined in clause 18.1.2.2 of [ITU-T G.709].

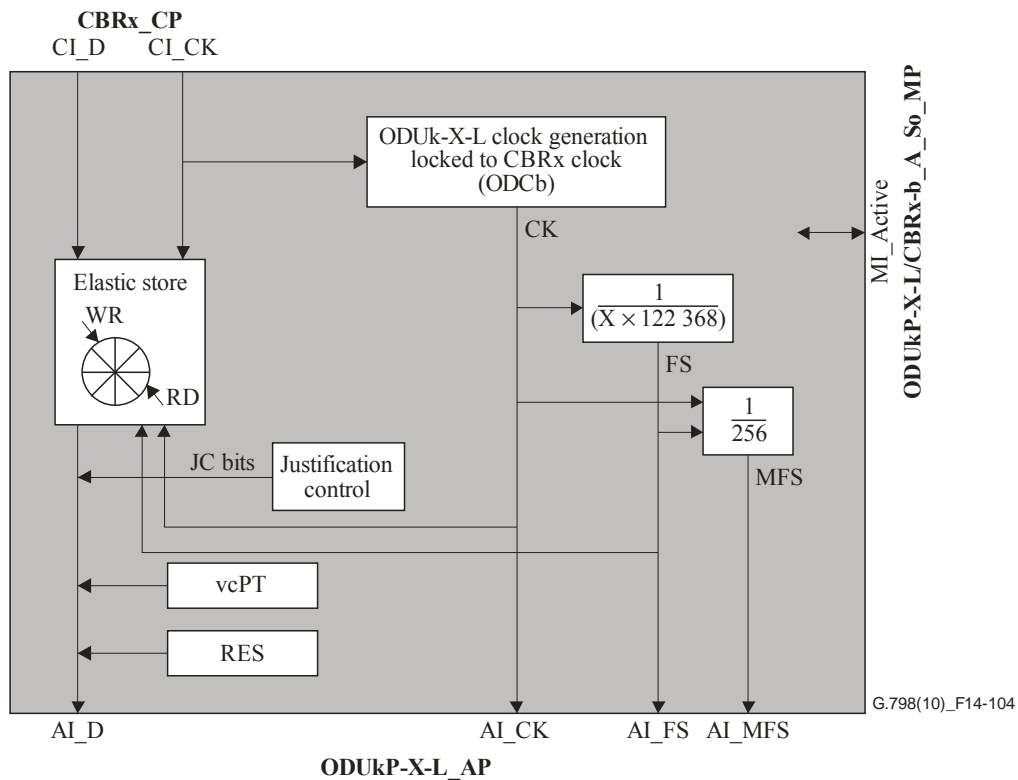

Figure 14-104 – ODUkP-X-L/CDRx-b_A_So processes

Defects: None.

Consequent actions: None.

Defect correlations: None.

Performance monitoring: None.

14.6.2.1.3 ODUkP-X-L to CDRx adaptation sink function (ODUkP-X-L/CDRx_A_Sk) (x = 10G, 40G)

The ODUkP-X-L/CDRx_A_Sk recovers the $X \times 4^{(k-1)} \times 2\,488\,320$ kbit/s ± 20 ppm constant bit-rate client signal from the OPUk-Xv payload using the justification control information (JC overhead) to determine if a data or stuff byte is present within the NJO and PJO bytes. It extracts the OPUk-Xv overhead (vcPT, JC, RES) and monitors the reception of the correct virtual concatenation payload type. Under signal fail condition, generic-AIS shall be generated.

The information flow and processing of the ODUkP-X-L/CDRx_A_Sk function is defined with reference to Figures 14-105 and 14-106.

Symbol

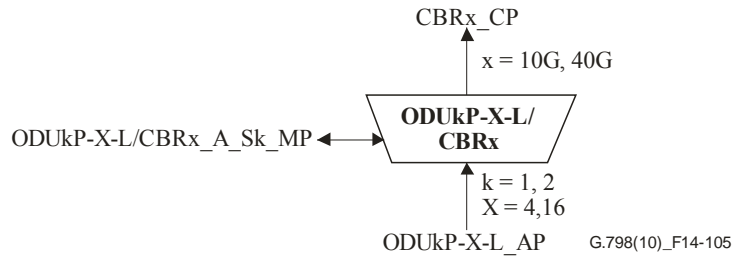

Figure 14-105 – ODUkP-X-L/ CBRx_A_Sk function

Interfaces

Table 14-58 – ODUkP-X-L/ CBRx_A_Sk inputs and outputs

Input(s)	Output(s)
ODUkP-X-L_AP: ODUkP-X-L_AI_CK ODUkP-X-L_AI_D ODUkP-X-L_AI_FS ODUkP-X-L_AI_MFS ODUkP-X-L_AI_TSF ODUkP-X-L/ CBRx_A_Sk_MP: ODUkP-X-L/ CBRx_A_Sk_MI_Active	CBRx_CP: CBRx_CI_CK CBRx_CI_D CBRx_CI_SSF ODUkP-X-L/ CBRx_A_Sk_MP: ODUkP-X-L/ CBRx_A_Sk_MI_cVcPLM ODUkP-X-L/ CBRx_A_Sk_MI_AcVcPT

Processes

Activation

- The ODUkP-X-L/ CBRx_A_Sk function shall access the access point and perform the common and specific processes operation specified below when it is activated (MI_Active is true). Otherwise, it shall activate the SSF signals and generate generic AIS at its output (CP) and not report its status via the management point.

vcPT: The function shall extract the vcPT byte from the PSI overhead as defined in clause 8.7.3. The accepted vcPT value is available at the MP (MI_AcVcPT) and is used for VcPLM defect detection.

RES: The value in the RES bytes shall be ignored.

JC: The function shall interpret the justification control information in the JC byte as defined in clause 18.2.1 of [ITU-T G.709] for OPUk-4v and in clause 18.2.2 of [ITU-T G.709] for OPUk-16v in order to determine the justification action (positive, negative, none) for the current frame. RES bits in the JC shall be ignored.

Demapping, CBR clock generation: The function shall provide an elastic store (buffer) process. The CBR data shall be written into the buffer from the D, PJO and NJO bytes in the OPUk-X-L frame. The information extraction of the PJO and NJO bytes shall be under control of the justification control information. The CBRx data (CI_D) shall be read out of the buffer under control of the CBRx clock (CI_CK).

Upon a positive justification action, the writing of one data byte into the buffer shall be cancelled once. No CBRx data shall be read from the PJO and NJO bytes. Upon a negative justification action, one extra data byte shall be written into the buffer once. CBRx data shall be read from the PJO and NJO bytes. If neither a positive nor a negative justification action is to be performed, CBRx data shall be read from the PJO byte and no CBRx data shall be read from the NJO byte.

Smoothing and jitter limiting process: The function shall provide for a clock smoothing and elastic store (buffer) process. The $X \times 4^{(k-1)} \times 2\,488\,320$ kbit/s ($k = 1, 2$) data signal shall be written into the buffer under control of the associated (gapped) input clock (with a frequency accuracy within ± 20 ppm). The data signal shall be read out of the buffer under control of a smoothed (equally spaced) $X \times 4^{(k-1)} \times 2\,488\,320 \pm 20$ ppm clock (the rate is determined by the 10 Gbit/s, 40 Gbit/s signal at the input of the remote ODUkP-X-L/CBRx_A_So).

The clock parameters, including jitter and wander requirements, as defined in Annex A of [ITU-T G.8251] (ODCp clock), apply.

Buffer size: In the presence of jitter as specified by [ITU-T G.825] and a frequency within the range $X \times 4^{(k-1)} \times 2\,488\,320 \pm 20$ ppm, this justification process shall not introduce any errors.

Following a step in frequency of the $X \times 4^{(k-1)} \times 2\,488\,320$ kbit/s signal transported by the ODUkP-X-L_AI (for example, due to reception of CBRx_CI from a new RSn_TT_So at the far end or removal of generic-AIS signal with a frequency offset), there will be a maximum recovery time of Y seconds after which this process shall not generate any bit errors. The value of Y is for further study; a value of one second has been proposed.

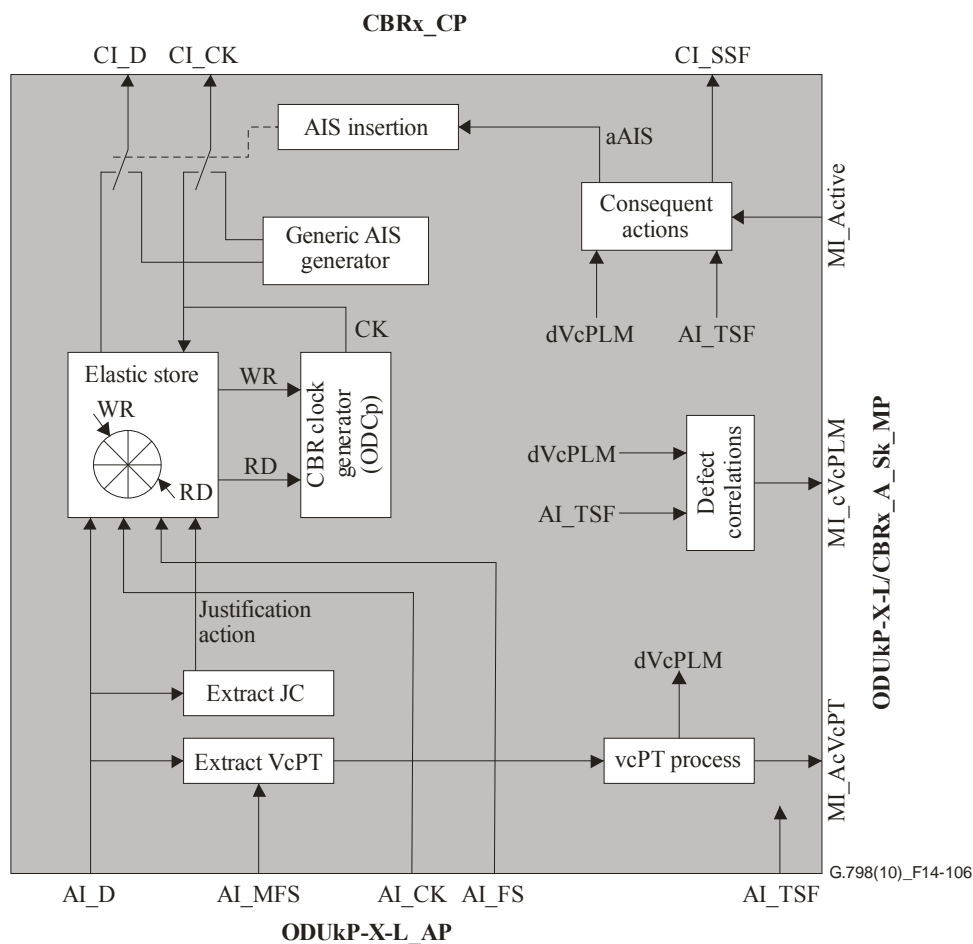

Figure 14-106 – ODUkP-X-L/CBRx_A_Sk processes

Defects

The function shall detect for dVcPLM.

dVcPLM: See clause 6.2.4.2. The expected payload types are "0000 0010" (asynchronous CBRx mapping) and "0000 0011" (bit synchronous CBRx mapping) as defined in [ITU-T G.709].

Consequent actions

aSSF ← AI_TSF or dVcPLM or (not MI_Active)

aAIS ← AI_TSF or dVcPLM or (not MI_Active)

On declaration of aAIS, the function shall output a GenericAIS pattern/signal as defined in clause 16.6 of [ITU-T G.709] within two frames. On clearing of aAIS, the GenericAIS pattern/signal shall be removed within two frames, with normal data being output. The GenericAIS clock start shall be independent from the incoming clock. The GenericAIS clock has to be within $X \times 4^{(k-1)} \times 2\,488\,320 \text{ kHz} \pm 20 \text{ ppm}$. Jitter and wander requirements, as defined in Annex A of [ITU-T G.8251] (ODCp clock), apply.

Defect correlations

cVcPLM ← dVcPLM and (not AI_TSF)

Performance monitoring: None.

14.6.2.2 ODUkP-X-L to RSn adaptation function (ODUkP-X-L/RSn_A)

The ODUkP-X-L to RSn adaptation functions perform the adaptation between the ODUkP-X-L ($k = 1, 2$; $L = 4, 16$) layer adapted information and the characteristic information of a RSn signal ($n = 64, 256$). Table 14-59 shows by which ODUkP-X-L signals the RSn signals are supported.

Table 14-59 – Defined values for x

RSn	STM-N signal	Bit rate	Supporting ODUkP-X-L
RS64	STM-64	9 953 280 kbit/s \pm 20 ppm	ODU1P-4-L
RS256	STM-256	39 813 120 kbit/s \pm 20 ppm	ODU1P-16-L ODU2P-4-L

Two different source functions are defined. The ODUkP-X-L/RSn-a_A_So provides asynchronous mapping, while the ODUkP-X-L/RSn-b_A_So provides bit synchronous mapping. In the sink direction, the ODUkP-X-L/RSn_A_Sk can handle both (bit synchronous and asynchronous) mappings.

NOTE 1 – The source functions are identical to the ODUkP-X-L/CBRx adaptation source functions, except for the different CI at the CP (CBRx_CI replaced by RSn_CI). In the sink direction, the function provides framing on the SDH signal and GenericAIS supervision. In the ODUkP/CBR_A_Sk function, no such functionality is available.

NOTE 2 – The ODUkP-X-L/RSn_A functions are only intended to be used together with RSn_TT functions (see [ITU-T G.783]). The direct interconnection of ODUkP-X-L/RSn_A functions with any other (server layer)/RS_A functions at the RSn_CP is not intended. The ODUkP-X-L/RSn functions are only used if further SDH processing is performed (e.g., RS termination). For example, Figure I.1 shows the ODUk/RSn_A_Sk together with a RS_TT_Sk for non-intrusive monitoring, and Figure I.4 shows the use of the ODUkP/RSn_A functions at OTN interfaces on SDH equipment. For transparent mapping of constant bit rate signals, the ODUkP[X-L]/CBRx_A functions shall be used as shown in Figure I.1.

14.6.2.2.1 ODUkP-X-L to RSn asynchronous mapping adaptation source function (ODUkP-X-L/RSn-a_A_So)

The ODUkP-X-L/RSn-a_A_So function creates the ODUk-X-L signal from a free-running clock. It asynchronously maps the STM-N ($N = 4^{(k+1)}$) client signal from the RSn_CP into the payload of the OPUk-Xv ($k = 1, 2$; $X = 4, 16$) and adds OPUk-Xv overhead (RES, vcPT, JC).

The information flow and processing of the ODUkP-X-L/RSn-a_A_So function is defined with reference to Figures 14-107 and 14-108.

Symbol

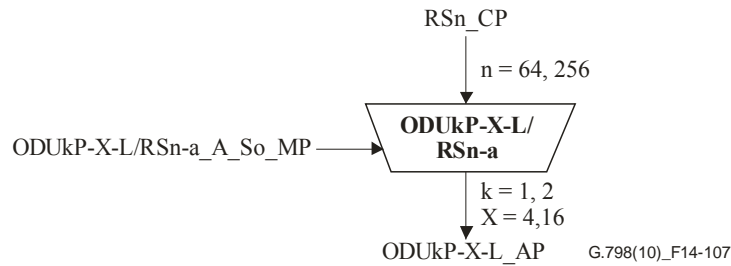

Figure 14-107 – ODUkP-X-L/RSn-a_A_So function

Interfaces

Table 14-60 – ODUkP-X-L/RSn-a_A_So inputs and outputs

Input(s)	Output(s)
RSn_CP: RSn_CI_CK RSn_CI_D ODUkP-X-L/RSn-a_A_So_MP: ODUkP-X-L/RSn-a_A_So_MI_Active	ODUkP-X-L_AP: ODUkP-X-L_AI_CK ODUkP-X-L_AI_D ODUkP-X-L_AI_FS ODUkP-X-L_AI_MFS

Processes

Activation:

- The ODUkP-X-L/RSn-a_A_So function shall access the access point when it is activated (MI_Active is true). Otherwise, it shall not access the access point.

Clock and (multi)frame start signal generation: The function shall generate a local ODUk-X-L clock (ODUkP-X-L_AI_CK) of " $X \times 239 / (239 - k) \times 4^{(k-1)} \times 2\,488\,320$ kHz \pm 20 ppm" from a free-running oscillator. The clock parameters, including jitter and wander requirements, as defined in Annex A of [ITU-T G.8251] (ODCa clock), apply.

The function shall generate the (multi)frame start reference signals AI_FS and AI_MFS for the ODUk-X-L signal. The AI_FS signal shall be active once per $X \times 122\,368$ clock cycles. AI_MFS shall be active once every 256 frames.

Mapping, frequency justification and bit-rate adaptation: The function shall provide an elastic store (buffer) process. The data signal RSn_CI shall be written into the buffer under control of the associated input clock. The data shall be read out of the buffer and written onto the D and N/PJO bytes in the OPUk-Xv frame under control of the ODUk-X-L clock and justification decisions as defined in clause 18.2.1 of [ITU-T G.709] for OPUk-4v and in clause 18.2.2 of [ITU-T G.709] for OPUk-16v.

A justification decision shall be performed each frame. Each justification decision results in a corresponding positive, negative or no justification action. Upon a positive justification action, the reading of one data byte out of the buffer shall be cancelled once. No RSn data shall be written onto the PJO and NJO bytes. Upon a negative justification action, one extra data byte shall be read once out of the buffer. RSn data shall be written onto the PJO and NJO bytes. If neither a positive nor a negative justification action is to be performed, RSn data shall be written onto the PJO byte and no RSn data shall be written onto the NJO byte.

The justification decisions determine the phase error introduced by the function.

Buffer size: In the presence of jitter as specified by [ITU-T G.825] and a frequency within the range $X \times 4^{(k-1)} \times 2\,488\,320\text{ kHz} \pm 20\text{ ppm}$, this mapping process shall not introduce any errors. The maximum buffer hysteresis, and therefore the maximum phase error introduced, shall be as listed in Table 14-56.

JC bits: The function shall generate the justification control (JC) bits based on the justification decision performed in the current frame according to the specification in clause 18.2.1 of [ITU-T G.709] for OPUk-4v and in clause 18.2.2 of [ITU-T G.709] for OPUk-16v. It shall insert the justification control bits in the appropriate JC bit positions in the JC bytes of the current frame.

vcPT: The function shall insert code "0000 0010" into the vcPT byte position of the PSI overhead as defined in clause 18.1.2.2 of [ITU-T G.709].

RES: The function shall insert all-ZEROs into the RES bytes and reserved bits within the JC bytes.

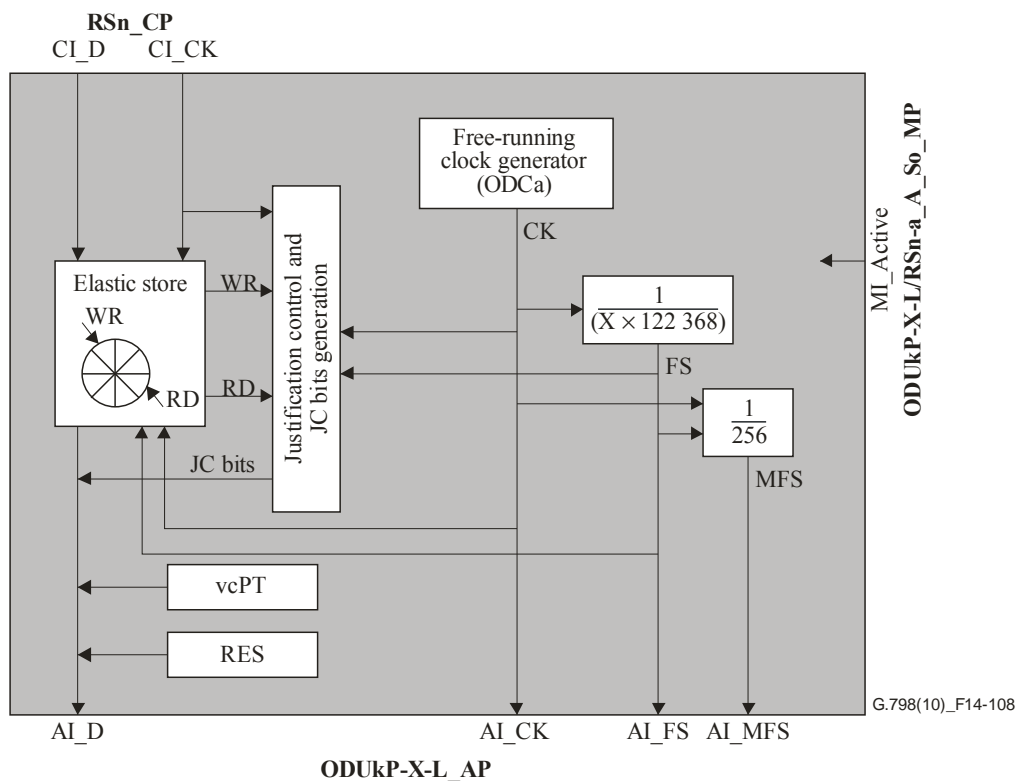

Figure 14-108 – ODUkP-X-L/Rsn-a_A_So processes

Defects: None.

Consequent actions: None.

Defect correlations: None.

Performance monitoring: None.

14.6.2.2.2 ODUkP-X-L to RSn bit synchronous mapping adaptation source function (ODUkP-X-L/Rsn-b_A_So)

The ODUkP-X-L/Rsn-b_A_So function creates the ODUk-X-L signal from a clock, derived from the incoming RSn_CI clock. It bit synchronously maps the STM-N ($N = 4^{(k+1)}$) client signal from the RSn_CP into the payload of the OPUk-Xv and adds OPUk-Xv overhead (vcPT, JC, RES).

The information flow and processing of the ODUkP-X-L/Rsn-b_A_So function is defined with reference to Figures 14-109 and 14-110.

Symbol

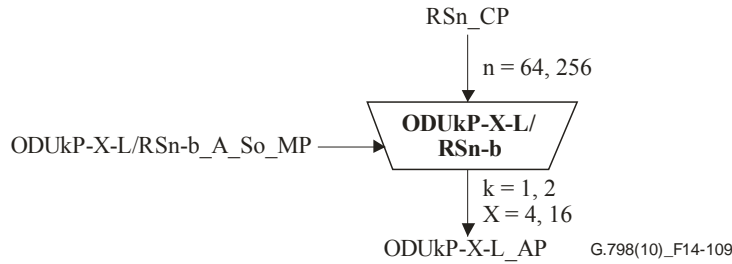

Figure 14-109 – ODUkP-X-L/RSn-b_A_So function

Interfaces

Table 14-61 – ODUkP-X-L/RSn-b_A_So inputs and outputs

Input(s)	Output(s)
RSn_CP: RSn_CI_CK RSn_CI_D ODUkP-X-L/RSn-b_A_So_MP: ODUkP-X-L/RSn-b_A_So_MI_Active	ODUkP-X-L_AP: ODUkP-X-L_AI_CK ODUkP-X-L_AI_D ODUkP-X-L_AI_FS ODUkP-X-L_AI_MFS

Processes

Activation

- The ODUkP-X-L/RSn-b_A_So function shall access the access point when it is activated (MI_Active is true). Otherwise, it shall not access the access point.

Clock and (multi)frame start signal generation: The function shall generate the ODUk-X-L (AI_CK) clock by multiplying the incoming RSn clock (CI_CK) by a factor of $239/(239 - k)$. The clock parameters, including jitter and wander requirements, as defined in Annex A of [ITU-T G.8251] (ODCb clock), apply.

NOTE 1 – The ODUk-X-L clock is " $X \times 239/(239 - k) \times 4^{(k-1)} \times 2\,488\,320\text{ kHz} \pm 20\text{ ppm}$ ".

NOTE 2 – The incoming RSn CK (CI_CK) signal has to be within the range of $X \times 4^{(k-1)} \times 2\,488\,320\text{ kHz} \pm 20\text{ ppm}$.

During failure conditions of the incoming RS clock signal (CI_CK), the ODUk-X-L clock shall stay within its limits as defined in [ITU-T G.8251] and no frame phase discontinuity shall be introduced.

The function shall generate the (multi)frame start reference signals AI_FS and AI_MFS for the ODUk-X-L signal. The AI_FS signal shall be active once per $X \times 122\,368$ clock cycles. AI_MFS shall be active once every 256 frames.

Mapping, frequency justification and bit-rate adaptation: The function shall provide an elastic store (buffer) process. The data signal RSn_CI shall be written into the buffer under control of the associated input clock. The data shall be read out of the buffer and written onto the D and PJO bytes in the OPUk-Xv frame under control of the ODUk-X-L clock as defined in clause 18.2.1 of [ITU-T G.709] for OPUk-4v and in clause 18.2.2 of [ITU-T G.709] for OPUk-16v.

Neither negative nor positive justification is to be performed. No data shall be written onto the NJO byte and data shall always be written onto the PJO byte.

Buffer size: In the presence of jitter as specified by [ITU-T G.825] and a frequency within the range $X \times 4^{(k-1)} \times 2\,488\,320\text{ kHz} \pm 20\text{ ppm}$, this mapping process shall not introduce any errors.

Following a step in frequency of the $X \times 4^{(k-1)} \times 2\,488\,320$ kbit/s CI_CK signal (for example, due to the removal of AIS (RS-AIS)), there will be a maximum recovery time of Y seconds after which this process shall not generate any bit errors. The value of Y is for further study; a value of one second has been proposed.

JC bits: The function shall generate the fixed justification control (JC) bits "00" according to clause 18.2.1 of [ITU-T G.709] for OPUk-4v and clause 18.2.2 of [ITU-T G.709] for OPUk-16v. It shall insert the justification control bits in the appropriate JC bit positions in the JC bytes.

RES: The function shall insert all-ZEROs into the RES bytes and reserved bits within the JC bytes.

vcPT: The function shall insert code "0000 0010" into the vcPT byte position of the PSI overhead as defined in clause 18.1.2.2 of [ITU-T G.709].

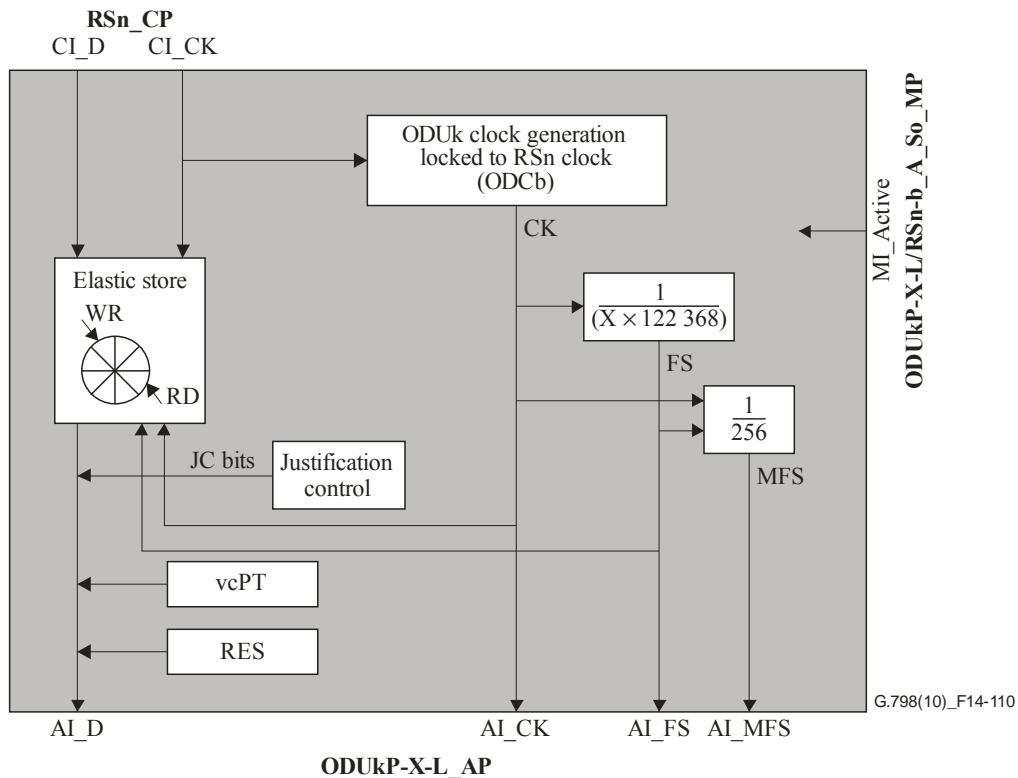

Figure 14-110 – ODUkP-X-L/RSn-b_A_So processes

Defects: None.

Consequent actions: None.

Defect correlations: None.

Performance monitoring: None.

14.6.2.2.3 ODUkP-X-L to RSn adaptation sink function (ODUkP-X-L/RSn_A_Sk)

The ODUkP-X-L/RSn_A_Sk recovers the STM-N ($N = 4^{(k+1)}$) client signal from the OPUk-Xv payload using the justification control information (JC overhead) to determine if a data or stuff byte is present within the NJO and PJO bytes. It extracts the OPUk-Xv overhead (vcPT, JC, RES) and monitors the reception of the correct payload type. It detects GenericAIS and recovers the frame start of the STM-N signal. Under signal fail condition, a logical all-ONES (AIS) signal shall be generated.

The information flow and processing of the ODUkP-X-L/RSn_A_Sk function is defined with reference to Figures 14-111 and 14-112.

Symbol

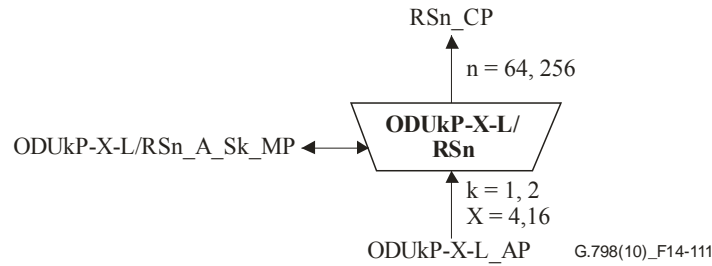

Figure 14-111 – ODUkP-X-L/RSn_A_Sk function

Interfaces

Table 14-62 – ODUkP-X-L/RSn_A_Sk inputs and outputs

Input(s)	Output(s)
ODUkP-X-L_AP: ODUkP-X-L_AI_CK ODUkP-X-L_AI_D ODUkP-X-L_AI_FS ODUkP-X-L_AI_MFS ODUkP-X-L_AI_TSF ODUkP-X-L/RSn_A_Sk_MP: ODUkP-X-L/RSn_A_Sk_MI_Active	RSn_CP: RSn_CI_CK RSn_CI_D RSn_CI_FS RSn_CI_SSF ODUkP-X-L/RSn_A_Sk_MP: ODUkP-X-L/RSn_A_Sk_MI_cVcPLM ODUkP-X-L/RSn_A_Sk_MI_AcVcPT ODUkP-X-L/RSn_A_Sk_MI_cLOF

Processes

Activation

- The ODUkP-X-L/RSn_A_Sk function shall access the access point and perform the common and specific processes operation specified below when it is activated (MI_Active is true). Otherwise, it shall activate the SSF signals and generate AIS at its output (CP) and not report its status via the management point.

vcPT: The function shall extract the vcPT byte from the PSI overhead as defined in clause 8.7.3. The accepted vcPT value is available at the MP (MI_AcVcPT) and is used for VcPLM defect detection.

RES: The value in the RES bytes shall be ignored.

JC: The function shall interpret the justification control information in the JC byte as defined in clause 18.2.1 of [ITU-T G.709] for OPUk-4v and in clause 18.2.2 of [ITU-T G.709] for OPUk-16v in order to determine the justification action (positive, negative, none) for the current frame. RES bits in the JC shall be ignored.

Demapping, CBR clock generation: The function shall provide an elastic store (buffer) process. The CBR data shall be written into the buffer from the D, PJO and NJO bytes in the OPUk frame. The information extraction of the PJO and NJO bytes shall be under control of the justification control information. The RSn data (CI_D) shall be read out of the buffer under control of the RSn clock (CI_CK).

Upon a positive justification action, the writing of one data byte into the buffer shall be cancelled once. No RSn data shall be read from the PJO and NJO bytes. Upon a negative justification action, one extra data byte shall be written into the buffer once. RSn data shall be read from the PJO and NJO bytes. If neither a positive nor a negative justification action is to be performed, RSn data shall be read from the PJO byte and no RSn data shall be read from the NJO byte.

Smoothing and jitter limiting process: The function shall provide for a clock smoothing and elastic store (buffer) process. The $X \times 4^{(k-1)} \times 2\,488\,320$ kbit/s ($k = 1, 2$) data signal shall be written into the buffer under control of the associated (gapped) input clock (with a frequency accuracy within ± 20 ppm). The data signal shall be read out of the buffer under control of a smoothed (equally spaced) $X \times 4^{(k-1)} \times 2\,488\,320$ kbit/s ± 20 ppm clock (the rate is determined by the 10 Gbit/s, 40 Gbit/s signal at the input of the remote ODUkP-X-L/RSn_A_So).

The clock parameters, including jitter and wander requirements, as defined in Annex A of [ITU-T G.8251] (ODCp clock), apply.

Buffer size: In the presence of jitter as specified by [UIT-T G.825] and a frequency within the range $X \times 4^{(k-1)} \times 2\,488\,320$ kbit/s ± 20 ppm, this justification process shall not introduce any errors.

Following a step in frequency of the $X \times 4^{(k-1)} \times 2\,488\,320$ kbit/s signal transported by the ODUkP-X-L_AI (for example, due to reception of RSn_CI from a new RSn_TT_So at the far end or removal of generic-AIS signal with a frequency offset), there will be a maximum recovery time of Y seconds after which this process shall not generate any bit errors. The value of Y is for further study; a value of one second has been proposed.

Frame alignment: The function shall perform frame alignment on the STM-N frame as described in clause 8.2.1 of [ITU-T G.783].

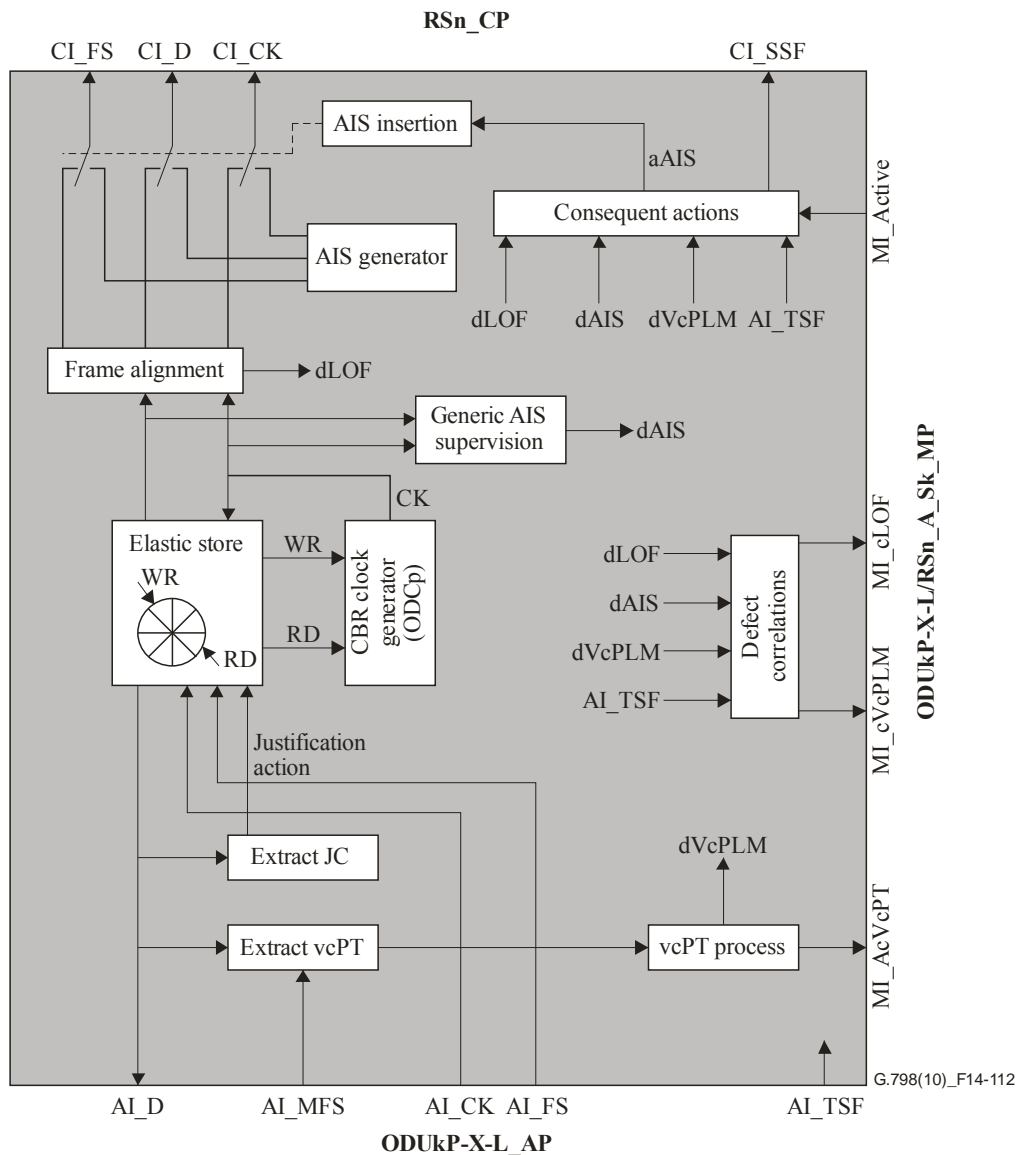

Figure 14-112 – ODUkP-X-L/RSn_A_Sk processes

Defects

The function shall detect for dVcPLM, dAIS and dLOF.

dVcPLM: See clause 6.2.4.2. The expected payload types are "0000 0010" (asynchronous CBRx mapping) and "0000 0011" (bit synchronous CBRx mapping) as defined in [ITU-T G.709].

dAIS: See clause 6.2.6.3.3.

dLOF: See clause 6.2.5.1 of [ITU-T G.783].

Consequent actions

aSSF ← AI_TSF or dVcPLM or dAIS or dLOF or (not MI_Active)

aAIS ← AI_TSF or dVcPLM or dAIS or dLOF or (not MI_Active)

On declaration of aAIS, the function shall output a logical all-ONES (AIS) signal within two STM-N frames. On clearing of aAIS, the logical all-ONES (AIS) signal shall be removed within two STM-N frames, with normal data being output. The AIS clock start shall be independent from the incoming clock. The AIS clock has to be within $X \times 4^{(k-1)} \times 2\,488\,320\text{ kHz} \pm 20\text{ ppm}$. The jitter and wander requirements, as defined in Annex A of [ITU-T G.8251] (ODCp clock), apply.

Defect correlations

cVcPLM ← dVcPLM and (not AI_TSF)

cLOF ← dLOF and (not dAIS) and (not dVcPLM) and (not AI_TSF)

NOTE – dAIS is not reported as fault cause as it is a secondary alarm and will result in aSSF, which is reported as cSSF fault cause in the RSn_TT_Sk that directly follows this function.

Performance monitoring: None.

14.6.2.3 ODUkP-X-L to ATM VP adaptation function (ODUkP-X-L/VP_A)

NOTE – The specification of this adaptation function is derived from equivalent adaptation functions defined in Annex D of [ITU-T I.732].

14.6.2.3.1 ODUkP-X-L to ATM VP adaptation source function (ODUkP-X-L/VP_A_So)

Symbol

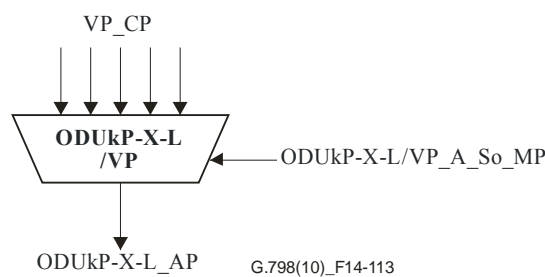

Figure 14-113 – ODUkP-X-L/VP_A_So symbol

Interfaces

Table 14-63 – ODUkP-X-L/VP_A_So input and output signals

Input(s)	Output(s)
<p>per VP_CP, for each VP configured: VP_CI_D VP_CI_ACS VP_CI_SSF</p> <p>ODUkP-X-L_AP: ODUkP-X-L_AI_X_{AT}</p> <p>ODUkP-X-L/VP_A_So_MP: ODUkP-X-L/VP_A_So_MI_Active ODUkP-X-L/VP_A_So_MI_CellDiscardActive ODUkP-X-L/VP_A_So_MI_TPusgActive ODUkP-X-L/VP_A_So_MI_GFCActive ODUkP-X-L/VP_A_So_MI_VPI-KActive</p>	<p>ODUkP-X-L_AP: ODUkP-X-L_AI_CK ODUkP-X-L_AI_D ODUkP-X-L_AI_FS ODUkP-X-L_AI_MFS</p>

Processes

The ODUkP-X-L/VP_A_So function provides adaptation from the ATM virtual path layer to the ODUk-X-L path. This is performed by a grouping of specific processes and common processes as shown in Figure 14-114.

Activation

- The ODUkP-X-L/VP_A_So function shall access the access point when it is activated (MI_Active is true). Otherwise, it shall not access the access point.

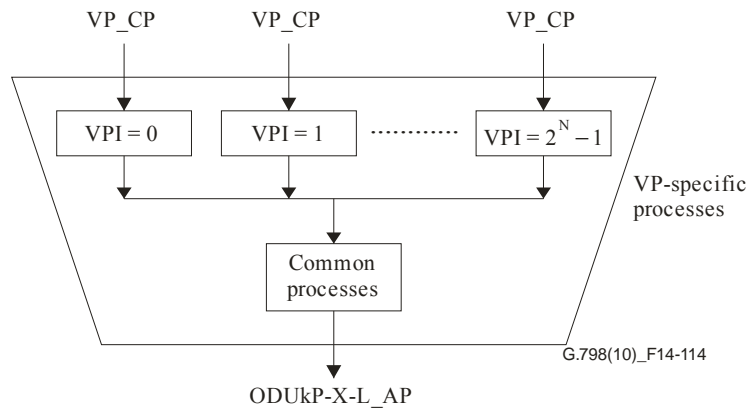

Figure 14-114 – ODUkP-X-L/VP_A So atomic function decomposed into specific and common processes parts

NOTE 1 – The sequential order of the processes within the atomic functions is important. For the correct order, refer to the ordering of the processes given below.

Clock and (multi)frame start signal generation: The function shall generate a local ODUk-X-L clock (ODUkP-X-L_AI_CK) of " $X_{AT} \times 239 / (239 - k) \times 4^{(k-1)} \times 2\,488\,320$ kHz \pm 20 ppm". The jitter and wander requirements, as defined in Annex A of [ITU-T G.8251] (ODCa clock), apply.

The function shall generate the (multi)frame start reference signals ODUkP-X-L_AI_FS and ODUkP-X-L_AI_MFS for the ODUk-X-L signal. The ODUkP-X-L_AI_FS signal shall be active once per $X_{AT} \times 122\,368$ clock cycles. ODUkP-X-L_AI_MFS shall be active once every 256 frames.

NOTE 2 – The size and clock rate of the OPUk-Xv is defined by AI_X_{AT}. In case of a change of X_{AT} the clock rate shall be adjusted immediately. This shall not introduce any loss or errors to the mapped ATM cells except for the case where the incoming ATM cell rate exceeds the available ODUk-Xv payload capacity.

VP-specific processes

These processes include VPI setting as well as VP asynchronous multiplexing. Each of these specific processes is characterized by the virtual path identifier number K, where $0 \leq K \leq 2^N - 1$.

NOTE 3 – The value of N represents the number of bits in the VPI field and is an integer number. Its maximum value is equal to 12 for the ATM NNI. Its maximum value is equal to 8 for the ATM UNI.

VPI-K activation

- Layer management function: The specific processes perform the operation specified below when it is activated (MI_VPI-KActive is true).

The format of the characteristic information (VP_CI) is given in Figure 14-115.

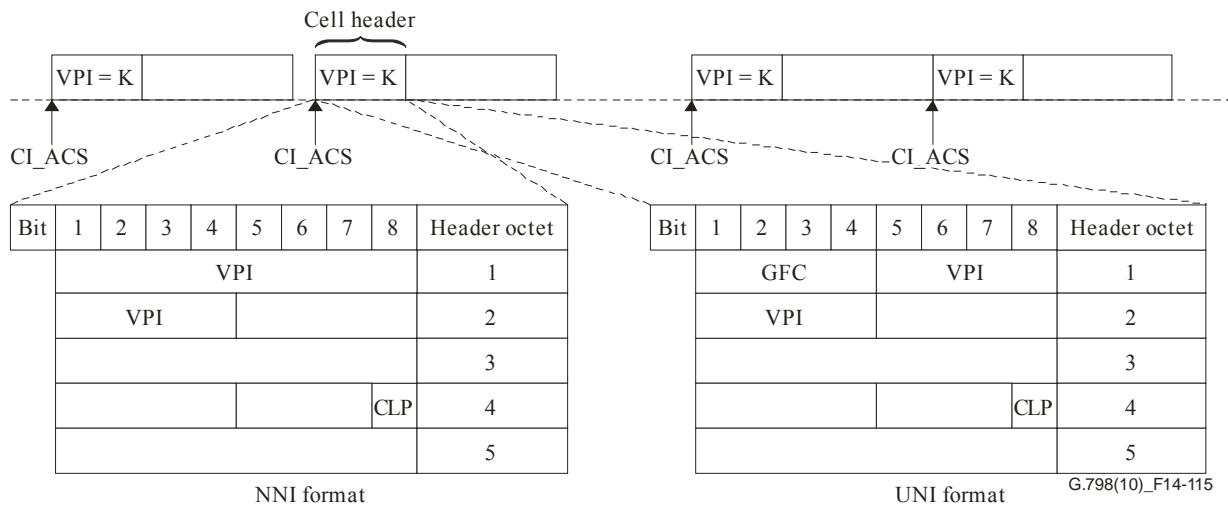

Figure 14-115 – VP_CI (NNI format)

VPI setting

- Transfer function: VPI setting inserts the value of "K" as VPI for each active specific function.
- Layer management function: VPI setting is based on the activation of the specific function by MI_VPI-KActive.

VP multiplexing

- Transfer function: Asynchronous multiplexing is performed for each active specific function.

Common processes

The common processes include: Congestion control (selective cell discard (CLP-based)), GFC processing, TP usage measurement, cell rate decoupling, HEC processing, cell information field scrambling, cell stream mapping and processing of the payload-specific bytes vcPT and RES, to the OPUk OH. The logical ordering of the processes from input to output must be maintained.

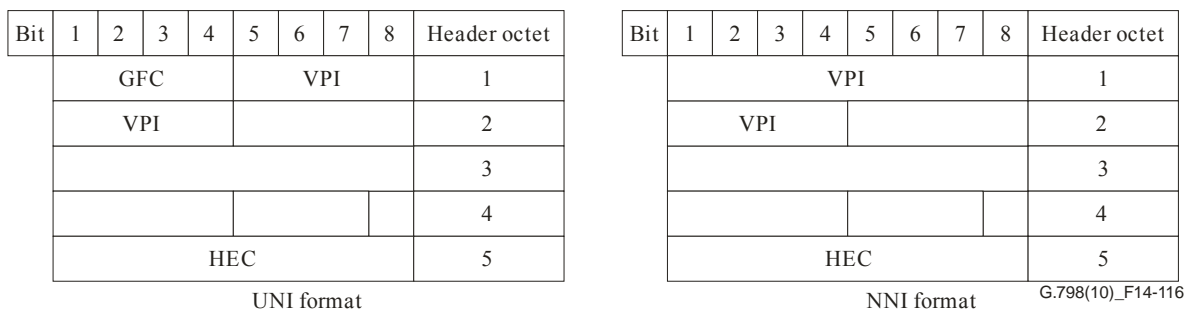

Figure 14-116 – Cell header information processed in ODUkP-X-L/VP_A_So

Congestion control

- Transfer function: If enabled by MI_CellDiscard = Active, this process shall perform selective cell discard according to CLP value. In the event of congestion, cells with CLP = 1 are subject to be discarded prior to cells with CLP = 0. See [ITU-T I.371] for further details about the use of the CLP. In the event of congestion, the EFCI marking in the PTI field is set according to [ITU-T I.361].

GFC processing

- Transfer function: The support of the GFC protocol applies to the UNI and in point-to-point configuration only and is an option. This process sets the GFC field. The GFC field processing is defined in [ITU-T I.150] and [ITU-T I.361].
- Layer management function: The GFC function uses assigned and unassigned cells. Two modes of operation are available: uncontrolled transmission (MI_GFCActive is false) and controlled transmission (MI_GFCActive is true). In uncontrolled transmission mode, neither the controlling nor the controlled NE performs the GFC procedure. If enabled by MI_GFCActive = true, this process shall insert the GFC protocol in the GFC field. If the GFC function is not supported or the GFC function disabled by MI_GFCActive = false, the binary contents of the GFC field shall be set to "0000".

TP usage measurement

- Transfer function: Cell transmission is indicated to layer management.
- Layer management function: The process shall count the transmitted cells for cell measurement purposes. This cell counting shall be activated/deactivated by MI_TPusgActive.

Cell rate decoupling

- Transfer function: This process takes the ATM cell stream present at its input and inserts it into the OPUk-Xv payload having a capacity of $X_{AT} \times 4 \times 3808$ bytes adding fixed stuff idle cells. The idle cells format is specified in [ITU-T I.361]. The cell rate decoupling process makes use of the ODUk-X-L local timing clock, frame position, and idle cell generator.

NOTE 4 – The clock rate and size of the OPUk-Xv is defined by AI_X_{AT}. In case of a change of X_{AT} the size shall be adjusted immediately. This shall not introduce any loss or errors to the mapped ATM cells except for the case where the incoming ATM cell rate exceeds the available ODUk-Xv payload capacity.

HEC processing

- Transfer function: The HEC value for each cell is calculated and inserted into the HEC field. The method of HEC value calculation shall be according to [ITU-T I.432.1].

Cell information field scrambling

- Transfer function: The self-synchronizing scrambler polynomial $x^{43} + 1$ has been identified for the SDH-based transmission paths and minimizes the error multiplication introduced by the self-synchronizing scrambling process. It is also used here for the mapping into ODUks. It scrambles the information field bits only. The operation of the scrambler shall be according to clause 7.3.4.1 of [ITU-T I.432.1].

Cell stream mapping

- Transfer function: The octet structure of ATM cells shall be aligned with the octet structure of the OPUk-Xv and mapped into the OPUk-Xv payload area as defined in clause 18.2.3 of [ITU-T G.709].

NOTE 5 – The clock rate and size of the OPUk-Xv is defined by AI_X_{AT}. In case of a change of X_{AT}, the size shall be adjusted immediately. This shall not introduce any loss or errors to the mapped ATM cells except for the case where the incoming ATM cell rate exceeds the available ODUk-Xv payload capacity.

Processing of the payload-specific bytes

RES: This payload-dependent set of bytes is not used for the mapping of ATM cells into OPUk-Xv. The contents of this byte shall be 00Hex.

vcPT: The function shall insert code "0000 0100" (ATM mapping) into the vcPT byte position of the PSI overhead as defined in clause 18.1.2.2 of [ITU-T G.709].

Defects: None.

Consequent actions: None.

Defect correlations: None.

Performance monitoring

The use of the performance monitoring parameters is for further study. The parameters for the following processes need to be defined:

- TP usage measurement;
- count of discarded cells from congestion control.

14.6.2.3.2 ODUkP-X-L to ATM VP adaptation sink function (ODUkP-X-L/VP_A_Sk)

Symbol

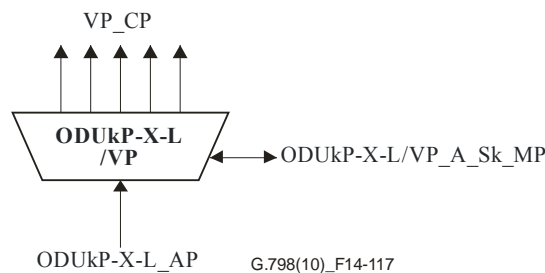

Figure 14-117 – ODUkP-X-L/VP_A_Sk symbol

Interfaces

Table 14-64 – ODUkP-X-L/VP_A_Sk input and output signals

Input(s)	Output(s)
<p>ODUkP-X-L_AP: ODUkP-X-L_AI_CK ODUkP-X-L_AI_D ODUkP-X-L_AI_FS ODUkP-X-L_AI_TSF ODUkP-X-L_AI_TSD ODUkP-X-L_AI_XAR</p> <p>ODUkP-X-L/VP_A_Sk_MP: ODUkP-X-L/VP_A_Sk_MI_Active ODUkP-X-L/VP_A_Sk_MI_CellDiscardActive ODUkP-X-L/VP_A_Sk_MI_TPusgActive ODUkP-X-L/VP_A_Sk_MI_VPIrange ODUkP-X-L/VP_A_Sk_MI_HECActive ODUkP-X-L/VP_A_Sk_MI_GFCActive ODUkP-X-L/VP_A_Sk_MI_DTDLuseEnabled ODUkP-X-L/VP_A_Sk_MI_VPI-KActive ODUkP-X-L/VP_A_Sk_MI_VPI-K_SAISActive</p>	<p>per VP_CP, for each VP configured: VP_CI_D VP_CI_ACS VP_CI_SSF VP_CI_CNGI</p> <p>ODUkP-X-L/VP_A_Sk_MP: ODUkP-X-L/VP_A_Sk_MI_cVcPLM ODUkP-X-L/VP_A_Sk_MI_cLCD ODUkP-X-L/VP_A_Sk_MI_AcVcPT</p>

Processes

The ODUkP-X-L/VP_A_Sk function provides adaptation from the ODUk-X-L to the ATM virtual path. This is performed by a grouping of specific processes and common processes as shown in Figure 14-118.

Activation

- The ODUkP-X-L/VP_A_Sk function shall access the access point and perform the common and specific processes operation specified below when it is activated (MI_Active is true). Otherwise, it shall activate the SSF signals and generate AIS at its output (CP) and not report its status via the management point.

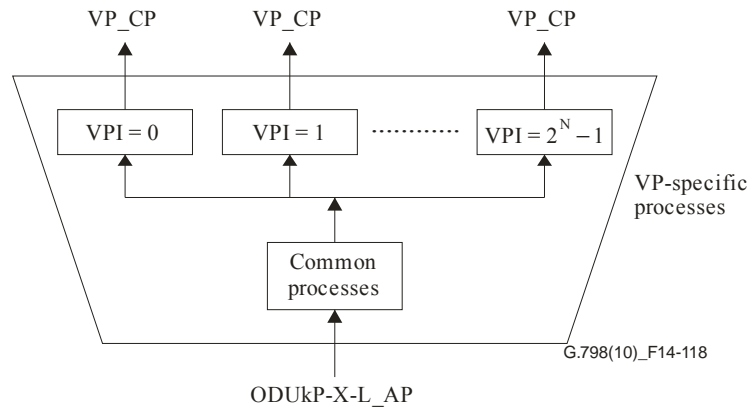

Figure 14-118 – ODUkP-X-L/VP_A_Sk atomic function decomposed into specific and common processes parts

NOTE 1 – The sequential order of the processes within the atomic functions is important. For the correct order, refer to the ordering of the processes given below.

Common processes

These common processes include: handling of the payload-specific bytes (vcPT, PSI, RES), demapping, cell delineation, cell information field descrambling, HEC processing, cell rate decoupling, TP usage measurement, header verification, GFC processing, VPI verification and congestion control (selective cell discard (CLP-based)). The logical ordering of these processes from input to output must be maintained.

Handling of payload-specific bytes

vcPT: The function shall extract the vcPT byte from the PSI overhead as defined in clause 8.7.3. The accepted vcPT value is available at the MP (MI_AcVcPT) and is used for VcPLM defect detection.

RES: This payload-dependent byte is not used for this mapping and the receiver shall ignore its contents.

Demapping

- Transfer function: The cell stream shall be extracted from OPuk-XV payload in the ODUkP-X-L_AI as defined in clause 18.2.3 of [ITU-T G.709].

NOTE 2 – The clock rate and size of the OPuk-Xv is defined by AI_X_{AR}. In case of a change of X_{AR} the size shall be adjusted immediately. This shall not introduce any loss or errors to the demapped ATM cells.

Cell delineation

- Transfer function: Cell delineation is performed on the continuous cell stream. The cell delineation algorithm should be in accordance with [ITU-T I.432.1]. The OCD events are indicated to the layer management function.
- Layer management function: Loss of cell delineation defect (dLCD) shall be declared as in the defect clause below.

Cell information field descrambling

- Transfer function: The self-synchronizing descrambler polynomial $x^{43} + 1$ has been identified for the SDH-based transmission paths and minimizes the error multiplication introduced by the self-synchronizing scrambling process (factor 2). It is also used here for the mapping into ODUks. It descrambles the information field bits only. The operation of the descrambler in relation to the HEC cell delineation state diagram shall be according to clause 7.3.4.1 of [ITU-T I.432.1].

HEC processing

- Transfer function: HEC verification and correction shall be according to [ITU-T I.432.1]. Cells determined to have an invalid and inconvertible HEC pattern shall be discarded.
- Layer management function: A count of invalid HEC events and a count of invalid HEC cell discard events are maintained with threshold crossings checked. HEC correction mode may be activated/deactivated by MI_HECActive. The HEC correction mode should be activated by default.

Cell rate decoupling

- Transfer function: The process shall extract the idle cells used as fixed stuff in the far-end ODUkP-X-L/VP adaptation source function.

TP usage measurement

- Transfer function: The cell reception is indicated to the layer management function.
- Layer management function: The process shall count the received cells for cell measurement purposes. This cell counting shall be activated/deactivated by MI_TPActive.

Header verification

- Transfer function: The receiving function shall verify that the first four octets of the ATM cell header are recognizable as being a valid header pattern. Cells with unrecognized header patterns shall be discarded. An indication of an invalid header cell discard event is provided to layer management.

Invalid header patterns from paths based on OTN transmission systems are as follows (except idle cell) (x = any value):

UNI	GFC xxxx	VPI all 0's	VCI all 0's	PTI xxx	CLP 1
NNI	VPI all 0's	VCI all 0's	PTI xxx	CLP 1	

- Layer management function: The process shall count the invalid header cell discard event.

GFC processing

- Transfer function: The support of the GFC protocol applies to the UNI and in point-to-point configuration only and is an option. This process extracts the GFC field. The GFC field processing is defined in [ITU-T I.150] and [ITU-T I.361].
- Layer management function: The GFC function uses assigned and unassigned cells. Two modes of operation are available: uncontrolled transmission (MI_GFCActive is false) and controlled transmission (MI_GFCActive is true). In uncontrolled transmission mode, neither the controlling nor the controlled NE performs the GFC procedure. If enabled by MI_GFCActive = true, this process shall extract the GFC protocol from the GFC field.

NOTE 3 – According to the protocol reference model ([ITU-T I.321]), the unassigned cells should be processed in the ATM layer. Some of the ATM layer processes are adaptation processes belonging to the adaptation function between the TP and the VP layer network. The unassigned cells as well as idle cells are per physical connection (VPI = 0, VCI = 0). For this reason, the idle and unassigned cells' processing is allocated to the same atomic function.

VPI verification

- Transfer function: The process shall verify that the received cell VPI is valid. If the VPI is determined to be invalid (i.e., out-of-range VPI or not assigned), the cell shall be discarded. An indication of the invalid VPI cell discard events is provided to the layer management function.
- Layer management function: The range of valid VPIs is given by MI_VPIrange. The invalid VPI cell discard events are counted.

Congestion control

- Transfer function: In the event of congestion, cells with CLP = 1 are subject to be discarded prior to cells with CLP = 0. See [ITU-T I.371] for further details about the use of the CLP. In the event of congestion, the indication VP_CI_CNGI is set for the traffic management function VPTM_TT_So to insert EFCI on all VPs.
- Layer management function: If enabled by MI_CellDiscardActive, this process shall perform selective cell discard according to CLP value.

VP-specific processes

The function performs end-to-end VP-AIS insertion, segment VP-AIS insertion and demultiplexing on a per-VP basis.

VPI-K activation

- Layer management function: The specific processes perform the operation specified below when it is activated (MI_VPI-KActive is true). Otherwise, it shall send no cells and SSF = false.

End-to-end VP-AIS insertion

- Transfer function: This process inserts end-to-end VP-AIS cells from the layer management function for each active specific function.
- Layer management function: End-to-end VP-AIS cells (Figure 14-119) shall be generated according to the consequent actions section of the coordination function below for each active specific function.

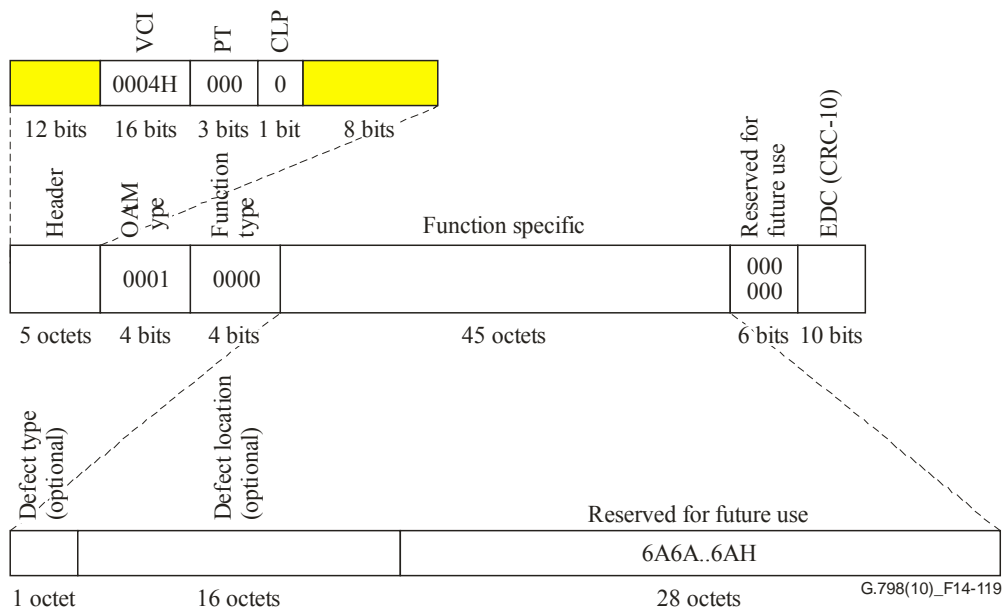

Figure 14-119 – End-to-end VP-AIS OAM cell as part of the VP_CI

Segment VP-AIS insertion

- Transfer function: This process inserts segment VP-AIS cells from the layer management function for each active specific function.
- Layer management function: Segment VP-AIS cells (Figure 14-110) shall be generated according to the consequent actions section of the coordination function below for each active specific function and the segment VP-AIS cells insertion is also activated (MI_VPI-K_SAISActive is true).

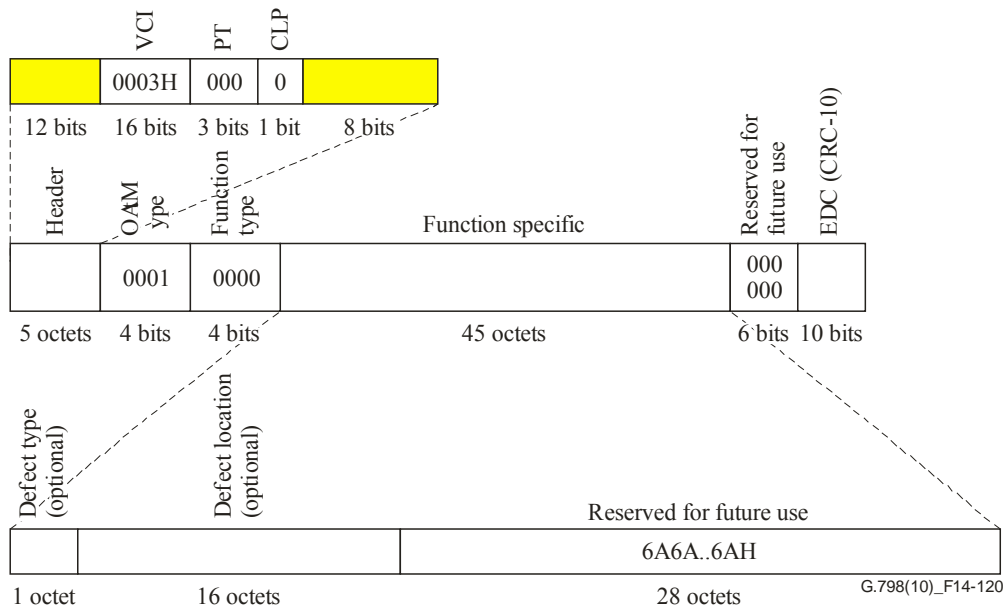

Figure 14-120 – Segment VP-AIS OAM cell as part of the VP_CI

VP demultiplexing

- Transfer function: The adaptation sink function has access to a specific VP identified by the number K ($0 \leq K \leq 2^N - 1$). For each active specific function, only the cells of that specific VPI-K are passed in the client direction.

NOTE 4 – The value of N represents the number of bits in the VPI field and is an integer number. Its maximum value is equal to 12 for the ATM NNI. Its maximum value is equal to 8 for the ATM UNI.

Defects

The function shall detect for the dVcPLM and dLCD defects.

dVcPLM: See clause 6.2.4.2. The expected payload type is "000 0100" (ATM mapping).

dLCD: See [ITU-T I.432.1].

Consequent actions

aCNGI ← "Event of congestion" and CellDiscardActive
aSSF ← dVcPLM or dLCD or AI_TSF or (not MI_Active)
aAIS ← dVcPLM or dLCD or AI_TSF or (not MI_Active)

On declaration of aAIS, the function shall output end-to-end VP-AIS cells (Figure 14-119) on all active VPCs and segment VP-AIS cells (Figure 14-120) on all active VPCs for which MI_SAISActive is true, according to clause 9.2.1.1.1.1 of [ITU-T I.610]. On clearing of aAIS, the generation of end-to-end and segment VP-AIS cells shall be stopped. If either the function does not support the defect type and defect location (DTDL) option, or the function supports the DTDL option and the MI_DTDLuseEnabled is false, the binary contents of the defect type and defect location fields of the end-to-end and segment VP-AIS cell shall be coded as 6AH. If the function supports the DTDL option and if the MI_DTDLuseEnabled is true, the defect type and defect location values shall be inserted in the information field of the end-to-end and segment VP-AIS cells.

NOTE 5 – As long as the coding scheme of defect type and defect location fields is not defined, the fields shall be encoded as 6AH.

The consequent action aSSF is conveyed by CI_SSF through the VP_CI.

Defect correlations

cVcPLM ← dVcPLM and (not AI_TSF)
cLCD ← dLCD and (not dVcPLM) and (not AI_TSF)

Performance monitoring

The use of the performance monitoring parameters is for further study. The parameters for the following functions need to be defined:

- TP usage measurement;
- count of discarded cells from congestion control;
- count of invalid HEC events;
- count of invalid HEC discard events;
- count of invalid header discard events (one common counter for invalid header/invalid VPI/invalid VCI is maintained);
- OCD event.

14.6.2.4 ODUkP-X-L to NULL adaptation function (ODUkP-X-L/NULL_A)

The ODUkP-X-L to NULL adaptation functions perform the adaptation of a NULL test signal as defined in clause 18.2.5.1 of [ITU-T G.709] into the ODUkP-X-L. The NULL signal is an all-ZEROs pattern.

14.6.2.4.1 ODUkP-X-L to NULL adaptation source function (ODUkP-X-L/NULL_A_So)

The ODUkP-X-L/NULL_A_So function creates the ODUk-X-L signal from a free-running clock. It maps the NULL signal into the payload of the OPUk-Xv and adds OPUk-Xv overhead (RES, vcPT).

The information flow and processing of the ODUkP-X-L/NULL_A_So function is defined with reference to Figures 14-121 and 14-122.

Symbol

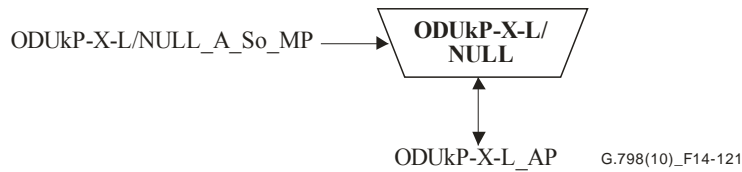

Figure 14-121 – ODUkP-X-L/NULL_A_So function

Interfaces

Table 14-65 – ODUkP-X-L/NULL_A_So inputs and outputs

Input(s)	Output(s)
ODUkP-X-L_AP: ODUkP-X-L_AI_X _{AT} ODUkP-X-L/NULL_A_So_MP: ODUkP-X-L/NULL_A_So_MI_Active	ODUkP-X-L_AP: ODUkP-X-L_AI_CK ODUkP-X-L_AI_D ODUkP-X-L_AI_FS ODUkP-X-L_AI_MFS

Processes

Activation

- The ODUkP-X-L/NULL_A_So function shall access the access point when it is activated (MI_Active is true). Otherwise, it shall not access the access point.

Clock and (multi)frame start signal generation: The function shall generate a local ODUk-X-L clock (ODUkP-X-L_AI_CK) of " $X_{AT} \times 239 / (239 - k) \times 4^{(k-1)} \times 2\,488\,320$ kHz \pm 20 ppm". The jitter and wander requirements, as defined in Annex A of [ITU-T G.8251] (ODCa clock), apply.

The function shall generate the (multi)frame start reference signals ODUkP-X-L_AI_FS and ODUkP-X-L_AI_MFS for the ODUk-X-L signal. The ODUkP-X-L_AI_FS signal shall be active once per $X_{AT} \times 122\,368$ clock cycles. ODUkP-X-L_AI_MFS shall be active once every 256 frames.

NOTE 1 – The size and clock rate of the OPUk-Xv is defined by AI_X_{AT}. In case of a change of X_{AT}, the clock rate shall be adjusted immediately. This shall not introduce any loss or errors to the mapped NULL signal.

Insert NULL signal: The function shall insert an all-ZEROs pattern into the OPUk-Xv payload area as defined in clause 18.2.5.1 of [ITU-T G.709].

NOTE 2 – The clock rate and size of the OPUk-Xv is defined by AI_X_{AT}. In case of a change of X_{AT}, the size shall be adjusted immediately. This shall not introduce any loss or errors to the mapped NULL signal.

vcPT: The function shall insert code "1111 1101" into the vcPT byte position of the PSI overhead as defined in clause 18.1.2.2 of [ITU-T G.709].

RES: The function shall insert all-ZEROs into the RES bytes.

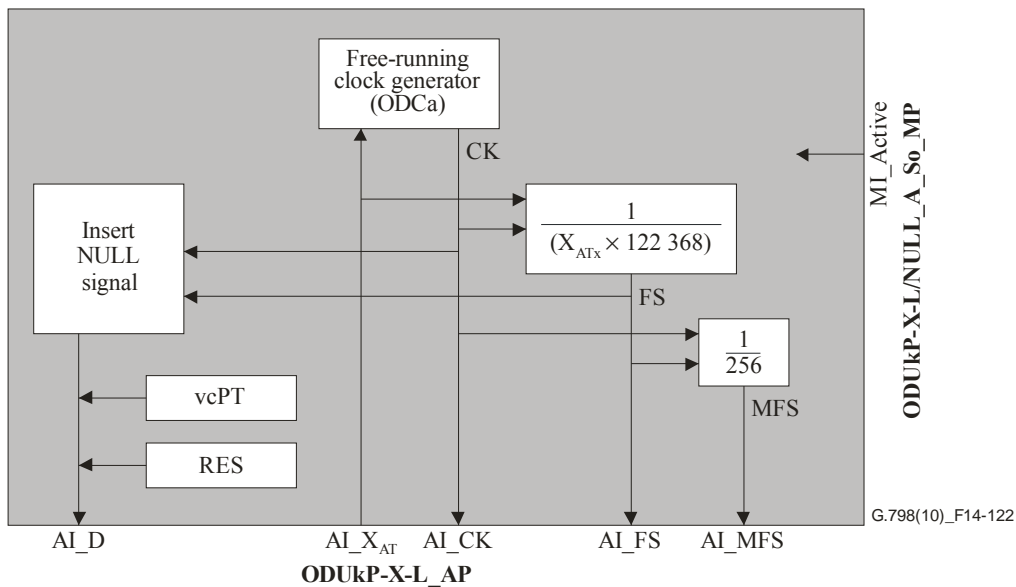

Figure 14-122 – ODUkP-X-L/NULL_A_So processes

Defects: None.

Consequent actions: None.

Defect correlations: None.

Performance monitoring: None.

14.6.2.4.2 ODUkP-X-L to NULL adaptation sink function (ODUkP-X-L/NULL_A_Sk)

The ODUkP-X-L/NULL_A_Sk extracts the OPUk-Xv overhead (vcPT and RES) and monitors the reception of the correct payload type.

The information flow and processing of the ODUkP-X-L/NULL_A_Sk function is defined with reference to Figures 14-123 and 14-124.

Symbol

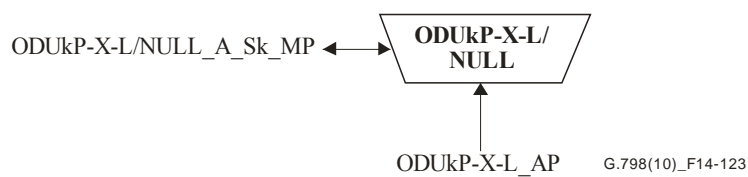

Figure 14-123 – ODUkP-X-L/NULL_A_Sk function

Interfaces

Table 14-66 – ODUkP-X-L/NULL_A_Sk inputs and outputs

Input(s)	Output(s)
ODUkP-X-L_AP: ODUkP-X-L_AI_CK ODUkP-X-L_AI_D ODUkP-X-L_AI_FS ODUkP-X-L_AI_MFS ODUkP-X-L_AI_TSF ODUkP-X-L_AI_X _{AR} ODUkP-X-L/NULL_A_Sk_MP: ODUkP-X-L/NULL_A_Sk_MI_Active	ODUkP-X-L/NULL_A_Sk_MP: ODUkP-X-L/NULL_A_Sk_MI_cVcPLM ODUkP-X-L/NULL_A_Sk_MI_AcVcPT

Processes

Activation

- The ODUkP-X-L/NULL_A_Sk function shall access the access point and perform the common and specific processes operation specified below when it is activated (MI_Active is true). Otherwise, it shall not report its status via the management point.

vcPT: The function shall extract the vcPT byte from the PSI overhead as defined in clause 8.7.3. The accepted vcPT value is available at the MP (MI_AcVcPT) and is used for VcPLM defect detection.

RES: The value in the RES bytes shall be ignored.

Payload: The value in the OPUk-Xv payload area shall be ignored.

NOTE – The clock rate and size of the OPUk-Xv is defined by AI_X_{AR}. In case of a change of X_{AR}, the size shall be adjusted immediately. This shall not introduce any error.

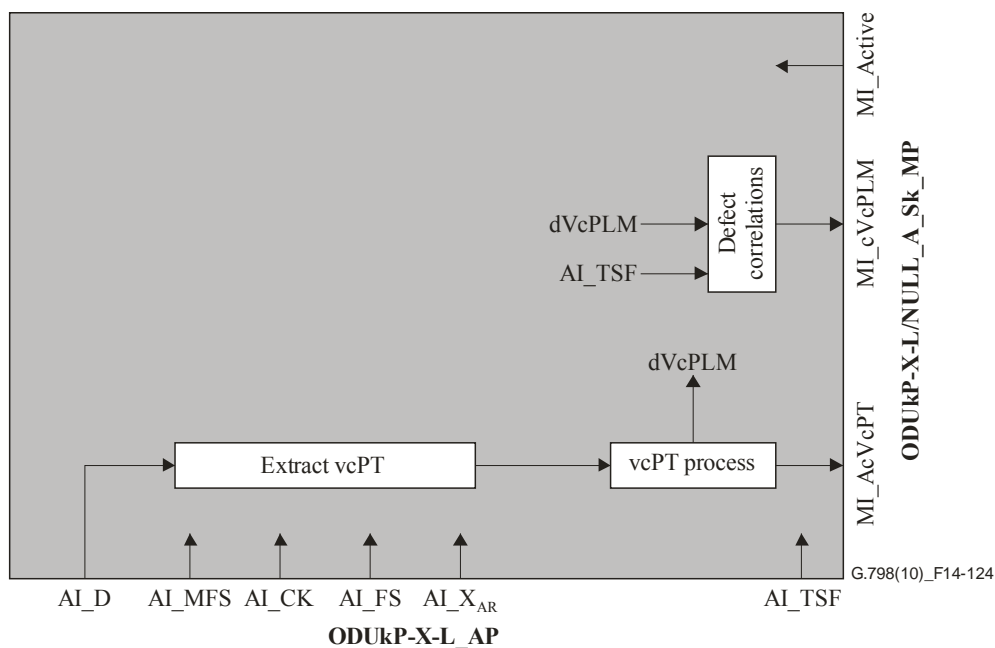

Figure 14-124 – ODUkP-X-L/NULL_A_Sk processes

Defects

The function shall detect for dVcPLM.

dVcPLM: See clause 6.2.4.2. The expected payload type is "1111 1101" (NULL test signal mapping) as defined in [ITU-T G.709].

Consequent actions: None.

Defect correlations

cVcPLM ← dVcPLM and (not AI_TSF)

Performance monitoring: None.

14.6.2.5 ODUkP-X-L to PRBS adaptation function (ODUkP-X-L/PRBS_A)

The ODUkP-X-L to PRBS adaptation functions perform the adaptation of a PRBS test signal as defined in clause 18.2.5.2 of [ITU-T G.709] into the ODUkP-X-L. The PRBS signal is a 2 147 483 647-bit pseudo-random test sequence ($2^{31} - 1$) as specified in clause 5.8 of [ITU-T O.150].

14.6.2.5.1 ODUkP-X-L to PRBS adaptation source function (ODUkP-X-L/PRBS_A_So)

The ODUkP-X-L/PRBS_A_So function creates the ODUk-X-L signal from a free-running clock. It maps the PRBS signal into the payload of the OPUk-Xv and adds OPUk overhead (RES, vcPT).

The information flow and processing of the ODUkP-X-L/PRBS_A_So function is defined with reference to Figures 14-125 and 14-126.

Symbol

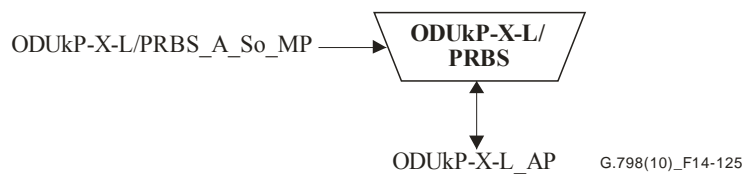

Figure 14-125 – ODUkP-X-L/PRBS_A_So function

Interfaces

Table 14-67 – ODUkP-X-L/PRBS_A_So inputs and outputs

Input(s)	Output(s)
ODUkP-X-L_AP: ODUkP-X-L_AI_X _{AT} ODUkP-X-L/PRBS_A_So_MP: ODUkP-X-L/PRBS_A_So_MI_Active	ODUkP-X-L_AP: ODUkP-X-L_AI_CK ODUkP-X-L_AI_D ODUkP-X-L_AI_FS ODUkP-X-L_AI_MFS

Processes

Activation

- The ODUkP-X-L/PRBS_A_So function shall access the access point when it is activated (MI_Active is true). Otherwise, it shall not access the access point.

Clock and (multi)frame start signal generation: The function shall generate a local ODUk-X-L clock (ODUkP-X-L_AI_CK) of " $X_{AT} \times 239 / (239 - k) \times 4^{(k-1)} \times 2\,488\,320$ kHz \pm 20 ppm". The jitter and wander requirements, as defined in Annex A of [ITU-T G.8251] (ODCa clock), apply.

The function shall generate the (multi)frame start reference signals ODUkP-X-L_AI_FS and ODUkP-X-L_AI_MFS for the ODUk-X-L signal. The ODUkP-X-L_AI_FS signal shall be active once per $X_{AT} \times 122\,368$ clock cycles. ODUkP-X-L_AI_MFS shall be active once every 256 frames.

NOTE 1 – The size and clock rate of the OPUk-Xv is defined by AI_X_{AT}. In case of a change of X_{AT}, the clock rate shall be adjusted immediately. This shall not introduce any loss or errors to the mapped NULL signal.

Generate and insert PRBS signal: The function shall generate the PRBS signal and insert it into the OPUk-Xv payload area as defined in clause 18.2.5.2 of [ITU-T G.709].

NOTE 2 – The clock rate and size of the OPUk-Xv is defined by AI_X_{AT}. In case of a change of X_{AT}, the size shall be adjusted immediately. This shall not introduce any loss or errors to the mapped PRBS signal.

vcPT: The function shall insert code "1111 1110" into the vcPT byte position of the PSI overhead as defined in clause 18.1.2.2 of [ITU-T G.709].

RES: The function shall insert all-ZEROs into the RES bytes.

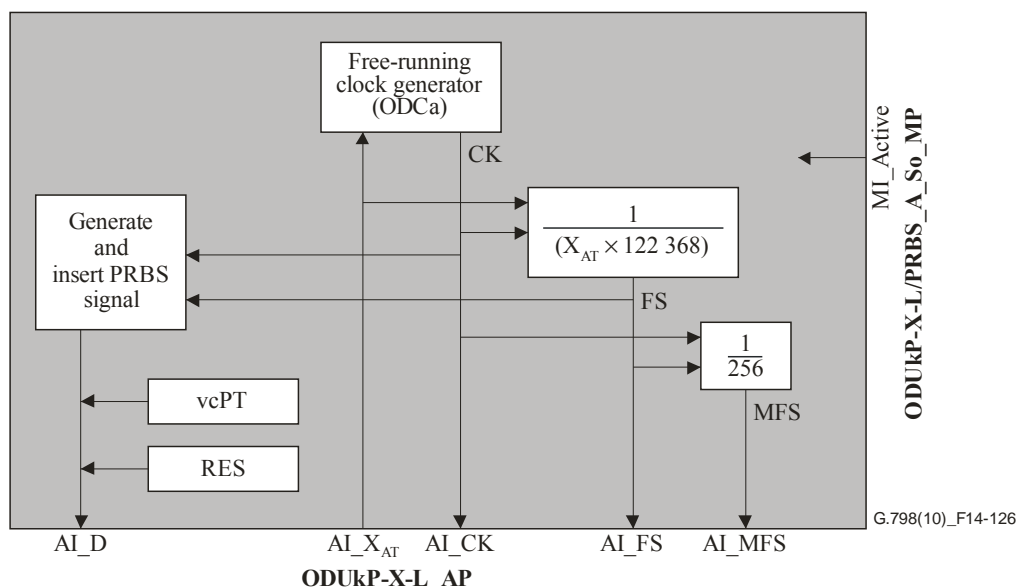

Figure 14-126 – ODUkP-X-L/PRBS_A_So processes

Defects: None.

Consequent actions: None.

Defect correlations: None.

Performance monitoring: None.

14.6.2.5.2 ODUkP-X-L to PRBS adaptation sink function (ODUkP-X-L/PRBS_A_Sk)

The ODUkP-X-L/PRBS_A_Sk recovers the PRBS test signal from the OPUk-Xv payload area and monitors test sequence errors (TSEs) in the PRBS sequence. It extracts the OPUk-Xv overhead (vcPT, RES) and monitors the reception of the correct payload type.

The information flow and processing of the ODUkP-X-L/PRBS_A_Sk function is defined with reference to Figures 14-127 and 14-128.

Symbol

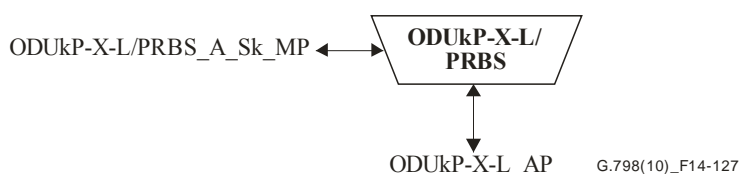

Figure 14-127 – ODUkP-X-L/PRBS_A_Sk function

Interfaces

Table 14-68 – ODUkP-X-L/PRBS_A_Sk inputs and outputs

Input(s)	Output(s)
ODUkP-X-L_AP: ODUkP-X-L_AI_CK ODUkP-X-L_AI_D ODUkP-X-L_AI_FS ODUkP-X-L_AI_MFS ODUkP-X-L_AI_TSF ODUkP-X-L_AI_X _{AR} ODUkP-X-L/PRBS_A_Sk_MP: ODUkP-X-L/PRBS_A_Sk_MI_Active	ODUkP-X-L/PRBS_A_Sk_MP: ODUkP-X-L/PRBS_A_Sk_MI_cVcPLM ODUkP-X-L/PRBS_A_Sk_MI_AcVcPT ODUkP-X-L/PRBS_A_Sk_MI_cLSS ODUkP-X-L/PRBS_A_Sk_MI_pN_TSE

Processes

Activation

- The ODUkP-X-L/PRBS_A_Sk function shall access the access point and perform the common and specific processes operation specified below when it is activated (MI_Active is true). Otherwise, it shall not report its status via the management point.

vcPT: The function shall extract the vcPT byte from the PSI overhead as defined in clause 8.7.3. The accepted vcPT value is available at the MP (MI_AcVcPT) and is used for VcPLM defect detection.

RES: The value in the RES bytes shall be ignored.

TSE check: Test sequence errors (TSEs) are bit errors in the PRBS data stream extracted from the OPUk-Xv payload area and shall be detected whenever the PRBS detector is in lock and the received data bit does not match the expected value.

NOTE – The clock rate and size of the OPUk-Xv is defined by AI_X_{AR}. In case of a change of X_{AR}, the size shall be adjusted immediately. This shall not introduce any error.

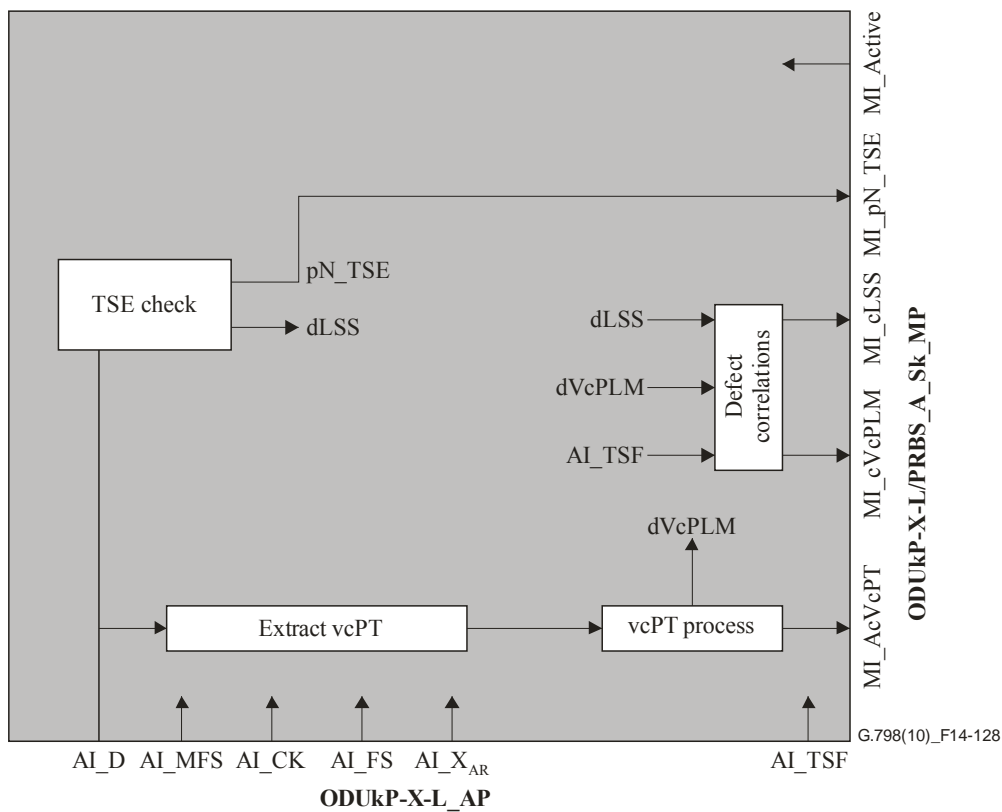

Figure 14-128 – ODUkP-X-L/PRBS_A_Sk processes

Defects

The function shall detect for dVcPLM and dLSS.

dVcPLM: See clause 6.2.4.2. The expected payload type is "1111 1110" (PRBS test signal mapping) as defined in [ITU-T G.709].

dLSS: The function shall detect for loss of PRBS lock (dLSS) according to the criteria defined in clause 2.6 of [ITU-T O.151].

Consequent actions: None.

Defect correlations

cVcPLM ← dVcPLM and (not AI_TSF)

cLSS ← dLSS and (not AI_TSF) and (not dVcPLM)

Performance monitoring

pN_TSE ← Sum of test sequence errors (TSEs) within one second period.

Annex A

Optical section (OSx) and constant bit rate (CBRx) layer functions

(This annex forms an integral part of this Recommendation.)

Introduction

The OSx and CBRx layer functions are not part of the OTN. They are defined in this Recommendation in order to provide transparent transport of constant bit rate (CBR) signals over the OTN. The CBR signal is either mapped into the ODU (see clause 14.3.1) or directly into the OCh (see clause 12.3.3).

The parameter x defines the supported bit rate or bit-rate range. The values x = 2G5, 10G and 40G are defined for client signals that comply to the SDH bit rates as defined in Table A.1. Support for other bit rates and bit-rate ranges is for further study.

Table A.1 – Defined values for x

x	Bit rate	Clock range
2G5	2 488 320 kbit/s \pm 20 ppm	2 488 320 kHz \pm 20 ppm
10G	9 953 280 kbit/s \pm 20 ppm	9 953 280 kHz \pm 20 ppm
40G	39 813 120 kbit/s \pm 20 ppm	39 813 120 kHz \pm 20 ppm

Figure A.1 illustrates the OSx layer network and CBRx layer adaptation functions. The OSx layer network represents physical optical interface for constant bit-rate signals. The information crossing the OSx termination connection point (OSx_TCP) is referred to as the OSx characteristic information (OSx_CI). The information crossing the OSx access point (OSx_AP) is referred to as the OSx adapted information (OSx_AI).

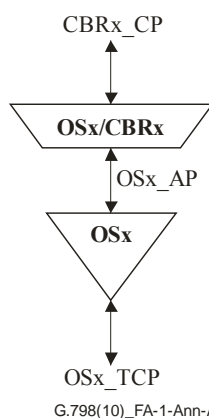

Figure A.1 – OSx layer network and client layer adaptation functions

A.1 Connection functions

Not applicable.

A.2 Termination functions

A.2.1 OS_x trail termination function (OS_x_TT) (x = 2G5, 10G, 40G)

The OS_x_TT functions are responsible for the end-to-end supervision of the OS_x trail. Figure A.2 shows the combination of the unidirectional sink and source functions to form a bidirectional function.

NOTE – For the case where an STM-N signal is to be transported as a CBR signal, the OS_x_TT functions are equivalent to the OS_n_TT functions specified in [ITU-T G.783].

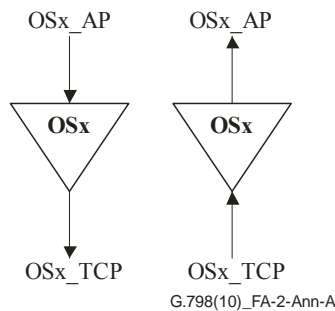

Figure A.2 – OS_x_TT

A.2.1.1 OS trail termination source function (OS_x_TT_So) (x = 2G5, 10G, 40G)

The information flow and processing of the OS_x_TT_So function is defined with reference to Figures A.3 and A.4. The OS_x_TT_So generates an optical signal. The physical parameters of the signal depend on the application. For SDH type interfaces, the specifications in [ITU-T G.957] or [ITU-T G.691] apply.

Symbol

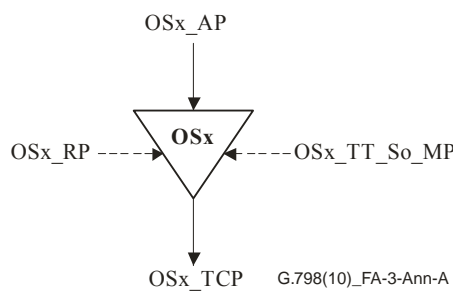

Figure A.3 – OS_x_TT_So function

Interfaces

Table A.2 – OSx_TT_So inputs and outputs

Input(s)	Output(s)
OSx_AP: OSx_AI_D OSx_RP: OSx_RI_APR (Note 1) OSx_TT_So_MP: OSx_TT_So_MI_APRCntrl (Notes 1 and 2)	OSx_TCP: OSx_CI
NOTE 1 – If APR is required.	
NOTE 2 – The APRCntrl commands depend on the specific APR process.	

Processes

The processes associated with the OSx_TT_So function are depicted in Figure A.4.

Automatic power reduction (APR): For eye safety considerations, according to [IEC 60825-1] and [IEC 60825-2], it may be necessary to provide for a capability for automatic (optical) power reduction (APR) in case of loss of the optical input signal at the sink function. The OSx_TT_So performs in this case the power reduction for the outgoing OSx signal based on the trigger criteria from the sink (RI_APR) and control information (MI_APRCntrl). The specific APR procedures and trigger criteria are outside the scope of this Recommendation. Clause 6.2 of [ITU-T G.664] provides basic requirements for APR.

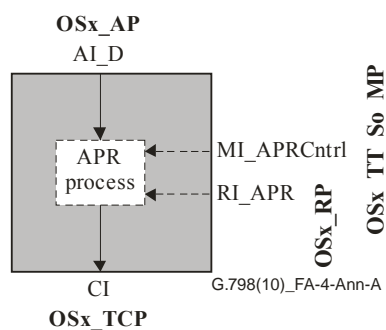

Figure A.4 – OSx_TT_So processes

Defects: None.

Consequent actions: None.

Defect correlations: None.

Performance monitoring: None.

A.2.1.2 OSx trail termination sink function (OSx_TT_Sk) (x = 2G5, 10G, 40G)

The information flow and processing of the OSx_TT_Sk function is defined with reference to Figures A.5 and A.6. The OSx_TT_Sk reports the state of the OSx trail. The OSx_TT_Sk accepts an optical signal. The physical parameters of the signal depend on the application. For SDH type interfaces, the specifications in [ITU-T G.957] or [ITU-T G.691] apply.

Symbol

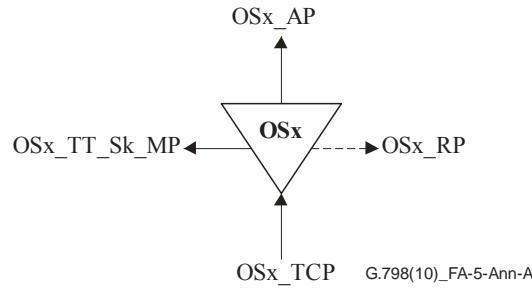

Figure A.5 – OSx_TT_Sk function

Interfaces

Table A.3 – OSx_TT_Sk inputs and outputs

Input(s)	Output(s)
OSx_TCP: OSx_CI	OSx_AP: OSx_AI_D OSx_AI_TSF OSx_RP: OSx_RI_APR (Note) OSx_TT_Sk_MP: OSx_TT_Sk_MI_cLOS OSx_TT_Sk_MI_pN_DS
NOTE – If APR is required.	

Processes

The processes associated with the OSx_TT_Sk function are depicted in Figure A.6.

Automatic Power Reduction (APR): For eye safety considerations, according to [IEC 60825-1] and [IEC 60825-2], it may be necessary to provide for a capability for automatic (optical) power reduction (APR) in case of loss of the optical input signal at the sink function. The OSx_TT_Sk generates in this case the APR trigger criteria based on the incoming OSx signal (OSx_CI) and forwards it to the OSx_TT_So (RI_APR). The specific APR procedures and trigger criteria are outside the scope of this Recommendation. Clause 6.2 of [ITU-T G.664] provides basic requirements for APR.

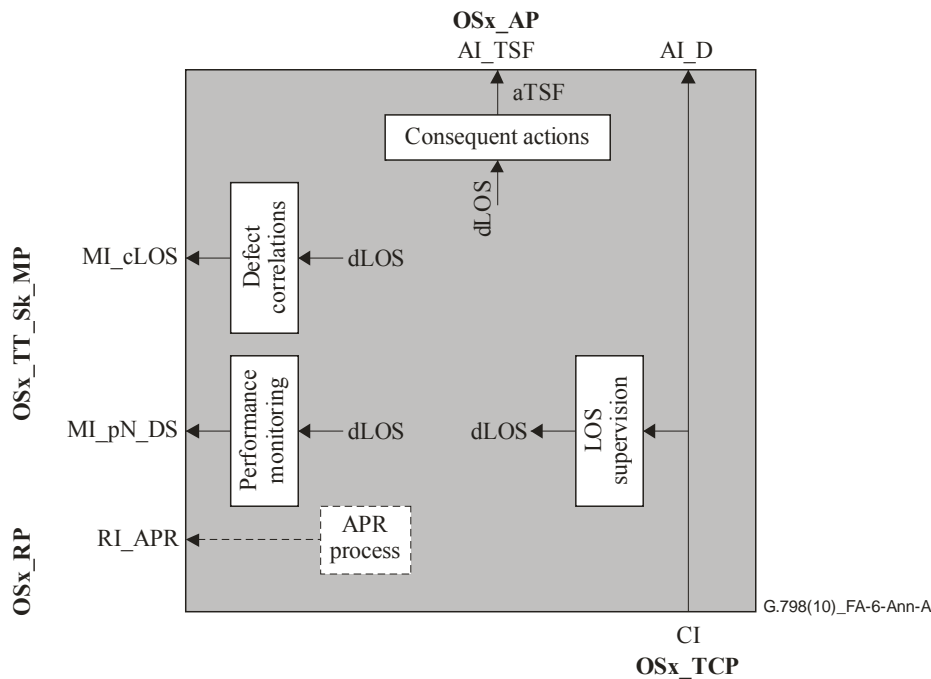

Figure A.6 – OSx_TT_Sk processes

Defects

The OSx_TT_Sk function shall detect for dLOS defect.

dLOS: See clause 6.2.1.1 of [ITU-T G.783].

Consequent actions

The OSx_TT_Sk function shall perform the following consequent action:

aTSF ← dLOS

Defect correlations

The OSx_TT_Sk function shall perform the following defect correlation:

cLOS ← dLOS

Performance monitoring

The OSx_TT_Sk function shall perform the following performance monitoring primitive. The performance monitoring primitive shall be reported to the EMF.

pN_DS ← dLOS

A.3 Adaptation functions

A.3.1 OSx to CBRx adaptation (OSx/CBRx_A) (x = 2G5, 10G, 40G)

The OSx to CBRx adaptation functions perform the adaptation between the OSx layer adapted information and the characteristic information of a CBRx layer signal.

A.3.1.1 OSx to CBRx adaptation source function (OSx/CBRx_A_So) (x = 2G5, 10G, 40G)

The information flow and processing of the OSx/CBRx_A_So function is defined with reference to Figures A.7 and A.8.

Symbol

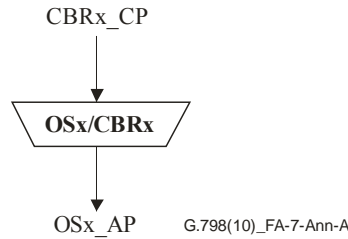

Figure A.7 – OSx/CBRx_A_So function

Interfaces

Table A.4 – OSx/CBRx_A_So inputs and outputs

Input(s)	Output(s)
CBRx_CP: CBRx_CI_D CBRx_CI_CK	OSx_AP: OSx_AI_D

Processes

The processes associated with the OSx/CBRx_A_So function are depicted in Figure A.8.

Mod (optical carrier modulation): See clause 8.11.1. For parameters of SDH type interfaces, [ITU-T G.957] and [ITU-T G.691] apply.

Optical signal pre-conditioning: Pre-conditioning of the single wavelength optical signal might be required. The specific conditioning processes depend on the OSx interface type (see [ITU-T G.957] and [ITU-T G.691] for SDH type interfaces). For optical pre-conditioning processes, see clause 8.11.2.

For the defined values of x, the jitter and wander requirements, as defined in clause 9.3.1.1 of [ITU-T G.783], apply.

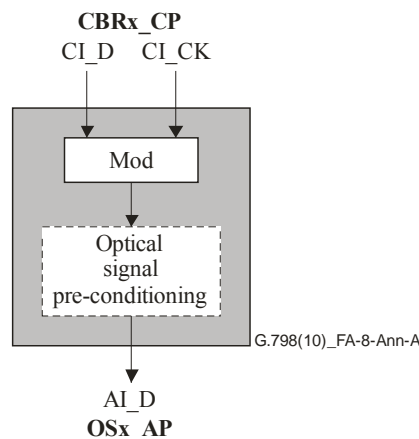

Figure A.8 – OSx/CBRx_A_So processes

Defects: None.

Consequent actions: None.

Defect correlations: None.

Performance monitoring: None.

A.3.1.2 OSx to CBRx adaptation sink function (OSx/CDRx_A_Sk) (x = 2G5, 10G, 40G)

The information flow and processing of the OSx/CDRx_A_Sk function is defined with reference to Figures A.9 and A.10.

Symbol

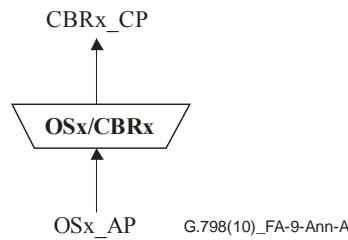

Figure A.9 – OSx/CDRx_A_Sk function

Interfaces

Table A.5 – OSx/CDRx_A_Sk inputs and outputs

Input(s)	Output(s)
OSx_AP: OSx_AI_D OSx_AI_TSF	CDRx_CP: CDRx_CI_D CDRx_CI_CK CDRx_CI_SSF

Processes

The processes associated with the OSx/CDRx_A_Sk function are depicted in Figure A.10.

Optical signal post-conditioning: Post-conditioning of the single wavelength signal might be required. The specific conditioning processes depend on the OSx interface type (see [ITU-T G.957] and [ITU-T G.691] for SDH type interfaces). For optical post-conditioning processes, see clause 8.11.2.

DMod (optical carrier demodulation): See clause 8.11.1. For parameters of SDH type interfaces, [ITU-T G.957] and [ITU-T G.691] apply.

Clock recovery: The function shall recover the clock signal from the incoming data. For the defined values of x, the input clock ranges are defined in Table A.1 and the jitter and wander requirements, as defined in clause 9.3.1.2 of [ITU-T G.783], apply.

To ensure adequate immunity against the presence of consecutive identical digits (CID) in the signal, the function shall comply with the specification in clause 15.1.4 of [ITU-T G.783].

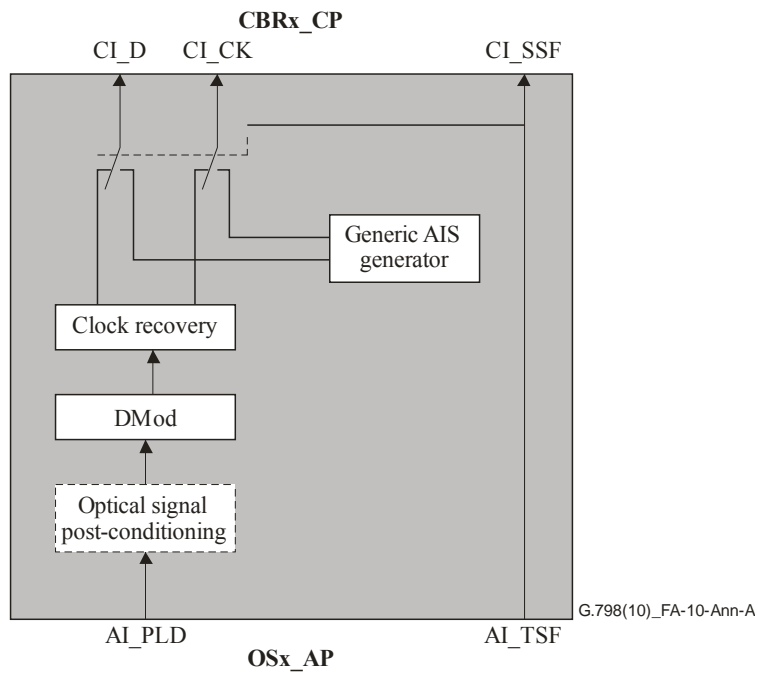

Figure A.10 – OSx/CBRx_A_Sk processes

Defects: None.

Consequent actions

The OSx/CBRx_A_Sk function performs the following consequent actions.

aSSF ← AI_TSF

aAIS ← AI_TSF

On declaration of aAIS, the function shall output a GenericAIS pattern/signal as defined in clause 16.6 of [ITU-T G.709] within X ms. On clearing of aAIS, the GenericAIS pattern/signal shall be removed within Y ms, with normal data being output. The values for X and Y are for further study.

The GenericAIS clock start shall be independent from the incoming clock. For the defined values of x, the GenericAIS clock has to be within the range defined in Table A.1.

Defect correlations: None.

Performance monitoring: None.

Appendix I

Applications and functional diagrams

(This appendix does not form an integral part of this Recommendation.)

This appendix shows example functional diagrams for a number of OTN and non-OTN interface ports on OTN equipment and a number of OTN interface ports on non-OTN equipment.

NOTE – The following functional diagrams are for illustrative purposes only.

I.1 Transparent CBRx tributary interface port with optional SDH RS non-intrusive monitor on OTN equipment

NOTE – A generic, bit rate non-specific model is presented. Actual interface ports will be bit rate specific; e.g., 10 Gbit/s (n = 64, x = 10G).

Figure I.1 shows the equipment functions for this application. The processing down to the ODUk layer, in the direction of the line interface, is shown.

The following operations are performed:

- termination of the ITU-T G.957/ITU-T G.691 optical signal;
- optional RSn non-intrusive monitoring in ingress and egress directions;
- mapping of CBR signal into the ODUk;
- termination of ODUk path overhead;
- termination of up to three levels of ODUk TCM overhead in line port direction (for TCM applications, see Appendix II).

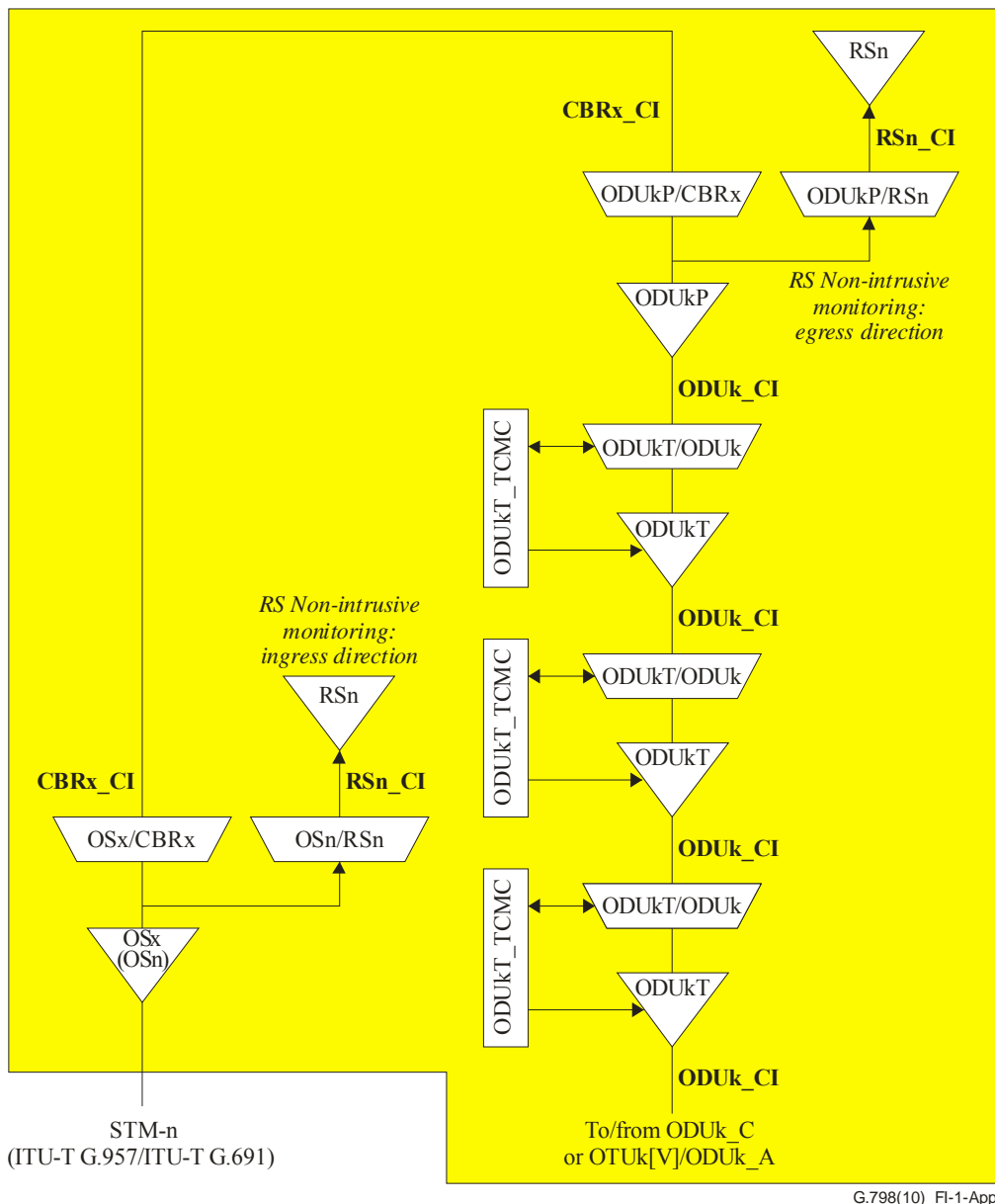

G.798(10)_FI-1-App-I

Figure I.1 – Transparent CBRx tributary interface port with optional SDH RS non-intrusive monitor on OTN equipment

I.2 OTM-0.m tributary interface port on OTN equipment

NOTE – A generic, bit rate non-specific model is presented. Actual interface ports will be bit rate specific; e.g., 10 Gbit/s ($m = 2$).

Figure I.2 shows the equipment functions for this application. The processing down to the ODUk layer, in the direction of the line interface, is shown.

The following operations are performed:

- termination of the ITU-T G.959.1 optical signal;
- termination of OTUk section overhead;
- termination of up to three levels of ODUk TCM overhead in tributary port direction (for TCM applications, see Appendix II);
- ODUkP non-intrusive monitoring in ingress and egress directions;
- termination of up to three levels of ODUk TCM overhead in the line port direction (for TCM applications, see Appendix II).

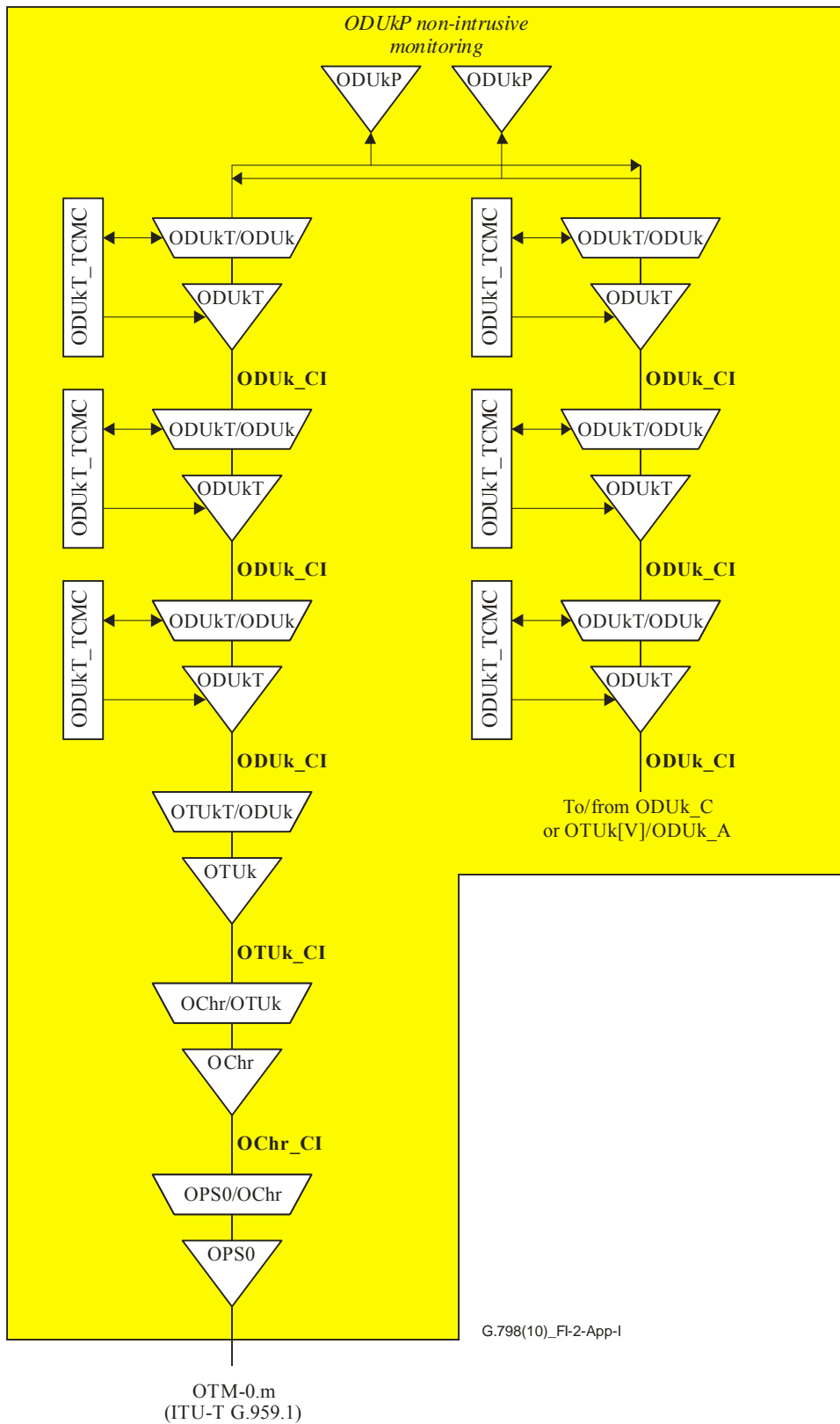

Figure I.2 – OTM-0.m tributary interface port on OTN equipment

I.3 Selectable CBRx/OTM-0.m tributary interface port on OTN equipment

NOTE – A generic, bit rate non-specific model is presented. Actual interface ports will be bit rate specific; e.g., 10 Gbit/s ($n = 64$, $x = 10G$, $m = 2$).

As the optical interfaces for CBRx (STM-n) and OTM-0.m are similar, it is possible to build equipment that can switch the processing between the two signals at the same tributary port. This is a combination of the two applications defined above. Depending on the selected interface mode, one of two function sets is active.

Figure I.3 shows the equipment functions for this application. The processing down to the ODUk layer, in the direction of the line interface, is shown.

The following operations, independent of the interface mode, are performed:

- termination of up to three levels of ODUk TCM overhead in the line port direction (for TCM applications, see Appendix II);
- termination of OTUk section overhead.

The following operations, specific to the OTM-0.n mode, are performed:

- termination of up to three levels of ODUk TCM overhead in tributary port direction (for TCM applications, see Appendix II);
- ODUkP non-intrusive monitoring in ingress and egress directions.

The following operations, specific to the CBRx mode, are performed:

- optional RSn non-intrusive monitoring in ingress and egress directions;
- mapping of CBR signal into the ODUk;
- termination of ODUk path overhead.

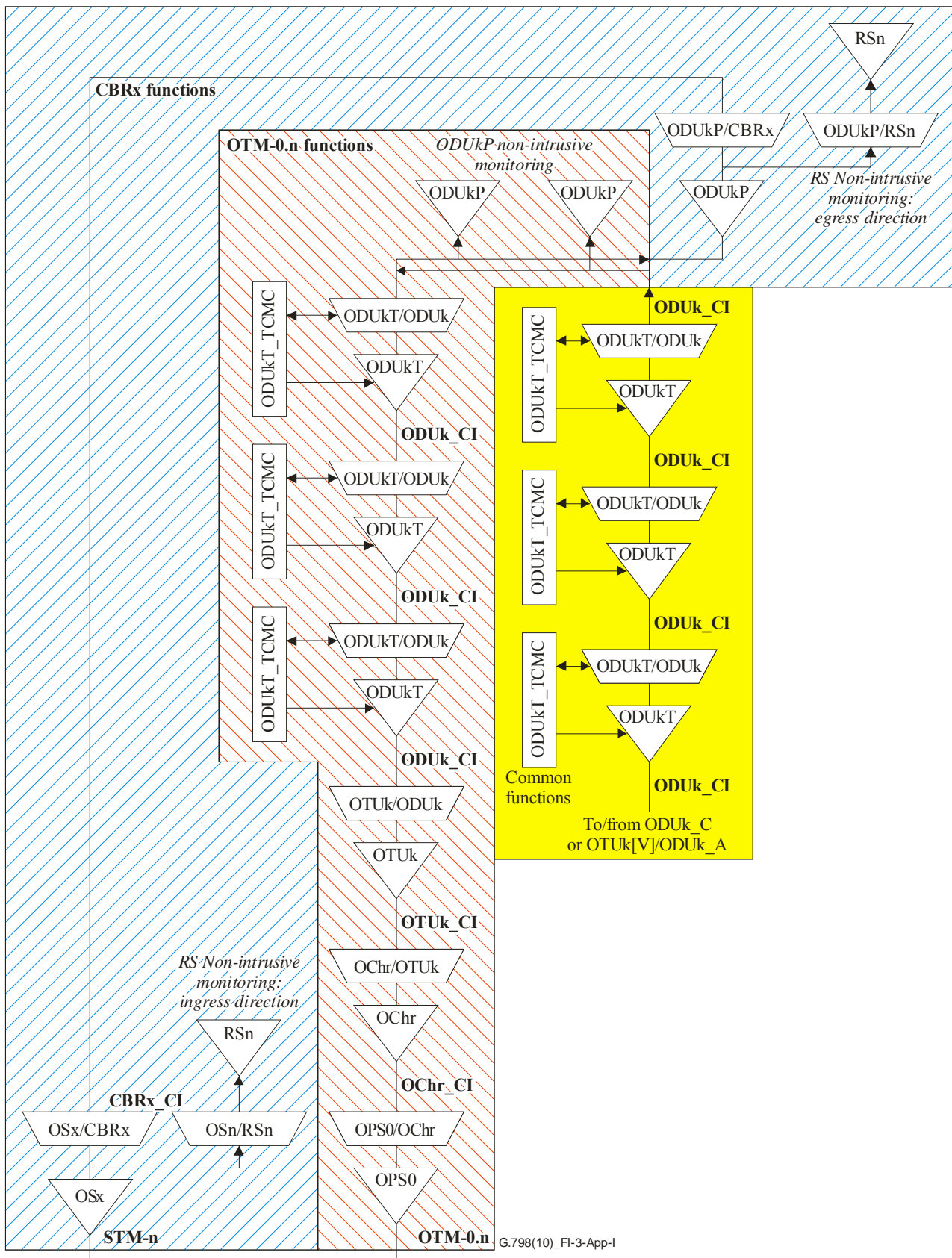

OTM-0.m/STM-n
(ITU-T G.959.1)

Figure I.3 – Selectable CBRx/OTM-0.m tributary interface port on OTN equipment

I.4 OTM-0.m interface ports on non-OTN equipment

OTN interfaces can be used in non-OTN equipment in the same way as SDH interfaces in non-SDH equipment (e.g., STM-n interfaces for IP routers and IP switches). Figure I.4 shows three examples, an OTM-0.1 interface port on an ATM network element, an OTM-0.2 interface port on an IP/Ethernet network element and an OTM-0.3 interface port on an SDH network element:

The OTM-0.1 interface port on ATM equipment supports:

- mapping and multiplexing of ATM VP signals into the ODU2;
- termination of ODU1 path overhead;
- termination of OTU1 section overhead;
- termination of the ITU-T G.959.1 optical signal.

The OTM-0.2 interface port on IP/Ethernet equipment supports:

- mapping and multiplexing of IP [or Ethernet] packet signals into the ODU3 using GFP;
- termination of ODU2 path overhead;
- termination of OTU2 section overhead;
- termination of the ITU-T G.959.1 optical signal.

The OTM-0.3 interface port on SDH equipment supports:

- mapping and multiplexing of the STM-256 signal (RS256 layer) into the ODU3;
- termination of ODU2 path overhead;
- termination of up to one level of ODU2 TCM overhead (for TCM applications, see Appendix II);
- termination of OTU2 section overhead;
- termination of the ITU-T G.959.1 optical signal.

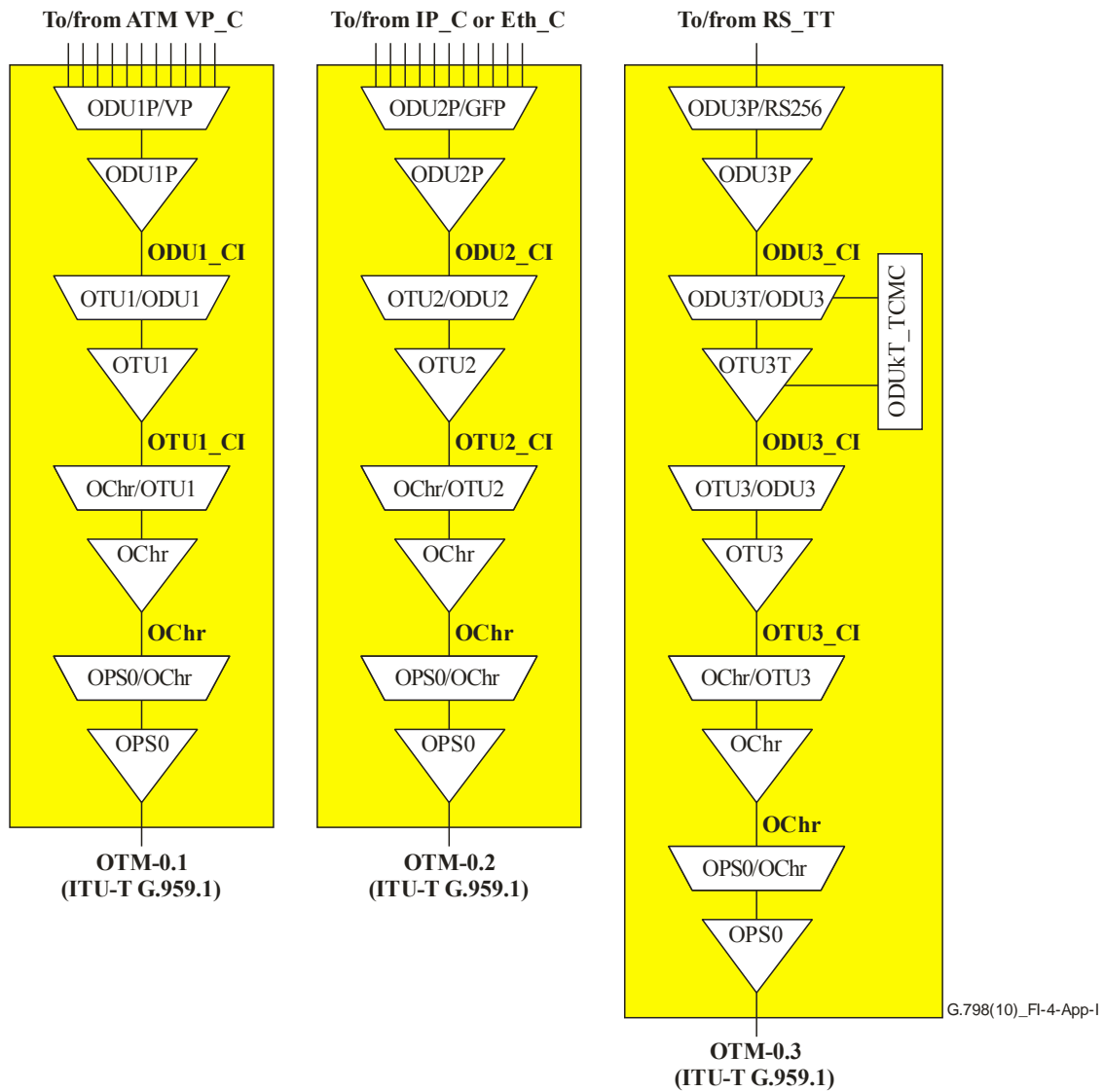

Figure I.4 – OTM-0.m interface ports on non-OTN equipment

For the above applications without ODUk TCM processing, the OTUk/ODUk overhead in the OTM-n.m signal has the following fields in use as a minimum (see Figure I.5):

- client-specific overhead if applicable;
- OPUk payload type in the payload structure identifier (PSI);
- ODUk path monitoring (PM) overhead;
- OTUk section monitoring (SM) overhead;
- frame alignment (FAS, MFAS).

The other overhead fields are set to all-ZEROs.

	1	2	3	4	5	6	7	8	9	10	11	12	13	14	15	16		
1	FAS						MFAS	SM								Client specific	OPUk payload	OTUk FEC
2																		
3										PM								
4													PSI					

G.798(10)_FI-5-App-1

 All-ZEROs pattern

Figure I.5 – Minimum OTUk/ODUk overhead

I.5 OTM-n.m interface port with 3-R regeneration functionality for an ODUk connection function

Figure I.6 shows the equipment functions for this application. The processing up to the ODUk layer is shown. A vendor-specific OTUkV signal is used in the example.

The OTM-n.m interface port supports:

- termination of the optical DWDM signal;
- termination of the OTSn and OMSn overhead;
- wavelength multiplexing and demultiplexing;
- termination of the OCh overhead;
- termination of OTUkV section overhead;
- termination of up to three levels of ODUk TCM overhead (for TCM applications, see Appendix II);
- ODUkP non-intrusive monitoring in ingress and egress directions;
- ODUk cross-connection.

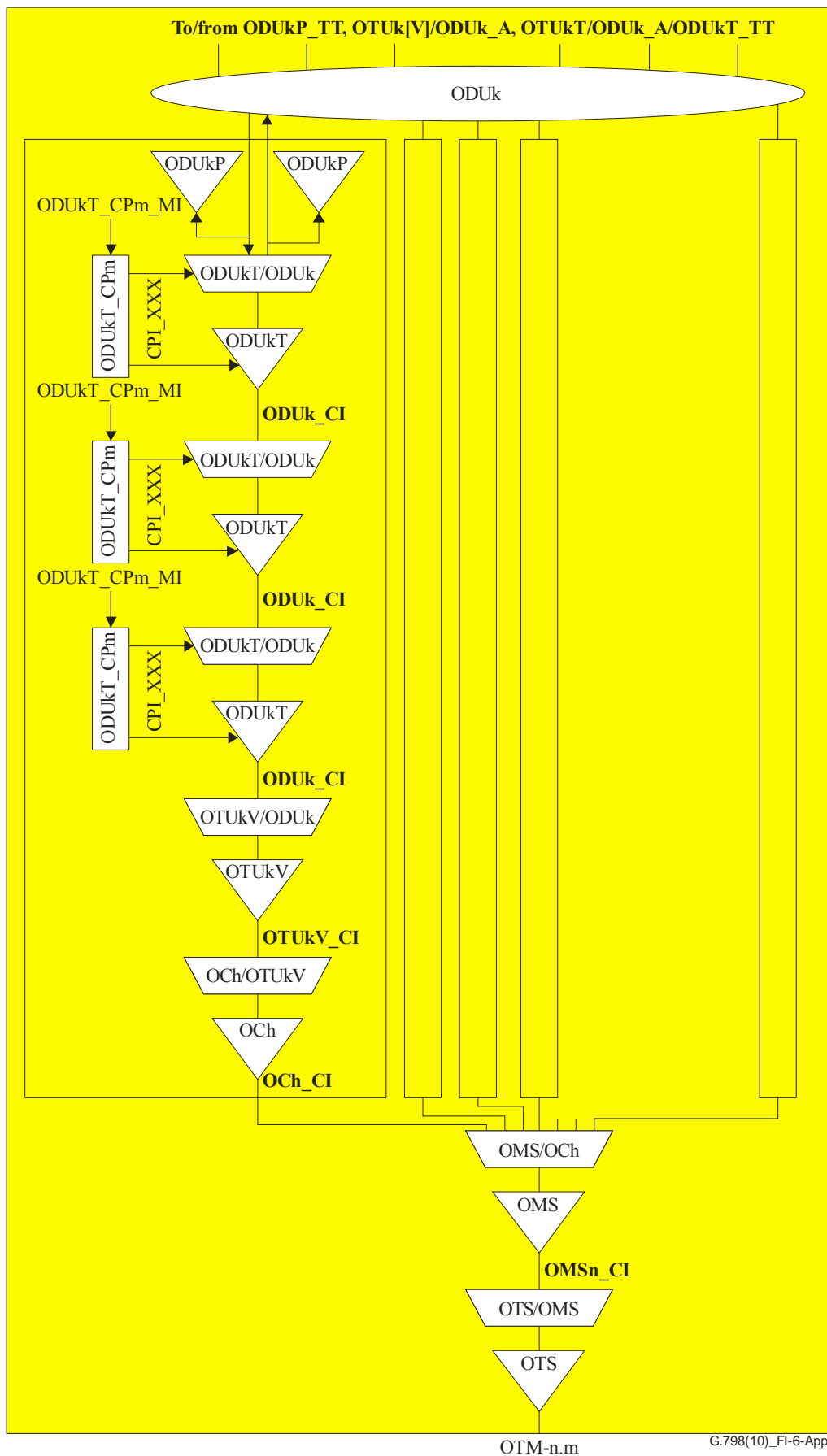

Figure I.6 – OTM-n.m interface port with 3-R regeneration functionality for an ODUk connection function

Appendix II

TCM applications

(This appendix does not form an integral part of this Recommendation.)

In several of the examples in Appendix I, ODUk TCM functions (ODUKT_TT + ODUkT/ODUK_A) are shown.

The activation of TCM functions is dependent on the location/role of the interface port in the network:

- Verification of provided quality of service to the user (provider TCM):
 - For the case of STM UNI interfaces (Figure II.1), the UNI-UNI connection is monitored on the network side using ODUk path monitoring (PM).
 - For the case of mixed STM/OTM and pure OTM UNI interfaces (Figures II.2, II.3 and II.4), the UNI-UNI connection is monitored on the network side using one level of ODUk tandem connection monitoring (TCM).
 - In case of a multi-operator environment as shown in the figures, each operator monitors the quality of service in its own network using an additional level of ODUk tandem connection monitoring (TCM) to monitor the NNI-NNI connection.
- Verification of received quality of service from the provider (user TCM):
 - In case of OTM UNI interfaces, the UNI-UNI connection is monitored on the user side:
 - either by using ODUk path monitoring (PM) if the ODUk and, as such, the OTN is terminated on the user sides of both UNIs (Figure II.3); or
 - using ODUk tandem connection monitoring (TCM) if the ODUk and, as such, the OTN continues into one or both user networks (Figure II.4).
 - In case of a multi-operator environment as shown in the figures, the service provided by an operator can be monitored by the other operators using an additional level of ODUk tandem connection monitoring (TCM) to monitor the NNI-NNI connection.

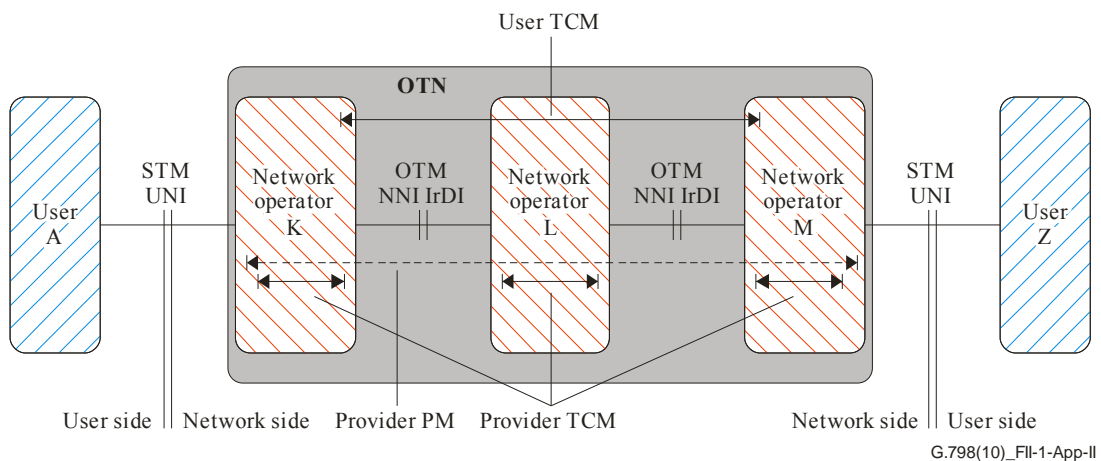

Figure II.1 – Provider and user tandem connections for case of STM-N UNI interface

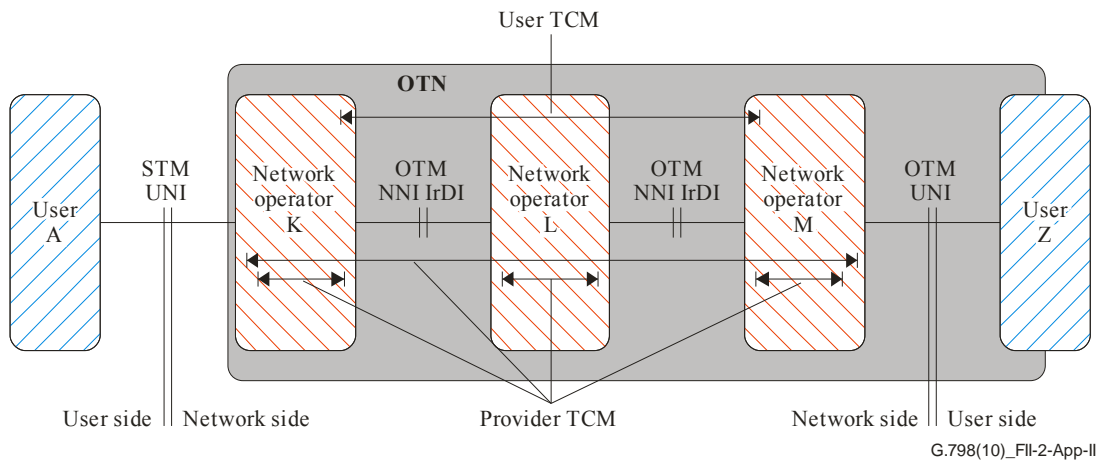

Figure II.2 – Provider and user tandem connections for case of mixed STM and OTM UNI interfaces

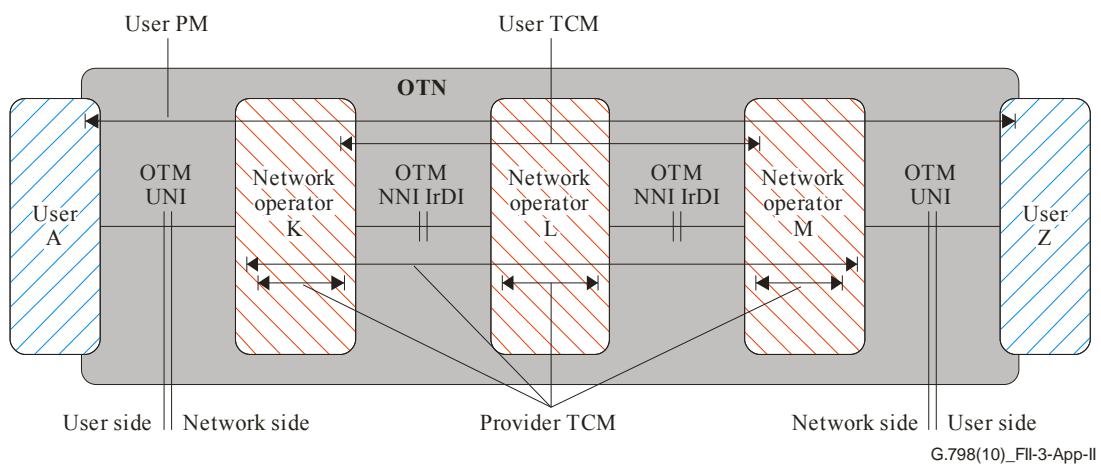

Figure II.3 – Provider and user tandem connections for case of OTM UNI interfaces and termination of the OTN on the user side of the UNI

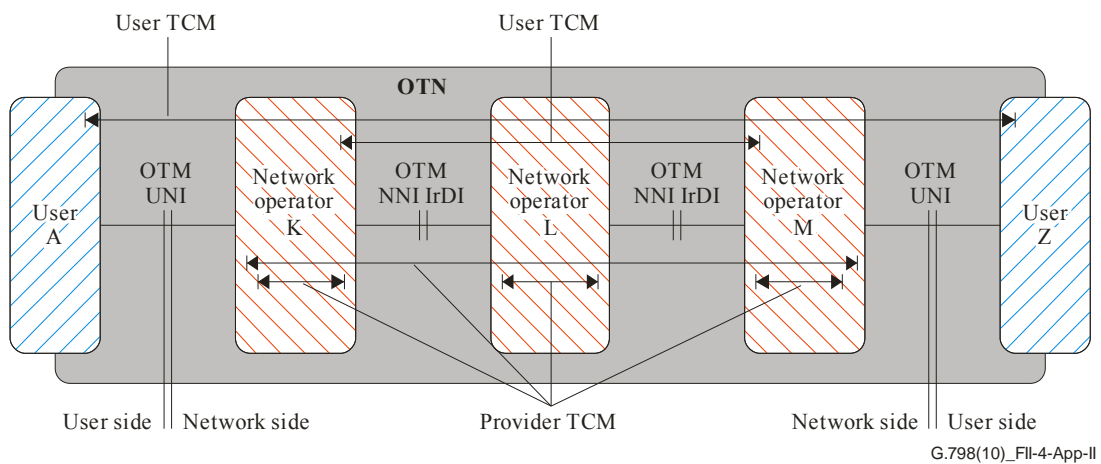

Figure II.4 – Provider and user tandem connections for case of OTM UNI interfaces and no termination of the OTN on the user side of the UNI

The TCM functions may furthermore be used to, for example:

- test a subnetwork connection consisting of multiple cascaded OTUk[V] trails for, e.g., fault localization;
- monitor working and protection connections for the case of ODUk SNC/S protection.

Appendix III

Performance of processes

(This appendix does not form an integral part of this Recommendation.)

III.1 Introduction

This appendix provides information on the performance of some processes such as defect detection and frame alignment.

III.2 OTUk frame alignment process

III.2.1 False out-of-frame events

False out-of-frame events will occur whenever the in-frame state is lost due to the line bit error rate. This event is related to the probability P_{wFAS} of receiving a corrupted FAS, which is equal to:

$$P_{wFAS} = 1 - (1 - \varepsilon)^{FASL} \cong \varepsilon \times FASL$$

Where ε is the line bit error rate, with Poisson distribution, and FASL is the number of bits of the FAS to be checked. The probability P_{fOOF} that the system will detect an OOF state coincides with the probability that α consecutive FAS are received. It means that:

$$P_{fOOF} = P_{wFAS}^{\alpha} \cong (\varepsilon \times FASL)^{\alpha}$$

It shall be noted that such a probability of occurrence is directly proportional to the FAS length and inversely proportional to the number of pre-alarm states (i.e., $\alpha - 1$) defined in the alignment process.

The average time between two false out-of-frame events is defined as follows:

$$T_{fOOF} = \frac{T_{frame}}{P_{fOOF}}$$

III.2.2 Minimum average time between false out-of-frame events

It is not possible to give the exact expression for the minimum average time between two out-of-frame events, due to it being a stochastic process. It is instead possible to give an approximate value for it. Given that the distribution of the OOF events is Poisson-like, it is possible to evaluate the minimum interval between two events with a given probability of occurrence. In other words, assuming that the probability of occurrence of an out-of-frame event in an interval shorter than T_{\min} is $P[t \leq T_{\min}] = p$, it can be demonstrated that:

$$T_{\min} = -T_{OOF} \times \ln(1 - p)$$

With $p = 10^{-3}$ the minimum average time between false OOF events results: $T_{\min} \cong T_{OOF} \times 10^{-3}$.

Figure III.1 shows the numerical results.

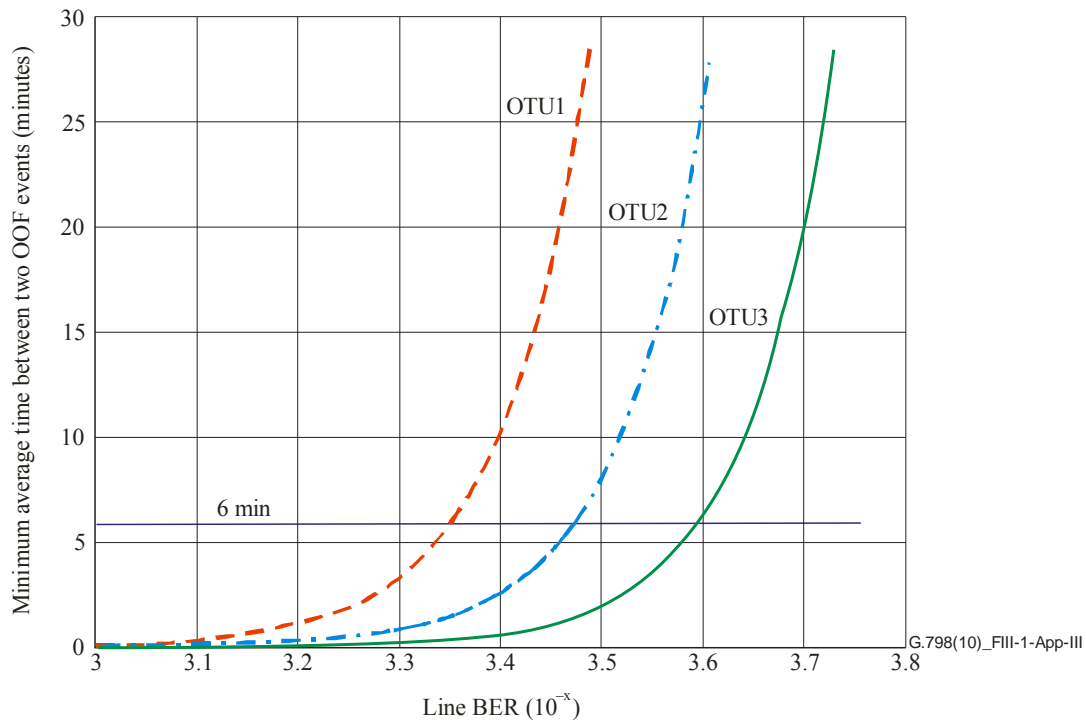

Figure III.1 – Minimum average time between false out-of-frame events

III.2.3 False in-frame events

The probability for false in-frame alignment can be obtained noting that the FAS is searched for up to one frame (FL bit long) with FL-1 possibilities for a false (simulated) FAS and confirmed the following δ frames. Given the equi-probability of receiving the symbol '0' or symbol '1', it is clear that the simulation of FAS only depends on FAS length. In fact, it results:

$$P_{fFAS} = \left(\frac{1}{2}\right)^{FASL}$$

False frame recovery probability can be defined as:

$$P_{ff} = 1 - (1 - P_{fFAS})^{FL-1}$$

The resulting probability for the false in-frame event thus results:

$$P_{fIF} = P_{ff} \times P_{fFAS}^{\delta}$$

The resulting rate of false frame recovery occurrence depends on frame length and is equal to:

$$T_{fIF} = \frac{T_{frame}}{P_{fIF}}$$

III.2.4 Frame alignment time

The frame alignment time is the time needed to reach the in-frame state starting from out-of-frame state.

In case of no FAS simulation, it is clear that this time is $T_{frame} \times (1 + \delta)$. Otherwise, the detection of a false FAS will start an alignment process that will lead inevitably to OOF state. This time is taken into account in the above defined relation with an aleatory variable, H , depending on false frame alignment probability; that means:

$$T_{IF} = T_{frame} \times (1 + \delta + H)$$

The value of the variable H is approximated by:

$$H = P_{fFAS} \times FASL$$

It shall be noted that in practice the frame alignment time is not affected by the false alignment occurrence. It means that, in any case, the in-frame state will be reached in two periods of the OTUk frame.

III.3 STAT acceptance process and related defect detection (ODUkP/TdAIS, ODUkP/TdOCI, ODUkP/TdLCK, ODUkTdTLC, ODUkTdIAE)

III.3.1 Average acceptance, raising and clearing time

The average acceptance time for the STAT field can be calculated using Equation 33 (clause III.1) of [b-Choi] as the STAT acceptance procedure is analogous to the misframe declaration procedure in Figure 7 (clause III.1) of [b-Choi] by reading p_d as probability for a disturbed STAT value.

Table III.1 – Average STAT acceptance time

BER	ODU frames	Time		
		ODU1	ODU2	ODU3
1.000E-03	3.02	147.8 μ s	36.8 μ s	9.1 μ s
1.000E-04	3.00	147.0 μ s	36.6 μ s	9.1 μ s
1.000E-05	3.00	146.9 μ s	36.6 μ s	9.1 μ s
1.000E-06	3.00	146.9 μ s	36.6 μ s	9.1 μ s

The average dAIS, dOCI, dLTC, dLCK and dIAE raising/clearing time is equal to the average acceptance time.

III.3.2 Mean time between false ODUkP/TdAIS and ODUkTdIAE defects due to bit errors assuming a transmitted STAT value of "001" (normal path signal)

$$p_d(\text{false dAIS}) = (\text{BER}^2 \cdot (1 - \text{BER}))^X$$

where X is the number of consecutive STAT fields for acceptance ($X = 3$)

The mean number of frames between false defects is approximately the reciprocal of p_d : $t_{dm} = 1/p_d$.

Table III.2 – Mean time between false ODUkP/TdAIS and ODUkTdIAE defects

BER	ODU frames	Time		
		ODU1	ODU2	ODU3
1.000E-03	1.00E+18	1.5E+06 years	3.9E+05 years	9.6E+04 years
1.000E-04	1.00E+24	1.5E+12 years	3.9E+11 years	9.6E+10 years
1.000E-05	1.00E+30	1.5E+18 years	3.9E+17 years	9.6E+16 years
1.000E-06	1.00E+36	1.5E+22 years	3.9E+23 years	9.6E+22 years

III.3.3 Mean time between false ODUkP/TdOCI defects due to bit errors assuming a transmitted STAT value of "001" (normal path signal)

$$p_d(\text{false dOCI}) = (\text{BER}^3)^N$$

The mean number of frames between false defects is approximately the reciprocal of p_d : $t_{dm} = 1/p_d$.

Table III.3 – Mean time between false ODUkP/TdOCI defects

BER	ODU frames	Time		
		ODU1	ODU2	ODU3
1.000E-03	1.00E+27	1.5E+15 years	3.9E+14 years	9.6E+13 years
1.000E-04	1.00E+36	1.5E+24 years	3.9E+23 years	9.6E+22 years
1.000E-05	1.00E+45	1.5E+33 years	3.9E+32 years	9.6E+31 years
1.000E-06	1.00E+54	1.5E+42 years	3.9E+41 years	9.6E+40 years

III.3.4 Mean time between false ODUkTdLTC and ODUkP/TdLCK defects due to bit errors assuming a transmitted STAT value of "001" (normal path signal)

$$p_d(\text{false dLTC, dLCK}) = (\text{BER} \cdot (1 - \text{BER})^2)^X$$

where X is the number of consecutive STAT fields for acceptance (X = 3)

The mean number of frames between false defects is approximately the reciprocal of p_d : $t_{dm} = 1/p_d$.

Table III.4 – Mean time between false ODUkTdLTC and ODUkP/TdLCK defects

BER	ODU frames	Time		
		ODU1	ODU2	ODU3
1.000E-03	1.01E+09	13.6 h	3.4 h	0.8 h
1.000E-04	1.00E+12	1.5 years	3.9E-01 years	842.2 h
1.000E-05	1.00E+15	1.5E+03 years	3.9E+02 years	9.6E+01 years
1.000E-06	1.00E+18	1.5E+6 years	3.9E+05 years	9.6E+04 years

III.4 OTUkdIAE, OTUkdBDI, ODUkP/TdBDI detection

III.4.1 Average raising and clearing time

The average raising/clearing delay can be calculated using Equation 33 of [b-Choi] as the detection procedure is analogous to the misframe declaration procedure in Figure 7 of [b-Choi] by reading p_d as probability for a disturbed value.

Table III.5 – Average OTUkdIAE, ODUkdBDI, ODUkP/dBDI raising/clearing time

BER	ODU frames	Time		
		ODU1	ODU2	ODU3
1.000E-03	5.02	245.8 μs	61.1 μs	15.2 μs
1.000E-04	5.00	244.8 μs	61.0 μs	15.2 μs
1.000E-05	5.00	244.8 μs	61.0 μs	15.2 μs
1.000E-06	5.00	244.8 μs	61.0 μs	15.2 μs

III.4.2 Mean time between false defects due to bit errors

$$p_d(\text{false dBDI}) = \text{BER}^X$$

where X is the number of consecutive fields for acceptance (X = 5)

The mean number of frames between false defects is approximately the reciprocal of p_d : $t_{dm} = 1/p_d$.

Table III.6 – Mean time between false OTUkdIAE, OTUkdBDI, ODUkP/TdBDI defects

BER	ODU frames	Time		
		ODU1	ODU2	ODU3
1.000E-03	1.00E+15	1.5E+03 years	3.9E+02 years	9.6E+01 years
1.000E-04	1.00E+20	1.5E+08 years	3.9E+07 years	9.6E+06 years
1.000E-05	1.00E+25	1.5E+13 years	3.9E+12 years	9.6E+11 years
1.000E-06	1.00E+30	1.5E+18 years	3.9E+17 years	9.6E+16 years

III.5 PT acceptance process and ODUkPdPLM detection

III.5.1 Average acceptance, raising and clearing time

The average acceptance time for the PT field can be calculated using Equation 33 of [b-Choi] as the PT acceptance procedure is analogous to the misframe declaration procedure in Figure 7 of [b-Choi] by reading p_d as probability for a disturbed PT value.

Table III.7 – Average PT acceptance time

BER	ODU multiframe	Time		
		ODU1	ODU2	ODU3
1.000E-03	3.05	38.2 ms	9.5 ms	2.4 ms
1.000E-04	3.00	37.6 ms	9.4 ms	2.3 ms
1.000E-05	3.00	37.6 ms	9.4 ms	2.3 ms
1.000E-06	3.00	37.6 ms	9.4 ms	2.3 ms

The average dPLM raising/clearing time is equal to the average acceptance time.

III.5.2 Mean time between false PLM defects due to bit errors

A false PLM defect is declared if the same i bits (out of $n = 8$) are disturbed in $X = 3$ consecutive multiframes. According to Equation 33 of [b-Choi], the mean number of multiframes between the acceptance of a false PT byte with i certain false bits is:

$$t_{mf, i} = \frac{1}{p_i^X} \frac{1 - p_i^X}{1 - p_i}$$

with the probability p_i of i certain bits being disturbed within one multiframe.

$$p_i = BER^i \cdot (1 - BER)^{n-i}$$

The mean number of multiframes between any false acceptance resulting in a false dPLM is:

$$t_{mf} = \frac{1}{\sum_i \binom{n}{i} \cdot \frac{1}{t_{mf, i}}}$$

Table III.8 – Mean time between false ODUkP PLM defects

BER	ODU frames	Time		
		ODU1	ODU2	ODU3
1.000E-03	1.25E+08	434.4 h	108.2 h	26.9 h
1.000E-04	1.25E+11	49.6 years	12.4 years	3.1 years
1.000E-05	1.25E+14	4.97E+04 years	1.24E+04 years	3077 years
1.000E-06	1.25E+17	4.97E+07 years	1.24E+07 years	3.08E+06 years

III.6 Generic AIS and OTUk AIS detection

III.6.1 Average dAIS detection time

The probability of detecting the generic AIS pattern within one counting interval is:

$$p_d = \sum_{k=0}^{255} \binom{Nb}{k} \cdot (3 \cdot BER)^k \cdot (1 - 3 \cdot BER)^{(Nb-k)}$$

with $Nb = 8192$ being the number of bits per counting interval. Inserting p_d and the number of counting intervals in which the generic AIS signal must be detected before raising the defect, $c = 3$, into Equation 33 of [b-Choi] leads to the average dAIS detection time. The factors of three found in the above equation are due to the error multiplication that occurs within the generic AIS detection circuit (see clause 6.2.6.3.3).

Table III.9 – Average dAIS detection time

BER	intervals (8192 bits)	Time		
		ODU1	ODU2	ODU3
2.00E-02	5.0E+98	5.2E+85 years	1.3E+85 years	3.2E+84 years
1.00E-02	5.7	18.6 μ s	4.6 μ s	1.2 μ s
1.00E-03	3	9.8 μ s	2.4 μ s	0.61 μ s
1.00E-04	3	9.8 μ s	2.4 μ s	0.61 μ s

Table III.9 – Average dAIS detection time

BER	intervals (8192 bits)	Time		
		ODU1	ODU2	ODU3
1.00E-05	3	9.8 μs	2.4 μs	0.61 μs
1.00E-06	3	9.8 μs	2.4 μs	0.61 μs

III.7 OTUkdBIAE and ODUkTdBIAE detection process

III.7.1 Average dBIAE detection time

The average dBIAE detection/clearing time can be calculated using Equation 33 of [b-Choi], as the procedure is analogous to the misframe declaration procedure in Figure 7 of [b-Choi] by reading q_d as probability for an undisturbed BIAE value.

$$q_d = (1 - BER)^n$$

$$t_d = \frac{1}{q_d^X} \frac{1 - q_d^X}{1 - q_d}$$

n: number of BEI/BIAE bits (n = 4)

X: number of consecutive BIAE values for dBIAE (X = 3)

Table III.10 – Average dBIAE detection/clearing time

BER	OTU/ODU frames	Time		
		ODU1	ODU2	ODU3
1.000E-03	3.02	148.1 μs	36.9 μs	9.2 μs
1.000E-04	3.00	147.0 μs	36.6 μs	9.1 μs
1.000E-05	3.00	146.9 μs	36.6 μs	9.1 μs
1.000E-06	3.00	146.9 μs	36.6 μs	9.1 μs

III.7.2 Mean time between false BIAE defects due to bit errors

A false BIAE defect is declared if the received BEI value is disturbed in such a way that the BIAE value (i.e., '1011') is falsely detected in $X = 3$ consecutive frames. Since the BEI value changes each frame due to received far-end bit errors, the probability of a false BIAE value occurring depends on the specific value of BEI generated each frame. Therefore, the probability of detecting a false BIAE value is the product of the conditional probability of a false BIAE value occurring given a particular BEI value and the probability of the occurrence of the particular BEI value. Summing over all possible BEI values gives the total probability of a false BIAE being detected in any single frame:

$$P = \sum_{k=0}^8 P_{BEI, k} \cdot P_{BIAE|BEI, k}$$

where:

$$P_{BEI, k} = \binom{8}{k} (P_{BIP1})^k \cdot (1 - P_{BIP1})^{8-k}, \quad 0 \leq k \leq 8$$

and:

$$p_{BIAE|BEI, k} = (BER)^n \cdot (1 - BER)^{4-n}, \quad 0 \leq k \leq 8$$

where n represents the number of BEI bit errors required to convert the BEI value to a false BIAE value ($n = 3, 2, 2, 1, 4, 3, 3, 2, 2$, for $k = 0, 1, 2, 3, 4, 5, 6, 7$ and 8 , respectively). Additionally, Equation C.3 of [b-ATIS 0300231.01] provides a closed form expression for the probability of an error in a single BIP thread as follows:

$$p_{BIP1} = \frac{1 - (1 - 2 \cdot BER)^m}{2}, \quad m = 15240$$

The value 15240 represents the number of bits per thread of the BIP8 of the ODU tandem connection and path monitors.

According to Equation 33 of [b-Choi], the mean number of frames between false BIAE defects because of bit errors within the BEI/BIAE field is:

$$t_{mf} = \frac{1}{p^X} \frac{1 - p^X}{1 - p}$$

with the probability p of a false BIAE.

In Table III.11, the same BER for both directions of a bidirectional connection is assumed.

Table III.11 – Mean time between false BIAE defects

BER	OTU/ODU frames	Time		
		ODU1	ODU2	ODU3
1.000E-03	9.6E+10	1310 h	326 h	81.1 h
1.000E-04	7.4E+13	115 years	28.6 years	7.1 years
1.000E-05	4.0E+18	6.3E+06 years	1.6E+06 years	3.9E+05 years
1.000E-06	1.8E+29	2.9E+17 years	7.1E+16 years	1.8E+16 years

Appendix IV

TTI processing examples

(This appendix does not form an integral part of this Recommendation.)

This appendix gives implementation examples for TTI processing that fulfil the definitions given in the main body of this Recommendation. Other implementations that fulfil the definitions are possible.

IV.1 Example 1

IV.1.1 Trail trace identifier (TTI) acceptance and reporting process

A new TTI is accepted if a new consistent value is received in the 64 TTI bytes in X consecutive multiframes. X shall be 3.

The accepted TTI shall be reported to the management system (MI_AcTI) if requested (MI_GetAcTI). The SAPI and DAPI part of the accepted TTI shall be compared with the expected SAPI and DAPI for TTI mismatch detection (see clause IV.I.2).

IV.1.2 SAPI/DAPI compare process

The SAPI/DAPI compare process compares the SAPI/DAPI part of the accepted TTI (AcTI, see clause IV.1.1) with the equivalent expected SAPI/DAPI values set via the MP (MI_ExSAPI/DAPI). The comparison result is "match" if all 16 bytes were equal, and "mismatch" if one or more bytes were unequal.

For the dTIM generation based on the results of the SAPI/DAPI compare process, see clause 6.2.2.1.

IV.1.3 Performance of example 1

IV.1.3.1 Average TTI acceptance time

The average TTI acceptance time can be calculated using Equation 33 of [b-Choi], as the procedure is analogous to the misframe declaration procedure in Figure 7 of [b-Choi] by reading q_d as probability for the received TTI value being equal to the last one.

$$q_d = (1 - BER)^n$$

$$t_d = \frac{1}{q_d^X} \frac{1 - q_d^X}{1 - q_d}$$

n: number of TTI bits (n = 512)

X: number of consecutive equal comparison results for TTI acceptance (X = 3)

Table IV.1 – Average TTI acceptance time for ODU1, ODU2 and ODU3

BER	TTI periods	Time		
		ODU1	ODU2	ODU3
1.000E-03	9.10	28.5 ms	7.1 ms	1.8 ms
1.000E-04	3.33	10.4 ms	2.6 ms	0.6 ms
1.000E-05	3.03	9.5 ms	2.4 ms	0.6 ms
1.000E-06	3.00	9.4 ms	2.3 ms	0.6 ms

IV.1.3.2 Average dTIM detection and clearing time

The average dTIM detection and clearing times are equal to the TTI acceptance time.

IV.1.3.3 Mean time between false TIM defects due to bit errors

A false TTI defect is declared if a TTI with bit errors is accepted and an errored bit is within the compared SAPI, respectively DAPI, field of the TTI. The same i bits (out of $n = 512$) have to be disturbed in $X = 3$ consecutive TTIs. According to Equation 33 of [b-Choi], the mean number of TTIs between the acceptance of a false TTI with i certain false bits is:

$$t_{mf, i} = \frac{1}{p_i^X} \cdot \frac{1 - p_i^X}{1 - p_i}$$

with the probability p_i of i certain bits being disturbed within one TTI:

$$p_i = BER^i \cdot (1 - BER)^{n-i}$$

The mean number of TTIs between any false dTIM is:

$$t_{mf} = \frac{1}{\sum_i \frac{P_{API, i}}{t_{mf, i}}}$$

with the probability $P_{API, i}$ that the API field contains an errored bit of the false accepted TTI with i bit errors.

n : number of TTI bits

X : number of consecutive equal comparison results for TTI acceptance ($X = 3$)

Table IV.2 – Mean time between false TIM defects for ODU1, ODU2 and ODU3

BER	TTI periods	Time		
		ODU1	ODU2	ODU3
1.000E-03	3.62E+07	31.5 h	7.9 h	2.0 h
1.000E-04	9.11E+09	0.9 years	0.2 years	0.06 years
1.000E-05	7.93E+12	788 years	196 years	49 years
1.000E-06	7.82E+15	777 093 years	193 457 years	481 60 years

IV.2 Example 2

IV.2.1 TTI reporting

TTI reporting consists of control, compare and store, and persistency processes as shown in Figure IV.1. When a request for TTI reporting is received via MI_GetAcTI by the control process, it starts the compare and store, and persistency processes.

The compare and store process contains a 64-byte store, holding the latest stored TTI. Once started, this process compares the received TTI byte with the equivalent byte in the store. After the comparison the byte is copied into the store. After all 64 bytes have been compared and stored, the total comparison result is sent to the persistency process. This total comparison result is "equal" if all 64 bytes were equal, and "unequal" if one or more bytes were unequal. Now processing is continued for the next TTI sample.

When the persistency process is started, it outputs "unstable" to the control process. When it receives three consecutive "equal" comparison results from the compare and store process, it outputs "stable" to the control processes.

When the control process receives "stable" from the persistency process, it stops the compare and store, and persistency process. The compare and store process makes the stored TTI available at MI_AcTI.

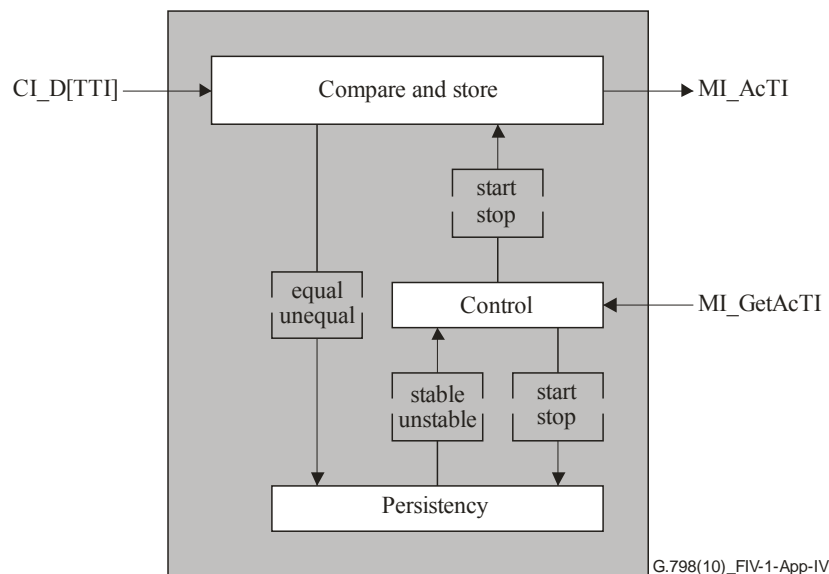

Figure IV.1 – TTI reporting process

IV.2.2 SAPI/DAPI compare process

The SAPI/DAPI compare process compares the received SAPI/DAPI byte (RxTI) with the equivalent expected SAPI/DAPI byte set via the MP (MI_ExSAPI/DAPI). After all 16 bytes have been compared, the total comparison result is sent to the SAPI/DAPI persistency process. This total comparison result is "equal" if all 16 bytes were equal, and "unequal" if one or more bytes were unequal. Now processing is continued for the next SAPI/DAPI, consecutive with the previous one.

The SAPI/DAPI persistency process outputs its state, either "match" or "mismatch" to the control process. The process enters the "match" state after having received three consecutive "equal" comparison results. The process enters the "mismatch" state when seven consecutive "unequal" comparison results are received.

For the dTIM generation based on the results of the SAPI/DAPI compare process, see clause 6.2.2.1.

IV.2.3 Performance of example 2

IV.2.3.1 Average TTI acceptance time

The average TTI acceptance time can be calculated using Equation 33 of [b-Choi], as the procedure is analogous to the misframe declaration procedure in Figure 7 of [b-Choi] by reading q_d as probability for the received TTI value being equal to the last one. For the calculation, it is assumed that the compare and store process holds the current TTI when the TTI reporting process is started.

$$q_d = (1 - BER)^n$$

$$t_d = \frac{1}{q_d^X} \frac{1 - q_d^X}{1 - q_d}$$

n: number of TTI bits (n = 512)

X: number of consecutive equal comparison results for a stable TTI (X = 3)

Table IV.3 – Average TTI acceptance time for ODU1, ODU2 and ODU3

BER	TTI periods	Time		
		ODU1	ODU2	ODU3
1.000E-03	9.10	28.5 ms	7.1 ms	1.8 ms
1.000E-04	3.33	10.4 ms	2.6 ms	0.6 ms
1.000E-05	3.03	9.5 ms	2.4 ms	0.6 ms
1.000E-06	3.00	9.4 ms	2.3 ms	0.6 ms

IV.2.3.2 Average dTIM detection time

The average dTIM detection time can be calculated using Equation 33 of [b-Choi], as the procedure is analogous to the misframe declaration procedure in Figure 7 of [b-Choi] by reading q_d as probability for an unequal SAPI, respectively DAPI, value. Here the worst case is calculated where ExSAPI and RxSAPI, respectively ExDAPI and RxDAPI, differ in only one bit.

$$q_d = 1 - BER$$

$$t_d = \frac{1}{q_d^X} \frac{1 - q_d^X}{1 - q_d}$$

X: number of consecutive unequal comparison results for dTIM (X = 7)

Table IV.4 – Average dTIM detection time for ODU1, ODU2 and ODU3

BER	TTI periods	Time		
		ODU1	ODU2	ODU3
1.000E-03	7.03	22.0 ms	5.5 ms	1.4 ms
1.000E-04	7.00	21.9 ms	5.5 ms	1.4 ms
1.000E-05	7.00	21.9 ms	5.5 ms	1.4 ms
1.000E-06	7.00	21.9 ms	5.5 ms	1.4 ms

IV.2.3.3 Average dTIM clearing time

The average dTIM clearing time can be calculated using Equation 33 of [b-Choi], as the procedure is analogous to the misframe declaration procedure in Figure 7 of [b-Choi] by reading q_d as probability for an equal SAPI, respectively DAPI, value.

$$q_d = (1 - BER)^n$$

$$t_d = \frac{1}{q_d^X} \frac{1 - q_d^X}{1 - q_d}$$

n: number of SAPI, respectively DAPI, bits (n = 128)

X: number of consecutive equal comparison results for dTIM clearance (X = 3)

Table IV.5 – Average dTIM clearance time for point-to-multipoint and multipoint-to-point configurations for ODU1, ODU2 and ODU3

BER	TTI periods	Time		
		ODU1	ODU2	ODU3
1.000E-03	3.90	12.2 ms	3.0 ms	0.8 ms
1.000E-04	3.08	9.6 ms	2.4 ms	0.6 ms
1.000E-05	3.01	9.4 ms	2.3 ms	0.6 ms
1.000E-06	3.00	9.4 ms	2.3 ms	0.6 ms

IV.2.3.4 Mean time between false TIM defects due to bit errors

The mean time between false TIM defects can be calculated using Equation 33 of [b-Choi], as the procedure is analogous to the misframe declaration procedure in Figure 7 of [b-Choi] by reading q_d as probability for an unequal SAPI, respectively DAPI, value due to bit errors.

$$q_d = 1 - (1 - BER)^n$$

$$t_d = \frac{1}{q_d^X} \frac{1 - q_d^X}{1 - q_d}$$

n: number of SAPI, respectively DAPI, bits (n = 128)

X: number of consecutive unequal comparison results for dTIM (X = 7)

Table IV.6 – Mean time between false TIM defects for point-to-multipoint and multipoint-to-point configurations for ODU1, ODU2 and ODU3

BER	TTI periods	Time		
		ODU1	ODU2	ODU3
1.000E-03	3.13E+06	2.7 h	0.7 h	0.2 h
1.000E-04	1.88E+13	1868 years	465 years	116 years
1.000E-05	1.79E+20	1.8E+10 years	4.4E+09 years	1.8E+10 years
1.000E-06	1.78E+27	1.8E+17 years	4.4E+16 years	1.8E+17 years

Appendix V

Client services of sub ODU1 rate mapping into OTN using higher order virtual container mapping

(This appendix does not form an integral part of this Recommendation.)

V.1 Description of the application

Current SDH and OTN standards (i.e., [ITU-T G.783] and this Recommendation) allow mapping of a generic packet-based client signal over OTN, mapping it into a virtually concatenated group (VCG) composed of a number of VC-4s, as represented in Figure V.1. The VCG is therefore mapped into an STM-N container which is (a)synchronously mapped into ODUk.

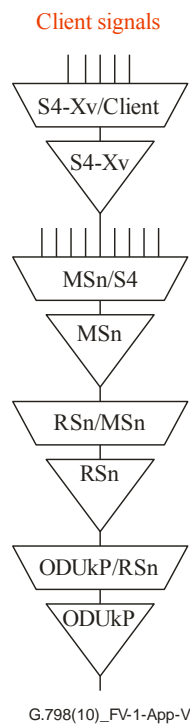

Figure V.1 – Mapping of clients over OTN

The great advantage of this mapping procedure is that all the basic functionalities are already defined in the standards and deployed in the installed base.

Operators can decide whether to simplify this mapping procedure by switching off the OAM information of the MS-OH and RS-OH SDH layers, considering that within the transport network the client service monitoring and cross-connection are provided at the Sn level while the MS and RS layers provide a duplication of the OAM functionalities already present in the ODUk layer. As such, MS and RS could be considered for mapping purposes only. The result is a compound function (Figure V.2), defined as ODUkP/Sn, that provides the direct mapping of the Sn-Xv into an ODUk container.

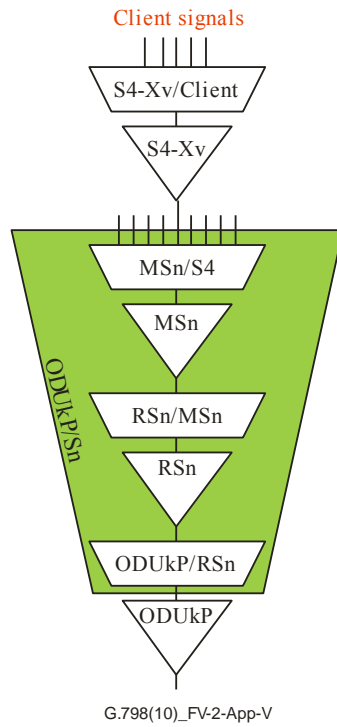

Figure V.2 – Compound function for mapping of clients over OTN via ODUkP/Sn

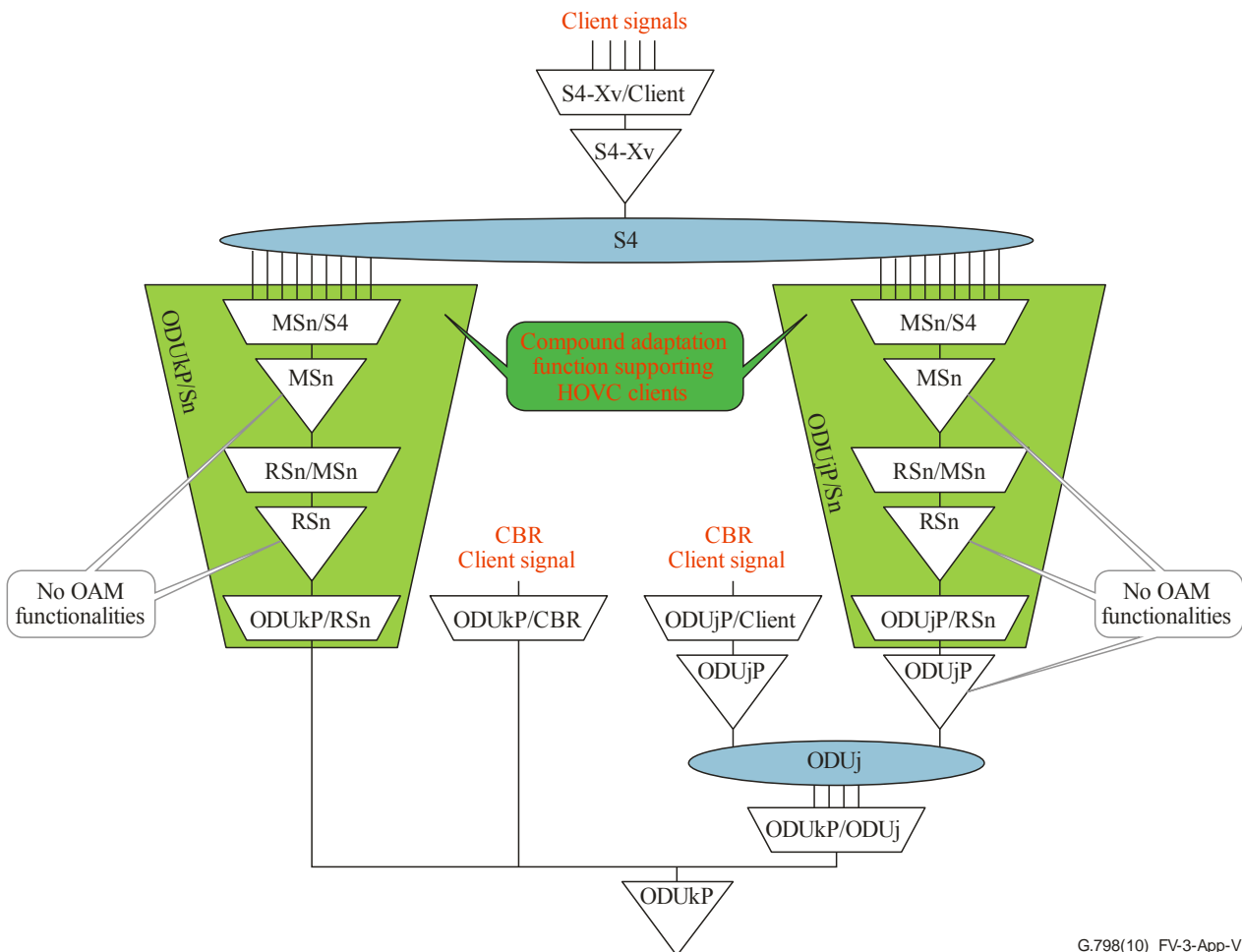
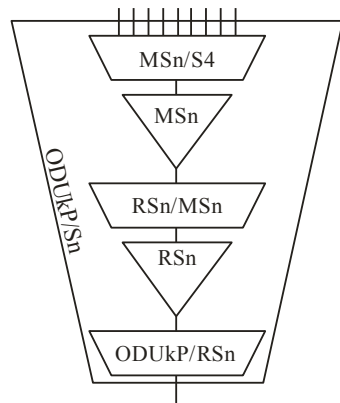

Figure V.3 – Equipment model example for mapping of clients over OTN via ODUkP/Sn

V.2 ODUk/Sn compound function

V.2.1 ODUkP to Sn compound adaptation function (ODUkP/Sn_A)

The ODUkP to Sn adaptation functions perform the adaptation between the ODUkP ($k = 1, 2, 3$) layer adapted information and the characteristic information of an Sn signal belonging to a virtually concatenated group. It is the composite of a set of functionalities described in this Recommendation and [ITU-T G.783], with a simplified management.



G.798(10)_FV-4-App-V

Figure V.4 – ODUkP/Sn compound function

V.2.1.1 ODUkP to Sn compound adaptation source function (ODUkP/Sn_A_So)

The ODUkP to Sn compound adaptation source function is composed of the following functionalities, defined in this Recommendation and [ITU-T G.783]:

- MSn/Sn adaptation source.
- MSn termination source.
- RSn/MSn adaptation source.
- RSn termination source.
- ODUkP/RSn adaptation source.

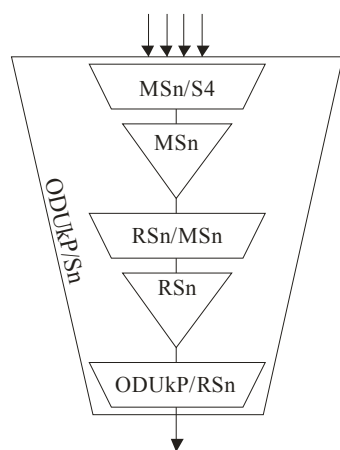

G.798(10)_FV-5-App-V

Figure V.5 – ODUkP/Sn compound adaptation source function

V.2.1.2 ODUkP to Sn compound adaptation sink function (ODUkP/Sn_A_Sk)

The ODUkP to Sn compound adaptation sink function is composed of the following functionalities, defined in this Recommendation and [ITU-T G.783]:

- ODUkP/Rn adaptation sink.
- RSn termination sink.
- RSn/MSn adaptation sink.
- MSn termination sink.
- MSn/Sn adaptation sink.

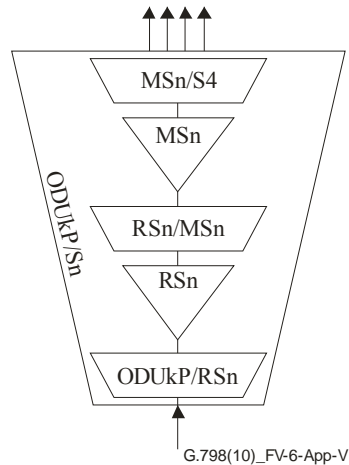

Figure V.6 – ODUkP/Sn compound adaptation sink function

V.3 Migration from SDH towards OTN networking

Using the approach described in this appendix for client services mapping into OTN via HOVC allows a smooth migration from the existing SONET/SDH transport network towards the new optical transport network deployment, as depicted in Figure V.7, saving the investment that operators are still making in SONET/SDH technologies.

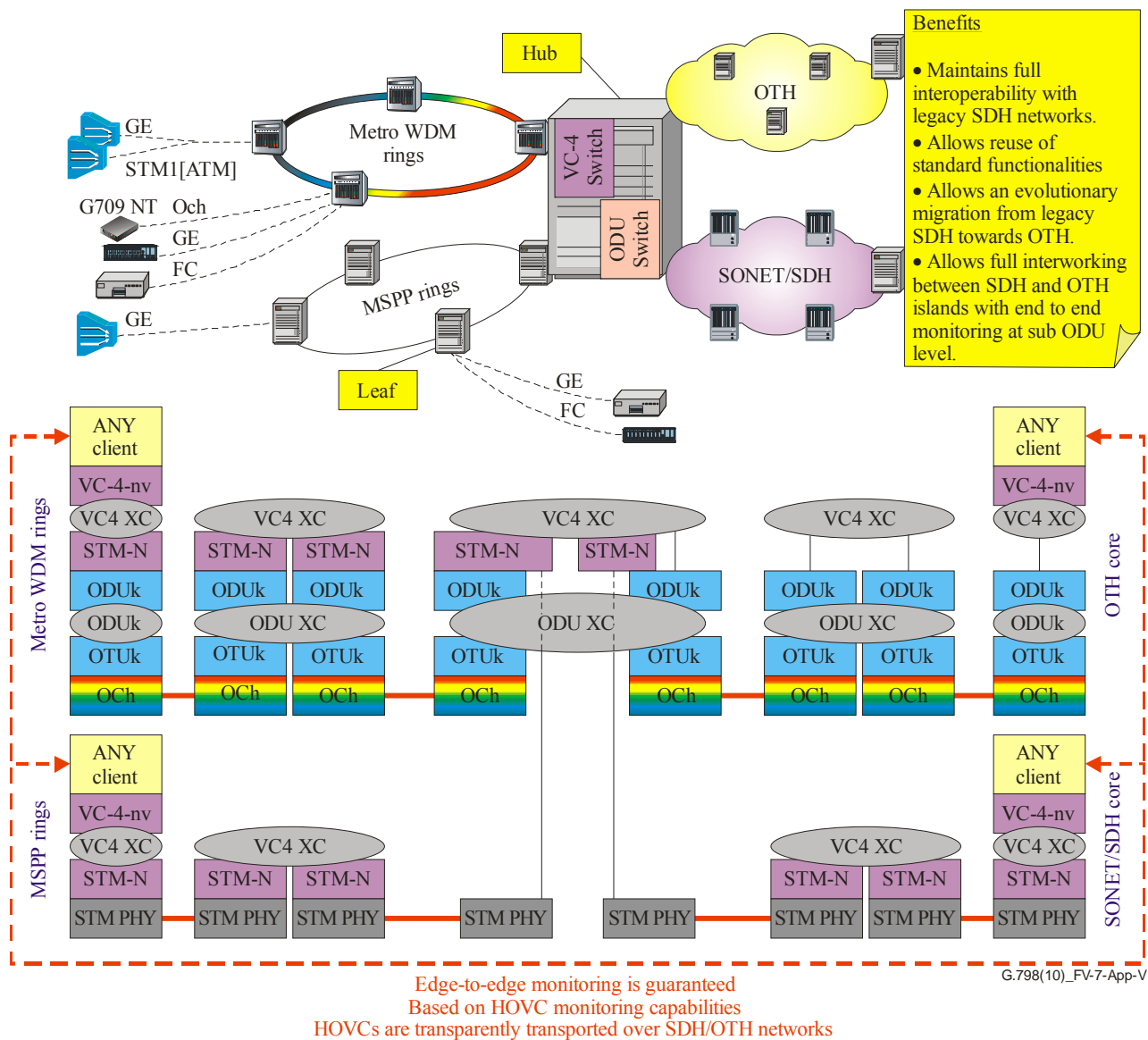

Figure V.7 – Migration from SDH/SONET towards OTN

At the same time, operators who do not today see the need for investment in SONET/SDH, can have an efficient way to map directly into OTN a generic client service without waiting for the definition of new mapping techniques that would require a non-negligible amount of time for a new standard definition and new implementations.

Bibliography

- [b-ANSI INCITS 352] ANSI INCITS 352-2002, *Information Technology – Fibre Channel – Physical Interfaces (FC-PI)*.
- [b-ANSI INCITS 364] ANSI INCITS 364-2003, *Information Technology – Fibre Channel 10 Gigabit (10GFC)*.
- [b-ATIS-0300231.01] ATIS 0300231.01-1997, *In-service Digital Transmission Performance Monitoring*.
- [b-Choi] Choi, D. (1990), *Frame alignment in digital carrier system – a tutorial*, IEEE Communications Magazine.

SERIES OF ITU-T RECOMMENDATIONS

Series A	Organization of the work of ITU-T
Series D	General tariff principles
Series E	Overall network operation, telephone service, service operation and human factors
Series F	Non-telephone telecommunication services
Series G	Transmission systems and media, digital systems and networks
Series H	Audiovisual and multimedia systems
Series I	Integrated services digital network
Series J	Cable networks and transmission of television, sound programme and other multimedia signals
Series K	Protection against interference
Series L	Construction, installation and protection of cables and other elements of outside plant
Series M	Telecommunication management, including TMN and network maintenance
Series N	Maintenance: international sound programme and television transmission circuits
Series O	Specifications of measuring equipment
Series P	Terminals and subjective and objective assessment methods
Series Q	Switching and signalling
Series R	Telegraph transmission
Series S	Telegraph services terminal equipment
Series T	Terminals for telematic services
Series U	Telegraph switching
Series V	Data communication over the telephone network
Series X	Data networks, open system communications and security
Series Y	Global information infrastructure, Internet protocol aspects and next-generation networks
Series Z	Languages and general software aspects for telecommunication systems