



INTERNATIONAL TELECOMMUNICATION UNION

CCITT

THE INTERNATIONAL
TELEGRAPH AND TELEPHONE
CONSULTATIVE COMMITTEE

U.201

(11/1988)

SERIES U: TELEGRAPH SWITCHING

Definitions

**INTERWORKING BETWEEN THE TELETEX
SERVICE AND THE TELEX SERVICE**

Reedition of CCITT Recommendation U.201 published in
the Blue Book, Fascicle VII.2 (1988)

NOTES

- 1 CCITT Recommendation U.201 was published in Fascicle VII.2 of the *Blue Book*. This file is an extract from the *Blue Book*. While the presentation and layout of the text might be slightly different from the *Blue Book* version, the contents of the file are identical to the *Blue Book* version and copyright conditions remain unchanged (see below).
- 2 In this Recommendation, the expression “Administration” is used for conciseness to indicate both a telecommunication administration and a recognized operating agency.

Recommendation U.201

INTERWORKING BETWEEN THE TELETEx SERVICE AND THE TELEX SERVICE

(Melbourne, 1988)

1 Introduction

1.1 This Recommendation defines the procedures to be followed for interworking between the Teletex service and the telex service.

1.2 This Recommendation is one of the a series which define interworking between the telex service and the Teletex service.

The other Recommendations are:

- a) Recommendation F.200: Teletex service
- b) Recommendation T.390: Requirements for interworking with the telex service
- c) Recommendation F.201: Interworking between the Teletex service and the telex service – General principles

2 Basic interworking service

2.1 Types of interworking

2.1.1 Interworking between the Teletex service and the telex service consists of two directions:

- a) the telex to Teletex direction;
- b) the Teletex to telex direction.

2.2 Methods of interworking

2.2.1 considering:

- (a) that the Teletex service can be provided upon various networks (see Recommendation F.200, § 2);
- (b) that an Administration¹⁾ can provide the Teletex service on more than one network (e.g. PSTN and PSPDN . . .);

(c) that the technical constraints of the existing networks (e.g. numbering plans, . . .),

the two following methods of interworking between the telex service and the Teletex service can be provided:

- i) interworking with one-stage selection;
- ii) interworking with two-stage selection.

2.2.2 The service requirements of each method are described in Recommendation F.201, §§ 3 and 4 respectively.

3 Telex access to a conversion facility (CF)

3.1 One-stage selection

Recommendation F.201, § 3 describes the service principles for this method of interworking.

¹⁾ or a recognized private operating agency.

3.1.1 Access from a manual telex terminal

Interworking in the telex to Teletex direction using one-stage selection, in case of manual terminals, is described in Figure 1/U.201 and associated notes.

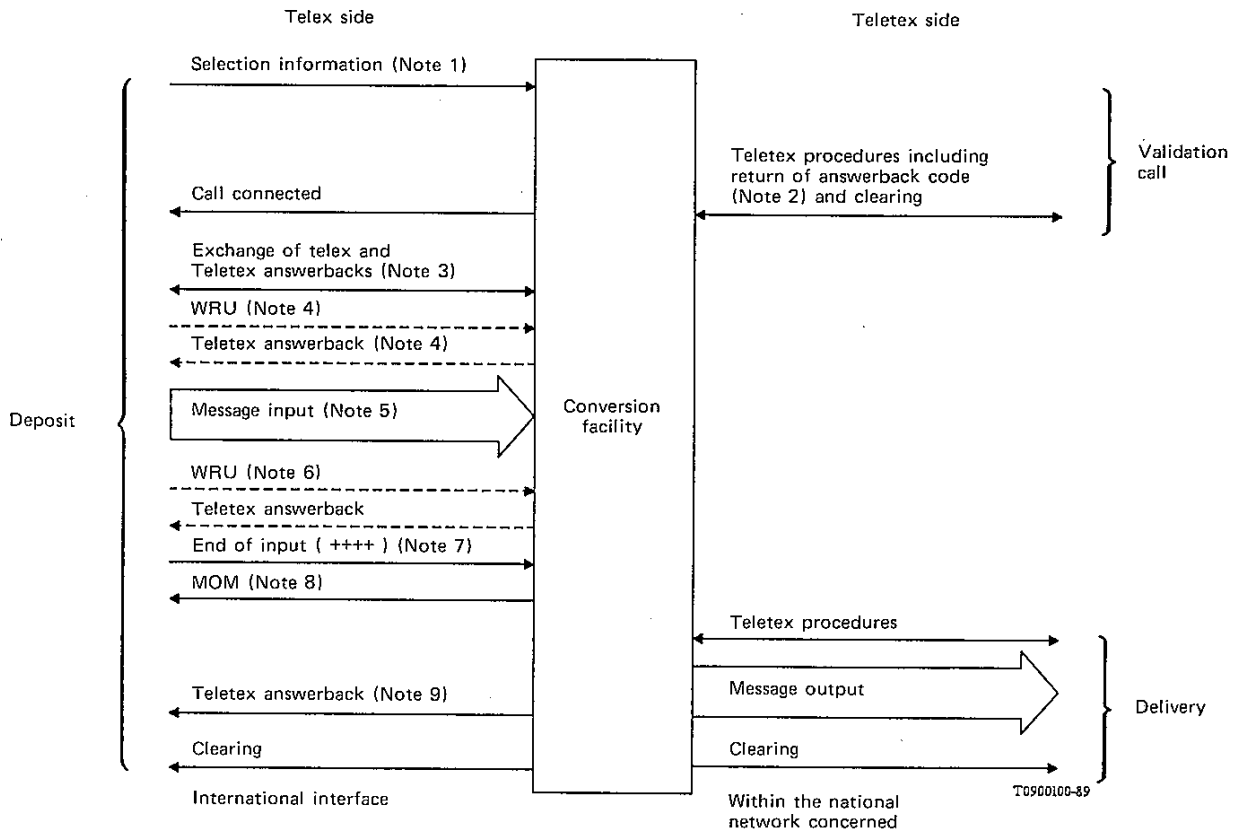

FIGURE 1/U.201
Interworking in the telex to Teletex direction using one-stage selection procedure
(case of manual telex)

Notes relative to Figure 1/U.201:

Note 1 – The total selection information of the Teletex subscriber should not be longer than 12 digits.

Note 2 – See Recommendations T.90 and U.70.

Note 3 – The Teletex answerback sent to the telex subscriber is a rearranged Teletex terminal identification, as follows:

↑ ← ≡	Part 2 of TTX-id	[= ↓ Part 4 of TTX-id]	[] → ∅
1 1 1	up to 12		
	up to 15		up to 4
20 characters			

where:

“TTX-id” is for Teletex terminal identification according to Figure 2/F.200 (Red Book).

Q is the telex network identification code as provided in Recommendation F.69 (Red Book).

[] indicate an optional part or signal.

- i) [↓] before “→ Ø” does not exist if Part 4 of TTX-id is included.
- ii) Part 2 of TTX-id has the same definition as given in § 7.5.4 of Recommendation F.200.
- iii) Part 4 of TTX-id, whenever included, has the same definition as given in § 7.5.6 of Recommendation F.200 but the minimum of letters could be reduced to one (instead of three);
- iv) The length of the Teletex answerback is set to 20 characters, the eventual unused positions are filled with “↓” according to Recommendation F.60.
- v) As far as possible, the mnemonic part is included in the Teletex answerback.

Examples of TTX-A/B:

1	2	3	4	5	6	7	8	9	10	11	12	13	14	15	16	17	18	19	20
↑	←	≡	6	1	5	1	9	1	7	=	↓	F	T	Z	↓	↓	↓	→	O
↑	←	≡	1	2	3	4	5	6	7	8	9	10	11	12	=	↓	→	N	L
↑	←	≡	1	2	3	4	5	6	7	8	=	↓	M	N	E	M	O	→	F

Note 4 – The CF shall accept the possible occurrence of an extra WRU at this stage. The answerback returned by the CF is the Teletex answerback obtained during the validation call. (See Note 3.)

Note 5 – The CF shall wait at least 15 seconds for the message input. See Annex for abnormal conditions during text input.

- Note 6* – i) This procedure is recommended but not mandatory. (See Recommendation F.60.)
- ii) The answerback returned by the CF is the Teletex answerback obtained during the validation call. (See Note 3.)

- Note 7* – i) The end of input (EOI) signal is the plus symbol (ITA No. 2 combination No. 26 Figure case) repeated four times (++ ++). This EOI signal need not be transferred to the Teletex side.
- ii) If the caller clears without the EOI signal, the network will endeavour to deliver the message as received. However, customers must be clearly warned that the network cannot guarantee delivery in these circumstances.

- Note 8* – i) The CF shall wait 800 ms for WRU after EOI. If no WRU is received within this period, the terminal is considered as a manual one. A MOM signal is then sent by the CF at each call attempt. If a WRU is sent by the telex terminal within this period the terminal is considered as a telex automatic emitting device.
- ii) When the EOI signal is received, the conversion facility shall immediately establish the delivery call to the Teletex terminal. In the case of unsuccessful calls on the PSPDN and CSPDN, the conversion facility shall make several attempts with five-second intervals measured from the end of one attempt to the beginning of the next. At each attempt, the MOM signal followed by service signals defined in Recommendation U.70, if appropriate, shall be sent to the waiting telex terminal. As a whole, the telex line is not to be held for a period exceeding 30 seconds. If all these attempts are unsuccessful, the conversion facility shall send the service message ITL→TTX→Ø/(ITL - I'll transmit later) to the waiting telex terminal and clear down. It shall then be the responsibility of the Administration operating the conversion facility to effect delivery of the message by whatever means are available.

Note 9 – This answerback returned by the CF is the Teletex answerback obtained during the delivery call to the Teletex terminal and having the same format and content as described in Note 3. This answerback is an “on-line” delivery acknowledgement for the telex user.

3.1.2 *Access from a telex automatic emitting device (TAED)*

Interworking on the telex to Teletex direction, using one-stage selection, in case of TAEDs is described in Figure 2/U.201 and associated notes.

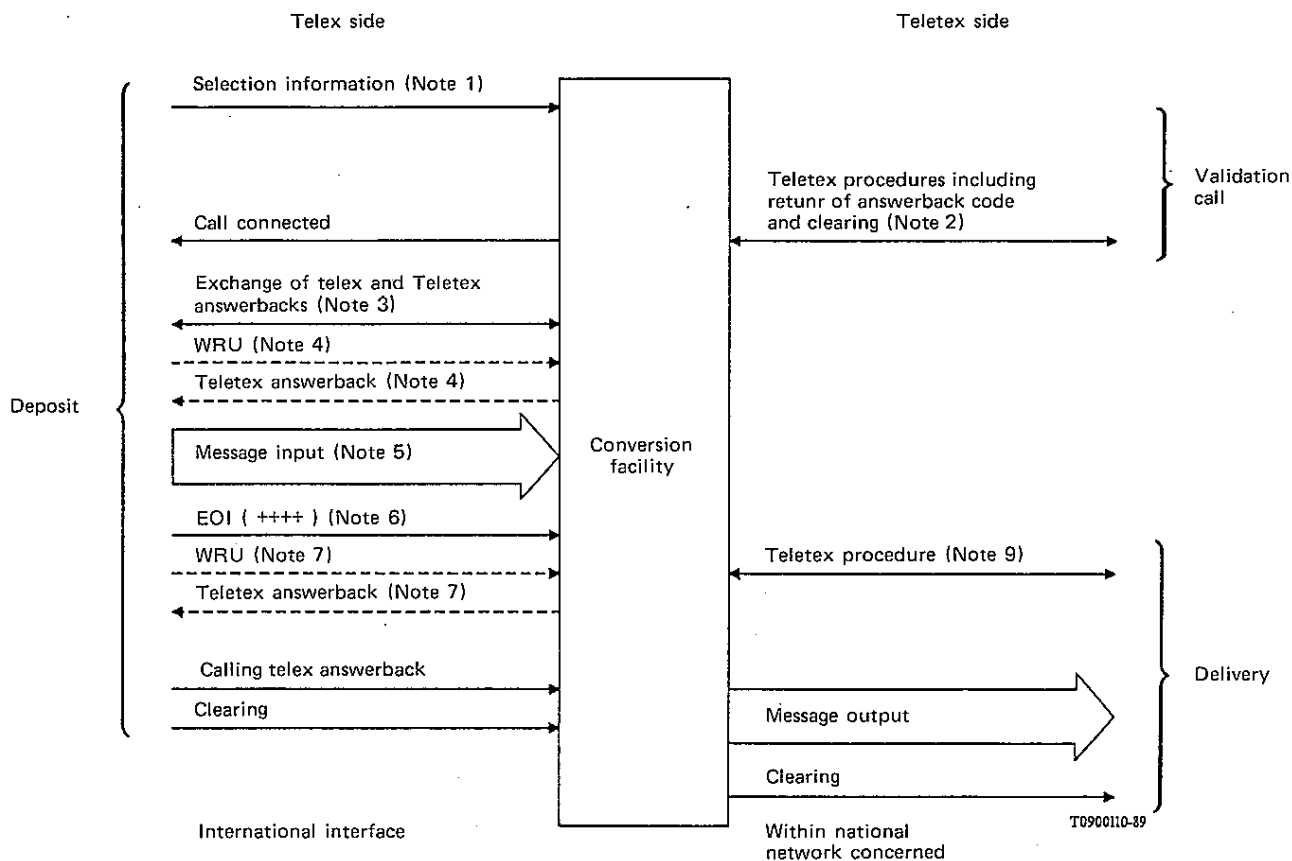

FIGURE 2/U.201

**Interworking in the telex to Teletex direction using one-stage selection procedure
(case of Telex Automatic Emitting Devices – TAEDs)**

Notes relative to Figure 2/U.201:

Remark – Taking into account that most of the notes related to the two figures are similar, the notes related to Figure 2/U.201 only emphasize the differences from notes to Figure 1/U.201.

Notes 1 to 5 – Identical to notes of Figure 1/U.201.

Note 6 – Same as Note 7, Figure 1/U.201.

Note 7 – i) The CF shall wait 800 ms for WRU after EOI. The terminal is considered a telex automatic emitting device (TAED) if a WRU is sent within this period.

The answerback returned by the CF is the Teletex answerback obtained during the validation call (see Note 3) to confirm that the connection still exists. It is not a proof of delivery.

No progress signal (e.g. MOM, ITL→TTX→Ø) will be returned by the CF to the telex automatic emitting device after the EOI signal.

ii) When the EOI signal is received, the CF should establish immediately a delivery call to the Teletex terminal.

Note 8 – The CF shall make several attempts with five-second intervals measured from the end of each attempt to the beginning of the next. It is the responsibility of each Administration operating the conversion facility to effect the delivery of the message by whatever means are available.

3.2 Two-stage selection

3.2.1 Service principles

Recommendation F.201, § 4, describes the service principles for this method of interworking.

3.2.2 Access from a manual terminal

3.2.2.1 Interworking in the telex to Teletex direction, using two-stage selection, in case of manual terminals, is described in Figure 3/U.201 and associated notes.

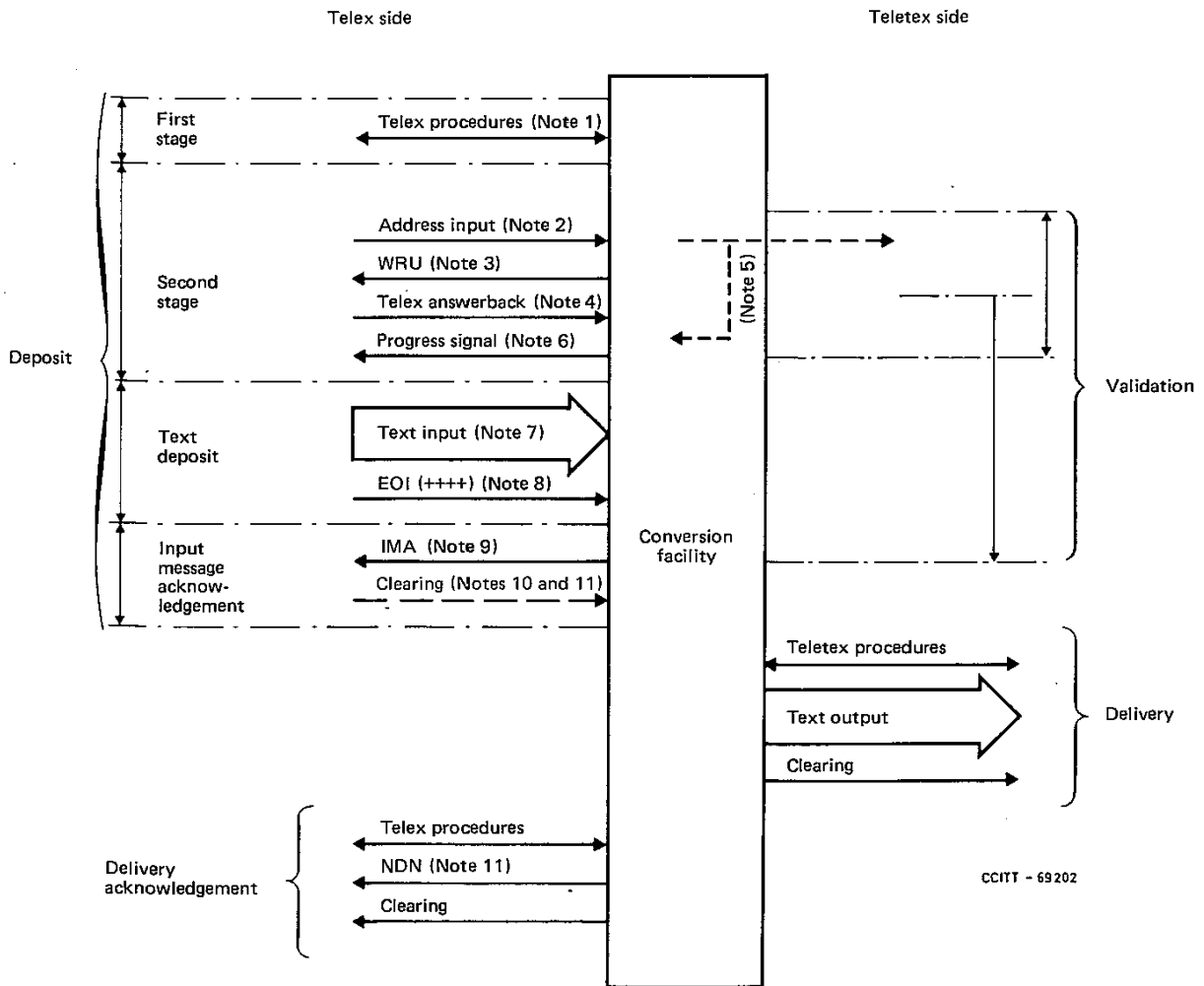
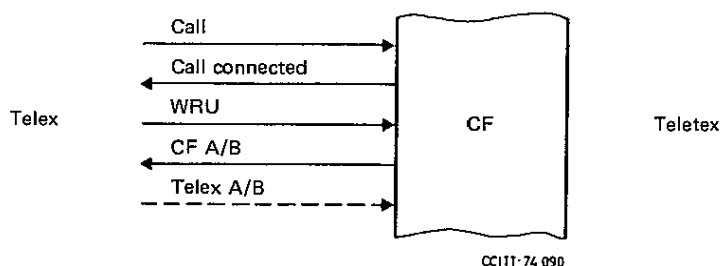

FIGURE 3/U.201

Interworking in the telex to Teletex direction using two-stage selection procedure (case of manual telex terminals)

Notes relative to Figure 3/U.201:

Note 1 – An example of telex procedures is:



If a WRU is received by the CF, it shall return its answerback. Coding of the CF answerback is the following:

↑ ← ≡ CF NATIONAL NUMBER → ↓ T → TTX → Ø
up to 7 digits

Note 2 – Address input: see § 3.2.2.2 of this Recommendation.

Note 3 – WRU signal should be sent immediately after the address input.

Note 4 – If the returned telex answerback cannot be processed according to Recommendation U.74 and if no telex address was input, and no skipping indication was given [see § 3.2.2.1 b) of this Recommendation], then the CF shall request the telex address with a specific prompt signal:

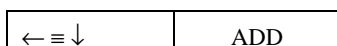

Remark – The telex address input in response to this ADD must be terminated with a “+”, Combination No. 26 of ITA2 in figure case.

If a telex address is not received within 15 seconds after the prompt signal ADD has been sent, the CF should proceed by sending back a GA signal. In this case, an NDN signal cannot be sent to this telex user.

Note 5 – Validation of the Teletex address by means of a validation call or data base retrieval of the Teletex address (see Recommendation F.201).

Note 6 – Validation result (see § 3.2.2.4 of this Recommendation).

Note 7 – See Note 5, Figure 1/U.201.

Note 8 – EOI is coded as four ITA2 Combination No. 26 “++++” in figure case. This EOI signal needs not to be transferred to the Teletex side.

Note 9 – Content of IMA is defined in § 3.2.2.5.

Note 10 – The telex user may maintain connection at this step of the procedure in order to obtain an on-line delivery acknowledgement (see § 3.2.2.7 of this Recommendation).

Note 11 – The CF may offer the follow-on message facility at this step (see § 3.2.2.8 of this Recommendation).

Note 12 – After the call reattempt procedures have been completed and the message cannot be delivered to the Teletex terminal, a non-delivery notification (NDN) should be sent to the originating telex customer (see § 3.2.2.6 of this Recommendation).

3.2.2.2 Address input

3.2.2.2.1 Single address input format

- a) Case 1 – If the telex subscriber has a processable answerback according to Recommendation U.74, minimum address input is:

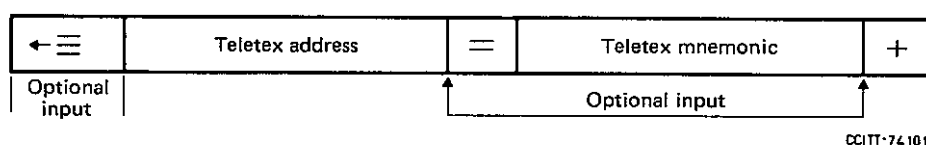

Teletex address is the call-numeric string necessary to select the Teletex terminal, i.e.

- if there is only one network supporting the Teletex service, the Teletex address is the national Teletex number;
 - if there is more than one network supporting the Teletex service, the Teletex address includes the DNIC/TCC number according to Recommendation X.121. DNIC or TCC may be separated from the national Teletex number by a hyphen (-), Combination No. 1 of ITA2.
- b) *Case 2* – If the telex subscriber has a non-processable answerback according to Recommendation U.74, he should input the following string:

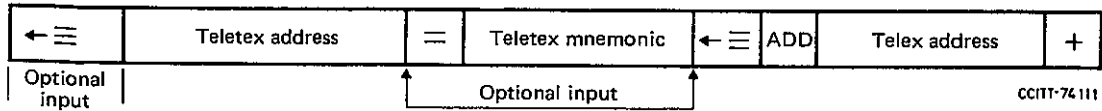

Telex address is the Recommendation F.69 code followed by the national telex number. Any spaces shall be ignored by the CF.

- c) *Case 3* – A telex subscriber may omit specifying the calling address, either inadvertently or intentionally, by transmitting:

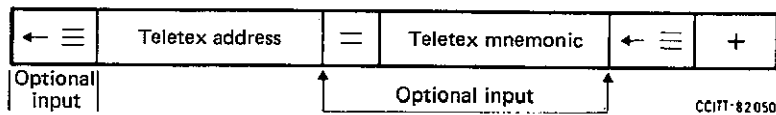

In this case no “ADD” signal should be sent by the CF.

- d) *Remark* – In all cases the signal “+” is not to be used within the address input for other purposes than to indicate “end of address”.

3.2.2.2.2 Multiple address input facility

- This facility enables the calling telex subscriber to deposit messages addressed to multiple Teletex recipients.
- If this facility is provided by the CF, the calling telex subscriber should separate each Teletex address (including or not the mnemonic part) by:

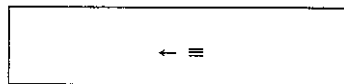

- The input of the last address, the calling telex address (if required) and the EOA signal, shall follow the rules established for the single address in § 3.2.2.2.1 of this Recommendation.
- The calling telex subscriber should know whether the called CF offers the multi-address facility. However, if the facility is invoked by the calling telex subscriber but not offered by the CF, this will be treated as an abnormal condition and the suggested reaction of the CF is in the annex to this Recommendation.

3.2.2.3 *Request for positive delivery notification (PDN)*

– If this facility is provided by the CF the method of requesting a PDN shall be to follow the Teletex address (or each Teletex addresses if multi-address is also offered) for which a PDN is required, by the sequence:

,	ACK
---	-----

– Example: (in this example both the PDN and the multi-address facilities are offered)

...

3029 - 500 9145 = XYZ, ACK

3029 - 500 9090

+

...

– The possibility of requesting a PDN for all Teletex addresses by means of a single indicator, is for further study.

– The calling telex subscriber should be aware whether the CF offers this facility or not.

However, if a calling telex subscriber requests a PDN from a CF which does not offer this facility, this shall be treated as an abnormal condition and is described in the annex to this Recommendation.

3.2.2.4 *Validation result*

3.2.2.4.1 *Positive validation result*

– The format of the positive validation result is:

← ≡	↓	VAL	→ ↑	Telex terminal identification
-----	---	-----	-----	-------------------------------

– The Teletex terminal identification shall be in accordance with Note 6 to Figure 7/U.201.

– The format of the progress signal following the validation result is:

← ≡ ↓	GA
-------	----

– If the CF offers the multi-address input facility, validation of addresses shall continue until a valid address is found.

– If the timing constraints have been met (i.e. a valid address has been found within 5 seconds of receipt of the EOA signal) it is the Teletex terminal identification of this valid address which is returned with the validation result, in the format described above.

– Where time to find a valid address exceeds 5 seconds after receipt of the EOA signal, the CF shall behave according to § 4.1.4 of Recommendation F.201 and Table 1/F.201.

3.2.2.4.2 *Negative validation answer*

– If the validation leads to a negative result, the CF should send at least the telex service signal “NP” or, if available, other appropriate service signals according to Recommendation U.70. The CF should then clear the call.

– Where the CF offers multi-address input, all addresses shall be validated. As this may be difficult in real-time, the CF should return the addresses found to be invalid in a single non-delivery notification.

4.2.2.4.3 *Action of the CF following validation*

The action of the CF following validation shall be as prescribed in § 4.1.4 of Recommendation F.201, and Table 1/F.201.

3.2.2.5 *Input message acknowledgement*

The input message acknowledgement (IMA) is to be returned by the CF to the calling telex subscriber after the EOI.

This information is used as the message reference in case of notifications (NDN or PDN).

The format of the input message acknowledgement is:

← ≡ ↓	IMA	→ ↑ yy → mm → dd → hh:mm ← ≡	xxx xxx ← ≡
-------	-----	------------------------------	-------------

where the xxx xxx← ≡ is an additional reference number and is optional.

3.2.2.6 *Notifications format*

3.2.2.6.1 *Non-delivery notification (NDN) format*

- The NDN message has the format and content described in Figure 4/U.201:

	Field	Comment
	Telex subscriber's answerback	
C o n t e n t	↑ ← ≡ CF NATIONAL NUMBER → ↓ T → TTX → Ø [↓] ← ≡ ← ≡ ← ≡ NDN [→ TELETEX] ← ≡ ↑ YY → MM → DD → HH:MM ← ≡ ← ≡ ↓ TELETEX → ADDRESS ↑:XX - - - XX ← ≡ ↓ IMA → ↑ YY → MM → DD → HH:MM ← ≡ [xxxxxx ← ≡] ← ≡ ↓ CAUSE ↑:xxx ← ≡ ← ≡ ← ≡	Date and time of the CF Address received by the CF during deposit (The same information as given after the input of the message) Telex service signal of the last delivery attempt, as specified in Recommendation U.70
	Telex subscriber's answerback	
	↑ ← ≡ CF NATIONAL NUMBER → ↓ T → TTX → Ø ← ≡ ← ≡ ← ≡ ← ≡ ← ≡ ← ≡ ← ≡ ← ≡	

Note - Text given in [] is optional.

- ↑ Figure shift
- ← Carriage return
- ≡ Line feed
- ↓ Letter shift
- Space

FIGURE 4/U.201

When the multi-address facility is offered, one separate NDN is returned to the originator, for each non-delivered address (recipient).

3.2.2.6.2 Positive delivery notification (PDN) format

– The PDN message has the format and content described in Figure 5/U.201.

	Field	Comment
	Telex subscriber's answerback	
C o n t e n t	↑ ← ≡ CF NATIONAL NUMBER → ↓ T → TTX → Ø [↓] ← ≡ ← ≡ ← ≡ PDN [→ TELETEX] ← ≡ ↑ YY → MM → DD → HH:MM ← ≡ ← ≡ ↓ TELETEX ADDRESS ↑:XX - - - XX ← ≡ ↓ YOUR → MESSAGE → REF ↑: ← ≡ ↓ IMA → ↑ YY → MM → DD → HH:MM ← ≡ [xxxxxx ← ≡] ← ≡ ↓ DELIVERED → TO ↑: ← ≡ ↓ TELETEX ADDRESS ↑:XX - - - XX ← ≡ ↓ DELIVERY → TIME ↑: ← ≡ ↑ YY → MM → DD → HH:MM ← ≡ ← ≡	Current date and time of the CF Teletex address received by the CF during deposit Information provided by the CF at message deposit Teletex address received by the CF during delivery CF's time of delivery
	Telex subscriber's answerback	
	↑ ← ≡ CF NATIONAL NUMBER → ↓ T → TTX → Ø ← ≡ ← ≡ ← ≡ ← ≡ ← ≡ ← ≡ ← ≡ ← ≡ ← ≡	

Note – Text given in [] is optional.

- ↑ Figure shift
- ← Carriage return
- ≡ Line feed
- ↓ Letter-shift
- Space

FIGURE 5/U.201

3.2.2.7 Text delivery

3.2.2.7.1 Text delivery with ODA

If the CF provides the On-line delivery acknowledgement (ODA) facility, it sends a MOM signal immediately after the IMA.

The CF attempts to establish the delivery call within a maximum period of 30 seconds, with several attempts (at least one in the case of PSTN). Attempts should be made at 5-second intervals measured from the end of one attempt to the beginning of the next.

A MOM signal is returned after each attempt followed eventually by network service signals.

If the message delivery succeeds the CF returns to the telex user the called party's Teletex answerback, as described in Note 6 of Figure 7/U.201, and clears the call.

If the Teletex call establishment fails within 30 seconds, the CF sends service signal "ITL" and clears the call, the procedure is then as in § 3.2.2.7.2 below.

3.2.2.7.2 *Text delivery without ODA*

If the ODA facility is not provided, the CF sends a service signal “ITL” immediately after the IMA, and clears the call.

After sending an ITL signal, in all cases, the CF should attempt to deliver the message within four hours. The CF should make at least 16 series of four calls, with 15 minutes between each series. (These figures may be revised in some cases, e.g. in the case of a PSTN.)

If the delivery fails despite the performance of the cycle of delivery attempts, the CF should send a non-delivery notification (NDN) with the format described in § 3.2.2.6.1.

3.2.2.8 *Follow-on message facility*

– Where this facility is offered, rather than clearing the call (as stated in §§ 3.2.7.1 and 3.2.7.2) the CF should generate a prompt in the format below:

← ≡	TTX → NBR↑:
-----	-------------

– The CF shall wait up to 15 seconds for the start of a new input to appear, after this delay the CF shall clear the call.

– The CF shall treat the follow-on message as if it had been received in a completely separate session.

3.2.3 *Access from a telex automatic emitting device (TAED)*

3.2.3.1 Interworking on the telex to Teletex direction, using two-stage selection, in case of TAEDs is described in Figure 6/U.201 and appending notes.

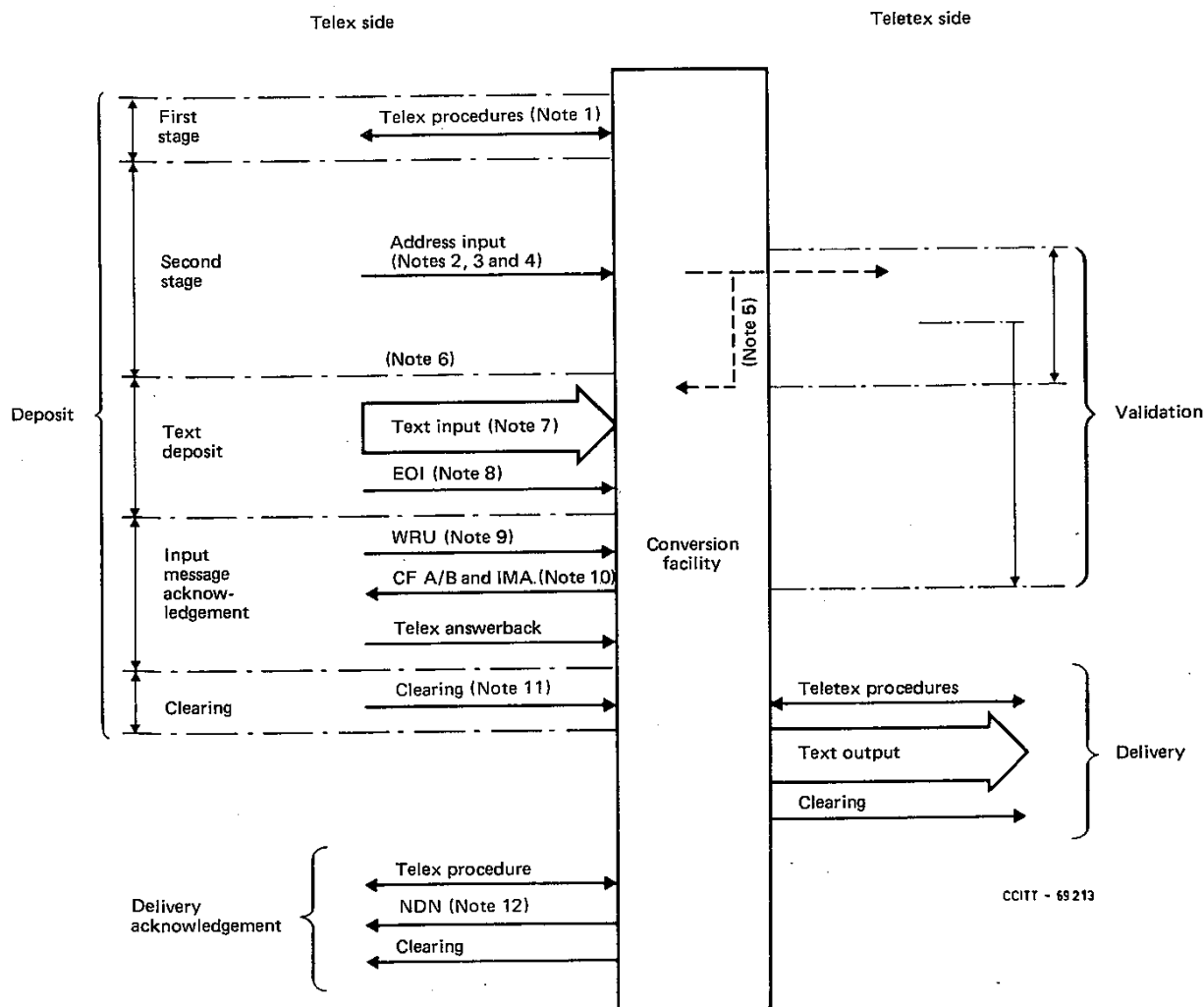
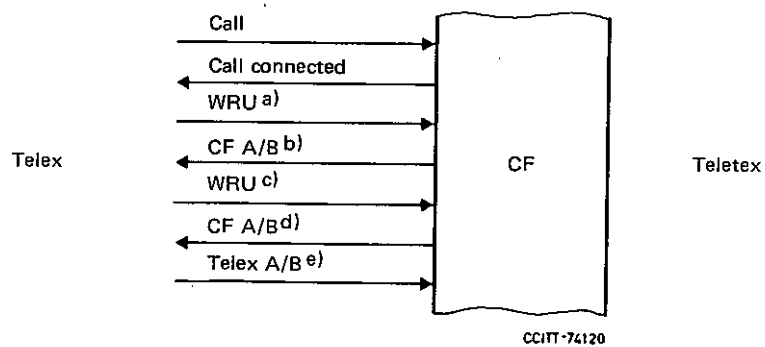

FIGURE 6/U.201

Interworking in the telex to Teletex direction
using two-stage selection procedure
(case of telex automatic emitting devices)

Notes relative to Figure 6/U.201:

Note 1 – An example of a call procedure by means of telex automatic emitting device is shown below:



- a) Network generated WRU.
- b) CF answerback may be preceded by date/time information and register numbers, etc. which may be followed by a recorded message.
- c) WRU generated by telex automatic emitting devices.
- d) Clear CF answerback for validation purposes.
- e) Telex automatic emitting devices transmit their answerback at this stage in accordance with Recommendation F.60, § A.1.

Notes 2, 3 and 4 – See § 3.2.3.2.

Note 5 – Same as for Figure 3/U.201

Note 6 – Negative validation result, if it occurs, is returned according to § 3.2.3.4.2 of this Recommendation.

Notes 7 and 8 – Same as for Figure 3/U.201.

Note 9 – The clearing procedure is in accordance with Recommendation S.20.

Note 10 – See § 3.2.3.4 of this Recommendation.

– If the validation result is positive, but abnormal conditions have occurred during text input (see annex to this Recommendation), the CF should send a service code instead of its answerback.

– If the validation result is negative and arrives after text input, the CF answerback will be replaced by a service signal as defined in Recommendation U.70.

Note 11 – If the subscriber is still on-line, at this stage, the CF should clear the call.

If the follow-on message facility is offered the CF should wait 15 seconds before clearing, for a possible new message input. No prompt should be sent to the user by the CF.

Note 12 – Same as for Figure 3/U.201.

3.2.3.2 Address input

3.2.3.2.1 Single address input format

- a) *Case 1* – Whether or not the telex subscriber has a processable answerback according to Recommendation U.74, he should input his telex address as described below:

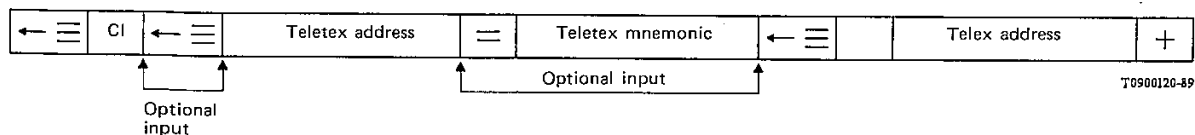

– The start of address “CI” informs the CF that prompts that validation information and WRU signal must not be returned to the telex automatic emitting devices.

– Teletex address and telex address have the same definition as in § 3.2.2.2.1 to this Recommendation.

- b) *Case 2* – A telex subscriber may omit his address input either inadvertently or intentionally by transmitting:

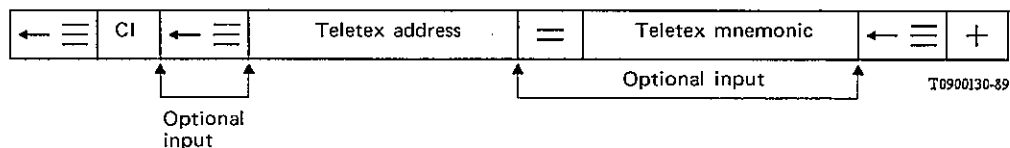

- c) *Remark*

In all cases:

- no “ADD” signal should be sent by the CF;
- the signal “+” is not to be used within the address line for other purposes than to indicate “end of address”.

3.2.3.2.2 *Multi-address input format*

(See § 3.2.2.2.2, Recommendation U.201.)

3.2.3.3 *Positive delivery notification (PDN) facility request*

(See § 3.2.2.3.)

3.2.3.4 *Validation result*

3.2.3.4.1 *Positive validation answer*

– The result of the address validation, if positive, should be sent to the user together with the IMA, after successful completion of the message input.

– The positive validation result, in the format defined in § 3.2.2.4.1 of Recommendation U.201, and the IMA in the format defined in § 3.2.2.5, should follow without pause, the transmission of the CF's answerback in response to the first "WRU" requested by the user after the end of message input "EOI" (see step referred by Note 10 in Figure 6/U.201).

– If no answerback is requested by the telex user at this stage (Note 10, Figure 6/U.201) positive validation answer and IMA cannot be returned.

– In all cases, if a second WRU is issued by the telex user, at this stage (Note 10, Figure 6/U.201), the CF shall return only its answerback.

– This is in order to allow a positive match, if the telex TAED performs a comparison between the answerbacks returned at the start and the end of the call.

– Where the multi-address input facility is offered the CF should continue validating addresses until a valid one is found, and return the result of the first positive one in the way described above.

3.2.3.4.2 *Negative validation answer*

If the validation result is negative, the CF should transmit sequences of characters "T" according to Recommendation S.4 to interrupt the telex terminal transmission. If the terminal continues to transmit for more than 20 seconds, the CF shall clear the call. This will be followed, after a pause of one second, by the appropriate service signal, according to Recommendation U.70, and clear the call.

Where the multi-address input facility is provided and all addresses are found to be invalid, this should be treated as a negative validation result and the CF shall act in accordance with § 4.1.4 of Recommendation F.201 and Table 1/F.201.

3.2.3.5 *Notification formats*

Positive and negative notification (PDN and NDNs) formats are as described in §§ 3.2.2.6.2 and 3.2.2.6.1 respectively.

4 Delivery procedure to Teletex from a CF

4.1 *Service principles*

Recommendation F.201, §§ 3.2 and 4.2 describe the service principles for this direction.

4.2 *Text delivery*

After clearing, the CF should attempt to deliver the message within four hours. The CF should make at least 16 series of four calls, with 15 minutes between each series. (These figures may be revised in some cases, e.g. in the case of a PSTN.)

If the delivery fails despite the performance of the cycle of delivery attempts, the CF should send a non-delivery notification (NDN). This information is sent to the Teletex user with the complete reference of the related message in order to allow the Teletex user to take further action. No further delivery action shall be taken by the CF.

Text delivery to the telex terminal is described by Figure 7/U.201, for both one- and two-stage selection CFs.

The main difference between these two CFs is the content of the answerback of the CF.

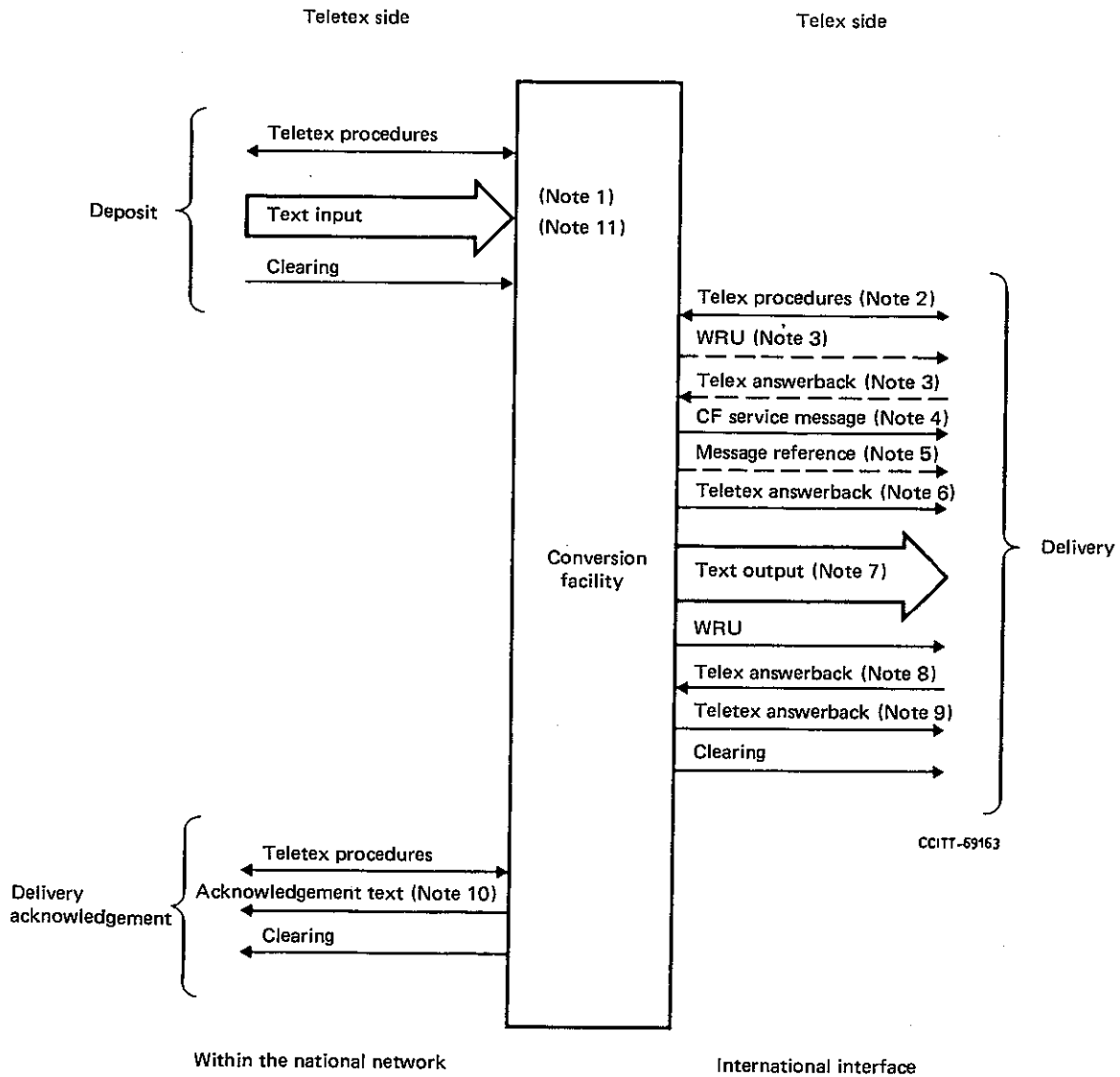

FIGURE 7/U.201

**Interworking in the Teletex to telex direction
using one- or two-stage selection**

Notes relative to Figure 7/U.201:

Note 1 – See Recommendation T.90.

Note 2 – a) Case of one-stage selection CF

If a WRU is received by the CF, it shall return the rearranged Teletex terminal identification, as described in Note 3 to Figure 1/U.201.

b) Case of two-stage selection CF

If a WRU is received by the CF, it shall return its answerback. Coding of the CF answerback is the following:

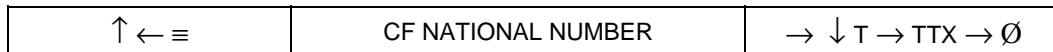

↓ up to 7 digits →

Note 3 – This step is only necessary if the answerback was not available during normal telex procedures.

Note 4 – a) Case of one-stage selection CF

Service message indicating that the call is being made by a telex automatic emitting device and showing clearly the origin of the call. The coding of the service message to be returned is the following:

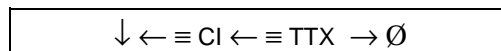

b) Case of two-stage selection CF

Service message indicating that the call is being made by an automatic installation and showing clearly the origin of the call.

The coding of the service message to be returned is the CF telex answerback [as described in Note 2 b] preceded by:

← ≡ CI

Note 5 – Reference of the message is the Teletex date and time of the message input, in the following format:

← ≡ ↓ REF → ↑ yy → mm → dd → hh:mm ← ≡ xxx xxx ← ≡

Remark – xxx xxx ← ≡ is an additional reference and is optional.

Note 6 – a) Case of one-stage selection CF (see Note 3 to Figure 1/U.201).

b) Case of two-stage selection CF

This rearranged Teletex terminal identification (or “Teletex answerback”) contains the Teletex subscriber directory information:

- DNIC or TCC and national number according to Recommendation X.121 if there is more than one network for Teletex service (in this case, DNIC or TCC are separated from the national number by a hyphen (-), Combination No. 1 of ITA2);
- National number if only one network.

If space is available, the Teletex answerback will contain the mnemonic part of the Teletex identification.

Note 7 – The CF shall transmit to the telex terminal the stored message in the format in which it was originated.

Note 8 – After text transmission is completed, the (telex) answerback should be taken and compared with that received at the start of message delivery. In the event of a mismatch of answerbacks, the (telex) answerback shall be taken again, and if there is a match with that received at the start of delivery, the delivery shall be deemed successful. If there is a second mismatch, the call shall be cleared and one further attempt to deliver the message may be made after an interval of at least three minutes. In this case, the text shall be preceded by “POSSIBLE DUPLICATE MESSAGE”.

Note 9 – After text transmission is complete, the CF shall send to the telex terminal the Teletex answerback, as described in Note 6 to this figure.

Note 10 – The acknowledgement call is mandatory if the telex call is unsuccessful, but optional if the telex call succeeds.

Note 11 – Administrations should advise their customers of the meaning and possible consequences of using special telex character sequences (see Recommendation S.4) in the submitted text.

ANNEX A

(to Recommendation U.201)

Reactions to abnormal conditions during the telex input

A.1 *Telex connection clearing without the end of input signal*

After a clear without the end of input (EOI) signal, the conversion facility should forward the message to the Teletex subscriber.

A.2 *Telex subscriber pausing during input of address information*

If there is a delay greater than 15 seconds at the start of the address input or between characters within the address input, the CF shall clear the connection.

A.3 *Telex subscriber stopping transmission without sending the end of input signal*

After at least a 30 seconds time-out, the conversion facility should send a prompt “GA” to the telex subscriber in order to request more information input (e.g. a text or the end of the input signal). If after a further 30 seconds time-out there is no more information, then the conversion facility should send the input message acknowledgement signal, followed by a service message BK. After this the conversion facility should clear the call.

A.4 *Telex subscriber sending a WRU to the conversion facility during text input*

- i) In case of one-stage selection procedure, the CF should return the rearranged Teletex answerback (see Note 3 of Figure 1/U.201).
- ii) In case of two-stage selection procedure, in any step of the procedure, the conversion facility should return its answerback after receiving a WRU. In addition:

- if WRU is followed by text, message input is continued after the conversion facility answerback. Also the WRU is deleted from the message text;
- if WRU is followed by a clear from the telex network, the conversion facility proceeds as in § A.1 above;
- if WRU is followed by an idle condition, the conversion facility proceeds as in § 3 above.

A.5 *Telex subscriber sending a text after the end of input signal*

Any characters received after the end of input signal will be ignored. The conversion facility should use the “TTT . . .” characters to attempt to stop the telex transmission and if successful, then send an input message acknowledgement signal followed by clearing. After clearing, the message should be normally forwarded to the Teletex terminal.

This does not apply in a case of a two-stage selection CF offering the follow-on message facility.

A.6 *Telex subscriber clearing after the end of input signal and before the input message acknowledgement signal*

The message shall be normally forwarded to the Teletex terminal.

A.7 *Telex subscriber sending national variants of ITA2 characters (figure shift characters of F, G and H)*

These combinations could either be converted into a Teletex code which is a non-telex character (e.g. “*”), or into the national use of these combinations. The choice is a national matter.

A.8 *The conversion facility detecting signal distortion during text input*

Reactions to the detection of distortion are a national matter.

A.9 *Telex subscriber sending a bell signal*

The conversion facility has to ignore the bell signal in text input.

A.10 *CFs storage capacity overflow during telex message input*

- In order to avoid memory overflow occurring during message input, a guaranteed message length of 12 000 characters is defined.
- The CF should return an “NC” service signal if guaranteed storage space is not available.
- Messages exceeding the guaranteed length will continue to be accepted if storage is available.
- If the number of characters received by the conversion facility during a message input exceeds the available storage to that input, the conversion facility should discard the excess characters and no attempt should be made by the conversion facility to overwrite previously stored characters. When this occurs, the conversion facility should immediately attempt to prevent the telex subscriber from sending further characters by transmitting a sequence of “TTT . . .” characters for a maximum of 20 seconds.

If the calling terminal stops transmission within this period, the conversion facility should return the message length exceeded indication, “LDE”, return IMA in case of the two-stage selection procedure and then behave as normal, as if the text input phase had finished.

If the terminal continues to transmit characters after this period, the conversion facility should forcefully clear the connection.

- The conversion facility should attempt to deliver the message text, accepted and stored, preceded by a special text prefix to indicate to the called Teletex subscriber that the message may be incomplete.

A.11 *Request of optional facilities, when not provided by the CF*

If a user requests an optional facility not offered by a CF (e.g. multi-address or positive delivery notification), the CF shall use sequences of character “T” (according to Recommendation S.4) to attempt to stop the telex transmission. After the successful stop, the CF should then send an “NA” service signal.

ITU-T RECOMMENDATIONS SERIES

Series A	Organization of the work of the ITU-T
Series B	Means of expression: definitions, symbols, classification
Series C	General telecommunication statistics
Series D	General tariff principles
Series E	Overall network operation, telephone service, service operation and human factors
Series F	Non-telephone telecommunication services
Series G	Transmission systems and media, digital systems and networks
Series H	Audiovisual and multimedia systems
Series I	Integrated services digital network
Series J	Transmission of television, sound programme and other multimedia signals
Series K	Protection against interference
Series L	Construction, installation and protection of cables and other elements of outside plant
Series M	TMN and network maintenance: international transmission systems, telephone circuits, telegraphy, facsimile and leased circuits
Series N	Maintenance: international sound programme and television transmission circuits
Series O	Specifications of measuring equipment
Series P	Telephone transmission quality, telephone installations, local line networks
Series Q	Switching and signalling
Series R	Telegraph transmission
Series S	Telegraph services terminal equipment
Series T	Terminals for telematic services
Series U	Telegraph switching
Series V	Data communication over the telephone network
Series X	Data networks and open system communications
Series Y	Global information infrastructure and Internet protocol aspects
Series Z	Languages and general software aspects for telecommunication systems