



INTERNATIONAL TELECOMMUNICATION UNION

CCITT

THE INTERNATIONAL
TELEGRAPH AND TELEPHONE
CONSULTATIVE COMMITTEE

U.12

(11/1988)

SERIES U: TELEGRAPH SWITCHING

Specific signalling schemes and interworking between
signalling systems

**TERMINAL AND TRANSIT CONTROL
SIGNALLING SYSTEM FOR TELEX AND
SIMILAR SERVICES ON INTERNATIONAL
CIRCUITS (TYPE D SIGNALLING)**

Reedition of CCITT Recommendation U.12 published in
the Blue Book, Fascicle VII.2 (1988)

NOTES

- 1 CCITT Recommendation U.12 was published in Fascicle VII.2 of the *Blue Book*. This file is an extract from the *Blue Book*. While the presentation and layout of the text might be slightly different from the *Blue Book* version, the contents of the file are identical to the *Blue Book* version and copyright conditions remain unchanged (see below).
- 2 In this Recommendation, the expression “Administration” is used for conciseness to indicate both a telecommunication administration and a recognized operating agency.

Recommendation U.12

TERMINAL AND TRANSIT CONTROL SIGNALLING SYSTEM FOR TELEX AND SIMILAR SERVICES ON INTERNATIONAL CIRCUITS (TYPE D SIGNALLING)

(Geneva, 1972; amended at Geneva, 1976, 1980 and Malaga-Torremolinos, 1984)

The CCITT,

considering

- (a) that new networks are being introduced based upon stored programme control techniques;
- (b) that these networks, which may be synchronous or anisochronous, are being provided to carry either telex and similar services or these services in combination with data traffic;
- (c) that the equipment provided for these networks facilitates an enhanced range of facilities compared with those available on existing types of telex network;
- (d) that these factors justify the establishment of a new type of signalling, enabling both telex and other traffic to be handled, as far as practicable, by common processes;
- (e) that, for interworking between these anisochronous networks for telex and similar switched telegraph services, a signalling standard (designated type D) has been adopted, based upon that described in Recommendation X.70 [1] for start-stop data services on anisochronous networks;
- (f) that the decentralized signalling to apply on connections between synchronous public data networks is described in Recommendation X.71 [2],

unanimously declares the view

1 Signal conversion

1.1 Recommendation U.1, § 1.1 concerning the responsibility for signal conversion, should be the ultimate aim for interworking between networks using type D signalling on the one hand and type A, B or C signalling on the other hand.

1.2 However, in order to avoid unnecessary inconvenience during the introductory stages of the new signalling system, it is recommended that countries employing type D signalling systems should provide for incoming international traffic type A or B signalling and possibly for transit working type C signalling. The question as to when Recommendation U.1, § 1.1 will become fully effective is yet to be resolved.

1.3 Rules for interworking Recommendation U.12 signalling with signalling standards defined in Recommendations U.1 and U.11 are given in Recommendation U.15.

2 General switching and signalling principles

2.1 Decentralized signalling will apply, the same channel being used for control signalling and information transfer.

2.2 Both terminal and transit operation will be required. Due to the inclusion of transit operation, link-by-link signalling control of calls will be adopted.

2.3 Onward selection from transit and incoming terminal centres should be arranged to overlap the receipt of selection signals, this in order to minimize call set-up times. Selection signals will be transmitted by the originating country at automatic speed in a single block that includes an end-of-selection signal. It is nevertheless necessary to coordinate the transmission of signals on the forward path to allow sufficient time for retransmission or conversion of backward path signals.

2.4 The schedule of telex destination codes laid down in Recommendation F.69 [3] will apply. The same numerical codes will be used for network identification purposes.

2.5 Alternative routing will be permitted. The principle of a few high usage circuits will be adopted, with overflow on to adequately provided routes between centres. In order to prevent repeated alternative routing causing traffic to circulate back to the originating point, alternative routing will be restricted to once per call.

2.6 Both-way operation will be assumed and inverse order testing of circuits on both-way routes, or a close approximation to it by testing the route in small groups in fixed order always starting the search from the same position, will be specified in order to minimize head-on collisions.

2.7 In all cases (including transit switching) the originating network will be responsible for recording accounting information.

2.8 The grade of service for the provision of circuits should not be worse than one lost call in 50 for routes carrying overflow traffic or from which overflow is not permitted. For high-usage direct links, circuits would be provided at a grade of service to be agreed bilaterally, but should not be worse than one lost call in ten.

2.9 Sufficient switching equipment will be provided to ensure that congestion will not be signalled on more than 0.4% of calls in the busy hour, and only then when congestion has been positively identified.

3 Specific signalling characteristics

Notes applicable to § 3

Note 1 – X denotes the international centre that originates the call under consideration on the international link concerned. Y denotes the international centre that receives the call under consideration on the international link.

Centre X and centre Y will provide any necessary signalling conversion to the type of signalling employed on the preceding and succeeding links if these do not use type D signalling.

Note 2 – Timings shown are within the centre concerned with no allowance being made for propagation and other delays, such as slow sending of selection signals by the originating subscriber.

Note 3 – The times for permanent start polarity (A) and stop polarity (Z) are generally indicated in the following signal descriptions as integral multiples of a character (see Note 4). Compared with Recommendation X.70 [1], some other multiples are selected in order to enable simpler interworking with systems operating in accordance with Recommendations U.1 and U.11.

Note 4 – The control signalling code (CSC) used in this signalling system is described in Table 8/U.12.

3.1 The signalling system for telex and similar services between two anisochronous networks using type D signalling is described in Table 1/U.12.

3.2 The incoming equipment may release the connection if the calling signal exceeds the maximum period of two characters, or of four characters in exceptional cases where extension of call signals has been requested by centre Y. Start polarity will be maintained on the backward signalling path from centre Y to centre X.

3.3 The first forward path signal following the calling signal (class-of-traffic signal) is distinctive from the first backward path signal to provide a guard against head-on collisions in the case of bothway operation. A head-on collision is detected by the fact that centre X receives a first class-of-traffic character instead of the reception-confirmation or reception-congestion signal.

When a head-on collision is detected, the switching equipment at each end of the circuit should make another attempt to select a free circuit, either on the same group of circuits or on a group of overflow circuits, if they exist and there are no free circuits on the primary route. In the event of a further head-on collision on the recall, or on the call attempt via the overflow route, no further recall will be made and the call will be cleared down. In the case of a transit centre, the service signal No. 20 (NC) followed immediately by the clearing signal will be returned to the preceding centre after the reception-confirmation signal and the network identification signal (Recommendation F.69 [3]).

3.4 If there is failure to receive the reception-confirmation or reception-congestion signal within 4 seconds from the start of the calling signal or receipt of a spurious signal, as indicated by a character other than a first class-of-traffic character, the reception-confirmation signal or reception-congestion signal should then initiate the automatic retest signal on the circuit concerned.

In the case of failure to receive the correct reception-confirmation or reception-congestion signal, another attempt to select a circuit should be made (once only). If the second attempt is unsuccessful, the service signal No. 20 (NC) followed by the clearing signal will be returned to the preceding centre after the reception-confirmation signal and the network identification signal (Recommendation F.69 [3]).

3.5 Selection signals can be divided into two parts. The first part, designated as the network selection signals, contains information regarding network and subscriber requirements and may be composed of one or more characters (see Tables 2/U.12, 3/U.12, 4/U.12, 4a/U.12, 5/U.12 and 5a/U.12). The second part comprises the address signals (the called subscriber number, which is preceded by the destination code in the case of a transit call). The network selection signals used in the forward direction (see also Appendix II) are further subdivided and assembled as follows (§§ 3.5.1 to 3.5.4 below) for signalling purposes:

3.5.1 *First class-of-traffic character* (see Table 2/U.12)

The calling signal is always followed by at least one class-of-traffic character. The bit functions of this character were so chosen that no further characters are needed for most connections. If there is a need for indication of further requirements, a second class-of-traffic character may be used. Whether the second class-of-traffic and user-class characters follow or not will be indicated by the bits b_3 and b_4 of the first class-of-traffic character.

3.5.2 *User-class character* (see Table 3/U.12)

This character, if used, will follow the first class-of-traffic character and will be required when, for example, this information cannot be derived from the incoming line. Whether a second user-class character follows or not will be indicated by the bits b_1 , b_2 and b_3 of the first user-class character. When seven user classes in Table 3/U.12 are not sufficient, a second user-class character may be added by means of an escape character. Whether a second class-of-traffic character follows or not will be indicated by bit b_4 of the first user-class character.

3.5.3 *Second and subsequent class-of-traffic characters* (see Tables 4/U.12 and 4a/U.12)

These characters follow any user-class characters required. The number of these class-of-traffic characters depends on the number of user facilities available. The bit b_4 of the second or subsequent class-of-traffic characters will indicate whether another class-of-traffic character follows or not.

3.5.4 *Closed user group character* (see Tables 5/U.12 and 5a/U.12)

closed user group is defined as follows: A number of users of a public switched communication service who have the facility that they can communicate with each other but access is barred to and from all other users of the service.

Note 1 – A special facility, permitting a user in a closed group to call any other user connected to a public switched communication service or to any other network with which interworking is permitted, may be offered. This is termed *Closed user group with outgoing access*. Access to users of this facility is restricted to other members of the closed user group.

The start of closed user group character would precede the closed user group number which would be coded into a number of hexadecimal characters up to a maximum of four (see Table 5/U.12).

Note 2 – Further study is required concerning administrative aspects of the method to provide the closed user group facility.

3.5.5 The numerical characters used for the second part of the selection signals are shown in Table 6/U.12. When the first class-of-traffic character indicates a terminal call, the Recommendation F.69 [3] telex destination code will be omitted.

3.6 The incoming equipment should maintain start polarity on the backward signalling path by releasing the connection if the first received character is spurious, as indicated by a character other than a valid first class-of-traffic signal. This procedure prevents the possibility of regarding a second selection signal as a first class-of-traffic character and provides a further safeguard against false calls.

In the case of receipt of a spurious signal as indicated by a parity error or by a character other than a valid selection signal (with the exception of the first class-of-traffic signal), the incoming equipment should return the service signal No. 20 (NC) to the preceding centre – after the reception-confirmation and the network identification signal (Recommendation F.69 [3]) – followed by the clearing signal.

The incoming equipment may release the connection if all of the selection signals are not correctly received within a period of 15 seconds from the reception of the first class-of-traffic signal. In this event, the service signal No. 20 (NC) is returned to the preceding centre, followed by the clearing signal.

3.7 For the address signals, i.e. the destination code and the national number, the maximum number of digits to be expected is 12.

3.8 In the case of receipt of the reception-congestion signal at a transit centre, the service signal No. 61 (NC) should be returned to the preceding centre (after the reception-confirmation and the network identification signal) and followed by the clearing signal.

3.9 The network identification signal shall be sent following the reception-confirmation signal.

If several networks are involved in setting up a call, the calling network will receive the network identification signals one after the other. If a transit centre fails to receive the first character of a network identification signal within two seconds of the reception-confirmation signal, it will return the service signal No. 20 (**NC**) to the preceding centre, followed by the clearing signal. The network identification signals could be useful for retracing the route followed by a call (for traffic statistics, international accounts, analyses of unsuccessful calls and the clearing of faults).

It is possible for a transit centre to receive backward path signals, such as network identification signals, a call-connected signal or service signals, from subsequent centres whilst the backward path signals originated locally are still being sent. It is necessary for the transit centre to ensure that the received signals are retransmitted to the preceding centre without mutilation or loss. This can be ensured if the forward seizure does not occur before complete transmission of the reception confirmation signal.

3.10 The backward path signals indicating effective and ineffective call conditions are scheduled in Tables 7/U.12, 7a/U.12 and 7b/U.12.

3.11 If the last backward path signalling character, call-connected, or service signal is not received within 90 seconds from the end of selection, then the service signal No. 20 (**NC**) will be returned to the preceding centre and followed by the clearing signal.

3.12 If the called station is not able to receive information immediately, the return of the start-of-transit-through-connect or call-connected signals to the calling station should be delayed accordingly (up to a maximum of 3 seconds for telex in accordance with Recommendation S.9 [4]).

3.13 In this type of signalling, originating and terminating national centres contain the identification of the calling or called subscribers respectively. These identifications may be exchanged within the network as an optional subscriber's feature.

In the case of a call terminating in a network with a signalling standard other than type D, and hence called line identification is not available, the last type D centre in the connection should send only the call-connected signal in response to a request for the called line identification. The last type D centre may be either an international transit centre, the last international gateway or a national type D centre.

In the case of a call originating in a network with a signalling standard other than type D, and hence the calling line identification is not available, the first type D centre in the connection should send only the end-of-line-identification signal (CSC character No. 12) in response to a request for the line identification. The corresponding printed service signal to indicate the absence of the line identification to the calling or called subscriber as appropriate is **NL**.

3.14 The call connected signal confirms that the call is extended to the called subscriber and, if applicable, that the calling line identification has been completely received by the terminating centre and passed to the called subscriber and, when applicable, that the called line identification has been completely transmitted to the originating centre (see Appendix III).

Regardless of the action taken on calling and/or called line identifications, tripping of the called subscribers answerback is required. Normally this is initiated by the originating type D centre. The rules for taking the called subscribers answerback in interworking cases are given in Recommendation U.15.

Return of the answerback is supervised by the originating centre. If it does not arrive within 6 seconds of the commencement of the WRU sequence, the originating centre returns the **DER** signal in International Telegraph Alphabet No. 2 (ITA2) to the calling subscriber and clears the connection.

The WRU signal confirms that the call-connected signal has been received by the originating centre and, when applicable, that the called line identification has been completely received by the originating centre and passed to the calling subscriber (see Appendix III).

The call-connected signal is sent on the backward path by the terminating centre, the WRU signal is sent by the originating centre to the called subscriber, but not before the calling subscriber is ready to receive the answerback signal.

The connection must be switched through in the originating centre and in the terminating centre within the timings shown in Appendix III.

In transit centres the connection can be switched through earlier provided that losses and mutilations of characters are avoided.

Connect-through procedures at centres where interworking between type D and other standards takes place are described in Recommendation U.15.

Complete network through-connection is assured when the called subscriber's answerback is received by the calling terminal.

3.15 The guard delays on clearing are measured from the moment when start polarity has been established on both signalling paths by:

- either recognizing or transmitting the clearing signal on one signalling path, and
- either transmitting or recognizing the clear-confirmation signal on the other signalling path.

On all type D signalling paths the guard period for incoming calls should be a period of 3-4 characters. A new call shall not be accepted until this guard period has elapsed. This is on the assumption that the terminating centre will be able to accept the first selection signal after a negligible period of stop polarity and will also be able to return the reception-confirmation signal within a negligible delay after the receipt of the first class-of-traffic character.

On all type D signalling paths the guard period for outgoing calls should be a period of at least eight characters. If centres are able to distinguish between the different clearing conditions, shorter periods may be introduced accordingly.

3.16 The automatic retest signal will be initiated as indicated in § 3.4 above.

The circuit should be marked *unavailable* for outgoing traffic and should be tested up to five times at nominal intervals of 1.0 minute or 1.2 minutes and a check made to confirm the receipt of a reception-confirmation signal in response to each test. If a valid reception-confirmation signal has not been received at the end of this first group of tests, the retest will continue with a further group of up to five tests at either 5.0/6.0- or 30/36-minute intervals. If 5.0- or 6.0-minute intervals are used and a valid reception-confirmation signal has not been received at the end of this second group of tests, a further group of up to nominally five retests will be made at 30- or 36-minute intervals. An alarm will be given at an appropriate time. However, this retest procedure may be discontinued at any stage at the discretion of the outgoing Administration.

If, however, during the above sequence of retests, a valid reception-confirmation signal is received, a clearing signal will be transmitted in the place of the retest signal. Following a valid clear-confirmation signal, the incoming and the outgoing sides of the trunk circuit should not be returned to service until after expiry of the appropriate guard delay time. In order to cater for the possibility that a faulty circuit may be seized at both ends, the automatic retest equipment should be arranged to allow an incoming call to be received during the start polarity period of the automatic retest signals. Administrations may, however, ignore such calls that occur during the incoming guard delay period. Where an exchange has knowledge of a transmission system failure, it is desirable that retest signals shall not be applied to the affected circuits.

The intervals between the tests at the two ends of the trunk circuit should be made different to be sure that successive retests do not overlap at both ends. In general, the international/intercontinental transit centre having the higher Recommendation F.69 [3] telex destination code should take the longer interval (i.e. 1.2, 6 and 36 minutes). The tolerance on all above time intervals is $\pm 10\%$. Nevertheless, when this requirement would entail considerable difficulty, alternative arrangements may be adopted by agreement between the two Administrations concerned.

The use of a special first class-of-traffic character for retest permits the incoming centre to be informed about retests on its incoming circuits.

3.17 If at the receiving end parity does not check, provisionally the connection should be cleared down unless otherwise specified. However, the possibility of different actions remains open for further study.

TABLE 1/U.12

Signalling for telex and similar services between anisochronous networks

Note – For the Control Signalling Code (CSC) numbers mentioned, refer to Table 8/U.12.

Signal or function	Forward path (X towards Y)	Backward path (Y towards X)	Remarks
Free line	Start polarity (polarity A)	Start polarity (polarity A)	
Call	Stop polarity (polarity Z) for a minimum period of one character and a maximum period of two characters followed immediately by selection signals		<p>The equipment at centre Y must be connected and ready to receive selection signals within one character period.</p> <p>Exceptionally the minimum and consequently the maximum period may be lengthened to no more than four characters at the request of the incoming country (Y).</p>
Reception-confirmation		Stop polarity followed by CSC No. 14	<p>Stop polarity returned within three character periods after the end of the receipt of the first class-of-traffic signals.</p> <p>The return of CSC No. 14 shall commence within one to two character periods after the inversion to stop polarity.</p> <p>The reception-confirmation signal will have to be absorbed by the switching equipment of X and should not be able to go through that equipment to arrive at the preceding centre.</p>
Selection	At least one (first class-of-traffic signal only) or possibly several network selection signals depending on the network requirement (see Appendix I), the two or three digits of the F.69 [3] telex destination code of the called country, the digits of the called station number and an end-of-selection signal (CSC No. 11)		<p>These signals are transmitted immediately after the calling signal without awaiting the reception at X of the reception-confirmation signal.</p> <p>The destination code will be omitted for terminal calls.</p> <p>The selection signals will be transmitted in a single group at automatic speed.</p>
Network identification		CSC No. 12 followed by the F.69 [3] code for the network concerned	<p>The CSC No. 12 follows the reception confirmation signal at automatic speed after one to two character periods. These signals must go through centre X and arrive at the originating country.</p>

TABLE 1/U.12 (continued)

Signal or function	Forward path (X towards Y)	Backward path (Y towards X)	Remarks
Reception-congestion		Stop polarity for a period of one or two characters followed by the clearing signal	When selection signals cannot be accepted (refer to § 2.9 of this text), this signal should be returned as soon as possible and in any event within three character periods (exceptionally five character periods where centre X sends prolonged call signals) after the start of receipt of the call signal. The reception-congestion signal should be absorbed by centre X and not allowed to be received by a preceding country.
Service signal without clearing		CSC characters (see Table 7b/X.12) followed by the idle circuit condition	Service signals consist of CSC No. 11 followed by two characters from Table 7b/U.12.
Call connected		One CSC character (see Table 7/U.12)	See Appendix III.
Start of transit through-connect signal (STTC)		CSC No. 15 (see Table 7/U.12)	This signal always precedes the transit through-connect signal.
Transit through-connect signal (TTC)		One CSC character (see Table 7a/U.12)	This signal will always be prefaced by the start of transit through-connect signal and will be returned preceding a service signal without clearing when this has to be sent. It will also be transmitted when the calling and/or called line identification is required (for further details, see Appendix III).
Transit centres through-connect signal (TTD)	CSC No. 11 (see Table 6/U.12)		This signal will be transmitted within one to two character periods after the receipt of the transit through-connect signal (TTC) when no calling line identification is required (for further details, see Appendix III).
Called line identification (if required)		The called line identification signal transmitted at automatic speed commencing within one character period of the receipt of the TTD signal or the first character of the calling line identification signals.	The called or calling line identification signal consists of the F.69 [3] code followed by the digits of the subscriber's number and then the end-of-identification character (CSC No. 12). The receipt of only the CSC No. 12 indicates that the line identification is not available. Where the called line identification has been requested, the reception of the call-connected signal, not preceded by the STTC and TTC, will also indicate that the called line identification is not available. For further details, see Appendix III.
Calling line identification (if required)	The calling line identification transmitted at automatic speed commencing within one to two character periods of receipt of the transit through-connect signal (TTC)		

TABLE 1/U.12 (end)

Signal or function	Forward path (X towards Y)	Backward path (Y towards X)	Remarks
WRU (<i>Who are you?</i>)	WRU characters (combinations Nos. 30 and 4) of ITA No. 2		For definition, see § 3.14 of the text and for further details, see Appendix III.
Service signal with clearing		CSC characters (see Table 7b/U.12), followed by clearing signal	The service signal consists of CSC No. 11, followed by two characters of Table 7b/U.12.
Idle circuit	Stop polarity	Stop polarity	
Clearing	Inversion to start polarity in the direction of clearing. The minimum recognition time is 2 characters and the maximum time is 4 characters.		The minimum period of start polarity on one signalling path that it itself ensures the complete release of the connection is 4 characters.
Clear confirmation	Inversion to continuous start polarity in the opposite direction after a minimum duration of 2 characters of clearing signal and a maximum duration of 7 characters		The minimum and maximum periods for the release of the international circuit by a centre are 2 and 7 characters respectively.
Incoming guard delay	Period of 3-4 characters measured from the appearance of start polarity on both signalling paths		A new incoming call shall not be accepted until this guard period is elapsed. For further details, see § 3.15 of the text.
Outgoing guard delay	Period of 8 characters measured from the appearance of start polarity on both signalling paths		The outgoing equipment should not open the trunk circuit for service until this guard period has elapsed. For further details, see § 3.15 of the text.
Automatic re-test	Stop polarity for 1-2 (exceptionally 4) character periods followed by CSC No. 13, stop polarity for 4 seconds and then start polarity, repeated		For further details on the repetition periods, see § 3.16 of the text.
Backward busy		Continuous stop polarity for a maximum of 5 minutes	

TABLE 2/U.12

First CSC^{a)} character on the forward and backward paths

Combination				Condition signalled
b ₄	b ₃	b ₂	b ₁	
A	A			No further network selection signal follows ^{b)}
A	Z			Second class-of-traffic character follows ^{b)} (see Table 4/U.12)
Z	A			User-class character follows ^{b)} (see Table 3/U.12)
		A		Alternative routing not allowed ^{b)}
		Z		Alternative routing allowed ^{b)}
			A	Transit traffic ^{b)}
			Z	Terminal traffic ^{b)}
Z	Z	A	A	Re-test signal ^{b)}
Z	Z	A	Z	Reception-confirmation
Z	Z	Z	A	} Not allocated
Z	Z	Z	Z	

^{a)} CSC = control signalling code.^{b)} First class-of-traffic character.

TABLE 3/U.12
First user-class character

Combination				Condition signalled from X to Y ^{a)}
b ₄	b ₃	b ₂	b ₁	
A				No second class-of-traffic character follows
Z				A second class-of-traffic character follows (see Table 3/U.12)
	A	A	A	} Reserve
	A	A	Z	
	A	Z	A	Service
	A	Z	Z	Telex
	Z	A	A	Gentex
	Z	A	Z	} Reserve
	Z	Z	A	
	Z	Z	Z	A second user-class character follows ^{b)}

^{a)} The user class character may be omitted, if, for example, the information can be derived from the incoming line.

^{b)} Reserved for future needs.

TABLE 4/U.12

Second class-of-traffic character

Combination				Condition signalled from X to Y	
b ₄	b ₃	b ₂	b ₁		
A				No third class-of-traffic character follows	
Z				Third class-of-traffic character follows ^{a)}	
	A			No closed user group sequence follows	
	Z			Closed user group sequence follows (see Table 5/U.12)	
				A	Called line identification not required
				Z	Called line identification required
				A	Reserved for national use ^{b)}
	Z				

^{a)} Reserved for future needs. If implemented, the allocations should be the same as in Table 4a/X.70 [5].

^{b)} On international circuits, b₁ should be set to A polarity.

TABLE 4a/U.12

Third class-of-traffic character

Combination				Condition signalled from X to Y	
b ₄	b ₃	b ₂	b ₁		
A				No fourth class-of-traffic character follows	
Z				Fourth class-of-traffic character follows ^{a)}	
	A			Reserved ^{b)}	
	Z				
				A	Reserved ^{b)}
				Z	
				A	No delay of forward selection is required ^{c)}
	Z	Delay of forward selection is required ^{c)}			

^{a)} Reserved for future needs.

^{b)} See Table 4a/X.70.

^{c)} See Recommendation U.15.

TABLE 5/U.12

Start of closed user group character ^{a), b)}

Combination				Condition signalled from X to Y			
b ₄	b ₃	b ₂	b ₁				
A				Without outgoing access			
Z				With outgoing access			
	A			No DNIC follows ^{c)}			
	Z			DNIC follows ^{c) d)}			
				A	A	1	} Number of hexadecimal closed user group characters that follow
				A	Z	2	
	Z	A	3				
	Z	Z	4				

^{a)} The application of closed user groups is provisional and for further study in the telex service.

^{b)} The start of closed user group character shall precede the data network identification code (DNIC – Recommendation X.121 [6]) of the representative user (see Recommendation X.87 [7]) followed by the closed user group number, which would be coded into a number of hexadecimal characters up to a maximum of four, as indicated. The closed user group number would be transmitted with the least significant bit of the least significant character first.

^{c)} For further information, see Recommendation X.121 [6].

^{d)} On international circuits, b₃ should be set to Z-polarity.

TABLE 5a/U.12

Closed user group characters

Combination				Condition signalled from X to Y	
b ₄	b ₃	b ₂	b ₁		
A	A	A	A	0	} Hexadecimal closed user group character
A	A	A	Z	1	
A	A	Z	A	2	
A	A	Z	Z	3	
A	Z	A	A	4	
A	Z	A	Z	5	
A	Z	Z	A	6	
A	Z	Z	Z	7	
Z	A	A	A	8	
Z	A	A	Z	9	
Z	A	Z	A	A	
Z	A	Z	Z	B	
Z	Z	A	A	C	
Z	Z	A	Z	D	
Z	Z	Z	A	E	
Z	Z	Z	Z	F	

TABLE 6/U.12

Miscellaneous forward path signals

Combination				Condition signalled from X to Y	
b ₄	b ₃	b ₂	b ₁		
A	A	A	A	0	} Digits for: – telex destination code, – called subscriber's number, – calling line identification, – DNIC.
A	A	A	Z	1	
A	A	Z	A	2	
A	A	Z	Z	3	
A	Z	A	A	4	
A	Z	A	Z	5	
A	Z	Z	A	6	
A	Z	Z	Z	7	
Z	A	A	A	8	
Z	A	A	Z	9	
Z	A	Z	A		End-of-selection signal and transit centres through-connected signal (TTD)
Z	A	Z	Z		End-of-calling-line-identification signal ^{a)}
Z	Z	A	A		} Not allocated
Z	Z	A	Z		
Z	Z	Z	A		
Z	Z	Z	Z		

^{a)} This signal is also used without any pre-service signal when the calling line identification is not available.

TABLE 7/U.12

Miscellaneous backward path signals

Combination				Condition signalled from Y to X	
b ₄	b ₃	b ₂	b ₁		
A	A	A	A	0	Digits for: – network identification signal (Recommendation F.69 [3]), – called line identification, – service signals.
A	A	A	Z	1	
A	A	Z	A	2	
A	A	Z	Z	3	
A	Z	A	A	4	
A	Z	A	Z	5	
A	Z	Z	A	6	
A	Z	Z	Z	7	
Z	A	A	A	8	
Z	A	A	Z	9	
Z	A	Z	A		Start-of-service signal (see Table 7a/U.12)
Z	A	Z	Z		{ End-of-called-line identification ^{a)} Start-of-network identification signal
Z	Z	A			Call-connected signal
			A		Call metering
			Z		No call metering
Z	Z	Z	A		Start of transit through-connect signal (STTC)
Z	Z	Z	Z		Further backward path signal follows ^{b)}

^{a)} This signal is also used without any pre-service signal when the called line identification is not available.

^{b)} Use of this combination is for future need.

TABLE 7a/U.12

Transit through-connect signals ^{a)}

Combination				Condition signalled from Y to X	
b ₄	b ₃	b ₂	b ₁		
A	A	A	A	Not allocated	
A	A	A	Z		
A	A	Z	A		
A	A	Z	Z		
A	Z	A	A		
A	Z	A	Z		
A	Z	Z	A		
A	Z	Z	Z		
Z	A	A	A		
Z	A	A	Z		
Z	A	Z	A		
Z	A	Z	Z		
Z	Z				Transit through-connect signal (TTC)
		A			Calling line identification not required
		Z		Calling line identification required	
			A	Call metering	
			Z	No call metering	

^{a)} These signals follow the start of transit through-connect signal (STTC) in Table 7/U.12.

TABLE 7b/U.12

Service signals on the backward path

Numerical code, first/second digit	Category	Significance	Equivalent alphabetical code
01	Without clearing	a)	–
02		Redirected call ^{b)}	RDI
03		Connect when free ^{c)}	MOM
20	With clearing, due to subscriber – short term ^{d)}	Network failure	NC
21		Number busy	OCC
22		a)	–
23		a)	–
41	With clearing, due to subscriber – long term ^{d)}	Access barred	NA
42		Changed number	NCH
43		Not obtainable	NP
44		Out of order (general)	DER
45		Controlled not ready	ABS
46		Uncontrolled not ready	DER
47		(Answerback failure)	–
48		a)	–
49		Network fault in local loop	DER
51		Call information service	INF
52		a)	–
61	With clearing, due to network – short term ^{d)}	Network congestion	NC
71	With clearing, due to network – long term ^{d)}	a)	–
72		a)	–
81	With clearing, due to subscriber – network procedure	a)	–
82		a)	–
83		a)	–

^{a)} Used only in data networks. Not applicable to telex.

^{b)} Procedures concerning the use of this signal are left for further study (see Recommendation U.41).

^{c)} Only utilized within national networks.

^{d)} “Short-term” in this context approximates to the holding time of a call, whilst “long-term” implies a condition that can persist for some hours or even days.

TABLE 8/U.12
Control signalling code (CSC)

CSC character number	CSC character structure				
	b ₅	b ₄	b ₃	b ₂	b ₁
1	A	A	A	A	A
2	Z	A	A	A	Z
3	Z	A	A	Z	A
4	A	A	A	Z	Z
5	Z	A	Z	A	A
6	A	A	Z	A	Z
7	A	A	Z	Z	A
8	Z	A	Z	Z	Z
9	Z	Z	A	A	A
10	Z	Z	A	A	Z
11	A	Z	A	Z	A
12	Z	Z	A	Z	Z
13	A	Z	Z	A	A
14	Z	Z	Z	A	Z
15	Z	Z	Z	Z	A
16	A	Z	Z	Z	Z

Note 1 – The 4-unit code with one parity check bit used in this control signalling system is listed in the table. A complete control signalling code (CSC) character consists of a one-unit start element, four information bits ((b₁, b₂, b₃ and b₄), a parity check bit (b₅) and a stop element of nominally one and a half units.

Note 2 – The parity bit of the signal should correspond to even parity with regard to unit elements of Z polarity. The individual bits should be transmitted at the nominal modulation rate of 50 bauds with the low order bit (b₁) first and completed by the parity check bit (b₅).

Note 3 – The transmitting part of the signalling device shall send the control characters at the nominal modulation of 50 bauds \pm 0.5% with a maximum degree of gross start-stop distortion of 5%. The receiving part of the signalling device shall have an effective margin of not less than 40%.

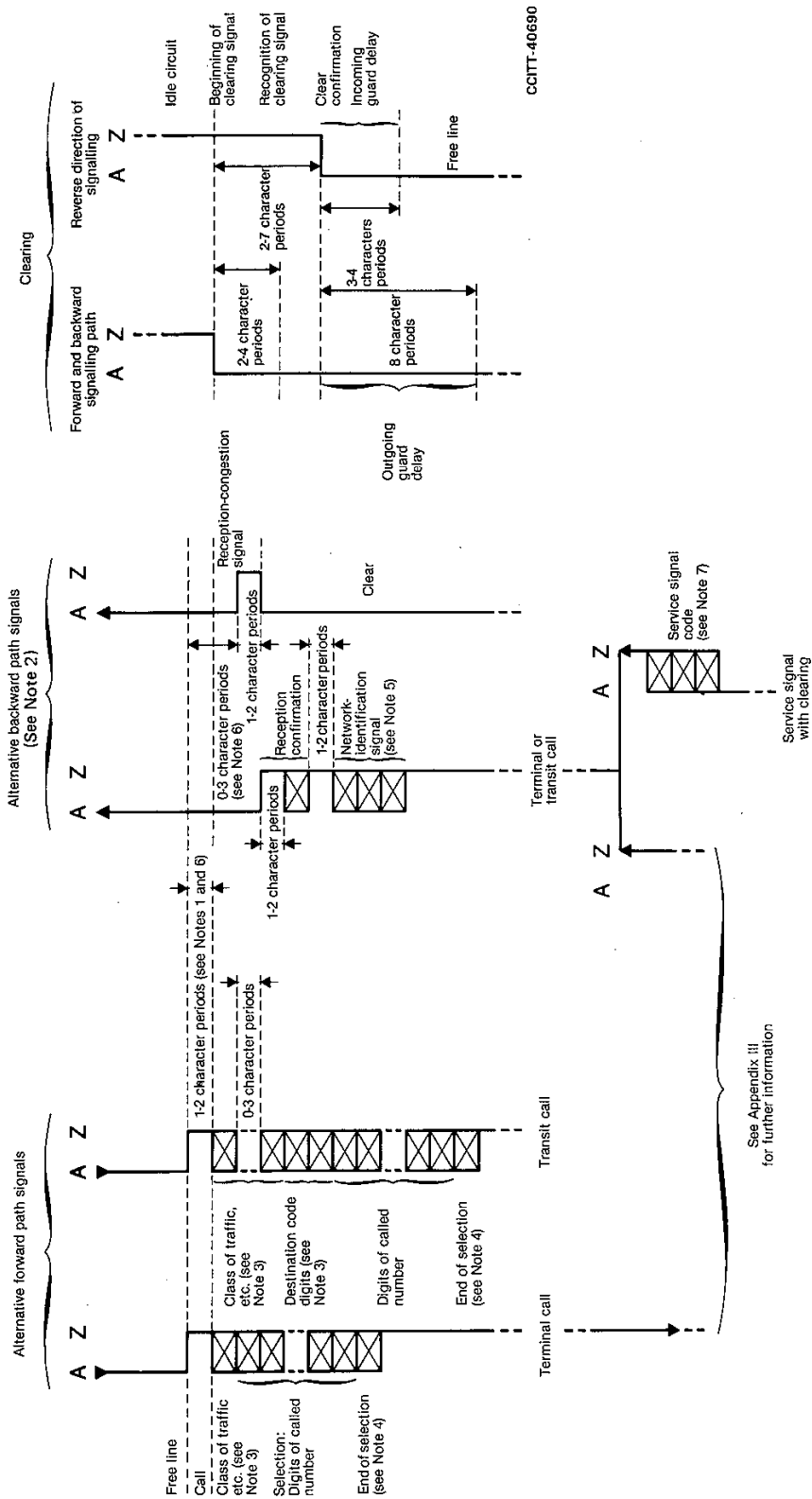

CCITT-40690

- Note 1 – Timings are shown as character periods of the 4 (+ 1 parity) bit code. Switching and propagation delays are not included.
- Note 2 – Forward path signals may also appear on the backward path, indicating a head-on collision on both-way circuits.
- Note 3 – Network selection signals (class-of-traffic), user-class signals, etc.: see Tables 2-5/U.12. Destination codes may comprise two or three digits.
- Note 4 – Selection signals will always be sent as a single block by the originating country. An end-of-selection signal must be included.
- Note 5 – The network identification signal comprises a distinctive character followed by the destination code of the network concerned.
- Note 6 – The minimum and consequently the maximum periods will be lengthened at the request of the incoming country.
- Note 7 – Service signals comprise a distinctive character followed by a 2-digit number.

FIGURE 1/U.12

Signalling system type D

APPENDIX I

(to Recommendation U.12)

Possible sequences of network selection signals

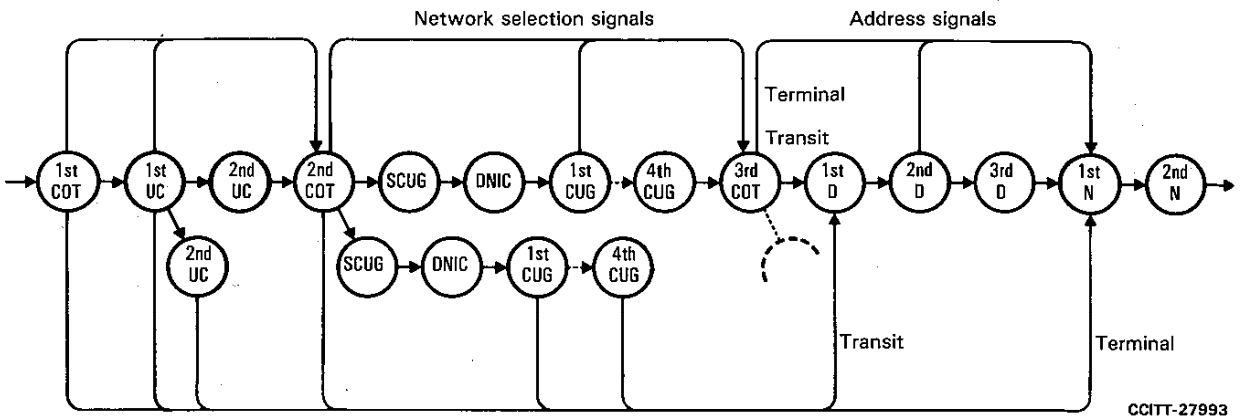

CCITT-27993

- COT Class-of-traffic character
- UC User-class character
- SCUG Start of closed user group sequence
- DNIC Data network identification code (see Recommendation X.121 [6])
- CUG Closed user group character
- D Destination code digit
- N Called number digit

Dotted lines: reserved for further extension

APPENDIX II

(to Recommendation U.12)

Examples of network selection signals

II.1 First example (minimum sequence of network selection signals)

This example shows a sequence of minimal length. (The preceding calling signal, the start and stop elements and the parity bit are not shown. The bits are shown in the order b_4, b_3, b_2 and b_1 .)

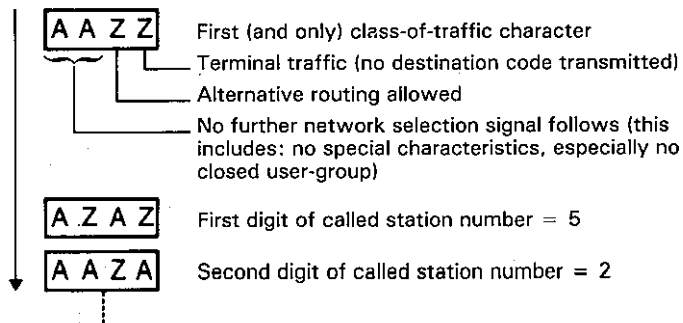

II.2 *Second example* (a sequence of network selection signals including closed user-group characters)

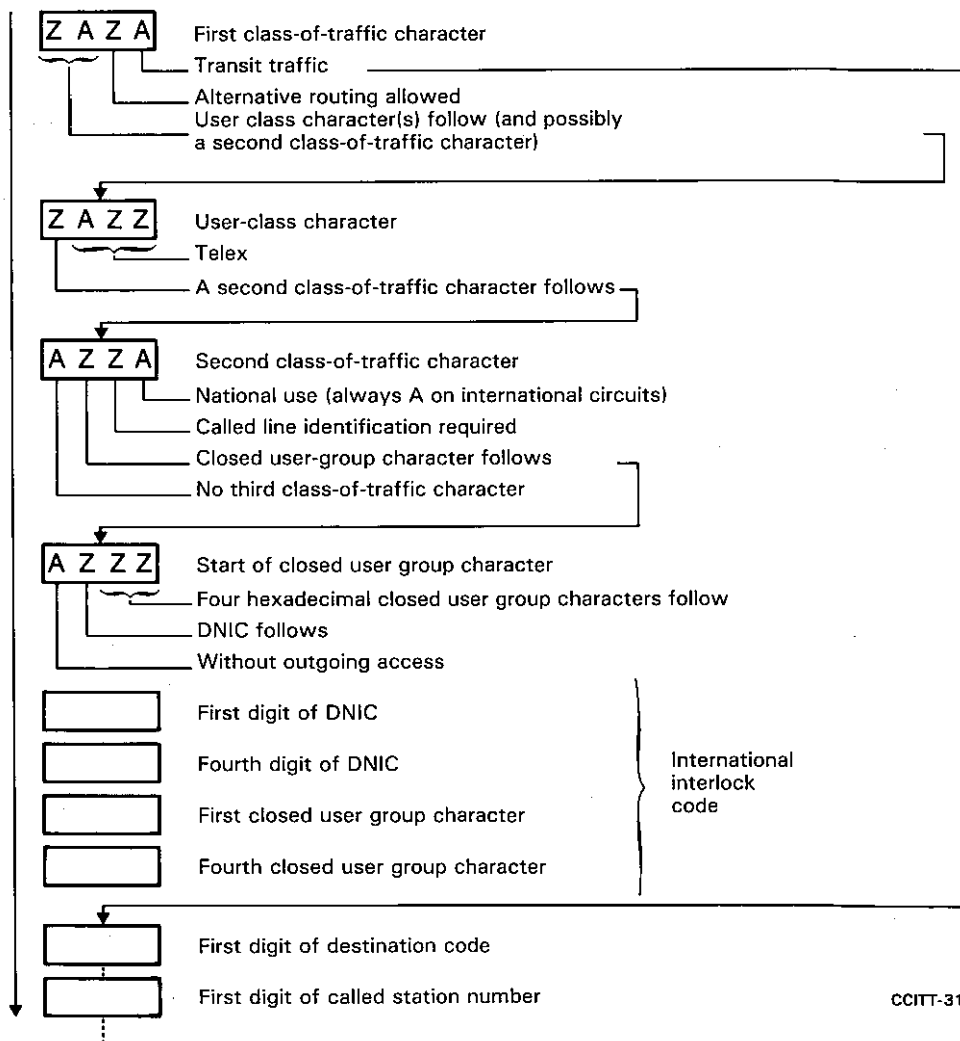

APPENDIX IIIa

(to Recommendation U.12)

Through-connection procedure

Called and calling line identification not required

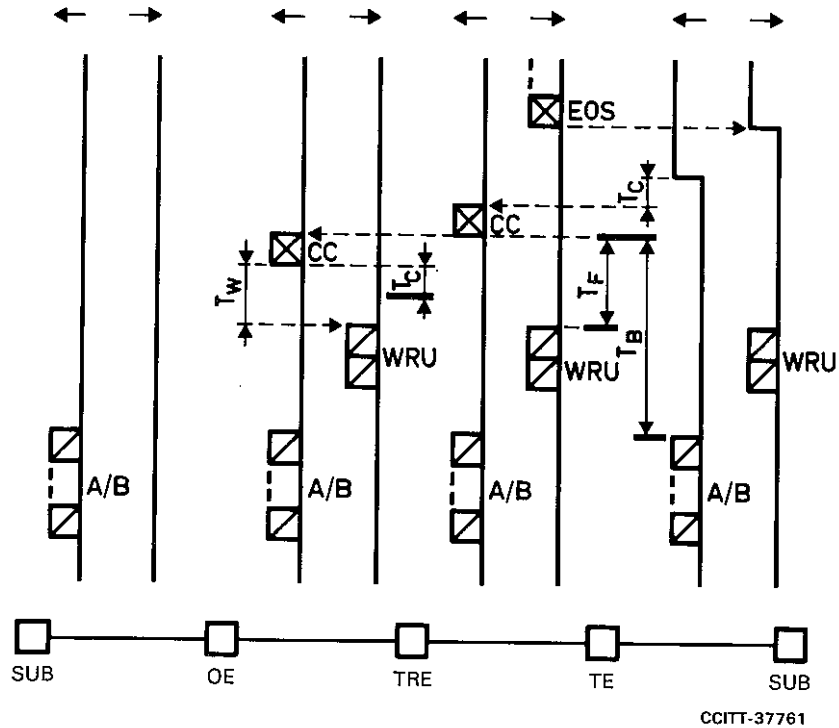

Legends to Appendices IIIa to IIIc

--->	Correlation line	CDI	Called line identification signals
—	Through-connection	CC	Call connected signal
T_B	Upper and lower limits for through-connection of backward path	WRU	Who are you?
T_F	Upper and lower limits for through-connection of forward path	A/B	Answerback
▢	ITA2 character	SUB	Subscribers
⊠	CSC character	OE	Originating exchange
EOS	End of selection signal	TRE	Transit exchange
STTC	Start of transit through-connect signal	TE	Terminating exchange
TTC	Transit through-connect signal	C	Character period
TTD	Transit centres through-connected signal	T_C	0 to 1 C, see also § 3.12
CLI	Calling line identification signals	T_W	1 to 2 C, see also § 3.14

APPENDIX IIIb

(to Recommendation U.12)

Through-connection procedure

Called line identification not required,
calling line identification required

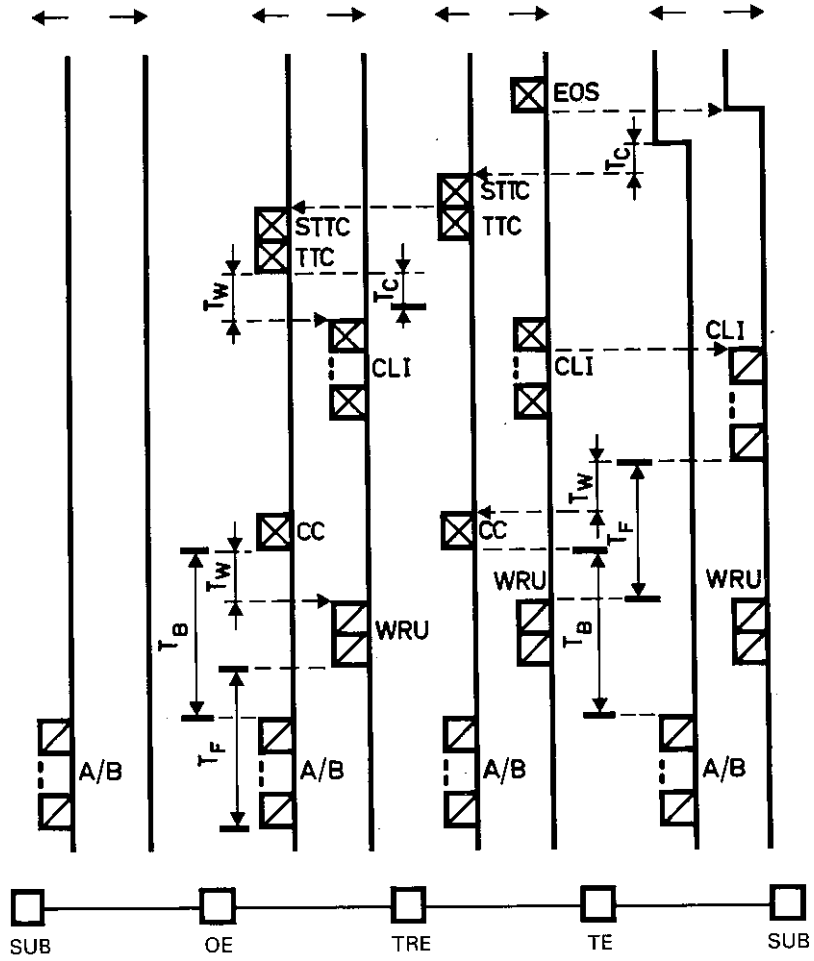

CCITT-37741

APPENDIX IIIc

(to Recommendation U.12)

Through-connection procedure

Called line identification required,
calling line identification not required

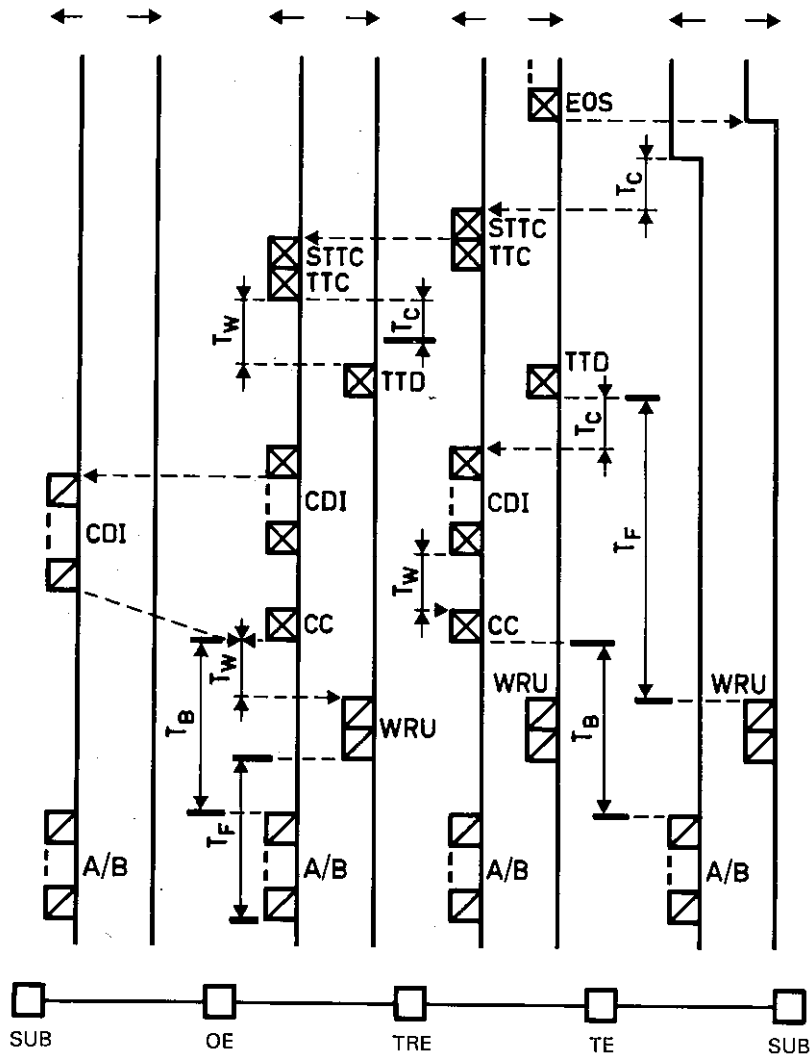

CCITT-37731

APPENDIX III d

(to Recommendation U.12)

Through-connection procedure

Called and calling line identification required

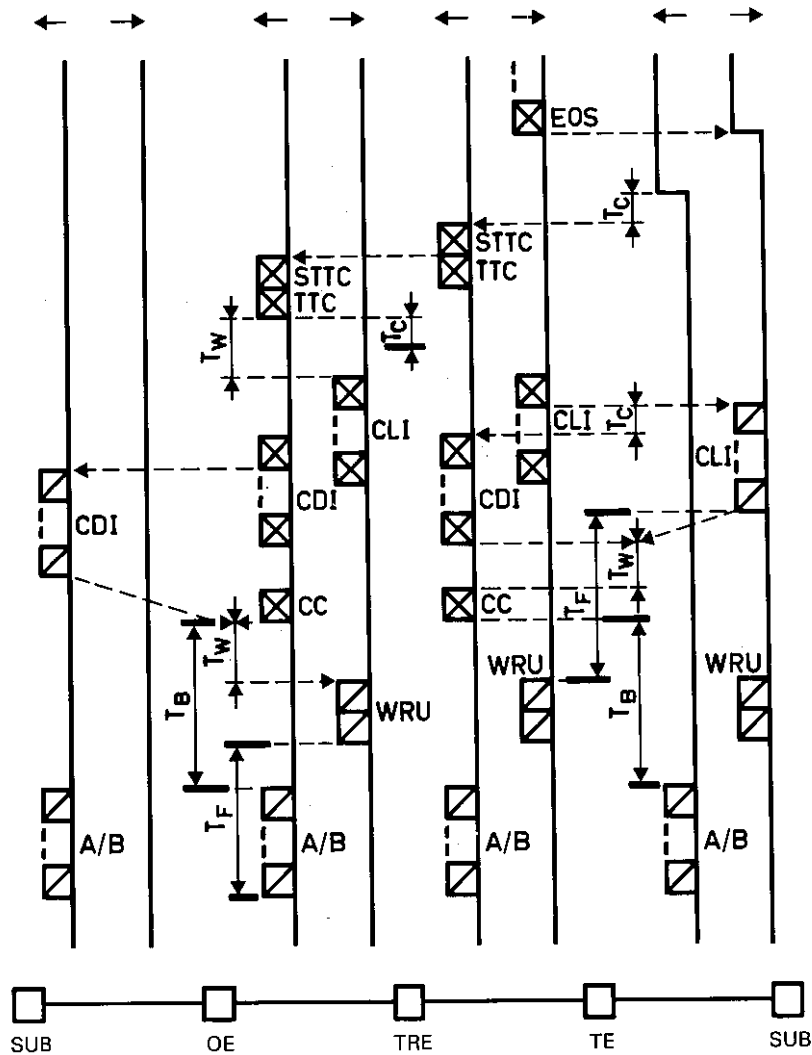

CCITT-37751

References

- [1] CCITT Recommendation *Terminal and transit control signalling system for start-stop services on international circuits between anisochronous data networks*, Rec. X.70.
- [2] CCITT Recommendation *Decentralized terminal and transit control signalling system on international circuits between synchronous data networks*, Rec. X.71.
- [3] CCITT Recommendation *Plan for telex destination codes*, Rec. F.69.
- [4] CCITT Recommendation *Switching equipment of start-stop apparatus*, Rec. S.9.
- [5] CCITT Recommendation *Terminal and transit control signalling system for start-stop services on international circuits between anisochronous data networks*, Rec. X.70, Table 4a/X.70.
- [6] CCITT Recommendation *International numbering plan for public data networks*, Rec. X.121.
- [7] CCITT Recommendation *Principles and procedures for realization of international user facilities and network utilities in public data networks*, Rec. X.87.

ITU-T RECOMMENDATIONS SERIES

Series A	Organization of the work of the ITU-T
Series B	Means of expression: definitions, symbols, classification
Series C	General telecommunication statistics
Series D	General tariff principles
Series E	Overall network operation, telephone service, service operation and human factors
Series F	Non-telephone telecommunication services
Series G	Transmission systems and media, digital systems and networks
Series H	Audiovisual and multimedia systems
Series I	Integrated services digital network
Series J	Transmission of television, sound programme and other multimedia signals
Series K	Protection against interference
Series L	Construction, installation and protection of cables and other elements of outside plant
Series M	TMN and network maintenance: international transmission systems, telephone circuits, telegraphy, facsimile and leased circuits
Series N	Maintenance: international sound programme and television transmission circuits
Series O	Specifications of measuring equipment
Series P	Telephone transmission quality, telephone installations, local line networks
Series Q	Switching and signalling
Series R	Telegraph transmission
Series S	Telegraph services terminal equipment
Series T	Terminals for telematic services
Series U	Telegraph switching
Series V	Data communication over the telephone network
Series X	Data networks and open system communications
Series Y	Global information infrastructure and Internet protocol aspects
Series Z	Languages and general software aspects for telecommunication systems