

Mobile Payment Application Security Tests

Arnold Kibuuka

Project Officer, TSB, ITU



Overview

1. USSD & STK App security tests
2. Android, iOS app security tests

USSD and STK Tests

USSD and STK App Security Tests



a. **SIM Swap** and **SIM cloning**



b. susceptibility to **binary OTA attacks**
(SIM jacker, WIB attacks)

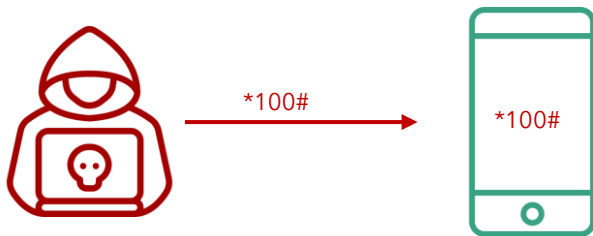

c. **remote USSD** execution attacks

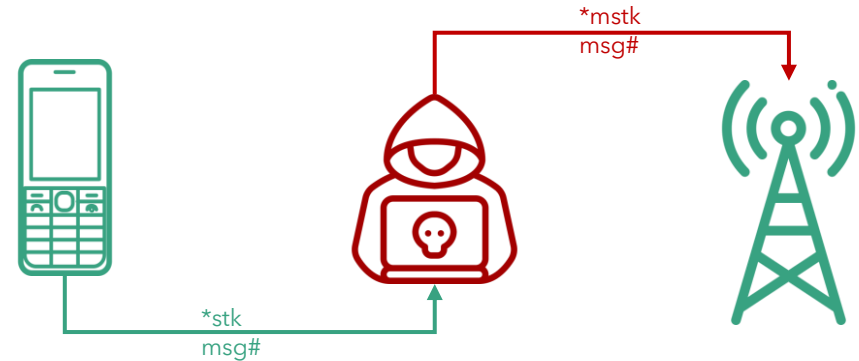

d. **man-in-the-middle attacks** on STK
based DFS applications

Man-in-the-Middle attacks on STK based DFS applications

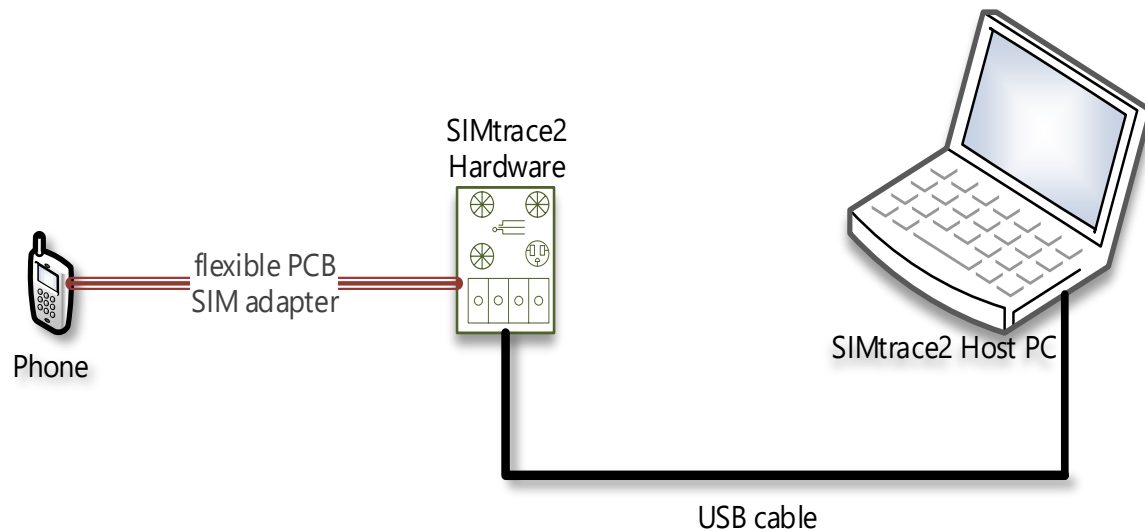

MiTM attack simulation on STK using a SIMtrace



Man-in-the-Middle attacks on STK based DFS applications

405	125....	lo...	lo...	GSM ...	65	ETSI TS 102.221	STATUS : Terminal should repeat command, Leng...	38229 (38229),gsmtap (4729)
54	32.8...	lo...	lo...	GSM ...	83	ETSI TS 102.221	TERMINAL PROFILE	38229 (38229),gsmtap (4729)
349	85.5...	lo...	lo...	GSM ...	77	ETSI TS 102.221	TERMINAL RESPONSE DISPLAY TEXT	38229 (38229),gsmtap (4729)
393	105....	lo...	lo...	GSM ...	77	ETSI TS 102.221	TERMINAL RESPONSE DISPLAY TEXT	38229 (38229),gsmtap (4729)
407	128....	lo...	lo...	GSM ...	77	ETSI TS 102.221	TERMINAL RESPONSE DISPLAY TEXT	38229 (38229),gsmtap (4729)
434	149....	lo...	lo...	GSM ...	77	ETSI TS 102.221	TERMINAL RESPONSE DISPLAY TEXT	38229 (38229),gsmtap (4729)
345	80.2...	lo...	lo...	GSM ...	84	ETSI TS 102.221	TERMINAL RESPONSE GET INPUT	38229 (38229),gsmtap (4729)
403	121....	lo...	lo...	GSM ...	84	ETSI TS 102.221	TERMINAL RESPONSE GET INPUT	38229 (38229),gsmtap (4729)
157	33.4...	lo...	lo...	GSM ...	81	ETSI TS 102.221	TERMINAL RESPONSE POLL INTERVAL	38229 (38229),gsmtap (4729)
351	86.0...	lo...	lo...	GSM ...	87	ETSI TS 102.221	TERMINAL RESPONSE PROVIDE LOCAL INFORMATION	38229 (38229),gsmtap (4729)
409	129....	lo...	lo...	GSM ...	87	ETSI TS 102.221	TERMINAL RESPONSE PROVIDE LOCAL INFORMATION	38229 (38229),gsmtap (4729)
332	62.8...	lo...	lo...	GSM ...	80	ETSI TS 102.221	TERMINAL RESPONSE SELECT ITEM	38229 (38229),gsmtap (4729)
336	65.0...	lo...	lo...	GSM ...	77	ETSI TS 102.221	TERMINAL RESPONSE SELECT ITEM	38229 (38229),gsmtap (4729)
338	68.3...	lo...	lo...	GSM ...	80	ETSI TS 102.221	TERMINAL RESPONSE SELECT ITEM	38229 (38229),gsmtap (4729)
340	71.5...	lo...	lo...	GSM ...	80	ETSI TS 102.221	TERMINAL RESPONSE SELECT ITEM	38229 (38229),gsmtap (4729)
396	111....	lo...	lo...	GSM ...	80	ETSI TS 102.221	TERMINAL RESPONSE SELECT ITEM	38229 (38229),gsmtap (4729)
401	116....	lo...	lo...	GSM ...	80	ETSI TS 102.221	TERMINAL RESPONSE SELECT ITEM	38229 (38229),gsmtap (4729)
370	89.9...	lo...	lo...	GSM ...	77	ETSI TS 102.221	TERMINAL RESPONSE SEND SHORT MESSAGE	38229 (38229),gsmtap (4729)
428	133....	lo...	lo...	GSM ...	77	ETSI TS 102.221	TERMINAL RESPONSE SEND SHORT MESSAGE	38229 (38229),gsmtap (4729)
121	33.2...	lo...	lo...	GSM ...	77	ETSI TS 102.221	TERMINAL RESPONSE SET UP EVENT LIST	38229 (38229),gsmtap (4729)

Command details: 012304
 Command Number: 0x01
 Command Type: GET INPUT (0x23)
 Command Qualifier: 0x04

Device identity: 8281
 Source Device ID: Terminal (Card Reader) (0x82)
 Destination Device ID: SIM / USIM / UICC (0x81)

Result: 00
 Result: Command performed successfully (0x00)

Text string: 0435343533
 Text String Encoding: GSM default alphabet, 8 bits (0x04)
Text String: 5453

Status Word: 911c Normal ending of command with info from proactive SIM



Testing susceptibility to binary OTA attacks (SIMjacker, WIB attacks)

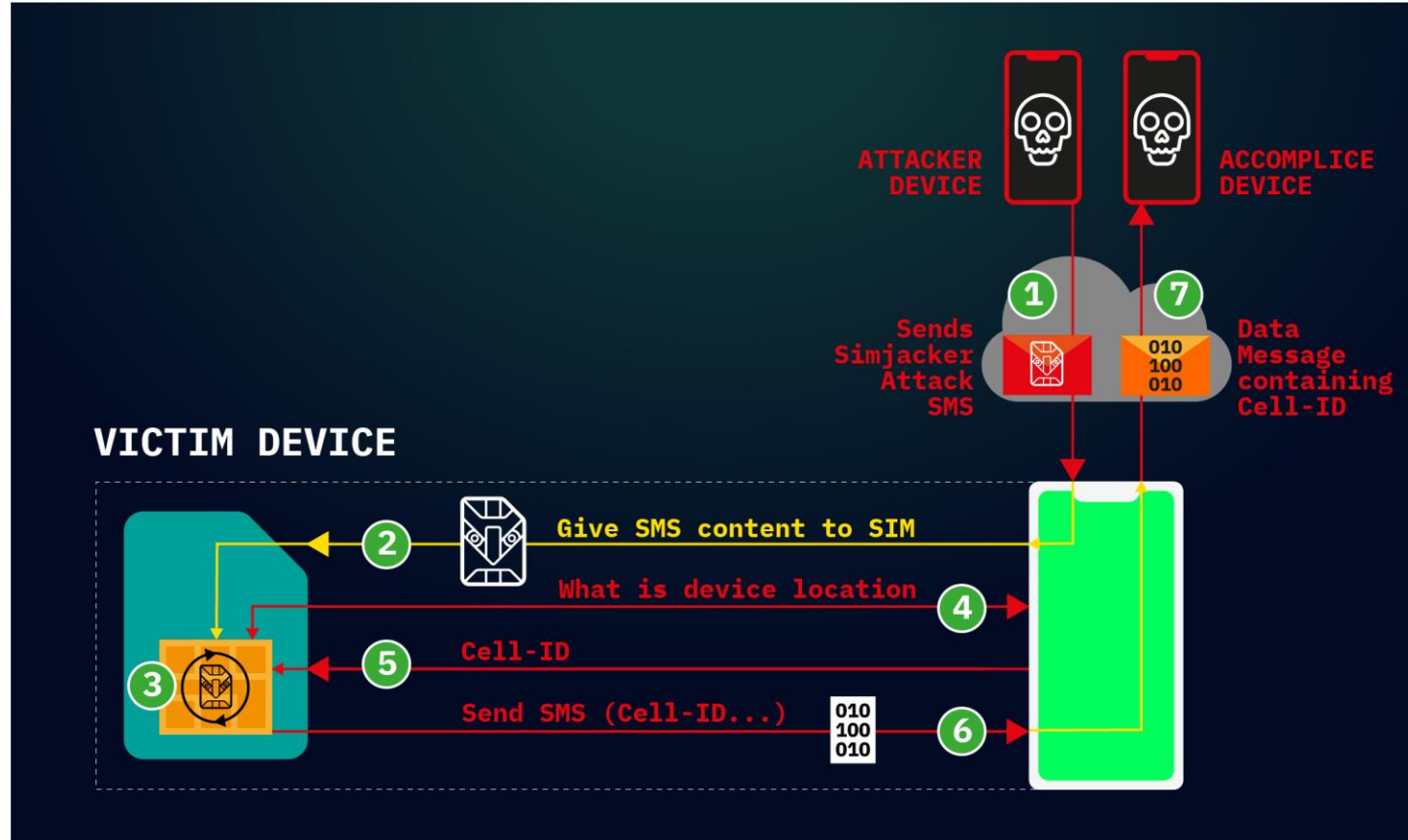

A binary OTA message can instruct the SIM to:

- initiate SS,
 - Send SMS
 - Initiate a phone call
- on a vulnerable SIM and will affect both USSD and STK apps.

(see [CVE-2019-16256](https://nvd.nist.gov/vuln/detail/CVE-2019-16256))

Source: Adaptive Mobile

Testing remote USSD execution attacks

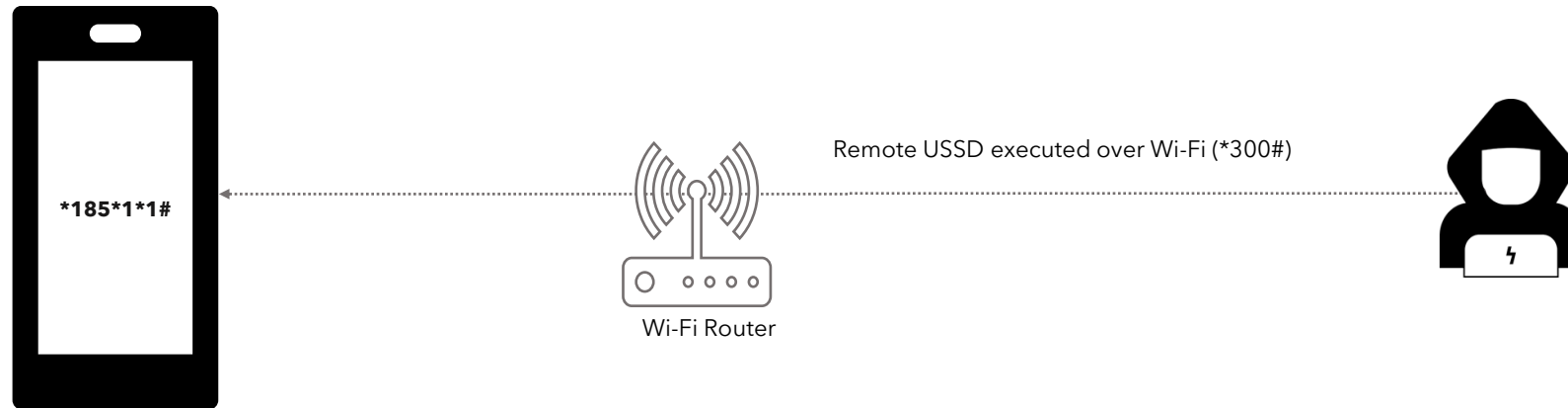

USSD remote attacks through open ADB ports

```
figisit@ubuntu: ~/LAB/platform-tools
figisit@ubuntu:~/LAB/platform-tools$ ./adb shell
HWEVA:/ $ am start -a android.intent.action.CALL -d tel:*185%23
Starting: Intent { act=android.intent.action.CALL dat=tel:xxxxx }
HWEVA:/ $ am start -a android.intent.action.CALL -d tel:*185*1*1%23
Starting: Intent { act=android.intent.action.CALL dat=tel:xxxxxxxxx }
HWEVA:/ $
```

USSD execution through a terminal for a device connected to Wi-Fi

Remote USSD execution attacks

Shodan Developers Book View All...

SHODAN android debug bridge product:"Android Debug Bridge" Explore Downloads Reports Developer Pricing Enterprise Access

Exploits Maps Like 1 Download Results Create Report

TOTAL RESULTS
31,471

TOP COUNTRIES

Taiwan	7,611
Korea, Republic of	7,548
China	4,961
United States	2,864
Russian Federation	1,792

TOP ORGANIZATIONS

HiNet	5,568
Korea Telecom	4,805
SK Broadband	1,475
China Unicom FuJian	1,198
China Telecom jiangsu	300

TOP OPERATING SYSTEMS

Linux 3.x	99
Windows XP	44
FreeBSD 8.x-9.x	3
Windows 7 or 8	1

219.78.245.136
n219078245136.netvigator.com
Netvigator
Added on 2018-08-25 14:58:24 GMT
📍 Hong Kong, Kowloon
Details
scanner

Android Debug Bridge
Name: mars_a31s
Model: Q-BOX_02
Device: mars-a31s

211.193.83.5
Korea Telecom
Added on 2018-08-25 14:57:57 GMT
📍 Korea, Republic of, Changwon
Details

Android Debug Bridge
Name: ghost_retasia
Model: XT1052
Device: ghost

121.161.37.75
Korea Telecom
Added on 2018-08-25 14:57:27 GMT
📍 Korea, Republic of, Koyang
Details

Android Debug Bridge
Name: taimen
Model: PIXEL 2 XL
Device: taimen

62.152.25.229
cpe-405323.ip.primehome.com
Primetel PLC
Added on 2018-08-25 14:57:23 GMT
📍 Cyprus, Paphos
Details

Android Debug Bridge
Name: p212_8189
Model: p212_8189
Device: p212_8189

118.34.155.116
Korea Telecom
Added on 2018-08-25 14:57:20 GMT
📍 Korea, Republic of, Seoul
Details

Android Debug Bridge
Name: ghost_retasia
Model: XT1052
Device: ghost

Shodan report: showing services with ADB open connected to the internet

adb can also be used to attack services on IoT devices

Recommendations

Remote USSD execution on devices

- Disable ADB
- User education
- Discourage use rooted devices

SIM exploitation using binary OTA

- Binary OTA SMS filtering & blocking.
- SMS home routing.
- SIM card security

Man-in-the-Middle attacks

- Use session timeout
- Secure radio channel communication
- SS7 controls and mitigations

SIM swap and SIM clone attacks

- SIM change detection. (ICCID, IMEI)
- Secure storage of SIM data like IMSI and secret key (KI values)

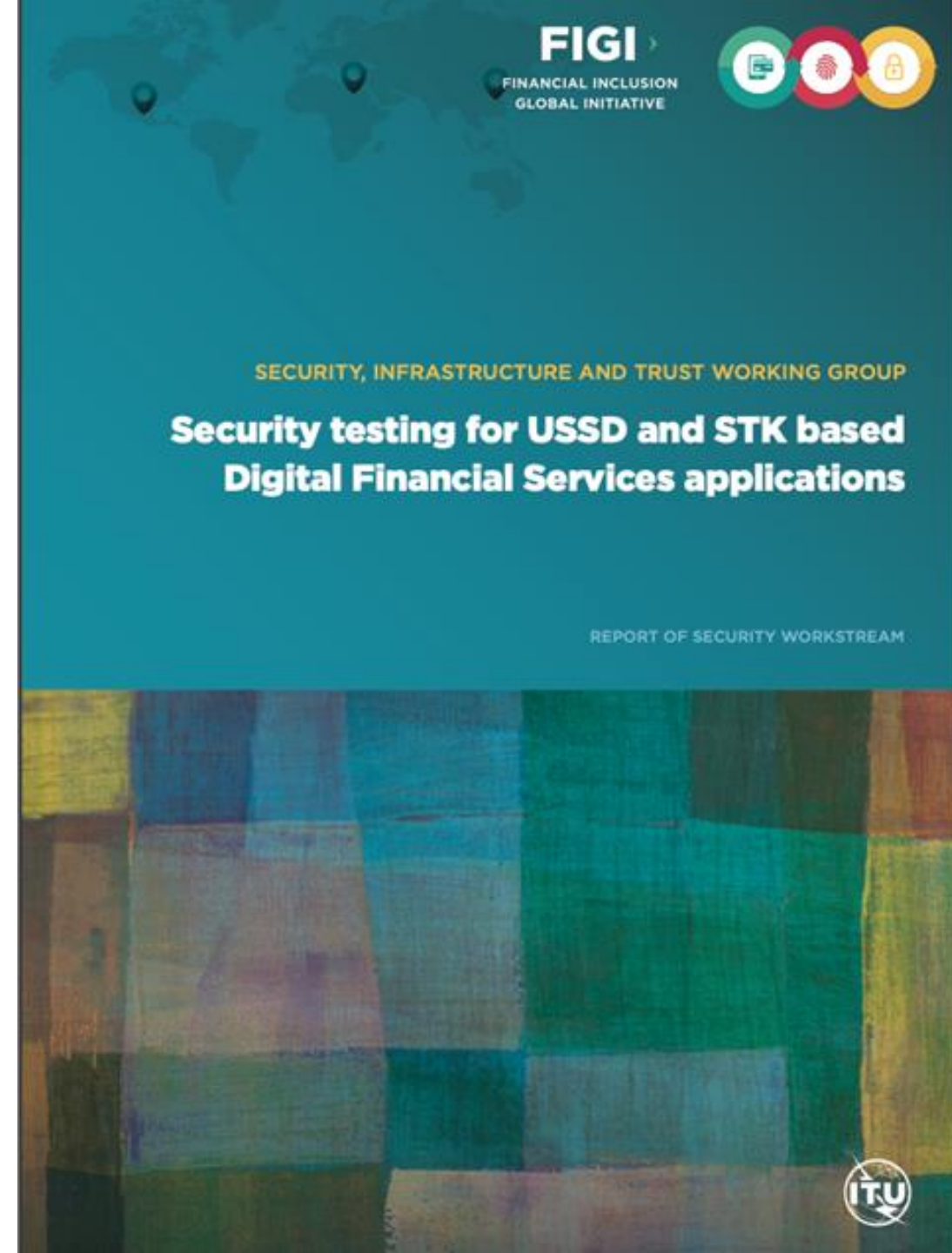

Hardware for security testing of USSD and STK based DFS

1. Laptop
2. Mobile Android smartphone, Samsung S4
3. Card reader
4. SIM card adapter
5. Mobile featurephone, Samsung 1200
6. Programmable/blank SIMs
7. SIMtrace microSIM & SIM (3FF) FPC Cab
8. SIMtrace2 Hardware Kit
9. Wi-Fi router - Synology RT2600AC

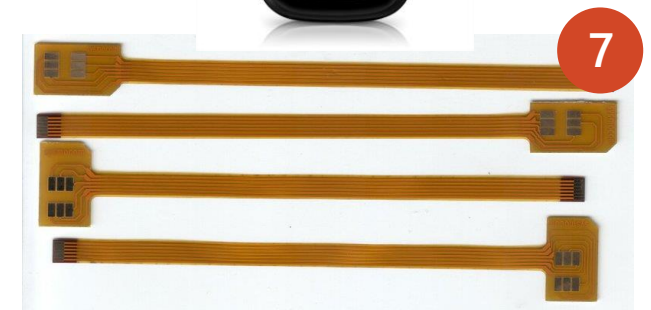

Software for USSD and STK based DFS security testing

- i. pySIM: - SIM cloning
- ii. SIMtrace: - Man-in-the-middle attacks
- iii. SIM tester: - Binary OTA attacks
- iv. ADB platform tools: - Remote USSD attack
- v. Wireshark: - STK analysis

Android App Security Tests

Introduction

The Open Web Application Security Project

A collaborative, non-for-profit foundation that works to improve the security of web applications

Also works on security of mobile applications.

OWASP Mobile Top Ten

OWASP project that aims to identify and document the top ten vulnerabilities of mobile applications

Lab methodology

18 tests organized according to OWASP mobile top ten

Smartphone tests

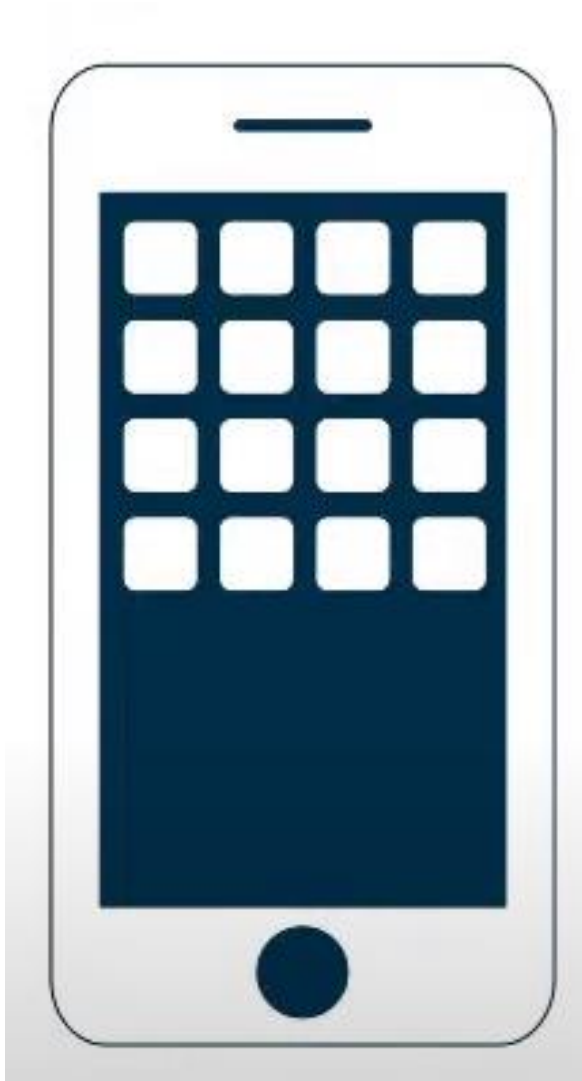

- Our tests are organized according to the subjects of the OWASP Mobile Top Ten:
 - M1 Improper Platform Usage
 - M2 Insecure Data Storage
 - M3 Insecure Communication
 - M4 Insecure Authentication
 - M5 Insufficient Cryptography
 - M6 *Insecure Authorization*
 - M7 *Client Code Quality*
 - M8 Code Tampering
 - M9 Reverse Engineering
 - M10 *Extraneous Functionality*
- M6, M7, M10 out of scope because they would need access to the source code or require collaboration with the editor

M1 Improper Platform Usage

The application should make correct use of the features of the platform

T1.1 Android:allowBackup

- Backup of the application and its data into the cloud should be disabled

T1.2 Android:debuggable

- Debugging features of the application should be disabled

T1.3 Android:installLocation

- The application should be installed in the internal, more secure, memory

T1.4 Dangerous permissions

- The application should not require dangerous permissions, as defined by Android.

PERMISSION	STATUS	INFO	DESCRIPTION
android.permission.ACCESS_COARSE_LOCATION	dangerous	coarse (network-based) location	Access coarse location sources, such as the mobile network database, to determine an approximate phone location, where available. Malicious applications can use this to determine approximately where you are.
android.permission.ACCESS_FINE_LOCATION	dangerous	fine (GPS) location	Access fine location sources, such as the Global Positioning System on the phone, where available. Malicious applications can use this to determine where you are and may consume additional battery power.

M2 Insecure Data Storage

```
<uses-sdk android:minSdkVersion="16" android:targetSdkVersion="28" />
<uses-feature android:name="android.hardware.telephony" android:required="false" />
<uses-feature android:name="android.hardware.telephony.cdma" android:required="false" />
<uses-feature android:name="android.hardware.telephony.gsm" android:required="false" />
<uses-feature android:name="android.hardware.camera" android:required="false" />
<uses-feature android:name="android.hardware.camera.autofocus" android:required="false" />
<uses-feature android:name="android.hardware.camera.flash" android:required="false" />
<uses-feature android:name="android.hardware.camera.front" android:required="false" />
<uses-feature android:name="android.hardware.camera.any" android:required="false" />
<uses-feature android:name="android.hardware.bluetooth" android:required="false" />
<uses-feature android:name="android.hardware.location" android:required="false" />
<uses-feature android:name="android.hardware.location.network" android:required="false" />
<uses-feature android:name="android.hardware.location.gps" android:required="false" />
<uses-feature android:name="android.hardware.microphone" android:required="false" />
<uses-feature android:name="android.hardware.wifi" android:required="false" />
<uses-feature android:name="android.hardware.wifi.direct" android:required="false" />
<uses-feature android:name="android.hardware.screen.landscape" android:required="false" />
<uses-feature android:name="android.hardware.screen.portrait" android:required="false" />
<uses-feature android:glEsVersion="0x00020000" android:required="true" />
<uses-permission android:name="android.permission.INTERNET" />
<uses-permission android:name="android.permission.ACCESS_NETWORK_STATE" />
<uses-permission android:name="android.permission.ACCESS_WIFI_STATE" />
<uses-permission android:name="android.permission.VIBRATE" />
<uses-permission android:name="android.permission.WAKE_LOCK" />
<uses-permission android:name="android.permission.USE_FINGERPRINT" />
<uses-permission android:name="android.permission.ACCESS_FINE_LOCATION" />
<uses-permission android:name="android.permission.READ_PHONE_STATE" />
<uses-permission android:name="android.permission.READ_CONTACTS" />
<uses-permission android:name="android.permission.WRITE_CALENDAR" />
<uses-permission android:name="android.permission.CAMERA" />
<uses-permission android:name="android.permission.FLASHLIGHT" />
<uses-permission android:name="android.permission.WRITE_EXTERNAL_STORAGE" />
<supports-screens android:largeScreens="true" android:xlargeScreens="true" />
<uses-permission android:name="com.google.android.c2dm.permission.RECEIVE" />
```

Data should be stored in a way that limits the risks in case of loss or compromise of the phone

T2.1 Android.permission.WRITE_EXTERNAL_STORAGE

- No permission to write to a removable memory card

T2.2 Disabling screenshots

- If not disabled, screen shots are done automatically to generate thumbnails for task switching

M3 Insecure Communication

Protect against eavesdropping and manipulation of traffic

T3.1 Application should only use HTTPS connections

- Test by sniffing traffic

T3.2 Application should detect Machine-in-the-Middle attacks with untrusted Certificates

- Would allow anybody to intercept traffic
- Test by intercepting traffic with proxy

T3.3 Application should detect Machine-in-the-Middle attacks with trusted certificate

- Would allow authorities to intercept traffic
- Test by installing root certificate on phone, intercept with proxy

T3.4 App manifest should not allow clear text traffic

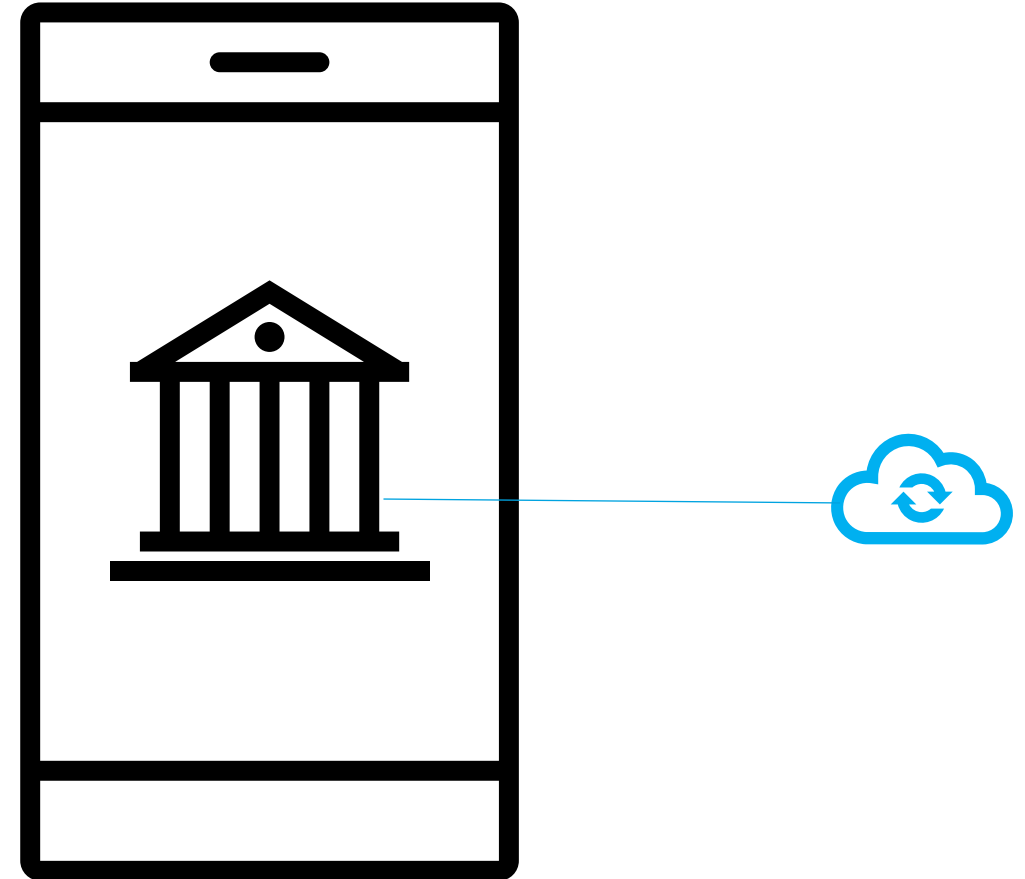

Intercept HTTP history WebSockets history Options

Filter: Hiding out of scope items

#	Host	Method	URL	Params	Edited	Status	Length	MIME type	Extension	Title	Comment	TLS	IP	Cookies	Time
148	https://[REDACTED]	GET	/iizwlm?_=1594371899392		✓	200	491	JSON				✓	[REDACTED]		11:04:54
145	https://[REDACTED]	GET	/iizwlm?_=1594371717242		✓	200	491	JSON				✓	[REDACTED]		11:01:51
144	https://[REDACTED]	GET	/iizwlm?_=1594371530169		✓	200	491	JSON				✓	[REDACTED]		10:58:40
141	https://[REDACTED]	GET	/P2PPaymentSystem/P2PInterfaceP2PLogin/V4_...		✓	200	576	JSON				✓	[REDACTED]		10:55:41
139	https://[REDACTED]	POST	/smartphone/service/v11/privateCustomers/me...		✓	200	1480	JSON				✓	[REDACTED]		10:55:21
138	https://[REDACTED]	GET	/smartphone/service/v11/privateCustomers/me...		✓	200	870	JSON				✓	[REDACTED]		10:55:20
137	https://[REDACTED]	POST	/P2PPaymentSystem/P2PInterfaceP2PLogin/V4_...		✓	200	805	JSON				✓	[REDACTED]		10:55:12
136	https://[REDACTED]	POST	/smartphone/service/v11/orders/p2p/send		✓	200	777	JSON				✓	[REDACTED]		10:55:09
135	https://[REDACTED]	GET	/P2PPaymentSystem/P2PInterfaceP2PLogin/V4_...		✓	200	576	JSON				✓	[REDACTED]		10:55:00
134	https://[REDACTED]	GET	/P2PPaymentSystem/P2PInterfaceP2PLogin/V4_...		✓	200	576	JSON				✓	[REDACTED]		10:54:47
133	https://[REDACTED]	GET	/P2PPaymentSystem/P2PInterfaceP2PLogin/V4_...		✓	200	576	JSON				✓	[REDACTED]		10:54:17
132	https://[REDACTED]	GET	/smartphone/service/v11/orders?limit=100&pa...		✓	200	18539	JSON				✓	[REDACTED]		10:53:47
131	https://[REDACTED]	POST	/smartphone/service/v11/privateCustomers/me...		✓	200	1480	JSON				✓	[REDACTED]		10:53:46
130	https://[REDACTED]	GET	/smartphone/service/v11/privateCustomers/me...		✓	200	870	JSON				✓	[REDACTED]		10:53:45
129	https://[REDACTED]	GET	/smartphone/service/v11/orders?since=1970-0...		✓	200	50014	JSON				✓	[REDACTED]		10:53:45
128	https://[REDACTED]	POST	/P2PPaymentSystem/P2PInterfaceP2PLogin/V4_...		✓	200	1340	JSON				✓	[REDACTED]		10:53:44

Request Response

Raw Params Headers Hex JSON JSON Beautifier

```

1 POST /smartphone/service/v11/orders/p2p/send HTTP/1.1
2 Accept-Encoding: gzip, deflate
3 Accept: application/json
4 Accept-Language: fr_CH
5 X-TWINT-WALLETAPP-LIB-VERSION: 15.3.0.18
6 Cookie: Navajo=UNBjXyUG2vyu2A3NYol+qgo/M3ThiBT8PhA944Z6Do/24f5NEDkkahF2VEohHy0zNKx2UuZivUg-
7 Content-Type: application/json; charset=UTF-8
8 Content-Length: 764
9 Host: [REDACTED]
10 Connection: close
11 User-Agent: okhttp/3.12.0
12 ADRUM_1: isMobile:true
13 ADRUM: isAjax:true
14
15 {
  "amount": {
    "amount": 20,
    "currency": "CHF"
  },
  "certificateFingerprint": "ef[REDACTED]417b",
  "moneyReceiver": {
    "firstName": [REDACTED],
    "lastName": [REDACTED]
  },
  "moneyReceiverMobileNumber": "+4179[REDACTED]",
  "moneySender": {
    "firstName": [REDACTED],
    "lastName": [REDACTED]
  },
  "orderId": "13976b6e-a57c-448a-8535-51d97f01928d",
  "reservationDate": "2020-07-10T08:55:12",
  "sendMoneyEvenIfCustomerUnknown": true,
  "signature": "gu2DEXJ5pqGx+0c6vQm0cU04MmYqyb+RIHT8iZ4jHGcul/Jx8iIwV1m6WU64G58oJnnEGH8WAr1dOmmc61/bZEjOEF3fRXR/2kffAreQNhE01Uc18sJFxx96iAt3Hfe336yHehB0qZ9zTKgtMZwGu8s3tzJNRpvrRszio2QCk5X7SIh26Ai04KD047uFmKEPThC

```

M4 Insecure Authentication

Prevent unauthorized access to the application

T4.1 Authentication required before accessing sensitive information

- Application must require PIN or fingerprint

T4.2 The application should have an inactivity timeout

T4.3 If a new fingerprint is added, authentication with fingerprints should be temporarily disabled

- User should provide PIN to enable fingerprints again
- Prevents attacks where an attacker adds their fingerprint to access the application

T4.4 It should not be possible to replay intercepted requests (e.g. a money transfer)

- An attacker intercepting a request for a money transfer could replay it to steal money from the victim.

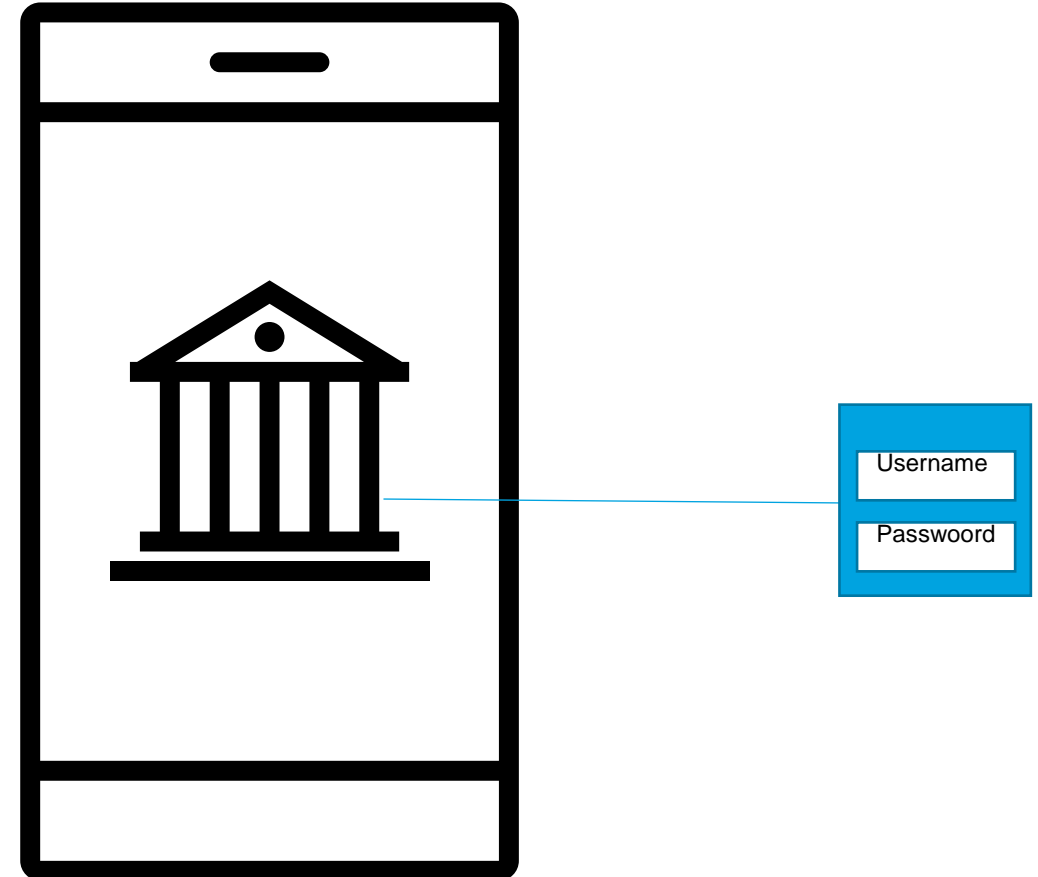

M5: Insufficient Cryptography

```
"moneyReceiverMobileNumber": "+4179 [REDACTED]"
"moneySender": {
  "firstName": [REDACTED]
  "lastName": [REDACTED]
},
```

Cryptography can only protect confidentiality and integrity of data if correctly implemented

```
112.     }
113.
114.     @TargetApi(8)
115.     public static File b(Context context) {
116.         if (bl.a()) {
117.             return context.getExternalCacheDir();
118.         }
119.         return new File(Environment.getExternalStorageDirectory().getPath() + "/");
120.     }
121.
122.     public static String b(String str) {
123.         try {
124.             MessageDigest instance = MessageDigest.getInstance("SHA-1");
125.             instance.update(str.getBytes());
126.             return a(instance.digest());
127.         } catch (NoSuchAlgorithmException unused) {
128.             return String.valueOf(str.hashCode());
129.         }
130.     }
131.
132.     @TargetApi(9)
133.     public static boolean b() {
134.         if (bl.b()) {
135.             return Environment.isExternalStorageRemovable();
136.         }
137.     }
138. }
```

T5.1 The app should not use unsafe crypto primitives

- E.g., MD5, SHA-1, RC4, DES, 3DES, Blowfish, ECB
- Search for these in the code
- Detection of these primitives does not imply that they are used for protecting critical information!

T5.2 The HTTPS connections should be configured according to best practices

- Watch where the app connects to, use Qualys SSL labs to evaluate configuration, expect a grade of B or more

M8: Code Tampering

Prevent an attacker from tampering the code on the telephone

T8.1 The application should refuse to run on a rooted device

- On a rooted device, users can manipulate the code of the application

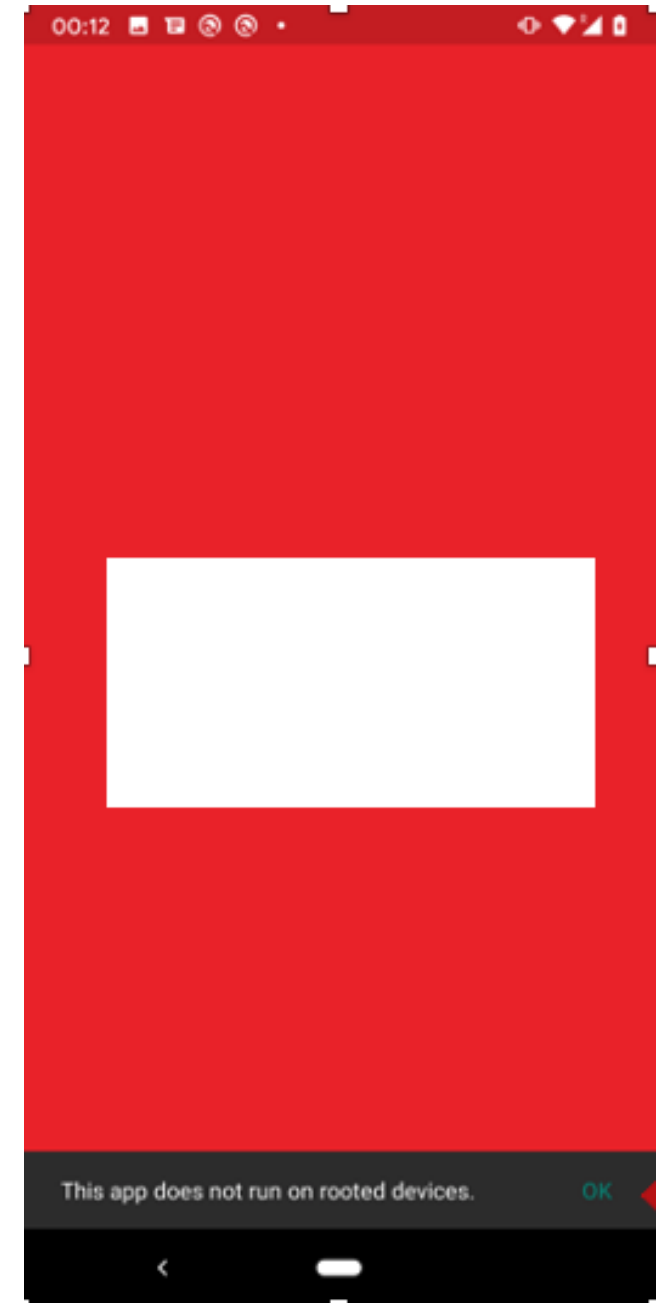

M9 Reverse engineering

```
        instance.update(str.getBytes());
        return a(instance.digest());
    } catch (NoSuchAlgorithmException unused) {
        return String.valueOf(str.hashCode());
    }
}

@TargetApi(9)
public static boolean b() {
    if (bl.b()) {
        return Environment.isExternalStorageRemovable();
    }
    return true;
}

public Bitmap a(String str) {
    dt<String, Bitmap> dtVar = this.d;
    if (dtVar != null) {
        return dtVar.a(str);
    }
    return null;
}

public void a() {
    synchronized (this.g) {
        if (this.c == null || this.c.a()) {
            File file = this.f.c;
            if (this.f.g && file != null) {
                if (!file.exists()) {
                    file.mkdirs();
                }
            }
        }
    }
}
```

Prevent attackers from analyzing the logic of the application

T9.1 The code should be obfuscated

- When the code is obfuscated, it is much more difficult to understand the logic of the code
- This makes it more difficult to manipulate the code or to find potential vulnerabilities
- Decompile the code and assess its readability

Android apps tests summary

Application security best practices

Corresponding tests

9.1 Device integrity

T1.2 Android:debuggable
T1.4 Dangerous permissions
T8.1 The application should refuse to run on a rooted device

9.2 Communication Security and Certificate Handling

T3.1 Application should only use HTTPS connections
T3.2 Application should detect Machine-in-the-Middle attacks with untrusted certificates
T3.3 Application should detect Machine-in-the-Middle attacks with trusted certificates
T3.4 App manifest should not allow clear text traffic
T5.1 The app should not use unsafe crypto primitives
T5.2 The HTTPS connections should be configured according to best practices
T5.3 The app should encrypt sensitive data that is sent over HTTPS

9.3 User authentication

T4.1 Authentication required before accessing sensitive information
T4.2 The application should have an inactivity timeout
T4.3 If a fingerprint is added, authentication with fingerprints should be disabled
T4.4 It should not be possible to replay intercepted requests

9.4 Secure Data Handling

T1.1 Android:allowBackup
T1.3 Android:installLocation
T2.1 Android.permission.WRITE_EXTERNAL_STORAGE
T2.2 Disabling screenshots

9.5 Secure Application Development

T9.1 The code of the app should be obfuscated

What ITU needs to test DFS applications

USSD and STK Tests

- 2 SIM cards of the networks to be tested.
- Active DFS account on each SIM card.
- DFS Wallet PINs
- Prepaid mobile credit on SIM cards – SIM cards must have mobile roaming enabled for Switzerland
- USSD codes for each of the DFS providers.
- Credit on DFS Wallets (\$10 to be used for testing)

Android application tests

- In addition to the above requirements,
- Android apps (apk file) must be shared, or links to download the apps from the Play Store.



Questions

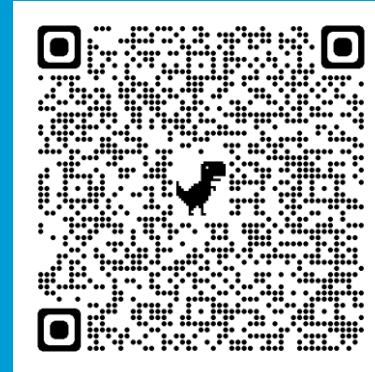

Contact: dfssecuritylab@itu.int

<https://figi.itu.int/figi-resources/dfs-security-lab/>





www.itu.int