

L.250 Topologies for optical access network

- ITU-T L.250 defines optical single-mode fibre access network architectures and provides information on planning new deployments and upgrading existing networks. Moreover, this Recommendation considers optical transmission performance and optical safety which depends on the architecture design of an optical access network.
- ITU-T L.250 recommends cost-effective, quick and efficient access network construction, to meet the demand for high quality network services from FTTH, 5G, IoT and other scenarios.
- The 2nd edition of L.250 introduces optical fibre level and cable architectures, as well as the optical fibres, cables and passive components to be used in access networks.

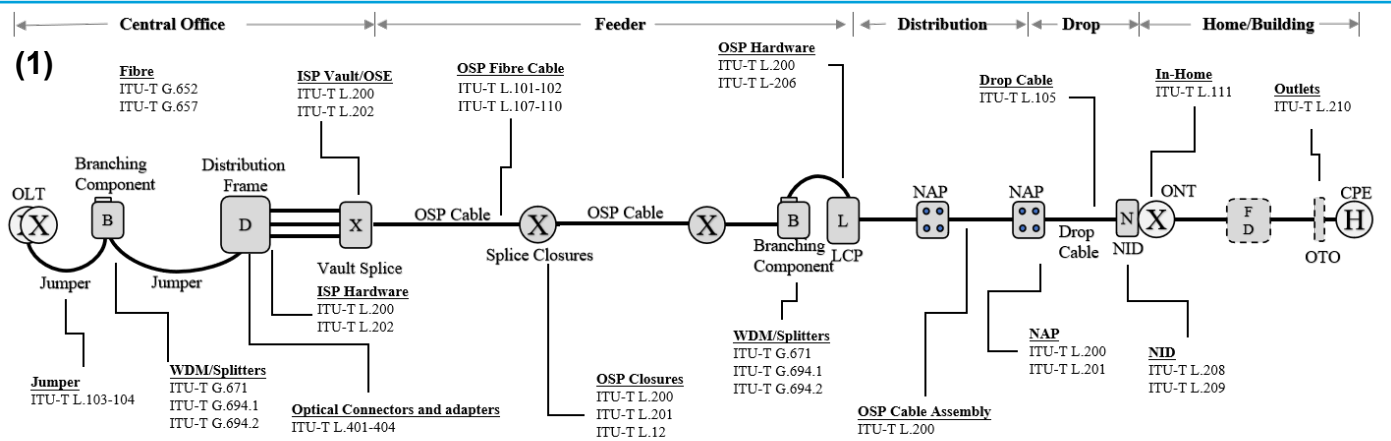

Figure 1 Optical fibres, cables and passive components and ITU-T Recommendations

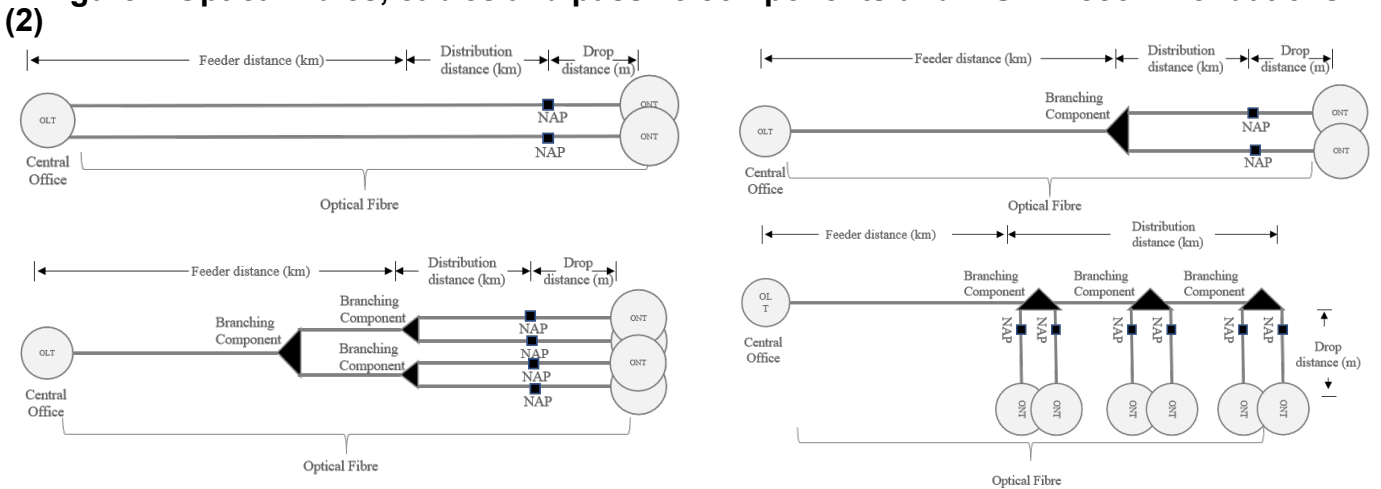

Figure 2 Optical fibre level architectures

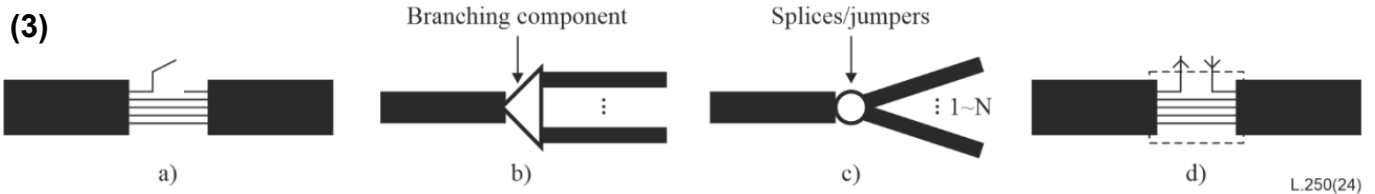

Figure 3 Optical cable level architectures

- Clause 6 identifies the optical fibres, cables and passive components to be deployed across the access network from central office to home/building.
- Clause 7 describes basic optical fibre level architectures and cable level architectures, as well as the converged architectures with multiple combinations.
- Clause 9 and 10 describe the deployment methods for high reliability and guidelines for upgrading access network from architecture point of view, respectively.