

Presentation at the ITU Workshop on “Evolution of Optical Networks for AI”, Montreal, Canada, 29 June 2026

International Optical Networks towards 2030 and Beyond (ION-2030) for Ubiquitous Intelligence

Xiang Liu

Hong Kong Research Center of Huawei, Hong Kong, China



Optical Network Standards & Ecosystem Landscape

Mobile Network

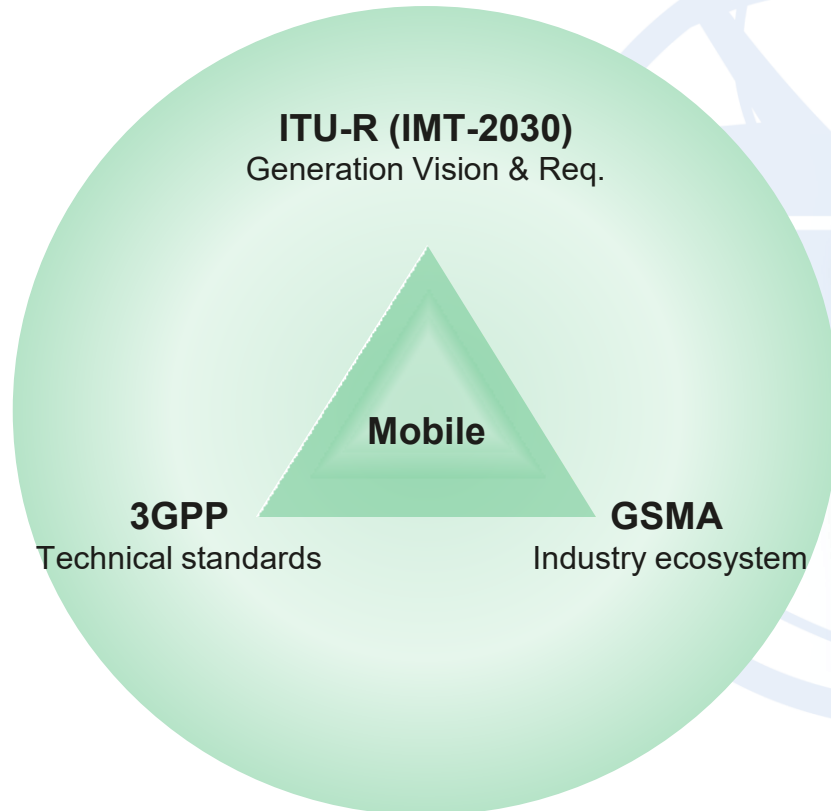

Optical Network

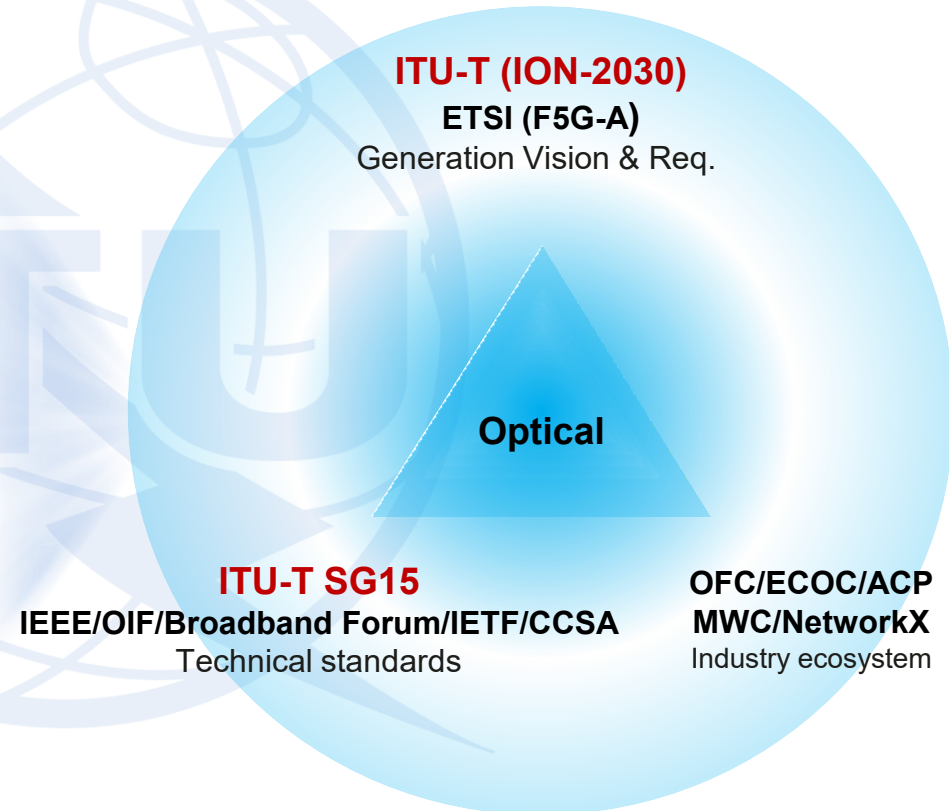

ION-2030: Enabling the Intelligent Optical Network Era

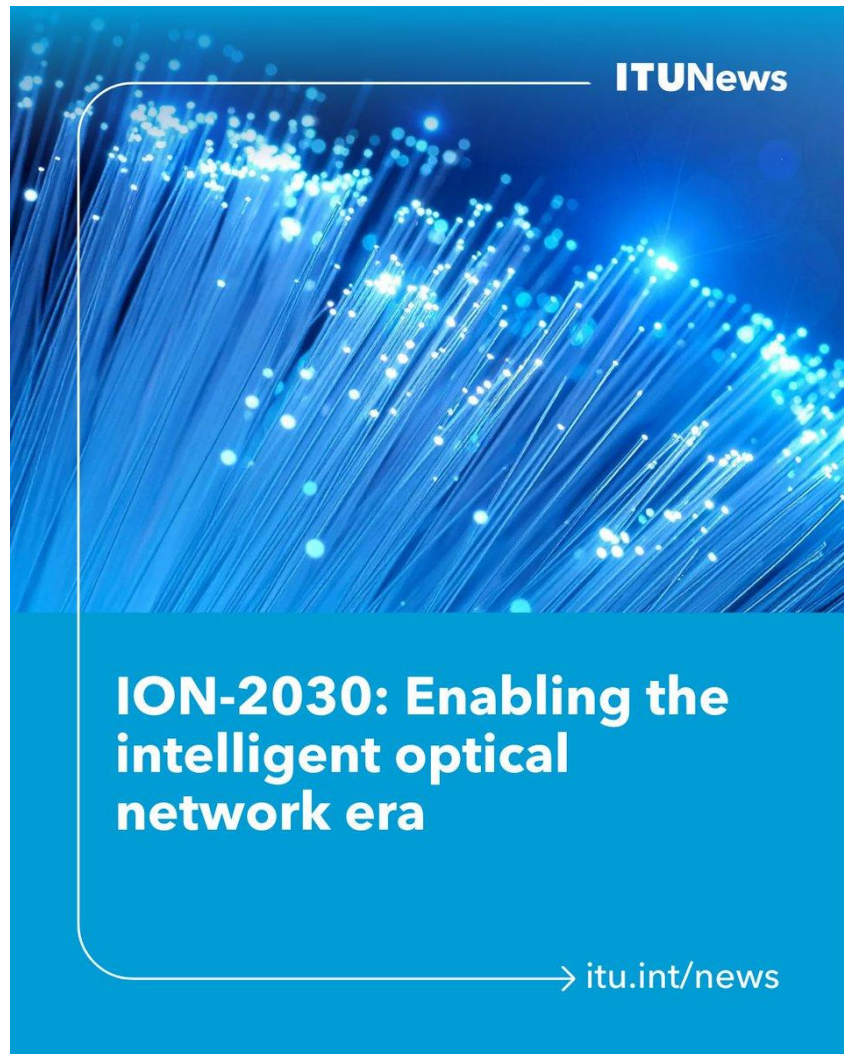

The International Telecommunication Union (ITU) has released a new framework to guide the evolution of global optical connectivity in the age of artificial intelligence (AI).

The framework – [International Optical Networks towards 2030 and Beyond \(ION-2030\)](#) – was developed by ITU-T Study Group 15, the expert group responsible for standards on networks, technologies, and infrastructures for transport, access, and home.

ION-2030 sets out a strategic vision for how optical networks should evolve to [meet the demands of 6G mobile networks \(IMT-2030\)](#), AI, data centres, broadband access, home networking, and integrated sensing and communication (ISAC).

The framework emphasizes the [mutual empowerment of AI and optical networking](#), positioning both as drivers of the next wave of digital transformation.

Reference: <https://www.itu.int/hub/2026/02/ion-2030-enabling-the-intelligent-optical-network-era/>



ION-2030 Vision, Characteristics and Features

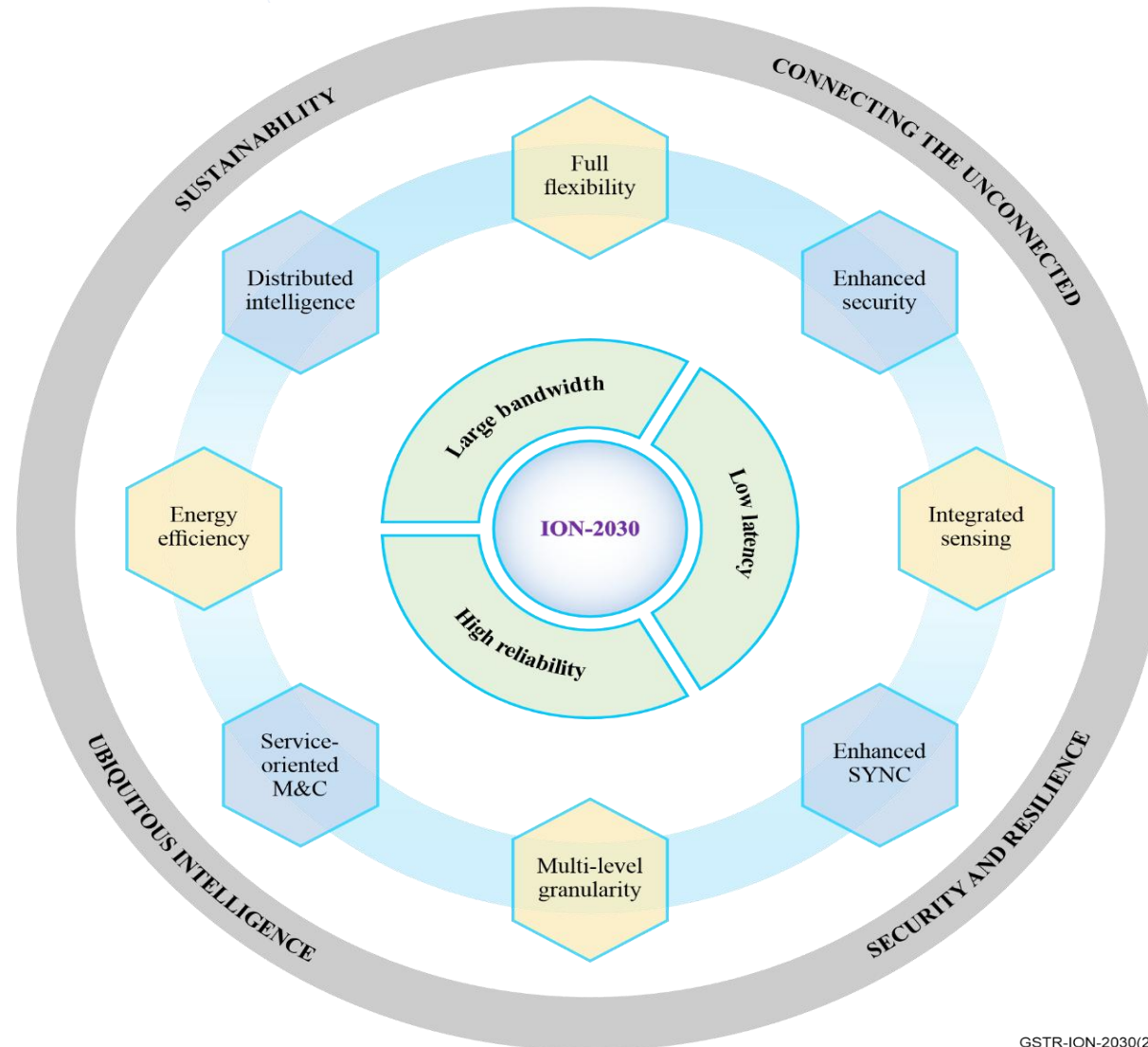

GSTR-ION-2030(25)

Reference: GSTR-ION-2030 (<https://www.itu.int/pub/T-TUT-HOME-2025-2>)



ION-2030 for AI & AI for ION-2030

- Sustainability
- Connecting the unconnected
- Security and resilience
- Ubiquitous intelligence

ION-2030 for AI:

Large bandwidth and coverage

Low latency and jitter

High availability and resilience

AI for ION-2030: E2E guarantee of QoS and QoE with automation, optimization, and protection

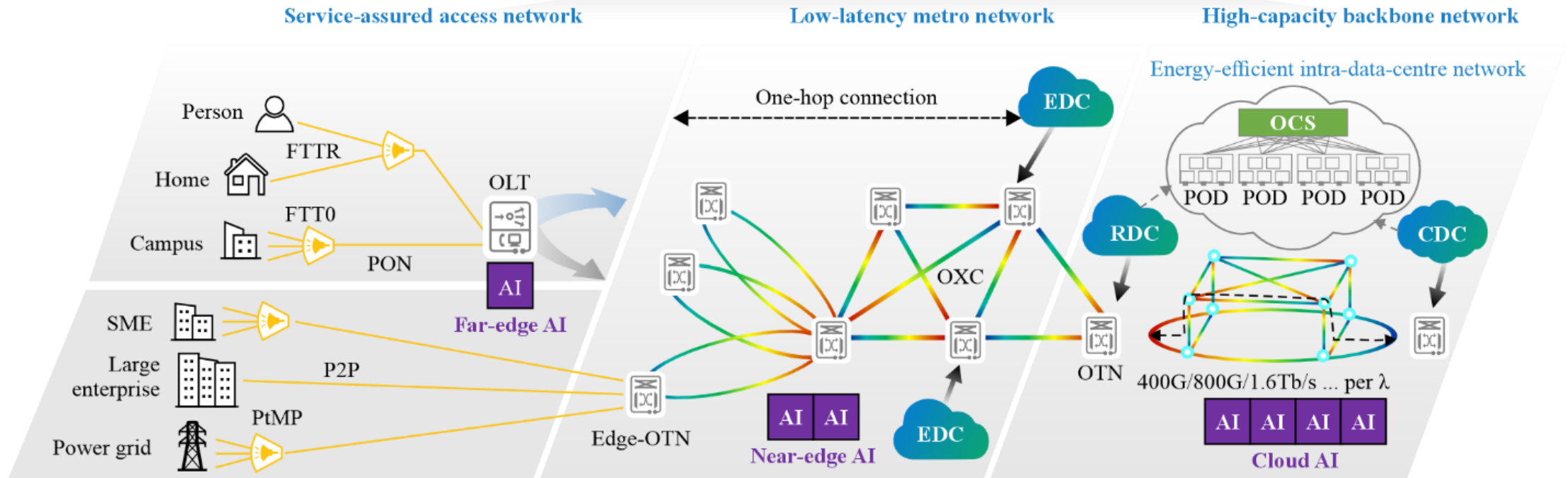

GSTR-ION-2030(25)

Reference: GSTR-ION-2030 (<https://www.itu.int/pub/T-TUT-HOME-2025-2>)



ION-2030 Framework: Continues to Grow and Expand

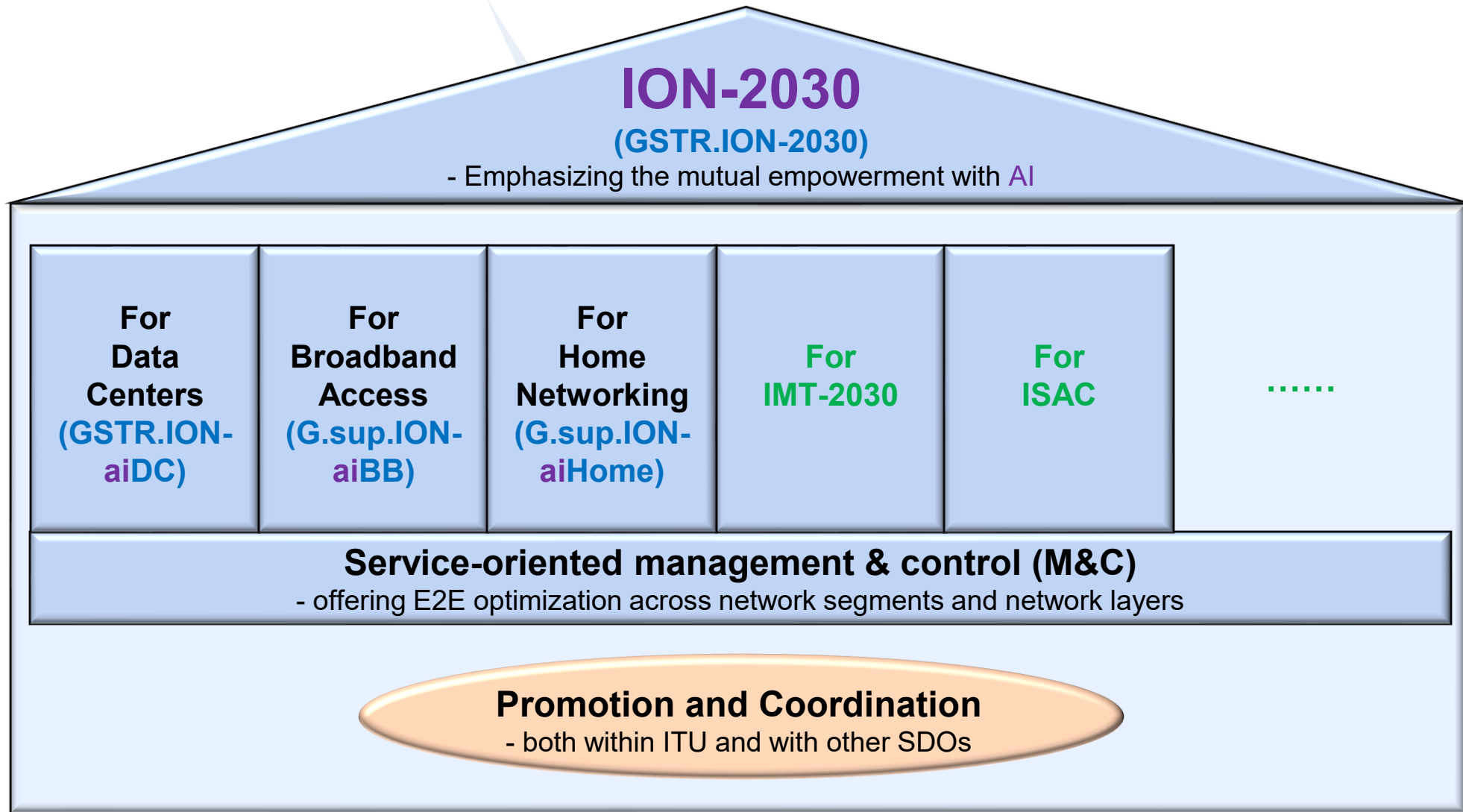

GSTR.ION-aiDC Progress (1)

Data centre network architecture optimized for AI

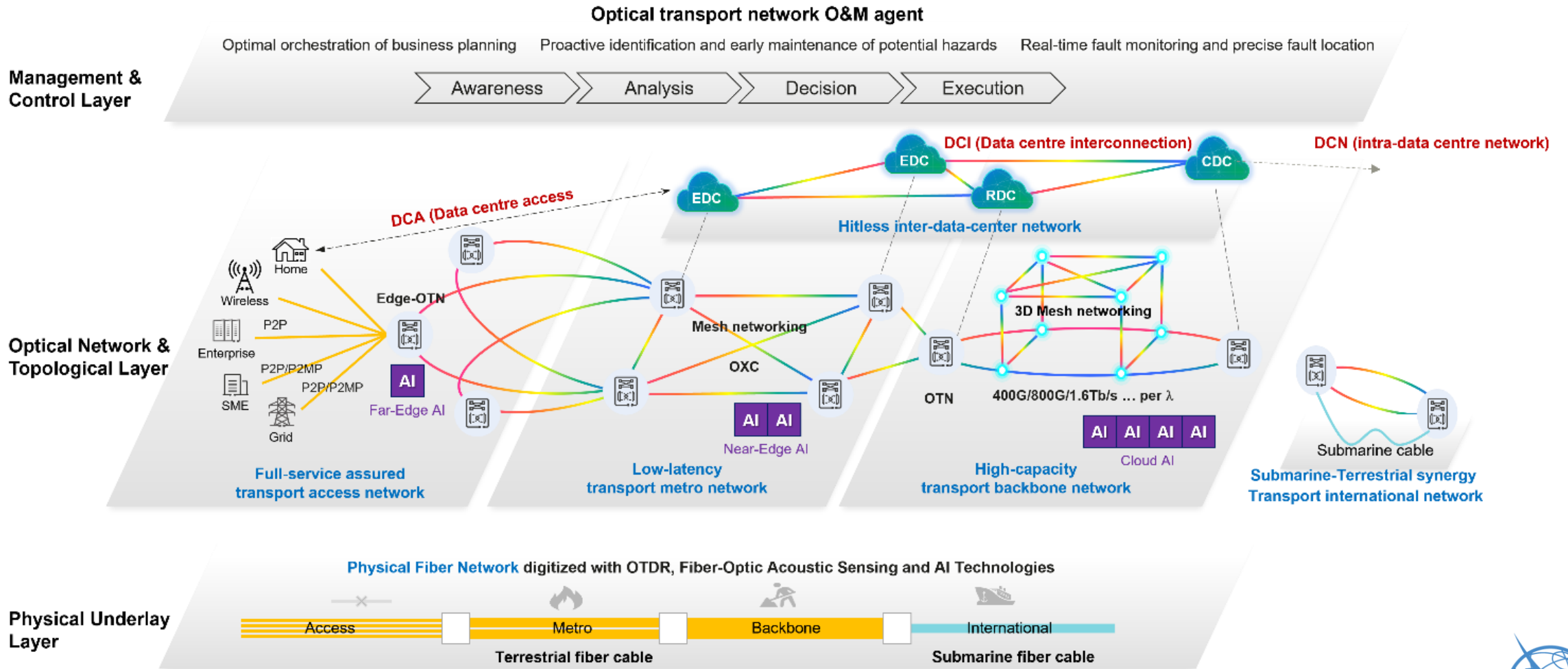

Reference: ITU-T SG15 June-July 2026 Plenary Contribution T25-SG15-C-1010 (CTTC, China Telecom)



GSTR.ION-aiDC Progress (2)

Overall architecture for AI DCN

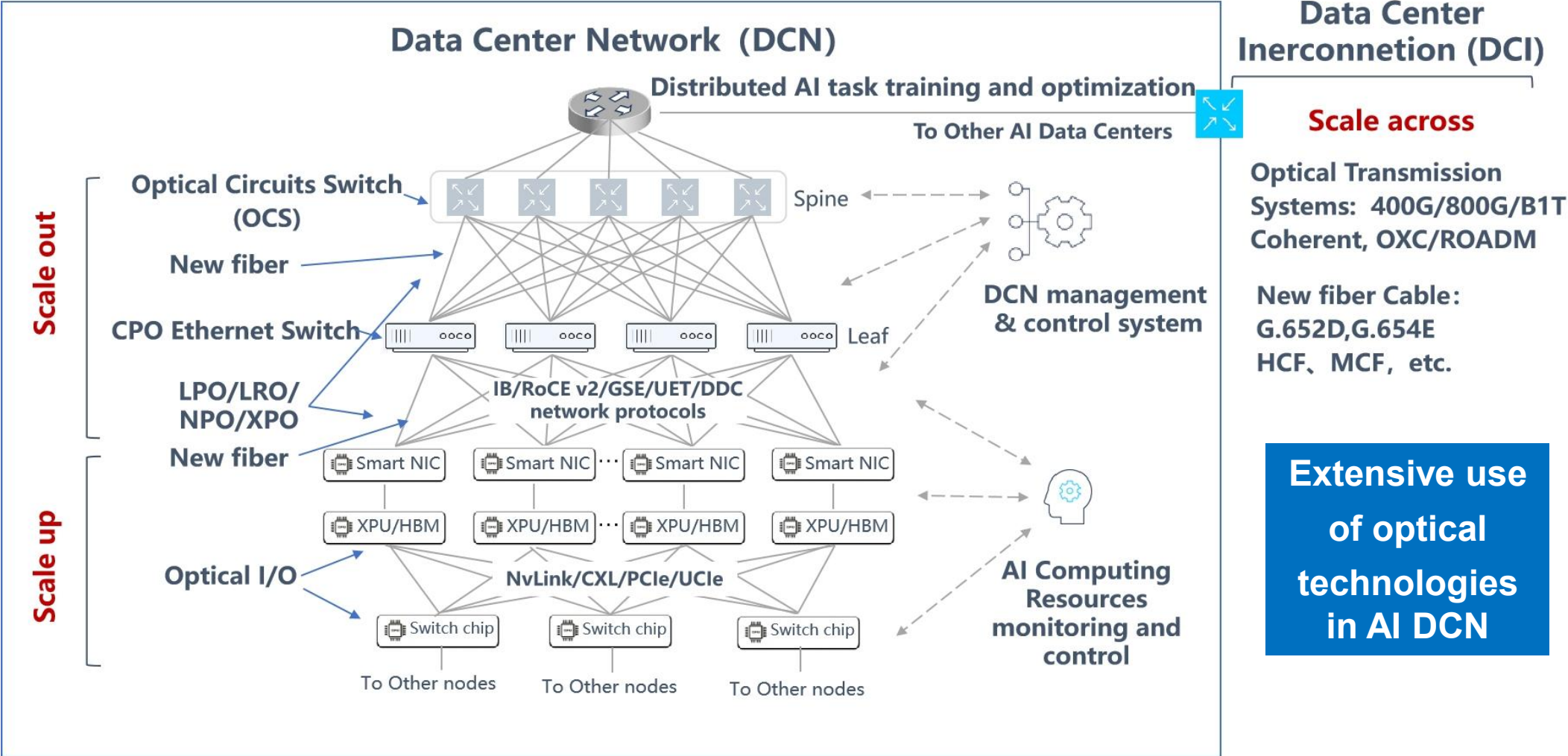

Reference: ITU-T SG15 June-July 2026 Plenary Contribution T25-SG15-C-1079 (CAICT)



GSTR.ION-aiDC Progress (4)

Three distributed AI use cases enabled by Telco Edge aiDC infrastructures

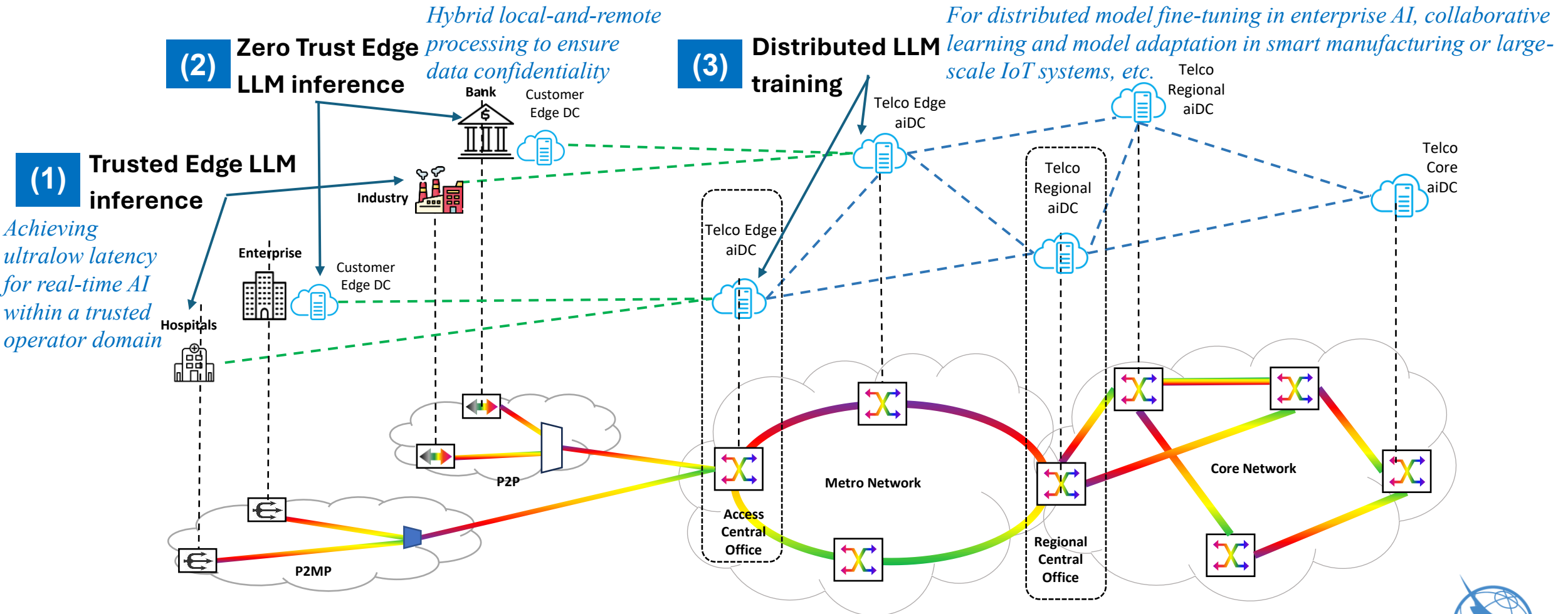

G.sup.ION-aiBB and G.sup.ION-aiHome Progress (1)

ION-2030 for access & in-premises networks

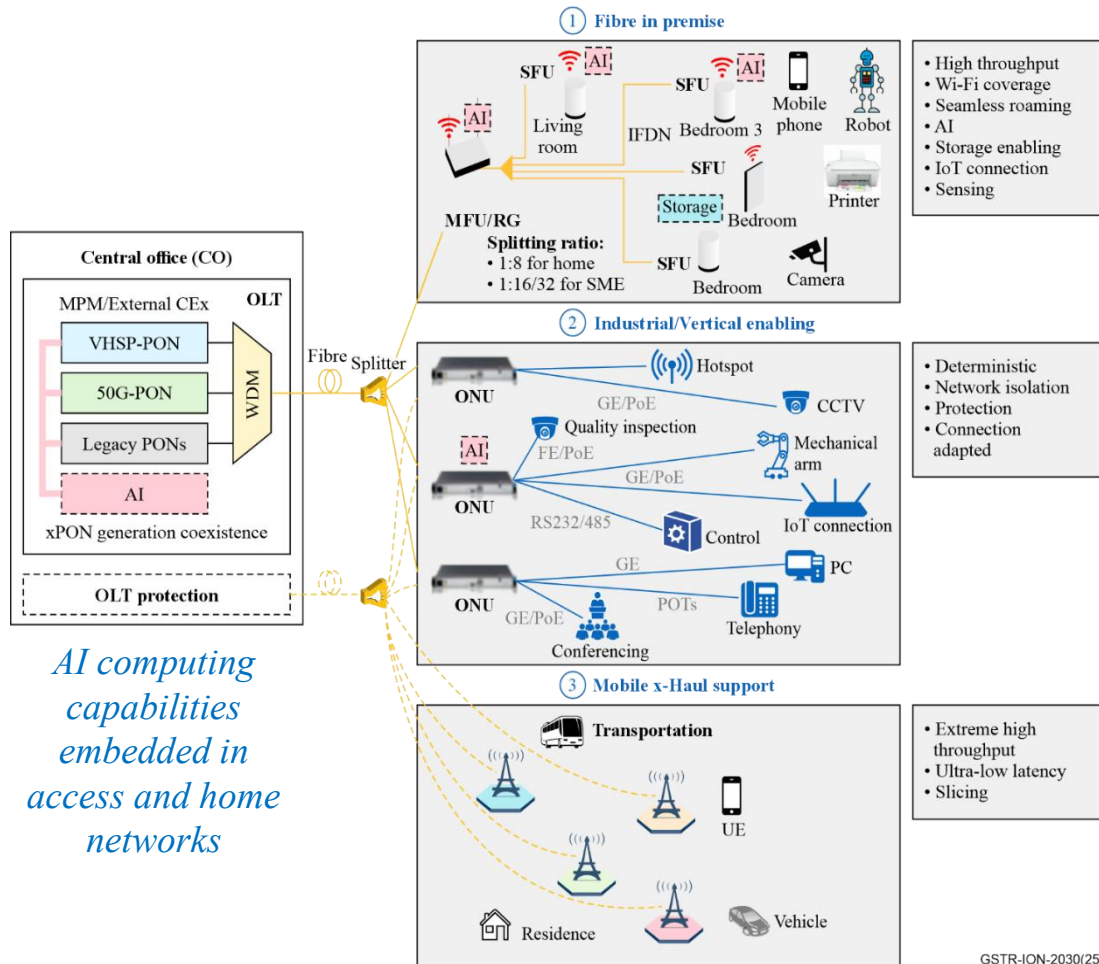

Interconnection of AI computing resources

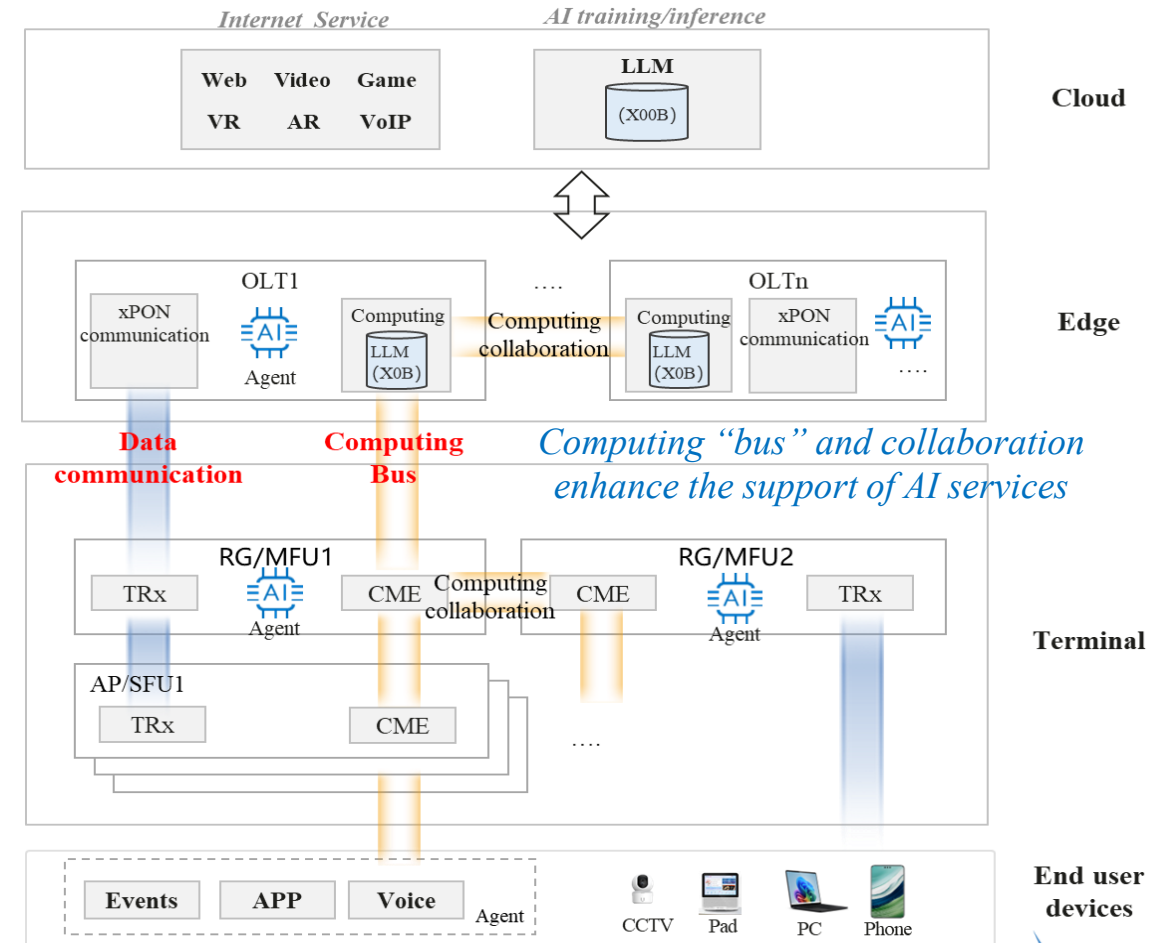

G.sup.ION-aiBB and G.sup.ION-aiHome Progress (2)

Integrated End-Edge-Cloud Computing Bus/Interconnect

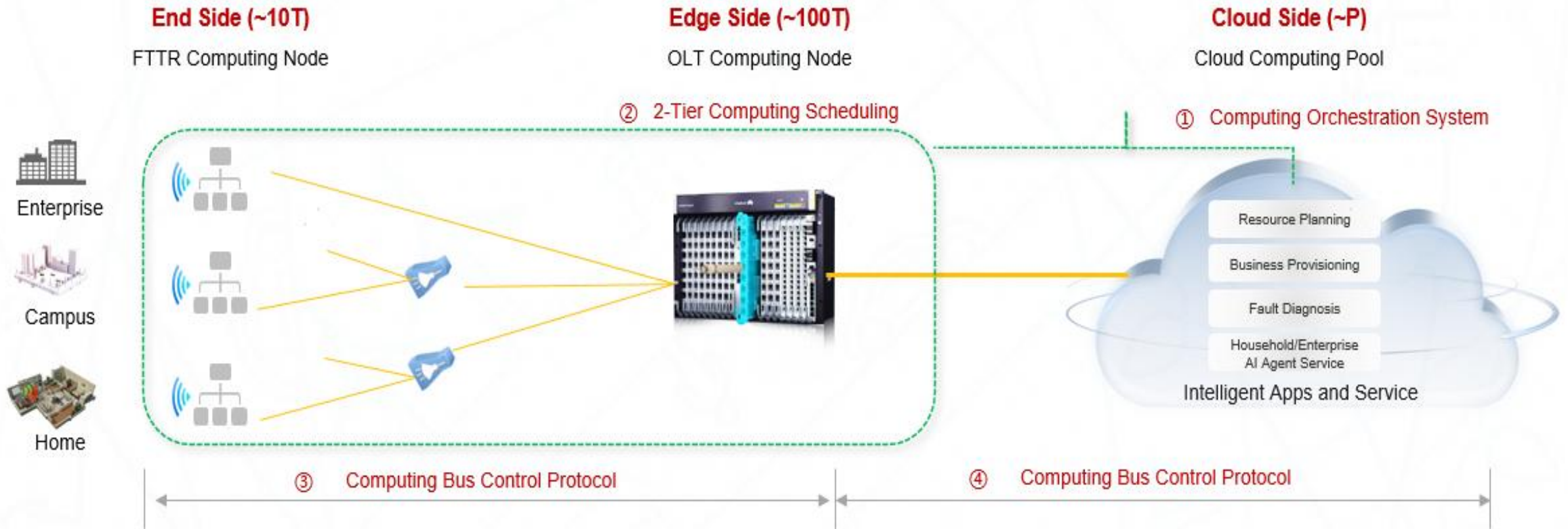

Effectively forming a distributed intelligent computing infrastructure, providing network operators with new opportunities to generate value from emerging AI services

ION-2030 Gaining Momentum Globally



52nd European Conference on
Optical Communication

SEPTEMBER 20-24 2026 • MÁLAGA, SPAIN

ITU-T ION-2030: Architectures and Standards of Optical Networks for the AI Era - Advancing United Nations' Sustainable Development Goals (SDGs)

Special Symposium Organisers: Raul Muñoz (CTTC), Xiang Liu (Huawei), Glenn Parsons (Ericsson)

Wednesday, September 23, 9:00–10:30, coffee break, 11:00–12:30

References: [https://www.ofconference.org/program/special-events/advances-in-international-optical-networks-towards-2030-and-beyond-\(ion-2030\)](https://www.ofconference.org/program/special-events/advances-in-international-optical-networks-towards-2030-and-beyond-(ion-2030)); <https://ecoc2026.org/ecoc2026/programme/special-events>.



Jointly Contributing to ION-2030 for Ubiquitous Intelligence

- **Global cooperation and collaboration in international standards essential** to the realization of the full value of ION-2030 for the common benefit of our global society.
- **Great opportunities to jointly contribute to the vision of ubiquitous intelligence via ITU-T SG15's ION-2030 framework** for AI, data centres, broadband access, home networking, IMT-2030, ISAC, and more.



Thank you all!

