

**ITU Workshop on "Onboarding Africa in ITU-T Study Group 15 Standardization Process"**  
**19 May 2026, 10:30 - 15:30**

# **Sharing on How to Get Involved in SG15 Standardization**

*- From an ITU OTN expert's point of view*

**Wei SU (Huawei)**



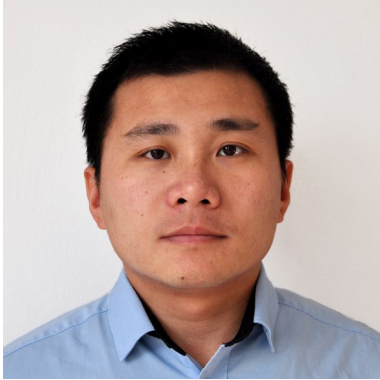

## **Wei SU**

ITU-T OTN standard expert

E-mail: [water.suwei@huawei.com](mailto:water.suwei@huawei.com)

## **Abstract**

- With 20 years of experience in standards and technologies research in the optical communication field
- Research on optical transport technologies including MS-OTN, FlexO, fgOTN, B1T OTN, Ethernet, FlexE, etc.
- 300+ technical contributions to ITU-T SG15
- Editors of ITU-T G.709, G.798.4, G.8023

# ITU-T SG15: The Leading SDO for Optical Networks

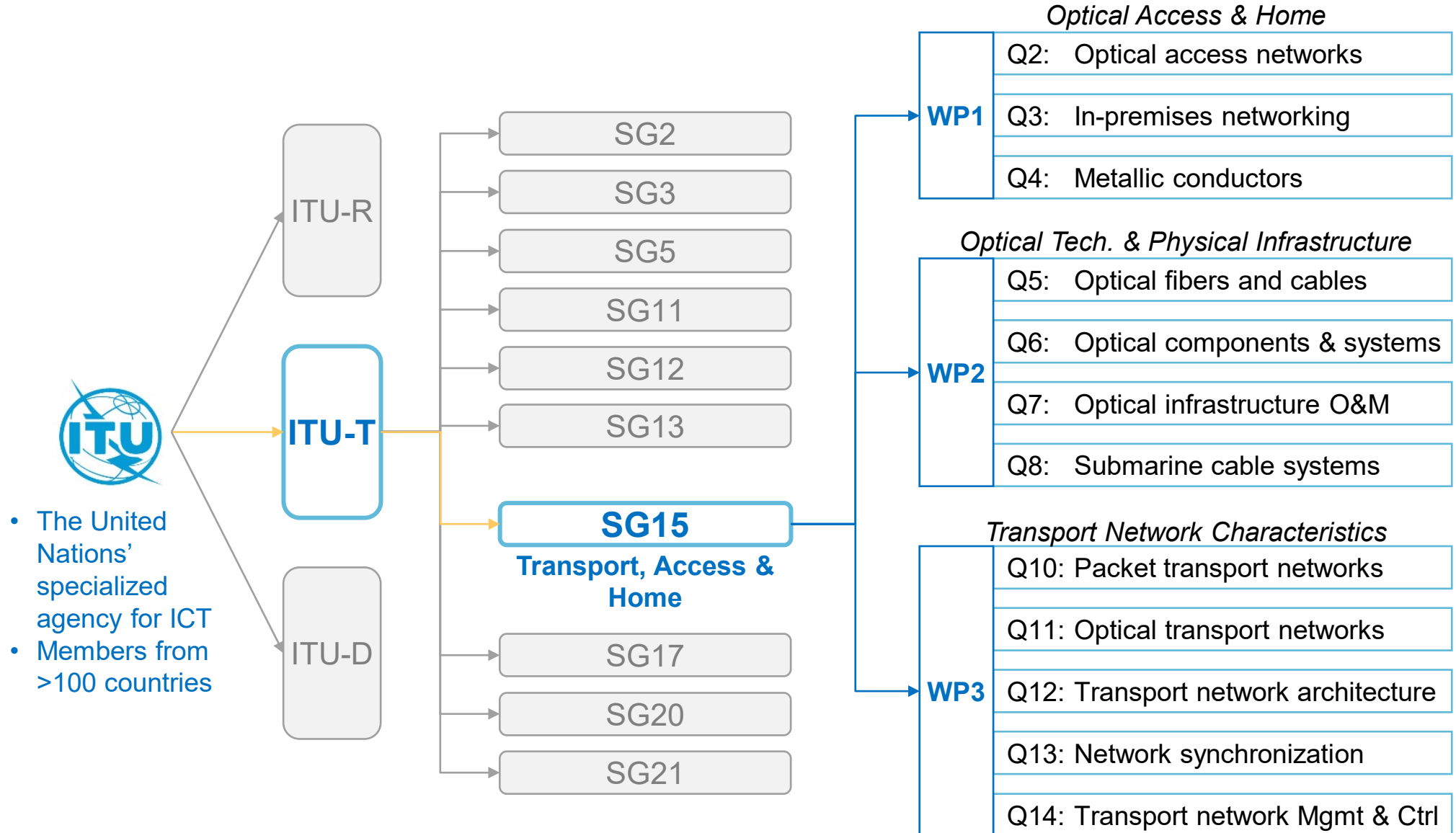

# ITU-T SG15's Influential Standards on Fiber, OTN and PON

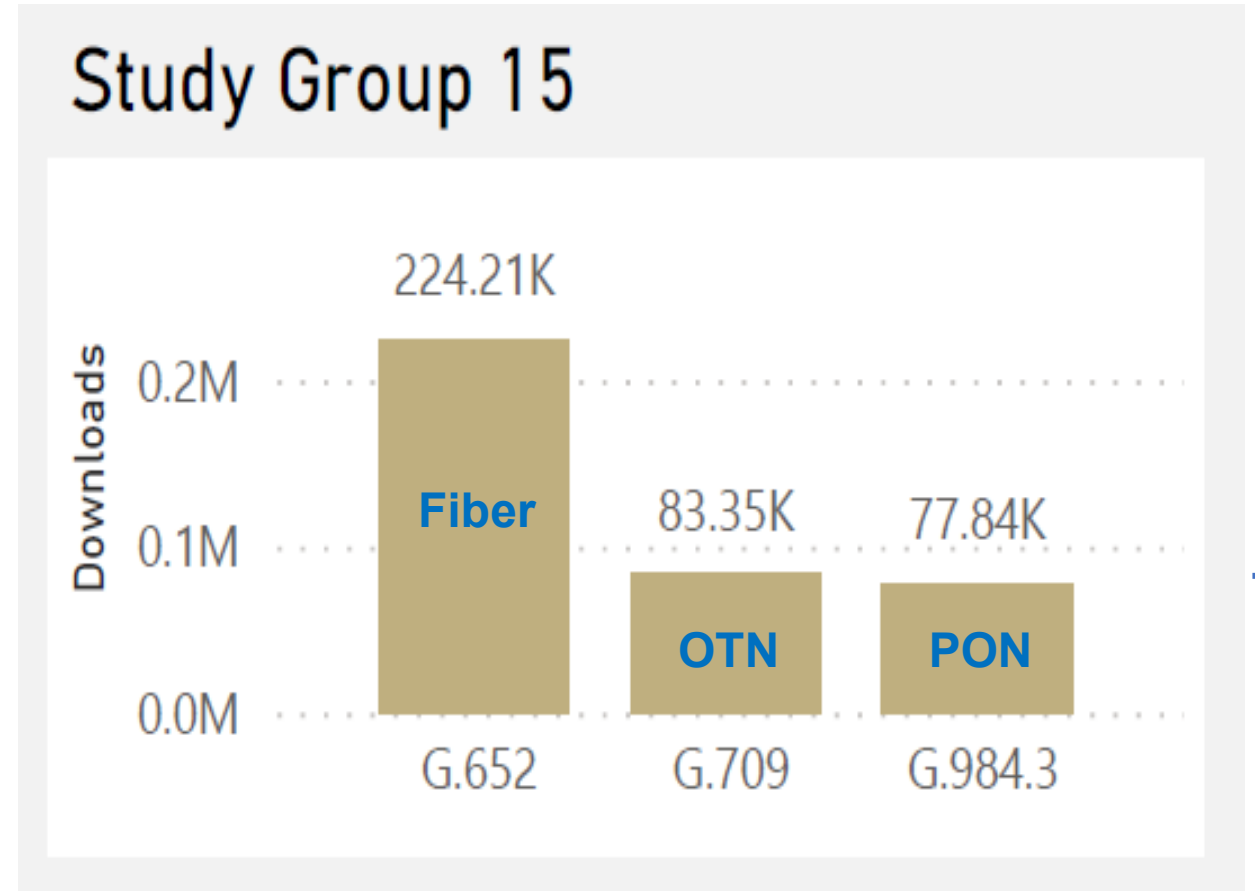
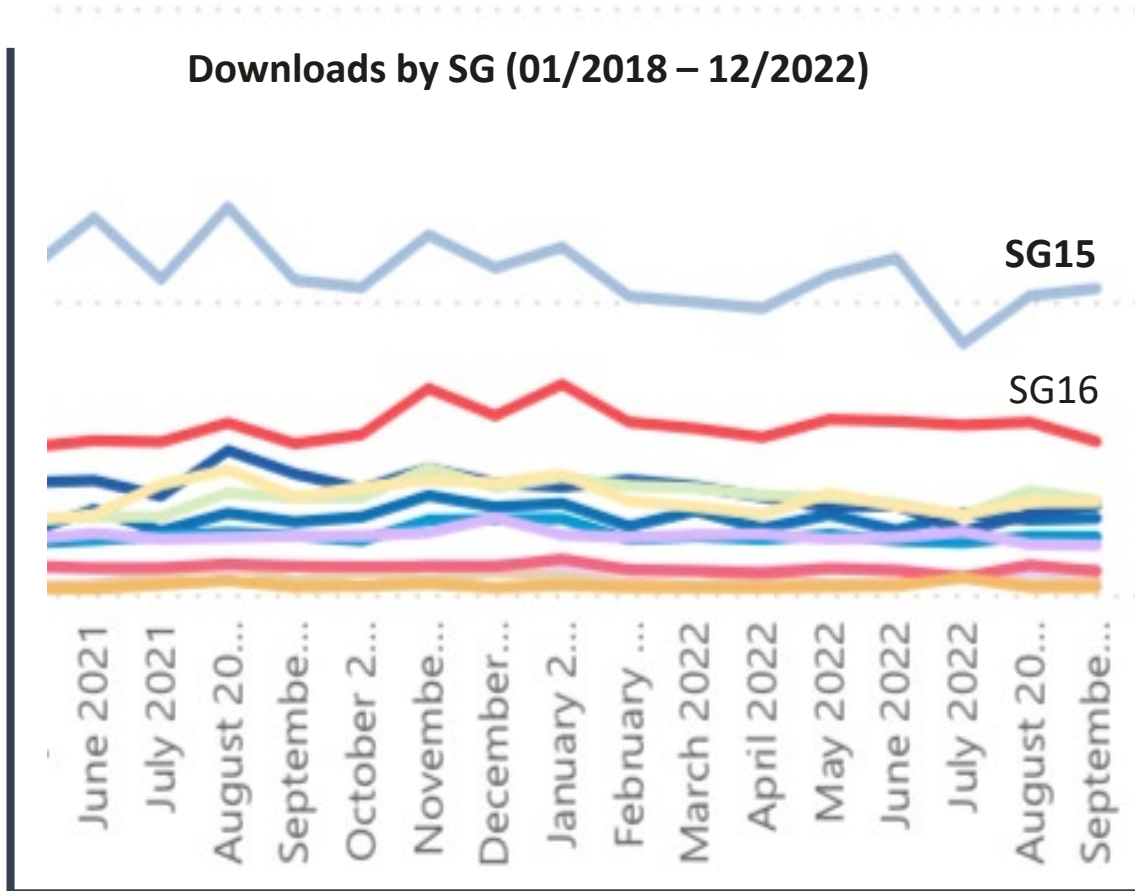

OTN: Optical Transport Network  
PON: Passive Optical Network

# ITU-T SG15's Important Contributions to Optical Transport

- ❑ Optical transport capacity per fiber has been remarkably increased by >10,000 times over the past 40 years!
- ❑ ITU-T SG15 has developed multiple generations of OTN standards, ranging from 10Gb/s to beyond-1Tb/s (B1T) interface speeds

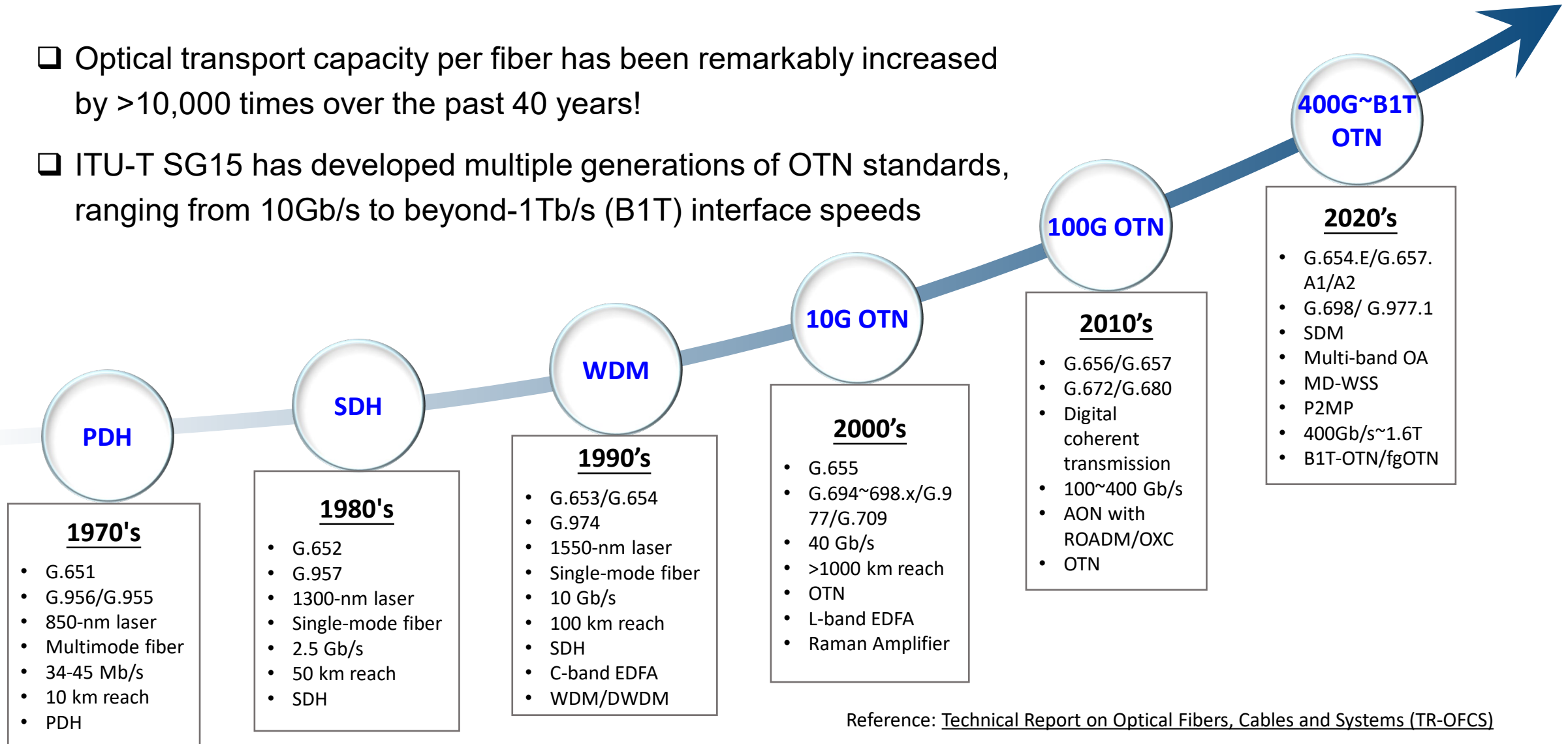

Reference: [Technical Report on Optical Fibers, Cables and Systems \(TR-OFCS\)](#)

# ION-2030: Enabling the Intelligent Optical Network Era



The International Telecommunication Union (ITU) has released a new framework to guide the evolution of global optical connectivity in the age of artificial intelligence (AI).

The framework – [International Optical Networks towards 2030 and Beyond \(ION-2030\)](#) – was developed by ITU-T Study Group 15, the expert group responsible for standards on networks, technologies, and infrastructures for transport, access, and home.

ION-2030 sets out a strategic vision for how optical networks should evolve to meet the demands of 6G mobile networks (IMT-2030), AI, data centres, broadband access, home networking, and integrated sensing and communication (ISAC).

The framework emphasizes the mutual empowerment of AI and optical networking, positioning both as drivers of the next wave of digital transformation.

# OTN is a Key Technology for Supporting ION-2030

- Sustainability
- Connecting the unconnected
- Security and resilience
- Ubiquitous intelligence

ION-2030 for AI:

Large bandwidth and coverage

Low latency and jitter

High availability and resilience

AI for ION-2030: E2E guarantee of QoS and QoE with automation, optimization, and protection

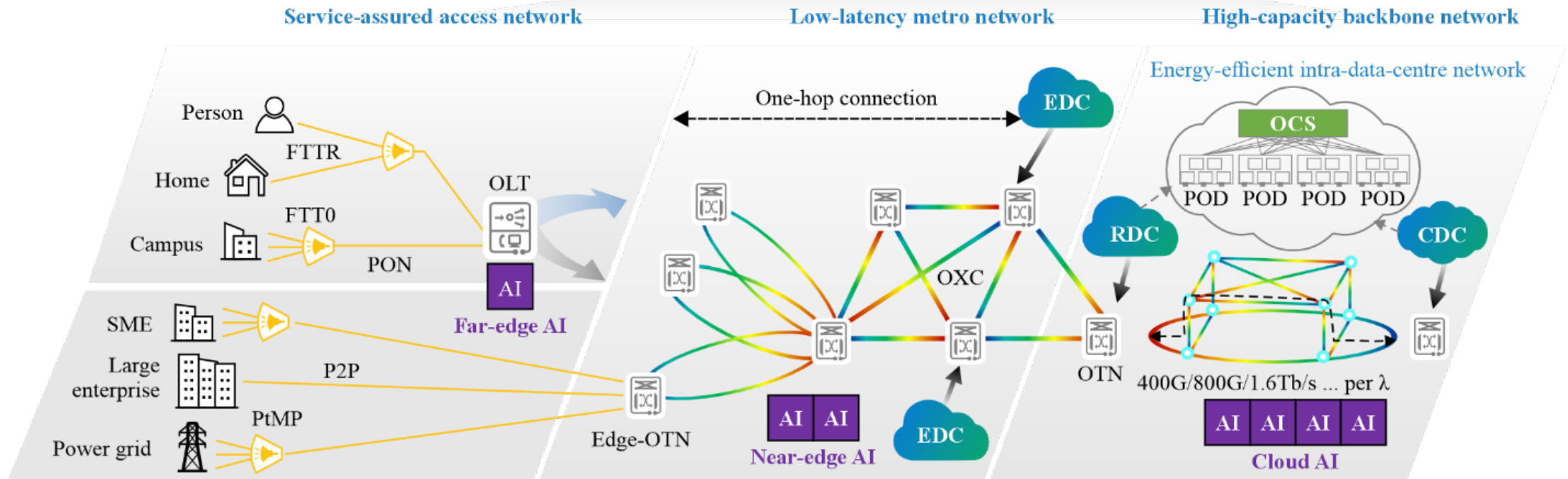

GSTR-ION-2030(25)

Reference: GSTR-ION-2030 (<https://www.itu.int/pub/T-TUT-HOME-2025-2>)

# ITU-T SG15 OTN Evolution: Higher Rate & Better Flexibility

Better Flexibility, TDM-based hard pipe with fine-grained and flexible bandwidth

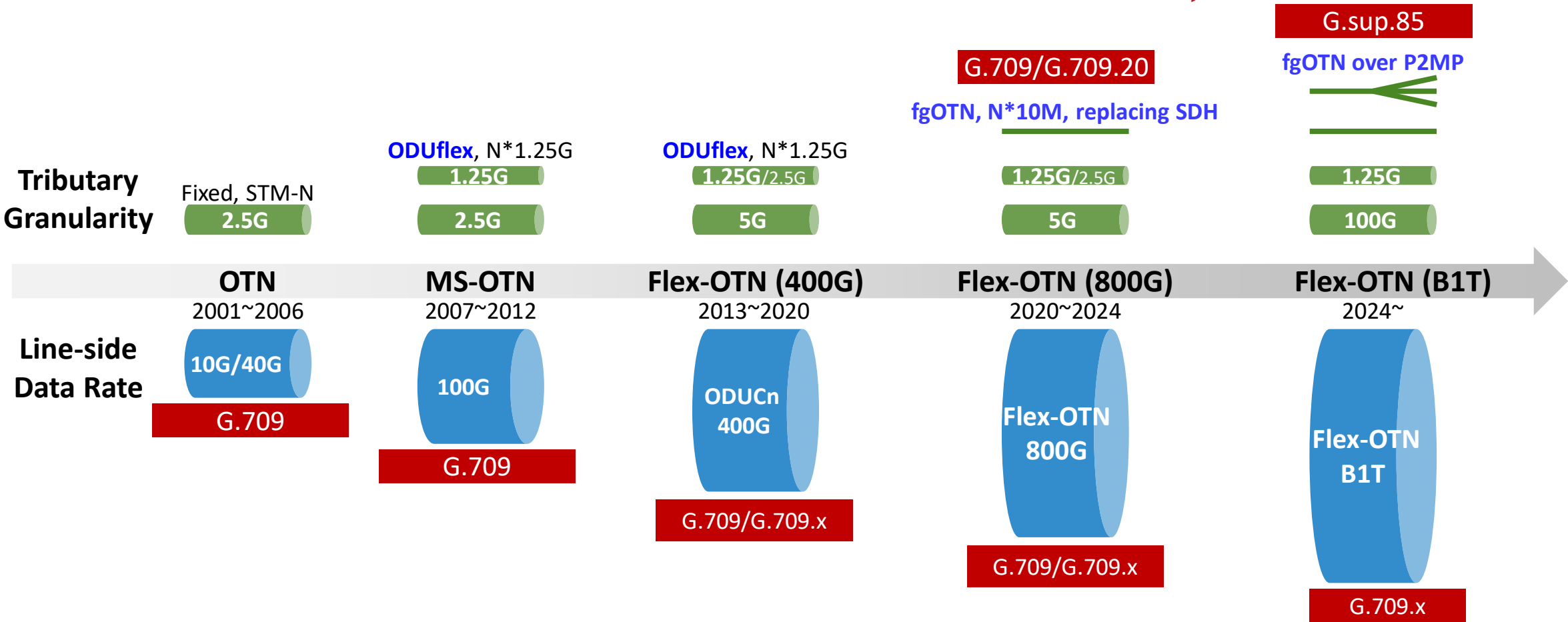

Higher Data Rate, with better efficiency (64B/66B → 256B/257B, 0.4% OH) To be consented in 2026.07

# ITU-T SG15 OTN Standard Series - Leading the Industry

Topics	Standards	Questions
<b>Common (Map, OAM, Int)</b>	G.709: Interfaces for the optical transport network	Q11
	G.709.1: Flexible OTN common elements	
<b>Interface</b>	G.709.3: Flexible OTN B100G long-reach interfaces	
	G.709.4: OTU25 and OTU50 short-reach interfaces	
	G.709.5: Flexible OTN short-reach interfaces	
	G.709.6: Flexible OTN B400G long-reach interfaces	
<b>Equipment functions</b>	G.798: Characteristics of optical transport network hierarchy equipment functional blocks – Overview	
	G.798.1: Types and characteristics of optical transport network equipment	
	G.798.2: Characteristics of optical transport network hierarchy equipment functional blocks – Media	
	G.798.3: Characteristics of optical transport network hierarchy equipment functional blocks - OTU and ODU	
<b>Protection</b>	G.798.4: Characteristics of optical transport network hierarchy equipment functional blocks – FlexO	
	G.873.1: Optical transport network (OTN): Linear protection	
	G.873.2: ODUk shared ring protection	
	G.873.3: Optical transport network – Shared mesh protection	
<b>Architecture</b>	G.808.4: Linear protection for fine grain Metro Transport Network (fgMTN) and fine grain Optical Transport Network (fgOTN)	Q12
	G.872: Architecture of the optical transport network	Q13
<b>Clock Sync</b>	G.8251: The control of jitter and wander within the optical transport network (OTN)	Q14
	G.874: Management aspects of optical transport network elements	
<b>M&amp;C</b>	G.875: Optical transport network: Protocol-neutral management information model for the network element view	

# Getting Involved with ITU-T SG15 via Various Meetings

## SG15 Plenary meeting schedule (once per eight months)

### Formal meeting

- **SG15 opening meeting:** SG15 Overall review of work, introduction to updates in work methods and processes
- **WP opening meeting :** Review of each WP, including progress of each Question, liaisons, etc.

- **Question meetings:**
  - Review meeting reports, liaisons
  - Contribution discussion according topics
  - Drafting according discussion conclusion and prepare text
  - Review the updated proposal text and summarize the meeting report.

- **WP closing meeting:** review meeting reports and outcomes
- **SG15 closing meeting:** form an official report

**Interim meeting schedule**  
(1 to 2 between two plenary meetings)

---

### Informal meeting

- ✓ Small group discussion for key topics
- ✓ More efficient than a formal meeting
- ✓ Facilitate coordination and reach consensus

**Coffee Break**  
**Social Dinner**

# Getting Involved with SG15 via Technical Contributions

## Expert Perspective: Contribution preparation

### ❑ Typical content included:

- ✓ **Introduction:** The conclusion of previous discussions, the main issues addressed in this contribution, and standardization thoughts;
- ✓ **Analysis:** Analysis provided for key issues, and when necessary, test data and other supporting materials can be included;
- ✓ **Proposal:** For specific projects, which can be direct textual revision proposal; or directional proposal such as adding new paragraphs. The project initiation draft must provide A.1.



### ❑ Promotion results:

- ✓ **(Partial) Acceptance:** directly write into standard;
- ✓ **Further discussion:** No text has been modified, but it has been recorded in the Living List or Editor Notes;
- ✓ **Rejection:** Directly form a conclusion, do not accept it, and do not discuss it further.

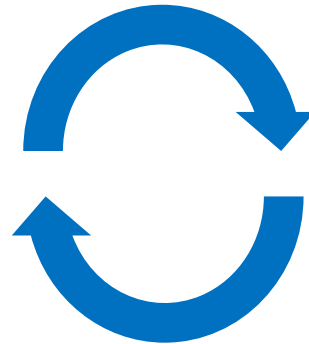

## Editor Perspective: Standard drafting

According to the ITU-T general recommendation format and scope of work, clarify the standard directory



Based on the discussion results to revise the draft text, and the responsibilities include text editing and version maintenance.



For uncertain parts, record Editor notes or maintain the Living List, and invite experts to study and supplement the parts.



After the completion, submit the consent and handle AAP comments.

# Getting Involved with SG15 – Some suggestions

- Follow the important standard topics based on your company's interests
- Prepare before meeting: Read contributions, and prepare comments and suggestions
- Submit high-quality contributions or suggestions to progress standards
  - ✓ Addressing actual requirements, unresolved issues, and feasible technical solutions
- Present contribution clearly: clearly express core viewpoints
- Discuss actively with other experts: understand others' viewpoints
- Build consensus:
  - ✓ sincerely listen, identify common interests and differences, and find the best aggregable solutions
  - ✓ use offline discussions during coffee breaks and lunches: many times agreements were made during these offline discussions 😊

# SG15's Exciting Future Workplan – Welcome to Join Us!

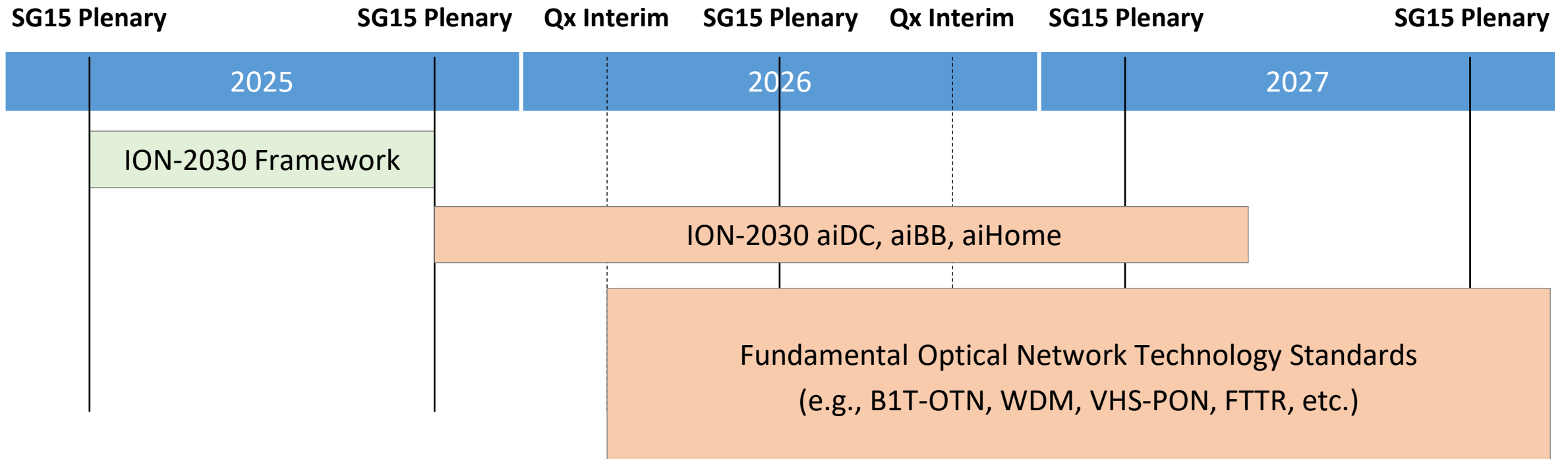

**Thank you all!**