

TRANSMITTING ANTENNAS FOR HF BROADCASTING

Broadcasting Services Division bcd@itu.int

1. INTRODUCTION

Transmitting antenna remains one of the key components of any broadcasting system. For HF broadcasting, where the signal is propagated via ionospheric transmission over long distances, the selection and design of a suitable transmitting antenna system is therefore extremely important. Careful design of transmitting antenna systems results in adequate coverage of the intended target areas and at the same time reduces radiation outside the target areas. This minimises the potential for interference to between HF services and consequently improves the spectrum productivity of the already crowded HF broadcasting bands.

As part of the new planning procedures for the HF bands (Article S12 of the Radio Regulations), a compatibility analysis of all HF requirements submitted is to be made available for Administrations, broadcasters, frequency manager organisations to use in their coordination of the broadcasting requirements. This analysis requires accurate descriptions of broadcasting systems in use, particularly of the transmitting antenna systems. Furthermore, the analysis also requires a common set of antenna code in order to facilitates the identification and notification of transmitting antenna systems.

This paper discusses a number of common used HF transmitting antenna systems and proposes a corresponding system of reference antenna codes. The latter was developed in close consultation with regional coordination groups ABU-HFC, ABSU and HFCC.

A summary of the proposal is below:

Type	Antenna Description	Band	Feed	Reflector	Reference Code
1	Curtain antenna, half-wave dipole array	multi	centre/ end	aperiodic screen	100-299
2	Curtain antenna, half-wave dipole array	dual	centre	tuned dipole	300-499
3	Curtain antenna, half-wave dipole array	dual	end	tuned dipole	500-699
4	Curtain antenna, half-wave dipole array		centre	no	700-749
5	Tropical antenna, half-wave dipole array		centre	no	750-799
6	Horizontal log-periodic				800-849
7	Vertical log-periodic				850-899
8	Rhombic				900-924
9	Quadrant				925-949
10	Cross-dipole				950-974
11	Vertical monopole				975-990

2. TRANSMITTING ANTENNA TYPES

It is proposed that HF transmitting antennas be grouped into eleven (11) types. Type 1 to 4 are Curtain Antennas with different feeding arrangements and reflector types. Type 5 covers Tropical Antennas. Type 6 and Type 7 are Log-periodic Antennas, horizontal and vertical respectively. Type 8, Rhombic Antennas, Type 9, Quadrant Antennas, Type 10, Cross Dipole Antennas and Type 11 Vertical Monopoles.

2.1 Type 1: Multi band centre/end-fed curtain antenna arrays with aperiodic screen reflector

Designation: **AHR(S) m/n/h**

m : number of half-wave dipoles in each horizontal row

n : number of rows spaced half a wavelength apart one above the other

h : height above the ground in wavelengths of the bottom row of dipoles

* slew angle and the design frequency are notified separately.

Centre-fed dipole array with aperiodic reflector

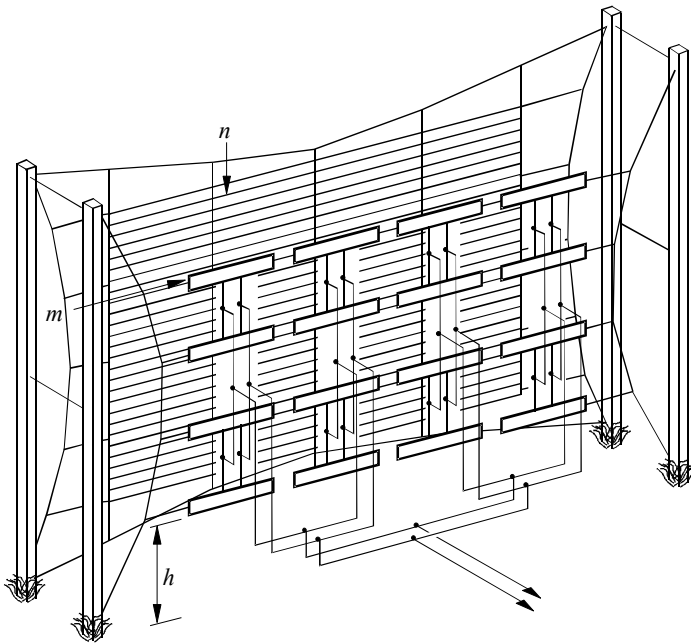

D010 Rec. ITU-R BS.705-1, Fig. 10

End-fed dipole array with aperiodic reflector

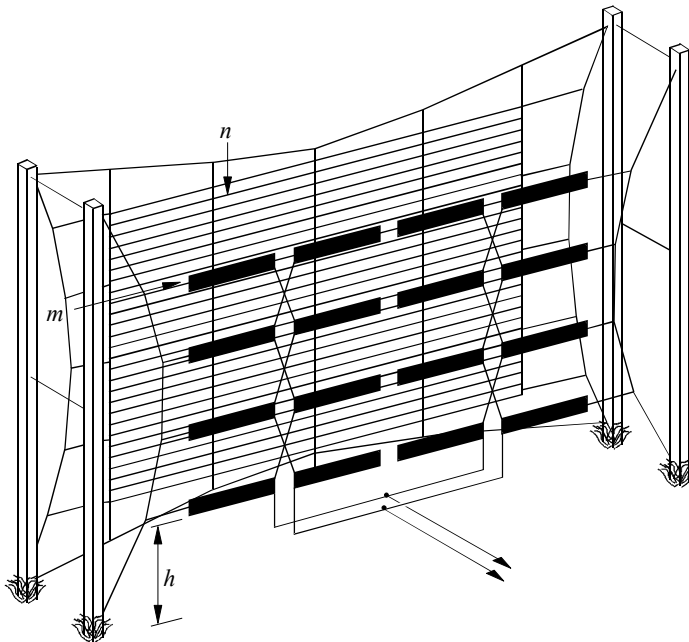

D011 Rec. ITU-R BS.705-1, Fig. 11

Curtain Arrays of co-linear horizontal half wavelength dipoles arranged in a vertical plane in order to reduce the beamwidth of the main lobe and hence increase the directivity of the antenna. Directional patterns are generally obtained by the use of an aperiodic reflector. An periodic reflector is normally a screen consisting of horizontal wires which act as an untuned reflector.

The front-to-back ratio of an aperiodic reflector depends on such factors as: number of wires per wavelength, wire gauge, distance between radiating elements and reflector, and size of reflector. To achieve a front-to-back ratio, which approaches the gain figure of the antenna would require a screen density of about 40 to 50 wires per wavelength for the highest operating band of the antenna.

In practice a number of antennas of this form can be operated over a maximum of five consecutive broadcasting bands giving an operating frequency range of up to 2:1. This range is limited by the performance of the radiating elements.

2.2 Type 2: Dual band centre-fed curtain antenna arrays with tuned dipole reflector

Designation: **CHR(S) m/n/h**

m : number of half-wave dipoles in each horizontal row

n : number of rows spaced half a wavelength apart one above the other

h : height above the ground in wavelengths of the bottom row of dipoles

Slew angle and the design frequency are notified separately.

Curtain antenna arrays use tuned dipole reflector instead of aperiodic screen as of Type 1 antennas. Tuned dipole reflector includes an identical array of dipoles tuned to provide an optimum front-to-back ratio over a limited range of operating frequencies. In practice antennas of this form have a maximum operating frequency range which covers two adjacent broadcasting bands, giving a frequency range from the lowest to the highest frequency of approximately 1.25:1.

This type of reflector is generally tuned to provide the optimum front-to-back ratio for a single frequency within the required frequency band and the front-to-back ratio can be expected to decrease if the antenna is operated at any other frequency.

This type of reflector is also known as “parasitic” reflector. It can also be electrically driven to obtain an improved performance. However this technique is not generally used.

2.3 Type 3: Dual band end-fed curtain antenna arrays with tuned dipole reflector

Designation: **EHR(S) m/n/h**

- m : number of half-wave dipoles in each horizontal row
- n : number of rows spaced half a wavelength apart one above the other
- h : height above the ground in wavelengths of the bottom row of dipoles
- * Slew angle and the design frequency are notified separately.

End-fed dipole array with tuned reflector

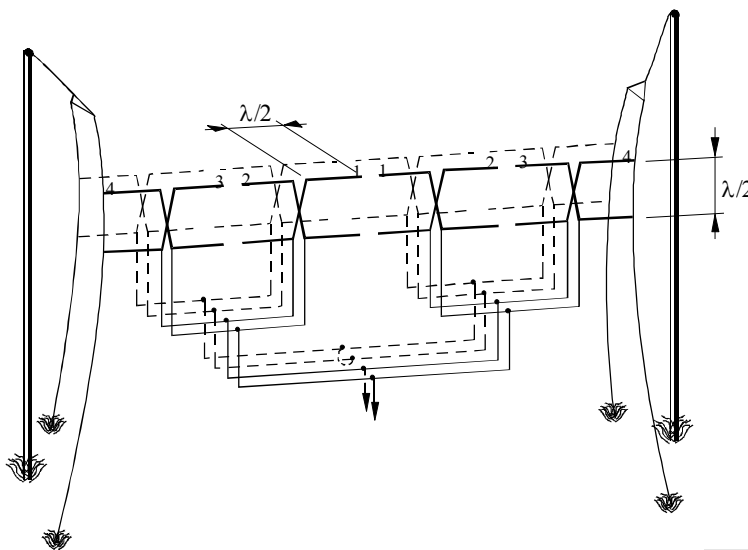

D012 Rec. ITU-R BS.705-1, Fig. 12

Similar to Type 2 antennas except that dipoles are end fed.

2.4 Type 4: Centre-fed curtain antenna arrays without reflector

Designation: **CH m/n/h**

- m : number of half-wave dipoles in each horizontal row
- n : number of parallel rows spaced half a wavelength apart
- h : height above the ground in wavelengths

2.5 Type 5: Tropical antennas

Designation: **CT m/n/h**

- m : number of half-wave dipoles in each horizontal row
- n : number of parallel rows spaced half a wavelength apart
- h : height above the ground in wavelengths

Tropical antenna

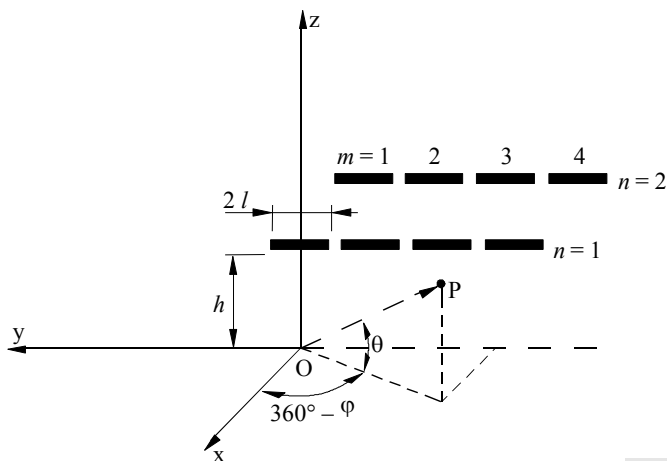

D006 Rec. ITU-R BS.705-1, Fig. 6

Arrays of co-linear half wavelength horizontal dipoles arranged in a plane parallel to and at a specified height above the ground. Radiation mainly concentrates at high elevation angles (up to 90°). These antennas are often used for short distance broadcasting in the Tropical Zone.

2.6 Type 6: Horizontal log-periodic antenna

Designation: **LPH $N / L / h_1 / h_N / l_1 / l_N / Z$**

- N : number of elements
- L : distance between the centers of the shortest and the longest element (m)
- h_1 : height of the shortest element (m)
- h_N : height of the longest element (m)
- l_1 : half-length of the shortest element (m)
- l_N : half-length of the longest element (m)
- Z : impedance of the antenna internal feeder line (Ω).

horizontal log-periodic array

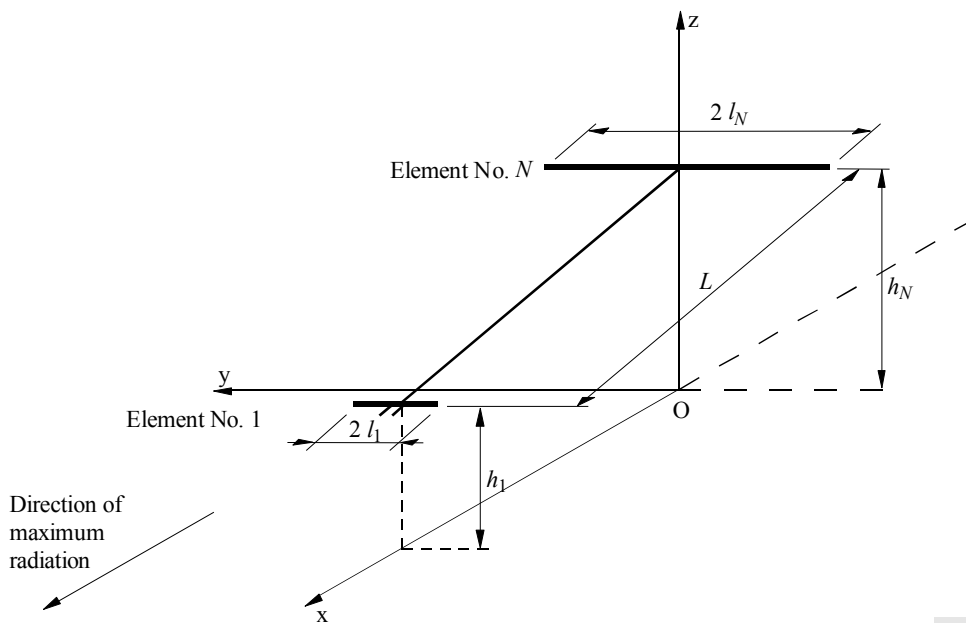

D027

Rec. ITU-R BS.705-1, Fig.27

Log-periodic dipole arrays are tapered linear arrays of dipole elements of varying lengths that operate over a wide frequency range. Wide band operation is achieved by different groups of elements radiating at different frequencies. The spacing between the elements is proportional to their length and the system is fed using a transmission line. As the frequency ratio varies, the elements that are at or near resonance, couple energy from the transmission line. The resulting radiation pattern is directional and has a broadly constant radiation characteristic over the full operating frequency range.

2.7 Type 7: Vertical log-periodic antennas

Designation: **LPV $N / L / h_1 / h_N / l_1 / l_N / Z$**

- N : number of elements
- L : distance between the centers of the shortest and the longest element (m)
- h_1 : height of the shortest element (m)
- h_N : height of the longest element (m)
- l_1 : half-length of the shortest element (m)
- l_N : half-length of the longest element (m)
- Z : impedance of the antenna internal feeder line (Ω).

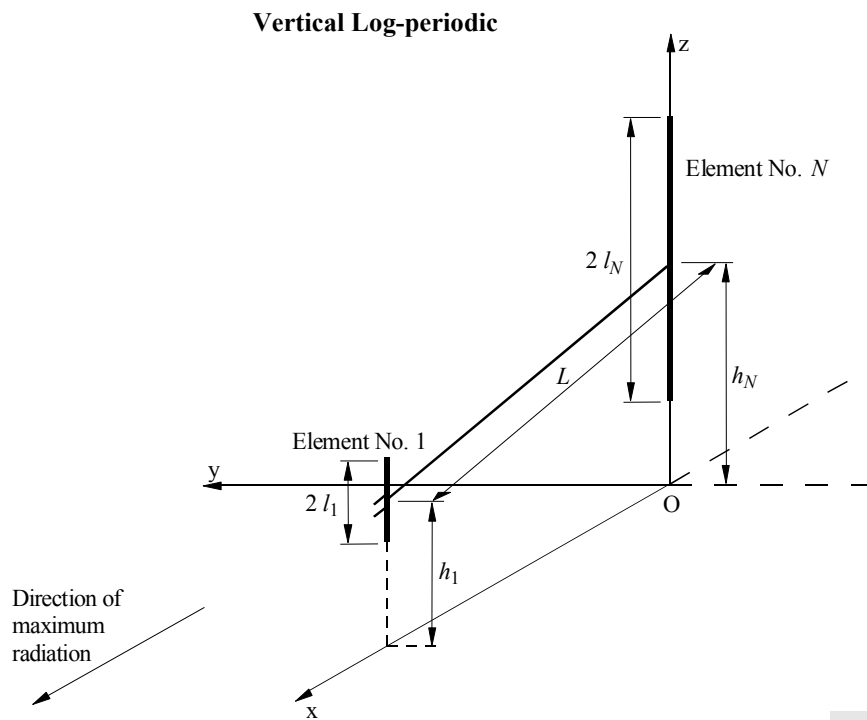

2.8 Type 8: Rhombic antennas

Designation: **RH** $l/\gamma/h$

- l : length of one side of the rhombus (m)
- γ : one half of the interior obtuse angle of rhombus
- h : height of rhombus above ground (m).

Horizontal rhombic antenna

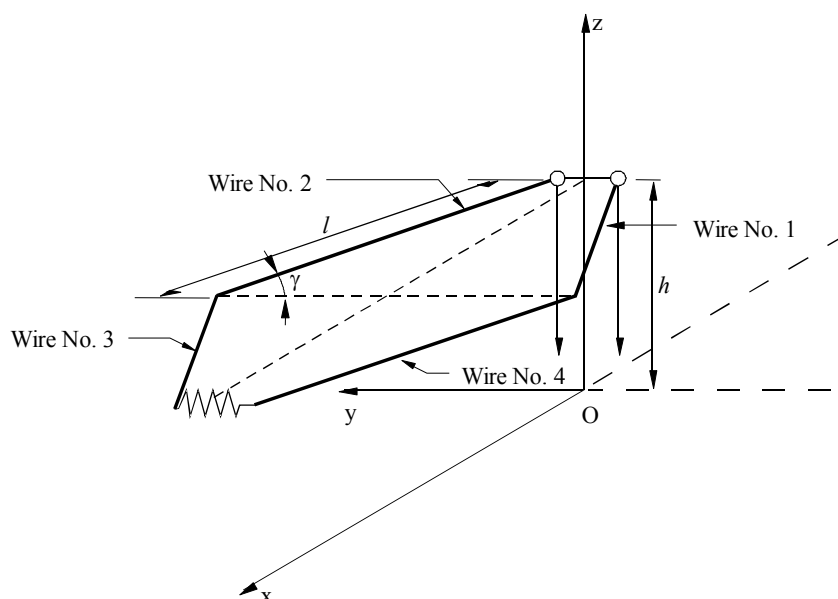

The rhombic antenna has been extensively used for HF communications. It continues to be used for fixed-services point-to-point links. It has also been used for HF broadcasting but is no longer recommended for this purpose. The antenna consists of four straight wires of the same length l arranged in the form of a rhombus.

A typical rhombic antenna design would use side lengths of several wavelengths and be at a height of between $0.5-1.0 \lambda$ at the middle of the operating frequency range.

The rhombic antenna differs from the array of dipoles since it belongs to the traveling-wave antenna category, i.e. the currents in the conductors of the antenna are substantially traveling waves originated from the feeding point and propagating through the wires towards the terminating resistance.

A considerable amount of power may be lost in the terminating resistance and represents the price that has to be paid for some desirable features such as simplicity of construction, relatively wide bandwidth of operation and high directivity gain.

2.9 Type 9: Quadrant Antennas

Designation: **HQ n/h**

n : number of elements stacked above the other
h : height of dipoles above the ground in wavelength

Quadrant antenna

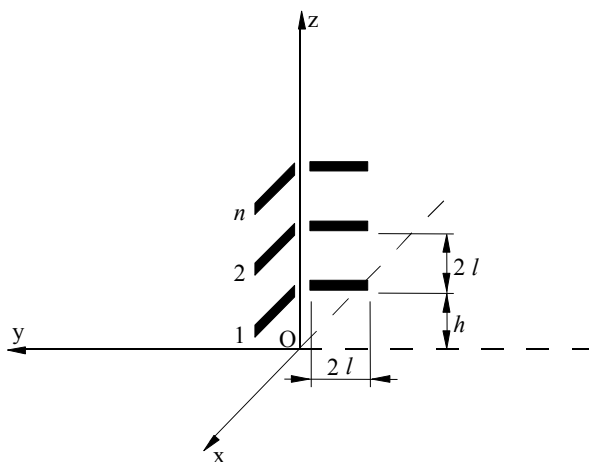

D007 Rec. ITU-R BS.705-1, Fig. 7

4-leg quadrant antenna

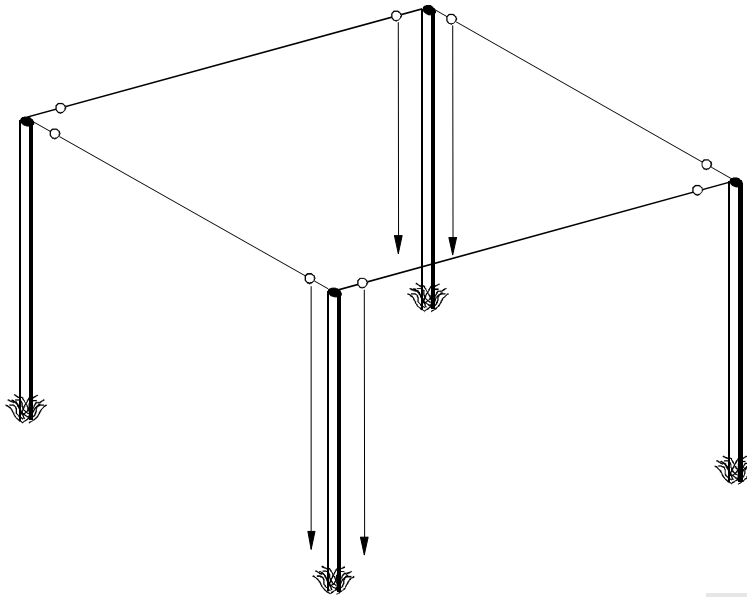

D014 Rec. ITU-R BS.705-1, Fig. 14

The simplest form of quadrant antenna is represented by an arrangement of two horizontal end-fed half-wave dipoles placed at right angles. Another form of quadrant antenna consists of four dipole elements in the form of a square and fed at opposite corners. Quadrant antennas may also be stacked to achieve more directive vertical radiation pattern and consequently higher directivity gain.

2.10 Type 10: Crossed dipole antennas

Designation: **HX h**

h : height of dipoles above the ground in wavelength.

* The design frequency is entered in a separate field of the requirement.

FIGURE 8
Crossed dipole antenna

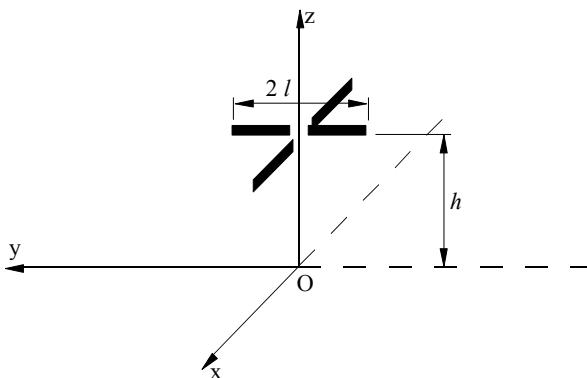

D008 Rec. ITU-R BS.705-1, Fig. 8

A crossed dipole antenna consists of two horizontal centre-fed half wave dipoles placed at right angles to form a cross.

2.11 Type 11: Vertical monopoles

Designation: **VM $h / a_s / N / d$**

- VM :vertical monopole antenna
- h : height of the monopole (m)
- a_s : earth system radius (m)
- N : number of radial wires in the earth system
- d : diameter of the radial wires (mm).

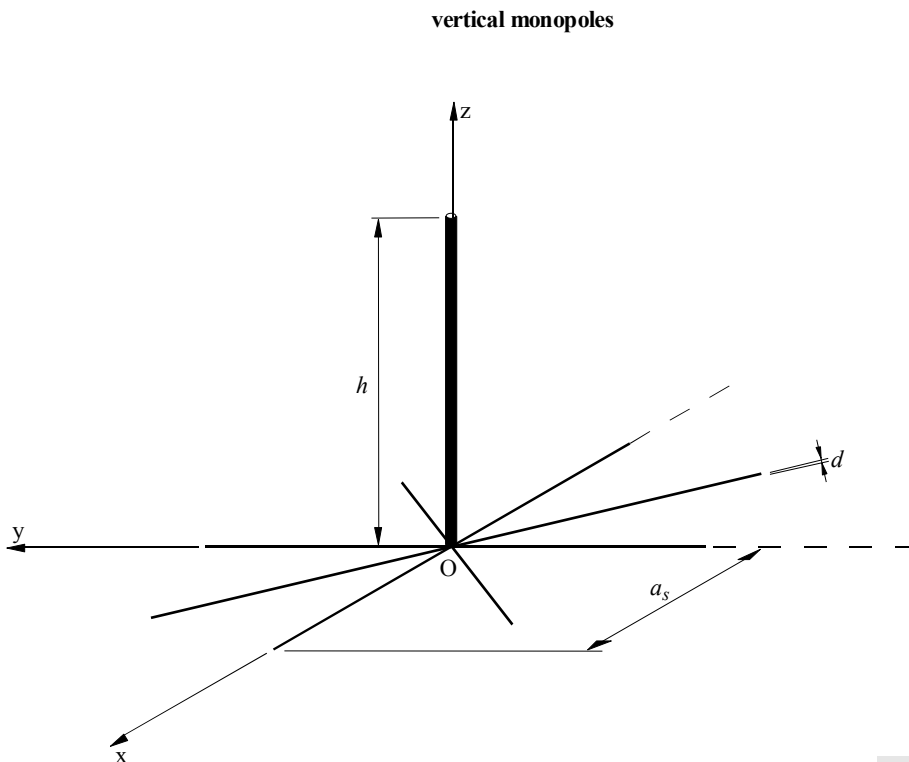

D041 Rec. ITU-R BS.705-1, Fig. 41

A vertical monopole is considered to consist of an infinitely thin, electrically short (less than a half-wave) vertical radiating element erected on a reflecting plane.

To obtain efficient radiation from the antenna, if it is erected on poorly reflecting ground, an earth system normally consisting of a number of radial wires should be used. For the purposes of calculating radiation patterns, it is usually assumed that the input power is applied at the base of the antenna.

The vertical monopole provides an omnidirectional pattern on the azimuthal plane, however the associated vertical pattern is always significantly affected by the ground constants as well as by other physical parameters, e.g. the electrical antenna height, etc.

The presence of an earth system does not significantly affect the geometrical shape of the pattern, but it significantly affects the value of the absolute gain.

The vertical monopole will be considered in two basic conditions:

- above flat homogeneous imperfect ground, taking into account only ground reflection;
- above flat homogeneous imperfect ground with an earth system consisting of either a circular disk having infinite conductivity, or a number of radial wires of given length and diameter.

3 REFERENCE ANTENNA CODES

3.1 Type 1 (AHR): 100 - 299

Curtain antenna, half-wave dipole array, multi-band, centre-fed, aperiodic screen reflector.

Designation: **AHR(S) m/n/h**

- m : number of half-wave dipoles in each horizontal row
- n : number of rows spaced half a wavelength apart one above the other
- h : height above the ground in wavelengths of the bottom row of dipoles

* Possible slew and the design frequency are entered in separate requirement fields.

Antenna Code	Antenna Definition	Antenna Code	Antenna Definition
100	AHR1/1/0.3	200	AHR(S)4/1/0.3
101	AHR1/1/0.5	201	AHR(S)4/1/0.5
102	AHR1/1/0.8	202	AHR(S)4/1/0.8
103	AHR1/1/1.0	203	AHR(S)4/1/1.0
104	AHR1/1/1.5	204	AHR(S)4/1/1.5
105	AHR1/2/0.3	205	AHR(S)4/2/0.3
106	AHR1/2/0.5	206	AHR(S)4/2/0.5
107	AHR1/2/0.8	207	AHR(S)4/2/0.8
108	AHR1/2/1.0	208	AHR(S)4/2/1.0
109	AHR1/2/1.5	209	AHR(S)4/2/1.5
110	AHR1/3/0.3	210	AHR(S)4/3/0.3
111	AHR1/3/0.5	211	AHR(S)4/3/0.5
112	AHR1/3/0.8	212	AHR(S)4/3/0.8
113	AHR1/3/1.0	213	AHR(S)4/3/1.0
114	AHR1/3/1.5	214	AHR(S)4/3/1.5
115	AHR1/4/0.3	215	AHR(S)4/4/0.3
116	AHR1/4/0.5	216	AHR(S)4/4/0.5
117	AHR1/4/0.8	217	AHR(S)4/4/0.8
118	AHR1/4/1.0	218	AHR(S)4/4/1.0
119	AHR1/4/1.5	219	AHR(S)4/4/1.5
120	AHR1/5/0.3	220	AHR(S)4/5/0.3
121	AHR1/5/0.5	221	AHR(S)4/5/0.5
122	AHR1/5/0.8	222	AHR(S)4/5/0.8
123	AHR1/5/1.0	223	AHR(S)4/5/1.0
124	AHR1/5/1.5	224	AHR(S)4/5/1.5
125	AHR1/6/0.3	225	AHR(S)4/6/0.3
126	AHR1/6/0.5	226	AHR(S)4/6/0.5
127	AHR1/6/0.8	227	AHR(S)4/6/0.8
128	AHR1/6/1.0	228	AHR(S)4/6/1.0
129	AHR1/6/1.5	229	AHR(S)4/6/1.5
130	AHR1/7/0.3	230	AHR(S)4/7/0.3
131	AHR1/7/0.5	231	AHR(S)4/7/0.5
132	AHR1/7/0.8	232	AHR(S)4/7/0.8

133	AHR1/7/1.0	233	AHR(S)4/7/1.0
134	AHR1/7/1.5	234	AHR(S)4/7/1.5
135	AHR1/8/0.3	235	AHR(S)4/8/0.3
136	AHR1/8/0.5	236	AHR(S)4/8/0.5
137	AHR1/8/0.8	237	AHR(S)4/8/0.8
138	AHR1/8/1.0	238	AHR(S)4/8/1.0
139	AHR1/8/1.5	239	AHR(S)4/8/1.5
140	AHR(S)2/1/0.3	240	AHR(S)6/1/0.3
141	AHR(S)2/1/0.5	241	AHR(S)6/1/0.5
142	AHR(S)2/1/0.8	242	AHR(S)6/1/0.8
143	AHR(S)2/1/1.0	243	AHR(S)6/1/1.0
144	AHR(S)2/1/1.5	244	AHR(S)6/1/1.5
145	AHR(S)2/2/0.3	245	AHR(S)6/2/0.3
146	AHR(S)2/2/0.5	246	AHR(S)6/2/0.5
147	AHR(S)2/2/0.8	247	AHR(S)6/2/0.8
148	AHR(S)2/2/1.0	248	AHR(S)6/2/1.0
149	AHR(S)2/2/1.5	249	AHR(S)6/2/1.5
150	AHR(S)2/3/0.3	250	AHR(S)6/3/0.3
151	AHR(S)2/3/0.5	251	AHR(S)6/3/0.5
152	AHR(S)2/3/0.8	252	AHR(S)6/3/0.8
153	AHR(S)2/3/1.0	253	AHR(S)6/3/1.0
154	AHR(S)2/3/1.5	254	AHR(S)6/3/1.5
155	AHR(S)2/4/0.3	255	AHR(S)6/4/0.3
156	AHR(S)2/4/0.5	256	AHR(S)6/4/0.5
157	AHR(S)2/4/0.8	257	AHR(S)6/4/0.8
158	AHR(S)2/4/1.0	258	AHR(S)6/4/1.0
159	AHR(S)2/4/1.5	259	AHR(S)6/4/1.5
160	AHR(S)2/5/0.3	260	AHR(S)6/6/0.3
161	AHR(S)2/5/0.5	261	AHR(S)6/6/0.5
162	AHR(S)2/5/0.8	262	AHR(S)6/6/0.8
163	AHR(S)2/5/1.0	263	AHR(S)6/6/1.0
164	AHR(S)2/5/1.5	264	AHR(S)6/6/1.5
165	AHR(S)2/6/0.3	265	AHR(S)6/8/0.3
166	AHR(S)2/6/0.5	266	AHR(S)6/8/0.5
167	AHR(S)2/6/0.8	267	AHR(S)6/8/0.8
168	AHR(S)2/6/1.0	268	AHR(S)6/8/1.0
169	AHR(S)2/6/1.5	269	AHR(S)6/8/1.5
170	AHR(S)2/7/0.3	270	AHR(S)8/1/0.3
171	AHR(S)2/7/0.5	271	AHR(S)8/1/0.5
172	AHR(S)2/7/0.8	272	AHR(S)8/1/0.8
173	AHR(S)2/7/1.0	273	AHR(S)8/1/1.0
174	AHR(S)2/7/1.5	274	AHR(S)8/1/1.5
175	AHR(S)2/8/0.3	275	AHR(S)8/2/0.3
176	AHR(S)2/8/0.5	276	AHR(S)8/2/0.5
177	AHR(S)2/8/0.8	277	AHR(S)8/2/0.8
178	AHR(S)2/8/1.0	278	AHR(S)8/2/1.0
179	AHR(S)2/8/1.5	279	AHR(S)8/2/1.5
180	AHR(S)3/1/0.3	280	AHR(S)8/3/0.3
181	AHR(S)3/1/0.5	281	AHR(S)8/3/0.5
182	AHR(S)3/1/0.8	282	AHR(S)8/3/0.8
183	AHR(S)3/1/1.0	283	AHR(S)8/3/1.0
184	AHR(S)3/1/1.5	284	AHR(S)8/3/1.5
185	AHR(S)3/2/0.3	285	AHR(S)8/4/0.3
186	AHR(S)3/2/0.5	286	AHR(S)8/4/0.5
187	AHR(S)3/2/0.8	287	AHR(S)8/4/0.8
188	AHR(S)3/2/1.0	288	AHR(S)8/4/1.0
189	AHR(S)3/2/1.5	289	AHR(S)8/4/1.5
190	AHR(S)3/3/0.3	290	AHR(S)8/6/0.3

191	AHR(S)3/3/0.5	291	AHR(S)8/6/0.5
192	AHR(S)3/3/0.8	292	AHR(S)8/6/0.8
193	AHR(S)3/3/1.0	293	AHR(S)8/6/1.0
194	AHR(S)3/3/1.5	294	AHR(S)8/6/1.5
195	AHR(S)3/4/0.3	295	AHR(S)8/8/0.3
196	AHR(S)3/4/0.5	296	AHR(S)8/8/0.5
197	AHR(S)3/4/0.8	297	AHR(S)8/8/0.8
198	AHR(S)3/4/1.0	298	AHR(S)8/8/1.0
199	AHR(S)3/4/1.5	299	AHR(S)8/8/1.5
		999	AHR(S)2/2/0.5

3.2 Type 2 (CHR): 300 - 499

Curtain antenna, half-wave dipole array, dual-band, center-fed, tuned dipole reflector.

Designation: **CHR(S) m/n/h**

m : number of half-wave dipoles in each horizontal row

n : number of rows spaced half a wavelength apart one above the other

h : height above the ground in wavelengths of the bottom row of dipoles

Possible slew and the design frequency are entered in separate requirement fields.

Antenna Code	Antenna Definition	Antenna Code	Antenna Definition
300	CHR1/1/0.3	400	CHR(S)4/1/0.3
301	CHR1/1/0.5	401	CHR(S)4/1/0.5
302	CHR1/1/0.8	402	CHR(S)4/1/0.8
303	CHR1/1/1.0	403	CHR(S)4/1/1.0
304	CHR1/1/1.5	404	CHR(S)4/1/1.5
305	CHR1/2/0.3	405	CHR(S)4/2/0.3
306	CHR1/2/0.5	406	CHR(S)4/2/0.5
307	CHR1/2/0.8	407	CHR(S)4/2/0.8
308	CHR1/2/1.0	408	CHR(S)4/2/1.0
309	CHR1/2/1.5	409	CHR(S)4/2/1.5
310	CHR1/3/0.3	410	CHR(S)4/3/0.3
311	CHR1/3/0.5	411	CHR(S)4/3/0.5
312	CHR1/3/0.8	412	CHR(S)4/3/0.8
313	CHR1/3/1.0	413	CHR(S)4/3/1.0
314	CHR1/3/1.5	414	CHR(S)4/3/1.5
315	CHR1/4/0.3	415	CHR(S)4/4/0.3
316	CHR1/4/0.5	416	CHR(S)4/4/0.5
317	CHR1/4/0.8	417	CHR(S)4/4/0.8
318	CHR1/4/1.0	418	CHR(S)4/4/1.0
319	CHR1/4/1.5	419	CHR(S)4/4/1.5
320	CHR1/5/0.3	420	CHR(S)4/5/0.3
321	CHR1/5/0.5	421	CHR(S)4/5/0.5
322	CHR1/5/0.8	422	CHR(S)4/5/0.8
323	CHR1/5/1.0	423	CHR(S)4/5/1.0
324	CHR1/5/1.5	424	CHR(S)4/5/1.5
325	CHR1/6/0.3	425	CHR(S)4/6/0.3
326	CHR1/6/0.5	426	CHR(S)4/6/0.5
327	CHR1/6/0.8	427	CHR(S)4/6/0.8
328	CHR1/6/1.0	428	CHR(S)4/6/1.0
329	CHR1/6/1.5	429	CHR(S)4/6/1.5
330	CHR1/7/0.3	430	CHR(S)4/7/0.3
331	CHR1/7/0.5	431	CHR(S)4/7/0.5

332	CHR1/7/0.8	432	CHR(S)4/7/0.8
333	CHR1/7/1.0	433	CHR(S)4/7/1.0
334	CHR1/7/1.5	434	CHR(S)4/7/1.5
335	CHR1/8/0.3	435	CHR(S)4/8/0.3
336	CHR1/8/0.5	436	CHR(S)4/8/0.5
337	CHR1/8/0.8	437	CHR(S)4/8/0.8
338	CHR1/8/1.0	438	CHR(S)4/8/1.0
339	CHR1/8/1.5	439	CHR(S)4/8/1.5
340	CHR(S)2/1/0.3	440	CHR(S)6/1/0.3
341	CHR(S)2/1/0.5	441	CHR(S)6/1/0.5
342	CHR(S)2/1/0.8	442	CHR(S)6/1/0.8
343	CHR(S)2/1/1.0	443	CHR(S)6/1/1.0
344	CHR(S)2/1/1.5	444	CHR(S)6/1/1.5
345	CHR(S)2/2/0.3	445	CHR(S)6/2/0.3
346	CHR(S)2/2/0.5	446	CHR(S)6/2/0.5
347	CHR(S)2/2/0.8	447	CHR(S)6/2/0.8
348	CHR(S)2/2/1.0	448	CHR(S)6/2/1.0
349	CHR(S)2/2/1.5	449	CHR(S)6/2/1.5
350	CHR(S)2/3/0.3	450	CHR(S)6/3/0.3
351	CHR(S)2/3/0.5	451	CHR(S)6/3/0.5
352	CHR(S)2/3/0.8	452	CHR(S)6/3/0.8
353	CHR(S)2/3/1.0	453	CHR(S)6/3/1.0
354	CHR(S)2/3/1.5	454	CHR(S)6/3/1.5
355	CHR(S)2/4/0.3	455	CHR(S)6/4/0.3
356	CHR(S)2/4/0.5	456	CHR(S)6/4/0.5
357	CHR(S)2/4/0.8	457	CHR(S)6/4/0.8
358	CHR(S)2/4/1.0	458	CHR(S)6/4/1.0
359	CHR(S)2/4/1.5	459	CHR(S)6/4/1.5
360	CHR(S)2/5/0.3	460	CHR(S)6/6/0.3
361	CHR(S)2/5/0.5	461	CHR(S)6/6/0.5
362	CHR(S)2/5/0.8	462	CHR(S)6/6/0.8
363	CHR(S)2/5/1.0	463	CHR(S)6/6/1.0
364	CHR(S)2/5/1.5	464	CHR(S)6/6/1.5
365	CHR(S)2/6/0.3	465	CHR(S)6/8/0.3
366	CHR(S)2/6/0.5	466	CHR(S)6/8/0.5
367	CHR(S)2/6/0.8	467	CHR(S)6/8/0.8
368	CHR(S)2/6/1.0	468	CHR(S)6/8/1.0
369	CHR(S)2/6/1.5	469	CHR(S)6/8/1.5
370	CHR(S)2/7/0.3	470	CHR(S)8/1/0.3
371	CHR(S)2/7/0.5	471	CHR(S)8/1/0.5
372	CHR(S)2/7/0.8	472	CHR(S)8/1/0.8
373	CHR(S)2/7/1.0	473	CHR(S)8/1/1.0
374	CHR(S)2/7/1.5	474	CHR(S)8/1/1.5
375	CHR(S)2/8/0.3	475	CHR(S)8/2/0.3
376	CHR(S)2/8/0.5	476	CHR(S)8/2/0.5
377	CHR(S)2/8/0.8	477	CHR(S)8/2/0.8
378	CHR(S)2/8/1.0	478	CHR(S)8/2/1.0
379	CHR(S)2/8/1.5	479	CHR(S)8/2/1.5
380	CHR(S)3/1/0.3	480	CHR(S)8/3/0.3
381	CHR(S)3/1/0.5	481	CHR(S)8/3/0.5
382	CHR(S)3/1/0.8	482	CHR(S)8/3/0.8
383	CHR(S)3/1/1.0	483	CHR(S)8/3/1.0
384	CHR(S)3/1/1.5	484	CHR(S)8/3/1.5
385	CHR(S)3/2/0.3	485	CHR(S)8/4/0.3
386	CHR(S)3/2/0.5	486	CHR(S)8/4/0.5
387	CHR(S)3/2/0.8	487	CHR(S)8/4/0.8
388	CHR(S)3/2/1.0	488	CHR(S)8/4/1.0
389	CHR(S)3/2/1.5	489	CHR(S)8/4/1.5

390	CHR(S)3/3/0.3	490	CHR(S)8/6/0.3
391	CHR(S)3/3/0.5	491	CHR(S)8/6/0.5
392	CHR(S)3/3/0.8	492	CHR(S)8/6/0.8
393	CHR(S)3/3/1.0	493	CHR(S)8/6/1.0
394	CHR(S)3/3/1.5	494	CHR(S)8/6/1.5
395	CHR(S)3/4/0.3	495	CHR(S)8/8/0.3
396	CHR(S)3/4/0.5	496	CHR(S)8/8/0.5
397	CHR(S)3/4/0.8	497	CHR(S)8/8/0.8
398	CHR(S)3/4/1.0	498	CHR(S)8/8/1.0
399	CHR(S)3/4/1.5	499	CHR(S)8/8/1.5

3.3 Type 3 (EHR): 500 - 699

Curtain antenna, half-wave dipole array, dual-band, end-fed, tuned dipole reflector.

Designation: **EHR(S) m/n/h**

m : number of half-wave dipoles in each horizontal row

n : number of rows spaced half a wavelength apart one above the other

h : height above the ground in wavelengths of the bottom row of dipoles

* Possible slew and the design frequency are entered in separate requirement fields.

Antenna Code	Antenna Definition	Antenna Code	Antenna Definition
500	EHR1/1/0.3	600	EHR(S)4/1/0.3
501	EHR1/1/0.5	601	EHR(S)4/1/0.5
502	EHR1/1/0.8	602	EHR(S)4/1/0.8
503	EHR1/1/1.0	603	EHR(S)4/1/1.0
504	EHR1/1/1.5	604	EHR(S)4/1/1.5
505	EHR1/2/0.3	605	EHR(S)4/2/0.3
506	EHR1/2/0.5	606	EHR(S)4/2/0.5
507	EHR1/2/0.8	607	EHR(S)4/2/0.8
508	EHR1/2/1.0	608	EHR(S)4/2/1.0
509	EHR1/2/1.5	609	EHR(S)4/2/1.5
510	EHR1/3/0.3	610	EHR(S)4/3/0.3
511	EHR1/3/0.5	611	EHR(S)4/3/0.5
512	EHR1/3/0.8	612	EHR(S)4/3/0.8
513	EHR1/3/1.0	613	EHR(S)4/3/1.0
514	EHR1/3/1.5	614	EHR(S)4/3/1.5
515	EHR1/4/0.3	615	EHR(S)4/4/0.3
516	EHR1/4/0.5	616	EHR(S)4/4/0.5
517	EHR1/4/0.8	617	EHR(S)4/4/0.8
518	EHR1/4/1.0	618	EHR(S)4/4/1.0
519	EHR1/4/1.5	619	EHR(S)4/4/1.5
520	EHR1/5/0.3	620	EHR(S)4/5/0.3
521	EHR1/5/0.5	621	EHR(S)4/5/0.5
522	EHR1/5/0.8	622	EHR(S)4/5/0.8
523	EHR1/5/1.0	623	EHR(S)4/5/1.0
524	EHR1/5/1.5	624	EHR(S)4/5/1.5
525	EHR1/6/0.3	625	EHR(S)4/6/0.3
526	EHR1/6/0.5	626	EHR(S)4/6/0.5
527	EHR1/6/0.8	627	EHR(S)4/6/0.8
528	EHR1/6/1.0	628	EHR(S)4/6/1.0
529	EHR1/6/1.5	629	EHR(S)4/6/1.5
530	EHR1/7/0.3	630	EHR(S)4/7/0.3
531	EHR1/7/0.5	631	EHR(S)4/7/0.5

532	EHR1/7/0.8	632	EHR(S)4/7/0.8
533	EHR1/7/1.0	633	EHR(S)4/7/1.0
534	EHR1/7/1.5	634	EHR(S)4/7/1.5
535	EHR1/8/0.3	635	EHR(S)4/8/0.3
536	EHR1/8/0.5	636	EHR(S)4/8/0.5
537	EHR1/8/0.8	637	EHR(S)4/8/0.8
538	EHR1/8/1.0	638	EHR(S)4/8/1.0
539	EHR1/8/1.5	639	EHR(S)4/8/1.5
540	EHR(S)2/1/0.3	640	EHR(S)6/1/0.3
541	EHR(S)2/1/0.5	641	EHR(S)6/1/0.5
542	EHR(S)2/1/0.8	642	EHR(S)6/1/0.8
543	EHR(S)2/1/1.0	643	EHR(S)6/1/1.0
544	EHR(S)2/1/1.5	644	EHR(S)6/1/1.5
545	EHR(S)2/2/0.3	645	EHR(S)6/2/0.3
546	EHR(S)2/2/0.5	646	EHR(S)6/2/0.5
547	EHR(S)2/2/0.8	647	EHR(S)6/2/0.8
548	EHR(S)2/2/1.0	648	EHR(S)6/2/1.0
549	EHR(S)2/2/1.5	649	EHR(S)6/2/1.5
550	EHR(S)2/3/0.3	650	EHR(S)6/3/0.3
551	EHR(S)2/3/0.5	651	EHR(S)6/3/0.5
552	EHR(S)2/3/0.8	652	EHR(S)6/3/0.8
553	EHR(S)2/3/1.0	653	EHR(S)6/3/1.0
554	EHR(S)2/3/1.5	654	EHR(S)6/3/1.5
555	EHR(S)2/4/0.3	655	EHR(S)6/4/0.3
556	EHR(S)2/4/0.5	656	EHR(S)6/4/0.5
557	EHR(S)2/4/0.8	657	EHR(S)6/4/0.8
558	EHR(S)2/4/1.0	658	EHR(S)6/4/1.0
559	EHR(S)2/4/1.5	659	EHR(S)6/4/1.5
560	EHR(S)2/5/0.3	660	EHR(S)6/6/0.3
561	EHR(S)2/5/0.5	661	EHR(S)6/6/0.5
562	EHR(S)2/5/0.8	662	EHR(S)6/6/0.8
563	EHR(S)2/5/1.0	663	EHR(S)6/6/1.0
564	EHR(S)2/5/1.5	664	EHR(S)6/6/1.5
565	EHR(S)2/6/0.3	665	EHR(S)6/8/0.3
566	EHR(S)2/6/0.5	666	EHR(S)6/8/0.5
567	EHR(S)2/6/0.8	667	EHR(S)6/8/0.8
568	EHR(S)2/6/1.0	668	EHR(S)6/8/1.0
569	EHR(S)2/6/1.5	669	EHR(S)6/8/1.5
570	EHR(S)2/7/0.3	670	EHR(S)8/1/0.3
571	EHR(S)2/7/0.5	671	EHR(S)8/1/0.5
572	EHR(S)2/7/0.8	672	EHR(S)8/1/0.8
573	EHR(S)2/7/1.0	673	EHR(S)8/1/1.0
574	EHR(S)2/7/1.5	674	EHR(S)8/1/1.5
575	EHR(S)2/8/0.3	675	EHR(S)8/2/0.3
576	EHR(S)2/8/0.5	676	EHR(S)8/2/0.5
577	EHR(S)2/8/0.8	677	EHR(S)8/2/0.8
578	EHR(S)2/8/1.0	678	EHR(S)8/2/1.0
579	EHR(S)2/8/1.5	679	EHR(S)8/2/1.5
580	EHR(S)3/1/0.3	680	EHR(S)8/3/0.3
581	EHR(S)3/1/0.5	681	EHR(S)8/3/0.5
582	EHR(S)3/1/0.8	682	EHR(S)8/3/0.8
583	EHR(S)3/1/1.0	683	EHR(S)8/3/1.0
584	EHR(S)3/1/1.5	684	EHR(S)8/3/1.5
585	EHR(S)3/2/0.3	685	EHR(S)8/4/0.3
586	EHR(S)3/2/0.5	686	EHR(S)8/4/0.5
587	EHR(S)3/2/0.8	687	EHR(S)8/4/0.8
588	EHR(S)3/2/1.0	688	EHR(S)8/4/1.0
589	EHR(S)3/2/1.5	689	EHR(S)8/4/1.5

590	EHR(S)3/3/0.3	690	EHR(S)8/6/0.3
591	EHR(S)3/3/0.5	691	EHR(S)8/6/0.5
592	EHR(S)3/3/0.8	692	EHR(S)8/6/0.8
593	EHR(S)3/3/1.0	693	EHR(S)8/6/1.0
594	EHR(S)3/3/1.5	694	EHR(S)8/6/1.5
595	EHR(S)3/4/0.3	695	EHR(S)8/8/0.3
596	EHR(S)3/4/0.5	696	EHR(S)8/8/0.5
597	EHR(S)3/4/0.8	697	EHR(S)8/8/0.8
598	EHR(S)3/4/1.0	698	EHR(S)8/8/1.0
599	EHR(S)3/4/1.5	699	EHR(S)8/8/1.5

3.4 Type 4 (CH): 700 - 749

Curtain antenna, arrays of horizontal half-wave dipoles, centre fed, without reflector.

Designation: **CH m/n/h**

m : number of half-wave dipoles in each horizontal row
n : number of parallel rows spaced half a wavelength apart
h : height above the ground in wavelengths

* Possible slew and the design frequency are entered in separate requirement fields.

Antenna Code	Antenna Definition	Antenna Code	Antenna Definition
700	CH1/1/0.3	713	CH2/1/1.0
701	CH1/1/0.5	714	CH2/1/1.5
702	CH1/1/0.8	715	CH2/2/0.3
703	CH1/1/1.0	716	CH2/2/0.5
704	CH1/1/1.5	717	CH2/2/0.8
705	CH1/2/0.3	718	CH2/2/1.0
706	CH1/2/0.5	719	CH2/2/1.5
707	CH1/2/0.8	720	CH2/3/0.3
708	CH1/2/1.0	721	CH2/3/0.5
709	CH1/2/1.5	722	CH2/3/0.8
710	CH2/1/0.3	723	CH2/3/1.0
711	CH2/1/0.5	724	CH2/3/1.5
712	CH2/1/0.8		

3.5 Type 5 (CT): 750 - 799

Tropical antenna, arrays of horizontal half-wave dipoles arranged horizontally, without reflector.

Designation: **CT m/n/h**

m : number of half-wave dipoles in each horizontal row
n : number of parallel rows spaced half a wavelength apart
h : height above the ground in wavelengths

Possible slew and the design frequency are entered in separate requirement fields.

Antenna Code	Antenna Definition
750	CT1/1/0.3
751	CT1/1/0.5
752	CT1/1/0.8

753	CT1/1/1.0
754	CT1/1/1.5
755	CT1/2/0.3
756	CT1/2/0.5
757	CT1/2/0.8
758	CT1/2/1.0
759	CT1/2/1.5
760	CT2/1/0.3
761	CT2/1/0.5
762	CT2/1/0.8
763	CT2/1/1.0
764	CT2/1/1.5
765	CT2/2/0.3
766	CT2/2/0.5
767	CT2/2/0.8
768	CT2/2/1.0
769	CT2/2/1.5
770	CT2/3/0.3
771	CT2/3/0.5
772	CT2/3/0.8
773	CT2/3/1.0
774	CT2/3/1.5

3.6 Type 6 (LPH): 800 - 849

Horizontal log-periodic antenna

Designation: **LPH N / L / h_1 / h_N / l_1 / l_N / Z**

- N : number of elements
- L : distance between the centers of the shortest and the longest element (m)
- h_1 : height of the shortest element (m)
- h_N : height of the longest element (m)
- l_1 : half-length of the shortest element (m)
- l_N : half-length of the longest element (m)
- Z : impedance of the antenna internal feeder line (Ω).

Antenna Code	Antenna Definition
800	LPH18/35/30/30/3/26/89
801	LPH19/5/45/45/1/20/300
802	LPH20/23.8/21.7/25.8/1.4/12.7/200
803	LPH17/55/2.4/32.15/0.88/33.6/300
804	LPH16/33.9/3.1/36.9/1.5/26/600
805	LPH18/36.5/32.2/16.7/1.4/13.2/200
806	LPH18/36.5/27.4/21/1.4/13.2/200
807	LPH18/36.5/20.6/27/1.4/13.2/200
808	LPH18/36.5/15.8/31.3/1.4/13.2/200
809	LPH18/36.5/14.4/32.6/1.4/13.2/300
810	LPH18/36.5/22.3/25.5/1.4/13.2/300
811	LPH19/22/30.5/30.5/1.5/12.5/50
812	LPH13/33.5/27.3/30.7/1.6/16.6/300
820	LPH16/32/20/20/3.3/26.1/89
822	LPH16/35.6/16/16/3.2/26.1/50
823	LPH18/50/7.5/29/1.74/22/50

3.7 Type 7 (LPV): 850 - 899

Vertical log-periodic antenna

Designation: **LPV N / L / h₁ / h_N / l₁ / l_N / Z***N* : number of elements*L* : distance between the centers of the shortest and the longest element (m)*h*₁ : height of the shortest element (m)*h*_{*N*} : height of the longest element (m)*l*₁ : half-length of the shortest element (m)*l*_{*N*} : half-length of the longest element (m)*Z* : impedance of the antenna internal feeder line (Ω).

Antenna Code	Antenna Definition
850	LPV18/45/3/17/6/34/220
851	LPV12/56/2/14/2/12.5/450

3.8 Type 8 (RH): 900 - 924

Rhombic antenna.

Designation: **RH l/γ/h***l* : length of one side of the rhombus in meters*γ* : one half angle of the interior obtuse angle of rhombus in degrees.*h* : height of rhombus above ground in meters

Antenna Code	Antenna Definition
875	RH50/50/30
876	RH50/60/20
877	RH60/60/20
878	RH70/60/30
879	RH70/60/40
880	RH80/60/20
881	RH80/60/30
882	RH80/60/40
883	RH80/70/20
884	RH80/70/30
885	RH90/60/40
886	RH90/70/180
887	RH100/70/40
888	RH100/70/40
889	RH110/70/50
890	RH120/60/30
891	RH120/70/30
892	RH120/70/40
893	RH120/80/20
894	RH130/70/30
895	RH130/70/50

896	RH140/70/30
897	RH140/70/40
898	RH140/80/10
899	RH210/80/30
900	RH90/55/15
901	RH67/88/17
902	RH155/68/40
903	RH140/53/90
904	RH100/60/25
905	RH250/70/100
906	RH250/70/80
907	RH300/70/50
908	RH300/80/40
909	RH80/65/30
910	RH80/65/20
911	RH140/65/35
912	RH120/65/30
913	RH155/56/40

3.9 Type 9 (HQ): 925 - 949

Quadrant antenna.

Designation: **HQ n/h**

n : number of elements stacked above the other
h : height of dipoles above the ground in wavelength

The design frequency is entered in a separate field of the requirement.

Antenna Code	Antenna Definition
925	HQ1/0.3
926	HQ1/0.5
927	HQ1/0.8
928	HQ1/1.0
929	HQ1/1.5
930	HQ2/0.3
931	HQ2/0.5
932	HQ2/0.8
933	HQ2/1.0
934	HQ2/1.5
935	HQ1/0.4

3.10 Type 10 (HX): 950 - 974

Cross-dipole antenna.

Designation: **HX h**

h : height of dipoles above the ground in wavelength.

The design frequency is entered in a separate field of the requirement.

Antenna Code	Antenna Definition
950	HX0.3
951	HX0.5
952	HX0.8
953	HX1.0
954	HX1.5

3.11 Type 11 (VM): 975 - 990

Vertical monopoles.

Designation: **VM h/a_s/N/d**

h : height of monopole in meters
a_s : earth system radius in meters
N : number of radial wires in the earth system
d : diameter of the radial wires in millimeter

When no earth system a_s, N and d are set to zero.

Antenna Code	Antenna Definition
975	VM8/8/120/3
976	VM12.5/12.5/120/3

4. ADDITION OF NEW REFERENCE ANTENNA CODE

Antenna systems that are not covered by the codes given in the above Section 3 can also be notified to the Radiocommunication Bureau. Antenna codes between 991 and 995 can be used and their corresponding technical parameters must be forwarded to the Bureau. The Bureau will then assign appropriate reference codes to the new antenna system, advise the administrations / broadcasters concerned and update the antenna code reference table accordingly. The antenna reference table and other reference tables are available for viewing and download from the ITU Website.

Last updated: 30 October 2017