

Fabien Migneret  
7<sup>th</sup>/9<sup>th</sup> May 2013

---

# 1000x vision and spectrum implications

---

QUALCOMM®

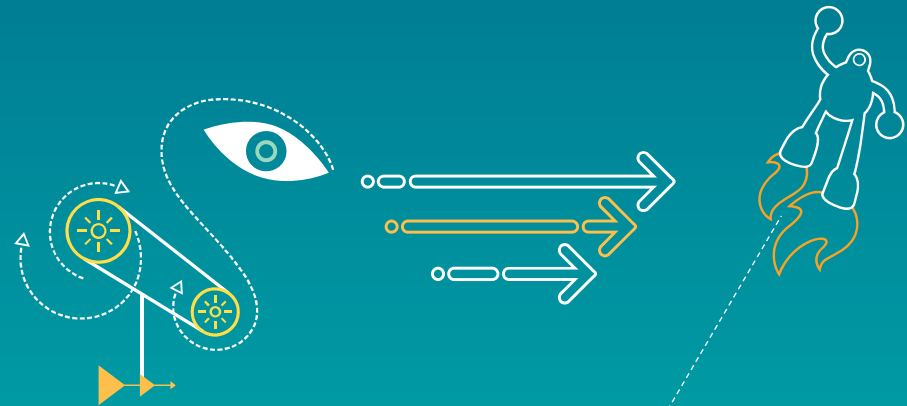

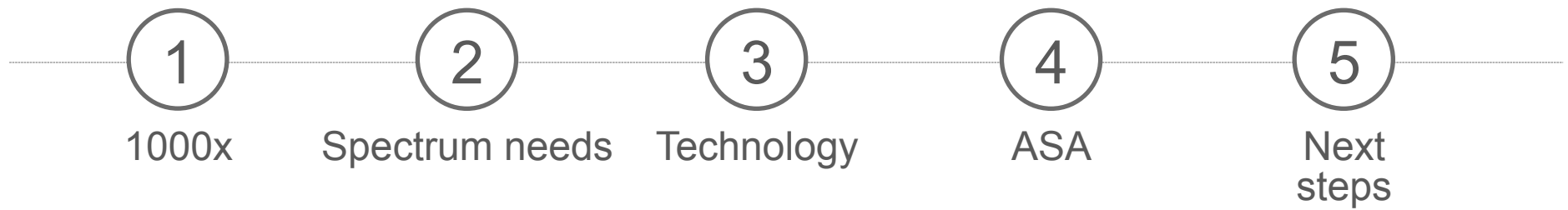

---

## Agenda

---

1000x data traffic  
growth

---

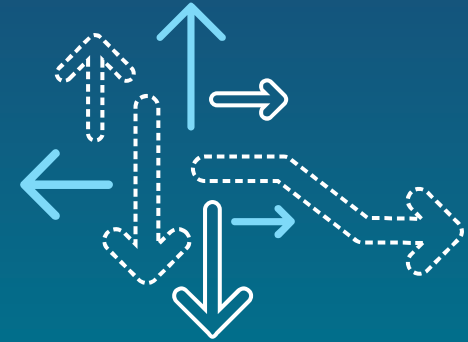

## And in particular in Middle East and North Africa

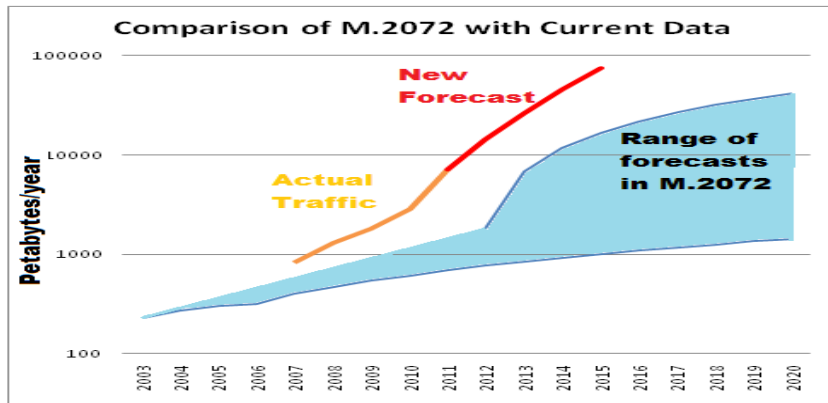

- ITU estimates x18 over the next 10 years
  - Tablets and smartphone penetrations
  - Applications, high throughputs and falling prices
- Traffic increased between 2011 and 2012
  - 450% for one operator in Saudi
  - 650% for one operator in Bahrain
- Estimations always underestimated growth
  - Technology innovation has responded with introductions of techniques

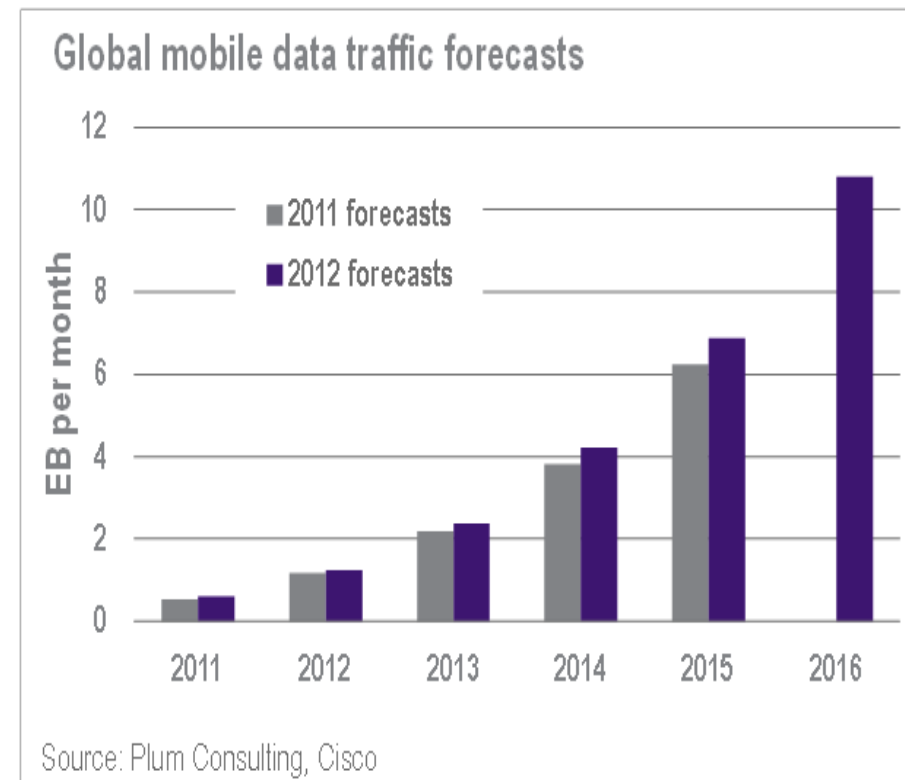

# Challenge of 1000x

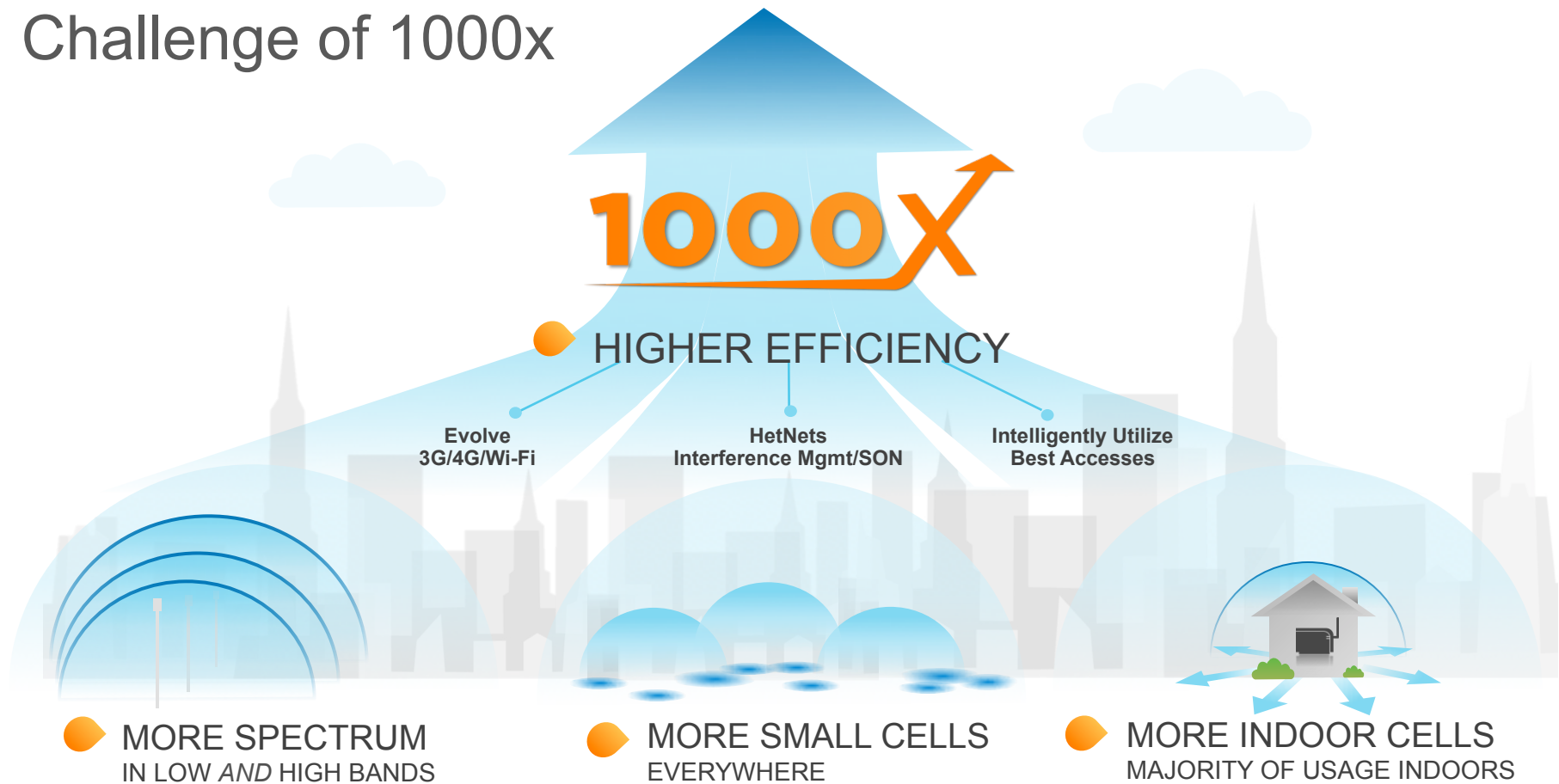

---

# Technology & spectrum challenges

---

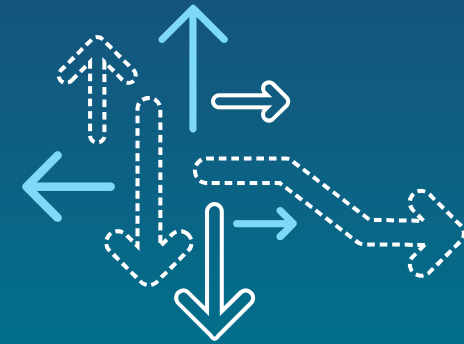

# Technology and spectrum

- **Technology**
  - More efficient technologies (3G and 4G)
  - Interference management
  - More bands to be supported
- **Deployments**
  - Refarming
  - Small cells
- **Techniques could cope with a 100x... Still need 10x to come from spectrum**
  - Mix of both low and high frequency ranges
- **Preferred candidates band for short, medium and long terms**
  - Short medium term: 700 MHz and 1.4 GHz
  - Longer term: below and above existing IMT bands

Truly global. Entirely integrated. Easily customizable.

**The problem**  
2G+3G+4G LTE  
40+Cellular Radio Bands  
+ 10+SKUs  
= 1big headache

**The solution**

One solution designed for All modes. All bands.

Qualcomm  
Processors  
MTC  
MNC.

Qualcomm  
RF360  
Half the size



# Sub-1GHz bands: 700, 800, 850, 900 MHz

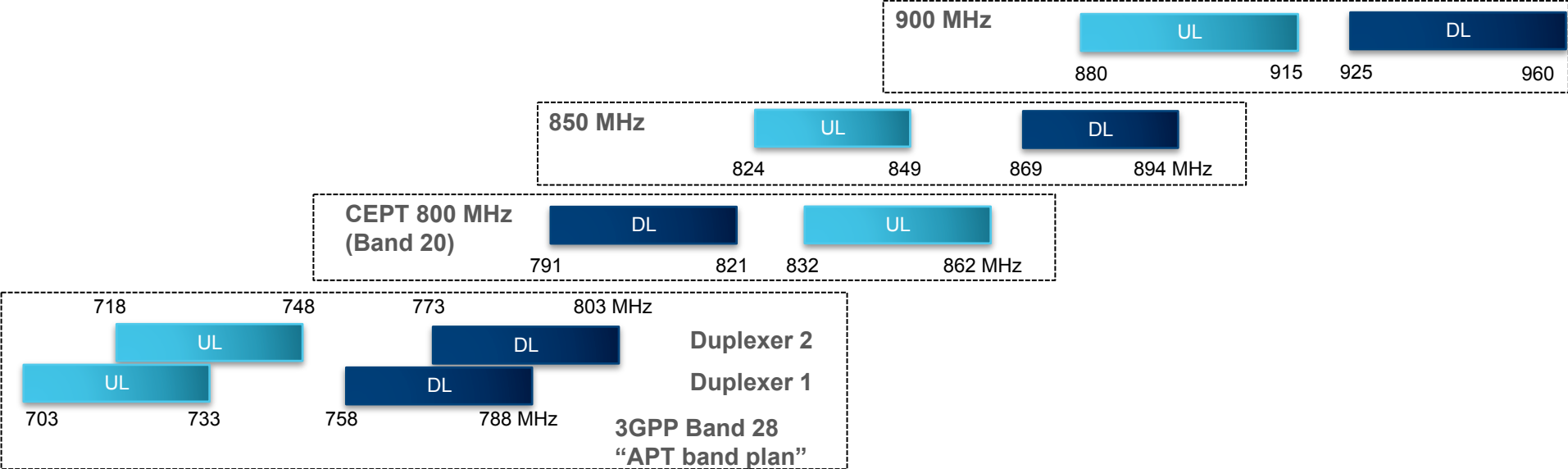

# Optimal band plan for Europe Middle East North Africa

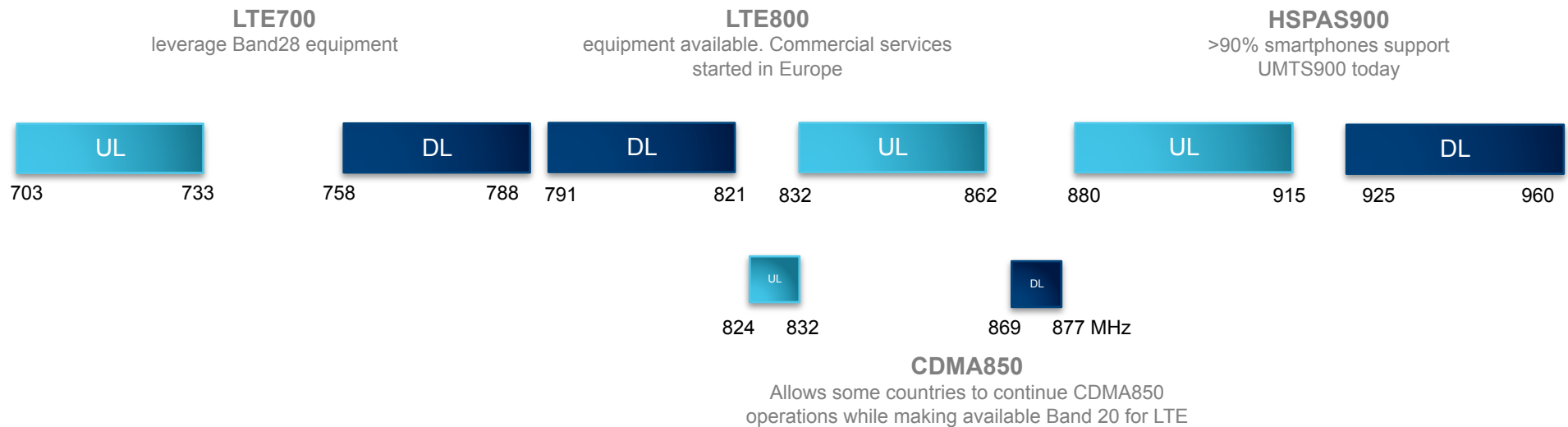

- 2x30 MHz approved by GSMA for Region 1 before MWC-13
  - Work on extension of the spectrum use in particular in the 25 MHz duplex gap
- All bands are already standardized in 3GPP and easily implemented in terminals
- Implementation of nearly worldwide 3GPP Band 28
- Around 2x100MHz harmonized band plan for mobile broadband in MENA

# Supplemental downlink technology overview

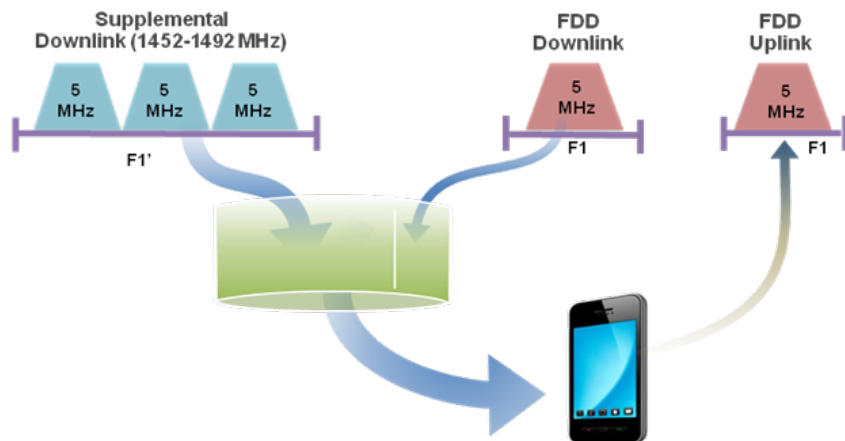

- Carrier aggregation of SDL with usual FDD
  - Multicarrier HSPA+
  - LTE carrier aggregation

- Increase downlink capacity for asymmetry services

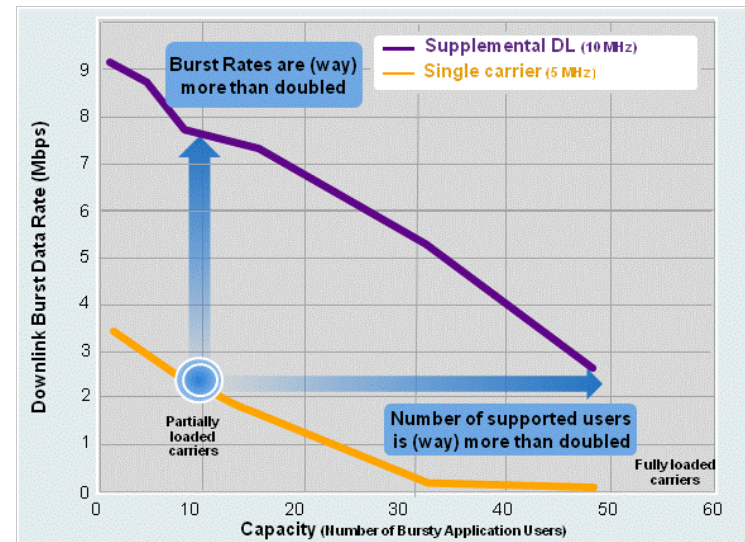

---

# Improved user experience is a reality



# Economic and social benefits in MENA



- Economic benefits of SDL in L-band
  - Europe: €54 billion (10 years NPV)
  - MENA: \$26 billion (10 years NPV)
- Preliminary study of the European decisions

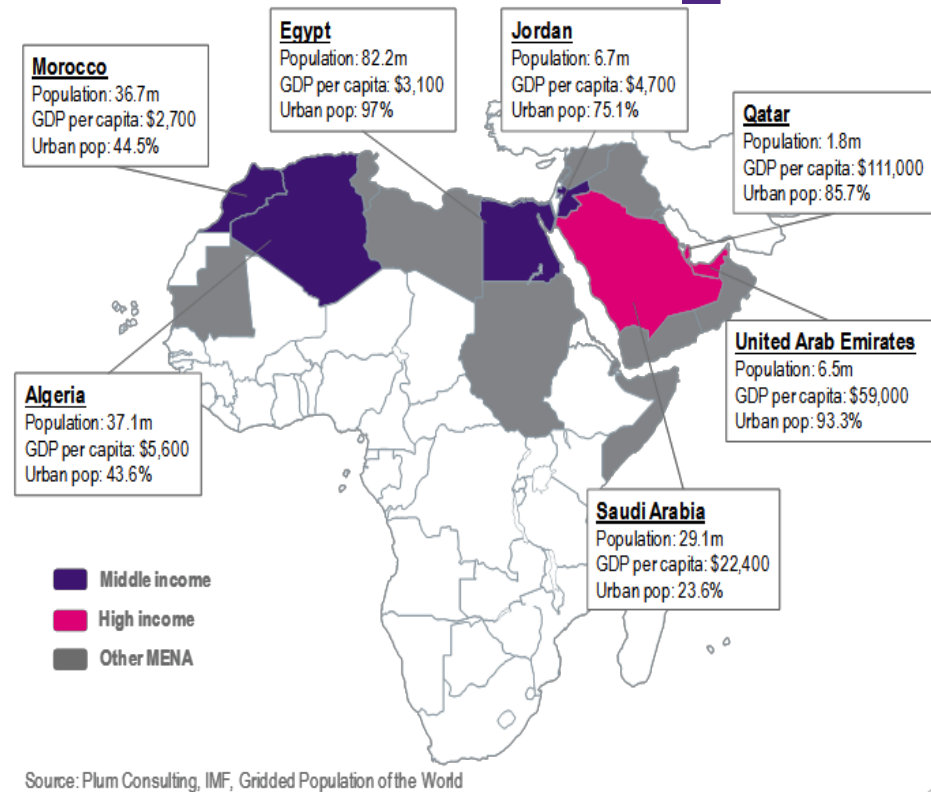
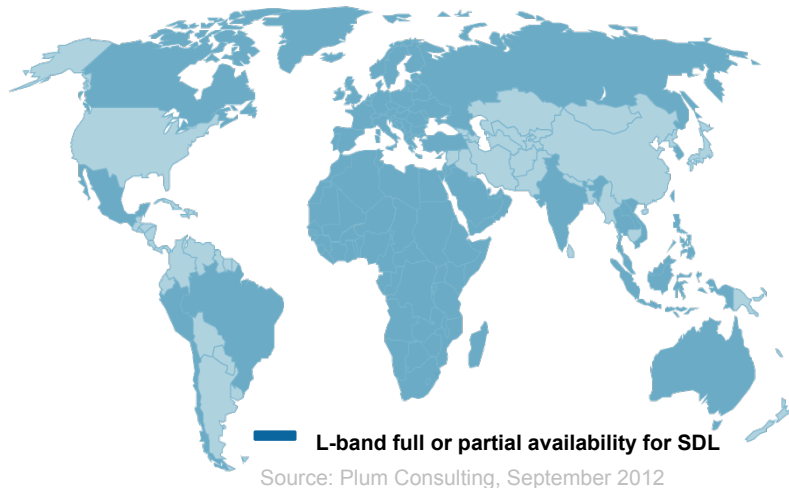

# SDL already supported by HSPA+ and LTE standards

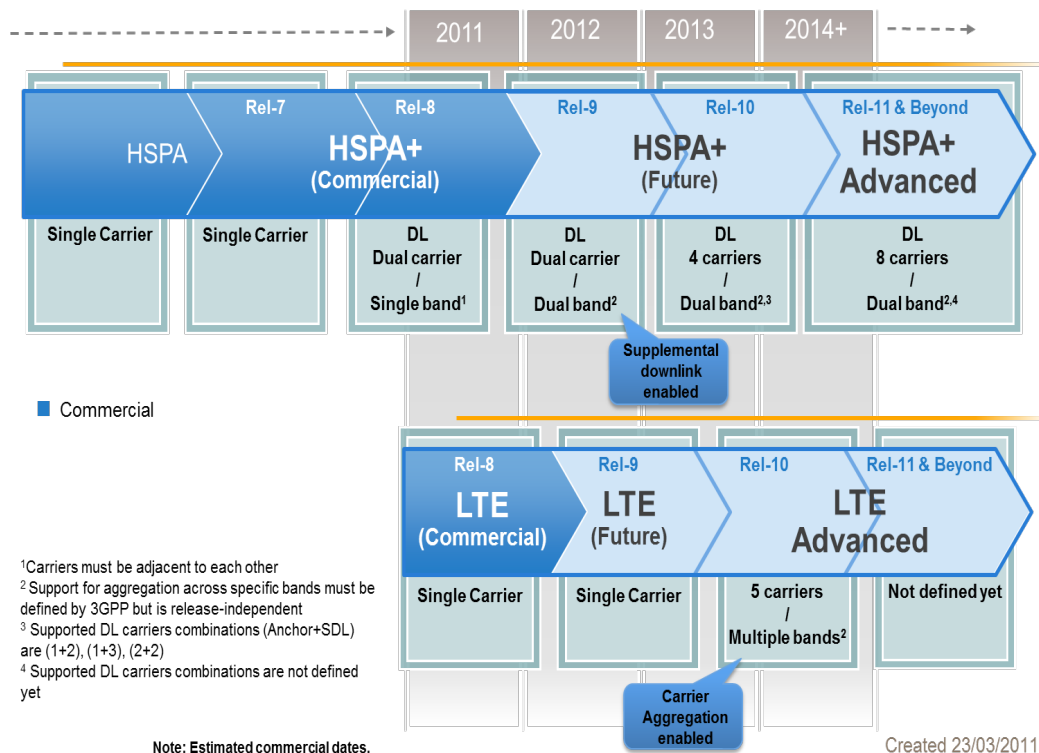

- SDL already supported by HSPA+ and LTE 3GPP standards
- AT&T plans to use SDL in 700MHz as early as 2014
- Harmonization of the 40MHz in 1452-1492 MHz in Europe ongoing

---

# ECC activities in 2013

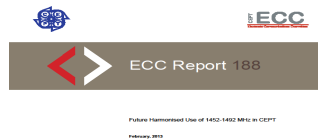

## ECC Report 188

The report "Future harmonized Use of 1452-1492 MHz in CEPT" has been approved. This concludes the ECC preferred use of the 1452-1492 MHz by SDL

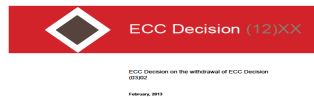

## ECC Decision to withdraw satellite

This new decision to suppress satellite allocation in L-band in Europe is now under public consultation and should be approved in May 2013

---

# ECC activities in 2013

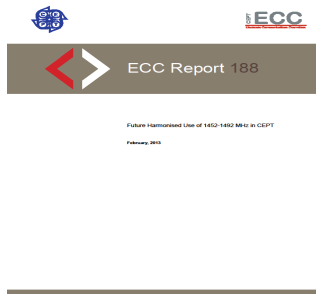

## ECC Report

Out Of Band emission limits for MFCN SDL operating in the 1452-1492 MHz band due in September 2013

- Coexistence with services in the adjacent bands
- In-band coexistence with other services

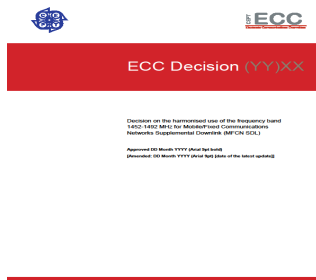

## ECC Decision

The ECC Dec on "Harmonized use of the frequency band 1452-1492 MHz for SDL" be on public consultation in May 2013 when MFCN SDL OOBE will be finalized. It is still anticipated that the ECC Decision will be published in October 2013



---

# EU activities in 2013



## RSPG Opinion

EU27 RSPG approved for public consultation its strategic spectrum roadmap for mobile broadband. Adoption in June 13

- Release of L-band for SDL in 2013-2015
- Harmonize technical implementation of SDL in 1452-1492MHz

# Time schedule

- Trials and Demos since February
  - Toulouse (France) with Ericsson and Orange on real live mobile network
  - Barcelona (Spain) with Ericsson during the Mobile World Congress
- Standardization completion and commercial availability planned in 2014/2015

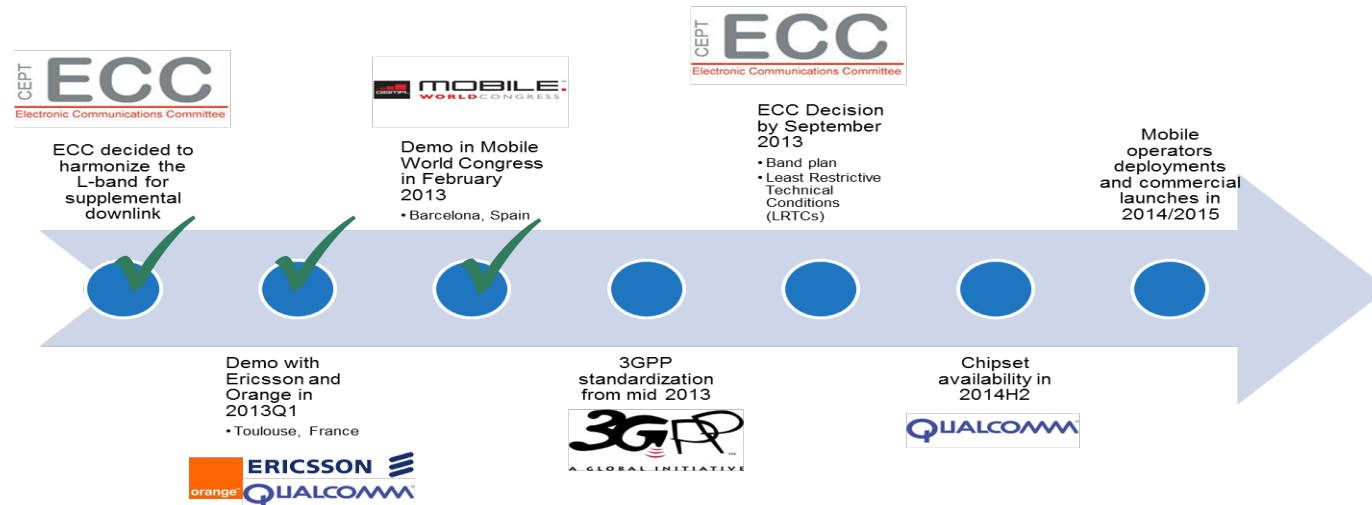

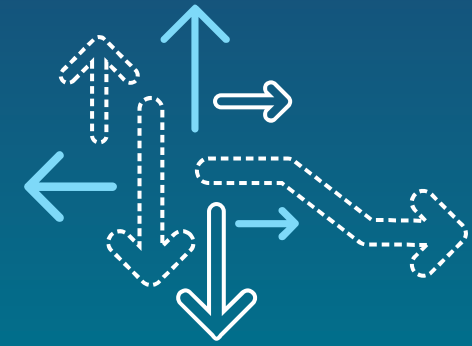

---

# ASA

---

---

# Authorized Shared Access concept

3 complementary ways to use the spectrum

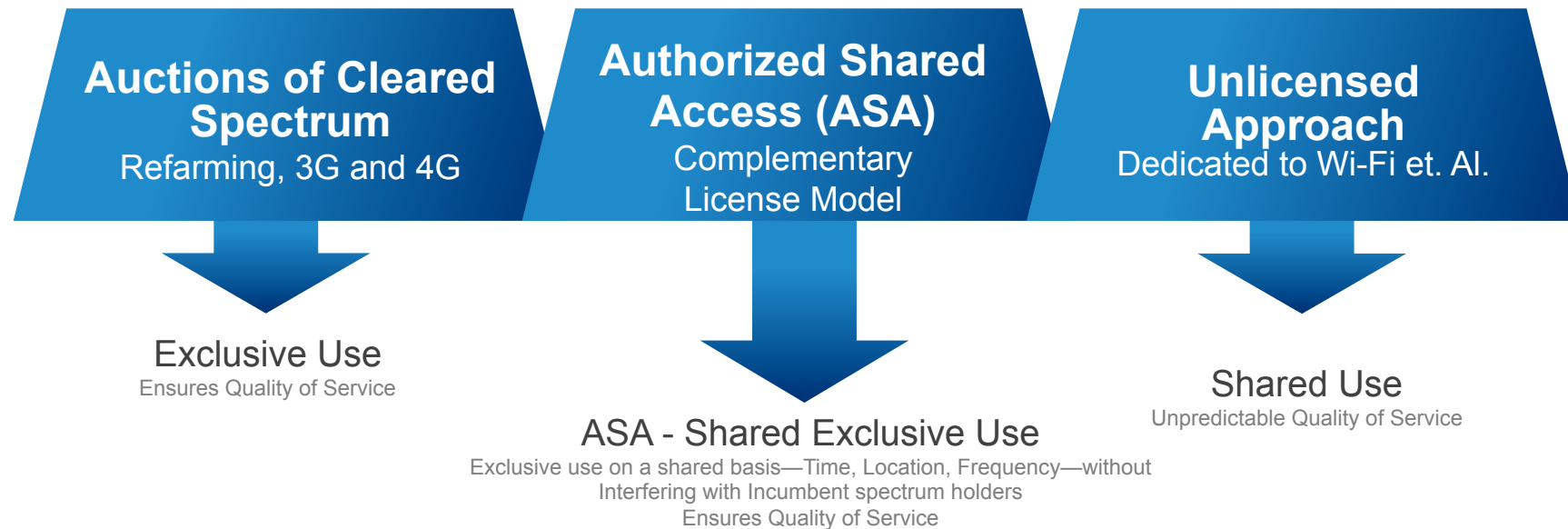

# ASA principles

## SIMPLE

- Simple technology with defined interfaces
- Regulatory framework

## REGULAR MULTI-BAND DEVICE

- Opportunity to aggregate wider spectrum

## COST-EFFECTIVE

- Use available 3G/4G infrastructure – no ASA impact on standards
- Complements installed 3G/4G

## EXCLUSIVE USE

- At given locations, times ensures predictability for long-term investments

## PROTECTS INCUMBENTS

- Binary use—either incumbent or rights holder
- Protection zones

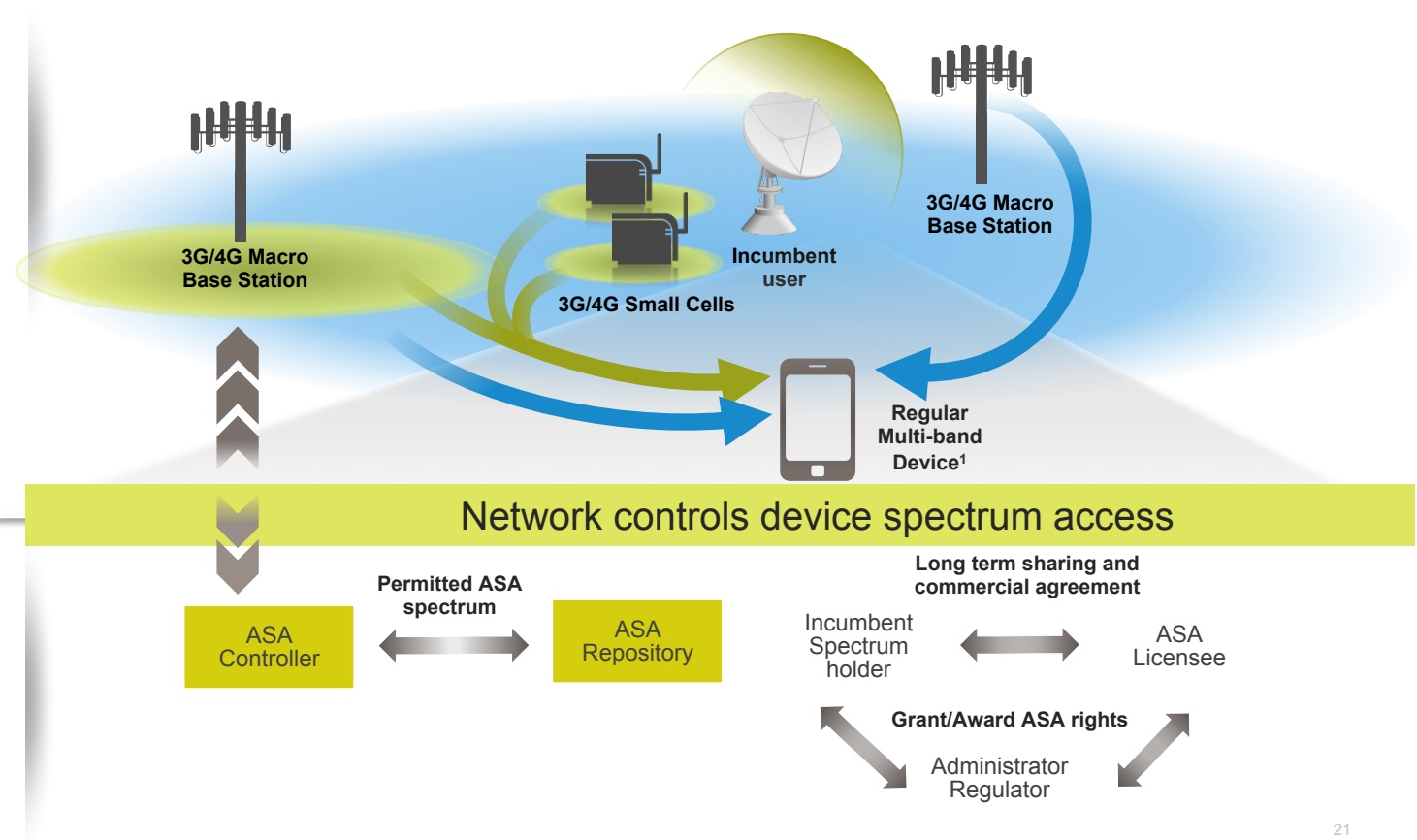

---

# Progress made in Europe to release 2.3 GHz band

## Two parallel activities in specific band and generic principles

- Typical example of the band where ASA can be implemented
  - Identified for IMT during the WRC-07
  - 3GPP standard (3GPP band 40)
  - Economies of scale
  - Widely used for mobile broadband outside of Europe
  - Unavailable for mobile broadband in Europe due to incumbents
- CEPT works on procedures for this band and more generally on the benefits of the LSA/ASA
  - Benefits compared to TVWS and other common uses of the spectrum bands
  - ECC Decision on the use of the 2.3 GHz band under ASA framework is planned in H1 2014

---

# ASA to unlock spectrum in EU and US



- Endorsed by EU 27 Member States, calling it LSA (Licensed Shared Access)
- Endorsed by CEPT releasing a report on ASA benefits and working on LSA authorisations guidelines
- Implemented by CEPT for the harmonisation and release of the 2.3GHz (3GPP Band 40) on ASA basis with various incumbents – telemetry, defense, fixed...



- Studied by ETSI defining sharing requirements and network architecture



- Spectrum sharing adopted by FCC for the release of the 3.5GHz (3550-3650MHz) for small cells on shared basis with radars

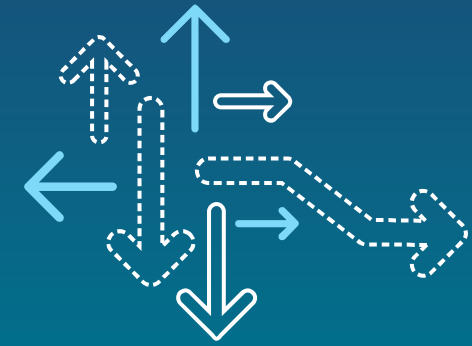

---

# Next steps

---



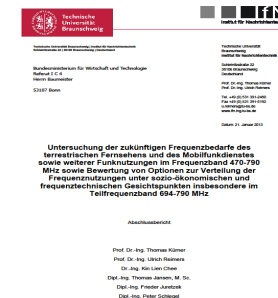
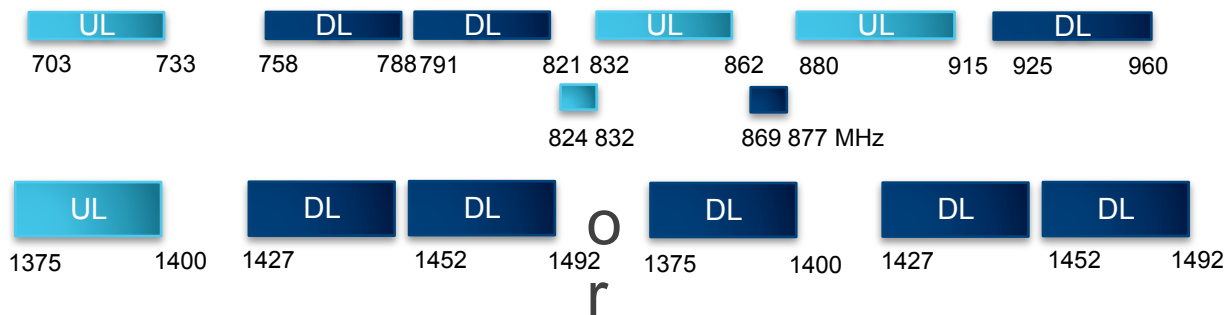

# Spectrum conclusions before WRC-15



- Finalize the band plan in 700 MHz
  - A.I#1.2: harmonized Band Plan for 700 MHz in Europe Middle East and Africa (ITU Region 1)
- Look at different initiatives for new frequency bands below 1 GHz and around 1.4 GHz
  - A.I#1.1: new Spectrum for IMT / Mobile Broadband for 2015-2025 (600 MHz, 1.4 GHz, 3.8 GHz, 4 GHz)
- Describe ASA framework to efficiently release underused spectrum
  - Bring certainties to the incumbent and the licensee

---

# Thank you

Follow us on:  

For more information on Qualcomm, visit us at:  
[www.qualcomm.com](http://www.qualcomm.com) & [www.qualcomm.com/blog](http://www.qualcomm.com/blog)

Qualcomm is a trademark of Qualcomm Incorporated, registered in the United States and other countries.  
Other products and brand names may be trademarks or registered trademarks of their respective owners

