

# Regional Initiatives for Europe

*EUR2 - Development of broadband access and adoption of broadband*

Manuel da Costa Cabral

- 1. Broadband in Portugal**
- 2. Market driven forces**
- 3. Removing barriers**
- 4. Lessons Learned**
- 5. Regional Initiative for Europe**



## 1. Broadband in Portugal

Fixed broadband coverage, 2013

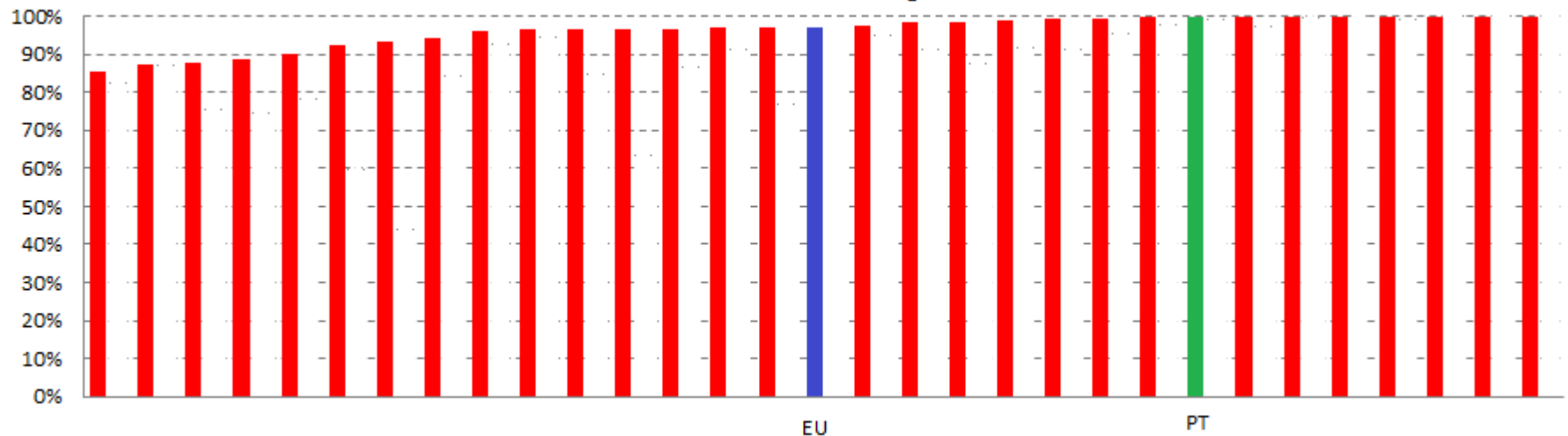

Source: IHS and VVA

Digital Agenda Scoreboard 2014 – European Commission

## Fixed Broadband

Next Generation Access (FTTP, VDSL and Docsis 3.0 cable) coverage, 2013

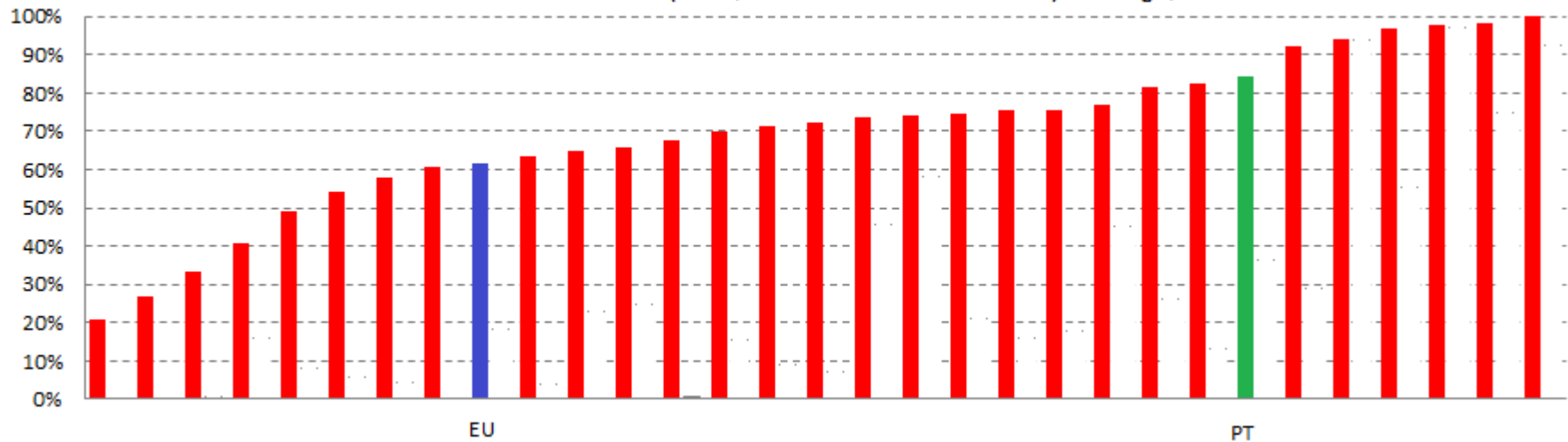

Source: IHS and VVA

Digital Agenda Scoreboard 2014 – European Commission

## Fixed Broadband

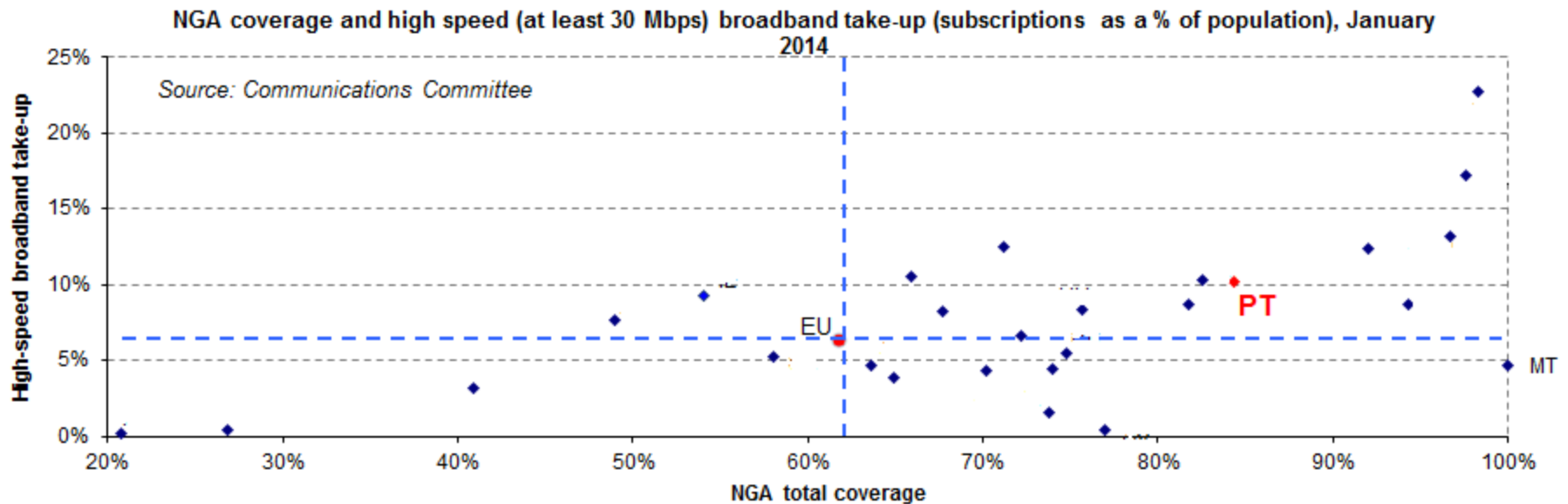

Digital Agenda Scoreboard 2014 – European Commission

## Mobile Broadband

4G (LTE) coverage, 2013

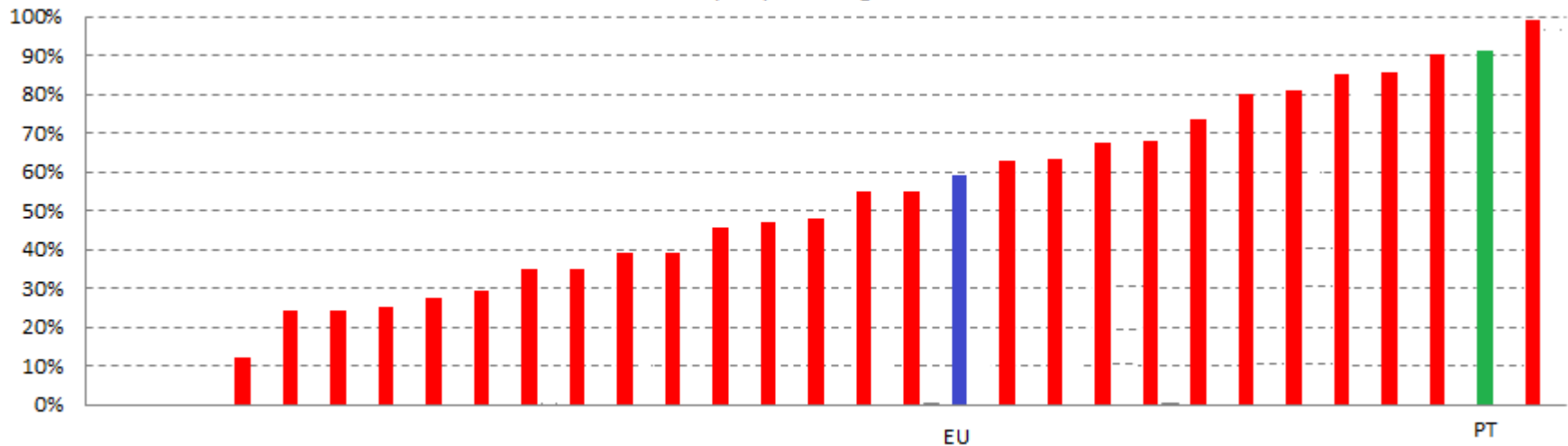

Source: IHS and VVA

Digital Agenda Scoreboard 2014 – European Commission



## 2. Market driven forces



The dynamics of competition in the domestic market has been very important.

- Portugal Telecom spun off its cable television business and, as a result, had to build up a pay television service from scratch;
- Mobile operators have been investing in infrastructure;
- Mobile operators sharing fiber network;
- Merger between the largest cable television operator and the smallest mobile operator.

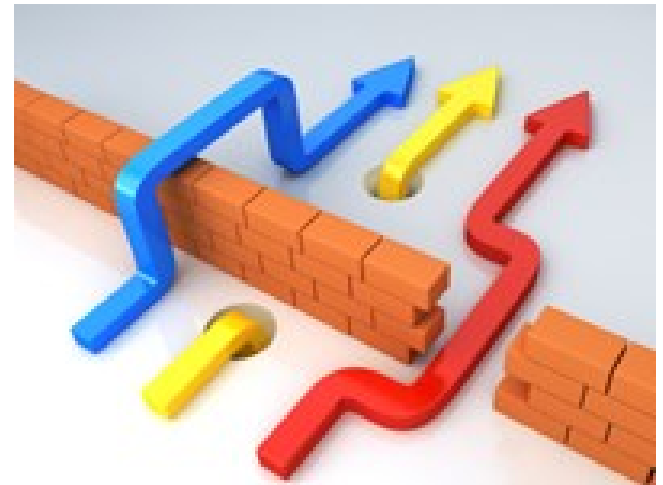

## 3. Removing barriers

- To adopt the legislative acts or others needed to ensure access by all operators, under equal terms, to the network of ducts and remaining relevant facilities from all entities holding this type of underground infrastructure;
- To eliminate barriers to the roll– out of optical solutions in connection with next Generation networks in buildings, including the introduction of the appropriate changes to the technical regulations currently in force (namely ITED and ITUR)



Horizontal Barriers



Vertical Barriers

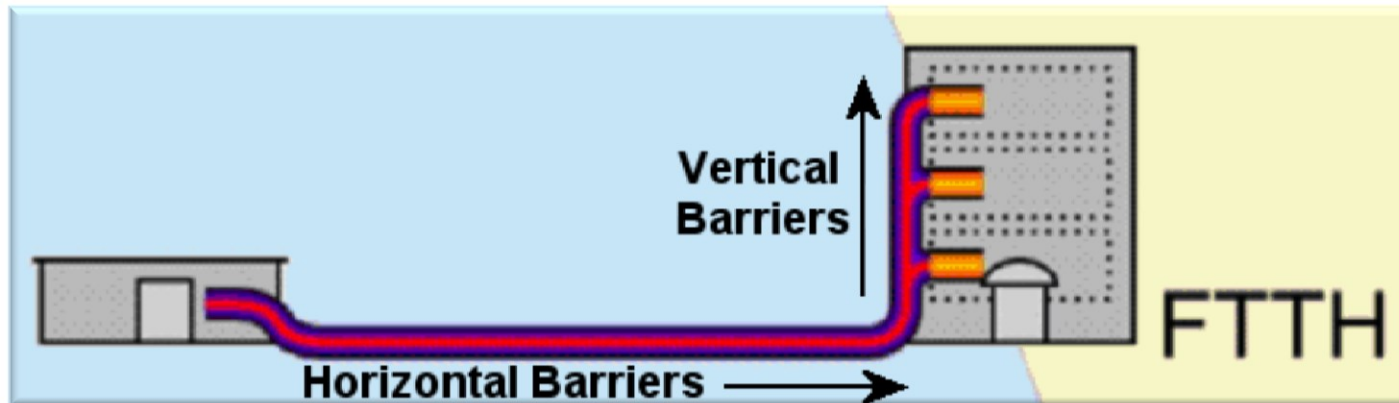



The horizontal barriers are related to the construction of new ducts, as well as difficulties concerning passing fibre in existing ducts to deliver fibre to the buildings.





- **ORAC** - Duct sharing offer (2004);
- **SIC** - Implementation of the centralized information system (DL 123/2009);
- **ITUR** - Manual of Infrastructures for telecommunications in housing developments, urban settlements and concentrations of buildings (DL 123/2009).



- **ORAC** – Reference offer for Access to Ducts
  - The historical operator, was obliged to publish a reference offer for access to ducts (ORAC), which entered in force in July 2006.
  - The reference offer specifies the key operational aspects and processes for enabling duct sharing, namely, request for information on ducts, feasibility analysis on duct occupation, accreditation, physical access, co-ordination procedures, pricing, service level agreements and penalties and is important in fostering the use of the incumbent's duct by other operators.

## ITUR - Infrastructures for telecommunications in housing developments, urban settlements and concentrations of buildings

- Infrastructures must be set up in housing developments and urban settlements:
  - a) Space for the set up of piping, cables, equipment and other devices;
  - b) Piping network or piping for the set up of cables, equipment and other devices.

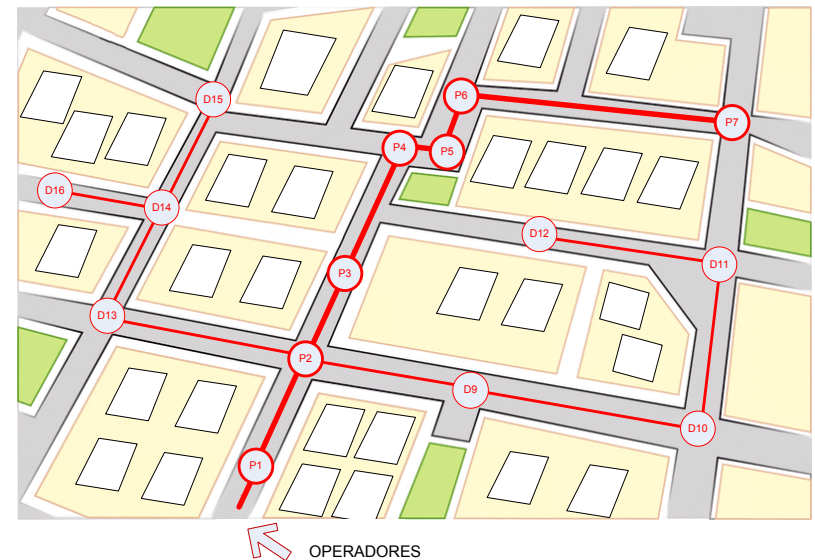





The vertical barriers are related to the obstacles that operators find in entering and install optical cables inside buildings.





- Open access to all buildings by operators;
- Optical cabling shared with multiple operators in all buildings;
- New technical rules and technical specifications to install infrastructures in new and existing buildings (ITED);

### **Infrastructures for telecommunications in buildings (ITED)**

- The following infrastructures must be set up in buildings:
  - a) Spaces for the set up of piping;
  - b) Piping network necessary for the set up of equipment, cables and other devices;
  - c) Cabling systems in copper pair, coaxial cable, for the distribution of radio or television signals, and fibre optic cabling.

## *ITED NGN*

### Manual of Telecommunications Infrastructures in Buildings

#### **Neutral Infrastructure:**

- All operators share the same network in each technology;
- Future proof networks architecture;
- Interfaces precisely defined;
- Churn between operators guaranteed.



## ITED NGN

### Building Flexible Point (Neutral technology):

For each home:

- 1 Coaxial cable;
- 4 Twisted pairs;
- 2 Optical fibres (SM).

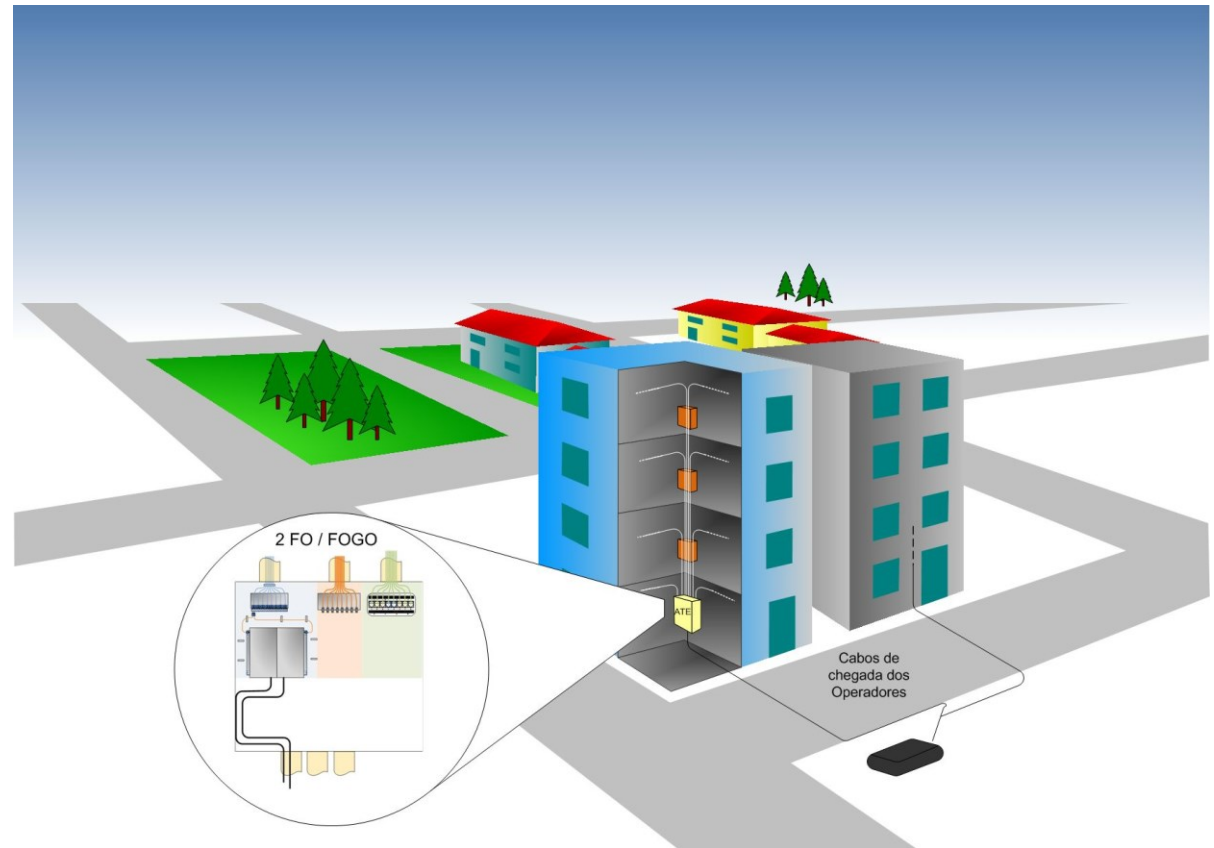

All 3 networks are totally sharable by multiple operators

Fibre to the home...  
And now?



Each home has a Distribution Point where the user sets the configuration of his home network.

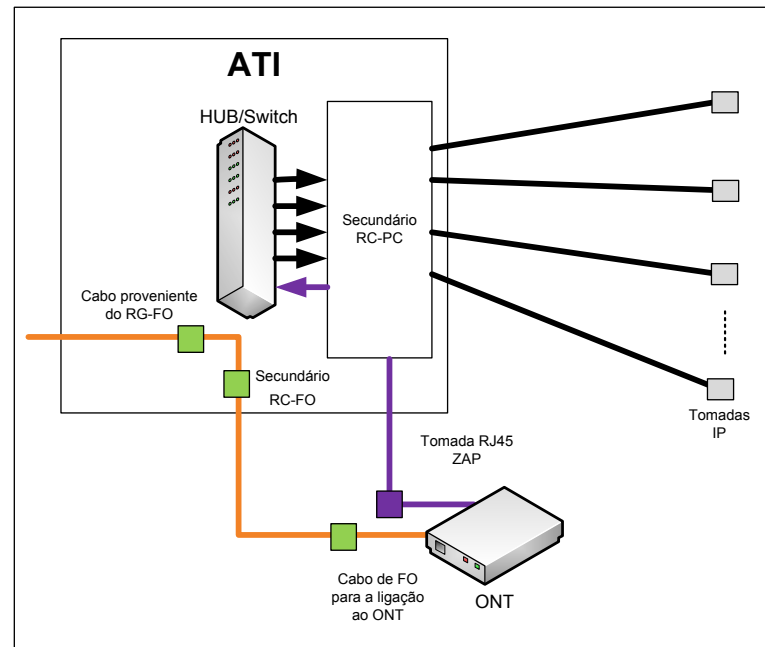

Home wiring is based on metallic cables:

- Twisted Pair (2 outlets per division);
- Coaxial (1 outlet per division);
- Fibre (2 outlets in one division).

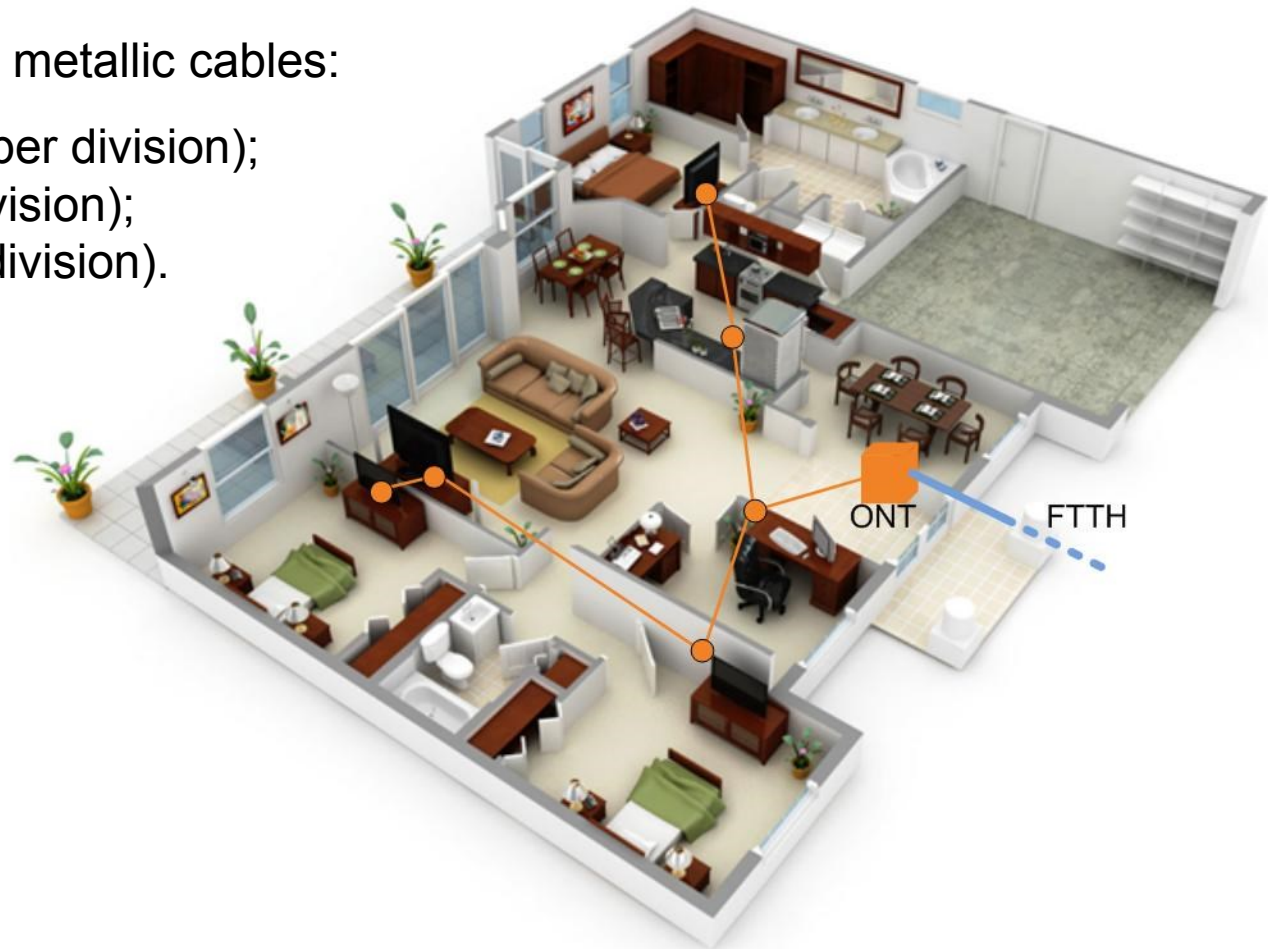



# III. Vertical barriers - remedies

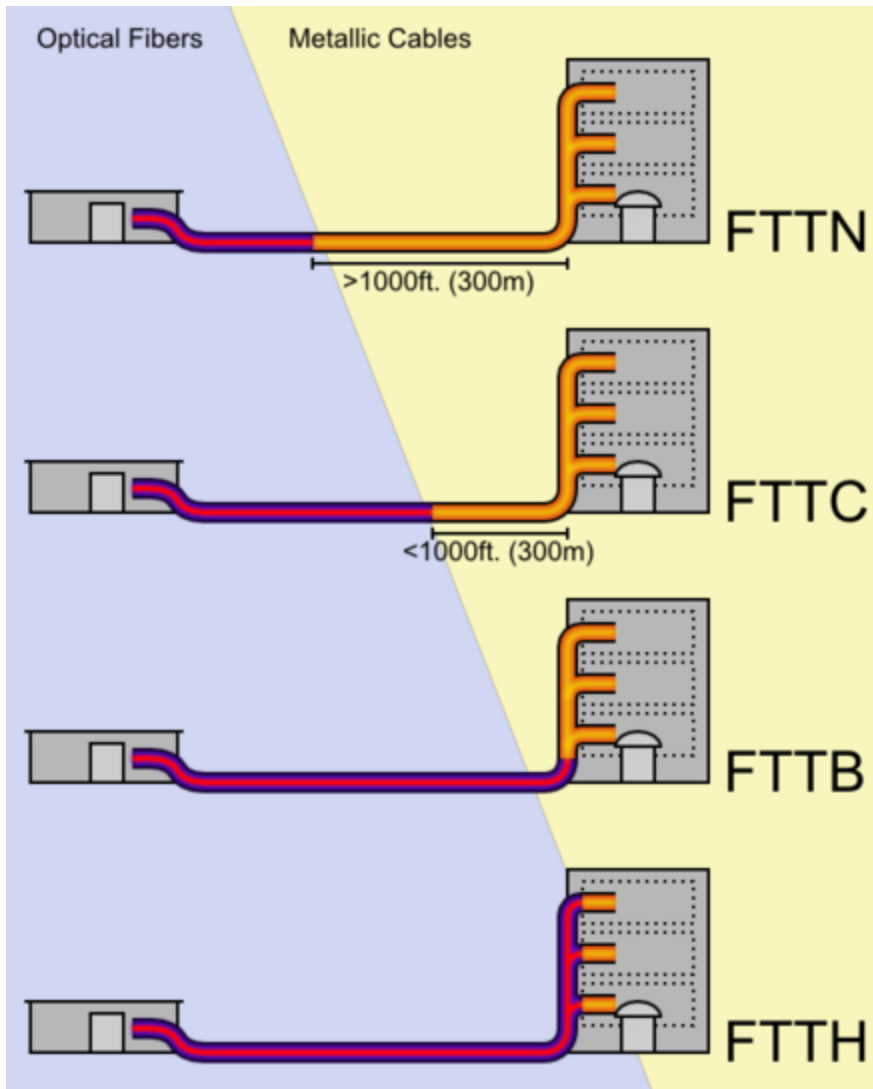

The ITED Building is prepared for FTTN, FTTC, FTTB and FTTH Also for xDSL, Cable and Ethernet services

## ***NGN BUILDING***

- All operators share the network in each technology;
- Future proof networks architecture;
- Digital Terrestrial TV;
- A regime for ITED / ITUR technical staff is applied to all operators, construction companies, designers, installers and training bodies
- Surveillance and monitoring is required

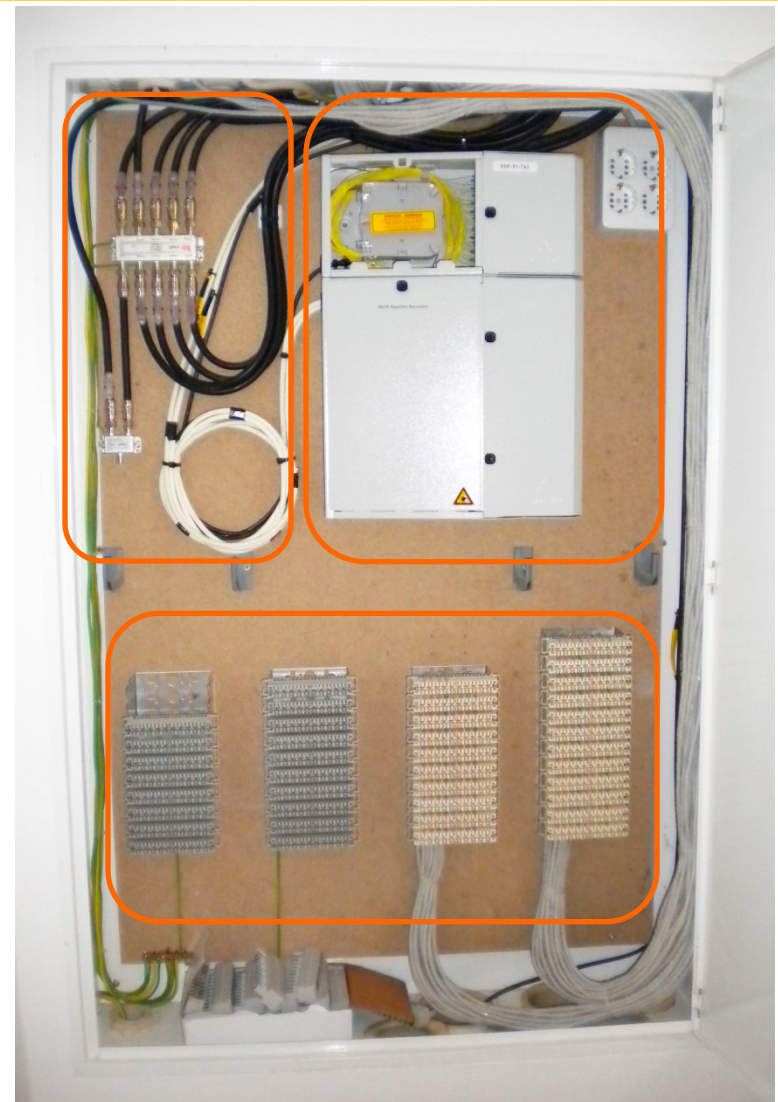



## 4. Lessons learned

- Dynamics of competition in the domestic market is crucial.
- When barriers to the roll-out of optical solutions are found, legislators and regulators play an important role to promote such competition.
- Challenging to find the right balance between regulatory intervention and appropriate incentives for investment.

- Laying down telecom infrastructure is costly and the involvement of several stakeholders (operators, construction companies, designers, installers and training bodies) may be necessary in order to rationalize such investments.
- Pioneering project related to building construction specifications is well received among operators:
  - Reduces duration of installation;
  - Reduces technical difficulties as building specifications are standardized;
  - Technological neutral
  - Churn made easy!
- ITED solution is raising interest in other countries (eg. CPLP and EMERG).



## 5. Regional Initiative for Europe

- Sharing our experience with legislators and regulators of other countries;
- Benefit from the experience of others to improve our decisions and practices.

# Regional Initiatives for Europe

*EUR2 - Development of broadband access and adoption of broadband*