



**Recommendation ITU-R RS.1165-3**  
(12/2018)

**Technical characteristics and performance  
criteria for systems in the meteorological  
aids service in the 403 MHz  
and 1 680 MHz bands**

**RS Series**  
**Remote sensing systems**

## Foreword

The role of the Radiocommunication Sector is to ensure the rational, equitable, efficient and economical use of the radio-frequency spectrum by all radiocommunication services, including satellite services, and carry out studies without limit of frequency range on the basis of which Recommendations are adopted.

The regulatory and policy functions of the Radiocommunication Sector are performed by World and Regional Radiocommunication Conferences and Radiocommunication Assemblies supported by Study Groups.

## Policy on Intellectual Property Right (IPR)

ITU-R policy on IPR is described in the Common Patent Policy for ITU-T/ITU-R/ISO/IEC referenced in Annex 1 of Resolution ITU-R 1. Forms to be used for the submission of patent statements and licensing declarations by patent holders are available from <http://www.itu.int/ITU-R/go/patents/en> where the Guidelines for Implementation of the Common Patent Policy for ITU-T/ITU-R/ISO/IEC and the ITU-R patent information database can also be found.

### Series of ITU-R Recommendations

(Also available online at <http://www.itu.int/publ/R-REC/en>)

Series	Title
<b>BO</b>	Satellite delivery
<b>BR</b>	Recording for production, archival and play-out; film for television
<b>BS</b>	Broadcasting service (sound)
<b>BT</b>	Broadcasting service (television)
<b>F</b>	Fixed service
<b>M</b>	Mobile, radiodetermination, amateur and related satellite services
<b>P</b>	Radiowave propagation
<b>RA</b>	Radio astronomy
<b>RS</b>	<b>Remote sensing systems</b>
<b>S</b>	Fixed-satellite service
<b>SA</b>	Space applications and meteorology
<b>SF</b>	Frequency sharing and coordination between fixed-satellite and fixed service systems
<b>SM</b>	Spectrum management
<b>SNG</b>	Satellite news gathering
<b>TF</b>	Time signals and frequency standards emissions
<b>V</b>	Vocabulary and related subjects

*Note: This ITU-R Recommendation was approved in English under the procedure detailed in Resolution ITU-R 1.*

Electronic Publication  
Geneva, 2018

© ITU 2018

All rights reserved. No part of this publication may be reproduced, by any means whatsoever, without written permission of ITU.

## RECOMMENDATION ITU-R RS.1165-3

**Technical characteristics and performance criteria for systems in the meteorological aids service in the 403 MHz and 1 680 MHz bands**

(1995-1997-2006-2018)

**Scope**

This Recommendation gives the technical characteristics and performance criteria for systems in the meteorological aids service in the 403 MHz and 1 680 MHz bands. All the various MetAids systems are covered: radiosondes, dropsondes and rocketsondes.

**Related ITU-R Recommendations, Reports**

Recommendation ITU-R RS.1263-1 – Interference criteria for meteorological aids operated in the 400.15-406 MHz and 1668.4-1700 MHz bands

Recommendation ITU-R P.528 – Propagation curves for aeronautical mobile and radionavigation services using the VHF, UHF and SHF bands

Recommendation ITU-R SA.1021 – Methodology for determining performance objectives for systems in the Earth exploration-satellite and meteorological-satellite services

**Keywords**

MetAids, radiosonde, rocketsonde, dropsonde

**Abbreviations/Glossary**

AFC	Automatic frequency control
AXBT	Airborne expendable bathythermograph
FM	Frequency modulation
GDPS	Global data-processing system
GFSK	Gaussian frequency shift keying
GMSK	Gaussian minimum shift keying
GOS	Global observing system
GTS	Global telecommunications system
OECD	Organization for Economic Co-operation and Development
PTU	Pressure, temperature and relative humidity
QAM	Quadrature amplitude modulation
RDF	Radio direction finding
RNSS	Radionavigation satellite service
RR	Radio Regulations
WMO	World Meteorological Organization

The ITU Radiocommunication Assembly,

*considering*

- a) that upper-air meteorological measurements carried out by radiosondes are an essential element of the World Weather Watch Programme of the World Meteorological Organization (WMO);
- b) that many defence services deploy radiosonde systems in order to support a variety of operations, independent of the World Weather Watch Programme;
- c) that many radiosonde systems are used for local and regional monitoring of atmospheric pollution conditions and also for tracking the trajectories of hazardous discharges from natural or man-made disasters;
- d) that radiosonde systems operating in the meteorological aids (MetAids) service have unique radiocommunication requirements;
- e) that radiosonde, dropsonde, and rocketsonde systems under MetAids service mainly operate in the frequency bands 400.15-406 MHz (called the 403 MHz frequency band) and 1 668.4 1 700 MHz (called the 1 680 MHz frequency band) with limitations as per the provision No. **5.379E** of the Radio Regulations (RR);
- f) that radiosondes in the MetAids service are carried by ascending balloons launched from land stations or ships, dropsondes deployed from aircraft and carried by a parachute, and rocketsondes lifted into the atmosphere by rockets;
- g) that performance objectives for transmissions to and from radiosondes must be consistent with the attendant functional requirements and with the performance limitations associated with the systems and frequency bands in which the requirements will be fulfilled;
- h) that performance objectives for representative systems operating in the MetAids service are intended to provide guidelines for the development of actual systems that must operate in a frequency sharing environment;
- i) that performance objectives for particular systems may be determined using the methodology similar to that described in Recommendation ITU-R SA.1021;
- j) that performance objectives are a prerequisite for the determination of interference criteria;
- k) that Recommendation ITU-R RS.1263 provides the interference criteria for systems of the meteorological aids service operating in the 403 MHz and 1 680 MHz frequency bands;
- l) that Resolution **205 (Rev.WRC-15)** deals with the protection of the systems operating in the mobile-satellite service in the frequency band 406-406.1 MHz,

*recommends*

- 1** that the technical and operational characteristics in Annex 1 should be considered as typical for meteorological aids in the 403 and 1 680 MHz frequency bands;
- 2** that the performance criteria specified in Table 3 of Annex 1 should be considered when developing interference criteria and conducting sharing studies with other services.

**Annex 1**

## TABLE OF CONTENTS

	<i>Page</i>
Annex 1 .....	3
1 Introduction .....	4
1.1 Daily meteorological operations .....	4
1.2 Monitoring climate change .....	5
1.3 Other users .....	5
2 Characteristics of radiosonde operation .....	5
3 Radio-frequency spectrum used in operations for WMO reporting .....	6
3.1 Results from WMO survey .....	6
3.2 Radio-frequency spectrum used in Western and Northern Europe .....	7
3.3 Radio-frequency spectrum used in North and South America .....	7
4 Operational requirements .....	8
5 Future spectrum requirements .....	8
5.1 Very strong upper winds .....	8
5.2 Manpower efficiency resulting from highly automated systems .....	9
5.3 Issues related to the cost of radiosondes .....	9
5.4 Independence from international NAVAID systems .....	9
5.5 Spectrum congestion .....	10
5.6 Current improvement of spectrum efficiency .....	10
5.7 Error detection/correction .....	10
6 MetAids availability requirements .....	11
6.1 Propagation conditions .....	11
6.2 Critical periods of flight .....	14
6.3 Synoptic operations radiosonde data availability requirements .....	15
6.4 Summary of data availability requirements .....	18
7 Radiocommunication characteristics of current radiosonde systems .....	18
7.1 Transmitter characteristics .....	18
7.2 Receiving systems .....	20
8 Radiocommunication characteristics of dropsonde systems .....	24

8.1	Operational practices for dropsondes .....	24
8.2	Dropsonde system characteristics .....	24
8.3	Dropsonde future plans .....	25
9	Radiocommunication characteristics of rocketsonde systems.....	25
9.1	Operational practices for rocketsondes.....	26
9.2	Rocketsonde system characteristics.....	26
9.3	Rocketsonde descent profile .....	27

## 1 Introduction

### 1.1 Daily meteorological operations

Meteorological aids<sup>1</sup> are mainly used for *in situ* upper air measurements of meteorological variables (pressure, temperature, relative humidity, windspeed and direction) in the atmosphere up to an altitude of 36 km. The measurements are vital to national weather forecasting capability (and hence severe weather warning services for the public involving protection of life and property). The meteorological aids and associated tracking systems provide simultaneous measurements of the vertical structure of temperature, relative humidity and wind speed and direction over the full height range required. The variation of these meteorological variables in the vertical contains the majority of the critical information for weather forecasting. The MetAids systems are the only meteorological observing systems able to regularly provide the vertical resolution that meteorologists need for all four variables. Identification of the heights where sudden changes in a variable occur is vital. Thus, it is essential that continuity of reliable measurements is sustained throughout the ascent of the radiosonde.

The MetAids observations are produced by radiosondes carried by ascending balloons launched from land stations or ships, dropsondes deployed from aircraft and carried by a parachute, and rocketsondes lifted into the atmosphere by rocket and descend under a parachute during data collection. Radiosonde observations are carried out routinely by almost all countries, two to four times a day. The observation data are then circulated immediately to all other countries within a few hours via the WMO Global Telecommunications System (GTS). The observing systems and data dissemination are all organized under the framework of the World Weather Watch Programme of the WMO.

The radiosonde network provides the primary global source of real-time *in situ* measurements. WMO Regulations (Manual on the Global Data-Processing System (GDPS)) require that radiosonde measurements should be made and circulated to all GDPS centres worldwide at national, regional and global levels for numerical weather prediction. The observation stations are required, worldwide, at a horizontal spacing of less than or equal to 250 km, during the first decade of the twenty-first century, with a frequency of observation of from one to four times per day. However,

---

<sup>1</sup> This Recommendation addresses radiosondes, dropsondes, and rocketsondes operated in the meteorological aids (MetAids) service. The term MetAids is used when the discussion applies to all three types of systems. The specific system name (radiosonde, dropsonde and rocketsonde) is used when the discussion applies to one or two of the specific types of systems.

the numerical weather prediction models for small scale meteorological phenomena (e.g. thunderstorm, local winds, tornadoes) and environmental emergencies will actually require local upper air observations every one to three hours at a horizontal resolution from 50 to 100 km. Observations are to be provided from a variety of observing systems, chosen according to the needs of the national administration, including MetAids measurements, wind profiler radar measurements or satellite measurements.

The radiosonde observations are essential to maintain stability in the WMO Global Observing System (GOS). Remotely sensed measurements from satellites do not have the vertical resolution that is available from radiosondes. Successful derivation of vertical temperature structure from these satellite measurements usually requires a computation initialized either directly from radiosonde statistics or from the numerical weather forecast itself. In the latter case, the radiosonde measurements ensure that the vertical structure in these forecasts remains accurate and stable with time. In addition, the radiosonde measurements are used to calibrate satellite observations by a variety of techniques. Radiosonde observations are thus seen to remain absolutely necessary for meteorological operations for the foreseeable future.

## **1.2 Monitoring climate change**

Changes in atmospheric temperature and ozone have been observed over the past 20 years, many of the largest changes taking place at heights between 12 and 30 km above the surface of the Earth. Routine daily radiosonde observations to heights above 30 km identify the distribution in the vertical of the changes that occur and hence allow the causes of the changes to be evaluated. Ozonesonde measurements to similar heights determine the vertical distribution of the ozone depletion that now appears to be occurring in both Southern and Northern Hemisphere winter and spring. Many countries fly ozonesondes at least three times per week during these seasons to monitor developments.

Successful sampling of changes in climate requires the use of radiosondes with established systematic error characteristics. The requirement for continuity in the time series of upper air measurements worldwide means that new radiosonde designs are only introduced into operation after several years of intensive testing, that occurs both in the laboratory and in the free atmosphere.

## **1.3 Other users**

Other MetAids systems may be deployed independently of the main civilian meteorological organization by national research institutes and other users. Specific investigations will include environmental pollution, hydrology, radioactivity in the free atmosphere, significant weather phenomena (e.g. winter storms, hurricanes, thunderstorms, etc.) and investigation of a range of physical and chemical properties of the atmosphere. This use is not decreasing with time, since with modern automation it is now much easier to successfully operate mobile systems and shipboard systems without highly skilled operators and a large amount of supporting equipment. MetAids operations have to accommodate these users, and this expands the radio-frequency spectrum required for MetAids operations. This is particularly critical when launch sites of these other users are within 150 km of the meteorological organization launch sites.

## **2 Characteristics of radiosonde operation**

While many radiosonde operations are normally conducted on a specific schedule, operations can be conducted at any time of the day or night in response to specific operational requirements, atmospheric conditions, or testing requirements. Synoptic radiosonde observations are carried out worldwide to provide the observations necessary for daily weather forecasting. The standard observations are nominally performed at 0000 and 1200 UTC, but the actual launch times vary

according to national practice and in some cases will be at least three-quarters of an hour earlier than the nominal time. The launch may also be up to two hours later than nominal if there are problems with preparation of the radiosonde prior to flight, if local air traffic regulations limit launch times or if there is a malfunction during the initial flight. Intermediate observations at 0600 and 1800 UTC are also performed routinely in several countries. Additional radiosondes and dropsondes are launched periodically by synoptic operators, often from temporary sites using mobile systems, in response to abnormal weather or requirements for testing. Non-synoptic flights are scheduled to meet operational requirements.

The radiosonde networks are implemented and operated by national meteorological services in compliance with recommended practices and procedures internationally agreed upon by WMO. The current number of radiosonde stations reporting regularly is about 650. About 500 000 radiosondes are routinely launched in a year in association with the WMO network and it is estimated that about another 350 000 radiosondes are used for defense use and specialized applications.

### **3 Radio-frequency spectrum used in operations for WMO reporting**

#### **3.1 Results from WMO survey**

Table 1 presents estimates of the radio frequency use at synoptic radiosonde stations reporting information daily for WMO meteorological data exchange. This information is based on the WMO Catalogue of Radiosondes and Upperwind Systems in use by Members. The survey results are grouped into regions to illustrate the variation in use worldwide. More detailed information is available from the WMO Catalogue of Radiosondes and Upperwind Systems in use by Members. Proposals for band segmentation would have to take account of the fact that frequency bands internationally allocated to MetAids on a primary basis are not available to this service in all countries. For instance, in Australia, at least half of the 403 MHz frequency band is currently not available for MetAids operations.

Use of the two main frequency bands allocated to MetAids (403 and 1 680 MHz frequency bands) varies widely in different parts of the world. Systems operating in the 1 680 MHz frequency band have been operated in the United States of America but are being replaced by 403 MHz systems. 1 680 MHz systems are operated primarily in Japan and China. These systems are providing synoptic data to the WMO GTS. Within these countries other users primarily use the 403 MHz frequency band for non-synoptic operations. Within Europe, the 403 MHz frequency band is used heavily to support synoptic radiosonde operations. Russia and some countries with cooperating arrangements use frequencies around 1 780 MHz for radiosonde operations. Many of the countries using 1 780 MHz radiosondes have transferred their operations to one of the two main allocated frequency bands in order to take advantage of commercially available equipment.



TABLE 1

**Summary of radio frequency use for radiosondes for daily synoptic operations<sup>2</sup>**

Region	Total number of sites	Total number of active sites	Number of silent sites <sup>(1)</sup>	Number of active sites using 400 MHz	Number of active sites using 1 680 MHz	Number of active sites using 1 780 MHz <sup>(2)</sup>
Europe and Western Russia	192	154	38	112	28	14
Asia and Eastern Russia	471	288	183	95	158	35
Africa	237	60	177	58	2	0
North America	277	148	129	58	90	0
South America and Antarctica	114	86	28	84	0	2
Australia and Oceania	191	90	101	81	9	0
Ship systems	166	70	96	67	3	0
Overall	1648	636	752	555	290	51

<sup>(1)</sup> Silent sites are locations where operations have been suspended, but the site may become operational again in the future.

<sup>(2)</sup> The 1 780 MHz band (1 774-1 790 MHz) is used in a few countries around the world but is not allocated to the meteorological aids service in the RR.

### 3.2 Radio-frequency spectrum used in Western and Northern Europe

In Western and Northern European areas the radiosonde network is dense, with stations operated for routine meteorological operations, environmental monitoring and a variety of defence operations. Most of the radiosondes are operating in the 403 MHz frequency band. Although some analog systems are still in use the majority of these radiosondes are now digital. In the near future it is expected that the analog systems that are still in use will be replaced by digital systems. Harmonized European standards covering the essential requirements for spectral mask and transmission power have been developed for all digital radiosondes used in Europe. There is no harmonized standard for analogue radiosondes and their use is based on national approval.

### 3.3 Radio-frequency spectrum used in North and South America

The civilian weather service in the United States of America had been the main user of the 1 680 MHz frequency band but is moving radiosonde operations to the 400.15 to 406 MHz frequency band. Other users within the United States of America also utilize the 403 MHz frequency band. In addition large numbers of 403 MHz systems are deployed by the non-synoptic users. Additional systems are used by universities or other United States agencies.

<sup>2</sup> Data for this table were extracted from the WMO VOLA Legacy Report dated 05-18-2016.

#### 4 Operational requirements

Apart from accuracy, the chief features required in radiosonde design are reliability, robustness, small weight, small bulk, small power consumption, efficient use of the spectrum and frequency stability. Since a radiosonde is generally used only once, it should be designed for production at low cost. Ease and stability of the sensor calibration are also important factors. A radiosonde should be capable of providing data over a radio link range of at least 200 km and operating in a temperature range from  $-90^{\circ}\text{C}$  to  $+60^{\circ}\text{C}$ . Since the voltage of a battery varies with time and temperature, the radiosonde must be designed to accept the variations without exceeding the accuracy and radio-frequency drift requirements. The associated ground equipment should not be unduly complicated or require frequent highly skilled maintenance. It is preferable, however, to keep the radiosonde itself as simple as possible, even at the expense of complication in the ground equipment, since failure of the latter is more readily corrected and since the costs of expendable flight equipment should be kept to a minimum.

The ascent time of a full radiosonde flight is 90 to 120 min, and the descent time is about half of the ascent time if a parachute is used. The radiosonde is usually still transmitting while descending. The maximum range of the proper reception of the radiosonde is in the range of 200 to 350 km, depending on system design. The ascent speed is about 5 m/s and the trajectory depends on the prevailing wind conditions. In general, within an area of radius about 400 to 650 km around the radiosounding ground station the same downlink frequency cannot be reused. In high-density areas, more than ten radiosonde operators are located within the effective area of one radiosonde.

In Western and Northern European areas the radiosonde network is dense. Meteorological, environmental monitoring, research and defence activities force related users to share the frequency band with the synoptic observations. Coordination between radiosonde operators is required to prevent interference between the radiosondes of different stations.

#### 5 Future spectrum requirements

It is expected that radiosonde operations will need to continue in both the 403 and 1 680 MHz frequency bands. It is important to recognize that though MetAids do have an allocation greater than 30 MHz in 1 668.4-1 700 MHz, much of that frequency band cannot be used by MetAids due to incompatibility with other radio services allocated in the frequency band. In many parts of the world, only the sub-band 1 675-1 683 MHz is available for MetAids operations. The following factors are likely to influence the national choice of the frequency band to use.

##### 5.1 Very strong upper winds

The average strength of upper winds varies with geographical location. Japan and many of the coastal areas of North-West Europe have much stronger winds on average between the surface and heights of 16 km than much of the rest of the Northern Hemisphere. The situation becomes more serious for radiosonde operations in North-West Europe since at higher latitudes the winds between 16 and 30 km may often be even stronger than in the lower layers for much of the winter. Thus, the radiosondes must regularly be tracked at ranges well in excess of 150 km at very low elevation angles. These strong wind conditions can persist for several weeks and significant gaps will appear in climate records if the radiosonde data at upper levels cannot be received during this time.

Wintertime observations are very important for ozone depletion investigations and it is vital that as much information as possible is obtained at upper level from the radiosondes carrying ozone sensors used in these conditions. For this reason, the superior reception provided at 403 MHz is considered essential for radiosonde operations in locations that have high winds aloft for long periods of time. This is true whether NAVAID or primary radar tracking is used to measure the upper winds.

Therefore, for sites which regularly experience high wind speeds, the use of the 403 MHz frequency band is preferable for two reasons. First, the propagation characteristics of 403 MHz produce greater link reliability at long distances. Second, multipath is a limitation to radiotheodolite accuracy at elevation angles near the horizon. Thus use of a RNSS receiver on the radiosonde is essential for accurate wind measurements in these harsh conditions.

## **5.2 Manpower efficiency resulting from highly automated systems**

In the past, a large number of national weather services around the world moved to NAVAID windfinding (mainly Loran-C) for MetAids operated in the 403 MHz frequency band, to improve the manpower efficiency of their operations. Systems operated in the 403 MHz frequency band are typically easier to operate and are less difficult to maintain. The additional cost of the NAVAID windfinding radiosonde was outweighed by the large efficiency savings associated with single-man operations and major reductions in maintenance to the ground system.

However, RNSS-based radiosondes are now being produced that operate in both the 403 MHz and 1 680 MHz frequency bands. These radiosondes offer advantages that had previously only be available in the NAVAID-based radiosondes operated in the 403 MHz band.

Operation of the conventional terrestrial NAVAID systems, such as LORAN-C, ceased between 1997 and 2001. Continued use of LORAN-C radiosondes is possible in areas of the world where LORAN-C operations will continue.

## **5.3 Issues related to the cost of radiosondes**

The major limitation of the radiosonde observation in the worldwide network is the cost. In the Organization for Economic Co-operation and Development (OECD) countries, the cost of the radiosonde is about one fourth of the total radiosonde observation costs. The cost structure is noteworthy different in developing countries, where the cost of the radiosonde is the most important element. As meteorological data requirements are global, some developed countries are donating systems and part of the radiosondes for some developing countries with a view to sustained upper-air observations. There is therefore a strong requirement for keeping the radiosonde price as low as possible in order to ensure the continuation of the observations vital to operational meteorology, including its aspects related to the protection of life. In the total cost of the radiosonde the sensors and wind finding represent the major part, whereas the transmitters are intentionally kept as simple as possible, hence maintaining a low total price. Transmitter costs represent about 15-35% of the current radiosonde electronic equipment costs.

Use of the 1 680 MHz frequency band is desirable in some countries where the occurrence of high wind situations is low and/or there is a concern over the cost of using RNSS-based radiosondes in the 403 MHz frequency band. The 1 680 MHz frequency band offers the ability to use radio direction finding to measure winds rather than a higher cost GPS radiosonde. Radiosondes used for meteorological operations with radiotheodolites or primary radars are the most basic design, leading to the lowest cost per unit. Though the procurement of a more complex ground station results in a higher initial cost, there may be cost savings realized in the yearly operating costs when large numbers of radiosondes are procured and manpower costs are not critical.

## **5.4 Independence from international NAVAID systems**

Some countries may also have a national requirement for upper air sounding systems to be capable of operation independent of international NAVAID systems. International NAVAID systems may not be available during times of emergency. In that situation, use of radiotheodolites in the 1 680 MHz frequency band or primary radars in the 403 MHz frequency band are viable options.

## 5.5 Spectrum congestion

In parts of the world a single frequency band would be insufficient to serve the spectrum requirements of MetAids users. In these areas, both frequency bands are used to provide sufficient spectrum for synoptic operations, defence operations, atmospheric research and other applications. Recent developments in the design of radiosondes have resulted in reducing the operational bandwidth of a radiosonde by a factor of 10, or more, thereby easing the congestion issue.

## 5.6 Current improvement of spectrum efficiency

One way to improve the spectrum efficiency for radiosondes is to develop the use of digital telemetry. The advantages of such systems are mainly lower occupied bandwidth that allows higher simultaneous use of the spectrum by radiosondes. The introduction of an ETSI standard for digital radiosondes (Type B in Table 4) specifies the frequency drift to be no more than  $\pm 20$  kHz with occupied bandwidth of 200 kHz. Newer radiosondes have improved these specification even more so, reducing the frequency drift to less than  $\pm 5$  kHz. In some designs the frequency drift has been reduced to  $\pm 2$  kHz and the occupied bandwidth to 12 kHz.

Some countries continue to use LORAN-C as the windfinding method, because the cost is lower than with RNSS. Extremely dense network operation (i.e. 100 km spacing) will be difficult due to the large bandwidth of LORAN-C radiosondes.

Other regions of the world that use very broad-band radars for windfinding are being encouraged by the WMO to implement narrow band systems because of the need to share the radio spectrum with other systems.

1 680 MHz frequency band systems have not been used in networks with such close spacing and the equivalent developments in transmitter stability have not yet been required of the major suppliers. Thus, some improvement in efficiency of spectrum use is possible in this frequency band in parts of the world requiring more than approximately 8 MHz, given that the changes can be introduced on a time-scale that does not lead to a significant cost increase in the radiosondes supplied.

Any proposal for band segmentation would have to take account of the fact that frequency bands internationally allocated to MetAids on a primary basis are not available to this service in all countries. For instance, in Australia, at least half of the 403 MHz frequency band is currently not available for MetAids operations.

## 5.7 Error detection/correction

The spectral efficiency of digital MetAids systems has been improved through improvements in frequency stability, bit-error rate (BER) performance and lower transmitter power. BER performance has been improved through the use of forward error correction (FEC). Coding adds bits to the data at the transmitter, which are used in the reception for error detection; e.g. block coding, more specifically Reed-Solomon (RS) coding. The RS codes are widely used in today's digital communications like in compact disks and mobile and satellite communications. The bit error correction code improves the telemetry link performance.

The RS code is specified in the form  $RS(n, k)$ , where  $n$  is the length of the codeword and  $k$  is the number of the data symbols. The encoder takes  $k$  data symbols of  $s$  bits and adds a parity symbol to make a code word of the length  $n$ . There are  $n-k$  parity symbols of  $s$  bits. In general the maximum codeword length can be calculated from  $n = 2^S - 1$ . A RS decoder can correct up to  $t$  symbols that contains errors in a codeword, where  $2t = n - k$ . Use of RS coding can provide on the order of 5 dB link performance improvement.

## 6 MetAids availability requirements

The radio link unavailability is the main cause of data unavailability apart of the radiosonde failure or premature balloon rupture, which may result in a repeated sounding. There are two main causes to the degradation of the radio link availability, propagation conditions and interference.

Unlike telecommunication systems for which unavailability is statistically spread over the entire operational duration, unavailability of radiosonde systems is mainly concentrated in the last portion of measurements when the radiosonde is at its highest distance above the ground and normally at its greatest slant range from the receiver.

The link budget of the radiosonde is mostly controlled by the distance between the radiosonde and the receiver which, in general, increases as the altitude increases. Any reduction of the radiosonde link availability for any reason (e.g. interference) would mainly impact the high altitude measurements that represent a critical part of the collected data (that would be lost due to non-redundancy of the transmission) and hence would limit de facto the operational range of radiosondes.

Radiosonde systems perform *in situ* measurement of the atmospheric pressure, temperature and relative humidity (PTU). The wind speed and direction is determined using either a NAVAID method or radio direction finding (RDF) measuring the azimuth and elevation angle of the radiosonde in respect of the receiving antenna.

For 1 680 MHz frequency band radiosondes, signal losses of greater than 10 s will generally cause loss of ground receiver tracking. A radiosonde whose track is lost will only rarely be re-acquired so all information from the flight is lost even if the interfering signal goes away. The radio receiver will track the strongest amplitude signal in its instantaneous bandwidth.

### 6.1 Propagation conditions

Recommendation ITU-R P.528 relates to propagation curves for aeronautical mobile and radionavigation services using the VHF, UHF and SHF bands. In particular, propagation conditions in the 300 and 1 200 MHz are provided that compare reasonably well with field tests performed respectively in the 403 and 1 680 MHz frequency bands.

Figures 1 and 2 provide extrapolations of transmission losses curves from Recommendation ITU-R P.528 to the specific case of radiosondes under the following assumptions:

- 97% time availability (formula from Recommendation ITU-R P.618 has been used to extrapolate from 95% availability as given in Recommendation ITU-R P.528);
- continental temperate climate;
- maximum slant path distance of 300 km;
- antenna height scenarios A, C and E corresponding to a receiving antenna of 15 m and transmitting antenna height of respectively 1 000, 10 000 and 20 000 m;
- respectively 2.6 and 2.9 dB additional attenuation in, respectively, the 403 MHz and 1 680 MHz frequency bands, to take into account the difference in frequency compared to those described in Recommendation ITU-R P.528.

FIGURE 1  
Transmission losses for 97% of the time in the 403 MHz band

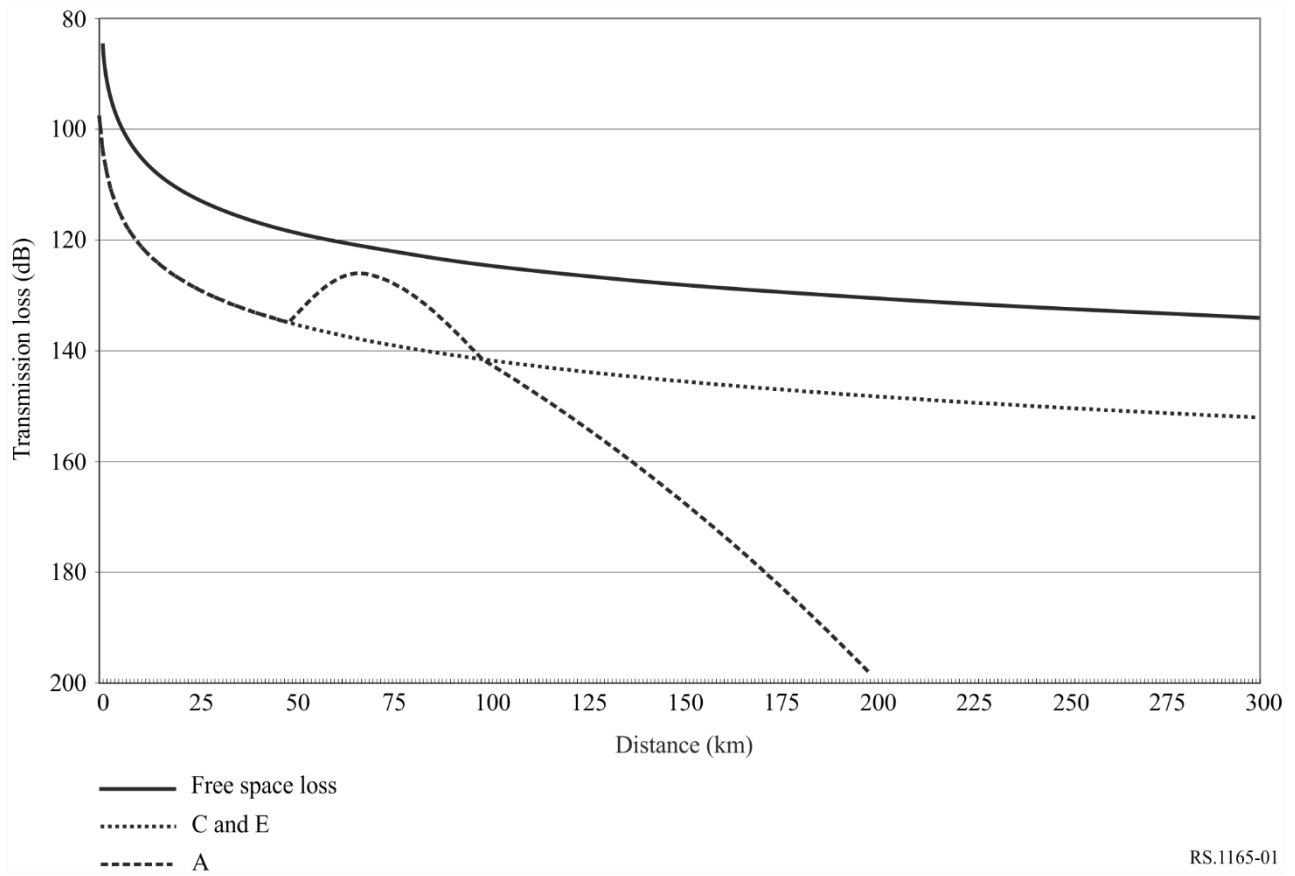
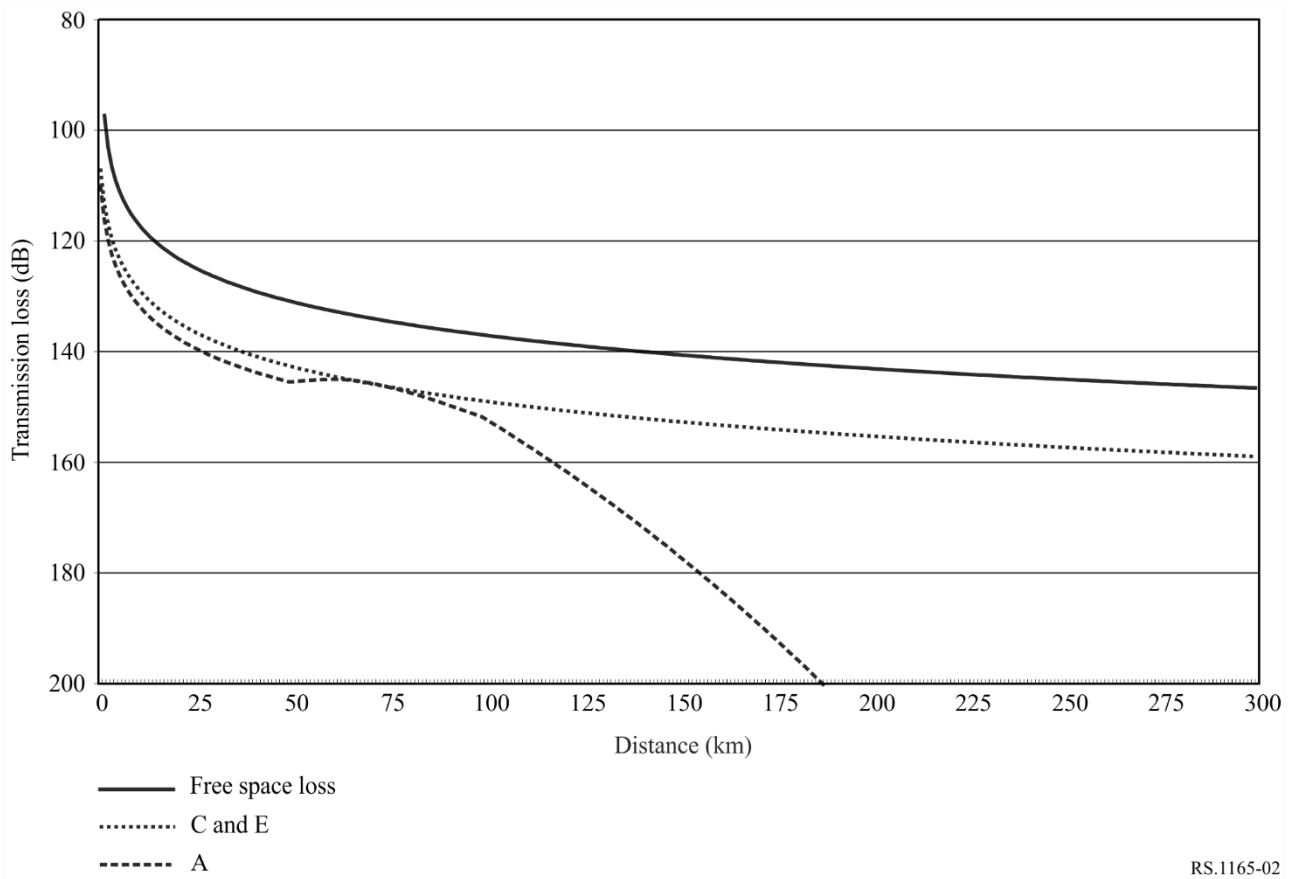

FIGURE 2  
Transmission losses for 97% of the time in the 1 680 MHz band



RS.1165-02

It can be noted from these curves that, in the range of distance representative of radiosonde operations, curves C and E are similar. Also, for curve A corresponding to a radiosonde height of 1 000 m, similar transmission losses occur up to about 50 km whereas, at higher distance, a sensible variation can be seen. However, it is more than likely that, at 1 000 m height, a radiosonde would be at a slant path distance lower than 50 km, which means that, for the two frequency bands, the propagation curves related to this radiosonde height is similar than the one for higher heights, as on the blue curve.

On this basis, Figs 3 and 4 hence provide the necessary margin for radiosonde operations with a 95% availability, representing the difference between the free-space loss curves and the transmission loss curve.

FIGURE 3

Necessary margin for 97% of the time in the 403 MHz band

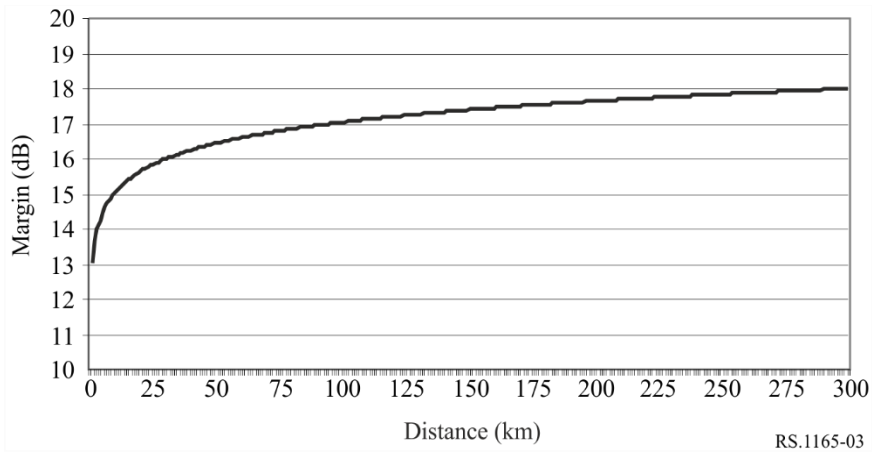
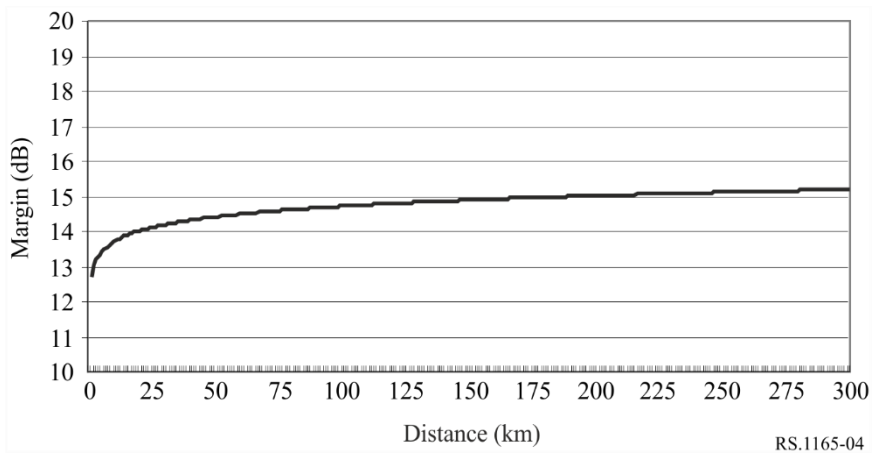

FIGURE 4

Necessary margin for 97% of the time in the 1 680 MHz band



## 6.2 Critical periods of flight

In general there are periods of time in all radiosonde flights where data may be more important than other periods of time. But these time periods cannot be specified in terms of time or altitude. The example in Fig. 5 was taken from the WMO/ITU Handbook “Use of Radio Spectrum for Meteorology” (edition 2002). It provides a plot temperature and humidity from a radiosonde flight. While data reception is important throughout the flight, data loss during an abrupt change (shown in the circles in Fig. 5) in temperature, humidity or wind can have a significant impact on forecast capabilities since that particular transition point cannot be accurately determined. For interference studies, the entire data profile should be assumed to be equally important.



FIGURE 5  
An example plot of a radiosonde temperature and humidity profile

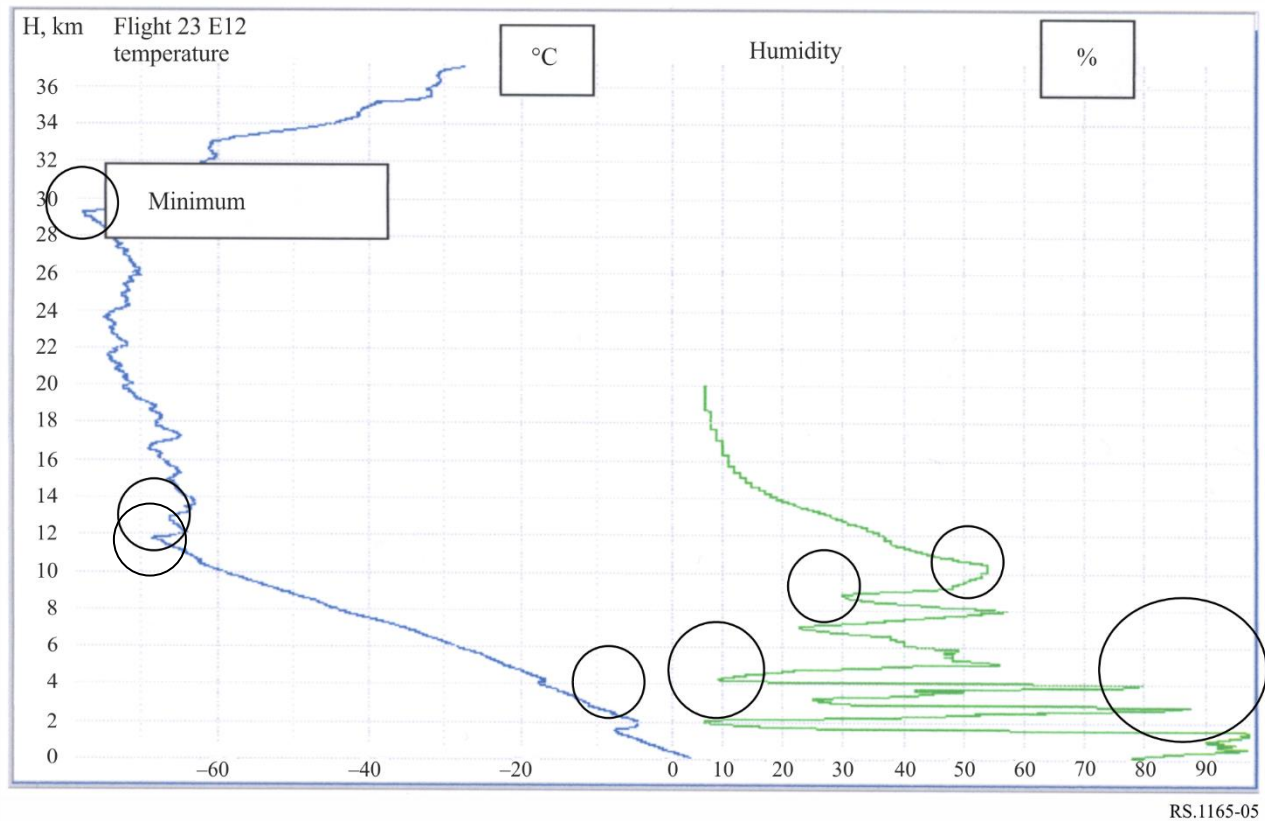

RS.1165-05

### 6.3 Synoptic operations radiosonde data availability requirements

Data availability requirements even within the synoptic networks vary. While other requirements may exist which are established by individual meteorological services, four different categories can be established for this Recommendation. The first category includes all radiosonde systems operated in the 403 MHz frequency band. These are represented by Systems A and B in § 7. The second category is newer digital radiosondes operated in the 403 MHz frequency band represented by C through F in § 7, the third category is older radiosonde systems operated in the 1 680 MHz frequency band. Systems that fall in this category are Systems C and D in § 7. The fourth and final category is new systems that are being deployed in the 1 680 MHz frequency band. System G in § 7 falls in this category.

#### 6.3.1 Radiosonde systems operated in 403 MHz band

The requirements for systems operated in the 403 MHz band are somewhat different.

For analogue radiosondes operated in the 403 MHz band, a maximum limit of 4 min is acceptable for periods of missing pressure, temperature, humidity and wind data. During these periods of missing data the radiosonde processing system will interpolate values. Once the period of missing data exceeds 4 min, the data is then deemed to be missing and data during these periods are not used in any products. Assuming a 120 min flight, these 4 min of unavailable time transfer to a 97% required link availability. The system uses an additional criterion if the period of missing RNSS wind data exceeds 30 min from the surface a new flight might be scheduled. Data availability is the same importance across all levels throughout the flight. After examining a sample of radiosonde data in approximately 65 000 flights, the data availability for pressure, temperature, humidity and wind data is 98.5%.

For digital radiosondes, operating in the 403 MHz frequency band, the data availability requirements are as follows:

- no data loss is acceptable during launch of radiosondes (<100 m);
- for wind velocity data:
  - from 100 m to 3 km above the surface, the data availability must be at least 97%;
  - from 3 km to the end of the flight the data availability must be at least 95%;
- for pressure, temperature, humidity and wind data the availability must be at least 96% for 120 min of flight;
- in addition, continuous data loss of more than 5 min is unacceptable.

At this time the vast majority of users with operations in the 403 MHz frequency band have moved from using the older analogue radiosondes to the newer digital models. Finally, as a summary, it appears that data availability requirement for both analogue and digital radiosondes systems in the 403 MHz frequency band is 97%.

### 6.3.2 Older radiosonde systems operated in the 1 680 MHz frequency band

Table 2 lists the proposed radiosonde link availability requirements that apply to the older radiosonde systems that operate in the 1 680 MHz frequency band. All limits within the data loss column must be met in order to meet the objective. The numbers are not cumulative; each requirement applies to only the time period specified. In addition to the requirements of Table 2, missing and/or rejected pressure or temperature data must not occur for more than three consecutive minutes at any point in the flight.

TABLE 2

#### Synoptic operations performance objectives of radiosondes as used in North America

Flight time (min)	Maximum data loss for no more than 2% of the soundings (per site, per month) <sup>(1)</sup>
0-120 (entire flight)	15 min (12.5%)
0-5	60 s (20%)
5-15	2 min (20%)
15-30	3 min (20%)
30-60	6 min (20%)
60-120	12 min (20%)

<sup>(1)</sup> Soundings that fail to meet the 2% requirement are considered failed flights and will necessitate a second release if the failure determination is made within 30 min after launch. Flights which do not meet the requirement after the 30 min time are classified failures.

The specified data availability objective is for data loss from all sources (interference, operator error, equipment failure, radiosonde failure and sensor data error). For the period covering the end of the flight (60-120 min), a maximum of 20% data loss may occur. Furthermore, if a flight is not flown to the 120 min completion point, it is also classified a failure. Many factors may reduce a flight length, including interference. Interference will typically cause loss of receiver system lock on the desired signal. If the signal is not reacquired in sufficient time (approximately 1 s or less), the receiver automatic frequency control (AFC) will retune the receiver to another signal of sufficient strength to achieve receiver lock. In RDF systems, the problem is further aggravated by the RDF

antenna with a small antenna beamwidth losing the movement of the radiosonde. For this particular system, loss of the flight may occur with link losses greater than 0.8 s.

### 6.3.3 Newer systems operated in the 1 680 MHz frequency band

In recent years radiosondes operating in the 1 680 MHz frequency band have taken advantage of newer technology to improve the RF characteristics and performance of radiosonde systems. These changes were needed to increase the data availability and accuracy for use in more complex forecast models sensitive to significant losses of data. One example system was designed with an availability objective of 98%. Testing has shown that this system meets this availability requirement. As with the older systems, the availability value applies to all sources of lost data. The maximum 2% unavailability must be apportioned between all the sources of data loss, including link failure due to fading and interference.

In the 1 680 MHz frequency band, radiosonde systems are being deployed with other characteristics and other data availability requirements. WMO has identified two additional sets of requirements that should be considered.

The first new requirement applies to a radiosonde system made up of Radiosonde Type F and Receive System F. The data availability requirement is stated as:

- All radiosondes shall not lose more than a total of 4 min of meteorological data during a 120 min flight of a radiosonde rising at a rate of  $300 \pm 50$  m per min to a slant range of 250 km. For flights of less than 120 min due to balloon burst or excess range, the allowable total data loss shall be the ratio of the actual flight time in minutes divided by 120, multiplied by the maximum data loss specified herein for thermodynamic data or wind velocity and radiosonde position data.
- In addition, for data loss in small segments, the system shall not lose more than 15 s of pressure, temperature, relative humidity, GPS position or wind velocity in any period of 5 min of flight time. A failure of any of these requirements results in an unsuccessful flight.

The second requirement that was identified by the WMO applies to a system not referenced in this Recommendation. This system is vulnerable to data loss during the initial phase of ascent up to 1 km (i.e. ~200 s after release), where angular velocity of radiosonde motion under windy conditions and unfavourable geometry may be too high for the successful tracking in the presence of interference. This may result in poor or missing wind data for the boundary layer. Above 1 km, missing of two or more standard isobaric levels (~10-15 min) is considered as unacceptable data loss and results in termination of data processing. Gaps in profiles larger than 20 hPa should be marked as missing. From practical experience, under normal conditions, the level of data loss for this system is negligible for both telemetry and tracking.

The data availability requirement for newer radiosonde systems in the 1 680 MHz frequency band is 98%.

## 6.4 Summary of data availability requirements

TABLE 3  
Performance criteria of systems operated in the MetAids service

System	Receiver location	Maximum link range (km)	System minimum S/N (dB)	Data availability requirement over the total flight (%)	Short-term data availability requirement
RDF radiosonde system operated in 1 680 MHz	Ground	250	12	87.5	See § 6.3.2
RNSS radiosonde system operated in 1 680 MHz	Ground	250	12	97	15 s/5 min (95%)
Digital radiosonde system operated in 403 MHz	Ground	250	12	97	–
Digital radiosonde w/GPS operated in 403 MHz	Ground	250	12	97	–
NAVAID radiosonde system operated in 403 MHz with high gain receive antenna	Ground or ship	250	12	97	–
NAVAID radiosonde system operated in 403 MHz with low gain receive antenna	Ground or ship	150	12	97	–
NAVAID radiosonde system operated in 403 MHz with high gain receive antenna and digital receiver	Ground or ship	250	7	97	–
NAVAID radiosonde system operated in 403 MHz with low gain receive antenna and digital receiver	Ground or ship	250	7	97	–

## 7 Radiocommunication characteristics of current radiosonde systems

Radiosonde systems are composed of radiosonde transmitters and ground receiving stations associating a receiver and an antenna.

### 7.1 Transmitter characteristics

Typical characteristics of currently used transmitter systems in the 403 and 1 680 MHz frequency bands are given in Tables 4 and 5.

TABLE 4

**Radiocommunication characteristics of 403 MHz frequency band radiosonde transmitters**

<b>Parameter</b>	<b>Type A (analogue)</b>	<b>Type B (digital)</b>	<b>Type C (digital)</b>	<b>Type D (digital)</b>	<b>Type E (digital)</b>
Tuning range (MHz)	400.15-406	400.15-406	400.15-406	400.15-405.9900	400.25-405.875
Maximum drift in flight (kHz)	± 800	±20	±2	±3	±5
Nominal output power (dBm)	+24.0	+24.0	+ 18.5	20	18.5
Maximum antenna gain (dBi)	2	2	2	3	2
ITU-R emission type	F9D	F7D	F1D	F2D	F1D
Modulation	FM	GMSK	GFSK	QAM	FSK
Occupied bandwidth (kHz) (-40 dBc level)	200	61	27.6	15	28
Out-of-band emission (dBc)	< -43	< -48	< 49	< -37	< -48.5

TABLE 5

**Radiocommunication characteristics of 1 680 MHz frequency band radiosonde transmitters**

<b>Parameter</b>	<b>Type G(analogue)</b>	<b>Type H (analogue)</b>	<b>Type I (digital)</b>
Tuning range (MHz)	1 668.4-1 700	1 668.4-1 700	1 675-1 683
Maximum drift in flight (MHz)	± 4	±4	±1
Nominal output power (dBm)	+24.0	+24.0	+23.8
Maximum antenna gain (dBi)	2.0	2.0	2.0
Minimum antenna gain (dBi)	< -10	< -10	-4
Modulation	AM, 100%	FM	FSK
Modulating PTU signal (kHz)	0.7-1.0	7-10	N/A
Deviation (kHz)	Not applicable	45 ± 15	< 50
Windfinding	Detection of the reception angles	Detection of the reception angles	GPS

TABLE 5 (end)

Parameter	Type G (analogue)	Type H (analogue)	Type I (digital)
Occupied bandwidth	-40 dBc: 0.5 MHz -50 dBc: 1.0 MHz	180 kHz	120 kHz
Information rate (bit/s)	1 200	1 200	2 400
Out-of-band emission (dBc)	< -43	< -43	< -48

## 7.2 Receiving systems

### 7.2.1 403 MHz frequency band

Typical characteristics of currently used receivers in the 403 MHz frequency band are given in Table 6 and typical receive antenna characteristics for the 403 MHz frequency band are contained in Table 7.

TABLE 6  
Characteristics of 403 MHz frequency band receivers

Parameter	System A	System B	System C	System D	System E
Type	Analogue	Digital	Digital	Digital	Digital
Frequency range (MHz)	400.15-406	400.15-406	400-406	400.15-405.99	400.25-405.875
Modulation	FM	GMSK	GFSK,	QAM	FSK
Sensitivity (dBm for required $S/N$ or $E_b/N_0$ )	-104	-124	-122	-121	-119
Required $S/N$ (dB)	12 <sup>(2)</sup>	12	12 <sup>(2)</sup>	12	12 <sup>(2)</sup>
IF bandwidth (kHz)	300	6	11	17	18.8
Radiosonde types	A	B	C	D	E
Receive antenna type <sup>(1)</sup>	Antenna 2	Antenna 3	Antenna 2	Antenna 3	Antenna 4

<sup>(1)</sup> See Table 7.

<sup>(2)</sup> 12 dB for 0.2 Data Loss, 7 dB for 0.02 Track Loss.

TABLE 7

Characteristics of 403 MHz frequency band receiving antennas

	Antenna 1	Antenna 2	Antenna 3	Antenna 4
<b>Type</b>	<b>Omnidirectional (dipole, ground plane)</b>	<b>Directional corner reflector, six corners</b>	<b>Omnidirectional (dipole)</b>	<b>Steerable Yagi</b>
Frequency range	397-409	400-406	400-406	400-406
Main Beam gain (dB)	Omnidirectional	8	2.15	11
Amplifier NF (dB)	< 3.5	< 2.5	< 3.0	< 4.0
Amplifier gain (dB)	13	20	20	38
Bandpass filter insertion loss (dB)	Not Applicable	0.5	0.5	0.5
Band pass filter bandwidth (MHz)	Not Applicable	400-406	400-406	400-406

Antennas 1 and 3 are omnidirectional in the horizontal plane so that no antenna movement or element switching is required to track the radiosonde signal. Antenna 2 is an array of six corner reflectors and a dipole antenna. The corner reflectors and the dipole antenna are switched by a diode switch so the most suitable element for best reception is connected to the receiver. Antenna 4 is a Yagi antenna mounted on a steerable mast for tracking antenna azimuth. The elevation of the main lobe is approximately 20 degrees for Antenna 4.

FIGURE 6  
Radiation pattern of antenna 3

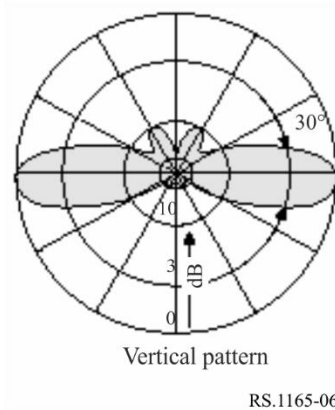

RS.1165-06

FIGURE 7

Illustration of antenna 2

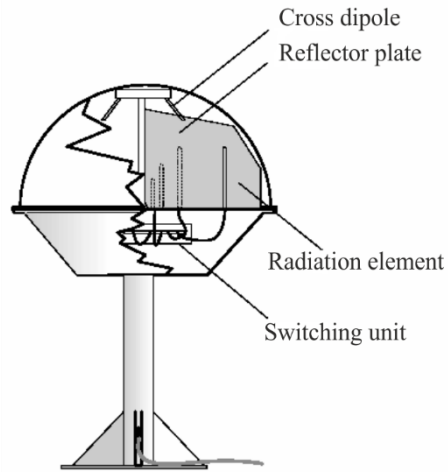

RS.1165-07

FIGURE 8

Radiation pattern (H-plane, 12 degrees angle) of antenna 2

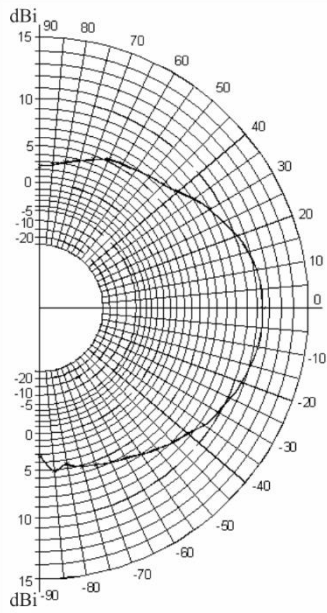

RS.1165-08



FIGURE 9  
Radiation pattern of antenna 4

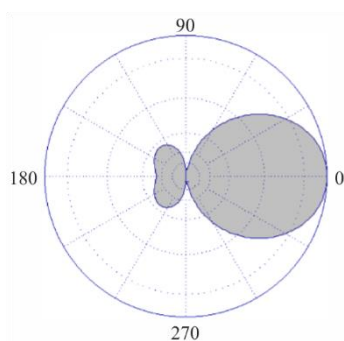

RS.1165-09

### 7.2.2 1 680 MHz frequency band

Typical characteristics of currently used receiving systems in the 1 680 MHz frequency band are given in Table 8.

TABLE 8  
Characteristics of 1 680 MHz antenna and receiving system

	System G	System H	System I
<b>Type</b>	<b>Phased array</b>	<b>Conical scan</b>	<b>Conical scan<sup>(1)</sup></b>
Frequency range (MHz)	1 668.4-1 700	1 668.4-1 700	1 668.4-1 700
3 dB beamwidth (degrees)			
(horizontal)	20	8.8	8.0
(vertical)	15	8.8	8.0
Gain (dBi)	16	28	26
Side lobe attenuation (dB)	> 20 to the direction of specular ground reflection on flat terrain when elevation > 14°	15 at ±60° from boresight	>20
Sensitivity (dBm) for 12 dB S/N	-110	-97	-106.8
Automatic gain control (dB)	110		123
IF bandwidth, PTU measure (kHz)	300	180	150
– Tracking (MHz)	Not applicable	1.3	150
Used with radiosonde type(s)	G	DH	I

<sup>(1)</sup> System does not use true conical scanning where a rotating reflector in the feedhorn rotates the main beam about the antenna centre-line axis. This system has four discrete elements in the feedhorn that form four discrete beams in the up, down, left and right directions for signal level comparison and tracking.

## **8 Radiocommunication characteristics of dropsonde systems**

Dropsondes are meteorological sensor packages that are carried aloft on aircraft and dropped beneath a parachute to profile the atmosphere. While they can be used over landmasses, they are typically used over ocean areas where operation of a radiosonde site is not possible. Dropsondes are used extensively for monitoring conditions within tropical storms, hurricanes and typhoons since the aircraft can drop them at key points as the aircraft traverses the storm. Dropsondes transmit sensor data to a receiver on board the aircraft. An aircraft may be receiving data from up to eight dropsondes at one time, requiring the use of a multi-channel receiver system.

Dropsondes dropped from an aircraft pass through the atmosphere very quickly as they descend beneath the parachute. Data loss for even a brief period of time can lead to large portions of missing data for significant parts of the atmosphere. While all data during the descent is critical, many applications place additional emphasis on the last data point before the dropsonde reaches the surface. The last data point represents the conditions on the surface, which are critical for forecasting applications.

### **8.1 Operational practices for dropsondes**

Dropsondes are deployed from altitudes ranging from 3 000 to 21 400 m, and tracked to the Earth's surface. An aircraft deploying dropsondes may track and receive data from as many as eight dropsondes simultaneously. This allows the aircraft to fly a pattern through a storm, releasing dropsondes and to collect data from key points within the storm. Dropsondes use RNSS receivers to calculate winds. The GPS data from the dropsonde location is combined and transmitted with the measured pressure, temperature and humidity data.

The most common use of dropsondes is the monitoring of conditions within tropical storms, hurricanes and typhoons. Dropsondes allow profiling of the atmosphere within large storms while they are still far from land. The data is critical to monitoring the strength of the storm and predicting the future strength and track.

Dropsondes have also been used worldwide for meteorological and climatological research over oceans and over land. Dropsondes allow rapid deployment of a high density of sensor packages in areas where deployment of radiosonde stations is not possible. Their use also allows rapid reconfiguration of the network in response to changing conditions; something ground based radiosonde stations cannot quickly respond to.

### **8.2 Dropsonde system characteristics**

Dropsonde systems are designed to operate with the receiver on board an aircraft. Highly directional antennas required for operations in the 1 680 MHz frequency band are not practical. Dropsondes are designed to operate in the 403 MHz frequency band allocated to MetAids where low-gain omnidirectional antennas can be used. Tables 9 and 10 contain the typical characteristics for dropsonde transmitters and dropsonde receivers, respectively.

TABLE 9

**Dropsonde transmitter characteristics**

<b>Parameter</b>	<b>Type 1</b>
Frequency range	400.15-406 MHz
Transmitter output power	21 dBm
Antenna type	Vertical monopole
Antenna gain	+ 2 dBi at horizon
	−10 at zenith and nadir
Modulation	FM (640 BPS FSK and 1 200 BPS AFSK)
Emission bandwidth	15 kHz
Operational altitude	Surface to 21 400 m

TABLE 10

**Dropsonde receiver characteristics**

<b>Parameter</b>	<b>Type 1</b>
Frequency range (multi-channel)	400.15-406 MHz (multi-channel)
Number of receiver channels	8
Receiver sensitivity (for 12 dB <i>S/N</i> )	−121 dBm
Minimum <i>S/N</i> for data reception	12 dB
IF bandwidth (3 dB)	18 kHz
Antenna type	Omnidirectional blade
Operational altitude	Surface to 21 400 m

**8.3 Dropsonde future plans**

Several adaptations of the current dropsonde are being considered for more advanced applications. These applications will allow collection of additional data and collection of data in areas where data collection is now difficult.

The first future modification of the dropsonde is to include the capability to perform an airborne expendable bathythermograph (AXBT) function once it drops into the ocean. In addition to providing a profile of atmospheric conditions, the AXBT dropsonde would provide data on the ocean conditions, providing forecasters with additional data for use in the prediction models.

Applications are also under consideration where dropsondes would be deployed by a drifting balloon or unmanned aerial vehicle. These systems would allow routine collection of data in areas over the oceans where collection is sparse or non-existent at this time.

**9 Radiocommunication characteristics of rocketsonde systems**

Rocketsondes are used by space agencies and other users that have data requirements that cannot be met with use of radiosondes or dropsondes. Rocketsonde systems, like dropsondes, collect

atmospheric data as they descend through the atmosphere. Rather than being dropped from aircraft like dropsondes, rocketsondes are lifted quickly into the atmosphere on a small solid fuel rocket and data is collected as the rocketsonde falls back to earth under a parachute.

### 9.1 Operational practices for rocketsondes

Rocketsondes are deployed for atmospheric measurements by a small solid fuel rocket. Both low altitude and high altitude rocketsonde systems are used. Use of rocketsondes is not extensive, though they are critical when only their unique data performance will satisfy data requirements.

The low altitude version is used to very quickly deploy a measurement package to a height of approximately 1 000 m so the boundary layer conditions can be measured. In this version, the sensor package is ejected from the rocket body at apogee.

The high altitude version is used to deploy atmospheric measurement packages to altitudes (above 32 km) that cannot be reached with balloon borne radiosondes. After launch the rocket motor quickly burns out at a low altitude (~2 000 m) and separates from a dart that carries the rocketsonde payload to apogee (73 to 125 km). At apogee the rocketsonde payload is ejected from the dart and descends through the atmosphere below a parachute. In addition to transmission of meteorological data from the rocketsonde, the parachute is constructed of aluminized Mylar to enable radar skin tracking for atmospheric winds measurement. The time period from deployment at apogee to termination of data collection at 14 km is typically 100 min. The radar skin tracking is performed in a radiodetermination frequency band rather than in a frequency band allocated to MetAids.

### 9.2 Rocketsonde system characteristics

Rocketsonde systems are operated in both the 403 MHz and the 1 680 MHz frequency band. The following sections provide the characteristics for systems operated in the 403 MHz and 1 680 MHz frequency bands. Table 11 contains the characteristics of rocketsonde transmitters operated in the 403 MHz frequency band, and Table 12 contains characteristics of rocketsonde transmitters operated in the 1 680 MHz frequency band.

TABLE 11

#### Low altitude rocketsonde transmitters operated in 403 MHz frequency band

Parameter	Type 1
Tunable range (MHz)	400.15-406
Transmitter power (dBm)	15.0
Modulation	GFSK
Maximum altitude (relative to area launch elevation) (m)	~ 1 000
Maximum range (km)	20

For the characteristics of receiver systems used with rocketsonde systems operated in the 403 MHz frequency band, refer to System B in Table 6. For antenna systems used with rocketsondes operated in the 403 MHz frequency band, refer to Antenna 1 in Table 7.

TABLE 12

**Rocketsonde transmitters operated in 1 680 MHz frequency band**

Parameter	Type 1
Tunable range (MHz)	1 680-1 684
Transmitter power (dBm)	26.5
Modulation	FM
Maximum altitude (relative to area launch elevation) (km)	82

Table 13 contains the characteristics of receive systems operated with 1 680 MHz rocketsondes.

TABLE 13

**Rocketsonde antenna/receiver system operated in 1 680 MHz frequency band**

Parameter	Type 1
Tunable range (MHz)	1 660-1 700
Antenna beamwidth (degrees)	5.4
Antenna gain (dBi)	29
Antenna polarization	Right-hand circular
Elevation range (degrees)	-5 to 95
Receiver noise figure (dB)	6.4 dB
Modulation	AM and FM
Maximum range (km)	300

**9.3 Rocketsonde descent profile**

The descent of a rocketsonde is not linear. The descent profile may be a critical part of performing calculations or simulations to determine compatibility with other radio services. Figures 10 and 11 provide a representative launch/descent profile for a high altitude rocketsonde.

FIGURE 10  
**High altitude rocketsonde descent profile (time vs. altitude)**

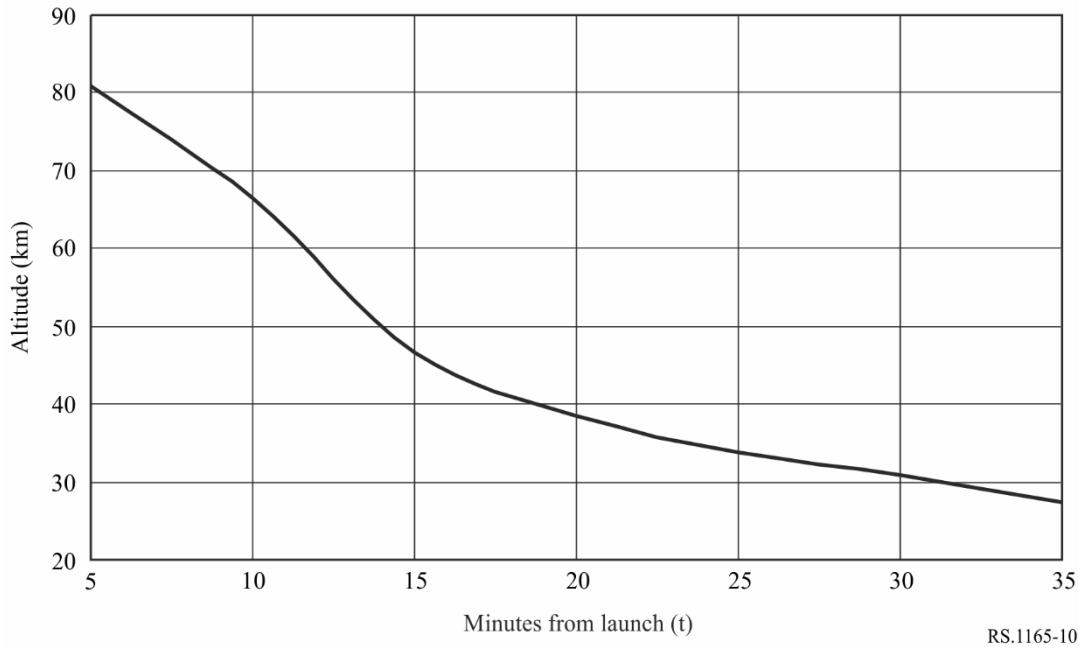

FIGURE 11  
**High altitude rocketsonde descent profile (altitude vs. descent velocity)**

