

# **Recommendation ITU-R M.2012-6 (12/2023)**

M Series: Mobile, radiodetermination, amateur  
and related satellite services

**Detailed specifications of the terrestrial  
radio interfaces of International Mobile  
Telecommunications-Advanced  
(IMT-Advanced)**



## Foreword

The role of the Radiocommunication Sector is to ensure the rational, equitable, efficient and economical use of the radio-frequency spectrum by all radiocommunication services, including satellite services, and carry out studies without limit of frequency range on the basis of which Recommendations are adopted.

The regulatory and policy functions of the Radiocommunication Sector are performed by World and Regional Radiocommunication Conferences and Radiocommunication Assemblies supported by Study Groups.

## Policy on Intellectual Property Right (IPR)

ITU-R policy on IPR is described in the Common Patent Policy for ITU-T/ITU-R/ISO/IEC referenced in Resolution ITU-R 1. Forms to be used for the submission of patent statements and licensing declarations by patent holders are available from <http://www.itu.int/ITU-R/go/patents/en> where the Guidelines for Implementation of the Common Patent Policy for ITU-T/ITU-R/ISO/IEC and the ITU-R patent information database can also be found.

### Series of ITU-R Recommendations

(Also available online at <https://www.itu.int/publ/R-REC/en>)

Series	Title
<b>BO</b>	Satellite delivery
<b>BR</b>	Recording for production, archival and play-out; film for television
<b>BS</b>	Broadcasting service (sound)
<b>BT</b>	Broadcasting service (television)
<b>F</b>	Fixed service
<b>M</b>	<b>Mobile, radiodetermination, amateur and related satellite services</b>
<b>P</b>	Radiowave propagation
<b>RA</b>	Radio astronomy
<b>RS</b>	Remote sensing systems
<b>S</b>	Fixed-satellite service
<b>SA</b>	Space applications and meteorology
<b>SF</b>	Frequency sharing and coordination between fixed-satellite and fixed service systems
<b>SM</b>	Spectrum management
<b>SNG</b>	Satellite news gathering
<b>TF</b>	Time signals and frequency standards emissions
<b>V</b>	Vocabulary and related subjects

*Note: This ITU-R Recommendation was approved in English under the procedure detailed in Resolution ITU-R 1.*

*Electronic Publication  
Geneva, 2024*

© ITU 2024

All rights reserved. No part of this publication may be reproduced, by any means whatsoever, without written permission of ITU.

## RECOMMENDATION ITU-R M.2012-6

**Detailed specifications of the terrestrial radio interfaces of International Mobile Telecommunications-Advanced (IMT-Advanced)**

(2012-2014-2015-2017-2019-2022-2023)

**Scope**

This Recommendation identifies the terrestrial radio interface technologies of International Mobile Telecommunications-Advanced (IMT-Advanced) and provides the detailed radio interface specifications.

These radio interface specifications detail the features and parameters of IMT-Advanced. This Recommendation includes the capability to ensure worldwide compatibility, international roaming, and access to high-speed data services.

**Keywords**

IMT, IMT-Advanced, LTE-Advanced, LTE-Advanced Pro, WirelessMAN-Advanced, radio interface specifications

**Related ITU-R Recommendations, Reports and Resolutions<sup>1</sup>**

Recommendation ITU-R M.1036 – Frequency arrangements for implementation of the terrestrial component of International Mobile Telecommunications (IMT) in the bands identified for IMT in the Radio Regulations (RR)

Recommendation ITU-R M.1224 – Vocabulary of Terms for International Mobile Telecommunications (IMT)

Recommendation ITU-R M.1579 – Global circulation of IMT terrestrial terminals

Recommendation ITU-R M.1645 – Framework and overall objectives of the future development of IMT-2000 and systems beyond IMT-2000

Recommendation ITU-R M.1822 – Framework for services supported by IMT

Recommendation ITU-R M.2047 – Detailed specifications of the satellite radio interface of International Mobile Telecommunications-Advanced (IMT-Advanced)

Recommendation ITU-R M.2070 – Generic unwanted emission characteristics of base stations using the terrestrial radio interfaces of IMT-Advanced

Recommendation ITU-R M.2071 – Generic unwanted emission characteristics of mobile stations using the terrestrial radio interfaces of IMT-Advanced

Recommendation ITU-R M.2090 – Specific unwanted emission limit of IMT mobile stations operating in the frequency band 694-790 MHz to facilitate protection of existing services in Region 1 in the frequency band 470-694 MHz

Report ITU-R M.2072 – World mobile telecommunication market forecast

Report ITU-R M.2074 – Radio aspects for the terrestrial component of IMT-2000 and systems beyond IMT-2000

Report ITU-R M.2133 – Requirements, evaluation criteria and submission templates for the development of IMT-Advanced

Report ITU-R M.2134 – Requirements related to technical performance for IMT-Advanced radio interface(s)

Report ITU-R M.2135 – Guidelines for evaluation of radio interface technologies for IMT-Advanced

---

<sup>1</sup> The latest edition of the Recommendation/Reports in force should be used.

Report ITU-R M.2198 – The outcome of the evaluation, consensus building and decision of the IMT-Advanced process (steps 4-7), including characteristics of IMT-Advanced radio interfaces

Report ITU-R M.2291 – The use of International Mobile Telecommunications for the broadband public protection and disaster relief applications

Report ITU-R M.2320 – Future technology trends of terrestrial IMT systems

Report ITU-R M.2334 – Passive and active antenna systems for base stations of IMT systems

Report ITU-R M.2370 – IMT traffic estimates for the years 2020 to 2030

Report ITU-R M.2373 – Audio-visual capabilities and applications supported by terrestrial IMT systems

Report ITU-R M.2375 – Architecture and topology of IMT networks

Resolution ITU-R 56 – Naming for International Mobile Telecommunications

Resolution ITU-R 57 – Principles for the process of development of IMT-Advanced

Handbook on Global Trends in International Mobile Telecommunication.

The ITU Radiocommunication Assembly,

*considering*

- a) that IMT systems are mobile broadband systems including IMT-2000, IMT-Advanced and IMT-2020;
- b) that IMT-Advanced systems include the new capabilities of IMT that go beyond those of IMT-2000<sup>2</sup>;
- c) that such systems provide access to a wide range of telecommunication services including advanced mobile services, supported by mobile and fixed networks, which are increasingly packet-based;
- d) that IMT-Advanced systems support low to high mobility applications and a wide range of data rates in accordance with user and service demands in multiple user environments;
- e) that IMT-Advanced also has capabilities for high-quality multimedia applications within a wide range of services and platforms providing a significant improvement in performance and quality of service;
- f) that the key features of IMT-Advanced are:
  - a high degree of commonality of functionality worldwide while retaining the flexibility to support a wide range of services and applications in a cost-efficient manner;
  - compatibility of services within IMT and with fixed networks;
  - capability of interworking with other radio access systems;
  - high-quality mobile services;
  - user equipment suitable for worldwide use;
  - user-friendly applications, services and equipment;
  - worldwide roaming capability;

---

<sup>2</sup> Recommendations ITU-R M.1457 and ITU-R M.2012 are two separate, independent, and self-contained Recommendations, each one with a specific scope. Both Recommendations will evolve independently, and there could be some overlap reflected by commonality in content between the two documents.

- enhanced peak data rates to support advanced services and applications (100 Mbit/s for high and 1 Gbit/s for low mobility were established as targets for research)<sup>3</sup>;
- g) that these features enable IMT-Advanced to address evolving user needs;
- h) that the capabilities of IMT-Advanced systems are being continuously enhanced in line with technology developments;
- i) the necessity of priority services (e.g. emergency calls shall be supported as higher priority than other commercial services);
- j) that due to the large effective bandwidths required to support the very high data rates needed for the various services offered, allowances must be made for either much larger single carrier bandwidths (even as spectral efficiencies increase) or aggregation of RF carriers;
- k) that the rapid development of information technology, including the Internet, has resulted in the aggregation and convergence of various networks and digital devices,

*further considering*

that Resolution ITU-R 57-2 on the “Principles for the process of development of IMT-Advanced” outlines the essential criteria and principles used in the process of developing the Recommendations and Reports for IMT-Advanced, including Recommendation(s) for the radio interface specification,

*noting*

that Report ITU-R M.2198 contains the outcome and conclusions of Steps 4 through 7 of the IMT-Advanced process, including the evaluation and consensus building, and provides the characteristics of the IMT-Advanced terrestrial radio interfaces for the first release of Recommendation ITU-R M.2012-0 (01-2012),

*recommends*

- 1 that the terrestrial radio interfaces for IMT-Advanced should be:
  - “LTE-Advanced”<sup>4</sup>; and
  - “WirelessMAN-Advanced”<sup>5</sup>;
- 2 that the information provided or referenced in Annexes 1 and 2 should be used according to the terrestrial radio interfaces referred to in *recommends* 1 above as the complete set of standards for the detailed specifications of the terrestrial radio interfaces of IMT-Advanced.

---

<sup>3</sup> Data rates sourced from Recommendation ITU-R M.1645.

<sup>4</sup> Developed by 3GPP as LTE Release 10 and Beyond (Long Term Evolution-Advanced).

<sup>5</sup> Developed by IEEE as the WirelessMAN-Advanced specification incorporated in IEEE Std 802.16 beginning with approval of IEEE Std 802.16m.

## Annex 1

### Specification of the LTE-Advanced radio interface technology

#### Background

IMT-Advanced is a system with global development activity and the IMT-Advanced terrestrial radio interface specifications identified in this Recommendation have been developed by the ITU in collaboration with the GCS<sup>6</sup> Proponents and the Transposing Organizations. It is noted from Document [IMT-ADV/24\(Rev.3\)](#), that:

- The GCS Proponent must be one of the RIT<sup>7</sup>/SRIT<sup>8</sup> Proponents for the relevant technology and must have legal authority to grant to ITU-R the relevant legal usage rights to the relevant specifications provided within a GCS corresponding to a technology in Recommendation ITU-R M.2012.
- A Transposing Organization must have been authorized by the relevant GCS Proponent to produce transposed standards for a particular technology and must have the relevant legal usage rights.

It is further noted that GCS Proponents and Transposing Organizations must also qualify appropriately under the auspices of Resolution ITU-R 9-5 and the ITU-R “Guidelines for the contribution of material of other organizations to the work of the Study Groups and for inviting other organizations to take part in the study of specific matters (Resolution ITU-R 9-5)”.

The ITU has provided the global and overall framework and requirements and has developed the Global Core Specification jointly with the GCS Proponent. The detailed standardization has been undertaken within the recognized Transposing Organizations which operate in concert with the GCS Proponent. This Recommendation therefore makes extensive use of references to externally developed specifications.

This approach was considered to be the most appropriate solution to enable completion of this Recommendation within the aggressive schedules set by the ITU and by the needs of administrations, operators and manufacturers.

This Recommendation has therefore been constructed to take full advantage of this method of work and to allow the global standardization time-scales to be maintained. The main body of this Recommendation has been developed by the ITU, with each Annex containing references pointing to the location of the more detailed information.

This Annex 1 contains the detailed information developed by the ITU and “ARIB, ATIS, CCSA, ETSI, TSDSI, TTA, and TTC on behalf of 3GPP” (the GCS Proponent) and ARIB, ATIS, CCSA, ETSI, TSDSI, TTA, and TTC (the Transposing Organizations).

Such use of referencing enables timely completion and update of the high-level elements of this Recommendation, with change control procedures, transposition, and public enquiry procedures being undertaken within the external organization. This information has generally been adopted unchanged, recognizing the need to minimize duplication of work, and the need to facilitate and support an ongoing maintenance and update process.

---

<sup>6</sup> A “GCS” (Global Core Specification) is the set of specifications that defines a single RIT, an SRIT, or a RIT within an SRIT.

<sup>7</sup> Radio Interface Technology.

<sup>8</sup> Set of Radio Interface Technologies.

This general agreement, noting that the detailed information of the radio interface should to a large extent be achieved by reference to the work of external organizations, highlights not only the ITU's significant role as a catalyst in stimulating, coordinating and facilitating the development of advanced telecommunications technologies, but also its forward-looking and flexible approach to the development of this and other telecommunications standards for the 21<sup>st</sup> century.

A more detailed understanding of the process for the development of the first release of this Recommendation may be found in Document IMT-ADV/24(Rev.3) whereas details on the process for the development of revisions of this Recommendation may be found in Document [IMT-ADV/25\(Rev.2\)](#).

## **1 Overview of the radio interface technology**

### **1.1 Overview of the SRIT**

The IMT-Advanced terrestrial radio interface specifications known as LTE-Advanced is based on LTE Release 10 and Beyond are developed by 3GPP. In 3GPP terminology, the term E-UTRA (Evolved-UTRA) is also used to indicate the LTE radio interface, and 3GPP LTE Release 13 and beyond is marked as "LTE-Advanced Pro".

*LTE-Advanced* is a Set of RITs (Radio Interface Technologies) consisting of one FDD RIT and one TDD RIT designed for operation in paired and unpaired spectrum, respectively. The TDD RIT is also known as TD-LTE Release 10 and Beyond or *TD-LTE-Advanced*. The two RITs have been jointly developed, providing a high degree of commonality while, at the same time, allowing for optimization of each RIT with respect to its specific spectrum/duplex arrangement.

Both the FDD RIT and the TDD RIT individually, and consequently the Set of RITs (SRIT), meet all the ITU IMT-Advanced minimum requirements in all four test environments defined in all aspects of Services, Spectrum and Technical performance. Furthermore, both the FDD RIT and TDD RIT individually, and consequently the SRIT, meet the requirements of Resolution ITU-R 57-2, *resolves 6 e) and f)* in all four test environments.

The complete set of standards for the terrestrial radio interface of IMT-Advanced identified as *LTE-Advanced* includes not only the key characteristics of IMT-Advanced but also the additional capabilities of *LTE-Advanced* both of which are continuing to be enhanced.

The radio aspects of *LTE-Advanced* also include the capabilities of LTE Release 8 and LTE Release 9. Furthermore, information on system and core network specifications is also provided for a complete system perspective. These system and core network specifications address the network, terminal, and service aspects required to provide an integrated mobility solution including aspects such as user services, connectivity, interoperability, mobility and roaming, security, codecs and media, operations and maintenance, charging, etc. Information on the Radio specifications Release 8 and Release 9 as well as on the System and Core Network specifications is provided in § 2.2.

### **1.2 Overview of the Radio Interface Technology (RIT)**

#### **1.2.1 Overview of the FDD RIT**

The FDD RIT is the evolution of LTE FDD. The FDD RIT uses Frequency Division Duplex operation and therefore is applicable for operation with paired spectrum. Both full-duplex and half-duplex FDD are supported.

### 1.2.2 Overview of the TDD RIT

The TDD RIT, also known as *TD-LTE-Advanced*, is the evolution of TD-LTE. The TDD RIT uses Time-Division Duplex operation and therefore is applicable for operation with unpaired spectrum. The TDD RIT provides flexibility in terms of downlink-uplink resource allocation by supporting multiple uplink-downlink resource-allocation configurations that can be used to match different traffic scenarios. The uplink-downlink resource-allocation configuration can be adapted to the varying instantaneous traffic and interference conditions even during operation.

It is also designed to exploit the more extensive channel reciprocity inherent in case of TDD operation, e.g. for beamforming, and facilitates coexistence with TD-SCDMA as well as other TDD-based IMT-2000 technologies.

### 1.3 Overview of the system aspects of the SRIT

The FDD and TDD RITs represent the evolution of the first releases of LTE FDD and TDD, respectively. The two RITs share many of the underlying structures to simplify implementation of dual-mode radio-access equipment. Transmission bandwidths up to 640 MHz are supported, yielding peak data rates up to roughly 32 Gbit/s in the downlink and 13.6 Gbit/s in the uplink.

The downlink transmission scheme is based on conventional OFDM to provide a high degree of robustness against channel frequency selectivity while still allowing for low-complexity receiver implementations also at very large bandwidths.

The uplink transmission scheme is based on Discrete Fourier Transform-spread OFDM (DFTS-OFDM). The use of DFTS-OFDM transmission for the uplink is motivated by the lower Peak-to-Average Power Ratio (PAPR) of the transmitted signal compared to conventional OFDM. This allows for more efficient usage of the power amplifier at the terminal, which translates into an increased coverage and/or reduced terminal power consumption. The uplink numerology is aligned with the downlink numerology. The Narrow-band Internet of Things (NB-IoT) UL allows allocating a single-tone in addition to multi-tone DFTS-OFDM with the possibility of a lower subcarrier spacing in addition to the normal subcarrier spacing.

Channel coding is based on rate-1/3 Turbo coding (Tail Biting Convolutional Code for NB-IoT DL) and is complemented by Hybrid-ARQ with soft combining to handle decoding errors at the receiver side. Data modulation supports QPSK, 16-QAM, 64-QAM, and 256-QAM for both the downlink and the uplink. In downlink, 1 024-QAM is also supported.

NB-IoT, supports QPSK and 16-QAM on downlink and for uplink when multi-tones are allocated;  $\pi/2$ -BPSK and  $\pi/4$ -QPSK are supported in uplink when a single-tone is allocated.

LTE-M supports QPSK, 16-QAM, and 64-QAM in downlink and QPSK, 16-QAM in uplink;  $\pi/2$  BPSK is supported in uplink when two tones are allocated and QPSK is supported in uplink for sub-PRB allocation (physical resource block) with more than two tones.

The FDD and TDD RITs support bandwidths from approximately 1.4 MHz to 640 MHz. NB-IoT supports 200 kHz bandwidth. Carrier aggregation, i.e. the simultaneous transmission of multiple component carriers in parallel to/from the same terminal/eNB, is used to support bandwidths larger than 20 MHz. Component carriers do not have to be contiguous in frequency and can even be located in different frequency bands in order to enable exploitation of fragmented spectrum allocations by means of spectrum aggregation. Licensed-Assisted Access (LAA) allows secondary component carriers to operate in the unlicensed 5 GHz band. In order to fairly coexist, LAA uses a Listen-Before-Talk (LBT) medium access in the unlicensed frequency bands. Carrier Aggregation supports the functionality to aggregate TDD bands with different uplink and downlink allocations as well as the functionality to support multiple timing advancements. Carrier Aggregation also supports to



aggregate FDD and TDD component carriers. Dual Connectivity allows aggregating component carriers of different eNBs that are connected via a non-ideal backhaul over the X2 interface.

The RITs allow co-existence with NR and the operation of the RITs and NR on the same frequency is possible. NR is not part of this Recommendation, and its description is contained in Recommendation ITU-R M.2150-2, Annex 1, § 1.1.

Channel-dependent scheduling in both the time and frequency domains is supported for both downlink and uplink with the base-station scheduler being responsible for (dynamically) selecting the transmission resource as well as the data rate. The basic operation is dynamic scheduling, where the base-station scheduler takes a decision for each 1 ms Transmission Time Interval (TTI), but there is also a possibility for semi-persistent scheduling. Semi-persistent scheduling (SPS) enables transmission resources and data rates to be semi-statically allocated to a given User Equipment (UE) for a longer time period than one TTI to reduce the control-signalling overhead. For low latency UL transmissions, the SPS periodicity can be as low as 1 ms and UEs are allowed to skip the UL grant. For better uplink coverage, TTI bundling allows UEs to transmit in four consecutive TTIs. NB-IoT and enhanced Machine-type Communication (eMTC) allows for widespread coverage extension by means of scheduling multiple TTIs (up to several thousands).

For low latency communication there is support for reduced processing time as well as TTI shorter than 1 ms in the form of subslot or slot transmission, also referred to as short TTI (sTTI). The TTI for subslot transmission is two or three symbols and the TTI for slot transmission is half a subframe.

For increased reliability and lower latency, the SRIT provides functionality for transmission repetition and for packet duplication whereby packets can be transmitted over two paths using carrier aggregation or dual connectivity. The SRIT also supports provisioning of granular time reference.

To increase robustness and minimize interruption time during mobility, the SRIT supports techniques such as Dual Active Protocol Stack, where the UE maintains connectivity with the source eNB until successful completion of handover (HO) to the target eNB, and Conditional HO, where the UE maintains the connectivity with the source eNB until one or more HO execution conditions are met.

Multi-antenna transmission schemes are an integral part of both RITs. Multi-antenna precoding with dynamic rank adaptation supports both spatial multiplexing (single-user MIMO) and beam-forming. Beam-forming by means of two-dimensional antenna arrays can exploit the horizontal as well as the vertical domain. Spatial multiplexing with up to eight layers in the downlink and four layers in the uplink is supported. Multi-user MIMO, where multiple users (up to eight) are assigned the same time-frequency resources, is also supported. Coordinated MultiPoint (CoMP) operation is also supported, where multiple transmission points or reception points are coordinated in their transmission or reception respectively. The coordinated transmission points can belong to the same cell, to different cells of the same eNB or to different cells of different eNBs. A discovery reference signal can be used to identify transmission points or cells for CoMP and/or Carrier aggregation operation. In addition, non-coherent joint transmission is supported, where the transmission of the multiple MIMO layers is performed from two transmission points (TPs) without joint precoding across the TPs. Finally, transmit diversity based on Space-Frequency Block Coding (SFBC) or a combination of SFBC and Frequency Switched Transmit Diversity (FSTD) is supported. Large antenna arrays are efficiently supported, e.g. through codebook based channel state information (CSI) feedback for up to 32 eNB antenna ports or beamformed CSI reference signals.

Inter-cell interference coordination (ICIC), where neighbour cells exchange information aiding the scheduling in order to reduce interference, is supported for the RITs. ICIC can be used for homogenous deployments with non-overlapping cells of similar transmission power, as well as for heterogeneous deployments where a higher-power cell overlays one or several lower-power nodes. In order to increase the potential of cell range expansion, functionality for terminal-side interference

mitigation of reference and synchronization signals as well as the broadcast channel exists. A terminal-side mitigation of inter-cell interference caused by the data channel is supported with network assistance. A network-side interference mitigation technique is supported, which is based on the ability to turn on and off secondary cells. Another network-based interference mitigation technique is also supported, in which the bandwidth of Cell Specific Reference Symbol (CRS) can be reduced when UEs do not perform any DL or UL operation requiring CRS.

Relaying functionality is included in both the FDD and TDD RITs. The relay node appears as a conventional eNB to terminals but is wirelessly backhauled to the remaining part of the radio-access network using the LTE radio-interface technology.

Both RITs support various types of machine-type communication. In order to better address the low-cost segment, a low-complexity terminal (Category 0) is supported, which approximately 50% has reduced modem complexity as compared to the least complex 'normal' UE (Category 1), e.g. by a single receive antenna, half-duplex operation and greatly reduced peak data rate support.

With the introduction of LTE-M, complexity is further reduced, e.g. by reducing the UE bandwidth down to 1.4 or 5 MHz and lower UE power classes (20 dBm/14 dBm). Two coverage extension modes have been added to LTE/LTE-M, one for moderate and another for large coverage extension basically using repetitions.

NB-IoT is introduced aiming at extreme low complexity, e.g. by reducing the UE bandwidth down to 200 kHz, by even further limiting the UE peak data rate, and by introducing low UE power classes (20 dBm/14 dBm). Coverage extension of ~20 dB is enabled also basically through repetitions. NB-IoT can operate in band in LTE, in the LTE guardband, or standalone.

In order to improve UE power consumption, a Power Saving mode was introduced and extended Discontinuous Reception (eDRX) cycles range up to 10.24 s in connected mode, 43.69 min in idle mode for LTE-M and 2.91 h in idle mode for NB-IoT. For NB-IoT and LTE-M, further reduced UE power consumption has been enabled with support for: Wake-Up Signals (WUS) allowing the UE to reduce control channel processing before a WUS is detected; Early Data Transmission (EDT) and Transmission using Pre-configured UL Resource (PUR) which enable UEs to transmit and receive small data with minimal signaling; and relaxed monitoring for cell reselection when mobility is low. For LTE-M and NB-IoT, it is possible to configure an additional uplink and an additional downlink carrier for traffic which is dedicated to a particular User Equipment, whilst common transmissions such as synchronization signals, and uplink transmissions during cell access, occur on the same carrier for all User Equipment.

In order to enhance data offloading, both RITs support LTE/Wi-Fi interworking functionality via RAN-assisted and RAN-controlled WLAN interworking. Based on configurable rules or eNB command, the UE steers its data traffic to the most appropriate radio access. Additionally, from Release 13 onwards, both RITs support LTE-WLAN aggregation (LWA) and LTE-WLAN Radio Level Integration with IPsec Tunnel (LWIP). LWA allows utilizing both LTE and WLAN in the unlicensed 2.4 GHz and 5 GHz bands simultaneously under the control of eNB.

From Release 12 onwards, sidelink transmissions are defined for Proximity based Services (ProSe) Direct Discovery and ProSe Direct Communication between terminals. ProSe Direct Communication is targeting only Public Safety applications and allows terminals to communicate with each other directly without routing the data via the eNB. ProSe Direct Discovery allows discovering other terminals in close proximity. Direct communication is also supported when a terminal is out of LTE coverage. The sidelink has been further enhanced in order to address direct vehicle-to-vehicle (V2V) communication. The sidelink supports carrier aggregation and transmit diversity.

### 1.3.1 Network architecture

The *LTE-Advanced* radio-access network has a flat architecture with a single type of node, the *eNodeB*, which is responsible for all radio-related functions in one or several cells. The *eNodeB* is connected to the core network by means of the S1 interface, more specifically to the *serving gateway* (S-GW) by means of the user-plane part, S1-u, and to the *Mobility Management Entity* (MME) by means of the control-plane part, S1-c. One *eNodeB* can interface to multiple MMEs/S-GWs for the purpose of load sharing and redundancy. MMEs/S-GWs can be (re)selected for support of separate dedicated core networks that are designed to meet the requirements of a certain group of devices/customers.

The X2 interface, connecting *eNodeB*s to each other, is mainly used to support active-mode mobility. This interface may also be used for multi-cell *Radio Resource Management* (RRM) functions such as ICIC or CoMP. The X2 interface is also used to support lossless mobility between neighbouring cells by means of packet forwarding.

FIGURE 1  
Radio-access network interfaces

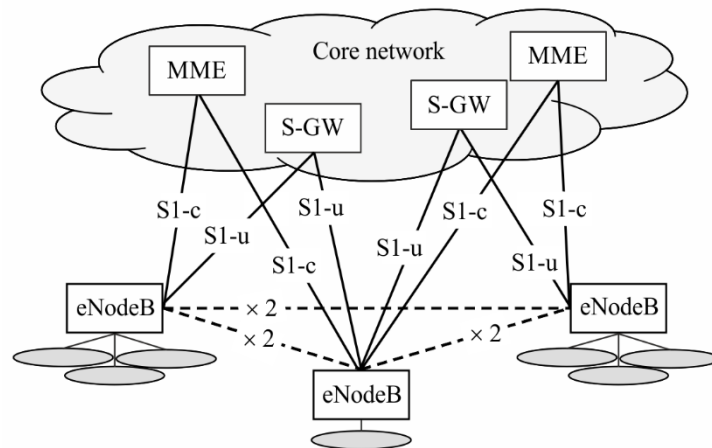

M.2012-01

E-UTRA also supports other architectures. These other architectures are not part of this Recommendation and their description is contained in Recommendation ITU-R M.2150-2, Annex 1, § 1.1.

### 1.3.2 Layer 2 protocol architecture

Layer 2 (L2) consists of several sub-layers: *Packet Data Convergence Protocol* (PDCP), *Radio Link Control* (RLC) and *Medium Access Control* (MAC). The downlink and uplink protocol structures are illustrated in Fig. 2 and Fig. 3, respectively. Layer 2 provides one or more Radio Bearers to higher layers to which IP packets are mapped according to their Quality-of-Service (QoS) requirements. L2/MAC PDUs, also referred to as transport blocks, are created according to instantaneous scheduling decisions and delivered to the physical layer on one or several transport channels (one transport channel of the same type per component carrier).

FIGURE 2

Downlink L2 protocol structure

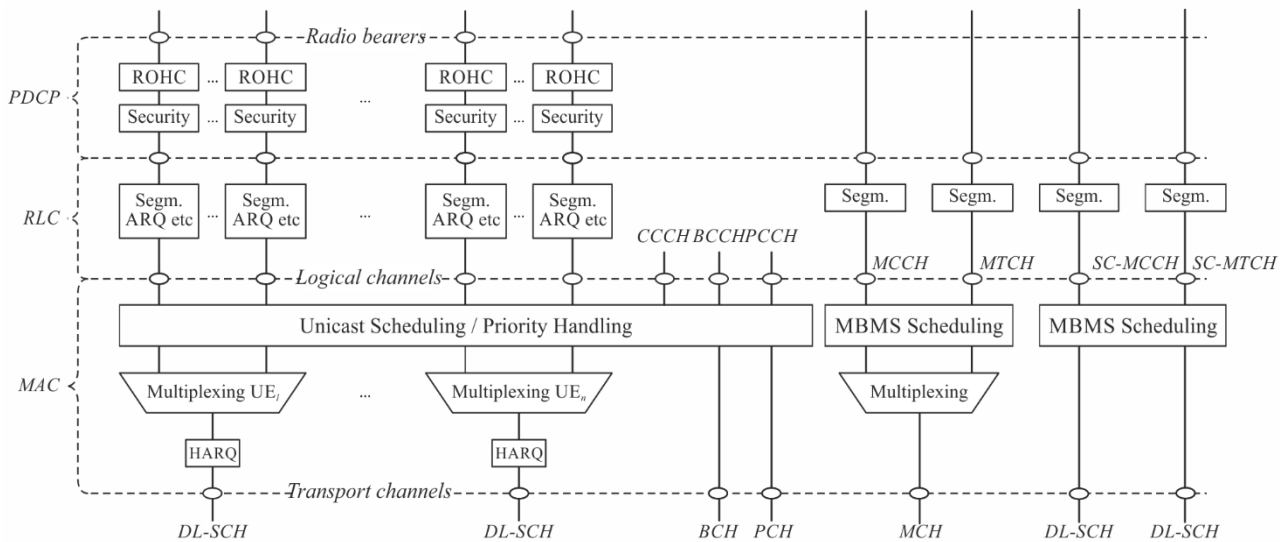

M.2012-02

FIGURE 3

Uplink L2 protocol structure

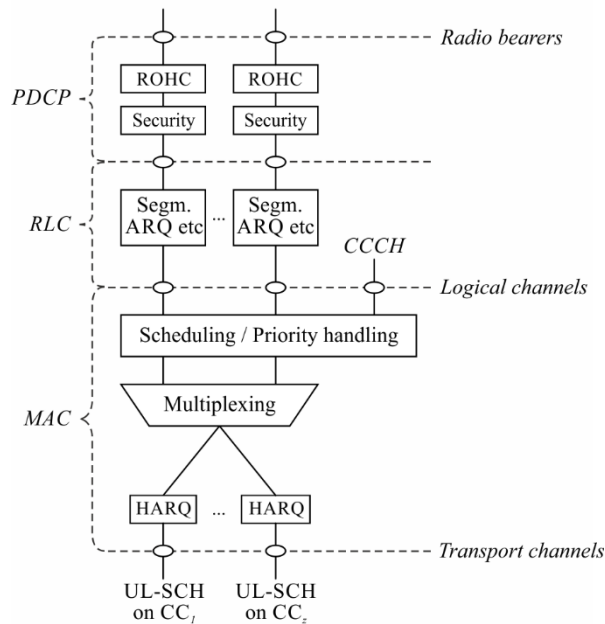

M.2012-03

In Dual Connectivity, a data radio bearer can be configured as Master Cell Group (MCG) bearer, Secondary Cell Group (SCG) bearer or a split bearer. The MCG bearer is served by the Master eNB (MeNB), SCG bearer by the Secondary eNB (SeNB) and the split bearer is served by both eNBs. For a split bearer, a common PDCP entity is located in the MeNB, but there are two RLC entities, one terminating in the MeNB and one in the SeNB.

**1.3.2.1 Packet Data Convergence Protocol (PDCP)**

Except for NB-IoT, the main services and functions of the PDCP sublayer for the user plane include:

- Header compression and decompression of IP data flows using ROHC.

- Header compression and decompression of Ethernet packet streams.
- Compression and decompression of uplink PDCP SDUs: DEFLATE based UDC only.
- Transfer of user data.
- In-sequence delivery of upper layer PDUs at PDCP re-establishment procedure for RLC AM.
- For split bearers in Dual Connectivity (only support for RLC AM) and LWA bearers (only support for RLC AM and RLC UM): PDCP PDU routing for transmission and PDCP PDU reordering for reception.
- Duplicate detection of lower layer SDUs at PDCP re-establishment procedure for RLC AM.
- Retransmission of PDCP SDUs at handover and, for split bearers in DC and LWA bearers, of PDCP PDUs at PDCP data-recovery procedure, for RLC AM.
- Cipherring and deciphering.
- Timer-based SDU discard in uplink.
- Duplication of PDCP PDUs.
- For PDCP duplication, reordering and duplicate detection at the receiver.

For NB-IoT UE when AS security is activated, the main services and functions of the PDCP sublayer for the user plane include:

- Header compression and decompression: ROHC only;
- Transfer of user data;
- In-sequence delivery of upper layer PDUs at PDCP re-establishment procedure for RLC AM;
- Duplicate detection of lower layer SDUs at PDCP re-establishment procedure for RLC AM;
- Cipherring and deciphering;
- Timer-based SDU discard in uplink.

The main services and functions of the PDCP for the control plane include:

- Cipherring and Integrity Protection and Verification.
- Transfer of control plane data.

Except for NB-IoT, the main services and functions of the PDCP sublayer for the control plane also include:

- Duplication of PDCP PDUs.
- For PDCP duplication, reordering and duplicate detection at the receiver.

For a NB-IoT UE that supports Control Plane CIoT EPS optimizations only, PDCP is bypassed. For a NB-IoT UE that supports both Control Plane CIoT EPS optimizations and User Plane CIoT EPS optimizations PDCP is not used until AS security is activated.

PDCP uses the services provided by the RLC sub-layer. There is one PDCP entity per radio bearer configured for a UE.

### 1.3.2.2 Radio Link Control (RLC)

*Radio Link Control* (RLC) is responsible for:

- Transfer of upper layer PDUs.
- Error correction through ARQ (only for AM data transfer).
- Concatenation, segmentation and reassembly of RLC SDUs (only for UM and AM data transfer).

- Resegmentation of RLC data PDUs (only for AM data transfer).
- Reordering of RLC data PDUs (only for UM and AM data transfer).
- Duplicate detection (only for UM and AM data transfer).
- Protocol error detection (only for AM data transfer).
- RLC SDU discard (only for UM and AM data transfer).
- RLC re-establishment.

Depending on the mode-of-operation, an RLC entity may provide all, a subset of, or none of the services above. The RLC can operate in three different modes:

- *Transparent mode* (TM), where the RLC is completely transparent and is in essence bypassed. This configuration is used for control-plane broadcast channels such as Broadcast Control Channel (BCCH), Common Control Channel (CCCH) and Paging Control Channel (PCCH) only where the information should reach multiple users.
- *Unacknowledged mode* (UM), where the RLC provides all the functionality above except error correction, is used when error-free delivery is not required, for example for Multicast Control Channel (MCCH) and Multicast Traffic Channel (MTCH) using Multimedia Broadcast over a Single Frequency Network (MBSFN) and for Voice-over-IP (VoIP).
- *Acknowledged mode* (AM), where the RLC provides all the services above, is the main mode-of-operation for TCP/IP packet data transmission on the Downlink Shared Channel (DL-SCH). Segmentation/reassembly, in-sequence delivery and retransmissions of erroneous data are all supported.

The RLC offers services to the PDCP in the form of *radio bearers* and uses services from the MAC layer in the form of *logical channels*. There is one RLC entity per radio bearer configured for a terminal, except for radio bearers configured with PDCP duplication and for DAPS bearers, for which there are two for UL and DL, respectively.

### 1.3.2.3 Medium access control (MAC)

The MAC layer is responsible for:

- Mapping between logical channels and transport channels.
- Multiplexing/demultiplexing of MAC SDUs belonging to one or different logical channels into/from transport blocks delivered to/from the physical layer on transport channels.
- Scheduling information reporting.
- Error correction through N-process stop-and-wait hybrid-ARQ (HARQ) with synchronous (for the uplink) and asynchronous (for the downlink and optionally for the uplink) retransmissions.
- Priority handling between logical channels of one UE.
- Priority handling between UEs by means of dynamic scheduling.
- Multimedia Broadcast/Multicast Service (MBMS) identification.
- Transport format selection.
- Padding.

The ProSe specific services and functions of the MAC sublayer include:

- Radio resource selection.
- Packet filtering for Prose Direct Communication.

In case of Dual Connectivity, the UE is configured with two independent MAC entities, one for MCG and one for SCG.

The MAC offers services to the RLC in the form of *logical channels*. A logical channel is defined by the *type* of information it carries and is generally classified as a *control channel*, used for transmission of control and configuration information necessary for operating an *LTE-Advanced* system, or as a *traffic channel*, used for the user data. The set of logical-channel types specified for *LTE-Advanced* includes:

- *Broadcast Control Channel (BCCH)*, used for broadcasting system control information.
- *Bandwidth Reduced Broadcast Control Channel (BR-BCCH)*, used for broadcasting system control information to bandwidth limited eMTC UEs.
- *Paging Control Channel (PCCH)*, a downlink channel used for paging when the network is not aware of the location of the UE and for system information change notifications.
- *Common Control Channel (CCCH)*, used for transmission of control information between UEs and network when the UE has no RRC connection.
- *Dedicated Control Channel (DCCH)*, used for transmission of control information to/from a mobile terminal when the UE has a RRC connection.
- *Multicast Control Channel (MCCH)*, used for transmission of control information required for reception of the MTCH.
- *Single-Cell Multicast Control Channel (SC-MCCH)*, used for transmission of control information required for reception of MBMS using single-cell point-to-multipoint (SC-PTM).
- *Sidelink Broadcast Control Channel (SBCCH)* used for broadcasting sidelink system information from one UE to other UE(s). This channel is used only by ProSe Direct Communication capable UEs and V2X sidelink communication capable UEs.
- *Dedicated Traffic Channel (DTCH)*, used for transmission of user data to/from a mobile terminal. This is the logical channel type used for transmission of all uplink and non-MBSFN downlink user data. DTCH is not supported for a NB-IoT UE that only uses Control Plane CIoT EPS optimizations.
- *Multicast Traffic Channel (MTCH)*, used for downlink transmission of MBMS services.
- *Single-Cell Multicast Traffic Channel (SC-MTCH)*, used for downlink transmission of MBMS services using SC-PTM.
- *Sidelink Traffic Channel (STCH)* is a point-to-multipoint channel, for transfer of user information from one UE to other UEs. This channel is used only by Prose Direct Communication capable UEs and V2X sidelink communication capable UEs.

For a NB-IoT UE that only uses Control Plane CIoT EPS optimizations there is only one dedicated logical channel per UE.

From the physical layer, the MAC layer uses services in the form of *Transport Channels*. A transport channel is defined by *how* and *with what characteristics* the information is transmitted over the radio interface. Data on a transport channel is organized into *transport blocks*. In each *Transmission Time Interval (TTI)*, at most one or two (in case of spatial multiplexing) transport blocks are transmitted per component carrier.

Associated with each transport block is a *Transport Format (TF)*, specifying *how* the transport block is to be transmitted over the radio interface. The transport format includes information about the transport-block size, the modulation scheme, and the antenna mapping. The scheduler is responsible for (dynamically) determining the uplink as well as downlink transport format in each TTI.

The following transport-channel types are defined:

- *Broadcast Channel* (BCH) has a fixed transport format, provided by the specifications. It is used for transmission of parts of the BCCH system information, more specifically the so-called *Master Information Block* (MIB).
- *Paging Channel* (PCH) is used for transmission of paging information from the PCCH logical channel. The PCH supports *discontinuous reception* (DRX) to allow the mobile terminal to save battery power by waking up to receive the PCH only at predefined time instants.
- *Downlink Shared Channel* (DL-SCH) is the main transport-channel type used for transmission of downlink data in *LTE-Advanced*. It supports dynamic rate adaptation and channel-dependent scheduling, hybrid-ARQ with soft combining, and spatial multiplexing. It also supports DRX to reduce mobile-terminal power consumption while still providing an always-on experience.

The DL-SCH is also used for transmission of the parts of the BCCH system information not mapped to the BCH. In case of transmission to a terminal using multiple component carriers the UE receives one DL-SCH per component carrier.

- *Multicast Channel* (MCH) is used to support MBMS. It is characterized by a semi-static transport format and semi-persistent scheduling. In case of multi-cell transmission using MBSFN, the scheduling and transport format configuration is coordinated among the cells involved in the MBSFN transmission.
- *Uplink Shared Channel* (UL-SCH) is the uplink counterpart to the DL-SCH, i.e. it is the uplink transport channel used for transmission of uplink data.
- *Random Access Channel* (RACH) is also defined as an uplink transport channel although it does not carry transport blocks. The RACH is used in the uplink to respond to the paging message or to initiate the move to the RRC\_CONNECTED state according to terminal data transmission needs.
- *Sidelink broadcast channel* (SL-BCH) uses a pre-defined transport format.
- *Sidelink discovery channel* (SL-DCH) supports both UE autonomous resource selection and scheduled resource allocation by eNodeB; it uses a fixed size, pre-defined format periodic broadcast transmission.
- *Sidelink shared channel* (SL-SCH) supports both UE autonomous resource selection and scheduled resource allocation by eNodeB; it supports HARQ combining and dynamic link adaptation by varying the transmit power, modulation and coding.

The mapping between logical channels, transport channels and physical channels (described in § 1.1.3.3) is illustrated in Fig. 4 for the downlink, Fig. 5 for the uplink, Fig. 6 for the sidelink, Fig. 7 for the NB-IoT downlink and Fig. 8 for the NB-IoT uplink.



FIGURE 4

**Downlink channel mapping**

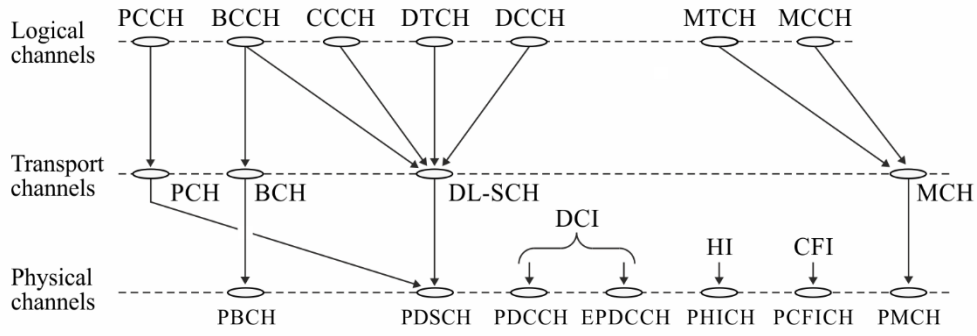

M.2012-04

FIGURE 5

**Uplink channel mapping**

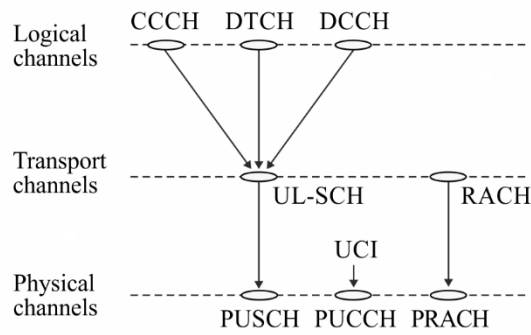

M.2012-05

FIGURE 6

**Sidelink channel mapping**

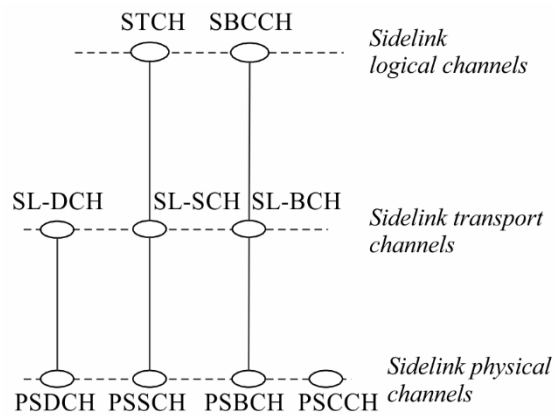

M.2012-06

FIGURE 7

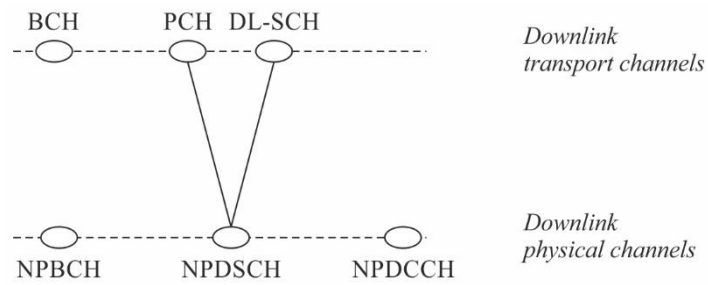
**NB-IoT DL channel mapping**

M.2012-07

FIGURE 8

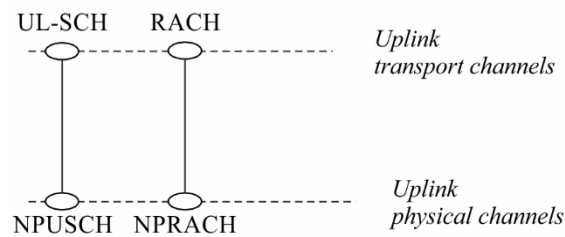
**NB-IoT UL channel mapping**

M.2012-08

**1.3.3 Physical layer**

The physical layer is responsible for:

- Modulation and demodulation of physical channels.
- Error detection on the transport channel and indication to higher layers.
- Forward Error Correction (FEC) encoding and decoding of transport channels.
- Rate matching of the coded transport channel to physical channels.
- Mapping of the coded transport channel onto physical channels according to Fig. 4 (downlink) and Fig. 5 (uplink).
- Hybrid ARQ soft-combining.
- Frequency and time synchronization.
- Power weighting of physical channels.
- Multi-antenna processing and beamforming.
- Characteristic measurements and indication to higher layers.
- RF processing.

A simplified overview of the processing for the DL-SCH is given in Fig. 9.

FIGURE 9  
Simplified physical-layer processing for DL-SCH on one component carrier

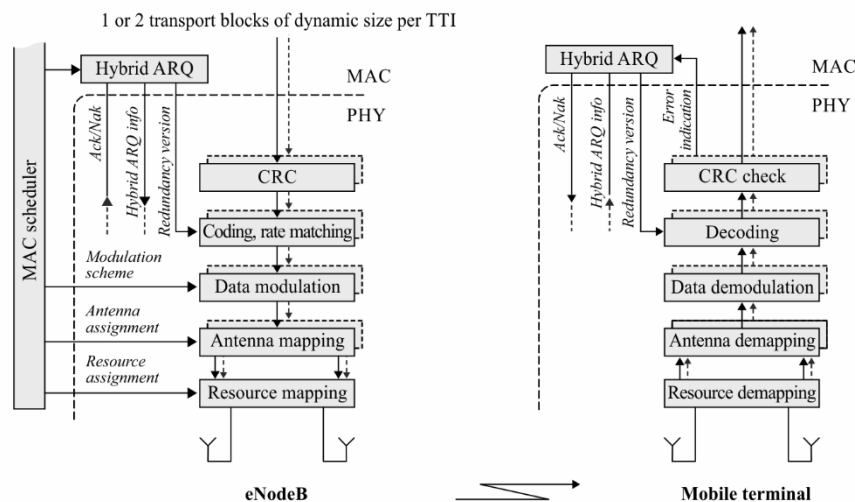

M.2012-09

### 1.3.3.1 Physical channels

The following different types of physical channels are defined for the downlink:

- Physical Downlink Shared Channel (PDSCH): Used for transmission of user and control plane data services.
- Physical Multicast Channel (PMCH): Used for transmission of control and user-plane broadcast services during MBSFN subframes.
- Physical Downlink Control Channel (PDCCH): Used for transmission of control information such as resource allocation, transport format and H-ARQ related information.
- Enhanced Physical Downlink Control Channel (EPDCCH): Used for transmission of control information such as resource allocation, transport format and HARQ related information.
- MTC physical downlink control channel (MPDCCH): Used for transmission of control information in bandwidth-reduced operation and/or using coverage extension mode.
- Short physical downlink control channel (SPDCCH): Used for transmission of control information such as resource allocation, transport format and HARQ related information.
- Physical Broadcast Channel (PBCH): Used for conveying cell and/or system specific information.
- Physical Control Format Indicator Channel (PCFICH): It indicates to the UE the control format (number of symbols comprising PDCCH, PHICH) of the current subframe.
- Physical Hybrid ARQ Indicator Channel (PHICH): It conveys the ACK/NAK information for UL (PUSCH) transmissions received at the eNodeB.

Three different types of physical channels are defined for the uplink:

- Physical Random Access Channel (PRACH): It conveys a preamble which is used to trigger a random-access procedure in the eNodeB.
- Physical Uplink Shared Channel (PUSCH): It conveys both user data and upper layer control information.
- Physical Uplink Control Channel (PUCCH): It conveys control information (scheduling requests, CQI, PMI, RI, HARQ ACK/NAK for PDSCH, etc.).

- Short physical uplink control channel (SPUCCH): It conveys control information (scheduling requests, HARQ ACK/NAK for PDSCH, etc.).

The following types of physical channels are defined for the sidelink:

- Physical sidelink broadcast channel (PSBCH): Carries system and synchronization related information, transmitted from the UE.
- Physical sidelink discovery channel (PSDCH): Carries ProSe Direct Discovery message from the UE.
- Physical sidelink control channel (PSCCH): Carries control from a UE for ProSe Direct Communication.
- Physical sidelink shared channel (PSSCH): Carries data from a UE for ProSe Direct Communication.

The following types of physical channels are defined for NB-IoT:

- Narrowband Physical broadcast channel (NPBCH): Carries the BCH for NB-IoT UEs. Used for conveying cell and/or system specific information using a transport block mapped to sixty-four subframes within a 640 ms interval.
- Narrowband Physical downlink shared channel (NPDSCH): Carries the DL-SCH and PCH for NB-IoT UEs.
- Narrowband Physical downlink control channel (NPDCCH): Informs the NB-IoT UE about the resource allocation of PCH and DL-SCH. Carries the uplink scheduling grant for the NB-IoT UE. Carries the direct indication information.
- Narrowband Physical uplink shared channel (NPUSCH): Carries the UL-SCH and Hybrid ARQ ACK/NAKs in response to downlink transmission for the NB-IoT UE.
- Narrowband Physical random access channel (NPRACH): Carries the random access preamble for the NB-IoT UE.

### 1.3.3.2 Time-domain structure and duplex schemes

Figure 10 illustrates the high-level time-domain structure for transmission, with each (*radio*) *frame* of length 10 ms consisting of ten equally sized *subframes* of length 1 ms. Each subframe consists of two equally sized *slots* of length  $T_{\text{slot}} = 0.5$  ms with each slot consisting of a number of OFDM symbols including cyclic prefix.

FIGURE 10  
*LTE-Advanced* time-domain structure

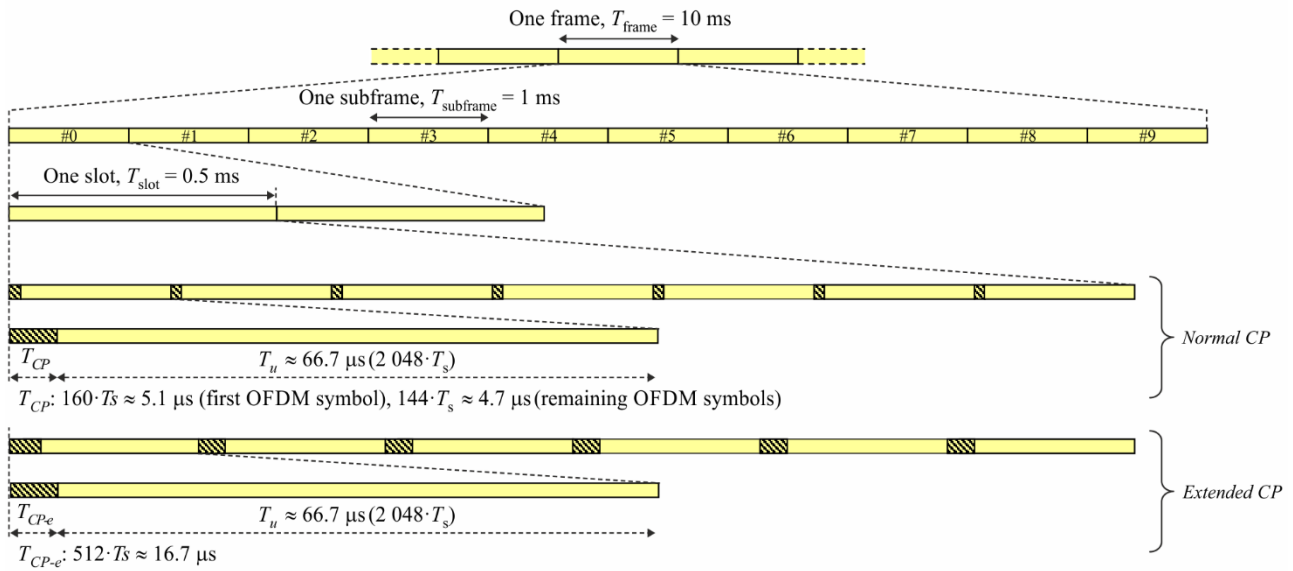

M.2012-10

*LTE-Advanced* can operate in both FDD and TDD as illustrated in Fig. 11. Although the time-domain structure is, in most respects, the same for FDD and TDD there are some differences between the two duplex modes, most notably the presence of a *special subframe* in case of TDD. The special subframe is used to provide the necessary guard time for downlink-to-uplink switching.

FIGURE 11  
Uplink/downlink time/frequency structure in case of FDD and TDD

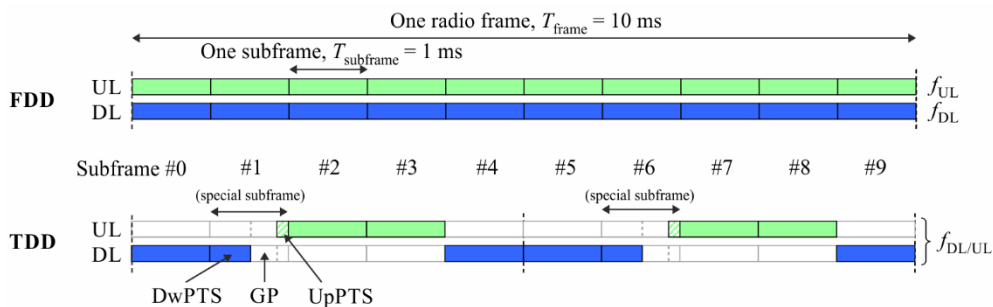

M.2012-11

In case of FDD operation (upper part of Fig. 11), there are two carrier frequencies for each component carrier, one for uplink transmission ( $f_{UL}$ ) and one for downlink transmission ( $f_{DL}$ ). During each frame, there are thus ten uplink subframes and ten downlink subframes and uplink and downlink transmission can occur simultaneously within a cell. Half-duplex operation at the UE side is supported by the scheduler ensuring non-simultaneous reception and transmission at the UE.

In case of TDD operation (lower part of Fig. 11), there is only a single carrier frequency per component carrier and uplink and downlink transmissions are always separated in time also on a cell basis. As seen in the Figure, some subframes are allocated for uplink transmissions and some subframes for downlink transmission with the switch between downlink and uplink occurring in the *special subframe*. The special subframe is split into three parts: a downlink part (DwPTS), a guard period (GP) where the switch occurs, and an uplink part (UpPTS). The DwPTS is in essence treated as a normal downlink subframe, although the amount of data that it is possible to transmit is smaller

due to the reduced length of the DwPTS. The UpPTS can be used for UL data transmission, channel sounding or random access. The DwPTS, GP, and UpPTS have configurable individual lengths to support different deployment scenarios, and a total length of 1 ms.

Different asymmetries in terms of the amount of resources allocated for uplink and downlink transmission, respectively, are provided through seven different downlink/uplink configurations as shown in Fig. 12. In case of carrier aggregation, the downlink/uplink configuration is identical across component carriers in the same band and may be the same or different across component carriers in different bands.

Coexistence between the TDD RIT and other (IMT-2000) TDD systems such as TD-SCDMA is catered for by aligning the switch points between the two systems and selecting the appropriate special subframe configuration and uplink-downlink asymmetry.

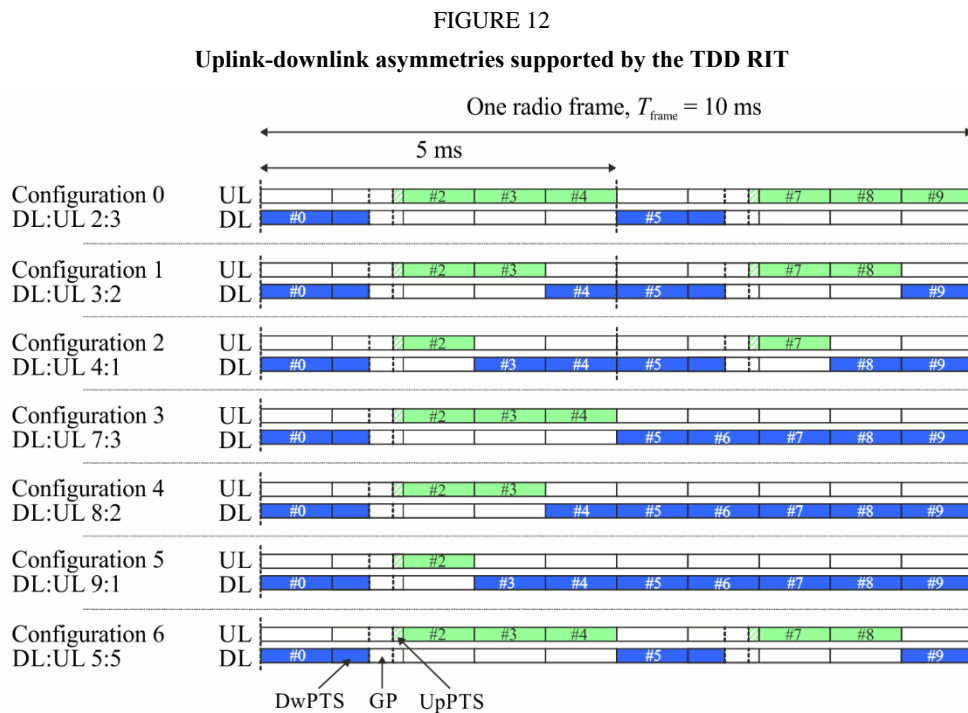

M.2012-12

Sidelink transmissions use the same frame structure as the frame structure that is defined for uplink and downlink when UEs are in network coverage. However, the sidelink transmissions are restricted to a sub-set of the uplink resources in time and frequency domain.

The physical channel structure is similar to uplink transmissions and the same basic transmission scheme as the UL transmission scheme is used. However, sidelink is limited to single cluster transmissions and it uses a 1 symbol gap at the end of each sidelink subframe.

### 1.3.3.3 Physical layer processing

To the transport block(s) to be transmitted on a DL-SCH or UL-SCH, a CRC is attached, followed by rate-1/3 Turbo coding for error correction (Tail Biting Convolutional Code for NPDSCH). Rate matching is used not only to match the number of coded bits to the amount of resources allocated for the DL-SCH/UL-SCH transmission, but also to generate the different redundancy versions as controlled by the hybrid-ARQ protocol. In case of spatial multiplexing, the processing is duplicated for the two transport blocks. After rate matching, the coded bits are modulated (QPSK, 16-QAM, 64-QAM, 256-QAM, 1024-QAM). In case of multi-antenna transmission, the modulation symbols

are mapped to multiple layers and precoded before being mapped to the different antenna ports. Alternatively, transmit diversity can be applied. Finally, the (precoded) modulation symbols are mapped to the time-frequency resources allocated for the transmission.

Downlink transmission is based on conventional OFDM with a cyclic prefix. The subcarrier spacing is  $\Delta f = 15$  kHz and two cyclic prefix lengths are supported: normal cyclic prefix  $\approx 4.7$   $\mu$ s and extended cyclic prefix  $\approx 16.7$   $\mu$ s. In the frequency domain, the number of resource blocks can range from 6 to 100 per component carrier (for channel bandwidths ranging from 1.4 to 20 MHz respectively), where a resource block is 180 kHz in the frequency domain. There can be up to 32 component carriers transmitted in parallel implying an overall bandwidth up to 640 MHz. In inband mode, NB-IoT allocates a single resource block. In standalone mode, NB-IoT uses a channel bandwidth of 200 kHz. MBSFN subframes can use subcarrier spacings of  $\Delta f = 7.5$  kHz or  $\Delta f = 1.25$  kHz with an extended cyclic prefix of  $\approx 33.4$   $\mu$ s and  $\approx 200$   $\mu$ s, respectively. PMCH additionally supports 100  $\mu$ s cyclic prefix and  $\Delta f = 2.5$  kHz subcarrier spacing for support of high mobility scenarios (up to 250 km/h) and 300  $\mu$ s cyclic prefix and approximately  $\Delta f \approx 0.37$  kHz subcarrier spacing for support of rooftop reception.

Uplink transmission is based on DFT-spread OFDM (DFTS-OFDM). DFTS-OFDM can be seen as a DFT precoder, followed by conventional OFDM with the same numerology as in the downlink. The NB-IoT UL allows allocating a single-tone with  $\Delta f = 3.75$  kHz or  $\Delta f = 15$  kHz subcarrier spacing. Multiple DFT precoding sizes, corresponding to transmission with different scheduled bandwidths, can be used.

The remaining downlink transport channels (PCH, BCH, MCH) are based on the same general physical-layer processing as DL-SCH, although with some restrictions in the set of features used.

#### 1.3.3.4 Multi-antenna transmission

A wide range of multi-antenna transmission schemes are supported in the downlink:

- Single-antenna transmission using a single cell-specific reference signal.
- Closed-loop spatial multiplexing, also known as codebook-based beam-forming or precoding, of up to four layers using cell-specific reference signals. Feedback reports from the terminal are used to assist the eNodeB in selecting a suitable precoding matrix.
- Open-loop spatial multiplexing, also known as large-delay cyclic delay diversity, of up to four layers using cell-specific reference signals.
- Spatial multiplexing of up to eight layers using UE-specific reference signals. The eNodeB may use feedback reports or exploit channel reciprocity to set the beam-forming weights.
- Transmit diversity based on space-frequency block coding (SFBC) or a combination of SFBC and Frequency Switched Transmit Diversity (FSTD).
- Multi-user MIMO where multiple terminals are assigned overlapping time-frequency resources.
- Non-precoded CSI-RS operation is supported, which comprises schemes where different CSI-RS ports have the same wide beam width and direction and hence generally cell wide coverage.
- Beamformed CSI-RS operation is supported, which comprises schemes where (at least at a given time/frequency) CSI-RS ports have narrow beam widths and hence not cell wide coverage, and (at least from the eNB perspective) at least some CSI-RS port-resource combinations have different beam directions.
- Downlink Coordinated MultiPoint (DL-CoMP) operation where multiple transmission points are coordinated.

The following multi-antenna transmission schemes are supported in the uplink:

- Single-antenna transmission.
- Precoding supporting rank-adaptive spatial multiplexing with one up to four layers.
- Uplink Coordinated MultiPoint (UL-CoMP) operation where multiple reception points are coordinated.

### 1.3.3.5 Link adaptation and power control

According to the radio channel conditions, the Modulation and Coding Scheme (MCS) can be adapted flexibly. The same modulation and coding is applied to all resource units assigned to the same transport block within a TTI. Uplink power control determines the average power over a DFTS-OFDM symbol in which the physical channel is transmitted.

### 1.3.3.6 L1/L2 control signalling

Downlink control information (DCI) is transmitted on either a PDCCH, an EPDCCH or an SPDCCH. In bandwidth-reduced operation and/or when using coverage extension mode, a DCI is transmitted on an MPDCCH. For NB-IoT, a DCI is transmitted on NPDCCH.

The PDCCH is transmitted in the first one to three OFDM symbols of each downlink subframe in each component carrier with the number of OFDM symbols being indicated on the PCFICH. Downlink and uplink scheduling grants (consisting of UE identity, time-frequency resources and transport format) and hybrid-ARQ acknowledgements are transmitted on the PDCCH and PHICH, respectively. Each grant is transmitted on a separate PDCCH using QPSK modulation and cell-specific reference signals.

The EPDCCH/MPDCCH is transmitted in pairs of Physical Resource Blocks (PRBs) multiplexed in frequency with the PDSCH; it carries downlink and uplink scheduling grants (consisting of UE identity, time-frequency resources and transport format). The EPDCCH/MPDCCH uses QPSK modulation and demodulation reference signals, and it may use either frequency-localized or frequency-distributed transmission.

The SPDCCH is transmitted in UE-specifically configured physical resource blocks and carries downlink and uplink scheduling grants.

For NB-IoT, the NPDCCH is transmitted in all available OFDM symbols of pairs of PRBs, with no multiplexing with NPDSCH; it carries downlink and uplink scheduling grants (consisting of UE identity, time-frequency resources and transport format). The NPDCCH uses QPSK modulation and narrowband reference signals.

Sidelink resource allocation can be transmitted on the PDCCH/EPDCCH.

Uplink control information (UCI), consisting of channel-state information (CSI), scheduling requests and hybrid-ARQ acknowledgements, is transmitted at the band edges of the primary uplink component carrier. Alternatively, parts of the control signalling can be multiplexed with data on PUSCH. To support downlink CoMP transmission, a UE may be configured with multiple CSI processes.

### 1.3.3.7 MBSFN operation

Multicast/Broadcast over Single Frequency Network (MBSFN) transmission, where the same signal is transmitted from multiple, time-synchronized cells, is supported by the MCH transport channel. One component carrier can support simultaneous unicast and broadcast support through time-domain multiplexing of MCH and DL-SCH transmissions.



## 2 Detailed specification of the radio interface technology

Detailed specifications described in this Annex are developed around a Global Core Specification (GCS), which is related to externally developed materials incorporated by specific references for a specific technology. The process and use of the GCS, references, and related notifications and certifications are found as Document IMT-ADV/24(Rev.3).

The IMT-Advanced standards contained in this section are derived from the global core specification for LTE-Advanced contained at [Global Core Specifications M.2012-6](#). For information, additional specifications are contained in Recommendation ITU-R M.2150-2, Annex 1, section 1.2. The following notes apply to the sections below:

- 1) The identified Transposing Organizations<sup>9</sup> should make their reference material available from their website.
- 2) This information was supplied by the Transposing Organizations and relates to their own deliverables of the transposed global core specification.

Section 2.1 contains titles and synopses of the Global Core Specification of IMT-Advanced radio interface technology entitled LTE-Advanced and the related hyperlinks to the transposed standards. Specifications listed in § 2.2 are not part of the LTE-Advanced GCS.

The specific 3GPP specifications of the GCS for LTE-Advanced that are being transposed in § 2.1 are summarized in Table 1.

---

<sup>9</sup> The following identified Transposing Organizations have provided their transposed sets of standards information contained in this section:

- Association of Radio Industries and Businesses (ARIB)
- Alliance for Telecommunications Industry Solutions (ATIS)
- China Communications Standards Association (CCSA)
- European Telecommunications Standards Institute (ETSI)
- Telecommunications Standards Development Society, India (TSDSI)
- Telecommunications Technology Association (TTA)
- Telecommunication Technology Committee (TTC).

TABLE 1  
3GPP specifications in § 2.1 that are to be transposed

36.100 Series	36.200 Series	36.300 Series	36.400 Series	36.500 series	37.xxx Series	25.400 Series
TS 36.101	TS 36.201	TS 36.300	TS 36.401	TS 36.508	TS 37.104	TS 25.446
TS 36.104	TS 36.211	TS 36.302	TS 36.410	TS 36.509	TS 37.105	
TS 36.106	TS 36.212	TS 36.304	TS 36.411	TS 36.521-1	TS 37.113	
TS 36.111	TS 36.213	TS 36.305	TS 36.412	TS 36.521-2	TS 37.114	
TS 36.112	TS 36.214	TS 36.306	TS 36.413	TS 36.521-3	TS 37.141	
TS 36.113	TS 36.216	TS 36.307	TS 36.414	TS 36.523-1	TS 37.144	
TS 36.116		TS 36.314	TS 36.420	TS 36.523-2	TS 37.145-1	
TS 36.117		TS 36.321	TS 36.421	TS 36.523-3	TS 37.145-2	
TS 36.124		TS 36.322	TS 36.422	TS 36.579-1	TS 37.171	
TS 36.133		TS 36.323	TS 36.423	TS 36.579-2	TS 37.320	
TS 36.141		TS 36.331	TS 36.424	TS 36.579-3	TS 37.355	
TS 36.143		TS 36.355	TS 36.425	TS 36.579-4	TS 37.460	
TS 36.171		TS 36.360	TS 36.440	TS 36.579-5	TS 37.461	
		TS 36.361	TS 36.441	TS 36.579-6	TS 37.462	
			TS 36.442	TS 36.579-7	TS 37.466	
			TS 36.443		TS 37.470	
			TS 36.444		TS 37.471	
			TS 36.445		TS 37.472	
			TS 36.455		TS 37.473	
			TS 36.456		TS 37.480	
			TS 36.457		TS 37.481	
			TS 36.458		TS 37.482	
			TS 36.459		TS 37.483	
			TS 36.461		TS 37.544	
			TS 36.462		TS 37.571-1	
			TS 36.463		TS 37.571-2	
			TS 36.464		TS 37.571-3	
			TS 36.465		TS 37.571-4	
					TS 37.571-5	

## 2.1 Titles and synopses of the global core specification and the transposed standards

### 2.1.1 Introduction

The standards documents referenced below, as transposed from the relevant 3GPP specifications, are provided by the identified *Transposing Organizations* as the transposed sets of standards for the terrestrial radio interface of IMT-Advanced identified as *LTE-Advanced* and includes not only the key characteristics of IMT-Advanced but also the additional capabilities of *LTE-Advanced* both of which are continuing to be enhanced.

### 2.1.2 Radio Layer 1

#### 2.1.2.1 TS 36.201

#### Evolved Universal Terrestrial Radio Access (E-UTRA); LTE physical layer; General description

This document provides a general description of the physical layer of the E-UTRA radio interface. This document also describes the document structure of the 3GPP E-UTRA physical layer specifications, i.e. TS 36.200 series. The TS 36.200 series specifies the Uu point for the LTE mobile system, and defines the minimum level of specifications required for basic connections in terms of mutual connectivity and compatibility.

SDO	Document No.	Version	Status	Issued date	Location
<b>Release 10</b>					
ARIB	ARIB STD-T120-36.201.V10.0.0	10.0.0	Published	03.03.2023	<a href="https://www.arib.or.jp/english/html/overview/doc/T120_T23_SPECS/ARIB-STD-T120/Rel10/36/A36201-a00.pdf">https://www.arib.or.jp/english/html/overview/doc/T120_T23_SPECS/ARIB-STD-T120/Rel10/36/A36201-a00.pdf</a>
ATIS	ATIS.3GPP.36.201V1000	10.0.0	Published	28.06.2021	<a href="https://www.atis.org/3gpp-documents/Rel99-14/">https://www.atis.org/3gpp-documents/Rel99-14/</a>
CCSA	CCSA.36.201V1000	10.0.0	Published	01.12.2010	<a href="https://www.ccsa.org.cn/api/portalsFile/downloadOldFile?type=19&amp;oldFileUrl=ITU-R/M.2012-6/CCSA.36.201V1000.doc">https://www.ccsa.org.cn/api/portalsFile/downloadOldFile?type=19&amp;oldFileUrl=ITU-R/M.2012-6/CCSA.36.201V1000.doc</a>
ETSI	ETSI TS 136 201	10.0.0	Published	14.01.2011	<a href="https://www.etsi.org/deliver/etsi_ts/136200_136299/136201/10.00.00_60/ts_136201v100000p.pdf">https://www.etsi.org/deliver/etsi_ts/136200_136299/136201/10.00.00_60/ts_136201v100000p.pdf</a>
TSDSI	TSDSI STD T1.3GPP 36.201-10.0.0 V1.0.0	10.0.0	Published	30.08.2021	<a href="https://members.tdsi.in/index.php/s/CHXbJzapAmAchJ2">https://members.tdsi.in/index.php/s/CHXbJzapAmAchJ2</a>
TTA	TTAT.3G-36.201V10.0.0	10.0.0	Published	02.08.2021	<a href="http://committee.tta.or.kr/data/ttasDown.jsp?kind=ttastd&amp;pk_num=TTAT.3G-36.201V10.0.0">http://committee.tta.or.kr/data/ttasDown.jsp?kind=ttastd&amp;pk_num=TTAT.3G-36.201V10.0.0</a>
<b>Release 11</b>					
ARIB	ARIB STD-T120-36.201.V11.1.0	11.1.0	Published	03.03.2023	<a href="https://www.arib.or.jp/english/html/overview/doc/T120_T23_SPECS/ARIB-STD-T120/Rel11/36/A36201-b10.pdf">https://www.arib.or.jp/english/html/overview/doc/T120_T23_SPECS/ARIB-STD-T120/Rel11/36/A36201-b10.pdf</a>
ATIS	ATIS.3GPP.36.201V1110	11.1.0	Published	28.06.2021	<a href="https://www.atis.org/3gpp-documents/Rel99-14/">https://www.atis.org/3gpp-documents/Rel99-14/</a>
CCSA	CCSA.36.201V1110	11.1.0	Published	01.12.2012	<a href="https://www.ccsa.org.cn/api/portalsFile/downloadOldFile?type=19&amp;oldFileUrl=ITU-R/M.2012-6/CCSA.36.201V1110.doc">https://www.ccsa.org.cn/api/portalsFile/downloadOldFile?type=19&amp;oldFileUrl=ITU-R/M.2012-6/CCSA.36.201V1110.doc</a>
ETSI	ETSI TS 136 201	11.1.0	Published	06.02.2013	<a href="https://www.etsi.org/deliver/etsi_ts/136200_136299/136201/11.01.00_60/ts_136201v110100p.pdf">https://www.etsi.org/deliver/etsi_ts/136200_136299/136201/11.01.00_60/ts_136201v110100p.pdf</a>
TSDSI	TSDSI STD T1.3GPP 36.201-11.1.0 V1.0.0	11.1.0	Published	30.08.2021	<a href="https://members.tdsi.in/index.php/s/mrNtac65YwHtTAn">https://members.tdsi.in/index.php/s/mrNtac65YwHtTAn</a>
TTA	TTAT.3G-36.201V11.1.0	11.1.0	Published	02.08.2021	<a href="http://committee.tta.or.kr/data/ttasDown.jsp?kind=ttastd&amp;pk_num=TTAT.3G-36.201V11.1.0">http://committee.tta.or.kr/data/ttasDown.jsp?kind=ttastd&amp;pk_num=TTAT.3G-36.201V11.1.0</a>
<b>Release 12</b>					
ARIB	ARIB STD-T120-36.201.V12.2.0	12.2.0	Published	03.03.2023	<a href="https://www.arib.or.jp/english/html/overview/doc/T120_T23_SPECS/ARIB-STD-T120/Rel12/36/A36201-c20.pdf">https://www.arib.or.jp/english/html/overview/doc/T120_T23_SPECS/ARIB-STD-T120/Rel12/36/A36201-c20.pdf</a>
ATIS	ATIS.3GPP.36.201V1220	12.2.0	Published	28.06.2021	<a href="https://www.atis.org/3gpp-documents/Rel99-14/">https://www.atis.org/3gpp-documents/Rel99-14/</a>
CCSA	CCSA.36.201V1220	12.2.0	Published	01.03.2015	<a href="https://www.ccsa.org.cn/api/portalsFile/downloadOldFile?type=19&amp;oldFileUrl=ITU-R/M.2012-6/CCSA.36.201V1220.doc">https://www.ccsa.org.cn/api/portalsFile/downloadOldFile?type=19&amp;oldFileUrl=ITU-R/M.2012-6/CCSA.36.201V1220.doc</a>
ETSI	ETSI TS 136 201	12.2.0	Published	20.04.2015	<a href="https://www.etsi.org/deliver/etsi_ts/136200_136299/136201/12.02.00_60/ts_136201v120200p.pdf">https://www.etsi.org/deliver/etsi_ts/136200_136299/136201/12.02.00_60/ts_136201v120200p.pdf</a>
TSDSI	TSDSI STD T1.3GPP 36.201-12.2.0 V1.0.0	12.2.0	Published	30.08.2021	<a href="https://members.tdsi.in/index.php/s/8YffDz9LCmepfXC">https://members.tdsi.in/index.php/s/8YffDz9LCmepfXC</a>
TTA	TTAT.3G-36.201V12.2.0	12.2.0	Published	02.08.2021	<a href="http://committee.tta.or.kr/data/ttasDown.jsp?kind=ttastd&amp;pk_num=TTAT.3G-36.201V12.2.0">http://committee.tta.or.kr/data/ttasDown.jsp?kind=ttastd&amp;pk_num=TTAT.3G-36.201V12.2.0</a>
<b>Release 13</b>					
ARIB	ARIB STD-T120-36.201.V13.3.0	13.3.0	Published	03.03.2023	<a href="https://www.arib.or.jp/english/html/overview/doc/T120_T23_SPECS/ARIB-STD-T120/Rel13/36/A36201-d30.pdf">https://www.arib.or.jp/english/html/overview/doc/T120_T23_SPECS/ARIB-STD-T120/Rel13/36/A36201-d30.pdf</a>
ATIS	ATIS.3GPP.36.201V1330	13.3.0	Published	28.06.2021	<a href="https://www.atis.org/3gpp-documents/Rel99-14/">https://www.atis.org/3gpp-documents/Rel99-14/</a>
CCSA	CCSA.36.201V1330	13.3.0	Published	01.03.2017	<a href="https://www.ccsa.org.cn/api/portalsFile/downloadOldFile?type=19&amp;oldFileUrl=ITU-R/M.2012-6/CCSA.36.201V1330.doc">https://www.ccsa.org.cn/api/portalsFile/downloadOldFile?type=19&amp;oldFileUrl=ITU-R/M.2012-6/CCSA.36.201V1330.doc</a>
ETSI	ETSI TS 136 201	13.3.0	Published	11.04.2017	<a href="https://www.etsi.org/deliver/etsi_ts/136200_136299/136201/13.03.00_60/ts_136201v130300p.pdf">https://www.etsi.org/deliver/etsi_ts/136200_136299/136201/13.03.00_60/ts_136201v130300p.pdf</a>

## 26

## Rec. ITU-R M.2012-6

TSDSI	TSDSI STD T1.3GPP 36.201-13.3.0 V1.0.0	13.3.0	Published	30.08.2021	<a href="https://members.tdsi.in/index.php/s/i8gxXYCj2CofBws">https://members.tdsi.in/index.php/s/i8gxXYCj2CofBws</a>
TTA	TTAT.3G-36.201V13.3.0	13.3.0	Published	02.08.2021	<a href="http://committee.tta.or.kr/data/ttasDown.jsp?kind=ttastd&amp;pk_num=TTAT.3G-36.201V13.3.0">http://committee.tta.or.kr/data/ttasDown.jsp?kind=ttastd&amp;pk_num=TTAT.3G-36.201V13.3.0</a>
<b>Release 14</b>					
ARIB	ARIB STD-T120-36.201.V14.1.0	14.1.0	Published	03.03.2023	<a href="https://www.arib.or.jp/english/html/overview/doc/T120_T23_SPECS/ARIB-STD-T120/Rel14/36/A36201-e10.pdf">https://www.arib.or.jp/english/html/overview/doc/T120_T23_SPECS/ARIB-STD-T120/Rel14/36/A36201-e10.pdf</a>
ATIS	ATIS.3GPP.36.201V1410	14.1.0	Published	28.06.2021	<a href="https://www.atis.org/3gpp-documents/Rel99-14/">https://www.atis.org/3gpp-documents/Rel99-14/</a>
CCSA	CCSA.36.201V1410	14.1.0	Published	01.03.2017	<a href="https://www.ccsa.org.cn/api/portalsFile/downloadOldFile?type=19&amp;oldFileUrl=ITU-R/M.2012-6/CCSA.36.201V1410.doc">https://www.ccsa.org.cn/api/portalsFile/downloadOldFile?type=19&amp;oldFileUrl=ITU-R/M.2012-6/CCSA.36.201V1410.doc</a>
ETSI	ETSI TS 136 201	14.1.0	Published	11.04.2017	<a href="https://www.etsi.org/deliver/etsi_ts/136200_136299/136201/14.01.00_60/ts_136201v140100p.pdf">https://www.etsi.org/deliver/etsi_ts/136200_136299/136201/14.01.00_60/ts_136201v140100p.pdf</a>
TSDSI	TSDSI STD T1.3GPP 36.201-14.1.0 V1.0.0	14.1.0	Published	30.08.2021	<a href="https://members.tdsi.in/index.php/s/wSg6cD9KwZSbZn6">https://members.tdsi.in/index.php/s/wSg6cD9KwZSbZn6</a>
TTA	TTAT.3G-36.201V14.1.0	14.1.0	Published	02.08.2021	<a href="http://committee.tta.or.kr/data/ttasDown.jsp?kind=ttastd&amp;pk_num=TTAT.3G-36.201V14.1.0">http://committee.tta.or.kr/data/ttasDown.jsp?kind=ttastd&amp;pk_num=TTAT.3G-36.201V14.1.0</a>
<b>Release 15</b>					
ARIB	ARIB STD-T120-36.201.V15.3.0	15.3.0	Published	03.03.2023	<a href="https://www.arib.or.jp/english/html/overview/doc/T120_T23_SPECS/ARIB-STD-T120/Rel15/36/A36201-f30.pdf">https://www.arib.or.jp/english/html/overview/doc/T120_T23_SPECS/ARIB-STD-T120/Rel15/36/A36201-f30.pdf</a>
ATIS	ATIS.3GPP.36.201V1530	15.3.0	Published	28.06.2021	<a href="https://www.atis.org/3gpp-documents/Rel15/">https://www.atis.org/3gpp-documents/Rel15/</a>
CCSA	CCSA.36.201V1530	15.3.0	Published	01.03.2020	<a href="https://www.ccsa.org.cn/api/portalsFile/downloadOldFile?type=19&amp;oldFileUrl=ITU-R/M.2012-6/CCSA.36.201V1530.doc">https://www.ccsa.org.cn/api/portalsFile/downloadOldFile?type=19&amp;oldFileUrl=ITU-R/M.2012-6/CCSA.36.201V1530.doc</a>
ETSI	ETSI TS 136 201	15.3.0	Published	14.04.2020	<a href="https://www.etsi.org/deliver/etsi_ts/136200_136299/136201/15.03.00_60/ts_136201v150300p.pdf">https://www.etsi.org/deliver/etsi_ts/136200_136299/136201/15.03.00_60/ts_136201v150300p.pdf</a>
TSDSI	TSDSI STD T1.3GPP 36.201-15.3.0 V1.0.0	15.3.0	Published	30.08.2021	<a href="https://members.tdsi.in/index.php/s/TJ5e7eMFzoNENaw">https://members.tdsi.in/index.php/s/TJ5e7eMFzoNENaw</a>
TTA	TTAT.3G-36.201V15.3.0	15.3.0	Published	11.09.2020	<a href="http://committee.tta.or.kr/data/ttasDown.jsp?kind=ttastd&amp;pk_num=TTAT.3G-36.201V15.3.0">http://committee.tta.or.kr/data/ttasDown.jsp?kind=ttastd&amp;pk_num=TTAT.3G-36.201V15.3.0</a>
<b>Release 16</b>					
ARIB	ARIB STD-T120-36.201.V16.0.0	16.0.0	Published	03.03.2023	<a href="https://www.arib.or.jp/english/html/overview/doc/T120_T23_SPECS/ARIB-STD-T120/Rel16/36/A36201-g00.pdf">https://www.arib.or.jp/english/html/overview/doc/T120_T23_SPECS/ARIB-STD-T120/Rel16/36/A36201-g00.pdf</a>
ATIS	ATIS.3GPP.36.201V1600	16.0.0	Published	28.06.2021	<a href="https://www.atis.org/3gpp-documents/Rel16/">https://www.atis.org/3gpp-documents/Rel16/</a>
CCSA	CCSA.36.201V1600	16.0.0	Published	01.06.2020	<a href="https://www.ccsa.org.cn/api/portalsFile/downloadOldFile?type=19&amp;oldFileUrl=ITU-R/M.2012-6/CCSA.36.201V1600.doc">https://www.ccsa.org.cn/api/portalsFile/downloadOldFile?type=19&amp;oldFileUrl=ITU-R/M.2012-6/CCSA.36.201V1600.doc</a>
ETSI	ETSI TS 136 201	16.0.0	Published	20.07.2020	<a href="https://www.etsi.org/deliver/etsi_ts/136200_136299/136201/16.00.00_60/ts_136201v160000p.pdf">https://www.etsi.org/deliver/etsi_ts/136200_136299/136201/16.00.00_60/ts_136201v160000p.pdf</a>
TSDSI	TSDSI STD T1.3GPP 36.201-16.0.0 V1.0.0	16.0.0	Published	30.08.2021	<a href="https://members.tdsi.in/index.php/s/rNFgxpDc5zbTma">https://members.tdsi.in/index.php/s/rNFgxpDc5zbTma</a>
TTA	TTAT.3G-36.201V16.0.0	16.0.0	Published	11.09.2020	<a href="http://committee.tta.or.kr/data/ttasDown.jsp?kind=ttastd&amp;pk_num=TTAT.3G-36.201V16.0.0">http://committee.tta.or.kr/data/ttasDown.jsp?kind=ttastd&amp;pk_num=TTAT.3G-36.201V16.0.0</a>
<b>Release 17</b>					
ARIB	ARIB STD-T120-36.201.V17.0.0	17.0.0	Published	03.03.2023	<a href="https://www.arib.or.jp/english/html/overview/doc/T120_T23_SPECS/ARIB-STD-T120/Rel17/36/A36201-h00.pdf">https://www.arib.or.jp/english/html/overview/doc/T120_T23_SPECS/ARIB-STD-T120/Rel17/36/A36201-h00.pdf</a>
ATIS	ATIS.3GPP.36.201.V17.0.0	17.0.0	Published	21.02.2023	<a href="https://www.atis.org/3gpp-transpositions - Rel-17">https://www.atis.org/3gpp-transpositions - Rel-17</a>
CCSA	CCSA.36.201V1700	17.0.0	Published	01.03.2022	<a href="https://www.ccsa.org.cn/api/portalsFile/downloadOldFile?type=19&amp;oldFileUrl=ITU-R/M.2012-6/CCSA.36.201V1700.doc">https://www.ccsa.org.cn/api/portalsFile/downloadOldFile?type=19&amp;oldFileUrl=ITU-R/M.2012-6/CCSA.36.201V1700.doc</a>
ETSI	ETSI TS 136 201	17.0.0	Published	20.04.2022	<a href="https://www.etsi.org/deliver/etsi_ts/136200_136299/136201/17.00.00_60/ts_136201v170000p.pdf">https://www.etsi.org/deliver/etsi_ts/136200_136299/136201/17.00.00_60/ts_136201v170000p.pdf</a>
TSDSI	TSDSI STD T1.3GPP 36.201-17.0.0 V1.0.0	17.0.0	Published	29.07.2022	<a href="https://members.tdsi.in/s/oFAG4NYgpSWpf3A">https://members.tdsi.in/s/oFAG4NYgpSWpf3A</a>
TTA	TTAT.3G-36.201V17.0.0	17.0.0	Published	05.08.2022	<a href="http://committee.tta.or.kr/data/ttasDown.jsp?kind=ttastd&amp;pk_num=TTAT.3G-36.201V17.0.0">http://committee.tta.or.kr/data/ttasDown.jsp?kind=ttastd&amp;pk_num=TTAT.3G-36.201V17.0.0</a>

### 2.1.2.2 TS 36.211

#### Evolved Universal Terrestrial Radio Access (E-UTRA); Physical channels and modulation

This document describes the physical channels and modulation for E-UTRA.

SDO	Document No.	Version	Status	Issued date	Location
<b>Release 10</b>					
ARIB	ARIB STD-T120-36.211.V10.7.0	10.7.0	Published	03.03.2023	<a href="https://www.arib.or.jp/english/html/overview/doc/T120_T23_SPECS/ARIB-STD-T120/Rel10/36/A36211-a70.pdf">https://www.arib.or.jp/english/html/overview/doc/T120_T23_SPECS/ARIB-STD-T120/Rel10/36/A36211-a70.pdf</a>
ATIS	ATIS.3GPP.36.211V1070	10.7.0	Published	28.06.2021	<a href="https://www.atis.org/3gpp-documents/Rel99-14/">https://www.atis.org/3gpp-documents/Rel99-14/</a>
CCSA	CCSA.36.211V1070	10.7.0	Published	01.02.2013	<a href="https://www.ccsa.org.cn/api/portalsFile/downloadOldFile?type=19&amp;oldFileUrl=ITU-R/M.2012-6/CCSA.36.211V1070.doc">https://www.ccsa.org.cn/api/portalsFile/downloadOldFile?type=19&amp;oldFileUrl=ITU-R/M.2012-6/CCSA.36.211V1070.doc</a>
ETSI	ETSI TS 136 211	10.7.0	Published	19.04.2013	<a href="https://www.etsi.org/deliver/etsi_ts/136200_136299/136211/10.07.00_60/ts_136211v100700p.pdf">https://www.etsi.org/deliver/etsi_ts/136200_136299/136211/10.07.00_60/ts_136211v100700p.pdf</a>
TSDSI	TSDSI STD T1.3GPP 36.211-10.7.0 V1.0.0	10.7.0	Published	30.08.2021	<a href="https://members.tdsi.in/index.php/s/DPfNWSe8jimdPsr">https://members.tdsi.in/index.php/s/DPfNWSe8jimdPsr</a>
TTA	TTAT.3G-36.211V10.7.0	10.7.0	Published	02.08.2021	<a href="http://committee.tta.or.kr/data/ttasDown.jsp?kind=ttastd&amp;pk_num=TTAT.3G-36.211V10.7.0">http://committee.tta.or.kr/data/ttasDown.jsp?kind=ttastd&amp;pk_num=TTAT.3G-36.211V10.7.0</a>

<b>Release 11</b>									
ARIB	ARIB STD-T120-36.211.V11.7.0	11.7.0	Published	03.03.2023	<a href="https://www.arib.or.jp/english/html/overview/doc/T120_T23_SPECS/ARIB-STD-T120/Rel11/36/A36211-b70.pdf">https://www.arib.or.jp/english/html/overview/doc/T120_T23_SPECS/ARIB-STD-T120/Rel11/36/A36211-b70.pdf</a>				
ATIS	ATIS.3GPP.36.211V1170	11.7.0	Published	28.06.2021	<a href="https://www.atis.org/3gpp-documents/Rel99-14/">https://www.atis.org/3gpp-documents/Rel99-14/</a>				
CCSA	CCSA.36.211V1170	11.7.0	Published	01.03.2017	<a href="https://www.ccsa.org.cn/api/portalsFile/downloadOldFile?type=19&amp;oldFileUrl=ITU-R/M.2012-6/CCSA.36.211V1170.doc">https://www.ccsa.org.cn/api/portalsFile/downloadOldFile?type=19&amp;oldFileUrl=ITU-R/M.2012-6/CCSA.36.211V1170.doc</a>				
ETSI	ETSI TS 136 211	11.7.0	Published	11.04.2017	<a href="https://www.etsi.org/deliver/etsi_ts/136200_136299/136211/11.07.00_60/ts_136211v110700p.pdf">https://www.etsi.org/deliver/etsi_ts/136200_136299/136211/11.07.00_60/ts_136211v110700p.pdf</a>				
TSDSI	TSDSI STD T1.3GPP 36.211-11.7.0 V1.0.0	11.7.0	Published	30.08.2021	<a href="https://members.tdsi.in/index.php/s/W6kTXTgssYXwmMd">https://members.tdsi.in/index.php/s/W6kTXTgssYXwmMd</a>				
TTA	TTAT.3G-36.211V11.7.0	11.7.0	Published	02.08.2021	<a href="http://committee.tta.or.kr/data/ttasDown.jsp?kind=ttastd&amp;pk_num=TTAT.3G-36.211V11.7.0">http://committee.tta.or.kr/data/ttasDown.jsp?kind=ttastd&amp;pk_num=TTAT.3G-36.211V11.7.0</a>				
<b>Release 12</b>									
ARIB	ARIB STD-T120-36.211.V12.9.0	12.9.0	Published	03.03.2023	<a href="https://www.arib.or.jp/english/html/overview/doc/T120_T23_SPECS/ARIB-STD-T120/Rel12/36/A36211-c90.pdf">https://www.arib.or.jp/english/html/overview/doc/T120_T23_SPECS/ARIB-STD-T120/Rel12/36/A36211-c90.pdf</a>				
ATIS	ATIS.3GPP.36.211V1290	12.9.0	Published	28.06.2021	<a href="https://www.atis.org/3gpp-documents/Rel99-14/">https://www.atis.org/3gpp-documents/Rel99-14/</a>				
CCSA	CCSA.36.211V1290	12.9.0	Published	01.03.2017	<a href="https://www.ccsa.org.cn/api/portalsFile/downloadOldFile?type=19&amp;oldFileUrl=ITU-R/M.2012-6/CCSA.36.211V1290.doc">https://www.ccsa.org.cn/api/portalsFile/downloadOldFile?type=19&amp;oldFileUrl=ITU-R/M.2012-6/CCSA.36.211V1290.doc</a>				
ETSI	ETSI TS 136 211	12.9.0	Published	11.04.2017	<a href="https://www.etsi.org/deliver/etsi_ts/136200_136299/136211/12.09.00_60/ts_136211v120900p.pdf">https://www.etsi.org/deliver/etsi_ts/136200_136299/136211/12.09.00_60/ts_136211v120900p.pdf</a>				
TSDSI	TSDSI STD T1.3GPP 36.211-12.9.0 V1.0.0	12.9.0	Published	30.08.2021	<a href="https://members.tdsi.in/index.php/s/mtpcGmGdqQXw56n">https://members.tdsi.in/index.php/s/mtpcGmGdqQXw56n</a>				
TTA	TTAT.3G-36.211V12.9.0	12.9.0	Published	02.08.2021	<a href="http://committee.tta.or.kr/data/ttasDown.jsp?kind=ttastd&amp;pk_num=TTAT.3G-36.211V12.9.0">http://committee.tta.or.kr/data/ttasDown.jsp?kind=ttastd&amp;pk_num=TTAT.3G-36.211V12.9.0</a>				
<b>Release 13</b>									
ARIB	ARIB STD-T120-36.211.V13.13.0	13.13.0	Published	03.03.2023	<a href="https://www.arib.or.jp/english/html/overview/doc/T120_T23_SPECS/ARIB-STD-T120/Rel13/36/A36211-dd0.pdf">https://www.arib.or.jp/english/html/overview/doc/T120_T23_SPECS/ARIB-STD-T120/Rel13/36/A36211-dd0.pdf</a>				
ATIS	ATIS.3GPP.36.211V13130	13.13.0	Published	28.06.2021	<a href="https://www.atis.org/3gpp-documents/Rel99-14/">https://www.atis.org/3gpp-documents/Rel99-14/</a>				
CCSA	CCSA.36.211V13130	13.13.0	Published	01.12.2019	<a href="https://www.ccsa.org.cn/api/portalsFile/downloadOldFile?type=19&amp;oldFileUrl=ITU-R/M.2012-6/CCSA.36.211V13130.doc">https://www.ccsa.org.cn/api/portalsFile/downloadOldFile?type=19&amp;oldFileUrl=ITU-R/M.2012-6/CCSA.36.211V13130.doc</a>				
ETSI	ETSI TS 136 211	13.13.0	Published	17.01.2020	<a href="https://www.etsi.org/deliver/etsi_ts/136200_136299/136211/13.13.00_60/ts_136211v131300p.pdf">https://www.etsi.org/deliver/etsi_ts/136200_136299/136211/13.13.00_60/ts_136211v131300p.pdf</a>				
TSDSI	TSDSI STD T1.3GPP 36.211-13.13.0 V1.1.0	13.13.0	Published	30.08.2021	<a href="https://members.tdsi.in/index.php/s/mLg9faJHR3zo2kQ">https://members.tdsi.in/index.php/s/mLg9faJHR3zo2kQ</a>				
TTA	TTAT.3G-36.211V13.13.0	13.13.0	Published	02.08.2021	<a href="http://committee.tta.or.kr/data/ttasDown.jsp?kind=ttastd&amp;pk_num=TTAT.3G-36.211V13.13.0">http://committee.tta.or.kr/data/ttasDown.jsp?kind=ttastd&amp;pk_num=TTAT.3G-36.211V13.13.0</a>				
<b>Release 14</b>									
ARIB	ARIB STD-T120-36.211.V14.15.0	14.15.0	Published	03.03.2023	<a href="https://www.arib.or.jp/english/html/overview/doc/T120_T23_SPECS/ARIB-STD-T120/Rel14/36/A36211-ef0.pdf">https://www.arib.or.jp/english/html/overview/doc/T120_T23_SPECS/ARIB-STD-T120/Rel14/36/A36211-ef0.pdf</a>				
ATIS	ATIS.3GPP.36.211V14150	14.15.0	Published	28.06.2021	<a href="https://www.atis.org/3gpp-documents/Rel99-14/">https://www.atis.org/3gpp-documents/Rel99-14/</a>				
CCSA	CCSA.36.211V14150	14.15.0	Published	01.06.2020	<a href="https://www.ccsa.org.cn/api/portalsFile/downloadOldFile?type=19&amp;oldFileUrl=ITU-R/M.2012-6/CCSA.36.211V14150.rar">https://www.ccsa.org.cn/api/portalsFile/downloadOldFile?type=19&amp;oldFileUrl=ITU-R/M.2012-6/CCSA.36.211V14150.rar</a>				
ETSI	ETSI TS 136 211	14.15.0	Published	24.09.2020	<a href="https://www.etsi.org/deliver/etsi_ts/136200_136299/136211/14.15.00_60/ts_136211v141500p.pdf">https://www.etsi.org/deliver/etsi_ts/136200_136299/136211/14.15.00_60/ts_136211v141500p.pdf</a>				
TSDSI	TSDSI STD T1.3GPP 36.211-14.15.0 V1.1.0	14.15.0	Published	30.08.2021	<a href="https://members.tdsi.in/index.php/s/MAXz8cc82Ta4swx">https://members.tdsi.in/index.php/s/MAXz8cc82Ta4swx</a>				
TTA	TTAT.3G-36.211V14.15.0	14.15.0	Published	02.08.2021	<a href="http://committee.tta.or.kr/data/ttasDown.jsp?kind=ttastd&amp;pk_num=TTAT.3G-36.211V14.15.0">http://committee.tta.or.kr/data/ttasDown.jsp?kind=ttastd&amp;pk_num=TTAT.3G-36.211V14.15.0</a>				
<b>Release 15</b>									
ARIB	ARIB STD-T120-36.211.V15.14.0	15.14.0	Published	03.03.2023	<a href="https://www.arib.or.jp/english/html/overview/doc/T120_T23_SPECS/ARIB-STD-T120/Rel15/36/A36211-fe0.pdf">https://www.arib.or.jp/english/html/overview/doc/T120_T23_SPECS/ARIB-STD-T120/Rel15/36/A36211-fe0.pdf</a>				
ATIS	ATIS.3GPP.36.211.V15.14.0	15.14.0	Published	21.02.2023	<a href="https://www.atis.org/3gpp-transpositions - Rel-15">https://www.atis.org/3gpp-transpositions - Rel-15</a>				
CCSA	CCSA.36.211V15140	15.14.0	Published	01.09.2021	<a href="https://www.ccsa.org.cn/api/portalsFile/downloadOldFile?type=19&amp;oldFileUrl=ITU-R/M.2012-6/CCSA.36.211V15140.rar">https://www.ccsa.org.cn/api/portalsFile/downloadOldFile?type=19&amp;oldFileUrl=ITU-R/M.2012-6/CCSA.36.211V15140.rar</a>				
ETSI	ETSI TS 136 211	15.14.0	Published	22.10.2021	<a href="https://www.etsi.org/deliver/etsi_ts/136200_136299/136211/15.14.00_60/ts_136211v151400p.pdf">https://www.etsi.org/deliver/etsi_ts/136200_136299/136211/15.14.00_60/ts_136211v151400p.pdf</a>				
TSDSI	TSDSI STD T1.3GPP 36.211-15.14.0 V1.1.0	15.14.0	Published	01.11.2022	<a href="https://members.tdsi.in/s/8fBRoRs3A5ebRbQ">https://members.tdsi.in/s/8fBRoRs3A5ebRbQ</a>				
TTA	TTAT.3G-36.211V15.14.0	15.14.0	Published	27.01.2022	<a href="http://committee.tta.or.kr/data/ttasDown.jsp?kind=ttastd&amp;pk_num=TTAT.3G-36.211V15.14.0">http://committee.tta.or.kr/data/ttasDown.jsp?kind=ttastd&amp;pk_num=TTAT.3G-36.211V15.14.0</a>				
<b>Release 16</b>									
ARIB	ARIB STD-T120-36.211.V16.7.0	16.7.0	Published	03.03.2023	<a href="https://www.arib.or.jp/english/html/overview/doc/T120_T23_SPECS/ARIB-STD-T120/Rel16/36/A36211-g70.pdf">https://www.arib.or.jp/english/html/overview/doc/T120_T23_SPECS/ARIB-STD-T120/Rel16/36/A36211-g70.pdf</a>				
ATIS	ATIS.3GPP.36.211.V16.7.0	16.7.0	Published	21.02.2023	<a href="https://www.atis.org/3gpp-transpositions - Rel-16">https://www.atis.org/3gpp-transpositions - Rel-16</a>				
CCSA	CCSA.36.211V1670	16.7.0	Published	01.09.2021	<a href="https://www.ccsa.org.cn/api/portalsFile/downloadOldFile?type=19&amp;oldFileUrl=ITU-R/M.2012-6/CCSA.36.211V1670.rar">https://www.ccsa.org.cn/api/portalsFile/downloadOldFile?type=19&amp;oldFileUrl=ITU-R/M.2012-6/CCSA.36.211V1670.rar</a>				
ETSI	ETSI TS 136 211	16.7.0	Published	22.10.2021	<a href="https://www.etsi.org/deliver/etsi_ts/136200_136299/136211/16.07.00_60/ts_136211v160700p.pdf">https://www.etsi.org/deliver/etsi_ts/136200_136299/136211/16.07.00_60/ts_136211v160700p.pdf</a>				
TSDSI	TSDSI STD T1.3GPP 36.211-16.7.0 V1.1.0	16.7.0	Published	01.11.2022	<a href="https://members.tdsi.in/s/M7PpkNMMcznHw7C">https://members.tdsi.in/s/M7PpkNMMcznHw7C</a>				
TTA	TTAT.3G-36.211V16.7.0	16.7.0	Published	27.01.2022	<a href="http://committee.tta.or.kr/data/ttasDown.jsp?kind=ttastd&amp;pk_num=TTAT.3G-36.211V16.7.0">http://committee.tta.or.kr/data/ttasDown.jsp?kind=ttastd&amp;pk_num=TTAT.3G-36.211V16.7.0</a>				
<b>Release 17</b>									
ARIB	ARIB STD-T120-36.211.V17.2.0	17.2.0	Published	03.03.2023	<a href="https://www.arib.or.jp/english/html/overview/doc/T120_T23_SPECS/ARIB-STD-T120/Rel17/36/A36211-h20.pdf">https://www.arib.or.jp/english/html/overview/doc/T120_T23_SPECS/ARIB-STD-T120/Rel17/36/A36211-h20.pdf</a>				
ATIS	ATIS.3GPP.36.211.V17.2.0	17.2.0	Published	21.02.2023	<a href="https://www.atis.org/3gpp-transpositions - Rel-17">https://www.atis.org/3gpp-transpositions - Rel-17</a>				
CCSA	CCSA.36.211V1720	17.2.0	Published	01.06.2022	<a href="https://www.ccsa.org.cn/api/portalsFile/downloadOldFile?type=19&amp;oldFileUrl=ITU-R/M.2012-6/CCSA.36.211V1720.rar">https://www.ccsa.org.cn/api/portalsFile/downloadOldFile?type=19&amp;oldFileUrl=ITU-R/M.2012-6/CCSA.36.211V1720.rar</a>				

ETSI	ETSI TS 136 211	17.2.0	Published	12.08.2022	<a href="https://www.etsi.org/deliver/etsi_ts/136200_136299/136211/17.02.00_60/ts_136211v170200p.pdf">https://www.etsi.org/deliver/etsi_ts/136200_136299/136211/17.02.00_60/ts_136211v170200p.pdf</a>
TSDSI	TSDSI STD T1.3GPP 36.211-17.2.0 V1.1.0	17.2.0	Published	01.11.2022	<a href="https://members.tdsi.in/s/3b2n56EtwiWqFMW">https://members.tdsi.in/s/3b2n56EtwiWqFMW</a>
TTA	TTAT.3G-36.211V17.2.0	17.2.0	Published	21.10.2022	<a href="http://committee.tta.or.kr/data/ttasDown.jsp?kind=ttastd&amp;pk_num=TTAT.3G-36.211V17.2.0">http://committee.tta.or.kr/data/ttasDown.jsp?kind=ttastd&amp;pk_num=TTAT.3G-36.211V17.2.0</a>

### 2.1.2.3 TS 36.212

## Evolved Universal Terrestrial Radio Access (E-UTRA); Multiplexing and channel coding

This document specifies the coding, multiplexing and mapping to physical channels for E-UTRA.

SDO	Document No.	Version	Status	Issued date	Location
<b>Release 10</b>					
ARIB	ARIB STD-T120-36.212.V10.9.0	10.9.0	Published	03.03.2023	<a href="https://www.arib.or.jp/english/html/overview/doc/T120_T23_SPECS/ARIB-STD-T120/Rel10/36/A36212-a90.pdf">https://www.arib.or.jp/english/html/overview/doc/T120_T23_SPECS/ARIB-STD-T120/Rel10/36/A36212-a90.pdf</a>
ATIS	ATIS.3GPP.36.212V1090	10.9.0	Published	28.06.2021	<a href="https://www.atis.org/3gpp-documents/Rel99-14/">https://www.atis.org/3gpp-documents/Rel99-14/</a>
CCSA	CCSA.36.212V1090	10.9.0	Published	01.09.2015	<a href="https://www.ccsa.org.cn/api/portalsFile/downloadOldFile?type=19&amp;oldFileUrl=ITU-R/M.2012-6/CCSA.36.212V1090.doc">https://www.ccsa.org.cn/api/portalsFile/downloadOldFile?type=19&amp;oldFileUrl=ITU-R/M.2012-6/CCSA.36.212V1090.doc</a>
ETSI	ETSI TS 136 212	10.9.0	Published	19.10.2015	<a href="https://www.etsi.org/deliver/etsi_ts/136200_136299/136212/10.09.00_60/ts_136212v100900p.pdf">https://www.etsi.org/deliver/etsi_ts/136200_136299/136212/10.09.00_60/ts_136212v100900p.pdf</a>
TSDSI	TSDSI STD T1.3GPP 36.212-10.9.0 V1.0.0	10.9.0	Published	30.08.2021	<a href="https://members.tdsi.in/index.php/s/3kdGD6SqZaB47qC">https://members.tdsi.in/index.php/s/3kdGD6SqZaB47qC</a>
TTA	TTAT.3G-36.212V10.9.0	10.9.0	Published	02.08.2021	<a href="http://committee.tta.or.kr/data/ttasDown.jsp?kind=ttastd&amp;pk_num=TTAT.3G-36.212V10.9.0">http://committee.tta.or.kr/data/ttasDown.jsp?kind=ttastd&amp;pk_num=TTAT.3G-36.212V10.9.0</a>
<b>Release 11</b>					
ARIB	ARIB STD-T120-36.212.V11.7.0	11.7.0	Published	03.03.2023	<a href="https://www.arib.or.jp/english/html/overview/doc/T120_T23_SPECS/ARIB-STD-T120/Rel11/36/A36212-b70.pdf">https://www.arib.or.jp/english/html/overview/doc/T120_T23_SPECS/ARIB-STD-T120/Rel11/36/A36212-b70.pdf</a>
ATIS	ATIS.3GPP.36.212V1170	11.7.0	Published	28.06.2021	<a href="https://www.atis.org/3gpp-documents/Rel99-14/">https://www.atis.org/3gpp-documents/Rel99-14/</a>
CCSA	CCSA.36.212V1170	11.7.0	Published	01.03.2016	<a href="https://www.ccsa.org.cn/api/portalsFile/downloadOldFile?type=19&amp;oldFileUrl=ITU-R/M.2012-6/CCSA.36.212V1170.doc">https://www.ccsa.org.cn/api/portalsFile/downloadOldFile?type=19&amp;oldFileUrl=ITU-R/M.2012-6/CCSA.36.212V1170.doc</a>
ETSI	ETSI TS 136 212	11.7.0	Published	22.04.2016	<a href="https://www.etsi.org/deliver/etsi_ts/136200_136299/136212/11.07.00_60/ts_136212v110700p.pdf">https://www.etsi.org/deliver/etsi_ts/136200_136299/136212/11.07.00_60/ts_136212v110700p.pdf</a>
TSDSI	TSDSI STD T1.3GPP 36.212-11.7.0 V1.0.0	11.7.0	Published	30.08.2021	<a href="https://members.tdsi.in/index.php/s/gqmibqdbcHqGCKm">https://members.tdsi.in/index.php/s/gqmibqdbcHqGCKm</a>
TTA	TTAT.3G-36.212V11.7.0	11.7.0	Published	02.08.2021	<a href="http://committee.tta.or.kr/data/ttasDown.jsp?kind=ttastd&amp;pk_num=TTAT.3G-36.212V11.7.0">http://committee.tta.or.kr/data/ttasDown.jsp?kind=ttastd&amp;pk_num=TTAT.3G-36.212V11.7.0</a>
<b>Release 12</b>					
ARIB	ARIB STD-T120-36.212.V12.9.1	12.9.1	Published	03.03.2023	<a href="https://www.arib.or.jp/english/html/overview/doc/T120_T23_SPECS/ARIB-STD-T120/Rel12/36/A36212-c91.pdf">https://www.arib.or.jp/english/html/overview/doc/T120_T23_SPECS/ARIB-STD-T120/Rel12/36/A36212-c91.pdf</a>
ATIS	ATIS.3GPP.36.212V1291	12.9.1	Published	28.06.2021	<a href="https://www.atis.org/3gpp-documents/Rel99-14/">https://www.atis.org/3gpp-documents/Rel99-14/</a>
CCSA	CCSA.36.212V1291	12.9.1	Published	01.01.2018	<a href="https://www.ccsa.org.cn/api/portalsFile/downloadOldFile?type=19&amp;oldFileUrl=ITU-R/M.2012-6/CCSA.36.212V1291.doc">https://www.ccsa.org.cn/api/portalsFile/downloadOldFile?type=19&amp;oldFileUrl=ITU-R/M.2012-6/CCSA.36.212V1291.doc</a>
ETSI	ETSI TS 136 212	12.9.1	Published	25.01.2018	<a href="https://www.etsi.org/deliver/etsi_ts/136200_136299/136212/12.09.01_60/ts_136212v120901p.pdf">https://www.etsi.org/deliver/etsi_ts/136200_136299/136212/12.09.01_60/ts_136212v120901p.pdf</a>
TSDSI	TSDSI STD T1.3GPP 36.212-12.9.1 V1.0.0	12.9.1	Published	30.08.2021	<a href="https://members.tdsi.in/index.php/s/PsP3zoTE8rsrkJR">https://members.tdsi.in/index.php/s/PsP3zoTE8rsrkJR</a>
TTA	TTAT.3G-36.212V12.9.1	12.9.1	Published	02.08.2021	<a href="http://committee.tta.or.kr/data/ttasDown.jsp?kind=ttastd&amp;pk_num=TTAT.3G-36.212V12.9.1">http://committee.tta.or.kr/data/ttasDown.jsp?kind=ttastd&amp;pk_num=TTAT.3G-36.212V12.9.1</a>
<b>Release 13</b>					
ARIB	ARIB STD-T120-36.212.V13.11.0	13.11.0	Published	03.03.2023	<a href="https://www.arib.or.jp/english/html/overview/doc/T120_T23_SPECS/ARIB-STD-T120/Rel13/36/A36212-db0.pdf">https://www.arib.or.jp/english/html/overview/doc/T120_T23_SPECS/ARIB-STD-T120/Rel13/36/A36212-db0.pdf</a>
ATIS	ATIS.3GPP.36.212.V13.11.0	13.11.0	Published	21.02.2023	<a href="https://www.atis.org/3gpp-transpositions - Rel-13">https://www.atis.org/3gpp-transpositions - Rel-13</a>
CCSA	CCSA.36.212V13110	13.11.0	Published	01.03.2021	<a href="https://www.ccsa.org.cn/api/portalsFile/downloadOldFile?type=19&amp;oldFileUrl=ITU-R/M.2012-6/CCSA.36.212V13110.doc">https://www.ccsa.org.cn/api/portalsFile/downloadOldFile?type=19&amp;oldFileUrl=ITU-R/M.2012-6/CCSA.36.212V13110.doc</a>
ETSI	ETSI TS 136 212	13.11.0	Published	20.04.2021	<a href="https://www.etsi.org/deliver/etsi_ts/136200_136299/136212/13.11.00_60/ts_136212v131100p.pdf">https://www.etsi.org/deliver/etsi_ts/136200_136299/136212/13.11.00_60/ts_136212v131100p.pdf</a>
TSDSI	TSDSI STD T1.3GPP 36.212-13.11.0 V1.1.0	13.11.0	Published	17.01.2023	<a href="https://members.tdsi.in/s/nYXMEqYfn88b6tx">https://members.tdsi.in/s/nYXMEqYfn88b6tx</a>
TTA	TTAT.3G-36.212V13.11.0	13.11.0	Published	10.06.2021	<a href="http://committee.tta.or.kr/data/ttasDown.jsp?kind=ttastd&amp;pk_num=TTAT.3G-36.212V13.11.0">http://committee.tta.or.kr/data/ttasDown.jsp?kind=ttastd&amp;pk_num=TTAT.3G-36.212V13.11.0</a>
<b>Release 14</b>					
ARIB	ARIB STD-T120-36.212.V14.16.0	14.16.0	Published	03.03.2023	<a href="https://www.arib.or.jp/english/html/overview/doc/T120_T23_SPECS/ARIB-STD-T120/Rel14/36/A36212-eg0.pdf">https://www.arib.or.jp/english/html/overview/doc/T120_T23_SPECS/ARIB-STD-T120/Rel14/36/A36212-eg0.pdf</a>
ATIS	ATIS.3GPP.36.212.V14.16.0	14.16.0	Published	21.02.2023	<a href="https://www.atis.org/3gpp-transpositions - Rel-14">https://www.atis.org/3gpp-transpositions - Rel-14</a>
CCSA	CCSA.36.212V14160	14.16.0	Published	01.06.2021	<a href="https://www.ccsa.org.cn/api/portalsFile/downloadOldFile?type=19&amp;oldFileUrl=ITU-R/M.2012-6/CCSA.36.212V14160.doc">https://www.ccsa.org.cn/api/portalsFile/downloadOldFile?type=19&amp;oldFileUrl=ITU-R/M.2012-6/CCSA.36.212V14160.doc</a>
ETSI	ETSI TS 136 212	14.16.0	Published	19.08.2021	<a href="https://www.etsi.org/deliver/etsi_ts/136200_136299/136212/14.16.00_60/ts_136212v141600p.pdf">https://www.etsi.org/deliver/etsi_ts/136200_136299/136212/14.16.00_60/ts_136212v141600p.pdf</a>
TSDSI	TSDSI STD T1.3GPP 36.212-14.16.0 V1.1.0	14.16.0	Published	17.01.2023	<a href="https://members.tdsi.in/s/nX26a2LDBCY4QZA">https://members.tdsi.in/s/nX26a2LDBCY4QZA</a>
TTA	TTAT.3G-36.212V14.16.0	14.16.0	Published	30.09.2021	<a href="http://committee.tta.or.kr/data/ttasDown.jsp?kind=ttastd&amp;pk_num=TTAT.3G-36.212V14.16.0">http://committee.tta.or.kr/data/ttasDown.jsp?kind=ttastd&amp;pk_num=TTAT.3G-36.212V14.16.0</a>
<b>Release 15</b>					

ARIB	ARIB STD-T120-36.212.V15.15.0	15.15.0	Published	03.03.2023	<a href="https://www.arib.or.jp/english/html/overview/doc/T120_T23_SPECS/ARIB-STD-T120/Rel15/36/A36212-ff0.pdf">https://www.arib.or.jp/english/html/overview/doc/T120_T23_SPECS/ARIB-STD-T120/Rel15/36/A36212-ff0.pdf</a>
ATIS	ATIS.3GPP.36.212.V15.15.0	15.15.0	Published	21.02.2023	<a href="https://www.atis.org/3gpp-transpositions - Rel-15">https://www.atis.org/3gpp-transpositions - Rel-15</a>
CCSA	CCSA.36.212V15150	15.15.0	Published	01.12.2021	<a href="https://www.ccsa.org.cn/api/portalsFile/downloadOldFile?type=19&amp;oldFileUrl=ITU-R/M.2012-6/CCSA.36.212V15150.doc">https://www.ccsa.org.cn/api/portalsFile/downloadOldFile?type=19&amp;oldFileUrl=ITU-R/M.2012-6/CCSA.36.212V15150.doc</a>
ETSI	ETSI TS 136 212	15.15.0	Published	26.01.2022	<a href="https://www.etsi.org/deliver/etsi_ts/136200_136299/136212/15.15.00_60/ts_136212v151500p.pdf">https://www.etsi.org/deliver/etsi_ts/136200_136299/136212/15.15.00_60/ts_136212v151500p.pdf</a>
TSDSI	TSDSI STD T1.3GPP 36.212-15.15.0 V1.1.0	15.15.0	Published	01.11.2022	<a href="https://members.tdsi.in/s/sDEXdk3iDT5D733">https://members.tdsi.in/s/sDEXdk3iDT5D733</a>
TTA	TTAT.3G-36.212V15.15.0	15.15.0	Published	14.03.2022	<a href="http://committee.tta.or.kr/data/ttasDown.jsp?kind=ttastd&amp;pk_num=TTAT.3G-36.212V15.15.0">http://committee.tta.or.kr/data/ttasDown.jsp?kind=ttastd&amp;pk_num=TTAT.3G-36.212V15.15.0</a>

**Release 16**

ARIB	ARIB STD-T120-36.212.V16.7.0	16.7.0	Published	03.03.2023	<a href="https://www.arib.or.jp/english/html/overview/doc/T120_T23_SPECS/ARIB-STD-T120/Rel16/36/A36212-g70.pdf">https://www.arib.or.jp/english/html/overview/doc/T120_T23_SPECS/ARIB-STD-T120/Rel16/36/A36212-g70.pdf</a>
ATIS	ATIS.3GPP.36.212.V16.7.0	16.7.0	Published	21.02.2023	<a href="https://www.atis.org/3gpp-transpositions - Rel-16">https://www.atis.org/3gpp-transpositions - Rel-16</a>
CCSA	CCSA.36.212V1670	16.7.0	Published	01.12.2021	<a href="https://www.ccsa.org.cn/api/portalsFile/downloadOldFile?type=19&amp;oldFileUrl=ITU-R/M.2012-6/CCSA.36.212V1670.doc">https://www.ccsa.org.cn/api/portalsFile/downloadOldFile?type=19&amp;oldFileUrl=ITU-R/M.2012-6/CCSA.36.212V1670.doc</a>
ETSI	ETSI TS 136 212	16.7.0	Published	26.01.2022	<a href="https://www.etsi.org/deliver/etsi_ts/136200_136299/136212/16.07.00_60/ts_136212v160700p.pdf">https://www.etsi.org/deliver/etsi_ts/136200_136299/136212/16.07.00_60/ts_136212v160700p.pdf</a>
TSDSI	TSDSI STD T1.3GPP 36.212-16.7.0 V1.1.0	16.7.0	Published	01.11.2022	<a href="https://members.tdsi.in/s/KedSYDx4diX8oWg">https://members.tdsi.in/s/KedSYDx4diX8oWg</a>
TTA	TTAT.3G-36.212V16.7.0	16.7.0	Published	14.03.2022	<a href="http://committee.tta.or.kr/data/ttasDown.jsp?kind=ttastd&amp;pk_num=TTAT.3G-36.212V16.7.0">http://committee.tta.or.kr/data/ttasDown.jsp?kind=ttastd&amp;pk_num=TTAT.3G-36.212V16.7.0</a>

**Release 17**

ARIB	ARIB STD-T120-36.212.V17.1.0	17.1.0	Published	03.03.2023	<a href="https://www.arib.or.jp/english/html/overview/doc/T120_T23_SPECS/ARIB-STD-T120/Rel17/36/A36212-h10.pdf">https://www.arib.or.jp/english/html/overview/doc/T120_T23_SPECS/ARIB-STD-T120/Rel17/36/A36212-h10.pdf</a>
ATIS	ATIS.3GPP.36.212.V17.1.0	17.1.0	Published	21.02.2023	<a href="https://www.atis.org/3gpp-transpositions - Rel-17">https://www.atis.org/3gpp-transpositions - Rel-17</a>
CCSA	CCSA.36.212V1710	17.1.0	Published	01.03.2022	<a href="https://www.ccsa.org.cn/api/portalsFile/downloadOldFile?type=19&amp;oldFileUrl=ITU-R/M.2012-6/CCSA.36.212V1710.doc">https://www.ccsa.org.cn/api/portalsFile/downloadOldFile?type=19&amp;oldFileUrl=ITU-R/M.2012-6/CCSA.36.212V1710.doc</a>
ETSI	ETSI TS 136 212	17.1.0	Published	26.04.2022	<a href="https://www.etsi.org/deliver/etsi_ts/136200_136299/136212/17.01.00_60/ts_136212v170100p.pdf">https://www.etsi.org/deliver/etsi_ts/136200_136299/136212/17.01.00_60/ts_136212v170100p.pdf</a>
TSDSI	TSDSI STD T1.3GPP 36.212-17.1.0 V1.0.0	17.1.0	Published	29.07.2022	<a href="https://members.tdsi.in/s/b5peAp4oKRTQdJL">https://members.tdsi.in/s/b5peAp4oKRTQdJL</a>
TTA	TTAT.3G-36.212V17.1.0	17.1.0	Published	05.08.2022	<a href="http://committee.tta.or.kr/data/ttasDown.jsp?kind=ttastd&amp;pk_num=TTAT.3G-36.212V17.1.0">http://committee.tta.or.kr/data/ttasDown.jsp?kind=ttastd&amp;pk_num=TTAT.3G-36.212V17.1.0</a>

**2.1.2.4 TS 36.213**

**Evolved Universal Terrestrial Radio Access (E-UTRA); Physical layer procedures**

This document specifies and establishes the characteristics of the physical layer procedures for E-UTRA.

SDO	Document No.	Version	Status	Issued date	Location
<b>Release 10</b>					
ARIB	ARIB STD-T120-36.213.V10.13.0	10.13.0	Published	03.03.2023	<a href="https://www.arib.or.jp/english/html/overview/doc/T120_T23_SPECS/ARIB-STD-T120/Rel10/36/A36213-ad0.pdf">https://www.arib.or.jp/english/html/overview/doc/T120_T23_SPECS/ARIB-STD-T120/Rel10/36/A36213-ad0.pdf</a>
ATIS	ATIS.3GPP.36.213V10130	10.13.0	Published	28.06.2021	<a href="https://www.atis.org/3gpp-documents/Rel99-14/">https://www.atis.org/3gpp-documents/Rel99-14/</a>
CCSA	CCSA.36.213V10130	10.13.0	Published	01.06.2015	<a href="https://www.ccsa.org.cn/api/portalsFile/downloadOldFile?type=19&amp;oldFileUrl=ITU-R/M.2012-6/CCSA.36.213V10130.doc">https://www.ccsa.org.cn/api/portalsFile/downloadOldFile?type=19&amp;oldFileUrl=ITU-R/M.2012-6/CCSA.36.213V10130.doc</a>
ETSI	ETSI TS 136 213	10.13.0	Published	27.07.2015	<a href="https://www.etsi.org/deliver/etsi_ts/136200_136299/136213/10.13.00_60/ts_136213v101300p.pdf">https://www.etsi.org/deliver/etsi_ts/136200_136299/136213/10.13.00_60/ts_136213v101300p.pdf</a>
TSDSI	TSDSI STD T1.3GPP 36.213-10.13.0 V1.0.0	10.13.0	Published	30.08.2021	<a href="https://members.tdsi.in/index.php/s/ebEi7p7H2424pmW">https://members.tdsi.in/index.php/s/ebEi7p7H2424pmW</a>
TTA	TTAT.3G-36.213V10.13.0	10.13.0	Published	02.08.2021	<a href="http://committee.tta.or.kr/data/ttasDown.jsp?kind=ttastd&amp;pk_num=TTAT.3G-36.213V10.13.0">http://committee.tta.or.kr/data/ttasDown.jsp?kind=ttastd&amp;pk_num=TTAT.3G-36.213V10.13.0</a>
<b>Release 11</b>					
ARIB	ARIB STD-T120-36.213.V11.13.0	11.13.0	Published	03.03.2023	<a href="https://www.arib.or.jp/english/html/overview/doc/T120_T23_SPECS/ARIB-STD-T120/Rel11/36/A36213-bd0.pdf">https://www.arib.or.jp/english/html/overview/doc/T120_T23_SPECS/ARIB-STD-T120/Rel11/36/A36213-bd0.pdf</a>
ATIS	ATIS.3GPP.36.213V11130	11.13.0	Published	28.06.2021	<a href="https://www.atis.org/3gpp-documents/Rel99-14/">https://www.atis.org/3gpp-documents/Rel99-14/</a>
CCSA	CCSA.36.213V11130	11.13.0	Published	01.09.2017	<a href="https://www.ccsa.org.cn/api/portalsFile/downloadOldFile?type=19&amp;oldFileUrl=ITU-R/M.2012-6/CCSA.36.213V11130.doc">https://www.ccsa.org.cn/api/portalsFile/downloadOldFile?type=19&amp;oldFileUrl=ITU-R/M.2012-6/CCSA.36.213V11130.doc</a>
ETSI	ETSI TS 136 213	11.13.0	Published	10.10.2017	<a href="https://www.etsi.org/deliver/etsi_ts/136200_136299/136213/11.13.00_60/ts_136213v111300p.pdf">https://www.etsi.org/deliver/etsi_ts/136200_136299/136213/11.13.00_60/ts_136213v111300p.pdf</a>
TSDSI	TSDSI STD T1.3GPP 36.213-11.13.0 V1.0.0	11.13.0	Published	30.08.2021	<a href="https://members.tdsi.in/index.php/s/9JmdxpCipMi8947">https://members.tdsi.in/index.php/s/9JmdxpCipMi8947</a>
TTA	TTAT.3G-36.213V11.13.0	11.13.0	Published	02.08.2021	<a href="http://committee.tta.or.kr/data/ttasDown.jsp?kind=ttastd&amp;pk_num=TTAT.3G-36.213V11.13.0">http://committee.tta.or.kr/data/ttasDown.jsp?kind=ttastd&amp;pk_num=TTAT.3G-36.213V11.13.0</a>
<b>Release 12</b>					
ARIB	ARIB STD-T120-36.213.V12.13.0	12.13.0	Published	03.03.2023	<a href="https://www.arib.or.jp/english/html/overview/doc/T120_T23_SPECS/ARIB-STD-T120/Rel12/36/A36213-cd0.pdf">https://www.arib.or.jp/english/html/overview/doc/T120_T23_SPECS/ARIB-STD-T120/Rel12/36/A36213-cd0.pdf</a>
ATIS	ATIS.3GPP.36.213V12130	12.13.0	Published	28.06.2021	<a href="https://www.atis.org/3gpp-documents/Rel99-14/">https://www.atis.org/3gpp-documents/Rel99-14/</a>
CCSA	CCSA.36.213V12130	12.13.0	Published	01.09.2018	<a href="https://www.ccsa.org.cn/api/portalsFile/downloadOldFile?type=19&amp;oldFileUrl=ITU-R/M.2012-6/CCSA.36.213V12130.rar">https://www.ccsa.org.cn/api/portalsFile/downloadOldFile?type=19&amp;oldFileUrl=ITU-R/M.2012-6/CCSA.36.213V12130.rar</a>
ETSI	ETSI TS 136 213	12.13.0	Published	14.03.2019	<a href="https://www.etsi.org/deliver/etsi_ts/136200_136299/136213/12.13.00_60/ts_136213v121300p.pdf">https://www.etsi.org/deliver/etsi_ts/136200_136299/136213/12.13.00_60/ts_136213v121300p.pdf</a>

TSDSI	TSDSI STD T1.3GPP 36.213-12.13.0 V1.1.0	12.13.0	Published	30.08.2021	<a href="https://members.tdsi.in/index.php/s/2pwjABTZd73665f">https://members.tdsi.in/index.php/s/2pwjABTZd73665f</a>
TTA	TTAT.3G-36.213V12.13.0	12.13.0	Published	02.08.2021	<a href="http://committee.tta.or.kr/data/ttasDown.jsp?kind=ttastd&amp;pk_num=TTAT.3G-36.213V12.13.0">http://committee.tta.or.kr/data/ttasDown.jsp?kind=ttastd&amp;pk_num=TTAT.3G-36.213V12.13.0</a>
<b>Release 13</b>					
ARIB	ARIB STD-T120-36.213.V13.16.0	13.16.0	Published	03.03.2023	<a href="https://www.arib.or.jp/english/html/overview/doc/T120_T23_SPECS/ARIB-STD-T120/Rel13/36/A36213-dg0.pdf">https://www.arib.or.jp/english/html/overview/doc/T120_T23_SPECS/ARIB-STD-T120/Rel13/36/A36213-dg0.pdf</a>
ATIS	ATIS.3GPP.36.213V13160	13.16.0	Published	28.06.2021	<a href="https://www.atis.org/3gpp-documents/Rel99-14/">https://www.atis.org/3gpp-documents/Rel99-14/</a>
CCSA	CCSA.36.213V13160	13.16.0	Published	01.03.2020	<a href="https://www.ccsa.org.cn/api/portalsFile/downloadOldFile?type=19&amp;oldFileUrl=ITU-R/M.2012-6/CCSA.36.213V13160.rar">https://www.ccsa.org.cn/api/portalsFile/downloadOldFile?type=19&amp;oldFileUrl=ITU-R/M.2012-6/CCSA.36.213V13160.rar</a>
ETSI	ETSI TS 136 213	13.16.0	Published	23.04.2020	<a href="https://www.etsi.org/deliver/etsi_ts/136200_136299/136213/13.16.00_60/ts_136213v131600p.pdf">https://www.etsi.org/deliver/etsi_ts/136200_136299/136213/13.16.00_60/ts_136213v131600p.pdf</a>
TSDSI	TSDSI STD T1.3GPP 36.213-13.16.0 V1.1.0	13.16.0	Published	30.08.2021	<a href="https://members.tdsi.in/index.php/s/deGQxdTRDDG5zSq">https://members.tdsi.in/index.php/s/deGQxdTRDDG5zSq</a>
TTA	TTAT.3G-36.213V13.16.0	13.16.0	Published	02.08.2021	<a href="http://committee.tta.or.kr/data/ttasDown.jsp?kind=ttastd&amp;pk_num=TTAT.3G-36.213V13.16.0">http://committee.tta.or.kr/data/ttasDown.jsp?kind=ttastd&amp;pk_num=TTAT.3G-36.213V13.16.0</a>
<b>Release 14</b>					
ARIB	ARIB STD-T120-36.213.V14.17.0	14.17.0	Published	03.03.2023	<a href="https://www.arib.or.jp/english/html/overview/doc/T120_T23_SPECS/ARIB-STD-T120/Rel14/36/A36213-eh0.pdf">https://www.arib.or.jp/english/html/overview/doc/T120_T23_SPECS/ARIB-STD-T120/Rel14/36/A36213-eh0.pdf</a>
ATIS	ATIS.3GPP.36.213.V14.17.0	14.17.0	Published	21.02.2023	<a href="https://www.atis.org/3gpp-transpositions-Rel-14">https://www.atis.org/3gpp-transpositions-Rel-14</a>
CCSA	CCSA.36.213V14170	14.17.0	Published	01.06.2021	<a href="https://www.ccsa.org.cn/api/portalsFile/downloadOldFile?type=19&amp;oldFileUrl=ITU-R/M.2012-6/CCSA.36.213V14170.rar">https://www.ccsa.org.cn/api/portalsFile/downloadOldFile?type=19&amp;oldFileUrl=ITU-R/M.2012-6/CCSA.36.213V14170.rar</a>
ETSI	ETSI TS 136 213	14.17.0	Published	17.09.2021	<a href="https://www.etsi.org/deliver/etsi_ts/136200_136299/136213/14.17.00_60/ts_136213v141700p.pdf">https://www.etsi.org/deliver/etsi_ts/136200_136299/136213/14.17.00_60/ts_136213v141700p.pdf</a>
TSDSI	TSDSI STD T1.3GPP 36.213-14.17.0 V1.1.0	14.17.0	Published	17.01.2023	<a href="https://members.tdsi.in/s/6Ds22P4syXD7THL">https://members.tdsi.in/s/6Ds22P4syXD7THL</a>
TTA	TTAT.3G-36.213V14.17.0	14.17.0	Published	30.09.2021	<a href="http://committee.tta.or.kr/data/ttasDown.jsp?kind=ttastd&amp;pk_num=TTAT.3G-36.213V14.17.0">http://committee.tta.or.kr/data/ttasDown.jsp?kind=ttastd&amp;pk_num=TTAT.3G-36.213V14.17.0</a>
<b>Release 15</b>					
ARIB	ARIB STD-T120-36.213.V15.16.0	15.16.0	Published	03.03.2023	<a href="https://www.arib.or.jp/english/html/overview/doc/T120_T23_SPECS/ARIB-STD-T120/Rel15/36/A36213-fg0.pdf">https://www.arib.or.jp/english/html/overview/doc/T120_T23_SPECS/ARIB-STD-T120/Rel15/36/A36213-fg0.pdf</a>
ATIS	ATIS.3GPP.36.213.V15.16.0	15.16.0	Published	21.02.2023	<a href="https://www.atis.org/3gpp-transpositions-Rel-15">https://www.atis.org/3gpp-transpositions-Rel-15</a>
CCSA	CCSA.36.213V15160	15.16.0	Published	01.09.2022	<a href="https://www.ccsa.org.cn/api/portalsFile/downloadOldFile?type=19&amp;oldFileUrl=ITU-R/M.2012-6/CCSA.36.213V15160.rar">https://www.ccsa.org.cn/api/portalsFile/downloadOldFile?type=19&amp;oldFileUrl=ITU-R/M.2012-6/CCSA.36.213V15160.rar</a>
ETSI	ETSI TS 136 213	15.16.0	Published	19.10.2022	<a href="https://www.etsi.org/deliver/etsi_ts/136200_136299/136213/15.16.00_60/ts_136213v151600p.pdf">https://www.etsi.org/deliver/etsi_ts/136200_136299/136213/15.16.00_60/ts_136213v151600p.pdf</a>
TSDSI	TSDSI STD T1.3GPP 36.213-15.16.0 V1.2.0	15.16.0	Published	17.01.2023	<a href="https://members.tdsi.in/s/cJ5XWtX5rApwSRg">https://members.tdsi.in/s/cJ5XWtX5rApwSRg</a>
TTA	TTAT.3G-36.213V15.16.0	15.16.0	Published	11.01.2023	<a href="http://committee.tta.or.kr/data/ttasDown.jsp?kind=ttastd&amp;pk_num=TTAT.3G-36.213V15.16.0">http://committee.tta.or.kr/data/ttasDown.jsp?kind=ttastd&amp;pk_num=TTAT.3G-36.213V15.16.0</a>
<b>Release 16</b>					
ARIB	ARIB STD-T120-36.213.V16.9.0	16.9.0	Published	03.03.2023	<a href="https://www.arib.or.jp/english/html/overview/doc/T120_T23_SPECS/ARIB-STD-T120/Rel16/36/A36213-g90.pdf">https://www.arib.or.jp/english/html/overview/doc/T120_T23_SPECS/ARIB-STD-T120/Rel16/36/A36213-g90.pdf</a>
ATIS	ATIS.3GPP.36.213.V16.9.0	16.9.0	Published	21.02.2023	<a href="https://www.atis.org/3gpp-transpositions-Rel-16">https://www.atis.org/3gpp-transpositions-Rel-16</a>
CCSA	CCSA.36.213V1690	16.9.0	Published	01.09.2022	<a href="https://www.ccsa.org.cn/api/portalsFile/downloadOldFile?type=19&amp;oldFileUrl=ITU-R/M.2012-6/CCSA.36.213V1690.rar">https://www.ccsa.org.cn/api/portalsFile/downloadOldFile?type=19&amp;oldFileUrl=ITU-R/M.2012-6/CCSA.36.213V1690.rar</a>
ETSI	ETSI TS 136 213	16.9.0	Published	19.10.2022	<a href="https://www.etsi.org/deliver/etsi_ts/136200_136299/136213/16.09.00_60/ts_136213v160900p.pdf">https://www.etsi.org/deliver/etsi_ts/136200_136299/136213/16.09.00_60/ts_136213v160900p.pdf</a>
TSDSI	TSDSI STD T1.3GPP 36.213-16.9.0 V1.2.0	16.9.0	Published	17.01.2023	<a href="https://members.tdsi.in/s/Y22BnB6f9Rfbp6R">https://members.tdsi.in/s/Y22BnB6f9Rfbp6R</a>
TTA	TTAT.3G-36.213V16.9.0	16.9.0	Published	11.01.2023	<a href="http://committee.tta.or.kr/data/ttasDown.jsp?kind=ttastd&amp;pk_num=TTAT.3G-36.213V16.9.0">http://committee.tta.or.kr/data/ttasDown.jsp?kind=ttastd&amp;pk_num=TTAT.3G-36.213V16.9.0</a>
<b>Release 17</b>					
ARIB	ARIB STD-T120-36.213.V17.4.0	17.4.0	Published	03.03.2023	<a href="https://www.arib.or.jp/english/html/overview/doc/T120_T23_SPECS/ARIB-STD-T120/Rel17/36/A36213-h40.pdf">https://www.arib.or.jp/english/html/overview/doc/T120_T23_SPECS/ARIB-STD-T120/Rel17/36/A36213-h40.pdf</a>
ATIS	ATIS.3GPP.36.213.V17.4.0	17.4.0	Published	21.02.2023	<a href="https://www.atis.org/3gpp-transpositions-Rel-17">https://www.atis.org/3gpp-transpositions-Rel-17</a>
CCSA	CCSA.36.213V1740	17.4.0	Published	01.12.2022	<a href="https://www.ccsa.org.cn/api/portalsFile/downloadOldFile?type=19&amp;oldFileUrl=ITU-R/M.2012-6/CCSA.36.213V1740.rar">https://www.ccsa.org.cn/api/portalsFile/downloadOldFile?type=19&amp;oldFileUrl=ITU-R/M.2012-6/CCSA.36.213V1740.rar</a>
ETSI	ETSI TS 136 213	17.4.0	Published	20.01.2023	<a href="https://www.etsi.org/deliver/etsi_ts/136200_136299/136213/17.04.00_60/ts_136213v170400p.pdf">https://www.etsi.org/deliver/etsi_ts/136200_136299/136213/17.04.00_60/ts_136213v170400p.pdf</a>
TSDSI	TSDSI STD T1.3GPP 36.213 17.4.0 V1.3.0	17.4.0	Published	02.05.2023	<a href="https://members.tdsi.in/s/AdE6MZbaZgRDHMe">https://members.tdsi.in/s/AdE6MZbaZgRDHMe</a>
TTA	TTAT.3G-36.213V17.4.0	17.4.0	Published	16.03.2023	<a href="http://committee.tta.or.kr/data/ttasDown.jsp?kind=ttastd&amp;pk_num=TTAT.3G-36.213V17.4.0">http://committee.tta.or.kr/data/ttasDown.jsp?kind=ttastd&amp;pk_num=TTAT.3G-36.213V17.4.0</a>

### 2.1.2.5 TS 36.214

#### Evolved Universal Terrestrial Radio Access (E-UTRA); Physical layer; Measurements

This document contains the description and definition of the measurements done at the UE and network in order to support operation in idle mode and connected mode in E-UTRA.

SDO	Document No.	Version	Status	Issued date	Location
-----	--------------	---------	--------	-------------	----------



<b>Release 10</b>									
ARIB	ARIB STD-T120-36.214.V10.1.0	10.1.0	Published	03.03.2023	<a href="https://www.arib.or.jp/english/html/overview/doc/T120_T23_SPECS/ARIB-STD-T120/Rel10/36/A36214-a10.pdf">https://www.arib.or.jp/english/html/overview/doc/T120_T23_SPECS/ARIB-STD-T120/Rel10/36/A36214-a10.pdf</a>				
ATIS	ATIS.3GPP.36.214V1010	10.1.0	Published	28.06.2021	<a href="https://www.atis.org/3gpp-documents/Rel99-14/">https://www.atis.org/3gpp-documents/Rel99-14/</a>				
CCSA	CCSA.36.214V1010	10.1.0	Published	01.03.2011	<a href="https://www.ccsa.org.cn/api/portalsFile/downloadOldFile?type=19&amp;oldFileUrl=ITU-R/M.2012-6/CCSA.36.214V1010.doc">https://www.ccsa.org.cn/api/portalsFile/downloadOldFile?type=19&amp;oldFileUrl=ITU-R/M.2012-6/CCSA.36.214V1010.doc</a>				
ETSI	ETSI TS 136 214	10.1.0	Published	04.04.2011	<a href="https://www.etsi.org/deliver/etsi_ts/136200_136299/136214/10.01.00_60/ts_136214v100100p.pdf">https://www.etsi.org/deliver/etsi_ts/136200_136299/136214/10.01.00_60/ts_136214v100100p.pdf</a>				
TSDSI	TSDSI STD T1.3GPP 36.214-10.1.0 V1.0.0	10.1.0	Published	30.08.2021	<a href="https://members.tdsi.in/index.php/s/DXN6edfSM8S87Rc">https://members.tdsi.in/index.php/s/DXN6edfSM8S87Rc</a>				
TTA	TTAT.3G-36.214V10.1.0	10.1.0	Published	02.08.2021	<a href="http://committee.tta.or.kr/data/ttasDown.jsp?kind=ttastd&amp;pk_num=TTAT.3G-36.214V10.1.0">http://committee.tta.or.kr/data/ttasDown.jsp?kind=ttastd&amp;pk_num=TTAT.3G-36.214V10.1.0</a>				
<b>Release 11</b>									
ARIB	ARIB STD-T120-36.214.V11.1.0	11.1.0	Published	03.03.2023	<a href="https://www.arib.or.jp/english/html/overview/doc/T120_T23_SPECS/ARIB-STD-T120/Rel11/36/A36214-b10.pdf">https://www.arib.or.jp/english/html/overview/doc/T120_T23_SPECS/ARIB-STD-T120/Rel11/36/A36214-b10.pdf</a>				
ATIS	ATIS.3GPP.36.214V1110	11.1.0	Published	28.06.2021	<a href="https://www.atis.org/3gpp-documents/Rel99-14/">https://www.atis.org/3gpp-documents/Rel99-14/</a>				
CCSA	CCSA.36.214V1110	11.1.0	Published	01.12.2012	<a href="https://www.ccsa.org.cn/api/portalsFile/downloadOldFile?type=19&amp;oldFileUrl=ITU-R/M.2012-6/CCSA.36.214V1110.doc">https://www.ccsa.org.cn/api/portalsFile/downloadOldFile?type=19&amp;oldFileUrl=ITU-R/M.2012-6/CCSA.36.214V1110.doc</a>				
ETSI	ETSI TS 136 214	11.1.0	Published	06.02.2013	<a href="https://www.etsi.org/deliver/etsi_ts/136200_136299/136214/11.01.00_60/ts_136214v110100p.pdf">https://www.etsi.org/deliver/etsi_ts/136200_136299/136214/11.01.00_60/ts_136214v110100p.pdf</a>				
TSDSI	TSDSI STD T1.3GPP 36.214-11.1.0 V1.0.0	11.1.0	Published	30.08.2021	<a href="https://members.tdsi.in/index.php/s/4rZPNXpPE9TyRtf">https://members.tdsi.in/index.php/s/4rZPNXpPE9TyRtf</a>				
TTA	TTAT.3G-36.214V11.1.0	11.1.0	Published	02.08.2021	<a href="http://committee.tta.or.kr/data/ttasDown.jsp?kind=ttastd&amp;pk_num=TTAT.3G-36.214V11.1.0">http://committee.tta.or.kr/data/ttasDown.jsp?kind=ttastd&amp;pk_num=TTAT.3G-36.214V11.1.0</a>				
<b>Release 12</b>									
ARIB	ARIB STD-T120-36.214.V12.3.0	12.3.0	Published	03.03.2023	<a href="https://www.arib.or.jp/english/html/overview/doc/T120_T23_SPECS/ARIB-STD-T120/Rel12/36/A36214-c30.pdf">https://www.arib.or.jp/english/html/overview/doc/T120_T23_SPECS/ARIB-STD-T120/Rel12/36/A36214-c30.pdf</a>				
ATIS	ATIS.3GPP.36.214V1230	12.3.0	Published	28.06.2021	<a href="https://www.atis.org/3gpp-documents/Rel99-14/">https://www.atis.org/3gpp-documents/Rel99-14/</a>				
CCSA	CCSA.36.214V1230	12.3.0	Published	01.09.2016	<a href="https://www.ccsa.org.cn/api/portalsFile/downloadOldFile?type=19&amp;oldFileUrl=ITU-R/M.2012-6/CCSA.36.214V1230.doc">https://www.ccsa.org.cn/api/portalsFile/downloadOldFile?type=19&amp;oldFileUrl=ITU-R/M.2012-6/CCSA.36.214V1230.doc</a>				
ETSI	ETSI TS 136 214	12.3.0	Published	06.10.2016	<a href="https://www.etsi.org/deliver/etsi_ts/136200_136299/136214/12.03.00_60/ts_136214v120300p.pdf">https://www.etsi.org/deliver/etsi_ts/136200_136299/136214/12.03.00_60/ts_136214v120300p.pdf</a>				
TSDSI	TSDSI STD T1.3GPP 36.214-12.3.0 V1.0.0	12.3.0	Published	30.08.2021	<a href="https://members.tdsi.in/index.php/s/iRNfG32Cb4aHErT">https://members.tdsi.in/index.php/s/iRNfG32Cb4aHErT</a>				
TTA	TTAT.3G-36.214V12.3.0	12.3.0	Published	02.08.2021	<a href="http://committee.tta.or.kr/data/ttasDown.jsp?kind=ttastd&amp;pk_num=TTAT.3G-36.214V12.3.0">http://committee.tta.or.kr/data/ttasDown.jsp?kind=ttastd&amp;pk_num=TTAT.3G-36.214V12.3.0</a>				
<b>Release 13</b>									
ARIB	ARIB STD-T120-36.214.V13.5.0	13.5.0	Published	03.03.2023	<a href="https://www.arib.or.jp/english/html/overview/doc/T120_T23_SPECS/ARIB-STD-T120/Rel13/36/A36214-d50.pdf">https://www.arib.or.jp/english/html/overview/doc/T120_T23_SPECS/ARIB-STD-T120/Rel13/36/A36214-d50.pdf</a>				
ATIS	ATIS.3GPP.36.214V1350	13.5.0	Published	28.06.2021	<a href="https://www.atis.org/3gpp-documents/Rel99-14/">https://www.atis.org/3gpp-documents/Rel99-14/</a>				
CCSA	CCSA.36.214V1350	13.5.0	Published	01.09.2017	<a href="https://www.ccsa.org.cn/api/portalsFile/downloadOldFile?type=19&amp;oldFileUrl=ITU-R/M.2012-6/CCSA.36.214V1350.doc">https://www.ccsa.org.cn/api/portalsFile/downloadOldFile?type=19&amp;oldFileUrl=ITU-R/M.2012-6/CCSA.36.214V1350.doc</a>				
ETSI	ETSI TS 136 214	13.5.0	Published	09.10.2017	<a href="https://www.etsi.org/deliver/etsi_ts/136200_136299/136214/13.05.00_60/ts_136214v130500p.pdf">https://www.etsi.org/deliver/etsi_ts/136200_136299/136214/13.05.00_60/ts_136214v130500p.pdf</a>				
TSDSI	TSDSI STD T1.3GPP 36.214-13.5.0 V1.0.0	13.5.0	Published	30.08.2021	<a href="https://members.tdsi.in/index.php/s/nNgsZmMBzMQgPXF">https://members.tdsi.in/index.php/s/nNgsZmMBzMQgPXF</a>				
TTA	TTAT.3G-36.214V13.5.0	13.5.0	Published	02.08.2021	<a href="http://committee.tta.or.kr/data/ttasDown.jsp?kind=ttastd&amp;pk_num=TTAT.3G-36.214V13.5.0">http://committee.tta.or.kr/data/ttasDown.jsp?kind=ttastd&amp;pk_num=TTAT.3G-36.214V13.5.0</a>				
<b>Release 14</b>									
ARIB	ARIB STD-T120-36.214.V14.4.0	14.4.0	Published	03.03.2023	<a href="https://www.arib.or.jp/english/html/overview/doc/T120_T23_SPECS/ARIB-STD-T120/Rel14/36/A36214-e40.pdf">https://www.arib.or.jp/english/html/overview/doc/T120_T23_SPECS/ARIB-STD-T120/Rel14/36/A36214-e40.pdf</a>				
ATIS	ATIS.3GPP.36.214V1440	14.4.0	Published	28.06.2021	<a href="https://www.atis.org/3gpp-documents/Rel99-14/">https://www.atis.org/3gpp-documents/Rel99-14/</a>				
CCSA	CCSA.36.214V1440	14.4.0	Published	01.12.2017	<a href="https://www.ccsa.org.cn/api/portalsFile/downloadOldFile?type=19&amp;oldFileUrl=ITU-R/M.2012-6/CCSA.36.214V1440.doc">https://www.ccsa.org.cn/api/portalsFile/downloadOldFile?type=19&amp;oldFileUrl=ITU-R/M.2012-6/CCSA.36.214V1440.doc</a>				
ETSI	ETSI TS 136 214	14.4.0	Published	17.01.2018	<a href="https://www.etsi.org/deliver/etsi_ts/136200_136299/136214/14.04.00_60/ts_136214v140400p.pdf">https://www.etsi.org/deliver/etsi_ts/136200_136299/136214/14.04.00_60/ts_136214v140400p.pdf</a>				
TSDSI	TSDSI STD T1.3GPP 36.214-14.4.0 V1.0.0	14.4.0	Published	30.08.2021	<a href="https://members.tdsi.in/index.php/s/tLoQGyWEHKQ3Pia">https://members.tdsi.in/index.php/s/tLoQGyWEHKQ3Pia</a>				
TTA	TTAT.3G-36.214V14.4.0	14.4.0	Published	02.08.2021	<a href="http://committee.tta.or.kr/data/ttasDown.jsp?kind=ttastd&amp;pk_num=TTAT.3G-36.214V14.4.0">http://committee.tta.or.kr/data/ttasDown.jsp?kind=ttastd&amp;pk_num=TTAT.3G-36.214V14.4.0</a>				
<b>Release 15</b>									
ARIB	ARIB STD-T120-36.214.V15.5.0	15.5.0	Published	03.03.2023	<a href="https://www.arib.or.jp/english/html/overview/doc/T120_T23_SPECS/ARIB-STD-T120/Rel15/36/A36214-f50.pdf">https://www.arib.or.jp/english/html/overview/doc/T120_T23_SPECS/ARIB-STD-T120/Rel15/36/A36214-f50.pdf</a>				
ATIS	ATIS.3GPP.36.214V1550	15.5.0	Published	28.06.2021	<a href="https://www.atis.org/3gpp-documents/Rel15/">https://www.atis.org/3gpp-documents/Rel15/</a>				
CCSA	CCSA.36.214V1550	15.5.0	Published	01.12.2019	<a href="https://www.ccsa.org.cn/api/portalsFile/downloadOldFile?type=19&amp;oldFileUrl=ITU-R/M.2012-6/CCSA.36.214V1550.doc">https://www.ccsa.org.cn/api/portalsFile/downloadOldFile?type=19&amp;oldFileUrl=ITU-R/M.2012-6/CCSA.36.214V1550.doc</a>				
ETSI	ETSI TS 136 214	15.5.0	Published	17.01.2020	<a href="https://www.etsi.org/deliver/etsi_ts/136200_136299/136214/15.05.00_60/ts_136214v150500p.pdf">https://www.etsi.org/deliver/etsi_ts/136200_136299/136214/15.05.00_60/ts_136214v150500p.pdf</a>				
TSDSI	TSDSI STD T1.3GPP 36.214-15.5.0 V1.0.0	15.5.0	Published	30.08.2021	<a href="https://members.tdsi.in/index.php/s/5paPZBtz47S9qWG">https://members.tdsi.in/index.php/s/5paPZBtz47S9qWG</a>				
TTA	TTAT.3G-36.214V15.5.0	15.5.0	Published	11.09.2020	<a href="http://committee.tta.or.kr/data/ttasDown.jsp?kind=ttastd&amp;pk_num=TTAT.3G-36.214V15.5.0">http://committee.tta.or.kr/data/ttasDown.jsp?kind=ttastd&amp;pk_num=TTAT.3G-36.214V15.5.0</a>				
<b>Release 16</b>									
ARIB	ARIB STD-T120-36.214.V16.2.0	16.2.0	Published	03.03.2023	<a href="https://www.arib.or.jp/english/html/overview/doc/T120_T23_SPECS/ARIB-STD-T120/Rel16/36/A36214-g20.pdf">https://www.arib.or.jp/english/html/overview/doc/T120_T23_SPECS/ARIB-STD-T120/Rel16/36/A36214-g20.pdf</a>				
ATIS	ATIS.3GPP.36.214.V16.2.0	16.2.0	Published	21.02.2023	<a href="https://www.atis.org/3gpp-transpositions - Rel-16">https://www.atis.org/3gpp-transpositions - Rel-16</a>				
CCSA	CCSA.36.214V1620	16.2.0	Published	01.03.2021	<a href="https://www.ccsa.org.cn/api/portalsFile/downloadOldFile?type=19&amp;oldFileUrl=ITU-R/M.2012-6/CCSA.36.214V1620.doc">https://www.ccsa.org.cn/api/portalsFile/downloadOldFile?type=19&amp;oldFileUrl=ITU-R/M.2012-6/CCSA.36.214V1620.doc</a>				

ETSI	ETSI TS 136 214	16.2.0	Published	20.04.2021	<a href="https://www.etsi.org/deliver/etsi_ts/136200_136299/136214/16.02.00_60/ts_136214v160200p.pdf">https://www.etsi.org/deliver/etsi_ts/136200_136299/136214/16.02.00_60/ts_136214v160200p.pdf</a>
TSDSI	TSDSI STD T1.3GPP 36.214-16.2.0 V1.1.0	16.2.0	Published	01.11.2022	<a href="https://members.tdsi.in/s/xyLzCDYcjsSjC93">https://members.tdsi.in/s/xyLzCDYcjsSjC93</a>
TTA	TTAT.3G-36.214V16.2.0	16.2.0	Published	10.06.2021	<a href="http://committee.tta.or.kr/data/ttasDown.jsp?kind=ttastd&amp;pk_num=TTAT.3G-36.214V16.2.0">http://committee.tta.or.kr/data/ttasDown.jsp?kind=ttastd&amp;pk_num=TTAT.3G-36.214V16.2.0</a>

**Release 17**

ARIB	ARIB STD-T120-36.214.V17.0.0	17.0.0	Published	03.03.2023	<a href="https://www.arib.or.jp/english/html/overview/doc/T120_T23_SPECS/ARIB-STD-T120/Rel17/36/A36214-h00.pdf">https://www.arib.or.jp/english/html/overview/doc/T120_T23_SPECS/ARIB-STD-T120/Rel17/36/A36214-h00.pdf</a>
ATIS	ATIS.3GPP.36.214.V17.0.0	17.0.0	Published	21.02.2023	<a href="https://www.atis.org/3gpp-transpositions-Rel-17">https://www.atis.org/3gpp-transpositions-Rel-17</a>
CCSA	CCSA.36.214V1700	17.0.0	Published	01.03.2022	<a href="https://www.ccsa.org.cn/api/portalsFile/downloadOldFile?type=19&amp;oldFileUrl=ITU-R/M.2012-6/CCSA.36.214V1700.doc">https://www.ccsa.org.cn/api/portalsFile/downloadOldFile?type=19&amp;oldFileUrl=ITU-R/M.2012-6/CCSA.36.214V1700.doc</a>
ETSI	ETSI TS 136 214	17.0.0	Published	20.04.2022	<a href="https://www.etsi.org/deliver/etsi_ts/136200_136299/136214/17.00.00_60/ts_136214v170000p.pdf">https://www.etsi.org/deliver/etsi_ts/136200_136299/136214/17.00.00_60/ts_136214v170000p.pdf</a>
TSDSI	TSDSI STD T1.3GPP 36.214-17.0.0 V1.0.0	17.0.0	Published	29.07.2022	<a href="https://members.tdsi.in/s/ktGLRtM7YsK5Jy3">https://members.tdsi.in/s/ktGLRtM7YsK5Jy3</a>
TTA	TTAT.3G-36.214V17.0.0	17.0.0	Published	05.08.2022	<a href="http://committee.tta.or.kr/data/ttasDown.jsp?kind=ttastd&amp;pk_num=TTAT.3G-36.214V17.0.0">http://committee.tta.or.kr/data/ttasDown.jsp?kind=ttastd&amp;pk_num=TTAT.3G-36.214V17.0.0</a>

**2.1.2.6 TS 36.216****Evolved Universal Terrestrial Radio Access (E-UTRA); Physical layer for relaying operation**

This document describes the characteristics of eNodeB – relay node transmissions.

SDO	Document No.	Version	Status	Issued date	Location
<b>Release 10</b>					
ARIB	ARIB STD-T120-36.216.V10.3.1	10.3.1	Published	03.03.2023	<a href="https://www.arib.or.jp/english/html/overview/doc/T120_T23_SPECS/ARIB-STD-T120/Rel10/36/A36216-a31.pdf">https://www.arib.or.jp/english/html/overview/doc/T120_T23_SPECS/ARIB-STD-T120/Rel10/36/A36216-a31.pdf</a>
ATIS	ATIS.3GPP.36.216V1031	10.3.1	Published	28.06.2021	<a href="https://www.atis.org/3gpp-documents/Rel99-14/">https://www.atis.org/3gpp-documents/Rel99-14/</a>
CCSA	CCSA.36.216V1031	10.3.1	Published	01.09.2011	<a href="https://www.ccsa.org.cn/api/portalsFile/downloadOldFile?type=19&amp;oldFileUrl=ITU-R/M.2012-6/CCSA.36.216V1031.doc">https://www.ccsa.org.cn/api/portalsFile/downloadOldFile?type=19&amp;oldFileUrl=ITU-R/M.2012-6/CCSA.36.216V1031.doc</a>
ETSI	ETSI TS 136 216	10.3.1	Published	21.10.2011	<a href="https://www.etsi.org/deliver/etsi_ts/136200_136299/136216/10.03.01_60/ts_136216v100301p.pdf">https://www.etsi.org/deliver/etsi_ts/136200_136299/136216/10.03.01_60/ts_136216v100301p.pdf</a>
TSDSI	TSDSI STD T1.3GPP 36.216-10.3.1 V1.0.0	10.3.1	Published	30.08.2021	<a href="https://members.tdsi.in/index.php/s/CnqYYMfSYxyngBT">https://members.tdsi.in/index.php/s/CnqYYMfSYxyngBT</a>
TTA	TTAT.3G-36.216V10.3.1	10.3.1	Published	02.08.2021	<a href="http://committee.tta.or.kr/data/ttasDown.jsp?kind=ttastd&amp;pk_num=TTAT.3G-36.216V10.3.1">http://committee.tta.or.kr/data/ttasDown.jsp?kind=ttastd&amp;pk_num=TTAT.3G-36.216V10.3.1</a>
<b>Release 11</b>					
ARIB	ARIB STD-T120-36.216.V11.0.0	11.0.0	Published	03.03.2023	<a href="https://www.arib.or.jp/english/html/overview/doc/T120_T23_SPECS/ARIB-STD-T120/Rel11/36/A36216-b00.pdf">https://www.arib.or.jp/english/html/overview/doc/T120_T23_SPECS/ARIB-STD-T120/Rel11/36/A36216-b00.pdf</a>
ATIS	ATIS.3GPP.36.216V1100	11.0.0	Published	28.06.2021	<a href="https://www.atis.org/3gpp-documents/Rel99-14/">https://www.atis.org/3gpp-documents/Rel99-14/</a>
CCSA	CCSA.36.216V1100	11.0.0	Published	01.09.2012	<a href="https://www.ccsa.org.cn/api/portalsFile/downloadOldFile?type=19&amp;oldFileUrl=ITU-R/M.2012-6/CCSA.36.216V1100.doc">https://www.ccsa.org.cn/api/portalsFile/downloadOldFile?type=19&amp;oldFileUrl=ITU-R/M.2012-6/CCSA.36.216V1100.doc</a>
ETSI	ETSI TS 136 216	11.0.0	Published	02.10.2012	<a href="https://www.etsi.org/deliver/etsi_ts/136200_136299/136216/11.00.00_60/ts_136216v110000p.pdf">https://www.etsi.org/deliver/etsi_ts/136200_136299/136216/11.00.00_60/ts_136216v110000p.pdf</a>
TSDSI	TSDSI STD T1.3GPP 36.216-11.0.0 V1.0.0	11.0.0	Published	30.08.2021	<a href="https://members.tdsi.in/index.php/s/mkye76qJDG9omBm">https://members.tdsi.in/index.php/s/mkye76qJDG9omBm</a>
TTA	TTAT.3G-36.216V11.0.0	11.0.0	Published	02.08.2021	<a href="http://committee.tta.or.kr/data/ttasDown.jsp?kind=ttastd&amp;pk_num=TTAT.3G-36.216V11.0.0">http://committee.tta.or.kr/data/ttasDown.jsp?kind=ttastd&amp;pk_num=TTAT.3G-36.216V11.0.0</a>
<b>Release 12</b>					
ARIB	ARIB STD-T120-36.216.V12.0.0	12.0.0	Published	03.03.2023	<a href="https://www.arib.or.jp/english/html/overview/doc/T120_T23_SPECS/ARIB-STD-T120/Rel12/36/A36216-c00.pdf">https://www.arib.or.jp/english/html/overview/doc/T120_T23_SPECS/ARIB-STD-T120/Rel12/36/A36216-c00.pdf</a>
ATIS	ATIS.3GPP.36.216V1200	12.0.0	Published	28.06.2021	<a href="https://www.atis.org/3gpp-documents/Rel99-14/">https://www.atis.org/3gpp-documents/Rel99-14/</a>
CCSA	CCSA.36.216V1200	12.0.0	Published	01.09.2014	<a href="https://www.ccsa.org.cn/api/portalsFile/downloadOldFile?type=19&amp;oldFileUrl=ITU-R/M.2012-6/CCSA.36.216V1200.doc">https://www.ccsa.org.cn/api/portalsFile/downloadOldFile?type=19&amp;oldFileUrl=ITU-R/M.2012-6/CCSA.36.216V1200.doc</a>
ETSI	ETSI TS 136 216	12.0.0	Published	02.10.2014	<a href="https://www.etsi.org/deliver/etsi_ts/136200_136299/136216/12.00.00_60/ts_136216v120000p.pdf">https://www.etsi.org/deliver/etsi_ts/136200_136299/136216/12.00.00_60/ts_136216v120000p.pdf</a>
TSDSI	TSDSI STD T1.3GPP 36.216-12.0.0 V1.0.0	12.0.0	Published	30.08.2021	<a href="https://members.tdsi.in/index.php/s/jGMqmAaH3LaeAxQ">https://members.tdsi.in/index.php/s/jGMqmAaH3LaeAxQ</a>
TTA	TTAT.3G-36.216V12.0.0	12.0.0	Published	02.08.2021	<a href="http://committee.tta.or.kr/data/ttasDown.jsp?kind=ttastd&amp;pk_num=TTAT.3G-36.216V12.0.0">http://committee.tta.or.kr/data/ttasDown.jsp?kind=ttastd&amp;pk_num=TTAT.3G-36.216V12.0.0</a>
<b>Release 13</b>					
ARIB	ARIB STD-T120-36.216.V13.0.0	13.0.0	Published	03.03.2023	<a href="https://www.arib.or.jp/english/html/overview/doc/T120_T23_SPECS/ARIB-STD-T120/Rel13/36/A36216-d00.pdf">https://www.arib.or.jp/english/html/overview/doc/T120_T23_SPECS/ARIB-STD-T120/Rel13/36/A36216-d00.pdf</a>
ATIS	ATIS.3GPP.36.216V1300	13.0.0	Published	28.06.2021	<a href="https://www.atis.org/3gpp-documents/Rel99-14/">https://www.atis.org/3gpp-documents/Rel99-14/</a>
CCSA	CCSA.36.216V1300	13.0.0	Published	01.12.2015	<a href="https://www.ccsa.org.cn/api/portalsFile/downloadOldFile?type=19&amp;oldFileUrl=ITU-R/M.2012-6/CCSA.36.216V1300.doc">https://www.ccsa.org.cn/api/portalsFile/downloadOldFile?type=19&amp;oldFileUrl=ITU-R/M.2012-6/CCSA.36.216V1300.doc</a>
ETSI	ETSI TS 136 216	13.0.0	Published	26.01.2016	<a href="https://www.etsi.org/deliver/etsi_ts/136200_136299/136216/13.00.00_60/ts_136216v130000p.pdf">https://www.etsi.org/deliver/etsi_ts/136200_136299/136216/13.00.00_60/ts_136216v130000p.pdf</a>
TSDSI	TSDSI STD T1.3GPP 36.216-13.0.0 V1.0.0	13.0.0	Published	30.08.2021	<a href="https://members.tdsi.in/index.php/s/qdx9DbcwtW5kcak">https://members.tdsi.in/index.php/s/qdx9DbcwtW5kcak</a>
TTA	TTAT.3G-36.216V13.0.0	13.0.0	Published	02.08.2021	<a href="http://committee.tta.or.kr/data/ttasDown.jsp?kind=ttastd&amp;pk_num=TTAT.3G-36.216V13.0.0">http://committee.tta.or.kr/data/ttasDown.jsp?kind=ttastd&amp;pk_num=TTAT.3G-36.216V13.0.0</a>

**Release 14**

ARIB	ARIB STD-T120-36.216.V14.0.0	14.0.0	Published	03.03.2023	<a href="https://www.arib.or.jp/english/html/overview/doc/T120_T23_SPECS/ARIB-STD-T120/Rel14/36/A36216-e00.pdf">https://www.arib.or.jp/english/html/overview/doc/T120_T23_SPECS/ARIB-STD-T120/Rel14/36/A36216-e00.pdf</a>
ATIS	ATIS.3GPP.36.216V1400	14.0.0	Published	28.06.2021	<a href="https://www.atis.org/3gpp-documents/Rel99-14/">https://www.atis.org/3gpp-documents/Rel99-14/</a>
CCSA	CCSA.36.216V1400	14.0.0	Published	01.03.2017	<a href="https://www.ccsa.org.cn/api/portalsFile/downloadOldFile?type=19&amp;oldFileUrl=ITU-R/M.2012-6/CCSA.36.216V1400.doc">https://www.ccsa.org.cn/api/portalsFile/downloadOldFile?type=19&amp;oldFileUrl=ITU-R/M.2012-6/CCSA.36.216V1400.doc</a>
ETSI	ETSI TS 136 216	14.0.0	Published	11.04.2017	<a href="https://www.etsi.org/deliver/etsi_ts/136200_136299/136216/14.00.00_60/ts_136216v140000p.pdf">https://www.etsi.org/deliver/etsi_ts/136200_136299/136216/14.00.00_60/ts_136216v140000p.pdf</a>
TSDSI	TSDSI STD T1.3GPP 36.216-14.0.0 V1.0.0	14.0.0	Published	30.08.2021	<a href="https://members.tdsi.in/index.php/s/6B56Y3Y9SD3wr5P">https://members.tdsi.in/index.php/s/6B56Y3Y9SD3wr5P</a>
TTA	TTAT.3G-36.216V14.0.0	14.0.0	Published	02.08.2021	<a href="http://committee.tta.or.kr/data/ttasDown.jsp?kind=ttastd&amp;pk_num=TTAT.3G-36.216V14.0.0">http://committee.tta.or.kr/data/ttasDown.jsp?kind=ttastd&amp;pk_num=TTAT.3G-36.216V14.0.0</a>
<b>Release 15</b>					
ARIB	ARIB STD-T120-36.216.V15.0.0	15.0.0	Published	03.03.2023	<a href="https://www.arib.or.jp/english/html/overview/doc/T120_T23_SPECS/ARIB-STD-T120/Rel15/36/A36216-f00.pdf">https://www.arib.or.jp/english/html/overview/doc/T120_T23_SPECS/ARIB-STD-T120/Rel15/36/A36216-f00.pdf</a>
ATIS	ATIS.3GPP.36.216V1500	15.0.0	Published	28.06.2021	<a href="https://www.atis.org/3gpp-documents/Rel15/">https://www.atis.org/3gpp-documents/Rel15/</a>
CCSA	CCSA.36.216V1500	15.0.0	Published	01.06.2018	<a href="https://www.ccsa.org.cn/api/portalsFile/downloadOldFile?type=19&amp;oldFileUrl=ITU-R/M.2012-6/CCSA.36.216V1500.doc">https://www.ccsa.org.cn/api/portalsFile/downloadOldFile?type=19&amp;oldFileUrl=ITU-R/M.2012-6/CCSA.36.216V1500.doc</a>
ETSI	ETSI TS 136 216	15.0.0	Published	13.07.2018	<a href="https://www.etsi.org/deliver/etsi_ts/136200_136299/136216/15.00.00_60/ts_136216v150000p.pdf">https://www.etsi.org/deliver/etsi_ts/136200_136299/136216/15.00.00_60/ts_136216v150000p.pdf</a>
TSDSI	TSDSI STD T1.3GPP 36.216-15.0.0 V1.0.0	15.0.0	Published	30.08.2021	<a href="https://members.tdsi.in/index.php/s/jcqMsxTx8j5DXcd">https://members.tdsi.in/index.php/s/jcqMsxTx8j5DXcd</a>
TTA	TTAT.3G-36.216V15.0.0	15.0.0	Published	11.09.2020	<a href="http://committee.tta.or.kr/data/ttasDown.jsp?kind=ttastd&amp;pk_num=TTAT.3G-36.216V15.0.0">http://committee.tta.or.kr/data/ttasDown.jsp?kind=ttastd&amp;pk_num=TTAT.3G-36.216V15.0.0</a>
<b>Release 16</b>					
ARIB	ARIB STD-T120-36.216.V16.0.0	16.0.0	Published	03.03.2023	<a href="https://www.arib.or.jp/english/html/overview/doc/T120_T23_SPECS/ARIB-STD-T120/Rel16/36/A36216-g00.pdf">https://www.arib.or.jp/english/html/overview/doc/T120_T23_SPECS/ARIB-STD-T120/Rel16/36/A36216-g00.pdf</a>
ATIS	ATIS.3GPP.36.216V1600	16.0.0	Published	28.06.2021	<a href="https://www.atis.org/3gpp-documents/Rel16/">https://www.atis.org/3gpp-documents/Rel16/</a>
CCSA	CCSA.36.216V1600	16.0.0	Published	01.06.2020	<a href="https://www.ccsa.org.cn/api/portalsFile/downloadOldFile?type=19&amp;oldFileUrl=ITU-R/M.2012-6/CCSA.36.216V1600.doc">https://www.ccsa.org.cn/api/portalsFile/downloadOldFile?type=19&amp;oldFileUrl=ITU-R/M.2012-6/CCSA.36.216V1600.doc</a>
ETSI	ETSI TS 136 216	16.0.0	Published	20.07.2020	<a href="https://www.etsi.org/deliver/etsi_ts/136200_136299/136216/16.00.00_60/ts_136216v160000p.pdf">https://www.etsi.org/deliver/etsi_ts/136200_136299/136216/16.00.00_60/ts_136216v160000p.pdf</a>
TSDSI	TSDSI STD T1.3GPP 36.216-16.0.0 V1.0.0	16.0.0	Published	30.08.2021	<a href="https://members.tdsi.in/index.php/s/Cte6XjCgzyQ4y7S">https://members.tdsi.in/index.php/s/Cte6XjCgzyQ4y7S</a>
TTA	TTAT.3G-36.216V16.0.0	16.0.0	Published	11.09.2020	<a href="http://committee.tta.or.kr/data/ttasDown.jsp?kind=ttastd&amp;pk_num=TTAT.3G-36.216V16.0.0">http://committee.tta.or.kr/data/ttasDown.jsp?kind=ttastd&amp;pk_num=TTAT.3G-36.216V16.0.0</a>
<b>Release 17</b>					
ARIB	ARIB STD-T120-36.216.V17.0.0	17.0.0	Published	03.03.2023	<a href="https://www.arib.or.jp/english/html/overview/doc/T120_T23_SPECS/ARIB-STD-T120/Rel17/36/A36216-h00.pdf">https://www.arib.or.jp/english/html/overview/doc/T120_T23_SPECS/ARIB-STD-T120/Rel17/36/A36216-h00.pdf</a>
ATIS	ATIS.3GPP.36.216.V17.0.0	17.0.0	Published	21.02.2023	<a href="https://www.atis.org/3gpp-transpositions - Rel-17">https://www.atis.org/3gpp-transpositions - Rel-17</a>
CCSA	CCSA.36.216V1700	17.0.0	Published	01.03.2022	<a href="https://www.ccsa.org.cn/api/portalsFile/downloadOldFile?type=19&amp;oldFileUrl=ITU-R/M.2012-6/CCSA.36.216V1700.doc">https://www.ccsa.org.cn/api/portalsFile/downloadOldFile?type=19&amp;oldFileUrl=ITU-R/M.2012-6/CCSA.36.216V1700.doc</a>
ETSI	ETSI TS 136 216	17.0.0	Published	20.04.2022	<a href="https://www.etsi.org/deliver/etsi_ts/136200_136299/136216/17.00.00_60/ts_136216v170000p.pdf">https://www.etsi.org/deliver/etsi_ts/136200_136299/136216/17.00.00_60/ts_136216v170000p.pdf</a>
TSDSI	TSDSI STD T1.3GPP 36.216-17.0.0 V1.0.0	17.0.0	Published	29.07.2022	<a href="https://members.tdsi.in/s/NaTRG5z28Jjwst8">https://members.tdsi.in/s/NaTRG5z28Jjwst8</a>
TTA	TTAT.3G-36.216V17.0.0	17.0.0	Published	05.08.2022	<a href="http://committee.tta.or.kr/data/ttasDown.jsp?kind=ttastd&amp;pk_num=TTAT.3G-36.216V17.0.0">http://committee.tta.or.kr/data/ttasDown.jsp?kind=ttastd&amp;pk_num=TTAT.3G-36.216V17.0.0</a>

## 2.1.3 Radio Layers 2 and 3

### 2.1.3.1 TS 36.300

#### Evolved Universal Terrestrial Radio Access (E-UTRA) and Evolved Universal Terrestrial Radio Access Network (E-UTRAN); Overall description; Stage 2

This document provides an overview and overall description of the E-UTRAN radio interface protocol architecture. Details of the radio interface protocols are specified in companion specifications of the 36 series.

SDO	Document No.	Version	Status	Issued date	Location
<b>Release 10</b>					
ARIB	ARIB STD-T120-36.300.V10.12.0	10.12.0	Published	03.03.2023	<a href="https://www.arib.or.jp/english/html/overview/doc/T120_T23_SPECS/ARIB-STD-T120/Rel10/36/A36300-ac0.pdf">https://www.arib.or.jp/english/html/overview/doc/T120_T23_SPECS/ARIB-STD-T120/Rel10/36/A36300-ac0.pdf</a>
ATIS	ATIS.3GPP.36.300V10120	10.12.0	Published	28.06.2021	<a href="https://www.atis.org/3gpp-documents/Rel99-14/">https://www.atis.org/3gpp-documents/Rel99-14/</a>
CCSA	CCSA.36.300V10120	10.12.0	Published	01.12.2014	<a href="https://www.ccsa.org.cn/api/portalsFile/downloadOldFile?type=19&amp;oldFileUrl=ITU-R/M.2012-6/CCSA.36.300V10120.doc">https://www.ccsa.org.cn/api/portalsFile/downloadOldFile?type=19&amp;oldFileUrl=ITU-R/M.2012-6/CCSA.36.300V10120.doc</a>
ETSI	ETSI TS 136 300	10.12.0	Published	04.02.2015	<a href="https://www.etsi.org/deliver/etsi_ts/136300_136399/136300/10.12.00_60/ts_136300v101200p.pdf">https://www.etsi.org/deliver/etsi_ts/136300_136399/136300/10.12.00_60/ts_136300v101200p.pdf</a>
TSDSI	TSDSI STD T1.3GPP 36.300-10.12.0 V1.0.0	10.12.0	Published	30.08.2021	<a href="https://members.tdsi.in/index.php/s/ajGMJLWspBZy5xF">https://members.tdsi.in/index.php/s/ajGMJLWspBZy5xF</a>
TTA	TTAT.3G-36.300V10.12.0	10.12.0	Published	02.08.2021	<a href="http://committee.tta.or.kr/data/ttasDown.jsp?kind=ttastd&amp;pk_num=TTAT.3G-36.300V10.12.0">http://committee.tta.or.kr/data/ttasDown.jsp?kind=ttastd&amp;pk_num=TTAT.3G-36.300V10.12.0</a>

#### Release 11

## 34

## Rec. ITU-R M.2012-6

ARIB	ARIB STD-T120-36.300.V11.14.0	11.14.0	Published	03.03.2023	<a href="https://www.arib.or.jp/english/html/overview/doc/T120_T23_SPECS/ARIB-STD-T120/Rel11/36/A36300-be0.pdf">https://www.arib.or.jp/english/html/overview/doc/T120_T23_SPECS/ARIB-STD-T120/Rel11/36/A36300-be0.pdf</a>
ATIS	ATIS.3GPP.36.300V11140	11.14.0	Published	28.06.2021	<a href="https://www.atis.org/3gpp-documents/Rel99-14/">https://www.atis.org/3gpp-documents/Rel99-14/</a>
CCSA	CCSA.36.300V11140	11.14.0	Published	01.12.2015	<a href="https://www.ccsa.org.cn/api/portalsFile/downloadOldFile?type=19&amp;oldFileUrl=ITU-R/M.2012-6/CCSA.36.300V11140.doc">https://www.ccsa.org.cn/api/portalsFile/downloadOldFile?type=19&amp;oldFileUrl=ITU-R/M.2012-6/CCSA.36.300V11140.doc</a>
ETSI	ETSI TS 136 300	11.14.0	Published	18.01.2016	<a href="https://www.etsi.org/deliver/etsi_ts/136300_136399/136300/11.14.00_60/ts_136300v111400p.pdf">https://www.etsi.org/deliver/etsi_ts/136300_136399/136300/11.14.00_60/ts_136300v111400p.pdf</a>
TSDSI	TSDSI STD T1.3GPP 36.300-11.14.0 V1.0.0	11.14.0	Published	30.08.2021	<a href="https://members.tdsi.in/index.php/s/HCGqWySTCaQFj4y">https://members.tdsi.in/index.php/s/HCGqWySTCaQFj4y</a>
TTA	TTAT.3G-36.300V11.14.0	11.14.0	Published	02.08.2021	<a href="http://committee.tta.or.kr/data/ttasDown.jsp?kind=ttastd&amp;pk_num=TTAT.3G-36.300V11.14.0">http://committee.tta.or.kr/data/ttasDown.jsp?kind=ttastd&amp;pk_num=TTAT.3G-36.300V11.14.0</a>
<b>Release 12</b>					
ARIB	ARIB STD-T120-36.300.V12.10.0	12.10.0	Published	03.03.2023	<a href="https://www.arib.or.jp/english/html/overview/doc/T120_T23_SPECS/ARIB-STD-T120/Rel12/36/A36300-ca0.pdf">https://www.arib.or.jp/english/html/overview/doc/T120_T23_SPECS/ARIB-STD-T120/Rel12/36/A36300-ca0.pdf</a>
ATIS	ATIS.3GPP.36.300V12100	12.10.0	Published	28.06.2021	<a href="https://www.atis.org/3gpp-documents/Rel99-14/">https://www.atis.org/3gpp-documents/Rel99-14/</a>
CCSA	CCSA.36.300V12100	12.10.0	Published	01.06.2016	<a href="https://www.ccsa.org.cn/api/portalsFile/downloadOldFile?type=19&amp;oldFileUrl=ITU-R/M.2012-6/CCSA.36.300V12100.doc">https://www.ccsa.org.cn/api/portalsFile/downloadOldFile?type=19&amp;oldFileUrl=ITU-R/M.2012-6/CCSA.36.300V12100.doc</a>
ETSI	ETSI TS 136 300	12.10.0	Published	24.08.2016	<a href="https://www.etsi.org/deliver/etsi_ts/136300_136399/136300/12.10.00_60/ts_136300v121000p.pdf">https://www.etsi.org/deliver/etsi_ts/136300_136399/136300/12.10.00_60/ts_136300v121000p.pdf</a>
TSDSI	TSDSI STD T1.3GPP 36.300-12.10.0 V1.0.0	12.10.0	Published	30.08.2021	<a href="https://members.tdsi.in/index.php/s/XXwQ6CmwDoLbmG">https://members.tdsi.in/index.php/s/XXwQ6CmwDoLbmG</a>
TTA	TTAT.3G-36.300V12.10.0	12.10.0	Published	02.08.2021	<a href="http://committee.tta.or.kr/data/ttasDown.jsp?kind=ttastd&amp;pk_num=TTAT.3G-36.300V12.10.0">http://committee.tta.or.kr/data/ttasDown.jsp?kind=ttastd&amp;pk_num=TTAT.3G-36.300V12.10.0</a>
<b>Release 13</b>					
ARIB	ARIB STD-T120-36.300.V13.14.0	13.14.0	Published	03.03.2023	<a href="https://www.arib.or.jp/english/html/overview/doc/T120_T23_SPECS/ARIB-STD-T120/Rel13/36/A36300-de0.pdf">https://www.arib.or.jp/english/html/overview/doc/T120_T23_SPECS/ARIB-STD-T120/Rel13/36/A36300-de0.pdf</a>
ATIS	ATIS.3GPP.36.300V13140	13.14.0	Published	28.06.2021	<a href="https://www.atis.org/3gpp-documents/Rel99-14/">https://www.atis.org/3gpp-documents/Rel99-14/</a>
CCSA	CCSA.36.300V13140	13.14.0	Published	01.03.2020	<a href="https://www.ccsa.org.cn/api/portalsFile/downloadOldFile?type=19&amp;oldFileUrl=ITU-R/M.2012-6/CCSA.36.300V13140.doc">https://www.ccsa.org.cn/api/portalsFile/downloadOldFile?type=19&amp;oldFileUrl=ITU-R/M.2012-6/CCSA.36.300V13140.doc</a>
ETSI	ETSI TS 136 300	13.14.0	Published	16.04.2020	<a href="https://www.etsi.org/deliver/etsi_ts/136300_136399/136300/13.14.00_60/ts_136300v131400p.pdf">https://www.etsi.org/deliver/etsi_ts/136300_136399/136300/13.14.00_60/ts_136300v131400p.pdf</a>
TSDSI	TSDSI STD T1.3GPP 36.300-13.14.0 V1.1.0	13.14.0	Published	30.08.2021	<a href="https://members.tdsi.in/index.php/s/qgoXiKtiMnJDvy8">https://members.tdsi.in/index.php/s/qgoXiKtiMnJDvy8</a>
TTA	TTAT.3G-36.300V13.14.0	13.14.0	Published	02.08.2021	<a href="http://committee.tta.or.kr/data/ttasDown.jsp?kind=ttastd&amp;pk_num=TTAT.3G-36.300V13.14.0">http://committee.tta.or.kr/data/ttasDown.jsp?kind=ttastd&amp;pk_num=TTAT.3G-36.300V13.14.0</a>
<b>Release 14</b>					
ARIB	ARIB STD-T120-36.300.V14.13.0	14.13.0	Published	03.03.2023	<a href="https://www.arib.or.jp/english/html/overview/doc/T120_T23_SPECS/ARIB-STD-T120/Rel14/36/A36300-ed0.pdf">https://www.arib.or.jp/english/html/overview/doc/T120_T23_SPECS/ARIB-STD-T120/Rel14/36/A36300-ed0.pdf</a>
ATIS	ATIS.3GPP.36.300.V14.13.0	14.13.0	Published	21.02.2023	<a href="https://www.atis.org/3gpp-transpositions - Rel-14">https://www.atis.org/3gpp-transpositions - Rel-14</a>
CCSA	CCSA.36.300V14130	14.13.0	Published	01.12.2020	<a href="https://www.ccsa.org.cn/api/portalsFile/downloadOldFile?type=19&amp;oldFileUrl=ITU-R/M.2012-6/CCSA.36.300V14130.doc">https://www.ccsa.org.cn/api/portalsFile/downloadOldFile?type=19&amp;oldFileUrl=ITU-R/M.2012-6/CCSA.36.300V14130.doc</a>
ETSI	ETSI TS 136 300	14.13.0	Published	20.01.2021	<a href="https://www.etsi.org/deliver/etsi_ts/136300_136399/136300/14.13.00_60/ts_136300v141300p.pdf">https://www.etsi.org/deliver/etsi_ts/136300_136399/136300/14.13.00_60/ts_136300v141300p.pdf</a>
TSDSI	TSDSI STD T1.3GPP 36.3-14.13.0 V1.1.0	14.13.0	Published	17.01.2023	<a href="https://members.tdsi.in/s/RFKcJDWA9XNcWFn">https://members.tdsi.in/s/RFKcJDWA9XNcWFn</a>
TTA	TTAT.3G-36.300V14.13.0	14.13.0	Published	16.03.2023	<a href="http://committee.tta.or.kr/data/ttasDown.jsp?kind=ttastd&amp;pk_num=TTAT.3G-36.300V14.13.0">http://committee.tta.or.kr/data/ttasDown.jsp?kind=ttastd&amp;pk_num=TTAT.3G-36.300V14.13.0</a>
<b>Release 15</b>					
ARIB	ARIB STD-T120-36.300.V15.14.0	15.14.0	Published	03.03.2023	<a href="https://www.arib.or.jp/english/html/overview/doc/T120_T23_SPECS/ARIB-STD-T120/Rel15/36/A36300-fe0.pdf">https://www.arib.or.jp/english/html/overview/doc/T120_T23_SPECS/ARIB-STD-T120/Rel15/36/A36300-fe0.pdf</a>
ATIS	ATIS.3GPP.36.300.V15.14.0	15.14.0	Published	21.02.2023	<a href="https://www.atis.org/3gpp-transpositions - Rel-15">https://www.atis.org/3gpp-transpositions - Rel-15</a>
CCSA	CCSA.36.300V15140	15.14.0	Published	01.12.2022	<a href="https://www.ccsa.org.cn/api/portalsFile/downloadOldFile?type=19&amp;oldFileUrl=ITU-R/M.2012-6/CCSA.36.300V15140.doc">https://www.ccsa.org.cn/api/portalsFile/downloadOldFile?type=19&amp;oldFileUrl=ITU-R/M.2012-6/CCSA.36.300V15140.doc</a>
ETSI	ETSI TS 136 300	15.14.0	Published	20.01.2023	<a href="https://www.etsi.org/deliver/etsi_ts/136300_136399/136300/15.14.00_60/ts_136300v151400p.pdf">https://www.etsi.org/deliver/etsi_ts/136300_136399/136300/15.14.00_60/ts_136300v151400p.pdf</a>
TSDSI	TSDSI STD T1.3GPP 36.300-15.14.0 V1.2.0	15.14.0	Published	02.05.2023	<a href="https://members.tdsi.in/s/iPS7dTFXsrdfaW7">https://members.tdsi.in/s/iPS7dTFXsrdfaW7</a>
TTA	TTAT.3G-36.300V15.14.0	15.14.0	Published	16.03.2023	<a href="http://committee.tta.or.kr/data/ttasDown.jsp?kind=ttastd&amp;pk_num=TTAT.3G-36.300V15.14.0">http://committee.tta.or.kr/data/ttasDown.jsp?kind=ttastd&amp;pk_num=TTAT.3G-36.300V15.14.0</a>
<b>Release 16</b>					
ARIB	ARIB STD-T120-36.300.V16.9.0	16.9.0	Published	03.03.2023	<a href="https://www.arib.or.jp/english/html/overview/doc/T120_T23_SPECS/ARIB-STD-T120/Rel16/36/A36300-g90.pdf">https://www.arib.or.jp/english/html/overview/doc/T120_T23_SPECS/ARIB-STD-T120/Rel16/36/A36300-g90.pdf</a>
ATIS	ATIS.3GPP.36.300.V16.9.0	16.9.0	Published	21.02.2023	<a href="https://www.atis.org/3gpp-transpositions - Rel-16">https://www.atis.org/3gpp-transpositions - Rel-16</a>
CCSA	CCSA.36.300V1690	16.9.0	Published	01.12.2022	<a href="https://www.ccsa.org.cn/api/portalsFile/downloadOldFile?type=19&amp;oldFileUrl=ITU-R/M.2012-6/CCSA.36.300V1690.doc">https://www.ccsa.org.cn/api/portalsFile/downloadOldFile?type=19&amp;oldFileUrl=ITU-R/M.2012-6/CCSA.36.300V1690.doc</a>
ETSI	ETSI TS 136 300	16.9.0	Published	20.01.2023	<a href="https://www.etsi.org/deliver/etsi_ts/136300_136399/136300/16.09.00_60/ts_136300v160900p.pdf">https://www.etsi.org/deliver/etsi_ts/136300_136399/136300/16.09.00_60/ts_136300v160900p.pdf</a>
TSDSI	TSDSI STD T1.3GPP 36.300-16.9.0 V1.2.0	16.9.0	Published	02.05.2023	<a href="https://members.tdsi.in/s/cKno7LBFQB75WdS">https://members.tdsi.in/s/cKno7LBFQB75WdS</a>
TTA	TTAT.3G-36.300V16.9.0	16.9.0	Published	16.03.2023	<a href="http://committee.tta.or.kr/data/ttasDown.jsp?kind=ttastd&amp;pk_num=TTAT.3G-36.300V16.9.0">http://committee.tta.or.kr/data/ttasDown.jsp?kind=ttastd&amp;pk_num=TTAT.3G-36.300V16.9.0</a>
<b>Release 17</b>					
ARIB	ARIB STD-T120-36.300.V17.3.0	17.3.0	Published	03.03.2023	<a href="https://www.arib.or.jp/english/html/overview/doc/T120_T23_SPECS/ARIB-STD-T120/Rel17/36/A36300-h30.pdf">https://www.arib.or.jp/english/html/overview/doc/T120_T23_SPECS/ARIB-STD-T120/Rel17/36/A36300-h30.pdf</a>
ATIS	ATIS.3GPP.36.300.V17.3.0	17.3.0	Published	21.02.2023	<a href="https://www.atis.org/3gpp-transpositions - Rel-17">https://www.atis.org/3gpp-transpositions - Rel-17</a>
CCSA	CCSA.36.300V1730	17.3.0	Published	01.12.2022	<a href="https://www.ccsa.org.cn/api/portalsFile/downloadOldFile?type=19&amp;oldFileUrl=ITU-R/M.2012-6/CCSA.36.300V1730.doc">https://www.ccsa.org.cn/api/portalsFile/downloadOldFile?type=19&amp;oldFileUrl=ITU-R/M.2012-6/CCSA.36.300V1730.doc</a>
ETSI	ETSI TS 136 300	17.3.0	Published	20.01.2023	<a href="https://www.etsi.org/deliver/etsi_ts/136300_136399/136300/17.03.00_60/ts_136300v170300p.pdf">https://www.etsi.org/deliver/etsi_ts/136300_136399/136300/17.03.00_60/ts_136300v170300p.pdf</a>

TSDSI	TSDSI STD T1.3GPP 36.300 17.3.0 V1.3.0	17.3.0	Published	02.05.2023	<a href="https://members.tdsi.in/s/3e7Tz6SPq6zRNDK">https://members.tdsi.in/s/3e7Tz6SPq6zRNDK</a>
TTA	TTAT.3G-36.300V17.3.0	17.3.0	Published	16.03.2023	<a href="http://committee.tta.or.kr/data/ttasDown.jsp?kind=ttastd&amp;pk_num=TTAT.3G-36.300V17.3.0">http://committee.tta.or.kr/data/ttasDown.jsp?kind=ttastd&amp;pk_num=TTAT.3G-36.300V17.3.0</a>

### 2.1.3.2 TS 36.302

#### Evolved Universal Terrestrial Radio Access (E-UTRA); Services provided by the physical layer

This document is a technical specification of the services provided by the physical layer of E-UTRA to upper layers.

SDO	Document No.	Version	Status	Issued date	Location
<b>Release 10</b>					
ARIB	ARIB STD-T120-36.302.V10.6.0	10.6.0	Published	03.03.2023	<a href="https://www.arib.or.jp/english/html/overview/doc/T120_T23_SPECS/ARIB-STD-T120/Rel10/36/A36302-a60.pdf">https://www.arib.or.jp/english/html/overview/doc/T120_T23_SPECS/ARIB-STD-T120/Rel10/36/A36302-a60.pdf</a>
ATIS	ATIS.3GPP.36.302V1060	10.6.0	Published	28.06.2021	<a href="https://www.atis.org/3gpp-documents/Rel99-14/">https://www.atis.org/3gpp-documents/Rel99-14/</a>
CCSA	CCSA.36.302V1060	10.6.0	Published	01.09.2013	<a href="https://www.ccsa.org.cn/api/portalsFile/downloadOldFile?type=19&amp;oldFileUrl=ITU-R/M.2012-6/CCSA.36.302V1060.doc">https://www.ccsa.org.cn/api/portalsFile/downloadOldFile?type=19&amp;oldFileUrl=ITU-R/M.2012-6/CCSA.36.302V1060.doc</a>
ETSI	ETSI TS 136 302	10.6.0	Published	25.09.2013	<a href="https://www.etsi.org/deliver/etsi_ts/136300_136399/136302/10.06.00_60/ts_136302v100600p.pdf">https://www.etsi.org/deliver/etsi_ts/136300_136399/136302/10.06.00_60/ts_136302v100600p.pdf</a>
TSDSI	TSDSI STD T1.3GPP 36.302-10.6.0 V1.0.0	10.6.0	Published	30.08.2021	<a href="https://members.tdsi.in/index.php/s/Q7EbHNYig2zKryi">https://members.tdsi.in/index.php/s/Q7EbHNYig2zKryi</a>
TTA	TTAT.3G-36.302V10.6.0	10.6.0	Published	02.08.2021	<a href="http://committee.tta.or.kr/data/ttasDown.jsp?kind=ttastd&amp;pk_num=TTAT.3G-36.302V10.6.0">http://committee.tta.or.kr/data/ttasDown.jsp?kind=ttastd&amp;pk_num=TTAT.3G-36.302V10.6.0</a>
<b>Release 11</b>					
ARIB	ARIB STD-T120-36.302.V11.5.0	11.5.0	Published	03.03.2023	<a href="https://www.arib.or.jp/english/html/overview/doc/T120_T23_SPECS/ARIB-STD-T120/Rel11/36/A36302-b50.pdf">https://www.arib.or.jp/english/html/overview/doc/T120_T23_SPECS/ARIB-STD-T120/Rel11/36/A36302-b50.pdf</a>
ATIS	ATIS.3GPP.36.302V1150	11.5.0	Published	28.06.2021	<a href="https://www.atis.org/3gpp-documents/Rel99-14/">https://www.atis.org/3gpp-documents/Rel99-14/</a>
CCSA	CCSA.36.302V1150	11.5.0	Published	01.03.2014	<a href="https://www.ccsa.org.cn/api/portalsFile/downloadOldFile?type=19&amp;oldFileUrl=ITU-R/M.2012-6/CCSA.36.302V1150.doc">https://www.ccsa.org.cn/api/portalsFile/downloadOldFile?type=19&amp;oldFileUrl=ITU-R/M.2012-6/CCSA.36.302V1150.doc</a>
ETSI	ETSI TS 136 302	11.5.0	Published	26.03.2014	<a href="https://www.etsi.org/deliver/etsi_ts/136300_136399/136302/11.05.00_60/ts_136302v110500p.pdf">https://www.etsi.org/deliver/etsi_ts/136300_136399/136302/11.05.00_60/ts_136302v110500p.pdf</a>
TSDSI	TSDSI STD T1.3GPP 36.302-11.5.0 V1.0.0	11.5.0	Published	30.08.2021	<a href="https://members.tdsi.in/index.php/s/8b79bPodtAKpxRE">https://members.tdsi.in/index.php/s/8b79bPodtAKpxRE</a>
TTA	TTAT.3G-36.302V11.5.0	11.5.0	Published	02.08.2021	<a href="http://committee.tta.or.kr/data/ttasDown.jsp?kind=ttastd&amp;pk_num=TTAT.3G-36.302V11.5.0">http://committee.tta.or.kr/data/ttasDown.jsp?kind=ttastd&amp;pk_num=TTAT.3G-36.302V11.5.0</a>
<b>Release 12</b>					
ARIB	ARIB STD-T120-36.302.V12.8.0	12.8.0	Published	03.03.2023	<a href="https://www.arib.or.jp/english/html/overview/doc/T120_T23_SPECS/ARIB-STD-T120/Rel12/36/A36302-c80.pdf">https://www.arib.or.jp/english/html/overview/doc/T120_T23_SPECS/ARIB-STD-T120/Rel12/36/A36302-c80.pdf</a>
ATIS	ATIS.3GPP.36.302V1280	12.8.0	Published	28.06.2021	<a href="https://www.atis.org/3gpp-documents/Rel99-14/">https://www.atis.org/3gpp-documents/Rel99-14/</a>
CCSA	CCSA.36.302V1280	12.8.0	Published	01.09.2016	<a href="https://www.ccsa.org.cn/api/portalsFile/downloadOldFile?type=19&amp;oldFileUrl=ITU-R/M.2012-6/CCSA.36.302V1280.doc">https://www.ccsa.org.cn/api/portalsFile/downloadOldFile?type=19&amp;oldFileUrl=ITU-R/M.2012-6/CCSA.36.302V1280.doc</a>
ETSI	ETSI TS 136 302	12.8.0	Published	05.10.2016	<a href="https://www.etsi.org/deliver/etsi_ts/136300_136399/136302/12.08.00_60/ts_136302v120800p.pdf">https://www.etsi.org/deliver/etsi_ts/136300_136399/136302/12.08.00_60/ts_136302v120800p.pdf</a>
TSDSI	TSDSI STD T1.3GPP 36.302-12.8.0 V1.0.0	12.8.0	Published	30.08.2021	<a href="https://members.tdsi.in/index.php/s/bSNWgG79FesyPmA">https://members.tdsi.in/index.php/s/bSNWgG79FesyPmA</a>
TTA	TTAT.3G-36.302V12.8.0	12.8.0	Published	02.08.2021	<a href="http://committee.tta.or.kr/data/ttasDown.jsp?kind=ttastd&amp;pk_num=TTAT.3G-36.302V12.8.0">http://committee.tta.or.kr/data/ttasDown.jsp?kind=ttastd&amp;pk_num=TTAT.3G-36.302V12.8.0</a>
<b>Release 13</b>					
ARIB	ARIB STD-T120-36.302.V13.8.0	13.8.0	Published	03.03.2023	<a href="https://www.arib.or.jp/english/html/overview/doc/T120_T23_SPECS/ARIB-STD-T120/Rel13/36/A36302-d80.pdf">https://www.arib.or.jp/english/html/overview/doc/T120_T23_SPECS/ARIB-STD-T120/Rel13/36/A36302-d80.pdf</a>
ATIS	ATIS.3GPP.36.302V1380	13.8.0	Published	28.06.2021	<a href="https://www.atis.org/3gpp-documents/Rel99-14/">https://www.atis.org/3gpp-documents/Rel99-14/</a>
CCSA	CCSA.36.302V1380	13.8.0	Published	01.07.2020	<a href="https://www.ccsa.org.cn/api/portalsFile/downloadOldFile?type=19&amp;oldFileUrl=ITU-R/M.2012-6/CCSA.36.302V1380.doc">https://www.ccsa.org.cn/api/portalsFile/downloadOldFile?type=19&amp;oldFileUrl=ITU-R/M.2012-6/CCSA.36.302V1380.doc</a>
ETSI	ETSI TS 136 302	13.8.0	Published	31.07.2020	<a href="https://www.etsi.org/deliver/etsi_ts/136300_136399/136302/13.08.00_60/ts_136302v130800p.pdf">https://www.etsi.org/deliver/etsi_ts/136300_136399/136302/13.08.00_60/ts_136302v130800p.pdf</a>
TSDSI	TSDSI STD T1.3GPP 36.302-13.8.0 V1.1.0	13.8.0	Published	30.08.2021	<a href="https://members.tdsi.in/index.php/s/dmnr2X5dsOqHiW">https://members.tdsi.in/index.php/s/dmnr2X5dsOqHiW</a>
TTA	TTAT.3G-36.302V13.8.0	13.8.0	Published	02.08.2021	<a href="http://committee.tta.or.kr/data/ttasDown.jsp?kind=ttastd&amp;pk_num=TTAT.3G-36.302V13.8.0">http://committee.tta.or.kr/data/ttasDown.jsp?kind=ttastd&amp;pk_num=TTAT.3G-36.302V13.8.0</a>
<b>Release 14</b>					
ARIB	ARIB STD-T120-36.302.V14.6.0	14.6.0	Published	03.03.2023	<a href="https://www.arib.or.jp/english/html/overview/doc/T120_T23_SPECS/ARIB-STD-T120/Rel14/36/A36302-e60.pdf">https://www.arib.or.jp/english/html/overview/doc/T120_T23_SPECS/ARIB-STD-T120/Rel14/36/A36302-e60.pdf</a>
ATIS	ATIS.3GPP.36.302V1460	14.6.0	Published	28.06.2021	<a href="https://www.atis.org/3gpp-documents/Rel99-14/">https://www.atis.org/3gpp-documents/Rel99-14/</a>
CCSA	CCSA.36.302V1460	14.6.0	Published	01.07.2020	<a href="https://www.ccsa.org.cn/api/portalsFile/downloadOldFile?type=19&amp;oldFileUrl=ITU-R/M.2012-6/CCSA.36.302V1460.doc">https://www.ccsa.org.cn/api/portalsFile/downloadOldFile?type=19&amp;oldFileUrl=ITU-R/M.2012-6/CCSA.36.302V1460.doc</a>
ETSI	ETSI TS 136 302	14.6.0	Published	31.07.2020	<a href="https://www.etsi.org/deliver/etsi_ts/136300_136399/136302/14.06.00_60/ts_136302v140600p.pdf">https://www.etsi.org/deliver/etsi_ts/136300_136399/136302/14.06.00_60/ts_136302v140600p.pdf</a>
TSDSI	TSDSI STD T1.3GPP 36.302-14.6.0 V1.1.0	14.6.0	Published	30.08.2021	<a href="https://members.tdsi.in/index.php/s/ydpQPqjFY4ykjdp">https://members.tdsi.in/index.php/s/ydpQPqjFY4ykjdp</a>
TTA	TTAT.3G-36.302V14.6.0	14.6.0	Published	02.08.2021	<a href="http://committee.tta.or.kr/data/ttasDown.jsp?kind=ttastd&amp;pk_num=TTAT.3G-36.302V14.6.0">http://committee.tta.or.kr/data/ttasDown.jsp?kind=ttastd&amp;pk_num=TTAT.3G-36.302V14.6.0</a>

## 36

## Rec. ITU-R M.2012-6

### Release 15

ARIB	ARIB STD-T120-36.302.V15.3.0	15.3.0	Published	03.03.2023	<a href="https://www.arib.or.jp/english/html/overview/doc/T120_T23_SPECS/ARIB-STD-T120/Rel15/36/A36302-f30.pdf">https://www.arib.or.jp/english/html/overview/doc/T120_T23_SPECS/ARIB-STD-T120/Rel15/36/A36302-f30.pdf</a>
ATIS	ATIS.3GPP.36.302V1530	15.3.0	Published	28.06.2021	<a href="https://www.atis.org/3gpp-documents/Rel15/">https://www.atis.org/3gpp-documents/Rel15/</a>
CCSA	CCSA.36.302V1530	15.3.0	Published	01.07.2020	<a href="https://www.ccsa.org.cn/api/portalsFile/downloadOldFile?type=19&amp;oldFileUrl=ITU-R/M.2012-6/CCSA.36.302V1530.doc">https://www.ccsa.org.cn/api/portalsFile/downloadOldFile?type=19&amp;oldFileUrl=ITU-R/M.2012-6/CCSA.36.302V1530.doc</a>
ETSI	ETSI TS 136 302	15.3.0	Published	31.07.2020	<a href="https://www.etsi.org/deliver/etsi_ts/136300_136399/136302/15.03.00_60/ts_136302v150300p.pdf">https://www.etsi.org/deliver/etsi_ts/136300_136399/136302/15.03.00_60/ts_136302v150300p.pdf</a>
TSDSI	TSDSI STD T1.3GPP 36.302-15.3.0 V1.0.0	15.3.0	Published	30.08.2021	<a href="https://members.tdsi.in/index.php/s/cwDCA7K772aMqcB">https://members.tdsi.in/index.php/s/cwDCA7K772aMqcB</a>
TTA	TTAT.3G-36.302V15.3.0	15.3.0	Published	11.09.2020	<a href="http://committee.tta.or.kr/data/ttasDown.jsp?kind=ttastd&amp;pk_num=TTAT.3G-36.302V15.3.0">http://committee.tta.or.kr/data/ttasDown.jsp?kind=ttastd&amp;pk_num=TTAT.3G-36.302V15.3.0</a>

### Release 16

ARIB	ARIB STD-T120-36.302.V16.1.0	16.1.0	Published	03.03.2023	<a href="https://www.arib.or.jp/english/html/overview/doc/T120_T23_SPECS/ARIB-STD-T120/Rel16/36/A36302-g10.pdf">https://www.arib.or.jp/english/html/overview/doc/T120_T23_SPECS/ARIB-STD-T120/Rel16/36/A36302-g10.pdf</a>
ATIS	ATIS.3GPP.36.302V1610	16.1.0	Published	28.06.2021	<a href="https://www.atis.org/3gpp-documents/Rel16/">https://www.atis.org/3gpp-documents/Rel16/</a>
CCSA	CCSA.36.302V1610	16.1.0	Published	01.07.2020	<a href="https://www.ccsa.org.cn/api/portalsFile/downloadOldFile?type=19&amp;oldFileUrl=ITU-R/M.2012-6/CCSA.36.302V1610.doc">https://www.ccsa.org.cn/api/portalsFile/downloadOldFile?type=19&amp;oldFileUrl=ITU-R/M.2012-6/CCSA.36.302V1610.doc</a>
ETSI	ETSI TS 136 302	16.1.0	Published	30.07.2020	<a href="https://www.etsi.org/deliver/etsi_ts/136300_136399/136302/16.01.00_60/ts_136302v160100p.pdf">https://www.etsi.org/deliver/etsi_ts/136300_136399/136302/16.01.00_60/ts_136302v160100p.pdf</a>
TSDSI	TSDSI STD T1.3GPP 36.302-16.1.0 V1.0.0	16.1.0	Published	30.08.2021	<a href="https://members.tdsi.in/index.php/s/CzsjbiJL6YjCQtR">https://members.tdsi.in/index.php/s/CzsjbiJL6YjCQtR</a>
TTA	TTAT.3G-36.302V16.1.0	16.1.0	Published	11.09.2020	<a href="http://committee.tta.or.kr/data/ttasDown.jsp?kind=ttastd&amp;pk_num=TTAT.3G-36.302V16.1.0">http://committee.tta.or.kr/data/ttasDown.jsp?kind=ttastd&amp;pk_num=TTAT.3G-36.302V16.1.0</a>

### Release 17

ARIB	ARIB STD-T120-36.302.V17.0.0	17.0.0	Published	03.03.2023	<a href="https://www.arib.or.jp/english/html/overview/doc/T120_T23_SPECS/ARIB-STD-T120/Rel17/36/A36302-h00.pdf">https://www.arib.or.jp/english/html/overview/doc/T120_T23_SPECS/ARIB-STD-T120/Rel17/36/A36302-h00.pdf</a>
ATIS	ATIS.3GPP.36.302.V17.0.0	17.0.0	Published	21.02.2023	<a href="https://www.atis.org/3gpp-transpositions - Rel-17">https://www.atis.org/3gpp-transpositions - Rel-17</a>
CCSA	CCSA.36.302V1700	17.0.0	Published	01.03.2022	<a href="https://www.ccsa.org.cn/api/portalsFile/downloadOldFile?type=19&amp;oldFileUrl=ITU-R/M.2012-6/CCSA.36.302V1700.doc">https://www.ccsa.org.cn/api/portalsFile/downloadOldFile?type=19&amp;oldFileUrl=ITU-R/M.2012-6/CCSA.36.302V1700.doc</a>
ETSI	ETSI TS 136 302	17.0.0	Published	09.05.2022	<a href="https://www.etsi.org/deliver/etsi_ts/136300_136399/136302/17.00.00_60/ts_136302v170000p.pdf">https://www.etsi.org/deliver/etsi_ts/136300_136399/136302/17.00.00_60/ts_136302v170000p.pdf</a>
TSDSI	TSDSI STD T1.3GPP 36.302-17.0.0 V1.0.0	17.0.0	Published	29.07.2022	<a href="https://members.tdsi.in/s/fOp7mMYTBgmgOci">https://members.tdsi.in/s/fOp7mMYTBgmgOci</a>
TTA	TTAT.3G-36.302V17.0.0	17.0.0	Published	05.08.2022	<a href="http://committee.tta.or.kr/data/ttasDown.jsp?kind=ttastd&amp;pk_num=TTAT.3G-36.302V17.0.0">http://committee.tta.or.kr/data/ttasDown.jsp?kind=ttastd&amp;pk_num=TTAT.3G-36.302V17.0.0</a>

### 2.1.3.3 TS 36.304

#### Evolved Universal Terrestrial Radio Access (E-UTRA); User Equipment (UE) procedures in idle mode

This document specifies the Access Stratum (AS) part of the Idle Mode procedures applicable to a UE. This document specifies the model for the functional division between the NAS and AS in a UE. This document applies to all UEs that support at least E-UTRA, including multi-RAT UEs as described in 3GPP specifications, in the following cases: (i) When the UE is camped on an E-UTRA cell; (ii) When the UE is searching for a cell to camp on.

SDO	Document No.	Version	Status	Issued date	Location
<b>Release 10</b>					
ARIB	ARIB STD-T120-36.304.V10.9.0	10.9.0	Published	03.03.2023	<a href="https://www.arib.or.jp/english/html/overview/doc/T120_T23_SPECS/ARIB-STD-T120/Rel10/36/A36304-a90.pdf">https://www.arib.or.jp/english/html/overview/doc/T120_T23_SPECS/ARIB-STD-T120/Rel10/36/A36304-a90.pdf</a>
ATIS	ATIS.3GPP.36.304V1090	10.9.0	Published	28.06.2021	<a href="https://www.atis.org/3gpp-documents/Rel99-14/">https://www.atis.org/3gpp-documents/Rel99-14/</a>
CCSA	CCSA.36.304V1090	10.9.0	Published	01.12.2015	<a href="https://www.ccsa.org.cn/api/portalsFile/downloadOldFile?type=19&amp;oldFileUrl=ITU-R/M.2012-6/CCSA.36.304V1090.doc">https://www.ccsa.org.cn/api/portalsFile/downloadOldFile?type=19&amp;oldFileUrl=ITU-R/M.2012-6/CCSA.36.304V1090.doc</a>
ETSI	ETSI TS 136 304	10.9.0	Published	18.01.2016	<a href="https://www.etsi.org/deliver/etsi_ts/136300_136399/136304/10.09.00_60/ts_136304v100900p.pdf">https://www.etsi.org/deliver/etsi_ts/136300_136399/136304/10.09.00_60/ts_136304v100900p.pdf</a>
TSDSI	TSDSI STD T1.3GPP 36.304-10.9.0 V1.0.0	10.9.0	Published	30.08.2021	<a href="https://members.tdsi.in/index.php/s/NnzoPWNZQ7b2o6g">https://members.tdsi.in/index.php/s/NnzoPWNZQ7b2o6g</a>
TTA	TTAT.3G-36.304V10.9.0	10.9.0	Published	02.08.2021	<a href="http://committee.tta.or.kr/data/ttasDown.jsp?kind=ttastd&amp;pk_num=TTAT.3G-36.304V10.9.0">http://committee.tta.or.kr/data/ttasDown.jsp?kind=ttastd&amp;pk_num=TTAT.3G-36.304V10.9.0</a>
<b>Release 11</b>					
ARIB	ARIB STD-T120-36.304.V11.7.0	11.7.0	Published	03.03.2023	<a href="https://www.arib.or.jp/english/html/overview/doc/T120_T23_SPECS/ARIB-STD-T120/Rel11/36/A36304-b70.pdf">https://www.arib.or.jp/english/html/overview/doc/T120_T23_SPECS/ARIB-STD-T120/Rel11/36/A36304-b70.pdf</a>
ATIS	ATIS.3GPP.36.304V1170	11.7.0	Published	28.06.2021	<a href="https://www.atis.org/3gpp-documents/Rel99-14/">https://www.atis.org/3gpp-documents/Rel99-14/</a>
CCSA	CCSA.36.304V1170	11.7.0	Published	01.12.2015	<a href="https://www.ccsa.org.cn/api/portalsFile/downloadOldFile?type=19&amp;oldFileUrl=ITU-R/M.2012-6/CCSA.36.304V1170.doc">https://www.ccsa.org.cn/api/portalsFile/downloadOldFile?type=19&amp;oldFileUrl=ITU-R/M.2012-6/CCSA.36.304V1170.doc</a>
ETSI	ETSI TS 136 304	11.7.0	Published	18.01.2016	<a href="https://www.etsi.org/deliver/etsi_ts/136300_136399/136304/11.07.00_60/ts_136304v110700p.pdf">https://www.etsi.org/deliver/etsi_ts/136300_136399/136304/11.07.00_60/ts_136304v110700p.pdf</a>
TSDSI	TSDSI STD T1.3GPP 36.304-11.7.0 V1.0.0	11.7.0	Published	30.08.2021	<a href="https://members.tdsi.in/index.php/s/w6FQjGKcXbnw9k5">https://members.tdsi.in/index.php/s/w6FQjGKcXbnw9k5</a>
TTA	TTAT.3G-36.304V11.7.0	11.7.0	Published	02.08.2021	<a href="http://committee.tta.or.kr/data/ttasDown.jsp?kind=ttastd&amp;pk_num=TTAT.3G-36.304V11.7.0">http://committee.tta.or.kr/data/ttasDown.jsp?kind=ttastd&amp;pk_num=TTAT.3G-36.304V11.7.0</a>

<b>Release 12</b>									
ARIB	ARIB STD-T120-36.304.V12.8.0	12.8.0	Published	03.03.2023	<a href="https://www.arib.or.jp/english/html/overview/doc/T120_T23_SPECS/ARIB-STD-T120/Rel12/36/A36304-c80.pdf">https://www.arib.or.jp/english/html/overview/doc/T120_T23_SPECS/ARIB-STD-T120/Rel12/36/A36304-c80.pdf</a>				
ATIS	ATIS.3GPP.36.304V1280	12.8.0	Published	28.06.2021	<a href="https://www.atis.org/3gpp-documents/Rel99-14/">https://www.atis.org/3gpp-documents/Rel99-14/</a>				
CCSA	CCSA.36.304V1280	12.8.0	Published	01.06.2016	<a href="https://www.ccsa.org.cn/api/portalsFile/downloadOldFile?type=19&amp;oldFileUrl=ITU-R/M.2012-6/CCSA.36.304V1280.doc">https://www.ccsa.org.cn/api/portalsFile/downloadOldFile?type=19&amp;oldFileUrl=ITU-R/M.2012-6/CCSA.36.304V1280.doc</a>				
ETSI	ETSI TS 136 304	12.8.0	Published	25.08.2016	<a href="https://www.etsi.org/deliver/etsi_ts/136300_136399/136304/12.08.00_60/ts_136304v120800p.pdf">https://www.etsi.org/deliver/etsi_ts/136300_136399/136304/12.08.00_60/ts_136304v120800p.pdf</a>				
TSDSI	TSDSI STD T1.3GPP 36.304-12.8.0 V1.0.0	12.8.0	Published	30.08.2021	<a href="https://members.tdsi.in/index.php/s/jxX8S4W7xC8zFdZ">https://members.tdsi.in/index.php/s/jxX8S4W7xC8zFdZ</a>				
TTA	TTAT.3G-36.304V12.8.0	12.8.0	Published	02.08.2021	<a href="http://committee.tta.or.kr/data/ttasDown.jsp?kind=ttastd&amp;pk_num=TTAT.3G-36.304V12.8.0">http://committee.tta.or.kr/data/ttasDown.jsp?kind=ttastd&amp;pk_num=TTAT.3G-36.304V12.8.0</a>				
<b>Release 13</b>									
ARIB	ARIB STD-T120-36.304.V13.8.0	13.8.0	Published	03.03.2023	<a href="https://www.arib.or.jp/english/html/overview/doc/T120_T23_SPECS/ARIB-STD-T120/Rel13/36/A36304-d80.pdf">https://www.arib.or.jp/english/html/overview/doc/T120_T23_SPECS/ARIB-STD-T120/Rel13/36/A36304-d80.pdf</a>				
ATIS	ATIS.3GPP.36.304V1380	13.8.0	Published	28.06.2021	<a href="https://www.atis.org/3gpp-documents/Rel99-14/">https://www.atis.org/3gpp-documents/Rel99-14/</a>				
CCSA	CCSA.36.304V1380	13.8.0	Published	01.12.2017	<a href="https://www.ccsa.org.cn/api/portalsFile/downloadOldFile?type=19&amp;oldFileUrl=ITU-R/M.2012-6/CCSA.36.304V1380.doc">https://www.ccsa.org.cn/api/portalsFile/downloadOldFile?type=19&amp;oldFileUrl=ITU-R/M.2012-6/CCSA.36.304V1380.doc</a>				
ETSI	ETSI TS 136 304	13.8.0	Published	17.01.2018	<a href="https://www.etsi.org/deliver/etsi_ts/136300_136399/136304/13.08.00_60/ts_136304v130800p.pdf">https://www.etsi.org/deliver/etsi_ts/136300_136399/136304/13.08.00_60/ts_136304v130800p.pdf</a>				
TSDSI	TSDSI STD T1.3GPP 36.304-13.8.0 V1.0.0	13.8.0	Published	30.08.2021	<a href="https://members.tdsi.in/index.php/s/Hr8rGe6RXrN4syS">https://members.tdsi.in/index.php/s/Hr8rGe6RXrN4syS</a>				
TTA	TTAT.3G-36.304V13.8.0	13.8.0	Published	02.08.2021	<a href="http://committee.tta.or.kr/data/ttasDown.jsp?kind=ttastd&amp;pk_num=TTAT.3G-36.304V13.8.0">http://committee.tta.or.kr/data/ttasDown.jsp?kind=ttastd&amp;pk_num=TTAT.3G-36.304V13.8.0</a>				
<b>Release 14</b>									
ARIB	ARIB STD-T120-36.304.V14.7.0	14.7.0	Published	03.03.2023	<a href="https://www.arib.or.jp/english/html/overview/doc/T120_T23_SPECS/ARIB-STD-T120/Rel14/36/A36304-e70.pdf">https://www.arib.or.jp/english/html/overview/doc/T120_T23_SPECS/ARIB-STD-T120/Rel14/36/A36304-e70.pdf</a>				
ATIS	ATIS.3GPP.36.304V1470	14.7.0	Published	28.06.2021	<a href="https://www.atis.org/3gpp-documents/Rel99-14/">https://www.atis.org/3gpp-documents/Rel99-14/</a>				
CCSA	CCSA.36.304V1470	14.7.0	Published	01.09.2018	<a href="https://www.ccsa.org.cn/api/portalsFile/downloadOldFile?type=19&amp;oldFileUrl=ITU-R/M.2012-6/CCSA.36.304V1470.doc">https://www.ccsa.org.cn/api/portalsFile/downloadOldFile?type=19&amp;oldFileUrl=ITU-R/M.2012-6/CCSA.36.304V1470.doc</a>				
ETSI	ETSI TS 136 304	14.7.0	Published	17.10.2018	<a href="https://www.etsi.org/deliver/etsi_ts/136300_136399/136304/14.07.00_60/ts_136304v140700p.pdf">https://www.etsi.org/deliver/etsi_ts/136300_136399/136304/14.07.00_60/ts_136304v140700p.pdf</a>				
TSDSI	TSDSI STD T1.3GPP 36.304-14.7.0 V1.1.0	14.7.0	Published	30.08.2021	<a href="https://members.tdsi.in/index.php/s/jYXc6a2KfwEFSLc">https://members.tdsi.in/index.php/s/jYXc6a2KfwEFSLc</a>				
TTA	TTAT.3G-36.304V14.7.0	14.7.0	Published	02.08.2021	<a href="http://committee.tta.or.kr/data/ttasDown.jsp?kind=ttastd&amp;pk_num=TTAT.3G-36.304V14.7.0">http://committee.tta.or.kr/data/ttasDown.jsp?kind=ttastd&amp;pk_num=TTAT.3G-36.304V14.7.0</a>				
<b>Release 15</b>									
ARIB	ARIB STD-T120-36.304.V15.8.0	15.8.0	Published	03.03.2023	<a href="https://www.arib.or.jp/english/html/overview/doc/T120_T23_SPECS/ARIB-STD-T120/Rel15/36/A36304-f80.pdf">https://www.arib.or.jp/english/html/overview/doc/T120_T23_SPECS/ARIB-STD-T120/Rel15/36/A36304-f80.pdf</a>				
ATIS	ATIS.3GPP.36.304.V15.8.0	15.8.0	Published	21.02.2023	<a href="https://www.atis.org/3gpp-transpositions - Rel-15">https://www.atis.org/3gpp-transpositions - Rel-15</a>				
CCSA	CCSA.36.304V1580	15.8.0	Published	01.03.2022	<a href="https://www.ccsa.org.cn/api/portalsFile/downloadOldFile?type=19&amp;oldFileUrl=ITU-R/M.2012-6/CCSA.36.304V1580.doc">https://www.ccsa.org.cn/api/portalsFile/downloadOldFile?type=19&amp;oldFileUrl=ITU-R/M.2012-6/CCSA.36.304V1580.doc</a>				
ETSI	ETSI TS 136 304	15.8.0	Published	09.05.2022	<a href="https://www.etsi.org/deliver/etsi_ts/136300_136399/136304/15.08.00_60/ts_136304v150800p.pdf">https://www.etsi.org/deliver/etsi_ts/136300_136399/136304/15.08.00_60/ts_136304v150800p.pdf</a>				
TSDSI	TSDSI STD T1.3GPP 36.304-15.8.0 V1.1.0	15.8.0	Published	01.11.2022	<a href="https://members.tdsi.in/s/p2cryGpngrEDrWb">https://members.tdsi.in/s/p2cryGpngrEDrWb</a>				
TTA	TTAT.3G-36.304V15.8.0	15.8.0	Published	05.08.2022	<a href="http://committee.tta.or.kr/data/ttasDown.jsp?kind=ttastd&amp;pk_num=TTAT.3G-36.304V15.8.0">http://committee.tta.or.kr/data/ttasDown.jsp?kind=ttastd&amp;pk_num=TTAT.3G-36.304V15.8.0</a>				
<b>Release 16</b>									
ARIB	ARIB STD-T120-36.304.V16.7.0	16.7.0	Published	03.03.2023	<a href="https://www.arib.or.jp/english/html/overview/doc/T120_T23_SPECS/ARIB-STD-T120/Rel16/36/A36304-g70.pdf">https://www.arib.or.jp/english/html/overview/doc/T120_T23_SPECS/ARIB-STD-T120/Rel16/36/A36304-g70.pdf</a>				
ATIS	ATIS.3GPP.36.304.V16.7.0	16.7.0	Published	21.02.2023	<a href="https://www.atis.org/3gpp-transpositions - Rel-16">https://www.atis.org/3gpp-transpositions - Rel-16</a>				
CCSA	CCSA.36.304V1670	16.7.0	Published	01.03.2022	<a href="https://www.ccsa.org.cn/api/portalsFile/downloadOldFile?type=19&amp;oldFileUrl=ITU-R/M.2012-6/CCSA.36.304V1670.doc">https://www.ccsa.org.cn/api/portalsFile/downloadOldFile?type=19&amp;oldFileUrl=ITU-R/M.2012-6/CCSA.36.304V1670.doc</a>				
ETSI	ETSI TS 136 304	16.7.0	Published	09.05.2022	<a href="https://www.etsi.org/deliver/etsi_ts/136300_136399/136304/16.07.00_60/ts_136304v160700p.pdf">https://www.etsi.org/deliver/etsi_ts/136300_136399/136304/16.07.00_60/ts_136304v160700p.pdf</a>				
TSDSI	TSDSI STD T1.3GPP 36.304-16.7.0 V1.1.0	16.7.0	Published	01.11.2022	<a href="https://members.tdsi.in/s/rkfYPfS4nEwmEBX">https://members.tdsi.in/s/rkfYPfS4nEwmEBX</a>				
TTA	TTAT.3G-36.304V16.7.0	16.7.0	Published	05.08.2022	<a href="http://committee.tta.or.kr/data/ttasDown.jsp?kind=ttastd&amp;pk_num=TTAT.3G-36.304V16.7.0">http://committee.tta.or.kr/data/ttasDown.jsp?kind=ttastd&amp;pk_num=TTAT.3G-36.304V16.7.0</a>				
<b>Release 17</b>									
ARIB	ARIB STD-T120-36.304.V17.3.0	17.3.0	Published	03.03.2023	<a href="https://www.arib.or.jp/english/html/overview/doc/T120_T23_SPECS/ARIB-STD-T120/Rel17/36/A36304-h30.pdf">https://www.arib.or.jp/english/html/overview/doc/T120_T23_SPECS/ARIB-STD-T120/Rel17/36/A36304-h30.pdf</a>				
ATIS	ATIS.3GPP.36.304.V17.3.0	17.3.0	Published	21.02.2023	<a href="https://www.atis.org/3gpp-transpositions - Rel-17">https://www.atis.org/3gpp-transpositions - Rel-17</a>				
CCSA	CCSA.36.304V1730	17.3.0	Published	01.12.2022	<a href="https://www.ccsa.org.cn/api/portalsFile/downloadOldFile?type=19&amp;oldFileUrl=ITU-R/M.2012-6/CCSA.36.304V1730.doc">https://www.ccsa.org.cn/api/portalsFile/downloadOldFile?type=19&amp;oldFileUrl=ITU-R/M.2012-6/CCSA.36.304V1730.doc</a>				
ETSI	ETSI TS 136 304	17.3.0	Published	20.01.2023	<a href="https://www.etsi.org/deliver/etsi_ts/136300_136399/136304/17.03.00_60/ts_136304v170300p.pdf">https://www.etsi.org/deliver/etsi_ts/136300_136399/136304/17.03.00_60/ts_136304v170300p.pdf</a>				
TSDSI	TSDSI STD T1.3GPP 36.304 17.3.0 V1.3.0	17.3.0	Published	02.05.2023	<a href="https://members.tdsi.in/s/sNiCGPHTGp5joYg">https://members.tdsi.in/s/sNiCGPHTGp5joYg</a>				
TTA	TTAT.3G-36.304V17.3.0	17.3.0	Published	16.03.2023	<a href="http://committee.tta.or.kr/data/ttasDown.jsp?kind=ttastd&amp;pk_num=TTAT.3G-36.304V17.3.0">http://committee.tta.or.kr/data/ttasDown.jsp?kind=ttastd&amp;pk_num=TTAT.3G-36.304V17.3.0</a>				

## 2.1.3.4 TS 36.305

**Evolved Universal Terrestrial Radio Access Network (E-UTRAN); Stage 2 functional specification of User Equipment (UE) positioning in E-UTRAN**

This document specifies the stage 2 of the UE positioning function of E-UTRAN, which provides the mechanisms to support or assist the calculation of the geographical position of a UE. The purpose of this stage 2 specification is to define the E-UTRAN UE Positioning architecture, functional entities and operations to support positioning methods. This description is confined to the E-UTRAN Access Stratum. This stage 2 specification covers the E-UTRAN positioning methods, state descriptions, and message flows to support UE positioning.

SDO	Document No.	Version	Status	Issued date	Location
<b>Release 10</b>					
ARIB	ARIB STD-T120-36.305.V10.5.0	10.5.0	Published	03.03.2023	<a href="https://www.arib.or.jp/english/html/overview/doc/T120_T23_SPECS/ARIB-STD-T120/Rel10/36/A36305-a50.pdf">https://www.arib.or.jp/english/html/overview/doc/T120_T23_SPECS/ARIB-STD-T120/Rel10/36/A36305-a50.pdf</a>
ATIS	ATIS.3GPP.36.305V1050	10.5.0	Published	28.06.2021	<a href="https://www.atis.org/3gpp-documents/Rel99-14/">https://www.atis.org/3gpp-documents/Rel99-14/</a>
CCSA	CCSA.36.305V1050	10.5.0	Published	01.12.2012	<a href="https://www.ccsa.org.cn/api/portalsFile/downloadOldFile?type=19&amp;oldFileUrl=ITU-R/M.2012-6/CCSA.36.305V1050.doc">https://www.ccsa.org.cn/api/portalsFile/downloadOldFile?type=19&amp;oldFileUrl=ITU-R/M.2012-6/CCSA.36.305V1050.doc</a>
ETSI	ETSI TS 136 305	10.5.0	Published	07.02.2013	<a href="https://www.etsi.org/deliver/etsi_ts/136300_136399/136305/10.05.00_60/ts_136305v100500p.pdf">https://www.etsi.org/deliver/etsi_ts/136300_136399/136305/10.05.00_60/ts_136305v100500p.pdf</a>
TSDSI	TSDSI STD T1.3GPP 36.305-10.5.0 V1.0.0	10.5.0	Published	30.08.2021	<a href="https://members.tdsi.in/index.php/s/xjmqnW5PwOf4FWr">https://members.tdsi.in/index.php/s/xjmqnW5PwOf4FWr</a>
TTA	TTAT.3G-36.305V10.5.0	10.5.0	Published	02.08.2021	<a href="http://committee.tta.or.kr/data/ttasDown.jsp?kind=ttastd&amp;pk_num=TTAT.3G-36.305V10.5.0">http://committee.tta.or.kr/data/ttasDown.jsp?kind=ttastd&amp;pk_num=TTAT.3G-36.305V10.5.0</a>
<b>Release 11</b>					
ARIB	ARIB STD-T120-36.305.V11.3.0	11.3.0	Published	03.03.2023	<a href="https://www.arib.or.jp/english/html/overview/doc/T120_T23_SPECS/ARIB-STD-T120/Rel11/36/A36305-b30.pdf">https://www.arib.or.jp/english/html/overview/doc/T120_T23_SPECS/ARIB-STD-T120/Rel11/36/A36305-b30.pdf</a>
ATIS	ATIS.3GPP.36.305V1130	11.3.0	Published	28.06.2021	<a href="https://www.atis.org/3gpp-documents/Rel99-14/">https://www.atis.org/3gpp-documents/Rel99-14/</a>
CCSA	CCSA.36.305V1130	11.3.0	Published	01.03.2013	<a href="https://www.ccsa.org.cn/api/portalsFile/downloadOldFile?type=19&amp;oldFileUrl=ITU-R/M.2012-6/CCSA.36.305V1130.doc">https://www.ccsa.org.cn/api/portalsFile/downloadOldFile?type=19&amp;oldFileUrl=ITU-R/M.2012-6/CCSA.36.305V1130.doc</a>
ETSI	ETSI TS 136 305	11.3.0	Published	19.04.2013	<a href="https://www.etsi.org/deliver/etsi_ts/136300_136399/136305/11.03.00_60/ts_136305v110300p.pdf">https://www.etsi.org/deliver/etsi_ts/136300_136399/136305/11.03.00_60/ts_136305v110300p.pdf</a>
TSDSI	TSDSI STD T1.3GPP 36.305-11.3.0 V1.0.0	11.3.0	Published	30.08.2021	<a href="https://members.tdsi.in/index.php/s/WgdWCDQTIqztnB2">https://members.tdsi.in/index.php/s/WgdWCDQTIqztnB2</a>
TTA	TTAT.3G-36.305V11.3.0	11.3.0	Published	02.08.2021	<a href="http://committee.tta.or.kr/data/ttasDown.jsp?kind=ttastd&amp;pk_num=TTAT.3G-36.305V11.3.0">http://committee.tta.or.kr/data/ttasDown.jsp?kind=ttastd&amp;pk_num=TTAT.3G-36.305V11.3.0</a>
<b>Release 12</b>					
ARIB	ARIB STD-T120-36.305.V12.2.0	12.2.0	Published	03.03.2023	<a href="https://www.arib.or.jp/english/html/overview/doc/T120_T23_SPECS/ARIB-STD-T120/Rel12/36/A36305-c20.pdf">https://www.arib.or.jp/english/html/overview/doc/T120_T23_SPECS/ARIB-STD-T120/Rel12/36/A36305-c20.pdf</a>
ATIS	ATIS.3GPP.36.305V1220	12.2.0	Published	28.06.2021	<a href="https://www.atis.org/3gpp-documents/Rel99-14/">https://www.atis.org/3gpp-documents/Rel99-14/</a>
CCSA	CCSA.36.305V1220	12.2.0	Published	01.12.2014	<a href="https://www.ccsa.org.cn/api/portalsFile/downloadOldFile?type=19&amp;oldFileUrl=ITU-R/M.2012-6/CCSA.36.305V1220.doc">https://www.ccsa.org.cn/api/portalsFile/downloadOldFile?type=19&amp;oldFileUrl=ITU-R/M.2012-6/CCSA.36.305V1220.doc</a>
ETSI	ETSI TS 136 305	12.2.0	Published	04.02.2015	<a href="https://www.etsi.org/deliver/etsi_ts/136300_136399/136305/12.02.00_60/ts_136305v120200p.pdf">https://www.etsi.org/deliver/etsi_ts/136300_136399/136305/12.02.00_60/ts_136305v120200p.pdf</a>
TSDSI	TSDSI STD T1.3GPP 36.305-12.2.0 V1.0.0	12.2.0	Published	30.08.2021	<a href="https://members.tdsi.in/index.php/s/JoayxmdQwYT4gy4">https://members.tdsi.in/index.php/s/JoayxmdQwYT4gy4</a>
TTA	TTAT.3G-36.305V12.2.0	12.2.0	Published	02.08.2021	<a href="http://committee.tta.or.kr/data/ttasDown.jsp?kind=ttastd&amp;pk_num=TTAT.3G-36.305V12.2.0">http://committee.tta.or.kr/data/ttasDown.jsp?kind=ttastd&amp;pk_num=TTAT.3G-36.305V12.2.0</a>
<b>Release 13</b>					
ARIB	ARIB STD-T120-36.305.V13.0.0	13.0.0	Published	03.03.2023	<a href="https://www.arib.or.jp/english/html/overview/doc/T120_T23_SPECS/ARIB-STD-T120/Rel13/36/A36305-d00.pdf">https://www.arib.or.jp/english/html/overview/doc/T120_T23_SPECS/ARIB-STD-T120/Rel13/36/A36305-d00.pdf</a>
ATIS	ATIS.3GPP.36.305V1300	13.0.0	Published	28.06.2021	<a href="https://www.atis.org/3gpp-documents/Rel99-14/">https://www.atis.org/3gpp-documents/Rel99-14/</a>
CCSA	CCSA.36.305V1300	13.0.0	Published	01.12.2015	<a href="https://www.ccsa.org.cn/api/portalsFile/downloadOldFile?type=19&amp;oldFileUrl=ITU-R/M.2012-6/CCSA.36.305V1300.doc">https://www.ccsa.org.cn/api/portalsFile/downloadOldFile?type=19&amp;oldFileUrl=ITU-R/M.2012-6/CCSA.36.305V1300.doc</a>
ETSI	ETSI TS 136 305	13.0.0	Published	27.01.2016	<a href="https://www.etsi.org/deliver/etsi_ts/136300_136399/136305/13.00.00_60/ts_136305v130000p.pdf">https://www.etsi.org/deliver/etsi_ts/136300_136399/136305/13.00.00_60/ts_136305v130000p.pdf</a>
TSDSI	TSDSI STD T1.3GPP 36.305-13.0.0 V1.0.0	13.0.0	Published	30.08.2021	<a href="https://members.tdsi.in/index.php/s/LCnMmDbWpkbH62J">https://members.tdsi.in/index.php/s/LCnMmDbWpkbH62J</a>
TTA	TTAT.3G-36.305V13.0.0	13.0.0	Published	02.08.2021	<a href="http://committee.tta.or.kr/data/ttasDown.jsp?kind=ttastd&amp;pk_num=TTAT.3G-36.305V13.0.0">http://committee.tta.or.kr/data/ttasDown.jsp?kind=ttastd&amp;pk_num=TTAT.3G-36.305V13.0.0</a>
<b>Release 14</b>					
ARIB	ARIB STD-T120-36.305.V14.3.0	14.3.0	Published	03.03.2023	<a href="https://www.arib.or.jp/english/html/overview/doc/T120_T23_SPECS/ARIB-STD-T120/Rel14/36/A36305-e30.pdf">https://www.arib.or.jp/english/html/overview/doc/T120_T23_SPECS/ARIB-STD-T120/Rel14/36/A36305-e30.pdf</a>
ATIS	ATIS.3GPP.36.305V1430	14.3.0	Published	28.06.2021	<a href="https://www.atis.org/3gpp-documents/Rel99-14/">https://www.atis.org/3gpp-documents/Rel99-14/</a>
CCSA	CCSA.36.305V1430	14.3.0	Published	01.09.2017	<a href="https://www.ccsa.org.cn/api/portalsFile/downloadOldFile?type=19&amp;oldFileUrl=ITU-R/M.2012-6/CCSA.36.305V1430.doc">https://www.ccsa.org.cn/api/portalsFile/downloadOldFile?type=19&amp;oldFileUrl=ITU-R/M.2012-6/CCSA.36.305V1430.doc</a>
ETSI	ETSI TS 136 305	14.3.0	Published	09.10.2017	<a href="https://www.etsi.org/deliver/etsi_ts/136300_136399/136305/14.03.00_60/ts_136305v140300p.pdf">https://www.etsi.org/deliver/etsi_ts/136300_136399/136305/14.03.00_60/ts_136305v140300p.pdf</a>
TSDSI	TSDSI STD T1.3GPP 36.305-14.3.0 V1.0.0	14.3.0	Published	30.08.2021	<a href="https://members.tdsi.in/index.php/s/bF3YAgBCANrQcSB">https://members.tdsi.in/index.php/s/bF3YAgBCANrQcSB</a>
TTA	TTAT.3G-36.305V14.3.0	14.3.0	Published	02.08.2021	<a href="http://committee.tta.or.kr/data/ttasDown.jsp?kind=ttastd&amp;pk_num=TTAT.3G-36.305V14.3.0">http://committee.tta.or.kr/data/ttasDown.jsp?kind=ttastd&amp;pk_num=TTAT.3G-36.305V14.3.0</a>
<b>Release 15</b>					



ARIB	ARIB STD-T120-36.305.V15.5.0	15.5.0	Published	03.03.2023	<a href="https://www.arib.or.jp/english/html/overview/doc/T120_T23_SPECS/ARIB-STD-T120/Rel15/36/A36305-f50.pdf">https://www.arib.or.jp/english/html/overview/doc/T120_T23_SPECS/ARIB-STD-T120/Rel15/36/A36305-f50.pdf</a>
ATIS	ATIS.3GPP.36.305V1550	15.5.0	Published	28.06.2021	<a href="https://www.atis.org/3gpp-documents/Rel15/">https://www.atis.org/3gpp-documents/Rel15/</a>
CCSA	CCSA.36.305V1550	15.5.0	Published	01.07.2020	<a href="https://www.ccsa.org.cn/api/portalsFile/downloadOldFile?type=19&amp;oldFileUrl=ITU-R/M.2012-6/CCSA.36.305V1550.doc">https://www.ccsa.org.cn/api/portalsFile/downloadOldFile?type=19&amp;oldFileUrl=ITU-R/M.2012-6/CCSA.36.305V1550.doc</a>
ETSI	ETSI TS 136 305	15.5.0	Published	31.07.2020	<a href="https://www.etsi.org/deliver/etsi_ts/136300_136399/136305/15.05.00_60/ts_136305v150500p.pdf">https://www.etsi.org/deliver/etsi_ts/136300_136399/136305/15.05.00_60/ts_136305v150500p.pdf</a>
TSDSI	TSDSI STD T1.3GPP 36.305-15.5.0 V1.0.0	15.5.0	Published	30.08.2021	<a href="https://members.tdsi.in/index.php/s/HXRJ3fxtcr2RK8b">https://members.tdsi.in/index.php/s/HXRJ3fxtcr2RK8b</a>
TTA	TTAT.3G-36.305V15.5.0	15.5.0	Published	11.09.2020	<a href="http://committee.tta.or.kr/data/ttasDown.jsp?kind=ttastd&amp;pk_num=TTAT.3G-36.305V15.5.0">http://committee.tta.or.kr/data/ttasDown.jsp?kind=ttastd&amp;pk_num=TTAT.3G-36.305V15.5.0</a>

**Release 16**

ARIB	ARIB STD-T120-36.305.V16.4.0	16.4.0	Published	03.03.2023	<a href="https://www.arib.or.jp/english/html/overview/doc/T120_T23_SPECS/ARIB-STD-T120/Rel16/36/A36305-g40.pdf">https://www.arib.or.jp/english/html/overview/doc/T120_T23_SPECS/ARIB-STD-T120/Rel16/36/A36305-g40.pdf</a>
ATIS	ATIS.3GPP.36.305.V16.4.0	16.4.0	Published	21.02.2023	<a href="https://www.atis.org/3gpp-transpositions-Rel-16">https://www.atis.org/3gpp-transpositions-Rel-16</a>
CCSA	CCSA.36.305V1640	16.4.0	Published	01.09.2021	<a href="https://www.ccsa.org.cn/api/portalsFile/downloadOldFile?type=19&amp;oldFileUrl=ITU-R/M.2012-6/CCSA.36.305V1640.doc">https://www.ccsa.org.cn/api/portalsFile/downloadOldFile?type=19&amp;oldFileUrl=ITU-R/M.2012-6/CCSA.36.305V1640.doc</a>
ETSI	ETSI TS 136 305	16.4.0	Published	06.10.2021	<a href="https://www.etsi.org/deliver/etsi_ts/136300_136399/136305/16.04.00_60/ts_136305v160400p.pdf">https://www.etsi.org/deliver/etsi_ts/136300_136399/136305/16.04.00_60/ts_136305v160400p.pdf</a>
TSDSI	TSDSI STD T1.3GPP 36.305-16.4.0 V1.1.0	16.4.0	Published	01.11.2022	<a href="https://members.tdsi.in/s/9MH59o4kysjgn8Y">https://members.tdsi.in/s/9MH59o4kysjgn8Y</a>
TTA	TTAT.3G-36.305V16.4.0	16.4.0	Published	27.01.2022	<a href="http://committee.tta.or.kr/data/ttasDown.jsp?kind=ttastd&amp;pk_num=TTAT.3G-36.305V16.4.0">http://committee.tta.or.kr/data/ttasDown.jsp?kind=ttastd&amp;pk_num=TTAT.3G-36.305V16.4.0</a>

**Release 17**

ARIB	ARIB STD-T120-36.305.V17.2.0	17.2.0	Published	03.03.2023	<a href="https://www.arib.or.jp/english/html/overview/doc/T120_T23_SPECS/ARIB-STD-T120/Rel17/36/A36305-h20.pdf">https://www.arib.or.jp/english/html/overview/doc/T120_T23_SPECS/ARIB-STD-T120/Rel17/36/A36305-h20.pdf</a>
ATIS	ATIS.3GPP.36.305.V17.2.0	17.2.0	Published	21.02.2023	<a href="https://www.atis.org/3gpp-transpositions-Rel-17">https://www.atis.org/3gpp-transpositions-Rel-17</a>
CCSA	CCSA.36.305V1720	17.2.0	Published	01.09.2022	<a href="https://www.ccsa.org.cn/api/portalsFile/downloadOldFile?type=19&amp;oldFileUrl=ITU-R/M.2012-6/CCSA.36.305V1720.doc">https://www.ccsa.org.cn/api/portalsFile/downloadOldFile?type=19&amp;oldFileUrl=ITU-R/M.2012-6/CCSA.36.305V1720.doc</a>
ETSI	ETSI TS 136 305	17.2.0	Published	20.10.2022	<a href="https://www.etsi.org/deliver/etsi_ts/136300_136399/136305/17.02.00_60/ts_136305v170200p.pdf">https://www.etsi.org/deliver/etsi_ts/136300_136399/136305/17.02.00_60/ts_136305v170200p.pdf</a>
TSDSI	TSDSI STD T1.3GPP 36.305-17.2.0 V1.2.0	17.2.0	Published	17.01.2023	<a href="https://members.tdsi.in/s/CDdsHiEXivyRpqq">https://members.tdsi.in/s/CDdsHiEXivyRpqq</a>
TTA	TTAT.3G-36.305V17.2.0	17.2.0	Published	11.01.2023	<a href="http://committee.tta.or.kr/data/ttasDown.jsp?kind=ttastd&amp;pk_num=TTAT.3G-36.305V17.2.0">http://committee.tta.or.kr/data/ttasDown.jsp?kind=ttastd&amp;pk_num=TTAT.3G-36.305V17.2.0</a>

**2.1.3.5 TS 36.306**

**Evolved Universal Terrestrial Radio Access (E-UTRA); User Equipment (UE) radio access capabilities**

This document defines the E-UTRA UE Radio Access Capability Parameters.

SDO	Document No.	Version	Status	Issued date	Location
<b>Release 10</b>					
ARIB	ARIB STD-T120-36.306.V10.15.0	10.15.0	Published	03.03.2023	<a href="https://www.arib.or.jp/english/html/overview/doc/T120_T23_SPECS/ARIB-STD-T120/Rel10/36/A36306-af0.pdf">https://www.arib.or.jp/english/html/overview/doc/T120_T23_SPECS/ARIB-STD-T120/Rel10/36/A36306-af0.pdf</a>
ATIS	ATIS.3GPP.36.306V10150	10.15.0	Published	28.06.2021	<a href="https://www.atis.org/3gpp-documents/Rel99-14/">https://www.atis.org/3gpp-documents/Rel99-14/</a>
CCSA	CCSA.36.306V10150	10.15.0	Published	01.12.2015	<a href="https://www.ccsa.org.cn/api/portalsFile/downloadOldFile?type=19&amp;oldFileUrl=ITU-R/M.2012-6/CCSA.36.306V10150.doc">https://www.ccsa.org.cn/api/portalsFile/downloadOldFile?type=19&amp;oldFileUrl=ITU-R/M.2012-6/CCSA.36.306V10150.doc</a>
ETSI	ETSI TS 136 306	10.15.0	Published	28.01.2016	<a href="https://www.etsi.org/deliver/etsi_ts/136300_136399/136306/10.15.00_60/ts_136306v101500p.pdf">https://www.etsi.org/deliver/etsi_ts/136300_136399/136306/10.15.00_60/ts_136306v101500p.pdf</a>
TSDSI	TSDSI STD T1.3GPP 36.306-10.15.0 V1.0.0	10.15.0	Published	30.08.2021	<a href="https://members.tdsi.in/index.php/s/2kJ6i3M3DBKkbFz">https://members.tdsi.in/index.php/s/2kJ6i3M3DBKkbFz</a>
TTA	TTAT.3G-36.306V10.15.0	10.15.0	Published	02.08.2021	<a href="http://committee.tta.or.kr/data/ttasDown.jsp?kind=ttastd&amp;pk_num=TTAT.3G-36.306V10.15.0">http://committee.tta.or.kr/data/ttasDown.jsp?kind=ttastd&amp;pk_num=TTAT.3G-36.306V10.15.0</a>
<b>Release 11</b>					
ARIB	ARIB STD-T120-36.306.V11.14.0	11.14.0	Published	03.03.2023	<a href="https://www.arib.or.jp/english/html/overview/doc/T120_T23_SPECS/ARIB-STD-T120/Rel11/36/A36306-be0.pdf">https://www.arib.or.jp/english/html/overview/doc/T120_T23_SPECS/ARIB-STD-T120/Rel11/36/A36306-be0.pdf</a>
ATIS	ATIS.3GPP.36.306V11140	11.14.0	Published	28.06.2021	<a href="https://www.atis.org/3gpp-documents/Rel99-14/">https://www.atis.org/3gpp-documents/Rel99-14/</a>
CCSA	CCSA.36.306V11140	11.14.0	Published	01.12.2016	<a href="https://www.ccsa.org.cn/api/portalsFile/downloadOldFile?type=19&amp;oldFileUrl=ITU-R/M.2012-6/CCSA.36.306V11140.doc">https://www.ccsa.org.cn/api/portalsFile/downloadOldFile?type=19&amp;oldFileUrl=ITU-R/M.2012-6/CCSA.36.306V11140.doc</a>
ETSI	ETSI TS 136 306	11.14.0	Published	16.02.2017	<a href="https://www.etsi.org/deliver/etsi_ts/136300_136399/136306/11.14.00_60/ts_136306v111400p.pdf">https://www.etsi.org/deliver/etsi_ts/136300_136399/136306/11.14.00_60/ts_136306v111400p.pdf</a>
TSDSI	TSDSI STD T1.3GPP 36.306-11.14.0 V1.0.0	11.14.0	Published	30.08.2021	<a href="https://members.tdsi.in/index.php/s/eGBKHZRsbk32Ex5">https://members.tdsi.in/index.php/s/eGBKHZRsbk32Ex5</a>
TTA	TTAT.3G-36.306V11.14.0	11.14.0	Published	02.08.2021	<a href="http://committee.tta.or.kr/data/ttasDown.jsp?kind=ttastd&amp;pk_num=TTAT.3G-36.306V11.14.0">http://committee.tta.or.kr/data/ttasDown.jsp?kind=ttastd&amp;pk_num=TTAT.3G-36.306V11.14.0</a>
<b>Release 12</b>					
ARIB	ARIB STD-T120-36.306.V12.13.0	12.13.0	Published	03.03.2023	<a href="https://www.arib.or.jp/english/html/overview/doc/T120_T23_SPECS/ARIB-STD-T120/Rel12/36/A36306-cd0.pdf">https://www.arib.or.jp/english/html/overview/doc/T120_T23_SPECS/ARIB-STD-T120/Rel12/36/A36306-cd0.pdf</a>
ATIS	ATIS.3GPP.36.306V12130	12.13.0	Published	28.06.2021	<a href="https://www.atis.org/3gpp-documents/Rel99-14/">https://www.atis.org/3gpp-documents/Rel99-14/</a>
CCSA	CCSA.36.306V12130	12.13.0	Published	01.09.2017	<a href="https://www.ccsa.org.cn/api/portalsFile/downloadOldFile?type=19&amp;oldFileUrl=ITU-R/M.2012-6/CCSA.36.306V12130.doc">https://www.ccsa.org.cn/api/portalsFile/downloadOldFile?type=19&amp;oldFileUrl=ITU-R/M.2012-6/CCSA.36.306V12130.doc</a>
ETSI	ETSI TS 136 306	12.13.0	Published	09.10.2017	<a href="https://www.etsi.org/deliver/etsi_ts/136300_136399/136306/12.13.00_60/ts_136306v121300p.pdf">https://www.etsi.org/deliver/etsi_ts/136300_136399/136306/12.13.00_60/ts_136306v121300p.pdf</a>

TSDSI	TSDSI STD T1.3GPP 36.306-12.13.0 V1.0.0	12.13.0	Published	30.08.2021	<a href="https://members.tdsi.in/index.php/s/2DrPYbCjsL54Fj2">https://members.tdsi.in/index.php/s/2DrPYbCjsL54Fj2</a>
TTA	TTAT.3G-36.306V12.13.0	12.13.0	Published	02.08.2021	<a href="http://committee.tta.or.kr/data/ttasDown.jsp?kind=ttastd&amp;pk_num=TTAT.3G-36.306V12.13.0">http://committee.tta.or.kr/data/ttasDown.jsp?kind=ttastd&amp;pk_num=TTAT.3G-36.306V12.13.0</a>
<b>Release 13</b>					
ARIB	ARIB STD-T120-36.306.V13.13.0	13.13.0	Published	03.03.2023	<a href="https://www.arib.or.jp/english/html/overview/doc/T120_T23_SPECS/ARIB-STD-T120/Rel13/36/A36306-dd0.pdf">https://www.arib.or.jp/english/html/overview/doc/T120_T23_SPECS/ARIB-STD-T120/Rel13/36/A36306-dd0.pdf</a>
ATIS	ATIS.3GPP.36.306V13130	13.13.0	Published	28.06.2021	<a href="https://www.atis.org/3gpp-documents/Rel99-14/">https://www.atis.org/3gpp-documents/Rel99-14/</a>
CCSA	CCSA.36.306V13130	13.13.0	Published	01.07.2020	<a href="https://www.ccsa.org.cn/api/portalsFile/downloadOldFile?type=19&amp;oldFileUrl=ITU-R/M.2012-6/CCSA.36.306V13130.doc">https://www.ccsa.org.cn/api/portalsFile/downloadOldFile?type=19&amp;oldFileUrl=ITU-R/M.2012-6/CCSA.36.306V13130.doc</a>
ETSI	ETSI TS 136 306	13.13.0	Published	31.07.2020	<a href="https://www.etsi.org/deliver/etsi_ts/136300_136399/136306/13.13.00_60/ts_136306v131300p.pdf">https://www.etsi.org/deliver/etsi_ts/136300_136399/136306/13.13.00_60/ts_136306v131300p.pdf</a>
TSDSI	TSDSI STD T1.3GPP 36.306-13.8.0 V1.0.0	13.13.0	Published	30.08.2021	<a href="https://members.tdsi.in/index.php/s/DWSYyCkXw7meqM">https://members.tdsi.in/index.php/s/DWSYyCkXw7meqM</a>
TTA	TTAT.3G-36.306V13.13.0	13.13.0	Published	02.08.2021	<a href="http://committee.tta.or.kr/data/ttasDown.jsp?kind=ttastd&amp;pk_num=TTAT.3G-36.306V13.13.0">http://committee.tta.or.kr/data/ttasDown.jsp?kind=ttastd&amp;pk_num=TTAT.3G-36.306V13.13.0</a>
<b>Release 14</b>					
ARIB	ARIB STD-T120-36.306.V14.12.0	14.12.0	Published	03.03.2023	<a href="https://www.arib.or.jp/english/html/overview/doc/T120_T23_SPECS/ARIB-STD-T120/Rel14/36/A36306-ec0.pdf">https://www.arib.or.jp/english/html/overview/doc/T120_T23_SPECS/ARIB-STD-T120/Rel14/36/A36306-ec0.pdf</a>
ATIS	ATIS.3GPP.36.306V14120	14.12.0	Published	28.06.2021	<a href="https://www.atis.org/3gpp-documents/Rel99-14/">https://www.atis.org/3gpp-documents/Rel99-14/</a>
CCSA	CCSA.36.306V14120	14.12.0	Published	01.07.2020	<a href="https://www.ccsa.org.cn/api/portalsFile/downloadOldFile?type=19&amp;oldFileUrl=ITU-R/M.2012-6/CCSA.36.306V14120.doc">https://www.ccsa.org.cn/api/portalsFile/downloadOldFile?type=19&amp;oldFileUrl=ITU-R/M.2012-6/CCSA.36.306V14120.doc</a>
ETSI	ETSI TS 136 306	14.12.0	Published	31.07.2020	<a href="https://www.etsi.org/deliver/etsi_ts/136300_136399/136306/14.12.00_60/ts_136306v141200p.pdf">https://www.etsi.org/deliver/etsi_ts/136300_136399/136306/14.12.00_60/ts_136306v141200p.pdf</a>
TSDSI	TSDSI STD T1.3GPP 36.306-14.12.0 V1.1.0	14.12.0	Published	30.08.2021	<a href="https://members.tdsi.in/index.php/s/yMjM3Ra83DkPw2Q">https://members.tdsi.in/index.php/s/yMjM3Ra83DkPw2Q</a>
TTA	TTAT.3G-36.306V14.12.0	14.12.0	Published	02.08.2021	<a href="http://committee.tta.or.kr/data/ttasDown.jsp?kind=ttastd&amp;pk_num=TTAT.3G-36.306V14.12.0">http://committee.tta.or.kr/data/ttasDown.jsp?kind=ttastd&amp;pk_num=TTAT.3G-36.306V14.12.0</a>
<b>Release 15</b>					
ARIB	ARIB STD-T120-36.306.V15.11.0	15.11.0	Published	03.03.2023	<a href="https://www.arib.or.jp/english/html/overview/doc/T120_T23_SPECS/ARIB-STD-T120/Rel15/36/A36306-fb0.pdf">https://www.arib.or.jp/english/html/overview/doc/T120_T23_SPECS/ARIB-STD-T120/Rel15/36/A36306-fb0.pdf</a>
ATIS	ATIS.3GPP.36.306.V15.11.0	15.11.0	Published	21.02.2023	<a href="https://www.atis.org/3gpp-transpositions - Rel-15">https://www.atis.org/3gpp-transpositions - Rel-15</a>
CCSA	CCSA.36.306V15110	15.11.0	Published	01.12.2021	<a href="https://www.ccsa.org.cn/api/portalsFile/downloadOldFile?type=19&amp;oldFileUrl=ITU-R/M.2012-6/CCSA.36.306V15110.doc">https://www.ccsa.org.cn/api/portalsFile/downloadOldFile?type=19&amp;oldFileUrl=ITU-R/M.2012-6/CCSA.36.306V15110.doc</a>
ETSI	ETSI TS 136 306	15.11.0	Published	20.01.2022	<a href="https://www.etsi.org/deliver/etsi_ts/136300_136399/136306/15.11.00_60/ts_136306v151100p.pdf">https://www.etsi.org/deliver/etsi_ts/136300_136399/136306/15.11.00_60/ts_136306v151100p.pdf</a>
TSDSI	TSDSI STD T1.3GPP 36.306-15.11.0 V1.1.0	15.11.0	Published	01.11.2022	<a href="https://members.tdsi.in/s/6A2BsydY9YJL6Ta">https://members.tdsi.in/s/6A2BsydY9YJL6Ta</a>
TTA	TTAT.3G-36.306V15.11.0	15.11.0	Published	14.03.2022	<a href="http://committee.tta.or.kr/data/ttasDown.jsp?kind=ttastd&amp;pk_num=TTAT.3G-36.306V15.11.0">http://committee.tta.or.kr/data/ttasDown.jsp?kind=ttastd&amp;pk_num=TTAT.3G-36.306V15.11.0</a>
<b>Release 16</b>					
ARIB	ARIB STD-T120-36.306.V16.10.0	16.10.0	Published	03.03.2023	<a href="https://www.arib.or.jp/english/html/overview/doc/T120_T23_SPECS/ARIB-STD-T120/Rel16/36/A36306-ga0.pdf">https://www.arib.or.jp/english/html/overview/doc/T120_T23_SPECS/ARIB-STD-T120/Rel16/36/A36306-ga0.pdf</a>
ATIS	ATIS.3GPP.36.306.V16.10.0	16.10.0	Published	21.02.2023	<a href="https://www.atis.org/3gpp-transpositions - Rel-16">https://www.atis.org/3gpp-transpositions - Rel-16</a>
CCSA	CCSA.36.306V16100	16.10.0	Published	01.09.2022	<a href="https://www.ccsa.org.cn/api/portalsFile/downloadOldFile?type=19&amp;oldFileUrl=ITU-R/M.2012-6/CCSA.36.306V16100.doc">https://www.ccsa.org.cn/api/portalsFile/downloadOldFile?type=19&amp;oldFileUrl=ITU-R/M.2012-6/CCSA.36.306V16100.doc</a>
ETSI	ETSI TS 136 306	16.10.0	Published	20.10.2022	<a href="https://www.etsi.org/deliver/etsi_ts/136300_136399/136306/16.10.00_60/ts_136306v161000p.pdf">https://www.etsi.org/deliver/etsi_ts/136300_136399/136306/16.10.00_60/ts_136306v161000p.pdf</a>
TSDSI	TSDSI STD T1.3GPP 36.306-16.10.0 V1.2.0	16.10.0	Published	17.01.2023	<a href="https://members.tdsi.in/s/cWjBtZCNxXm7kTz">https://members.tdsi.in/s/cWjBtZCNxXm7kTz</a>
TTA	TTAT.3G-36.306V16.10.0	16.10.0	Published	11.01.2023	<a href="http://committee.tta.or.kr/data/ttasDown.jsp?kind=ttastd&amp;pk_num=TTAT.3G-36.306V16.10.0">http://committee.tta.or.kr/data/ttasDown.jsp?kind=ttastd&amp;pk_num=TTAT.3G-36.306V16.10.0</a>
<b>Release 17</b>					
ARIB	ARIB STD-T120-36.306.V17.3.0	17.3.0	Published	03.03.2023	<a href="https://www.arib.or.jp/english/html/overview/doc/T120_T23_SPECS/ARIB-STD-T120/Rel17/36/A36306-h30.pdf">https://www.arib.or.jp/english/html/overview/doc/T120_T23_SPECS/ARIB-STD-T120/Rel17/36/A36306-h30.pdf</a>
ATIS	ATIS.3GPP.36.306.V17.3.0	17.3.0	Published	21.02.2023	<a href="https://www.atis.org/3gpp-transpositions - Rel-17">https://www.atis.org/3gpp-transpositions - Rel-17</a>
CCSA	CCSA.36.306V1730	17.3.0	Published	01.12.2022	<a href="https://www.ccsa.org.cn/api/portalsFile/downloadOldFile?type=19&amp;oldFileUrl=ITU-R/M.2012-6/CCSA.36.306V1730.doc">https://www.ccsa.org.cn/api/portalsFile/downloadOldFile?type=19&amp;oldFileUrl=ITU-R/M.2012-6/CCSA.36.306V1730.doc</a>
ETSI	ETSI TS 136 306	17.3.0	Published	20.01.2023	<a href="https://www.etsi.org/deliver/etsi_ts/136300_136399/136306/17.03.00_60/ts_136306v170300p.pdf">https://www.etsi.org/deliver/etsi_ts/136300_136399/136306/17.03.00_60/ts_136306v170300p.pdf</a>
TSDSI	TSDSI STD T1.3GPP 36.306 17.3.0 V1.3.0	17.3.0	Published	02.05.2023	<a href="https://members.tdsi.in/s/e8HfNfx5bqKdw7B">https://members.tdsi.in/s/e8HfNfx5bqKdw7B</a>
TTA	TTAT.3G-36.306V17.3.0	17.3.0	Published	16.03.2023	<a href="http://committee.tta.or.kr/data/ttasDown.jsp?kind=ttastd&amp;pk_num=TTAT.3G-36.306V17.3.0">http://committee.tta.or.kr/data/ttasDown.jsp?kind=ttastd&amp;pk_num=TTAT.3G-36.306V17.3.0</a>

### 2.1.3.6 TS 36.314

#### Evolved Universal Terrestrial Radio Access (E-UTRA); Layer 2 – Measurements

This document contains the description and definition of the measurements performed by E-UTRAN that are transferred over the standardized interfaces in order to support E-UTRA radio link operations, radio resource management (RRM), network operations and maintenance (OAM), and self-organizing networks (SON).

SDO	Document No.	Version	Status	Issued date	Location
-----	--------------	---------	--------	-------------	----------

<b>Release 10</b>									
ARIB	ARIB STD-T120-36.314.V10.2.0	10.2.0	Published	03.03.2023	<a href="https://www.arib.or.jp/english/html/overview/doc/T120_T23_SPECS/ARIB-STD-T120/Rel10/36/A36314-a20.pdf">https://www.arib.or.jp/english/html/overview/doc/T120_T23_SPECS/ARIB-STD-T120/Rel10/36/A36314-a20.pdf</a>				
ATIS	ATIS.3GPP.36.314V1020	10.2.0	Published	28.06.2021	<a href="https://www.atis.org/3gpp-documents/Rel99-14/">https://www.atis.org/3gpp-documents/Rel99-14/</a>				
CCSA	CCSA.36.314V1020	10.2.0	Published	01.09.2011	<a href="https://www.ccsa.org.cn/api/portalsFile/downloadOldFile?type=19&amp;oldFileUrl=ITU-R/M.2012-6/CCSA.36.314V1020.doc">https://www.ccsa.org.cn/api/portalsFile/downloadOldFile?type=19&amp;oldFileUrl=ITU-R/M.2012-6/CCSA.36.314V1020.doc</a>				
ETSI	ETSI TS 136 314	10.2.0	Published	04.11.2011	<a href="https://www.etsi.org/deliver/etsi_ts/136300_136399/136314/10.02.00_60/ts_136314v100200p.pdf">https://www.etsi.org/deliver/etsi_ts/136300_136399/136314/10.02.00_60/ts_136314v100200p.pdf</a>				
TSDSI	TSDSI STD T1.3GPP 36.314-10.2.0 V1.0.0	10.2.0	Published	30.08.2021	<a href="https://members.tdsi.in/index.php/s/5gmcGt2tp8SfoDg">https://members.tdsi.in/index.php/s/5gmcGt2tp8SfoDg</a>				
TTA	TTAT.3G-36.314V10.2.0	10.2.0	Published	02.08.2021	<a href="http://committee.tta.or.kr/data/ttasDown.jsp?kind=ttastd&amp;pk_num=TTAT.3G-36.314V10.2.0">http://committee.tta.or.kr/data/ttasDown.jsp?kind=ttastd&amp;pk_num=TTAT.3G-36.314V10.2.0</a>				
<b>Release 11</b>									
ARIB	ARIB STD-T120-36.314.V11.1.0	11.1.0	Published	03.03.2023	<a href="https://www.arib.or.jp/english/html/overview/doc/T120_T23_SPECS/ARIB-STD-T120/Rel11/36/A36314-b10.pdf">https://www.arib.or.jp/english/html/overview/doc/T120_T23_SPECS/ARIB-STD-T120/Rel11/36/A36314-b10.pdf</a>				
ATIS	ATIS.3GPP.36.314V1110	11.1.0	Published	28.06.2021	<a href="https://www.atis.org/3gpp-documents/Rel99-14/">https://www.atis.org/3gpp-documents/Rel99-14/</a>				
CCSA	CCSA.36.314V1110	11.1.0	Published	01.12.2012	<a href="https://www.ccsa.org.cn/api/portalsFile/downloadOldFile?type=19&amp;oldFileUrl=ITU-R/M.2012-6/CCSA.36.314V1110.doc">https://www.ccsa.org.cn/api/portalsFile/downloadOldFile?type=19&amp;oldFileUrl=ITU-R/M.2012-6/CCSA.36.314V1110.doc</a>				
ETSI	ETSI TS 136 314	11.1.0	Published	12.02.2013	<a href="https://www.etsi.org/deliver/etsi_ts/136300_136399/136314/11.01.00_60/ts_136314v110100p.pdf">https://www.etsi.org/deliver/etsi_ts/136300_136399/136314/11.01.00_60/ts_136314v110100p.pdf</a>				
TSDSI	TSDSI STD T1.3GPP 36.314-11.1.0 V1.0.0	11.1.0	Published	30.08.2021	<a href="https://members.tdsi.in/index.php/s/tGLXCfZ6qK7oem4">https://members.tdsi.in/index.php/s/tGLXCfZ6qK7oem4</a>				
TTA	TTAT.3G-36.314V11.1.0	11.1.0	Published	02.08.2021	<a href="http://committee.tta.or.kr/data/ttasDown.jsp?kind=ttastd&amp;pk_num=TTAT.3G-36.314V11.1.0">http://committee.tta.or.kr/data/ttasDown.jsp?kind=ttastd&amp;pk_num=TTAT.3G-36.314V11.1.0</a>				
<b>Release 12</b>									
ARIB	ARIB STD-T120-36.314.V12.0.0	12.0.0	Published	03.03.2023	<a href="https://www.arib.or.jp/english/html/overview/doc/T120_T23_SPECS/ARIB-STD-T120/Rel12/36/A36314-c00.pdf">https://www.arib.or.jp/english/html/overview/doc/T120_T23_SPECS/ARIB-STD-T120/Rel12/36/A36314-c00.pdf</a>				
ATIS	ATIS.3GPP.36.314V1200	12.0.0	Published	28.06.2021	<a href="https://www.atis.org/3gpp-documents/Rel99-14/">https://www.atis.org/3gpp-documents/Rel99-14/</a>				
CCSA	CCSA.36.314V1200	12.0.0	Published	01.09.2014	<a href="https://www.ccsa.org.cn/api/portalsFile/downloadOldFile?type=19&amp;oldFileUrl=ITU-R/M.2012-6/CCSA.36.314V1200.doc">https://www.ccsa.org.cn/api/portalsFile/downloadOldFile?type=19&amp;oldFileUrl=ITU-R/M.2012-6/CCSA.36.314V1200.doc</a>				
ETSI	ETSI TS 136 314	12.0.0	Published	29.09.2014	<a href="https://www.etsi.org/deliver/etsi_ts/136300_136399/136314/12.00.00_60/ts_136314v120000p.pdf">https://www.etsi.org/deliver/etsi_ts/136300_136399/136314/12.00.00_60/ts_136314v120000p.pdf</a>				
TSDSI	TSDSI STD T1.3GPP 36.314-12.0.0 V1.0.0	12.0.0	Published	30.08.2021	<a href="https://members.tdsi.in/index.php/s/i6RNLRGik8seB2J">https://members.tdsi.in/index.php/s/i6RNLRGik8seB2J</a>				
TTA	TTAT.3G-36.314V12.0.0	12.0.0	Published	02.08.2021	<a href="http://committee.tta.or.kr/data/ttasDown.jsp?kind=ttastd&amp;pk_num=TTAT.3G-36.314V12.0.0">http://committee.tta.or.kr/data/ttasDown.jsp?kind=ttastd&amp;pk_num=TTAT.3G-36.314V12.0.0</a>				
<b>Release 13</b>									
ARIB	ARIB STD-T120-36.314.V13.1.0	13.1.0	Published	03.03.2023	<a href="https://www.arib.or.jp/english/html/overview/doc/T120_T23_SPECS/ARIB-STD-T120/Rel13/36/A36314-d10.pdf">https://www.arib.or.jp/english/html/overview/doc/T120_T23_SPECS/ARIB-STD-T120/Rel13/36/A36314-d10.pdf</a>				
ATIS	ATIS.3GPP.36.314V1310	13.1.0	Published	28.06.2021	<a href="https://www.atis.org/3gpp-documents/Rel99-14/">https://www.atis.org/3gpp-documents/Rel99-14/</a>				
CCSA	CCSA.36.314V1310	13.1.0	Published	01.03.2016	<a href="https://www.ccsa.org.cn/api/portalsFile/downloadOldFile?type=19&amp;oldFileUrl=ITU-R/M.2012-6/CCSA.36.314V1310.doc">https://www.ccsa.org.cn/api/portalsFile/downloadOldFile?type=19&amp;oldFileUrl=ITU-R/M.2012-6/CCSA.36.314V1310.doc</a>				
ETSI	ETSI TS 136 314	13.1.0	Published	27.04.2016	<a href="https://www.etsi.org/deliver/etsi_ts/136300_136399/136314/13.01.00_60/ts_136314v130100p.pdf">https://www.etsi.org/deliver/etsi_ts/136300_136399/136314/13.01.00_60/ts_136314v130100p.pdf</a>				
TSDSI	TSDSI STD T1.3GPP 36.314-13.1.0 V1.0.0	13.1.0	Published	30.08.2021	<a href="https://members.tdsi.in/index.php/s/8oirGq4tYJsBXsA">https://members.tdsi.in/index.php/s/8oirGq4tYJsBXsA</a>				
TTA	TTAT.3G-36.314V13.1.0	13.1.0	Published	02.08.2021	<a href="http://committee.tta.or.kr/data/ttasDown.jsp?kind=ttastd&amp;pk_num=TTAT.3G-36.314V13.1.0">http://committee.tta.or.kr/data/ttasDown.jsp?kind=ttastd&amp;pk_num=TTAT.3G-36.314V13.1.0</a>				
<b>Release 14</b>									
ARIB	ARIB STD-T120-36.314.V14.0.0	14.0.0	Published	03.03.2023	<a href="https://www.arib.or.jp/english/html/overview/doc/T120_T23_SPECS/ARIB-STD-T120/Rel14/36/A36314-e00.pdf">https://www.arib.or.jp/english/html/overview/doc/T120_T23_SPECS/ARIB-STD-T120/Rel14/36/A36314-e00.pdf</a>				
ATIS	ATIS.3GPP.36.314V1400	14.0.0	Published	28.06.2021	<a href="https://www.atis.org/3gpp-documents/Rel99-14/">https://www.atis.org/3gpp-documents/Rel99-14/</a>				
CCSA	CCSA.36.314V1400	14.0.0	Published	01.03.2017	<a href="https://www.ccsa.org.cn/api/portalsFile/downloadOldFile?type=19&amp;oldFileUrl=ITU-R/M.2012-6/CCSA.36.314V1400.doc">https://www.ccsa.org.cn/api/portalsFile/downloadOldFile?type=19&amp;oldFileUrl=ITU-R/M.2012-6/CCSA.36.314V1400.doc</a>				
ETSI	ETSI TS 136 314	14.0.0	Published	11.04.2017	<a href="https://www.etsi.org/deliver/etsi_ts/136300_136399/136314/14.00.00_60/ts_136314v140000p.pdf">https://www.etsi.org/deliver/etsi_ts/136300_136399/136314/14.00.00_60/ts_136314v140000p.pdf</a>				
TSDSI	TSDSI STD T1.3GPP 36.314-14.0.0 V1.0.0	14.0.0	Published	30.08.2021	<a href="https://members.tdsi.in/index.php/s/e2YEGk2TNcf6EPx">https://members.tdsi.in/index.php/s/e2YEGk2TNcf6EPx</a>				
TTA	TTAT.3G-36.314V14.0.0	14.0.0	Published	02.08.2021	<a href="http://committee.tta.or.kr/data/ttasDown.jsp?kind=ttastd&amp;pk_num=TTAT.3G-36.314V14.0.0">http://committee.tta.or.kr/data/ttasDown.jsp?kind=ttastd&amp;pk_num=TTAT.3G-36.314V14.0.0</a>				
<b>Release 15</b>									
ARIB	ARIB STD-T120-36.314.V15.2.0	15.2.0	Published	03.03.2023	<a href="https://www.arib.or.jp/english/html/overview/doc/T120_T23_SPECS/ARIB-STD-T120/Rel15/36/A36314-f20.pdf">https://www.arib.or.jp/english/html/overview/doc/T120_T23_SPECS/ARIB-STD-T120/Rel15/36/A36314-f20.pdf</a>				
ATIS	ATIS.3GPP.36.314V1520	15.2.0	Published	28.06.2021	<a href="https://www.atis.org/3gpp-documents/Rel15/">https://www.atis.org/3gpp-documents/Rel15/</a>				
CCSA	CCSA.36.314V1520	15.2.0	Published	01.12.2018	<a href="https://www.ccsa.org.cn/api/portalsFile/downloadOldFile?type=19&amp;oldFileUrl=ITU-R/M.2012-6/CCSA.36.314V1520.doc">https://www.ccsa.org.cn/api/portalsFile/downloadOldFile?type=19&amp;oldFileUrl=ITU-R/M.2012-6/CCSA.36.314V1520.doc</a>				
ETSI	ETSI TS 136 314	15.2.0	Published	17.04.2019	<a href="https://www.etsi.org/deliver/etsi_ts/136300_136399/136314/15.02.00_60/ts_136314v150200p.pdf">https://www.etsi.org/deliver/etsi_ts/136300_136399/136314/15.02.00_60/ts_136314v150200p.pdf</a>				
TSDSI	TSDSI STD T1.3GPP 36.314-15.2.0 V1.0.0	15.2.0	Published	30.08.2021	<a href="https://members.tdsi.in/index.php/s/5QmYq3a9BaHpdH9">https://members.tdsi.in/index.php/s/5QmYq3a9BaHpdH9</a>				
TTA	TTAT.3G-36.314V15.2.0	15.2.0	Published	11.09.2020	<a href="http://committee.tta.or.kr/data/ttasDown.jsp?kind=ttastd&amp;pk_num=TTAT.3G-36.314V15.2.0">http://committee.tta.or.kr/data/ttasDown.jsp?kind=ttastd&amp;pk_num=TTAT.3G-36.314V15.2.0</a>				
<b>Release 16</b>									
ARIB	ARIB STD-T120-36.314.V16.0.0	16.0.0	Published	03.03.2023	<a href="https://www.arib.or.jp/english/html/overview/doc/T120_T23_SPECS/ARIB-STD-T120/Rel16/36/A36314-g00.pdf">https://www.arib.or.jp/english/html/overview/doc/T120_T23_SPECS/ARIB-STD-T120/Rel16/36/A36314-g00.pdf</a>				
ATIS	ATIS.3GPP.36.314V1600	16.0.0	Published	28.06.2021	<a href="https://www.atis.org/3gpp-documents/Rel16/">https://www.atis.org/3gpp-documents/Rel16/</a>				
CCSA	CCSA.36.314V1600	16.0.0	Published	01.07.2020	<a href="https://www.ccsa.org.cn/api/portalsFile/downloadOldFile?type=19&amp;oldFileUrl=ITU-R/M.2012-6/CCSA.36.314V1600.doc">https://www.ccsa.org.cn/api/portalsFile/downloadOldFile?type=19&amp;oldFileUrl=ITU-R/M.2012-6/CCSA.36.314V1600.doc</a>				

ETSI	ETSI TS 136 314	16.0.0	Published	31.07.2020	<a href="https://www.etsi.org/deliver/etsi_ts/136300_136399/136314/16.00.00_60/ts_136314v160000p.pdf">https://www.etsi.org/deliver/etsi_ts/136300_136399/136314/16.00.00_60/ts_136314v160000p.pdf</a>
TSDSI	TSDSI STD T1.3GPP 36.314-16.0.0 V1.0.0	16.0.0	Published	30.08.2021	<a href="https://members.tdsi.in/index.php/s/5BcnS8fdPrk3kpn">https://members.tdsi.in/index.php/s/5BcnS8fdPrk3kpn</a>
TTA	TTAT.3G-36.314V16.0.0	16.0.0	Published	11.09.2020	<a href="http://committee.tta.or.kr/data/ttasDown.jsp?kind=ttastd&amp;pk_num=TTAT.3G-36.314V16.0.0">http://committee.tta.or.kr/data/ttasDown.jsp?kind=ttastd&amp;pk_num=TTAT.3G-36.314V16.0.0</a>

**Release 17**

ARIB	ARIB STD-T120-36.314.V17.0.0	17.0.0	Published	03.03.2023	<a href="https://www.arib.or.jp/english/html/overview/doc/T120_T23_SPECS/ARIB-STD-T120/Rel17/36/A36314-h00.pdf">https://www.arib.or.jp/english/html/overview/doc/T120_T23_SPECS/ARIB-STD-T120/Rel17/36/A36314-h00.pdf</a>
ATIS	ATIS.3GPP.36.314.V17.0.0	17.0.0	Published	21.02.2023	<a href="https://www.atis.org/3gpp-transpositions-Rel-17">https://www.atis.org/3gpp-transpositions-Rel-17</a>
CCSA	CCSA.36.314V1700	17.0.0	Published	01.03.2022	<a href="https://www.ccsa.org.cn/api/portalsFile/downloadOldFile?type=19&amp;oldFileUrl=ITU-R/M.2012-6/CCSA.36.314V1700.doc">https://www.ccsa.org.cn/api/portalsFile/downloadOldFile?type=19&amp;oldFileUrl=ITU-R/M.2012-6/CCSA.36.314V1700.doc</a>
ETSI	ETSI TS 136 314	17.0.0	Published	09.05.2022	<a href="https://www.etsi.org/deliver/etsi_ts/136300_136399/136314/17.00.00_60/ts_136314v170000p.pdf">https://www.etsi.org/deliver/etsi_ts/136300_136399/136314/17.00.00_60/ts_136314v170000p.pdf</a>
TSDSI	TSDSI STD T1.3GPP 36.314-17.0.0 V1.0.0	17.0.0	Published	29.07.2022	<a href="https://members.tdsi.in/s/WwrAHxRQrJPLBD2">https://members.tdsi.in/s/WwrAHxRQrJPLBD2</a>
TTA	TTAT.3G-36.314V17.0.0	17.0.0	Published	05.08.2022	<a href="http://committee.tta.or.kr/data/ttasDown.jsp?kind=ttastd&amp;pk_num=TTAT.3G-36.314V17.0.0">http://committee.tta.or.kr/data/ttasDown.jsp?kind=ttastd&amp;pk_num=TTAT.3G-36.314V17.0.0</a>

**2.1.3.7 TS 36.321****Evolved Universal Terrestrial Radio Access (E-UTRA); Medium Access Control (MAC) protocol specification**

This document specifies the E-UTRA Medium Access Control (MAC) protocol.

SDO	Document No.	Version	Status	Issued date	Location
<b>Release 10</b>					
ARIB	ARIB STD-T120-36.321.V10.10.0	10.10.0	Published	03.03.2023	<a href="https://www.arib.or.jp/english/html/overview/doc/T120_T23_SPECS/ARIB-STD-T120/Rel10/36/A36321-aa0.pdf">https://www.arib.or.jp/english/html/overview/doc/T120_T23_SPECS/ARIB-STD-T120/Rel10/36/A36321-aa0.pdf</a>
ATIS	ATIS.3GPP.36.321V10100	10.10.0	Published	28.06.2021	<a href="https://www.atis.org/3gpp-documents/Rel99-14/">https://www.atis.org/3gpp-documents/Rel99-14/</a>
CCSA	CCSA.36.321V10100	10.10.0	Published	01.12.2013	<a href="https://www.ccsa.org.cn/api/portalsFile/downloadOldFile?type=19&amp;oldFileUrl=ITU-R/M.2012-6/CCSA.36.321V10100.doc">https://www.ccsa.org.cn/api/portalsFile/downloadOldFile?type=19&amp;oldFileUrl=ITU-R/M.2012-6/CCSA.36.321V10100.doc</a>
ETSI	ETSI TS 136 321	10.10.0	Published	28.01.2014	<a href="https://www.etsi.org/deliver/etsi_ts/136300_136399/136321/10.10.00_60/ts_136321v101000p.pdf">https://www.etsi.org/deliver/etsi_ts/136300_136399/136321/10.10.00_60/ts_136321v101000p.pdf</a>
TSDSI	TSDSI STD T1.3GPP 36.321-10.10.0 V1.0.0	10.10.0	Published	30.08.2021	<a href="https://members.tdsi.in/index.php/s/MB44bcWyQEeALwC">https://members.tdsi.in/index.php/s/MB44bcWyQEeALwC</a>
TTA	TTAT.3G-36.321V10.10.0	10.10.0	Published	02.08.2021	<a href="http://committee.tta.or.kr/data/ttasDown.jsp?kind=ttastd&amp;pk_num=TTAT.3G-36.321V10.10.0">http://committee.tta.or.kr/data/ttasDown.jsp?kind=ttastd&amp;pk_num=TTAT.3G-36.321V10.10.0</a>
<b>Release 11</b>					
ARIB	ARIB STD-T120-36.321.V11.6.0	11.6.0	Published	03.03.2023	<a href="https://www.arib.or.jp/english/html/overview/doc/T120_T23_SPECS/ARIB-STD-T120/Rel11/36/A36321-b60.pdf">https://www.arib.or.jp/english/html/overview/doc/T120_T23_SPECS/ARIB-STD-T120/Rel11/36/A36321-b60.pdf</a>
ATIS	ATIS.3GPP.36.321V1160	11.6.0	Published	28.06.2021	<a href="https://www.atis.org/3gpp-documents/Rel99-14/">https://www.atis.org/3gpp-documents/Rel99-14/</a>
CCSA	CCSA.36.321V1160	11.6.0	Published	01.03.2015	<a href="https://www.ccsa.org.cn/api/portalsFile/downloadOldFile?type=19&amp;oldFileUrl=ITU-R/M.2012-6/CCSA.36.321V1160.doc">https://www.ccsa.org.cn/api/portalsFile/downloadOldFile?type=19&amp;oldFileUrl=ITU-R/M.2012-6/CCSA.36.321V1160.doc</a>
ETSI	ETSI TS 136 321	11.6.0	Published	21.04.2015	<a href="https://www.etsi.org/deliver/etsi_ts/136300_136399/136321/11.06.00_60/ts_136321v110600p.pdf">https://www.etsi.org/deliver/etsi_ts/136300_136399/136321/11.06.00_60/ts_136321v110600p.pdf</a>
TSDSI	TSDSI STD T1.3GPP 36.321-11.6.0 V1.0.0	11.6.0	Published	30.08.2021	<a href="https://members.tdsi.in/index.php/s/pkoCZHcFcq5nikR">https://members.tdsi.in/index.php/s/pkoCZHcFcq5nikR</a>
TTA	TTAT.3G-36.321V11.6.0	11.6.0	Published	02.08.2021	<a href="http://committee.tta.or.kr/data/ttasDown.jsp?kind=ttastd&amp;pk_num=TTAT.3G-36.321V11.6.0">http://committee.tta.or.kr/data/ttasDown.jsp?kind=ttastd&amp;pk_num=TTAT.3G-36.321V11.6.0</a>
<b>Release 12</b>					
ARIB	ARIB STD-T120-36.321.V12.10.0	12.10.0	Published	03.03.2023	<a href="https://www.arib.or.jp/english/html/overview/doc/T120_T23_SPECS/ARIB-STD-T120/Rel12/36/A36321-ca0.pdf">https://www.arib.or.jp/english/html/overview/doc/T120_T23_SPECS/ARIB-STD-T120/Rel12/36/A36321-ca0.pdf</a>
ATIS	ATIS.3GPP.36.321V12100	12.10.0	Published	28.06.2021	<a href="https://www.atis.org/3gpp-documents/Rel99-14/">https://www.atis.org/3gpp-documents/Rel99-14/</a>
CCSA	CCSA.36.321V12100	12.10.0	Published	01.09.2017	<a href="https://www.ccsa.org.cn/api/portalsFile/downloadOldFile?type=19&amp;oldFileUrl=ITU-R/M.2012-6/CCSA.36.321V12100.doc">https://www.ccsa.org.cn/api/portalsFile/downloadOldFile?type=19&amp;oldFileUrl=ITU-R/M.2012-6/CCSA.36.321V12100.doc</a>
ETSI	ETSI TS 136 321	12.10.0	Published	09.10.2017	<a href="https://www.etsi.org/deliver/etsi_ts/136300_136399/136321/12.10.00_60/ts_136321v121000p.pdf">https://www.etsi.org/deliver/etsi_ts/136300_136399/136321/12.10.00_60/ts_136321v121000p.pdf</a>
TSDSI	TSDSI STD T1.3GPP 36.321-12.10.0 V1.0.0	12.10.0	Published	30.08.2021	<a href="https://members.tdsi.in/index.php/s/eay7KbSBijFwCEX">https://members.tdsi.in/index.php/s/eay7KbSBijFwCEX</a>
TTA	TTAT.3G-36.321V12.10.0	12.10.0	Published	02.08.2021	<a href="http://committee.tta.or.kr/data/ttasDown.jsp?kind=ttastd&amp;pk_num=TTAT.3G-36.321V12.10.0">http://committee.tta.or.kr/data/ttasDown.jsp?kind=ttastd&amp;pk_num=TTAT.3G-36.321V12.10.0</a>
<b>Release 13</b>					
ARIB	ARIB STD-T120-36.321.V13.9.0	13.9.0	Published	03.03.2023	<a href="https://www.arib.or.jp/english/html/overview/doc/T120_T23_SPECS/ARIB-STD-T120/Rel13/36/A36321-d90.pdf">https://www.arib.or.jp/english/html/overview/doc/T120_T23_SPECS/ARIB-STD-T120/Rel13/36/A36321-d90.pdf</a>
ATIS	ATIS.3GPP.36.321V1390	13.9.0	Published	28.06.2021	<a href="https://www.atis.org/3gpp-documents/Rel99-14/">https://www.atis.org/3gpp-documents/Rel99-14/</a>
CCSA	CCSA.36.321V1390	13.9.0	Published	01.07.2018	<a href="https://www.ccsa.org.cn/api/portalsFile/downloadOldFile?type=19&amp;oldFileUrl=ITU-R/M.2012-6/CCSA.36.321V1390.doc">https://www.ccsa.org.cn/api/portalsFile/downloadOldFile?type=19&amp;oldFileUrl=ITU-R/M.2012-6/CCSA.36.321V1390.doc</a>
ETSI	ETSI TS 136 321	13.9.0	Published	16.07.2018	<a href="https://www.etsi.org/deliver/etsi_ts/136300_136399/136321/13.09.00_60/ts_136321v130900p.pdf">https://www.etsi.org/deliver/etsi_ts/136300_136399/136321/13.09.00_60/ts_136321v130900p.pdf</a>
TSDSI	TSDSI STD T1.3GPP 36.321-13.9.0 V1.1.0	13.9.0	Published	30.08.2021	<a href="https://members.tdsi.in/index.php/s/jqpKbKdFMyOyT3Z">https://members.tdsi.in/index.php/s/jqpKbKdFMyOyT3Z</a>
TTA	TTAT.3G-36.321V13.9.0	13.9.0	Published	02.08.2021	<a href="http://committee.tta.or.kr/data/ttasDown.jsp?kind=ttastd&amp;pk_num=TTAT.3G-36.321V13.9.0">http://committee.tta.or.kr/data/ttasDown.jsp?kind=ttastd&amp;pk_num=TTAT.3G-36.321V13.9.0</a>

**Release 14**

ARIB	ARIB STD-T120-36.321.V14.13.0	14.13.0	Published	03.03.2023	<a href="https://www.arib.or.jp/english/html/overview/doc/T120_T23_SPECS/ARIB-STD-T120/Rel14/36/A36321-ed0.pdf">https://www.arib.or.jp/english/html/overview/doc/T120_T23_SPECS/ARIB-STD-T120/Rel14/36/A36321-ed0.pdf</a>
ATIS	ATIS.3GPP.36.321.V14.13.0	14.13.0	Published	21.02.2023	<a href="https://www.atis.org/3gpp-transpositions - Rel-14">https://www.atis.org/3gpp-transpositions - Rel-14</a>
CCSA	CCSA.36.321V14130	14.13.0	Published	01.09.2020	<a href="https://www.ccsa.org.cn/api/portalsFile/downloadOldFile?type=19&amp;oldFileUrl=ITU-R/M.2012-6/CCSA.36.321V14130.doc">https://www.ccsa.org.cn/api/portalsFile/downloadOldFile?type=19&amp;oldFileUrl=ITU-R/M.2012-6/CCSA.36.321V14130.doc</a>
ETSI	ETSI TS 136 321	14.13.0	Published	16.11.2020	<a href="https://www.etsi.org/deliver/etsi_ts/136300_136399/136321/14.13.00_60/ts_136321v141300p.pdf">https://www.etsi.org/deliver/etsi_ts/136300_136399/136321/14.13.00_60/ts_136321v141300p.pdf</a>
TSDSI	TSDSI STD T1.3GPP 36.321-14.13.0 V1.1.0	14.13.0	Published	17.01.2023	<a href="https://members.tdsi.in/s/qOnx8qM8qeeQcaA">https://members.tdsi.in/s/qOnx8qM8qeeQcaA</a>
TTA	TTAT.3G-36.321V14.13.0	14.13.0	Published	16.03.2023	<a href="http://committee.tta.or.kr/data/ttasDown.jsp?kind=ttastd&amp;pk_num=TTAT.3G-36.321V14.13.0">http://committee.tta.or.kr/data/ttasDown.jsp?kind=ttastd&amp;pk_num=TTAT.3G-36.321V14.13.0</a>
<b>Release 15</b>					
ARIB	ARIB STD-T120-36.321.V15.11.0	15.11.0	Published	03.03.2023	<a href="https://www.arib.or.jp/english/html/overview/doc/T120_T23_SPECS/ARIB-STD-T120/Rel15/36/A36321-fb0.pdf">https://www.arib.or.jp/english/html/overview/doc/T120_T23_SPECS/ARIB-STD-T120/Rel15/36/A36321-fb0.pdf</a>
ATIS	ATIS.3GPP.36.321.V15.11.0	15.11.0	Published	21.02.2023	<a href="https://www.atis.org/3gpp-transpositions - Rel-15">https://www.atis.org/3gpp-transpositions - Rel-15</a>
CCSA	CCSA.36.321V15110	15.11.0	Published	01.12.2020	<a href="https://www.ccsa.org.cn/api/portalsFile/downloadOldFile?type=19&amp;oldFileUrl=ITU-R/M.2012-6/CCSA.36.321V15110.doc">https://www.ccsa.org.cn/api/portalsFile/downloadOldFile?type=19&amp;oldFileUrl=ITU-R/M.2012-6/CCSA.36.321V15110.doc</a>
ETSI	ETSI TS 136 321	15.11.0	Published	20.01.2021	<a href="https://www.etsi.org/deliver/etsi_ts/136300_136399/136321/15.11.00_60/ts_136321v151100p.pdf">https://www.etsi.org/deliver/etsi_ts/136300_136399/136321/15.11.00_60/ts_136321v151100p.pdf</a>
TSDSI	TSDSI STD T1.3GPP 36.321-15.11.0 V1.1.0	15.11.0	Published	01.11.2022	<a href="https://members.tdsi.in/s/xEHHx2KLpZAnrKa">https://members.tdsi.in/s/xEHHx2KLpZAnrKa</a>
TTA	TTAT.3G-36.321V15.11.0	15.11.0	Published	16.03.2023	<a href="http://committee.tta.or.kr/data/ttasDown.jsp?kind=ttastd&amp;pk_num=TTAT.3G-36.321V15.11.0">http://committee.tta.or.kr/data/ttasDown.jsp?kind=ttastd&amp;pk_num=TTAT.3G-36.321V15.11.0</a>
<b>Release 16</b>					
ARIB	ARIB STD-T120-36.321.V16.8.0	16.8.0	Published	03.03.2023	<a href="https://www.arib.or.jp/english/html/overview/doc/T120_T23_SPECS/ARIB-STD-T120/Rel16/36/A36321-g80.pdf">https://www.arib.or.jp/english/html/overview/doc/T120_T23_SPECS/ARIB-STD-T120/Rel16/36/A36321-g80.pdf</a>
ATIS	ATIS.3GPP.36.321.V16.8.0	16.8.0	Published	21.02.2023	<a href="https://www.atis.org/3gpp-transpositions - Rel-16">https://www.atis.org/3gpp-transpositions - Rel-16</a>
CCSA	CCSA.36.321V1680	16.8.0	Published	01.06.2022	<a href="https://www.ccsa.org.cn/api/portalsFile/downloadOldFile?type=19&amp;oldFileUrl=ITU-R/M.2012-6/CCSA.36.321V1680.doc">https://www.ccsa.org.cn/api/portalsFile/downloadOldFile?type=19&amp;oldFileUrl=ITU-R/M.2012-6/CCSA.36.321V1680.doc</a>
ETSI	ETSI TS 136 321	16.8.0	Published	17.08.2022	<a href="https://www.etsi.org/deliver/etsi_ts/136300_136399/136321/16.08.00_60/ts_136321v160800p.pdf">https://www.etsi.org/deliver/etsi_ts/136300_136399/136321/16.08.00_60/ts_136321v160800p.pdf</a>
TSDSI	TSDSI STD T1.3GPP 36.321-16.8.0 V1.1.0	16.8.0	Published	01.11.2022	<a href="https://members.tdsi.in/s/CJCW5ZJAKKHk2nH">https://members.tdsi.in/s/CJCW5ZJAKKHk2nH</a>
TTA	TTAT.3G-36.321V16.8.0	16.8.0	Published	21.10.2022	<a href="http://committee.tta.or.kr/data/ttasDown.jsp?kind=ttastd&amp;pk_num=TTAT.3G-36.321V16.8.0">http://committee.tta.or.kr/data/ttasDown.jsp?kind=ttastd&amp;pk_num=TTAT.3G-36.321V16.8.0</a>
<b>Release 17</b>					
ARIB	ARIB STD-T120-36.321.V17.3.0	17.3.0	Published	03.03.2023	<a href="https://www.arib.or.jp/english/html/overview/doc/T120_T23_SPECS/ARIB-STD-T120/Rel17/36/A36321-h30.pdf">https://www.arib.or.jp/english/html/overview/doc/T120_T23_SPECS/ARIB-STD-T120/Rel17/36/A36321-h30.pdf</a>
ATIS	ATIS.3GPP.36.321.V17.3.0	17.3.0	Published	21.02.2023	<a href="https://www.atis.org/3gpp-transpositions - Rel-17">https://www.atis.org/3gpp-transpositions - Rel-17</a>
CCSA	CCSA.36.321V1730	17.3.0	Published	01.12.2022	<a href="https://www.ccsa.org.cn/api/portalsFile/downloadOldFile?type=19&amp;oldFileUrl=ITU-R/M.2012-6/CCSA.36.321V1730.doc">https://www.ccsa.org.cn/api/portalsFile/downloadOldFile?type=19&amp;oldFileUrl=ITU-R/M.2012-6/CCSA.36.321V1730.doc</a>
ETSI	ETSI TS 136 321	17.3.0	Published	20.01.2023	<a href="https://www.etsi.org/deliver/etsi_ts/136300_136399/136321/17.03.00_60/ts_136321v170300p.pdf">https://www.etsi.org/deliver/etsi_ts/136300_136399/136321/17.03.00_60/ts_136321v170300p.pdf</a>
TSDSI	TSDSI STD T1.3GPP 36.321 17.3.0 V1.3.0	17.3.0	Published	02.05.2023	<a href="https://members.tdsi.in/s/oRML3LDPMyTNwG">https://members.tdsi.in/s/oRML3LDPMyTNwG</a>
TTA	TTAT.3G-36.321V17.3.0	17.3.0	Published	16.03.2023	<a href="http://committee.tta.or.kr/data/ttasDown.jsp?kind=ttastd&amp;pk_num=TTAT.3G-36.321V17.3.0">http://committee.tta.or.kr/data/ttasDown.jsp?kind=ttastd&amp;pk_num=TTAT.3G-36.321V17.3.0</a>

### 2.1.3.8 TS 36.322

## Evolved Universal Terrestrial Radio Access (E-UTRA); Radio Link Control (RLC) protocol specification

This document specifies the E-UTRA Radio Link Control (RLC) protocol.

SDO	Document No.	Version	Status	Issued date	Location
<b>Release 10</b>					
ARIB	ARIB STD-T120-36.322.V10.0.0	10.0.0	Published	03.03.2023	<a href="https://www.arib.or.jp/english/html/overview/doc/T120_T23_SPECS/ARIB-STD-T120/Rel10/36/A36322-a00.pdf">https://www.arib.or.jp/english/html/overview/doc/T120_T23_SPECS/ARIB-STD-T120/Rel10/36/A36322-a00.pdf</a>
ATIS	ATIS.3GPP.36.322V1000	10.0.0	Published	28.06.2021	<a href="https://www.atis.org/3gpp-documents/Rel99-14/">https://www.atis.org/3gpp-documents/Rel99-14/</a>
CCSA	CCSA.36.322V1000	10.0.0	Published	01.12.2010	<a href="https://www.ccsa.org.cn/api/portalsFile/downloadOldFile?type=19&amp;oldFileUrl=ITU-R/M.2012-6/CCSA.36.322V1000.doc">https://www.ccsa.org.cn/api/portalsFile/downloadOldFile?type=19&amp;oldFileUrl=ITU-R/M.2012-6/CCSA.36.322V1000.doc</a>
ETSI	ETSI TS 136 322	10.0.0	Published	14.01.2011	<a href="https://www.etsi.org/deliver/etsi_ts/136300_136399/136322/10.00.00_60/ts_136322v100000p.pdf">https://www.etsi.org/deliver/etsi_ts/136300_136399/136322/10.00.00_60/ts_136322v100000p.pdf</a>
TSDSI	TSDSI STD T1.3GPP 36.322-10.0.0 V1.0.0	10.0.0	Published	30.08.2021	<a href="https://members.tdsi.in/index.php/s/R8dkysc5p36JBAA">https://members.tdsi.in/index.php/s/R8dkysc5p36JBAA</a>
TTA	TTAT.3G-36.322V10.0.0	10.0.0	Published	02.08.2021	<a href="http://committee.tta.or.kr/data/ttasDown.jsp?kind=ttastd&amp;pk_num=TTAT.3G-36.322V10.0.0">http://committee.tta.or.kr/data/ttasDown.jsp?kind=ttastd&amp;pk_num=TTAT.3G-36.322V10.0.0</a>
<b>Release 11</b>					
ARIB	ARIB STD-T120-36.322.V11.0.0	11.0.0	Published	03.03.2023	<a href="https://www.arib.or.jp/english/html/overview/doc/T120_T23_SPECS/ARIB-STD-T120/Rel11/36/A36322-b00.pdf">https://www.arib.or.jp/english/html/overview/doc/T120_T23_SPECS/ARIB-STD-T120/Rel11/36/A36322-b00.pdf</a>
ATIS	ATIS.3GPP.36.322V1100	11.0.0	Published	28.06.2021	<a href="https://www.atis.org/3gpp-documents/Rel99-14/">https://www.atis.org/3gpp-documents/Rel99-14/</a>
CCSA	CCSA.36.322V1100	11.0.0	Published	01.09.2012	<a href="https://www.ccsa.org.cn/api/portalsFile/downloadOldFile?type=19&amp;oldFileUrl=ITU-R/M.2012-6/CCSA.36.322V1100.doc">https://www.ccsa.org.cn/api/portalsFile/downloadOldFile?type=19&amp;oldFileUrl=ITU-R/M.2012-6/CCSA.36.322V1100.doc</a>
ETSI	ETSI TS 136 322	11.0.0	Published	02.10.2012	<a href="https://www.etsi.org/deliver/etsi_ts/136300_136399/136322/11.00.00_60/ts_136322v110000p.pdf">https://www.etsi.org/deliver/etsi_ts/136300_136399/136322/11.00.00_60/ts_136322v110000p.pdf</a>

TSDSI	TSDSI STD T1.3GPP 36.322-11.0.0 V1.0.0	11.0.0	Published	30.08.2021	<a href="https://members.tdsi.in/index.php/s/WKibimcf4Z7SB7b">https://members.tdsi.in/index.php/s/WKibimcf4Z7SB7b</a>
TTA	TTAT.3G-36.322V11.0.0	11.0.0	Published	02.08.2021	<a href="http://committee.tta.or.kr/data/ttasDown.jsp?kind=ttastd&amp;pk_num=TTAT.3G-36.322V11.0.0">http://committee.tta.or.kr/data/ttasDown.jsp?kind=ttastd&amp;pk_num=TTAT.3G-36.322V11.0.0</a>
<b>Release 12</b>					
ARIB	ARIB STD-T120-36.322.V12.4.0	12.4.0	Published	03.03.2023	<a href="https://www.arib.or.jp/english/html/overview/doc/T120_T23_SPECS/ARIB-STD-T120/Rel12/36/A36322-c40.pdf">https://www.arib.or.jp/english/html/overview/doc/T120_T23_SPECS/ARIB-STD-T120/Rel12/36/A36322-c40.pdf</a>
ATIS	ATIS.3GPP.36.322V1240	12.4.0	Published	28.06.2021	<a href="https://www.atis.org/3gpp-documents/Rel99-14/">https://www.atis.org/3gpp-documents/Rel99-14/</a>
CCSA	CCSA.36.322V1240	12.4.0	Published	01.06.2016	<a href="https://www.ccsa.org.cn/api/portalsFile/downloadOldFile?type=19&amp;oldFileUrl=ITU-R/M.2012-6/CCSA.36.322V1240.doc">https://www.ccsa.org.cn/api/portalsFile/downloadOldFile?type=19&amp;oldFileUrl=ITU-R/M.2012-6/CCSA.36.322V1240.doc</a>
ETSI	ETSI TS 136 322	12.4.0	Published	25.08.2016	<a href="https://www.etsi.org/deliver/etsi_ts/136300_136399/136322/12.04.00_60/ts_136322v120400p.pdf">https://www.etsi.org/deliver/etsi_ts/136300_136399/136322/12.04.00_60/ts_136322v120400p.pdf</a>
TSDSI	TSDSI STD T1.3GPP 36.322-12.4.0 V1.0.0	12.4.0	Published	30.08.2021	<a href="https://members.tdsi.in/index.php/s/oaJLz9tA8wZ5GZA">https://members.tdsi.in/index.php/s/oaJLz9tA8wZ5GZA</a>
TTA	TTAT.3G-36.322V12.4.0	12.4.0	Published	02.08.2021	<a href="http://committee.tta.or.kr/data/ttasDown.jsp?kind=ttastd&amp;pk_num=TTAT.3G-36.322V12.4.0">http://committee.tta.or.kr/data/ttasDown.jsp?kind=ttastd&amp;pk_num=TTAT.3G-36.322V12.4.0</a>
<b>Release 13</b>					
ARIB	ARIB STD-T120-36.322.V13.4.0	13.4.0	Published	03.03.2023	<a href="https://www.arib.or.jp/english/html/overview/doc/T120_T23_SPECS/ARIB-STD-T120/Rel13/36/A36322-d40.pdf">https://www.arib.or.jp/english/html/overview/doc/T120_T23_SPECS/ARIB-STD-T120/Rel13/36/A36322-d40.pdf</a>
ATIS	ATIS.3GPP.36.322V1340	13.4.0	Published	28.06.2021	<a href="https://www.atis.org/3gpp-documents/Rel99-14/">https://www.atis.org/3gpp-documents/Rel99-14/</a>
CCSA	CCSA.36.322V1340	13.4.0	Published	01.09.2017	<a href="https://www.ccsa.org.cn/api/portalsFile/downloadOldFile?type=19&amp;oldFileUrl=ITU-R/M.2012-6/CCSA.36.322V1340.doc">https://www.ccsa.org.cn/api/portalsFile/downloadOldFile?type=19&amp;oldFileUrl=ITU-R/M.2012-6/CCSA.36.322V1340.doc</a>
ETSI	ETSI TS 136 322	13.4.0	Published	09.10.2017	<a href="https://www.etsi.org/deliver/etsi_ts/136300_136399/136322/13.04.00_60/ts_136322v130400p.pdf">https://www.etsi.org/deliver/etsi_ts/136300_136399/136322/13.04.00_60/ts_136322v130400p.pdf</a>
TSDSI	TSDSI STD T1.3GPP 36.322-13.4.0 V1.0.0	13.4.0	Published	30.08.2021	<a href="https://members.tdsi.in/index.php/s/kNWxwgr5TqfZ4N6">https://members.tdsi.in/index.php/s/kNWxwgr5TqfZ4N6</a>
TTA	TTAT.3G-36.322V13.4.0	13.4.0	Published	02.08.2021	<a href="http://committee.tta.or.kr/data/ttasDown.jsp?kind=ttastd&amp;pk_num=TTAT.3G-36.322V13.4.0">http://committee.tta.or.kr/data/ttasDown.jsp?kind=ttastd&amp;pk_num=TTAT.3G-36.322V13.4.0</a>
<b>Release 14</b>					
ARIB	ARIB STD-T120-36.322.V14.1.0	14.1.0	Published	03.03.2023	<a href="https://www.arib.or.jp/english/html/overview/doc/T120_T23_SPECS/ARIB-STD-T120/Rel14/36/A36322-e10.pdf">https://www.arib.or.jp/english/html/overview/doc/T120_T23_SPECS/ARIB-STD-T120/Rel14/36/A36322-e10.pdf</a>
ATIS	ATIS.3GPP.36.322V1410	14.1.0	Published	28.06.2021	<a href="https://www.atis.org/3gpp-documents/Rel99-14/">https://www.atis.org/3gpp-documents/Rel99-14/</a>
CCSA	CCSA.36.322V1410	14.1.0	Published	01.09.2017	<a href="https://www.ccsa.org.cn/api/portalsFile/downloadOldFile?type=19&amp;oldFileUrl=ITU-R/M.2012-6/CCSA.36.322V1410.doc">https://www.ccsa.org.cn/api/portalsFile/downloadOldFile?type=19&amp;oldFileUrl=ITU-R/M.2012-6/CCSA.36.322V1410.doc</a>
ETSI	ETSI TS 136 322	14.1.0	Published	09.10.2017	<a href="https://www.etsi.org/deliver/etsi_ts/136300_136399/136322/14.01.00_60/ts_136322v140100p.pdf">https://www.etsi.org/deliver/etsi_ts/136300_136399/136322/14.01.00_60/ts_136322v140100p.pdf</a>
TSDSI	TSDSI STD T1.3GPP 36.322-14.1.0 V1.0.0	14.1.0	Published	30.08.2021	<a href="https://members.tdsi.in/index.php/s/TzRoGfkECEGpqHn">https://members.tdsi.in/index.php/s/TzRoGfkECEGpqHn</a>
TTA	TTAT.3G-36.322V14.1.0	14.1.0	Published	02.08.2021	<a href="http://committee.tta.or.kr/data/ttasDown.jsp?kind=ttastd&amp;pk_num=TTAT.3G-36.322V14.1.0">http://committee.tta.or.kr/data/ttasDown.jsp?kind=ttastd&amp;pk_num=TTAT.3G-36.322V14.1.0</a>
<b>Release 15</b>					
ARIB	ARIB STD-T120-36.322.V15.4.0	15.4.0	Published	03.03.2023	<a href="https://www.arib.or.jp/english/html/overview/doc/T120_T23_SPECS/ARIB-STD-T120/Rel15/36/A36322-f40.pdf">https://www.arib.or.jp/english/html/overview/doc/T120_T23_SPECS/ARIB-STD-T120/Rel15/36/A36322-f40.pdf</a>
ATIS	ATIS.3GPP.36.322V1540	15.4.0	Published	28.06.2021	<a href="https://www.atis.org/3gpp-documents/Rel15/">https://www.atis.org/3gpp-documents/Rel15/</a>
CCSA	CCSA.36.322V1540	15.4.0	Published	01.07.2020	<a href="https://www.ccsa.org.cn/api/portalsFile/downloadOldFile?type=19&amp;oldFileUrl=ITU-R/M.2012-6/CCSA.36.322V1540.doc">https://www.ccsa.org.cn/api/portalsFile/downloadOldFile?type=19&amp;oldFileUrl=ITU-R/M.2012-6/CCSA.36.322V1540.doc</a>
ETSI	ETSI TS 136 322	15.4.0	Published	31.07.2020	<a href="https://www.etsi.org/deliver/etsi_ts/136300_136399/136322/15.04.00_60/ts_136322v150400p.pdf">https://www.etsi.org/deliver/etsi_ts/136300_136399/136322/15.04.00_60/ts_136322v150400p.pdf</a>
TSDSI	TSDSI STD T1.3GPP 36.322-15.4.0 V1.0.0	15.4.0	Published	30.08.2021	<a href="https://members.tdsi.in/index.php/s/aX4PcAK4LzzaByX">https://members.tdsi.in/index.php/s/aX4PcAK4LzzaByX</a>
TTA	TTAT.3G-36.322V15.4.0	15.4.0	Published	11.09.2020	<a href="http://committee.tta.or.kr/data/ttasDown.jsp?kind=ttastd&amp;pk_num=TTAT.3G-36.322V15.4.0">http://committee.tta.or.kr/data/ttasDown.jsp?kind=ttastd&amp;pk_num=TTAT.3G-36.322V15.4.0</a>
<b>Release 16</b>					
ARIB	ARIB STD-T120-36.322.V16.0.0	16.0.0	Published	03.03.2023	<a href="https://www.arib.or.jp/english/html/overview/doc/T120_T23_SPECS/ARIB-STD-T120/Rel16/36/A36322-g00.pdf">https://www.arib.or.jp/english/html/overview/doc/T120_T23_SPECS/ARIB-STD-T120/Rel16/36/A36322-g00.pdf</a>
ATIS	ATIS.3GPP.36.322V1600	16.0.0	Published	28.06.2021	<a href="https://www.atis.org/3gpp-documents/Rel16/">https://www.atis.org/3gpp-documents/Rel16/</a>
CCSA	CCSA.36.322V1600	16.0.0	Published	01.07.2020	<a href="https://www.ccsa.org.cn/api/portalsFile/downloadOldFile?type=19&amp;oldFileUrl=ITU-R/M.2012-6/CCSA.36.322V1600.doc">https://www.ccsa.org.cn/api/portalsFile/downloadOldFile?type=19&amp;oldFileUrl=ITU-R/M.2012-6/CCSA.36.322V1600.doc</a>
ETSI	ETSI TS 136 322	16.0.0	Published	31.07.2020	<a href="https://www.etsi.org/deliver/etsi_ts/136300_136399/136322/16.00.00_60/ts_136322v160000p.pdf">https://www.etsi.org/deliver/etsi_ts/136300_136399/136322/16.00.00_60/ts_136322v160000p.pdf</a>
TSDSI	TSDSI STD T1.3GPP 36.322-16.0.0 V1.0.0	16.0.0	Published	30.08.2021	<a href="https://members.tdsi.in/index.php/s/RjPMqqcxkMFt2gL">https://members.tdsi.in/index.php/s/RjPMqqcxkMFt2gL</a>
TTA	TTAT.3G-36.322V16.0.0	16.0.0	Published	11.09.2020	<a href="http://committee.tta.or.kr/data/ttasDown.jsp?kind=ttastd&amp;pk_num=TTAT.3G-36.322V16.0.0">http://committee.tta.or.kr/data/ttasDown.jsp?kind=ttastd&amp;pk_num=TTAT.3G-36.322V16.0.0</a>
<b>Release 17</b>					
ARIB	ARIB STD-T120-36.322.V17.0.0	17.0.0	Published	03.03.2023	<a href="https://www.arib.or.jp/english/html/overview/doc/T120_T23_SPECS/ARIB-STD-T120/Rel17/36/A36322-h00.pdf">https://www.arib.or.jp/english/html/overview/doc/T120_T23_SPECS/ARIB-STD-T120/Rel17/36/A36322-h00.pdf</a>
ATIS	ATIS.3GPP.36.322.V17.0.0	17.0.0	Published	21.02.2023	<a href="https://www.atis.org/3gpp-transpositions - Rel-17">https://www.atis.org/3gpp-transpositions - Rel-17</a>
CCSA	CCSA.36.322V1700	17.0.0	Published	01.03.2022	<a href="https://www.ccsa.org.cn/api/portalsFile/downloadOldFile?type=19&amp;oldFileUrl=ITU-R/M.2012-6/CCSA.36.322V1700.doc">https://www.ccsa.org.cn/api/portalsFile/downloadOldFile?type=19&amp;oldFileUrl=ITU-R/M.2012-6/CCSA.36.322V1700.doc</a>
ETSI	ETSI TS 136 322	17.0.0	Published	09.05.2022	<a href="https://www.etsi.org/deliver/etsi_ts/136300_136399/136322/17.00.00_60/ts_136322v170000p.pdf">https://www.etsi.org/deliver/etsi_ts/136300_136399/136322/17.00.00_60/ts_136322v170000p.pdf</a>
TSDSI	TSDSI STD T1.3GPP 36.322-17.0.0 V1.0.0	17.0.0	Published	01.11.2022	<a href="https://members.tdsi.in/s/5PdEsQ5jxmSLKYJ">https://members.tdsi.in/s/5PdEsQ5jxmSLKYJ</a>
TTA	TTAT.3G-36.322V17.0.0	17.0.0	Published	05.08.2022	<a href="http://committee.tta.or.kr/data/ttasDown.jsp?kind=ttastd&amp;pk_num=TTAT.3G-36.322V17.0.0">http://committee.tta.or.kr/data/ttasDown.jsp?kind=ttastd&amp;pk_num=TTAT.3G-36.322V17.0.0</a>

## 2.1.3.9 TS 36.323

## Evolved Universal Terrestrial Radio Access (E-UTRA); Packet Data Convergence Protocol (PDCP) specification

This document specifies the E-UTRA Packet Data Convergence Protocol (PDCP).

SDO	Document No.	Version	Status	Issued date	Location
<b>Release 10</b>					
ARIB	ARIB STD-T120-36.323.V10.3.0	10.3.0	Published	03.03.2023	<a href="https://www.arib.or.jp/english/html/overview/doc/T120_T23_SPECS/ARIB-STD-T120/Rel10/36/A36323-a30.pdf">https://www.arib.or.jp/english/html/overview/doc/T120_T23_SPECS/ARIB-STD-T120/Rel10/36/A36323-a30.pdf</a>
ATIS	ATIS.3GPP.36.323V1030	10.3.0	Published	28.06.2021	<a href="https://www.atis.org/3gpp-documents/Rel99-14/">https://www.atis.org/3gpp-documents/Rel99-14/</a>
CCSA	CCSA.36.323V1030	10.3.0	Published	01.06.2014	<a href="https://www.ccsa.org.cn/api/portalsFile/downloadOldFile?type=19&amp;oldFileUrl=ITU-R/M.2012-6/CCSA.36.323V1030.doc">https://www.ccsa.org.cn/api/portalsFile/downloadOldFile?type=19&amp;oldFileUrl=ITU-R/M.2012-6/CCSA.36.323V1030.doc</a>
ETSI	ETSI TS 136 323	10.3.0	Published	22.07.2014	<a href="https://www.etsi.org/deliver/etsi_ts/136300_136399/136323/10.03.00_60/ts_136323v100300p.pdf">https://www.etsi.org/deliver/etsi_ts/136300_136399/136323/10.03.00_60/ts_136323v100300p.pdf</a>
TSDSI	TSDSI STD T1.3GPP 36.323-10.3.0 V1.0.0	10.3.0	Published	30.08.2021	<a href="https://members.tdsi.in/index.php/s/w6b6yCNo7D636sw">https://members.tdsi.in/index.php/s/w6b6yCNo7D636sw</a>
TTA	TTAT.3G-36.323V10.3.0	10.3.0	Published	02.08.2021	<a href="http://committee.tta.or.kr/data/ttasDown.jsp?kind=ttastd&amp;pk_num=TTAT.3G-36.323V10.3.0">http://committee.tta.or.kr/data/ttasDown.jsp?kind=ttastd&amp;pk_num=TTAT.3G-36.323V10.3.0</a>
<b>Release 11</b>					
ARIB	ARIB STD-T120-36.323.V11.4.0	11.4.0	Published	03.03.2023	<a href="https://www.arib.or.jp/english/html/overview/doc/T120_T23_SPECS/ARIB-STD-T120/Rel11/36/A36323-b40.pdf">https://www.arib.or.jp/english/html/overview/doc/T120_T23_SPECS/ARIB-STD-T120/Rel11/36/A36323-b40.pdf</a>
ATIS	ATIS.3GPP.36.323V1140	11.4.0	Published	28.06.2021	<a href="https://www.atis.org/3gpp-documents/Rel99-14/">https://www.atis.org/3gpp-documents/Rel99-14/</a>
CCSA	CCSA.36.323V1140	11.4.0	Published	01.09.2014	<a href="https://www.ccsa.org.cn/api/portalsFile/downloadOldFile?type=19&amp;oldFileUrl=ITU-R/M.2012-6/CCSA.36.323V1140.doc">https://www.ccsa.org.cn/api/portalsFile/downloadOldFile?type=19&amp;oldFileUrl=ITU-R/M.2012-6/CCSA.36.323V1140.doc</a>
ETSI	ETSI TS 136 323	11.4.0	Published	29.09.2014	<a href="https://www.etsi.org/deliver/etsi_ts/136300_136399/136323/11.04.00_60/ts_136323v110400p.pdf">https://www.etsi.org/deliver/etsi_ts/136300_136399/136323/11.04.00_60/ts_136323v110400p.pdf</a>
TSDSI	TSDSI STD T1.3GPP 36.323-11.4.0 V1.0.0	11.4.0	Published	30.08.2021	<a href="https://members.tdsi.in/index.php/s/aDjpo6iP6fLJpg8">https://members.tdsi.in/index.php/s/aDjpo6iP6fLJpg8</a>
TTA	TTAT.3G-36.323V11.4.0	11.4.0	Published	02.08.2021	<a href="http://committee.tta.or.kr/data/ttasDown.jsp?kind=ttastd&amp;pk_num=TTAT.3G-36.323V11.4.0">http://committee.tta.or.kr/data/ttasDown.jsp?kind=ttastd&amp;pk_num=TTAT.3G-36.323V11.4.0</a>
<b>Release 12</b>					
ARIB	ARIB STD-T120-36.323.V12.6.0	12.6.0	Published	03.03.2023	<a href="https://www.arib.or.jp/english/html/overview/doc/T120_T23_SPECS/ARIB-STD-T120/Rel12/36/A36323-c60.pdf">https://www.arib.or.jp/english/html/overview/doc/T120_T23_SPECS/ARIB-STD-T120/Rel12/36/A36323-c60.pdf</a>
ATIS	ATIS.3GPP.36.323V1260	12.6.0	Published	28.06.2021	<a href="https://www.atis.org/3gpp-documents/Rel99-14/">https://www.atis.org/3gpp-documents/Rel99-14/</a>
CCSA	CCSA.36.323V1260	12.6.0	Published	01.06.2016	<a href="https://www.ccsa.org.cn/api/portalsFile/downloadOldFile?type=19&amp;oldFileUrl=ITU-R/M.2012-6/CCSA.36.323V1260.doc">https://www.ccsa.org.cn/api/portalsFile/downloadOldFile?type=19&amp;oldFileUrl=ITU-R/M.2012-6/CCSA.36.323V1260.doc</a>
ETSI	ETSI TS 136 323	12.6.0	Published	25.08.2016	<a href="https://www.etsi.org/deliver/etsi_ts/136300_136399/136323/12.06.00_60/ts_136323v120600p.pdf">https://www.etsi.org/deliver/etsi_ts/136300_136399/136323/12.06.00_60/ts_136323v120600p.pdf</a>
TSDSI	TSDSI STD T1.3GPP 36.323-12.6.0 V1.0.0	12.6.0	Published	30.08.2021	<a href="https://members.tdsi.in/index.php/s/DxEpbAatGw847zp">https://members.tdsi.in/index.php/s/DxEpbAatGw847zp</a>
TTA	TTAT.3G-36.323V12.6.0	12.6.0	Published	02.08.2021	<a href="http://committee.tta.or.kr/data/ttasDown.jsp?kind=ttastd&amp;pk_num=TTAT.3G-36.323V12.6.0">http://committee.tta.or.kr/data/ttasDown.jsp?kind=ttastd&amp;pk_num=TTAT.3G-36.323V12.6.0</a>
<b>Release 13</b>					
ARIB	ARIB STD-T120-36.323.V13.6.0	13.6.0	Published	03.03.2023	<a href="https://www.arib.or.jp/english/html/overview/doc/T120_T23_SPECS/ARIB-STD-T120/Rel13/36/A36323-d60.pdf">https://www.arib.or.jp/english/html/overview/doc/T120_T23_SPECS/ARIB-STD-T120/Rel13/36/A36323-d60.pdf</a>
ATIS	ATIS.3GPP.36.323V1360	13.6.0	Published	28.06.2021	<a href="https://www.atis.org/3gpp-documents/Rel99-14/">https://www.atis.org/3gpp-documents/Rel99-14/</a>
CCSA	CCSA.36.323V1360	13.6.0	Published	01.06.2017	<a href="https://www.ccsa.org.cn/api/portalsFile/downloadOldFile?type=19&amp;oldFileUrl=ITU-R/M.2012-6/CCSA.36.323V1360.doc">https://www.ccsa.org.cn/api/portalsFile/downloadOldFile?type=19&amp;oldFileUrl=ITU-R/M.2012-6/CCSA.36.323V1360.doc</a>
ETSI	ETSI TS 136 323	13.6.0	Published	27.07.2017	<a href="https://www.etsi.org/deliver/etsi_ts/136300_136399/136323/13.06.00_60/ts_136323v130600p.pdf">https://www.etsi.org/deliver/etsi_ts/136300_136399/136323/13.06.00_60/ts_136323v130600p.pdf</a>
TSDSI	TSDSI STD T1.3GPP 36.323-13.6.0 V1.0.0	13.6.0	Published	30.08.2021	<a href="https://members.tdsi.in/index.php/s/coH9DtTTyqcY9SD">https://members.tdsi.in/index.php/s/coH9DtTTyqcY9SD</a>
TTA	TTAT.3G-36.323V13.6.0	13.6.0	Published	02.08.2021	<a href="http://committee.tta.or.kr/data/ttasDown.jsp?kind=ttastd&amp;pk_num=TTAT.3G-36.323V13.6.0">http://committee.tta.or.kr/data/ttasDown.jsp?kind=ttastd&amp;pk_num=TTAT.3G-36.323V13.6.0</a>
<b>Release 14</b>					
ARIB	ARIB STD-T120-36.323.V14.5.0	14.5.0	Published	03.03.2023	<a href="https://www.arib.or.jp/english/html/overview/doc/T120_T23_SPECS/ARIB-STD-T120/Rel14/36/A36323-e50.pdf">https://www.arib.or.jp/english/html/overview/doc/T120_T23_SPECS/ARIB-STD-T120/Rel14/36/A36323-e50.pdf</a>
ATIS	ATIS.3GPP.36.323V1450	14.5.0	Published	28.06.2021	<a href="https://www.atis.org/3gpp-documents/Rel99-14/">https://www.atis.org/3gpp-documents/Rel99-14/</a>
CCSA	CCSA.36.323V1450	14.5.0	Published	01.12.2017	<a href="https://www.ccsa.org.cn/api/portalsFile/downloadOldFile?type=19&amp;oldFileUrl=ITU-R/M.2012-6/CCSA.36.323V1450.doc">https://www.ccsa.org.cn/api/portalsFile/downloadOldFile?type=19&amp;oldFileUrl=ITU-R/M.2012-6/CCSA.36.323V1450.doc</a>
ETSI	ETSI TS 136 323	14.5.0	Published	19.01.2018	<a href="https://www.etsi.org/deliver/etsi_ts/136300_136399/136323/14.05.00_60/ts_136323v140500p.pdf">https://www.etsi.org/deliver/etsi_ts/136300_136399/136323/14.05.00_60/ts_136323v140500p.pdf</a>
TSDSI	TSDSI STD T1.3GPP 36.323-14.5.0 V1.0.0	14.5.0	Published	30.08.2021	<a href="https://members.tdsi.in/index.php/s/gcPzHTsWnM8grag">https://members.tdsi.in/index.php/s/gcPzHTsWnM8grag</a>
TTA	TTAT.3G-36.323V14.5.0	14.5.0	Published	02.08.2021	<a href="http://committee.tta.or.kr/data/ttasDown.jsp?kind=ttastd&amp;pk_num=TTAT.3G-36.323V14.5.0">http://committee.tta.or.kr/data/ttasDown.jsp?kind=ttastd&amp;pk_num=TTAT.3G-36.323V14.5.0</a>
<b>Release 15</b>					
ARIB	ARIB STD-T120-36.323.V15.7.0	15.7.0	Published	03.03.2023	<a href="https://www.arib.or.jp/english/html/overview/doc/T120_T23_SPECS/ARIB-STD-T120/Rel15/36/A36323-f70.pdf">https://www.arib.or.jp/english/html/overview/doc/T120_T23_SPECS/ARIB-STD-T120/Rel15/36/A36323-f70.pdf</a>
ATIS	ATIS.3GPP.36.323.V15.7.0	15.7.0	Published	21.02.2023	<a href="https://www.atis.org/3gpp-transpositions-Rel-15">https://www.atis.org/3gpp-transpositions-Rel-15</a>
CCSA	CCSA.36.323V1570	15.7.0	Published	01.12.2021	<a href="https://www.ccsa.org.cn/api/portalsFile/downloadOldFile?type=19&amp;oldFileUrl=ITU-R/M.2012-6/CCSA.36.323V1570.doc">https://www.ccsa.org.cn/api/portalsFile/downloadOldFile?type=19&amp;oldFileUrl=ITU-R/M.2012-6/CCSA.36.323V1570.doc</a>

## 46

## Rec. ITU-R M.2012-6

ETSI	ETSI TS 136 323	15.7.0	Published	20.01.2022	<a href="https://www.etsi.org/deliver/etsi_ts/136300_136399/136323/15.07.00_60/ts_136323v150700p.pdf">https://www.etsi.org/deliver/etsi_ts/136300_136399/136323/15.07.00_60/ts_136323v150700p.pdf</a>
TSDSI	TSDSI STD T1.3GPP 36.323-15.7.0 V1.1.0	15.7.0	Published	01.11.2022	<a href="https://members.tdsi.in/s/BBLTcFk8xLAK4iL">https://members.tdsi.in/s/BBLTcFk8xLAK4iL</a>
TTA	TTAT.3G-36.323V15.7.0	15.7.0	Published	14.03.2022	<a href="http://committee.tta.or.kr/data/ttasDown.jsp?kind=ttastd&amp;pk_num=TTAT.3G-36.323V15.7.0">http://committee.tta.or.kr/data/ttasDown.jsp?kind=ttastd&amp;pk_num=TTAT.3G-36.323V15.7.0</a>

### Release 16

ARIB	ARIB STD-T120-36.323.V16.7.0	16.7.0	Published	03.03.2023	<a href="https://www.arib.or.jp/english/html/overview/doc/T120_T23_SPECS/ARIB-STD-T120/Rel16/36/A36323-g70.pdf">https://www.arib.or.jp/english/html/overview/doc/T120_T23_SPECS/ARIB-STD-T120/Rel16/36/A36323-g70.pdf</a>
ATIS	ATIS.3GPP.36.323.V16.7.0	16.7.0	Published	21.02.2023	<a href="https://www.atis.org/3gpp-transpositions - Rel-16">https://www.atis.org/3gpp-transpositions - Rel-16</a>
CCSA	CCSA.36.323V1670	16.7.0	Published	01.12.2022	<a href="https://www.ccsa.org.cn/api/portalsFile/downloadOldFile?type=19&amp;oldFileUrl=ITU-R/M.2012-6/CCSA.36.323V1670.doc">https://www.ccsa.org.cn/api/portalsFile/downloadOldFile?type=19&amp;oldFileUrl=ITU-R/M.2012-6/CCSA.36.323V1670.doc</a>
ETSI	ETSI TS 136 323	16.7.0	Published	20.01.2023	<a href="https://www.etsi.org/deliver/etsi_ts/136300_136399/136323/16.07.00_60/ts_136323v160700p.pdf">https://www.etsi.org/deliver/etsi_ts/136300_136399/136323/16.07.00_60/ts_136323v160700p.pdf</a>
TSDSI	TSDSI STD T1.3GPP 36.323 16.7.0 V1.2.0	16.7.0	Published	02.05.2023	<a href="https://members.tdsi.in/s/dMnx8ztmQdXZH3x">https://members.tdsi.in/s/dMnx8ztmQdXZH3x</a>
TTA	TTAT.3G-36.323V16.7.0	16.7.0	Published	16.03.2023	<a href="http://committee.tta.or.kr/data/ttasDown.jsp?kind=ttastd&amp;pk_num=TTAT.3G-36.323V16.7.0">http://committee.tta.or.kr/data/ttasDown.jsp?kind=ttastd&amp;pk_num=TTAT.3G-36.323V16.7.0</a>

### Release 17

ARIB	ARIB STD-T120-36.323.V17.2.0	17.2.0	Published	03.03.2023	<a href="https://www.arib.or.jp/english/html/overview/doc/T120_T23_SPECS/ARIB-STD-T120/Rel17/36/A36323-h20.pdf">https://www.arib.or.jp/english/html/overview/doc/T120_T23_SPECS/ARIB-STD-T120/Rel17/36/A36323-h20.pdf</a>
ATIS	ATIS.3GPP.36.323.V17.2.0	17.2.0	Published	21.02.2023	<a href="https://www.atis.org/3gpp-transpositions - Rel-17">https://www.atis.org/3gpp-transpositions - Rel-17</a>
CCSA	CCSA.36.323V1720	17.2.0	Published	01.12.2022	<a href="https://www.ccsa.org.cn/api/portalsFile/downloadOldFile?type=19&amp;oldFileUrl=ITU-R/M.2012-6/CCSA.36.323V1720.doc">https://www.ccsa.org.cn/api/portalsFile/downloadOldFile?type=19&amp;oldFileUrl=ITU-R/M.2012-6/CCSA.36.323V1720.doc</a>
ETSI	ETSI TS 136 323	17.2.0	Published	20.01.2023	<a href="https://www.etsi.org/deliver/etsi_ts/136300_136399/136323/17.02.00_60/ts_136323v170200p.pdf">https://www.etsi.org/deliver/etsi_ts/136300_136399/136323/17.02.00_60/ts_136323v170200p.pdf</a>
TSDSI	TSDSI STD T1.3GPP 36.323 17.2.0 V1.2.0	17.2.0	Published	02.05.2023	<a href="https://members.tdsi.in/s/nqMRwxfqRJSxN3">https://members.tdsi.in/s/nqMRwxfqRJSxN3</a>
TTA	TTAT.3G-36.323V17.2.0	17.2.0	Published	16.03.2023	<a href="http://committee.tta.or.kr/data/ttasDown.jsp?kind=ttastd&amp;pk_num=TTAT.3G-36.323V17.2.0">http://committee.tta.or.kr/data/ttasDown.jsp?kind=ttastd&amp;pk_num=TTAT.3G-36.323V17.2.0</a>

### 2.1.3.10 TS 36.331

#### Evolved Universal Terrestrial Radio Access (E-UTRA); Radio Resource Control (RRC); Protocol specification

This document specifies the Radio Resource Control protocol for the radio interface between UE and E-UTRAN as well as for the radio interface between RN and E-UTRAN. The scope of this document also includes: (i) the radio related information transported in a transparent container between source eNodeB and target eNodeB upon inter eNodeB handover; (ii) the radio related information transported in a transparent container between a source or target eNodeB and another system upon inter RAT handover.

SDO	Document No.	Version	Status	Issued date	Location
<b>Release 10</b>					
ARIB	ARIB STD-T120-36.331.V10.22.0	10.22.0	Published	03.03.2023	<a href="https://www.arib.or.jp/english/html/overview/doc/T120_T23_SPECS/ARIB-STD-T120/Rel10/36/A36331-am0.pdf">https://www.arib.or.jp/english/html/overview/doc/T120_T23_SPECS/ARIB-STD-T120/Rel10/36/A36331-am0.pdf</a>
ATIS	ATIS.3GPP.36.331V10220	10.22.0	Published	28.06.2021	<a href="https://www.atis.org/3gpp-documents/Rel99-14/">https://www.atis.org/3gpp-documents/Rel99-14/</a>
CCSA	CCSA.36.331V10220	10.22.0	Published	01.06.2018	<a href="https://www.ccsa.org.cn/api/portalsFile/downloadOldFile?type=19&amp;oldFileUrl=ITU-R/M.2012-6/CCSA.36.331V10220.doc">https://www.ccsa.org.cn/api/portalsFile/downloadOldFile?type=19&amp;oldFileUrl=ITU-R/M.2012-6/CCSA.36.331V10220.doc</a>
ETSI	ETSI TS 136 331	10.22.0	Published	25.07.2018	<a href="https://www.etsi.org/deliver/etsi_ts/136300_136399/136331/10.22.00_60/ts_136331v102200p.pdf">https://www.etsi.org/deliver/etsi_ts/136300_136399/136331/10.22.00_60/ts_136331v102200p.pdf</a>
TSDSI	TSDSI STD T1.3GPP 36.331-10.22.0 V1.1.0	10.22.0	Published	30.08.2021	<a href="https://members.tdsi.in/index.php/s/mgmeip5DCfsyHSN">https://members.tdsi.in/index.php/s/mgmeip5DCfsyHSN</a>
TTA	TTAT.3G-36.331V10.22.0	10.22.0	Published	02.08.2021	<a href="http://committee.tta.or.kr/data/ttasDown.jsp?kind=ttastd&amp;pk_num=TTAT.3G-36.331V10.22.0">http://committee.tta.or.kr/data/ttasDown.jsp?kind=ttastd&amp;pk_num=TTAT.3G-36.331V10.22.0</a>
<b>Release 11</b>					
ARIB	ARIB STD-T120-36.331.V11.19.0	11.19.0	Published	03.03.2023	<a href="https://www.arib.or.jp/english/html/overview/doc/T120_T23_SPECS/ARIB-STD-T120/Rel11/36/A36331-bj0.pdf">https://www.arib.or.jp/english/html/overview/doc/T120_T23_SPECS/ARIB-STD-T120/Rel11/36/A36331-bj0.pdf</a>
ATIS	ATIS.3GPP.36.331V11190	11.19.0	Published	28.06.2021	<a href="https://www.atis.org/3gpp-documents/Rel99-14/">https://www.atis.org/3gpp-documents/Rel99-14/</a>
CCSA	CCSA.36.331V11190	11.19.0	Published	01.06.2018	<a href="https://www.ccsa.org.cn/api/portalsFile/downloadOldFile?type=19&amp;oldFileUrl=ITU-R/M.2012-6/CCSA.36.331V11190.doc">https://www.ccsa.org.cn/api/portalsFile/downloadOldFile?type=19&amp;oldFileUrl=ITU-R/M.2012-6/CCSA.36.331V11190.doc</a>
ETSI	ETSI TS 136 331	11.19.0	Published	25.07.2018	<a href="https://www.etsi.org/deliver/etsi_ts/136300_136399/136331/11.19.00_60/ts_136331v111900p.pdf">https://www.etsi.org/deliver/etsi_ts/136300_136399/136331/11.19.00_60/ts_136331v111900p.pdf</a>
TSDSI	TSDSI STD T1.3GPP 36.331-11.19.0 V1.1.0	11.19.0	Published	30.08.2021	<a href="https://members.tdsi.in/index.php/s/8Pmite7jcgPHbas">https://members.tdsi.in/index.php/s/8Pmite7jcgPHbas</a>
TTA	TTAT.3G-36.331V11.19.0	11.19.0	Published	02.08.2021	<a href="http://committee.tta.or.kr/data/ttasDown.jsp?kind=ttastd&amp;pk_num=TTAT.3G-36.331V11.19.0">http://committee.tta.or.kr/data/ttasDown.jsp?kind=ttastd&amp;pk_num=TTAT.3G-36.331V11.19.0</a>
<b>Release 12</b>					
ARIB	ARIB STD-T120-36.331.V12.20.0	12.20.0	Published	03.03.2023	<a href="https://www.arib.or.jp/english/html/overview/doc/T120_T23_SPECS/ARIB-STD-T120/Rel12/36/A36331-ck0.pdf">https://www.arib.or.jp/english/html/overview/doc/T120_T23_SPECS/ARIB-STD-T120/Rel12/36/A36331-ck0.pdf</a>
ATIS	ATIS.3GPP.36.331.V12.20.0	12.20.0	Published	21.02.2023	<a href="https://www.atis.org/3gpp-transpositions - Rel-12">https://www.atis.org/3gpp-transpositions - Rel-12</a>
CCSA	CCSA.36.331V12200	12.20.0	Published	01.12.2020	<a href="https://www.ccsa.org.cn/api/portalsFile/downloadOldFile?type=19&amp;oldFileUrl=ITU-R/M.2012-6/CCSA.36.331V12200.doc">https://www.ccsa.org.cn/api/portalsFile/downloadOldFile?type=19&amp;oldFileUrl=ITU-R/M.2012-6/CCSA.36.331V12200.doc</a>
ETSI	ETSI TS 136 331	12.20.0	Published	20.01.2021	<a href="https://www.etsi.org/deliver/etsi_ts/136300_136399/136331/12.20.00_60/ts_136331v122000p.pdf">https://www.etsi.org/deliver/etsi_ts/136300_136399/136331/12.20.00_60/ts_136331v122000p.pdf</a>



TSDSI	TSDSI STD T1.3GPP 36.331 12.20.0 V1.1.0	12.20.0	Published	02.05.2023	<a href="https://members.tdsi.in/s/SZNec4xbm49bXkE">https://members.tdsi.in/s/SZNec4xbm49bXkE</a>
TTA	TTAT.3G-36.331V12.20.0	12.20.0	Published	16.03.2023	<a href="http://committee.tta.or.kr/data/ttasDown.jsp?kind=ttastd&amp;pk_num=TTAT.3G-36.331V12.20.0">http://committee.tta.or.kr/data/ttasDown.jsp?kind=ttastd&amp;pk_num=TTAT.3G-36.331V12.20.0</a>
<b>Release 13</b>					
ARIB	ARIB STD-T120-36.331.V13.17.0	13.17.0	Published	03.03.2023	<a href="https://www.arib.or.jp/english/html/overview/doc/T120_T23_SPECS/ARIB-STD-T120/Rel13/36/A36331-dh0.pdf">https://www.arib.or.jp/english/html/overview/doc/T120_T23_SPECS/ARIB-STD-T120/Rel13/36/A36331-dh0.pdf</a>
ATIS	ATIS.3GPP.36.331.V13.17.0	13.17.0	Published	21.02.2023	<a href="https://www.atis.org/3gpp-transpositions - Rel-13">https://www.atis.org/3gpp-transpositions - Rel-13</a>
CCSA	CCSA.36.331V13170	13.17.0	Published	01.12.2020	<a href="https://www.ccsa.org.cn/api/portalsFile/downloadOldFile?type=19&amp;oldFileUrl=ITU-R/M.2012-6/CCSA.36.331V13170.doc">https://www.ccsa.org.cn/api/portalsFile/downloadOldFile?type=19&amp;oldFileUrl=ITU-R/M.2012-6/CCSA.36.331V13170.doc</a>
ETSI	ETSI TS 136 331	13.17.0	Published	20.01.2021	<a href="https://www.etsi.org/deliver/etsi_ts/136300_136399/136331/13.17.00_60/ts_136331v131700p.pdf">https://www.etsi.org/deliver/etsi_ts/136300_136399/136331/13.17.00_60/ts_136331v131700p.pdf</a>
TSDSI	TSDSI STD T1.3GPP 36.331-13.17.0 V1.1.0	13.17.0	Published	17.01.2023	<a href="https://members.tdsi.in/index.php/s/yaotn9TMr5fijPF">https://members.tdsi.in/index.php/s/yaotn9TMr5fijPF</a>
TTA	TTAT.3G-36.331V13.17.0	13.17.0	Published	16.03.2023	<a href="http://committee.tta.or.kr/data/ttasDown.jsp?kind=ttastd&amp;pk_num=TTAT.3G-36.331V13.17.0">http://committee.tta.or.kr/data/ttasDown.jsp?kind=ttastd&amp;pk_num=TTAT.3G-36.331V13.17.0</a>
<b>Release 14</b>					
ARIB	ARIB STD-T120-36.331.V14.16.0	14.16.0	Published	03.03.2023	<a href="https://www.arib.or.jp/english/html/overview/doc/T120_T23_SPECS/ARIB-STD-T120/Rel14/36/A36331-eg0.pdf">https://www.arib.or.jp/english/html/overview/doc/T120_T23_SPECS/ARIB-STD-T120/Rel14/36/A36331-eg0.pdf</a>
ATIS	ATIS.3GPP.36.331.V14.16.0	14.16.0	Published	21.02.2023	<a href="https://www.atis.org/3gpp-transpositions - Rel-14">https://www.atis.org/3gpp-transpositions - Rel-14</a>
CCSA	CCSA.36.331V14160	14.16.0	Published	01.12.2020	<a href="https://www.ccsa.org.cn/api/portalsFile/downloadOldFile?type=19&amp;oldFileUrl=ITU-R/M.2012-6/CCSA.36.331V14160.doc">https://www.ccsa.org.cn/api/portalsFile/downloadOldFile?type=19&amp;oldFileUrl=ITU-R/M.2012-6/CCSA.36.331V14160.doc</a>
ETSI	ETSI TS 136 331	14.16.0	Published	20.01.2021	<a href="https://www.etsi.org/deliver/etsi_ts/136300_136399/136331/14.16.00_60/ts_136331v141600p.pdf">https://www.etsi.org/deliver/etsi_ts/136300_136399/136331/14.16.00_60/ts_136331v141600p.pdf</a>
TSDSI	TSDSI STD T1.3GPP 36.331-14.16.0 V1.1.0	14.16.0	Published	17.01.2023	<a href="https://members.tdsi.in/s/YE6QkNsbQK9kr">https://members.tdsi.in/s/YE6QkNsbQK9kr</a>
TTA	TTAT.3G-36.331V14.16.0	14.16.0	Published	16.03.2023	<a href="http://committee.tta.or.kr/data/ttasDown.jsp?kind=ttastd&amp;pk_num=TTAT.3G-36.331V14.16.0">http://committee.tta.or.kr/data/ttasDown.jsp?kind=ttastd&amp;pk_num=TTAT.3G-36.331V14.16.0</a>
<b>Release 15</b>					
ARIB	ARIB STD-T120-36.331.V15.20.0	15.20.0	Published	03.03.2023	<a href="https://www.arib.or.jp/english/html/overview/doc/T120_T23_SPECS/ARIB-STD-T120/Rel15/36/A36331-fk0.pdf">https://www.arib.or.jp/english/html/overview/doc/T120_T23_SPECS/ARIB-STD-T120/Rel15/36/A36331-fk0.pdf</a>
ATIS	ATIS.3GPP.36.331.V15.20.0	15.20.0	Published	21.02.2023	<a href="https://www.atis.org/3gpp-transpositions - Rel-15">https://www.atis.org/3gpp-transpositions - Rel-15</a>
CCSA	CCSA.36.331V15200	15.20.0	Published	01.12.2022	<a href="https://www.ccsa.org.cn/api/portalsFile/downloadOldFile?type=19&amp;oldFileUrl=ITU-R/M.2012-6/CCSA.36.331V15200.doc">https://www.ccsa.org.cn/api/portalsFile/downloadOldFile?type=19&amp;oldFileUrl=ITU-R/M.2012-6/CCSA.36.331V15200.doc</a>
ETSI	ETSI TS 136 331	15.20.0	Published	20.01.2023	<a href="https://www.etsi.org/deliver/etsi_ts/136300_136399/136331/15.20.00_60/ts_136331v152000p.pdf">https://www.etsi.org/deliver/etsi_ts/136300_136399/136331/15.20.00_60/ts_136331v152000p.pdf</a>
TSDSI	TSDSI STD T1.3GPP 36.331 15.20.0 V1.3.0	15.20.0	Published	02.05.2023	<a href="https://members.tdsi.in/s/ZZe84FpNQ3qcFLg">https://members.tdsi.in/s/ZZe84FpNQ3qcFLg</a>
TTA	TTAT.3G-36.331V15.20.0	15.20.0	Published	16.03.2023	<a href="http://committee.tta.or.kr/data/ttasDown.jsp?kind=ttastd&amp;pk_num=TTAT.3G-36.331V15.20.0">http://committee.tta.or.kr/data/ttasDown.jsp?kind=ttastd&amp;pk_num=TTAT.3G-36.331V15.20.0</a>
<b>Release 16</b>					
ARIB	ARIB STD-T120-36.331.V16.11.0	16.11.0	Published	03.03.2023	<a href="https://www.arib.or.jp/english/html/overview/doc/T120_T23_SPECS/ARIB-STD-T120/Rel16/36/A36331-gb0.pdf">https://www.arib.or.jp/english/html/overview/doc/T120_T23_SPECS/ARIB-STD-T120/Rel16/36/A36331-gb0.pdf</a>
ATIS	ATIS.3GPP.36.331.V16.11.0	16.11.0	Published	21.02.2023	<a href="https://www.atis.org/3gpp-transpositions - Rel-16">https://www.atis.org/3gpp-transpositions - Rel-16</a>
CCSA	CCSA.36.331V16110	16.11.0	Published	01.12.2022	<a href="https://www.ccsa.org.cn/api/portalsFile/downloadOldFile?type=19&amp;oldFileUrl=ITU-R/M.2012-6/CCSA.36.331V16110.doc">https://www.ccsa.org.cn/api/portalsFile/downloadOldFile?type=19&amp;oldFileUrl=ITU-R/M.2012-6/CCSA.36.331V16110.doc</a>
ETSI	ETSI TS 136 331	16.11.0	Published	20.01.2023	<a href="https://www.etsi.org/deliver/etsi_ts/136300_136399/136331/16.11.00_60/ts_136331v161100p.pdf">https://www.etsi.org/deliver/etsi_ts/136300_136399/136331/16.11.00_60/ts_136331v161100p.pdf</a>
TSDSI	TSDSI STD T1.3GPP 36.331 16.11.0 V1.3.0	16.11.0	Published	02.05.2023	<a href="https://members.tdsi.in/s/nKTYiEA5LcGHp6S">https://members.tdsi.in/s/nKTYiEA5LcGHp6S</a>
TTA	TTAT.3G-36.331V16.11.0	16.11.0	Published	16.03.2023	<a href="http://committee.tta.or.kr/data/ttasDown.jsp?kind=ttastd&amp;pk_num=TTAT.3G-36.331V16.11.0">http://committee.tta.or.kr/data/ttasDown.jsp?kind=ttastd&amp;pk_num=TTAT.3G-36.331V16.11.0</a>
<b>Release 17</b>					
ARIB	ARIB STD-T120-36.331.V17.3.0	17.3.0	Published	03.03.2023	<a href="https://www.arib.or.jp/english/html/overview/doc/T120_T23_SPECS/ARIB-STD-T120/Rel17/36/A36331-h30.pdf">https://www.arib.or.jp/english/html/overview/doc/T120_T23_SPECS/ARIB-STD-T120/Rel17/36/A36331-h30.pdf</a>
ATIS	ATIS.3GPP.36.331.V17.3.0	17.3.0	Published	21.02.2023	<a href="https://www.atis.org/3gpp-transpositions - Rel-17">https://www.atis.org/3gpp-transpositions - Rel-17</a>
CCSA	CCSA.36.331V1730	17.3.0	Published	01.12.2022	<a href="https://www.ccsa.org.cn/api/portalsFile/downloadOldFile?type=19&amp;oldFileUrl=ITU-R/M.2012-6/CCSA.36.331V1730.doc">https://www.ccsa.org.cn/api/portalsFile/downloadOldFile?type=19&amp;oldFileUrl=ITU-R/M.2012-6/CCSA.36.331V1730.doc</a>
ETSI	ETSI TS 136 331	17.3.0	Published	20.01.2023	<a href="https://www.etsi.org/deliver/etsi_ts/136300_136399/136331/17.03.00_60/ts_136331v170300p.pdf">https://www.etsi.org/deliver/etsi_ts/136300_136399/136331/17.03.00_60/ts_136331v170300p.pdf</a>
TSDSI	TSDSI STD T1.3GPP 36.331 17.3.0 V1.3.0	17.3.0	Published	02.05.2023	<a href="https://members.tdsi.in/s/e5wgZBWL6bqFfE4">https://members.tdsi.in/s/e5wgZBWL6bqFfE4</a>
TTA	TTAT.3G-36.331V17.3.0	17.3.0	Published	16.03.2023	<a href="http://committee.tta.or.kr/data/ttasDown.jsp?kind=ttastd&amp;pk_num=TTAT.3G-36.331V17.3.0">http://committee.tta.or.kr/data/ttasDown.jsp?kind=ttastd&amp;pk_num=TTAT.3G-36.331V17.3.0</a>

### 2.1.3.11 TS 36.355

#### Evolved Universal Terrestrial Radio Access (E-UTRA); LTE Positioning Protocol (LPP)

This document contains the definition of the LTE Positioning Protocol (LPP).

SDO	Document No.	Version	Status	Issued date	Location
<b>Release 10</b>					

ARIB	ARIB STD-T120-36.355.V10.12.0	10.12.0	Published	03.03.2023	<a href="https://www.arib.or.jp/english/html/overview/doc/T120_T23_SPECS/ARIB-STD-T120/Rel10/36/A36355-ac0.pdf">https://www.arib.or.jp/english/html/overview/doc/T120_T23_SPECS/ARIB-STD-T120/Rel10/36/A36355-ac0.pdf</a>
ATIS	ATIS.3GPP.36.355V10120	10.12.0	Published	28.06.2021	<a href="https://www.atis.org/3gpp-documents/Rel99-14/">https://www.atis.org/3gpp-documents/Rel99-14/</a>
CCSA	CCSA.36.355V10120	10.12.0	Published	01.06.2014	<a href="https://www.ccsa.org.cn/api/portalsFile/downloadOldFile?type=19&amp;oldFileUrl=ITU-R/M.2012-">https://www.ccsa.org.cn/api/portalsFile/downloadOldFile?type=19&amp;oldFileUrl=ITU-R/M.2012-</a>
ETSI	ETSI TS 136 355	10.12.0	Published	18.07.2014	<a href="https://www.etsi.org/deliver/etsi_ts/136300_136399/136355/10.12.00_60/ts_136355v101200p.pdf">https://www.etsi.org/deliver/etsi_ts/136300_136399/136355/10.12.00_60/ts_136355v101200p.pdf</a>
TSDSI	TSDSI STD T1.3GPP 36.355-10.12.0 V1.0.0	10.12.0	Published	30.08.2021	<a href="https://members.tdsi.in/index.php/s/aZLPDx7H3TjYLeJ">https://members.tdsi.in/index.php/s/aZLPDx7H3TjYLeJ</a>
TTA	TTAT.3G-36.355V10.12.0	10.12.0	Published	02.08.2021	<a href="http://committee.tta.or.kr/data/ttasDown.jsp?kind=ttastd&amp;pk_num=TTAT.3G-36.355V10.12.0">http://committee.tta.or.kr/data/ttasDown.jsp?kind=ttastd&amp;pk_num=TTAT.3G-36.355V10.12.0</a>
<b>Release 11</b>					
ARIB	ARIB STD-T120-36.355.V11.6.0	11.6.0	Published	03.03.2023	<a href="https://www.arib.or.jp/english/html/overview/doc/T120_T23_SPECS/ARIB-STD-T120/Rel11/36/A36355-b60.pdf">https://www.arib.or.jp/english/html/overview/doc/T120_T23_SPECS/ARIB-STD-T120/Rel11/36/A36355-b60.pdf</a>
ATIS	ATIS.3GPP.36.355V1160	11.6.0	Published	28.06.2021	<a href="https://www.atis.org/3gpp-documents/Rel99-14/">https://www.atis.org/3gpp-documents/Rel99-14/</a>
CCSA	CCSA.36.355V1160	11.6.0	Published	01.06.2014	<a href="https://www.ccsa.org.cn/api/portalsFile/downloadOldFile?type=19&amp;oldFileUrl=ITU-R/M.2012-6/CCSA.36.355V1160.doc">https://www.ccsa.org.cn/api/portalsFile/downloadOldFile?type=19&amp;oldFileUrl=ITU-R/M.2012-6/CCSA.36.355V1160.doc</a>
ETSI	ETSI TS 136 355	11.6.0	Published	22.07.2014	<a href="https://www.etsi.org/deliver/etsi_ts/136300_136399/136355/11.06.00_60/ts_136355v110600p.pdf">https://www.etsi.org/deliver/etsi_ts/136300_136399/136355/11.06.00_60/ts_136355v110600p.pdf</a>
TSDSI	TSDSI STD T1.3GPP 36.355-11.6.0 V1.0.0	11.6.0	Published	30.08.2021	<a href="https://members.tdsi.in/index.php/s/KpeCgfsYnotjYBc">https://members.tdsi.in/index.php/s/KpeCgfsYnotjYBc</a>
TTA	TTAT.3G-36.355V11.6.0	11.6.0	Published	02.08.2021	<a href="http://committee.tta.or.kr/data/ttasDown.jsp?kind=ttastd&amp;pk_num=TTAT.3G-36.355V11.6.0">http://committee.tta.or.kr/data/ttasDown.jsp?kind=ttastd&amp;pk_num=TTAT.3G-36.355V11.6.0</a>
<b>Release 12</b>					
ARIB	ARIB STD-T120-36.355.V12.5.0	12.5.0	Published	03.03.2023	<a href="https://www.arib.or.jp/english/html/overview/doc/T120_T23_SPECS/ARIB-STD-T120/Rel12/36/A36355-c50.pdf">https://www.arib.or.jp/english/html/overview/doc/T120_T23_SPECS/ARIB-STD-T120/Rel12/36/A36355-c50.pdf</a>
ATIS	ATIS.3GPP.36.355V1250	12.5.0	Published	28.06.2021	<a href="https://www.atis.org/3gpp-documents/Rel99-14/">https://www.atis.org/3gpp-documents/Rel99-14/</a>
CCSA	CCSA.36.355V1250	12.5.0	Published	01.12.2015	<a href="https://www.ccsa.org.cn/api/portalsFile/downloadOldFile?type=19&amp;oldFileUrl=ITU-R/M.2012-6/CCSA.36.355V1250.doc">https://www.ccsa.org.cn/api/portalsFile/downloadOldFile?type=19&amp;oldFileUrl=ITU-R/M.2012-6/CCSA.36.355V1250.doc</a>
ETSI	ETSI TS 136 355	12.5.0	Published	18.01.2016	<a href="https://www.etsi.org/deliver/etsi_ts/136300_136399/136355/12.05.00_60/ts_136355v120500p.pdf">https://www.etsi.org/deliver/etsi_ts/136300_136399/136355/12.05.00_60/ts_136355v120500p.pdf</a>
TSDSI	TSDSI STD T1.3GPP 36.355-12.5.0 V1.0.0	12.5.0	Published	30.08.2021	<a href="https://members.tdsi.in/index.php/s/y29QxrGNSt4xwAN">https://members.tdsi.in/index.php/s/y29QxrGNSt4xwAN</a>
TTA	TTAT.3G-36.355V12.5.0	12.5.0	Published	02.08.2021	<a href="http://committee.tta.or.kr/data/ttasDown.jsp?kind=ttastd&amp;pk_num=TTAT.3G-36.355V12.5.0">http://committee.tta.or.kr/data/ttasDown.jsp?kind=ttastd&amp;pk_num=TTAT.3G-36.355V12.5.0</a>
<b>Release 13</b>					
ARIB	ARIB STD-T120-36.355.V13.3.0	13.3.0	Published	03.03.2023	<a href="https://www.arib.or.jp/english/html/overview/doc/T120_T23_SPECS/ARIB-STD-T120/Rel13/36/A36355-d30.pdf">https://www.arib.or.jp/english/html/overview/doc/T120_T23_SPECS/ARIB-STD-T120/Rel13/36/A36355-d30.pdf</a>
ATIS	ATIS.3GPP.36.355V1330	13.3.0	Published	28.06.2021	<a href="https://www.atis.org/3gpp-documents/Rel99-14/">https://www.atis.org/3gpp-documents/Rel99-14/</a>
CCSA	CCSA.36.355V1330	13.3.0	Published	01.12.2016	<a href="https://www.ccsa.org.cn/api/portalsFile/downloadOldFile?type=19&amp;oldFileUrl=ITU-R/M.2012-6/CCSA.36.355V1330.doc">https://www.ccsa.org.cn/api/portalsFile/downloadOldFile?type=19&amp;oldFileUrl=ITU-R/M.2012-6/CCSA.36.355V1330.doc</a>
ETSI	ETSI TS 136 355	13.3.0	Published	16.02.2017	<a href="https://www.etsi.org/deliver/etsi_ts/136300_136399/136355/13.03.00_60/ts_136355v130300p.pdf">https://www.etsi.org/deliver/etsi_ts/136300_136399/136355/13.03.00_60/ts_136355v130300p.pdf</a>
TSDSI	TSDSI STD T1.3GPP 36.355-13.3.0 V1.0.0	13.3.0	Published	30.08.2021	<a href="https://members.tdsi.in/index.php/s/wK5HwSZmXZxJrmZ">https://members.tdsi.in/index.php/s/wK5HwSZmXZxJrmZ</a>
TTA	TTAT.3G-36.355V13.3.0	13.3.0	Published	02.08.2021	<a href="http://committee.tta.or.kr/data/ttasDown.jsp?kind=ttastd&amp;pk_num=TTAT.3G-36.355V13.3.0">http://committee.tta.or.kr/data/ttasDown.jsp?kind=ttastd&amp;pk_num=TTAT.3G-36.355V13.3.0</a>
<b>Release 14</b>					
ARIB	ARIB STD-T120-36.355.V14.7.0	14.7.0	Published	03.03.2023	<a href="https://www.arib.or.jp/english/html/overview/doc/T120_T23_SPECS/ARIB-STD-T120/Rel14/36/A36355-e70.pdf">https://www.arib.or.jp/english/html/overview/doc/T120_T23_SPECS/ARIB-STD-T120/Rel14/36/A36355-e70.pdf</a>
ATIS	ATIS.3GPP.36.355V1470	14.7.0	Published	28.06.2021	<a href="https://www.atis.org/3gpp-documents/Rel99-14/">https://www.atis.org/3gpp-documents/Rel99-14/</a>
CCSA	CCSA.36.355V1470	14.7.0	Published	01.09.2018	<a href="https://www.ccsa.org.cn/api/portalsFile/downloadOldFile?type=19&amp;oldFileUrl=ITU-R/M.2012-6/CCSA.36.355V1470.doc">https://www.ccsa.org.cn/api/portalsFile/downloadOldFile?type=19&amp;oldFileUrl=ITU-R/M.2012-6/CCSA.36.355V1470.doc</a>
ETSI	ETSI TS 136 355	14.7.0	Published	17.10.2018	<a href="https://www.etsi.org/deliver/etsi_ts/136300_136399/136355/14.07.00_60/ts_136355v140700p.pdf">https://www.etsi.org/deliver/etsi_ts/136300_136399/136355/14.07.00_60/ts_136355v140700p.pdf</a>
TSDSI	TSDSI STD T1.3GPP 36.355-14.7.0 V1.1.0	14.7.0	Published	30.08.2021	<a href="https://members.tdsi.in/index.php/s/ECRLwraJTTfq4Cp">https://members.tdsi.in/index.php/s/ECRLwraJTTfq4Cp</a>
TTA	TTAT.3G-36.355V14.7.0	14.7.0	Published	02.08.2021	<a href="http://committee.tta.or.kr/data/ttasDown.jsp?kind=ttastd&amp;pk_num=TTAT.3G-36.355V14.7.0">http://committee.tta.or.kr/data/ttasDown.jsp?kind=ttastd&amp;pk_num=TTAT.3G-36.355V14.7.0</a>
<b>Release 15</b>					
ARIB	ARIB STD-T120-36.355.V15.6.0	15.6.0	Published	03.03.2023	<a href="https://www.arib.or.jp/english/html/overview/doc/T120_T23_SPECS/ARIB-STD-T120/Rel15/36/A36355-f60.pdf">https://www.arib.or.jp/english/html/overview/doc/T120_T23_SPECS/ARIB-STD-T120/Rel15/36/A36355-f60.pdf</a>
ATIS	ATIS.3GPP.36.355.V15.6.0	15.6.0	Published	21.02.2023	<a href="https://www.atis.org/3gpp-transpositions - Rel-15">https://www.atis.org/3gpp-transpositions - Rel-15</a>
CCSA	CCSA.36.355V1560	15.6.0	Published	01.12.2019	<a href="https://www.ccsa.org.cn/api/portalsFile/downloadOldFile?type=19&amp;oldFileUrl=ITU-R/M.2012-6/CCSA.36.355V1560.doc">https://www.ccsa.org.cn/api/portalsFile/downloadOldFile?type=19&amp;oldFileUrl=ITU-R/M.2012-6/CCSA.36.355V1560.doc</a>
ETSI	ETSI TS 136 355	15.6.0	Published	17.01.2020	<a href="https://www.etsi.org/deliver/etsi_ts/136300_136399/136355/15.06.00_60/ts_136355v150600p.pdf">https://www.etsi.org/deliver/etsi_ts/136300_136399/136355/15.06.00_60/ts_136355v150600p.pdf</a>
TSDSI	TSDSI STD T1.3GPP 36.355-15.6.0 V1.0.0	15.6.0	Published	06.10.2020	<a href="https://members.tdsi.in/index.php/s/f2pmS6dSwAGMXfm">https://members.tdsi.in/index.php/s/f2pmS6dSwAGMXfm</a>
TTA	TTAT.3G-36.355V15.6.0	15.6.0	Published	11.09.2020	<a href="http://committee.tta.or.kr/data/ttasDown.jsp?kind=ttastd&amp;pk_num=TTAT.3G-36.355V15.6.0">http://committee.tta.or.kr/data/ttasDown.jsp?kind=ttastd&amp;pk_num=TTAT.3G-36.355V15.6.0</a>
<b>Release 16</b>					
ARIB	ARIB STD-T120-36.355.V16.0.0	16.0.0	Published	03.03.2023	<a href="https://www.arib.or.jp/english/html/overview/doc/T120_T23_SPECS/ARIB-STD-T120/Rel16/36/A36355-g00.pdf">https://www.arib.or.jp/english/html/overview/doc/T120_T23_SPECS/ARIB-STD-T120/Rel16/36/A36355-g00.pdf</a>
ATIS	ATIS.3GPP.36.355.V16.0.0	16.0.0	Published	21.02.2023	<a href="https://www.atis.org/3gpp-transpositions - Rel-16">https://www.atis.org/3gpp-transpositions - Rel-16</a>
CCSA	CCSA.36.355V1600	16.0.0	Published	01.07.2020	<a href="https://www.ccsa.org.cn/api/portalsFile/downloadOldFile?type=19&amp;oldFileUrl=ITU-R/M.2012-6/CCSA.36.355V1600.doc">https://www.ccsa.org.cn/api/portalsFile/downloadOldFile?type=19&amp;oldFileUrl=ITU-R/M.2012-6/CCSA.36.355V1600.doc</a>
ETSI	ETSI TS 136 355	16.0.0	Published	31.07.2020	<a href="https://www.etsi.org/deliver/etsi_ts/136300_136399/136355/16.00.00_60/ts_136355v160000p.pdf">https://www.etsi.org/deliver/etsi_ts/136300_136399/136355/16.00.00_60/ts_136355v160000p.pdf</a>

TSDSI	TSDSI STD T1.3GPP 36.355-16.0.0 V1.0.0	16.0.0	Published	06.10.2020	<a href="https://members.tdsi.in/index.php/s/ANXCtGtwpDrZf8B">https://members.tdsi.in/index.php/s/ANXCtGtwpDrZf8B</a>
TTA	TTAT.3G-36.355V16.0.0	16.0.0	Published	11.09.2020	<a href="http://committee.tta.or.kr/data/ttasDown.jsp?kind=ttastd&amp;pk_num=TTAT.3G-36.355V16.0.0">http://committee.tta.or.kr/data/ttasDown.jsp?kind=ttastd&amp;pk_num=TTAT.3G-36.355V16.0.0</a>

**Release 17**

ARIB	ARIB STD-T120-36.355.V17.0.0	17.0.0	Published	03.03.2023	<a href="https://www.arib.or.jp/english/html/overview/doc/T120_T23_SPECS/ARIB-STD-T120/Rel17/36/A36355-h00.pdf">https://www.arib.or.jp/english/html/overview/doc/T120_T23_SPECS/ARIB-STD-T120/Rel17/36/A36355-h00.pdf</a>
ATIS	ATIS.3GPP.36.355.V17.0.0	17.0.0	Published	21.02.2023	<a href="https://www.atis.org/3gpp-transpositions-Rel-17">https://www.atis.org/3gpp-transpositions-Rel-17</a>
CCSA	CCSA.36.355V1700	17.0.0	Published	01.03.2022	<a href="https://www.ccsa.org.cn/api/portalsFile/downloadOldFile?type=19&amp;oldFileUrl=ITU-R/M.2012-6/CCSA.36.355V1700.doc">https://www.ccsa.org.cn/api/portalsFile/downloadOldFile?type=19&amp;oldFileUrl=ITU-R/M.2012-6/CCSA.36.355V1700.doc</a>
ETSI	ETSI TS 136 355	17.0.0	Published	09.05.2022	<a href="https://www.etsi.org/deliver/etsi_ts/136300_136399/136355/17.00.00_60/ts_136355v170000p.pdf">https://www.etsi.org/deliver/etsi_ts/136300_136399/136355/17.00.00_60/ts_136355v170000p.pdf</a>
TSDSI	TSDSI STD T1.3GPP 36.355-17.0.0 V1.0.0	17.0.0	Published	29.07.2022	<a href="https://members.tdsi.in/s/xNmyXMiQN8szZwt">https://members.tdsi.in/s/xNmyXMiQN8szZwt</a>
TTA	TTAT.3G-36.355V17.0.0	17.0.0	Published	05.08.2022	<a href="http://committee.tta.or.kr/data/ttasDown.jsp?kind=ttastd&amp;pk_num=TTAT.3G-36.355V17.0.0">http://committee.tta.or.kr/data/ttasDown.jsp?kind=ttastd&amp;pk_num=TTAT.3G-36.355V17.0.0</a>

**2.1.3.12 TS 36.360****Evolved Universal Terrestrial Radio Access (E-UTRA); LTE-WLAN Aggregation Adaptation Protocol (LWAAP) specification**

This document specifies the E-UTRA LTE-WLAN Aggregation Adaptation Protocol (LWAAP).

SDO	Document No.	Version	Status	Issued date	Location
<b>Release 13</b>					
ARIB	ARIB STD-T120-36.360.V13.1.0	13.1.0	Published	03.03.2023	<a href="https://www.arib.or.jp/english/html/overview/doc/T120_T23_SPECS/ARIB-STD-T120/Rel13/36/A36360-d10.pdf">https://www.arib.or.jp/english/html/overview/doc/T120_T23_SPECS/ARIB-STD-T120/Rel13/36/A36360-d10.pdf</a>
ATIS	ATIS.3GPP.36.360V1310	13.1.0	Published	28.06.2021	<a href="https://www.atis.org/3gpp-documents/Rel99-14/">https://www.atis.org/3gpp-documents/Rel99-14/</a>
CCSA	CCSA.36.360V1310	13.1.0	Published	01.03.2017	<a href="https://www.ccsa.org.cn/api/portalsFile/downloadOldFile?type=19&amp;oldFileUrl=ITU-R/M.2012-6/CCSA.36.360V1310.doc">https://www.ccsa.org.cn/api/portalsFile/downloadOldFile?type=19&amp;oldFileUrl=ITU-R/M.2012-6/CCSA.36.360V1310.doc</a>
ETSI	ETSI TS 136 360	13.1.0	Published	11.04.2017	<a href="https://www.etsi.org/deliver/etsi_ts/136300_136399/136360/13.01.00_60/ts_136360v130100p.pdf">https://www.etsi.org/deliver/etsi_ts/136300_136399/136360/13.01.00_60/ts_136360v130100p.pdf</a>
TSDSI	TSDSI STD T1.3GPP 36.36-13.1.0 V1.0.0	13.1.0	Published	30.08.2021	<a href="https://members.tdsi.in/index.php/s/ZpCnoGW2Dgiwprp">https://members.tdsi.in/index.php/s/ZpCnoGW2Dgiwprp</a>
TTA	TTAT.3G-36.360V13.1.0	13.1.0	Published	02.08.2021	<a href="http://committee.tta.or.kr/data/ttasDown.jsp?kind=ttastd&amp;pk_num=TTAT.3G-36.360V13.1.0">http://committee.tta.or.kr/data/ttasDown.jsp?kind=ttastd&amp;pk_num=TTAT.3G-36.360V13.1.0</a>
TTC	TS-3GA-36.360(Rel13)v13.1.0	13.1.0	Published	13.04.2018	<a href="https://www.ttc.or.jp/st/docs/3gppts2018/TS/TS-3GA-36.360(Rel13)v13.1.0.pdf">https://www.ttc.or.jp/st/docs/3gppts2018/TS/TS-3GA-36.360(Rel13)v13.1.0.pdf</a>
<b>Release 14</b>					
ARIB	ARIB STD-T120-36.360.V14.0.0	14.0.0	Published	03.03.2023	<a href="https://www.arib.or.jp/english/html/overview/doc/T120_T23_SPECS/ARIB-STD-T120/Rel14/36/A36360-e00.pdf">https://www.arib.or.jp/english/html/overview/doc/T120_T23_SPECS/ARIB-STD-T120/Rel14/36/A36360-e00.pdf</a>
ATIS	ATIS.3GPP.36.360V1400	14.0.0	Published	28.06.2021	<a href="https://www.atis.org/3gpp-documents/Rel99-14/">https://www.atis.org/3gpp-documents/Rel99-14/</a>
CCSA	CCSA.36.360V1400	14.0.0	Published	01.03.2017	<a href="https://www.ccsa.org.cn/api/portalsFile/downloadOldFile?type=19&amp;oldFileUrl=ITU-R/M.2012-6/CCSA.36.360V1400.doc">https://www.ccsa.org.cn/api/portalsFile/downloadOldFile?type=19&amp;oldFileUrl=ITU-R/M.2012-6/CCSA.36.360V1400.doc</a>
ETSI	ETSI TS 136 360	14.0.0	Published	11.04.2017	<a href="https://www.etsi.org/deliver/etsi_ts/136300_136399/136360/14.00.00_60/ts_136360v140000p.pdf">https://www.etsi.org/deliver/etsi_ts/136300_136399/136360/14.00.00_60/ts_136360v140000p.pdf</a>
TSDSI	TSDSI STD T1.3GPP 36.360-14.0.0 V1.0.0	14.0.0	Published	30.08.2021	<a href="https://members.tdsi.in/index.php/s/535Tro5jY2y9NSA">https://members.tdsi.in/index.php/s/535Tro5jY2y9NSA</a>
TTA	TTAT.3G-36.360V14.0.0	14.0.0	Published	02.08.2021	<a href="http://committee.tta.or.kr/data/ttasDown.jsp?kind=ttastd&amp;pk_num=TTAT.3G-36.360V14.0.0">http://committee.tta.or.kr/data/ttasDown.jsp?kind=ttastd&amp;pk_num=TTAT.3G-36.360V14.0.0</a>
TTC	TS-3GA-36.360(Rel14)v14.0.0	14.0.0	Published	13.04.2018	<a href="https://www.ttc.or.jp/st/docs/3gppts2018/TS/TS-3GA-36.360(Rel14)v14.0.0.pdf">https://www.ttc.or.jp/st/docs/3gppts2018/TS/TS-3GA-36.360(Rel14)v14.0.0.pdf</a>
<b>Release 15</b>					
ARIB	ARIB STD-T120-36.360.V15.0.0	15.0.0	Published	03.03.2023	<a href="https://www.arib.or.jp/english/html/overview/doc/T120_T23_SPECS/ARIB-STD-T120/Rel15/36/A36360-f00.pdf">https://www.arib.or.jp/english/html/overview/doc/T120_T23_SPECS/ARIB-STD-T120/Rel15/36/A36360-f00.pdf</a>
ATIS	ATIS.3GPP.36.360V1500	15.0.0	Published	28.06.2021	<a href="https://www.atis.org/3gpp-documents/Rel15/">https://www.atis.org/3gpp-documents/Rel15/</a>
CCSA	CCSA.36.360V1500	15.0.0	Published	01.07.2018	<a href="https://www.ccsa.org.cn/api/portalsFile/downloadOldFile?type=19&amp;oldFileUrl=ITU-R/M.2012-6/CCSA.36.360V1500.doc">https://www.ccsa.org.cn/api/portalsFile/downloadOldFile?type=19&amp;oldFileUrl=ITU-R/M.2012-6/CCSA.36.360V1500.doc</a>
ETSI	ETSI TS 136 360	15.0.0	Published	16.07.2018	<a href="https://www.etsi.org/deliver/etsi_ts/136300_136399/136360/15.00.00_60/ts_136360v150000p.pdf">https://www.etsi.org/deliver/etsi_ts/136300_136399/136360/15.00.00_60/ts_136360v150000p.pdf</a>
TSDSI	TSDSI STD T1.3GPP 36.360-15.0.0 V1.0.0	15.0.0	Published	30.08.2021	<a href="https://members.tdsi.in/index.php/s/W3F5oEyY8jYZH8f">https://members.tdsi.in/index.php/s/W3F5oEyY8jYZH8f</a>
TTA	TTAT.3G-36.360V15.0.0	15.0.0	Published	11.09.2020	<a href="http://committee.tta.or.kr/data/ttasDown.jsp?kind=ttastd&amp;pk_num=TTAT.3G-36.360V15.0.0">http://committee.tta.or.kr/data/ttasDown.jsp?kind=ttastd&amp;pk_num=TTAT.3G-36.360V15.0.0</a>
TTC	TS-3GA-36.360(Rel15)v15.0.0	15.0.0	Published	28.09.2018	<a href="https://www.ttc.or.jp/st/docs/3gppts2018/TS/TS-3GA-36.360(Rel15)v15.0.0.pdf">https://www.ttc.or.jp/st/docs/3gppts2018/TS/TS-3GA-36.360(Rel15)v15.0.0.pdf</a>
<b>Release 16</b>					
ARIB	ARIB STD-T120-36.360.V16.0.0	16.0.0	Published	03.03.2023	<a href="https://www.arib.or.jp/english/html/overview/doc/T120_T23_SPECS/ARIB-STD-T120/Rel16/36/A36360-g00.pdf">https://www.arib.or.jp/english/html/overview/doc/T120_T23_SPECS/ARIB-STD-T120/Rel16/36/A36360-g00.pdf</a>
ATIS	ATIS.3GPP.36.360V1600	16.0.0	Published	28.06.2021	<a href="https://www.atis.org/3gpp-documents/Rel16/">https://www.atis.org/3gpp-documents/Rel16/</a>
CCSA	CCSA.36.360V1600	16.0.0	Published	01.07.2020	<a href="https://www.ccsa.org.cn/api/portalsFile/downloadOldFile?type=19&amp;oldFileUrl=ITU-R/M.2012-6/CCSA.36.360V1600.doc">https://www.ccsa.org.cn/api/portalsFile/downloadOldFile?type=19&amp;oldFileUrl=ITU-R/M.2012-6/CCSA.36.360V1600.doc</a>
ETSI	ETSI TS 136 360	16.0.0	Published	31.07.2020	<a href="https://www.etsi.org/deliver/etsi_ts/136300_136399/136360/16.00.00_60/ts_136360v160000p.pdf">https://www.etsi.org/deliver/etsi_ts/136300_136399/136360/16.00.00_60/ts_136360v160000p.pdf</a>
TSDSI	TSDSI STD T1.3GPP 36.360-16.0.0 V1.0.0	16.0.0	Published	30.08.2021	<a href="https://members.tdsi.in/index.php/s/eHY2dSadTCysDZp">https://members.tdsi.in/index.php/s/eHY2dSadTCysDZp</a>
TTA	TTAT.3G-36.360V16.0.0	16.0.0	Published	11.09.2020	<a href="http://committee.tta.or.kr/data/ttasDown.jsp?kind=ttastd&amp;pk_num=TTAT.3G-36.360V16.0.0">http://committee.tta.or.kr/data/ttasDown.jsp?kind=ttastd&amp;pk_num=TTAT.3G-36.360V16.0.0</a>

TTC	TS-3GA-36.360(Rel16)v16.0.0	16.0.0	Published	02.10.2020	<a href="https://www.ttc.or.jp/st/docs/3gpps2020/TS/TS-3GA-36_360_Rel16v16_0_0.pdf">https://www.ttc.or.jp/st/docs/3gpps2020/TS/TS-3GA-36_360_Rel16v16_0_0.pdf</a>
-----	-----------------------------	--------	-----------	------------	---

**Release 17**

ARIB	ARIB STD-T120-36.360.V17.0.0	17.0.0	Published	03.03.2023	<a href="https://www.arib.or.jp/english/html/overview/doc/T120_T23_SPECS/ARIB-STD-T120/Rel17/36/A36360-h00.pdf">https://www.arib.or.jp/english/html/overview/doc/T120_T23_SPECS/ARIB-STD-T120/Rel17/36/A36360-h00.pdf</a>
ATIS	ATIS.3GPP.36.360.V17.0.0	17.0.0	Published	21.02.2023	<a href="https://www.atis.org/3gpp-transpositions - Rel-17">https://www.atis.org/3gpp-transpositions - Rel-17</a>
CCSA	CCSA.36.360V1700	17.0.0	Published	01.03.2022	<a href="https://www.ccsa.org.cn/api/portalsFile/downloadOldFile?type=19&amp;oldFileUrl=ITU-R/M.2012-6/CCSA.36.360V1700.doc">https://www.ccsa.org.cn/api/portalsFile/downloadOldFile?type=19&amp;oldFileUrl=ITU-R/M.2012-6/CCSA.36.360V1700.doc</a>
ETSI	ETSI TS 136 360	17.0.0	Published	09.05.2022	<a href="https://www.etsi.org/deliver/etsi_ts/136300_136399/136360/17.00.00_60/ts_136360v170000p.pdf">https://www.etsi.org/deliver/etsi_ts/136300_136399/136360/17.00.00_60/ts_136360v170000p.pdf</a>
TSDSI	TSDSI STD T1.3GPP 36.36-17.0.0 V1.0.0	17.0.0	Published	29.07.2022	<a href="https://members.tdsi.in/s/xNmyXMiQN8szZwt">https://members.tdsi.in/s/xNmyXMiQN8szZwt</a>
TTA	TTAT.3G-36.360V17.0.0	17.0.0	Published	05.08.2022	<a href="http://committee.tta.or.kr/data/ttasDown.jsp?kind=ttastd&amp;pk_num=TTAT.3G-36.360V17.0.0">http://committee.tta.or.kr/data/ttasDown.jsp?kind=ttastd&amp;pk_num=TTAT.3G-36.360V17.0.0</a>
TTC	TS-3GA-36.360(Rel17)v17.0.0	17.0.0	Published	07.10.2022	<a href="https://www.ttc.or.jp/st/docs/3gpp/2022/TS/TS-3GA-36.360v17.0.0.pdf">https://www.ttc.or.jp/st/docs/3gpp/2022/TS/TS-3GA-36.360v17.0.0.pdf</a>

**2.1.3.13 TS 36.361****Evolved Universal Terrestrial Radio Access (E-UTRA); LTE/WLAN Radio Level Integration Using IPsec Tunnel (LWIP) encapsulation; Protocol specification**

This document specifies the LWIP Encapsulation Protocol.

SDO	Document No.	Version	Status	Issued date	Location
-----	--------------	---------	--------	-------------	----------

**Release 13**

ARIB	ARIB STD-T120-36.361.V13.2.0	13.2.0	Published	03.03.2023	<a href="https://www.arib.or.jp/english/html/overview/doc/T120_T23_SPECS/ARIB-STD-T120/Rel13/36/A36361-d20.pdf">https://www.arib.or.jp/english/html/overview/doc/T120_T23_SPECS/ARIB-STD-T120/Rel13/36/A36361-d20.pdf</a>
ATIS	ATIS.3GPP.36.361V1320	13.2.0	Published	28.06.2021	<a href="https://www.atis.org/3gpp-documents/Rel99-14/">https://www.atis.org/3gpp-documents/Rel99-14/</a>
CCSA	CCSA.36.361V1320	13.2.0	Published	01.09.2016	<a href="https://www.ccsa.org.cn/api/portalsFile/downloadOldFile?type=19&amp;oldFileUrl=ITU-R/M.2012-6/CCSA.36.361V1320.doc">https://www.ccsa.org.cn/api/portalsFile/downloadOldFile?type=19&amp;oldFileUrl=ITU-R/M.2012-6/CCSA.36.361V1320.doc</a>
ETSI	ETSI TS 136 361	13.2.0	Published	06.10.2016	<a href="https://www.etsi.org/deliver/etsi_ts/136300_136399/136361/13.02.00_60/ts_136361v130200p.pdf">https://www.etsi.org/deliver/etsi_ts/136300_136399/136361/13.02.00_60/ts_136361v130200p.pdf</a>
TSDSI	TSDSI STD T1.3GPP 36.361-13.2.0 V1.0.0	13.2.0	Published	30.08.2021	<a href="https://members.tdsi.in/index.php/s/7QmsAB733fzwHM2">https://members.tdsi.in/index.php/s/7QmsAB733fzwHM2</a>
TTA	TTAT.3G-36.361V13.2.0	13.2.0	Published	02.08.2021	<a href="http://committee.tta.or.kr/data/ttasDown.jsp?kind=ttastd&amp;pk_num=TTAT.3G-36.361V13.2.0">http://committee.tta.or.kr/data/ttasDown.jsp?kind=ttastd&amp;pk_num=TTAT.3G-36.361V13.2.0</a>
TTC	TS-3GA-36.361(Rel13)v13.2.0	13.2.0	Published	13.04.2018	<a href="https://www.ttc.or.jp/st/docs/3gpps2018/TS/TS-3GA-36.361(Rel13)v13.2.0.pdf">https://www.ttc.or.jp/st/docs/3gpps2018/TS/TS-3GA-36.361(Rel13)v13.2.0.pdf</a>

**Release 14**

ARIB	ARIB STD-T120-36.361.V14.1.0	14.1.0	Published	03.03.2023	<a href="https://www.arib.or.jp/english/html/overview/doc/T120_T23_SPECS/ARIB-STD-T120/Rel14/36/A36361-e10.pdf">https://www.arib.or.jp/english/html/overview/doc/T120_T23_SPECS/ARIB-STD-T120/Rel14/36/A36361-e10.pdf</a>
ATIS	ATIS.3GPP.36.361V1410	14.1.0	Published	28.06.2021	<a href="https://www.atis.org/3gpp-documents/Rel99-14/">https://www.atis.org/3gpp-documents/Rel99-14/</a>
CCSA	CCSA.36.361V1410	14.1.0	Published	01.06.2017	<a href="https://www.ccsa.org.cn/api/portalsFile/downloadOldFile?type=19&amp;oldFileUrl=ITU-R/M.2012-6/CCSA.36.361V1410.doc">https://www.ccsa.org.cn/api/portalsFile/downloadOldFile?type=19&amp;oldFileUrl=ITU-R/M.2012-6/CCSA.36.361V1410.doc</a>
ETSI	ETSI TS 136 361	14.1.0	Published	24.08.2017	<a href="https://www.etsi.org/deliver/etsi_ts/136300_136399/136361/14.01.00_60/ts_136361v140100p.pdf">https://www.etsi.org/deliver/etsi_ts/136300_136399/136361/14.01.00_60/ts_136361v140100p.pdf</a>
TSDSI	TSDSI STD T1.3GPP 36.361-14.1.0 V1.0.0	14.1.0	Published	30.08.2021	<a href="https://members.tdsi.in/index.php/s/eZW8axwjCpmZL8N">https://members.tdsi.in/index.php/s/eZW8axwjCpmZL8N</a>
TTA	TTAT.3G-36.361V14.1.0	14.1.0	Published	02.08.2021	<a href="http://committee.tta.or.kr/data/ttasDown.jsp?kind=ttastd&amp;pk_num=TTAT.3G-36.361V14.1.0">http://committee.tta.or.kr/data/ttasDown.jsp?kind=ttastd&amp;pk_num=TTAT.3G-36.361V14.1.0</a>
TTC	TS-3GA-36.361(Rel14)v14.1.0	14.1.0	Published	13.04.2018	<a href="https://www.ttc.or.jp/st/docs/3gpps2018/TS/TS-3GA-36.361(Rel14)v14.1.0.pdf">https://www.ttc.or.jp/st/docs/3gpps2018/TS/TS-3GA-36.361(Rel14)v14.1.0.pdf</a>

**Release 15**

ARIB	ARIB STD-T120-36.361.V15.0.0	15.0.0	Published	03.03.2023	<a href="https://www.arib.or.jp/english/html/overview/doc/T120_T23_SPECS/ARIB-STD-T120/Rel15/36/A36361-f00.pdf">https://www.arib.or.jp/english/html/overview/doc/T120_T23_SPECS/ARIB-STD-T120/Rel15/36/A36361-f00.pdf</a>
ATIS	ATIS.3GPP.36.361V1500	15.0.0	Published	28.06.2021	<a href="https://www.atis.org/3gpp-documents/Rel15/">https://www.atis.org/3gpp-documents/Rel15/</a>
CCSA	CCSA.36.361V1500	15.0.0	Published	01.07.2018	<a href="https://www.ccsa.org.cn/api/portalsFile/downloadOldFile?type=19&amp;oldFileUrl=ITU-R/M.2012-6/CCSA.36.361V1500.doc">https://www.ccsa.org.cn/api/portalsFile/downloadOldFile?type=19&amp;oldFileUrl=ITU-R/M.2012-6/CCSA.36.361V1500.doc</a>
ETSI	ETSI TS 136 361	15.0.0	Published	16.07.2018	<a href="https://www.etsi.org/deliver/etsi_ts/136300_136399/136361/15.00.00_60/ts_136361v150000p.pdf">https://www.etsi.org/deliver/etsi_ts/136300_136399/136361/15.00.00_60/ts_136361v150000p.pdf</a>
TSDSI	TSDSI STD T1.3GPP 36.361-15.0.0 V1.0.0	15.0.0	Published	30.08.2021	<a href="https://members.tdsi.in/index.php/s/FMT7KpL9YbN92ZX">https://members.tdsi.in/index.php/s/FMT7KpL9YbN92ZX</a>
TTA	TTAT.3G-36.361V15.0.0	15.0.0	Published	11.09.2020	<a href="http://committee.tta.or.kr/data/ttasDown.jsp?kind=ttastd&amp;pk_num=TTAT.3G-36.361V15.0.0">http://committee.tta.or.kr/data/ttasDown.jsp?kind=ttastd&amp;pk_num=TTAT.3G-36.361V15.0.0</a>
TTC	TS-3GA-36.361(Rel15)v15.0.0	15.0.0	Published	28.09.2018	<a href="https://www.ttc.or.jp/st/docs/3gpps2018/TS/TS-3GA-36.361(Rel15)v15.0.0.pdf">https://www.ttc.or.jp/st/docs/3gpps2018/TS/TS-3GA-36.361(Rel15)v15.0.0.pdf</a>

**Release 16**

ARIB	ARIB STD-T120-36.361.V16.0.0	16.0.0	Published	03.03.2023	<a href="https://www.arib.or.jp/english/html/overview/doc/T120_T23_SPECS/ARIB-STD-T120/Rel16/36/A36361-g00.pdf">https://www.arib.or.jp/english/html/overview/doc/T120_T23_SPECS/ARIB-STD-T120/Rel16/36/A36361-g00.pdf</a>
ATIS	ATIS.3GPP.36.361V1600	16.0.0	Published	28.06.2021	<a href="https://www.atis.org/3gpp-documents/Rel16/">https://www.atis.org/3gpp-documents/Rel16/</a>
CCSA	CCSA.36.361V1600	16.0.0	Published	01.07.2020	<a href="https://www.ccsa.org.cn/api/portalsFile/downloadOldFile?type=19&amp;oldFileUrl=ITU-R/M.2012-6/CCSA.36.361V1600.doc">https://www.ccsa.org.cn/api/portalsFile/downloadOldFile?type=19&amp;oldFileUrl=ITU-R/M.2012-6/CCSA.36.361V1600.doc</a>
ETSI	ETSI TS 136 361	16.0.0	Published	31.07.2020	<a href="https://www.etsi.org/deliver/etsi_ts/136300_136399/136361/16.00.00_60/ts_136361v160000p.pdf">https://www.etsi.org/deliver/etsi_ts/136300_136399/136361/16.00.00_60/ts_136361v160000p.pdf</a>
TSDSI	TSDSI STD T1.3GPP 36.361-16.0.0 V1.0.0	16.0.0	Published	30.08.2021	<a href="https://members.tdsi.in/index.php/s/A3bNCZcF7t9Q5f7">https://members.tdsi.in/index.php/s/A3bNCZcF7t9Q5f7</a>
TTA	TTAT.3G-36.361V16.0.0	16.0.0	Published	11.09.2020	<a href="http://committee.tta.or.kr/data/ttasDown.jsp?kind=ttastd&amp;pk_num=TTAT.3G-36.361V16.0.0">http://committee.tta.or.kr/data/ttasDown.jsp?kind=ttastd&amp;pk_num=TTAT.3G-36.361V16.0.0</a>

TTC	TS-3GA-36.361(Rel16)v16.0.0	16.0.0	Published	02.10.2020	<a href="https://www.ttc.or.jp/st/docs/3gpps2020/TS/TS-3GA-36_361_Rel16v16_0_0.pdf">https://www.ttc.or.jp/st/docs/3gpps2020/TS/TS-3GA-36_361_Rel16v16_0_0.pdf</a>
<b>Release 17</b>					
ARIB	ARIB STD-T120-36.361.V17.0.0	17.0.0	Published	03.03.2023	<a href="https://www.arib.or.jp/english/html/overview/doc/T120_T23_SPECS/ARIB-STD-T120/Rel17/36/A36361-h00.pdf">https://www.arib.or.jp/english/html/overview/doc/T120_T23_SPECS/ARIB-STD-T120/Rel17/36/A36361-h00.pdf</a>
ATIS	ATIS.3GPP.36.361.V17.0.0	17.0.0	Published	21.02.2023	<a href="https://www.atis.org/3gpp-transpositions-Rel-17">https://www.atis.org/3gpp-transpositions-Rel-17</a>
CCSA	CCSA.36.361V1700	17.0.0	Published	01.03.2022	<a href="https://www.ccsa.org.cn/api/portalsFile/downloadOldFile?type=19&amp;oldFileUrl=ITU-R/M.2012-6/CCSA.36.361V1700.doc">https://www.ccsa.org.cn/api/portalsFile/downloadOldFile?type=19&amp;oldFileUrl=ITU-R/M.2012-6/CCSA.36.361V1700.doc</a>
ETSI	ETSI TS 136 361	17.0.0	Published	09.05.2022	<a href="https://www.etsi.org/deliver/etsi_ts/136300_136399/136361/17.00.00_60/ts_136361v170000p.pdf">https://www.etsi.org/deliver/etsi_ts/136300_136399/136361/17.00.00_60/ts_136361v170000p.pdf</a>
TSDSI	TSDSI STD T1.3GPP 36.361-17.0.0 V1.0.0	17.0.0	Published	29.07.2022	<a href="https://members.tdsi.in/s/oTtwpBB32zkHZmT">https://members.tdsi.in/s/oTtwpBB32zkHZmT</a>
TTA	TTAT.3G-36.361V17.0.0	17.0.0	Published	05.08.2022	<a href="http://committee.tta.or.kr/data/ttasDown.jsp?kind=ttastd&amp;pk_num=TTAT.3G-36.361V17.0.0">http://committee.tta.or.kr/data/ttasDown.jsp?kind=ttastd&amp;pk_num=TTAT.3G-36.361V17.0.0</a>
TTC	TS-3GA-36.361(Rel17)v17.0.0	17.0.0	Published	07.10.2022	<a href="https://www.ttc.or.jp/st/docs/3gpp/2022/TS/TS-3GA-36.361v17.0.0.pdf">https://www.ttc.or.jp/st/docs/3gpp/2022/TS/TS-3GA-36.361v17.0.0.pdf</a>

### 2.1.3.14 TS 37.320

#### Radio measurement collection for Minimization of Drive Tests (MDT); Overall description; Stage 2

This document provides an overview and overall description of the minimization of drive tests functionality. The document describes functions and procedures to support collection of UE-specific measurements for MDT using Control Plane architecture, for both UTRAN and E-UTRAN. Details of the signalling procedures for single-RAT operation are specified in the appropriate radio interface protocol specification. Network operation and overall control of MDT is described in O&M specifications.

SDO	Document No.	Version	Status	Issued date	Location
<b>Release 10</b>					
ARIB	ARIB STD-T120-37.320.V10.4.0	10.4.0	Published	03.03.2023	<a href="https://www.arib.or.jp/english/html/overview/doc/T120_T23_SPECS/ARIB-STD-T120/Rel10/37/A37320-a40.pdf">https://www.arib.or.jp/english/html/overview/doc/T120_T23_SPECS/ARIB-STD-T120/Rel10/37/A37320-a40.pdf</a>
ATIS	ATIS.3GPP.37.320V1040	10.4.0	Published	28.06.2021	<a href="https://www.atis.org/3gpp-documents/Rel99-14/">https://www.atis.org/3gpp-documents/Rel99-14/</a>
CCSA	CCSA.37.320V1040	10.4.0	Published	01.12.2011	<a href="https://www.ccsa.org.cn/api/portalsFile/downloadOldFile?type=19&amp;oldFileUrl=ITU-R/M.2012-6/CCSA.37.320V1040.doc">https://www.ccsa.org.cn/api/portalsFile/downloadOldFile?type=19&amp;oldFileUrl=ITU-R/M.2012-6/CCSA.37.320V1040.doc</a>
ETSI	ETSI TS 137 320	10.4.0	Published	19.01.2012	<a href="https://www.etsi.org/deliver/etsi_ts/137300_137399/137320/10.04.00_60/ts_137320v100400p.pdf">https://www.etsi.org/deliver/etsi_ts/137300_137399/137320/10.04.00_60/ts_137320v100400p.pdf</a>
TSDSI	TSDSI STD T1.3GPP 37.320-10.4.0 V1.0.0	10.4.0	Published	30.08.2021	<a href="https://members.tdsi.in/index.php/s/rxR7fMpK38e8gfg">https://members.tdsi.in/index.php/s/rxR7fMpK38e8gfg</a>
TTA	TTAT.3G-37.320V10.4.0	10.4.0	Published	02.08.2021	<a href="http://committee.tta.or.kr/data/ttasDown.jsp?kind=ttastd&amp;pk_num=TTAT.3G-37.320V10.4.0">http://committee.tta.or.kr/data/ttasDown.jsp?kind=ttastd&amp;pk_num=TTAT.3G-37.320V10.4.0</a>
<b>Release 11</b>					
ARIB	ARIB STD-T120-37.320.V11.4.0	11.4.0	Published	03.03.2023	<a href="https://www.arib.or.jp/english/html/overview/doc/T120_T23_SPECS/ARIB-STD-T120/Rel11/37/A37320-b40.pdf">https://www.arib.or.jp/english/html/overview/doc/T120_T23_SPECS/ARIB-STD-T120/Rel11/37/A37320-b40.pdf</a>
ATIS	ATIS.3GPP.37.320V1140	11.4.0	Published	28.06.2021	<a href="https://www.atis.org/3gpp-documents/Rel99-14/">https://www.atis.org/3gpp-documents/Rel99-14/</a>
CCSA	CCSA.37.320V1140	11.4.0	Published	01.09.2014	<a href="https://www.ccsa.org.cn/api/portalsFile/downloadOldFile?type=19&amp;oldFileUrl=ITU-R/M.2012-6/CCSA.37.320V1140.doc">https://www.ccsa.org.cn/api/portalsFile/downloadOldFile?type=19&amp;oldFileUrl=ITU-R/M.2012-6/CCSA.37.320V1140.doc</a>
ETSI	ETSI TS 137 320	11.4.0	Published	29.09.2014	<a href="https://www.etsi.org/deliver/etsi_ts/137300_137399/137320/11.04.00_60/ts_137320v110400p.pdf">https://www.etsi.org/deliver/etsi_ts/137300_137399/137320/11.04.00_60/ts_137320v110400p.pdf</a>
TSDSI	TSDSI STD T1.3GPP 37.320-11.4.0 V1.0.0	11.4.0	Published	30.08.2021	<a href="https://members.tdsi.in/index.php/s/65JxwsKLxHkWsps">https://members.tdsi.in/index.php/s/65JxwsKLxHkWsps</a>
TTA	TTAT.3G-37.320V11.4.0	11.4.0	Published	02.08.2021	<a href="http://committee.tta.or.kr/data/ttasDown.jsp?kind=ttastd&amp;pk_num=TTAT.3G-37.320V11.4.0">http://committee.tta.or.kr/data/ttasDown.jsp?kind=ttastd&amp;pk_num=TTAT.3G-37.320V11.4.0</a>
<b>Release 12</b>					
ARIB	ARIB STD-T120-37.320.V12.2.0	12.2.0	Published	03.03.2023	<a href="https://www.arib.or.jp/english/html/overview/doc/T120_T23_SPECS/ARIB-STD-T120/Rel12/37/A37320-c20.pdf">https://www.arib.or.jp/english/html/overview/doc/T120_T23_SPECS/ARIB-STD-T120/Rel12/37/A37320-c20.pdf</a>
ATIS	ATIS.3GPP.37.320V1220	12.2.0	Published	28.06.2021	<a href="https://www.atis.org/3gpp-documents/Rel99-14/">https://www.atis.org/3gpp-documents/Rel99-14/</a>
CCSA	CCSA.37.320V1220	12.2.0	Published	01.09.2014	<a href="https://www.ccsa.org.cn/api/portalsFile/downloadOldFile?type=19&amp;oldFileUrl=ITU-R/M.2012-6/CCSA.37.320V1220.doc">https://www.ccsa.org.cn/api/portalsFile/downloadOldFile?type=19&amp;oldFileUrl=ITU-R/M.2012-6/CCSA.37.320V1220.doc</a>
ETSI	ETSI TS 137 320	12.2.0	Published	29.09.2014	<a href="https://www.etsi.org/deliver/etsi_ts/137300_137399/137320/12.02.00_60/ts_137320v120200p.pdf">https://www.etsi.org/deliver/etsi_ts/137300_137399/137320/12.02.00_60/ts_137320v120200p.pdf</a>
TSDSI	TSDSI STD T1.3GPP 37.32-12.2.0 V1.0.0	12.2.0	Published	30.08.2021	<a href="https://members.tdsi.in/index.php/s/fAkXpxKFT66cAkW">https://members.tdsi.in/index.php/s/fAkXpxKFT66cAkW</a>
TTA	TTAT.3G-37.320V12.2.0	12.2.0	Published	02.08.2021	<a href="http://committee.tta.or.kr/data/ttasDown.jsp?kind=ttastd&amp;pk_num=TTAT.3G-37.320V12.2.0">http://committee.tta.or.kr/data/ttasDown.jsp?kind=ttastd&amp;pk_num=TTAT.3G-37.320V12.2.0</a>
<b>Release 13</b>					
ARIB	ARIB STD-T120-37.320.V13.1.0	13.1.0	Published	03.03.2023	<a href="https://www.arib.or.jp/english/html/overview/doc/T120_T23_SPECS/ARIB-STD-T120/Rel13/37/A37320-d10.pdf">https://www.arib.or.jp/english/html/overview/doc/T120_T23_SPECS/ARIB-STD-T120/Rel13/37/A37320-d10.pdf</a>
ATIS	ATIS.3GPP.37.320V1310	13.1.0	Published	28.06.2021	<a href="https://www.atis.org/3gpp-documents/Rel99-14/">https://www.atis.org/3gpp-documents/Rel99-14/</a>
CCSA	CCSA.37.320V1310	13.1.0	Published	01.03.2016	<a href="https://www.ccsa.org.cn/api/portalsFile/downloadOldFile?type=19&amp;oldFileUrl=ITU-R/M.2012-6/CCSA.37.320V1310.doc">https://www.ccsa.org.cn/api/portalsFile/downloadOldFile?type=19&amp;oldFileUrl=ITU-R/M.2012-6/CCSA.37.320V1310.doc</a>
ETSI	ETSI TS 137 320	13.1.0	Published	27.04.2016	<a href="https://www.etsi.org/deliver/etsi_ts/137300_137399/137320/13.01.00_60/ts_137320v130100p.pdf">https://www.etsi.org/deliver/etsi_ts/137300_137399/137320/13.01.00_60/ts_137320v130100p.pdf</a>

TSDSI	TSDSI STD T1.3GPP 37.32-13.1.0 V1.0.0	13.1.0	Published	30.08.2021	<a href="https://members.tdsi.in/index.php/s/BGbEfeNY9b56YeC">https://members.tdsi.in/index.php/s/BGbEfeNY9b56YeC</a>
TTA	TTAT.3G-37.320V13.1.0	13.1.0	Published	02.08.2021	<a href="http://committee.tta.or.kr/data/ttasDown.jsp?kind=ttastd&amp;pk_num=TTAT.3G-37.320V13.1.0">http://committee.tta.or.kr/data/ttasDown.jsp?kind=ttastd&amp;pk_num=TTAT.3G-37.320V13.1.0</a>
<b>Release 14</b>					
ARIB	ARIB STD-T120-37.320.V14.0.0	14.0.0	Published	03.03.2023	<a href="https://www.arib.or.jp/english/html/overview/doc/T120_T23_SPECS/ARIB-STD-T120/Rel14/37/A37320-e00.pdf">https://www.arib.or.jp/english/html/overview/doc/T120_T23_SPECS/ARIB-STD-T120/Rel14/37/A37320-e00.pdf</a>
ATIS	ATIS.3GPP.37.320V1400	14.0.0	Published	28.06.2021	<a href="https://www.atis.org/3gpp-documents/Rel99-14/">https://www.atis.org/3gpp-documents/Rel99-14/</a>
CCSA	CCSA.37.320V1400	14.0.0	Published	01.03.2017	<a href="https://www.ccsa.org.cn/api/portalsFile/downloadOldFile?type=19&amp;oldFileUrl=ITU-R/M.2012-6/CCSA.37.320V1400.doc">https://www.ccsa.org.cn/api/portalsFile/downloadOldFile?type=19&amp;oldFileUrl=ITU-R/M.2012-6/CCSA.37.320V1400.doc</a>
ETSI	ETSI TS 137 320	14.0.0	Published	11.04.2017	<a href="https://www.etsi.org/deliver/etsi_ts/137300_137399/137320/14.00.00_60/ts_137320v140000p.pdf">https://www.etsi.org/deliver/etsi_ts/137300_137399/137320/14.00.00_60/ts_137320v140000p.pdf</a>
TSDSI	TSDSI STD T1.3GPP 37.320-14.0.0 V1.0.0	14.0.0	Published	30.08.2021	<a href="https://members.tdsi.in/index.php/s/87HnW9ocwo55Cs2">https://members.tdsi.in/index.php/s/87HnW9ocwo55Cs2</a>
TTA	TTAT.3G-37.320V14.0.0	14.0.0	Published	02.08.2021	<a href="http://committee.tta.or.kr/data/ttasDown.jsp?kind=ttastd&amp;pk_num=TTAT.3G-37.320V14.0.0">http://committee.tta.or.kr/data/ttasDown.jsp?kind=ttastd&amp;pk_num=TTAT.3G-37.320V14.0.0</a>
<b>Release 15</b>					
ARIB	ARIB STD-T120-37.320.V15.0.0	15.0.0	Published	03.03.2023	<a href="https://www.arib.or.jp/english/html/overview/doc/T120_T23_SPECS/ARIB-STD-T120/Rel15/37/A37320-f00.pdf">https://www.arib.or.jp/english/html/overview/doc/T120_T23_SPECS/ARIB-STD-T120/Rel15/37/A37320-f00.pdf</a>
ATIS	ATIS.3GPP.37.320V1500	15.0.0	Published	28.06.2021	<a href="https://www.atis.org/3gpp-documents/Rel15/">https://www.atis.org/3gpp-documents/Rel15/</a>
CCSA	CCSA.37.320V1500	15.0.0	Published	01.06.2018	<a href="https://www.ccsa.org.cn/api/portalsFile/downloadOldFile?type=19&amp;oldFileUrl=ITU-R/M.2012-6/CCSA.37.320V1500.doc">https://www.ccsa.org.cn/api/portalsFile/downloadOldFile?type=19&amp;oldFileUrl=ITU-R/M.2012-6/CCSA.37.320V1500.doc</a>
ETSI	ETSI TS 137 320	15.0.0	Published	17.07.2018	<a href="https://www.etsi.org/deliver/etsi_ts/137300_137399/137320/15.00.00_60/ts_137320v150000p.pdf">https://www.etsi.org/deliver/etsi_ts/137300_137399/137320/15.00.00_60/ts_137320v150000p.pdf</a>
TSDSI	TSDSI STD T1.3GPP 37.320-15.0.0 V1.0.0	15.0.0	Published	30.08.2021	<a href="https://members.tdsi.in/index.php/s/ZonFpABk5TG4HSc">https://members.tdsi.in/index.php/s/ZonFpABk5TG4HSc</a>
TTA	TTAT.3G-37.320V15.0.0	15.0.0	Published	11.09.2020	<a href="http://committee.tta.or.kr/data/ttasDown.jsp?kind=ttastd&amp;pk_num=TTAT.3G-37.320V15.0.0">http://committee.tta.or.kr/data/ttasDown.jsp?kind=ttastd&amp;pk_num=TTAT.3G-37.320V15.0.0</a>
<b>Release 16</b>					
ARIB	ARIB STD-T120-37.320.V16.8.0	16.8.0	Published	03.03.2023	<a href="https://www.arib.or.jp/english/html/overview/doc/T120_T23_SPECS/ARIB-STD-T120/Rel16/37/A37320-g80.pdf">https://www.arib.or.jp/english/html/overview/doc/T120_T23_SPECS/ARIB-STD-T120/Rel16/37/A37320-g80.pdf</a>
ATIS	ATIS.3GPP.37.320.V16.8.0	16.8.0	Published	21.02.2023	<a href="https://www.atis.org/3gpp-transpositions - Rel-16">https://www.atis.org/3gpp-transpositions - Rel-16</a>
CCSA	CCSA.37.320V1680	16.8.0	Published	01.03.2022	<a href="https://www.ccsa.org.cn/api/portalsFile/downloadOldFile?type=19&amp;oldFileUrl=ITU-R/M.2012-6/CCSA.37.320V1680.doc">https://www.ccsa.org.cn/api/portalsFile/downloadOldFile?type=19&amp;oldFileUrl=ITU-R/M.2012-6/CCSA.37.320V1680.doc</a>
ETSI	ETSI TS 137 320	16.8.0	Published	09.05.2022	<a href="https://www.etsi.org/deliver/etsi_ts/137300_137399/137320/16.08.00_60/ts_137320v160800p.pdf">https://www.etsi.org/deliver/etsi_ts/137300_137399/137320/16.08.00_60/ts_137320v160800p.pdf</a>
TSDSI	TSDSI STD T1.3GPP 37.32-16.8.0 V1.1.0	16.8.0	Published	01.11.2022	<a href="https://members.tdsi.in/s/kszQrafgmFP3npd">https://members.tdsi.in/s/kszQrafgmFP3npd</a>
TTA	TTAT.3G-37.320V16.8.0	16.8.0	Published	05.08.2022	<a href="http://committee.tta.or.kr/data/ttasDown.jsp?kind=ttastd&amp;pk_num=TTAT.3G-37.320V16.8.0">http://committee.tta.or.kr/data/ttasDown.jsp?kind=ttastd&amp;pk_num=TTAT.3G-37.320V16.8.0</a>
<b>Release 17</b>					
ARIB	ARIB STD-T120-37.320.V17.2.0	17.2.0	Published	03.03.2023	<a href="https://www.arib.or.jp/english/html/overview/doc/T120_T23_SPECS/ARIB-STD-T120/Rel17/37/A37320-h20.pdf">https://www.arib.or.jp/english/html/overview/doc/T120_T23_SPECS/ARIB-STD-T120/Rel17/37/A37320-h20.pdf</a>
ATIS	ATIS.3GPP.37.320.V17.2.0	17.2.0	Published	21.02.2023	<a href="https://www.atis.org/3gpp-transpositions - Rel-17">https://www.atis.org/3gpp-transpositions - Rel-17</a>
CCSA	CCSA.37.320V1720	17.2.0	Published	01.12.2022	<a href="https://www.ccsa.org.cn/api/portalsFile/downloadOldFile?type=19&amp;oldFileUrl=ITU-R/M.2012-6/CCSA.37.320V1720.doc">https://www.ccsa.org.cn/api/portalsFile/downloadOldFile?type=19&amp;oldFileUrl=ITU-R/M.2012-6/CCSA.37.320V1720.doc</a>
ETSI	ETSI TS 137 320	17.2.0	Published	20.01.2023	<a href="https://www.etsi.org/deliver/etsi_ts/137300_137399/137320/17.02.00_60/ts_137320v170200p.pdf">https://www.etsi.org/deliver/etsi_ts/137300_137399/137320/17.02.00_60/ts_137320v170200p.pdf</a>
TSDSI	TSDSI STD T1.3GPP 37.320 17.2.0 V1.2.0	17.2.0	Published	02.05.2023	<a href="https://members.tdsi.in/s/ka6P6SkHRecEbJA">https://members.tdsi.in/s/ka6P6SkHRecEbJA</a>
TTA	TTAT.3G-37.320V17.2.0	17.2.0	Published	16.03.2023	<a href="http://committee.tta.or.kr/data/ttasDown.jsp?kind=ttastd&amp;pk_num=TTAT.3G-37.320V17.2.0">http://committee.tta.or.kr/data/ttasDown.jsp?kind=ttastd&amp;pk_num=TTAT.3G-37.320V17.2.0</a>

### 2.1.3.15 TS 37.355

#### LTE Positioning Protocol (LPP)

This document contains the definition of the LTE Positioning Protocol (LPP) for the radio access technologies E-UTRA/LTE and NR.

SDO	Document No.	Version	Status	Issued date	Location
<b>Release 15</b>					
ARIB	ARIB STD-T120-37.355.V15.3.0	15.3.0	Published	03.03.2023	<a href="https://www.arib.or.jp/english/html/overview/doc/T120_T23_SPECS/ARIB-STD-T120/Rel15/37/A37355-f30.pdf">https://www.arib.or.jp/english/html/overview/doc/T120_T23_SPECS/ARIB-STD-T120/Rel15/37/A37355-f30.pdf</a>
ATIS	ATIS.3GPP.37.355.V15.3.0	15.3.0	Published	21.02.2023	<a href="https://www.atis.org/3gpp-transpositions - Rel-15">https://www.atis.org/3gpp-transpositions - Rel-15</a>
CCSA	CCSA.37.355V1530	15.3.0	Published	01.03.2022	<a href="https://www.ccsa.org.cn/api/portalsFile/downloadOldFile?type=19&amp;oldFileUrl=ITU-R/M.2012-6/CCSA.37.355V1530.doc">https://www.ccsa.org.cn/api/portalsFile/downloadOldFile?type=19&amp;oldFileUrl=ITU-R/M.2012-6/CCSA.37.355V1530.doc</a>
ETSI	ETSI TS 137 355	15.3.0	Published	09.05.2022	<a href="https://www.etsi.org/deliver/etsi_ts/137300_137399/137355/15.03.00_60/ts_137355v150300p.pdf">https://www.etsi.org/deliver/etsi_ts/137300_137399/137355/15.03.00_60/ts_137355v150300p.pdf</a>
TSDSI	TSDSI STD T1.3GPP 37.355-15.3.0 V1.1.0	15.3.0	Published	01.11.2022	<a href="https://members.tdsi.in/s/MmqwaBwCDsoqW8a">https://members.tdsi.in/s/MmqwaBwCDsoqW8a</a>
TTA	TTAT.3G-37.355V15.3.0	15.3.0	Published	05.08.2022	<a href="http://committee.tta.or.kr/data/ttasDown.jsp?kind=ttastd&amp;pk_num=TTAT.3G-37.355V15.3.0">http://committee.tta.or.kr/data/ttasDown.jsp?kind=ttastd&amp;pk_num=TTAT.3G-37.355V15.3.0</a>

#### Release 16

ARIB	ARIB STD-T120-37.355.V16.9.0	16.9.0	Published	03.03.2023	<a href="https://www.arib.or.jp/english/html/overview/doc/T120_T23_SPECS/ARIB-STD-T120/Rel16/37/A37355-g90.pdf">https://www.arib.or.jp/english/html/overview/doc/T120_T23_SPECS/ARIB-STD-T120/Rel16/37/A37355-g90.pdf</a>
ATIS	ATIS.3GPP.37.355.V16.9.0	16.9.0	Published	21.02.2023	<a href="https://www.atis.org/3gpp-transpositions - Rel-16">https://www.atis.org/3gpp-transpositions - Rel-16</a>
CCSA	CCSA.37.355V1690	16.9.0	Published	01.12.2022	<a href="https://www.ccsa.org.cn/api/portalsFile/downloadOldFile?type=19&amp;oldFileUrl=ITU-R/M.2012-6/CCSA.37.355V1690.doc">https://www.ccsa.org.cn/api/portalsFile/downloadOldFile?type=19&amp;oldFileUrl=ITU-R/M.2012-6/CCSA.37.355V1690.doc</a>
ETSI	ETSI TS 137 355	16.9.0	Published	20.01.2023	<a href="https://www.etsi.org/deliver/etsi_ts/137300_137399/137355/16.09.00_60/ts_137355v160900p.pdf">https://www.etsi.org/deliver/etsi_ts/137300_137399/137355/16.09.00_60/ts_137355v160900p.pdf</a>
TSDSI	TSDSI STD T1.3GPP 37.355 16.9.0 V1.2.0	16.9.0	Published	02.05.2023	<a href="https://members.tdsi.in/s/CYENAFxp8C5B2k">https://members.tdsi.in/s/CYENAFxp8C5B2k</a>
TTA	TTAT.3G-37.355V16.9.0	16.9.0	Published	16.03.2023	<a href="http://committee.tta.or.kr/data/ttasDown.jsp?kind=ttastd&amp;pk_num=TTAT.3G-37.355V16.9.0">http://committee.tta.or.kr/data/ttasDown.jsp?kind=ttastd&amp;pk_num=TTAT.3G-37.355V16.9.0</a>

**Release 17**

ARIB	ARIB STD-T120-37.355.V17.3.0	17.3.0	Published	03.03.2023	<a href="https://www.arib.or.jp/english/html/overview/doc/T120_T23_SPECS/ARIB-STD-T120/Rel17/37/A37355-h30.pdf">https://www.arib.or.jp/english/html/overview/doc/T120_T23_SPECS/ARIB-STD-T120/Rel17/37/A37355-h30.pdf</a>
ATIS	ATIS.3GPP.37.355.V17.3.0	17.3.0	Published	21.02.2023	<a href="https://www.atis.org/3gpp-transpositions - Rel-17">https://www.atis.org/3gpp-transpositions - Rel-17</a>
CCSA	CCSA.37.355V1730	17.3.0	Published	01.12.2022	<a href="https://www.ccsa.org.cn/api/portalsFile/downloadOldFile?type=19&amp;oldFileUrl=ITU-R/M.2012-6/CCSA.37.355V1730.doc">https://www.ccsa.org.cn/api/portalsFile/downloadOldFile?type=19&amp;oldFileUrl=ITU-R/M.2012-6/CCSA.37.355V1730.doc</a>
ETSI	ETSI TS 137 355	17.3.0	Published	20.01.2023	<a href="https://www.etsi.org/deliver/etsi_ts/137300_137399/137355/17.03.00_60/ts_137355v170300p.pdf">https://www.etsi.org/deliver/etsi_ts/137300_137399/137355/17.03.00_60/ts_137355v170300p.pdf</a>
TSDSI	TSDSI STD T1.3GPP 37.355 17.3.0 V1.3.0	17.3.0	Published	02.05.2023	<a href="https://members.tdsi.in/s/r5ciGSaf2RSZe7">https://members.tdsi.in/s/r5ciGSaf2RSZe7</a>
TTA	TTAT.3G-37.355V17.3.0	17.3.0	Published	16.03.2023	<a href="http://committee.tta.or.kr/data/ttasDown.jsp?kind=ttastd&amp;pk_num=TTAT.3G-37.355V17.3.0">http://committee.tta.or.kr/data/ttasDown.jsp?kind=ttastd&amp;pk_num=TTAT.3G-37.355V17.3.0</a>

**2.1.4 Architecture****2.1.4.1 TS 36.401****Evolved Universal Terrestrial Radio Access Network (E-UTRAN); Architecture description**

This document describes the overall architecture of the E-UTRAN, including internal interfaces and assumptions on the radio, S1 and X2 interfaces.

SDO	Document No.	Version	Status	Issued date	Location
<b>Release 10</b>					
ATIS	ATIS.3GPP.36.401V1040	10.4.0	Published	28.06.2021	<a href="https://www.atis.org/3gpp-documents/Rel99-14/">https://www.atis.org/3gpp-documents/Rel99-14/</a>
CCSA	CCSA.36.401V1040	10.4.0	Published	01.06.2012	<a href="https://www.ccsa.org.cn/api/portalsFile/downloadOldFile?type=19&amp;oldFileUrl=ITU-R/M.2012-6/CCSA.36.401V1040.doc">https://www.ccsa.org.cn/api/portalsFile/downloadOldFile?type=19&amp;oldFileUrl=ITU-R/M.2012-6/CCSA.36.401V1040.doc</a>
ETSI	ETSI TS 136 401	10.4.0	Published	18.07.2012	<a href="https://www.etsi.org/deliver/etsi_ts/136400_136499/136401/10.04.00_60/ts_136401v100400p.pdf">https://www.etsi.org/deliver/etsi_ts/136400_136499/136401/10.04.00_60/ts_136401v100400p.pdf</a>
TSDSI	TSDSI STD T1.3GPP 36.401-10.4.0 V1.0.0	10.4.0	Published	30.08.2021	<a href="https://members.tdsi.in/index.php/s/2j8sweYygNKjReb">https://members.tdsi.in/index.php/s/2j8sweYygNKjReb</a>
TTA	TTAT.3G-36.401V10.4.0	10.4.0	Published	02.08.2021	<a href="http://committee.tta.or.kr/data/ttasDown.jsp?kind=ttastd&amp;pk_num=TTAT.3G-36.401V10.4.0">http://committee.tta.or.kr/data/ttasDown.jsp?kind=ttastd&amp;pk_num=TTAT.3G-36.401V10.4.0</a>
TTC	TS-3GA-36.401(Rel10)v10.4.0	10.4.0	Published	19.09.2012	<a href="https://www.ttc.or.jp/st/docs/3gpps2012/TS/TS-3GA-36.401(Rel10)v10.4.0.pdf">https://www.ttc.or.jp/st/docs/3gpps2012/TS/TS-3GA-36.401(Rel10)v10.4.0.pdf</a>
<b>Release 11</b>					
ATIS	ATIS.3GPP.36.401V1120	11.2.0	Published	28.06.2021	<a href="https://www.atis.org/3gpp-documents/Rel99-14/">https://www.atis.org/3gpp-documents/Rel99-14/</a>
CCSA	CCSA.36.401V1120	11.2.0	Published	01.09.2013	<a href="https://www.ccsa.org.cn/api/portalsFile/downloadOldFile?type=19&amp;oldFileUrl=ITU-R/M.2012-6/CCSA.36.401V1120.doc">https://www.ccsa.org.cn/api/portalsFile/downloadOldFile?type=19&amp;oldFileUrl=ITU-R/M.2012-6/CCSA.36.401V1120.doc</a>
ETSI	ETSI TS 136 401	11.2.0	Published	26.09.2013	<a href="https://www.etsi.org/deliver/etsi_ts/136400_136499/136401/11.02.00_60/ts_136401v110200p.pdf">https://www.etsi.org/deliver/etsi_ts/136400_136499/136401/11.02.00_60/ts_136401v110200p.pdf</a>
TSDSI	TSDSI STD T1.3GPP 36.401-11.2.0 V1.0.0	11.2.0	Published	30.08.2021	<a href="https://members.tdsi.in/index.php/s/CNtEs9rPROXb7nC">https://members.tdsi.in/index.php/s/CNtEs9rPROXb7nC</a>
TTA	TTAT.3G-36.401V11.2.0	11.2.0	Published	02.08.2021	<a href="http://committee.tta.or.kr/data/ttasDown.jsp?kind=ttastd&amp;pk_num=TTAT.3G-36.401V11.2.0">http://committee.tta.or.kr/data/ttasDown.jsp?kind=ttastd&amp;pk_num=TTAT.3G-36.401V11.2.0</a>
TTC	TS-3GA-36.401(Rel11)v11.2.0	11.2.0	Published	22.11.2013	<a href="https://www.ttc.or.jp/st/docs/3gpps2013/TS/TS-3GA-36.401(Rel11)v11.2.0.pdf">https://www.ttc.or.jp/st/docs/3gpps2013/TS/TS-3GA-36.401(Rel11)v11.2.0.pdf</a>
<b>Release 12</b>					
ATIS	ATIS.3GPP.36.401V1230	12.3.0	Published	28.06.2021	<a href="https://www.atis.org/3gpp-documents/Rel99-14/">https://www.atis.org/3gpp-documents/Rel99-14/</a>
CCSA	CCSA.36.401V1230	12.3.0	Published	01.12.2015	<a href="https://www.ccsa.org.cn/api/portalsFile/downloadOldFile?type=19&amp;oldFileUrl=ITU-R/M.2012-6/CCSA.36.401V1230.doc">https://www.ccsa.org.cn/api/portalsFile/downloadOldFile?type=19&amp;oldFileUrl=ITU-R/M.2012-6/CCSA.36.401V1230.doc</a>
ETSI	ETSI TS 136 401	12.3.0	Published	15.01.2016	<a href="https://www.etsi.org/deliver/etsi_ts/136400_136499/136401/12.03.00_60/ts_136401v120300p.pdf">https://www.etsi.org/deliver/etsi_ts/136400_136499/136401/12.03.00_60/ts_136401v120300p.pdf</a>
TSDSI	TSDSI STD T1.3GPP 36.401-12.3.0 V1.0.0	12.3.0	Published	30.08.2021	<a href="https://members.tdsi.in/index.php/s/pRdCWrd7mXZD6To">https://members.tdsi.in/index.php/s/pRdCWrd7mXZD6To</a>
TTA	TTAT.3G-36.401V12.3.0	12.3.0	Published	02.08.2021	<a href="http://committee.tta.or.kr/data/ttasDown.jsp?kind=ttastd&amp;pk_num=TTAT.3G-36.401V12.3.0">http://committee.tta.or.kr/data/ttasDown.jsp?kind=ttastd&amp;pk_num=TTAT.3G-36.401V12.3.0</a>
TTC	TS-3GA-36.401(Rel12)v12.3.0	12.3.0	Published	25.03.2016	<a href="https://www.ttc.or.jp/st/docs/3gpps2016/TS/TS-3GA-36.401(Rel12)v12.3.0.pdf">https://www.ttc.or.jp/st/docs/3gpps2016/TS/TS-3GA-36.401(Rel12)v12.3.0.pdf</a>
<b>Release 13</b>					
ATIS	ATIS.3GPP.36.401V1320	13.2.0	Published	28.06.2021	<a href="https://www.atis.org/3gpp-documents/Rel99-14/">https://www.atis.org/3gpp-documents/Rel99-14/</a>
CCSA	CCSA.36.401V1320	13.2.0	Published	01.06.2016	<a href="https://www.ccsa.org.cn/api/portalsFile/downloadOldFile?type=19&amp;oldFileUrl=ITU-R/M.2012-6/CCSA.36.401V1320.doc">https://www.ccsa.org.cn/api/portalsFile/downloadOldFile?type=19&amp;oldFileUrl=ITU-R/M.2012-6/CCSA.36.401V1320.doc</a>

ETSI	ETSI TS 136 401	13.2.0	Published	25.08.2016	<a href="https://www.etsi.org/deliver/etsi_ts/136400_136499/136401/13.02.00_60/ts_136401v130200p.pdf">https://www.etsi.org/deliver/etsi_ts/136400_136499/136401/13.02.00_60/ts_136401v130200p.pdf</a>
TSDSI	TSDSI STD T1.3GPP 36.401-13.2.0 V1.0.0	13.2.0	Published	30.08.2021	<a href="https://members.tdsi.in/index.php/s/YE4ECWCiNb7pPXi">https://members.tdsi.in/index.php/s/YE4ECWCiNb7pPXi</a>
TTA	TTAT.3G-36.401V13.2.0	13.2.0	Published	02.08.2021	<a href="http://committee.tta.or.kr/data/ttasDown.jsp?kind=ttastd&amp;pk_num=TTAT.3G-36.401V13.2.0">http://committee.tta.or.kr/data/ttasDown.jsp?kind=ttastd&amp;pk_num=TTAT.3G-36.401V13.2.0</a>
TTC	TS-3GA-36.401(Rel13)v13.2.0	13.2.0	Published	31.03.2017	<a href="https://www.ttc.or.jp/st/docs/3gpps2017/TS/TS-3GA-36.401(Rel13)v13.2.0.pdf">https://www.ttc.or.jp/st/docs/3gpps2017/TS/TS-3GA-36.401(Rel13)v13.2.0.pdf</a>

**Release 14**

ATIS	ATIS.3GPP.36.401V1400	14.0.0	Published	28.06.2021	<a href="https://www.atis.org/3gpp-documents/Rel99-14/">https://www.atis.org/3gpp-documents/Rel99-14/</a>
CCSA	CCSA.36.401V1400	14.0.0	Published	01.03.2017	<a href="https://www.ccsa.org.cn/api/portalsFile/downloadOldFile?type=19&amp;oldFileUrl=ITU-R/M.2012-6/CCSA.36.401V1400.doc">https://www.ccsa.org.cn/api/portalsFile/downloadOldFile?type=19&amp;oldFileUrl=ITU-R/M.2012-6/CCSA.36.401V1400.doc</a>
ETSI	ETSI TS 136 401	14.0.0	Published	11.04.2017	<a href="https://www.etsi.org/deliver/etsi_ts/136400_136499/136401/14.00.00_60/ts_136401v140000p.pdf">https://www.etsi.org/deliver/etsi_ts/136400_136499/136401/14.00.00_60/ts_136401v140000p.pdf</a>
TSDSI	TSDSI STD T1.3GPP 36.401-14.0.0 V1.0.0	14.0.0	Published	30.08.2021	<a href="https://members.tdsi.in/index.php/s/gb9YPBLbRz5SiiJ">https://members.tdsi.in/index.php/s/gb9YPBLbRz5SiiJ</a>
TTA	TTAT.3G-36.401V14.0.0	14.0.0	Published	02.08.2021	<a href="http://committee.tta.or.kr/data/ttasDown.jsp?kind=ttastd&amp;pk_num=TTAT.3G-36.401V14.0.0">http://committee.tta.or.kr/data/ttasDown.jsp?kind=ttastd&amp;pk_num=TTAT.3G-36.401V14.0.0</a>
TTC	TS-3GA-36.401(Rel14)v14.0.0	14.0.0	Published	13.04.2018	<a href="https://www.ttc.or.jp/st/docs/3gpps2018/TS/TS-3GA-36.401(Rel14)v14.0.0.pdf">https://www.ttc.or.jp/st/docs/3gpps2018/TS/TS-3GA-36.401(Rel14)v14.0.0.pdf</a>

**Release 15**

ATIS	ATIS.3GPP.36.401V1510	15.1.0	Published	28.06.2021	<a href="https://www.atis.org/3gpp-documents/Rel15/">https://www.atis.org/3gpp-documents/Rel15/</a>
CCSA	CCSA.36.401V1510	15.1.0	Published	01.12.2018	<a href="https://www.ccsa.org.cn/api/portalsFile/downloadOldFile?type=19&amp;oldFileUrl=ITU-R/M.2012-6/CCSA.36.401V1510.doc">https://www.ccsa.org.cn/api/portalsFile/downloadOldFile?type=19&amp;oldFileUrl=ITU-R/M.2012-6/CCSA.36.401V1510.doc</a>
ETSI	ETSI TS 136 401	15.1.0	Published	17.04.2019	<a href="https://www.etsi.org/deliver/etsi_ts/136400_136499/136401/15.01.00_60/ts_136401v150100p.pdf">https://www.etsi.org/deliver/etsi_ts/136400_136499/136401/15.01.00_60/ts_136401v150100p.pdf</a>
TSDSI	TSDSI STD T1.3GPP 36.401-15.1.0 V1.0.0	15.1.0	Published	30.08.2021	<a href="https://members.tdsi.in/index.php/s/keKTFKqYJxrPbkC">https://members.tdsi.in/index.php/s/keKTFKqYJxrPbkC</a>
TTA	TTAT.3G-36.401V15.1.0	15.1.0	Published	11.09.2020	<a href="http://committee.tta.or.kr/data/ttasDown.jsp?kind=ttastd&amp;pk_num=TTAT.3G-36.401V15.1.0">http://committee.tta.or.kr/data/ttasDown.jsp?kind=ttastd&amp;pk_num=TTAT.3G-36.401V15.1.0</a>
TTC	TS-3GA-36.401(Rel15)v15.1.0	15.1.0	Published	29.03.2019	<a href="https://www.ttc.or.jp/st/docs/3gpps2019/TS/TS-3GA-36.401(Rel15)v15.1.0.pdf">https://www.ttc.or.jp/st/docs/3gpps2019/TS/TS-3GA-36.401(Rel15)v15.1.0.pdf</a>

**Release 16**

ATIS	ATIS.3GPP.36.401V1600	16.0.0	Published	28.06.2021	<a href="https://www.atis.org/3gpp-documents/Rel16/">https://www.atis.org/3gpp-documents/Rel16/</a>
CCSA	CCSA.36.401V1600	16.0.0	Published	01.07.2020	<a href="https://www.ccsa.org.cn/api/portalsFile/downloadOldFile?type=19&amp;oldFileUrl=ITU-R/M.2012-6/CCSA.36.401V1600.doc">https://www.ccsa.org.cn/api/portalsFile/downloadOldFile?type=19&amp;oldFileUrl=ITU-R/M.2012-6/CCSA.36.401V1600.doc</a>
ETSI	ETSI TS 136 401	16.0.0	Published	21.07.2020	<a href="https://www.etsi.org/deliver/etsi_ts/136400_136499/136401/16.00.00_60/ts_136401v160000p.pdf">https://www.etsi.org/deliver/etsi_ts/136400_136499/136401/16.00.00_60/ts_136401v160000p.pdf</a>
TSDSI	TSDSI STD T1.3GPP 36.401-16.0.0 V1.0.0	16.0.0	Published	30.08.2021	<a href="https://members.tdsi.in/index.php/s/ekXa3HgJwqHjY9">https://members.tdsi.in/index.php/s/ekXa3HgJwqHjY9</a>
TTA	TTAT.3G-36.401V16.0.0	16.0.0	Published	11.09.2020	<a href="http://committee.tta.or.kr/data/ttasDown.jsp?kind=ttastd&amp;pk_num=TTAT.3G-36.401V16.0.0">http://committee.tta.or.kr/data/ttasDown.jsp?kind=ttastd&amp;pk_num=TTAT.3G-36.401V16.0.0</a>
TTC	TS-3GA-36.401(Rel16)v16.0.0	16.0.0	Published	02.10.2020	<a href="https://www.ttc.or.jp/st/docs/3gpps2020/TS/TS-3GA-36_401_Rel16v16_0_0.pdf">https://www.ttc.or.jp/st/docs/3gpps2020/TS/TS-3GA-36_401_Rel16v16_0_0.pdf</a>

**Release 17**

ATIS	ATIS.3GPP.36.401.V17.1.0	17.1.0	Published	21.02.2023	<a href="https://www.atis.org/3gpp-transpositions - Rel-17">https://www.atis.org/3gpp-transpositions - Rel-17</a>
CCSA	CCSA.36.401V1710	17.1.0	Published	01.06.2022	<a href="https://www.ccsa.org.cn/api/portalsFile/downloadOldFile?type=19&amp;oldFileUrl=ITU-R/M.2012-6/CCSA.36.401V1710.doc">https://www.ccsa.org.cn/api/portalsFile/downloadOldFile?type=19&amp;oldFileUrl=ITU-R/M.2012-6/CCSA.36.401V1710.doc</a>
ETSI	ETSI TS 136 401	17.1.0	Published	20.07.2022	<a href="https://www.etsi.org/deliver/etsi_ts/136400_136499/136401/17.01.00_60/ts_136401v170100p.pdf">https://www.etsi.org/deliver/etsi_ts/136400_136499/136401/17.01.00_60/ts_136401v170100p.pdf</a>
TSDSI	TSDSI STD T1.3GPP 36.401-17.1.0 V1.1.0	17.1.0	Published	01.11.2022	<a href="https://members.tdsi.in/s/Se5scLtlmpwP3jy">https://members.tdsi.in/s/Se5scLtlmpwP3jy</a>
TTA	TTAT.3G-36.401V17.1.0	17.1.0	Published	21.10.2022	<a href="http://committee.tta.or.kr/data/ttasDown.jsp?kind=ttastd&amp;pk_num=TTAT.3G-36.401V17.1.0">http://committee.tta.or.kr/data/ttasDown.jsp?kind=ttastd&amp;pk_num=TTAT.3G-36.401V17.1.0</a>
TTC	TS-3GA-36.401(Rel17)v17.1.0	17.1.0	Published	07.10.2022	<a href="https://www.ttc.or.jp/st/docs/3gpp/2022/TS/TS-3GA-36.401v17.1.0.pdf">https://www.ttc.or.jp/st/docs/3gpp/2022/TS/TS-3GA-36.401v17.1.0.pdf</a>

**2.1.4.2 TS 36.410****Evolved Universal Terrestrial Radio Access Network (E-UTRAN); S1 layer 1 general aspects and principles**

This document is an introduction to the 3GPP TS 36.41x series of technical specifications that define the S1 interface for the interconnection of the eNodeB component of the Evolved Universal Terrestrial Radio Access Network (E UTRAN) to the Core Network of the EPS system.

SDO	Document No.	Version	Status	Issued date	Location
-----	--------------	---------	--------	-------------	----------

**Release 10**

ATIS	ATIS.3GPP.36.410V1030	10.3.0	Published	28.06.2021	<a href="https://www.atis.org/3gpp-documents/Rel99-14/">https://www.atis.org/3gpp-documents/Rel99-14/</a>
CCSA	CCSA.36.410V1030	10.3.0	Published	01.06.2012	<a href="https://www.ccsa.org.cn/api/portalsFile/downloadOldFile?type=19&amp;oldFileUrl=ITU-R/M.2012-6/CCSA.36.410V1030.doc">https://www.ccsa.org.cn/api/portalsFile/downloadOldFile?type=19&amp;oldFileUrl=ITU-R/M.2012-6/CCSA.36.410V1030.doc</a>
ETSI	ETSI TS 136 410	10.3.0	Published	18.07.2012	<a href="https://www.etsi.org/deliver/etsi_ts/136400_136499/136410/10.03.00_60/ts_136410v100300p.pdf">https://www.etsi.org/deliver/etsi_ts/136400_136499/136410/10.03.00_60/ts_136410v100300p.pdf</a>
TSDSI	TSDSI STD T1.3GPP 36.41-10.3.0 V1.0.0	10.3.0	Published	30.08.2021	<a href="https://members.tdsi.in/index.php/s/8RRRny8po3XJAFWH">https://members.tdsi.in/index.php/s/8RRRny8po3XJAFWH</a>
TTA	TTAT.3G-36.410V10.3.0	10.3.0	Published	02.08.2021	<a href="http://committee.tta.or.kr/data/ttasDown.jsp?kind=ttastd&amp;pk_num=TTAT.3G-36.410V10.3.0">http://committee.tta.or.kr/data/ttasDown.jsp?kind=ttastd&amp;pk_num=TTAT.3G-36.410V10.3.0</a>



TTC	TS-3GA-36.410(Rel10)v10.3.0	10.3.0	Published	19.09.2012	<a href="https://www.ttc.or.jp/st/docs/3gpps2012/TS/TS-3GA-36.410(Rel10)v10.3.0.pdf">https://www.ttc.or.jp/st/docs/3gpps2012/TS/TS-3GA-36.410(Rel10)v10.3.0.pdf</a>
<b>Release 11</b>					
ATIS	ATIS.3GPP.36.410V1110	11.1.0	Published	28.06.2021	<a href="https://www.atis.org/3gpp-documents/Rel99-14/">https://www.atis.org/3gpp-documents/Rel99-14/</a>
CCSA	CCSA.36.410V1110	11.1.0	Published	01.09.2013	<a href="https://www.ccsa.org.cn/api/portalsFile/downloadOldFile?type=19&amp;oldFileUrl=ITU-R/M.2012-6/CCSA.36.410V1110.doc">https://www.ccsa.org.cn/api/portalsFile/downloadOldFile?type=19&amp;oldFileUrl=ITU-R/M.2012-6/CCSA.36.410V1110.doc</a>
ETSI	ETSI TS 136 410	11.1.0	Published	26.09.2013	<a href="https://www.etsi.org/deliver/etsi_ts/136400_136499/136410/11.01.00_60/ts_136410v110100p.pdf">https://www.etsi.org/deliver/etsi_ts/136400_136499/136410/11.01.00_60/ts_136410v110100p.pdf</a>
TSDSI	TSDSI STD T1.3GPP 36.41-11.1.0 V1.0.0	11.1.0	Published	30.08.2021	<a href="https://members.tdsi.in/index.php/s/8CybmdLzF5gCzWs">https://members.tdsi.in/index.php/s/8CybmdLzF5gCzWs</a>
TTA	TTAT.3G-36.410V11.1.0	11.1.0	Published	02.08.2021	<a href="http://committee.tta.or.kr/data/ttasDown.jsp?kind=ttastd&amp;pk_num=TTAT.3G-36.410V11.1.0">http://committee.tta.or.kr/data/ttasDown.jsp?kind=ttastd&amp;pk_num=TTAT.3G-36.410V11.1.0</a>
TTC	TS-3GA-36.410(Rel11)v11.1.0	11.1.0	Published	22.11.2013	<a href="https://www.ttc.or.jp/st/docs/3gpps2013/TS/TS-3GA-36.410(Rel11)v11.1.0.pdf">https://www.ttc.or.jp/st/docs/3gpps2013/TS/TS-3GA-36.410(Rel11)v11.1.0.pdf</a>
<b>Release 12</b>					
ATIS	ATIS.3GPP.36.410V1210	12.1.0	Published	28.06.2021	<a href="https://www.atis.org/3gpp-documents/Rel99-14/">https://www.atis.org/3gpp-documents/Rel99-14/</a>
CCSA	CCSA.36.410V1210	12.1.0	Published	01.12.2014	<a href="https://www.ccsa.org.cn/api/portalsFile/downloadOldFile?type=19&amp;oldFileUrl=ITU-R/M.2012-6/CCSA.36.410V1210.doc">https://www.ccsa.org.cn/api/portalsFile/downloadOldFile?type=19&amp;oldFileUrl=ITU-R/M.2012-6/CCSA.36.410V1210.doc</a>
ETSI	ETSI TS 136 410	12.1.0	Published	04.02.2015	<a href="https://www.etsi.org/deliver/etsi_ts/136400_136499/136410/12.01.00_60/ts_136410v120100p.pdf">https://www.etsi.org/deliver/etsi_ts/136400_136499/136410/12.01.00_60/ts_136410v120100p.pdf</a>
TSDSI	TSDSI STD T1.3GPP 36.41-12.1.0 V1.0.0	12.1.0	Published	30.08.2021	<a href="https://members.tdsi.in/index.php/s/QiYJ2bd2rAHaSNc">https://members.tdsi.in/index.php/s/QiYJ2bd2rAHaSNc</a>
TTA	TTAT.3G-36.410V12.1.0	12.1.0	Published	02.08.2021	<a href="http://committee.tta.or.kr/data/ttasDown.jsp?kind=ttastd&amp;pk_num=TTAT.3G-36.410V12.1.0">http://committee.tta.or.kr/data/ttasDown.jsp?kind=ttastd&amp;pk_num=TTAT.3G-36.410V12.1.0</a>
TTC	TS-3GA-36.410(Rel12)v12.1.0	12.1.0	Published	05.03.2015	<a href="https://www.ttc.or.jp/st/docs/3gpps2015/TS/TS-3GA-36.410(Rel12)v12.1.0.pdf">https://www.ttc.or.jp/st/docs/3gpps2015/TS/TS-3GA-36.410(Rel12)v12.1.0.pdf</a>
<b>Release 13</b>					
ATIS	ATIS.3GPP.36.410V1300	13.0.0	Published	28.06.2021	<a href="https://www.atis.org/3gpp-documents/Rel99-14/">https://www.atis.org/3gpp-documents/Rel99-14/</a>
CCSA	CCSA.36.410V1300	13.0.0	Published	01.12.2015	<a href="https://www.ccsa.org.cn/api/portalsFile/downloadOldFile?type=19&amp;oldFileUrl=ITU-R/M.2012-6/CCSA.36.410V1300.doc">https://www.ccsa.org.cn/api/portalsFile/downloadOldFile?type=19&amp;oldFileUrl=ITU-R/M.2012-6/CCSA.36.410V1300.doc</a>
ETSI	ETSI TS 136 410	13.0.0	Published	21.01.2016	<a href="https://www.etsi.org/deliver/etsi_ts/136400_136499/136410/13.00.00_60/ts_136410v130000p.pdf">https://www.etsi.org/deliver/etsi_ts/136400_136499/136410/13.00.00_60/ts_136410v130000p.pdf</a>
TSDSI	TSDSI STD T1.3GPP 36.41-13.0.0 V1.0.0	13.0.0	Published	30.08.2021	<a href="https://members.tdsi.in/index.php/s/apkPye9jcExwoWw">https://members.tdsi.in/index.php/s/apkPye9jcExwoWw</a>
TTA	TTAT.3G-36.410V13.0.0	13.0.0	Published	02.08.2021	<a href="http://committee.tta.or.kr/data/ttasDown.jsp?kind=ttastd&amp;pk_num=TTAT.3G-36.410V13.0.0">http://committee.tta.or.kr/data/ttasDown.jsp?kind=ttastd&amp;pk_num=TTAT.3G-36.410V13.0.0</a>
TTC	TS-3GA-36.410(Rel13)v13.0.0	13.0.0	Published	31.03.2017	<a href="https://www.ttc.or.jp/st/docs/3gpps2017/TS/TS-3GA-36.410(Rel13)v13.0.0.pdf">https://www.ttc.or.jp/st/docs/3gpps2017/TS/TS-3GA-36.410(Rel13)v13.0.0.pdf</a>
<b>Release 14</b>					
ATIS	ATIS.3GPP.36.410V1400	14.0.0	Published	28.06.2021	<a href="https://www.atis.org/3gpp-documents/Rel99-14/">https://www.atis.org/3gpp-documents/Rel99-14/</a>
CCSA	CCSA.36.410V1400	14.0.0	Published	01.03.2017	<a href="https://www.ccsa.org.cn/api/portalsFile/downloadOldFile?type=19&amp;oldFileUrl=ITU-R/M.2012-6/CCSA.36.410V1400.doc">https://www.ccsa.org.cn/api/portalsFile/downloadOldFile?type=19&amp;oldFileUrl=ITU-R/M.2012-6/CCSA.36.410V1400.doc</a>
ETSI	ETSI TS 136 410	14.0.0	Published	11.04.2017	<a href="https://www.etsi.org/deliver/etsi_ts/136400_136499/136410/14.00.00_60/ts_136410v140000p.pdf">https://www.etsi.org/deliver/etsi_ts/136400_136499/136410/14.00.00_60/ts_136410v140000p.pdf</a>
TSDSI	TSDSI STD T1.3GPP 36.410-14.0.0 V1.0.0	14.0.0	Published	30.08.2021	<a href="https://members.tdsi.in/index.php/s/M7DNCyBrxNein2N">https://members.tdsi.in/index.php/s/M7DNCyBrxNein2N</a>
TTA	TTAT.3G-36.410V14.0.0	14.0.0	Published	02.08.2021	<a href="http://committee.tta.or.kr/data/ttasDown.jsp?kind=ttastd&amp;pk_num=TTAT.3G-36.410V14.0.0">http://committee.tta.or.kr/data/ttasDown.jsp?kind=ttastd&amp;pk_num=TTAT.3G-36.410V14.0.0</a>
TTC	TS-3GA-36.410(Rel14)v14.0.0	14.0.0	Published	13.04.2018	<a href="https://www.ttc.or.jp/st/docs/3gpps2018/TS/TS-3GA-36.410(Rel14)v14.0.0.pdf">https://www.ttc.or.jp/st/docs/3gpps2018/TS/TS-3GA-36.410(Rel14)v14.0.0.pdf</a>
<b>Release 15</b>					
ATIS	ATIS.3GPP.36.410V1500	15.0.0	Published	28.06.2021	<a href="https://www.atis.org/3gpp-documents/Rel15/">https://www.atis.org/3gpp-documents/Rel15/</a>
CCSA	CCSA.36.410V1500	15.0.0	Published	01.06.2018	<a href="https://www.ccsa.org.cn/api/portalsFile/downloadOldFile?type=19&amp;oldFileUrl=ITU-R/M.2012-6/CCSA.36.410V1500.doc">https://www.ccsa.org.cn/api/portalsFile/downloadOldFile?type=19&amp;oldFileUrl=ITU-R/M.2012-6/CCSA.36.410V1500.doc</a>
ETSI	ETSI TS 136 410	15.0.0	Published	04.07.2018	<a href="https://www.etsi.org/deliver/etsi_ts/136400_136499/136410/15.00.00_60/ts_136410v150000p.pdf">https://www.etsi.org/deliver/etsi_ts/136400_136499/136410/15.00.00_60/ts_136410v150000p.pdf</a>
TSDSI	TSDSI STD T1.3GPP 36.410-15.0.0 V1.0.0	15.0.0	Published	30.08.2021	<a href="https://members.tdsi.in/index.php/s/wLNHBt3xXET4Rk3">https://members.tdsi.in/index.php/s/wLNHBt3xXET4Rk3</a>
TTA	TTAT.3G-36.410V15.0.0	15.0.0	Published	11.09.2020	<a href="http://committee.tta.or.kr/data/ttasDown.jsp?kind=ttastd&amp;pk_num=TTAT.3G-36.410V15.0.0">http://committee.tta.or.kr/data/ttasDown.jsp?kind=ttastd&amp;pk_num=TTAT.3G-36.410V15.0.0</a>
TTC	TS-3GA-36.410(Rel15)v15.0.0	15.0.0	Published	28.09.2018	<a href="https://www.ttc.or.jp/st/docs/3gpps2018/TS/TS-3GA-36.410(Rel15)v15.0.0.pdf">https://www.ttc.or.jp/st/docs/3gpps2018/TS/TS-3GA-36.410(Rel15)v15.0.0.pdf</a>
<b>Release 16</b>					
ATIS	ATIS.3GPP.36.410V1600	16.0.0	Published	28.06.2021	<a href="https://www.atis.org/3gpp-documents/Rel16/">https://www.atis.org/3gpp-documents/Rel16/</a>
CCSA	CCSA.36.410V1600	16.0.0	Published	01.07.2020	<a href="https://www.ccsa.org.cn/api/portalsFile/downloadOldFile?type=19&amp;oldFileUrl=ITU-R/M.2012-6/CCSA.36.410V1600.doc">https://www.ccsa.org.cn/api/portalsFile/downloadOldFile?type=19&amp;oldFileUrl=ITU-R/M.2012-6/CCSA.36.410V1600.doc</a>
ETSI	ETSI TS 136 410	16.0.0	Published	21.07.2020	<a href="https://www.etsi.org/deliver/etsi_ts/136400_136499/136410/16.00.00_60/ts_136410v160000p.pdf">https://www.etsi.org/deliver/etsi_ts/136400_136499/136410/16.00.00_60/ts_136410v160000p.pdf</a>
TSDSI	TSDSI STD T1.3GPP 36.410-16.0.0 V1.0.0	16.0.0	Published	30.08.2021	<a href="https://members.tdsi.in/index.php/s/yjep3ZKHsSgSbL">https://members.tdsi.in/index.php/s/yjep3ZKHsSgSbL</a>
TTA	TTAT.3G-36.410V16.0.0	16.0.0	Published	11.09.2020	<a href="http://committee.tta.or.kr/data/ttasDown.jsp?kind=ttastd&amp;pk_num=TTAT.3G-36.410V16.0.0">http://committee.tta.or.kr/data/ttasDown.jsp?kind=ttastd&amp;pk_num=TTAT.3G-36.410V16.0.0</a>
TTC	TS-3GA-36.410(Rel16)v16.0.0	16.0.0	Published	02.10.2020	<a href="https://www.ttc.or.jp/st/docs/3gpps2020/TS/TS-3GA-36.410_Rel16v16.0.0.pdf">https://www.ttc.or.jp/st/docs/3gpps2020/TS/TS-3GA-36.410_Rel16v16.0.0.pdf</a>

## Release 17

ATIS	ATIS.3GPP.36.410.V17.0.0	17.0.0	Published	21.02.2023	<a href="https://www.atis.org/3gpp-transpositions - Rel-17">https://www.atis.org/3gpp-transpositions - Rel-17</a>
CCSA	CCSA.36.410V1700	17.0.0	Published	01.04.2022	<a href="https://www.ccsa.org.cn/api/portalsFile/downloadOldFile?type=19&amp;oldFileUrl=ITU-R/M.2012-6/CCSA.36.410V1700.doc">https://www.ccsa.org.cn/api/portalsFile/downloadOldFile?type=19&amp;oldFileUrl=ITU-R/M.2012-6/CCSA.36.410V1700.doc</a>
ETSI	ETSI TS 136 410	17.0.0	Published	02.05.2022	<a href="https://www.etsi.org/deliver/etsi_ts/136400_136499/136410/17.00.00_60/ts_136410v170000p.pdf">https://www.etsi.org/deliver/etsi_ts/136400_136499/136410/17.00.00_60/ts_136410v170000p.pdf</a>
TSDSI	TSDSI STD T1.3GPP 36.41-17.0.0 V1.0.0	17.0.0	Published	29.07.2022	<a href="https://members.tdsi.in/s/NqFA6jnE7EBY43o">https://members.tdsi.in/s/NqFA6jnE7EBY43o</a>
TTA	TTAT.3G-36.410V17.0.0	17.0.0	Published	05.08.2022	<a href="http://committee.tta.or.kr/data/ttasDown.jsp?kind=ttastd&amp;pk_num=TTAT.3G-36.410V17.0.0">http://committee.tta.or.kr/data/ttasDown.jsp?kind=ttastd&amp;pk_num=TTAT.3G-36.410V17.0.0</a>
TTC	TS-3GA-36.410(Rel17)v17.0.0	17.0.0	Published	07.10.2022	<a href="https://www.ttc.or.jp/st/docs/3gpp/2022/TS/TS-3GA-36.410v17.0.0.pdf">https://www.ttc.or.jp/st/docs/3gpp/2022/TS/TS-3GA-36.410v17.0.0.pdf</a>

## 2.1.4.3 TS 36.411

## Evolved Universal Terrestrial Radio Access Network (E-UTRAN); S1 layer 1

This document specifies the standards allowed to implement layer 1 on the S1 interface. The specification of transmission delay requirements and O&M requirements are not in the scope of this document. In the following, “layer 1” and “physical layer” are assumed to be synonymous.

SDO	Document No.	Version	Status	Issued date	Location
<b>Release 10</b>					
ATIS	ATIS.3GPP.36.411V1010	10.1.0	Published	28.06.2021	<a href="https://www.atis.org/3gpp-documents/Rel99-14/">https://www.atis.org/3gpp-documents/Rel99-14/</a>
CCSA	CCSA.36.411V1010	10.1.0	Published	01.06.2011	<a href="https://www.ccsa.org.cn/api/portalsFile/downloadOldFile?type=19&amp;oldFileUrl=ITU-R/M.2012-6/CCSA.36.411V1010.doc">https://www.ccsa.org.cn/api/portalsFile/downloadOldFile?type=19&amp;oldFileUrl=ITU-R/M.2012-6/CCSA.36.411V1010.doc</a>
ETSI	ETSI TS 136 411	10.1.0	Published	30.06.2011	<a href="https://www.etsi.org/deliver/etsi_ts/136400_136499/136411/10.01.00_60/ts_136411v100100p.pdf">https://www.etsi.org/deliver/etsi_ts/136400_136499/136411/10.01.00_60/ts_136411v100100p.pdf</a>
TSDSI	TSDSI STD T1.3GPP 36.411-10.1.0 V1.0.0	10.1.0	Published	30.08.2021	<a href="https://members.tdsi.in/index.php/s/NqJrPasswMRgink">https://members.tdsi.in/index.php/s/NqJrPasswMRgink</a>
TTA	TTAT.3G-36.411V10.1.0	10.1.0	Published	02.08.2021	<a href="http://committee.tta.or.kr/data/ttasDown.jsp?kind=ttastd&amp;pk_num=TTAT.3G-36.411V10.1.0">http://committee.tta.or.kr/data/ttasDown.jsp?kind=ttastd&amp;pk_num=TTAT.3G-36.411V10.1.0</a>
TTC	TS-3GA-36.411(Rel10)v10.1.0	10.1.0	Published	31.08.2011	<a href="https://www.ttc.or.jp/st/docs/3gpps2011/TS/TS-3GA-36.411(Rel10)v10.1.0.pdf">https://www.ttc.or.jp/st/docs/3gpps2011/TS/TS-3GA-36.411(Rel10)v10.1.0.pdf</a>
<b>Release 11</b>					
ATIS	ATIS.3GPP.36.411V1100	11.0.0	Published	28.06.2021	<a href="https://www.atis.org/3gpp-documents/Rel99-14/">https://www.atis.org/3gpp-documents/Rel99-14/</a>
CCSA	CCSA.36.411V1100	11.0.0	Published	01.09.2012	<a href="https://www.ccsa.org.cn/api/portalsFile/downloadOldFile?type=19&amp;oldFileUrl=ITU-R/M.2012-6/CCSA.36.411V1100.doc">https://www.ccsa.org.cn/api/portalsFile/downloadOldFile?type=19&amp;oldFileUrl=ITU-R/M.2012-6/CCSA.36.411V1100.doc</a>
ETSI	ETSI TS 136 411	11.0.0	Published	18.10.2012	<a href="https://www.etsi.org/deliver/etsi_ts/136400_136499/136411/11.00.00_60/ts_136411v110000p.pdf">https://www.etsi.org/deliver/etsi_ts/136400_136499/136411/11.00.00_60/ts_136411v110000p.pdf</a>
TSDSI	TSDSI STD T1.3GPP 36.411-11.0.0 V1.0.0	11.0.0	Published	30.08.2021	<a href="https://members.tdsi.in/index.php/s/TixPjqJfq3792NY">https://members.tdsi.in/index.php/s/TixPjqJfq3792NY</a>
TTA	TTAT.3G-36.411V11.0.0	11.0.0	Published	02.08.2021	<a href="http://committee.tta.or.kr/data/ttasDown.jsp?kind=ttastd&amp;pk_num=TTAT.3G-36.411V11.0.0">http://committee.tta.or.kr/data/ttasDown.jsp?kind=ttastd&amp;pk_num=TTAT.3G-36.411V11.0.0</a>
TTC	TS-3GA-36.411(Rel11)v11.0.0	11.0.0	Published	25.06.2013	<a href="https://www.ttc.or.jp/st/docs/3gpps2013/TS/TS-3GA-36.411(Rel11)v11.0.0.pdf">https://www.ttc.or.jp/st/docs/3gpps2013/TS/TS-3GA-36.411(Rel11)v11.0.0.pdf</a>
<b>Release 12</b>					
ATIS	ATIS.3GPP.36.411V1200	12.0.0	Published	28.06.2021	<a href="https://www.atis.org/3gpp-documents/Rel99-14/">https://www.atis.org/3gpp-documents/Rel99-14/</a>
CCSA	CCSA.36.411V1200	12.0.0	Published	01.09.2014	<a href="https://www.ccsa.org.cn/api/portalsFile/downloadOldFile?type=19&amp;oldFileUrl=ITU-R/M.2012-6/CCSA.36.411V1200.doc">https://www.ccsa.org.cn/api/portalsFile/downloadOldFile?type=19&amp;oldFileUrl=ITU-R/M.2012-6/CCSA.36.411V1200.doc</a>
ETSI	ETSI TS 136 411	12.0.0	Published	25.09.2014	<a href="https://www.etsi.org/deliver/etsi_ts/136400_136499/136411/12.00.00_60/ts_136411v120000p.pdf">https://www.etsi.org/deliver/etsi_ts/136400_136499/136411/12.00.00_60/ts_136411v120000p.pdf</a>
TSDSI	TSDSI STD T1.3GPP 36.411-12.0.0 V1.0.0	12.0.0	Published	30.08.2021	<a href="https://members.tdsi.in/index.php/s/CKjMft8Cm5bs4Pm">https://members.tdsi.in/index.php/s/CKjMft8Cm5bs4Pm</a>
TTA	TTAT.3G-36.411V12.0.0	12.0.0	Published	02.08.2021	<a href="http://committee.tta.or.kr/data/ttasDown.jsp?kind=ttastd&amp;pk_num=TTAT.3G-36.411V12.0.0">http://committee.tta.or.kr/data/ttasDown.jsp?kind=ttastd&amp;pk_num=TTAT.3G-36.411V12.0.0</a>
TTC	TS-3GA-36.411(Rel12)v12.0.0	12.0.0	Published	05.03.2015	<a href="https://www.ttc.or.jp/st/docs/3gpps2015/TS/TS-3GA-36.411(Rel12)v12.0.0.pdf">https://www.ttc.or.jp/st/docs/3gpps2015/TS/TS-3GA-36.411(Rel12)v12.0.0.pdf</a>
<b>Release 13</b>					
ATIS	ATIS.3GPP.36.411V1300	13.0.0	Published	28.06.2021	<a href="https://www.atis.org/3gpp-documents/Rel99-14/">https://www.atis.org/3gpp-documents/Rel99-14/</a>
CCSA	CCSA.36.411V1300	13.0.0	Published	01.12.2015	<a href="https://www.ccsa.org.cn/api/portalsFile/downloadOldFile?type=19&amp;oldFileUrl=ITU-R/M.2012-6/CCSA.36.411V1300.doc">https://www.ccsa.org.cn/api/portalsFile/downloadOldFile?type=19&amp;oldFileUrl=ITU-R/M.2012-6/CCSA.36.411V1300.doc</a>
ETSI	ETSI TS 136 411	13.0.0	Published	21.01.2016	<a href="https://www.etsi.org/deliver/etsi_ts/136400_136499/136411/13.00.00_60/ts_136411v130000p.pdf">https://www.etsi.org/deliver/etsi_ts/136400_136499/136411/13.00.00_60/ts_136411v130000p.pdf</a>
TSDSI	TSDSI STD T1.3GPP 36.411-13.0.0 V1.0.0	13.0.0	Published	30.08.2021	<a href="https://members.tdsi.in/index.php/s/pGE3oTrZ7xMWRk">https://members.tdsi.in/index.php/s/pGE3oTrZ7xMWRk</a>
TTA	TTAT.3G-36.411V13.0.0	13.0.0	Published	02.08.2021	<a href="http://committee.tta.or.kr/data/ttasDown.jsp?kind=ttastd&amp;pk_num=TTAT.3G-36.411V13.0.0">http://committee.tta.or.kr/data/ttasDown.jsp?kind=ttastd&amp;pk_num=TTAT.3G-36.411V13.0.0</a>
TTC	TS-3GA-36.411(Rel13)v13.0.0	13.0.0	Published	31.03.2017	<a href="https://www.ttc.or.jp/st/docs/3gpps2017/TS/TS-3GA-36.411(Rel13)v13.0.0.pdf">https://www.ttc.or.jp/st/docs/3gpps2017/TS/TS-3GA-36.411(Rel13)v13.0.0.pdf</a>

<b>Release 14</b>						
ATIS	ATIS.3GPP.36.411V1400	14.0.0	Published	28.06.2021	<a href="https://www.atis.org/3gpp-documents/Rel99-14/">https://www.atis.org/3gpp-documents/Rel99-14/</a>	
CCSA	CCSA.36.411V1400	14.0.0	Published	01.03.2017	<a href="https://www.ccsa.org.cn/api/portalsFile/downloadOldFile?type=19&amp;oldFileUrl=ITU-R/M.2012-6/CCSA.36.411V1400.doc">https://www.ccsa.org.cn/api/portalsFile/downloadOldFile?type=19&amp;oldFileUrl=ITU-R/M.2012-6/CCSA.36.411V1400.doc</a>	
ETSI	ETSI TS 136 411	14.0.0	Published	11.04.2017	<a href="https://www.etsi.org/deliver/etsi_ts/136400_136499/136411/14.00.00_60/ts_136411v140000p.pdf">https://www.etsi.org/deliver/etsi_ts/136400_136499/136411/14.00.00_60/ts_136411v140000p.pdf</a>	
TSDSI	TSDSI STD T1.3GPP 36.411-14.0.0 V1.0.0	14.0.0	Published	30.08.2021	<a href="https://members.tdsi.in/index.php/s/P7HzopDTN3Yin83">https://members.tdsi.in/index.php/s/P7HzopDTN3Yin83</a>	
TTA	TTAT.3G-36.411V14.0.0	14.0.0	Published	02.08.2021	<a href="http://committee.tta.or.kr/data/ttasDown.jsp?kind=ttastd&amp;pk_num=TTAT.3G-36.411V14.0.0">http://committee.tta.or.kr/data/ttasDown.jsp?kind=ttastd&amp;pk_num=TTAT.3G-36.411V14.0.0</a>	
TTC	TS-3GA-36.411(Rel14)v14.0.0	14.0.0	Published	13.04.2018	<a href="https://www.ttc.or.jp/st/docs/3gpps2018/TS/TS-3GA-36.411(Rel14)v14.0.0.pdf">https://www.ttc.or.jp/st/docs/3gpps2018/TS/TS-3GA-36.411(Rel14)v14.0.0.pdf</a>	
<b>Release 15</b>						
ATIS	ATIS.3GPP.36.411V1500	15.0.0	Published	28.06.2021	<a href="https://www.atis.org/3gpp-documents/Rel15/">https://www.atis.org/3gpp-documents/Rel15/</a>	
CCSA	CCSA.36.411V1500	15.0.0	Published	01.06.2018	<a href="https://www.ccsa.org.cn/api/portalsFile/downloadOldFile?type=19&amp;oldFileUrl=ITU-R/M.2012-6/CCSA.36.411V1500.doc">https://www.ccsa.org.cn/api/portalsFile/downloadOldFile?type=19&amp;oldFileUrl=ITU-R/M.2012-6/CCSA.36.411V1500.doc</a>	
ETSI	ETSI TS 136 411	15.0.0	Published	04.07.2018	<a href="https://www.etsi.org/deliver/etsi_ts/136400_136499/136411/15.00.00_60/ts_136411v150000p.pdf">https://www.etsi.org/deliver/etsi_ts/136400_136499/136411/15.00.00_60/ts_136411v150000p.pdf</a>	
TSDSI	TSDSI STD T1.3GPP 36.411-15.0.0 V1.0.0	15.0.0	Published	30.08.2021	<a href="https://members.tdsi.in/index.php/s/PckqmjFsPC5dGj4">https://members.tdsi.in/index.php/s/PckqmjFsPC5dGj4</a>	
TTA	TTAT.3G-36.411V15.0.0	15.0.0	Published	11.09.2020	<a href="http://committee.tta.or.kr/data/ttasDown.jsp?kind=ttastd&amp;pk_num=TTAT.3G-36.411V15.0.0">http://committee.tta.or.kr/data/ttasDown.jsp?kind=ttastd&amp;pk_num=TTAT.3G-36.411V15.0.0</a>	
TTC	TS-3GA-36.411(Rel15)v15.0.0	15.0.0	Published	28.09.2018	<a href="https://www.ttc.or.jp/st/docs/3gpps2018/TS/TS-3GA-36.411(Rel15)v15.0.0.pdf">https://www.ttc.or.jp/st/docs/3gpps2018/TS/TS-3GA-36.411(Rel15)v15.0.0.pdf</a>	
<b>Release 16</b>						
ATIS	ATIS.3GPP.36.411V1600	16.0.0	Published	28.06.2021	<a href="https://www.atis.org/3gpp-documents/Rel16/">https://www.atis.org/3gpp-documents/Rel16/</a>	
CCSA	CCSA.36.411V1600	16.0.0	Published	01.07.2020	<a href="https://www.ccsa.org.cn/api/portalsFile/downloadOldFile?type=19&amp;oldFileUrl=ITU-R/M.2012-6/CCSA.36.411V1600.doc">https://www.ccsa.org.cn/api/portalsFile/downloadOldFile?type=19&amp;oldFileUrl=ITU-R/M.2012-6/CCSA.36.411V1600.doc</a>	
ETSI	ETSI TS 136 411	16.0.0	Published	21.07.2020	<a href="https://www.etsi.org/deliver/etsi_ts/136400_136499/136411/16.00.00_60/ts_136411v160000p.pdf">https://www.etsi.org/deliver/etsi_ts/136400_136499/136411/16.00.00_60/ts_136411v160000p.pdf</a>	
TSDSI	TSDSI STD T1.3GPP 36.411-16.0.0 V1.0.0	16.0.0	Published	30.08.2021	<a href="https://members.tdsi.in/index.php/s/3CXRFYt7DZHE7Nw">https://members.tdsi.in/index.php/s/3CXRFYt7DZHE7Nw</a>	
TTA	TTAT.3G-36.411V16.0.0	16.0.0	Published	11.09.2020	<a href="http://committee.tta.or.kr/data/ttasDown.jsp?kind=ttastd&amp;pk_num=TTAT.3G-36.411V16.0.0">http://committee.tta.or.kr/data/ttasDown.jsp?kind=ttastd&amp;pk_num=TTAT.3G-36.411V16.0.0</a>	
TTC	TS-3GA-36.411(Rel16)v16.0.0	16.0.0	Published	02.10.2020	<a href="https://www.ttc.or.jp/st/docs/3gpps2020/TS/TS-3GA-36_411_Rel16v16_0_0.pdf">https://www.ttc.or.jp/st/docs/3gpps2020/TS/TS-3GA-36_411_Rel16v16_0_0.pdf</a>	
<b>Release 17</b>						
ATIS	ATIS.3GPP.36.411.V17.0.0	17.0.0	Published	21.02.2023	<a href="https://www.atis.org/3gpp-transpositions - Rel-17">https://www.atis.org/3gpp-transpositions - Rel-17</a>	
CCSA	CCSA.36.411V1700	17.0.0	Published	01.04.2022	<a href="https://www.ccsa.org.cn/api/portalsFile/downloadOldFile?type=19&amp;oldFileUrl=ITU-R/M.2012-6/CCSA.36.411V1700.doc">https://www.ccsa.org.cn/api/portalsFile/downloadOldFile?type=19&amp;oldFileUrl=ITU-R/M.2012-6/CCSA.36.411V1700.doc</a>	
ETSI	ETSI TS 136 411	17.0.0	Published	02.05.2022	<a href="https://www.etsi.org/deliver/etsi_ts/136400_136499/136411/17.00.00_60/ts_136411v170000p.pdf">https://www.etsi.org/deliver/etsi_ts/136400_136499/136411/17.00.00_60/ts_136411v170000p.pdf</a>	
TSDSI	TSDSI STD T1.3GPP 36.411-17.0.0 V1.0.0	17.0.0	Published	29.07.2022	<a href="https://members.tdsi.in/s/Ky565mPKGTMCSr">https://members.tdsi.in/s/Ky565mPKGTMCSr</a>	
TTA	TTAT.3G-36.411V17.0.0	17.0.0	Published	05.08.2022	<a href="http://committee.tta.or.kr/data/ttasDown.jsp?kind=ttastd&amp;pk_num=TTAT.3G-36.411V17.0.0">http://committee.tta.or.kr/data/ttasDown.jsp?kind=ttastd&amp;pk_num=TTAT.3G-36.411V17.0.0</a>	
TTC	TS-3GA-36.411(Rel17)v17.0.0	17.0.0	Published	07.10.2022	<a href="https://www.ttc.or.jp/st/docs/3gpp/2022/TS/TS-3GA-36.411v17.0.0.pdf">https://www.ttc.or.jp/st/docs/3gpp/2022/TS/TS-3GA-36.411v17.0.0.pdf</a>	

#### 2.1.4.4 TS 36.412

### Evolved Universal Terrestrial Radio Access Network (E-UTRAN); S1 signalling transport

This document specifies the standards for signalling transport to be used across S1 interface. S1 interface is a logical interface between the eNodeB and the E-UTRAN core network. This document describes how the S1-AP signalling messages are transported over S1.

SDO	Document No.	Version	Status	Issued date	Location
<b>Release 10</b>					
ATIS	ATIS.3GPP.36.412V1010	10.1.0	Published	28.06.2021	<a href="https://www.atis.org/3gpp-documents/Rel99-14/">https://www.atis.org/3gpp-documents/Rel99-14/</a>
CCSA	CCSA.36.412V1010	10.1.0	Published	01.06.2011	<a href="https://www.ccsa.org.cn/api/portalsFile/downloadOldFile?type=19&amp;oldFileUrl=ITU-R/M.2012-6/CCSA.36.412V1010.doc">https://www.ccsa.org.cn/api/portalsFile/downloadOldFile?type=19&amp;oldFileUrl=ITU-R/M.2012-6/CCSA.36.412V1010.doc</a>
ETSI	ETSI TS 136 412	10.1.0	Published	30.06.2011	<a href="https://www.etsi.org/deliver/etsi_ts/136400_136499/136412/10.01.00_60/ts_136412v100100p.pdf">https://www.etsi.org/deliver/etsi_ts/136400_136499/136412/10.01.00_60/ts_136412v100100p.pdf</a>
TSDSI	TSDSI STD T1.3GPP 36.412-10.1.0 V1.0.0	10.1.0	Published	30.08.2021	<a href="https://members.tdsi.in/index.php/s/XTrKKa9Yqd4JqtW">https://members.tdsi.in/index.php/s/XTrKKa9Yqd4JqtW</a>
TTA	TTAT.3G-36.412V10.1.0	10.1.0	Published	02.08.2021	<a href="http://committee.tta.or.kr/data/ttasDown.jsp?kind=ttastd&amp;pk_num=TTAT.3G-36.412V10.1.0">http://committee.tta.or.kr/data/ttasDown.jsp?kind=ttastd&amp;pk_num=TTAT.3G-36.412V10.1.0</a>
TTC	TS-3GA-36.412(Rel10)v10.1.0	10.1.0	Published	31.08.2011	<a href="https://www.ttc.or.jp/st/docs/3gpps2011/TS/TS-3GA-36.412(Rel10)v10.1.0.pdf">https://www.ttc.or.jp/st/docs/3gpps2011/TS/TS-3GA-36.412(Rel10)v10.1.0.pdf</a>

## 58

## Rec. ITU-R M.2012-6

Release 11								
ATIS	ATIS.3GPP.36.412V1100	11.0.0	Published	28.06.2021	<a href="https://www.atis.org/3gpp-documents/Rel99-14/">https://www.atis.org/3gpp-documents/Rel99-14/</a>			
CCSA	CCSA.36.412V1100	11.0.0	Published	01.09.2012	<a href="https://www.ccsa.org.cn/api/portalsFile/downloadOldFile?type=19&amp;oldFileUrl=ITU-R/M.2012-6/CCSA.36.412V1100.doc">https://www.ccsa.org.cn/api/portalsFile/downloadOldFile?type=19&amp;oldFileUrl=ITU-R/M.2012-6/CCSA.36.412V1100.doc</a>			
ETSI	ETSI TS 136 412	11.0.0	Published	18.10.2012	<a href="https://www.etsi.org/deliver/etsi_ts/136400_136499/136412/11.00.00_60/ts_136412v110000p.pdf">https://www.etsi.org/deliver/etsi_ts/136400_136499/136412/11.00.00_60/ts_136412v110000p.pdf</a>			
TSDSI	TSDSI STD T1.3GPP 36.412-11.0.0 V1.0.0	11.0.0	Published	30.08.2021	<a href="https://members.tdsi.in/index.php/s/p8mxwmnS84F8ntW">https://members.tdsi.in/index.php/s/p8mxwmnS84F8ntW</a>			
TTA	TTAT.3G-36.412V11.0.0	11.0.0	Published	02.08.2021	<a href="http://committee.tta.or.kr/data/ttasDown.jsp?kind=ttastd&amp;pk_num=TTAT.3G-36.412V11.0.0">http://committee.tta.or.kr/data/ttasDown.jsp?kind=ttastd&amp;pk_num=TTAT.3G-36.412V11.0.0</a>			
TTC	TS-3GA-36.412(Rel11)v11.0.0	11.0.0	Published	25.06.2013	<a href="https://www.ttc.or.jp/st/docs/3gpps2013/TS/TS-3GA-36.412(Rel11)v11.0.0.pdf">https://www.ttc.or.jp/st/docs/3gpps2013/TS/TS-3GA-36.412(Rel11)v11.0.0.pdf</a>			
Release 12								
ATIS	ATIS.3GPP.36.412V1200	12.0.0	Published	28.06.2021	<a href="https://www.atis.org/3gpp-documents/Rel99-14/">https://www.atis.org/3gpp-documents/Rel99-14/</a>			
CCSA	CCSA.36.412V1200	12.0.0	Published	01.09.2014	<a href="https://www.ccsa.org.cn/api/portalsFile/downloadOldFile?type=19&amp;oldFileUrl=ITU-R/M.2012-6/CCSA.36.412V1200.doc">https://www.ccsa.org.cn/api/portalsFile/downloadOldFile?type=19&amp;oldFileUrl=ITU-R/M.2012-6/CCSA.36.412V1200.doc</a>			
ETSI	ETSI TS 136 412	12.0.0	Published	25.09.2014	<a href="https://www.etsi.org/deliver/etsi_ts/136400_136499/136412/12.00.00_60/ts_136412v120000p.pdf">https://www.etsi.org/deliver/etsi_ts/136400_136499/136412/12.00.00_60/ts_136412v120000p.pdf</a>			
TSDSI	TSDSI STD T1.3GPP 36.412-12.0.0 V1.0.0	12.0.0	Published	30.08.2021	<a href="https://members.tdsi.in/index.php/s/oJeSp7rBNygQDSt">https://members.tdsi.in/index.php/s/oJeSp7rBNygQDSt</a>			
TTA	TTAT.3G-36.412V12.0.0	12.0.0	Published	02.08.2021	<a href="http://committee.tta.or.kr/data/ttasDown.jsp?kind=ttastd&amp;pk_num=TTAT.3G-36.412V12.0.0">http://committee.tta.or.kr/data/ttasDown.jsp?kind=ttastd&amp;pk_num=TTAT.3G-36.412V12.0.0</a>			
TTC	TS-3GA-36.412(Rel12)v12.0.0	12.0.0	Published	05.03.2015	<a href="https://www.ttc.or.jp/st/docs/3gpps2015/TS/TS-3GA-36.412(Rel12)v12.0.0.pdf">https://www.ttc.or.jp/st/docs/3gpps2015/TS/TS-3GA-36.412(Rel12)v12.0.0.pdf</a>			
Release 13								
ATIS	ATIS.3GPP.36.412V1300	13.0.0	Published	28.06.2021	<a href="https://www.atis.org/3gpp-documents/Rel99-14/">https://www.atis.org/3gpp-documents/Rel99-14/</a>			
CCSA	CCSA.36.412V1300	13.0.0	Published	01.12.2015	<a href="https://www.ccsa.org.cn/api/portalsFile/downloadOldFile?type=19&amp;oldFileUrl=ITU-R/M.2012-6/CCSA.36.412V1300.doc">https://www.ccsa.org.cn/api/portalsFile/downloadOldFile?type=19&amp;oldFileUrl=ITU-R/M.2012-6/CCSA.36.412V1300.doc</a>			
ETSI	ETSI TS 136 412	13.0.0	Published	21.01.2016	<a href="https://www.etsi.org/deliver/etsi_ts/136400_136499/136412/13.00.00_60/ts_136412v130000p.pdf">https://www.etsi.org/deliver/etsi_ts/136400_136499/136412/13.00.00_60/ts_136412v130000p.pdf</a>			
TSDSI	TSDSI STD T1.3GPP 36.412-13.0.0 V1.0.0	13.0.0	Published	30.08.2021	<a href="https://members.tdsi.in/index.php/s/CWAa9gXX5CxjW6Q">https://members.tdsi.in/index.php/s/CWAa9gXX5CxjW6Q</a>			
TTA	TTAT.3G-36.412V13.0.0	13.0.0	Published	02.08.2021	<a href="http://committee.tta.or.kr/data/ttasDown.jsp?kind=ttastd&amp;pk_num=TTAT.3G-36.412V13.0.0">http://committee.tta.or.kr/data/ttasDown.jsp?kind=ttastd&amp;pk_num=TTAT.3G-36.412V13.0.0</a>			
TTC	TS-3GA-36.412(Rel13)v13.0.0	13.0.0	Published	31.03.2017	<a href="https://www.ttc.or.jp/st/docs/3gpps2017/TS/TS-3GA-36.412(Rel13)v13.0.0.pdf">https://www.ttc.or.jp/st/docs/3gpps2017/TS/TS-3GA-36.412(Rel13)v13.0.0.pdf</a>			
Release 14								
ATIS	ATIS.3GPP.36.412V1400	14.0.0	Published	28.06.2021	<a href="https://www.atis.org/3gpp-documents/Rel99-14/">https://www.atis.org/3gpp-documents/Rel99-14/</a>			
CCSA	CCSA.36.412V1400	14.0.0	Published	01.03.2017	<a href="https://www.ccsa.org.cn/api/portalsFile/downloadOldFile?type=19&amp;oldFileUrl=ITU-R/M.2012-6/CCSA.36.412V1400.doc">https://www.ccsa.org.cn/api/portalsFile/downloadOldFile?type=19&amp;oldFileUrl=ITU-R/M.2012-6/CCSA.36.412V1400.doc</a>			
ETSI	ETSI TS 136 412	14.0.0	Published	11.04.2017	<a href="https://www.etsi.org/deliver/etsi_ts/136400_136499/136412/14.00.00_60/ts_136412v140000p.pdf">https://www.etsi.org/deliver/etsi_ts/136400_136499/136412/14.00.00_60/ts_136412v140000p.pdf</a>			
TSDSI	TSDSI STD T1.3GPP 36.412-14.0.0 V1.0.0	14.0.0	Published	30.08.2021	<a href="https://members.tdsi.in/index.php/s/SNnHLLGiFo5a6n">https://members.tdsi.in/index.php/s/SNnHLLGiFo5a6n</a>			
TTA	TTAT.3G-36.412V14.0.0	14.0.0	Published	02.08.2021	<a href="http://committee.tta.or.kr/data/ttasDown.jsp?kind=ttastd&amp;pk_num=TTAT.3G-36.412V14.0.0">http://committee.tta.or.kr/data/ttasDown.jsp?kind=ttastd&amp;pk_num=TTAT.3G-36.412V14.0.0</a>			
TTC	TS-3GA-36.412(Rel14)v14.0.0	14.0.0	Published	13.04.2018	<a href="https://www.ttc.or.jp/st/docs/3gpps2018/TS/TS-3GA-36.412(Rel14)v14.0.0.pdf">https://www.ttc.or.jp/st/docs/3gpps2018/TS/TS-3GA-36.412(Rel14)v14.0.0.pdf</a>			
Release 15								
ATIS	ATIS.3GPP.36.412V1500	15.0.0	Published	28.06.2021	<a href="https://www.atis.org/3gpp-documents/Rel15/">https://www.atis.org/3gpp-documents/Rel15/</a>			
CCSA	CCSA.36.412V1500	15.0.0	Published	01.06.2018	<a href="https://www.ccsa.org.cn/api/portalsFile/downloadOldFile?type=19&amp;oldFileUrl=ITU-R/M.2012-6/CCSA.36.412V1500.doc">https://www.ccsa.org.cn/api/portalsFile/downloadOldFile?type=19&amp;oldFileUrl=ITU-R/M.2012-6/CCSA.36.412V1500.doc</a>			
ETSI	ETSI TS 136 412	15.0.0	Published	04.07.2018	<a href="https://www.etsi.org/deliver/etsi_ts/136400_136499/136412/15.00.00_60/ts_136412v150000p.pdf">https://www.etsi.org/deliver/etsi_ts/136400_136499/136412/15.00.00_60/ts_136412v150000p.pdf</a>			
TSDSI	TSDSI STD T1.3GPP 36.412-15.0.0 V1.0.0	15.0.0	Published	30.08.2021	<a href="https://members.tdsi.in/index.php/s/3CxGHsojZ4fBy94">https://members.tdsi.in/index.php/s/3CxGHsojZ4fBy94</a>			
TTA	TTAT.3G-36.412V15.0.0	15.0.0	Published	11.09.2020	<a href="http://committee.tta.or.kr/data/ttasDown.jsp?kind=ttastd&amp;pk_num=TTAT.3G-36.412V15.0.0">http://committee.tta.or.kr/data/ttasDown.jsp?kind=ttastd&amp;pk_num=TTAT.3G-36.412V15.0.0</a>			
TTC	TS-3GA-36.412(Rel15)v15.0.0	15.0.0	Published	28.09.2018	<a href="https://www.ttc.or.jp/st/docs/3gpps2018/TS/TS-3GA-36.412(Rel15)v15.0.0.pdf">https://www.ttc.or.jp/st/docs/3gpps2018/TS/TS-3GA-36.412(Rel15)v15.0.0.pdf</a>			
Release 16								
ATIS	ATIS.3GPP.36.412V1600	16.0.0	Published	28.06.2021	<a href="https://www.atis.org/3gpp-documents/Rel16/">https://www.atis.org/3gpp-documents/Rel16/</a>			
CCSA	CCSA.36.412V1600	16.0.0	Published	01.03.2020	<a href="https://www.ccsa.org.cn/api/portalsFile/downloadOldFile?type=19&amp;oldFileUrl=ITU-R/M.2012-6/CCSA.36.412V1600.doc">https://www.ccsa.org.cn/api/portalsFile/downloadOldFile?type=19&amp;oldFileUrl=ITU-R/M.2012-6/CCSA.36.412V1600.doc</a>			
ETSI	ETSI TS 136 412	16.0.0	Published	21.09.2020	<a href="https://www.etsi.org/deliver/etsi_ts/136400_136499/136412/16.00.00_60/ts_136412v160000p.pdf">https://www.etsi.org/deliver/etsi_ts/136400_136499/136412/16.00.00_60/ts_136412v160000p.pdf</a>			
TSDSI	TSDSI STD T1.3GPP 36.412-16.0.0 V1.0.0	16.0.0	Published	30.08.2021	<a href="https://members.tdsi.in/index.php/s/cw7yJaBMg3baAbQ">https://members.tdsi.in/index.php/s/cw7yJaBMg3baAbQ</a>			
TTA	TTAT.3G-36.412V16.0.0	16.0.0	Published	11.09.2020	<a href="http://committee.tta.or.kr/data/ttasDown.jsp?kind=ttastd&amp;pk_num=TTAT.3G-36.412V16.0.0">http://committee.tta.or.kr/data/ttasDown.jsp?kind=ttastd&amp;pk_num=TTAT.3G-36.412V16.0.0</a>			
TTC	TS-3GA-36.412(Rel16)v16.0.0	16.0.0	Published	02.10.2020	<a href="https://www.ttc.or.jp/st/docs/3gpps2020/TS/TS-3GA-36_412_Rel16v16_0_0.pdf">https://www.ttc.or.jp/st/docs/3gpps2020/TS/TS-3GA-36_412_Rel16v16_0_0.pdf</a>			

Release 17						
ATIS	ATIS.3GPP.36.412.V17.0.0	17.0.0	Published	21.02.2023	<a href="https://www.atis.org/3gpp-transpositions - Rel-17">https://www.atis.org/3gpp-transpositions - Rel-17</a>	
CCSA	CCSA.36.412V1700	17.0.0	Published	01.04.2022	<a href="https://www.ccsa.org.cn/api/portalsFile/downloadOldFile?type=19&amp;oldFileUrl=ITU-R/M.2012-6/CCSA.36.412V1700.doc">https://www.ccsa.org.cn/api/portalsFile/downloadOldFile?type=19&amp;oldFileUrl=ITU-R/M.2012-6/CCSA.36.412V1700.doc</a>	
ETSI	ETSI TS 136 412	17.0.0	Published	02.05.2022	<a href="https://www.etsi.org/deliver/etsi_ts/136400_136499/136412/17.00.00_60/ts_136412v170000p.pdf">https://www.etsi.org/deliver/etsi_ts/136400_136499/136412/17.00.00_60/ts_136412v170000p.pdf</a>	
TSDSI	TSDSI STD T1.3GPP 36.412-17.0.0 V1.0.0	17.0.0	Published	29.07.2022	<a href="https://members.tdsi.in/s/5XWtFk7jRHmFeFD">https://members.tdsi.in/s/5XWtFk7jRHmFeFD</a>	
TTA	TTAT.3G-36.412V17.0.0	17.0.0	Published	05.08.2022	<a href="http://committee.tta.or.kr/data/ttasDown.jsp?kind=ttastd&amp;pk_num=TTAT.3G-36.412V17.0.0">http://committee.tta.or.kr/data/ttasDown.jsp?kind=ttastd&amp;pk_num=TTAT.3G-36.412V17.0.0</a>	
TTC	TS-3GA-36.412(Rel17)v17.0.0	17.0.0	Published	07.10.2022	<a href="https://www.ttc.or.jp/st/docs/3gpp/2022/TS/TS-3GA-36.412v17.0.0.pdf">https://www.ttc.or.jp/st/docs/3gpp/2022/TS/TS-3GA-36.412v17.0.0.pdf</a>	

### 2.1.4.5 TS 36.413

#### Evolved Universal Terrestrial Radio Access Network (E-UTRAN); S1 Application Protocol (S1AP)

This document specifies the E-UTRAN radio network layer signalling protocol for the S1 interface. The S1 Application Protocol (S1AP) supports the functions of S1 interface by signalling procedures defined in this document.

SDO	Document No.	Version	Status	Issued date	Location
<b>Release 10</b>					
ATIS	ATIS.3GPP.36.413V1090	10.9.0	Published	28.06.2021	<a href="https://www.atis.org/3gpp-documents/Rel99-14/">https://www.atis.org/3gpp-documents/Rel99-14/</a>
CCSA	CCSA.36.413V1090	10.9.0	Published	01.09.2014	<a href="https://www.ccsa.org.cn/api/portalsFile/downloadOldFile?type=19&amp;oldFileUrl=ITU-R/M.2012-6/CCSA.36.413V1090.doc">https://www.ccsa.org.cn/api/portalsFile/downloadOldFile?type=19&amp;oldFileUrl=ITU-R/M.2012-6/CCSA.36.413V1090.doc</a>
ETSI	ETSI TS 136 413	10.9.0	Published	26.09.2014	<a href="https://www.etsi.org/deliver/etsi_ts/136400_136499/136413/10.09.00_60/ts_136413v100900p.pdf">https://www.etsi.org/deliver/etsi_ts/136400_136499/136413/10.09.00_60/ts_136413v100900p.pdf</a>
TSDSI	TSDSI STD T1.3GPP 36.413-10.9.0 V1.0.0	10.9.0	Published	30.08.2021	<a href="https://members.tdsi.in/index.php/s/BBewMzKtdwD9MZf">https://members.tdsi.in/index.php/s/BBewMzKtdwD9MZf</a>
TTA	TTAT.3G-36.413V10.9.0	10.9.0	Published	02.08.2021	<a href="http://committee.tta.or.kr/data/ttasDown.jsp?kind=ttastd&amp;pk_num=TTAT.3G-36.413V10.9.0">http://committee.tta.or.kr/data/ttasDown.jsp?kind=ttastd&amp;pk_num=TTAT.3G-36.413V10.9.0</a>
TTC	TS-3GA-36.413(Rel10)v10.9.0	10.9.0	Published	18.12.2014	<a href="https://www.ttc.or.jp/st/docs/3gpps2014/TS/TS-3GA-36.413(Rel10)v10.9.0.pdf">https://www.ttc.or.jp/st/docs/3gpps2014/TS/TS-3GA-36.413(Rel10)v10.9.0.pdf</a>
<b>Release 11</b>					
ATIS	ATIS.3GPP.36.413V1180	11.8.0	Published	28.06.2021	<a href="https://www.atis.org/3gpp-documents/Rel99-14/">https://www.atis.org/3gpp-documents/Rel99-14/</a>
CCSA	CCSA.36.413V1180	11.8.0	Published	01.09.2014	<a href="https://www.ccsa.org.cn/api/portalsFile/downloadOldFile?type=19&amp;oldFileUrl=ITU-R/M.2012-6/CCSA.36.413V1180.doc">https://www.ccsa.org.cn/api/portalsFile/downloadOldFile?type=19&amp;oldFileUrl=ITU-R/M.2012-6/CCSA.36.413V1180.doc</a>
ETSI	ETSI TS 136 413	11.8.0	Published	26.09.2014	<a href="https://www.etsi.org/deliver/etsi_ts/136400_136499/136413/11.08.00_60/ts_136413v110800p.pdf">https://www.etsi.org/deliver/etsi_ts/136400_136499/136413/11.08.00_60/ts_136413v110800p.pdf</a>
TSDSI	TSDSI STD T1.3GPP 36.413-11.8.0 V1.0.0	11.8.0	Published	30.08.2021	<a href="https://members.tdsi.in/index.php/s/r8pWPjdCgeJn36o">https://members.tdsi.in/index.php/s/r8pWPjdCgeJn36o</a>
TTA	TTAT.3G-36.413V11.8.0	11.8.0	Published	02.08.2021	<a href="http://committee.tta.or.kr/data/ttasDown.jsp?kind=ttastd&amp;pk_num=TTAT.3G-36.413V11.8.0">http://committee.tta.or.kr/data/ttasDown.jsp?kind=ttastd&amp;pk_num=TTAT.3G-36.413V11.8.0</a>
TTC	TS-3GA-36.413(Rel11)v11.8.0	11.8.0	Published	18.12.2014	<a href="https://www.ttc.or.jp/st/docs/3gpps2014/TS/TS-3GA-36.413(Rel11)v11.8.0.pdf">https://www.ttc.or.jp/st/docs/3gpps2014/TS/TS-3GA-36.413(Rel11)v11.8.0.pdf</a>
<b>Release 12</b>					
ATIS	ATIS.3GPP.36.413V1270	12.7.0	Published	28.06.2021	<a href="https://www.atis.org/3gpp-documents/Rel99-14/">https://www.atis.org/3gpp-documents/Rel99-14/</a>
CCSA	CCSA.36.413V1270	12.7.0	Published	01.03.2016	<a href="https://www.ccsa.org.cn/api/portalsFile/downloadOldFile?type=19&amp;oldFileUrl=ITU-R/M.2012-6/CCSA.36.413V1270.doc">https://www.ccsa.org.cn/api/portalsFile/downloadOldFile?type=19&amp;oldFileUrl=ITU-R/M.2012-6/CCSA.36.413V1270.doc</a>
ETSI	ETSI TS 136 413	12.7.0	Published	20.05.2016	<a href="https://www.etsi.org/deliver/etsi_ts/136400_136499/136413/12.07.00_60/ts_136413v120700p.pdf">https://www.etsi.org/deliver/etsi_ts/136400_136499/136413/12.07.00_60/ts_136413v120700p.pdf</a>
TSDSI	TSDSI STD T1.3GPP 36.413-12.7.0 V1.0.0	12.7.0	Published	30.08.2021	<a href="https://members.tdsi.in/index.php/s/k5KzafaXDrLxZBM">https://members.tdsi.in/index.php/s/k5KzafaXDrLxZBM</a>
TTA	TTAT.3G-36.413V12.7.0	12.7.0	Published	02.08.2021	<a href="http://committee.tta.or.kr/data/ttasDown.jsp?kind=ttastd&amp;pk_num=TTAT.3G-36.413V12.7.0">http://committee.tta.or.kr/data/ttasDown.jsp?kind=ttastd&amp;pk_num=TTAT.3G-36.413V12.7.0</a>
TTC	TS-3GA-36.413(Rel12)v12.7.0	12.7.0	Published	30.06.2016	<a href="https://www.ttc.or.jp/st/docs/3gpps2016/TS/TS-3GA-36.413(Rel12)v12.7.0.pdf">https://www.ttc.or.jp/st/docs/3gpps2016/TS/TS-3GA-36.413(Rel12)v12.7.0.pdf</a>
<b>Release 13</b>					
ATIS	ATIS.3GPP.36.413V1380	13.8.0	Published	28.06.2021	<a href="https://www.atis.org/3gpp-documents/Rel99-14/">https://www.atis.org/3gpp-documents/Rel99-14/</a>
CCSA	CCSA.36.413V1380	13.8.0	Published	01.09.2018	<a href="https://www.ccsa.org.cn/api/portalsFile/downloadOldFile?type=19&amp;oldFileUrl=ITU-R/M.2012-6/CCSA.36.413V1380.doc">https://www.ccsa.org.cn/api/portalsFile/downloadOldFile?type=19&amp;oldFileUrl=ITU-R/M.2012-6/CCSA.36.413V1380.doc</a>
ETSI	ETSI TS 136 413	13.8.0	Published	28.09.2018	<a href="https://www.etsi.org/deliver/etsi_ts/136400_136499/136413/13.08.00_60/ts_136413v130800p.pdf">https://www.etsi.org/deliver/etsi_ts/136400_136499/136413/13.08.00_60/ts_136413v130800p.pdf</a>
TSDSI	TSDSI STD T1.3GPP 36.413-13.8.0 V1.1.0	13.8.0	Published	30.08.2021	<a href="https://members.tdsi.in/index.php/s/326q2kceP4B7is2">https://members.tdsi.in/index.php/s/326q2kceP4B7is2</a>
TTA	TTAT.3G-36.413V13.8.0	13.8.0	Published	02.08.2021	<a href="http://committee.tta.or.kr/data/ttasDown.jsp?kind=ttastd&amp;pk_num=TTAT.3G-36.413V13.8.0">http://committee.tta.or.kr/data/ttasDown.jsp?kind=ttastd&amp;pk_num=TTAT.3G-36.413V13.8.0</a>
TTC	TS-3GA-36.413(Rel13)v13.8.0	13.8.0	Published	21.12.2018	<a href="https://www.ttc.or.jp/st/docs/3gpps2018/TS/TS-3GA-36.413(Rel13)v13.8.0.pdf">https://www.ttc.or.jp/st/docs/3gpps2018/TS/TS-3GA-36.413(Rel13)v13.8.0.pdf</a>

## 60

## Rec. ITU-R M.2012-6

### Release 14

ATIS	ATIS.3GPP.36.413V1490	14.9.0	Published	28.06.2021	<a href="https://www.atis.org/3gpp-documents/Rel99-14/">https://www.atis.org/3gpp-documents/Rel99-14/</a>
CCSA	CCSA.36.413V1490	14.9.0	Published	01.07.2019	<a href="https://www.ccsa.org.cn/api/portalsFile/downloadOldFile?type=19&amp;oldFileUrl=ITU-R/M.2012-6/CCSA.36.413V1490.doc">https://www.ccsa.org.cn/api/portalsFile/downloadOldFile?type=19&amp;oldFileUrl=ITU-R/M.2012-6/CCSA.36.413V1490.doc</a>
ETSI	ETSI TS 136 413	14.9.0	Published	23.07.2019	<a href="https://www.etsi.org/deliver/etsi_ts/136400_136499/136413/14.09.00_60/ts_136413v140900p.pdf">https://www.etsi.org/deliver/etsi_ts/136400_136499/136413/14.09.00_60/ts_136413v140900p.pdf</a>
TSDSI	TSDSI STD T1.3GPP 36.413-14.9.0 V1.1.0	14.9.0	Published	30.08.2021	<a href="https://members.tdsi.in/index.php/s/tcHcLRLxyANCS7j">https://members.tdsi.in/index.php/s/tcHcLRLxyANCS7j</a>
TTA	TTAT.3G-36.413V14.9.0	14.9.0	Published	02.08.2021	<a href="http://committee.tta.or.kr/data/ttasDown.jsp?kind=ttastd&amp;pk_num=TTAT.3G-36.413V14.9.0">http://committee.tta.or.kr/data/ttasDown.jsp?kind=ttastd&amp;pk_num=TTAT.3G-36.413V14.9.0</a>
TTC	TS-3GA-36.413(Rel14)v14.9.0	14.9.0	Published	11.10.2019	<a href="https://www.ttc.or.jp/st/docs/3gpps2019/TS/TS-3GA-36.413(Rel14)v14.9.0.pdf">https://www.ttc.or.jp/st/docs/3gpps2019/TS/TS-3GA-36.413(Rel14)v14.9.0.pdf</a>

### Release 15

ATIS	ATIS.3GPP.36.413.V15.11.0	15.11.0	Published	21.02.2023	<a href="https://www.atis.org/3gpp-transpositions - Rel-15">https://www.atis.org/3gpp-transpositions - Rel-15</a>
CCSA	CCSA.36.413V15110	15.11.0	Published	01.04.2022	<a href="https://www.ccsa.org.cn/api/portalsFile/downloadOldFile?type=19&amp;oldFileUrl=ITU-R/M.2012-6/CCSA.36.413V15110.doc">https://www.ccsa.org.cn/api/portalsFile/downloadOldFile?type=19&amp;oldFileUrl=ITU-R/M.2012-6/CCSA.36.413V15110.doc</a>
ETSI	ETSI TS 136 413	15.11.0	Published	02.05.2022	<a href="https://www.etsi.org/deliver/etsi_ts/136400_136499/136413/15.11.00_60/ts_136413v151100p.pdf">https://www.etsi.org/deliver/etsi_ts/136400_136499/136413/15.11.00_60/ts_136413v151100p.pdf</a>
TSDSI	TSDSI STD T1.3GPP 36.413-15.11.0 V1.1.0	15.11.0	Published	01.11.2022	<a href="https://members.tdsi.in/s/8G5tqf9KX2a7myB">https://members.tdsi.in/s/8G5tqf9KX2a7myB</a>
TTA	TTAT.3G-36.413V15.11.0	15.11.0	Published	05.08.2022	<a href="http://committee.tta.or.kr/data/ttasDown.jsp?kind=ttastd&amp;pk_num=TTAT.3G-36.413V15.11.0">http://committee.tta.or.kr/data/ttasDown.jsp?kind=ttastd&amp;pk_num=TTAT.3G-36.413V15.11.0</a>
TTC	TS-3GA-36.413(Rel15)v15.11.0	15.11.0	Published	08.07.2022	<a href="https://www.ttc.or.jp/st/docs/3gpp/2022/TS/TS-3GA-36.413v15.11.0.pdf">https://www.ttc.or.jp/st/docs/3gpp/2022/TS/TS-3GA-36.413v15.11.0.pdf</a>

### Release 16

ATIS	ATIS.3GPP.36.413.V16.11.0	16.11.0	Published	21.02.2023	<a href="https://www.atis.org/3gpp-transpositions - Rel-16">https://www.atis.org/3gpp-transpositions - Rel-16</a>
CCSA	CCSA.36.413V16110	16.11.0	Published	01.09.2022	<a href="https://www.ccsa.org.cn/api/portalsFile/downloadOldFile?type=19&amp;oldFileUrl=ITU-R/M.2012-6/CCSA.36.413V16110.doc">https://www.ccsa.org.cn/api/portalsFile/downloadOldFile?type=19&amp;oldFileUrl=ITU-R/M.2012-6/CCSA.36.413V16110.doc</a>
ETSI	ETSI TS 136 413	16.11.0	Published	14.10.2022	<a href="https://www.etsi.org/deliver/etsi_ts/136400_136499/136413/16.11.00_60/ts_136413v161100p.pdf">https://www.etsi.org/deliver/etsi_ts/136400_136499/136413/16.11.00_60/ts_136413v161100p.pdf</a>
TSDSI	TSDSI STD T1.3GPP 36.413-16.11.0 V1.2.0	16.11.0	Published	17.01.2023	<a href="https://members.tdsi.in/s/SapPC7tXsRFERQy">https://members.tdsi.in/s/SapPC7tXsRFERQy</a>
TTA	TTAT.3G-36.413V16.11.0	16.11.0	Published	11.01.2023	<a href="http://committee.tta.or.kr/data/ttasDown.jsp?kind=ttastd&amp;pk_num=TTAT.3G-36.413V16.11.0">http://committee.tta.or.kr/data/ttasDown.jsp?kind=ttastd&amp;pk_num=TTAT.3G-36.413V16.11.0</a>
TTC	TS-3GA-36.413(Rel16)v16.11.0	16.11.0	Published	13.01.2023	<a href="https://www.ttc.or.jp/st/docs/3gpp/2023/TS/TS-3GA-36.413v16.11.0.pdf">https://www.ttc.or.jp/st/docs/3gpp/2023/TS/TS-3GA-36.413v16.11.0.pdf</a>

### Release 17

ATIS	ATIS.3GPP.36.413.V17.3.0	17.3.0	Published	21.02.2023	<a href="https://www.atis.org/3gpp-transpositions - Rel-17">https://www.atis.org/3gpp-transpositions - Rel-17</a>
CCSA	CCSA.36.413V1730	17.3.0	Published	01.12.2022	<a href="https://www.ccsa.org.cn/api/portalsFile/downloadOldFile?type=19&amp;oldFileUrl=ITU-R/M.2012-6/CCSA.36.413V1730.doc">https://www.ccsa.org.cn/api/portalsFile/downloadOldFile?type=19&amp;oldFileUrl=ITU-R/M.2012-6/CCSA.36.413V1730.doc</a>
ETSI	ETSI TS 136 413	17.3.0	Published	13.01.2023	<a href="https://www.etsi.org/deliver/etsi_ts/136400_136499/136413/17.03.00_60/ts_136413v170300p.pdf">https://www.etsi.org/deliver/etsi_ts/136400_136499/136413/17.03.00_60/ts_136413v170300p.pdf</a>
TSDSI	TSDSI STD T1.3GPP 36.413 17.3.0 V1.3.0	17.3.0	Published	02.05.2023	<a href="https://members.tdsi.in/s/zk77YgL2Q82SJAq">https://members.tdsi.in/s/zk77YgL2Q82SJAq</a>
TTA	TTAT.3G-36.413V17.3.0	17.3.0	Published	16.03.2023	<a href="http://committee.tta.or.kr/data/ttasDown.jsp?kind=ttastd&amp;pk_num=TTAT.3G-36.413V17.3.0">http://committee.tta.or.kr/data/ttasDown.jsp?kind=ttastd&amp;pk_num=TTAT.3G-36.413V17.3.0</a>
TTC	TS-3GA-36.413(Rel17)v17.3.0	17.3.0	Published	14.04.2023	<a href="https://www.ttc.or.jp/st/docs/3gpp/2023/TS/TS-3GA-36.413v17.3.0.pdf">https://www.ttc.or.jp/st/docs/3gpp/2023/TS/TS-3GA-36.413v17.3.0.pdf</a>

## 2.1.4.6 TS 36.414

### Evolved Universal Terrestrial Radio Access Network (E-UTRAN); S1 data transport

This document specifies the standards for user data transport protocols and related signalling protocols to establish user plane transport bearers over the S1 interface.

SDO	Document No.	Version	Status	Issued date	Location
<b>Release 10</b>					
ATIS	ATIS.3GPP.36.414V1010	10.1.0	Published	28.06.2021	<a href="https://www.atis.org/3gpp-documents/Rel99-14/">https://www.atis.org/3gpp-documents/Rel99-14/</a>
CCSA	CCSA.36.414V1010	10.1.0	Published	01.06.2011	<a href="https://www.ccsa.org.cn/api/portalsFile/downloadOldFile?type=19&amp;oldFileUrl=ITU-R/M.2012-6/CCSA.36.414V1010.doc">https://www.ccsa.org.cn/api/portalsFile/downloadOldFile?type=19&amp;oldFileUrl=ITU-R/M.2012-6/CCSA.36.414V1010.doc</a>
ETSI	ETSI TS 136 414	10.1.0	Published	30.06.2011	<a href="https://www.etsi.org/deliver/etsi_ts/136400_136499/136414/10.01.00_60/ts_136414v100100p.pdf">https://www.etsi.org/deliver/etsi_ts/136400_136499/136414/10.01.00_60/ts_136414v100100p.pdf</a>
TSDSI	TSDSI STD T1.3GPP 36.414-10.1.0 V1.0.0	10.1.0	Published	30.08.2021	<a href="https://members.tdsi.in/index.php/s/Xfy2Y9MPn7oZEWW">https://members.tdsi.in/index.php/s/Xfy2Y9MPn7oZEWW</a>
TTA	TTAT.3G-36.414V10.1.0	10.1.0	Published	02.08.2021	<a href="http://committee.tta.or.kr/data/ttasDown.jsp?kind=ttastd&amp;pk_num=TTAT.3G-36.414V10.1.0">http://committee.tta.or.kr/data/ttasDown.jsp?kind=ttastd&amp;pk_num=TTAT.3G-36.414V10.1.0</a>
TTC	TS-3GA-36.414(Rel10)v10.1.0	10.1.0	Published	31.08.2011	<a href="https://www.ttc.or.jp/st/docs/3gpps2011/TS/TS-3GA-36.414(Rel10)v10.1.0.pdf">https://www.ttc.or.jp/st/docs/3gpps2011/TS/TS-3GA-36.414(Rel10)v10.1.0.pdf</a>

<b>Release 11</b>									
ATIS	ATIS.3GPP.36.414V1100	11.0.0	Published	28.06.2021	<a href="https://www.atis.org/3gpp-documents/Rel99-14/">https://www.atis.org/3gpp-documents/Rel99-14/</a>				
CCSA	CCSA.36.414V1100	11.0.0	Published	01.09.2012	<a href="https://www.ccsa.org.cn/api/portalsFile/downloadOldFile?type=19&amp;oldFileUrl=ITU-R/M.2012-6/CCSA.36.414V1100.doc">https://www.ccsa.org.cn/api/portalsFile/downloadOldFile?type=19&amp;oldFileUrl=ITU-R/M.2012-6/CCSA.36.414V1100.doc</a>				
ETSI	ETSI TS 136 414	11.0.0	Published	18.10.2012	<a href="https://www.etsi.org/deliver/etsi_ts/136400_136499/136414/11.00.00_60/ts_136414v110000p.pdf">https://www.etsi.org/deliver/etsi_ts/136400_136499/136414/11.00.00_60/ts_136414v110000p.pdf</a>				
TSDSI	TSDSI STD T1.3GPP 36.414-11.0.0 V1.0.0	11.0.0	Published	30.08.2021	<a href="https://members.tdsi.in/index.php/s/G98tLbnMSFPLwTz">https://members.tdsi.in/index.php/s/G98tLbnMSFPLwTz</a>				
TTA	TTAT.3G-36.414V11.0.0	11.0.0	Published	02.08.2021	<a href="http://committee.tta.or.kr/data/ttasDown.jsp?kind=ttastd&amp;pk_num=TTAT.3G-36.414V11.0.0">http://committee.tta.or.kr/data/ttasDown.jsp?kind=ttastd&amp;pk_num=TTAT.3G-36.414V11.0.0</a>				
TTC	TS-3GA-36.414(Rel11)v11.0.0	11.0.0	Published	25.06.2013	<a href="https://www.ttc.or.jp/st/docs/3gpps2013/TS/TS-3GA-36.414(Rel11)v11.0.0.pdf">https://www.ttc.or.jp/st/docs/3gpps2013/TS/TS-3GA-36.414(Rel11)v11.0.0.pdf</a>				
<b>Release 12</b>									
ATIS	ATIS.3GPP.36.414V1210	12.1.0	Published	28.06.2021	<a href="https://www.atis.org/3gpp-documents/Rel99-14/">https://www.atis.org/3gpp-documents/Rel99-14/</a>				
CCSA	CCSA.36.414V1210	12.1.0	Published	01.12.2014	<a href="https://www.ccsa.org.cn/api/portalsFile/downloadOldFile?type=19&amp;oldFileUrl=ITU-R/M.2012-6/CCSA.36.414V1210.doc">https://www.ccsa.org.cn/api/portalsFile/downloadOldFile?type=19&amp;oldFileUrl=ITU-R/M.2012-6/CCSA.36.414V1210.doc</a>				
ETSI	ETSI TS 136 414	12.1.0	Published	04.02.2015	<a href="https://www.etsi.org/deliver/etsi_ts/136400_136499/136414/12.01.00_60/ts_136414v120100p.pdf">https://www.etsi.org/deliver/etsi_ts/136400_136499/136414/12.01.00_60/ts_136414v120100p.pdf</a>				
TSDSI	TSDSI STD T1.3GPP 36.414-12.1.0 V1.0.0	12.1.0	Published	30.08.2021	<a href="https://members.tdsi.in/index.php/s/F5MisjaTMYnN4Pn">https://members.tdsi.in/index.php/s/F5MisjaTMYnN4Pn</a>				
TTA	TTAT.3G-36.414V12.1.0	12.1.0	Published	02.08.2021	<a href="http://committee.tta.or.kr/data/ttasDown.jsp?kind=ttastd&amp;pk_num=TTAT.3G-36.414V12.1.0">http://committee.tta.or.kr/data/ttasDown.jsp?kind=ttastd&amp;pk_num=TTAT.3G-36.414V12.1.0</a>				
TTC	TS-3GA-36.414(Rel12)v12.1.0	12.1.0	Published	05.03.2015	<a href="https://www.ttc.or.jp/st/docs/3gpps2015/TS/TS-3GA-36.414(Rel12)v12.1.0.pdf">https://www.ttc.or.jp/st/docs/3gpps2015/TS/TS-3GA-36.414(Rel12)v12.1.0.pdf</a>				
<b>Release 13</b>									
ATIS	ATIS.3GPP.36.414V1300	13.0.0	Published	28.06.2021	<a href="https://www.atis.org/3gpp-documents/Rel99-14/">https://www.atis.org/3gpp-documents/Rel99-14/</a>				
CCSA	CCSA.36.414V1300	13.0.0	Published	01.12.2015	<a href="https://www.ccsa.org.cn/api/portalsFile/downloadOldFile?type=19&amp;oldFileUrl=ITU-R/M.2012-6/CCSA.36.414V1300.doc">https://www.ccsa.org.cn/api/portalsFile/downloadOldFile?type=19&amp;oldFileUrl=ITU-R/M.2012-6/CCSA.36.414V1300.doc</a>				
ETSI	ETSI TS 136 414	13.0.0	Published	21.01.2016	<a href="https://www.etsi.org/deliver/etsi_ts/136400_136499/136414/13.00.00_60/ts_136414v130000p.pdf">https://www.etsi.org/deliver/etsi_ts/136400_136499/136414/13.00.00_60/ts_136414v130000p.pdf</a>				
TSDSI	TSDSI STD T1.3GPP 36.414-13.0.0 V1.0.0	13.0.0	Published	30.08.2021	<a href="https://members.tdsi.in/index.php/s/gTDtCkyJGRqE6fX">https://members.tdsi.in/index.php/s/gTDtCkyJGRqE6fX</a>				
TTA	TTAT.3G-36.414V13.0.0	13.0.0	Published	02.08.2021	<a href="http://committee.tta.or.kr/data/ttasDown.jsp?kind=ttastd&amp;pk_num=TTAT.3G-36.414V13.0.0">http://committee.tta.or.kr/data/ttasDown.jsp?kind=ttastd&amp;pk_num=TTAT.3G-36.414V13.0.0</a>				
TTC	TS-3GA-36.414(Rel13)v13.0.0	13.0.0	Published	31.03.2017	<a href="https://www.ttc.or.jp/st/docs/3gpps2017/TS/TS-3GA-36.414(Rel13)v13.0.0.pdf">https://www.ttc.or.jp/st/docs/3gpps2017/TS/TS-3GA-36.414(Rel13)v13.0.0.pdf</a>				
<b>Release 14</b>									
ATIS	ATIS.3GPP.36.414V1410	14.1.0	Published	28.06.2021	<a href="https://www.atis.org/3gpp-documents/Rel99-14/">https://www.atis.org/3gpp-documents/Rel99-14/</a>				
CCSA	CCSA.36.414V1410	14.1.0	Published	01.06.2017	<a href="https://www.ccsa.org.cn/api/portalsFile/downloadOldFile?type=19&amp;oldFileUrl=ITU-R/M.2012-6/CCSA.36.414V1410.doc">https://www.ccsa.org.cn/api/portalsFile/downloadOldFile?type=19&amp;oldFileUrl=ITU-R/M.2012-6/CCSA.36.414V1410.doc</a>				
ETSI	ETSI TS 136 414	14.1.0	Published	24.08.2017	<a href="https://www.etsi.org/deliver/etsi_ts/136400_136499/136414/14.01.00_60/ts_136414v140100p.pdf">https://www.etsi.org/deliver/etsi_ts/136400_136499/136414/14.01.00_60/ts_136414v140100p.pdf</a>				
TSDSI	TSDSI STD T1.3GPP 36.414-14.1.0 V1.0.0	14.1.0	Published	30.08.2021	<a href="https://members.tdsi.in/index.php/s/rBGf3Fwbb5PDgbd">https://members.tdsi.in/index.php/s/rBGf3Fwbb5PDgbd</a>				
TTA	TTAT.3G-36.414V14.1.0	14.1.0	Published	02.08.2021	<a href="http://committee.tta.or.kr/data/ttasDown.jsp?kind=ttastd&amp;pk_num=TTAT.3G-36.414V14.1.0">http://committee.tta.or.kr/data/ttasDown.jsp?kind=ttastd&amp;pk_num=TTAT.3G-36.414V14.1.0</a>				
TTC	TS-3GA-36.414(Rel14)v14.1.0	14.1.0	Published	13.04.2018	<a href="https://www.ttc.or.jp/st/docs/3gpps2018/TS/TS-3GA-36.414(Rel14)v14.1.0.pdf">https://www.ttc.or.jp/st/docs/3gpps2018/TS/TS-3GA-36.414(Rel14)v14.1.0.pdf</a>				
<b>Release 15</b>									
ATIS	ATIS.3GPP.36.414V1500	15.0.0	Published	28.06.2021	<a href="https://www.atis.org/3gpp-documents/Rel15/">https://www.atis.org/3gpp-documents/Rel15/</a>				
CCSA	CCSA.36.414V1500	15.0.0	Published	01.06.2018	<a href="https://www.ccsa.org.cn/api/portalsFile/downloadOldFile?type=19&amp;oldFileUrl=ITU-R/M.2012-6/CCSA.36.414V1500.doc">https://www.ccsa.org.cn/api/portalsFile/downloadOldFile?type=19&amp;oldFileUrl=ITU-R/M.2012-6/CCSA.36.414V1500.doc</a>				
ETSI	ETSI TS 136 414	15.0.0	Published	04.07.2018	<a href="https://www.etsi.org/deliver/etsi_ts/136400_136499/136414/15.00.00_60/ts_136414v150000p.pdf">https://www.etsi.org/deliver/etsi_ts/136400_136499/136414/15.00.00_60/ts_136414v150000p.pdf</a>				
TSDSI	TSDSI STD T1.3GPP 36.414-15.0.0 V1.0.0	15.0.0	Published	30.08.2021	<a href="https://members.tdsi.in/index.php/s/rBbRyPf5gQZrJsm">https://members.tdsi.in/index.php/s/rBbRyPf5gQZrJsm</a>				
TTA	TTAT.3G-36.414V15.0.0	15.0.0	Published	11.09.2020	<a href="http://committee.tta.or.kr/data/ttasDown.jsp?kind=ttastd&amp;pk_num=TTAT.3G-36.414V15.0.0">http://committee.tta.or.kr/data/ttasDown.jsp?kind=ttastd&amp;pk_num=TTAT.3G-36.414V15.0.0</a>				
TTC	TS-3GA-36.414(Rel15)v15.0.0	15.0.0	Published	28.09.2018	<a href="https://www.ttc.or.jp/st/docs/3gpps2018/TS/TS-3GA-36.414(Rel15)v15.0.0.pdf">https://www.ttc.or.jp/st/docs/3gpps2018/TS/TS-3GA-36.414(Rel15)v15.0.0.pdf</a>				
<b>Release 16</b>									
ATIS	ATIS.3GPP.36.414V1600	16.0.0	Published	28.06.2021	<a href="https://www.atis.org/3gpp-documents/Rel16/">https://www.atis.org/3gpp-documents/Rel16/</a>				
CCSA	CCSA.36.414V1600	16.0.0	Published	01.07.2020	<a href="https://www.ccsa.org.cn/api/portalsFile/downloadOldFile?type=19&amp;oldFileUrl=ITU-R/M.2012-6/CCSA.36.414V1600.doc">https://www.ccsa.org.cn/api/portalsFile/downloadOldFile?type=19&amp;oldFileUrl=ITU-R/M.2012-6/CCSA.36.414V1600.doc</a>				
ETSI	ETSI TS 136 414	16.0.0	Published	21.07.2020	<a href="https://www.etsi.org/deliver/etsi_ts/136400_136499/136414/16.00.00_60/ts_136414v160000p.pdf">https://www.etsi.org/deliver/etsi_ts/136400_136499/136414/16.00.00_60/ts_136414v160000p.pdf</a>				
TSDSI	TSDSI STD T1.3GPP 36.414-16.0.0 V1.0.0	16.0.0	Published	30.08.2021	<a href="https://members.tdsi.in/index.php/s/y6R7BGNQqMJZY22">https://members.tdsi.in/index.php/s/y6R7BGNQqMJZY22</a>				
TTA	TTAT.3G-36.414V16.0.0	16.0.0	Published	11.09.2020	<a href="http://committee.tta.or.kr/data/ttasDown.jsp?kind=ttastd&amp;pk_num=TTAT.3G-36.414V16.0.0">http://committee.tta.or.kr/data/ttasDown.jsp?kind=ttastd&amp;pk_num=TTAT.3G-36.414V16.0.0</a>				
TTC	TS-3GA-36.414(Rel16)v16.0.0	16.0.0	Published	02.10.2020	<a href="https://www.ttc.or.jp/st/docs/3gpps2020/TS/TS-3GA-36_414_Rel16v16_0_0.pdf">https://www.ttc.or.jp/st/docs/3gpps2020/TS/TS-3GA-36_414_Rel16v16_0_0.pdf</a>				

## Release 17

ATIS	ATIS.3GPP.36.414.V17.0.0	17.0.0	Published	21.02.2023	<a href="https://www.atis.org/3gpp-transpositions - Rel-17">https://www.atis.org/3gpp-transpositions - Rel-17</a>
CCSA	CCSA.36.414V1700	17.0.0	Published	01.04.2022	<a href="https://www.ccsa.org.cn/api/portalsFile/downloadOldFile?type=19&amp;oldFileUrl=ITU-R/M.2012-6/CCSA.36.414V1700.doc">https://www.ccsa.org.cn/api/portalsFile/downloadOldFile?type=19&amp;oldFileUrl=ITU-R/M.2012-6/CCSA.36.414V1700.doc</a>
ETSI	ETSI TS 136 414	17.0.0	Published	02.05.2022	<a href="https://www.etsi.org/deliver/etsi_ts/136400_136499/136414/17.00.00_60/ts_136414v170000p.pdf">https://www.etsi.org/deliver/etsi_ts/136400_136499/136414/17.00.00_60/ts_136414v170000p.pdf</a>
TSDSI	TSDSI STD T1.3GPP 36.414-17.0.0 V1.0.0	17.0.0	Published	29.07.2022	<a href="https://members.tdsi.in/s/fpqTF5fxqwYacFK">https://members.tdsi.in/s/fpqTF5fxqwYacFK</a>
TTA	TTAT.3G-36.414V17.0.0	17.0.0	Published	05.08.2022	<a href="http://committee.tta.or.kr/data/ttasDown.jsp?kind=ttastd&amp;pk_num=TTAT.3G-36.414V17.0.0">http://committee.tta.or.kr/data/ttasDown.jsp?kind=ttastd&amp;pk_num=TTAT.3G-36.414V17.0.0</a>
TTC	TS-3GA-36.414(Rel17)v17.0.0	17.0.0	Published	07.10.2022	<a href="https://www.ttc.or.jp/st/docs/3gpp/2022/TS/TS-3GA-36.414v17.0.0.pdf">https://www.ttc.or.jp/st/docs/3gpp/2022/TS/TS-3GA-36.414v17.0.0.pdf</a>

## 2.1.4.7 TS 36.420

## Evolved Universal Terrestrial Radio Access Network (E-UTRAN); X2 general aspects and principles

This document is an introduction to the TSG RAN TS 36.42x series of UMTS technical specifications that define the X2 interface. It is an interface for the interconnection of two E-UTRAN NodeB (eNodeB) components within the Evolved Universal Terrestrial Radio Access Network (E-UTRAN) architecture.

SDO	Document No.	Version	Status	Issued date	Location
<b>Release 10</b>					
ATIS	ATIS.3GPP.36.420V1020	10.2.0	Published	28.06.2021	<a href="https://www.atis.org/3gpp-documents/Rel99-14/">https://www.atis.org/3gpp-documents/Rel99-14/</a>
CCSA	CCSA.36.420V1020	10.2.0	Published	01.09.2011	<a href="https://www.ccsa.org.cn/api/portalsFile/downloadOldFile?type=19&amp;oldFileUrl=ITU-R/M.2012-6/CCSA.36.420V1020.doc">https://www.ccsa.org.cn/api/portalsFile/downloadOldFile?type=19&amp;oldFileUrl=ITU-R/M.2012-6/CCSA.36.420V1020.doc</a>
ETSI	ETSI TS 136 420	10.2.0	Published	21.10.2011	<a href="https://www.etsi.org/deliver/etsi_ts/136400_136499/136420/10.02.00_60/ts_136420v100200p.pdf">https://www.etsi.org/deliver/etsi_ts/136400_136499/136420/10.02.00_60/ts_136420v100200p.pdf</a>
TSDSI	TSDSI STD T1.3GPP 36.42-10.2.0 V1.0.0	10.2.0	Published	30.08.2021	<a href="https://members.tdsi.in/index.php/s/b4YnSNsXJRNKPdg">https://members.tdsi.in/index.php/s/b4YnSNsXJRNKPdg</a>
TTA	TTAT.3G-36.420V10.2.0	10.2.0	Published	02.08.2021	<a href="http://committee.tta.or.kr/data/ttasDown.jsp?kind=ttastd&amp;pk_num=TTAT.3G-36.420V10.2.0">http://committee.tta.or.kr/data/ttasDown.jsp?kind=ttastd&amp;pk_num=TTAT.3G-36.420V10.2.0</a>
TTC	TS-3GA-36.420(Rel10)v10.2.0	10.2.0	Published	21.12.2011	<a href="https://www.ttc.or.jp/st/docs/3gpss2011/TS/TS-3GA-36.420(Rel10)v10.2.0.pdf">https://www.ttc.or.jp/st/docs/3gpss2011/TS/TS-3GA-36.420(Rel10)v10.2.0.pdf</a>
<b>Release 11</b>					
ATIS	ATIS.3GPP.36.420V1100	11.0.0	Published	28.06.2021	<a href="https://www.atis.org/3gpp-documents/Rel99-14/">https://www.atis.org/3gpp-documents/Rel99-14/</a>
CCSA	CCSA.36.420V1100	11.0.0	Published	01.09.2012	<a href="https://www.ccsa.org.cn/api/portalsFile/downloadOldFile?type=19&amp;oldFileUrl=ITU-R/M.2012-6/CCSA.36.420V1100.doc">https://www.ccsa.org.cn/api/portalsFile/downloadOldFile?type=19&amp;oldFileUrl=ITU-R/M.2012-6/CCSA.36.420V1100.doc</a>
ETSI	ETSI TS 136 420	11.0.0	Published	18.10.2012	<a href="https://www.etsi.org/deliver/etsi_ts/136400_136499/136420/11.00.00_60/ts_136420v110000p.pdf">https://www.etsi.org/deliver/etsi_ts/136400_136499/136420/11.00.00_60/ts_136420v110000p.pdf</a>
TSDSI	TSDSI STD T1.3GPP 36.42-11.0.0 V1.0.0	11.0.0	Published	30.08.2021	<a href="https://members.tdsi.in/index.php/s/k4Rg3553TR4WpPx">https://members.tdsi.in/index.php/s/k4Rg3553TR4WpPx</a>
TTA	TTAT.3G-36.420V11.0.0	11.0.0	Published	02.08.2021	<a href="http://committee.tta.or.kr/data/ttasDown.jsp?kind=ttastd&amp;pk_num=TTAT.3G-36.420V11.0.0">http://committee.tta.or.kr/data/ttasDown.jsp?kind=ttastd&amp;pk_num=TTAT.3G-36.420V11.0.0</a>
TTC	TS-3GA-36.420(Rel11)v11.0.0	11.0.0	Published	25.06.2013	<a href="https://www.ttc.or.jp/st/docs/3gpss2013/TS/TS-3GA-36.420(Rel11)v11.0.0.pdf">https://www.ttc.or.jp/st/docs/3gpss2013/TS/TS-3GA-36.420(Rel11)v11.0.0.pdf</a>
<b>Release 12</b>					
ATIS	ATIS.3GPP.36.420V1210	12.1.0	Published	28.06.2021	<a href="https://www.atis.org/3gpp-documents/Rel99-14/">https://www.atis.org/3gpp-documents/Rel99-14/</a>
CCSA	CCSA.36.420V1210	12.1.0	Published	01.12.2014	<a href="https://www.ccsa.org.cn/api/portalsFile/downloadOldFile?type=19&amp;oldFileUrl=ITU-R/M.2012-6/CCSA.36.420V1210.doc">https://www.ccsa.org.cn/api/portalsFile/downloadOldFile?type=19&amp;oldFileUrl=ITU-R/M.2012-6/CCSA.36.420V1210.doc</a>
ETSI	ETSI TS 136 420	12.1.0	Published	04.02.2015	<a href="https://www.etsi.org/deliver/etsi_ts/136400_136499/136420/12.01.00_60/ts_136420v120100p.pdf">https://www.etsi.org/deliver/etsi_ts/136400_136499/136420/12.01.00_60/ts_136420v120100p.pdf</a>
TSDSI	TSDSI STD T1.3GPP 36.42-12.1.0 V1.0.0	12.1.0	Published	30.08.2021	<a href="https://members.tdsi.in/index.php/s/ckko6be79jfmkMY">https://members.tdsi.in/index.php/s/ckko6be79jfmkMY</a>
TTA	TTAT.3G-36.420V12.1.0	12.1.0	Published	02.08.2021	<a href="http://committee.tta.or.kr/data/ttasDown.jsp?kind=ttastd&amp;pk_num=TTAT.3G-36.420V12.1.0">http://committee.tta.or.kr/data/ttasDown.jsp?kind=ttastd&amp;pk_num=TTAT.3G-36.420V12.1.0</a>
TTC	TS-3GA-36.420(Rel12)v12.1.0	12.1.0	Published	05.03.2015	<a href="https://www.ttc.or.jp/st/docs/3gpss2015/TS/TS-3GA-36.420(Rel12)v12.1.0.pdf">https://www.ttc.or.jp/st/docs/3gpss2015/TS/TS-3GA-36.420(Rel12)v12.1.0.pdf</a>
<b>Release 13</b>					
ATIS	ATIS.3GPP.36.420V1300	13.0.0	Published	28.06.2021	<a href="https://www.atis.org/3gpp-documents/Rel99-14/">https://www.atis.org/3gpp-documents/Rel99-14/</a>
CCSA	CCSA.36.420V1300	13.0.0	Published	01.12.2015	<a href="https://www.ccsa.org.cn/api/portalsFile/downloadOldFile?type=19&amp;oldFileUrl=ITU-R/M.2012-6/CCSA.36.420V1300.doc">https://www.ccsa.org.cn/api/portalsFile/downloadOldFile?type=19&amp;oldFileUrl=ITU-R/M.2012-6/CCSA.36.420V1300.doc</a>
ETSI	ETSI TS 136 420	13.0.0	Published	21.01.2016	<a href="https://www.etsi.org/deliver/etsi_ts/136400_136499/136420/13.00.00_60/ts_136420v130000p.pdf">https://www.etsi.org/deliver/etsi_ts/136400_136499/136420/13.00.00_60/ts_136420v130000p.pdf</a>
TSDSI	TSDSI STD T1.3GPP 36.42-13.0.0 V1.0.0	13.0.0	Published	30.08.2021	<a href="https://members.tdsi.in/index.php/s/axe2kmzetbjdFSa">https://members.tdsi.in/index.php/s/axe2kmzetbjdFSa</a>
TTA	TTAT.3G-36.420V13.0.0	13.0.0	Published	02.08.2021	<a href="http://committee.tta.or.kr/data/ttasDown.jsp?kind=ttastd&amp;pk_num=TTAT.3G-36.420V13.0.0">http://committee.tta.or.kr/data/ttasDown.jsp?kind=ttastd&amp;pk_num=TTAT.3G-36.420V13.0.0</a>
TTC	TS-3GA-36.420(Rel13)v13.0.0	13.0.0	Published	31.03.2017	<a href="https://www.ttc.or.jp/st/docs/3gpss2017/TS/TS-3GA-36.420(Rel13)v13.0.0.pdf">https://www.ttc.or.jp/st/docs/3gpss2017/TS/TS-3GA-36.420(Rel13)v13.0.0.pdf</a>



<b>Release 14</b>					
ATIS	ATIS.3GPP.36.420V1401	14.0.1	Published	28.06.2021	<a href="https://www.atis.org/3gpp-documents/Rel99-14/">https://www.atis.org/3gpp-documents/Rel99-14/</a>
CCSA	CCSA.36.420V1401	14.0.1	Published	01.03.2017	<a href="https://www.ccsa.org.cn/api/portalsFile/downloadOldFile?type=19&amp;oldFileUrl=ITU-R/M.2012-6/CCSA.36.420V1401.doc">https://www.ccsa.org.cn/api/portalsFile/downloadOldFile?type=19&amp;oldFileUrl=ITU-R/M.2012-6/CCSA.36.420V1401.doc</a>
ETSI	ETSI TS 136 420	14.0.1	Published	11.04.2017	<a href="https://www.etsi.org/deliver/etsi_ts/136400_136499/136420/14.00.01_60/ts_136420v140001p.pdf">https://www.etsi.org/deliver/etsi_ts/136400_136499/136420/14.00.01_60/ts_136420v140001p.pdf</a>
TSDSI	TSDSI STD T1.3GPP 36.420-14.0.1 V1.0.0	14.0.1	Published	30.08.2021	<a href="https://members.tdsi.in/index.php/s/gMLAZP63YtoitKo">https://members.tdsi.in/index.php/s/gMLAZP63YtoitKo</a>
TTA	TTAT.3G-36.420V14.0.1	14.0.1	Published	02.08.2021	<a href="http://committee.tta.or.kr/data/ttasDown.jsp?kind=ttastd&amp;pk_num=TTAT.3G-36.420V14.0.1">http://committee.tta.or.kr/data/ttasDown.jsp?kind=ttastd&amp;pk_num=TTAT.3G-36.420V14.0.1</a>
TTC	TS-3GA-36.420(Rel14)v14.0.1	14.0.1	Published	13.04.2018	<a href="https://www.ttc.or.jp/st/docs/3gpps2018/TS/TS-3GA-36.420(Rel14)v14.0.1.pdf">https://www.ttc.or.jp/st/docs/3gpps2018/TS/TS-3GA-36.420(Rel14)v14.0.1.pdf</a>
<b>Release 15</b>					
ATIS	ATIS.3GPP.36.420V1520	15.2.0	Published	28.06.2021	<a href="https://www.atis.org/3gpp-documents/Rel15/">https://www.atis.org/3gpp-documents/Rel15/</a>
CCSA	CCSA.36.420V1520	15.2.0	Published	01.12.2019	<a href="https://www.ccsa.org.cn/api/portalsFile/downloadOldFile?type=19&amp;oldFileUrl=ITU-R/M.2012-6/CCSA.36.420V1520.doc">https://www.ccsa.org.cn/api/portalsFile/downloadOldFile?type=19&amp;oldFileUrl=ITU-R/M.2012-6/CCSA.36.420V1520.doc</a>
ETSI	ETSI TS 136 420	15.2.0	Published	17.01.2020	<a href="https://www.etsi.org/deliver/etsi_ts/136400_136499/136420/15.02.00_60/ts_136420v150200p.pdf">https://www.etsi.org/deliver/etsi_ts/136400_136499/136420/15.02.00_60/ts_136420v150200p.pdf</a>
TSDSI	TSDSI STD T1.3GPP 36.420-15.2.0 V1.0.0	15.2.0	Published	30.08.2021	<a href="https://members.tdsi.in/index.php/s/9PK4K3jApf6tYW7">https://members.tdsi.in/index.php/s/9PK4K3jApf6tYW7</a>
TTA	TTAT.3G-36.420V15.2.0	15.2.0	Published	11.09.2020	<a href="http://committee.tta.or.kr/data/ttasDown.jsp?kind=ttastd&amp;pk_num=TTAT.3G-36.420V15.2.0">http://committee.tta.or.kr/data/ttasDown.jsp?kind=ttastd&amp;pk_num=TTAT.3G-36.420V15.2.0</a>
TTC	TS-3GA-36.420(Rel15)v15.2.0	15.2.0	Published	16.04.2020	<a href="https://www.ttc.or.jp/st/docs/3gpps2020/TS/TS-3GA-36_420_Rel15v15_2_0.pdf">https://www.ttc.or.jp/st/docs/3gpps2020/TS/TS-3GA-36_420_Rel15v15_2_0.pdf</a>
<b>Release 16</b>					
ATIS	ATIS.3GPP.36.420V1600	16.0.0	Published	28.06.2021	<a href="https://www.atis.org/3gpp-documents/Rel16/">https://www.atis.org/3gpp-documents/Rel16/</a>
CCSA	CCSA.36.420V1600	16.0.0	Published	01.07.2020	<a href="https://www.ccsa.org.cn/api/portalsFile/downloadOldFile?type=19&amp;oldFileUrl=ITU-R/M.2012-6/CCSA.36.420V1600.doc">https://www.ccsa.org.cn/api/portalsFile/downloadOldFile?type=19&amp;oldFileUrl=ITU-R/M.2012-6/CCSA.36.420V1600.doc</a>
ETSI	ETSI TS 136 420	16.0.0	Published	23.07.2020	<a href="https://www.etsi.org/deliver/etsi_ts/136400_136499/136420/16.00.00_60/ts_136420v160000p.pdf">https://www.etsi.org/deliver/etsi_ts/136400_136499/136420/16.00.00_60/ts_136420v160000p.pdf</a>
TSDSI	TSDSI STD T1.3GPP 36.420-16.0.0 V1.0.0	16.0.0	Published	30.08.2021	<a href="https://members.tdsi.in/index.php/s/7mpQW2MFtKHGc8b">https://members.tdsi.in/index.php/s/7mpQW2MFtKHGc8b</a>
TTA	TTAT.3G-36.420V16.0.0	16.0.0	Published	11.09.2020	<a href="http://committee.tta.or.kr/data/ttasDown.jsp?kind=ttastd&amp;pk_num=TTAT.3G-36.420V16.0.0">http://committee.tta.or.kr/data/ttasDown.jsp?kind=ttastd&amp;pk_num=TTAT.3G-36.420V16.0.0</a>
TTC	TS-3GA-36.420(Rel16)v16.0.0	16.0.0	Published	02.10.2020	<a href="https://www.ttc.or.jp/st/docs/3gpps2020/TS/TS-3GA-36_420_Rel16v16_0_0.pdf">https://www.ttc.or.jp/st/docs/3gpps2020/TS/TS-3GA-36_420_Rel16v16_0_0.pdf</a>
<b>Release 17</b>					
ATIS	ATIS.3GPP.36.420.V17.0.0	17.0.0	Published	21.02.2023	<a href="https://www.atis.org/3gpp-transpositions - Rel-17">https://www.atis.org/3gpp-transpositions - Rel-17</a>
CCSA	CCSA.36.420V1700	17.0.0	Published	01.04.2022	<a href="https://www.ccsa.org.cn/api/portalsFile/downloadOldFile?type=19&amp;oldFileUrl=ITU-R/M.2012-6/CCSA.36.420V1700.doc">https://www.ccsa.org.cn/api/portalsFile/downloadOldFile?type=19&amp;oldFileUrl=ITU-R/M.2012-6/CCSA.36.420V1700.doc</a>
ETSI	ETSI TS 136 420	17.0.0	Published	02.05.2022	<a href="https://www.etsi.org/deliver/etsi_ts/136400_136499/136420/17.00.00_60/ts_136420v170000p.pdf">https://www.etsi.org/deliver/etsi_ts/136400_136499/136420/17.00.00_60/ts_136420v170000p.pdf</a>
TSDSI	TSDSI STD T1.3GPP 36.42-17.0.0 V1.0.0	17.0.0	Published	29.07.2022	<a href="https://members.tdsi.in/s/WiRLJt8zDHPeM2c">https://members.tdsi.in/s/WiRLJt8zDHPeM2c</a>
TTA	TTAT.3G-36.420V17.0.0	17.0.0	Published	05.08.2022	<a href="http://committee.tta.or.kr/data/ttasDown.jsp?kind=ttastd&amp;pk_num=TTAT.3G-36.420V17.0.0">http://committee.tta.or.kr/data/ttasDown.jsp?kind=ttastd&amp;pk_num=TTAT.3G-36.420V17.0.0</a>
TTC	TS-3GA-36.420(Rel17)v17.0.0	17.0.0	Published	07.10.2022	<a href="https://www.ttc.or.jp/st/docs/3gpp/2022/TS/TS-3GA-36.420v17.0.0.pdf">https://www.ttc.or.jp/st/docs/3gpp/2022/TS/TS-3GA-36.420v17.0.0.pdf</a>

### 2.1.4.8 TS 36.421

#### Evolved Universal Terrestrial Radio Access Network (E-UTRAN); X2 layer 1

This document specifies the standards allowed to implement Layer 1 on the X2 interface. The specification of transmission delay requirements and O & M requirements are not in the scope of this document. In the following “Layer 1” and “Physical Layer” are assumed to be synonymous.

SDO	Document No.	Version	Status	Issued date	Location
<b>Release 10</b>					
ATIS	ATIS.3GPP.36.421V1001	10.0.1	Published	28.06.2021	<a href="https://www.atis.org/3gpp-documents/Rel99-14/">https://www.atis.org/3gpp-documents/Rel99-14/</a>
CCSA	CCSA.36.421V1001	10.0.1	Published	01.03.2011	<a href="https://www.ccsa.org.cn/api/portalsFile/downloadOldFile?type=19&amp;oldFileUrl=ITU-R/M.2012-6/CCSA.36.421V1001.doc">https://www.ccsa.org.cn/api/portalsFile/downloadOldFile?type=19&amp;oldFileUrl=ITU-R/M.2012-6/CCSA.36.421V1001.doc</a>
ETSI	ETSI TS 136 421	10.0.1	Published	16.05.2011	<a href="https://www.etsi.org/deliver/etsi_ts/136400_136499/136421/10.00.01_60/ts_136421v100001p.pdf">https://www.etsi.org/deliver/etsi_ts/136400_136499/136421/10.00.01_60/ts_136421v100001p.pdf</a>
TSDSI	TSDSI STD T1.3GPP 36.421-10.0.1 V1.0.0	10.0.1	Published	30.08.2021	<a href="https://members.tdsi.in/index.php/s/4fM5mcG9QGdfWnK">https://members.tdsi.in/index.php/s/4fM5mcG9QGdfWnK</a>
TTA	TTAT.3G-36.421V10.0.1	10.0.1	Published	02.08.2021	<a href="http://committee.tta.or.kr/data/ttasDown.jsp?kind=ttastd&amp;pk_num=TTAT.3G-36.421V10.0.1">http://committee.tta.or.kr/data/ttasDown.jsp?kind=ttastd&amp;pk_num=TTAT.3G-36.421V10.0.1</a>
TTC	TS-3GA-36.421(Rel10)v10.0.1	10.0.1	Published	22.06.2011	<a href="https://www.ttc.or.jp/st/docs/3gpps2011/TS/TS-3GA-36.421(Rel10)v10.0.1.pdf">https://www.ttc.or.jp/st/docs/3gpps2011/TS/TS-3GA-36.421(Rel10)v10.0.1.pdf</a>

<b>Release 11</b>									
ATIS	ATIS.3GPP.36.421V1110	11.1.0	Published	28.06.2021	<a href="https://www.atis.org/3gpp-documents/Rel99-14/">https://www.atis.org/3gpp-documents/Rel99-14/</a>				
CCSA	CCSA.36.421V1110	11.1.0	Published	01.12.2012	<a href="https://www.ccsa.org.cn/api/portalsFile/downloadOldFile?type=19&amp;oldFileUrl=ITU-R/M.2012-6/CCSA.36.421V1110.doc">https://www.ccsa.org.cn/api/portalsFile/downloadOldFile?type=19&amp;oldFileUrl=ITU-R/M.2012-6/CCSA.36.421V1110.doc</a>				
ETSI	ETSI TS 136 421	11.1.0	Published	16.01.2013	<a href="https://www.etsi.org/deliver/etsi_ts/136400_136499/136421/11.01.00_60/ts_136421v110100p.pdf">https://www.etsi.org/deliver/etsi_ts/136400_136499/136421/11.01.00_60/ts_136421v110100p.pdf</a>				
TSDSI	TSDSI STD T1.3GPP 36.421-11.1.0 V1.0.0	11.1.0	Published	30.08.2021	<a href="https://members.tdsi.in/index.php/s/djTrWZCFtpfHM">https://members.tdsi.in/index.php/s/djTrWZCFtpfHM</a>				
TTA	TTAT.3G-36.421V11.1.0	11.1.0	Published	02.08.2021	<a href="http://committee.tta.or.kr/data/ttasDown.jsp?kind=ttastd&amp;pk_num=TTAT.3G-36.421V11.1.0">http://committee.tta.or.kr/data/ttasDown.jsp?kind=ttastd&amp;pk_num=TTAT.3G-36.421V11.1.0</a>				
TTC	TS-3GA-36.421(Rel11)v11.1.0	11.1.0	Published	25.06.2013	<a href="https://www.ttc.or.jp/st/docs/3gpps2013/TS/TS-3GA-36.421(Rel11)v11.1.0.pdf">https://www.ttc.or.jp/st/docs/3gpps2013/TS/TS-3GA-36.421(Rel11)v11.1.0.pdf</a>				
<b>Release 12</b>									
ATIS	ATIS.3GPP.36.421V1200	12.0.0	Published	28.06.2021	<a href="https://www.atis.org/3gpp-documents/Rel99-14/">https://www.atis.org/3gpp-documents/Rel99-14/</a>				
CCSA	CCSA.36.421V1200	12.0.0	Published	01.09.2014	<a href="https://www.ccsa.org.cn/api/portalsFile/downloadOldFile?type=19&amp;oldFileUrl=ITU-R/M.2012-6/CCSA.36.421V1200.doc">https://www.ccsa.org.cn/api/portalsFile/downloadOldFile?type=19&amp;oldFileUrl=ITU-R/M.2012-6/CCSA.36.421V1200.doc</a>				
ETSI	ETSI TS 136 421	12.0.0	Published	25.09.2014	<a href="https://www.etsi.org/deliver/etsi_ts/136400_136499/136421/12.00.00_60/ts_136421v120000p.pdf">https://www.etsi.org/deliver/etsi_ts/136400_136499/136421/12.00.00_60/ts_136421v120000p.pdf</a>				
TSDSI	TSDSI STD T1.3GPP 36.421-12.0.0 V1.0.0	12.0.0	Published	30.08.2021	<a href="https://members.tdsi.in/index.php/s/cYsRfCypzNRFLp">https://members.tdsi.in/index.php/s/cYsRfCypzNRFLp</a>				
TTA	TTAT.3G-36.421V12.0.0	12.0.0	Published	02.08.2021	<a href="http://committee.tta.or.kr/data/ttasDown.jsp?kind=ttastd&amp;pk_num=TTAT.3G-36.421V12.0.0">http://committee.tta.or.kr/data/ttasDown.jsp?kind=ttastd&amp;pk_num=TTAT.3G-36.421V12.0.0</a>				
TTC	TS-3GA-36.421(Rel12)v12.0.0	12.0.0	Published	05.03.2015	<a href="https://www.ttc.or.jp/st/docs/3gpps2015/TS/TS-3GA-36.421(Rel12)v12.0.0.pdf">https://www.ttc.or.jp/st/docs/3gpps2015/TS/TS-3GA-36.421(Rel12)v12.0.0.pdf</a>				
<b>Release 13</b>									
ATIS	ATIS.3GPP.36.421V1300	13.0.0	Published	28.06.2021	<a href="https://www.atis.org/3gpp-documents/Rel99-14/">https://www.atis.org/3gpp-documents/Rel99-14/</a>				
CCSA	CCSA.36.421V1300	13.0.0	Published	01.12.2015	<a href="https://www.ccsa.org.cn/api/portalsFile/downloadOldFile?type=19&amp;oldFileUrl=ITU-R/M.2012-6/CCSA.36.421V1300.doc">https://www.ccsa.org.cn/api/portalsFile/downloadOldFile?type=19&amp;oldFileUrl=ITU-R/M.2012-6/CCSA.36.421V1300.doc</a>				
ETSI	ETSI TS 136 421	13.0.0	Published	21.01.2016	<a href="https://www.etsi.org/deliver/etsi_ts/136400_136499/136421/13.00.00_60/ts_136421v130000p.pdf">https://www.etsi.org/deliver/etsi_ts/136400_136499/136421/13.00.00_60/ts_136421v130000p.pdf</a>				
TSDSI	TSDSI STD T1.3GPP 36.421-13.0.0 V1.0.0	13.0.0	Published	30.08.2021	<a href="https://members.tdsi.in/index.php/s/oq2HeawSmEf4Kd">https://members.tdsi.in/index.php/s/oq2HeawSmEf4Kd</a>				
TTA	TTAT.3G-36.421V13.0.0	13.0.0	Published	02.08.2021	<a href="http://committee.tta.or.kr/data/ttasDown.jsp?kind=ttastd&amp;pk_num=TTAT.3G-36.421V13.0.0">http://committee.tta.or.kr/data/ttasDown.jsp?kind=ttastd&amp;pk_num=TTAT.3G-36.421V13.0.0</a>				
TTC	TS-3GA-36.421(Rel13)v13.0.0	13.0.0	Published	31.03.2017	<a href="https://www.ttc.or.jp/st/docs/3gpps2017/TS/TS-3GA-36.421(Rel13)v13.0.0.pdf">https://www.ttc.or.jp/st/docs/3gpps2017/TS/TS-3GA-36.421(Rel13)v13.0.0.pdf</a>				
<b>Release 14</b>									
ATIS	ATIS.3GPP.36.421V1400	14.0.0	Published	28.06.2021	<a href="https://www.atis.org/3gpp-documents/Rel99-14/">https://www.atis.org/3gpp-documents/Rel99-14/</a>				
CCSA	CCSA.36.421V1400	14.0.0	Published	01.03.2017	<a href="https://www.ccsa.org.cn/api/portalsFile/downloadOldFile?type=19&amp;oldFileUrl=ITU-R/M.2012-6/CCSA.36.421V1400.doc">https://www.ccsa.org.cn/api/portalsFile/downloadOldFile?type=19&amp;oldFileUrl=ITU-R/M.2012-6/CCSA.36.421V1400.doc</a>				
ETSI	ETSI TS 136 421	14.0.0	Published	11.04.2017	<a href="https://www.etsi.org/deliver/etsi_ts/136400_136499/136421/14.00.00_60/ts_136421v140000p.pdf">https://www.etsi.org/deliver/etsi_ts/136400_136499/136421/14.00.00_60/ts_136421v140000p.pdf</a>				
TSDSI	TSDSI STD T1.3GPP 36.421-14.0.0 V1.0.0	14.0.0	Published	30.08.2021	<a href="https://members.tdsi.in/index.php/s/ZraGo2r4o9jLrkO">https://members.tdsi.in/index.php/s/ZraGo2r4o9jLrkO</a>				
TTA	TTAT.3G-36.421V14.0.0	14.0.0	Published	02.08.2021	<a href="http://committee.tta.or.kr/data/ttasDown.jsp?kind=ttastd&amp;pk_num=TTAT.3G-36.421V14.0.0">http://committee.tta.or.kr/data/ttasDown.jsp?kind=ttastd&amp;pk_num=TTAT.3G-36.421V14.0.0</a>				
TTC	TS-3GA-36.421(Rel14)v14.0.0	14.0.0	Published	13.04.2018	<a href="https://www.ttc.or.jp/st/docs/3gpps2018/TS/TS-3GA-36.421(Rel14)v14.0.0.pdf">https://www.ttc.or.jp/st/docs/3gpps2018/TS/TS-3GA-36.421(Rel14)v14.0.0.pdf</a>				
<b>Release 15</b>									
ATIS	ATIS.3GPP.36.421V1500	15.0.0	Published	28.06.2021	<a href="https://www.atis.org/3gpp-documents/Rel15/">https://www.atis.org/3gpp-documents/Rel15/</a>				
CCSA	CCSA.36.421V1500	15.0.0	Published	01.06.2018	<a href="https://www.ccsa.org.cn/api/portalsFile/downloadOldFile?type=19&amp;oldFileUrl=ITU-R/M.2012-6/CCSA.36.421V1500.doc">https://www.ccsa.org.cn/api/portalsFile/downloadOldFile?type=19&amp;oldFileUrl=ITU-R/M.2012-6/CCSA.36.421V1500.doc</a>				
ETSI	ETSI TS 136 421	15.0.0	Published	04.07.2018	<a href="https://www.etsi.org/deliver/etsi_ts/136400_136499/136421/15.00.00_60/ts_136421v150000p.pdf">https://www.etsi.org/deliver/etsi_ts/136400_136499/136421/15.00.00_60/ts_136421v150000p.pdf</a>				
TSDSI	TSDSI STD T1.3GPP 36.421-15.0.0 V1.0.0	15.0.0	Published	30.08.2021	<a href="https://members.tdsi.in/index.php/s/oHOTHbiE4GnTJcF">https://members.tdsi.in/index.php/s/oHOTHbiE4GnTJcF</a>				
TTA	TTAT.3G-36.421V15.0.0	15.0.0	Published	11.09.2020	<a href="http://committee.tta.or.kr/data/ttasDown.jsp?kind=ttastd&amp;pk_num=TTAT.3G-36.421V15.0.0">http://committee.tta.or.kr/data/ttasDown.jsp?kind=ttastd&amp;pk_num=TTAT.3G-36.421V15.0.0</a>				
TTC	TS-3GA-36.421(Rel15)v15.0.0	15.0.0	Published	28.09.2018	<a href="https://www.ttc.or.jp/st/docs/3gpps2018/TS/TS-3GA-36.421(Rel15)v15.0.0.pdf">https://www.ttc.or.jp/st/docs/3gpps2018/TS/TS-3GA-36.421(Rel15)v15.0.0.pdf</a>				
<b>Release 16</b>									
ATIS	ATIS.3GPP.36.421V1600	16.0.0	Published	28.06.2021	<a href="https://www.atis.org/3gpp-documents/Rel16/">https://www.atis.org/3gpp-documents/Rel16/</a>				
CCSA	CCSA.36.421V1600	16.0.0	Published	01.07.2020	<a href="https://www.ccsa.org.cn/api/portalsFile/downloadOldFile?type=19&amp;oldFileUrl=ITU-R/M.2012-6/CCSA.36.421V1600.doc">https://www.ccsa.org.cn/api/portalsFile/downloadOldFile?type=19&amp;oldFileUrl=ITU-R/M.2012-6/CCSA.36.421V1600.doc</a>				
ETSI	ETSI TS 136 421	16.0.0	Published	21.07.2020	<a href="https://www.etsi.org/deliver/etsi_ts/136400_136499/136421/16.00.00_60/ts_136421v160000p.pdf">https://www.etsi.org/deliver/etsi_ts/136400_136499/136421/16.00.00_60/ts_136421v160000p.pdf</a>				
TSDSI	TSDSI STD T1.3GPP 36.421-16.0.0 V1.0.0	16.0.0	Published	30.08.2021	<a href="https://members.tdsi.in/index.php/s/DGRSem7PLiDpeSi">https://members.tdsi.in/index.php/s/DGRSem7PLiDpeSi</a>				
TTA	TTAT.3G-36.421V16.0.0	16.0.0	Published	11.09.2020	<a href="http://committee.tta.or.kr/data/ttasDown.jsp?kind=ttastd&amp;pk_num=TTAT.3G-36.421V16.0.0">http://committee.tta.or.kr/data/ttasDown.jsp?kind=ttastd&amp;pk_num=TTAT.3G-36.421V16.0.0</a>				
TTC	TS-3GA-36.421(Rel16)v16.0.0	16.0.0	Published	02.10.2020	<a href="https://www.ttc.or.jp/st/docs/3gpps2020/TS/TS-3GA-36_421_Rel16v16_0_0.pdf">https://www.ttc.or.jp/st/docs/3gpps2020/TS/TS-3GA-36_421_Rel16v16_0_0.pdf</a>				

<b>Release 17</b>						
ATIS	ATIS.3GPP.36.421.V17.0.0	17.0.0	Published	21.02.2023	<a href="https://www.atis.org/3gpp-transpositions - Rel-17">https://www.atis.org/3gpp-transpositions - Rel-17</a>	
CCSA	CCSA.36.421V1700	17.0.0	Published	01.04.2022	<a href="https://www.ccsa.org.cn/api/portalsFile/downloadOldFile?type=19&amp;oldFileUrl=ITU-R/M.2012-6/CCSA.36.421V1700.doc">https://www.ccsa.org.cn/api/portalsFile/downloadOldFile?type=19&amp;oldFileUrl=ITU-R/M.2012-6/CCSA.36.421V1700.doc</a>	
ETSI	ETSI TS 136 421	17.0.0	Published	02.05.2022	<a href="https://www.etsi.org/deliver/etsi_ts/136400_136499/136421/17.00.00_60/ts_136421v170000p.pdf">https://www.etsi.org/deliver/etsi_ts/136400_136499/136421/17.00.00_60/ts_136421v170000p.pdf</a>	
TSDSI	TSDSI STD T1.3GPP 36.421-17.0.0 V1.0.0	17.0.0	Published	29.07.2022	<a href="https://members.tdsi.in/s/bjQw5fCRta8FEyq">https://members.tdsi.in/s/bjQw5fCRta8FEyq</a>	
TTA	TTAT.3G-36.421V17.0.0	17.0.0	Published	05.08.2022	<a href="http://committee.tta.or.kr/data/ttasDown.jsp?kind=ttastd&amp;pk_num=TTAT.3G-36.421V17.0.0">http://committee.tta.or.kr/data/ttasDown.jsp?kind=ttastd&amp;pk_num=TTAT.3G-36.421V17.0.0</a>	
TTC	TS-3GA-36.421(Rel17)v17.0.0	17.0.0	Published	07.10.2022	<a href="https://www.ttc.or.jp/st/docs/3gpp/2022/TS/TS-3GA-36.421v17.0.0.pdf">https://www.ttc.or.jp/st/docs/3gpp/2022/TS/TS-3GA-36.421v17.0.0.pdf</a>	

### 2.1.4.9 TS 36.422

#### Evolved Universal Terrestrial Radio Access Network (E-UTRAN); X2 signalling transport

This document specifies the standards for Signalling Transport to be used across X2 interface. X2 interface is a logical interface between eNodeBs. This document describes how the X2-AP signalling messages are transported over X2.

SDO	Document No.	Version	Status	Issued date	Location
<b>Release 10</b>					
ATIS	ATIS.3GPP.36.422V1010	10.1.0	Published	28.06.2021	<a href="https://www.atis.org/3gpp-documents/Rel99-14/">https://www.atis.org/3gpp-documents/Rel99-14/</a>
CCSA	CCSA.36.422V1010	10.1.0	Published	01.06.2011	<a href="https://www.ccsa.org.cn/api/portalsFile/downloadOldFile?type=19&amp;oldFileUrl=ITU-R/M.2012-6/CCSA.36.422V1010.doc">https://www.ccsa.org.cn/api/portalsFile/downloadOldFile?type=19&amp;oldFileUrl=ITU-R/M.2012-6/CCSA.36.422V1010.doc</a>
ETSI	ETSI TS 136 422	10.1.0	Published	30.06.2011	<a href="https://www.etsi.org/deliver/etsi_ts/136400_136499/136422/10.01.00_60/ts_136422v100100p.pdf">https://www.etsi.org/deliver/etsi_ts/136400_136499/136422/10.01.00_60/ts_136422v100100p.pdf</a>
TSDSI	TSDSI STD T1.3GPP 36.422-10.1.0 V1.0.0	10.1.0	Published	30.08.2021	<a href="https://members.tdsi.in/index.php/s/Z4dmgsmpzdrXbfz">https://members.tdsi.in/index.php/s/Z4dmgsmpzdrXbfz</a>
TTA	TTAT.3G-36.422V10.1.0	10.1.0	Published	02.08.2021	<a href="http://committee.tta.or.kr/data/ttasDown.jsp?kind=ttastd&amp;pk_num=TTAT.3G-36.422V10.1.0">http://committee.tta.or.kr/data/ttasDown.jsp?kind=ttastd&amp;pk_num=TTAT.3G-36.422V10.1.0</a>
TTC	TS-3GA-36.422(Rel10)v10.1.0	10.1.0	Published	31.08.2011	<a href="https://www.ttc.or.jp/st/docs/3gpss2011/TS/TS-3GA-36.422(Rel10)v10.1.0.pdf">https://www.ttc.or.jp/st/docs/3gpss2011/TS/TS-3GA-36.422(Rel10)v10.1.0.pdf</a>
<b>Release 11</b>					
ATIS	ATIS.3GPP.36.422V1100	11.0.0	Published	28.06.2021	<a href="https://www.atis.org/3gpp-documents/Rel99-14/">https://www.atis.org/3gpp-documents/Rel99-14/</a>
CCSA	CCSA.36.422V1100	11.0.0	Published	01.09.2012	<a href="https://www.ccsa.org.cn/api/portalsFile/downloadOldFile?type=19&amp;oldFileUrl=ITU-R/M.2012-6/CCSA.36.422V1100.doc">https://www.ccsa.org.cn/api/portalsFile/downloadOldFile?type=19&amp;oldFileUrl=ITU-R/M.2012-6/CCSA.36.422V1100.doc</a>
ETSI	ETSI TS 136 422	11.0.0	Published	18.10.2012	<a href="https://www.etsi.org/deliver/etsi_ts/136400_136499/136422/11.00.00_60/ts_136422v110000p.pdf">https://www.etsi.org/deliver/etsi_ts/136400_136499/136422/11.00.00_60/ts_136422v110000p.pdf</a>
TSDSI	TSDSI STD T1.3GPP 36.422-11.0.0 V1.0.0	11.0.0	Published	30.08.2021	<a href="https://members.tdsi.in/index.php/s/YGxoigTMfNW7J8G">https://members.tdsi.in/index.php/s/YGxoigTMfNW7J8G</a>
TTA	TTAT.3G-36.422V11.0.0	11.0.0	Published	02.08.2021	<a href="http://committee.tta.or.kr/data/ttasDown.jsp?kind=ttastd&amp;pk_num=TTAT.3G-36.422V11.0.0">http://committee.tta.or.kr/data/ttasDown.jsp?kind=ttastd&amp;pk_num=TTAT.3G-36.422V11.0.0</a>
TTC	TS-3GA-36.422(Rel11)v11.0.0	11.0.0	Published	25.06.2013	<a href="https://www.ttc.or.jp/st/docs/3gpss2013/TS/TS-3GA-36.422(Rel11)v11.0.0.pdf">https://www.ttc.or.jp/st/docs/3gpss2013/TS/TS-3GA-36.422(Rel11)v11.0.0.pdf</a>
<b>Release 12</b>					
ATIS	ATIS.3GPP.36.422V1200	12.0.0	Published	28.06.2021	<a href="https://www.atis.org/3gpp-documents/Rel99-14/">https://www.atis.org/3gpp-documents/Rel99-14/</a>
CCSA	CCSA.36.422V1200	12.0.0	Published	01.09.2014	<a href="https://www.ccsa.org.cn/api/portalsFile/downloadOldFile?type=19&amp;oldFileUrl=ITU-R/M.2012-6/CCSA.36.422V1200.doc">https://www.ccsa.org.cn/api/portalsFile/downloadOldFile?type=19&amp;oldFileUrl=ITU-R/M.2012-6/CCSA.36.422V1200.doc</a>
ETSI	ETSI TS 136 422	12.0.0	Published	25.09.2014	<a href="https://www.etsi.org/deliver/etsi_ts/136400_136499/136422/12.00.00_60/ts_136422v120000p.pdf">https://www.etsi.org/deliver/etsi_ts/136400_136499/136422/12.00.00_60/ts_136422v120000p.pdf</a>
TSDSI	TSDSI STD T1.3GPP 36.422-12.0.0 V1.0.0	12.0.0	Published	30.08.2021	<a href="https://members.tdsi.in/index.php/s/rscoj6P4LDN9CWk">https://members.tdsi.in/index.php/s/rscoj6P4LDN9CWk</a>
TTA	TTAT.3G-36.422V12.0.0	12.0.0	Published	02.08.2021	<a href="http://committee.tta.or.kr/data/ttasDown.jsp?kind=ttastd&amp;pk_num=TTAT.3G-36.422V12.0.0">http://committee.tta.or.kr/data/ttasDown.jsp?kind=ttastd&amp;pk_num=TTAT.3G-36.422V12.0.0</a>
TTC	TS-3GA-36.422(Rel12)v12.0.0	12.0.0	Published	05.03.2015	<a href="https://www.ttc.or.jp/st/docs/3gpss2015/TS/TS-3GA-36.422(Rel12)v12.0.0.pdf">https://www.ttc.or.jp/st/docs/3gpss2015/TS/TS-3GA-36.422(Rel12)v12.0.0.pdf</a>
<b>Release 13</b>					
ATIS	ATIS.3GPP.36.422V1300	13.0.0	Published	28.06.2021	<a href="https://www.atis.org/3gpp-documents/Rel99-14/">https://www.atis.org/3gpp-documents/Rel99-14/</a>
CCSA	CCSA.36.422V1300	13.0.0	Published	01.12.2015	<a href="https://www.ccsa.org.cn/api/portalsFile/downloadOldFile?type=19&amp;oldFileUrl=ITU-R/M.2012-6/CCSA.36.422V1300.doc">https://www.ccsa.org.cn/api/portalsFile/downloadOldFile?type=19&amp;oldFileUrl=ITU-R/M.2012-6/CCSA.36.422V1300.doc</a>
ETSI	ETSI TS 136 422	13.0.0	Published	21.01.2016	<a href="https://www.etsi.org/deliver/etsi_ts/136400_136499/136422/13.00.00_60/ts_136422v130000p.pdf">https://www.etsi.org/deliver/etsi_ts/136400_136499/136422/13.00.00_60/ts_136422v130000p.pdf</a>
TSDSI	TSDSI STD T1.3GPP 36.422-13.0.0 V1.0.0	13.0.0	Published	30.08.2021	<a href="https://members.tdsi.in/index.php/s/nY5L5tsaoq2zXKR">https://members.tdsi.in/index.php/s/nY5L5tsaoq2zXKR</a>
TTA	TTAT.3G-36.422V13.0.0	13.0.0	Published	02.08.2021	<a href="http://committee.tta.or.kr/data/ttasDown.jsp?kind=ttastd&amp;pk_num=TTAT.3G-36.422V13.0.0">http://committee.tta.or.kr/data/ttasDown.jsp?kind=ttastd&amp;pk_num=TTAT.3G-36.422V13.0.0</a>
TTC	TS-3GA-36.422(Rel13)v13.0.0	13.0.0	Published	31.03.2017	<a href="https://www.ttc.or.jp/st/docs/3gpss2017/TS/TS-3GA-36.422(Rel13)v13.0.0.pdf">https://www.ttc.or.jp/st/docs/3gpss2017/TS/TS-3GA-36.422(Rel13)v13.0.0.pdf</a>

## 66

## Rec. ITU-R M.2012-6

### Release 14

ATIS	ATIS.3GPP.36.422V1400	14.0.0	Published	28.06.2021	<a href="https://www.atis.org/3gpp-documents/Rel99-14/">https://www.atis.org/3gpp-documents/Rel99-14/</a>
CCSA	CCSA.36.422V1400	14.0.0	Published	01.03.2017	<a href="https://www.ccsa.org.cn/api/portalsFile/downloadOldFile?type=19&amp;oldFileUrl=ITU-R/M.2012-6/CCSA.36.422V1400.doc">https://www.ccsa.org.cn/api/portalsFile/downloadOldFile?type=19&amp;oldFileUrl=ITU-R/M.2012-6/CCSA.36.422V1400.doc</a>
ETSI	ETSI TS 136 422	14.0.0	Published	11.04.2017	<a href="https://www.etsi.org/deliver/etsi_ts/136400_136499/136422/14.00.00_60/ts_136422v140000p.pdf">https://www.etsi.org/deliver/etsi_ts/136400_136499/136422/14.00.00_60/ts_136422v140000p.pdf</a>
TSDSI	TSDSI STD T1.3GPP 36.422-14.0.0 V1.0.0	14.0.0	Published	30.08.2021	<a href="https://members.tdsi.in/index.php/s/ScTQkdRPTH3M7qb">https://members.tdsi.in/index.php/s/ScTQkdRPTH3M7qb</a>
TTA	TTAT.3G-36.422V14.0.0	14.0.0	Published	02.08.2021	<a href="http://committee.tta.or.kr/data/ttasDown.jsp?kind=ttastd&amp;pk_num=TTAT.3G-36.422V14.0.0">http://committee.tta.or.kr/data/ttasDown.jsp?kind=ttastd&amp;pk_num=TTAT.3G-36.422V14.0.0</a>
TTC	TS-3GA-36.422(Rel14)v14.0.0	14.0.0	Published	13.04.2018	<a href="https://www.ttc.or.jp/st/docs/3gpps2018/TS/TS-3GA-36.422(Rel14)v14.0.0.pdf">https://www.ttc.or.jp/st/docs/3gpps2018/TS/TS-3GA-36.422(Rel14)v14.0.0.pdf</a>

### Release 15

ATIS	ATIS.3GPP.36.422V1510	15.1.0	Published	28.06.2021	<a href="https://www.atis.org/3gpp-documents/Rel15/">https://www.atis.org/3gpp-documents/Rel15/</a>
CCSA	CCSA.36.422V1510	15.1.0	Published	01.12.2018	<a href="https://www.ccsa.org.cn/api/portalsFile/downloadOldFile?type=19&amp;oldFileUrl=ITU-R/M.2012-6/CCSA.36.422V1510.doc">https://www.ccsa.org.cn/api/portalsFile/downloadOldFile?type=19&amp;oldFileUrl=ITU-R/M.2012-6/CCSA.36.422V1510.doc</a>
ETSI	ETSI TS 136 422	15.1.0	Published	17.04.2019	<a href="https://www.etsi.org/deliver/etsi_ts/136400_136499/136422/15.01.00_60/ts_136422v150100p.pdf">https://www.etsi.org/deliver/etsi_ts/136400_136499/136422/15.01.00_60/ts_136422v150100p.pdf</a>
TSDSI	TSDSI STD T1.3GPP 36.422-15.1.0 V1.0.0	15.1.0	Published	30.08.2021	<a href="https://members.tdsi.in/index.php/s/zSdFHNCjNAKXAnH">https://members.tdsi.in/index.php/s/zSdFHNCjNAKXAnH</a>
TTA	TTAT.3G-36.422V15.1.0	15.1.0	Published	11.09.2020	<a href="http://committee.tta.or.kr/data/ttasDown.jsp?kind=ttastd&amp;pk_num=TTAT.3G-36.422V15.1.0">http://committee.tta.or.kr/data/ttasDown.jsp?kind=ttastd&amp;pk_num=TTAT.3G-36.422V15.1.0</a>
TTC	TS-3GA-36.422(Rel15)v15.1.0	15.1.0	Published	29.03.2019	<a href="https://www.ttc.or.jp/st/docs/3gpps2019/TS/TS-3GA-36.422(Rel15)v15.1.0.pdf">https://www.ttc.or.jp/st/docs/3gpps2019/TS/TS-3GA-36.422(Rel15)v15.1.0.pdf</a>

### Release 16

ATIS	ATIS.3GPP.36.422.V16.1.0	16.1.0	Published	21.02.2023	<a href="https://www.atis.org/3gpp-transpositions - Rel-16">https://www.atis.org/3gpp-transpositions - Rel-16</a>
CCSA	CCSA.36.422V1610	16.1.0	Published	01.09.2020	<a href="https://www.ccsa.org.cn/api/portalsFile/downloadOldFile?type=19&amp;oldFileUrl=ITU-R/M.2012-6/CCSA.36.422V1610.doc">https://www.ccsa.org.cn/api/portalsFile/downloadOldFile?type=19&amp;oldFileUrl=ITU-R/M.2012-6/CCSA.36.422V1610.doc</a>
ETSI	ETSI TS 136 422	16.1.0	Published	16.11.2020	<a href="https://www.etsi.org/deliver/etsi_ts/136400_136499/136422/16.01.00_60/ts_136422v160100p.pdf">https://www.etsi.org/deliver/etsi_ts/136400_136499/136422/16.01.00_60/ts_136422v160100p.pdf</a>
TSDSI	TSDSI STD T1.3GPP 36.422-16.1.0 V1.1.0	16.1.0	Published	01.11.2022	<a href="https://members.tdsi.in/s/A4PnXPQHDtkg6in">https://members.tdsi.in/s/A4PnXPQHDtkg6in</a>
TTA	TTAT.3G-36.422V16.1.0	16.1.0	Published	16.03.2023	<a href="http://committee.tta.or.kr/data/ttasDown.jsp?kind=ttastd&amp;pk_num=TTAT.3G-36.422V16.1.0">http://committee.tta.or.kr/data/ttasDown.jsp?kind=ttastd&amp;pk_num=TTAT.3G-36.422V16.1.0</a>
TTC	TS-3GA-36.422(Rel16)v16.1.0	16.1.0	Published	22.12.2020	<a href="https://www.ttc.or.jp/st/docs/3gpp/2020/TS/TS-3GA-36.422v16.1.0.pdf">https://www.ttc.or.jp/st/docs/3gpp/2020/TS/TS-3GA-36.422v16.1.0.pdf</a>

### Release 17

ATIS	ATIS.3GPP.36.422.V17.0.0	17.0.0	Published	21.02.2023	<a href="https://www.atis.org/3gpp-transpositions - Rel-17">https://www.atis.org/3gpp-transpositions - Rel-17</a>
CCSA	CCSA.36.422V1700	17.0.0	Published	01.04.2022	<a href="https://www.ccsa.org.cn/api/portalsFile/downloadOldFile?type=19&amp;oldFileUrl=ITU-R/M.2012-6/CCSA.36.422V1700.doc">https://www.ccsa.org.cn/api/portalsFile/downloadOldFile?type=19&amp;oldFileUrl=ITU-R/M.2012-6/CCSA.36.422V1700.doc</a>
ETSI	ETSI TS 136 422	17.0.0	Published	02.05.2022	<a href="https://www.etsi.org/deliver/etsi_ts/136400_136499/136422/17.00.00_60/ts_136422v170000p.pdf">https://www.etsi.org/deliver/etsi_ts/136400_136499/136422/17.00.00_60/ts_136422v170000p.pdf</a>
TSDSI	TSDSI STD T1.3GPP 36.422-17.0.0 V1.0.0	17.0.0	Published	29.07.2022	<a href="https://members.tdsi.in/s/AbtymeJSHdT5xoy">https://members.tdsi.in/s/AbtymeJSHdT5xoy</a>
TTA	TTAT.3G-36.422V17.0.0	17.0.0	Published	05.08.2022	<a href="http://committee.tta.or.kr/data/ttasDown.jsp?kind=ttastd&amp;pk_num=TTAT.3G-36.422V17.0.0">http://committee.tta.or.kr/data/ttasDown.jsp?kind=ttastd&amp;pk_num=TTAT.3G-36.422V17.0.0</a>
TTC	TS-3GA-36.422(Rel17)v17.0.0	17.0.0	Published	07.10.2022	<a href="https://www.ttc.or.jp/st/docs/3gpp/2022/TS/TS-3GA-36.422v17.0.0.pdf">https://www.ttc.or.jp/st/docs/3gpp/2022/TS/TS-3GA-36.422v17.0.0.pdf</a>

## 2.1.4.10 TS 36.423

### Evolved Universal Terrestrial Radio Access Network (E-UTRAN); X2 Application Protocol (X2AP)

This document specifies the radio network layer signalling procedures of the control plane between eNodeBs in E-UTRAN. X2AP supports the functions of X2 interface by signalling procedures defined in this document.

SDO	Document No.	Version	Status	Issued date	Location
-----	--------------	---------	--------	-------------	----------

### Release 10

ATIS	ATIS.3GPP.36.423V1070	10.7.0	Published	28.06.2021	<a href="https://www.atis.org/3gpp-documents/Rel99-14/">https://www.atis.org/3gpp-documents/Rel99-14/</a>
CCSA	CCSA.36.423V1070	10.7.0	Published	01.09.2013	<a href="https://www.ccsa.org.cn/api/portalsFile/downloadOldFile?type=19&amp;oldFileUrl=ITU-R/M.2012-6/CCSA.36.423V1070.doc">https://www.ccsa.org.cn/api/portalsFile/downloadOldFile?type=19&amp;oldFileUrl=ITU-R/M.2012-6/CCSA.36.423V1070.doc</a>
ETSI	ETSI TS 136 423	10.7.0	Published	26.09.2013	<a href="https://www.etsi.org/deliver/etsi_ts/136400_136499/136423/10.07.00_60/ts_136423v100700p.pdf">https://www.etsi.org/deliver/etsi_ts/136400_136499/136423/10.07.00_60/ts_136423v100700p.pdf</a>
TSDSI	TSDSI STD T1.3GPP 36.423-10.7.0 V1.0.0	10.7.0	Published	30.08.2021	<a href="https://members.tdsi.in/index.php/s/mxzbkpFbiaoiMmj">https://members.tdsi.in/index.php/s/mxzbkpFbiaoiMmj</a>
TTA	TTAT.3G-36.423V10.7.0	10.7.0	Published	02.08.2021	<a href="http://committee.tta.or.kr/data/ttasDown.jsp?kind=ttastd&amp;pk_num=TTAT.3G-36.423V10.7.0">http://committee.tta.or.kr/data/ttasDown.jsp?kind=ttastd&amp;pk_num=TTAT.3G-36.423V10.7.0</a>
TTC	TS-3GA-36.423(Rel10)v10.7.0	10.7.0	Published	22.11.2013	<a href="https://www.ttc.or.jp/st/docs/3gpps2013/TS/TS-3GA-36.423(Rel10)v10.7.0.pdf">https://www.ttc.or.jp/st/docs/3gpps2013/TS/TS-3GA-36.423(Rel10)v10.7.0.pdf</a>

<b>Release 11</b>						
ATIS	ATIS.3GPP.36.423V1190	11.9.0	Published	28.06.2021	<a href="https://www.atis.org/3gpp-documents/Rel99-14/">https://www.atis.org/3gpp-documents/Rel99-14/</a>	
CCSA	CCSA.36.423V1190	11.9.0	Published	01.03.2015	<a href="https://www.ccsa.org.cn/api/portalsFile/downloadOldFile?type=19&amp;oldFileUrl=ITU-R/M.2012-6/CCSA.36.423V1190.doc">https://www.ccsa.org.cn/api/portalsFile/downloadOldFile?type=19&amp;oldFileUrl=ITU-R/M.2012-6/CCSA.36.423V1190.doc</a>	
ETSI	ETSI TS 136 423	11.9.0	Published	14.04.2015	<a href="https://www.etsi.org/deliver/etsi_ts/136400_136499/136423/11.09.00_60/ts_136423v110900p.pdf">https://www.etsi.org/deliver/etsi_ts/136400_136499/136423/11.09.00_60/ts_136423v110900p.pdf</a>	
TSDSI	TSDSI STD T1.3GPP 36.423-11.9.0 V1.0.0	11.9.0	Published	30.08.2021	<a href="https://members.tdsi.in/index.php/s/w4Ao2ZZ94Gp5nSL">https://members.tdsi.in/index.php/s/w4Ao2ZZ94Gp5nSL</a>	
TTA	TTAT.3G-36.423V11.9.0	11.9.0	Published	02.08.2021	<a href="http://committee.tta.or.kr/data/ttasDown.jsp?kind=ttastd&amp;pk_num=TTAT.3G-36.423V11.9.0">http://committee.tta.or.kr/data/ttasDown.jsp?kind=ttastd&amp;pk_num=TTAT.3G-36.423V11.9.0</a>	
TTC	TS-3GA-36.423(Rel11)v11.9.0	11.9.0	Published	30.06.2015	<a href="https://www.ttc.or.jp/st/docs/3gpps2015/TS/TS-3GA-36.423(Rel11)v11.9.0.pdf">https://www.ttc.or.jp/st/docs/3gpps2015/TS/TS-3GA-36.423(Rel11)v11.9.0.pdf</a>	
<b>Release 12</b>						
ATIS	ATIS.3GPP.36.423V1290	12.9.0	Published	28.06.2021	<a href="https://www.atis.org/3gpp-documents/Rel99-14/">https://www.atis.org/3gpp-documents/Rel99-14/</a>	
CCSA	CCSA.36.423V1290	12.9.0	Published	01.06.2016	<a href="https://www.ccsa.org.cn/api/portalsFile/downloadOldFile?type=19&amp;oldFileUrl=ITU-R/M.2012-6/CCSA.36.423V1290.doc">https://www.ccsa.org.cn/api/portalsFile/downloadOldFile?type=19&amp;oldFileUrl=ITU-R/M.2012-6/CCSA.36.423V1290.doc</a>	
ETSI	ETSI TS 136 423	12.9.0	Published	25.08.2016	<a href="https://www.etsi.org/deliver/etsi_ts/136400_136499/136423/12.09.00_60/ts_136423v120900p.pdf">https://www.etsi.org/deliver/etsi_ts/136400_136499/136423/12.09.00_60/ts_136423v120900p.pdf</a>	
TSDSI	TSDSI STD T1.3GPP 36.423-12.9.0 V1.0.0	12.9.0	Published	30.08.2021	<a href="https://members.tdsi.in/index.php/s/RiCkioem5p4DDKM">https://members.tdsi.in/index.php/s/RiCkioem5p4DDKM</a>	
TTA	TTAT.3G-36.423V12.9.0	12.9.0	Published	02.08.2021	<a href="http://committee.tta.or.kr/data/ttasDown.jsp?kind=ttastd&amp;pk_num=TTAT.3G-36.423V12.9.0">http://committee.tta.or.kr/data/ttasDown.jsp?kind=ttastd&amp;pk_num=TTAT.3G-36.423V12.9.0</a>	
TTC	TS-3GA-36.423(Rel12)v12.9.0	12.9.0	Published	31.03.2017	<a href="https://www.ttc.or.jp/st/docs/3gpps2017/TS/TS-3GA-36.423(Rel12)v12.9.0.pdf">https://www.ttc.or.jp/st/docs/3gpps2017/TS/TS-3GA-36.423(Rel12)v12.9.0.pdf</a>	
<b>Release 13</b>						
ATIS	ATIS.3GPP.36.423V1380	13.8.0	Published	28.06.2021	<a href="https://www.atis.org/3gpp-documents/Rel99-14/">https://www.atis.org/3gpp-documents/Rel99-14/</a>	
CCSA	CCSA.36.423V1380	13.8.0	Published	01.09.2019	<a href="https://www.ccsa.org.cn/api/portalsFile/downloadOldFile?type=19&amp;oldFileUrl=ITU-R/M.2012-6/CCSA.36.423V1380.doc">https://www.ccsa.org.cn/api/portalsFile/downloadOldFile?type=19&amp;oldFileUrl=ITU-R/M.2012-6/CCSA.36.423V1380.doc</a>	
ETSI	ETSI TS 136 423	13.8.0	Published	16.10.2019	<a href="https://www.etsi.org/deliver/etsi_ts/136400_136499/136423/13.08.00_60/ts_136423v130800p.pdf">https://www.etsi.org/deliver/etsi_ts/136400_136499/136423/13.08.00_60/ts_136423v130800p.pdf</a>	
TSDSI	TSDSI STD T1.3GPP 36.423-13.8.0 V1.1.0	13.8.0	Published	30.08.2021	<a href="https://members.tdsi.in/index.php/s/cP4rFMMYavjyxZX">https://members.tdsi.in/index.php/s/cP4rFMMYavjyxZX</a>	
TTA	TTAT.3G-36.423V13.8.0	13.8.0	Published	02.08.2021	<a href="http://committee.tta.or.kr/data/ttasDown.jsp?kind=ttastd&amp;pk_num=TTAT.3G-36.423V13.8.0">http://committee.tta.or.kr/data/ttasDown.jsp?kind=ttastd&amp;pk_num=TTAT.3G-36.423V13.8.0</a>	
TTC	TS-3GA-36.423(Rel13)v13.8.0	13.8.0	Published	20.12.2019	<a href="https://www.ttc.or.jp/st/docs/3gpps2019/TS/TS-3GA-36.423(Rel13)v13.8.0.pdf">https://www.ttc.or.jp/st/docs/3gpps2019/TS/TS-3GA-36.423(Rel13)v13.8.0.pdf</a>	
<b>Release 14</b>						
ATIS	ATIS.3GPP.36.423V1480	14.8.0	Published	28.06.2021	<a href="https://www.atis.org/3gpp-documents/Rel99-14/">https://www.atis.org/3gpp-documents/Rel99-14/</a>	
CCSA	CCSA.36.423V1480	14.8.0	Published	01.09.2019	<a href="https://www.ccsa.org.cn/api/portalsFile/downloadOldFile?type=19&amp;oldFileUrl=ITU-R/M.2012-6/CCSA.36.423V1480.doc">https://www.ccsa.org.cn/api/portalsFile/downloadOldFile?type=19&amp;oldFileUrl=ITU-R/M.2012-6/CCSA.36.423V1480.doc</a>	
ETSI	ETSI TS 136 423	14.8.0	Published	16.10.2019	<a href="https://www.etsi.org/deliver/etsi_ts/136400_136499/136423/14.08.00_60/ts_136423v140800p.pdf">https://www.etsi.org/deliver/etsi_ts/136400_136499/136423/14.08.00_60/ts_136423v140800p.pdf</a>	
TSDSI	TSDSI STD T1.3GPP 36.423-14.8.0 V1.1.0	14.8.0	Published	30.08.2021	<a href="https://members.tdsi.in/index.php/s/PE5Kecw6e3bsR3E">https://members.tdsi.in/index.php/s/PE5Kecw6e3bsR3E</a>	
TTA	TTAT.3G-36.423V14.8.0	14.8.0	Published	02.08.2021	<a href="http://committee.tta.or.kr/data/ttasDown.jsp?kind=ttastd&amp;pk_num=TTAT.3G-36.423V14.8.0">http://committee.tta.or.kr/data/ttasDown.jsp?kind=ttastd&amp;pk_num=TTAT.3G-36.423V14.8.0</a>	
TTC	TS-3GA-36.423(Rel14)v14.8.0	14.8.0	Published	20.12.2019	<a href="https://www.ttc.or.jp/st/docs/3gpps2019/TS/TS-3GA-36.423(Rel14)v14.8.0.pdf">https://www.ttc.or.jp/st/docs/3gpps2019/TS/TS-3GA-36.423(Rel14)v14.8.0.pdf</a>	
<b>Release 15</b>						
ATIS	ATIS.3GPP.36.423.V15.13.0	15.13.0	Published	21.02.2023	<a href="https://www.atis.org/3gpp-transpositions - Rel-15">https://www.atis.org/3gpp-transpositions - Rel-15</a>	
CCSA	CCSA.36.423V15130	15.13.0	Published	01.04.2022	<a href="https://www.ccsa.org.cn/api/portalsFile/downloadOldFile?type=19&amp;oldFileUrl=ITU-R/M.2012-6/CCSA.36.423V15130.doc">https://www.ccsa.org.cn/api/portalsFile/downloadOldFile?type=19&amp;oldFileUrl=ITU-R/M.2012-6/CCSA.36.423V15130.doc</a>	
ETSI	ETSI TS 136 423	15.13.0	Published	02.05.2022	<a href="https://www.etsi.org/deliver/etsi_ts/136400_136499/136423/15.13.00_60/ts_136423v151300p.pdf">https://www.etsi.org/deliver/etsi_ts/136400_136499/136423/15.13.00_60/ts_136423v151300p.pdf</a>	
TSDSI	TSDSI STD T1.3GPP 36.423-15.13.0 V1.1.0	15.13.0	Published	01.11.2022	<a href="https://members.tdsi.in/s/qMMJAdcZAdcCtLS">https://members.tdsi.in/s/qMMJAdcZAdcCtLS</a>	
TTA	TTAT.3G-36.423V15.13.0	15.13.0	Published	05.08.2022	<a href="http://committee.tta.or.kr/data/ttasDown.jsp?kind=ttastd&amp;pk_num=TTAT.3G-36.423V15.13.0">http://committee.tta.or.kr/data/ttasDown.jsp?kind=ttastd&amp;pk_num=TTAT.3G-36.423V15.13.0</a>	
TTC	TS-3GA-36.423(Rel15)v15.13.0	15.13.0	Published	08.07.2022	<a href="https://www.ttc.or.jp/st/docs/3gpp/2022/TS/TS-3GA-36.423v15.13.0.pdf">https://www.ttc.or.jp/st/docs/3gpp/2022/TS/TS-3GA-36.423v15.13.0.pdf</a>	
<b>Release 16</b>						
ATIS	ATIS.3GPP.36.423.V16.10.1	16.10.1	Published	21.02.2023	<a href="https://www.atis.org/3gpp-transpositions - Rel-16">https://www.atis.org/3gpp-transpositions - Rel-16</a>	
CCSA	CCSA.36.423V16101	16.10.1	Published	01.06.2022	<a href="https://www.ccsa.org.cn/api/portalsFile/downloadOldFile?type=19&amp;oldFileUrl=ITU-R/M.2012-6/CCSA.36.423V16101.doc">https://www.ccsa.org.cn/api/portalsFile/downloadOldFile?type=19&amp;oldFileUrl=ITU-R/M.2012-6/CCSA.36.423V16101.doc</a>	
ETSI	ETSI TS 136 423	16.10.1	Published	20.07.2022	<a href="https://www.etsi.org/deliver/etsi_ts/136400_136499/136423/16.10.01_60/ts_136423v161001p.pdf">https://www.etsi.org/deliver/etsi_ts/136400_136499/136423/16.10.01_60/ts_136423v161001p.pdf</a>	
TSDSI	TSDSI STD T1.3GPP 36.423-16.10.1 V1.1.0	16.10.1	Published	01.11.2022	<a href="https://members.tdsi.in/s/kRLRxTyaHRZipAB">https://members.tdsi.in/s/kRLRxTyaHRZipAB</a>	
TTA	TTAT.3G-36.423V16.10.1	16.10.1	Published	16.03.2023	<a href="http://committee.tta.or.kr/data/ttasDown.jsp?kind=ttastd&amp;pk_num=TTAT.3G-36.423V16.10.1">http://committee.tta.or.kr/data/ttasDown.jsp?kind=ttastd&amp;pk_num=TTAT.3G-36.423V16.10.1</a>	
TTC	TS-3GA-36.423(Rel16)v16.10.1	16.10.1	Published	14.04.2023	<a href="https://www.ttc.or.jp/st/docs/3gpp/2023/TS/TS-3GA-36.423v16.10.1.pdf">https://www.ttc.or.jp/st/docs/3gpp/2023/TS/TS-3GA-36.423v16.10.1.pdf</a>	

## Release 17

ATIS	ATIS.3GPP.36.423.V17.3.0	17.3.0	Published	21.02.2023	<a href="https://www.atis.org/3gpp-transpositions - Rel-17">https://www.atis.org/3gpp-transpositions - Rel-17</a>
CCSA	CCSA.36.423V1730	17.3.0	Published	01.12.2022	<a href="https://www.ccsa.org.cn/api/portalsFile/downloadOldFile?type=19&amp;oldFileUrl=ITU-R/M.2012-6/CCSA.36.423V1730.doc">https://www.ccsa.org.cn/api/portalsFile/downloadOldFile?type=19&amp;oldFileUrl=ITU-R/M.2012-6/CCSA.36.423V1730.doc</a>
ETSI	ETSI TS 136 423	17.3.0	Published	13.01.2023	<a href="https://www.etsi.org/deliver/etsi_ts/136400_136499/136423/17.03.00_60/ts_136423v170300p.pdf">https://www.etsi.org/deliver/etsi_ts/136400_136499/136423/17.03.00_60/ts_136423v170300p.pdf</a>
TSDSI	TSDSI STD T1.3GPP 36.423 17.3.0 V1.3.0	17.3.0	Published	02.05.2023	<a href="https://members.tdsi.in/s/ND3TiCBpkm7tNcP">https://members.tdsi.in/s/ND3TiCBpkm7tNcP</a>
TTA	TTAT.3G-36.423V17.3.0	17.3.0	Published	16.03.2023	<a href="http://committee.tta.or.kr/data/ttasDown.jsp?kind=ttastd&amp;pk_num=TTAT.3G-36.423V17.3.0">http://committee.tta.or.kr/data/ttasDown.jsp?kind=ttastd&amp;pk_num=TTAT.3G-36.423V17.3.0</a>
TTC	TS-3GA-36.423(Rel17)v17.3.0	17.3.0	Published	14.04.2023	<a href="https://www.ttc.or.jp/st/docs/3gpp/2023/TS/TS-3GA-36.423v17.3.0.pdf">https://www.ttc.or.jp/st/docs/3gpp/2023/TS/TS-3GA-36.423v17.3.0.pdf</a>

## 2.1.4.11 TS 36.424

## Evolved Universal Terrestrial Radio Access Network (E-UTRAN); X2 data transport

This document specifies the standards for user data transport protocols and related signalling protocols to establish user plane transport bearers over the X2 interface.

SDO	Document No.	Version	Status	Issued date	Location
<b>Release 10</b>					
ATIS	ATIS.3GPP.36.424V1010	10.1.0	Published	28.06.2021	<a href="https://www.atis.org/3gpp-documents/Rel99-14/">https://www.atis.org/3gpp-documents/Rel99-14/</a>
CCSA	CCSA.36.424V1010	10.1.0	Published	01.06.2011	<a href="https://www.ccsa.org.cn/api/portalsFile/downloadOldFile?type=19&amp;oldFileUrl=ITU-R/M.2012-6/CCSA.36.424V1010.doc">https://www.ccsa.org.cn/api/portalsFile/downloadOldFile?type=19&amp;oldFileUrl=ITU-R/M.2012-6/CCSA.36.424V1010.doc</a>
ETSI	ETSI TS 136 424	10.1.0	Published	30.06.2011	<a href="https://www.etsi.org/deliver/etsi_ts/136400_136499/136424/10.01.00_60/ts_136424v100100p.pdf">https://www.etsi.org/deliver/etsi_ts/136400_136499/136424/10.01.00_60/ts_136424v100100p.pdf</a>
TSDSI	TSDSI STD T1.3GPP 36.424-10.1.0 V1.0.0	10.1.0	Published	30.08.2021	<a href="https://members.tdsi.in/index.php/s/OmXiQBLP9DcdiAm">https://members.tdsi.in/index.php/s/OmXiQBLP9DcdiAm</a>
TTA	TTAT.3G-36.424V10.1.0	10.1.0	Published	02.08.2021	<a href="http://committee.tta.or.kr/data/ttasDown.jsp?kind=ttastd&amp;pk_num=TTAT.3G-36.424V10.1.0">http://committee.tta.or.kr/data/ttasDown.jsp?kind=ttastd&amp;pk_num=TTAT.3G-36.424V10.1.0</a>
TTC	TS-3GA-36.424(Rel10)v10.1.0	10.1.0	Published	31.08.2011	<a href="https://www.ttc.or.jp/st/docs/3gpps2011/TS/TS-3GA-36.424(Rel10)v10.1.0.pdf">https://www.ttc.or.jp/st/docs/3gpps2011/TS/TS-3GA-36.424(Rel10)v10.1.0.pdf</a>
<b>Release 11</b>					
ATIS	ATIS.3GPP.36.424V1100	11.0.0	Published	28.06.2021	<a href="https://www.atis.org/3gpp-documents/Rel99-14/">https://www.atis.org/3gpp-documents/Rel99-14/</a>
CCSA	CCSA.36.424V1100	11.0.0	Published	01.09.2012	<a href="https://www.ccsa.org.cn/api/portalsFile/downloadOldFile?type=19&amp;oldFileUrl=ITU-R/M.2012-6/CCSA.36.424V1100.doc">https://www.ccsa.org.cn/api/portalsFile/downloadOldFile?type=19&amp;oldFileUrl=ITU-R/M.2012-6/CCSA.36.424V1100.doc</a>
ETSI	ETSI TS 136 424	11.0.0	Published	18.10.2012	<a href="https://www.etsi.org/deliver/etsi_ts/136400_136499/136424/11.00.00_60/ts_136424v110000p.pdf">https://www.etsi.org/deliver/etsi_ts/136400_136499/136424/11.00.00_60/ts_136424v110000p.pdf</a>
TSDSI	TSDSI STD T1.3GPP 36.424-11.0.0 V1.0.0	11.0.0	Published	30.08.2021	<a href="https://members.tdsi.in/index.php/s/3AYwwFW6bFgXTi5">https://members.tdsi.in/index.php/s/3AYwwFW6bFgXTi5</a>
TTA	TTAT.3G-36.424V11.0.0	11.0.0	Published	02.08.2021	<a href="http://committee.tta.or.kr/data/ttasDown.jsp?kind=ttastd&amp;pk_num=TTAT.3G-36.424V11.0.0">http://committee.tta.or.kr/data/ttasDown.jsp?kind=ttastd&amp;pk_num=TTAT.3G-36.424V11.0.0</a>
TTC	TS-3GA-36.424(Rel11)v11.0.0	11.0.0	Published	25.06.2013	<a href="https://www.ttc.or.jp/st/docs/3gpps2013/TS/TS-3GA-36.424(Rel11)v11.0.0.pdf">https://www.ttc.or.jp/st/docs/3gpps2013/TS/TS-3GA-36.424(Rel11)v11.0.0.pdf</a>
<b>Release 12</b>					
ATIS	ATIS.3GPP.36.424V1220	12.2.0	Published	28.06.2021	<a href="https://www.atis.org/3gpp-documents/Rel99-14/">https://www.atis.org/3gpp-documents/Rel99-14/</a>
CCSA	CCSA.36.424V1220	12.2.0	Published	01.03.2015	<a href="https://www.ccsa.org.cn/api/portalsFile/downloadOldFile?type=19&amp;oldFileUrl=ITU-R/M.2012-6/CCSA.36.424V1220.doc">https://www.ccsa.org.cn/api/portalsFile/downloadOldFile?type=19&amp;oldFileUrl=ITU-R/M.2012-6/CCSA.36.424V1220.doc</a>
ETSI	ETSI TS 136 424	12.2.0	Published	15.04.2015	<a href="https://www.etsi.org/deliver/etsi_ts/136400_136499/136424/12.02.00_60/ts_136424v120200p.pdf">https://www.etsi.org/deliver/etsi_ts/136400_136499/136424/12.02.00_60/ts_136424v120200p.pdf</a>
TSDSI	TSDSI STD T1.3GPP 36.424-12.2.0 V1.0.0	12.2.0	Published	30.08.2021	<a href="https://members.tdsi.in/index.php/s/24FjXtt6Zcn4ZCa">https://members.tdsi.in/index.php/s/24FjXtt6Zcn4ZCa</a>
TTA	TTAT.3G-36.424V12.2.0	12.2.0	Published	02.08.2021	<a href="http://committee.tta.or.kr/data/ttasDown.jsp?kind=ttastd&amp;pk_num=TTAT.3G-36.424V12.2.0">http://committee.tta.or.kr/data/ttasDown.jsp?kind=ttastd&amp;pk_num=TTAT.3G-36.424V12.2.0</a>
TTC	TS-3GA-36.424(Rel12)v12.2.0	12.2.0	Published	30.06.2015	<a href="https://www.ttc.or.jp/st/docs/3gpps2015/TS/TS-3GA-36.424(Rel12)v12.2.0.pdf">https://www.ttc.or.jp/st/docs/3gpps2015/TS/TS-3GA-36.424(Rel12)v12.2.0.pdf</a>
<b>Release 13</b>					
ATIS	ATIS.3GPP.36.424V1310	13.1.0	Published	28.06.2021	<a href="https://www.atis.org/3gpp-documents/Rel99-14/">https://www.atis.org/3gpp-documents/Rel99-14/</a>
CCSA	CCSA.36.424V1310	13.1.0	Published	01.03.2016	<a href="https://www.ccsa.org.cn/api/portalsFile/downloadOldFile?type=19&amp;oldFileUrl=ITU-R/M.2012-6/CCSA.36.424V1310.doc">https://www.ccsa.org.cn/api/portalsFile/downloadOldFile?type=19&amp;oldFileUrl=ITU-R/M.2012-6/CCSA.36.424V1310.doc</a>
ETSI	ETSI TS 136 424	13.1.0	Published	20.05.2016	<a href="https://www.etsi.org/deliver/etsi_ts/136400_136499/136424/13.01.00_60/ts_136424v130100p.pdf">https://www.etsi.org/deliver/etsi_ts/136400_136499/136424/13.01.00_60/ts_136424v130100p.pdf</a>
TSDSI	TSDSI STD T1.3GPP 36.424-13.1.0 V1.0.0	13.1.0	Published	30.08.2021	<a href="https://members.tdsi.in/index.php/s/iL3MY7HYyJRPyWy">https://members.tdsi.in/index.php/s/iL3MY7HYyJRPyWy</a>
TTA	TTAT.3G-36.424V13.1.0	13.1.0	Published	02.08.2021	<a href="http://committee.tta.or.kr/data/ttasDown.jsp?kind=ttastd&amp;pk_num=TTAT.3G-36.424V13.1.0">http://committee.tta.or.kr/data/ttasDown.jsp?kind=ttastd&amp;pk_num=TTAT.3G-36.424V13.1.0</a>
TTC	TS-3GA-36.424(Rel13)v13.1.0	13.1.0	Published	31.03.2017	<a href="https://www.ttc.or.jp/st/docs/3gpps2017/TS/TS-3GA-36.424(Rel13)v13.1.0.pdf">https://www.ttc.or.jp/st/docs/3gpps2017/TS/TS-3GA-36.424(Rel13)v13.1.0.pdf</a>

<b>Release 14</b>					
ATIS	ATIS.3GPP.36.424V1410	14.1.0	Published	28.06.2021	<a href="https://www.atis.org/3gpp-documents/Rel14/">https://www.atis.org/3gpp-documents/Rel14/</a>
CCSA	CCSA.36.424V1410	14.1.0	Published	01.06.2017	<a href="https://www.ccsa.org.cn/api/portalsFile/downloadOldFile?type=19&amp;oldFileUrl=ITU-R/M.2012-6/CCSA.36.424V1410.doc">https://www.ccsa.org.cn/api/portalsFile/downloadOldFile?type=19&amp;oldFileUrl=ITU-R/M.2012-6/CCSA.36.424V1410.doc</a>
ETSI	ETSI TS 136 424	14.1.0	Published	24.08.2017	<a href="https://www.etsi.org/deliver/etsi_ts/136400_136499/136424/14.01.00_60/ts_136424v140100p.pdf">https://www.etsi.org/deliver/etsi_ts/136400_136499/136424/14.01.00_60/ts_136424v140100p.pdf</a>
TSDSI	TSDSI STD T1.3GPP 36.424-14.1.0 V1.0.0	14.1.0	Published	30.08.2021	<a href="https://members.tdsi.in/index.php/s/a648z9ZACxFgDFo">https://members.tdsi.in/index.php/s/a648z9ZACxFgDFo</a>
TTA	TTAT.3G-36.424V14.1.0	14.1.0	Published	02.08.2021	<a href="http://committee.tta.or.kr/data/ttasDown.jsp?kind=ttastd&amp;pk_num=TTAT.3G-36.424V14.1.0">http://committee.tta.or.kr/data/ttasDown.jsp?kind=ttastd&amp;pk_num=TTAT.3G-36.424V14.1.0</a>
TTC	TS-3GA-36.424(Rel14)v14.1.0	14.1.0	Published	13.04.2018	<a href="https://www.ttc.or.jp/st/docs/3gpps2018/TS/TS-3GA-36.424(Rel14)v14.1.0.pdf">https://www.ttc.or.jp/st/docs/3gpps2018/TS/TS-3GA-36.424(Rel14)v14.1.0.pdf</a>
<b>Release 15</b>					
ATIS	ATIS.3GPP.36.424V1510	15.1.0	Published	28.06.2021	<a href="https://www.atis.org/3gpp-documents/Rel15/">https://www.atis.org/3gpp-documents/Rel15/</a>
CCSA	CCSA.36.424V1510	15.1.0	Published	01.12.2019	<a href="https://www.ccsa.org.cn/api/portalsFile/downloadOldFile?type=19&amp;oldFileUrl=ITU-R/M.2012-6/CCSA.36.424V1510.doc">https://www.ccsa.org.cn/api/portalsFile/downloadOldFile?type=19&amp;oldFileUrl=ITU-R/M.2012-6/CCSA.36.424V1510.doc</a>
ETSI	ETSI TS 136 424	15.1.0	Published	17.01.2020	<a href="https://www.etsi.org/deliver/etsi_ts/136400_136499/136424/15.01.00_60/ts_136424v150100p.pdf">https://www.etsi.org/deliver/etsi_ts/136400_136499/136424/15.01.00_60/ts_136424v150100p.pdf</a>
TSDSI	TSDSI STD T1.3GPP 36.424-15.1.0 V1.0.0	15.1.0	Published	30.08.2021	<a href="https://members.tdsi.in/index.php/s/kpf94ny3RKq3eRD">https://members.tdsi.in/index.php/s/kpf94ny3RKq3eRD</a>
TTA	TTAT.3G-36.424V15.1.0	15.1.0	Published	11.09.2020	<a href="http://committee.tta.or.kr/data/ttasDown.jsp?kind=ttastd&amp;pk_num=TTAT.3G-36.424V15.1.0">http://committee.tta.or.kr/data/ttasDown.jsp?kind=ttastd&amp;pk_num=TTAT.3G-36.424V15.1.0</a>
TTC	TS-3GA-36.424(Rel15)v15.1.0	15.1.0	Published	16.04.2020	<a href="https://www.ttc.or.jp/st/docs/3gpps2020/TS/TS-3GA-36_424_Rel15v15_1_0.pdf">https://www.ttc.or.jp/st/docs/3gpps2020/TS/TS-3GA-36_424_Rel15v15_1_0.pdf</a>
<b>Release 16</b>					
ATIS	ATIS.3GPP.36.424V1600	16.0.0	Published	28.06.2021	<a href="https://www.atis.org/3gpp-documents/Rel16/">https://www.atis.org/3gpp-documents/Rel16/</a>
CCSA	CCSA.36.424V1600	16.0.0	Published	01.07.2020	<a href="https://www.ccsa.org.cn/api/portalsFile/downloadOldFile?type=19&amp;oldFileUrl=ITU-R/M.2012-6/CCSA.36.424V1600.doc">https://www.ccsa.org.cn/api/portalsFile/downloadOldFile?type=19&amp;oldFileUrl=ITU-R/M.2012-6/CCSA.36.424V1600.doc</a>
ETSI	ETSI TS 136 424	16.0.0	Published	21.07.2020	<a href="https://www.etsi.org/deliver/etsi_ts/136400_136499/136424/16.00.00_60/ts_136424v160000p.pdf">https://www.etsi.org/deliver/etsi_ts/136400_136499/136424/16.00.00_60/ts_136424v160000p.pdf</a>
TSDSI	TSDSI STD T1.3GPP 36.424-16.0.0 V1.0.0	16.0.0	Published	30.08.2021	<a href="https://members.tdsi.in/index.php/s/HexHwXSiQxoWdT2">https://members.tdsi.in/index.php/s/HexHwXSiQxoWdT2</a>
TTA	TTAT.3G-36.424V16.0.0	16.0.0	Published	11.09.2020	<a href="http://committee.tta.or.kr/data/ttasDown.jsp?kind=ttastd&amp;pk_num=TTAT.3G-36.424V16.0.0">http://committee.tta.or.kr/data/ttasDown.jsp?kind=ttastd&amp;pk_num=TTAT.3G-36.424V16.0.0</a>
TTC	TS-3GA-36.424(Rel16)v16.0.0	16.0.0	Published	02.10.2020	<a href="https://www.ttc.or.jp/st/docs/3gpps2020/TS/TS-3GA-36_424_Rel16v16_0_0.pdf">https://www.ttc.or.jp/st/docs/3gpps2020/TS/TS-3GA-36_424_Rel16v16_0_0.pdf</a>
<b>Release 17</b>					
ATIS	ATIS.3GPP.36.424.V17.0.0	17.0.0	Published	21.02.2023	<a href="https://www.atis.org/3gpp-transpositions - Rel-17">https://www.atis.org/3gpp-transpositions - Rel-17</a>
CCSA	CCSA.36.424V1700	17.0.0	Published	01.04.2022	<a href="https://www.ccsa.org.cn/api/portalsFile/downloadOldFile?type=19&amp;oldFileUrl=ITU-R/M.2012-6/CCSA.36.424V1700.doc">https://www.ccsa.org.cn/api/portalsFile/downloadOldFile?type=19&amp;oldFileUrl=ITU-R/M.2012-6/CCSA.36.424V1700.doc</a>
ETSI	ETSI TS 136 424	17.0.0	Published	02.05.2022	<a href="https://www.etsi.org/deliver/etsi_ts/136400_136499/136424/17.00.00_60/ts_136424v170000p.pdf">https://www.etsi.org/deliver/etsi_ts/136400_136499/136424/17.00.00_60/ts_136424v170000p.pdf</a>
TSDSI	TSDSI STD T1.3GPP 36.424-17.0.0 V1.0.0	17.0.0	Published	29.07.2022	<a href="https://members.tdsi.in/s/oXXYRaQjGoQBYNe">https://members.tdsi.in/s/oXXYRaQjGoQBYNe</a>
TTA	TTAT.3G-36.424V17.0.0	17.0.0	Published	05.08.2022	<a href="http://committee.tta.or.kr/data/ttasDown.jsp?kind=ttastd&amp;pk_num=TTAT.3G-36.424V17.0.0">http://committee.tta.or.kr/data/ttasDown.jsp?kind=ttastd&amp;pk_num=TTAT.3G-36.424V17.0.0</a>
TTC	TS-3GA-36.424(Rel17)v17.0.0	17.0.0	Published	07.10.2022	<a href="https://www.ttc.or.jp/st/docs/3gpp/2022/TS/TS-3GA-36.424v17.0.0.pdf">https://www.ttc.or.jp/st/docs/3gpp/2022/TS/TS-3GA-36.424v17.0.0.pdf</a>

### 2.1.4.12 TS 36.425

#### Evolved Universal Terrestrial Radio Access Network (E-UTRAN); X2 interface user plane protocol

This document specifies the X2 user plane protocol being used over the X2 interface.

SDO	Document No.	Version	Status	Issued date	Location
<b>Release 12</b>					
ATIS	ATIS.3GPP.36.425V1210	12.1.0	Published	28.06.2021	<a href="https://www.atis.org/3gpp-documents/Rel12/">https://www.atis.org/3gpp-documents/Rel12/</a>
CCSA	CCSA.36.425V1210	12.1.0	Published	01.03.2015	<a href="https://www.ccsa.org.cn/api/portalsFile/downloadOldFile?type=19&amp;oldFileUrl=ITU-R/M.2012-6/CCSA.36.425V1210.doc">https://www.ccsa.org.cn/api/portalsFile/downloadOldFile?type=19&amp;oldFileUrl=ITU-R/M.2012-6/CCSA.36.425V1210.doc</a>
ETSI	ETSI TS 136 425	12.1.0	Published	15.04.2015	<a href="https://www.etsi.org/deliver/etsi_ts/136400_136499/136425/12.01.00_60/ts_136425v120100p.pdf">https://www.etsi.org/deliver/etsi_ts/136400_136499/136425/12.01.00_60/ts_136425v120100p.pdf</a>
TSDSI	TSDSI STD T1.3GPP 36.425-12.1.0 V1.0.0	12.1.0	Published	30.08.2021	<a href="https://members.tdsi.in/index.php/s/CR9oWoeQCDFbqF4">https://members.tdsi.in/index.php/s/CR9oWoeQCDFbqF4</a>
TTA	TTAT.3G-36.425V12.1.0	12.1.0	Published	02.08.2021	<a href="http://committee.tta.or.kr/data/ttasDown.jsp?kind=ttastd&amp;pk_num=TTAT.3G-36.425V12.1.0">http://committee.tta.or.kr/data/ttasDown.jsp?kind=ttastd&amp;pk_num=TTAT.3G-36.425V12.1.0</a>
TTC	TS-3GA-36.425(Rel12)v12.1.0	12.1.0	Published	30.06.2015	<a href="https://www.ttc.or.jp/st/docs/3gpps2015/TS/TS-3GA-36.425(Rel12)v12.1.0.pdf">https://www.ttc.or.jp/st/docs/3gpps2015/TS/TS-3GA-36.425(Rel12)v12.1.0.pdf</a>

**70****Rec. ITU-R M.2012-6**

				<b>Release 13</b>	
ATIS	ATIS.3GPP.36.425V1311	13.1.1	Published	28.06.2021	<a href="https://www.atis.org/3gpp-documents/Rel99-14/">https://www.atis.org/3gpp-documents/Rel99-14/</a>
CCSA	CCSA.36.425V1311	13.1.1	Published	01.09.2016	<a href="https://www.ccsa.org.cn/api/portalsFile/downloadOldFile?type=19&amp;oldFileUrl=ITU-R/M.2012-6/CCSA.36.425V1311.doc">https://www.ccsa.org.cn/api/portalsFile/downloadOldFile?type=19&amp;oldFileUrl=ITU-R/M.2012-6/CCSA.36.425V1311.doc</a>
ETSI	ETSI TS 136 425	13.1.1	Published	06.10.2016	<a href="https://www.etsi.org/deliver/etsi_ts/136400_136499/136425/13.01.01_60/ts_136425v130101p.pdf">https://www.etsi.org/deliver/etsi_ts/136400_136499/136425/13.01.01_60/ts_136425v130101p.pdf</a>
TSDSI	TSDSI STD T1.3GPP 36.425-13.1.1 V1.0.0	13.1.1	Published	30.08.2021	<a href="https://members.tdsi.in/index.php/s/TZSfNZsiTPbf6Qk">https://members.tdsi.in/index.php/s/TZSfNZsiTPbf6Qk</a>
TTA	TTAT.3G-36.425V13.1.1	13.1.1	Published	02.08.2021	<a href="http://committee.tta.or.kr/data/ttasDown.jsp?kind=ttastd&amp;pk_num=TTAT.3G-36.425V13.1.1">http://committee.tta.or.kr/data/ttasDown.jsp?kind=ttastd&amp;pk_num=TTAT.3G-36.425V13.1.1</a>
TTC	TS-3GA-36.425(Rel13)v13.1.1	13.1.1	Published	31.03.2017	<a href="https://www.ttc.or.jp/st/docs/3gpps2017/TS/TS-3GA-36.425(Rel13)v13.1.1.pdf">https://www.ttc.or.jp/st/docs/3gpps2017/TS/TS-3GA-36.425(Rel13)v13.1.1.pdf</a>
				<b>Release 14</b>	
ATIS	ATIS.3GPP.36.425V1420	14.2.0	Published	28.06.2021	<a href="https://www.atis.org/3gpp-documents/Rel99-14/">https://www.atis.org/3gpp-documents/Rel99-14/</a>
CCSA	CCSA.36.425V1420	14.2.0	Published	01.06.2018	<a href="https://www.ccsa.org.cn/api/portalsFile/downloadOldFile?type=19&amp;oldFileUrl=ITU-R/M.2012-6/CCSA.36.425V1420.doc">https://www.ccsa.org.cn/api/portalsFile/downloadOldFile?type=19&amp;oldFileUrl=ITU-R/M.2012-6/CCSA.36.425V1420.doc</a>
ETSI	ETSI TS 136 425	14.2.0	Published	04.07.2018	<a href="https://www.etsi.org/deliver/etsi_ts/136400_136499/136425/14.02.00_60/ts_136425v140200p.pdf">https://www.etsi.org/deliver/etsi_ts/136400_136499/136425/14.02.00_60/ts_136425v140200p.pdf</a>
TSDSI	TSDSI STD T1.3GPP 36.425-14.2.0 V1.1.0	14.2.0	Published	30.08.2021	<a href="https://members.tdsi.in/index.php/s/asM5gZtPAJ2Q3js">https://members.tdsi.in/index.php/s/asM5gZtPAJ2Q3js</a>
TTA	TTAT.3G-36.425V14.2.0	14.2.0	Published	02.08.2021	<a href="http://committee.tta.or.kr/data/ttasDown.jsp?kind=ttastd&amp;pk_num=TTAT.3G-36.425V14.2.0">http://committee.tta.or.kr/data/ttasDown.jsp?kind=ttastd&amp;pk_num=TTAT.3G-36.425V14.2.0</a>
TTC	TS-3GA-36.425(Rel14)v14.2.0	14.2.0	Published	28.09.2018	<a href="https://www.ttc.or.jp/st/docs/3gpps2018/TS/TS-3GA-36.425(Rel14)v14.2.0.pdf">https://www.ttc.or.jp/st/docs/3gpps2018/TS/TS-3GA-36.425(Rel14)v14.2.0.pdf</a>
				<b>Release 15</b>	
ATIS	ATIS.3GPP.36.425V1500	15.0.0	Published	28.06.2021	<a href="https://www.atis.org/3gpp-documents/Rel15/">https://www.atis.org/3gpp-documents/Rel15/</a>
CCSA	CCSA.36.425V1500	15.0.0	Published	01.06.2018	<a href="https://www.ccsa.org.cn/api/portalsFile/downloadOldFile?type=19&amp;oldFileUrl=ITU-R/M.2012-6/CCSA.36.425V1500.doc">https://www.ccsa.org.cn/api/portalsFile/downloadOldFile?type=19&amp;oldFileUrl=ITU-R/M.2012-6/CCSA.36.425V1500.doc</a>
ETSI	ETSI TS 136 425	15.0.0	Published	04.07.2018	<a href="https://www.etsi.org/deliver/etsi_ts/136400_136499/136425/15.00.00_60/ts_136425v150000p.pdf">https://www.etsi.org/deliver/etsi_ts/136400_136499/136425/15.00.00_60/ts_136425v150000p.pdf</a>
TSDSI	TSDSI STD T1.3GPP 36.425-15.0.0 V1.0.0	15.0.0	Published	30.08.2021	<a href="https://members.tdsi.in/index.php/s/gTrKqLPwwFo8tE2">https://members.tdsi.in/index.php/s/gTrKqLPwwFo8tE2</a>
TTA	TTAT.3G-36.425V15.0.0	15.0.0	Published	11.09.2020	<a href="http://committee.tta.or.kr/data/ttasDown.jsp?kind=ttastd&amp;pk_num=TTAT.3G-36.425V15.0.0">http://committee.tta.or.kr/data/ttasDown.jsp?kind=ttastd&amp;pk_num=TTAT.3G-36.425V15.0.0</a>
TTC	TS-3GA-36.425(Rel15)v15.0.0	15.0.0	Published	28.09.2018	<a href="https://www.ttc.or.jp/st/docs/3gpps2018/TS/TS-3GA-36.425(Rel15)v15.0.0.pdf">https://www.ttc.or.jp/st/docs/3gpps2018/TS/TS-3GA-36.425(Rel15)v15.0.0.pdf</a>
				<b>Release 16</b>	
ATIS	ATIS.3GPP.36.425V1600	16.0.0	Published	28.06.2021	<a href="https://www.atis.org/3gpp-documents/Rel16/">https://www.atis.org/3gpp-documents/Rel16/</a>
CCSA	CCSA.36.425V1600	16.0.0	Published	01.07.2020	<a href="https://www.ccsa.org.cn/api/portalsFile/downloadOldFile?type=19&amp;oldFileUrl=ITU-R/M.2012-6/CCSA.36.425V1600.doc">https://www.ccsa.org.cn/api/portalsFile/downloadOldFile?type=19&amp;oldFileUrl=ITU-R/M.2012-6/CCSA.36.425V1600.doc</a>
ETSI	ETSI TS 136 425	16.0.0	Published	21.07.2020	<a href="https://www.etsi.org/deliver/etsi_ts/136400_136499/136425/16.00.00_60/ts_136425v160000p.pdf">https://www.etsi.org/deliver/etsi_ts/136400_136499/136425/16.00.00_60/ts_136425v160000p.pdf</a>
TSDSI	TSDSI STD T1.3GPP 36.425-16.0.0 V1.0.0	16.0.0	Published	30.08.2021	<a href="https://members.tdsi.in/index.php/s/RzRNx4Tcqoqs2tH">https://members.tdsi.in/index.php/s/RzRNx4Tcqoqs2tH</a>
TTA	TTAT.3G-36.425V16.0.0	16.0.0	Published	11.09.2020	<a href="http://committee.tta.or.kr/data/ttasDown.jsp?kind=ttastd&amp;pk_num=TTAT.3G-36.425V16.0.0">http://committee.tta.or.kr/data/ttasDown.jsp?kind=ttastd&amp;pk_num=TTAT.3G-36.425V16.0.0</a>
TTC	TS-3GA-36.425(Rel16)v16.0.0	16.0.0	Published	02.10.2020	<a href="https://www.ttc.or.jp/st/docs/3gpps2020/TS/TS-3GA-36_425_Rel16v16_0_0.pdf">https://www.ttc.or.jp/st/docs/3gpps2020/TS/TS-3GA-36_425_Rel16v16_0_0.pdf</a>
				<b>Release 17</b>	
ATIS	ATIS.3GPP.36.425.V17.0.0	17.0.0	Published	21.02.2023	<a href="https://www.atis.org/3gpp-transpositions - Rel-17">https://www.atis.org/3gpp-transpositions - Rel-17</a>
CCSA	CCSA.36.425V1700	17.0.0	Published	01.04.2022	<a href="https://www.ccsa.org.cn/api/portalsFile/downloadOldFile?type=19&amp;oldFileUrl=ITU-R/M.2012-6/CCSA.36.425V1700.doc">https://www.ccsa.org.cn/api/portalsFile/downloadOldFile?type=19&amp;oldFileUrl=ITU-R/M.2012-6/CCSA.36.425V1700.doc</a>
ETSI	ETSI TS 136 425	17.0.0	Published	02.05.2022	<a href="https://www.etsi.org/deliver/etsi_ts/136400_136499/136425/17.00.00_60/ts_136425v170000p.pdf">https://www.etsi.org/deliver/etsi_ts/136400_136499/136425/17.00.00_60/ts_136425v170000p.pdf</a>
TSDSI	TSDSI STD T1.3GPP 36.425-17.0.0 V1.0.0	17.0.0	Published	29.07.2022	<a href="https://members.tdsi.in/s/oQBkSm9zJs2btOD">https://members.tdsi.in/s/oQBkSm9zJs2btOD</a>
TTA	TTAT.3G-36.425V17.0.0	17.0.0	Published	05.08.2022	<a href="http://committee.tta.or.kr/data/ttasDown.jsp?kind=ttastd&amp;pk_num=TTAT.3G-36.425V17.0.0">http://committee.tta.or.kr/data/ttasDown.jsp?kind=ttastd&amp;pk_num=TTAT.3G-36.425V17.0.0</a>
TTC	TS-3GA-36.425(Rel17)v17.0.0	17.0.0	Published	07.10.2022	<a href="https://www.ttc.or.jp/st/docs/3gpp/2022/TS/TS-3GA-36.425v17.0.0.pdf">https://www.ttc.or.jp/st/docs/3gpp/2022/TS/TS-3GA-36.425v17.0.0.pdf</a>



**2.1.4.13 TS 36.440****Evolved Universal Terrestrial Radio Access Network (E-UTRAN); General aspects and principles for interfaces supporting Multimedia Broadcast Multicast Service (MBMS) within E-UTRAN**

This document describes the overall architecture of the interface for the provision of MBMS in the E-UTRAN. This includes also a description of the general aspects, assumptions and principles guiding the architecture and interface. The MBMS functions to be provided within that architecture are summarized. It provides an introduction to the TSG RAN TS 36.44x series of UMTS technical specifications that define the different interfaces introduced for MBMS provision in E-UTRAN.

SDO	Document No.	Version	Status	Issued date	Location
<b>Release 10</b>					
ATIS	ATIS.3GPP.36.440V1030	10.3.0	Published	28.06.2021	<a href="https://www.atis.org/3gpp-documents/Rel99-14/">https://www.atis.org/3gpp-documents/Rel99-14/</a>
CCSA	CCSA.36.440V1030	10.3.0	Published	01.06.2012	<a href="https://www.ccsa.org.cn/api/portalsFile/downloadOldFile?type=19&amp;oldFileUrl=ITU-R/M.2012-6/CCSA.36.440V1030.doc">https://www.ccsa.org.cn/api/portalsFile/downloadOldFile?type=19&amp;oldFileUrl=ITU-R/M.2012-6/CCSA.36.440V1030.doc</a>
ETSI	ETSI TS 136 440	10.3.0	Published	20.07.2012	<a href="https://www.etsi.org/deliver/etsi_ts/136400_136499/136440/10.03.00_60/ts_136440v100300p.pdf">https://www.etsi.org/deliver/etsi_ts/136400_136499/136440/10.03.00_60/ts_136440v100300p.pdf</a>
TSDSI	TSDSI STD T1.3GPP 36.44-10.3.0 V1.0.0	10.3.0	Published	30.08.2021	<a href="https://members.tdsi.in/index.php/s/58BScMp37S6pQ2w">https://members.tdsi.in/index.php/s/58BScMp37S6pQ2w</a>
TTA	TTAT.3G-36.440V10.3.0	10.3.0	Published	02.08.2021	<a href="http://committee.tta.or.kr/data/ttasDown.jsp?kind=ttastd&amp;pk_num=TTAT.3G-36.440V10.3.0">http://committee.tta.or.kr/data/ttasDown.jsp?kind=ttastd&amp;pk_num=TTAT.3G-36.440V10.3.0</a>
TTC	TS-3GA-36.440(Rel10)v10.3.0	10.3.0	Published	19.09.2012	<a href="https://www.ttc.or.jp/st/docs/3gpps2012/TS/TS-3GA-36.440(Rel10)v10.3.0.pdf">https://www.ttc.or.jp/st/docs/3gpps2012/TS/TS-3GA-36.440(Rel10)v10.3.0.pdf</a>
<b>Release 11</b>					
ATIS	ATIS.3GPP.36.440V1120	11.2.0	Published	28.06.2021	<a href="https://www.atis.org/3gpp-documents/Rel99-14/">https://www.atis.org/3gpp-documents/Rel99-14/</a>
CCSA	CCSA.36.440V1120	11.2.0	Published	01.03.2013	<a href="https://www.ccsa.org.cn/api/portalsFile/downloadOldFile?type=19&amp;oldFileUrl=ITU-R/M.2012-6/CCSA.36.440V1120.doc">https://www.ccsa.org.cn/api/portalsFile/downloadOldFile?type=19&amp;oldFileUrl=ITU-R/M.2012-6/CCSA.36.440V1120.doc</a>
ETSI	ETSI TS 136 440	11.2.0	Published	22.04.2013	<a href="https://www.etsi.org/deliver/etsi_ts/136400_136499/136440/11.02.00_60/ts_136440v110200p.pdf">https://www.etsi.org/deliver/etsi_ts/136400_136499/136440/11.02.00_60/ts_136440v110200p.pdf</a>
TSDSI	TSDSI STD T1.3GPP 36.44-11.2.0 V1.0.0	11.2.0	Published	30.08.2021	<a href="https://members.tdsi.in/index.php/s/Hq2PdH3FzxHEDXi">https://members.tdsi.in/index.php/s/Hq2PdH3FzxHEDXi</a>
TTA	TTAT.3G-36.440V11.2.0	11.2.0	Published	02.08.2021	<a href="http://committee.tta.or.kr/data/ttasDown.jsp?kind=ttastd&amp;pk_num=TTAT.3G-36.440V11.2.0">http://committee.tta.or.kr/data/ttasDown.jsp?kind=ttastd&amp;pk_num=TTAT.3G-36.440V11.2.0</a>
TTC	TS-3GA-36.440(Rel11)v11.2.0	11.2.0	Published	25.06.2013	<a href="https://www.ttc.or.jp/st/docs/3gpps2013/TS/TS-3GA-36.440(Rel11)v11.2.0.pdf">https://www.ttc.or.jp/st/docs/3gpps2013/TS/TS-3GA-36.440(Rel11)v11.2.0.pdf</a>
<b>Release 12</b>					
ATIS	ATIS.3GPP.36.440V1200	12.0.0	Published	28.06.2021	<a href="https://www.atis.org/3gpp-documents/Rel99-14/">https://www.atis.org/3gpp-documents/Rel99-14/</a>
CCSA	CCSA.36.440V1200	12.0.0	Published	01.09.2014	<a href="https://www.ccsa.org.cn/api/portalsFile/downloadOldFile?type=19&amp;oldFileUrl=ITU-R/M.2012-6/CCSA.36.440V1200.doc">https://www.ccsa.org.cn/api/portalsFile/downloadOldFile?type=19&amp;oldFileUrl=ITU-R/M.2012-6/CCSA.36.440V1200.doc</a>
ETSI	ETSI TS 136 440	12.0.0	Published	26.09.2014	<a href="https://www.etsi.org/deliver/etsi_ts/136400_136499/136440/12.00.00_60/ts_136440v120000p.pdf">https://www.etsi.org/deliver/etsi_ts/136400_136499/136440/12.00.00_60/ts_136440v120000p.pdf</a>
TSDSI	TSDSI STD T1.3GPP 36.44-12.0.0 V1.0.0	12.0.0	Published	30.08.2021	<a href="https://members.tdsi.in/index.php/s/HFy2BR48fRwf2CM">https://members.tdsi.in/index.php/s/HFy2BR48fRwf2CM</a>
TTA	TTAT.3G-36.440V12.0.0	12.0.0	Published	02.08.2021	<a href="http://committee.tta.or.kr/data/ttasDown.jsp?kind=ttastd&amp;pk_num=TTAT.3G-36.440V12.0.0">http://committee.tta.or.kr/data/ttasDown.jsp?kind=ttastd&amp;pk_num=TTAT.3G-36.440V12.0.0</a>
TTC	TS-3GA-36.440(Rel12)v12.0.0	12.0.0	Published	05.03.2015	<a href="https://www.ttc.or.jp/st/docs/3gpps2015/TS/TS-3GA-36.440(Rel12)v12.0.0.pdf">https://www.ttc.or.jp/st/docs/3gpps2015/TS/TS-3GA-36.440(Rel12)v12.0.0.pdf</a>
<b>Release 13</b>					
ATIS	ATIS.3GPP.36.440V1300	13.0.0	Published	28.06.2021	<a href="https://www.atis.org/3gpp-documents/Rel99-14/">https://www.atis.org/3gpp-documents/Rel99-14/</a>
CCSA	CCSA.36.440V1300	13.0.0	Published	01.12.2015	<a href="https://www.ccsa.org.cn/api/portalsFile/downloadOldFile?type=19&amp;oldFileUrl=ITU-R/M.2012-6/CCSA.36.440V1300.doc">https://www.ccsa.org.cn/api/portalsFile/downloadOldFile?type=19&amp;oldFileUrl=ITU-R/M.2012-6/CCSA.36.440V1300.doc</a>
ETSI	ETSI TS 136 440	13.0.0	Published	21.01.2016	<a href="https://www.etsi.org/deliver/etsi_ts/136400_136499/136440/13.00.00_60/ts_136440v130000p.pdf">https://www.etsi.org/deliver/etsi_ts/136400_136499/136440/13.00.00_60/ts_136440v130000p.pdf</a>
TSDSI	TSDSI STD T1.3GPP 36.44-13.0.0 V1.0.0	13.0.0	Published	30.08.2021	<a href="https://members.tdsi.in/index.php/s/nS32bACrPNLs4XJ">https://members.tdsi.in/index.php/s/nS32bACrPNLs4XJ</a>
TTA	TTAT.3G-36.440V13.0.0	13.0.0	Published	02.08.2021	<a href="http://committee.tta.or.kr/data/ttasDown.jsp?kind=ttastd&amp;pk_num=TTAT.3G-36.440V13.0.0">http://committee.tta.or.kr/data/ttasDown.jsp?kind=ttastd&amp;pk_num=TTAT.3G-36.440V13.0.0</a>
TTC	TS-3GA-36.440(Rel13)v13.0.0	13.0.0	Published	31.03.2017	<a href="https://www.ttc.or.jp/st/docs/3gpps2017/TS/TS-3GA-36.440(Rel13)v13.0.0.pdf">https://www.ttc.or.jp/st/docs/3gpps2017/TS/TS-3GA-36.440(Rel13)v13.0.0.pdf</a>
<b>Release 14</b>					
ATIS	ATIS.3GPP.36.440V1400	14.0.0	Published	28.06.2021	<a href="https://www.atis.org/3gpp-documents/Rel99-14/">https://www.atis.org/3gpp-documents/Rel99-14/</a>
CCSA	CCSA.36.440V1400	14.0.0	Published	01.03.2017	<a href="https://www.ccsa.org.cn/api/portalsFile/downloadOldFile?type=19&amp;oldFileUrl=ITU-R/M.2012-6/CCSA.36.440V1400.doc">https://www.ccsa.org.cn/api/portalsFile/downloadOldFile?type=19&amp;oldFileUrl=ITU-R/M.2012-6/CCSA.36.440V1400.doc</a>
ETSI	ETSI TS 136 440	14.0.0	Published	11.04.2017	<a href="https://www.etsi.org/deliver/etsi_ts/136400_136499/136440/14.00.00_60/ts_136440v140000p.pdf">https://www.etsi.org/deliver/etsi_ts/136400_136499/136440/14.00.00_60/ts_136440v140000p.pdf</a>
TSDSI	TSDSI STD T1.3GPP 36.440-14.0.0 V1.0.0	14.0.0	Published	30.08.2021	<a href="https://members.tdsi.in/index.php/s/zk2a77pN7DCaMzN">https://members.tdsi.in/index.php/s/zk2a77pN7DCaMzN</a>
TTA	TTAT.3G-36.440V14.0.0	14.0.0	Published	02.08.2021	<a href="http://committee.tta.or.kr/data/ttasDown.jsp?kind=ttastd&amp;pk_num=TTAT.3G-36.440V14.0.0">http://committee.tta.or.kr/data/ttasDown.jsp?kind=ttastd&amp;pk_num=TTAT.3G-36.440V14.0.0</a>
TTC	TS-3GA-36.440(Rel14)v14.0.0	14.0.0	Published	13.04.2018	<a href="https://www.ttc.or.jp/st/docs/3gpps2018/TS/TS-3GA-36.440(Rel14)v14.0.0.pdf">https://www.ttc.or.jp/st/docs/3gpps2018/TS/TS-3GA-36.440(Rel14)v14.0.0.pdf</a>

<b>Release 15</b>					
ATIS	ATIS.3GPP.36.440V1500	15.0.0	Published	28.06.2021	<a href="https://www.atis.org/3gpp-documents/Rel15/">https://www.atis.org/3gpp-documents/Rel15/</a>
CCSA	CCSA.36.440V1500	15.0.0	Published	01.09.2018	<a href="https://www.ccsa.org.cn/api/portalsFile/downloadOldFile?type=19&amp;oldFileUrl=ITU-R/M.2012-6/CCSA.36.440V1500.doc">https://www.ccsa.org.cn/api/portalsFile/downloadOldFile?type=19&amp;oldFileUrl=ITU-R/M.2012-6/CCSA.36.440V1500.doc</a>
ETSI	ETSI TS 136 440	15.0.0	Published	28.09.2018	<a href="https://www.etsi.org/deliver/etsi_ts/136400_136499/136440/15.00.00_60/ts_136440v150000p.pdf">https://www.etsi.org/deliver/etsi_ts/136400_136499/136440/15.00.00_60/ts_136440v150000p.pdf</a>
TSDSI	TSDSI STD T1.3GPP 36.440-15.0.0 V1.0.0	15.0.0	Published	30.08.2021	<a href="https://members.tdsi.in/index.php/s/3Jm8Z92BtjgmArd">https://members.tdsi.in/index.php/s/3Jm8Z92BtjgmArd</a>
TTA	TTAT.3G-36.440V15.0.0	15.0.0	Published	11.09.2020	<a href="http://committee.tta.or.kr/data/ttasDown.jsp?kind=ttastd&amp;pk_num=TTAT.3G-36.440V15.0.0">http://committee.tta.or.kr/data/ttasDown.jsp?kind=ttastd&amp;pk_num=TTAT.3G-36.440V15.0.0</a>
TTC	TS-3GA-36.440(Rel15)v15.0.0	15.0.0	Published	21.12.2018	<a href="https://www.ttc.or.jp/st/docs/3gpps2018/TS/TS-3GA-36.440(Rel15)v15.0.0.pdf">https://www.ttc.or.jp/st/docs/3gpps2018/TS/TS-3GA-36.440(Rel15)v15.0.0.pdf</a>
<b>Release 16</b>					
ATIS	ATIS.3GPP.36.440V1600	16.0.0	Published	28.06.2021	<a href="https://www.atis.org/3gpp-documents/Rel16/">https://www.atis.org/3gpp-documents/Rel16/</a>
CCSA	CCSA.36.440V1600	16.0.0	Published	01.07.2020	<a href="https://www.ccsa.org.cn/api/portalsFile/downloadOldFile?type=19&amp;oldFileUrl=ITU-R/M.2012-6/CCSA.36.440V1600.doc">https://www.ccsa.org.cn/api/portalsFile/downloadOldFile?type=19&amp;oldFileUrl=ITU-R/M.2012-6/CCSA.36.440V1600.doc</a>
ETSI	ETSI TS 136 440	16.0.0	Published	21.07.2020	<a href="https://www.etsi.org/deliver/etsi_ts/136400_136499/136440/16.00.00_60/ts_136440v160000p.pdf">https://www.etsi.org/deliver/etsi_ts/136400_136499/136440/16.00.00_60/ts_136440v160000p.pdf</a>
TSDSI	TSDSI STD T1.3GPP 36.440-16.0.0 V1.0.0	16.0.0	Published	30.08.2021	<a href="https://members.tdsi.in/index.php/s/DMwSp2Y5nGQMkXM">https://members.tdsi.in/index.php/s/DMwSp2Y5nGQMkXM</a>
TTA	TTAT.3G-36.440V16.0.0	16.0.0	Published	11.09.2020	<a href="http://committee.tta.or.kr/data/ttasDown.jsp?kind=ttastd&amp;pk_num=TTAT.3G-36.440V16.0.0">http://committee.tta.or.kr/data/ttasDown.jsp?kind=ttastd&amp;pk_num=TTAT.3G-36.440V16.0.0</a>
TTC	TS-3GA-36.440(Rel16)v16.0.0	16.0.0	Published	02.10.2020	<a href="https://www.ttc.or.jp/st/docs/3gpps2020/TS/TS-3GA-36_440_Rel16v16_0_0.pdf">https://www.ttc.or.jp/st/docs/3gpps2020/TS/TS-3GA-36_440_Rel16v16_0_0.pdf</a>
<b>Release 17</b>					
ATIS	ATIS.3GPP.36.440.V17.0.0	17.0.0	Published	21.02.2023	<a href="https://www.atis.org/3gpp-transpositions - Rel-17">https://www.atis.org/3gpp-transpositions - Rel-17</a>
CCSA	CCSA.36.440V1700	17.0.0	Published	01.04.2022	<a href="https://www.ccsa.org.cn/api/portalsFile/downloadOldFile?type=19&amp;oldFileUrl=ITU-R/M.2012-6/CCSA.36.440V1700.doc">https://www.ccsa.org.cn/api/portalsFile/downloadOldFile?type=19&amp;oldFileUrl=ITU-R/M.2012-6/CCSA.36.440V1700.doc</a>
ETSI	ETSI TS 136 440	17.0.0	Published	02.05.2022	<a href="https://www.etsi.org/deliver/etsi_ts/136400_136499/136440/17.00.00_60/ts_136440v170000p.pdf">https://www.etsi.org/deliver/etsi_ts/136400_136499/136440/17.00.00_60/ts_136440v170000p.pdf</a>
TSDSI	TSDSI STD T1.3GPP 36.44-17.0.0 V1.0.0	17.0.0	Published	29.07.2022	<a href="https://members.tdsi.in/s/sSiEnGLTbX2SaYw">https://members.tdsi.in/s/sSiEnGLTbX2SaYw</a>
TTA	TTAT.3G-36.440V17.0.0	17.0.0	Published	05.08.2022	<a href="http://committee.tta.or.kr/data/ttasDown.jsp?kind=ttastd&amp;pk_num=TTAT.3G-36.440V17.0.0">http://committee.tta.or.kr/data/ttasDown.jsp?kind=ttastd&amp;pk_num=TTAT.3G-36.440V17.0.0</a>
TTC	TS-3GA-36.440(Rel17)v17.0.0	17.0.0	Published	07.10.2022	<a href="https://www.ttc.or.jp/st/docs/3gpp/2022/TS/TS-3GA-36.440v17.0.0.pdf">https://www.ttc.or.jp/st/docs/3gpp/2022/TS/TS-3GA-36.440v17.0.0.pdf</a>

#### 2.1.4.14 TS 36.441

### Evolved Universal Terrestrial Radio Access Network (E-UTRAN); Layer 1 for interfaces supporting Multimedia Broadcast Multicast Service (MBMS) within E-UTRAN

This document specifies the standards allowed to implement layer 1 on the interfaces supporting Multimedia Broadcast Multicast Service (MBMS) within E-UTRAN. In the following, “layer 1” and “physical layer” are assumed to be synonymous.

SDO	Document No.	Version	Status	Issued date	Location
<b>Release 10</b>					
ATIS	ATIS.3GPP.36.441V1010	10.1.0	Published	28.06.2021	<a href="https://www.atis.org/3gpp-documents/Rel99-14/">https://www.atis.org/3gpp-documents/Rel99-14/</a>
CCSA	CCSA.36.441V1010	10.1.0	Published	01.06.2011	<a href="https://www.ccsa.org.cn/api/portalsFile/downloadOldFile?type=19&amp;oldFileUrl=ITU-R/M.2012-6/CCSA.36.441V1010.doc">https://www.ccsa.org.cn/api/portalsFile/downloadOldFile?type=19&amp;oldFileUrl=ITU-R/M.2012-6/CCSA.36.441V1010.doc</a>
ETSI	ETSI TS 136 441	10.1.0	Published	30.06.2011	<a href="https://www.etsi.org/deliver/etsi_ts/136400_136499/136441/10.01.00_60/ts_136441v100100p.pdf">https://www.etsi.org/deliver/etsi_ts/136400_136499/136441/10.01.00_60/ts_136441v100100p.pdf</a>
TSDSI	TSDSI STD T1.3GPP 36.441-10.1.0 V1.0.0	10.1.0	Published	30.08.2021	<a href="https://members.tdsi.in/index.php/s/JYSQ5DDgFAMGia5">https://members.tdsi.in/index.php/s/JYSQ5DDgFAMGia5</a>
TTA	TTAT.3G-36.441V10.1.0	10.1.0	Published	02.08.2021	<a href="http://committee.tta.or.kr/data/ttasDown.jsp?kind=ttastd&amp;pk_num=TTAT.3G-36.441V10.1.0">http://committee.tta.or.kr/data/ttasDown.jsp?kind=ttastd&amp;pk_num=TTAT.3G-36.441V10.1.0</a>
TTC	TS-3GA-36.441(Rel10)v10.1.0	10.1.0	Published	31.08.2011	<a href="https://www.ttc.or.jp/st/docs/3gpps2011/TS/TS-3GA-36.441(Rel10)v10.1.0.pdf">https://www.ttc.or.jp/st/docs/3gpps2011/TS/TS-3GA-36.441(Rel10)v10.1.0.pdf</a>
<b>Release 11</b>					
ATIS	ATIS.3GPP.36.441V1100	11.0.0	Published	28.06.2021	<a href="https://www.atis.org/3gpp-documents/Rel99-14/">https://www.atis.org/3gpp-documents/Rel99-14/</a>
CCSA	CCSA.36.441V1100	11.0.0	Published	01.09.2012	<a href="https://www.ccsa.org.cn/api/portalsFile/downloadOldFile?type=19&amp;oldFileUrl=ITU-R/M.2012-6/CCSA.36.441V1100.doc">https://www.ccsa.org.cn/api/portalsFile/downloadOldFile?type=19&amp;oldFileUrl=ITU-R/M.2012-6/CCSA.36.441V1100.doc</a>
ETSI	ETSI TS 136 441	11.0.0	Published	18.10.2012	<a href="https://www.etsi.org/deliver/etsi_ts/136400_136499/136441/11.00.00_60/ts_136441v110000p.pdf">https://www.etsi.org/deliver/etsi_ts/136400_136499/136441/11.00.00_60/ts_136441v110000p.pdf</a>
TSDSI	TSDSI STD T1.3GPP 36.441-11.0.0 V1.0.0	11.0.0	Published	30.08.2021	<a href="https://members.tdsi.in/index.php/s/FGSZY9eddGKHpFa">https://members.tdsi.in/index.php/s/FGSZY9eddGKHpFa</a>
TTA	TTAT.3G-36.441V11.0.0	11.0.0	Published	02.08.2021	<a href="http://committee.tta.or.kr/data/ttasDown.jsp?kind=ttastd&amp;pk_num=TTAT.3G-36.441V11.0.0">http://committee.tta.or.kr/data/ttasDown.jsp?kind=ttastd&amp;pk_num=TTAT.3G-36.441V11.0.0</a>
TTC	TS-3GA-36.441(Rel11)v11.0.0	11.0.0	Published	25.06.2013	<a href="https://www.ttc.or.jp/st/docs/3gpps2013/TS/TS-3GA-36.441(Rel11)v11.0.0.pdf">https://www.ttc.or.jp/st/docs/3gpps2013/TS/TS-3GA-36.441(Rel11)v11.0.0.pdf</a>

<b>Release 12</b>									
ATIS	ATIS.3GPP.36.441V1200	12.0.0	Published	28.06.2021	<a href="https://www.atis.org/3gpp-documents/Rel99-14/">https://www.atis.org/3gpp-documents/Rel99-14/</a>				
CCSA	CCSA.36.441V1200	12.0.0	Published	01.09.2014	<a href="https://www.ccsa.org.cn/api/portalsFile/downloadOldFile?type=19&amp;oldFileUrl=ITU-R/M.2012-6/CCSA.36.441V1200.doc">https://www.ccsa.org.cn/api/portalsFile/downloadOldFile?type=19&amp;oldFileUrl=ITU-R/M.2012-6/CCSA.36.441V1200.doc</a>				
ETSI	ETSI TS 136 441	12.0.0	Published	26.09.2014	<a href="https://www.etsi.org/deliver/etsi_ts/136400_136499/136441/12.00.00_60/ts_136441v120000p.pdf">https://www.etsi.org/deliver/etsi_ts/136400_136499/136441/12.00.00_60/ts_136441v120000p.pdf</a>				
TSDSI	TSDSI STD T1.3GPP 36.441-12.0.0 V1.0.0	12.0.0	Published	30.08.2021	<a href="https://members.tdsi.in/index.php/s/3qRBR9xRoSfSmge">https://members.tdsi.in/index.php/s/3qRBR9xRoSfSmge</a>				
TTA	TTAT.3G-36.441V12.0.0	12.0.0	Published	02.08.2021	<a href="http://committee.tta.or.kr/data/ttasDown.jsp?kind=ttastd&amp;pk_num=TTAT.3G-36.441V12.0.0">http://committee.tta.or.kr/data/ttasDown.jsp?kind=ttastd&amp;pk_num=TTAT.3G-36.441V12.0.0</a>				
TTC	TS-3GA-36.441(Rel12)v12.0.0	12.0.0	Published	05.03.2015	<a href="https://www.ttc.or.jp/st/docs/3gpps2015/TS/TS-3GA-36.441(Rel12)v12.0.0.pdf">https://www.ttc.or.jp/st/docs/3gpps2015/TS/TS-3GA-36.441(Rel12)v12.0.0.pdf</a>				
<b>Release 13</b>									
ATIS	ATIS.3GPP.36.441V1300	13.0.0	Published	28.06.2021	<a href="https://www.atis.org/3gpp-documents/Rel99-14/">https://www.atis.org/3gpp-documents/Rel99-14/</a>				
CCSA	CCSA.36.441V1300	13.0.0	Published	01.12.2015	<a href="https://www.ccsa.org.cn/api/portalsFile/downloadOldFile?type=19&amp;oldFileUrl=ITU-R/M.2012-6/CCSA.36.441V1300.doc">https://www.ccsa.org.cn/api/portalsFile/downloadOldFile?type=19&amp;oldFileUrl=ITU-R/M.2012-6/CCSA.36.441V1300.doc</a>				
ETSI	ETSI TS 136 441	13.0.0	Published	21.01.2016	<a href="https://www.etsi.org/deliver/etsi_ts/136400_136499/136441/13.00.00_60/ts_136441v130000p.pdf">https://www.etsi.org/deliver/etsi_ts/136400_136499/136441/13.00.00_60/ts_136441v130000p.pdf</a>				
TSDSI	TSDSI STD T1.3GPP 36.441-13.0.0 V1.0.0	13.0.0	Published	30.08.2021	<a href="https://members.tdsi.in/index.php/s/rPpc5ggcKPbd5jr">https://members.tdsi.in/index.php/s/rPpc5ggcKPbd5jr</a>				
TTA	TTAT.3G-36.441V13.0.0	13.0.0	Published	02.08.2021	<a href="http://committee.tta.or.kr/data/ttasDown.jsp?kind=ttastd&amp;pk_num=TTAT.3G-36.441V13.0.0">http://committee.tta.or.kr/data/ttasDown.jsp?kind=ttastd&amp;pk_num=TTAT.3G-36.441V13.0.0</a>				
TTC	TS-3GA-36.441(Rel13)v13.0.0	13.0.0	Published	31.03.2017	<a href="https://www.ttc.or.jp/st/docs/3gpps2017/TS/TS-3GA-36.441(Rel13)v13.0.0.pdf">https://www.ttc.or.jp/st/docs/3gpps2017/TS/TS-3GA-36.441(Rel13)v13.0.0.pdf</a>				
<b>Release 14</b>									
ATIS	ATIS.3GPP.36.441V1400	14.0.0	Published	28.06.2021	<a href="https://www.atis.org/3gpp-documents/Rel99-14/">https://www.atis.org/3gpp-documents/Rel99-14/</a>				
CCSA	CCSA.36.441V1400	14.0.0	Published	01.03.2017	<a href="https://www.ccsa.org.cn/api/portalsFile/downloadOldFile?type=19&amp;oldFileUrl=ITU-R/M.2012-6/CCSA.36.441V1400.doc">https://www.ccsa.org.cn/api/portalsFile/downloadOldFile?type=19&amp;oldFileUrl=ITU-R/M.2012-6/CCSA.36.441V1400.doc</a>				
ETSI	ETSI TS 136 441	14.0.0	Published	11.04.2017	<a href="https://www.etsi.org/deliver/etsi_ts/136400_136499/136441/14.00.00_60/ts_136441v140000p.pdf">https://www.etsi.org/deliver/etsi_ts/136400_136499/136441/14.00.00_60/ts_136441v140000p.pdf</a>				
TSDSI	TSDSI STD T1.3GPP 36.441-14.0.0 V1.0.0	14.0.0	Published	30.08.2021	<a href="https://members.tdsi.in/index.php/s/SSedrwSgHyHXpCW">https://members.tdsi.in/index.php/s/SSedrwSgHyHXpCW</a>				
TTA	TTAT.3G-36.441V14.0.0	14.0.0	Published	02.08.2021	<a href="http://committee.tta.or.kr/data/ttasDown.jsp?kind=ttastd&amp;pk_num=TTAT.3G-36.441V14.0.0">http://committee.tta.or.kr/data/ttasDown.jsp?kind=ttastd&amp;pk_num=TTAT.3G-36.441V14.0.0</a>				
TTC	TS-3GA-36.441(Rel14)v14.0.0	14.0.0	Published	13.04.2018	<a href="https://www.ttc.or.jp/st/docs/3gpps2018/TS/TS-3GA-36.441(Rel14)v14.0.0.pdf">https://www.ttc.or.jp/st/docs/3gpps2018/TS/TS-3GA-36.441(Rel14)v14.0.0.pdf</a>				
<b>Release 15</b>									
ATIS	ATIS.3GPP.36.441V1500	15.0.0	Published	28.06.2021	<a href="https://www.atis.org/3gpp-documents/Rel15/">https://www.atis.org/3gpp-documents/Rel15/</a>				
CCSA	CCSA.36.441V1500	15.0.0	Published	01.09.2018	<a href="https://www.ccsa.org.cn/api/portalsFile/downloadOldFile?type=19&amp;oldFileUrl=ITU-R/M.2012-6/CCSA.36.441V1500.doc">https://www.ccsa.org.cn/api/portalsFile/downloadOldFile?type=19&amp;oldFileUrl=ITU-R/M.2012-6/CCSA.36.441V1500.doc</a>				
ETSI	ETSI TS 136 441	15.0.0	Published	28.09.2018	<a href="https://www.etsi.org/deliver/etsi_ts/136400_136499/136441/15.00.00_60/ts_136441v150000p.pdf">https://www.etsi.org/deliver/etsi_ts/136400_136499/136441/15.00.00_60/ts_136441v150000p.pdf</a>				
TSDSI	TSDSI STD T1.3GPP 36.441-15.0.0 V1.0.0	15.0.0	Published	30.08.2021	<a href="https://members.tdsi.in/index.php/s/qKjT5XfHNPpB3MG">https://members.tdsi.in/index.php/s/qKjT5XfHNPpB3MG</a>				
TTA	TTAT.3G-36.441V15.0.0	15.0.0	Published	11.09.2020	<a href="http://committee.tta.or.kr/data/ttasDown.jsp?kind=ttastd&amp;pk_num=TTAT.3G-36.441V15.0.0">http://committee.tta.or.kr/data/ttasDown.jsp?kind=ttastd&amp;pk_num=TTAT.3G-36.441V15.0.0</a>				
TTC	TS-3GA-36.441(Rel15)v15.0.0	15.0.0	Published	21.12.2018	<a href="https://www.ttc.or.jp/st/docs/3gpps2018/TS/TS-3GA-36.441(Rel15)v15.0.0.pdf">https://www.ttc.or.jp/st/docs/3gpps2018/TS/TS-3GA-36.441(Rel15)v15.0.0.pdf</a>				
<b>Release 16</b>									
ATIS	ATIS.3GPP.36.441V1600	16.0.0	Published	28.06.2021	<a href="https://www.atis.org/3gpp-documents/Rel16/">https://www.atis.org/3gpp-documents/Rel16/</a>				
CCSA	CCSA.36.441V1600	16.0.0	Published	01.07.2020	<a href="https://www.ccsa.org.cn/api/portalsFile/downloadOldFile?type=19&amp;oldFileUrl=ITU-R/M.2012-6/CCSA.36.441V1600.doc">https://www.ccsa.org.cn/api/portalsFile/downloadOldFile?type=19&amp;oldFileUrl=ITU-R/M.2012-6/CCSA.36.441V1600.doc</a>				
ETSI	ETSI TS 136 441	16.0.0	Published	21.07.2020	<a href="https://www.etsi.org/deliver/etsi_ts/136400_136499/136441/16.00.00_60/ts_136441v160000p.pdf">https://www.etsi.org/deliver/etsi_ts/136400_136499/136441/16.00.00_60/ts_136441v160000p.pdf</a>				
TSDSI	TSDSI STD T1.3GPP 36.441-16.0.0 V1.0.0	16.0.0	Published	30.08.2021	<a href="https://members.tdsi.in/index.php/s/enp8P2MAYEWR4B7">https://members.tdsi.in/index.php/s/enp8P2MAYEWR4B7</a>				
TTA	TTAT.3G-36.441V16.0.0	16.0.0	Published	11.09.2020	<a href="http://committee.tta.or.kr/data/ttasDown.jsp?kind=ttastd&amp;pk_num=TTAT.3G-36.441V16.0.0">http://committee.tta.or.kr/data/ttasDown.jsp?kind=ttastd&amp;pk_num=TTAT.3G-36.441V16.0.0</a>				
TTC	TS-3GA-36.441(Rel16)v16.0.0	16.0.0	Published	02.10.2020	<a href="https://www.ttc.or.jp/st/docs/3gpps2020/TS/TS-3GA-36_441_Rel16v16_0_0.pdf">https://www.ttc.or.jp/st/docs/3gpps2020/TS/TS-3GA-36_441_Rel16v16_0_0.pdf</a>				
<b>Release 17</b>									
ATIS	ATIS.3GPP.36.441.V17.0.0	17.0.0	Published	21.02.2023	<a href="https://www.atis.org/3gpp-transpositions - Rel-17">https://www.atis.org/3gpp-transpositions - Rel-17</a>				
CCSA	CCSA.36.441V1700	17.0.0	Published	01.04.2022	<a href="https://www.ccsa.org.cn/api/portalsFile/downloadOldFile?type=19&amp;oldFileUrl=ITU-R/M.2012-6/CCSA.36.441V1700.doc">https://www.ccsa.org.cn/api/portalsFile/downloadOldFile?type=19&amp;oldFileUrl=ITU-R/M.2012-6/CCSA.36.441V1700.doc</a>				
ETSI	ETSI TS 136 441	17.0.0	Published	02.05.2022	<a href="https://www.etsi.org/deliver/etsi_ts/136400_136499/136441/17.00.00_60/ts_136441v170000p.pdf">https://www.etsi.org/deliver/etsi_ts/136400_136499/136441/17.00.00_60/ts_136441v170000p.pdf</a>				
TSDSI	TSDSI STD T1.3GPP 36.441-17.0.0 V1.0.0	17.0.0	Published	29.07.2022	<a href="https://members.tdsi.in/s/z25kTsPPnJGcYBJ">https://members.tdsi.in/s/z25kTsPPnJGcYBJ</a>				
TTA	TTAT.3G-36.441V17.0.0	17.0.0	Published	05.08.2022	<a href="http://committee.tta.or.kr/data/ttasDown.jsp?kind=ttastd&amp;pk_num=TTAT.3G-36.441V17.0.0">http://committee.tta.or.kr/data/ttasDown.jsp?kind=ttastd&amp;pk_num=TTAT.3G-36.441V17.0.0</a>				
TTC	TS-3GA-36.441(Rel17)v17.0.0	17.0.0	Published	07.10.2022	<a href="https://www.ttc.or.jp/st/docs/3gpp/2022/TS/TS-3GA-36.441v17.0.0.pdf">https://www.ttc.or.jp/st/docs/3gpp/2022/TS/TS-3GA-36.441v17.0.0.pdf</a>				

## 2.1.4.15 TS 36.442

**Evolved Universal Terrestrial Radio Access Network (E-UTRAN); Signalling Transport for interfaces supporting Multimedia Broadcast Multicast Service (MBMS) within E-UTRAN**

This document specifies the standards for signalling transport to be used across M2 and M3 interfaces. M2 interface is a logical interface between the eNodeB and the MCE. M3 interface is a logical interface between the MCE and the MME. This document describes how the M2-AP signalling messages are transported over M2, and how the M3-AP signalling messages are transported over M3.

SDO	Document No.	Version	Status	Issued date	Location
<b>Release 10</b>					
ATIS	ATIS.3GPP.36.442V1020	10.2.0	Published	28.06.2021	<a href="https://www.atis.org/3gpp-documents/Rel99-14/">https://www.atis.org/3gpp-documents/Rel99-14/</a>
CCSA	CCSA.36.442V1020	10.2.0	Published	01.09.2011	<a href="https://www.ccsa.org.cn/api/portalsFile/downloadOldFile?type=19&amp;oldFileUrl=ITU-R/M.2012-6/CCSA.36.442V1020.doc">https://www.ccsa.org.cn/api/portalsFile/downloadOldFile?type=19&amp;oldFileUrl=ITU-R/M.2012-6/CCSA.36.442V1020.doc</a>
ETSI	ETSI TS 136 442	10.2.0	Published	21.10.2011	<a href="https://www.etsi.org/deliver/etsi_ts/136400_136499/136442/10.02.00_60/ts_136442v100200p.pdf">https://www.etsi.org/deliver/etsi_ts/136400_136499/136442/10.02.00_60/ts_136442v100200p.pdf</a>
TSDSI	TSDSI STD T1.3GPP 36.442-10.2.0 V1.0.0	10.2.0	Published	30.08.2021	<a href="https://members.tdsi.in/index.php/s/j4ReMoQkfDJ6LtB">https://members.tdsi.in/index.php/s/j4ReMoQkfDJ6LtB</a>
TTA	TTAT.3G-36.442V10.2.0	10.2.0	Published	02.08.2021	<a href="http://committee.tta.or.kr/data/ttasDown.jsp?kind=ttastd&amp;pk_num=TTAT.3G-36.442V10.2.0">http://committee.tta.or.kr/data/ttasDown.jsp?kind=ttastd&amp;pk_num=TTAT.3G-36.442V10.2.0</a>
TTC	TS-3GA-36.442(Rel10)v10.2.0	10.2.0	Published	21.12.2011	<a href="https://www.ttc.or.jp/st/docs/3gpps2011/TS/TS-3GA-36.442(Rel10)v10.2.0.pdf">https://www.ttc.or.jp/st/docs/3gpps2011/TS/TS-3GA-36.442(Rel10)v10.2.0.pdf</a>
<b>Release 11</b>					
ATIS	ATIS.3GPP.36.442V1100	11.0.0	Published	28.06.2021	<a href="https://www.atis.org/3gpp-documents/Rel99-14/">https://www.atis.org/3gpp-documents/Rel99-14/</a>
CCSA	CCSA.36.442V1100	11.0.0	Published	01.09.2012	<a href="https://www.ccsa.org.cn/api/portalsFile/downloadOldFile?type=19&amp;oldFileUrl=ITU-R/M.2012-6/CCSA.36.442V1100.doc">https://www.ccsa.org.cn/api/portalsFile/downloadOldFile?type=19&amp;oldFileUrl=ITU-R/M.2012-6/CCSA.36.442V1100.doc</a>
ETSI	ETSI TS 136 442	11.0.0	Published	18.10.2012	<a href="https://www.etsi.org/deliver/etsi_ts/136400_136499/136442/11.00.00_60/ts_136442v110000p.pdf">https://www.etsi.org/deliver/etsi_ts/136400_136499/136442/11.00.00_60/ts_136442v110000p.pdf</a>
TSDSI	TSDSI STD T1.3GPP 36.442-11.0.0 V1.0.0	11.0.0	Published	30.08.2021	<a href="https://members.tdsi.in/index.php/s/ZAcSdwiCAJSeFcD">https://members.tdsi.in/index.php/s/ZAcSdwiCAJSeFcD</a>
TTA	TTAT.3G-36.442V11.0.0	11.0.0	Published	02.08.2021	<a href="http://committee.tta.or.kr/data/ttasDown.jsp?kind=ttastd&amp;pk_num=TTAT.3G-36.442V11.0.0">http://committee.tta.or.kr/data/ttasDown.jsp?kind=ttastd&amp;pk_num=TTAT.3G-36.442V11.0.0</a>
TTC	TS-3GA-36.442(Rel11)v11.0.0	11.0.0	Published	25.06.2013	<a href="https://www.ttc.or.jp/st/docs/3gpps2013/TS/TS-3GA-36.442(Rel11)v11.0.0.pdf">https://www.ttc.or.jp/st/docs/3gpps2013/TS/TS-3GA-36.442(Rel11)v11.0.0.pdf</a>
<b>Release 12</b>					
ATIS	ATIS.3GPP.36.442V1200	12.0.0	Published	28.06.2021	<a href="https://www.atis.org/3gpp-documents/Rel99-14/">https://www.atis.org/3gpp-documents/Rel99-14/</a>
CCSA	CCSA.36.442V1200	12.0.0	Published	01.09.2014	<a href="https://www.ccsa.org.cn/api/portalsFile/downloadOldFile?type=19&amp;oldFileUrl=ITU-R/M.2012-6/CCSA.36.442V1200.doc">https://www.ccsa.org.cn/api/portalsFile/downloadOldFile?type=19&amp;oldFileUrl=ITU-R/M.2012-6/CCSA.36.442V1200.doc</a>
ETSI	ETSI TS 136 442	12.0.0	Published	26.09.2014	<a href="https://www.etsi.org/deliver/etsi_ts/136400_136499/136442/12.00.00_60/ts_136442v120000p.pdf">https://www.etsi.org/deliver/etsi_ts/136400_136499/136442/12.00.00_60/ts_136442v120000p.pdf</a>
TSDSI	TSDSI STD T1.3GPP 36.442-12.0.0 V1.0.0	12.0.0	Published	30.08.2021	<a href="https://members.tdsi.in/index.php/s/j7i9bPMb3gb2jLe">https://members.tdsi.in/index.php/s/j7i9bPMb3gb2jLe</a>
TTA	TTAT.3G-36.442V12.0.0	12.0.0	Published	02.08.2021	<a href="http://committee.tta.or.kr/data/ttasDown.jsp?kind=ttastd&amp;pk_num=TTAT.3G-36.442V12.0.0">http://committee.tta.or.kr/data/ttasDown.jsp?kind=ttastd&amp;pk_num=TTAT.3G-36.442V12.0.0</a>
TTC	TS-3GA-36.442(Rel12)v12.0.0	12.0.0	Published	05.03.2015	<a href="https://www.ttc.or.jp/st/docs/3gpps2015/TS/TS-3GA-36.442(Rel12)v12.0.0.pdf">https://www.ttc.or.jp/st/docs/3gpps2015/TS/TS-3GA-36.442(Rel12)v12.0.0.pdf</a>
<b>Release 13</b>					
ATIS	ATIS.3GPP.36.442V1300	13.0.0	Published	28.06.2021	<a href="https://www.atis.org/3gpp-documents/Rel99-14/">https://www.atis.org/3gpp-documents/Rel99-14/</a>
CCSA	CCSA.36.442V1300	13.0.0	Published	01.12.2015	<a href="https://www.ccsa.org.cn/api/portalsFile/downloadOldFile?type=19&amp;oldFileUrl=ITU-R/M.2012-6/CCSA.36.442V1300.doc">https://www.ccsa.org.cn/api/portalsFile/downloadOldFile?type=19&amp;oldFileUrl=ITU-R/M.2012-6/CCSA.36.442V1300.doc</a>
ETSI	ETSI TS 136 442	13.0.0	Published	21.01.2016	<a href="https://www.etsi.org/deliver/etsi_ts/136400_136499/136442/13.00.00_60/ts_136442v130000p.pdf">https://www.etsi.org/deliver/etsi_ts/136400_136499/136442/13.00.00_60/ts_136442v130000p.pdf</a>
TSDSI	TSDSI STD T1.3GPP 36.442-13.0.0 V1.0.0	13.0.0	Published	30.08.2021	<a href="https://members.tdsi.in/index.php/s/Lze7pDDTkZm8mng">https://members.tdsi.in/index.php/s/Lze7pDDTkZm8mng</a>
TTA	TTAT.3G-36.442V13.0.0	13.0.0	Published	02.08.2021	<a href="http://committee.tta.or.kr/data/ttasDown.jsp?kind=ttastd&amp;pk_num=TTAT.3G-36.442V13.0.0">http://committee.tta.or.kr/data/ttasDown.jsp?kind=ttastd&amp;pk_num=TTAT.3G-36.442V13.0.0</a>
TTC	TS-3GA-36.442(Rel13)v13.0.0	13.0.0	Published	31.03.2017	<a href="https://www.ttc.or.jp/st/docs/3gpps2017/TS/TS-3GA-36.442(Rel13)v13.0.0.pdf">https://www.ttc.or.jp/st/docs/3gpps2017/TS/TS-3GA-36.442(Rel13)v13.0.0.pdf</a>
<b>Release 14</b>					
ATIS	ATIS.3GPP.36.442V1400	14.0.0	Published	28.06.2021	<a href="https://www.atis.org/3gpp-documents/Rel99-14/">https://www.atis.org/3gpp-documents/Rel99-14/</a>
CCSA	CCSA.36.442V1400	14.0.0	Published	01.03.2017	<a href="https://www.ccsa.org.cn/api/portalsFile/downloadOldFile?type=19&amp;oldFileUrl=ITU-R/M.2012-6/CCSA.36.442V1400.doc">https://www.ccsa.org.cn/api/portalsFile/downloadOldFile?type=19&amp;oldFileUrl=ITU-R/M.2012-6/CCSA.36.442V1400.doc</a>
ETSI	ETSI TS 136 442	14.0.0	Published	11.04.2017	<a href="https://www.etsi.org/deliver/etsi_ts/136400_136499/136442/14.00.00_60/ts_136442v140000p.pdf">https://www.etsi.org/deliver/etsi_ts/136400_136499/136442/14.00.00_60/ts_136442v140000p.pdf</a>
TSDSI	TSDSI STD T1.3GPP 36.442-14.0.0 V1.0.0	14.0.0	Published	30.08.2021	<a href="https://members.tdsi.in/index.php/s/NtGnpsyFSKDGisN">https://members.tdsi.in/index.php/s/NtGnpsyFSKDGisN</a>
TTA	TTAT.3G-36.442V14.0.0	14.0.0	Published	30.07.2021	<a href="http://committee.tta.or.kr/data/ttasDown.jsp?kind=ttastd&amp;pk_num=TTAT.3G-36.442V14.0.0">http://committee.tta.or.kr/data/ttasDown.jsp?kind=ttastd&amp;pk_num=TTAT.3G-36.442V14.0.0</a>
TTC	TS-3GA-36.442(Rel14)v14.0.0	14.0.0	Published	13.04.2018	<a href="https://www.ttc.or.jp/st/docs/3gpps2018/TS/TS-3GA-36.442(Rel14)v14.0.0.pdf">https://www.ttc.or.jp/st/docs/3gpps2018/TS/TS-3GA-36.442(Rel14)v14.0.0.pdf</a>
<b>Release 15</b>					

ATIS	ATIS.3GPP.36.442V1500	15.0.0	Published	28.06.2021	<a href="https://www.atis.org/3gpp-documents/Rel15/">https://www.atis.org/3gpp-documents/Rel15/</a>
CCSA	CCSA.36.442V1500	15.0.0	Published	01.09.2018	<a href="https://www.ccsa.org.cn/api/portalsFile/downloadOldFile?type=19&amp;oldFileUrl=ITU-R/M.2012-6/CCSA.36.442V1500.doc">https://www.ccsa.org.cn/api/portalsFile/downloadOldFile?type=19&amp;oldFileUrl=ITU-R/M.2012-6/CCSA.36.442V1500.doc</a>
ETSI	ETSI TS 136 442	15.0.0	Published	28.09.2018	<a href="https://www.etsi.org/deliver/etsi_ts/136400_136499/136442/15.00.00_60/ts_136442v150000p.pdf">https://www.etsi.org/deliver/etsi_ts/136400_136499/136442/15.00.00_60/ts_136442v150000p.pdf</a>
TSDSI	TSDSI STD T1.3GPP 36.442-15.0.0 V1.0.0	15.0.0	Published	30.08.2021	<a href="https://members.tdsi.in/index.php/s/SdqLi2EkrJRE43Q">https://members.tdsi.in/index.php/s/SdqLi2EkrJRE43Q</a>
TTA	TTAT.3G-36.442V15.0.0	15.0.0	Published	11.09.2020	<a href="http://committee.tta.or.kr/data/ttasDown.jsp?kind=ttastd&amp;pk_num=TTAT.3G-36.442V15.0.0">http://committee.tta.or.kr/data/ttasDown.jsp?kind=ttastd&amp;pk_num=TTAT.3G-36.442V15.0.0</a>
TTC	TS-3GA-36.442(Rel15)v15.0.0	15.0.0	Published	21.12.2018	<a href="https://www.ttc.or.jp/st/docs/3gpps2018/TS/TS-3GA-36.442(Rel15)v15.0.0.pdf">https://www.ttc.or.jp/st/docs/3gpps2018/TS/TS-3GA-36.442(Rel15)v15.0.0.pdf</a>

**Release 16**

ATIS	ATIS.3GPP.36.442V1600	16.0.0	Published	28.06.2021	<a href="https://www.atis.org/3gpp-documents/Rel16/">https://www.atis.org/3gpp-documents/Rel16/</a>
CCSA	CCSA.36.442V1600	16.0.0	Published	01.07.2020	<a href="https://www.ccsa.org.cn/api/portalsFile/downloadOldFile?type=19&amp;oldFileUrl=ITU-R/M.2012-6/CCSA.36.442V1600.doc">https://www.ccsa.org.cn/api/portalsFile/downloadOldFile?type=19&amp;oldFileUrl=ITU-R/M.2012-6/CCSA.36.442V1600.doc</a>
ETSI	ETSI TS 136 442	16.0.0	Published	21.07.2020	<a href="https://www.etsi.org/deliver/etsi_ts/136400_136499/136442/16.00.00_60/ts_136442v160000p.pdf">https://www.etsi.org/deliver/etsi_ts/136400_136499/136442/16.00.00_60/ts_136442v160000p.pdf</a>
TSDSI	TSDSI STD T1.3GPP 36.442-16.0.0 V1.0.0	16.0.0	Published	30.08.2021	<a href="https://members.tdsi.in/index.php/s/CXyeK6nEpoFWC4o">https://members.tdsi.in/index.php/s/CXyeK6nEpoFWC4o</a>
TTA	TTAT.3G-36.442V16.0.0	16.0.0	Published	11.09.2020	<a href="http://committee.tta.or.kr/data/ttasDown.jsp?kind=ttastd&amp;pk_num=TTAT.3G-36.442V16.0.0">http://committee.tta.or.kr/data/ttasDown.jsp?kind=ttastd&amp;pk_num=TTAT.3G-36.442V16.0.0</a>
TTC	TS-3GA-36.442(Rel16)v16.0.0	16.0.0	Published	02.10.2020	<a href="https://www.ttc.or.jp/st/docs/3gpps2020/TS/TS-3GA-36_442_Rel16v16_0_0.pdf">https://www.ttc.or.jp/st/docs/3gpps2020/TS/TS-3GA-36_442_Rel16v16_0_0.pdf</a>

**Release 17**

ATIS	ATIS.3GPP.36.442.V17.0.0	17.0.0	Published	21.02.2023	<a href="https://www.atis.org/3gpp-transpositions - Rel-17">https://www.atis.org/3gpp-transpositions - Rel-17</a>
CCSA	CCSA.36.442V1700	17.0.0	Published	01.04.2022	<a href="https://www.ccsa.org.cn/api/portalsFile/downloadOldFile?type=19&amp;oldFileUrl=ITU-R/M.2012-6/CCSA.36.442V1700.doc">https://www.ccsa.org.cn/api/portalsFile/downloadOldFile?type=19&amp;oldFileUrl=ITU-R/M.2012-6/CCSA.36.442V1700.doc</a>
ETSI	ETSI TS 136 442	17.0.0	Published	02.05.2022	<a href="https://www.etsi.org/deliver/etsi_ts/136400_136499/136442/17.00.00_60/ts_136442v170000p.pdf">https://www.etsi.org/deliver/etsi_ts/136400_136499/136442/17.00.00_60/ts_136442v170000p.pdf</a>
TSDSI	TSDSI STD T1.3GPP 36.442-17.0.0 V1.0.0	17.0.0	Published	01.11.2022	<a href="https://members.tdsi.in/s/DHCoi9f3H4s4xiQ">https://members.tdsi.in/s/DHCoi9f3H4s4xiQ</a>
TTA	TTAT.3G-36.442V17.0.0	17.0.0	Published	05.08.2022	<a href="http://committee.tta.or.kr/data/ttasDown.jsp?kind=ttastd&amp;pk_num=TTAT.3G-36.442V17.0.0">http://committee.tta.or.kr/data/ttasDown.jsp?kind=ttastd&amp;pk_num=TTAT.3G-36.442V17.0.0</a>
TTC	TS-3GA-36.442(Rel17)v17.0.0	17.0.0	Published	07.10.2022	<a href="https://www.ttc.or.jp/st/docs/3gpp/2022/TS/TS-3GA-36.442v17.0.0.pdf">https://www.ttc.or.jp/st/docs/3gpp/2022/TS/TS-3GA-36.442v17.0.0.pdf</a>

**2.1.4.16 TS 36.443****Evolved Universal Terrestrial Radio Access Network (E-UTRAN); M2 Application Protocol (M2AP)**

This document specifies the E-UTRAN radio network layer signalling protocol for the M2 interface. The M2 Application Protocol (M2AP) supports the functions of M2 interface by signalling procedures defined in this document.

SDO	Document No.	Version	Status	Issued date	Location
<b>Release 10</b>					
ATIS	ATIS.3GPP.36.443V1050	10.5.0	Published	28.06.2021	<a href="https://www.atis.org/3gpp-documents/Rel99-14/">https://www.atis.org/3gpp-documents/Rel99-14/</a>
CCSA	CCSA.36.443V1050	10.5.0	Published	01.03.2012	<a href="https://www.ccsa.org.cn/api/portalsFile/downloadOldFile?type=19&amp;oldFileUrl=ITU-R/M.2012-6/CCSA.36.443V1050.doc">https://www.ccsa.org.cn/api/portalsFile/downloadOldFile?type=19&amp;oldFileUrl=ITU-R/M.2012-6/CCSA.36.443V1050.doc</a>
ETSI	ETSI TS 136 443	10.5.0	Published	21.03.2012	<a href="https://www.etsi.org/deliver/etsi_ts/136400_136499/136443/10.05.00_60/ts_136443v100500p.pdf">https://www.etsi.org/deliver/etsi_ts/136400_136499/136443/10.05.00_60/ts_136443v100500p.pdf</a>
TSDSI	TSDSI STD T1.3GPP 36.443-10.5.0 V1.0.0	10.5.0	Published	30.08.2021	<a href="https://members.tdsi.in/index.php/s/5gOsCJRAviCg2B8">https://members.tdsi.in/index.php/s/5gOsCJRAviCg2B8</a>
TTA	TTAT.3G-36.443V10.5.0	10.5.0	Published	30.07.2021	<a href="http://committee.tta.or.kr/data/ttasDown.jsp?kind=ttastd&amp;pk_num=TTAT.3G-36.443V10.5.0">http://committee.tta.or.kr/data/ttasDown.jsp?kind=ttastd&amp;pk_num=TTAT.3G-36.443V10.5.0</a>
TTC	TS-3GA-36.443(Rel10)v10.5.0	10.5.0	Published	27.06.2012	<a href="https://www.ttc.or.jp/st/docs/3gpps2012/TS/TS-3GA-36.443(Rel10)v10.5.0.pdf">https://www.ttc.or.jp/st/docs/3gpps2012/TS/TS-3GA-36.443(Rel10)v10.5.0.pdf</a>
<b>Release 11</b>					
ATIS	ATIS.3GPP.36.443V1140	11.4.0	Published	28.06.2021	<a href="https://www.atis.org/3gpp-documents/Rel99-14/">https://www.atis.org/3gpp-documents/Rel99-14/</a>
CCSA	CCSA.36.443V1140	11.4.0	Published	01.03.2015	<a href="https://www.ccsa.org.cn/api/portalsFile/downloadOldFile?type=19&amp;oldFileUrl=ITU-R/M.2012-6/CCSA.36.443V1140.doc">https://www.ccsa.org.cn/api/portalsFile/downloadOldFile?type=19&amp;oldFileUrl=ITU-R/M.2012-6/CCSA.36.443V1140.doc</a>
ETSI	ETSI TS 136 443	11.4.0	Published	15.04.2015	<a href="https://www.etsi.org/deliver/etsi_ts/136400_136499/136443/11.04.00_60/ts_136443v110400p.pdf">https://www.etsi.org/deliver/etsi_ts/136400_136499/136443/11.04.00_60/ts_136443v110400p.pdf</a>
TSDSI	TSDSI STD T1.3GPP 36.443-11.4.0 V1.0.0	11.4.0	Published	30.08.2021	<a href="https://members.tdsi.in/index.php/s/Jk2stbJA46gTRPc">https://members.tdsi.in/index.php/s/Jk2stbJA46gTRPc</a>
TTA	TTAT.3G-36.443V11.4.0	11.4.0	Published	30.07.2021	<a href="http://committee.tta.or.kr/data/ttasDown.jsp?kind=ttastd&amp;pk_num=TTAT.3G-36.443V11.4.0">http://committee.tta.or.kr/data/ttasDown.jsp?kind=ttastd&amp;pk_num=TTAT.3G-36.443V11.4.0</a>
TTC	TS-3GA-36.443(Rel11)v11.4.0	11.4.0	Published	30.06.2015	<a href="https://www.ttc.or.jp/st/docs/3gpps2015/TS/TS-3GA-36.443(Rel11)v11.4.0.pdf">https://www.ttc.or.jp/st/docs/3gpps2015/TS/TS-3GA-36.443(Rel11)v11.4.0.pdf</a>
<b>Release 12</b>					
ATIS	ATIS.3GPP.36.443V1220	12.2.0	Published	28.06.2021	<a href="https://www.atis.org/3gpp-documents/Rel99-14/">https://www.atis.org/3gpp-documents/Rel99-14/</a>
CCSA	CCSA.36.443V1220	12.2.0	Published	01.03.2015	<a href="https://www.ccsa.org.cn/api/portalsFile/downloadOldFile?type=19&amp;oldFileUrl=ITU-R/M.2012-6/CCSA.36.443V1220.doc">https://www.ccsa.org.cn/api/portalsFile/downloadOldFile?type=19&amp;oldFileUrl=ITU-R/M.2012-6/CCSA.36.443V1220.doc</a>
ETSI	ETSI TS 136 443	12.2.0	Published	15.04.2015	<a href="https://www.etsi.org/deliver/etsi_ts/136400_136499/136443/12.02.00_60/ts_136443v120200p.pdf">https://www.etsi.org/deliver/etsi_ts/136400_136499/136443/12.02.00_60/ts_136443v120200p.pdf</a>

**76****Rec. ITU-R M.2012-6**

TSDSI	TSDSI STD T1.3GPP 36.443-12.2.0 V1.0.0	12.2.0	Published	30.08.2021	<a href="https://members.tdsi.in/index.php/s/CmafAeSF3psntq5">https://members.tdsi.in/index.php/s/CmafAeSF3psntq5</a>
TTA	TTAT.3G-36.443V12.2.0	12.2.0	Published	30.07.2021	<a href="http://committee.tta.or.kr/data/ttasDown.jsp?kind=ttastd&amp;pk_num=TTAT.3G-36.443V12.2.0">http://committee.tta.or.kr/data/ttasDown.jsp?kind=ttastd&amp;pk_num=TTAT.3G-36.443V12.2.0</a>
TTC	TS-3GA-36.443(Rel12)v12.2.0	12.2.0	Published	30.06.2015	<a href="https://www.ttc.or.jp/st/docs/3gpps2015/TS/TS-3GA-36.443(Rel12)v12.2.0.pdf">https://www.ttc.or.jp/st/docs/3gpps2015/TS/TS-3GA-36.443(Rel12)v12.2.0.pdf</a>

**Release 13**

ATIS	ATIS.3GPP.36.443V1330	13.3.0	Published	28.06.2021	<a href="https://www.atis.org/3gpp-documents/Rel99-14/">https://www.atis.org/3gpp-documents/Rel99-14/</a>
CCSA	CCSA.36.443V1330	13.3.0	Published	01.03.2016	<a href="https://www.ccsa.org.cn/api/portalsFile/downloadOldFile?type=19&amp;oldFileUrl=ITU-R/M.2012-6/CCSA.36.443V1330.doc">https://www.ccsa.org.cn/api/portalsFile/downloadOldFile?type=19&amp;oldFileUrl=ITU-R/M.2012-6/CCSA.36.443V1330.doc</a>
ETSI	ETSI TS 136 443	13.3.0	Published	20.05.2016	<a href="https://www.etsi.org/deliver/etsi_ts/136400_136499/136443/13.03.00_60/ts_136443v130300p.pdf">https://www.etsi.org/deliver/etsi_ts/136400_136499/136443/13.03.00_60/ts_136443v130300p.pdf</a>
TSDSI	TSDSI STD T1.3GPP 36.443-13.3.0 V1.0.0	13.3.0	Published	30.08.2021	<a href="https://members.tdsi.in/index.php/s/HgX53BkGFNf4CD">https://members.tdsi.in/index.php/s/HgX53BkGFNf4CD</a>
TTA	TTAT.3G-36.443V13.3.0	13.3.0	Published	30.07.2021	<a href="http://committee.tta.or.kr/data/ttasDown.jsp?kind=ttastd&amp;pk_num=TTAT.3G-36.443V13.3.0">http://committee.tta.or.kr/data/ttasDown.jsp?kind=ttastd&amp;pk_num=TTAT.3G-36.443V13.3.0</a>
TTC	TS-3GA-36.443(Rel13)v13.3.0	13.3.0	Published	31.03.2017	<a href="https://www.ttc.or.jp/st/docs/3gpps2017/TS/TS-3GA-36.443(Rel13)v13.3.0.pdf">https://www.ttc.or.jp/st/docs/3gpps2017/TS/TS-3GA-36.443(Rel13)v13.3.0.pdf</a>

**Release 14**

ATIS	ATIS.3GPP.36.443V1410	14.1.0	Published	28.06.2021	<a href="https://www.atis.org/3gpp-documents/Rel99-14/">https://www.atis.org/3gpp-documents/Rel99-14/</a>
CCSA	CCSA.36.443V1410	14.1.0	Published	01.09.2018	<a href="https://www.ccsa.org.cn/api/portalsFile/downloadOldFile?type=19&amp;oldFileUrl=ITU-R/M.2012-6/CCSA.36.443V1410.doc">https://www.ccsa.org.cn/api/portalsFile/downloadOldFile?type=19&amp;oldFileUrl=ITU-R/M.2012-6/CCSA.36.443V1410.doc</a>
ETSI	ETSI TS 136 443	14.1.0	Published	28.09.2018	<a href="https://www.etsi.org/deliver/etsi_ts/136400_136499/136443/14.01.00_60/ts_136443v140100p.pdf">https://www.etsi.org/deliver/etsi_ts/136400_136499/136443/14.01.00_60/ts_136443v140100p.pdf</a>
TSDSI	TSDSI STD T1.3GPP 36.443-14.1.0 V1.1.0	14.1.0	Published	30.08.2021	<a href="https://members.tdsi.in/index.php/s/4P5ZdAdaLcNj5z8">https://members.tdsi.in/index.php/s/4P5ZdAdaLcNj5z8</a>
TTA	TTAT.3G-36.443V14.1.0	14.1.0	Published	30.07.2021	<a href="http://committee.tta.or.kr/data/ttasDown.jsp?kind=ttastd&amp;pk_num=TTAT.3G-36.443V14.1.0">http://committee.tta.or.kr/data/ttasDown.jsp?kind=ttastd&amp;pk_num=TTAT.3G-36.443V14.1.0</a>
TTC	TS-3GA-36.443(Rel14)v14.1.0	14.1.0	Published	21.12.2018	<a href="https://www.ttc.or.jp/st/docs/3gpps2018/TS/TS-3GA-36.443(Rel14)v14.1.0.pdf">https://www.ttc.or.jp/st/docs/3gpps2018/TS/TS-3GA-36.443(Rel14)v14.1.0.pdf</a>

**Release 15**

ATIS	ATIS.3GPP.36.443V1500	15.0.0	Published	28.06.2021	<a href="https://www.atis.org/3gpp-documents/Rel15/">https://www.atis.org/3gpp-documents/Rel15/</a>
CCSA	CCSA.36.443V1500	15.0.0	Published	01.09.2018	<a href="https://www.ccsa.org.cn/api/portalsFile/downloadOldFile?type=19&amp;oldFileUrl=ITU-R/M.2012-6/CCSA.36.443V1500.doc">https://www.ccsa.org.cn/api/portalsFile/downloadOldFile?type=19&amp;oldFileUrl=ITU-R/M.2012-6/CCSA.36.443V1500.doc</a>
ETSI	ETSI TS 136 443	15.0.0	Published	28.09.2018	<a href="https://www.etsi.org/deliver/etsi_ts/136400_136499/136443/15.00.00_60/ts_136443v150000p.pdf">https://www.etsi.org/deliver/etsi_ts/136400_136499/136443/15.00.00_60/ts_136443v150000p.pdf</a>
TSDSI	TSDSI STD T1.3GPP 36.443-15.0.0 V1.0.0	15.0.0	Published	30.08.2021	<a href="https://members.tdsi.in/index.php/s/witLz5XMM3CFHxp">https://members.tdsi.in/index.php/s/witLz5XMM3CFHxp</a>
TTA	TTAT.3G-36.443V15.0.0	15.0.0	Published	11.09.2020	<a href="http://committee.tta.or.kr/data/ttasDown.jsp?kind=ttastd&amp;pk_num=TTAT.3G-36.443V15.0.0">http://committee.tta.or.kr/data/ttasDown.jsp?kind=ttastd&amp;pk_num=TTAT.3G-36.443V15.0.0</a>
TTC	TS-3GA-36.443(Rel15)v15.0.0	15.0.0	Published	21.12.2018	<a href="https://www.ttc.or.jp/st/docs/3gpps2018/TS/TS-3GA-36.443(Rel15)v15.0.0.pdf">https://www.ttc.or.jp/st/docs/3gpps2018/TS/TS-3GA-36.443(Rel15)v15.0.0.pdf</a>

**Release 16**

ATIS	ATIS.3GPP.36.443.V16.1.0	16.1.0	Published	21.02.2023	<a href="https://www.atis.org/3gpp-transpositions - Rel-16">https://www.atis.org/3gpp-transpositions - Rel-16</a>
CCSA	CCSA.36.443V1610	16.1.0	Published	01.01.2021	<a href="https://www.ccsa.org.cn/api/portalsFile/downloadOldFile?type=19&amp;oldFileUrl=ITU-R/M.2012-6/CCSA.36.443V1610.doc">https://www.ccsa.org.cn/api/portalsFile/downloadOldFile?type=19&amp;oldFileUrl=ITU-R/M.2012-6/CCSA.36.443V1610.doc</a>
ETSI	ETSI TS 136 443	16.1.0	Published	27.01.2021	<a href="https://www.etsi.org/deliver/etsi_ts/136400_136499/136443/16.01.00_60/ts_136443v160100p.pdf">https://www.etsi.org/deliver/etsi_ts/136400_136499/136443/16.01.00_60/ts_136443v160100p.pdf</a>
TSDSI	TSDSI STD T1.3GPP 36.443-16.1.0 V1.1.0	16.1.0	Published	01.11.2022	<a href="https://members.tdsi.in/index.php/s/FYfjn77KfHjJnk9">https://members.tdsi.in/index.php/s/FYfjn77KfHjJnk9</a>
TTA	TTAT.3G-36.443V16.1.0	16.1.0	Published	16.03.2023	<a href="http://committee.tta.or.kr/data/ttasDown.jsp?kind=ttastd&amp;pk_num=TTAT.3G-36.443V16.1.0">http://committee.tta.or.kr/data/ttasDown.jsp?kind=ttastd&amp;pk_num=TTAT.3G-36.443V16.1.0</a>
TTC	TS-3GA-36.443(Rel16)v16.1.0	16.1.0	Published	09.04.2021	<a href="https://www.ttc.or.jp/st/docs/3gpp/2021/TS/TS-3GA-36.443v16.1.0.pdf">https://www.ttc.or.jp/st/docs/3gpp/2021/TS/TS-3GA-36.443v16.1.0.pdf</a>

**Release 17**

ATIS	ATIS.3GPP.36.443.V17.0.1	17.0.1	Published	21.02.2023	<a href="https://www.atis.org/3gpp-transpositions - Rel-17">https://www.atis.org/3gpp-transpositions - Rel-17</a>
CCSA	CCSA.36.443V1701	17.0.1	Published	01.04.2022	<a href="https://www.ccsa.org.cn/api/portalsFile/downloadOldFile?type=19&amp;oldFileUrl=ITU-R/M.2012-6/CCSA.36.443V1701.doc">https://www.ccsa.org.cn/api/portalsFile/downloadOldFile?type=19&amp;oldFileUrl=ITU-R/M.2012-6/CCSA.36.443V1701.doc</a>
ETSI	ETSI TS 136 443	17.0.1	Published	02.05.2022	<a href="https://www.etsi.org/deliver/etsi_ts/136400_136499/136443/17.00.01_60/ts_136443v170001p.pdf">https://www.etsi.org/deliver/etsi_ts/136400_136499/136443/17.00.01_60/ts_136443v170001p.pdf</a>
TSDSI	TSDSI STD T1.3GPP 36.443-17.0.1 V1.1.0	17.0.1	Published	01.11.2022	<a href="https://members.tdsi.in/s/YqaHXECgmaeQjA">https://members.tdsi.in/s/YqaHXECgmaeQjA</a>
TTA	TTAT.3G-36.443V17.0.1	17.0.1	Published	05.08.2022	<a href="http://committee.tta.or.kr/data/ttasDown.jsp?kind=ttastd&amp;pk_num=TTAT.3G-36.443V17.0.1">http://committee.tta.or.kr/data/ttasDown.jsp?kind=ttastd&amp;pk_num=TTAT.3G-36.443V17.0.1</a>
TTC	TS-3GA-36.443(Rel17)v17.0.1	17.0.1	Published	07.10.2022	<a href="https://www.ttc.or.jp/st/docs/3gpp/2022/TS/TS-3GA-36.443v17.0.1.pdf">https://www.ttc.or.jp/st/docs/3gpp/2022/TS/TS-3GA-36.443v17.0.1.pdf</a>

**2.1.4.17 TS 36.444****Evolved Universal Terrestrial Radio Access Network (E-UTRAN); M3 Application Protocol (M3AP)**

This document specifies the E-UTRAN radio network layer signalling protocol for the M3 interface. The M3 Application Protocol (M3AP) supports the functions of M3 interface by signalling procedures defined in this document.

SDO	Document No.	Version	Status	Issued date	Location
-----	--------------	---------	--------	-------------	----------

<b>Release 10</b>						
ATIS	ATIS.3GPP.36.444V1040	10.4.0	Published	28.06.2021	<a href="https://www.atis.org/3gpp-documents/Rel99-14/">https://www.atis.org/3gpp-documents/Rel99-14/</a>	
CCSA	CCSA.36.444V1040	10.4.0	Published	01.12.2012	<a href="https://www.ccsa.org.cn/api/portalsFile/downloadOldFile?type=19&amp;oldFileUrl=ITU-R/M.2012-6/CCSA.36.444V1040.doc">https://www.ccsa.org.cn/api/portalsFile/downloadOldFile?type=19&amp;oldFileUrl=ITU-R/M.2012-6/CCSA.36.444V1040.doc</a>	
ETSI	ETSI TS 136 444	10.4.0	Published	16.01.2013	<a href="https://www.etsi.org/deliver/etsi_ts/136400_136499/136444/10.04.00_60/ts_136444v100400p.pdf">https://www.etsi.org/deliver/etsi_ts/136400_136499/136444/10.04.00_60/ts_136444v100400p.pdf</a>	
TSDSI	TSDSI STD T1.3GPP 36.444-10.4.0 V1.0.0	10.4.0	Published	30.08.2021	<a href="https://members.tdsi.in/index.php/s/kxo4P2EH53HBPRR">https://members.tdsi.in/index.php/s/kxo4P2EH53HBPRR</a>	
TTA	TTAT.3G-36.444V10.4.0	10.4.0	Published	30.07.2021	<a href="http://committee.tta.or.kr/data/ttasDown.jsp?kind=ttastd&amp;pk_num=TTAT.3G-36.444V10.4.0">http://committee.tta.or.kr/data/ttasDown.jsp?kind=ttastd&amp;pk_num=TTAT.3G-36.444V10.4.0</a>	
TTC	TS-3GA-36.444(Rel10)v10.4.0	10.4.0	Published	25.06.2013	<a href="https://www.ttc.or.jp/st/docs/3gpps2013/TS/TS-3GA-36.444(Rel10)v10.4.0.pdf">https://www.ttc.or.jp/st/docs/3gpps2013/TS/TS-3GA-36.444(Rel10)v10.4.0.pdf</a>	
<b>Release 11</b>						
ATIS	ATIS.3GPP.36.444V1160	11.6.0	Published	28.06.2021	<a href="https://www.atis.org/3gpp-documents/Rel99-14/">https://www.atis.org/3gpp-documents/Rel99-14/</a>	
CCSA	CCSA.36.444V1160	11.6.0	Published	01.06.2013	<a href="https://www.ccsa.org.cn/api/portalsFile/downloadOldFile?type=19&amp;oldFileUrl=ITU-R/M.2012-6/CCSA.36.444V1160.doc">https://www.ccsa.org.cn/api/portalsFile/downloadOldFile?type=19&amp;oldFileUrl=ITU-R/M.2012-6/CCSA.36.444V1160.doc</a>	
ETSI	ETSI TS 136 444	11.6.0	Published	11.07.2013	<a href="https://www.etsi.org/deliver/etsi_ts/136400_136499/136444/11.06.00_60/ts_136444v110600p.pdf">https://www.etsi.org/deliver/etsi_ts/136400_136499/136444/11.06.00_60/ts_136444v110600p.pdf</a>	
TSDSI	TSDSI STD T1.3GPP 36.444-11.6.0 V1.0.0	11.6.0	Published	30.08.2021	<a href="https://members.tdsi.in/index.php/s/6tJ8c9EGPJzGe5">https://members.tdsi.in/index.php/s/6tJ8c9EGPJzGe5</a>	
TTA	TTAT.3G-36.444V11.6.0	11.6.0	Published	30.07.2021	<a href="http://committee.tta.or.kr/data/ttasDown.jsp?kind=ttastd&amp;pk_num=TTAT.3G-36.444V11.6.0">http://committee.tta.or.kr/data/ttasDown.jsp?kind=ttastd&amp;pk_num=TTAT.3G-36.444V11.6.0</a>	
TTC	TS-3GA-36.444(Rel11)v11.6.0	11.6.0	Published	30.08.2013	<a href="https://www.ttc.or.jp/st/docs/3gpps2013/TS/TS-3GA-36.444(Rel11)v11.6.0.pdf">https://www.ttc.or.jp/st/docs/3gpps2013/TS/TS-3GA-36.444(Rel11)v11.6.0.pdf</a>	
<b>Release 12</b>						
ATIS	ATIS.3GPP.36.444V1220	12.2.0	Published	28.06.2021	<a href="https://www.atis.org/3gpp-documents/Rel99-14/">https://www.atis.org/3gpp-documents/Rel99-14/</a>	
CCSA	CCSA.36.444V1220	12.2.0	Published	01.03.2015	<a href="https://www.ccsa.org.cn/api/portalsFile/downloadOldFile?type=19&amp;oldFileUrl=ITU-R/M.2012-6/CCSA.36.444V1220.doc">https://www.ccsa.org.cn/api/portalsFile/downloadOldFile?type=19&amp;oldFileUrl=ITU-R/M.2012-6/CCSA.36.444V1220.doc</a>	
ETSI	ETSI TS 136 444	12.2.0	Published	15.04.2015	<a href="https://www.etsi.org/deliver/etsi_ts/136400_136499/136444/12.02.00_60/ts_136444v120200p.pdf">https://www.etsi.org/deliver/etsi_ts/136400_136499/136444/12.02.00_60/ts_136444v120200p.pdf</a>	
TSDSI	TSDSI STD T1.3GPP 36.444-12.2.0 V1.0.0	12.2.0	Published	30.08.2021	<a href="https://members.tdsi.in/index.php/s/3YxtbgFmNz49SGw">https://members.tdsi.in/index.php/s/3YxtbgFmNz49SGw</a>	
TTA	TTAT.3G-36.444V12.2.0	12.2.0	Published	30.07.2021	<a href="http://committee.tta.or.kr/data/ttasDown.jsp?kind=ttastd&amp;pk_num=TTAT.3G-36.444V12.2.0">http://committee.tta.or.kr/data/ttasDown.jsp?kind=ttastd&amp;pk_num=TTAT.3G-36.444V12.2.0</a>	
TTC	TS-3GA-36.444(Rel12)v12.2.0	12.2.0	Published	30.06.2015	<a href="https://www.ttc.or.jp/st/docs/3gpps2015/TS/TS-3GA-36.444(Rel12)v12.2.0.pdf">https://www.ttc.or.jp/st/docs/3gpps2015/TS/TS-3GA-36.444(Rel12)v12.2.0.pdf</a>	
<b>Release 13</b>						
ATIS	ATIS.3GPP.36.444V1320	13.2.0	Published	28.06.2021	<a href="https://www.atis.org/3gpp-documents/Rel99-14/">https://www.atis.org/3gpp-documents/Rel99-14/</a>	
CCSA	CCSA.36.444V1320	13.2.0	Published	01.03.2016	<a href="https://www.ccsa.org.cn/api/portalsFile/downloadOldFile?type=19&amp;oldFileUrl=ITU-R/M.2012-6/CCSA.36.444V1320.doc">https://www.ccsa.org.cn/api/portalsFile/downloadOldFile?type=19&amp;oldFileUrl=ITU-R/M.2012-6/CCSA.36.444V1320.doc</a>	
ETSI	ETSI TS 136 444	13.2.0	Published	20.05.2016	<a href="https://www.etsi.org/deliver/etsi_ts/136400_136499/136444/13.02.00_60/ts_136444v130200p.pdf">https://www.etsi.org/deliver/etsi_ts/136400_136499/136444/13.02.00_60/ts_136444v130200p.pdf</a>	
TSDSI	TSDSI STD T1.3GPP 36.444-13.2.0 V1.0.0	13.2.0	Published	30.08.2021	<a href="https://members.tdsi.in/index.php/s/ybnTZzCL5k7nnBa">https://members.tdsi.in/index.php/s/ybnTZzCL5k7nnBa</a>	
TTA	TTAT.3G-36.444V13.2.0	13.2.0	Published	02.08.2021	<a href="http://committee.tta.or.kr/data/ttasDown.jsp?kind=ttastd&amp;pk_num=TTAT.3G-36.444V13.2.0">http://committee.tta.or.kr/data/ttasDown.jsp?kind=ttastd&amp;pk_num=TTAT.3G-36.444V13.2.0</a>	
TTC	TS-3GA-36.444(Rel13)v13.2.0	13.2.0	Published	31.03.2017	<a href="https://www.ttc.or.jp/st/docs/3gpps2017/TS/TS-3GA-36.444(Rel13)v13.2.0.pdf">https://www.ttc.or.jp/st/docs/3gpps2017/TS/TS-3GA-36.444(Rel13)v13.2.0.pdf</a>	
<b>Release 14</b>						
ATIS	ATIS.3GPP.36.444V1410	14.1.0	Published	28.06.2021	<a href="https://www.atis.org/3gpp-documents/Rel99-14/">https://www.atis.org/3gpp-documents/Rel99-14/</a>	
CCSA	CCSA.36.444V1410	14.1.0	Published	01.06.2017	<a href="https://www.ccsa.org.cn/api/portalsFile/downloadOldFile?type=19&amp;oldFileUrl=ITU-R/M.2012-6/CCSA.36.444V1410.doc">https://www.ccsa.org.cn/api/portalsFile/downloadOldFile?type=19&amp;oldFileUrl=ITU-R/M.2012-6/CCSA.36.444V1410.doc</a>	
ETSI	ETSI TS 136 444	14.1.0	Published	24.08.2017	<a href="https://www.etsi.org/deliver/etsi_ts/136400_136499/136444/14.01.00_60/ts_136444v140100p.pdf">https://www.etsi.org/deliver/etsi_ts/136400_136499/136444/14.01.00_60/ts_136444v140100p.pdf</a>	
TSDSI	TSDSI STD T1.3GPP 36.444-14.1.0 V1.0.0	14.1.0	Published	30.08.2021	<a href="https://members.tdsi.in/index.php/s/BRp7P6Cg8Xws4LA">https://members.tdsi.in/index.php/s/BRp7P6Cg8Xws4LA</a>	
TTA	TTAT.3G-36.444V14.1.0	14.1.0	Published	02.08.2021	<a href="http://committee.tta.or.kr/data/ttasDown.jsp?kind=ttastd&amp;pk_num=TTAT.3G-36.444V14.1.0">http://committee.tta.or.kr/data/ttasDown.jsp?kind=ttastd&amp;pk_num=TTAT.3G-36.444V14.1.0</a>	
TTC	TS-3GA-36.444(Rel14)v14.1.0	14.1.0	Published	13.04.2018	<a href="https://www.ttc.or.jp/st/docs/3gpps2018/TS/TS-3GA-36.444(Rel14)v14.1.0.pdf">https://www.ttc.or.jp/st/docs/3gpps2018/TS/TS-3GA-36.444(Rel14)v14.1.0.pdf</a>	
<b>Release 15</b>						
ATIS	ATIS.3GPP.36.444V1500	15.0.0	Published	28.06.2021	<a href="https://www.atis.org/3gpp-documents/Rel15/">https://www.atis.org/3gpp-documents/Rel15/</a>	
CCSA	CCSA.36.444V1500	15.0.0	Published	01.09.2018	<a href="https://www.ccsa.org.cn/api/portalsFile/downloadOldFile?type=19&amp;oldFileUrl=ITU-R/M.2012-6/CCSA.36.444V1500.doc">https://www.ccsa.org.cn/api/portalsFile/downloadOldFile?type=19&amp;oldFileUrl=ITU-R/M.2012-6/CCSA.36.444V1500.doc</a>	
ETSI	ETSI TS 136 444	15.0.0	Published	28.09.2018	<a href="https://www.etsi.org/deliver/etsi_ts/136400_136499/136444/15.00.00_60/ts_136444v150000p.pdf">https://www.etsi.org/deliver/etsi_ts/136400_136499/136444/15.00.00_60/ts_136444v150000p.pdf</a>	
TSDSI	TSDSI STD T1.3GPP 36.444-15.0.0 V1.0.0	15.0.0	Published	30.08.2021	<a href="https://members.tdsi.in/index.php/s/Wc5skLztjkrFKr">https://members.tdsi.in/index.php/s/Wc5skLztjkrFKr</a>	
TTA	TTAT.3G-36.444V15.0.0	15.0.0	Published	11.09.2020	<a href="http://committee.tta.or.kr/data/ttasDown.jsp?kind=ttastd&amp;pk_num=TTAT.3G-36.444V15.0.0">http://committee.tta.or.kr/data/ttasDown.jsp?kind=ttastd&amp;pk_num=TTAT.3G-36.444V15.0.0</a>	
TTC	TS-3GA-36.444(Rel15)v15.0.0	15.0.0	Published	21.12.2018	<a href="https://www.ttc.or.jp/st/docs/3gpps2018/TS/TS-3GA-36.444(Rel15)v15.0.0.pdf">https://www.ttc.or.jp/st/docs/3gpps2018/TS/TS-3GA-36.444(Rel15)v15.0.0.pdf</a>	
<b>Release 16</b>						
ATIS	ATIS.3GPP.36.444V1600	16.0.0	Published	28.06.2021	<a href="https://www.atis.org/3gpp-documents/Rel16/">https://www.atis.org/3gpp-documents/Rel16/</a>	
CCSA	CCSA.36.444V1600	16.0.0	Published	01.07.2020	<a href="https://www.ccsa.org.cn/api/portalsFile/downloadOldFile?type=19&amp;oldFileUrl=ITU-R/M.2012-6/CCSA.36.444V1600.doc">https://www.ccsa.org.cn/api/portalsFile/downloadOldFile?type=19&amp;oldFileUrl=ITU-R/M.2012-6/CCSA.36.444V1600.doc</a>	
ETSI	ETSI TS 136 444	16.0.0	Published	21.07.2020	<a href="https://www.etsi.org/deliver/etsi_ts/136400_136499/136444/16.00.00_60/ts_136444v160000p.pdf">https://www.etsi.org/deliver/etsi_ts/136400_136499/136444/16.00.00_60/ts_136444v160000p.pdf</a>	

TSDSI	TSDSI STD T1.3GPP 36.444-16.0.0 V1.0.0	16.0.0	Published	30.08.2021	<a href="https://members.tdsi.in/index.php/s/fp3fn2q65LM88gG">https://members.tdsi.in/index.php/s/fp3fn2q65LM88gG</a>
TTA	TTAT.3G-36.444V16.0.0	16.0.0	Published	11.09.2020	<a href="http://committee.tta.or.kr/data/ttasDown.jsp?kind=ttastd&amp;pk_num=TTAT.3G-36.444V16.0.0">http://committee.tta.or.kr/data/ttasDown.jsp?kind=ttastd&amp;pk_num=TTAT.3G-36.444V16.0.0</a>
TTC	TS-3GA-36.444(Rel16)v16.0.0	16.0.0	Published	02.10.2020	<a href="https://www.ttc.or.jp/st/docs/3gpps2020/TS/TS-3GA-36_444_Rel16v16_0_0.pdf">https://www.ttc.or.jp/st/docs/3gpps2020/TS/TS-3GA-36_444_Rel16v16_0_0.pdf</a>

**Release 17**

ATIS	ATIS.3GPP.36.444.V17.0.0	17.0.0	Published	21.02.2023	<a href="https://www.atis.org/3gpp-transpositions - Rel-17">https://www.atis.org/3gpp-transpositions - Rel-17</a>
CCSA	CCSA.36.444V1700	17.0.0	Published	01.04.2022	<a href="https://www.ccsa.org.cn/api/portalsFile/downloadOldFile?type=19&amp;oldFileUrl=ITU-R/M.2012-6/CCSA.36.444V1700.doc">https://www.ccsa.org.cn/api/portalsFile/downloadOldFile?type=19&amp;oldFileUrl=ITU-R/M.2012-6/CCSA.36.444V1700.doc</a>
ETSI	ETSI TS 136 444	17.0.0	Published	02.05.2022	<a href="https://www.etsi.org/deliver/etsi_ts/136400_136499/136444/17.00.00_60/ts_136444v170000p.pdf">https://www.etsi.org/deliver/etsi_ts/136400_136499/136444/17.00.00_60/ts_136444v170000p.pdf</a>
TSDSI	TSDSI STD T1.3GPP 36.444-17.0.0 V1.0.0	17.0.0	Published	29.07.2022	<a href="https://members.tdsi.in/s/8LMJBsgZdXWgtqc">https://members.tdsi.in/s/8LMJBsgZdXWgtqc</a>
TTA	TTAT.3G-36.444V17.0.0	17.0.0	Published	05.08.2022	<a href="http://committee.tta.or.kr/data/ttasDown.jsp?kind=ttastd&amp;pk_num=TTAT.3G-36.444V17.0.0">http://committee.tta.or.kr/data/ttasDown.jsp?kind=ttastd&amp;pk_num=TTAT.3G-36.444V17.0.0</a>
TTC	TS-3GA-36.444(Rel17)v17.0.0	17.0.0	Published	07.10.2022	<a href="https://www.ttc.or.jp/st/docs/3gpp/2022/TS/TS-3GA-36.444v17.0.0.pdf">https://www.ttc.or.jp/st/docs/3gpp/2022/TS/TS-3GA-36.444v17.0.0.pdf</a>

**2.1.4.18 TS 36.445****Evolved Universal Terrestrial Radio Access Network (E-UTRAN); M1 data transport**

This document specifies the standards for user data transport protocols over the E-UTRAN M1 interface.

SDO	Document No.	Version	Status	Issued date	Location
<b>Release 10</b>					
ATIS	ATIS.3GPP.36.445V1010	10.1.0	Published	28.06.2021	<a href="https://www.atis.org/3gpp-documents/Rel99-14/">https://www.atis.org/3gpp-documents/Rel99-14/</a>
CCSA	CCSA.36.445V1010	10.1.0	Published	01.06.2011	<a href="https://www.ccsa.org.cn/api/portalsFile/downloadOldFile?type=19&amp;oldFileUrl=ITU-R/M.2012-6/CCSA.36.445V1010.doc">https://www.ccsa.org.cn/api/portalsFile/downloadOldFile?type=19&amp;oldFileUrl=ITU-R/M.2012-6/CCSA.36.445V1010.doc</a>
ETSI	ETSI TS 136 445	10.1.0	Published	30.06.2011	<a href="https://www.etsi.org/deliver/etsi_ts/136400_136499/136445/10.01.00_60/ts_136445v100100p.pdf">https://www.etsi.org/deliver/etsi_ts/136400_136499/136445/10.01.00_60/ts_136445v100100p.pdf</a>
TSDSI	TSDSI STD T1.3GPP 36.445-10.1.0 V1.0.0	10.1.0	Published	30.08.2021	<a href="https://members.tdsi.in/index.php/s/9XFe3jtokxo5ezt">https://members.tdsi.in/index.php/s/9XFe3jtokxo5ezt</a>
TTA	TTAT.3G-36.445V10.1.0	10.1.0	Published	02.08.2021	<a href="http://committee.tta.or.kr/data/ttasDown.jsp?kind=ttastd&amp;pk_num=TTAT.3G-36.445V10.1.0">http://committee.tta.or.kr/data/ttasDown.jsp?kind=ttastd&amp;pk_num=TTAT.3G-36.445V10.1.0</a>
TTC	TS-3GA-36.445(Rel10)v10.1.0	10.1.0	Published	31.08.2011	<a href="https://www.ttc.or.jp/st/docs/3gpps2011/TS/TS-3GA-36.445(Rel10)v10.1.0.pdf">https://www.ttc.or.jp/st/docs/3gpps2011/TS/TS-3GA-36.445(Rel10)v10.1.0.pdf</a>
<b>Release 11</b>					
ATIS	ATIS.3GPP.36.445V1100	11.0.0	Published	28.06.2021	<a href="https://www.atis.org/3gpp-documents/Rel99-14/">https://www.atis.org/3gpp-documents/Rel99-14/</a>
CCSA	CCSA.36.445V1100	11.0.0	Published	01.09.2012	<a href="https://www.ccsa.org.cn/api/portalsFile/downloadOldFile?type=19&amp;oldFileUrl=ITU-R/M.2012-6/CCSA.36.445V1100.doc">https://www.ccsa.org.cn/api/portalsFile/downloadOldFile?type=19&amp;oldFileUrl=ITU-R/M.2012-6/CCSA.36.445V1100.doc</a>
ETSI	ETSI TS 136 445	11.0.0	Published	18.10.2012	<a href="https://www.etsi.org/deliver/etsi_ts/136400_136499/136445/11.00.00_60/ts_136445v110000p.pdf">https://www.etsi.org/deliver/etsi_ts/136400_136499/136445/11.00.00_60/ts_136445v110000p.pdf</a>
TSDSI	TSDSI STD T1.3GPP 36.445-11.0.0 V1.0.0	11.0.0	Published	30.08.2021	<a href="https://members.tdsi.in/index.php/s/fqqPAYomZcrcCBK">https://members.tdsi.in/index.php/s/fqqPAYomZcrcCBK</a>
TTA	TTAT.3G-36.445V11.0.0	11.0.0	Published	02.08.2021	<a href="http://committee.tta.or.kr/data/ttasDown.jsp?kind=ttastd&amp;pk_num=TTAT.3G-36.445V11.0.0">http://committee.tta.or.kr/data/ttasDown.jsp?kind=ttastd&amp;pk_num=TTAT.3G-36.445V11.0.0</a>
TTC	TS-3GA-36.445(Rel11)v11.0.0	11.0.0	Published	25.06.2013	<a href="https://www.ttc.or.jp/st/docs/3gpps2013/TS/TS-3GA-36.445(Rel11)v11.0.0.pdf">https://www.ttc.or.jp/st/docs/3gpps2013/TS/TS-3GA-36.445(Rel11)v11.0.0.pdf</a>
<b>Release 12</b>					
ATIS	ATIS.3GPP.36.445V1200	12.0.0	Published	28.06.2021	<a href="https://www.atis.org/3gpp-documents/Rel99-14/">https://www.atis.org/3gpp-documents/Rel99-14/</a>
CCSA	CCSA.36.445V1200	12.0.0	Published	01.09.2014	<a href="https://www.ccsa.org.cn/api/portalsFile/downloadOldFile?type=19&amp;oldFileUrl=ITU-R/M.2012-6/CCSA.36.445V1200.doc">https://www.ccsa.org.cn/api/portalsFile/downloadOldFile?type=19&amp;oldFileUrl=ITU-R/M.2012-6/CCSA.36.445V1200.doc</a>
ETSI	ETSI TS 136 445	12.0.0	Published	26.09.2014	<a href="https://www.etsi.org/deliver/etsi_ts/136400_136499/136445/12.00.00_60/ts_136445v120000p.pdf">https://www.etsi.org/deliver/etsi_ts/136400_136499/136445/12.00.00_60/ts_136445v120000p.pdf</a>
TSDSI	TSDSI STD T1.3GPP 36.445-12.0.0 V1.0.0	12.0.0	Published	30.08.2021	<a href="https://members.tdsi.in/index.php/s/EJqrMzmmGiYaF5P">https://members.tdsi.in/index.php/s/EJqrMzmmGiYaF5P</a>
TTA	TTAT.3G-36.445V12.0.0	12.0.0	Published	02.08.2021	<a href="http://committee.tta.or.kr/data/ttasDown.jsp?kind=ttastd&amp;pk_num=TTAT.3G-36.445V12.0.0">http://committee.tta.or.kr/data/ttasDown.jsp?kind=ttastd&amp;pk_num=TTAT.3G-36.445V12.0.0</a>
TTC	TS-3GA-36.445(Rel12)v12.0.0	12.0.0	Published	05.03.2015	<a href="https://www.ttc.or.jp/st/docs/3gpps2015/TS/TS-3GA-36.445(Rel12)v12.0.0.pdf">https://www.ttc.or.jp/st/docs/3gpps2015/TS/TS-3GA-36.445(Rel12)v12.0.0.pdf</a>
<b>Release 13</b>					
ATIS	ATIS.3GPP.36.445V1300	13.0.0	Published	28.06.2021	<a href="https://www.atis.org/3gpp-documents/Rel99-14/">https://www.atis.org/3gpp-documents/Rel99-14/</a>
CCSA	CCSA.36.445V1300	13.0.0	Published	01.12.2015	<a href="https://www.ccsa.org.cn/api/portalsFile/downloadOldFile?type=19&amp;oldFileUrl=ITU-R/M.2012-6/CCSA.36.445V1300.doc">https://www.ccsa.org.cn/api/portalsFile/downloadOldFile?type=19&amp;oldFileUrl=ITU-R/M.2012-6/CCSA.36.445V1300.doc</a>
ETSI	ETSI TS 136 445	13.0.0	Published	21.01.2016	<a href="https://www.etsi.org/deliver/etsi_ts/136400_136499/136445/13.00.00_60/ts_136445v130000p.pdf">https://www.etsi.org/deliver/etsi_ts/136400_136499/136445/13.00.00_60/ts_136445v130000p.pdf</a>
TSDSI	TSDSI STD T1.3GPP 36.445-13.0.0 V1.0.0	13.0.0	Published	30.08.2021	<a href="https://members.tdsi.in/index.php/s/eFYWsRG6DewxD5t">https://members.tdsi.in/index.php/s/eFYWsRG6DewxD5t</a>
TTA	TTAT.3G-36.445V13.0.0	13.0.0	Published	02.08.2021	<a href="http://committee.tta.or.kr/data/ttasDown.jsp?kind=ttastd&amp;pk_num=TTAT.3G-36.445V13.0.0">http://committee.tta.or.kr/data/ttasDown.jsp?kind=ttastd&amp;pk_num=TTAT.3G-36.445V13.0.0</a>
TTC	TS-3GA-36.445(Rel13)v13.0.0	13.0.0	Published	31.03.2017	<a href="https://www.ttc.or.jp/st/docs/3gpps2017/TS/TS-3GA-36.445(Rel13)v13.0.0.pdf">https://www.ttc.or.jp/st/docs/3gpps2017/TS/TS-3GA-36.445(Rel13)v13.0.0.pdf</a>

**Release 14**



ATIS	ATIS.3GPP.36.445V1400	14.0.0	Published	28.06.2021	<a href="https://www.atis.org/3gpp-documents/Rel99-14/">https://www.atis.org/3gpp-documents/Rel99-14/</a>
CCSA	CCSA.36.445V1400	14.0.0	Published	01.03.2017	<a href="https://www.ccsa.org.cn/api/portalsFile/downloadOldFile?type=19&amp;oldFileUrl=ITU-R/M.2012-6/CCSA.36.445V1400.doc">https://www.ccsa.org.cn/api/portalsFile/downloadOldFile?type=19&amp;oldFileUrl=ITU-R/M.2012-6/CCSA.36.445V1400.doc</a>
ETSI	ETSI TS 136 445	14.0.0	Published	11.04.2017	<a href="https://www.etsi.org/deliver/etsi_ts/136400_136499/136445/14.00.00_60/ts_136445v140000p.pdf">https://www.etsi.org/deliver/etsi_ts/136400_136499/136445/14.00.00_60/ts_136445v140000p.pdf</a>
TSDSI	TSDSI STD T1.3GPP 36.445-14.0.0 V1.0.0	14.0.0	Published	30.08.2021	<a href="https://members.tdsi.in/index.php/s/YyK76JaXxcnZ4gf">https://members.tdsi.in/index.php/s/YyK76JaXxcnZ4gf</a>
TTA	TTAT.3G-36.445V14.0.0	14.0.0	Published	02.08.2021	<a href="http://committee.tta.or.kr/data/ttasDown.jsp?kind=ttastd&amp;pk_num=TTAT.3G-36.445V14.0.0">http://committee.tta.or.kr/data/ttasDown.jsp?kind=ttastd&amp;pk_num=TTAT.3G-36.445V14.0.0</a>
TTC	TS-3GA-36.445(Rel14)v14.0.0	14.0.0	Published	13.04.2018	<a href="https://www.ttc.or.jp/st/docs/3gpps2018/TS/TS-3GA-36.445(Rel14)v14.0.0.pdf">https://www.ttc.or.jp/st/docs/3gpps2018/TS/TS-3GA-36.445(Rel14)v14.0.0.pdf</a>

**Release 15**

ATIS	ATIS.3GPP.36.445V1500	15.0.0	Published	28.06.2021	<a href="https://www.atis.org/3gpp-documents/Rel15/">https://www.atis.org/3gpp-documents/Rel15/</a>
CCSA	CCSA.36.445V1500	15.0.0	Published	01.09.2018	<a href="https://www.ccsa.org.cn/api/portalsFile/downloadOldFile?type=19&amp;oldFileUrl=ITU-R/M.2012-6/CCSA.36.445V1500.doc">https://www.ccsa.org.cn/api/portalsFile/downloadOldFile?type=19&amp;oldFileUrl=ITU-R/M.2012-6/CCSA.36.445V1500.doc</a>
ETSI	ETSI TS 136 445	15.0.0	Published	28.09.2018	<a href="https://www.etsi.org/deliver/etsi_ts/136400_136499/136445/15.00.00_60/ts_136445v150000p.pdf">https://www.etsi.org/deliver/etsi_ts/136400_136499/136445/15.00.00_60/ts_136445v150000p.pdf</a>
TSDSI	TSDSI STD T1.3GPP 36.445-15.0.0 V1.0.0	15.0.0	Published	30.08.2021	<a href="https://members.tdsi.in/index.php/s/MdCjGc9BERPXbaA">https://members.tdsi.in/index.php/s/MdCjGc9BERPXbaA</a>
TTA	TTAT.3G-36.445V15.0.0	15.0.0	Published	11.09.2020	<a href="http://committee.tta.or.kr/data/ttasDown.jsp?kind=ttastd&amp;pk_num=TTAT.3G-36.445V15.0.0">http://committee.tta.or.kr/data/ttasDown.jsp?kind=ttastd&amp;pk_num=TTAT.3G-36.445V15.0.0</a>
TTC	TS-3GA-36.445(Rel15)v15.0.0	15.0.0	Published	21.12.2018	<a href="https://www.ttc.or.jp/st/docs/3gpps2018/TS/TS-3GA-36.445(Rel15)v15.0.0.pdf">https://www.ttc.or.jp/st/docs/3gpps2018/TS/TS-3GA-36.445(Rel15)v15.0.0.pdf</a>

**Release 16**

ATIS	ATIS.3GPP.36.445V1600	16.0.0	Published	28.06.2021	<a href="https://www.atis.org/3gpp-documents/Rel16/">https://www.atis.org/3gpp-documents/Rel16/</a>
CCSA	CCSA.36.445V1600	16.0.0	Published	01.07.2020	<a href="https://www.ccsa.org.cn/api/portalsFile/downloadOldFile?type=19&amp;oldFileUrl=ITU-R/M.2012-6/CCSA.36.445V1600.doc">https://www.ccsa.org.cn/api/portalsFile/downloadOldFile?type=19&amp;oldFileUrl=ITU-R/M.2012-6/CCSA.36.445V1600.doc</a>
ETSI	ETSI TS 136 445	16.0.0	Published	21.07.2020	<a href="https://www.etsi.org/deliver/etsi_ts/136400_136499/136445/16.00.00_60/ts_136445v160000p.pdf">https://www.etsi.org/deliver/etsi_ts/136400_136499/136445/16.00.00_60/ts_136445v160000p.pdf</a>
TSDSI	TSDSI STD T1.3GPP 36.445-16.0.0 V1.0.0	16.0.0	Published	30.08.2021	<a href="https://members.tdsi.in/index.php/s/HEBzkYbBZw2KnPQ">https://members.tdsi.in/index.php/s/HEBzkYbBZw2KnPQ</a>
TTA	TTAT.3G-36.445V16.0.0	16.0.0	Published	11.09.2020	<a href="http://committee.tta.or.kr/data/ttasDown.jsp?kind=ttastd&amp;pk_num=TTAT.3G-36.445V16.0.0">http://committee.tta.or.kr/data/ttasDown.jsp?kind=ttastd&amp;pk_num=TTAT.3G-36.445V16.0.0</a>
TTC	TS-3GA-36.445(Rel16)v16.0.0	16.0.0	Published	02.10.2020	<a href="https://www.ttc.or.jp/st/docs/3gpps2020/TS/TS-3GA-36_445_Rel16v16_0_0.pdf">https://www.ttc.or.jp/st/docs/3gpps2020/TS/TS-3GA-36_445_Rel16v16_0_0.pdf</a>

**Release 17**

ATIS	ATIS.3GPP.36.445.V17.0.0	17.0.0	Published	21.02.2023	<a href="https://www.atis.org/3gpp-transpositions - Rel-17">https://www.atis.org/3gpp-transpositions - Rel-17</a>
CCSA	CCSA.36.445V1700	17.0.0	Published	01.04.2022	<a href="https://www.ccsa.org.cn/api/portalsFile/downloadOldFile?type=19&amp;oldFileUrl=ITU-R/M.2012-6/CCSA.36.445V1700.doc">https://www.ccsa.org.cn/api/portalsFile/downloadOldFile?type=19&amp;oldFileUrl=ITU-R/M.2012-6/CCSA.36.445V1700.doc</a>
ETSI	ETSI TS 136 445	17.0.0	Published	02.05.2022	<a href="https://www.etsi.org/deliver/etsi_ts/136400_136499/136445/17.00.00_60/ts_136445v170000p.pdf">https://www.etsi.org/deliver/etsi_ts/136400_136499/136445/17.00.00_60/ts_136445v170000p.pdf</a>
TSDSI	TSDSI STD T1.3GPP 36.445-17.0.0 V1.0.0	17.0.0	Published	29.07.2022	<a href="https://members.tdsi.in/s/oQBkSm9zJs2btOD">https://members.tdsi.in/s/oQBkSm9zJs2btOD</a>
TTA	TTAT.3G-36.445V17.0.0	17.0.0	Published	05.08.2022	<a href="http://committee.tta.or.kr/data/ttasDown.jsp?kind=ttastd&amp;pk_num=TTAT.3G-36.445V17.0.0">http://committee.tta.or.kr/data/ttasDown.jsp?kind=ttastd&amp;pk_num=TTAT.3G-36.445V17.0.0</a>
TTC	TS-3GA-36.445(Rel17)v17.0.0	17.0.0	Published	07.10.2022	<a href="https://www.ttc.or.jp/st/docs/3gpp/2022/TS/TS-3GA-36.445v17.0.0.pdf">https://www.ttc.or.jp/st/docs/3gpp/2022/TS/TS-3GA-36.445v17.0.0.pdf</a>

**2.1.4.19 TS 36.455**

**Evolved Universal Terrestrial Radio Access (E-UTRA); LTE Positioning Protocol A (LPPa)**

This document specifies the control plane radio network layer signalling procedures between eNodeB and E-SMLC. LPPa supports the concerned functions by signalling procedures defined in this document.

SDO	Document No.	Version	Status	Issued date	Location
<b>Release 10</b>					
ATIS	ATIS.3GPP.36.455V1040	10.4.0	Published	28.06.2021	<a href="https://www.atis.org/3gpp-documents/Rel99-14/">https://www.atis.org/3gpp-documents/Rel99-14/</a>
CCSA	CCSA.36.455V1040	10.4.0	Published	01.09.2012	<a href="https://www.ccsa.org.cn/api/portalsFile/downloadOldFile?type=19&amp;oldFileUrl=ITU-R/M.2012-6/CCSA.36.455V1040.doc">https://www.ccsa.org.cn/api/portalsFile/downloadOldFile?type=19&amp;oldFileUrl=ITU-R/M.2012-6/CCSA.36.455V1040.doc</a>
ETSI	ETSI TS 136 455	10.4.0	Published	18.10.2012	<a href="https://www.etsi.org/deliver/etsi_ts/136400_136499/136455/10.04.00_60/ts_136455v100400p.pdf">https://www.etsi.org/deliver/etsi_ts/136400_136499/136455/10.04.00_60/ts_136455v100400p.pdf</a>
TSDSI	TSDSI STD T1.3GPP 36.455-10.4.0 V1.0.0	10.4.0	Published	30.08.2021	<a href="https://members.tdsi.in/index.php/s/HLXKWMYHNori4N9">https://members.tdsi.in/index.php/s/HLXKWMYHNori4N9</a>
TTA	TTAT.3G-36.455V10.4.0	10.4.0	Published	02.08.2021	<a href="http://committee.tta.or.kr/data/ttasDown.jsp?kind=ttastd&amp;pk_num=TTAT.3G-36.455V10.4.0">http://committee.tta.or.kr/data/ttasDown.jsp?kind=ttastd&amp;pk_num=TTAT.3G-36.455V10.4.0</a>
TTC	TS-3GA-36.455(Rel10)v10.4.0	10.4.0	Published	19.12.2012	<a href="https://www.ttc.or.jp/st/docs/3gpps2012/TS/TS-3GA-36.455(Rel10)v10.4.0.pdf">https://www.ttc.or.jp/st/docs/3gpps2012/TS/TS-3GA-36.455(Rel10)v10.4.0.pdf</a>
<b>Release 11</b>					
ATIS	ATIS.3GPP.36.455V1130	11.3.0	Published	28.06.2021	<a href="https://www.atis.org/3gpp-documents/Rel99-14/">https://www.atis.org/3gpp-documents/Rel99-14/</a>
CCSA	CCSA.36.455V1130	11.3.0	Published	01.06.2013	<a href="https://www.ccsa.org.cn/api/portalsFile/downloadOldFile?type=19&amp;oldFileUrl=ITU-R/M.2012-6/CCSA.36.455V1130.doc">https://www.ccsa.org.cn/api/portalsFile/downloadOldFile?type=19&amp;oldFileUrl=ITU-R/M.2012-6/CCSA.36.455V1130.doc</a>
ETSI	ETSI TS 136 455	11.3.0	Published	11.07.2013	<a href="https://www.etsi.org/deliver/etsi_ts/136400_136499/136455/11.03.00_60/ts_136455v110300p.pdf">https://www.etsi.org/deliver/etsi_ts/136400_136499/136455/11.03.00_60/ts_136455v110300p.pdf</a>

TSDSI	TSDSI STD T1.3GPP 36.455-11.3.0 V1.0.0	11.3.0	Published	30.08.2021	<a href="https://members.tdsi.in/index.php/s/TnaifqzHGxnGJEw">https://members.tdsi.in/index.php/s/TnaifqzHGxnGJEw</a>
TTA	TTAT.3G-36.455V11.3.0	11.3.0	Published	02.08.2021	<a href="http://committee.tta.or.kr/data/ttasDown.jsp?kind=ttastd&amp;pk_num=TTAT.3G-36.455V11.3.0">http://committee.tta.or.kr/data/ttasDown.jsp?kind=ttastd&amp;pk_num=TTAT.3G-36.455V11.3.0</a>
TTC	TS-3GA-36.455(Rel11)v11.3.0	11.3.0	Published	30.08.2013	<a href="https://www.ttc.or.jp/st/docs/3gpps2013/TS/TS-3GA-36.455(Rel11)v11.3.0.pdf">https://www.ttc.or.jp/st/docs/3gpps2013/TS/TS-3GA-36.455(Rel11)v11.3.0.pdf</a>
<b>Release 12</b>					
ATIS	ATIS.3GPP.36.455V1220	12.2.0	Published	28.06.2021	<a href="https://www.atis.org/3gpp-documents/Rel99-14/">https://www.atis.org/3gpp-documents/Rel99-14/</a>
CCSA	CCSA.36.455V1220	12.2.0	Published	01.03.2015	<a href="https://www.ccsa.org.cn/api/portalsFile/downloadOldFile?type=19&amp;oldFileUrl=ITU-R/M.2012-6/CCSA.36.455V1220.doc">https://www.ccsa.org.cn/api/portalsFile/downloadOldFile?type=19&amp;oldFileUrl=ITU-R/M.2012-6/CCSA.36.455V1220.doc</a>
ETSI	ETSI TS 136 455	12.2.0	Published	15.04.2015	<a href="https://www.etsi.org/deliver/etsi_ts/136400_136499/136455/12.02.00_60/ts_136455v120200p.pdf">https://www.etsi.org/deliver/etsi_ts/136400_136499/136455/12.02.00_60/ts_136455v120200p.pdf</a>
TSDSI	TSDSI STD T1.3GPP 36.455-12.2.0 V1.0.0	12.2.0	Published	30.08.2021	<a href="https://members.tdsi.in/index.php/s/fTqx9cf37KB3Rzp">https://members.tdsi.in/index.php/s/fTqx9cf37KB3Rzp</a>
TTA	TTAT.3G-36.455V12.2.0	12.2.0	Published	02.08.2021	<a href="http://committee.tta.or.kr/data/ttasDown.jsp?kind=ttastd&amp;pk_num=TTAT.3G-36.455V12.2.0">http://committee.tta.or.kr/data/ttasDown.jsp?kind=ttastd&amp;pk_num=TTAT.3G-36.455V12.2.0</a>
TTC	TS-3GA-36.455(Rel12)v12.2.0	12.2.0	Published	30.06.2015	<a href="https://www.ttc.or.jp/st/docs/3gpps2015/TS/TS-3GA-36.455(Rel12)v12.2.0.pdf">https://www.ttc.or.jp/st/docs/3gpps2015/TS/TS-3GA-36.455(Rel12)v12.2.0.pdf</a>
<b>Release 13</b>					
ATIS	ATIS.3GPP.36.455V1310	13.1.0	Published	28.06.2021	<a href="https://www.atis.org/3gpp-documents/Rel99-14/">https://www.atis.org/3gpp-documents/Rel99-14/</a>
CCSA	CCSA.36.455V1310	13.1.0	Published	01.03.2016	<a href="https://www.ccsa.org.cn/api/portalsFile/downloadOldFile?type=19&amp;oldFileUrl=ITU-R/M.2012-6/CCSA.36.455V1310.doc">https://www.ccsa.org.cn/api/portalsFile/downloadOldFile?type=19&amp;oldFileUrl=ITU-R/M.2012-6/CCSA.36.455V1310.doc</a>
ETSI	ETSI TS 136 455	13.1.0	Published	26.05.2016	<a href="https://www.etsi.org/deliver/etsi_ts/136400_136499/136455/13.01.00_60/ts_136455v130100p.pdf">https://www.etsi.org/deliver/etsi_ts/136400_136499/136455/13.01.00_60/ts_136455v130100p.pdf</a>
TSDSI	TSDSI STD T1.3GPP 36.455-13.1.0 V1.0.0	13.1.0	Published	30.08.2021	<a href="https://members.tdsi.in/index.php/s/2NpBdiokSNByKcF">https://members.tdsi.in/index.php/s/2NpBdiokSNByKcF</a>
TTA	TTAT.3G-36.455V13.1.0	13.1.0	Published	02.08.2021	<a href="http://committee.tta.or.kr/data/ttasDown.jsp?kind=ttastd&amp;pk_num=TTAT.3G-36.455V13.1.0">http://committee.tta.or.kr/data/ttasDown.jsp?kind=ttastd&amp;pk_num=TTAT.3G-36.455V13.1.0</a>
TTC	TS-3GA-36.455(Rel13)v13.1.0	13.1.0	Published	31.03.2017	<a href="https://www.ttc.or.jp/st/docs/3gpps2017/TS/TS-3GA-36.455(Rel13)v13.1.0.pdf">https://www.ttc.or.jp/st/docs/3gpps2017/TS/TS-3GA-36.455(Rel13)v13.1.0.pdf</a>
<b>Release 14</b>					
ATIS	ATIS.3GPP.36.455V1450	14.5.0	Published	28.06.2021	<a href="https://www.atis.org/3gpp-documents/Rel99-14/">https://www.atis.org/3gpp-documents/Rel99-14/</a>
CCSA	CCSA.36.455V1450	14.5.0	Published	01.09.2018	<a href="https://www.ccsa.org.cn/api/portalsFile/downloadOldFile?type=19&amp;oldFileUrl=ITU-R/M.2012-6/CCSA.36.455V1450.doc">https://www.ccsa.org.cn/api/portalsFile/downloadOldFile?type=19&amp;oldFileUrl=ITU-R/M.2012-6/CCSA.36.455V1450.doc</a>
ETSI	ETSI TS 136 455	14.5.0	Published	28.09.2018	<a href="https://www.etsi.org/deliver/etsi_ts/136400_136499/136455/14.05.00_60/ts_136455v140500p.pdf">https://www.etsi.org/deliver/etsi_ts/136400_136499/136455/14.05.00_60/ts_136455v140500p.pdf</a>
TSDSI	TSDSI STD T1.3GPP 36.455-14.5.0 V1.1.0	14.5.0	Published	30.08.2021	<a href="https://members.tdsi.in/index.php/s/8fZET4gi6d56BXz">https://members.tdsi.in/index.php/s/8fZET4gi6d56BXz</a>
TTA	TTAT.3G-36.455V14.5.0	14.5.0	Published	02.08.2021	<a href="http://committee.tta.or.kr/data/ttasDown.jsp?kind=ttastd&amp;pk_num=TTAT.3G-36.455V14.5.0">http://committee.tta.or.kr/data/ttasDown.jsp?kind=ttastd&amp;pk_num=TTAT.3G-36.455V14.5.0</a>
TTC	TS-3GA-36.455(Rel14)v14.5.0	14.5.0	Published	21.12.2018	<a href="https://www.ttc.or.jp/st/docs/3gpps2018/TS/TS-3GA-36.455(Rel14)v14.5.0.pdf">https://www.ttc.or.jp/st/docs/3gpps2018/TS/TS-3GA-36.455(Rel14)v14.5.0.pdf</a>
<b>Release 15</b>					
ATIS	ATIS.3GPP.36.455V1521	15.2.1	Published	28.06.2021	<a href="https://www.atis.org/3gpp-documents/Rel15/">https://www.atis.org/3gpp-documents/Rel15/</a>
CCSA	CCSA.36.455V1521	15.2.1	Published	01.01.2019	<a href="https://www.ccsa.org.cn/api/portalsFile/downloadOldFile?type=19&amp;oldFileUrl=ITU-R/M.2012-6/CCSA.36.455V1521.doc">https://www.ccsa.org.cn/api/portalsFile/downloadOldFile?type=19&amp;oldFileUrl=ITU-R/M.2012-6/CCSA.36.455V1521.doc</a>
ETSI	ETSI TS 136 455	15.2.1	Published	17.04.2019	<a href="https://www.etsi.org/deliver/etsi_ts/136400_136499/136455/15.02.01_60/ts_136455v150201p.pdf">https://www.etsi.org/deliver/etsi_ts/136400_136499/136455/15.02.01_60/ts_136455v150201p.pdf</a>
TSDSI	TSDSI STD T1.3GPP 36.455-15.2.1 V1.0.0	15.2.1	Published	30.08.2021	<a href="https://members.tdsi.in/index.php/s/yHwzCP7d52qtnnJ">https://members.tdsi.in/index.php/s/yHwzCP7d52qtnnJ</a>
TTA	TTAT.3G-36.455V15.2.1	15.2.1	Published	11.09.2020	<a href="http://committee.tta.or.kr/data/ttasDown.jsp?kind=ttastd&amp;pk_num=TTAT.3G-36.455V15.2.1">http://committee.tta.or.kr/data/ttasDown.jsp?kind=ttastd&amp;pk_num=TTAT.3G-36.455V15.2.1</a>
TTC	TS-3GA-36.455(Rel15)v15.2.1	15.2.1	Published	29.03.2019	<a href="https://www.ttc.or.jp/st/docs/3gpps2019/TS/TS-3GA-36.455(Rel15)v15.2.1.pdf">https://www.ttc.or.jp/st/docs/3gpps2019/TS/TS-3GA-36.455(Rel15)v15.2.1.pdf</a>
<b>Release 16</b>					
ATIS	ATIS.3GPP.36.455.V16.1.0	16.1.0	Published	21.02.2023	<a href="https://www.atis.org/3gpp-transpositions - Rel-16">https://www.atis.org/3gpp-transpositions - Rel-16</a>
CCSA	CCSA.36.455V1610	16.1.0	Published	01.09.2020	<a href="https://www.ccsa.org.cn/api/portalsFile/downloadOldFile?type=19&amp;oldFileUrl=ITU-R/M.2012-6/CCSA.36.455V1610.doc">https://www.ccsa.org.cn/api/portalsFile/downloadOldFile?type=19&amp;oldFileUrl=ITU-R/M.2012-6/CCSA.36.455V1610.doc</a>
ETSI	ETSI TS 136 455	16.1.0	Published	16.11.2020	<a href="https://www.etsi.org/deliver/etsi_ts/136400_136499/136455/16.01.00_60/ts_136455v160100p.pdf">https://www.etsi.org/deliver/etsi_ts/136400_136499/136455/16.01.00_60/ts_136455v160100p.pdf</a>
TSDSI	TSDSI STD T1.3GPP 36.455-16.1.0 V1.1.0	16.1.0	Published	01.11.2022	<a href="https://members.tdsi.in/s/TG9xS7wT78BkOBA">https://members.tdsi.in/s/TG9xS7wT78BkOBA</a>
TTA	TTAT.3G-36.455V16.1.0	16.1.0	Published	16.03.2023	<a href="http://committee.tta.or.kr/data/ttasDown.jsp?kind=ttastd&amp;pk_num=TTAT.3G-36.455V16.1.0">http://committee.tta.or.kr/data/ttasDown.jsp?kind=ttastd&amp;pk_num=TTAT.3G-36.455V16.1.0</a>
TTC	TS-3GA-36.455(Rel16)v16.1.0	16.1.0	Published	22.12.2020	<a href="https://www.ttc.or.jp/st/docs/3gpp/2020/TS/TS-3GA-36.455v16.1.0.pdf">https://www.ttc.or.jp/st/docs/3gpp/2020/TS/TS-3GA-36.455v16.1.0.pdf</a>
<b>Release 17</b>					
ATIS	ATIS.3GPP.36.455.V17.0.0	17.0.0	Published	21.02.2023	<a href="https://www.atis.org/3gpp-transpositions - Rel-17">https://www.atis.org/3gpp-transpositions - Rel-17</a>
CCSA	CCSA.36.455V1700	17.0.0	Published	01.04.2022	<a href="https://www.ccsa.org.cn/api/portalsFile/downloadOldFile?type=19&amp;oldFileUrl=ITU-R/M.2012-6/CCSA.36.455V1700.doc">https://www.ccsa.org.cn/api/portalsFile/downloadOldFile?type=19&amp;oldFileUrl=ITU-R/M.2012-6/CCSA.36.455V1700.doc</a>
ETSI	ETSI TS 136 455	17.0.0	Published	02.05.2022	<a href="https://www.etsi.org/deliver/etsi_ts/136400_136499/136455/17.00.00_60/ts_136455v170000p.pdf">https://www.etsi.org/deliver/etsi_ts/136400_136499/136455/17.00.00_60/ts_136455v170000p.pdf</a>
TSDSI	TSDSI STD T1.3GPP 36.455-17.0.0 V1.0.0	17.0.0	Published	29.07.2022	<a href="https://members.tdsi.in/s/ZXHL3gKeiPNJJ3">https://members.tdsi.in/s/ZXHL3gKeiPNJJ3</a>
TTA	TTAT.3G-36.455V17.0.0	17.0.0	Published	05.08.2022	<a href="http://committee.tta.or.kr/data/ttasDown.jsp?kind=ttastd&amp;pk_num=TTAT.3G-36.455V17.0.0">http://committee.tta.or.kr/data/ttasDown.jsp?kind=ttastd&amp;pk_num=TTAT.3G-36.455V17.0.0</a>
TTC	TS-3GA-36.455(Rel17)v17.0.0	17.0.0	Published	07.10.2022	<a href="https://www.ttc.or.jp/st/docs/3gpp/2022/TS/TS-3GA-36.455v17.0.0.pdf">https://www.ttc.or.jp/st/docs/3gpp/2022/TS/TS-3GA-36.455v17.0.0.pdf</a>

## 2.1.4.20 TS 36.456

## SLm interface general aspects and principles

This document is an introduction to the 3GPP TS 36.45x series of technical specifications that define the SLm interface for the interconnection of the Evolved Serving Mobile Location Centre (E-SMLC) to the Location Measurement Unit (LMU) components of the Evolved Universal Terrestrial Radio Access Network (E-UTRAN).

SDO	Document No.	Version	Status	Issued date	Location
<b>Release 11</b>					
ATIS	ATIS.3GPP.36.456V1100	11.0.0	Published	28.06.2021	<a href="https://www.atis.org/3gpp-documents/Rel11-14/">https://www.atis.org/3gpp-documents/Rel11-14/</a>
CCSA	CCSA.36.456V1100	11.0.0	Published	01.12.2012	<a href="https://www.ccsa.org.cn/api/portalsFile/downloadOldFile?type=19&amp;oldFileUrl=ITU-R/M.2012-6/CCSA.36.456V1100.doc">https://www.ccsa.org.cn/api/portalsFile/downloadOldFile?type=19&amp;oldFileUrl=ITU-R/M.2012-6/CCSA.36.456V1100.doc</a>
ETSI	ETSI TS 136 456	11.0.0	Published	12.02.2013	<a href="https://www.etsi.org/deliver/etsi_ts/136400_136499/136456/11.00.00_60/ts_136456v110000p.pdf">https://www.etsi.org/deliver/etsi_ts/136400_136499/136456/11.00.00_60/ts_136456v110000p.pdf</a>
TSDSI	TSDSI STD T1.3GPP 36.456-11.0.0 V1.0.0	11.0.0	Published	30.08.2021	<a href="https://members.tdsi.in/index.php/s/Yecb9JgRDmLDbrz">https://members.tdsi.in/index.php/s/Yecb9JgRDmLDbrz</a>
TTA	TTAT.3G-36.456V11.0.0	11.0.0	Published	02.08.2021	<a href="http://committee.tta.or.kr/data/ttasDown.jsp?kind=ttastd&amp;pk_num=TTAT.3G-36.456V11.0.0">http://committee.tta.or.kr/data/ttasDown.jsp?kind=ttastd&amp;pk_num=TTAT.3G-36.456V11.0.0</a>
TTC	TS-3GA-36.456(Rel11)v11.0.0	11.0.0	Published	25.06.2013	<a href="https://www.ttc.or.jp/st/docs/3gpps2013/TS/TS-3GA-36.456(Rel11)v11.0.0.pdf">https://www.ttc.or.jp/st/docs/3gpps2013/TS/TS-3GA-36.456(Rel11)v11.0.0.pdf</a>
<b>Release 12</b>					
ATIS	ATIS.3GPP.36.456V1200	12.0.0	Published	28.06.2021	<a href="https://www.atis.org/3gpp-documents/Rel11-14/">https://www.atis.org/3gpp-documents/Rel11-14/</a>
CCSA	CCSA.36.456V1200	12.0.0	Published	01.09.2014	<a href="https://www.ccsa.org.cn/api/portalsFile/downloadOldFile?type=19&amp;oldFileUrl=ITU-R/M.2012-6/CCSA.36.456V1200.doc">https://www.ccsa.org.cn/api/portalsFile/downloadOldFile?type=19&amp;oldFileUrl=ITU-R/M.2012-6/CCSA.36.456V1200.doc</a>
ETSI	ETSI TS 136 456	12.0.0	Published	26.09.2014	<a href="https://www.etsi.org/deliver/etsi_ts/136400_136499/136456/12.00.00_60/ts_136456v120000p.pdf">https://www.etsi.org/deliver/etsi_ts/136400_136499/136456/12.00.00_60/ts_136456v120000p.pdf</a>
TSDSI	TSDSI STD T1.3GPP 36.456-12.0.0 V1.0.0	12.0.0	Published	30.08.2021	<a href="https://members.tdsi.in/index.php/s/7ZNrFRPqAbte3mK">https://members.tdsi.in/index.php/s/7ZNrFRPqAbte3mK</a>
TTA	TTAT.3G-36.456V12.0.0	12.0.0	Published	02.08.2021	<a href="http://committee.tta.or.kr/data/ttasDown.jsp?kind=ttastd&amp;pk_num=TTAT.3G-36.456V12.0.0">http://committee.tta.or.kr/data/ttasDown.jsp?kind=ttastd&amp;pk_num=TTAT.3G-36.456V12.0.0</a>
TTC	TS-3GA-36.456(Rel12)v12.0.0	12.0.0	Published	05.03.2015	<a href="https://www.ttc.or.jp/st/docs/3gpps2015/TS/TS-3GA-36.456(Rel12)v12.0.0.pdf">https://www.ttc.or.jp/st/docs/3gpps2015/TS/TS-3GA-36.456(Rel12)v12.0.0.pdf</a>
<b>Release 13</b>					
ATIS	ATIS.3GPP.36.456V1300	13.0.0	Published	28.06.2021	<a href="https://www.atis.org/3gpp-documents/Rel11-14/">https://www.atis.org/3gpp-documents/Rel11-14/</a>
CCSA	CCSA.36.456V1300	13.0.0	Published	01.12.2015	<a href="https://www.ccsa.org.cn/api/portalsFile/downloadOldFile?type=19&amp;oldFileUrl=ITU-R/M.2012-6/CCSA.36.456V1300.doc">https://www.ccsa.org.cn/api/portalsFile/downloadOldFile?type=19&amp;oldFileUrl=ITU-R/M.2012-6/CCSA.36.456V1300.doc</a>
ETSI	ETSI TS 136 456	13.0.0	Published	21.01.2016	<a href="https://www.etsi.org/deliver/etsi_ts/136400_136499/136456/13.00.00_60/ts_136456v130000p.pdf">https://www.etsi.org/deliver/etsi_ts/136400_136499/136456/13.00.00_60/ts_136456v130000p.pdf</a>
TSDSI	TSDSI STD T1.3GPP 36.456-13.0.0 V1.0.0	13.0.0	Published	30.08.2021	<a href="https://members.tdsi.in/index.php/s/y88jaknLEqfsW45">https://members.tdsi.in/index.php/s/y88jaknLEqfsW45</a>
TTA	TTAT.3G-36.456V13.0.0	13.0.0	Published	02.08.2021	<a href="http://committee.tta.or.kr/data/ttasDown.jsp?kind=ttastd&amp;pk_num=TTAT.3G-36.456V13.0.0">http://committee.tta.or.kr/data/ttasDown.jsp?kind=ttastd&amp;pk_num=TTAT.3G-36.456V13.0.0</a>
TTC	TS-3GA-36.456(Rel13)v13.0.0	13.0.0	Published	31.03.2017	<a href="https://www.ttc.or.jp/st/docs/3gpps2017/TS/TS-3GA-36.456(Rel13)v13.0.0.pdf">https://www.ttc.or.jp/st/docs/3gpps2017/TS/TS-3GA-36.456(Rel13)v13.0.0.pdf</a>
<b>Release 14</b>					
ATIS	ATIS.3GPP.36.456V1400	14.0.0	Published	28.06.2021	<a href="https://www.atis.org/3gpp-documents/Rel11-14/">https://www.atis.org/3gpp-documents/Rel11-14/</a>
CCSA	CCSA.36.456V1400	14.0.0	Published	01.03.2017	<a href="https://www.ccsa.org.cn/api/portalsFile/downloadOldFile?type=19&amp;oldFileUrl=ITU-R/M.2012-6/CCSA.36.456V1400.doc">https://www.ccsa.org.cn/api/portalsFile/downloadOldFile?type=19&amp;oldFileUrl=ITU-R/M.2012-6/CCSA.36.456V1400.doc</a>
ETSI	ETSI TS 136 456	14.0.0	Published	11.04.2017	<a href="https://www.etsi.org/deliver/etsi_ts/136400_136499/136456/14.00.00_60/ts_136456v140000p.pdf">https://www.etsi.org/deliver/etsi_ts/136400_136499/136456/14.00.00_60/ts_136456v140000p.pdf</a>
TSDSI	TSDSI STD T1.3GPP 36.456-14.0.0 V1.0.0	14.0.0	Published	30.08.2021	<a href="https://members.tdsi.in/index.php/s/kcMPCmtSHaPcZJM">https://members.tdsi.in/index.php/s/kcMPCmtSHaPcZJM</a>
TTA	TTAT.3G-36.456V14.0.0	14.0.0	Published	02.08.2021	<a href="http://committee.tta.or.kr/data/ttasDown.jsp?kind=ttastd&amp;pk_num=TTAT.3G-36.456V14.0.0">http://committee.tta.or.kr/data/ttasDown.jsp?kind=ttastd&amp;pk_num=TTAT.3G-36.456V14.0.0</a>
TTC	TS-3GA-36.456(Rel14)v14.0.0	14.0.0	Published	13.04.2018	<a href="https://www.ttc.or.jp/st/docs/3gpps2018/TS/TS-3GA-36.456(Rel14)v14.0.0.pdf">https://www.ttc.or.jp/st/docs/3gpps2018/TS/TS-3GA-36.456(Rel14)v14.0.0.pdf</a>
<b>Release 15</b>					
ATIS	ATIS.3GPP.36.456V1500	15.0.0	Published	28.06.2021	<a href="https://www.atis.org/3gpp-documents/Rel15/">https://www.atis.org/3gpp-documents/Rel15/</a>
CCSA	CCSA.36.456V1500	15.0.0	Published	01.06.2018	<a href="https://www.ccsa.org.cn/api/portalsFile/downloadOldFile?type=19&amp;oldFileUrl=ITU-R/M.2012-6/CCSA.36.456V1500.doc">https://www.ccsa.org.cn/api/portalsFile/downloadOldFile?type=19&amp;oldFileUrl=ITU-R/M.2012-6/CCSA.36.456V1500.doc</a>
ETSI	ETSI TS 136 456	15.0.0	Published	04.07.2018	<a href="https://www.etsi.org/deliver/etsi_ts/136400_136499/136456/15.00.00_60/ts_136456v150000p.pdf">https://www.etsi.org/deliver/etsi_ts/136400_136499/136456/15.00.00_60/ts_136456v150000p.pdf</a>
TSDSI	TSDSI STD T1.3GPP 36.456-15.0.0 V1.0.0	15.0.0	Published	30.08.2021	<a href="https://members.tdsi.in/index.php/s/o3sdASpA7tyGaSp">https://members.tdsi.in/index.php/s/o3sdASpA7tyGaSp</a>
TTA	TTAT.3G-36.456V15.0.0	15.0.0	Published	11.09.2020	<a href="http://committee.tta.or.kr/data/ttasDown.jsp?kind=ttastd&amp;pk_num=TTAT.3G-36.456V15.0.0">http://committee.tta.or.kr/data/ttasDown.jsp?kind=ttastd&amp;pk_num=TTAT.3G-36.456V15.0.0</a>
TTC	TS-3GA-36.456(Rel15)v15.0.0	15.0.0	Published	28.09.2018	<a href="https://www.ttc.or.jp/st/docs/3gpps2018/TS/TS-3GA-36.456(Rel15)v15.0.0.pdf">https://www.ttc.or.jp/st/docs/3gpps2018/TS/TS-3GA-36.456(Rel15)v15.0.0.pdf</a>
<b>Release 16</b>					
ATIS	ATIS.3GPP.36.456V1600	16.0.0	Published	28.06.2021	<a href="https://www.atis.org/3gpp-documents/Rel16/">https://www.atis.org/3gpp-documents/Rel16/</a>

## 82

## Rec. ITU-R M.2012-6

CCSA	CCSA.36.456V1600	16.0.0	Published	01.07.2020	<a href="https://www.ccsa.org.cn/api/portalsFile/downloadOldFile?type=19&amp;oldFileUrl=ITU-R/M.2012-6/CCSA.36.456V1600.doc">https://www.ccsa.org.cn/api/portalsFile/downloadOldFile?type=19&amp;oldFileUrl=ITU-R/M.2012-6/CCSA.36.456V1600.doc</a>
ETSI	ETSI TS 136 456	16.0.0	Published	21.07.2020	<a href="https://www.etsi.org/deliver/etsi_ts/136400_136499/136456/16.00.00_60/ts_136456v160000p.pdf">https://www.etsi.org/deliver/etsi_ts/136400_136499/136456/16.00.00_60/ts_136456v160000p.pdf</a>
TSDSI	TSDSI STD T1.3GPP 36.456-16.0.0 V1.0.0	16.0.0	Published	30.08.2021	<a href="https://members.tdsi.in/index.php/s/GtMXxWeAM5osqkr">https://members.tdsi.in/index.php/s/GtMXxWeAM5osqkr</a>
TTA	TTAT.3G-36.456V16.0.0	16.0.0	Published	11.09.2020	<a href="http://committee.tta.or.kr/data/ttasDown.jsp?kind=ttastd&amp;pk_num=TTAT.3G-36.456V16.0.0">http://committee.tta.or.kr/data/ttasDown.jsp?kind=ttastd&amp;pk_num=TTAT.3G-36.456V16.0.0</a>
TTC	TS-3GA-36.456(Rel16)v16.0.0	16.0.0	Published	02.10.2020	<a href="https://www.ttc.or.jp/st/docs/3gpps2020/TS/TS-3GA-36_456_Rel16v16_0_0.pdf">https://www.ttc.or.jp/st/docs/3gpps2020/TS/TS-3GA-36_456_Rel16v16_0_0.pdf</a>

### Release 17

ATIS	ATIS.3GPP.36.456.V17.0.1	17.0.1	Published	21.02.2023	<a href="https://www.atis.org/3gpp-transpositions - Rel-17">https://www.atis.org/3gpp-transpositions - Rel-17</a>
CCSA	CCSA.36.456V1701	17.0.1	Published	01.04.2022	<a href="https://www.ccsa.org.cn/api/portalsFile/downloadOldFile?type=19&amp;oldFileUrl=ITU-R/M.2012-6/CCSA.36.456V1701.doc">https://www.ccsa.org.cn/api/portalsFile/downloadOldFile?type=19&amp;oldFileUrl=ITU-R/M.2012-6/CCSA.36.456V1701.doc</a>
ETSI	ETSI TS 136 456	17.0.1	Published	02.05.2022	<a href="https://www.etsi.org/deliver/etsi_ts/136400_136499/136456/17.00.01_60/ts_136456v170001p.pdf">https://www.etsi.org/deliver/etsi_ts/136400_136499/136456/17.00.01_60/ts_136456v170001p.pdf</a>
TSDSI	TSDSI STD T1.3GPP 36.456-17.0.1 V1.1.0	17.0.1	Published	01.11.2022	<a href="https://members.tdsi.in/s/jX8esYtacjCGGED">https://members.tdsi.in/s/jX8esYtacjCGGED</a>
TTA	TTAT.3G-36.456V17.0.1	17.0.1	Published	05.08.2022	<a href="http://committee.tta.or.kr/data/ttasDown.jsp?kind=ttastd&amp;pk_num=TTAT.3G-36.456V17.0.1">http://committee.tta.or.kr/data/ttasDown.jsp?kind=ttastd&amp;pk_num=TTAT.3G-36.456V17.0.1</a>
TTC	TS-3GA-36.456(Rel17)v17.0.1	17.0.1	Published	07.10.2022	<a href="https://www.ttc.or.jp/st/docs/3gpp/2022/TS/TS-3GA-36.456v17.0.1.pdf">https://www.ttc.or.jp/st/docs/3gpp/2022/TS/TS-3GA-36.456v17.0.1.pdf</a>

### 2.1.4.21 TS 36.457

#### SLm interface layer 1

This document specifies the standards allowed to implement layer 1 on the SLm interface.

SDO	Document No.	Version	Status	Issued date	Location
<b>Release 11</b>					
ATIS	ATIS.3GPP.36.457V1100	11.0.0	Published	28.06.2021	<a href="https://www.atis.org/3gpp-documents/Rel99-14/">https://www.atis.org/3gpp-documents/Rel99-14/</a>
CCSA	CCSA.36.457V1100	11.0.0	Published	01.12.2012	<a href="https://www.ccsa.org.cn/api/portalsFile/downloadOldFile?type=19&amp;oldFileUrl=ITU-R/M.2012-6/CCSA.36.457V1100.doc">https://www.ccsa.org.cn/api/portalsFile/downloadOldFile?type=19&amp;oldFileUrl=ITU-R/M.2012-6/CCSA.36.457V1100.doc</a>
ETSI	ETSI TS 136 457	11.0.0	Published	12.02.2013	<a href="https://www.etsi.org/deliver/etsi_ts/136400_136499/136457/11.00.00_60/ts_136457v110000p.pdf">https://www.etsi.org/deliver/etsi_ts/136400_136499/136457/11.00.00_60/ts_136457v110000p.pdf</a>
TSDSI	TSDSI STD T1.3GPP 36.457-11.0.0 V1.0.0	11.0.0	Published	30.08.2021	<a href="https://members.tdsi.in/index.php/s/TtHCddJRsw7z6aj">https://members.tdsi.in/index.php/s/TtHCddJRsw7z6aj</a>
TTA	TTAT.3G-36.457V11.0.0	11.0.0	Published	02.08.2021	<a href="http://committee.tta.or.kr/data/ttasDown.jsp?kind=ttastd&amp;pk_num=TTAT.3G-36.457V11.0.0">http://committee.tta.or.kr/data/ttasDown.jsp?kind=ttastd&amp;pk_num=TTAT.3G-36.457V11.0.0</a>
TTC	TS-3GA-36.457(Rel11)v11.0.0	11.0.0	Published	25.06.2013	<a href="https://www.ttc.or.jp/st/docs/3gpps2013/TS/TS-3GA-36.457(Rel11)v11.0.0.pdf">https://www.ttc.or.jp/st/docs/3gpps2013/TS/TS-3GA-36.457(Rel11)v11.0.0.pdf</a>
<b>Release 12</b>					
ATIS	ATIS.3GPP.36.457V1200	12.0.0	Published	28.06.2021	<a href="https://www.atis.org/3gpp-documents/Rel99-14/">https://www.atis.org/3gpp-documents/Rel99-14/</a>
CCSA	CCSA.36.457V1200	12.0.0	Published	01.09.2014	<a href="https://www.ccsa.org.cn/api/portalsFile/downloadOldFile?type=19&amp;oldFileUrl=ITU-R/M.2012-6/CCSA.36.457V1200.doc">https://www.ccsa.org.cn/api/portalsFile/downloadOldFile?type=19&amp;oldFileUrl=ITU-R/M.2012-6/CCSA.36.457V1200.doc</a>
ETSI	ETSI TS 136 457	12.0.0	Published	26.09.2014	<a href="https://www.etsi.org/deliver/etsi_ts/136400_136499/136457/12.00.00_60/ts_136457v120000p.pdf">https://www.etsi.org/deliver/etsi_ts/136400_136499/136457/12.00.00_60/ts_136457v120000p.pdf</a>
TSDSI	TSDSI STD T1.3GPP 36.457-12.0.0 V1.0.0	12.0.0	Published	30.08.2021	<a href="https://members.tdsi.in/index.php/s/WwDznfZpnWCmfTF">https://members.tdsi.in/index.php/s/WwDznfZpnWCmfTF</a>
TTA	TTAT.3G-36.457V12.0.0	12.0.0	Published	02.08.2021	<a href="http://committee.tta.or.kr/data/ttasDown.jsp?kind=ttastd&amp;pk_num=TTAT.3G-36.457V12.0.0">http://committee.tta.or.kr/data/ttasDown.jsp?kind=ttastd&amp;pk_num=TTAT.3G-36.457V12.0.0</a>
TTC	TS-3GA-36.457(Rel12)v12.0.0	12.0.0	Published	05.03.2015	<a href="https://www.ttc.or.jp/st/docs/3gpps2015/TS/TS-3GA-36.457(Rel12)v12.0.0.pdf">https://www.ttc.or.jp/st/docs/3gpps2015/TS/TS-3GA-36.457(Rel12)v12.0.0.pdf</a>
<b>Release 13</b>					
ATIS	ATIS.3GPP.36.457V1300	13.0.0	Published	28.06.2021	<a href="https://www.atis.org/3gpp-documents/Rel99-14/">https://www.atis.org/3gpp-documents/Rel99-14/</a>
CCSA	CCSA.36.457V1300	13.0.0	Published	01.12.2015	<a href="https://www.ccsa.org.cn/api/portalsFile/downloadOldFile?type=19&amp;oldFileUrl=ITU-R/M.2012-6/CCSA.36.457V1300.doc">https://www.ccsa.org.cn/api/portalsFile/downloadOldFile?type=19&amp;oldFileUrl=ITU-R/M.2012-6/CCSA.36.457V1300.doc</a>
ETSI	ETSI TS 136 457	13.0.0	Published	21.01.2016	<a href="https://www.etsi.org/deliver/etsi_ts/136400_136499/136457/13.00.00_60/ts_136457v130000p.pdf">https://www.etsi.org/deliver/etsi_ts/136400_136499/136457/13.00.00_60/ts_136457v130000p.pdf</a>
TSDSI	TSDSI STD T1.3GPP 36.457-13.0.0 V1.0.0	13.0.0	Published	30.08.2021	<a href="https://members.tdsi.in/index.php/s/Wkzp2KaCXcaHjxd">https://members.tdsi.in/index.php/s/Wkzp2KaCXcaHjxd</a>
TTA	TTAT.3G-36.457V13.0.0	13.0.0	Published	30.07.2021	<a href="http://committee.tta.or.kr/data/ttasDown.jsp?kind=ttastd&amp;pk_num=TTAT.3G-36.457V13.0.0">http://committee.tta.or.kr/data/ttasDown.jsp?kind=ttastd&amp;pk_num=TTAT.3G-36.457V13.0.0</a>
TTC	TS-3GA-36.457(Rel13)v13.0.0	13.0.0	Published	31.03.2017	<a href="https://www.ttc.or.jp/st/docs/3gpps2017/TS/TS-3GA-36.457(Rel13)v13.0.0.pdf">https://www.ttc.or.jp/st/docs/3gpps2017/TS/TS-3GA-36.457(Rel13)v13.0.0.pdf</a>
<b>Release 14</b>					
ATIS	ATIS.3GPP.36.457V1400	14.0.0	Published	28.06.2021	<a href="https://www.atis.org/3gpp-documents/Rel99-14/">https://www.atis.org/3gpp-documents/Rel99-14/</a>
CCSA	CCSA.36.457V1400	14.0.0	Published	01.03.2017	<a href="https://www.ccsa.org.cn/api/portalsFile/downloadOldFile?type=19&amp;oldFileUrl=ITU-R/M.2012-6/CCSA.36.457V1400.doc">https://www.ccsa.org.cn/api/portalsFile/downloadOldFile?type=19&amp;oldFileUrl=ITU-R/M.2012-6/CCSA.36.457V1400.doc</a>
ETSI	ETSI TS 136 457	14.0.0	Published	11.04.2017	<a href="https://www.etsi.org/deliver/etsi_ts/136400_136499/136457/14.00.00_60/ts_136457v140000p.pdf">https://www.etsi.org/deliver/etsi_ts/136400_136499/136457/14.00.00_60/ts_136457v140000p.pdf</a>
TSDSI	TSDSI STD T1.3GPP 36.457-14.0.0 V1.0.0	14.0.0	Published	30.08.2021	<a href="https://members.tdsi.in/index.php/s/A5XrCnzW5tqqbmM">https://members.tdsi.in/index.php/s/A5XrCnzW5tqqbmM</a>
TTA	TTAT.3G-36.457V14.0.0	14.0.0	Published	02.08.2021	<a href="http://committee.tta.or.kr/data/ttasDown.jsp?kind=ttastd&amp;pk_num=TTAT.3G-36.457V14.0.0">http://committee.tta.or.kr/data/ttasDown.jsp?kind=ttastd&amp;pk_num=TTAT.3G-36.457V14.0.0</a>

TTC	TS-3GA-36.457(Rel14)v14.0.0	14.0.0	Published	13.04.2018	<a href="https://www.ttc.or.jp/st/docs/3gpps2018/TS/TS-3GA-36.457(Rel14)v14.0.0.pdf">https://www.ttc.or.jp/st/docs/3gpps2018/TS/TS-3GA-36.457(Rel14)v14.0.0.pdf</a>
<b>Release 15</b>					
ATIS	ATIS.3GPP.36.457V1500	15.0.0	Published	28.06.2021	<a href="https://www.atis.org/3gpp-documents/Rel15/">https://www.atis.org/3gpp-documents/Rel15/</a>
CCSA	CCSA.36.457V1500	15.0.0	Published	01.06.2018	<a href="https://www.ccsa.org.cn/api/portalsFile/downloadOldFile?type=19&amp;oldFileUrl=ITU-R/M.2012-6/CCSA.36.457V1500.doc">https://www.ccsa.org.cn/api/portalsFile/downloadOldFile?type=19&amp;oldFileUrl=ITU-R/M.2012-6/CCSA.36.457V1500.doc</a>
ETSI	ETSI TS 136 457	15.0.0	Published	04.07.2018	<a href="https://www.etsi.org/deliver/etsi_ts/136400_136499/136457/15.00.00_60/ts_136457v150000p.pdf">https://www.etsi.org/deliver/etsi_ts/136400_136499/136457/15.00.00_60/ts_136457v150000p.pdf</a>
TSDSI	TSDSI STD T1.3GPP 36.457-15.0.0 V1.0.0	15.0.0	Published	30.08.2021	<a href="https://members.tdsi.in/index.php/s/frGMbayaG4qekcz">https://members.tdsi.in/index.php/s/frGMbayaG4qekcz</a>
TTA	TTAT.3G-36.457V15.0.0	15.0.0	Published	11.09.2020	<a href="http://committee.tta.or.kr/data/ttasDown.jsp?kind=ttastd&amp;pk_num=TTAT.3G-36.457V15.0.0">http://committee.tta.or.kr/data/ttasDown.jsp?kind=ttastd&amp;pk_num=TTAT.3G-36.457V15.0.0</a>
TTC	TS-3GA-36.457(Rel15)v15.0.0	15.0.0	Published	28.09.2018	<a href="https://www.ttc.or.jp/st/docs/3gpps2018/TS/TS-3GA-36.457(Rel15)v15.0.0.pdf">https://www.ttc.or.jp/st/docs/3gpps2018/TS/TS-3GA-36.457(Rel15)v15.0.0.pdf</a>
<b>Release 16</b>					
ATIS	ATIS.3GPP.36.457V1600	16.0.0	Published	28.06.2021	<a href="https://www.atis.org/3gpp-documents/Rel16/">https://www.atis.org/3gpp-documents/Rel16/</a>
CCSA	CCSA.36.457V1600	16.0.0	Published	01.07.2020	<a href="https://www.ccsa.org.cn/api/portalsFile/downloadOldFile?type=19&amp;oldFileUrl=ITU-R/M.2012-6/CCSA.36.457V1600.doc">https://www.ccsa.org.cn/api/portalsFile/downloadOldFile?type=19&amp;oldFileUrl=ITU-R/M.2012-6/CCSA.36.457V1600.doc</a>
ETSI	ETSI TS 136 457	16.0.0	Published	21.07.2020	<a href="https://www.etsi.org/deliver/etsi_ts/136400_136499/136457/16.00.00_60/ts_136457v160000p.pdf">https://www.etsi.org/deliver/etsi_ts/136400_136499/136457/16.00.00_60/ts_136457v160000p.pdf</a>
TSDSI	TSDSI STD T1.3GPP 36.457-16.0.0 V1.0.0	16.0.0	Published	30.08.2021	<a href="https://members.tdsi.in/index.php/s/WfDtPTxwia8HRDw">https://members.tdsi.in/index.php/s/WfDtPTxwia8HRDw</a>
TTA	TTAT.3G-36.457V16.0.0	16.0.0	Published	11.09.2020	<a href="http://committee.tta.or.kr/data/ttasDown.jsp?kind=ttastd&amp;pk_num=TTAT.3G-36.457V16.0.0">http://committee.tta.or.kr/data/ttasDown.jsp?kind=ttastd&amp;pk_num=TTAT.3G-36.457V16.0.0</a>
TTC	TS-3GA-36.457(Rel16)v16.0.0	16.0.0	Published	02.10.2020	<a href="https://www.ttc.or.jp/st/docs/3gpps2020/TS/TS-3GA-36_457_Rel16v16_0_0.pdf">https://www.ttc.or.jp/st/docs/3gpps2020/TS/TS-3GA-36_457_Rel16v16_0_0.pdf</a>
<b>Release 17</b>					
ATIS	ATIS.3GPP.36.457.V17.0.0	17.0.0	Published	21.02.2023	<a href="https://www.atis.org/3gpp-transpositions - Rel-17">https://www.atis.org/3gpp-transpositions - Rel-17</a>
CCSA	CCSA.36.457V1700	17.0.0	Published	01.04.2022	<a href="https://www.ccsa.org.cn/api/portalsFile/downloadOldFile?type=19&amp;oldFileUrl=ITU-R/M.2012-6/CCSA.36.457V1700.doc">https://www.ccsa.org.cn/api/portalsFile/downloadOldFile?type=19&amp;oldFileUrl=ITU-R/M.2012-6/CCSA.36.457V1700.doc</a>
ETSI	ETSI TS 136 457	17.0.0	Published	02.05.2022	<a href="https://www.etsi.org/deliver/etsi_ts/136400_136499/136457/17.00.00_60/ts_136457v170000p.pdf">https://www.etsi.org/deliver/etsi_ts/136400_136499/136457/17.00.00_60/ts_136457v170000p.pdf</a>
TSDSI	TSDSI STD T1.3GPP 36.457-17.0.0 V1.0.0	17.0.0	Published	29.07.2022	<a href="https://members.tdsi.in/s/zN2EHEA73PiYcgx">https://members.tdsi.in/s/zN2EHEA73PiYcgx</a>
TTA	TTAT.3G-36.457V17.0.0	17.0.0	Published	05.08.2022	<a href="http://committee.tta.or.kr/data/ttasDown.jsp?kind=ttastd&amp;pk_num=TTAT.3G-36.457V17.0.0">http://committee.tta.or.kr/data/ttasDown.jsp?kind=ttastd&amp;pk_num=TTAT.3G-36.457V17.0.0</a>
TTC	TS-3GA-36.457(Rel17)v17.0.0	17.0.0	Published	07.10.2022	<a href="https://www.ttc.or.jp/st/docs/3gpp/2022/TS/TS-3GA-36.457v17.0.0.pdf">https://www.ttc.or.jp/st/docs/3gpp/2022/TS/TS-3GA-36.457v17.0.0.pdf</a>

### 2.1.4.22 TS 36.458

#### SLm interface signalling transport

This document specifies the standards for signalling transport to be used across the SLm interface. The SLm interface is a logical interface between the LMU and the E-SMLC in the E-UTRAN core network. This document describes how the SLmAP signalling messages are transported over SLm.

SDO	Document No.	Version	Status	Issued date	Location
<b>Release 11</b>					
ATIS	ATIS.3GPP.36.458V1100	11.0.0	Published	28.06.2021	<a href="https://www.atis.org/3gpp-documents/Rel99-14/">https://www.atis.org/3gpp-documents/Rel99-14/</a>
CCSA	CCSA.36.458V1100	11.0.0	Published	01.12.2012	<a href="https://www.ccsa.org.cn/api/portalsFile/downloadOldFile?type=19&amp;oldFileUrl=ITU-R/M.2012-6/CCSA.36.458V1100.doc">https://www.ccsa.org.cn/api/portalsFile/downloadOldFile?type=19&amp;oldFileUrl=ITU-R/M.2012-6/CCSA.36.458V1100.doc</a>
ETSI	ETSI TS 136 458	11.0.0	Published	12.02.2013	<a href="https://www.etsi.org/deliver/etsi_ts/136400_136499/136458/11.00.00_60/ts_136458v110000p.pdf">https://www.etsi.org/deliver/etsi_ts/136400_136499/136458/11.00.00_60/ts_136458v110000p.pdf</a>
TSDSI	TSDSI STD T1.3GPP 36.458-11.0.0 V1.0.0	11.0.0	Published	30.08.2021	<a href="https://members.tdsi.in/index.php/s/eacqsjWJjLLMKB8">https://members.tdsi.in/index.php/s/eacqsjWJjLLMKB8</a>
TTA	TTAT.3G-36.458V11.0.0	11.0.0	Published	02.08.2021	<a href="http://committee.tta.or.kr/data/ttasDown.jsp?kind=ttastd&amp;pk_num=TTAT.3G-36.458V11.0.0">http://committee.tta.or.kr/data/ttasDown.jsp?kind=ttastd&amp;pk_num=TTAT.3G-36.458V11.0.0</a>
TTC	TS-3GA-36.458(Rel11)v11.0.0	11.0.0	Published	25.06.2013	<a href="https://www.ttc.or.jp/st/docs/3gpps2013/TS/TS-3GA-36.458(Rel11)v11.0.0.pdf">https://www.ttc.or.jp/st/docs/3gpps2013/TS/TS-3GA-36.458(Rel11)v11.0.0.pdf</a>
<b>Release 12</b>					
ATIS	ATIS.3GPP.36.458V1200	12.0.0	Published	28.06.2021	<a href="https://www.atis.org/3gpp-documents/Rel99-14/">https://www.atis.org/3gpp-documents/Rel99-14/</a>
CCSA	CCSA.36.458V1200	12.0.0	Published	01.09.2014	<a href="https://www.ccsa.org.cn/api/portalsFile/downloadOldFile?type=19&amp;oldFileUrl=ITU-R/M.2012-6/CCSA.36.458V1200.doc">https://www.ccsa.org.cn/api/portalsFile/downloadOldFile?type=19&amp;oldFileUrl=ITU-R/M.2012-6/CCSA.36.458V1200.doc</a>
ETSI	ETSI TS 136 458	12.0.0	Published	26.09.2014	<a href="https://www.etsi.org/deliver/etsi_ts/136400_136499/136458/12.00.00_60/ts_136458v120000p.pdf">https://www.etsi.org/deliver/etsi_ts/136400_136499/136458/12.00.00_60/ts_136458v120000p.pdf</a>
TSDSI	TSDSI STD T1.3GPP 36.458-12.0.0 V1.0.0	12.0.0	Published	30.08.2021	<a href="https://members.tdsi.in/index.php/s/4E52XoPcxZzgxGQ">https://members.tdsi.in/index.php/s/4E52XoPcxZzgxGQ</a>
TTA	TTAT.3G-36.458V12.0.0	12.0.0	Published	02.08.2021	<a href="http://committee.tta.or.kr/data/ttasDown.jsp?kind=ttastd&amp;pk_num=TTAT.3G-36.458V12.0.0">http://committee.tta.or.kr/data/ttasDown.jsp?kind=ttastd&amp;pk_num=TTAT.3G-36.458V12.0.0</a>
TTC	TS-3GA-36.458(Rel12)v12.0.0	12.0.0	Published	05.03.2015	<a href="https://www.ttc.or.jp/st/docs/3gpps2015/TS/TS-3GA-36.458(Rel12)v12.0.0.pdf">https://www.ttc.or.jp/st/docs/3gpps2015/TS/TS-3GA-36.458(Rel12)v12.0.0.pdf</a>

#### Release 13

**84****Rec. ITU-R M.2012-6**

ATIS	ATIS.3GPP.36.458V1300	13.0.0	Published	28.06.2021	<a href="https://www.atis.org/3gpp-documents/Rel99-14/">https://www.atis.org/3gpp-documents/Rel99-14/</a>
CCSA	CCSA.36.458V1300	13.0.0	Published	01.12.2015	<a href="https://www.ccsa.org.cn/api/portalsFile/downloadOldFile?type=19&amp;oldFileUrl=ITU-R/M.2012-6/CCSA.36.458V1300.doc">https://www.ccsa.org.cn/api/portalsFile/downloadOldFile?type=19&amp;oldFileUrl=ITU-R/M.2012-6/CCSA.36.458V1300.doc</a>
ETSI	ETSI TS 136 458	13.0.0	Published	21.01.2016	<a href="https://www.etsi.org/deliver/etsi_ts/136400_136499/136458/13.00.00_60/ts_136458v130000p.pdf">https://www.etsi.org/deliver/etsi_ts/136400_136499/136458/13.00.00_60/ts_136458v130000p.pdf</a>
TSDSI	TSDSI STD T1.3GPP 36.458-13.0.0 V1.0.0	13.0.0	Published	30.08.2021	<a href="https://members.tdsi.in/index.php/s/7jzxoQwXTafBX4">https://members.tdsi.in/index.php/s/7jzxoQwXTafBX4</a>
TTA	TTAT.3G-36.458V13.0.0	13.0.0	Published	02.08.2021	<a href="http://committee.tta.or.kr/data/ttasDown.jsp?kind=ttastd&amp;pk_num=TTAT.3G-36.458V13.0.0">http://committee.tta.or.kr/data/ttasDown.jsp?kind=ttastd&amp;pk_num=TTAT.3G-36.458V13.0.0</a>
TTC	TS-3GA-36.458(Rel13)v13.0.0	13.0.0	Published	31.03.2017	<a href="https://www.ttc.or.jp/st/docs/3gpps2017/TS/TS-3GA-36.458(Rel13)v13.0.0.pdf">https://www.ttc.or.jp/st/docs/3gpps2017/TS/TS-3GA-36.458(Rel13)v13.0.0.pdf</a>

**Release 14**

ATIS	ATIS.3GPP.36.458V1400	14.0.0	Published	28.06.2021	<a href="https://www.atis.org/3gpp-documents/Rel99-14/">https://www.atis.org/3gpp-documents/Rel99-14/</a>
CCSA	CCSA.36.458V1400	14.0.0	Published	01.03.2017	<a href="https://www.ccsa.org.cn/api/portalsFile/downloadOldFile?type=19&amp;oldFileUrl=ITU-R/M.2012-6/CCSA.36.458V1400.doc">https://www.ccsa.org.cn/api/portalsFile/downloadOldFile?type=19&amp;oldFileUrl=ITU-R/M.2012-6/CCSA.36.458V1400.doc</a>
ETSI	ETSI TS 136 458	14.0.0	Published	11.04.2017	<a href="https://www.etsi.org/deliver/etsi_ts/136400_136499/136458/14.00.00_60/ts_136458v140000p.pdf">https://www.etsi.org/deliver/etsi_ts/136400_136499/136458/14.00.00_60/ts_136458v140000p.pdf</a>
TSDSI	TSDSI STD T1.3GPP 36.458-14.0.0 V1.0.0	14.0.0	Published	30.08.2021	<a href="https://members.tdsi.in/index.php/s/kKrsXngBGaKzS8n">https://members.tdsi.in/index.php/s/kKrsXngBGaKzS8n</a>
TTA	TTAT.3G-36.458V14.0.0	14.0.0	Published	02.08.2021	<a href="http://committee.tta.or.kr/data/ttasDown.jsp?kind=ttastd&amp;pk_num=TTAT.3G-36.458V14.0.0">http://committee.tta.or.kr/data/ttasDown.jsp?kind=ttastd&amp;pk_num=TTAT.3G-36.458V14.0.0</a>
TTC	TS-3GA-36.458(Rel14)v14.0.0	14.0.0	Published	13.04.2018	<a href="https://www.ttc.or.jp/st/docs/3gpps2018/TS/TS-3GA-36.458(Rel14)v14.0.0.pdf">https://www.ttc.or.jp/st/docs/3gpps2018/TS/TS-3GA-36.458(Rel14)v14.0.0.pdf</a>

**Release 15**

ATIS	ATIS.3GPP.36.458V1500	15.0.0	Published	28.06.2021	<a href="https://www.atis.org/3gpp-documents/Rel15/">https://www.atis.org/3gpp-documents/Rel15/</a>
CCSA	CCSA.36.458V1500	15.0.0	Published	01.06.2018	<a href="https://www.ccsa.org.cn/api/portalsFile/downloadOldFile?type=19&amp;oldFileUrl=ITU-R/M.2012-6/CCSA.36.458V1500.doc">https://www.ccsa.org.cn/api/portalsFile/downloadOldFile?type=19&amp;oldFileUrl=ITU-R/M.2012-6/CCSA.36.458V1500.doc</a>
ETSI	ETSI TS 136 458	15.0.0	Published	04.07.2018	<a href="https://www.etsi.org/deliver/etsi_ts/136400_136499/136458/15.00.00_60/ts_136458v150000p.pdf">https://www.etsi.org/deliver/etsi_ts/136400_136499/136458/15.00.00_60/ts_136458v150000p.pdf</a>
TSDSI	TSDSI STD T1.3GPP 36.458-15.0.0 V1.0.0	15.0.0	Published	30.08.2021	<a href="https://members.tdsi.in/index.php/s/GC5wiixejnwf7s">https://members.tdsi.in/index.php/s/GC5wiixejnwf7s</a>
TTA	TTAT.3G-36.458V15.0.0	15.0.0	Published	11.09.2020	<a href="http://committee.tta.or.kr/data/ttasDown.jsp?kind=ttastd&amp;pk_num=TTAT.3G-36.458V15.0.0">http://committee.tta.or.kr/data/ttasDown.jsp?kind=ttastd&amp;pk_num=TTAT.3G-36.458V15.0.0</a>
TTC	TS-3GA-36.458(Rel15)v15.0.0	15.0.0	Published	28.09.2018	<a href="https://www.ttc.or.jp/st/docs/3gpps2018/TS/TS-3GA-36.458(Rel15)v15.0.0.pdf">https://www.ttc.or.jp/st/docs/3gpps2018/TS/TS-3GA-36.458(Rel15)v15.0.0.pdf</a>

**Release 16**

ATIS	ATIS.3GPP.36.458V1600	16.0.0	Published	28.06.2021	<a href="https://www.atis.org/3gpp-documents/Rel16/">https://www.atis.org/3gpp-documents/Rel16/</a>
CCSA	CCSA.36.458V1600	16.0.0	Published	01.07.2020	<a href="https://www.ccsa.org.cn/api/portalsFile/downloadOldFile?type=19&amp;oldFileUrl=ITU-R/M.2012-6/CCSA.36.458V1600.doc">https://www.ccsa.org.cn/api/portalsFile/downloadOldFile?type=19&amp;oldFileUrl=ITU-R/M.2012-6/CCSA.36.458V1600.doc</a>
ETSI	ETSI TS 136 458	16.0.0	Published	21.07.2020	<a href="https://www.etsi.org/deliver/etsi_ts/136400_136499/136458/16.00.00_60/ts_136458v160000p.pdf">https://www.etsi.org/deliver/etsi_ts/136400_136499/136458/16.00.00_60/ts_136458v160000p.pdf</a>
TSDSI	TSDSI STD T1.3GPP 36.458-16.0.0 V1.0.0	16.0.0	Published	30.08.2021	<a href="https://members.tdsi.in/index.php/s/4LdWKNHwzkbniec">https://members.tdsi.in/index.php/s/4LdWKNHwzkbniec</a>
TTA	TTAT.3G-36.458V16.0.0	16.0.0	Published	11.09.2020	<a href="http://committee.tta.or.kr/data/ttasDown.jsp?kind=ttastd&amp;pk_num=TTAT.3G-36.458V16.0.0">http://committee.tta.or.kr/data/ttasDown.jsp?kind=ttastd&amp;pk_num=TTAT.3G-36.458V16.0.0</a>
TTC	TS-3GA-36.458(Rel16)v16.0.0	16.0.0	Published	02.10.2020	<a href="https://www.ttc.or.jp/st/docs/3gpps2020/TS/TS-3GA-36_458_Rel16v16_0_0.pdf">https://www.ttc.or.jp/st/docs/3gpps2020/TS/TS-3GA-36_458_Rel16v16_0_0.pdf</a>

**Release 17**

ATIS	ATIS.3GPP.36.458.V17.0.0	17.0.0	Published	21.02.2023	<a href="https://www.atis.org/3gpp-transpositions - Rel-17">https://www.atis.org/3gpp-transpositions - Rel-17</a>
CCSA	CCSA.36.458V1700	17.0.0	Published	01.04.2022	<a href="https://www.ccsa.org.cn/api/portalsFile/downloadOldFile?type=19&amp;oldFileUrl=ITU-R/M.2012-6/CCSA.36.458V1700.doc">https://www.ccsa.org.cn/api/portalsFile/downloadOldFile?type=19&amp;oldFileUrl=ITU-R/M.2012-6/CCSA.36.458V1700.doc</a>
ETSI	ETSI TS 136 458	17.0.0	Published	02.05.2022	<a href="https://www.etsi.org/deliver/etsi_ts/136400_136499/136458/17.00.00_60/ts_136458v170000p.pdf">https://www.etsi.org/deliver/etsi_ts/136400_136499/136458/17.00.00_60/ts_136458v170000p.pdf</a>
TSDSI	TSDSI STD T1.3GPP 36.458-17.0.0 V1.0.0	17.0.0	Published	29.07.2022	<a href="https://members.tdsi.in/s/5yA92nHeZ2f2k6M">https://members.tdsi.in/s/5yA92nHeZ2f2k6M</a>
TTA	TTAT.3G-36.458V17.0.0	17.0.0	Published	05.08.2022	<a href="http://committee.tta.or.kr/data/ttasDown.jsp?kind=ttastd&amp;pk_num=TTAT.3G-36.458V17.0.0">http://committee.tta.or.kr/data/ttasDown.jsp?kind=ttastd&amp;pk_num=TTAT.3G-36.458V17.0.0</a>
TTC	TS-3GA-36.458(Rel17)v17.0.0	17.0.0	Published	07.10.2022	<a href="https://www.ttc.or.jp/st/docs/3gpp/2022/TS/TS-3GA-36.458v17.0.0.pdf">https://www.ttc.or.jp/st/docs/3gpp/2022/TS/TS-3GA-36.458v17.0.0.pdf</a>

**2.1.4.23 TS 36.459****SLm interface Application Protocol (SLmAP)**

This document specifies the E-UTRAN radio network layer signalling protocol for the SLm interface. The SLm Application Protocol (SLmAP) supports the functions of the SLm interface by signalling procedures defined in this document.

SDO	Document No.	Version	Status	Issued date	Location
-----	--------------	---------	--------	-------------	----------

**Release 11**

ATIS	ATIS.3GPP.36.459V1130	11.3.0	Published	28.06.2021	<a href="https://www.atis.org/3gpp-documents/Rel99-14/">https://www.atis.org/3gpp-documents/Rel99-14/</a>
CCSA	CCSA.36.459V1130	11.3.0	Published	01.09.2013	<a href="https://www.ccsa.org.cn/api/portalsFile/downloadOldFile?type=19&amp;oldFileUrl=ITU-R/M.2012-6/CCSA.36.459V1130.doc">https://www.ccsa.org.cn/api/portalsFile/downloadOldFile?type=19&amp;oldFileUrl=ITU-R/M.2012-6/CCSA.36.459V1130.doc</a>
ETSI	ETSI TS 136 459	11.3.0	Published	26.09.2013	<a href="https://www.etsi.org/deliver/etsi_ts/136400_136499/136459/11.03.00_60/ts_136459v110300p.pdf">https://www.etsi.org/deliver/etsi_ts/136400_136499/136459/11.03.00_60/ts_136459v110300p.pdf</a>

TSDSI	TSDSI STD T1.3GPP 36.459-11.3.0 V1.0.0	11.3.0	Published	30.08.2021	<a href="https://members.tdsi.in/index.php/s/cKt3x2cAx8SnoDi">https://members.tdsi.in/index.php/s/cKt3x2cAx8SnoDi</a>
TTA	TTAT.3G-36.459V11.3.0	11.3.0	Published	02.08.2021	<a href="http://committee.tta.or.kr/data/ttasDown.jsp?kind=ttastd&amp;pk_num=TTAT.3G-36.459V11.3.0">http://committee.tta.or.kr/data/ttasDown.jsp?kind=ttastd&amp;pk_num=TTAT.3G-36.459V11.3.0</a>
TTC	TS-3GA-36.459(Rel11)v11.3.0	11.3.0	Published	22.11.2013	<a href="https://www.ttc.or.jp/st/docs/3gpps2013/TS/TS-3GA-36.459(Rel11)v11.3.0.pdf">https://www.ttc.or.jp/st/docs/3gpps2013/TS/TS-3GA-36.459(Rel11)v11.3.0.pdf</a>
<b>Release 12</b>					
ATIS	ATIS.3GPP.36.459V1210	12.1.0	Published	28.06.2021	<a href="https://www.atis.org/3gpp-documents/Rel99-14/">https://www.atis.org/3gpp-documents/Rel99-14/</a>
CCSA	CCSA.36.459V1210	12.1.0	Published	01.03.2015	<a href="https://www.ccsa.org.cn/api/portalsFile/downloadOldFile?type=19&amp;oldFileUrl=ITU-R/M.2012-6/CCSA.36.459V1210.doc">https://www.ccsa.org.cn/api/portalsFile/downloadOldFile?type=19&amp;oldFileUrl=ITU-R/M.2012-6/CCSA.36.459V1210.doc</a>
ETSI	ETSI TS 136 459	12.1.0	Published	27.04.2015	<a href="https://www.etsi.org/deliver/etsi_ts/136400_136499/136459/12.01.00_60/ts_136459v120100p.pdf">https://www.etsi.org/deliver/etsi_ts/136400_136499/136459/12.01.00_60/ts_136459v120100p.pdf</a>
TSDSI	TSDSI STD T1.3GPP 36.459-12.1.0 V1.0.0	12.1.0	Published	30.08.2021	<a href="https://members.tdsi.in/index.php/s/o7xqSTgP3iJdfeq">https://members.tdsi.in/index.php/s/o7xqSTgP3iJdfeq</a>
TTA	TTAT.3G-36.459V12.1.0	12.1.0	Published	02.08.2021	<a href="http://committee.tta.or.kr/data/ttasDown.jsp?kind=ttastd&amp;pk_num=TTAT.3G-36.459V12.1.0">http://committee.tta.or.kr/data/ttasDown.jsp?kind=ttastd&amp;pk_num=TTAT.3G-36.459V12.1.0</a>
TTC	TS-3GA-36.459(Rel12)v12.1.0	12.1.0	Published	30.06.2015	<a href="https://www.ttc.or.jp/st/docs/3gpps2015/TS/TS-3GA-36.459(Rel12)v12.1.0.pdf">https://www.ttc.or.jp/st/docs/3gpps2015/TS/TS-3GA-36.459(Rel12)v12.1.0.pdf</a>
<b>Release 13</b>					
ATIS	ATIS.3GPP.36.459V1310	13.1.0	Published	28.06.2021	<a href="https://www.atis.org/3gpp-documents/Rel99-14/">https://www.atis.org/3gpp-documents/Rel99-14/</a>
CCSA	CCSA.36.459V1310	13.1.0	Published	01.03.2016	<a href="https://www.ccsa.org.cn/api/portalsFile/downloadOldFile?type=19&amp;oldFileUrl=ITU-R/M.2012-6/CCSA.36.459V1310.doc">https://www.ccsa.org.cn/api/portalsFile/downloadOldFile?type=19&amp;oldFileUrl=ITU-R/M.2012-6/CCSA.36.459V1310.doc</a>
ETSI	ETSI TS 136 459	13.1.0	Published	20.05.2016	<a href="https://www.etsi.org/deliver/etsi_ts/136400_136499/136459/13.01.00_60/ts_136459v130100p.pdf">https://www.etsi.org/deliver/etsi_ts/136400_136499/136459/13.01.00_60/ts_136459v130100p.pdf</a>
TSDSI	TSDSI STD T1.3GPP 36.459-13.1.0 V1.0.0	13.1.0	Published	30.08.2021	<a href="https://members.tdsi.in/index.php/s/C7MjjATKtrgsetX">https://members.tdsi.in/index.php/s/C7MjjATKtrgsetX</a>
TTA	TTAT.3G-36.459V13.1.0	13.1.0	Published	02.08.2021	<a href="http://committee.tta.or.kr/data/ttasDown.jsp?kind=ttastd&amp;pk_num=TTAT.3G-36.459V13.1.0">http://committee.tta.or.kr/data/ttasDown.jsp?kind=ttastd&amp;pk_num=TTAT.3G-36.459V13.1.0</a>
TTC	TS-3GA-36.459(Rel13)v13.1.0	13.1.0	Published	31.03.2017	<a href="https://www.ttc.or.jp/st/docs/3gpps2017/TS/TS-3GA-36.459(Rel13)v13.1.0.pdf">https://www.ttc.or.jp/st/docs/3gpps2017/TS/TS-3GA-36.459(Rel13)v13.1.0.pdf</a>
<b>Release 14</b>					
ATIS	ATIS.3GPP.36.459V1400	14.0.0	Published	28.06.2021	<a href="https://www.atis.org/3gpp-documents/Rel99-14/">https://www.atis.org/3gpp-documents/Rel99-14/</a>
CCSA	CCSA.36.459V1400	14.0.0	Published	01.03.2017	<a href="https://www.ccsa.org.cn/api/portalsFile/downloadOldFile?type=19&amp;oldFileUrl=ITU-R/M.2012-6/CCSA.36.459V1400.doc">https://www.ccsa.org.cn/api/portalsFile/downloadOldFile?type=19&amp;oldFileUrl=ITU-R/M.2012-6/CCSA.36.459V1400.doc</a>
ETSI	ETSI TS 136 459	14.0.0	Published	11.04.2017	<a href="https://www.etsi.org/deliver/etsi_ts/136400_136499/136459/14.00.00_60/ts_136459v140000p.pdf">https://www.etsi.org/deliver/etsi_ts/136400_136499/136459/14.00.00_60/ts_136459v140000p.pdf</a>
TSDSI	TSDSI STD T1.3GPP 36.459-14.0.0 V1.0.0	14.0.0	Published	30.08.2021	<a href="https://members.tdsi.in/index.php/s/a44xf76P2reseqg">https://members.tdsi.in/index.php/s/a44xf76P2reseqg</a>
TTA	TTAT.3G-36.459V14.0.0	14.0.0	Published	02.08.2021	<a href="http://committee.tta.or.kr/data/ttasDown.jsp?kind=ttastd&amp;pk_num=TTAT.3G-36.459V14.0.0">http://committee.tta.or.kr/data/ttasDown.jsp?kind=ttastd&amp;pk_num=TTAT.3G-36.459V14.0.0</a>
TTC	TS-3GA-36.459(Rel14)v14.0.0	14.0.0	Published	13.04.2018	<a href="https://www.ttc.or.jp/st/docs/3gpps2018/TS/TS-3GA-36.459(Rel14)v14.0.0.pdf">https://www.ttc.or.jp/st/docs/3gpps2018/TS/TS-3GA-36.459(Rel14)v14.0.0.pdf</a>
<b>Release 15</b>					
ATIS	ATIS.3GPP.36.459V1500	15.0.0	Published	28.06.2021	<a href="https://www.atis.org/3gpp-documents/Rel15/">https://www.atis.org/3gpp-documents/Rel15/</a>
CCSA	CCSA.36.459V1500	15.0.0	Published	01.06.2018	<a href="https://www.ccsa.org.cn/api/portalsFile/downloadOldFile?type=19&amp;oldFileUrl=ITU-R/M.2012-6/CCSA.36.459V1500.doc">https://www.ccsa.org.cn/api/portalsFile/downloadOldFile?type=19&amp;oldFileUrl=ITU-R/M.2012-6/CCSA.36.459V1500.doc</a>
ETSI	ETSI TS 136 459	15.0.0	Published	04.07.2018	<a href="https://www.etsi.org/deliver/etsi_ts/136400_136499/136459/15.00.00_60/ts_136459v150000p.pdf">https://www.etsi.org/deliver/etsi_ts/136400_136499/136459/15.00.00_60/ts_136459v150000p.pdf</a>
TSDSI	TSDSI STD T1.3GPP 36.459-15.0.0 V1.0.0	15.0.0	Published	30.08.2021	<a href="https://members.tdsi.in/index.php/s/N2wpD2iCw92r37Q">https://members.tdsi.in/index.php/s/N2wpD2iCw92r37Q</a>
TTA	TTAT.3G-36.459V15.0.0	15.0.0	Published	11.09.2020	<a href="http://committee.tta.or.kr/data/ttasDown.jsp?kind=ttastd&amp;pk_num=TTAT.3G-36.459V15.0.0">http://committee.tta.or.kr/data/ttasDown.jsp?kind=ttastd&amp;pk_num=TTAT.3G-36.459V15.0.0</a>
TTC	TS-3GA-36.459(Rel15)v15.0.0	15.0.0	Published	28.09.2018	<a href="https://www.ttc.or.jp/st/docs/3gpps2018/TS/TS-3GA-36.459(Rel15)v15.0.0.pdf">https://www.ttc.or.jp/st/docs/3gpps2018/TS/TS-3GA-36.459(Rel15)v15.0.0.pdf</a>
<b>Release 16</b>					
ATIS	ATIS.3GPP.36.459V1600	16.0.0	Published	28.06.2021	<a href="https://www.atis.org/3gpp-documents/Rel16/">https://www.atis.org/3gpp-documents/Rel16/</a>
CCSA	CCSA.36.459V1600	16.0.0	Published	01.07.2020	<a href="https://www.ccsa.org.cn/api/portalsFile/downloadOldFile?type=19&amp;oldFileUrl=ITU-R/M.2012-6/CCSA.36.459V1600.doc">https://www.ccsa.org.cn/api/portalsFile/downloadOldFile?type=19&amp;oldFileUrl=ITU-R/M.2012-6/CCSA.36.459V1600.doc</a>
ETSI	ETSI TS 136 459	16.0.0	Published	21.07.2020	<a href="https://www.etsi.org/deliver/etsi_ts/136400_136499/136459/16.00.00_60/ts_136459v160000p.pdf">https://www.etsi.org/deliver/etsi_ts/136400_136499/136459/16.00.00_60/ts_136459v160000p.pdf</a>
TSDSI	TSDSI STD T1.3GPP 36.459-16.0.0 V1.0.0	16.0.0	Published	30.08.2021	<a href="https://members.tdsi.in/index.php/s/WpS6xsiExFwW9MT">https://members.tdsi.in/index.php/s/WpS6xsiExFwW9MT</a>
TTA	TTAT.3G-36.459V16.0.0	16.0.0	Published	11.09.2020	<a href="http://committee.tta.or.kr/data/ttasDown.jsp?kind=ttastd&amp;pk_num=TTAT.3G-36.459V16.0.0">http://committee.tta.or.kr/data/ttasDown.jsp?kind=ttastd&amp;pk_num=TTAT.3G-36.459V16.0.0</a>
TTC	TS-3GA-36.459(Rel16)v16.0.0	16.0.0	Published	02.10.2020	<a href="https://www.ttc.or.jp/st/docs/3gpps2020/TS/TS-3GA-36_459_Rel16v16_0_0.pdf">https://www.ttc.or.jp/st/docs/3gpps2020/TS/TS-3GA-36_459_Rel16v16_0_0.pdf</a>
<b>Release 17</b>					
ATIS	ATIS.3GPP.36.459.V17.0.0	17.0.0	Published	21.02.2023	<a href="https://www.atis.org/3gpp-transpositions - Rel-17">https://www.atis.org/3gpp-transpositions - Rel-17</a>
CCSA	CCSA.36.459V1700	17.0.0	Published	01.04.2022	<a href="https://www.ccsa.org.cn/api/portalsFile/downloadOldFile?type=19&amp;oldFileUrl=ITU-R/M.2012-6/CCSA.36.459V1700.doc">https://www.ccsa.org.cn/api/portalsFile/downloadOldFile?type=19&amp;oldFileUrl=ITU-R/M.2012-6/CCSA.36.459V1700.doc</a>
ETSI	ETSI TS 136 459	17.0.0	Published	02.05.2022	<a href="https://www.etsi.org/deliver/etsi_ts/136400_136499/136459/17.00.00_60/ts_136459v170000p.pdf">https://www.etsi.org/deliver/etsi_ts/136400_136499/136459/17.00.00_60/ts_136459v170000p.pdf</a>
TSDSI	TSDSI STD T1.3GPP 36.459-17.0.0 V1.0.0	17.0.0	Published	29.07.2022	<a href="https://members.tdsi.in/s/R9Efm2igWzbkyXm">https://members.tdsi.in/s/R9Efm2igWzbkyXm</a>
TTA	TTAT.3G-36.459V17.0.0	17.0.0	Published	05.08.2022	<a href="http://committee.tta.or.kr/data/ttasDown.jsp?kind=ttastd&amp;pk_num=TTAT.3G-36.459V17.0.0">http://committee.tta.or.kr/data/ttasDown.jsp?kind=ttastd&amp;pk_num=TTAT.3G-36.459V17.0.0</a>
TTC	TS-3GA-36.459(Rel17)v17.0.0	17.0.0	Published	07.10.2022	<a href="https://www.ttc.or.jp/st/docs/3gpp/2022/TS/TS-3GA-36.459v17.0.0.pdf">https://www.ttc.or.jp/st/docs/3gpp/2022/TS/TS-3GA-36.459v17.0.0.pdf</a>

## 2.1.4.24 TS 36.461

## Evolved Universal Terrestrial Radio Access Network (E-UTRAN) and Wireless LAN (WLAN); Xw layer 1

This document specifies the standards allowed to implement Layer 1 on the Xw interface. The specification of transmission delay requirements and O&M requirements are not in the scope of this document.

SDO	Document No.	Version	Status	Issued date	Location
<b>Release 13</b>					
ARIB	ARIB STD-T120-36.461.V13.0.0	13.0.0	Published	03.03.2023	<a href="https://www.arib.or.jp/english/html/overview/doc/T120_T23_SPECS/ARIB-STD-T120/Rel13/36/A36461-d00.pdf">https://www.arib.or.jp/english/html/overview/doc/T120_T23_SPECS/ARIB-STD-T120/Rel13/36/A36461-d00.pdf</a>
ATIS	ATIS.3GPP.36.461V1300	13.0.0	Published	28.06.2021	<a href="https://www.atis.org/3gpp-documents/Rel99-14/">https://www.atis.org/3gpp-documents/Rel99-14/</a>
CCSA	CCSA.36.461V1300	13.0.0	Published	01.03.2016	<a href="https://www.ccsa.org.cn/api/portalsFile/downloadOldFile?type=19&amp;oldFileUrl=ITU-R/M.2012-6/CCSA.36.461V1300.doc">https://www.ccsa.org.cn/api/portalsFile/downloadOldFile?type=19&amp;oldFileUrl=ITU-R/M.2012-6/CCSA.36.461V1300.doc</a>
ETSI	ETSI TS 136 461	13.0.0	Published	22.04.2016	<a href="https://www.etsi.org/deliver/etsi_ts/136400_136499/136461/13.00.00_60/ts_136461v130000p.pdf">https://www.etsi.org/deliver/etsi_ts/136400_136499/136461/13.00.00_60/ts_136461v130000p.pdf</a>
TSDSI	TSDSI STD T1.3GPP 36.461-13.0.0 V1.0.0	13.0.0	Published	30.08.2021	<a href="https://members.tdsi.in/index.php/s/JbYGd9LLmMwMwDbo">https://members.tdsi.in/index.php/s/JbYGd9LLmMwMwDbo</a>
TTA	TTAT.3G-36.461V13.0.0	13.0.0	Published	02.08.2021	<a href="http://committee.tta.or.kr/data/ttasDown.jsp?kind=ttastd&amp;pk_num=TTAT.3G-36.461V13.0.0">http://committee.tta.or.kr/data/ttasDown.jsp?kind=ttastd&amp;pk_num=TTAT.3G-36.461V13.0.0</a>
<b>Release 14</b>					
ARIB	ARIB STD-T120-36.461.V14.0.0	14.0.0	Published	03.03.2023	<a href="https://www.arib.or.jp/english/html/overview/doc/T120_T23_SPECS/ARIB-STD-T120/Rel14/36/A36461-e00.pdf">https://www.arib.or.jp/english/html/overview/doc/T120_T23_SPECS/ARIB-STD-T120/Rel14/36/A36461-e00.pdf</a>
ATIS	ATIS.3GPP.36.461V1400	14.0.0	Published	28.06.2021	<a href="https://www.atis.org/3gpp-documents/Rel99-14/">https://www.atis.org/3gpp-documents/Rel99-14/</a>
CCSA	CCSA.36.461V1400	14.0.0	Published	01.03.2017	<a href="https://www.ccsa.org.cn/api/portalsFile/downloadOldFile?type=19&amp;oldFileUrl=ITU-R/M.2012-6/CCSA.36.461V1400.doc">https://www.ccsa.org.cn/api/portalsFile/downloadOldFile?type=19&amp;oldFileUrl=ITU-R/M.2012-6/CCSA.36.461V1400.doc</a>
ETSI	ETSI TS 136 461	14.0.0	Published	11.04.2017	<a href="https://www.etsi.org/deliver/etsi_ts/136400_136499/136461/14.00.00_60/ts_136461v140000p.pdf">https://www.etsi.org/deliver/etsi_ts/136400_136499/136461/14.00.00_60/ts_136461v140000p.pdf</a>
TSDSI	TSDSI STD T1.3GPP 36.461-14.0.0 V1.0.0	14.0.0	Published	30.08.2021	<a href="https://members.tdsi.in/index.php/s/NNHqz3RNWGoGs3">https://members.tdsi.in/index.php/s/NNHqz3RNWGoGs3</a>
TTA	TTAT.3G-36.461V14.0.0	14.0.0	Published	02.08.2021	<a href="http://committee.tta.or.kr/data/ttasDown.jsp?kind=ttastd&amp;pk_num=TTAT.3G-36.461V14.0.0">http://committee.tta.or.kr/data/ttasDown.jsp?kind=ttastd&amp;pk_num=TTAT.3G-36.461V14.0.0</a>
<b>Release 15</b>					
ARIB	ARIB STD-T120-36.461.V15.0.0	15.0.0	Published	03.03.2023	<a href="https://www.arib.or.jp/english/html/overview/doc/T120_T23_SPECS/ARIB-STD-T120/Rel15/36/A36461-f00.pdf">https://www.arib.or.jp/english/html/overview/doc/T120_T23_SPECS/ARIB-STD-T120/Rel15/36/A36461-f00.pdf</a>
ATIS	ATIS.3GPP.36.461V1500	15.0.0	Published	28.06.2021	<a href="https://www.atis.org/3gpp-documents/Rel15/">https://www.atis.org/3gpp-documents/Rel15/</a>
CCSA	CCSA.36.461V1500	15.0.0	Published	01.06.2018	<a href="https://www.ccsa.org.cn/api/portalsFile/downloadOldFile?type=19&amp;oldFileUrl=ITU-R/M.2012-6/CCSA.36.461V1500.doc">https://www.ccsa.org.cn/api/portalsFile/downloadOldFile?type=19&amp;oldFileUrl=ITU-R/M.2012-6/CCSA.36.461V1500.doc</a>
ETSI	ETSI TS 136 461	15.0.0	Published	04.07.2018	<a href="https://www.etsi.org/deliver/etsi_ts/136400_136499/136461/15.00.00_60/ts_136461v150000p.pdf">https://www.etsi.org/deliver/etsi_ts/136400_136499/136461/15.00.00_60/ts_136461v150000p.pdf</a>
TSDSI	TSDSI STD T1.3GPP 36.461-15.0.0 V1.0.0	15.0.0	Published	30.08.2021	<a href="https://members.tdsi.in/index.php/s/DNAy2doqCc3gQD3">https://members.tdsi.in/index.php/s/DNAy2doqCc3gQD3</a>
TTA	TTAT.3G-36.461V15.0.0	15.0.0	Published	11.09.2020	<a href="http://committee.tta.or.kr/data/ttasDown.jsp?kind=ttastd&amp;pk_num=TTAT.3G-36.461V15.0.0">http://committee.tta.or.kr/data/ttasDown.jsp?kind=ttastd&amp;pk_num=TTAT.3G-36.461V15.0.0</a>
<b>Release 16</b>					
ARIB	ARIB STD-T120-36.461.V16.0.0	16.0.0	Published	03.03.2023	<a href="https://www.arib.or.jp/english/html/overview/doc/T120_T23_SPECS/ARIB-STD-T120/Rel16/36/A36461-g00.pdf">https://www.arib.or.jp/english/html/overview/doc/T120_T23_SPECS/ARIB-STD-T120/Rel16/36/A36461-g00.pdf</a>
ATIS	ATIS.3GPP.36.461V1600	16.0.0	Published	28.06.2021	<a href="https://www.atis.org/3gpp-documents/Rel16/">https://www.atis.org/3gpp-documents/Rel16/</a>
CCSA	CCSA.36.461V1600	16.0.0	Published	01.07.2020	<a href="https://www.ccsa.org.cn/api/portalsFile/downloadOldFile?type=19&amp;oldFileUrl=ITU-R/M.2012-6/CCSA.36.461V1600.doc">https://www.ccsa.org.cn/api/portalsFile/downloadOldFile?type=19&amp;oldFileUrl=ITU-R/M.2012-6/CCSA.36.461V1600.doc</a>
ETSI	ETSI TS 136 461	16.0.0	Published	23.07.2020	<a href="https://www.etsi.org/deliver/etsi_ts/136400_136499/136461/16.00.00_60/ts_136461v160000p.pdf">https://www.etsi.org/deliver/etsi_ts/136400_136499/136461/16.00.00_60/ts_136461v160000p.pdf</a>
TSDSI	TSDSI STD T1.3GPP 36.461-16.0.0 V1.0.0	16.0.0	Published	30.08.2021	<a href="https://members.tdsi.in/index.php/s/g6c2TKsZTeZEZDx">https://members.tdsi.in/index.php/s/g6c2TKsZTeZEZDx</a>
TTA	TTAT.3G-36.461V16.0.0	16.0.0	Published	11.09.2020	<a href="http://committee.tta.or.kr/data/ttasDown.jsp?kind=ttastd&amp;pk_num=TTAT.3G-36.461V16.0.0">http://committee.tta.or.kr/data/ttasDown.jsp?kind=ttastd&amp;pk_num=TTAT.3G-36.461V16.0.0</a>
<b>Release 17</b>					
ARIB	ARIB STD-T120-36.461.V17.0.0	17.0.0	Published	03.03.2023	<a href="https://www.arib.or.jp/english/html/overview/doc/T120_T23_SPECS/ARIB-STD-T120/Rel17/36/A36461-h00.pdf">https://www.arib.or.jp/english/html/overview/doc/T120_T23_SPECS/ARIB-STD-T120/Rel17/36/A36461-h00.pdf</a>
ATIS	ATIS.3GPP.36.461.V17.0.0	17.0.0	Published	21.02.2023	<a href="https://www.atis.org/3gpp-transpositions-Rel-17/">https://www.atis.org/3gpp-transpositions-Rel-17/</a>
CCSA	CCSA.36.461V1700	17.0.0	Published	01.04.2022	<a href="https://www.ccsa.org.cn/api/portalsFile/downloadOldFile?type=19&amp;oldFileUrl=ITU-R/M.2012-6/CCSA.36.461V1700.doc">https://www.ccsa.org.cn/api/portalsFile/downloadOldFile?type=19&amp;oldFileUrl=ITU-R/M.2012-6/CCSA.36.461V1700.doc</a>
ETSI	ETSI TS 136 461	17.0.0	Published	02.05.2022	<a href="https://www.etsi.org/deliver/etsi_ts/136400_136499/136461/17.00.00_60/ts_136461v170000p.pdf">https://www.etsi.org/deliver/etsi_ts/136400_136499/136461/17.00.00_60/ts_136461v170000p.pdf</a>
TSDSI	TSDSI STD T1.3GPP 36.461-17.0.0 V1.0.0	17.0.0	Published	29.07.2022	<a href="https://members.tdsi.in/s/ra9X6ZN4iSGcb9e">https://members.tdsi.in/s/ra9X6ZN4iSGcb9e</a>
TTA	TTAT.3G-36.461V17.0.0	17.0.0	Published	05.08.2022	<a href="http://committee.tta.or.kr/data/ttasDown.jsp?kind=ttastd&amp;pk_num=TTAT.3G-36.461V17.0.0">http://committee.tta.or.kr/data/ttasDown.jsp?kind=ttastd&amp;pk_num=TTAT.3G-36.461V17.0.0</a>



## 2.1.4.25 TS 36.462

**Evolved Universal Terrestrial Radio Access Network (E-UTRAN) and Wireless LAN (WLAN); Xw signalling transport**

This document specifies the standards for Signalling Transport to be used across the Xw interface. The Xw interface is a logical interface between the eNB and the WLAN Termination (WT). This document describes how the Xw-AP signalling messages are transported over Xw.

SDO	Document No.	Version	Status	Issued date	Location
<b>Release 13</b>					
ARIB	ARIB STD-T120-36.462.V13.0.0	13.0.0	Published	03.03.2023	<a href="https://www.arib.or.jp/english/html/overview/doc/T120_T23_SPECS/ARIB-STD-T120/Rel13/36/A36462-d00.pdf">https://www.arib.or.jp/english/html/overview/doc/T120_T23_SPECS/ARIB-STD-T120/Rel13/36/A36462-d00.pdf</a>
ATIS	ATIS.3GPP.36.462V1300	13.0.0	Published	28.06.2021	<a href="https://www.atis.org/3gpp-documents/Rel99-14/">https://www.atis.org/3gpp-documents/Rel99-14/</a>
CCSA	CCSA.36.462V1300	13.0.0	Published	01.03.2016	<a href="https://www.ccsa.org.cn/api/portalsFile/downloadOldFile?type=19&amp;oldFileUrl=ITU-R/M.2012-6/CCSA.36.462V1300.doc">https://www.ccsa.org.cn/api/portalsFile/downloadOldFile?type=19&amp;oldFileUrl=ITU-R/M.2012-6/CCSA.36.462V1300.doc</a>
ETSI	ETSI TS 136 462	13.0.0	Published	22.04.2016	<a href="https://www.etsi.org/deliver/etsi_ts/136400_136499/136462/13.00.00_60/ts_136462v130000p.pdf">https://www.etsi.org/deliver/etsi_ts/136400_136499/136462/13.00.00_60/ts_136462v130000p.pdf</a>
TSDSI	TSDSI STD T1.3GPP 36.462-13.0.0 V1.0.0	13.0.0	Published	30.08.2021	<a href="https://members.tdsi.in/index.php/s/9ZsqwsbHkciyW5S">https://members.tdsi.in/index.php/s/9ZsqwsbHkciyW5S</a>
TTA	TTAT.3G-36.462V13.0.0	13.0.0	Published	02.08.2021	<a href="http://committee.tta.or.kr/data/ttasDown.jsp?kind=ttastd&amp;pk_num=TTAT.3G-36.462V13.0.0">http://committee.tta.or.kr/data/ttasDown.jsp?kind=ttastd&amp;pk_num=TTAT.3G-36.462V13.0.0</a>
<b>Release 14</b>					
ARIB	ARIB STD-T120-36.462.V14.0.0	14.0.0	Published	03.03.2023	<a href="https://www.arib.or.jp/english/html/overview/doc/T120_T23_SPECS/ARIB-STD-T120/Rel14/36/A36462-e00.pdf">https://www.arib.or.jp/english/html/overview/doc/T120_T23_SPECS/ARIB-STD-T120/Rel14/36/A36462-e00.pdf</a>
ATIS	ATIS.3GPP.36.462V1400	14.0.0	Published	28.06.2021	<a href="https://www.atis.org/3gpp-documents/Rel99-14/">https://www.atis.org/3gpp-documents/Rel99-14/</a>
CCSA	CCSA.36.462V1400	14.0.0	Published	01.03.2017	<a href="https://www.ccsa.org.cn/api/portalsFile/downloadOldFile?type=19&amp;oldFileUrl=ITU-R/M.2012-6/CCSA.36.462V1400.doc">https://www.ccsa.org.cn/api/portalsFile/downloadOldFile?type=19&amp;oldFileUrl=ITU-R/M.2012-6/CCSA.36.462V1400.doc</a>
ETSI	ETSI TS 136 462	14.0.0	Published	11.04.2017	<a href="https://www.etsi.org/deliver/etsi_ts/136400_136499/136462/14.00.00_60/ts_136462v140000p.pdf">https://www.etsi.org/deliver/etsi_ts/136400_136499/136462/14.00.00_60/ts_136462v140000p.pdf</a>
TSDSI	TSDSI STD T1.3GPP 36.462-14.0.0 V1.0.0	14.0.0	Published	30.08.2021	<a href="https://members.tdsi.in/index.php/s/8RtZkedzim655Ri">https://members.tdsi.in/index.php/s/8RtZkedzim655Ri</a>
TTA	TTAT.3G-36.462V14.0.0	14.0.0	Published	02.08.2021	<a href="http://committee.tta.or.kr/data/ttasDown.jsp?kind=ttastd&amp;pk_num=TTAT.3G-36.462V14.0.0">http://committee.tta.or.kr/data/ttasDown.jsp?kind=ttastd&amp;pk_num=TTAT.3G-36.462V14.0.0</a>
<b>Release 15</b>					
ARIB	ARIB STD-T120-36.462.V15.0.0	15.0.0	Published	03.03.2023	<a href="https://www.arib.or.jp/english/html/overview/doc/T120_T23_SPECS/ARIB-STD-T120/Rel15/36/A36462-f00.pdf">https://www.arib.or.jp/english/html/overview/doc/T120_T23_SPECS/ARIB-STD-T120/Rel15/36/A36462-f00.pdf</a>
ATIS	ATIS.3GPP.36.462V1500	15.0.0	Published	28.06.2021	<a href="https://www.atis.org/3gpp-documents/Rel15/">https://www.atis.org/3gpp-documents/Rel15/</a>
CCSA	CCSA.36.462V1500	15.0.0	Published	01.06.2018	<a href="https://www.ccsa.org.cn/api/portalsFile/downloadOldFile?type=19&amp;oldFileUrl=ITU-R/M.2012-6/CCSA.36.462V1500.doc">https://www.ccsa.org.cn/api/portalsFile/downloadOldFile?type=19&amp;oldFileUrl=ITU-R/M.2012-6/CCSA.36.462V1500.doc</a>
ETSI	ETSI TS 136 462	15.0.0	Published	04.07.2018	<a href="https://www.etsi.org/deliver/etsi_ts/136400_136499/136462/15.00.00_60/ts_136462v150000p.pdf">https://www.etsi.org/deliver/etsi_ts/136400_136499/136462/15.00.00_60/ts_136462v150000p.pdf</a>
TSDSI	TSDSI STD T1.3GPP 36.462-15.0.0 V1.0.0	15.0.0	Published	30.08.2021	<a href="https://members.tdsi.in/index.php/s/H9iiG9iA3ZAskQz">https://members.tdsi.in/index.php/s/H9iiG9iA3ZAskQz</a>
TTA	TTAT.3G-36.462V15.0.0	15.0.0	Published	11.09.2020	<a href="http://committee.tta.or.kr/data/ttasDown.jsp?kind=ttastd&amp;pk_num=TTAT.3G-36.462V15.0.0">http://committee.tta.or.kr/data/ttasDown.jsp?kind=ttastd&amp;pk_num=TTAT.3G-36.462V15.0.0</a>
<b>Release 16</b>					
ARIB	ARIB STD-T120-36.462.V16.0.0	16.0.0	Published	03.03.2023	<a href="https://www.arib.or.jp/english/html/overview/doc/T120_T23_SPECS/ARIB-STD-T120/Rel16/36/A36462-g00.pdf">https://www.arib.or.jp/english/html/overview/doc/T120_T23_SPECS/ARIB-STD-T120/Rel16/36/A36462-g00.pdf</a>
ATIS	ATIS.3GPP.36.462V1600	16.0.0	Published	28.06.2021	<a href="https://www.atis.org/3gpp-documents/Rel16/">https://www.atis.org/3gpp-documents/Rel16/</a>
CCSA	CCSA.36.462V1600	16.0.0	Published	01.07.2020	<a href="https://www.ccsa.org.cn/api/portalsFile/downloadOldFile?type=19&amp;oldFileUrl=ITU-R/M.2012-6/CCSA.36.462V1600.doc">https://www.ccsa.org.cn/api/portalsFile/downloadOldFile?type=19&amp;oldFileUrl=ITU-R/M.2012-6/CCSA.36.462V1600.doc</a>
ETSI	ETSI TS 136 462	16.0.0	Published	21.07.2020	<a href="https://www.etsi.org/deliver/etsi_ts/136400_136499/136462/16.00.00_60/ts_136462v160000p.pdf">https://www.etsi.org/deliver/etsi_ts/136400_136499/136462/16.00.00_60/ts_136462v160000p.pdf</a>
TSDSI	TSDSI STD T1.3GPP 36.462-16.0.0 V1.0.0	16.0.0	Published	30.08.2021	<a href="https://members.tdsi.in/index.php/s/G7XwpExMFLAZH4L">https://members.tdsi.in/index.php/s/G7XwpExMFLAZH4L</a>
TTA	TTAT.3G-36.462V16.0.0	16.0.0	Published	11.09.2020	<a href="http://committee.tta.or.kr/data/ttasDown.jsp?kind=ttastd&amp;pk_num=TTAT.3G-36.462V16.0.0">http://committee.tta.or.kr/data/ttasDown.jsp?kind=ttastd&amp;pk_num=TTAT.3G-36.462V16.0.0</a>
<b>Release 17</b>					
ARIB	ARIB STD-T120-36.462.V17.0.0	17.0.0	Published	03.03.2023	<a href="https://www.arib.or.jp/english/html/overview/doc/T120_T23_SPECS/ARIB-STD-T120/Rel17/36/A36462-h00.pdf">https://www.arib.or.jp/english/html/overview/doc/T120_T23_SPECS/ARIB-STD-T120/Rel17/36/A36462-h00.pdf</a>
ATIS	ATIS.3GPP.36.462.V17.0.0	17.0.0	Published	21.02.2023	<a href="https://www.atis.org/3gpp-transpositions-Rel-17">https://www.atis.org/3gpp-transpositions-Rel-17</a>
CCSA	CCSA.36.462V1700	17.0.0	Published	01.04.2022	<a href="https://www.ccsa.org.cn/api/portalsFile/downloadOldFile?type=19&amp;oldFileUrl=ITU-R/M.2012-6/CCSA.36.462V1700.doc">https://www.ccsa.org.cn/api/portalsFile/downloadOldFile?type=19&amp;oldFileUrl=ITU-R/M.2012-6/CCSA.36.462V1700.doc</a>
ETSI	ETSI TS 136 462	17.0.0	Published	02.05.2022	<a href="https://www.etsi.org/deliver/etsi_ts/136400_136499/136462/17.00.00_60/ts_136462v170000p.pdf">https://www.etsi.org/deliver/etsi_ts/136400_136499/136462/17.00.00_60/ts_136462v170000p.pdf</a>
TSDSI	TSDSI STD T1.3GPP 36.462-17.0.0 V1.0.0	17.0.0	Published	29.07.2022	<a href="https://members.tdsi.in/s/aeQ2foMDXWaGgM6">https://members.tdsi.in/s/aeQ2foMDXWaGgM6</a>
TTA	TTAT.3G-36.462V17.0.0	17.0.0	Published	05.08.2022	<a href="http://committee.tta.or.kr/data/ttasDown.jsp?kind=ttastd&amp;pk_num=TTAT.3G-36.462V17.0.0">http://committee.tta.or.kr/data/ttasDown.jsp?kind=ttastd&amp;pk_num=TTAT.3G-36.462V17.0.0</a>

## 2.1.4.26 TS 36.463

**Evolved Universal Terrestrial Radio Access Network (E-UTRAN) and Wireless LAN (WLAN); Xw application protocol (XwAP)**

This document specifies the signalling procedures of the control plane between an eNB and WLAN Termination (WT). The Xw Application Protocol (XwAP) supports the functions of Xw interface by signalling procedures defined in this document.

SDO	Document No.	Version	Status	Issued date	Location
<b>Release 13</b>					
ARIB	ARIB STD-T120-36.463.V13.1.0	13.1.0	Published	03.03.2023	<a href="https://www.arib.or.jp/english/html/overview/doc/T120_T23_SPECS/ARIB-STD-T120/Rel13/36/A36463-d10.pdf">https://www.arib.or.jp/english/html/overview/doc/T120_T23_SPECS/ARIB-STD-T120/Rel13/36/A36463-d10.pdf</a>
ATIS	ATIS.3GPP.36.463V1310	13.1.0	Published	28.06.2021	<a href="https://www.atis.org/3gpp-documents/Rel99-14/">https://www.atis.org/3gpp-documents/Rel99-14/</a>
CCSA	CCSA.36.463V1310	13.1.0	Published	01.06.2016	<a href="https://www.ccsa.org.cn/api/portalsFile/downloadOldFile?type=19&amp;oldFileUrl=ITU-R/M.2012-6/CCSA.36.463V1310.doc">https://www.ccsa.org.cn/api/portalsFile/downloadOldFile?type=19&amp;oldFileUrl=ITU-R/M.2012-6/CCSA.36.463V1310.doc</a>
ETSI	ETSI TS 136 463	13.1.0	Published	25.08.2016	<a href="https://www.etsi.org/deliver/etsi_ts/136400_136499/136463/13.01.00_60/ts_136463v130100p.pdf">https://www.etsi.org/deliver/etsi_ts/136400_136499/136463/13.01.00_60/ts_136463v130100p.pdf</a>
TSDSI	TSDSI STD T1.3GPP 36.463-13.1.0 V1.0.0	13.1.0	Published	30.08.2021	<a href="https://members.tdsi.in/index.php/s/SAB8mEdF5nfyiYg">https://members.tdsi.in/index.php/s/SAB8mEdF5nfyiYg</a>
TTA	TTAT.3G-36.463V13.1.0	13.1.0	Published	02.08.2021	<a href="http://committee.tta.or.kr/data/ttasDown.jsp?kind=ttastd&amp;pk_num=TTAT.3G-36.463V13.1.0">http://committee.tta.or.kr/data/ttasDown.jsp?kind=ttastd&amp;pk_num=TTAT.3G-36.463V13.1.0</a>
<b>Release 14</b>					
ARIB	ARIB STD-T120-36.463.V14.2.0	14.2.0	Published	03.03.2023	<a href="https://www.arib.or.jp/english/html/overview/doc/T120_T23_SPECS/ARIB-STD-T120/Rel14/36/A36463-e20.pdf">https://www.arib.or.jp/english/html/overview/doc/T120_T23_SPECS/ARIB-STD-T120/Rel14/36/A36463-e20.pdf</a>
ATIS	ATIS.3GPP.36.463V1420	14.2.0	Published	28.06.2021	<a href="https://www.atis.org/3gpp-documents/Rel99-14/">https://www.atis.org/3gpp-documents/Rel99-14/</a>
CCSA	CCSA.36.463V1420	14.2.0	Published	01.06.2017	<a href="https://www.ccsa.org.cn/api/portalsFile/downloadOldFile?type=19&amp;oldFileUrl=ITU-R/M.2012-6/CCSA.36.463V1420.doc">https://www.ccsa.org.cn/api/portalsFile/downloadOldFile?type=19&amp;oldFileUrl=ITU-R/M.2012-6/CCSA.36.463V1420.doc</a>
ETSI	ETSI TS 136 463	14.2.0	Published	24.08.2017	<a href="https://www.etsi.org/deliver/etsi_ts/136400_136499/136463/14.02.00_60/ts_136463v140200p.pdf">https://www.etsi.org/deliver/etsi_ts/136400_136499/136463/14.02.00_60/ts_136463v140200p.pdf</a>
TSDSI	TSDSI STD T1.3GPP 36.463-14.2.0 V1.0.0	14.2.0	Published	30.08.2021	<a href="https://members.tdsi.in/index.php/s/SpN6tosYaECDaPF">https://members.tdsi.in/index.php/s/SpN6tosYaECDaPF</a>
TTA	TTAT.3G-36.463V14.2.0	14.2.0	Published	02.08.2021	<a href="http://committee.tta.or.kr/data/ttasDown.jsp?kind=ttastd&amp;pk_num=TTAT.3G-36.463V14.2.0">http://committee.tta.or.kr/data/ttasDown.jsp?kind=ttastd&amp;pk_num=TTAT.3G-36.463V14.2.0</a>
<b>Release 15</b>					
ARIB	ARIB STD-T120-36.463.V15.0.0	15.0.0	Published	03.03.2023	<a href="https://www.arib.or.jp/english/html/overview/doc/T120_T23_SPECS/ARIB-STD-T120/Rel15/36/A36463-f00.pdf">https://www.arib.or.jp/english/html/overview/doc/T120_T23_SPECS/ARIB-STD-T120/Rel15/36/A36463-f00.pdf</a>
ATIS	ATIS.3GPP.36.463V1500	15.0.0	Published	28.06.2021	<a href="https://www.atis.org/3gpp-documents/Rel15/">https://www.atis.org/3gpp-documents/Rel15/</a>
CCSA	CCSA.36.463V1500	15.0.0	Published	01.06.2018	<a href="https://www.ccsa.org.cn/api/portalsFile/downloadOldFile?type=19&amp;oldFileUrl=ITU-R/M.2012-6/CCSA.36.463V1500.doc">https://www.ccsa.org.cn/api/portalsFile/downloadOldFile?type=19&amp;oldFileUrl=ITU-R/M.2012-6/CCSA.36.463V1500.doc</a>
ETSI	ETSI TS 136 463	15.0.0	Published	04.07.2018	<a href="https://www.etsi.org/deliver/etsi_ts/136400_136499/136463/15.00.00_60/ts_136463v150000p.pdf">https://www.etsi.org/deliver/etsi_ts/136400_136499/136463/15.00.00_60/ts_136463v150000p.pdf</a>
TSDSI	TSDSI STD T1.3GPP 36.463-15.0.0 V1.0.0	15.0.0	Published	30.08.2021	<a href="https://members.tdsi.in/index.php/s/MFem6KcmqncDwpe">https://members.tdsi.in/index.php/s/MFem6KcmqncDwpe</a>
TTA	TTAT.3G-36.463V15.0.0	15.0.0	Published	11.09.2020	<a href="http://committee.tta.or.kr/data/ttasDown.jsp?kind=ttastd&amp;pk_num=TTAT.3G-36.463V15.0.0">http://committee.tta.or.kr/data/ttasDown.jsp?kind=ttastd&amp;pk_num=TTAT.3G-36.463V15.0.0</a>
<b>Release 16</b>					
ARIB	ARIB STD-T120-36.463.V16.0.0	16.0.0	Published	03.03.2023	<a href="https://www.arib.or.jp/english/html/overview/doc/T120_T23_SPECS/ARIB-STD-T120/Rel16/36/A36463-g00.pdf">https://www.arib.or.jp/english/html/overview/doc/T120_T23_SPECS/ARIB-STD-T120/Rel16/36/A36463-g00.pdf</a>
ATIS	ATIS.3GPP.36.463V1600	16.0.0	Published	28.06.2021	<a href="https://www.atis.org/3gpp-documents/Rel16/">https://www.atis.org/3gpp-documents/Rel16/</a>
CCSA	CCSA.36.463V1600	16.0.0	Published	01.07.2020	<a href="https://www.ccsa.org.cn/api/portalsFile/downloadOldFile?type=19&amp;oldFileUrl=ITU-R/M.2012-6/CCSA.36.463V1600.doc">https://www.ccsa.org.cn/api/portalsFile/downloadOldFile?type=19&amp;oldFileUrl=ITU-R/M.2012-6/CCSA.36.463V1600.doc</a>
ETSI	ETSI TS 136 463	16.0.0	Published	21.07.2020	<a href="https://www.etsi.org/deliver/etsi_ts/136400_136499/136463/16.00.00_60/ts_136463v160000p.pdf">https://www.etsi.org/deliver/etsi_ts/136400_136499/136463/16.00.00_60/ts_136463v160000p.pdf</a>
TSDSI	TSDSI STD T1.3GPP 36.463-16.0.0 V1.0.0	16.0.0	Published	30.08.2021	<a href="https://members.tdsi.in/index.php/s/L4dbZFLbtrH4HtA">https://members.tdsi.in/index.php/s/L4dbZFLbtrH4HtA</a>
TTA	TTAT.3G-36.463V16.0.0	16.0.0	Published	11.09.2020	<a href="http://committee.tta.or.kr/data/ttasDown.jsp?kind=ttastd&amp;pk_num=TTAT.3G-36.463V16.0.0">http://committee.tta.or.kr/data/ttasDown.jsp?kind=ttastd&amp;pk_num=TTAT.3G-36.463V16.0.0</a>
<b>Release 17</b>					
ARIB	ARIB STD-T120-36.463.V17.0.0	17.0.0	Published	03.03.2023	<a href="https://www.arib.or.jp/english/html/overview/doc/T120_T23_SPECS/ARIB-STD-T120/Rel17/36/A36463-h00.pdf">https://www.arib.or.jp/english/html/overview/doc/T120_T23_SPECS/ARIB-STD-T120/Rel17/36/A36463-h00.pdf</a>
ATIS	ATIS.3GPP.36.463.V17.0.0	17.0.0	Published	21.02.2023	<a href="https://www.atis.org/3gpp-transpositions-Rel-17">https://www.atis.org/3gpp-transpositions-Rel-17</a>
CCSA	CCSA.36.463V1700	17.0.0	Published	01.04.2022	<a href="https://www.ccsa.org.cn/api/portalsFile/downloadOldFile?type=19&amp;oldFileUrl=ITU-R/M.2012-6/CCSA.36.463V1700.doc">https://www.ccsa.org.cn/api/portalsFile/downloadOldFile?type=19&amp;oldFileUrl=ITU-R/M.2012-6/CCSA.36.463V1700.doc</a>
ETSI	ETSI TS 136 463	17.0.0	Published	02.05.2022	<a href="https://www.etsi.org/deliver/etsi_ts/136400_136499/136463/17.00.00_60/ts_136463v170000p.pdf">https://www.etsi.org/deliver/etsi_ts/136400_136499/136463/17.00.00_60/ts_136463v170000p.pdf</a>
TSDSI	TSDSI STD T1.3GPP 36.463-17.0.0 V1.0.0	17.0.0	Published	29.07.2022	<a href="https://members.tdsi.in/s/JbEna9JddfRa7qj">https://members.tdsi.in/s/JbEna9JddfRa7qj</a>
TTA	TTAT.3G-36.463V17.0.0	17.0.0	Published	05.08.2022	<a href="http://committee.tta.or.kr/data/ttasDown.jsp?kind=ttastd&amp;pk_num=TTAT.3G-36.463V17.0.0">http://committee.tta.or.kr/data/ttasDown.jsp?kind=ttastd&amp;pk_num=TTAT.3G-36.463V17.0.0</a>

## 2.1.4.27 TS 36.464

**Evolved Universal Terrestrial Radio Access Network (E-UTRAN) and Wireless LAN (WLAN); Xw data transport**

This document specifies the standards for user data transport protocols and related signalling protocols to establish user plane transport bearers over the Xw interface for LTE/WLAN Aggregation (LWA).

SDO	Document No.	Version	Status	Issued date	Location
<b>Release 13</b>					
ARIB	ARIB STD-T120-36.464.V13.3.0	13.3.0	Published	03.03.2023	<a href="https://www.arib.or.jp/english/html/overview/doc/T120_T23_SPECS/ARIB-STD-T120/Rel13/36/A36464-d30.pdf">https://www.arib.or.jp/english/html/overview/doc/T120_T23_SPECS/ARIB-STD-T120/Rel13/36/A36464-d30.pdf</a>
ATIS	ATIS.3GPP.36.464V1330	13.3.0	Published	28.06.2021	<a href="https://www.atis.org/3gpp-documents/Rel99-14/">https://www.atis.org/3gpp-documents/Rel99-14/</a>
CCSA	CCSA.36.464V1330	13.3.0	Published	01.09.2017	<a href="https://www.ccsa.org.cn/api/portalsFile/downloadOldFile?type=19&amp;oldFileUrl=ITU-R/M.2012-6/CCSA.36.464V1330.doc">https://www.ccsa.org.cn/api/portalsFile/downloadOldFile?type=19&amp;oldFileUrl=ITU-R/M.2012-6/CCSA.36.464V1330.doc</a>
ETSI	ETSI TS 136 464	13.3.0	Published	18.10.2017	<a href="https://www.etsi.org/deliver/etsi_ts/136400_136499/136464/13.03.00_60/ts_136464v130300p.pdf">https://www.etsi.org/deliver/etsi_ts/136400_136499/136464/13.03.00_60/ts_136464v130300p.pdf</a>
TSDSI	TSDSI STD T1.3GPP 36.464-13.3.0 V1.0.0	13.3.0	Published	30.08.2021	<a href="https://members.tdsi.in/index.php/s/BYY38Ed6bLLt9rD">https://members.tdsi.in/index.php/s/BYY38Ed6bLLt9rD</a>
TTA	TTAT.3G-36.464V13.3.0	13.3.0	Published	02.08.2021	<a href="http://committee.tta.or.kr/data/ttasDown.jsp?kind=ttastd&amp;pk_num=TTAT.3G-36.464V13.3.0">http://committee.tta.or.kr/data/ttasDown.jsp?kind=ttastd&amp;pk_num=TTAT.3G-36.464V13.3.0</a>
<b>Release 14</b>					
ARIB	ARIB STD-T120-36.464.V14.2.0	14.2.0	Published	03.03.2023	<a href="https://www.arib.or.jp/english/html/overview/doc/T120_T23_SPECS/ARIB-STD-T120/Rel14/36/A36464-e20.pdf">https://www.arib.or.jp/english/html/overview/doc/T120_T23_SPECS/ARIB-STD-T120/Rel14/36/A36464-e20.pdf</a>
ATIS	ATIS.3GPP.36.464V1420	14.2.0	Published	28.06.2021	<a href="https://www.atis.org/3gpp-documents/Rel99-14/">https://www.atis.org/3gpp-documents/Rel99-14/</a>
CCSA	CCSA.36.464V1420	14.2.0	Published	01.09.2017	<a href="https://www.ccsa.org.cn/api/portalsFile/downloadOldFile?type=19&amp;oldFileUrl=ITU-R/M.2012-6/CCSA.36.464V1420.doc">https://www.ccsa.org.cn/api/portalsFile/downloadOldFile?type=19&amp;oldFileUrl=ITU-R/M.2012-6/CCSA.36.464V1420.doc</a>
ETSI	ETSI TS 136 464	14.2.0	Published	18.10.2017	<a href="https://www.etsi.org/deliver/etsi_ts/136400_136499/136464/14.02.00_60/ts_136464v140200p.pdf">https://www.etsi.org/deliver/etsi_ts/136400_136499/136464/14.02.00_60/ts_136464v140200p.pdf</a>
TSDSI	TSDSI STD T1.3GPP 36.464-14.2.0 V1.0.0	14.2.0	Published	30.08.2021	<a href="https://members.tdsi.in/index.php/s/8KebCeGkLS8R8b6">https://members.tdsi.in/index.php/s/8KebCeGkLS8R8b6</a>
TTA	TTAT.3G-36.464V14.2.0	14.2.0	Published	02.08.2021	<a href="http://committee.tta.or.kr/data/ttasDown.jsp?kind=ttastd&amp;pk_num=TTAT.3G-36.464V14.2.0">http://committee.tta.or.kr/data/ttasDown.jsp?kind=ttastd&amp;pk_num=TTAT.3G-36.464V14.2.0</a>
<b>Release 15</b>					
ARIB	ARIB STD-T120-36.464.V15.0.0	15.0.0	Published	03.03.2023	<a href="https://www.arib.or.jp/english/html/overview/doc/T120_T23_SPECS/ARIB-STD-T120/Rel15/36/A36464-f00.pdf">https://www.arib.or.jp/english/html/overview/doc/T120_T23_SPECS/ARIB-STD-T120/Rel15/36/A36464-f00.pdf</a>
ATIS	ATIS.3GPP.36.464V1500	15.0.0	Published	28.06.2021	<a href="https://www.atis.org/3gpp-documents/Rel15/">https://www.atis.org/3gpp-documents/Rel15/</a>
CCSA	CCSA.36.464V1500	15.0.0	Published	01.06.2018	<a href="https://www.ccsa.org.cn/api/portalsFile/downloadOldFile?type=19&amp;oldFileUrl=ITU-R/M.2012-6/CCSA.36.464V1500.doc">https://www.ccsa.org.cn/api/portalsFile/downloadOldFile?type=19&amp;oldFileUrl=ITU-R/M.2012-6/CCSA.36.464V1500.doc</a>
ETSI	ETSI TS 136 464	15.0.0	Published	04.07.2018	<a href="https://www.etsi.org/deliver/etsi_ts/136400_136499/136464/15.00.00_60/ts_136464v150000p.pdf">https://www.etsi.org/deliver/etsi_ts/136400_136499/136464/15.00.00_60/ts_136464v150000p.pdf</a>
TSDSI	TSDSI STD T1.3GPP 36.464-15.0.0 V1.0.0	15.0.0	Published	30.08.2021	<a href="https://members.tdsi.in/index.php/s/mwyWy73GX5A45m3">https://members.tdsi.in/index.php/s/mwyWy73GX5A45m3</a>
TTA	TTAT.3G-36.464V15.0.0	15.0.0	Published	11.09.2020	<a href="http://committee.tta.or.kr/data/ttasDown.jsp?kind=ttastd&amp;pk_num=TTAT.3G-36.464V15.0.0">http://committee.tta.or.kr/data/ttasDown.jsp?kind=ttastd&amp;pk_num=TTAT.3G-36.464V15.0.0</a>
<b>Release 16</b>					
ARIB	ARIB STD-T120-36.464.V16.0.0	16.0.0	Published	03.03.2023	<a href="https://www.arib.or.jp/english/html/overview/doc/T120_T23_SPECS/ARIB-STD-T120/Rel16/36/A36464-g00.pdf">https://www.arib.or.jp/english/html/overview/doc/T120_T23_SPECS/ARIB-STD-T120/Rel16/36/A36464-g00.pdf</a>
ATIS	ATIS.3GPP.36.464V1600	16.0.0	Published	28.06.2021	<a href="https://www.atis.org/3gpp-documents/Rel16/">https://www.atis.org/3gpp-documents/Rel16/</a>
CCSA	CCSA.36.464V1600	16.0.0	Published	01.07.2020	<a href="https://www.ccsa.org.cn/api/portalsFile/downloadOldFile?type=19&amp;oldFileUrl=ITU-R/M.2012-6/CCSA.36.464V1600.doc">https://www.ccsa.org.cn/api/portalsFile/downloadOldFile?type=19&amp;oldFileUrl=ITU-R/M.2012-6/CCSA.36.464V1600.doc</a>
ETSI	ETSI TS 136 464	16.0.0	Published	21.07.2020	<a href="https://www.etsi.org/deliver/etsi_ts/136400_136499/136464/16.00.00_60/ts_136464v160000p.pdf">https://www.etsi.org/deliver/etsi_ts/136400_136499/136464/16.00.00_60/ts_136464v160000p.pdf</a>
TSDSI	TSDSI STD T1.3GPP 36.464-16.0.0 V1.0.0	16.0.0	Published	30.08.2021	<a href="https://members.tdsi.in/index.php/s/MFNqYFSH8zGkzfc">https://members.tdsi.in/index.php/s/MFNqYFSH8zGkzfc</a>
TTA	TTAT.3G-36.464V16.0.0	16.0.0	Published	11.09.2020	<a href="http://committee.tta.or.kr/data/ttasDown.jsp?kind=ttastd&amp;pk_num=TTAT.3G-36.464V16.0.0">http://committee.tta.or.kr/data/ttasDown.jsp?kind=ttastd&amp;pk_num=TTAT.3G-36.464V16.0.0</a>
<b>Release 17</b>					
ARIB	ARIB STD-T120-36.464.V17.0.0	17.0.0	Published	03.03.2023	<a href="https://www.arib.or.jp/english/html/overview/doc/T120_T23_SPECS/ARIB-STD-T120/Rel17/36/A36464-h00.pdf">https://www.arib.or.jp/english/html/overview/doc/T120_T23_SPECS/ARIB-STD-T120/Rel17/36/A36464-h00.pdf</a>
ATIS	ATIS.3GPP.36.464.V17.0.0	17.0.0	Published	21.02.2023	<a href="https://www.atis.org/3gpp-transpositions-Rel17/">https://www.atis.org/3gpp-transpositions-Rel17/</a>
CCSA	CCSA.36.464V1700	17.0.0	Published	01.04.2022	<a href="https://www.ccsa.org.cn/api/portalsFile/downloadOldFile?type=19&amp;oldFileUrl=ITU-R/M.2012-6/CCSA.36.464V1700.doc">https://www.ccsa.org.cn/api/portalsFile/downloadOldFile?type=19&amp;oldFileUrl=ITU-R/M.2012-6/CCSA.36.464V1700.doc</a>
ETSI	ETSI TS 136 464	17.0.0	Published	02.05.2022	<a href="https://www.etsi.org/deliver/etsi_ts/136400_136499/136464/17.00.00_60/ts_136464v170000p.pdf">https://www.etsi.org/deliver/etsi_ts/136400_136499/136464/17.00.00_60/ts_136464v170000p.pdf</a>
TSDSI	TSDSI STD T1.3GPP 36.464-17.0.0 V1.0.0	17.0.0	Published	29.07.2022	<a href="https://members.tdsi.in/s/qd6jGpeES4mqrSZ">https://members.tdsi.in/s/qd6jGpeES4mqrSZ</a>
TTA	TTAT.3G-36.464V17.0.0	17.0.0	Published	05.08.2022	<a href="http://committee.tta.or.kr/data/ttasDown.jsp?kind=ttastd&amp;pk_num=TTAT.3G-36.464V17.0.0">http://committee.tta.or.kr/data/ttasDown.jsp?kind=ttastd&amp;pk_num=TTAT.3G-36.464V17.0.0</a>

## 2.1.4.28 TS 36.465

**Evolved Universal Terrestrial Radio Access Network (E-UTRAN) and Wireless LAN (WLAN); Xw interface user plane protocol**

This document specifies the Xw user plane protocol being used over the Xw interface for LTE/WLAN Aggregation (LWA).

SDO	Document No.	Version	Status	Issued date	Location
<b>Release 13</b>					
ARIB	ARIB STD-T120-36.465.V13.2.0	13.2.0	Published	03.03.2023	<a href="https://www.arib.or.jp/english/html/overview/doc/T120_T23_SPECS/ARIB-STD-T120/Rel13/36/A36465-d20.pdf">https://www.arib.or.jp/english/html/overview/doc/T120_T23_SPECS/ARIB-STD-T120/Rel13/36/A36465-d20.pdf</a>
ATIS	ATIS.3GPP.36.465V1320	13.2.0	Published	28.06.2021	<a href="https://www.atis.org/3gpp-documents/Rel13-14/">https://www.atis.org/3gpp-documents/Rel13-14/</a>
CCSA	CCSA.36.465V1320	13.2.0	Published	01.09.2017	<a href="https://www.ccsa.org.cn/api/portalsFile/downloadOldFile?type=19&amp;oldFileUrl=ITU-R/M.2012-6/CCSA.36.465V1320.doc">https://www.ccsa.org.cn/api/portalsFile/downloadOldFile?type=19&amp;oldFileUrl=ITU-R/M.2012-6/CCSA.36.465V1320.doc</a>
ETSI	ETSI TS 136 465	13.2.0	Published	19.10.2017	<a href="https://www.etsi.org/deliver/etsi_ts/136400_136499/136465/13.02.00_60/ts_136465v130200p.pdf">https://www.etsi.org/deliver/etsi_ts/136400_136499/136465/13.02.00_60/ts_136465v130200p.pdf</a>
TSDSI	TSDSI STD T1.3GPP 36.465-13.2.0 V1.0.0	13.2.0	Published	30.08.2021	<a href="https://members.tdsi.in/index.php/s/JApjLQbtRx7e8A">https://members.tdsi.in/index.php/s/JApjLQbtRx7e8A</a>
TTA	TTAT.3G-36.465V13.2.0	13.2.0	Published	02.08.2021	<a href="http://committee.tta.or.kr/data/ttasDown.jsp?kind=ttastd&amp;pk_num=TTAT.3G-36.465V13.2.0">http://committee.tta.or.kr/data/ttasDown.jsp?kind=ttastd&amp;pk_num=TTAT.3G-36.465V13.2.0</a>
<b>Release 14</b>					
ARIB	ARIB STD-T120-36.465.V14.3.0	14.3.0	Published	03.03.2023	<a href="https://www.arib.or.jp/english/html/overview/doc/T120_T23_SPECS/ARIB-STD-T120/Rel14/36/A36465-e30.pdf">https://www.arib.or.jp/english/html/overview/doc/T120_T23_SPECS/ARIB-STD-T120/Rel14/36/A36465-e30.pdf</a>
ATIS	ATIS.3GPP.36.465V1430	14.3.0	Published	28.06.2021	<a href="https://www.atis.org/3gpp-documents/Rel13-14/">https://www.atis.org/3gpp-documents/Rel13-14/</a>
CCSA	CCSA.36.465V1430	14.3.0	Published	01.06.2018	<a href="https://www.ccsa.org.cn/api/portalsFile/downloadOldFile?type=19&amp;oldFileUrl=ITU-R/M.2012-6/CCSA.36.465V1430.doc">https://www.ccsa.org.cn/api/portalsFile/downloadOldFile?type=19&amp;oldFileUrl=ITU-R/M.2012-6/CCSA.36.465V1430.doc</a>
ETSI	ETSI TS 136 465	14.3.0	Published	04.07.2018	<a href="https://www.etsi.org/deliver/etsi_ts/136400_136499/136465/14.03.00_60/ts_136465v140300p.pdf">https://www.etsi.org/deliver/etsi_ts/136400_136499/136465/14.03.00_60/ts_136465v140300p.pdf</a>
TSDSI	TSDSI STD T1.3GPP 36.465-14.3.0 V1.1.0	14.3.0	Published	30.08.2021	<a href="https://members.tdsi.in/index.php/s/4SWwTzms9yD7RaX">https://members.tdsi.in/index.php/s/4SWwTzms9yD7RaX</a>
TTA	TTAT.3G-36.465V14.3.0	14.3.0	Published	02.08.2021	<a href="http://committee.tta.or.kr/data/ttasDown.jsp?kind=ttastd&amp;pk_num=TTAT.3G-36.465V14.3.0">http://committee.tta.or.kr/data/ttasDown.jsp?kind=ttastd&amp;pk_num=TTAT.3G-36.465V14.3.0</a>
<b>Release 15</b>					
ARIB	ARIB STD-T120-36.465.V15.0.0	15.0.0	Published	03.03.2023	<a href="https://www.arib.or.jp/english/html/overview/doc/T120_T23_SPECS/ARIB-STD-T120/Rel15/36/A36465-f00.pdf">https://www.arib.or.jp/english/html/overview/doc/T120_T23_SPECS/ARIB-STD-T120/Rel15/36/A36465-f00.pdf</a>
ATIS	ATIS.3GPP.36.465V1500	15.0.0	Published	28.06.2021	<a href="https://www.atis.org/3gpp-documents/Rel15/">https://www.atis.org/3gpp-documents/Rel15/</a>
CCSA	CCSA.36.465V1500	15.0.0	Published	01.06.2018	<a href="https://www.ccsa.org.cn/api/portalsFile/downloadOldFile?type=19&amp;oldFileUrl=ITU-R/M.2012-6/CCSA.36.465V1500.doc">https://www.ccsa.org.cn/api/portalsFile/downloadOldFile?type=19&amp;oldFileUrl=ITU-R/M.2012-6/CCSA.36.465V1500.doc</a>
ETSI	ETSI TS 136 465	15.0.0	Published	04.07.2018	<a href="https://www.etsi.org/deliver/etsi_ts/136400_136499/136465/15.00.00_60/ts_136465v150000p.pdf">https://www.etsi.org/deliver/etsi_ts/136400_136499/136465/15.00.00_60/ts_136465v150000p.pdf</a>
TSDSI	TSDSI STD T1.3GPP 36.465-15.0.0 V1.0.0	15.0.0	Published	30.08.2021	<a href="https://members.tdsi.in/index.php/s/e4Br8i7KAjNkSTB">https://members.tdsi.in/index.php/s/e4Br8i7KAjNkSTB</a>
TTA	TTAT.3G-36.465V15.0.0	15.0.0	Published	11.09.2020	<a href="http://committee.tta.or.kr/data/ttasDown.jsp?kind=ttastd&amp;pk_num=TTAT.3G-36.465V15.0.0">http://committee.tta.or.kr/data/ttasDown.jsp?kind=ttastd&amp;pk_num=TTAT.3G-36.465V15.0.0</a>
<b>Release 16</b>					
ARIB	ARIB STD-T120-36.465.V16.0.0	16.0.0	Published	03.03.2023	<a href="https://www.arib.or.jp/english/html/overview/doc/T120_T23_SPECS/ARIB-STD-T120/Rel16/36/A36465-g00.pdf">https://www.arib.or.jp/english/html/overview/doc/T120_T23_SPECS/ARIB-STD-T120/Rel16/36/A36465-g00.pdf</a>
ATIS	ATIS.3GPP.36.465V1600	16.0.0	Published	28.06.2021	<a href="https://www.atis.org/3gpp-documents/Rel16/">https://www.atis.org/3gpp-documents/Rel16/</a>
CCSA	CCSA.36.465V1600	16.0.0	Published	01.07.2020	<a href="https://www.ccsa.org.cn/api/portalsFile/downloadOldFile?type=19&amp;oldFileUrl=ITU-R/M.2012-6/CCSA.36.465V1600.doc">https://www.ccsa.org.cn/api/portalsFile/downloadOldFile?type=19&amp;oldFileUrl=ITU-R/M.2012-6/CCSA.36.465V1600.doc</a>
ETSI	ETSI TS 136 465	16.0.0	Published	21.07.2020	<a href="https://www.etsi.org/deliver/etsi_ts/136400_136499/136465/16.00.00_60/ts_136465v160000p.pdf">https://www.etsi.org/deliver/etsi_ts/136400_136499/136465/16.00.00_60/ts_136465v160000p.pdf</a>
TSDSI	TSDSI STD T1.3GPP 36.465-16.0.0 V1.0.0	16.0.0	Published	30.08.2021	<a href="https://members.tdsi.in/index.php/s/si9g3X7gKpXAqM2">https://members.tdsi.in/index.php/s/si9g3X7gKpXAqM2</a>
TTA	TTAT.3G-36.465V16.0.0	16.0.0	Published	11.09.2020	<a href="http://committee.tta.or.kr/data/ttasDown.jsp?kind=ttastd&amp;pk_num=TTAT.3G-36.465V16.0.0">http://committee.tta.or.kr/data/ttasDown.jsp?kind=ttastd&amp;pk_num=TTAT.3G-36.465V16.0.0</a>
<b>Release 17</b>					
ARIB	ARIB STD-T120-36.465.V17.0.0	17.0.0	Published	03.03.2023	<a href="https://www.arib.or.jp/english/html/overview/doc/T120_T23_SPECS/ARIB-STD-T120/Rel17/36/A36465-h00.pdf">https://www.arib.or.jp/english/html/overview/doc/T120_T23_SPECS/ARIB-STD-T120/Rel17/36/A36465-h00.pdf</a>
ATIS	ATIS.3GPP.36.465.V17.0.0	17.0.0	Published	21.02.2023	<a href="https://www.atis.org/3gpp-transpositions-Rel-17/">https://www.atis.org/3gpp-transpositions-Rel-17/</a>
CCSA	CCSA.36.465V1700	17.0.0	Published	01.04.2022	<a href="https://www.ccsa.org.cn/api/portalsFile/downloadOldFile?type=19&amp;oldFileUrl=ITU-R/M.2012-6/CCSA.36.465V1700.doc">https://www.ccsa.org.cn/api/portalsFile/downloadOldFile?type=19&amp;oldFileUrl=ITU-R/M.2012-6/CCSA.36.465V1700.doc</a>
ETSI	ETSI TS 136 465	17.0.0	Published	29.04.2022	<a href="https://www.etsi.org/deliver/etsi_ts/136400_136499/136465/17.00.00_60/ts_136465v170000p.pdf">https://www.etsi.org/deliver/etsi_ts/136400_136499/136465/17.00.00_60/ts_136465v170000p.pdf</a>
TSDSI	TSDSI STD T1.3GPP 36.465-17.0.0 V1.0.0	17.0.0	Published	29.07.2022	<a href="https://members.tdsi.in/s/KaifEzQBkTeazXf">https://members.tdsi.in/s/KaifEzQBkTeazXf</a>
TTA	TTAT.3G-36.465V17.0.0	17.0.0	Published	05.08.2022	<a href="http://committee.tta.or.kr/data/ttasDown.jsp?kind=ttastd&amp;pk_num=TTAT.3G-36.465V17.0.0">http://committee.tta.or.kr/data/ttasDown.jsp?kind=ttastd&amp;pk_num=TTAT.3G-36.465V17.0.0</a>

**2.1.4.29 TS 37.460****Iuant interface: General aspects and principles**

This document is an introduction to the 3GPP TS 37.46x series of Technical Specifications that define the Iuant Interface. The Iuant interface is applicable for UTRAN, E-UTRAN and NG-RAN. In this specification UTRAN, E-UTRAN and NG-RAN are denoted as "RAN", whereas the corresponding network entities Node B, eNB, en-gNB and NG-RAN node are denoted as "RAN Node". The logical Iuant interface is an interface internal to the RAN Node and defined to reside between the implementation specific O&M function and the RET antennas and between the implementation specific O&M function and the TMA control unit function.

SDO	Document No.	Version	Status	Issued date	Location
<b>Release 10</b>					
ARIB	ARIB STD-T120-37.460.V10.1.0	10.1.0	Published	03.03.2023	<a href="https://www.arib.or.jp/english/html/overview/doc/T120_T23_SPECS/ARIB-STD-T120/Rel10/37/A37460-a10.pdf">https://www.arib.or.jp/english/html/overview/doc/T120_T23_SPECS/ARIB-STD-T120/Rel10/37/A37460-a10.pdf</a>
ATIS	ATIS.3GPP.37.460V1010	10.1.0	Published	28.06.2021	<a href="https://www.atis.org/3gpp-documents/Rel99-14/">https://www.atis.org/3gpp-documents/Rel99-14/</a>
CCSA	CCSA.37.460V1010	10.1.0	Published	01.04.2019	<a href="https://www.ccsa.org.cn/api/portalsFile/downloadOldFile?type=19&amp;oldFileUrl=ITU-R/M.2012-6/CCSA.37.460V1010.doc">https://www.ccsa.org.cn/api/portalsFile/downloadOldFile?type=19&amp;oldFileUrl=ITU-R/M.2012-6/CCSA.37.460V1010.doc</a>
ETSI	ETSI TS 137 460	10.1.0	Published	15.05.2019	<a href="https://www.etsi.org/deliver/etsi_ts/137400_137499/137460/10.01.00_60/ts_137460v100100p.pdf">https://www.etsi.org/deliver/etsi_ts/137400_137499/137460/10.01.00_60/ts_137460v100100p.pdf</a>
TSDSI	TSDSI STD T1.3GPP 37.460-10.1.0 V1.0.0	10.1.0	Published	30.08.2021	<a href="https://members.tdsi.in/index.php/s/RZSKyJaYKAq9fEP">https://members.tdsi.in/index.php/s/RZSKyJaYKAq9fEP</a>
TTA	TTAT.3G-37.460V10.1.0	10.1.0	Published	02.08.2021	<a href="http://committee.tta.or.kr/data/ttasDown.jsp?kind=ttastd&amp;pk_num=TTAT.3G-37.460V10.1.0">http://committee.tta.or.kr/data/ttasDown.jsp?kind=ttastd&amp;pk_num=TTAT.3G-37.460V10.1.0</a>
<b>Release 11</b>					
ARIB	ARIB STD-T120-37.460.V11.1.0	11.1.0	Published	03.03.2023	<a href="https://www.arib.or.jp/english/html/overview/doc/T120_T23_SPECS/ARIB-STD-T120/Rel11/37/A37460-b10.pdf">https://www.arib.or.jp/english/html/overview/doc/T120_T23_SPECS/ARIB-STD-T120/Rel11/37/A37460-b10.pdf</a>
ATIS	ATIS.3GPP.37.460V1110	11.1.0	Published	28.06.2021	<a href="https://www.atis.org/3gpp-documents/Rel99-14/">https://www.atis.org/3gpp-documents/Rel99-14/</a>
CCSA	CCSA.37.460V1110	11.1.0	Published	01.04.2019	<a href="https://www.ccsa.org.cn/api/portalsFile/downloadOldFile?type=19&amp;oldFileUrl=ITU-R/M.2012-6/CCSA.37.460V1110.doc">https://www.ccsa.org.cn/api/portalsFile/downloadOldFile?type=19&amp;oldFileUrl=ITU-R/M.2012-6/CCSA.37.460V1110.doc</a>
ETSI	ETSI TS 137 460	11.1.0	Published	15.05.2019	<a href="https://www.etsi.org/deliver/etsi_ts/137400_137499/137460/11.01.00_60/ts_137460v110100p.pdf">https://www.etsi.org/deliver/etsi_ts/137400_137499/137460/11.01.00_60/ts_137460v110100p.pdf</a>
TSDSI	TSDSI STD T1.3GPP 37.460-11.1.0 V1.0.0	11.1.0	Published	30.08.2021	<a href="https://members.tdsi.in/index.php/s/ed2324f5sQap9yL">https://members.tdsi.in/index.php/s/ed2324f5sQap9yL</a>
TTA	TTAT.3G-37.460V11.1.0	11.1.0	Published	02.08.2021	<a href="http://committee.tta.or.kr/data/ttasDown.jsp?kind=ttastd&amp;pk_num=TTAT.3G-37.460V11.1.0">http://committee.tta.or.kr/data/ttasDown.jsp?kind=ttastd&amp;pk_num=TTAT.3G-37.460V11.1.0</a>
<b>Release 12</b>					
ARIB	ARIB STD-T120-37.460.V12.1.0	12.1.0	Published	03.03.2023	<a href="https://www.arib.or.jp/english/html/overview/doc/T120_T23_SPECS/ARIB-STD-T120/Rel12/37/A37460-c10.pdf">https://www.arib.or.jp/english/html/overview/doc/T120_T23_SPECS/ARIB-STD-T120/Rel12/37/A37460-c10.pdf</a>
ATIS	ATIS.3GPP.37.460V1210	12.1.0	Published	28.06.2021	<a href="https://www.atis.org/3gpp-documents/Rel99-14/">https://www.atis.org/3gpp-documents/Rel99-14/</a>
CCSA	CCSA.37.460V1210	12.1.0	Published	01.04.2019	<a href="https://www.ccsa.org.cn/api/portalsFile/downloadOldFile?type=19&amp;oldFileUrl=ITU-R/M.2012-6/CCSA.37.460V1210.doc">https://www.ccsa.org.cn/api/portalsFile/downloadOldFile?type=19&amp;oldFileUrl=ITU-R/M.2012-6/CCSA.37.460V1210.doc</a>
ETSI	ETSI TS 137 460	12.1.0	Published	15.05.2019	<a href="https://www.etsi.org/deliver/etsi_ts/137400_137499/137460/12.01.00_60/ts_137460v120100p.pdf">https://www.etsi.org/deliver/etsi_ts/137400_137499/137460/12.01.00_60/ts_137460v120100p.pdf</a>
TSDSI	TSDSI STD T1.3GPP 37.460-12.1.0 V1.0.0	12.1.0	Published	30.08.2021	<a href="https://members.tdsi.in/index.php/s/6o6wYKn9ApFyHcf">https://members.tdsi.in/index.php/s/6o6wYKn9ApFyHcf</a>
TTA	TTAT.3G-37.460V12.1.0	12.1.0	Published	02.08.2021	<a href="http://committee.tta.or.kr/data/ttasDown.jsp?kind=ttastd&amp;pk_num=TTAT.3G-37.460V12.1.0">http://committee.tta.or.kr/data/ttasDown.jsp?kind=ttastd&amp;pk_num=TTAT.3G-37.460V12.1.0</a>
<b>Release 13</b>					
ARIB	ARIB STD-T120-37.460.V13.1.0	13.1.0	Published	03.03.2023	<a href="https://www.arib.or.jp/english/html/overview/doc/T120_T23_SPECS/ARIB-STD-T120/Rel13/37/A37460-d10.pdf">https://www.arib.or.jp/english/html/overview/doc/T120_T23_SPECS/ARIB-STD-T120/Rel13/37/A37460-d10.pdf</a>
ATIS	ATIS.3GPP.37.460V1310	13.1.0	Published	28.06.2021	<a href="https://www.atis.org/3gpp-documents/Rel99-14/">https://www.atis.org/3gpp-documents/Rel99-14/</a>
CCSA	CCSA.37.460V1310	13.1.0	Published	01.01.2019	<a href="https://www.ccsa.org.cn/api/portalsFile/downloadOldFile?type=19&amp;oldFileUrl=ITU-R/M.2012-6/CCSA.37.460V1310.doc">https://www.ccsa.org.cn/api/portalsFile/downloadOldFile?type=19&amp;oldFileUrl=ITU-R/M.2012-6/CCSA.37.460V1310.doc</a>
ETSI	ETSI TS 137 460	13.1.0	Published	15.05.2019	<a href="https://www.etsi.org/deliver/etsi_ts/137400_137499/137460/13.01.00_60/ts_137460v130100p.pdf">https://www.etsi.org/deliver/etsi_ts/137400_137499/137460/13.01.00_60/ts_137460v130100p.pdf</a>
TSDSI	TSDSI STD T1.3GPP 37.460-13.1.0 V1.0.0	13.1.0	Published	30.08.2021	<a href="https://members.tdsi.in/index.php/s/BbWjkYcaXK7HEjv">https://members.tdsi.in/index.php/s/BbWjkYcaXK7HEjv</a>
TTA	TTAT.3G-37.460V13.1.0	13.1.0	Published	02.08.2021	<a href="http://committee.tta.or.kr/data/ttasDown.jsp?kind=ttastd&amp;pk_num=TTAT.3G-37.460V13.1.0">http://committee.tta.or.kr/data/ttasDown.jsp?kind=ttastd&amp;pk_num=TTAT.3G-37.460V13.1.0</a>
<b>Release 14</b>					
ARIB	ARIB STD-T120-37.460.V14.1.0	14.1.0	Published	03.03.2023	<a href="https://www.arib.or.jp/english/html/overview/doc/T120_T23_SPECS/ARIB-STD-T120/Rel14/37/A37460-e10.pdf">https://www.arib.or.jp/english/html/overview/doc/T120_T23_SPECS/ARIB-STD-T120/Rel14/37/A37460-e10.pdf</a>
ATIS	ATIS.3GPP.37.460V1410	14.1.0	Published	28.06.2021	<a href="https://www.atis.org/3gpp-documents/Rel99-14/">https://www.atis.org/3gpp-documents/Rel99-14/</a>
CCSA	CCSA.37.460V1410	14.1.0	Published	01.04.2019	<a href="https://www.ccsa.org.cn/api/portalsFile/downloadOldFile?type=19&amp;oldFileUrl=ITU-R/M.2012-6/CCSA.37.460V1410.doc">https://www.ccsa.org.cn/api/portalsFile/downloadOldFile?type=19&amp;oldFileUrl=ITU-R/M.2012-6/CCSA.37.460V1410.doc</a>
ETSI	ETSI TS 137 460	14.1.0	Published	15.05.2019	<a href="https://www.etsi.org/deliver/etsi_ts/137400_137499/137460/14.01.00_60/ts_137460v140100p.pdf">https://www.etsi.org/deliver/etsi_ts/137400_137499/137460/14.01.00_60/ts_137460v140100p.pdf</a>
TSDSI	TSDSI STD T1.3GPP 37.460-14.1.0 V1.0.0	14.1.0	Published	30.08.2021	<a href="https://members.tdsi.in/index.php/s/oEPaP5L777ZA546">https://members.tdsi.in/index.php/s/oEPaP5L777ZA546</a>
TTA	TTAT.3G-37.460V14.1.0	14.1.0	Published	02.08.2021	<a href="http://committee.tta.or.kr/data/ttasDown.jsp?kind=ttastd&amp;pk_num=TTAT.3G-37.460V14.1.0">http://committee.tta.or.kr/data/ttasDown.jsp?kind=ttastd&amp;pk_num=TTAT.3G-37.460V14.1.0</a>

<b>Release 15</b>					
ARIB	ARIB STD-T120-37.460.V15.2.0	15.2.0	Published	03.03.2023	<a href="https://www.arib.or.jp/english/html/overview/doc/T120_T23_SPECS/ARIB-STD-T120/Rel15/37/A37460-f20.pdf">https://www.arib.or.jp/english/html/overview/doc/T120_T23_SPECS/ARIB-STD-T120/Rel15/37/A37460-f20.pdf</a>
ATIS	ATIS.3GPP.37.460V1520	15.2.0	Published	28.06.2021	<a href="https://www.atis.org/3gpp-documents/Rel15/">https://www.atis.org/3gpp-documents/Rel15/</a>
CCSA	CCSA.37.460V1520	15.2.0	Published	01.12.2019	<a href="https://www.ccsa.org.cn/api/portalsFile/downloadOldFile?type=19&amp;oldFileUrl=ITU-R/M.2012-6/CCSA.37.460V1520.doc">https://www.ccsa.org.cn/api/portalsFile/downloadOldFile?type=19&amp;oldFileUrl=ITU-R/M.2012-6/CCSA.37.460V1520.doc</a>
ETSI	ETSI TS 137 460	15.2.0	Published	17.01.2020	<a href="https://www.etsi.org/deliver/etsi_ts/137400_137499/137460/15.02.00_60/ts_137460v150200p.pdf">https://www.etsi.org/deliver/etsi_ts/137400_137499/137460/15.02.00_60/ts_137460v150200p.pdf</a>
TSDSI	TSDSI STD T1.3GPP 37.460-15.2.0 V1.0.0	15.2.0	Published	30.08.2021	<a href="https://members.tdsi.in/index.php/s/C3SDXoFkzxmPeeM">https://members.tdsi.in/index.php/s/C3SDXoFkzxmPeeM</a>
TTA	TTAT.3G-37.460V15.2.0	15.2.0	Published	11.09.2020	<a href="http://committee.tta.or.kr/data/ttasDown.jsp?kind=ttastd&amp;pk_num=TTAT.3G-37.460V15.2.0">http://committee.tta.or.kr/data/ttasDown.jsp?kind=ttastd&amp;pk_num=TTAT.3G-37.460V15.2.0</a>
<b>Release 16</b>					
ARIB	ARIB STD-T120-37.460.V16.0.0	16.0.0	Published	03.03.2023	<a href="https://www.arib.or.jp/english/html/overview/doc/T120_T23_SPECS/ARIB-STD-T120/Rel16/37/A37460-g00.pdf">https://www.arib.or.jp/english/html/overview/doc/T120_T23_SPECS/ARIB-STD-T120/Rel16/37/A37460-g00.pdf</a>
ATIS	ATIS.3GPP.37.460V1600	16.0.0	Published	28.06.2021	<a href="https://www.atis.org/3gpp-documents/Rel16/">https://www.atis.org/3gpp-documents/Rel16/</a>
CCSA	CCSA.37.460V1600	16.0.0	Published	01.07.2020	<a href="https://www.ccsa.org.cn/api/portalsFile/downloadOldFile?type=19&amp;oldFileUrl=ITU-R/M.2012-6/CCSA.37.460V1600.doc">https://www.ccsa.org.cn/api/portalsFile/downloadOldFile?type=19&amp;oldFileUrl=ITU-R/M.2012-6/CCSA.37.460V1600.doc</a>
ETSI	ETSI TS 137 460	16.0.0	Published	15.09.2020	<a href="https://www.etsi.org/deliver/etsi_ts/137400_137499/137460/16.00.00_60/ts_137460v160000p.pdf">https://www.etsi.org/deliver/etsi_ts/137400_137499/137460/16.00.00_60/ts_137460v160000p.pdf</a>
TSDSI	TSDSI STD T1.3GPP 37.460-16.0.0 V1.0.0	16.0.0	Published	30.08.2021	<a href="https://members.tdsi.in/index.php/s/3HG7csB4NabyzNQ">https://members.tdsi.in/index.php/s/3HG7csB4NabyzNQ</a>
TTA	TTAT.3G-37.460V16.0.0	16.0.0	Published	11.09.2020	<a href="http://committee.tta.or.kr/data/ttasDown.jsp?kind=ttastd&amp;pk_num=TTAT.3G-37.460V16.0.0">http://committee.tta.or.kr/data/ttasDown.jsp?kind=ttastd&amp;pk_num=TTAT.3G-37.460V16.0.0</a>
<b>Release 17</b>					
ARIB	ARIB STD-T120-37.460.V17.0.0	17.0.0	Published	03.03.2023	<a href="https://www.arib.or.jp/english/html/overview/doc/T120_T23_SPECS/ARIB-STD-T120/Rel17/37/A37460-h00.pdf">https://www.arib.or.jp/english/html/overview/doc/T120_T23_SPECS/ARIB-STD-T120/Rel17/37/A37460-h00.pdf</a>
ATIS	ATIS.3GPP.37.460.V17.0.0	17.0.0	Published	21.02.2023	<a href="https://www.atis.org/3gpp-transpositions - Rel-17">https://www.atis.org/3gpp-transpositions - Rel-17</a>
CCSA	CCSA.37.460V1700	17.0.0	Published	01.04.2022	<a href="https://www.ccsa.org.cn/api/portalsFile/downloadOldFile?type=19&amp;oldFileUrl=ITU-R/M.2012-6/CCSA.37.460V1700.doc">https://www.ccsa.org.cn/api/portalsFile/downloadOldFile?type=19&amp;oldFileUrl=ITU-R/M.2012-6/CCSA.37.460V1700.doc</a>
ETSI	ETSI TS 137 460	17.0.0	Published	29.04.2022	<a href="https://www.etsi.org/deliver/etsi_ts/137400_137499/137460/17.00.00_60/ts_137460v170000p.pdf">https://www.etsi.org/deliver/etsi_ts/137400_137499/137460/17.00.00_60/ts_137460v170000p.pdf</a>
TSDSI	TSDSI STD T1.3GPP 37.46-17.0.0 V1.0.0	17.0.0	Published	29.07.2022	<a href="https://members.tdsi.in/s/6jndrFL9wmEZ9S9">https://members.tdsi.in/s/6jndrFL9wmEZ9S9</a>
TTA	TTAT.3G-37.460V17.0.0	17.0.0	Published	05.08.2022	<a href="http://committee.tta.or.kr/data/ttasDown.jsp?kind=ttastd&amp;pk_num=TTAT.3G-37.460V17.0.0">http://committee.tta.or.kr/data/ttasDown.jsp?kind=ttastd&amp;pk_num=TTAT.3G-37.460V17.0.0</a>

### 2.1.4.30 TS 37.461

#### Iuant interface: Layer 1

This document specifies the standards allowed to implement layer 1 on the Iuant interface for UTRA, E-UTRA and NR. The specification of transmission delay requirements and O&M requirements are not in the scope of this document.

SDO	Document No.	Version	Status	Issued date	Location
<b>Release 10</b>					
ARIB	ARIB STD-T120-37.461.V10.3.0	10.3.0	Published	03.03.2023	<a href="https://www.arib.or.jp/english/html/overview/doc/T120_T23_SPECS/ARIB-STD-T120/Rel10/37/A37461-a30.pdf">https://www.arib.or.jp/english/html/overview/doc/T120_T23_SPECS/ARIB-STD-T120/Rel10/37/A37461-a30.pdf</a>
ATIS	ATIS.3GPP.37.461V1030	10.3.0	Published	28.06.2021	<a href="https://www.atis.org/3gpp-documents/Rel99-14/">https://www.atis.org/3gpp-documents/Rel99-14/</a>
CCSA	CCSA.37.461V1030	10.3.0	Published	01.04.2019	<a href="https://www.ccsa.org.cn/api/portalsFile/downloadOldFile?type=19&amp;oldFileUrl=ITU-R/M.2012-6/CCSA.37.461V1030.doc">https://www.ccsa.org.cn/api/portalsFile/downloadOldFile?type=19&amp;oldFileUrl=ITU-R/M.2012-6/CCSA.37.461V1030.doc</a>
ETSI	ETSI TS 137 461	10.3.0	Published	15.05.2019	<a href="https://www.etsi.org/deliver/etsi_ts/137400_137499/137461/10.03.00_60/ts_137461v100300p.pdf">https://www.etsi.org/deliver/etsi_ts/137400_137499/137461/10.03.00_60/ts_137461v100300p.pdf</a>
TSDSI	TSDSI STD T1.3GPP 37.461-10.3.0 V1.0.0	10.3.0	Published	30.08.2021	<a href="https://members.tdsi.in/index.php/s/qWekbjrDTY7k7sM">https://members.tdsi.in/index.php/s/qWekbjrDTY7k7sM</a>
TTA	TTAT.3G-37.461V10.3.0	10.3.0	Published	02.08.2021	<a href="http://committee.tta.or.kr/data/ttasDown.jsp?kind=ttastd&amp;pk_num=TTAT.3G-37.461V10.3.0">http://committee.tta.or.kr/data/ttasDown.jsp?kind=ttastd&amp;pk_num=TTAT.3G-37.461V10.3.0</a>
<b>Release 11</b>					
ARIB	ARIB STD-T120-37.461.V11.3.0	11.3.0	Published	03.03.2023	<a href="https://www.arib.or.jp/english/html/overview/doc/T120_T23_SPECS/ARIB-STD-T120/Rel11/37/A37461-b30.pdf">https://www.arib.or.jp/english/html/overview/doc/T120_T23_SPECS/ARIB-STD-T120/Rel11/37/A37461-b30.pdf</a>
ATIS	ATIS.3GPP.37.461V1130	11.3.0	Published	28.06.2021	<a href="https://www.atis.org/3gpp-documents/Rel99-14/">https://www.atis.org/3gpp-documents/Rel99-14/</a>
CCSA	CCSA.37.461V1130	11.3.0	Published	01.04.2019	<a href="https://www.ccsa.org.cn/api/portalsFile/downloadOldFile?type=19&amp;oldFileUrl=ITU-R/M.2012-6/CCSA.37.461V1130.doc">https://www.ccsa.org.cn/api/portalsFile/downloadOldFile?type=19&amp;oldFileUrl=ITU-R/M.2012-6/CCSA.37.461V1130.doc</a>
ETSI	ETSI TS 137 461	11.3.0	Published	15.05.2019	<a href="https://www.etsi.org/deliver/etsi_ts/137400_137499/137461/11.03.00_60/ts_137461v110300p.pdf">https://www.etsi.org/deliver/etsi_ts/137400_137499/137461/11.03.00_60/ts_137461v110300p.pdf</a>
TSDSI	TSDSI STD T1.3GPP 37.461-11.3.0 V1.0.0	11.3.0	Published	30.08.2021	<a href="https://members.tdsi.in/index.php/s/pmJ3NgrBWWPqyzq">https://members.tdsi.in/index.php/s/pmJ3NgrBWWPqyzq</a>
TTA	TTAT.3G-37.461V11.3.0	11.3.0	Published	02.08.2021	<a href="http://committee.tta.or.kr/data/ttasDown.jsp?kind=ttastd&amp;pk_num=TTAT.3G-37.461V11.3.0">http://committee.tta.or.kr/data/ttasDown.jsp?kind=ttastd&amp;pk_num=TTAT.3G-37.461V11.3.0</a>

<b>Release 12</b>									
ARIB	ARIB STD-T120-37.461.V12.2.0	12.2.0	Published	03.03.2023	<a href="https://www.arib.or.jp/english/html/overview/doc/T120_T23_SPECS/ARIB-STD-T120/Rel12/37/A37461-c20.pdf">https://www.arib.or.jp/english/html/overview/doc/T120_T23_SPECS/ARIB-STD-T120/Rel12/37/A37461-c20.pdf</a>				
ATIS	ATIS.3GPP.37.461V1220	12.2.0	Published	28.06.2021	<a href="https://www.atis.org/3gpp-documents/Rel99-14/">https://www.atis.org/3gpp-documents/Rel99-14/</a>				
CCSA	CCSA.37.461V1220	12.2.0	Published	01.04.2019	<a href="https://www.ccsa.org.cn/api/portalsFile/downloadOldFile?type=19&amp;oldFileUrl=ITU-R/M.2012-6/CCSA.37.461V1220.doc">https://www.ccsa.org.cn/api/portalsFile/downloadOldFile?type=19&amp;oldFileUrl=ITU-R/M.2012-6/CCSA.37.461V1220.doc</a>				
ETSI	ETSI TS 137 461	12.2.0	Published	15.05.2019	<a href="https://www.etsi.org/deliver/etsi_ts/137400_137499/137461/12.02.00_60/ts_137461v120200p.pdf">https://www.etsi.org/deliver/etsi_ts/137400_137499/137461/12.02.00_60/ts_137461v120200p.pdf</a>				
TSDSI	TSDSI STD T1.3GPP 37.461-12.2.0 V1.0.0	12.2.0	Published	30.08.2021	<a href="https://members.tdsi.in/index.php/s/27danogXaPN2ZPb">https://members.tdsi.in/index.php/s/27danogXaPN2ZPb</a>				
TTA	TTAT.3G-37.461V12.2.0	12.2.0	Published	02.08.2021	<a href="http://committee.tta.or.kr/data/ttasDown.jsp?kind=ttastd&amp;pk_num=TTAT.3G-37.461V12.2.0">http://committee.tta.or.kr/data/ttasDown.jsp?kind=ttastd&amp;pk_num=TTAT.3G-37.461V12.2.0</a>				
<b>Release 13</b>									
ARIB	ARIB STD-T120-37.461.V13.2.0	13.2.0	Published	03.03.2023	<a href="https://www.arib.or.jp/english/html/overview/doc/T120_T23_SPECS/ARIB-STD-T120/Rel13/37/A37461-d20.pdf">https://www.arib.or.jp/english/html/overview/doc/T120_T23_SPECS/ARIB-STD-T120/Rel13/37/A37461-d20.pdf</a>				
ATIS	ATIS.3GPP.37.461V1320	13.2.0	Published	28.06.2021	<a href="https://www.atis.org/3gpp-documents/Rel99-14/">https://www.atis.org/3gpp-documents/Rel99-14/</a>				
CCSA	CCSA.37.461V1320	13.2.0	Published	01.04.2019	<a href="https://www.ccsa.org.cn/api/portalsFile/downloadOldFile?type=19&amp;oldFileUrl=ITU-R/M.2012-6/CCSA.37.461V1320.doc">https://www.ccsa.org.cn/api/portalsFile/downloadOldFile?type=19&amp;oldFileUrl=ITU-R/M.2012-6/CCSA.37.461V1320.doc</a>				
ETSI	ETSI TS 137 461	13.2.0	Published	15.05.2019	<a href="https://www.etsi.org/deliver/etsi_ts/137400_137499/137461/13.02.00_60/ts_137461v130200p.pdf">https://www.etsi.org/deliver/etsi_ts/137400_137499/137461/13.02.00_60/ts_137461v130200p.pdf</a>				
TSDSI	TSDSI STD T1.3GPP 37.461-13.2.0 V1.0.0	13.2.0	Published	30.08.2021	<a href="https://members.tdsi.in/index.php/s/Co4p6378eSQZfM9">https://members.tdsi.in/index.php/s/Co4p6378eSQZfM9</a>				
TTA	TTAT.3G-37.461V13.2.0	13.2.0	Published	02.08.2021	<a href="http://committee.tta.or.kr/data/ttasDown.jsp?kind=ttastd&amp;pk_num=TTAT.3G-37.461V13.2.0">http://committee.tta.or.kr/data/ttasDown.jsp?kind=ttastd&amp;pk_num=TTAT.3G-37.461V13.2.0</a>				
<b>Release 14</b>									
ARIB	ARIB STD-T120-37.461.V14.2.0	14.2.0	Published	03.03.2023	<a href="https://www.arib.or.jp/english/html/overview/doc/T120_T23_SPECS/ARIB-STD-T120/Rel14/37/A37461-e20.pdf">https://www.arib.or.jp/english/html/overview/doc/T120_T23_SPECS/ARIB-STD-T120/Rel14/37/A37461-e20.pdf</a>				
ATIS	ATIS.3GPP.37.461V1420	14.2.0	Published	28.06.2021	<a href="https://www.atis.org/3gpp-documents/Rel99-14/">https://www.atis.org/3gpp-documents/Rel99-14/</a>				
CCSA	CCSA.37.461V1420	14.2.0	Published	01.04.2019	<a href="https://www.ccsa.org.cn/api/portalsFile/downloadOldFile?type=19&amp;oldFileUrl=ITU-R/M.2012-6/CCSA.37.461V1420.doc">https://www.ccsa.org.cn/api/portalsFile/downloadOldFile?type=19&amp;oldFileUrl=ITU-R/M.2012-6/CCSA.37.461V1420.doc</a>				
ETSI	ETSI TS 137 461	14.2.0	Published	15.05.2019	<a href="https://www.etsi.org/deliver/etsi_ts/137400_137499/137461/14.02.00_60/ts_137461v140200p.pdf">https://www.etsi.org/deliver/etsi_ts/137400_137499/137461/14.02.00_60/ts_137461v140200p.pdf</a>				
TSDSI	TSDSI STD T1.3GPP 37.461-14.2.0 V1.0.0	14.2.0	Published	30.08.2021	<a href="https://members.tdsi.in/index.php/s/DGMnMbJ7kD22BNB">https://members.tdsi.in/index.php/s/DGMnMbJ7kD22BNB</a>				
TTA	TTAT.3G-37.461V14.2.0	14.2.0	Published	02.08.2021	<a href="http://committee.tta.or.kr/data/ttasDown.jsp?kind=ttastd&amp;pk_num=TTAT.3G-37.461V14.2.0">http://committee.tta.or.kr/data/ttasDown.jsp?kind=ttastd&amp;pk_num=TTAT.3G-37.461V14.2.0</a>				
<b>Release 15</b>									
ARIB	ARIB STD-T120-37.461.V15.5.0	15.5.0	Published	03.03.2023	<a href="https://www.arib.or.jp/english/html/overview/doc/T120_T23_SPECS/ARIB-STD-T120/Rel15/37/A37461-f50.pdf">https://www.arib.or.jp/english/html/overview/doc/T120_T23_SPECS/ARIB-STD-T120/Rel15/37/A37461-f50.pdf</a>				
ATIS	ATIS.3GPP.37.461.V15.5.0	15.5.0	Published	21.02.2023	<a href="https://www.atis.org/3gpp-transpositions - Rel-15">https://www.atis.org/3gpp-transpositions - Rel-15</a>				
CCSA	CCSA.37.461V1550	15.5.0	Published	01.06.2022	<a href="https://www.ccsa.org.cn/api/portalsFile/downloadOldFile?type=19&amp;oldFileUrl=ITU-R/M.2012-6/CCSA.37.461V1550.doc">https://www.ccsa.org.cn/api/portalsFile/downloadOldFile?type=19&amp;oldFileUrl=ITU-R/M.2012-6/CCSA.37.461V1550.doc</a>				
ETSI	ETSI TS 137 461	15.5.0	Published	20.07.2022	<a href="https://www.etsi.org/deliver/etsi_ts/137400_137499/137461/15.05.00_60/ts_137461v150500p.pdf">https://www.etsi.org/deliver/etsi_ts/137400_137499/137461/15.05.00_60/ts_137461v150500p.pdf</a>				
TSDSI	TSDSI STD T1.3GPP 37.461-15.5.0 V1.1.0	15.5.0	Published	01.11.2022	<a href="https://members.tdsi.in/s/aT4ZWf4j3boQdji">https://members.tdsi.in/s/aT4ZWf4j3boQdji</a>				
TTA	TTAT.3G-37.461V15.5.0	15.5.0	Published	21.10.2022	<a href="http://committee.tta.or.kr/data/ttasDown.jsp?kind=ttastd&amp;pk_num=TTAT.3G-37.461V15.5.0">http://committee.tta.or.kr/data/ttasDown.jsp?kind=ttastd&amp;pk_num=TTAT.3G-37.461V15.5.0</a>				
<b>Release 16</b>									
ARIB	ARIB STD-T120-37.461.V16.1.0	16.1.0	Published	03.03.2023	<a href="https://www.arib.or.jp/english/html/overview/doc/T120_T23_SPECS/ARIB-STD-T120/Rel16/37/A37461-g10.pdf">https://www.arib.or.jp/english/html/overview/doc/T120_T23_SPECS/ARIB-STD-T120/Rel16/37/A37461-g10.pdf</a>				
ATIS	ATIS.3GPP.37.461.V16.1.0	16.1.0	Published	21.02.2023	<a href="https://www.atis.org/3gpp-transpositions - Rel-16">https://www.atis.org/3gpp-transpositions - Rel-16</a>				
CCSA	CCSA.37.461V1610	16.1.0	Published	01.06.2022	<a href="https://www.ccsa.org.cn/api/portalsFile/downloadOldFile?type=19&amp;oldFileUrl=ITU-R/M.2012-6/CCSA.37.461V1610.doc">https://www.ccsa.org.cn/api/portalsFile/downloadOldFile?type=19&amp;oldFileUrl=ITU-R/M.2012-6/CCSA.37.461V1610.doc</a>				
ETSI	ETSI TS 137 461	16.1.0	Published	20.07.2022	<a href="https://www.etsi.org/deliver/etsi_ts/137400_137499/137461/16.01.00_60/ts_137461v160100p.pdf">https://www.etsi.org/deliver/etsi_ts/137400_137499/137461/16.01.00_60/ts_137461v160100p.pdf</a>				
TSDSI	TSDSI STD T1.3GPP 37.461-16.1.0 V1.1.0	16.1.0	Published	01.11.2022	<a href="https://members.tdsi.in/s/iN9sbCdnNQYxFpa">https://members.tdsi.in/s/iN9sbCdnNQYxFpa</a>				
TTA	TTAT.3G-37.461V16.1.0	16.1.0	Published	21.10.2022	<a href="http://committee.tta.or.kr/data/ttasDown.jsp?kind=ttastd&amp;pk_num=TTAT.3G-37.461V16.1.0">http://committee.tta.or.kr/data/ttasDown.jsp?kind=ttastd&amp;pk_num=TTAT.3G-37.461V16.1.0</a>				
<b>Release 17</b>									
ARIB	ARIB STD-T120-37.461.V17.1.0	17.1.0	Published	03.03.2023	<a href="https://www.arib.or.jp/english/html/overview/doc/T120_T23_SPECS/ARIB-STD-T120/Rel17/37/A37461-h10.pdf">https://www.arib.or.jp/english/html/overview/doc/T120_T23_SPECS/ARIB-STD-T120/Rel17/37/A37461-h10.pdf</a>				
ATIS	ATIS.3GPP.37.461.V17.1.0	17.1.0	Published	21.02.2023	<a href="https://www.atis.org/3gpp-transpositions - Rel-17">https://www.atis.org/3gpp-transpositions - Rel-17</a>				
CCSA	CCSA.37.461V1710	17.1.0	Published	01.06.2022	<a href="https://www.ccsa.org.cn/api/portalsFile/downloadOldFile?type=19&amp;oldFileUrl=ITU-R/M.2012-6/CCSA.37.461V1710.doc">https://www.ccsa.org.cn/api/portalsFile/downloadOldFile?type=19&amp;oldFileUrl=ITU-R/M.2012-6/CCSA.37.461V1710.doc</a>				
ETSI	ETSI TS 137 461	17.1.0	Published	20.07.2022	<a href="https://www.etsi.org/deliver/etsi_ts/137400_137499/137461/17.01.00_60/ts_137461v170100p.pdf">https://www.etsi.org/deliver/etsi_ts/137400_137499/137461/17.01.00_60/ts_137461v170100p.pdf</a>				
TSDSI	TSDSI STD T1.3GPP 37.461-17.1.0 V1.1.0	17.1.0	Published	01.11.2022	<a href="https://members.tdsi.in/s/TW5nmHpmmaa6wrBL">https://members.tdsi.in/s/TW5nmHpmmaa6wrBL</a>				
TTA	TTAT.3G-37.461V17.1.0	17.1.0	Published	21.10.2022	<a href="http://committee.tta.or.kr/data/ttasDown.jsp?kind=ttastd&amp;pk_num=TTAT.3G-37.461V17.1.0">http://committee.tta.or.kr/data/ttasDown.jsp?kind=ttastd&amp;pk_num=TTAT.3G-37.461V17.1.0</a>				

## 2.1.4.31 TS 37.462

**Iuant interface: Signalling transport**

This document specifies the signalling transport related to RETAP and TMAAP signalling to be used across the Iuant interface for UTRAN, E-UTRAN and NG-RAN. In this specification UTRAN, E-UTRAN and NG-RAN are denoted as "RAN", whereas the corresponding network entities Node B, eNB, en-gNB and NG-RAN node are denoted as "RAN Node". The logical Iuant interface is an interface internal to the RAN Node and defined to reside between the implementation specific O&M function and the RET antennas and between the implementation specific O&M function and the TMA control unit function.

SDO	Document No.	Version	Status	Issued date	Location
<b>Release 10</b>					
ARIB	ARIB STD-T120-37.462.V10.2.0	10.2.0	Published	03.03.2023	<a href="https://www.arib.or.jp/english/html/overview/doc/T120_T23_SPECS/ARIB-STD-T120/Rel10/37/A37462-a20.pdf">https://www.arib.or.jp/english/html/overview/doc/T120_T23_SPECS/ARIB-STD-T120/Rel10/37/A37462-a20.pdf</a>
ATIS	ATIS.3GPP.37.462V1020	10.2.0	Published	28.06.2021	<a href="https://www.atis.org/3gpp-documents/Rel99-14/">https://www.atis.org/3gpp-documents/Rel99-14/</a>
CCSA	CCSA.37.462V1020	10.2.0	Published	01.04.2019	<a href="https://www.ccsa.org.cn/api/portalsFile/downloadOldFile?type=19&amp;oldFileUrl=ITU-R/M.2012-6/CCSA.37.462V1020.doc">https://www.ccsa.org.cn/api/portalsFile/downloadOldFile?type=19&amp;oldFileUrl=ITU-R/M.2012-6/CCSA.37.462V1020.doc</a>
ETSI	ETSI TS 137 462	10.2.0	Published	15.05.2019	<a href="https://www.etsi.org/deliver/etsi_ts/137400_137499/137462/10.02.00_60/ts_137462v100200p.pdf">https://www.etsi.org/deliver/etsi_ts/137400_137499/137462/10.02.00_60/ts_137462v100200p.pdf</a>
TSDSI	TSDSI STD T1.3GPP 37.462-10.2.0 V1.0.0	10.2.0	Published	30.08.2021	<a href="https://members.tdsi.in/index.php/s/r2eR3mwdwBPfojQ">https://members.tdsi.in/index.php/s/r2eR3mwdwBPfojQ</a>
TTA	TTAT.3G-37.462V10.2.0	10.2.0	Published	02.08.2021	<a href="http://committee.tta.or.kr/data/ttasDown.jsp?kind=ttastd&amp;pk_num=TTAT.3G-37.462V10.2.0">http://committee.tta.or.kr/data/ttasDown.jsp?kind=ttastd&amp;pk_num=TTAT.3G-37.462V10.2.0</a>
<b>Release 11</b>					
ARIB	ARIB STD-T120-37.462.V11.1.0	11.1.0	Published	03.03.2023	<a href="https://www.arib.or.jp/english/html/overview/doc/T120_T23_SPECS/ARIB-STD-T120/Rel11/37/A37462-b10.pdf">https://www.arib.or.jp/english/html/overview/doc/T120_T23_SPECS/ARIB-STD-T120/Rel11/37/A37462-b10.pdf</a>
ATIS	ATIS.3GPP.37.462V1110	11.1.0	Published	28.06.2021	<a href="https://www.atis.org/3gpp-documents/Rel99-14/">https://www.atis.org/3gpp-documents/Rel99-14/</a>
CCSA	CCSA.37.462V1110	11.1.0	Published	01.04.2019	<a href="https://www.ccsa.org.cn/api/portalsFile/downloadOldFile?type=19&amp;oldFileUrl=ITU-R/M.2012-6/CCSA.37.462V1110.doc">https://www.ccsa.org.cn/api/portalsFile/downloadOldFile?type=19&amp;oldFileUrl=ITU-R/M.2012-6/CCSA.37.462V1110.doc</a>
ETSI	ETSI TS 137 462	11.1.0	Published	15.05.2019	<a href="https://www.etsi.org/deliver/etsi_ts/137400_137499/137462/11.01.00_60/ts_137462v110100p.pdf">https://www.etsi.org/deliver/etsi_ts/137400_137499/137462/11.01.00_60/ts_137462v110100p.pdf</a>
TSDSI	TSDSI STD T1.3GPP 37.462-11.1.0 V1.0.0	11.1.0	Published	30.08.2021	<a href="https://members.tdsi.in/index.php/s/HNjdnmFpTQjoDdW">https://members.tdsi.in/index.php/s/HNjdnmFpTQjoDdW</a>
TTA	TTAT.3G-37.462V11.1.0	11.1.0	Published	02.08.2021	<a href="http://committee.tta.or.kr/data/ttasDown.jsp?kind=ttastd&amp;pk_num=TTAT.3G-37.462V11.1.0">http://committee.tta.or.kr/data/ttasDown.jsp?kind=ttastd&amp;pk_num=TTAT.3G-37.462V11.1.0</a>
<b>Release 12</b>					
ARIB	ARIB STD-T120-37.462.V12.1.0	12.1.0	Published	03.03.2023	<a href="https://www.arib.or.jp/english/html/overview/doc/T120_T23_SPECS/ARIB-STD-T120/Rel12/37/A37462-c10.pdf">https://www.arib.or.jp/english/html/overview/doc/T120_T23_SPECS/ARIB-STD-T120/Rel12/37/A37462-c10.pdf</a>
ATIS	ATIS.3GPP.37.462V1210	12.1.0	Published	28.06.2021	<a href="https://www.atis.org/3gpp-documents/Rel99-14/">https://www.atis.org/3gpp-documents/Rel99-14/</a>
CCSA	CCSA.37.462V1210	12.1.0	Published	01.04.2019	<a href="https://www.ccsa.org.cn/api/portalsFile/downloadOldFile?type=19&amp;oldFileUrl=ITU-R/M.2012-6/CCSA.37.462V1210.doc">https://www.ccsa.org.cn/api/portalsFile/downloadOldFile?type=19&amp;oldFileUrl=ITU-R/M.2012-6/CCSA.37.462V1210.doc</a>
ETSI	ETSI TS 137 462	12.1.0	Published	15.05.2019	<a href="https://www.etsi.org/deliver/etsi_ts/137400_137499/137462/12.01.00_60/ts_137462v120100p.pdf">https://www.etsi.org/deliver/etsi_ts/137400_137499/137462/12.01.00_60/ts_137462v120100p.pdf</a>
TSDSI	TSDSI STD T1.3GPP 37.462-12.1.0 V1.0.0	12.1.0	Published	30.08.2021	<a href="https://members.tdsi.in/index.php/s/KgmL.Roto8w3s4Q9">https://members.tdsi.in/index.php/s/KgmL.Roto8w3s4Q9</a>
TTA	TTAT.3G-37.462V12.1.0	12.1.0	Published	02.08.2021	<a href="http://committee.tta.or.kr/data/ttasDown.jsp?kind=ttastd&amp;pk_num=TTAT.3G-37.462V12.1.0">http://committee.tta.or.kr/data/ttasDown.jsp?kind=ttastd&amp;pk_num=TTAT.3G-37.462V12.1.0</a>
<b>Release 13</b>					
ARIB	ARIB STD-T120-37.462.V13.1.0	13.1.0	Published	03.03.2023	<a href="https://www.arib.or.jp/english/html/overview/doc/T120_T23_SPECS/ARIB-STD-T120/Rel13/37/A37462-d10.pdf">https://www.arib.or.jp/english/html/overview/doc/T120_T23_SPECS/ARIB-STD-T120/Rel13/37/A37462-d10.pdf</a>
ATIS	ATIS.3GPP.37.462V1310	13.1.0	Published	28.06.2021	<a href="https://www.atis.org/3gpp-documents/Rel99-14/">https://www.atis.org/3gpp-documents/Rel99-14/</a>
CCSA	CCSA.37.462V1310	13.1.0	Published	01.04.2019	<a href="https://www.ccsa.org.cn/api/portalsFile/downloadOldFile?type=19&amp;oldFileUrl=ITU-R/M.2012-6/CCSA.37.462V1310.doc">https://www.ccsa.org.cn/api/portalsFile/downloadOldFile?type=19&amp;oldFileUrl=ITU-R/M.2012-6/CCSA.37.462V1310.doc</a>
ETSI	ETSI TS 137 462	13.1.0	Published	15.05.2019	<a href="https://www.etsi.org/deliver/etsi_ts/137400_137499/137462/13.01.00_60/ts_137462v130100p.pdf">https://www.etsi.org/deliver/etsi_ts/137400_137499/137462/13.01.00_60/ts_137462v130100p.pdf</a>
TSDSI	TSDSI STD T1.3GPP 37.462-13.1.0 V1.0.0	13.1.0	Published	30.08.2021	<a href="https://members.tdsi.in/index.php/s/Tq7kjiwYTqCACRQR">https://members.tdsi.in/index.php/s/Tq7kjiwYTqCACRQR</a>
TTA	TTAT.3G-37.462V13.1.0	13.1.0	Published	02.08.2021	<a href="http://committee.tta.or.kr/data/ttasDown.jsp?kind=ttastd&amp;pk_num=TTAT.3G-37.462V13.1.0">http://committee.tta.or.kr/data/ttasDown.jsp?kind=ttastd&amp;pk_num=TTAT.3G-37.462V13.1.0</a>
<b>Release 14</b>					
ARIB	ARIB STD-T120-37.462.V14.1.0	14.1.0	Published	03.03.2023	<a href="https://www.arib.or.jp/english/html/overview/doc/T120_T23_SPECS/ARIB-STD-T120/Rel14/37/A37462-e10.pdf">https://www.arib.or.jp/english/html/overview/doc/T120_T23_SPECS/ARIB-STD-T120/Rel14/37/A37462-e10.pdf</a>
ATIS	ATIS.3GPP.37.462V1410	14.1.0	Published	28.06.2021	<a href="https://www.atis.org/3gpp-documents/Rel99-14/">https://www.atis.org/3gpp-documents/Rel99-14/</a>
CCSA	CCSA.37.462V1410	14.1.0	Published	01.04.2019	<a href="https://www.ccsa.org.cn/api/portalsFile/downloadOldFile?type=19&amp;oldFileUrl=ITU-R/M.2012-6/CCSA.37.462V1410.doc">https://www.ccsa.org.cn/api/portalsFile/downloadOldFile?type=19&amp;oldFileUrl=ITU-R/M.2012-6/CCSA.37.462V1410.doc</a>
ETSI	ETSI TS 137 462	14.1.0	Published	15.05.2019	<a href="https://www.etsi.org/deliver/etsi_ts/137400_137499/137462/14.01.00_60/ts_137462v140100p.pdf">https://www.etsi.org/deliver/etsi_ts/137400_137499/137462/14.01.00_60/ts_137462v140100p.pdf</a>
TSDSI	TSDSI STD T1.3GPP 37.462-14.1.0 V1.0.0	14.1.0	Published	30.08.2021	<a href="https://members.tdsi.in/index.php/s/pf8jg3oka9ea2K5">https://members.tdsi.in/index.php/s/pf8jg3oka9ea2K5</a>
TTA	TTAT.3G-37.462V14.1.0	14.1.0	Published	02.08.2021	<a href="http://committee.tta.or.kr/data/ttasDown.jsp?kind=ttastd&amp;pk_num=TTAT.3G-37.462V14.1.0">http://committee.tta.or.kr/data/ttasDown.jsp?kind=ttastd&amp;pk_num=TTAT.3G-37.462V14.1.0</a>
<b>Release 15</b>					



ARIB	ARIB STD-T120-37.462.V15.2.0	15.2.0	Published	03.03.2023	<a href="https://www.arib.or.jp/english/html/overview/doc/T120_T23_SPECS/ARIB-STD-T120/Rel15/37/A37462-f20.pdf">https://www.arib.or.jp/english/html/overview/doc/T120_T23_SPECS/ARIB-STD-T120/Rel15/37/A37462-f20.pdf</a>
ATIS	ATIS.3GPP.37.462V1520	15.2.0	Published	28.06.2021	<a href="https://www.atis.org/3gpp-documents/Rel15/">https://www.atis.org/3gpp-documents/Rel15/</a>
CCSA	CCSA.37.462V1520	15.2.0	Published	01.12.2019	<a href="https://www.ccsa.org.cn/api/portalsFile/downloadOldFile?type=19&amp;oldFileUrl=ITU-R/M.2012-6/CCSA.37.462V1520.doc">https://www.ccsa.org.cn/api/portalsFile/downloadOldFile?type=19&amp;oldFileUrl=ITU-R/M.2012-6/CCSA.37.462V1520.doc</a>
ETSI	ETSI TS 137 462	15.2.0	Published	17.01.2020	<a href="https://www.etsi.org/deliver/etsi_ts/137400_137499/137462/15.02.00_60/ts_137462v150200p.pdf">https://www.etsi.org/deliver/etsi_ts/137400_137499/137462/15.02.00_60/ts_137462v150200p.pdf</a>
TSDSI	TSDSI STD T1.3GPP 37.462-15.2.0 V1.0.0	15.2.0	Published	30.08.2021	<a href="https://members.tdsi.in/index.php/s/KNsFOxJcdmeTETQ">https://members.tdsi.in/index.php/s/KNsFOxJcdmeTETQ</a>
TTA	TTAT.3G-37.462V15.2.0	15.2.0	Published	11.09.2020	<a href="http://committee.tta.or.kr/data/ttasDown.jsp?kind=ttastd&amp;pk_num=TTAT.3G-37.462V15.2.0">http://committee.tta.or.kr/data/ttasDown.jsp?kind=ttastd&amp;pk_num=TTAT.3G-37.462V15.2.0</a>

**Release 16**

ARIB	ARIB STD-T120-37.462.V16.0.0	16.0.0	Published	03.03.2023	<a href="https://www.arib.or.jp/english/html/overview/doc/T120_T23_SPECS/ARIB-STD-T120/Rel16/37/A37462-g00.pdf">https://www.arib.or.jp/english/html/overview/doc/T120_T23_SPECS/ARIB-STD-T120/Rel16/37/A37462-g00.pdf</a>
ATIS	ATIS.3GPP.37.462V1600	16.0.0	Published	28.06.2021	<a href="https://www.atis.org/3gpp-documents/Rel16/">https://www.atis.org/3gpp-documents/Rel16/</a>
CCSA	CCSA.37.462V1600	16.0.0	Published	01.07.2020	<a href="https://www.ccsa.org.cn/api/portalsFile/downloadOldFile?type=19&amp;oldFileUrl=ITU-R/M.2012-6/CCSA.37.462V1600.doc">https://www.ccsa.org.cn/api/portalsFile/downloadOldFile?type=19&amp;oldFileUrl=ITU-R/M.2012-6/CCSA.37.462V1600.doc</a>
ETSI	ETSI TS 137 462	16.0.0	Published	17.09.2020	<a href="https://www.etsi.org/deliver/etsi_ts/137400_137499/137462/16.00.00_60/ts_137462v160000p.pdf">https://www.etsi.org/deliver/etsi_ts/137400_137499/137462/16.00.00_60/ts_137462v160000p.pdf</a>
TSDSI	TSDSI STD T1.3GPP 37.462-16.0.0 V1.0.0	16.0.0	Published	30.08.2021	<a href="https://members.tdsi.in/index.php/s/oCmRJwDcXTn8c4b">https://members.tdsi.in/index.php/s/oCmRJwDcXTn8c4b</a>
TTA	TTAT.3G-37.462V16.0.0	16.0.0	Published	11.09.2020	<a href="http://committee.tta.or.kr/data/ttasDown.jsp?kind=ttastd&amp;pk_num=TTAT.3G-37.462V16.0.0">http://committee.tta.or.kr/data/ttasDown.jsp?kind=ttastd&amp;pk_num=TTAT.3G-37.462V16.0.0</a>

**Release 17**

ARIB	ARIB STD-T120-37.462.V17.0.0	17.0.0	Published	03.03.2023	<a href="https://www.arib.or.jp/english/html/overview/doc/T120_T23_SPECS/ARIB-STD-T120/Rel17/37/A37462-h00.pdf">https://www.arib.or.jp/english/html/overview/doc/T120_T23_SPECS/ARIB-STD-T120/Rel17/37/A37462-h00.pdf</a>
ATIS	ATIS.3GPP.37.462.V17.0.0	17.0.0	Published	21.02.2023	<a href="https://www.atis.org/3gpp-transpositions - Rel-17">https://www.atis.org/3gpp-transpositions - Rel-17</a>
CCSA	CCSA.37.462V1700	17.0.0	Published	01.04.2022	<a href="https://www.ccsa.org.cn/api/portalsFile/downloadOldFile?type=19&amp;oldFileUrl=ITU-R/M.2012-6/CCSA.37.462V1700.doc">https://www.ccsa.org.cn/api/portalsFile/downloadOldFile?type=19&amp;oldFileUrl=ITU-R/M.2012-6/CCSA.37.462V1700.doc</a>
ETSI	ETSI TS 137 462	17.0.0	Published	29.04.2022	<a href="https://www.etsi.org/deliver/etsi_ts/137400_137499/137462/17.00.00_60/ts_137462v170000p.pdf">https://www.etsi.org/deliver/etsi_ts/137400_137499/137462/17.00.00_60/ts_137462v170000p.pdf</a>
TSDSI	TSDSI STD T1.3GPP 37.462-17.0.0 V1.0.0	17.0.0	Published	29.07.2022	<a href="https://members.tdsi.in/s/owHrgRgWzLSKS3a">https://members.tdsi.in/s/owHrgRgWzLSKS3a</a>
TTA	TTAT.3G-37.462V17.0.0	17.0.0	Published	05.08.2022	<a href="http://committee.tta.or.kr/data/ttasDown.jsp?kind=ttastd&amp;pk_num=TTAT.3G-37.462V17.0.0">http://committee.tta.or.kr/data/ttasDown.jsp?kind=ttastd&amp;pk_num=TTAT.3G-37.462V17.0.0</a>

**2.1.4.32 TS 37.466**

**Iuant interface: Application part**

This document is an introduction to the 3GPP TS 37.46x series of Technical Specifications that define the Iuant Interface. The Iuant interface is applicable for UTRAN, E-UTRAN and NG-RAN. In this specification UTRAN, E-UTRAN and NG-RAN are denoted as "RAN", whereas the corresponding network entities Node B, eNB, en-gNB and NG-RAN node are denoted as "RAN Node". The logical Iuant interface is an interface internal to the RAN Node and defined to reside between the implementation specific O&M function and the RET antennas together with the TMAs control unit function of the RAN Node.

This document is applicable for UTRAN, E-UTRAN and NG-RAN and specifies the Remote Electrical Tilting Application Part (RETAP) and the Tower Mounted Amplifier Application Part (TMAAP). In this specification UTRAN, E-UTRAN and NG-RAN are denoted as "RAN", whereas the corresponding network entities Node B, eNB, en-gNB and NG-RAN node are denoted as "RAN Node". RETAP supports the functions of the Iuant interface between the implementation specific O&M transport function and the RET Antenna Control unit function, TMAAP supports the functions of the Iuant interface between the implementation specific O&M transport function and the TMA control function.

SDO	Document No.	Version	Status	Issued date	Location
<b>Release 10</b>					
ARIB	ARIB STD-T120-37.466.V10.4.0	10.4.0	Published	03.03.2023	<a href="https://www.arib.or.jp/english/html/overview/doc/T120_T23_SPECS/ARIB-STD-T120/Rel10/37/A37466-a40.pdf">https://www.arib.or.jp/english/html/overview/doc/T120_T23_SPECS/ARIB-STD-T120/Rel10/37/A37466-a40.pdf</a>
ATIS	ATIS.3GPP.37.466V1040	10.4.0	Published	28.06.2021	<a href="https://www.atis.org/3gpp-documents/Rel99-14/">https://www.atis.org/3gpp-documents/Rel99-14/</a>
CCSA	CCSA.37.466V1040	10.4.0	Published	01.04.2019	<a href="https://www.ccsa.org.cn/api/portalsFile/downloadOldFile?type=19&amp;oldFileUrl=ITU-R/M.2012-6/CCSA.37.466V1040.doc">https://www.ccsa.org.cn/api/portalsFile/downloadOldFile?type=19&amp;oldFileUrl=ITU-R/M.2012-6/CCSA.37.466V1040.doc</a>
ETSI	ETSI TS 137 466	10.4.0	Published	15.05.2019	<a href="https://www.etsi.org/deliver/etsi_ts/137400_137499/137466/10.04.00_60/ts_137466v100400p.pdf">https://www.etsi.org/deliver/etsi_ts/137400_137499/137466/10.04.00_60/ts_137466v100400p.pdf</a>
TSDSI	TSDSI STD T1.3GPP 37.466-10.4.0 V1.0.0	10.4.0	Published	30.08.2021	<a href="https://members.tdsi.in/index.php/s/RM9jpi7fFeNSH7p">https://members.tdsi.in/index.php/s/RM9jpi7fFeNSH7p</a>
TTA	TTAT.3G-37.466V10.4.0	10.4.0	Published	02.08.2021	<a href="http://committee.tta.or.kr/data/ttasDown.jsp?kind=ttastd&amp;pk_num=TTAT.3G-37.466V10.4.0">http://committee.tta.or.kr/data/ttasDown.jsp?kind=ttastd&amp;pk_num=TTAT.3G-37.466V10.4.0</a>

**Release 11**

ARIB	ARIB STD-T120-37.466.V11.4.0	11.4.0	Published	03.03.2023	<a href="https://www.arib.or.jp/english/html/overview/doc/T120_T23_SPECS/ARIB-STD-T120/Rel11/37/A37466-b40.pdf">https://www.arib.or.jp/english/html/overview/doc/T120_T23_SPECS/ARIB-STD-T120/Rel11/37/A37466-b40.pdf</a>
ATIS	ATIS.3GPP.37.466V1140	11.4.0	Published	28.06.2021	<a href="https://www.atis.org/3gpp-documents/Rel99-14/">https://www.atis.org/3gpp-documents/Rel99-14/</a>

CCSA	CCSA.37.466V1140	11.4.0	Published	01.04.2019	<a href="https://www.ccsa.org.cn/api/portalsFile/downloadOldFile?type=19&amp;oldFileUrl=ITU-R/M.2012-6/CCSA.37.466V1140.doc">https://www.ccsa.org.cn/api/portalsFile/downloadOldFile?type=19&amp;oldFileUrl=ITU-R/M.2012-6/CCSA.37.466V1140.doc</a>
ETSI	ETSI TS 137 466	11.4.0	Published	15.05.2019	<a href="https://www.etsi.org/deliver/etsi_ts/137400_137499/137466/11.04.00_60/ts_137466v110400p.pdf">https://www.etsi.org/deliver/etsi_ts/137400_137499/137466/11.04.00_60/ts_137466v110400p.pdf</a>
TSDSI	TSDSI STD T1.3GPP 37.466-11.4.0 V1.0.0	11.4.0	Published	30.08.2021	<a href="https://members.tdsi.in/index.php/s/7e2iWg7LsZXmBoG">https://members.tdsi.in/index.php/s/7e2iWg7LsZXmBoG</a>
TTA	TTAT.3G-37.466V11.4.0	11.4.0	Published	02.08.2021	<a href="http://committee.tta.or.kr/data/ttasDown.jsp?kind=ttastd&amp;pk_num=TTAT.3G-37.466V11.4.0">http://committee.tta.or.kr/data/ttasDown.jsp?kind=ttastd&amp;pk_num=TTAT.3G-37.466V11.4.0</a>
<b>Release 12</b>					
ARIB	ARIB STD-T120-37.466.V12.3.0	12.3.0	Published	03.03.2023	<a href="https://www.arib.or.jp/english/html/overview/doc/T120_T23_SPECS/ARIB-STD-T120/Rel12/37/A37466-c30.pdf">https://www.arib.or.jp/english/html/overview/doc/T120_T23_SPECS/ARIB-STD-T120/Rel12/37/A37466-c30.pdf</a>
ATIS	ATIS.3GPP.37.466V1230	12.3.0	Published	28.06.2021	<a href="https://www.atis.org/3gpp-documents/Rel99-14/">https://www.atis.org/3gpp-documents/Rel99-14/</a>
CCSA	CCSA.37.466V1230	12.3.0	Published	01.04.2019	<a href="https://www.ccsa.org.cn/api/portalsFile/downloadOldFile?type=19&amp;oldFileUrl=ITU-R/M.2012-6/CCSA.37.466V1230.doc">https://www.ccsa.org.cn/api/portalsFile/downloadOldFile?type=19&amp;oldFileUrl=ITU-R/M.2012-6/CCSA.37.466V1230.doc</a>
ETSI	ETSI TS 137 466	12.3.0	Published	15.05.2019	<a href="https://www.etsi.org/deliver/etsi_ts/137400_137499/137466/12.03.00_60/ts_137466v120300p.pdf">https://www.etsi.org/deliver/etsi_ts/137400_137499/137466/12.03.00_60/ts_137466v120300p.pdf</a>
TSDSI	TSDSI STD T1.3GPP 37.466-12.3.0 V1.0.0	12.3.0	Published	30.08.2021	<a href="https://members.tdsi.in/index.php/s/PWT9dawTwQ5e2jT">https://members.tdsi.in/index.php/s/PWT9dawTwQ5e2jT</a>
TTA	TTAT.3G-37.466V12.3.0	12.3.0	Published	02.08.2021	<a href="http://committee.tta.or.kr/data/ttasDown.jsp?kind=ttastd&amp;pk_num=TTAT.3G-37.466V12.3.0">http://committee.tta.or.kr/data/ttasDown.jsp?kind=ttastd&amp;pk_num=TTAT.3G-37.466V12.3.0</a>
<b>Release 13</b>					
ARIB	ARIB STD-T120-37.466.V13.3.0	13.3.0	Published	03.03.2023	<a href="https://www.arib.or.jp/english/html/overview/doc/T120_T23_SPECS/ARIB-STD-T120/Rel13/37/A37466-d30.pdf">https://www.arib.or.jp/english/html/overview/doc/T120_T23_SPECS/ARIB-STD-T120/Rel13/37/A37466-d30.pdf</a>
ATIS	ATIS.3GPP.37.466V1330	13.3.0	Published	28.06.2021	<a href="https://www.atis.org/3gpp-documents/Rel99-14/">https://www.atis.org/3gpp-documents/Rel99-14/</a>
CCSA	CCSA.37.466V1330	13.3.0	Published	01.04.2019	<a href="https://www.ccsa.org.cn/api/portalsFile/downloadOldFile?type=19&amp;oldFileUrl=ITU-R/M.2012-6/CCSA.37.466V1330.doc">https://www.ccsa.org.cn/api/portalsFile/downloadOldFile?type=19&amp;oldFileUrl=ITU-R/M.2012-6/CCSA.37.466V1330.doc</a>
ETSI	ETSI TS 137 466	13.3.0	Published	15.05.2019	<a href="https://www.etsi.org/deliver/etsi_ts/137400_137499/137466/13.03.00_60/ts_137466v130300p.pdf">https://www.etsi.org/deliver/etsi_ts/137400_137499/137466/13.03.00_60/ts_137466v130300p.pdf</a>
TSDSI	TSDSI STD T1.3GPP 37.466-13.3.0 V1.0.0	13.3.0	Published	30.08.2021	<a href="https://members.tdsi.in/index.php/s/9CQsExkNbGqRaTx">https://members.tdsi.in/index.php/s/9CQsExkNbGqRaTx</a>
TTA	TTAT.3G-37.466V13.3.0	13.3.0	Published	02.08.2021	<a href="http://committee.tta.or.kr/data/ttasDown.jsp?kind=ttastd&amp;pk_num=TTAT.3G-37.466V13.3.0">http://committee.tta.or.kr/data/ttasDown.jsp?kind=ttastd&amp;pk_num=TTAT.3G-37.466V13.3.0</a>
<b>Release 14</b>					
ARIB	ARIB STD-T120-37.466.V14.3.0	14.3.0	Published	03.03.2023	<a href="https://www.arib.or.jp/english/html/overview/doc/T120_T23_SPECS/ARIB-STD-T120/Rel14/37/A37466-e30.pdf">https://www.arib.or.jp/english/html/overview/doc/T120_T23_SPECS/ARIB-STD-T120/Rel14/37/A37466-e30.pdf</a>
ATIS	ATIS.3GPP.37.466V1430	14.3.0	Published	28.06.2021	<a href="https://www.atis.org/3gpp-documents/Rel99-14/">https://www.atis.org/3gpp-documents/Rel99-14/</a>
CCSA	CCSA.37.466V1430	14.3.0	Published	01.04.2019	<a href="https://www.ccsa.org.cn/api/portalsFile/downloadOldFile?type=19&amp;oldFileUrl=ITU-R/M.2012-6/CCSA.37.466V1430.doc">https://www.ccsa.org.cn/api/portalsFile/downloadOldFile?type=19&amp;oldFileUrl=ITU-R/M.2012-6/CCSA.37.466V1430.doc</a>
ETSI	ETSI TS 137 466	14.3.0	Published	15.05.2019	<a href="https://www.etsi.org/deliver/etsi_ts/137400_137499/137466/14.03.00_60/ts_137466v140300p.pdf">https://www.etsi.org/deliver/etsi_ts/137400_137499/137466/14.03.00_60/ts_137466v140300p.pdf</a>
TSDSI	TSDSI STD T1.3GPP 37.466-14.3.0 V1.0.0	14.3.0	Published	30.08.2021	<a href="https://members.tdsi.in/index.php/s/tQyJWw7YPyPaf4">https://members.tdsi.in/index.php/s/tQyJWw7YPyPaf4</a>
TTA	TTAT.3G-37.466V14.3.0	14.3.0	Published	02.08.2021	<a href="http://committee.tta.or.kr/data/ttasDown.jsp?kind=ttastd&amp;pk_num=TTAT.3G-37.466V14.3.0">http://committee.tta.or.kr/data/ttasDown.jsp?kind=ttastd&amp;pk_num=TTAT.3G-37.466V14.3.0</a>
<b>Release 15</b>					
ARIB	ARIB STD-T120-37.466.V15.5.0	15.5.0	Published	03.03.2023	<a href="https://www.arib.or.jp/english/html/overview/doc/T120_T23_SPECS/ARIB-STD-T120/Rel15/37/A37466-f50.pdf">https://www.arib.or.jp/english/html/overview/doc/T120_T23_SPECS/ARIB-STD-T120/Rel15/37/A37466-f50.pdf</a>
ATIS	ATIS.3GPP.37.466V1550	15.5.0	Published	28.06.2021	<a href="https://www.atis.org/3gpp-documents/Rel15/">https://www.atis.org/3gpp-documents/Rel15/</a>
CCSA	CCSA.37.466V1550	15.5.0	Published	01.12.2019	<a href="https://www.ccsa.org.cn/api/portalsFile/downloadOldFile?type=19&amp;oldFileUrl=ITU-R/M.2012-6/CCSA.37.466V1550.doc">https://www.ccsa.org.cn/api/portalsFile/downloadOldFile?type=19&amp;oldFileUrl=ITU-R/M.2012-6/CCSA.37.466V1550.doc</a>
ETSI	ETSI TS 137 466	15.5.0	Published	17.01.2020	<a href="https://www.etsi.org/deliver/etsi_ts/137400_137499/137466/15.05.00_60/ts_137466v150500p.pdf">https://www.etsi.org/deliver/etsi_ts/137400_137499/137466/15.05.00_60/ts_137466v150500p.pdf</a>
TSDSI	TSDSI STD T1.3GPP 37.466-15.5.0 V1.0.0	15.5.0	Published	30.08.2021	<a href="https://members.tdsi.in/index.php/s/EeHNBLpXRMtgdtW">https://members.tdsi.in/index.php/s/EeHNBLpXRMtgdtW</a>
TTA	TTAT.3G-37.466V15.5.0	15.5.0	Published	11.09.2020	<a href="http://committee.tta.or.kr/data/ttasDown.jsp?kind=ttastd&amp;pk_num=TTAT.3G-37.466V15.5.0">http://committee.tta.or.kr/data/ttasDown.jsp?kind=ttastd&amp;pk_num=TTAT.3G-37.466V15.5.0</a>
<b>Release 16</b>					
ARIB	ARIB STD-T120-37.466.V16.0.0	16.0.0	Published	03.03.2023	<a href="https://www.arib.or.jp/english/html/overview/doc/T120_T23_SPECS/ARIB-STD-T120/Rel16/37/A37466-g00.pdf">https://www.arib.or.jp/english/html/overview/doc/T120_T23_SPECS/ARIB-STD-T120/Rel16/37/A37466-g00.pdf</a>
ATIS	ATIS.3GPP.37.466V1600	16.0.0	Published	28.06.2021	<a href="https://www.atis.org/3gpp-documents/Rel16/">https://www.atis.org/3gpp-documents/Rel16/</a>
CCSA	CCSA.37.466V1600	16.0.0	Published	01.07.2020	<a href="https://www.ccsa.org.cn/api/portalsFile/downloadOldFile?type=19&amp;oldFileUrl=ITU-R/M.2012-6/CCSA.37.466V1600.doc">https://www.ccsa.org.cn/api/portalsFile/downloadOldFile?type=19&amp;oldFileUrl=ITU-R/M.2012-6/CCSA.37.466V1600.doc</a>
ETSI	ETSI TS 137 466	16.0.0	Published	18.09.2020	<a href="https://www.etsi.org/deliver/etsi_ts/137400_137499/137466/16.00.00_60/ts_137466v160000p.pdf">https://www.etsi.org/deliver/etsi_ts/137400_137499/137466/16.00.00_60/ts_137466v160000p.pdf</a>
TSDSI	TSDSI STD T1.3GPP 37.466-16.0.0 V1.0.0	16.0.0	Published	30.08.2021	<a href="https://members.tdsi.in/index.php/s/e8qXqTXA69FcGtH">https://members.tdsi.in/index.php/s/e8qXqTXA69FcGtH</a>
TTA	TTAT.3G-37.466V16.0.0	16.0.0	Published	11.09.2020	<a href="http://committee.tta.or.kr/data/ttasDown.jsp?kind=ttastd&amp;pk_num=TTAT.3G-37.466V16.0.0">http://committee.tta.or.kr/data/ttasDown.jsp?kind=ttastd&amp;pk_num=TTAT.3G-37.466V16.0.0</a>
<b>Release 17</b>					
ARIB	ARIB STD-T120-37.466.V17.0.0	17.0.0	Published	03.03.2023	<a href="https://www.arib.or.jp/english/html/overview/doc/T120_T23_SPECS/ARIB-STD-T120/Rel17/37/A37466-h00.pdf">https://www.arib.or.jp/english/html/overview/doc/T120_T23_SPECS/ARIB-STD-T120/Rel17/37/A37466-h00.pdf</a>
ATIS	ATIS.3GPP.37.466.V17.0.0	17.0.0	Published	21.02.2023	<a href="https://www.atis.org/3gpp-transpositions - Rel-17">https://www.atis.org/3gpp-transpositions - Rel-17</a>
CCSA	CCSA.37.466V1700	17.0.0	Published	01.04.2022	<a href="https://www.ccsa.org.cn/api/portalsFile/downloadOldFile?type=19&amp;oldFileUrl=ITU-R/M.2012-6/CCSA.37.466V1700.doc">https://www.ccsa.org.cn/api/portalsFile/downloadOldFile?type=19&amp;oldFileUrl=ITU-R/M.2012-6/CCSA.37.466V1700.doc</a>
ETSI	ETSI TS 137 466	17.0.0	Published	29.04.2022	<a href="https://www.etsi.org/deliver/etsi_ts/137400_137499/137466/17.00.00_60/ts_137466v170000p.pdf">https://www.etsi.org/deliver/etsi_ts/137400_137499/137466/17.00.00_60/ts_137466v170000p.pdf</a>
TSDSI	TSDSI STD T1.3GPP 37.466-17.0.0 V1.0.0	17.0.0	Published	29.07.2022	<a href="https://members.tdsi.in/s/Sff9H5iDERXJc3L">https://members.tdsi.in/s/Sff9H5iDERXJc3L</a>
TTA	TTAT.3G-37.466V17.0.0	17.0.0	Published	05.08.2022	<a href="http://committee.tta.or.kr/data/ttasDown.jsp?kind=ttastd&amp;pk_num=TTAT.3G-37.466V17.0.0">http://committee.tta.or.kr/data/ttasDown.jsp?kind=ttastd&amp;pk_num=TTAT.3G-37.466V17.0.0</a>

**2.1.4.33 TS 37.470****W1 interface; General aspects and principles**

This document is an introduction to the 3GPP TS 37.4xx series of technical specifications that define the W1 interface. The W1 interface provides means for interconnecting a ng-eNB-CU and a ng-eNB-DU of a ng-eNB within a NG-RAN.

SDO	Document No.	Version	Status	Issued date	Location
<b>Release 16</b>					
ARIB	ARIB STD-T120-37.470.V16.2.0	16.2.0	Published	03.03.2023	<a href="https://www.arib.or.jp/english/html/overview/doc/T120_T23_SPECS/ARIB-STD-T120/Rel16/37/A37470-g20.pdf">https://www.arib.or.jp/english/html/overview/doc/T120_T23_SPECS/ARIB-STD-T120/Rel16/37/A37470-g20.pdf</a>
ATIS	ATIS.3GPP.37.470.V16.2.0	16.2.0	Published	21.02.2023	<a href="https://www.atis.org/3gpp-transpositions - Rel-16">https://www.atis.org/3gpp-transpositions - Rel-16</a>
CCSA	CCSA.37.470V1620	16.2.0	Published	01.07.2020	<a href="https://www.ccsa.org.cn/api/portalsFile/downloadOldFile?type=19&amp;oldFileUrl=ITU-R/M.2012-6/CCSA.37.470V1620.doc">https://www.ccsa.org.cn/api/portalsFile/downloadOldFile?type=19&amp;oldFileUrl=ITU-R/M.2012-6/CCSA.37.470V1620.doc</a>
ETSI	ETSI TS 137 470	16.2.0	Published	15.09.2020	<a href="https://www.etsi.org/deliver/etsi_ts/137400_137499/137470/16.02.00_60/ts_137470v160200p.pdf">https://www.etsi.org/deliver/etsi_ts/137400_137499/137470/16.02.00_60/ts_137470v160200p.pdf</a>
TSDSI	TSDSI STD T1.3GPP 37.470-16.2.0 V1.0.0	16.2.0	Published	06.10.2020	<a href="https://members.tdsi.in/index.php/s/5gdiKqeMnXQfK2X">https://members.tdsi.in/index.php/s/5gdiKqeMnXQfK2X</a>
TTA	TTAT.3G-37.470V16.2.0	16.2.0	Published	11.09.2020	<a href="http://committee.tta.or.kr/data/ttasDown.jsp?kind=ttastd&amp;pk_num=TTAT.3G-37.470V16.2.0">http://committee.tta.or.kr/data/ttasDown.jsp?kind=ttastd&amp;pk_num=TTAT.3G-37.470V16.2.0</a>
<b>Release 17</b>					
ARIB	ARIB STD-T120-37.470.V17.0.0	17.0.0	Published	03.03.2023	<a href="https://www.arib.or.jp/english/html/overview/doc/T120_T23_SPECS/ARIB-STD-T120/Rel17/37/A37470-h00.pdf">https://www.arib.or.jp/english/html/overview/doc/T120_T23_SPECS/ARIB-STD-T120/Rel17/37/A37470-h00.pdf</a>
ATIS	ATIS.3GPP.37.470.V17.0.0	17.0.0	Published	21.02.2023	<a href="https://www.atis.org/3gpp-transpositions - Rel-17">https://www.atis.org/3gpp-transpositions - Rel-17</a>
CCSA	CCSA.37.470V1700	17.0.0	Published	01.04.2022	<a href="https://www.ccsa.org.cn/api/portalsFile/downloadOldFile?type=19&amp;oldFileUrl=ITU-R/M.2012-6/CCSA.37.470V1700.doc">https://www.ccsa.org.cn/api/portalsFile/downloadOldFile?type=19&amp;oldFileUrl=ITU-R/M.2012-6/CCSA.37.470V1700.doc</a>
ETSI	ETSI TS 137 470	17.0.0	Published	29.04.2022	<a href="https://www.etsi.org/deliver/etsi_ts/137400_137499/137470/17.00.00_60/ts_137470v170000p.pdf">https://www.etsi.org/deliver/etsi_ts/137400_137499/137470/17.00.00_60/ts_137470v170000p.pdf</a>
TSDSI	TSDSI STD T1.3GPP 37.47-17.0.0 V1.0.0	17.0.0	Published	29.07.2022	<a href="https://members.tdsi.in/s/PAP6n6fkQcXgd5c">https://members.tdsi.in/s/PAP6n6fkQcXgd5c</a>
TTA	TTAT.3G-37.470V17.0.0	17.0.0	Published	05.08.2022	<a href="http://committee.tta.or.kr/data/ttasDown.jsp?kind=ttastd&amp;pk_num=TTAT.3G-37.470V17.0.0">http://committee.tta.or.kr/data/ttasDown.jsp?kind=ttastd&amp;pk_num=TTAT.3G-37.470V17.0.0</a>

**2.1.4.34 TS 37.471****W1 interface; Layer 1**

This document specifies the standards allowed to implement Layer 1 on the W1 interface. The W1 interface provides means for interconnecting a ng-eNB-CU and a ng-eNB-DU of a ng-eNB within a NG-RAN.

The specification of transmission delay requirements and O&M requirements are not in the scope of this document.

SDO	Document No.	Version	Status	Issued date	Location
<b>Release 16</b>					
ARIB	ARIB STD-T120-37.471.V16.1.0	16.1.0	Published	03.03.2023	<a href="https://www.arib.or.jp/english/html/overview/doc/T120_T23_SPECS/ARIB-STD-T120/Rel16/37/A37471-g10.pdf">https://www.arib.or.jp/english/html/overview/doc/T120_T23_SPECS/ARIB-STD-T120/Rel16/37/A37471-g10.pdf</a>
ATIS	ATIS.3GPP.37.471.V16.1.0	16.1.0	Published	21.02.2023	<a href="https://www.atis.org/3gpp-transpositions - Rel-16">https://www.atis.org/3gpp-transpositions - Rel-16</a>
CCSA	CCSA.37.471V1610	16.1.0	Published	01.03.2020	<a href="https://www.ccsa.org.cn/api/portalsFile/downloadOldFile?type=19&amp;oldFileUrl=ITU-R/M.2012-6/CCSA.37.471V1610.doc">https://www.ccsa.org.cn/api/portalsFile/downloadOldFile?type=19&amp;oldFileUrl=ITU-R/M.2012-6/CCSA.37.471V1610.doc</a>
ETSI	ETSI TS 137 471	16.1.0	Published	21.09.2020	<a href="https://www.etsi.org/deliver/etsi_ts/137400_137499/137471/16.01.00_60/ts_137471v160100p.pdf">https://www.etsi.org/deliver/etsi_ts/137400_137499/137471/16.01.00_60/ts_137471v160100p.pdf</a>
TSDSI	TSDSI STD T1.3GPP 37.471-16.1.0 V1.0.0	16.1.0	Published	06.10.2020	<a href="https://members.tdsi.in/index.php/s/YypzZHOEjmZYYjS">https://members.tdsi.in/index.php/s/YypzZHOEjmZYYjS</a>
TTA	TTAT.3G-37.471V16.1.0	16.1.0	Published	11.09.2020	<a href="http://committee.tta.or.kr/data/ttasDown.jsp?kind=ttastd&amp;pk_num=TTAT.3G-37.471V16.1.0">http://committee.tta.or.kr/data/ttasDown.jsp?kind=ttastd&amp;pk_num=TTAT.3G-37.471V16.1.0</a>
<b>Release 17</b>					
ARIB	ARIB STD-T120-37.471.V17.0.0	17.0.0	Published	03.03.2023	<a href="https://www.arib.or.jp/english/html/overview/doc/T120_T23_SPECS/ARIB-STD-T120/Rel17/37/A37471-h00.pdf">https://www.arib.or.jp/english/html/overview/doc/T120_T23_SPECS/ARIB-STD-T120/Rel17/37/A37471-h00.pdf</a>
ATIS	ATIS.3GPP.37.471.V17.0.0	17.0.0	Published	21.02.2023	<a href="https://www.atis.org/3gpp-transpositions - Rel-17">https://www.atis.org/3gpp-transpositions - Rel-17</a>
CCSA	CCSA.37.471V1700	17.0.0	Published	01.04.2022	<a href="https://www.ccsa.org.cn/api/portalsFile/downloadOldFile?type=19&amp;oldFileUrl=ITU-R/M.2012-6/CCSA.37.471V1700.doc">https://www.ccsa.org.cn/api/portalsFile/downloadOldFile?type=19&amp;oldFileUrl=ITU-R/M.2012-6/CCSA.37.471V1700.doc</a>
ETSI	ETSI TS 137 471	17.0.0	Published	29.04.2022	<a href="https://www.etsi.org/deliver/etsi_ts/137400_137499/137471/17.00.00_60/ts_137471v170000p.pdf">https://www.etsi.org/deliver/etsi_ts/137400_137499/137471/17.00.00_60/ts_137471v170000p.pdf</a>
TSDSI	TSDSI STD T1.3GPP 37.471-17.0.0 V1.0.0	17.0.0	Published	29.07.2022	<a href="https://members.tdsi.in/s/WcmKcYgJPBfk7d">https://members.tdsi.in/s/WcmKcYgJPBfk7d</a>
TTA	TTAT.3G-37.471V17.0.0	17.0.0	Published	05.08.2022	<a href="http://committee.tta.or.kr/data/ttasDown.jsp?kind=ttastd&amp;pk_num=TTAT.3G-37.471V17.0.0">http://committee.tta.or.kr/data/ttasDown.jsp?kind=ttastd&amp;pk_num=TTAT.3G-37.471V17.0.0</a>

## 2.1.4.35 TS 37.472

## W1 interface; Signalling transport

This document specifies the standards for Signalling Transport to be used across the W1 interface. The W1 interface provides means for interconnecting a ng-eNB-CU and a ng-eNB-DU of a ng-eNB within a NG-RAN. This document describes how the W1AP signalling messages are transported over W1.

SDO	Document No.	Version	Status	Issued date	Location
<b>Release 16</b>					
ARIB	ARIB STD-T120-37.472.V16.2.0	16.2.0	Published	03.03.2023	<a href="https://www.arib.or.jp/english/html/overview/doc/T120_T23_SPECS/ARIB-STD-T120/Rel16/37/A37472-g20.pdf">https://www.arib.or.jp/english/html/overview/doc/T120_T23_SPECS/ARIB-STD-T120/Rel16/37/A37472-g20.pdf</a>
ATIS	ATIS.3GPP.37.472.V16.2.0	16.2.0	Published	21.02.2023	<a href="https://www.atis.org/3gpp-transpositions - Rel-16">https://www.atis.org/3gpp-transpositions - Rel-16</a>
CCSA	CCSA.37.472V1620	16.2.0	Published	01.09.2020	<a href="https://www.ccsa.org.cn/api/portalsFile/downloadOldFile?type=19&amp;oldFileUrl=ITU-R/M.2012-6/CCSA.37.472V1620.doc">https://www.ccsa.org.cn/api/portalsFile/downloadOldFile?type=19&amp;oldFileUrl=ITU-R/M.2012-6/CCSA.37.472V1620.doc</a>
ETSI	ETSI TS 137 472	16.2.0	Published	16.11.2020	<a href="https://www.etsi.org/deliver/etsi_ts/137400_137499/137472/16.02.00_60/ts_137472v160200p.pdf">https://www.etsi.org/deliver/etsi_ts/137400_137499/137472/16.02.00_60/ts_137472v160200p.pdf</a>
TSDSI	TSDSI STD T1.3GPP 37.472-16.1.0 V1.0.0	16.2.0	Published	06.10.2020	<a href="https://members.tdsi.in/index.php/s/ecrHinLENfpwjE7">https://members.tdsi.in/index.php/s/ecrHinLENfpwjE7</a>
TTA	TTAT.3G-37.472V16.2.0	16.2.0	Published	16.03.2023	<a href="http://committee.tta.or.kr/data/ttasDown.jsp?kind=ttastd&amp;pk_num=TTAT.3G-37.472V16.2.0">http://committee.tta.or.kr/data/ttasDown.jsp?kind=ttastd&amp;pk_num=TTAT.3G-37.472V16.2.0</a>
<b>Release 17</b>					
ARIB	ARIB STD-T120-37.472.V17.0.0	17.0.0	Published	03.03.2023	<a href="https://www.arib.or.jp/english/html/overview/doc/T120_T23_SPECS/ARIB-STD-T120/Rel17/37/A37472-h00.pdf">https://www.arib.or.jp/english/html/overview/doc/T120_T23_SPECS/ARIB-STD-T120/Rel17/37/A37472-h00.pdf</a>
ATIS	ATIS.3GPP.37.472.V17.0.0	17.0.0	Published	21.02.2023	<a href="https://www.atis.org/3gpp-transpositions - Rel-17">https://www.atis.org/3gpp-transpositions - Rel-17</a>
CCSA	CCSA.37.472V1700	17.0.0	Published	01.04.2022	<a href="https://www.ccsa.org.cn/api/portalsFile/downloadOldFile?type=19&amp;oldFileUrl=ITU-R/M.2012-6/CCSA.37.472V1700.doc">https://www.ccsa.org.cn/api/portalsFile/downloadOldFile?type=19&amp;oldFileUrl=ITU-R/M.2012-6/CCSA.37.472V1700.doc</a>
ETSI	ETSI TS 137 472	17.0.0	Published	29.04.2022	<a href="https://www.etsi.org/deliver/etsi_ts/137400_137499/137472/17.00.00_60/ts_137472v170000p.pdf">https://www.etsi.org/deliver/etsi_ts/137400_137499/137472/17.00.00_60/ts_137472v170000p.pdf</a>
TSDSI	TSDSI STD T1.3GPP 37.472-17.0.0 V1.0.0	17.0.0	Published	29.07.2022	<a href="https://members.tdsi.in/s/d8cGE9pCSpkeJ2Q">https://members.tdsi.in/s/d8cGE9pCSpkeJ2Q</a>
TTA	TTAT.3G-37.472V17.0.0	17.0.0	Published	05.08.2022	<a href="http://committee.tta.or.kr/data/ttasDown.jsp?kind=ttastd&amp;pk_num=TTAT.3G-37.472V17.0.0">http://committee.tta.or.kr/data/ttasDown.jsp?kind=ttastd&amp;pk_num=TTAT.3G-37.472V17.0.0</a>

## 2.1.4.36 TS 37.473

## W1 interface; Application Protocol (W1AP)

This document specifies the 5G radio network layer signalling protocol for the W1 interface. The W1 interface provides means for interconnecting a ng-eNB-CU and a ng-eNB-DU of a ng-eNB within an NG-RAN. The W1 Application Protocol (W1AP) supports the functions of W1 interface by signalling procedures defined in this document. W1AP is developed in accordance with the general principles stated in TS 38.401 and TS 37.470.

SDO	Document No.	Version	Status	Issued date	Location
<b>Release 16</b>					
ARIB	ARIB STD-T120-37.473.V16.9.0	16.9.0	Published	03.03.2023	<a href="https://www.arib.or.jp/english/html/overview/doc/T120_T23_SPECS/ARIB-STD-T120/Rel16/37/A37473-g90.pdf">https://www.arib.or.jp/english/html/overview/doc/T120_T23_SPECS/ARIB-STD-T120/Rel16/37/A37473-g90.pdf</a>
ATIS	ATIS.3GPP.37.473.V16.9.0	16.9.0	Published	21.02.2023	<a href="https://www.atis.org/3gpp-transpositions - Rel-16">https://www.atis.org/3gpp-transpositions - Rel-16</a>
CCSA	CCSA.37.473V1690	16.9.0	Published	01.06.2022	<a href="https://www.ccsa.org.cn/api/portalsFile/downloadOldFile?type=19&amp;oldFileUrl=ITU-R/M.2012-6/CCSA.37.473V1690.doc">https://www.ccsa.org.cn/api/portalsFile/downloadOldFile?type=19&amp;oldFileUrl=ITU-R/M.2012-6/CCSA.37.473V1690.doc</a>
ETSI	ETSI TS 137 473	16.9.0	Published	20.07.2022	<a href="https://www.etsi.org/deliver/etsi_ts/137400_137499/137473/16.09.00_60/ts_137473v160900p.pdf">https://www.etsi.org/deliver/etsi_ts/137400_137499/137473/16.09.00_60/ts_137473v160900p.pdf</a>
TSDSI	TSDSI STD T1.3GPP 37.473-16.2.0 V1.0.0	16.9.0	Published	06.10.2020	<a href="https://members.tdsi.in/index.php/s/zi7XfEtayYzXDxa">https://members.tdsi.in/index.php/s/zi7XfEtayYzXDxa</a>
TTA	TTAT.3G-37.473V16.9.0	16.9.0	Published	21.10.2022	<a href="http://committee.tta.or.kr/data/ttasDown.jsp?kind=ttastd&amp;pk_num=TTAT.3G-37.473V16.9.0">http://committee.tta.or.kr/data/ttasDown.jsp?kind=ttastd&amp;pk_num=TTAT.3G-37.473V16.9.0</a>
<b>Release 17</b>					
ARIB	ARIB STD-T120-37.473.V17.1.0	17.1.0	Published	03.03.2023	<a href="https://www.arib.or.jp/english/html/overview/doc/T120_T23_SPECS/ARIB-STD-T120/Rel17/37/A37473-h10.pdf">https://www.arib.or.jp/english/html/overview/doc/T120_T23_SPECS/ARIB-STD-T120/Rel17/37/A37473-h10.pdf</a>
ATIS	ATIS.3GPP.37.473.V17.1.0	17.1.0	Published	21.02.2023	<a href="https://www.atis.org/3gpp-transpositions - Rel-17">https://www.atis.org/3gpp-transpositions - Rel-17</a>
CCSA	CCSA.37.473V1710	17.1.0	Published	01.06.2022	<a href="https://www.ccsa.org.cn/api/portalsFile/downloadOldFile?type=19&amp;oldFileUrl=ITU-R/M.2012-6/CCSA.37.473V1710.doc">https://www.ccsa.org.cn/api/portalsFile/downloadOldFile?type=19&amp;oldFileUrl=ITU-R/M.2012-6/CCSA.37.473V1710.doc</a>
ETSI	ETSI TS 137 473	17.1.0	Published	20.07.2022	<a href="https://www.etsi.org/deliver/etsi_ts/137400_137499/137473/17.01.00_60/ts_137473v170100p.pdf">https://www.etsi.org/deliver/etsi_ts/137400_137499/137473/17.01.00_60/ts_137473v170100p.pdf</a>
TSDSI	TSDSI STD T1.3GPP 37.473-17.1.0 V1.1.0	17.1.0	Published	01.11.2022	<a href="https://members.tdsi.in/s/wJdQkG33rSNTWCCQ">https://members.tdsi.in/s/wJdQkG33rSNTWCCQ</a>
TTA	TTAT.3G-37.473V17.1.0	17.1.0	Published	21.10.2022	<a href="http://committee.tta.or.kr/data/ttasDown.jsp?kind=ttastd&amp;pk_num=TTAT.3G-37.473V17.1.0">http://committee.tta.or.kr/data/ttasDown.jsp?kind=ttastd&amp;pk_num=TTAT.3G-37.473V17.1.0</a>

**2.1.4.37 TS 37.480****E1 general aspects and principles**

This document is an introduction to the 3GPP TS 37.48x series of technical specifications that define the E1 interface. The E1 interface provides means for interconnecting a gNB-CU-CP and a gNB-CU-UP of a gNB-CU within an NG-RAN, or for interconnecting a gNB-CU-CP and a gNB-CU-UP of an en-gNB within an E-UTRAN, or for interconnecting an eNB-CP and an eNB-UP of an eNB within an E-UTRAN, or for interconnecting an ng-eNB-CU-CP and an ng-eNB-CU-UP of an ng-eNB-CU within an NG-RAN.

SDO	Document No.	Version	Status	Issued date	Location
<b>Release 17</b>					
ATIS	ATIS.3GPP.37.480.V17.1.0	17.1.0	Published	21.02.2023	<a href="https://www.atis.org/3gpp-transpositions - Rel-17">https://www.atis.org/3gpp-transpositions - Rel-17</a>
CCSA	CCSA.37.480V1710	17.1.0	Published	01.06.2022	<a href="https://www.ccsa.org.cn/api/portalsFile/downloadOldFile?type=19&amp;oldFileUrl=ITU-R/M.2012-6/CCSA.37.480V1710.doc">https://www.ccsa.org.cn/api/portalsFile/downloadOldFile?type=19&amp;oldFileUrl=ITU-R/M.2012-6/CCSA.37.480V1710.doc</a>
ETSI	ETSI TS 137 480	17.1.0	Published	20.07.2022	<a href="https://www.etsi.org/deliver/etsi_ts/137400_137499/137480/17.01.00_60/ts_137480v170100p.pdf">https://www.etsi.org/deliver/etsi_ts/137400_137499/137480/17.01.00_60/ts_137480v170100p.pdf</a>
TSDSI	TSDSI STD T1.3GPP 37.48-17.1.0 V1.1.0	17.1.0	Published	01.11.2022	<a href="https://members.tdsi.in/s/jB8JTtH55TotYzq">https://members.tdsi.in/s/jB8JTtH55TotYzq</a>
TTA	TTAT.3G-37.480V17.1.0	17.1.0	Published	21.10.2022	<a href="http://committee.tta.or.kr/data/ttasDown.jsp?kind=ttastd&amp;pk_num=TTAT.3G-37.480V17.1.0">http://committee.tta.or.kr/data/ttasDown.jsp?kind=ttastd&amp;pk_num=TTAT.3G-37.480V17.1.0</a>
TTC	TS-3GA-37.480(Rel17)v17.1.0	17.1.0	Published	07.10.2022	<a href="https://www.ttc.or.jp/st/docs/3gpp/2022/TS/TS-3GA-37.480v17.1.0.pdf">https://www.ttc.or.jp/st/docs/3gpp/2022/TS/TS-3GA-37.480v17.1.0.pdf</a>

**2.1.4.38 TS 37.481****E1 layer 1**

This document specifies the standards allowed to implement layer 1 on the E1 interface.

The specification of transmission delay requirements and O&M requirements are not in the scope of this document.

SDO	Document No.	Version	Status	Issued date	Location
<b>Release 17</b>					
ATIS	ATIS.3GPP.37.481.V17.0.0	17.0.0	Published	21.02.2023	<a href="https://www.atis.org/3gpp-transpositions - Rel-17">https://www.atis.org/3gpp-transpositions - Rel-17</a>
CCSA	CCSA.37.481V1700	17.0.0	Published	01.04.2022	<a href="https://www.ccsa.org.cn/api/portalsFile/downloadOldFile?type=19&amp;oldFileUrl=ITU-R/M.2012-6/CCSA.37.481V1700.doc">https://www.ccsa.org.cn/api/portalsFile/downloadOldFile?type=19&amp;oldFileUrl=ITU-R/M.2012-6/CCSA.37.481V1700.doc</a>
ETSI	ETSI TS 137 481	17.0.0	Published	07.04.2022	<a href="https://www.etsi.org/deliver/etsi_ts/137400_137499/137481/17.00.00_60/ts_137481v170000p.pdf">https://www.etsi.org/deliver/etsi_ts/137400_137499/137481/17.00.00_60/ts_137481v170000p.pdf</a>
TSDSI	TSDSI STD T1.3GPP 37.481-17.0.0 V1.0.0	17.0.0	Published	29.07.2022	<a href="https://members.tdsi.in/s/dm65dLH8msHx3Em">https://members.tdsi.in/s/dm65dLH8msHx3Em</a>
TTA	TTAT.3G-37.481V17.0.0	17.0.0	Published	05.08.2022	<a href="http://committee.tta.or.kr/data/ttasDown.jsp?kind=ttastd&amp;pk_num=TTAT.3G-37.481V17.0.0">http://committee.tta.or.kr/data/ttasDown.jsp?kind=ttastd&amp;pk_num=TTAT.3G-37.481V17.0.0</a>
TTC	TS-3GA-37.481(Rel17)v17.0.0	17.0.0	Published	07.10.2022	<a href="https://www.ttc.or.jp/st/docs/3gpp/2022/TS/TS-3GA-37.481v17.0.0.pdf">https://www.ttc.or.jp/st/docs/3gpp/2022/TS/TS-3GA-37.481v17.0.0.pdf</a>

**2.1.4.39 TS 37.482****E1 signalling transport**

This document specifies the standards for Signalling Transport to be used across the E1 interface. The E1 interface provides means for the interconnection of gNB-CU-CP and gNB-CU-UP within the NG-RAN architecture (TS 38.401), or for the interconnection of ng-eNB-CU-CP and ng-eNB-CU-UP within the NG-RAN architecture (TS 38.401), or for the interconnection of eNB-CP and eNB-UP within the E-UTRAN architecture (TS 36.401).

SDO	Document No.	Version	Status	Issued date	Location
<b>Release 17</b>					
ATIS	ATIS.3GPP.37.482.V17.2.0	17.2.0	Published	21.02.2023	<a href="https://www.atis.org/3gpp-transpositions - Rel-17">https://www.atis.org/3gpp-transpositions - Rel-17</a>
CCSA	CCSA.37.482V1720	17.2.0	Published	01.09.2022	<a href="https://www.ccsa.org.cn/api/portalsFile/downloadOldFile?type=19&amp;oldFileUrl=ITU-R/M.2012-6/CCSA.37.482V1720.doc">https://www.ccsa.org.cn/api/portalsFile/downloadOldFile?type=19&amp;oldFileUrl=ITU-R/M.2012-6/CCSA.37.482V1720.doc</a>

ETSI	ETSI TS 137 482	17.2.0	Published	14.10.2022	<a href="https://www.etsi.org/deliver/etsi_ts/137400_137499/137482/17.02.00_60/ts_137482v170200p.pdf">https://www.etsi.org/deliver/etsi_ts/137400_137499/137482/17.02.00_60/ts_137482v170200p.pdf</a>
TSDSI	TSDSI STD T1.3GPP 37.482-17.2.0 V1.2.0	17.2.0	Published	17.01.2023	<a href="https://members.tdsi.in/s/3oK8tTx3P23AQtr">https://members.tdsi.in/s/3oK8tTx3P23AQtr</a>
TTA	TTAT.3G-37.482V17.2.0	17.2.0	Published	11.01.2023	<a href="http://committee.tta.or.kr/data/ttasDown.jsp?kind=ttastd&amp;pk_num=TTAT.3G-37.482V17.2.0">http://committee.tta.or.kr/data/ttasDown.jsp?kind=ttastd&amp;pk_num=TTAT.3G-37.482V17.2.0</a>
TTC	TS-3GA-37.482(Rel17)v17.2.0	17.2.0	Published	13.01.2023	<a href="https://www.ttc.or.jp/st/docs/3gpp/2023/TS/TS-3GA-37.482v17.2.0.pdf">https://www.ttc.or.jp/st/docs/3gpp/2023/TS/TS-3GA-37.482v17.2.0.pdf</a>

### 2.1.4.40 TS 37.483

#### E1 Application Protocol (E1AP)

This document specifies the 5G radio network layer signalling protocol for the E1 interface. The E1 interface provides means for interconnecting a gNB-CU-CP and a gNB-CU-UP of a gNB within an NG-RAN, or for interconnecting a gNB-CU-CP and a gNB-CU-UP of an en-gNB within an E-UTRAN, or for interconnecting an eNB-CP and an eNB-UP of an eNB within an E-UTRAN, or for interconnecting an ng-eNB-CU-CP and an ng-eNB-CU-UP of an ng-eNB within an NG-RAN. The E1 Application Protocol (E1AP) supports the functions of E1 interface by signalling procedures defined in this document. E1AP is developed in accordance to the general principles stated in TS 38.401 and TS 37.480.

SDO	Document No.	Version	Status	Issued date	Location
<b>Release 17</b>					
ATIS	ATIS.3GPP.37.483.V17.3.0	17.3.0	Published	21.02.2023	<a href="https://www.atis.org/3gpp-transpositions - Rel-17">https://www.atis.org/3gpp-transpositions - Rel-17</a>
CCSA	CCSA.37.483V1730	17.3.0	Published	01.12.2022	<a href="https://www.ccsa.org.cn/api/portalsFile/downloadOldFile?type=19&amp;oldFileUrl=ITU-R/M.2012-6/CCSA.37.483V1730.doc">https://www.ccsa.org.cn/api/portalsFile/downloadOldFile?type=19&amp;oldFileUrl=ITU-R/M.2012-6/CCSA.37.483V1730.doc</a>
ETSI	ETSI TS 137 483	17.3.0	Published	13.01.2023	<a href="https://www.etsi.org/deliver/etsi_ts/137400_137499/137483/17.03.00_60/ts_137483v170300p.pdf">https://www.etsi.org/deliver/etsi_ts/137400_137499/137483/17.03.00_60/ts_137483v170300p.pdf</a>
TSDSI	TSDSI STD T1.3GPP 37.483 17.3.0 V1.3.0	17.3.0	Published	02.05.2023	<a href="https://members.tdsi.in/s/RsKEMsDAPfy3xHi">https://members.tdsi.in/s/RsKEMsDAPfy3xHi</a>
TTA	TTAT.3G-37.483V17.3.0	17.3.0	Published	16.03.2023	<a href="http://committee.tta.or.kr/data/ttasDown.jsp?kind=ttastd&amp;pk_num=TTAT.3G-37.483V17.3.0">http://committee.tta.or.kr/data/ttasDown.jsp?kind=ttastd&amp;pk_num=TTAT.3G-37.483V17.3.0</a>
TTC	TS-3GA-37.483(Rel17)v17.3.0	17.3.0	Published	14.04.2023	<a href="https://www.ttc.or.jp/st/docs/3gpp/2023/TS/TS-3GA-37.483v17.3.0.pdf">https://www.ttc.or.jp/st/docs/3gpp/2023/TS/TS-3GA-37.483v17.3.0.pdf</a>

### 2.1.4.41 TS 25.446

#### MBMS synchronisation protocol (SYNC)

This document specifies the MBMS Synchronisation Protocol. For the release of this specification, it is used on Iu towards UTRAN and M1 towards E-UTRAN.

SDO	Document No.	Version	Status	Issued date	Location
<b>Release 10</b>					
ARIB	ARIB STD-T120-25.446.V10.2.0	10.2.0	Published	03.03.2023	<a href="https://www.arib.or.jp/english/html/overview/doc/T120_T23_SPECS/ARIB-STD-T120/Rel10/25/A25446-a20.pdf">https://www.arib.or.jp/english/html/overview/doc/T120_T23_SPECS/ARIB-STD-T120/Rel10/25/A25446-a20.pdf</a>
ATIS	ATIS.3GPP.25.446V1020	10.2.0	Published	28.06.2021	<a href="https://www.atis.org/3gpp-documents/Rel99-14/">https://www.atis.org/3gpp-documents/Rel99-14/</a>
CCSA	CCSA.25.446V1020	10.2.0	Published	01.12.2011	<a href="https://www.ccsa.org.cn/api/portalsFile/downloadOldFile?type=19&amp;oldFileUrl=ITU-R/M.2012-6/CCSA.25.446V1020.doc">https://www.ccsa.org.cn/api/portalsFile/downloadOldFile?type=19&amp;oldFileUrl=ITU-R/M.2012-6/CCSA.25.446V1020.doc</a>
ETSI	ETSI TS 125 446	10.2.0	Published	10.01.2012	<a href="https://www.etsi.org/deliver/etsi_ts/125400_125499/125446/10.02.00_60/ts_125446v100200p.pdf">https://www.etsi.org/deliver/etsi_ts/125400_125499/125446/10.02.00_60/ts_125446v100200p.pdf</a>
TSDSI	TSDSI STD T1.3GPP 25.446-10.2.0 V1.0.0	10.2.0	Published	30.08.2021	<a href="https://members.tdsi.in/index.php/s/KDDKeC5ganfz3HJ">https://members.tdsi.in/index.php/s/KDDKeC5ganfz3HJ</a>
TTA	TTAT.3G-25.446V10.2.0	10.2.0	Published	30.07.2021	<a href="http://committee.tta.or.kr/data/ttasDown.jsp?kind=ttastd&amp;pk_num=TTAT.3G-25.446V10.2.0">http://committee.tta.or.kr/data/ttasDown.jsp?kind=ttastd&amp;pk_num=TTAT.3G-25.446V10.2.0</a>
<b>Release 11</b>					
ARIB	ARIB STD-T120-25.446.V11.0.0	11.0.0	Published	03.03.2023	<a href="https://www.arib.or.jp/english/html/overview/doc/T120_T23_SPECS/ARIB-STD-T120/Rel11/25/A25446-b00.pdf">https://www.arib.or.jp/english/html/overview/doc/T120_T23_SPECS/ARIB-STD-T120/Rel11/25/A25446-b00.pdf</a>
ATIS	ATIS.3GPP.25.446V1100	11.0.0	Published	28.06.2021	<a href="https://www.atis.org/3gpp-documents/Rel99-14/">https://www.atis.org/3gpp-documents/Rel99-14/</a>
CCSA	CCSA.25.446V1100	11.0.0	Published	01.09.2012	<a href="https://www.ccsa.org.cn/api/portalsFile/downloadOldFile?type=19&amp;oldFileUrl=ITU-R/M.2012-6/CCSA.25.446V1100.doc">https://www.ccsa.org.cn/api/portalsFile/downloadOldFile?type=19&amp;oldFileUrl=ITU-R/M.2012-6/CCSA.25.446V1100.doc</a>
ETSI	ETSI TS 125 446	11.0.0	Published	10.10.2012	<a href="https://www.etsi.org/deliver/etsi_ts/125400_125499/125446/11.00.00_60/ts_125446v110000p.pdf">https://www.etsi.org/deliver/etsi_ts/125400_125499/125446/11.00.00_60/ts_125446v110000p.pdf</a>
TSDSI	TSDSI STD T1.3GPP 25.446-11.0.0 V1.0.0	11.0.0	Published	30.08.2021	<a href="https://members.tdsi.in/index.php/s/GrfQC7oG64TCN2">https://members.tdsi.in/index.php/s/GrfQC7oG64TCN2</a>
TTA	TTAT.3G-25.446V11.0.0	11.0.0	Published	30.07.2021	<a href="http://committee.tta.or.kr/data/ttasDown.jsp?kind=ttastd&amp;pk_num=TTAT.3G-25.446V11.0.0">http://committee.tta.or.kr/data/ttasDown.jsp?kind=ttastd&amp;pk_num=TTAT.3G-25.446V11.0.0</a>

#### Release 12

ARIB	ARIB STD-T120-25.446.V12.2.0	12.2.0	Published	03.03.2023	<a href="https://www.arib.or.jp/english/html/overview/doc/T120_T23_SPECS/ARIB-STD-T120/Rel12/25/A25446-c20.pdf">https://www.arib.or.jp/english/html/overview/doc/T120_T23_SPECS/ARIB-STD-T120/Rel12/25/A25446-c20.pdf</a>
ATIS	ATIS.3GPP.25.446V1220	12.2.0	Published	28.06.2021	<a href="https://www.atis.org/3gpp-documents/Rel99-14/">https://www.atis.org/3gpp-documents/Rel99-14/</a>
CCSA	CCSA.25.446V1220	12.2.0	Published	01.03.2016	<a href="https://www.ccsa.org.cn/api/portalsFile/downloadOldFile?type=19&amp;oldFileUrl=ITU-R/M.2012-6/CCSA.25.446V1220.doc">https://www.ccsa.org.cn/api/portalsFile/downloadOldFile?type=19&amp;oldFileUrl=ITU-R/M.2012-6/CCSA.25.446V1220.doc</a>
ETSI	ETSI TS 125 446	12.2.0	Published	11.05.2016	<a href="https://www.etsi.org/deliver/etsi_ts/125400_125499/125446/12.02.00_60/ts_125446v120200p.pdf">https://www.etsi.org/deliver/etsi_ts/125400_125499/125446/12.02.00_60/ts_125446v120200p.pdf</a>
TSDSI	TSDSI STD T1.3GPP 25.446-12.2.0 V1.0.0	12.2.0	Published	30.08.2021	<a href="https://members.tdsi.in/index.php/s/kGsermamLN6j6XQ">https://members.tdsi.in/index.php/s/kGsermamLN6j6XQ</a>
TTA	TTAT.3G-25.446V12.2.0	12.2.0	Published	30.07.2021	<a href="http://committee.tta.or.kr/data/ttasDown.jsp?kind=ttastd&amp;pk_num=TTAT.3G-25.446V12.2.0">http://committee.tta.or.kr/data/ttasDown.jsp?kind=ttastd&amp;pk_num=TTAT.3G-25.446V12.2.0</a>
<b>Release 13</b>					
ARIB	ARIB STD-T120-25.446.V13.1.0	13.1.0	Published	03.03.2023	<a href="https://www.arib.or.jp/english/html/overview/doc/T120_T23_SPECS/ARIB-STD-T120/Rel13/25/A25446-d10.pdf">https://www.arib.or.jp/english/html/overview/doc/T120_T23_SPECS/ARIB-STD-T120/Rel13/25/A25446-d10.pdf</a>
ATIS	ATIS.3GPP.25.446V1310	13.1.0	Published	28.06.2021	<a href="https://www.atis.org/3gpp-documents/Rel99-14/">https://www.atis.org/3gpp-documents/Rel99-14/</a>
CCSA	CCSA.25.446V1310	13.1.0	Published	01.03.2016	<a href="https://www.ccsa.org.cn/api/portalsFile/downloadOldFile?type=19&amp;oldFileUrl=ITU-R/M.2012-6/CCSA.25.446V1310.doc">https://www.ccsa.org.cn/api/portalsFile/downloadOldFile?type=19&amp;oldFileUrl=ITU-R/M.2012-6/CCSA.25.446V1310.doc</a>
ETSI	ETSI TS 125 446	13.1.0	Published	11.05.2016	<a href="https://www.etsi.org/deliver/etsi_ts/125400_125499/125446/13.01.00_60/ts_125446v130100p.pdf">https://www.etsi.org/deliver/etsi_ts/125400_125499/125446/13.01.00_60/ts_125446v130100p.pdf</a>
TSDSI	TSDSI STD T1.3GPP 25.446-13.1.0 V1.0.0	13.1.0	Published	30.08.2021	<a href="https://members.tdsi.in/index.php/s/LgGDYFkaqwEngZi">https://members.tdsi.in/index.php/s/LgGDYFkaqwEngZi</a>
TTA	TTAT.3G-25.446V13.1.0	13.1.0	Published	30.07.2021	<a href="http://committee.tta.or.kr/data/ttasDown.jsp?kind=ttastd&amp;pk_num=TTAT.3G-25.446V13.1.0">http://committee.tta.or.kr/data/ttasDown.jsp?kind=ttastd&amp;pk_num=TTAT.3G-25.446V13.1.0</a>
<b>Release 14</b>					
ARIB	ARIB STD-T120-25.446.V14.0.0	14.0.0	Published	03.03.2023	<a href="https://www.arib.or.jp/english/html/overview/doc/T120_T23_SPECS/ARIB-STD-T120/Rel14/25/A25446-e00.pdf">https://www.arib.or.jp/english/html/overview/doc/T120_T23_SPECS/ARIB-STD-T120/Rel14/25/A25446-e00.pdf</a>
ATIS	ATIS.3GPP.25.446V1400	14.0.0	Published	28.06.2021	<a href="https://www.atis.org/3gpp-documents/Rel99-14/">https://www.atis.org/3gpp-documents/Rel99-14/</a>
CCSA	CCSA.25.446V1400	14.0.0	Published	01.03.2017	<a href="https://www.ccsa.org.cn/api/portalsFile/downloadOldFile?type=19&amp;oldFileUrl=ITU-R/M.2012-6/CCSA.25.446V1400.doc">https://www.ccsa.org.cn/api/portalsFile/downloadOldFile?type=19&amp;oldFileUrl=ITU-R/M.2012-6/CCSA.25.446V1400.doc</a>
ETSI	ETSI TS 125 446	14.0.0	Published	05.04.2017	<a href="https://www.etsi.org/deliver/etsi_ts/125400_125499/125446/14.00.00_60/ts_125446v140000p.pdf">https://www.etsi.org/deliver/etsi_ts/125400_125499/125446/14.00.00_60/ts_125446v140000p.pdf</a>
TSDSI	TSDSI STD T1.3GPP 25.446-14.0.0 V1.0.0	14.0.0	Published	30.08.2021	<a href="https://members.tdsi.in/index.php/s/p24kSB6zr9Po9P">https://members.tdsi.in/index.php/s/p24kSB6zr9Po9P</a>
TTA	TTAT.3G-25.446V14.0.0	14.0.0	Published	30.07.2021	<a href="http://committee.tta.or.kr/data/ttasDown.jsp?kind=ttastd&amp;pk_num=TTAT.3G-25.446V14.0.0">http://committee.tta.or.kr/data/ttasDown.jsp?kind=ttastd&amp;pk_num=TTAT.3G-25.446V14.0.0</a>
<b>Release 15</b>					
ARIB	ARIB STD-T120-25.446.V15.0.0	15.0.0	Published	03.03.2023	<a href="https://www.arib.or.jp/english/html/overview/doc/T120_T23_SPECS/ARIB-STD-T120/Rel15/25/A25446-f00.pdf">https://www.arib.or.jp/english/html/overview/doc/T120_T23_SPECS/ARIB-STD-T120/Rel15/25/A25446-f00.pdf</a>
ATIS	ATIS.3GPP.25.446V1500	15.0.0	Published	28.06.2021	<a href="https://www.atis.org/3gpp-documents/Rel15/">https://www.atis.org/3gpp-documents/Rel15/</a>
CCSA	CCSA.25.446V1500	15.0.0	Published	01.07.2018	<a href="https://www.ccsa.org.cn/api/portalsFile/downloadOldFile?type=19&amp;oldFileUrl=ITU-R/M.2012-6/CCSA.25.446V1500.doc">https://www.ccsa.org.cn/api/portalsFile/downloadOldFile?type=19&amp;oldFileUrl=ITU-R/M.2012-6/CCSA.25.446V1500.doc</a>
ETSI	ETSI TS 125 446	15.0.0	Published	12.07.2018	<a href="https://www.etsi.org/deliver/etsi_ts/125400_125499/125446/15.00.00_60/ts_125446v150000p.pdf">https://www.etsi.org/deliver/etsi_ts/125400_125499/125446/15.00.00_60/ts_125446v150000p.pdf</a>
TSDSI	TSDSI STD T1.3GPP 25.446-15.0.0 V1.0.0	15.0.0	Published	30.08.2021	<a href="https://members.tdsi.in/index.php/s/fyxrMFWT6Zzn3SB">https://members.tdsi.in/index.php/s/fyxrMFWT6Zzn3SB</a>
TTA	TTAT.3G-25.446V15.0.0	15.0.0	Published	10.06.2021	<a href="http://committee.tta.or.kr/data/ttasDown.jsp?kind=ttastd&amp;pk_num=TTAT.3G-25.446V15.0.0">http://committee.tta.or.kr/data/ttasDown.jsp?kind=ttastd&amp;pk_num=TTAT.3G-25.446V15.0.0</a>
<b>Release 16</b>					
ARIB	ARIB STD-T120-25.446.V16.0.0	16.0.0	Published	03.03.2023	<a href="https://www.arib.or.jp/english/html/overview/doc/T120_T23_SPECS/ARIB-STD-T120/Rel16/25/A25446-g00.pdf">https://www.arib.or.jp/english/html/overview/doc/T120_T23_SPECS/ARIB-STD-T120/Rel16/25/A25446-g00.pdf</a>
ATIS	ATIS.3GPP.25.446V1600	16.0.0	Published	28.06.2021	<a href="https://www.atis.org/3gpp-documents/Rel16/">https://www.atis.org/3gpp-documents/Rel16/</a>
CCSA	CCSA.25.446V1600	16.0.0	Published	01.07.2020	<a href="https://www.ccsa.org.cn/api/portalsFile/downloadOldFile?type=19&amp;oldFileUrl=ITU-R/M.2012-6/CCSA.25.446V1600.doc">https://www.ccsa.org.cn/api/portalsFile/downloadOldFile?type=19&amp;oldFileUrl=ITU-R/M.2012-6/CCSA.25.446V1600.doc</a>
ETSI	ETSI TS 125 446	16.0.0	Published	19.08.2020	<a href="https://www.etsi.org/deliver/etsi_ts/125400_125499/125446/16.00.00_60/ts_125446v160000p.pdf">https://www.etsi.org/deliver/etsi_ts/125400_125499/125446/16.00.00_60/ts_125446v160000p.pdf</a>
TSDSI	TSDSI STD T1.3GPP 25.446-16.0.0 V1.0.0	16.0.0	Published	30.08.2021	<a href="https://members.tdsi.in/index.php/s/wdQ5S98NjBJa88D">https://members.tdsi.in/index.php/s/wdQ5S98NjBJa88D</a>
TTA	TTAT.3G-25.446V16.0.0	16.0.0	Published	10.06.2021	<a href="http://committee.tta.or.kr/data/ttasDown.jsp?kind=ttastd&amp;pk_num=TTAT.3G-25.446V16.0.0">http://committee.tta.or.kr/data/ttasDown.jsp?kind=ttastd&amp;pk_num=TTAT.3G-25.446V16.0.0</a>
<b>Release 17</b>					
ARIB	ARIB STD-T120-25.446.V17.0.0	17.0.0	Published	03.03.2023	<a href="https://www.arib.or.jp/english/html/overview/doc/T120_T23_SPECS/ARIB-STD-T120/Rel17/25/A25446-h00.pdf">https://www.arib.or.jp/english/html/overview/doc/T120_T23_SPECS/ARIB-STD-T120/Rel17/25/A25446-h00.pdf</a>
ATIS	ATIS.3GPP.25.446.V17.0.0	17.0.0	Published	21.02.2023	<a href="https://www.atis.org/3gpp-transpositions - Rel-17">https://www.atis.org/3gpp-transpositions - Rel-17</a>
CCSA	CCSA.25.446V1700	17.0.0	Published	01.04.2022	<a href="https://www.ccsa.org.cn/api/portalsFile/downloadOldFile?type=19&amp;oldFileUrl=ITU-R/M.2012-6/CCSA.25.446V1700.doc">https://www.ccsa.org.cn/api/portalsFile/downloadOldFile?type=19&amp;oldFileUrl=ITU-R/M.2012-6/CCSA.25.446V1700.doc</a>
ETSI	ETSI TS 125 446	17.0.0	Published	29.04.2022	<a href="https://www.etsi.org/deliver/etsi_ts/125400_125499/125446/17.00.00_60/ts_125446v170000p.pdf">https://www.etsi.org/deliver/etsi_ts/125400_125499/125446/17.00.00_60/ts_125446v170000p.pdf</a>
TSDSI	TSDSI STD T1.3GPP 25.446-17.0.0 V1.0.0	17.0.0	Published	29.07.2022	<a href="https://members.tdsi.in/s/noteNRRgTE92cnL">https://members.tdsi.in/s/noteNRRgTE92cnL</a>
TTA	TTAT.3G-25.446V17.0.0	17.0.0	Published	05.08.2022	<a href="http://committee.tta.or.kr/data/ttasDown.jsp?kind=ttastd&amp;pk_num=TTAT.3G-25.446V17.0.0">http://committee.tta.or.kr/data/ttasDown.jsp?kind=ttastd&amp;pk_num=TTAT.3G-25.446V17.0.0</a>

## 2.1.5 Radio-frequency aspects

## 2.1.5.1 TS 36.101

## Evolved Universal Terrestrial Radio Access (E-UTRA); User Equipment (UE) radio transmission and reception

This document establishes the minimum RF characteristics and minimum performance requirements for E-UTRA User Equipment (UE).

SDO	Document No.	Version	Status	Issued date	Location
<b>Release 10</b>					
ARIB	ARIB STD-T120-36.101.V10.33.0	10.33.0	Published	03.03.2023	<a href="https://www.arib.or.jp/english/html/overview/doc/T120_T23_SPECS/ARIB-STD-T120/Rel10/36/A36101-ax0.pdf">https://www.arib.or.jp/english/html/overview/doc/T120_T23_SPECS/ARIB-STD-T120/Rel10/36/A36101-ax0.pdf</a>
ATIS	ATIS.3GPP.36.101.V10.33.0	10.33.0	Published	21.02.2023	<a href="https://www.atis.org/3gpp-transpositions-Rel-10">https://www.atis.org/3gpp-transpositions-Rel-10</a>
CCSA	CCSA.36.101V10330	10.33.0	Published	01.09.2022	<a href="https://www.ccsa.org.cn/api/portalsFile/downloadOldFile?type=19&amp;oldFileUrl=ITU-R/M.2012-6/CCSA.36.101V10330.rar">https://www.ccsa.org.cn/api/portalsFile/downloadOldFile?type=19&amp;oldFileUrl=ITU-R/M.2012-6/CCSA.36.101V10330.rar</a>
ETSI	ETSI TS 136 101	10.33.0	Published	28.10.2022	<a href="https://www.etsi.org/deliver/etsi_ts/136100_136199/136101/10.33.00_60/ts_136101v103300p.pdf">https://www.etsi.org/deliver/etsi_ts/136100_136199/136101/10.33.00_60/ts_136101v103300p.pdf</a>
TSDSI	TSDSI STD T1.3GPP 36.101 10.33.0 V1.2.0	10.33.0	Published	02.05.2023	<a href="https://members.tdsi.in/s/Zbr4wT7a2fop5wM">https://members.tdsi.in/s/Zbr4wT7a2fop5wM</a>
TTA	TTAT.3G-36.101V10.33.0	10.33.0	Published	11.01.2023	<a href="http://committee.tta.or.kr/data/ttasDown.jsp?kind=ttastd&amp;pk_num=TTAT.3G-36.101V10.33.0">http://committee.tta.or.kr/data/ttasDown.jsp?kind=ttastd&amp;pk_num=TTAT.3G-36.101V10.33.0</a>
<b>Release 11</b>					
ARIB	ARIB STD-T120-36.101.V11.30.0	11.30.0	Published	03.03.2023	<a href="https://www.arib.or.jp/english/html/overview/doc/T120_T23_SPECS/ARIB-STD-T120/Rel11/36/A36101-bu0.pdf">https://www.arib.or.jp/english/html/overview/doc/T120_T23_SPECS/ARIB-STD-T120/Rel11/36/A36101-bu0.pdf</a>
ATIS	ATIS.3GPP.36.101.V11.30.0	11.30.0	Published	21.02.2023	<a href="https://www.atis.org/3gpp-transpositions-Rel-11">https://www.atis.org/3gpp-transpositions-Rel-11</a>
CCSA	CCSA.36.101V11300	11.30.0	Published	01.09.2022	<a href="https://www.ccsa.org.cn/api/portalsFile/downloadOldFile?type=19&amp;oldFileUrl=ITU-R/M.2012-6/CCSA.36.101V11300.rar">https://www.ccsa.org.cn/api/portalsFile/downloadOldFile?type=19&amp;oldFileUrl=ITU-R/M.2012-6/CCSA.36.101V11300.rar</a>
ETSI	ETSI TS 136 101	11.30.0	Published	28.10.2022	<a href="https://www.etsi.org/deliver/etsi_ts/136100_136199/136101/11.30.00_60/ts_136101v113000p.pdf">https://www.etsi.org/deliver/etsi_ts/136100_136199/136101/11.30.00_60/ts_136101v113000p.pdf</a>
TSDSI	TSDSI STD T1.3GPP 36.101 11.30.0 V1.2.0	11.30.0	Published	02.05.2023	<a href="https://members.tdsi.in/s/AfBcf4t8ZzaDnoj">https://members.tdsi.in/s/AfBcf4t8ZzaDnoj</a>
TTA	TTAT.3G-36.101V11.30.0	11.30.0	Published	11.01.2023	<a href="http://committee.tta.or.kr/data/ttasDown.jsp?kind=ttastd&amp;pk_num=TTAT.3G-36.101V11.30.0">http://committee.tta.or.kr/data/ttasDown.jsp?kind=ttastd&amp;pk_num=TTAT.3G-36.101V11.30.0</a>
<b>Release 12</b>					
ARIB	ARIB STD-T120-36.101.V12.30.0	12.30.0	Published	03.03.2023	<a href="https://www.arib.or.jp/english/html/overview/doc/T120_T23_SPECS/ARIB-STD-T120/Rel12/36/A36101-cu0.pdf">https://www.arib.or.jp/english/html/overview/doc/T120_T23_SPECS/ARIB-STD-T120/Rel12/36/A36101-cu0.pdf</a>
ATIS	ATIS.3GPP.36.101.V12.30.0	12.30.0	Published	21.02.2023	<a href="https://www.atis.org/3gpp-transpositions-Rel-12">https://www.atis.org/3gpp-transpositions-Rel-12</a>
CCSA	CCSA.36.101V12300	12.30.0	Published	01.09.2022	<a href="https://www.ccsa.org.cn/api/portalsFile/downloadOldFile?type=19&amp;oldFileUrl=ITU-R/M.2012-6/CCSA.36.101V12300.rar">https://www.ccsa.org.cn/api/portalsFile/downloadOldFile?type=19&amp;oldFileUrl=ITU-R/M.2012-6/CCSA.36.101V12300.rar</a>
ETSI	ETSI TS 136 101	12.30.0	Published	28.10.2022	<a href="https://www.etsi.org/deliver/etsi_ts/136100_136199/136101/12.30.00_60/ts_136101v123000p.pdf">https://www.etsi.org/deliver/etsi_ts/136100_136199/136101/12.30.00_60/ts_136101v123000p.pdf</a>
TSDSI	TSDSI STD T1.3GPP 36.101 12.30.0 V1.1.0	12.30.0	Published	02.05.2023	<a href="https://members.tdsi.in/s/RzoYEC2a3b8gWFP">https://members.tdsi.in/s/RzoYEC2a3b8gWFP</a>
TTA	TTAT.3G-36.101V12.30.0	12.30.0	Published	11.01.2023	<a href="http://committee.tta.or.kr/data/ttasDown.jsp?kind=ttastd&amp;pk_num=TTAT.3G-36.101V12.30.0">http://committee.tta.or.kr/data/ttasDown.jsp?kind=ttastd&amp;pk_num=TTAT.3G-36.101V12.30.0</a>
<b>Release 13</b>					
ARIB	ARIB STD-T120-36.101.V13.24.0	13.24.0	Published	03.03.2023	<a href="https://www.arib.or.jp/english/html/overview/doc/T120_T23_SPECS/ARIB-STD-T120/Rel13/36/A36101-do0.pdf">https://www.arib.or.jp/english/html/overview/doc/T120_T23_SPECS/ARIB-STD-T120/Rel13/36/A36101-do0.pdf</a>
ATIS	ATIS.3GPP.36.101.V13.24.0	13.24.0	Published	21.02.2023	<a href="https://www.atis.org/3gpp-transpositions-Rel-13">https://www.atis.org/3gpp-transpositions-Rel-13</a>
CCSA	CCSA.36.101V13240	13.24.0	Published	01.09.2022	<a href="https://www.ccsa.org.cn/api/portalsFile/downloadOldFile?type=19&amp;oldFileUrl=ITU-R/M.2012-6/CCSA.36.101V13240.rar">https://www.ccsa.org.cn/api/portalsFile/downloadOldFile?type=19&amp;oldFileUrl=ITU-R/M.2012-6/CCSA.36.101V13240.rar</a>
ETSI	ETSI TS 136 101	13.24.0	Published	28.10.2022	<a href="https://www.etsi.org/deliver/etsi_ts/136100_136199/136101/13.24.00_60/ts_136101v132400p.pdf">https://www.etsi.org/deliver/etsi_ts/136100_136199/136101/13.24.00_60/ts_136101v132400p.pdf</a>
TSDSI	TSDSI STD T1.3GPP 36.101-13.24.0 V1.1.0	13.24.0	Published	17.01.2023	<a href="https://members.tdsi.in/s/7dJre4c9ZeeWSnn">https://members.tdsi.in/s/7dJre4c9ZeeWSnn</a>
TTA	TTAT.3G-36.101V13.24.0	13.24.0	Published	11.01.2023	<a href="http://committee.tta.or.kr/data/ttasDown.jsp?kind=ttastd&amp;pk_num=TTAT.3G-36.101V13.24.0">http://committee.tta.or.kr/data/ttasDown.jsp?kind=ttastd&amp;pk_num=TTAT.3G-36.101V13.24.0</a>
<b>Release 14</b>					
ARIB	ARIB STD-T120-36.101.V14.24.0	14.24.0	Published	03.03.2023	<a href="https://www.arib.or.jp/english/html/overview/doc/T120_T23_SPECS/ARIB-STD-T120/Rel14/36/A36101-eo0.pdf">https://www.arib.or.jp/english/html/overview/doc/T120_T23_SPECS/ARIB-STD-T120/Rel14/36/A36101-eo0.pdf</a>
ATIS	ATIS.3GPP.36.101.V14.24.0	14.24.0	Published	21.02.2023	<a href="https://www.atis.org/3gpp-transpositions-Rel-14">https://www.atis.org/3gpp-transpositions-Rel-14</a>
CCSA	CCSA.36.101V14240	14.24.0	Published	01.09.2022	<a href="https://www.ccsa.org.cn/api/portalsFile/downloadOldFile?type=19&amp;oldFileUrl=ITU-R/M.2012-6/CCSA.36.101V14240.rar">https://www.ccsa.org.cn/api/portalsFile/downloadOldFile?type=19&amp;oldFileUrl=ITU-R/M.2012-6/CCSA.36.101V14240.rar</a>
ETSI	ETSI TS 136 101	14.24.0	Published	06.01.2023	<a href="https://www.etsi.org/deliver/etsi_ts/136100_136199/136101/14.24.00_60/ts_136101v142400p.pdf">https://www.etsi.org/deliver/etsi_ts/136100_136199/136101/14.24.00_60/ts_136101v142400p.pdf</a>
TSDSI	TSDSI STD T1.3GPP 36.101-14.24.0 V1.1.0	14.24.0	Published	17.01.2023	<a href="https://members.tdsi.in/s/CPkQG6BapKnNR3f">https://members.tdsi.in/s/CPkQG6BapKnNR3f</a>
TTA	TTAT.3G-36.101V14.24.0	14.24.0	Published	11.01.2023	<a href="http://committee.tta.or.kr/data/ttasDown.jsp?kind=ttastd&amp;pk_num=TTAT.3G-36.101V14.24.0">http://committee.tta.or.kr/data/ttasDown.jsp?kind=ttastd&amp;pk_num=TTAT.3G-36.101V14.24.0</a>
<b>Release 15</b>					
ARIB	ARIB STD-T120-36.101.V15.20.0	15.20.0	Published	03.03.2023	<a href="https://www.arib.or.jp/english/html/overview/doc/T120_T23_SPECS/ARIB-STD-T120/Rel15/36/A36101-fk0.pdf">https://www.arib.or.jp/english/html/overview/doc/T120_T23_SPECS/ARIB-STD-T120/Rel15/36/A36101-fk0.pdf</a>



ATIS	ATIS.3GPP.36.101.V15.20.0	15.20.0	Published	21.02.2023	<a href="https://www.atis.org/3gpp-transpositions - Rel-15">https://www.atis.org/3gpp-transpositions - Rel-15</a>
CCSA	CCSA.36.101V15200	15.20.0	Published	01.09.2022	<a href="https://www.ccsa.org.cn/api/portalsFile/downloadOldFile?type=19&amp;oldFileUrl=ITU-R/M.2012-6/CCSA.36.101V15200.rar">https://www.ccsa.org.cn/api/portalsFile/downloadOldFile?type=19&amp;oldFileUrl=ITU-R/M.2012-6/CCSA.36.101V15200.rar</a>
ETSI	ETSI TS 136 101	15.20.0	Published	06.01.2023	<a href="https://www.etsi.org/deliver/etsi_ts/136100_136199/136101/15.20.00_60/ts_136101v152000p.pdf">https://www.etsi.org/deliver/etsi_ts/136100_136199/136101/15.20.00_60/ts_136101v152000p.pdf</a>
TSDSI	TSDSI STD T1.3GPP 36.101-15.20.0 V1.2.0	15.20.0	Published	17.01.2023	<a href="https://members.tdsi.in/s/gssGM7HL6DMaDAf">https://members.tdsi.in/s/gssGM7HL6DMaDAf</a>
TTA	TTAT.3G-36.101V15.20.0	15.20.0	Published	11.01.2023	<a href="http://committee.tta.or.kr/data/ttasDown.jsp?kind=ttastd&amp;pk_num=TTAT.3G-36.101V15.20.0">http://committee.tta.or.kr/data/ttasDown.jsp?kind=ttastd&amp;pk_num=TTAT.3G-36.101V15.20.0</a>

**Release 16**

ARIB	ARIB STD-T120-36.101.V16.15.0	16.15.0	Published	03.03.2023	<a href="https://www.arib.or.jp/english/html/overview/doc/T120_T23_SPECS/ARIB-STD-T120/Rel16/36/A36101-gf0.pdf">https://www.arib.or.jp/english/html/overview/doc/T120_T23_SPECS/ARIB-STD-T120/Rel16/36/A36101-gf0.pdf</a>
ATIS	ATIS.3GPP.36.101.V16.15.0	16.15.0	Published	21.02.2023	<a href="https://www.atis.org/3gpp-transpositions - Rel-16">https://www.atis.org/3gpp-transpositions - Rel-16</a>
CCSA	CCSA.36.101V16150	16.15.0	Published	01.09.2022	<a href="https://www.ccsa.org.cn/api/portalsFile/downloadOldFile?type=19&amp;oldFileUrl=ITU-R/M.2012-6/CCSA.36.101V16150.rar">https://www.ccsa.org.cn/api/portalsFile/downloadOldFile?type=19&amp;oldFileUrl=ITU-R/M.2012-6/CCSA.36.101V16150.rar</a>
ETSI	ETSI TS 136 101	16.15.0	Published	11.01.2023	<a href="https://www.etsi.org/deliver/etsi_ts/136100_136199/136101/16.15.00_60/ts_136101v161500p.pdf">https://www.etsi.org/deliver/etsi_ts/136100_136199/136101/16.15.00_60/ts_136101v161500p.pdf</a>
TSDSI	TSDSI STD T1.3GPP 36.101-16.15.0 V1.2.0	16.15.0	Published	17.01.2023	<a href="https://members.tdsi.in/s/22a8snexzjtjJZn">https://members.tdsi.in/s/22a8snexzjtjJZn</a>
TTA	TTAT.3G-36.101V16.15.0	16.15.0	Published	11.01.2023	<a href="http://committee.tta.or.kr/data/ttasDown.jsp?kind=ttastd&amp;pk_num=TTAT.3G-36.101V16.15.0">http://committee.tta.or.kr/data/ttasDown.jsp?kind=ttastd&amp;pk_num=TTAT.3G-36.101V16.15.0</a>

**Release 17**

ARIB	ARIB STD-T120-36.101.V17.8.0	17.8.0	Published	03.03.2023	<a href="https://www.arib.or.jp/english/html/overview/doc/T120_T23_SPECS/ARIB-STD-T120/Rel17/36/A36101-h80.pdf">https://www.arib.or.jp/english/html/overview/doc/T120_T23_SPECS/ARIB-STD-T120/Rel17/36/A36101-h80.pdf</a>
ATIS	ATIS.3GPP.36.101.V17.8.0	17.8.0	Published	21.02.2023	<a href="https://www.atis.org/3gpp-transpositions - Rel-17">https://www.atis.org/3gpp-transpositions - Rel-17</a>
CCSA	CCSA.36.101V1780	17.8.0	Published	01.12.2022	<a href="https://www.ccsa.org.cn/api/portalsFile/downloadOldFile?type=19&amp;oldFileUrl=ITU-R/M.2012-6/CCSA.36.101V1780.rar">https://www.ccsa.org.cn/api/portalsFile/downloadOldFile?type=19&amp;oldFileUrl=ITU-R/M.2012-6/CCSA.36.101V1780.rar</a>
ETSI	ETSI TS 136 101	17.8.0	Published	20.01.2023	<a href="https://www.etsi.org/deliver/etsi_ts/136100_136199/136101/17.08.00_60/ts_136101v170800p.pdf">https://www.etsi.org/deliver/etsi_ts/136100_136199/136101/17.08.00_60/ts_136101v170800p.pdf</a>
TSDSI	TSDSI STD T1.3GPP 36.101 17.8.0 V1.3.0	17.8.0	Published	02.05.2023	<a href="https://members.tdsi.in/s/FqiFAewEZqCZtKk">https://members.tdsi.in/s/FqiFAewEZqCZtKk</a>
TTA	TTAT.3G-36.101V17.8.0	17.8.0	Published	16.03.2023	<a href="http://committee.tta.or.kr/data/ttasDown.jsp?kind=ttastd&amp;pk_num=TTAT.3G-36.101V17.8.0">http://committee.tta.or.kr/data/ttasDown.jsp?kind=ttastd&amp;pk_num=TTAT.3G-36.101V17.8.0</a>

**2.1.5.2 TS 36.104**

**Evolved Universal Terrestrial Radio Access (E-UTRA); Base Station (BS) radio transmission and reception**

This document establishes the minimum RF characteristics and minimum performance requirements of E-UTRA Base Station (BS).

SDO	Document No.	Version	Status	Issued date	Location
<b>Release 10</b>					
ARIB	ARIB STD-T120-36.104.V10.14.0	10.14.0	Published	03.03.2023	<a href="https://www.arib.or.jp/english/html/overview/doc/T120_T23_SPECS/ARIB-STD-T120/Rel10/36/A36104-ae0.pdf">https://www.arib.or.jp/english/html/overview/doc/T120_T23_SPECS/ARIB-STD-T120/Rel10/36/A36104-ae0.pdf</a>
ATIS	ATIS.3GPP.36.104.V10.14.0	10.14.0	Published	21.02.2023	<a href="https://www.atis.org/3gpp-transpositions - Rel-10">https://www.atis.org/3gpp-transpositions - Rel-10</a>
CCSA	CCSA.36.104V10140	10.14.0	Published	01.03.2021	<a href="https://www.ccsa.org.cn/api/portalsFile/downloadOldFile?type=19&amp;oldFileUrl=ITU-R/M.2012-6/CCSA.36.104V10140.doc">https://www.ccsa.org.cn/api/portalsFile/downloadOldFile?type=19&amp;oldFileUrl=ITU-R/M.2012-6/CCSA.36.104V10140.doc</a>
ETSI	ETSI TS 136 104	10.14.0	Published	30.04.2021	<a href="https://www.etsi.org/deliver/etsi_ts/136100_136199/136104/10.14.00_60/ts_136104v101400p.pdf">https://www.etsi.org/deliver/etsi_ts/136100_136199/136104/10.14.00_60/ts_136104v101400p.pdf</a>
TSDSI	TSDSI STD T1.3GPP 36.104 10.14.0 V1.1.0	10.14.0	Published	02.05.2023	<a href="https://members.tdsi.in/s/MDJWCEDF7WKxmjE">https://members.tdsi.in/s/MDJWCEDF7WKxmjE</a>
TTA	TTAT.3G-36.104V10.14.0	10.14.0	Published	10.06.2021	<a href="http://committee.tta.or.kr/data/ttasDown.jsp?kind=ttastd&amp;pk_num=TTAT.3G-36.104V10.14.0">http://committee.tta.or.kr/data/ttasDown.jsp?kind=ttastd&amp;pk_num=TTAT.3G-36.104V10.14.0</a>
<b>Release 11</b>					
ARIB	ARIB STD-T120-36.104.V11.18.0	11.18.0	Published	03.03.2023	<a href="https://www.arib.or.jp/english/html/overview/doc/T120_T23_SPECS/ARIB-STD-T120/Rel11/36/A36104-bi0.pdf">https://www.arib.or.jp/english/html/overview/doc/T120_T23_SPECS/ARIB-STD-T120/Rel11/36/A36104-bi0.pdf</a>
ATIS	ATIS.3GPP.36.104.V11.18.0	11.18.0	Published	21.02.2023	<a href="https://www.atis.org/3gpp-transpositions - Rel-11">https://www.atis.org/3gpp-transpositions - Rel-11</a>
CCSA	CCSA.36.104V11180	11.18.0	Published	01.03.2021	<a href="https://www.ccsa.org.cn/api/portalsFile/downloadOldFile?type=19&amp;oldFileUrl=ITU-R/M.2012-6/CCSA.36.104V11180.doc">https://www.ccsa.org.cn/api/portalsFile/downloadOldFile?type=19&amp;oldFileUrl=ITU-R/M.2012-6/CCSA.36.104V11180.doc</a>
ETSI	ETSI TS 136 104	11.18.0	Published	30.04.2021	<a href="https://www.etsi.org/deliver/etsi_ts/136100_136199/136104/11.18.00_60/ts_136104v111800p.pdf">https://www.etsi.org/deliver/etsi_ts/136100_136199/136104/11.18.00_60/ts_136104v111800p.pdf</a>
TSDSI	TSDSI STD T1.3GPP 36.104 11.18.0 V1.2.0	11.18.0	Published	30.08.2021	<a href="https://members.tdsi.in/s/fJaxnojNsFT75BQ">https://members.tdsi.in/s/fJaxnojNsFT75BQ</a>
TTA	TTAT.3G-36.104V11.18.0	11.18.0	Published	10.06.2021	<a href="http://committee.tta.or.kr/data/ttasDown.jsp?kind=ttastd&amp;pk_num=TTAT.3G-36.104V11.18.0">http://committee.tta.or.kr/data/ttasDown.jsp?kind=ttastd&amp;pk_num=TTAT.3G-36.104V11.18.0</a>
<b>Release 12</b>					
ARIB	ARIB STD-T120-36.104.V12.14.0	12.14.0	Published	03.03.2023	<a href="https://www.arib.or.jp/english/html/overview/doc/T120_T23_SPECS/ARIB-STD-T120/Rel12/36/A36104-ce0.pdf">https://www.arib.or.jp/english/html/overview/doc/T120_T23_SPECS/ARIB-STD-T120/Rel12/36/A36104-ce0.pdf</a>
ATIS	ATIS.3GPP.36.104.V12.14.0	12.14.0	Published	21.02.2023	<a href="https://www.atis.org/3gpp-transpositions - Rel-12">https://www.atis.org/3gpp-transpositions - Rel-12</a>
CCSA	CCSA.36.104V12140	12.14.0	Published	01.03.2021	<a href="https://www.ccsa.org.cn/api/portalsFile/downloadOldFile?type=19&amp;oldFileUrl=ITU-R/M.2012-6/CCSA.36.104V12140.doc">https://www.ccsa.org.cn/api/portalsFile/downloadOldFile?type=19&amp;oldFileUrl=ITU-R/M.2012-6/CCSA.36.104V12140.doc</a>
ETSI	ETSI TS 136 104	12.14.0	Published	30.04.2021	<a href="https://www.etsi.org/deliver/etsi_ts/136100_136199/136104/12.14.00_60/ts_136104v121400p.pdf">https://www.etsi.org/deliver/etsi_ts/136100_136199/136104/12.14.00_60/ts_136104v121400p.pdf</a>
TSDSI	TSDSI STD T1.3GPP 36.104 12.14.0 V1.1.0	12.14.0	Published	02.05.2023	<a href="https://members.tdsi.in/s/tL3p5NcLWnAkjPt">https://members.tdsi.in/s/tL3p5NcLWnAkjPt</a>

**104****Rec. ITU-R M.2012-6**

TTA	TTAT.3G-36.104V12.14.0	12.14.0	Published	10.06.2021	<a href="http://committee.tta.or.kr/data/ttasDown.jsp?kind=ttastd&amp;pk_num=TTAT.3G-36.104V12.14.0">http://committee.tta.or.kr/data/ttasDown.jsp?kind=ttastd&amp;pk_num=TTAT.3G-36.104V12.14.0</a>
-----	------------------------	---------	-----------	------------	---

**Release 13**

ARIB	ARIB STD-T120-36.104.V13.14.0	13.14.0	Published	03.03.2023	<a href="https://www.arib.or.jp/english/html/overview/doc/T120_T23_SPECS/ARIB-STD-T120/Rel13/36/A36104-de0.pdf">https://www.arib.or.jp/english/html/overview/doc/T120_T23_SPECS/ARIB-STD-T120/Rel13/36/A36104-de0.pdf</a>
ATIS	ATIS.3GPP.36.104.V13.14.0	13.14.0	Published	21.02.2023	<a href="https://www.atis.org/3gpp-transpositions - Rel-13">https://www.atis.org/3gpp-transpositions - Rel-13</a>
CCSA	CCSA.36.104V13140	13.14.0	Published	01.03.2021	<a href="https://www.ccsa.org.cn/api/portalsFile/downloadOldFile?type=19&amp;oldFileUrl=ITU-R/M.2012-6/CCSA.36.104V13140.doc">https://www.ccsa.org.cn/api/portalsFile/downloadOldFile?type=19&amp;oldFileUrl=ITU-R/M.2012-6/CCSA.36.104V13140.doc</a>
ETSI	ETSI TS 136 104	13.14.0	Published	30.04.2021	<a href="https://www.etsi.org/deliver/etsi_ts/136100_136199/136104/13.14.00_60/ts_136104v131400p.pdf">https://www.etsi.org/deliver/etsi_ts/136100_136199/136104/13.14.00_60/ts_136104v131400p.pdf</a>
TSDSI	TSDSI STD T1.3GPP 36.104-13.14.0 V1.1.0	13.14.0	Published	17.01.2023	<a href="https://members.tdsi.in/s/KXYWmRamDGWmZoM">https://members.tdsi.in/s/KXYWmRamDGWmZoM</a>
TTA	TTAT.3G-36.104V13.14.0	13.14.0	Published	10.06.2021	<a href="http://committee.tta.or.kr/data/ttasDown.jsp?kind=ttastd&amp;pk_num=TTAT.3G-36.104V13.14.0">http://committee.tta.or.kr/data/ttasDown.jsp?kind=ttastd&amp;pk_num=TTAT.3G-36.104V13.14.0</a>

**Release 14**

ARIB	ARIB STD-T120-36.104.V14.11.0	14.11.0	Published	03.03.2023	<a href="https://www.arib.or.jp/english/html/overview/doc/T120_T23_SPECS/ARIB-STD-T120/Rel14/36/A36104-eb0.pdf">https://www.arib.or.jp/english/html/overview/doc/T120_T23_SPECS/ARIB-STD-T120/Rel14/36/A36104-eb0.pdf</a>
ATIS	ATIS.3GPP.36.104.V14.11.0	14.11.0	Published	21.02.2023	<a href="https://www.atis.org/3gpp-transpositions - Rel-14">https://www.atis.org/3gpp-transpositions - Rel-14</a>
CCSA	CCSA.36.104V14110	14.11.0	Published	01.12.2021	<a href="https://www.ccsa.org.cn/api/portalsFile/downloadOldFile?type=19&amp;oldFileUrl=ITU-R/M.2012-6/CCSA.36.104V14110.doc">https://www.ccsa.org.cn/api/portalsFile/downloadOldFile?type=19&amp;oldFileUrl=ITU-R/M.2012-6/CCSA.36.104V14110.doc</a>
ETSI	ETSI TS 136 104	14.11.0	Published	16.03.2022	<a href="https://www.etsi.org/deliver/etsi_ts/136100_136199/136104/14.11.00_60/ts_136104v141100p.pdf">https://www.etsi.org/deliver/etsi_ts/136100_136199/136104/14.11.00_60/ts_136104v141100p.pdf</a>
TSDSI	TSDSI STD T1.3GPP 36.104-14.11.0 V1.1.0	14.11.0	Published	17.01.2023	<a href="https://members.tdsi.in/s/CPkQG6BapKnNR3f">https://members.tdsi.in/s/CPkQG6BapKnNR3f</a>
TTA	TTAT.3G-36.104V14.11.0	14.11.0	Published	14.03.2022	<a href="http://committee.tta.or.kr/data/ttasDown.jsp?kind=ttastd&amp;pk_num=TTAT.3G-36.104V14.11.0">http://committee.tta.or.kr/data/ttasDown.jsp?kind=ttastd&amp;pk_num=TTAT.3G-36.104V14.11.0</a>

**Release 15**

ARIB	ARIB STD-T120-36.104.V15.15.0	15.15.0	Published	03.03.2023	<a href="https://www.arib.or.jp/english/html/overview/doc/T120_T23_SPECS/ARIB-STD-T120/Rel15/36/A36104-ff0.pdf">https://www.arib.or.jp/english/html/overview/doc/T120_T23_SPECS/ARIB-STD-T120/Rel15/36/A36104-ff0.pdf</a>
ATIS	ATIS.3GPP.36.104.V15.15.0	15.15.0	Published	21.02.2023	<a href="https://www.atis.org/3gpp-transpositions - Rel-15">https://www.atis.org/3gpp-transpositions - Rel-15</a>
CCSA	CCSA.36.104V15150	15.15.0	Published	01.03.2022	<a href="https://www.ccsa.org.cn/api/portalsFile/downloadOldFile?type=19&amp;oldFileUrl=ITU-R/M.2012-6/CCSA.36.104V15150.doc">https://www.ccsa.org.cn/api/portalsFile/downloadOldFile?type=19&amp;oldFileUrl=ITU-R/M.2012-6/CCSA.36.104V15150.doc</a>
ETSI	ETSI TS 136 104	15.15.0	Published	26.04.2022	<a href="https://www.etsi.org/deliver/etsi_ts/136100_136199/136104/15.15.00_60/ts_136104v151500p.pdf">https://www.etsi.org/deliver/etsi_ts/136100_136199/136104/15.15.00_60/ts_136104v151500p.pdf</a>
TSDSI	TSDSI STD T1.3GPP 36.104-15.15.0 V1.1.0	15.15.0	Published	01.11.2022	<a href="https://members.tdsi.in/s/YM9tyGcebNtCSMj">https://members.tdsi.in/s/YM9tyGcebNtCSMj</a>
TTA	TTAT.3G-36.104V15.15.0	15.15.0	Published	05.08.2022	<a href="http://committee.tta.or.kr/data/ttasDown.jsp?kind=ttastd&amp;pk_num=TTAT.3G-36.104V15.15.0">http://committee.tta.or.kr/data/ttasDown.jsp?kind=ttastd&amp;pk_num=TTAT.3G-36.104V15.15.0</a>

**Release 16**

ARIB	ARIB STD-T120-36.104.V16.13.0	16.13.0	Published	03.03.2023	<a href="https://www.arib.or.jp/english/html/overview/doc/T120_T23_SPECS/ARIB-STD-T120/Rel16/36/A36104-gd0.pdf">https://www.arib.or.jp/english/html/overview/doc/T120_T23_SPECS/ARIB-STD-T120/Rel16/36/A36104-gd0.pdf</a>
ATIS	ATIS.3GPP.36.104.V16.13.0	16.13.0	Published	21.02.2023	<a href="https://www.atis.org/3gpp-transpositions - Rel-16">https://www.atis.org/3gpp-transpositions - Rel-16</a>
CCSA	CCSA.36.104V16130	16.13.0	Published	01.03.2022	<a href="https://www.ccsa.org.cn/api/portalsFile/downloadOldFile?type=19&amp;oldFileUrl=ITU-R/M.2012-6/CCSA.36.104V16130.doc">https://www.ccsa.org.cn/api/portalsFile/downloadOldFile?type=19&amp;oldFileUrl=ITU-R/M.2012-6/CCSA.36.104V16130.doc</a>
ETSI	ETSI TS 136 104	16.13.0	Published	26.04.2022	<a href="https://www.etsi.org/deliver/etsi_ts/136100_136199/136104/16.13.00_60/ts_136104v161300p.pdf">https://www.etsi.org/deliver/etsi_ts/136100_136199/136104/16.13.00_60/ts_136104v161300p.pdf</a>
TSDSI	TSDSI STD T1.3GPP 36.104-16.13.0 V1.1.0	16.13.0	Published	01.11.2022	<a href="https://members.tdsi.in/s/B2etAT6Rego39F5">https://members.tdsi.in/s/B2etAT6Rego39F5</a>
TTA	TTAT.3G-36.104V16.13.0	16.13.0	Published	05.08.2022	<a href="http://committee.tta.or.kr/data/ttasDown.jsp?kind=ttastd&amp;pk_num=TTAT.3G-36.104V16.13.0">http://committee.tta.or.kr/data/ttasDown.jsp?kind=ttastd&amp;pk_num=TTAT.3G-36.104V16.13.0</a>

**Release 17**

ARIB	ARIB STD-T120-36.104.V17.8.0	17.8.0	Published	03.03.2023	<a href="https://www.arib.or.jp/english/html/overview/doc/T120_T23_SPECS/ARIB-STD-T120/Rel17/36/A36104-h80.pdf">https://www.arib.or.jp/english/html/overview/doc/T120_T23_SPECS/ARIB-STD-T120/Rel17/36/A36104-h80.pdf</a>
ATIS	ATIS.3GPP.36.104.V17.8.0	17.8.0	Published	21.02.2023	<a href="https://www.atis.org/3gpp-transpositions - Rel-17">https://www.atis.org/3gpp-transpositions - Rel-17</a>
CCSA	CCSA.36.104V1780	17.8.0	Published	01.12.2022	<a href="https://www.ccsa.org.cn/api/portalsFile/downloadOldFile?type=19&amp;oldFileUrl=ITU-R/M.2012-6/CCSA.36.104V1780.doc">https://www.ccsa.org.cn/api/portalsFile/downloadOldFile?type=19&amp;oldFileUrl=ITU-R/M.2012-6/CCSA.36.104V1780.doc</a>
ETSI	ETSI TS 136 104	17.8.0	Published	19.01.2023	<a href="https://www.etsi.org/deliver/etsi_ts/136100_136199/136104/17.08.00_60/ts_136104v170800p.pdf">https://www.etsi.org/deliver/etsi_ts/136100_136199/136104/17.08.00_60/ts_136104v170800p.pdf</a>
TSDSI	TSDSI STD T1.3GPP 36.104 17.8.0 V1.3.0	17.8.0	Published	02.05.2023	<a href="https://members.tdsi.in/s/dJS32CSxiixwPQb">https://members.tdsi.in/s/dJS32CSxiixwPQb</a>
TTA	TTAT.3G-36.104V17.8.0	17.8.0	Published	16.03.2023	<a href="http://committee.tta.or.kr/data/ttasDown.jsp?kind=ttastd&amp;pk_num=TTAT.3G-36.104V17.8.0">http://committee.tta.or.kr/data/ttasDown.jsp?kind=ttastd&amp;pk_num=TTAT.3G-36.104V17.8.0</a>

**2.1.5.3 TS 36.106****Evolved Universal Terrestrial Radio Access (E-UTRA); FDD repeater radio transmission and reception**

This document establishes the minimum RF characteristics of E-UTRA FDD Repeater.

SDO	Document No.	Version	Status	Issued date	Location
-----	--------------	---------	--------	-------------	----------

**Release 10**

ATIS	ATIS.3GPP.36.106V1070	10.7.0	Published	28.06.2021	<a href="https://www.atis.org/3gpp-documents/Rel99-14/">https://www.atis.org/3gpp-documents/Rel99-14/</a>
CCSA	CCSA.36.106V1070	10.7.0	Published	01.03.2013	<a href="https://www.ccsa.org.cn/api/portalsFile/downloadOldFile?type=19&amp;oldFileUrl=ITU-R/M.2012-6/CCSA.36.106V1070.doc">https://www.ccsa.org.cn/api/portalsFile/downloadOldFile?type=19&amp;oldFileUrl=ITU-R/M.2012-6/CCSA.36.106V1070.doc</a>

**Rec. ITU-R M.2012-6**

ETSI	ETSI TS 136 106	10.7.0	Published	26.04.2013	<a href="https://www.etsi.org/deliver/etsi_ts/136100_136199/136106/10.07.00_60/ts_136106v100700p.pdf">https://www.etsi.org/deliver/etsi_ts/136100_136199/136106/10.07.00_60/ts_136106v100700p.pdf</a>
TSDSI	TSDSI STD T1.3GPP 36.106-10.7.0 V1.0.0	10.7.0	Published	30.08.2021	<a href="https://members.tdsi.in/index.php/s/cfwmNYw2mCZ6ayL">https://members.tdsi.in/index.php/s/cfwmNYw2mCZ6ayL</a>
TTA	TTAT.3G-36.106V10.7.0	10.7.0	Published	30.07.2021	<a href="http://committee.tta.or.kr/data/ttasDown.jsp?kind=ttastd&amp;pk_num=TTAT.3G-36.106V10.7.0">http://committee.tta.or.kr/data/ttasDown.jsp?kind=ttastd&amp;pk_num=TTAT.3G-36.106V10.7.0</a>
<b>Release 11</b>					
ATIS	ATIS.3GPP.36.106V1120	11.2.0	Published	28.06.2021	<a href="https://www.atis.org/3gpp-documents/Rel99-14/">https://www.atis.org/3gpp-documents/Rel99-14/</a>
CCSA	CCSA.36.106V1120	11.2.0	Published	01.03.2013	<a href="https://www.ccsa.org.cn/api/portalsFile/downloadOldFile?type=19&amp;oldFileUrl=ITU-R/M.2012-6/CCSA.36.106V1120.doc">https://www.ccsa.org.cn/api/portalsFile/downloadOldFile?type=19&amp;oldFileUrl=ITU-R/M.2012-6/CCSA.36.106V1120.doc</a>
ETSI	ETSI TS 136 106	11.2.0	Published	26.04.2013	<a href="https://www.etsi.org/deliver/etsi_ts/136100_136199/136106/11.02.00_60/ts_136106v110200p.pdf">https://www.etsi.org/deliver/etsi_ts/136100_136199/136106/11.02.00_60/ts_136106v110200p.pdf</a>
TSDSI	TSDSI STD T1.3GPP 36.106-11.2.0 V1.0.0	11.2.0	Published	30.08.2021	<a href="https://members.tdsi.in/index.php/s/DFSaPy8rszqjCXG">https://members.tdsi.in/index.php/s/DFSaPy8rszqjCXG</a>
TTA	TTAT.3G-36.106V11.2.0	11.2.0	Published	30.07.2021	<a href="http://committee.tta.or.kr/data/ttasDown.jsp?kind=ttastd&amp;pk_num=TTAT.3G-36.106V11.2.0">http://committee.tta.or.kr/data/ttasDown.jsp?kind=ttastd&amp;pk_num=TTAT.3G-36.106V11.2.0</a>
<b>Release 12</b>					
ATIS	ATIS.3GPP.36.106V1210	12.1.0	Published	28.06.2021	<a href="https://www.atis.org/3gpp-documents/Rel99-14/">https://www.atis.org/3gpp-documents/Rel99-14/</a>
CCSA	CCSA.36.106V1210	12.1.0	Published	01.12.2014	<a href="https://www.ccsa.org.cn/api/portalsFile/downloadOldFile?type=19&amp;oldFileUrl=ITU-R/M.2012-6/CCSA.36.106V1210.doc">https://www.ccsa.org.cn/api/portalsFile/downloadOldFile?type=19&amp;oldFileUrl=ITU-R/M.2012-6/CCSA.36.106V1210.doc</a>
ETSI	ETSI TS 136 106	12.1.0	Published	03.02.2015	<a href="https://www.etsi.org/deliver/etsi_ts/136100_136199/136106/12.01.00_60/ts_136106v120100p.pdf">https://www.etsi.org/deliver/etsi_ts/136100_136199/136106/12.01.00_60/ts_136106v120100p.pdf</a>
TSDSI	TSDSI STD T1.3GPP 36.106-12.1.0 V1.0.0	12.1.0	Published	30.08.2021	<a href="https://members.tdsi.in/index.php/s/i9Sn7Bx9qim6ons">https://members.tdsi.in/index.php/s/i9Sn7Bx9qim6ons</a>
TTA	TTAT.3G-36.106V12.1.0	12.1.0	Published	30.07.2021	<a href="http://committee.tta.or.kr/data/ttasDown.jsp?kind=ttastd&amp;pk_num=TTAT.3G-36.106V12.1.0">http://committee.tta.or.kr/data/ttasDown.jsp?kind=ttastd&amp;pk_num=TTAT.3G-36.106V12.1.0</a>
<b>Release 13</b>					
ATIS	ATIS.3GPP.36.106V1300	13.0.0	Published	28.06.2021	<a href="https://www.atis.org/3gpp-documents/Rel99-14/">https://www.atis.org/3gpp-documents/Rel99-14/</a>
CCSA	CCSA.36.106V1300	13.0.0	Published	01.01.2016	<a href="https://www.ccsa.org.cn/api/portalsFile/downloadOldFile?type=19&amp;oldFileUrl=ITU-R/M.2012-6/CCSA.36.106V1300.doc">https://www.ccsa.org.cn/api/portalsFile/downloadOldFile?type=19&amp;oldFileUrl=ITU-R/M.2012-6/CCSA.36.106V1300.doc</a>
ETSI	ETSI TS 136 106	13.0.0	Published	28.01.2016	<a href="https://www.etsi.org/deliver/etsi_ts/136100_136199/136106/13.00.00_60/ts_136106v130000p.pdf">https://www.etsi.org/deliver/etsi_ts/136100_136199/136106/13.00.00_60/ts_136106v130000p.pdf</a>
TSDSI	TSDSI STD T1.3GPP 36.106-13.0.0 V1.0.0	13.0.0	Published	30.08.2021	<a href="https://members.tdsi.in/index.php/s/wCnkwcCNFGxRlBs">https://members.tdsi.in/index.php/s/wCnkwcCNFGxRlBs</a>
TTA	TTAT.3G-36.106V13.0.0	13.0.0	Published	30.07.2021	<a href="http://committee.tta.or.kr/data/ttasDown.jsp?kind=ttastd&amp;pk_num=TTAT.3G-36.106V13.0.0">http://committee.tta.or.kr/data/ttasDown.jsp?kind=ttastd&amp;pk_num=TTAT.3G-36.106V13.0.0</a>
<b>Release 14</b>					
ATIS	ATIS.3GPP.36.106V1400	14.0.0	Published	28.06.2021	<a href="https://www.atis.org/3gpp-documents/Rel99-14/">https://www.atis.org/3gpp-documents/Rel99-14/</a>
CCSA	CCSA.36.106V1400	14.0.0	Published	01.03.2017	<a href="https://www.ccsa.org.cn/api/portalsFile/downloadOldFile?type=19&amp;oldFileUrl=ITU-R/M.2012-6/CCSA.36.106V1400.doc">https://www.ccsa.org.cn/api/portalsFile/downloadOldFile?type=19&amp;oldFileUrl=ITU-R/M.2012-6/CCSA.36.106V1400.doc</a>
ETSI	ETSI TS 136 106	14.0.0	Published	13.04.2017	<a href="https://www.etsi.org/deliver/etsi_ts/136100_136199/136106/14.00.00_60/ts_136106v140000p.pdf">https://www.etsi.org/deliver/etsi_ts/136100_136199/136106/14.00.00_60/ts_136106v140000p.pdf</a>
TSDSI	TSDSI STD T1.3GPP 36.106-14.0.0 V1.0.0	14.0.0	Published	30.08.2021	<a href="https://members.tdsi.in/index.php/s/GrR6Ne5MzHGGtEL">https://members.tdsi.in/index.php/s/GrR6Ne5MzHGGtEL</a>
TTA	TTAT.3G-36.106V14.0.0	14.0.0	Published	30.07.2021	<a href="http://committee.tta.or.kr/data/ttasDown.jsp?kind=ttastd&amp;pk_num=TTAT.3G-36.106V14.0.0">http://committee.tta.or.kr/data/ttasDown.jsp?kind=ttastd&amp;pk_num=TTAT.3G-36.106V14.0.0</a>
<b>Release 15</b>					
ATIS	ATIS.3GPP.36.106V1500	15.0.0	Published	28.06.2021	<a href="https://www.atis.org/3gpp-documents/Rel15/">https://www.atis.org/3gpp-documents/Rel15/</a>
CCSA	CCSA.36.106V1500	15.0.0	Published	01.12.2017	<a href="https://www.ccsa.org.cn/api/portalsFile/downloadOldFile?type=19&amp;oldFileUrl=ITU-R/M.2012-6/CCSA.36.106V1500.doc">https://www.ccsa.org.cn/api/portalsFile/downloadOldFile?type=19&amp;oldFileUrl=ITU-R/M.2012-6/CCSA.36.106V1500.doc</a>
ETSI	ETSI TS 136 106	15.0.0	Published	18.09.2018	<a href="https://www.etsi.org/deliver/etsi_ts/136100_136199/136106/15.00.00_60/ts_136106v150000p.pdf">https://www.etsi.org/deliver/etsi_ts/136100_136199/136106/15.00.00_60/ts_136106v150000p.pdf</a>
TSDSI	TSDSI STD T1.3GPP 36.106-15.0.0 V1.0.0	15.0.0	Published	30.08.2021	<a href="https://members.tdsi.in/index.php/s/RysS4xxkTACLk8">https://members.tdsi.in/index.php/s/RysS4xxkTACLk8</a>
TTA	TTAT.3G-36.106V15.0.0	15.0.0	Published	11.09.2020	<a href="http://committee.tta.or.kr/data/ttasDown.jsp?kind=ttastd&amp;pk_num=TTAT.3G-36.106V15.0.0">http://committee.tta.or.kr/data/ttasDown.jsp?kind=ttastd&amp;pk_num=TTAT.3G-36.106V15.0.0</a>
<b>Release 16</b>					
ATIS	ATIS.3GPP.36.106V1600	16.0.0	Published	28.06.2021	<a href="https://www.atis.org/3gpp-documents/Rel16/">https://www.atis.org/3gpp-documents/Rel16/</a>
CCSA	CCSA.36.106V1600	16.0.0	Published	01.06.2020	<a href="https://www.ccsa.org.cn/api/portalsFile/downloadOldFile?type=19&amp;oldFileUrl=ITU-R/M.2012-6/CCSA.36.106V1600.doc">https://www.ccsa.org.cn/api/portalsFile/downloadOldFile?type=19&amp;oldFileUrl=ITU-R/M.2012-6/CCSA.36.106V1600.doc</a>
ETSI	ETSI TS 136 106	16.0.0	Published	21.07.2020	<a href="https://www.etsi.org/deliver/etsi_ts/136100_136199/136106/16.00.00_60/ts_136106v160000p.pdf">https://www.etsi.org/deliver/etsi_ts/136100_136199/136106/16.00.00_60/ts_136106v160000p.pdf</a>
TSDSI	TSDSI STD T1.3GPP 36.106-16.0.0 V1.0.0	16.0.0	Published	30.08.2021	<a href="https://members.tdsi.in/index.php/s/AWoP6N4JdK22fPi">https://members.tdsi.in/index.php/s/AWoP6N4JdK22fPi</a>
TTA	TTAT.3G-36.106V16.0.0	16.0.0	Published	11.09.2020	<a href="http://committee.tta.or.kr/data/ttasDown.jsp?kind=ttastd&amp;pk_num=TTAT.3G-36.106V16.0.0">http://committee.tta.or.kr/data/ttasDown.jsp?kind=ttastd&amp;pk_num=TTAT.3G-36.106V16.0.0</a>
<b>Release 17</b>					
ATIS	ATIS.3GPP.36.106.V17.0.0	17.0.0	Published	21.02.2023	<a href="https://www.atis.org/3gpp-transpositions - Rel-17">https://www.atis.org/3gpp-transpositions - Rel-17</a>
CCSA	CCSA.36.106V1700	17.0.0	Published	01.03.2022	<a href="https://www.ccsa.org.cn/api/portalsFile/downloadOldFile?type=19&amp;oldFileUrl=ITU-R/M.2012-6/CCSA.36.106V1700.doc">https://www.ccsa.org.cn/api/portalsFile/downloadOldFile?type=19&amp;oldFileUrl=ITU-R/M.2012-6/CCSA.36.106V1700.doc</a>
ETSI	ETSI TS 136 106	17.0.0	Published	27.04.2022	<a href="https://www.etsi.org/deliver/etsi_ts/136100_136199/136106/17.00.00_60/ts_136106v170000p.pdf">https://www.etsi.org/deliver/etsi_ts/136100_136199/136106/17.00.00_60/ts_136106v170000p.pdf</a>
TSDSI	TSDSI STD T1.3GPP 36.106-17.0.0 V1.0.0	17.0.0	Published	29.07.2022	<a href="https://members.tdsi.in/s/PvXbPi8Lw5qaYG7">https://members.tdsi.in/s/PvXbPi8Lw5qaYG7</a>
TTA	TTAT.3G-36.106V17.0.0	17.0.0	Published	05.08.2022	<a href="http://committee.tta.or.kr/data/ttasDown.jsp?kind=ttastd&amp;pk_num=TTAT.3G-36.106V17.0.0">http://committee.tta.or.kr/data/ttasDown.jsp?kind=ttastd&amp;pk_num=TTAT.3G-36.106V17.0.0</a>

## 2.1.5.4 TS 36.111

## Location Measurement Unit (LMU) performance specification; Network based positioning systems in Evolved Universal Terrestrial Radio Access Network (E-UTRAN)

This document establishes the Location Measurement Unit (LMU) minimum UTDOA positioning requirement for the FDD and TDD mode of E-UTRAN.

SDO	Document No.	Version	Status	Issued date	Location
<b>Release 11</b>					
ARIB	ARIB STD-T120-36.111.V11.4.0	11.4.0	Published	03.03.2023	<a href="https://www.arib.or.jp/english/html/overview/doc/T120_T23_SPECS/ARIB-STD-T120/Rel11/36/A36111-b40.pdf">https://www.arib.or.jp/english/html/overview/doc/T120_T23_SPECS/ARIB-STD-T120/Rel11/36/A36111-b40.pdf</a>
ATIS	ATIS.3GPP.36.111V1140	11.4.0	Published	28.06.2021	<a href="https://www.atis.org/3gpp-documents/Rel99-14/">https://www.atis.org/3gpp-documents/Rel99-14/</a>
CCSA	CCSA.36.111V1140	11.4.0	Published	01.09.2014	<a href="https://www.ccsa.org.cn/api/portalsFile/downloadOldFile?type=19&amp;oldFileUrl=ITU-R/M.2012-6/CCSA.36.111V1140.doc">https://www.ccsa.org.cn/api/portalsFile/downloadOldFile?type=19&amp;oldFileUrl=ITU-R/M.2012-6/CCSA.36.111V1140.doc</a>
ETSI	ETSI TS 136 111	11.4.0	Published	24.10.2014	<a href="https://www.etsi.org/deliver/etsi_ts/136100_136199/136111/11.04.00_60/ts_136111v110400p.pdf">https://www.etsi.org/deliver/etsi_ts/136100_136199/136111/11.04.00_60/ts_136111v110400p.pdf</a>
TSDSI	TSDSI STD T1.3GPP 36.111-11.4.0 V1.0.0	11.4.0	Published	30.08.2021	<a href="https://members.tdsi.in/index.php/s/QPepNAoczm8SHn">https://members.tdsi.in/index.php/s/QPepNAoczm8SHn</a>
TTA	TTAT.3G-36.111V11.4.0	11.4.0	Published	30.07.2021	<a href="http://committee.tta.or.kr/data/ttasDown.jsp?kind=ttastd&amp;pk_num=TTAT.3G-36.111V11.4.0">http://committee.tta.or.kr/data/ttasDown.jsp?kind=ttastd&amp;pk_num=TTAT.3G-36.111V11.4.0</a>
<b>Release 12</b>					
ARIB	ARIB STD-T120-36.111.V12.0.0	12.0.0	Published	03.03.2023	<a href="https://www.arib.or.jp/english/html/overview/doc/T120_T23_SPECS/ARIB-STD-T120/Rel12/36/A36111-c00.pdf">https://www.arib.or.jp/english/html/overview/doc/T120_T23_SPECS/ARIB-STD-T120/Rel12/36/A36111-c00.pdf</a>
ATIS	ATIS.3GPP.36.111V1200	12.0.0	Published	28.06.2021	<a href="https://www.atis.org/3gpp-documents/Rel99-14/">https://www.atis.org/3gpp-documents/Rel99-14/</a>
CCSA	CCSA.36.111V1200	12.0.0	Published	01.09.2014	<a href="https://www.ccsa.org.cn/api/portalsFile/downloadOldFile?type=19&amp;oldFileUrl=ITU-R/M.2012-6/CCSA.36.111V1200.doc">https://www.ccsa.org.cn/api/portalsFile/downloadOldFile?type=19&amp;oldFileUrl=ITU-R/M.2012-6/CCSA.36.111V1200.doc</a>
ETSI	ETSI TS 136 111	12.0.0	Published	24.10.2014	<a href="https://www.etsi.org/deliver/etsi_ts/136100_136199/136111/12.00.00_60/ts_136111v120000p.pdf">https://www.etsi.org/deliver/etsi_ts/136100_136199/136111/12.00.00_60/ts_136111v120000p.pdf</a>
TSDSI	TSDSI STD T1.3GPP 36.111-12.0.0 V1.0.0	12.0.0	Published	30.08.2021	<a href="https://members.tdsi.in/index.php/s/6qkGjLiQG2AH3Se">https://members.tdsi.in/index.php/s/6qkGjLiQG2AH3Se</a>
TTA	TTAT.3G-36.111V12.0.0	12.0.0	Published	30.07.2021	<a href="http://committee.tta.or.kr/data/ttasDown.jsp?kind=ttastd&amp;pk_num=TTAT.3G-36.111V12.0.0">http://committee.tta.or.kr/data/ttasDown.jsp?kind=ttastd&amp;pk_num=TTAT.3G-36.111V12.0.0</a>
<b>Release 13</b>					
ARIB	ARIB STD-T120-36.111.V13.0.0	13.0.0	Published	03.03.2023	<a href="https://www.arib.or.jp/english/html/overview/doc/T120_T23_SPECS/ARIB-STD-T120/Rel13/36/A36111-d00.pdf">https://www.arib.or.jp/english/html/overview/doc/T120_T23_SPECS/ARIB-STD-T120/Rel13/36/A36111-d00.pdf</a>
ATIS	ATIS.3GPP.36.111V1300	13.0.0	Published	28.06.2021	<a href="https://www.atis.org/3gpp-documents/Rel99-14/">https://www.atis.org/3gpp-documents/Rel99-14/</a>
CCSA	CCSA.36.111V1300	13.0.0	Published	01.01.2016	<a href="https://www.ccsa.org.cn/api/portalsFile/downloadOldFile?type=19&amp;oldFileUrl=ITU-R/M.2012-6/CCSA.36.111V1300.doc">https://www.ccsa.org.cn/api/portalsFile/downloadOldFile?type=19&amp;oldFileUrl=ITU-R/M.2012-6/CCSA.36.111V1300.doc</a>
ETSI	ETSI TS 136 111	13.0.0	Published	28.01.2016	<a href="https://www.etsi.org/deliver/etsi_ts/136100_136199/136111/13.00.00_60/ts_136111v130000p.pdf">https://www.etsi.org/deliver/etsi_ts/136100_136199/136111/13.00.00_60/ts_136111v130000p.pdf</a>
TSDSI	TSDSI STD T1.3GPP 36.111-13.0.0 V1.0.0	13.0.0	Published	30.08.2021	<a href="https://members.tdsi.in/index.php/s/FoQwjsE8MfDJH5j">https://members.tdsi.in/index.php/s/FoQwjsE8MfDJH5j</a>
TTA	TTAT.3G-36.111V13.0.0	13.0.0	Published	30.07.2021	<a href="http://committee.tta.or.kr/data/ttasDown.jsp?kind=ttastd&amp;pk_num=TTAT.3G-36.111V13.0.0">http://committee.tta.or.kr/data/ttasDown.jsp?kind=ttastd&amp;pk_num=TTAT.3G-36.111V13.0.0</a>
<b>Release 14</b>					
ARIB	ARIB STD-T120-36.111.V14.0.0	14.0.0	Published	03.03.2023	<a href="https://www.arib.or.jp/english/html/overview/doc/T120_T23_SPECS/ARIB-STD-T120/Rel14/36/A36111-e00.pdf">https://www.arib.or.jp/english/html/overview/doc/T120_T23_SPECS/ARIB-STD-T120/Rel14/36/A36111-e00.pdf</a>
ATIS	ATIS.3GPP.36.111V1400	14.0.0	Published	28.06.2021	<a href="https://www.atis.org/3gpp-documents/Rel99-14/">https://www.atis.org/3gpp-documents/Rel99-14/</a>
CCSA	CCSA.36.111V1400	14.0.0	Published	01.03.2017	<a href="https://www.ccsa.org.cn/api/portalsFile/downloadOldFile?type=19&amp;oldFileUrl=ITU-R/M.2012-6/CCSA.36.111V1400.doc">https://www.ccsa.org.cn/api/portalsFile/downloadOldFile?type=19&amp;oldFileUrl=ITU-R/M.2012-6/CCSA.36.111V1400.doc</a>
ETSI	ETSI TS 136 111	14.0.0	Published	13.04.2017	<a href="https://www.etsi.org/deliver/etsi_ts/136100_136199/136111/14.00.00_60/ts_136111v140000p.pdf">https://www.etsi.org/deliver/etsi_ts/136100_136199/136111/14.00.00_60/ts_136111v140000p.pdf</a>
TSDSI	TSDSI STD T1.3GPP 36.111-14.0.0 V1.0.0	14.0.0	Published	30.08.2021	<a href="https://members.tdsi.in/index.php/s/jWkce776mXggNRo">https://members.tdsi.in/index.php/s/jWkce776mXggNRo</a>
TTA	TTAT.3G-36.111V14.0.0	14.0.0	Published	30.07.2021	<a href="http://committee.tta.or.kr/data/ttasDown.jsp?kind=ttastd&amp;pk_num=TTAT.3G-36.111V14.0.0">http://committee.tta.or.kr/data/ttasDown.jsp?kind=ttastd&amp;pk_num=TTAT.3G-36.111V14.0.0</a>
<b>Release 15</b>					
ARIB	ARIB STD-T120-36.111.V15.0.0	15.0.0	Published	03.03.2023	<a href="https://www.arib.or.jp/english/html/overview/doc/T120_T23_SPECS/ARIB-STD-T120/Rel15/36/A36111-f00.pdf">https://www.arib.or.jp/english/html/overview/doc/T120_T23_SPECS/ARIB-STD-T120/Rel15/36/A36111-f00.pdf</a>
ATIS	ATIS.3GPP.36.111V1500	15.0.0	Published	28.06.2021	<a href="https://www.atis.org/3gpp-documents/Rel15/">https://www.atis.org/3gpp-documents/Rel15/</a>
CCSA	CCSA.36.111V1500	15.0.0	Published	01.09.2018	<a href="https://www.ccsa.org.cn/api/portalsFile/downloadOldFile?type=19&amp;oldFileUrl=ITU-R/M.2012-6/CCSA.36.111V1500.doc">https://www.ccsa.org.cn/api/portalsFile/downloadOldFile?type=19&amp;oldFileUrl=ITU-R/M.2012-6/CCSA.36.111V1500.doc</a>
ETSI	ETSI TS 136 111	15.0.0	Published	12.11.2018	<a href="https://www.etsi.org/deliver/etsi_ts/136100_136199/136111/15.00.00_60/ts_136111v150000p.pdf">https://www.etsi.org/deliver/etsi_ts/136100_136199/136111/15.00.00_60/ts_136111v150000p.pdf</a>
TSDSI	TSDSI STD T1.3GPP 36.111-15.0.0 V1.0.0	15.0.0	Published	30.08.2021	<a href="https://members.tdsi.in/index.php/s/9gsiAgXd2obYC9e">https://members.tdsi.in/index.php/s/9gsiAgXd2obYC9e</a>
TTA	TTAT.3G-36.111V15.0.0	15.0.0	Published	11.09.2020	<a href="http://committee.tta.or.kr/data/ttasDown.jsp?kind=ttastd&amp;pk_num=TTAT.3G-36.111V15.0.0">http://committee.tta.or.kr/data/ttasDown.jsp?kind=ttastd&amp;pk_num=TTAT.3G-36.111V15.0.0</a>
<b>Release 16</b>					
ARIB	ARIB STD-T120-36.111.V16.0.0	16.0.0	Published	03.03.2023	<a href="https://www.arib.or.jp/english/html/overview/doc/T120_T23_SPECS/ARIB-STD-T120/Rel16/36/A36111-g00.pdf">https://www.arib.or.jp/english/html/overview/doc/T120_T23_SPECS/ARIB-STD-T120/Rel16/36/A36111-g00.pdf</a>
ATIS	ATIS.3GPP.36.111V1600	16.0.0	Published	28.06.2021	<a href="https://www.atis.org/3gpp-documents/Rel16/">https://www.atis.org/3gpp-documents/Rel16/</a>

CCSA	CCSA.36.111V1600	16.0.0	Published	01.06.2020	<a href="https://www.ccsa.org.cn/api/portalsFile/downloadOldFile?type=19&amp;oldFileUrl=ITU-R/M.2012-6/CCSA.36.111V1600.doc">https://www.ccsa.org.cn/api/portalsFile/downloadOldFile?type=19&amp;oldFileUrl=ITU-R/M.2012-6/CCSA.36.111V1600.doc</a>
ETSI	ETSI TS 136 111	16.0.0	Published	21.07.2020	<a href="https://www.etsi.org/deliver/etsi_ts/136100_136199/136111/16.00.00_60/ts_136111v160000p.pdf">https://www.etsi.org/deliver/etsi_ts/136100_136199/136111/16.00.00_60/ts_136111v160000p.pdf</a>
TSDSI	TSDSI STD T1.3GPP 36.111-16.0.0 V1.0.0	16.0.0	Published	30.08.2021	<a href="https://members.tdsi.in/index.php/s/NWadC5dNboZ2bnz">https://members.tdsi.in/index.php/s/NWadC5dNboZ2bnz</a>
TTA	TTAT.3G-36.111V16.0.0	16.0.0	Published	11.09.2020	<a href="http://committee.tta.or.kr/data/ttasDown.jsp?kind=ttastd&amp;pk_num=TTAT.3G-36.111V16.0.0">http://committee.tta.or.kr/data/ttasDown.jsp?kind=ttastd&amp;pk_num=TTAT.3G-36.111V16.0.0</a>

**Release 17**

ARIB	ARIB STD-T120-36.111.V17.0.0	17.0.0	Published	03.03.2023	<a href="https://www.arib.or.jp/english/html/overview/doc/T120_T23_SPECS/ARIB-STD-T120/Rel17/36/A36111-h00.pdf">https://www.arib.or.jp/english/html/overview/doc/T120_T23_SPECS/ARIB-STD-T120/Rel17/36/A36111-h00.pdf</a>
ATIS	ATIS.3GPP.36.111.V17.0.0	17.0.0	Published	21.02.2023	<a href="https://www.atis.org/3gpp-transpositions - Rel-17">https://www.atis.org/3gpp-transpositions - Rel-17</a>
CCSA	CCSA.36.111V1700	17.0.0	Published	01.03.2022	<a href="https://www.ccsa.org.cn/api/portalsFile/downloadOldFile?type=19&amp;oldFileUrl=ITU-R/M.2012-6/CCSA.36.111V1700.doc">https://www.ccsa.org.cn/api/portalsFile/downloadOldFile?type=19&amp;oldFileUrl=ITU-R/M.2012-6/CCSA.36.111V1700.doc</a>
ETSI	ETSI TS 136 111	17.0.0	Published	27.04.2022	<a href="https://www.etsi.org/deliver/etsi_ts/136100_136199/136111/17.00.00_60/ts_136111v170000p.pdf">https://www.etsi.org/deliver/etsi_ts/136100_136199/136111/17.00.00_60/ts_136111v170000p.pdf</a>
TSDSI	TSDSI STD T1.3GPP 36.111-17.0.0 V1.0.0	17.0.0	Published	29.07.2022	<a href="https://members.tdsi.in/s/XS6MwzYddx8K38p">https://members.tdsi.in/s/XS6MwzYddx8K38p</a>
TTA	TTAT.3G-36.111V17.0.0	17.0.0	Published	05.08.2022	<a href="http://committee.tta.or.kr/data/ttasDown.jsp?kind=ttastd&amp;pk_num=TTAT.3G-36.111V17.0.0">http://committee.tta.or.kr/data/ttasDown.jsp?kind=ttastd&amp;pk_num=TTAT.3G-36.111V17.0.0</a>

**2.1.5.5 TS 36.112****Location Measurement Unit (LMU) conformance specification; Network based positioning systems in Evolved Universal Terrestrial Radio Access Network (E-UTRAN)**

This document establishes the conformance requirements for E-UTRAN Location Measurement Units (LMU) operating in the FDD or TDD mode.

SDO	Document No.	Version	Status	Issued date	Location
<b>Release 11</b>					
ARIB	ARIB STD-T120-36.112.V11.1.0	11.1.0	Published	03.03.2023	<a href="https://www.arib.or.jp/english/html/overview/doc/T120_T23_SPECS/ARIB-STD-T120/Rel11/36/A36112-b10.pdf">https://www.arib.or.jp/english/html/overview/doc/T120_T23_SPECS/ARIB-STD-T120/Rel11/36/A36112-b10.pdf</a>
ATIS	ATIS.3GPP.36.112V1110	11.1.0	Published	28.06.2021	<a href="https://www.atis.org/3gpp-documents/Rel99-14/">https://www.atis.org/3gpp-documents/Rel99-14/</a>
CCSA	CCSA.36.112V1110	11.1.0	Published	01.12.2014	<a href="https://www.ccsa.org.cn/api/portalsFile/downloadOldFile?type=19&amp;oldFileUrl=ITU-R/M.2012-6/CCSA.36.112V1110.doc">https://www.ccsa.org.cn/api/portalsFile/downloadOldFile?type=19&amp;oldFileUrl=ITU-R/M.2012-6/CCSA.36.112V1110.doc</a>
ETSI	ETSI TS 136 112	11.1.0	Published	03.02.2015	<a href="https://www.etsi.org/deliver/etsi_ts/136100_136199/136112/11.01.00_60/ts_136112v110100p.pdf">https://www.etsi.org/deliver/etsi_ts/136100_136199/136112/11.01.00_60/ts_136112v110100p.pdf</a>
TSDSI	TSDSI STD T1.3GPP 36.112-11.1.0 V1.0.0	11.1.0	Published	30.08.2021	<a href="https://members.tdsi.in/index.php/s/m3dwJrw7YnPiQBx">https://members.tdsi.in/index.php/s/m3dwJrw7YnPiQBx</a>
TTA	TTAT.3G-36.112V11.1.0	11.1.0	Published	30.07.2021	<a href="http://committee.tta.or.kr/data/ttasDown.jsp?kind=ttastd&amp;pk_num=TTAT.3G-36.112V11.1.0">http://committee.tta.or.kr/data/ttasDown.jsp?kind=ttastd&amp;pk_num=TTAT.3G-36.112V11.1.0</a>
<b>Release 12</b>					
ARIB	ARIB STD-T120-36.112.V12.2.0	12.2.0	Published	03.03.2023	<a href="https://www.arib.or.jp/english/html/overview/doc/T120_T23_SPECS/ARIB-STD-T120/Rel12/36/A36112-c20.pdf">https://www.arib.or.jp/english/html/overview/doc/T120_T23_SPECS/ARIB-STD-T120/Rel12/36/A36112-c20.pdf</a>
ATIS	ATIS.3GPP.36.112V1220	12.2.0	Published	28.06.2021	<a href="https://www.atis.org/3gpp-documents/Rel99-14/">https://www.atis.org/3gpp-documents/Rel99-14/</a>
CCSA	CCSA.36.112V1220	12.2.0	Published	01.03.2015	<a href="https://www.ccsa.org.cn/api/portalsFile/downloadOldFile?type=19&amp;oldFileUrl=ITU-R/M.2012-6/CCSA.36.112V1220.doc">https://www.ccsa.org.cn/api/portalsFile/downloadOldFile?type=19&amp;oldFileUrl=ITU-R/M.2012-6/CCSA.36.112V1220.doc</a>
ETSI	ETSI TS 136 112	12.2.0	Published	20.04.2015	<a href="https://www.etsi.org/deliver/etsi_ts/136100_136199/136112/12.02.00_60/ts_136112v120200p.pdf">https://www.etsi.org/deliver/etsi_ts/136100_136199/136112/12.02.00_60/ts_136112v120200p.pdf</a>
TSDSI	TSDSI STD T1.3GPP 36.112-12.2.0 V1.0.0	12.2.0	Published	30.08.2021	<a href="https://members.tdsi.in/index.php/s/pQQY8eKJc4eXjP2">https://members.tdsi.in/index.php/s/pQQY8eKJc4eXjP2</a>
TTA	TTAT.3G-36.112V12.2.0	12.2.0	Published	30.07.2021	<a href="http://committee.tta.or.kr/data/ttasDown.jsp?kind=ttastd&amp;pk_num=TTAT.3G-36.112V12.2.0">http://committee.tta.or.kr/data/ttasDown.jsp?kind=ttastd&amp;pk_num=TTAT.3G-36.112V12.2.0</a>
<b>Release 13</b>					
ARIB	ARIB STD-T120-36.112.V13.0.1	13.0.1	Published	03.03.2023	<a href="https://www.arib.or.jp/english/html/overview/doc/T120_T23_SPECS/ARIB-STD-T120/Rel13/36/A36112-d01.pdf">https://www.arib.or.jp/english/html/overview/doc/T120_T23_SPECS/ARIB-STD-T120/Rel13/36/A36112-d01.pdf</a>
ATIS	ATIS.3GPP.36.112V1301	13.0.1	Published	28.06.2021	<a href="https://www.atis.org/3gpp-documents/Rel99-14/">https://www.atis.org/3gpp-documents/Rel99-14/</a>
CCSA	CCSA.36.112V1301	13.0.1	Published	01.01.2016	<a href="https://www.ccsa.org.cn/api/portalsFile/downloadOldFile?type=19&amp;oldFileUrl=ITU-R/M.2012-6/CCSA.36.112V1301.doc">https://www.ccsa.org.cn/api/portalsFile/downloadOldFile?type=19&amp;oldFileUrl=ITU-R/M.2012-6/CCSA.36.112V1301.doc</a>
ETSI	ETSI TS 136 112	13.0.1	Published	28.01.2016	<a href="https://www.etsi.org/deliver/etsi_ts/136100_136199/136112/13.00.01_60/ts_136112v130001p.pdf">https://www.etsi.org/deliver/etsi_ts/136100_136199/136112/13.00.01_60/ts_136112v130001p.pdf</a>
TSDSI	TSDSI STD T1.3GPP 36.112-13.0.1 V1.0.0	13.0.1	Published	30.08.2021	<a href="https://members.tdsi.in/index.php/s/WbLZReD9TjBiyx">https://members.tdsi.in/index.php/s/WbLZReD9TjBiyx</a>
TTA	TTAT.3G-36.112V13.0.1	13.0.1	Published	30.07.2021	<a href="http://committee.tta.or.kr/data/ttasDown.jsp?kind=ttastd&amp;pk_num=TTAT.3G-36.112V13.0.1">http://committee.tta.or.kr/data/ttasDown.jsp?kind=ttastd&amp;pk_num=TTAT.3G-36.112V13.0.1</a>
<b>Release 14</b>					
ARIB	ARIB STD-T120-36.112.V14.0.0	14.0.0	Published	03.03.2023	<a href="https://www.arib.or.jp/english/html/overview/doc/T120_T23_SPECS/ARIB-STD-T120/Rel14/36/A36112-e00.pdf">https://www.arib.or.jp/english/html/overview/doc/T120_T23_SPECS/ARIB-STD-T120/Rel14/36/A36112-e00.pdf</a>
ATIS	ATIS.3GPP.36.112V1400	14.0.0	Published	28.06.2021	<a href="https://www.atis.org/3gpp-documents/Rel99-14/">https://www.atis.org/3gpp-documents/Rel99-14/</a>
CCSA	CCSA.36.112V1400	14.0.0	Published	01.03.2017	<a href="https://www.ccsa.org.cn/api/portalsFile/downloadOldFile?type=19&amp;oldFileUrl=ITU-R/M.2012-6/CCSA.36.112V1400.doc">https://www.ccsa.org.cn/api/portalsFile/downloadOldFile?type=19&amp;oldFileUrl=ITU-R/M.2012-6/CCSA.36.112V1400.doc</a>
ETSI	ETSI TS 136 112	14.0.0	Published	13.04.2017	<a href="https://www.etsi.org/deliver/etsi_ts/136100_136199/136112/14.00.00_60/ts_136112v140000p.pdf">https://www.etsi.org/deliver/etsi_ts/136100_136199/136112/14.00.00_60/ts_136112v140000p.pdf</a>
TSDSI	TSDSI STD T1.3GPP 36.112-14.0.0 V1.0.0	14.0.0	Published	30.08.2021	<a href="https://members.tdsi.in/index.php/s/WYejTzg8gMJFtM">https://members.tdsi.in/index.php/s/WYejTzg8gMJFtM</a>

TTA	TTAT.3G-36.112V14.0.0	14.0.0	Published	30.07.2021	<a href="http://committee.tta.or.kr/data/ttasDown.jsp?kind=ttastd&amp;pk_num=TTAT.3G-36.112V14.0.0">http://committee.tta.or.kr/data/ttasDown.jsp?kind=ttastd&amp;pk_num=TTAT.3G-36.112V14.0.0</a>
<b>Release 15</b>					
ARIB	ARIB STD-T120-36.112.V15.0.0	15.0.0	Published	03.03.2023	<a href="https://www.arib.or.jp/english/html/overview/doc/T120_T23_SPECS/ARIB-STD-T120/Rel15/36/A36112-f00.pdf">https://www.arib.or.jp/english/html/overview/doc/T120_T23_SPECS/ARIB-STD-T120/Rel15/36/A36112-f00.pdf</a>
ATIS	ATIS.3GPP.36.112V1500	15.0.0	Published	28.06.2021	<a href="https://www.atis.org/3gpp-documents/Rel15/">https://www.atis.org/3gpp-documents/Rel15/</a>
CCSA	CCSA.36.112V1500	15.0.0	Published	01.06.2018	<a href="https://www.ccsa.org.cn/api/portalsFile/downloadOldFile?type=19&amp;oldFileUrl=ITU-R/M.2012-6/CCSA.36.112V1500.doc">https://www.ccsa.org.cn/api/portalsFile/downloadOldFile?type=19&amp;oldFileUrl=ITU-R/M.2012-6/CCSA.36.112V1500.doc</a>
ETSI	ETSI TS 136 112	15.0.0	Published	16.07.2018	<a href="https://www.etsi.org/deliver/etsi_ts/136100_136199/136112/15.00.00_60/ts_136112v150000p.pdf">https://www.etsi.org/deliver/etsi_ts/136100_136199/136112/15.00.00_60/ts_136112v150000p.pdf</a>
TSDSI	TSDSI STD T1.3GPP 36.112-15.0.0 V1.0.0	15.0.0	Published	30.08.2021	<a href="https://members.tdsi.in/index.php/s/S23CAqyCATfbm6w">https://members.tdsi.in/index.php/s/S23CAqyCATfbm6w</a>
TTA	TTAT.3G-36.112V15.0.0	15.0.0	Published	11.09.2020	<a href="http://committee.tta.or.kr/data/ttasDown.jsp?kind=ttastd&amp;pk_num=TTAT.3G-36.112V15.0.0">http://committee.tta.or.kr/data/ttasDown.jsp?kind=ttastd&amp;pk_num=TTAT.3G-36.112V15.0.0</a>
<b>Release 16</b>					
ARIB	ARIB STD-T120-36.112.V16.0.0	16.0.0	Published	03.03.2023	<a href="https://www.arib.or.jp/english/html/overview/doc/T120_T23_SPECS/ARIB-STD-T120/Rel16/36/A36112-g00.pdf">https://www.arib.or.jp/english/html/overview/doc/T120_T23_SPECS/ARIB-STD-T120/Rel16/36/A36112-g00.pdf</a>
ATIS	ATIS.3GPP.36.112V1600	16.0.0	Published	28.06.2021	<a href="https://www.atis.org/3gpp-documents/Rel16/">https://www.atis.org/3gpp-documents/Rel16/</a>
CCSA	CCSA.36.112V1600	16.0.0	Published	01.06.2020	<a href="https://www.ccsa.org.cn/api/portalsFile/downloadOldFile?type=19&amp;oldFileUrl=ITU-R/M.2012-6/CCSA.36.112V1600.doc">https://www.ccsa.org.cn/api/portalsFile/downloadOldFile?type=19&amp;oldFileUrl=ITU-R/M.2012-6/CCSA.36.112V1600.doc</a>
ETSI	ETSI TS 136 112	16.0.0	Published	21.07.2020	<a href="https://www.etsi.org/deliver/etsi_ts/136100_136199/136112/16.00.00_60/ts_136112v160000p.pdf">https://www.etsi.org/deliver/etsi_ts/136100_136199/136112/16.00.00_60/ts_136112v160000p.pdf</a>
TSDSI	TSDSI STD T1.3GPP 36.112-16.0.0 V1.0.0	16.0.0	Published	30.08.2021	<a href="https://members.tdsi.in/index.php/s/mAKMSQbaNN4YJnW">https://members.tdsi.in/index.php/s/mAKMSQbaNN4YJnW</a>
TTA	TTAT.3G-36.112V16.0.0	16.0.0	Published	11.09.2020	<a href="http://committee.tta.or.kr/data/ttasDown.jsp?kind=ttastd&amp;pk_num=TTAT.3G-36.112V16.0.0">http://committee.tta.or.kr/data/ttasDown.jsp?kind=ttastd&amp;pk_num=TTAT.3G-36.112V16.0.0</a>
<b>Release 17</b>					
ARIB	ARIB STD-T120-36.112.V17.0.0	17.0.0	Published	03.03.2023	<a href="https://www.arib.or.jp/english/html/overview/doc/T120_T23_SPECS/ARIB-STD-T120/Rel17/36/A36112-h00.pdf">https://www.arib.or.jp/english/html/overview/doc/T120_T23_SPECS/ARIB-STD-T120/Rel17/36/A36112-h00.pdf</a>
ATIS	ATIS.3GPP.36.112.V17.0.0	17.0.0	Published	21.02.2023	<a href="https://www.atis.org/3gpp-transpositions-Rel-17">https://www.atis.org/3gpp-transpositions-Rel-17</a>
CCSA	CCSA.36.112V1700	17.0.0	Published	01.03.2022	<a href="https://www.ccsa.org.cn/api/portalsFile/downloadOldFile?type=19&amp;oldFileUrl=ITU-R/M.2012-6/CCSA.36.112V1700.doc">https://www.ccsa.org.cn/api/portalsFile/downloadOldFile?type=19&amp;oldFileUrl=ITU-R/M.2012-6/CCSA.36.112V1700.doc</a>
ETSI	ETSI TS 136 112	17.0.0	Published	27.04.2022	<a href="https://www.etsi.org/deliver/etsi_ts/136100_136199/136112/17.00.00_60/ts_136112v170000p.pdf">https://www.etsi.org/deliver/etsi_ts/136100_136199/136112/17.00.00_60/ts_136112v170000p.pdf</a>
TSDSI	TSDSI STD T1.3GPP 36.112-17.0.0 V1.0.0	17.0.0	Published	29.07.2022	<a href="https://members.tdsi.in/s/DNkiQPsrEpdPL">https://members.tdsi.in/s/DNkiQPsrEpdPL</a>
TTA	TTAT.3G-36.112V17.0.0	17.0.0	Published	05.08.2022	<a href="http://committee.tta.or.kr/data/ttasDown.jsp?kind=ttastd&amp;pk_num=TTAT.3G-36.112V17.0.0">http://committee.tta.or.kr/data/ttasDown.jsp?kind=ttastd&amp;pk_num=TTAT.3G-36.112V17.0.0</a>

### 2.1.5.6 TS 36.113

#### Evolved Universal Terrestrial Radio Access (E-UTRA); Base Station (BS) and repeater ElectroMagnetic Compatibility (EMC)

This document covers the assessment of E-UTRA base stations, repeaters and associated ancillary equipment in respect of Electromagnetic Compatibility (EMC). This document specifies the applicable test conditions, performance assessment and performance criteria for E-UTRA base stations, repeaters and associated ancillary equipment in one of the following categories: (i) base stations of E-UTRA meeting the requirements of TS 36.104, with conformance demonstrated by compliance to TS 36.141; (ii) repeaters of FDD E-UTRA meeting the requirements of TS 36.106, with conformance demonstrated by compliance to TS 36.143. The environment classification used in this document refers to the environment classification used in IEC 61000-6-1 and IEC 61000-6-3. The EMC requirements have been selected to ensure an adequate level of compatibility for apparatus at residential, commercial and light industrial environments. The levels, however, do not cover extreme cases which may occur in any location but with low probability of occurrence.

SDO	Document No.	Version	Status	Issued date	Location
<b>Release 10</b>					
ARIB	ARIB STD-T120-36.113.V10.5.0	10.5.0	Published	03.03.2023	<a href="https://www.arib.or.jp/english/html/overview/doc/T120_T23_SPECS/ARIB-STD-T120/Rel10/36/A36113-a50.pdf">https://www.arib.or.jp/english/html/overview/doc/T120_T23_SPECS/ARIB-STD-T120/Rel10/36/A36113-a50.pdf</a>
ATIS	ATIS.3GPP.36.113V1050	10.5.0	Published	28.06.2021	<a href="https://www.atis.org/3gpp-documents/Rel99-14/">https://www.atis.org/3gpp-documents/Rel99-14/</a>
CCSA	CCSA.36.113V1050	10.5.0	Published	01.06.2012	<a href="https://www.ccsa.org.cn/api/portalsFile/downloadOldFile?type=19&amp;oldFileUrl=ITU-R/M.2012-6/CCSA.36.113V1050.doc">https://www.ccsa.org.cn/api/portalsFile/downloadOldFile?type=19&amp;oldFileUrl=ITU-R/M.2012-6/CCSA.36.113V1050.doc</a>
ETSI	ETSI TS 136 113	10.5.0	Published	30.07.2012	<a href="https://www.etsi.org/deliver/etsi_ts/136100_136199/136113/10.05.00_60/ts_136113v100500p.pdf">https://www.etsi.org/deliver/etsi_ts/136100_136199/136113/10.05.00_60/ts_136113v100500p.pdf</a>
TSDSI	TSDSI STD T1.3GPP 36.113-10.5.0 V1.0.0	10.5.0	Published	30.08.2021	<a href="https://members.tdsi.in/index.php/s/7PCn6dD3r5joj8e">https://members.tdsi.in/index.php/s/7PCn6dD3r5joj8e</a>
TTA	TTAT.3G-36.113V10.5.0	10.5.0	Published	30.07.2021	<a href="http://committee.tta.or.kr/data/ttasDown.jsp?kind=ttastd&amp;pk_num=TTAT.3G-36.113V10.5.0">http://committee.tta.or.kr/data/ttasDown.jsp?kind=ttastd&amp;pk_num=TTAT.3G-36.113V10.5.0</a>
<b>Release 11</b>					
ARIB	ARIB STD-T120-36.113.V11.3.0	11.3.0	Published	03.03.2023	<a href="https://www.arib.or.jp/english/html/overview/doc/T120_T23_SPECS/ARIB-STD-T120/Rel11/36/A36113-b30.pdf">https://www.arib.or.jp/english/html/overview/doc/T120_T23_SPECS/ARIB-STD-T120/Rel11/36/A36113-b30.pdf</a>

ATIS	ATIS.3GPP.36.113V1130	11.3.0	Published	28.06.2021	<a href="https://www.atis.org/3gpp-documents/Rel99-14/">https://www.atis.org/3gpp-documents/Rel99-14/</a>
CCSA	CCSA.36.113V1130	11.3.0	Published	01.12.2014	<a href="https://www.ccsa.org.cn/api/portalsFile/downloadOldFile?type=19&amp;oldFileUrl=ITU-R/M.2012-6/CCSA.36.113V1130.doc">https://www.ccsa.org.cn/api/portalsFile/downloadOldFile?type=19&amp;oldFileUrl=ITU-R/M.2012-6/CCSA.36.113V1130.doc</a>
ETSI	ETSI TS 136 113	11.3.0	Published	03.02.2015	<a href="https://www.etsi.org/deliver/etsi_ts/136100_136199/136113/11.03.00_60/ts_136113v110300p.pdf">https://www.etsi.org/deliver/etsi_ts/136100_136199/136113/11.03.00_60/ts_136113v110300p.pdf</a>
TSDSI	TSDSI STD T1.3GPP 36.113-11.3.0 V1.0.0	11.3.0	Published	30.08.2021	<a href="https://members.tdsi.in/index.php/s/6Mfwgax8qs9aFdA">https://members.tdsi.in/index.php/s/6Mfwgax8qs9aFdA</a>
TTA	TTAT.3G-36.113V11.3.0	11.3.0	Published	30.07.2021	<a href="http://committee.tta.or.kr/data/ttasDown.jsp?kind=ttastd&amp;pk_num=TTAT.3G-36.113V11.3.0">http://committee.tta.or.kr/data/ttasDown.jsp?kind=ttastd&amp;pk_num=TTAT.3G-36.113V11.3.0</a>
<b>Release 12</b>					
ARIB	ARIB STD-T120-36.113.V12.3.0	12.3.0	Published	03.03.2023	<a href="https://www.arib.or.jp/english/html/overview/doc/T120_T23_SPECS/ARIB-STD-T120/Rel12/36/A36113-c30.pdf">https://www.arib.or.jp/english/html/overview/doc/T120_T23_SPECS/ARIB-STD-T120/Rel12/36/A36113-c30.pdf</a>
ATIS	ATIS.3GPP.36.113V1230	12.3.0	Published	28.06.2021	<a href="https://www.atis.org/3gpp-documents/Rel99-14/">https://www.atis.org/3gpp-documents/Rel99-14/</a>
CCSA	CCSA.36.113V1230	12.3.0	Published	01.12.2014	<a href="https://www.ccsa.org.cn/api/portalsFile/downloadOldFile?type=19&amp;oldFileUrl=ITU-R/M.2012-6/CCSA.36.113V1230.doc">https://www.ccsa.org.cn/api/portalsFile/downloadOldFile?type=19&amp;oldFileUrl=ITU-R/M.2012-6/CCSA.36.113V1230.doc</a>
ETSI	ETSI TS 136 113	12.3.0	Published	03.02.2015	<a href="https://www.etsi.org/deliver/etsi_ts/136100_136199/136113/12.03.00_60/ts_136113v120300p.pdf">https://www.etsi.org/deliver/etsi_ts/136100_136199/136113/12.03.00_60/ts_136113v120300p.pdf</a>
TSDSI	TSDSI STD T1.3GPP 36.113-12.3.0 V1.0.0	12.3.0	Published	30.08.2021	<a href="https://members.tdsi.in/index.php/s/nfYHcy4zsz5XE2Q">https://members.tdsi.in/index.php/s/nfYHcy4zsz5XE2Q</a>
TTA	TTAT.3G-36.113V12.3.0	12.3.0	Published	30.07.2021	<a href="http://committee.tta.or.kr/data/ttasDown.jsp?kind=ttastd&amp;pk_num=TTAT.3G-36.113V12.3.0">http://committee.tta.or.kr/data/ttasDown.jsp?kind=ttastd&amp;pk_num=TTAT.3G-36.113V12.3.0</a>
<b>Release 13</b>					
ARIB	ARIB STD-T120-36.113.V13.3.0	13.3.0	Published	03.03.2023	<a href="https://www.arib.or.jp/english/html/overview/doc/T120_T23_SPECS/ARIB-STD-T120/Rel13/36/A36113-d30.pdf">https://www.arib.or.jp/english/html/overview/doc/T120_T23_SPECS/ARIB-STD-T120/Rel13/36/A36113-d30.pdf</a>
ATIS	ATIS.3GPP.36.113V1330	13.3.0	Published	28.06.2021	<a href="https://www.atis.org/3gpp-documents/Rel99-14/">https://www.atis.org/3gpp-documents/Rel99-14/</a>
CCSA	CCSA.36.113V1330	13.3.0	Published	01.12.2016	<a href="https://www.ccsa.org.cn/api/portalsFile/downloadOldFile?type=19&amp;oldFileUrl=ITU-R/M.2012-6/CCSA.36.113V1330.doc">https://www.ccsa.org.cn/api/portalsFile/downloadOldFile?type=19&amp;oldFileUrl=ITU-R/M.2012-6/CCSA.36.113V1330.doc</a>
ETSI	ETSI TS 136 113	13.3.0	Published	26.01.2017	<a href="https://www.etsi.org/deliver/etsi_ts/136100_136199/136113/13.03.00_60/ts_136113v130300p.pdf">https://www.etsi.org/deliver/etsi_ts/136100_136199/136113/13.03.00_60/ts_136113v130300p.pdf</a>
TSDSI	TSDSI STD T1.3GPP 36.113-13.3.0 V1.0.0	13.3.0	Published	30.08.2021	<a href="https://members.tdsi.in/index.php/s/FAgFKdCa4zZb2qK">https://members.tdsi.in/index.php/s/FAgFKdCa4zZb2qK</a>
TTA	TTAT.3G-36.113V13.3.0	13.3.0	Published	30.07.2021	<a href="http://committee.tta.or.kr/data/ttasDown.jsp?kind=ttastd&amp;pk_num=TTAT.3G-36.113V13.3.0">http://committee.tta.or.kr/data/ttasDown.jsp?kind=ttastd&amp;pk_num=TTAT.3G-36.113V13.3.0</a>
<b>Release 14</b>					
ARIB	ARIB STD-T120-36.113.V14.2.0	14.2.0	Published	03.03.2023	<a href="https://www.arib.or.jp/english/html/overview/doc/T120_T23_SPECS/ARIB-STD-T120/Rel14/36/A36113-e20.pdf">https://www.arib.or.jp/english/html/overview/doc/T120_T23_SPECS/ARIB-STD-T120/Rel14/36/A36113-e20.pdf</a>
ATIS	ATIS.3GPP.36.113V1420	14.2.0	Published	28.06.2021	<a href="https://www.atis.org/3gpp-documents/Rel99-14/">https://www.atis.org/3gpp-documents/Rel99-14/</a>
CCSA	CCSA.36.113V1420	14.2.0	Published	01.03.2017	<a href="https://www.ccsa.org.cn/api/portalsFile/downloadOldFile?type=19&amp;oldFileUrl=ITU-R/M.2012-6/CCSA.36.113V1420.doc">https://www.ccsa.org.cn/api/portalsFile/downloadOldFile?type=19&amp;oldFileUrl=ITU-R/M.2012-6/CCSA.36.113V1420.doc</a>
ETSI	ETSI TS 136 113	14.2.0	Published	13.04.2017	<a href="https://www.etsi.org/deliver/etsi_ts/136100_136199/136113/14.02.00_60/ts_136113v140200p.pdf">https://www.etsi.org/deliver/etsi_ts/136100_136199/136113/14.02.00_60/ts_136113v140200p.pdf</a>
TSDSI	TSDSI STD T1.3GPP 36.113-14.2.0 V1.0.0	14.2.0	Published	30.08.2021	<a href="https://members.tdsi.in/index.php/s/cZo5g97EH5TyyCW">https://members.tdsi.in/index.php/s/cZo5g97EH5TyyCW</a>
TTA	TTAT.3G-36.113V14.2.0	14.2.0	Published	30.07.2021	<a href="http://committee.tta.or.kr/data/ttasDown.jsp?kind=ttastd&amp;pk_num=TTAT.3G-36.113V14.2.0">http://committee.tta.or.kr/data/ttasDown.jsp?kind=ttastd&amp;pk_num=TTAT.3G-36.113V14.2.0</a>
<b>Release 15</b>					
ARIB	ARIB STD-T120-36.113.V15.4.0	15.4.0	Published	03.03.2023	<a href="https://www.arib.or.jp/english/html/overview/doc/T120_T23_SPECS/ARIB-STD-T120/Rel15/36/A36113-f40.pdf">https://www.arib.or.jp/english/html/overview/doc/T120_T23_SPECS/ARIB-STD-T120/Rel15/36/A36113-f40.pdf</a>
ATIS	ATIS.3GPP.36.113V1540	15.4.0	Published	28.06.2021	<a href="https://www.atis.org/3gpp-documents/Rel15/">https://www.atis.org/3gpp-documents/Rel15/</a>
CCSA	CCSA.36.113V1540	15.4.0	Published	01.09.2019	<a href="https://www.ccsa.org.cn/api/portalsFile/downloadOldFile?type=19&amp;oldFileUrl=ITU-R/M.2012-6/CCSA.36.113V1540.doc">https://www.ccsa.org.cn/api/portalsFile/downloadOldFile?type=19&amp;oldFileUrl=ITU-R/M.2012-6/CCSA.36.113V1540.doc</a>
ETSI	ETSI TS 136 113	15.4.0	Published	17.10.2019	<a href="https://www.etsi.org/deliver/etsi_ts/136100_136199/136113/15.04.00_60/ts_136113v150400p.pdf">https://www.etsi.org/deliver/etsi_ts/136100_136199/136113/15.04.00_60/ts_136113v150400p.pdf</a>
TSDSI	TSDSI STD T1.3GPP 36.113-15.4.0 V1.0.0	15.4.0	Published	30.08.2021	<a href="https://members.tdsi.in/index.php/s/EZY3yixL8takEMD">https://members.tdsi.in/index.php/s/EZY3yixL8takEMD</a>
TTA	TTAT.3G-36.113V15.4.0	15.4.0	Published	11.09.2020	<a href="http://committee.tta.or.kr/data/ttasDown.jsp?kind=ttastd&amp;pk_num=TTAT.3G-36.113V15.4.0">http://committee.tta.or.kr/data/ttasDown.jsp?kind=ttastd&amp;pk_num=TTAT.3G-36.113V15.4.0</a>
<b>Release 16</b>					
ARIB	ARIB STD-T120-36.113.V16.2.0	16.2.0	Published	03.03.2023	<a href="https://www.arib.or.jp/english/html/overview/doc/T120_T23_SPECS/ARIB-STD-T120/Rel16/36/A36113-g20.pdf">https://www.arib.or.jp/english/html/overview/doc/T120_T23_SPECS/ARIB-STD-T120/Rel16/36/A36113-g20.pdf</a>
ATIS	ATIS.3GPP.36.113V1620	16.2.0	Published	28.06.2021	<a href="https://www.atis.org/3gpp-documents/Rel16/">https://www.atis.org/3gpp-documents/Rel16/</a>
CCSA	CCSA.36.113V1620	16.2.0	Published	01.09.2019	<a href="https://www.ccsa.org.cn/api/portalsFile/downloadOldFile?type=19&amp;oldFileUrl=ITU-R/M.2012-6/CCSA.36.113V1620.doc">https://www.ccsa.org.cn/api/portalsFile/downloadOldFile?type=19&amp;oldFileUrl=ITU-R/M.2012-6/CCSA.36.113V1620.doc</a>
ETSI	ETSI TS 136 113	16.2.0	Published	21.09.2020	<a href="https://www.etsi.org/deliver/etsi_ts/136100_136199/136113/16.02.00_60/ts_136113v160200p.pdf">https://www.etsi.org/deliver/etsi_ts/136100_136199/136113/16.02.00_60/ts_136113v160200p.pdf</a>
TSDSI	TSDSI STD T1.3GPP 36.113-16.2.0 V1.0.0	16.2.0	Published	30.08.2021	<a href="https://members.tdsi.in/index.php/s/wpkcqpYb5yYsPB">https://members.tdsi.in/index.php/s/wpkcqpYb5yYsPB</a>
TTA	TTAT.3G-36.113V16.2.0	16.2.0	Published	11.09.2020	<a href="http://committee.tta.or.kr/data/ttasDown.jsp?kind=ttastd&amp;pk_num=TTAT.3G-36.113V16.2.0">http://committee.tta.or.kr/data/ttasDown.jsp?kind=ttastd&amp;pk_num=TTAT.3G-36.113V16.2.0</a>
<b>Release 17</b>					
ARIB	ARIB STD-T120-36.113.V17.0.0	17.0.0	Published	03.03.2023	<a href="https://www.arib.or.jp/english/html/overview/doc/T120_T23_SPECS/ARIB-STD-T120/Rel17/36/A36113-h00.pdf">https://www.arib.or.jp/english/html/overview/doc/T120_T23_SPECS/ARIB-STD-T120/Rel17/36/A36113-h00.pdf</a>
ATIS	ATIS.3GPP.36.113.V17.0.0	17.0.0	Published	21.02.2023	<a href="https://www.atis.org/3gpp-transpositions - Rel-17">https://www.atis.org/3gpp-transpositions - Rel-17</a>
CCSA	CCSA.36.113V1700	17.0.0	Published	01.03.2022	<a href="https://www.ccsa.org.cn/api/portalsFile/downloadOldFile?type=19&amp;oldFileUrl=ITU-R/M.2012-6/CCSA.36.113V1700.doc">https://www.ccsa.org.cn/api/portalsFile/downloadOldFile?type=19&amp;oldFileUrl=ITU-R/M.2012-6/CCSA.36.113V1700.doc</a>
ETSI	ETSI TS 136 113	17.0.0	Published	27.04.2022	<a href="https://www.etsi.org/deliver/etsi_ts/136100_136199/136113/17.00.00_60/ts_136113v170000p.pdf">https://www.etsi.org/deliver/etsi_ts/136100_136199/136113/17.00.00_60/ts_136113v170000p.pdf</a>
TSDSI	TSDSI STD T1.3GPP 36.113-17.0.0 V1.0.0	17.0.0	Published	29.07.2022	<a href="https://members.tdsi.in/s/8J66BHpMRsY9xw4">https://members.tdsi.in/s/8J66BHpMRsY9xw4</a>

TTA TTAT.3G-36.113V17.0.0 17.0.0 Published 05.08.2022 [http://committee.tta.or.kr/data/ttasDown.jsp?kind=ttastd&pk\\_num=TTAT.3G-36.113V17.0.0](http://committee.tta.or.kr/data/ttasDown.jsp?kind=ttastd&pk_num=TTAT.3G-36.113V17.0.0)

### 2.1.5.7 TS 36.116

#### Evolved Universal Terrestrial Radio Access (E-UTRA); Relay radio transmission and reception

This document establishes the minimum RF characteristics and minimum performance requirements of E-UTRA Relay.

SDO	Document No.	Version	Status	Issued date	Location
<b>Release 11</b>					
ATIS	ATIS.3GPP.36.116V1170	11.7.0	Published	28.06.2021	<a href="https://www.atis.org/3gpp-documents/Rel99-14/">https://www.atis.org/3gpp-documents/Rel99-14/</a>
CCSA	CCSA.36.116V1170	11.7.0	Published	01.01.2016	<a href="https://www.ccsa.org.cn/api/portalsFile/downloadOldFile?type=19&amp;oldFileUrl=ITU-R/M.2012-6/CCSA.36.116V1170.doc">https://www.ccsa.org.cn/api/portalsFile/downloadOldFile?type=19&amp;oldFileUrl=ITU-R/M.2012-6/CCSA.36.116V1170.doc</a>
ETSI	ETSI TS 136 116	11.7.0	Published	28.01.2016	<a href="https://www.etsi.org/deliver/etsi_ts/136100_136199/136116/11.07.00_60/ts_136116v110700p.pdf">https://www.etsi.org/deliver/etsi_ts/136100_136199/136116/11.07.00_60/ts_136116v110700p.pdf</a>
TSDSI	TSDSI STD T1.3GPP 36.116-11.7.0 V1.0.0	11.7.0	Published	30.08.2021	<a href="https://members.tdsi.in/index.php/s/HQeJK9RN93YZgWz">https://members.tdsi.in/index.php/s/HQeJK9RN93YZgWz</a>
TTA	TTAT.3G-36.116V11.7.0	11.7.0	Published	30.07.2021	<a href="http://committee.tta.or.kr/data/ttasDown.jsp?kind=ttastd&amp;pk_num=TTAT.3G-36.116V11.7.0">http://committee.tta.or.kr/data/ttasDown.jsp?kind=ttastd&amp;pk_num=TTAT.3G-36.116V11.7.0</a>
<b>Release 12</b>					
ATIS	ATIS.3GPP.36.116V1240	12.4.0	Published	28.06.2021	<a href="https://www.atis.org/3gpp-documents/Rel99-14/">https://www.atis.org/3gpp-documents/Rel99-14/</a>
CCSA	CCSA.36.116V1240	12.4.0	Published	01.01.2016	<a href="https://www.ccsa.org.cn/api/portalsFile/downloadOldFile?type=19&amp;oldFileUrl=ITU-R/M.2012-6/CCSA.36.116V1240.doc">https://www.ccsa.org.cn/api/portalsFile/downloadOldFile?type=19&amp;oldFileUrl=ITU-R/M.2012-6/CCSA.36.116V1240.doc</a>
ETSI	ETSI TS 136 116	12.4.0	Published	28.01.2016	<a href="https://www.etsi.org/deliver/etsi_ts/136100_136199/136116/12.04.00_60/ts_136116v120400p.pdf">https://www.etsi.org/deliver/etsi_ts/136100_136199/136116/12.04.00_60/ts_136116v120400p.pdf</a>
TSDSI	TSDSI STD T1.3GPP 36.116-12.4.0 V1.0.0	12.4.0	Published	30.08.2021	<a href="https://members.tdsi.in/index.php/s/KBWos2P56o4kZ4c">https://members.tdsi.in/index.php/s/KBWos2P56o4kZ4c</a>
TTA	TTAT.3G-36.116V12.4.0	12.4.0	Published	30.07.2021	<a href="http://committee.tta.or.kr/data/ttasDown.jsp?kind=ttastd&amp;pk_num=TTAT.3G-36.116V12.4.0">http://committee.tta.or.kr/data/ttasDown.jsp?kind=ttastd&amp;pk_num=TTAT.3G-36.116V12.4.0</a>
<b>Release 13</b>					
ATIS	ATIS.3GPP.36.116V1301	13.0.1	Published	28.06.2021	<a href="https://www.atis.org/3gpp-documents/Rel99-14/">https://www.atis.org/3gpp-documents/Rel99-14/</a>
CCSA	CCSA.36.116V1301	13.0.1	Published	01.01.2016	<a href="https://www.ccsa.org.cn/api/portalsFile/downloadOldFile?type=19&amp;oldFileUrl=ITU-R/M.2012-6/CCSA.36.116V1301.doc">https://www.ccsa.org.cn/api/portalsFile/downloadOldFile?type=19&amp;oldFileUrl=ITU-R/M.2012-6/CCSA.36.116V1301.doc</a>
ETSI	ETSI TS 136 116	13.0.1	Published	28.01.2016	<a href="https://www.etsi.org/deliver/etsi_ts/136100_136199/136116/13.00.01_60/ts_136116v130001p.pdf">https://www.etsi.org/deliver/etsi_ts/136100_136199/136116/13.00.01_60/ts_136116v130001p.pdf</a>
TSDSI	TSDSI STD T1.3GPP 36.116-13.0.1 V1.0.0	13.0.1	Published	30.08.2021	<a href="https://members.tdsi.in/index.php/s/qLawCJ4AKs6PyQf">https://members.tdsi.in/index.php/s/qLawCJ4AKs6PyQf</a>
TTA	TTAT.3G-36.116V13.0.1	13.0.1	Published	30.07.2021	<a href="http://committee.tta.or.kr/data/ttasDown.jsp?kind=ttastd&amp;pk_num=TTAT.3G-36.116V13.0.1">http://committee.tta.or.kr/data/ttasDown.jsp?kind=ttastd&amp;pk_num=TTAT.3G-36.116V13.0.1</a>
<b>Release 14</b>					
ATIS	ATIS.3GPP.36.116V1400	14.0.0	Published	28.06.2021	<a href="https://www.atis.org/3gpp-documents/Rel99-14/">https://www.atis.org/3gpp-documents/Rel99-14/</a>
CCSA	CCSA.36.116V1400	14.0.0	Published	01.03.2017	<a href="https://www.ccsa.org.cn/api/portalsFile/downloadOldFile?type=19&amp;oldFileUrl=ITU-R/M.2012-6/CCSA.36.116V1400.doc">https://www.ccsa.org.cn/api/portalsFile/downloadOldFile?type=19&amp;oldFileUrl=ITU-R/M.2012-6/CCSA.36.116V1400.doc</a>
ETSI	ETSI TS 136 116	14.0.0	Published	13.04.2017	<a href="https://www.etsi.org/deliver/etsi_ts/136100_136199/136116/14.00.00_60/ts_136116v140000p.pdf">https://www.etsi.org/deliver/etsi_ts/136100_136199/136116/14.00.00_60/ts_136116v140000p.pdf</a>
TSDSI	TSDSI STD T1.3GPP 36.116-14.0.0 V1.0.0	14.0.0	Published	30.08.2021	<a href="https://members.tdsi.in/index.php/s/TDrrzmHXirK78KQ">https://members.tdsi.in/index.php/s/TDrrzmHXirK78KQ</a>
TTA	TTAT.3G-36.116V14.0.0	14.0.0	Published	30.07.2021	<a href="http://committee.tta.or.kr/data/ttasDown.jsp?kind=ttastd&amp;pk_num=TTAT.3G-36.116V14.0.0">http://committee.tta.or.kr/data/ttasDown.jsp?kind=ttastd&amp;pk_num=TTAT.3G-36.116V14.0.0</a>
<b>Release 15</b>					
ATIS	ATIS.3GPP.36.116V1500	15.0.0	Published	28.06.2021	<a href="https://www.atis.org/3gpp-documents/Rel15/">https://www.atis.org/3gpp-documents/Rel15/</a>
CCSA	CCSA.36.116V1500	15.0.0	Published	01.09.2018	<a href="https://www.ccsa.org.cn/api/portalsFile/downloadOldFile?type=19&amp;oldFileUrl=ITU-R/M.2012-6/CCSA.36.116V1500.doc">https://www.ccsa.org.cn/api/portalsFile/downloadOldFile?type=19&amp;oldFileUrl=ITU-R/M.2012-6/CCSA.36.116V1500.doc</a>
ETSI	ETSI TS 136 116	15.0.0	Published	12.11.2018	<a href="https://www.etsi.org/deliver/etsi_ts/136100_136199/136116/15.00.00_60/ts_136116v150000p.pdf">https://www.etsi.org/deliver/etsi_ts/136100_136199/136116/15.00.00_60/ts_136116v150000p.pdf</a>
TSDSI	TSDSI STD T1.3GPP 36.116-15.0.0 V1.0.0	15.0.0	Published	30.08.2021	<a href="https://members.tdsi.in/index.php/s/j3WGG2XmZrL6mTx">https://members.tdsi.in/index.php/s/j3WGG2XmZrL6mTx</a>
TTA	TTAT.3G-36.116V15.0.0	15.0.0	Published	11.09.2020	<a href="http://committee.tta.or.kr/data/ttasDown.jsp?kind=ttastd&amp;pk_num=TTAT.3G-36.116V15.0.0">http://committee.tta.or.kr/data/ttasDown.jsp?kind=ttastd&amp;pk_num=TTAT.3G-36.116V15.0.0</a>
<b>Release 16</b>					
ATIS	ATIS.3GPP.36.116V1600	16.0.0	Published	28.06.2021	<a href="https://www.atis.org/3gpp-documents/Rel16/">https://www.atis.org/3gpp-documents/Rel16/</a>
CCSA	CCSA.36.116V1600	16.0.0	Published	01.06.2020	<a href="https://www.ccsa.org.cn/api/portalsFile/downloadOldFile?type=19&amp;oldFileUrl=ITU-R/M.2012-6/CCSA.36.116V1600.doc">https://www.ccsa.org.cn/api/portalsFile/downloadOldFile?type=19&amp;oldFileUrl=ITU-R/M.2012-6/CCSA.36.116V1600.doc</a>
ETSI	ETSI TS 136 116	16.0.0	Published	21.07.2020	<a href="https://www.etsi.org/deliver/etsi_ts/136100_136199/136116/16.00.00_60/ts_136116v160000p.pdf">https://www.etsi.org/deliver/etsi_ts/136100_136199/136116/16.00.00_60/ts_136116v160000p.pdf</a>
TSDSI	TSDSI STD T1.3GPP 36.116-16.0.0 V1.0.0	16.0.0	Published	30.08.2021	<a href="https://members.tdsi.in/index.php/s/oH5nyKqMWNnPMYw">https://members.tdsi.in/index.php/s/oH5nyKqMWNnPMYw</a>
TTA	TTAT.3G-36.116V16.0.0	16.0.0	Published	11.09.2020	<a href="http://committee.tta.or.kr/data/ttasDown.jsp?kind=ttastd&amp;pk_num=TTAT.3G-36.116V16.0.0">http://committee.tta.or.kr/data/ttasDown.jsp?kind=ttastd&amp;pk_num=TTAT.3G-36.116V16.0.0</a>



**Release 17**

ATIS	ATIS.3GPP.36.116.V17.0.0	17.0.0	Published	21.02.2023	<a href="https://www.atis.org/3gpp-transpositions - Rel-17">https://www.atis.org/3gpp-transpositions - Rel-17</a>
CCSA	CCSA.36.116V1700	17.0.0	Published	01.03.2022	<a href="https://www.ccsa.org.cn/api/portalsFile/downloadOldFile?type=19&amp;oldFileUrl=ITU-R/M.2012-6/CCSA.36.116V1700.doc">https://www.ccsa.org.cn/api/portalsFile/downloadOldFile?type=19&amp;oldFileUrl=ITU-R/M.2012-6/CCSA.36.116V1700.doc</a>
ETSI	ETSI TS 136 116	17.0.0	Published	27.04.2022	<a href="https://www.etsi.org/deliver/etsi_ts/136100_136199/136116/17.00.00_60/ts_136116v170000p.pdf">https://www.etsi.org/deliver/etsi_ts/136100_136199/136116/17.00.00_60/ts_136116v170000p.pdf</a>
TSDSI	TSDSI STD T1.3GPP 36.116-17.0.0 V1.0.0	17.0.0	Published	29.07.2022	<a href="https://members.tdsi.in/s/cdSZSLMtdKBjBQA">https://members.tdsi.in/s/cdSZSLMtdKBjBQA</a>
TTA	TTAT.3G-36.116V17.0.0	17.0.0	Published	05.08.2022	<a href="http://committee.tta.or.kr/data/ttasDown.jsp?kind=ttastd&amp;pk_num=TTAT.3G-36.116V17.0.0">http://committee.tta.or.kr/data/ttasDown.jsp?kind=ttastd&amp;pk_num=TTAT.3G-36.116V17.0.0</a>

**2.1.5.8 TS 36.117****Evolved Universal Terrestrial Radio Access (E-UTRA); Relay conformance testing**

This document specifies the Radio Frequency (RF) test methods and conformance requirements for E-UTRA Relay. These have been derived from, and are consistent with the E-UTRA Relay specifications defined in TS 36.116.

SDO	Document No.	Version	Status	Issued date	Location
<b>Release 11</b>					
ATIS	ATIS.3GPP.36.117V1140	11.4.0	Published	28.06.2021	<a href="https://www.atis.org/3gpp-documents/Rel99-14/">https://www.atis.org/3gpp-documents/Rel99-14/</a>
CCSA	CCSA.36.117V1140	11.4.0	Published	01.01.2016	<a href="https://www.ccsa.org.cn/api/portalsFile/downloadOldFile?type=19&amp;oldFileUrl=ITU-R/M.2012-6/CCSA.36.117V1140.doc">https://www.ccsa.org.cn/api/portalsFile/downloadOldFile?type=19&amp;oldFileUrl=ITU-R/M.2012-6/CCSA.36.117V1140.doc</a>
ETSI	ETSI TS 136 117	11.4.0	Published	28.01.2016	<a href="https://www.etsi.org/deliver/etsi_ts/136100_136199/136117/11.04.00_60/ts_136117v110400p.pdf">https://www.etsi.org/deliver/etsi_ts/136100_136199/136117/11.04.00_60/ts_136117v110400p.pdf</a>
TSDSI	TSDSI STD T1.3GPP 36.117-11.4.0 V1.0.0	11.4.0	Published	30.08.2021	<a href="https://members.tdsi.in/index.php/s/RKnPXNDyDzkNZL4">https://members.tdsi.in/index.php/s/RKnPXNDyDzkNZL4</a>
TTA	TTAT.3G-36.117V11.4.0	11.4.0	Published	30.07.2021	<a href="http://committee.tta.or.kr/data/ttasDown.jsp?kind=ttastd&amp;pk_num=TTAT.3G-36.117V11.4.0">http://committee.tta.or.kr/data/ttasDown.jsp?kind=ttastd&amp;pk_num=TTAT.3G-36.117V11.4.0</a>
<b>Release 12</b>					
ATIS	ATIS.3GPP.36.117V1230	12.3.0	Published	28.06.2021	<a href="https://www.atis.org/3gpp-documents/Rel99-14/">https://www.atis.org/3gpp-documents/Rel99-14/</a>
CCSA	CCSA.36.117V1230	12.3.0	Published	01.01.2016	<a href="https://www.ccsa.org.cn/api/portalsFile/downloadOldFile?type=19&amp;oldFileUrl=ITU-R/M.2012-6/CCSA.36.117V1230.doc">https://www.ccsa.org.cn/api/portalsFile/downloadOldFile?type=19&amp;oldFileUrl=ITU-R/M.2012-6/CCSA.36.117V1230.doc</a>
ETSI	ETSI TS 136 117	12.3.0	Published	28.01.2016	<a href="https://www.etsi.org/deliver/etsi_ts/136100_136199/136117/12.03.00_60/ts_136117v120300p.pdf">https://www.etsi.org/deliver/etsi_ts/136100_136199/136117/12.03.00_60/ts_136117v120300p.pdf</a>
TSDSI	TSDSI STD T1.3GPP 36.117-12.3.0 V1.0.0	12.3.0	Published	30.08.2021	<a href="https://members.tdsi.in/index.php/s/2Q4QgK9FjiMBpAS">https://members.tdsi.in/index.php/s/2Q4QgK9FjiMBpAS</a>
TTA	TTAT.3G-36.117V12.3.0	12.3.0	Published	30.07.2021	<a href="http://committee.tta.or.kr/data/ttasDown.jsp?kind=ttastd&amp;pk_num=TTAT.3G-36.117V12.3.0">http://committee.tta.or.kr/data/ttasDown.jsp?kind=ttastd&amp;pk_num=TTAT.3G-36.117V12.3.0</a>
<b>Release 13</b>					
ATIS	ATIS.3GPP.36.117V1301	13.0.1	Published	28.06.2021	<a href="https://www.atis.org/3gpp-documents/Rel99-14/">https://www.atis.org/3gpp-documents/Rel99-14/</a>
CCSA	CCSA.36.117V1301	13.0.1	Published	01.01.2016	<a href="https://www.ccsa.org.cn/api/portalsFile/downloadOldFile?type=19&amp;oldFileUrl=ITU-R/M.2012-6/CCSA.36.117V1301.doc">https://www.ccsa.org.cn/api/portalsFile/downloadOldFile?type=19&amp;oldFileUrl=ITU-R/M.2012-6/CCSA.36.117V1301.doc</a>
ETSI	ETSI TS 136 117	13.0.1	Published	28.01.2016	<a href="https://www.etsi.org/deliver/etsi_ts/136100_136199/136117/13.00.01_60/ts_136117v130001p.pdf">https://www.etsi.org/deliver/etsi_ts/136100_136199/136117/13.00.01_60/ts_136117v130001p.pdf</a>
TSDSI	TSDSI STD T1.3GPP 36.117-13.0.1 V1.0.0	13.0.1	Published	30.08.2021	<a href="https://members.tdsi.in/index.php/s/nKk4kZrBqBZyBo8">https://members.tdsi.in/index.php/s/nKk4kZrBqBZyBo8</a>
TTA	TTAT.3G-36.117V13.0.1	13.0.1	Published	30.07.2021	<a href="http://committee.tta.or.kr/data/ttasDown.jsp?kind=ttastd&amp;pk_num=TTAT.3G-36.117V13.0.1">http://committee.tta.or.kr/data/ttasDown.jsp?kind=ttastd&amp;pk_num=TTAT.3G-36.117V13.0.1</a>
<b>Release 14</b>					
ATIS	ATIS.3GPP.36.117V1400	14.0.0	Published	28.06.2021	<a href="https://www.atis.org/3gpp-documents/Rel99-14/">https://www.atis.org/3gpp-documents/Rel99-14/</a>
CCSA	CCSA.36.117V1400	14.0.0	Published	01.03.2017	<a href="https://www.ccsa.org.cn/api/portalsFile/downloadOldFile?type=19&amp;oldFileUrl=ITU-R/M.2012-6/CCSA.36.117V1400.doc">https://www.ccsa.org.cn/api/portalsFile/downloadOldFile?type=19&amp;oldFileUrl=ITU-R/M.2012-6/CCSA.36.117V1400.doc</a>
ETSI	ETSI TS 136 117	14.0.0	Published	13.04.2017	<a href="https://www.etsi.org/deliver/etsi_ts/136100_136199/136117/14.00.00_60/ts_136117v140000p.pdf">https://www.etsi.org/deliver/etsi_ts/136100_136199/136117/14.00.00_60/ts_136117v140000p.pdf</a>
TSDSI	TSDSI STD T1.3GPP 36.117-14.0.0 V1.0.0	14.0.0	Published	30.08.2021	<a href="https://members.tdsi.in/index.php/s/TPYzptyRNx4J9yW">https://members.tdsi.in/index.php/s/TPYzptyRNx4J9yW</a>
TTA	TTAT.3G-36.117V14.0.0	14.0.0	Published	30.07.2021	<a href="http://committee.tta.or.kr/data/ttasDown.jsp?kind=ttastd&amp;pk_num=TTAT.3G-36.117V14.0.0">http://committee.tta.or.kr/data/ttasDown.jsp?kind=ttastd&amp;pk_num=TTAT.3G-36.117V14.0.0</a>
<b>Release 15</b>					
ATIS	ATIS.3GPP.36.117V1500	15.0.0	Published	28.06.2021	<a href="https://www.atis.org/3gpp-documents/Rel15/">https://www.atis.org/3gpp-documents/Rel15/</a>
CCSA	CCSA.36.117V1500	15.0.0	Published	01.09.2018	<a href="https://www.ccsa.org.cn/api/portalsFile/downloadOldFile?type=19&amp;oldFileUrl=ITU-R/M.2012-6/CCSA.36.117V1500.doc">https://www.ccsa.org.cn/api/portalsFile/downloadOldFile?type=19&amp;oldFileUrl=ITU-R/M.2012-6/CCSA.36.117V1500.doc</a>
ETSI	ETSI TS 136 117	15.0.0	Published	12.11.2018	<a href="https://www.etsi.org/deliver/etsi_ts/136100_136199/136117/15.00.00_60/ts_136117v150000p.pdf">https://www.etsi.org/deliver/etsi_ts/136100_136199/136117/15.00.00_60/ts_136117v150000p.pdf</a>
TSDSI	TSDSI STD T1.3GPP 36.117-15.0.0 V1.0.0	15.0.0	Published	30.08.2021	<a href="https://members.tdsi.in/index.php/s/Yp4TfaXmbkn9DnB">https://members.tdsi.in/index.php/s/Yp4TfaXmbkn9DnB</a>
TTA	TTAT.3G-36.117V15.0.0	15.0.0	Published	11.09.2020	<a href="http://committee.tta.or.kr/data/ttasDown.jsp?kind=ttastd&amp;pk_num=TTAT.3G-36.117V15.0.0">http://committee.tta.or.kr/data/ttasDown.jsp?kind=ttastd&amp;pk_num=TTAT.3G-36.117V15.0.0</a>
<b>Release 16</b>					

## 112

SDO	Document No.	Version	Status	Issued date	Location
ATIS	ATIS.3GPP.36.117V1600	16.0.0	Published	28.06.2021	<a href="https://www.atis.org/3gpp-documents/Rel16/">https://www.atis.org/3gpp-documents/Rel16/</a>
CCSA	CCSA.36.117V1600	16.0.0	Published	01.06.2020	<a href="https://www.ccsa.org.cn/api/portalsFile/downloadOldFile?type=19&amp;oldFileUrl=ITU-R/M.2012-6/CCSA.36.117V1600.doc">https://www.ccsa.org.cn/api/portalsFile/downloadOldFile?type=19&amp;oldFileUrl=ITU-R/M.2012-6/CCSA.36.117V1600.doc</a>
ETSI	ETSI TS 136 117	16.0.0	Published	21.07.2020	<a href="https://www.etsi.org/deliver/etsi_ts/136100_136199/136117/16.00.00_60/ts_136117v160000p.pdf">https://www.etsi.org/deliver/etsi_ts/136100_136199/136117/16.00.00_60/ts_136117v160000p.pdf</a>
TSDSI	TSDSI STD T1.3GPP 36.117-16.0.0 V1.0.0	16.0.0	Published	30.08.2021	<a href="https://members.tdsi.in/index.php/s/mydXyzKwNcBAbpr">https://members.tdsi.in/index.php/s/mydXyzKwNcBAbpr</a>
TTA	TTAT.3G-36.117V16.0.0	16.0.0	Published	11.09.2020	<a href="http://committee.tta.or.kr/data/ttasDown.jsp?kind=ttastd&amp;pk_num=TTAT.3G-36.117V16.0.0">http://committee.tta.or.kr/data/ttasDown.jsp?kind=ttastd&amp;pk_num=TTAT.3G-36.117V16.0.0</a>

### Release 17

ATIS	ATIS.3GPP.36.117.V17.0.0	17.0.0	Published	21.02.2023	<a href="https://www.atis.org/3gpp-transpositions - Rel-17">https://www.atis.org/3gpp-transpositions - Rel-17</a>
CCSA	CCSA.36.117V1700	17.0.0	Published	01.03.2022	<a href="https://www.ccsa.org.cn/api/portalsFile/downloadOldFile?type=19&amp;oldFileUrl=ITU-R/M.2012-6/CCSA.36.117V1700.doc">https://www.ccsa.org.cn/api/portalsFile/downloadOldFile?type=19&amp;oldFileUrl=ITU-R/M.2012-6/CCSA.36.117V1700.doc</a>
ETSI	ETSI TS 136 117	17.0.0	Published	27.04.2022	<a href="https://www.etsi.org/deliver/etsi_ts/136100_136199/136117/17.00.00_60/ts_136117v170000p.pdf">https://www.etsi.org/deliver/etsi_ts/136100_136199/136117/17.00.00_60/ts_136117v170000p.pdf</a>
TSDSI	TSDSI STD T1.3GPP 36.117-17.0.0 V1.0.0	17.0.0	Published	01.11.2022	<a href="https://members.tdsi.in/s/Nq2gnXOwtzobYx">https://members.tdsi.in/s/Nq2gnXOwtzobYx</a>
TTA	TTAT.3G-36.117V17.0.0	17.0.0	Published	05.08.2022	<a href="http://committee.tta.or.kr/data/ttasDown.jsp?kind=ttastd&amp;pk_num=TTAT.3G-36.117V17.0.0">http://committee.tta.or.kr/data/ttasDown.jsp?kind=ttastd&amp;pk_num=TTAT.3G-36.117V17.0.0</a>

## 2.1.5.9 TS 36.124

### Evolved Universal Terrestrial Radio Access (E-UTRA); Electromagnetic compatibility (EMC) requirements for mobile terminals and ancillary equipment

This document establishes the essential EMC requirements for “3<sup>rd</sup> generation” digital cellular mobile terminal equipment and ancillary accessories in combination with a 3GPP E-UTRA user equipment (UE). This document specifies the applicable EMC tests, the methods of measurement, the frequency range, the limits and the minimum performance criteria for all types of E-UTRA UEs and their accessories. Requirements for the radiated emission from the enclosure port of integral antenna equipment and ancillaries have been included. The immunity requirements have been selected to ensure an adequate level of compatibility for apparatus in residential, commercial, light industrial and vehicular environments. The levels, however, do not cover extreme cases, which may occur in any location but with low probability of occurrence. Compliance of radio equipment to the requirements of this document does not signify compliance to any requirement related to the use of the equipment (i.e., licensing requirements). Compliance to the requirements of this document does not signify compliance to any safety requirement. However, any temporary or permanent unsafe condition caused by EMC is considered as non-compliance.

**SDO Document No. Version Status Issued date Location**

### Release 10

ARIB	ARIB STD-T120-36.124.V10.4.0	10.4.0	Published	03.03.2023	<a href="https://www.arib.or.jp/english/html/overview/doc/T120_T23_SPECS/ARIB-STD-T120/Rel10/36/A36124-a40.pdf">https://www.arib.or.jp/english/html/overview/doc/T120_T23_SPECS/ARIB-STD-T120/Rel10/36/A36124-a40.pdf</a>
ATIS	ATIS.3GPP.36.124.V10.4.0	10.4.0	Published	21.02.2023	<a href="https://www.atis.org/3gpp-transpositions - Rel-10">https://www.atis.org/3gpp-transpositions - Rel-10</a>
CCSA	CCSA.36.124V1040	10.4.0	Published	01.06.2022	<a href="https://www.ccsa.org.cn/api/portalsFile/downloadOldFile?type=19&amp;oldFileUrl=ITU-R/M.2012-6/CCSA.36.124V1040.doc">https://www.ccsa.org.cn/api/portalsFile/downloadOldFile?type=19&amp;oldFileUrl=ITU-R/M.2012-6/CCSA.36.124V1040.doc</a>
ETSI	ETSI TS 136 124	10.4.0	Published	17.08.2022	<a href="https://www.etsi.org/deliver/etsi_ts/136100_136199/136124/10.04.00_60/ts_136124v100400p.pdf">https://www.etsi.org/deliver/etsi_ts/136100_136199/136124/10.04.00_60/ts_136124v100400p.pdf</a>
TSDSI	TSDSI STD T1.3GPP 36.124 10.4.0 V1.1.0	10.4.0	Published	02.05.2023	<a href="https://members.tdsi.in/s/Ntaz3yNWa44WxAo">https://members.tdsi.in/s/Ntaz3yNWa44WxAo</a>
TTA	TTAT.3G-36.124V10.4.0	10.4.0	Published	21.10.2022	<a href="http://committee.tta.or.kr/data/ttasDown.jsp?kind=ttastd&amp;pk_num=TTAT.3G-36.124V10.4.0">http://committee.tta.or.kr/data/ttasDown.jsp?kind=ttastd&amp;pk_num=TTAT.3G-36.124V10.4.0</a>

### Release 11

ARIB	ARIB STD-T120-36.124.V11.3.0	11.3.0	Published	03.03.2023	<a href="https://www.arib.or.jp/english/html/overview/doc/T120_T23_SPECS/ARIB-STD-T120/Rel11/36/A36124-b30.pdf">https://www.arib.or.jp/english/html/overview/doc/T120_T23_SPECS/ARIB-STD-T120/Rel11/36/A36124-b30.pdf</a>
ATIS	ATIS.3GPP.36.124.V11.3.0	11.3.0	Published	21.02.2023	<a href="https://www.atis.org/3gpp-transpositions - Rel-11">https://www.atis.org/3gpp-transpositions - Rel-11</a>
CCSA	CCSA.36.124V1130	11.3.0	Published	01.06.2022	<a href="https://www.ccsa.org.cn/api/portalsFile/downloadOldFile?type=19&amp;oldFileUrl=ITU-R/M.2012-6/CCSA.36.124V1130.doc">https://www.ccsa.org.cn/api/portalsFile/downloadOldFile?type=19&amp;oldFileUrl=ITU-R/M.2012-6/CCSA.36.124V1130.doc</a>
ETSI	ETSI TS 136 124	11.3.0	Published	17.08.2022	<a href="https://www.etsi.org/deliver/etsi_ts/136100_136199/136124/11.03.00_60/ts_136124v110300p.pdf">https://www.etsi.org/deliver/etsi_ts/136100_136199/136124/11.03.00_60/ts_136124v110300p.pdf</a>
TSDSI	TSDSI STD T1.3GPP 36.124 11.3.0 V1.1.0	11.3.0	Published	30.08.2021	<a href="https://members.tdsi.in/s/kX9R4WW3Rv8BX5D">https://members.tdsi.in/s/kX9R4WW3Rv8BX5D</a>
TTA	TTAT.3G-36.124V11.3.0	11.3.0	Published	21.10.2022	<a href="http://committee.tta.or.kr/data/ttasDown.jsp?kind=ttastd&amp;pk_num=TTAT.3G-36.124V11.3.0">http://committee.tta.or.kr/data/ttasDown.jsp?kind=ttastd&amp;pk_num=TTAT.3G-36.124V11.3.0</a>

### Release 12

ARIB	ARIB STD-T120-36.124.V12.2.0	12.2.0	Published	03.03.2023	<a href="https://www.arib.or.jp/english/html/overview/doc/T120_T23_SPECS/ARIB-STD-T120/Rel12/36/A36124-c20.pdf">https://www.arib.or.jp/english/html/overview/doc/T120_T23_SPECS/ARIB-STD-T120/Rel12/36/A36124-c20.pdf</a>
ATIS	ATIS.3GPP.36.124.V12.2.0	12.2.0	Published	21.02.2023	<a href="https://www.atis.org/3gpp-transpositions - Rel-12">https://www.atis.org/3gpp-transpositions - Rel-12</a>
CCSA	CCSA.36.124V1220	12.2.0	Published	01.06.2022	<a href="https://www.ccsa.org.cn/api/portalsFile/downloadOldFile?type=19&amp;oldFileUrl=ITU-R/M.2012-6/CCSA.36.124V1220.doc">https://www.ccsa.org.cn/api/portalsFile/downloadOldFile?type=19&amp;oldFileUrl=ITU-R/M.2012-6/CCSA.36.124V1220.doc</a>

ETSI	ETSI TS 136 124	12.2.0	Published	17.08.2022	<a href="https://www.etsi.org/deliver/etsi_ts/136100_136199/136124/12.02.00_60/ts_136124v120200p.pdf">https://www.etsi.org/deliver/etsi_ts/136100_136199/136124/12.02.00_60/ts_136124v120200p.pdf</a>
TSDSI	TSDSI STD T1.3GPP 36.124 12.2.0 V1.1.0	12.2.0	Published	02.05.2023	<a href="https://members.tdsi.in/s/NEqitg3o8J9BgGS">https://members.tdsi.in/s/NEqitg3o8J9BgGS</a>
TTA	TTAT.3G-36.124V12.2.0	12.2.0	Published	21.10.2022	<a href="http://committee.tta.or.kr/data/ttasDown.jsp?kind=ttastd&amp;pk_num=TTAT.3G-36.124V12.2.0">http://committee.tta.or.kr/data/ttasDown.jsp?kind=ttastd&amp;pk_num=TTAT.3G-36.124V12.2.0</a>
<b>Release 13</b>					
ARIB	ARIB STD-T120-36.124.V13.2.0	13.2.0	Published	03.03.2023	<a href="https://www.arib.or.jp/english/html/overview/doc/T120_T23_SPECS/ARIB-STD-T120/Rel13/36/A36124-d20.pdf">https://www.arib.or.jp/english/html/overview/doc/T120_T23_SPECS/ARIB-STD-T120/Rel13/36/A36124-d20.pdf</a>
ATIS	ATIS.3GPP.36.124.V13.2.0	13.2.0	Published	21.02.2023	<a href="https://www.atis.org/3gpp-transpositions - Rel-13">https://www.atis.org/3gpp-transpositions - Rel-13</a>
CCSA	CCSA.36.124V1320	13.2.0	Published	01.06.2022	<a href="https://www.ccsa.org.cn/api/portalsFile/downloadOldFile?type=19&amp;oldFileUrl=ITU-R/M.2012-6/CCSA.36.124V1320.doc">https://www.ccsa.org.cn/api/portalsFile/downloadOldFile?type=19&amp;oldFileUrl=ITU-R/M.2012-6/CCSA.36.124V1320.doc</a>
ETSI	ETSI TS 136 124	13.2.0	Published	21.07.2022	<a href="https://www.etsi.org/deliver/etsi_ts/136100_136199/136124/13.02.00_60/ts_136124v130200p.pdf">https://www.etsi.org/deliver/etsi_ts/136100_136199/136124/13.02.00_60/ts_136124v130200p.pdf</a>
TSDSI	TSDSI STD T1.3GPP 36.124-13.2.0 V1.1.0	13.2.0	Published	17.01.2023	<a href="https://members.tdsi.in/s/QyNLo4mibmZ89HY">https://members.tdsi.in/s/QyNLo4mibmZ89HY</a>
TTA	TTAT.3G-36.124V13.2.0	13.2.0	Published	21.10.2022	<a href="http://committee.tta.or.kr/data/ttasDown.jsp?kind=ttastd&amp;pk_num=TTAT.3G-36.124V13.2.0">http://committee.tta.or.kr/data/ttasDown.jsp?kind=ttastd&amp;pk_num=TTAT.3G-36.124V13.2.0</a>
<b>Release 14</b>					
ARIB	ARIB STD-T120-36.124.V14.2.0	14.2.0	Published	03.03.2023	<a href="https://www.arib.or.jp/english/html/overview/doc/T120_T23_SPECS/ARIB-STD-T120/Rel14/36/A36124-e20.pdf">https://www.arib.or.jp/english/html/overview/doc/T120_T23_SPECS/ARIB-STD-T120/Rel14/36/A36124-e20.pdf</a>
ATIS	ATIS.3GPP.36.124.V14.2.0	14.2.0	Published	21.02.2023	<a href="https://www.atis.org/3gpp-transpositions - Rel-14">https://www.atis.org/3gpp-transpositions - Rel-14</a>
CCSA	CCSA.36.124V1420	14.2.0	Published	01.06.2022	<a href="https://www.ccsa.org.cn/api/portalsFile/downloadOldFile?type=19&amp;oldFileUrl=ITU-R/M.2012-6/CCSA.36.124V1420.doc">https://www.ccsa.org.cn/api/portalsFile/downloadOldFile?type=19&amp;oldFileUrl=ITU-R/M.2012-6/CCSA.36.124V1420.doc</a>
ETSI	ETSI TS 136 124	14.2.0	Published	21.07.2022	<a href="https://www.etsi.org/deliver/etsi_ts/136100_136199/136124/14.02.00_60/ts_136124v140200p.pdf">https://www.etsi.org/deliver/etsi_ts/136100_136199/136124/14.02.00_60/ts_136124v140200p.pdf</a>
TSDSI	TSDSI STD T1.3GPP 36.124-14.2.0 V1.1.0	14.2.0	Published	17.01.2023	<a href="https://members.tdsi.in/s/RganwoW4sCXXbMR">https://members.tdsi.in/s/RganwoW4sCXXbMR</a>
TTA	TTAT.3G-36.124V14.2.0	14.2.0	Published	21.10.2022	<a href="http://committee.tta.or.kr/data/ttasDown.jsp?kind=ttastd&amp;pk_num=TTAT.3G-36.124V14.2.0">http://committee.tta.or.kr/data/ttasDown.jsp?kind=ttastd&amp;pk_num=TTAT.3G-36.124V14.2.0</a>
<b>Release 15</b>					
ARIB	ARIB STD-T120-36.124.V15.4.0	15.4.0	Published	03.03.2023	<a href="https://www.arib.or.jp/english/html/overview/doc/T120_T23_SPECS/ARIB-STD-T120/Rel15/36/A36124-f40.pdf">https://www.arib.or.jp/english/html/overview/doc/T120_T23_SPECS/ARIB-STD-T120/Rel15/36/A36124-f40.pdf</a>
ATIS	ATIS.3GPP.36.124.V15.4.0	15.4.0	Published	21.02.2023	<a href="https://www.atis.org/3gpp-transpositions - Rel-15">https://www.atis.org/3gpp-transpositions - Rel-15</a>
CCSA	CCSA.36.124V1540	15.4.0	Published	01.06.2022	<a href="https://www.ccsa.org.cn/api/portalsFile/downloadOldFile?type=19&amp;oldFileUrl=ITU-R/M.2012-6/CCSA.36.124V1540.doc">https://www.ccsa.org.cn/api/portalsFile/downloadOldFile?type=19&amp;oldFileUrl=ITU-R/M.2012-6/CCSA.36.124V1540.doc</a>
ETSI	ETSI TS 136 124	15.4.0	Published	21.07.2022	<a href="https://www.etsi.org/deliver/etsi_ts/136100_136199/136124/15.04.00_60/ts_136124v150400p.pdf">https://www.etsi.org/deliver/etsi_ts/136100_136199/136124/15.04.00_60/ts_136124v150400p.pdf</a>
TSDSI	TSDSI STD T1.3GPP 36.124-15.4.0 V1.1.0	15.4.0	Published	01.11.2022	<a href="https://members.tdsi.in/s/Bf9TxRGkWC7e59L">https://members.tdsi.in/s/Bf9TxRGkWC7e59L</a>
TTA	TTAT.3G-36.124V15.4.0	15.4.0	Published	21.10.2022	<a href="http://committee.tta.or.kr/data/ttasDown.jsp?kind=ttastd&amp;pk_num=TTAT.3G-36.124V15.4.0">http://committee.tta.or.kr/data/ttasDown.jsp?kind=ttastd&amp;pk_num=TTAT.3G-36.124V15.4.0</a>
<b>Release 16</b>					
ARIB	ARIB STD-T120-36.124.V16.3.0	16.3.0	Published	03.03.2023	<a href="https://www.arib.or.jp/english/html/overview/doc/T120_T23_SPECS/ARIB-STD-T120/Rel16/36/A36124-g30.pdf">https://www.arib.or.jp/english/html/overview/doc/T120_T23_SPECS/ARIB-STD-T120/Rel16/36/A36124-g30.pdf</a>
ATIS	ATIS.3GPP.36.124.V16.3.0	16.3.0	Published	21.02.2023	<a href="https://www.atis.org/3gpp-transpositions - Rel-16">https://www.atis.org/3gpp-transpositions - Rel-16</a>
CCSA	CCSA.36.124V1630	16.3.0	Published	01.06.2022	<a href="https://www.ccsa.org.cn/api/portalsFile/downloadOldFile?type=19&amp;oldFileUrl=ITU-R/M.2012-6/CCSA.36.124V1630.doc">https://www.ccsa.org.cn/api/portalsFile/downloadOldFile?type=19&amp;oldFileUrl=ITU-R/M.2012-6/CCSA.36.124V1630.doc</a>
ETSI	ETSI TS 136 124	16.3.0	Published	21.07.2022	<a href="https://www.etsi.org/deliver/etsi_ts/136100_136199/136124/16.03.00_60/ts_136124v160300p.pdf">https://www.etsi.org/deliver/etsi_ts/136100_136199/136124/16.03.00_60/ts_136124v160300p.pdf</a>
TSDSI	TSDSI STD T1.3GPP 36.124-16.3.0 V1.1.0	16.3.0	Published	01.11.2022	<a href="https://members.tdsi.in/s/3cs8M58gOtDCKzA">https://members.tdsi.in/s/3cs8M58gOtDCKzA</a>
TTA	TTAT.3G-36.124V16.3.0	16.3.0	Published	21.10.2022	<a href="http://committee.tta.or.kr/data/ttasDown.jsp?kind=ttastd&amp;pk_num=TTAT.3G-36.124V16.3.0">http://committee.tta.or.kr/data/ttasDown.jsp?kind=ttastd&amp;pk_num=TTAT.3G-36.124V16.3.0</a>
<b>Release 17</b>					
ARIB	ARIB STD-T120-36.124.V17.1.0	17.1.0	Published	03.03.2023	<a href="https://www.arib.or.jp/english/html/overview/doc/T120_T23_SPECS/ARIB-STD-T120/Rel17/36/A36124-h10.pdf">https://www.arib.or.jp/english/html/overview/doc/T120_T23_SPECS/ARIB-STD-T120/Rel17/36/A36124-h10.pdf</a>
ATIS	ATIS.3GPP.36.124.V17.1.0	17.1.0	Published	21.02.2023	<a href="https://www.atis.org/3gpp-transpositions - Rel-17">https://www.atis.org/3gpp-transpositions - Rel-17</a>
CCSA	CCSA.36.124V1710	17.1.0	Published	01.06.2022	<a href="https://www.ccsa.org.cn/api/portalsFile/downloadOldFile?type=19&amp;oldFileUrl=ITU-R/M.2012-6/CCSA.36.124V1710.doc">https://www.ccsa.org.cn/api/portalsFile/downloadOldFile?type=19&amp;oldFileUrl=ITU-R/M.2012-6/CCSA.36.124V1710.doc</a>
ETSI	ETSI TS 136 124	17.1.0	Published	21.07.2022	<a href="https://www.etsi.org/deliver/etsi_ts/136100_136199/136124/17.01.00_60/ts_136124v170100p.pdf">https://www.etsi.org/deliver/etsi_ts/136100_136199/136124/17.01.00_60/ts_136124v170100p.pdf</a>
TSDSI	TSDSI STD T1.3GPP 36.124-17.1.0 V1.1.0	17.1.0	Published	01.11.2022	<a href="https://members.tdsi.in/index.php/s/YBQwC86xMdbFgk4">https://members.tdsi.in/index.php/s/YBQwC86xMdbFgk4</a>
TTA	TTAT.3G-36.124V17.1.0	17.1.0	Published	21.10.2022	<a href="http://committee.tta.or.kr/data/ttasDown.jsp?kind=ttastd&amp;pk_num=TTAT.3G-36.124V17.1.0">http://committee.tta.or.kr/data/ttasDown.jsp?kind=ttastd&amp;pk_num=TTAT.3G-36.124V17.1.0</a>

### 2.1.5.10 TS 36.133

#### Evolved Universal Terrestrial Radio Access (E-UTRA); Requirements for support of radio resource management

This document specifies requirements for support of Radio Resource Management for the FDD and TDD modes of E-UTRA. These requirements include requirements on measurements in UTRAN and the UE as well as requirements on node dynamical behaviour and interaction, in terms of delay and response characteristics.

SDO	Document No.	Version	Status	Issued date	Location
<b>Release 10</b>					
ARIB	ARIB STD-T120-36.133.V10.22.0	10.22.0	Published	03.03.2023	<a href="https://www.arib.or.jp/english/html/overview/doc/T120_T23_SPECS/ARIB-STD-T120/Rel10/36/A36133-am0.pdf">https://www.arib.or.jp/english/html/overview/doc/T120_T23_SPECS/ARIB-STD-T120/Rel10/36/A36133-am0.pdf</a>
ATIS	ATIS.3GPP.36.133V10220	10.22.0	Published	28.06.2021	<a href="https://www.atis.org/3gpp-documents/Rel99-14/">https://www.atis.org/3gpp-documents/Rel99-14/</a>
CCSA	CCSA.36.133V10220	10.22.0	Published	01.09.2016	<a href="https://www.ccsa.org.cn/api/portalsFile/downloadOldFile?type=19&amp;oldFileUrl=ITU-R/M.2012-6/CCSA.36.133V10220.rar">https://www.ccsa.org.cn/api/portalsFile/downloadOldFile?type=19&amp;oldFileUrl=ITU-R/M.2012-6/CCSA.36.133V10220.rar</a>
ETSI	ETSI TS 136 133	10.22.0	Published	19.12.2016	<a href="https://www.etsi.org/deliver/etsi_ts/136100_136199/136133/10.22.00_60/ts_136133v102200p.pdf">https://www.etsi.org/deliver/etsi_ts/136100_136199/136133/10.22.00_60/ts_136133v102200p.pdf</a>
TSDSI	TSDSI STD T1.3GPP 36.133-10.22.0 V1.0.0	10.22.0	Published	30.08.2021	<a href="https://members.tdsi.in/index.php/s/bJiHbyZAeDt92do">https://members.tdsi.in/index.php/s/bJiHbyZAeDt92do</a>
TTA	TTAT.3G-36.133V10.22.0	10.22.0	Published	30.07.2021	<a href="http://committee.tta.or.kr/data/ttasDown.jsp?kind=ttastd&amp;pk_num=TTAT.3G-36.133V10.22.0">http://committee.tta.or.kr/data/ttasDown.jsp?kind=ttastd&amp;pk_num=TTAT.3G-36.133V10.22.0</a>
<b>Release 11</b>					
ARIB	ARIB STD-T120-36.133.V11.18.0	11.18.0	Published	03.03.2023	<a href="https://www.arib.or.jp/english/html/overview/doc/T120_T23_SPECS/ARIB-STD-T120/Rel11/36/A36133-bi0.pdf">https://www.arib.or.jp/english/html/overview/doc/T120_T23_SPECS/ARIB-STD-T120/Rel11/36/A36133-bi0.pdf</a>
ATIS	ATIS.3GPP.36.133V11180	11.18.0	Published	28.06.2021	<a href="https://www.atis.org/3gpp-documents/Rel99-14/">https://www.atis.org/3gpp-documents/Rel99-14/</a>
CCSA	CCSA.36.133V11180	11.18.0	Published	01.09.2016	<a href="https://www.ccsa.org.cn/api/portalsFile/downloadOldFile?type=19&amp;oldFileUrl=ITU-R/M.2012-6/CCSA.36.133V11180.rar">https://www.ccsa.org.cn/api/portalsFile/downloadOldFile?type=19&amp;oldFileUrl=ITU-R/M.2012-6/CCSA.36.133V11180.rar</a>
ETSI	ETSI TS 136 133	11.18.0	Published	19.12.2016	<a href="https://www.etsi.org/deliver/etsi_ts/136100_136199/136133/11.18.00_60/ts_136133v111800p.pdf">https://www.etsi.org/deliver/etsi_ts/136100_136199/136133/11.18.00_60/ts_136133v111800p.pdf</a>
TSDSI	TSDSI STD T1.3GPP 36.133-11.18.0 V1.0.0	11.18.0	Published	30.08.2021	<a href="https://members.tdsi.in/index.php/s/BiAELDdQKocsjBX">https://members.tdsi.in/index.php/s/BiAELDdQKocsjBX</a>
TTA	TTAT.3G-36.133V11.18.0	11.18.0	Published	30.07.2021	<a href="http://committee.tta.or.kr/data/ttasDown.jsp?kind=ttastd&amp;pk_num=TTAT.3G-36.133V11.18.0">http://committee.tta.or.kr/data/ttasDown.jsp?kind=ttastd&amp;pk_num=TTAT.3G-36.133V11.18.0</a>
<b>Release 12</b>					
ARIB	ARIB STD-T120-36.133.V12.20.0	12.20.0	Published	03.03.2023	<a href="https://www.arib.or.jp/english/html/overview/doc/T120_T23_SPECS/ARIB-STD-T120/Rel12/36/A36133-ck0.pdf">https://www.arib.or.jp/english/html/overview/doc/T120_T23_SPECS/ARIB-STD-T120/Rel12/36/A36133-ck0.pdf</a>
ATIS	ATIS.3GPP.36.133V12200	12.20.0	Published	28.06.2021	<a href="https://www.atis.org/3gpp-documents/Rel99-14/">https://www.atis.org/3gpp-documents/Rel99-14/</a>
CCSA	CCSA.36.133V12200	12.20.0	Published	01.03.2019	<a href="https://www.ccsa.org.cn/api/portalsFile/downloadOldFile?type=19&amp;oldFileUrl=ITU-R/M.2012-6/CCSA.36.133V12200.rar">https://www.ccsa.org.cn/api/portalsFile/downloadOldFile?type=19&amp;oldFileUrl=ITU-R/M.2012-6/CCSA.36.133V12200.rar</a>
ETSI	ETSI TS 136 133	12.20.0	Published	19.07.2019	<a href="https://www.etsi.org/deliver/etsi_ts/136100_136199/136133/12.20.00_60/ts_136133v122000p.pdf">https://www.etsi.org/deliver/etsi_ts/136100_136199/136133/12.20.00_60/ts_136133v122000p.pdf</a>
TSDSI	TSDSI STD T1.3GPP 36.133-12.20.0 V1.1.0	12.20.0	Published	30.08.2021	<a href="https://members.tdsi.in/index.php/s/BiAELDdQKocsjBX">https://members.tdsi.in/index.php/s/BiAELDdQKocsjBX</a>
TTA	TTAT.3G-36.133V12.20.0	12.20.0	Published	30.07.2021	<a href="http://committee.tta.or.kr/data/ttasDown.jsp?kind=ttastd&amp;pk_num=TTAT.3G-36.133V12.20.0">http://committee.tta.or.kr/data/ttasDown.jsp?kind=ttastd&amp;pk_num=TTAT.3G-36.133V12.20.0</a>
<b>Release 13</b>					
ARIB	ARIB STD-T120-36.133.V13.23.0	13.23.0	Published	03.03.2023	<a href="https://www.arib.or.jp/english/html/overview/doc/T120_T23_SPECS/ARIB-STD-T120/Rel13/36/A36133-dn0.pdf">https://www.arib.or.jp/english/html/overview/doc/T120_T23_SPECS/ARIB-STD-T120/Rel13/36/A36133-dn0.pdf</a>
ATIS	ATIS.3GPP.36.133.V13.23.0	13.23.0	Published	21.02.2023	<a href="https://www.atis.org/3gpp-transpositions - Rel-13">https://www.atis.org/3gpp-transpositions - Rel-13</a>
CCSA	CCSA.36.133V13230	13.23.0	Published	01.09.2022	<a href="https://www.ccsa.org.cn/api/portalsFile/downloadOldFile?type=19&amp;oldFileUrl=ITU-R/M.2012-6/CCSA.36.133V13230.rar">https://www.ccsa.org.cn/api/portalsFile/downloadOldFile?type=19&amp;oldFileUrl=ITU-R/M.2012-6/CCSA.36.133V13230.rar</a>
ETSI	ETSI TS 136 133	13.23.0	Published	13.01.2023	<a href="https://www.etsi.org/deliver/etsi_ts/136100_136199/136133/13.23.00_60/ts_136133v132300p.pdf">https://www.etsi.org/deliver/etsi_ts/136100_136199/136133/13.23.00_60/ts_136133v132300p.pdf</a>
TSDSI	TSDSI STD T1.3GPP 36.133-13.23.0 V1.1.0	13.23.0	Published	17.01.2023	<a href="https://members.tdsi.in/s/AGP3QCbfQSZo75g">https://members.tdsi.in/s/AGP3QCbfQSZo75g</a>
TTA	TTAT.3G-36.133V13.23.0	13.23.0	Published	11.01.2023	<a href="http://committee.tta.or.kr/data/ttasDown.jsp?kind=ttastd&amp;pk_num=TTAT.3G-36.133V13.23.0">http://committee.tta.or.kr/data/ttasDown.jsp?kind=ttastd&amp;pk_num=TTAT.3G-36.133V13.23.0</a>
<b>Release 14</b>					
ARIB	ARIB STD-T120-36.133.V14.23.0	14.23.0	Published	03.03.2023	<a href="https://www.arib.or.jp/english/html/overview/doc/T120_T23_SPECS/ARIB-STD-T120/Rel14/36/A36133-en0.pdf">https://www.arib.or.jp/english/html/overview/doc/T120_T23_SPECS/ARIB-STD-T120/Rel14/36/A36133-en0.pdf</a>
ATIS	ATIS.3GPP.36.133.V14.23.0	14.23.0	Published	21.02.2023	<a href="https://www.atis.org/3gpp-transpositions - Rel-14">https://www.atis.org/3gpp-transpositions - Rel-14</a>
CCSA	CCSA.36.133V14230	14.23.0	Published	01.09.2022	<a href="https://www.ccsa.org.cn/api/portalsFile/downloadOldFile?type=19&amp;oldFileUrl=ITU-R/M.2012-6/CCSA.36.133V14230.rar">https://www.ccsa.org.cn/api/portalsFile/downloadOldFile?type=19&amp;oldFileUrl=ITU-R/M.2012-6/CCSA.36.133V14230.rar</a>
ETSI	ETSI TS 136 133	14.23.0	Published	18.01.2023	<a href="https://www.etsi.org/deliver/etsi_ts/136100_136199/136133/14.23.00_60/ts_136133v142300p.pdf">https://www.etsi.org/deliver/etsi_ts/136100_136199/136133/14.23.00_60/ts_136133v142300p.pdf</a>
TSDSI	TSDSI STD T1.3GPP 36.133-14.23.0 V1.1.0	14.23.0	Published	17.01.2023	<a href="https://members.tdsi.in/s/gPJCRyPPaOOyHtX">https://members.tdsi.in/s/gPJCRyPPaOOyHtX</a>
TTA	TTAT.3G-36.133V14.23.0	14.23.0	Published	11.01.2023	<a href="http://committee.tta.or.kr/data/ttasDown.jsp?kind=ttastd&amp;pk_num=TTAT.3G-36.133V14.23.0">http://committee.tta.or.kr/data/ttasDown.jsp?kind=ttastd&amp;pk_num=TTAT.3G-36.133V14.23.0</a>
<b>Release 15</b>					
ARIB	ARIB STD-T120-36.133.V15.18.0	15.18.0	Published	03.03.2023	<a href="https://www.arib.or.jp/english/html/overview/doc/T120_T23_SPECS/ARIB-STD-T120/Rel15/36/A36133-fi0.pdf">https://www.arib.or.jp/english/html/overview/doc/T120_T23_SPECS/ARIB-STD-T120/Rel15/36/A36133-fi0.pdf</a>
ATIS	ATIS.3GPP.36.133.V15.18.0	15.18.0	Published	21.02.2023	<a href="https://www.atis.org/3gpp-transpositions - Rel-15">https://www.atis.org/3gpp-transpositions - Rel-15</a>
CCSA	CCSA.36.133V15180	15.18.0	Published	01.09.2022	<a href="https://www.ccsa.org.cn/api/portalsFile/downloadOldFile?type=19&amp;oldFileUrl=ITU-R/M.2012-6/CCSA.36.133V15180.rar">https://www.ccsa.org.cn/api/portalsFile/downloadOldFile?type=19&amp;oldFileUrl=ITU-R/M.2012-6/CCSA.36.133V15180.rar</a>
ETSI	ETSI TS 136 133	15.18.0	Published	18.01.2023	<a href="https://www.etsi.org/deliver/etsi_ts/136100_136199/136133/15.18.00_60/ts_136133v151800p.pdf">https://www.etsi.org/deliver/etsi_ts/136100_136199/136133/15.18.00_60/ts_136133v151800p.pdf</a>
TSDSI	TSDSI STD T1.3GPP 36.133-15.18.0 V1.2.0	15.18.0	Published	17.01.2023	<a href="https://members.tdsi.in/s/8mRszCpdNq7t7qW">https://members.tdsi.in/s/8mRszCpdNq7t7qW</a>
TTA	TTAT.3G-36.133V15.18.0	15.18.0	Published	11.01.2023	<a href="http://committee.tta.or.kr/data/ttasDown.jsp?kind=ttastd&amp;pk_num=TTAT.3G-36.133V15.18.0">http://committee.tta.or.kr/data/ttasDown.jsp?kind=ttastd&amp;pk_num=TTAT.3G-36.133V15.18.0</a>
<b>Release 16</b>					
ARIB	ARIB STD-T120-36.133.V16.15.0	16.15.0	Published	03.03.2023	<a href="https://www.arib.or.jp/english/html/overview/doc/T120_T23_SPECS/ARIB-STD-T120/Rel16/36/A36133-gf0.pdf">https://www.arib.or.jp/english/html/overview/doc/T120_T23_SPECS/ARIB-STD-T120/Rel16/36/A36133-gf0.pdf</a>
ATIS	ATIS.3GPP.36.133.V16.15.0	16.15.0	Published	21.02.2023	<a href="https://www.atis.org/3gpp-transpositions - Rel-16">https://www.atis.org/3gpp-transpositions - Rel-16</a>

CCSA	CCSA.36.133V16150	16.15.0	Published	01.09.2022	<a href="https://www.ccsa.org.cn/api/portalsFile/downloadOldFile?type=19&amp;oldFileUrl=ITU-R/M.2012-6/CCSA.36.133V16150.rar">https://www.ccsa.org.cn/api/portalsFile/downloadOldFile?type=19&amp;oldFileUrl=ITU-R/M.2012-6/CCSA.36.133V16150.rar</a>
ETSI	ETSI TS 136 133	16.15.0	Published	19.01.2023	<a href="https://www.etsi.org/deliver/etsi_ts/136100_136199/136133/16.15.00_60/ts_136133v161500p.pdf">https://www.etsi.org/deliver/etsi_ts/136100_136199/136133/16.15.00_60/ts_136133v161500p.pdf</a>
TSDSI	TSDSI STD T1.3GPP 36.133-16.15.0 V1.2.0	16.15.0	Published	17.01.2023	<a href="https://members.tdsi.in/s/5YkMkp8w34NRc8B">https://members.tdsi.in/s/5YkMkp8w34NRc8B</a>
TTA	TTAT.3G-36.133V16.15.0	16.15.0	Published	11.01.2023	<a href="http://committee.tta.or.kr/data/ttasDown.jsp?kind=ttastd&amp;pk_num=TTAT.3G-36.133V16.15.0">http://committee.tta.or.kr/data/ttasDown.jsp?kind=ttastd&amp;pk_num=TTAT.3G-36.133V16.15.0</a>

**Release 17**

ARIB	ARIB STD-T120-36.133.V17.8.0	17.8.0	Published	03.03.2023	<a href="https://www.arib.or.jp/english/html/overview/doc/T120_T23_SPECS/ARIB-STD-T120/Rel17/36/A36133-h80.pdf">https://www.arib.or.jp/english/html/overview/doc/T120_T23_SPECS/ARIB-STD-T120/Rel17/36/A36133-h80.pdf</a>
ATIS	ATIS.3GPP.36.133.V17.8.0	17.8.0	Published	21.02.2023	<a href="https://www.atis.org/3gpp-transpositions - Rel-17">https://www.atis.org/3gpp-transpositions - Rel-17</a>
CCSA	CCSA.36.133V1780	17.8.0	Published	01.12.2022	<a href="https://www.ccsa.org.cn/api/portalsFile/downloadOldFile?type=19&amp;oldFileUrl=ITU-R/M.2012-6/CCSA.36.133V1780.rar">https://www.ccsa.org.cn/api/portalsFile/downloadOldFile?type=19&amp;oldFileUrl=ITU-R/M.2012-6/CCSA.36.133V1780.rar</a>
ETSI	ETSI TS 136 133	17.8.0	Published	23.01.2023	<a href="https://www.etsi.org/deliver/etsi_ts/136100_136199/136133/17.08.00_60/ts_136133v170800p.pdf">https://www.etsi.org/deliver/etsi_ts/136100_136199/136133/17.08.00_60/ts_136133v170800p.pdf</a>
TSDSI	TSDSI STD T1.3GPP 36.141 17.8.0 V1.2.0	17.8.0	Published	02.05.2023	<a href="https://members.tdsi.in/s/EmSd2mo9tw93g3Y">https://members.tdsi.in/s/EmSd2mo9tw93g3Y</a>
TTA	TTAT.3G-36.133V17.8.0	17.8.0	Published	16.03.2023	<a href="http://committee.tta.or.kr/data/ttasDown.jsp?kind=ttastd&amp;pk_num=TTAT.3G-36.133V17.8.0">http://committee.tta.or.kr/data/ttasDown.jsp?kind=ttastd&amp;pk_num=TTAT.3G-36.133V17.8.0</a>

**2.1.5.11 TS 36.141****Evolved Universal Terrestrial Radio Access (E-UTRA); Base Station (BS) conformance testing**

This document specifies the Radio Frequency (RF) test methods and conformance requirements for E-UTRA Base Stations (BS) operating either in the FDD mode (used in paired bands) or the TDD mode (used in unpaired bands). These have been derived from and are consistent with the E-UTRA Base Station (BS) specifications defined in TS 36 104.

SDO	Document No.	Version	Status	Issued date	Location
<b>Release 10</b>					
ARIB	ARIB STD-T120-36.141.V10.15.0	10.15.0	Published	03.03.2023	<a href="https://www.arib.or.jp/english/html/overview/doc/T120_T23_SPECS/ARIB-STD-T120/Rel10/36/A36141-af0.pdf">https://www.arib.or.jp/english/html/overview/doc/T120_T23_SPECS/ARIB-STD-T120/Rel10/36/A36141-af0.pdf</a>
ATIS	ATIS.3GPP.36.141.V10.15.0	10.15.0	Published	21.02.2023	<a href="https://www.atis.org/3gpp-transpositions - Rel-10">https://www.atis.org/3gpp-transpositions - Rel-10</a>
CCSA	CCSA.36.141V10150	10.15.0	Published	01.03.2021	<a href="https://www.ccsa.org.cn/api/portalsFile/downloadOldFile?type=19&amp;oldFileUrl=ITU-R/M.2012-6/CCSA.36.141V10150.doc">https://www.ccsa.org.cn/api/portalsFile/downloadOldFile?type=19&amp;oldFileUrl=ITU-R/M.2012-6/CCSA.36.141V10150.doc</a>
ETSI	ETSI TS 136 141	10.15.0	Published	30.04.2021	<a href="https://www.etsi.org/deliver/etsi_ts/136100_136199/136141/10.15.00_60/ts_136141v101500p.pdf">https://www.etsi.org/deliver/etsi_ts/136100_136199/136141/10.15.00_60/ts_136141v101500p.pdf</a>
TSDSI	TSDSI STD T1.3GPP 36.141 10.15.0 V1.1.0	10.15.0	Published	02.05.2023	<a href="https://members.tdsi.in/s/tknoAsZSjweNXpf">https://members.tdsi.in/s/tknoAsZSjweNXpf</a>
TTA	TTAT.3G-36.141V10.15.0	10.15.0	Published	10.06.2021	<a href="http://committee.tta.or.kr/data/ttasDown.jsp?kind=ttastd&amp;pk_num=TTAT.3G-36.141V10.15.0">http://committee.tta.or.kr/data/ttasDown.jsp?kind=ttastd&amp;pk_num=TTAT.3G-36.141V10.15.0</a>
<b>Release 11</b>					
ARIB	ARIB STD-T120-36.141.V11.18.0	11.18.0	Published	03.03.2023	<a href="https://www.arib.or.jp/english/html/overview/doc/T120_T23_SPECS/ARIB-STD-T120/Rel11/36/A36141-bi0.pdf">https://www.arib.or.jp/english/html/overview/doc/T120_T23_SPECS/ARIB-STD-T120/Rel11/36/A36141-bi0.pdf</a>
ATIS	ATIS.3GPP.36.141.V11.18.0	11.18.0	Published	21.02.2023	<a href="https://www.atis.org/3gpp-transpositions - Rel-11">https://www.atis.org/3gpp-transpositions - Rel-11</a>
CCSA	CCSA.36.141V11180	11.18.0	Published	01.03.2021	<a href="https://www.ccsa.org.cn/api/portalsFile/downloadOldFile?type=19&amp;oldFileUrl=ITU-R/M.2012-6/CCSA.36.141V11180.doc">https://www.ccsa.org.cn/api/portalsFile/downloadOldFile?type=19&amp;oldFileUrl=ITU-R/M.2012-6/CCSA.36.141V11180.doc</a>
ETSI	ETSI TS 136 141	11.18.0	Published	30.04.2021	<a href="https://www.etsi.org/deliver/etsi_ts/136100_136199/136141/11.18.00_60/ts_136141v111800p.pdf">https://www.etsi.org/deliver/etsi_ts/136100_136199/136141/11.18.00_60/ts_136141v111800p.pdf</a>
TSDSI	TSDSI STD T1.3GPP 36.141 11.18.0 V1.1.0	11.18.0	Published	30.08.2021	<a href="https://members.tdsi.in/s/DpBqf9MfSQoeK2J">https://members.tdsi.in/s/DpBqf9MfSQoeK2J</a>
TTA	TTAT.3G-36.141V11.18.0	11.18.0	Published	10.06.2021	<a href="http://committee.tta.or.kr/data/ttasDown.jsp?kind=ttastd&amp;pk_num=TTAT.3G-36.141V11.18.0">http://committee.tta.or.kr/data/ttasDown.jsp?kind=ttastd&amp;pk_num=TTAT.3G-36.141V11.18.0</a>
<b>Release 12</b>					
ARIB	ARIB STD-T120-36.141.V12.15.0	12.15.0	Published	03.03.2023	<a href="https://www.arib.or.jp/english/html/overview/doc/T120_T23_SPECS/ARIB-STD-T120/Rel12/36/A36141-cf0.pdf">https://www.arib.or.jp/english/html/overview/doc/T120_T23_SPECS/ARIB-STD-T120/Rel12/36/A36141-cf0.pdf</a>
ATIS	ATIS.3GPP.36.141.V12.15.0	12.15.0	Published	21.02.2023	<a href="https://www.atis.org/3gpp-transpositions - Rel-12">https://www.atis.org/3gpp-transpositions - Rel-12</a>
CCSA	CCSA.36.141V12150	12.15.0	Published	01.03.2021	<a href="https://www.ccsa.org.cn/api/portalsFile/downloadOldFile?type=19&amp;oldFileUrl=ITU-R/M.2012-6/CCSA.36.141V12150.doc">https://www.ccsa.org.cn/api/portalsFile/downloadOldFile?type=19&amp;oldFileUrl=ITU-R/M.2012-6/CCSA.36.141V12150.doc</a>
ETSI	ETSI TS 136 141	12.15.0	Published	30.04.2021	<a href="https://www.etsi.org/deliver/etsi_ts/136100_136199/136141/12.15.00_60/ts_136141v121500p.pdf">https://www.etsi.org/deliver/etsi_ts/136100_136199/136141/12.15.00_60/ts_136141v121500p.pdf</a>
TSDSI	TSDSI STD T1.3GPP 36.141 12.15.0 V1.1.0	12.15.0	Published	02.05.2023	<a href="https://members.tdsi.in/s/ytWf3wxn3eLnNat">https://members.tdsi.in/s/ytWf3wxn3eLnNat</a>
TTA	TTAT.3G-36.141V12.15.0	12.15.0	Published	10.06.2021	<a href="http://committee.tta.or.kr/data/ttasDown.jsp?kind=ttastd&amp;pk_num=TTAT.3G-36.141V12.15.0">http://committee.tta.or.kr/data/ttasDown.jsp?kind=ttastd&amp;pk_num=TTAT.3G-36.141V12.15.0</a>
<b>Release 13</b>					
ARIB	ARIB STD-T120-36.141.V13.16.0	13.16.0	Published	03.03.2023	<a href="https://www.arib.or.jp/english/html/overview/doc/T120_T23_SPECS/ARIB-STD-T120/Rel13/36/A36141-dg0.pdf">https://www.arib.or.jp/english/html/overview/doc/T120_T23_SPECS/ARIB-STD-T120/Rel13/36/A36141-dg0.pdf</a>
ATIS	ATIS.3GPP.36.141.V13.16.0	13.16.0	Published	21.02.2023	<a href="https://www.atis.org/3gpp-transpositions - Rel-13">https://www.atis.org/3gpp-transpositions - Rel-13</a>
CCSA	CCSA.36.141V13160	13.16.0	Published	01.03.2021	<a href="https://www.ccsa.org.cn/api/portalsFile/downloadOldFile?type=19&amp;oldFileUrl=ITU-R/M.2012-6/CCSA.36.141V13160.doc">https://www.ccsa.org.cn/api/portalsFile/downloadOldFile?type=19&amp;oldFileUrl=ITU-R/M.2012-6/CCSA.36.141V13160.doc</a>

## 116

ETSI	ETSI TS 136 141	13.16.0	Published	30.04.2021	<a href="https://www.etsi.org/deliver/etsi_ts/136100_136199/136141/13.16.00_60/ts_136141v131600p.pdf">https://www.etsi.org/deliver/etsi_ts/136100_136199/136141/13.16.00_60/ts_136141v131600p.pdf</a>
TSDSI	TSDSI STD T1.3GPP 36.141-13.16.0 V1.1.0	13.16.0	Published	17.01.2023	<a href="https://members.tdsi.in/s/xkZKDtP56spgMKK">https://members.tdsi.in/s/xkZKDtP56spgMKK</a>
TTA	TTAT.3G-36.141V13.16.0	13.16.0	Published	10.06.2021	<a href="http://committee.tta.or.kr/data/ttasDown.jsp?kind=ttastd&amp;pk_num=TTAT.3G-36.141V13.16.0">http://committee.tta.or.kr/data/ttasDown.jsp?kind=ttastd&amp;pk_num=TTAT.3G-36.141V13.16.0</a>

### Release 14

ARIB	ARIB STD-T120-36.141.V14.14.0	14.14.0	Published	03.03.2023	<a href="https://www.arib.or.jp/english/html/overview/doc/T120_T23_SPECS/ARIB-STD-T120/Rel14/36/A36141-ee0.pdf">https://www.arib.or.jp/english/html/overview/doc/T120_T23_SPECS/ARIB-STD-T120/Rel14/36/A36141-ee0.pdf</a>
ATIS	ATIS.3GPP.36.141.V14.14.0	14.14.0	Published	21.02.2023	<a href="https://www.atis.org/3gpp-transpositions - Rel-14">https://www.atis.org/3gpp-transpositions - Rel-14</a>
CCSA	CCSA.36.141V14140	14.14.0	Published	01.12.2021	<a href="https://www.ccsa.org.cn/api/portalsFile/downloadOldFile?type=19&amp;oldFileUrl=ITU-R/M.2012-6/CCSA.36.141V14140.doc">https://www.ccsa.org.cn/api/portalsFile/downloadOldFile?type=19&amp;oldFileUrl=ITU-R/M.2012-6/CCSA.36.141V14140.doc</a>
ETSI	ETSI TS 136 141	14.14.0	Published	16.03.2022	<a href="https://www.etsi.org/deliver/etsi_ts/136100_136199/136141/14.14.00_60/ts_136141v141400p.pdf">https://www.etsi.org/deliver/etsi_ts/136100_136199/136141/14.14.00_60/ts_136141v141400p.pdf</a>
TSDSI	TSDSI STD T1.3GPP 36.141-14.14.0 V1.1.0	14.14.0	Published	17.01.2023	<a href="https://members.tdsi.in/s/DgSDR2aJ7b5Yki6">https://members.tdsi.in/s/DgSDR2aJ7b5Yki6</a>
TTA	TTAT.3G-36.141V14.14.0	14.14.0	Published	14.03.2022	<a href="http://committee.tta.or.kr/data/ttasDown.jsp?kind=ttastd&amp;pk_num=TTAT.3G-36.141V14.14.0">http://committee.tta.or.kr/data/ttasDown.jsp?kind=ttastd&amp;pk_num=TTAT.3G-36.141V14.14.0</a>

### Release 15

ARIB	ARIB STD-T120-36.141.V15.17.0	15.17.0	Published	03.03.2023	<a href="https://www.arib.or.jp/english/html/overview/doc/T120_T23_SPECS/ARIB-STD-T120/Rel15/36/A36141-fh0.pdf">https://www.arib.or.jp/english/html/overview/doc/T120_T23_SPECS/ARIB-STD-T120/Rel15/36/A36141-fh0.pdf</a>
ATIS	ATIS.3GPP.36.141.V15.17.0	15.17.0	Published	21.02.2023	<a href="https://www.atis.org/3gpp-transpositions - Rel-15">https://www.atis.org/3gpp-transpositions - Rel-15</a>
CCSA	CCSA.36.141V15170	15.17.0	Published	01.12.2022	<a href="https://www.ccsa.org.cn/api/portalsFile/downloadOldFile?type=19&amp;oldFileUrl=ITU-R/M.2012-6/CCSA.36.141V15170.doc">https://www.ccsa.org.cn/api/portalsFile/downloadOldFile?type=19&amp;oldFileUrl=ITU-R/M.2012-6/CCSA.36.141V15170.doc</a>
ETSI	ETSI TS 136 141	15.17.0	Published	19.01.2023	<a href="https://www.etsi.org/deliver/etsi_ts/136100_136199/136141/15.17.00_60/ts_136141v151700p.pdf">https://www.etsi.org/deliver/etsi_ts/136100_136199/136141/15.17.00_60/ts_136141v151700p.pdf</a>
TSDSI	TSDSI STD T1.3GPP 36.141 15.17.0 V1.2.0	15.17.0	Published	02.05.2023	<a href="https://members.tdsi.in/s/tapbNRBDBLjYiG">https://members.tdsi.in/s/tapbNRBDBLjYiG</a>
TTA	TTAT.3G-36.141V15.17.0	15.17.0	Published	16.03.2023	<a href="http://committee.tta.or.kr/data/ttasDown.jsp?kind=ttastd&amp;pk_num=TTAT.3G-36.141V15.17.0">http://committee.tta.or.kr/data/ttasDown.jsp?kind=ttastd&amp;pk_num=TTAT.3G-36.141V15.17.0</a>

### Release 16

ARIB	ARIB STD-T120-36.141.V16.15.0	16.15.0	Published	03.03.2023	<a href="https://www.arib.or.jp/english/html/overview/doc/T120_T23_SPECS/ARIB-STD-T120/Rel16/36/A36141-gf0.pdf">https://www.arib.or.jp/english/html/overview/doc/T120_T23_SPECS/ARIB-STD-T120/Rel16/36/A36141-gf0.pdf</a>
ATIS	ATIS.3GPP.36.141.V16.15.0	16.15.0	Published	21.02.2023	<a href="https://www.atis.org/3gpp-transpositions - Rel-16">https://www.atis.org/3gpp-transpositions - Rel-16</a>
CCSA	CCSA.36.141V16150	16.15.0	Published	01.12.2022	<a href="https://www.ccsa.org.cn/api/portalsFile/downloadOldFile?type=19&amp;oldFileUrl=ITU-R/M.2012-6/CCSA.36.141V16150.doc">https://www.ccsa.org.cn/api/portalsFile/downloadOldFile?type=19&amp;oldFileUrl=ITU-R/M.2012-6/CCSA.36.141V16150.doc</a>
ETSI	ETSI TS 136 141	16.15.0	Published	19.01.2023	<a href="https://www.etsi.org/deliver/etsi_ts/136100_136199/136141/16.15.00_60/ts_136141v161500p.pdf">https://www.etsi.org/deliver/etsi_ts/136100_136199/136141/16.15.00_60/ts_136141v161500p.pdf</a>
TSDSI	TSDSI STD T1.3GPP 36.141 16.15.0 V1.2.0	16.15.0	Published	02.05.2023	<a href="https://members.tdsi.in/s/sRGAZqOk8xTLex9">https://members.tdsi.in/s/sRGAZqOk8xTLex9</a>
TTA	TTAT.3G-36.141V16.15.0	16.15.0	Published	16.03.2023	<a href="http://committee.tta.or.kr/data/ttasDown.jsp?kind=ttastd&amp;pk_num=TTAT.3G-36.141V16.15.0">http://committee.tta.or.kr/data/ttasDown.jsp?kind=ttastd&amp;pk_num=TTAT.3G-36.141V16.15.0</a>

### Release 17

ARIB	ARIB STD-T120-36.141.V17.8.0	17.8.0	Published	03.03.2023	<a href="https://www.arib.or.jp/english/html/overview/doc/T120_T23_SPECS/ARIB-STD-T120/Rel17/36/A36141-h80.pdf">https://www.arib.or.jp/english/html/overview/doc/T120_T23_SPECS/ARIB-STD-T120/Rel17/36/A36141-h80.pdf</a>
ATIS	ATIS.3GPP.36.141.V17.8.0	17.8.0	Published	21.02.2023	<a href="https://www.atis.org/3gpp-transpositions - Rel-17">https://www.atis.org/3gpp-transpositions - Rel-17</a>
CCSA	CCSA.36.141V1780	17.8.0	Published	01.12.2022	<a href="https://www.ccsa.org.cn/api/portalsFile/downloadOldFile?type=19&amp;oldFileUrl=ITU-R/M.2012-6/CCSA.36.141V1780.doc">https://www.ccsa.org.cn/api/portalsFile/downloadOldFile?type=19&amp;oldFileUrl=ITU-R/M.2012-6/CCSA.36.141V1780.doc</a>
ETSI	ETSI TS 136 141	17.8.0	Published	19.01.2023	<a href="https://www.etsi.org/deliver/etsi_ts/136100_136199/136141/17.08.00_60/ts_136141v170800p.pdf">https://www.etsi.org/deliver/etsi_ts/136100_136199/136141/17.08.00_60/ts_136141v170800p.pdf</a>
TSDSI	TSDSI STD T1.3GPP 36.141 17.8.0 V1.2.0	17.8.0	Published	02.05.2023	<a href="https://members.tdsi.in/s/EmSd2mo9tw93g3Y">https://members.tdsi.in/s/EmSd2mo9tw93g3Y</a>
TTA	TTAT.3G-36.141V17.8.0	17.8.0	Published	16.03.2023	<a href="http://committee.tta.or.kr/data/ttasDown.jsp?kind=ttastd&amp;pk_num=TTAT.3G-36.141V17.8.0">http://committee.tta.or.kr/data/ttasDown.jsp?kind=ttastd&amp;pk_num=TTAT.3G-36.141V17.8.0</a>

## 2.1.5.12 TS 36.143

### Evolved Universal Terrestrial Radio Access (E-UTRA); FDD repeater conformance testing

This document specifies the Radio Frequency (RF) test methods and conformance requirements for E-UTRA FDD Repeater. These have been derived from, and are consistent with the E-UTRA FDD repeater specifications defined in TS 36.106.

SDO	Document No.	Version	Status	Issued date	Location
-----	--------------	---------	--------	-------------	----------

#### Release 10

ATIS	ATIS.3GPP.36.143V1070	10.7.0	Published	28.06.2021	<a href="https://www.atis.org/3gpp-documents/Rel99-14/">https://www.atis.org/3gpp-documents/Rel99-14/</a>
CCSA	CCSA.36.143V1070	10.7.0	Published	01.03.2013	<a href="https://www.ccsa.org.cn/api/portalsFile/downloadOldFile?type=19&amp;oldFileUrl=ITU-R/M.2012-6/CCSA.36.143V1070.doc">https://www.ccsa.org.cn/api/portalsFile/downloadOldFile?type=19&amp;oldFileUrl=ITU-R/M.2012-6/CCSA.36.143V1070.doc</a>
ETSI	ETSI TS 136 143	10.7.0	Published	26.04.2013	<a href="https://www.etsi.org/deliver/etsi_ts/136100_136199/136143/10.07.00_60/ts_136143v100700p.pdf">https://www.etsi.org/deliver/etsi_ts/136100_136199/136143/10.07.00_60/ts_136143v100700p.pdf</a>
TSDSI	TSDSI STD T1.3GPP 36.143-10.7.0 V1.0.0	10.7.0	Published	30.08.2021	<a href="https://members.tdsi.in/index.php/s/ixRP9xTLjvMZZYZ">https://members.tdsi.in/index.php/s/ixRP9xTLjvMZZYZ</a>
TTA	TTAT.3G-36.143V10.7.0	10.7.0	Published	30.07.2021	<a href="http://committee.tta.or.kr/data/ttasDown.jsp?kind=ttastd&amp;pk_num=TTAT.3G-36.143V10.7.0">http://committee.tta.or.kr/data/ttasDown.jsp?kind=ttastd&amp;pk_num=TTAT.3G-36.143V10.7.0</a>

#### Release 11

ATIS ATIS.3GPP.36.143V1120	11.2.0	Published	28.06.2021	<a href="https://www.atis.org/3gpp-documents/Rel99-14/">https://www.atis.org/3gpp-documents/Rel99-14/</a>
CCSA CCSA.36.143V1120	11.2.0	Published	01.03.2013	<a href="https://www.ccsa.org.cn/api/portalsFile/downloadOldFile?type=19&amp;oldFileUrl=ITU-R/M.2012-6/CCSA.36.143V1120.doc">https://www.ccsa.org.cn/api/portalsFile/downloadOldFile?type=19&amp;oldFileUrl=ITU-R/M.2012-6/CCSA.36.143V1120.doc</a>
ETSI ETSI TS 136 143	11.2.0	Published	26.04.2013	<a href="https://www.etsi.org/deliver/etsi_ts/136100_136199/136143/11.02.00_60/ts_136143v110200p.pdf">https://www.etsi.org/deliver/etsi_ts/136100_136199/136143/11.02.00_60/ts_136143v110200p.pdf</a>
TSDSI TSDSI STD T1.3GPP 36.143-11.2.0 V1.0.0	11.2.0	Published	30.08.2021	<a href="https://members.tdsi.in/index.php/s/yECWx9K6A7rkqfX">https://members.tdsi.in/index.php/s/yECWx9K6A7rkqfX</a>
TTA TTAT.3G-36.143V11.2.0	11.2.0	Published	30.07.2021	<a href="http://committee.tta.or.kr/data/ttasDown.jsp?kind=ttastd&amp;pk_num=TTAT.3G-36.143V11.2.0">http://committee.tta.or.kr/data/ttasDown.jsp?kind=ttastd&amp;pk_num=TTAT.3G-36.143V11.2.0</a>
<b>Release 12</b>				
ATIS ATIS.3GPP.36.143V1210	12.1.0	Published	28.06.2021	<a href="https://www.atis.org/3gpp-documents/Rel99-14/">https://www.atis.org/3gpp-documents/Rel99-14/</a>
CCSA CCSA.36.143V1210	12.1.0	Published	01.12.2014	<a href="https://www.ccsa.org.cn/api/portalsFile/downloadOldFile?type=19&amp;oldFileUrl=ITU-R/M.2012-6/CCSA.36.143V1210.doc">https://www.ccsa.org.cn/api/portalsFile/downloadOldFile?type=19&amp;oldFileUrl=ITU-R/M.2012-6/CCSA.36.143V1210.doc</a>
ETSI ETSI TS 136 143	12.1.0	Published	03.02.2015	<a href="https://www.etsi.org/deliver/etsi_ts/136100_136199/136143/12.01.00_60/ts_136143v120100p.pdf">https://www.etsi.org/deliver/etsi_ts/136100_136199/136143/12.01.00_60/ts_136143v120100p.pdf</a>
TSDSI TSDSI STD T1.3GPP 36.143-12.1.0 V1.0.0	12.1.0	Published	30.08.2021	<a href="https://members.tdsi.in/index.php/s/xNNLYHR6iRRKww7">https://members.tdsi.in/index.php/s/xNNLYHR6iRRKww7</a>
TTA TTAT.3G-36.143V12.1.0	12.1.0	Published	30.07.2021	<a href="http://committee.tta.or.kr/data/ttasDown.jsp?kind=ttastd&amp;pk_num=TTAT.3G-36.143V12.1.0">http://committee.tta.or.kr/data/ttasDown.jsp?kind=ttastd&amp;pk_num=TTAT.3G-36.143V12.1.0</a>
<b>Release 13</b>				
ATIS ATIS.3GPP.36.143V1300	13.0.0	Published	28.06.2021	<a href="https://www.atis.org/3gpp-documents/Rel99-14/">https://www.atis.org/3gpp-documents/Rel99-14/</a>
CCSA CCSA.36.143V1300	13.0.0	Published	01.01.2016	<a href="https://www.ccsa.org.cn/api/portalsFile/downloadOldFile?type=19&amp;oldFileUrl=ITU-R/M.2012-6/CCSA.36.143V1300.doc">https://www.ccsa.org.cn/api/portalsFile/downloadOldFile?type=19&amp;oldFileUrl=ITU-R/M.2012-6/CCSA.36.143V1300.doc</a>
ETSI ETSI TS 136 143	13.0.0	Published	28.01.2016	<a href="https://www.etsi.org/deliver/etsi_ts/136100_136199/136143/13.00.00_60/ts_136143v130000p.pdf">https://www.etsi.org/deliver/etsi_ts/136100_136199/136143/13.00.00_60/ts_136143v130000p.pdf</a>
TSDSI TSDSI STD T1.3GPP 36.143-13.0.0 V1.0.0	13.0.0	Published	30.08.2021	<a href="https://members.tdsi.in/index.php/s/AFFxGASRwHsbtTG">https://members.tdsi.in/index.php/s/AFFxGASRwHsbtTG</a>
TTA TTAT.3G-36.143V13.0.0	13.0.0	Published	30.07.2021	<a href="http://committee.tta.or.kr/data/ttasDown.jsp?kind=ttastd&amp;pk_num=TTAT.3G-36.143V13.0.0">http://committee.tta.or.kr/data/ttasDown.jsp?kind=ttastd&amp;pk_num=TTAT.3G-36.143V13.0.0</a>
<b>Release 14</b>				
ATIS ATIS.3GPP.36.143V1400	14.0.0	Published	28.06.2021	<a href="https://www.atis.org/3gpp-documents/Rel99-14/">https://www.atis.org/3gpp-documents/Rel99-14/</a>
CCSA CCSA.36.143V1400	14.0.0	Published	01.03.2017	<a href="https://www.ccsa.org.cn/api/portalsFile/downloadOldFile?type=19&amp;oldFileUrl=ITU-R/M.2012-6/CCSA.36.143V1400.doc">https://www.ccsa.org.cn/api/portalsFile/downloadOldFile?type=19&amp;oldFileUrl=ITU-R/M.2012-6/CCSA.36.143V1400.doc</a>
ETSI ETSI TS 136 143	14.0.0	Published	13.04.2017	<a href="https://www.etsi.org/deliver/etsi_ts/136100_136199/136143/14.00.00_60/ts_136143v140000p.pdf">https://www.etsi.org/deliver/etsi_ts/136100_136199/136143/14.00.00_60/ts_136143v140000p.pdf</a>
TSDSI TSDSI STD T1.3GPP 36.143-14.0.0 V1.0.0	14.0.0	Published	30.08.2021	<a href="https://members.tdsi.in/index.php/s/gMLAZP63YtoitKo">https://members.tdsi.in/index.php/s/gMLAZP63YtoitKo</a>
TTA TTAT.3G-36.143V14.0.0	14.0.0	Published	30.07.2021	<a href="http://committee.tta.or.kr/data/ttasDown.jsp?kind=ttastd&amp;pk_num=TTAT.3G-36.143V14.0.0">http://committee.tta.or.kr/data/ttasDown.jsp?kind=ttastd&amp;pk_num=TTAT.3G-36.143V14.0.0</a>
<b>Release 15</b>				
ATIS ATIS.3GPP.36.143V1500	15.0.0	Published	28.06.2021	<a href="https://www.atis.org/3gpp-documents/Rel15/">https://www.atis.org/3gpp-documents/Rel15/</a>
CCSA CCSA.36.143V1500	15.0.0	Published	01.12.2017	<a href="https://www.ccsa.org.cn/api/portalsFile/downloadOldFile?type=19&amp;oldFileUrl=ITU-R/M.2012-6/CCSA.36.143V1500.doc">https://www.ccsa.org.cn/api/portalsFile/downloadOldFile?type=19&amp;oldFileUrl=ITU-R/M.2012-6/CCSA.36.143V1500.doc</a>
ETSI ETSI TS 136 143	15.0.0	Published	18.09.2018	<a href="https://www.etsi.org/deliver/etsi_ts/136100_136199/136143/15.00.00_60/ts_136143v150000p.pdf">https://www.etsi.org/deliver/etsi_ts/136100_136199/136143/15.00.00_60/ts_136143v150000p.pdf</a>
TSDSI TSDSI STD T1.3GPP 36.143-15.0.0 V1.0.0	15.0.0	Published	30.08.2021	<a href="https://members.tdsi.in/index.php/s/nJPKftY6cfffEcQ">https://members.tdsi.in/index.php/s/nJPKftY6cfffEcQ</a>
TTA TTAT.3G-36.143V15.0.0	15.0.0	Published	11.09.2020	<a href="http://committee.tta.or.kr/data/ttasDown.jsp?kind=ttastd&amp;pk_num=TTAT.3G-36.143V15.0.0">http://committee.tta.or.kr/data/ttasDown.jsp?kind=ttastd&amp;pk_num=TTAT.3G-36.143V15.0.0</a>
<b>Release 16</b>				
ATIS ATIS.3GPP.36.143V1600	16.0.0	Published	28.06.2021	<a href="https://www.atis.org/3gpp-documents/Rel16/">https://www.atis.org/3gpp-documents/Rel16/</a>
CCSA CCSA.36.143V1600	16.0.0	Published	01.06.2020	<a href="https://www.ccsa.org.cn/api/portalsFile/downloadOldFile?type=19&amp;oldFileUrl=ITU-R/M.2012-6/CCSA.36.143V1600.doc">https://www.ccsa.org.cn/api/portalsFile/downloadOldFile?type=19&amp;oldFileUrl=ITU-R/M.2012-6/CCSA.36.143V1600.doc</a>
ETSI ETSI TS 136 143	16.0.0	Published	21.07.2020	<a href="https://www.etsi.org/deliver/etsi_ts/136100_136199/136143/16.00.00_60/ts_136143v160000p.pdf">https://www.etsi.org/deliver/etsi_ts/136100_136199/136143/16.00.00_60/ts_136143v160000p.pdf</a>
TSDSI TSDSI STD T1.3GPP 36.143-16.0.0 V1.0.0	16.0.0	Published	30.08.2021	<a href="https://members.tdsi.in/index.php/s/JpKeWYn975DjQEi">https://members.tdsi.in/index.php/s/JpKeWYn975DjQEi</a>
TTA TTAT.3G-36.143V16.0.0	16.0.0	Published	11.09.2020	<a href="http://committee.tta.or.kr/data/ttasDown.jsp?kind=ttastd&amp;pk_num=TTAT.3G-36.143V16.0.0">http://committee.tta.or.kr/data/ttasDown.jsp?kind=ttastd&amp;pk_num=TTAT.3G-36.143V16.0.0</a>
<b>Release 17</b>				
ATIS ATIS.3GPP.36.143.V17.0.0	17.0.0	Published	21.02.2023	<a href="https://www.atis.org/3gpp-transpositions - Rel-17">https://www.atis.org/3gpp-transpositions - Rel-17</a>
CCSA CCSA.36.143V1700	17.0.0	Published	01.03.2022	<a href="https://www.ccsa.org.cn/api/portalsFile/downloadOldFile?type=19&amp;oldFileUrl=ITU-R/M.2012-6/CCSA.36.143V1700.doc">https://www.ccsa.org.cn/api/portalsFile/downloadOldFile?type=19&amp;oldFileUrl=ITU-R/M.2012-6/CCSA.36.143V1700.doc</a>
ETSI ETSI TS 136 143	17.0.0	Published	28.04.2022	<a href="https://www.etsi.org/deliver/etsi_ts/136100_136199/136143/17.00.00_60/ts_136143v170000p.pdf">https://www.etsi.org/deliver/etsi_ts/136100_136199/136143/17.00.00_60/ts_136143v170000p.pdf</a>
TSDSI TSDSI STD T1.3GPP 36.143-17.0.0 V1.0.0	17.0.0	Published	29.07.2022	<a href="https://members.tdsi.in/s/Tbi6S22zeNPsnec">https://members.tdsi.in/s/Tbi6S22zeNPsnec</a>
TTA TTAT.3G-36.143V17.0.0	17.0.0	Published	05.08.2022	<a href="http://committee.tta.or.kr/data/ttasDown.jsp?kind=ttastd&amp;pk_num=TTAT.3G-36.143V17.0.0">http://committee.tta.or.kr/data/ttasDown.jsp?kind=ttastd&amp;pk_num=TTAT.3G-36.143V17.0.0</a>

## 2.1.5.13 TS 36.171

**Evolved Universal Terrestrial Radio Access (E-UTRA); Requirements for Support of Assisted Global Navigation Satellite System (A-GNSS)**

This document establishes the minimum performance requirements for A-GNSS (including A-GPS) for FDD or TDD mode of E-UTRA for the User Equipment (UE).

SDO	Document No.	Version	Status	Issued date	Location
<b>Release 10</b>					
ARIB	ARIB STD-T120-36.171.V10.2.0	10.2.0	Published	03.03.2023	<a href="https://www.arib.or.jp/english/html/overview/doc/T120_T23_SPECS/ARIB-STD-T120/Rel10/36/A36171-a20.pdf">https://www.arib.or.jp/english/html/overview/doc/T120_T23_SPECS/ARIB-STD-T120/Rel10/36/A36171-a20.pdf</a>
ATIS	ATIS.3GPP.36.171V1020	10.2.0	Published	28.06.2021	<a href="https://www.atis.org/3gpp-documents/Rel99-14/">https://www.atis.org/3gpp-documents/Rel99-14/</a>
CCSA	CCSA.36.171V1020	10.2.0	Published	01.07.2013	<a href="https://www.ccsa.org.cn/api/portalsFile/downloadOldFile?type=19&amp;oldFileUrl=ITU-R/M.2012-6/CCSA.36.171V1020.doc">https://www.ccsa.org.cn/api/portalsFile/downloadOldFile?type=19&amp;oldFileUrl=ITU-R/M.2012-6/CCSA.36.171V1020.doc</a>
ETSI	ETSI TS 136 171	10.2.0	Published	19.07.2013	<a href="https://www.etsi.org/deliver/etsi_ts/136100_136199/136171/10.02.00_60/ts_136171v100200p.pdf">https://www.etsi.org/deliver/etsi_ts/136100_136199/136171/10.02.00_60/ts_136171v100200p.pdf</a>
TSDSI	TSDSI STD T1.3GPP 36.171-10.2.0 V1.0.0	10.2.0	Published	30.08.2021	<a href="https://members.tdsi.in/index.php/s/e7iTr777XQaiXRA">https://members.tdsi.in/index.php/s/e7iTr777XQaiXRA</a>
TTA	TTAT.3G-36.171V10.2.0	10.2.0	Published	30.07.2021	<a href="http://committee.tta.or.kr/data/ttasDown.jsp?kind=ttastd&amp;pk_num=TTAT.3G-36.171V10.2.0">http://committee.tta.or.kr/data/ttasDown.jsp?kind=ttastd&amp;pk_num=TTAT.3G-36.171V10.2.0</a>
<b>Release 11</b>					
ARIB	ARIB STD-T120-36.171.V11.1.0	11.1.0	Published	03.03.2023	<a href="https://www.arib.or.jp/english/html/overview/doc/T120_T23_SPECS/ARIB-STD-T120/Rel11/36/A36171-b10.pdf">https://www.arib.or.jp/english/html/overview/doc/T120_T23_SPECS/ARIB-STD-T120/Rel11/36/A36171-b10.pdf</a>
ATIS	ATIS.3GPP.36.171V1110	11.1.0	Published	28.06.2021	<a href="https://www.atis.org/3gpp-documents/Rel99-14/">https://www.atis.org/3gpp-documents/Rel99-14/</a>
CCSA	CCSA.36.171V1110	11.1.0	Published	01.07.2013	<a href="https://www.ccsa.org.cn/api/portalsFile/downloadOldFile?type=19&amp;oldFileUrl=ITU-R/M.2012-6/CCSA.36.171V1110.doc">https://www.ccsa.org.cn/api/portalsFile/downloadOldFile?type=19&amp;oldFileUrl=ITU-R/M.2012-6/CCSA.36.171V1110.doc</a>
ETSI	ETSI TS 136 171	11.1.0	Published	19.07.2013	<a href="https://www.etsi.org/deliver/etsi_ts/136100_136199/136171/11.01.00_60/ts_136171v110100p.pdf">https://www.etsi.org/deliver/etsi_ts/136100_136199/136171/11.01.00_60/ts_136171v110100p.pdf</a>
TSDSI	TSDSI STD T1.3GPP 36.171-11.1.0 V1.0.0	11.1.0	Published	30.08.2021	<a href="https://members.tdsi.in/index.php/s/7nFfDrMnN528rR">https://members.tdsi.in/index.php/s/7nFfDrMnN528rR</a>
TTA	TTAT.3G-36.171V11.1.0	11.1.0	Published	02.08.2021	<a href="http://committee.tta.or.kr/data/ttasDown.jsp?kind=ttastd&amp;pk_num=TTAT.3G-36.171V11.1.0">http://committee.tta.or.kr/data/ttasDown.jsp?kind=ttastd&amp;pk_num=TTAT.3G-36.171V11.1.0</a>
<b>Release 12</b>					
ARIB	ARIB STD-T120-36.171.V12.1.0	12.1.0	Published	03.03.2023	<a href="https://www.arib.or.jp/english/html/overview/doc/T120_T23_SPECS/ARIB-STD-T120/Rel12/36/A36171-c10.pdf">https://www.arib.or.jp/english/html/overview/doc/T120_T23_SPECS/ARIB-STD-T120/Rel12/36/A36171-c10.pdf</a>
ATIS	ATIS.3GPP.36.171V1210	12.1.0	Published	28.06.2021	<a href="https://www.atis.org/3gpp-documents/Rel99-14/">https://www.atis.org/3gpp-documents/Rel99-14/</a>
CCSA	CCSA.36.171V1210	12.1.0	Published	01.12.2014	<a href="https://www.ccsa.org.cn/api/portalsFile/downloadOldFile?type=19&amp;oldFileUrl=ITU-R/M.2012-6/CCSA.36.171V1210.doc">https://www.ccsa.org.cn/api/portalsFile/downloadOldFile?type=19&amp;oldFileUrl=ITU-R/M.2012-6/CCSA.36.171V1210.doc</a>
ETSI	ETSI TS 136 171	12.1.0	Published	03.02.2015	<a href="https://www.etsi.org/deliver/etsi_ts/136100_136199/136171/12.01.00_60/ts_136171v120100p.pdf">https://www.etsi.org/deliver/etsi_ts/136100_136199/136171/12.01.00_60/ts_136171v120100p.pdf</a>
TSDSI	TSDSI STD T1.3GPP 36.171-12.1.0 V1.0.0	12.1.0	Published	30.08.2021	<a href="https://members.tdsi.in/index.php/s/dHGTbKrEgq6fn">https://members.tdsi.in/index.php/s/dHGTbKrEgq6fn</a>
TTA	TTAT.3G-36.171V12.1.0	12.1.0	Published	02.08.2021	<a href="http://committee.tta.or.kr/data/ttasDown.jsp?kind=ttastd&amp;pk_num=TTAT.3G-36.171V12.1.0">http://committee.tta.or.kr/data/ttasDown.jsp?kind=ttastd&amp;pk_num=TTAT.3G-36.171V12.1.0</a>
<b>Release 13</b>					
ARIB	ARIB STD-T120-36.171.V13.1.0	13.1.0	Published	03.03.2023	<a href="https://www.arib.or.jp/english/html/overview/doc/T120_T23_SPECS/ARIB-STD-T120/Rel13/36/A36171-d10.pdf">https://www.arib.or.jp/english/html/overview/doc/T120_T23_SPECS/ARIB-STD-T120/Rel13/36/A36171-d10.pdf</a>
ATIS	ATIS.3GPP.36.171V1310	13.1.0	Published	28.06.2021	<a href="https://www.atis.org/3gpp-documents/Rel99-14/">https://www.atis.org/3gpp-documents/Rel99-14/</a>
CCSA	CCSA.36.171V1310	13.1.0	Published	01.06.2018	<a href="https://www.ccsa.org.cn/api/portalsFile/downloadOldFile?type=19&amp;oldFileUrl=ITU-R/M.2012-6/CCSA.36.171V1310.doc">https://www.ccsa.org.cn/api/portalsFile/downloadOldFile?type=19&amp;oldFileUrl=ITU-R/M.2012-6/CCSA.36.171V1310.doc</a>
ETSI	ETSI TS 136 171	13.1.0	Published	17.07.2018	<a href="https://www.etsi.org/deliver/etsi_ts/136100_136199/136171/13.01.00_60/ts_136171v130100p.pdf">https://www.etsi.org/deliver/etsi_ts/136100_136199/136171/13.01.00_60/ts_136171v130100p.pdf</a>
TSDSI	TSDSI STD T1.3GPP 36.171-13.1.0 V1.1.0	13.1.0	Published	30.08.2021	<a href="https://members.tdsi.in/index.php/s/8ZBPSoT2gqQBQtA">https://members.tdsi.in/index.php/s/8ZBPSoT2gqQBQtA</a>
TTA	TTAT.3G-36.171V13.1.0	13.1.0	Published	02.08.2021	<a href="http://committee.tta.or.kr/data/ttasDown.jsp?kind=ttastd&amp;pk_num=TTAT.3G-36.171V13.1.0">http://committee.tta.or.kr/data/ttasDown.jsp?kind=ttastd&amp;pk_num=TTAT.3G-36.171V13.1.0</a>
<b>Release 14</b>					
ARIB	ARIB STD-T120-36.171.V14.1.0	14.1.0	Published	03.03.2023	<a href="https://www.arib.or.jp/english/html/overview/doc/T120_T23_SPECS/ARIB-STD-T120/Rel14/36/A36171-e10.pdf">https://www.arib.or.jp/english/html/overview/doc/T120_T23_SPECS/ARIB-STD-T120/Rel14/36/A36171-e10.pdf</a>
ATIS	ATIS.3GPP.36.171V1410	14.1.0	Published	28.06.2021	<a href="https://www.atis.org/3gpp-documents/Rel99-14/">https://www.atis.org/3gpp-documents/Rel99-14/</a>
CCSA	CCSA.36.171V1410	14.1.0	Published	01.06.2018	<a href="https://www.ccsa.org.cn/api/portalsFile/downloadOldFile?type=19&amp;oldFileUrl=ITU-R/M.2012-6/CCSA.36.171V1410.doc">https://www.ccsa.org.cn/api/portalsFile/downloadOldFile?type=19&amp;oldFileUrl=ITU-R/M.2012-6/CCSA.36.171V1410.doc</a>
ETSI	ETSI TS 136 171	14.1.0	Published	17.07.2018	<a href="https://www.etsi.org/deliver/etsi_ts/136100_136199/136171/14.01.00_60/ts_136171v140100p.pdf">https://www.etsi.org/deliver/etsi_ts/136100_136199/136171/14.01.00_60/ts_136171v140100p.pdf</a>
TSDSI	TSDSI STD T1.3GPP 36.171-14.1.0 V1.1.0	14.1.0	Published	30.08.2021	<a href="https://members.tdsi.in/index.php/s/8ZwTEQmMrKPPwiD">https://members.tdsi.in/index.php/s/8ZwTEQmMrKPPwiD</a>
TTA	TTAT.3G-36.171V14.1.0	14.1.0	Published	02.08.2021	<a href="http://committee.tta.or.kr/data/ttasDown.jsp?kind=ttastd&amp;pk_num=TTAT.3G-36.171V14.1.0">http://committee.tta.or.kr/data/ttasDown.jsp?kind=ttastd&amp;pk_num=TTAT.3G-36.171V14.1.0</a>
<b>Release 15</b>					
ARIB	ARIB STD-T120-36.171.V15.2.0	15.2.0	Published	03.03.2023	<a href="https://www.arib.or.jp/english/html/overview/doc/T120_T23_SPECS/ARIB-STD-T120/Rel15/36/A36171-f20.pdf">https://www.arib.or.jp/english/html/overview/doc/T120_T23_SPECS/ARIB-STD-T120/Rel15/36/A36171-f20.pdf</a>
ATIS	ATIS.3GPP.36.171.V15.2.0	15.2.0	Published	21.02.2023	<a href="https://www.atis.org/3gpp-transpositions - Rel-15">https://www.atis.org/3gpp-transpositions - Rel-15</a>



CCSA	CCSA.36.171V1520	15.2.0	Published	01.09.2021	<a href="https://www.ccsa.org.cn/api/portalsFile/downloadOldFile?type=19&amp;oldFileUrl=ITU-R/M.2012-6/CCSA.36.171V1520.doc">https://www.ccsa.org.cn/api/portalsFile/downloadOldFile?type=19&amp;oldFileUrl=ITU-R/M.2012-6/CCSA.36.171V1520.doc</a>
ETSI	ETSI TS 136 171	15.2.0	Published	13.10.2021	<a href="https://www.etsi.org/deliver/etsi_ts/136100_136199/136171/15.02.00_60/ts_136171v150200p.pdf">https://www.etsi.org/deliver/etsi_ts/136100_136199/136171/15.02.00_60/ts_136171v150200p.pdf</a>
TSDSI	TSDSI STD T1.3GPP 36.171-15.2.0 V1.1.0	15.2.0	Published	01.11.2022	<a href="https://members.tdsi.in/s/FqjjiSJmEzFND9">https://members.tdsi.in/s/FqjjiSJmEzFND9</a>
TTA	TTAT.3G-36.171V15.2.0	15.2.0	Published	27.01.2022	<a href="http://committee.tta.or.kr/data/ttasDown.jsp?kind=ttastd&amp;pk_num=TTAT.3G-36.171V15.2.0">http://committee.tta.or.kr/data/ttasDown.jsp?kind=ttastd&amp;pk_num=TTAT.3G-36.171V15.2.0</a>

**Release 16**

ARIB	ARIB STD-T120-36.171.V16.5.0	16.5.0	Published	03.03.2023	<a href="https://www.arib.or.jp/english/html/overview/doc/T120_T23_SPECS/ARIB-STD-T120/Rel16/36/A36171-g50.pdf">https://www.arib.or.jp/english/html/overview/doc/T120_T23_SPECS/ARIB-STD-T120/Rel16/36/A36171-g50.pdf</a>
ATIS	ATIS.3GPP.36.171.V16.5.0	16.5.0	Published	21.02.2023	<a href="https://www.atis.org/3gpp-transpositions - Rel-16">https://www.atis.org/3gpp-transpositions - Rel-16</a>
CCSA	CCSA.36.171V1650	16.5.0	Published	01.06.2022	<a href="https://www.ccsa.org.cn/api/portalsFile/downloadOldFile?type=19&amp;oldFileUrl=ITU-R/M.2012-6/CCSA.36.171V1650.doc">https://www.ccsa.org.cn/api/portalsFile/downloadOldFile?type=19&amp;oldFileUrl=ITU-R/M.2012-6/CCSA.36.171V1650.doc</a>
ETSI	ETSI TS 136 171	16.5.0	Published	21.07.2022	<a href="https://www.etsi.org/deliver/etsi_ts/136100_136199/136171/16.05.00_60/ts_136171v160500p.pdf">https://www.etsi.org/deliver/etsi_ts/136100_136199/136171/16.05.00_60/ts_136171v160500p.pdf</a>
TSDSI	TSDSI STD T1.3GPP 36.171-16.5.0 V1.1.0	16.5.0	Published	01.11.2022	<a href="https://members.tdsi.in/s/mwW42ixJx7dZHC4">https://members.tdsi.in/s/mwW42ixJx7dZHC4</a>
TTA	TTAT.3G-36.171V16.5.0	16.5.0	Published	21.10.2022	<a href="http://committee.tta.or.kr/data/ttasDown.jsp?kind=ttastd&amp;pk_num=TTAT.3G-36.171V16.5.0">http://committee.tta.or.kr/data/ttasDown.jsp?kind=ttastd&amp;pk_num=TTAT.3G-36.171V16.5.0</a>

**Release 17**

ARIB	ARIB STD-T120-36.171.V17.2.0	17.2.0	Published	03.03.2023	<a href="https://www.arib.or.jp/english/html/overview/doc/T120_T23_SPECS/ARIB-STD-T120/Rel17/36/A36171-h20.pdf">https://www.arib.or.jp/english/html/overview/doc/T120_T23_SPECS/ARIB-STD-T120/Rel17/36/A36171-h20.pdf</a>
ATIS	ATIS.3GPP.36.171.V17.2.0	17.2.0	Published	21.02.2023	<a href="https://www.atis.org/3gpp-transpositions - Rel-17">https://www.atis.org/3gpp-transpositions - Rel-17</a>
CCSA	CCSA.36.171V1720	17.2.0	Published	01.09.2022	<a href="https://www.ccsa.org.cn/api/portalsFile/downloadOldFile?type=19&amp;oldFileUrl=ITU-R/M.2012-6/CCSA.36.171V1720.doc">https://www.ccsa.org.cn/api/portalsFile/downloadOldFile?type=19&amp;oldFileUrl=ITU-R/M.2012-6/CCSA.36.171V1720.doc</a>
ETSI	ETSI TS 136 171	17.2.0	Published	17.10.2022	<a href="https://www.etsi.org/deliver/etsi_ts/136100_136199/136171/17.02.00_60/ts_136171v170200p.pdf">https://www.etsi.org/deliver/etsi_ts/136100_136199/136171/17.02.00_60/ts_136171v170200p.pdf</a>
TSDSI	TSDSI STD T1.3GPP 36.171-17.2.0 V1.2.0	17.2.0	Published	17.01.2023	<a href="https://members.tdsi.in/s/Qc4qgZDZaCBtay3">https://members.tdsi.in/s/Qc4qgZDZaCBtay3</a>
TTA	TTAT.3G-36.171V17.2.0	17.2.0	Published	11.01.2023	<a href="http://committee.tta.or.kr/data/ttasDown.jsp?kind=ttastd&amp;pk_num=TTAT.3G-36.171V17.2.0">http://committee.tta.or.kr/data/ttasDown.jsp?kind=ttastd&amp;pk_num=TTAT.3G-36.171V17.2.0</a>

**2.1.5.14 TS 36.307****Evolved Universal Terrestrial Radio Access (E-UTRA); Requirements on User Equipments (UEs) supporting a release-independent frequency band**

This document specifies requirements on UEs supporting a frequency band that is independent of release. TSG-RAN has agreed that the standardization of new frequency bands may be independent of a release. However, in order to implement a UE that conforms to a particular release but supports a band of operation that is specified in a later release, it is necessary to specify some extra requirements. All frequency bands are fully specified in this release of the specifications. This document does not contain any requirements for UEs supporting frequency bands independent of release.

SDO	Document No.	Version	Status	Issued date	Location
<b>Release 10</b>					
ARIB	ARIB STD-T120-36.307.V10.24.0	10.24.0	Published	03.03.2023	<a href="https://www.arib.or.jp/english/html/overview/doc/T120_T23_SPECS/ARIB-STD-T120/Rel10/36/A36307-ao0.pdf">https://www.arib.or.jp/english/html/overview/doc/T120_T23_SPECS/ARIB-STD-T120/Rel10/36/A36307-ao0.pdf</a>
ATIS	ATIS.3GPP.36.307V10240	10.24.0	Published	28.06.2021	<a href="https://www.atis.org/3gpp-documents/Rel99-14/">https://www.atis.org/3gpp-documents/Rel99-14/</a>
CCSA	CCSA.36.307V10240	10.24.0	Published	01.06.201	<a href="https://www.ccsa.org.cn/api/portalsFile/downloadOldFile?type=19&amp;oldFileUrl=ITU-R/M.2012-6/CCSA.36.307V10240.docx">https://www.ccsa.org.cn/api/portalsFile/downloadOldFile?type=19&amp;oldFileUrl=ITU-R/M.2012-6/CCSA.36.307V10240.docx</a>
ETSI	ETSI TS 136 307	10.24.0	Published	17.07.2018	<a href="https://www.etsi.org/deliver/etsi_ts/136300_136399/136307/10.24.00_60/ts_136307v102400p.pdf">https://www.etsi.org/deliver/etsi_ts/136300_136399/136307/10.24.00_60/ts_136307v102400p.pdf</a>
TSDSI	TSDSI STD T1.3GPP 36.307-10.24.0 V1.1.0	10.24.0	Published	30.08.2021	<a href="https://members.tdsi.in/index.php/s/CcJs7GG7JSQXsqG">https://members.tdsi.in/index.php/s/CcJs7GG7JSQXsqG</a>
TTA	TTAT.3G-36.307V10.24.0	10.24.0	Published	02.08.2021	<a href="http://committee.tta.or.kr/data/ttasDown.jsp?kind=ttastd&amp;pk_num=TTAT.3G-36.307V10.24.0">http://committee.tta.or.kr/data/ttasDown.jsp?kind=ttastd&amp;pk_num=TTAT.3G-36.307V10.24.0</a>
<b>Release 11</b>					
ARIB	ARIB STD-T120-36.307.V11.21.0	11.21.0	Published	03.03.2023	<a href="https://www.arib.or.jp/english/html/overview/doc/T120_T23_SPECS/ARIB-STD-T120/Rel11/36/A36307-bl0.pdf">https://www.arib.or.jp/english/html/overview/doc/T120_T23_SPECS/ARIB-STD-T120/Rel11/36/A36307-bl0.pdf</a>
ATIS	ATIS.3GPP.36.307V11210	11.21.0	Published	28.06.2021	<a href="https://www.atis.org/3gpp-documents/Rel99-14/">https://www.atis.org/3gpp-documents/Rel99-14/</a>
CCSA	CCSA.36.307V11210	11.21.0	Published	01.06.2018	<a href="https://www.ccsa.org.cn/api/portalsFile/downloadOldFile?type=19&amp;oldFileUrl=ITU-R/M.2012-6/CCSA.36.307V11210.docx">https://www.ccsa.org.cn/api/portalsFile/downloadOldFile?type=19&amp;oldFileUrl=ITU-R/M.2012-6/CCSA.36.307V11210.docx</a>
ETSI	ETSI TS 136 307	11.21.0	Published	17.07.2018	<a href="https://www.etsi.org/deliver/etsi_ts/136300_136399/136307/11.21.00_60/ts_136307v112100p.pdf">https://www.etsi.org/deliver/etsi_ts/136300_136399/136307/11.21.00_60/ts_136307v112100p.pdf</a>
TSDSI	TSDSI STD T1.3GPP 36.307-11.21.0 V1.1.0	11.21.0	Published	30.08.2021	<a href="https://members.tdsi.in/index.php/s/AmYBzsFxfKPsD">https://members.tdsi.in/index.php/s/AmYBzsFxfKPsD</a>
TTA	TTAT.3G-36.307V11.21.0	11.21.0	Published	02.08.2021	<a href="http://committee.tta.or.kr/data/ttasDown.jsp?kind=ttastd&amp;pk_num=TTAT.3G-36.307V11.21.0">http://committee.tta.or.kr/data/ttasDown.jsp?kind=ttastd&amp;pk_num=TTAT.3G-36.307V11.21.0</a>
<b>Release 12</b>					
ARIB	ARIB STD-T120-36.307.V12.17.0	12.17.0	Published	03.03.2023	<a href="https://www.arib.or.jp/english/html/overview/doc/T120_T23_SPECS/ARIB-STD-T120/Rel12/36/A36307-ch0.pdf">https://www.arib.or.jp/english/html/overview/doc/T120_T23_SPECS/ARIB-STD-T120/Rel12/36/A36307-ch0.pdf</a>
ATIS	ATIS.3GPP.36.307V12170	12.17.0	Published	28.06.2021	<a href="https://www.atis.org/3gpp-documents/Rel99-14/">https://www.atis.org/3gpp-documents/Rel99-14/</a>

## 120

CCSA	CCSA.36.307V12170	12.17.0	Published	01.06.2018	<a href="https://www.ccsa.org.cn/api/portalsFile/downloadOldFile?type=19&amp;oldFileUrl=ITU-R/M.2012-6/CCSA.36.307V12170.docx">https://www.ccsa.org.cn/api/portalsFile/downloadOldFile?type=19&amp;oldFileUrl=ITU-R/M.2012-6/CCSA.36.307V12170.docx</a>
ETSI	ETSI TS 136 307	12.17.0	Published	17.07.2018	<a href="https://www.etsi.org/deliver/etsi_ts/136300_136399/136307/12.17.00_60/ts_136307v121700p.pdf">https://www.etsi.org/deliver/etsi_ts/136300_136399/136307/12.17.00_60/ts_136307v121700p.pdf</a>
TSDSI	TSDSI STD T1.3GPP 36.307-12.17.0 V1.1.0	12.17.0	Published	30.08.2021	<a href="https://members.tdsi.in/index.php/s/77NqP5WgAWiMNNR">https://members.tdsi.in/index.php/s/77NqP5WgAWiMNNR</a>
TTA	TTAT.3G-36.307V12.17.0	12.17.0	Published	30.07.2021	<a href="http://committee.tta.or.kr/data/ttasDown.jsp?kind=ttastd&amp;pk_num=TTAT.3G-36.307V12.17.0">http://committee.tta.or.kr/data/ttasDown.jsp?kind=ttastd&amp;pk_num=TTAT.3G-36.307V12.17.0</a>

### Release 13

ARIB	ARIB STD-T120-36.307.V13.15.0	13.15.0	Published	03.03.2023	<a href="https://www.arib.or.jp/english/html/overview/doc/T120_T23_SPECS/ARIB-STD-T120/Rel13/36/A36307-df0.pdf">https://www.arib.or.jp/english/html/overview/doc/T120_T23_SPECS/ARIB-STD-T120/Rel13/36/A36307-df0.pdf</a>
ATIS	ATIS.3GPP.36.307.V13.15.0	13.15.0	Published	21.02.2023	<a href="https://www.atis.org/3gpp-transpositions - Rel-13">https://www.atis.org/3gpp-transpositions - Rel-13</a>
CCSA	CCSA.36.307V13150	13.15.0	Published	01.06.2022	<a href="https://www.ccsa.org.cn/api/portalsFile/downloadOldFile?type=19&amp;oldFileUrl=ITU-R/M.2012-6/CCSA.36.307V13150.docx">https://www.ccsa.org.cn/api/portalsFile/downloadOldFile?type=19&amp;oldFileUrl=ITU-R/M.2012-6/CCSA.36.307V13150.docx</a>
ETSI	ETSI TS 136 307	13.15.0	Published	21.07.2022	<a href="https://www.etsi.org/deliver/etsi_ts/136300_136399/136307/13.15.00_60/ts_136307v131500p.pdf">https://www.etsi.org/deliver/etsi_ts/136300_136399/136307/13.15.00_60/ts_136307v131500p.pdf</a>
TSDSI	TSDSI STD T1.3GPP 36.307-13.15.0 V1.1.0	13.15.0	Published	17.01.2023	<a href="https://members.tdsi.in/s/ZDoZTEPTfzLEJjo">https://members.tdsi.in/s/ZDoZTEPTfzLEJjo</a>
TTA	TTAT.3G-36.307V13.15.0	13.15.0	Published	21.10.2022	<a href="http://committee.tta.or.kr/data/ttasDown.jsp?kind=ttastd&amp;pk_num=TTAT.3G-36.307V13.15.0">http://committee.tta.or.kr/data/ttasDown.jsp?kind=ttastd&amp;pk_num=TTAT.3G-36.307V13.15.0</a>

### Release 14

ARIB	ARIB STD-T120-36.307.V14.12.0	14.12.0	Published	03.03.2023	<a href="https://www.arib.or.jp/english/html/overview/doc/T120_T23_SPECS/ARIB-STD-T120/Rel14/36/A36307-ec0.pdf">https://www.arib.or.jp/english/html/overview/doc/T120_T23_SPECS/ARIB-STD-T120/Rel14/36/A36307-ec0.pdf</a>
ATIS	ATIS.3GPP.36.307.V14.12.0	14.12.0	Published	21.02.2023	<a href="https://www.atis.org/3gpp-transpositions - Rel-14">https://www.atis.org/3gpp-transpositions - Rel-14</a>
CCSA	CCSA.36.307V14120	14.12.0	Published	01.06.2022	<a href="https://www.ccsa.org.cn/api/portalsFile/downloadOldFile?type=19&amp;oldFileUrl=ITU-R/M.2012-6/CCSA.36.307V14120.docx">https://www.ccsa.org.cn/api/portalsFile/downloadOldFile?type=19&amp;oldFileUrl=ITU-R/M.2012-6/CCSA.36.307V14120.docx</a>
ETSI	ETSI TS 136 307	14.12.0	Published	21.07.2022	<a href="https://www.etsi.org/deliver/etsi_ts/136300_136399/136307/14.12.00_60/ts_136307v141200p.pdf">https://www.etsi.org/deliver/etsi_ts/136300_136399/136307/14.12.00_60/ts_136307v141200p.pdf</a>
TSDSI	TSDSI STD T1.3GPP 36.307-14.12.0 V1.1.0	14.12.0	Published	17.01.2023	<a href="https://members.tdsi.in/s/GB66Q9FAQgw2c4P">https://members.tdsi.in/s/GB66Q9FAQgw2c4P</a>
TTA	TTAT.3G-36.307V14.12.0	14.12.0	Published	21.10.2022	<a href="http://committee.tta.or.kr/data/ttasDown.jsp?kind=ttastd&amp;pk_num=TTAT.3G-36.307V14.12.0">http://committee.tta.or.kr/data/ttasDown.jsp?kind=ttastd&amp;pk_num=TTAT.3G-36.307V14.12.0</a>

### Release 15

ARIB	ARIB STD-T120-36.307.V15.9.0	15.9.0	Published	03.03.2023	<a href="https://www.arib.or.jp/english/html/overview/doc/T120_T23_SPECS/ARIB-STD-T120/Rel15/36/A36307-f90.pdf">https://www.arib.or.jp/english/html/overview/doc/T120_T23_SPECS/ARIB-STD-T120/Rel15/36/A36307-f90.pdf</a>
ATIS	ATIS.3GPP.36.307.V15.9.0	15.9.0	Published	21.02.2023	<a href="https://www.atis.org/3gpp-transpositions - Rel-15">https://www.atis.org/3gpp-transpositions - Rel-15</a>
CCSA	CCSA.36.307V1590	15.9.0	Published	01.06.2022	<a href="https://www.ccsa.org.cn/api/portalsFile/downloadOldFile?type=19&amp;oldFileUrl=ITU-R/M.2012-6/CCSA.36.307V1590.docx">https://www.ccsa.org.cn/api/portalsFile/downloadOldFile?type=19&amp;oldFileUrl=ITU-R/M.2012-6/CCSA.36.307V1590.docx</a>
ETSI	ETSI TS 136 307	15.9.0	Published	21.07.2022	<a href="https://www.etsi.org/deliver/etsi_ts/136300_136399/136307/15.09.00_60/ts_136307v150900p.pdf">https://www.etsi.org/deliver/etsi_ts/136300_136399/136307/15.09.00_60/ts_136307v150900p.pdf</a>
TSDSI	TSDSI STD T1.3GPP 36.307-15.9.0 V1.1.0	15.9.0	Published	01.11.2022	<a href="https://members.tdsi.in/s/By8RQ3YbcDZcJ7S">https://members.tdsi.in/s/By8RQ3YbcDZcJ7S</a>
TTA	TTAT.3G-36.307V15.9.0	15.9.0	Published	21.10.2022	<a href="http://committee.tta.or.kr/data/ttasDown.jsp?kind=ttastd&amp;pk_num=TTAT.3G-36.307V15.9.0">http://committee.tta.or.kr/data/ttasDown.jsp?kind=ttastd&amp;pk_num=TTAT.3G-36.307V15.9.0</a>

### Release 16

ARIB	ARIB STD-T120-36.307.V16.5.0	16.5.0	Published	03.03.2023	<a href="https://www.arib.or.jp/english/html/overview/doc/T120_T23_SPECS/ARIB-STD-T120/Rel16/36/A36307-g50.pdf">https://www.arib.or.jp/english/html/overview/doc/T120_T23_SPECS/ARIB-STD-T120/Rel16/36/A36307-g50.pdf</a>
ATIS	ATIS.3GPP.36.307.V16.5.0	16.5.0	Published	21.02.2023	<a href="https://www.atis.org/3gpp-transpositions - Rel-16">https://www.atis.org/3gpp-transpositions - Rel-16</a>
CCSA	CCSA.36.307V1650	16.5.0	Published	01.06.2022	<a href="https://www.ccsa.org.cn/api/portalsFile/downloadOldFile?type=19&amp;oldFileUrl=ITU-R/M.2012-6/CCSA.36.307V1650.docx">https://www.ccsa.org.cn/api/portalsFile/downloadOldFile?type=19&amp;oldFileUrl=ITU-R/M.2012-6/CCSA.36.307V1650.docx</a>
ETSI	ETSI TS 136 307	16.5.0	Published	21.07.2022	<a href="https://www.etsi.org/deliver/etsi_ts/136300_136399/136307/16.05.00_60/ts_136307v160500p.pdf">https://www.etsi.org/deliver/etsi_ts/136300_136399/136307/16.05.00_60/ts_136307v160500p.pdf</a>
TSDSI	TSDSI STD T1.3GPP 36.307-16.5.0 V1.1.0	16.5.0	Published	01.11.2022	<a href="https://members.tdsi.in/s/wdrCcSoAaT4KGap">https://members.tdsi.in/s/wdrCcSoAaT4KGap</a>
TTA	TTAT.3G-36.307V16.5.0	16.5.0	Published	21.10.2022	<a href="http://committee.tta.or.kr/data/ttasDown.jsp?kind=ttastd&amp;pk_num=TTAT.3G-36.307V16.5.0">http://committee.tta.or.kr/data/ttasDown.jsp?kind=ttastd&amp;pk_num=TTAT.3G-36.307V16.5.0</a>

### Release 17

ARIB	ARIB STD-T120-36.307.V17.3.0	17.3.0	Published	03.03.2023	<a href="https://www.arib.or.jp/english/html/overview/doc/T120_T23_SPECS/ARIB-STD-T120/Rel17/36/A36307-h30.pdf">https://www.arib.or.jp/english/html/overview/doc/T120_T23_SPECS/ARIB-STD-T120/Rel17/36/A36307-h30.pdf</a>
ATIS	ATIS.3GPP.36.307.V17.3.0	17.3.0	Published	21.02.2023	<a href="https://www.atis.org/3gpp-transpositions - Rel-17">https://www.atis.org/3gpp-transpositions - Rel-17</a>
CCSA	CCSA.36.307V1730	17.3.0	Published	01.12.2022	<a href="https://www.ccsa.org.cn/api/portalsFile/downloadOldFile?type=19&amp;oldFileUrl=ITU-R/M.2012-6/CCSA.36.307V1730.docx">https://www.ccsa.org.cn/api/portalsFile/downloadOldFile?type=19&amp;oldFileUrl=ITU-R/M.2012-6/CCSA.36.307V1730.docx</a>
ETSI	ETSI TS 136 307	17.3.0	Published	19.01.2023	<a href="https://www.etsi.org/deliver/etsi_ts/136300_136399/136307/17.03.00_60/ts_136307v170300p.pdf">https://www.etsi.org/deliver/etsi_ts/136300_136399/136307/17.03.00_60/ts_136307v170300p.pdf</a>
TSDSI	TSDSI STD T1.3GPP 36.307 17.3.0 V1.3.0	17.3.0	Published	02.05.2023	<a href="https://members.tdsi.in/s/gXc4HBJtX6msJQP">https://members.tdsi.in/s/gXc4HBJtX6msJQP</a>
TTA	TTAT.3G-36.307V17.3.0	17.3.0	Published	16.03.2023	<a href="http://committee.tta.or.kr/data/ttasDown.jsp?kind=ttastd&amp;pk_num=TTAT.3G-36.307V17.3.0">http://committee.tta.or.kr/data/ttasDown.jsp?kind=ttastd&amp;pk_num=TTAT.3G-36.307V17.3.0</a>

## 2.1.5.15 TS 37.104

### E-UTRA, UTRA and GSM/EDGE; Multi-Standard Radio (MSR) Base Station (BS) radio transmission and reception

This document establishes the minimum RF characteristics of E-UTRA, UTRA and GSM/EDGE Multi-Standard Radio (MSR) Base Station (BS). Requirements for multi-RAT and single-RAT operation of MSR BS are covered in this document. The requirements in this document for E-UTRA and UTRA single-RAT

operation of MSR BS are also applicable to E-UTRA and UTRA multi-carrier capable single-RAT BS. Requirements for GSM BS that are only single-RAT capable are not covered.

SDO	Document No.	Version	Status	Issued date	Location
<b>Release 10</b>					
ATIS	ATIS.3GPP.37.104.V10.15.0	10.15.0	Published	21.02.2023	<a href="https://www.atis.org/3gpp-transpositions - Rel-10">https://www.atis.org/3gpp-transpositions - Rel-10</a>
CCSA	CCSA.37.104V10150	10.15.0	Published	01.03.2021	<a href="https://www.ccsa.org.cn/api/portalsFile/downloadOldFile?type=19&amp;oldFileUrl=ITU-R/M.2012-6/CCSA.37.104V10150.doc">https://www.ccsa.org.cn/api/portalsFile/downloadOldFile?type=19&amp;oldFileUrl=ITU-R/M.2012-6/CCSA.37.104V10150.doc</a>
ETSI	ETSI TS 137 104	10.15.0	Published	30.04.2021	<a href="https://www.etsi.org/deliver/etsi_ts/137100_137199/137104/10.15.00_60/ts_137104v101500p.pdf">https://www.etsi.org/deliver/etsi_ts/137100_137199/137104/10.15.00_60/ts_137104v101500p.pdf</a>
TSDSI	TSDSI STD T1.3GPP 37.104 10.15.0 V1.1.0	10.15.0	Published	02.05.2023	<a href="https://members.tdsi.in/s/FsNFkqx9GxaieN9">https://members.tdsi.in/s/FsNFkqx9GxaieN9</a>
TTA	TTAT.3G-37.104V10.15.0	10.15.0	Published	10.06.2021	<a href="http://committee.tta.or.kr/data/ttasDown.jsp?kind=ttastd&amp;pk_num=TTAT.3G-37.104V10.15.0">http://committee.tta.or.kr/data/ttasDown.jsp?kind=ttastd&amp;pk_num=TTAT.3G-37.104V10.15.0</a>
<b>Release 11</b>					
ATIS	ATIS.3GPP.37.104.V11.15.0	11.15.0	Published	21.02.2023	<a href="https://www.atis.org/3gpp-transpositions - Rel-11">https://www.atis.org/3gpp-transpositions - Rel-11</a>
CCSA	CCSA.37.104V11150	11.15.0	Published	01.03.2021	<a href="https://www.ccsa.org.cn/api/portalsFile/downloadOldFile?type=19&amp;oldFileUrl=ITU-R/M.2012-6/CCSA.37.104V11150.doc">https://www.ccsa.org.cn/api/portalsFile/downloadOldFile?type=19&amp;oldFileUrl=ITU-R/M.2012-6/CCSA.37.104V11150.doc</a>
ETSI	ETSI TS 137 104	11.15.0	Published	30.04.2021	<a href="https://www.etsi.org/deliver/etsi_ts/137100_137199/137104/11.15.00_60/ts_137104v111500p.pdf">https://www.etsi.org/deliver/etsi_ts/137100_137199/137104/11.15.00_60/ts_137104v111500p.pdf</a>
TSDSI	TSDSI STD T1.3GPP 37.104 11.15.0 V1.1.0	11.15.0	Published	02.05.2023	<a href="https://members.tdsi.in/s/S8FBZPSsjMQSC8">https://members.tdsi.in/s/S8FBZPSsjMQSC8</a>
TTA	TTAT.3G-37.104V11.15.0	11.15.0	Published	10.06.2021	<a href="http://committee.tta.or.kr/data/ttasDown.jsp?kind=ttastd&amp;pk_num=TTAT.3G-37.104V11.15.0">http://committee.tta.or.kr/data/ttasDown.jsp?kind=ttastd&amp;pk_num=TTAT.3G-37.104V11.15.0</a>
<b>Release 12</b>					
ATIS	ATIS.3GPP.37.104.V12.14.0	12.14.0	Published	21.02.2023	<a href="https://www.atis.org/3gpp-transpositions - Rel-12">https://www.atis.org/3gpp-transpositions - Rel-12</a>
CCSA	CCSA.37.104V12140	12.14.0	Published	01.03.2021	<a href="https://www.ccsa.org.cn/api/portalsFile/downloadOldFile?type=19&amp;oldFileUrl=ITU-R/M.2012-6/CCSA.37.104V12140.doc">https://www.ccsa.org.cn/api/portalsFile/downloadOldFile?type=19&amp;oldFileUrl=ITU-R/M.2012-6/CCSA.37.104V12140.doc</a>
ETSI	ETSI TS 137 104	12.14.0	Published	30.04.2021	<a href="https://www.etsi.org/deliver/etsi_ts/137100_137199/137104/12.14.00_60/ts_137104v121400p.pdf">https://www.etsi.org/deliver/etsi_ts/137100_137199/137104/12.14.00_60/ts_137104v121400p.pdf</a>
TSDSI	TSDSI STD T1.3GPP 37.104 12.14.0 V1.1.0	12.14.0	Published	02.05.2023	<a href="https://members.tdsi.in/s/qkDEeGLezgsYaGa">https://members.tdsi.in/s/qkDEeGLezgsYaGa</a>
TTA	TTAT.3G-37.104V12.14.0	12.14.0	Published	10.06.2021	<a href="http://committee.tta.or.kr/data/ttasDown.jsp?kind=ttastd&amp;pk_num=TTAT.3G-37.104V12.14.0">http://committee.tta.or.kr/data/ttasDown.jsp?kind=ttastd&amp;pk_num=TTAT.3G-37.104V12.14.0</a>
<b>Release 13</b>					
ATIS	ATIS.3GPP.37.104.V13.9.0	13.9.0	Published	21.02.2023	<a href="https://www.atis.org/3gpp-transpositions - Rel-13">https://www.atis.org/3gpp-transpositions - Rel-13</a>
CCSA	CCSA.37.104V1390	13.9.0	Published	01.03.2021	<a href="https://www.ccsa.org.cn/api/portalsFile/downloadOldFile?type=19&amp;oldFileUrl=ITU-R/M.2012-6/CCSA.37.104V1390.doc">https://www.ccsa.org.cn/api/portalsFile/downloadOldFile?type=19&amp;oldFileUrl=ITU-R/M.2012-6/CCSA.37.104V1390.doc</a>
ETSI	ETSI TS 137 104	13.9.0	Published	30.04.2021	<a href="https://www.etsi.org/deliver/etsi_ts/137100_137199/137104/13.09.00_60/ts_137104v130900p.pdf">https://www.etsi.org/deliver/etsi_ts/137100_137199/137104/13.09.00_60/ts_137104v130900p.pdf</a>
TSDSI	TSDSI STD T1.3GPP 37.104-13.9.0 V1.1.0	13.9.0	Published	17.01.2023	<a href="https://members.tdsi.in/s/prn6frx8KE5LCzR">https://members.tdsi.in/s/prn6frx8KE5LCzR</a>
TTA	TTAT.3G-37.104V13.9.0	13.9.0	Published	10.06.2021	<a href="http://committee.tta.or.kr/data/ttasDown.jsp?kind=ttastd&amp;pk_num=TTAT.3G-37.104V13.9.0">http://committee.tta.or.kr/data/ttasDown.jsp?kind=ttastd&amp;pk_num=TTAT.3G-37.104V13.9.0</a>
<b>Release 14</b>					
ATIS	ATIS.3GPP.37.104.V14.8.0	14.8.0	Published	21.02.2023	<a href="https://www.atis.org/3gpp-transpositions - Rel-14">https://www.atis.org/3gpp-transpositions - Rel-14</a>
CCSA	CCSA.37.104V1480	14.8.0	Published	01.12.2021	<a href="https://www.ccsa.org.cn/api/portalsFile/downloadOldFile?type=19&amp;oldFileUrl=ITU-R/M.2012-6/CCSA.37.104V1480.doc">https://www.ccsa.org.cn/api/portalsFile/downloadOldFile?type=19&amp;oldFileUrl=ITU-R/M.2012-6/CCSA.37.104V1480.doc</a>
ETSI	ETSI TS 137 104	14.8.0	Published	16.03.2022	<a href="https://www.etsi.org/deliver/etsi_ts/137100_137199/137104/14.08.00_60/ts_137104v140800p.pdf">https://www.etsi.org/deliver/etsi_ts/137100_137199/137104/14.08.00_60/ts_137104v140800p.pdf</a>
TSDSI	TSDSI STD T1.3GPP 37.104-14.8.0 V1.1.0	14.8.0	Published	17.01.2023	<a href="https://members.tdsi.in/s/MSRboZDEQRWj5og">https://members.tdsi.in/s/MSRboZDEQRWj5og</a>
TTA	TTAT.3G-37.104V14.8.0	14.8.0	Published	14.03.2022	<a href="http://committee.tta.or.kr/data/ttasDown.jsp?kind=ttastd&amp;pk_num=TTAT.3G-37.104V14.8.0">http://committee.tta.or.kr/data/ttasDown.jsp?kind=ttastd&amp;pk_num=TTAT.3G-37.104V14.8.0</a>
<b>Release 15</b>					
ATIS	ATIS.3GPP.37.104.V15.18.0	15.18.0	Published	21.02.2023	<a href="https://www.atis.org/3gpp-transpositions - Rel-15">https://www.atis.org/3gpp-transpositions - Rel-15</a>
CCSA	CCSA.37.104V15180	15.18.0	Published	01.09.2022	<a href="https://www.ccsa.org.cn/api/portalsFile/downloadOldFile?type=19&amp;oldFileUrl=ITU-R/M.2012-6/CCSA.37.104V15180.doc">https://www.ccsa.org.cn/api/portalsFile/downloadOldFile?type=19&amp;oldFileUrl=ITU-R/M.2012-6/CCSA.37.104V15180.doc</a>
ETSI	ETSI TS 137 104	15.18.0	Published	17.10.2022	<a href="https://www.etsi.org/deliver/etsi_ts/137100_137199/137104/15.18.00_60/ts_137104v151800p.pdf">https://www.etsi.org/deliver/etsi_ts/137100_137199/137104/15.18.00_60/ts_137104v151800p.pdf</a>
TSDSI	TSDSI STD T1.3GPP 37.104-15.18.0 V1.2.0	15.18.0	Published	17.01.2023	<a href="https://members.tdsi.in/s/gERj7Rkq9LkkT8E">https://members.tdsi.in/s/gERj7Rkq9LkkT8E</a>
TTA	TTAT.3G-37.104V15.18.0	15.18.0	Published	11.01.2023	<a href="http://committee.tta.or.kr/data/ttasDown.jsp?kind=ttastd&amp;pk_num=TTAT.3G-37.104V15.18.0">http://committee.tta.or.kr/data/ttasDown.jsp?kind=ttastd&amp;pk_num=TTAT.3G-37.104V15.18.0</a>
<b>Release 16</b>					
ATIS	ATIS.3GPP.37.104.V16.15.0	16.15.0	Published	21.02.2023	<a href="https://www.atis.org/3gpp-transpositions - Rel-16">https://www.atis.org/3gpp-transpositions - Rel-16</a>
CCSA	CCSA.37.104V16150	16.15.0	Published	01.09.2022	<a href="https://www.ccsa.org.cn/api/portalsFile/downloadOldFile?type=19&amp;oldFileUrl=ITU-R/M.2012-6/CCSA.37.104V16150.doc">https://www.ccsa.org.cn/api/portalsFile/downloadOldFile?type=19&amp;oldFileUrl=ITU-R/M.2012-6/CCSA.37.104V16150.doc</a>
ETSI	ETSI TS 137 104	16.15.0	Published	17.10.2022	<a href="https://www.etsi.org/deliver/etsi_ts/137100_137199/137104/16.15.00_60/ts_137104v161500p.pdf">https://www.etsi.org/deliver/etsi_ts/137100_137199/137104/16.15.00_60/ts_137104v161500p.pdf</a>
TSDSI	TSDSI STD T1.3GPP 37.104-16.15.0 V1.2.0	16.15.0	Published	17.01.2023	<a href="https://members.tdsi.in/s/HGko7gGFAdfEHbi">https://members.tdsi.in/s/HGko7gGFAdfEHbi</a>
TTA	TTAT.3G-37.104V16.15.0	16.15.0	Published	11.01.2023	<a href="http://committee.tta.or.kr/data/ttasDown.jsp?kind=ttastd&amp;pk_num=TTAT.3G-37.104V16.15.0">http://committee.tta.or.kr/data/ttasDown.jsp?kind=ttastd&amp;pk_num=TTAT.3G-37.104V16.15.0</a>

## Release 17

ATIS	ATIS.3GPP.37.104.V17.7.0	17.7.0	Published	21.02.2023	<a href="https://www.atis.org/3gpp-transpositions - Rel-17">https://www.atis.org/3gpp-transpositions - Rel-17</a>
CCSA	CCSA.37.104V1770	17.7.0	Published	01.09.2022	<a href="https://www.ccsa.org.cn/api/portalsFile/downloadOldFile?type=19&amp;oldFileUrl=ITU-R/M.2012-6/CCSA.37.104V1770.doc">https://www.ccsa.org.cn/api/portalsFile/downloadOldFile?type=19&amp;oldFileUrl=ITU-R/M.2012-6/CCSA.37.104V1770.doc</a>
ETSI	ETSI TS 137 104	17.7.0	Published	17.10.2022	<a href="https://www.etsi.org/deliver/etsi_ts/137100_137199/137104/17.07.00_60/ts_137104v170700p.pdf">https://www.etsi.org/deliver/etsi_ts/137100_137199/137104/17.07.00_60/ts_137104v170700p.pdf</a>
TSDSI	TSDSI STD T1.3GPP 37.104-17.7.0 V1.2.0	17.7.0	Published	17.01.2023	<a href="https://members.tdsi.in/s/kbRpidnotPqyrb5">https://members.tdsi.in/s/kbRpidnotPqyrb5</a>
TTA	TTAT.3G-37.104V17.7.0	17.7.0	Published	11.01.2023	<a href="http://committee.tta.or.kr/data/ttasDown.jsp?kind=ttastd&amp;pk_num=TTAT.3G-37.104V17.7.0">http://committee.tta.or.kr/data/ttasDown.jsp?kind=ttastd&amp;pk_num=TTAT.3G-37.104V17.7.0</a>

## 2.1.5.16 TS 37.105

## Active Antenna System (AAS) Base Station (BS) transmission and reception

This document establishes the RF characteristics, the RF minimum requirements and minimum performance requirements for E-UTRA AAS Base Station (BS), the FDD mode of UTRA AAS Base Station (BS), the 1,28 Mchip/s TDD mode of UTRA AAS Base Station (BS) in single RAT and any MSR AAS Base Station (BS) implementation of these RATs.

SDO	Document No.	Version	Status	Issued date	Location
<b>Release 13</b>					
ATIS	ATIS.3GPP.37.105.V13.11.0	13.11.0	Published	21.02.2023	<a href="https://www.atis.org/3gpp-transpositions - Rel-13">https://www.atis.org/3gpp-transpositions - Rel-13</a>
CCSA	CCSA.37.105V13110	13.11.0	Published	01.09.2020	<a href="https://www.ccsa.org.cn/api/portalsFile/downloadOldFile?type=19&amp;oldFileUrl=ITU-R/M.2012-6/CCSA.37.105V13110.doc">https://www.ccsa.org.cn/api/portalsFile/downloadOldFile?type=19&amp;oldFileUrl=ITU-R/M.2012-6/CCSA.37.105V13110.doc</a>
ETSI	ETSI TS 137 105	13.11.0	Published	16.11.2020	<a href="https://www.etsi.org/deliver/etsi_ts/137100_137199/137105/13.11.00_60/ts_137105v131100p.pdf">https://www.etsi.org/deliver/etsi_ts/137100_137199/137105/13.11.00_60/ts_137105v131100p.pdf</a>
TSDSI	TSDSI STD T1.3GPP 37.105-13.11.0 V1.1.0	13.11.0	Published	17.01.2023	<a href="https://members.tdsi.in/s/8q4o4TQ8tDBMSyK">https://members.tdsi.in/s/8q4o4TQ8tDBMSyK</a>
TTA	TTAT.3G-37.105V13.11.0	13.11.0	Published	16.03.2023	<a href="http://committee.tta.or.kr/data/ttasDown.jsp?kind=ttastd&amp;pk_num=TTAT.3G-37.105V13.11.0">http://committee.tta.or.kr/data/ttasDown.jsp?kind=ttastd&amp;pk_num=TTAT.3G-37.105V13.11.0</a>
<b>Release 14</b>					
ATIS	ATIS.3GPP.37.105.V14.8.0	14.8.0	Published	21.02.2023	<a href="https://www.atis.org/3gpp-transpositions - Rel-14">https://www.atis.org/3gpp-transpositions - Rel-14</a>
CCSA	CCSA.37.105V1480	14.8.0	Published	01.12.2021	<a href="https://www.ccsa.org.cn/api/portalsFile/downloadOldFile?type=19&amp;oldFileUrl=ITU-R/M.2012-6/CCSA.37.105V1480.doc">https://www.ccsa.org.cn/api/portalsFile/downloadOldFile?type=19&amp;oldFileUrl=ITU-R/M.2012-6/CCSA.37.105V1480.doc</a>
ETSI	ETSI TS 137 105	14.8.0	Published	16.03.2022	<a href="https://www.etsi.org/deliver/etsi_ts/137100_137199/137105/14.08.00_60/ts_137105v140800p.pdf">https://www.etsi.org/deliver/etsi_ts/137100_137199/137105/14.08.00_60/ts_137105v140800p.pdf</a>
TSDSI	TSDSI STD T1.3GPP 37.105-14.8.0 V1.1.0	14.8.0	Published	17.01.2023	<a href="https://members.tdsi.in/s/3q8GxEAr4Xxws7b">https://members.tdsi.in/s/3q8GxEAr4Xxws7b</a>
TTA	TTAT.3G-37.105V14.8.0	14.8.0	Published	14.03.2022	<a href="http://committee.tta.or.kr/data/ttasDown.jsp?kind=ttastd&amp;pk_num=TTAT.3G-37.105V14.8.0">http://committee.tta.or.kr/data/ttasDown.jsp?kind=ttastd&amp;pk_num=TTAT.3G-37.105V14.8.0</a>
<b>Release 15</b>					
ATIS	ATIS.3GPP.37.105.V15.17.0	15.17.0	Published	21.02.2023	<a href="https://www.atis.org/3gpp-transpositions - Rel-15">https://www.atis.org/3gpp-transpositions - Rel-15</a>
CCSA	CCSA.37.105V15170	15.17.0	Published	01.06.2022	<a href="https://www.ccsa.org.cn/api/portalsFile/downloadOldFile?type=19&amp;oldFileUrl=ITU-R/M.2012-6/CCSA.37.105V15170.doc">https://www.ccsa.org.cn/api/portalsFile/downloadOldFile?type=19&amp;oldFileUrl=ITU-R/M.2012-6/CCSA.37.105V15170.doc</a>
ETSI	ETSI TS 137 105	15.17.0	Published	21.07.2022	<a href="https://www.etsi.org/deliver/etsi_ts/137100_137199/137105/15.17.00_60/ts_137105v151700p.pdf">https://www.etsi.org/deliver/etsi_ts/137100_137199/137105/15.17.00_60/ts_137105v151700p.pdf</a>
TSDSI	TSDSI STD T1.3GPP 37.105-15.17.0 V1.1.0	15.17.0	Published	01.11.2022	<a href="https://members.tdsi.in/s/NGPD2NqKWZjK7kW">https://members.tdsi.in/s/NGPD2NqKWZjK7kW</a>
TTA	TTAT.3G-37.105V15.17.0	15.17.0	Published	21.10.2022	<a href="http://committee.tta.or.kr/data/ttasDown.jsp?kind=ttastd&amp;pk_num=TTAT.3G-37.105V15.17.0">http://committee.tta.or.kr/data/ttasDown.jsp?kind=ttastd&amp;pk_num=TTAT.3G-37.105V15.17.0</a>
<b>Release 16</b>					
ATIS	ATIS.3GPP.37.105.V16.12.0	16.12.0	Published	21.02.2023	<a href="https://www.atis.org/3gpp-transpositions - Rel-16">https://www.atis.org/3gpp-transpositions - Rel-16</a>
CCSA	CCSA.37.105V16120	16.12.0	Published	01.06.2022	<a href="https://www.ccsa.org.cn/api/portalsFile/downloadOldFile?type=19&amp;oldFileUrl=ITU-R/M.2012-6/CCSA.37.105V16120.doc">https://www.ccsa.org.cn/api/portalsFile/downloadOldFile?type=19&amp;oldFileUrl=ITU-R/M.2012-6/CCSA.37.105V16120.doc</a>
ETSI	ETSI TS 137 105	16.12.0	Published	21.07.2022	<a href="https://www.etsi.org/deliver/etsi_ts/137100_137199/137105/16.12.00_60/ts_137105v161200p.pdf">https://www.etsi.org/deliver/etsi_ts/137100_137199/137105/16.12.00_60/ts_137105v161200p.pdf</a>
TSDSI	TSDSI STD T1.3GPP 37.105-16.12.0 V1.1.0	16.12.0	Published	01.11.2022	<a href="https://members.tdsi.in/s/3BAnDk4Hf72wmQe">https://members.tdsi.in/s/3BAnDk4Hf72wmQe</a>
TTA	TTAT.3G-37.105V16.12.0	16.12.0	Published	21.10.2022	<a href="http://committee.tta.or.kr/data/ttasDown.jsp?kind=ttastd&amp;pk_num=TTAT.3G-37.105V16.12.0">http://committee.tta.or.kr/data/ttasDown.jsp?kind=ttastd&amp;pk_num=TTAT.3G-37.105V16.12.0</a>
<b>Release 17</b>					
ATIS	ATIS.3GPP.37.105.V17.6.0	17.6.0	Published	21.02.2023	<a href="https://www.atis.org/3gpp-transpositions - Rel-17">https://www.atis.org/3gpp-transpositions - Rel-17</a>
CCSA	CCSA.37.105V1760	17.6.0	Published	01.06.2022	<a href="https://www.ccsa.org.cn/api/portalsFile/downloadOldFile?type=19&amp;oldFileUrl=ITU-R/M.2012-6/CCSA.37.105V1760.doc">https://www.ccsa.org.cn/api/portalsFile/downloadOldFile?type=19&amp;oldFileUrl=ITU-R/M.2012-6/CCSA.37.105V1760.doc</a>
ETSI	ETSI TS 137 105	17.6.0	Published	21.07.2022	<a href="https://www.etsi.org/deliver/etsi_ts/137100_137199/137105/17.06.00_60/ts_137105v170600p.pdf">https://www.etsi.org/deliver/etsi_ts/137100_137199/137105/17.06.00_60/ts_137105v170600p.pdf</a>
TSDSI	TSDSI STD T1.3GPP 37.105-17.6.0 V1.1.0	17.6.0	Published	01.11.2022	<a href="https://members.tdsi.in/s/CKXrky8KsdcZwMN">https://members.tdsi.in/s/CKXrky8KsdcZwMN</a>
TTA	TTAT.3G-37.105V17.6.0	17.6.0	Published	21.10.2022	<a href="http://committee.tta.or.kr/data/ttasDown.jsp?kind=ttastd&amp;pk_num=TTAT.3G-37.105V17.6.0">http://committee.tta.or.kr/data/ttasDown.jsp?kind=ttastd&amp;pk_num=TTAT.3G-37.105V17.6.0</a>

## 2.1.5.17 TS 37.113

**E-UTRA, UTRA and GSM/EDGE; Multi-Standard Radio (MSR) Base Station (BS) Electromagnetic Compatibility (EMC)**

This document covers the assessment of E-UTRA, UTRA and GSM/EDGE Multi-Standard Radio (MSR) Base Stations and associated ancillary equipment in respect of Electromagnetic Compatibility (EMC). This document specifies the applicable test conditions, performance assessment and performance criteria for E-UTRA, UTRA and GSM/EDGE Base Stations and associated ancillary equipment in one of the following categories: (i) Multi-Standard Radio (MSR) Base Stations for E-UTRA, UTRA and GSM/EDGE meeting the requirements of TS 37.104, with conformance demonstrated by compliance to TS 37.141; (ii) Base Stations for E-UTRA meeting the requirements of TS 36.104, with conformance demonstrated by compliance to TS 36.141; (iii) Base Stations for UTRA FDD meeting the requirements of TS 25.104, with conformance demonstrated by compliance to TS 25.141; (iv) Base Stations for UTRA TDD meeting the requirements of TS 25.105, with conformance demonstrated by compliance to TS 25.142; (v) Base Stations for GSM/EDGE meeting the requirements of TS 45.005, with conformance demonstrated by compliance to TS 51.021. The environment classification used in this document refers to the environment classification used in IEC 61000-6-1 and IEC 61000-6-3.

The EMC requirements have been selected to ensure an adequate level of compatibility for apparatus at residential, commercial and light industrial environments. The levels, however, do not cover extreme cases which may occur in any location but with low probability of occurrence.

SDO	Document No.	Version	Status	Issued date	Location
<b>Release 10</b>					
ATIS	ATIS.3GPP.37.113V1050	10.5.0	Published	28.06.2021	<a href="https://www.atis.org/3gpp-documents/Rel99-14/">https://www.atis.org/3gpp-documents/Rel99-14/</a>
CCSA	CCSA.37.113V1050	10.5.0	Published	01.06.2016	<a href="https://www.ccsa.org.cn/api/portalsFile/downloadOldFile?type=19&amp;oldFileUrl=ITU-R/M.2012-6/CCSA.37.113V1050.doc">https://www.ccsa.org.cn/api/portalsFile/downloadOldFile?type=19&amp;oldFileUrl=ITU-R/M.2012-6/CCSA.37.113V1050.doc</a>
ETSI	ETSI TS 137 113	10.5.0	Published	02.08.2016	<a href="https://www.etsi.org/deliver/etsi_ts/137100_137199/137113/10.05.00_60/ts_137113v100500p.pdf">https://www.etsi.org/deliver/etsi_ts/137100_137199/137113/10.05.00_60/ts_137113v100500p.pdf</a>
TSDSI	TSDSI STD T1.3GPP 37.113-10.5.0 V1.0.0	10.5.0	Published	30.08.2021	<a href="https://members.tdsi.in/index.php/s/aPi68oj3YGREKPN">https://members.tdsi.in/index.php/s/aPi68oj3YGREKPN</a>
TTA	TTAT.3G-37.113V10.5.0	10.5.0	Published	02.08.2021	<a href="http://committee.tta.or.kr/data/ttasDown.jsp?kind=ttastd&amp;pk_num=TTAT.3G-37.113V10.5.0">http://committee.tta.or.kr/data/ttasDown.jsp?kind=ttastd&amp;pk_num=TTAT.3G-37.113V10.5.0</a>
<b>Release 11</b>					
ATIS	ATIS.3GPP.37.113V1140	11.4.0	Published	28.06.2021	<a href="https://www.atis.org/3gpp-documents/Rel99-14/">https://www.atis.org/3gpp-documents/Rel99-14/</a>
CCSA	CCSA.37.113V1140	11.4.0	Published	01.06.2016	<a href="https://www.ccsa.org.cn/api/portalsFile/downloadOldFile?type=19&amp;oldFileUrl=ITU-R/M.2012-6/CCSA.37.113V1140.doc">https://www.ccsa.org.cn/api/portalsFile/downloadOldFile?type=19&amp;oldFileUrl=ITU-R/M.2012-6/CCSA.37.113V1140.doc</a>
ETSI	ETSI TS 137 113	11.4.0	Published	02.08.2016	<a href="https://www.etsi.org/deliver/etsi_ts/137100_137199/137113/11.04.00_60/ts_137113v110400p.pdf">https://www.etsi.org/deliver/etsi_ts/137100_137199/137113/11.04.00_60/ts_137113v110400p.pdf</a>
TSDSI	TSDSI STD T1.3GPP 37.113-11.4.0 V1.0.0	11.4.0	Published	30.08.2021	<a href="https://members.tdsi.in/index.php/s/WKATBwQoNYqj5Ks">https://members.tdsi.in/index.php/s/WKATBwQoNYqj5Ks</a>
TTA	TTAT.3G-37.113V11.4.0	11.4.0	Published	02.08.2021	<a href="http://committee.tta.or.kr/data/ttasDown.jsp?kind=ttastd&amp;pk_num=TTAT.3G-37.113V11.4.0">http://committee.tta.or.kr/data/ttasDown.jsp?kind=ttastd&amp;pk_num=TTAT.3G-37.113V11.4.0</a>
<b>Release 12</b>					
ATIS	ATIS.3GPP.37.113V1240	12.4.0	Published	28.06.2021	<a href="https://www.atis.org/3gpp-documents/Rel99-14/">https://www.atis.org/3gpp-documents/Rel99-14/</a>
CCSA	CCSA.37.113V1240	12.4.0	Published	01.06.2016	<a href="https://www.ccsa.org.cn/api/portalsFile/downloadOldFile?type=19&amp;oldFileUrl=ITU-R/M.2012-6/CCSA.37.113V1240.doc">https://www.ccsa.org.cn/api/portalsFile/downloadOldFile?type=19&amp;oldFileUrl=ITU-R/M.2012-6/CCSA.37.113V1240.doc</a>
ETSI	ETSI TS 137 113	12.4.0	Published	02.08.2016	<a href="https://www.etsi.org/deliver/etsi_ts/137100_137199/137113/12.04.00_60/ts_137113v120400p.pdf">https://www.etsi.org/deliver/etsi_ts/137100_137199/137113/12.04.00_60/ts_137113v120400p.pdf</a>
TSDSI	TSDSI STD T1.3GPP 37.113-12.4.0 V1.0.0	12.4.0	Published	30.08.2021	<a href="https://members.tdsi.in/index.php/s/a3oarXQHYPt3tQD">https://members.tdsi.in/index.php/s/a3oarXQHYPt3tQD</a>
TTA	TTAT.3G-37.113V12.4.0	12.4.0	Published	02.08.2021	<a href="http://committee.tta.or.kr/data/ttasDown.jsp?kind=ttastd&amp;pk_num=TTAT.3G-37.113V12.4.0">http://committee.tta.or.kr/data/ttasDown.jsp?kind=ttastd&amp;pk_num=TTAT.3G-37.113V12.4.0</a>
<b>Release 13</b>					
ATIS	ATIS.3GPP.37.113V1340	13.4.0	Published	28.06.2021	<a href="https://www.atis.org/3gpp-documents/Rel99-14/">https://www.atis.org/3gpp-documents/Rel99-14/</a>
CCSA	CCSA.37.113V1340	13.4.0	Published	01.06.2017	<a href="https://www.ccsa.org.cn/api/portalsFile/downloadOldFile?type=19&amp;oldFileUrl=ITU-R/M.2012-6/CCSA.37.113V1340.doc">https://www.ccsa.org.cn/api/portalsFile/downloadOldFile?type=19&amp;oldFileUrl=ITU-R/M.2012-6/CCSA.37.113V1340.doc</a>
ETSI	ETSI TS 137 113	13.4.0	Published	24.08.2017	<a href="https://www.etsi.org/deliver/etsi_ts/137100_137199/137113/13.04.00_60/ts_137113v130400p.pdf">https://www.etsi.org/deliver/etsi_ts/137100_137199/137113/13.04.00_60/ts_137113v130400p.pdf</a>
TSDSI	TSDSI STD T1.3GPP 37.113-13.4.0 V1.0.0	13.4.0	Published	30.08.2021	<a href="https://members.tdsi.in/index.php/s/LXrYdaHrTFa8ree">https://members.tdsi.in/index.php/s/LXrYdaHrTFa8ree</a>
TTA	TTAT.3G-37.113V13.4.0	13.4.0	Published	02.08.2021	<a href="http://committee.tta.or.kr/data/ttasDown.jsp?kind=ttastd&amp;pk_num=TTAT.3G-37.113V13.4.0">http://committee.tta.or.kr/data/ttasDown.jsp?kind=ttastd&amp;pk_num=TTAT.3G-37.113V13.4.0</a>

## 124

## Rec. ITU-R M.2012-6

Release 14				
ATIS	ATIS.3GPP.37.113V1420	14.2.0	Published 28.06.2021	<a href="https://www.atis.org/3gpp-documents/Rel99-14/">https://www.atis.org/3gpp-documents/Rel99-14/</a>
CCSA	CCSA.37.113V1420	14.2.0	Published 01.06.2017	<a href="https://www.ccsa.org.cn/api/portalsFile/downloadOldFile?type=19&amp;oldFileUrl=ITU-R/M.2012-6/CCSA.37.113V1420.doc">https://www.ccsa.org.cn/api/portalsFile/downloadOldFile?type=19&amp;oldFileUrl=ITU-R/M.2012-6/CCSA.37.113V1420.doc</a>
ETSI	ETSI TS 137 113	14.2.0	Published 24.08.2017	<a href="https://www.etsi.org/deliver/etsi_ts/137100_137199/137113/14.02.00_60/ts_137113v140200p.pdf">https://www.etsi.org/deliver/etsi_ts/137100_137199/137113/14.02.00_60/ts_137113v140200p.pdf</a>
TSDSI	TSDSI STD T1.3GPP 37.113-14.2.0 V1.0.0	14.2.0	Published 30.08.2021	<a href="https://members.tdsi.in/index.php/s/PFX68ypymo2NYGF">https://members.tdsi.in/index.php/s/PFX68ypymo2NYGF</a>
TTA	TTAT.3G-37.113V14.2.0	14.2.0	Published 02.08.2021	<a href="http://committee.tta.or.kr/data/ttasDown.jsp?kind=ttastd&amp;pk_num=TTAT.3G-37.113V14.2.0">http://committee.tta.or.kr/data/ttasDown.jsp?kind=ttastd&amp;pk_num=TTAT.3G-37.113V14.2.0</a>
Release 15				
ATIS	ATIS.3GPP.37.113.V15.11.0	15.11.0	Published 21.02.2023	<a href="https://www.atis.org/3gpp-transpositions - Rel-15">https://www.atis.org/3gpp-transpositions - Rel-15</a>
CCSA	CCSA.37.113V15110	15.11.0	Published 01.06.2021	<a href="https://www.ccsa.org.cn/api/portalsFile/downloadOldFile?type=19&amp;oldFileUrl=ITU-R/M.2012-6/CCSA.37.113V15110.doc">https://www.ccsa.org.cn/api/portalsFile/downloadOldFile?type=19&amp;oldFileUrl=ITU-R/M.2012-6/CCSA.37.113V15110.doc</a>
ETSI	ETSI TS 137 113	15.11.0	Published 10.09.2021	<a href="https://www.etsi.org/deliver/etsi_ts/137100_137199/137113/15.11.00_60/ts_137113v151100p.pdf">https://www.etsi.org/deliver/etsi_ts/137100_137199/137113/15.11.00_60/ts_137113v151100p.pdf</a>
TSDSI	TSDSI STD T1.3GPP 37.113-15.11.0 V1.1.0	15.11.0	Published 01.11.2022	<a href="https://members.tdsi.in/s/YLAA4FsyGsd4WHJ">https://members.tdsi.in/s/YLAA4FsyGsd4WHJ</a>
TTA	TTAT.3G-37.113V15.11.0	15.11.0	Published 30.09.2021	<a href="http://committee.tta.or.kr/data/ttasDown.jsp?kind=ttastd&amp;pk_num=TTAT.3G-37.113V15.11.0">http://committee.tta.or.kr/data/ttasDown.jsp?kind=ttastd&amp;pk_num=TTAT.3G-37.113V15.11.0</a>
Release 16				
ATIS	ATIS.3GPP.37.113.V16.2.0	16.2.0	Published 21.02.2023	<a href="https://www.atis.org/3gpp-transpositions - Rel-16">https://www.atis.org/3gpp-transpositions - Rel-16</a>
CCSA	CCSA.37.113V1620	16.2.0	Published 01.06.2021	<a href="https://www.ccsa.org.cn/api/portalsFile/downloadOldFile?type=19&amp;oldFileUrl=ITU-R/M.2012-6/CCSA.37.113V1620.doc">https://www.ccsa.org.cn/api/portalsFile/downloadOldFile?type=19&amp;oldFileUrl=ITU-R/M.2012-6/CCSA.37.113V1620.doc</a>
ETSI	ETSI TS 137 113	16.2.0	Published 10.09.2021	<a href="https://www.etsi.org/deliver/etsi_ts/137100_137199/137113/16.02.00_60/ts_137113v160200p.pdf">https://www.etsi.org/deliver/etsi_ts/137100_137199/137113/16.02.00_60/ts_137113v160200p.pdf</a>
TSDSI	TSDSI STD T1.3GPP 37.113-16.2.0 V1.1.0	16.2.0	Published 01.11.2022	<a href="https://members.tdsi.in/s/Q9qkHyT6iRLEKp3">https://members.tdsi.in/s/Q9qkHyT6iRLEKp3</a>
TTA	TTAT.3G-37.113V16.2.0	16.2.0	Published 30.09.2021	<a href="http://committee.tta.or.kr/data/ttasDown.jsp?kind=ttastd&amp;pk_num=TTAT.3G-37.113V16.2.0">http://committee.tta.or.kr/data/ttasDown.jsp?kind=ttastd&amp;pk_num=TTAT.3G-37.113V16.2.0</a>
Release 17				
ATIS	ATIS.3GPP.37.113.V17.0.0	17.0.0	Published 21.02.2023	<a href="https://www.atis.org/3gpp-transpositions - Rel-17">https://www.atis.org/3gpp-transpositions - Rel-17</a>
CCSA	CCSA.37.113V1700	17.0.0	Published 01.03.2022	<a href="https://www.ccsa.org.cn/api/portalsFile/downloadOldFile?type=19&amp;oldFileUrl=ITU-R/M.2012-6/CCSA.37.113V1700.doc">https://www.ccsa.org.cn/api/portalsFile/downloadOldFile?type=19&amp;oldFileUrl=ITU-R/M.2012-6/CCSA.37.113V1700.doc</a>
ETSI	ETSI TS 137 113	17.0.0	Published 28.04.2022	<a href="https://www.etsi.org/deliver/etsi_ts/137100_137199/137113/17.00.00_60/ts_137113v170000p.pdf">https://www.etsi.org/deliver/etsi_ts/137100_137199/137113/17.00.00_60/ts_137113v170000p.pdf</a>
TSDSI	TSDSI STD T1.3GPP 37.113-17.0.0 V1.0.0	17.0.0	Published 29.07.2022	<a href="https://members.tdsi.in/s/zbxtTHCzsTDLxbC">https://members.tdsi.in/s/zbxtTHCzsTDLxbC</a>
TTA	TTAT.3G-37.113V17.0.0	17.0.0	Published 05.08.2022	<a href="http://committee.tta.or.kr/data/ttasDown.jsp?kind=ttastd&amp;pk_num=TTAT.3G-37.113V17.0.0">http://committee.tta.or.kr/data/ttasDown.jsp?kind=ttastd&amp;pk_num=TTAT.3G-37.113V17.0.0</a>

### 2.1.5.18 TS 37.114

#### Active Antenna System (AAS) Base Station (BS) Electromagnetic Compatibility (EMC)

This document covers the assessment of E-UTRA, UTRA and Multi-Standard Radio (MSR) Active Antenna Systems Base Stations in respect of Electromagnetic Compatibility (EMC).

This document specifies the applicable test conditions, performance assessment and performance criteria for E-UTRA and UTRA Base Stations and associated ancillary equipment in one of the following categories:

- Active Antenna System Base Station for E-UTRA, UTRA and MSR meeting the requirements of 3GPP TS 37.105, with conformance demonstrated by compliance to 3GPP TS 37.145.

The scope of this document is AAS BS with TAB connectors for every transceiver unit at the Transceiver Array Boundary. Requirement, procedures and values of an AAS Base Station without TAB connectors are not included in this document and are FFS.

The environment classification used in this document refers to the residential, commercial and light industrial environment classification used in IEC 61000-6-1 and IEC 61000-6-3.

The EMC requirements have been selected to ensure an adequate level of compatibility for apparatus at residential, commercial and light industrial environments. The levels, however, do not cover extreme cases which may occur in any location but with low probability of occurrence.

SDO	Document No.	Version	Status	Issued date	Location
<b>Release 13</b>					
ATIS	ATIS.3GPP.37.114V1330	13.3.0	Published	28.06.2021	<a href="https://www.atis.org/3gpp-documents/Rel99-14/">https://www.atis.org/3gpp-documents/Rel99-14/</a>
CCSA	CCSA.37.114V1330	13.3.0	Published	01.06.2017	<a href="https://www.ccsa.org.cn/api/portalsFile/downloadOldFile?type=19&amp;oldFileUrl=ITU-R/M.2012-6/CCSA.37.114V1330.doc">https://www.ccsa.org.cn/api/portalsFile/downloadOldFile?type=19&amp;oldFileUrl=ITU-R/M.2012-6/CCSA.37.114V1330.doc</a>
ETSI	ETSI TS 137 114	13.3.0	Published	24.08.2017	<a href="https://www.etsi.org/deliver/etsi_ts/137100_137199/137114/13.03.00_60/ts_137114v130300p.pdf">https://www.etsi.org/deliver/etsi_ts/137100_137199/137114/13.03.00_60/ts_137114v130300p.pdf</a>
TSDSI	TSDSI STD T1.3GPP 37.114-13.3.0 V1.0.0	13.3.0	Published	30.08.2021	<a href="https://members.tdsi.in/index.php/s/Dt8NzxLgapDc925">https://members.tdsi.in/index.php/s/Dt8NzxLgapDc925</a>
TTA	TTAT.3G-37.114V13.3.0	13.3.0	Published	02.08.2021	<a href="http://committee.tta.or.kr/data/ttasDown.jsp?kind=ttastd&amp;pk_num=TTAT.3G-37.114V13.3.0">http://committee.tta.or.kr/data/ttasDown.jsp?kind=ttastd&amp;pk_num=TTAT.3G-37.114V13.3.0</a>
<b>Release 14</b>					
ATIS	ATIS.3GPP.37.114V1410	14.1.0	Published	28.06.2021	<a href="https://www.atis.org/3gpp-documents/Rel99-14/">https://www.atis.org/3gpp-documents/Rel99-14/</a>
CCSA	CCSA.37.114V1410	14.1.0	Published	01.06.2017	<a href="https://www.ccsa.org.cn/api/portalsFile/downloadOldFile?type=19&amp;oldFileUrl=ITU-R/M.2012-6/CCSA.37.114V1410.doc">https://www.ccsa.org.cn/api/portalsFile/downloadOldFile?type=19&amp;oldFileUrl=ITU-R/M.2012-6/CCSA.37.114V1410.doc</a>
ETSI	ETSI TS 137 114	14.1.0	Published	24.08.2017	<a href="https://www.etsi.org/deliver/etsi_ts/137100_137199/137114/14.01.00_60/ts_137114v140100p.pdf">https://www.etsi.org/deliver/etsi_ts/137100_137199/137114/14.01.00_60/ts_137114v140100p.pdf</a>
TSDSI	TSDSI STD T1.3GPP 37.114-14.1.0 V1.0.0	14.1.0	Published	30.08.2021	<a href="https://members.tdsi.in/index.php/s/4y3yJTMee9bzKbL">https://members.tdsi.in/index.php/s/4y3yJTMee9bzKbL</a>
TTA	TTAT.3G-37.114V14.1.0	14.1.0	Published	02.08.2021	<a href="http://committee.tta.or.kr/data/ttasDown.jsp?kind=ttastd&amp;pk_num=TTAT.3G-37.114V14.1.0">http://committee.tta.or.kr/data/ttasDown.jsp?kind=ttastd&amp;pk_num=TTAT.3G-37.114V14.1.0</a>
<b>Release 15</b>					
ATIS	ATIS.3GPP.37.114V1590	15.9.0	Published	28.06.2021	<a href="https://www.atis.org/3gpp-documents/Rel15/">https://www.atis.org/3gpp-documents/Rel15/</a>
CCSA	CCSA.37.114V1590	15.9.0	Published	01.06.2020	<a href="https://www.ccsa.org.cn/api/portalsFile/downloadOldFile?type=19&amp;oldFileUrl=ITU-R/M.2012-6/CCSA.37.114V1590.doc">https://www.ccsa.org.cn/api/portalsFile/downloadOldFile?type=19&amp;oldFileUrl=ITU-R/M.2012-6/CCSA.37.114V1590.doc</a>
ETSI	ETSI TS 137 114	15.9.0	Published	15.09.2020	<a href="https://www.etsi.org/deliver/etsi_ts/137100_137199/137114/15.09.00_60/ts_137114v150900p.pdf">https://www.etsi.org/deliver/etsi_ts/137100_137199/137114/15.09.00_60/ts_137114v150900p.pdf</a>
TSDSI	TSDSI STD T1.3GPP 37.114-15.9.0 V1.0.0	15.9.0	Published	30.08.2021	<a href="https://members.tdsi.in/index.php/s/fb7dpSMGiM7f82H">https://members.tdsi.in/index.php/s/fb7dpSMGiM7f82H</a>
TTA	TTAT.3G-37.114V15.9.0	15.9.0	Published	11.09.2020	<a href="http://committee.tta.or.kr/data/ttasDown.jsp?kind=ttastd&amp;pk_num=TTAT.3G-37.114V15.9.0">http://committee.tta.or.kr/data/ttasDown.jsp?kind=ttastd&amp;pk_num=TTAT.3G-37.114V15.9.0</a>
<b>Release 16</b>					
ATIS	ATIS.3GPP.37.114V1600	16.0.0	Published	28.06.2021	<a href="https://www.atis.org/3gpp-documents/Rel16/">https://www.atis.org/3gpp-documents/Rel16/</a>
CCSA	CCSA.37.114V1600	16.0.0	Published	01.06.2020	<a href="https://www.ccsa.org.cn/api/portalsFile/downloadOldFile?type=19&amp;oldFileUrl=ITU-R/M.2012-6/CCSA.37.114V1600.doc">https://www.ccsa.org.cn/api/portalsFile/downloadOldFile?type=19&amp;oldFileUrl=ITU-R/M.2012-6/CCSA.37.114V1600.doc</a>
ETSI	ETSI TS 137 114	16.0.0	Published	15.09.2020	<a href="https://www.etsi.org/deliver/etsi_ts/137100_137199/137114/16.00.00_60/ts_137114v160000p.pdf">https://www.etsi.org/deliver/etsi_ts/137100_137199/137114/16.00.00_60/ts_137114v160000p.pdf</a>
TSDSI	TSDSI STD T1.3GPP 37.114-16.0.0 V1.0.0	16.0.0	Published	30.08.2021	<a href="https://members.tdsi.in/index.php/s/cgij55wt4LKsgs">https://members.tdsi.in/index.php/s/cgij55wt4LKsgs</a>
TTA	TTAT.3G-37.114V16.0.0	16.0.0	Published	11.09.2020	<a href="http://committee.tta.or.kr/data/ttasDown.jsp?kind=ttastd&amp;pk_num=TTAT.3G-37.114V16.0.0">http://committee.tta.or.kr/data/ttasDown.jsp?kind=ttastd&amp;pk_num=TTAT.3G-37.114V16.0.0</a>
<b>Release 17</b>					
ATIS	ATIS.3GPP.37.114.V17.0.0	17.0.0	Published	21.02.2023	<a href="https://www.atis.org/3gpp-transpositions - Rel-17">https://www.atis.org/3gpp-transpositions - Rel-17</a>
CCSA	CCSA.37.114V1700	17.0.0	Published	01.03.2022	<a href="https://www.ccsa.org.cn/api/portalsFile/downloadOldFile?type=19&amp;oldFileUrl=ITU-R/M.2012-6/CCSA.37.114V1700.doc">https://www.ccsa.org.cn/api/portalsFile/downloadOldFile?type=19&amp;oldFileUrl=ITU-R/M.2012-6/CCSA.37.114V1700.doc</a>
ETSI	ETSI TS 137 114	17.0.0	Published	28.04.2022	<a href="https://www.etsi.org/deliver/etsi_ts/137100_137199/137114/17.00.00_60/ts_137114v170000p.pdf">https://www.etsi.org/deliver/etsi_ts/137100_137199/137114/17.00.00_60/ts_137114v170000p.pdf</a>
TSDSI	TSDSI STD T1.3GPP 37.114-17.0.0 V1.0.0	17.0.0	Published	29.07.2022	<a href="https://members.tdsi.in/s/dqy8kBj6zwKd7iy">https://members.tdsi.in/s/dqy8kBj6zwKd7iy</a>
TTA	TTAT.3G-37.114V17.0.0	17.0.0	Published	05.08.2022	<a href="http://committee.tta.or.kr/data/ttasDown.jsp?kind=ttastd&amp;pk_num=TTAT.3G-37.114V17.0.0">http://committee.tta.or.kr/data/ttasDown.jsp?kind=ttastd&amp;pk_num=TTAT.3G-37.114V17.0.0</a>

### 2.1.5.19 TS 37.141

#### E-UTRA, UTRA and GSM/EDGE; Multi-Standard Radio (MSR) Base Station (BS) conformance testing

This document specifies the Radio Frequency (RF) test methods and conformance requirements for E-UTRA, UTRA and GSM/EDGE Multi-Standard Radio (MSR) Base Station (BS).

SDO	Document No.	Version	Status	Issued date	Location
<b>Release 10</b>					
ATIS	ATIS.3GPP.37.141.V10.15.0	10.15.0	Published	21.02.2023	<a href="https://www.atis.org/3gpp-transpositions - Rel-10">https://www.atis.org/3gpp-transpositions - Rel-10</a>
CCSA	CCSA.37.141V10150	10.15.0	Published	01.03.2021	<a href="https://www.ccsa.org.cn/api/portalsFile/downloadOldFile?type=19&amp;oldFileUrl=ITU-R/M.2012-6/CCSA.37.141V10150.doc">https://www.ccsa.org.cn/api/portalsFile/downloadOldFile?type=19&amp;oldFileUrl=ITU-R/M.2012-6/CCSA.37.141V10150.doc</a>
ETSI	ETSI TS 137 141	10.15.0	Published	29.04.2021	<a href="https://www.etsi.org/deliver/etsi_ts/137100_137199/137141/10.15.00_60/ts_137141v101500p.pdf">https://www.etsi.org/deliver/etsi_ts/137100_137199/137141/10.15.00_60/ts_137141v101500p.pdf</a>
TSDSI	TSDSI STD T1.3GPP 37.141 10.15.0 V1.1.0	10.15.0	Published	02.05.2023	<a href="https://members.tdsi.in/s/xG6xyf2weQSLSeW">https://members.tdsi.in/s/xG6xyf2weQSLSeW</a>
TTA	TTAT.3G-37.141V10.15.0	10.15.0	Published	10.06.2021	<a href="http://committee.tta.or.kr/data/ttasDown.jsp?kind=ttastd&amp;pk_num=TTAT.3G-37.141V10.15.0">http://committee.tta.or.kr/data/ttasDown.jsp?kind=ttastd&amp;pk_num=TTAT.3G-37.141V10.15.0</a>

## 126

## Rec. ITU-R M.2012-6

### Release 11

ATIS	ATIS.3GPP.37.141.V11.16.0	11.16.0	Published	21.02.2023	<a href="https://www.atis.org/3gpp-transpositions - Rel-11">https://www.atis.org/3gpp-transpositions - Rel-11</a>
CCSA	CCSA.37.141V11160	11.16.0	Published	01.03.2021	<a href="https://www.ccsa.org.cn/api/portalsFile/downloadOldFile?type=19&amp;oldFileUrl=ITU-R/M.2012-6/CCSA.37.141V11160.doc">https://www.ccsa.org.cn/api/portalsFile/downloadOldFile?type=19&amp;oldFileUrl=ITU-R/M.2012-6/CCSA.37.141V11160.doc</a>
ETSI	ETSI TS 137 141	11.16.0	Published	27.04.2021	<a href="https://www.etsi.org/deliver/etsi_ts/137100_137199/137141/11.16.00_60/ts_137141v111600p.pdf">https://www.etsi.org/deliver/etsi_ts/137100_137199/137141/11.16.00_60/ts_137141v111600p.pdf</a>
TSDSI	TSDSI STD T1.3GPP 37.141 11.16.0 V1.1.0	11.16.0	Published	02.05.2023	<a href="https://members.tdsi.in/s/PXdEqgmwNWDNWCO">https://members.tdsi.in/s/PXdEqgmwNWDNWCO</a>
TTA	TTAT.3G-37.141V11.16.0	11.16.0	Published	10.06.2021	<a href="http://committee.tta.or.kr/data/ttasDown.jsp?kind=ttastd&amp;pk_num=TTAT.3G-37.141V11.16.0">http://committee.tta.or.kr/data/ttasDown.jsp?kind=ttastd&amp;pk_num=TTAT.3G-37.141V11.16.0</a>

### Release 12

ATIS	ATIS.3GPP.37.141.V12.14.0	12.14.0	Published	21.02.2023	<a href="https://www.atis.org/3gpp-transpositions - Rel-12">https://www.atis.org/3gpp-transpositions - Rel-12</a>
CCSA	CCSA.37.141V12140	12.14.0	Published	01.03.2021	<a href="https://www.ccsa.org.cn/api/portalsFile/downloadOldFile?type=19&amp;oldFileUrl=ITU-R/M.2012-6/CCSA.37.141V12140.doc">https://www.ccsa.org.cn/api/portalsFile/downloadOldFile?type=19&amp;oldFileUrl=ITU-R/M.2012-6/CCSA.37.141V12140.doc</a>
ETSI	ETSI TS 137 141	12.14.0	Published	29.04.2021	<a href="https://www.etsi.org/deliver/etsi_ts/137100_137199/137141/12.14.00_60/ts_137141v121400p.pdf">https://www.etsi.org/deliver/etsi_ts/137100_137199/137141/12.14.00_60/ts_137141v121400p.pdf</a>
TSDSI	TSDSI STD T1.3GPP 37.141 12.14.0 V1.1.0	12.14.0	Published	02.05.2023	<a href="https://members.tdsi.in/s/oE7XiotRxTSdRXX">https://members.tdsi.in/s/oE7XiotRxTSdRXX</a>
TTA	TTAT.3G-37.141V12.14.0	12.14.0	Published	10.06.2021	<a href="http://committee.tta.or.kr/data/ttasDown.jsp?kind=ttastd&amp;pk_num=TTAT.3G-37.141V12.14.0">http://committee.tta.or.kr/data/ttasDown.jsp?kind=ttastd&amp;pk_num=TTAT.3G-37.141V12.14.0</a>

### Release 13

ATIS	ATIS.3GPP.37.141.V13.15.0	13.15.0	Published	21.02.2023	<a href="https://www.atis.org/3gpp-transpositions - Rel-13">https://www.atis.org/3gpp-transpositions - Rel-13</a>
CCSA	CCSA.37.141V13150	13.15.0	Published	01.03.2021	<a href="https://www.ccsa.org.cn/api/portalsFile/downloadOldFile?type=19&amp;oldFileUrl=ITU-R/M.2012-6/CCSA.37.141V13150.doc">https://www.ccsa.org.cn/api/portalsFile/downloadOldFile?type=19&amp;oldFileUrl=ITU-R/M.2012-6/CCSA.37.141V13150.doc</a>
ETSI	ETSI TS 137 141	13.15.0	Published	29.04.2021	<a href="https://www.etsi.org/deliver/etsi_ts/137100_137199/137141/13.15.00_60/ts_137141v131500p.pdf">https://www.etsi.org/deliver/etsi_ts/137100_137199/137141/13.15.00_60/ts_137141v131500p.pdf</a>
TSDSI	TSDSI STD T1.3GPP 37.141-13.15.0 V1.1.0	13.15.0	Published	17.01.2023	<a href="https://members.tdsi.in/s/gzx4L4rO9rcQL7W">https://members.tdsi.in/s/gzx4L4rO9rcQL7W</a>
TTA	TTAT.3G-37.141V13.15.0	13.15.0	Published	10.06.2021	<a href="http://committee.tta.or.kr/data/ttasDown.jsp?kind=ttastd&amp;pk_num=TTAT.3G-37.141V13.15.0">http://committee.tta.or.kr/data/ttasDown.jsp?kind=ttastd&amp;pk_num=TTAT.3G-37.141V13.15.0</a>

### Release 14

ATIS	ATIS.3GPP.37.141.V14.14.0	14.14.0	Published	21.02.2023	<a href="https://www.atis.org/3gpp-transpositions - Rel-14">https://www.atis.org/3gpp-transpositions - Rel-14</a>
CCSA	CCSA.37.141V14140	14.14.0	Published	01.12.2021	<a href="https://www.ccsa.org.cn/api/portalsFile/downloadOldFile?type=19&amp;oldFileUrl=ITU-R/M.2012-6/CCSA.37.141V14140.doc">https://www.ccsa.org.cn/api/portalsFile/downloadOldFile?type=19&amp;oldFileUrl=ITU-R/M.2012-6/CCSA.37.141V14140.doc</a>
ETSI	ETSI TS 137 141	14.14.0	Published	16.03.2022	<a href="https://www.etsi.org/deliver/etsi_ts/137100_137199/137141/14.14.00_60/ts_137141v141400p.pdf">https://www.etsi.org/deliver/etsi_ts/137100_137199/137141/14.14.00_60/ts_137141v141400p.pdf</a>
TSDSI	TSDSI STD T1.3GPP 37.141-14.14.0 V1.1.0	14.14.0	Published	17.01.2023	<a href="https://members.tdsi.in/s/asJaD8xt9QxPrz5">https://members.tdsi.in/s/asJaD8xt9QxPrz5</a>
TTA	TTAT.3G-37.141V14.14.0	14.14.0	Published	14.03.2022	<a href="http://committee.tta.or.kr/data/ttasDown.jsp?kind=ttastd&amp;pk_num=TTAT.3G-37.141V14.14.0">http://committee.tta.or.kr/data/ttasDown.jsp?kind=ttastd&amp;pk_num=TTAT.3G-37.141V14.14.0</a>

### Release 15

ATIS	ATIS.3GPP.37.141.V15.20.0	15.20.0	Published	21.02.2023	<a href="https://www.atis.org/3gpp-transpositions - Rel-15">https://www.atis.org/3gpp-transpositions - Rel-15</a>
CCSA	CCSA.37.141V15200	15.20.0	Published	01.12.2022	<a href="https://www.ccsa.org.cn/api/portalsFile/downloadOldFile?type=19&amp;oldFileUrl=ITU-R/M.2012-6/CCSA.37.141V15200.doc">https://www.ccsa.org.cn/api/portalsFile/downloadOldFile?type=19&amp;oldFileUrl=ITU-R/M.2012-6/CCSA.37.141V15200.doc</a>
ETSI	ETSI TS 137 141	15.20.0	Published	19.01.2023	<a href="https://www.etsi.org/deliver/etsi_ts/137100_137199/137141/15.20.00_60/ts_137141v152000p.pdf">https://www.etsi.org/deliver/etsi_ts/137100_137199/137141/15.20.00_60/ts_137141v152000p.pdf</a>
TSDSI	TSDSI STD T1.3GPP 37.141 15.20.0 V1.3.0	15.20.0	Published	02.05.2023	<a href="https://members.tdsi.in/s/yMXoD5e7st3B8Pt">https://members.tdsi.in/s/yMXoD5e7st3B8Pt</a>
TTA	TTAT.3G-37.141V15.20.0	15.20.0	Published	16.03.2023	<a href="http://committee.tta.or.kr/data/ttasDown.jsp?kind=ttastd&amp;pk_num=TTAT.3G-37.141V15.20.0">http://committee.tta.or.kr/data/ttasDown.jsp?kind=ttastd&amp;pk_num=TTAT.3G-37.141V15.20.0</a>

### Release 16

ATIS	ATIS.3GPP.37.141.V16.16.0	16.16.0	Published	21.02.2023	<a href="https://www.atis.org/3gpp-transpositions - Rel-16">https://www.atis.org/3gpp-transpositions - Rel-16</a>
CCSA	CCSA.37.141V16160	16.16.0	Published	01.12.2022	<a href="https://www.ccsa.org.cn/api/portalsFile/downloadOldFile?type=19&amp;oldFileUrl=ITU-R/M.2012-6/CCSA.37.141V16160.doc">https://www.ccsa.org.cn/api/portalsFile/downloadOldFile?type=19&amp;oldFileUrl=ITU-R/M.2012-6/CCSA.37.141V16160.doc</a>
ETSI	ETSI TS 137 141	16.16.0	Published	19.01.2023	<a href="https://www.etsi.org/deliver/etsi_ts/137100_137199/137141/16.16.00_60/ts_137141v161600p.pdf">https://www.etsi.org/deliver/etsi_ts/137100_137199/137141/16.16.00_60/ts_137141v161600p.pdf</a>
TSDSI	TSDSI STD T1.3GPP 37.141 16.16.0 V1.3.0	16.16.0	Published	02.05.2023	<a href="https://members.tdsi.in/s/Kcs3Xsjc95rs8qq">https://members.tdsi.in/s/Kcs3Xsjc95rs8qq</a>
TTA	TTAT.3G-37.141V16.16.0	16.16.0	Published	16.03.2023	<a href="http://committee.tta.or.kr/data/ttasDown.jsp?kind=ttastd&amp;pk_num=TTAT.3G-37.141V16.16.0">http://committee.tta.or.kr/data/ttasDown.jsp?kind=ttastd&amp;pk_num=TTAT.3G-37.141V16.16.0</a>

### Release 17

ATIS	ATIS.3GPP.37.141.V17.8.0	17.8.0	Published	21.02.2023	<a href="https://www.atis.org/3gpp-transpositions - Rel-17">https://www.atis.org/3gpp-transpositions - Rel-17</a>
CCSA	CCSA.37.141V1780	17.8.0	Published	01.12.2022	<a href="https://www.ccsa.org.cn/api/portalsFile/downloadOldFile?type=19&amp;oldFileUrl=ITU-R/M.2012-6/CCSA.37.141V1780.doc">https://www.ccsa.org.cn/api/portalsFile/downloadOldFile?type=19&amp;oldFileUrl=ITU-R/M.2012-6/CCSA.37.141V1780.doc</a>
ETSI	ETSI TS 137 141	17.8.0	Published	19.01.2023	<a href="https://www.etsi.org/deliver/etsi_ts/137100_137199/137141/17.08.00_60/ts_137141v170800p.pdf">https://www.etsi.org/deliver/etsi_ts/137100_137199/137141/17.08.00_60/ts_137141v170800p.pdf</a>
TSDSI	TSDSI STD T1.3GPP 37.141 17.8.0 V1.3.0	17.8.0	Published	02.05.2023	<a href="https://members.tdsi.in/s/do8MjgHaKSONmii">https://members.tdsi.in/s/do8MjgHaKSONmii</a>
TTA	TTAT.3G-37.141V17.8.0	17.8.0	Published	16.03.2023	<a href="http://committee.tta.or.kr/data/ttasDown.jsp?kind=ttastd&amp;pk_num=TTAT.3G-37.141V17.8.0">http://committee.tta.or.kr/data/ttasDown.jsp?kind=ttastd&amp;pk_num=TTAT.3G-37.141V17.8.0</a>



## 2.1.5.20 TS 37.144

**User Equipment (UE) and Mobile Station (MS) GSM, UTRA and E-UTRA over the air performance requirements**

This document establishes over the air antenna minimum requirements for user equipment (UE) and mobile station (MS).

Handheld UE requirements are defined for roaming bands for the speech position (beside the head and beside the head and hand) and hand phantom browsing mode position. Laptop mounted equipment requirements are defined for roaming bands for the data transfer position (laptop ground plane phantom). Laptop embedded equipment requirements are defined for roaming bands for the data transfer position (free space).

All bands are potential roaming bands, and the requirements for roaming bands shall therefore be fulfilled for all bands supported by a UE/MS.

Requirements for operating bands are dependent on how the network has been built and are thus operator specific and cannot be specified here. Recommended performance values for operating bands (Annex B) are however included in this specification for information. It should be recognised that the ability to meet the recommended performance values depends on the number of frequency bands supported by the UE/MS.

SDO	Document No.	Version	Status	Issued date	Location
<b>Release 13</b>					
ATIS	ATIS.3GPP.37.144V1300	13.0.0	Published	28.06.2021	<a href="https://www.atis.org/3gpp-documents/Rel99-14/">https://www.atis.org/3gpp-documents/Rel99-14/</a>
CCSA	CCSA.37.144V1300	13.0.0	Published	01.06.2016	<a href="https://www.ccsa.org.cn/api/portalsFile/downloadOldFile?type=19&amp;oldFileUrl=ITU-R/M.2012-6/CCSA.37.144V1300.doc">https://www.ccsa.org.cn/api/portalsFile/downloadOldFile?type=19&amp;oldFileUrl=ITU-R/M.2012-6/CCSA.37.144V1300.doc</a>
ETSI	ETSI TS 137 144	13.0.0	Published	02.08.2016	<a href="https://www.etsi.org/deliver/etsi_ts/137100_137199/137144/13.00.00_60/ts_137144v130000p.pdf">https://www.etsi.org/deliver/etsi_ts/137100_137199/137144/13.00.00_60/ts_137144v130000p.pdf</a>
TSDSI	TSDSI STD T1.3GPP 37.144-13.0.0 V1.0.0	13.0.0	Published	30.08.2021	<a href="https://members.tdsi.in/index.php/s/gPjKy3NkXxXYPWp">https://members.tdsi.in/index.php/s/gPjKy3NkXxXYPWp</a>
TTA	TTAT.3G-37.144V13.0.0	13.0.0	Published	02.08.2021	<a href="http://committee.tta.or.kr/data/ttasDown.jsp?kind=ttastd&amp;pk_num=TTAT.3G-37.144V13.0.0">http://committee.tta.or.kr/data/ttasDown.jsp?kind=ttastd&amp;pk_num=TTAT.3G-37.144V13.0.0</a>
<b>Release 14</b>					
ATIS	ATIS.3GPP.37.144V1470	14.7.0	Published	28.06.2021	<a href="https://www.atis.org/3gpp-documents/Rel99-14/">https://www.atis.org/3gpp-documents/Rel99-14/</a>
CCSA	CCSA.37.144V1470	14.7.0	Published	01.06.2018	<a href="https://www.ccsa.org.cn/api/portalsFile/downloadOldFile?type=19&amp;oldFileUrl=ITU-R/M.2012-6/CCSA.37.144V1470.doc">https://www.ccsa.org.cn/api/portalsFile/downloadOldFile?type=19&amp;oldFileUrl=ITU-R/M.2012-6/CCSA.37.144V1470.doc</a>
ETSI	ETSI TS 137 144	14.7.0	Published	24.07.2018	<a href="https://www.etsi.org/deliver/etsi_ts/137100_137199/137144/14.07.00_60/ts_137144v140700p.pdf">https://www.etsi.org/deliver/etsi_ts/137100_137199/137144/14.07.00_60/ts_137144v140700p.pdf</a>
TSDSI	TSDSI STD T1.3GPP 37.144-14.7.0 V1.1.0	14.7.0	Published	30.08.2021	<a href="https://members.tdsi.in/index.php/s/OsTNDMcB8p3qnyM">https://members.tdsi.in/index.php/s/OsTNDMcB8p3qnyM</a>
TTA	TTAT.3G-37.144V14.7.0	14.7.0	Published	02.08.2021	<a href="http://committee.tta.or.kr/data/ttasDown.jsp?kind=ttastd&amp;pk_num=TTAT.3G-37.144V14.7.0">http://committee.tta.or.kr/data/ttasDown.jsp?kind=ttastd&amp;pk_num=TTAT.3G-37.144V14.7.0</a>
<b>Release 15</b>					
ATIS	ATIS.3GPP.37.144V1500	15.0.0	Published	28.06.2021	<a href="https://www.atis.org/3gpp-documents/Rel15/">https://www.atis.org/3gpp-documents/Rel15/</a>
CCSA	CCSA.37.144V1500	15.0.0	Published	01.06.2018	<a href="https://www.ccsa.org.cn/api/portalsFile/downloadOldFile?type=19&amp;oldFileUrl=ITU-R/M.2012-6/CCSA.37.144V1500.doc">https://www.ccsa.org.cn/api/portalsFile/downloadOldFile?type=19&amp;oldFileUrl=ITU-R/M.2012-6/CCSA.37.144V1500.doc</a>
ETSI	ETSI TS 137 144	15.0.0	Published	24.07.2018	<a href="https://www.etsi.org/deliver/etsi_ts/137100_137199/137144/15.00.00_60/ts_137144v150000p.pdf">https://www.etsi.org/deliver/etsi_ts/137100_137199/137144/15.00.00_60/ts_137144v150000p.pdf</a>
TSDSI	TSDSI STD T1.3GPP 37.144-15.0.0 V1.0.0	15.0.0	Published	30.08.2021	<a href="https://members.tdsi.in/index.php/s/n7oCHWkYB65cSfL">https://members.tdsi.in/index.php/s/n7oCHWkYB65cSfL</a>
TTA	TTAT.3G-37.144V15.0.0	15.0.0	Published	11.09.2020	<a href="http://committee.tta.or.kr/data/ttasDown.jsp?kind=ttastd&amp;pk_num=TTAT.3G-37.144V15.0.0">http://committee.tta.or.kr/data/ttasDown.jsp?kind=ttastd&amp;pk_num=TTAT.3G-37.144V15.0.0</a>
<b>Release 16</b>					
ATIS	ATIS.3GPP.37.144V1600	16.0.0	Published	28.06.2021	<a href="https://www.atis.org/3gpp-documents/Rel16/">https://www.atis.org/3gpp-documents/Rel16/</a>
CCSA	CCSA.37.144V1600	16.0.0	Published	01.06.2020	<a href="https://www.ccsa.org.cn/api/portalsFile/downloadOldFile?type=19&amp;oldFileUrl=ITU-R/M.2012-6/CCSA.37.144V1600.doc">https://www.ccsa.org.cn/api/portalsFile/downloadOldFile?type=19&amp;oldFileUrl=ITU-R/M.2012-6/CCSA.37.144V1600.doc</a>
ETSI	ETSI TS 137 144	16.0.0	Published	21.07.2020	<a href="https://www.etsi.org/deliver/etsi_ts/137100_137199/137144/16.00.00_60/ts_137144v160000p.pdf">https://www.etsi.org/deliver/etsi_ts/137100_137199/137144/16.00.00_60/ts_137144v160000p.pdf</a>
TSDSI	TSDSI STD T1.3GPP 37.144-16.0.0 V1.0.0	16.0.0	Published	30.08.2021	<a href="https://members.tdsi.in/index.php/s/7Q55f7Z6EsXzgbZ">https://members.tdsi.in/index.php/s/7Q55f7Z6EsXzgbZ</a>
TTA	TTAT.3G-37.144V16.0.0	16.0.0	Published	11.09.2020	<a href="http://committee.tta.or.kr/data/ttasDown.jsp?kind=ttastd&amp;pk_num=TTAT.3G-37.144V16.0.0">http://committee.tta.or.kr/data/ttasDown.jsp?kind=ttastd&amp;pk_num=TTAT.3G-37.144V16.0.0</a>
<b>Release 17</b>					
ATIS	ATIS.3GPP.37.144.V17.0.0	17.0.0	Published	21.02.2023	<a href="https://www.atis.org/3gpp-transpositions - Rel-17">https://www.atis.org/3gpp-transpositions - Rel-17</a>
CCSA	CCSA.37.144V1700	17.0.0	Published	01.03.2022	<a href="https://www.ccsa.org.cn/api/portalsFile/downloadOldFile?type=19&amp;oldFileUrl=ITU-R/M.2012-6/CCSA.37.144V1700.doc">https://www.ccsa.org.cn/api/portalsFile/downloadOldFile?type=19&amp;oldFileUrl=ITU-R/M.2012-6/CCSA.37.144V1700.doc</a>
ETSI	ETSI TS 137 144	17.0.0	Published	28.04.2022	<a href="https://www.etsi.org/deliver/etsi_ts/137100_137199/137144/17.00.00_60/ts_137144v170000p.pdf">https://www.etsi.org/deliver/etsi_ts/137100_137199/137144/17.00.00_60/ts_137144v170000p.pdf</a>
TSDSI	TSDSI STD T1.3GPP 37.144-17.0.0 V1.0.0	17.0.0	Published	29.07.2022	<a href="https://members.tdsi.in/s/adBKsprSnZMJxFL">https://members.tdsi.in/s/adBKsprSnZMJxFL</a>

**2.1.5.21 TS 37.145-1****Active Antenna System (AAS) Base Station (BS) conformance testing; Part 1: conducted conformance testing**

This document specifies the Radio Frequency (RF) test methods and conformance requirements for Single RAT E-UTRA, UTRA and Multi-Standard Radio (MSR) UTRA and EUTRA Active Antenna System (AAS) Base Station (BS). These have been derived from, and are consistent with the E-UTRA, UTRA AAS BS specification defined in 3GPP TS 25.104. The technical specification is in two parts: part 1 (this document) covers conducted requirements and part 2 covers radiated requirements.

SDO	Document No.	Version	Status	Issued date	Location
<b>Release 13</b>					
ATIS	ATIS.3GPP.37.145-1.V13.12.0	13.12.0	Published	21.02.2023	<a href="https://www.atis.org/3gpp-transpositions - Rel-13">https://www.atis.org/3gpp-transpositions - Rel-13</a>
CCSA	CCSA.37.145-1V13120	13.12.0	Published	01.03.2021	<a href="https://www.ccsa.org.cn/api/portalsFile/downloadOldFile?type=19&amp;oldFileUrl=ITU-R/M.2012-6/CCSA.37.145-1V13120.doc">https://www.ccsa.org.cn/api/portalsFile/downloadOldFile?type=19&amp;oldFileUrl=ITU-R/M.2012-6/CCSA.37.145-1V13120.doc</a>
ETSI	ETSI TS 137 145-1	13.12.0	Published	29.04.2021	<a href="https://www.etsi.org/deliver/etsi_ts/137100_137199/13714501/13.12.00_60/ts_13714501v131200p.pdf">https://www.etsi.org/deliver/etsi_ts/137100_137199/13714501/13.12.00_60/ts_13714501v131200p.pdf</a>
TSDSI	TSDSI STD T1.3GPP 37.145-1-13.12.0	13.12.0	Published	17.01.2023	<a href="https://members.tdsi.in/s/xTRSdf4WE3CjbSS">https://members.tdsi.in/s/xTRSdf4WE3CjbSS</a>
TTA	TTAT.3G-37.145-1V13.12.0	13.12.0	Published	10.06.2021	<a href="http://committee.tta.or.kr/data/ttasDown.jsp?kind=ttastd&amp;pk_num=TTAT.3G-37.145-1V13.12.0">http://committee.tta.or.kr/data/ttasDown.jsp?kind=ttastd&amp;pk_num=TTAT.3G-37.145-1V13.12.0</a>
<b>Release 14</b>					
ATIS	ATIS.3GPP.37.145-1.V14.11.0	14.11.0	Published	21.02.2023	<a href="https://www.atis.org/3gpp-transpositions - Rel-14">https://www.atis.org/3gpp-transpositions - Rel-14</a>
CCSA	CCSA.37.145-1V14110	14.11.0	Published	01.12.2021	<a href="https://www.ccsa.org.cn/api/portalsFile/downloadOldFile?type=19&amp;oldFileUrl=ITU-R/M.2012-6/CCSA.37.145-1V14110.doc">https://www.ccsa.org.cn/api/portalsFile/downloadOldFile?type=19&amp;oldFileUrl=ITU-R/M.2012-6/CCSA.37.145-1V14110.doc</a>
ETSI	ETSI TS 137 145-1	14.11.0	Published	16.03.2022	<a href="https://www.etsi.org/deliver/etsi_ts/137100_137199/13714501/14.11.00_60/ts_13714501v141100p.pdf">https://www.etsi.org/deliver/etsi_ts/137100_137199/13714501/14.11.00_60/ts_13714501v141100p.pdf</a>
TSDSI	TSDSI STD T1.3GPP 37.145-1-14.11.0	14.11.0	Published	17.01.2023	<a href="https://members.tdsi.in/s/C42DACKLciSX2Z3">https://members.tdsi.in/s/C42DACKLciSX2Z3</a>
TTA	TTAT.3G-37.145-1V14.11.0	14.11.0	Published	14.03.2022	<a href="http://committee.tta.or.kr/data/ttasDown.jsp?kind=ttastd&amp;pk_num=TTAT.3G-37.145-1V14.11.0">http://committee.tta.or.kr/data/ttasDown.jsp?kind=ttastd&amp;pk_num=TTAT.3G-37.145-1V14.11.0</a>
<b>Release 15</b>					
ATIS	ATIS.3GPP.37.145-1.V15.14.0	15.14.0	Published	21.02.2023	<a href="https://www.atis.org/3gpp-transpositions - Rel-15">https://www.atis.org/3gpp-transpositions - Rel-15</a>
CCSA	CCSA.37.145-1V15140	15.14.0	Published	01.06.2022	<a href="https://www.ccsa.org.cn/api/portalsFile/downloadOldFile?type=19&amp;oldFileUrl=ITU-R/M.2012-6/CCSA.37.145-1V15140.doc">https://www.ccsa.org.cn/api/portalsFile/downloadOldFile?type=19&amp;oldFileUrl=ITU-R/M.2012-6/CCSA.37.145-1V15140.doc</a>
ETSI	ETSI TS 137 145-1	15.14.0	Published	21.07.2022	<a href="https://www.etsi.org/deliver/etsi_ts/137100_137199/13714501/15.14.00_60/ts_13714501v151400p.pdf">https://www.etsi.org/deliver/etsi_ts/137100_137199/13714501/15.14.00_60/ts_13714501v151400p.pdf</a>
TSDSI	TSDSI STD T1.3GPP 37.145-1-15.14.0	15.14.0	Published	01.11.2022	<a href="https://members.tdsi.in/s/WwzDP3nRHQxaYCN">https://members.tdsi.in/s/WwzDP3nRHQxaYCN</a>
TTA	TTAT.3G-37.145-1V15.14.0	15.14.0	Published	21.10.2022	<a href="http://committee.tta.or.kr/data/ttasDown.jsp?kind=ttastd&amp;pk_num=TTAT.3G-37.145-1V15.14.0">http://committee.tta.or.kr/data/ttasDown.jsp?kind=ttastd&amp;pk_num=TTAT.3G-37.145-1V15.14.0</a>
<b>Release 16</b>					
ATIS	ATIS.3GPP.37.145-1.V16.11.0	16.11.0	Published	21.02.2023	<a href="https://www.atis.org/3gpp-transpositions - Rel-16">https://www.atis.org/3gpp-transpositions - Rel-16</a>
CCSA	CCSA.37.145-1V16110	16.11.0	Published	01.06.2022	<a href="https://www.ccsa.org.cn/api/portalsFile/downloadOldFile?type=19&amp;oldFileUrl=ITU-R/M.2012-6/CCSA.37.145-1V16110.doc">https://www.ccsa.org.cn/api/portalsFile/downloadOldFile?type=19&amp;oldFileUrl=ITU-R/M.2012-6/CCSA.37.145-1V16110.doc</a>
ETSI	ETSI TS 137 145-1	16.11.0	Published	21.07.2022	<a href="https://www.etsi.org/deliver/etsi_ts/137100_137199/13714501/16.11.00_60/ts_13714501v161100p.pdf">https://www.etsi.org/deliver/etsi_ts/137100_137199/13714501/16.11.00_60/ts_13714501v161100p.pdf</a>
TSDSI	TSDSI STD T1.3GPP 37.145-1-16.11.0	16.11.0	Published	01.11.2022	<a href="https://members.tdsi.in/s/tJsJm3gZAsp8Y9x">https://members.tdsi.in/s/tJsJm3gZAsp8Y9x</a>
TTA	TTAT.3G-37.145-1V16.11.0	16.11.0	Published	21.10.2022	<a href="http://committee.tta.or.kr/data/ttasDown.jsp?kind=ttastd&amp;pk_num=TTAT.3G-37.145-1V16.11.0">http://committee.tta.or.kr/data/ttasDown.jsp?kind=ttastd&amp;pk_num=TTAT.3G-37.145-1V16.11.0</a>
<b>Release 17</b>					
ATIS	ATIS.3GPP.37.145-1.V17.6.0	17.6.0	Published	21.02.2023	<a href="https://www.atis.org/3gpp-transpositions - Rel-17">https://www.atis.org/3gpp-transpositions - Rel-17</a>
CCSA	CCSA.37.145-1V1760	17.6.0	Published	01.06.2022	<a href="https://www.ccsa.org.cn/api/portalsFile/downloadOldFile?type=19&amp;oldFileUrl=ITU-R/M.2012-6/CCSA.37.145-1V1760.doc">https://www.ccsa.org.cn/api/portalsFile/downloadOldFile?type=19&amp;oldFileUrl=ITU-R/M.2012-6/CCSA.37.145-1V1760.doc</a>
ETSI	ETSI TS 137 145-1	17.6.0	Published	21.07.2022	<a href="https://www.etsi.org/deliver/etsi_ts/137100_137199/13714501/17.06.00_60/ts_13714501v170600p.pdf">https://www.etsi.org/deliver/etsi_ts/137100_137199/13714501/17.06.00_60/ts_13714501v170600p.pdf</a>
TSDSI	TSDSI STD T1.3GPP 37.145-1-17.6.0 V1.1.0	17.6.0	Published	01.11.2022	<a href="https://members.tdsi.in/s/Z3t5NrPpTqrXf3c">https://members.tdsi.in/s/Z3t5NrPpTqrXf3c</a>
TTA	TTAT.3G-37.145-1V17.6.0	17.6.0	Published	21.10.2022	<a href="http://committee.tta.or.kr/data/ttasDown.jsp?kind=ttastd&amp;pk_num=TTAT.3G-37.145-1V17.6.0">http://committee.tta.or.kr/data/ttasDown.jsp?kind=ttastd&amp;pk_num=TTAT.3G-37.145-1V17.6.0</a>

**2.1.5.22 TS 37.145-2****Active Antenna System (AAS) Base Station (BS) conformance testing; Part 2: radiated conformance testing**

This document specifies the Radio Frequency (RF) test methods and conformance requirements for Single RAT E-UTRA, UTRA and Multi-Standard Radio (MSR) UTRA and EUTRA Active Antenna System (AAS) Base Station (BS). These have been derived from, and are consistent with the E-UTRA, UTRA AAS BS specification defined in 3GPP TS 25.104. The technical specification is in 2 parts, part 1 covers conducted requirements and part 2 (this document) covers radiated requirements.

SDO	Document No.	Version	Status	Issued date	Location
<b>Release 13</b>					
ATIS	ATIS.3GPP.37.145-2.V13.13.1	13.13.1	Published	21.02.2023	<a href="https://www.atis.org/3gpp-transpositions - Rel-13">https://www.atis.org/3gpp-transpositions - Rel-13</a>
CCSA	CCSA.37.145-2V13131	13.13.1	Published	01.12.2020	<a href="https://www.ccsa.org.cn/api/portalsFile/downloadOldFile?type=19&amp;oldFileUrl=ITU-R/M.2012-6/CCSA.37.145-2V13131.doc">https://www.ccsa.org.cn/api/portalsFile/downloadOldFile?type=19&amp;oldFileUrl=ITU-R/M.2012-6/CCSA.37.145-2V13131.doc</a>
ETSI	ETSI TS 137 145-2	13.13.1	Published	25.01.2021	<a href="https://www.etsi.org/deliver/etsi_ts/137100_137199/13714502/13.13.01_60/ts_13714502v131301p.pdf">https://www.etsi.org/deliver/etsi_ts/137100_137199/13714502/13.13.01_60/ts_13714502v131301p.pdf</a>
TSDSI	TSDSI STD T1.3GPP 37.145-2-13.13.1	13.13.1	Published	17.01.2023	<a href="https://members.tdsi.in/s/TXmAnQ53wbmoK9b">https://members.tdsi.in/s/TXmAnQ53wbmoK9b</a>
TTA	TTAT.3G-37.145-2V13.13.1	13.13.1	Published	16.03.2023	<a href="http://committee.tta.or.kr/data/ttasDown.jsp?kind=ttastd&amp;pk_num=TTAT.3G-37.145-2V13.13.1">http://committee.tta.or.kr/data/ttasDown.jsp?kind=ttastd&amp;pk_num=TTAT.3G-37.145-2V13.13.1</a>
<b>Release 14</b>					
ATIS	ATIS.3GPP.37.145-2.V14.11.0	14.11.0	Published	21.02.2023	<a href="https://www.atis.org/3gpp-transpositions - Rel-14">https://www.atis.org/3gpp-transpositions - Rel-14</a>
CCSA	CCSA.37.145-2V14110	14.11.0	Published	01.12.2020	<a href="https://www.ccsa.org.cn/api/portalsFile/downloadOldFile?type=19&amp;oldFileUrl=ITU-R/M.2012-6/CCSA.37.145-2V14110.doc">https://www.ccsa.org.cn/api/portalsFile/downloadOldFile?type=19&amp;oldFileUrl=ITU-R/M.2012-6/CCSA.37.145-2V14110.doc</a>
ETSI	ETSI TS 137 145-2	14.11.0	Published	25.01.2021	<a href="https://www.etsi.org/deliver/etsi_ts/137100_137199/13714502/14.11.00_60/ts_13714502v141100p.pdf">https://www.etsi.org/deliver/etsi_ts/137100_137199/13714502/14.11.00_60/ts_13714502v141100p.pdf</a>
TSDSI	TSDSI STD T1.3GPP 37.145-2-14.11.0	14.11.0	Published	17.01.2023	<a href="https://members.tdsi.in/s/EdtRYBxZSowYPjR">https://members.tdsi.in/s/EdtRYBxZSowYPjR</a>
TTA	TTAT.3G-37.145-2V14.11.0	14.11.0	Published	16.03.2023	<a href="http://committee.tta.or.kr/data/ttasDown.jsp?kind=ttastd&amp;pk_num=TTAT.3G-37.145-2V14.11.0">http://committee.tta.or.kr/data/ttasDown.jsp?kind=ttastd&amp;pk_num=TTAT.3G-37.145-2V14.11.0</a>
<b>Release 15</b>					
ATIS	ATIS.3GPP.37.145-2.V15.15.0	15.15.0	Published	21.02.2023	<a href="https://www.atis.org/3gpp-transpositions - Rel-15">https://www.atis.org/3gpp-transpositions - Rel-15</a>
CCSA	CCSA.37.145-2V15150	15.15.0	Published	01.06.2022	<a href="https://www.ccsa.org.cn/api/portalsFile/downloadOldFile?type=19&amp;oldFileUrl=ITU-R/M.2012-6/CCSA.37.145-2V15150.doc">https://www.ccsa.org.cn/api/portalsFile/downloadOldFile?type=19&amp;oldFileUrl=ITU-R/M.2012-6/CCSA.37.145-2V15150.doc</a>
ETSI	ETSI TS 137 145-2	15.15.0	Published	21.07.2022	<a href="https://www.etsi.org/deliver/etsi_ts/137100_137199/13714502/15.15.00_60/ts_13714502v151500p.pdf">https://www.etsi.org/deliver/etsi_ts/137100_137199/13714502/15.15.00_60/ts_13714502v151500p.pdf</a>
TSDSI	TSDSI STD T1.3GPP 37.145-2-15.15.0	15.15.0	Published	01.11.2022	<a href="https://members.tdsi.in/s/DJqCcFKWMfMAe93">https://members.tdsi.in/s/DJqCcFKWMfMAe93</a>
TTA	TTAT.3G-37.145-2V15.15.0	15.15.0	Published	21.10.2022	<a href="http://committee.tta.or.kr/data/ttasDown.jsp?kind=ttastd&amp;pk_num=TTAT.3G-37.145-2V15.15.0">http://committee.tta.or.kr/data/ttasDown.jsp?kind=ttastd&amp;pk_num=TTAT.3G-37.145-2V15.15.0</a>
<b>Release 16</b>					
ATIS	ATIS.3GPP.37.145-2.V16.12.0	16.12.0	Published	21.02.2023	<a href="https://www.atis.org/3gpp-transpositions - Rel-16">https://www.atis.org/3gpp-transpositions - Rel-16</a>
CCSA	CCSA.37.145-2V16120	16.12.0	Published	01.06.2022	<a href="https://www.ccsa.org.cn/api/portalsFile/downloadOldFile?type=19&amp;oldFileUrl=ITU-R/M.2012-6/CCSA.37.145-2V16120.doc">https://www.ccsa.org.cn/api/portalsFile/downloadOldFile?type=19&amp;oldFileUrl=ITU-R/M.2012-6/CCSA.37.145-2V16120.doc</a>
ETSI	ETSI TS 137 145-2	16.12.0	Published	21.07.2022	<a href="https://www.etsi.org/deliver/etsi_ts/137100_137199/13714502/16.12.00_60/ts_13714502v161200p.pdf">https://www.etsi.org/deliver/etsi_ts/137100_137199/13714502/16.12.00_60/ts_13714502v161200p.pdf</a>
TSDSI	TSDSI STD T1.3GPP 37.145-2-16.12.0	16.12.0	Published	01.11.2022	<a href="https://members.tdsi.in/s/Rg5c6zJ2etbjxSF">https://members.tdsi.in/s/Rg5c6zJ2etbjxSF</a>
TTA	TTAT.3G-37.145-2V16.12.0	16.12.0	Published	21.10.2022	<a href="http://committee.tta.or.kr/data/ttasDown.jsp?kind=ttastd&amp;pk_num=TTAT.3G-37.145-2V16.12.0">http://committee.tta.or.kr/data/ttasDown.jsp?kind=ttastd&amp;pk_num=TTAT.3G-37.145-2V16.12.0</a>
<b>Release 17</b>					
ATIS	ATIS.3GPP.37.145-2.V17.6.0	17.6.0	Published	21.02.2023	<a href="https://www.atis.org/3gpp-transpositions - Rel-17">https://www.atis.org/3gpp-transpositions - Rel-17</a>
CCSA	CCSA.37.145-2V1760	17.6.0	Published	01.06.2022	<a href="https://www.ccsa.org.cn/api/portalsFile/downloadOldFile?type=19&amp;oldFileUrl=ITU-R/M.2012-6/CCSA.37.145-V1760.doc">https://www.ccsa.org.cn/api/portalsFile/downloadOldFile?type=19&amp;oldFileUrl=ITU-R/M.2012-6/CCSA.37.145-V1760.doc</a>
ETSI	ETSI TS 137 145-2	17.6.0	Published	21.07.2022	<a href="https://www.etsi.org/deliver/etsi_ts/137100_137199/13714502/17.06.00_60/ts_13714502v170600p.pdf">https://www.etsi.org/deliver/etsi_ts/137100_137199/13714502/17.06.00_60/ts_13714502v170600p.pdf</a>
TSDSI	TSDSI STD T1.3GPP 37.145-2-17.6.0 V1.1.0	17.6.0	Published	01.11.2022	<a href="https://members.tdsi.in/s/sY6zc4f4pz6RnYg">https://members.tdsi.in/s/sY6zc4f4pz6RnYg</a>
TTA	TTAT.3G-37.145-2V17.6.0	17.6.0	Published	21.10.2022	<a href="http://committee.tta.or.kr/data/ttasDown.jsp?kind=ttastd&amp;pk_num=TTAT.3G-37.145-2V17.6.0">http://committee.tta.or.kr/data/ttasDown.jsp?kind=ttastd&amp;pk_num=TTAT.3G-37.145-2V17.6.0</a>

## 2.1.5.23 TS 37.171

**Universal Terrestrial Radio Access (UTRA) and Evolved UTRA (E-UTRA); User Equipment (UE) performance requirements for RAT-Independent Positioning Enhancements**

This document establishes the minimum performance requirements for RAT-Independent Positioning Enhancements (e.g. MBS positioning technology) for FDD or TDD mode of UTRA and E-UTRA for the User Equipment (UE).

SDO	Document No.	Version	Status	Issued date	Location
<b>Release 13</b>					
ARIB	ARIB STD-T120-37.171.V13.2.0	13.2.0	Published	03.03.2023	<a href="https://www.arib.or.jp/english/html/overview/doc/T120_T23_SPECS/ARIB-STD-T120/Rel13/37/A37171-d20.pdf">https://www.arib.or.jp/english/html/overview/doc/T120_T23_SPECS/ARIB-STD-T120/Rel13/37/A37171-d20.pdf</a>
ATIS	ATIS.3GPP.37.171.V13.2.0	13.2.0	Published	21.02.2023	<a href="https://www.atis.org/3gpp-transpositions - Rel-13">https://www.atis.org/3gpp-transpositions - Rel-13</a>
CCSA	CCSA.37.171V1320	13.2.0	Published	01.09.2020	<a href="https://www.ccsa.org.cn/api/portalsFile/downloadOldFile?type=19&amp;oldFileUrl=ITU-R/M.2012-6/CCSA.37.171V1320.doc">https://www.ccsa.org.cn/api/portalsFile/downloadOldFile?type=19&amp;oldFileUrl=ITU-R/M.2012-6/CCSA.37.171V1320.doc</a>
ETSI	ETSI TS 137 171	13.2.0	Published	19.11.2020	<a href="https://www.etsi.org/deliver/etsi_ts/137100_137199/137171/13.02.00_60/ts_137171v130200p.pdf">https://www.etsi.org/deliver/etsi_ts/137100_137199/137171/13.02.00_60/ts_137171v130200p.pdf</a>
TSDSI	TSDSI STD T1.3GPP 37.171-13.2.0 V1.1.0	13.2.0	Published	17.01.2023	<a href="https://members.tdsi.in/s/cnj5esiWYcF8xqX">https://members.tdsi.in/s/cnj5esiWYcF8xqX</a>
TTA	TTAT.3G-37.171V13.2.0	13.2.0	Published	16.03.2023	<a href="http://committee.tta.or.kr/data/ttasDown.jsp?kind=ttastd&amp;pk_num=TTAT.3G-37.171V13.2.0">http://committee.tta.or.kr/data/ttasDown.jsp?kind=ttastd&amp;pk_num=TTAT.3G-37.171V13.2.0</a>
<b>Release 14</b>					
ARIB	ARIB STD-T120-37.171.V14.7.0	14.7.0	Published	03.03.2023	<a href="https://www.arib.or.jp/english/html/overview/doc/T120_T23_SPECS/ARIB-STD-T120/Rel14/37/A37171-e70.pdf">https://www.arib.or.jp/english/html/overview/doc/T120_T23_SPECS/ARIB-STD-T120/Rel14/37/A37171-e70.pdf</a>
ATIS	ATIS.3GPP.37.171.V14.7.0	14.7.0	Published	21.02.2023	<a href="https://www.atis.org/3gpp-transpositions - Rel-14">https://www.atis.org/3gpp-transpositions - Rel-14</a>
CCSA	CCSA.37.171V1470	14.7.0	Published	01.09.2020	<a href="https://www.ccsa.org.cn/api/portalsFile/downloadOldFile?type=19&amp;oldFileUrl=ITU-R/M.2012-6/CCSA.37.171V1470.doc">https://www.ccsa.org.cn/api/portalsFile/downloadOldFile?type=19&amp;oldFileUrl=ITU-R/M.2012-6/CCSA.37.171V1470.doc</a>
ETSI	ETSI TS 137 171	14.7.0	Published	19.11.2020	<a href="https://www.etsi.org/deliver/etsi_ts/137100_137199/137171/14.07.00_60/ts_137171v140700p.pdf">https://www.etsi.org/deliver/etsi_ts/137100_137199/137171/14.07.00_60/ts_137171v140700p.pdf</a>
TSDSI	TSDSI STD T1.3GPP 37.171-14.7.0 V1.1.0	14.7.0	Published	17.01.2023	<a href="https://members.tdsi.in/s/KJFS37t4xjPDQzm">https://members.tdsi.in/s/KJFS37t4xjPDQzm</a>
TTA	TTAT.3G-37.171V14.7.0	14.7.0	Published	16.03.2023	<a href="http://committee.tta.or.kr/data/ttasDown.jsp?kind=ttastd&amp;pk_num=TTAT.3G-37.171V14.7.0">http://committee.tta.or.kr/data/ttasDown.jsp?kind=ttastd&amp;pk_num=TTAT.3G-37.171V14.7.0</a>
<b>Release 15</b>					
ARIB	ARIB STD-T120-37.171.V15.4.0	15.4.0	Published	03.03.2023	<a href="https://www.arib.or.jp/english/html/overview/doc/T120_T23_SPECS/ARIB-STD-T120/Rel15/37/A37171-f40.pdf">https://www.arib.or.jp/english/html/overview/doc/T120_T23_SPECS/ARIB-STD-T120/Rel15/37/A37171-f40.pdf</a>
ATIS	ATIS.3GPP.37.171.V15.4.0	15.4.0	Published	21.02.2023	<a href="https://www.atis.org/3gpp-transpositions - Rel-15">https://www.atis.org/3gpp-transpositions - Rel-15</a>
CCSA	CCSA.37.171V1540	15.4.0	Published	01.09.2020	<a href="https://www.ccsa.org.cn/api/portalsFile/downloadOldFile?type=19&amp;oldFileUrl=ITU-R/M.2012-6/CCSA.37.171V1540.doc">https://www.ccsa.org.cn/api/portalsFile/downloadOldFile?type=19&amp;oldFileUrl=ITU-R/M.2012-6/CCSA.37.171V1540.doc</a>
ETSI	ETSI TS 137 171	15.4.0	Published	19.11.2020	<a href="https://www.etsi.org/deliver/etsi_ts/137100_137199/137171/15.04.00_60/ts_137171v150400p.pdf">https://www.etsi.org/deliver/etsi_ts/137100_137199/137171/15.04.00_60/ts_137171v150400p.pdf</a>
TSDSI	TSDSI STD T1.3GPP 37.171-15.4.0 V1.1.0	15.4.0	Published	01.11.2022	<a href="https://members.tdsi.in/s/94x9EG7SemxsE2s">https://members.tdsi.in/s/94x9EG7SemxsE2s</a>
TTA	TTAT.3G-37.171V15.4.0	15.4.0	Published	16.03.2023	<a href="http://committee.tta.or.kr/data/ttasDown.jsp?kind=ttastd&amp;pk_num=TTAT.3G-37.171V15.4.0">http://committee.tta.or.kr/data/ttasDown.jsp?kind=ttastd&amp;pk_num=TTAT.3G-37.171V15.4.0</a>
<b>Release 16</b>					
ARIB	ARIB STD-T120-37.171.V16.1.0	16.1.0	Published	03.03.2023	<a href="https://www.arib.or.jp/english/html/overview/doc/T120_T23_SPECS/ARIB-STD-T120/Rel16/37/A37171-g10.pdf">https://www.arib.or.jp/english/html/overview/doc/T120_T23_SPECS/ARIB-STD-T120/Rel16/37/A37171-g10.pdf</a>
ATIS	ATIS.3GPP.37.171.V16.1.0	16.1.0	Published	21.02.2023	<a href="https://www.atis.org/3gpp-transpositions - Rel-16">https://www.atis.org/3gpp-transpositions - Rel-16</a>
CCSA	CCSA.37.171V1610	16.1.0	Published	01.09.2020	<a href="https://www.ccsa.org.cn/api/portalsFile/downloadOldFile?type=19&amp;oldFileUrl=ITU-R/M.2012-6/CCSA.37.171V1610.doc">https://www.ccsa.org.cn/api/portalsFile/downloadOldFile?type=19&amp;oldFileUrl=ITU-R/M.2012-6/CCSA.37.171V1610.doc</a>
ETSI	ETSI TS 137 171	16.1.0	Published	19.11.2020	<a href="https://www.etsi.org/deliver/etsi_ts/137100_137199/137171/16.01.00_60/ts_137171v160100p.pdf">https://www.etsi.org/deliver/etsi_ts/137100_137199/137171/16.01.00_60/ts_137171v160100p.pdf</a>
TSDSI	TSDSI STD T1.3GPP 37.171-16.1.0 V1.1.0	16.1.0	Published	01.11.2022	<a href="https://members.tdsi.in/s/J3j2LzgEXYgM7Ba">https://members.tdsi.in/s/J3j2LzgEXYgM7Ba</a>
TTA	TTAT.3G-37.171V16.1.0	16.1.0	Published	16.03.2023	<a href="http://committee.tta.or.kr/data/ttasDown.jsp?kind=ttastd&amp;pk_num=TTAT.3G-37.171V16.1.0">http://committee.tta.or.kr/data/ttasDown.jsp?kind=ttastd&amp;pk_num=TTAT.3G-37.171V16.1.0</a>
<b>Release 17</b>					
ARIB	ARIB STD-T120-37.171.V17.0.0	17.0.0	Published	03.03.2023	<a href="https://www.arib.or.jp/english/html/overview/doc/T120_T23_SPECS/ARIB-STD-T120/Rel17/37/A37171-h00.pdf">https://www.arib.or.jp/english/html/overview/doc/T120_T23_SPECS/ARIB-STD-T120/Rel17/37/A37171-h00.pdf</a>
ATIS	ATIS.3GPP.37.171.V17.0.0	17.0.0	Published	21.02.2023	<a href="https://www.atis.org/3gpp-transpositions - Rel-17">https://www.atis.org/3gpp-transpositions - Rel-17</a>
CCSA	CCSA.37.171V1700	17.0.0	Published	01.03.2022	<a href="https://www.ccsa.org.cn/api/portalsFile/downloadOldFile?type=19&amp;oldFileUrl=ITU-R/M.2012-6/CCSA.37.171V1700.doc">https://www.ccsa.org.cn/api/portalsFile/downloadOldFile?type=19&amp;oldFileUrl=ITU-R/M.2012-6/CCSA.37.171V1700.doc</a>
ETSI	ETSI TS 137 171	17.0.0	Published	28.04.2022	<a href="https://www.etsi.org/deliver/etsi_ts/137100_137199/137171/17.00.00_60/ts_137171v170000p.pdf">https://www.etsi.org/deliver/etsi_ts/137100_137199/137171/17.00.00_60/ts_137171v170000p.pdf</a>
TSDSI	TSDSI STD T1.3GPP 37.171-17.0.0 V1.0.0	17.0.0	Published	29.07.2022	<a href="https://members.tdsi.in/s/jkGpq3tj2bwx527">https://members.tdsi.in/s/jkGpq3tj2bwx527</a>
TTA	TTAT.3G-37.171V17.0.0	17.0.0	Published	05.08.2022	<a href="http://committee.tta.or.kr/data/ttasDown.jsp?kind=ttastd&amp;pk_num=TTAT.3G-37.171V17.0.0">http://committee.tta.or.kr/data/ttasDown.jsp?kind=ttastd&amp;pk_num=TTAT.3G-37.171V17.0.0</a>

SDO	Document No.	Version	Issued date	Location
<b>Release 10</b>				
ARIB	ARIB STD-T120-37.320	10.4.0	28.09.2020	<a href="http://www.arib.or.jp/english/html/overview/doc/T120_T23_v2_00/2_T120/ARIB-STD-T120/Rel10/37/A37320-a40.pdf">http://www.arib.or.jp/english/html/overview/doc/T120_T23_v2_00/2_T120/ARIB-STD-T120/Rel10/37/A37320-a40.pdf</a>
ATIS	ATIS.3GPP.37.320V1040	10.4.0	28.06.2021	<a href="http://www.atis.org/3gpp-documents/Rel99-14/">http://www.atis.org/3gpp-documents/Rel99-14/</a>
CCSA	CCSA.37.320V1040	10.4.0	01.12.2011	<a href="http://www.ccsa.org.cn:9001/portalsFile/downloadOldFile?type=17&amp;oldFileUrl=M.2012.5/CCSA%20TS%2037.320%20V10.4.0.doc">http://www.ccsa.org.cn:9001/portalsFile/downloadOldFile?type=17&amp;oldFileUrl=M.2012.5/CCSA%20TS%2037.320%20V10.4.0.doc</a>
ETSI	ETSI TS 137 320	10.4.0	19.01.2012	<a href="https://www.etsi.org/deliver/etsi_ts/137300_137399/137320/10.04.00_60/ts_137320v100400p.pdf">https://www.etsi.org/deliver/etsi_ts/137300_137399/137320/10.04.00_60/ts_137320v100400p.pdf</a>
TSDSI	TSDSI STD T1.3GPP 37.320-10.4.0 V1.0.0	10.4.0	30.08.2021	<a href="https://members.tdsi.in/index.php/s/rxR7fMpK38e8fg">https://members.tdsi.in/index.php/s/rxR7fMpK38e8fg</a>
TTA	TTAT.3G-37.320V10.4.0	10.4.0	30.07.2021	<a href="http://www.tta.or.kr/data/ttasDown.jsp?where=14688&amp;pk_num=TTAT.3G-37.320V10.4.0">http://www.tta.or.kr/data/ttasDown.jsp?where=14688&amp;pk_num=TTAT.3G-37.320V10.4.0</a>
<b>Release 11</b>				
ARIB	ARIB STD-T120-37.320	11.4.0	28.09.2020	<a href="http://www.arib.or.jp/english/html/overview/doc/T120_T23_v2_00/2_T120/ARIB-STD-T120/Rel11/37/A37320-b40.pdf">http://www.arib.or.jp/english/html/overview/doc/T120_T23_v2_00/2_T120/ARIB-STD-T120/Rel11/37/A37320-b40.pdf</a>
ATIS	ATIS.3GPP.37.320V1140	11.4.0	28.06.2021	<a href="http://www.atis.org/3gpp-documents/Rel99-14/">http://www.atis.org/3gpp-documents/Rel99-14/</a>
CCSA	CCSA.37.320V1140	11.4.0	01.09.2014	<a href="http://www.ccsa.org.cn:9001/portalsFile/downloadOldFile?type=17&amp;oldFileUrl=M.2012.5/CCSA%20TS%2037.320%20V11.4.0.doc">http://www.ccsa.org.cn:9001/portalsFile/downloadOldFile?type=17&amp;oldFileUrl=M.2012.5/CCSA%20TS%2037.320%20V11.4.0.doc</a>
ETSI	ETSI TS 137 320	11.4.0	29.09.2014	<a href="https://www.etsi.org/deliver/etsi_ts/137300_137399/137320/11.04.00_60/ts_137320v110400p.pdf">https://www.etsi.org/deliver/etsi_ts/137300_137399/137320/11.04.00_60/ts_137320v110400p.pdf</a>
TSDSI	TSDSI STD T1.3GPP 37.320-11.4.0 V1.0.0	11.4.0	30.08.2021	<a href="https://members.tdsi.in/index.php/s/65JxwsKLxHkWsps">https://members.tdsi.in/index.php/s/65JxwsKLxHkWsps</a>
TTA	TTAT.3G-37.320V11.4.0	11.4.0	30.07.2021	<a href="http://www.tta.or.kr/data/ttasDown.jsp?where=14688&amp;pk_num=TTAT.3G-37.320V11.4.0">http://www.tta.or.kr/data/ttasDown.jsp?where=14688&amp;pk_num=TTAT.3G-37.320V11.4.0</a>
<b>Release 12</b>				
ARIB	ARIB STD-T120-37.320	12.2.0	28.09.2020	<a href="http://www.arib.or.jp/english/html/overview/doc/T120_T23_v2_00/2_T120/ARIB-STD-T120/Rel12/37/A37320-c20.pdf">http://www.arib.or.jp/english/html/overview/doc/T120_T23_v2_00/2_T120/ARIB-STD-T120/Rel12/37/A37320-c20.pdf</a>
ATIS	ATIS.3GPP.37.320V1220	12.2.0	28.06.2021	<a href="http://www.atis.org/3gpp-documents/Rel99-14/">http://www.atis.org/3gpp-documents/Rel99-14/</a>
CCSA	CCSA.37.320V1220	12.2.0	01.09.2014	<a href="http://www.ccsa.org.cn:9001/portalsFile/downloadOldFile?type=17&amp;oldFileUrl=M.2012.5/CCSA%20TS%2037.320%20V12.2.0.doc">http://www.ccsa.org.cn:9001/portalsFile/downloadOldFile?type=17&amp;oldFileUrl=M.2012.5/CCSA%20TS%2037.320%20V12.2.0.doc</a>
ETSI	ETSI TS 137 320	12.2.0	29.09.2014	<a href="https://www.etsi.org/deliver/etsi_ts/137300_137399/137320/12.02.00_60/ts_137320v120200p.pdf">https://www.etsi.org/deliver/etsi_ts/137300_137399/137320/12.02.00_60/ts_137320v120200p.pdf</a>
TSDSI	TSDSI STD T1.3GPP 37.320-12.2.0 V1.0.0	12.2.0	30.08.2021	<a href="https://members.tdsi.in/index.php/s/fAkXpxKFT66cAkw">https://members.tdsi.in/index.php/s/fAkXpxKFT66cAkw</a>
TTA	TTAT.3G-37.320V12.2.0	12.2.0	30.07.2021	<a href="http://www.tta.or.kr/data/ttasDown.jsp?where=14688&amp;pk_num=TTAT.3G-37.320V12.2.0">http://www.tta.or.kr/data/ttasDown.jsp?where=14688&amp;pk_num=TTAT.3G-37.320V12.2.0</a>
<b>Release 13</b>				
ARIB	ARIB STD-T120-37.320	13.1.0	28.09.2020	<a href="http://www.arib.or.jp/english/html/overview/doc/T120_T23_v2_00/2_T120/ARIB-STD-T120/Rel13/37/A37320-d10.pdf">http://www.arib.or.jp/english/html/overview/doc/T120_T23_v2_00/2_T120/ARIB-STD-T120/Rel13/37/A37320-d10.pdf</a>
ATIS	ATIS.3GPP.37.320V1310	13.1.0	28.06.2021	<a href="http://www.atis.org/3gpp-documents/Rel99-14/">http://www.atis.org/3gpp-documents/Rel99-14/</a>
CCSA	CCSA.37.320V1310	13.1.0	01.03.2016	<a href="http://www.ccsa.org.cn:9001/portalsFile/downloadOldFile?type=17&amp;oldFileUrl=M.2012.5/CCSA%20TS%2037.320%20V13.1.0.doc">http://www.ccsa.org.cn:9001/portalsFile/downloadOldFile?type=17&amp;oldFileUrl=M.2012.5/CCSA%20TS%2037.320%20V13.1.0.doc</a>
ETSI	ETSI TS 137 320	13.1.0	27.04.2016	<a href="https://www.etsi.org/deliver/etsi_ts/137300_137399/137320/13.01.00_60/ts_137320v130100p.pdf">https://www.etsi.org/deliver/etsi_ts/137300_137399/137320/13.01.00_60/ts_137320v130100p.pdf</a>
TSDSI	TSDSI STD T1.3GPP 37.320-13.1.0 V1.0.0	13.1.0	30.08.2021	<a href="https://members.tdsi.in/index.php/s/BGbEfeNY9b56YeC">https://members.tdsi.in/index.php/s/BGbEfeNY9b56YeC</a>
TTA	TTAT.3G-37.320V13.1.0	13.1.0	30.07.2021	<a href="http://www.tta.or.kr/data/ttasDown.jsp?where=14688&amp;pk_num=TTAT.3G-37.320V13.1.0">http://www.tta.or.kr/data/ttasDown.jsp?where=14688&amp;pk_num=TTAT.3G-37.320V13.1.0</a>
<b>Release 14</b>				
ARIB	ARIB STD-T120-37.320	14.0.0	28.09.2020	<a href="http://www.arib.or.jp/english/html/overview/doc/T120_T23_v2_00/2_T120/ARIB-STD-T120/Rel14/37/A37320-e00.pdf">http://www.arib.or.jp/english/html/overview/doc/T120_T23_v2_00/2_T120/ARIB-STD-T120/Rel14/37/A37320-e00.pdf</a>
ATIS	ATIS.3GPP.37.320V1400	14.0.0	28.06.2021	<a href="http://www.atis.org/3gpp-documents/Rel99-14/">http://www.atis.org/3gpp-documents/Rel99-14/</a>
CCSA	CCSA.37.320V1400	14.0.0	01.03.2017	<a href="http://www.ccsa.org.cn:9001/portalsFile/downloadOldFile?type=17&amp;oldFileUrl=M.2012.5/CCSA%20TS%2037.320%20V14.0.0.doc">http://www.ccsa.org.cn:9001/portalsFile/downloadOldFile?type=17&amp;oldFileUrl=M.2012.5/CCSA%20TS%2037.320%20V14.0.0.doc</a>
ETSI	ETSI TS 137 320	14.0.0	11.04.2017	<a href="https://www.etsi.org/deliver/etsi_ts/137300_137399/137320/14.00.00_60/ts_137320v140000p.pdf">https://www.etsi.org/deliver/etsi_ts/137300_137399/137320/14.00.00_60/ts_137320v140000p.pdf</a>
TSDSI	TSDSI STD T1.3GPP 37.320-14.0.0 V1.0.0	14.0.0	30.08.2021	<a href="https://members.tdsi.in/index.php/s/87HnW9ocwo55Cs2">https://members.tdsi.in/index.php/s/87HnW9ocwo55Cs2</a>
TTA	TTAT.3G-37.320V14.0.0	14.0.0	30.07.2021	<a href="http://www.tta.or.kr/data/ttasDown.jsp?where=14688&amp;pk_num=TTAT.3G-37.320V14.0.0">http://www.tta.or.kr/data/ttasDown.jsp?where=14688&amp;pk_num=TTAT.3G-37.320V14.0.0</a>
<b>Release 15</b>				
ARIB	ARIB STD-T120-37.320	15.0.0	28.09.2020	<a href="http://www.arib.or.jp/english/html/overview/doc/T120_T23_v2_00/2_T120/ARIB-STD-T120/Rel15/37/A37320-f00.pdf">http://www.arib.or.jp/english/html/overview/doc/T120_T23_v2_00/2_T120/ARIB-STD-T120/Rel15/37/A37320-f00.pdf</a>
ATIS	ATIS.3GPP.37.320V1500	15.0.0	28.06.2021	<a href="http://www.atis.org/3gpp-documents/Rel15">http://www.atis.org/3gpp-documents/Rel15</a>
CCSA	CCSA.37.320V1500	15.0.0	01.06.2018	<a href="http://www.ccsa.org.cn:9001/portalsFile/downloadOldFile?type=17&amp;oldFileUrl=M.2012.5/CCSA%20TS%2037.320%20V15.0.0.doc">http://www.ccsa.org.cn:9001/portalsFile/downloadOldFile?type=17&amp;oldFileUrl=M.2012.5/CCSA%20TS%2037.320%20V15.0.0.doc</a>
ETSI	ETSI TS 137 320	15.0.0	17.07.2018	<a href="https://www.etsi.org/deliver/etsi_ts/137300_137399/137320/15.00.00_60/ts_137320v150000p.pdf">https://www.etsi.org/deliver/etsi_ts/137300_137399/137320/15.00.00_60/ts_137320v150000p.pdf</a>
TSDSI	TSDSI STD T1.3GPP 37.320-15.0.0 V1.0.0	15.0.0	30.08.2021	<a href="https://members.tdsi.in/index.php/s/ZonFpABk5TG4HSc">https://members.tdsi.in/index.php/s/ZonFpABk5TG4HSc</a>
TTA	TTAT.3G-37.320V15.0.0	15.0.0	11.09.2020	<a href="http://www.tta.or.kr/data/ttasDown.jsp?where=14688&amp;pk_num=TTAT.3G-37.320V15.0.0">http://www.tta.or.kr/data/ttasDown.jsp?where=14688&amp;pk_num=TTAT.3G-37.320V15.0.0</a>
<b>Release 16</b>				
ARIB	ARIB STD-T120-37.320	16.1.0	28.09.2020	<a href="http://www.arib.or.jp/english/html/overview/doc/T120_T23_v2_00/2_T120/ARIB-STD-T120/Rel16/37/A37320-g10.pdf">http://www.arib.or.jp/english/html/overview/doc/T120_T23_v2_00/2_T120/ARIB-STD-T120/Rel16/37/A37320-g10.pdf</a>
ATIS	ATIS.3GPP.37.320V1610	16.1.0	28.06.2021	<a href="http://www.atis.org/3gpp-documents/Rel16">http://www.atis.org/3gpp-documents/Rel16</a>
CCSA	CCSA.37.320V1610	16.1.0	01.07.2020	<a href="http://www.ccsa.org.cn:9001/portalsFile/downloadOldFile?type=17&amp;oldFileUrl=M.2012.5/CCSA%20TS%2037.320%20V16.1.0.doc">http://www.ccsa.org.cn:9001/portalsFile/downloadOldFile?type=17&amp;oldFileUrl=M.2012.5/CCSA%20TS%2037.320%20V16.1.0.doc</a>

## 132

ETSI	ETSI TS 137 320	16.1.0	31.07.2020	<a href="https://www.etsi.org/deliver/etsi_ts/137300_137399/137320/16.01.00_60/ts_137320v160100p.pdf">https://www.etsi.org/deliver/etsi_ts/137300_137399/137320/16.01.00_60/ts_137320v160100p.pdf</a>
TSDSI	TSDSI STD T1.3GPP 37.320-16.1.0 V1.0.0	16.1.0	30.08.2021	<a href="https://members.tsd.si.in/index.php/s/Hm8dwf2YdJqExMw">https://members.tsd.si.in/index.php/s/Hm8dwf2YdJqExMw</a>
TTA	TTAT.3G-37.320V16.1.0	16.1.0	11.09.2020	<a href="http://www.tta.or.kr/data/ttasDown.jsp?where=14688&amp;pk_num=TTAT.3G-37.320V16.1.0">http://www.tta.or.kr/data/ttasDown.jsp?where=14688&amp;pk_num=TTAT.3G-37.320V16.1.0</a>

## Rec. ITU-R M.2012-6

### 2.1.6 User Equipment (UE) conformance testing

#### 2.1.6.1 TS 36.508

#### Evolved Universal Terrestrial Radio Access (E-UTRA) and Evolved Packet Core (EPC); Common test environments for User Equipment (UE) conformance testing

This document contains definitions of reference conditions and test signals, default parameters, reference radio bearer configurations used in radio bearer interoperability testing, common radio bearer configurations for other test purposes, common requirements for test equipment and generic set-up procedures for use in conformance tests for the 3<sup>rd</sup> Generation E-UTRAN User Equipment (UE).

SDO	Document No.	Version	Status	Issued date	Location
<b>Release 10</b>					
ARIB	ARIB STD-T120-36.508.V10.5.0	10.5.0	Published	03.03.2023	<a href="https://www.arib.or.jp/english/html/overview/doc/T120_T23_SPECS/ARIB-STD-T120/Rel10/36/A36508-a50.pdf">https://www.arib.or.jp/english/html/overview/doc/T120_T23_SPECS/ARIB-STD-T120/Rel10/36/A36508-a50.pdf</a>
ATIS	ATIS.3GPP.36.508V1050	10.5.0	Published	28.06.2021	<a href="https://www.atis.org/3gpp-documents/Rel99-14/">https://www.atis.org/3gpp-documents/Rel99-14/</a>
CCSA	CCSA.36.508V1050	10.5.0	Published	01.06.2013	<a href="https://www.ccsa.org.cn/api/portalsFile/downloadOldFile?type=19&amp;oldFileUrl=ITU-R/M.2012-6/CCSA.36.508V1050.doc">https://www.ccsa.org.cn/api/portalsFile/downloadOldFile?type=19&amp;oldFileUrl=ITU-R/M.2012-6/CCSA.36.508V1050.doc</a>
ETSI	ETSI TS 136 508	10.5.0	Published	02.07.2013	<a href="https://www.etsi.org/deliver/etsi_ts/136500_136599/136508/10.05.00_60/ts_136508v100500p.pdf">https://www.etsi.org/deliver/etsi_ts/136500_136599/136508/10.05.00_60/ts_136508v100500p.pdf</a>
TSDSI	TSDSI STD T1.3GPP 36.508-10.5.0 V1.0.0	10.5.0	Published	30.08.2021	<a href="https://members.tsd.si.in/index.php/s/ACeSX8Hngd3H7Ay">https://members.tsd.si.in/index.php/s/ACeSX8Hngd3H7Ay</a>
TTA	TTAT.3G-36.508V10.5.0	10.5.0	Published	02.08.2021	<a href="http://committee.tta.or.kr/data/ttasDown.jsp?kind=ttastd&amp;pk_num=TTAT.3G-36.508V10.5.0">http://committee.tta.or.kr/data/ttasDown.jsp?kind=ttastd&amp;pk_num=TTAT.3G-36.508V10.5.0</a>
<b>Release 11</b>					
ARIB	ARIB STD-T120-36.508.V11.4.0	11.4.0	Published	03.03.2023	<a href="https://www.arib.or.jp/english/html/overview/doc/T120_T23_SPECS/ARIB-STD-T120/Rel11/36/A36508-b40.pdf">https://www.arib.or.jp/english/html/overview/doc/T120_T23_SPECS/ARIB-STD-T120/Rel11/36/A36508-b40.pdf</a>
ATIS	ATIS.3GPP.36.508V1140	11.4.0	Published	28.06.2021	<a href="https://www.atis.org/3gpp-documents/Rel99-14/">https://www.atis.org/3gpp-documents/Rel99-14/</a>
CCSA	CCSA.36.508V1140	11.4.0	Published	01.03.2014	<a href="https://www.ccsa.org.cn/api/portalsFile/downloadOldFile?type=19&amp;oldFileUrl=ITU-R/M.2012-6/CCSA.36.508V1140.doc">https://www.ccsa.org.cn/api/portalsFile/downloadOldFile?type=19&amp;oldFileUrl=ITU-R/M.2012-6/CCSA.36.508V1140.doc</a>
ETSI	ETSI TS 136 508	11.4.0	Published	02.04.2014	<a href="https://www.etsi.org/deliver/etsi_ts/136500_136599/136508/11.04.00_60/ts_136508v110400p.pdf">https://www.etsi.org/deliver/etsi_ts/136500_136599/136508/11.04.00_60/ts_136508v110400p.pdf</a>
TSDSI	TSDSI STD T1.3GPP 36.508-11.4.0 V1.0.0	11.4.0	Published	30.08.2021	<a href="https://members.tsd.si.in/index.php/s/BAotreJ9A4BZ5a3">https://members.tsd.si.in/index.php/s/BAotreJ9A4BZ5a3</a>
TTA	TTAT.3G-36.508V11.4.0	11.4.0	Published	02.08.2021	<a href="http://committee.tta.or.kr/data/ttasDown.jsp?kind=ttastd&amp;pk_num=TTAT.3G-36.508V11.4.0">http://committee.tta.or.kr/data/ttasDown.jsp?kind=ttastd&amp;pk_num=TTAT.3G-36.508V11.4.0</a>
<b>Release 12</b>					
ARIB	ARIB STD-T120-36.508.V12.11.0	12.11.0	Published	03.03.2023	<a href="https://www.arib.or.jp/english/html/overview/doc/T120_T23_SPECS/ARIB-STD-T120/Rel12/36/A36508-cb0.pdf">https://www.arib.or.jp/english/html/overview/doc/T120_T23_SPECS/ARIB-STD-T120/Rel12/36/A36508-cb0.pdf</a>
ATIS	ATIS.3GPP.36.508V12110	12.11.0	Published	28.06.2021	<a href="https://www.atis.org/3gpp-documents/Rel99-14/">https://www.atis.org/3gpp-documents/Rel99-14/</a>
CCSA	CCSA.36.508V12110	12.11.0	Published	01.09.2016	<a href="https://www.ccsa.org.cn/api/portalsFile/downloadOldFile?type=19&amp;oldFileUrl=ITU-R/M.2012-6/CCSA.36.508V12110.doc">https://www.ccsa.org.cn/api/portalsFile/downloadOldFile?type=19&amp;oldFileUrl=ITU-R/M.2012-6/CCSA.36.508V12110.doc</a>
ETSI	ETSI TS 136 508	12.11.0	Published	02.11.2016	<a href="https://www.etsi.org/deliver/etsi_ts/136500_136599/136508/12.11.00_60/ts_136508v121100p.pdf">https://www.etsi.org/deliver/etsi_ts/136500_136599/136508/12.11.00_60/ts_136508v121100p.pdf</a>
TSDSI	TSDSI STD T1.3GPP 36.508-12.11.0 V1.0.0	12.11.0	Published	30.08.2021	<a href="https://members.tsd.si.in/index.php/s/i2ByLnJqXWjc6ji">https://members.tsd.si.in/index.php/s/i2ByLnJqXWjc6ji</a>
TTA	TTAT.3G-36.508V12.11.0	12.11.0	Published	02.08.2021	<a href="http://committee.tta.or.kr/data/ttasDown.jsp?kind=ttastd&amp;pk_num=TTAT.3G-36.508V12.11.0">http://committee.tta.or.kr/data/ttasDown.jsp?kind=ttastd&amp;pk_num=TTAT.3G-36.508V12.11.0</a>
<b>Release 13</b>					
ARIB	ARIB STD-T120-36.508.V13.3.1	13.3.1	Published	03.03.2023	<a href="https://www.arib.or.jp/english/html/overview/doc/T120_T23_SPECS/ARIB-STD-T120/Rel13/36/A36508-d31.pdf">https://www.arib.or.jp/english/html/overview/doc/T120_T23_SPECS/ARIB-STD-T120/Rel13/36/A36508-d31.pdf</a>
ATIS	ATIS.3GPP.36.508V1331	13.3.1	Published	28.06.2021	<a href="https://www.atis.org/3gpp-documents/Rel99-14/">https://www.atis.org/3gpp-documents/Rel99-14/</a>
CCSA	CCSA.36.508V1331	13.3.1	Published	01.03.2017	<a href="https://www.ccsa.org.cn/api/portalsFile/downloadOldFile?type=19&amp;oldFileUrl=ITU-R/M.2012-6/CCSA.36.508V1331.doc">https://www.ccsa.org.cn/api/portalsFile/downloadOldFile?type=19&amp;oldFileUrl=ITU-R/M.2012-6/CCSA.36.508V1331.doc</a>
ETSI	ETSI TS 136 508	13.3.1	Published	10.05.2017	<a href="https://www.etsi.org/deliver/etsi_ts/136500_136599/136508/13.03.01_60/ts_136508v130301p.pdf">https://www.etsi.org/deliver/etsi_ts/136500_136599/136508/13.03.01_60/ts_136508v130301p.pdf</a>
TSDSI	TSDSI STD T1.3GPP 36.508-13.3.1 V1.0.0	13.3.1	Published	30.08.2021	<a href="https://members.tsd.si.in/index.php/s/PTDS8BXWCad3GWj">https://members.tsd.si.in/index.php/s/PTDS8BXWCad3GWj</a>
TTA	TTAT.3G-36.508V13.3.1	13.3.1	Published	30.07.2021	<a href="http://committee.tta.or.kr/data/ttasDown.jsp?kind=ttastd&amp;pk_num=TTAT.3G-36.508V13.3.1">http://committee.tta.or.kr/data/ttasDown.jsp?kind=ttastd&amp;pk_num=TTAT.3G-36.508V13.3.1</a>
<b>Release 14</b>					
ARIB	ARIB STD-T120-36.508.V14.5.0	14.5.0	Published	03.03.2023	<a href="https://www.arib.or.jp/english/html/overview/doc/T120_T23_SPECS/ARIB-STD-T120/Rel14/36/A36508-e50.pdf">https://www.arib.or.jp/english/html/overview/doc/T120_T23_SPECS/ARIB-STD-T120/Rel14/36/A36508-e50.pdf</a>
ATIS	ATIS.3GPP.36.508V1450	14.5.0	Published	28.06.2021	<a href="https://www.atis.org/3gpp-documents/Rel99-14/">https://www.atis.org/3gpp-documents/Rel99-14/</a>
CCSA	CCSA.36.508V1450	14.5.0	Published	01.03.2018	<a href="https://www.ccsa.org.cn/api/portalsFile/downloadOldFile?type=19&amp;oldFileUrl=ITU-R/M.2012-6/CCSA.36.508V1450.doc">https://www.ccsa.org.cn/api/portalsFile/downloadOldFile?type=19&amp;oldFileUrl=ITU-R/M.2012-6/CCSA.36.508V1450.doc</a>

ETSI	ETSI TS 136 508	14.5.0	Published	10.04.2018	<a href="https://www.etsi.org/deliver/etsi_ts/136500_136599/136508/14.05.00_60/ts_136508v140500p.pdf">https://www.etsi.org/deliver/etsi_ts/136500_136599/136508/14.05.00_60/ts_136508v140500p.pdf</a>
TSDSI	TSDSI STD T1.3GPP 36.508-14.5.0 V1.1.0	14.5.0	Published	30.08.2021	<a href="https://members.tdsi.in/index.php/s/WHt8XryCXzmBGkq">https://members.tdsi.in/index.php/s/WHt8XryCXzmBGkq</a>
TTA	TTAT.3G-36.508V14.5.0	14.5.0	Published	30.07.2021	<a href="http://committee.tta.or.kr/data/ttasDown.jsp?kind=ttastd&amp;pk_num=TTAT.3G-36.508V14.5.0">http://committee.tta.or.kr/data/ttasDown.jsp?kind=ttastd&amp;pk_num=TTAT.3G-36.508V14.5.0</a>
<b>Release 15</b>					
ARIB	ARIB STD-T120-36.508.V15.6.0	15.6.0	Published	03.03.2023	<a href="https://www.arib.or.jp/english/html/overview/doc/T120_T23_SPECS/ARIB-STD-T120/Rel15/36/A36508-f60.pdf">https://www.arib.or.jp/english/html/overview/doc/T120_T23_SPECS/ARIB-STD-T120/Rel15/36/A36508-f60.pdf</a>
ATIS	ATIS.3GPP.36.508V1560	15.6.0	Published	28.06.2021	<a href="https://www.atis.org/3gpp-documents/Rel15/">https://www.atis.org/3gpp-documents/Rel15/</a>
CCSA	CCSA.36.508V1560	15.6.0	Published	01.03.2020	<a href="https://www.ccsa.org.cn/api/portalsFile/downloadOldFile?type=19&amp;oldFileUrl=ITU-R/M.2012-6/CCSA.36.508V1560.doc">https://www.ccsa.org.cn/api/portalsFile/downloadOldFile?type=19&amp;oldFileUrl=ITU-R/M.2012-6/CCSA.36.508V1560.doc</a>
ETSI	ETSI TS 136 508	15.6.0	Published	01.04.2020	<a href="https://www.etsi.org/deliver/etsi_ts/136500_136599/136508/15.06.00_60/ts_136508v150600p.pdf">https://www.etsi.org/deliver/etsi_ts/136500_136599/136508/15.06.00_60/ts_136508v150600p.pdf</a>
TSDSI	TSDSI STD T1.3GPP 36.508-15.6.0 V1.0.0	15.6.0	Published	30.08.2021	<a href="https://members.tdsi.in/index.php/s/eQ82dHHytdPKskQ">https://members.tdsi.in/index.php/s/eQ82dHHytdPKskQ</a>
TTA	TTAT.3G-36.508V15.6.0	15.6.0	Published	11.09.2020	<a href="http://committee.tta.or.kr/data/ttasDown.jsp?kind=ttastd&amp;pk_num=TTAT.3G-36.508V15.6.0">http://committee.tta.or.kr/data/ttasDown.jsp?kind=ttastd&amp;pk_num=TTAT.3G-36.508V15.6.0</a>
<b>Release 16</b>					
ARIB	ARIB STD-T120-36.508.V16.11.0	16.11.0	Published	03.03.2023	<a href="https://www.arib.or.jp/english/html/overview/doc/T120_T23_SPECS/ARIB-STD-T120/Rel16/36/A36508-gb0.pdf">https://www.arib.or.jp/english/html/overview/doc/T120_T23_SPECS/ARIB-STD-T120/Rel16/36/A36508-gb0.pdf</a>
ATIS	ATIS.3GPP.36.508.V16.11.0	16.11.0	Published	21.02.2023	<a href="https://www.atis.org/3gpp-transpositions - Rel-16">https://www.atis.org/3gpp-transpositions - Rel-16</a>
CCSA	CCSA.36.508V16110	16.11.0	Published	01.12.2021	<a href="https://www.ccsa.org.cn/api/portalsFile/downloadOldFile?type=19&amp;oldFileUrl=ITU-R/M.2012-6/CCSA.36.508V16110.doc">https://www.ccsa.org.cn/api/portalsFile/downloadOldFile?type=19&amp;oldFileUrl=ITU-R/M.2012-6/CCSA.36.508V16110.doc</a>
ETSI	ETSI TS 136 508	16.11.0	Published	20.01.2022	<a href="https://www.etsi.org/deliver/etsi_ts/136500_136599/136508/16.11.00_60/ts_136508v161100p.pdf">https://www.etsi.org/deliver/etsi_ts/136500_136599/136508/16.11.00_60/ts_136508v161100p.pdf</a>
TSDSI	TSDSI STD T1.3GPP 36.508-16.11.0 V1.1.0	16.11.0	Published	01.11.2022	<a href="https://members.tdsi.in/s/f9JwyRsM288rDbL">https://members.tdsi.in/s/f9JwyRsM288rDbL</a>
TTA	TTAT.3G-36.508V16.11.0	16.11.0	Published	14.03.2022	<a href="http://committee.tta.or.kr/data/ttasDown.jsp?kind=ttastd&amp;pk_num=TTAT.3G-36.508V16.11.0">http://committee.tta.or.kr/data/ttasDown.jsp?kind=ttastd&amp;pk_num=TTAT.3G-36.508V16.11.0</a>
<b>Release 17</b>					
ARIB	ARIB STD-T120-36.508.V17.4.0	17.4.0	Published	03.03.2023	<a href="https://www.arib.or.jp/english/html/overview/doc/T120_T23_SPECS/ARIB-STD-T120/Rel17/36/A36508-h40.pdf">https://www.arib.or.jp/english/html/overview/doc/T120_T23_SPECS/ARIB-STD-T120/Rel17/36/A36508-h40.pdf</a>
ATIS	ATIS.3GPP.36.508.V17.4.0	17.4.0	Published	21.02.2023	<a href="https://www.atis.org/3gpp-transpositions - Rel-17">https://www.atis.org/3gpp-transpositions - Rel-17</a>
CCSA	CCSA.36.508V1740	17.4.0	Published	01.12.2022	<a href="https://www.ccsa.org.cn/api/portalsFile/downloadOldFile?type=19&amp;oldFileUrl=ITU-R/M.2012-6/CCSA.36.508V1740.rar">https://www.ccsa.org.cn/api/portalsFile/downloadOldFile?type=19&amp;oldFileUrl=ITU-R/M.2012-6/CCSA.36.508V1740.rar</a>
ETSI	ETSI TS 136 508	17.4.0	Published	25.01.2023	<a href="https://www.etsi.org/deliver/etsi_ts/136500_136599/136508/17.04.00_60/ts_136508v170400p.pdf">https://www.etsi.org/deliver/etsi_ts/136500_136599/136508/17.04.00_60/ts_136508v170400p.pdf</a>
TSDSI	TSDSI STD T1.3GPP 36.508 17.4.0 V1.2.0	17.4.0	Published	02.05.2023	<a href="https://members.tdsi.in/s/3NDb9CBQjfMn46s">https://members.tdsi.in/s/3NDb9CBQjfMn46s</a>
TTA	TTAT.3G-36.508V17.4.0	17.4.0	Published	16.03.2023	<a href="http://committee.tta.or.kr/data/ttasDown.jsp?kind=ttastd&amp;pk_num=TTAT.3G-36.508V17.4.0">http://committee.tta.or.kr/data/ttasDown.jsp?kind=ttastd&amp;pk_num=TTAT.3G-36.508V17.4.0</a>

### 2.1.6.2 TS 36.509

#### Evolved Universal Terrestrial Radio Access (E-UTRA) and Evolved Packet Core (EPC); Special conformance testing functions for User Equipment (UE)

This document defines for User Equipment (UE) in E-UTRA FDD or TDD mode those special functions and their activation/deactivation methods that are required in UE for conformance testing purposes.

This document also describes the operation of these special functions for UEs supporting E-UTRA FDD or TDD mode, when operating in UTRA FDD and TDD mode, in GSM/GPRS mode, and in CDMA2000 mode.

SDO	Document No.	Version	Status	Issued date	Location
<b>Release 10</b>					
ARIB	ARIB STD-T120-36.509.V10.3.0	10.3.0	Published	03.03.2023	<a href="https://www.arib.or.jp/english/html/overview/doc/T120_T23_SPECS/ARIB-STD-T120/Rel10/36/A36509-a30.pdf">https://www.arib.or.jp/english/html/overview/doc/T120_T23_SPECS/ARIB-STD-T120/Rel10/36/A36509-a30.pdf</a>
ATIS	ATIS.3GPP.36.509V1030	10.3.0	Published	28.06.2021	<a href="https://www.atis.org/3gpp-documents/Rel99-14/">https://www.atis.org/3gpp-documents/Rel99-14/</a>
CCSA	CCSA.36.509V1030	10.3.0	Published	01.06.2013	<a href="https://www.ccsa.org.cn/api/portalsFile/downloadOldFile?type=19&amp;oldFileUrl=ITU-R/M.2012-6/CCSA.36.509V1030.doc">https://www.ccsa.org.cn/api/portalsFile/downloadOldFile?type=19&amp;oldFileUrl=ITU-R/M.2012-6/CCSA.36.509V1030.doc</a>
ETSI	ETSI TS 136 509	10.3.0	Published	26.09.2014	<a href="https://www.etsi.org/deliver/etsi_ts/136500_136599/136509/10.03.00_60/ts_136509v100300p.pdf">https://www.etsi.org/deliver/etsi_ts/136500_136599/136509/10.03.00_60/ts_136509v100300p.pdf</a>
TSDSI	TSDSI STD T1.3GPP 36.509-10.3.0 V1.0.0	10.3.0	Published	30.08.2021	<a href="https://members.tdsi.in/index.php/s/GACoEkT2fkfNXXW">https://members.tdsi.in/index.php/s/GACoEkT2fkfNXXW</a>
TTA	TTAT.3G-36.509V10.3.0	10.3.0	Published	30.07.2021	<a href="http://committee.tta.or.kr/data/ttasDown.jsp?kind=ttastd&amp;pk_num=TTAT.3G-36.509V10.3.0">http://committee.tta.or.kr/data/ttasDown.jsp?kind=ttastd&amp;pk_num=TTAT.3G-36.509V10.3.0</a>
<b>Release 11</b>					
ARIB	ARIB STD-T120-36.509.V11.0.0	11.0.0	Published	03.03.2023	<a href="https://www.arib.or.jp/english/html/overview/doc/T120_T23_SPECS/ARIB-STD-T120/Rel11/36/A36509-b00.pdf">https://www.arib.or.jp/english/html/overview/doc/T120_T23_SPECS/ARIB-STD-T120/Rel11/36/A36509-b00.pdf</a>
ATIS	ATIS.3GPP.36.509V1100	11.0.0	Published	28.06.2021	<a href="https://www.atis.org/3gpp-documents/Rel99-14/">https://www.atis.org/3gpp-documents/Rel99-14/</a>
CCSA	CCSA.36.509V1100	11.0.0	Published	01.06.2015	<a href="https://www.ccsa.org.cn/api/portalsFile/downloadOldFile?type=19&amp;oldFileUrl=ITU-R/M.2012-6/CCSA.36.509V1100.doc">https://www.ccsa.org.cn/api/portalsFile/downloadOldFile?type=19&amp;oldFileUrl=ITU-R/M.2012-6/CCSA.36.509V1100.doc</a>

**134**

ETSI	ETSI TS 136 509	11.0.0	Published	28.07.2015	<a href="https://www.etsi.org/deliver/etsi_ts/136500_136599/136509/11.00.00_60/ts_136509v110000p.pdf">https://www.etsi.org/deliver/etsi_ts/136500_136599/136509/11.00.00_60/ts_136509v110000p.pdf</a>
TSDSI	TSDSI STD T1.3GPP 36.509-11.0.0 V1.0.0	11.0.0	Published	30.08.2021	<a href="https://members.tdsi.in/index.php/s/dbrn6AMjaCrYqLy">https://members.tdsi.in/index.php/s/dbrn6AMjaCrYqLy</a>
TTA	TTAT.3G-36.509V11.0.0	11.0.0	Published	30.07.2021	<a href="http://committee.tta.or.kr/data/ttasDown.jsp?kind=ttastd&amp;pk_num=TTAT.3G-36.509V11.0.0">http://committee.tta.or.kr/data/ttasDown.jsp?kind=ttastd&amp;pk_num=TTAT.3G-36.509V11.0.0</a>

**Release 12**

ARIB	ARIB STD-T120-36.509.V12.4.0	12.4.0	Published	03.03.2023	<a href="https://www.arib.or.jp/english/html/overview/doc/T120_T23_SPECS/ARIB-STD-T120/Rel12/36/A36509-c40.pdf">https://www.arib.or.jp/english/html/overview/doc/T120_T23_SPECS/ARIB-STD-T120/Rel12/36/A36509-c40.pdf</a>
ATIS	ATIS.3GPP.36.509V1240	12.4.0	Published	28.06.2021	<a href="https://www.atis.org/3gpp-documents/Rel99-14/">https://www.atis.org/3gpp-documents/Rel99-14/</a>
CCSA	CCSA.36.509V1240	12.4.0	Published	01.06.2016	<a href="https://www.ccsa.org.cn/api/portalsFile/downloadOldFile?type=19&amp;oldFileUrl=ITU-R/M.2012-6/CCSA.36.509V1240.doc">https://www.ccsa.org.cn/api/portalsFile/downloadOldFile?type=19&amp;oldFileUrl=ITU-R/M.2012-6/CCSA.36.509V1240.doc</a>
ETSI	ETSI TS 136 509	12.4.0	Published	25.08.2016	<a href="https://www.etsi.org/deliver/etsi_ts/136500_136599/136509/12.04.00_60/ts_136509v120400p.pdf">https://www.etsi.org/deliver/etsi_ts/136500_136599/136509/12.04.00_60/ts_136509v120400p.pdf</a>
TSDSI	TSDSI STD T1.3GPP 36.509-12.4.0 V1.0.0	12.4.0	Published	30.08.2021	<a href="https://members.tdsi.in/index.php/s/rmMF7of2ywC8Xfz">https://members.tdsi.in/index.php/s/rmMF7of2ywC8Xfz</a>
TTA	TTAT.3G-36.509V12.4.0	12.4.0	Published	30.07.2021	<a href="http://committee.tta.or.kr/data/ttasDown.jsp?kind=ttastd&amp;pk_num=TTAT.3G-36.509V12.4.0">http://committee.tta.or.kr/data/ttasDown.jsp?kind=ttastd&amp;pk_num=TTAT.3G-36.509V12.4.0</a>

**Release 13**

ARIB	ARIB STD-T120-36.509.V13.8.0	13.8.0	Published	03.03.2023	<a href="https://www.arib.or.jp/english/html/overview/doc/T120_T23_SPECS/ARIB-STD-T120/Rel13/36/A36509-d80.pdf">https://www.arib.or.jp/english/html/overview/doc/T120_T23_SPECS/ARIB-STD-T120/Rel13/36/A36509-d80.pdf</a>
ATIS	ATIS.3GPP.36.509V1380	13.8.0	Published	28.06.2021	<a href="https://www.atis.org/3gpp-documents/Rel99-14/">https://www.atis.org/3gpp-documents/Rel99-14/</a>
CCSA	CCSA.36.509V1380	13.8.0	Published	01.12.2018	<a href="https://www.ccsa.org.cn/api/portalsFile/downloadOldFile?type=19&amp;oldFileUrl=ITU-R/M.2012-6/CCSA.36.509V1380.doc">https://www.ccsa.org.cn/api/portalsFile/downloadOldFile?type=19&amp;oldFileUrl=ITU-R/M.2012-6/CCSA.36.509V1380.doc</a>
ETSI	ETSI TS 136 509	13.8.0	Published	21.12.2018	<a href="https://www.etsi.org/deliver/etsi_ts/136500_136599/136509/13.08.00_60/ts_136509v130800p.pdf">https://www.etsi.org/deliver/etsi_ts/136500_136599/136509/13.08.00_60/ts_136509v130800p.pdf</a>
TSDSI	TSDSI STD T1.3GPP 36.509-13.8.0 V1.1.0	13.8.0	Published	30.08.2021	<a href="https://members.tdsi.in/index.php/s/mA3g4BdEQYjpDQb">https://members.tdsi.in/index.php/s/mA3g4BdEQYjpDQb</a>
TTA	TTAT.3G-36.509V13.8.0	13.8.0	Published	30.07.2021	<a href="http://committee.tta.or.kr/data/ttasDown.jsp?kind=ttastd&amp;pk_num=TTAT.3G-36.509V13.8.0">http://committee.tta.or.kr/data/ttasDown.jsp?kind=ttastd&amp;pk_num=TTAT.3G-36.509V13.8.0</a>

**Release 14**

ARIB	ARIB STD-T120-36.509.V14.7.0	14.7.0	Published	03.03.2023	<a href="https://www.arib.or.jp/english/html/overview/doc/T120_T23_SPECS/ARIB-STD-T120/Rel14/36/A36509-e70.pdf">https://www.arib.or.jp/english/html/overview/doc/T120_T23_SPECS/ARIB-STD-T120/Rel14/36/A36509-e70.pdf</a>
ATIS	ATIS.3GPP.36.509V1470	14.7.0	Published	28.06.2021	<a href="https://www.atis.org/3gpp-documents/Rel99-14/">https://www.atis.org/3gpp-documents/Rel99-14/</a>
CCSA	CCSA.36.509V1470	14.7.0	Published	01.12.2019	<a href="https://www.ccsa.org.cn/api/portalsFile/downloadOldFile?type=19&amp;oldFileUrl=ITU-R/M.2012-6/CCSA.36.509V1470.doc">https://www.ccsa.org.cn/api/portalsFile/downloadOldFile?type=19&amp;oldFileUrl=ITU-R/M.2012-6/CCSA.36.509V1470.doc</a>
ETSI	ETSI TS 136 509	14.7.0	Published	17.01.2020	<a href="https://www.etsi.org/deliver/etsi_ts/136500_136599/136509/14.07.00_60/ts_136509v140700p.pdf">https://www.etsi.org/deliver/etsi_ts/136500_136599/136509/14.07.00_60/ts_136509v140700p.pdf</a>
TSDSI	TSDSI STD T1.3GPP 36.509-14.7.0 V1.1.0	14.7.0	Published	30.08.2021	<a href="https://members.tdsi.in/index.php/s/p55SYk64oA2t44C">https://members.tdsi.in/index.php/s/p55SYk64oA2t44C</a>
TTA	TTAT.3G-36.509V14.7.0	14.7.0	Published	30.07.2021	<a href="http://committee.tta.or.kr/data/ttasDown.jsp?kind=ttastd&amp;pk_num=TTAT.3G-36.509V14.7.0">http://committee.tta.or.kr/data/ttasDown.jsp?kind=ttastd&amp;pk_num=TTAT.3G-36.509V14.7.0</a>

**Release 15**

ARIB	ARIB STD-T120-36.509.V15.5.0	15.5.0	Published	03.03.2023	<a href="https://www.arib.or.jp/english/html/overview/doc/T120_T23_SPECS/ARIB-STD-T120/Rel15/36/A36509-f50.pdf">https://www.arib.or.jp/english/html/overview/doc/T120_T23_SPECS/ARIB-STD-T120/Rel15/36/A36509-f50.pdf</a>
ATIS	ATIS.3GPP.36.509.V15.5.0	15.5.0	Published	21.02.2023	<a href="https://www.atis.org/3gpp-transpositions - Rel-15">https://www.atis.org/3gpp-transpositions - Rel-15</a>
CCSA	CCSA.36.509V1550	15.5.0	Published	01.03.2021	<a href="https://www.ccsa.org.cn/api/portalsFile/downloadOldFile?type=19&amp;oldFileUrl=ITU-R/M.2012-6/CCSA.36.509V1550.doc">https://www.ccsa.org.cn/api/portalsFile/downloadOldFile?type=19&amp;oldFileUrl=ITU-R/M.2012-6/CCSA.36.509V1550.doc</a>
ETSI	ETSI TS 136 509	15.5.0	Published	22.04.2021	<a href="https://www.etsi.org/deliver/etsi_ts/136500_136599/136509/15.05.00_60/ts_136509v150500p.pdf">https://www.etsi.org/deliver/etsi_ts/136500_136599/136509/15.05.00_60/ts_136509v150500p.pdf</a>
TSDSI	TSDSI STD T1.3GPP 36.509-15.5.0 V1.1.0	15.5.0	Published	01.11.2022	<a href="https://members.tdsi.in/s/sa2HQtpBpzZj23">https://members.tdsi.in/s/sa2HQtpBpzZj23</a>
TTA	TTAT.3G-36.509V15.5.0	15.5.0	Published	10.06.2021	<a href="http://committee.tta.or.kr/data/ttasDown.jsp?kind=ttastd&amp;pk_num=TTAT.3G-36.509V15.5.0">http://committee.tta.or.kr/data/ttasDown.jsp?kind=ttastd&amp;pk_num=TTAT.3G-36.509V15.5.0</a>

**Release 16**

ARIB	ARIB STD-T120-36.509.V16.4.0	16.4.0	Published	03.03.2023	<a href="https://www.arib.or.jp/english/html/overview/doc/T120_T23_SPECS/ARIB-STD-T120/Rel16/36/A36509-g40.pdf">https://www.arib.or.jp/english/html/overview/doc/T120_T23_SPECS/ARIB-STD-T120/Rel16/36/A36509-g40.pdf</a>
ATIS	ATIS.3GPP.36.509.V16.4.0	16.4.0	Published	21.02.2023	<a href="https://www.atis.org/3gpp-transpositions - Rel-16">https://www.atis.org/3gpp-transpositions - Rel-16</a>
CCSA	CCSA.36.509V1640	16.4.0	Published	01.12.2022	<a href="https://www.ccsa.org.cn/api/portalsFile/downloadOldFile?type=19&amp;oldFileUrl=ITU-R/M.2012-6/CCSA.36.509V1640.doc">https://www.ccsa.org.cn/api/portalsFile/downloadOldFile?type=19&amp;oldFileUrl=ITU-R/M.2012-6/CCSA.36.509V1640.doc</a>
ETSI	ETSI TS 136 509	16.4.0	Published	20.01.2023	<a href="https://www.etsi.org/deliver/etsi_ts/136500_136599/136509/16.04.00_60/ts_136509v160400p.pdf">https://www.etsi.org/deliver/etsi_ts/136500_136599/136509/16.04.00_60/ts_136509v160400p.pdf</a>
TSDSI	TSDSI STD T1.3GPP 36.509 16.4.0 V1.3.0	16.4.0	Published	02.05.2023	<a href="https://members.tdsi.in/s/iCnFDL2sxdqneiC">https://members.tdsi.in/s/iCnFDL2sxdqneiC</a>
TTA	TTAT.3G-36.509V16.4.0	16.4.0	Published	16.03.2023	<a href="http://committee.tta.or.kr/data/ttasDown.jsp?kind=ttastd&amp;pk_num=TTAT.3G-36.509V16.4.0">http://committee.tta.or.kr/data/ttasDown.jsp?kind=ttastd&amp;pk_num=TTAT.3G-36.509V16.4.0</a>

**Release 17**

ARIB	ARIB STD-T120-36.509.V17.2.0	17.2.0	Published	03.03.2023	<a href="https://www.arib.or.jp/english/html/overview/doc/T120_T23_SPECS/ARIB-STD-T120/Rel17/36/A36509-h20.pdf">https://www.arib.or.jp/english/html/overview/doc/T120_T23_SPECS/ARIB-STD-T120/Rel17/36/A36509-h20.pdf</a>
ATIS	ATIS.3GPP.36.509.V17.2.0	17.2.0	Published	21.02.2023	<a href="https://www.atis.org/3gpp-transpositions - Rel-17">https://www.atis.org/3gpp-transpositions - Rel-17</a>
CCSA	CCSA.36.509V1720	17.2.0	Published	01.12.2022	<a href="https://www.ccsa.org.cn/api/portalsFile/downloadOldFile?type=19&amp;oldFileUrl=ITU-R/M.2012-6/CCSA.36.509V1720.doc">https://www.ccsa.org.cn/api/portalsFile/downloadOldFile?type=19&amp;oldFileUrl=ITU-R/M.2012-6/CCSA.36.509V1720.doc</a>
ETSI	ETSI TS 136 509	17.2.0	Published	20.01.2023	<a href="https://www.etsi.org/deliver/etsi_ts/136500_136599/136509/17.02.00_60/ts_136509v170200p.pdf">https://www.etsi.org/deliver/etsi_ts/136500_136599/136509/17.02.00_60/ts_136509v170200p.pdf</a>
TSDSI	TSDSI STD T1.3GPP 36.509 17.2.0 V1.2.0	17.2.0	Published	02.05.2023	<a href="https://members.tdsi.in/s/ZHYqWb5oaHe22rQ">https://members.tdsi.in/s/ZHYqWb5oaHe22rQ</a>
TTA	TTAT.3G-36.509V17.2.0	17.2.0	Published	16.03.2023	<a href="http://committee.tta.or.kr/data/ttasDown.jsp?kind=ttastd&amp;pk_num=TTAT.3G-36.509V17.2.0">http://committee.tta.or.kr/data/ttasDown.jsp?kind=ttastd&amp;pk_num=TTAT.3G-36.509V17.2.0</a>



**2.1.6.3 TS 36.521-1****Evolved Universal Terrestrial Radio Access (E-UTRA); User Equipment (UE) conformance specification; Radio transmission and reception; Part 1: Conformance testing**

This document specifies the measurement procedures for the conformance test of the user equipment (UE) that contain transmitting characteristics, receiving characteristics and performance requirements as part of the 3G Long Term Evolution (3G LTE). Conformance test for the support of RRM (Radio Resource Management) are specified in TS 36.521-3.

The requirements are listed in different clauses only if the corresponding parameters deviate. More generally, tests are only applicable to those mobiles that are intended to support the appropriate functionality. To indicate the circumstances in which tests apply, this is noted in the “definition and applicability” part of the test.

For example, only Release 8 and later UE declared to support LTE shall be tested for this functionality. In the event that for some tests different conditions apply for different releases, this is indicated within the text of the test itself.

SDO	Document No.	Version	Status	Issued date	Location
<b>Release 10</b>					
ARIB	ARIB STD-T120-36.521-1.V10.6.0	10.6.0	Published	03.03.2023	<a href="https://www.arib.or.jp/english/html/overview/doc/T120_T23_SPECS/ARIB-STD-T120/Rel10/36/A36521-1-a60.pdf">https://www.arib.or.jp/english/html/overview/doc/T120_T23_SPECS/ARIB-STD-T120/Rel10/36/A36521-1-a60.pdf</a>
ATIS	ATIS.3GPP.36.521-1V1060	10.6.0	Published	28.06.2021	<a href="https://www.atis.org/3gpp-documents/Rel99-14/">https://www.atis.org/3gpp-documents/Rel99-14/</a>
CCSA	CCSA.36.521-1V1060	10.6.0	Published	01.03.2014	<a href="https://www.ccsa.org.cn/api/portalsFile/downloadOldFile?type=19&amp;oldFileUrl=ITU-R/M.2012-6/CCSA.36.521-1V1060.doc">https://www.ccsa.org.cn/api/portalsFile/downloadOldFile?type=19&amp;oldFileUrl=ITU-R/M.2012-6/CCSA.36.521-1V1060.doc</a>
ETSI	ETSI TS 136 521-1	10.6.0	Published	04.07.2013	<a href="https://www.etsi.org/deliver/etsi_ts/136500_136599/13652101/10.06.00_60/ts_13652101v100600p.pdf">https://www.etsi.org/deliver/etsi_ts/136500_136599/13652101/10.06.00_60/ts_13652101v100600p.pdf</a>
TSDSI	TSDSI STD T1.3GPP 36.521-1-10.6.0 V1.0.0	10.6.0	Published	30.08.2021	<a href="https://members.tdsi.in/index.php/s/J3XNA9kaTG9Nen9">https://members.tdsi.in/index.php/s/J3XNA9kaTG9Nen9</a>
TTA	TTAT.3G-36.521-1V10.6.0	10.6.0	Published	30.07.2021	<a href="http://committee.tta.or.kr/data/ttasDown.jsp?kind=ttastd&amp;pk_num=TTAT.3G-36.521-1V10.6.0">http://committee.tta.or.kr/data/ttasDown.jsp?kind=ttastd&amp;pk_num=TTAT.3G-36.521-1V10.6.0</a>
<b>Release 11</b>					
ARIB	ARIB STD-T120-36.521-1.V11.4.0	11.4.0	Published	03.03.2023	<a href="https://www.arib.or.jp/english/html/overview/doc/T120_T23_SPECS/ARIB-STD-T120/Rel11/36/A36521-1-b40.pdf">https://www.arib.or.jp/english/html/overview/doc/T120_T23_SPECS/ARIB-STD-T120/Rel11/36/A36521-1-b40.pdf</a>
ATIS	ATIS.3GPP.36.521-1V1140	11.4.0	Published	28.06.2021	<a href="https://www.atis.org/3gpp-documents/Rel99-14/">https://www.atis.org/3gpp-documents/Rel99-14/</a>
CCSA	CCSA.36.521-1V1140	11.4.0	Published	01.06.2013	<a href="https://www.ccsa.org.cn/api/portalsFile/downloadOldFile?type=19&amp;oldFileUrl=ITU-R/M.2012-6/CCSA.36.521-1V1140.doc">https://www.ccsa.org.cn/api/portalsFile/downloadOldFile?type=19&amp;oldFileUrl=ITU-R/M.2012-6/CCSA.36.521-1V1140.doc</a>
ETSI	ETSI TS 136 521-1	11.4.0	Published	26.03.2014	<a href="https://www.etsi.org/deliver/etsi_ts/136500_136599/13652101/11.04.00_60/ts_13652101v110400p.pdf">https://www.etsi.org/deliver/etsi_ts/136500_136599/13652101/11.04.00_60/ts_13652101v110400p.pdf</a>
TSDSI	TSDSI STD T1.3GPP 36.521-1-11.4.0 V1.0.0	11.4.0	Published	30.08.2021	<a href="https://members.tdsi.in/index.php/s/87PfCE9JBjtjG6P">https://members.tdsi.in/index.php/s/87PfCE9JBjtjG6P</a>
TTA	TTAT.3G-36.521-1V11.4.0	11.4.0	Published	30.07.2021	<a href="http://committee.tta.or.kr/data/ttasDown.jsp?kind=ttastd&amp;pk_num=TTAT.3G-36.521-1V11.4.0">http://committee.tta.or.kr/data/ttasDown.jsp?kind=ttastd&amp;pk_num=TTAT.3G-36.521-1V11.4.0</a>
<b>Release 12</b>					
ARIB	ARIB STD-T120-36.521-1.V12.9.0	12.9.0	Published	03.03.2023	<a href="https://www.arib.or.jp/english/html/overview/doc/T120_T23_SPECS/ARIB-STD-T120/Rel12/36/A36521-1-c90.pdf">https://www.arib.or.jp/english/html/overview/doc/T120_T23_SPECS/ARIB-STD-T120/Rel12/36/A36521-1-c90.pdf</a>
ATIS	ATIS.3GPP.36.521-1V1290	12.9.0	Published	28.06.2021	<a href="https://www.atis.org/3gpp-documents/Rel99-14/">https://www.atis.org/3gpp-documents/Rel99-14/</a>
CCSA	CCSA.36.521-1V1290	12.9.0	Published	01.03.2016	<a href="https://www.ccsa.org.cn/api/portalsFile/downloadOldFile?type=19&amp;oldFileUrl=ITU-R/M.2012-6/CCSA.36.521-1V1290.doc">https://www.ccsa.org.cn/api/portalsFile/downloadOldFile?type=19&amp;oldFileUrl=ITU-R/M.2012-6/CCSA.36.521-1V1290.doc</a>
ETSI	ETSI TS 136 521-1	12.9.0	Published	20.05.2016	<a href="https://www.etsi.org/deliver/etsi_ts/136500_136599/13652101/12.09.00_60/ts_13652101v120900p.pdf">https://www.etsi.org/deliver/etsi_ts/136500_136599/13652101/12.09.00_60/ts_13652101v120900p.pdf</a>
TSDSI	TSDSI STD T1.3GPP 36.521-1-12.9.0 V1.0.0	12.9.0	Published	30.08.2021	<a href="https://members.tdsi.in/index.php/s/fSb266AkCHBH8qp">https://members.tdsi.in/index.php/s/fSb266AkCHBH8qp</a>
TTA	TTAT.3G-36.521-1V12.9.0	12.9.0	Published	02.08.2021	<a href="http://committee.tta.or.kr/data/ttasDown.jsp?kind=ttastd&amp;pk_num=TTAT.3G-36.521-1V12.9.0">http://committee.tta.or.kr/data/ttasDown.jsp?kind=ttastd&amp;pk_num=TTAT.3G-36.521-1V12.9.0</a>
<b>Release 13</b>					
ARIB	ARIB STD-T120-36.521-1.V13.4.0	13.4.0	Published	03.03.2023	<a href="https://www.arib.or.jp/english/html/overview/doc/T120_T23_SPECS/ARIB-STD-T120/Rel13/36/A36521-1-d40.pdf">https://www.arib.or.jp/english/html/overview/doc/T120_T23_SPECS/ARIB-STD-T120/Rel13/36/A36521-1-d40.pdf</a>
ATIS	ATIS.3GPP.36.521-1V1340	13.4.0	Published	28.06.2021	<a href="https://www.atis.org/3gpp-documents/Rel99-14/">https://www.atis.org/3gpp-documents/Rel99-14/</a>
CCSA	CCSA.36.521-1V1340	13.4.0	Published	01.03.2017	<a href="https://www.ccsa.org.cn/api/portalsFile/downloadOldFile?type=19&amp;oldFileUrl=ITU-R/M.2012-6/CCSA.36.521-1V1340.doc">https://www.ccsa.org.cn/api/portalsFile/downloadOldFile?type=19&amp;oldFileUrl=ITU-R/M.2012-6/CCSA.36.521-1V1340.doc</a>
ETSI	ETSI TS 136 521-1	13.4.0	Published	11.04.2017	<a href="https://www.etsi.org/deliver/etsi_ts/136500_136599/13652101/13.04.00_60/ts_13652101v130400p.pdf">https://www.etsi.org/deliver/etsi_ts/136500_136599/13652101/13.04.00_60/ts_13652101v130400p.pdf</a>
TSDSI	TSDSI STD T1.3GPP 36.521-1-13.4.0 V1.0.0	13.4.0	Published	30.08.2021	<a href="https://members.tdsi.in/index.php/s/dkLcsY5ReL2ZQw8">https://members.tdsi.in/index.php/s/dkLcsY5ReL2ZQw8</a>
TTA	TTAT.3G-36.521-1V13.4.0	13.4.0	Published	02.08.2021	<a href="http://committee.tta.or.kr/data/ttasDown.jsp?kind=ttastd&amp;pk_num=TTAT.3G-36.521-1V13.4.0">http://committee.tta.or.kr/data/ttasDown.jsp?kind=ttastd&amp;pk_num=TTAT.3G-36.521-1V13.4.0</a>
<b>Release 14</b>					

## 136

## Rec. ITU-R M.2012-6

ARIB	ARIB STD-T120-36.521-1.V14.6.0	14.6.0	Published	03.03.2023	<a href="https://www.arib.or.jp/english/html/overview/doc/T120_T23_SPECS/ARIB-STD-T120/Rel14/36/A36521-1-e60.pdf">https://www.arib.or.jp/english/html/overview/doc/T120_T23_SPECS/ARIB-STD-T120/Rel14/36/A36521-1-e60.pdf</a>
ATIS	ATIS.3GPP.36.521-1V1460	14.6.0	Published	28.06.2021	<a href="https://www.atis.org/3gpp-documents/Rel99-14/">https://www.atis.org/3gpp-documents/Rel99-14/</a>
CCSA	CCSA.36.521-1V1460	14.6.0	Published	01.03.2018	<a href="https://www.ccsa.org.cn/api/portalsFile/downloadOldFile?type=19&amp;oldFileUrl=ITU-R/M.2012-6/CCSA.36.521-1V1460.doc">https://www.ccsa.org.cn/api/portalsFile/downloadOldFile?type=19&amp;oldFileUrl=ITU-R/M.2012-6/CCSA.36.521-1V1460.doc</a>
ETSI	ETSI TS 136 521-1	14.6.0	Published	10.04.2018	<a href="https://www.etsi.org/deliver/etsi_ts/136500_136599/13652101/14.06.00_60/ts_13652101v140600p.pdf">https://www.etsi.org/deliver/etsi_ts/136500_136599/13652101/14.06.00_60/ts_13652101v140600p.pdf</a>
TSDSI	TSDSI STD T1.3GPP 36.521-1-14.6.0 V1.1.0	14.6.0	Published	30.08.2021	<a href="https://members.tdsi.in/index.php/s/YcB4WWwt5nisCTT">https://members.tdsi.in/index.php/s/YcB4WWwt5nisCTT</a>
TTA	TTAT.3G-36.521-1V14.6.0	14.6.0	Published	02.08.2021	<a href="http://committee.tta.or.kr/data/ttasDown.jsp?kind=ttastd&amp;pk_num=TTAT.3G-36.521-1V14.6.0">http://committee.tta.or.kr/data/ttasDown.jsp?kind=ttastd&amp;pk_num=TTAT.3G-36.521-1V14.6.0</a>

### Release 15

ARIB	ARIB STD-T120-36.521-1.V15.6.0	15.6.0	Published	03.03.2023	<a href="https://www.arib.or.jp/english/html/overview/doc/T120_T23_SPECS/ARIB-STD-T120/Rel15/36/A36521-1-f60.pdf">https://www.arib.or.jp/english/html/overview/doc/T120_T23_SPECS/ARIB-STD-T120/Rel15/36/A36521-1-f60.pdf</a>
ATIS	ATIS.3GPP.36.521-1V1560	15.6.0	Published	28.06.2021	<a href="https://www.atis.org/3gpp-documents/Rel15/">https://www.atis.org/3gpp-documents/Rel15/</a>
CCSA	CCSA.36.521-1V1560	15.6.0	Published	01.03.2020	<a href="https://www.ccsa.org.cn/api/portalsFile/downloadOldFile?type=19&amp;oldFileUrl=ITU-R/M.2012-6/CCSA.36.521-1V1560.doc">https://www.ccsa.org.cn/api/portalsFile/downloadOldFile?type=19&amp;oldFileUrl=ITU-R/M.2012-6/CCSA.36.521-1V1560.doc</a>
ETSI	ETSI TS 136 521-1	15.6.0	Published	01.04.2020	<a href="https://www.etsi.org/deliver/etsi_ts/136500_136599/13652101/15.06.00_60/ts_13652101v150600p.pdf">https://www.etsi.org/deliver/etsi_ts/136500_136599/13652101/15.06.00_60/ts_13652101v150600p.pdf</a>
TSDSI	TSDSI STD T1.3GPP 36.521-1-15.6.0 V1.0.0	15.6.0	Published	30.08.2021	<a href="https://members.tdsi.in/index.php/s/Aeba2giLqtEJa3Q">https://members.tdsi.in/index.php/s/Aeba2giLqtEJa3Q</a>
TTA	TTAT.3G-36.521-1V15.6.0	15.6.0	Published	11.09.2020	<a href="http://committee.tta.or.kr/data/ttasDown.jsp?kind=ttastd&amp;pk_num=TTAT.3G-36.521-1V15.6.0">http://committee.tta.or.kr/data/ttasDown.jsp?kind=ttastd&amp;pk_num=TTAT.3G-36.521-1V15.6.0</a>

### Release 16

ARIB	ARIB STD-T120-36.521-1.V16.11.0	16.11.0	Published	03.03.2023	<a href="https://www.arib.or.jp/english/html/overview/doc/T120_T23_SPECS/ARIB-STD-T120/Rel16/36/A36521-1-gb0.pdf">https://www.arib.or.jp/english/html/overview/doc/T120_T23_SPECS/ARIB-STD-T120/Rel16/36/A36521-1-gb0.pdf</a>
ATIS	ATIS.3GPP.36.521-1.V16.11.0	16.11.0	Published	21.02.2023	<a href="https://www.atis.org/3gpp-transpositions - Rel-16">https://www.atis.org/3gpp-transpositions - Rel-16</a>
CCSA	CCSA.36.521-1V16110	16.11.0	Published	01.12.2021	<a href="https://www.ccsa.org.cn/api/portalsFile/downloadOldFile?type=19&amp;oldFileUrl=ITU-R/M.2012-6/CCSA.36.521-1V16110.doc">https://www.ccsa.org.cn/api/portalsFile/downloadOldFile?type=19&amp;oldFileUrl=ITU-R/M.2012-6/CCSA.36.521-1V16110.doc</a>
ETSI	ETSI TS 136 521-1	16.11.0	Published	26.01.2022	<a href="https://www.etsi.org/deliver/etsi_ts/136500_136599/13652101/16.11.00_60/ts_13652101v161100p.pdf">https://www.etsi.org/deliver/etsi_ts/136500_136599/13652101/16.11.00_60/ts_13652101v161100p.pdf</a>
TSDSI	TSDSI STD T1.3GPP 36.521-1-16.11.0	16.11.0	Published	01.11.2022	<a href="https://members.tdsi.in/s/crkEotFJk4nNWka">https://members.tdsi.in/s/crkEotFJk4nNWka</a>
TTA	TTAT.3G-36.521-1V16.11.0	16.11.0	Published	14.03.2022	<a href="http://committee.tta.or.kr/data/ttasDown.jsp?kind=ttastd&amp;pk_num=TTAT.3G-36.521-1V16.11.0">http://committee.tta.or.kr/data/ttasDown.jsp?kind=ttastd&amp;pk_num=TTAT.3G-36.521-1V16.11.0</a>

### Release 17

ARIB	ARIB STD-T120-36.521-1.V17.5.0	17.5.0	Published	03.03.2023	<a href="https://www.arib.or.jp/english/html/overview/doc/T120_T23_SPECS/ARIB-STD-T120/Rel17/36/A36521-1-h50.pdf">https://www.arib.or.jp/english/html/overview/doc/T120_T23_SPECS/ARIB-STD-T120/Rel17/36/A36521-1-h50.pdf</a>
ATIS	ATIS.3GPP.36.521-1.V17.5.0	17.5.0	Published	21.02.2023	<a href="https://www.atis.org/3gpp-transpositions - Rel-17">https://www.atis.org/3gpp-transpositions - Rel-17</a>
CCSA	CCSA.36.521-1V1750	17.5.0	Published	01.12.2022	<a href="https://www.ccsa.org.cn/api/portalsFile/downloadOldFile?type=19&amp;oldFileUrl=ITU-R/M.2012-6/CCSA.36.521-1V1750.rar">https://www.ccsa.org.cn/api/portalsFile/downloadOldFile?type=19&amp;oldFileUrl=ITU-R/M.2012-6/CCSA.36.521-1V1750.rar</a>
ETSI	ETSI TS 136 521-1	17.5.0	Published	31.01.2023	<a href="https://www.etsi.org/deliver/etsi_ts/136500_136599/13652101/17.05.00_60/ts_13652101v170500p.pdf">https://www.etsi.org/deliver/etsi_ts/136500_136599/13652101/17.05.00_60/ts_13652101v170500p.pdf</a>
TSDSI	TSDSI STD T1.3GPP 36.521-1 17.5.0 V1.3.0	17.5.0	Published	02.05.2023	<a href="https://members.tdsi.in/s/eMdazxb2cDLRqDH">https://members.tdsi.in/s/eMdazxb2cDLRqDH</a>
TTA	TTAT.3G-36.521-1V17.5.0	17.5.0	Published	16.03.2023	<a href="http://committee.tta.or.kr/data/ttasDown.jsp?kind=ttastd&amp;pk_num=TTAT.3G-36.521-1V17.5.0">http://committee.tta.or.kr/data/ttasDown.jsp?kind=ttastd&amp;pk_num=TTAT.3G-36.521-1V17.5.0</a>

## 2.1.6.4 TS 36.521-2

### Evolved Universal Terrestrial Radio Access (E-UTRA); User Equipment (UE) conformance specification; Radio transmission and reception; Part 2: Implementation Conformance Statement (ICS)

This document provides the ICS proforma for 3G Evolved Universal Terrestrial Radio Access (E-UTRA) User Equipment (UE), in compliance with the relevant requirements, and in accordance with the relevant guidance given in ISO/IEC 9646-1 and ISO/IEC 9646-7.

This document specifies the recommended applicability statement for the test cases included in 3GPP TS 36.521-1 and 3GPP TS 36.521-3. These applicability statements are based on the features implemented in the UE.

Special conformance testing functions can be found in 3GPP TS 36.509 and the common test environments are included in 3GPP TS 36.508.

This document is valid for UE implemented according to 3GPP releases starting from Release 8 up to the Release indicated on the cover page of this document.

SDO	Document No.	Version	Status	Issued date	Location
<b>Release 10</b>					
ARIB	ARIB STD-T120-36.521-2.V10.6.0	10.6.0	Published	03.03.2023	<a href="https://www.arib.or.jp/english/html/overview/doc/T120_T23_SPECS/ARIB-STD-T120/Rel10/36/A36521-2-a60.pdf">https://www.arib.or.jp/english/html/overview/doc/T120_T23_SPECS/ARIB-STD-T120/Rel10/36/A36521-2-a60.pdf</a>
ATIS	ATIS.3GPP.36.521-2V1060	10.6.0	Published	28.06.2021	<a href="https://www.atis.org/3gpp-documents/Rel99-14/">https://www.atis.org/3gpp-documents/Rel99-14/</a>
CCSA	CCSA.36.521-2V1060	10.6.0	Published	01.06.2013	<a href="https://www.ccsa.org.cn/api/portalsFile/downloadOldFile?type=19&amp;oldFileUrl=ITU-R/M.2012-6/CCSA.36.521-2V1060.doc">https://www.ccsa.org.cn/api/portalsFile/downloadOldFile?type=19&amp;oldFileUrl=ITU-R/M.2012-6/CCSA.36.521-2V1060.doc</a>
ETSI	ETSI TS 136 521-2	10.6.0	Published	02.07.2013	<a href="https://www.etsi.org/deliver/etsi_ts/136500_136599/13652102/10.06.00_60/ts_13652102v100600p.pdf">https://www.etsi.org/deliver/etsi_ts/136500_136599/13652102/10.06.00_60/ts_13652102v100600p.pdf</a>
TSDSI	TSDSI STD T1.3GPP 36.521-2-10.6.0 V1.0.0	10.6.0	Published	30.08.2021	<a href="https://members.tdsi.in/index.php/s/NeQgZ9G2rKfcNHg">https://members.tdsi.in/index.php/s/NeQgZ9G2rKfcNHg</a>
TTA	TTAT.3G-36.521-2V10.6.0	10.6.0	Published	02.08.2021	<a href="http://committee.tta.or.kr/data/ttasDown.jsp?kind=ttastd&amp;pk_num=TTAT.3G-36.521-2V10.6.0">http://committee.tta.or.kr/data/ttasDown.jsp?kind=ttastd&amp;pk_num=TTAT.3G-36.521-2V10.6.0</a>
<b>Release 11</b>					
ARIB	ARIB STD-T120-36.521-2.V11.4.0	11.4.0	Published	03.03.2023	<a href="https://www.arib.or.jp/english/html/overview/doc/T120_T23_SPECS/ARIB-STD-T120/Rel11/36/A36521-2-b40.pdf">https://www.arib.or.jp/english/html/overview/doc/T120_T23_SPECS/ARIB-STD-T120/Rel11/36/A36521-2-b40.pdf</a>
ATIS	ATIS.3GPP.36.521-2V1140	11.4.0	Published	28.06.2021	<a href="https://www.atis.org/3gpp-documents/Rel99-14/">https://www.atis.org/3gpp-documents/Rel99-14/</a>
CCSA	CCSA.36.521-2V1140	11.4.0	Published	01.03.2014	<a href="https://www.ccsa.org.cn/api/portalsFile/downloadOldFile?type=19&amp;oldFileUrl=ITU-R/M.2012-6/CCSA.36.521-2V1140.doc">https://www.ccsa.org.cn/api/portalsFile/downloadOldFile?type=19&amp;oldFileUrl=ITU-R/M.2012-6/CCSA.36.521-2V1140.doc</a>
ETSI	ETSI TS 136 521-2	11.4.0	Published	02.04.2014	<a href="https://www.etsi.org/deliver/etsi_ts/136500_136599/13652102/11.04.00_60/ts_13652102v110400p.pdf">https://www.etsi.org/deliver/etsi_ts/136500_136599/13652102/11.04.00_60/ts_13652102v110400p.pdf</a>
TSDSI	TSDSI STD T1.3GPP 36.521-2-11.4.0 V1.0.0	11.4.0	Published	30.08.2021	<a href="https://members.tdsi.in/index.php/s/SYo3b77S7MniQDn">https://members.tdsi.in/index.php/s/SYo3b77S7MniQDn</a>
TTA	TTAT.3G-36.521-2V11.4.0	11.4.0	Published	02.08.2021	<a href="http://committee.tta.or.kr/data/ttasDown.jsp?kind=ttastd&amp;pk_num=TTAT.3G-36.521-2V11.4.0">http://committee.tta.or.kr/data/ttasDown.jsp?kind=ttastd&amp;pk_num=TTAT.3G-36.521-2V11.4.0</a>
<b>Release 12</b>					
ARIB	ARIB STD-T120-36.521-2.V12.9.0	12.9.0	Published	03.03.2023	<a href="https://www.arib.or.jp/english/html/overview/doc/T120_T23_SPECS/ARIB-STD-T120/Rel12/36/A36521-2-c90.pdf">https://www.arib.or.jp/english/html/overview/doc/T120_T23_SPECS/ARIB-STD-T120/Rel12/36/A36521-2-c90.pdf</a>
ATIS	ATIS.3GPP.36.521-2V1290	12.9.0	Published	28.06.2021	<a href="https://www.atis.org/3gpp-documents/Rel99-14/">https://www.atis.org/3gpp-documents/Rel99-14/</a>
CCSA	CCSA.36.521-2V1290	12.9.0	Published	01.09.2016	<a href="https://www.ccsa.org.cn/api/portalsFile/downloadOldFile?type=19&amp;oldFileUrl=ITU-R/M.2012-6/CCSA.36.521-2V1290.doc">https://www.ccsa.org.cn/api/portalsFile/downloadOldFile?type=19&amp;oldFileUrl=ITU-R/M.2012-6/CCSA.36.521-2V1290.doc</a>
ETSI	ETSI TS 136 521-2	12.9.0	Published	14.11.2016	<a href="https://www.etsi.org/deliver/etsi_ts/136500_136599/13652102/12.09.00_60/ts_13652102v120900p.pdf">https://www.etsi.org/deliver/etsi_ts/136500_136599/13652102/12.09.00_60/ts_13652102v120900p.pdf</a>
TSDSI	TSDSI STD T1.3GPP 36.521-2-12.9.0 V1.0.0	12.9.0	Published	30.08.2021	<a href="https://members.tdsi.in/index.php/s/FawmDRMt5Wj23Zm">https://members.tdsi.in/index.php/s/FawmDRMt5Wj23Zm</a>
TTA	TTAT.3G-36.521-2V12.9.0	12.9.0	Published	02.08.2021	<a href="http://committee.tta.or.kr/data/ttasDown.jsp?kind=ttastd&amp;pk_num=TTAT.3G-36.521-2V12.9.0">http://committee.tta.or.kr/data/ttasDown.jsp?kind=ttastd&amp;pk_num=TTAT.3G-36.521-2V12.9.0</a>
<b>Release 13</b>					
ARIB	ARIB STD-T120-36.521-2.V13.4.0	13.4.0	Published	03.03.2023	<a href="https://www.arib.or.jp/english/html/overview/doc/T120_T23_SPECS/ARIB-STD-T120/Rel13/36/A36521-2-d40.pdf">https://www.arib.or.jp/english/html/overview/doc/T120_T23_SPECS/ARIB-STD-T120/Rel13/36/A36521-2-d40.pdf</a>
ATIS	ATIS.3GPP.36.521-2V1340	13.4.0	Published	28.06.2021	<a href="https://www.atis.org/3gpp-documents/Rel99-14/">https://www.atis.org/3gpp-documents/Rel99-14/</a>
CCSA	CCSA.36.521-2V1340	13.4.0	Published	01.03.2017	<a href="https://www.ccsa.org.cn/api/portalsFile/downloadOldFile?type=19&amp;oldFileUrl=ITU-R/M.2012-6/CCSA.36.521-2V1340.doc">https://www.ccsa.org.cn/api/portalsFile/downloadOldFile?type=19&amp;oldFileUrl=ITU-R/M.2012-6/CCSA.36.521-2V1340.doc</a>
ETSI	ETSI TS 136 521-2	13.4.0	Published	11.04.2017	<a href="https://www.etsi.org/deliver/etsi_ts/136500_136599/13652102/13.04.00_60/ts_13652102v130400p.pdf">https://www.etsi.org/deliver/etsi_ts/136500_136599/13652102/13.04.00_60/ts_13652102v130400p.pdf</a>
TSDSI	TSDSI STD T1.3GPP 36.521-2-13.4.0 V1.0.0	13.4.0	Published	30.08.2021	<a href="https://members.tdsi.in/index.php/s/eFDBzBqPmC55eSG">https://members.tdsi.in/index.php/s/eFDBzBqPmC55eSG</a>
TTA	TTAT.3G-36.521-2V13.4.0	13.4.0	Published	02.08.2021	<a href="http://committee.tta.or.kr/data/ttasDown.jsp?kind=ttastd&amp;pk_num=TTAT.3G-36.521-2V13.4.0">http://committee.tta.or.kr/data/ttasDown.jsp?kind=ttastd&amp;pk_num=TTAT.3G-36.521-2V13.4.0</a>
<b>Release 14</b>					
ARIB	ARIB STD-T120-36.521-2.V14.6.0	14.6.0	Published	03.03.2023	<a href="https://www.arib.or.jp/english/html/overview/doc/T120_T23_SPECS/ARIB-STD-T120/Rel14/36/A36521-2-e60.pdf">https://www.arib.or.jp/english/html/overview/doc/T120_T23_SPECS/ARIB-STD-T120/Rel14/36/A36521-2-e60.pdf</a>
ATIS	ATIS.3GPP.36.521-2V1460	14.6.0	Published	28.06.2021	<a href="https://www.atis.org/3gpp-documents/Rel99-14/">https://www.atis.org/3gpp-documents/Rel99-14/</a>
CCSA	CCSA.36.521-2V1460	14.6.0	Published	01.03.2018	<a href="https://www.ccsa.org.cn/api/portalsFile/downloadOldFile?type=19&amp;oldFileUrl=ITU-R/M.2012-6/CCSA.36.521-2V1460.doc">https://www.ccsa.org.cn/api/portalsFile/downloadOldFile?type=19&amp;oldFileUrl=ITU-R/M.2012-6/CCSA.36.521-2V1460.doc</a>
ETSI	ETSI TS 136 521-2	14.6.0	Published	10.04.2018	<a href="https://www.etsi.org/deliver/etsi_ts/136500_136599/13652102/14.06.00_60/ts_13652102v140600p.pdf">https://www.etsi.org/deliver/etsi_ts/136500_136599/13652102/14.06.00_60/ts_13652102v140600p.pdf</a>
TSDSI	TSDSI STD T1.3GPP 36.521-2-14.6.0 V1.1.0	14.6.0	Published	30.08.2021	<a href="https://members.tdsi.in/index.php/s/2Xk99x7driH8gwJ">https://members.tdsi.in/index.php/s/2Xk99x7driH8gwJ</a>
TTA	TTAT.3G-36.521-2V14.6.0	14.6.0	Published	02.08.2021	<a href="http://committee.tta.or.kr/data/ttasDown.jsp?kind=ttastd&amp;pk_num=TTAT.3G-36.521-2V14.6.0">http://committee.tta.or.kr/data/ttasDown.jsp?kind=ttastd&amp;pk_num=TTAT.3G-36.521-2V14.6.0</a>
<b>Release 15</b>					
ARIB	ARIB STD-T120-36.521-2.V15.6.0	15.6.0	Published	03.03.2023	<a href="https://www.arib.or.jp/english/html/overview/doc/T120_T23_SPECS/ARIB-STD-T120/Rel15/36/A36521-2-f60.pdf">https://www.arib.or.jp/english/html/overview/doc/T120_T23_SPECS/ARIB-STD-T120/Rel15/36/A36521-2-f60.pdf</a>
ATIS	ATIS.3GPP.36.521-2V1560	15.6.0	Published	28.06.2021	<a href="https://www.atis.org/3gpp-documents/Rel15/">https://www.atis.org/3gpp-documents/Rel15/</a>
CCSA	CCSA.36.521-2V1560	15.6.0	Published	01.03.2020	<a href="https://www.ccsa.org.cn/api/portalsFile/downloadOldFile?type=19&amp;oldFileUrl=ITU-R/M.2012-6/CCSA.36.521-2V1560.doc">https://www.ccsa.org.cn/api/portalsFile/downloadOldFile?type=19&amp;oldFileUrl=ITU-R/M.2012-6/CCSA.36.521-2V1560.doc</a>
ETSI	ETSI TS 136 521-2	15.6.0	Published	01.04.2020	<a href="https://www.etsi.org/deliver/etsi_ts/136500_136599/13652102/15.06.00_60/ts_13652102v150600p.pdf">https://www.etsi.org/deliver/etsi_ts/136500_136599/13652102/15.06.00_60/ts_13652102v150600p.pdf</a>
TSDSI	TSDSI STD T1.3GPP 36.521-2-15.6.0 V1.0.0	15.6.0	Published	30.08.2021	<a href="https://members.tdsi.in/index.php/s/7tH53FMJMEHB7x">https://members.tdsi.in/index.php/s/7tH53FMJMEHB7x</a>
TTA	TTAT.3G-36.521-2V15.6.0	15.6.0	Published	11.09.2020	<a href="http://committee.tta.or.kr/data/ttasDown.jsp?kind=ttastd&amp;pk_num=TTAT.3G-36.521-2V15.6.0">http://committee.tta.or.kr/data/ttasDown.jsp?kind=ttastd&amp;pk_num=TTAT.3G-36.521-2V15.6.0</a>

# 138

## Rec. ITU-R M.2012-6

<b>Release 16</b>					
ARIB	ARIB STD-T120-36.521-2.V16.15.0	16.15.0	Published	03.03.2023	<a href="https://www.arib.or.jp/english/html/overview/doc/T120_T23_SPECS/ARIB-STD-T120/Rel16/36/A36521-2-gf0.pdf">https://www.arib.or.jp/english/html/overview/doc/T120_T23_SPECS/ARIB-STD-T120/Rel16/36/A36521-2-gf0.pdf</a>
ATIS	ATIS.3GPP.36.521-2.V16.15.0	16.15.0	Published	21.02.2023	<a href="https://www.atis.org/3gpp-transpositions - Rel-16">https://www.atis.org/3gpp-transpositions - Rel-16</a>
CCSA	CCSA.36.521-2V16150	16.15.0	Published	01.12.2022	<a href="https://www.ccsa.org.cn/api/portalsFile/downloadOldFile?type=19&amp;oldFileUrl=ITU-R/M.2012-6/CCSA.36.521-2V16150.doc">https://www.ccsa.org.cn/api/portalsFile/downloadOldFile?type=19&amp;oldFileUrl=ITU-R/M.2012-6/CCSA.36.521-2V16150.doc</a>
ETSI	ETSI TS 136 521-2	16.15.0	Published	20.01.2023	<a href="https://www.etsi.org/deliver/etsi_ts/136500_136599/13652102/16.15.00_60/ts_13652102v161500p.pdf">https://www.etsi.org/deliver/etsi_ts/136500_136599/13652102/16.15.00_60/ts_13652102v161500p.pdf</a>
TSDSI	TSDSI STD T1.3GPP 36.521-2 16.15.0 V1.3.0	16.15.0	Published	02.05.2023	<a href="https://members.tdsi.in/s/8aBw9Xmmjf2HoNc">https://members.tdsi.in/s/8aBw9Xmmjf2HoNc</a>
TTA	TTAT.3G-36.521-2V16.15.0	16.15.0	Published	16.03.2023	<a href="http://committee.tta.or.kr/data/ttasDown.jsp?kind=ttastd&amp;pk_num=TTAT.3G-36.521-2V16.15.0">http://committee.tta.or.kr/data/ttasDown.jsp?kind=ttastd&amp;pk_num=TTAT.3G-36.521-2V16.15.0</a>
<b>Release 17</b>					
ARIB	ARIB STD-T120-36.521-2.V17.1.0	17.1.0	Published	03.03.2023	<a href="https://www.arib.or.jp/english/html/overview/doc/T120_T23_SPECS/ARIB-STD-T120/Rel17/36/A36521-2-h10.pdf">https://www.arib.or.jp/english/html/overview/doc/T120_T23_SPECS/ARIB-STD-T120/Rel17/36/A36521-2-h10.pdf</a>
ATIS	ATIS.3GPP.36.521-2.V17.1.0	17.1.0	Published	21.02.2023	<a href="https://www.atis.org/3gpp-transpositions - Rel-17">https://www.atis.org/3gpp-transpositions - Rel-17</a>
CCSA	CCSA.36.521-2V1710	17.1.0	Published	01.12.2022	<a href="https://www.ccsa.org.cn/api/portalsFile/downloadOldFile?type=19&amp;oldFileUrl=ITU-R/M.2012-6/CCSA.36.521-2V1710.doc">https://www.ccsa.org.cn/api/portalsFile/downloadOldFile?type=19&amp;oldFileUrl=ITU-R/M.2012-6/CCSA.36.521-2V1710.doc</a>
ETSI	ETSI TS 136 521-2	17.1.0	Published	24.01.2023	<a href="https://www.etsi.org/deliver/etsi_ts/136500_136599/13652102/17.01.00_60/ts_13652102v170100p.pdf">https://www.etsi.org/deliver/etsi_ts/136500_136599/13652102/17.01.00_60/ts_13652102v170100p.pdf</a>
TSDSI	TSDSI STD T1.3GPP 36.521-2 17.1.0 V1.1.0	17.1.0	Published	02.05.2023	<a href="https://members.tdsi.in/s/SH7aXsM3LG58kTj">https://members.tdsi.in/s/SH7aXsM3LG58kTj</a>
TTA	TTAT.3G-36.521-2V17.1.0	17.1.0	Published	16.03.2023	<a href="http://committee.tta.or.kr/data/ttasDown.jsp?kind=ttastd&amp;pk_num=TTAT.3G-36.521-2V17.1.0">http://committee.tta.or.kr/data/ttasDown.jsp?kind=ttastd&amp;pk_num=TTAT.3G-36.521-2V17.1.0</a>

### 2.1.6.5 TS 36.521-3

#### Evolved Universal Terrestrial Radio Access (E-UTRA); User Equipment (UE) conformance specification; Radio transmission and reception; Part 3: Radio Resource Management (RRM) conformance testing

This document specifies the measurement procedures for the conformance test of the user equipment (UE) that contain requirements for support of RRM (Radio Resource Management) as part of the 3G Long Term Evolution (3G LTE).

The requirements are listed in different clauses only if the corresponding parameters deviate. More generally, tests are only applicable to those mobiles that are intended to support the appropriate functionality. To indicate the circumstances in which tests apply, this is noted in the “test applicability” part of the test.

For example, only Release 8 and later UE declared to support LTE shall be tested for this functionality. In the event that for some tests different conditions apply for different releases, this is indicated within the text of the test itself.

SDO	Document No.	Version	Status	Issued date	Location
<b>Release 10</b>					
ARIB	ARIB STD-T120-36.521-3.V10.5.0	10.5.0	Published	03.03.2023	<a href="https://www.arib.or.jp/english/html/overview/doc/T120_T23_SPECS/ARIB-STD-T120/Rel10/36/A36521-3-a50.pdf">https://www.arib.or.jp/english/html/overview/doc/T120_T23_SPECS/ARIB-STD-T120/Rel10/36/A36521-3-a50.pdf</a>
ATIS	ATIS.3GPP.36.521-3V1050	10.5.0	Published	28.06.2021	<a href="https://www.atis.org/3gpp-documents/Rel99-14/">https://www.atis.org/3gpp-documents/Rel99-14/</a>
CCSA	CCSA.36.521-3V1050	10.5.0	Published	01.09.2016	<a href="https://www.ccsa.org.cn/api/portalsFile/downloadOldFile?type=19&amp;oldFileUrl=ITU-R/M.2012-6/CCSA.36.521-3V1050.doc">https://www.ccsa.org.cn/api/portalsFile/downloadOldFile?type=19&amp;oldFileUrl=ITU-R/M.2012-6/CCSA.36.521-3V1050.doc</a>
ETSI	ETSI TS 136 521-3	10.5.0	Published	14.11.2016	<a href="https://www.etsi.org/deliver/etsi_ts/136500_136599/13652103/10.05.00_60/ts_13652103v100500p.pdf">https://www.etsi.org/deliver/etsi_ts/136500_136599/13652103/10.05.00_60/ts_13652103v100500p.pdf</a>
TSDSI	TSDSI STD T1.3GPP 36.521-3-10.5.0 V1.0.0	10.5.0	Published	30.08.2021	<a href="https://members.tdsi.in/index.php/s/Gb5gAqHqYqz46wk">https://members.tdsi.in/index.php/s/Gb5gAqHqYqz46wk</a>
TTA	TTAT.3G-36.521-3V10.5.0	10.5.0	Published	02.08.2021	<a href="http://committee.tta.or.kr/data/ttasDown.jsp?kind=ttastd&amp;pk_num=TTAT.3G-36.521-3V10.5.0">http://committee.tta.or.kr/data/ttasDown.jsp?kind=ttastd&amp;pk_num=TTAT.3G-36.521-3V10.5.0</a>
<b>Release 11</b>					
ARIB	ARIB STD-T120-36.521-3.V11.4.0	11.4.0	Published	03.03.2023	<a href="https://www.arib.or.jp/english/html/overview/doc/T120_T23_SPECS/ARIB-STD-T120/Rel11/36/A36521-3-b40.pdf">https://www.arib.or.jp/english/html/overview/doc/T120_T23_SPECS/ARIB-STD-T120/Rel11/36/A36521-3-b40.pdf</a>
ATIS	ATIS.3GPP.36.521-3V1140	11.4.0	Published	28.06.2021	<a href="https://www.atis.org/3gpp-documents/Rel99-14/">https://www.atis.org/3gpp-documents/Rel99-14/</a>
CCSA	CCSA.36.521-3V1140	11.4.0	Published	01.03.2014	<a href="https://www.ccsa.org.cn/api/portalsFile/downloadOldFile?type=19&amp;oldFileUrl=ITU-R/M.2012-6/CCSA.36.521-3V1140.doc">https://www.ccsa.org.cn/api/portalsFile/downloadOldFile?type=19&amp;oldFileUrl=ITU-R/M.2012-6/CCSA.36.521-3V1140.doc</a>
ETSI	ETSI TS 136 521-3	11.4.0	Published	03.04.2014	<a href="https://www.etsi.org/deliver/etsi_ts/136500_136599/13652103/11.04.00_60/ts_13652103v110400p.pdf">https://www.etsi.org/deliver/etsi_ts/136500_136599/13652103/11.04.00_60/ts_13652103v110400p.pdf</a>
TSDSI	TSDSI STD T1.3GPP 36.521-3-11.4.0 V1.0.0	11.4.0	Published	30.08.2021	<a href="https://members.tdsi.in/index.php/s/gHkJASN22wKkjA">https://members.tdsi.in/index.php/s/gHkJASN22wKkjA</a>
TTA	TTAT.3G-36.521-3V11.4.0	11.4.0	Published	30.07.2021	<a href="http://committee.tta.or.kr/data/ttasDown.jsp?kind=ttastd&amp;pk_num=TTAT.3G-36.521-3V11.4.0">http://committee.tta.or.kr/data/ttasDown.jsp?kind=ttastd&amp;pk_num=TTAT.3G-36.521-3V11.4.0</a>

<b>Release 12</b>									
ARIB	ARIB STD-T120-36.521-3.V12.12.0	12.12.0	Published	03.03.2023	<a href="https://www.arib.or.jp/english/html/overview/doc/T120_T23_SPECS/ARIB-STD-T120/Rel12/36/A36521-3-cc0.pdf">https://www.arib.or.jp/english/html/overview/doc/T120_T23_SPECS/ARIB-STD-T120/Rel12/36/A36521-3-cc0.pdf</a>				
ATIS	ATIS.3GPP.36.521-3V12120	12.12.0	Published	28.06.2021	<a href="https://www.atis.org/3gpp-documents/Rel99-14/">https://www.atis.org/3gpp-documents/Rel99-14/</a>				
CCSA	CCSA.36.521-3V12120	12.12.0	Published	01.03.2017	<a href="https://www.ccsa.org.cn/api/portalsFile/downloadOldFile?type=19&amp;oldFileUrl=ITU-R/M.2012-6/CCSA.36.521-3V12120.doc">https://www.ccsa.org.cn/api/portalsFile/downloadOldFile?type=19&amp;oldFileUrl=ITU-R/M.2012-6/CCSA.36.521-3V12120.doc</a>				
ETSI	ETSI TS 136 521-3	12.12.0	Published	11.04.2017	<a href="https://www.etsi.org/deliver/etsi_ts/136500_136599/13652103/12.12.00_60/ts_13652103v121200p.pdf">https://www.etsi.org/deliver/etsi_ts/136500_136599/13652103/12.12.00_60/ts_13652103v121200p.pdf</a>				
TSDSI	TSDSI STD T1.3GPP 36.521-3-12.12.0	12.12.0	Published	30.08.2021	<a href="https://members.tdsi.in/index.php/s/8CTJ7Rt426prYJj">https://members.tdsi.in/index.php/s/8CTJ7Rt426prYJj</a>				
TTA	TTAT.3G-36.521-3V12.12.0	12.12.0	Published	30.07.2021	<a href="http://committee.tta.or.kr/data/ttasDown.jsp?kind=ttastd&amp;pk_num=TTAT.3G-36.521-3V12.12.0">http://committee.tta.or.kr/data/ttasDown.jsp?kind=ttastd&amp;pk_num=TTAT.3G-36.521-3V12.12.0</a>				
<b>Release 13</b>									
ARIB	ARIB STD-T120-36.521-3.V13.2.0	13.2.0	Published	03.03.2023	<a href="https://www.arib.or.jp/english/html/overview/doc/T120_T23_SPECS/ARIB-STD-T120/Rel13/36/A36521-3-d20.pdf">https://www.arib.or.jp/english/html/overview/doc/T120_T23_SPECS/ARIB-STD-T120/Rel13/36/A36521-3-d20.pdf</a>				
ATIS	ATIS.3GPP.36.521-3V1320	13.2.0	Published	28.06.2021	<a href="https://www.atis.org/3gpp-documents/Rel99-14/">https://www.atis.org/3gpp-documents/Rel99-14/</a>				
CCSA	CCSA.36.521-3V1320	13.2.0	Published	01.03.2017	<a href="https://www.ccsa.org.cn/api/portalsFile/downloadOldFile?type=19&amp;oldFileUrl=ITU-R/M.2012-6/CCSA.36.521-3V1320.doc">https://www.ccsa.org.cn/api/portalsFile/downloadOldFile?type=19&amp;oldFileUrl=ITU-R/M.2012-6/CCSA.36.521-3V1320.doc</a>				
ETSI	ETSI TS 136 521-3	13.2.0	Published	11.04.2017	<a href="https://www.etsi.org/deliver/etsi_ts/136500_136599/13652103/13.02.00_60/ts_13652103v130200p.pdf">https://www.etsi.org/deliver/etsi_ts/136500_136599/13652103/13.02.00_60/ts_13652103v130200p.pdf</a>				
TSDSI	TSDSI STD T1.3GPP 36.521-3-13.2.0 V1.0.0	13.2.0	Published	30.08.2021	<a href="https://members.tdsi.in/index.php/s/r6HcXZoFjG8Txn">https://members.tdsi.in/index.php/s/r6HcXZoFjG8Txn</a>				
TTA	TTAT.3G-36.521-3V13.2.0	13.2.0	Published	30.07.2021	<a href="http://committee.tta.or.kr/data/ttasDown.jsp?kind=ttastd&amp;pk_num=TTAT.3G-36.521-3V13.2.0">http://committee.tta.or.kr/data/ttasDown.jsp?kind=ttastd&amp;pk_num=TTAT.3G-36.521-3V13.2.0</a>				
<b>Release 14</b>									
ARIB	ARIB STD-T120-36.521-3.V14.5.0	14.5.0	Published	03.03.2023	<a href="https://www.arib.or.jp/english/html/overview/doc/T120_T23_SPECS/ARIB-STD-T120/Rel14/36/A36521-3-e50.pdf">https://www.arib.or.jp/english/html/overview/doc/T120_T23_SPECS/ARIB-STD-T120/Rel14/36/A36521-3-e50.pdf</a>				
ATIS	ATIS.3GPP.36.521-3V1450	14.5.0	Published	28.06.2021	<a href="https://www.atis.org/3gpp-documents/Rel99-14/">https://www.atis.org/3gpp-documents/Rel99-14/</a>				
CCSA	CCSA.36.521-3V1450	14.5.0	Published	01.09.2018	<a href="https://www.ccsa.org.cn/api/portalsFile/downloadOldFile?type=19&amp;oldFileUrl=ITU-R/M.2012-6/CCSA.36.521-3V1450.doc">https://www.ccsa.org.cn/api/portalsFile/downloadOldFile?type=19&amp;oldFileUrl=ITU-R/M.2012-6/CCSA.36.521-3V1450.doc</a>				
ETSI	ETSI TS 136 521-3	14.5.0	Published	28.09.2018	<a href="https://www.etsi.org/deliver/etsi_ts/136500_136599/13652103/14.05.00_60/ts_13652103v140500p.pdf">https://www.etsi.org/deliver/etsi_ts/136500_136599/13652103/14.05.00_60/ts_13652103v140500p.pdf</a>				
TSDSI	TSDSI STD T1.3GPP 36.521-3-14.5.0 V1.1.0	14.5.0	Published	30.08.2021	<a href="https://members.tdsi.in/index.php/s/qA3mARPGWENcaRC">https://members.tdsi.in/index.php/s/qA3mARPGWENcaRC</a>				
TTA	TTAT.3G-36.521-3V14.5.0	14.5.0	Published	30.07.2021	<a href="http://committee.tta.or.kr/data/ttasDown.jsp?kind=ttastd&amp;pk_num=TTAT.3G-36.521-3V14.5.0">http://committee.tta.or.kr/data/ttasDown.jsp?kind=ttastd&amp;pk_num=TTAT.3G-36.521-3V14.5.0</a>				
<b>Release 15</b>									
ARIB	ARIB STD-T120-36.521-3.V15.6.0	15.6.0	Published	03.03.2023	<a href="https://www.arib.or.jp/english/html/overview/doc/T120_T23_SPECS/ARIB-STD-T120/Rel15/36/A36521-3-f60.pdf">https://www.arib.or.jp/english/html/overview/doc/T120_T23_SPECS/ARIB-STD-T120/Rel15/36/A36521-3-f60.pdf</a>				
ATIS	ATIS.3GPP.36.521-3V1560	15.6.0	Published	28.06.2021	<a href="https://www.atis.org/3gpp-documents/Rel15/">https://www.atis.org/3gpp-documents/Rel15/</a>				
CCSA	CCSA.36.521-3V1560	15.6.0	Published	01.03.2020	<a href="https://www.ccsa.org.cn/api/portalsFile/downloadOldFile?type=19&amp;oldFileUrl=ITU-R/M.2012-6/CCSA.36.521-3V1560.doc">https://www.ccsa.org.cn/api/portalsFile/downloadOldFile?type=19&amp;oldFileUrl=ITU-R/M.2012-6/CCSA.36.521-3V1560.doc</a>				
ETSI	ETSI TS 136 521-3	15.6.0	Published	02.04.2020	<a href="https://www.etsi.org/deliver/etsi_ts/136500_136599/13652103/15.06.00_60/ts_13652103v150600p.pdf">https://www.etsi.org/deliver/etsi_ts/136500_136599/13652103/15.06.00_60/ts_13652103v150600p.pdf</a>				
TSDSI	TSDSI STD T1.3GPP 36.521-3-15.6.0 V1.0.0	15.6.0	Published	30.08.2021	<a href="https://members.tdsi.in/index.php/s/n8tGAomSyqGcJg3">https://members.tdsi.in/index.php/s/n8tGAomSyqGcJg3</a>				
TTA	TTAT.3G-36.521-3V15.6.0	15.6.0	Published	11.09.2020	<a href="http://committee.tta.or.kr/data/ttasDown.jsp?kind=ttastd&amp;pk_num=TTAT.3G-36.521-3V15.6.0">http://committee.tta.or.kr/data/ttasDown.jsp?kind=ttastd&amp;pk_num=TTAT.3G-36.521-3V15.6.0</a>				
<b>Release 16</b>									
ARIB	ARIB STD-T120-36.521-3.V16.15.0	16.15.0	Published	03.03.2023	<a href="https://www.arib.or.jp/english/html/overview/doc/T120_T23_SPECS/ARIB-STD-T120/Rel16/36/A36521-3-gf0.pdf">https://www.arib.or.jp/english/html/overview/doc/T120_T23_SPECS/ARIB-STD-T120/Rel16/36/A36521-3-gf0.pdf</a>				
ATIS	ATIS.3GPP.36.521-3.V16.15.0	16.15.0	Published	21.02.2023	<a href="https://www.atis.org/3gpp-transpositions-Rel-16">https://www.atis.org/3gpp-transpositions-Rel-16</a>				
CCSA	CCSA.36.521-3V16150	16.15.0	Published	01.12.2022	<a href="https://www.ccsa.org.cn/api/portalsFile/downloadOldFile?type=19&amp;oldFileUrl=ITU-R/M.2012-6/CCSA.36.521-3V16150.doc">https://www.ccsa.org.cn/api/portalsFile/downloadOldFile?type=19&amp;oldFileUrl=ITU-R/M.2012-6/CCSA.36.521-3V16150.doc</a>				
ETSI	ETSI TS 136 521-3	16.15.0	Published	20.01.2023	<a href="https://www.etsi.org/deliver/etsi_ts/136500_136599/13652103/16.15.00_60/ts_13652103v161500p.pdf">https://www.etsi.org/deliver/etsi_ts/136500_136599/13652103/16.15.00_60/ts_13652103v161500p.pdf</a>				
TSDSI	TSDSI STD T1.3GPP 36.521-3 16.15.0 V1.3.0	16.15.0	Published	01.12.2022	<a href="https://members.tdsi.in/s/NfCPdbKTJYEAAkT">https://members.tdsi.in/s/NfCPdbKTJYEAAkT</a>				
TTA	TTAT.3G-36.521-3V16.15.0	16.15.0	Published	16.03.2023	<a href="http://committee.tta.or.kr/data/ttasDown.jsp?kind=ttastd&amp;pk_num=TTAT.3G-36.521-3V16.15.0">http://committee.tta.or.kr/data/ttasDown.jsp?kind=ttastd&amp;pk_num=TTAT.3G-36.521-3V16.15.0</a>				
<b>Release 17</b>									
ARIB	ARIB STD-T120-36.521-3.V17.1.0	17.1.0	Published	03.03.2023	<a href="https://www.arib.or.jp/english/html/overview/doc/T120_T23_SPECS/ARIB-STD-T120/Rel17/36/A36521-3-h10.pdf">https://www.arib.or.jp/english/html/overview/doc/T120_T23_SPECS/ARIB-STD-T120/Rel17/36/A36521-3-h10.pdf</a>				
ATIS	ATIS.3GPP.36.521-3.V17.1.0	17.1.0	Published	21.02.2023	<a href="https://www.atis.org/3gpp-transpositions-Rel-17">https://www.atis.org/3gpp-transpositions-Rel-17</a>				
CCSA	CCSA.36.521-3V1710	17.1.0	Published	01.12.2022	<a href="https://www.ccsa.org.cn/api/portalsFile/downloadOldFile?type=19&amp;oldFileUrl=ITU-R/M.2012-6/CCSA.36.521-3V1710.rar">https://www.ccsa.org.cn/api/portalsFile/downloadOldFile?type=19&amp;oldFileUrl=ITU-R/M.2012-6/CCSA.36.521-3V1710.rar</a>				
ETSI	ETSI TS 136 521-3	17.1.0	Published	01.02.2023	<a href="https://www.etsi.org/deliver/etsi_ts/136500_136599/13652103/17.01.00_60/ts_13652103v170100p.pdf">https://www.etsi.org/deliver/etsi_ts/136500_136599/13652103/17.01.00_60/ts_13652103v170100p.pdf</a>				
TSDSI	TSDSI STD T1.3GPP 36.521-3 17.1.0 V1.1.0	17.1.0	Published	02.05.2023	<a href="https://members.tdsi.in/s/QtxFEWX9zysGTxp">https://members.tdsi.in/s/QtxFEWX9zysGTxp</a>				
TTA	TTAT.3G-36.521-3V17.1.0	17.1.0	Published	16.03.2023	<a href="http://committee.tta.or.kr/data/ttasDown.jsp?kind=ttastd&amp;pk_num=TTAT.3G-36.521-3V17.1.0">http://committee.tta.or.kr/data/ttasDown.jsp?kind=ttastd&amp;pk_num=TTAT.3G-36.521-3V17.1.0</a>				

## 2.1.6.6 TS 36.523-1

**Evolved Universal Terrestrial Radio Access (E-UTRA) and Evolved Packet Core (EPC); User Equipment (UE) conformance specification; Part 1: Protocol conformance specification**

This document specifies the protocol conformance testing for the 3<sup>rd</sup> Generation E-UTRAN User Equipment (UE).

This is the first part of a multi-part test specification. The following information can be found in this part:

- the overall test structure;
- the test configurations;
- the conformance requirement and reference to the core specifications;
- the test purposes; and
- a brief description of the test procedure, the specific test requirements and short message exchange table.

The following information relevant to testing could be found in accompanying specifications:

- the default setting of the test parameters (TS 36.508);
- the applicability of each test case (TS 36.523-2).

A detailed description of the expected sequence of messages could be found in the 3<sup>rd</sup> part of this test specification.

The Implementation Conformance Statement (ICS) pro-forma could be found in the 2<sup>nd</sup> part of this document.

This document is valid for UE implemented according to 3GPP releases starting from Release 8 up to the Release indicated on the cover page of this document.

SDO	Document No.	Version	Status	Issued date	Location
<b>Release 10</b>					
ARIB	ARIB STD-T120-36.523-1.V10.4.0	10.4.0	Published	03.03.2023	<a href="https://www.arib.or.jp/english/html/overview/doc/T120_T23_SPECS/ARIB-STD-T120/Rel10/36/A36523-1-a40.pdf">https://www.arib.or.jp/english/html/overview/doc/T120_T23_SPECS/ARIB-STD-T120/Rel10/36/A36523-1-a40.pdf</a>
ATIS	ATIS.3GPP.36.523-1V1040	10.4.0	Published	28.06.2021	<a href="https://www.atis.org/3gpp-documents/Rel99-14/">https://www.atis.org/3gpp-documents/Rel99-14/</a>
CCSA	CCSA.36.523-1V1040	10.4.0	Published	01.06.2015	<a href="https://www.ccsa.org.cn/api/portalsFile/downloadOldFile?type=19&amp;oldFileUrl=ITU-R/M.2012-6/CCSA.36.523-1V1040.doc">https://www.ccsa.org.cn/api/portalsFile/downloadOldFile?type=19&amp;oldFileUrl=ITU-R/M.2012-6/CCSA.36.523-1V1040.doc</a>
ETSI	ETSI TS 136 523-1	10.4.0	Published	29.07.2015	<a href="https://www.etsi.org/deliver/etsi_ts/136500_136599/13652301/10.04.00_60/ts_13652301v100400p.pdf">https://www.etsi.org/deliver/etsi_ts/136500_136599/13652301/10.04.00_60/ts_13652301v100400p.pdf</a>
TSDSI	TSDSI STD T1.3GPP 36.523-1-10.4.0 V1.0.0	10.4.0	Published	30.08.2021	<a href="https://members.tdsi.in/index.php/s/rAGmFQ32df6Sios">https://members.tdsi.in/index.php/s/rAGmFQ32df6Sios</a>
TTA	TTAT.3G-36.523-1V10.4.0	10.4.0	Published	30.07.2021	<a href="http://committee.tta.or.kr/data/ttasDown.jsp?kind=ttastd&amp;pk_num=TTAT.3G-36.523-1V10.4.0">http://committee.tta.or.kr/data/ttasDown.jsp?kind=ttastd&amp;pk_num=TTAT.3G-36.523-1V10.4.0</a>
<b>Release 11</b>					
ARIB	ARIB STD-T120-36.523-1.V11.7.0	11.7.0	Published	03.03.2023	<a href="https://www.arib.or.jp/english/html/overview/doc/T120_T23_SPECS/ARIB-STD-T120/Rel11/36/A36523-1-b70.pdf">https://www.arib.or.jp/english/html/overview/doc/T120_T23_SPECS/ARIB-STD-T120/Rel11/36/A36523-1-b70.pdf</a>
ATIS	ATIS.3GPP.36.523-1V1170	11.7.0	Published	28.06.2021	<a href="https://www.atis.org/3gpp-documents/Rel99-14/">https://www.atis.org/3gpp-documents/Rel99-14/</a>
CCSA	CCSA.36.523-1V1170	11.7.0	Published	01.06.2015	<a href="https://www.ccsa.org.cn/api/portalsFile/downloadOldFile?type=19&amp;oldFileUrl=ITU-R/M.2012-6/CCSA.36.523-1V1170.doc">https://www.ccsa.org.cn/api/portalsFile/downloadOldFile?type=19&amp;oldFileUrl=ITU-R/M.2012-6/CCSA.36.523-1V1170.doc</a>
ETSI	ETSI TS 136 523-1	11.7.0	Published	29.07.2015	<a href="https://www.etsi.org/deliver/etsi_ts/136500_136599/13652301/11.07.00_60/ts_13652301v110700p.pdf">https://www.etsi.org/deliver/etsi_ts/136500_136599/13652301/11.07.00_60/ts_13652301v110700p.pdf</a>
TSDSI	TSDSI STD T1.3GPP 36.523-1-11.7.0 V1.0.0	11.7.0	Published	30.08.2021	<a href="https://members.tdsi.in/index.php/s/G3j7x2mRtmD8d4A">https://members.tdsi.in/index.php/s/G3j7x2mRtmD8d4A</a>
TTA	TTAT.3G-36.523-1V11.7.0	11.7.0	Published	30.07.2021	<a href="http://committee.tta.or.kr/data/ttasDown.jsp?kind=ttastd&amp;pk_num=TTAT.3G-36.523-1V11.7.0">http://committee.tta.or.kr/data/ttasDown.jsp?kind=ttastd&amp;pk_num=TTAT.3G-36.523-1V11.7.0</a>

<b>Release 12</b>							
ARIB	ARIB STD-T120-36.523-1.V12.10.0	12.10.0	Published	03.03.2023	<a href="https://www.arib.or.jp/english/html/overview/doc/T120_T23_SPECS/ARIB-STD-T120/Rel12/36/A36523-1-ca0.pdf">https://www.arib.or.jp/english/html/overview/doc/T120_T23_SPECS/ARIB-STD-T120/Rel12/36/A36523-1-ca0.pdf</a>		
ATIS	ATIS.3GPP.36.523-1V12100	12.10.0	Published	28.06.2021	<a href="https://www.atis.org/3gpp-documents/Rel99-14/">https://www.atis.org/3gpp-documents/Rel99-14/</a>		
CCSA	CCSA.36.523-1V12100	12.10.0	Published	01.09.2016	<a href="https://www.ccsa.org.cn/api/portalsFile/downloadOldFile?type=19&amp;oldFileUrl=ITU-R/M.2012-6/CCSA.36.523-1V12100.doc">https://www.ccsa.org.cn/api/portalsFile/downloadOldFile?type=19&amp;oldFileUrl=ITU-R/M.2012-6/CCSA.36.523-1V12100.doc</a>		
ETSI	ETSI TS 136 523-1	12.10.0	Published	07.11.2016	<a href="https://www.etsi.org/deliver/etsi_ts/136500_136599/13652301/12.10.00_60/ts_13652301v121000p.pdf">https://www.etsi.org/deliver/etsi_ts/136500_136599/13652301/12.10.00_60/ts_13652301v121000p.pdf</a>		
TSDSI	TSDSI STD T1.3GPP 36.523-1-12.10.0	12.10.0	Published	30.08.2021	<a href="https://members.tdsi.in/index.php/s/Ayayit2Bapn8g9">https://members.tdsi.in/index.php/s/Ayayit2Bapn8g9</a>		
TTA	TTAT.3G-36.523-1V12.10.0	12.10.0	Published	30.07.2021	<a href="http://committee.tta.or.kr/data/ttasDown.jsp?kind=ttastd&amp;pk_num=TTAT.3G-36.523-1V12.10.0">http://committee.tta.or.kr/data/ttasDown.jsp?kind=ttastd&amp;pk_num=TTAT.3G-36.523-1V12.10.0</a>		
<b>Release 13</b>							
ARIB	ARIB STD-T120-36.523-1.V13.5.0	13.5.0	Published	03.03.2023	<a href="https://www.arib.or.jp/english/html/overview/doc/T120_T23_SPECS/ARIB-STD-T120/Rel13/36/A36523-1-d50.pdf">https://www.arib.or.jp/english/html/overview/doc/T120_T23_SPECS/ARIB-STD-T120/Rel13/36/A36523-1-d50.pdf</a>		
ATIS	ATIS.3GPP.36.523-1V1350	13.5.0	Published	28.06.2021	<a href="https://www.atis.org/3gpp-documents/Rel99-14/">https://www.atis.org/3gpp-documents/Rel99-14/</a>		
CCSA	CCSA.36.523-1V1350	13.5.0	Published	01.09.2017	<a href="https://www.ccsa.org.cn/api/portalsFile/downloadOldFile?type=19&amp;oldFileUrl=ITU-R/M.2012-6/CCSA.36.523-1V1350.doc">https://www.ccsa.org.cn/api/portalsFile/downloadOldFile?type=19&amp;oldFileUrl=ITU-R/M.2012-6/CCSA.36.523-1V1350.doc</a>		
ETSI	ETSI TS 136 523-1	13.5.0	Published	19.10.2017	<a href="https://www.etsi.org/deliver/etsi_ts/136500_136599/13652301/13.05.00_60/ts_13652301v130500p.pdf">https://www.etsi.org/deliver/etsi_ts/136500_136599/13652301/13.05.00_60/ts_13652301v130500p.pdf</a>		
TSDSI	TSDSI STD T1.3GPP 36.523-1-13.5.0 V1.0.0	13.5.0	Published	30.08.2021	<a href="https://members.tdsi.in/index.php/s/CmwenDgP47D8EEH">https://members.tdsi.in/index.php/s/CmwenDgP47D8EEH</a>		
TTA	TTAT.3G-36.523-1V13.5.0	13.5.0	Published	02.08.2021	<a href="http://committee.tta.or.kr/data/ttasDown.jsp?kind=ttastd&amp;pk_num=TTAT.3G-36.523-1V13.5.0">http://committee.tta.or.kr/data/ttasDown.jsp?kind=ttastd&amp;pk_num=TTAT.3G-36.523-1V13.5.0</a>		
<b>Release 14</b>							
ARIB	ARIB STD-T120-36.523-1.V14.4.0	14.4.0	Published	03.03.2023	<a href="https://www.arib.or.jp/english/html/overview/doc/T120_T23_SPECS/ARIB-STD-T120/Rel14/36/A36523-1-e40.pdf">https://www.arib.or.jp/english/html/overview/doc/T120_T23_SPECS/ARIB-STD-T120/Rel14/36/A36523-1-e40.pdf</a>		
ATIS	ATIS.3GPP.36.523-1V1440	14.4.0	Published	28.06.2021	<a href="https://www.atis.org/3gpp-documents/Rel99-14/">https://www.atis.org/3gpp-documents/Rel99-14/</a>		
CCSA	CCSA.36.523-1V1440	14.4.0	Published	01.03.2018	<a href="https://www.ccsa.org.cn/api/portalsFile/downloadOldFile?type=19&amp;oldFileUrl=ITU-R/M.2012-6/CCSA.36.523-1V1440.doc">https://www.ccsa.org.cn/api/portalsFile/downloadOldFile?type=19&amp;oldFileUrl=ITU-R/M.2012-6/CCSA.36.523-1V1440.doc</a>		
ETSI	ETSI TS 136 523-1	14.4.0	Published	11.04.2018	<a href="https://www.etsi.org/deliver/etsi_ts/136500_136599/13652301/14.04.00_60/ts_13652301v140400p.pdf">https://www.etsi.org/deliver/etsi_ts/136500_136599/13652301/14.04.00_60/ts_13652301v140400p.pdf</a>		
TSDSI	TSDSI STD T1.3GPP 36.523-1-14.4.0 V1.1.0	14.4.0	Published	30.08.2021	<a href="https://members.tdsi.in/index.php/s/Okss2J7CbpfQSTD">https://members.tdsi.in/index.php/s/Okss2J7CbpfQSTD</a>		
TTA	TTAT.3G-36.523-1V14.4.0	14.4.0	Published	02.08.2021	<a href="http://committee.tta.or.kr/data/ttasDown.jsp?kind=ttastd&amp;pk_num=TTAT.3G-36.523-1V14.4.0">http://committee.tta.or.kr/data/ttasDown.jsp?kind=ttastd&amp;pk_num=TTAT.3G-36.523-1V14.4.0</a>		
<b>Release 15</b>							
ARIB	ARIB STD-T120-36.523-1.V15.6.1	15.6.1	Published	03.03.2023	<a href="https://www.arib.or.jp/english/html/overview/doc/T120_T23_SPECS/ARIB-STD-T120/Rel15/36/A36523-1-f61.pdf">https://www.arib.or.jp/english/html/overview/doc/T120_T23_SPECS/ARIB-STD-T120/Rel15/36/A36523-1-f61.pdf</a>		
ATIS	ATIS.3GPP.36.523-1V1561	15.6.1	Published	28.06.2021	<a href="https://www.atis.org/3gpp-documents/Rel15/">https://www.atis.org/3gpp-documents/Rel15/</a>		
CCSA	CCSA.36.523-1V1561	15.6.1	Published	01.03.2020	<a href="https://www.ccsa.org.cn/api/portalsFile/downloadOldFile?type=19&amp;oldFileUrl=ITU-R/M.2012-6/CCSA.36.523-1V1561.doc">https://www.ccsa.org.cn/api/portalsFile/downloadOldFile?type=19&amp;oldFileUrl=ITU-R/M.2012-6/CCSA.36.523-1V1561.doc</a>		
ETSI	ETSI TS 136 523-1	15.6.1	Published	02.04.2020	<a href="https://www.etsi.org/deliver/etsi_ts/136500_136599/13652301/15.06.01_60/ts_13652301v150601p.pdf">https://www.etsi.org/deliver/etsi_ts/136500_136599/13652301/15.06.01_60/ts_13652301v150601p.pdf</a>		
TSDSI	TSDSI STD T1.3GPP 36.523-1-15.6.1 V1.0.0	15.6.1	Published	30.08.2021	<a href="https://members.tdsi.in/index.php/s/mRQkSGFt3ybgvZH">https://members.tdsi.in/index.php/s/mRQkSGFt3ybgvZH</a>		
TTA	TTAT.3G-36.523-1V15.6.1	15.6.1	Published	11.09.2020	<a href="http://committee.tta.or.kr/data/ttasDown.jsp?kind=ttastd&amp;pk_num=TTAT.3G-36.523-1V15.6.1">http://committee.tta.or.kr/data/ttasDown.jsp?kind=ttastd&amp;pk_num=TTAT.3G-36.523-1V15.6.1</a>		
<b>Release 16</b>							
ARIB	ARIB STD-T120-36.523-1.V16.12.0	16.12.0	Published	03.03.2023	<a href="https://www.arib.or.jp/english/html/overview/doc/T120_T23_SPECS/ARIB-STD-T120/Rel16/36/A36523-1-gc0.pdf">https://www.arib.or.jp/english/html/overview/doc/T120_T23_SPECS/ARIB-STD-T120/Rel16/36/A36523-1-gc0.pdf</a>		
ATIS	ATIS.3GPP.36.523-1.V16.12.0	16.12.0	Published	21.02.2023	<a href="https://www.atis.org/3gpp-transpositions - Rel-16">https://www.atis.org/3gpp-transpositions - Rel-16</a>		
CCSA	CCSA.36.523-1V16120	16.12.0	Published	01.12.2022	<a href="https://www.ccsa.org.cn/api/portalsFile/downloadOldFile?type=19&amp;oldFileUrl=ITU-R/M.2012-6/CCSA.36.523-1V16120.doc">https://www.ccsa.org.cn/api/portalsFile/downloadOldFile?type=19&amp;oldFileUrl=ITU-R/M.2012-6/CCSA.36.523-1V16120.doc</a>		
ETSI	ETSI TS 136 523-1	16.12.0	Published	20.01.2023	<a href="https://www.etsi.org/deliver/etsi_ts/136500_136599/13652301/16.12.00_60/ts_13652301v161200p.pdf">https://www.etsi.org/deliver/etsi_ts/136500_136599/13652301/16.12.00_60/ts_13652301v161200p.pdf</a>		
TSDSI	TSDSI STD T1.3GPP 36.523-1 16.12.0 V1.2.0	16.12.0	Published	02.05.2023	<a href="https://members.tdsi.in/s/KNoxcbKsbs3aY7x">https://members.tdsi.in/s/KNoxcbKsbs3aY7x</a>		
TTA	TTAT.3G-36.523-1V16.12.0	16.12.0	Published	16.03.2023	<a href="http://committee.tta.or.kr/data/ttasDown.jsp?kind=ttastd&amp;pk_num=TTAT.3G-36.523-1V16.12.0">http://committee.tta.or.kr/data/ttasDown.jsp?kind=ttastd&amp;pk_num=TTAT.3G-36.523-1V16.12.0</a>		
<b>Release 17</b>							
ARIB	ARIB STD-T120-36.523-1.V17.4.0	17.4.0	Published	03.03.2023	<a href="https://www.arib.or.jp/english/html/overview/doc/T120_T23_SPECS/ARIB-STD-T120/Rel17/36/A36523-1-h40.pdf">https://www.arib.or.jp/english/html/overview/doc/T120_T23_SPECS/ARIB-STD-T120/Rel17/36/A36523-1-h40.pdf</a>		
ATIS	ATIS.3GPP.36.523-1.V17.4.0	17.4.0	Published	21.02.2023	<a href="https://www.atis.org/3gpp-transpositions - Rel-17">https://www.atis.org/3gpp-transpositions - Rel-17</a>		
CCSA	CCSA.36.523-1V1740	17.4.0	Published	01.12.2022	<a href="https://www.ccsa.org.cn/api/portalsFile/downloadOldFile?type=19&amp;oldFileUrl=ITU-R/M.2012-6/CCSA.36.523-1V1740.rar">https://www.ccsa.org.cn/api/portalsFile/downloadOldFile?type=19&amp;oldFileUrl=ITU-R/M.2012-6/CCSA.36.523-1V1740.rar</a>		
ETSI	ETSI TS 136 523-1	17.4.0	Published	07.02.2023	<a href="https://www.etsi.org/deliver/etsi_ts/136500_136599/13652301/17.04.00_60/ts_13652301v170400p.pdf">https://www.etsi.org/deliver/etsi_ts/136500_136599/13652301/17.04.00_60/ts_13652301v170400p.pdf</a>		
TSDSI	TSDSI STD T1.3GPP 36.523-1 17.4.0 V1.3.0	17.4.0	Published	02.05.2023	<a href="https://members.tdsi.in/s/j2fZ3f8kF64qwdR">https://members.tdsi.in/s/j2fZ3f8kF64qwdR</a>		
TTA	TTAT.3G-36.523-1V17.4.0	17.4.0	Published	16.03.2023	<a href="http://committee.tta.or.kr/data/ttasDown.jsp?kind=ttastd&amp;pk_num=TTAT.3G-36.523-1V17.4.0">http://committee.tta.or.kr/data/ttasDown.jsp?kind=ttastd&amp;pk_num=TTAT.3G-36.523-1V17.4.0</a>		

## 2.1.6.7 TS 36.523-2

**Evolved Universal Terrestrial Radio Access (E-UTRA) and Evolved Packet Core (EPC); User Equipment (UE) conformance specification; Part 2: Implementation Conformance Statement (ICS) proforma specification**

This document provides the ICS proforma for 3<sup>rd</sup> Generation User Equipment (UE), in compliance with the relevant EPS (E-UTRA/EPC) requirements, and in accordance with the relevant guidance given in ISO/IEC 9646-1 and ISO/IEC 9646-7.

This document also specifies a recommended applicability statement for the test cases included in TS 36.523-1. These applicability statements are based on the features implemented in the UE.

Special conformance testing functions can be found in TS 36.509 and the common test environments are included in 3GPP TS 36.508.

This document is valid for UE complying with EPS (E-UTRA/EPC) and implemented according to 3GPP releases starting from Release 8 up to the Release indicated on the cover page of this document.

SDO	Document No.	Version	Status	Issued date	Location
<b>Release 10</b>					
ARIB	ARIB STD-T120-36.523-2.V10.3.0	10.3.0	Published	03.03.2023	<a href="https://www.arib.or.jp/english/html/overview/doc/T120_T23_SPECS/ARIB-STD-T120/Rel10/36/A36523-2-a30.pdf">https://www.arib.or.jp/english/html/overview/doc/T120_T23_SPECS/ARIB-STD-T120/Rel10/36/A36523-2-a30.pdf</a>
ATIS	ATIS.3GPP.36.523-2V1030	10.3.0	Published	28.06.2021	<a href="https://www.atis.org/3gpp-documents/Rel99-14/">https://www.atis.org/3gpp-documents/Rel99-14/</a>
CCSA	CCSA.36.523-2V1030	10.3.0	Published	01.12.2012	<a href="https://www.ccsa.org.cn/api/portalsFile/downloadOldFile?type=19&amp;oldFileUrl=ITU-R/M.2012-6/CCSA.36.523-2V1030.doc">https://www.ccsa.org.cn/api/portalsFile/downloadOldFile?type=19&amp;oldFileUrl=ITU-R/M.2012-6/CCSA.36.523-2V1030.doc</a>
ETSI	ETSI TS 136 523-2	10.3.0	Published	14.01.2013	<a href="https://www.etsi.org/deliver/etsi_ts/136500_136599/13652302/10.03.00_60/ts_13652302v100300p.pdf">https://www.etsi.org/deliver/etsi_ts/136500_136599/13652302/10.03.00_60/ts_13652302v100300p.pdf</a>
TSDSI	TSDSI STD T1.3GPP 36.523-2-10.3.0 V1.0.0	10.3.0	Published	30.08.2021	<a href="https://members.tdsi.in/index.php/s/JxpmArYtYaa2B6c">https://members.tdsi.in/index.php/s/JxpmArYtYaa2B6c</a>
TTA	TTAT.3G-36.523-2V10.3.0	10.3.0	Published	02.08.2021	<a href="http://committee.tta.or.kr/data/ttasDown.jsp?kind=ttastd&amp;pk_num=TTAT.3G-36.523-2V10.3.0">http://committee.tta.or.kr/data/ttasDown.jsp?kind=ttastd&amp;pk_num=TTAT.3G-36.523-2V10.3.0</a>
<b>Release 11</b>					
ARIB	ARIB STD-T120-36.523-2.V11.6.0	11.6.0	Published	03.03.2023	<a href="https://www.arib.or.jp/english/html/overview/doc/T120_T23_SPECS/ARIB-STD-T120/Rel11/36/A36523-2-b60.pdf">https://www.arib.or.jp/english/html/overview/doc/T120_T23_SPECS/ARIB-STD-T120/Rel11/36/A36523-2-b60.pdf</a>
ATIS	ATIS.3GPP.36.523-2V1160	11.6.0	Published	28.06.2021	<a href="https://www.atis.org/3gpp-documents/Rel99-14/">https://www.atis.org/3gpp-documents/Rel99-14/</a>
CCSA	CCSA.36.523-2V1160	11.6.0	Published	01.03.2014	<a href="https://www.ccsa.org.cn/api/portalsFile/downloadOldFile?type=19&amp;oldFileUrl=ITU-R/M.2012-6/CCSA.36.523-2V1160.doc">https://www.ccsa.org.cn/api/portalsFile/downloadOldFile?type=19&amp;oldFileUrl=ITU-R/M.2012-6/CCSA.36.523-2V1160.doc</a>
ETSI	ETSI TS 136 523-2	11.6.0	Published	03.04.2014	<a href="https://www.etsi.org/deliver/etsi_ts/136500_136599/13652302/11.06.00_60/ts_13652302v110600p.pdf">https://www.etsi.org/deliver/etsi_ts/136500_136599/13652302/11.06.00_60/ts_13652302v110600p.pdf</a>
TSDSI	TSDSI STD T1.3GPP 36.523-2-11.6.0 V1.0.0	11.6.0	Published	30.08.2021	<a href="https://members.tdsi.in/index.php/s/qzSaq2aXvY97oC5">https://members.tdsi.in/index.php/s/qzSaq2aXvY97oC5</a>
TTA	TTAT.3G-36.523-2V11.6.0	11.6.0	Published	02.08.2021	<a href="http://committee.tta.or.kr/data/ttasDown.jsp?kind=ttastd&amp;pk_num=TTAT.3G-36.523-2V11.6.0">http://committee.tta.or.kr/data/ttasDown.jsp?kind=ttastd&amp;pk_num=TTAT.3G-36.523-2V11.6.0</a>
<b>Release 12</b>					
ARIB	ARIB STD-T120-36.523-2.V12.10.0	12.10.0	Published	03.03.2023	<a href="https://www.arib.or.jp/english/html/overview/doc/T120_T23_SPECS/ARIB-STD-T120/Rel12/36/A36523-2-ca0.pdf">https://www.arib.or.jp/english/html/overview/doc/T120_T23_SPECS/ARIB-STD-T120/Rel12/36/A36523-2-ca0.pdf</a>
ATIS	ATIS.3GPP.36.523-2V12100	12.10.0	Published	28.06.2021	<a href="https://www.atis.org/3gpp-documents/Rel99-14/">https://www.atis.org/3gpp-documents/Rel99-14/</a>
CCSA	CCSA.36.523-2V12100	12.10.0	Published	01.09.2016	<a href="https://www.ccsa.org.cn/api/portalsFile/downloadOldFile?type=19&amp;oldFileUrl=ITU-R/M.2012-6/CCSA.36.523-2V12100.doc">https://www.ccsa.org.cn/api/portalsFile/downloadOldFile?type=19&amp;oldFileUrl=ITU-R/M.2012-6/CCSA.36.523-2V12100.doc</a>
ETSI	ETSI TS 136 523-2	12.10.0	Published	02.11.2016	<a href="https://www.etsi.org/deliver/etsi_ts/136500_136599/13652302/12.10.00_60/ts_13652302v121000p.pdf">https://www.etsi.org/deliver/etsi_ts/136500_136599/13652302/12.10.00_60/ts_13652302v121000p.pdf</a>
TSDSI	TSDSI STD T1.3GPP 36.523-2-12.10.0	12.10.0	Published	30.08.2021	<a href="https://members.tdsi.in/index.php/s/WsW3QAR2Y733AXo">https://members.tdsi.in/index.php/s/WsW3QAR2Y733AXo</a>
TTA	TTAT.3G-36.523-2V12.10.0	12.10.0	Published	02.08.2021	<a href="http://committee.tta.or.kr/data/ttasDown.jsp?kind=ttastd&amp;pk_num=TTAT.3G-36.523-2V12.10.0">http://committee.tta.or.kr/data/ttasDown.jsp?kind=ttastd&amp;pk_num=TTAT.3G-36.523-2V12.10.0</a>
<b>Release 13</b>					
ARIB	ARIB STD-T120-36.523-2.V13.4.0	13.4.0	Published	03.03.2023	<a href="https://www.arib.or.jp/english/html/overview/doc/T120_T23_SPECS/ARIB-STD-T120/Rel13/36/A36523-2-d40.pdf">https://www.arib.or.jp/english/html/overview/doc/T120_T23_SPECS/ARIB-STD-T120/Rel13/36/A36523-2-d40.pdf</a>
ATIS	ATIS.3GPP.36.523-2V1340	13.4.0	Published	28.06.2021	<a href="https://www.atis.org/3gpp-documents/Rel99-14/">https://www.atis.org/3gpp-documents/Rel99-14/</a>
CCSA	CCSA.36.523-2V1340	13.4.0	Published	01.03.2017	<a href="https://www.ccsa.org.cn/api/portalsFile/downloadOldFile?type=19&amp;oldFileUrl=ITU-R/M.2012-6/CCSA.36.523-2V1340.doc">https://www.ccsa.org.cn/api/portalsFile/downloadOldFile?type=19&amp;oldFileUrl=ITU-R/M.2012-6/CCSA.36.523-2V1340.doc</a>
ETSI	ETSI TS 136 523-2	13.4.0	Published	11.04.2017	<a href="https://www.etsi.org/deliver/etsi_ts/136500_136599/13652302/13.04.00_60/ts_13652302v130400p.pdf">https://www.etsi.org/deliver/etsi_ts/136500_136599/13652302/13.04.00_60/ts_13652302v130400p.pdf</a>
TSDSI	TSDSI STD T1.3GPP 36.523-2-13.4.0 V1.0.0	13.4.0	Published	30.08.2021	<a href="https://members.tdsi.in/index.php/s/6L3nAco3DDK8MFt">https://members.tdsi.in/index.php/s/6L3nAco3DDK8MFt</a>
TTA	TTAT.3G-36.523-2V13.4.0	13.4.0	Published	02.08.2021	<a href="http://committee.tta.or.kr/data/ttasDown.jsp?kind=ttastd&amp;pk_num=TTAT.3G-36.523-2V13.4.0">http://committee.tta.or.kr/data/ttasDown.jsp?kind=ttastd&amp;pk_num=TTAT.3G-36.523-2V13.4.0</a>
<b>Release 14</b>					



ARIB	ARIB STD-T120-36.523-2.V14.5.0	14.5.0	Published	03.03.2023	<a href="https://www.arib.or.jp/english/html/overview/doc/T120_T23_SPECS/ARIB-STD-T120/Rel14/36/A36523-2-e50.pdf">https://www.arib.or.jp/english/html/overview/doc/T120_T23_SPECS/ARIB-STD-T120/Rel14/36/A36523-2-e50.pdf</a>
ATIS	ATIS.3GPP.36.523-2V1450	14.5.0	Published	28.06.2021	<a href="https://www.atis.org/3gpp-documents/Rel99-14/">https://www.atis.org/3gpp-documents/Rel99-14/</a>
CCSA	CCSA.36.523-2V1450	14.5.0	Published	01.03.2018	<a href="https://www.ccsa.org.cn/api/portalsFile/downloadOldFile?type=19&amp;oldFileUrl=ITU-R/M.2012-6/CCSA.36.523-2V1450.doc">https://www.ccsa.org.cn/api/portalsFile/downloadOldFile?type=19&amp;oldFileUrl=ITU-R/M.2012-6/CCSA.36.523-2V1450.doc</a>
ETSI	ETSI TS 136 523-2	14.5.0	Published	10.04.2018	<a href="https://www.etsi.org/deliver/etsi_ts/136500_136599/13652302/14.05.00_60/ts_13652302v140500p.pdf">https://www.etsi.org/deliver/etsi_ts/136500_136599/13652302/14.05.00_60/ts_13652302v140500p.pdf</a>
TSDSI	TSDSI STD T1.3GPP 36.523-2-14.5.0 V1.1.0	14.5.0	Published	30.08.2021	<a href="https://members.tdsi.in/index.php/s/dFXFgqkNBjLNL3j">https://members.tdsi.in/index.php/s/dFXFgqkNBjLNL3j</a>
TTA	TTAT.3G-36.523-2V14.5.0	14.5.0	Published	02.08.2021	<a href="http://committee.tta.or.kr/data/ttasDown.jsp?kind=ttastd&amp;pk_num=TTAT.3G-36.523-2V14.5.0">http://committee.tta.or.kr/data/ttasDown.jsp?kind=ttastd&amp;pk_num=TTAT.3G-36.523-2V14.5.0</a>
<b>Release 15</b>					
ARIB	ARIB STD-T120-36.523-2.V15.6.0	15.6.0	Published	03.03.2023	<a href="https://www.arib.or.jp/english/html/overview/doc/T120_T23_SPECS/ARIB-STD-T120/Rel15/36/A36523-2-f60.pdf">https://www.arib.or.jp/english/html/overview/doc/T120_T23_SPECS/ARIB-STD-T120/Rel15/36/A36523-2-f60.pdf</a>
ATIS	ATIS.3GPP.36.523-2V1560	15.6.0	Published	28.06.2021	<a href="https://www.atis.org/3gpp-documents/Rel15/">https://www.atis.org/3gpp-documents/Rel15/</a>
CCSA	CCSA.36.523-2V1560	15.6.0	Published	01.03.2020	<a href="https://www.ccsa.org.cn/api/portalsFile/downloadOldFile?type=19&amp;oldFileUrl=ITU-R/M.2012-6/CCSA.36.523-2V1560.doc">https://www.ccsa.org.cn/api/portalsFile/downloadOldFile?type=19&amp;oldFileUrl=ITU-R/M.2012-6/CCSA.36.523-2V1560.doc</a>
ETSI	ETSI TS 136 523-2	15.6.0	Published	02.04.2020	<a href="https://www.etsi.org/deliver/etsi_ts/136500_136599/13652302/15.06.00_60/ts_13652302v150600p.pdf">https://www.etsi.org/deliver/etsi_ts/136500_136599/13652302/15.06.00_60/ts_13652302v150600p.pdf</a>
TSDSI	TSDSI STD T1.3GPP 36.523-2-15.6.0 V1.0.0	15.6.0	Published	30.08.2021	<a href="https://members.tdsi.in/index.php/s/wKe3kzjayBoPRRy">https://members.tdsi.in/index.php/s/wKe3kzjayBoPRRy</a>
TTA	TTAT.3G-36.523-2V15.6.0	15.6.0	Published	11.09.2020	<a href="http://committee.tta.or.kr/data/ttasDown.jsp?kind=ttastd&amp;pk_num=TTAT.3G-36.523-2V15.6.0">http://committee.tta.or.kr/data/ttasDown.jsp?kind=ttastd&amp;pk_num=TTAT.3G-36.523-2V15.6.0</a>
<b>Release 16</b>					
ARIB	ARIB STD-T120-36.523-2.V16.12.0	16.12.0	Published	03.03.2023	<a href="https://www.arib.or.jp/english/html/overview/doc/T120_T23_SPECS/ARIB-STD-T120/Rel16/36/A36523-2-gc0.pdf">https://www.arib.or.jp/english/html/overview/doc/T120_T23_SPECS/ARIB-STD-T120/Rel16/36/A36523-2-gc0.pdf</a>
ATIS	ATIS.3GPP.36.523-2.V16.12.0	16.12.0	Published	21.02.2023	<a href="https://www.atis.org/3gpp-transpositions - Rel-16">https://www.atis.org/3gpp-transpositions - Rel-16</a>
CCSA	CCSA.36.523-2V16120	16.12.0	Published	01.12.2022	<a href="https://www.ccsa.org.cn/api/portalsFile/downloadOldFile?type=19&amp;oldFileUrl=ITU-R/M.2012-6/CCSA.36.523-2V16120.doc">https://www.ccsa.org.cn/api/portalsFile/downloadOldFile?type=19&amp;oldFileUrl=ITU-R/M.2012-6/CCSA.36.523-2V16120.doc</a>
ETSI	ETSI TS 136 523-2	16.12.0	Published	20.01.2023	<a href="https://www.etsi.org/deliver/etsi_ts/136500_136599/13652302/16.12.00_60/ts_13652302v161200p.pdf">https://www.etsi.org/deliver/etsi_ts/136500_136599/13652302/16.12.00_60/ts_13652302v161200p.pdf</a>
TSDSI	TSDSI STD T1.3GPP 36.523-2 16.12.0 V1.2.0	16.12.0	Published	02.05.2023	<a href="https://members.tdsi.in/s/F8g4yQrK2cqsBk">https://members.tdsi.in/s/F8g4yQrK2cqsBk</a>
TTA	TTAT.3G-36.523-2V16.12.0	16.12.0	Published	16.03.2023	<a href="http://committee.tta.or.kr/data/ttasDown.jsp?kind=ttastd&amp;pk_num=TTAT.3G-36.523-2V16.12.0">http://committee.tta.or.kr/data/ttasDown.jsp?kind=ttastd&amp;pk_num=TTAT.3G-36.523-2V16.12.0</a>
<b>Release 17</b>					
ARIB	ARIB STD-T120-36.523-2.V17.4.0	17.4.0	Published	03.03.2023	<a href="https://www.arib.or.jp/english/html/overview/doc/T120_T23_SPECS/ARIB-STD-T120/Rel17/36/A36523-2-h40.pdf">https://www.arib.or.jp/english/html/overview/doc/T120_T23_SPECS/ARIB-STD-T120/Rel17/36/A36523-2-h40.pdf</a>
ATIS	ATIS.3GPP.36.523-2.V17.4.0	17.4.0	Published	21.02.2023	<a href="https://www.atis.org/3gpp-transpositions - Rel-17">https://www.atis.org/3gpp-transpositions - Rel-17</a>
CCSA	CCSA.36.523-2V1740	17.4.0	Published	01.12.2022	<a href="https://www.ccsa.org.cn/api/portalsFile/downloadOldFile?type=19&amp;oldFileUrl=ITU-R/M.2012-6/CCSA.36.523-2V1740.doc">https://www.ccsa.org.cn/api/portalsFile/downloadOldFile?type=19&amp;oldFileUrl=ITU-R/M.2012-6/CCSA.36.523-2V1740.doc</a>
ETSI	ETSI TS 136 523-2	17.4.0	Published	24.01.2023	<a href="https://www.etsi.org/deliver/etsi_ts/136500_136599/13652302/17.04.00_60/ts_13652302v170400p.pdf">https://www.etsi.org/deliver/etsi_ts/136500_136599/13652302/17.04.00_60/ts_13652302v170400p.pdf</a>
TSDSI	TSDSI STD T1.3GPP 36.523-2 17.4.0 V1.2.0	17.4.0	Published	02.05.2023	<a href="https://members.tdsi.in/s/ofpFP2Gt67jtLbc">https://members.tdsi.in/s/ofpFP2Gt67jtLbc</a>
TTA	TTAT.3G-36.523-2V17.4.0	17.4.0	Published	16.03.2023	<a href="http://committee.tta.or.kr/data/ttasDown.jsp?kind=ttastd&amp;pk_num=TTAT.3G-36.523-2V17.4.0">http://committee.tta.or.kr/data/ttasDown.jsp?kind=ttastd&amp;pk_num=TTAT.3G-36.523-2V17.4.0</a>

### 2.1.6.8 TS 36.523-3

#### Evolved Universal Terrestrial Radio Access (E-UTRA) and Evolved Packet Core (EPC); User Equipment (UE) conformance specification; Part 3: Test suites

This document specifies the protocol and signalling conformance testing in TTCN-3 for the 3GPP UE at the UE-E-UTRAN radio interface.

The following TTCN test specification and design considerations can be found in this document:

- the test system architecture;
- the overall test suite structure;
- the test models and ASP definitions;
- the test methods and usage of communication ports definitions;
- the test configurations;
- the design principles and assumptions;

- TTCN styles and conventions;
- the partial PIXIT proforma;
- the test suites.

The Abstract Test Suites designed in the document are based on the test cases specified in prose (3GPP TS 36.523-1). The applicability of the individual test cases is specified in the test ICS proforma specification (3GPP TS 36.523-2).

This document is valid for UE implemented according to 3GPP Rel-9 upwards.

SDO	Document No.	Version	Status	Issued date	Location
<b>Release 10</b>					
ARIB	ARIB STD-T120-36.523-3.V10.5.1	10.5.1	Published	03.03.2023	<a href="https://www.arib.or.jp/english/html/overview/doc/T120_T23_SPECS/ARIB-STD-T120/Rel10/36/A36523-3-a51.pdf">https://www.arib.or.jp/english/html/overview/doc/T120_T23_SPECS/ARIB-STD-T120/Rel10/36/A36523-3-a51.pdf</a>
ATIS	ATIS.3GPP.36.523-3V1051	10.5.1	Published	28.06.2021	<a href="https://www.atis.org/3gpp-documents/Rel99-14/">https://www.atis.org/3gpp-documents/Rel99-14/</a>
CCSA	CCSA.36.523-3V1051	10.5.1	Published	01.10.2013	<a href="https://www.ccsa.org.cn/api/portalsFile/downloadOldFile?type=19&amp;oldFileUrl=ITU-R/M.2012-6/CCSA.36.523-3V1051.doc">https://www.ccsa.org.cn/api/portalsFile/downloadOldFile?type=19&amp;oldFileUrl=ITU-R/M.2012-6/CCSA.36.523-3V1051.doc</a>
ETSI	ETSI TS 136 523-3	10.5.1	Published	15.10.2013	<a href="https://www.etsi.org/deliver/etsi_ts/136500_136599/13652303/10.05.01_60/ts_13652303v100501p.pdf">https://www.etsi.org/deliver/etsi_ts/136500_136599/13652303/10.05.01_60/ts_13652303v100501p.pdf</a>
TSDSI	TSDSI STD T1.3GPP 36.523-3-10.5.1 V1.0.0	10.5.1	Published	30.08.2021	<a href="https://members.tdsi.in/index.php/s/nitCdPtqsgnrSGr">https://members.tdsi.in/index.php/s/nitCdPtqsgnrSGr</a>
TTA	TTAT.3G-36.523-3V10.5.1	10.5.1	Published	02.08.2021	<a href="http://committee.tta.or.kr/data/ttasDown.jsp?kind=ttastd&amp;pk_num=TTAT.3G-36.523-3V10.5.1">http://committee.tta.or.kr/data/ttasDown.jsp?kind=ttastd&amp;pk_num=TTAT.3G-36.523-3V10.5.1</a>
<b>Release 11</b>					
ARIB	ARIB STD-T120-36.523-3.V11.7.0	11.7.0	Published	03.03.2023	<a href="https://www.arib.or.jp/english/html/overview/doc/T120_T23_SPECS/ARIB-STD-T120/Rel11/36/A36523-3-b70.pdf">https://www.arib.or.jp/english/html/overview/doc/T120_T23_SPECS/ARIB-STD-T120/Rel11/36/A36523-3-b70.pdf</a>
ATIS	ATIS.3GPP.36.523-3V1170	11.7.0	Published	28.06.2021	<a href="https://www.atis.org/3gpp-documents/Rel99-14/">https://www.atis.org/3gpp-documents/Rel99-14/</a>
CCSA	CCSA.36.523-3V1170	11.7.0	Published	01.12.2015	<a href="https://www.ccsa.org.cn/api/portalsFile/downloadOldFile?type=19&amp;oldFileUrl=ITU-R/M.2012-6/CCSA.36.523-3V1170.doc">https://www.ccsa.org.cn/api/portalsFile/downloadOldFile?type=19&amp;oldFileUrl=ITU-R/M.2012-6/CCSA.36.523-3V1170.doc</a>
ETSI	ETSI TS 136 523-3	11.7.0	Published	18.01.2016	<a href="https://www.etsi.org/deliver/etsi_ts/136500_136599/13652303/11.07.00_60/ts_13652303v110700p.pdf">https://www.etsi.org/deliver/etsi_ts/136500_136599/13652303/11.07.00_60/ts_13652303v110700p.pdf</a>
TSDSI	TSDSI STD T1.3GPP 36.523-3-11.7.0 V1.0.0	11.7.0	Published	30.08.2021	<a href="https://members.tdsi.in/index.php/s/j2X2fmHAftiifbW">https://members.tdsi.in/index.php/s/j2X2fmHAftiifbW</a>
TTA	TTAT.3G-36.523-3V11.7.0	11.7.0	Published	02.08.2021	<a href="http://committee.tta.or.kr/data/ttasDown.jsp?kind=ttastd&amp;pk_num=TTAT.3G-36.523-3V11.7.0">http://committee.tta.or.kr/data/ttasDown.jsp?kind=ttastd&amp;pk_num=TTAT.3G-36.523-3V11.7.0</a>
<b>Release 12</b>					
ARIB	ARIB STD-T120-36.523-3.V12.8.0	12.8.0	Published	03.03.2023	<a href="https://www.arib.or.jp/english/html/overview/doc/T120_T23_SPECS/ARIB-STD-T120/Rel12/36/A36523-3-c80.pdf">https://www.arib.or.jp/english/html/overview/doc/T120_T23_SPECS/ARIB-STD-T120/Rel12/36/A36523-3-c80.pdf</a>
ATIS	ATIS.3GPP.36.523-3V1280	12.8.0	Published	28.06.2021	<a href="https://www.atis.org/3gpp-documents/Rel99-14/">https://www.atis.org/3gpp-documents/Rel99-14/</a>
CCSA	CCSA.36.523-3V1280	12.8.0	Published	01.03.2017	<a href="https://www.ccsa.org.cn/api/portalsFile/downloadOldFile?type=19&amp;oldFileUrl=ITU-R/M.2012-6/CCSA.36.523-3V1280.doc">https://www.ccsa.org.cn/api/portalsFile/downloadOldFile?type=19&amp;oldFileUrl=ITU-R/M.2012-6/CCSA.36.523-3V1280.doc</a>
ETSI	ETSI TS 136 523-3	12.8.0	Published	11.04.2017	<a href="https://www.etsi.org/deliver/etsi_ts/136500_136599/13652303/12.08.00_60/ts_13652303v120800p.pdf">https://www.etsi.org/deliver/etsi_ts/136500_136599/13652303/12.08.00_60/ts_13652303v120800p.pdf</a>
TSDSI	TSDSI STD T1.3GPP 36.523-3-12.8.0 V1.0.0	12.8.0	Published	30.08.2021	<a href="https://members.tdsi.in/index.php/s/aoyMf6eEerg6yJA">https://members.tdsi.in/index.php/s/aoyMf6eEerg6yJA</a>
TTA	TTAT.3G-36.523-3V12.8.0	12.8.0	Published	02.08.2021	<a href="http://committee.tta.or.kr/data/ttasDown.jsp?kind=ttastd&amp;pk_num=TTAT.3G-36.523-3V12.8.0">http://committee.tta.or.kr/data/ttasDown.jsp?kind=ttastd&amp;pk_num=TTAT.3G-36.523-3V12.8.0</a>
<b>Release 13</b>					
ARIB	ARIB STD-T120-36.523-3.V13.4.0	13.4.0	Published	03.03.2023	<a href="https://www.arib.or.jp/english/html/overview/doc/T120_T23_SPECS/ARIB-STD-T120/Rel13/36/A36523-3-d40.pdf">https://www.arib.or.jp/english/html/overview/doc/T120_T23_SPECS/ARIB-STD-T120/Rel13/36/A36523-3-d40.pdf</a>
ATIS	ATIS.3GPP.36.523-3V1340	13.4.0	Published	28.06.2021	<a href="https://www.atis.org/3gpp-documents/Rel99-14/">https://www.atis.org/3gpp-documents/Rel99-14/</a>
CCSA	CCSA.36.523-3V1340	13.4.0	Published	01.09.2017	<a href="https://www.ccsa.org.cn/api/portalsFile/downloadOldFile?type=19&amp;oldFileUrl=ITU-R/M.2012-6/CCSA.36.523-3V1340.doc">https://www.ccsa.org.cn/api/portalsFile/downloadOldFile?type=19&amp;oldFileUrl=ITU-R/M.2012-6/CCSA.36.523-3V1340.doc</a>
ETSI	ETSI TS 136 523-3	13.4.0	Published	11.10.2017	<a href="https://www.etsi.org/deliver/etsi_ts/136500_136599/13652303/13.04.00_60/ts_13652303v130400p.pdf">https://www.etsi.org/deliver/etsi_ts/136500_136599/13652303/13.04.00_60/ts_13652303v130400p.pdf</a>
TSDSI	TSDSI STD T1.3GPP 36.523-3-13.4.0 V1.0.0	13.4.0	Published	30.08.2021	<a href="https://members.tdsi.in/index.php/s/RWBcYQQY8wRz2bH">https://members.tdsi.in/index.php/s/RWBcYQQY8wRz2bH</a>
TTA	TTAT.3G-36.523-3V13.4.0	13.4.0	Published	02.08.2021	<a href="http://committee.tta.or.kr/data/ttasDown.jsp?kind=ttastd&amp;pk_num=TTAT.3G-36.523-3V13.4.0">http://committee.tta.or.kr/data/ttasDown.jsp?kind=ttastd&amp;pk_num=TTAT.3G-36.523-3V13.4.0</a>
<b>Release 14</b>					
ARIB	ARIB STD-T120-36.523-3.V14.5.0	14.5.0	Published	03.03.2023	<a href="https://www.arib.or.jp/english/html/overview/doc/T120_T23_SPECS/ARIB-STD-T120/Rel14/36/A36523-3-e50.pdf">https://www.arib.or.jp/english/html/overview/doc/T120_T23_SPECS/ARIB-STD-T120/Rel14/36/A36523-3-e50.pdf</a>
ATIS	ATIS.3GPP.36.523-3V1450	14.5.0	Published	28.06.2021	<a href="https://www.atis.org/3gpp-documents/Rel99-14/">https://www.atis.org/3gpp-documents/Rel99-14/</a>
CCSA	CCSA.36.523-3V1450	14.5.0	Published	01.09.2018	<a href="https://www.ccsa.org.cn/api/portalsFile/downloadOldFile?type=19&amp;oldFileUrl=ITU-R/M.2012-6/CCSA.36.523-3V1450.doc">https://www.ccsa.org.cn/api/portalsFile/downloadOldFile?type=19&amp;oldFileUrl=ITU-R/M.2012-6/CCSA.36.523-3V1450.doc</a>
ETSI	ETSI TS 136 523-3	14.5.0	Published	16.10.2018	<a href="https://www.etsi.org/deliver/etsi_ts/136500_136599/13652303/14.05.00_60/ts_13652303v140500p.pdf">https://www.etsi.org/deliver/etsi_ts/136500_136599/13652303/14.05.00_60/ts_13652303v140500p.pdf</a>
TSDSI	TSDSI STD T1.3GPP 36.523-3-14.5.0 V1.1.0	14.5.0	Published	30.08.2021	<a href="https://members.tdsi.in/index.php/s/yNEdt4DHDY07X6Y">https://members.tdsi.in/index.php/s/yNEdt4DHDY07X6Y</a>
TTA	TTAT.3G-36.523-3V14.5.0	14.5.0	Published	02.08.2021	<a href="http://committee.tta.or.kr/data/ttasDown.jsp?kind=ttastd&amp;pk_num=TTAT.3G-36.523-3V14.5.0">http://committee.tta.or.kr/data/ttasDown.jsp?kind=ttastd&amp;pk_num=TTAT.3G-36.523-3V14.5.0</a>

**Release 15**

ARIB	ARIB STD-T120-36.523-3.V15.4.0	15.4.0	Published	03.03.2023	<a href="https://www.arib.or.jp/english/html/overview/doc/T120_T23_SPECS/ARIB-STD-T120/Rel15/36/A36523-3-f40.pdf">https://www.arib.or.jp/english/html/overview/doc/T120_T23_SPECS/ARIB-STD-T120/Rel15/36/A36523-3-f40.pdf</a>
ATIS	ATIS.3GPP.36.523-3V1540	15.4.0	Published	28.06.2021	<a href="https://www.atis.org/3gpp-documents/Rel15/">https://www.atis.org/3gpp-documents/Rel15/</a>
CCSA	CCSA.36.523-3V1540	15.4.0	Published	01.03.2020	<a href="https://www.ccsa.org.cn/api/portalsFile/downloadOldFile?type=19&amp;oldFileUrl=ITU-R/M.2012-6/CCSA.36.523-3V1540.doc">https://www.ccsa.org.cn/api/portalsFile/downloadOldFile?type=19&amp;oldFileUrl=ITU-R/M.2012-6/CCSA.36.523-3V1540.doc</a>
ETSI	ETSI TS 136 523-3	15.4.0	Published	02.04.2020	<a href="https://www.etsi.org/deliver/etsi_ts/136500_136599/13652303/15.04.00_60/ts_13652303v150400p.pdf">https://www.etsi.org/deliver/etsi_ts/136500_136599/13652303/15.04.00_60/ts_13652303v150400p.pdf</a>
TSDSI	TSDSI STD T1.3GPP 36.523-3-15.4.0 V1.0.0	15.4.0	Published	30.08.2021	<a href="https://members.tdsi.in/index.php/s/XDJGtZmTYEeYrbb">https://members.tdsi.in/index.php/s/XDJGtZmTYEeYrbb</a>
TTA	TTAT.3G-36.523-3V15.4.0	15.4.0	Published	11.09.2020	<a href="http://committee.tta.or.kr/data/ttasDown.jsp?kind=ttastd&amp;pk_num=TTAT.3G-36.523-3V15.4.0">http://committee.tta.or.kr/data/ttasDown.jsp?kind=ttastd&amp;pk_num=TTAT.3G-36.523-3V15.4.0</a>

**Release 16**

ARIB	ARIB STD-T120-36.523-3.V16.11.0	16.11.0	Published	03.03.2023	<a href="https://www.arib.or.jp/english/html/overview/doc/T120_T23_SPECS/ARIB-STD-T120/Rel16/36/A36523-3-gb0.pdf">https://www.arib.or.jp/english/html/overview/doc/T120_T23_SPECS/ARIB-STD-T120/Rel16/36/A36523-3-gb0.pdf</a>
ATIS	ATIS.3GPP.36.523-3.V16.11.0	16.11.0	Published	21.02.2023	<a href="https://www.atis.org/3gpp-transpositions - Rel-16">https://www.atis.org/3gpp-transpositions - Rel-16</a>
CCSA	CCSA.36.523-3V16110	16.11.0	Published	01.12.2021	<a href="https://www.ccsa.org.cn/api/portalsFile/downloadOldFile?type=19&amp;oldFileUrl=ITU-R/M.2012-6/CCSA.36.523-3V16110.doc">https://www.ccsa.org.cn/api/portalsFile/downloadOldFile?type=19&amp;oldFileUrl=ITU-R/M.2012-6/CCSA.36.523-3V16110.doc</a>
ETSI	ETSI TS 136 523-3	16.11.0	Published	26.01.2022	<a href="https://www.etsi.org/deliver/etsi_ts/136500_136599/13652303/16.11.00_60/ts_13652303v161100p.pdf">https://www.etsi.org/deliver/etsi_ts/136500_136599/13652303/16.11.00_60/ts_13652303v161100p.pdf</a>
TSDSI	TSDSI STD T1.3GPP 36.523-3-16.11.0	16.11.0	Published	01.11.2022	<a href="https://members.tdsi.in/s/KQBeo6prZ6MZ2Cg">https://members.tdsi.in/s/KQBeo6prZ6MZ2Cg</a>
TTA	TTAT.3G-36.523-3V16.11.0	16.11.0	Published	14.03.2022	<a href="http://committee.tta.or.kr/data/ttasDown.jsp?kind=ttastd&amp;pk_num=TTAT.3G-36.523-3V16.11.0">http://committee.tta.or.kr/data/ttasDown.jsp?kind=ttastd&amp;pk_num=TTAT.3G-36.523-3V16.11.0</a>

**Release 17**

ARIB	ARIB STD-T120-36.523-3.V17.5.0	17.5.0	Published	03.03.2023	<a href="https://www.arib.or.jp/english/html/overview/doc/T120_T23_SPECS/ARIB-STD-T120/Rel17/36/A36523-3-h50.pdf">https://www.arib.or.jp/english/html/overview/doc/T120_T23_SPECS/ARIB-STD-T120/Rel17/36/A36523-3-h50.pdf</a>
ATIS	ATIS.3GPP.36.523-3.V17.5.0	17.5.0	Published	21.02.2023	<a href="https://www.atis.org/3gpp-transpositions - Rel-17">https://www.atis.org/3gpp-transpositions - Rel-17</a>
CCSA	CCSA.36.523-3V1750	17.5.0	Published	01.12.2022	<a href="https://www.ccsa.org.cn/api/portalsFile/downloadOldFile?type=19&amp;oldFileUrl=ITU-R/M.2012-6/CCSA.36.523-3V1750.rar">https://www.ccsa.org.cn/api/portalsFile/downloadOldFile?type=19&amp;oldFileUrl=ITU-R/M.2012-6/CCSA.36.523-3V1750.rar</a>
ETSI	ETSI TS 136 523-3	17.5.0	Published	30.01.2023	<a href="https://www.etsi.org/deliver/etsi_ts/136500_136599/13652303/17.05.00_60/ts_13652303v170500p.pdf">https://www.etsi.org/deliver/etsi_ts/136500_136599/13652303/17.05.00_60/ts_13652303v170500p.pdf</a>
TSDSI	TSDSI STD T1.3GPP 36.523-3 17.5.0 V1.3.0	17.5.0	Published	02.05.2023	<a href="https://members.tdsi.in/s/7bXd26e6zZAPcAB">https://members.tdsi.in/s/7bXd26e6zZAPcAB</a>
TTA	TTAT.3G-36.523-3V17.5.0	17.5.0	Published	16.03.2023	<a href="http://committee.tta.or.kr/data/ttasDown.jsp?kind=ttastd&amp;pk_num=TTAT.3G-36.523-3V17.5.0">http://committee.tta.or.kr/data/ttasDown.jsp?kind=ttastd&amp;pk_num=TTAT.3G-36.523-3V17.5.0</a>

**2.1.6.9 TS 36.579-1****Mission Critical (MC) services over LTE; Part 1: Common test environment**

This document defines the common test environment required for testing Client and Server implementations for compliance to the Mission Critical Services over LTE protocol requirements defined by 3GPP.

It contains definitions of reference conditions and test signals, default messages and other parameters, generic procedures, and common requirements for test equipment with the goal for facilitating testing in general and test procedures specification in particular. Various parts of its content are referred to from other parts of the Mission Critical Services over LTE protocol conformance testing specification e.g. TS 36.579-2 and TS 36.579-3.

This document does not define the common test environment required for testing the implementation of the underlying LTE protocols, i.e. the LTE bearers used for transport of the Mission Critical Services signalling and media. This is defined in TS 36.508 and referred to from this document whenever needed.

In regard to default messages or other information elements contents, this document refers to content defined in requirements specifications specified by 3GPP or other organisations. In the case of Session Initiation Protocol (SIP) and Session Description Protocol (SDP) information elements this document refers to those specified in TS 34.229-1 and explicitly specifies only those relevant for the purposes of the Mission Critical Services over LTE protocol conformance testing.

In this release of the specification only Mission Critical Push To Talk (MCPTT) Services are considered. Future releases may include other Mission Critical Services.

SDO	Document No.	Version	Status	Issued date	Location
-----	--------------	---------	--------	-------------	----------

**Release 13**

ARIB	ARIB STD-T120-36.579-1.V13.3.0	13.3.0	Published	03.03.2023	<a href="https://www.arib.or.jp/english/html/overview/doc/T120_T23_SPECS/ARIB-STD-T120/Rel13/36/A36579-1-d30.pdf">https://www.arib.or.jp/english/html/overview/doc/T120_T23_SPECS/ARIB-STD-T120/Rel13/36/A36579-1-d30.pdf</a>
------	--------------------------------	--------	-----------	------------	---

## 146

## Rec. ITU-R M.2012-6

ATIS	ATIS.3GPP.36.579-1V1330	13.3.0	Published	28.06.2021	<a href="https://www.atis.org/3gpp-documents/Rel99-14/">https://www.atis.org/3gpp-documents/Rel99-14/</a>
CCSA	CCSA.36.579-1V1330	13.3.0	Published	01.03.2020	<a href="https://www.ccsa.org.cn/api/portalsFile/downloadOldFile?type=19&amp;oldFileUrl=ITU-R/M.2012-6/CCSA.36.579-1V1330.doc">https://www.ccsa.org.cn/api/portalsFile/downloadOldFile?type=19&amp;oldFileUrl=ITU-R/M.2012-6/CCSA.36.579-1V1330.doc</a>
ETSI	ETSI TS 136 579-1	13.3.0	Published	02.04.2020	<a href="https://www.etsi.org/deliver/etsi_ts/136500_136599/13657901/13.03.00_60/ts_13657901v130300p.pdf">https://www.etsi.org/deliver/etsi_ts/136500_136599/13657901/13.03.00_60/ts_13657901v130300p.pdf</a>
TSDSI	TSDSI STD T1.3GPP 36.579-1-13.3.0 V1.1.0	13.3.0	Published	30.08.2021	<a href="https://members.tdsi.in/index.php/s/mAwDMFjRARgeEqj">https://members.tdsi.in/index.php/s/mAwDMFjRARgeEqj</a>
TTA	TTAT.3G-36.579-1V13.3.0	13.3.0	Published	02.08.2021	<a href="http://committee.tta.or.kr/data/ttasDown.jsp?kind=ttastd&amp;pk_num=TTAT.3G-36.579-1V13.3.0">http://committee.tta.or.kr/data/ttasDown.jsp?kind=ttastd&amp;pk_num=TTAT.3G-36.579-1V13.3.0</a>

### Release 14

ARIB	ARIB STD-T120-36.579-1.V14.10.0	14.10.0	Published	03.03.2023	<a href="https://www.arib.or.jp/english/html/overview/doc/T120_T23_SPECS/ARIB-STD-T120/Rel14/36/A36579-1-ea0.pdf">https://www.arib.or.jp/english/html/overview/doc/T120_T23_SPECS/ARIB-STD-T120/Rel14/36/A36579-1-ea0.pdf</a>
ATIS	ATIS.3GPP.36.579-1.V14.10.0	14.10.0	Published	21.02.2023	<a href="https://www.atis.org/3gpp-transpositions - Rel-14">https://www.atis.org/3gpp-transpositions - Rel-14</a>
CCSA	CCSA.36.579-1V14100	14.10.0	Published	01.06.2021	<a href="https://www.ccsa.org.cn/api/portalsFile/downloadOldFile?type=19&amp;oldFileUrl=ITU-R/M.2012-6/CCSA.36.579-1V14100.doc">https://www.ccsa.org.cn/api/portalsFile/downloadOldFile?type=19&amp;oldFileUrl=ITU-R/M.2012-6/CCSA.36.579-1V14100.doc</a>
ETSI	ETSI TS 136 579-1	14.10.0	Published	19.08.2021	<a href="https://www.etsi.org/deliver/etsi_ts/136500_136599/13657901/14.10.00_60/ts_13657901v141000p.pdf">https://www.etsi.org/deliver/etsi_ts/136500_136599/13657901/14.10.00_60/ts_13657901v141000p.pdf</a>
TSDSI	TSDSI STD T1.3GPP 36.579-1-14.10.0	14.10.0	Published	17.01.2023	<a href="https://members.tdsi.in/s/xodb9tZkWKMW7Ly">https://members.tdsi.in/s/xodb9tZkWKMW7Ly</a>
TTA	TTAT.3G-36.579-1V14.10.0	14.10.0	Published	30.09.2021	<a href="http://committee.tta.or.kr/data/ttasDown.jsp?kind=ttastd&amp;pk_num=TTAT.3G-36.579-1V14.10.0">http://committee.tta.or.kr/data/ttasDown.jsp?kind=ttastd&amp;pk_num=TTAT.3G-36.579-1V14.10.0</a>

### Release 15

ARIB	ARIB STD-T120-36.579-1.V15.8.0	15.8.0	Published	03.03.2023	<a href="https://www.arib.or.jp/english/html/overview/doc/T120_T23_SPECS/ARIB-STD-T120/Rel15/36/A36579-1-f80.pdf">https://www.arib.or.jp/english/html/overview/doc/T120_T23_SPECS/ARIB-STD-T120/Rel15/36/A36579-1-f80.pdf</a>
ATIS	ATIS.3GPP.36.579-1.V15.8.0	15.8.0	Published	21.02.2023	<a href="https://www.atis.org/3gpp-transpositions - Rel-15">https://www.atis.org/3gpp-transpositions - Rel-15</a>
CCSA	CCSA.36.579-1V1580	15.8.0	Published	01.12.2022	<a href="https://www.ccsa.org.cn/api/portalsFile/downloadOldFile?type=19&amp;oldFileUrl=ITU-R/M.2012-6/CCSA.36.579-1V1580.doc">https://www.ccsa.org.cn/api/portalsFile/downloadOldFile?type=19&amp;oldFileUrl=ITU-R/M.2012-6/CCSA.36.579-1V1580.doc</a>
ETSI	ETSI TS 136 579-1	15.8.0	Published	24.01.2023	<a href="https://www.etsi.org/deliver/etsi_ts/136500_136599/13657901/15.08.00_60/ts_13657901v150800p.pdf">https://www.etsi.org/deliver/etsi_ts/136500_136599/13657901/15.08.00_60/ts_13657901v150800p.pdf</a>
TSDSI	TSDSI STD T1.3GPP 36.579-1 15.8.0 V1.3.0	15.8.0	Published	02.05.2023	<a href="https://members.tdsi.in/s/weXkRmsGbHcLM8g">https://members.tdsi.in/s/weXkRmsGbHcLM8g</a>
TTA	TTAT.3G-36.579-1V15.8.0	15.8.0	Published	16.03.2023	<a href="http://committee.tta.or.kr/data/ttasDown.jsp?kind=ttastd&amp;pk_num=TTAT.3G-36.579-1V15.8.0">http://committee.tta.or.kr/data/ttasDown.jsp?kind=ttastd&amp;pk_num=TTAT.3G-36.579-1V15.8.0</a>

### 2.1.6.10 TS 36.579-2

#### Mission Critical (MC) services over LTE; Part 2: Mission Critical Push To Talk (MCPTT) User Equipment (UE) Protocol conformance specification

This document specifies the protocol conformance testing for testing a MCPTT Client for compliance to the Mission Critical Push To Talk (MCPTT) over LTE protocol requirements defined by 3GPP.

In particular this document contains:

- the overall test structure;
- the test configurations;
- the conformance requirement and reference to the core specifications;
- the test purposes; and
- a brief description of the test procedure, the specific test requirements and short message exchange table.

This document is valid for MCPTT Clients implemented according to 3GPP releases starting from Release 13 up to the Release indicated on the cover page of this document.

The following information relevant to testing specified in this document could be found in accompanying specifications:

- default setting of the test parameters TS 36.579-1;
- Implementation Conformance Statement (ICS) TS 36.579-4 and Implementation eXtra Information for Testing (IXIT) TS 36.579-5;
- the applicability of each test case TS 36.579-4.

The test cases are expected to be executed through the 3GPP radio interface. This document does not specify the protocol conformance testing for the EPS (LTE) bearers, which carry the MCPTT data sent or received by the MCPTT Client and which are required to be supported by the UE in which the MCPTT Client is installed. This is defined in TS 36.523-1.

SDO	Document No.	Version	Status	Issued date	Location
<b>Release 13</b>					
ARIB	ARIB STD-T120-36.579-2.V13.3.0	13.3.0	Published	03.03.2023	<a href="https://www.arib.or.jp/english/html/overview/doc/T120_T23_SPECS/ARIB-STD-T120/Rel13/36/A36579-2-d30.pdf">https://www.arib.or.jp/english/html/overview/doc/T120_T23_SPECS/ARIB-STD-T120/Rel13/36/A36579-2-d30.pdf</a>
ATIS	ATIS.3GPP.36.579-2V1330	13.3.0	Published	28.06.2021	<a href="https://www.atis.org/3gpp-documents/Rel99-14/">https://www.atis.org/3gpp-documents/Rel99-14/</a>
CCSA	CCSA.36.579-2V1330	13.3.0	Published	01.03.2020	<a href="https://www.ccsa.org.cn/api/portalsFile/downloadOldFile?type=19&amp;oldFileUrl=ITU-R/M.2012-6/CCSA.36.579-2V1330.doc">https://www.ccsa.org.cn/api/portalsFile/downloadOldFile?type=19&amp;oldFileUrl=ITU-R/M.2012-6/CCSA.36.579-2V1330.doc</a>
ETSI	ETSI TS 136 579-2	13.3.0	Published	02.04.2020	<a href="https://www.etsi.org/deliver/etsi_ts/136500_136599/13657902/13.03.00_60/ts_13657902v130300p.pdf">https://www.etsi.org/deliver/etsi_ts/136500_136599/13657902/13.03.00_60/ts_13657902v130300p.pdf</a>
TSDSI	TSDSI STD T1.3GPP 36.579-2-13.3.0 V1.1.0	13.3.0	Published	30.08.2021	<a href="https://members.tdsi.in/index.php/s/KTtP8diTHxksCwz">https://members.tdsi.in/index.php/s/KTtP8diTHxksCwz</a>
TTA	TTAT.3G-36.579-2V13.3.0	13.3.0	Published	02.08.2021	<a href="http://committee.tta.or.kr/data/ttasDown.jsp?kind=ttastd&amp;pk_num=TTAT.3G-36.579-2V13.3.0">http://committee.tta.or.kr/data/ttasDown.jsp?kind=ttastd&amp;pk_num=TTAT.3G-36.579-2V13.3.0</a>
<b>Release 14</b>					
ARIB	ARIB STD-T120-36.579-2.V14.12.0	14.12.0	Published	03.03.2023	<a href="https://www.arib.or.jp/english/html/overview/doc/T120_T23_SPECS/ARIB-STD-T120/Rel14/36/A36579-2-ec0.pdf">https://www.arib.or.jp/english/html/overview/doc/T120_T23_SPECS/ARIB-STD-T120/Rel14/36/A36579-2-ec0.pdf</a>
ATIS	ATIS.3GPP.36.579-2.V14.12.0	14.12.0	Published	21.02.2023	<a href="https://www.atis.org/3gpp-transpositions - Rel-14">https://www.atis.org/3gpp-transpositions - Rel-14</a>
CCSA	CCSA.36.579-2V14120	14.12.0	Published	01.12.2022	<a href="https://www.ccsa.org.cn/api/portalsFile/downloadOldFile?type=19&amp;oldFileUrl=ITU-R/M.2012-6/CCSA.36.579-2V14120.doc">https://www.ccsa.org.cn/api/portalsFile/downloadOldFile?type=19&amp;oldFileUrl=ITU-R/M.2012-6/CCSA.36.579-2V14120.doc</a>
ETSI	ETSI TS 136 579-2	14.12.0	Published	24.01.2023	<a href="https://www.etsi.org/deliver/etsi_ts/136500_136599/13657902/14.12.00_60/ts_13657902v141200p.pdf">https://www.etsi.org/deliver/etsi_ts/136500_136599/13657902/14.12.00_60/ts_13657902v141200p.pdf</a>
TSDSI	TSDSI STD T1.3GPP 36.579-2 14.12.0 V1.2.0	14.12.0	Published	02.05.2023	<a href="https://members.tdsi.in/s/PcYFnKRksPqmQZZ">https://members.tdsi.in/s/PcYFnKRksPqmQZZ</a>
TTA	TTAT.3G-36.579-2V14.12.0	14.12.0	Published	16.03.2023	<a href="http://committee.tta.or.kr/data/ttasDown.jsp?kind=ttastd&amp;pk_num=TTAT.3G-36.579-2V14.12.0">http://committee.tta.or.kr/data/ttasDown.jsp?kind=ttastd&amp;pk_num=TTAT.3G-36.579-2V14.12.0</a>
<b>Release 15</b>					
ARIB	ARIB STD-T120-36.579-2.V15.6.0	15.6.0	Published	03.03.2023	<a href="https://www.arib.or.jp/english/html/overview/doc/T120_T23_SPECS/ARIB-STD-T120/Rel15/36/A36579-2-f60.pdf">https://www.arib.or.jp/english/html/overview/doc/T120_T23_SPECS/ARIB-STD-T120/Rel15/36/A36579-2-f60.pdf</a>
ATIS	ATIS.3GPP.36.579-2.V15.6.0	15.6.0	Published	21.02.2023	<a href="https://www.atis.org/3gpp-transpositions - Rel-15">https://www.atis.org/3gpp-transpositions - Rel-15</a>
CCSA	CCSA.36.579-2V1560	15.6.0	Published	01.12.2022	<a href="https://www.ccsa.org.cn/api/portalsFile/downloadOldFile?type=19&amp;oldFileUrl=ITU-R/M.2012-6/CCSA.36.579-2V1560.doc">https://www.ccsa.org.cn/api/portalsFile/downloadOldFile?type=19&amp;oldFileUrl=ITU-R/M.2012-6/CCSA.36.579-2V1560.doc</a>
ETSI	ETSI TS 136 579-2	15.6.0	Published	24.01.2023	<a href="https://www.etsi.org/deliver/etsi_ts/136500_136599/13657902/15.06.00_60/ts_13657902v150600p.pdf">https://www.etsi.org/deliver/etsi_ts/136500_136599/13657902/15.06.00_60/ts_13657902v150600p.pdf</a>
TSDSI	TSDSI STD T1.3GPP 36.579-2 15.6.0 V1.2.0	15.6.0	Published	02.05.2023	<a href="https://members.tdsi.in/s/kALqkaXYqe4jJ8t">https://members.tdsi.in/s/kALqkaXYqe4jJ8t</a>
TTA	TTAT.3G-36.579-2V15.6.0	15.6.0	Published	16.03.2023	<a href="http://committee.tta.or.kr/data/ttasDown.jsp?kind=ttastd&amp;pk_num=TTAT.3G-36.579-2V15.6.0">http://committee.tta.or.kr/data/ttasDown.jsp?kind=ttastd&amp;pk_num=TTAT.3G-36.579-2V15.6.0</a>

### 2.1.6.11 TS 36.579-3

#### Mission Critical (MC) services over LTE; Part 3: Mission Critical Push To Talk (MCPTT) Server Application conformance specification

This document specifies the protocol conformance testing for testing a MCPTT Server for compliance to the Mission Critical Push To Talk (MCPTT) over LTE protocol requirements defined by 3GPP. This document addresses only MCPTT Server-Client, and MCPTT Server-Server communication scenarios. It does not cover, e.g. MCPTT Server-EPS, MCPTT Server-SIP Core, etc., scenarios which involve interfaces which implementation may widely vary.

In particular this specification contains:

- the overall test structure;
- the test configurations;
- the conformance requirement and reference to the core specifications;
- the test purposes; and
- a brief description of the test procedure, the specific test requirements and short message exchange table.

This document is valid for MCPTT Servers implemented according to 3GPP releases starting from Release 13 up to the Release indicated on the cover page of this document.

The following information relevant to testing specified in this document could be found in accompanying specifications:

- default setting of the test parameters TS 36.579-1;
- Implementation Conformance Statement (ICS) TS 36.579-4 and Implementation eXtra Information for Testing (IXIT) TS 36.579-5;
- the applicability of each test case TS 36.579-4.

This document does not specify the protocol conformance testing for the EPS (LTE) bearers which carry the MCPTT data sent or received by the MCPTT Server. The specification of such testing is out of the scope of RAN5.

SDO	Document No.	Version	Status	Issued date	Location
<b>Release 13</b>					
ARIB	ARIB STD-T120-36.579-3.V13.2.0	13.2.0	Published	03.03.2023	<a href="https://www.arib.or.jp/english/html/overview/doc/T120_T23_SPECS/ARIB-STD-T120/Rel13/36/A36579-3-d20.pdf">https://www.arib.or.jp/english/html/overview/doc/T120_T23_SPECS/ARIB-STD-T120/Rel13/36/A36579-3-d20.pdf</a>
ATIS	ATIS.3GPP.36.579-3.V13.2.0	13.2.0	Published	21.02.2023	<a href="https://www.atis.org/3gpp-transpositions - Rel-13">https://www.atis.org/3gpp-transpositions - Rel-13</a>
CCSA	CCSA.36.579-3V1320	13.2.0	Published	01.12.2021	<a href="https://www.ccsa.org.cn/api/portalsFile/downloadOldFile?type=19&amp;oldFileUrl=ITU-R/M.2012-6/CCSA.36.579-3V1320.doc">https://www.ccsa.org.cn/api/portalsFile/downloadOldFile?type=19&amp;oldFileUrl=ITU-R/M.2012-6/CCSA.36.579-3V1320.doc</a>
ETSI	ETSI TS 136 579-3	13.2.0	Published	26.01.2022	<a href="https://www.etsi.org/deliver/etsi_ts/136500_136599/13657903/13.02.00_60/ts_13657903v130200p.pdf">https://www.etsi.org/deliver/etsi_ts/136500_136599/13657903/13.02.00_60/ts_13657903v130200p.pdf</a>
TSDSI	TSDSI STD T1.3GPP 36.579-3-13.1.0 V1.1.0	13.2.0	Published	30.08.2021	<a href="https://members.tdsi.in/index.php/s/YEFt3n93aBzgP2j">https://members.tdsi.in/index.php/s/YEFt3n93aBzgP2j</a>
TTA	TTAT.3G-36.579-3V13.2.0	13.2.0	Published	14.03.2022	<a href="http://committee.tta.or.kr/data/ttasDown.jsp?kind=ttastd&amp;pk_num=TTAT.3G-36.579-3V13.2.0">http://committee.tta.or.kr/data/ttasDown.jsp?kind=ttastd&amp;pk_num=TTAT.3G-36.579-3V13.2.0</a>

#### 2.1.6.12 TS 36.579-4

##### **Mission Critical (MC) services over LTE; Part 4: Test Applicability and Implementation Conformance Statement (ICS) proforma specification**

This document provides the Implementation Conformance Statement (ICS) proforma for testing Client or Server implementations for compliance to the Mission Critical Services over LTE protocol requirements defined by 3GPP, and in accordance with the relevant guidance given in ISO/IEC 9646-1 and ISO/IEC 9646-7.

This document specifies the recommended applicability statement for the test cases included in 3GPP TS 36.579-2 and 3GPP TS 36.579-3. These applicability statements are based on the features implemented in the Client or the Server respectively.

This document is valid for Mission Critical Services Servers and Clients implemented according to 3GPP releases starting from Release 13 up to the Release indicated on the cover page of this document.

This document does not specify applicability or ICS for protocol conformance testing for the EPS (LTE) bearers which carry the Mission Critical Services data sent or received by the Client and/or the Server. These are defined in TS 36.523-2.

SDO	Document No.	Version	Status	Issued date	Location
<b>Release 13</b>					

ARIB	ARIB STD-T120-36.579-4.V13.2.0	13.2.0	Published	03.03.2023	<a href="https://www.arib.or.jp/english/html/overview/doc/T120_T23_SPECS/ARIB-STD-T120/Rel13/36/A36579-4-d20.pdf">https://www.arib.or.jp/english/html/overview/doc/T120_T23_SPECS/ARIB-STD-T120/Rel13/36/A36579-4-d20.pdf</a>
ATIS	ATIS.3GPP.36.579-4V1320	13.2.0	Published	28.06.2021	<a href="https://www.atis.org/3gpp-documents/Rel99-14/">https://www.atis.org/3gpp-documents/Rel99-14/</a>
CCSA	CCSA.36.579-4V1320	13.2.0	Published	01.03.2020	<a href="https://www.ccsa.org.cn/api/portalsFile/downloadOldFile?type=19&amp;oldFileUrl=ITU-R/M.2012-6/CCSA.36.579-4V1320.doc">https://www.ccsa.org.cn/api/portalsFile/downloadOldFile?type=19&amp;oldFileUrl=ITU-R/M.2012-6/CCSA.36.579-4V1320.doc</a>
ETSI	ETSI TS 136 579-4	13.2.0	Published	02.04.2020	<a href="https://www.etsi.org/deliver/etsi_ts/136500_136599/13657904/13.02.00_60/ts_13657904v130200p.pdf">https://www.etsi.org/deliver/etsi_ts/136500_136599/13657904/13.02.00_60/ts_13657904v130200p.pdf</a>
TSDSI	TSDSI STD T1.3GPP 36.579-4-13.2.0 V1.1.0	13.2.0	Published	30.08.2021	<a href="https://members.tdsi.in/index.php/s/cqnfqkzsysboFn7">https://members.tdsi.in/index.php/s/cqnfqkzsysboFn7</a>
TTA	TTAT.3G-36.579-4V13.2.0	13.2.0	Published	02.08.2021	<a href="http://committee.tta.or.kr/data/ttasDown.jsp?kind=ttastd&amp;pk_num=TTAT.3G-36.579-4V13.2.0">http://committee.tta.or.kr/data/ttasDown.jsp?kind=ttastd&amp;pk_num=TTAT.3G-36.579-4V13.2.0</a>
<b>Release 14</b>					
ARIB	ARIB STD-T120-36.579-4.V14.7.0	14.7.0	Published	03.03.2023	<a href="https://www.arib.or.jp/english/html/overview/doc/T120_T23_SPECS/ARIB-STD-T120/Rel14/36/A36579-4-e70.pdf">https://www.arib.or.jp/english/html/overview/doc/T120_T23_SPECS/ARIB-STD-T120/Rel14/36/A36579-4-e70.pdf</a>
ATIS	ATIS.3GPP.36.579-4.V14.7.0	14.7.0	Published	21.02.2023	<a href="https://www.atis.org/3gpp-transpositions - Rel-14">https://www.atis.org/3gpp-transpositions - Rel-14</a>
CCSA	CCSA.36.579-4V1470	14.7.0	Published	01.12.2021	<a href="https://www.ccsa.org.cn/api/portalsFile/downloadOldFile?type=19&amp;oldFileUrl=ITU-R/M.2012-6/CCSA.36.579-4V1470.doc">https://www.ccsa.org.cn/api/portalsFile/downloadOldFile?type=19&amp;oldFileUrl=ITU-R/M.2012-6/CCSA.36.579-4V1470.doc</a>
ETSI	ETSI TS 136 579-4	14.7.0	Published	20.01.2022	<a href="https://www.etsi.org/deliver/etsi_ts/136500_136599/13657904/14.07.00_60/ts_13657904v140700p.pdf">https://www.etsi.org/deliver/etsi_ts/136500_136599/13657904/14.07.00_60/ts_13657904v140700p.pdf</a>
TSDSI	TSDSI STD T1.3GPP 36.579-4-14.7.0 V1.1.0	14.7.0	Published	17.01.2023	<a href="https://members.tdsi.in/s/axkD423A2TaEB2b">https://members.tdsi.in/s/axkD423A2TaEB2b</a>
TTA	TTAT.3G-36.579-4V14.7.0	14.7.0	Published	14.03.2022	<a href="http://committee.tta.or.kr/data/ttasDown.jsp?kind=ttastd&amp;pk_num=TTAT.3G-36.579-4V14.7.0">http://committee.tta.or.kr/data/ttasDown.jsp?kind=ttastd&amp;pk_num=TTAT.3G-36.579-4V14.7.0</a>
<b>Release 15</b>					
ARIB	ARIB STD-T120-36.579-4.V15.4.0	15.4.0	Published	03.03.2023	<a href="https://www.arib.or.jp/english/html/overview/doc/T120_T23_SPECS/ARIB-STD-T120/Rel15/36/A36579-4-f40.pdf">https://www.arib.or.jp/english/html/overview/doc/T120_T23_SPECS/ARIB-STD-T120/Rel15/36/A36579-4-f40.pdf</a>
ATIS	ATIS.3GPP.36.579-4.V15.4.0	15.4.0	Published	21.02.2023	<a href="https://www.atis.org/3gpp-transpositions - Rel-15">https://www.atis.org/3gpp-transpositions - Rel-15</a>
CCSA	CCSA.36.579-4V1540	15.4.0	Published	01.06.2022	<a href="https://www.ccsa.org.cn/api/portalsFile/downloadOldFile?type=19&amp;oldFileUrl=ITU-R/M.2012-6/CCSA.36.579-4V1540.doc">https://www.ccsa.org.cn/api/portalsFile/downloadOldFile?type=19&amp;oldFileUrl=ITU-R/M.2012-6/CCSA.36.579-4V1540.doc</a>
ETSI	ETSI TS 136 579-4	15.4.0	Published	16.08.2022	<a href="https://www.etsi.org/deliver/etsi_ts/136500_136599/13657904/15.04.00_60/ts_13657904v150400p.pdf">https://www.etsi.org/deliver/etsi_ts/136500_136599/13657904/15.04.00_60/ts_13657904v150400p.pdf</a>
TSDSI	TSDSI STD T1.3GPP 36.579-4-15.4.0 V1.0.0	15.4.0	Published	01.11.2022	<a href="https://members.tdsi.in/s/LfptMjRwEsiNSxQ">https://members.tdsi.in/s/LfptMjRwEsiNSxQ</a>
TTA	TTAT.3G-36.579-4V15.4.0	15.4.0	Published	21.10.2022	<a href="http://committee.tta.or.kr/data/ttasDown.jsp?kind=ttastd&amp;pk_num=TTAT.3G-36.579-4V15.4.0">http://committee.tta.or.kr/data/ttasDown.jsp?kind=ttastd&amp;pk_num=TTAT.3G-36.579-4V15.4.0</a>

### 2.1.6.13 TS 36.579-5

#### Mission Critical (MC) services over LTE; Part 5: Abstract test suite (ATS)

This document specifies the protocol and signalling conformance testing in TTCN-3 for the Mission Critical services over LTE signalling and protocol requirements defined by 3GPP.

The following TTCN test specification and design considerations can be found in this document:

- the test system architecture;
- the overall test suite structure;
- the test models and ASP definitions;
- the test methods and usage of communication ports definitions;
- the test configurations;
- the design principles and assumptions;
- TTCN styles and conventions;
- the partial Implementation eXtra Information for Testing (IXIT) proforma;
- the test suites.

The Abstract Test Suites designed in the document are based on the test cases specified in 3GPP TS 36.579-2. The test cases specified in 3GPP TS 36.579-3 are out of scope of this document.

The applicability of the individual test cases is specified in the test ICS proforma specification in 3GPP TS 36.579-4). Where appropriate the Abstract Test Suites belonging to this specification may refer to other Abstract Test Suites, e.g. 3GPP TS 36.523-3 for test requirements related to the EPS (LTE) bearers which carry the Mission Critical services data.

This document is valid for TTCN development for Mission Critical services clients' conformance tests according to 3GPP Releases starting from Release 13 up to the Release indicated on the cover page of this document.

SDO	Document No.	Version	Status	Issued date	Location
<b>Release 13</b>					
ARIB	ARIB STD-T120-36.579-5.V13.8.0	13.8.0	Published	03.03.2023	<a href="https://www.arib.or.jp/english/html/overview/doc/T120_T23_SPECS/ARIB-STD-T120/Rel13/36/A36579-5-d80.pdf">https://www.arib.or.jp/english/html/overview/doc/T120_T23_SPECS/ARIB-STD-T120/Rel13/36/A36579-5-d80.pdf</a>
ATIS	ATIS.3GPP.36.579-5.V13.8.0	13.8.0	Published	21.02.2023	<a href="https://www.atis.org/3gpp-transpositions - Rel-13">https://www.atis.org/3gpp-transpositions - Rel-13</a>
CCSA	CCSA.36.579-5V1380	13.8.0	Published	01.06.2021	<a href="https://www.ccsa.org.cn/api/portalsFile/downloadOldFile?type=19&amp;oldFileUrl=ITU-R/M.2012-6/CCSA.36.579-5V1380.doc">https://www.ccsa.org.cn/api/portalsFile/downloadOldFile?type=19&amp;oldFileUrl=ITU-R/M.2012-6/CCSA.36.579-5V1380.doc</a>
ETSI	ETSI TS 136 579-5	13.8.0	Published	19.08.2021	<a href="https://www.etsi.org/deliver/etsi_ts/136500_136599/13657905/13.08.00_60/ts_13657905v130800p.pdf">https://www.etsi.org/deliver/etsi_ts/136500_136599/13657905/13.08.00_60/ts_13657905v130800p.pdf</a>
TSDSI	TSDSI STD T1.3GPP 36.579-5-13.8.0 V1.1.0	13.8.0	Published	17.01.2023	<a href="https://members.tdsi.in/s/PZsssMwDKdx82SB">https://members.tdsi.in/s/PZsssMwDKdx82SB</a>
TTA	TTAT.3G-36.579-5V13.8.0	13.8.0	Published	30.09.2021	<a href="http://committee.tta.or.kr/data/ttasDown.jsp?kind=ttastd&amp;pk_num=TTAT.3G-36.579-5V13.8.0">http://committee.tta.or.kr/data/ttasDown.jsp?kind=ttastd&amp;pk_num=TTAT.3G-36.579-5V13.8.0</a>
<b>Release 14</b>					
ARIB	ARIB STD-T120-36.579-5.V14.9.0	14.9.0	Published	03.03.2023	<a href="https://www.arib.or.jp/english/html/overview/doc/T120_T23_SPECS/ARIB-STD-T120/Rel14/36/A36579-5-e90.pdf">https://www.arib.or.jp/english/html/overview/doc/T120_T23_SPECS/ARIB-STD-T120/Rel14/36/A36579-5-e90.pdf</a>
ATIS	ATIS.3GPP.36.579-5.V14.9.0	14.9.0	Published	21.02.2023	<a href="https://www.atis.org/3gpp-transpositions - Rel-14">https://www.atis.org/3gpp-transpositions - Rel-14</a>
CCSA	CCSA.36.579-5V1490	14.9.0	Published	01.12.2022	<a href="https://www.ccsa.org.cn/api/portalsFile/downloadOldFile?type=19&amp;oldFileUrl=ITU-R/M.2012-6/CCSA.36.579-5V1490.doc">https://www.ccsa.org.cn/api/portalsFile/downloadOldFile?type=19&amp;oldFileUrl=ITU-R/M.2012-6/CCSA.36.579-5V1490.doc</a>
ETSI	ETSI TS 136 579-5	14.9.0	Published	24.01.2023	<a href="https://www.etsi.org/deliver/etsi_ts/136500_136599/13657905/14.09.00_60/ts_13657905v140900p.pdf">https://www.etsi.org/deliver/etsi_ts/136500_136599/13657905/14.09.00_60/ts_13657905v140900p.pdf</a>
TSDSI	TSDSI STD T1.3GPP 36.579-5 14.9.0 V1.2.0	14.9.0	Published	02.05.2023	<a href="https://members.tdsi.in/s/Xa9yCKqzMGsDfoe">https://members.tdsi.in/s/Xa9yCKqzMGsDfoe</a>
TTA	TTAT.3G-36.579-5V14.9.0	14.9.0	Published	16.03.2023	<a href="http://committee.tta.or.kr/data/ttasDown.jsp?kind=ttastd&amp;pk_num=TTAT.3G-36.579-5V14.9.0">http://committee.tta.or.kr/data/ttasDown.jsp?kind=ttastd&amp;pk_num=TTAT.3G-36.579-5V14.9.0</a>
<b>Release 15</b>					
ARIB	ARIB STD-T120-36.579-5.V15.1.0	15.1.0	Published	03.03.2023	<a href="https://www.arib.or.jp/english/html/overview/doc/T120_T23_SPECS/ARIB-STD-T120/Rel15/36/A36579-5-f10.pdf">https://www.arib.or.jp/english/html/overview/doc/T120_T23_SPECS/ARIB-STD-T120/Rel15/36/A36579-5-f10.pdf</a>
ATIS	ATIS.3GPP.36.579-5.V15.1.0	15.1.0	Published	21.02.2023	<a href="https://www.atis.org/3gpp-transpositions - Rel-15">https://www.atis.org/3gpp-transpositions - Rel-15</a>
CCSA	CCSA.36.579-5V1510	15.1.0	Published	01.12.2022	<a href="https://www.ccsa.org.cn/api/portalsFile/downloadOldFile?type=19&amp;oldFileUrl=ITU-R/M.2012-6/CCSA.36.579-5V1510.doc">https://www.ccsa.org.cn/api/portalsFile/downloadOldFile?type=19&amp;oldFileUrl=ITU-R/M.2012-6/CCSA.36.579-5V1510.doc</a>
ETSI	ETSI TS 136 579-5	15.1.0	Published	24.01.2023	<a href="https://www.etsi.org/deliver/etsi_ts/136500_136599/13657905/15.01.00_60/ts_13657905v150100p.pdf">https://www.etsi.org/deliver/etsi_ts/136500_136599/13657905/15.01.00_60/ts_13657905v150100p.pdf</a>
TSDSI	TSDSI STD T1.3GPP 36.579-5-15.1.0 V1.1.0	15.1.0	Published	02.05.2023	<a href="https://members.tdsi.in/s/j9DrLe96XbaRmtr">https://members.tdsi.in/s/j9DrLe96XbaRmtr</a>
TTA	TTAT.3G-36.579-5V15.1.0	15.1.0	Published	16.03.2023	<a href="http://committee.tta.or.kr/data/ttasDown.jsp?kind=ttastd&amp;pk_num=TTAT.3G-36.579-5V15.1.0">http://committee.tta.or.kr/data/ttasDown.jsp?kind=ttastd&amp;pk_num=TTAT.3G-36.579-5V15.1.0</a>
<b>Release 16</b>					
ARIB	ARIB STD-T120-36.579-5.V16.0.0	16.0.0	Published	03.03.2023	<a href="https://www.arib.or.jp/english/html/overview/doc/T120_T23_SPECS/ARIB-STD-T120/Rel16/36/A36579-5-g00.pdf">https://www.arib.or.jp/english/html/overview/doc/T120_T23_SPECS/ARIB-STD-T120/Rel16/36/A36579-5-g00.pdf</a>
ATIS	ATIS.3GPP.36.579-5.V16.0.0	16.0.0	Published	21.02.2023	<a href="https://www.atis.org/3gpp-transpositions - Rel-16">https://www.atis.org/3gpp-transpositions - Rel-16</a>
CCSA	CCSA.36.579-5V1600	16.0.0	Published	01.12.2022	<a href="https://www.ccsa.org.cn/api/portalsFile/downloadOldFile?type=19&amp;oldFileUrl=ITU-R/M.2012-6/CCSA.36.579-5V1600.doc">https://www.ccsa.org.cn/api/portalsFile/downloadOldFile?type=19&amp;oldFileUrl=ITU-R/M.2012-6/CCSA.36.579-5V1600.doc</a>
ETSI	ETSI TS 136 579-5	16.0.0	Published	24.01.2023	<a href="https://www.etsi.org/deliver/etsi_ts/136500_136599/13657905/16.00.00_60/ts_13657905v160000p.pdf">https://www.etsi.org/deliver/etsi_ts/136500_136599/13657905/16.00.00_60/ts_13657905v160000p.pdf</a>
TSDSI	TSDSI STD T1.3GPP 36.579-5-16.0.0 V1.0.0	16.0.0	Published	02.05.2023	<a href="https://members.tdsi.in/s/q7cALPjpRLZNfAb">https://members.tdsi.in/s/q7cALPjpRLZNfAb</a>
TTA	TTAT.3G-36.579-5V16.0.0	16.0.0	Published	16.03.2023	<a href="http://committee.tta.or.kr/data/ttasDown.jsp?kind=ttastd&amp;pk_num=TTAT.3G-36.579-5V16.0.0">http://committee.tta.or.kr/data/ttasDown.jsp?kind=ttastd&amp;pk_num=TTAT.3G-36.579-5V16.0.0</a>
<b>Release 17</b>					
ARIB	ARIB STD-T120-36.579-5.V17.0.0	17.0.0	Published	03.03.2023	<a href="https://www.arib.or.jp/english/html/overview/doc/T120_T23_SPECS/ARIB-STD-T120/Rel17/36/A36579-5-h00.pdf">https://www.arib.or.jp/english/html/overview/doc/T120_T23_SPECS/ARIB-STD-T120/Rel17/36/A36579-5-h00.pdf</a>
ATIS	ATIS.3GPP.36.579-5.V17.0.0	17.0.0	Published	21.02.2023	<a href="https://www.atis.org/3gpp-transpositions - Rel-17">https://www.atis.org/3gpp-transpositions - Rel-17</a>
CCSA	CCSA.36.579-5V1700	17.0.0	Published	01.12.2022	<a href="https://www.ccsa.org.cn/api/portalsFile/downloadOldFile?type=19&amp;oldFileUrl=ITU-R/M.2012-6/CCSA.36.579-5V1700.doc">https://www.ccsa.org.cn/api/portalsFile/downloadOldFile?type=19&amp;oldFileUrl=ITU-R/M.2012-6/CCSA.36.579-5V1700.doc</a>
ETSI	ETSI TS 136 579-5	17.0.0	Published	24.01.2023	<a href="https://www.etsi.org/deliver/etsi_ts/136500_136599/13657905/17.00.00_60/ts_13657905v170000p.pdf">https://www.etsi.org/deliver/etsi_ts/136500_136599/13657905/17.00.00_60/ts_13657905v170000p.pdf</a>
TSDSI	TSDSI STD T1.3GPP 36.579-5 17.0.0 V1.0.0	17.0.0	Published	02.05.2023	<a href="https://members.tdsi.in/s/B9EaEYQ2pYPWKGS">https://members.tdsi.in/s/B9EaEYQ2pYPWKGS</a>
TTA	TTAT.3G-36.579-5V17.0.0	17.0.0	Published	16.03.2023	<a href="http://committee.tta.or.kr/data/ttasDown.jsp?kind=ttastd&amp;pk_num=TTAT.3G-36.579-5V17.0.0">http://committee.tta.or.kr/data/ttasDown.jsp?kind=ttastd&amp;pk_num=TTAT.3G-36.579-5V17.0.0</a>



**2.1.6.14 TS 36.579-6****Mission Critical (MC) services over LTE; Part 6: Mission Critical Video (MCVideo) User Equipment (UE) Protocol conformance specification**

This document specifies the protocol conformance testing for testing a MCVideo Client for compliance to the Mission Critical Video (MCVideo) over LTE protocol requirements defined by 3GPP.

In particular this document contains:

- the overall test structure;
- the test configurations;
- the conformance requirement and reference to the core specifications;
- the test purposes; and
- a brief description of the test procedure, the specific test requirements and short message exchange table.

This document is valid for MCVideo Clients implemented according to 3GPP releases starting from Release 13 up to the Release indicated on the cover page of this document.

The following information relevant to testing specified in this document could be found in accompanying specifications:

- default setting of the test parameters TS 36.579-1;
- Implementation Conformance Statement (ICS) TS 36.579-4 and Implementation eXtra Information for Testing (IXIT) TS 36.579-5;
- the applicability of each test case TS 36.579-4.

The test cases are expected to be executed through the 3GPP radio interface. This document does not specify the protocol conformance testing for the EPS (LTE) bearers which carry the MCVideo data sent or received by the MCVideo Client and which are required to be supported by the UE in which the MCVideo Client is installed. This is defined in TS 36.523-1.

SDO	Document No.	Version	Status	Issued date	Location
<b>Release 14</b>					
ARIB	ARIB STD-T120-36.579-6.V14.3.0	14.3.0	Published	03.03.2023	<a href="https://www.arib.or.jp/english/html/overview/doc/T120_T23_SPECS/ARIB-STD-T120/Rel14/36/A36579-6-e30.pdf">https://www.arib.or.jp/english/html/overview/doc/T120_T23_SPECS/ARIB-STD-T120/Rel14/36/A36579-6-e30.pdf</a>
ATIS	ATIS.3GPP.36.579-6.V14.3.0	14.3.0	Published	21.02.2023	<a href="https://www.atis.org/3gpp-transpositions - Rel-14">https://www.atis.org/3gpp-transpositions - Rel-14</a>
CCSA	CCSA.36.579-6V1430	14.3.0	Published	01.12.2021	<a href="https://www.ccsa.org.cn/api/portalsFile/downloadOldFile?type=19&amp;oldFileUrl=ITU-R/M.2012-6/CCSA.36.579-6V1430.doc">https://www.ccsa.org.cn/api/portalsFile/downloadOldFile?type=19&amp;oldFileUrl=ITU-R/M.2012-6/CCSA.36.579-6V1430.doc</a>
ETSI	ETSI TS 136 579-6	14.3.0	Published	20.01.2022	<a href="https://www.etsi.org/deliver/etsi_ts/136500_136599/13657906/14.03.00_60/ts_13657906v140300p.pdf">https://www.etsi.org/deliver/etsi_ts/136500_136599/13657906/14.03.00_60/ts_13657906v140300p.pdf</a>
TSDSI	TSDSI STD T1.3GPP 36.579-6-14.3.0 V1.1.0	14.3.0	Published	17.01.2023	<a href="https://members.tdsi.in/s/9YxCY5c3FsyBMKW">https://members.tdsi.in/s/9YxCY5c3FsyBMKW</a>
TTA	TTAT.3G-36.579-6V14.3.0	14.3.0	Published	14.03.2022	<a href="http://committee.tta.or.kr/data/ttasDown.jsp?kind=ttastd&amp;pk_num=TTAT.3G-36.579-6V14.3.0">http://committee.tta.or.kr/data/ttasDown.jsp?kind=ttastd&amp;pk_num=TTAT.3G-36.579-6V14.3.0</a>
<b>Release 15</b>					
ARIB	ARIB STD-T120-36.579-6.V15.5.0	15.5.0	Published	03.03.2023	<a href="https://www.arib.or.jp/english/html/overview/doc/T120_T23_SPECS/ARIB-STD-T120/Rel15/36/A36579-6-f50.pdf">https://www.arib.or.jp/english/html/overview/doc/T120_T23_SPECS/ARIB-STD-T120/Rel15/36/A36579-6-f50.pdf</a>
ATIS	ATIS.3GPP.36.579-6.V15.5.0	15.5.0	Published	21.02.2023	<a href="https://www.atis.org/3gpp-transpositions - Rel-15">https://www.atis.org/3gpp-transpositions - Rel-15</a>
CCSA	CCSA.36.579-6V1550	15.5.0	Published	01.12.2022	<a href="https://www.ccsa.org.cn/api/portalsFile/downloadOldFile?type=19&amp;oldFileUrl=ITU-R/M.2012-6/CCSA.36.579-6V1550.doc">https://www.ccsa.org.cn/api/portalsFile/downloadOldFile?type=19&amp;oldFileUrl=ITU-R/M.2012-6/CCSA.36.579-6V1550.doc</a>
ETSI	ETSI TS 136 579-6	15.5.0	Published	24.01.2023	<a href="https://www.etsi.org/deliver/etsi_ts/136500_136599/13657906/15.05.00_60/ts_13657906v150500p.pdf">https://www.etsi.org/deliver/etsi_ts/136500_136599/13657906/15.05.00_60/ts_13657906v150500p.pdf</a>
TSDSI	TSDSI STD T1.3GPP 36.579-6-15.5.0 V1.2.0	15.5.0	Published	02.05.2023	<a href="https://members.tdsi.in/s/bg7sKfPrdDH7a8W">https://members.tdsi.in/s/bg7sKfPrdDH7a8W</a>
TTA	TTAT.3G-36.579-6V15.5.0	15.5.0	Published	16.03.2023	<a href="http://committee.tta.or.kr/data/ttasDown.jsp?kind=ttastd&amp;pk_num=TTAT.3G-36.579-6V15.5.0">http://committee.tta.or.kr/data/ttasDown.jsp?kind=ttastd&amp;pk_num=TTAT.3G-36.579-6V15.5.0</a>

**2.1.6.15 TS 36.579-7****Mission Critical (MC) services over LTE; Part 7: Mission Critical Data (MCData) User Equipment (UE) Protocol conformance specification**

This document specifies the protocol conformance testing for testing a MCData Client for compliance to the Mission Critical Data (MCData) over LTE protocol requirements defined by 3GPP.

In particular this document contains:

- the overall test structure;
- the test configurations;
- the conformance requirement and reference to the core specifications;
- the test purposes; and
- a brief description of the test procedure, the specific test requirements and short message exchange table.

This document is valid for MCData Clients implemented according to 3GPP releases starting from Release 13 up to the Release indicated on the cover page of this document.

The following information relevant to testing specified in this document could be found in accompanying specifications:

- default setting of the test parameters TS 36.579-1;
- Implementation Conformance Statement (ICS) TS 36.579-4 and Implementation eXtra Information for Testing (IXIT) TS 36.579-5;
- the applicability of each test case TS 36.579-4.

The test cases are expected to be executed through the 3GPP radio interface. This document does not specify the protocol conformance testing for the EPS (LTE) bearers which carry the MCData data sent or received by the MCData Client and which are required to be supported by the UE in which the MCData Client is installed. This is defined in TS 36.523-1.

According to 3GPP drafting rules, the references clause shall list only documents that are explicitly mentioned in the deliverable. This reference is not used within the document and thus shall be removed from references clause.

SDO	Document No.	Version	Status	Issued date	Location
<b>Release 14</b>					
ARIB	ARIB STD-T120-36.579-7.V14.3.0	14.3.0	Published	03.03.2023	<a href="https://www.arib.or.jp/english/html/overview/doc/T120_T23_SPECS/ARIB-STD-T120/Rel14/36/A36579-7-e30.pdf">https://www.arib.or.jp/english/html/overview/doc/T120_T23_SPECS/ARIB-STD-T120/Rel14/36/A36579-7-e30.pdf</a>
ATIS	ATIS.3GPP.36.579-7.V14.3.0	14.3.0	Published	21.02.2023	<a href="https://www.atis.org/3gpp-transpositions - Rel-14">https://www.atis.org/3gpp-transpositions - Rel-14</a>
CCSA	CCSA.36.579-7V1430	14.3.0	Published	01.09.2021	<a href="https://www.ccsa.org.cn/api/portalsFile/downloadOldFile?type=19&amp;oldFileUrl=ITU-R/M.2012-6/CCSA.36.579-7V1430.doc">https://www.ccsa.org.cn/api/portalsFile/downloadOldFile?type=19&amp;oldFileUrl=ITU-R/M.2012-6/CCSA.36.579-7V1430.doc</a>
ETSI	ETSI TS 136 579-7	14.3.0	Published	13.10.2021	<a href="https://www.etsi.org/deliver/etsi_ts/136500_136599/13657907/14.03.00_60/ts_13657907v140300p.pdf">https://www.etsi.org/deliver/etsi_ts/136500_136599/13657907/14.03.00_60/ts_13657907v140300p.pdf</a>
TSDSI	TSDSI STD T1.3GPP 36.579-7-14.3.0 V1.1.0	14.3.0	Published	17.01.2023	<a href="https://members.tdsi.in/s/DiZtGNwXoxYfiXY">https://members.tdsi.in/s/DiZtGNwXoxYfiXY</a>
TTA	TTAT.3G-36.579-7V14.3.0	14.3.0	Published	27.01.2022	<a href="http://committee.tta.or.kr/data/ttasDown.jsp?kind=ttastd&amp;pk_num=TTAT.3G-36.579-7V14.3.0">http://committee.tta.or.kr/data/ttasDown.jsp?kind=ttastd&amp;pk_num=TTAT.3G-36.579-7V14.3.0</a>
<b>Release 15</b>					
ARIB	ARIB STD-T120-36.579-7.V15.4.0	15.4.0	Published	03.03.2023	<a href="https://www.arib.or.jp/english/html/overview/doc/T120_T23_SPECS/ARIB-STD-T120/Rel15/36/A36579-7-f40.pdf">https://www.arib.or.jp/english/html/overview/doc/T120_T23_SPECS/ARIB-STD-T120/Rel15/36/A36579-7-f40.pdf</a>
ATIS	ATIS.3GPP.36.579-7.V15.4.0	15.4.0	Published	21.02.2023	<a href="https://www.atis.org/3gpp-transpositions - Rel-15">https://www.atis.org/3gpp-transpositions - Rel-15</a>
CCSA	CCSA.36.579-7V1540	15.4.0	Published	01.12.2022	<a href="https://www.ccsa.org.cn/api/portalsFile/downloadOldFile?type=19&amp;oldFileUrl=ITU-R/M.2012-6/CCSA.36.579-7V1540.doc">https://www.ccsa.org.cn/api/portalsFile/downloadOldFile?type=19&amp;oldFileUrl=ITU-R/M.2012-6/CCSA.36.579-7V1540.doc</a>

ETSI	ETSI TS 136 579-7	15.4.0	Published	24.01.2023	<a href="https://www.etsi.org/deliver/etsi_ts/136500_136599/13657907/15.04.00_60/ts_13657907v150400p.pdf">https://www.etsi.org/deliver/etsi_ts/136500_136599/13657907/15.04.00_60/ts_13657907v150400p.pdf</a>
TSDSI	TSDSI STD T1.3GPP 36.579-7-15.4.0 V1.1.0	15.4.0	Published	02.05.2023	<a href="https://members.tdsi.in/s/TqxFE48et2GxGEi">https://members.tdsi.in/s/TqxFE48et2GxGEi</a>
TTA	TTAT.3G-36.579-7V15.4.0	15.4.0	Published	16.03.2023	<a href="http://committee.tta.or.kr/data/ttasDown.jsp?kind=ttastd&amp;pk_num=TTAT.3G-36.579-7V15.4.0">http://committee.tta.or.kr/data/ttasDown.jsp?kind=ttastd&amp;pk_num=TTAT.3G-36.579-7V15.4.0</a>

**2.1.6.16 TS 37.544**

**Universal Terrestrial Radio Access (UTRA) and Evolved UTRA (E-UTRA); User Equipment (UE) Over The Air (OTA) performance; Conformance testing**

This document describes the test procedure for the radiated performances measurements of the user equipment (UE).

The handheld UE measurement procedures explained in this document are defined for roaming bands for the speech mode position (beside the head and beside the head and hand) and hand phantom browsing mode position. Laptop mounted equipment (LME) measurement procedures are defined for roaming bands for the data mode transfer position (laptop ground plane phantom). Laptop embedded equipment (LEE) measurement procedures are defined for roaming bands for the data mode transfer position (free space).

The browsing mode position explained in this document applies when the UE is held in hand, but not pressed against ear (such as web browsing and navigation).

The data mode transfer position (free space) explained in this document applies when the UE is used away from the user’s head. Free space measurements are applicable to devices used in the data mode transfer position that consist of the laptop mounted equipment (LME) plug-in UEs and laptop embedded equipment (LEE) UEs.

All bands are potential roaming bands, and the requirements for roaming bands shall therefore be fulfilled for all bands supported by a UE.

Radiated performance of multiple-antenna receivers for handheld UE is defined for roaming bands in free space configuration.

Recommended performance values for operating bands (Annex I) are however included in this specification for information. It should be recognised that the ability to meet the recommended performance values depends on the number of frequency bands supported by the UE.

The radiated radio tests considered here are:

- 1 The measurement of the Total Radiated Power (TRP)
- 2 The measurement of the Total Radiated Sensitivity (TRS)
- 3 The measurement of Total Radiated Multi-antenna Sensitivity (TRMS).

The test procedure described in this document measures the performance of the transmitter and the receiver, including the antenna and also the effects of the user.

SDO	Document No.	Version	Status	Issued date	Location
<b>Release 14</b>					
ARIB	ARIB STD-T120-37.544.V14.7.0	14.7.0	Published	03.03.2023	<a href="https://www.arib.or.jp/english/html/overview/doc/T120_T23_SPECS/ARIB-STD-T120/Rel14/37/A37544-e70.pdf">https://www.arib.or.jp/english/html/overview/doc/T120_T23_SPECS/ARIB-STD-T120/Rel14/37/A37544-e70.pdf</a>
ATIS	ATIS.3GPP.37.544V1470	14.7.0	Published	28.06.2021	<a href="https://www.atis.org/3gpp-documents/Rel99-14/">https://www.atis.org/3gpp-documents/Rel99-14/</a>
CCSA	CCSA.37.544V1470	14.7.0	Published	01.12.2018	<a href="https://www.ccsa.org.cn/api/portalsFile/downloadOldFile?type=19&amp;oldFileUrl=ITU-R/M.2012-6/CCSA.37.544V1470.doc">https://www.ccsa.org.cn/api/portalsFile/downloadOldFile?type=19&amp;oldFileUrl=ITU-R/M.2012-6/CCSA.37.544V1470.doc</a>
ETSI	ETSI TS 137 544	14.7.0	Published	21.12.2018	<a href="https://www.etsi.org/deliver/etsi_ts/137500_137599/137544/14.07.00_60/ts_137544v140700p.pdf">https://www.etsi.org/deliver/etsi_ts/137500_137599/137544/14.07.00_60/ts_137544v140700p.pdf</a>
TSDSI	TSDSI STD T1.3GPP 37.544-14.7.0 V1.1.0	14.7.0	Published	30.08.2021	<a href="https://members.tdsi.in/index.php/s/6cc8e3xytwnE8Hs">https://members.tdsi.in/index.php/s/6cc8e3xytwnE8Hs</a>
TTA	TTAT.3G-37.544V14.7.0	14.7.0	Published	02.08.2021	<a href="http://committee.tta.or.kr/data/ttasDown.jsp?kind=ttastd&amp;pk_num=TTAT.3G-37.544V14.7.0">http://committee.tta.or.kr/data/ttasDown.jsp?kind=ttastd&amp;pk_num=TTAT.3G-37.544V14.7.0</a>

## 154

## Rec. ITU-R M.2012-6

### Release 15

ARIB	ARIB STD-T120-37.544.V15.0.0	15.0.0	Published	03.03.2023	<a href="https://www.arib.or.jp/english/html/overview/doc/T120_T23_SPECS/ARIB-STD-T120/Rel15/37/A37544-f00.pdf">https://www.arib.or.jp/english/html/overview/doc/T120_T23_SPECS/ARIB-STD-T120/Rel15/37/A37544-f00.pdf</a>
ATIS	ATIS.3GPP.37.544V1500	15.0.0	Published	28.06.2021	<a href="https://www.atis.org/3gpp-documents/Rel15/">https://www.atis.org/3gpp-documents/Rel15/</a>
CCSA	CCSA.37.544V1500	15.0.0	Published	01.06.2019	<a href="https://www.ccsa.org.cn/api/portalsFile/downloadOldFile?type=19&amp;oldFileUrl=ITU-R/M.2012-6/CCSA.37.544V1500.doc">https://www.ccsa.org.cn/api/portalsFile/downloadOldFile?type=19&amp;oldFileUrl=ITU-R/M.2012-6/CCSA.37.544V1500.doc</a>
ETSI	ETSI TS 137 544	15.0.0	Published	17.09.2020	<a href="https://www.etsi.org/deliver/etsi_ts/137500_137599/137544/15.00.00_60/ts_137544v150000p.pdf">https://www.etsi.org/deliver/etsi_ts/137500_137599/137544/15.00.00_60/ts_137544v150000p.pdf</a>
TSDSI	TSDSI STD T1.3GPP 37.544-15.0.0 V1.0.0	15.0.0	Published	30.08.2021	<a href="https://members.tdsi.in/index.php/s/RKw3SewHzjybmRZ">https://members.tdsi.in/index.php/s/RKw3SewHzjybmRZ</a>
TTA	TTAT.3G-37.544V15.0.0	15.0.0	Published	10.06.2021	<a href="http://committee.tta.or.kr/data/ttasDown.jsp?kind=ttastd&amp;pk_num=TTAT.3G-37.544V15.0.0">http://committee.tta.or.kr/data/ttasDown.jsp?kind=ttastd&amp;pk_num=TTAT.3G-37.544V15.0.0</a>

### Release 16

ARIB	ARIB STD-T120-37.544.V16.2.0	16.2.0	Published	03.03.2023	<a href="https://www.arib.or.jp/english/html/overview/doc/T120_T23_SPECS/ARIB-STD-T120/Rel16/37/A37544-g20.pdf">https://www.arib.or.jp/english/html/overview/doc/T120_T23_SPECS/ARIB-STD-T120/Rel16/37/A37544-g20.pdf</a>
ATIS	ATIS.3GPP.37.544.V16.2.0	16.2.0	Published	21.02.2023	<a href="https://www.atis.org/3gpp-transpositions-Rel-16">https://www.atis.org/3gpp-transpositions-Rel-16</a>
CCSA	CCSA.37.544V1620	16.2.0	Published	01.09.2021	<a href="https://www.ccsa.org.cn/api/portalsFile/downloadOldFile?type=19&amp;oldFileUrl=ITU-R/M.2012-6/CCSA.37.544V1620.doc">https://www.ccsa.org.cn/api/portalsFile/downloadOldFile?type=19&amp;oldFileUrl=ITU-R/M.2012-6/CCSA.37.544V1620.doc</a>
ETSI	ETSI TS 137 544	16.2.0	Published	13.10.2021	<a href="https://www.etsi.org/deliver/etsi_ts/137500_137599/137544/16.02.00_60/ts_137544v160200p.pdf">https://www.etsi.org/deliver/etsi_ts/137500_137599/137544/16.02.00_60/ts_137544v160200p.pdf</a>
TSDSI	TSDSI STD T1.3GPP 37.544-16.2.0 V1.1.0	16.2.0	Published	01.11.2022	<a href="https://members.tdsi.in/s/dLWrZkoGSPbOSgH">https://members.tdsi.in/s/dLWrZkoGSPbOSgH</a>
TTA	TTAT.3G-37.544V16.2.0	16.2.0	Published	27.01.2022	<a href="http://committee.tta.or.kr/data/ttasDown.jsp?kind=ttastd&amp;pk_num=TTAT.3G-37.544V16.2.0">http://committee.tta.or.kr/data/ttasDown.jsp?kind=ttastd&amp;pk_num=TTAT.3G-37.544V16.2.0</a>

### 2.1.6.17 TS 37.571-1

#### Universal Terrestrial Radio Access (UTRA) and Evolved UTRA (E-UTRA) and Evolved Packet Core (EPC); User Equipment (UE) conformance specification for UE positioning; Part 1: Conformance test specification

This document specifies the procedures for the conformance test of the measurement requirements for FDD mode of UTRA and FDD or TDD mode of E-UTRA for the User Equipment (UE) that supports one or more of the defined positioning methods. These positioning methods are for UTRA: Assisted Global Positioning System (A-GPS), Assisted Global Navigation Satellite Systems (A-GNSS) and for E-UTRA: Assisted Global Navigation Satellite System (A-GNSS), Observed Time Difference of Arrival (OTDOA), Enhanced Cell ID (ECID).

Tests are only applicable to those mobiles that are intended to support the appropriate functionality. To indicate the circumstances in which tests apply, this is noted in the “Test applicability” part of the test.

The Implementation Conformance Statement (ICS) pro-forma could be found in the 3<sup>rd</sup> part of this document.

SDO	Document No.	Version	Status	Issued date	Location
<b>Release 10</b>					
ARIB	ARIB STD-T120-37.571-1.V10.8.0	10.8.0	Published	03.03.2023	<a href="https://www.arib.or.jp/english/html/overview/doc/T120_T23_SPECS/ARIB-STD-T120/Rel10/37/A37571-1-a80.pdf">https://www.arib.or.jp/english/html/overview/doc/T120_T23_SPECS/ARIB-STD-T120/Rel10/37/A37571-1-a80.pdf</a>
ATIS	ATIS.3GPP.37.571-1V1080	10.8.0	Published	28.06.2021	<a href="https://www.atis.org/3gpp-documents/Rel99-14/">https://www.atis.org/3gpp-documents/Rel99-14/</a>
CCSA	CCSA.37.571-1V1080	10.8.0	Published	01.12.2015	<a href="https://www.ccsa.org.cn/api/portalsFile/downloadOldFile?type=19&amp;oldFileUrl=ITU-R/M.2012-6/CCSA.37.571-1V1080.doc">https://www.ccsa.org.cn/api/portalsFile/downloadOldFile?type=19&amp;oldFileUrl=ITU-R/M.2012-6/CCSA.37.571-1V1080.doc</a>
ETSI	ETSI TS 137 571-1	10.8.0	Published	15.01.2016	<a href="https://www.etsi.org/deliver/etsi_ts/137500_137599/13757101/10.08.00_60/ts_13757101v100800p.pdf">https://www.etsi.org/deliver/etsi_ts/137500_137599/13757101/10.08.00_60/ts_13757101v100800p.pdf</a>
TSDSI	TSDSI STD T1.3GPP 37.571-1-10.8.0 V1.0.0	10.8.0	Published	30.08.2021	<a href="https://members.tdsi.in/index.php/s/66PirScocYmJySf">https://members.tdsi.in/index.php/s/66PirScocYmJySf</a>
TTA	TTAT.3G-37.571-1V10.8.0	10.8.0	Published	02.08.2021	<a href="http://committee.tta.or.kr/data/ttasDown.jsp?kind=ttastd&amp;pk_num=TTAT.3G-37.571-1V10.8.0">http://committee.tta.or.kr/data/ttasDown.jsp?kind=ttastd&amp;pk_num=TTAT.3G-37.571-1V10.8.0</a>
<b>Release 11</b>					
ARIB	ARIB STD-T120-37.571-1.V11.3.0	11.3.0	Published	03.03.2023	<a href="https://www.arib.or.jp/english/html/overview/doc/T120_T23_SPECS/ARIB-STD-T120/Rel11/37/A37571-1-b30.pdf">https://www.arib.or.jp/english/html/overview/doc/T120_T23_SPECS/ARIB-STD-T120/Rel11/37/A37571-1-b30.pdf</a>
ATIS	ATIS.3GPP.37.571-1V1130	11.3.0	Published	28.06.2021	<a href="https://www.atis.org/3gpp-documents/Rel99-14/">https://www.atis.org/3gpp-documents/Rel99-14/</a>
CCSA	CCSA.37.571-1V1130	11.3.0	Published	01.12.2015	<a href="https://www.ccsa.org.cn/api/portalsFile/downloadOldFile?type=19&amp;oldFileUrl=ITU-R/M.2012-6/CCSA.37.571-1V1130.doc">https://www.ccsa.org.cn/api/portalsFile/downloadOldFile?type=19&amp;oldFileUrl=ITU-R/M.2012-6/CCSA.37.571-1V1130.doc</a>
ETSI	ETSI TS 137 571-1	11.3.0	Published	15.01.2016	<a href="https://www.etsi.org/deliver/etsi_ts/137500_137599/13757101/11.03.00_60/ts_13757101v110300p.pdf">https://www.etsi.org/deliver/etsi_ts/137500_137599/13757101/11.03.00_60/ts_13757101v110300p.pdf</a>
TSDSI	TSDSI STD T1.3GPP 37.571-1-11.3.0 V1.0.0	11.3.0	Published	30.08.2021	<a href="https://members.tdsi.in/index.php/s/DEbKBrx9Zq3DSjF">https://members.tdsi.in/index.php/s/DEbKBrx9Zq3DSjF</a>
TTA	TTAT.3G-37.571-1V11.3.0	11.3.0	Published	02.08.2021	<a href="http://committee.tta.or.kr/data/ttasDown.jsp?kind=ttastd&amp;pk_num=TTAT.3G-37.571-1V11.3.0">http://committee.tta.or.kr/data/ttasDown.jsp?kind=ttastd&amp;pk_num=TTAT.3G-37.571-1V11.3.0</a>

### Release 12

ARIB	ARIB STD-T120-37.571-1.V12.8.0	12.8.0	Published	03.03.2023	<a href="https://www.arib.or.jp/english/html/overview/doc/T120_T23_SPECS/ARIB-STD-T120/Rel12/37/A37571-1-c80.pdf">https://www.arib.or.jp/english/html/overview/doc/T120_T23_SPECS/ARIB-STD-T120/Rel12/37/A37571-1-c80.pdf</a>
ATIS	ATIS.3GPP.37.571-1V1280	12.8.0	Published	28.06.2021	<a href="https://www.atis.org/3gpp-documents/Rel99-14/">https://www.atis.org/3gpp-documents/Rel99-14/</a>
CCSA	CCSA.37.571-1V1280	12.8.0	Published	01.09.2016	<a href="https://www.ccsa.org.cn/api/portalsFile/downloadOldFile?type=19&amp;oldFileUrl=ITU-R/M.2012-6/CCSA.37.571-1V1280.doc">https://www.ccsa.org.cn/api/portalsFile/downloadOldFile?type=19&amp;oldFileUrl=ITU-R/M.2012-6/CCSA.37.571-1V1280.doc</a>
ETSI	ETSI TS 137 571-1	12.8.0	Published	03.11.2016	<a href="https://www.etsi.org/deliver/etsi_ts/137500_137599/13757101/12.08.00_60/ts_13757101v120800p.pdf">https://www.etsi.org/deliver/etsi_ts/137500_137599/13757101/12.08.00_60/ts_13757101v120800p.pdf</a>
TSDSI	TSDSI STD T1.3GPP 37.571-1-12.8.0 V1.0.0	12.8.0	Published	30.08.2021	<a href="https://members.tdsi.in/index.php/s/59zY8gjMsSznBji">https://members.tdsi.in/index.php/s/59zY8gjMsSznBji</a>
TTA	TTAT.3G-37.571-1V12.8.0	12.8.0	Published	02.08.2021	<a href="http://committee.tta.or.kr/data/ttasDown.jsp?kind=ttastd&amp;pk_num=TTAT.3G-37.571-1V12.8.0">http://committee.tta.or.kr/data/ttasDown.jsp?kind=ttastd&amp;pk_num=TTAT.3G-37.571-1V12.8.0</a>
<b>Release 13</b>					
ARIB	ARIB STD-T120-37.571-1.V13.3.0	13.3.0	Published	03.03.2023	<a href="https://www.arib.or.jp/english/html/overview/doc/T120_T23_SPECS/ARIB-STD-T120/Rel13/37/A37571-1-d30.pdf">https://www.arib.or.jp/english/html/overview/doc/T120_T23_SPECS/ARIB-STD-T120/Rel13/37/A37571-1-d30.pdf</a>
ATIS	ATIS.3GPP.37.571-1V1330	13.3.0	Published	28.06.2021	<a href="https://www.atis.org/3gpp-documents/Rel99-14/">https://www.atis.org/3gpp-documents/Rel99-14/</a>
CCSA	CCSA.37.571-1V1330	13.3.0	Published	01.03.2017	<a href="https://www.ccsa.org.cn/api/portalsFile/downloadOldFile?type=19&amp;oldFileUrl=ITU-R/M.2012-6/CCSA.37.571-1V1330.doc">https://www.ccsa.org.cn/api/portalsFile/downloadOldFile?type=19&amp;oldFileUrl=ITU-R/M.2012-6/CCSA.37.571-1V1330.doc</a>
ETSI	ETSI TS 137 571-1	13.3.0	Published	10.04.2017	<a href="https://www.etsi.org/deliver/etsi_ts/137500_137599/13757101/13.03.00_60/ts_13757101v130300p.pdf">https://www.etsi.org/deliver/etsi_ts/137500_137599/13757101/13.03.00_60/ts_13757101v130300p.pdf</a>
TSDSI	TSDSI STD T1.3GPP 37.571-1-13.3.0 V1.0.0	13.3.0	Published	30.08.2021	<a href="https://members.tdsi.in/index.php/s/EZNXTCE4BDctjeX">https://members.tdsi.in/index.php/s/EZNXTCE4BDctjeX</a>
TTA	TTAT.3G-37.571-1V13.3.0	13.3.0	Published	02.08.2021	<a href="http://committee.tta.or.kr/data/ttasDown.jsp?kind=ttastd&amp;pk_num=TTAT.3G-37.571-1V13.3.0">http://committee.tta.or.kr/data/ttasDown.jsp?kind=ttastd&amp;pk_num=TTAT.3G-37.571-1V13.3.0</a>
<b>Release 14</b>					
ARIB	ARIB STD-T120-37.571-1.V14.5.0	14.5.0	Published	03.03.2023	<a href="https://www.arib.or.jp/english/html/overview/doc/T120_T23_SPECS/ARIB-STD-T120/Rel14/37/A37571-1-e50.pdf">https://www.arib.or.jp/english/html/overview/doc/T120_T23_SPECS/ARIB-STD-T120/Rel14/37/A37571-1-e50.pdf</a>
ATIS	ATIS.3GPP.37.571-1V1450	14.5.0	Published	28.06.2021	<a href="https://www.atis.org/3gpp-documents/Rel99-14/">https://www.atis.org/3gpp-documents/Rel99-14/</a>
CCSA	CCSA.37.571-1V1450	14.5.0	Published	01.03.2018	<a href="https://www.ccsa.org.cn/api/portalsFile/downloadOldFile?type=19&amp;oldFileUrl=ITU-R/M.2012-6/CCSA.37.571-1V1450.doc">https://www.ccsa.org.cn/api/portalsFile/downloadOldFile?type=19&amp;oldFileUrl=ITU-R/M.2012-6/CCSA.37.571-1V1450.doc</a>
ETSI	ETSI TS 137 571-1	14.5.0	Published	10.04.2018	<a href="https://www.etsi.org/deliver/etsi_ts/137500_137599/13757101/14.05.00_60/ts_13757101v140500p.pdf">https://www.etsi.org/deliver/etsi_ts/137500_137599/13757101/14.05.00_60/ts_13757101v140500p.pdf</a>
TSDSI	TSDSI STD T1.3GPP 37.571-1-14.5.0 V1.1.0	14.5.0	Published	30.08.2021	<a href="https://members.tdsi.in/index.php/s/cL35DJ4S5MXjsB8">https://members.tdsi.in/index.php/s/cL35DJ4S5MXjsB8</a>
TTA	TTAT.3G-37.571-1V14.5.0	14.5.0	Published	02.08.2021	<a href="http://committee.tta.or.kr/data/ttasDown.jsp?kind=ttastd&amp;pk_num=TTAT.3G-37.571-1V14.5.0">http://committee.tta.or.kr/data/ttasDown.jsp?kind=ttastd&amp;pk_num=TTAT.3G-37.571-1V14.5.0</a>
<b>Release 15</b>					
ARIB	ARIB STD-T120-37.571-1.V15.6.0	15.6.0	Published	03.03.2023	<a href="https://www.arib.or.jp/english/html/overview/doc/T120_T23_SPECS/ARIB-STD-T120/Rel15/37/A37571-1-f60.pdf">https://www.arib.or.jp/english/html/overview/doc/T120_T23_SPECS/ARIB-STD-T120/Rel15/37/A37571-1-f60.pdf</a>
ATIS	ATIS.3GPP.37.571-1V1560	15.6.0	Published	28.06.2021	<a href="https://www.atis.org/3gpp-documents/Rel15/">https://www.atis.org/3gpp-documents/Rel15/</a>
CCSA	CCSA.37.571-1V1560	15.6.0	Published	01.03.2020	<a href="https://www.ccsa.org.cn/api/portalsFile/downloadOldFile?type=19&amp;oldFileUrl=ITU-R/M.2012-6/CCSA.37.571-1V1560.doc">https://www.ccsa.org.cn/api/portalsFile/downloadOldFile?type=19&amp;oldFileUrl=ITU-R/M.2012-6/CCSA.37.571-1V1560.doc</a>
ETSI	ETSI TS 137 571-1	15.6.0	Published	03.04.2020	<a href="https://www.etsi.org/deliver/etsi_ts/137500_137599/13757101/15.06.00_60/ts_13757101v150600p.pdf">https://www.etsi.org/deliver/etsi_ts/137500_137599/13757101/15.06.00_60/ts_13757101v150600p.pdf</a>
TSDSI	TSDSI STD T1.3GPP 37.571-1-15.6.0 V1.0.0	15.6.0	Published	30.08.2021	<a href="https://members.tdsi.in/index.php/s/op6HXcHwP4TXQF2">https://members.tdsi.in/index.php/s/op6HXcHwP4TXQF2</a>
TTA	TTAT.3G-37.571-1V15.6.0	15.6.0	Published	11.09.2020	<a href="http://committee.tta.or.kr/data/ttasDown.jsp?kind=ttastd&amp;pk_num=TTAT.3G-37.571-1V15.6.0">http://committee.tta.or.kr/data/ttasDown.jsp?kind=ttastd&amp;pk_num=TTAT.3G-37.571-1V15.6.0</a>
<b>Release 16</b>					
ARIB	ARIB STD-T120-37.571-1.V16.15.0	16.15.0	Published	03.03.2023	<a href="https://www.arib.or.jp/english/html/overview/doc/T120_T23_SPECS/ARIB-STD-T120/Rel16/37/A37571-1-gf0.pdf">https://www.arib.or.jp/english/html/overview/doc/T120_T23_SPECS/ARIB-STD-T120/Rel16/37/A37571-1-gf0.pdf</a>
ATIS	ATIS.3GPP.37.571-1.V16.15.0	16.15.0	Published	21.02.2023	<a href="https://www.atis.org/3gpp-transpositions - Rel-16">https://www.atis.org/3gpp-transpositions - Rel-16</a>
CCSA	CCSA.37.571-1V16150	16.15.0	Published	01.12.2022	<a href="https://www.ccsa.org.cn/api/portalsFile/downloadOldFile?type=19&amp;oldFileUrl=ITU-R/M.2012-6/CCSA.37.571-1V16150.rar">https://www.ccsa.org.cn/api/portalsFile/downloadOldFile?type=19&amp;oldFileUrl=ITU-R/M.2012-6/CCSA.37.571-1V16150.rar</a>
ETSI	ETSI TS 137 571-1	16.15.0	Published	31.01.2023	<a href="https://www.etsi.org/deliver/etsi_ts/137500_137599/13757101/16.15.00_60/ts_13757101v161500p.pdf">https://www.etsi.org/deliver/etsi_ts/137500_137599/13757101/16.15.00_60/ts_13757101v161500p.pdf</a>
TSDSI	TSDSI STD T1.3GPP 37.571-1 16.15.0 V1.3.0	16.15.0	Published	02.05.2023	<a href="https://members.tdsi.in/s/cgvpFoFdJTp9pkH">https://members.tdsi.in/s/cgvpFoFdJTp9pkH</a>
TTA	TTAT.3G-37.571-1V16.15.0	16.15.0	Published	16.03.2023	<a href="http://committee.tta.or.kr/data/ttasDown.jsp?kind=ttastd&amp;pk_num=TTAT.3G-37.571-1V16.15.0">http://committee.tta.or.kr/data/ttasDown.jsp?kind=ttastd&amp;pk_num=TTAT.3G-37.571-1V16.15.0</a>

### 2.1.6.18 TS 37.571-2

#### Universal Terrestrial Radio Access (UTRA) and Evolved UTRA (E-UTRA) and Evolved Packet Core (EPC); User Equipment (UE) conformance specification for UE positioning; Part 2: Protocol conformance

This document specifies the protocol conformance testing for the 3<sup>rd</sup> Generation UTRAN and E-UTRAN User Equipment (UE) supporting UE positioning.

This is the second part of a multi-part test specification. The following information can be found in this part:

- the overall protocol conformance test structure;
- the protocol conformance test configurations;

- the conformance requirement and reference to the core specifications;
- the test purposes; and
- a brief description of the test procedure, the specific test requirements and short message exchange table.

The Implementation Conformance Statement (ICS) pro-forma could be found in the 3<sup>rd</sup> part of this document.

This document is valid for UE supporting UE positioning implemented according to 3GPP releases starting from Release 99 up to the Release indicated on the cover page of this document.

SDO	Document No.	Version	Status	Issued date	Location
<b>Release 10</b>					
ARIB	ARIB STD-T120-37.571-2.V10.10.0	10.10.0	Published	03.03.2023	<a href="https://www.arib.or.jp/english/html/overview/doc/T120_T23_SPECS/ARIB-STD-T120/Rel10/37/A37571-2-aa0.pdf">https://www.arib.or.jp/english/html/overview/doc/T120_T23_SPECS/ARIB-STD-T120/Rel10/37/A37571-2-aa0.pdf</a>
ATIS	ATIS.3GPP.37.571-2V10100	10.10.0	Published	28.06.2021	<a href="https://www.atis.org/3gpp-documents/Rel99-14/">https://www.atis.org/3gpp-documents/Rel99-14/</a>
CCSA	CCSA.37.571-2V10100	10.10.0	Published	01.12.2015	<a href="https://www.ccsa.org.cn/api/portalsFile/downloadOldFile?type=19&amp;oldFileUrl=ITU-R/M.2012-6/CCSA.37.571-2V10100.doc">https://www.ccsa.org.cn/api/portalsFile/downloadOldFile?type=19&amp;oldFileUrl=ITU-R/M.2012-6/CCSA.37.571-2V10100.doc</a>
ETSI	ETSI TS 137 571-2	10.10.0	Published	15.01.2016	<a href="https://www.etsi.org/deliver/etsi_ts/137500_137599/13757102/10.10.00_60/ts_13757102v101000p.pdf">https://www.etsi.org/deliver/etsi_ts/137500_137599/13757102/10.10.00_60/ts_13757102v101000p.pdf</a>
TSDSI	TSDSI STD T1.3GPP 37.571-2-10.10.0	10.10.0	Published	30.08.2021	<a href="https://members.tdsi.in/index.php/s/BOXFsMWW4PaFFYx">https://members.tdsi.in/index.php/s/BOXFsMWW4PaFFYx</a>
TTA	TTAT.3G-37.571-2V10.10.0	10.10.0	Published	02.08.2021	<a href="http://committee.tta.or.kr/data/ttasDown.jsp?kind=ttastd&amp;pk_num=TTAT.3G-37.571-2V10.10.0">http://committee.tta.or.kr/data/ttasDown.jsp?kind=ttastd&amp;pk_num=TTAT.3G-37.571-2V10.10.0</a>
<b>Release 11</b>					
ARIB	ARIB STD-T120-37.571-2.V11.1.0	11.1.0	Published	03.03.2023	<a href="https://www.arib.or.jp/english/html/overview/doc/T120_T23_SPECS/ARIB-STD-T120/Rel11/37/A37571-2-b10.pdf">https://www.arib.or.jp/english/html/overview/doc/T120_T23_SPECS/ARIB-STD-T120/Rel11/37/A37571-2-b10.pdf</a>
ATIS	ATIS.3GPP.37.571-2V1110	11.1.0	Published	28.06.2021	<a href="https://www.atis.org/3gpp-documents/Rel99-14/">https://www.atis.org/3gpp-documents/Rel99-14/</a>
CCSA	CCSA.37.571-2V1110	11.1.0	Published	01.12.2015	<a href="https://www.ccsa.org.cn/api/portalsFile/downloadOldFile?type=19&amp;oldFileUrl=ITU-R/M.2012-6/CCSA.37.571-2V1110.doc">https://www.ccsa.org.cn/api/portalsFile/downloadOldFile?type=19&amp;oldFileUrl=ITU-R/M.2012-6/CCSA.37.571-2V1110.doc</a>
ETSI	ETSI TS 137 571-2	11.1.0	Published	15.01.2016	<a href="https://www.etsi.org/deliver/etsi_ts/137500_137599/13757102/11.01.00_60/ts_13757102v110100p.pdf">https://www.etsi.org/deliver/etsi_ts/137500_137599/13757102/11.01.00_60/ts_13757102v110100p.pdf</a>
TSDSI	TSDSI STD T1.3GPP 37.571-2-11.1.0 V1.0.0	11.1.0	Published	30.08.2021	<a href="https://members.tdsi.in/index.php/s/cPPERyXyMtZyTLC">https://members.tdsi.in/index.php/s/cPPERyXyMtZyTLC</a>
TTA	TTAT.3G-37.571-2V11.1.0	11.1.0	Published	02.08.2021	<a href="http://committee.tta.or.kr/data/ttasDown.jsp?kind=ttastd&amp;pk_num=TTAT.3G-37.571-2V11.1.0">http://committee.tta.or.kr/data/ttasDown.jsp?kind=ttastd&amp;pk_num=TTAT.3G-37.571-2V11.1.0</a>
<b>Release 12</b>					
ARIB	ARIB STD-T120-37.571-2.V12.7.0	12.7.0	Published	03.03.2023	<a href="https://www.arib.or.jp/english/html/overview/doc/T120_T23_SPECS/ARIB-STD-T120/Rel12/37/A37571-2-c70.pdf">https://www.arib.or.jp/english/html/overview/doc/T120_T23_SPECS/ARIB-STD-T120/Rel12/37/A37571-2-c70.pdf</a>
ATIS	ATIS.3GPP.37.571-2V1270	12.7.0	Published	28.06.2021	<a href="https://www.atis.org/3gpp-documents/Rel99-14/">https://www.atis.org/3gpp-documents/Rel99-14/</a>
CCSA	CCSA.37.571-2V1270	12.7.0	Published	01.03.2017	<a href="https://www.ccsa.org.cn/api/portalsFile/downloadOldFile?type=19&amp;oldFileUrl=ITU-R/M.2012-6/CCSA.37.571-2V1270.doc">https://www.ccsa.org.cn/api/portalsFile/downloadOldFile?type=19&amp;oldFileUrl=ITU-R/M.2012-6/CCSA.37.571-2V1270.doc</a>
ETSI	ETSI TS 137 571-2	12.7.0	Published	10.04.2017	<a href="https://www.etsi.org/deliver/etsi_ts/137500_137599/13757102/12.07.00_60/ts_13757102v120700p.pdf">https://www.etsi.org/deliver/etsi_ts/137500_137599/13757102/12.07.00_60/ts_13757102v120700p.pdf</a>
TSDSI	TSDSI STD T1.3GPP 37.571-2-12.7.0 V1.0.0	12.7.0	Published	30.08.2021	<a href="https://members.tdsi.in/index.php/s/cMFFDi9qjJsbZBP">https://members.tdsi.in/index.php/s/cMFFDi9qjJsbZBP</a>
TTA	TTAT.3G-37.571-2V12.7.0	12.7.0	Published	02.08.2021	<a href="http://committee.tta.or.kr/data/ttasDown.jsp?kind=ttastd&amp;pk_num=TTAT.3G-37.571-2V12.7.0">http://committee.tta.or.kr/data/ttasDown.jsp?kind=ttastd&amp;pk_num=TTAT.3G-37.571-2V12.7.0</a>
<b>Release 13</b>					
ARIB	ARIB STD-T120-37.571-2.V13.3.0	13.3.0	Published	03.03.2023	<a href="https://www.arib.or.jp/english/html/overview/doc/T120_T23_SPECS/ARIB-STD-T120/Rel13/37/A37571-2-d30.pdf">https://www.arib.or.jp/english/html/overview/doc/T120_T23_SPECS/ARIB-STD-T120/Rel13/37/A37571-2-d30.pdf</a>
ATIS	ATIS.3GPP.37.571-2V1330	13.3.0	Published	28.06.2021	<a href="https://www.atis.org/3gpp-documents/Rel99-14/">https://www.atis.org/3gpp-documents/Rel99-14/</a>
CCSA	CCSA.37.571-2V1330	13.3.0	Published	01.09.2017	<a href="https://www.ccsa.org.cn/api/portalsFile/downloadOldFile?type=19&amp;oldFileUrl=ITU-R/M.2012-6/CCSA.37.571-2V1330.doc">https://www.ccsa.org.cn/api/portalsFile/downloadOldFile?type=19&amp;oldFileUrl=ITU-R/M.2012-6/CCSA.37.571-2V1330.doc</a>
ETSI	ETSI TS 137 571-2	13.3.0	Published	11.10.2017	<a href="https://www.etsi.org/deliver/etsi_ts/137500_137599/13757102/13.03.00_60/ts_13757102v130300p.pdf">https://www.etsi.org/deliver/etsi_ts/137500_137599/13757102/13.03.00_60/ts_13757102v130300p.pdf</a>
TSDSI	TSDSI STD T1.3GPP 37.571-2-13.3.0 V1.0.0	13.3.0	Published	30.08.2021	<a href="https://members.tdsi.in/index.php/s/wkcd34oKwbwfg6s">https://members.tdsi.in/index.php/s/wkcd34oKwbwfg6s</a>
TTA	TTAT.3G-37.571-2V13.3.0	13.3.0	Published	02.08.2021	<a href="http://committee.tta.or.kr/data/ttasDown.jsp?kind=ttastd&amp;pk_num=TTAT.3G-37.571-2V13.3.0">http://committee.tta.or.kr/data/ttasDown.jsp?kind=ttastd&amp;pk_num=TTAT.3G-37.571-2V13.3.0</a>
<b>Release 14</b>					
ARIB	ARIB STD-T120-37.571-2.V14.4.0	14.4.0	Published	03.03.2023	<a href="https://www.arib.or.jp/english/html/overview/doc/T120_T23_SPECS/ARIB-STD-T120/Rel14/37/A37571-2-e40.pdf">https://www.arib.or.jp/english/html/overview/doc/T120_T23_SPECS/ARIB-STD-T120/Rel14/37/A37571-2-e40.pdf</a>
ATIS	ATIS.3GPP.37.571-2V1440	14.4.0	Published	28.06.2021	<a href="https://www.atis.org/3gpp-documents/Rel99-14/">https://www.atis.org/3gpp-documents/Rel99-14/</a>
CCSA	CCSA.37.571-2V1440	14.4.0	Published	01.03.2018	<a href="https://www.ccsa.org.cn/api/portalsFile/downloadOldFile?type=19&amp;oldFileUrl=ITU-R/M.2012-6/CCSA.37.571-2V1440.doc">https://www.ccsa.org.cn/api/portalsFile/downloadOldFile?type=19&amp;oldFileUrl=ITU-R/M.2012-6/CCSA.37.571-2V1440.doc</a>
ETSI	ETSI TS 137 571-2	14.4.0	Published	10.04.2018	<a href="https://www.etsi.org/deliver/etsi_ts/137500_137599/13757102/14.04.00_60/ts_13757102v140400p.pdf">https://www.etsi.org/deliver/etsi_ts/137500_137599/13757102/14.04.00_60/ts_13757102v140400p.pdf</a>
TSDSI	TSDSI STD T1.3GPP 37.571-2-14.4.0 V1.1.0	14.4.0	Published	30.08.2021	<a href="https://members.tdsi.in/index.php/s/DRaQZkyt6Xkowta">https://members.tdsi.in/index.php/s/DRaQZkyt6Xkowta</a>
TTA	TTAT.3G-37.571-2V14.4.0	14.4.0	Published	02.08.2021	<a href="http://committee.tta.or.kr/data/ttasDown.jsp?kind=ttastd&amp;pk_num=TTAT.3G-37.571-2V14.4.0">http://committee.tta.or.kr/data/ttasDown.jsp?kind=ttastd&amp;pk_num=TTAT.3G-37.571-2V14.4.0</a>

**Release 15**

ARIB	ARIB STD-T120-37.571-2.V15.6.0	15.6.0	Published	03.03.2023	<a href="https://www.arib.or.jp/english/html/overview/doc/T120_T23_SPECS/ARIB-STD-T120/Rel15/37/A37571-2-f60.pdf">https://www.arib.or.jp/english/html/overview/doc/T120_T23_SPECS/ARIB-STD-T120/Rel15/37/A37571-2-f60.pdf</a>
ATIS	ATIS.3GPP.37.571-2V1560	15.6.0	Published	28.06.2021	<a href="https://www.atis.org/3gpp-documents/Rel15/">https://www.atis.org/3gpp-documents/Rel15/</a>
CCSA	CCSA.37.571-2V1560	15.6.0	Published	01.03.2020	<a href="https://www.ccsa.org.cn/api/portalsFile/downloadOldFile?type=19&amp;oldFileUrl=ITU-R/M.2012-6/CCSA.37.571-2V1560.doc">https://www.ccsa.org.cn/api/portalsFile/downloadOldFile?type=19&amp;oldFileUrl=ITU-R/M.2012-6/CCSA.37.571-2V1560.doc</a>
ETSI	ETSI TS 137 571-2	15.6.0	Published	03.04.2020	<a href="https://www.etsi.org/deliver/etsi_ts/137500_137599/13757102/15.06.00_60/ts_13757102v150600p.pdf">https://www.etsi.org/deliver/etsi_ts/137500_137599/13757102/15.06.00_60/ts_13757102v150600p.pdf</a>
TSDSI	TSDSI STD T1.3GPP 37.571-2-15.6.0 V1.0.0	15.6.0	Published	30.08.2021	<a href="https://members.tdsi.in/index.php/s/PJDJoNBmFfyq2P7">https://members.tdsi.in/index.php/s/PJDJoNBmFfyq2P7</a>
TTA	TTAT.3G-37.571-2V15.6.0	15.6.0	Published	11.09.2020	<a href="http://committee.tta.or.kr/data/ttasDown.jsp?kind=ttastd&amp;pk_num=TTAT.3G-37.571-2V15.6.0">http://committee.tta.or.kr/data/ttasDown.jsp?kind=ttastd&amp;pk_num=TTAT.3G-37.571-2V15.6.0</a>

**Release 16**

ARIB	ARIB STD-T120-37.571-2.V16.14.0	16.14.0	Published	03.03.2023	<a href="https://www.arib.or.jp/english/html/overview/doc/T120_T23_SPECS/ARIB-STD-T120/Rel16/37/A37571-2-ge0.pdf">https://www.arib.or.jp/english/html/overview/doc/T120_T23_SPECS/ARIB-STD-T120/Rel16/37/A37571-2-ge0.pdf</a>
ATIS	ATIS.3GPP.37.571-2.V16.14.0	16.14.0	Published	21.02.2023	<a href="https://www.atis.org/3gpp-transpositions - Rel-16">https://www.atis.org/3gpp-transpositions - Rel-16</a>
CCSA	CCSA.37.571-2V16140	16.14.0	Published	01.12.2022	<a href="https://www.ccsa.org.cn/api/portalsFile/downloadOldFile?type=19&amp;oldFileUrl=ITU-R/M.2012-6/CCSA.37.571-2V16140.doc">https://www.ccsa.org.cn/api/portalsFile/downloadOldFile?type=19&amp;oldFileUrl=ITU-R/M.2012-6/CCSA.37.571-2V16140.doc</a>
ETSI	ETSI TS 137 571-2	16.14.0	Published	24.01.2023	<a href="https://www.etsi.org/deliver/etsi_ts/137500_137599/13757102/16.14.00_60/ts_13757102v161400p.pdf">https://www.etsi.org/deliver/etsi_ts/137500_137599/13757102/16.14.00_60/ts_13757102v161400p.pdf</a>
TSDSI	TSDSI STD T1.3GPP 37.571-2 16.14.0 V1.3.0	16.14.0	Published	02.05.2023	<a href="https://members.tdsi.in/s/iRDiSssAbdk9tDG">https://members.tdsi.in/s/iRDiSssAbdk9tDG</a>
TTA	TTAT.3G-37.571-2V16.14.0	16.14.0	Published	16.03.2023	<a href="http://committee.tta.or.kr/data/ttasDown.jsp?kind=ttastd&amp;pk_num=TTAT.3G-37.571-2V16.14.0">http://committee.tta.or.kr/data/ttasDown.jsp?kind=ttastd&amp;pk_num=TTAT.3G-37.571-2V16.14.0</a>

**2.1.6.19 TS 37.571-3****Universal Terrestrial Radio Access (UTRA) and Evolved UTRA (E-UTRA) and Evolved Packet Core (EPC); User Equipment (UE) conformance specification for UE positioning; Part 3: Implementation Conformance Statement (ICS)**

This document provides the ICS proforma for 3<sup>rd</sup> Generation UTRAN and E-UTRAN User Equipment (UE) supporting UE positioning, in compliance with the relevant requirements, and in accordance with the relevant guidance given in ISO/IEC 9646-1 and ISO/IEC 9646-7.

This document also specifies a recommended applicability statement for the test cases included in 3GPP TS 37.571-1 and 3GPP TS 37.571-2. These applicability statements are based on the features implemented in the UE.

Special conformance testing functions can be found in 3GPP TS 34.109 for UTRA and 3GPP TS 36.509 for E-UTRA. The common test environments are included in 3GPP TS 34.108 for UTRA and in 3GPP TS 36.508 for E-UTRA.

This document is valid for UE supporting UE positioning implemented according to 3GPP releases starting from Release 99 up to the Release indicated on the cover page of this document.

SDO	Document No.	Version	Status	Issued date	Location
<b>Release 10</b>					
ARIB	ARIB STD-T120-37.571-3.V10.8.0	10.8.0	Published	03.03.2023	<a href="https://www.arib.or.jp/english/html/overview/doc/T120_T23_SPECS/ARIB-STD-T120/Rel10/37/A37571-3-a80.pdf">https://www.arib.or.jp/english/html/overview/doc/T120_T23_SPECS/ARIB-STD-T120/Rel10/37/A37571-3-a80.pdf</a>
ATIS	ATIS.3GPP.37.571-3V1080	10.8.0	Published	28.06.2021	<a href="https://www.atis.org/3gpp-documents/Rel99-14/">https://www.atis.org/3gpp-documents/Rel99-14/</a>
CCSA	CCSA.37.571-3V1080	10.8.0	Published	01.12.2015	<a href="https://www.ccsa.org.cn/api/portalsFile/downloadOldFile?type=19&amp;oldFileUrl=ITU-R/M.2012-6/CCSA.37.571-3V1080.doc">https://www.ccsa.org.cn/api/portalsFile/downloadOldFile?type=19&amp;oldFileUrl=ITU-R/M.2012-6/CCSA.37.571-3V1080.doc</a>
ETSI	ETSI TS 137 571-3	10.8.0	Published	15.01.2016	<a href="https://www.etsi.org/deliver/etsi_ts/137500_137599/13757103/10.08.00_60/ts_13757103v100800p.pdf">https://www.etsi.org/deliver/etsi_ts/137500_137599/13757103/10.08.00_60/ts_13757103v100800p.pdf</a>
TSDSI	TSDSI STD T1.3GPP 37.571-3-10.8.0 V1.0.0	10.8.0	Published	30.08.2021	<a href="https://members.tdsi.in/index.php/s/BdoFYCBQm3WmyNR">https://members.tdsi.in/index.php/s/BdoFYCBQm3WmyNR</a>
TTA	TTAT.3G-37.571-3V10.8.0	10.8.0	Published	02.08.2021	<a href="http://committee.tta.or.kr/data/ttasDown.jsp?kind=ttastd&amp;pk_num=TTAT.3G-37.571-3V10.8.0">http://committee.tta.or.kr/data/ttasDown.jsp?kind=ttastd&amp;pk_num=TTAT.3G-37.571-3V10.8.0</a>
<b>Release 11</b>					
ARIB	ARIB STD-T120-37.571-3.V11.1.0	11.1.0	Published	03.03.2023	<a href="https://www.arib.or.jp/english/html/overview/doc/T120_T23_SPECS/ARIB-STD-T120/Rel11/37/A37571-3-b10.pdf">https://www.arib.or.jp/english/html/overview/doc/T120_T23_SPECS/ARIB-STD-T120/Rel11/37/A37571-3-b10.pdf</a>
ATIS	ATIS.3GPP.37.571-3V1110	11.1.0	Published	28.06.2021	<a href="https://www.atis.org/3gpp-documents/Rel99-14/">https://www.atis.org/3gpp-documents/Rel99-14/</a>
CCSA	CCSA.37.571-3V1110	11.1.0	Published	01.12.2015	<a href="https://www.ccsa.org.cn/api/portalsFile/downloadOldFile?type=19&amp;oldFileUrl=ITU-R/M.2012-6/CCSA.37.571-3V1110.doc">https://www.ccsa.org.cn/api/portalsFile/downloadOldFile?type=19&amp;oldFileUrl=ITU-R/M.2012-6/CCSA.37.571-3V1110.doc</a>
ETSI	ETSI TS 137 571-3	11.1.0	Published	15.01.2016	<a href="https://www.etsi.org/deliver/etsi_ts/137500_137599/13757103/11.01.00_60/ts_13757103v110100p.pdf">https://www.etsi.org/deliver/etsi_ts/137500_137599/13757103/11.01.00_60/ts_13757103v110100p.pdf</a>
TSDSI	TSDSI STD T1.3GPP 37.571-3-11.1.0 V1.0.0	11.1.0	Published	30.08.2021	<a href="https://members.tdsi.in/index.php/s/L3nHCnJqajg92cQ">https://members.tdsi.in/index.php/s/L3nHCnJqajg92cQ</a>

TTA	TTAT.3G-37.571-3V11.1.0	11.1.0	Published	02.08.2021	<a href="http://committee.tta.or.kr/data/ttasDown.jsp?kind=ttastd&amp;pk_num=TTAT.3G-37.571-3V11.1.0">http://committee.tta.or.kr/data/ttasDown.jsp?kind=ttastd&amp;pk_num=TTAT.3G-37.571-3V11.1.0</a>
<b>Release 12</b>					
ARIB	ARIB STD-T120-37.571-3.V12.9.0	12.9.0	Published	03.03.2023	<a href="https://www.arib.or.jp/english/html/overview/doc/T120_T23_SPECS/ARIB-STD-T120/Rel12/37/A37571-3-c90.pdf">https://www.arib.or.jp/english/html/overview/doc/T120_T23_SPECS/ARIB-STD-T120/Rel12/37/A37571-3-c90.pdf</a>
ATIS	ATIS.3GPP.37.571-3V1290	12.9.0	Published	28.06.2021	<a href="https://www.atis.org/3gpp-documents/Rel99-14/">https://www.atis.org/3gpp-documents/Rel99-14/</a>
CCSA	CCSA.37.571-3V1290	12.9.0	Published	01.03.2017	<a href="https://www.ccsa.org.cn/api/portalsFile/downloadOldFile?type=19&amp;oldFileUrl=ITU-R/M.2012-6/CCSA.37.571-3V1290.doc">https://www.ccsa.org.cn/api/portalsFile/downloadOldFile?type=19&amp;oldFileUrl=ITU-R/M.2012-6/CCSA.37.571-3V1290.doc</a>
ETSI	ETSI TS 137 571-3	12.9.0	Published	10.04.2017	<a href="https://www.etsi.org/deliver/etsi_ts/137500_137599/13757103/12.09.00_60/ts_13757103v120900p.pdf">https://www.etsi.org/deliver/etsi_ts/137500_137599/13757103/12.09.00_60/ts_13757103v120900p.pdf</a>
TSDSI	TSDSI STD T1.3GPP 37.571-3-12.9.0 V1.0.0	12.9.0	Published	30.08.2021	<a href="https://members.tdsi.in/index.php/s/GFMwWLCBGPWQCM">https://members.tdsi.in/index.php/s/GFMwWLCBGPWQCM</a>
TTA	TTAT.3G-37.571-3V12.9.0	12.9.0	Published	02.08.2021	<a href="http://committee.tta.or.kr/data/ttasDown.jsp?kind=ttastd&amp;pk_num=TTAT.3G-37.571-3V12.9.0">http://committee.tta.or.kr/data/ttasDown.jsp?kind=ttastd&amp;pk_num=TTAT.3G-37.571-3V12.9.0</a>
<b>Release 13</b>					
ARIB	ARIB STD-T120-37.571-3.V13.3.0	13.3.0	Published	03.03.2023	<a href="https://www.arib.or.jp/english/html/overview/doc/T120_T23_SPECS/ARIB-STD-T120/Rel13/37/A37571-3-d30.pdf">https://www.arib.or.jp/english/html/overview/doc/T120_T23_SPECS/ARIB-STD-T120/Rel13/37/A37571-3-d30.pdf</a>
ATIS	ATIS.3GPP.37.571-3V1330	13.3.0	Published	28.06.2021	<a href="https://www.atis.org/3gpp-documents/Rel99-14/">https://www.atis.org/3gpp-documents/Rel99-14/</a>
CCSA	CCSA.37.571-3V1330	13.3.0	Published	01.09.2017	<a href="https://www.ccsa.org.cn/api/portalsFile/downloadOldFile?type=19&amp;oldFileUrl=ITU-R/M.2012-6/CCSA.37.571-3V1330.doc">https://www.ccsa.org.cn/api/portalsFile/downloadOldFile?type=19&amp;oldFileUrl=ITU-R/M.2012-6/CCSA.37.571-3V1330.doc</a>
ETSI	ETSI TS 137 571-3	13.3.0	Published	11.10.2017	<a href="https://www.etsi.org/deliver/etsi_ts/137500_137599/13757103/13.03.00_60/ts_13757103v130300p.pdf">https://www.etsi.org/deliver/etsi_ts/137500_137599/13757103/13.03.00_60/ts_13757103v130300p.pdf</a>
TSDSI	TSDSI STD T1.3GPP 37.571-3-13.3.0 V1.0.0	13.3.0	Published	30.08.2021	<a href="https://members.tdsi.in/index.php/s/JPFYBWgra7wKpYM">https://members.tdsi.in/index.php/s/JPFYBWgra7wKpYM</a>
TTA	TTAT.3G-37.571-3V13.3.0	13.3.0	Published	02.08.2021	<a href="http://committee.tta.or.kr/data/ttasDown.jsp?kind=ttastd&amp;pk_num=TTAT.3G-37.571-3V13.3.0">http://committee.tta.or.kr/data/ttasDown.jsp?kind=ttastd&amp;pk_num=TTAT.3G-37.571-3V13.3.0</a>
<b>Release 14</b>					
ARIB	ARIB STD-T120-37.571-3.V14.4.0	14.4.0	Published	03.03.2023	<a href="https://www.arib.or.jp/english/html/overview/doc/T120_T23_SPECS/ARIB-STD-T120/Rel14/37/A37571-3-e40.pdf">https://www.arib.or.jp/english/html/overview/doc/T120_T23_SPECS/ARIB-STD-T120/Rel14/37/A37571-3-e40.pdf</a>
ATIS	ATIS.3GPP.37.571-3V1440	14.4.0	Published	28.06.2021	<a href="https://www.atis.org/3gpp-documents/Rel99-14/">https://www.atis.org/3gpp-documents/Rel99-14/</a>
CCSA	CCSA.37.571-3V1440	14.4.0	Published	01.03.2018	<a href="https://www.ccsa.org.cn/api/portalsFile/downloadOldFile?type=19&amp;oldFileUrl=ITU-R/M.2012-6/CCSA.37.571-3V1440.doc">https://www.ccsa.org.cn/api/portalsFile/downloadOldFile?type=19&amp;oldFileUrl=ITU-R/M.2012-6/CCSA.37.571-3V1440.doc</a>
ETSI	ETSI TS 137 571-3	14.4.0	Published	10.04.2018	<a href="https://www.etsi.org/deliver/etsi_ts/137500_137599/13757103/14.04.00_60/ts_13757103v140400p.pdf">https://www.etsi.org/deliver/etsi_ts/137500_137599/13757103/14.04.00_60/ts_13757103v140400p.pdf</a>
TSDSI	TSDSI STD T1.3GPP 37.571-3-14.4.0 V1.1.0	14.4.0	Published	30.08.2021	<a href="https://members.tdsi.in/index.php/s/4L39X7WwtqZ5GY">https://members.tdsi.in/index.php/s/4L39X7WwtqZ5GY</a>
TTA	TTAT.3G-37.571-3V14.4.0	14.4.0	Published	02.08.2021	<a href="http://committee.tta.or.kr/data/ttasDown.jsp?kind=ttastd&amp;pk_num=TTAT.3G-37.571-3V14.4.0">http://committee.tta.or.kr/data/ttasDown.jsp?kind=ttastd&amp;pk_num=TTAT.3G-37.571-3V14.4.0</a>
<b>Release 15</b>					
ARIB	ARIB STD-T120-37.571-3.V15.6.0	15.6.0	Published	03.03.2023	<a href="https://www.arib.or.jp/english/html/overview/doc/T120_T23_SPECS/ARIB-STD-T120/Rel15/37/A37571-3-f60.pdf">https://www.arib.or.jp/english/html/overview/doc/T120_T23_SPECS/ARIB-STD-T120/Rel15/37/A37571-3-f60.pdf</a>
ATIS	ATIS.3GPP.37.571-3V1560	15.6.0	Published	28.06.2021	<a href="https://www.atis.org/3gpp-documents/Rel15/">https://www.atis.org/3gpp-documents/Rel15/</a>
CCSA	CCSA.37.571-3V1560	15.6.0	Published	01.03.2020	<a href="https://www.ccsa.org.cn/api/portalsFile/downloadOldFile?type=19&amp;oldFileUrl=ITU-R/M.2012-6/CCSA.37.571-3V1560.doc">https://www.ccsa.org.cn/api/portalsFile/downloadOldFile?type=19&amp;oldFileUrl=ITU-R/M.2012-6/CCSA.37.571-3V1560.doc</a>
ETSI	ETSI TS 137 571-3	15.6.0	Published	03.04.2020	<a href="https://www.etsi.org/deliver/etsi_ts/137500_137599/13757103/15.06.00_60/ts_13757103v150600p.pdf">https://www.etsi.org/deliver/etsi_ts/137500_137599/13757103/15.06.00_60/ts_13757103v150600p.pdf</a>
TSDSI	TSDSI STD T1.3GPP 37.571-3-15.6.0 V1.0.0	15.6.0	Published	30.08.2021	<a href="https://members.tdsi.in/index.php/s/Wy9YEKjZkrrmss">https://members.tdsi.in/index.php/s/Wy9YEKjZkrrmss</a>
TTA	TTAT.3G-37.571-3V15.6.0	15.6.0	Published	11.09.2020	<a href="http://committee.tta.or.kr/data/ttasDown.jsp?kind=ttastd&amp;pk_num=TTAT.3G-37.571-3V15.6.0">http://committee.tta.or.kr/data/ttasDown.jsp?kind=ttastd&amp;pk_num=TTAT.3G-37.571-3V15.6.0</a>
<b>Release 16</b>					
ARIB	ARIB STD-T120-37.571-3.V16.14.0	16.14.0	Published	03.03.2023	<a href="https://www.arib.or.jp/english/html/overview/doc/T120_T23_SPECS/ARIB-STD-T120/Rel16/37/A37571-3-ge0.pdf">https://www.arib.or.jp/english/html/overview/doc/T120_T23_SPECS/ARIB-STD-T120/Rel16/37/A37571-3-ge0.pdf</a>
ATIS	ATIS.3GPP.37.571-3.V16.14.0	16.14.0	Published	21.02.2023	<a href="https://www.atis.org/3gpp-transpositions - Rel-16">https://www.atis.org/3gpp-transpositions - Rel-16</a>
CCSA	CCSA.37.571-3V16140	16.14.0	Published	01.12.2022	<a href="https://www.ccsa.org.cn/api/portalsFile/downloadOldFile?type=19&amp;oldFileUrl=ITU-R/M.2012-6/CCSA.37.571-3V16140.doc">https://www.ccsa.org.cn/api/portalsFile/downloadOldFile?type=19&amp;oldFileUrl=ITU-R/M.2012-6/CCSA.37.571-3V16140.doc</a>
ETSI	ETSI TS 137 571-3	16.14.0	Published	24.01.2023	<a href="https://www.etsi.org/deliver/etsi_ts/137500_137599/13757103/16.14.00_60/ts_13757103v161400p.pdf">https://www.etsi.org/deliver/etsi_ts/137500_137599/13757103/16.14.00_60/ts_13757103v161400p.pdf</a>
TSDSI	TSDSI STD T1.3GPP 37.571-3 16.14.0 V1.3.0	16.14.0	Published	02.05.2023	<a href="https://members.tdsi.in/s/9eerwaRaAySYoDj">https://members.tdsi.in/s/9eerwaRaAySYoDj</a>
TTA	TTAT.3G-37.571-3V16.14.0	16.14.0	Published	16.03.2023	<a href="http://committee.tta.or.kr/data/ttasDown.jsp?kind=ttastd&amp;pk_num=TTAT.3G-37.571-3V16.14.0">http://committee.tta.or.kr/data/ttasDown.jsp?kind=ttastd&amp;pk_num=TTAT.3G-37.571-3V16.14.0</a>

#### 2.1.6.20 TS 37.571-4

### Universal Terrestrial Radio Access (UTRA) and Evolved UTRA (E-UTRA) and Evolved Packet Core (EPC); User Equipment (UE) conformance specification for UE positioning; Part 4: Test suites

This document specifies the protocol and signalling conformance testing in TTCN for the UE:

- A-GPS at the UTRA Uu interface;
- LTE positioning at the LTE-Uu interface;



- A-GNSS at the UTRA Uu interface.

The following TTCN test specification and design considerations can be found in this document:

- Test system architecture;
- Test models and ASP definitions;
- Test methods and usage of communication ports definitions;
- Test configurations;
- Design principles and assumptions;
- TTCN styles and conventions;
- Partial PIXIT proforma;
- Test suites in TTCN-2 and TTCN-3;
- The Test Suites designed and implemented in this document are based on the test specifications in prose in 3GPP TS 37.571-2;
- The applicability of the individual test cases is specified in the test ICS proforma specification in 3GPP TS 37.571-3.

SDO	Document No.	Version	Status	Issued date	Location
<b>Release 10</b>					
ARIB	ARIB STD-T120-37.571-4.V10.10.0	10.10.0	Published	03.03.2023	<a href="https://www.arib.or.jp/english/html/overview/doc/T120_T23_SPECS/ARIB-STD-T120/Rel10/37/A37571-4-aa0.pdf">https://www.arib.or.jp/english/html/overview/doc/T120_T23_SPECS/ARIB-STD-T120/Rel10/37/A37571-4-aa0.pdf</a>
ATIS	ATIS.3GPP.37.571-4V10100	10.10.0	Published	28.06.2021	<a href="https://www.atis.org/3gpp-documents/Rel99-14/">https://www.atis.org/3gpp-documents/Rel99-14/</a>
CCSA	CCSA.37.571-4V10100	10.10.0	Published	01.12.2015	<a href="https://www.ccsa.org.cn/api/portalsFile/downloadOldFile?type=19&amp;oldFileUrl=ITU-R/M.2012-6/CCSA.37.571-4V10100.doc">https://www.ccsa.org.cn/api/portalsFile/downloadOldFile?type=19&amp;oldFileUrl=ITU-R/M.2012-6/CCSA.37.571-4V10100.doc</a>
ETSI	ETSI TS 137 571-4	10.10.0	Published	15.01.2016	<a href="https://www.etsi.org/deliver/etsi_ts/137500_137599/13757104/10.10.00_60/ts_13757104v101000p.pdf">https://www.etsi.org/deliver/etsi_ts/137500_137599/13757104/10.10.00_60/ts_13757104v101000p.pdf</a>
TSDSI	TSDSI STD T1.3GPP 37.571-4-10.10.0	10.10.0	Published	30.08.2021	<a href="https://members.tdsi.in/index.php/s/xojNjmDibeiAPwD">https://members.tdsi.in/index.php/s/xojNjmDibeiAPwD</a>
TTA	TTAT.3G-37.571-4V10.10.0	10.10.0	Published	30.07.2021	<a href="http://committee.tta.or.kr/data/ttasDown.jsp?kind=ttastd&amp;pk_num=TTAT.3G-37.571-4V10.10.0">http://committee.tta.or.kr/data/ttasDown.jsp?kind=ttastd&amp;pk_num=TTAT.3G-37.571-4V10.10.0</a>
<b>Release 11</b>					
ARIB	ARIB STD-T120-37.571-4.V11.1.0	11.1.0	Published	03.03.2023	<a href="https://www.arib.or.jp/english/html/overview/doc/T120_T23_SPECS/ARIB-STD-T120/Rel11/37/A37571-4-b10.pdf">https://www.arib.or.jp/english/html/overview/doc/T120_T23_SPECS/ARIB-STD-T120/Rel11/37/A37571-4-b10.pdf</a>
ATIS	ATIS.3GPP.37.571-4V1110	11.1.0	Published	28.06.2021	<a href="https://www.atis.org/3gpp-documents/Rel99-14/">https://www.atis.org/3gpp-documents/Rel99-14/</a>
CCSA	CCSA.37.571-4V1110	11.1.0	Published	01.12.2015	<a href="https://www.ccsa.org.cn/api/portalsFile/downloadOldFile?type=19&amp;oldFileUrl=ITU-R/M.2012-6/CCSA.37.571-4V1110.doc">https://www.ccsa.org.cn/api/portalsFile/downloadOldFile?type=19&amp;oldFileUrl=ITU-R/M.2012-6/CCSA.37.571-4V1110.doc</a>
ETSI	ETSI TS 137 571-4	11.1.0	Published	15.01.2016	<a href="https://www.etsi.org/deliver/etsi_ts/137500_137599/13757104/11.01.00_60/ts_13757104v110100p.pdf">https://www.etsi.org/deliver/etsi_ts/137500_137599/13757104/11.01.00_60/ts_13757104v110100p.pdf</a>
TSDSI	TSDSI STD T1.3GPP 37.571-4-11.1.0 V1.0.0	11.1.0	Published	30.08.2021	<a href="https://members.tdsi.in/index.php/s/6YixRnkgyH5Cxn">https://members.tdsi.in/index.php/s/6YixRnkgyH5Cxn</a>
TTA	TTAT.3G-37.571-4V11.1.0	11.1.0	Published	30.07.2021	<a href="http://committee.tta.or.kr/data/ttasDown.jsp?kind=ttastd&amp;pk_num=TTAT.3G-37.571-4V11.1.0">http://committee.tta.or.kr/data/ttasDown.jsp?kind=ttastd&amp;pk_num=TTAT.3G-37.571-4V11.1.0</a>
<b>Release 12</b>					
ARIB	ARIB STD-T120-37.571-4.V12.6.0	12.6.0	Published	03.03.2023	<a href="https://www.arib.or.jp/english/html/overview/doc/T120_T23_SPECS/ARIB-STD-T120/Rel12/37/A37571-4-c60.pdf">https://www.arib.or.jp/english/html/overview/doc/T120_T23_SPECS/ARIB-STD-T120/Rel12/37/A37571-4-c60.pdf</a>
ATIS	ATIS.3GPP.37.571-4V1260	12.6.0	Published	28.06.2021	<a href="https://www.atis.org/3gpp-documents/Rel99-14/">https://www.atis.org/3gpp-documents/Rel99-14/</a>
CCSA	CCSA.37.571-4V1260	12.6.0	Published	01.03.2016	<a href="https://www.ccsa.org.cn/api/portalsFile/downloadOldFile?type=19&amp;oldFileUrl=ITU-R/M.2012-6/CCSA.37.571-4V1260.doc">https://www.ccsa.org.cn/api/portalsFile/downloadOldFile?type=19&amp;oldFileUrl=ITU-R/M.2012-6/CCSA.37.571-4V1260.doc</a>
ETSI	ETSI TS 137 571-4	12.6.0	Published	10.04.2017	<a href="https://www.etsi.org/deliver/etsi_ts/137500_137599/13757104/12.06.00_60/ts_13757104v120600p.pdf">https://www.etsi.org/deliver/etsi_ts/137500_137599/13757104/12.06.00_60/ts_13757104v120600p.pdf</a>
TSDSI	TSDSI STD T1.3GPP 37.571-4-12.6.0 V1.0.0	12.6.0	Published	30.08.2021	<a href="https://members.tdsi.in/index.php/s/4dQct5Nbotmy7Ar">https://members.tdsi.in/index.php/s/4dQct5Nbotmy7Ar</a>
TTA	TTAT.3G-37.571-4V12.6.0	12.6.0	Published	30.07.2021	<a href="http://committee.tta.or.kr/data/ttasDown.jsp?kind=ttastd&amp;pk_num=TTAT.3G-37.571-4V12.6.0">http://committee.tta.or.kr/data/ttasDown.jsp?kind=ttastd&amp;pk_num=TTAT.3G-37.571-4V12.6.0</a>
<b>Release 13</b>					
ARIB	ARIB STD-T120-37.571-4.V13.5.0	13.5.0	Published	03.03.2023	<a href="https://www.arib.or.jp/english/html/overview/doc/T120_T23_SPECS/ARIB-STD-T120/Rel13/37/A37571-4-d50.pdf">https://www.arib.or.jp/english/html/overview/doc/T120_T23_SPECS/ARIB-STD-T120/Rel13/37/A37571-4-d50.pdf</a>
ATIS	ATIS.3GPP.37.571-4V1350	13.5.0	Published	28.06.2021	<a href="https://www.atis.org/3gpp-documents/Rel99-14/">https://www.atis.org/3gpp-documents/Rel99-14/</a>
CCSA	CCSA.37.571-4V1350	13.5.0	Published	01.03.2018	<a href="https://www.ccsa.org.cn/api/portalsFile/downloadOldFile?type=19&amp;oldFileUrl=ITU-R/M.2012-6/CCSA.37.571-4V1350.doc">https://www.ccsa.org.cn/api/portalsFile/downloadOldFile?type=19&amp;oldFileUrl=ITU-R/M.2012-6/CCSA.37.571-4V1350.doc</a>

**160****Rec. ITU-R M.2012-6**

ETSI	ETSI TS 137 571-4	13.5.0	Published	10.04.2018	<a href="https://www.etsi.org/deliver/etsi_ts/137500_137599/13757104/13.05.00_60/ts_13757104v130500p.pdf">https://www.etsi.org/deliver/etsi_ts/137500_137599/13757104/13.05.00_60/ts_13757104v130500p.pdf</a>
TSDSI	TSDSI STD T1.3GPP 37.571-4-13.5.0 V1.1.0	13.5.0	Published	30.08.2021	<a href="https://members.tdsi.in/index.php/s/GdZ9BgBME6P8JZY">https://members.tdsi.in/index.php/s/GdZ9BgBME6P8JZY</a>
TTA	TTAT.3G-37.571-4V13.5.0	13.5.0	Published	30.07.2021	<a href="http://committee.tta.or.kr/data/ttasDown.jsp?kind=ttastd&amp;pk_num=TTAT.3G-37.571-4V13.5.0">http://committee.tta.or.kr/data/ttasDown.jsp?kind=ttastd&amp;pk_num=TTAT.3G-37.571-4V13.5.0</a>

**Release 14**

ARIB	ARIB STD-T120-37.571-4.V14.5.0	14.5.0	Published	03.03.2023	<a href="https://www.arib.or.jp/english/html/overview/doc/T120_T23_SPECS/ARIB-STD-T120/Rel14/37/A37571-4-e50.pdf">https://www.arib.or.jp/english/html/overview/doc/T120_T23_SPECS/ARIB-STD-T120/Rel14/37/A37571-4-e50.pdf</a>
ATIS	ATIS.3GPP.37.571-4V1450	14.5.0	Published	28.06.2021	<a href="https://www.atis.org/3gpp-documents/Rel99-14/">https://www.atis.org/3gpp-documents/Rel99-14/</a>
CCSA	CCSA.37.571-4V1450	14.5.0	Published	01.03.2020	<a href="https://www.ccsa.org.cn/api/portalsFile/downloadOldFile?type=19&amp;oldFileUrl=ITU-R/M.2012-6/CCSA.37.571-4V1450.doc">https://www.ccsa.org.cn/api/portalsFile/downloadOldFile?type=19&amp;oldFileUrl=ITU-R/M.2012-6/CCSA.37.571-4V1450.doc</a>
ETSI	ETSI TS 137 571-4	14.5.0	Published	17.04.2020	<a href="https://www.etsi.org/deliver/etsi_ts/137500_137599/13757104/14.05.00_60/ts_13757104v140500p.pdf">https://www.etsi.org/deliver/etsi_ts/137500_137599/13757104/14.05.00_60/ts_13757104v140500p.pdf</a>
TSDSI	TSDSI STD T1.3GPP 37.571-4-14.5.0 V1.1.0	14.5.0	Published	30.08.2021	<a href="https://members.tdsi.in/index.php/s/73RoEPrKz2jXdTr">https://members.tdsi.in/index.php/s/73RoEPrKz2jXdTr</a>
TTA	TTAT.3G-37.571-4V14.5.0	14.5.0	Published	30.07.2021	<a href="http://committee.tta.or.kr/data/ttasDown.jsp?kind=ttastd&amp;pk_num=TTAT.3G-37.571-4V14.5.0">http://committee.tta.or.kr/data/ttasDown.jsp?kind=ttastd&amp;pk_num=TTAT.3G-37.571-4V14.5.0</a>

**Release 15**

ARIB	ARIB STD-T120-37.571-4.V15.7.0	15.7.0	Published	03.03.2023	<a href="https://www.arib.or.jp/english/html/overview/doc/T120_T23_SPECS/ARIB-STD-T120/Rel15/37/A37571-4-f70.pdf">https://www.arib.or.jp/english/html/overview/doc/T120_T23_SPECS/ARIB-STD-T120/Rel15/37/A37571-4-f70.pdf</a>
ATIS	ATIS.3GPP.37.571-4.V15.7.0	15.7.0	Published	21.02.2023	<a href="https://www.atis.org/3gpp-transpositions - Rel-15">https://www.atis.org/3gpp-transpositions - Rel-15</a>
CCSA	CCSA.37.571-4V1570	15.7.0	Published	01.06.2021	<a href="https://www.ccsa.org.cn/api/portalsFile/downloadOldFile?type=19&amp;oldFileUrl=ITU-R/M.2012-6/CCSA.37.571-4V1570.doc">https://www.ccsa.org.cn/api/portalsFile/downloadOldFile?type=19&amp;oldFileUrl=ITU-R/M.2012-6/CCSA.37.571-4V1570.doc</a>
ETSI	ETSI TS 137 571-4	15.7.0	Published	19.08.2021	<a href="https://www.etsi.org/deliver/etsi_ts/137500_137599/13757104/15.07.00_60/ts_13757104v150700p.pdf">https://www.etsi.org/deliver/etsi_ts/137500_137599/13757104/15.07.00_60/ts_13757104v150700p.pdf</a>
TSDSI	TSDSI STD T1.3GPP 37.571-4-15.5.0 V1.0.0	15.7.0	Published	30.08.2021	<a href="https://members.tdsi.in/index.php/s/8zYXoTRfTMLCi2">https://members.tdsi.in/index.php/s/8zYXoTRfTMLCi2</a>
TTA	TTAT.3G-37.571-4V15.7.0	15.7.0	Published	30.09.2021	<a href="http://committee.tta.or.kr/data/ttasDown.jsp?kind=ttastd&amp;pk_num=TTAT.3G-37.571-4V15.7.0">http://committee.tta.or.kr/data/ttasDown.jsp?kind=ttastd&amp;pk_num=TTAT.3G-37.571-4V15.7.0</a>

**Release 16**

ARIB	ARIB STD-T120-37.571-4.V16.8.0	16.8.0	Published	03.03.2023	<a href="https://www.arib.or.jp/english/html/overview/doc/T120_T23_SPECS/ARIB-STD-T120/Rel16/37/A37571-4-g80.pdf">https://www.arib.or.jp/english/html/overview/doc/T120_T23_SPECS/ARIB-STD-T120/Rel16/37/A37571-4-g80.pdf</a>
ATIS	ATIS.3GPP.37.571-4.V16.8.0	16.8.0	Published	21.02.2023	<a href="https://www.atis.org/3gpp-transpositions - Rel-16">https://www.atis.org/3gpp-transpositions - Rel-16</a>
CCSA	CCSA.37.571-4V1680	16.8.0	Published	01.12.2022	<a href="https://www.ccsa.org.cn/api/portalsFile/downloadOldFile?type=19&amp;oldFileUrl=ITU-R/M.2012-6/CCSA.37.571-4V1680.doc">https://www.ccsa.org.cn/api/portalsFile/downloadOldFile?type=19&amp;oldFileUrl=ITU-R/M.2012-6/CCSA.37.571-4V1680.doc</a>
ETSI	ETSI TS 137 571-4	16.8.0	Published	24.01.2023	<a href="https://www.etsi.org/deliver/etsi_ts/137500_137599/13757104/16.08.00_60/ts_13757104v160800p.pdf">https://www.etsi.org/deliver/etsi_ts/137500_137599/13757104/16.08.00_60/ts_13757104v160800p.pdf</a>
TSDSI	TSDSI STD T1.3GPP 37.571-4 16.8.0 V1.3.0	16.8.0	Published	02.05.2023	<a href="https://members.tdsi.in/s/eyYgpZHB9XrpQff">https://members.tdsi.in/s/eyYgpZHB9XrpQff</a>
TTA	TTAT.3G-37.571-4V16.8.0	16.8.0	Published	16.03.2023	<a href="http://committee.tta.or.kr/data/ttasDown.jsp?kind=ttastd&amp;pk_num=TTAT.3G-37.571-4V16.8.0">http://committee.tta.or.kr/data/ttasDown.jsp?kind=ttastd&amp;pk_num=TTAT.3G-37.571-4V16.8.0</a>

**Release 17**

ARIB	ARIB STD-T120-37.571-4.V17.0.0	17.0.0	Published	03.03.2023	<a href="https://www.arib.or.jp/english/html/overview/doc/T120_T23_SPECS/ARIB-STD-T120/Rel17/37/A37571-4-h00.pdf">https://www.arib.or.jp/english/html/overview/doc/T120_T23_SPECS/ARIB-STD-T120/Rel17/37/A37571-4-h00.pdf</a>
ATIS	ATIS.3GPP.37.571-4.V17.0.0	17.0.0	Published	21.02.2023	<a href="https://www.atis.org/3gpp-transpositions - Rel-17">https://www.atis.org/3gpp-transpositions - Rel-17</a>
CCSA	CCSA.37.571-4V1700	17.0.0	Published	01.12.2022	<a href="https://www.ccsa.org.cn/api/portalsFile/downloadOldFile?type=19&amp;oldFileUrl=ITU-R/M.2012-6/CCSA.37.571-4V1700.doc">https://www.ccsa.org.cn/api/portalsFile/downloadOldFile?type=19&amp;oldFileUrl=ITU-R/M.2012-6/CCSA.37.571-4V1700.doc</a>
ETSI	ETSI TS 137 571-4	17.0.0	Published	24.01.2023	<a href="https://www.etsi.org/deliver/etsi_ts/137500_137599/13757104/17.00.00_60/ts_13757104v170000p.pdf">https://www.etsi.org/deliver/etsi_ts/137500_137599/13757104/17.00.00_60/ts_13757104v170000p.pdf</a>
TSDSI	TSDSI STD T1.3GPP 37.571-4 17.0.0 V1.0.0	17.0.0	Published	02.05.2023	<a href="https://members.tdsi.in/s/ZQs4XeXyRQNb7LL">https://members.tdsi.in/s/ZQs4XeXyRQNb7LL</a>
TTA	TTAT.3G-37.571-4V17.0.0	17.0.0	Published	16.03.2023	<a href="http://committee.tta.or.kr/data/ttasDown.jsp?kind=ttastd&amp;pk_num=TTAT.3G-37.571-4V17.0.0">http://committee.tta.or.kr/data/ttasDown.jsp?kind=ttastd&amp;pk_num=TTAT.3G-37.571-4V17.0.0</a>

**2.1.6.21 TS 37.571-5****Universal Terrestrial Radio Access (UTRA) and Evolved UTRA (E-UTRA) and Evolved Packet Core (EPC); User Equipment (UE) conformance specification for UE positioning; Part 5: Test scenarios and assistance data**

This document specifies the test scenarios and assistance data required for the conformance test for FDD or TDD mode of UTRA and E-UTRA for the User Equipment (UE) that supports one or more of the defined positioning methods. For UTRA these are Assisted Global Positioning System (A-GPS) and Assisted Global Navigation Satellite System (A-GNSS). For E-UTRA these are A-GNSS, Observed Time Difference of Arrival (OTDOA) and Enhanced Cell ID (ECID).

SDO	Document No.	Version	Status	Issued date	Location
-----	--------------	---------	--------	-------------	----------

**Release 10**

ARIB	ARIB STD-T120-37.571-5.V10.11.0	10.11.0	Published	03.03.2023	<a href="https://www.arib.or.jp/english/html/overview/doc/T120_T23_SPECS/ARIB-STD-T120/Rel10/37/A37571-5-ab0.pdf">https://www.arib.or.jp/english/html/overview/doc/T120_T23_SPECS/ARIB-STD-T120/Rel10/37/A37571-5-ab0.pdf</a>
ATIS	ATIS.3GPP.37.571-5V10110	10.11.0	Published	28.06.2021	<a href="https://www.atis.org/3gpp-documents/Rel99-14/">https://www.atis.org/3gpp-documents/Rel99-14/</a>
CCSA	CCSA.37.571-5V10110	10.11.0	Published	01.12.2015	<a href="https://www.ccsa.org.cn/api/portalsFile/downloadOldFile?type=19&amp;oldFileUrl=ITU-R/M.2012-6/CCSA.37.571-5V10110.doc">https://www.ccsa.org.cn/api/portalsFile/downloadOldFile?type=19&amp;oldFileUrl=ITU-R/M.2012-6/CCSA.37.571-5V10110.doc</a>

ETSI	ETSI TS 137 571-5	10.11.0	Published	18.01.2016	<a href="https://www.etsi.org/deliver/etsi_ts/137500_137599/13757105/10.11.00_60/ts_13757105v101100p.pdf">https://www.etsi.org/deliver/etsi_ts/137500_137599/13757105/10.11.00_60/ts_13757105v101100p.pdf</a>
TSDSI	TSDSI STD T1.3GPP 37.571-5-10.11.0	10.11.0	Published	30.08.2021	<a href="https://members.tdsi.in/index.php/s/P63DTWqAwdkirk">https://members.tdsi.in/index.php/s/P63DTWqAwdkirk</a>
TTA	TTAT.3G-37.571-5V10.11.0	10.11.0	Published	30.07.2021	<a href="http://committee.tta.or.kr/data/ttasDown.jsp?kind=ttastd&amp;pk_num=TTAT.3G-37.571-5V10.11.0">http://committee.tta.or.kr/data/ttasDown.jsp?kind=ttastd&amp;pk_num=TTAT.3G-37.571-5V10.11.0</a>
<b>Release 11</b>					
ARIB	ARIB STD-T120-37.571-5.V11.1.0	11.1.0	Published	03.03.2023	<a href="https://www.arib.or.jp/english/html/overview/doc/T120_T23_SPECS/ARIB-STD-T120/Rel11/37/A37571-5-b10.pdf">https://www.arib.or.jp/english/html/overview/doc/T120_T23_SPECS/ARIB-STD-T120/Rel11/37/A37571-5-b10.pdf</a>
ATIS	ATIS.3GPP.37.571-5V1110	11.1.0	Published	28.06.2021	<a href="https://www.atis.org/3gpp-documents/Rel99-14/">https://www.atis.org/3gpp-documents/Rel99-14/</a>
CCSA	CCSA.37.571-5V1110	11.1.0	Published	01.12.2015	<a href="https://www.ccsa.org.cn/api/portalsFile/downloadOldFile?type=19&amp;oldFileUrl=ITU-R/M.2012-6/CCSA.37.571-5V1110.doc">https://www.ccsa.org.cn/api/portalsFile/downloadOldFile?type=19&amp;oldFileUrl=ITU-R/M.2012-6/CCSA.37.571-5V1110.doc</a>
ETSI	ETSI TS 137 571-5	11.1.0	Published	18.01.2016	<a href="https://www.etsi.org/deliver/etsi_ts/137500_137599/13757105/11.01.00_60/ts_13757105v110100p.pdf">https://www.etsi.org/deliver/etsi_ts/137500_137599/13757105/11.01.00_60/ts_13757105v110100p.pdf</a>
TSDSI	TSDSI STD T1.3GPP 37.571-5-11.1.0 V1.0.0	11.1.0	Published	30.08.2021	<a href="https://members.tdsi.in/index.php/s/rjyPXTKmEDaHsd5">https://members.tdsi.in/index.php/s/rjyPXTKmEDaHsd5</a>
TTA	TTAT.3G-37.571-5V11.1.0	11.1.0	Published	30.07.2021	<a href="http://committee.tta.or.kr/data/ttasDown.jsp?kind=ttastd&amp;pk_num=TTAT.3G-37.571-5V11.1.0">http://committee.tta.or.kr/data/ttasDown.jsp?kind=ttastd&amp;pk_num=TTAT.3G-37.571-5V11.1.0</a>
<b>Release 12</b>					
ARIB	ARIB STD-T120-37.571-5.V12.7.0	12.7.0	Published	03.03.2023	<a href="https://www.arib.or.jp/english/html/overview/doc/T120_T23_SPECS/ARIB-STD-T120/Rel12/37/A37571-5-c70.pdf">https://www.arib.or.jp/english/html/overview/doc/T120_T23_SPECS/ARIB-STD-T120/Rel12/37/A37571-5-c70.pdf</a>
ATIS	ATIS.3GPP.37.571-5V1270	12.7.0	Published	28.06.2021	<a href="https://www.atis.org/3gpp-documents/Rel99-14/">https://www.atis.org/3gpp-documents/Rel99-14/</a>
CCSA	CCSA.37.571-5V1270	12.7.0	Published	01.03.2017	<a href="https://www.ccsa.org.cn/api/portalsFile/downloadOldFile?type=19&amp;oldFileUrl=ITU-R/M.2012-6/CCSA.37.571-5V1270.doc">https://www.ccsa.org.cn/api/portalsFile/downloadOldFile?type=19&amp;oldFileUrl=ITU-R/M.2012-6/CCSA.37.571-5V1270.doc</a>
ETSI	ETSI TS 137 571-5	12.7.0	Published	10.04.2017	<a href="https://www.etsi.org/deliver/etsi_ts/137500_137599/13757105/12.07.00_60/ts_13757105v120700p.pdf">https://www.etsi.org/deliver/etsi_ts/137500_137599/13757105/12.07.00_60/ts_13757105v120700p.pdf</a>
TSDSI	TSDSI STD T1.3GPP 37.571-5-12.7.0 V1.0.0	12.7.0	Published	30.08.2021	<a href="https://members.tdsi.in/index.php/s/63P4nFFF5zL96Fb">https://members.tdsi.in/index.php/s/63P4nFFF5zL96Fb</a>
TTA	TTAT.3G-37.571-5V12.7.0	12.7.0	Published	30.07.2021	<a href="http://committee.tta.or.kr/data/ttasDown.jsp?kind=ttastd&amp;pk_num=TTAT.3G-37.571-5V12.7.0">http://committee.tta.or.kr/data/ttasDown.jsp?kind=ttastd&amp;pk_num=TTAT.3G-37.571-5V12.7.0</a>
<b>Release 13</b>					
ARIB	ARIB STD-T120-37.571-5.V13.3.0	13.3.0	Published	03.03.2023	<a href="https://www.arib.or.jp/english/html/overview/doc/T120_T23_SPECS/ARIB-STD-T120/Rel13/37/A37571-5-d30.pdf">https://www.arib.or.jp/english/html/overview/doc/T120_T23_SPECS/ARIB-STD-T120/Rel13/37/A37571-5-d30.pdf</a>
ATIS	ATIS.3GPP.37.571-5V1330	13.3.0	Published	28.06.2021	<a href="https://www.atis.org/3gpp-documents/Rel99-14/">https://www.atis.org/3gpp-documents/Rel99-14/</a>
CCSA	CCSA.37.571-5V1330	13.3.0	Published	01.09.2017	<a href="https://www.ccsa.org.cn/api/portalsFile/downloadOldFile?type=19&amp;oldFileUrl=ITU-R/M.2012-6/CCSA.37.571-5V1330.doc">https://www.ccsa.org.cn/api/portalsFile/downloadOldFile?type=19&amp;oldFileUrl=ITU-R/M.2012-6/CCSA.37.571-5V1330.doc</a>
ETSI	ETSI TS 137 571-5	13.3.0	Published	11.10.2017	<a href="https://www.etsi.org/deliver/etsi_ts/137500_137599/13757105/13.03.00_60/ts_13757105v130300p.pdf">https://www.etsi.org/deliver/etsi_ts/137500_137599/13757105/13.03.00_60/ts_13757105v130300p.pdf</a>
TSDSI	TSDSI STD T1.3GPP 37.571-5-13.3.0 V1.0.0	13.3.0	Published	30.08.2021	<a href="https://members.tdsi.in/index.php/s/bQCngiMb6gGJTao">https://members.tdsi.in/index.php/s/bQCngiMb6gGJTao</a>
TTA	TTAT.3G-37.571-5V13.3.0	13.3.0	Published	30.07.2021	<a href="http://committee.tta.or.kr/data/ttasDown.jsp?kind=ttastd&amp;pk_num=TTAT.3G-37.571-5V13.3.0">http://committee.tta.or.kr/data/ttasDown.jsp?kind=ttastd&amp;pk_num=TTAT.3G-37.571-5V13.3.0</a>
<b>Release 14</b>					
ARIB	ARIB STD-T120-37.571-5.V14.3.0	14.3.0	Published	03.03.2023	<a href="https://www.arib.or.jp/english/html/overview/doc/T120_T23_SPECS/ARIB-STD-T120/Rel14/37/A37571-5-e30.pdf">https://www.arib.or.jp/english/html/overview/doc/T120_T23_SPECS/ARIB-STD-T120/Rel14/37/A37571-5-e30.pdf</a>
ATIS	ATIS.3GPP.37.571-5V1430	14.3.0	Published	28.06.2021	<a href="https://www.atis.org/3gpp-documents/Rel99-14/">https://www.atis.org/3gpp-documents/Rel99-14/</a>
CCSA	CCSA.37.571-5V1430	14.3.0	Published	01.03.2018	<a href="https://www.ccsa.org.cn/api/portalsFile/downloadOldFile?type=19&amp;oldFileUrl=ITU-R/M.2012-6/CCSA.37.571-5V1430.doc">https://www.ccsa.org.cn/api/portalsFile/downloadOldFile?type=19&amp;oldFileUrl=ITU-R/M.2012-6/CCSA.37.571-5V1430.doc</a>
ETSI	ETSI TS 137 571-5	14.3.0	Published	10.04.2018	<a href="https://www.etsi.org/deliver/etsi_ts/137500_137599/13757105/14.03.00_60/ts_13757105v140300p.pdf">https://www.etsi.org/deliver/etsi_ts/137500_137599/13757105/14.03.00_60/ts_13757105v140300p.pdf</a>
TSDSI	TSDSI STD T1.3GPP 37.571-5-14.3.0 V1.1.0	14.3.0	Published	30.08.2021	<a href="https://members.tdsi.in/index.php/s/X8si6GBjD72w99y">https://members.tdsi.in/index.php/s/X8si6GBjD72w99y</a>
TTA	TTAT.3G-37.571-5V14.3.0	14.3.0	Published	30.07.2021	<a href="http://committee.tta.or.kr/data/ttasDown.jsp?kind=ttastd&amp;pk_num=TTAT.3G-37.571-5V14.3.0">http://committee.tta.or.kr/data/ttasDown.jsp?kind=ttastd&amp;pk_num=TTAT.3G-37.571-5V14.3.0</a>
<b>Release 15</b>					
ARIB	ARIB STD-T120-37.571-5.V15.6.0	15.6.0	Published	03.03.2023	<a href="https://www.arib.or.jp/english/html/overview/doc/T120_T23_SPECS/ARIB-STD-T120/Rel15/37/A37571-5-f60.pdf">https://www.arib.or.jp/english/html/overview/doc/T120_T23_SPECS/ARIB-STD-T120/Rel15/37/A37571-5-f60.pdf</a>
ATIS	ATIS.3GPP.37.571-5V1560	15.6.0	Published	28.06.2021	<a href="https://www.atis.org/3gpp-documents/Rel15/">https://www.atis.org/3gpp-documents/Rel15/</a>
CCSA	CCSA.37.571-5V1560	15.6.0	Published	01.03.2020	<a href="https://www.ccsa.org.cn/api/portalsFile/downloadOldFile?type=19&amp;oldFileUrl=ITU-R/M.2012-6/CCSA.37.571-5V1560.doc">https://www.ccsa.org.cn/api/portalsFile/downloadOldFile?type=19&amp;oldFileUrl=ITU-R/M.2012-6/CCSA.37.571-5V1560.doc</a>
ETSI	ETSI TS 137 571-5	15.6.0	Published	03.04.2020	<a href="https://www.etsi.org/deliver/etsi_ts/137500_137599/13757105/15.06.00_60/ts_13757105v150600p.pdf">https://www.etsi.org/deliver/etsi_ts/137500_137599/13757105/15.06.00_60/ts_13757105v150600p.pdf</a>
TSDSI	TSDSI STD T1.3GPP 37.571-5-15.6.0 V1.0.0	15.6.0	Published	30.08.2021	<a href="https://members.tdsi.in/index.php/s/7tzqwKEn4m2oznj">https://members.tdsi.in/index.php/s/7tzqwKEn4m2oznj</a>
TTA	TTAT.3G-37.571-5V15.6.0	15.6.0	Published	11.09.2020	<a href="http://committee.tta.or.kr/data/ttasDown.jsp?kind=ttastd&amp;pk_num=TTAT.3G-37.571-5V15.6.0">http://committee.tta.or.kr/data/ttasDown.jsp?kind=ttastd&amp;pk_num=TTAT.3G-37.571-5V15.6.0</a>
<b>Release 16</b>					
ARIB	ARIB STD-T120-37.571-5.V16.10.0	16.10.0	Published	03.03.2023	<a href="https://www.arib.or.jp/english/html/overview/doc/T120_T23_SPECS/ARIB-STD-T120/Rel16/37/A37571-5-ga0.pdf">https://www.arib.or.jp/english/html/overview/doc/T120_T23_SPECS/ARIB-STD-T120/Rel16/37/A37571-5-ga0.pdf</a>
ATIS	ATIS.3GPP.37.571-5.V16.10.0	16.10.0	Published	21.02.2023	<a href="https://www.atis.org/3gpp-transpositions - Rel-16">https://www.atis.org/3gpp-transpositions - Rel-16</a>
CCSA	CCSA.37.571-5V16100	16.10.0	Published	01.12.2022	<a href="https://www.ccsa.org.cn/api/portalsFile/downloadOldFile?type=19&amp;oldFileUrl=ITU-R/M.2012-6/CCSA.37.571-5V16100.doc">https://www.ccsa.org.cn/api/portalsFile/downloadOldFile?type=19&amp;oldFileUrl=ITU-R/M.2012-6/CCSA.37.571-5V16100.doc</a>
ETSI	ETSI TS 137 571-5	16.10.0	Published	24.01.2023	<a href="https://www.etsi.org/deliver/etsi_ts/137500_137599/13757105/16.10.00_60/ts_13757105v161000p.pdf">https://www.etsi.org/deliver/etsi_ts/137500_137599/13757105/16.10.00_60/ts_13757105v161000p.pdf</a>
TSDSI	TSDSI STD T1.3GPP 37.571-5 16.10.0 V1.3.0	16.10.0	Published	02.05.2023	<a href="https://members.tdsi.in/s/NqYNTJGmTZZNHpF">https://members.tdsi.in/s/NqYNTJGmTZZNHpF</a>
TTA	TTAT.3G-37.571-5V16.10.0	16.10.0	Published	16.03.2023	<a href="http://committee.tta.or.kr/data/ttasDown.jsp?kind=ttastd&amp;pk_num=TTAT.3G-37.571-5V16.10.0">http://committee.tta.or.kr/data/ttasDown.jsp?kind=ttastd&amp;pk_num=TTAT.3G-37.571-5V16.10.0</a>

## 2.2 Other specifications

The foundations of the radio aspects of *LTE-Advanced* are based on LTE Release 8 and LTE Release 9 specifications, available on the 3GPP web site.

Information on system and core network specifications can be found in the 3GPP web site for a complete system perspective. These system and core network specifications address the network, terminal, and service aspects required to provide an integrated mobility solution including aspects such as user services, connectivity, interoperability, mobility and roaming, security, codecs and media, operations and maintenance, charging, etc.

All the 3GPP specifications can be found at the following link: <https://www.3gpp.org/specifications/specification-numbering>. 3GPP specifications are reviewed and updated after each Technical Specification Group Plenary meeting (held every year in March, June, September and December).

## Annex 2

### Specification of the WirelessMAN-Advanced radio interface technology

#### Background

IMT-Advanced is a system with global development activity and the IMT-Advanced terrestrial radio interface specifications identified in this Recommendation have been developed by the ITU in collaboration with the GCS<sup>10</sup> Proponents and the Transposing Organizations. It is noted from Document IMT-ADV/24(Rev.3), that:

- The GCS Proponent must be one of the RIT<sup>11</sup>/SRIT<sup>12</sup> Proponents for the relevant technology, and must have legal authority to grant to ITU-R the relevant legal usage rights to the relevant specifications provided within a GCS corresponding to a technology in Recommendation ITU-R M.2012
- A Transposing Organization must have been authorized by the relevant GCS Proponent to produce transposed standards for a particular technology, and must have the relevant legal usage rights.

It is further noted that GCS Proponents and Transposing Organizations must also qualify appropriately under the auspices of Resolution ITU-R 9-5 and the ITU-R “Guidelines for the contribution of material of other organizations to the work of the Study Groups and for inviting other organizations to take part in the study of specific matters (Resolution ITU-R 9-5)”.

The ITU has provided the global and overall framework and requirements, and has developed the Global Core Specification jointly with the GCS Proponent. The detailed standardization has been undertaken within the recognized Transposing Organizations which operate in concert with the GCS

---

<sup>10</sup> Global Core Specifications.

<sup>11</sup> Radio Interface Technology.

<sup>12</sup> Set of Radio Interface Technologies.

Proponent. This Recommendation therefore makes extensive use of references to externally developed specifications.

This approach was considered to be the most appropriate solution to enable completion of this Recommendation within the aggressive schedules set by the ITU and by the needs of administrations, operators and manufacturers.

This Recommendation has therefore been constructed to take full advantage of this method of work and to allow the global standardization time-scales to be maintained. The main body of this Recommendation has been developed by the ITU, with each Annex containing references pointing to the location of the more detailed information.

This Annex 2 contains the detailed information developed by the ITU and “IEEE” (the GCS Proponent) and IEEE, ARIB, TTA, ITRI and WiMAX Forum (the Transposing Organizations). Such use of referencing enables timely completion and update of the high-level elements of this Recommendation, with change control procedures, transposition, and public enquiry procedures being undertaken within the external organization. This information has generally been adopted unchanged, recognizing the need to minimize duplication of work, and the need to facilitate and support an ongoing maintenance and update process.

This general agreement, noting that the detailed information of the radio interface should to a large extent be achieved by reference to the work of external organizations, highlights not only the ITU’s significant role as a catalyst in stimulating, coordinating and facilitating the development of advanced telecommunications technologies, but also its forward-looking and flexible approach to the development of this and other telecommunications standards for the 21<sup>st</sup> century.

A more detailed understanding of the process for the development of the first release of this Recommendation may be found in Document IMT-ADV/24(Rev.3) whereas details on the process for the development of Revisions of this Recommendation may be found in Document IMT-ADV/25(Rev.2).

## **1 Overview of the radio interface technology**

The WirelessMAN-Advanced radio interface specification is developed by IEEE. A complete end-to-end system based on WirelessMAN-Advanced is called WiMAX 2, as developed by the WiMAX Forum.

### **1.1 Overview of physical layer**

The following sections highlights selected physical layer (PHY) features.

#### **1.1.1 Multiple access scheme**

*WirelessMAN-Advanced* uses OFDMA as the multiple-access scheme in downlink (DL) and uplink (UL). It further supports both TDD and FDD duplex schemes including H-FDD operation of the mobile stations (MSs) in the FDD networks. The frame structure attributes, and baseband processing are common for both duplex schemes. The OFDMA parameters are summarized in Table 2. *WirelessMAN-Advanced* also supports wider channel bandwidths, up to 160 MHz, with carrier aggregation. In Table 2, TTG and RTG denote transmit/receive and receive/transmit transition gaps, respectively.

TABLE 2  
OFDMA parameters

Nominal channel bandwidth (MHz)		5	7	8.75	10	20	
Sampling factor		28/25	8/7	8/7	28/25	28/25	
Sampling frequency (MHz)		5.6	8	10	11.2	22.4	
FFT size		512	1 024	1 024	1 024	2 048	
Subcarrier spacing (kHz)		10.94	7.81	9.76	10.94	10.94	
Useful symbol time $T_u$ ( $\mu$ s)		91.429	128	102.4	91.429	91.429	
CP $T_g = 1/8 T_u$	Symbol time $T_s$ ( $\mu$ s)		102.857	144	115.2	102.857	
	FDD	Number of OFDM symbols per 5 ms frame	48	34	43	48	48
		Idle time ( $\mu$ s)	62.857	104	46.40	62.857	62.857
	TDD	Number of OFDM symbols per 5 ms frame	47	33	42	47	47
		TTG + RTG ( $\mu$ s)	165.714	248	161.6	165.714	165.714
CP $T_g = 1/16 T_u$	Symbol time $T_s$ ( $\mu$ s)		97.143	136	108.8	97.143	
	FDD	Number of OFDM symbols per 5 ms frame	51	36	45	51	51
		Idle time ( $\mu$ s)	45.71	104	104	45.71	45.71
	TDD	Number of OFDM symbols per 5 ms frame	50	35	44	50	50
		TTG + RTG ( $\mu$ s)	142.853	240	212.8	142.853	142.853
CP $T_g = 1/4 T_u$	Symbol Time $T_s$ ( $\mu$ s)		114.286	160	128	114.286	
	FDD	Number of OFDM symbols per 5 ms frame	43	31	39	43	43
		Idle time ( $\mu$ s)	85.694	40	8	85.694	85.694
	TDD	Number of OFDM symbols per 5 ms frame	42	30	37	42	42
		TTG + RTG ( $\mu$ s)	199.98	200	264	199.98	199.98

### 1.1.2 Frame structure

A superframe is a collection of consecutive equally-sized radio frames whose beginning is marked with a superframe header (SFH), which carries short-term and long-term system configuration information.

In order to decrease the air-link access latency, the radio frames are further divided into a number of subframes where each subframe comprises of an integer number of OFDM symbols. The transmission time interval (TTI) is defined as the transmission latency over the air-link and is equal to a multiple of subframe length (default is one subframe). There are four types of subframes: 1) type-1 subframe, which consists of six OFDM symbols, 2) type-2 subframe, which consists of seven OFDM symbols, 3) type-3 subframe which consists of five OFDM symbols, and 4) type-4 subframe, which consists of nine OFDM symbols and can be used only in UL for channel bandwidth of 8.75 MHz when supporting legacy, i.e. OFDMA TDD WMAN, frames.

The basic frame structure is shown in Fig. 13, where superframe length is 20 ms (comprised of four radio frames), radio frame size is 5 ms, and subframe length depends on channel bandwidth, length

of cyclic prefix, and subframe type, i.e. type-1/2/3/4. The number of subframes per radio frame is predetermined to maximize the spectral efficiency for each frame configuration depending on channel bandwidth, length of cyclic prefix, subframe type, and duplex mode.

The concept of time zones applies to both TDD and FDD systems. These time zones are time-division multiplexed across time domain in the DL to support both new and legacy MSs. For UL transmissions both time and frequency-division multiplexing approaches can be used to support legacy and new terminals. The non-backward compatible improvements and features are restricted to the new zones. All backward compatible features and functions are used in the legacy zones.

FIGURE 13

Basic frame structure

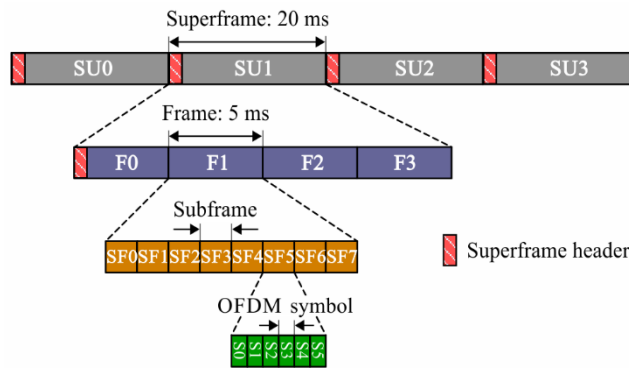

M.2012-13

### 1.1.3 Physical structure and resource unit

The DL/UL subframes are divided into a number of frequency partitions, where each partition consists of a set of physical resource units (PRUs) over the available number of OFDM symbols in the subframe. Each frequency partition can include localized and/or distributed physical resource units. Frequency partitions can be used for different purposes such as fractional frequency reuse (FFR). The DL/UL resource partitioning and mapping is illustrated in Fig. 14. PRU is the basic physical unit for resource allocation that comprises 18 contiguous subcarriers by  $N_{\text{sym}}$  contiguous OFDM symbols where  $N_{\text{sym}}$  is 6, 7, 5 and 9 OFDM symbols for type-1, type-2, type-3 and type-4 subframes, respectively (type-4 is used only for UL). A logical resource unit (LRU) is the basic logical unit for distributed and localized resource allocations. LRU comprises of  $18 \times N_{\text{sym}}$  subcarriers.

FIGURE 14

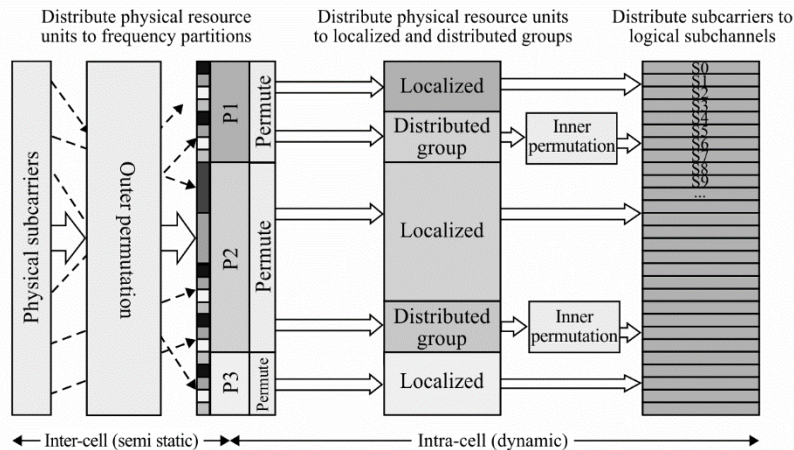
**Resource mapping process**

M.2012-14

**1.1.4 Resource mapping**

The resource mapping process is defined as follows as illustrated in Fig. 14, where  $P_i$  denotes the  $i$ -th frequency partition.

The PRUs are first subdivided into sub-bands and mini-bands where a sub-band comprises four adjacent PRUs and a mini-band comprises one PRU. The sub-bands are suitable for frequency selective allocations as they provide a contiguous allocation of PRUs in frequency. The mini-bands are suitable for frequency diverse allocations and are permuted in frequency (outer permutation in Fig. 14).

After frequency partitioning, the partition between localized or contiguous resource units (CRUs) and distributed resource units (DRUs) is done on a sector specific basis. All sub-bands are categorized into CRU, while mini-bands are categorized into either CRU or DRU. CRUs are used to achieve frequency-selective scheduling gain. A CRU comprises a group of subcarriers which are contiguous across frequency. DRUs are used to achieve frequency diversity gain. A DRU contains a group of subcarriers which are spread across a frequency partition. The sizes of the CRU and DRU are equal to that of PRU.

To form CRUs and DRUs, the subcarriers over the OFDM symbols of a sub-frame are partitioned into guard and used subcarriers. The DC subcarrier is not used. The used subcarriers are divided into PRUs. Each PRU contains pilot and data subcarriers. The number of used pilot and data subcarriers depends on MIMO mode, rank and number of multiplexed MS, as well as the number of OFDM symbols within a sub-frame.

The subcarrier (tone-pair) permutation defined for DRU of a DL frequency partition spreads the subcarriers across all the distributed resource allocations within a frequency partition. After mapping all pilots, the remaining used subcarriers are paired into contiguous subcarrier-pairs (tone-pairs), and then are permuted to define the distributed logical resource units (DLRUs). The DL subcarrier permutation is performed per OFDM symbol within a sub-frame. Each of the DRUs of an UL frequency partition is divided into 3 tiles of 6 adjacent subcarriers over  $N_{\text{sym}}$  symbols. The tiles are collectively permuted across all the distributed resource allocations within a frequency partition to define DLRUs. The contiguous logical resource unit (CLRUs) are obtained from direct mapping of CRUs. CLRUs are categorized into sub-band-based LRUs, so-called sub-band logical resource unit (SLRU), and mini-band-based LRUs, so called mini-band logical resource unit (NLRU).



### 1.1.5 Modulation and coding

FIGURE 15  
Coding and modulation procedures

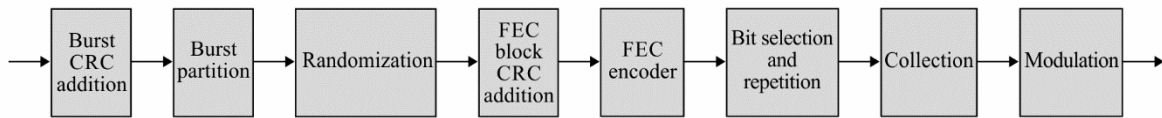

M.2012-15

Figure 15 shows the channel coding and modulation procedures. A cyclic redundancy check (CRC) is appended to a burst (i.e. a physical layer data unit) prior to partitioning. The 16-bit CRC is calculated over the entire bits in the burst. If the burst size including burst CRC exceeds the maximum FEC block size, the burst is partitioned into KFB FEC blocks, each of which is encoded separately. If a burst is partitioned into more than one forward error correction (FEC) blocks, a FEC block CRC is appended to each FEC block before the FEC encoding. The FEC block CRC of a FEC block is calculated based on the entire bits in that FEC block. Each partitioned FEC block including 16-bit FEC block CRC has the same length. The maximum FEC block size is 4 800 bits. Concatenation rules are based on the number of information bits and do not depend on the structure of the resource allocation (number of logical resource units and their size). *WirelessMAN-Advanced* utilizes the convolutional turbo code (CTC) with code rate of 1/3. The CTC scheme is extended to support additional FEC block sizes. Furthermore, the FEC block sizes can be regularly increased with predetermined block size resolutions. The FEC block sizes which are multiple of seven are removed for the tail-biting encoding structure. The encoder block depicted in Fig. 15 includes the interleaver.

Bit selection and repetition are used in *WirelessMAN-Advanced* to achieve rate matching. Bit selection adapts the number of coded-bits to the size of the resource allocation which may vary depending on the resource unit size and sub-frame type. The total subcarriers in the allocated resource unit are segmented to each FEC block. The total number of information and parity bits generated by FEC encoder are considered as the maximum size of circular buffer. Repetition is performed when the number of transmitted bits is larger than the number of selected bits. The selection of coded bits is done cyclically over the buffer. The mother-code bits, the total number of information and parity bits generated by FEC encoder, are considered as a maximum size of circular buffer. In case that the size of the circular buffer  $N_{\text{buffer}}$  is smaller than the number of mother-code bits, the first  $N_{\text{buffer}}$  bits of mother-code bits are considered as selected bits.

Modulation constellations of QPSK, 16-QAM, and 64-QAM are supported. The mapping of bits to the constellation point depends on the constellation-rearrangement (CoRe) version used for HARQ retransmission as described and further depends on the MIMO scheme. The QAM symbols are mapped into the input of the MIMO encoder. The sizes include the addition of CRC (per burst and per FEC block), if applicable. Other sizes require padding to the next burst size. The code rate and modulation depend on the burst size and the resource allocation.

Incremental redundancy HARQ (HARQ-IR) is used in *WirelessMAN-Advanced* by determining the starting position of the bit selection for HARQ retransmissions. Chase combining HARQ (HARQ-CC) is also supported and considered as a special case of HARQ-IR. The 2-bit sub-packet identifier (SPID) is used to identify the starting position. The CoRe scheme can be expressed by a bit-level interleaver.

The resource allocation and transmission formats in each retransmission in DL can be adapted with control signalling. The resource allocation in each retransmission in UL can be fixed or adaptive according to control signalling. In HARQ re-transmissions, the bits or symbols can be transmitted in a different order to exploit the frequency diversity of the channel.

For HARQ retransmission, the mapping of bits or modulated symbols to spatial streams may be applied to exploit spatial diversity with given mapping pattern, depending on the type of HARQ-IR. In this case, the predefined set of mapping patterns should be known to the transmitter and receiver. In DL HARQ, the base station (BS) may transmit coded bits exceeding current available soft buffer capacity.

**1.1.6 Pilot structure**

Transmission of pilot subcarriers in DL is necessary to allow channel estimation, channel quality measurement (e.g. channel quality indicator, CQI), frequency offset estimation, etc. To optimize the system performance in different propagation environments, *WirelessMAN-Advanced* supports both common and dedicated pilot structures. The classification of pilots into common and dedicated is done based on their usage. The common pilots can be used in distributed allocation by all MSs. Dedicated pilots can be used with both localized and distributed allocations. They are associated with user specific pilot index. The dedicated pilots are associated with a specific resource allocation, are intended to be used by the MSs allocated to specific resource allocation, and therefore shall be precoded or beamformed in the same way as the data subcarriers of the resource allocation. The pilot structure is defined for up to eight streams and there is a unified design for common and dedicated pilots. There is equal pilot density per spatial stream; however, there is not necessarily equal pilot density per OFDM symbols.

FIGURE 16  
Pilot structures for 1, 2, 4 and 8 streams for Type-1 sub-frame

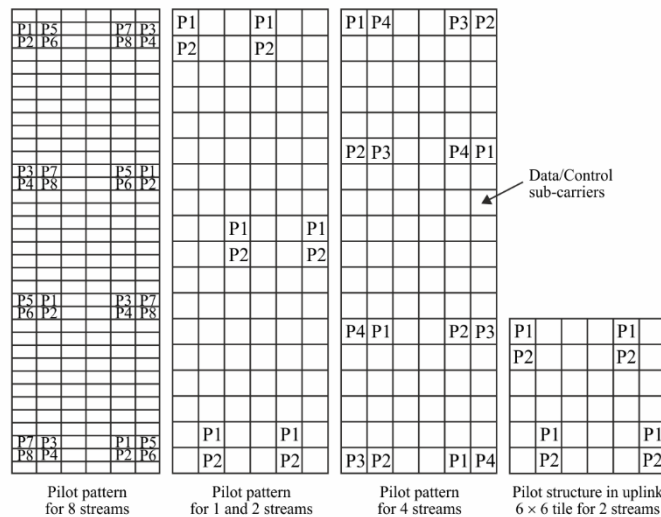

M.2012-16

For the sub-frame consisting of five OFDM symbols, the last OFDM symbol is deleted. For the sub-frame consisting of seven OFDM symbols, the first OFDM symbol is added as the 7<sup>th</sup> OFDM symbol. To overcome the effects of pilot interference among the neighbouring sectors or BSs, an interlaced pilot structure is utilized by cyclically shifting the base pilot pattern such that the pilots of neighbouring cells do not overlap.

The UL pilots are dedicated to localized and distributed resource units and are precoded using the same precoding as the data subcarriers of the resource allocation. The pilot structure is defined for up to four transmit streams for SU-MIMO and up to eight streams for CSM. When pilots are power-boosted, each data subcarrier should have the same transmission power across all OFDM symbols in a resource block.

The  $18 \times 6$  UL resource blocks use the same pilot patterns as the DL counterpart. The pilot pattern for  $6 \times 6$  tile structure is used for DLRU only in case the number of streams is one or two and it is also shown in Fig. 16.

### 1.1.7 Control channels

DL control channels carry essential information for system operation. Depending on the type of control signalling, information is transmitted over different time intervals (i.e. from superframe to sub-frame intervals). The system configuration parameters are transmitted at the superframe intervals, whereas control signalling related to user data allocations is transmitted at the frame/sub-frame intervals.

#### 1.1.7.1 Downlink control channels

##### Superframe Header (SFH)

The superframe header (SFH) carries essential system parameters and configuration information. The content of SFH is divided into two segments; i.e. primary and secondary SFHs. The primary SFH is transmitted every superframe, whereas the secondary SFH is transmitted over one or more superframes. The primary and secondary SFHs are located in the first sub-frame within a superframe and are time-division-multiplexed with the advanced preamble. The SFH occupies no more than 5 MHz bandwidth. The primary SFH is transmitted using predetermined modulation and coding scheme. The secondary SFH is transmitted using predetermined modulation scheme while its repetition coding factor is signalled in the primary SFH. The primary and secondary SFHs are transmitted using two spatial streams and space-frequency block coding to improve coverage and reliability. The MS is not required to know the antenna configuration prior to decoding the primary SFH. The information transmitted in the secondary SFH is divided into different sub-packets. The secondary SFH sub-packet 1 (SP1) includes information needed for network re-entry. The secondary SFH sub-packet 2 (SP2) contains information for initial network entry. The secondary SFH sub-packet 3 (SP3) contains remaining system information for maintaining communication with the BS.

##### Advanced MAP (A-MAP)

The advanced MAP (A-MAP) consists of both user-specific and non-user-specific control information. Non-user-specific control information includes information that is not dedicated to a specific user or a specific group of users. It contains information required to decode user-specific control signalling. User specific control information consists of information intended for one or more users. It includes scheduling assignment, power control information, and HARQ feedback. Resources can be allocated persistently to the MSs. Group control information is used to allocate resources and/or configure resources to one or multiple MSs within a user group. Within a subframe, control and data channels are frequency-division-multiplexed. Both control and data channels are transmitted on logical resource units that span over all OFDM symbols within a subframe.

Each DL subframe contains a control region including both non-user-specific and user-specific control information. All A-MAPs share a time-frequency region known as A-MAP region. The control regions are located in every subframe. The corresponding UL allocations occurs L subframes later, where L is determined by A-MAP relevance. The coding rate is predetermined for non-user-specific information while it is indicated by SFH for user-specific control information.

An A-MAP allocation Information Element (IE) is defined as the basic element of unicast service control. A unicast control IE may be addressed to one user using a unicast identifier or to multiple users using a multicast/broadcast identifier. The identifier is masked with CRC in the A-MAP allocation IE. It may contain information related to resource allocation, HARQ, MIMO transmission mode, etc. Each A-MAP IE is coded separately.

Non-user-specific control information is encoded separately from the user-specific control information. In the DL subframes, frequency partition for reuse-1 and/or frequency partition for power-boostered reuse-3 may contain an A-MAP region. The A-MAP region occupies the first few DL RUs in a frequency partition. The structure of an A-MAP region is illustrated in Fig. 17. The resource occupied by each A-MAP physical channel may vary depending on the system configuration and scheduler operation. There are different types of A-MAPs as follows:

- **Assignment A-MAP** contains resource assignment information which is categorized into multiple types of resource assignment IEs (assignment A-MAP IE).
- **HARQ Feedback A-MAP** contains HARQ ACK/NACK information for UL data transmission.
- **Power Control A-MAP** includes fast power control command to MSs.

There are different assignment A-MAP IE types that distinguish between DL/UL, persistent/non-persistent, single user/group resource allocation, basic/extended IE scenarios.

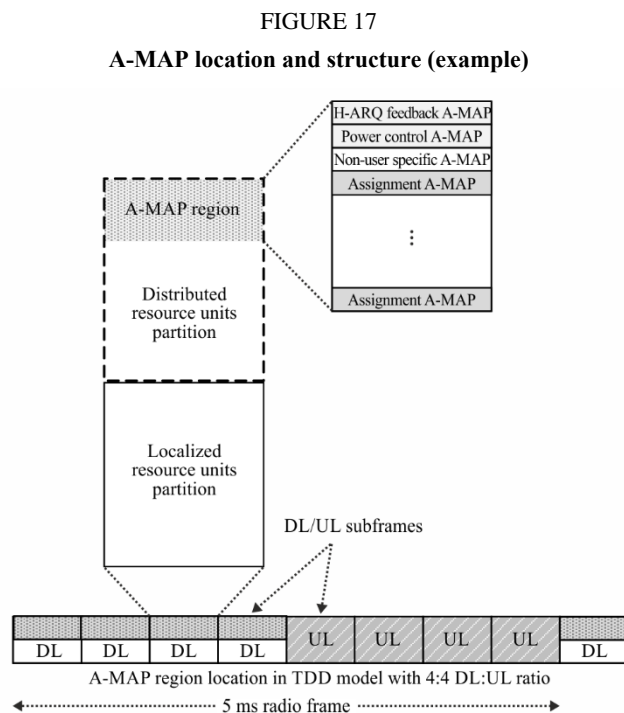

M.2012-17

### 1.1.7.2 Uplink control channels

#### Fast Feedback Channel (FBCH)

The UL fast feedback channel (FBCH) carries CQI and MIMO feedback.

CQI feedback provides information about channel conditions as seen by the MS. This information is used by the BS for link adaptation, resource allocation, power control, etc. The channel quality measurement includes both narrowband and wideband measurements. The CQI feedback overhead can be reduced through differential feedback or other compression techniques. Examples of CQI include effective carrier to interference plus noise ratio (CINR), band selection, etc.

MIMO feedback provides wideband and/or narrowband spatial characteristics of the channel that are required for MIMO operation. The MIMO mode, preferred matrix index, rank adaptation information, channel covariance matrix elements, and best sub-band index are examples of MIMO feedback information.

There are two types of UL FBCHs: a) primary fast feedback channel (P-FBCH) and b) secondary fast feedback channel (S-FBCH). S-FBCH can be used to support CQI reporting at higher code rate and thus more CQI information bits. FBCH is frequency-division-multiplexed with other UL control and data channels.

FBCH starts at a predetermined location, with the size defined in a DL broadcast control message. Fast feedback allocations to an MS can be periodic and the allocations are configurable. The specific type of feedback information carried on each fast feedback opportunity can be different. The number of bits carried in the fast feedback channel can be adaptive. For efficient transmission of feedback channels, a mini-tile is defined comprising two subcarriers by six OFDM symbols. One LRU consists of nine mini-tiles and can be shared by multiple FBCHs.

### **HARQ feedback channel**

HARQ feedback (ACK/NACK) is used to acknowledge DL data transmissions. The UL HARQ feedback channel starts at a predetermined offset with respect to the corresponding DL transmission. The HARQ feedback channel is frequency-division-multiplexed with other control and data channels. Orthogonal codes are used to multiplex multiple HARQ feedback channels. The HARQ feedback channel comprises three distributed mini-tiles.

### **Sounding channel**

The sounding channel is used by an MS to transmit sounding reference signals to enable the BS to measure UL channel conditions. The sounding channel may occupy either specific UL sub-bands or the entire bandwidth over an OFDM symbol. The BS can configure an MS to transmit the UL sounding signal over predefined subcarriers within specific sub-bands or the entire bandwidth. The sounding channel is orthogonally multiplexed (in time or frequency) with other control and data channels. Furthermore, the BS can configure multiple user terminals to transmit sounding signals on the corresponding sounding channels using code-, frequency-, or time-division multiplexing. Power control for the sounding channel can be utilized to adjust the sounding quality. The transmit power from each mobile terminal may be separately controlled according to certain CINR target values.

### **Ranging channel**

The ranging channel is used for UL synchronization. The ranging channel can be further classified into ranging for non-synchronized and synchronized MSs. The ranging channel for non-synchronized MS(NS-RCH) is used for initial network entry and for handover to a target BS. The ranging channel for synchronized MS(S-RCH) is used for periodic ranging. In a femtocell, MSs shall perform initial ranging, handover ranging, and periodic ranging by using the S-RCH.

### **Bandwidth request (BR) channel**

Bandwidth request (BR) channels are used to request UL grant. BRs are transmitted through BR preamble with or without messages. BR messages can include information about the status of queued traffic at the MS such as buffer size and quality of service parameters. Contention or non-contention based random access is used to transmit BR information on this control channel.

The BR channel starts at a configurable location with the configuration defined in a DL broadcast control message. The BR channel is frequency-division-multiplexed with other UL control and data channels. A BR tile is defined as six contiguous subcarriers by six OFDMA symbols. Each BR channel consists of three distributed BR tiles. Multiple BR preamble can be transmitted on the same BR channel using code-division multiplexing.

### 1.1.8 Power control

Power control mechanism is supported for DL and UL. Using DL power control, user-specific information with dedicated pilot is received by the terminal with the controlled power level. The DL advanced MAPs can be power-controlled based on the terminal UL channel quality feedback.

The UL power control is supported to compensate the path loss, shadowing, fast fading and implementation loss as well as to mitigate inter-cell and intra-cell interference. The BS can transmit necessary information through control channel or message to terminals to support UL power control. The parameters of power control algorithm are optimized on system-wide basis by the BS and broadcasted periodically.

In high-mobility scenarios, power control scheme may not be able to compensate the fast fading channel effect because of the variations of the channel impulse response. As a result, the power control is used to compensate the distance-dependent path loss, shadowing and implementation loss only.

The channel variations and implementation loss are compensated via open-loop power control without frequently interacting with the BS. The terminal can determine the transmit power based on the transmission parameters sent by the serving BS, UL channel transmission quality, DL channel state information, and interference knowledge obtained from DL. Open-loop power control provides a coarse initial power setting of the terminal when an initial connection is established.

The dynamic channel variations are compensated via closed-loop power control with power control commands from the serving BS. The BS measures UL channel state and interference information using UL data and/or control channel transmissions and sends power control commands to the terminal. The terminal adjusts its transmission power based on the power control commands from the BS.

### 1.1.9 Downlink synchronization

WirelessMAN-Advanced utilizes a new hierarchical structure for the DL synchronization where two types of preambles, a) primary advanced preamble (PA-Preamble) and b) secondary advanced preamble (SA-Preamble), are transmitted (Fig. 18). One PA-Preamble symbol and two SA-Preamble symbols exist within the superframe. The location of the A-Preamble symbol is specified as the first symbol of frame except for the last frame. PA-Preamble is located at the first symbol of second frame in a superframe while SA-Preamble is located at the first symbol of the first and the third frames. The PA-Preamble carries information about system bandwidth and carrier configuration. The PA-Preamble has a fixed bandwidth of 5 MHz. A frequency reuse of one is applied to the PA-Preamble in frequency domain. SA-Preamble is repeated once every two frames and spans the entire system bandwidth and carries the cell ID. A frequency reuse of three is used for this set of sequences to mitigate inter-cell interference. SA-Preamble carries 768 distinct cell IDs.

The set of SA-Preamble sequences is partitioned, and each partition is dedicated to specific BS type such as macro BS, femto BS, etc. The partition information is broadcasted in the secondary SFH and AAI-SCD message.

FIGURE 18  
Structure of advanced preambles

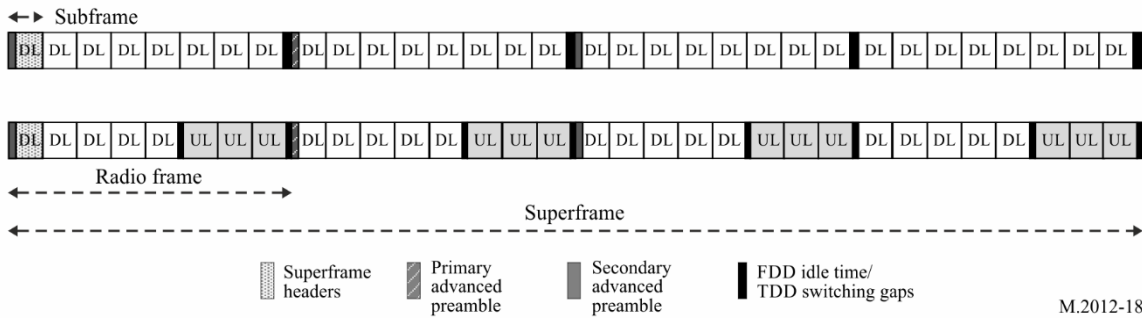

M.2012-18

### 1.1.10 Multi-antenna techniques

#### 1.1.10.1 MIMO structure

*WirelessMAN-Advanced* supports several advanced multi-antenna techniques including single and multi-user MIMO (spatial multiplexing and beamforming) as well as a number of transmit diversity schemes. In single-user MIMO (SU-MIMO) scheme only one user can be scheduled over one (time, frequency, space) resource unit. In multi-user MIMO (MU-MIMO), on the other hand, multiple users can be scheduled in one resource unit. Vertical encoding utilizes one encoder block (or layer), whereas multi-layer encoding uses multiple encoders (or multiple layers). A layer is defined as a coding and modulation input path to the MIMO encoder. A stream is defined as the output of the MIMO encoder that is further processed through the beamforming or the precoder block. For spatial multiplexing, the rank is defined as the number of streams to be used for the user.

FIGURE 19  
MIMO structure

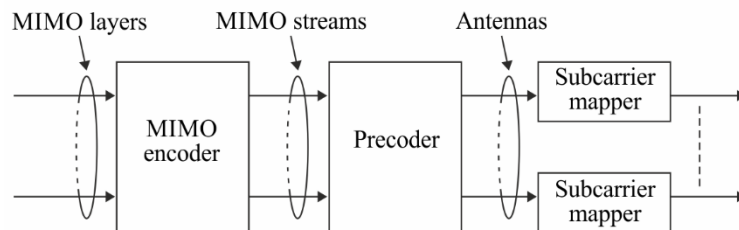

M.2012-19

The MIMO transmitter structure is shown in Fig. 19. The encoder block contains the channel encoder, interleaving, rate-matching, and modulating blocks per layer. The resource mapping block maps the complex-valued modulation symbols to the corresponding time-frequency resources. The MIMO encoder block maps the layers onto the streams, which are further processed through the precoder block.

The precoder block maps the streams to antennas by generating the antenna-specific data symbols according to the selected MIMO mode. The OFDM symbol construction block maps antenna-specific data to the OFDM symbols. Table 3 contains information on various MIMO modes supported by *WirelessMAN-Advanced*.

TABLE 3  
DL MIMO modes

Mode index	Description	MIMO encoding format	MIMO precoding
Mode 0	Open-Loop SU-MIMO (TX Diversity)	Space-Frequency Block Coding (SFBC)	Non-Adaptive
Mode 1	Open-Loop SU-MIMO (Spatial Multiplexing)	Vertical Encoding	Non-Adaptive
Mode 2	Closed-Loop SU-MIMO (Spatial Multiplexing)	Vertical Encoding	Adaptive
Mode 3	Open-Loop MU-MIMO (Spatial Multiplexing)	Multi-layer Encoding	Non-Adaptive
Mode 4	Closed-Loop MU-MIMO (Spatial Multiplexing)	Multi-layer Encoding	Adaptive
Mode 5	Open-Loop SU-MIMO (TX Diversity)	Conjugate Data Repetition (CDR)	Non-Adaptive

The minimum antenna configuration in the DL and UL is  $2 \times 2$  and  $1 \times 2$ , respectively. For open-loop spatial multiplexing and closed-loop SU-MIMO, the number of streams is constrained to the minimum of number of transmit or receive antennas. The MU-MIMO can support up to two streams with two transmit antennas and up to four streams for four transmit antennas and up to eight streams for eight transmit antennas. Table 4 summarized the DL MIMO parameters for various MIMO modes.

TABLE 4  
DL MIMO parameters

	Number of transmit antennas	STC rate per layer	Number of streams	Number of subcarriers	Number of layers
MIMO Mode 0	2	1	2	2	1
	4	1	2	2	1
	8	1	2	2	1
MIMO Mode 1 and MIMO Mode 2	2	1	1	1	1
	2	2	2	1	1
	4	1	1	1	1
	4	2	2	1	1
	4	3	3	1	1
	4	4	4	1	1
	8	1	1	1	1
	8	2	2	1	1
	8	3	3	1	1
	8	4	4	1	1
8	5	5	1	1	



TABLE 4 (end)

	Number of transmit antennas	STC rate per layer	Number of streams	Number of subcarriers	Number of layers
	8	6	6	1	1
	8	7	7	1	1
	8	8	8	1	1
MIMO Mode 3 and MIMO Mode 4	2	1	2	1	2
	4	1	2	1	2
	4	1	3	1	3
	4	1	4	1	4
	8	1	2	1	2
	8	1	3	1	3
	8	1	4	1	4
MIMO Mode 4	4	2 and 1 <sup>a</sup>	3	1	2
	4	2 and 1 <sup>b</sup>	4	1	3
	4	2	4	1	2
	8	2 and 1 <sup>a</sup>	3	1	2
	8	2 and 1 <sup>b</sup>	4	1	3
	8	2	4	1	2
	8	1	8	1	8
	8	2 and 1 <sup>c</sup>	8	1	7
	8	2 and 1 <sup>d</sup>	8	1	6
	8	2 and 1 <sup>e</sup>	8	1	5
	8	2	8	1	4
MIMO Mode 5	2	1/2	1	2	1
	4	1/2	1	2	1
	7	1/2	1	2	1

<sup>a</sup> 2 streams to one MS and 1 stream to another MS, with 1 layer each.

<sup>b</sup> 2 streams to one MS and 1 stream each to the other two MSs, with 1 layer each.

<sup>c</sup> 2 streams to one MS and 1 stream each to the other six MSs, with 1 layer each.

<sup>d</sup> 2 streams each to two MS and 1 stream each to the other four MSs, with 1 layer each.

<sup>e</sup> 2 streams each to three MS and 1 stream each to the other two MSs, with 1 layer each.

The stream to antenna mapping depends on the MIMO scheme. In DL, the CQI and rank feedback are transmitted to assist the BS in rank adaptation, mode switching, and rate adaptation. For spatial multiplexing, the rank is defined as the number of streams to be used for each user. In FDD and TDD systems, unitary codebook based precoding is used for closed-loop SU-MIMO. In DL, an MS may feedback some information to the BS in closed-loop SU-MIMO such as rank, sub-band selection, CQI, precoding matrix index, and long-term channel state information.

In DL, the MU-MIMO transmission with up to two streams per user is supported. Beamforming is enabled with this precoding mechanism. *WirelessMAN-Advanced* has the capability to adapt between SU-MIMO and MU-MIMO in a predefined and flexible manner. Multi-BS MIMO techniques are

also supported for improving sector and cell-edge throughput using multi-BS collaborative precoding, network coordinated beamforming, or inter-cell interference cancellation.

For UL MIMO, the BS will schedule users to resource blocks and determines the modulation and coding scheme (MCS) level and MIMO parameters (mode, rank, etc.). The supported antenna configurations include one, two or four transmit antennas and more than two receive antennas. The UL MIMO modes and parameters are shown in Table 5 and Table 6, respectively.

TABLE 5  
UL MIMO modes

Mode Index	Description	MIMO Encoding Format	MIMO Precoding
Mode 0	Open-Loop SU-MIMO (TX Diversity)	SFBC	Non-Adaptive
Mode 1	Open-Loop SU-MIMO (Spatial Multiplexing)	Vertical Encoding	Non-Adaptive
Mode 2	Closed-Loop SU-MIMO (Spatial Multiplexing)	Vertical Encoding	Adaptive
Mode 3	Open-Loop Collaborative Spatial Multiplexing (MU-MIMO)	Vertical Encoding	Non-Adaptive
Mode 4	Closed-Loop Collaborative Spatial Multiplexing (MU-MIMO)	Vertical Encoding	Adaptive

TABLE 6  
UL MIMO parameters

	Number of transmit antennas	STC rate per layer	Number of streams	Number of subcarriers	Number of layers
MIMO Mode 0	2	1	2	2	1
	4	1	2	2	1
MIMO Mode 1	1	1	1	1	1
MIMO Mode 1 and MIMO Mode 2	2	1	1	1	1
	2	2	2	1	1
	4	1	1	1	1
	4	2	2	1	1
	4	3	3	1	1
	4	4	4	1	1
MIMO Mode 3 and MIMO Mode 4	1	1	1	1	1
	2	1	1	1	1
	2	2	2	1	1
	4	1	1	1	1
	4	2	2	1	1
	4	3	3	1	1
	4	4	4	1	1

The supported UL transmit diversity modes include two and four transmit antenna schemes with rate 1 such as space frequency block coding (SFBC) and two stream precoder. In FDD and TDD systems, unitary codebook-based precoding is supported. In this mode, the MS transmits a sounding reference signal in the UL to assist the UL scheduling and precoder selection in the BS. The BS signals the resource allocation, MCS, rank, preferred precoder index, and packet size to the MS. UL MU-MIMO enables multiple MSs to be spatially multiplexed on the same radio resources. Both open-loop and closed-loop MU-MIMO are supported. The MSs with single transmit antenna can operate in open-loop SU- or MU-MIMO mode.

## 1.2 Overview of MAC layer

The following sections describe selected MAC features.

### 1.2.1 MAC addressing

*WirelessMAN-Advanced* defines global and logical addresses for an MS that identify the user and its connections during a session. The MS is identified by the globally unique 48-bit IEEE extended unique identifier assigned by the IEEE Registration Authority. The MS is further assigned the following logical identifiers: 1) A station identifier during network entry (or network re-entry), that uniquely identifies the MS within the cell, and 2) a flow identifier (FID) that uniquely identifies the control connections and transport connections with the MS. A temporary station identifier is used to protect the mapping between the actual station identifier during network entry. A deregistration identifier is defined to uniquely identify the MS within the set of paging group identifiers, paging cycle, and paging offset.

### 1.2.2 Network entry

Network entry is the procedure through which an MS detects a cellular network and establishes a connection with that network. The network entry has the following steps (see Fig. 20):

- synchronization with the BS by acquiring the preambles;
- acquiring necessary system information such as BS and network service provider identifiers for initial network entry and cell selection;
- initial ranging;
- basic capability negotiation;
- authentication/authorization and key exchange;
- registration and service flow setup.

FIGURE 20  
Network entry procedures

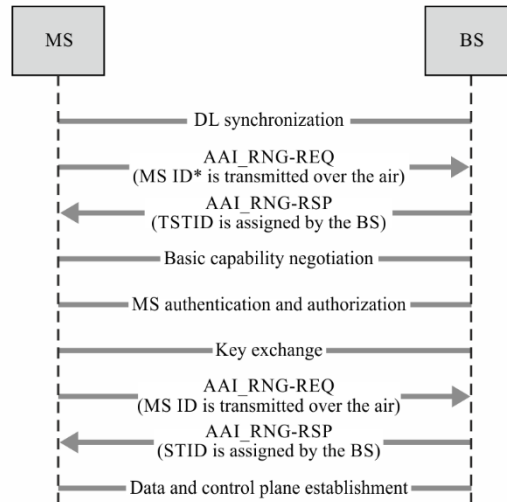

M.2012-20

### 1.2.3 Connection management and quality of service

A connection is defined as a mapping between the MAC layers of a BS and one (or several) MS. If there is a one-to-one mapping between one BS and one MS, the connection is called a unicast connection; otherwise, it is called a multicast or broadcast connection. Two types of connections are specified: control connections and transport connections. Control connections are used to carry MAC control messages. Transport connections are used to carry user data including upper layer signalling messages. A MAC control message is never transferred over transport connection, and user data is never transferred over the control connections. One pair of bi-directional (DL/UL) unicast control connections are automatically established when an MS performs initial network entry.

All the user data communications are in the context of transport connections. A transport connection is unidirectional and established with a unique FID. Each transport connection is associated with an active service flow to provide various levels of QoS required by the service flow. An MS may have multiple transport connections which have different set of QoS parameters, and each transport connection may have one or more sets of QoS parameters.

The transport connection is established when the associated active service flow is admitted or activated, and released when the associated service flow becomes inactive. Transport connections can be preprovisioned or dynamically created. Pre-provisioned connections are those established by system for an MS during the MS network entry. On the other hand, the BS or the MS can create new connections dynamically if required.

### 1.2.4 MAC header

WirelessMAN-Advanced specifies a number of efficient MAC headers for various applications comprising of fewer fields with shorter size compared to the generic MAC header of OFDMA TDD WMAN. The advanced generic MAC header in Fig. 21 consists of Extended Header Indicator, FID, and Payload Length fields. Other MAC header types include two-byte short-packet MAC header, which is defined to support small-payload applications such as VoIP and is characterized by small data packets and non-ARQ connection, Fragmentation extended header, Packing extended header for transport connections, MAC Control extended header for control connections, and Multiplexing extended header that is used when data from multiple connections associated with the same security association is present in the payload of the MAC protocol data unit (PDU).

FIGURE 21  
Advanced generic MAC headers

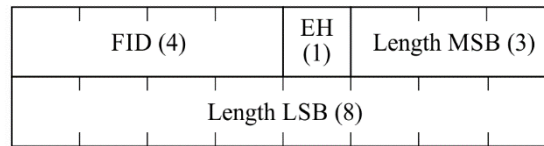

M.2012-21

**1.2.5 ARQ and HARQ functions**

An ARQ block is generated from one or multiple MAC service data units (SDUs) or MAC SDU fragment(s). ARQ blocks can be variable in size and are sequentially numbered.

WirelessMAN-Advanced uses adaptive asynchronous and non-adaptive synchronous HARQ schemes in the DL and UL, respectively. The HARQ operation is relying on an N-process (multi-channel) stop-and-wait protocol. In adaptive asynchronous HARQ, the resource allocation and transmission format for the HARQ retransmissions may be different from the initial transmission. In case of retransmission, control signalling is required to indicate the resource allocation and transmission format along with other HARQ necessary parameters. A non-adaptive synchronous HARQ scheme is used in the UL where the parameters and the resource allocation for the retransmission are known a priori.

**1.2.6 Mobility management and handover**

WirelessMAN-Advanced supports both network-controlled and MS-assisted handover (HO). As illustrated in Fig. 22, the handover procedures may be initiated by either MS or BS; the final handover decision and target BS selection may be made either by the serving BS or the MS. The MS executes the handover or cancels the procedure through HO cancellation message. The network re-entry procedures with the target BS, as shown in Fig. 22, may be optimized by target BS possession of MS information obtained from serving BS via core network. The MS may also maintain communication with serving BS while performing network re-entry at target BS as directed by serving BS.

FIGURE 22  
Handover procedures

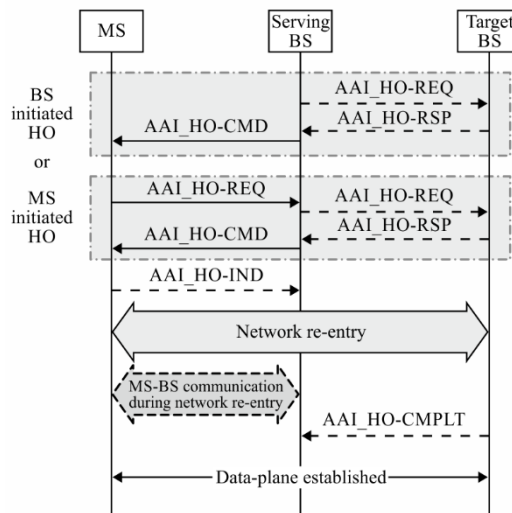

M.2012-22

### 1.2.7 Power management

WirelessMAN-Advanced provides power management functions including sleep mode and idle mode to mitigate power consumption of the MS. Sleep mode is a state in which an MS performs prenegotiated periods of absence from the serving BS. The sleep mode may be enacted when an MS is in the connected state. Using the sleep mode, the MS is provided with a series of alternative listening and sleep windows. The listening window is the time interval in which MS is available for transmit/receive of control signalling and data. The WirelessMAN-Advanced has the capability of dynamically adjusting the duration of sleep and listening windows within a sleep cycle based on changing traffic patterns and HARQ operations. When MS is in active mode, sleep parameters are negotiated between MS and BS. The base station instructs the MS to enter sleep mode. MAC management messages can be used for sleep mode request/response. The period of the sleep cycle is measured in units of frames or superframes and is the sum of a sleep and listening windows. During the MS listening window, BS may transmit the traffic indication message intended for one or multiple MSs. The listening window can be extended through explicit or implicit signalling. The maximum length of the extension is to the end of the current sleep cycle.

Idle mode allows the MS to become periodically available for DL broadcast traffic messaging such as paging message without registration with the network. The network assigns MSs in the idle mode to a paging group during idle mode entry or location update. If an MS is assigned to multiple paging groups, it may also be assigned multiple paging offsets within a paging cycle where each paging offset corresponds to a separate paging group. The assignment of multiple paging offsets to an MS allows monitoring of the paging messages at different paging offset when the MS is located in one of its paging groups. The distance between two adjacent paging offsets should be long enough so that the MS paged in the first paging offset can inform the network before the next paging offset in the same paging cycle occurs, thereby avoiding unnecessary paging in the next paging offset. The MS monitors the paging message during listening interval. The paging message contains identification of the MSs to be notified of pending traffic or location update. The start of the paging listening interval is calculated based on paging cycle and paging offset are defined in terms of number of superframes.

The serving BS transmits the list of paging group identifiers (PGID) at the predetermined location at the beginning of the paging available interval. During paging available interval, the MS monitors the SFH and if there is an indication of any change in system configuration information, the MS will acquire the latest system information at the next instance of SFH transmission (i.e. next SFH). To provide location privacy, the paging controller assigns Deregistration identifiers to uniquely identify the MSs in the idle mode in a particular paging group.

An MS in idle mode performs location update, if either of these conditions are met, paging group location update, timer based location update, or power down location update. The MS performs the location update when the MS detects a change in paging group by monitoring the PGIDs, which are transmitted by the BS. The MS periodically performs location update procedure prior to the expiration of idle mode timer. At every location update including paging group update, the idle mode timer is reset.

### 1.2.8 Security

Security functions provide subscribers with privacy, authentication, and confidentiality across WirelessMAN-Advanced network. The PKM protocol provides mutual and unilateral authentication and establishes confidentiality between the MS and the BS by supporting transparent exchange of authentication and authorization (EAP) messages.

The MS and the BS may support encryption methods and algorithms for secure transmission of MAC PDUs. WirelessMAN-Advanced supports selectively confidentiality or integrity protection over MAC control messages. Figure 23 shows the functional blocks of security architecture.

FIGURE 23  
Functional blocks of security architecture

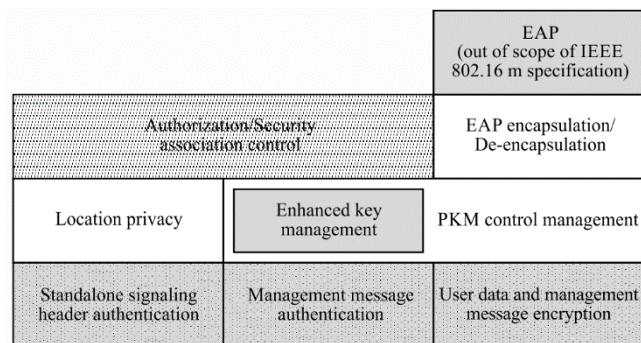

M.2012-23

The security architecture is divided into security management and encryption and integrity logical entities. The security management functions include overall security management and control, EAP encapsulation/de-encapsulation, privacy key management (PKM) control, security association management, and identity/location privacy. To accomplish identity/location privacy, the MSID (i.e. MS MAC address) is not disclosed over the air even during network entry. The BS assigns a station identifier (STID) to the MS which is securely transmitted to the MS so that the MS's identity and location can be hidden. The encryption and integrity protection entity functions include encryption of user data and authentication, control message authentication, message confidentiality protection.

## 2 Detailed specification of the radio interface technology<sup>13</sup>

The material in § 2 reflects the structure of the IEEE specifications from the first release of Recommendation ITU-R M.2012 (01-2012) prior to the IEEE revising the structure of the specifications related to WirelessMAN-Advanced on 8 June 2013.

Detailed specifications described in this Annex are developed around a "Global Core Specification" (GCS)<sup>14</sup>, which is related to externally developed materials incorporated by specific references for a specific technology. The process and use of the GCS, references, and related notifications and certifications are found as Document IMT-ADV/24(Rev.3).

The IMT-Advanced standards contained in this section are derived from the global core specification for WirelessMAN-Advanced contained at <http://ties.itu.int/u/itu-r/ede/rsg5/IMT-Advanced/GCS/M.2012-0/WirelessMAN-Advanced/here> (ITU-Extranet). The following notes apply to the sections below:

<sup>13</sup> On 8 June 2012, the IEEE-SA Standards Board approved IEEE Std 802.16.1 (*WirelessMAN-Advanced Air Interface for Broadband Wireless Access Systems*) as a new IEEE standard. IEEE Std 802.16.1 encompasses the WirelessMAN-Advanced air interface, with some minor improvements. On the same date, the Standards Board approved IEEE Std 802.16-2012 as a new revision of IEEE Std 802.16, which now excludes the WirelessMAN-Advanced air interface.

Accordingly, the material in § 2.2 reflects IEEE's structure of the WirelessMAN-Advanced air interface specification IEEE Std 802.16 which is composed of IEEE Std 802.16-2009, as amended, consecutively, by IEEE Std 802.16j-2009, IEEE Std 802.16h-2010, and IEEE Std 802.16m-2011.

<sup>14</sup> A "GCS" (Global Core Specification) is the set of specifications that defines a single RIT, an SRIT, or a RIT within an SRIT.

- 1) The identified relevant *Transposing Organizations* should make their reference material available from their website.
- 2) This information was supplied by the *Transposing Organizations* and relates to their own deliverables of the transposed global core specification.

## 2.1 Description of the global core specification and the transposed standards

IEEE Std 802.16 is composed of IEEE Std 802.16-2009, as amended, consecutively, by IEEE Std 802.16j-2009, IEEE Std 802.16h-2010, and IEEE Std 802.16m-2011. IEEE Std 802.16 is described in § 2.2.1.1.

In accordance with clause 16.1.1 of IEEE Std 802.16, the *WirelessMAN-Advanced* GCS is specified in the clauses of IEEE Std 802.16 as indicated in Table 7. Anything in IEEE Std 802.16 that is not included in Table 7 is excluded from the *WirelessMAN-Advanced* GCS.

TABLE 7

Description of the *WirelessMAN-Advanced* GCS

IEEE Std 802.16 Clause and Subject	IEEE Std 802.16-2009	IEEE Std 802.16j-2009	IEEE Std 802.16h- 2010	IEEE Std 802.16m-2011
Clause 1.4: Reference models	Base specification		Amended	Amended
Clause 2: Normative references	Base specification		Amended	Amended
Clause 3: Definitions	Base specification	Amended	Amended	Amended
Clause 4: Abbreviations and acronyms	Base specification	Amended	Amended	Amended
Clause 5.2: Packet convergence sublayer	Base specification			Amended
Clause 16: <i>WirelessMAN-Advanced</i> air interface				Base specification
Annex R: MAC control messages				Base specification
Annex S: Test vectors				Base specification
Annex T: Supported frequency bands				Base specification
Annex U: Radio specifications				Base specification
Annex V: Default capability class and parameters				Base specification



### 2.1.1 IEEE Std 802.16

#### **IEEE Std 802.16: Standard for local and metropolitan area networks – Air interface for broadband wireless access systems**

This standard specifies the air interface, including the medium access control layer (MAC) and physical layer (PHY), of combined fixed and mobile point-to-multipoint broadband wireless access (BWA) systems providing multiple services. The MAC is structured to support multiple PHY specifications, each suited to a particular operational environment.

IEEE Std 802.16 is composed of IEEE Std 802.16-2009, as amended, consecutively, by IEEE Std 802.16j-2009, IEEE Std 802.16h-2010, and IEEE Std 802.16m-2011.

#### 2.1.1.1 IEEE Std 802.16-2009

##### **Standard for local and metropolitan area networks – Part 16: Air interface for broadband wireless access systems**

This standard specifies the air interface, including the medium access control layer (MAC) and physical layer (PHY), of combined fixed and mobile point-to-multipoint broadband wireless access (BWA) systems providing multiple services. The MAC is structured to support multiple PHY specifications, each suited to a particular operational environment.

#### 2.1.1.2 IEEE Std 802.16j-2009

##### **Standard for local and metropolitan area networks – Part 16: Air interface for broadband wireless access systems – Amendment 1: Multiple relay specification**

This amendment updates and expands IEEE Std 802.16-2009, specifying physical layer and medium access control layer enhancements to IEEE Std 802.16 for licensed bands to enable the operation of relay stations. Subscriber station specifications are not changed.

#### 2.1.1.3 IEEE Std 802.16h-2010

##### **Standard for local and metropolitan area networks – Part 16: Air interface for broadband wireless access systems – Amendment 2: Improved coexistence mechanisms for license-exempt operation**

This amendment updates and expands IEEE Std 802.16, specifying improved mechanisms, as policies and medium access control enhancements, to enable coexistence among license-exempt systems and to facilitate the coexistence of such systems with primary users.

#### 2.1.1.4 IEEE Std 802.16m-2011

##### **Standard for local and metropolitan area networks – Part 16: Air interface for broadband wireless access systems – Amendment 3: Advanced air interface**

This amendment specifies the *WirelessMAN-Advanced* air interface, an enhanced air interface designed to meet the requirements of the IMT-Advanced standardization activity conducted by the ITU-R. The amendment is based on the *WirelessMAN-OFDMA* specification of IEEE Std 802.16 and provides continuing support for *WirelessMAN-OFDMA* subscriber stations.

### 2.1.2 Transposed standards

#### 2.1.2.1 Transpositions: IEEE

Reserved.

## 2.1.2.2 Transpositions: ARIB

	Base specification per IEEE Std 802.16-2009	Amendment per IEEE Std 802.16j-2009	Amendment per IEEE Std 802.16h-2010	Amendment per IEEE Std 802.16m-2011
Transposing Organization	ARIB	ARIB	ARIB	ARIB
Document number	ARIB STD-T105 Annex 1	ARIB STD-T105 Annex 2	ARIB STD-T105 Annex 3	ARIB STD-T105 Annex 4
Version	1.30	1.30	1.30	1.30
Date	18 December 2012	18 December 2012	18 December 2012	18 December 2012
Clause 1.4: Reference models	<a href="http://www.arib.or.jp/IMT-Advanced/WirelessMAN-Advanced.1.30/ARIB%20STD-T105%20Annex%201_IEEE%20Std%20802%2016-2009.pdf">http://www.arib.or.jp/IMT-Advanced/WirelessMAN-Advanced.1.30/ARIB%20STD-T105%20Annex%201_IEEE%20Std%20802%2016-2009.pdf</a> (Clause 1.4, ARIB transposition of IEEE Std 802.16-2009)	Not applicable	<a href="http://www.arib.or.jp/IMT-Advanced/WirelessMAN-Advanced.1.30/ARIB%20STD-T105%20Annex%203_IEEE%20Std%20802%2016h-2010.pdf">http://www.arib.or.jp/IMT-Advanced/WirelessMAN-Advanced.1.30/ARIB%20STD-T105%20Annex%203_IEEE%20Std%20802%2016h-2010.pdf</a> (Clause 1.4, ARIB transposition of IEEE Std 802.16h)	<a href="http://www.arib.or.jp/IMT-Advanced/WirelessMAN-Advanced.1.30/ARIB%20STD-T105%20Annex%204_IEEE%20Std%20802%2016m-2011.pdf">http://www.arib.or.jp/IMT-Advanced/WirelessMAN-Advanced.1.30/ARIB%20STD-T105%20Annex%204_IEEE%20Std%20802%2016m-2011.pdf</a> (Clause 1.4, ARIB transposition of IEEE Std 802.16m)
Clause 2: Normative references	<a href="http://www.arib.or.jp/IMT-Advanced/WirelessMAN-Advanced.1.30/ARIB%20STD-T105%20Annex%201_IEEE%20Std%20802%2016-2009.pdf">http://www.arib.or.jp/IMT-Advanced/WirelessMAN-Advanced.1.30/ARIB%20STD-T105%20Annex%201_IEEE%20Std%20802%2016-2009.pdf</a> (Clause 2, ARIB transposition of IEEE Std 802.16-2009)	Not applicable	<a href="http://www.arib.or.jp/IMT-Advanced/WirelessMAN-Advanced.1.30/ARIB%20STD-T105%20Annex%203_IEEE%20Std%20802%2016h-2010.pdf">http://www.arib.or.jp/IMT-Advanced/WirelessMAN-Advanced.1.30/ARIB%20STD-T105%20Annex%203_IEEE%20Std%20802%2016h-2010.pdf</a> (Clause 2, ARIB transposition of IEEE Std 802.16h)	<a href="http://www.arib.or.jp/IMT-Advanced/WirelessMAN-Advanced.1.30/ARIB%20STD-T105%20Annex%204_IEEE%20Std%20802%2016m-2011.pdf">http://www.arib.or.jp/IMT-Advanced/WirelessMAN-Advanced.1.30/ARIB%20STD-T105%20Annex%204_IEEE%20Std%20802%2016m-2011.pdf</a> (Clause 2, ARIB transposition of IEEE Std 802.16m)
Clause 3: Definitions	<a href="http://www.arib.or.jp/IMT-Advanced/WirelessMAN-Advanced.1.30/ARIB%20STD-T105%20Annex%201_IEEE%20Std%20802%2016-2009.pdf">http://www.arib.or.jp/IMT-Advanced/WirelessMAN-Advanced.1.30/ARIB%20STD-T105%20Annex%201_IEEE%20Std%20802%2016-2009.pdf</a> (Clause 3, ARIB transposition of IEEE Std 802.16-2009)	<a href="http://www.arib.or.jp/IMT-Advanced/WirelessMAN-Advanced.1.30/ARIB%20STD-T105%20Annex%202_IEEE%20Std%20802%2016j-2009.pdf">http://www.arib.or.jp/IMT-Advanced/WirelessMAN-Advanced.1.30/ARIB%20STD-T105%20Annex%202_IEEE%20Std%20802%2016j-2009.pdf</a> (Clause 3, ARIB transposition of IEEE Std 802.16j)	<a href="http://www.arib.or.jp/IMT-Advanced/WirelessMAN-Advanced.1.30/ARIB%20STD-T105%20Annex%203_IEEE%20Std%20802%2016h-2010.pdf">http://www.arib.or.jp/IMT-Advanced/WirelessMAN-Advanced.1.30/ARIB%20STD-T105%20Annex%203_IEEE%20Std%20802%2016h-2010.pdf</a> (Clause 3, ARIB transposition of IEEE Std 802.16h)	<a href="http://www.arib.or.jp/IMT-Advanced/WirelessMAN-Advanced.1.30/ARIB%20STD-T105%20Annex%204_IEEE%20Std%20802%2016m-2011.pdf">http://www.arib.or.jp/IMT-Advanced/WirelessMAN-Advanced.1.30/ARIB%20STD-T105%20Annex%204_IEEE%20Std%20802%2016m-2011.pdf</a> (Clause 3, ARIB transposition of IEEE Std 802.16m)
Clause 4: Abbreviations and acronyms	<a href="http://www.arib.or.jp/IMT-Advanced/WirelessMAN-Advanced.1.30/ARIB%20STD-T105%20Annex%201_IEEE%20Std%20802%2016-2009.pdf">http://www.arib.or.jp/IMT-Advanced/WirelessMAN-Advanced.1.30/ARIB%20STD-T105%20Annex%201_IEEE%20Std%20802%2016-2009.pdf</a> (Clause 4, ARIB transposition of IEEE Std 802.16-2009)	<a href="http://www.arib.or.jp/IMT-Advanced/WirelessMAN-Advanced.1.30/ARIB%20STD-T105%20Annex%202_IEEE%20Std%20802%2016j-2009.pdf">http://www.arib.or.jp/IMT-Advanced/WirelessMAN-Advanced.1.30/ARIB%20STD-T105%20Annex%202_IEEE%20Std%20802%2016j-2009.pdf</a> (Clause 4, ARIB transposition of IEEE Std 802.16j)	<a href="http://www.arib.or.jp/IMT-Advanced/WirelessMAN-Advanced.1.30/ARIB%20STD-T105%20Annex%203_IEEE%20Std%20802%2016h-2010.pdf">http://www.arib.or.jp/IMT-Advanced/WirelessMAN-Advanced.1.30/ARIB%20STD-T105%20Annex%203_IEEE%20Std%20802%2016h-2010.pdf</a> (Clause 4, ARIB transposition of IEEE Std 802.16h)	<a href="http://www.arib.or.jp/IMT-Advanced/WirelessMAN-Advanced.1.30/ARIB%20STD-T105%20Annex%204_IEEE%20Std%20802%2016m-2011.pdf">http://www.arib.or.jp/IMT-Advanced/WirelessMAN-Advanced.1.30/ARIB%20STD-T105%20Annex%204_IEEE%20Std%20802%2016m-2011.pdf</a> (Clause 4, ARIB transposition of IEEE Std 802.16m)
Clause 5.2: Packet convergence sublayer	<a href="http://www.arib.or.jp/IMT-Advanced/WirelessMAN-Advanced.1.30/ARIB%20STD-T105%20Annex%201_IEEE%20Std%20802%2016-2009.pdf">http://www.arib.or.jp/IMT-Advanced/WirelessMAN-Advanced.1.30/ARIB%20STD-T105%20Annex%201_IEEE%20Std%20802%2016-2009.pdf</a> (Clause 5.2, ARIB transposition of IEEE Std 802.16-2009)	Not applicable	Not applicable	<a href="http://www.arib.or.jp/IMT-Advanced/WirelessMAN-Advanced.1.30/ARIB%20STD-T105%20Annex%204_IEEE%20Std%20802%2016m-2011.pdf">http://www.arib.or.jp/IMT-Advanced/WirelessMAN-Advanced.1.30/ARIB%20STD-T105%20Annex%204_IEEE%20Std%20802%2016m-2011.pdf</a> (Clause 5.2, ARIB transposition of IEEE Std 802.16m)

	Base specification per IEEE Std 802.16-2009	Amendment per IEEE Std 802.16j-2009	Amendment per IEEE Std 802.16h-2010	Amendment per IEEE Std 802.16m-2011
Clause 16: WirelessMAN- Advanced air interface	Not applicable	Not applicable	Not applicable	<a href="http://www.arib.or.jp/IMT-Advanced/WirelessMAN-Advanced.1.30/ARIB%20STD-T105%20Annex%204-IEEE%20Std%20802%2016m-2011.pdf">http://www.arib.or.jp/IMT-Advanced/WirelessMAN-Advanced.1.30/ARIB%20STD-T105%20Annex%204-IEEE%20Std%20802%2016m-2011.pdf</a> (Clause 16, ARIB transposition of IEEE Std 802.16m)
Annex R: MAC control messages	Not applicable	Not applicable	Not applicable	<a href="http://www.arib.or.jp/IMT-Advanced/WirelessMAN-Advanced.1.30/ARIB%20STD-T105%20Annex%204-IEEE%20Std%20802%2016m-2011.pdf">http://www.arib.or.jp/IMT-Advanced/WirelessMAN-Advanced.1.30/ARIB%20STD-T105%20Annex%204-IEEE%20Std%20802%2016m-2011.pdf</a> (Annex R, ARIB transposition of IEEE Std 802.16m)
Annex S: Test vectors	Not applicable	Not applicable	Not applicable	<a href="http://www.arib.or.jp/IMT-Advanced/WirelessMAN-Advanced.1.30/ARIB%20STD-T105%20Annex%204-IEEE%20Std%20802%2016m-2011.pdf">http://www.arib.or.jp/IMT-Advanced/WirelessMAN-Advanced.1.30/ARIB%20STD-T105%20Annex%204-IEEE%20Std%20802%2016m-2011.pdf</a> (Annex S, ARIB transposition of IEEE Std 802.16m)
Annex T: Supported frequency bands	Not applicable	Not applicable	Not applicable	<a href="http://www.arib.or.jp/IMT-Advanced/WirelessMAN-Advanced.1.30/ARIB%20STD-T105%20Annex%204-IEEE%20Std%20802%2016m-2011.pdf">http://www.arib.or.jp/IMT-Advanced/WirelessMAN-Advanced.1.30/ARIB%20STD-T105%20Annex%204-IEEE%20Std%20802%2016m-2011.pdf</a> (Annex T, ARIB transposition of IEEE Std 802.16m)
Annex U: Radio specifications	Not applicable	Not applicable	Not applicable	<a href="http://www.arib.or.jp/IMT-Advanced/WirelessMAN-Advanced.1.30/ARIB%20STD-T105%20Annex%204-IEEE%20Std%20802%2016m-2011.pdf">http://www.arib.or.jp/IMT-Advanced/WirelessMAN-Advanced.1.30/ARIB%20STD-T105%20Annex%204-IEEE%20Std%20802%2016m-2011.pdf</a> (Annex U, ARIB transposition of IEEE Std 802.16m)
Annex V: Default capability class and parameters	Not applicable	Not applicable	Not applicable	<a href="http://www.arib.or.jp/IMT-Advanced/WirelessMAN-Advanced.1.30/ARIB%20STD-T105%20Annex%204-IEEE%20Std%20802%2016m-2011.pdf">http://www.arib.or.jp/IMT-Advanced/WirelessMAN-Advanced.1.30/ARIB%20STD-T105%20Annex%204-IEEE%20Std%20802%2016m-2011.pdf</a> (Annex V, ARIB transposition of IEEE Std 802.16m)

## 2.1.2.3 Transpositions: TTA

	Base specification per IEEE Std 802.16-2009	Amendment per IEEE Std 802.16j-2009	Amendment per IEEE Std 802.16h-2010	Amendment per IEEE Std 802.16m-2011
Transposing Organization	TTA	TTA	TTA	TTA
Document number	TTAE.IE-802.16-2009	TTAE.IE-802.16j	TTAE.IE-802.16h	TTAE.IE-802.16m
Version	1.0	1.0	1.0	1.0
Date	29 June 2011	29 June 2011	29 June 2011	29 June 2011
Clause 1.4: Reference models	<a href="http://www.tta.or.kr/data/tt&lt;br/&gt;asDown.jsp?where=14688&lt;br/&gt;&amp;pk_num=TTAE.IE-&lt;br/&gt;802.16-2009">http://www.tta.or.kr/data/tt asDown.jsp?where=14688 &amp;pk_num=TTAE.IE- 802.16-2009</a> (Clause 1.4, TTA transposition of IEEE Std 802.16-2009)	Not applicable	<a href="http://www.tta.or.kr/data/tt&lt;br/&gt;asDown.jsp?where=14688&lt;br/&gt;&amp;pk_num=TTAE.IE-&lt;br/&gt;802.16h">http://www.tta.or.kr/data/tt asDown.jsp?where=14688 &amp;pk_num=TTAE.IE- 802.16h</a> (Clause 1.4, TTA transposition of IEEE Std 802.16h)	<a href="http://www.tta.or.kr/data/tt&lt;br/&gt;asDown.jsp?where=14688&lt;br/&gt;&amp;pk_num=TTAE.IE-&lt;br/&gt;802.16m">http://www.tta.or.kr/data/tt asDown.jsp?where=14688 &amp;pk_num=TTAE.IE- 802.16m</a> (Clause 1.4, TTA transposition of IEEE Std 802.16m)
Clause 2: Normative references	<a href="http://www.tta.or.kr/data/tt&lt;br/&gt;asDown.jsp?where=14688&lt;br/&gt;&amp;pk_num=TTAE.IE-&lt;br/&gt;802.16-2009">http://www.tta.or.kr/data/tt asDown.jsp?where=14688 &amp;pk_num=TTAE.IE- 802.16-2009</a> (Clause 2, TTA transposition of IEEE Std 802.16-2009)	Not applicable	<a href="http://www.tta.or.kr/data/tt&lt;br/&gt;asDown.jsp?where=14688&lt;br/&gt;&amp;pk_num=TTAE.IE-&lt;br/&gt;802.16h">http://www.tta.or.kr/data/tt asDown.jsp?where=14688 &amp;pk_num=TTAE.IE- 802.16h</a> (Clause 2, TTA transposition of IEEE Std 802.16h)	<a href="http://www.tta.or.kr/data/tt&lt;br/&gt;asDown.jsp?where=14688&lt;br/&gt;&amp;pk_num=TTAE.IE-&lt;br/&gt;802.16m">http://www.tta.or.kr/data/tt asDown.jsp?where=14688 &amp;pk_num=TTAE.IE- 802.16m</a> (Clause 2, TTA transposition of IEEE Std 802.16m)
Clause 3: Definitions	<a href="http://www.tta.or.kr/data/tt&lt;br/&gt;asDown.jsp?where=14688&lt;br/&gt;&amp;pk_num=TTAE.IE-&lt;br/&gt;802.16-2009">http://www.tta.or.kr/data/tt asDown.jsp?where=14688 &amp;pk_num=TTAE.IE- 802.16-2009</a> (Clause 3, TTA transposition of IEEE Std 802.16-2009)	<a href="http://www.tta.or.kr/data/tt&lt;br/&gt;asDown.jsp?where=14688&lt;br/&gt;&amp;pk_num=TTAE.IE-&lt;br/&gt;802.16j">http://www.tta.or.kr/data/tt asDown.jsp?where=14688 &amp;pk_num=TTAE.IE- 802.16j</a> (Clause 3, TTA transposition of IEEE Std 802.16j)	<a href="http://www.tta.or.kr/data/tt&lt;br/&gt;asDown.jsp?where=14688&lt;br/&gt;&amp;pk_num=TTAE.IE-&lt;br/&gt;802.16h">http://www.tta.or.kr/data/tt asDown.jsp?where=14688 &amp;pk_num=TTAE.IE- 802.16h</a> (Clause 3, TTA transposition of IEEE Std 802.16h)	<a href="http://www.tta.or.kr/data/tt&lt;br/&gt;asDown.jsp?where=14688&lt;br/&gt;&amp;pk_num=TTAE.IE-&lt;br/&gt;802.16m">http://www.tta.or.kr/data/tt asDown.jsp?where=14688 &amp;pk_num=TTAE.IE- 802.16m</a> (Clause 3, TTA transposition of IEEE Std 802.16m)
Clause 4: Abbreviations and acronyms	<a href="http://www.tta.or.kr/data/tt&lt;br/&gt;asDown.jsp?where=14688&lt;br/&gt;&amp;pk_num=TTAE.IE-&lt;br/&gt;802.16-2009">http://www.tta.or.kr/data/tt asDown.jsp?where=14688 &amp;pk_num=TTAE.IE- 802.16-2009</a> (Clause 4, TTA transposition of IEEE Std 802.16-2009)	<a href="http://www.tta.or.kr/data/tt&lt;br/&gt;asDown.jsp?where=14688&lt;br/&gt;&amp;pk_num=TTAE.IE-&lt;br/&gt;802.16j">http://www.tta.or.kr/data/tt asDown.jsp?where=14688 &amp;pk_num=TTAE.IE- 802.16j</a> (Clause 4, TTA transposition of IEEE Std 802.16j)	<a href="http://www.tta.or.kr/data/tt&lt;br/&gt;asDown.jsp?where=14688&lt;br/&gt;&amp;pk_num=TTAE.IE-&lt;br/&gt;802.16h">http://www.tta.or.kr/data/tt asDown.jsp?where=14688 &amp;pk_num=TTAE.IE- 802.16h</a> (Clause 4, TTA transposition of IEEE Std 802.16h)	<a href="http://www.tta.or.kr/data/tt&lt;br/&gt;asDown.jsp?where=14688&lt;br/&gt;&amp;pk_num=TTAE.IE-&lt;br/&gt;802.16m">http://www.tta.or.kr/data/tt asDown.jsp?where=14688 &amp;pk_num=TTAE.IE- 802.16m</a> (Clause 4, TTA transposition of IEEE Std 802.16m)
Clause 5.2: Packet convergence sublayer	<a href="http://www.tta.or.kr/data/tt&lt;br/&gt;asDown.jsp?where=14688&lt;br/&gt;&amp;pk_num=TTAE.IE-&lt;br/&gt;802.16-2009">http://www.tta.or.kr/data/tt asDown.jsp?where=14688 &amp;pk_num=TTAE.IE- 802.16-2009</a> (Clause 5.2, TTA transposition of IEEE Std 802.16-2009)	Not applicable	Not applicable	<a href="http://www.tta.or.kr/data/tt&lt;br/&gt;asDown.jsp?where=14688&lt;br/&gt;&amp;pk_num=TTAE.IE-&lt;br/&gt;802.16m">http://www.tta.or.kr/data/tt asDown.jsp?where=14688 &amp;pk_num=TTAE.IE- 802.16m</a> (Clause 5.2, TTA transposition of IEEE Std 802.16m)
Clause 16: WirelessMAN- Advanced air interface	Not applicable	Not applicable	Not applicable	<a href="http://www.tta.or.kr/data/tt&lt;br/&gt;asDown.jsp?where=14688&lt;br/&gt;&amp;pk_num=TTAE.IE-&lt;br/&gt;802.16m">http://www.tta.or.kr/data/tt asDown.jsp?where=14688 &amp;pk_num=TTAE.IE- 802.16m</a> (Clause 16, TTA transposition of IEEE Std 802.16m)
Annex R: MAC control messages	Not applicable	Not applicable	Not applicable	<a href="http://www.tta.or.kr/data/tt&lt;br/&gt;asDown.jsp?where=14688&lt;br/&gt;&amp;pk_num=TTAE.IE-&lt;br/&gt;802.16m">http://www.tta.or.kr/data/tt asDown.jsp?where=14688 &amp;pk_num=TTAE.IE- 802.16m</a> (Annex R, TTA transposition of IEEE Std 802.16m)

	<b>Base specification per IEEE Std 802.16-2009</b>	<b>Amendment per IEEE Std 802.16j-2009</b>	<b>Amendment per IEEE Std 802.16h-2010</b>	<b>Amendment per IEEE Std 802.16m-2011</b>
Annex S: Test vectors	Not applicable	Not applicable	Not applicable	<a href="http://www.tta.or.kr/data/tt asDown.jsp?where=14688 &amp;pk_num=TTAE.IE-802.16m">http://www.tta.or.kr/data/tt asDown.jsp?where=14688 &amp;pk_num=TTAE.IE-802.16m</a> (Annex S, TTA transposition of IEEE Std 802.16m)
Annex T: Supported frequency bands	Not applicable	Not applicable	Not applicable	<a href="http://www.tta.or.kr/data/tt asDown.jsp?where=14688 &amp;pk_num=TTAE.IE-802.16m">http://www.tta.or.kr/data/tt asDown.jsp?where=14688 &amp;pk_num=TTAE.IE-802.16m</a> (Annex T, TTA transposition of IEEE Std 802.16m)
Annex U: Radio specifications	Not applicable	Not applicable	Not applicable	<a href="http://www.tta.or.kr/data/tt asDown.jsp?where=14688 &amp;pk_num=TTAE.IE-802.16m">http://www.tta.or.kr/data/tt asDown.jsp?where=14688 &amp;pk_num=TTAE.IE-802.16m</a> (Annex U, TTA transposition of IEEE Std 802.16m)
Annex V: Default capability class and parameters	Not applicable	Not applicable	Not applicable	<a href="http://www.tta.or.kr/data/tt asDown.jsp?where=14688 &amp;pk_num=TTAE.IE-802.16m">http://www.tta.or.kr/data/tt asDown.jsp?where=14688 &amp;pk_num=TTAE.IE-802.16m</a> (Annex V, TTA transposition of IEEE Std 802.16m)

## 2.1.2.4 Transpositions: WiMAX Forum

	Base specification per IEEE Std 802.16-2009	Amendment per IEEE Std 802.16j-2009	Amendment per IEEE Std 802.16h-2010	Amendment per IEEE Std 802.16m-2011
Transposing Organization	WIMAX FORUM	WIMAX FORUM	WIMAX FORUM	WIMAX FORUM
Document number	T28-001-R020v01, WIMAX FORUM transposition of IEEE Std 802.16-2009	T28-001-R020v01, WIMAX FORUM transposition of IEEE Std 802.16j	T28-001-R020v01, WIMAX FORUM transposition of IEEE Std 802.16h	T28-001-R020v01, WIMAX FORUM transposition of IEEE Std 802.16m
Version	V01	V01	V01	V01
Date	20 September 2011	20 September 2011	20 September 2011	20 September 2011
Clause 1.4: Reference models	<a href="http://www.wimaxforum.org/files/WMF-IMT-Advanced-Spec-T28-001-R020v01.pdf">http://www.wimaxforum.org/files/WMF-IMT-Advanced-Spec-T28-001-R020v01.pdf</a> (Clause 1.4, WIMAX FORUM transposition of IEEE Std 802.16-2009)	Not applicable	<a href="http://www.wimaxforum.org/files/WMF-IMT-Advanced-Spec-T28-001-R020v01.pdf">http://www.wimaxforum.org/files/WMF-IMT-Advanced-Spec-T28-001-R020v01.pdf</a> (Clause 1.4, WIMAX FORUM transposition of IEEE Std 802.16h)	<a href="http://www.wimaxforum.org/files/WMF-IMT-Advanced-Spec-T28-001-R020v01.pdf">http://www.wimaxforum.org/files/WMF-IMT-Advanced-Spec-T28-001-R020v01.pdf</a> (Clause 1.4, WIMAX FORUM transposition of IEEE Std 802.16m)
Clause 2: Normative references	<a href="http://www.wimaxforum.org/files/WMF-IMT-Advanced-Spec-T28-001-R020v01.pdf">http://www.wimaxforum.org/files/WMF-IMT-Advanced-Spec-T28-001-R020v01.pdf</a> (Clause 2, WIMAX FORUM transposition of IEEE Std 802.16-2009)	Not applicable	<a href="http://www.wimaxforum.org/files/WMF-IMT-Advanced-Spec-T28-001-R020v01.pdf">http://www.wimaxforum.org/files/WMF-IMT-Advanced-Spec-T28-001-R020v01.pdf</a> (Clause 2, WIMAX FORUM transposition of IEEE Std 802.16h)	<a href="http://www.wimaxforum.org/files/WMF-IMT-Advanced-Spec-T28-001-R020v01.pdf">http://www.wimaxforum.org/files/WMF-IMT-Advanced-Spec-T28-001-R020v01.pdf</a> (Clause 2, WIMAX FORUM transposition of IEEE Std 802.16m)
Clause 3: Definitions	<a href="http://www.wimaxforum.org/files/WMF-IMT-Advanced-Spec-T28-001-R020v01.pdf">http://www.wimaxforum.org/files/WMF-IMT-Advanced-Spec-T28-001-R020v01.pdf</a> (Clause 3, WIMAX FORUM transposition of IEEE Std 802.16-2009)	<a href="http://www.wimaxforum.org/files/WMF-IMT-Advanced-Spec-T28-001-R020v01.pdf">http://www.wimaxforum.org/files/WMF-IMT-Advanced-Spec-T28-001-R020v01.pdf</a> (Clause 3, WIMAX FORUM transposition of IEEE Std 802.16j)	<a href="http://www.wimaxforum.org/files/WMF-IMT-Advanced-Spec-T28-001-R020v01.pdf">http://www.wimaxforum.org/files/WMF-IMT-Advanced-Spec-T28-001-R020v01.pdf</a> (Clause 3, WIMAX FORUM transposition of IEEE Std 802.16h)	<a href="http://www.wimaxforum.org/files/WMF-IMT-Advanced-Spec-T28-001-R020v01.pdf">http://www.wimaxforum.org/files/WMF-IMT-Advanced-Spec-T28-001-R020v01.pdf</a> (Clause 3, WIMAX FORUM transposition of IEEE Std 802.16m)
Clause 4: Abbreviations and acronyms	<a href="http://www.wimaxforum.org/files/WMF-IMT-Advanced-Spec-T28-001-R020v01.pdf">http://www.wimaxforum.org/files/WMF-IMT-Advanced-Spec-T28-001-R020v01.pdf</a> (Clause 4, WIMAX FORUM transposition of IEEE Std 802.16-2009)	<a href="http://www.wimaxforum.org/files/WMF-IMT-Advanced-Spec-T28-001-R020v01.pdf">http://www.wimaxforum.org/files/WMF-IMT-Advanced-Spec-T28-001-R020v01.pdf</a> (Clause 4, WIMAX FORUM transposition of IEEE Std 802.16j)	<a href="http://www.wimaxforum.org/files/WMF-IMT-Advanced-Spec-T28-001-R020v01.pdf">http://www.wimaxforum.org/files/WMF-IMT-Advanced-Spec-T28-001-R020v01.pdf</a> (Clause 4, WIMAX FORUM transposition of IEEE Std 802.16h)	<a href="http://www.wimaxforum.org/files/WMF-IMT-Advanced-Spec-T28-001-R020v01.pdf">http://www.wimaxforum.org/files/WMF-IMT-Advanced-Spec-T28-001-R020v01.pdf</a> (Clause 4, WIMAX FORUM transposition of IEEE Std 802.16m)
Clause 5.2: Packet convergence sublayer	<a href="http://www.wimaxforum.org/files/WMF-IMT-Advanced-Spec-T28-001-R020v01.pdf">http://www.wimaxforum.org/files/WMF-IMT-Advanced-Spec-T28-001-R020v01.pdf</a> (Clause 5.2, WIMAX FORUM transposition of IEEE Std 802.16-2009)	Not applicable	Not applicable	<a href="http://www.wimaxforum.org/files/WMF-IMT-Advanced-Spec-T28-001-R020v01.pdf">http://www.wimaxforum.org/files/WMF-IMT-Advanced-Spec-T28-001-R020v01.pdf</a> (Clause 5.2, WIMAX FORUM transposition of IEEE Std 802.16m)
Clause 16: WirelessMAN-Advanced air interface	Not applicable	Not applicable	Not applicable	<a href="http://www.wimaxforum.org/files/WMF-IMT-Advanced-Spec-T28-001-R020v01.pdf">http://www.wimaxforum.org/files/WMF-IMT-Advanced-Spec-T28-001-R020v01.pdf</a> (Clause 16, WIMAX FORUM transposition of IEEE Std 802.16m)
Annex R: MAC control messages	Not applicable	Not applicable	Not applicable	<a href="http://www.wimaxforum.org/files/WMF-IMT-Advanced-Spec-T28-001-R020v01.pdf">http://www.wimaxforum.org/files/WMF-IMT-Advanced-Spec-T28-001-R020v01.pdf</a> (Annex R, WIMAX FORUM transposition of IEEE Std 802.16m)

	Base specification per IEEE Std 802.16-2009	Amendment per IEEE Std 802.16j-2009	Amendment per IEEE Std 802.16h-2010	Amendment per IEEE Std 802.16m-2011
Annex S: Test vectors	Not applicable	Not applicable	Not applicable	<a href="http://www.wimaxforum.org/files/WMF-IMT-Advanced-Spec-T28-001-R020v01.pdf">http://www.wimaxforum.org/files/WMF-IMT-Advanced-Spec-T28-001-R020v01.pdf</a> (Annex S, WIMAX FORUM transposition of IEEE Std 802.16m)
Annex T: Supported frequency bands	Not applicable	Not applicable	Not applicable	<a href="http://www.wimaxforum.org/files/WMF-IMT-Advanced-Spec-T28-001-R020v01.pdf">http://www.wimaxforum.org/files/WMF-IMT-Advanced-Spec-T28-001-R020v01.pdf</a> (Annex T, WIMAX FORUM transposition of IEEE Std 802.16m)
Annex U: Radio specifications	Not applicable	Not applicable	Not applicable	<a href="http://www.wimaxforum.org/files/WMF-IMT-Advanced-Spec-T28-001-R020v01.pdf">http://www.wimaxforum.org/files/WMF-IMT-Advanced-Spec-T28-001-R020v01.pdf</a> (Annex U, WIMAX FORUM transposition of IEEE Std 802.16m)
Annex V: Default capability class and parameters	Not applicable	Not applicable	Not applicable	<a href="http://www.wimaxforum.org/files/WMF-IMT-Advanced-Spec-T28-001-R020v01.pdf">http://www.wimaxforum.org/files/WMF-IMT-Advanced-Spec-T28-001-R020v01.pdf</a> (Annex V, WIMAX FORUM transposition of IEEE Std 802.16m)

### 3 Detailed specification of the radio interface technology<sup>15</sup>

The material in § 2.3 reflects the structure of the IEEE specifications subsequent to the IEEE revising the structure of the relevant IEEE specifications related to WirelessMAN-Advanced on 8 June 2013 beginning with Revision 1 of Recommendation ITU-R M.2012 (2014).

<sup>15</sup> On 8 June 2012, the IEEE-SA Standards Board approved IEEE Std 802.16.1 (*WirelessMAN-Advanced Air Interface for Broadband Wireless Access Systems*) as a new IEEE standard. IEEE Std 802.16.1 encompasses the WirelessMAN-Advanced air interface, with some minor improvements. On the same date, the Standards Board approved IEEE Std 802.16-2012 as a new revision of IEEE Std 802.16, which now excludes the WirelessMAN-Advanced air interface.

Accordingly, the material in § 3 reflects IEEE's transfer of the WirelessMAN-Advanced air interface specification to IEEE Std 802.16.1. The WirelessMAN-Advanced GCS for § 3 includes IEEE Std 802.16.1 but not IEEE Std 802.16.

IEEE has further enhanced IEEE Std 802.16.1 with two amendments:

- IEEE Std 802.16.1a: WirelessMAN-Advanced Air Interface for Broadband Wireless Access Systems – Amendment: Higher Reliability Networks.
- IEEE Std 802.16.1b: WirelessMAN-Advanced Air Interface for Broadband Wireless Access Systems – Amendment: Enhancements to Support Machine-to-Machine Applications.

The content of these two standards is also included in § 3.

Detailed specifications described in this Annex are developed around a “Global Core Specification” (GCS), which is related to externally developed materials incorporated by specific references for a specific technology. The process and use of the GCS, references, and related notifications and certifications are found as Document IMT-ADV/24(Rev.3).

The IMT-Advanced standards contained in this section are derived from the global core specification for WirelessMAN-Advanced contained [here](#) (ITU-Extranet). The following notes apply to the sections below:

- 1) The identified relevant Transposing Organizations should make their reference material available from their website.
- 2) This information was supplied by the *Transposing Organizations* and relates to their own deliverables of the transposed global core specification.

### 3.1 Description of the global core specification and the transposed standards

IEEE Std 802.16.1 is composed of IEEE Std 802.16.1-2012, as amended, consecutively, by IEEE Std 802.16.1b-2012 and IEEE Std 802.16.1a-2013. IEEE Std 802.16.1 is described in § 3.1.1.

TABLE 8  
Description of the *WirelessMAN-Advanced* GCS

IEEE Std 802.16.1 Clause and Subject	IEEE Std 802.16.1-2012	IEEE Std 802.16.1b-2012	IEEE Std 802.16.1a-2013
Clause 1: Overview	Base specification	Amended	Amended
Clause 2: Normative references	Base specification		
Clause 3: Definitions	Base specification	Amended	Amended
Clause 4: Abbreviations and acronyms	Base specification		Amended
Clause 5: Service-Specific Convergence Sublayer	Base specification		Amended
Clause 6: WirelessMAN-Advanced Air Interface	Base specification	Amended	Amended
Annex A: Bibliography	Base specification		
Annex B: Control Messages	Base specification	Amended	Amended
Annex C: Test Vectors	Base specification		
Annex D: Supported frequency bands	Base specification		
Annex E: Radio specifications	Base specification		
Annex F: Default capability class and parameters	Base specification		

#### 3.1.1 IEEE Std 802.16.1

##### IEEE Std 802.16.1: IEEE Standard for WirelessMAN-Advanced Air Interface for Broadband Wireless Access Systems

This standard specifies the WirelessMAN-Advanced Air Interface, including the medium access control layer (MAC) and physical layer (PHY), of a broadband wireless access (BWA) system supporting multiple services.



IEEE Std 802.16.1 is composed of IEEE Std 802.16.1-2012, as amended, consecutively, by IEEE Std 802.16.1b-2012 and IEEE Std 802.16.1a-2013.

**3.1.1.1 IEEE Std 802.16.1-2012**

**IEEE Standard for WirelessMAN-Advanced Air Interface for Broadband Wireless Access Systems**

This standard specifies the WirelessMAN-Advanced Air Interface, including the medium access control layer (MAC) and physical layer (PHY), of a broadband wireless access (BWA) system supporting multiple services.

**3.1.1.2 IEEE Std 802.16.1b-2012**

**IEEE Standard for WirelessMAN-Advanced Air Interface for Broadband Wireless Access Systems – Amendment 1: Enhancements to Support Machine-to-Machine Applications**

This amendment specifies enhancements to the WirelessMAN-Advanced Air Interface. The enhancements provide improved support for machine-to-machine applications. As of the approval date, the applicable version of IEEE Std 802.16.1 is IEEE Std 802.16.1-2012, as amended by IEEE 802.16.1b-2012.

**3.1.1.3 IEEE Std 802.16.1a-2013**

**IEEE Standard for WirelessMAN-Advanced Air Interface for Broadband Wireless Access Systems – Amendment 2: Higher Reliability Networks**

This amendment updates and expands IEEE Std 802.16.1, specifying enhanced mechanisms to support Higher Reliability Networks. As of the publication date, the current version of IEEE Std 802.16.1 is IEEE Std 802.16.1-2012, as amended by IEEE Std 802.16.1b-2012 and IEEE Std 802.16.1a-2013.

**3.1.2 Transposed standards**

**3.1.2.1 Transpositions: IEEE**

	<b>Base standard per IEEE Std 802.16.1-2012</b>	<b>Amendment per IEEE Std 802.16.1b-2012</b>	<b>Amendment per IEEE Std 802.16.1a-2013</b>
Transposing Organization	IEEE	IEEE	IEEE
Document Number	IEEE Std 802.16.1-2012	IEEE Std 802.16.1b-2012	IEEE Std 802.16.1a-2013
Version	2012	2012	2013
Issued Date	8 June 2012	30 August 2012	6 March 2013
Document	IEEE transposition of IEEE Std 802.16.1-2012	IEEE transposition of IEEE Std 802.16.1b-2012	IEEE transposition of IEEE Std 802.16.1a-2013

**3.1.2.2 Transpositions: ARIB**

Reserved.

## 3.1.2.3 Transpositions: TTA

	<b>Base standard per IEEE Std 802.16.1-2012</b>	<b>Amendment per IEEE Std 802.16.1b-2012</b>	<b>Amendment per IEEE Std 802.16.1a-2013</b>
Transposing Organization	TTA	TTA	TTA
Document Number	TTAE.IE-802.16.1-2012	TTAE.IE-802.16.1b-2012	<i>Not applicable</i>
Version	1.0	1.0	<i>Not applicable</i>
Issued Date	21 December 2012	26 June 2013	<i>Not applicable</i>
Document	<a href="http://committee.tta.or.kr/include/Download.jsp?filename=stnfile/TTAE_11.IE-802.16.1-2012.pdf">http://committee.tta.or.kr/include/Download.jsp?filename=stnfile/TTAE_11.IE-802.16.1-2012.pdf</a> (TTA transposition of IEEE Std 802.16.1-2012)	<a href="http://committee.tta.or.kr/include/Download.jsp?filename=stnfile/TTAE.IE-802.16.1b-2012.zip">http://committee.tta.or.kr/include/Download.jsp?filename=stnfile/TTAE.IE-802.16.1b-2012.zip</a> (TTA transposition of IEEE Std 802.16.1b-2012)	<i>Not applicable</i>

## 3.1.2.4 Transpositions: WiMAX Forum

Reserved.

## 3.1.2.5 Transpositions: ITRI

	<b>Base standard per IEEE Std 802.16.1-2012</b>	<b>Amendment per IEEE Std 802.16.1b-2012</b>	<b>Amendment per IEEE Std 802.16.1a-2013</b>
Transposing Organization	ITRI	ITRI	ITRI
Document Number	ITRI-2013-Std-001	ITRI-2013-Std-001	ITRI-2013-Std-001
Version	2013	2013	2013
Issued Date	6 September 2013	6 September 2013	6 September 2013
Document	<a href="http://std-share.itri.org.tw/Content/Files/Stdlink/ITRI-BWA-001.pdf">http://std-share.itri.org.tw/Content/Files/Stdlink/ITRI-BWA-001.pdf</a>	<a href="http://std-share.itri.org.tw/Content/Files/Stdlink/ITRI-BWA-001.pdf">http://std-share.itri.org.tw/Content/Files/Stdlink/ITRI-BWA-001.pdf</a>	<a href="http://std-share.itri.org.tw/Content/Files/Stdlink/ITRI-BWA-001.pdf">http://std-share.itri.org.tw/Content/Files/Stdlink/ITRI-BWA-001.pdf</a>

**Attachment  
to Annex 2****Abbreviations**

AAS	Active antenna system
ACK/NAK	Acknowledgement / Negative acknowledgement
A-GNSS	Assisted global navigation satellite systems
A-GPS	Assisted global positioning system
AP	Application protocol
ARIB	Association of Radio Industries and Businesses
ARQ	Automatic repeat request
AS	Access stratum
ATIS	Alliance for Telecommunications Industry Solutions
ATS	Abstract test suite
BCH	Broadcast channel
CCSA	China Communications Standards Association
CMAS	Commercial mobile alert system
CoMP	Coordinated multipoint
CQI	Channel quality identifier
CSI	Channel-state information
CTC	Convolutional turbo code
DCI	Downlink control information
DFTS	Discrete Fourier transform-spread
DLC	Data link control layer
DL-CoMP	Downlink coordinated multipoint
DL-SCH	Downlink shared channel
DRX	Discontinuous reception
DwPTS	Downlink part
ECID	Enhanced Cell ID
EMC	Electromagnetic compatibility
EPC	Evolved packet core
EPDCCH	Enhanced physical downlink control channel
E-SMLC	Evolved serving mobile location centre
ETSI	European Telecommunications Standards Institute
ETWS	Earthquake and tsunami warning system
E-UTRA	Evolved universal terrestrial radio access
FDD	Frequency-division duplex
FEC	Forward error correction
FFR	Fractional frequency reuse

FSTD	Frequency switched transmit diversity
GCS	Global core specifications
GNSS	Global navigation satellite system
GPRS	General packet radio service
GPS	Global positioning system
GSM	Global system for mobile communications
HARQ	Hybrid automatic-repeat-request
ICIC	Inter-cell interference coordination
ICS	Implementation conformance statement
IMEI	International mobile station equipment identities
IMS	IP multimedia subsystems
IMT	International mobile telecommunications
IXIT	Implementation eXtra Information for Testing
LAA	Licensed-assisted access
LBT	Listen before talk
LEE	laptop embedded equipment
LME	Laptop mounted equipment
LMU	Location measurement unit
LPP	LTE positioning protocol
LTE	Long term evolution
LWA	LTE/WLAN aggregation
LWAAP	LTE-WLAN aggregation adaptation protocol
LWIP	Level integration using IPsec tunnel
MAC	Medium access control
MBMS	Multimedia broadcast multicast service
MBSFN	Multimedia broadcast multicast service single frequency network
MC	Mission critical
MCE	Multiple channel equipment
MCPTT	Mission critical push to talk
MCS	Modulation and coding scheme
MIMO	Multiple-input/multiple-output
MME	Mobility management entity
MPDCCH	MTC physical downlink control channel
MTC	Machine-type communications
NB-IoT	Narrow-band Internet of Things
NPBCH	Narrowband physical broadcast channel
NPDCCH	Narrowband physical downlink control channel
NPDSCH	Narrowband physical downlink shared channel
NPRACH	Narrowband physical random access channel
NPUSCH	Narrowband physical uplink shared channel

O&M	Operations and maintenance
OFDM	Orthogonal frequency-division multiplexing
OFDMA	Orthogonal frequency-division multiple access
OTA	Over the air
OTDOA	Observed time difference of arrival
PAPR	Peak-to-average power ratio
PBCH	Physical broadcast channel
PCFICH	Physical control format indicator channel
PDCCH	Physical downlink control channel
PDCP	Packet data convergence protocol
PDSCH	Physical downlink shared channel
PDU	Protocol data unit
PHICH	Physical hybrid automatic-repeat-request indicator channel
PHS	Payload header suppression
PHY	Physical layer
PIXIT	Protocol implementation extra information for testing
PMCH	Physical multicast channel
PRACH	Physical random access channel
PRBs	Physical resource blocks
ProSe	Proximity based Services
PSBCH	Physical sidelink broadcast channel
PSCCH	Physical sidelink control channel
PSDCH	Physical sidelink discovery channel
PSSCH	Physical sidelink shared channel
PUCCH	Physical uplink control channel
PUSCH	Physical uplink shared channel
PWS	Public warning system
QAM	Quadrature amplitude modulation
QoS	Quality of service
QPSK	Quadrature phase shift keying
RI	Radio interface
RIT	Radio interface technology
RLC	Radio link control
RRC	Radio resource control
RRM	Radio resource management
SDP	Session description protocol
SDU	Service data unit
SFBC	Space-frequency block coding
SFH	Super frame header
SIM	Subscriber identity module

SIP	Session initiation protocol
SLmAP	SLm interface application protocol
SON	Self-organizing networks
SPDCCH	Short physical downlink control channel
SPS	Semi-persistent scheduling
SPUCCH	Short physical uplink control channel
SRIT	Set of radio interface technology
TDD	Time division duplex
TD-SCDMA	Time division synchronous code division multiple access
TF	Transport format
TRMS	Total radiated multi-antenna sensitivity
TRP	Total radiated power
TRS	Total radiated sensitivity
TSDSI	Telecommunications Standards Development Society, India
TTA	Telecommunications Technology Association
TTC	Telecommunication Technology Committee
TTCN	Testing and test control notation
TTI	Transmission time interval
UCI	Uplink control information
UE	User equipment
UL-CoMP	Uplink coordinated multipoint
UL-SCH	Uplink shared channel
UpPTS	Uplink part
V2V	Vehicle to vehicle
WirelessMAN	Wireless metropolitan area networks
WLAN	Wireless local area network
WT	Wireless local area network termination
XwAP	Xw application protocol

---