



Recommendation ITU-R F.1569
(05/2002)

**Technical and operational characteristics
for the fixed service using high altitude
platform stations in the bands
27.5-28.35 GHz and 31-31.3 GHz**

F Series
Fixed service

Foreword

The role of the Radiocommunication Sector is to ensure the rational, equitable, efficient and economical use of the radio-frequency spectrum by all radiocommunication services, including satellite services, and carry out studies without limit of frequency range on the basis of which Recommendations are adopted.

The regulatory and policy functions of the Radiocommunication Sector are performed by World and Regional Radiocommunication Conferences and Radiocommunication Assemblies supported by Study Groups.

Policy on Intellectual Property Right (IPR)

ITU-R policy on IPR is described in the Common Patent Policy for ITU-T/ITU-R/ISO/IEC referenced in Annex 1 of Resolution ITU-R 1. Forms to be used for the submission of patent statements and licensing declarations by patent holders are available from <http://www.itu.int/ITU-R/go/patents/en> where the Guidelines for Implementation of the Common Patent Policy for ITU-T/ITU-R/ISO/IEC and the ITU-R patent information database can also be found.

Series of ITU-R Recommendations

(Also available online at <http://www.itu.int/publ/R-REC/en>)

Series	Title
BO	Satellite delivery
BR	Recording for production, archival and play-out; film for television
BS	Broadcasting service (sound)
BT	Broadcasting service (television)
F	Fixed service
M	Mobile, radiodetermination, amateur and related satellite services
P	Radiowave propagation
RA	Radio astronomy
RS	Remote sensing systems
S	Fixed-satellite service
SA	Space applications and meteorology
SF	Frequency sharing and coordination between fixed-satellite and fixed service systems
SM	Spectrum management
SNG	Satellite news gathering
TF	Time signals and frequency standards emissions
V	Vocabulary and related subjects

Note: This ITU-R Recommendation was approved in English under the procedure detailed in Resolution ITU-R 1.

Electronic Publication
Geneva, 2010

© ITU 2010

All rights reserved. No part of this publication may be reproduced, by any means whatsoever, without written permission of ITU.

RECOMMENDATION ITU-R F.1569*

Technical and operational characteristics for the fixed service using high altitude platform stations in the bands 27.5-28.35 GHz and 31-31.3 GHz

(2002)

Scope

This Recommendation provides technical and operational characteristics for the fixed service using high altitude platform stations (HAPS) in the bands 27.5-28.35 GHz and 31-31.3 GHz. The specified characteristics include the frequency reuse factor of the cell illuminated by the HAPS antenna spot beams, the shielding effect of the metal-coated airship body and other typical technical parameters for HAPS systems to be used for the sharing studies with other systems.

The ITU Radiocommunication Assembly,

considering

- a) that new technology utilizing high altitude platform stations (HAPS) in the stratosphere is being developed;
- b) that the 31.3-31.8 GHz band is allocated to the radio astronomy, Earth exploration-satellite service (EESS) (passive) and space research service (passive), and it is necessary to appropriately protect these services from unwanted emissions from HAPS ground stations operated in the band 31-31.3 GHz, taking into account the interference criteria given in the relevant ITU-R Recommendations,

recognizing

- a) that the bands 27.9-28.2 GHz and 31-31.3 GHz may also be used by HAPS in the fixed service in certain countries on a non-interference, non-protection basis,

noting

- a) that receivers in the HAPS-based system in the bands 27.5-28.35 GHz and 31-31.3 GHz are designed to operate under the maximum aggregate interference of 10% of the receiving system thermal noise at HAPS platforms and HAPS ground stations,

* Radiocommunication Study Group 5 made editorial amendments to this Recommendation in December 2009 in accordance with Resolution ITU-R 1.

recommends

- 1 that HAPS using the bands 27.5-28.35 GHz and 31-31.3 GHz should be operated between the altitude of 20 to 25 km;
- 2 that the frequency reuse factor of the cell illuminated by the spot beams of HAPS antenna should be equal to or more than four in the bands 27.5-28.35 GHz and 31-31.3 GHz (see Note 1);
- 3 that, the signal power attenuation due to the shielding effect of the metal-coated airship body in the frequency range 18-32 GHz should be calculated with the following equations:

$$\begin{array}{lll}
 0 & \text{dB} & \text{for } 0^\circ \leq \theta < 90^\circ \\
 0.5(\theta - 90) & \text{dB} & \text{for } 90^\circ \leq \theta < 120^\circ \\
 15 & \text{dB} & \text{for } 120^\circ \leq \theta \leq 180^\circ
 \end{array}$$

where θ is the separation angle to the direction of interest from the nadir direction of HAPS;

- 4 that automatic transmitting power control (ATPC) technique may be used to reduce probability of unacceptable interference to other services and to increase link availability in the HAPS-based system;
- 5 that the upper bound of the number of simultaneously transmitting carriers at the ground station in the HAPS-based system determined by available bandwidth in the uplink and the bandwidth of each transmitting signal should be taken into account for sharing study;
- 6 that the HAPS-based system in Annex 1 should be used for the relevant studies in ITU-R in the bands 27.5-28.35 GHz and 31-31.3 GHz.

NOTE 1 – The term “frequency reuse factor” in *recommends 2* means the number of divided frequency sub-bands for the effective frequency use in the radiocommunication system with cellular configuration. For example, when the frequency reuse factor is 4, one of the divided frequency sub-bands is used repeatedly in every 4 cell.

Annex 1

Typical technical parameters for the FS using HAPS in the bands 27.5-28.35 GHz and 31-31.3 GHz

1 Introduction

This Annex provides typical technical characteristics for the FS using HAPS in the frequency range of 18-32 GHz focusing on the bands 27.5-28.35 GHz and 31-31.3 GHz, which may be used in the relevant studies.

2 Outline of a typical HAPS-based system

A typical HAPS system in the frequency range 18-32 GHz may have the following features:

- a HAPS is mounted on an airship controlled to be located at a nominal fixed point at the altitude of 20 to 25 km;
- the airship is supplied with electric power necessary for the system maintenance and the operation of communication mission from solar batteries being put on the upper surface of the airship and second batteries being charged for night-time use;
- the airship is equipped with a multi-spot beam antenna under its bottom providing access links to the ground stations with a certain minimum elevation angle;
- each beam formed by the multi-spot beam antenna corresponds to a cell on the ground with at least four times frequency reuse;
- the gas envelope of the airship is made of the skin material with metal layer such as that of aluminium, which is expected to block electromagnetic waves in the frequency around 18-32 GHz or higher;
- multiple airships are deployed to cover a wide range of area on the ground and the stations on board them are connected by wireless links such as optical wave links to build an all-wireless mesh-like network.

Figure 1 illustrates an image of communication system using HAPS. Two examples for minimum elevation angle, 20° and 40° , are shown in the Fig. 1.

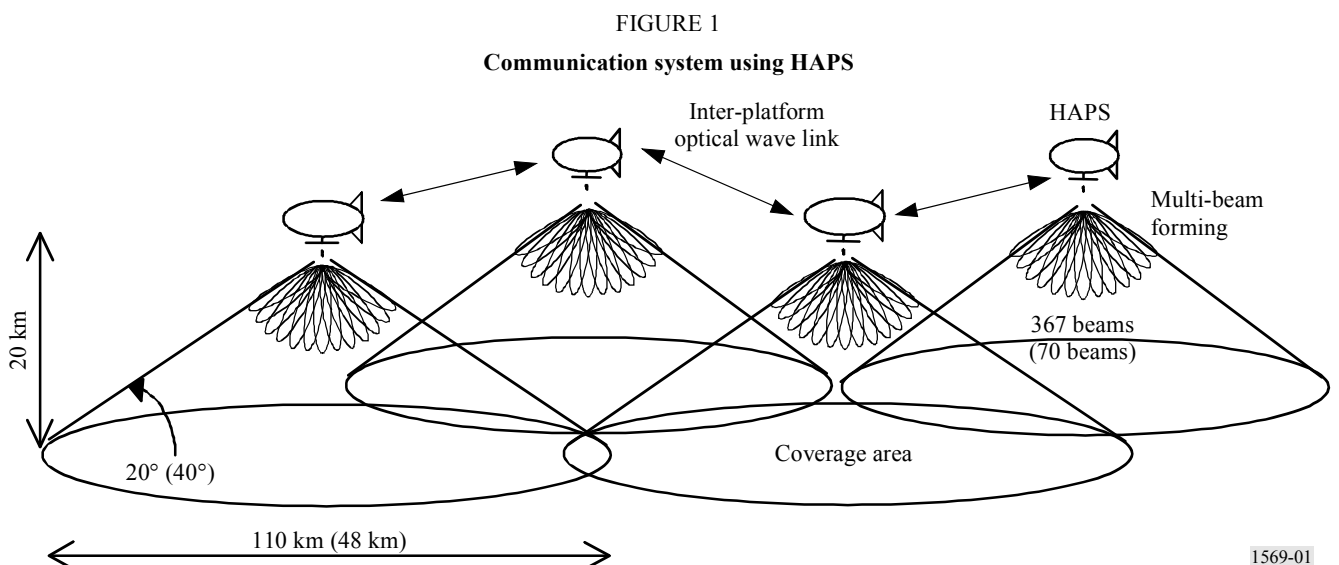

3 Altitude of HAPS

The altitude of HAPS is defined in RR No. 1.66A as 20-50 km. The line-of-sight coverage from a HAPS becomes large at higher altitude. The atmospheric density, however, decreases significantly at higher altitude. Table 1 shows the atmospheric density and pressure at various altitudes. The atmospheric density at the altitude of 50 km is much lower than that at the altitude of 20 km by about 1/90. This means the airship at the altitude of 50 km needs Helium gas as 90 times as that at the altitude of 20 km and needs the body length as 4.5 times. Assuming that a 200 m long airship is needed at the altitude of 20 km to carry a certain weight a 900 m long airship is needed at the altitude of 50 km to carry the same weight. It is absolutely impossible to build such a huge airship with the current and near-future technology.

TABLE 1

The atmospheric density and pressure in the stratosphere

Altitude (km)	Atmospheric density (kg/m ³)	Pressure (hpa)
0	1.22	1 013
15	0.195	121
20	0.0889	55.3
25	0.0401	25.5
30	0.0184	12
50	0.00103	0.798

Figure 2 shows an average wind profile in the upper atmosphere. The wind speed has a local minimum around the altitude of 20-25 km. It becomes larger at the altitude higher than 25 km and is four times larger at the altitude of 50 km than at that of 20 km. To keep the position of the airship at a nominal fixed point against the wind, much larger propulsion power is necessary, which also requires heavier batteries for night operation. On this point of view, the operation of an airship at an altitude less than 25 km is reasonable reflecting the current technology.

Taking into account the above considerations, it can be concluded that the altitude of HAPS is less than about 25 km from a technical viewpoint.

4 Minimum operational elevation angle

The minimum operational elevation angle determines the area of service coverage by a single HAPS. If the smaller minimum elevation angle is assumed, the larger the service coverage can be obtained. The rain path, however, becomes longer and the required e.i.r.p. increases because the larger rain margin is needed.

The typical value of the minimum operational elevation angle for a HAPS system using 28/31 GHz band may be more than 20°. An operation with a smaller elevation angle needs higher e.i.r.p. in uplinks and downlinks because of a longer propagation path and larger rain attenuation. It could cause a difficult sharing situation between HAPS system and other systems such as satellite systems, fixed service, space science services and so on. Moreover, shadowing by buildings or mountains will degrade site availability for lower elevation angle in the urban or mountain areas.

Elevation angles smaller than 20° could be introduced under the conditions that:

- e.i.r.p.s in uplinks and downlinks with the elevation angle more than 20° are kept to constant values and these can be increased only for links with smaller elevation angle;
- appropriate minimum operation angle is determined in accordance with sharing requirement with other services at each area; and
- ATPC is appropriately used in uplinks and downlinks.

A larger minimum elevation angle, for instance 40°, is also possible in order to reduce interference to/from other services and to increase the site availability against shadowing by buildings or mountains. The larger the minimum elevation angle is, the more the number of HAPS will be needed to cover a certain area on the ground, while the total number of the spot beams for all the HAPS is unchanged.

5 On-board multibeam antenna

A multi-spot beam antenna (multibeam antenna) is preferable for the purpose to cover many subscriber ground stations by a single HAPS with a high frequency reuse efficiency.

Figure 3 shows a typical footprint given by a multibeam antenna when the minimum elevation angle is 20°. The number of the spot beams is 367. All of the footprint sizes of the single beam are equal (up to 6 km in diameter) in this case. This can be achieved by assigning the different antenna gain to each spot beam according to its elevation angle (see Table 2) and using elliptical beam patterns. This multibeam design is expected to give smaller interference into/from other services with the path in low elevation angles because the beams near the edge of the service coverage in small elevation angle have higher gain, narrower beamwidth, and smaller side-lobe level than the beams near the centre of the service coverage do. In the design of link budget, the gain at the edge of the spot beam is assumed to be –3 dB. Figure 4 shows an example of the elliptical beam pattern for the spot beam (the elevation angles are 20° and 90°). The pattern for the spot beam with the elevation angle of 90° is given by Recommendation ITU-R F.1245 and is a circular beam. The elliptic patterns for the spot beams with the elevation angle less than 90° are modified from the

pattern given by Recommendation ITU-R F.1245. They consist of two Recommendation ITU-R F.1245 patterns for the major and minor axes of the elliptic pattern. For sharing studies that use the side-lobe level of this elliptic pattern, it is preferable for safety to use the side lobe of the major axis even for that of the minor axis (solid curve in Fig. 4). The Recommendation ITU-R F.1245 pattern may also be used for the antenna of HAPS ground station without modification.

FIGURE 2
Average wind profile in the upper atmosphere

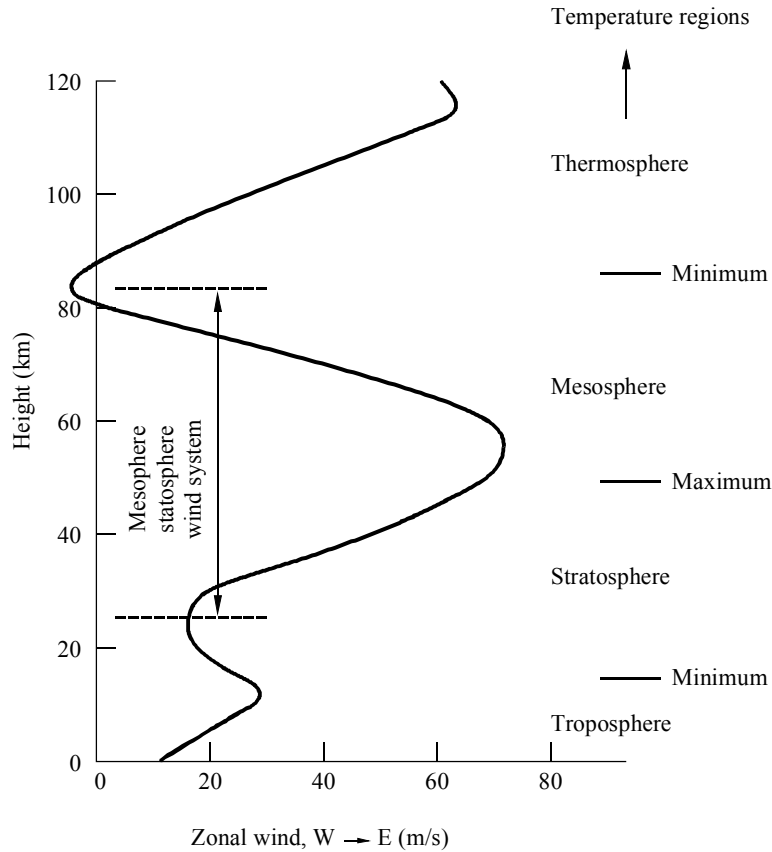

General magnitude of zonal winds in the upper atmosphere, illustrated by a height profile for 45° N in January. (Committee on Space Research (COSPAR) International Reference Atmosphere. Akademie-Verlag, 1972.)

1569-02

FIGURE 3
Typical footprint illuminated by a multibeam antenna on-board HAPS using 28/31 GHz (equal spot-beam footprint)

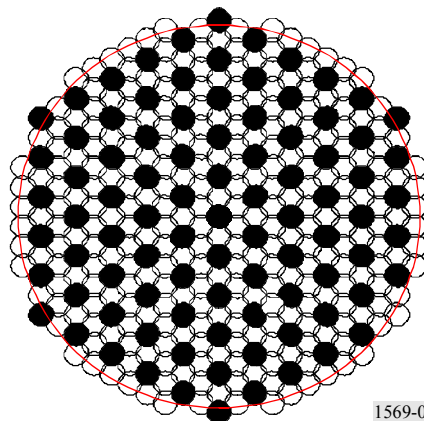

1569-03

TABLE 2

Typical gain assignment to the spot beams

Elevation angle at the beam centre (degrees)	81	66	53.9	44.7	37.8	32.6	28.5	25.2	22.5	20.3	20
Spot beam peak gain (dBi)	19.5	19.7	20.8	22.4	24.2	25.9	27.6	29.1	30.5	31.9	32.5

FIGURE 4

**Typical elliptic mask pattern of a spot beam
(elevation angle = 20° and 90°)**

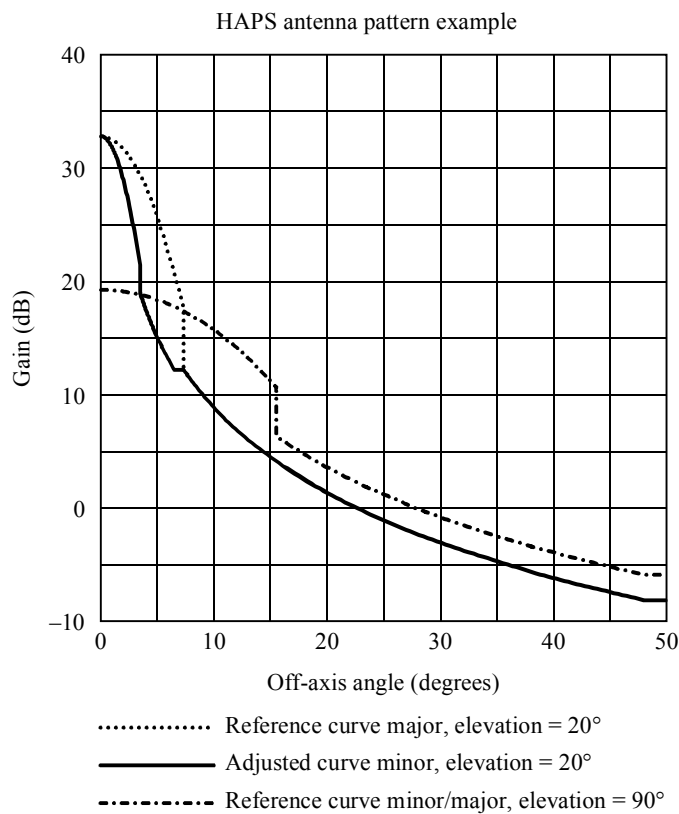

1569-04

The frequency reuse factor of spot beams is assumed to be four for sharing studies, because it could give the worst aggregate interference into other co-primary services from the downlink of HAPS. It may be difficult to keep sufficient inter-beam isolation within a permissible level with the smaller reuse factor than four.

6 Shielding effect by airship on backward radiation

The envelope of a HAPS airship will be coated by metal film (typically aluminium). This coating will block the backward radiation from the on-board antenna installed at the base of the airship, because the body size of the airship will be considerably large compared with the wavelength of the signal.

In order to obtain the attenuation by the shielding effect, a simple two-dimensional scattering problem shown in Fig. 5 is considered. The relative electromagnetic power on the surface of the cylinder in the direction of φ (degree) is expressed by equation (1) as functions of carrier signal frequency and radius of cylinder.

$$P = 20 \log_{10} \left| \frac{1}{\pi ka} \sum_{n=0}^{\infty} \epsilon_n \frac{(-j)^{n-1}}{H_n^{(1)'}(ka)} \cos n\varphi \right| \quad \text{dB} \quad (1)$$

where:

a : radius of cylinder

$k = 2\pi/\lambda$ (λ is the carrier wavelength)

ϵ_n ($n = 0$), 1 ($n \neq 0$) and $H_n^{(1)'}(x)$: derivative of the n -th order Hankel function of the first kind.

FIGURE 5
2-D scattering model of a plane wave (H-wave) by infinite conducting cylinder

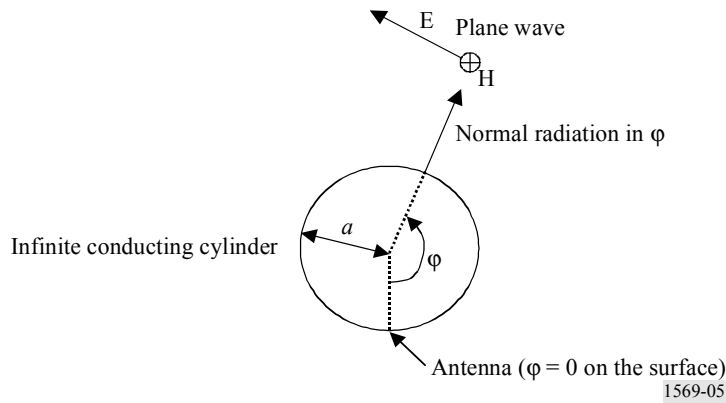

Figure 6 shows the relative electromagnetic power on the cylinder surface in case of $a = 7.5$ m and frequency = 20 GHz. Attenuation by the shielding effect increases as the cylinder radius becomes larger or as frequency becomes higher. Therefore the attenuation mask expressed by equation (2) associated with the shielding effect of the HAPS airship body could be used for a HAPS system using the airship with the radius larger than 7.5 m and carrier signal frequency higher than 20 GHz:

$$\begin{array}{lll} 0 & \text{dB} & \text{for } 0^\circ \leq \theta < 90^\circ \\ 0.5(\theta - 90) & \text{dB} & \text{for } 90^\circ \leq \theta < 120^\circ \\ 15 & \text{dB} & \text{for } 120^\circ \leq \theta \leq 180^\circ \end{array} \quad (2)$$

where θ is the separation angle to the direction of interest (such as a satellite) from the nadir direction of HAPS as shown in Fig. 7. It is noted that the antenna gain at $\theta = 90^\circ$ should be used in the calculation of backward radiation power from the antenna at the base of the airship, because the wave transmitted in the direction of $\theta = 90^\circ$ propagates along the round body surface and is radiated backward.

FIGURE 6
 Induced power towards the direction φ when $a = 7.5$ m
 and frequency = 20 GHz

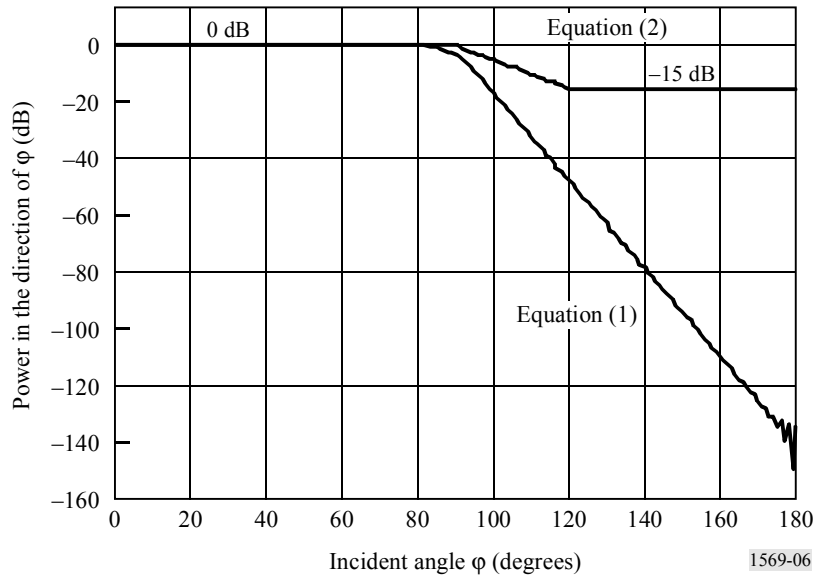
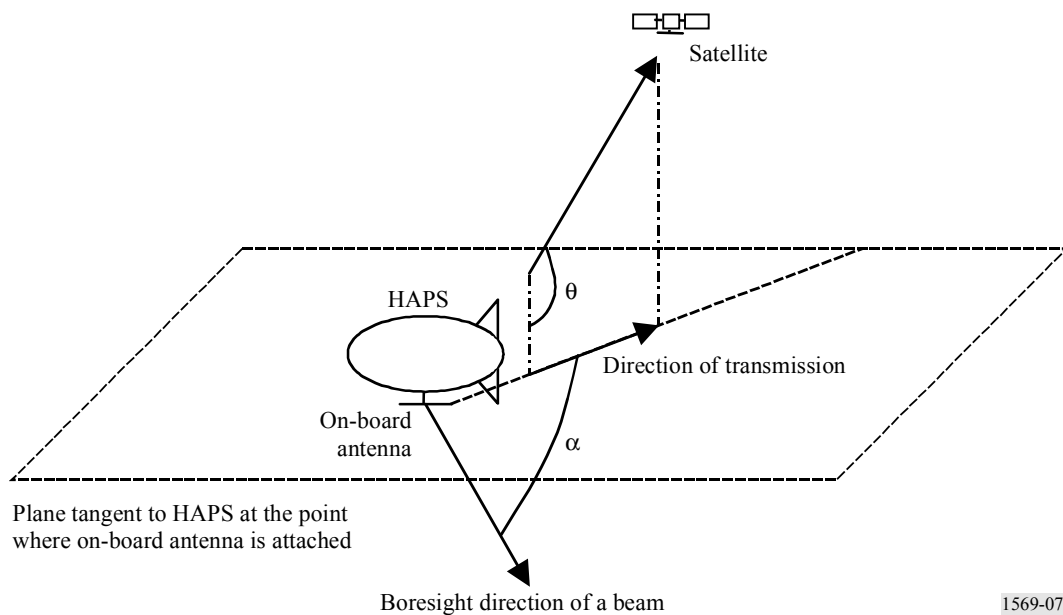

FIGURE 7
 Direction of radiation in case of the interference into satellite from HAPS



7 ATPC

If the transmitting power is fixed, a large rain margin is needed and it could cause interference into other services under the clear-sky condition. An ATPC, therefore, is effective to reduce the probability of interference.

The ATPC is implemented in a variable-gain high power amplifier (HPA) that uses variable attenuator inside the HPA module. Variety of options for gain step are possible and the device cost may differ accordingly. The most simple ATPC could be made using a single step attenuator that is switched on and off.

When the HAPS system uses the band 31-31.3 GHz for uplink, the ATPC in the transmitter of HAPS ground station reduces the uplink interference under clear-sky condition into the conventional FS using the same band, whereas the interference power increases under rain condition. The time and site percentages of the interference can, therefore, be totally reduced under all weather conditions without loss of link availability for the HAPS system. When the signal path and interfering path include the same rain path (the uplink interference into EESS from out-of-band emission is the case), the interference does not increase even with high power transmission in uplink under rain condition.

When the HAPS system uses the band 27.5-28.35 GHz in downlink, the ATPC at the HAPS-on-board transmitter of individual spot beams reduces the downlink interference into satellites using the same band under the clear-sky condition, whereas the interference power increases under rain condition. The heavy rain areas that need high power transmission by ATPC and the time percentage for such needs, however, would actually be very limited and impact of the aggregate interference from all the spot beams and all the HAPS into the satellites could not be so large.

8 Link availability

The link availability required for the FS may be different whether the use of the link is like exclusive line or by packet network. Relatively high availability is required for the use like exclusive line, but not always for the use by packet network. Because the packet network usually uses automatic repeat request technique, the transmission data cannot be lost even with temporal bit errors or line break at the cost of the throughput reduction. Therefore, assuming the wireless packet network service by HAPS using the band 28/31 GHz, the link availability 99.4% could be sufficient in temperate areas rain intensity $R_{0.01} = 50$ (mm/h) in uplink and downlink. Table 3a) shows the expected link availability in other area assuming the same transmission power. In many countries with less rainfall, the link availability of 99.7-99.9% is obtained. In the tropical areas, the link

availability of 99.4% is obtained assuming additional increase of transmission power by 5-14 dB (maximum transmission power = 2.5 W) under rain condition using ATPC. Because the uplink and downlink frequencies are close, the round trip link availability may not be much different from that in uplink or downlink.

Some subscribers who need more link availability in the HAPS uplink could also equip with additional ATPC mechanism in the ground station. The increase of transmission power by up to 12.2 dB (transmission power = 1.5 W) under the rain condition gives the link availability of 99.8% at a place in the zone with rain intensity $R_{0,01} = 50$ (mm/h) (Table 3b)).

The link availability in the HAPS downlink could also be increased by additional downlink ATPC for individual spot beams. At a place in the area with rain intensity $R_{0,01} = 50$ (mm/h), the increase of transmission power by up to 10.2 dB under the rain condition gives the link availability of 99.8% and that by up to 17.5 dB gives the link availability of 99.9%. As described in § 7, the heavy rain areas that need high power transmission by the ATPC and the time percentage for such needs would actually be very limited and the impact of the aggregate interference from all spot beams and all HAPS into the satellites could not be so much.

Transmission rate control and adaptive modulation scheme could also compensate for the link availability degradation due to rain attenuation and/or increase the availability. Table 3c) shows one example of the effect of transmission data rate control to increase the availability in the case of Tokyo.

TABLE 3

**a) Link availability for various areas
(elevation angle = 20°)**

Example city		Ulaanbaatar	London	Paris	Washington, D.C.	Tokyo
Rain intensity (mm/h) $R_{0,01}$		14	24	27	50	50
Latitude (degrees)		47.5 N	51.3 N	48.5 N	38.5 N	35.5 N
Link availability (%)	Uplink (31 GHz)	99.95	99.9	99.87	99.6	99.4
	Downlink (28 GHz)	99.95	99.9	99.87	99.6	99.4

TABLE 3 (*end*)

**b) Required uplink ATPC range and transmission power
to increase link availability
(Tokyo, rain intensity = 50 mm/h)**

Uplink availability (%)		99.4	99.6	99.8	99.9
ATPC range (dB)/ maximum transmit power (W)	Elevation angle: 20°	0/0.093	+4.3/0.25	+12.2/1.5	+20.8/11.2
	Elevation angle: 90°	0/0.093	+2.2/0.16	+6.8/0.45	+13/1.9

**c) Effect of uplink data control to increase link availability
(Tokyo, rain intensity = 50 mm/h)**

Uplink availability (%)		99.4	99.5	99.6	99.7
Uplink data rate (Mbit/s)	Elevation angle: 20°	20	12.9	7.4	3.5
	Elevation angle: 90°	20	16.2	12	8.1

9 Interference considerations

The design I/N is 10% including aggregate interference from primary services. There is a possibility to maximize this design value to improve the interference situation to other services.

10 Upper bound of the number of simultaneously transmitting carriers

The bandwidth which is allowed to be used by the HAPS uplink in the 31 GHz band is 300 MHz (use of upper 150 MHz is not allowed until WRC-03). Upper bound of the number of simultaneously transmitting carriers in uplink is, consequently, 15 assuming one carrier has the bandwidth of 20 MHz. If we assume the frequency reuse factor as four, the maximum number of simultaneously transmitting carriers from the HAPS ground station is 15 for four spot beams. This upper bound must be considered in the sharing study in uplink.

In a practical system, access requests from a lot of subscribers will be controlled by access control schemes implemented in the on-board transponder for resource assignment, in which the simultaneous transmitting carriers in uplink is limited to the upper bound.

Mix of signals having different bandwidths needs to be considered in the future because various demands for bit rate will be expected for multimedia applications. The upper bound of the number of simultaneously transmitting carriers could be changed in those cases. However, it should be taken into account that signals with smaller bandwidth could be transmitted with smaller power and smaller out-of-band emission.

In order to avoid unexpected out-of-band noise transmission in uplink when no signal is transmitted, the transmitter in the HAPS ground station will need to equip with the mechanism to decrease the HPA gain when no signal is transmitted. This mechanism also helps power saving for the operation of the HAPS ground station.

11 Out-of-band emission for HAPS uplink using the 31 GHz band

A HAPS ground station using the band 31-31.3 GHz in uplink needs to be operated to avoid interference into science services allocated in the adjacent band 31.3-31.8 GHz from unwanted out-of-band emission. The out-of-band emission from a transmitter of the HAPS ground station depends on the cut-off characteristics of the IF band-pass filter at the frequency near the band edge of the HAPS signal and the output noise level of transmitting RF module (including HPA) at the frequency apart from the band edge of the HAPS signal. A typical configuration of a transmitter to be used in the HAPS ground station is shown in Fig. 8.

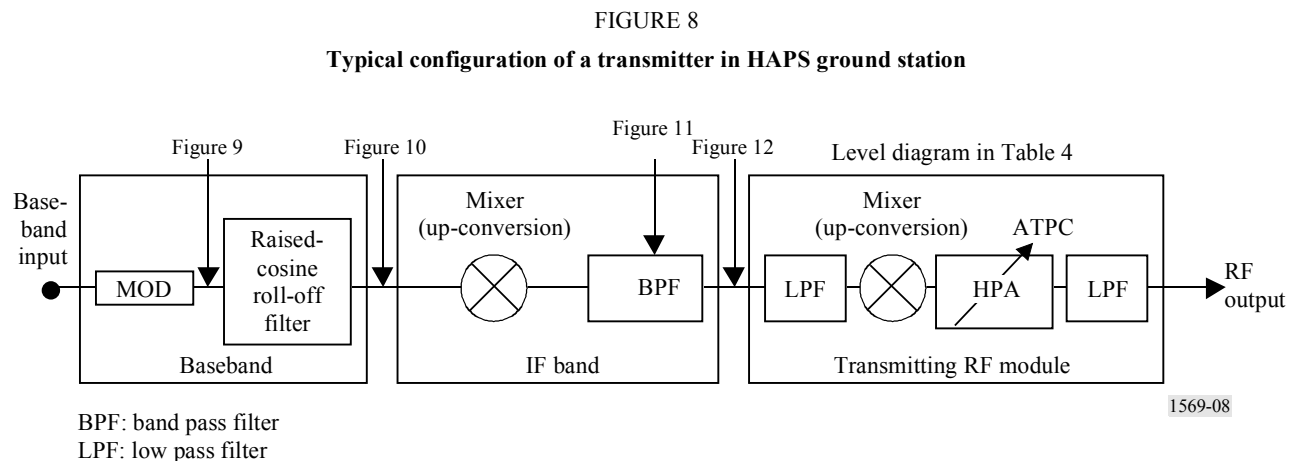

11.1 Cut-off characteristics of IF BPF

Out-of-band emission power at the input to the RF module needs to be designed as the same level as the thermal noise level by using adequate IF BPFs.

Figures 9-11 show an example of IF filtering for a quadrature phase shift keying (QPSK) signal. Figure 9 shows the power spectrum of an original QPSK signal with a bit rate of 20 Mbit/s. Figure 10 shows the spectrum of the QPSK signal after the raised-cosine roll-off filtering (roll-off factor = 0.5). Figure 11 shows an example of cut-off characteristics of a BPF. This BPF is designed by Chebyshev with the order of 6 and bandwidth (−3 dB) is 20.2 MHz at the centre IF (1.8 GHz). Figure 12 shows the spectrum of the QPSK signal after the BPF. As shown in Fig. 12, the out-of-band emission is attenuated below −143.83 dB(W/MHz), which is the thermal noise level at the temperature of 300 K, in the frequency region more than 20.1 MHz apart from the centre frequency (1.8 GHz).

$$B_G = \left| f_{pmt} \right| - \frac{B_{IF}}{2} \quad \text{MHz} \quad (3)$$

where:

f_{pmt} : frequency at which the out-of-band emission level is attenuated to permissible level (relative to the centre frequency of the signal) (MHz)

B_{IF} : bandwidth of IF filter (−3 dB) (MHz).

Typical spectrum of a transmitting signal in IF in the HAPS ground station is given below.

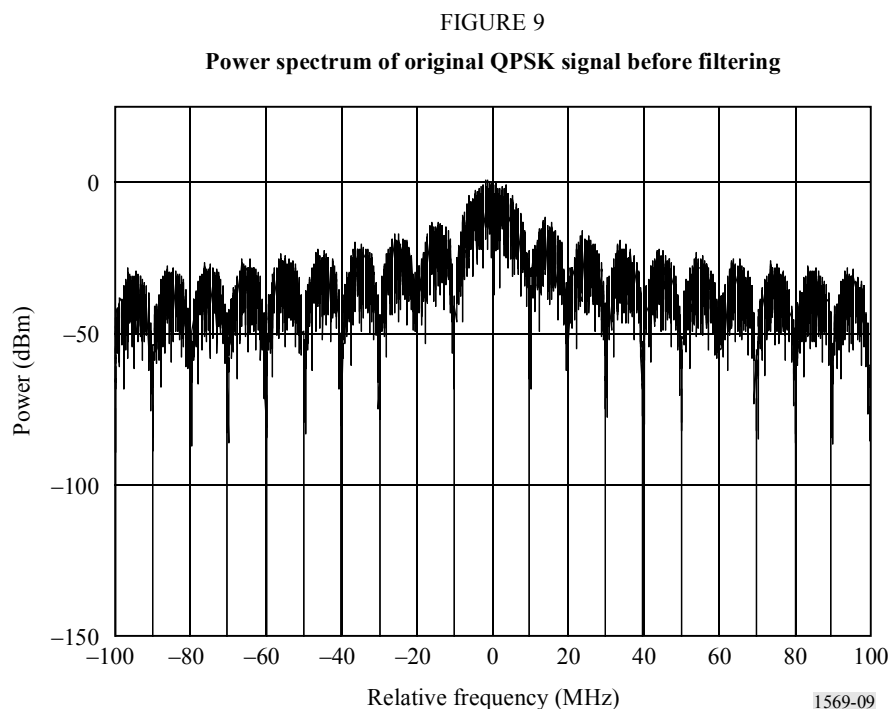

FIGURE 10
Power spectrum of QPSK signal after raised cosine roll-off filtering
(roll-off factor = 0.5)

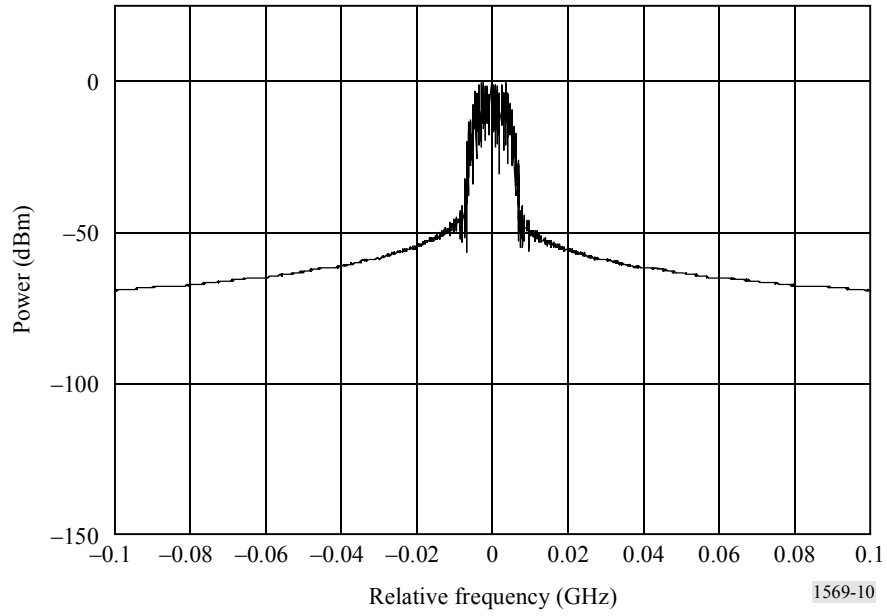
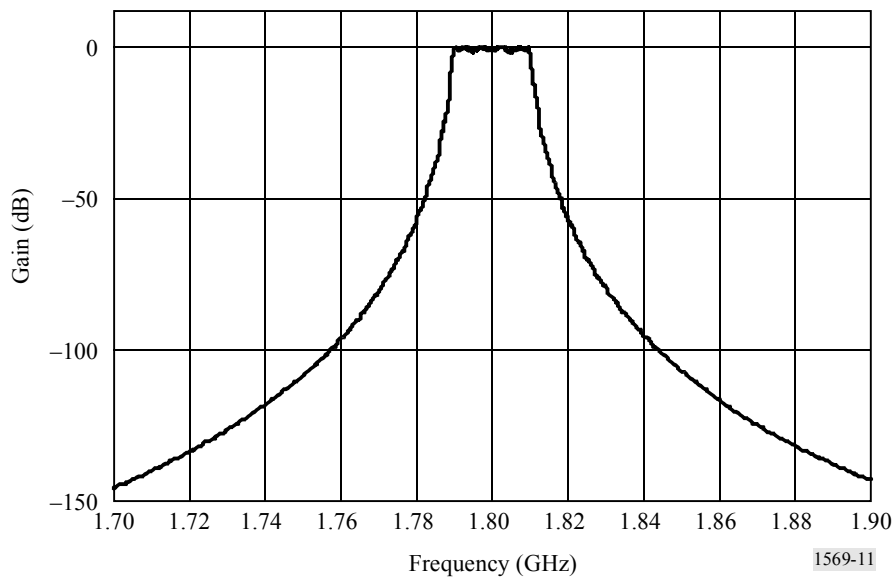
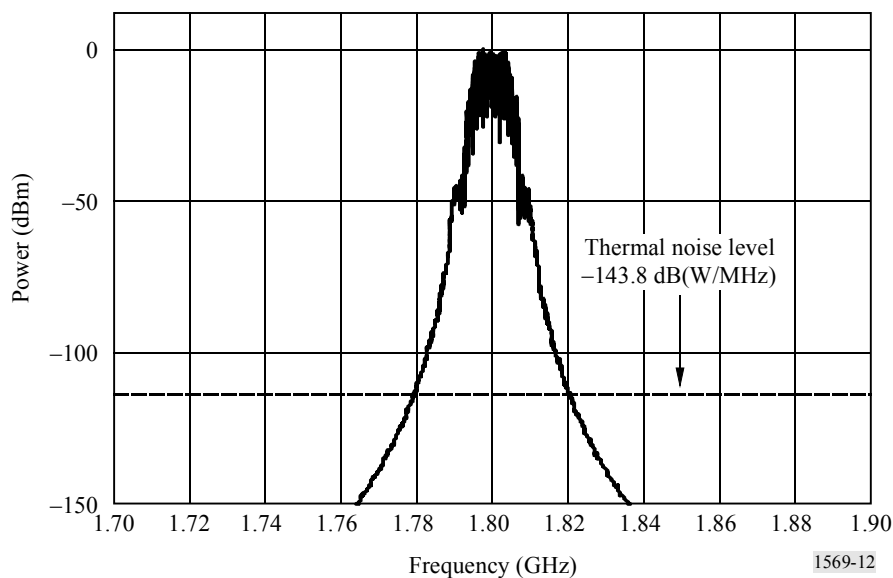

FIGURE 11
An example of cut-off characteristics of a Chebyshev type ($n = 6$) BPF



Assuming that the out-of-band emission at the IF output should be attenuated to the thermal noise level to make the out-of-band emission at the RF output below the permissible level and that ideal linear mixers and amplifiers are used in succeeding RF module, the above example filtering gives the required guardband of 10 MHz ($= 20.1-20.2/2$) between 31.29 GHz and 31.3 GHz. The required guardband could increase when non-linear RF devices are used. It could also depend on the bandwidth of the transmitting signal assigned near 31.3 GHz.

FIGURE 12
**Power spectrum of QPSK signal after Chebyshev type ($n = 6$)
 band-pass filtering at the IF output
 (output power -29.82 dBW within 20.2 MHz bandwidth)**



11.2 Output noise power of transmitting RF module

The out-of-band emission power of transmitting RF module (transmitter) at 30 GHz depends mainly on the HPA gain, providing that the input out-of-band noise level in IF is equal to the thermal noise level.

Table 4 shows a typical level diagram of RF module in the HAPS ground station. This module contains a mixer for up-conversion from IF (1.8 GHz) to RF (31 GHz) and HPA with 42 dB gain (noise figure = 6 dB) at maximum. The maximum in-band output signal power of the module is -10.3 dBW which gives the required carrier power under rain condition (see also the typical link budget shown in Appendix 1). The ATPC is achieved by variable-gain HPA, which has a variable attenuator inside.

The out-of-band emission power of the RF module is calculated by the following equation:

$$P_{ob-out} = P_{ob-in} + G_{HPA} + NF_{HPA} - L_{LPF} \quad \text{dB(W/MHz)} \quad (4)$$

where:

P_{ob-out} : out-of-band emission power from the RF module (dB(W/MHz))

P_{ob-in} : out-of-band input power for the RF module (dB(W/MHz))

G_{HPA} : HPA gain (dB)

NF_{HPA} : noise figure in HPA (dB)

L_{LPF} : attenuation in LPF located at the output of HPA (dB).

In Table 4, the out-of-band input power P_{ob-in} ($= -143.83$ dB(W/MHz)) is assumed to be equal to the thermal noise power at the temperature of 300 K. As a result of calculation, the maximum out-of-band emission power -99.85 dB(W/MHz) at the output of the module under rain condition is feasible. ATPC further reduces the out-of-band emission by the decrease of HPA gain under clear-sky condition. The level diagram assumes ATPC with the range of 6 dB (typical). The out-of-band emission, therefore, decreases to -105.85 dB(W/MHz) under clear-sky condition. The linearity of RF devices (amplifiers and mixers) and the design of level diagram are important to get a low out-of-band emission power. The gain of the HPA should not be too high and a low noise figure is required.

TABLE 4

Typical design level diagram of 30 GHz band transmitting RF module

	Input	LPF, etc.	Mixer, etc.	HPA	LPF, etc.	Output
Gain (dB)		-1.2	-17.25	42 (36) ⁽¹⁾	-4.02	
NF (dB)		1.2	17.25	6	4.02	
Signal power (dBW)	-29.83	-31.03	-48.28	-6.28 (-12.28) ⁽¹⁾	-10.3 (-16.3) ⁽¹⁾	-10.3 (-16.3) ⁽¹⁾
Noise in out-of-band (dB(W/MHz))	-143.83	-143.83	-143.83	-95.83 (-101.83) ⁽¹⁾	-99.85 (-105.85) ⁽¹⁾	-99.85 (-105.85) ⁽¹⁾
Centre frequency (GHz)	1.8	1.8	31.28	31.28	31.28	31.28

⁽¹⁾ Design values in clear-sky conditions.

12 Summary

The FS using HAPS in the bands 31-31.3 GHz for uplink and 27.5-28.35 GHz for downlink may have the typical technical and operational characteristics as follows:

- the altitude of HAPS may be between 20 and 25 km;
- the value of minimum operational elevation angle may be more than 20°, but the operation with smaller elevation angle could also be feasible under a certain operational condition;
- the on-board antenna forms multiple spot beams with the frequency reuse factor equal to or more than four at their footprints and may be designed to reduce interference in the path in low elevation angle;
- the envelope material of the airship has a shielding effect on the backward radiation;
- the HAPS ground station may have the ATPC mechanism to reduce interference into other services operating in the same band or the adjacent band and to improve the link availability without increasing the interference to other services;
- the link availability may be 99.4% or more for packet network applications in climatic zone M;
- the design I/N value for HAPS system is 10%;
- the number of simultaneously transmitting signals has an upper bound determined by the total bandwidth allowed to be used and the bandwidth of each signal;
- the out-of-band emission in the band 31.3-31.8 GHz from the uplink transmitter can be lower than -105 dB(W/MHz) under clear-sky condition and lower than -100 dB(W/MHz) under rain condition and these values depend on the selection of IF and RF devices and the design of level diagram in the uplink transmitter; and
- the guardband 31.26-31.3 GHz may be required in HAPS uplink assuming linear mixers and amplifiers in the RF transmitter of HAPS ground station, but it could increase with non-linear RF devices and depends on the bandwidth of the transmitting signal assigned near 31.3 GHz.

The technical and operational characteristics of the HAPS system presented in this Annex are of a typical example for future sharing studies and give a guideline for development of HAPS using the band 28/31 GHz.

**Appendix 1
to Annex 1**

Typical link budgets for HAPS system using 28/31 GHz band

TABLE 5

Typical link budget for HAPS at the altitude of 20 km

a) Clear-sky condition

	Uplink	Downlink	Uplink	Downlink
Elevation angle (degrees)	20		90	
Frequency (GHz)	31.28	28	31.28	28
Bandwidth (MHz)	20	20	20	20
Transmitting antenna:				
– output power (dBW)	–16.3	–14.5	–16.3	–15.2
– feeder loss (dB)	0.5	0.5	0.5	0.5
– gain (dBi)	35	29.5	35	16.5
– e.i.r.p. (dBW)	18.2	14.5	18.2	0.7
– e.i.r.p. (per MHz) (dB(W/MHz))	5.2	1.5	5.2	–12.3
Path length (km)	58.5	58.5	20	20
Free space path loss (dB)	157.7	156.7	148.4	147.4
Rain attenuation (dB)	0	0	0	0
Availability in the zone M (%)	100	100	100	100
Atmospheric gases attenuation (dB)	0.4	0.4	0	0
pf _d (dB(W/m ² · MHz))	–	–105.2	–	–109.3
Receiving antenna:				
– gain (dBi)	29.5	35	16.5	35
– feeder loss (dB)	0.5	0.5	0.5	0.5
– received power (dBW)	–110.9	–108.1	–114.2	–112.2
– noise temperature (K)	700	500	700	500
– noise temperature (dB(W/Hz))	–200.2	–201.6	–200.2	–201.6
– designed interference power objective (dB(W/MHz)) ($I/N = 10\%$)	–150.2	–151.6	–150.2	–151.6
– technical receiver losses (dB)	2.5	2.5	2.5	2.5
Available C/N_0 (dB(Hz))	86.3	90.6	83	86.5
User data rate (Mbit/s)	13.3	13.3	13.3	13.3
User data rate (dB(Hz))	71.2	71.2	71.2	71.2
Required E_b/N_0 (dB) (QPSK, BER = 1×10^{-6})	10.5	10.5	10.5	10.5
Coding gain (dB) (Viterbi coding, $K = 7$, $r = 2/3$)	5	5	5	5
Necessary E_b/N_0 (dB)	5.5	5.5	5.5	5.5
Necessary C/N_0 (dB(Hz))	76.7	76.7	76.7	76.7
Link margin (dB)	9.6	13.9	6.3	9.8

TABLE 5 (end)

b) Rainy condition (ATPC is used in uplink)

	Uplink	Downlink	Uplink	Downlink
Elevation angle (degrees)	20		90	
Frequency (GHz)	31.28	28	31.28	28
Bandwidth (MHz)	20	20	20	20
Transmitting antenna:				
– output power (dBW)	–10.3	–14.5	–10.3	–15.2
– feeder loss (dB)	0.5	0.5	0.5	0.5
– gain (dBi)	35	29.5	35	16.5
– e.i.r.p. (dBW)	24.2	14.5	24.2	0.7
– e.i.r.p. (per MHz) (dB(W/MHz))	11.2	1.5	11.2	–12.3
Path length (km)	58.5	58.5	20	20
Free space path loss (dB)	157.7	156.7	148.4	147.4
Rain attenuation (dB)	12.2	10.1	8.05	6.43
Availability in the zone M (%)	99.4	99.4	99.4	99.4
Atmospheric gases attenuation (dB)	0.4	0.4	0	0
pdf (dB(W/m ² · MHz))	–	–105.2	–	–109.3
Receiving antenna:				
– gain (dBi)	29.5	35	16.5	35
– feeder loss (dB)	0.5	0.5	0.5	0.5
– received power (dBW)	–117.1	–118.2	–116.3	–118.6
– noise temperature (K)	700	500	700	500
– noise temperature (dB(W/Hz))	–200.2	–201.6	–200.2	–201.6
– designed interference power objective (dB(W/MHz)) ($I/N = 10\%$)	–150.2	–151.6	–150.2	–151.6
– technical receiver losses (dB)	2.5	2.5	2.5	2.5
Available C/N_0 (dB(Hz))	80.1	80.5	80.9	80.1
User data rate (Mbit/s)	13.3	13.3	13.3	13.3
User data rate (dB(Hz))	71.2	71.2	71.2	71.2
Required E_b/N_0 (dB) (QPSK, BER = 1×10^{-6})	10.5	10.5	10.5	10.5
Coding gain (dB) (Viterbi coding, $K = 7$, $r = 2/3$)	5	5	5	5
Necessary E_b/N_0 (dB)	5.5	5.5	5.5	5.5
Necessary C/N_0 (dB(Hz))	76.7	76.7	76.7	76.7
Link margin (dB)	3.4	3.8	4.2	3.4

BER: bit error ratio

TABLE 6

Typical link budget for HAPS at the altitude of 25 km

a) Clear-sky condition

	Uplink	Downlink	Uplink	Downlink
Elevation angle (degrees)	20		90	
Frequency (GHz)	31.28	28	31.28	28
Bandwidth (MHz)	20	20	20	20
Transmitting antenna:				
– output power (dBW)	–16.3	–14.5	–16.3	–15.2
– feeder loss (dB)	0.5	0.5	0.5	0.5
– gain (dBi)	35	29.5	35	16.5
– e.i.r.p. (dBW)	18.2	14.5	18.2	0.7
– e.i.r.p. (per MHz) (dB(W/MHz))	5.2	1.5	5.2	–12.3
Path length (km)	73.1	73.1	25	25
Free space path loss (dB)	159.6	158.7	150.3	149.3
Rain attenuation (dB)	0	0	0	0
Availability in the zone M (%)	100	100	100	100
Atmospheric gases attenuation (dB)	0.4	0.4	0	0
pdf (dB(W/m ² · MHz))	–	–107.2	–	–111.3
Receiving antenna:				
– gain (dBi)	29.5	35	16.5	35
– feeder loss (dB)	0.5	0.5	0.5	0.5
– received power (dBW)	–112.8	–110.1	–116.1	–114.1
– noise temperature (K)	700	500	700	500
– noise temperature (dB(W/Hz))	–200.2	–201.6	–200.2	–201.6
– designed interference power objective (dB(W/MHz)) ($I/N = 10\%$)	–150.2	–151.6	–150.2	–151.6
– technical receiver losses (dB)	2.5	2.5	2.5	2.5
Available C/N_0 (dB(Hz))	84.4	88.6	81.1	84.6
User data rate (Mbit/s)	13.3	13.3	13.3	13.3
User data rate (dB(Hz))	71.2	71.2	71.2	71.2
Required E_b/N_0 (dB) (QPSK, BER = 1×10^{-6})	10.5	10.5	10.5	10.5
Coding gain (dB) (Viterbi coding, $K = 7$, $r = 2/3$)	5	5	5	5
Necessary E_b/N_0 (dB)	5.5	5.5	5.5	5.5
Necessary C/N_0 (dB(Hz))	76.7	76.7	76.7	76.7
Link margin (dB)	7.7	11.9	4.4	7.9

TABLE 6 (end)

b) Rainy condition (ATPC is used in uplink)

	Uplink	Downlink	Uplink	Downlink
Elevation angle (degrees)	20		90	
Frequency (GHz)	31.28	28	31.28	28
Bandwidth (MHz)	20	20	20	20
Transmitting antenna:				
– output power (dBW)	–10.3	–14.5	–10.3	–15.2
– feeder loss (dB)	0.5	0.5	0.5	0.5
– gain (dBi)	35	29.5	35	16.5
– e.i.r.p. (dBW)	24.2	14.5	24.2	0.7
– e.i.r.p. (per MHz) (dB(W/MHz))	11.2	1.5	11.2	–12.3
Path length (km)	73.1	73.1	25	25
Free space path loss (dB)	159.6	158.7	150.3	149.3
Rain attenuation (dB)	12.2	10.1	8.1	6.4
Availability in the zone M (%)	99.4	99.4	99.4	99.4
Atmospheric gases attenuation (dB)	0.4	0.4	0	0
pdf (dB(W/m ² · MHz))	–	–107.2	–	–111.3
Receiving antenna:				
– gain (dBi)	29.5	35	16.5	35
– feeder loss (dB)	0.5	0.5	0.5	0.5
– received power (dBW)	–119	–120.2	–118.2	–120.5
– noise temperature (K)	700	500	700	500
– noise temperature (dB(W/Hz))	–200.2	–201.6	–200.2	–201.6
– designed interference power objective (dB(W/MHz)) ($I/N = 10\%$)	–150.2	–151.6	–150.2	–151.6
– technical receiver losses (dB)	2.5	2.5	2.5	2.5
Available C/N_0 (dB(Hz))	78.2	78.5	79	78.2
User data rate (Mbit/s)	13.3	13.3	13.3	13.3
User data rate (dB(Hz))	71.2	71.2	71.2	71.2
Required E_b/N_0 (dB) (QPSK, BER = 1×10^{-6})	10.5	10.5	10.5	10.5
Coding gain (dB) (Viterbi coding, $K = 7$, $r = 2/3$)	5	5	5	5
Necessary E_b/N_0 (dB)	5.5	5.5	5.5	5.5
Necessary C/N_0 (dB(Hz))	76.7	76.7	76.7	76.7
Link margin (dB)	1.5	1.8	2.3	1.5

Appendix 2 to Annex 1

Measured results of unwanted emission from transmitter at 31 GHz band

1 Introduction

This Appendix provides a development status of an RF module at 31 GHz band to be used for the HAPS ground station featuring sharp cut-off characteristics of the BPF. The measured data shows that the assumed filter characteristics are achieved and the studies in § 11 of Annex 1 could be realistic in general. Since the RF module consists of commercially available devices, it is expected that the RF module could be produced at reasonable cost.

2 Configuration of transmitter

Table 7 shows the configuration of the developed RF module and corresponding level diagram at each port. Three types of monolithic microwave integrated circuit (MMIC) amplifier are used to provide the output in-band signal power (approximately -10 dBW) to satisfy the specification of the link budget in Tables 5 and 6.

3 Measured results

3.1 Measurement system

Figure 13 shows a set-up for measuring the unwanted emission levels of the developed transmitting RF module. In this measurement, the ATT between the spectrum analyser and developed RF module can be adjusted in 2 dB steps (0 dB to 6 dB) to simulate ATPC to be installed in the HAPS ground station.

Figure 14 shows the frequency characteristics of thermal noise power of the spectrum analyser itself in the frequency range around 31.15 GHz (without input signal). As seen from this Figure, the noise power level of the spectrum analyser itself is -80.3 dBm/MHz ($= -110.3$ dB(W/MHz)) in the frequency range below 31.15 GHz and -74.5 dBm/MHz ($= -104.5$ dB(W/MHz) = 3.548×10^{-11} W/MHz) in the frequency range above 31.15 GHz.

TABLE 7
Level diagram and configuration of 30 GHz band transmitting RF module

	Input	Connector	LPF	ATT	Mixer diode	ATT	BPF	ATT	Line	MMIC	Line/ATT	MMIC	Line/ATT	MMIC	Line	ATT	FLT	Connector
P1 dB (dBW)					-36					-18.5		-9		-2				
Gain (dB)		-0.11	0	-3	-11	0	-4	-0.5	-0.15	20	-4.95	16	-2.95	13	-0.3	0	-4	-0.3
Noise figure (dB)		0.11	0	3	11	0	4	0.5	0.15	4.2	4.95	10	2.95	13	0.3	0	4	0.3
Signal power (dBW)	-27.80	-27.91	-46.56	-30.91	-41.91	-41.91	-45.91	-46.41	-46.56	-26.56	-31.51	-15.51	-18.46	-5.46	-5.76	-5.76	-9.76	-10.06
Noise in the out-of-band (dB(W/MHz))	-143.83	-143.83	-143.83	-143.83	-143.83	-143.83	-143.83	-143.83	-143.83	-119.63	-124.55	-108.11	-111.06	-98.01	-98.31	-98.31	-102.31	-102.61
Centre frequency (GHz)	1.8	1.8	1.8	1.8	1.8	31.15	31.15	31.15	31.15	31.15	31.15	31.15	31.15	31.15	31.15	31.15	31.15	31.15

ATT: attenuator

FLT: feeder-link transmitter

FIGURE 13
Set-up for measuring unwanted emission level of developed RF module

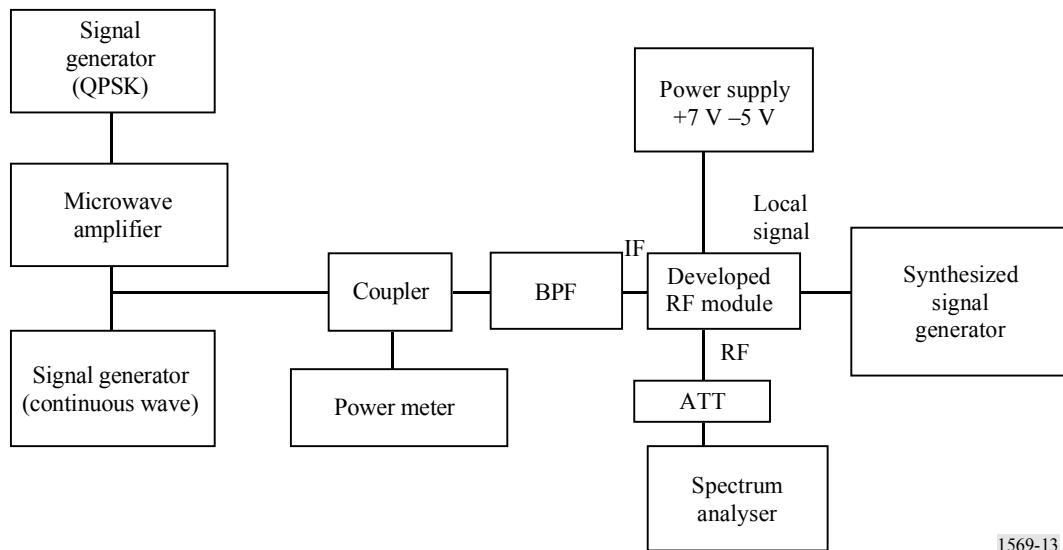

1569-13

FIGURE 14
Frequency characteristics of thermal noise power of spectrum analyser

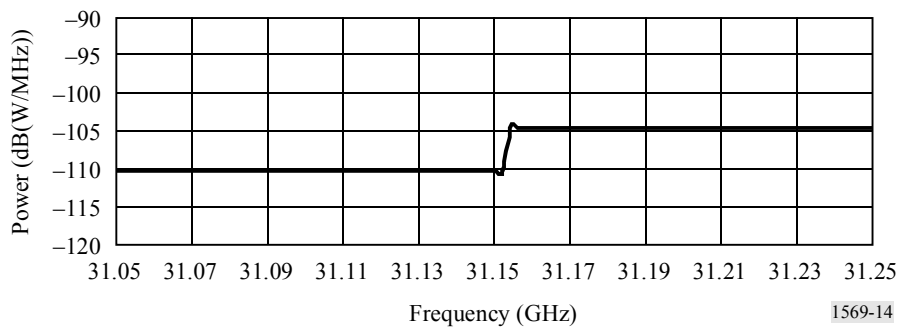

1569-14

3.2 Measured results of unwanted emission

Figure 15 shows the measured spectrum of IF-band QPSK signal with 20 MHz bandwidth after cosine roll-off filtering (roll-off factor = 0.5) and Chebyshev-type band-pass filtering. In this Figure, centre frequency (or 0 in horizontal axis) corresponds to 1.8 GHz. The signal is supplied to the input to the developed RF module at a level of -27.8 dBW. Figures 15 and 16 show the output signal spectrum of the developed transmitting RF module without ATPC and with ATPC (power increases in 6 dB), respectively. In these Figures, centre frequency (0 in horizontal axis) corresponds to 31.15 GHz and the plotted curves show the results after subtracting the noise level of the spectrum analyser obtained in Fig. 14 from the measured spectrum. It is found from Fig. 17 that the unwanted emission level is less than -76 dBm/MHz ($= -106$ dB(W/MHz)) in the frequency

region more than 40 MHz away from the centre frequency, that is, the required bandwidth for 20 MHz modulated signal is approximately 40 MHz from the centre frequency. For the case where ATPC is conducted (or power increases in 6 dB), the unwanted emission level can be reduced to be less than -70 dBm/MHz ($= -100$ dB(W/MHz)) in the frequency region 40 MHz away from the centre frequency. Figure 18 shows the input-output characteristics of the developed RF module. It is found from this Figure that the output signal level of 20 dBm which is required for the HAPS uplink, is achieved in the linear region of the RF module.

FIGURE 15

Measured spectrum of IF-band QPSK signal after band-pass filtering

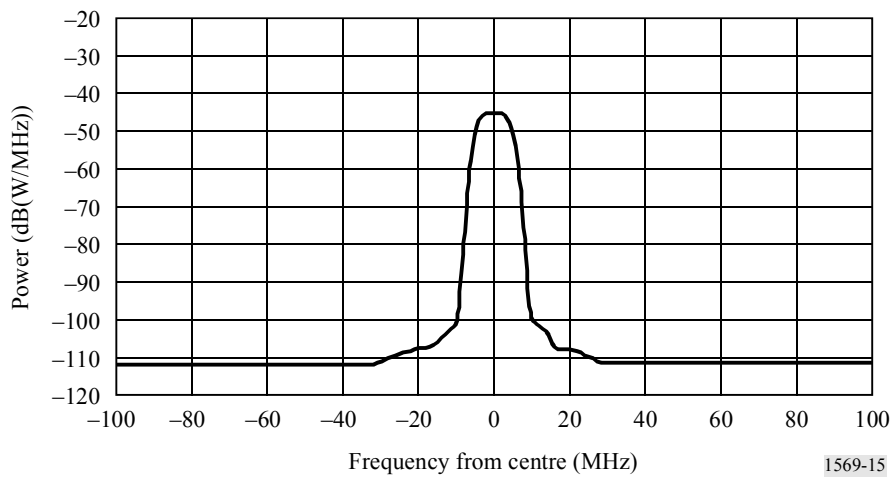

1569-15

FIGURE 16

Measured spectrum of output signal of RF module at 31 GHz band

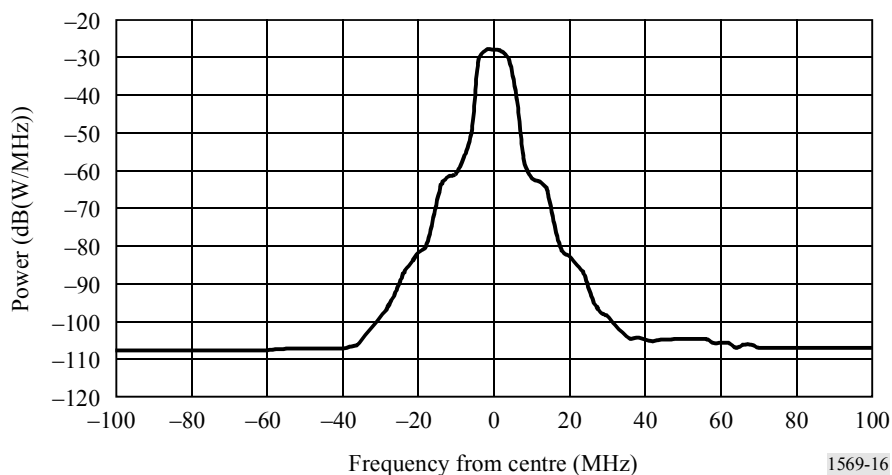

1569-16

FIGURE 17
 Measured spectrum of output signal of RF module at 31 GHz band
 when using ATPC increasing power 6 dB

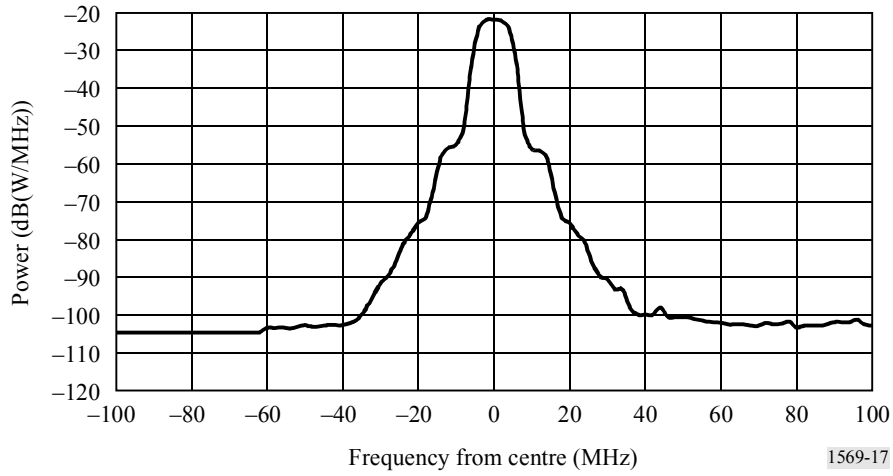
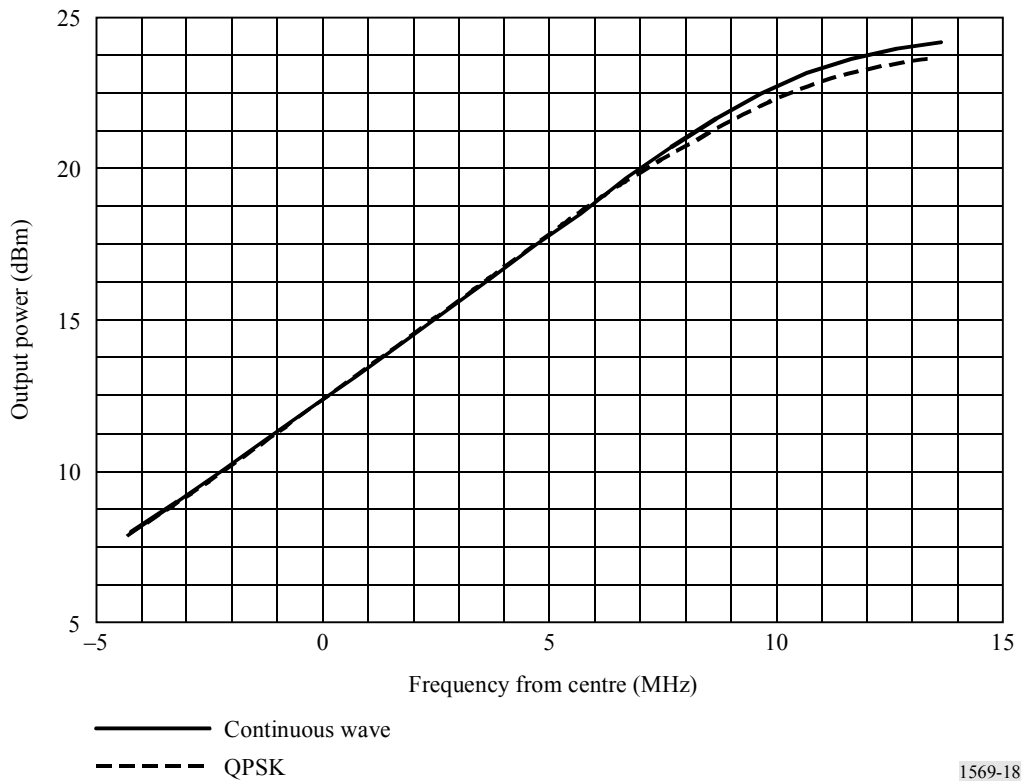

FIGURE 18
 Measured spectrum of output signal of RF module at 31 GHz band
 when using ATPC increasing power 6 dB



4 Summary

This Appendix showed the measured results of unwanted emission from the transmitting RF module at 31 GHz band developed for the HAPS ground station. It was shown that the unwanted emission of -106 dB(W/MHz) under clear-sky condition and -100 dB(W/MHz) under rainy condition can be achieved for 20 MHz bandwidth signal with the guardband of approximately 40 MHz from the centre frequency by an appropriate level diagram adjustment using devices in practical use in the transmitting RF module. If the signal bandwidth is narrower, necessary guardband to meet the required unwanted emission level will be smaller than 40 MHz from the centre frequency.

Appendix 3 to Annex 1

Alternative cell configuration

A cell configuration in Fig. 3 in Annex 1 with the equal-sized circles illuminated by elliptical beams has been used for the ITU-R studies. This Appendix provides alternative cell configuration illuminated by circular beams. Fig. 19 shows one example of the alternative cell configuration illuminated by 397 circular beams with 5 different antenna gains. In this Figure, the cells where the same characters are marked are illuminated by the circular beams with the same antenna gain. The gains assigned to each group are also shown in Fig. 19. The antenna gain for illuminating the most inner area is 22.4 dBi and the gain for illuminating the most outer area is 31.7 dBi. The transmitting power for each beam is determined so that the pfd on the ground might be equal among all the beams. Fig. 20 shows the aggregate e.i.r.p. from 397 beams for several azimuth directions. In this calculation, the antenna beam pattern for each circular beam is calculated by Recommendation ITU-R F.1245. It is observed from this Figure that the interference from the HAPS downlink to other system will not increase compared to that for the cell configuration in Fig. 3 in Annex 1.

FIGURE 19

Alternative cell configuration illuminated by circular beams with five different antenna gains

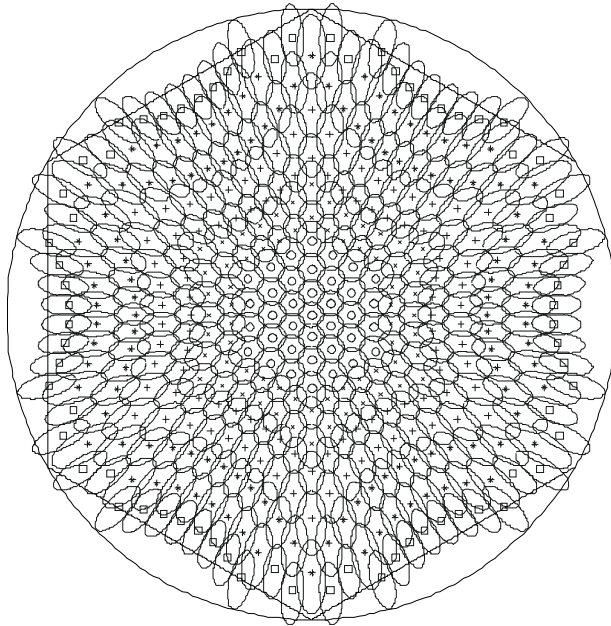

- 22.4 dBi
- × 25.1 dBi
- + 27.1 dBi
- * 29.1 dBi
- 31.7 dBi

FIGURE 20
Aggregate e.i.r.p. from 397 spot beams

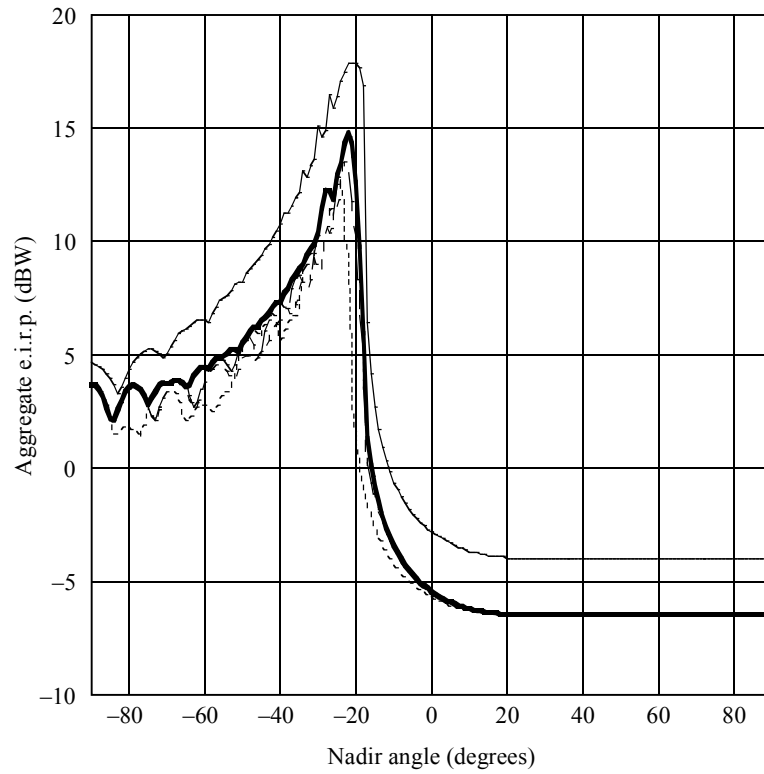

- Practical model (azimuth = 30°)
- Practical model (azimuth = 26°)
- · - · Practical model (azimuth = 0°)
- Practical model (worst value)
- Traditional model (worst value)

1569-20