

RECOMMENDATION ITU-R BT.1576

**Transport of alternate source formats through
Recommendation ITU-R BT.1120**

(Question ITU-R 20/6)

(2002)

The ITU Radiocommunication Assembly,

considering

- a) that many countries are installing digital television production facilities based on the use of digital video components conforming to Recommendations ITU-R BT.601, ITU-R BT.656 and ITU-R BT.799;
- b) that high-definition television (HDTV) production systems are being installed based on digital HDTV interfaces conforming to Recommendation ITU-R BT.1120;
- c) that there exists the capacity within a signal conforming to Recommendation ITU-R BT.1120 for alternate source formats to be carried by these serial digital interconnections;
- d) that there are operational and economic benefits if a single infrastructure is used to carry a variety of source formats,

recommends

1 that the data formatting described in SMPTE 349M-2001 “Transport of Alternate Source Image Formats through SMPTE 292M” be used as a method for transmission of a variety of source formats using the high definition serial digital interface.

Normative References

SMPTE 349M includes a reference to SMPTE 296M “1280 × 720 Progressive Image Sample Structure – Analog and Digital Representation and Analog Interface”. The following formats listed in Table 1 of SMPTE 296M shall not be considered part of this Recommendation.

Table 1 item	System nomenclature	Frame rate
3	1280 × 720/50	50
6	1280 × 720/25	25
7	1280 × 720/24	24
8	1280 × 720/23.98	24/1.001

Note by the Secretariat: The SMPTE Standard 349M-2001, previously referred to as a web link site in electronic form, has been annexed to the text of this Recommendation.

SMPTE 349M includes a reference to SMPTE 292M “Bit-Serial Digital Interface for High-Definition Television Systems”. The 1250 line, 50 Hz format listed in Table 1, Column C of SMPTE 292M shall not be considered part of this Recommendation.

Summary of SMPTE 349M-2001

High-definition television equipment and systems capable of a variety of image formats use the 1.485 Gbit/s or 1.485/1.001 Gbit/s serial digital interface. This high-definition equipment and these systems will, in many cases, be capable of processing other scanning formats, such as 525-line interlaced/progressive and 625-line interlaced/progressive. To allow the use of a single digital interface for these formats, in addition to the originally intended 1125-line interlaced/progressive and 750-line progressive scan formats, this Standard defines the transport of alternate formats through an SMPTE 292M serial digital interface. The specification is based on adjusting the number of lines to match those of the source formats while keeping a common clock rate. Frame and line structure, parallel and multiplexed word rate, and reference standards for the alternate source formats to be transmitted through a 1.485 Gbit/s serial digital interface are specified.

NOTE 1 – SMPTE Standard 349M-2001 is given in Annex 1. SMPTE Standard 349M-2001 and its summary refer to Version 2001 only, which is the version approved by Administrations of Member States of the ITU and Radiocommunication Sector Members participating in the work of Radiocommunication Study Group 6 in application of Resolution ITU-R 45 on 28 June 2002. By agreement between ITU and SMPTE, this version was provided and authorized for use by SMPTE and accepted by ITU-R for inclusion in this Recommendation. Any subsequent version of SMPTE Standard 349M-2001, which has not been accepted and approved by Study Group 6 is not part of this Recommendation. For subsequent versions of SMPTE documents, the reader should consult the SMPTE website: <http://www.smpite.org/>.

SMPTE STANDARD

SMPTE 349M-2001

for Television — Transport of Alternate Source Image Formats through SMPTE 292M



Page 1 of 11 pages

1 Scope

This standard specifies the transport of component 525-line interlaced, 525-line progressive, 625-line interlaced, and 625-line progressive scan source formats through SMPTE 292M, the bit-serial digital interface for high-definition television systems.

2 Normative references

The following standards contain provisions which, through reference in this text, constitute provisions of this standard. At the time of publication, the editions indicated were valid. All standards are subject to revision, and parties to agreements based on this standard are encouraged to investigate the possibility of applying the most recent edition of the standards indicated below.

ANSI/SMPTE 125M-1995, Television — Component Video Signal 4:2:2 — Bit-Parallel Digital Interface

ANSI/SMPTE 259M-1997, Television — 10-Bit 4:2:2 Component and $4f_{sc}$ Composite Digital Signals — Serial Digital Interface

ANSI/SMPTE 267M-1995, Television — Bit-Parallel Digital Interface — Component Video Signal 4:2:2 16×9 Aspect Ratio

ANSI/SMPTE 293M-1996, Television — 720 × 483 Active Line at 59.94-Hz Progressive Scan Production — Digital Representation

ANSI/SMPTE 294M-1997, Television — 720 × 483 Active Line at 59.94-Hz Progressive Scan Production — Bit-Serial Interfaces

SMPTE 291M-1998, Television — Ancillary Data Packet and Space Formatting

SMPTE 292M-1998, Television — Bit-Serial Digital Interface for High-Definition Television Systems

SMPTE 344M-2000, Television — 540-Mb/s Serial Digital Interface

SMPTE 352M-2001, Television — Video Payload Identification for Digital Television Interfaces

SMPTE RP 174-1993, Bit-Parallel Digital Interface for 4:4:4 Component Video Signal (Single Link)

ITU-R BT.601-5 (10/95), Studio Encoding Parameters of Digital Television for Standard 4:3 and Wide-Screen 16:9 Aspect Ratios

ITU-R BT.656-4 (02/98), Interfaces for Digital Component Video Signals in 525-Line and 625-Line Television Systems Operating at the 4:2:2 Level of Recommendation ITU-R BT.601 (Part A)

ITU-R BT.799-3 (02/98), Interfaces for Digital Component Video Signals in 525-Line and 625-Line Television Systems Operating at the 4:4:4 Level of Recommendation ITU-R BT.601 (Part A)

ITU-R BT.1358 (02/98), Studio Parameters of 625 and 525 Line Progressive Scan Television Systems

ITU-R BT.1362 (02/98), Interfaces for Digital Component Video Signals in 525- and 625-Line Progressive Scan Television Systems

SMPTE 349M-2001

3 Introduction

High-definition television equipment and systems capable of a variety of image formats use the 1.485 Gb/s or 1.485/1.001 Gb/s serial digital interface. This high-definition equipment and these systems will, in many cases, be capable of processing other scanning formats, such as 525-line interlaced/progressive and 625-line interlaced/progressive.

To allow the use of a single digital interface for these formats, in addition to the originally intended 1125-line interlaced/progressive and 750-line progressive scan formats, this standard defines the transport of alternate formats through an SMPTE 292M serial digital interface.

This specification is based on adjusting the number of lines to match those of the source formats while keeping a common clock rate. Each source format is mapped onto the interface format, as specified in clause 5.

4 Source formats

Frame and line structure, parallel and multiplexed word rate, and reference standards for the alternate source formats to be transmitted through a 1.485 Gb/s serial digital interface are shown in the top half of table 1. The meanings of the case and type values in table 1 are described in the next clause. Word count values in the table are for either the Y, C_b/C_r source format or the R, G, B, A source format.

5 Interface format

5.1 Serial data formatting

The serial data format, channel coding, coaxial cable interface, and optical fiber interface shall be as specified in SMPTE 292M.

5.2 Interface format parameters

The frame and line structure, parallel and serial word rate, and case and type of the interface format shall be as shown in the bottom half of table 1 and figure 1. Word count values in the table are for either the Y or C channel of the interface format.

5.3 Case value

The case value of table 1 shall be used to define

the number of lines per frame and whether the available data area is a standard (S) or extended (E) length. The length value defines the horizontal line parameters including total line length, data area length, and H-ANC length. The specification of the available data area is dependent on the interface line number rate and the values are defined in table 1.

5.4 Type value

The type value of table 1 shall be used to define the method of source format data packing onto the interface. Source format data may be either interlaced (I) or progressive (P) and mapped onto the interface as defined later in this standard.

5.5 Interface word rate

The interface parallel word rate shall be exactly 74.25 Mwords/s.

NOTE – The interface parallel word rate is exactly 74.25 Mwords/s even for 525-line 29.97 frame rate source formats.

5.6 Interface frame rate

In the case of 525-line source formats, the frame rate of the interface format shall be 30/1.001 Hz 2:1 interlaced. In the case of 625-line source formats, the frame rate of the interface format shall be 25 Hz 2:1 interlaced.

5.7 Lines per frame

The total lines per frame of the interface format shall be the same as the total lines per frame of the source format.

5.8 Words per line

In the case of 525-line interlaced and progressive source formats, the total words per line of the interface format shall be 4719. In the case of 625-line interlaced source formats, the total words per line of the interface format shall be 4752.

NOTE – These numbers are derived from the following equation:

$$74.25 \text{ Mwords} = 525 \times 4719 \times 30/1.001 = 625 \times 4752 \times 25$$

Table 1 – Parameters of source and interface format

Source format										
No.	Total lines per frame	Total words per line	Frame rate (Hz)	Fields per frame	Parallel and multiplexed word rate	Signal type	Reference standards			
1	525	858	30/M	2	27 Mb/s	4:2:2i	SMPTE 125M/SMPTE 259M			
2		1144	30/M	2	36 Mb/s	4:2:2i	SMPTE 267M/SMPTE 259M			
3		858	30/M	2	54 Mb/s	4:4:4:4i	SMPTE RP 174/SMPTE 344M			
4		858	60/M	1	27 Mb/s x2	4:2:2p	SMPTE 293M/SMPTE 294M			
5		858	60/M	1	54 Mb/s	4:2:2p	SMPTE 293M/SMPTE 344M			
6		858	60/M	1	36 Mb/s	4:2:0p	SMPTE 293M/SMPTE 294M			
7	625	864	25	2	27 Mb/s	4:2:2i	ITU-R BT.601/ITU-R BT.656			
8		1152	25	2	36 Mb/s	4:2:2i	ITU-R BT.601/ITU-R BT.656			
9		864	25	2	54 Mb/s	4:4:4:4i	ITU-R BT.799/SMPTE 344M			
10		864	50	1	27 Mb/s x2	4:2:2p	ITU-R BT.1358/ITU-R BT.1362			
11		864	50	1	54 Mb/s	4:2:2p	ITU-R BT.1358/SMPTE 344M			
12		864	50	1	36 Mb/s	4:2:0p	ITU-R BT.1358/ITU-R BT.1362			
Interface format										
No.	Total lines per frame	Total words per line	Frame rate (Hz)	Fields per frame	Parallel and multiplexed word rate	Words per data area	Words per H-ANC	Case	Length	Type
1	525	4719	30/M	2	74.25 Mb/s	4100	607	A	S	I
2						4100	607	A	S	I
3						4580	127	B	E	I
4						4100	607	A	S	I
5						4100	607	A	S	P
6						4580	127	B	E	I
7	625	4752	25	2	74.25 Mb/s	4100	640	C	S	I
8						4100	640	C	S	I
9						4612	128	D	E	I
10						4100	640	C	S	I
11						4100	640	C	S	P
12						4612	128	D	E	I
NOTE – M = 1.001, S = standard, E = extended.										

SMPTE 349M-2001

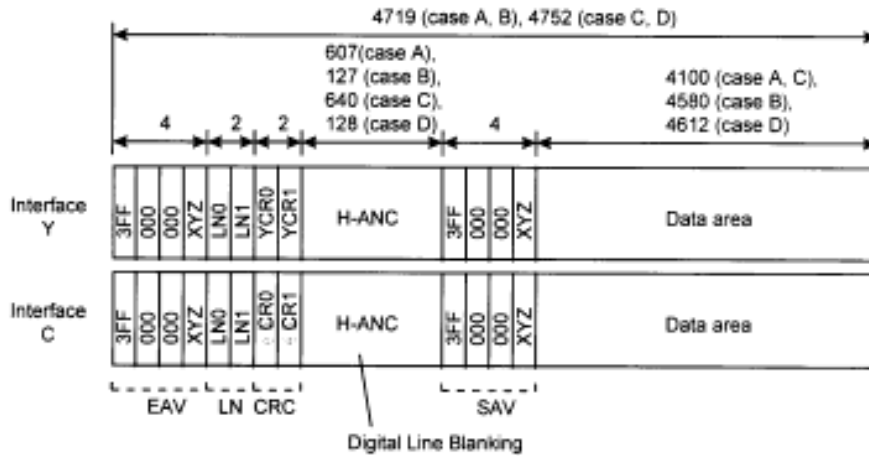

Figure 1 – Interface format

5.9 Line description

The data for each line shall be comprised of the following sequence of component parts: EAV (end of active video), LN (line number), CRC (cyclic redundancy code), H-ANC (digital line blanking), SAV (start of active video), and data area. Each of these component parts is as shown in figure 1, including standard and extended length values defined for the different line rates.

5.10 EAV, SAV, LN and CRC

The EAV and SAV for each of the two parallel data streams (Y channel and C channel) including the F and V bits for cases A and B shall be as specified in ANSI/SMPTE 125M and for cases C and D in ITU-R BT.656. Values of the F and V bits for cases A, B, C,

and D shall be as shown in table 2. Line 1 of the source format shall be mapped onto line 1 of the interface format. The LN and CRC for each of the two parallel data streams shall be as specified in SMPTE 292M.

5.11 Ancillary data space

Ancillary data space consists of H-ANC and V-ANC data space and each of two parallel data streams (Y channel and C channel) of the interface format shall be available for ancillary data packets as specified in SMPTE 291M. Ancillary data space where no ancillary data exists shall be set to 040h for the Y channel and 200h for the C channel.

Code words 00h, 01h, 02h, 03h, 3FC_h, 3FD_h, 3FE_h, and 3FF_h shall be prohibited from ancillary data words.

Table 2 – F and V bits of EAV and SAV

Case		A, B (525-lines)	C, D (625-lines)
F bit	F = 0 during field 1	Lines 4 to 265	Lines 1 to 312
	F = 1 during field 2	Lines 266 to 3	Lines 313 to 625
V bit	V = 0 elsewhere	Lines 20 to 263 Lines 283 to 525	Lines 23 to 310 Lines 336 to 623
	V = 1 during field blanking	Lines 1 to 19 Lines 264 to 282	Lines 624 to 22 Lines 311 to 335

5.11.1 H-Ancillary data space

The H-ANC space shall be in the digital line blanking area as shown in figure 1.

5.11.2 V-Ancillary data space

The V-ANC space shall be in the data area where the V bits of EAV and SAV are 1 as shown in table 2.

5.12 Format identification H-ANC packet

The format identification shall be provided by a 4-byte label encapsulated in an H-ANC data packet according to SMPTE 352M.

6 Mapping data formats

The active video of the source format shall be mapped onto the data area of the interface format. The C and Y channels shall have the same mapping mode.

This clause describes the normal mapping mode. An alternative whole-line mapping mode is defined in annex A. The normal mapping mode shall be supported by all equipment designed to this standard whereas whole-line mapping is provided as an option and may not be supported by all equipment.

6.1 Mapping mode

The mapping mode bit shall be set to 0 as specified in SMPTE 352M.

6.2 Data area

The data area consists of two portions of data and an antipathological (AP) sequence of four words as shown in figure 2. The active video data of the source format shall be mapped on this area.

6.2.1 Data size

The total size of the two portions of the data in both the interface-C and interface-Y is 4096 words for the standard length mode (cases A and C), 4576 words for 525 lines in the extended length mode (case B), and 4608 words for 625 lines in the extended length mode (case D) as shown in figure 2. The two portions of the data consist of four channels: Ch1 and Ch2 in the interface-C and Ch3 and Ch4 in the interface-Y. Each channel has 2048 words for the standard length mode (cases A and C), 2288 words for 525 lines in the

extended length mode (case B), and 2304 words for 625 lines in the extended length mode (case D).

6.2.2 Source format and the channel

Each component of the source formats, Y, C_b/C_r, R, G, B, and A in table 1 are firstly word-multiplexed either as a pair of (Y, C_b/C_r), a pair of (R, G) or a pair of (B, A), then mapped onto the channels of the data of the interface format either as a type I or type P. The mapped order shall be Ch1, Ch2, Ch3, and Ch4. Source formats 1, 2, 6, 7, 8, and 12 in table 1 shall be mapped onto Ch1. Source formats 3, 4, 5, 9, 10, and 11 shall be mapped onto Ch1 and Ch2. Mixed source formats on one interface (interface C or interface Y) are not permissible. Ch3 and Ch4 are optional. When the source format does not exist, the default value of each word of the associated channels shall be set to 040_h.

NOTE – Link A of source formats 4 and 10 shall be mapped onto Ch1 of the interface format.

6.2.3 Types I and P

Source formats are mapped onto the source data channels of the interface format as either type I or type P as shown in figures 2a and 2b. Column 11 of table 1 identifies whether a source format is mapped as type I or type P.

Type I: Word-multiplexed pairs of the source format shall be diversely mapped onto Ch1 (and Ch2 if necessary) of the interface format as shown in figure 2a. All the source formats except 5 and 11 shall be mapped as this type.

Type P: Word-multiplexed pairs of each odd line of the source format shall be consecutively mapped onto Ch1 of the interface format, and those of each even line onto Ch2 as shown in figure 2b.

6.2.4 AP

The AP (antipathological) signal shall consist of four words each set to 040_h. The AP sequence provides the capability to prevent pathological sequences in one source channel from affecting another source channel. The AP signal shall not be put on the V-ANC area.

6.2.5 Channel structure

The source format on each channel consists of an inner EAV, vacant area, inner SAV, and video as shown in figure 3 and table 3.

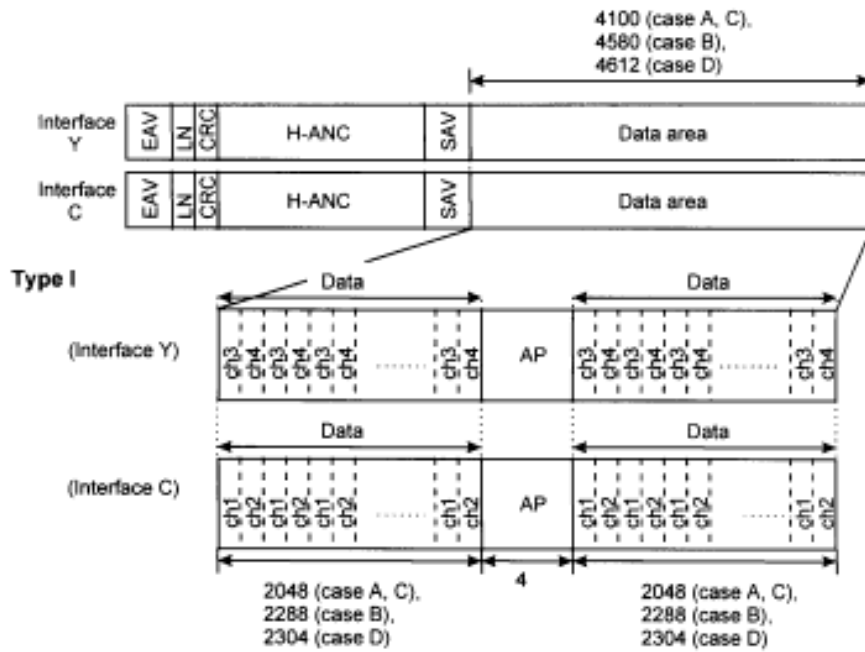

2-a - Type I

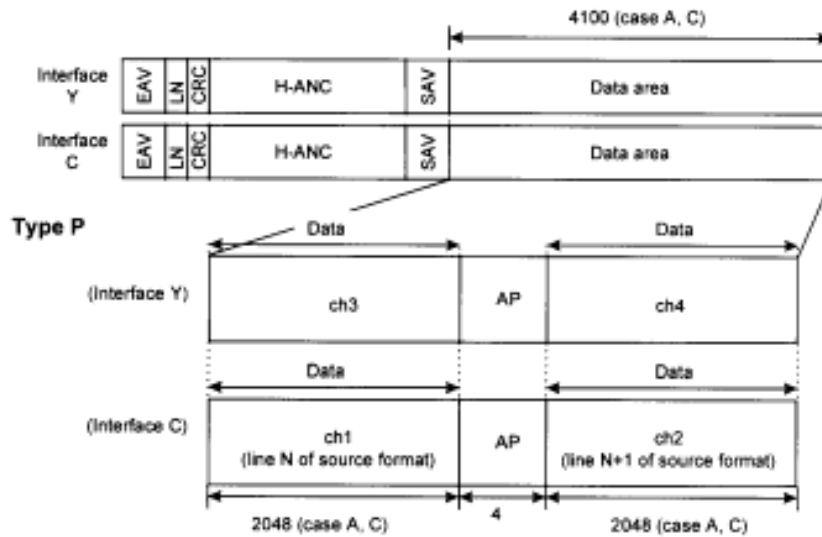

2-b - Type P

Figure 2 - Types I and P

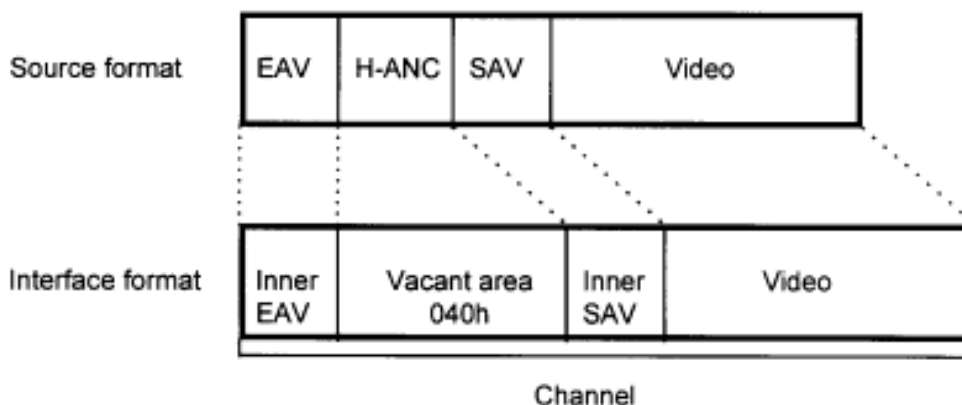
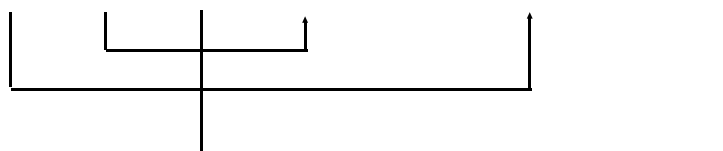

Figure 3 – Source format mapping onto the channel (normal mapping)

Table 3 – Mapping onto the channel

Source format					Interface format						
No.	Total word pairs per line	EAV SAV	Word pairs per H-ANC	Word pairs per video	H-ANC	Mapping on the channel					
						Channel size	Inner EAV Inner SAV	Vacant area	Video	Number of channels	Case
1	1716	8	268	1440	607	2048	8	600	1440	1	A
2	2288		360	1920	607	2048		120	1920	1	A
3	1716		268	1440	—	—		—	—	—	—
4	1716		268	1440	607	2048		600	1440	2	A
5	1716		268	1440	607	2048		600	1440	2	A
6	2288		120	2160	127	2288		120	2160	1	B
7	1728		280	1440	640	2048		600	1440	1	C
8	2304		376	1920	640	2048		120	1920	1	C
9	1728		280	1440	—	—		—	—	—	—
10	1728		280	1440	640	2048		600	1440	2	C
11	1728		280	1440	640	2048		600	1440	2	C
12	2304		136	2160	128	2304		136	2160	2	D



SMPTE 349M-2001

6.2.6 Inner EAV and inner SAV

When mapping the word-multiplexed pairs of the source format onto the channel, inner EAV and inner SAV shall be used to define the location of the video and vacant area in the channel as shown in figure 3 and table 3.

The size of inner EAV and inner SAV in each channel shall be four words. Each value of the four words shall be $3FE_h$, 001_h , 001_h , XYZ . The change of the LSB value in the inner EAV and SAV words is to distinguish from the interface EAV and SAV words. When the source format does not exist, each value of the inner EAV and inner SAV shall be set to 040_h .

The first word of the inner EAV shall be located at the first word of the channel. The last word of the inner SAV shall be immediately before the first word of the video. The inner EAV and inner SAV word sequences

Annex A (normative) Whole-line mapping

Occasionally direct mapping of the H-ANC data packets of the source format into the vacant area is required instead of mapping to the H-ANC area of the interface format. Such a case can happen where 270 Mb/s SDI data are mapped directly onto 1.485 Gb/s SDI with only simple data reallocation. This mapping method, although not recommended as a standard, may be used as an option to normal mapping. Note that all equipment designed to this standard shall operate with the normal mapping mode. Equipment may optionally support whole-line mapping as well as the normal mapping mode.

The similarities and differences between normal mapping and whole-line mapping are shown as follows.

A.1 Format ID

The mapping mode bit shall be set to 1 as specified in SMPTE 352M.

A.2 Data area

The data area consists of two portions of data and an antipathological (AP) sequence of 4 words as shown in figure 2. Active video data and embedded ancillary data shall be mapped on this area.

A.2.1 Data size

As specified in 6.2.1.

shall be used as the reference timing for the source format of each channel.

Inner EAV and inner SAV shall not be put on the V-ANC area.

6.2.7 Video

The sizes of the videos in a source format (word-multiplexed pairs per video) and in a channel shall be the same as shown in figure 3 and table 3. The last word of the video of the source format shall be located at the last word of the channel. Code words 00_h , 01_h , 02_h , 03_h , $3FC_h$, $3FD_h$, $3FE_h$, and $3FF_h$ shall be prohibited from video data words.

6.2.8 Vacant area

Sizes of the vacant area for each source format shall be as shown in table 3. The value of the words in the vacant area shall be set to 040_h .

A.2.2 Source format and the channel

As specified in 6.2.2.

NOTE – 270 Mb/s, 360 Mb/s, or 540 Mb/s SDI sources already have a word-multiplexed structure.

A.2.3 Types I and P

As specified in 6.2.3.

A.2.4 AP

The AP (antipathological) signal shall consist of the 4 words. The word value of each AP word is set to 040_h . The AP sequence provides the capability to prevent pathological sequences in one source channel from affecting another source channel. The AP signal shall be put on the lines where the source format is mapped.

A.2.5 Channel structure

Each channel consists of an inner EAV, inner H-ANC, inner SAV, and video as shown in figure A.1.

A.2.6 Inner EAV and inner SAV

When mapping the word-multiplexed pairs of the source format onto the channel, inner EAV and inner SAV shall be used to define the location of the video and inner H-ANC area in the channel as shown in figure A.1 and table A.1.

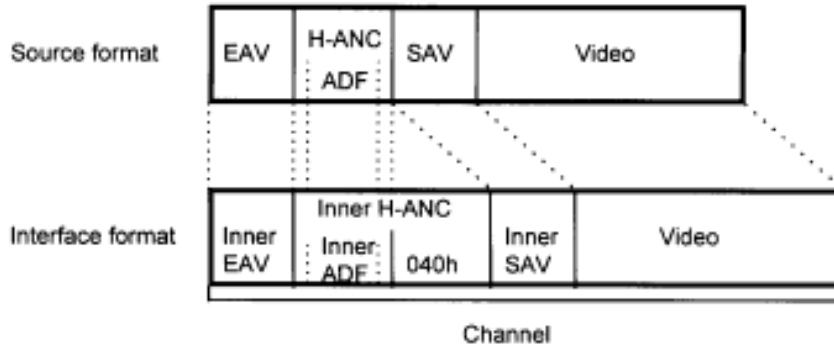
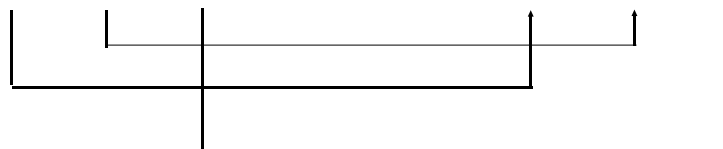

Figure A.1 – Source format mapping onto the channel (whole-line mapping)

Table A.1 – Mapping onto the channel (whole-line mapping)

Source format					Interface format							
No.	Total word pairs per line	EAV SAV	Word pairs per H-ANC	Word pairs per video	H-ANC	Mapping on the channel						
						Channel size	Inner EAV Inner SAV	Inner H-ANC	Video	Number of channels	Case	
1	1716	8	268	1440	607	2048	8	600	1440	1	A	
2	2288		360	1920	—	—		—	—	1920	—	—
3	1716		268	1440	607	2048		600	1440	2	A	
4	1716		268	1440	607	2048		600	1440	2	A	
5	1716		268	1440	607	2048		600	1440	2	A	
6	2288		120	2160	127	2288		120	2160	1	B	
7	1728		280	1440	640	2048		600	1440	1	C	
8	2304		376	1920	—	—		—	1920	—	—	
9	1728		280	1440	640	2048		600	1440	2	C	
10	1728		280	1440	640	2048		600	1440	2	C	
11	1728		280	1440	640	2048		600	1440	2	C	
12	2304		136	2160	128	2304		136	2160	2	D	



SMPTE 349M-2001

The sizes of inner EAV and inner SAV in each channel shall be four words. Each value of the four words shall be 3FE_h, 001_h, 001_h, XYZ. The change of the LSB value in the inner EAV and SAV words is to distinguish from the interface EAV and SAV words. When the source format does not exist, each value of the inner EAV and inner SAV shall be set to 040_h.

The first word of the inner EAV shall be located at the first word of the channel. The last word of the inner SAV shall be immediately before the first word of the video. The inner EAV and inner SAV word sequences shall be used as the reference timing for the source format of each channel. Inner EAV and inner SAV shall be put on the lines where the source format is mapped.

A.2.7 Video

As specified in 6.2.7.

A.2.8 Inner ADF

The size of the inner ADF for each interface format shall be three words. Each value of the three words shall be 001_h, 3FE_h, 3FE_h. The change of the LSB in the inner ADF words is to distinguish from the interface ADF words. The position of the inner ADF shall be the same as the ADF of the source channel. The inner ADF shall be used as the reference timing of the inner H-ANC.

A.2.9 Inner H-ANC

Sizes of the inner H-ANC for each source format shall be as shown in table A.1. The value of the inner H-ANC shall be the same as that of the H-ANC of the source format except for the inner ADF. The place where no H-ANC exists shall be set to 040_h.

Annex B (informative)
Examples of alternate source image format mapping

Examples of alternate source image format mapping are shown in figures B.1 and B.2.

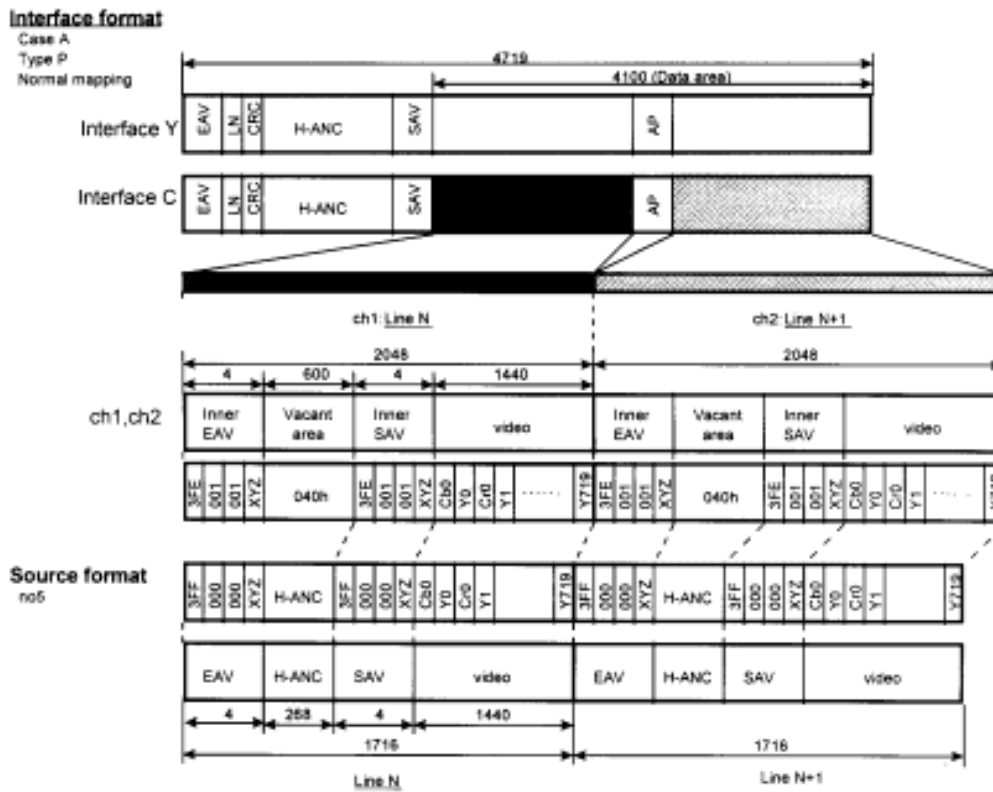

Figure B.1 – Mapping a 525 progressive source into channels 1 and 2 of the interface (normal mapping)

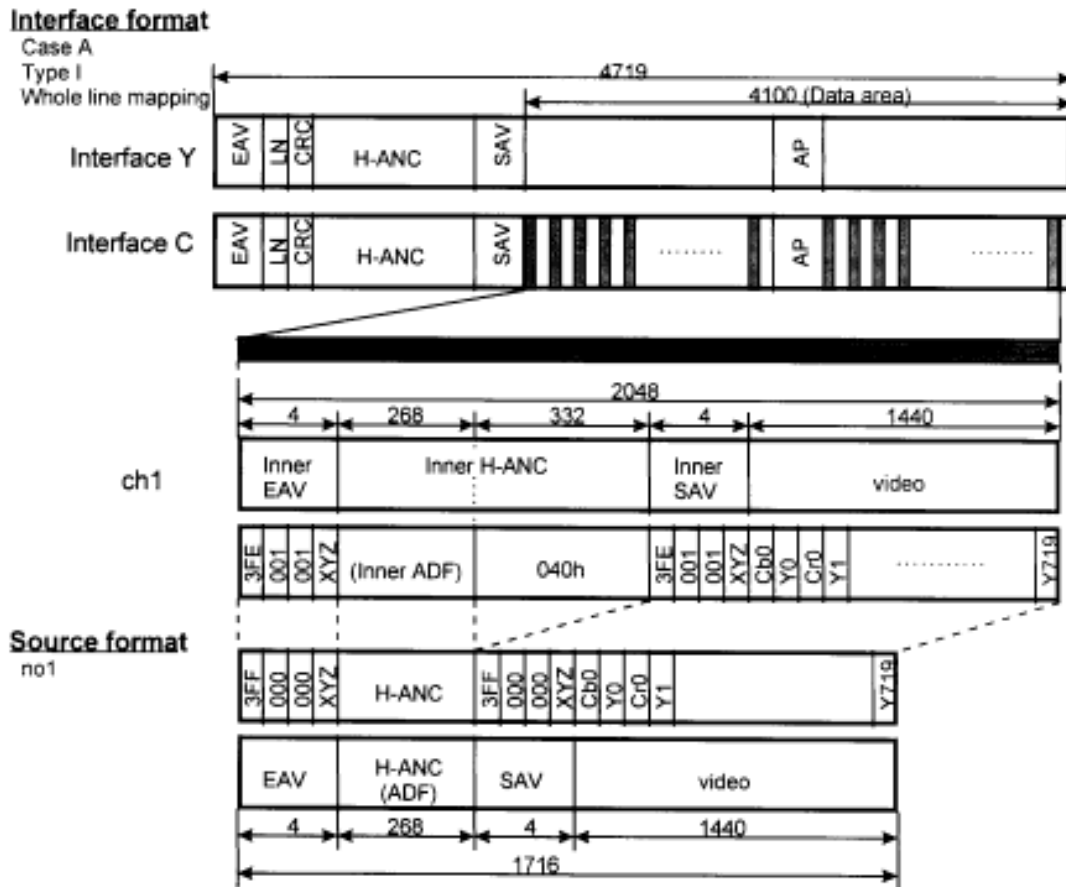

Figure B.2 – Mapping a 525 interlaced source into channel 1 of the interface (whole-line mapping)

Annex C (informative)
Bibliography

ANSI/SMPTE 299M-1997, Television — 24-Bit Digital Audio Format for HDTV Bit-Serial Interface

SMPTE 347M-2001, Television — 540-Mb/s Serial Digital Interface — Source Image Format Mapping