



Recommendation ITU-R BS.1114-8
(06/2014)

**Systems for terrestrial digital sound
broadcasting to vehicular, portable and
fixed receivers in the frequency range
30-3 000 MHz**

BS Series
Broadcasting service (sound)

Foreword

The role of the Radiocommunication Sector is to ensure the rational, equitable, efficient and economical use of the radio-frequency spectrum by all radiocommunication services, including satellite services, and carry out studies without limit of frequency range on the basis of which Recommendations are adopted.

The regulatory and policy functions of the Radiocommunication Sector are performed by World and Regional Radiocommunication Conferences and Radiocommunication Assemblies supported by Study Groups.

Policy on Intellectual Property Right (IPR)

ITU-R policy on IPR is described in the Common Patent Policy for ITU-T/ITU-R/ISO/IEC referenced in Annex 1 of Resolution ITU-R 1. Forms to be used for the submission of patent statements and licensing declarations by patent holders are available from <http://www.itu.int/ITU-R/go/patents/en> where the Guidelines for Implementation of the Common Patent Policy for ITU-T/ITU-R/ISO/IEC and the ITU-R patent information database can also be found.

Series of ITU-R Recommendations

(Also available online at <http://www.itu.int/publ/R-REC/en>)

Series	Title
BO	Satellite delivery
BR	Recording for production, archival and play-out; film for television
BS	Broadcasting service (sound)
BT	Broadcasting service (television)
F	Fixed service
M	Mobile, radiodetermination, amateur and related satellite services
P	Radiowave propagation
RA	Radio astronomy
RS	Remote sensing systems
S	Fixed-satellite service
SA	Space applications and meteorology
SF	Frequency sharing and coordination between fixed-satellite and fixed service systems
SM	Spectrum management
SNG	Satellite news gathering
TF	Time signals and frequency standards emissions
V	Vocabulary and related subjects

Note: This ITU-R Recommendation was approved in English under the procedure detailed in Resolution ITU-R 1.

Electronic Publication
Geneva, 2014

© ITU 2014

All rights reserved. No part of this publication may be reproduced, by any means whatsoever, without written permission of ITU.

RECOMMENDATION ITU-R BS.1114-8

Systems for terrestrial digital sound broadcasting to vehicular, portable and fixed receivers in the frequency range 30-3 000 MHz

(Question ITU-R 56/6)

(1994-1995-2001-2002-2003-2004-2007-2011-2014)

Scope

This Recommendation describes several systems for terrestrial digital sound broadcasting to vehicular, portable and fixed receivers in the frequency range 30-3 000 MHz. The main features of each system, such as source coding, channel coding, modulation, transmission structure and threshold levels to achieve good quality of service, are described.

Keywords

Digital Sound Broadcasting, DAB, ISDB-TSB, IBOC, DRM.

The ITU Radiocommunication Assembly,

considering

- a)* that there is an increasing interest worldwide for terrestrial digital sound broadcasting (DSB) to vehicular, portable and fixed receivers in the frequency range 30-3 000 MHz for local, regional and national coverage;
- b)* that the ITU-R has already adopted Recommendations ITU-R BS.774 and ITU-R BO.789 to indicate the necessary requirements for DSB systems to vehicular, portable and fixed receivers for terrestrial and satellite delivery, respectively;
- c)* that Recommendations ITU-R BS.774 and ITU-R BO.789 recognize the benefits of complementary use of terrestrial and satellite systems, and call for a DSB system allowing for a common receiver with common processing very large scale integration (VLSI) circuits and manufacturing of low-cost receivers through mass production;
- d)* that Digital System A described in Annex 2 meets all the requirements of Recommendations ITU-R BS.774 and ITU-R BO.789, and that the system has been field-tested and demonstrated in various frequency bands between 200 MHz and 1 500 MHz in a number of countries;
- e)* that Digital System F described in Annex 3 meets the requirements of Recommendation ITU-R BS.774, and that the system has been field-tested and demonstrated in the 188-192 MHz and 2 535-2 655 MHz bands in more than one country;
- f)* that Digital System C described in Annex 4 meets the requirements of Recommendation ITU-R BS.774, and that the system has been field-tested and demonstrated in the 88-108 MHz band;
- g)* that Digital System G described in Annex 5 meets the requirements of Recommendation ITU-R BS.774, and that the system with Mode E has been successfully field-tested and demonstrated in VHF Band I (47-68 MHz), in VHF Band II (87.5-108 MHz) and in VHF Band III (174-230 MHz);

h) that at the 7th World Conference of Broadcasting Unions (México, 27-30 April 1992), the World Broadcasting Unions unanimously resolved:

“1 that efforts should be made to agree on a unique worldwide standard for DAB and

2 to urge administrations to give consideration to the benefits for the consumer of common source and channel coding and implementation of Digital Sound Broadcasting on a worldwide basis at 1.5 GHz;”

i) that the MPEG-2 transport stream (MPEG-2 TS) is widely applied as containers of digitally coded information;

j) that a standardization process in Europe has resulted in the adoption of Digital System A (Eureka 147 as an ETSI Standard ETS 300 401) for BSS (sound) broadcasting sound to vehicular, portable and fixed receivers;

k) that a standardization process in Japan has resulted in the adoption of Digital System F for integrated services digital broadcasting-terrestrial for sound broadcasting (ISDB-T_{SB}) for digital terrestrial sound broadcasting system to vehicular, portable and fixed receivers;

l) that ISDB techniques can be used to implement services exploiting the full advantages of digital broadcasting, and that Recommendation ITU-R BT.1306 includes the ISDB-T system for digital terrestrial television broadcasting;

m) that a standardization process in the United States of America has resulted in the adoption of Digital System C (the IBOC system) as NRSC-5 for digital terrestrial sound broadcasting to vehicular, portable and fixed receivers;

n) that a standardization process in Europe has resulted in the adoption of Digital System G (DRM as an ETSI Standard ES 201 980 3.1.1) for digital terrestrial sound broadcasting system to vehicular, portable and fixed receivers,

noting

a) that a summary of digital systems is presented in Annex 1;

b) that the condensed system descriptions for Digital Systems A, C, F and G are given in Annexes 2, 3, 4 and 5, respectively;

c) that complete system descriptions of Digital Systems A, F and C are contained in the Digital Sound Broadcasting Handbook,

recommends

1 that Digital Systems A, F, C and/or G, as described in Annexes 2, 3, 4 and 5, respectively, should be used for terrestrial DSB services to vehicular, portable and fixed receivers in the frequency range 30-3 000 MHz;

2 that administrations that wish to implement terrestrial DSB services meeting some or all of the requirements as stated in Recommendation ITU-R BS.774, should use Table 1 to evaluate the respective merits of Digital Systems A, F, C and G in selecting systems,

invites the ITU membership and radio-receiver manufacturers to consider

- 1** economically viable, portable, multiband, multistandard radio receivers designed to work, through manual or preferably automatic selection, with all the different analogue and digital radio broadcasting systems currently in use in all the relevant frequency bands;
- 2** digital radio receivers allowing downloading of upgrades for some of their specific functionalities, such as decoding, navigation, management capability etc.;
- 3** a simple indicator of the received RF field level and of the bit error rate.

TABLE 1

Performance of Digital Systems A, F, C and G evaluated on the basis of the recommended technical and operating characteristics listed in Recommendation ITU-R BS.774

Characteristics from Recommendation ITU-R BS.774 (condensed wording)	Digital System A	Digital System F	Digital System C	Digital System G
Range of audio quality and types of reception	Range is from 8 to 384 kbit/s per audio channel in increments of 8 kbit/s. MPEG-2 Layer II audio decoder typically operating at 192 kbit/s is implemented in receivers. The system is intended for vehicular, portable and fixed reception	Range is from phone quality to CD quality. It is also capable of 5.1 multi-channel audio. MPEG-2 advanced audio coding (AAC) decoder typically operates at 144 kbit/s for stereo. The system is intended for vehicular, portable and fixed reception	Range is from 36 kbit/s to 96 kbit/s using the HD Codec ⁽¹⁾ decoder. The system is intended for vehicular ⁽²⁾ , portable and fixed reception	Range of the useful content bit rate is from 37-186 kbit/s for the whole multiplex ensemble with a maximum of four services in all modes. Using the MPEG-4 HE-AAC v2 audio decoder CD quality is achieved. It is also capable of 5.1 multichannel audio. The system is intended for vehicular, portable and fixed reception ⁽³⁾
Spectrum efficiency better than FM	FM stereo quality achievable in less than 200 kHz bandwidth; co-channel and adjacent channel protection requirements much less than those for FM. Efficiency is especially high in the case of repeaters reusing the same frequency. (Orthogonal multi-carrier modulation with convolution error correcting coding, coded orthogonal frequency division multiplex (COFDM))	FM stereo quality achievable in less than 200 kHz bandwidth; co-channel and adjacent channel protection requirements much less than those for FM. Efficiency is especially high in the case of repeaters reusing the same frequency. It can be more effective by using 16/64-quadrature amplitude modulation (QAM) carrier modulation. (Orthogonal frequency division multiplex (OFDM) with concatenated block and convolutional error correcting coding)	FM stereo quality and data achievable without additional spectrum; co-channel and adjacent channel protection requirements much less than those for FM. System is interleaved to mitigate first adjacent channel issues and is more robust in the presence of co-channel analogue digital interference	FM stereo quality and data achievable within 100 kHz bandwidth; co-channel and adjacent channel protection requirements much less than those for FM. Further improvement in the efficiency of spectrum use can be achieved by operating multiple transmitters on the same frequency (i.e. SFN single frequency network). Efficiency is especially high in the case of repeaters reusing the same frequency. It can be more efficient by using 16-quadrature amplitude modulation (QAM) carrier modulation besides 4-QAM. (Orthogonal frequency division multiplex (OFDM) with multilevel error correcting coding)

TABLE 1 (continued)

Characteristics from Recommendation ITU-R BS.774 (condensed wording)	Digital System A	Digital System F	Digital System C	Digital System G
Performance in multipath and shadowing environments	System is especially designed for multipath operation. It works on the basis of a power summation of echoes falling within a given time interval. This feature allows use of on-channel repeaters to cover terrain shadowed areas	System is especially designed for multipath environment. It works on the basis of a power summation of echoes falling within a given time interval. This feature allows the use of on-channel repeaters to cover terrain shadowed areas	System is especially designed for multipath operation. It is OFDM modulated thereby achieving a high degree of performance in multipath. This feature allows the use of on-channel repeaters to cover terrain shadowed areas	System is especially designed for multipath environment. It works on the basis of a power summation of echoes falling within a given time interval. This feature allows the use of on-channel repeaters to cover terrain shadowed areas
Common receiver signal processing for satellite (S) and terrestrial (T) broadcasting	Not applicable. Terrestrial only	Not applicable. Terrestrial only	Not applicable. Terrestrial only	Not applicable. Terrestrial only

TABLE 1 (continued)

Characteristics from Recommendation ITU-R BS.774 (condensed wording)	Digital System A	Digital System F	Digital System C	Digital System G
Reconfiguration and quality vs. number of programmes tradeoff	Service multiplex is based on 64 sub-channels of capacity varying from 8 kbit/s to about 1 Mbit/s, depending on the error protection level, and is totally reconfigurable in a dynamic fashion. Each sub-channel can also contain an unlimited number of variable capacity data packet channels	Multiplexing of payload data is based on MPEG-2 systems. Audio data rate can be selected in any step in order to trade off programme audio quality against the number of services. Transmission parameters such as modulation and error correction are dynamically reconfigurable by transmission and multiplexing configuration control (TMCC)	Bits can be dynamically re-allocated to audio or data using the HDC transport functionalities at the discretion of the broadcaster within the range of 36 to 96 kbit/s for audio to increase or decrease the data rate. The receiver dynamically re-configures to match the transmission mode of operation	Service multiplex can support up to four streams, the capacity of which can vary according to broadcaster needs and is totally reconfigurable in a dynamic fashion. Each stream may carry audio or data content with the packet size configurable by the broadcaster to maximize efficiency. The receiver dynamically reconfigures to match the transmission mode of operation
Extent of coverage vs. number of programme trade-offs	Five levels of protection for audio and eight levels of protection for data services are available through using punctured convolutional coding for each of the 64 sub-channels (forward error correction (FEC) ranges from 1/4 to 3/4)	Four kinds of modulation and five levels of protection are available. (Carrier modulation: differential quaternary phase shift keying (DQPSK), QPSK, 16-QAM, 64-QAM, coding rate: 1/2, 2/3, 3/4, 5/6, 7/8)	The system maintains uniform coverage for all programs. Secondary carriers may have reduced range in presence of adjacent channel interference. (Carrier modulation: QPSK)	Two kinds of modulation (4-QAM, 16-QAM) and different levels of protection (two levels for the SDC and four levels for the MSC) are available. Each stream may be dynamically configured. Forward error correction (FEC) ranges from 1/4 to 5/8)

TABLE 1 (continued)

<p>Characteristics from Recommendation ITU-R BS.774 (condensed wording)</p>	<p>Digital System A</p>	<p>Digital System F</p>	<p>Digital System C</p>	<p>Digital System G</p>
<p>Common receiver for different means of programme delivery – Terrestrial services</p>	<p>Allows local, subnational and national terrestrial services with the same modulation with single transmitter or multiple transmitters operating in a single frequency network to take advantage of a common receiver</p>	<p>Allows local, subnational and national terrestrial services with the same modulation with a single transmitter or multiple transmitters operating in a single frequency network to take advantage of a common receiver</p>	<p>System uses common antenna and front end that is compatible with existing analogue FM broadcast services. Allows for local service as well as subnational and national terrestrial services with a single transmitter or multiple transmitters operating in a single frequency network in the case of the digital portion of the hybrid mode or the all digital mode. Allows for common delivery of FM programming that makes a seamless transition from digital to analogue and back. Permits simulcasting of identical programming in analogue and digital mode</p>	<p>Allows local, subnational and national terrestrial services with the same modulation with a single transmitter or multiple transmitters operating in a single frequency network to take advantage of a common receiver. Designed as a terrestrial digital only system</p>

TABLE 1 (continued)

Characteristics from Recommendation ITU-R BS.774 (condensed wording)	Digital System A	Digital System F	Digital System C	Digital System G
<ul style="list-style-type: none"> – Mixed/hybrid – Cable distribution 	<p>Allows the use of the same band as terrestrial sound broadcasting (mixed) as well as the use of terrestrial on-channel repeaters to reinforce the satellite coverage (hybrid) resulting in all these channels being received transparently by a common receiver.</p> <p>Signal can be carried transparently by cable</p>	<p>Allows the use of the same band as terrestrial sound broadcasting (mixed) as well as the use of terrestrial on-channel repeaters to reinforce the satellite coverage (hybrid) resulting in all these channels being received transparently by a common receiver.</p> <p>Signal can be carried transparently by cable</p>	<p>Signal can be carried transparently by cable</p>	<p>Signal can be carried transparently by cable</p>

TABLE 1 (continued)

Characteristics from Recommendation ITU-R BS.774 (condensed wording)	Digital System A	Digital System F	Digital System C	Digital System G
Programme-associated data (PAD) capability	PAD channel from 0.66 kbit/s to 64 kbit/s capacity is available through a reduction of any audio channel by the corresponding amount. Dynamic label for programme and service identification showing only receiver alphanumeric display is available to all receivers. Basic hypertext markup language (HTML) decoding and Joint Photographic Experts Group (JPEG) picture decoding is available on receivers with graphic displays (1/4 video graphic array (VGA)), etc.	PAD multiplexing is based on MPEG-2 systems	PAD is an integral part of the system and can be provided through opportunistic data without any reduction of audio quality or data channels. Dynamic label for programme and service identification showing on any receiver alphanumeric display is available to all receivers	PAD with broadcaster selected capacity is available. Dynamic label for programme and service identification showing on any receiver alphanumeric display is available to all receivers (DRM TextMessages; programme accompanying labels (Unicode)); Electronic programme guide; advanced text-based information service (Unicode), supporting all classes of receivers, triggers interactivity and geo-awareness; programme accompanying images + animation traffic information small-scale video
Flexible assignment of services	The multiplex can be dynamically re-configured in a fashion transparent to the user	The multiplex can be dynamically re-configured in a fashion transparent to the user	The system automatically reconfigures between audio and data in a fashion transparent to user	The multiplex can be dynamically reconfigured in a fashion transparent to the user

TABLE 1 (continued)

Characteristics from Recommendation ITU-R BS.774 (condensed wording)	Digital System A	Digital System F	Digital System C	Digital System G
Compatibility of multiplex structure with open system interconnection (OSI)	The system multiplex structure is compliant with the OSI layered model, especially for the data channels, except for the unequal error protection features of the MPEG-2 Layer II audio channel	The system multiplex structure is fully compliant with MPEG-2 systems architecture	The system is based on an OSI layered model including both data and audio except for the unique error protection afforded the audio codec	The system multiplex structure is compliant with the OSI layered model for all services
Value-added data capability	Any sub-channel (out of 64) not used for audio can be used for programme-independent data services. Data packet channels for high priority services available to all receivers tuned to any service of the multiplex can be carried in the fast information channel (FIC). Total capacity is up to 16 kbit/s. Receivers are equipped with a radio data interface (RDI) for data transfer to a computer	Capacity at any rate up to the full payload capacity can be assigned to independent data for the delivery of business data, paging, still pictures graphics, etc. under conditional access control if desired	Capacity at any rate up to the full payload capacity can be assigned to independent data for the delivery of business data, paging still pictures graphics, etc. under conditional access control if desired	Capacity at any rate up to the full payload capacity can be assigned to independent data for the delivery of business data, paging still pictures graphics, etc. under conditional access control if desired

TABLE 1 (end)

Characteristics from Recommendation ITU-R BS.774 (condensed wording)	Digital System A	Digital System F	Digital System C	Digital System G
Receiver low-cost manufacturing	Allows for mass-production manufacturing and low-cost consumer receivers. Typical receivers have been integrated in two chips. One chip manufacturer has integrated the full receiver circuitry into one chip	The system was specifically optimized to enable an initial low complexity vehicular receiver deployment. Standardization group has been established to achieve low cost receivers based on large scale integration (LSI) mass production techniques	The system was specifically optimized to enable an initial low complexity vehicular receiver deployment	Allows for mass-production manufacturing and low-cost consumer receivers

⁽¹⁾ Additional information about the HD Codec (HDC) can be found at www.ibequity.com.

⁽²⁾ The modes implemented in the in-band on-channel (IBOC) chipset (Digital System C) do not support vehicular operation at frequencies above 230 MHz.

⁽³⁾ The system was successfully tested in Regions 1 and 3.

With respect to Region 2, field test data is not available to demonstrate compatibility with analogue broadcasting in areas with significant co- and adjacent-channel interference.

Annex 1

Summaries of Digital Systems

1 Summary of Digital System A

Digital System A, also known as the Eureka 147 digital audio broadcasting (DAB) system, has been developed for both satellite and terrestrial broadcasting applications in order to allow a common low-cost receiver to be used. The system has been designed to provide vehicular, portable and fixed reception with low gain omni-directional receive antennas located at 1.5 m above ground. Digital System A allows for complementary use of satellite and terrestrial broadcast transmitters resulting in better spectrum efficiency and higher service availability in all receiving situations. It especially offers improved performance in multipath and shadowing environments which are typical of urban reception conditions by the use of on-channel terrestrial repeaters to serve as gap-fillers. Digital System A is capable of offering various levels of sound quality up to high quality sound comparable to that obtained from consumer digital recorded media. It can also offer various data services and different levels of conditional access and the capability of dynamically re-arranging the various services contained in the multiplex.

2 Summary of Digital System F

Digital System F, also known as the ISDB-TSB system, is designed to provide high-quality sound and data broadcasting with high reliability even in mobile reception. The system is also designed to provide flexibility, expandability, and commonality for multimedia broadcasting using terrestrial networks. The system is a rugged system which uses OFDM modulation, two-dimensional frequency-time interleaving and concatenated error correction codes. The OFDM modulation used in the system is called band segmented transmission (BST)-OFDM. The system has commonality with the ISDB-T system for digital terrestrial television broadcasting in the physical layer. The system has a wide variety of transmission parameters such as carrier modulation scheme, coding rates of the inner error correction code, and length of time interleaving. Some of the carriers are assigned to TMCC carriers which transmit the information on the transmission parameters for receiver control. Digital System F can use high compression audio coding methods such as MPEG-2 AAC. And also, the system adopts MPEG-2 systems. It has commonality and interoperability with many other systems which adopt MPEG-2 systems such as ISDB-S, ISDB-T, DVB-S and DVB-T.

3 Summary of Digital System C

Digital System C, also known as the IBOC DSB system, is a fully developed system. The system was designed to provide vehicular¹, portable and fixed reception using terrestrial transmitters. Although Digital System C can be implemented in unoccupied spectrum, a significant feature of the system is its ability to offer simul-casting of analogue and digital signals in the existing FM broadcasting band. This system feature would allow for a rational transition for existing FM broadcasters seeking to transition from analogue to digital broadcasting. The system offers improved performance in multipath environments resulting in greater reliability than is offered by existing analogue FM operations. Digital System C offers enhanced audio quality comparable to

¹ The modes implemented in the IBOC chipset (Digital System C) do not support vehicular operation at frequencies above 230 MHz.

that obtained from consumer digital recorded media. Moreover, the system incorporates flexibility for broadcasters to offer new data-casting services in addition to the enhanced audio programming. In addition, the system allows for allocation of bits between audio and data-casting capacity to maximize the data-casting capabilities.

4 Summary of Digital System G

Digital System G, also known as the Digital Radio Mondiale (DRM) system, has been developed for terrestrial broadcasting applications in all the frequency bands allocated worldwide for analogue sound broadcasting. It respects the ITU-defined spectrum masks, allowing a smooth transition from analogue to digital broadcasting. The system is designed as a digital-only system. In the bands above 30 MHz, it defines Robustness Mode E (also known as DRM+) to offer audio quality comparable to that obtained from consumer digital recorded media. In addition, Digital System G also offers various data services, including images and electronic programme guides, and the capability of dynamically rearranging the various services contained in the multiplex without loss of audio.

Annex 2

Digital System A

1 Introduction

Digital System A is designed to provide high-quality, multi-service digital radio broadcasting for reception by vehicular, portable and fixed receivers. It is designed to operate at any frequency up to 3 000 MHz for terrestrial, satellite, hybrid (satellite and terrestrial), and cable broadcast delivery. The system is also designed as a flexible, general-purpose ISDB system which can support a wide range of source and channel coding options, sound-programme associated data and independent data services, in conformity with the flexible and broad-ranging service and system requirements given in Recommendations ITU-R BO.789 and ITU-R BS.774, supported by the Digital Sound Broadcasting Handbook and Report ITU-R BS.1203.

This System is a rugged, yet highly spectrum- and power-efficient, sound and data broadcasting system. It uses advanced digital techniques to remove redundancy and perceptually irrelevant information from the audio source signal, then applies closely-controlled redundancy to the transmitted signal for error correction. The transmitted information is then spread in both the frequency and time domains so that a high quality signal is obtained in the receiver, even when working in conditions of severe multipath propagation, whether stationary or mobile. Efficient spectrum utilization is achieved by interleaving multiple programme signals and a special feature of frequency reuse permits broadcasting networks to be extended, virtually without limit, using additional transmitters all operating on the same radiated frequency.

The conceptual diagram of the transmission part of System A is given in Fig. 1.

Digital System A has been developed by the Eureka 147 DAB Consortium and is known as the Eureka DAB System. It has been actively supported by the European Broadcasting Union (EBU) in view of introducing digital sound-broadcasting services in Europe in 1995. Since 1988, the system has been successfully demonstrated and extensively tested in Europe, Canada, the United

States of America and in other countries worldwide. In Annex 2, Digital System A is referred to as “System A”. The full system specification is available as European Telecommunications Standard ETS 300 401 (see Note 1).

NOTE 1 – The addition of a new transmission mode, bridging the gap between current Modes I and II, has been found to be desirable, and is being considered as a compatible enhancement to System A to allow for larger separation distances between co-channel re-transmitters used in a single-frequency-network, or used as coverage extenders or gap-fillers, thus resulting in better flexibility and lower cost in implementing terrestrial DSB in the 1 452-1 492 MHz band.

FIGURE 1
Conceptual diagram of the transmission part of System A

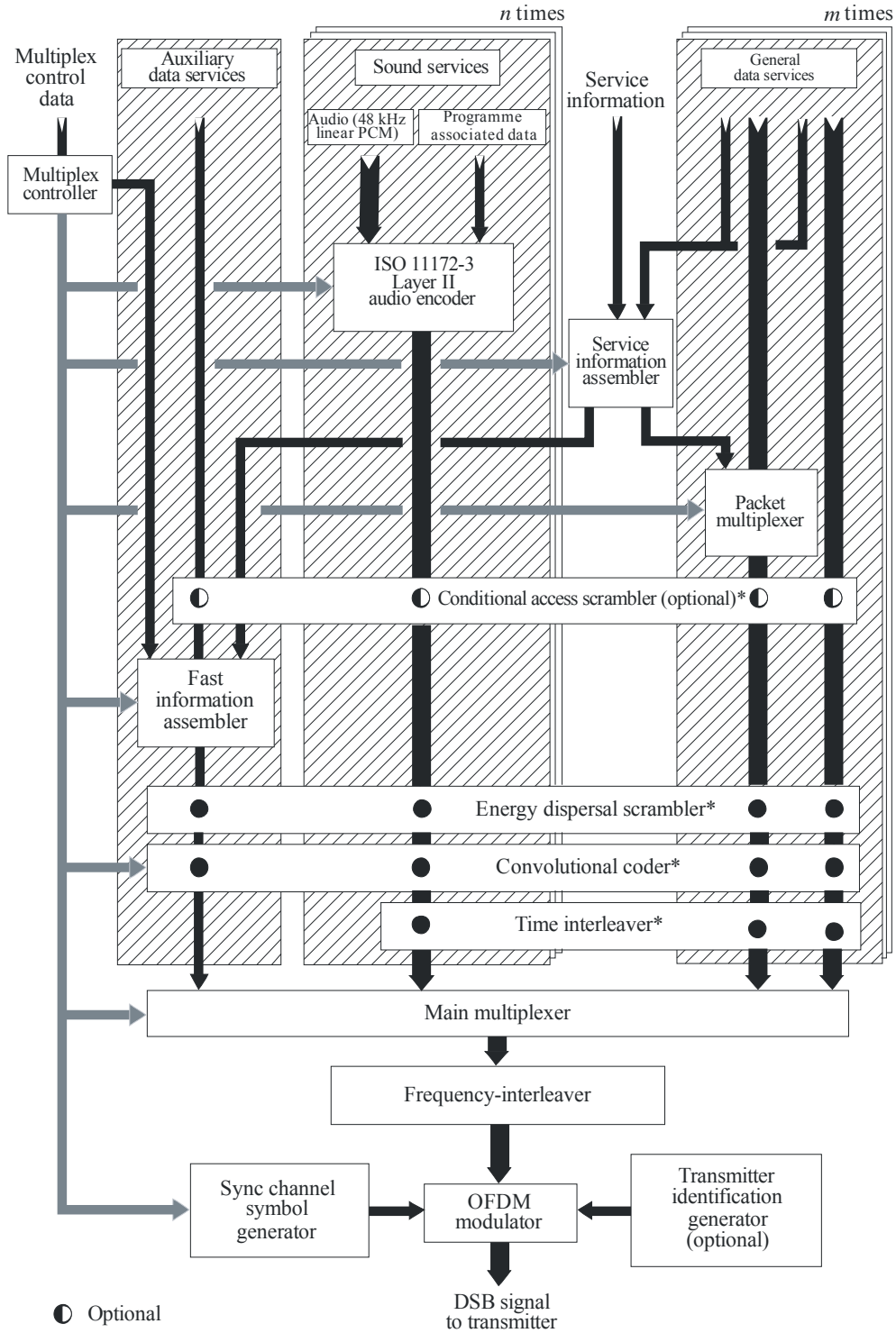

- Optional
- Function applied

* These processors operate independently on each service channel.

2 Use of a layered model

The System A is capable of complying with the International Organization for Standardization (ISO) OSI basic reference model described in ISO 7498 (1984). The use of this model is recommended in Recommendation ITU-R BT.807 and Report ITU-R BT.1207, and a suitable interpretation for use with layered broadcasting systems is given in the Recommendation. In accordance with this guidance, the System A will be described in relation to the layers of the model, and the interpretation applied here is illustrated in Table 2.

Descriptions of many of the techniques involved are most easily given in relation to the operation of the equipment at the transmitter, or at the central point of a distribution network in the case of a network of transmitters.

TABLE 2
Interpretation of the OSI layered model

Name of layer	Description	Features specific to the System
Application layer	Practical use of the System	System facilities Audio quality Transmission modes
Presentation layer	Conversion for presentation	Audio encoding and decoding Audio presentation Service information
Session layer	Data selection	Programme selection Conditional access
Transport layer	Grouping of data	Programme services Main service multiplex Ancillary data Association of data
Network layer	Logical channel	ISO audio frames Programme associated data
Data link layer	Format of the transmitted signal	Transmission frames Synchronization
Physical layer	Physical (radio) transmission	Energy dispersal Convolutional encoding Time interleaving Frequency interleaving Modulation by DQPSK OFDM Radio transmission

The fundamental purpose of System A is to provide sound programmes to the radio listener, so the order of sections in the following description will start from the application layer (use of the broadcast information), and proceed downwards to the physical layer (the means for radio transmission).

3 Application layer

This layer concerns the use of System A at the application level. It considers the facilities and audio quality which System A provides and which broadcasters can offer to their listeners, and the different transmission modes.

3.1 Facilities offered by the System

System A provides a signal which carries a multiplex of digital data, and this conveys several programmes at the same time. The multiplex contains audio programme data, and ancillary data comprising PAD, multiplex configuration information (MCI) and service information (SI). The multiplex may also carry general data services which may not be related to the transmission of sound programmes.

In particular, the following facilities are made available to users of the System A:

- the audio signal (i.e. the programme) being provided by the selected programme service;
- the optional application of receiver functions, for example dynamic range control, which may use ancillary data carried with the programme;
- a text display of selected information carried in the SI. This may be information about the selected programme, or about others which are available for optional selection;
- options which are available for selecting other programmes, other receiver functions, and other SI;
- one or more general data services, for example a traffic message channel (TMC).

System A includes facilities for conditional access, and a receiver can be equipped with digital outputs for audio and data signals.

3.2 Audio quality

Within the capacity of the multiplex, the number of programme services and, for each, the presentation format (e.g. stereo, mono, surround-sound, etc.), the audio quality and the degree of error protection (and hence ruggedness) can be chosen to meet the needs of the broadcasters.

The following range of options is available for the audio quality:

- very high quality, with audio processing margin;
- subjectively transparent quality, sufficient for the highest quality broadcasting;
- high quality, equivalent to good FM service quality;
- medium quality, equivalent to good AM service quality;
- speech-only quality.

System A provides full quality reception within the limits of transmitter coverage; beyond these limits reception degrades in a subjectively graceful manner.

3.3 Transmission modes

System A has four alternative transmission modes which allow the use of a wide range of transmitting frequencies up to 3 GHz. These transmission modes have been designed to cope with Doppler spread and delay spread, for mobile reception in presence of multipath echoes.

Table 3 gives the constructive echo delay and nominal frequency range for mobile reception. The noise degradation at the highest frequency and in the most critical multipath condition, occurring infrequently in practice, is equal to 1 dB at 100 km/h.

TABLE 3

Parameter	Mode I	Mode II	Mode III	Mode IV
Guard interval duration (μ s)	246	62	31	123
Constructive echo delay up to (μ s)	300	75	37.5	150

From Table 3, it can be seen that the use of higher frequencies imposes a greater limitation on the maximum echo delay. Mode I is most suitable for a terrestrial single-frequency network (SFN), because it allows the greatest transmitter separations. Mode II is most suitable for local radio applications requiring one terrestrial transmitter, and hybrid satellite/terrestrial transmission up to 1.5 GHz. However, Mode II can also be used for a medium-to-large scale SFN in the UHF band (e.g. at 1.5 GHz) by inserting, if necessary, artificial delays at the transmitters and/or by using directive transmitting antennas. Mode III is most appropriate for satellite and complementary terrestrial transmission at all frequencies up to 3 GHz.

Mode III is also the preferred mode for cable transmission up to 3 GHz.

Mode IV is most suitable for medium-to-large scale SFN in the UHF band.

4 Presentation layer

This layer concerns the conversion and presentation of the broadcast information.

4.1 Audio source encoding

The audio source encoding method used by the System is ISO/IEC MPEG-Audio Layer II, given in the ISO Standard 11172-3. This sub-band coding compression system is also known as the MUSICAM system.

System A accepts a number of PCM audio signals at a sampling rate of 48 kHz with PAD. The number of possible audio sources depends on the bit rate and the error protection profile. The audio encoder can work at 32, 48, 56, 64, 80, 96, 112, 128, 160 or 192 kbit/s per monophonic channel. In stereophonic or dual channel mode, the encoder produces twice the bit rate of a mono channel.

The different bit-rate options can be exploited by broadcasters depending on the intrinsic quality required and/or the number of sound programmes to be provided. For example, the use of bit rates greater than, or equal to 128 kbit/s for mono, or greater than or equal to 256 kbit/s for a stereo programme, provides not only very high quality, but also some processing margin, sufficient for further multiple encoding/decoding processes, including audio post-processing. For high-quality broadcasting purposes, a bit rate of 128 kbit/s for mono or 256 kbit/s for stereo is preferred, giving fully transparent audio quality. Even the bit rate of 192 kbit/s per stereo programme generally fulfils the EBU requirement for digital audio bit-rate reduction systems. A bit-rate of 96 kbit/s for mono gives good sound quality, and 48 kbit/s can provide roughly the same quality as normal AM broadcasts. For some speech-only programmes, a bit rate of 32 kbit/s may be sufficient where the greatest number of services is required within the system multiplex.

A block diagram of the functional units in the audio encoder is given in Fig. 2. The input PCM audio samples are fed into the audio encoder. One encoder is capable of processing both channels of a stereo signal, although it may, optionally, be presented with a mono signal. A polyphase filter bank divides the digital audio signal into 32 sub-band signals, and creates a filtered and sub-sampled representation of the input audio signal. The filtered samples are called sub-band samples. A perceptual model of the human ear creates a set of data to control the quantizer and coding. These data can be different, depending on the actual implementation of the encoder. One possibility is to use an estimation of the masking threshold to obtain these quantizer control data. Successive samples of each sub-band signal are grouped into blocks, then in each block, the maximum amplitude attained by each sub-band signal is determined and indicated by a scale factor. The quantizer and coding unit creates a set of coding words from the sub-band samples. These processes are carried out during ISO audio frames, which will be described in the network layer.

FIGURE 2

Block diagram of the basic system audio encoder

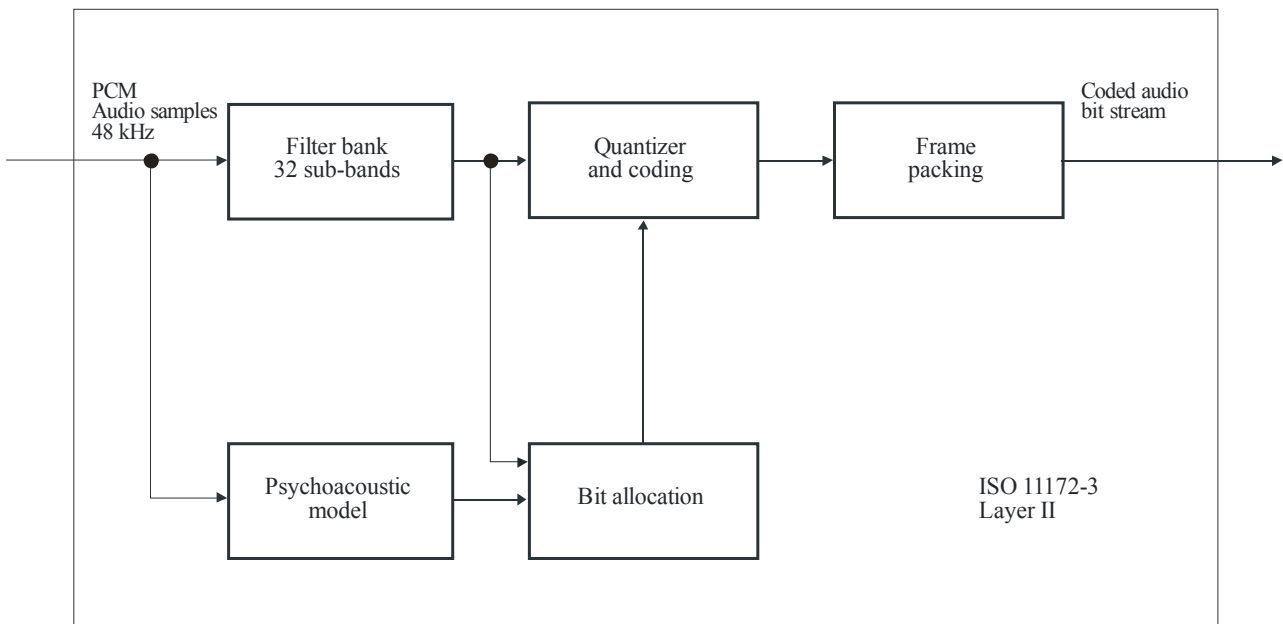

BS.1114-02

4.2 Audio decoding

Decoding in the receiver is straightforward and economical using a simple signal processing technique, requiring only de-multiplexing, expanding and inverse-filtering operations. A block diagram of the functional units in the decoder is given in Fig. 3.

FIGURE 3

Block diagram of the basic system audio decoder

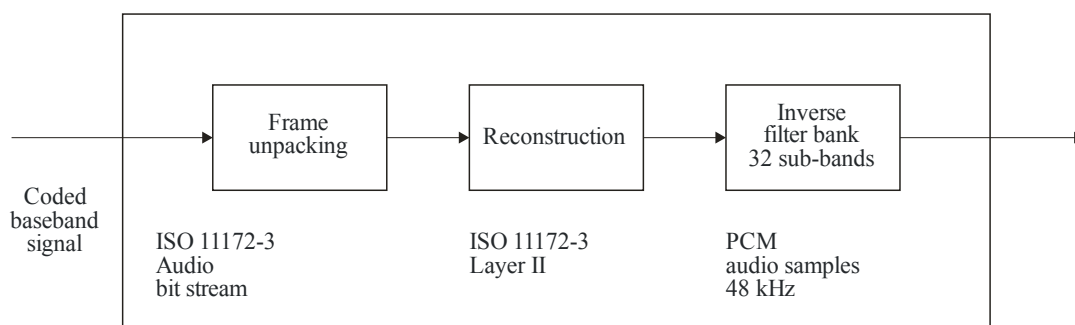

BS.1114-03

The ISO audio frame is fed into the ISO/MPEG-Audio Layer II decoder, which unpacks the data of the frame to recover the various elements of information. The reconstruction unit reconstructs the quantized sub-band samples, and an inverse filter bank transforms the sub-band samples back to produce digital uniform PCM audio signals at 48 kHz sampling rate.

4.3 Audio presentation

Audio signals may be presented monophonically or stereophonically, or audio channels may be grouped for surround-sound. Programmes may be linked to provide the same programme simultaneously in a number of different languages. In order to satisfy listeners in both hi-fi and

noisy environments, the broadcaster can optionally transmit a dynamic range control (DRC) signal which can be used in the receiver in a noisy environment to compress the dynamic range of the reproduced audio signal. Note that this technique can also be beneficial to listeners with impaired hearing.

4.4 Presentation of service information

With each programme transmitted by the system, the following elements of SI can be made available for display on a receiver:

- basic programme label (i.e. the name of the programme),
- time and date,
- cross-reference to the same, or similar programme (e.g. in another language) being transmitted in another ensemble or being simulcast by an AM or FM service,
- extended service label for programme-related services,
- programme information (e.g. the names of performers),
- language,
- programme type (e.g. news, sport, music, etc.),
- transmitter identifier,
- traffic message channel (TMC, which may use a speech synthesizer in the receiver).

Transmitter network data can also be included for internal use by broadcasters.

5 Session layer

This layer concerns the selection of, and access to, broadcast information.

5.1 Programme selection

In order that a receiver can gain access to any or all of the individual services with a minimum overall delay, information about the current and future content of the multiplex is carried by the FIC. This information is the MCI, which is machine-readable data. Data in the FIC are not time-interleaved, so the MCI is not subject to the delay inherent in the time-interleaving process applied to audio and general data services. However, these data are repeated frequently to ensure their ruggedness. When the multiplex configuration is about to change, the new information, together with the timing of the change is sent in advance in the MCI.

The user of a receiver can select programmes on the basis of textual information carried in the SI, using the programme service name, the programme type identity or the language. The selection is then implemented in the receiver using the corresponding elements of the MCI.

If alternative sources of a chosen programme service are available and an original digital service becomes untenable, then linking data carried in the SI (i.e. the “cross reference”) may be used to identify an alternative (e.g. on an FM service) and switch to it. However, in such a case, the receiver will switch back to the original service as soon as reception is possible.

5.2 Conditional access

Provision is made for both synchronization and control of conditional access.

Conditional access can be applied independently to the service components (carried either in the main service channel (MSC) or FIC), services or the whole multiplex.

6 Transport layer

This layer concerns the identification of groups of data as programme services, the multiplexing of data for those services and the association of elements of the multiplexed data.

6.1 Programme services

A programme service generally comprises an audio service component and optionally additional audio and/or data service components, provided by one service provider. The whole capacity of the multiplex may be devoted to one service provider (e.g. broadcasting five or six high-quality sound programme services), or it may be divided amongst several service providers (e.g. collectively broadcasting some twenty medium quality programme services).

6.2 Main service multiplex

With reference to Fig. 1, the data representing each of the programmes being broadcast (digital audio data with some ancillary data, and maybe also general data) are subjected to convolutional encoding (see § 9.2) and time-interleaving, both for error protection. Time-interleaving improves the ruggedness of data transmission in a changing environment (e.g. reception by a moving vehicular receiver) and imposes a predictable transmission delay. The interleaved and encoded data are then fed to the main service multiplexer where, each 24 ms, the data are gathered in sequence into the multiplex frame. The combined bit stream output from the multiplexer is known as the MSC which has a gross capacity of 2.3 Mbit/s. Depending on the chosen code rate (which can be different from one service component to another), this gives a net bit rate ranging from approximately 0.8 to 1.7 Mbit/s, through a 1.5 MHz bandwidth. The main service multiplexer is the point at which synchronized data from all of the programme services using the multiplex are brought together.

General data may be sent in the MSC as an unstructured stream or organized as a packet multiplex where several sources are combined. The data rate may be any multiple of 8 kbit/s, synchronized to the system multiplex, subject to sufficient total multiplex capacity, taking into account the demand for audio services.

The FIC is external to the MSC and is not time-interleaved.

6.3 Ancillary data

There are three areas where ancillary data may be carried within the system multiplex:

- the FIC, which has limited capacity, depending on the amount of essential MCI included;
- there is special provision for a moderate amount of PAD to be carried within each audio channel;
- all remaining ancillary data are treated as a separate service within the MSC. The presence of this information is signalled in the MCI.

6.4 Association of data

A precise description of the current and future content of the MSC is provided by the MCI, which is carried by the FIC. Essential items of SI which concern the content of the MSC (i.e. for programme selection) must also be carried in the FIC. More extensive text, such as a list of all the day's programmes, must be carried separately as a general data service. Thus, the MCI and SI contain contributions from all of the programmes being broadcast.

The PAD, carried within each audio channel, comprises mainly the information which is intimately linked to the sound programme and therefore cannot be sent in a different data channel which may be subject to a different transmission delay.

7 Network layer

This layer concerns the identification of groups of data as programmes.

7.1 ISO audio frames

The processes in the audio source encoder are carried out during ISO audio frames of 24 ms duration. The bit allocation, which varies from frame to frame, and the scale factors are coded and multiplexed with the sub-band samples in each ISO audio frame. The frame packing unit (see Fig. 2) assembles the actual bit stream from the output data of the quantizer and coding unit, and adds other information, such as header information, CRC words for error detection, and PAD, which travel along with the coded audio signal. Each audio channel contains a PAD channel having a variable capacity (generally at least 2 kbit/s), which can be used to convey information which is intimately linked to the sound programme. Typical examples are lyrics, speech/music indication and DRC information.

The resulting audio frame carries data representing 24 ms duration of stereo (or mono) audio, plus the PAD, for a single programme and complies with the ISO 11172-3 Layer II format, so it can be called an ISO frame. This allows the use of an ISO/MPEG-Audio Layer II decoder in the receiver.

8 Data link layer

This layer provides the means for receiver synchronization.

8.1 The transmission frame

In order to facilitate receiver synchronization, the transmitted signal is built up with a regular frame structure (see Fig. 4). The transmission frame comprises a fixed sequence of symbols. The first is a null symbol to provide a coarse synchronization (when no RF signal is transmitted), followed by a fixed reference symbol to provide a fine synchronization, automatic gain control (AGC), automatic frequency control (AFC) and phase reference functions in the receiver; these symbols make up the synchronization channel. The next symbols are reserved for the FIC, and the remaining symbols provide the MSC. The total frame duration T_F is either 96 ms, 48 ms or 24 ms, depending on the transmission mode as given in Table 4.

FIGURE 4
Multiplex frame structure

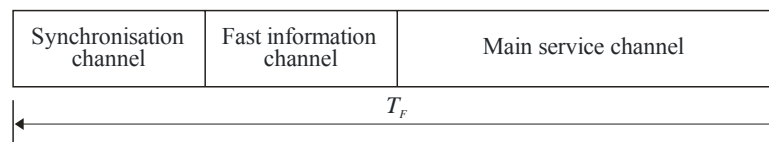

TABLE 4
Transmission parameters of System A

Parameter	Mode I	Mode II	Mode III	Mode IV
Transmission frame duration, T_F	96 ms	24 ms	24 ms	48 ms
Null symbol duration, T_{NULL}	1.297 ms	324 μ s	168 μ s	648 μ s
Duration of OFDM symbols, T_s	1.246 ms	312 μ s	156 μ s	623 μ s
Inverse of the carrier spacing, T_u	1 ms	250 μ s	125 μ s	500 μ s
Duration of the time interval called guard interval, Δ ($T_s = T_u + \Delta$)	246 μ s	62 μ s	31 μ s	123 μ s
Number of transmitted carriers, K	1 536	384	192	768

Each audio service within the MSC is allotted a fixed time slot in the frame.

9 The physical layer

This layer concerns the means for radio transmission (i.e. the modulation scheme and the associated error protection).

9.1 Energy dispersal

In order to ensure appropriate energy dispersal in the transmitted signal, the individual sources feeding the multiplex are scrambled.

9.2 Convolutional encoding

Convolutional encoding is applied to each of the data sources feeding the multiplex to ensure reliable reception. The encoding process involves adding deliberate redundancy to the source data bursts (using a constraint length of 7). This gives “gross” data bursts.

In the case of an audio signal, greater protection is given to some source-encoded bits than others, following a preselected pattern known as the unequal error protection (UEP) profile. The average code rate, defined as the ratio of the number of source-encoded bits to the number of encoded bits after convolutional encoding, may take a value from 1/3 (the highest protection level) to 3/4 (the lowest protection level). Different average code rates can be applied to different audio sources, subject to the protection level required and the bit rate of the source-encoded data. For example, the protection level of audio services carried by cable networks may be lower than that of services transmitted in radio-frequency channels.

General data services are convolutionally encoded using one of a selection of uniform rates. Data in the FIC are encoded at a constant 1/3 rate.

9.3 Time interleaving

Time interleaving with an interleaving depth of 16 frames is applied to the convolutionally encoded data in order to provide further assistance to a mobile receiver.

9.4 Frequency interleaving

In the presence of multipath propagation, some of the carriers are enhanced by constructive signals, while others suffer destructive interference (frequency selective fading). Therefore, the system

provides frequency interleaving by a rearrangement of the digital bit stream amongst the carriers, such that successive source samples are not affected by a selective fade. When the receiver is stationary, the diversity in the frequency domain is the prime means to ensure successful reception.

9.5 Modulation by 4-DPSK OFDM

System A uses DQPSK OFDM. This scheme meets the exacting requirements of high bit-rate digital broadcasting to mobile, portable and fixed receivers, especially in multipath environments.

The basic principle consists of dividing the information to be transmitted into a large number of bit streams having low bit rates individually, which are then used to modulate individual carriers. The corresponding symbol duration becomes larger than the delay spread of the transmission channel. In the receiver any echo shorter than the guard interval will not cause intersymbol interference but rather contribute positively to the received power (see Fig. 5). The large number K of carriers is known collectively as an ensemble.

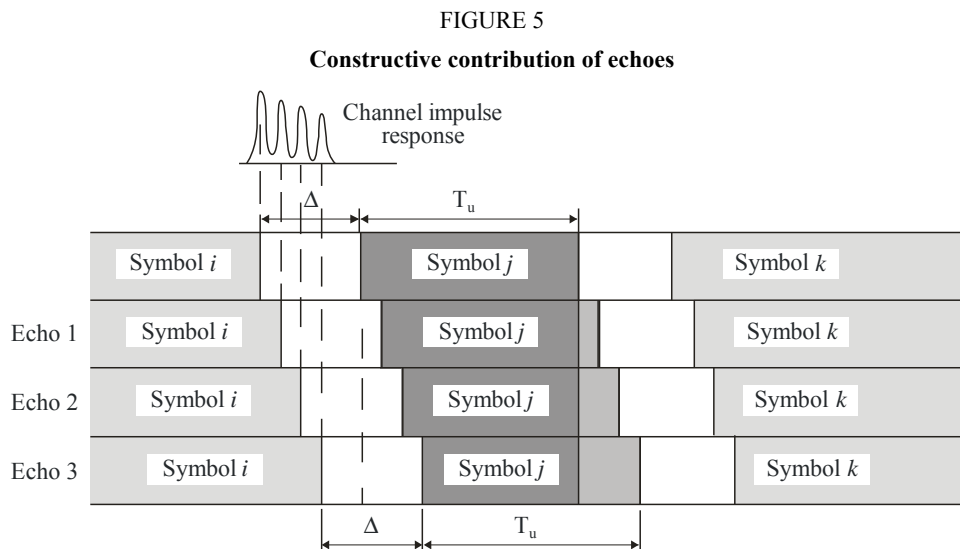

BS.1114-05

In the presence of multipath propagation, some of the carriers are enhanced by constructive signals, while others suffer destructive interference (frequency selective fading). Therefore, System A includes a redistribution of the elements of the digital bit stream in time and frequency, such that successive source samples are affected by independent fades. When the receiver is stationary, the diversity in the frequency domain is the only means to ensure successful reception; the time diversity provided by time-interleaving does not assist a static receiver. For System A, multipath propagation is a form of space-diversity and is considered to be a significant advantage, in stark contrast to conventional FM or narrow-band digital systems where multipath propagation can completely destroy a service.

In any system able to benefit from multipath, the larger the transmission channel bandwidth, the more rugged the system. In System A, an ensemble bandwidth of 1.5 MHz was chosen to secure the advantages of the wideband technique, as well as to allow planning flexibility. Table 4 also indicates the number of OFDM carriers within this bandwidth for each transmission mode.

A further benefit of using OFDM is that high spectrum and power efficiency can be obtained with single frequency networks for large area coverage and also for dense city area networks. Any number of transmitters providing the same programmes may be operated on the same frequency, which also results in an overall reduction in the required operating powers. As a further consequence distances between different service areas are significantly reduced.

Because echoes contribute to the received signal, all types of receiver (i.e. portable, home and vehicular) may utilize simple, non-directional antennas.

9.6 Transmission signal spectrum of System A

As an example, the theoretical spectrum of System A is illustrated in Fig. 6 for transmission Mode II.

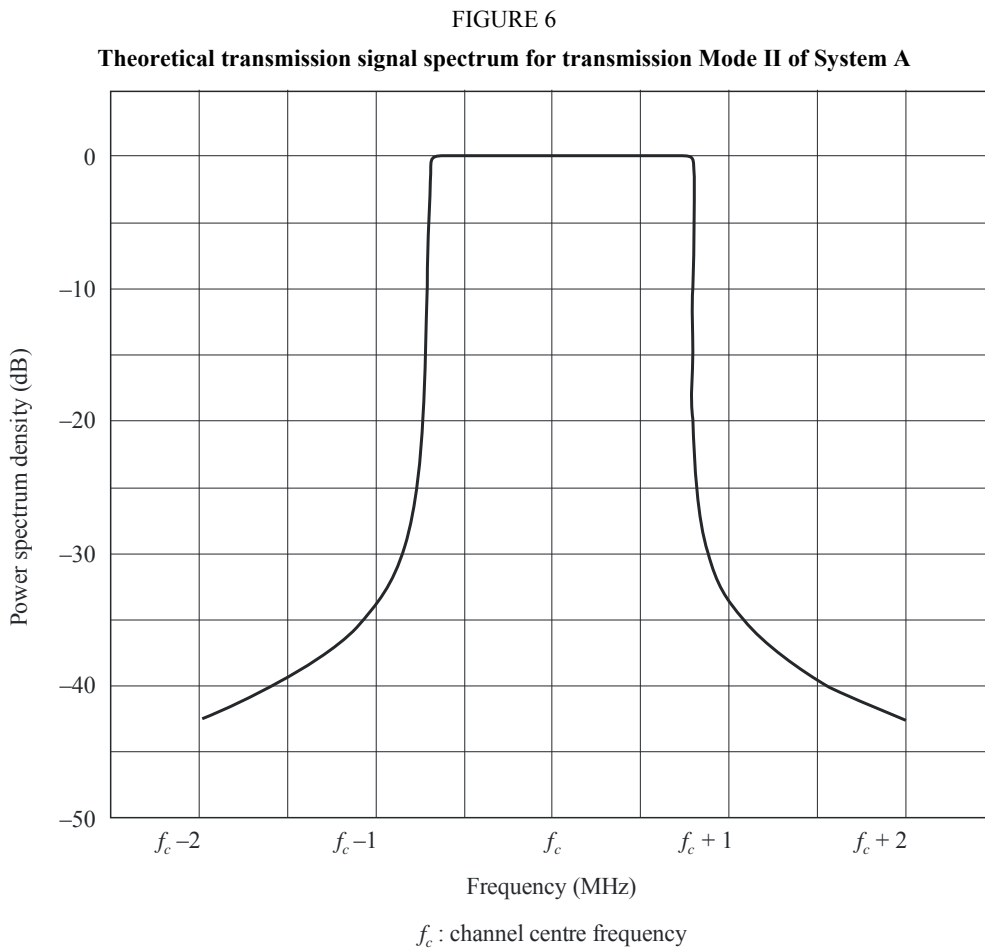

BS.1114-06

The out-of-band radiated signal spectrum in any 4 kHz band should be constrained by one of the masks defined in Fig. 7.

FIGURE 7

Out-of-band spectrum masks for a transmission signal of System A

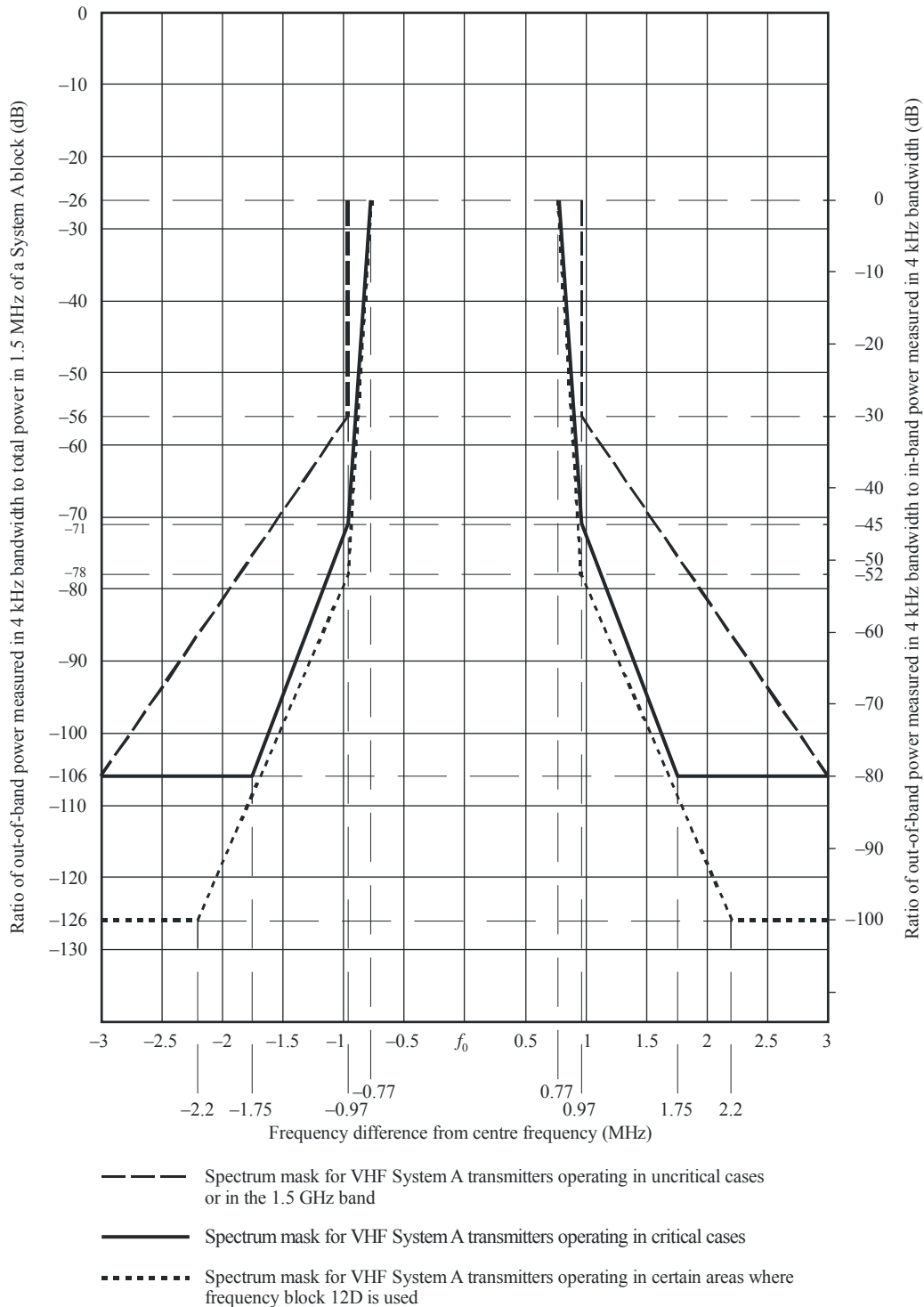

BS.1114-07

The solid line mask should apply to VHF transmitters operating in critical cases. The dashed line mask should apply to VHF transmitters operating in uncritical cases or in the 1.5 GHz band and the dotted line mask should apply to VHF transmitters operating in certain areas where frequency block 12D is used.

The level of the signal at frequencies outside the normal 1.536 MHz bandwidth can be reduced by applying an appropriate filtering.

TABLE 5

Out-of-band spectrum table for a transmission signal of System A

	Frequency relative to the centre of the 1.54 MHz channel (MHz)	Relative level (dB)
Spectrum mask for VHF System A transmitters operating in uncritical cases or in the 1.5 GHz band	± 0.97	-26
	± 0.97	-56
	± 3.0	-106
Spectrum mask for VHF System A transmitters operating in critical cases	± 0.77	-26
	± 0.97	-71
	± 1.75	-106
	± 3.0	-106
Spectrum mask for VHF System A transmitters operating in certain areas where frequency block 12D is used	± 0.77	-26
	± 0.97	-78
	± 2.2	-126
	± 3.0	-126

10 RF performance characteristics of System A

RF evaluation tests have been carried out on System A using Mode I at 226 MHz and Mode II at 1 480 MHz for a variety of conditions representing mobile and fixed reception. Measurements of bit error ratio (BER) vs. S/N in the transmission channel were made on a data channel using the following conditions:

$$D = 64 \text{ kbit/s}, \quad R = 0.5$$

$$D = 24 \text{ kbit/s}, \quad R = 0.375$$

where:

D : source data rate

R : average channel code rate.

10.1 BER vs. S/N (in 1.5 MHz) in a Gaussian channel

Additive, Gaussian white noise was added to set the S/N at the input of the receiver. The results are shown in Figs. 8 and 9. As an example, for $R = 0.5$, the measured results in Fig. 8 can be compared with those from a software simulation, to show the inherent performance of the system. It can be seen that an implementation margin of less than 1.0 dB is obtained at a BER of 1×10^{-4} .

FIGURE 8
BER vs. S/N for System A
(Transmission Mode I) – Gaussian channel

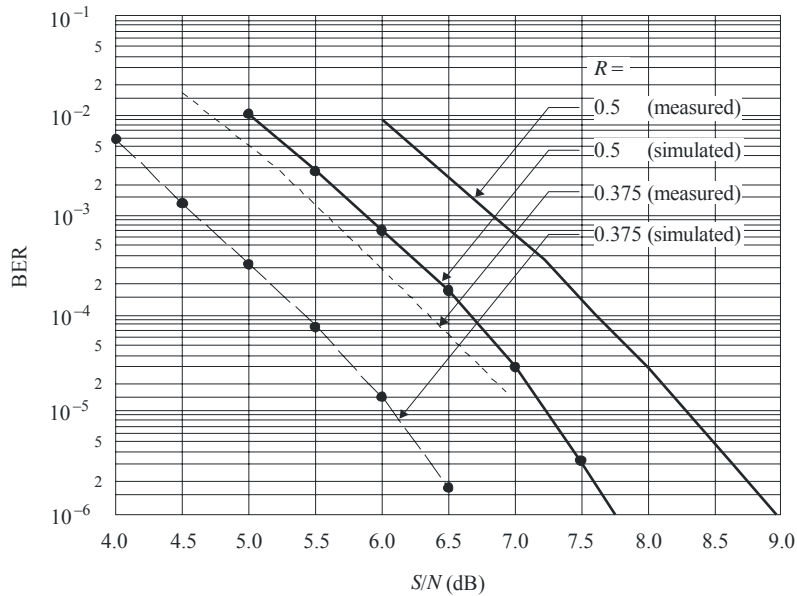

BS.1114-08

FIGURE 9
BER vs. S/N for System A
(Transmission Mode II or III): Gaussian channel

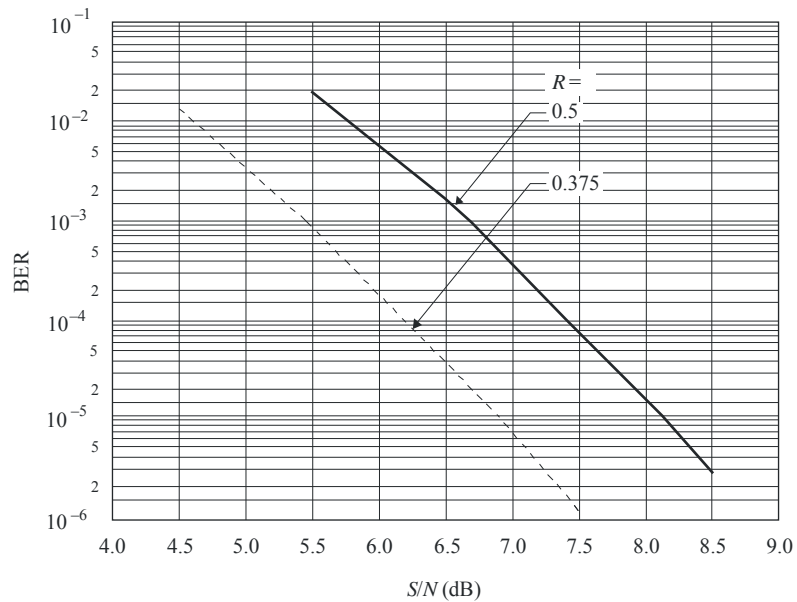

BS.1114-09

10.2 BER vs. S/N (in 1.5 MHz) in a Rayleigh channel simulated in urban environment

Measurements of BER vs. S/N were made on the data channels, using a fading channel simulator. The Rayleigh channel simulations correspond to Fig. 5 in Cost 207 documentation (typical urban area, 0-0.5 μs) and the receiver travelling at a speed of 15 km/h.

The results are shown in Figs 10 and 11.

FIGURE 10

**BER vs. S/N for System A
(Transmission Mode I, 226 MHz)**

Simulated Rayleigh channel (urban environment, 15 km/h speed)

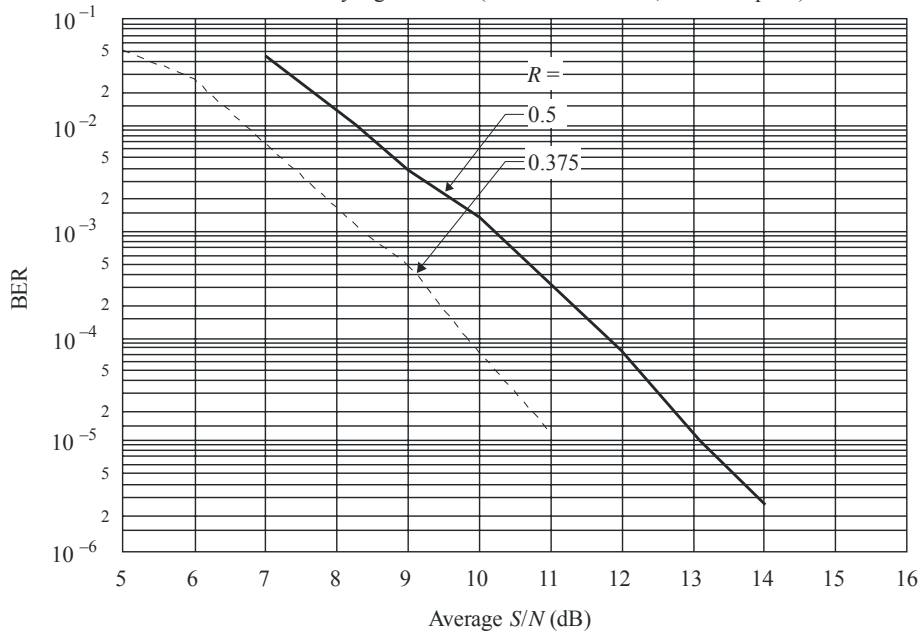

BS.1114-10

FIGURE 11

**BER vs. S/N for System A
(Transmission Mode II, 1 480 MHz)**

Simulated Rayleigh channel (urban environment, 15 km/h speed)

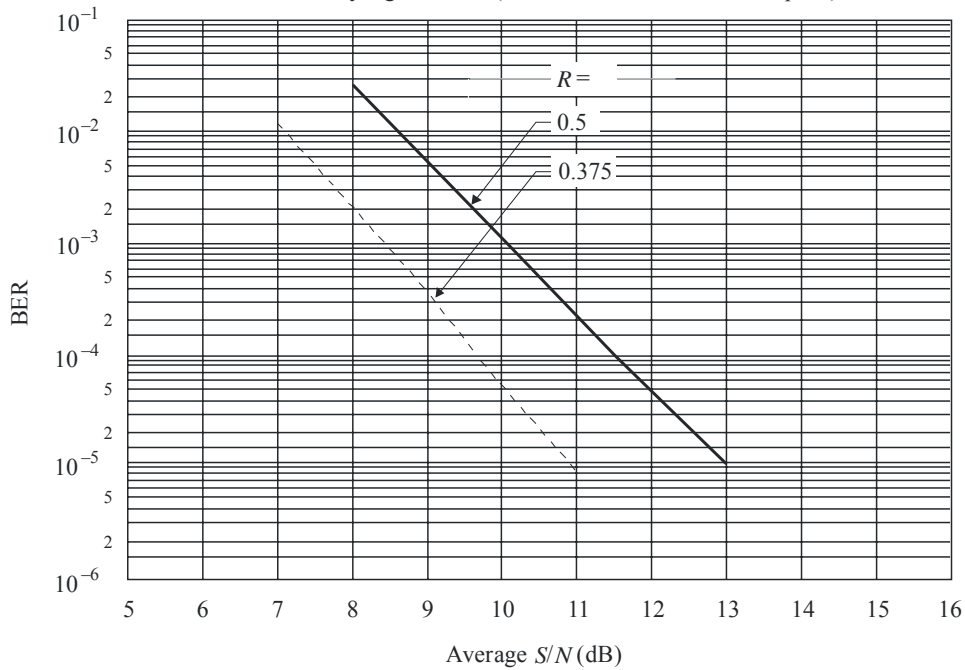

BS.1114-11

10.3 BER vs. S/N (in 1.5 MHz) in a Rayleigh channel simulated in rural environment

Measurements of BER vs. S/N were made on the data channels using a fading channel simulator. The Rayleigh channel simulations correspond to Fig. 4 in Cost 207 documentation (rural area, non-hilly, 0-5 μ s) and the receiver travelling at 130 km/h. The results are shown in Figs 12 and 13.

FIGURE 12

**BER vs. S/N for System A
(Transmission Mode I, 226 MHz)**

Simulated Rayleigh channel (rural environment, 130 km/h speed)

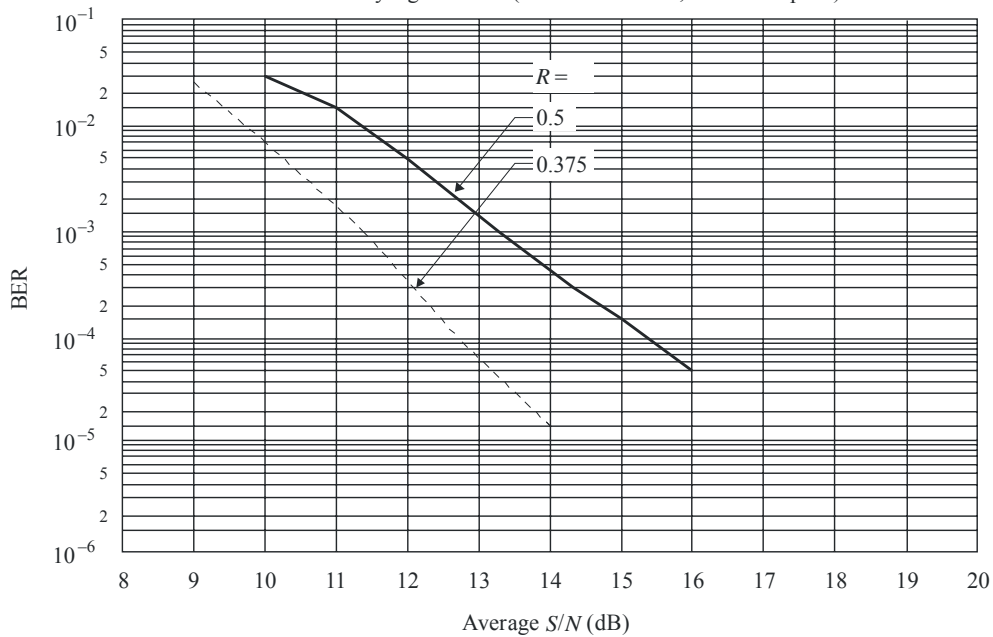

BS.1114-12

FIGURE 13

**BER vs. S/N for System A
(Transmission Mode II, 1 480 MHz)**

Simulated Rayleigh channel (rural environment, 130 km/h speed)

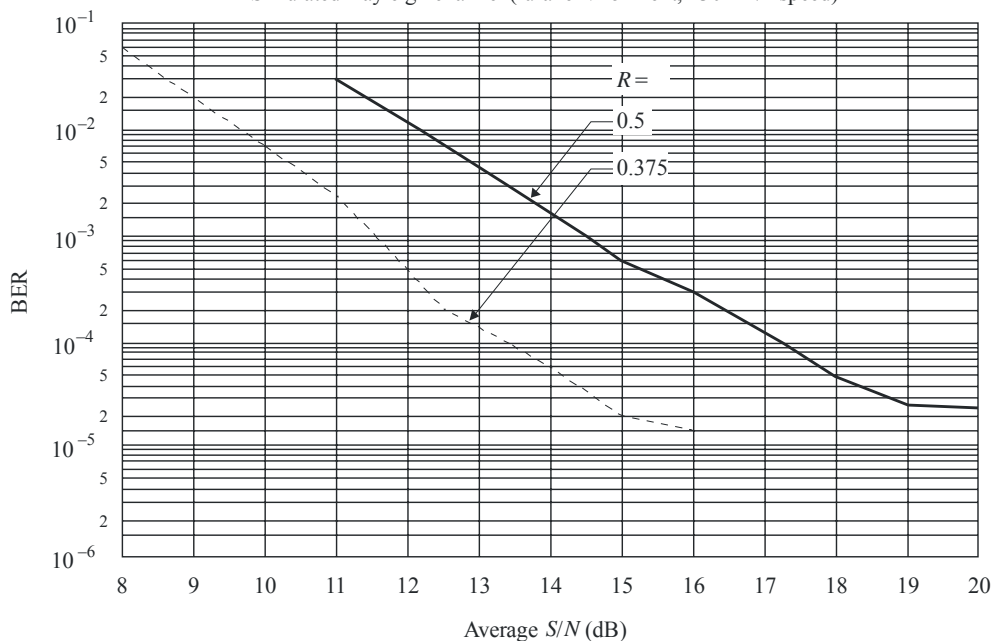

BS.1114-13

10.4 Sound quality versus RF S/N

A number of subjective assessments have been performed in order to evaluate the sound quality versus the S/N . The transmission path included equipment for establishing the S/N in a Gaussian channel and, using a fading channel simulator, in a Rayleigh channel. Two different simulation “models” were used in the case of a Rayleigh channel, the same as those described in §§ 10.2 and 10.3.

In each case a listening test was conducted in which the average S/N was reduced in 0.5 dB steps to establish, in sequence, the following two conditions:

- the onset of impairment, which is the point at which the effects of errors start to become noticeable. This was defined as the point where 3 or 4 error-related events could be heard in a period of about 30 s;
- the point of failure, which is the point at which a listener would probably stop listening to the programme because it became unintelligible or because it no longer provided the enjoyment sought. This was defined as the point where the error-related events occurred virtually continuously, and muting took place two or three times in a period of about 30 s.

Two values of S/N were recorded for each test, representing the consensus view of the panel of audio engineers. The results presented here are the mean values of several tests using different programme material.

TABLE 6
Sound quality vs. S/N for System A
(Transmission Mode I): Gaussian channel

Source-coding		Channel-coding average rate	Onset of impairment S/N (dB)	Point of failure S/N (dB)
Bit rate (kbit/s)	Mode			
256	Stereo	0.6	7.6	5.5
224	Stereo	0.6	8.3	5.9
224	Stereo	0.5	7.0	4.8
224	Joint stereo	0.5	6.8	4.5
192	Joint stereo	0.5	7.2	4.7
64	Mono	0.5	6.8	4.5

TABLE 7

**Sound quality vs. *S/N* for System A
(Transmission Mode II or III): Gaussian channel**

Source-coding		Channel-coding average rate	Onset of impairment <i>S/N</i> (dB)	Point of failure <i>S/N</i> (dB)
Bit rate (kbit/s)	Mode			
256	Stereo	0.6	7.7	5.7
224	Stereo	0.6	8.2	5.8
224	Stereo	0.5	6.7	4.9
224	Joint stereo	0.5	6.6	4.6
192	Joint stereo	0.5	7.2	4.6
64	Mono	0.5	6.9	4.5

TABLE 8

**Sound quality vs. *S/N* for System A
Simulated Rayleigh channels (224 kbit/s stereo, rate 0.5)**

Mode	Frequency (MHz)	Channel mode	Speed (km/h)	Onset of impairment <i>S/N</i> (dB)	Point of failure <i>S/N</i> (dB)
I	226	Urban	15	16.0	9.0
II	1 500	Urban	15	13.0	7.0
I	226	Rural	130	17.6	10.0
II	1 500	Rural	130	18.0	10.0

10.5 Capability for operating in single-frequency networks

A System A signal (Transmission Mode II) was processed by a channel simulator to produce two versions of the signal; one representing the signal received over a reference, undelayed transmission path with constant power, and one representing a delayed signal from a second transmitter in a single-frequency network (or some other long delay echo). The Doppler shift applied to the second signal was compatible with the limit of the capability of System A. Two sets of measurements were carried out setting the *S/N* of the total received signal to 12 dB and 35 dB. The relative power of the second, delayed, signal was measured for a BER of 1×10^{-4} in the 64 kbit/s, rate 0.5, data channel, as the delay was increased. The results are shown in Fig. 14.

The magnitude of the guard interval is 64 μ s in Transmission Mode II, so the results illustrate that no impairment is caused as long as the second signal falls within the guard interval.

FIGURE 14
 Example of single-frequency capability for System A
 (Transmission Mode II)

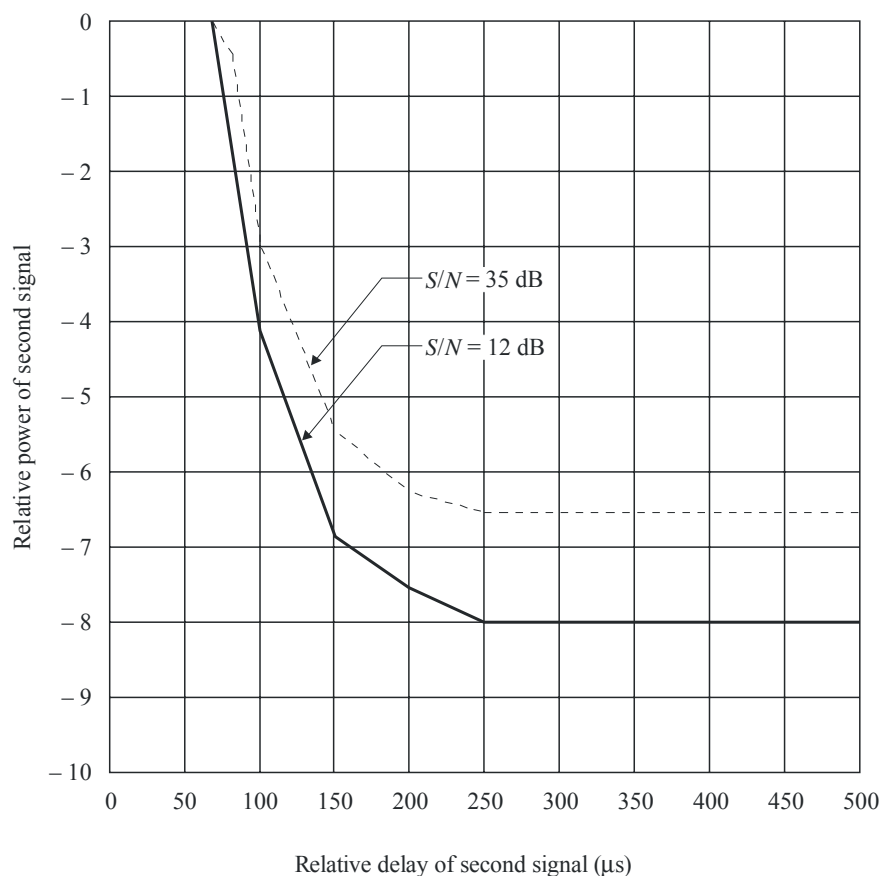

BS.1114-14

Annex 3

Digital System F

1 Introduction

Digital System F (System F), also known as the ISDB-T_{SB} system, is designed to provide high-quality sound and data broadcasting with high reliability even in mobile reception. System F is also designed to provide flexibility, expandability, and commonality for multimedia broadcasting using terrestrial networks, and conform to system requirements given in Recommendation ITU-R BS.774.

System F is a rugged system which uses OFDM modulation, two-dimensional frequency-time interleaving and concatenated error correction codes. The OFDM modulation used in System F is called band segmented transmission (BST)-OFDM. System F has commonality with the ISDB-T system for digital terrestrial television broadcasting in the physical layer. The bandwidth of an OFDM block called OFDM-segment is approximately 500 kHz. System F consists of one or three OFDM-segments, therefore the bandwidth of the system is approximately 500 kHz or 1.5 MHz.

System F has a wide variety of transmission parameters such as carrier modulation scheme, coding rates of the inner error correction code, and length of time interleaving. Some of the carriers are

assigned to control carriers which transmit the information on the transmission parameters. These control carriers are called TMCC carriers.

System F can use high compression audio coding methods such as MPEG-2 Layer II, AC-3 and MPEG-2 AAC. Also, the system adopts MPEG-2 systems. It has commonality and interoperability with many other systems which adopt MPEG-2 systems such as ISDB-S, ISDB-T, DVB-S and DVB-T.

Figure 15 shows the ISDB-T_{SB} and full-band ISDB-T transmission concept and its reception.

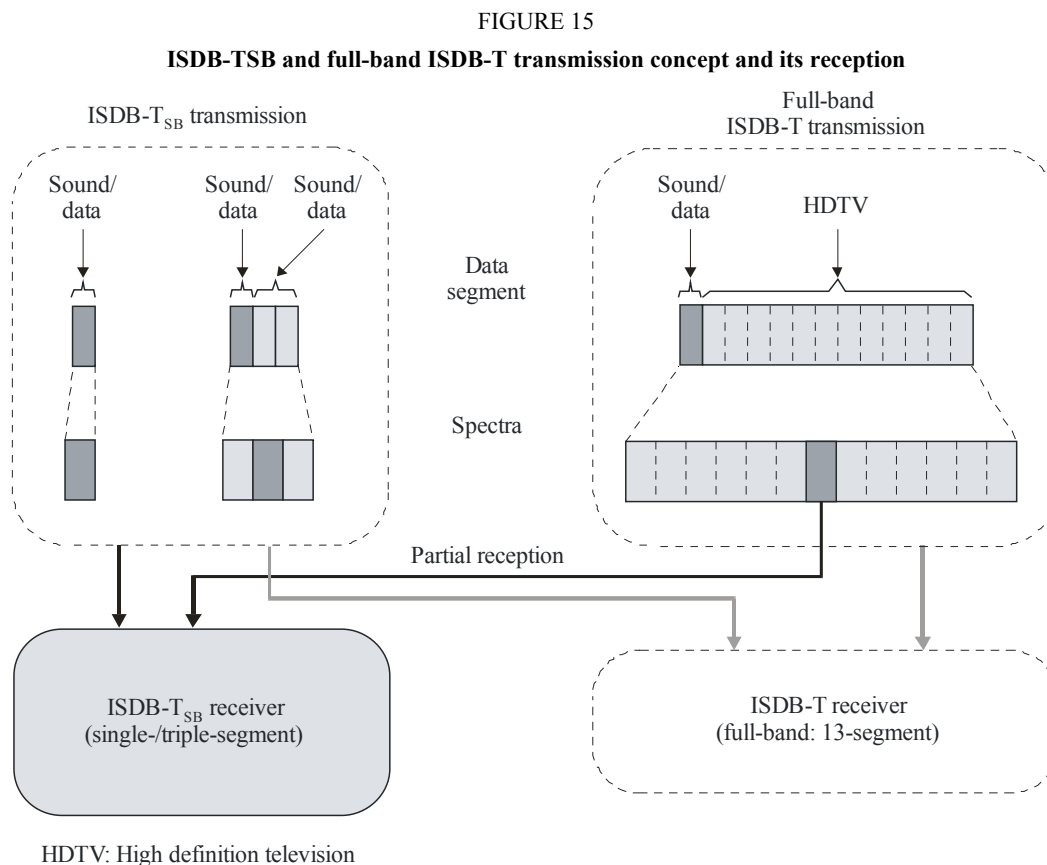

BS.1114-15

2 Features of System F

2.1 Ruggedness of System F

System F uses OFDM modulation, two-dimensional frequency-time interleaving and concatenated error correction codes. OFDM is a multi-carrier modulation method, and it is a multipath-proof modulation method, especially adding a guard interval in the time domain. The transmitted information is spread in both the frequency and time domains by interleaving, and then the information is corrected by the Viterbi and Reed-Solomon (RS) decoder. Therefore a high quality signal is obtained in the receiver, even when working in conditions of severe multipath propagation, whether stationary or mobile.

2.2 Wide variety of transmission

System F adopts BST-OFDM, and consists of one or three OFDM-segments. That is single-segment transmission and triple-segment transmission. A bandwidth of OFDM-segment is defined in one of

three ways depending on the reference channel raster of 6, 7 or 8 MHz. The bandwidth is a fourteenth of the reference channel bandwidth (6, 7 or 8 MHz), that is, 429 kHz (6/14 MHz), 500 kHz (7/14 MHz) or 571 kHz (8/14 MHz). The bandwidth of OFDM-segment should be selected in compliance with the frequency situation in each country.

The bandwidth of single-segment is around 500 kHz, therefore the bandwidth of single-segment transmission and triple-segment transmission is approximately 500 kHz and 1.5 MHz.

System F has three alternative transmission modes which allow the use of a wide range of transmitting frequencies, and four alternative guard interval lengths for the design of the distance between SFN transmitters. These transmission modes have been designed to cope with Doppler spread and delay spread, for mobile reception in presence of multipath echoes.

2.3 Flexibility

System F multiplex structure is fully compliant with MPEG-2 systems architecture. Therefore various digital contents such as sound, text, still picture and data can be transmitted simultaneously.

In addition, according to the broadcaster's purpose, they can select the carrier modulation method, error correction coding rate, length of time interleaving, etc. of the system. There are four kinds of carrier modulation method of DQPSK, QPSK, 16-QAM and 64-QAM, five kinds of coding rate of 1/2, 2/3, 3/4, 5/6 and 7/8, and five kinds of time interleaving length from 0 to approximately 1 s. The TMCC carrier transmits the information to the receiver indicating the kind of modulation method and coding rate that are used in the system.

2.4 Commonality and interoperability

System F uses BST-OFDM modulation and adopts MPEG-2 systems. Therefore the system has commonality with the ISDB-T system for digital terrestrial television broadcasting (DTTB) in the physical layer, and has commonality with the systems such as ISDB-T, ISDB-S, DVB-T and DVB-S which adopt MPEG-2 Systems in the transport layer.

2.5 Efficient transmission and source coding

System F uses a highly-spectrum efficient modulation method of OFDM. Also, it permits frequency reuse broadcasting networks to be extended using additional transmitters all operating on the same radiated frequency.

In addition, the channels of independent broadcasters can be transmitted together without guardbands from the same transmitter as long as the frequency and bit synchronization are kept the same between the channels.

System F can adopt MPEG-2 AAC. Near CD quality can be realized at a bit rate of 144 kbit/s for stereo.

2.6 Independency of broadcasters

System F is a narrow-band system for transmission of one sound programme at least. Therefore broadcasters can have their own RF channel in which they can select transmission parameters independently.

2.7 Low-power consumption

Almost all devices can be made small and light weight by developing LSI chips. The most important aspect of efforts to reduce battery size is that the power consumption of a device must be low. The slower the system clock, the lower the power consumption. Therefore, a narrow-band, low

bit rate system like single-segment transmission can allow for the receiver to be both portable and lightweight.

2.8 Hierarchical transmission and partial reception

In the triple-segment transmission, both one layer transmission and hierarchical transmission can be achieved. There are two layers of A and B in the hierarchical transmission. The transmission parameters of carrier modulation scheme, coding rates of the inner code and a length of the time interleaving can be changed in the different layers.

The centre segment of hierarchical transmission is able to be received by single-segment receiver. Owing to the common structure of an OFDM segment, a single-segment receiver can partially receive a centre segment of full-band ISDB-T signal whenever an independent program is transmitted in the centre segment.

Figure 16 shows an example of hierarchical transmission and partial reception.

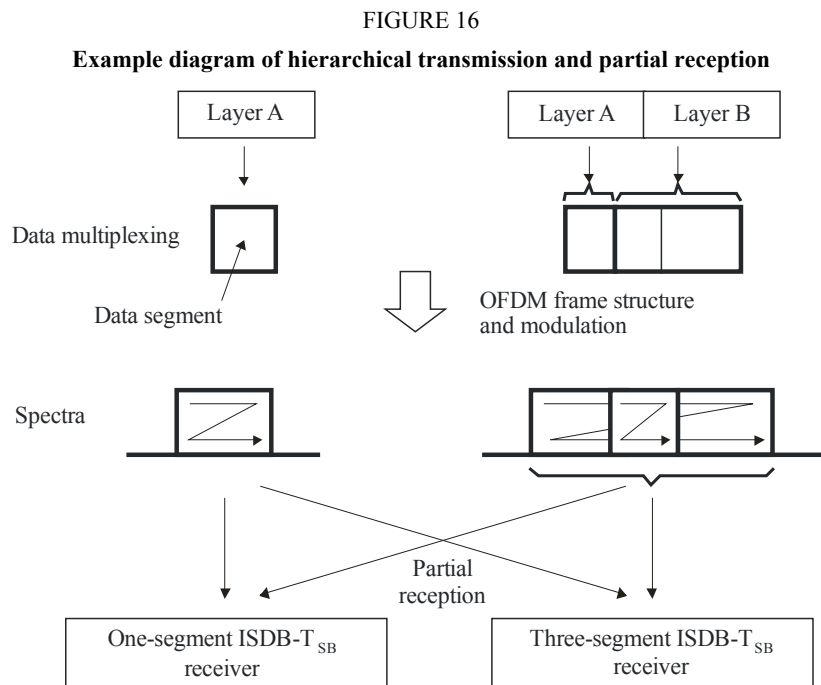

BS.1114-16

3 Transmission parameters

System F can be assigned to 6 MHz, 7 MHz or 8 MHz channel raster. Segment bandwidth is defined to be a fourteenth of channel bandwidth, therefore that is 429 kHz (6/14 MHz), 500 kHz (7/14 MHz) or 571 kHz (8/14 MHz). However, the segment bandwidth should be selected in compliance with the frequency situation in each country.

The transmission parameters for the ISDB-T_{SB} system are shown in Table 9.

TABLE 9
Transmission parameters for the ISDB-T_{SB}

Mode		Mode 1	Mode 2	Mode 3
Total number of segments ⁽¹⁾ ($N_s = n_d + n_c$)		1, 3		
Reference channel raster (BW_f) (MHz)		6, 7, 8		
Segment bandwidth (BW_s) (kHz)		$BW_f \times 1\,000/14$		
Used bandwidth (BW_u) (kHz)		$BW_s \times N_s + C_s$		
Number of segments for differential modulation		n_d		
Number of segments for coherent modulation		n_c		
Carrier spacing (C_s) (kHz)		$BW_s/108$	$BW_s/216$	$BW_s/432$
Number of carriers	Total	$108 \times N_s + 1$	$216 \times N_s + 1$	$432 \times N_s + 1$
	Data	$96 \times N_s$	$192 \times N_s$	$384 \times N_s$
	SP ⁽²⁾	$9 \times n_c$	$18 \times n_c$	$36 \times n_c$
	CP ⁽²⁾	$n_d + 1$	$n_d + 1$	$n_d + 1$
	TMCC ⁽³⁾	$n_c + 5 \times n_d$	$2 \times n_c + 10 \times n_d$	$4 \times n_c + 20 \times n_d$
	AC1 ⁽⁴⁾	$2 \times N_s$	$4 + N_s$	$8 \times N_s$
	AC2 ⁽⁴⁾	$4 \times n_d$	$9 \times n_d$	$19 \times n_d$
Carrier modulation		DQPSK, QPSK, 16-QAM, 64-QAM		
Number of symbol per frame		204		
Useful symbol duration (T_u) (μ s)		$1\,000/C_s$		
Guard interval duration (T_g)		$1/4, 1/8, 1/16$ or $1/32$ of T_u		
Total symbol duration (T_s)		$T_u + T_g$		
Frame duration (T_f)		$T_s \times 204$		
FFT samples (F_s)		$256 (N_s = 1)$ $512 (N_s = 3)$	$512 (N_s = 1)$ $1024 (N_s = 3)$	$1024 (N_s = 1)$ $2048 (N_s = 3)$
FFT sample clock (F_{sc}) (MHz)		$F_{sc} = F_s/T_u$		
Inner code		Convolutional code (Coding rate = $1/2, 2/3, 3/4, 5/6, 7/8$) (Mother code = $1/2$)		
Outer code		(204,188) RS code		
Time interleave parameter (I)		0, 4, 8, 16, 32	0, 2, 4, 8, 16	0, 1, 2, 4, 8
Length of time interleaving		$I \times 95 \times T_s$		

FFT: fast Fourier transform

- (1) System F uses 1 or 3 segments for sound services, while any number of segments may be used for other services such as television services. (Compare with System C of Recommendation ITU-R BT.1306.)
- (2) SP (scattered pilot), and CP (continual pilot) can be used for frequency synchronization and channel estimation. The number of CP includes CPs on all segments and a CP for higher edge of whole bandwidth.
- (3) TMCC carries information on transmission parameters.
- (4) AC (auxiliary channel) carries ancillary information for network operation.

4 Source coding

System F multiplex structure is fully compliant with MPEG-2 systems architecture, therefore MPEG-2 transport stream packets (TSPs) containing compressed digital audio signal can be transmitted. Digital audio compression methods such as MPEG-2 Layer II audio specified in ISO/IEC 13818-3, AC-3 (Digital Audio Compression Standard specified in ATSC Document A/52) and MPEG-2 AAC specified in ISO/IEC 13818-7 can be applied to System F.

5 Multiplexing

The multiplex of System F is compatible with MPEG-2 TS ISO/IEC 13818-1. In addition, multiplex frame and TMCC descriptors are defined for hierarchical transmission with single TS.

Considering maximum interoperation among a number of digital broadcasting systems, e.g. ISDB-S recommended in Recommendation ITU-R BO.1408, ISDB-T recommended in Recommendation ITU-R BT.1306 (System C) and broadcasting-satellite service (sound) system using the 2.6 GHz band recommended in Recommendation ITU-R BO.1130 (System E), these systems can exchange broadcasting data streams with other broadcasting systems through this interface.

5.1 Multiplex frame

To achieve hierarchical transmission using the BST-OFDM scheme, the ISDB-T_{SB} system defines a multiplex frame of TS within the scope of MPEG-2 systems. In the multiplex frame, the TS is a continual stream of 204-byte RS-TSP composed of 188-byte TSP and 16 bytes of null data or RS parity.

The duration of the multiplex frame is adjusted to that of the OFDM frame by counting RS-TSPs using a clock that is two times faster than the inverse FFT (IFFT) sampling clock in the case of single-segment transmission. In the case of the triple-segment transmission the duration of the multiple frame is adjusted to that of the OFDM frame by counting RS-TSPs using a clock that is four times faster than the IFFT sampling clock.

6 Channel coding

This section describes the channel coding block, which receives the packets arranged in the multiplex frame and passes the channel-coded blocks forward to the OFDM modulation block.

6.1 Functional block diagram of channel coding

Figure 17 shows the functional block diagram of channel coding of the ISDB-T_{SB} system.

The duration of the multiplex frame coincides with the OFDM frame by counting the bytes in the multiplex frame using a faster clock than IFFT-sampling rate described in the previous section.

At the interface between the multiplex block and the outer coding block, the head byte of the multiplex frame (corresponding to the sync-byte of TSP) is regarded as the head byte of the OFDM frame. In bit-wise description, the most significant bit of the head byte is regarded as the synchronization bit of OFDM frame.

For the triple-segment layered transmission, the RS-TSP stream is divided into two layers in accordance with the transmission-control information. In each layer, coding rate of the inner error correction code, carrier-modulation scheme, and time-interleaving length can be specified independently.

FIGURE 17
Channel coding diagram

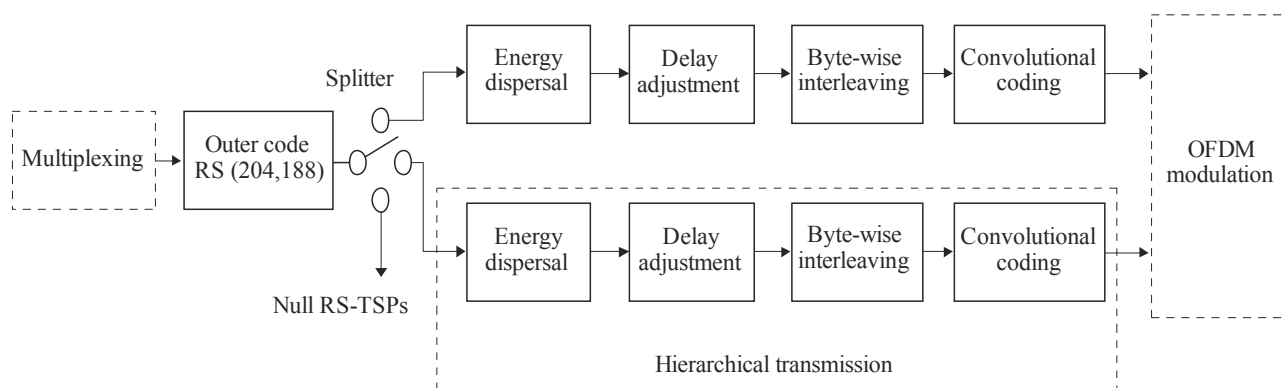

BS.1114-17

6.2 Outer coding

RS (204,188) shortened code is applied to each MPEG-2 TSP to generate an error protected TSP that is RS-TSP. The RS (208,188) code can correct up to eight random erroneous bytes in a received 204-byte word.

Field generator polynomial: $p(x) = x^8 + x^4 + x^3 + x^2 + 1$

Code generator polynomial: $g(x) = (x - \lambda^0)(x - \lambda^1)(x - \lambda^2)(x - \lambda^3) \cdots (x - \lambda^{15})$

where $\lambda = 02_h$

It should be noted that null TSPs from the multiplexer are also coded to RS (204,188) packets.

MPEG-2 TSP and RS-TSP (RS error protected TSP) are shown in Fig. 18. RS error protected TSP is also called transmission TSP.

FIGURE 18
MPEG-2 TSP and RS-TSP (transmission TSP)

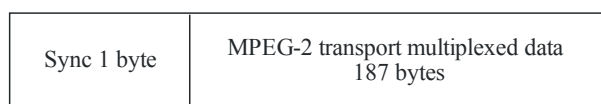

a) MPEG-2 TSP

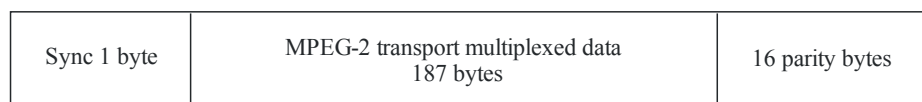

b) RS-TSP (transmission TSP), RS (204,188) error protected TSP

BS.1114-18

6.3 Energy dispersal

In order to ensure adequate binary transitions, the data from the splitter is randomized with pseudo-random binary sequence (PRBS).

The polynomial for the PRBS generator shall be:

$$g(x) = x^{15} + x^{14} + 1$$

6.4 Delay adjustment

In the byte-wise interleaving, the delay caused in the interleaving process differs from stream to stream of different layers depending on its properties (i.e. modulation and channel coding). In order to compensate for the delay difference including de-interleaving in the receiver, the delay adjustment is carried out prior to the byte-wise interleaving on the transmission side.

6.5 Byte-wise interleaving (inter-code interleaving)

Convolutional byte-wise interleaving with length of $I = 12$ is applied to the 204-byte error protected and randomized packets. The interleaving may be composed of $I = 12$ branches, cyclically connected to the input byte-stream by the input switch. Each branch j shall be a first-in first-out (FIFO) shift register, with length of $j \times 17$ bytes. The cells of the FIFO shall contain 1 byte, and the input and output switches shall be synchronized.

The de-interleaving is similar, in principle, to the interleaving, but the branch indices are reversed. Total delay caused by interleaving and de-interleaving is $17 \times 11 \times 12$ bytes (corresponding to 11 TSPs).

6.6 Inner coding (convolutional codes)

System F shall allow for a range of punctured convolutional codes, based on a mother convolutional code of rate $1/2$ with 64 states. Coding rates of the codes are $1/2$, $2/3$, $3/4$, $5/6$ and $7/8$. This will allow selection of the most appropriate property of error correction for a given service or data rate in the ISDB-T_{SB} services including mobile services. The generator polynomials of the mother code are $G_1 = 171_{\text{oct}}$ for X output and $G_2 = 133_{\text{oct}}$ for Y output.

7 Modulation

Configuration of the modulation block is shown in Figs 19 and 20. After bit-wise interleaving, data of each layer are mapped to the complex domain.

7.1 Delay adjustment for bit interleave

Bit interleave causes the delay of 120 complex data ($I + jQ$) as described in the next section. By adding proper delay, total delay in transmitter and receiver is adjusted to the amount of two OFDM symbols.

7.2 Bit interleaving and mapping

One of the carrier modulation schemes among DQPSK, QPSK, 16-QAM and 64-QAM is selectable for this System. The serial bit-sequence at the output of the inner coder is converted into a 2-bit parallel sequence to undergo $\pi/4$ -shift DQPSK mapping or QPSK mapping, by which n bits of I-axis and Q-axis data are delivered. The number n may depend on the hardware implementation. In the case of 16-QAM, the sequence is converted into a 4-bit parallel sequence. In 64-QAM, it is converted into a 6-bit parallel sequence. After the serial-to-parallel conversion, bit-interleaving is carried out by inserting maximum 120-bit delay.

7.3 Data segment

Data segment is defined as a table of addresses for complex data, on which rate conversion, time interleaving, and frequency interleaving shall be executed. The data segment corresponds to the data portion of OFDM segment.

FIGURE 19

Modulation block diagram

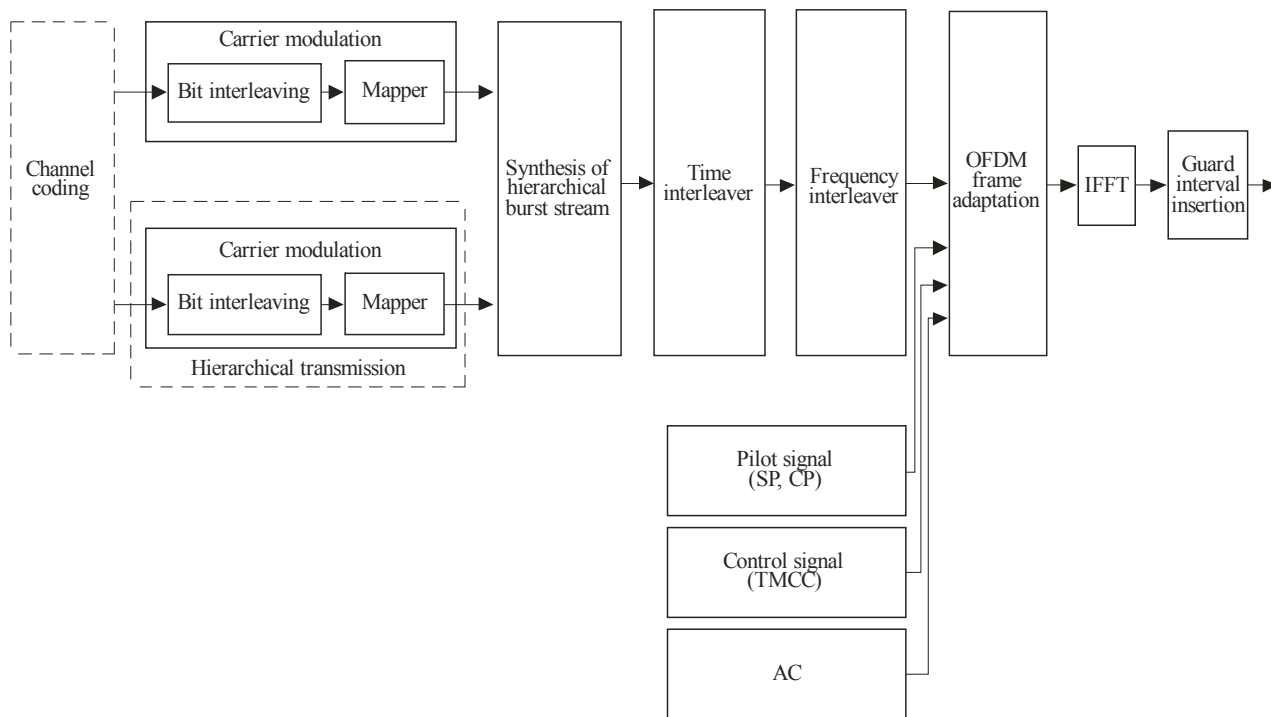

BS.1114-19

FIGURE 20

Configuration of carrier modulation block

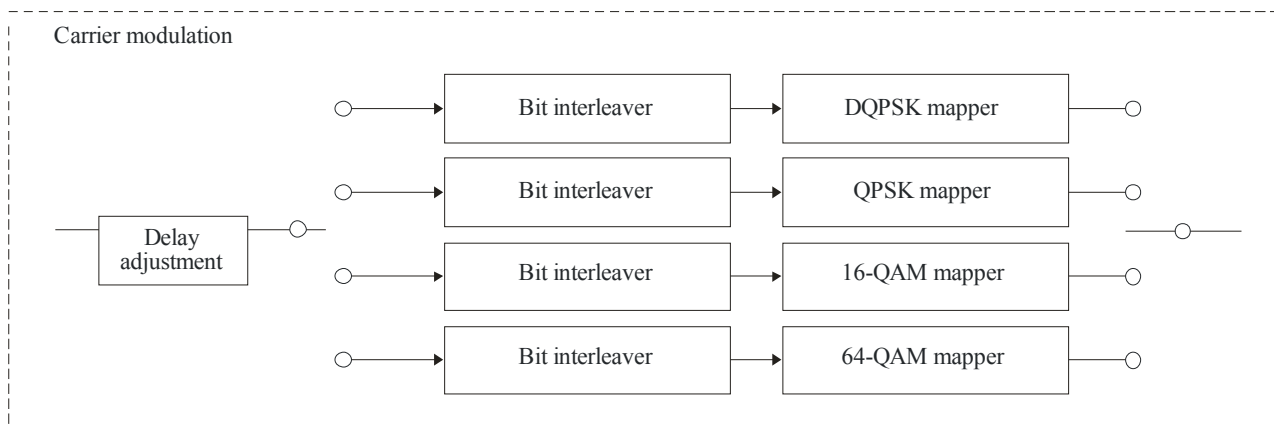

BS.1114-20

7.4 Synthesis of layer-data streams

After being channel-coded and mapped, complex data of each layer are inputted every one symbol to pre-assigned data-segments.

The data stored in all data segments are cyclically read with the IFFT-sample clock; then rate conversions and synthesis of layer data streams are carried out.

7.5 Time interleaving

After synthesis, symbol-wise time interleaving is carried out. The length of time-interleaving is changeable from 0 to approximately 1 s, and shall be specified for each layer.

7.6 Frequency interleaving

Frequency interleaving consists of inter-segment frequency interleaving, intra-segment carrier rotation, and intra-segment carrier randomization. Inter-segment frequency interleaving is taken among the segments having the same modulation scheme. Inter-segment frequency interleaving can be carried out only for triple-segment transmission. After carrier rotation, carrier randomization is performed depending on the randomization table.

7.7 OFDM segment-frame structure

Data segments are arranged into OFDM segment-frame every 204 symbols by adding pilots such as CP, SP, TMCC and AC. The modulation phase of CP is fixed at every OFDM symbol. SP is inserted in every 12 carriers and in every 4 OFDM symbols in the case of coherent modulation method. The TMCC carrier carries transmission parameters such as carrier modulation, coding rate and time interleaving for the receiver control. The AC carrier carries the ancillary information.

8 Spectrum mask

The radiated signal spectrum of single-segment transmission for 6/14 MHz segment system should be constrained by the mask defined in Fig. 21 and Table 10. The level of the signal at frequencies outside the 429 kHz bandwidth (6/14 MHz) can be reduced by applying an appropriate filtering.

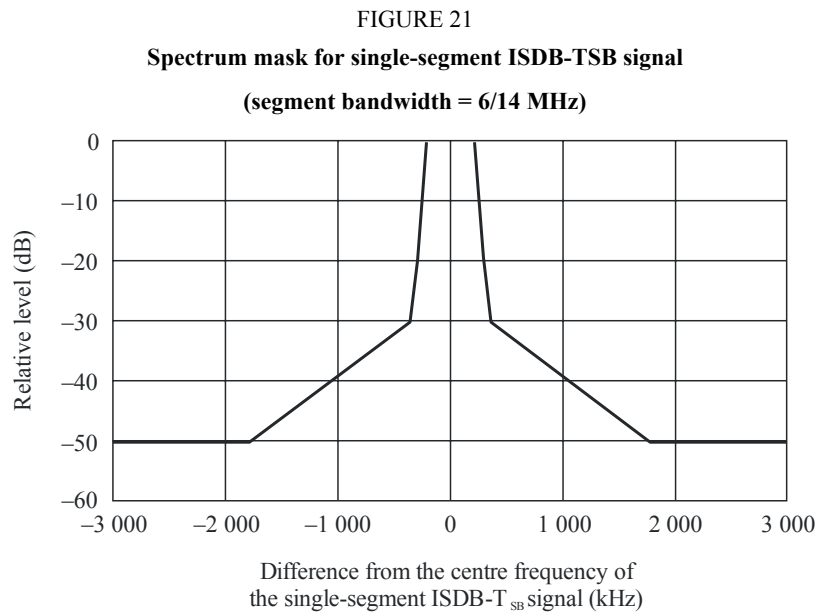

TABLE 10
Breakpoints of the spectrum mask for the single-segment transmission
(segment bandwidth = 6/14 MHz)

Frequency difference from the centre frequency of the transmitted signal (kHz)	Relative level (dB)
±220	0
±290	-20
±360	-30
±1 790	-50

NOTE 1 – The radiated signal spectrum is measured by the spectrum analyser. A resolution bandwidth of the spectrum analyser should be set to 10 kHz or 3 kHz. Concerning the video bandwidth, it is between 300 Hz and 30 kHz, and video averaging is desirable. The frequency span is set to the minimum value required for measuring the transmission spectrum mask.

Figure 22 and Table 11 define the spectrum mask of triple-segment transmission for 6/14 MHz segment system.

NOTE 1 – The spectrum mask of 7/14 MHz and 8/14 MHz segment systems should be modified in accordance with the spectrum shape of its system.

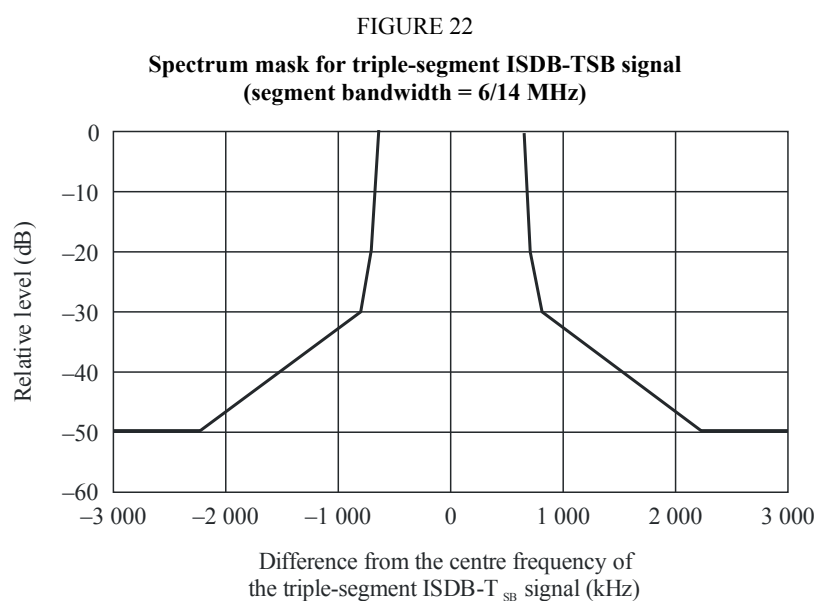

TABLE 11

Breakpoints of the spectrum mask for the triple-segment transmission (segment bandwidth = 6/14 MHz)

Difference from the centre frequency of the terrestrial digital sound signal (kHz)	Relative level (dB)
±650	0
±720	-20
±790	-30
±2 220	-50

9 RF performance characteristics

RF evaluation tests have been carried out on the ISDB-T_{SB} system for a variety of transmission conditions. The results of laboratory tests are described in this section.

Laboratory transmission experiments for BER performance against random noise and multipath fading were conducted. Measurements of BER vs. C/N in the transmission channel were made under the following conditions (see Table 12).

9.1 BER vs. C/N in a Gaussian channel

Additive white Gaussian noise was added to set the C/N at the input of the receiver. The results are shown in Figs 23, 24 and 25. These figures can be compared with those obtained from computer simulation to show the inherent performance of the system. It can be seen that an implementation margin loss of less than 1 dB was obtained at a BER of 2×10^{-4} before RS decoding.

TABLE 12

Transmission parameters for laboratory tests

Number of segments	1 (bandwidth: 429 kHz)
Transmission mode	3 (useful symbol duration: 1.008 ms)
Number of carriers	433
Carrier modulations	DQPSK, 16-QAM, and 64-QAM
Guard interval	63 μ s (guard interval ratio: 1/16)
Coding rates of inner code	1/2, 2/3, 3/4, and 7/8
Time interleaving	0 and 407 ms

FIGURE 23

BER before RS decoding vs. C/N

(Transmission mode: 3, carrier modulation: DQPSK,
time interleaving: 407 ms): Gaussian channel

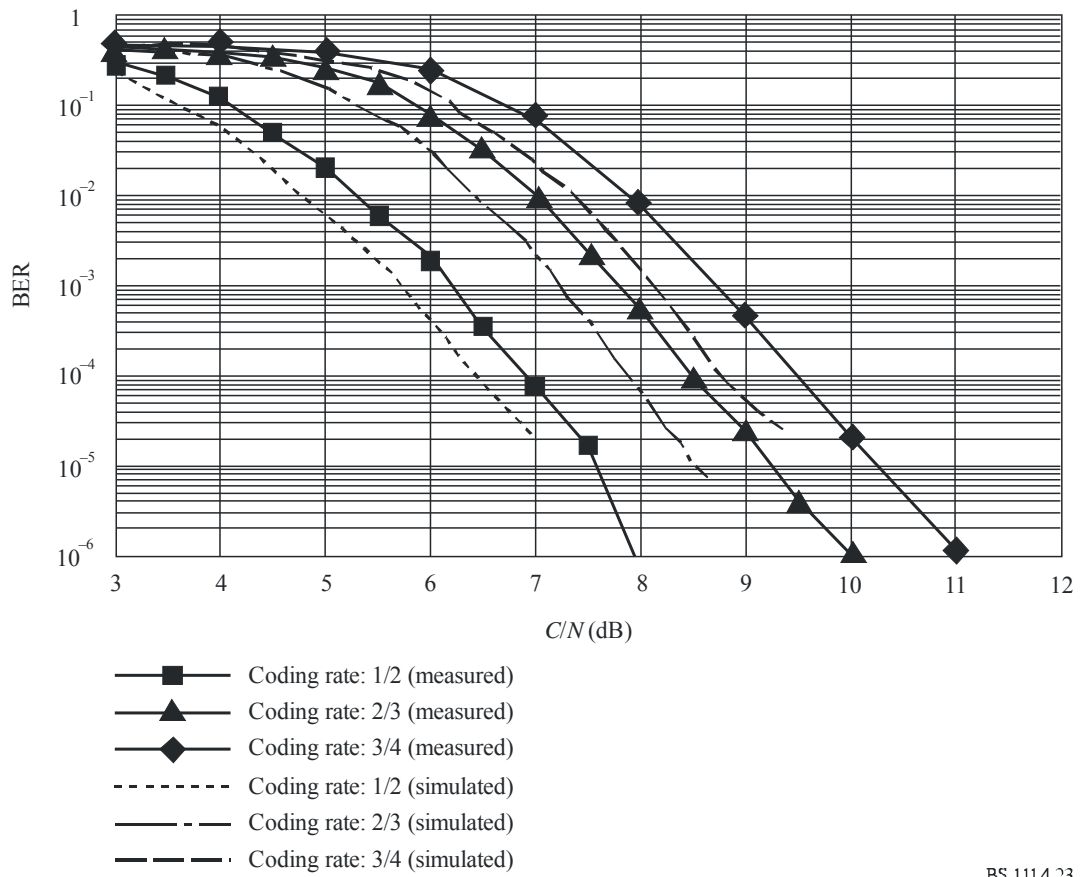

FIGURE 24

BER before RS decoding vs. C/N

(Transmission mode: 3, carrier modulation: 16-QAM,
time interleaving: 407 ms): Gaussian channel

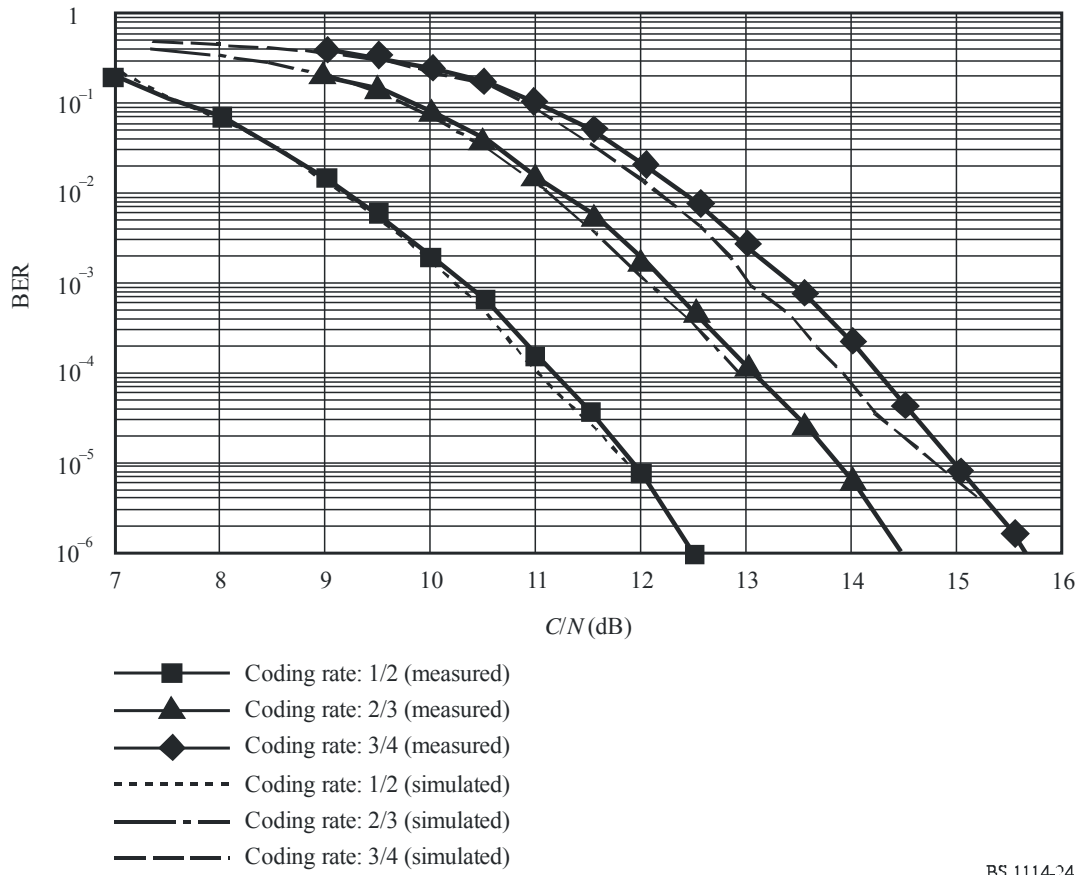
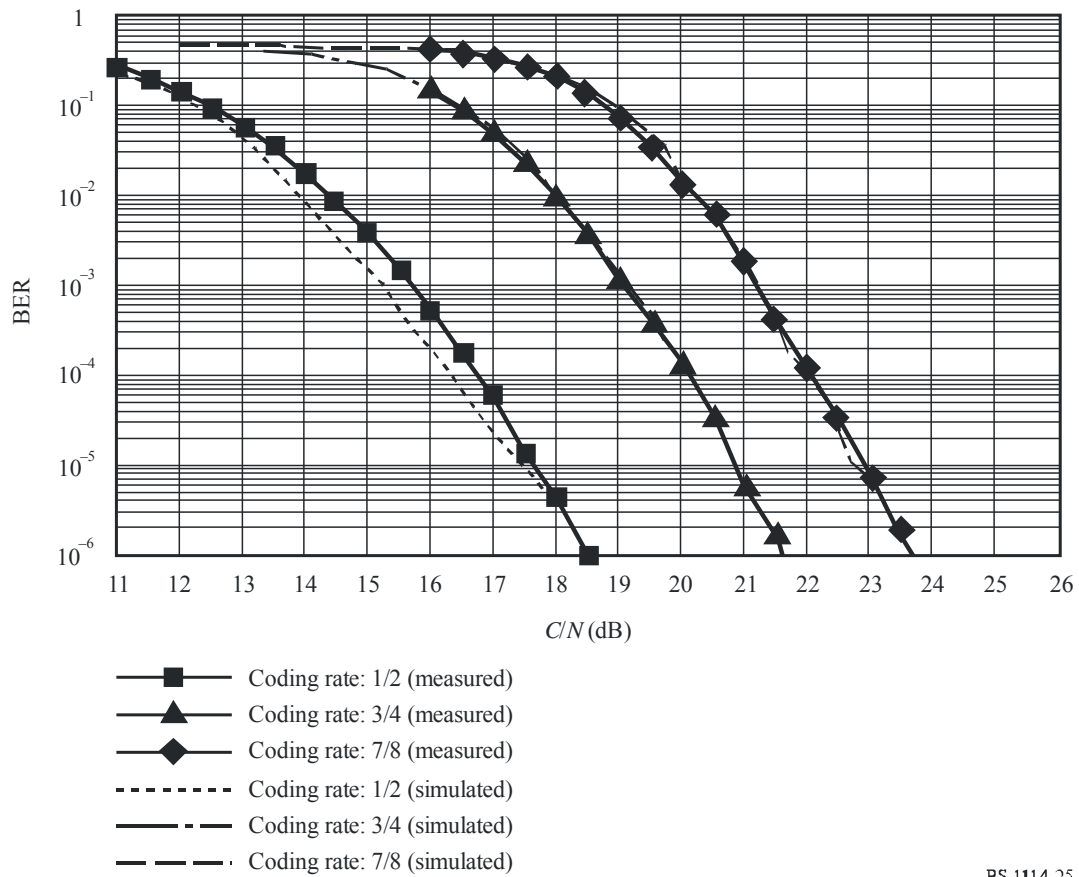

FIGURE 25
BER before RS decoding vs. C/N
 (Transmission mode: 3, carrier modulation: 64-QAM,
 time interleaving: 407 ms): Gaussian channel



BS.1114-25

9.2 BER vs. C/N in a multipath channel

Measurements of BER vs. C/N were made using a multipath channel simulator. The desired signal level to undesired or interfering signal level ratio D/U of the main signal and a delay signal were set to 3 and 10 dB. The delay time of a delayed signal relative to the main signal was set to 15 μ s. The results are shown in Fig. 26.

9.3 BER vs. C/N in a Rayleigh channel

Measurements of BER vs. C/N were made using a fading channel simulator. The channel was set to two-path Rayleigh fading channel, and the D/U of the two paths was set to 0 dB. The time of the delayed signal was set to 15 μ s. The maximum Doppler frequencies of the signal were set to 5 and 20 Hz. The results are shown in Fig. 27.

FIGURE 26

BER before RS decoding vs. C/N

(Transmission mode: 3, coding rate: 1/2, time interleaving: 407 ms): multipath channel

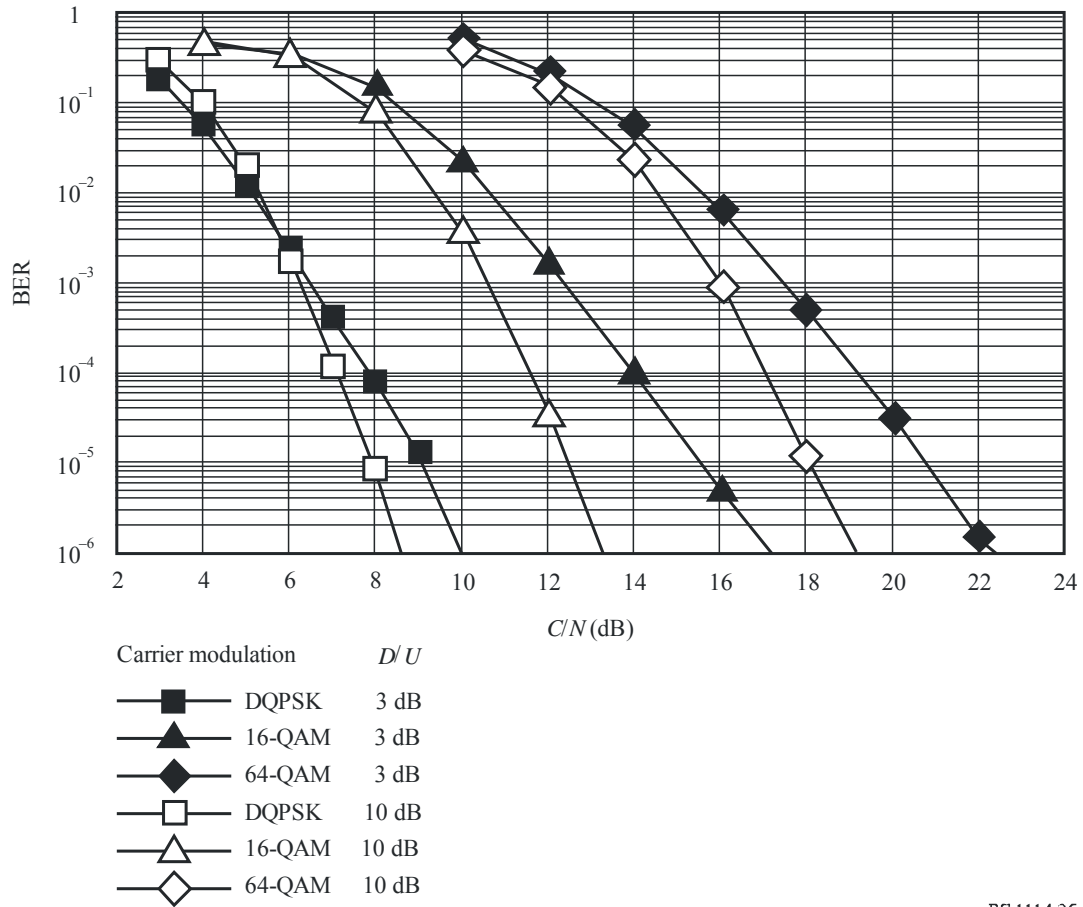
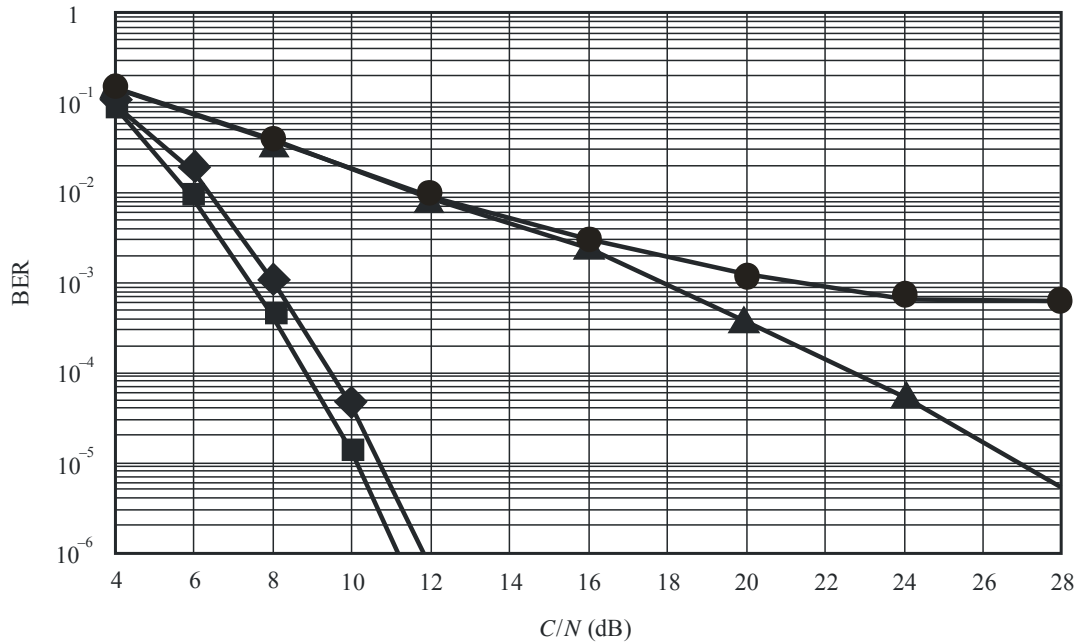

FIGURE 27

BER before RS decoding vs. C/N

(Transmission mode: 3, carrier modulation: DQPSK, coding rate: 1/2): 2-path Rayleigh channel



- Time interleaving: 407 ms
Fading frequency: 20 Hz
- ▲ Time interleaving: 0 ms
Fading frequency: 5 Hz
- ◆ Time interleaving: 407 ms
Fading frequency: 5 Hz
- Time interleaving: 0 ms
Fading frequency: 20 Hz

BS.1114-27

Annex 4

Digital System C

1 System overview

Digital System C employs IBOC technology to facilitate the introduction of DSB. DSB offers broadcasters the ability to upgrade their analogue service by providing enhanced audio fidelity, improved signal robustness, and expanded auxiliary services. IBOC technology allows broadcasters to introduce these upgrades without the need for new spectrum allocations for the digital signal by allowing existing stations to broadcast the same programming in analogue and digital. This provides a spectrally efficient means to make a rational transition from the existing analogue environment to a digital future.

2 IBOC layers

The IBOC detailed performance specifications are organized in terms of the ISO OSI layered model. Each OSI layer of the broadcasting system has a corresponding layer, termed a peer, in the receiving system. The functionality of these layers is such that the combined result of lower layers is to effect a virtual communication between a given layer and its peer on the other side.

2.1 Hybrid Layer 1

Layer 1 (L1) of Digital System C converts information and system control from Layer 2 (L2) into the IBOC waveform for transmission in the VHF band. The information and control is transported in discrete transfer frames via multiple logical channels through the L1 service access points (SAPs). These transfer frames are also referred to as L2 service data units (SDUs) and service control units (SCUs), respectively.

The L2 SDUs vary in size and format depending on the service mode. The service mode, a major component of system control, determines the transmission characteristics of each logical channel. After assessing the requirements of their candidate applications, higher protocol layers select service modes that most suitably configure the logical channels. The plurality of logical channels reflects the inherent flexibility of the system, which supports simultaneous delivery of various classes of digital audio and data.

L1 also receives system control as SCUs from L2. System control is processed in the system control processor.

The following sections present:

- an overview of the waveforms and spectra;
- an overview of the system control, including the available service modes;
- an overview of the logical channels;
- a high-level discussion of each of the functional components comprising the L1 FM air interface.

2.2 Waveforms and spectra

The design provides a flexible means of introducing to a digital broadcast system by providing three new waveform types: hybrid, extended hybrid, and all digital. The hybrid and extended hybrid types retain the analogue FM signal, while the all digital type does not. All three waveforms operate well below allocated spectral emissions mask as currently defined by the Federal Communications Commission (FCC).

The digital signal is modulated using orthogonal frequency division multiplexing (OFDM). OFDM is a parallel modulation scheme in which the data stream modulates a large number of orthogonal subcarriers, which are transmitted simultaneously. OFDM is inherently flexible, readily allowing the mapping of logical channels to different groups of subcarriers.

The symbol timing parameters are defined in Table 13.

2.2.1 Hybrid Waveform

The digital signal is transmitted in primary main (PM) sidebands on either side of the analogue FM signal in the hybrid waveform. The power level of each sideband is approximately 23 dB below the total power in the analogue FM signal. The analogue signal may be monophonic or stereo, and may include subsidiary communications authorization (SCA) channels.

TABLE 13
Symbol timing parameters

Parameter name	Symbol	Units	Exact value	Computed value (to 4 significant figures)
OFDM subcarrier spacing	Δf	Hz	1 488 375/4 096	363.4
Cyclic prefix width	α	None	7/128	5.469×10^{-2}
OFDM symbol duration	T_s	s	$(1 + \alpha) / \Delta f =$ $(135/128) \cdot (4 096/1 488 375)$	2.902×10^{-3}
OFDM symbol rate	R_s	Hz	$= 1/T_s$	344.5
L1 frame duration	T_f	s	$65 536/44 100 = 512 \cdot T_s$	1.486
L1 frame rate	R_f	Hz	$= 1/T_f$	6.729×10^{-1}
L1 block duration	T_b	s	$= 32 \cdot T_s$	9.288×10^{-2}
L1 block rate	R_b	Hz	$= 1/T_b$	10.77
L1 block pair duration	T_p	s	$= 64 \cdot T_s$	1.858×10^{-1}
L1 block pair rate	R_p	Hz	$= 1/T_p$	5.383
Diversity delay frames	N_{dd}	None	= number of L1 frames of diversity delay	3

2.2.2 Extended hybrid waveform

In the extended hybrid waveform, the bandwidth of the hybrid sidebands can be extended toward the analogue FM signal to increase digital capacity. This additional spectrum, allocated to the inner edge of each primary main sideband, is termed the primary extended (PX) sideband.

2.2.3 All digital waveform

The greatest system enhancements are realized with the all digital waveform, in which the analogue signal is removed and the bandwidth of the primary digital sidebands is fully extended as in the extended hybrid waveform. In addition, this waveform allows lower-power digital secondary sidebands to be transmitted in the spectrum vacated by the analogue FM signal.

2.3 System control channel

The system control channel (SCCH) transports control and status information. Primary and secondary service modes and diversity delay control are sent from L2 to L1, while synchronization information is sent from L1 to L2.

The service modes dictate all permissible configurations of the logical channels. There are a total of eleven service modes.

2.4 Logical channels

A logical channel is a signal path that conducts L2 SDUs in transfer frames into L1 with a specific grade of service, determined by the service mode. L1 of the Digital System C provides ten logical channels to higher layer protocols. Not all logical channels are used in every service mode.

2.4.1 Primary logical channels

There are four primary logical channels which are used with both the hybrid and all digital waveforms. They are denoted as P1, P2, P3, and primary IBOC data service (PIDS). Table 14 shows the theoretical information rate supported by each primary logical channel as a function of primary service mode.

TABLE 14
Theoretical information rate of primary logical channels

Service mode	Theoretical information rate (kbit/s)				Waveform
	P1	P2	P3	PIDS	
MP1	25	74	0	1	Hybrid
MP2	25	74	12	1	Extended hybrid
MP3	25	74	25	1	Extended hybrid
MP4	25	74	50	1	Extended hybrid
MP5	25	74	25	1	Extended hybrid, all digital
MP6	50	49	0	1	Extended hybrid, all digital
MP7	25	98	25	1	Extended hybrid, all digital

2.4.2 Secondary logical channels

There are six secondary logical channels that are used only with the all digital waveform. They are denoted as S1, S2, S3, S4, S5, and secondary IBOC data service (SIDS). Table 15 shows the approximate theoretical information rate supported by each secondary logical channel as a function of secondary service mode.

TABLE 15
Approximate theoretical information rate of secondary logical channels

Service mode	Approximate information rate (kbit/s)						Waveform
	S1	S2	S3	S4	S5	SIDS	
MS1	0	0	0	98	6	1	All digital
MS2	25	74	25	0	6	1	All digital
MS3	50	49	0	0	6	1	All digital
MS4	25	98	25	0	6	1	All digital

2.4.3 Logical channel functionality

Logical channels P1 through P3 are designed to convey audio and data. S1 through S5 can be configured to carry data or surround sound audio. PIDS and SIDS logical channels are designed to carry IBOC data service (IDS) information.

The performance of each logical channel is completely described through three characterization parameters: transfer, latency, and robustness. Channel encoding, spectral mapping, interleaver

depth, and diversity delay are the components of these characterization parameters. The service mode uniquely configures these components for each active logical channel, thereby allowing the assignment of appropriate characterization parameters.

In addition, the service mode specifies the framing and synchronization of the transfer frames through each active logical channel.

2.5 Functional components

This subsection includes a high-level description of each L1 functional block and the associated signal flow. Figure 28 is a functional block diagram of L1 processing. Audio and data are passed from the higher OSI layers to the physical layer, the modem, through the L1 SAPs.

2.5.1 Service access points

The L1 SAPs define the interface between L2 and L1 of the system protocol stack. Each logical channel and the SCCH have their own SAP. Each channel enters L1 in discrete transfer frames, with unique size and rate determined by the service mode. These L2 transfer frames are typically referred to as L2 SDUs and SCUs.

2.5.2 Scrambling

This function randomizes the digital data in each logical channel to “whiten” and mitigate signal periodicities when the waveform is demodulated in a conventional analogue FM demodulator.

2.5.3 Channel encoding

Digital System C uses Viterbi convolutional codes with an effective coding rate of 2/5. This convolutional encoding adds redundancy to the digital data in each logical channel to improve its reliability in the presence of channel impairments. The size of the logical channel vectors is increased in inverse proportion to the code rate. The encoding techniques are configurable by service mode. Diversity delay is also imposed on selected logical channels. At the output of the channel encoder, the logical channel vectors retain their identity.

2.5.4 Interleaving

Interleaving in time and frequency is employed to mitigate the effects of burst errors. The interleaving techniques are tailored to the VHF fading environment and are configurable by service mode. Each logical channel is individually interleaved. The depth of the interleaver is based on the use of the channel. The length of the interleaver in the primary audio channels (P1 and P2) is equivalent to one L1 frame. In this process, the logical channels lose their identity. The interleaver output is structured in a matrix format; each matrix is comprised of one or more logical channels and is associated with a particular portion of the transmitted spectrum. Total diversity delay including interleaving is three L1 frames (3×1.486 s).

2.5.5 System control processing

This function generates a matrix of system control data sequences which includes control and status (such as service mode), for broadcast on the reference subcarriers.

FIGURE 28
FM air interface L1 functional block diagram

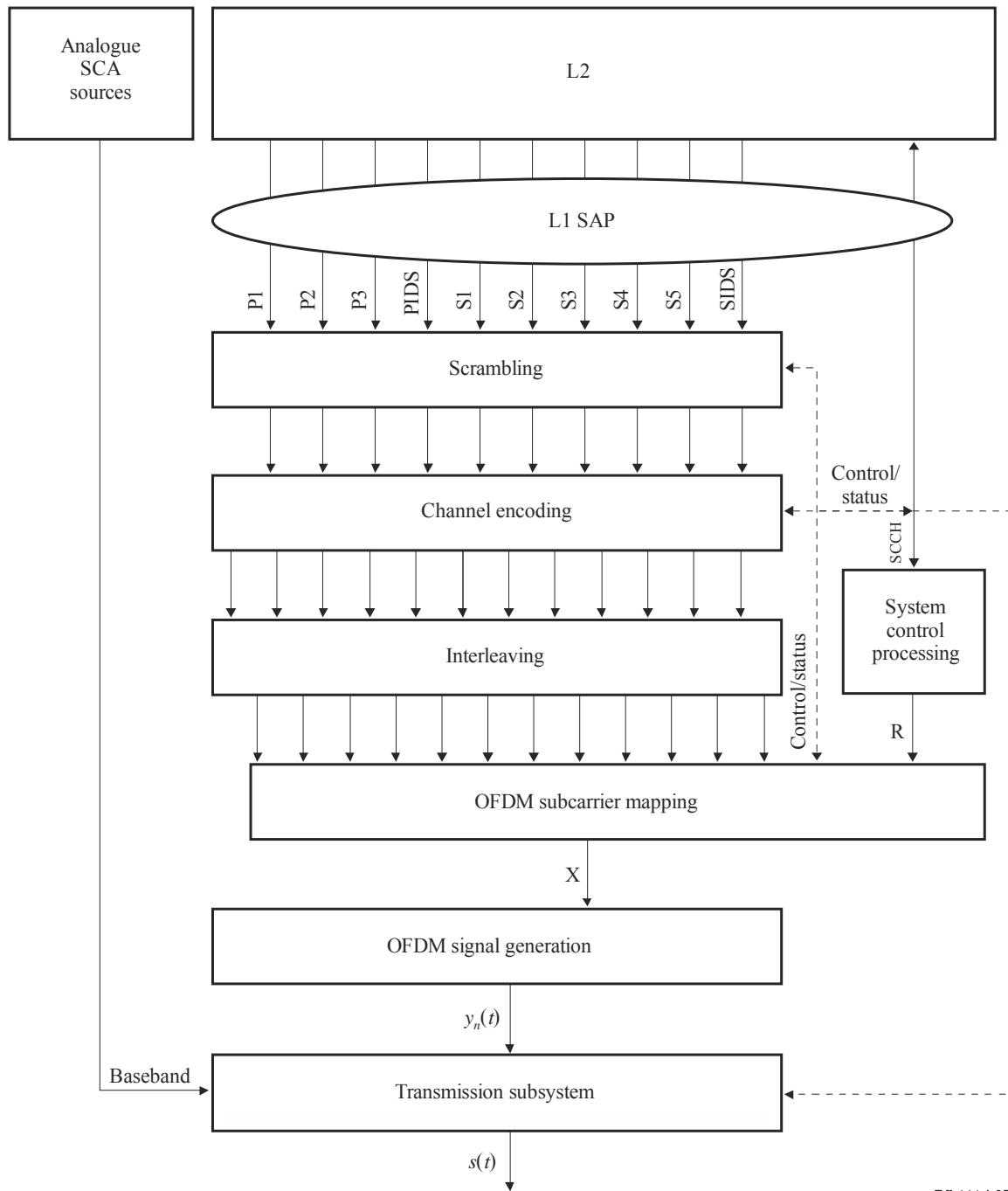

BS.1114-28

2.5.6 OFDM subcarrier mapping

This function assigns the interleaved matrices and the system control matrix to the OFDM subcarriers. One row of each active interleaver matrix is processed every OFDM symbol T_s to produce one output vector \mathbf{X} , which is a frequency-domain representation of the signal. The mapping is specifically tailored to the non-uniform interference environment and is a function of the service mode.

2.5.7 OFDM signal generation

This function generates the digital portion of the time-domain signal. The input vectors are transformed into a shaped time-domain baseband pulse, $y_n(t)$, defining one OFDM symbol.

2.5.8 Transmission subsystem

This function formats the baseband waveform for transmission through the VHF channel. Major sub-functions include symbol concatenation and frequency up-conversion. In addition, when transmitting the hybrid waveform, this function modulates the source and combines it with the digital signal to form a composite hybrid signal, $s(t)$, ready for transmission.

3 Functional description

3.1 Introduction

OFDM signal generation receives complex, frequency-domain OFDM symbols from OFDM subcarrier mapping, and outputs time-domain pulses representing the digital portion of the Digital System C signal. A conceptual block diagram of OFDM signal generation is shown in Fig. 29.

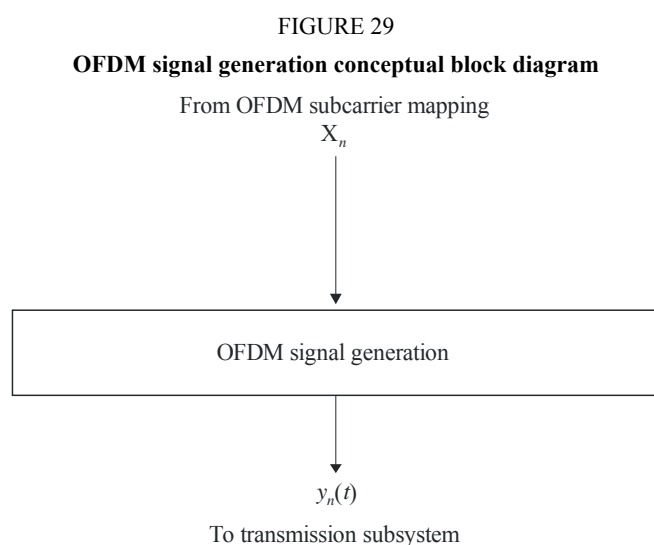

BS.1114-29

The input to OFDM signal generation is a complex vector \mathbf{X}_n of length L , representing the complex constellation values for each OFDM subcarrier in OFDM symbol n . The output of OFDM signal generation is a complex, baseband, time-domain waveform $y_n(t)$, representing the digital portion of the Digital System C signal for OFDM symbol n .

3.2 Transmission subsystem

3.2.1 Introduction

The transmission subsystem formats the baseband IBOC waveform for transmission through the VHF channel. Functions include symbol concatenation and frequency up-conversion. In addition, when transmitting the hybrid or extended hybrid waveforms, this function delays and modulates the baseband analogue signal before combining it with the digital waveform.

The input to this module is a complex, baseband, time-domain OFDM waveform, $y_n(t)$, from the OFDM signal generation function. A baseband analogue signal $m(t)$ is also input from an analogue source, along with optional SCA signals, when transmitting the hybrid or extended hybrid waveform. In addition, analogue diversity delay (DD) control is input from L2 via the control channel. The output of this module is the IBOC waveform.

FIGURE 30

Hybrid/extended hybrid transmission subsystem functional block diagram

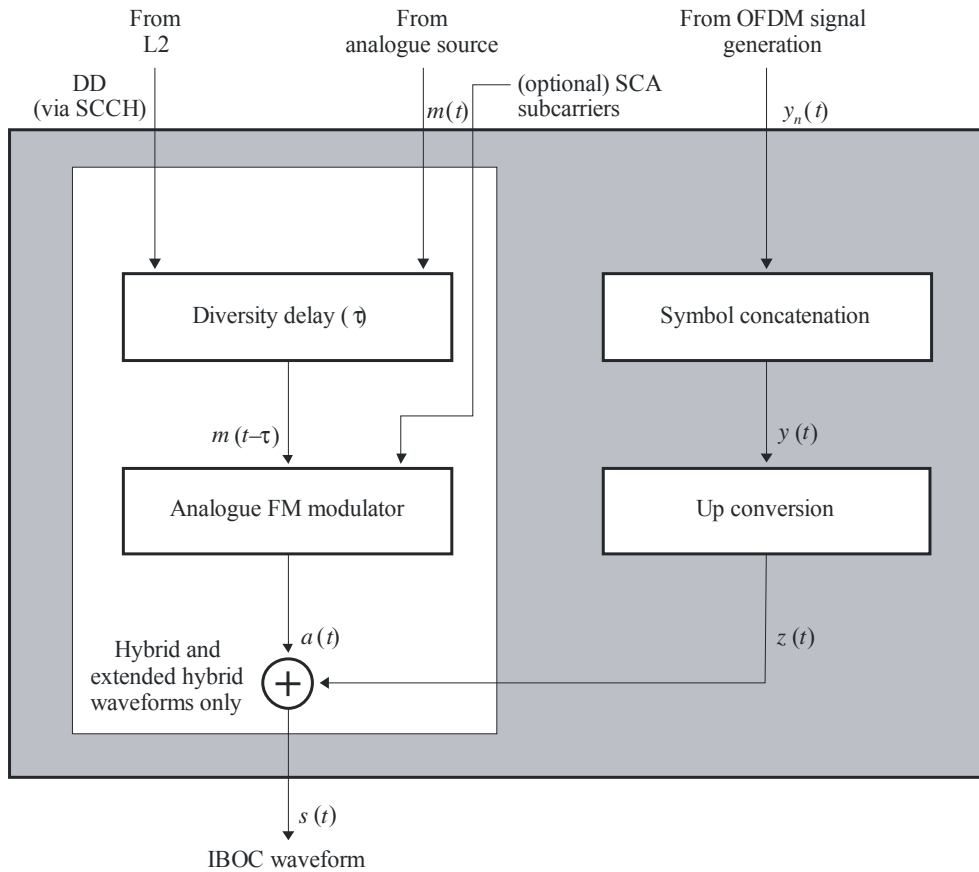
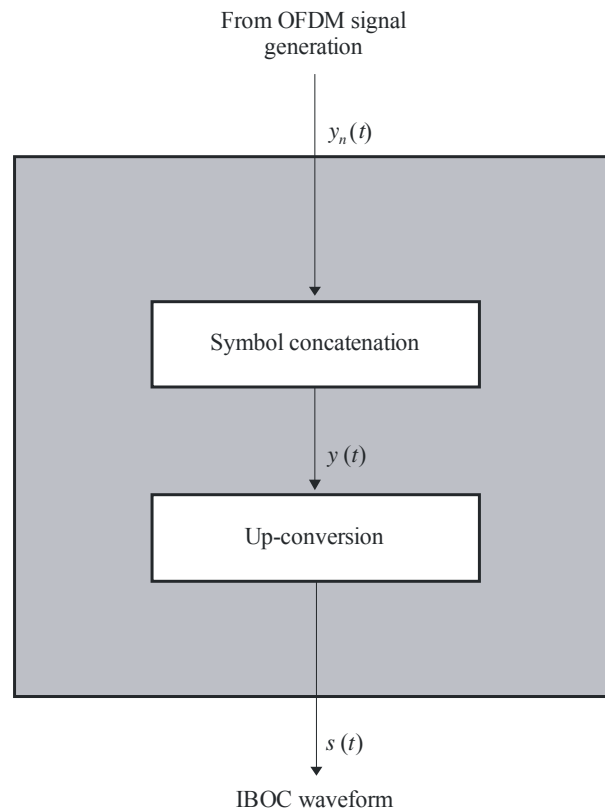

FIGURE 31
All digital transmission subsystem functional block diagram



BS.1114-31

3.2.2 Diversity delay

When broadcasting the hybrid and extended hybrid waveforms, $z(t)$ is combined with the analogue FM signal $a(t)$. The first step in generating $a(t)$ is the application of DD to the baseband analogue signal $m(t)$. The analogue DD control bit received from L2 via the SCCH, is used by upper protocol layers to enable or disable the DD. If DD is 0, the DD is disabled; if DD is 1, it is enabled. When DD is enabled, an adjustable delay τ is applied to the baseband analogue signal $m(t)$. The delay is set so that, at the output of the analogue/digital combiner, $a(t)$ lags the corresponding digital signal $z(t)$ by T_{dd} . In the Digital System C the analogue and digital signals carry the same audio program with the analogue audio delayed from the corresponding digital audio by T_{dd} at the output of the analogue/digital combiner. The delay is adjustable to account for processing delays in the analogue and digital chains.

3.2.3 Analogue FM modulator

For the hybrid and extended hybrid waveforms, the appropriately delayed baseband analogue signal $m(t-\tau)$ is frequency modulated to produce an RF analogue FM waveform identical to existing analogue signals.

3.2.4 Analogue/digital combiner

When broadcasting the hybrid or extended hybrid waveform, the analogue-modulated FM RF signal is combined with the digitally-modulated IBOC RF signal to produce the Digital System C signal, $s(t)$. Both the analogue and digital portions of the waveform are centred on the same carrier frequency. The levels of each digital sideband in the output spectrum are appropriately scaled by OFDM subcarrier mapping.

3.3 Use of on channel repeaters

The use of OFDM modulation in Digital System C allows on-channel digital repeaters or a single frequency network to fill areas of desired coverage where signal losses due to terrain and/or shadowing are severe. A typical application would be where mountains or other terrain obstructions within the station's service areas limit analogue or digital performance.

Digital System C operates with an effective guard time between OFDM symbols of approximately $150 \mu\text{s}^2$. To avoid significant intersymbol interference the effective coverage in the direction of the primary transmission system should be limited to within 22 km. Specifically the ratio of the signal from the primary transmitter to the booster signal should be at least 10 dB at locations more than 22 km from the repeater in the direction of the primary antenna. Performance and distances between on-channel boosters can be improved through the use of directional antennas to protect the main station.

3.4 Global positioning system (GPS) synchronization

In order to ensure precise time synchronization, for rapid station acquisition and booster synchronization, each station is GPS locked. This is normally accomplished through synchronization with a signal synchronized in time and frequency to the GPS³. Transmissions that are not locked to GPS, would not be able to provide fast tuning at the receiver in the case of SFN since they cannot be synchronized with other stations⁴.

4 Digital sideband levels

The amplitude scaling of each OFDM subcarrier within each digital sideband is given in Table 16 for the hybrid, extended hybrid and all digital waveforms. The values for the hybrid waveforms are specified relative to the total power of the unmodulated analogue FM carrier (assumed equal to 1). The values for the all digital waveform are specified relative to the total power of the unmodulated analogue FM carrier (assumed equal to 1) that would have been transmitted in the hybrid and extended hybrid modes.

² $150 \mu\text{s}$ equates to a 45 km propagation distance.

³ GPS locked stations are referred to as Level I: GPS-locked transmission facilities.

⁴ Level II: non-GPS locked transmission facilities.

TABLE 16
OFDM subcarrier scaling

Waveform	Mode	Sidebands	Amplitude scale factor notation	Amplitude scale factor ⁽¹⁾ (relative to total analogue FM power)	Amplitude scale factor ⁽²⁾ (relative to total analogue FM power) (dB)
Hybrid	MP1	Primary	a_0	5.123×10^{-3}	-41.39
Extended hybrid	MP2-MP7	Primary	a_0	5.123×10^{-3}	-41.39
All digital	MP5-MP7	Primary	a_2	1.67×10^{-2}	-31.39
	MS1-MS4	Secondary	a_4	5.123×10^{-3}	-41.39
		Secondary	a_5	3.627×10^{-3}	-44.39
		Secondary	a_6	2.567×10^{-3}	-47.39
		Secondary	a_7	1.181×10^{-3}	-50.39

⁽¹⁾ Amplitude scale factor per IBOC subcarrier range.

⁽²⁾ Amplitude scale factor in dB measured in 1 kHz bandwidth.

For the hybrid and extended hybrid waveforms, the values were chosen so that the total average power in a primary digital sideband (upper or lower) is 23 dB below the total power of unmodulated analogue FM carrier.

For the all digital waveform, the values were chosen so that the total average power in a primary digital sideband (upper or lower) is at least 10 dB above the total power in the hybrid primary digital sidebands. In addition, the values were chosen so that the total average power in the secondary digital sidebands (upper and lower) is at least 20 dB below the total power in the all digital primary digital sidebands.

5 Spectrum for hybrid mode

The digital signal is transmitted in Primary Main sidebands on either side of the analogue FM signal. Each Primary Main sideband is comprised of ten frequency partitions, which are allocated among subcarriers 356 through 545, or -356 through -545 (see Fig. 32 and Table 17). Subcarriers 546 and -546, also included in the PM sidebands, are additional reference subcarriers. The amplitude of the subcarrier within PM sidebands is uniformly scaled by an amplitude scale factor.

FIGURE 32

Spectrum of the hybrid waveform – Service mode MP1

(The level of the digital subcarriers is such that the total power of these carriers is 20 dB below the nominal power of the FM analogue carrier)

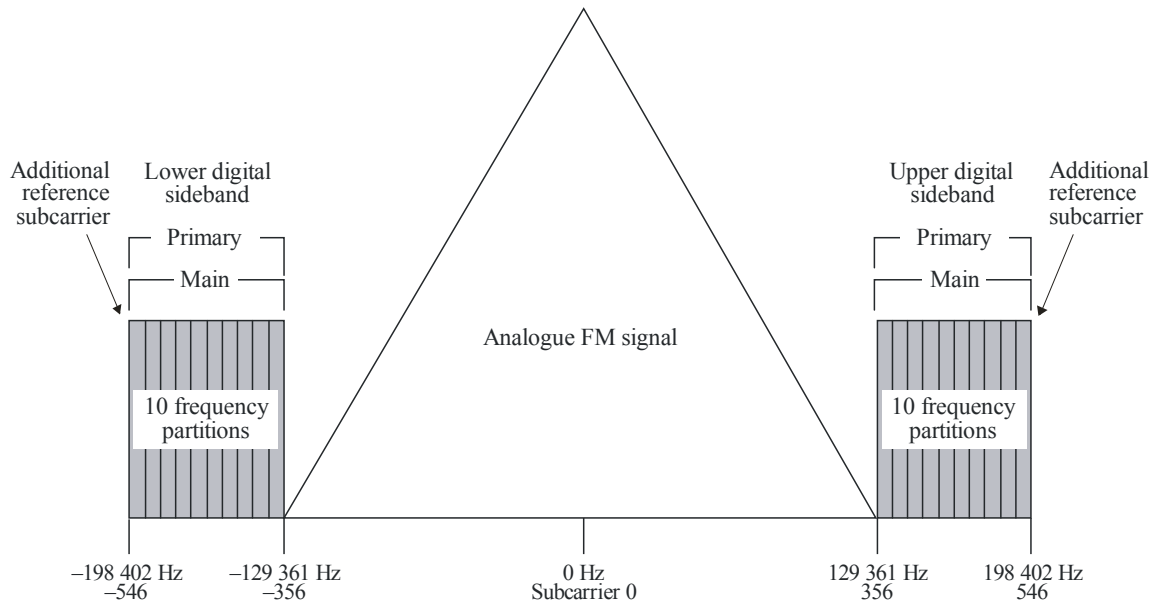

BS.1114-32

TABLE 17

Hybrid waveform spectral summary – service mode MP1

Sideband	Number of frequency partitions	Frequency partition ordering	Subcarrier range	Subcarrier frequencies (from channel centre) (Hz)	Amplitude scale factor	Frequency span (Hz)	Comments
Upper PM	10	A	356 to 546	129 361 to 198 402	a_0	69 041	Includes additional reference subcarrier 546
Lower PM	10	B	-356 to -546	-129 361 to -198 402	a_0	69 041	Includes additional reference subcarrier -546

6 Spectrum for extended hybrid mode

The extended hybrid waveform is created by adding primary extended sidebands to the PM sidebands present in the hybrid waveform. Depending on the service mode, one, two, or four frequency partitions can be added to the inner edge of each PM sideband. Each PM sideband consists of ten frequency partitions and an additional reference subcarrier spanning subcarriers 356 through 546, or -356 through -546 . The upper primary extended sidebands include subcarriers 337 through 355 (one frequency partition), 318 through 355 (two frequency partitions) or 280 through 355 (four frequency partitions). The lower primary extended sidebands include subcarriers -337 through -355 (one frequency partition), -318 through -355 (two frequency partitions) or -280 through -355 (four frequency partitions). The subcarriers within primary extended sidebands are uniformly scaled the same amplitude scale factor, a_0 , as the PM sidebands (see Fig. 33 and Table 18).

FIGURE 33

Spectrum of the extended hybrid waveform – Service modes MP2 through MP4

(The level of the digital subcarriers is such that the total power of these carriers is 20 dB below the nominal power of the FM analogue carrier)

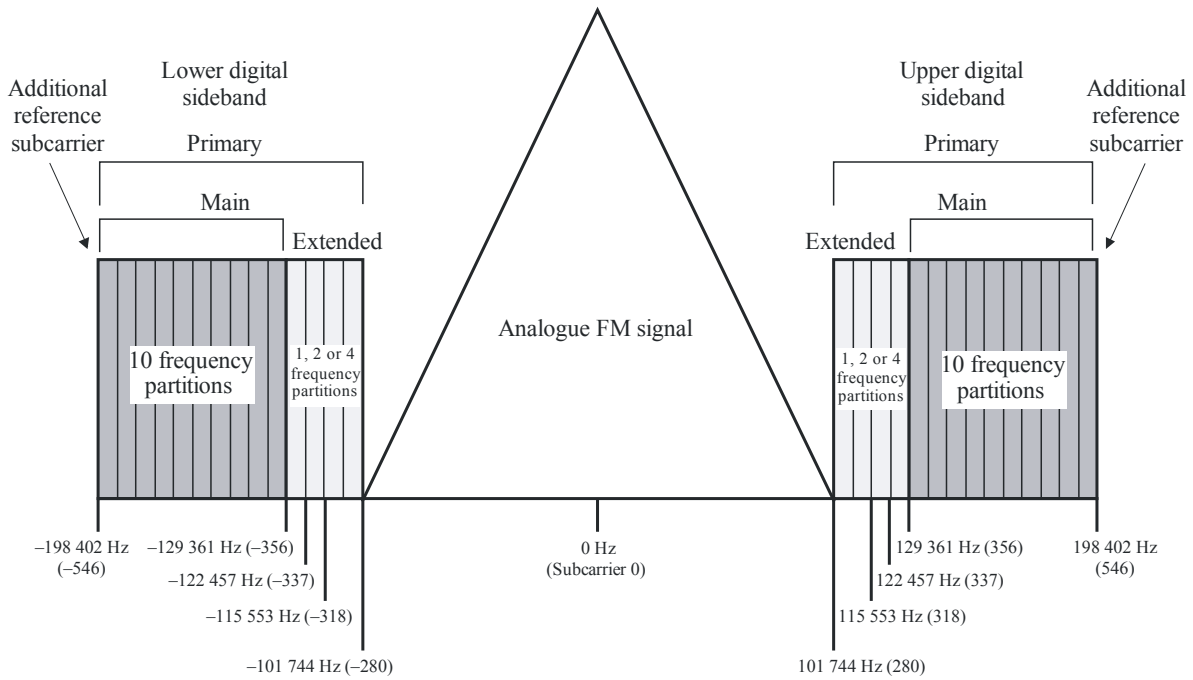

TABLE 18

Extended hybrid waveform spectral summary – service modes MP2 through MP4

Sideband	Number of frequency partitions	Frequency partition ordering	Subcarrier range	Subcarrier frequencies (from channel centre) (Hz)	Amplitude scale factor	Frequency span (Hz)	Comments
Upper PM	10	A	356 to 546	129 361 to 198 402	a_0	69 041	Includes additional reference subcarrier 546
Lower PM	10	B	-356 to -546	-129 361 to -198 402	a_0	69 041	Includes additional reference subcarrier -546
Upper primary extended (1 frequency partition)	1	A	337 to 355	122 457 to 128 997	a_0	6 540	None
Lower primary extended (1 frequency partition)	1	B	-337 to -355	-122 457 to -128 997	a_0	6 540	None
Upper primary extended (2 frequency partitions)	2	A	318 to 355	115 553 to 128 997	a_0	13 444	None
Lower primary extended (2 frequency partitions)	2	B	-318 to -355	-115 553 to -128 997	a_0	13 444	None
Upper primary extended (4 frequency partitions)	4	A	280 to 355	101 744 to 128 997	a_0	27 253	None
Lower primary extended (4 frequency partitions)	4	B	-280 to -355	-101 744 to -128 997	a_0	27 253	None

7 Spectrum for all digital mode

The all digital waveform is constructed by removing the analogue signal, fully expanding the bandwidth of the primary digital sidebands and adding lower-power secondary sidebands in the spectrum vacated by the analogue signal. The spectrum of the all digital waveform is shown in Fig. 34.

FIGURE 34
 Spectrum of the all digital waveform – Service modes MP5 through MP7, MS1 through MS4
 (The level of the digital subcarriers is such that the total power of these carriers is no more than 10 dB below the nominal power of the FM analogue carrier that it replaces)

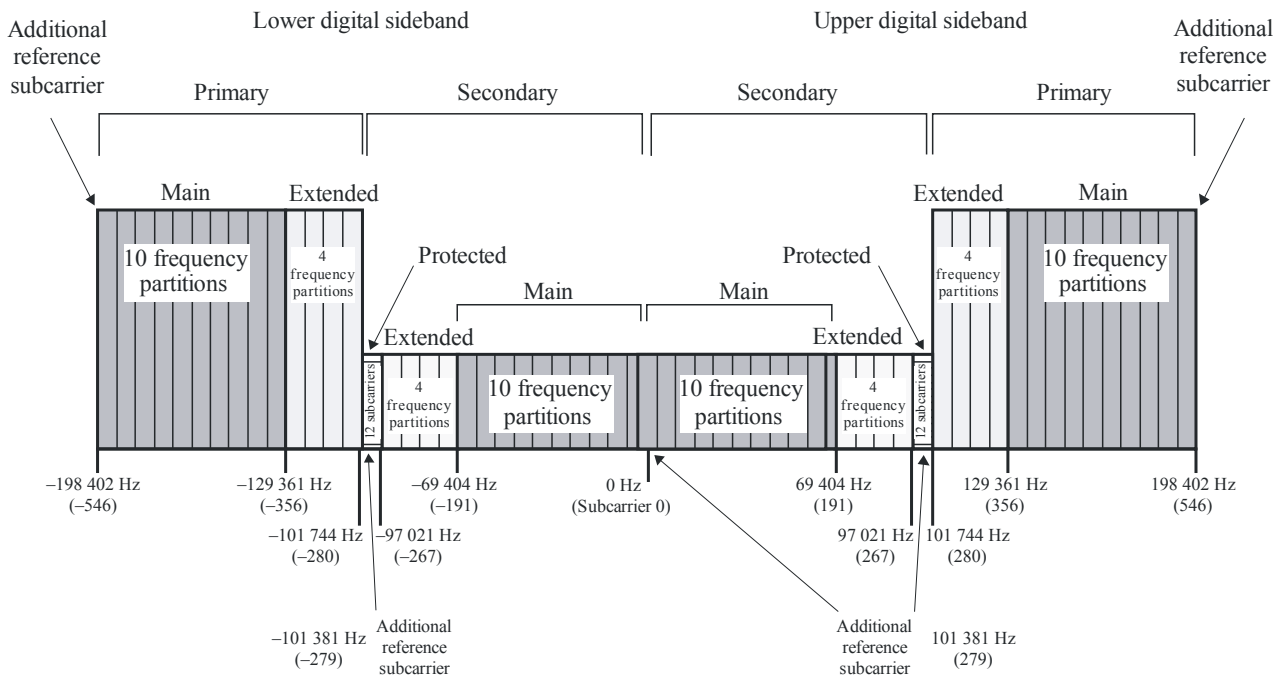

BS.1114-34

In addition to the ten main frequency partitions, all four extended frequency partitions are present in each primary sideband of the all digital waveform. Each secondary sideband also has ten secondary main (SM) and four secondary extended frequency partitions. Unlike the primary sidebands, however, the SM frequency partitions are mapped nearer to channel centre with the extended frequency partitions farther from the centre.

Each secondary sideband also supports a small secondary protected (SP) region consisting of 12 OFDM subcarriers and reference subcarriers 279 and -279. The sidebands are referred to as “protected” because they are located in the area of spectrum least likely to be affected by analogue or digital interference. An additional reference subcarrier is placed at the centre of the channel (0). Frequency partition ordering of the SP region does not apply since the SP region does not contain frequency partitions

Each SM sideband spans subcarriers 1 through 190 or -1 through -190. The upper secondary extended sideband includes subcarriers 191 through 266 and the upper SP sideband includes subcarriers 267 through 278, plus additional reference subcarrier 279. The lower secondary extended sideband includes subcarriers -191 through -266 and the lower SP sideband includes subcarriers -267 through -278, plus additional reference subcarrier -279. The total frequency span of the entire all digital spectrum is 396 803 Hz. The subcarriers within the PM and primary extended sidebands are scaled by an amplitude scale factor, a_2 . The subcarriers within the SM, secondary

extended and SP sidebands are uniformly scaled by an amplitude scale factor having four discrete levels a_4 - a_7 .

TABLE 19

**All digital waveform spectral summary – service modes MP5 through MP7,
MS1 through MS4**

Sideband	Number of frequency partitions	Frequency partition ordering	Sub-carrier range	Sub-carrier frequencies (from channel centre) (Hz)	Amplitude scale factor	Frequency span (Hz)	Comments
Upper PM	10	A	356 to 546	129 361 to 198 402	a_2	69 041	Includes additional reference subcarrier 546
Lower PM	10	B	-356 to -546	-129 361 to -198 402	a_2	69 041	Includes additional reference subcarrier -546
Upper primary extended	4	A	280 to 355	101 744 to 128 997	a_2	27 253	None
Lower primary extended	4	B	-280 to -355	-101 744 to -128 997	a_2	27 253	None
Upper SM	10	B	0 to 190	0 to 69 041	a_2	69 041	Includes additional reference subcarrier 0
Lower SM	10	A	-1 to -190	-363 to -69 041	a_2	68 678	None
Upper secondary extended	4	B	191 to 266	69 404 to 96 657	a_4 - a_7	27 253	None
Lower secondary extended	4	A	-191 to -266	-69 404 to -96 657	a_4 - a_7	27 253	None
Upper SP	Not applicable	Not applicable	267 to 279	97 021 to 101 381	a_4 - a_7	4 360	Includes additional reference subcarrier 279
Lower SP	Not applicable	Not applicable	-267 to -279	-97 021 to -101 381	a_4 - a_7	4 360	Includes additional reference subcarrier 279

8 Emission limitations

8.1 Emission limits for IBOC operation

Hybrid and all digital carrier levels are operated well below the FM emissions mask. An example of one administration's mask, from the United States of America, Code of Federal Regulations (CFR), Title 47 § 73.317 is summarized in Table 20.

TABLE 20
Emission limits as a function of off-set from carrier frequency for
FM channels in the United States of America

Offset from carrier frequency (kHz)	Power spectral density relative to unmodulated analogue FM carrier (dBc/kHz) ⁽¹⁾
120 to 240	-25
240 to 600	-35
Greater than 600	-80, or $-43 - 10 \log_{10} x$, whichever is less, where x is power (W) refers to the total unmodulated transmitter output carrier power

⁽¹⁾ Measurements are made by averaging the power spectral density in a 1 kHz bandwidth over a 10 s segment of time.

Figures 35 and 36 depict the noise level from all sources in dB relative to the nominal power spectral density of the digital sidebands as measured in a 1 kHz bandwidth. This noise measurement is inclusive of all sources including:

- phase noise of the IBOC exciter and
- intermodulation products from the transmitter. In Tables 20, 21, 22 and 23 the levels have been adjusted to depict the level below the 0 dBc emissions mask.

TABLE 21
IBOC digital carrier power⁽¹⁾

Hybrid mode	All-digital mode	
	Main programme carriers	Secondary auxiliary service carriers
-41.39	-31.39	-50.39

⁽¹⁾ Nominal power spectral density in a 1 kHz bandwidth to the reference 0 dBc mask.

8.1.1 Emission limits for hybrid mode operation

Noise from all sources, excluding frequencies removed from the carrier between 100 to 200 kHz, including phase noise of the IBOC exciter and intermodulation products, shall conform to the limits of Fig. 35 and Table 22. Requirements are summarized as follows, where dB is relative to the nominal power spectral density in a 1 kHz bandwidth of the digital sidebands.

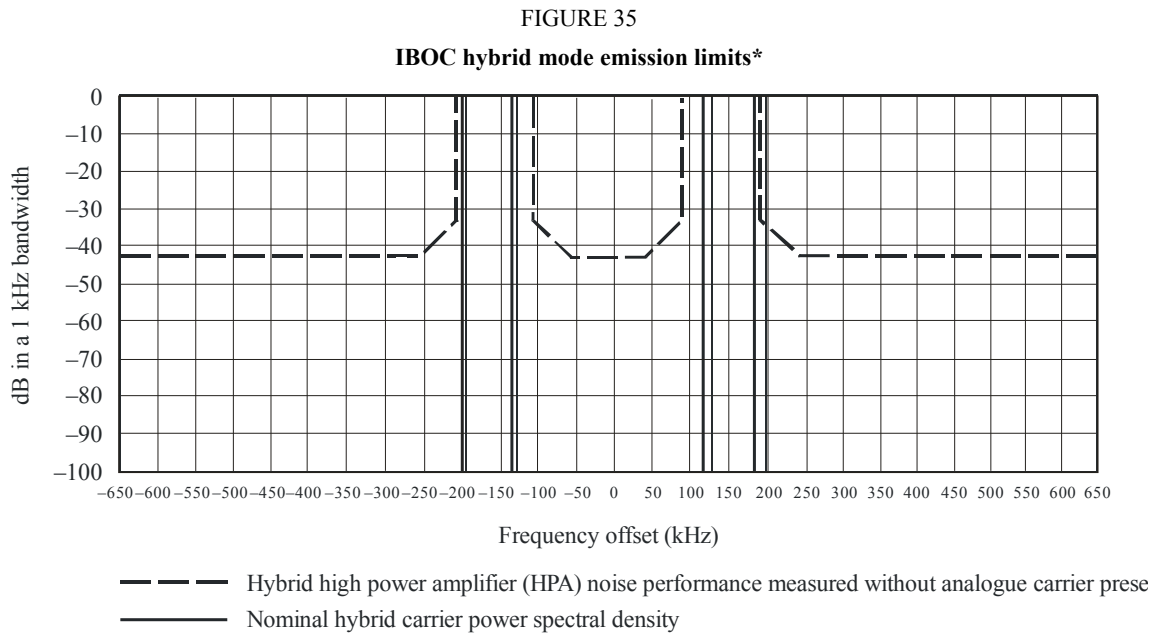

* 0 dB is relative to the nominal power spectral density in a 1 kHz bandwidth of the digital sidebands.

BS.1114-35

TABLE 22

Hybrid mode emission limits

Frequency, F , offset relative to carrier (kHz)	Level (dB/kHz)
0-50	-83.39 dB
50-95	$\{-83.39 + (\text{frequency (kHz)} - 50 \text{ kHz}) \cdot 0.2\}$ dB
95-100	$\{-61.39 + (\text{frequency (kHz)} - 100 \text{ kHz}) \cdot 2.6\}$ dB
200-205	$\{-61.39 - (\text{frequency (kHz)} - 200 \text{ kHz}) \cdot 2.6\}$ dB
205-250	$\{-74.39 - (\text{frequency (kHz)} - 205 \text{ kHz}) \cdot 0.2\}$ dB
>250	-83.39 dB

8.1.2 Emission limits for all-digital mode operation

Noise from all sources, for frequencies removed from the carrier by more than 200 kHz, including phase noise of the IBOC exciter and intermodulation products, shall conform to the limits of Fig. 36 and Table 23.

FIGURE 36
All-digital emission limits*

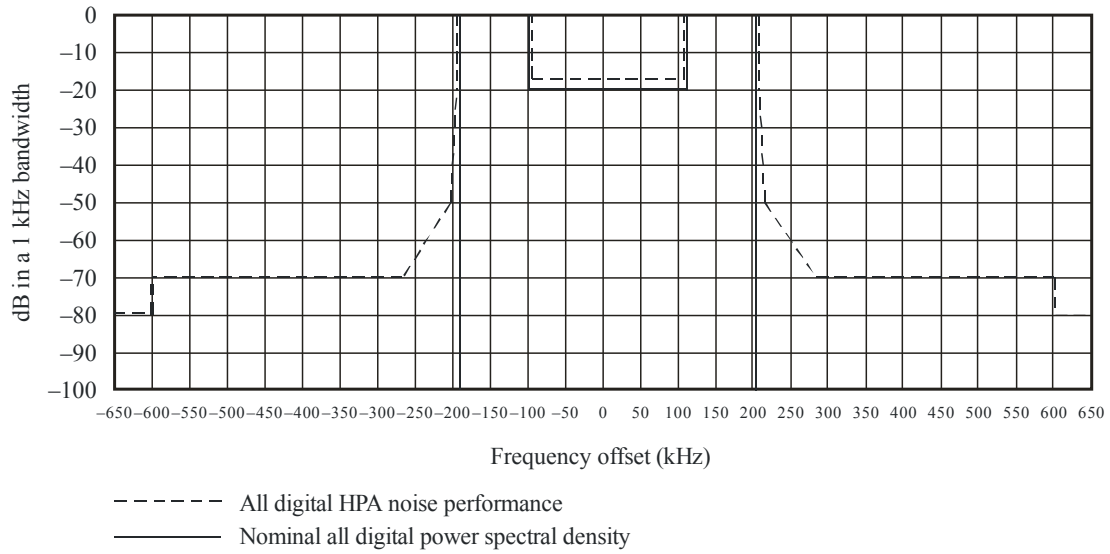

* 0 dB is relative to the nominal power spectral density in a 1 kHz bandwidth of the digital sidebands.

BS.1114-36

Requirements are summarized as follows, where dB is relative to the nominal power spectral density in a 1 kHz bandwidth of the digital sidebands.

TABLE 23
All-digital emission limits

Frequency, F , offset relative to carrier (kHz)	Level (dB/kHz)
200-207.5	$\{-51.39 - (\text{frequency (kHz)} - 200 \text{ kHz}) \cdot 1.733\}$ dB
207.5-250	$\{-64.39 - (\text{frequency (kHz)} - 207.5 \text{ kHz}) \cdot 0.2118\}$ dB
250-300	$\{-73.39 - (\text{frequency (kHz)} - 250 \text{ kHz}) \cdot 0.56\}$ dB
300-600	-101.39 dB
>600	-111.39 dB

9 Summary of laboratory test results

Laboratory tests of Digital System C are summarized below. The fading profiles used are denoted by urban fast (UF), urban slow (US), rural fast (RF), or terrain-obstructed (TO) fast and were independently applied to the desired signal and each of the interferers. The interference level is given in units of dB_{des} , which is defined as dB relative to the total power of the desired hybrid signal. For each block error rate test, Table 24 lists the interference scenario under which it was run, the C_d/N_0 (dB/Hz), the fading profile, the level of the interference and the measured block error rate.

TABLE 24

FM hybrid IBOC DSB performance test results

Tests	Input parameters					Measurements				
						Digital performance	Analogue subjective evaluation at digital ToA			
	C_d/N_0 (dB/Hz)	Fading	Co-Channel (dB _{des})	1 st adjacent (dB _{des})	2 nd adjacent (dB _{des})	Block error rate	File	Subjective audio degradation		
Gaussian noise no fading/ no interference	54.1					0.16	audio1.wav	Audible		
	54.5					0.032				
	55.1					0.0029				
9-ray fading	55.4	UF				0.8	audio2.wav	Audible		
	56.4					0.056				
	57.3					0.012				
	59.3	US				0.106	audio3.wav	Audible		
	60.4					0.054				
	61.4					0.0202				
	55.9	RF				0.6	audio4.wav	Audible		
	56.8					0.087				
	57.8					0.007				
	55.9	TO				0.317	audio5.wav	Audible		
	56.9					0.026				
	57.8					0.001				
1 st adjacent interference	61.5	UF		-6.0		0.075	audio6.wav	Audible		
	62.4								0.045	
	63.4								0.00842	
	59.4	UF		-18.0		0.077	audio7.wav	Audible		
	60.3								0.012	
	61.3								0.006	
	58.2	UF		-24.0		0.0735	audio8.wav	Audible		
	59.2								0.0109	
	60.1								0.005	
	57.2	UF		-30.0		0.0287	audio9.wav	Audible		
58.2						0.0082				
2 nd adjacent interference	57.9	UF			20.0	0.1	audio10.wav	Audible		
	58.9								0.018	
	60.5								0.00085	
Co-channel interference	60.2	UF	-10.0			0.013	audio11.wav	Beyond point of failure		
	61.3									0.0097
	65.3									0.00014
	58.4	UF	-20.0			0.013	audio12.wav	Audible		
	59.3									0.0011
	60.4									0.00035

9.1 Performance in Gaussian noise

This test measured an upper bound to system performance and recorded analogue audio at the digital threshold of audibility (ToA) in the presence of Gaussian noise, in the absence of Rayleigh fading and interference. Performance is shown in the block error rate curves of Fig. 37, and summarized in Table 24. Table 24 indicates that just prior to digital ToA, analogue audio quality is audibly degraded.

FIGURE 37
Block error rate results of the hybrid system in different types of 9-ray fading and additive white Gaussian noise (AWGN)

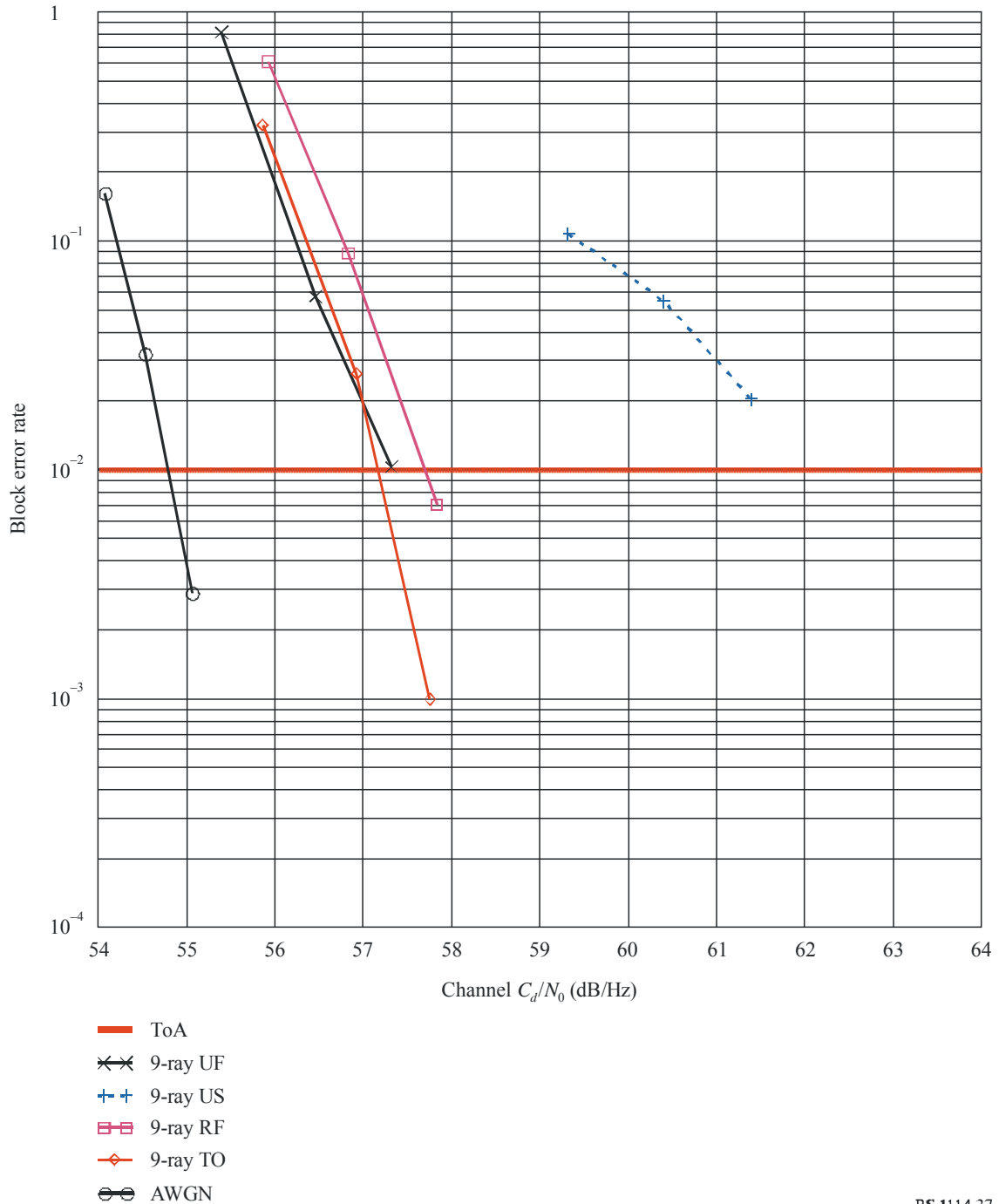

9.2 Performance in Rayleigh fading

This test measured system performance and recorded analogue audio at the digital ToA in Gaussian noise and in various types of Rayleigh fading. Performance is shown in the block error rate curves of Fig. 38 and summarized in Table 24. Results indicate an insensitivity to fading profile, except in the case of urban slow fading, which produces signal fades of very long duration. The urban slow fading profile produces particularly annoying outages in existing analogue transmissions.

FIGURE 38
Block error rate results of a hybrid system in 9-ray UF fading with an independently faded first-adjacent interferer

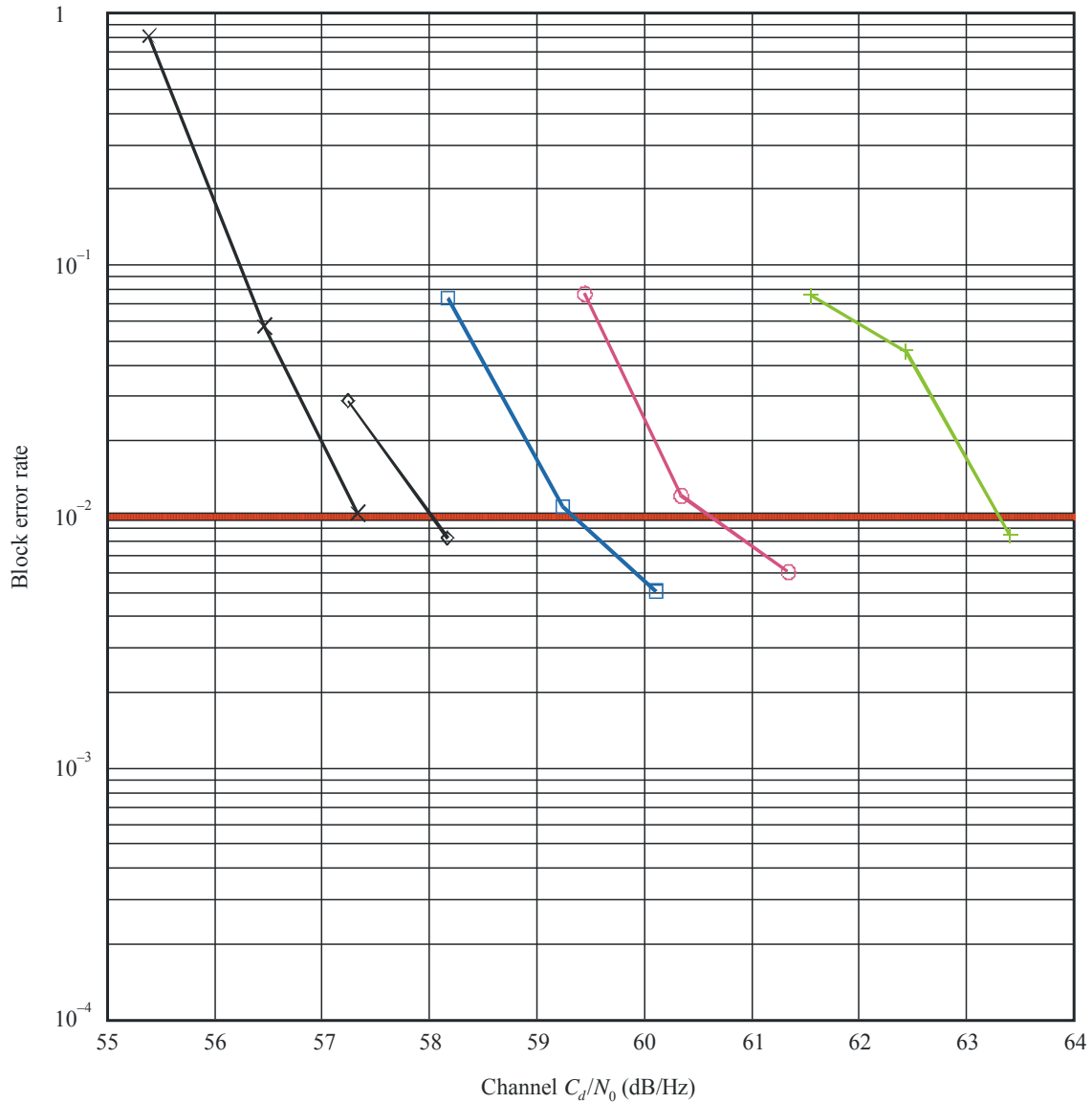

- ToA
- ◇— -30 dB 1st adjacent
- -24 dB 1st adjacent
- -18 dB 1st adjacent
- +— -6 dB 1st adjacent
- ×— 9-ray UF

9.2.1 Urban fast (UF)

Table 24 gives the subjective analogue audio evaluation which indicates that, just prior to digital ToA, analogue audio quality is audibly degraded.

9.2.2 Urban slow (US)

Table 24 gives the subjective analogue audio evaluation which indicates that, just prior to digital ToA, analogue audio quality is audibly degraded.

9.2.3 Rural fast (RF)

Table 24 gives the subjective analogue audio evaluation which indicates that, just prior to digital ToA, analogue audio quality is audibly degraded.

9.2.4 Terrain obstructed fast (TO)

Table 24 gives the subjective analogue audio evaluation which indicates that, just prior to digital ToA, analogue audio quality is audibly degraded.

9.3 Performance in the presence of independently faded interference

This test measured system performance and recorded analogue audio in Gaussian noise and Rayleigh fading, in the presence of independently faded first-adjacent, second-adjacent, and co-channel hybrid IBOC interferers. Each interferer was passed through the same type of Rayleigh fading channel as the desired signal; however, all signals were independently faded, and were therefore uncorrelated.

9.3.1 Single first-adjacent interference

In the United States of America, properly spaced Class B stations are protected to the 54 dBu contour from first-adjacent channel interference exceeding 48 dBu in 50% of the locations for 10% of the time. As a result, tests were performed with first-adjacent hybrid interferers of varying power, up to a level that is 6 dB below that of the desired signal. The block error rate results are shown in Fig. 38 and summarized in Table 24. As might be expected, performance degrades as the interference level increases from -30 dB_{des} to -6 dB_{des}. However, the first-adjacent cancellation algorithm employed in the receiver ensures superior system performance, even with a high-level first-adjacent interferer in an urban fast-fading environment. Table 24 gives the subjective analogue audio evaluation, which indicates that, just prior to digital ToA, analogue audio quality is audibly degraded for all levels of first adjacents.

9.3.2 Single co-channel interference

In the United States of America, properly spaced Class B stations are protected to the 54 dBu contour from co-channel interference exceeding 34 dBu in 50% of the locations for 10% of the time. This means that 90% of the time at the 54 dBu contour the D/U exceeds 20 dB. Based on this information, a number of observations can be made regarding the character of co-channel interference. A hybrid co-channel interferer should have a minimal effect on the performance of the desired digital signal, since it will usually be at least 20 dB lower in power than the digital sidebands at the 54 dBu analogue protected contour. This has been verified via laboratory test. A -20 dB_{des} hybrid co-channel interferer was applied to the desired hybrid signal in an urban fast-fading environment. The block error rate results are shown in Fig. 38 and are summarized in Table 24. Figure 39 indicates that adding a -20 dB_{des} hybrid co-channel interferer degrades performance by only about 1 dB. Figure 38 also shows that, even if the level of the co-channel interferer were increased to -10 dB_{des}, the incremental degradation would be limited to less than 3 dB. Table 24 gives the subjective analogue audio evaluation which indicates that, just prior to

digital ToA, analogue audio quality is audibly degraded for a -20 dB_{des} co-channel interferer. For a -10 dB_{des} co-channel interferer, analogue audio quality is degraded beyond the point of failure before the digital audio even reaches its ToA.

FIGURE 39
Block error rate results of the hybrid system with an independently faded
10-channel interferer

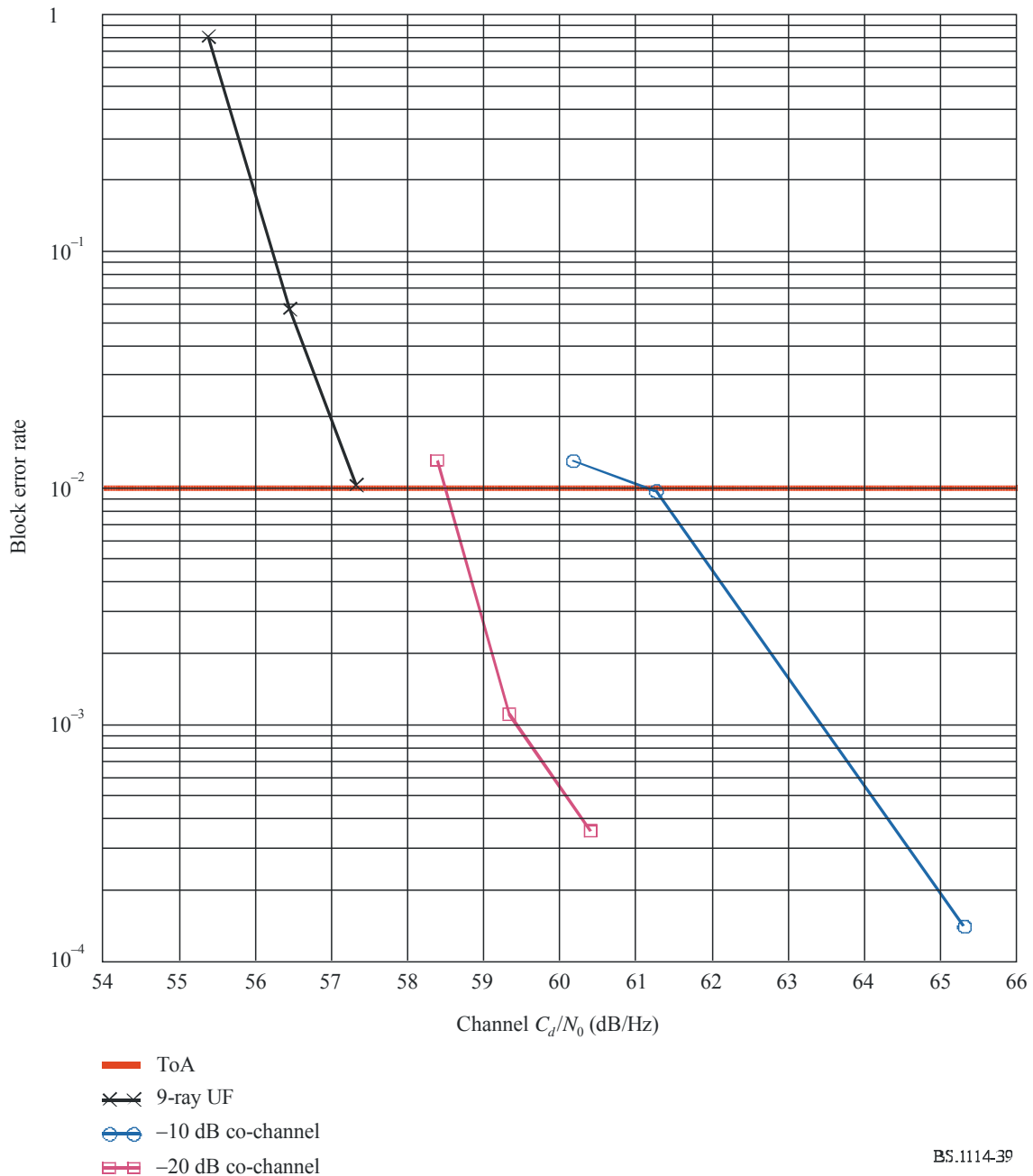

BS.1114-39

9.3.3 Single second-adjacent interference

A hybrid IBOC second-adjacent interferer may have a slight effect on digital performance, since interference side lobes could spill into the desired digital sidebands. This effect has been quantified in laboratory tests. A single $+20$ dB hybrid second-adjacent interferer was applied to the desired hybrid signal in an urban fast-fading environment. The block error rate results are shown in Fig. 40

and are summarized in Table 24. Figure 40 indicates that adding a +20 dB hybrid second-adjacent interferer degrades performance by about 2 dB. Table 24 gives the subjective analogue audio evaluation which indicates that, just prior to digital ToA, analogue audio quality is audibly degraded.

FIGURE 40
Block error rate results of the hybrid system with an independently faded second-adjacent interferer

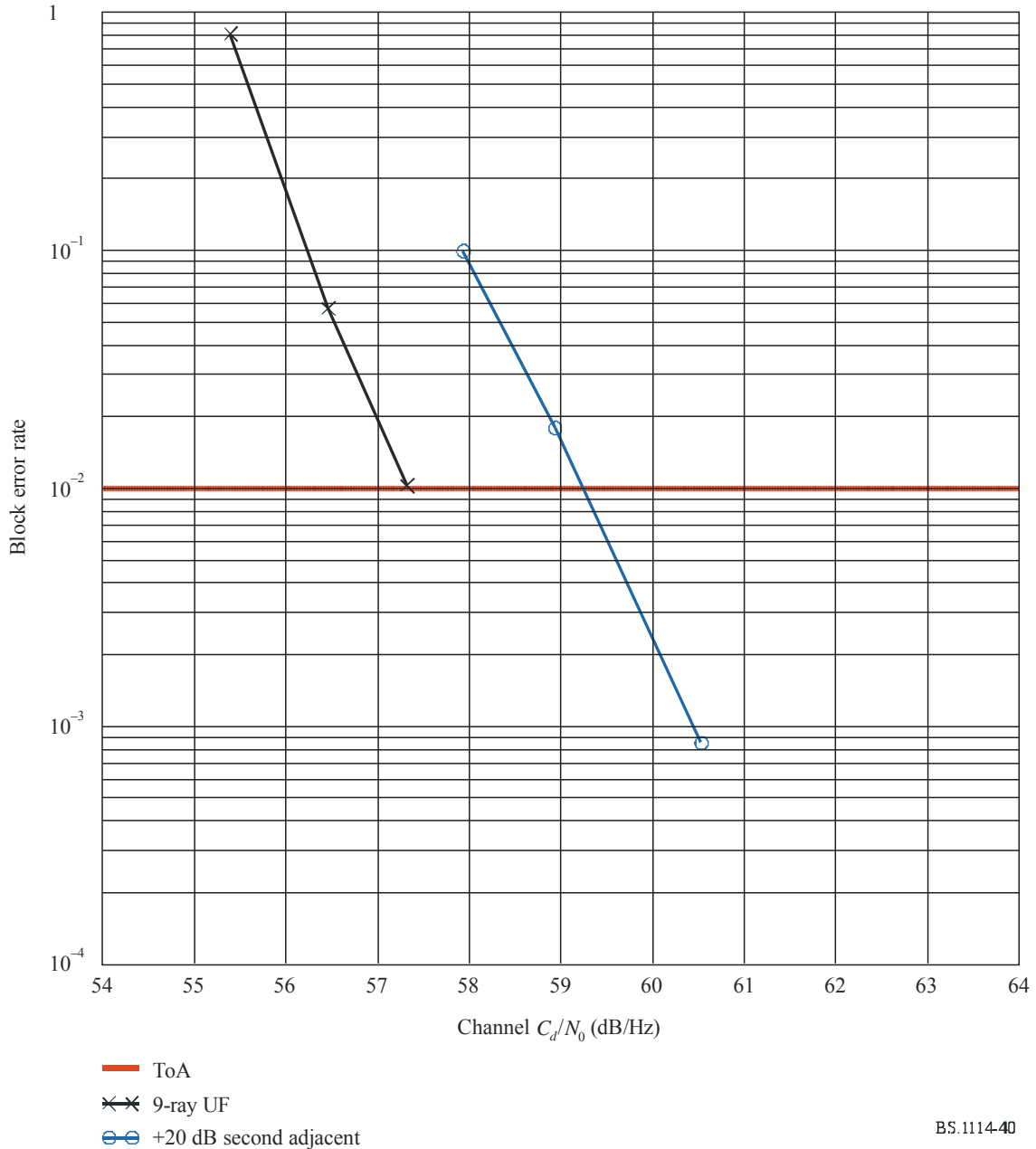

BS.1114-40

9.4 Conclusions

The recordings indicate that, in all environments tested, at the point where the digital signal begins to degrade, the corresponding analogue audio itself exhibits audible degradation. This implies that analogue audio is degraded at signal levels where digital audio degradation is not yet perceptible.

As a result, up to the point of digital ToA, the performance of the digital signal surpasses that of the existing analogue signal. And when the digital signal finally begins to exhibit degradation, the IBOC receiver will automatically change to its analogue signal. Therefore, the performance of the Digital System C is better than the performance of existing analogue FM service.

Annex 5

Digital System G

1 Introduction

Digital system G, also known as the DRM system, is designed to be used at any frequency in the VHF bands, with variable channelization constraints and propagation conditions throughout these bands. In order to satisfy these operating constraints, different transmission modes are available. A transmission mode is defined by transmission parameters classified in two types:

- signal bandwidth related parameters;
- transmission efficiency related parameters.

The first type of parameter defines the total amount of frequency bandwidth for one transmission. Efficiency-related parameters allow a trade-off between capacity (useful bit rate) and ruggedness to noise, multipath and Doppler.

Digital System G is standardized at ETSI as ES 201 980V3.1.1 (2009.08) “Digital Radio Mondiale (DRM); System specification”.

Digital System G has a number of robustness modes, each designed for different bands and propagation conditions, as illustrated in Table 25.

TABLE 25

Robustness mode uses

Robustness mode	Typical propagation conditions
A	Gaussian channels, with minor fading
B	Time and frequency selective channels, with longer delay spread
C	As robustness mode B, but with higher Doppler spread
D	As robustness mode B, but with severe delay and Doppler spread
E	Time and frequency selective channels

DRM+ consists of robustness Mode E and is designed for all the VHF bands and is the subject of this Recommendation as Digital System G.

2 System architecture

Figure 41 describes the general flow of different classes of information (audio, data, etc.) and does not differentiate between different services that may be conveyed within one or more classes of information.

FIGURE 41

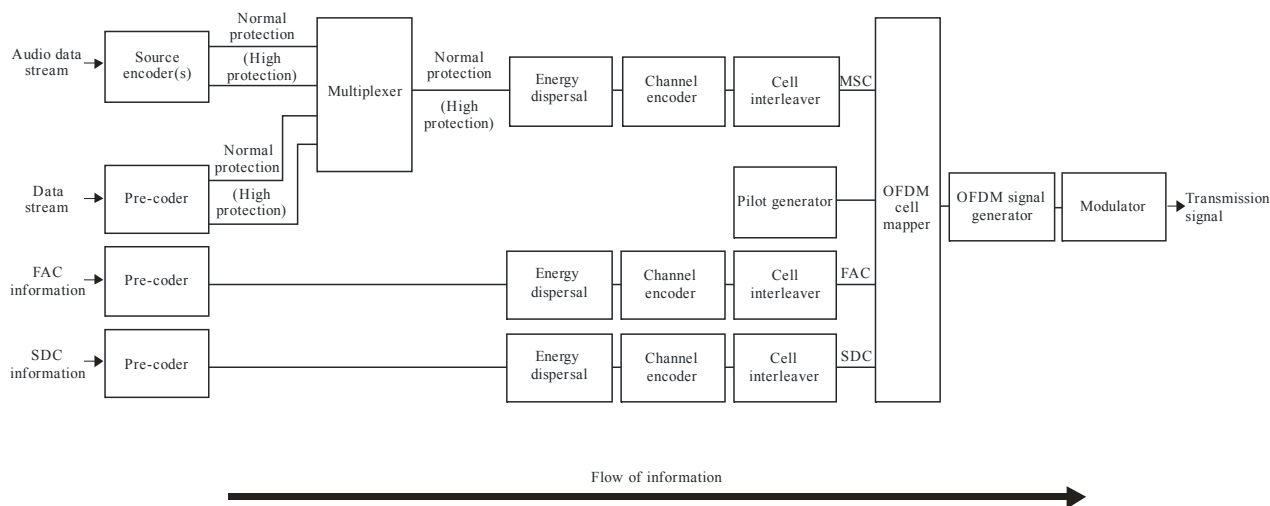

BS.1114-41

The figure describes the general flow of the different classes of information (audio, data, ...) from encoding on the left to a transmitter on the right. Although a receiver diagram is not included it would represent the inverse of the process shown in this diagram.

- on the left are two classes of input information: the encoded audio and data that are combined in the main service multiplexer, and the information channels that bypass the multiplexer that are known as the FAC and SDC;
- the audio source encoder and the data pre-coders ensure the adaptation of the input streams onto an appropriate digital format. Their output may comprise two parts requiring two different levels of protection within the subsequent channel encoder;
- the multiplexer combines the protection levels of all data and audio services;
- the energy dispersal provides a deterministic, selective complementing of bits in order to reduce the possibility that systematic patterns result in unwanted regularity in the transmitted signal;
- the channel encoder adds redundant information as a means for error correction and defines the mapping of the digitally encoded information into QAM cells. The system has the capability, if a broadcaster desires, to convey two categories of “bits”, with one category more heavily protected than the other;
- cell interleaving spreads consecutive QAM cells onto a sequence of cells, quasi-randomly separated in time and frequency, in order to provide an additional element of robustness in the transmission of the audio in time-frequency dispersive channels;
- the pilot generator injects information that permits a receiver to derive channel-equalization information, thereby allowing for coherent demodulation of the signal;

- the OFDM cell mapper collects the different classes of cells and places them on a time-frequency grid;
- the OFDM signal generator transforms each ensemble of cells with the same time index to a time domain representation of the signal, containing a plurality of carriers. The complete time-domain OFDM symbol is then obtained from this time domain representation by inserting a guard interval – a cyclic repetition of a portion of the signal;
- the modulator converts the digital representation of the OFDM signal into the analogue signal that will be transmitted via a transmitter/antenna over the air. This operation involves frequency up-conversion, digital-to-analogue conversion, and filtering so that the emitted signal complies with ITU-R spectral requirements.

3 Audio coding, text messages and packet data

3.1 Audio

Within the constraints of broadcasting regulations in broadcasting channels in the VHF bands and the parameters of the coding and modulation scheme applied, the bit rate available for audio coding is in the range from 37 kbit/s to 186 kbit/s.

In order to offer optimum quality at a given bit rate, the system offers different audio coding schemes:

- a subset of MPEG-4 AAC (Advanced Audio Coding) including error robustness tools for generic mono and stereo audio broadcasting;
- spectral band replication (SBR), an audio coding enhancement tool that allows the full audio bandwidth to be achieved at low bit rates;
- parametric stereo (PS), an audio coding enhancement tool relevant to SBR that allows for stereo coding at low bit rates;
- MPEG surround (MPS), an audio coding enhancement tool that allows for multichannel coding at low bit rates.

AAC is highly optimized in terms of coding efficiency and according to information theory this should lead to the fact that the entropy of the bits is nearly equal. If this assumption is true, then the channel coding must be optimized such that the total amount of residual errors usually referred to as bit error rate (BER) is minimized. This criterion can be fulfilled by a channel coding method called equal error protection (EEP), where all information bits are protected with the same amount of redundancy.

However, the audible effects of errors are not independent of the part of the bitstream that was hit by the error. The optimized solution to cope with this unequal error sensitivity is called unequal error protection (UEP). In such a system, higher protection is assigned to the more sensitive information, whereas lower protection is assigned to the less sensitive part of the bit stream.

To accommodate UEP channel coding, it is necessary to have frames with a constant length and a UEP profile that is constant as well for a given bit rate. Since AAC is a coding scheme with a variable length, Digital System G groups several coded frames together to build one audio super frame. The bit rate of the audio super frame is constant. Since the channel coding is based on audio super frames, the audio super frames themselves consist of two parts: a higher protected part and a lower protected part. Therefore, the coded audio frames have to be split into these two parts.

The bit-stream transport format of MPEG AAC has been modified to meet the requirements of Digital System G (audio superframing). Unequal error protection (UEP) can be applied to improve the system behaviour in error-prone channels.

3.2 Text message application

Text messages can provide a highly valuable additional element to an audio service without consuming much data capacity. The text message is a basic part of Digital System G and consumes only 320 bits/s. This capacity can be saved if the service provider does not use text messaging.

3.3 Packet data mode

Data services generally consist of either streams of information, in either synchronous or asynchronous form, or files of information. Digital System G provides a generalized packet delivery system which allows the delivery of asynchronous streams and files for various services in the same data stream and allows the bit rate of the (synchronous) data stream to be shared on a frame-by-frame basis between the various services. The data stream may be provided with additional error control by the addition of forward error correction. Services can be carried by a series of single packets or as a series of data units. A data unit is a series of packets that are considered as one entity with regard to error handling – one received incorrect packet within a data unit causes the whole data unit to be rejected. This mechanism can be used to transfer files and also to allow simpler synchronization of asynchronous streams. The packet data mode of Digital System G is configurable by the broadcaster to allow optimized use of any capacity: both the packet length and strength of the forward error protection may be varied and signalled to receivers.

4 Multiplex, including special channels

Receivers must be easy to use. Digital System G provides signalling data to allow the listener to access the service he wants with a simple button press, and to allow the radio to track the broadcast to find the best frequency at all times and so leave the listener free to enjoy the programme.

DRM uses a combination of techniques to provide user friendliness. First, the total data capacity is divided into a multiplex of three sub-channels:

- the fast access channel (FAC);
- the service description channel (SDC);
- the main service channel (MSC).

The FAC contains useful information to allow the receiver to find services of interest to the listener quickly. For example, the receiver can scan the bands looking for services with a particular programme type or in a particular language. It also contains information about the broadcast mode to allow further decoding of the signal.

The SDC contains further information about the service (or multiplex of services – up to four) to enhance user friendliness. This includes a label of up to 16 characters (the UTF-8 coding standard is used so all characters are available, not just Latin-based ones) and how to find alternative sources of the same data, and gives attributes to the services within the multiplex. The size of the SDC varies according to the mode.

Alternative frequency checking may be achieved, without loss of service, by keeping the data carried in the SDC quasi-static. Therefore, the data in the SDC frames has to be carefully managed.

The MSC contains the audio and/or data services. The overall frame structure is designed to allow a receiver to jump to an alternate frequency and back without losing any data from the MSC. This means that when a number of frequencies are needed to provide the service, the receiver can always be checking for the best frequency and re-tune when necessary without any interruption to the audio. The SDC provides the list of frequencies and can also give a frequency schedule to allow for services that need different frequencies during the day and week.

By using these features, receivers can present services in a friendly way to the listener, who no longer has to be dependent on knowing the frequency or frequency schedule, and gets a positive confirmation from the displayed label that he is tuned to the service he wants.

The main service channel (MSC) contains the data for all the services contained in the multiplex. The multiplex may contain between one and four services, and each service may be either audio or data. The gross bit rate of the MSC is dependent upon the selected transmission parameters.

The MSC contains between one and four streams. Each stream is divided into logical frames. Audio streams comprise compressed audio and optionally they can carry text messages. Data streams may be composed of data packets, carrying information for up to four “sub-streams”. An audio service comprises one audio stream and optionally one data stream or one data sub-stream. A data service comprises one data stream or one data sub-stream.

Each logical frame generally consists of two parts, each with its own protection level. The lengths of the two parts are independently assigned. Unequal error protection for a stream is provided by setting different protection levels to the two parts.

The logical frames are each 100 ms long. If the stream carries audio, the logical frame carries the data for either the first or the second part of one audio super frame containing the audio information for 200 ms duration. Since, in general, the stream may be assigned two protection levels, the logical frames carry precisely half of the bytes from each protection level.

The logical frames from all the streams are mapped together to form multiplex frames of the same duration, which are passed to the channel coder.

The multiplex configuration is signalled using the SDC. The multiplex may be reconfigured at transmission super frame boundaries. A reconfiguration of the multiplex occurs when the channel parameters in the FAC are changed, or when the services in the multiplex are reorganized. The new configuration is signalled ahead of time in the SDC and the timing is indicated by the reconfiguration index in the FAC.

5 Channel coding and modulation

5.1 Introduction

Because of the different needs of the three sub-channels, the MSC, SDC and FAC, these sub-channels apply different coding and mapping schemes. An overview of the encoding process is shown in Fig. 42.

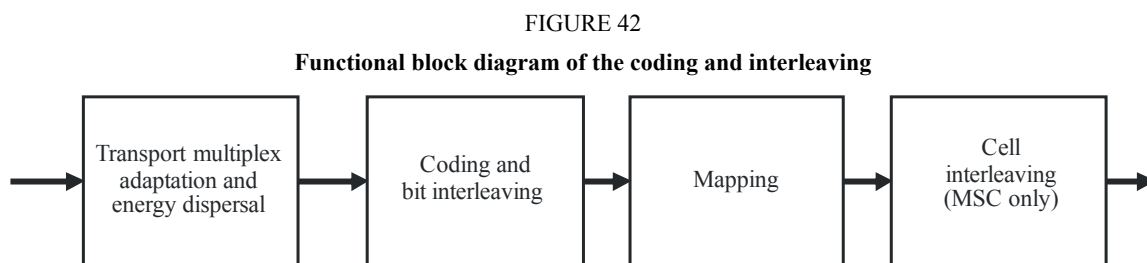

BS.1114-42

The coding is based on a multilevel coding scheme. Due to different error protection needs within one service or for different services within one multiplex different mapping schemes and combinations of code rates are applicable: unequal error protection (UEP) and equal error protection (EEP) are available. Equal error protection uses a single code rate to protect all the data

in a channel. EEP is mandatory for the FAC and SDC. Instead of EEP, unequal error protection can be used with two code rates to allow the data in the main service channel to be assigned to the higher protected part and the lower protected part.

5.2 Multilevel coding

The channel encoding process is based on a multilevel coding scheme. The principle of multilevel coding is the joint optimization of coding and modulation to reach the best transmission performance. This denotes that more error-prone bit positions in the QAM mapping get a higher protection. The different levels of protection are reached with different component codes which are realized with punctured convolutional codes, derived from the same mother code.

The decoding in the receiver can be done either straightforwardly or through an iterative process. Consequently the performance of the decoder with errored data can be increased with the number of iterations and hence is dependent on the decoder implementation.

5.3 Coding the MSC

The MSC may use either 4-QAM or 16-QAM mapping: the lower constellation provides a more robust error performance whereas the higher constellation provides high-spectral efficiency.

In each case, a range of code rates is available to provide the most appropriate level of error correction for a given transmission. The available combinations of constellation and code rate provide a large degree of flexibility over a wide range of transmission channels. Unequal error protection can be used to provide two levels of protection for the MSC.

Two protection levels within one multiplex frame are possible resulting in the use of two overall code rates. The overall code rates and code rates for each level are defined in Tables 26 and 27. The protection level is signalled in the multiplex description data entity of the SDC.

TABLE 26

Code rates for the MSC with 4-QAM

Protection level	R_{all}	R_0
0	0.25	1/4
1	0.33	1/3
2	0.4	2/5
3	0.5	1/2

TABLE 27

Code rate combinations for the MSC with 16-QAM

Protection level	R_{all}	R_0	R_1	R_{ylcm}
0	0.33	1/6	1/2	6
1	0.41	1/4	4/7	28
2	0.5	1/3	2/3	3
3	0.62	1/2	3/4	4

One or two overall code rates shall be applied to one multiplex frame. When using two overall code rates, both shall belong to the same constellation.

5.4 Coding the SDC

The SDC uses 4-QAM mapping with code rate 0.5 or 0.25: a choice is available between greater capacity and a more robust error performance.

The constellation and code rate should be chosen with respect to the MSC parameters to provide more robustness for the SDC than for the MSC.

5.5 Coding the FAC

The FAC shall use 4-QAM mapping with code rate 0.25.

6 Transmission structure

The propagation-related OFDM parameters of DRM Mode E are given in Table 28.

TABLE 28
OFDM parameters

Elementary time period T	83 1/3 μ s
Duration of useful (orthogonal) part $T_u = 27 \cdot T$	2.25 ms
Duration of guard interval $T_g = 3 \cdot T$	0.25 ms
Duration of symbol $T_s = T_u + T_g$	2.5 ms
T_g/T_u	1/9
Duration of transmission frame T_f	100 ms
Number of symbols per frame N_s	40
Channel bandwidth B	96 kHz
Carrier spacing $1/T_u$	444 4/9 Hz
Carrier number space	$K_{min} = -106$; $K_{max} = 106$
Unused carriers	None

The transmitted signal is organized in transmission super frames which consist of four transmission frames.

Each transmission frame has duration T_f , and consists of N_s OFDM symbols.

Each OFDM symbol is constituted by a set of K carriers and transmitted with a duration T_s .

The spacing between adjacent carriers is $1/T_u$.

The symbol duration is the sum of two parts:

- a useful part with duration T_u ;
- a guard interval with duration T_g .

The guard interval consists in a cyclic continuation of the useful part, T_u , and is inserted before it.

The OFDM symbols in a transmission frame are numbered from 0 to $N_s - 1$.

All symbols contain data and reference information.

Since the OFDM signal comprises many separately modulated carriers, each symbol can in turn be considered to be divided into cells, each cell corresponding to the modulation carried on one carrier during one symbol.

An OFDM frame contains:

- pilot cells;
- control cells;
- data cells.

The pilot cells can be used for frame, frequency and time synchronization, channel estimation, and robustness mode identification.

7 Combined transmission of digital and analogue signals

A close placement of a Digital System G signal to an analogue FM signal is possible and can be flexibly configured depending on the existing use of spectrum. In this way, Digital System G may be introduced into the FM frequency bands.

FIGURE 43
Example configuration for Digital System G (DRM mode E, left)
and FM signal (right)

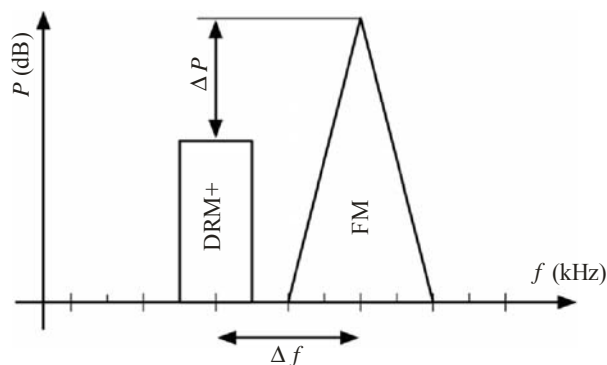

BS.1114-43

Figure 43 shows that the Digital System G signal can be placed closely to the left or right of the existing FM signal. To guarantee the respective protection levels and audio quality of the FM signal, the carrier frequency distance (Δf) and the power level difference (ΔP) of the FM and the Digital System G signals can be planned accordingly. Δf can be chosen according to a 50 kHz channel raster. $\Delta f \geq 150$ kHz is recommended. ΔP can be varied flexibly; however, a $\Delta P > 20$ dB is recommended for the minimum $\Delta f = 150$ kHz.

Two transmission configurations are possible: the analogue and digital signals can be combined and transmitted via the same antenna; or the two signals can be transmitted from different antennas.

Different configurations for the Digital System G signal are possible. The Digital System G signal can have the same programme as the FM service, a different programme or the same programme as well as additional programmes. If the same programme is available via Digital System G and FM, the alternative frequency switching (AFS) flag should be sent in the service description channel (SDC) of the transmission multiplex allowing for a support of heterogeneous networks.

Figure 44 shows some example configurations.

FIGURE 44
 Example configuration with Digital System G (left) and 2 FM stations (right)

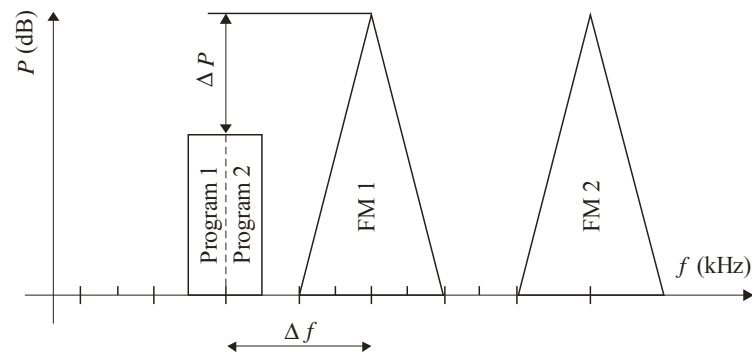

BS.1114-44

8 Simulated system performance

The radio-wave propagation in the VHF bands is characterized by diffraction, scattering and reflection of the electromagnetic waves on their way between the transmitter and the receiver. Typically the waves arrive at different times at the receiver (multipath propagation) resulting in more or less strong frequency-selective fading (dependent on system bandwidth). In addition movements of the receiver or surrounding objects cause a time variation of the channel characteristic (Doppler effect). In contrast to sky-wave propagation e.g. at short waves, ionospheric variations play no role for channel modelling for the VHF bands.

The approach is to use stochastic time-varying models with stationary statistics and define models for good, moderate and bad conditions by taking appropriate parameter values of the general model. One of those models with adaptable parameters is the wide sense stationary uncorrelated scattering model (WSSUS model). The justification for the stationary approach with different parameter sets is that results on real channels lead to BER curves between best and worst cases found in the simulation.

Additional variations of the short-term average power (slow or log normal fading) caused by a changing environment (e.g. building structure) or phenomena like sporadic-E layer propagation are not incorporated in the WSSUS model. Their effects, as well as the influence of disturbances like man-made noise, are normally integrated in the computation of the coverage probability during the network planning process.

Simulated system performance anticipating perfect channel estimation, ideal synchronization and the absence of phase noise and quantization effects has been performed. The signal power includes pilots and the guard interval. Channel decoding is assumed to be done with single stage Viterbi decoding for 4-QAM modulation and with a multistage decoder with two iterations for 16-QAM modulation.

The results in Table 29 are given for six channels, which represent different reception scenarios, whereby the associated robustness mode is E. The code rate is $R = 0.33$ and the modulation is 4-QAM.

TABLE 29

Required C/N for a transmission to achieve a $BER = 1 \times 10^{-4}$ after the channel decoder for the MSC (Mode E)

Channel model	C/N
Channel 7 (AWGN)	1.3 dB
Channel 8 (urban) at 60 km/h	7.3 dB
Channel 9 (rural)	5.6 dB
Channel 10 (terrain obstructed)	5.4 dB
Channel 11 (hilly terrain)	5.5 dB
Channel 12 (SFN)	5.4 dB

The results in Table 30 are given for six channels which represent different reception scenarios, whereby the associated robustness mode is E. The code rate is $R = 0.5$ and the modulation is 16-QAM.

TABLE 30

Required C/N for a transmission to achieve a $BER = 1 \times 10^{-4}$ after the channel decoder for the MSC (Mode E)

Channel model	C/N
Channel 7 (AWGN)	7.9 dB
Channel 8 (urban) at 60 km/h	15.4 dB
Channel 9 (rural)	13.1 dB
Channel 10 (terrain obstructed)	12.6 dB
Channel 11 (hilly terrain)	12.8 dB
Channel 12 (SFN)	12.3 dB