

RECOMMENDATION ITU-R BS.1114-4

Systems for terrestrial digital sound broadcasting to vehicular, portable and fixed receivers in the frequency range 30-3 000 MHz

(Question ITU-R 56/6)

(1994-1995-2001-2002-2003)

The ITU Radiocommunication Assembly,

considering

- a) that there is an increasing interest worldwide for terrestrial digital sound broadcasting (DSB) to vehicular, portable and fixed receivers in the frequency range 30-3 000 MHz for local, regional and national coverage;
- b) that the ITU-R has already adopted Recommendations ITU-R BS.774 and ITU-R BO.789 to indicate the necessary requirements for DSB systems to vehicular, portable and fixed receivers for terrestrial and satellite delivery, respectively;
- c) that Recommendations ITU-R BS.774 and ITU-R BO.789 recognize the benefits of complementary use of terrestrial and satellite systems, and call for a DSB system allowing for a common receiver with common processing very large scale integration (VLSI) circuits and manufacturing of low-cost receivers through mass production;
- d) that Digital System A described in Annex 2 meets all the requirements of Recommendations ITU-R BS.774 and ITU-R BO.789, and that the system has been field-tested and demonstrated in various frequency bands between 200 MHz and 1 500 MHz in a number of countries;
- e) that Digital System F described in Annex 3 meets the requirements of Recommendation ITU-R BS.774, and that the system has been field-tested and demonstrated in the 188-192 MHz and 2 535-2 655 MHz bands in more than one country;
- f) that Digital System C described in Annex 4 meets the requirements of Recommendation ITU-R BS.774, and that the system has been field-tested and demonstrated in the 88-108 MHz band;
- g) that at the 7th World Conference of Broadcasting Unions (Mexico, 27-30 April 1992), the World Broadcasting Unions unanimously resolved:
 - “1 that efforts should be made to agree on a unique worldwide standard for DAB and
 - 2 to urge administrations to give consideration to the benefits for the consumer of common source and channel coding and implementation of Digital Sound Broadcasting on a worldwide basis at 1.5 GHz;”

- h) that the World Administrative Radio Conference for Dealing with Frequency Allocations in Certain Parts of the Spectrum (Malaga-Torremolinos, 1992) (WARC-92) has allocated the band 1 452-1 492 MHz to the broadcasting-satellite service (BSS) (sound) and complementary terrestrial broadcasting service for the provision of DSB. Also, additional footnote allocations were included for specific countries in the band 2 310-2 360 MHz and in the band 2 535-2 655 MHz Nos. 750B and 757A (currently Nos. 5.393 and 5.418) respectively of the Radio Regulations (RR). In addition, Resolution 527 (WARC-92) addresses the subject of terrestrial VHF;
- j) that the MPEG-2 transport stream (MPEG-2 TS) is widely applied as containers of digitally coded information;
- k) that a standardization process in Europe has resulted in the adoption of Digital System A (Eureka 147 as an ETSI Standard ETS 300 401) for BSS (sound) broadcasting sound to vehicular, portable and fixed receivers;
- l) that a standardization process in Japan has resulted in the adoption of Digital System F for integrated services digital broadcasting-terrestrial for sound broadcasting (ISDB-T_{SB}) for digital terrestrial sound broadcasting system to vehicular, portable and fixed receivers;
- m) that ISDB techniques can be used to implement services exploiting the full advantages of digital broadcasting, and that Recommendation ITU-R BT.1306 includes the ISDB-T system for digital terrestrial television broadcasting,

noting

- a) that a summary of digital systems is presented in Annex 1;
- b) that the condensed system descriptions for Digital Systems A, F and C are given in Annexes 2, 3 and 4, respectively;
- c) that complete system descriptions of Digital Systems A, F and C are contained in the Digital Sound Broadcasting Handbook,

recommends

- 1** that Digital Systems A, F and/or C, as described in Annexes 2, 3 and 4, respectively, be used for terrestrial DSB services to vehicular, portable and fixed receivers in the frequency range 30-3 000 MHz;
- 2** that administrations that wish to implement terrestrial DSB services meeting some or all of the requirements as stated in Recommendation ITU-R BS.774, should use Table 1 to evaluate the respective merits of Digital Systems A, F and C in selecting systems.

TABLE 1

Performance of Digital Systems A, F and C evaluated on the basis of the recommended technical and operating characteristics listed in Recommendation ITU-R BS.774

Characteristics from Recommendation ITU-R BS.774 (condensed wording)	Digital System A	Digital System F	Digital System C
<p>Range of audio quality and types of reception</p>	<p>Range is from 8 to 384 kbit/s per audio channel in increments of 8 kbit/s. MPEG-2 Layer II audio decoder typically operating at 192 kbit/s is implemented in receivers.</p> <p>The system is intended for vehicular, portable and fixed reception</p>	<p>Range is from phone quality to CD quality. It is also capable of 5.1 multi-channel audio. MPEG-2 advanced audio coding (AAC) decoder typically operates at 144 kbit/s for stereo.</p> <p>The system is intended for vehicular, portable and fixed reception</p>	<p>Range is from 48 kbit/s to 96 kbit/s using the MPEG-2 AAC decoder.</p> <p>The system is intended for vehicular⁽¹⁾, portable and fixed reception</p>
<p>Spectrum efficiency better than FM</p>	<p>FM stereo quality achievable in less than 200 kHz bandwidth; co-channel and adjacent channel protection requirements much less than those for FM. Efficiency is especially high in the case of repeaters reusing the same frequency. (Orthogonal multi-carrier modulation with convolution error correcting coding, coded orthogonal frequency division multiplex (COFDM))</p>	<p>FM stereo quality achievable in less than 200 kHz bandwidth; co-channel and adjacent channel protection requirements much less than those for FM. Efficiency is especially high in the case of repeaters reusing the same frequency. It can be more effective by using 16/64-quadrature amplitude modulation (QAM) carrier modulation. (orthogonal frequency division multiplex (OFDM) with concatenated block and convolutional error correcting coding)</p>	<p>FM stereo quality and data achievable without additional spectrum; co-channel and adjacent channel protection requirements much less than those for FM. System is interleaved to mitigate first adjacent channel issues and is more robust in the presence of co-channel analogue digital interference</p>

TABLE 1 (continued)

Characteristics from Recommendation ITU-R BS.774 (condensed wording)	Digital System A	Digital System F	Digital System C
Performance in multipath and shadowing environments	<p>System is especially designed for multipath operation. It works on the basis of a power summation of echoes falling within a given time interval.</p> <p>This feature allows use of on-channel repeaters to cover terrain shadowed areas</p>	<p>System is especially designed for multipath environment. It works on the basis of a power summation of echoes falling within a given time interval.</p> <p>This feature allows the use of on-channel repeaters to cover terrain shadowed areas</p>	<p>System is especially designed for multipath operation. It is OFDM modulated thereby achieving a high degree of performance in multipath.</p> <p>This feature allows the use of on-channel repeaters to cover terrain shadowed areas</p>
Common receiver signal processing for satellite (S) and terrestrial (T) broadcasting	<p>Not applicable</p> <p>Terrestrial only</p>	<p>Not applicable</p> <p>Terrestrial only</p>	<p>Not applicable</p> <p>Terrestrial only</p>
Reconfiguration and quality vs. number of programmes tradeoff	<p>Service multiplex is based on 64 sub-channels of capacity varying from 8 kbit/s to about 1 Mbit/s, depending on the error protection level, and is totally reconfigurable in a dynamic fashion. Each sub-channel can also contain an unlimited number of variable capacity data packet channels</p>	<p>Multiplexing of payload data is based on MPEG-2 systems. Audio data rate can be selected in any step in order to trade off programme audio quality against the number of services. Transmission parameters such as modulation and error correction are dynamically reconfigurable by transmission and multiplexing configuration control (TMCC)</p>	<p>Bits can be dynamically re-allocated to audio or data using the MPEG-2 transport functionalities at the discretion of the broadcaster within the range of 48 to 96 kbit/s for audio to increase or decrease the data rate.</p> <p>The receiver dynamically re-configures to match the transmission mode of operation</p>

TABLE 1 (continued)

Characteristics from Recommendation ITU-R BS.774 (condensed wording)	Digital System A	Digital System F	Digital System C
Extent of coverage vs. number of programme trade-offs	Five levels of protection for audio and eight levels of protection for data services are available through using punctured convolutional coding for each of the 64 sub-channels (forward error correction (FEC) ranges from 1/4 to 3/4)	Four kinds of modulation and five levels of protection are available. (Carrier modulation: differential quaternary phase shift keying (DQPSK), QPSK, 16-QAM, 64-QAM, coding rate: 1/2, 2/3, 3/4, 5/6, 7/8)	The system maintains uniform coverage for all programs. Secondary carriers may have reduced range in presence of adjacent channel interference. (Carrier modulation: QPSK)
Common receiver for different means of programme delivery – Terrestrial services	Allows local, subnational and national terrestrial services with the same modulation with single transmitter or multiple transmitters operating in a single frequency network to take advantage of a common receiver	Allows local, subnational and national terrestrial services with the same modulation with a single transmitter or multiple transmitters operating in a single frequency network to take advantage of a common receiver	System uses common antenna and front end that is compatible with existing analogue FM broadcast services. Allows for local service as well as subnational and national terrestrial services with a single transmitter or multiple transmitters operating in a single frequency network in the case of the digital portion of the hybrid mode or the all digital mode. Allows for common delivery of FM programming that makes a seamless transition from digital to analogue and back.

TABLE 1 (continued)

Characteristics from Recommendation ITU-R BS.774 (condensed wording)	Digital System A	Digital System F	Digital System C
<p>Common receiver for different means of programme delivery (<i>cont.</i>)</p> <ul style="list-style-type: none"> <li data-bbox="161 629 363 663">– Mixed/hybrid <li data-bbox="161 1088 336 1149">– Cable distribution 	<p>Allows the use of the same band as terrestrial sound broadcasting (mixed) as well as the use of terrestrial on-channel repeaters to reinforce the satellite coverage (hybrid) resulting in all these channels being received transparently by a common receiver.</p> <p>Signal can be carried transparently by cable</p>	<p>Allows the use of the same band as terrestrial sound broadcasting (mixed) as well as the use of terrestrial on-channel repeaters to reinforce the satellite coverage (hybrid) resulting in all these channels being received transparently by a common receiver.</p> <p>Signal can be carried transparently by cable</p>	<p>Signal can be carried transparently by cable.</p>
<p>Programme-associated data (PAD) capability</p>	<p>PAD channel from 0.66 kbit/s to 64 kbit/s capacity is available through a reduction of any audio channel by the corresponding amount. Dynamic label for programme and service identification showing only receiver alphanumeric display is available to all receivers. Basic hypertext markup language (HTML) decoding and Joint Photographic Experts Group (JPEG) picture decoding is available on receivers with graphic displays (1/4 video graphic array (VGA)), etc.</p>	<p>PAD multiplexing is based on MPEG-2 systems</p>	<p>PAD is an integral part of the system and can be provided through opportunistic data without any reduction of audio quality or data channels. Dynamic label for programme and service identification showing on any receiver alphanumeric display is available to all receivers</p>

TABLE 1 (continued)

Characteristics from Recommendation ITU-R BS.774 (condensed wording)	Digital System A	Digital System F	Digital System C
Flexible assignment of services	The multiplex can be dynamically re-configured in a fashion transparent to the user	The multiplex can be dynamically re-configured in a fashion transparent to the user	The system automatically reconfigures between audio and data in a fashion transparent to user
Compatibility of multiplex structure with open system interconnection (OSI)	The system multiplex structure is compliant with the OSI layered model, especially for the data channels, except for the unequal error protection features of the MPEG-2 Layer II audio channel	The system multiplex structure is fully compliant with MPEG-2 systems architecture	The system is based on an OSI layered model including both data and audio except for the unique error protection afforded the audio codec
Value-added data capability	Any sub-channel (out of 64) not used for audio can be used for programme-independent data services. Data packet channels for high priority services available to all receivers tuned to any service of the multiplex can be carried in the fast information channel (FIC). Total capacity is up to 16 kbit/s. Receivers are equipped with a radio data interface (RDI) for data transfer to a computer	Capacity at any rate up to the full payload capacity can be assigned to independent data for the delivery of business data, paging, still pictures graphics, etc. under conditional access control if desired	Capacity at any rate up to the full payload capacity can be assigned to independent data for the delivery of business data, paging still pictures graphics, etc. under conditional access control if desired

TABLE 1 (*end*)

Characteristics from Recommendation ITU-R BS.774 (condensed wording)	Digital System A	Digital System F	Digital System C
Receiver low-cost manufacturing	Allows for mass-production manufacturing and low-cost consumer receivers. Typical receivers have been integrated in two chips. One chip manufacturer has integrated the full receiver circuitry into one chip	The system was specifically optimized to enable an initial low complexity vehicular receiver deployment. Standardization group has been established to achieve low cost receivers based on large scale integration (LSI) mass production techniques	The system was specifically optimized to enable an initial low complexity vehicular receiver deployment

⁽¹⁾ The modes implemented in the in-band on-channel (IBOC) chipset (Digital System C) do not support vehicular operation at frequencies above 230 MHz.

Annex 1

Summaries of Digital Systems

1 Summary of Digital System A

Digital System A, also known as the Eureka 147 digital audio broadcasting (DAB) system, has been developed for both satellite and terrestrial broadcasting applications in order to allow a common low-cost receiver to be used. The system has been designed to provide vehicular, portable and fixed reception with low gain omnidirectional receive antennas located at 1.5 m above ground. Digital System A allows for complementary use of satellite and terrestrial broadcast transmitters resulting in better spectrum efficiency and higher service availability in all receiving situations. It especially offers improved performance in multipath and shadowing environments which are typical of urban reception conditions by the use of on-channel terrestrial repeaters to serve as gap-fillers. Digital System A is capable of offering various levels of sound quality up to high quality sound comparable to that obtained from consumer digital recorded media. It can also offer various data services and different levels of conditional access and the capability of dynamically re-arranging the various services contained in the multiplex.

2 Summary of Digital System F

Digital System F, also known as the ISDB-T_{SB} system, is designed to provide high-quality sound and data broadcasting with high reliability even in mobile reception. The system is also designed to provide flexibility, expandability, and commonality for multimedia broadcasting using terrestrial

networks. The system is a rugged system which uses OFDM modulation, two-dimensional frequency-time interleaving and concatenated error correction codes. The OFDM modulation used in the system is called band segmented transmission (BST)-OFDM. The system has commonality with the ISDB-T system for digital terrestrial television broadcasting in the physical layer. The system has a wide variety of transmission parameters such as carrier modulation scheme, coding rates of the inner error correction code, and length of time interleaving. Some of the carriers are assigned to TMCC carriers which transmit the information on the transmission parameters for receiver control. Digital System F can use high compression audio coding methods such as MPEG-2 AAC. And also, the system adopts MPEG-2 systems. It has commonality and interoperability with many other systems which adopt MPEG-2 systems such as ISDB-S, ISDB-T, DVB-S, DVB-T.

3 Summary of Digital System C

Digital System C, also known as the IBOC DSB system, is a fully developed system with experimental operations in five major metropolitan areas in the United States of America. The system was designed to provide vehicular¹, portable and fixed reception using terrestrial transmitters. Although Digital System C can be implemented in unoccupied spectrum, a significant feature of the system is its ability to offer simulcasting of analogue and digital signals in the existing FM broadcasting band. This system feature would allow for a rational transition for existing FM broadcasters seeking to transition from analogue to digital broadcasting. The system offers improved performance in multipath environments resulting in greater reliability than is offered by existing analogue FM operations. Digital System C offers enhanced audio quality comparable to that obtained from consumer digital recorded media. Moreover, the system incorporates flexibility for broadcasters to offer new datacasting services in addition to the enhanced audio programming. In addition, the system allows for allocation of bits between audio and datacasting capacity to maximize the datacasting capabilities.

Annex 2

Digital System A

1 Introduction

Digital System A is designed to provide high-quality, multi-service digital radio broadcasting for reception by vehicular, portable and fixed receivers. It is designed to operate at any frequency up to 3 000 MHz for terrestrial, satellite, hybrid (satellite and terrestrial), and cable broadcast delivery. The system is also designed as a flexible, general-purpose ISDB system which can support a wide range of source and channel coding options, sound-programme associated data and independent

¹ The modes implemented in the IBOC chipset (Digital System C) do not support vehicular operation at frequencies above 230 MHz.

data services, in conformity with the flexible and broad-ranging service and system requirements given in Recommendations ITU-R BO.789 and ITU-R BS.774, supported by the on Digital Sound Broadcasting Handbook and Report ITU-R BS.1203.

This System is a rugged, yet highly spectrum- and power-efficient, sound and data broadcasting system. It uses advanced digital techniques to remove redundancy and perceptually irrelevant information from the audio source signal, then it applies closely-controlled redundancy to the transmitted signal for error correction. The transmitted information is then spread in both the frequency and time domains so that a high quality signal is obtained in the receiver, even when working in conditions of severe multipath propagation, whether stationary or mobile. Efficient spectrum utilization is achieved by interleaving multiple programme signals and a special feature of frequency reuse permits broadcasting networks to be extended, virtually without limit, using additional transmitters all operating on the same radiated frequency.

The conceptual diagram of the transmission part of System A is given in Fig. 1.

Digital System A has been developed by the Eureka 147 DAB Consortium and is known as the Eureka DAB System. It has been actively supported by the European Broadcasting Union (EBU) in view of introducing digital sound-broadcasting services in Europe in 1995. Since 1988, the system has been successfully demonstrated and extensively tested in Europe, Canada, the United States of America and in other countries worldwide. In Annex 2, Digital System A is referred to as "System A". The full system specification is available as European Telecommunications Standard ETS 300 401 (see Note 1).

NOTE 1 – The addition of a new transmission mode, bridging the gap between current Modes I and II, has been found to be desirable, and is being considered as a compatible enhancement to System A to allow for larger separation distances between co-channel re-transmitters used in a single-frequency-network, or used as coverage extenders or gap-fillers, thus resulting in better flexibility and lower cost in implementing terrestrial DSB in the 1 452-1 492 MHz band.

2 Use of a layered model

The System A is capable of complying with the International Organization for Standardization (ISO) OSI basic reference model described in ISO 7498 (1984). The use of this model is recommended in Recommendation ITU-R BT.807 and Report ITU-R BT.1207, and a suitable interpretation for use with layered broadcasting systems is given in the Recommendation. In accordance with this guidance, the System A will be described in relation to the layers of the model, and the interpretation applied here is illustrated in Table 2.

Descriptions of many of the techniques involved are most easily given in relation to the operation of the equipment at the transmitter, or at the central point of a distribution network in the case of a network of transmitters.

FIGURE 1
 Conceptual diagram of the transmission part of System A

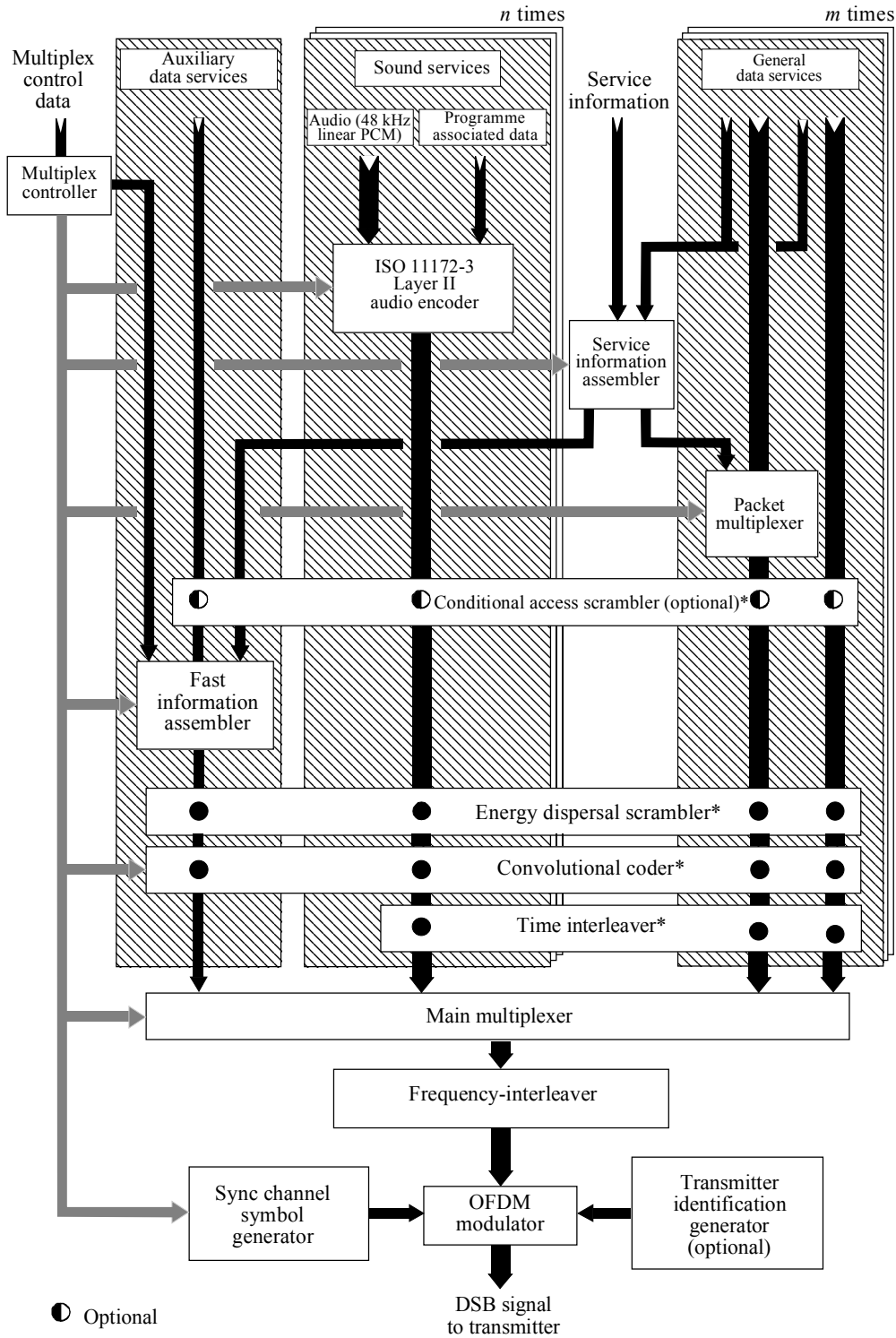

TABLE 2

Interpretation of the OSI layered model

Name of layer	Description	Features specific to the System
Application layer	Practical use of the System	System facilities Audio quality Transmission modes
Presentation layer	Conversion for presentation	Audio encoding and decoding Audio presentation Service information
Session layer	Data selection	Programme selection Conditional access
Transport layer	Grouping of data	Programme services Main service multiplex Ancillary data Association of data
Network layer	Logical channel	ISO audio frames Programme associated data
Data link layer	Format of the transmitted signal	Transmission frames Synchronization
Physical layer	Physical (radio) transmission	Energy dispersal Convolutional encoding Time interleaving Frequency interleaving Modulation by DQPSK OFDM Radio transmission

The fundamental purpose of System A is to provide sound programmes to the radio listener, so the order of sections in the following description will start from the application layer (use of the broadcast information), and proceed downwards to the physical layer (the means for radio transmission).

3 Application layer

This layer concerns the use of System A at the application level. It considers the facilities and audio quality which System A provides and which broadcasters can offer to their listeners, and the different transmission modes.

3.1 Facilities offered by the System

System A provides a signal which carries a multiplex of digital data, and this conveys several programmes at the same time. The multiplex contains audio programme data, and ancillary data comprising PAD, multiplex configuration information (MCI) and service information (SI). The multiplex may also carry general data services which may not be related to the transmission of sound programmes.

In particular, the following facilities are made available to users of the System A:

- the audio signal (i.e. the programme) being provided by the selected programme service;
- the optional application of receiver functions, for example dynamic range control, which may use ancillary data carried with the programme;
- a text display of selected information carried in the SI. This may be information about the selected programme, or about others which are available for optional selection;
- options which are available for selecting other programmes, other receiver functions, and other SI;
- one or more general data services, for example a traffic message channel (TMC).

System A includes facilities for conditional access, and a receiver can be equipped with digital outputs for audio and data signals.

3.2 Audio quality

Within the capacity of the multiplex, the number of programme services and, for each, the presentation format (e.g. stereo, mono, surround-sound, etc.), the audio quality and the degree of error protection (and hence ruggedness) can be chosen to meet the needs of the broadcasters.

The following range of options is available for the audio quality:

- very high quality, with audio processing margin;
- subjectively transparent quality, sufficient for the highest quality broadcasting;
- high quality, equivalent to good FM service quality;
- medium quality, equivalent to good AM service quality;
- speech-only quality.

System A provides full quality reception within the limits of transmitter coverage; beyond these limits reception degrades in a subjectively graceful manner.

3.3 Transmission modes

System A has four alternative transmission modes which allow the use of a wide range of transmitting frequencies up to 3 GHz. These transmission modes have been designed to cope with Doppler spread and delay spread, for mobile reception in presence of multipath echoes.

Table 3 gives the constructive echo delay and nominal frequency range for mobile reception. The noise degradation at the highest frequency and in the most critical multipath condition, occurring infrequently in practice, is equal to 1 dB at 100 km/h.

TABLE 3

Parameter	Mode I	Mode II	Mode III	Mode IV
Guard interval duration (μs)	246	62	31	123
Constructive echo delay up to (μs)	300	75	37.5	150

From Table 3, it can be seen that the use of higher frequencies imposes a greater limitation on the maximum echo delay. Mode I is most suitable for a terrestrial single-frequency network (SFN), because it allows the greatest transmitter separations. Mode II is most suitable for local radio applications requiring one terrestrial transmitter, and hybrid satellite/terrestrial transmission up to 1.5 GHz. However, Mode II can also be used for a medium-to-large scale SFN in the UHF band (e.g. at 1.5 GHz) by inserting, if necessary, artificial delays at the transmitters and/or by using directive transmitting antennas. Mode III is most appropriate for satellite and complementary terrestrial transmission at all frequencies up to 3 GHz.

Mode III is also the preferred mode for cable transmission up to 3 GHz.

Mode IV is most suitable for medium to large scale SFN in the UHF band.

4 Presentation layer

This layer concerns the conversion and presentation of the broadcast information.

4.1 Audio source encoding

The audio source encoding method used by the System is ISO/IEC MPEG-Audio Layer II, given in the ISO Standard 11172-3. This sub-band coding compression system is also known as the MUSICAM system.

System A accepts a number of PCM audio signals at a sampling rate of 48 kHz with PAD. The number of possible audio sources depends on the bit rate and the error protection profile. The audio encoder can work at 32, 48, 56, 64, 80, 96, 112, 128, 160 or 192 kbit/s per monophonic channel. In stereophonic or dual channel mode, the encoder produces twice the bit rate of a mono channel.

The different bit-rate options can be exploited by broadcasters depending on the intrinsic quality required and/or the number of sound programmes to be provided. For example, the use of bit rates greater than or equal to 128 kbit/s for mono, or greater than or equal to 256 kbit/s for a stereo programme, provides not only very high quality, but also some processing margin, sufficient for further multiple encoding/decoding processes, including audio post-processing. For high-quality broadcasting purposes, a bit rate of 128 kbit/s for mono or 256 kbit/s for stereo is preferred, giving fully transparent audio quality. Even the bit rate of 192 kbit/s per stereo programme generally fulfils the EBU requirement for digital audio bit-rate reduction systems. A bit-rate of 96 kbit/s for mono gives good sound quality, and 48 kbit/s can provide roughly the same quality as normal AM broadcasts. For some speech-only programmes, a bit rate of 32 kbit/s may be sufficient where the greatest number of services is required within the system multiplex.

A block diagram of the functional units in the audio encoder is given in Fig. 2. The input PCM audio samples are fed into the audio encoder. One encoder is capable of processing both channels of a stereo signal, although it may, optionally, be presented with a mono signal. A polyphase filter bank divides the digital audio signal into 32 sub-band signals, and creates a filtered and sub-sampled representation of the input audio signal. The filtered samples are called sub-band samples. A perceptual model of the human ear creates a set of data to control the quantizer and coding. These data can be different, depending on the actual implementation of the encoder. One possibility is to use an estimation of the masking threshold to obtain these quantizer control data. Successive samples of each sub-band signal are grouped into blocks, then in each block, the maximum amplitude attained by each sub-band signal is determined and indicated by a scale factor. The quantizer and coding unit creates a set of coding words from the sub-band samples. These processes are carried out during ISO audio frames, which will be described in the network layer.

FIGURE 2
Block diagram of the basic system audio encoder

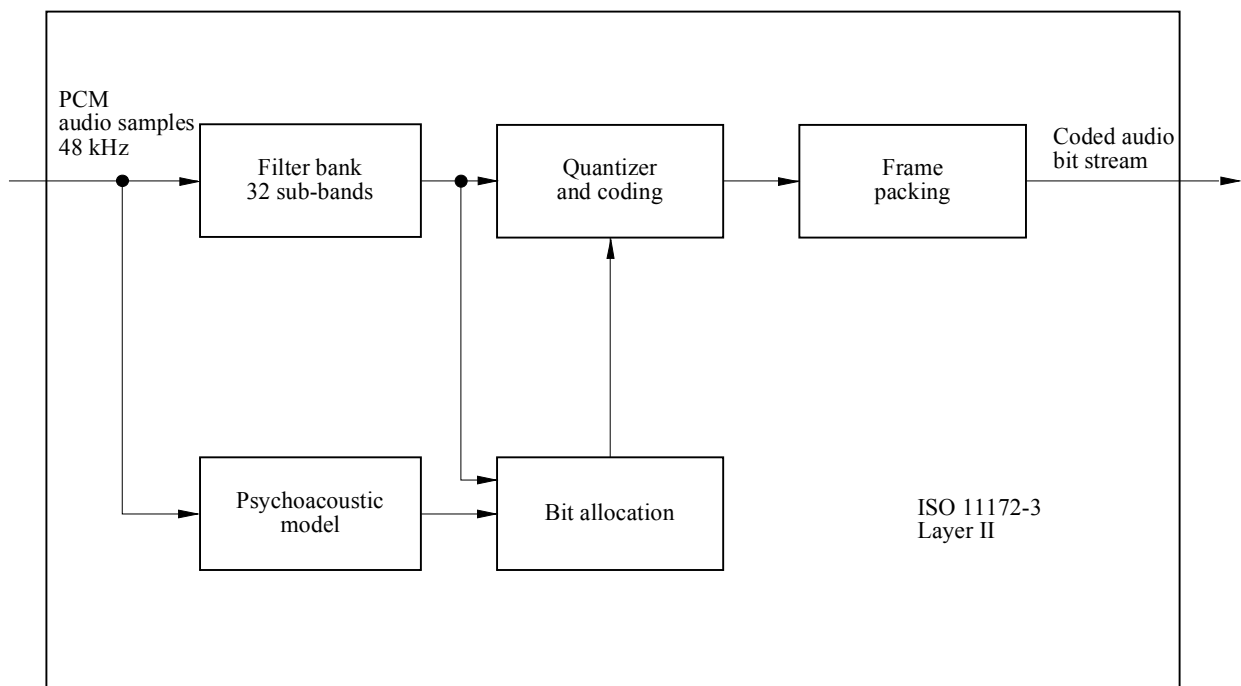

1114-02

4.2 Audio decoding

Decoding in the receiver is straightforward and economical using a simple signal processing technique, requiring only de-multiplexing, expanding and inverse-filtering operations. A block diagram of the functional units in the decoder is given in Fig. 3.

FIGURE 3
Block diagram of the basic system audio decoder

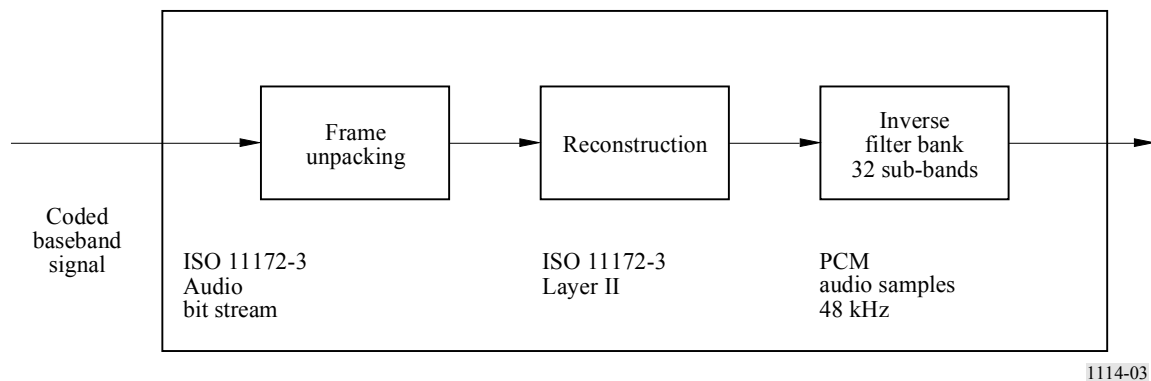

The ISO audio frame is fed into the ISO/MPEG-Audio Layer II decoder, which unpacks the data of the frame to recover the various elements of information. The reconstruction unit reconstructs the quantized sub-band samples, and an inverse filter bank transforms the sub-band samples back to produce digital uniform PCM audio signals at 48 kHz sampling rate.

4.3 Audio presentation

Audio signals may be presented monophonically or stereophonically, or audio channels may be grouped for surround-sound. Programmes may be linked to provide the same programme simultaneously in a number of different languages. In order to satisfy listeners in both hi-fi and noisy environments, the broadcaster can optionally transmit a dynamic range control (DRC) signal which can be used in the receiver in a noisy environment to compress the dynamic range of the reproduced audio signal. Note that this technique can also be beneficial to listeners with impaired hearing.

4.4 Presentation of service information

With each programme transmitted by the system, the following elements of SI can be made available for display on a receiver:

- basic programme label (i.e. the name of the programme),
- time and date,
- cross-reference to the same, or similar programme (e.g. in another language) being transmitted in another ensemble or being simulcast by an AM or FM service,
- extended service label for programme-related services,
- programme information (e.g. the names of performers),
- language,
- programme type (e.g. news, sport, music, etc.),
- transmitter identifier,
- traffic message channel (TMC, which may use a speech synthesizer in the receiver).

Transmitter network data can also be included for internal use by broadcasters.

5 Session layer

This layer concerns the selection of, and access to, broadcast information.

5.1 Programme selection

In order that a receiver can gain access to any or all of the individual services with a minimum overall delay, information about the current and future content of the multiplex is carried by the FIC. This information is the MCI, which is machine-readable data. Data in the FIC are not time-interleaved, so the MCI is not subject to the delay inherent in the time-interleaving process applied to audio and general data services. However, these data are repeated frequently to ensure their ruggedness. When the multiplex configuration is about to change, the new information, together with the timing of the change is sent in advance in the MCI.

The user of a receiver can select programmes on the basis of textual information carried in the SI, using the programme service name, the programme type identity or the language. The selection is then implemented in the receiver using the corresponding elements of the MCI.

If alternative sources of a chosen programme service are available and an original digital service becomes untenable, then linking data carried in the SI (i.e. the “cross reference”) may be used to identify an alternative (e.g. on an FM service) and switch to it. However, in such a case, the receiver will switch back to the original service as soon as reception is possible.

5.2 Conditional access

Provision is made for both synchronization and control of conditional access.

Conditional access can be applied independently to the service components (carried either in the main service channel (MSC) or FIC), services or the whole multiplex.

6 Transport layer

This layer concerns the identification of groups of data as programme services, the multiplexing of data for those services and the association of elements of the multiplexed data.

6.1 Programme services

A programme service generally comprises an audio service component and optionally additional audio and/or data service components, provided by one service provider. The whole capacity of the multiplex may be devoted to one service provider (e.g. broadcasting five or six high-quality sound programme services), or it may be divided amongst several service providers (e.g. collectively broadcasting some twenty medium quality programme services).

6.2 Main service multiplex

With reference to Fig. 1, the data representing each of the programmes being broadcast (digital audio data with some ancillary data, and maybe also general data) are subjected to convolutional encoding (see § 9.2) and time-interleaving, both for error protection. Time-interleaving improves the ruggedness of data transmission in a changing environment (e.g. reception by a moving vehicular receiver) and imposes a predictable transmission delay. The interleaved and encoded data are then fed to the main service multiplexer where, each 24 ms, the data are gathered in sequence into the multiplex frame. The combined bit stream output from the multiplexer is known as the MSC which has a gross capacity of 2.3 Mbit/s. Depending on the chosen code rate (which can be different from one service component to another), this gives a net bit rate ranging from approximately 0.8 to 1.7 Mbit/s, through a 1.5 MHz bandwidth. The main service multiplexer is the point at which synchronized data from all of the programme services using the multiplex are brought together.

General data may be sent in the MSC as an unstructured stream or organized as a packet multiplex where several sources are combined. The data rate may be any multiple of 8 kbit/s, synchronized to the system multiplex, subject to sufficient total multiplex capacity, taking into account the demand for audio services.

The FIC is external to the MSC and is not time-interleaved.

6.3 Ancillary data

There are three areas where ancillary data may be carried within the system multiplex:

- the FIC, which has limited capacity, depending on the amount of essential MCI included;
- there is special provision for a moderate amount of PAD to be carried within each audio channel;
- all remaining ancillary data are treated as a separate service within the MSC. The presence of this information is signalled in the MCI.

6.4 Association of data

A precise description of the current and future content of the MSC is provided by the MCI, which is carried by the FIC. Essential items of SI which concern the content of the MSC (i.e. for programme selection) must also be carried in the FIC. More extensive text, such as a list of all the day's programmes, must be carried separately as a general data service. Thus, the MCI and SI contain contributions from all of the programmes being broadcast.

The PAD, carried within each audio channel, comprises mainly the information which is intimately linked to the sound programme and therefore cannot be sent in a different data channel which may be subject to a different transmission delay.

7 Network layer

This layer concerns the identification of groups of data as programmes.

7.1 ISO audio frames

The processes in the audio source encoder are carried out during ISO audio frames of 24 ms duration. The bit allocation, which varies from frame to frame, and the scale factors are coded and multiplexed with the sub-band samples in each ISO audio frame. The frame packing unit (see Fig. 2) assembles the actual bit stream from the output data of the quantizer and coding unit, and adds other information, such as header information, CRC words for error detection, and PAD, which travel along with the coded audio signal. Each audio channel contains a PAD channel having a variable capacity (generally at least 2 kbit/s), which can be used to convey information which is intimately linked to the sound programme. Typical examples are lyrics, speech/music indication and DRC information.

The resulting audio frame carries data representing 24 ms duration of stereo (or mono) audio, plus the PAD, for a single programme and complies with the ISO 11172-3 Layer II format, so it can be called an ISO frame. This allows the use of an ISO/MPEG-Audio Layer II decoder in the receiver.

8 Data link layer

This layer provides the means for receiver synchronization.

8.1 The transmission frame

In order to facilitate receiver synchronization, the transmitted signal is built up with a regular frame structure (see Fig. 4). The transmission frame comprises a fixed sequence of symbols. The first is a null symbol to provide a coarse synchronization (when no RF signal is transmitted), followed by a fixed reference symbol to provide a fine synchronization, automatic gain control (AGC), automatic frequency control (AFC) and phase reference functions in the receiver; these symbols make up the synchronization channel. The next symbols are reserved for the FIC, and the remaining symbols provide the MSC. The total frame duration T_F is either 96 ms, 48 ms or 24 ms, depending on the transmission mode as given in Table 4.

FIGURE 4
Multiplex frame structure

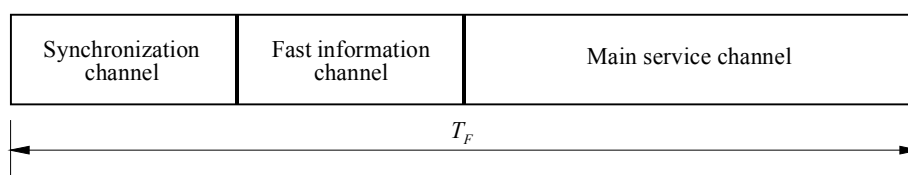

TABLE 4

Transmission parameters of System A

Parameter	Mode I	Mode II	Mode III	Mode IV
Transmission frame duration, T_F	96 ms	24 ms	24 ms	48 ms
Null symbol duration, T_{NULL}	1.297 ms	324 μ s	168 μ s	648 μ s
Duration of OFDM symbols, T_s	1.246 ms	312 μ s	156 μ s	623 μ s
Inverse of the carrier spacing, T_u	1 ms	250 μ s	125 μ s	500 μ s
Duration of the time interval called guard interval, Δ ($T_s = T_u + \Delta$)	246 μ s	62 μ s	31 μ s	123 μ s
Number of transmitted carriers, K	1 536	384	192	768

Each audio service within the MSC is allotted a fixed time slot in the frame.

9 The physical layer

This layer concerns the means for radio transmission (i.e. the modulation scheme and the associated error protection).

9.1 Energy dispersal

In order to ensure appropriate energy dispersal in the transmitted signal, the individual sources feeding the multiplex are scrambled.

9.2 Convolutional encoding

Convolutional encoding is applied to each of the data sources feeding the multiplex to ensure reliable reception. The encoding process involves adding deliberate redundancy to the source data bursts (using a constraint length of 7). This gives “gross” data bursts.

In the case of an audio signal, greater protection is given to some source-encoded bits than others, following a preselected pattern known as the unequal error protection (UEP) profile. The average code rate, defined as the ratio of the number of source-encoded bits to the number of encoded bits after convolutional encoding, may take a value from 1/3 (the highest protection level) to 3/4 (the lowest protection level). Different average code rates can be applied to different audio sources, subject to the protection level required and the bit rate of the source-encoded data. For example, the protection level of audio services carried by cable networks may be lower than that of services transmitted in radio-frequency channels.

General data services are convolutionally encoded using one of a selection of uniform rates. Data in the FIC are encoded at a constant 1/3 rate.

9.3 Time interleaving

Time interleaving with an interleaving depth of 16 frames is applied to the convolutionally encoded data in order to provide further assistance to a mobile receiver.

9.4 Frequency interleaving

In the presence of multipath propagation, some of the carriers are enhanced by constructive signals, while others suffer destructive interference (frequency selective fading). Therefore, the System provides frequency interleaving by a rearrangement of the digital bit stream amongst the carriers, such that successive source samples are not affected by a selective fade. When the receiver is stationary, the diversity in the frequency domain is the prime means to ensure successful reception.

9.5 Modulation by 4-DPSK OFDM

System A uses DQPSK OFDM. This scheme meets the exacting requirements of high bit-rate digital broadcasting to mobile, portable and fixed receivers, especially in multipath environments.

The basic principle consists of dividing the information to be transmitted into a large number of bit streams having low bit rates individually, which are then used to modulate individual carriers. The corresponding symbol duration becomes larger than the delay spread of the transmission channel. In the receiver any echo shorter than the guard interval will not cause intersymbol interference but rather contribute positively to the received power (see Fig. 5). The large number K of carriers is known collectively as an ensemble.

FIGURE 5
Constructive contribution of echoes

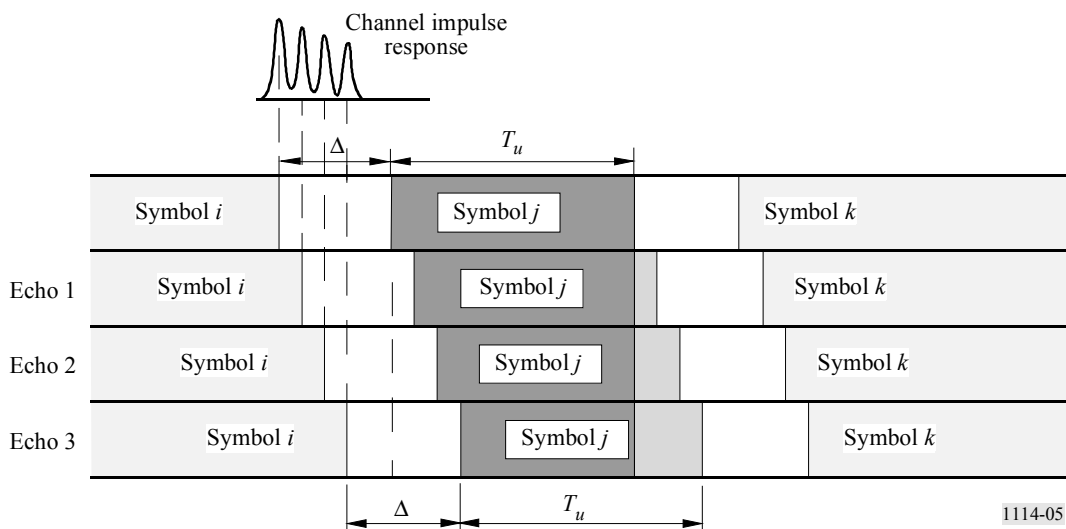

In the presence of multipath propagation, some of the carriers are enhanced by constructive signals, while others suffer destructive interference (frequency selective fading). Therefore, System A includes a redistribution of the elements of the digital bit stream in time and frequency, such that successive source samples are affected by independent fades. When the receiver is stationary, the diversity in the frequency domain is the only means to ensure successful reception; the time diversity provided by time-interleaving does not assist a static receiver. For System A, multipath propagation is a form of space-diversity and is considered to be a significant advantage, in stark contrast to conventional FM or narrow-band digital systems where multipath propagation can completely destroy a service.

In any system able to benefit from multipath, the larger the transmission channel bandwidth, the more rugged the system. In System A, an ensemble bandwidth of 1.5 MHz was chosen to secure the advantages of the wideband technique, as well as to allow planning flexibility. Table 4 also indicates the number of OFDM carriers within this bandwidth for each transmission mode.

A further benefit of using OFDM is that high spectrum and power efficiency can be obtained with single frequency networks for large area coverage and also for dense city area networks. Any number of transmitters providing the same programmes may be operated on the same frequency, which also results in an overall reduction in the required operating powers. As a further consequence distances between different service areas are significantly reduced.

Because echoes contribute to the received signal, all types of receiver (i.e. portable, home and vehicular) may utilize simple, non-directional antennas.

9.6 Transmission signal spectrum of System A

As an example, the theoretical spectrum of System A is illustrated in Fig. 6 for transmission Mode II.

The out-of-band radiated signal spectrum in any 4 kHz band should be constrained by one of the masks defined in Fig. 7.

The solid line mask should apply to VHF transmitters in critical areas for adjacent channel interference. The dotted line mask should apply to VHF transmitters in other circumstances and to UHF transmitters in critical cases for adjacent channel interference.

The level of the signal at frequencies outside the normal 1.536 MHz bandwidth can be reduced by applying an appropriate filtering.

FIGURE 6
Theoretical transmission signal spectrum for transmission Mode II of System A

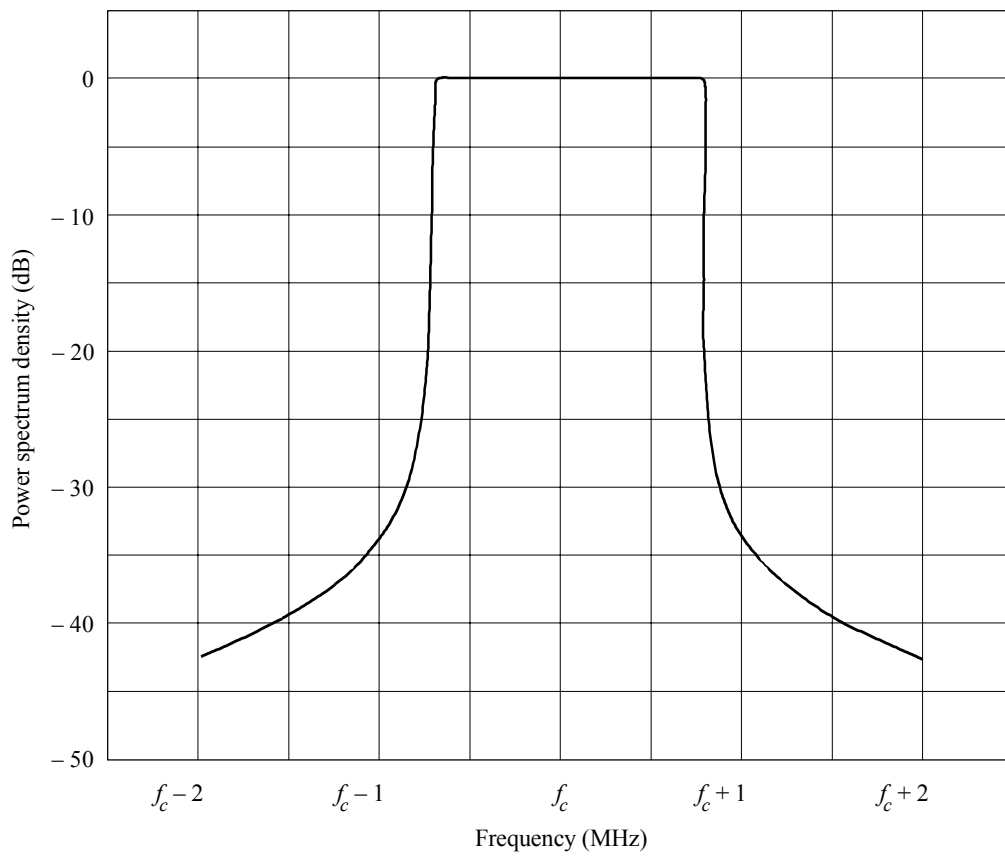

f_c : channel centre frequency

1114-06

FIGURE 7

Out-of-band spectrum mask for a transmission signal of System A
(all transmission modes)

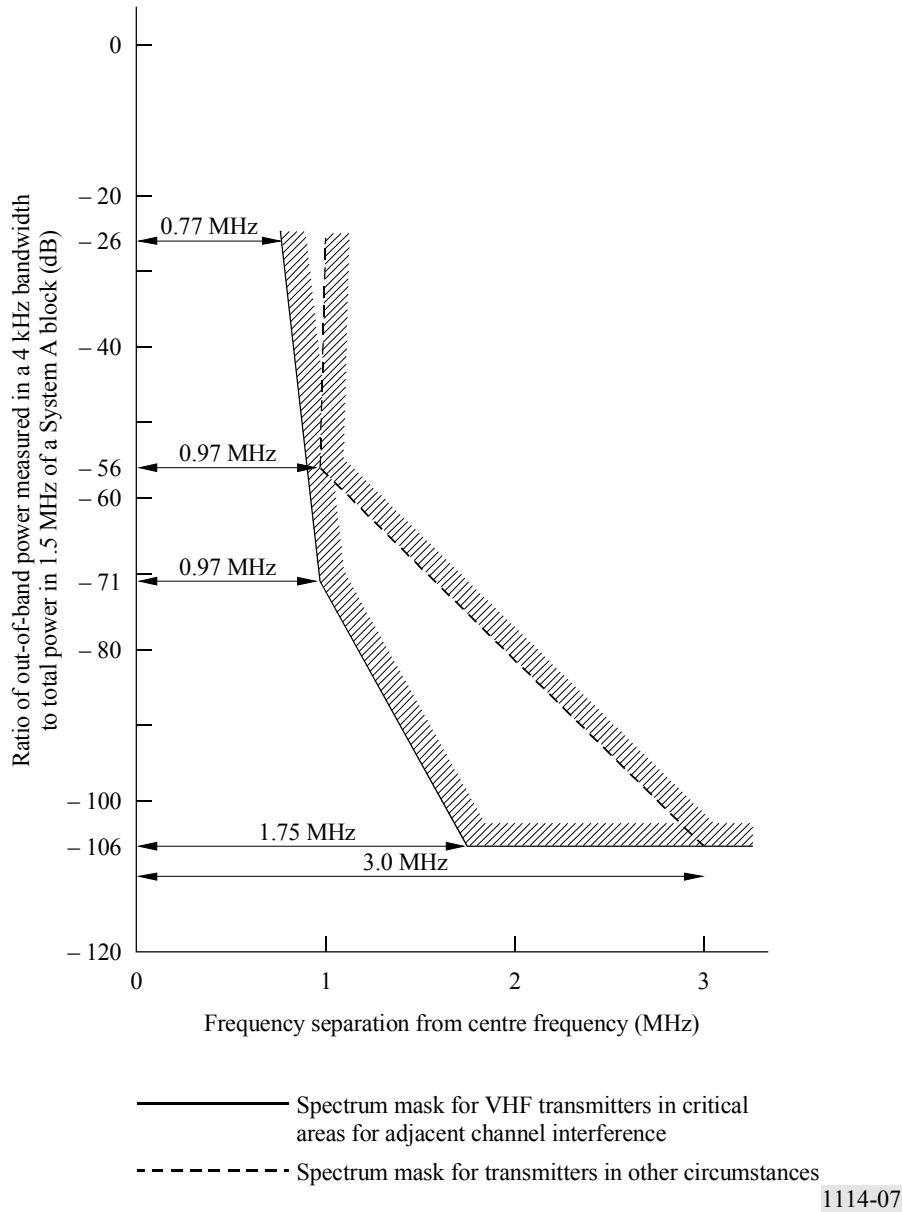

10 RF performance characteristics of System A

RF evaluation tests have been carried out on System A using Mode I at 226 MHz and Mode II at 1 480 MHz for a variety of conditions representing mobile and fixed reception. Measurements of bit error ratio (BER) vs. S/N in the transmission channel were made on a data channel using the following conditions:

$$D = 64 \text{ kbit/s}, \quad R = 0.5$$

$$D = 24 \text{ kbit/s}, \quad R = 0.375$$

where:

D : source data rate

R : average channel code rate.

10.1 BER vs. S/N (in 1.5 MHz) in a Gaussian channel

Additive, Gaussian white noise was added to set the S/N at the input of the receiver. The results are shown in Figs. 8-9. As an example, for $R = 0.5$, the measured results in Fig. 8 can be compared with those from a software simulation, to show the inherent performance of the system. It can be seen that an implementation margin of less than 1.0 dB is obtained at a BER of 1×10^{-4} .

10.2 BER vs. S/N (in 1.5 MHz) in a Rayleigh channel simulated in urban environment

Measurements of BER vs. S/N were made on the data channels, using a fading channel simulator. The Rayleigh channel simulations correspond to Fig. 5 in Cost 207 documentation (typical urban area, 0-0.5 μ s) and the receiver travelling at a speed of 15 km/h.

The results are shown in Figs. 10 and 11.

10.3 BER vs. S/N (in 1.5 MHz) in a Rayleigh channel simulated in rural environment

Measurements of BER vs. S/N were made on the data channels using a fading channel simulator. The Rayleigh channel simulations correspond to Fig. 4 in Cost 207 documentation (rural area, non-hilly, 0-5 μ s) and the receiver travelling at 130 km/h. The results are shown in Figs. 12 and 13.

FIGURE 8

**BER vs. S/N for System A
(Transmission Mode I) - Gaussian channel**

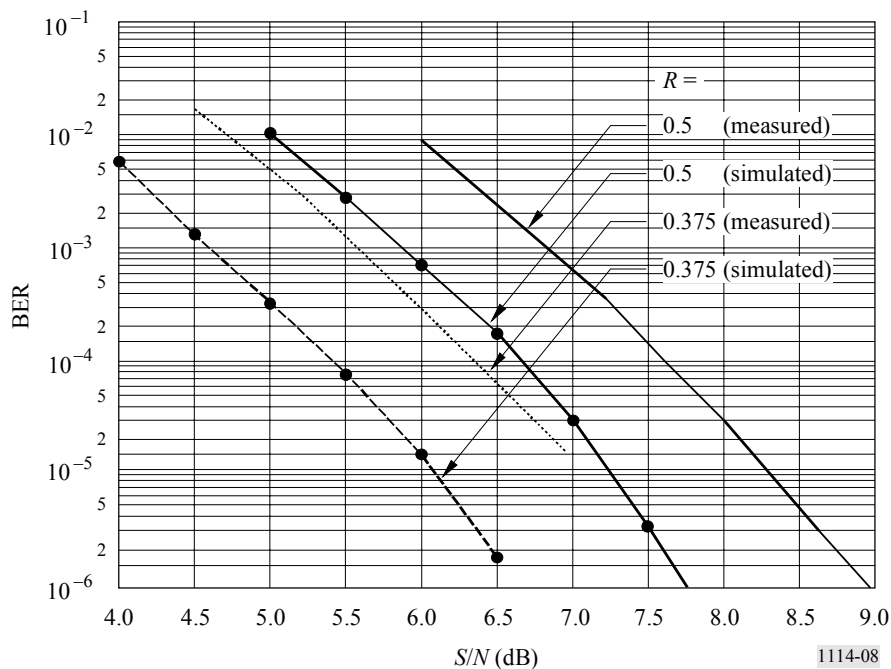

FIGURE 9

**BER vs. S/N for System A
(Transmission Mode II or III): Gaussian channel**

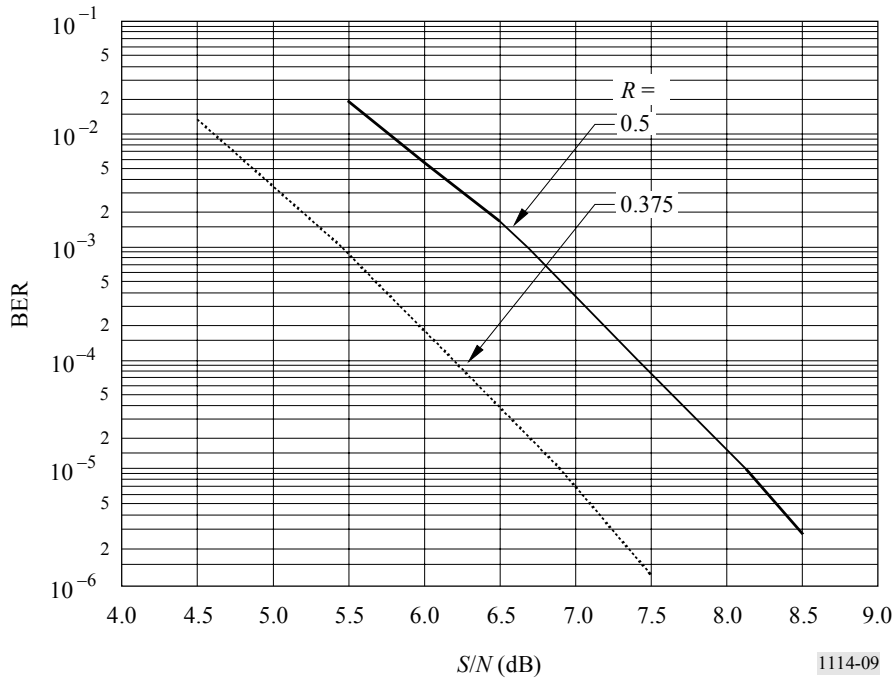

FIGURE 10

**BER vs. S/N for System A
(Transmission Mode I, 226 MHz)**

Simulated Rayleigh channel (urban environment, 15 km/h speed)

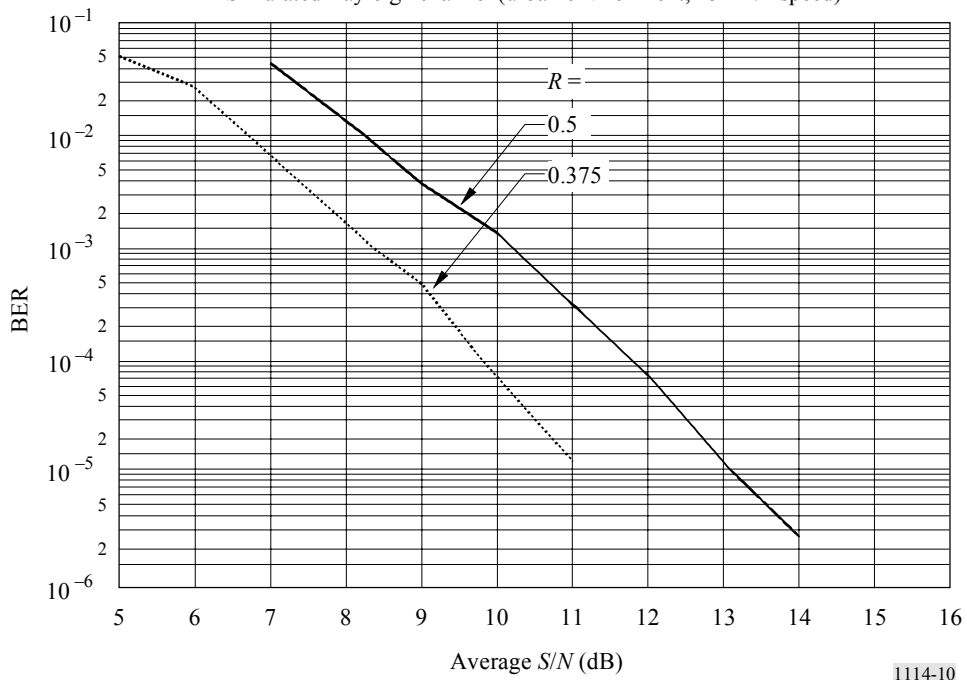

FIGURE 11
BER vs. S/N for System A
(Transmission Mode II, 1 480 MHz)

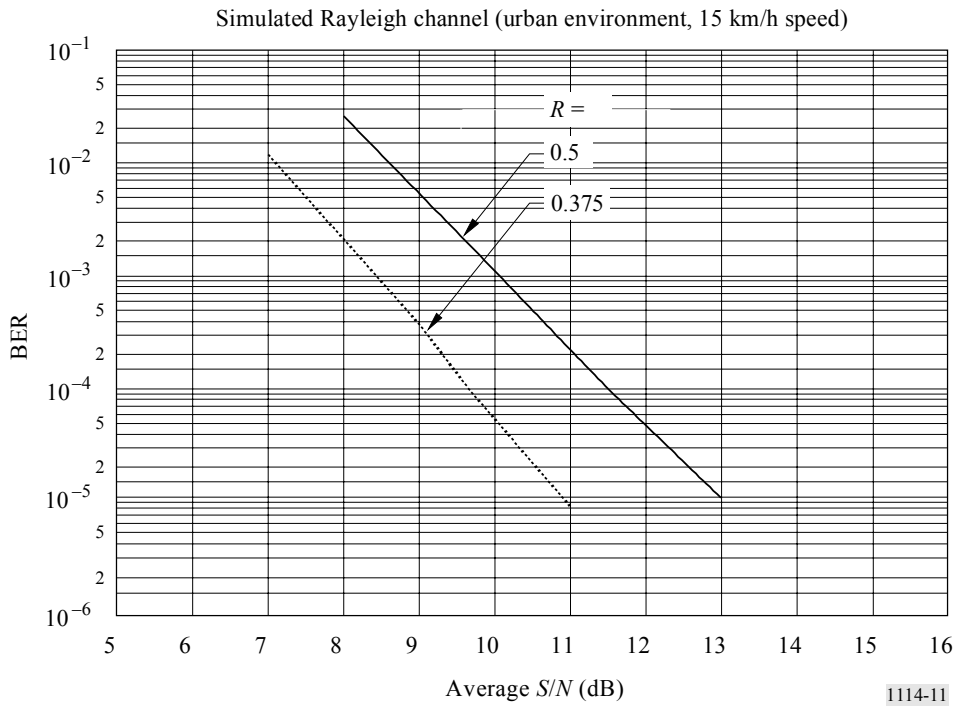

FIGURE 12
BER vs. S/N for System A
(Transmission Mode I, 226 MHz)

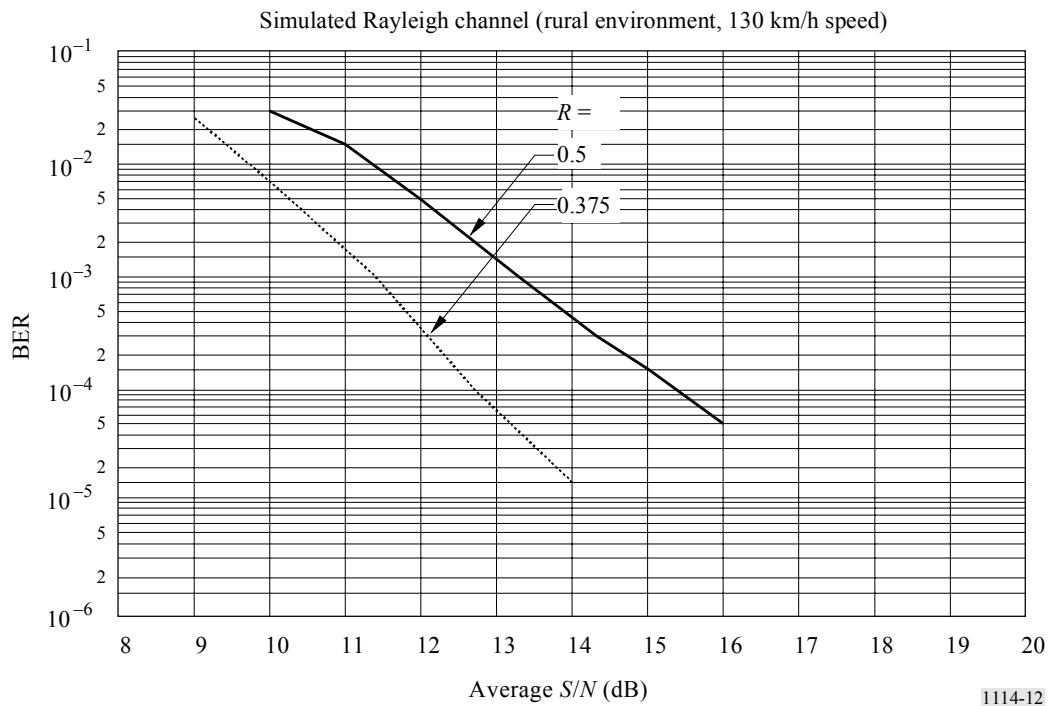
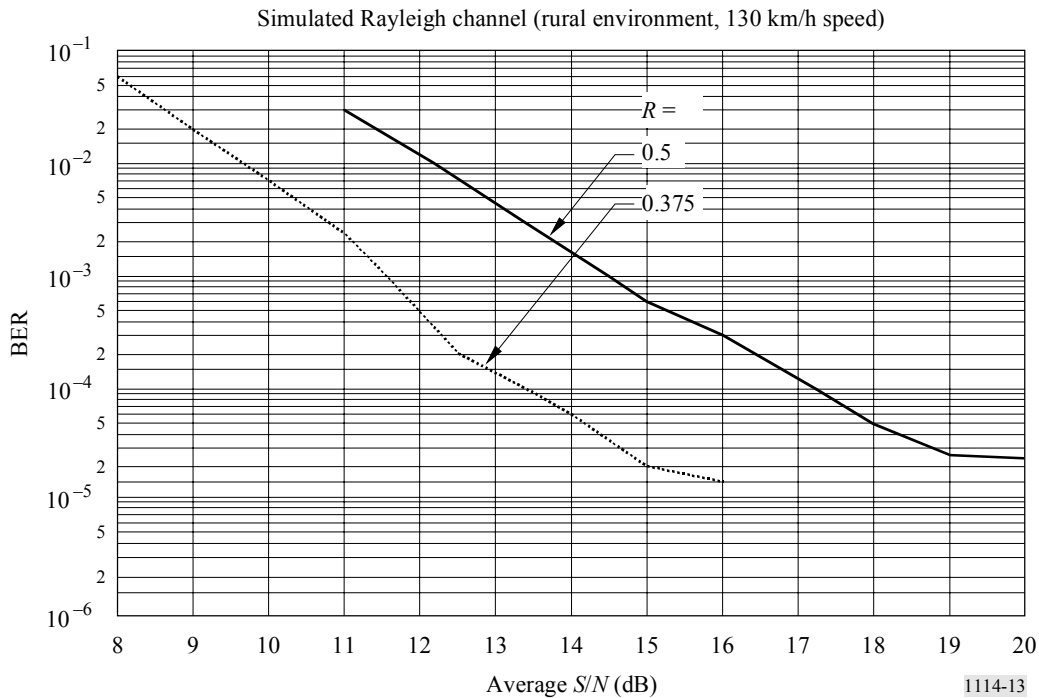

FIGURE 13

BER vs. S/N for System A
(Transmission Mode II, 1 480 MHz)



10.4 Sound quality versus RF S/N

A number of subjective assessments have been performed in order to evaluate the sound quality versus the S/N . The transmission path included equipment for establishing the S/N in a Gaussian channel and, using a fading channel simulator, in a Rayleigh channel. Two different simulation “models” were used in the case of a Rayleigh channel, the same as those described in § 10.2 and 10.3.

In each case a listening test was conducted in which the average S/N was reduced in 0.5 dB steps to establish, in sequence, the following two conditions:

- the onset of impairment, which is the point at which the effects of errors start to become noticeable. This was defined as the point where 3 or 4 error-related events could be heard in a period of about 30 s;
- the point of failure, which is the point at which a listener would probably stop listening to the programme because it became unintelligible or because it no longer provided the enjoyment sought. This was defined as the point where the error-related events occurred virtually continuously, and muting took place two or three times in a period of about 30 s.

Two values of S/N were recorded for each test, representing the consensus view of the panel of audio engineers. The results presented here are the mean values of several tests using different programme material.

TABLE 5
**Sound quality vs. S/N for System A
 (Transmission Mode I): Gaussian channel**

Source-coding		Channel-coding average rate	Onset of impairment S/N (dB)	Point of failure S/N (dB)
Bit rate (kbit/s)	Mode			
256	Stereo	0.6	7.6	5.5
224	Stereo	0.6	8.3	5.9
224	Stereo	0.5	7.0	4.8
224	Joint stereo	0.5	6.8	4.5
192	Joint stereo	0.5	7.2	4.7
64	Mono	0.5	6.8	4.5

TABLE 6
**Sound quality vs. S/N for System A
 (Transmission Mode II or III): Gaussian channel**

Source-coding		Channel-coding average rate	Onset of impairment S/N (dB)	Point of failure S/N (dB)
Bit rate (kbit/s)	Mode			
256	Stereo	0.6	7.7	5.7
224	Stereo	0.6	8.2	5.8
224	Stereo	0.5	6.7	4.9
224	Joint stereo	0.5	6.6	4.6
192	Joint stereo	0.5	7.2	4.6
64	Mono	0.5	6.9	4.5

TABLE 7
**Sound quality vs. S/N for System A
 Simulated Rayleigh channels (224 kbit/s stereo, rate 0.5)**

Mode	Frequency (MHz)	Channel mode	Speed (km/h)	Onset of impairment S/N (dB)	Point of failure S/N (dB)
I	226	Urban	15	16.0	9.0
II	1 500	Urban	15	13.0	7.0
I	226	Rural	130	17.6	10.0
II	1 500	Rural	130	18.0	10.0

10.5 Capability for operating in single-frequency networks

A System A signal (Transmission Mode II) was processed by a channel simulator to produce two versions of the signal; one representing the signal received over a reference, undelayed transmission path with constant power, and one representing a delayed signal from a second transmitter in a single-frequency network (or some other long delay echo). The Doppler shift applied to the second signal was compatible with the limit of the capability of System A. Two sets of measurements were carried out setting the S/N of the total received signal to 12 dB and 35 dB. The relative power of the second, delayed, signal was measured for a BER of 1×10^{-4} in the 64 kbit/s, rate 0.5, data channel, as the delay was increased. The results are shown in Fig. 14.

The magnitude of the guard interval is 64 μs in Transmission Mode II, so the results illustrate that no impairment is caused as long as the second signal falls within the guard interval.

FIGURE 14
Example of single-frequency capability for System A
(Transmission Mode II)

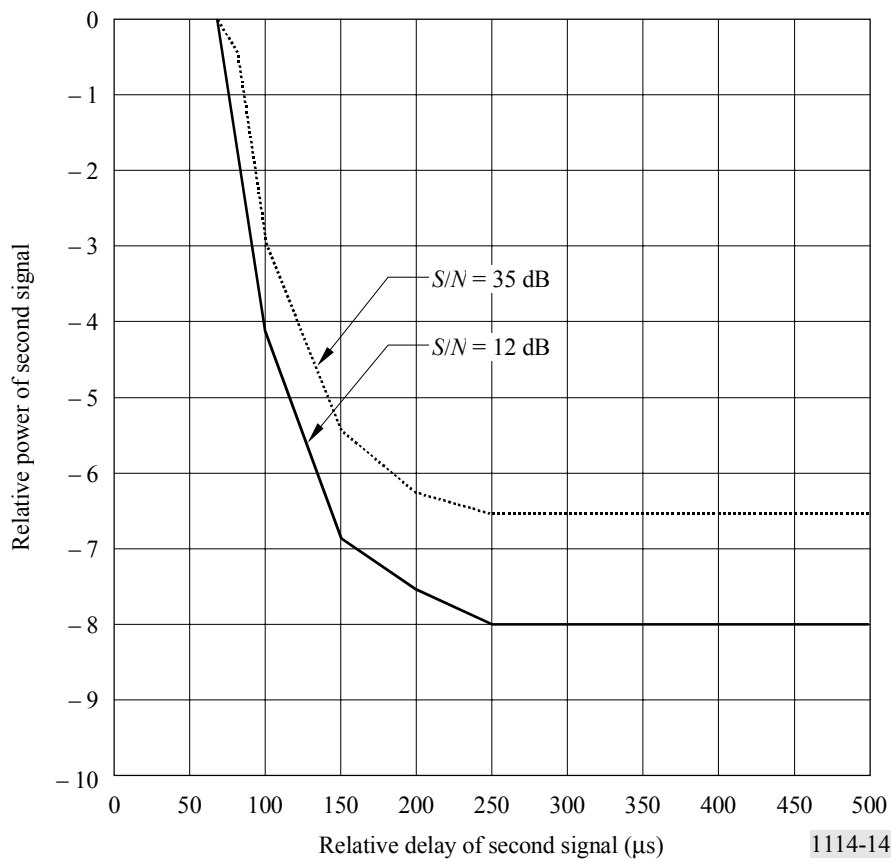

Annex 3

Digital System F

1 Introduction

Digital System F (System F), also known as the ISDB-T_{SB} system is designed to provide high-quality sound and data broadcasting with high reliability even in mobile reception. System F is also designed to provide flexibility, expandability, and commonality for multimedia broadcasting using terrestrial networks, and conform to system requirements given in Recommendation ITU-R BS.774.

System F is a rugged system which uses OFDM modulation, two-dimensional frequency-time interleaving and concatenated error correction codes. The OFDM modulation used in System F is called band segmented transmission (BST)-OFDM. System F has commonality with the ISDB-T system for digital terrestrial television broadcasting in the physical layer. The bandwidth of an OFDM block called OFDM-segment is approximately 500 kHz. System F consists of one or three OFDM-segments, therefore the bandwidth of the system is approximately 500 kHz or 1.5 MHz.

System F has a wide variety of transmission parameters such as carrier modulation scheme, coding rates of the inner error correction code, and length of time interleaving. Some of the carriers are assigned to control carriers which transmit the information on the transmission parameters. These control carriers are called TMCC carriers.

System F can use high compression audio coding methods such as MPEG-2 Layer II, AC-3 and MPEG-2 AAC. Also, the system adopts MPEG-2 systems. It has commonality and interoperability with many other systems which adopt MPEG-2 systems such as ISDB-S, ISDB-T, DVB-S, DVB-T.

Figure 15 shows the ISDB-T_{SB} and full-band ISDB-T transmission concept and its reception.

2 Features of System F

2.1 Ruggedness of System F

System F uses OFDM modulation, two-dimensional frequency-time interleaving and concatenated error correction codes. OFDM is a multi-carrier modulation method, and it is a multipath-proof modulation method, especially adding a guard interval in the time domain. The transmitted information is spread in both the frequency and time domains by interleaving, and then the information is corrected by the Viterbi and Reed-Solomon (RS) decoder. Therefore a high quality signal is obtained in the receiver, even when working in conditions of severe multipath propagation, whether stationary or mobile.

FIGURE 15

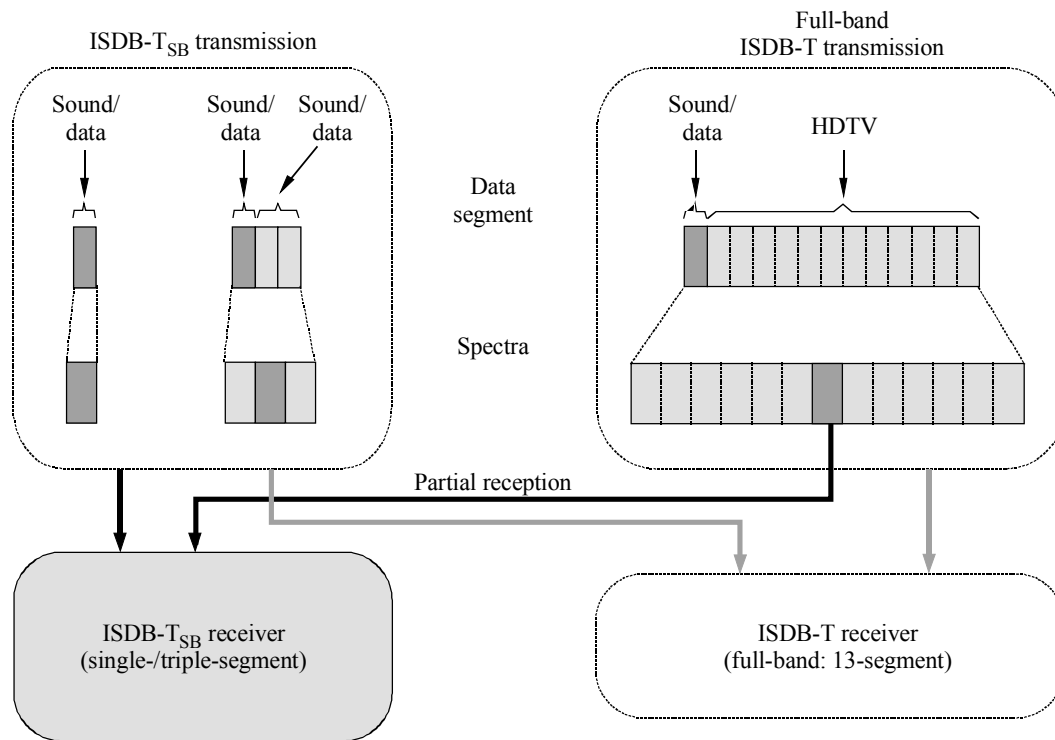
ISDB-T_{SB} and full-band ISDB-T transmission concept and its reception

HDTV: High definition television

1114-15

2.2 Wide variety of transmission

System F adopts BST-OFDM, and consists of one or three OFDM-segments. That is single-segment transmission and triple-segment transmission. A bandwidth of OFDM-segment is defined in one of three ways depending on the reference channel raster of 6, 7 or 8 MHz. The bandwidth is a fourteenth of the reference channel bandwidth (6, 7 or 8 MHz), that is, 429 kHz (6/14 MHz), 500 kHz (7/14 MHz), 571 kHz (8/14 MHz). The bandwidth of OFDM-segment should be selected in compliance with the frequency situation in each country.

The bandwidth of single-segment is around 500 kHz, therefore the bandwidth of single-segment transmission and triple-segment transmission is approximately 500 kHz and 1.5 MHz.

System F has three alternative transmission modes which allow the use of a wide range of transmitting frequencies, and four alternative guard interval lengths for the design of the distance between SFN transmitters. These transmission modes have been designed to cope with Doppler spread and delay spread, for mobile reception in presence of multipath echoes.

2.3 Flexibility

System F multiplex structure is fully compliant with MPEG-2 systems architecture. Therefore various digital contents such as sound, text, still picture and data can be transmitted simultaneously.

In addition, according to the broadcaster's purpose, they can select the carrier modulation method, error correction coding rate, length of time interleaving, etc. of the system. There are four kinds of carrier modulation method of DQPSK, QPSK, 16-QAM and 64-QAM, five kinds of coding rate of 1/2, 2/3, 3/4, 5/6 and 7/8, and five kinds of time interleaving length from 0 to approximately 1 s. The TMCC carrier transmits the information to the receiver indicating the kind of modulation method and coding rate that are used in the system.

2.4 Commonality and interoperability

System F uses BST-OFDM modulation and adopts MPEG-2 systems. Therefore the system has commonality with the ISDB-T system for digital terrestrial television broadcasting (DTTB) in the physical layer, and has commonality with the systems such as ISDB-T, ISDB-S, DVB-T and DVB-S which adopt MPEG-2 Systems in the transport layer.

2.5 Efficient transmission and source coding

System F uses a highly-spectrum efficient modulation method of OFDM. Also, it permits frequency reuse broadcasting networks to be extended using additional transmitters all operating on the same radiated frequency.

In addition, the channels of independent broadcasters can be transmitted together without guardbands from the same transmitter as long as the frequency and bit synchronization are kept the same between the channels.

System F can adopt MPEG-2 AAC. Near CD quality can be realized at a bit rate of 144 kbit/s for stereo.

2.6 Independency of broadcasters

System F is a narrow-band system for transmission of one sound programme at least. Therefore broadcasters can have their own RF channel in which they can select transmission parameters independently.

2.7 Low-power consumption

Almost all devices can be made small and light weight by developing LSI chips. The most important aspect of efforts to reduce battery size is that the power consumption of a device must be low. The slower the system clock, the lower the power consumption. Therefore, a narrow-band, low bit rate system like single-segment transmission can allow for the receiver to be both portable and lightweight.

2.8 Hierarchical transmission and partial reception

In the triple-segment transmission, both one layer transmission and hierarchical transmission can be achieved. There are two layers of A and B in the hierarchical transmission. The transmission parameters of carrier modulation scheme, coding rates of the inner code and a length of the time interleaving can be changed in the different layers.

The centre segment of hierarchical transmission is able to be received by single-segment receiver. Owing to the common structure of an OFDM segment, a single-segment receiver can partially receive a centre segment of full-band ISDB-T signal whenever an independent program is transmitted in the centre segment.

Figure 16 shows an example of hierarchical transmission and partial reception.

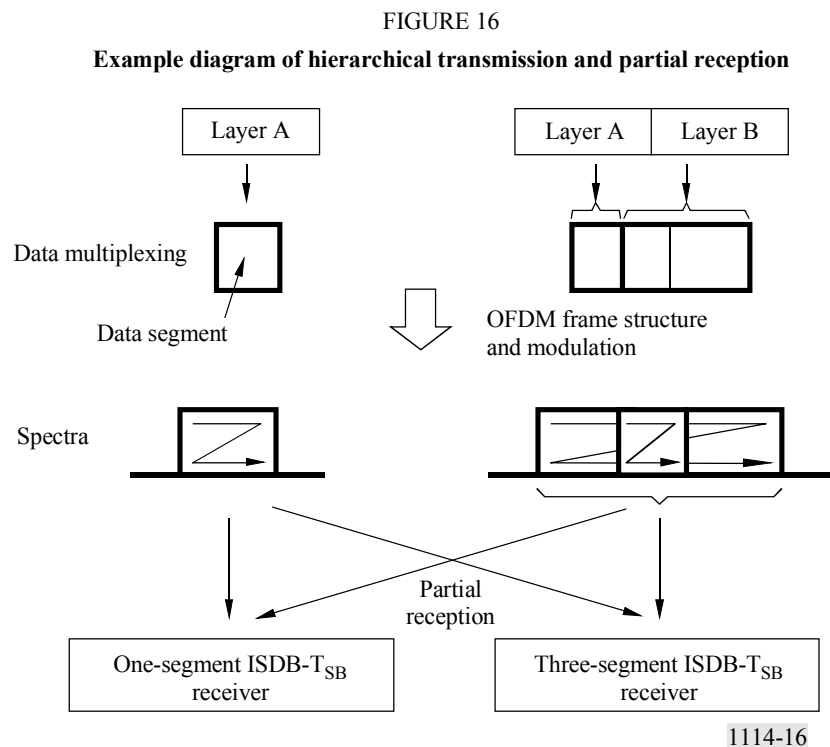

3 Transmission parameters

System F can be assigned to 6 MHz, 7 MHz or 8 MHz channel raster. Segment bandwidth is defined to be a fourteenth of channel bandwidth, therefore that is 429 kHz (6/14 MHz), 500 kHz (7/14 MHz) or 571 kHz (8/14 MHz). However, the segment bandwidth should be selected in compliance with the frequency situation in each country.

The transmission parameters for the ISDB-T_{SB} system are shown in Table 8.

TABLE 8

Transmission parameters for the ISDB-T_{SB}

Mode		Mode 1	Mode 2	Mode 3
Total number of segments ⁽¹⁾ ($N_s = n_d + n_c$)		1, 3		
Reference channel raster (BWf) (MHz)		6, 7, 8		
Segment bandwidth (BWs) (kHz)		$BWf \times 1000/14$		
Used bandwidth (BWu) (kHz)		$BWs \times N_s + C_s$		
Number of segments for differential modulation		n_d		
Number of segments for coherent modulation		n_c		
Carrier spacing (C_s) (kHz)		$BWs/108$	$BWs/216$	$BWs/432$
Number of carriers	Total	$108 \times N_s + 1$	$216 \times N_s + 1$	$432 \times N_s + 1$
	Data	$96 \times N_s$	$192 \times N_s$	$384 \times N_s$
	SP ⁽²⁾	$9 \times n_c$	$18 \times n_c$	$36 \times n_c$
	CP ⁽²⁾	$n_d + 1$	$n_d + 1$	$n_d + 1$
	TMCC ⁽³⁾	$n_c + 5 \times n_d$	$2 \times n_c + 10 \times n_d$	$4 \times n_c + 20 \times n_d$
	AC1 ⁽⁴⁾	$2 \times N_s$	$4 + N_s$	$8 \times N_s$
	AC2 ⁽⁴⁾	$4 \times n_d$	$9 \times n_d$	$19 \times n_d$
Carrier modulation		DQPSK, QPSK, 16-QAM, 64-QAM		
Number of symbol per frame		204		
Useful symbol duration (T_u) (μ s)		$1000/C_s$		
Guard interval duration (T_g)		$1/4, 1/8, 1/16$ or $1/32$ of T_u		
Total symbol duration (T_s)		$T_u + T_g$		
Frame duration (T_f)		$T_s \times 204$		
FFT samples (F_s)		$256 (N_s = 1)$ $512 (N_s = 3)$	$512 (N_s = 1)$ $1024 (N_s = 3)$	$1024 (N_s = 1)$ $2048 (N_s = 3)$
FFT sample clock (F_{sc}) (MHz)		$F_{sc} = F_s/T_u$		
Inner code		Convolutional code (Coding rate = $1/2, 2/3, 3/4, 5/6, 7/8$) (Mother code = $1/2$)		
Outer code		(204,188) RS code		
Time interleave parameter (I)		0, 4, 8, 16, 32	0, 2, 4, 8, 16	0, 1, 2, 4, 8
Length of time interleaving		$I \times 95 \times T_s$		

FFT: fast Fourier transform

- (1) System F uses 1 or 3 segments for sound services, while any number of segments may be used for other services such as television services. (Compare with System C of Recommendation ITU-R BT.1306.)
- (2) SP (scattered pilot), and CP (continual pilot) can be used for frequency synchronization and channel estimation. The number of CP includes CPs on all segments and a CP for higher edge of whole bandwidth.
- (3) TMCC carries information on transmission parameters.
- (4) AC (auxiliary channel) carries ancillary information for network operation.

4 Source coding

System F multiplex structure is fully compliant with MPEG-2 systems architecture, therefore MPEG-2 transport stream packets (TSPs) containing compressed digital audio signal can be transmitted. Digital audio compression methods such as MPEG-2 Layer II audio specified in ISO/IEC 13818-3, AC-3 (Digital Audio Compression Standard specified in ATSC Document A/52) and MPEG-2 AAC specified in ISO/IEC 13818-7 can be applied to System F.

5 Multiplexing

The multiplex of System F is compatible with MPEG-2 TS ISO/IEC 13818-1. In addition, multiplex frame and TMCC descriptors are defined for hierarchical transmission with single TS.

Considering maximum interoperation among a number of digital broadcasting systems, e.g. ISDB-S recommended in Recommendation ITU-R BO.1408, ISDB-T recommended in Recommendation ITU-R BT.1306 (System C) and broadcasting-satellite service (sound) system using the 2.6 GHz band recommended in Recommendation ITU-R BO.1130 (System E), these systems can exchange broadcasting data streams with other broadcasting systems through this interface.

5.1 Multiplex frame

To achieve hierarchical transmission using the BST-OFDM scheme, the ISDB-T_{SB} system defines a multiplex frame of TS within the scope of MPEG-2 systems. In the multiplex frame, the TS is a continual stream of 204-byte RS-TSP composed of 188-byte TSP and 16 bytes of null data or RS parity.

The duration of the multiplex frame is adjusted to that of the OFDM frame by counting RS-TSPs using a clock that is two times faster than the inverse FFT (IFFT) sampling clock in the case of single-segment transmission. In the case of the triple-segment transmission the duration of the multiple frame is adjusted to that of the OFDM frame by counting RS-TSPs using a clock that is four times faster than the IFFT sampling clock.

6 Channel coding

This section describes the channel coding block, which receives the packets arranged in the multiplex frame and passes the channel-coded blocks forward to the OFDM modulation block.

6.1 Functional block diagram of channel coding

Figure 17 shows the functional block diagram of channel coding of the ISDB-T_{SB} system.

The duration of the multiplex frame coincides with the OFDM frame by counting the bytes in the multiplex frame using a faster clock than IFFT-sampling rate described in the previous section.

At the interface between the multiplex block and the outer coding block, the head byte of the multiplex frame (corresponding to the sync-byte of TSP) is regarded as the head byte of the OFDM frame. In bit-wise description, the most significant bit of the head byte is regarded as the synchronization bit of OFDM frame.

For the triple-segment layered transmission, the RS-TSP stream is divided into two layers in accordance with the transmission-control information. In each layer, coding rate of the inner error correction code, carrier-modulation scheme, and time-interleaving length can be specified independently.

FIGURE 17

Channel coding diagram

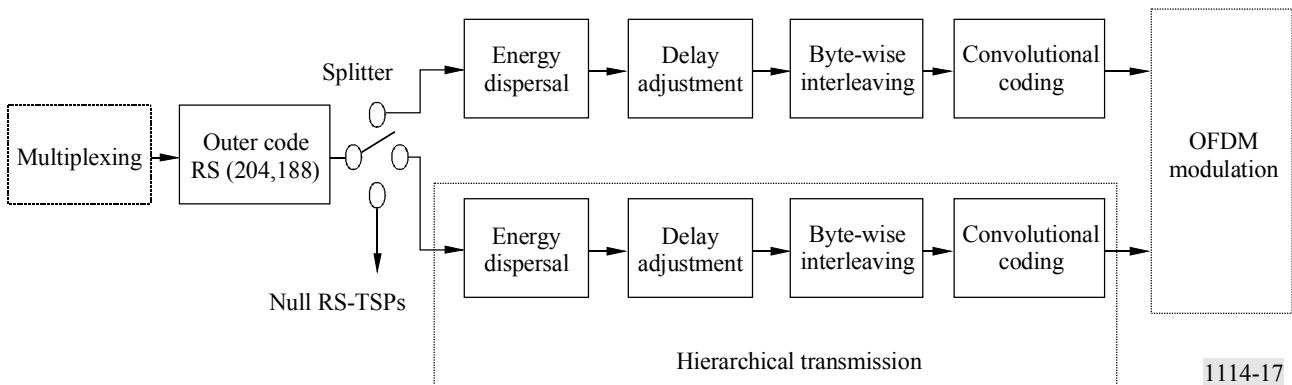

6.2 Outer coding

RS (204,188) shortened code is applied to each MPEG-2 TSP to generate an error protected TSP that is RS-TSP. The RS (208,188) code can correct up to eight random erroneous bytes in a received 204-byte word.

$$\text{Field generator polynomial: } p(x) = x^8 + x^4 + x^3 + x^2 + 1$$

$$\text{Code generator polynomial: } g(x) = (x - \lambda^0)(x - \lambda^1)(x - \lambda^2)(x - \lambda^3) \cdots (x - \lambda^{15})$$

where $\lambda = 02_h$

It should be noted that null TSPs from the multiplexer are also coded to RS (204,188) packets.

MPEG-2 TSP and RS-TSP (RS error protected TSP) are shown in Fig. 18. RS error protected TSP is also called transmission TSP.

FIGURE 18
MPEG-2 TSP and RS-TSP (transmission TSP)

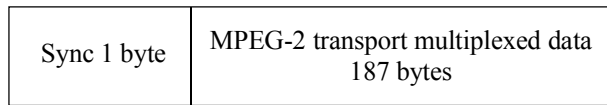

a) MPEG-2 TSP

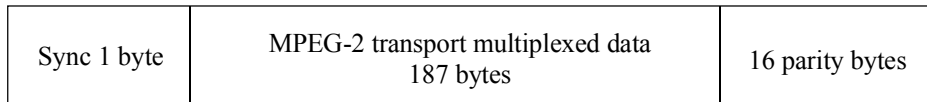

b) RS-TSP (transmission TSP), RS (204,188) error protected TSP

1114-18

6.3 Energy dispersal

In order to ensure adequate binary transitions, the data from the splitter is randomized with pseudo-random binary sequence (PRBS).

The polynomial for the PRBS generator shall be:

$$g(x) = x^{15} + x^{14} + 1$$

6.4 Delay adjustment

In the byte-wise interleaving, the delay caused in the interleaving process differs from stream to stream of different layer depending on its properties (i.e. modulation and channel coding). In order to compensate for the delay difference including de-interleaving in the receiver, the delay adjustment is carried out prior to the byte-wise interleaving on the transmission side.

6.5 Byte-wise interleaving (inter-code interleaving)

Convolutional byte-wise interleaving with length of $I = 12$ is applied to the 204-byte error protected and randomized packets. The interleaving may be composed of $I = 12$ branches, cyclically connected to the input byte-stream by the input switch. Each branch j shall be a first-in first-out (FIFO) shift register, with length of $j \times 17$ bytes. The cells of the FIFO shall contain 1 byte, and the input and output switches shall be synchronized.

The de-interleaving is similar, in principle, to the interleaving, but the branch indices are reversed. Total delay caused by interleaving and de-interleaving is $17 \times 11 \times 12$ bytes (corresponding to 11 TSPs).

6.6 Inner coding (convolutional codes)

System F shall allow for a range of punctured convolutional codes, based on a mother convolutional code of rate 1/2 with 64 states. Coding rates of the codes are 1/2, 2/3, 3/4, 5/6 and 7/8. This will allow selection of the most appropriate property of error correction for a given service or data rate in the ISDB-T_{SB} services including mobile services. The generator polynomials of the mother code are $G_1 = 171_{\text{oct}}$ for X output and $G_2 = 133_{\text{oct}}$ for Y output.

7 Modulation

Configuration of the modulation block is shown in Figs. 19 and 20. After bit-wise interleaving, data of each layer are mapped to the complex domain.

7.1 Delay adjustment for bit interleave

Bit interleave causes the delay of 120 complex data ($I + jQ$) as described in the next section. By adding proper delay, total delay in transmitter and receiver is adjusted to the amount of two OFDM symbols.

7.2 Bit interleaving and mapping

One of the carrier modulation schemes among DQPSK, QPSK, 16-QAM and 64-QAM is selectable for this System. The serial bit-sequence at the output of the inner coder is converted into a 2-bit parallel sequence to undergo $\pi/4$ -shift DQPSK mapping or QPSK mapping, by which n bits of I-axis and Q-axis data are delivered. The number n may depend on the hardware implementation. In the case of 16-QAM, the sequence is converted into a 4-bit parallel sequence. In 64-QAM, it is converted into a 6-bit parallel sequence. After the serial-to-parallel conversion, bit-interleaving is carried out by inserting maximum 120-bit delay.

7.3 Data segment

Data segment is defined as a table of addresses for complex data, on which rate conversion, time interleaving, and frequency interleaving shall be executed. The data segment corresponds to the data portion of OFDM segment.

7.4 Synthesis of layer-data streams

After being channel-coded and mapped, complex data of each layer are inputted every one symbol to pre-assigned data-segments.

The data stored in all data segments are cyclically read with the IFFT-sample clock; then rate conversions and synthesis of layer data streams are carried out.

7.5 Time interleaving

After synthesis, symbol-wise time interleaving is carried out. The length of time-interleaving is changeable from 0 to approximately 1 s, and shall be specified for each layer.

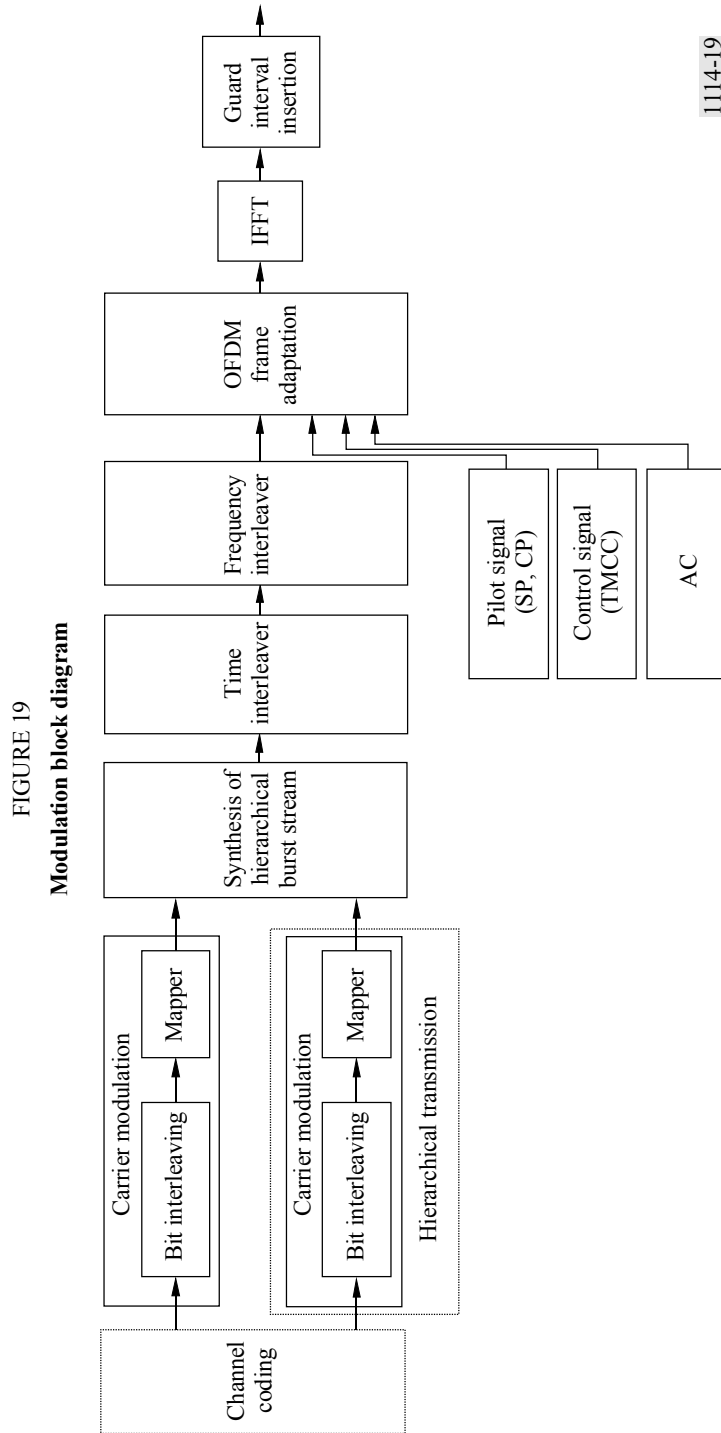
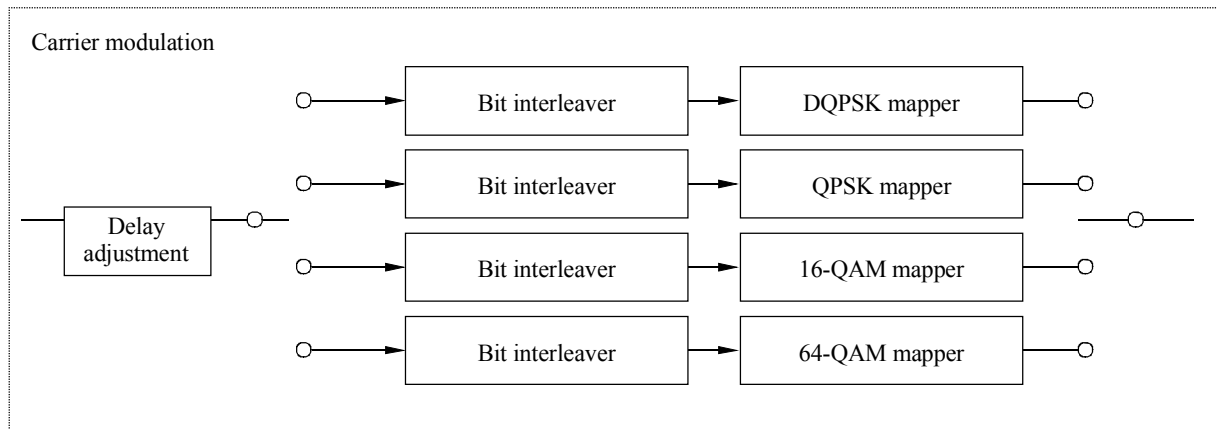

FIGURE 20
Configuration of carrier modulation block



1114-20

7.6 Frequency interleaving

Frequency interleaving consists of inter-segment frequency interleaving, intra-segment carrier rotation, and intra-segment carrier randomization. Inter-segment frequency interleaving is taken among the segments having the same modulation scheme. Inter-segment frequency interleaving can be carried out only for triple-segment transmission. After carrier rotation, carrier randomization is performed depending on the randomization table.

7.7 OFDM segment-frame structure

Data segments are arranged into OFDM segment-frame every 204 symbols by adding pilots such as CP, SP, TMCC and AC. The modulation phase of CP is fixed at every OFDM symbol. SP is inserted in every 12 carriers and in every 4 OFDM symbols in the case of coherent modulation method. The TMCC carrier carries transmission parameters such as carrier modulation, coding rate and time interleaving for the receiver control. The AC carrier carries the ancillary information.

8 Spectrum mask

The radiated signal spectrum of single-segment transmission for 6/14 MHz segment system should be constrained by the mask defined in Fig. 21 and Table 9. The level of the signal at frequencies outside the 429 kHz bandwidth (6/14 MHz) can be reduced by applying an appropriate filtering.

Figure 22 and Table 10 define the spectrum mask of triple-segment transmission for 6/14 MHz segment system.

NOTE 1 – The spectrum mask of 7/14 MHz and 8/14 MHz segment systems should be modified in accordance with the spectrum shape of its system.

FIGURE 21

**Spectrum mask for single-segment ISDB-T_{SB} signal
(segment bandwidth = 6/14 MHz)**

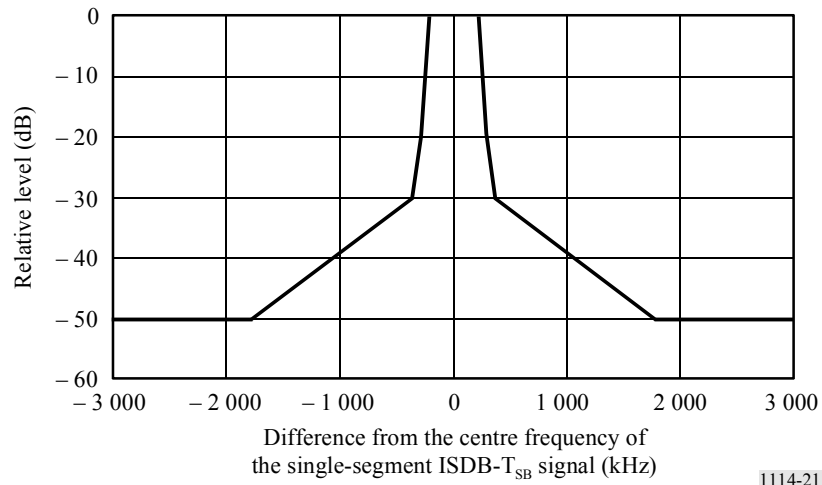

TABLE 9

**Breakpoints of the spectrum mask for the single-segment transmission
(segment bandwidth = 6/14 MHz)**

Frequency difference from the centre frequency of the transmitted signal (kHz)	Relative level (dB)
±220	0
±290	-20
±360	-30
±1 790	-50

NOTE 1 – The radiated signal spectrum is measured by the spectrum analyser. A resolution bandwidth of the spectrum analyser should be set to 10 kHz or 3 kHz. Concerning the video bandwidth, it is between 300 Hz and 30 kHz, and video averaging is desirable. The frequency span is set to the minimum value required for measuring the transmission spectrum mask.

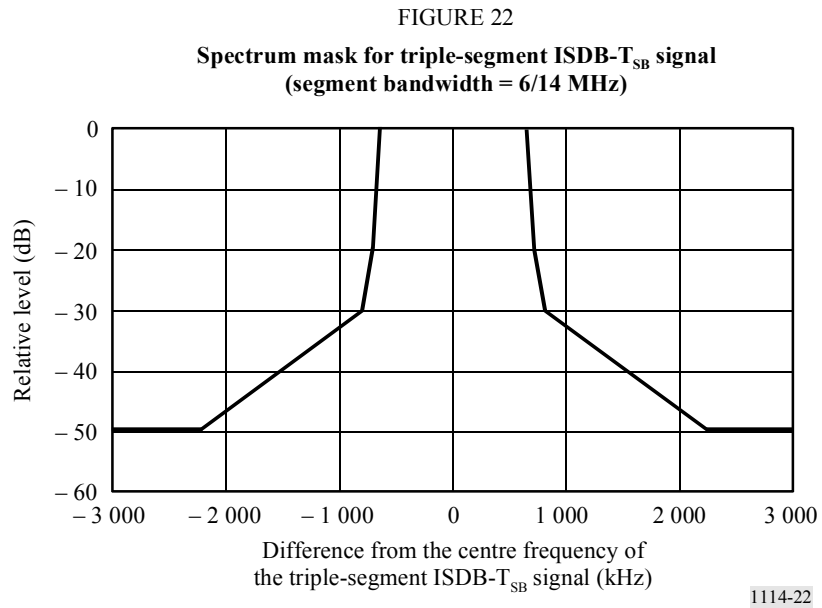

TABLE 10

**Breakpoints of the spectrum mask for the triple-segment transmission
(segment bandwidth = 6/14 MHz)**

Difference from the centre frequency of the terrestrial digital sound signal (kHz)	Relative level (dB)
±650	0
±720	-20
±790	-30
±2 220	-50

9 RF performance characteristics

RF evaluation tests have been carried out on the ISDB-T_{SB} system for a variety of transmission conditions. The results of laboratory tests are described in this section.

Laboratory transmission experiments for BER performance against random noise and multipath fading were conducted. Measurements of BER vs. C/N in the transmission channel were made under the following conditions (see Table 11).

TABLE 11

Transmission parameters for laboratory tests

Number of segments	1 (bandwidth: 429 kHz)
Transmission mode	3 (useful symbol duration: 1.008 ms)
Number of carriers	433
Carrier modulations	DQPSK, 16-QAM, and 64-QAM
Guard interval	63 μ s (guard interval ratio: 1/16)
Coding rates of inner code	1/2, 2/3, 3/4, and 7/8
Time interleaving	0 and 407 ms

9.1 BER vs. C/N in a Gaussian channel

Additive white Gaussian noise was added to set the C/N at the input of the receiver. The results are shown in Figs. 23, 24 and 25. These figures can be compared with those obtained from computer simulation to show the inherent performance of the system. It can be seen that an implementation margin loss of less than 1 dB was obtained at a BER of 2×10^{-4} before RS decoding.

9.2 BER vs. C/N in a multipath channel

Measurements of BER vs. C/N were made using a multipath channel simulator. The desired signal level to undesired or interfering signal level ratio D/U of the main signal and a delay signal were set to 3 and 10 dB. The delay time of a delayed signal relative to the main signal was set to 15 μ s. The results are shown in Fig. 26.

9.3 BER vs. C/N in a Rayleigh channel

Measurements of BER vs. C/N were made using a fading channel simulator. The channel was set to two-path Rayleigh fading channel, and the D/U of the two paths was set to 0 dB. The time of the delayed signal was set to 15 μ s. The maximum Doppler frequencies of the signal were set to 5 and 20 Hz. The results are shown in Fig. 27.

FIGURE 23

BER before RS decoding vs. C/N

(Transmission mode: 3, carrier modulation: DQPSK,
time interleaving: 407 ms): Gaussian channel

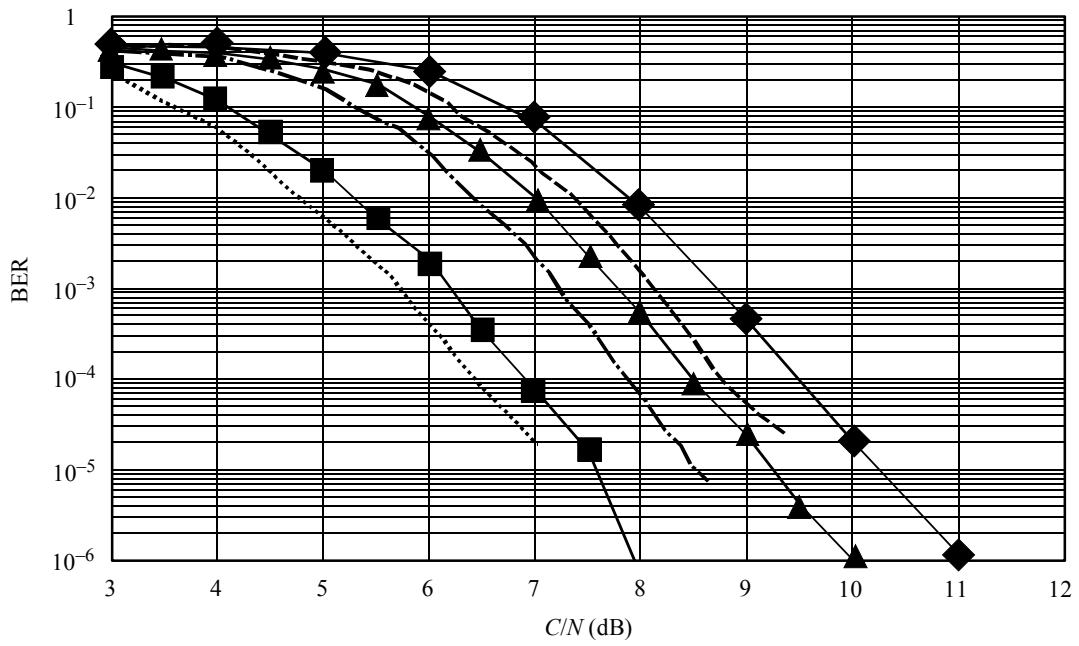

- Coding rate: 1/2 (measured)
- ▲— Coding rate: 2/3 (measured)
- ◆— Coding rate: 3/4 (measured)
- Coding rate: 1/2 (simulated)
- .-.- Coding rate: 2/3 (simulated)
- - - Coding rate: 3/4 (simulated)

FIGURE 24

BER before RS decoding vs. C/N

(Transmission mode: 3, carrier modulation: 16-QAM,
time interleaving: 407 ms): Gaussian channel

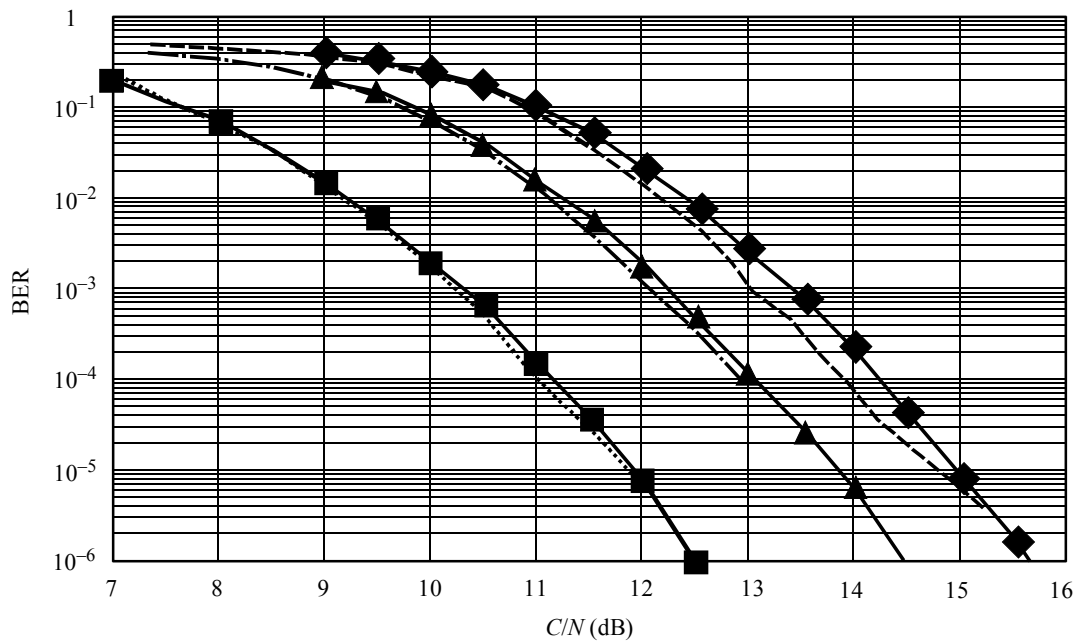

- Coding rate: 1/2 (measured)
- ▲— Coding rate: 2/3 (measured)
- ◆— Coding rate: 3/4 (measured)
- Coding rate: 1/2 (simulated)
- .-.- Coding rate: 2/3 (simulated)
- Coding rate: 3/4 (simulated)

1114-24

FIGURE 25

BER before RS decoding vs. C/N

(Transmission mode: 3, carrier modulation: 64-QAM,
time interleaving: 407 ms): Gaussian channel

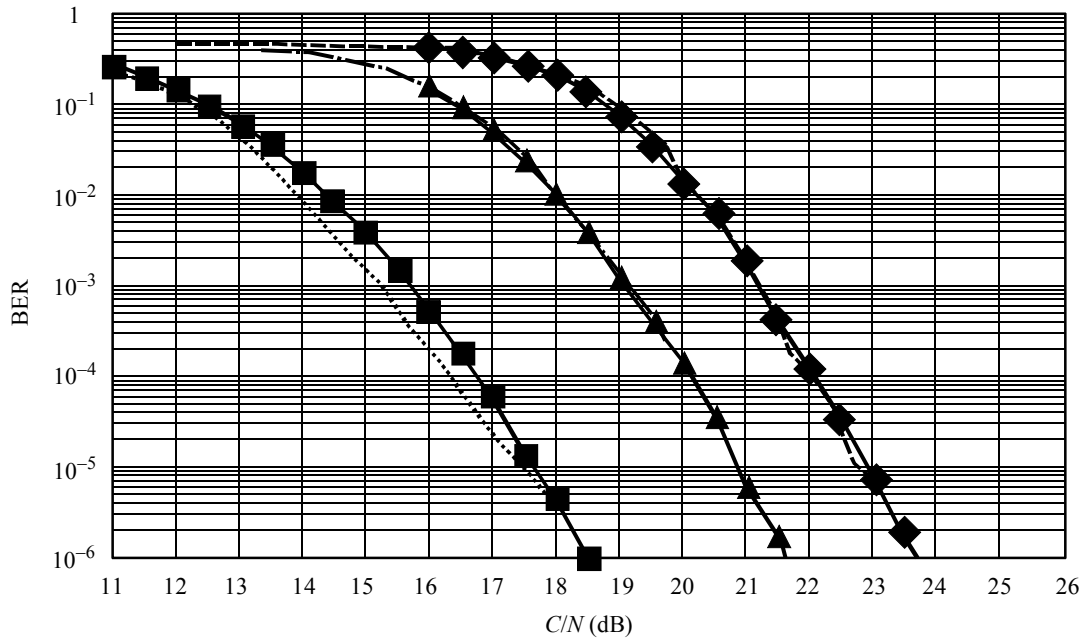

- Coding rate: 1/2 (measured)
- ▲— Coding rate: 3/4 (measured)
- ◆— Coding rate: 7/8 (measured)
- Coding rate: 1/2 (simulated)
- .-.- Coding rate: 3/4 (simulated)
- Coding rate: 7/8 (simulated)

FIGURE 26

BER before RS decoding vs. C/N

(Transmission mode: 3, coding rate: 1/2, time interleaving: 407 ms): multipath channel

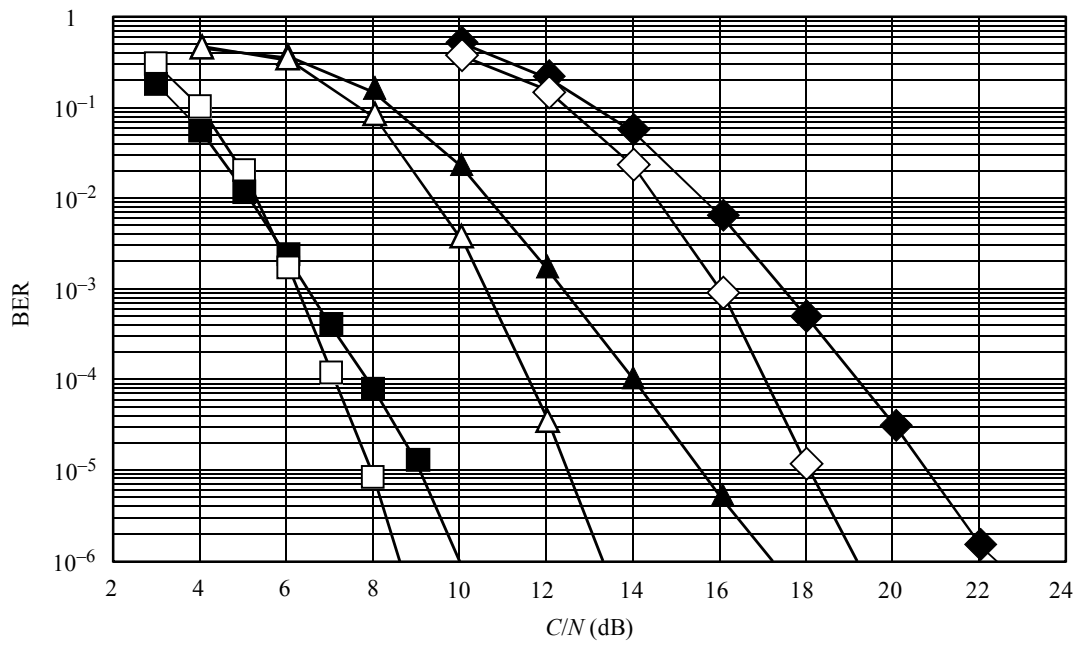

Carrier modulation	D/U
—■—	DQPSK 3 dB
—▲—	16-QAM 3 dB
—◆—	64-QAM 3 dB
—□—	DQPSK 10 dB
—△—	16-QAM 10 dB
—◇—	64-QAM 10 dB

FIGURE 27

BER before RS decoding vs. C/N

(Transmission mode: 3, carrier modulation: DQPSK, coding rate: 1/2): 2-path Rayleigh channel

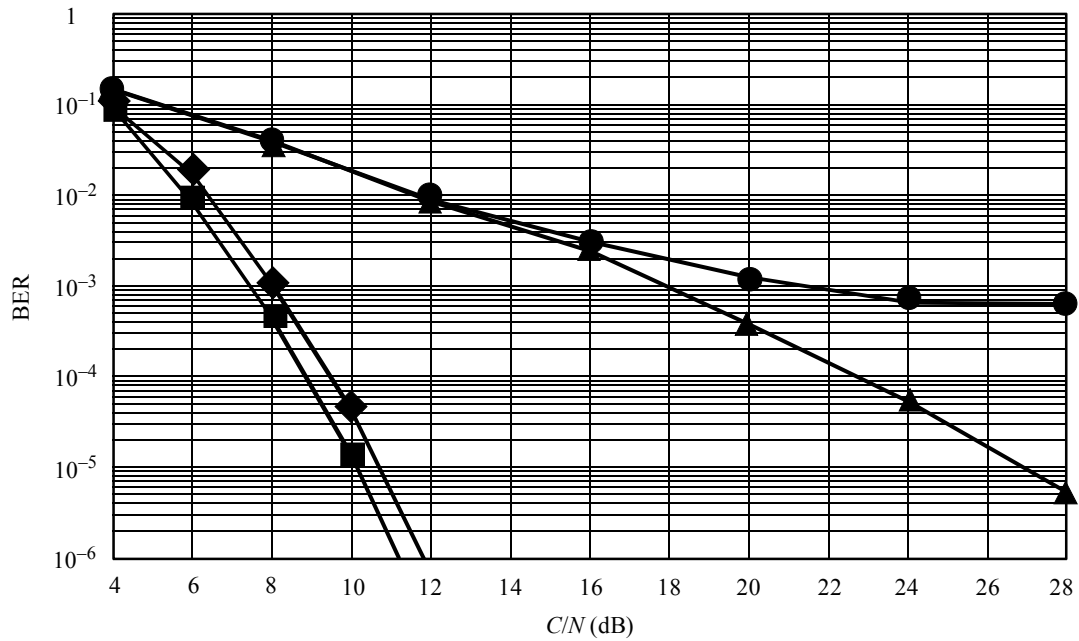

- Time interleaving : 407 ms
Fading frequency: 20 Hz
- ▲— Time interleaving : 0 ms
Fading frequency: 5 Hz
- ◆— Time interleaving : 407 ms
Fading frequency: 5 Hz
- Time interleaving : 0 ms
Fading frequency: 20 Hz

1114-27

Annex 4

Digital System C

1 System overview

Digital System C employs IBOC technology to facilitate the introduction of DSB. DSB offers broadcasters the ability to upgrade their analogue service by providing enhanced audio fidelity, improved signal robustness, and expanded auxiliary services. IBOC technology allows broadcasters to introduce these upgrades without the need for new spectrum allocations for the digital signal by allowing existing stations to broadcast the same programming in analogue and digital. This provides a spectrally efficient means to make a rational transition from the existing analogue environment to a digital future.

2 IBOC layers

The IBOC detailed performance specifications are organized in terms of the ISO OSI layered model. Each OSI layer of the broadcasting system has a corresponding layer, termed a peer, in the receiving system. The functionality of these layers is such that the combined result of lower layers is to effect a virtual communication between a given layer and its peer on the other side.

2.1 Hybrid Layer 1

Layer 1 (L1) of Digital System C converts information and system control from Layer 2 (L2) into the IBOC waveform for transmission in the VHF band. The information and control is transported in discrete transfer frames via multiple logical channels through the L1 service access points (SAPs). These transfer frames are also referred to as L2 service data units (SDUs) and service control units (SCUs), respectively.

The L2 SDUs vary in size and format depending on the service mode. The service mode, a major component of system control, determines the transmission characteristics of each logical channel. After assessing the requirements of their candidate applications, higher protocol layers select service modes that most suitably configure the logical channels. The plurality of logical channels reflects the inherent flexibility of the system, which supports simultaneous delivery of various classes of digital audio and data.

L1 also receives system control as SCUs from L2. System control is processed in the system control processor.

The following sections present:

- an overview of the waveforms and spectra;
- an overview of the system control, including the available service modes;
- an overview of the logical channels;
- a high-level discussion of each of the functional components comprising the L1 FM air interface.

2.2 Waveforms and spectra

The design provides a flexible means of introducing to a digital broadcast system by providing three new waveform types: hybrid, extended hybrid, and all digital. The hybrid and extended hybrid types retain the analogue FM signal, while the all digital type does not. All three waveforms operate well below allocated spectral emissions mask as currently defined by the Federal Communications Commission (FCC).

The digital signal is modulated using orthogonal frequency division multiplexing (OFDM). OFDM is a parallel modulation scheme in which the data stream modulates a large number of orthogonal subcarriers, which are transmitted simultaneously. OFDM is inherently flexible, readily allowing the mapping of logical channels to different groups of subcarriers.

The symbol timing parameters are defined in Table 12.

TABLE 12

Symbol timing parameters

Parameter name	Symbol	Units	Exact value	Computed value (to 4 significant figures)
OFDM subcarrier spacing	Δf	Hz	1 488 375/4 096	363.4
Cyclic prefix width	α	None	7/128	5.469×10^{-2}
OFDM symbol duration	T_s	s	$(1 + \alpha) / \Delta f =$ $(135/128) \cdot (4 096/1 488 375)$	2.902×10^{-3}
OFDM symbol rate	R_s	Hz	$= 1/T_s$	344.5
L1 frame duration	T_f	s	$65 536/44 100 = 512 \cdot T_s$	1.486
L1 frame rate	R_f	Hz	$= 1/T_f$	6.729×10^{-1}
L1 block duration	T_b	s	$= 32 \cdot T_s$	9.288×10^{-2}
L1 block rate	R_b	Hz	$= 1/T_b$	10.77
L1 block pair duration	T_p	s	$= 64 \cdot T_s$	1.858×10^{-1}
L1 block pair rate	R_p	Hz	$= 1/T_p$	5.383
Diversity delay frames	N_{dd}	None	= number of L1 frames of diversity delay	3

2.2.1 Hybrid Waveform

The digital signal is transmitted in primary main (PM) sidebands on either side of the analogue FM signal in the hybrid waveform. The power level of each sideband is approximately 23 dB below the total power in the analogue FM signal. The analogue signal may be monophonic or stereo, and may include subsidiary communications authorization (SCA) channels.

2.2.2 Extended hybrid waveform

In the extended hybrid waveform, the bandwidth of the hybrid sidebands can be extended toward the analogue FM signal to increase digital capacity. This additional spectrum, allocated to the inner edge of each primary main sideband, is termed the primary extended (PX) sideband.

2.2.3 All digital waveform

The greatest system enhancements are realized with the all digital waveform, in which the analogue signal is removed and the bandwidth of the primary digital sidebands is fully extended as in the extended hybrid waveform. In addition, this waveform allows lower-power digital secondary sidebands to be transmitted in the spectrum vacated by the analogue FM signal.

2.3 System control channel

The system control channel (SCCH) transports control and status information. Primary and secondary service modes and diversity delay control are sent from L2 to L1, while synchronization information is sent from L1 to L2.

The service modes dictate all permissible configurations of the logical channels. There are a total of eleven service modes.

2.4 Logical channels

A logical channel is a signal path that conducts L2 SDUs in transfer frames into L1 with a specific grade of service, determined by the service mode. L1 of the Digital System C provides ten logical channels to higher layer protocols. Not all logical channels are used in every service mode.

2.4.1 Primary logical channels

There are four primary logical channels which are used with both the hybrid and all digital waveforms. They are denoted as P1, P2, P3, and primary IBOC data service (PIDS). Table 13 shows the theoretical information rate supported by each primary logical channel as a function of primary service mode.

TABLE 13

Theoretical information rate of primary logical channels

Service mode	Theoretical information rate (kbit/s)				Waveform
	P1	P2	P3	PIDS	
MP1	25	74	0	1	Hybrid
MP2	25	74	12	1	Extended hybrid
MP3	25	74	25	1	Extended hybrid
MP4	25	74	50	1	Extended hybrid
MP5	25	74	25	1	Extended hybrid, all digital
MP6	50	49	0	1	Extended hybrid, all digital
MP7	25	98	25	1	Extended hybrid, all digital

2.4.2 Secondary logical channels

There are six secondary logical channels that are used only with the all digital waveform. They are denoted as S1, S2, S3, S4, S5, and secondary IBOC data service (SIDS). Table 14 shows the approximate theoretical information rate supported by each secondary logical channel as a function of secondary service mode.

TABLE 14

Approximate theoretical information rate of secondary logical channels

Service mode	Approximate information rate (kbit/s)						Waveform
	S1	S2	S3	S4	S5	SIDS	
MS1	0	0	0	98	6	1	All digital
MS2	25	74	25	0	6	1	All digital
MS3	50	49	0	0	6	1	All digital
MS4	25	98	25	0	6	1	All digital

2.4.3 Logical channel functionality

Logical channels P1 through P3 are designed to convey audio and data. S1 through S5 can be configured to carry data or surround sound audio. PIDS and SIDS logical channels are designed to carry IBOC data service (IDS) information.

The performance of each logical channel is completely described through three characterization parameters: transfer, latency, and robustness. Channel encoding, spectral mapping, interleaver depth, and diversity delay are the components of these characterization parameters. The service mode uniquely configures these components for each active logical channel, thereby allowing the assignment of appropriate characterization parameters.

In addition, the service mode specifies the framing and synchronization of the transfer frames through each active logical channel.

2.5 Functional components

This subsection includes a high-level description of each L1 functional block and the associated signal flow. Figure 28 is a functional block diagram of L1 processing. Audio and data are passed from the higher OSI layers to the physical layer, the modem, through the L1 SAPs.

2.5.1 Service access points

The L1 SAPs define the interface between L2 and L1 of the system protocol stack. Each logical channel and the SCCH have their own SAP. Each channel enters L1 in discrete transfer frames, with unique size and rate determined by the service mode. These L2 transfer frames are typically referred to as L2 SDUs and SCUs.

2.5.2 Scrambling

This function randomizes the digital data in each logical channel to “whiten” and mitigate signal periodicities when the waveform is demodulated in a conventional analogue FM demodulator.

2.5.3 Channel encoding

Digital System C uses Viterbi convolutional codes with an effective coding rate of 2/5. This convolutional encoding adds redundancy to the digital data in each logical channel to improve its reliability in the presence of channel impairments. The size of the logical channel vectors is increased in inverse proportion to the code rate. The encoding techniques are configurable by service mode. Diversity delay is also imposed on selected logical channels. At the output of the channel encoder, the logical channel vectors retain their identity.

FIGURE 28
 FM air interface L1 functional block diagram

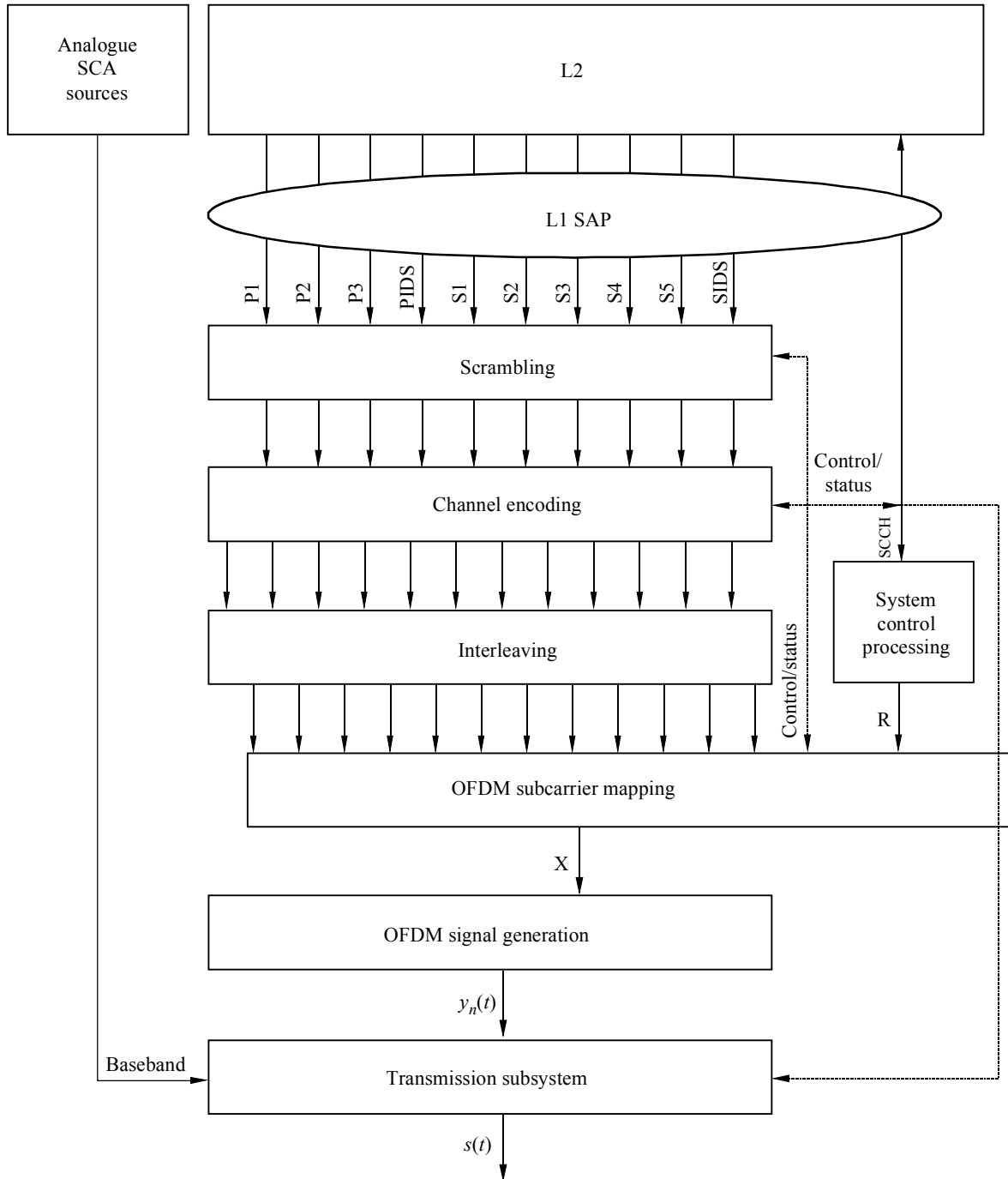

2.5.4 Interleaving

Interleaving in time and frequency is employed to mitigate the effects of burst errors. The interleaving techniques are tailored to the VHF fading environment and are configurable by service mode. Each logical channel is individually interleaved. The depth of the interleaver is based on the use of the channel. The length of the interleaver in the primary audio channels (P1 and P2) is equivalent to one L1 frame. In this process, the logical channels lose their identity. The interleaver output is structured in a matrix format; each matrix is comprised of one or more logical channels and is associated with a particular portion of the transmitted spectrum. Total diversity delay including interleaving is three L1 frames (3×1.486 s).

2.5.5 System control processing

This function generates a matrix of system control data sequences which includes control and status (such as service mode), for broadcast on the reference subcarriers.

2.5.6 OFDM subcarrier mapping

This function assigns the interleaved matrices and the system control matrix to the OFDM subcarriers. One row of each active interleaver matrix is processed every OFDM symbol T_s to produce one output vector \mathbf{X} , which is a frequency-domain representation of the signal. The mapping is specifically tailored to the non-uniform interference environment and is a function of the service mode.

2.5.7 OFDM signal generation

This function generates the digital portion of the time-domain signal. The input vectors are transformed into a shaped time-domain baseband pulse, $y_n(t)$, defining one OFDM symbol.

2.5.8 Transmission subsystem

This function formats the baseband waveform for transmission through the VHF channel. Major sub-functions include symbol concatenation and frequency up-conversion. In addition, when transmitting the hybrid waveform, this function modulates the source and combines it with the digital signal to form a composite hybrid signal, $s(t)$, ready for transmission.

3 Functional description

3.1 Introduction

OFDM signal generation receives complex, frequency-domain OFDM symbols from OFDM subcarrier mapping, and outputs time-domain pulses representing the digital portion of the Digital System C signal. A conceptual block diagram of OFDM signal generation is shown in Fig. 29.

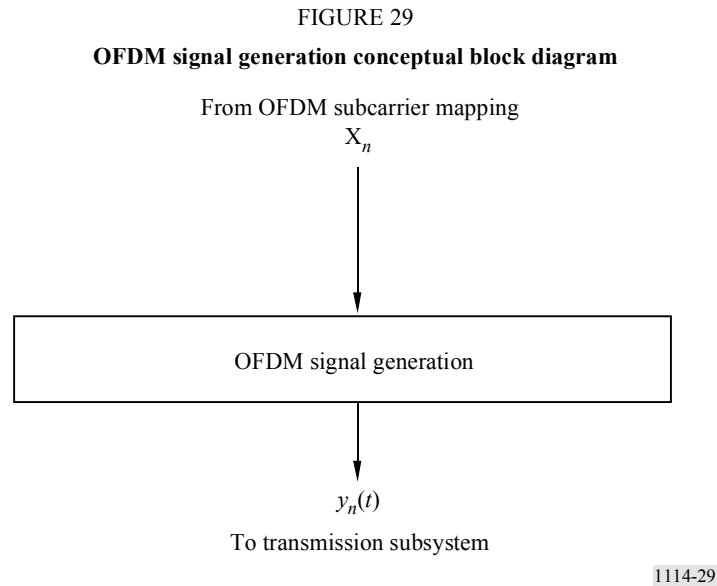

The input to OFDM signal generation is a complex vector \mathbf{X}_n of length L , representing the complex constellation values for each OFDM subcarrier in OFDM symbol n . The output of OFDM signal generation is a complex, baseband, time-domain waveform $y_n(t)$, representing the digital portion of the Digital System C signal for OFDM symbol n .

3.2 Transmission subsystem

3.2.1 Introduction

The transmission subsystem formats the baseband IBOC waveform for transmission through the VHF channel. Functions include symbol concatenation and frequency up-conversion. In addition, when transmitting the hybrid or extended hybrid waveforms, this function delays and modulates the baseband analogue signal before combining it with the digital waveform.

The input to this module is a complex, baseband, time-domain OFDM waveform, $y_n(t)$, from the OFDM signal generation function. A baseband analogue signal $m(t)$ is also input from an analogue source, along with optional SCA signals, when transmitting the hybrid or extended hybrid waveform. In addition, analogue diversity delay (DD) control is input from L2 via the control channel. The output of this module is the IBOC waveform.

FIGURE 30

Hybrid/extended hybrid transmission subsystem functional block diagram

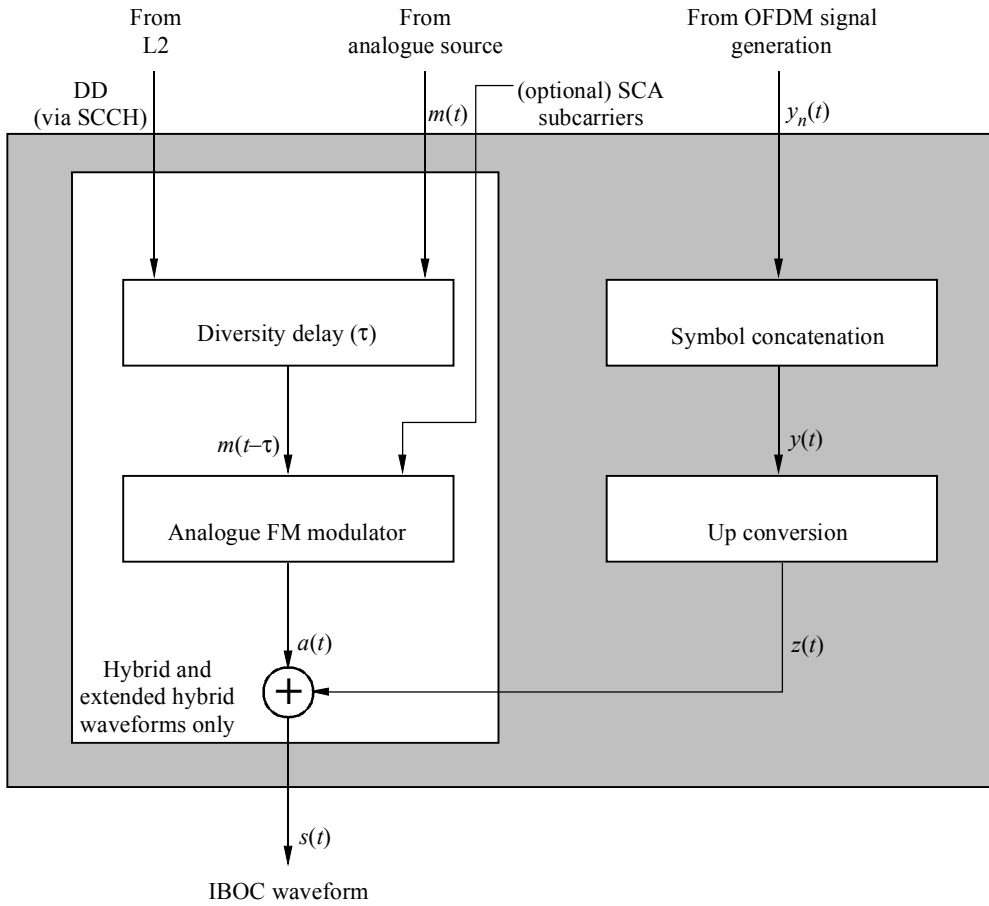
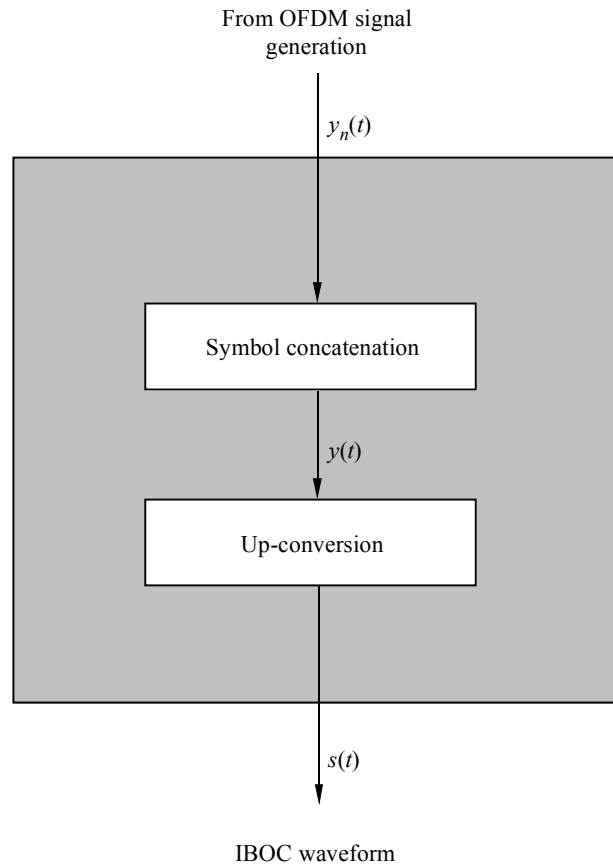

FIGURE 31

All digital transmission subsystem functional block diagram

1114-31

3.2.2 Diversity delay

When broadcasting the hybrid and extended hybrid waveforms, $z(t)$ is combined with the analogue FM signal $a(t)$. The first step in generating $a(t)$ is the application of DD to the baseband analogue signal $m(t)$. The analogue DD control bit received from L2 via the SCCH, is used by upper protocol layers to enable or disable the DD. If DD is 0, the DD is disabled; if DD is 1, it is enabled. When DD is enabled, an adjustable delay τ is applied to the baseband analogue signal $m(t)$. The delay is set so that, at the output of the analogue/digital combiner, $a(t)$ lags the corresponding digital signal $z(t)$ by T_{dd} . In the Digital System C the analogue and digital signals carry the same audio program with the analogue audio delayed from the corresponding digital audio by T_{dd} at the output of the analogue/digital combiner. The delay is adjustable to account for processing delays in the analogue and digital chains.

3.2.3 Analogue FM modulator

For the hybrid and extended hybrid waveforms, the appropriately delayed baseband analogue signal $m(t-\tau)$ is frequency modulated to produce an RF analogue FM waveform identical to existing analogue signals.

3.2.4 Analogue/digital combiner

When broadcasting the hybrid or extended hybrid waveform, the analogue-modulated FM RF signal is combined with the digitally-modulated IBOC RF signal to produce the Digital System C signal, $s(t)$. Both the analogue and digital portions of the waveform are centred on the same carrier frequency. The levels of each digital sideband in the output spectrum are appropriately scaled by OFDM subcarrier mapping.

3.3 Use of on channel repeaters

The use of OFDM modulation in Digital System C allows on-channel digital repeaters or a single frequency network to fill areas of desired coverage where signal losses due to terrain and/or shadowing are severe. A typical application would be where mountains or other terrain obstructions within the station's service areas limit analogue or digital performance.

Digital System C operates with an effective guard time between OFDM symbols of approximately $150 \mu\text{s}^2$. To avoid significant intersymbol interference the effective coverage in the direction of the primary transmission system should be limited to within 22 km. Specifically the ratio of the signal from the primary transmitter to the booster signal should be at least 10 dB at locations more than 22 km from the repeater in the direction of the primary antenna. Performance and distances between on-channel boosters can be improved through the use of directional antennas to protect the main station.

3.4 Global positioning system (GPS) synchronization

In order to ensure precise time synchronization, for rapid station acquisition and booster synchronization, each station is GPS locked. This is normally accomplished through synchronization with a signal synchronized in time and frequency to the GPS³. Transmissions that are not locked to GPS, would not be able to provide fast tuning at the receiver in the case of SFN since they cannot be synchronized with other stations⁴.

4 Digital sideband levels

The amplitude scaling of each OFDM subcarrier within each digital sideband is given in Table 15 for the hybrid, extended hybrid and all digital waveforms. The values for the hybrid waveforms are specified relative to the total power of the unmodulated analog FM carrier (assumed equal to 1). The values for the all digital waveform are specified relative to the total power of the unmodulated analog FM carrier (assumed equal to 1) that would have been transmitted in the hybrid and extended hybrid modes.

For the hybrid and extended hybrid waveforms, the values were chosen so that the total average power in a primary digital sideband (upper or lower) is 23 dB below the total power of unmodulated analog FM carrier.

² $150 \mu\text{s}$ equates to a 45 km propagation distance.

³ GPS locked stations are referred to as Level I: GPS-locked transmission facilities.

⁴ Level II: non-GPS locked transmission facilities.

For the all digital waveform, the values were chosen so that the total average power in a primary digital sideband (upper or lower) is at least 10 dB above the total power in the hybrid primary digital sidebands. In addition, the values were chosen so that the total average power in the secondary digital sidebands (upper and lower) is at least 20 dB below the total power in the all digital primary digital sidebands.

TABLE 15

OFDM subcarrier scaling

Waveform	Mode	Sidebands	Amplitude scale factor notation	Amplitude scale factor ⁽¹⁾ (relative to total analog FM power)	Amplitude scale factor ⁽²⁾ (relative to total analog FM power) (dB)
Hybrid	MP1	Primary	a_0	5.123×10^{-3}	-41.39
Extended hybrid	MP2-MP7	Primary	a_0	5.123×10^{-3}	-41.39
All digital	MP5-MP7	Primary	a_2	1.67×10^{-2}	-31.39
	MS1-MS4	Secondary	a_4	5.123×10^{-3}	-41.39
		Secondary	a_5	3.627×10^{-3}	-44.39
		Secondary	a_6	2.567×10^{-3}	-47.39
		Secondary	a_7	1.181×10^{-3}	-50.39

⁽¹⁾ Amplitude scale factor per IBOC subcarrier range

⁽²⁾ Amplitude scale factor in dB measured in 1 kHz bandwidth

5 Spectrum for hybrid mode

The digital signal is transmitted in Primary Main sidebands on either side of the analogue FM signal. Each Primary Main sideband is comprised of ten frequency partitions, which are allocated among subcarriers 356 through 545, or -356 through -545 (see Fig. 32 and Table 16). Subcarriers 546 and -546, also included in the PM sidebands, are additional reference subcarriers. The amplitude of the subcarrier within PM sidebands is uniformly scaled by an amplitude scale factor.

FIGURE 32

Spectrum of the hybrid waveform – Service mode MP1

(The level of the digital subcarriers is such that the total power of these carriers is 20 dB below the nominal power of the FM analogue carrier)

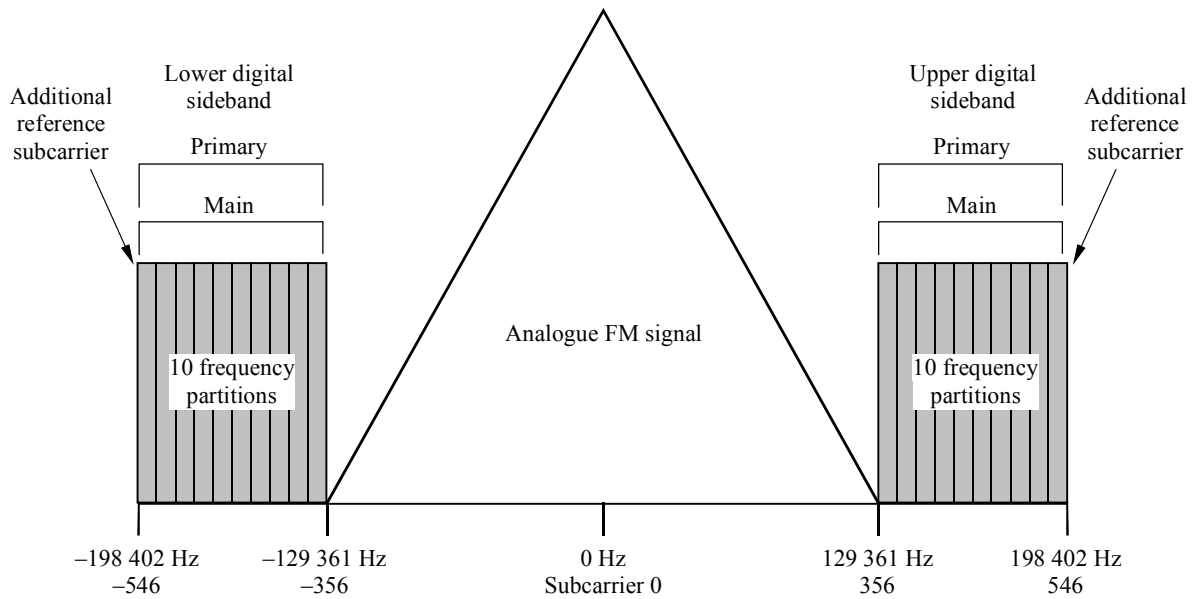

1114-32

TABLE 16

Hybrid waveform spectral summary – service mode MP1

Sideband	Number of frequency partitions	Frequency partition ordering	Subcarrier range	Subcarrier frequencies (from channel centre) (Hz)	Amplitude Scale Factor	Frequency span (Hz)	Comments
Upper PM	10	A	356 to 546	129 361 to 198 402	a_0	69 041	Includes additional reference sub-carrier 546
Lower PM	10	B	-356 to -546	-129 361 to -198 402	a_0	69 041	Includes additional reference sub-carrier -546

6 Spectrum for extended hybrid mode

The extended hybrid waveform is created by adding primary Extended sidebands to the PM sidebands present in the hybrid waveform. Depending on the service mode, one, two, or four frequency partitions can be added to the inner edge of each PM sideband. Each PM sideband consists of ten frequency partitions and an additional reference subcarrier spanning subcarriers 356 through 546, or -356 through -546. The upper primary extended sidebands include subcarriers 337 through 355 (one frequency partition), 318 through 355 (two frequency partitions), or 280 through 355 (four frequency partitions). The lower primary extended sidebands include subcarriers -337 through -355 (one frequency partition), -318 through -355 (two frequency partitions), or -280 through -355 (four frequency partitions). The subcarriers within primary extended sidebands are uniformly scaled the same amplitude scale factor, a_0 , as the PM sidebands (see Fig. 33 and Table 17).

FIGURE 33
Spectrum of the extended hybrid waveform – Service modes MP2 through MP4
 (The level of the digital subcarriers is such that the total power of these carriers is 20 dB below the nominal power of the FM analogue carrier)

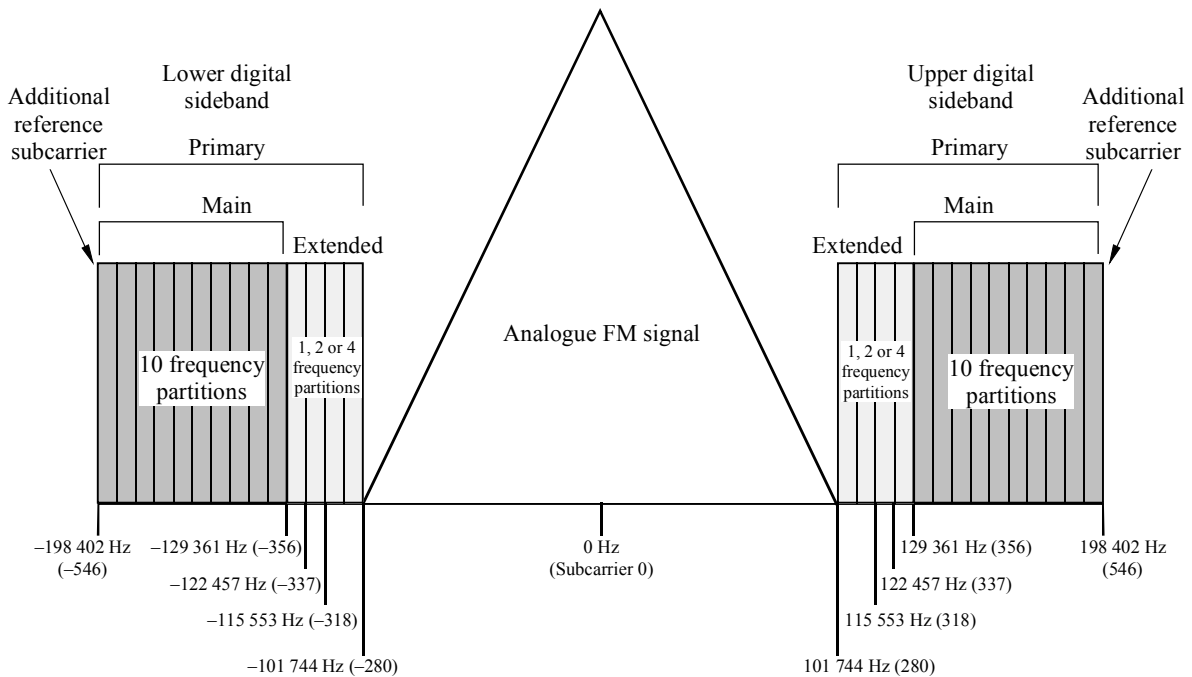

TABLE 17

Extended hybrid waveform spectral summary – service modes MP2 through MP4

Sideband	Number of frequency partitions	Frequency partition ordering	Subcarrier range	Subcarrier frequencies (from channel centre) (Hz)	Amplitude scale factor	Frequency span (Hz)	Comments
Upper PM	10	A	356 to 546	129 361 to 198 402	a_0	69 041	Includes additional reference subcarrier 546
Lower PM	10	B	-356 to -546	-129 361 to -198 402	a_0	69 041	Includes additional reference subcarrier -546
Upper primary extended (1 frequency partition)	1	A	337 to 355	122 457 to 128 997	a_0	6 540	None
Lower primary extended (1 frequency partition)	1	B	-337 to -355	-122 457 to -128 997	a_0	6 540	None
Upper primary extended (2 frequency partitions)	2	A	318 to 355	115 553 to 128 997	a_0	13 444	None
Lower primary extended (2 frequency partitions)	2	B	-318 to -355	-115 553 to -128 997	a_0	13 444	None
Upper primary extended (4 frequency partitions)	4	A	280 to 355	101 744 to 128 997	a_0	27 253	None
Lower primary extended (4 frequency partitions)	4	B	-280 to -355	-101 744 to -128 997	a_0	27 253	None

7 Spectrum for all digital mode

The all digital waveform is constructed by removing the analogue signal, fully expanding the bandwidth of the primary digital sidebands, and adding lower-power secondary sidebands in the spectrum vacated by the analogue signal. The spectrum of the all digital waveform is shown in Fig. 34.

FIGURE 34
Spectrum of the all digital waveform – Service modes MP5 through MP7, MS1 through MS4
 (The level of the digital subcarriers is such that the total power of these carriers is no more than 10 dB below the nominal power of the FM analogue carrier that it replaces)

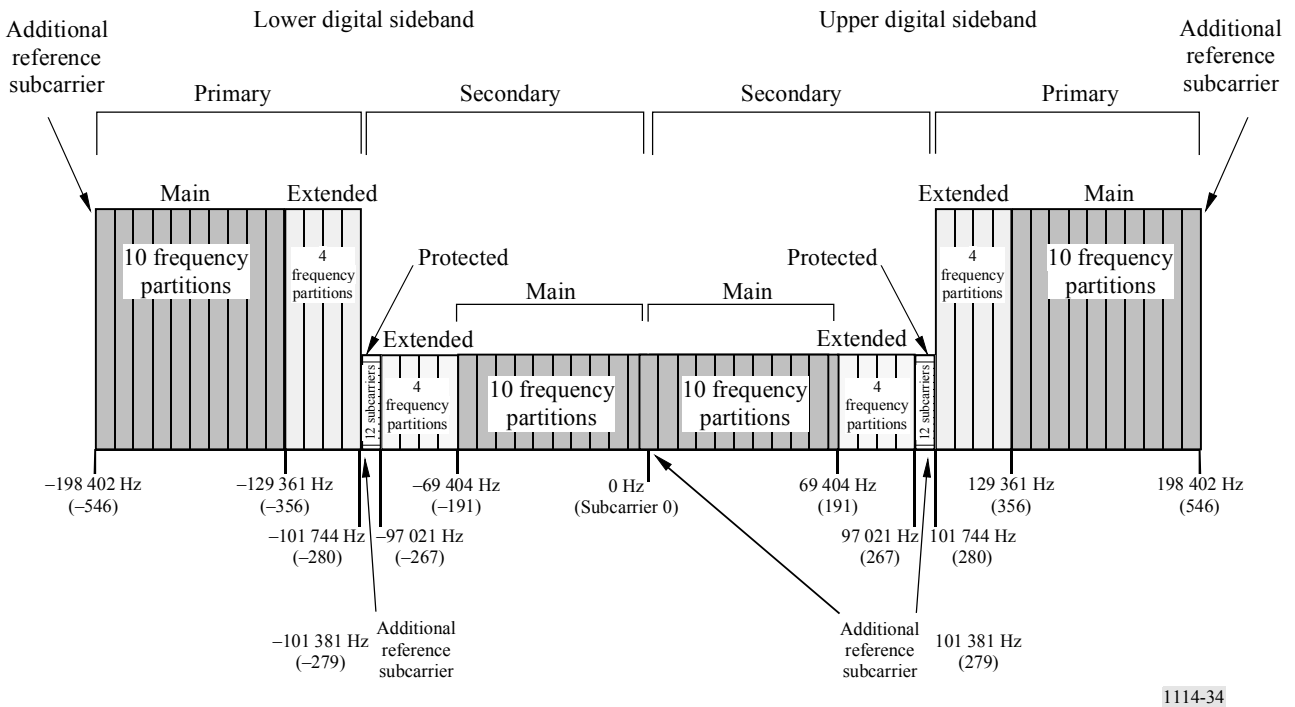

In addition to the ten main frequency partitions, all four extended frequency partitions are present in each primary sideband of the all digital waveform. Each secondary sideband also has ten secondary main (SM) and four secondary extended frequency partitions. Unlike the primary sidebands, however, the SM frequency partitions are mapped nearer to channel centre with the extended frequency partitions farther from the centre.

Each secondary sideband also supports a small secondary protected (SP) region consisting of 12 OFDM subcarriers and reference subcarriers 279 and -279. The sidebands are referred to as “protected” because they are located in the area of spectrum least likely to be affected by analogue or digital interference. An additional reference subcarrier is placed at the centre of the channel (0). Frequency partition ordering of the SP region does not apply since the SP region does not contain frequency partitions

Each SM sideband spans subcarriers 1 through 190 or -1 through -190 . The upper secondary extended sideband includes subcarriers 191 through 266, and the upper SP sideband includes subcarriers 267 through 278, plus additional reference subcarrier 279. The lower secondary extended sideband includes subcarriers -191 through -266 , and the lower SP sideband includes subcarriers -267 through -278 , plus additional reference subcarrier -279 . The total frequency span of the entire all digital spectrum is 396 803 Hz. The subcarriers within the PM and primary extended sidebands are scaled by an amplitude scale factor, a_2 . The subcarriers within the SM, secondary extended and SP sidebands are uniformly scaled by an amplitude scale factor having four discrete levels a_4 - a_7 .

TABLE 18

**All digital waveform spectral summary – service modes MP5 through MP7,
MS1 through MS4**

Sideband	Number of frequency partitions	Frequency partition ordering	Sub-carrier range	Sub-carrier frequencies (from channel centre) (Hz)	Amplitude scale factor	Frequency span (Hz)	Comments
Upper PM	10	A	356 to 546	129 361 to 198 402	a_2	69 041	Includes additional reference subcarrier 546
Lower PM	10	B	-356 to -546	$-129 361$ to $-198 402$	a_2	69 041	Includes additional reference subcarrier -546
Upper primary extended	4	A	280 to 355	101 744 to 128 997	a_2	27 253	None
Lower primary extended	4	B	-280 to -355	$-101 744$ to $-128 997$	a_2	27 253	None
Upper SM	10	B	0 to 190	0 to 69 041	a_2	69 041	Includes additional reference subcarrier 0
Lower SM	10	A	-1 to -190	-363 to $-69 041$	a_2	68 678	None
Upper secondary extended	4	B	191 to 266	69 404 to 96 657	a_4 - a_7	27 253	None
Lower secondary extended	4	A	-191 to -266	$-69 404$ to $-96 657$	a_4 - a_7	27 253	None
Upper SP	Not applicable	Not applicable	267 to 279	97 021 to 101 381	a_4 - a_7	4 360	Includes additional reference subcarrier 279
Lower SP	Not applicable	Not applicable	-267 to -279	$-97 021$ to $-101 381$	a_4 - a_7	4 360	Includes additional reference subcarrier 279

8 Emission limitations

8.1 Emission limits for IBOC operation

Hybrid and all digital carrier levels are operated well below the FM emissions mask. An example of one administration's mask, from the United States of America, Code of Federal Regulations (CFR), Title 47 § 73.317 is summarized in Table 19.

TABLE 19

Emission limits as a function of off-set from carrier frequency for FM channels in the United States of America

Offset from carrier frequency (kHz)	Power spectral density relative to unmodulated analogue FM carrier (dBc/kHz) ⁽¹⁾
120 to 240	-25
240 to 600	-35
Greater than 600	-80, or $-43 - 10 \log_{10} x$, whichever is less, where x is power (W) refers to the total unmodulated transmitter output carrier power

⁽¹⁾ Measurements are made by averaging the power spectral density in a 1 kHz bandwidth over a 10s segment of time.

Figures 35 and 36 depict the noise level from all sources in dB relative to the nominal power spectral density of the digital sidebands as measured in a 1 kHz bandwidth. This noise measurement is inclusive of all sources including:

- phase noise of the IBOC exciter and
- intermodulation products from the transmitter. In Tables 19, 20, 21 and 22 the levels have been adjusted to depict the level below the 0 dBc emissions mask.

TABLE 20

IBOC digital carrier power⁽¹⁾

Hybrid mode	All-digital mode	
	Main programme carriers	Secondary auxiliary service carriers
-41.39	-31.39	-50.39

⁽¹⁾ Nominal power spectral density in a 1 kHz bandwidth to the reference 0 dBc mask.

8.1.1 Emission limits for hybrid mode operation

Noise from all sources, excluding frequencies removed from the carrier between 100 to 200 kHz, including phase noise of the IBOC exciter and intermodulation products, shall conform to the limits of Fig. 35 and Table 21. Requirements are summarized as follows, where dB is relative to the nominal power spectral density in a 1 kHz bandwidth of the digital sidebands.

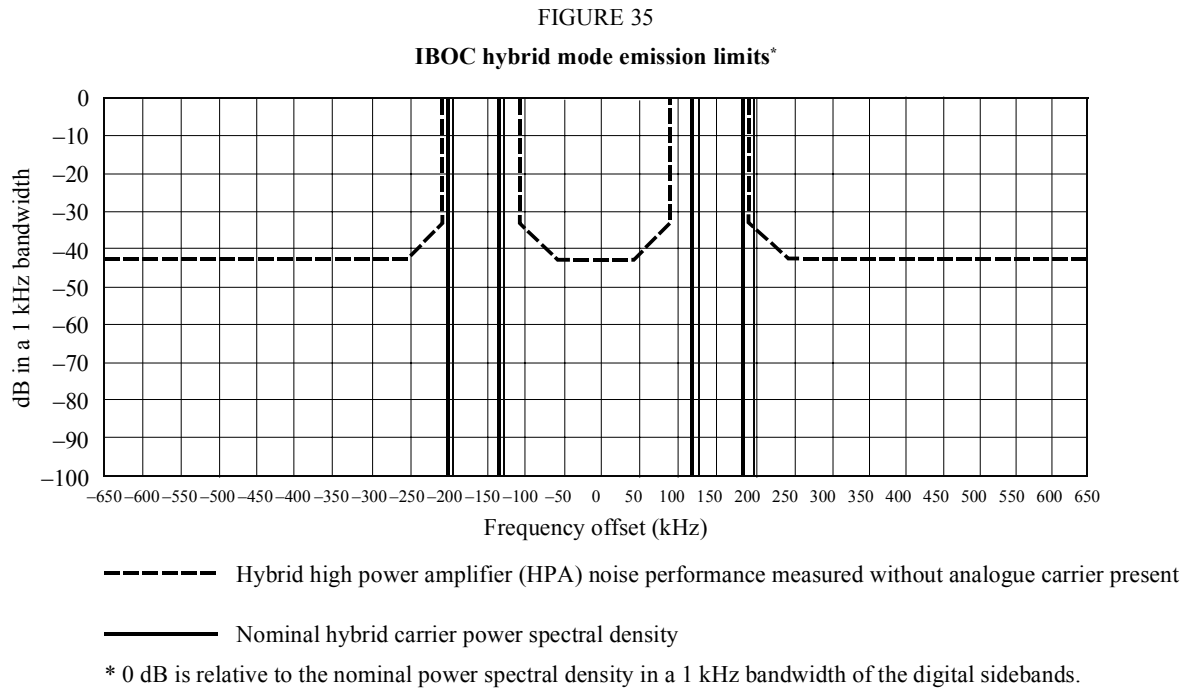

1114-35

TABLE 21

Hybrid mode emission limits

Frequency, F , offset relative to carrier	Level (dB/kHz)
0-50 kHz offset	-83.39 dB
50-95 kHz offset	$\{-83.39 + (\text{frequency (kHz)} - 50 \text{ kHz}) \cdot 0.2\}$ dB
95-100 kHz offset	$\{-61.39 + (\text{frequency (kHz)} - 100 \text{ kHz}) \cdot 2.6\}$ dB
200-205 kHz offset	$\{-61.39 - (\text{frequency (kHz)} - 200 \text{ kHz}) \cdot 2.6\}$ dB
205-250 kHz offset	$\{-74.39 - (\text{frequency (kHz)} - 205 \text{ kHz}) \cdot 0.2\}$ dB
>250 kHz offset	-83.39 dB

8.1.2 Emission limits for all-digital mode operation

Noise from all sources, for frequencies removed from the carrier by more than 200 kHz, including phase noise of the IBOC exciter and intermodulation products, shall conform to the limits of Fig. 36 and Table 22.

FIGURE 36
All-digital emission limits*

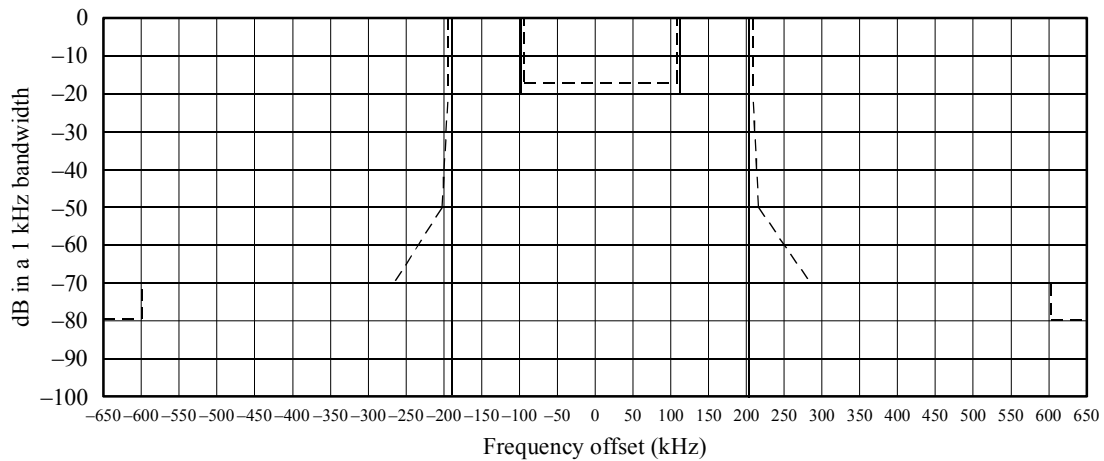

----- All digital HPA noise performance
 ————— Nominal all digital power spectral density

* 0 dB is relative to the nominal power spectral density in a 1 kHz bandwidth of the digital sidebands.

1114-36

Requirements are summarized as follows, where dB is relative to the nominal power spectral density in a 1 kHz bandwidth of the digital sidebands.

TABLE 22

All-digital emission limits

Frequency, <i>F</i> , offset relative to carrier	Level (dB/kHz)
200-207.5 kHz offset	$\{-51.39 - (\text{frequency (kHz)} - 200 \text{ kHz}) \cdot 1.733\}$ dB
207.5-250 kHz offset	$\{-64.39 - (\text{frequency (kHz)} - 207.5 \text{ kHz}) \cdot 0.2118\}$ dB
250-300 kHz offset	$\{-73.39 - (\text{frequency (kHz)} - 250 \text{ kHz}) \cdot 0.56\}$ dB
300-600 kHz offset	-101.39 dB
>600 kHz offset	-111.39 dB

9 Summary of laboratory test results

Laboratory tests of Digital System C are summarized below. The fading profiles used are denoted by urban fast (UF), urban slow (US), rural fast (RF), or terrain-obstructed (TO) fast, and were independently applied to the desired signal and each of the interferers. The interference level is given in units of dB_{des}, which is defined as dB relative to the total power of the desired hybrid signal. For each block error rate test, Table 23 lists the interference scenario under which it was run, the C_d/N_0 (dB/Hz), the fading profile, the level of the interference, and the measured block error rate.

TABLE 23

FM hybrid IBOC DSB performance test results

Tests	Input parameters					Measurements		
						Digital performance	Analogue subjective evaluation at digital ToA	
	C_d/N_0 (dB/Hz)	Fading	Co-Channel (dB _{des})	1st adjacent (dB _{des})	2nd adjacent (dB _{des})	Block error rate	File	Subjective audio degradation
Gaussian noise no fading/ no interference	54.1					0.16	audio1.wav	Audible
	54.5					0.032		
	55.1					0.0029		
9-ray fading	55.4	UF				0.8	audio2.wav	Audible
	56.4					0.056		
	57.3					0.012		
	59.3	US				0.106	audio3.wav	Audible
	60.4					0.054		
	61.4					0.0202		
	55.9	RF				0.6	audio4.wav	Audible
	56.8					0.087		
	57.8					0.007		
	55.9	TO				0.317	audio5.wav	Audible
	56.9					0.026		
	57.8					0.001		
1st adjacent interference	61.5	UF		-6.0		0.075	audio6.wav	Audible
	62.4					0.045		
	63.4					0.00842		
	59.4	UF		-18.0		0.077	audio7.wav	Audible
	60.3					0.012		
	61.3					0.006		
	58.2	UF		-24.0		0.0735	audio8.wav	Audible
	59.2					0.0109		
	60.1					0.005		
	57.2	UF		-30.0		0.0287	audio9.wav	Audible
58.2					0.0082			
2nd adjacent interference	57.9	UF			20.0	0.1	audio10.wav	Audible
	58.9				0.018			
	60.5				0.00085			
Co-channel interference	60.2	UF	-10.0			0.013	audio11.wav	Beyond point of failure
	61.3					0.0097		
	65.3					0.00014		
	58.4	UF	-20.0			0.013	audio12.wav	Audible
	59.3					0.0011		
	60.4					0.00035		

9.1 Performance in Gaussian noise

This test measured an upper bound to system performance and recorded analogue audio at the digital threshold of audibility (ToA) in the presence of Gaussian noise, in the absence of Rayleigh fading and interference. Performance is shown in the block error rate curves of Fig. 37, and summarized in Table 23. Table 23 indicates that just prior to digital ToA, analogue audio quality is audibly degraded.

FIGURE 37
Block error rate results of the hybrid system in different types of 9-ray fading and additive white Gaussian noise (AWGN)

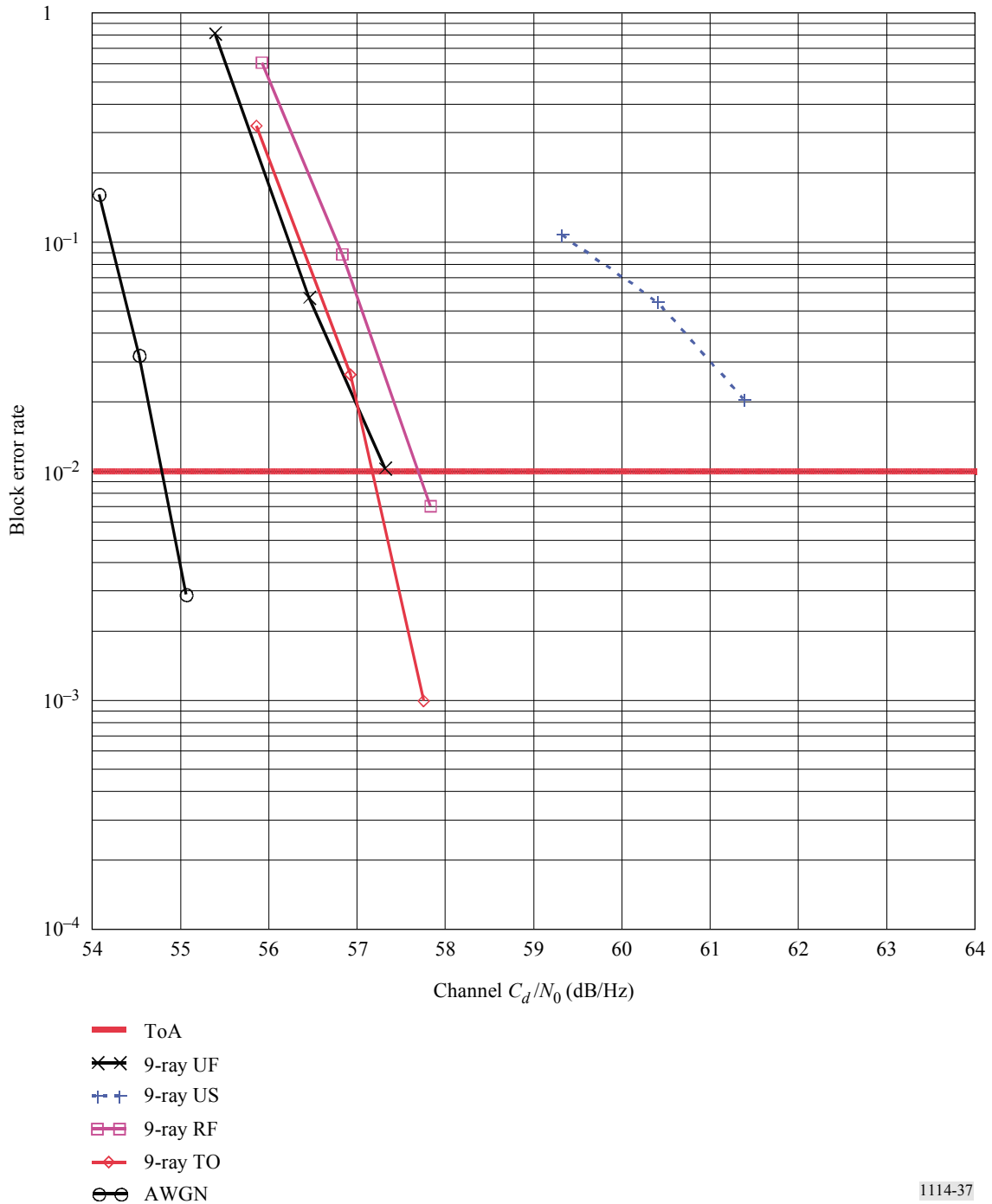

9.2 Performance in Rayleigh fading

This test measured system performance and recorded analogue audio at the digital ToA in Gaussian noise and in various types of Rayleigh fading. Performance is shown in the block error rate curves of Fig. 38, and summarized in Table 23. Results indicate an insensitivity to fading profile, except in the case of urban slow fading, which produces signal fades of very long duration. The urban slow fading profile produces particularly annoying outages in existing analogue transmissions.

9.2.1 Urban fast (UF)

Table 23 gives the subjective analogue audio evaluation, which indicates that, just prior to digital ToA, analogue audio quality is audibly degraded.

9.2.2 Urban slow (US)

Table 23 gives the subjective analogue audio evaluation, which indicates that, just prior to digital ToA, analogue audio quality is audibly degraded.

9.2.3 Rural fast (RF)

Table 23 gives the subjective analogue audio evaluation, which indicates that, just prior to digital ToA, analogue audio quality is audibly degraded.

9.2.4 Terrain obstructed fast (TO)

Table 23 gives the subjective analogue audio evaluation, which indicates that, just prior to digital ToA, analogue audio quality is audibly degraded.

9.3 Performance in the presence of independently faded interference

This test measured system performance and recorded analogue audio in Gaussian noise and Rayleigh fading, in the presence of independently faded first-adjacent, second-adjacent, and co-channel hybrid IBOC interferers. Each interferer was passed through the same type of Rayleigh fading channel as the desired signal; however, all signals were independently faded, and were therefore uncorrelated.

9.3.1 Single first-adjacent interference

In the United States of America, properly spaced Class B stations are protected to the 54 dBu contour from first-adjacent channel interference exceeding 48 dBu in 50% of the locations for 10% of the time. As a result, tests were performed with first-adjacent hybrid interferers of varying power, up to a level that is 6 dB below that of the desired signal. The block error rate results are shown in Fig. 38, and summarized in Table 23. As might be expected, performance degrades as the interference level increases from $-30 \text{ dB}_{\text{des}}$ to $-6 \text{ dB}_{\text{des}}$. However, the first-adjacent cancellation algorithm employed in the receiver ensures superior system performance, even with a high-level first-adjacent interferer in an urban fast-fading environment. Table 23 gives the subjective analogue audio evaluation, which indicates that, just prior to digital ToA, analogue audio quality is audibly degraded for all levels of first adjacents.

FIGURE 38
 Block error rate results of a hybrid system in 9-ray UF fading
 with an independently faded first-adjacent interferer

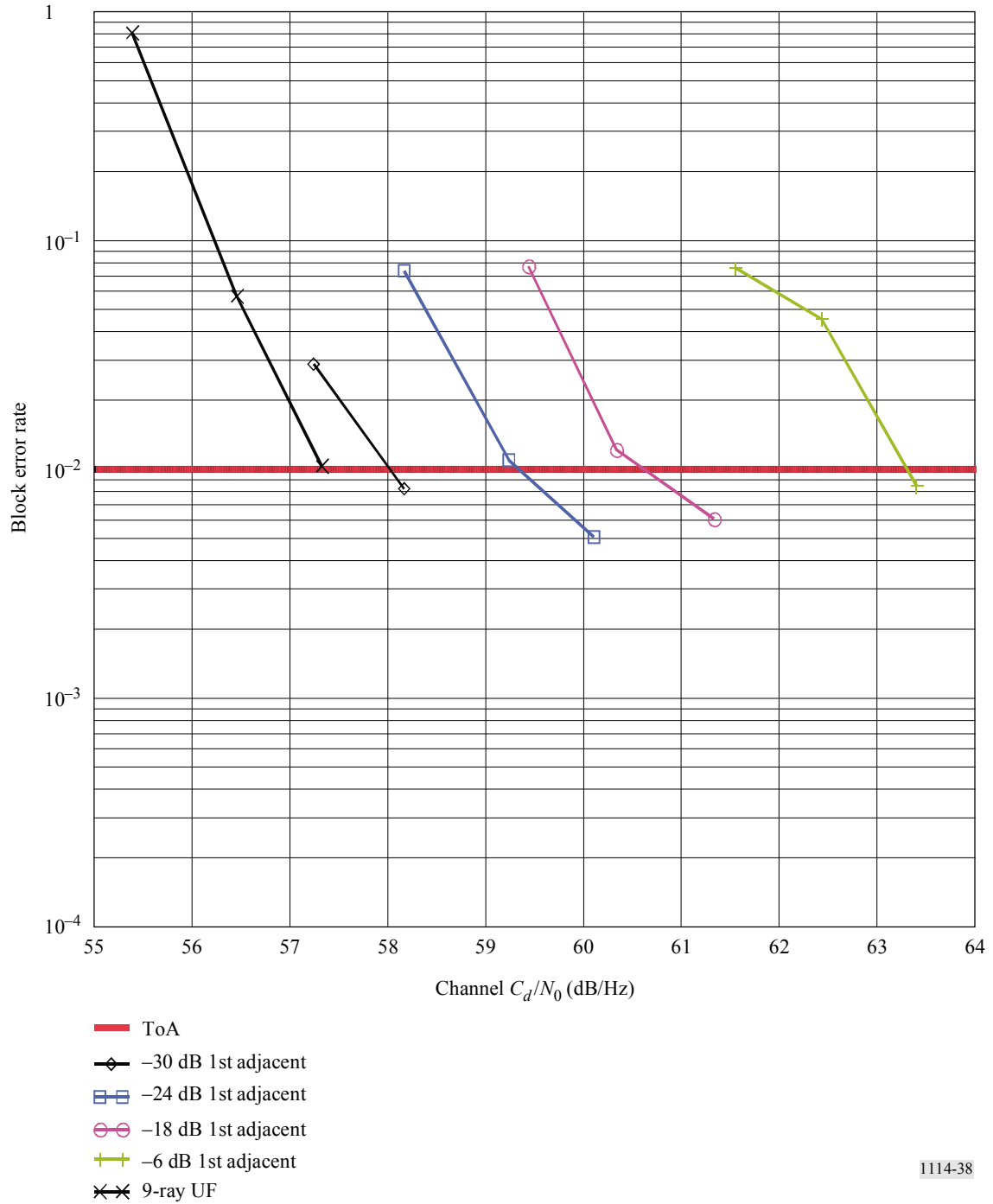

9.3.2 Single co-channel interference

In the United States of America, properly spaced Class B stations are protected to the 54 dBu contour from co-channel interference exceeding 34 dBu in 50% of the locations for 10% of the time. This means that 90% of the time at the 54 dBu contour the D/U exceeds 20 dB. Based on this information, a number of observations can be made regarding the character of co-channel interference. A hybrid co-channel interferer should have a minimal effect on the performance of the desired digital signal, since it will usually be at least 20 dB lower in power than the digital sidebands at the 54 dBu analogue protected contour. This has been verified via laboratory test. A -20 dB_{des} hybrid co-channel interferer was applied to the desired hybrid signal in an urban fast-fading environment. The block error rate results are shown in Fig. 38, and are summarized in Table 23. Fig. 39 indicates that adding a -20 dB_{des} hybrid co-channel interferer degrades performance by only about 1 dB. Fig. 38 also shows that, even if the level of the co-channel interferer were increased to -10 dB_{des}, the incremental degradation would be limited to less than 3 dB. Table 23 gives the subjective analogue audio evaluation, which indicates that, just prior to digital ToA, analogue audio quality is audibly degraded for a -20 dB_{des} co-channel interferer. For a -10 dB_{des} co-channel interferer, analogue audio quality is degraded beyond the point of failure before the digital audio even reaches its ToA.

9.3.3 Single second-adjacent interference

A hybrid IBOC second-adjacent interferer may have a slight effect on digital performance, since interference side lobes could spill into the desired digital sidebands. This effect has been quantified in laboratory tests. A single $+20$ dB hybrid second-adjacent interferer was applied to the desired hybrid signal in an urban fast-fading environment. The block error rate results are shown in Fig. 40, and are summarized in Table 23. Fig. 40 indicates that adding a $+20$ dB hybrid second-adjacent interferer degrades performance by about 2 dB. Table 23 gives the subjective analogue audio evaluation, which indicates that, just prior to digital ToA, analogue audio quality is audibly degraded.

9.4 Conclusions

The recordings indicate that, in all environments tested, at the point where the digital signal begins to degrade, the corresponding analogue audio itself exhibits audible degradation. This implies that analogue audio is degraded at signal levels where digital audio degradation is not yet perceptible. As a result, up to the point of digital ToA, the performance of the digital signal surpasses that of the existing analogue signal. And when the digital signal finally begins to exhibit degradation, the IBOC receiver will automatically change to its analogue signal. Therefore, the performance of the Digital System C is better than the performance of existing analogue FM service.

FIGURE 39
 Black error rate results of the hybrid system with an independently faded
 10-channel interferer

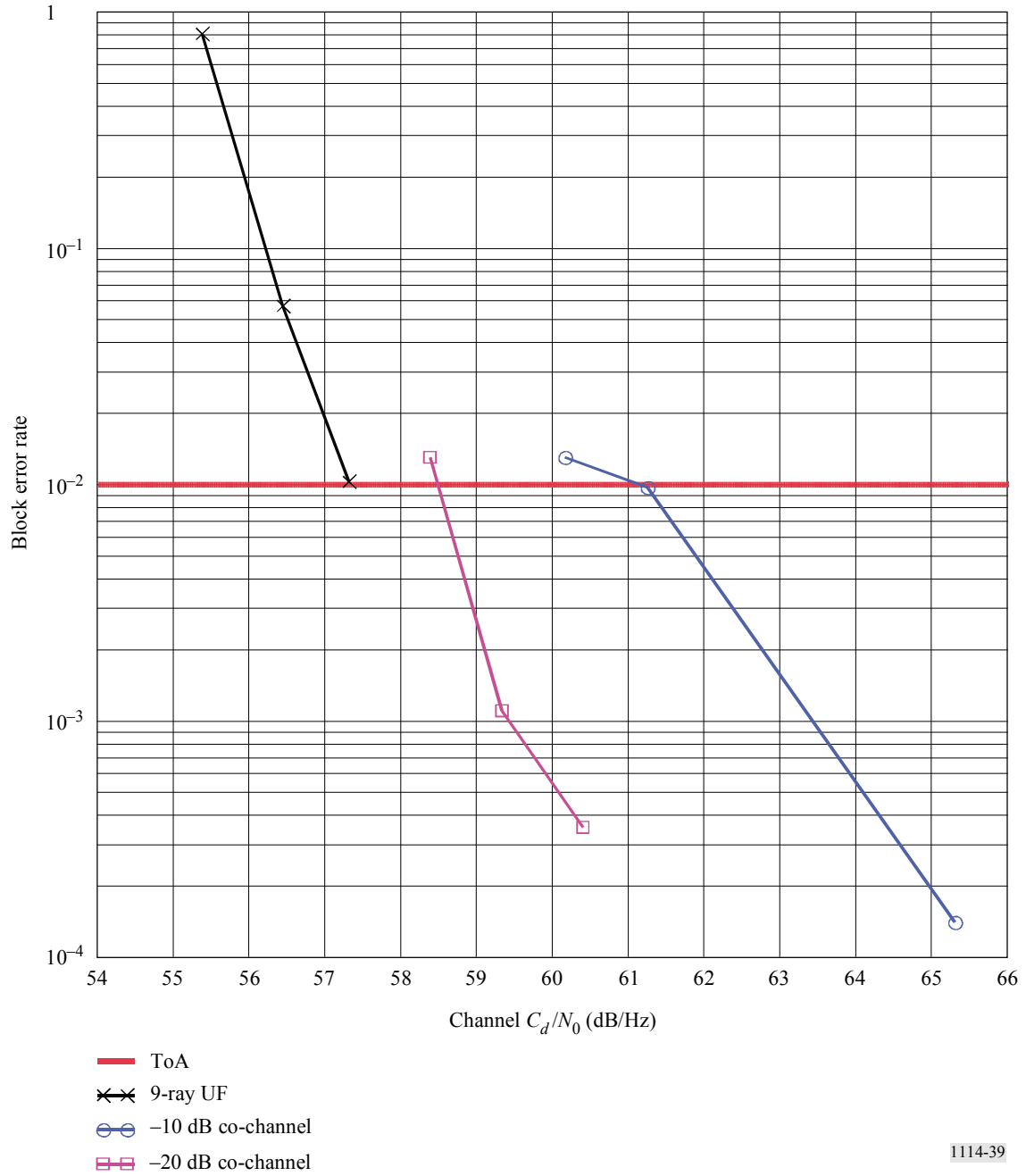
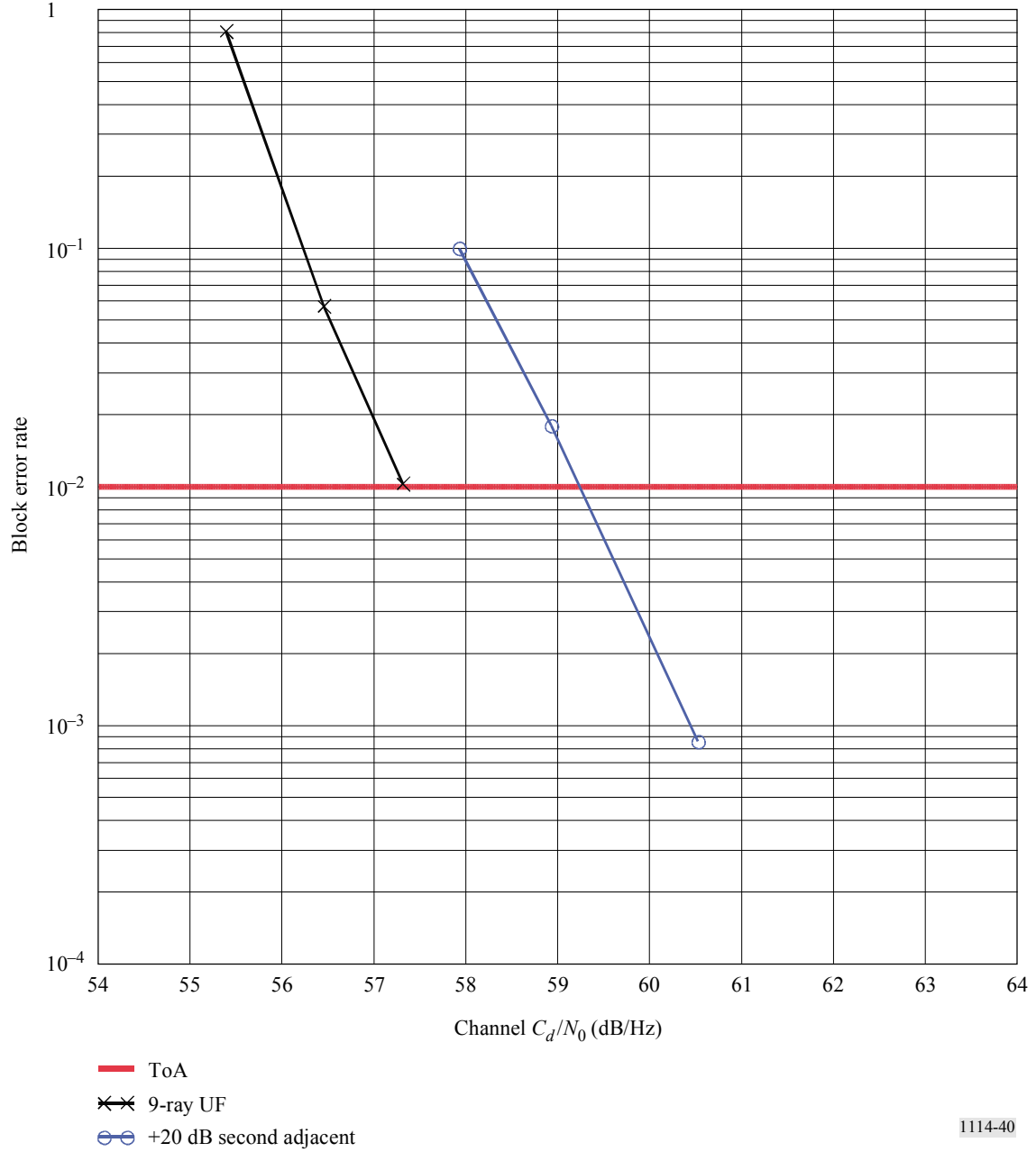

FIGURE 40
 Block error rate results of the hybrid system with an independently faded
 second-adjacent interferer



1114-40