

International Telecommunication Union

ITU-T Technical Report

TELECOMMUNICATION
STANDARDIZATION SECTOR
OF ITU

(02/2015)

HSTR-IPTV-GB

IPTV Green Book

ITU-T



ITU-T Technical Report HSTR-IPTV-GB

ITU IPTV Green Book

Summary

This Technical Report lists all ITU-T Recommendations relevant to Internet protocol television (IPTV). These ITU-T Recommendations have been grouped and assigned to different chapters. Each clause starts with the list of relevant Recommendations followed by their summaries.

Extended summaries have been drafted for a number of these Recommendations and inserted after extracted summaries. If, in the table of contents below, a Recommendation appears with its identifier and complete title, this means that an extended summary has been drafted and is inserted there.

Keywords

Audience measurement, audiovisual content delivery, functional architecture, internet protocol television, IPTV, metadata, multimedia application frameworks, quality of experience, requirements, security, signalling and control plane architecture, terminal devices, terms and definitions.

© ITU 2019

All rights reserved. No part of this publication may be reproduced, by any means whatsoever, without the prior written permission of ITU.

Table of Contents

	Page
1	Scope..... 1
2	References..... 1
3	Definitions 4
4	Abbreviations..... 4
5	Conventions 5
6	Evolution from Focus Group to Study Groups..... 6
6.1	ITU-T Focus Group on IPTV (FG IPTV) 6
6.2	The work in the IPTV Global Standards Initiative (IPTV-GSI) 6
7	Overview of IP content delivery..... 7
8	Architecture, requirements and use cases 7
8.1	ITU-T Y.1901: Requirements for the support of IPTV services..... 8
8.2	ITU-T Y.1910: IPTV functional architecture..... 10
8.3	ITU-T Y.1991: Terms and definitions for IPTV 20
8.4	ITU-T Y-series Suppl. 5: Supplement 5 to Y-series Recommendations ITU-T Y.1900-series, Supplement on IPTV service use cases 21
8.5	Other Recommendations 23
9	IPTV security (X-series)..... 25
10	IPTV terminal devices 26
10.1	ITU-T H.720: Overview of IPTV terminal devices and end systems 26
10.2	ITU-T H.721: IPTV terminal device: Basic model 29
10.3	ITU-T H.722: IPTV terminal device: Full-fledged model 31
10.4	ITU-T J.702: Enablement of current terminal devices for the support of IPTV services 34
10.5	ITU-T J.703: IPTV client control interface definition 36
10.6	ITU-T J.705: IPTV client provisioning, activation, configuration and management interface definition 39
11	IPTV middleware..... 40
12	IPTV application event handling (with big emphasis on AM)..... 40
12.1	ITU-T H.740: Application event handling for IPTV services..... 41
12.2	ITU-T H.741.0: IPTV application event handling: Overall aspects of audience measurement for IPTV services 43
12.3	ITU-T H.741.1: IPTV application event handling: Audience measurement operations for IPTV services 45
12.4	ITU-T H.741.2: IPTV application event handling: Data structures of audience measurement for IPTV services 51
12.5	ITU-T H.741.3: IPTV application event handling: Audience measurement for IPTV distributed content services..... 53
12.6	ITU-T H.741.4: IPTV application event handling: Transport mechanisms for audience measurement 55

	Page
12.7 Other Recommendations	57
13 IPTV metadata	57
13.1 ITU-T H.750: High-level specification of metadata for IPTV services	57
13.2 ITU-T H.751: common specification with IEC TC 100 on metadata for rights interoperability (or for "security")	59
14 IPTV multimedia application frameworks	60
14.1 ITU-T H.760: Overview of multimedia application frameworks for IPTV ...	60
14.2 ITU-T H.761: Nested context language (NCL) and Ginga-NCL for IPTV services	64
14.3 ITU-T H.762: Lightweight interactive multimedia environment (LIME) for IPTV services	66
14.4 ITU-T H.764: IPTV service enhanced script language (SESL)	68
14.5 Other Recommendations	71
15 IPTV service discovery up to consumption	72
15.1 ITU-T H.770: Mechanisms for service discovery and selection for IPTV services	72
15.2 Other Recommendations	76
16 Application of IPTV technology	76
16.1 ITU-T H.780: Digital signage: Service requirements and IPTV-based architecture	76
16.2 ITU-T H.810: Interoperability design guidelines for personal health systems	79

List of Tables

Table 8-1 – Differences in functional blocks for the three IPTV architecture approaches	15
Table 12-1 – Delivery mechanisms for each data structure (Table 1 of [ITU-T H.741.4])	55
Table 16-1 – Documents conforming to the CDG (Table 0-1 of [ITU-T H.810])	79

List of Figures

Figure 8-1 – IPTV domains (Figure 6-1 of [ITU-T Y.1910])	11
Figure 8-2 – IPTV architectural overview (Figure 9-1 of [ITU-T Y.1910])	12
Figure 8-3 – Reference points of NGN non-IMS IPTV architecture (Figure 11-1 of [ITU-T Y.1910])	15
Figure 8-4 – High level procedural flows for loosely coupled content-on-demand (Figure I.1 of [ITU-T Y.1910])	19
Figure 8-5 – Use case of linear TV with trick mode (Figure 6-3 of [ITU-T Y-Supp.5])	21
Figure 10-1 – Functional architecture block diagram of IPTV terminal device (Figure 7-1 of [ITU-T H.720])	27
Figure 10-2 – Examples of IPTV terminal device interfaces (Figure 8-1 of [ITU-T H.720])	28
Figure 10-3 – IPTV terminal software architecture – Overview (Figure 9-1 of [ITU-T H.720])	28

Figure 10-4 – Implementation example of the IPTV terminal functions (Figure II.1 of [ITU-T H.721])	30
Figure 10-5 – Full-fledged IPTV TD functional architecture (Figure 8-1 of [ITU-T H.722])	32
Figure 10-6 – Full-fledged IPTV TD software architecture (Figure 10-1 of [ITU-T H.722])	33
Figure 10-7 – Full-fledged IPTV TD interfaces (Figure 11-1 of [ITU-T H.722]).....	33
Figure 10-8 – IPTV network reference points (Figure 1 of [ITU-T J.703]).....	37
Figure 12-1 – Audience measurement components within IPTV architecture (Figure 1 of [ITU-T H.741.0]).....	44
Figure 12-2 – Information interfaces associated with the operation of AM (Figure 2 of [ITU-T H.741.0]).....	44
Figure 12-3 – Sample values and events are measured within the effective measurement period (Figure 14 of [ITU-T H.741.1]).....	47
Figure 13-1 – IPTV metadata service overview (Figure 6-1 of [ITU-T H.750]).....	57
Figure 14-1 – Example of an NCL Multi-device application [ITU-T H.761]	64
Figure 14-2 – Ginga architecture (Figure 3.1 of [ITU-T H.761]).....	65
Figure 14-3 – LIME document rendered on an IPTV terminal device	66
Figure 14-4 – Example of IPTV terminal device functions [ITU-T H.721].....	67
Figure 14-5 – IPTV SESL implemented by IPTV terminal device	69
Figure 14-6 – Working flow of user interaction implemented with IPTV SESL.....	69
Figure 15-1 – From entry point data to service/content acquisition (Figure 5-2 of [ITU-T H.770]).....	72
Figure 16-1 – Overview of digital signage architecture (based on [ITU-T Y.1910]).....	76
Figure 16-2 – Continua E2E reference architecture (Figure 0-1 of [ITU-T H.810]).....	79

ITU-T Technical Report HSTR-IPTV-GB

ITU IPTV Green Book

1 Scope

This Technical Report lists all ITU-T Recommendations relevant to Internet protocol television (IPTV). They have been grouped and assigned to different chapters. Each clause starts with the list of relevant recommendations followed by their summaries.

Extended summaries have been drafted for a number of Recommendations and inserted after extracted summaries. If, in the table of contents below, a recommendation appears with its identifier and complete title, this means that an extended summary has been drafted and is inserted there.

2 References

- [ITU-T G.1080] Recommendation ITU-T G.1080 (2008), *Quality of experience requirements for IPTV services.*
- [ITU-T G.1081] Recommendation ITU-T G.1081 (2008), *Performance monitoring points for IPTV.*
- [ITU-T G.1082] Recommendation ITU-T G.1082 (2009), *Measurement-based methods for improving the robustness of IPTV performance.*
- [ITU-T H.262] Recommendation ITU-T H.262 (2012), *Information technology – Generic coding of moving pictures and associated audio information: Video.*
- [ITU-T H.264] Recommendation ITU-T H.264 (2017), *Advanced video coding for generic audiovisual services.*
- [ITU-T H.622.1] Recommendation ITU-T H.622.1 (2008), *Architecture and functional requirements for home networks supporting IPTV services.*
- [ITU-T H.701] Recommendation ITU-T H.701 (2009), *Content delivery error recovery for IPTV services.*
- [ITU-T H.720] Recommendation ITU-T H.720 (2008), *Overview of IPTV terminal devices and end systems.*
- [ITU-T H.721] Recommendation ITU-T H.721 (2015), *IPTV terminal devices: Basic model.*
- [ITU-T H.722] Recommendation ITU-T H.722 (2014), *IPTV terminal device: Full-fledged model.*
- [ITU-T H.730] Recommendation ITU-T H.730 (2012), *Web-based terminal middleware for IPTV services.*
- [ITU-T H.740] Recommendation ITU-T H.740 (2010), *Application event handling for IPTV services.*
- [ITU-T H.741.0] Recommendation ITU-T H.741.0 (2012), *IPTV application event handling: Overall aspects of audience measurement for IPTV services.*
- [ITU-T H.741.1] Recommendation ITU-T H.741.1 (2012), *IPTV application event handling: Audience measurement operations for IPTV services.*
- [ITU-T H.741.2] Recommendation ITU-T H.741.2 (2012), *IPTV application event handling: Data structures of audience measurement for IPTV services.*

- [ITU-T H.741.3] Recommendation ITU-T H.741.3 (2012), *IPTV application event handling: Audience measurement for IPTV distributed content services.*
- [ITU-T H.741.4] Recommendation ITU-T H.741.4 (2012), *IPTV application event handling: Transport mechanisms for audience measurement.*
- [ITU-T H.750] Recommendation ITU-T H.750 (2008), *High-level specification of metadata for IPTV services.*
- [ITU-T H.751] Recommendation ITU-T H.751 (2013), *Metadata for rights information interoperability in IPTV services.*
- [ITU-T H.760] Recommendation ITU-T H.760 (2009), *Overview of multimedia application frameworks for IPTV services.*
- [ITU-T H.761] Recommendation ITU-T H.761 (2014), *Nested context language (NCL) and Ginga-NCL.*
- [ITU-T H.762] Recommendation ITU-T H.762 (2011), *Lightweight interactive multimedia environment (LIME) for IPTV services.*
- [ITU-T H.763.1] Recommendation ITU-T H.763.1 (2010), *Cascading style sheets for IPTV services.*
- [ITU-T H.764] Recommendation ITU-T H.764 (2012), *IPTV services enhanced script language.*
- [ITU-T H.765] Recommendation ITU-T H.765 (2015), *Packaged IPTV application (widget) service.*
- [ITU-T H.770] Recommendation ITU-T H.770 (2015), *Mechanisms for service discovery and selection for IPTV services.*
- [ITU-T H.771] Recommendation ITU-T H.771 (2011), *SIP-based discovery of IPTV services.*
- [ITU-T H.780] Recommendation ITU-T H.780 (2012), *Digital signage: Service requirements and IPTV-based architecture.*
- [ITU-T H.810] Recommendation ITU-T H.810 (2017), *Interoperability design guidelines for personal connected health systems: Introduction.*
- [ITU-T J.201] Recommendation ITU-T J.201 (2014), *Harmonization of declarative content format for interactive television applications.*
- [ITU-T J.293] Recommendation ITU-T J.293 (2008), *Component definition and interface specification for the next generation set-top box.*
- [ITU-T J.700] Recommendation ITU-T J.700 (2009), *IPTV service requirements and framework for secondary distribution.*
- [ITU-T J.701] Recommendation ITU-T J.701 (2008), *Broadcast-centric IPTV terminal middleware.*
- [ITU-T J.702] Recommendation ITU-T J.702 (2008), *Enablement of current terminal devices for the support of IPTV services.*
- [ITU-T J.703] Recommendation ITU-T J.703 (2010), *IPTV client control interface definition.*
- [ITU-T J.704] Recommendation ITU-T J.704 (2009), *Functional requirements of the service provider interface for television primary and secondary distribution and associated interactive services.*
- [ITU-T J.705] Recommendation ITU-T J.705 (2011), *IPTV client provisioning, activation, configuration and management interface definition.*

- [ITU-T M.60] Recommendation ITU-T M.60 (1993), *Maintenance terminology and definitions*.
- [ITU-T M.1400] Recommendation ITU-T M.1400 (2015), *Designations for interconnections among operators' networks*.
- [ITU-T M.2301] Recommendation ITU-T M.2301 (2002), *Performance objectives and procedures for provisioning and maintenance of IP-based networks*.
- [ITU T M.3050.1] Recommendation ITU-T M.3050.1 (2007), *Enhanced Telecom Operations Map (eTOM) – The business process framework*.
- [ITU-T P.10] Recommendation ITU-T P.10 (2017), *Vocabulary for performance, quality of service and quality of experience*.
- [ITU-T Q.1706] Recommendation ITU-T Q.1706 (2006), *Mobility management requirements for NGN*.
- [ITU-T Q.1741.3] Recommendation ITU-T Q.1741.3 (2003), *IMT-2000 references to release 5 of GSM evolved UMTS core network*.
- [ITU-T Q.3040] Recommendation ITU-T Q.3040 (2010), *Signalling architecture for IPTV control plane*.
- [ITU-T T.170] Recommendation ITU-T T.170 (1998), *Framework of the T.170-Series of Recommendations*.
- [ITU-T T.172] Recommendation ITU-T T.172 (1998), *MHEG-5 – Support for base-level interactive applications*.
- [ITU-T T.175] Recommendation ITU-T T.175 (1998), *Application programming interface (API) for MHEG-5*.
- [ITU-T X.509] Recommendation ITU-T X.509 (2016), *Information technology – Open Systems Interconnection – The Directory: Public-key and attribute certificate frameworks*.
- [ITU-T X.800] Recommendation ITU-T X.800 (1991), *Security architecture for Open Systems Interconnection for CCITT applications*.
- [ITU-T X.1191] Recommendation ITU-T X.1191 (2009), *Functional requirements and architecture for IPTV security aspects*.
- [ITU-T X.1192] Recommendation ITU-T X.1192 (2011), *Functional requirements and mechanisms for the secure transcoding of IPTV*.
- [ITU-T X.1193] Recommendation ITU-T X.1193 (2011), *Key management framework for secure internet protocol television (IPTV) services*.
- [ITU-T X.1194] Recommendation ITU-T X.1194 (2012), *Algorithm selection scheme for service and content protection descrambling*.
- [ITU-T X.1195] Recommendation ITU-T X.1195 (2011), *Service and content protection interoperability scheme*.
- [ITU-T X.1196] Recommendation ITU-T X.1196 (2012), *Framework for the downloadable service and content protection system in the mobile Internet Protocol television environment*.
- [ITU-T X.1197] Recommendation ITU-T X.1197 (2012), *Guidelines on criteria for selecting cryptographic algorithms for IPTV service and content protection*.
- [ITU-T X.1198] Recommendation ITU-T X.1198 (2013), *Virtual machine-based security platform for renewable IPTV service and content protection*.

- [ITU-T X.1303] Recommendation ITU-T X.1303 (2007), *Common alerting protocol (CAP 1.1)*.
- [ITU-T Y.101] Recommendation ITU-T Y.101 (2000), *Global Information Infrastructure terminology: Terms and definitions*.
- [ITU-T Y.1901] Recommendation ITU-T Y.1901 (2009), *Requirements for the support of IPTV services*.
- [ITU-T Y.1902] Recommendation ITU-T Y.1902 (2011), *Framework for multicast-based IPTV content delivery*.
- [ITU-T Y.1910] Recommendation ITU-T Y.1910 (2008), *IPTV functional architecture*.
- [ITU-T Y.1911] Recommendation ITU-T Y.1911 (2010), *IPTV services and nomadism: Scenarios and functional architecture for unicast delivery*.
- [ITU-T Y.1920] Recommendation ITU-T Y.1920 (2012), *Guidelines for the use of traffic management mechanisms in support of IPTV services*.
- [ITU-T Y.1991] Recommendation ITU-T Y.1991 (2010), *Terms and definitions for IPTV*.
- [ITU T Y.2012] Recommendation ITU-T Y.2012 (2010), *Functional requirements and architecture of next generation networks*.
- [ITU-T Y-Sup.5] Supplement 5 to Y-series Recommendations, ITU-T Y.1900-series (2008), *Supplement on IPTV service use cases*.
- [ITU-T Y-Sup.16] Supplement 16 to Y-series Recommendations, ITU-T Y.1900-series (2012), *Supplement on guidelines on deployment of IP multicast for IPTV content delivery*.
- [ITU-T Y-Sup.20] Supplement 20 to Y-series Recommendations, ITU-T Y.1900-series (2012), *Supplement on scenarios and use cases of mobile IPTV*.

3 Definitions

None.

4 Abbreviations

ACAP	Advanced Common Application Platform
AMF	Audience Measurement Functions
ARQ	Automatic Repeat Query
ASS	Algorithm Selection Scheme
CDER	Content Delivery Error Recovery
CD&LCF	Content Distribution and Location Control Functions
CD&SF	Content Delivery and Storage Functions
CDF	Content Delivery Function
DDL	Description Definition Language
DNGF	Delivery Network Gateway Functions
ECG	Electronic Content Guide
FEC	Forward Error Correction
FUMO	Firmware Update Management Object
HFC	Hybrid Fiber/Coaxial

HFS	Health & Fitness Service
HIS	Healthcare Information System
IGMP	Internet Group Management Protocol
IMS	IP Multimedia Subsystem
ITF	IPTV Terminal Function
IPTV	Internet Protocol Television
LIME	Lightweight Interactive Multimedia Environment
NACF	Network Attachment Control Functions
NAT	Network Address Translation
NCL	Nested Context Language
NGN	Next Generation Network
NVoD	Near VoD
OAM&P	Operations, Administration, Maintenance and Provisioning
OCAP	Open Cable Application Platform
OSS	Operations Support Systems
PHD	Personal Health Devices
PHG	Personal Health Gateway
PVR	Personal Video Recorder
QoE	Quality of Experience
QoS	Quality of Service
RACF	Resource and Admission Control Functions
RII	Rights Information Interoperability
SADS	Service and Application Discovery and Selection
SCF	Service Control Function
SCP	Service and Content Protection
SESL	Service Enhanced Script Language
SHE	Super Head End
SVG	Scalable Vector Graphics
TTS	Time-stamped Transport Stream
VGA	Video Graphic Array
VHO	Video Hub Office
VoD	Video on Demand
VSO	Video Serving Office
WBTM	Web-based Terminal Middleware
WTVML	Worldwide TV Markup Language

5 Conventions

None.

6 Evolution from Focus Group to Study Groups

Work on IP-based television (IPTV) started to take shape with a consultation meeting of the Telecommunication Standardization Bureau (TSB) Director with industry and government partners held in Geneva, 4-6 April 2006. There was a clear consensus that standardization work was quickly needed. Out of that meeting, it was decided that a short-term analysis and early development of architecture and framework specifications should be done under a Focus Group under the responsibility of ITU-T Study Group 13. The ITU-T Focus Group on IPTV (<https://itu.int/en/ITU-T/focusgroups/iptv>) operated from April 2006 until January 2008. The Joint Coordination Activity on IPTV (JCA-IPTV) was created to ensure harmonious progress of the standardization work. The deliverables of the Focus Group were provided back to ITU-T study groups according to their areas of expertise and work continued as a coordinated effort under the IPTV Global Standards Initiative (IPTV-GSI), as of January 2008. In 2012, in view of the conclusion of the architectural work and as the development of new IPTV specifications were in the multimedia systems and applications, the responsibility for coordinating the IPTV work was transferred to [ITU-T SG16].

6.1 ITU-T Focus Group on IPTV (FG IPTV)

The mission of FG IPTV¹ was to coordinate and promote the development of global IPTV standards taking into account the existing work of the ITU study groups as well as that of the Standards Developing Organizations (SDOs), Fora and Consortia.

The FG operated from April 2006 until January 2008 and produced a set of deliverables documented in the ITU-T FG IPTV Proceedings². The following areas were addressed:

- Architecture, requirements and service scenarios.
- QoS and performance aspects.
- Service security and content protection.
- IPTV network control, multicast frameworks and related protocols.
- End systems, terminal devices and interoperability aspects.
- Middleware, application and content platforms.
- IPTV vocabulary of terms.

These deliverables contained early drafts that could be developed into various specifications: ITU-T Recommendations, Technical Papers and Supplements.

The ITU-T standardization work continued under the IPTV Global Standards Initiative on IPTV ([IPTV-GSI](https://itu.int/en/ITU-T/focusgroups/iptv)).

6.2 The work in the IPTV Global Standards Initiative (IPTV-GSI)

In accordance with decisions taken at the April 2007 meeting of Study Group 13 the work of the [IPTV Focus Group](https://itu.int/en/ITU-T/focusgroups/iptv) has ended and its documents have been transferred to the appropriate study groups via Study Group 13 for the development of draft Recommendations based on the focus group outputs as appropriate and for the continuation of the work on the unfinished topics.

Based on proposals developed by the chairman of Study Group 13 and the chairman of the IPTV Focus Group and endorsed by TSAG the ongoing work will be carried out under the umbrella of a Global Standards Initiative (the IPTV-GSI). The ongoing work on the outputs from the IPTV Focus Group will be done by the study groups (based on allocations developed by the IPTV-JCA) with coordinated planning of the activities and through co-located meetings of the involved rapporteur groups to progress certain areas of the work as appropriate.

¹ <https://www.itu.int/en/ITU-T/focusgroups/iptv>, consulted 2019-02-07.

² ITU-T IPTV Focus Group Proceedings (2008), <http://itu.int/pub/T-PROC-IPTVFG-2008>.

As part of the establishment of the IPTV-GSI the membership of the IPTV-JCA is being extended to include other standards organizations involved with the ITU-T in the IPTV work stemming from the results of the IPTV Focus Group. An [IPTV-GSI Technical and Strategic Review \(TSR\)](#) process was also set up. This will operate at every IPTV-GSI event (Study Group meetings and collocated rapporteur meetings) and will bring to the IPTV-JCA any issues requiring guidance or recommendations for action, e.g., concerning work allocation.

TSAG, at its meeting of July 2012, endorsed the SG 13's request to hand over the parent group responsibility for IPTV-JCA to ITU-T SG 16, which continued to lead the IPTV standardization work in ITU-T. The IPTV-JCA and IPTV-GSI were discontinued at the end of the 2013-2016 study period.

7 Overview of IP content delivery

This topic will be addressed in future versions of this Technical Report.

8 Architecture, requirements and use cases

The Y-Series Recommendations cover IPTV architecture, requirements and use cases. Quality related aspects are covered in the G-Series Recommendations, while some other related aspects are found in the H-, J- and Q-Series Recommendations:

- [ITU-T Y.1901], *Requirements for the support of IPTV services.*
- [ITU-T Y.1902], *Framework for multicast-based IPTV content delivery.*
- [ITU-T Y.1910], *IPTV functional architecture.*
- [ITU-T Y.1911], *IPTV services and nomadism: Scenarios and functional architecture for unicast delivery.*
- [ITU-T Y.1920], *Guidelines for the use of traffic management mechanisms in support of IPTV services.*
- [ITU-T Y.1991], *Terms and definitions for IPTV.*
- [ITU-T Y-Sup.5], *Supplement on IPTV service use cases.*
- [ITU-T Y-Sup.16], *Guidelines on deployment of IP multicast for IPTV content delivery.*
- [ITU-T Y-Sup.20], *Scenarios and use cases of mobile IPTV.*
- [ITU-T G.1080], *Quality of experience requirements for IPTV services.*
- [ITU-T G.1081], *Performance monitoring points for IPTV.*
- [ITU-T G.1082], *Measurement-based methods for improving the robustness of IPTV performance.*
- [ITU-T H.622.1], *Architecture and functional requirements for home network supporting IPTV services.*
- [ITU-T J.700], *IPTV service requirements and framework for secondary distribution.*
- [ITU-T Q.3040], *Signalling and control plane architecture for IPTV.*
- [ITU-T H.701], *Content delivery error recovery for IPTV services.*

The following Recommendation provides specifications for content delivery within the context of DOCSYS systems:

- [ITU-T J.704], *Functional requirements of the service provider interface for television primary and secondary distribution and associated interactive services.*

8.1 ITU-T Y.1901: Requirements for the support of IPTV services

Extracted summary

Recommendation ITU-T Y.1901 specifies the high-level requirements to support IPTV services. These include IPTV requirements for service offering, network aspects, QoS and QoE, service and content protection, end system, middleware and content.

Extended summary

For each issue requirements are listed in three sections, first the requirements which are to be strictly followed and from which no deviation is permitted, second the requirements which are recommended but which are not absolutely required and third optional requirements.

Requirements are listed for different issues and features of the IPTV architecture, namely:

- General aspects (e.g., multiple content resolutions and multiple content aspects ratios or two-way communication between the end-user and the service provider)
 - Service offering (e.g., ability to support interactive services, communications services and information services or ability for the service provider to prevent the sending of bulk unsolicited content to end-users).
 - Accounting and charging (e.g., ability for the service provider to authenticate, authorize and charge the subscriber or capabilities for transferring settlement information between service providers).
 - Service consumption (e.g., mechanisms so that the end-user can filter unwanted contents or ability for the end-user to turn on and off the audio, the subtitles, captioning, etc.).
 - Miscellaneous (e.g., means to present the IPTV terminal function (ITF) with the time of day reference or mechanisms for the service provider to operate, administer, maintain and provision IPTV devices).
- Quality of service (QoS) and performance aspects (e.g., framework that identifies the components and measurement points for quality of service measurement or capabilities for management of capacity on service and network elements)
 - Quality of experience (QoE) (e.g., mechanisms for supporting appropriate resiliency in the service provider infrastructure to maintain high QoE or means to provide channel changing times with sufficient QoE).
 - Traffic management (e.g., traffic management mechanisms for the differential treatment of IPTV traffic or mechanisms for assigning IPTV traffic priorities).
- Security aspects including service and content protection
 - General IPTV security (e.g., content protection or service and content protection of end-user shared content).
 - Service and content protection (e.g., association of content with protection and content management metadata to permit the expression of its rights of usage or protection of content transferred over multicast and/or over unicast streams).
 - Service security (e.g., authorization and authentication of end-user or rights management independent of specific content formats or specifications).
 - Network security (e.g., provision of security measures to block illegal or unwanted traffic or protection against attacks on multicast capabilities).
 - IPTV terminal device security (e.g., means to authenticate IPTV terminal devices or physical tampering resistance for IPTV terminal devices).

- Subscriber security (e.g., user privacy protection or support to allow a subscriber to set an access control mechanism (e.g., a password) in order to restrict access to content and/or services).
- Network related aspects (e.g., ability of both multicasting and unicasting transmission schemes or content delivery in several yet optional versions to be selected according to the capabilities of the IPTV terminal device)
 - Network (e.g., mechanism to appropriately distinguish different forms of traffic or mechanism for network address translation (NAT) traversal).
 - Multicast distribution (e.g., multicast means of communication to all end-users or mechanisms that allow IPTV services to be distributed to specific groups of end-users).
 - Mobility aspects (e.g., mechanisms for exchanging subscriber-related information between the visited network and the home IPTV service provider or mechanisms for discovering and selecting IPTV services provided by the home IPTV service provider for roaming users).
 - Interworking between IPTV and PSTN/ISDN (e.g., network facilities for processing PSTN/ISDN incoming/outgoing calls or voice encoding/decoding capabilities, as per PSTN/ISDN incoming/outgoing calls).
- End systems and interoperability aspects
 - End-user aspects on IPTV services (e.g., end-user ability to choose and select one subtitle or closed caption flow from several or mechanism for end-users to make the content they produced/created available to other end-users). Requirements are also listed for end-user aspects on linear TV, on linear TV with trick mode, on time-shift TV, on VoD, on push VoD, on Personal Video Recorder (PVR) service and on service information.
 - IPTV terminal device (e.g., decoding of at least one video and one audio format or system start-up and initialization function). Requirements are further listed for interfaces, provisioning, PVR control, security and authentication functions, SCP functions, end-user interaction functions, terminal management, system resource management functions, Internet access functions and aspects related to ITF.
 - Remote management (e.g., ability for the service provider to retrieve device information such as manufacturer name, software version, firmware version and supported profiles or ability for the service provider to retrieve statistical information of usage).
 - Home network (e.g., IP filtering functions in the delivery network gateway functions (DNGF) in order to prevent selected local multicast traffic on the home network side from appearing on the network side or mechanisms for transport of time of day to the home network).
- Middleware, application and content aspects
 - General (e.g., ability to search for available content or capability of receiving and processing content metadata available from content providers).
 - Middleware (e.g., terminal device start-up and initialization function or support for play, pause and stop functions).
 - Metadata (e.g., description of accessibility features, including language or extensible content description). Requirements are further detailed for metadata structure, metadata for service navigation, metadata for package service, metadata provisioning and metadata delivery.

- Content:
 - Content delivery (e.g., mechanisms for content downloading or both a pull and a push method of content delivery).
 - Video (e.g., wide range of temporal sampling standards, bit-rates and picture resolutions or accurate lip-synchronisation).
 - Audio (e.g., audio depth equivalent to existing broadcasts or mechanisms for single (mono), dual (stereo) and multichannel (at least 5.1 surround sound) audio transmission).
 - Content replay (e.g., playback of recorded content in the same way as typical DVD players or mechanisms to assist in locating random access points in the media stream).
 - Content provisioning and management (e.g., mechanism for the service provider to ingest and store VoD content or transfer interface between content provider and service provider independent of content formats).
- Service navigation (e.g., content selection through an electronic content guide or service selection through an electronic service guide).
- Service/content discovery and selection (e.g., capabilities for service discovery or capabilities for the end-user to select the content to be delivered).
- Returned data (e.g., acquisition of demographic data from the IPTV terminal device).

– Public interest

- Accessibility (e.g., mechanisms to support subtitles and captions or ability to select and receive two (related) video sources simultaneously).
- Emergency telecommunications and regulatory information services (e.g., emergency alert service, where required, by regulation or law of the country or routing of emergency telecommunications from the end-user to appropriate emergency response service).
- Provider selection and number portability (e.g., support a mechanism for end-users to select IPTV network providers, IPTV service providers and IPTV content providers according to their preferences or number portability capabilities).

Appendix I concerns "Public interest cross-reference". Cross-references to individual requirements in the main body are given for "Public interest" requirements.

8.2 ITU-T Y.1910: IPTV functional architecture

Extracted summary

Recommendation ITU-T Y.1910 describes the IPTV functional architecture intended to support IPTV services based on the IPTV service requirements and definitions. Starting from a basic description of IPTV roles and services, a high-level IPTV functional model is outlined. This model is then developed into a set of functional architectures that support next generation network (NGN) and non-NGN transport networks, as well as operation modes with or without IP multimedia subsystem (IMS).

Extended summary

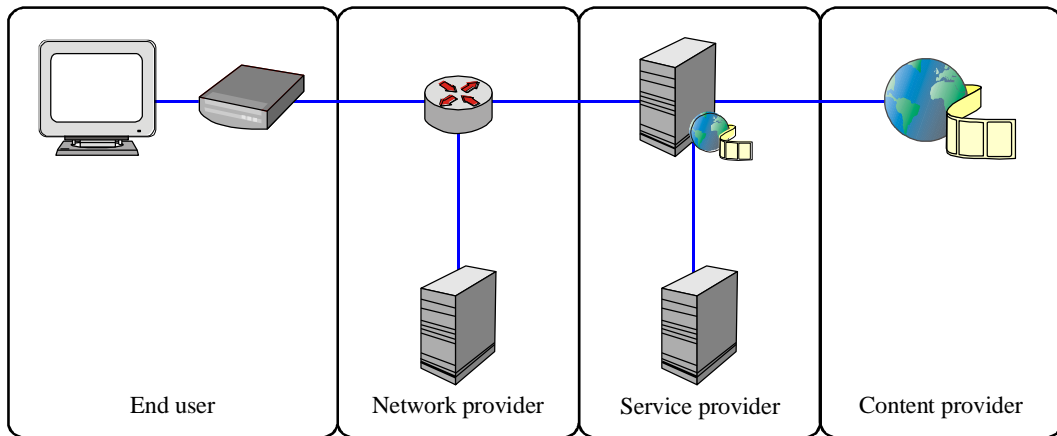

Figure 8-1 – IPTV domains (Figure 6-1 of [ITU-T Y.1910])

Figure 8-1 shows the main domains that are involved in the provision of an IPTV service.

This Recommendation identifies three IPTV architecture approaches that enable service providers to deliver IPTV services:

- 1) "Non-NGN IPTV functional architecture" (non-NGN IPTV): The non-NGN IPTV architecture is based on existing network components and protocols/interfaces.
- 2) "NGN-based non-IMS IPTV functional architecture" (NGN non-IMS IPTV): The NGN non-IMS IPTV architecture utilizes components of the NGN framework reference architecture as identified in [ITU-T Y.2012] to support the provision of IPTV services, in conjunction with other NGN services if required.
- 3) "NGN IMS-based IPTV functional architecture" (NGN-IMS IPTV): The NGN IMS-based IPTV architecture utilizes components of the NGN architecture including the IMS component to support the provision of IPTV services in conjunction with other IMS services if required.

Architectural differences between the three IPTV functional architectures are outlined, especially for service control functions.

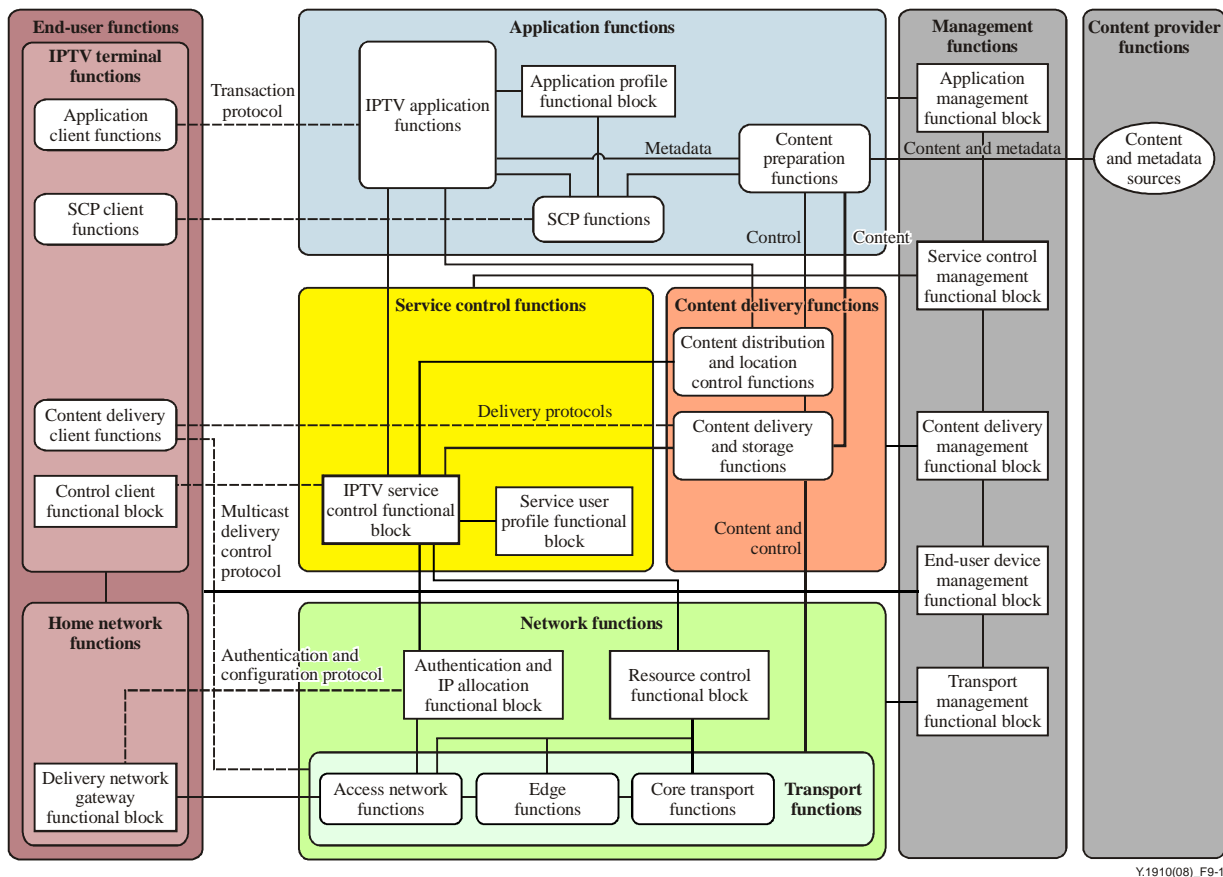

Y.1910(08)_F9-1

Figure 8-2 – IPTV architectural overview (Figure 9-1 of [ITU-T Y.1910])

Figure 8-2 provides an overview of the IPTV functional architecture.

The highest level in the IPTV functional overview is the level of functional groups as follows:

- End-user functions: to perform mediation between the end user and the IPTV infrastructure.
- Application functions to enable the end-user functions to select and purchase or rent a content item.
- Service control functions (SCF): to request and release network and service resources required to support the IPTV services.
- Content delivery functions (CDF): to receive content from the application functions, store, process and deliver it to the end-user functions using the capabilities of the network functions, under control of the service control functions.
- Network functions: to provide IP layer connectivity between the IPTV service components and the end-user functions.
- Management functions: to perform overall system management (i.e., operations, administration, maintenance and provisioning (OAM&P)).
- Content provider functions: to provide (i.e., sell, rent or give free usage permission) content or content assets.

Each functional group is further decomposed in smaller functional groups or functional blocks as illustrated on Figure 8-2.

The end-user functions are comprised of:

- IPTV terminal functions: to collect control commands from the end user, to interact with the application functions to obtain service information (e.g., EPG), content licenses and keys for decryption, to interact with the service control and content delivery functions to receive the IPTV services and also provide the capability for content reception, decryption and decoding
 - Application client functions: to exchange information with the IPTV application functions to support IPTV services and other interactive applications.
 - Service and content protection (SCP) client functions: to provide service protection and content protection, to verify the usage rights and decrypt and optionally watermark the content.
 - Content delivery client functions: to receive and control the delivery of the content from the content delivery and storage functions (CD&SF).
 - Control client functional block: to initiate service requests to the IPTV service control functional block in order to prepare for the connection to the content delivery functions.
- Home network functions
 - Delivery network gateway functional block: to provides IP connectivity between the external network (i.e., external to the home network) and the IPTV terminal device, to manage IP connectivity, to obtain IP addresses and configurations for the home network functions and IPTV terminal devices.

The application functions are comprised of:

- IPTV application functions: to enable the IPTV terminal functions to select and purchase content.
- Application profile functional block: to include end-user settings (capabilities of IPTV terminal devices), global settings (e.g., language preference), linear TV settings, list of subscribed linear TV service packages, VoD settings (e.g., parental control level), personal video recorder (PVR), information related to actions taken by the user while accessing services.
- Content preparation functions: to control the preparation and aggregation of the contents, metadata and EPG data, as received from the content provider functions.
- Service and content protection (SCP) functions: to control access to services and protect services using methods such as encryption, to control access to contents and to protect them using methods such as encryption.

The service control functions are comprised of:

- IPTV service control functional block: to handle service initiation, modification and termination requests, perform service access control, establish and maintain the network and system resources required to support the IPTV services requested by the IPTV terminal functions.
- Service user profile functional block: to store end-user service profile (i.e., IPTV services subscribed to), subscriber-related data (e.g., who pays the incurred charges), end-user location data, end-user presence status (e.g., online/offline), to perform basic data management and maintenance functions.

Content delivery functions (CDF). They are used to perform cache and storage functionalities and deliver the content according to the request from the end-user functions. They are comprised of:

- Content distribution and location control functions (CD&LCF): to include at least interactions with the IPTV service control functional block, control of content distribution from the content preparation functions to the content delivery and storage functions.

- Content delivery and storage functions: to store and cache content, process it under the control of content preparation functions and distribute it among instances of content delivery and storage functions based on the policy of content distribution and location control functions.

Network functions. They are shared across all services delivered by IP to end-user functions, they provide the IP layer connectivity to support IPTV services. They are comprised of:

- Authentication and IP allocation functional block: for authentication of the delivery network gateway functional block which connects to the network functions, as well as allocation of IP addresses to the delivery network gateway functional block and optionally to the IPTV terminal functions.
- Resource control functional block: to provide control of the resources that have been allocated for the delivery of the IPTV services through the access network, edge and core transport functions.
- Transport functions: to provide IP layer connectivity between the content delivery functions and the end-user functions:
 - Access network functions: to aggregate and forward IPTV traffic sent by the end-user functions into the edge of the core network, to forward IPTV traffic from the edge of the core network towards the end-user functions.
 - Edge functions: to forward IPTV traffic aggregated by the access network functions towards the core network and to forward the IPTV traffic from the core network to the access network functions.
 - Core transport functions: to forward IPTV traffic throughout the core network.

Management functions. They are used to handle overall system status monitoring and configuration. They include functional blocks for application management, content delivery management, service control management, end-user device management and transport management.

Content provider functions. They are used to provide the content and associated metadata to content preparation functions. They include:

- Content and metadata sources: to include content protection rights sources, content sources and metadata sources for the IPTV services.

Differences in functional blocks for the three IPTV architecture approaches are shown on Table 8-1.

Interworking between these various architectures can be achieved by means of interworking functions or interworking gateways in between two different IPTV architectures.

Another form of interworking is the third-party application interworking in which a third-party application gateway functional block added to the application functions functional block provides a controlled interface to enable outside third party application functions to utilize the IPTV-related capabilities and resources.

The three IPTV architectures are further detailed as illustrated in Figure 8-3 for NGN non-IMS IPTV architecture.

Table 8-1 – Differences in functional blocks for the three IPTV architecture approaches

Functional block	Non-NGN IPTV architecture	NGN non-IMS IPTV architecture	NGN IMS IPTV architecture
Control client functional block	Control client functional block	Control client functional block	Session client functional block
IPTV service control functional block	IPTV service control functional block	IPTV service control functional block	Core IMS functions
Network functions	Network functions	NGN transport stratum functions	NGN transport stratum functions
Authentication and IP allocation functional block Resource control functional block	Authentication and IP allocation functional block Resource control functional block	Transport control functions including network attachment control functions (NACF) and resource and admission control functions (RACF)	Transport control functions including network attachment control functions (NACF) and resource and admission control functions (RACF)

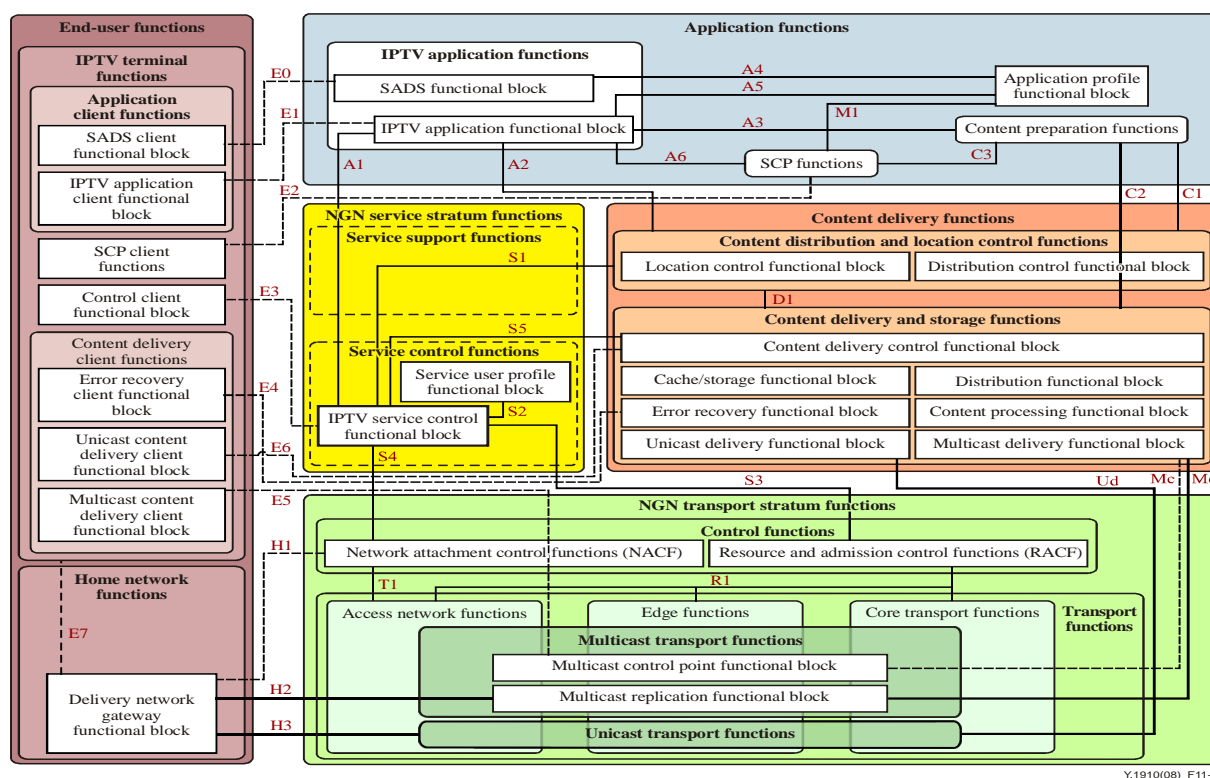

Figure 8-3 – Reference points of NGN non-IMS IPTV architecture (Figure 11-1 of [ITU-T Y.1910])

Reference points are identified for the three IPTV architectures, as illustrated in Figure 8-3 for the non-NGN IPTV architecture:

Reference points with characteristics common to all three IPTV architectures:

- A2 used by the IPTV applications functional block to request service parameters from CD&LCF.
- A3 used to transmit the metadata stored in content preparation functions to the IPTV application functional block.

- A4 used by the service and application discovery and selection (SADS) functional block to retrieve application profiles.
- A5 used by the IPTV application functional block to retrieve application profiles.
- A6 used for transferring keys related to service and content protection information from SCP functions to the IPTV application functional block.
- C1 used to facilitate content preparation functions to configure policies such as content distribution rules, selection criteria, etc., in the CD&LCF.
- C2 used to transfer content from content preparation functions to CD&SF.
- C3 used by the SCP functions to acquire the content rights or licenses from the content preparation functions.
- E0 used by the ITF to discover and select IPTV services and applications.
- E1 reference point used by the ITF to support service and application configuration.
- E2 used for delivering security information (e.g., rights object or keys) from SCP functions to SCP client functions.
- E4 used to exchange messages for requesting and delivering error recovery information, for example FEC repair data or retransmission data.
- E5 used to exchange messages for joining multicast channels, e.g., Internet group management protocol (IGMP) messages.
- E6 used to exchange content control messages, e.g., video recording commands.
- E7 used to deliver control messages and content streams.
- D1 used by the CD&LCF to get status information from the content delivery and storage functions (CD&SF), such as load status, the contents catalogue on each CD&SF, etc.
- H2 provides multicast-based IP connectivity between the delivery network gateway functional block and access network functions in order to deliver control messages and content streams.
- H3 provides unicast-based IP connectivity between the delivery network gateway functional block and access network functions in order to deliver control messages and content streams.
- M1 used by SCP functions to get security-related information from the application profile functional block.
- Mc used to pass information to allow for the dynamic computation, establishment and maintenance of multicast trees.
- Md used by the CD&SF to deliver content streams in multicast mode.
- Ud used by the CD&SF to deliver content streams in unicast mode.

Reference points with characteristics specific to non-NGN IPTV architecture:

- A1 used for forwarding service signalling information between the IPTV service control functional block and the IPTV application functional block and for forwarding signalling information between the IPTV application functional block and other functions, such as the ITF, CD&LCF.
- E3 used to exchange session signalling information, e.g., session establishment, modification and termination.
- H1 used to perform authentication and obtain necessary network parameters, e.g., IP address, etc., when the ITF within end-user functions attaches to the network.
- R1 used by the resource control functional block to control network resources within the transport functions.

- S1 used to forward the service signalling messages, e.g., service requests, content resource requests, between the ITF/IPTV application functions and the CD&LCF.
- S2 used by the IPTV service control functional block to access service user profiles.
- S3 used by the IPTV service control functional block for requesting control of network resources.
- S4 used by the IPTV service control functional block to get information from the authentication and IP allocation functional block such as the ITF location.
- S5 used to exchange messages for session management, e.g., session establishment, modification, or termination.
- T1 used for management of network configuration parameters as well as authentication of data.

Reference points with characteristics specific to NGN non-IMS IPTV architecture:

- A1, E3, S1, S2, S5 same as in the non-NGN architecture.
- H1 used to perform authentication and get necessary network parameters, e.g., IP address, when the ITF within the end-user functions attaches to the network.
- R1 between RACF and the transport functions. It corresponds to the Rw reference point in [ITU-T Y.2111].
- S3 between the IPTV service control functional block and RACF. It corresponds to the Rs reference point in [ITU-T Y.2111].
- S4 between the IPTV service control functional block and NACF. It corresponds to the S-TC1 reference point in [ITU-T Y.2014].
- T1 between NACF and the access network functions. It corresponds to the TC-T1 reference point in [ITU-T Y.2014].

Reference Points specific to NGN IMS IPTV Architecture:

- H1, R1, T1 same as in the NGN non-IMS architecture.
- A0 used for exchanging service and application discovery information towards the ITF.
- A1 used for forwarding service signalling information between the core IMS and IPTV application functional block and for forwarding signalling information between the IPTV application functional block and other functions, such as the ITF, CD&LCF. It corresponds to the ISC reference point defined in [ITU-T Y.2021].
- E3 used by the session client functional block to initiate a service request to the IPTV application functions via the core IMS functions, to identify and prepare for the connection to the content delivery functions, e.g., request for suitable content delivery and storage functions in a VoD case and request for network parameters in a linear TV case, etc.
- S1 used to forward the service signalling messages, e.g., service requests, content resource requests, between the ITF/IPTV application functions and CD&LCF.
- S2 used by core IMS functions to store and get service user profiles. The profile includes end-user information, e.g., end-user identity, security information, etc., as well as a service profile specific to an IPTV application. It corresponds to the Cx reference point defined in [ITU-T Y.2021].
- S3 used by the core IMS functions to request RACF for the control of transport resources. It corresponds to the Rs reference point as defined in [ITU-T Y.2111].
- S4 used by core IMS functions to interact with NACF in order to retrieve information related to the IP connectivity access information (e.g., physical location of the ITF). It corresponds to the S-TC1 reference point as defined in [ITU-T Y.2012].
- S5 used to exchange messages for session management, e.g., session establishment, modification or termination.

Annex A is about "Relationship between IPTV and NGN architectures". It provides a functional mapping between NGN-based IPTV and NGN functional architectures.

Appendix I is about "Procedural flows relating to IPTV services". These procedural flows are intended as illustrative examples of interactions between functional blocks and functions.

There are two main approaches to timing of the allocation resources:

- **Tightly coupled:** The delivery and network resources are allocated and released at the request of the application during the transactional phase of the service.
- **Loosely coupled:** The delivery and network resources are allocated in response to the establishment of the streaming protocol session and released when this streaming protocol session is terminated.

High level procedural flows are provided for loosely coupled content-on-demand, tightly coupled content-on-demand, loosely coupled linear TV, tightly coupled linear TV, initialization of IPTV application access, file-based content distribution and stream-based content distribution.

Figure 8-4 illustrates the procedural flow for loosely coupled content-on-demand.

Procedural flows for IPTV services based on NGN non-IMS IPTV architectures are also provided.

There are two ways in which the IPTV control and the content delivery functions interoperate:

- **Proxy:** One approach is for IPTV service control functional block to proxy all requests between the ITF and the content functions.
- **Redirect:** The other approach is for the IPTV service control functional block to request the allocation of delivery and network resources and then redirect the ITF to communicate directly with the actual content storage and delivery functions that have been allocated.

Procedural flows are provided for content on-demand with loose coupling and redirect, content on-demand with loose coupling and proxy, content on-demand with tight coupling and redirect, content on-demand with tight coupling and proxy and local programme adaptation for NGN-based linear IPTV.

Procedural flows for IPTV services based on NGN IMS IPTV architecture are provided for VoD service and linear TV service.

Procedural flows for IPTV interconnection between two NGN networks are also provided.

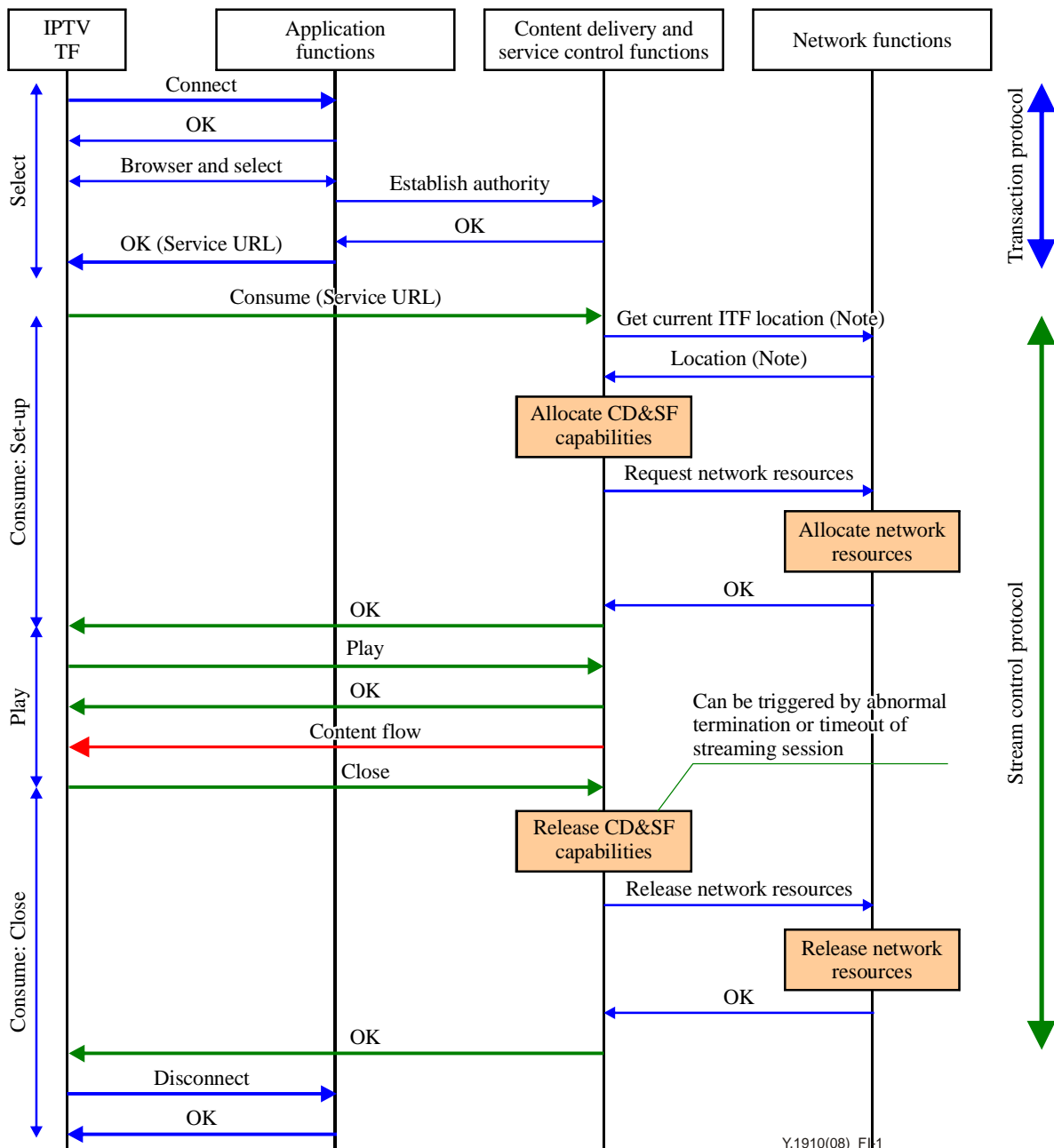

NOTE – Optional procedure.

Figure 8-4 – High level procedural flows for loosely coupled content-on-demand (Figure I.1 of [ITU-T Y.1910])

Appendix II lists "Potential protocols that could be used on IPTV reference points".

Appendix III deals with "IPTV physical network hierarchy". It involves between content providers and IPTV terminal devices:

- Super head end (SHE) network node(s) with the broadest content scope: The SHE sources content to an entire IPTV network.
- Video hub office (VHO) network node(s) with a local/regional content scope: The VHO sources region dependent off-air content (e.g., local programming) and houses local off-line storage of content.
- Video serving office (VSO) network node(s) that connect end users (via access systems) to the IPTV network.

Appendix IV is about "Overlay networking function for IPTV services and multicast".

Appendix V deals with "Adaptation of the IPTV architecture for HFC networks".

Appendix VI is about "Nomadism for IPTV services". Roaming in this appendix means nomadism of the terminal device.

This appendix describes:

- Interconnection with the visited network.
- Interconnection with the visited network without service control functions.
- Interconnection with third party service providers.

8.3 ITU-T Y.1991: Terms and definitions for IPTV

Extracted summary

Recommendation ITU-T Y.1991 contains terms and definitions and a framework relevant to providing a general understanding of IPTV. The primary purpose of this Recommendation is to provide a context for the use of certain terms and definitions to avoid misunderstandings in IPTV and IPTV-related activities.

Extended summary

[ITU-T Y.1991] collected terms and their definitions from other ITU-T Recommendations.

[ITU-T Y.1901] has 49 terms (with their definitions) related to requirements to support IPTV services (accessibility feature, acquisition, aspect ratio, audio description, captions, channel, etc.) with just a few (7) defined in [ITU-T Y-Sup.5] (application provider, content aggregator), [ITU-T M.60] (broadcast), [ITU-T Q.1706] (mobility), [ITU-T M.1400] (service provider), [ITU-T M.3050.1] (subscriber) and [ITU-T Q.1741.3] (subscription).

Among the 9 terms (with their definitions) related to IPTV architecture, 5 are defined in [ITU-T Y.1910] (content provider, delivery, distribution, end-user, network provider), 3 in [ITU-T Y.2012] (functional architecture, functional entity, reference point) and one in [ITU-T Y.101] (application).

Among the 7 terms (with their definitions) related to performance, QoE, QoS and traffic management, 5 are defined in [ITU-T G.1080] (channel zapping, clean audio, group of pictures, triple play service, VoD trick modes), one in [ITU-T G.1081] (platform) and one in [ITU-T P.10] Amd.2 (quality of experience (QoE)).

82 terms (with their definitions) related to metadata, terminal devices and home network are taken from [ITU-T H.761] (author, authoring tool, event, hybrid application, hybrid declarative application, hybrid imperative application, media object, profile, stream, etc.), [ITU-T J.200] (declarative application, element, execution engine, markup language, plug-in, presentation engine, etc.), [ITU-T H.720] (distributed PVR, IPTV network, service navigation, etc.), [ITU-T H.721] (electronic content guide, portal), [ITU-T H.701] (forward error correction), [ITU-T H.622] (home network), [ITU-T H.750] (metadata fragment, metadata schema), [ITU-T H.770] (service platform, set-top box, etc.).

8 terms (with their definitions) related to secondary distribution are mainly from [ITU-T J.700] (enhanced broadcasting, hybrid CPE) and [ITU-T J.701] (resource abstraction/middleware interface, service components) and one from [ITU-T M.2301] (provisioning).

40 terms (with their definitions) related to IPTV security aspects are extracted from [ITU-T X.800] (access control, authentication, authorization, availability, key, key management, scrambling, threat, etc.) and [ITU-T X.1191] (content export, content protection, content tracing, entitlements, etc.).

8.4 ITU-T Y-series Suppl. 5: Supplement 5 to Y-series Recommendations ITU-T Y.1900-series, Supplement on IPTV service use cases

Extracted summary

Y-series Suppl. 5: This IPTV service use cases supplement provides a list of IPTV use cases that are informative illustrations of how IPTV services can be designed, deployed and operated. From the end-user's perspective, use cases have been categorized by distributed content services, interactive services, communication services, etc.

Extended summary

This informative supplement describes IPTV use cases with all steps necessary to operate them. As an example, Figure 8-5 shows how the use case of linear TV with trick mode is illustrated.

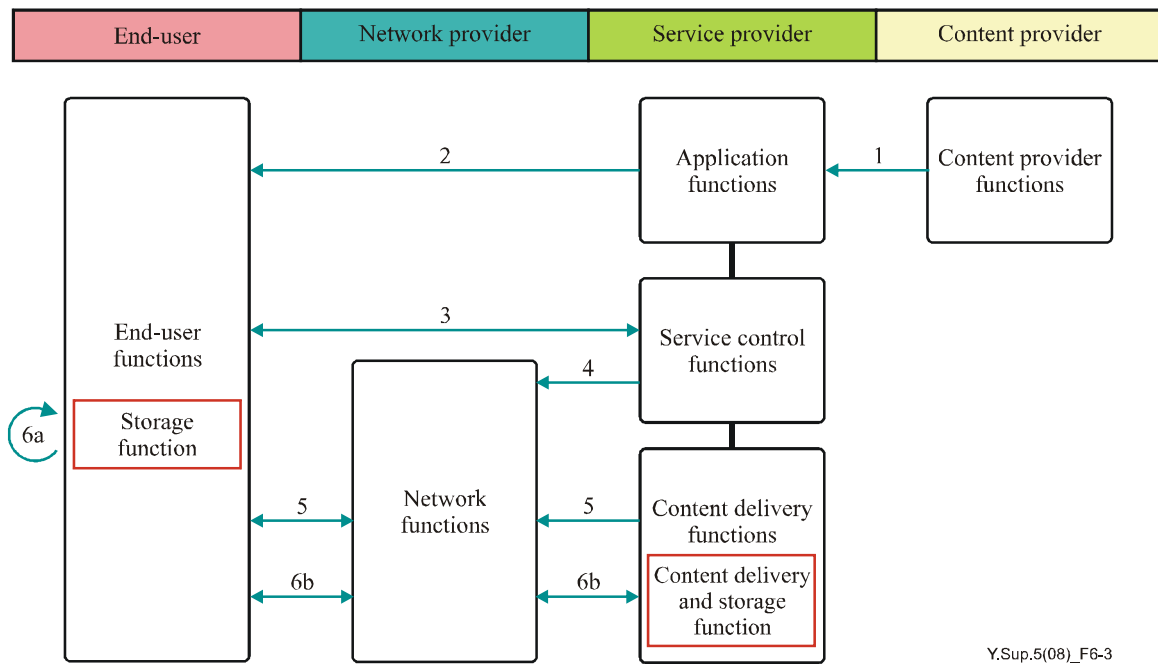

Y.Sup.5(08)_F6-3

**Figure 8-5 – Use case of linear TV with trick mode
(Figure 6-3 of [ITU-T Y-Supp.5])**

Use cases are first detailed for the following "distributed content services":

- Broadcast services
 - Linear TV (including audio only, audio + video + data).
 - Linear TV with trick mode.
 - Pay per view (PPV).
 - Electronic program guide (EPG).
 - Personal broadcast service.
 - Hybrid: Online and off-air TV delivery.
 - Linear TV with multi-view service.
- On-demand services
 - Video on demand (VoD).
 - Near VoD (NVoD), video service where a program is broadcasted multiple times at short time offsets (typically 10-20 minutes).

- Reserved delivery service (e.g., video delivery cannot be immediately carried out in VoD, following the end-user request, but will be triggered at a later stage by some wake-up mechanisms).
- On-demand with multi-view service (various camera angles in addition to the one station view provided by the video on-demand service).
- Music on demand (MoD).
- Advertising services
 - Traditional advertising service (advertising content is inserted into the video stream prior to the video being incorporated by the IPTV acquisition system and delivered to the end-user).
 - Targeted advertising (targeted advertisements are defined according to the end-user's preferences, usage history, personal characteristics and usage environments and according to advertisers who want to ensure their commercials are only seen in areas where their products or services are available).
 - On-demand advertising (the end-user navigates a business advertising directory information created and delivered by the service provider and selects an advertisement).
 - Advertising message logging (a tool used to record information about advertising messages, such as message text, channel, click time, etc.).
- Time-shifting and place-shifting services (IPTV content access and control (pause, rewind, fast forward, etc.) without time limitations with two approaches: end-user-based time-shifting service and network-based time-shifting service. Two approaches also for subscriber-based place-shifting and network-based place-shifting).
- Supplementary content (e.g., Sub-titles and captions, audio description, Sign language interpretation, alternative audio track for comments, etc.).

IPTV use cases are also provided for the following "interactive services" with a generic flow diagram:

- Information services (news, weather and traffic forecasts and advertisements).
- Commercial services (to purchase goods and use financial services, such as banking, stocks, shopping, ticketing, auctions, etc.).
- Entertainment services (games, karaoke, lottery, blog and photo albums, etc.).
- Learning services (educational content, e.g., languages, financial skill, etc., to remote students. Teachers and students can communicate in real and/or non-real time through video, audio, pictures and text, etc.).
- Medical services (remote diagnosis, remote consultation, remote medical examination, medical education, etc., in real time and/or non-real time through video, audio, pictures and text, etc.).
- Monitoring services (health monitoring, location surveillance, etc.).
- Portal services (branded aggregation of products and services designed to satisfy a large majority of end-users' needs, such as VoD, shopping, banking, communication, entertainment and other interactive services with a portal menu). This use case is illustrated by a flow diagram.
- Interactive advertising (icon shown during an advertisement to connect to a website to get additional information on the product or "click-to-call" button to initiate a free call to purchase the product).

For communication services, a number of well-known services are listed without detailed use cases: messaging, telephony (i.e., VoIP), video telephony, multi-party conference calls, video conference.

Among public interest services the following services are identified:

- Support for end-users with disabilities. It is not a stand-alone service but a feature added to IPTV services. It is about sub-titling (language translation of the dialogue), captioning, (transcript of sound effects and dialogue), visual sign language translation, audio description.
- Emergency communications (insertion of emergency alert notification (EAN) message in IPTV services with all pertinent details for presentation in a way easily and quickly understandable by the population: multiple languages in some cases, multimedia for illiterate or hearing/visually impaired individuals).
- Community-related communications
 - From public authority (announcements, bus routes, weather reports and government services related information).
 - To public authority (fire warning, medical alert and illegal house intrusion event, etc.).
 - Between user groups (end-user contents, warnings).

Hosting services to allow organizations and end-users to store information, images, video, or any content on the IPTV platforms are briefly described without any flow diagram.

Presence services allow information about end-user's location to be made available to applications and services. The following use cases are identified:

- Basic presence service (End-users are notified when one of their friends connects to the IPTV service).
- Channel-based presence service (to discover buddies watching the same channel now).
- Targeted advertising based on presence service (presence information and user information are used for targeted advertisement).

Session mobility service (Transfer of multimedia session seamlessly between different devices based on user preferences) is detailed with a flow diagram.

A number of payment methods for accessing IPTV services are listed, namely: free, subscription, Pay per view (PPV) or pay per use (PPU), à la carte (The end-user can purchase only the channel(s) he or she wants to receive), cash-back point (credit acquired by using or purchasing IPTV services with real money to be used for future payment instead of real money), package (combination of channels, content, applications organized by the service provider).

8.5 Other Recommendations

[ITU-T Y.1902] describes a framework for multicast-based IPTV content delivery based upon different content delivery functional models and their associated requirements. The content delivery functional models are defined according to different methods of multicast-based IPTV content delivery in terms of IPTV functional architecture described in [ITU-T Y.1910]. Requirements for multicast capabilities specified in this Recommendation are based on the requirements provided in [ITU-T Y.1901].

[ITU-T Y.1911] describes scenarios and functional architecture aspects related to the support of IPTV services in conjunction with nomadism. Recommendation [ITU-T Y.1911] addresses IPTV services supported via the use of unicast delivery.

[ITU-T Y.1920] describes a set of traffic management mechanisms which are aimed to facilitate the efficient support of IPTV services over the network infrastructure and provides guidelines on the use of the traffic management mechanisms in various IPTV services such as VoD and Live TV.

Supplement 16 to ITU-T Y-series Recommendations [ITU-T Y-Sup.16], describes the technical guidelines for the deployment of IP multicast technologies for IPTV content delivery. The deployment guidelines identify the technical issues and considerations regarding the capabilities of IP multicast from the perspective of supporting the IPTV services.

Supplement 20 to ITU-T Y-series Recommendations [ITU-T Y-Sup.20], provides mobile IPTV use cases as informative illustrations of how mobile IPTV services can be designed, deployed and operated. The use cases are described with sample scenarios and operational procedures of mobile IPTV services. In addition, the use cases detail functional procedures to illustrate how the service scenarios can be supported with IPTV architectural functions. Finally, the use cases have been categorized in terms of service aspects and capability aspects.

[ITU-T G.1080] defines user requirements for quality of experience (QoE) for Internet protocol television (IPTV) services. The QoE requirements are defined from an end user perspective and are agnostic to network deployment architectures and transport protocols. The QoE requirements are specified as end-to-end and information is provided on how they influence network transport and application layer behaviour. QoE requirements for video, audio, text, graphics, control functions and meta-data are provided. Compression coding schemes addressed in this Recommendation are examples and detailed numeric values as performance targets, e.g., bit rate, packet loss rate, are also examples. The readers may appropriately choose or replace these parameter values in order to be consistent with the requirements of each IPTV service context to which they are intended to be applied.

[ITU-T G.1081]: Successful deployment of IPTV services requires performance parameters to be monitored at various points in the complete end-to-end chain, including the customer premises, key aggregation points and at interconnect points between disparate and service provider network domains. [ITU-T G.1081] defines five monitoring points where such performance measurements can be made.

[ITU-T G.1082] provides a framework for improving the robustness of IPTV performance based on the results of real-time measurements. The primary application of this framework is to control the media and network resources based on the measurement information and according to policy rules to support high quality of experience of IPTV services. For IPTV services, service providers and network providers may have separate monitoring systems. Measurement information is provided by the monitoring system. This Recommendation first describes the possible measurement information used in different monitoring domains and the information exchanged between providers. It then gives guidance on how to take these factors into account to adjust media and network resources in order to maintain the quality of experience for IPTV services.

[ITU-T H.622.1] describes an architecture for home networks supporting IPTV services and its functional requirements. In this Recommendation, home networks and IPTV-related entities are defined and interfaces between these entities are identified. Functions needed for the home network to support IPTV services are described. Requirements for these functions are also described in this Recommendation.

[ITU-T J.700]: The telecommunications industry today is pursuing development of a new generation of television services, typically called IPTV, built upon IP networking technology to deliver integrated triple-play voice, data and video services across a converged network infrastructure. The cable industry has a long history of successfully delivering video services over hybrid fibre/coaxial (HFC) networks while adding support for data and voice through the DOCSIS and IPCablecom architectures. [ITU-T J.700] describes the use of the IPTV mechanism and is intended to support IPTV services over existing cable-based secondary distribution networks and/or other networks to enhance the existing television distribution services. This revised Recommendation provides a clearer relationship of the IPTV architecture between this Recommendation and [ITU-T Y.1910] and the relationship to the service provider interface is newly described. In addition, the latest access network technologies for secondary distribution such as radio frequency over glass (RFoG), wavelength-multiplexed video transport over optical fibre and hybrid use of HFC and optical fibre, are mentioned. This revision is also intended to provide a number of editorial corrections.

[ITU-T Q.3040] describes the overall signalling architecture for IPTV control plane. It identifies the functions, functional blocks, physical entities, interfaces and protocols that will model the control plane for IPTV.

[ITU-T J.704]: To encourage the successive growth of television broadcasting services, it is important to enable third-party operators to provide services by making the best use of television distribution facilities and functionalities. [ITU-T J.704] defines functional requirements of the service provider's interface for television primary and secondary distribution and associated interactive services for integrated broadband cable and primary distribution television networks. This Recommendation provides interfaces and functionalities to enable third-party service providers to offer television and associated interactive services including RF-based linear TV, video on demand (VoD), cable telephony and enhanced broadcast services.

[ITU-T H.701] provides content delivery error recovery (CDER) mechanisms for IPTV services. It details the error recovery functions in the IPTV architecture and specifies detailed CDER mechanisms. It also provides guidelines on the applicability of the CDER mechanisms to different IPTV services and network conditions.

9 IPTV security (X-series)

The security framework for IPTV security is found in the X-Series Recommendations:

- [ITU-T X.1191], *Functional requirements and architecture for IPTV security aspects.*
- [ITU-T X.1192], *Functional requirements and mechanisms for the secure transcodable scheme of IPTV.*
- [ITU-T X.1193], *Key management framework for secure internet protocol television (IPTV) services.*
- [ITU-T X.1194], *Algorithm selection scheme for service and content protection (SCP) descrambling.*
- [ITU-T X.1195], *Service and content protection (SCP) interoperability scheme.*
- [ITU-T X.1196], *Framework for the downloadable service and content protection system in the mobile Internet Protocol Television (IPTV) environment.*
- [ITU-T X.1197], *Guidelines on criteria for selecting cryptographic algorithms for IPTV service and content protection.*
- [ITU-T X.1198], *Virtual machine-based security platform for renewable IPTV service and content protection.*

[ITU-T X.1191] addresses the functional requirements, architecture and mechanisms dealing with the security aspects of IPTV content, services, networks, terminal devices and subscribers (end users).

[ITU-T X.1192] deals with the functional requirements, architecture and mechanisms that pertain to the security of transcoding protected IPTV content. Generic security of IPTV content is not discussed in this Recommendation.

[ITU-T X.1193] describes the requirements and architecture for key management, including key hierarchy, for unicast and multicast IPTV services in the IPTV context. It also specifies key management for downloadable service and content protection (SCP), if deployed. This Recommendation does not include any other key management architecture or mechanisms described in [ITU-T X.1191].

[ITU-T X.1194] develops an algorithm selection standard for descrambling in various terminal devices. This Recommendation provides the general service and content protection (SCP) architecture, security requirements and algorithm selection scheme (ASS). In particular, the algorithm selection scheme consists of the SCP control client function, ASS descrambler/demuxer control function and descrambler authentication function.

[ITU-T X.1195] develops a complete set of requirements for interoperable service and content protection (SCP) to support interoperability between multiple SCP mechanisms. This includes interoperable SCP scenarios, interoperable SCP architecture and interoperable SCP process.

[ITU-T X.1196] provides a framework for the downloadable service and content protection (SCP) scheme in the mobile Internet Protocol television (IPTV) environment. It also describes functional architecture and requirements for the downloadable service and content protection (SCP) scheme for roaming in the mobile IPTV environment.

[ITU-T X.1197] provides guidelines on the criteria for selecting cryptographic algorithms for IPTV service and content protection (SCP). It also provides a list of cryptographic algorithms to provide confidentiality, data origin authentication and integrity for IPTV SCP services.

[ITU-T X.1198] specifies a virtual machine-based security platform for the renewable service and content protection (SCP) system. The virtual machine supports an abstract function of hardware devices. This Recommendation defines a common interface and functional logic in the Internet protocol television (IPTV) terminal device and includes the data structure of SCP client and system components for a terminal device such as an embedded SCP, media client and control client.

10 IPTV terminal devices

IPTV terminal devices are mostly specified in the H-series, while some aspects are also described in the J-series:

- [ITU-T H.720], *Overview of IPTV terminal devices and end systems*.
- [ITU-T H.721], *IPTV Terminal Device: Basic model*.
- [ITU-T H.721] Amd.1 (2010), *IPTV Terminal Device: Basic model: New Appendix II on terminal device implementation example*.
- [ITU-T J.702], *Enablement of current terminal devices for the support of IPTV services*.
- [ITU-T J.703], *IPTV Client Control Interface Definition*.
- [ITU-T J.705], *IPTV client provisioning, activation, configuration and management Interface Definition*.

10.1 ITU-T H.720: Overview of IPTV terminal devices and end systems

Extracted summary

Recommendation ITU-T H.720 gives an overview of the architecture and functional components of an Internet protocol television (IPTV) terminal device and provides a high-level description of the functionality necessary to support IPTV services. This Recommendation provides the definitions of terminal device and end system, the location of terminal devices and end systems within the overall architecture of IPTV, examples of IPTV services, an abstract description of the terminal device architecture and descriptions of other Recommendations that discuss IPTV terminal devices.

Extended summary

[ITU-T H.720] identifies basic IPTV services, namely:

- Distributed content service with service navigation (to discover, select and consume), linear TV and content on demand.
- Interactive services including information services, learning services and entertainment services.
- Public interest services including emergency alert system, closed captions, subtitles, audio description and sign language interpretation.

Advanced services that a full-fledged IPTV terminal device might be able to render are also listed:

- Linear TV with trick mode.
- Personal video recorder (PVR) services (client PVR, network PVR and distributed PVR).

- Advertising services (targeted advertising, on-demand advertising).
- Audience measurement information.
- Interactive services requiring high security (commerce services, medical services and personal IPTV broadcast).

The key features of IPTV terminal devices are described: network attachment, service provider discovery, service discovery, service attachment, service navigation, security, privacy, quality and performance monitoring.

Based on the IPTV functional architecture framework defined in of [ITU-T Y.1910], [ITU-T H.720] specifies the functional architecture of IPTV terminal devices as shown in Figure 10-1.

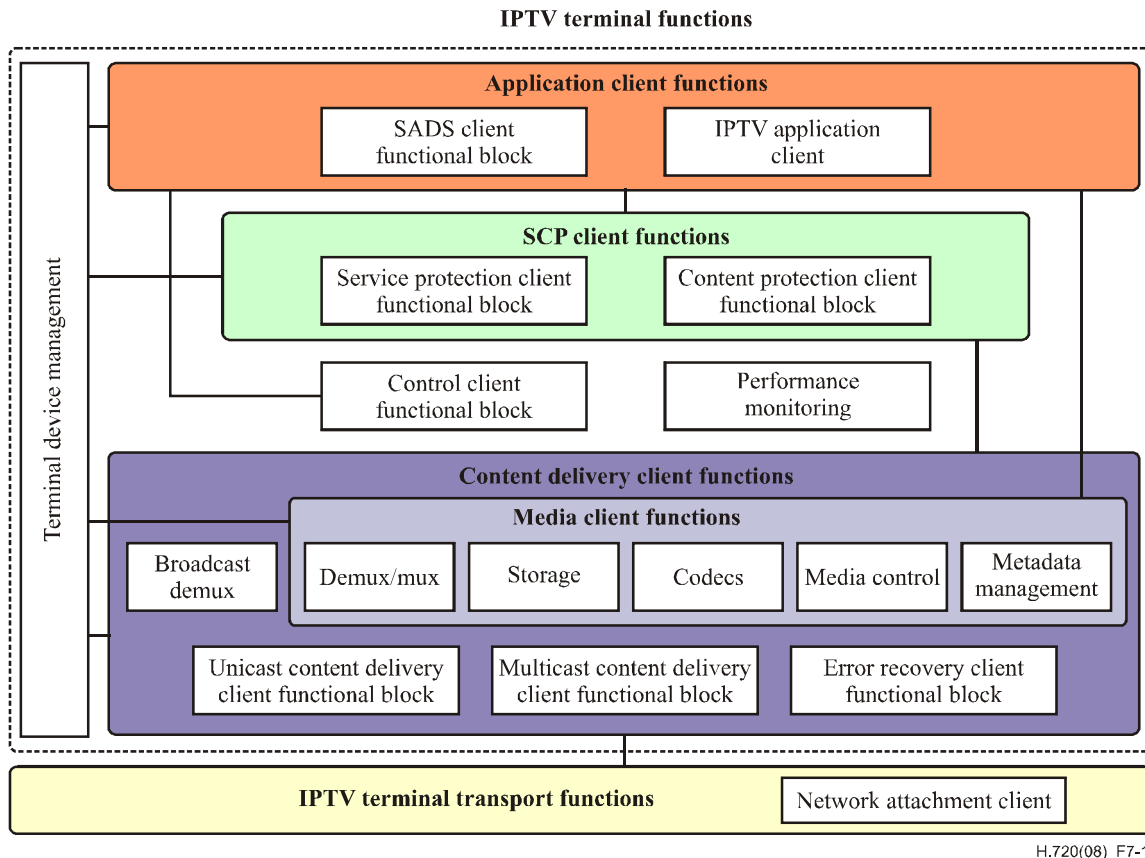
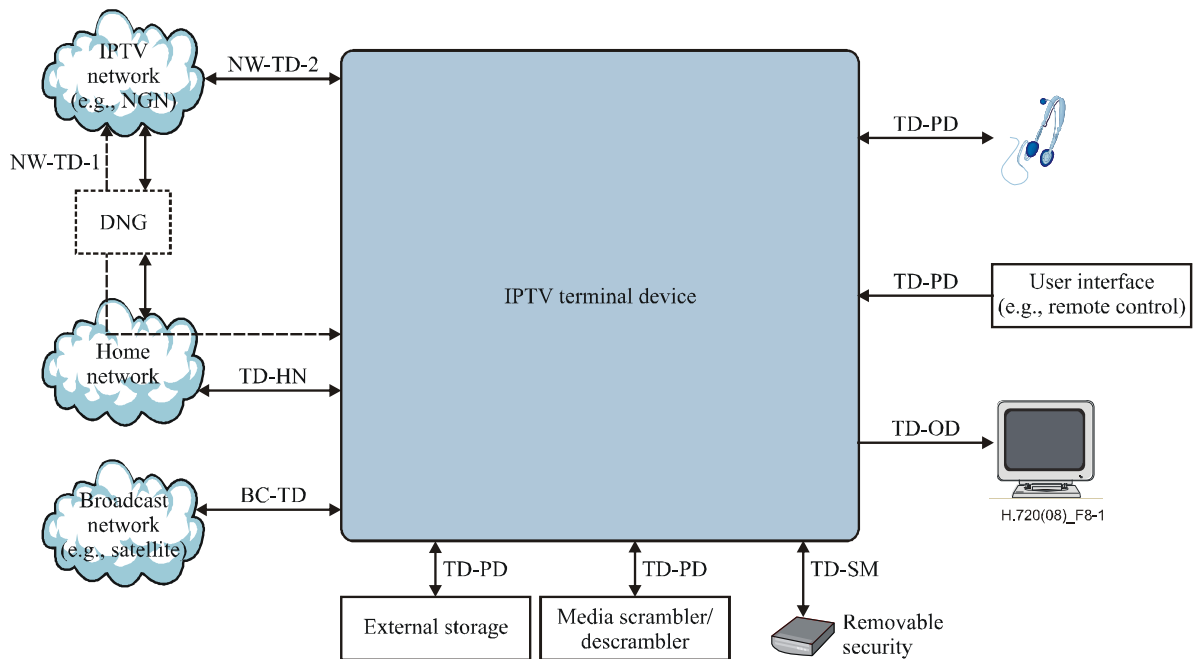

Figure 10-1 – Functional architecture block diagram of IPTV terminal device (Figure 7-1 of [ITU-T H.720])

A brief explanation of each component/functional entity is provided with references to other Recommendations for more details.

[ITU-T H.720] identifies also possible terminal device interfaces as shown in Figure 10-2.



**Figure 10-2 – Examples of IPTV terminal device interfaces
(Figure 8-1 of [ITU-T H.720])**

[ITU-T H.720] describes also an overview of the IPTV terminal software architecture as shown in Figure 10-3.

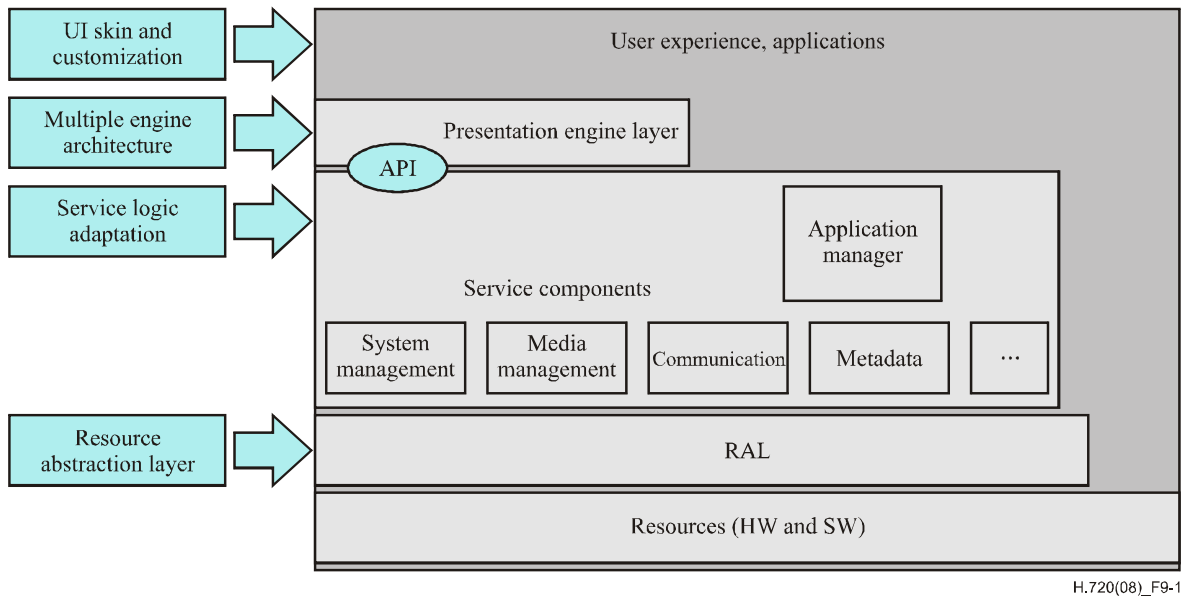

**Figure 10-3 – IPTV terminal software architecture – Overview
(Figure 9-1 of [ITU-T H.720])**

Appendix I lists various ITU-T Recommendations which should be developed based on this Recommendation: "IPTV terminal devices for basic services" (published as [ITU-T H.721]), "IPTV terminal device full-fledged model" and "IPTV terminal device mobile model".

10.2 ITU-T H.721: IPTV terminal device: Basic model

Extracted summary

Recommendation ITU-T H.721 describes and specifies the functionalities of the IPTV terminal devices for the IPTV basic services defined in Recommendation ITU-T H.720. This Recommendation is targeted at IPTV terminal devices capable of receiving linear TV service and video-on-demand services, with additional data content (such as text) using a managed content delivery network. The service definition takes into consideration conditions on content delivery such as QoS. The expected types of IPTV terminal devices are set-top boxes and digital TV sets with embedded IPTV capabilities.

Amendment 1 introduces a new Appendix II, which describes implementation examples that support ITU-T H.721 terminal device specifications.

Extended summary

Using the same structure as [ITU-T H.720], [ITU-T H.721] provides a list of applicable specifications for each basic IPTV service defined in [ITU-T H.720], namely:

- Linear TV: video (MPEG-2, H.264), audio (MPEG-2 AAC, MPEG-1 Layer II), captioning (ARIB captioning, ATSC closed captioning, EBU teletext subtitles, DVB subtitling), multiplex format (MPEG-2 TS, TTS), streaming (RTP).
- Content-on-demand: video (MPEG-2, H.264), audio (MPEG-2 AAC, MPEG-1 Layer II, MPEG-4 HE AAC v1, Dolby AC-3), captioning (ARIB captioning, ATSC closed captioning), multiplex format (MPEG-2 TS, TTS), streaming (RTP, RTSP).
- Service navigation and content selection using remote controller, EPG, ECG or portal service.
- Interactive services: same presentation and control functionalities as for linear and content-on-demand services.
- Public interest services: Closed caption, subtitles, audio description and sign language interpretation may be provided alongside with all of the above-mentioned basic services with accessibility.

Applicable Recommendations are listed for the following features of the basic IPTV terminal device:

- Terminal device attachment and initialization. Applicable protocols are: IP, ICMP, IPv6, ICMPv6, DHCP, DNS.
- Service provider discovery and service attachment: Multiplex format (MPEG-2 TS, TTS), streaming (RTP, RTSP), multicast (IGMPv2, MLDv2), unicast (HTTP).
- Security: Secure communication (SSL/TLS), encryption algorithm (AES, CSA).
- Quality of service: error correction [ITU-T H.701], clock synchronization and jitter removal (solutions described in appendix I).

Media control functional block is required to support playback, stopping and pausing, fast-forwarding and rewinding of VoD contents either using specialized contents or usual contents. It can optionally support the skip forward and skip backward functionalities, chapter playback functionality for VoD contents.

For video, the following resolutions are required to be supported:

- [ITU-T H.262]: 1920x1080i MP@HL, 1440x1080i MP@HL, 1280x720p MP@HL and 720, 544, 480x480i MP@ML.
- [ITU-T H.264]: 1920x1080i HPorMP@Level4.0, 1440x1080i HPorMP@Level4.0, 1280x720p HPorMP@Level4.0, 720x480i HPorMP@Level3.0/3.1/3.2, 720x576i (the format used in Europe).

Temporary and permanent data to be stored in the storage functional block are listed.

The Recommendation describes as well the operation of the service protection and content protection functional blocks.

For IPTV application client functions a reference is made to [ITU-T H.760].

For SADS client functions a reference is made to [ITU-T H.770].

Physical interfaces are listed but only reset button and remote controller interfaces are recommended to be supported by the basic model, other interfaces are optional.

Appendix I provides an overview of the "Clock synchronization and jitter removal" issue and specifies a solution for "Time-stamped TS (TTS) clock reconstruction".

Appendix II provides implementation examples of [ITU-T H.721] terminal device (TD) specifications supporting linear TV, video on-demand and interactive services, see Figure 10-4.

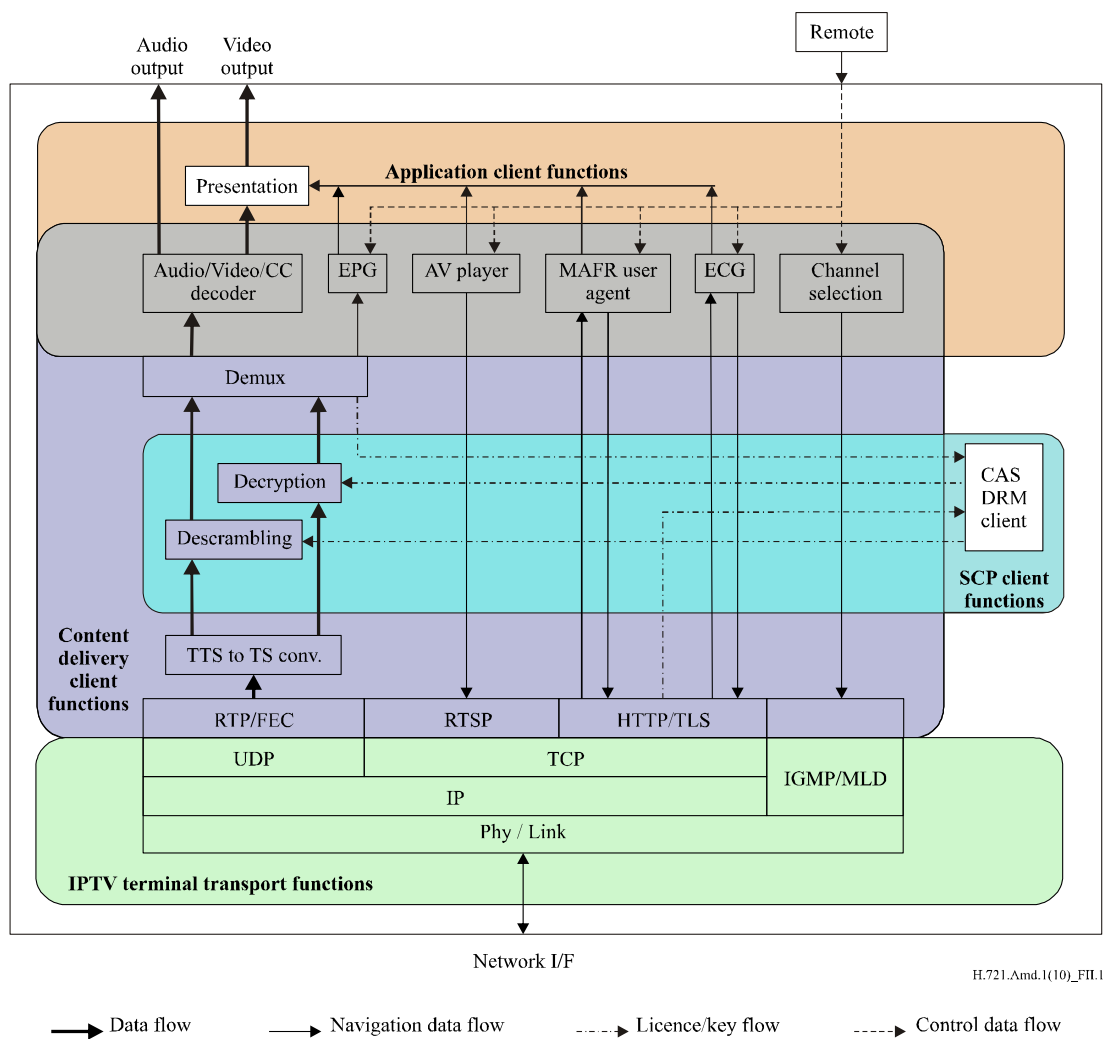

Figure 10-4 – Implementation example of the IPTV terminal functions (Figure II.1 of [ITU-T H.721])

It shows in more detail how terminal functions communicate with each other above the applicable delivery protocols listed in the main body.

10.3 ITU-T H.722: IPTV terminal device: Full-fledged model

Extracted summary

Recommendation ITU-T H.722 describes the services and key features of the full-fledged Internet Protocol TV terminal device (IPTV TD) defined in Recommendation ITU-T H.720. In comparison with the IPTV TD-basic model defined in Recommendation ITU-T H.721, the full-fledged IPTV TD supports not only such basic services as linear TV and video-on-demand (VoD), but also advanced services such as Internet, medical applications, communications, etc. Based on these services and key features, this Recommendation specifies the architecture of the full-fledged IPTV TD, functional components within its architecture, software architecture for implementation reference and physical interfaces.

Extended summary

A full-fledged IPTV TD will not be limited to the services provided by the IPTV TD-basic model, but will support the following additional services:

- Broadcast services: Linear TV with trick mode, Personal broadcast service, Hybrid: online and off-air TV delivery, Linear TV with multi-view service.
- On-demand services: Reserved delivery service, On-demand with multi-view service.
- Advertising service: Targeted advertising, On-demand advertising.
- Interactive services: Commercial service, Entertainment service, Learning service, Medical service.
- Communication service: Messaging service, Telephony service, Video communication service.
- Personal video recorder (PVR) service: Client PVR (cPVR), Network PVR (nPVR), Distributed PVR (dPVR).
- Audience measurement information.
- Internet service.
- Application store service.
- Multi-device interactive service.
- It is recommended that the device support the following features (in addition to the features provided by the IPTV TD-basic model).
- Application framework, to support the end user in installing, un-installing, running and closing the applications sanctioned (signed) by the service providers, to offer:
 - supplementary IPTV service using e.g., [ITU-T H.765], etc.,
 - application installation, un-installation, running and stop,
 - application life-cycle management,
 - web-based applications using [ITU-T H.761], [ITU-T H.762], [ITU-T H.763.1] and [ITU-T H.764].
- Audience measurement function (information about end-user content consumption).
- Capabilities to encode and process IPTV multimedia contents using high-capacity storage, high-performance processor and easy-to-use peripheral devices.
- Picture-in-picture (PIP) with two different contents, full screen HD/SD video for the first and SD video in a window for the second.
- Local storage and trick mode such as pause, fast forward, fast rewind, etc.
- Peripheral devices to transfer the sound information through a non-IP-based connection.

- Network attachment and service discovery.
- "Service security items" and "content protection items", which are fully described in clause 7.2.2 in [ITU-T H.721].
- Privacy: the IPTV TD is required to have the capability to initialize and delete the private information stored in the local storage but not to be mistakenly operated and unintentionally activated.
- Automatic repeat query (ARQ) and forward error correction (FEC) to ensure a sustainable and stable delivery of streamed content (Quality of Service).
- Public SDK and/or NDK for applications, which may refer to [ITU-T H.730] to allow applications to be created by third-party developers.
- Powerful enough to act as a media centric device: media server, media player, media renderer, media controller.

The functional architecture of the full-fledged IPTV TD is shown in Figure 10-5.

The software architecture of a full-fledged IPTV TD is shown in Figure 10-6.

The physical interfaces of the full-fledged IPTV TD are illustrated in Figure 10-7.

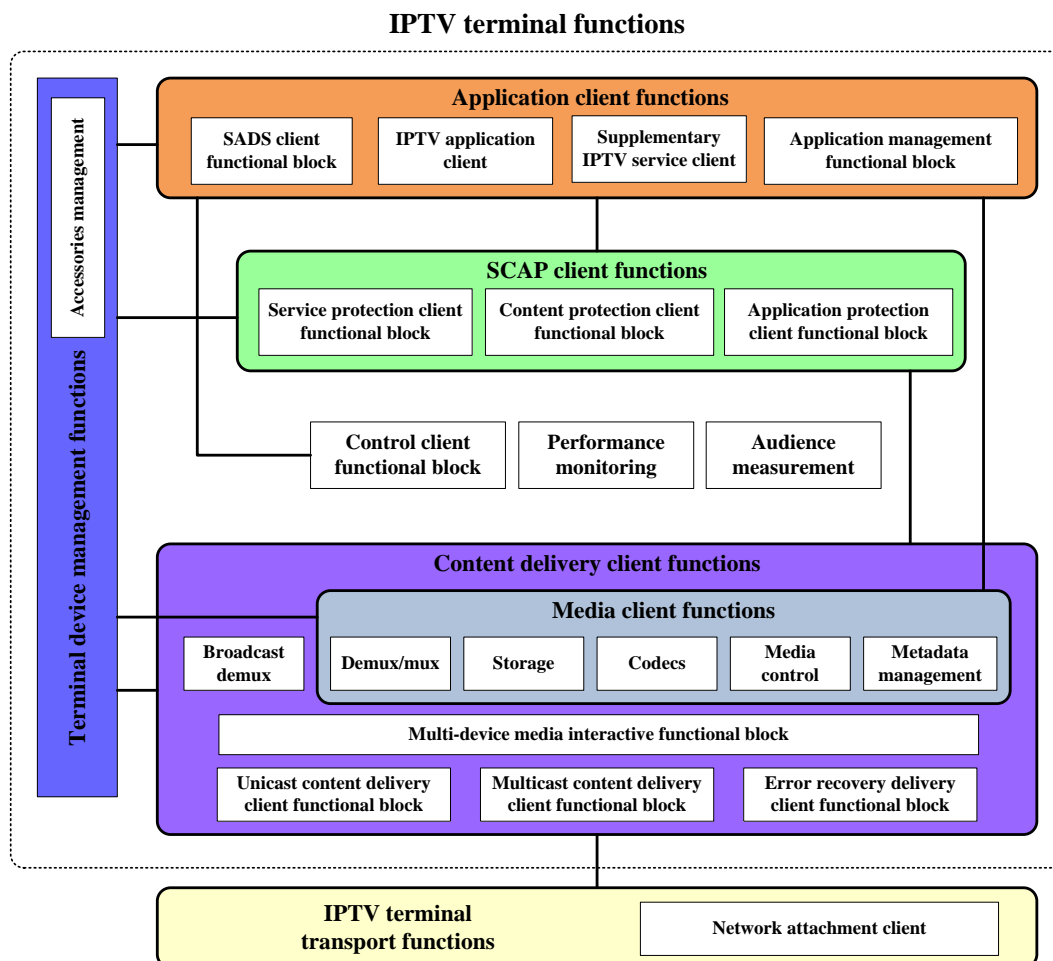

**Figure 10-5 – Full-fledged IPTV TD functional architecture
(Figure 8-1 of [ITU-T H.722])**

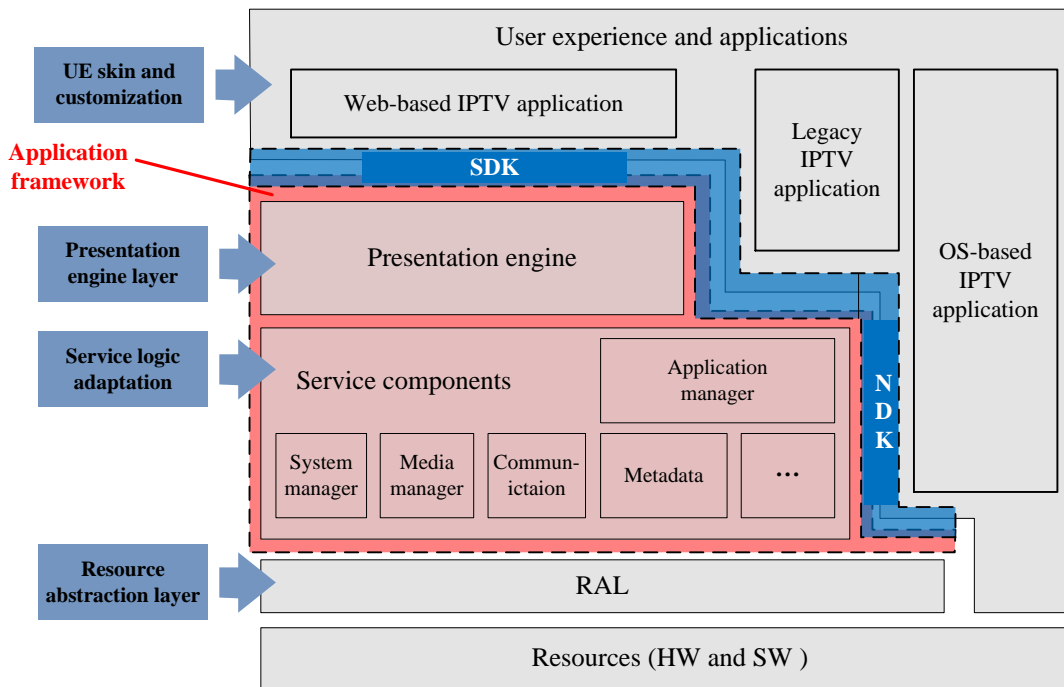

Figure 10-6 – Full-fledged IPTV TD software architecture (Figure 10-1 of [ITU-T H.722])

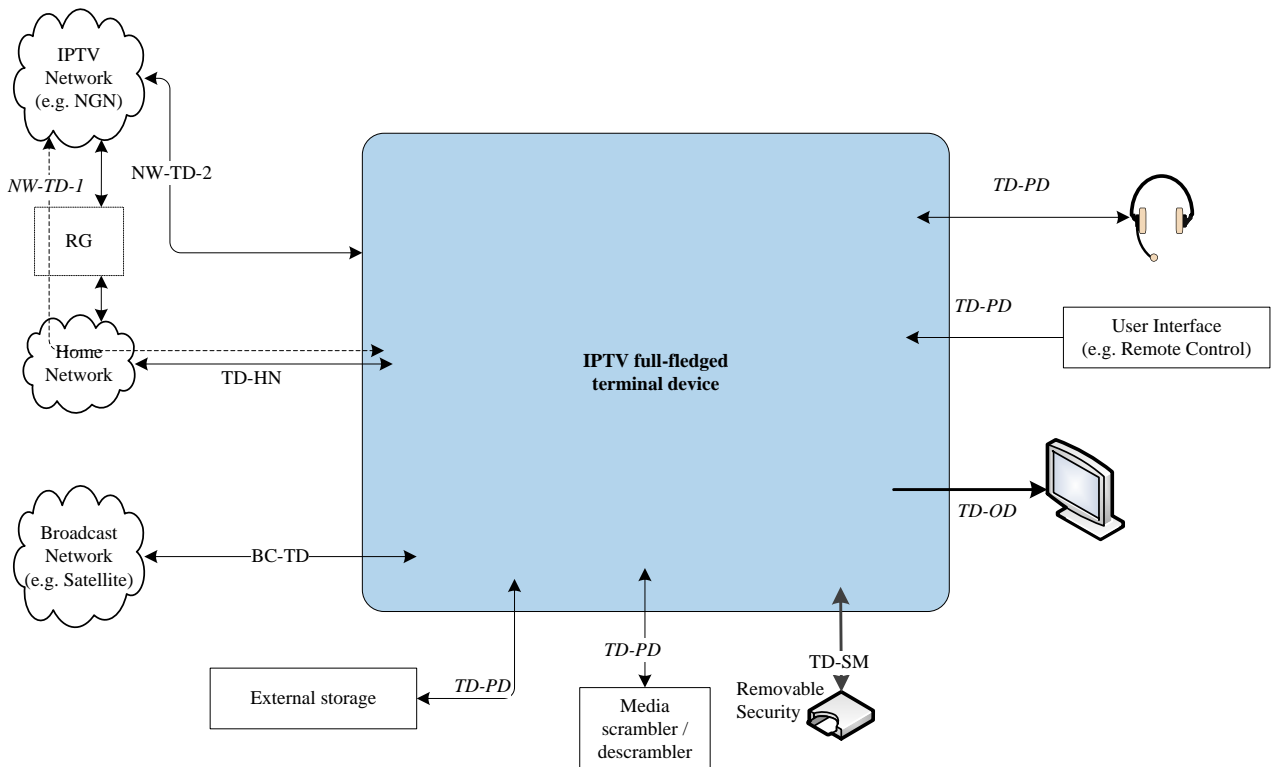

Figure 10-7 – Full-fledged IPTV TD interfaces (Figure 11-1 of [ITU-T H.722])

For the input interface, the full-fledged IPTV TD is recommended to support:

- a reset button to manually resolve its hang-up status,
- a remote controller,
- a keyboard and mouse for convenient text input and control,

- a microphone for voice input,
- a camera for video communication and other necessary services,
- an IP-based connection from other devices like a smart phone or tablet with a virtual control software for text input or controller simulation.

For the output interface, the full-fledged IPTV TD is recommended to support:

- a high-definition multimedia interface. Then it is required to provide appropriate protection according to the high-definition content protection (HDCP) specification to allow content to be output with copy control and protection.

For the output interface, the full-fledged IPTV TD can optionally support:

- an RGB analogue interface,
- a video graphic array (VGA) interface and a digital visual interface (DVI) interface with analogue output,
- a digital audio interface,
- a headset audio output interface.

For external data access interface, the full-fledged IPTV TD is recommended to support removable external storage devices with appropriate protection according to the HDCP specification if the contents in the removable storage require copy control or protection.

For network access interface, the full-fledged IPTV TD is recommended to support:

- a wired or wireless data connection for IP-based data transmission,
- a personal area network (PAN) interface; refer to [ITU-T H.810].

10.4 ITU-T J.702: Enablement of current terminal devices for the support of IPTV services

Extracted summary

Recommendation ITU-T J.702 describes an IPTV terminal device (IPTV TD) that enables a migration path for the support of basic IPTV services, for current terminal devices used for other TV delivery services. This Recommendation identifies architectures and functions needed for the IPTV TD to support basic IPTV services and is intended to meet immediate demands of current TV delivery services to rapidly deploy basic IPTV services.

Extended summary

Starting from existing TV devices, [ITU-T J.702] identifies what has to added to enable them to support basic IPTV services.

Based on requirements and recommendations identified in [ITU-T Y.1901], [ITU-T J.702] defines the basic services that the IPTV TD is recommended to support, namely:

- Content delivery service: Service navigation, linear TV, content on-demand.
- Interactive services: Information services, commercial services, entertainment services (e.g., games, karaoke, etc.), learning services, medical services, monitoring services, portal services, etc.
- Public interest services: Accessibility features, emergency telecommunications, regulatory information services, provider selection and number portability.

The IPTV TD is required to support national regulations, if any.

Functional requirements are listed with applicable Recommendations:

- Network attachment ([ITU-T J.293] is recommended to be supported).

- Service discovery ETSI TS 102 034 (DVB-IPI) and service information (SI) of the MPEG transport stream are recommended to be supported).
- Service navigation (recommended capability, metadata described in [ITU-T H.750] is recommended with caching and searching capabilities, parental control functionality is recommended).
- Provisioning and management (support recommended, polling and report-back should be supported, recommended accounting and management, software download and upgrade capability is recommended).
- Service and content protection: TD authentication, physical tamper-resistance for TD and secure means for performing security critical processes in TD are required, clause 6.5 of [ITU-T X.1191] is recommended to be supported).
- Privacy: following items are recommended to be securely handled within the IPTV TD:
 - viewing history, return/interaction channel usage and audience measurement information,
 - history of interactive operation,
 - personal profiles and preferences and ID number with reference to clause 6.6 and Annex A of [ITU-T X.1191].
- Video content: support of commonly used video formats is recommended with optional capability for regional video and graphics output (e.g., NTSC, PAL, SECAM) and HDMI outputs.
- Audio content: support of commonly used audio formats is recommended, audio transcoding is optional.
- Diagnostics: monitoring capabilities to provide diagnostic information about configuration and operation are recommended to be supported.
- Network architecture: one of them is required to be supported: "Non-NGN IPTV functional architecture", "NGN-based non-IMS IPTV functional architecture" and "NGN IMS-based IPTV functional architecture".

The IPTV terminal device functional architecture is introduced with a figure representing the Functional architecture block diagram for IPTV terminal devices very similar to Figure 10-4 (from [ITU-T H.721]) with the same title.

All functional blocks are described.

The IPTV TD is required to support RTSP for the delivery of unicast on-demand content or for the support of linear TV with trick mode and the remote control of a streaming media server.

Error recovery functional entity is recommended based on retransmission, forward error correction (FEC), or hybrid combinations of both.

The terminal device management functional entity provides the functions "provisioning and management" and "diagnostics".

Home Network interface is optional.

Possible interfaces are identified and described with the same figure as in [ITU-T H.720]. For the definition of many interfaces reference is made to [ITU-T J.293].

The IPTV terminal software architecture is presented with the same figure as in [ITU-T H.720].

Two basic configurations are defined for the basic IPTV terminal device:

- "basic IPTV-centric terminal device configuration" (no broadcast reception, no PVR).
- "basic IPTV-centric terminal device with PVR".

Annex A defines the baseline functionality for support of basic IPTV services and optional step-up functions.

Annex B is about content selection.

At least one of the following audio codecs is required to be supported: MPEG-1 Layer II, AC-3, MPEG-2 AAC.

At least one of the following video codecs is required to be supported: MPEG-2, [ITU-T H.264] AVC.

Appendix I provides a list of codecs that might be supported by the IPTV terminal device for IPTV content coding for content delivery services and for IPTV applications on interactive services.

Appendix II is about VBI data processing. The IPTV TD should be capable of passing through, extracting, decoding and rendering vertical blanking interval (VBI) lines carried in an encoded content stream and should make the VBI data available to the operating system and applications for processing.

Appendix III presents service flow charts of interactions between applications, service platforms and terminal middleware for software upgrade, boot-strap and initialization, service authentication, living broadcast service, time-shift service, VoD service, log upload, status report and configuration.

Appendix IV describes how the IPTV TD can use the service/system information to find out where on the network to access any content that the user selects.

Appendix V is about service discovery schemes. The service provider discovery is based on a three-layered record structure containing the network provider configuration record, the service provider discovery record and the service discovery record.

A comparison is made between ETSI TS 102 034 (DVB-IP) and Japan.

10.5 ITU-T J.703: IPTV client control interface definition

Extracted summary

Recommendation ITU-T J.703 defines the interface that enables the service client in the customer's network to send requests for content and application transport using Internet Protocol (IP) technology to the Internet Protocol Television (IPTV) service functions in the operator's network. Examples of IPTV content include digital video and audio programme content, including the metadata describing the programme content. Examples of IPTV requests include requests for broadcast or video on demand (VoD) content, requests to manipulate VoD content delivery (pause, play, rewind, etc.) and requests to record content for later viewing.

Extended summary

The scope of this Recommendation is the i-3 interface between service client in the customer network and IPTV service functions in the operator network, shown in Figure 10-8.

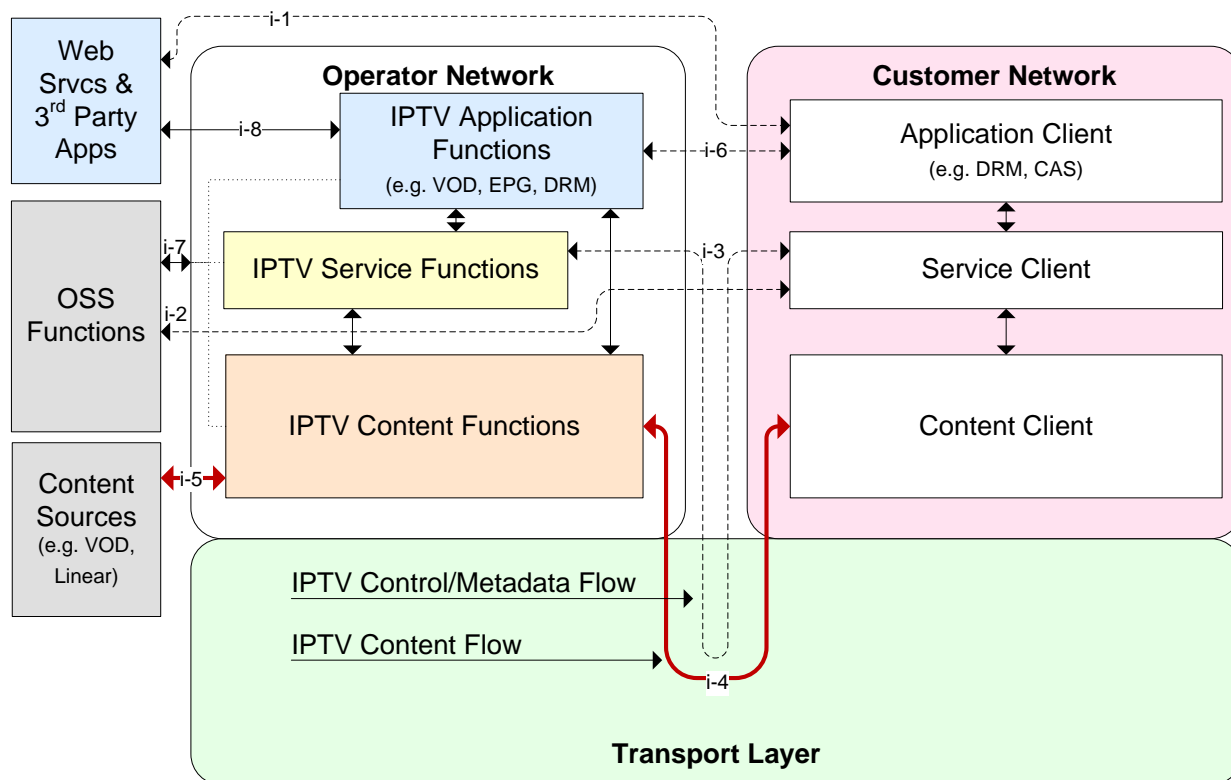

**Figure 10-8 – IPTV network reference points
(Figure 1 of [ITU-T J.703])**

The i-3 interface enables the service client in the customer's network to send requests for content and application transport, using IP technology to the IPTV service functions in the operator's network.

Examples of content and application to be requested through the i-3 interface include digital video and audio programme content, including the metadata describing the programme content and applications to be presented or executed at the service client.

There are requests for broadcast or VoD content, to manipulate VoD content delivery (pause, play, rewind, etc.) and to record content for later viewing.

The Recommendation describes and specifies operation modes and protocols for the following issues, namely:

- Client sign-on. The operator provides information about itself and its network topology to CPEs using a set of IP multicast flows. The first multicast flow is the system-wide flow at a well-known IP multicast address. It contains IP names or address of the various IPTV application functions and servers in the system and a code download list that tells the set-tops in the system when to upgrade boot and client code. The operator assigns each CPE in a system to a cluster (permanently joined multicast flow from CPE) and each cluster to a hub (multicast flow for system information or service information (SI) table delivery).

DSM-CC (ISO/IEC 13818-6) UNPassThru messages are used for change notifications.

- CPE booting. The booting process is described step by step. First, the boot loader must obtain an IP address using DHCP and check for a new code. If a new code is available, the boot loader must obtain the new code from the service functions, then boot the new code. Second, the boot loader must start the video applications (client code).

- System information or service information management. System information or service information (SI) acquisition can be done on a hub-by-hub basis over the hub multicast flow. CPEs can be placed in individual hubs and different services can be provided and provisioned to different CPEs (and subscribers) based on hub.
- EPG acquisition and management. The EPG is acquired by the CPE, it is parsed and presented to the end-user for selection. Then the referenced system information (SI) is used to acquire the service as directed. [ITU-T H.770] provides the method for service discovery, using EPG data acquisition and management.
- Emergency alert service. Only relevant to deployments in the United States. Emergency alert messages (EAMs) are sent to the appropriate group of set-top boxes using a DSM-CC UNPassthru message on the cluster multicast flow.
- Broadcast/multicast content signalling. The IPTV client accesses broadcast/multicast content using IGMP procedures (IETF RFC 3376). Using source specific multicast (SSM), clients specify a source and a group (S, G) when sending a join message to request a stream. Client must support IGMPv3.
- On-demand content signalling. The IPTV client accesses on-demand content using either RTSP (IETF RFC 2326) or DSM-CC (ISO/IEC 13818-6) for content session setup and control. On-demand, content catalogues can be browsed from the CPE using HTTP or HTTPS protocols, with the on-demand catalogue returning XML formatted metadata query results.
- Admission control and policy management. There are three options currently available for admission control. First, the RSVP can be used as on path admission control for applications that support it. Second, application-based rate limiting (as known as application admission control) can be used to manage bandwidth within a manually provisioned partition. Third, a feature called "multicast rate limiting" can be used to limit the multicast bandwidth used on certain links.

Multicast rate limiting can be used in conjunction with any of the access link QoS models below:

- Fully provisioned. The access line is sized such that all available service provider video streams can be carried simultaneously.
- Under provisioned with application admission control in home. The next level is to support limited oversubscription of service provider video of the access *line*, with admission control done in the home.
- Under provisioned with home-to-network admission control. The next level is to support oversubscription of service provider video on the access *network*, with access line admission control done between the home and the service provider's network.

In each of these models, the service provider uses a diffserv marking for its video traffic so that this traffic can receive appropriate QoS treatment.

Potential supporting protocols include IGMP/MLD (IETF RFC 3376), RTSP (IETF RFC 2326), SDP and DSM-CC (ISO/IEC 13818-6).

Appendix I is about IPTV client bootup sequence. It shows a high-level example flow diagram illustrating fundamental steps in the IPTV client bootup sequence adapted from ATIS-0800017.

10.6 ITU-T J.705: IPTV client provisioning, activation, configuration and management interface definition

Extracted summary

Recommendation ITU-T J.705 describes the i-2 interface, identified in Recommendation ITU-T J.700 that enables the service client in the customer network to interface with the operations support systems (OSS) functions in the operator network to provision and manage the IPTV client functions in the customer network. Examples of OSS functions include client provisioning, activation, configuration and management (PACM).

Extended summary

The i-2 interface and other IPTV network reference points are shown for [ITU-T J.703] in Figure 10-8.

The following types of functions are supported over the interface:

- 1) Configuration functions at the network level.
- 2) Accounting management.
- 3) Security management.
- 4) Fault management in the CPE.

In particular, the following functions are supported, aligned with (ATIS-0300092):

- a) Service(s) management including messaging and management of 3rd party applications.
- b) CAS/DRM control processing and client handling (complementing i-3).
- c) Event accounting, e.g., pay per view.
- d) Subscriber resource management.
- e) Service quality and performance management, through (BBF TR-069) ACS or other probes (e.g., channel changes, dropped packets, MPEG); and VQE statistics.
- f) CPE and RG management (remotely), including secure software download and settings.
- g) Service problem management and resource trouble management.

Potential supporting protocols include the following: HTTP, XML, XCAP for Web services, SIP for configuration framework, TFTP for client configuration, TR-069, SNMP, OMA DM, DSM-CC for data carousel; polling and report back for event accounting, DHCP used in discovery, UPnP used in discovery.

For reporting, at least one of the following protocols is required to be supported by the CPE if it is designed for the use with an embedded-DOCSIS cable modem.

- SNMPv3 defined in IETF Standard 62 [IETF RFC 3411] through [IETF RFC 3418].
- SNMPv1/v2c coexistence [IETF RFC 3584].
- SNMPv2 community-based access [IETF RFC 1901].

If the CPE uses a baseband IP communication method such as Ethernet, one of the following protocols is required to be used: HTTP version 1.1 (IETF RFC 2616), HTTP over TLS (IETF RFC 2818), TFTP (IETF RFC 1350) or TCP (IETF RFC 793).

For event accounting, it is required to support the following (service control layer) event accounting through the i-2 interface between a head-end controller and a CPE:

- PPV purchase information.
- CPE internal event, e.g., panic dump, system error.
- CPE internal log, e.g., keypad press history of remote control.

As a protocol for event accounting, it is required to use HTTP over TLS (IETF RFC 2818).

For secure software download. The CPE should support software download and upgrade capability using methods such as in-band DSM-CC carousels, multicast IP, or TCP/IP.

Non-DSM-CC solution: The authentication aspects for secure software download shall follow (ATIS-0800014) and the protocols used by a terminal device for software download shall follow (ATIS-0800009) which are based on (BBF TR-069) and (ETSI TS 102 824).

DSM-CC solution: The different steps for software download are described and illustrated by flow diagrams on: CPE component version determination, CPE component download, CPE component validation, CPE recovery from error and CPE download monitoring.

In a cable TV network, CPE using DOCSIS software upgrade mechanisms should follow the specification for privacy on the DOCSIS channel and authentication of the software image.

For a CPE with wireless WAN-based access (such as a hybrid set-top), the firmware upgrade protocol shall follow (OMA DM FUMO) which refers to the firmware update management object (FUMO).

11 IPTV middleware

Currently, there are two middleware Recommendations defined for IPTV:

- [ITU-T H.730], *Web-based terminal middleware for IPTV services*.
- [ITU-T J.701], *Broadcast-centric IPTV Terminal middleware*.

[ITU-T H.730]: Web-based terminal middleware (WBTM) defines the functional interfaces for high-level resource management over an IPTV terminal device and describes the structure of a web-based presentation engine, which basically supports IPTV multimedia application frameworks in the ITU-T H.76x series of Recommendations. Web-based IPTV terminal middleware is based on ITU-T IPTV functional architecture and ITU-T terminal devices in the ITU-T H.72x series of Recommendations. ITU-T web-based IPTV terminal middleware is necessary to support basic and advanced interactive IPTV services for IPTV terminal devices. This Recommendation also describes the general WBTM requirements for IPTV services and any additional functionality for basic and advanced IPTV services. Annex A summarizes the general requirements.

[ITU-T J.701] defines components of a broadcast-centric IPTV terminal middleware and provides a high-level description of functionality necessary to support IPTV services. These definitions and descriptions are intended to provide a migration path from existing terminal middleware for current digital broadcasting, with enhancements for IPTV support, to meet immediate market demand to deploy IPTV services. This Recommendation also describes the terminal middleware architecture and its relationship with the service platform. Additionally, this Recommendation provides a table of application programming interface (API) classifications.

12 IPTV application event handling (with big emphasis on AM)

IPTV application event handling is defined in the ITU-T H.740-subseries. While [ITU-T H.740] is general in nature, the ITU-T H.740-subseries specify how to perform audience measurement in the context of IPTV services:

- [ITU-T H.740], *Application event handling for IPTV services*.
- [ITU-T H.740] Amd. 1 (2011), *Application event handling for IPTV services: New video handling sensor event scenario in Appendix II*.
- [ITU-T H.741.0], *IPTV application event handling: Overall aspects of audience measurement for IPTV services*.
- [ITU-T H.741.1] and Amd. 1 (2013), *IPTV application event handling: Audience measurement operations for IPTV services*.

- [ITU-T H.741.2], *IPTV application event handling: Data structures of audience measurement for IPTV services.*
- [ITU-T H.741.2] Amd. 1 (2013), *New Appendix I with XML schema on the data structures of audience measurement for IPTV services.*
- [ITU-T H.741.3] (2012), *IPTV application event handling: Audience measurement for IPTV distributed content services.*
- [ITU-T H.741.4] (2012), *IPTV application event handling: Transport mechanisms for audience measurement.*
- HSTP.IPTV-AM.101, *Introduction to [ITU-T H.741-series] – A video engagement audience measurement standard.*
<https://www.itu.int/en/publications/Pages/publications.aspx?lang=fr&media=electronic&parent=T-TUT-IPTV-2013-PITD>
- [ITU-T J.706] (2012), *Overview of the distribution of target-specific content.*
- [ITU-T J.707] (2012), *Messages and protocols enabling the distribution of target-specific content within integrated broadband cable networks.*

12.1 ITU-T H.740: Application event handling for IPTV services

Extracted summary

Recommendation ITU-T H.740 provides a framework for application event handling for IPTV, such as emergency alert and audience measurement. This Recommendation provides a basic framework for application event model, application event description and notification, metadata model, delivery methods and security mechanism for application event for IPTV.

Amendment 1 includes a new use case about a video handling sensor event. This event can be used as supplemental information on audience measurement and other IPTV applications.

Extended summary

Every user interaction or every occurrence related to multimedia content in IPTV is called an event (e.g., video play start, button press, changed in metadata). Application events are events detectable at the application level.

Application events can be used for audience measurement, intelligent charging (only on what has been consumed), target marketing, personalized service by user's behaviour, commerce, monitoring of illegal copies, proof of purchase, managing of network bandwidth, or an emergency alert notification (EAN).

The application event handling model is introduced. Application events have at least two components: a description and a communication way.

There are two strict requirements for emergency events (no turn-off by end-user for incoming events, no turn-off by terminal device for outgoing events). For other events, it is recommended to enable the user to turn on or off events with privacy information.

The high-level architecture illustrates the application event live cycle, as it consists in a sequence of five functional blocks: generation, recognition, notification, reception, consumption.

The application event description is detailed and may contain:

Recommended elements for application event metadata are identified and described as follows:

- Event message identifier (unique).
- Message type with values: "Notification", "Update", "Cancel", "Ack" or "Error".
- Identifier(s) of referenced message.

- Event information: event description, event data recommended to be encoded as set of pairs of parameters (name and value), event time and date, resource (file with additional event information with resource description, MIME type, size and URI).
- Expiry date.
- Sender information (globally unique identifier and some additional elements such as sender's name, location and descriptive information).
- Recipient information (same structure as the sender information).
- Forward information (to identify the entity which receives the forwarded event description message).

For emergency events, the common alerting protocol (CAP) [ITU-T X.1303] can be used. It is an extensible mark-up language (XML) (W3C XML) based data format for exchanging public warnings and emergencies between alerting technologies.

When application events are related to user privacy information, privacy protection laws in each country, region and/or those described in IPTV or interactive broadcasting related Recommendations such as [ITU-T X.1191] and [ITU-R BT.2052] need to be respected. This means end-user permission is required.

Appendix I is about "Delivery methods". It is recommended to encode metadata in XML, application event record can optionally be encoded in XML and compressed.

Delivery of application event and metadata over IP can use HTTP (version 1.1 of IETF RFC 2616) or TFTP (IETF RFC 1350) over unicast, HTTP over TLS (IETF RFC 2818) over secured unicast, but without limitation to them.

Appendix II deals with "Scenarios for application event handling".

Three scenarios are described with flow diagrams:

- Emergency alert notification scenario (to notify the public about disasters such as earthquakes, fires, typhoons, snow storms, or catastrophic flooding).

The emergency alert notification should include: kind, rate, affected area, time, instructions, etc.

- Interactive advertisement and T-commerce notification scenario (interaction with TV content to trigger a request to purchase background music or to get additional information).

The event notification should include: user info, time, program info, commerce info, advertisement info, etc.

- Audience measurement application scenario (e.g., to inform service provider whenever end-users change channel to measure channel audience and/or to track popular programs).

Event notification should include: channel number before and after channel change, time of change, end-user information, etc.

Amendment 1 added a fourth scenario to Appendix II.

- Video sensor devices event scenario. A video sensor is a device that generates information such as gender and age of persons, their emotions, or their number and movements, by processing video data captured by a camera. This can be used to refine audience measurement or to switch off unwatched television sets to reduce electric power consumption.

12.2 ITU-T H.741.0: IPTV application event handling: Overall aspects of audience measurement for IPTV services

Extracted summary

Recommendation ITU-T H.741.0 defines a foundational platform for audience measurement (AM) of Internet protocol television (IPTV) services. This Recommendation focuses on the interface between terminal devices (TDs) and an audience measurement aggregation function.

The AM platform integrates a method for end users to report personal information and is designed to easily add time-shifted and interactive services and non-terminal device measurement points. While ITU-T H.741.0 allows the implementation of audience measurement for IPTV services, its mechanism may be equally applicable to non-IPTV services.

The audience measurement mechanism specified here provides additional benefits when compared to traditional audience measurement. Such benefits include, in particular, a larger audience population sample, more detailed engagement metrics, passive data collection and feedback for the enhancement of services.

The design philosophy in ITU-T H.741.0 is focused on scalability, on minimizing the use of resources, on optimizing security, on flexibility to support a variety of service provider deployments and on a rich set of privacy settings to meet emerging regulations and legislation.

The ITU-T H.741 sub-series of Recommendations defines a foundational platform for audience measurement (AM) of IPTV services. They focus on the interface between terminal devices and an audience measurement aggregation function.

Extended summary

[ITU-T H.741.0] starts with an overview.

When an end-user consumes an IPTV service, audience measurement (AM), implemented by an IPTV application, collects data about the end-user behaviour with his/her permission including audience presence and engagement. Measurement services may be provided in real-time or offline.

The targeted IPTV services for audience measurement include:

- Distributed content services such as linear TV, video on demand (VoD), network personal video recorder (n-PVR) and consumer personal video recorder (c-PVR).
- Interactive services such as games, learning, commerce and information access.

Requirements on the audience measurement architecture are listed starting with 20 strict requirements (e.g., ability to measure selected services, events, to select users to be measured, to ensure confidentiality and integrity of end-user data), 16 recommended (broad granularity of measurements, daily change of measurement configuration, recovery from storage or network congestion) and 6 optional (ability to configure on a per user basis, a per content basis, or a combination of both, presence detection).

End-users may optionally restrict audience measurement by configuration of measurement permits based upon service type (e.g., linear TV, VoD, PVR), content type (e.g., children's TV, adult TV, religious, political, etc.), event type (e.g., channel change, record, etc.), end-user type (e.g., children under 13, adults, etc.), device type (e.g., TV, mobile phone, etc.), etc.

There are also requirements for IPTV architecture such as a mechanism for discovery of multiple audience measurement services, ability for the user to select a particular audience measurement service.

The audience measurement architecture is illustrated in Figure 12-1, in which audience measurement functions (AMF), potentially located in different functional blocks of the IPTV architecture (terminal device, home network, service control, content delivery or network), measure the end-user behaviour and deliver this information to aggregation functions.

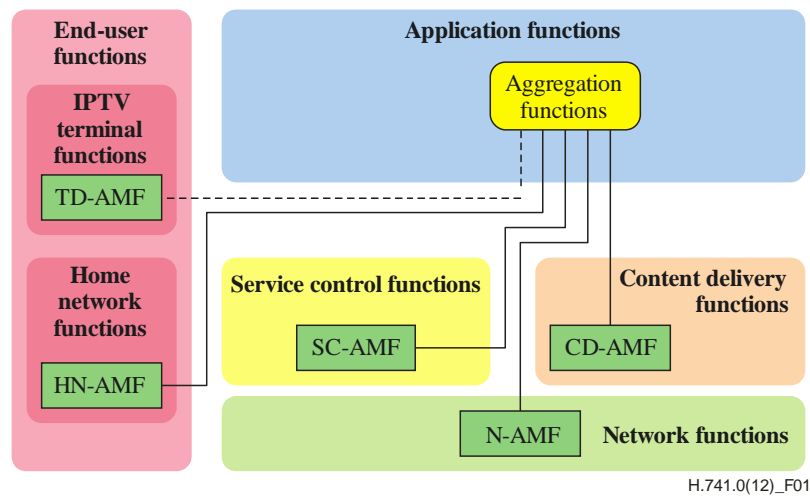

Figure 12-1 – Audience measurement components within IPTV architecture (Figure 1 of [ITU-T H.741.0])

This Recommendation specifies IPTV audience measurement only for terminal device audience measurement functions (TD-AMFs).

The audience measurement lifecycle is described from service discovery, permit inputs, orders from stakeholders (e.g., content providers, advertisers, etc.), TD-AMF configuration by aggregation function, AMF measurement reports to aggregated reports to stakeholders.

Figure 12-2 illustrates the interfaces of the audience measurement and aggregation functions

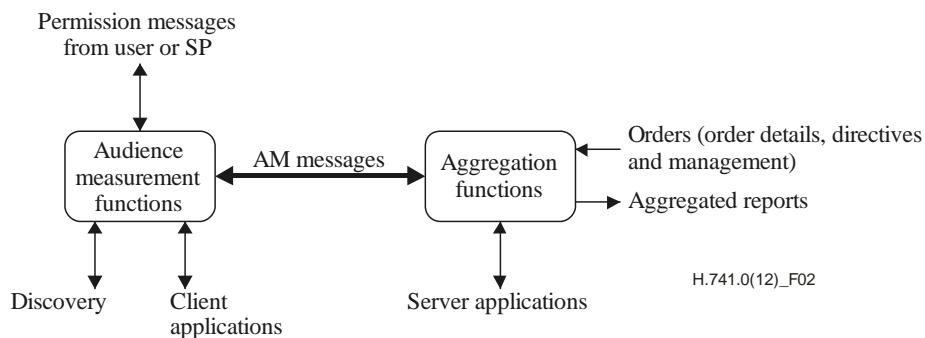

Figure 12-2 – Information interfaces associated with the operation of AM (Figure 2 of [ITU-T H.741.0])

The configuration of terminal device audience measurement functions (TD-AMFs) may be initiated by either the TD-AMF and/or the aggregation functions. Message sequences are used to illustrate both cases.

Measurement reporting may be initiated also by either the TD-AMF and/or the aggregation functions. Four types of delivery modes can be configured:

- Immediate push mode (only a short delay to send reports is allowed for traffic efficiency).
- Delayed push mode (reports are stored and sent later in a delivery window starting at a randomized time for traffic shaping).

- Pull mode (only on request from aggregation function).
- Delayed push and pull mode (reports are stored for later delivery but reports can also be requested at any time).

Three permission modes are possible and the permission mode to be used is discovered during the AM discovery process:

- External permission mode: no end-user permits are used at TD-AMFs.
- Internal permission mode: permits are created at TD-AMFs and delivered to the TD-AMF separately from the configuration messages.
- Hybrid permission mode: The TD-AMF requests permits from the IPTV SP and receives them separately from configuration messages.

Appendix I deals with "Potential relationships between end users, audience measurement service providers and content distribution service providers".

As audience measurement services may be provided by IPTV service providers or independent providers. These roles may be distributed in different ways in the real world and this appendix identifies a number of possible configurations, namely:

- Service provider offering both content distribution and audience measurement services.
- Separate audience measurement service and content distribution service providers (e.g., the same Linear TV channel is distributed by two IPTV service providers but there is only one audience measurement service provide by one of the service providers).
- Multiple audience measurement service providers (in this case end-users can choose the audience measurement service they prefer).

Appendix II is about "Context of audience measurement". It provides an example to show how AM might fit into a larger context with stakeholders (service providers, content providers, advertisers/agencies, programmers and audience research companies) providing measurement orders to a measurement management function relating to the aggregation functions to ask for measurements and to get aggregated reports. Interfaces are shown with other IPTV functions for both aggregation functions and audience measurement functions.

12.3 ITU-T H.741.1: IPTV application event handling: Audience measurement operations for IPTV services

Extracted summary

Recommendation ITU-T H.741.1 specifies the operations of AM, including procedures prior to configuration of terminals, configuration of terminals, reporting by terminals, security mechanisms and recovery from abnormal situations. Informative Appendices I-VII discuss discovery metadata, implementation considerations, examples, permission levels, vendor considerations, alternative privacy schemes and discuss capabilities and profiles.

Amendment 1 to Recommendation ITU-T H.741.1 (integrated into this edition) includes XML schema on audience measurement service discovery in Appendix VIII and XML schema instances for TD-AMF configurations, reports and permits in Appendix IX.

Extended summary

[ITU-T H.741.1] starts with the description of the pre-configuration which is the first step in the audience measurement lifecycle, in which the terminal device discovers, selects and connects to an IPTV service provider. The discovery of service providers and their services are described in [ITU-T H.770].

The sequence of operations leading to configuration of audience measurement functions by aggregation functions following connection to an IPTV service provider for the first time is shown on a figure. This Recommendation describes how TD-AMFs are provided with audience measurement configuration package not already obtained from discovery, to participate in audience measurement. As this configuration package may change over the time, mechanisms to get updated information are describes for all configuration modes (pull, push, pull and push), with the introduction of a package check delay to trigger subsequent checks for availability of a new configuration package.

The next step is the effective configuration of the TD-AMF, which is the result of constraining the received configuration package(s) with an effective end-user permit if present.

The configuration package is then described. Configuration packages are sent to TD-AMFs for immediate use, or sent in advance with an operation start time. Components of a configuration package are:

- Package header (depending on message delivery mode)
 - Common elements: message-expiration time, version, compression algorithm, identifier, start time, configuration package check delay.
 - Multicast-specific elements:
 - Filtering element. There are four ways to define targeted subsets of TD-AMFs which are to process the associated configuration packages (lower and upper thresholds in between a random number generated by the terminal device has to be to process the configuration package, device type(s), MAC addresses or match with end-user information, e.g., occupation= doctor, income above 100000 USD).
 - Ack request (optional).
 - Error reporting (optional).
- Measurement requests. Measurement requests contain services to be measured, measurement schedules, events and sample values to be measured and measurement report message delivery schedules. Reference is made to [ITU-T H.741.2] for corresponding metadata elements.
 - Services to be measured: linear TV (with channel identification), VoD or cPVR.
 - Content classes to be filtered: e.g., genres as defined by different organizations which may indicate children's TV, adult TV, religious and political programmes, etc.
 - Measurement schedule(s): duration of time during which measurements may occur. Multiple measurement periods are possible within a day, or cross the boundaries of a single day, independently for each day of the week.
 - Elements to be measured (events and sample values).
 - "Service-common" events and samples are defined for two or more specific services in [ITU-T H.741.2].
 - "Service-specific" events and samples apply to one specific service. They are defined in [ITU-T H.741.3].
 - Three types of measurement trigger can be used: event name, scheduled sample time or service start (to get slowly changing information with the first IPTV service started every N days). A list of elements to be reported is associated to each trigger.

Figure 12-3 illustrates what is meant by "measurement period" or measurement schedule, "service period" in which an IPTV service is consumed, "effective measurement period" in which measurement reports are generated and "periodicity" for sampling time.

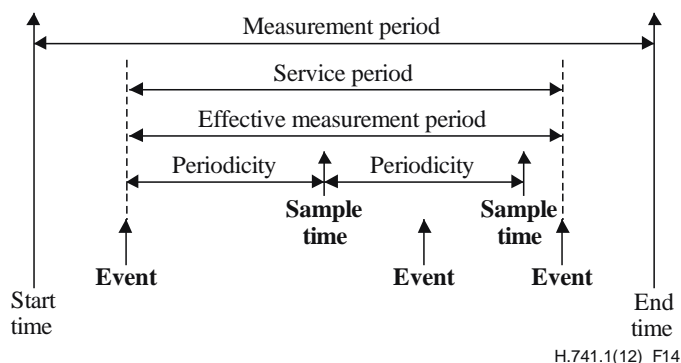

Figure 12-3 – Sample values and events are measured within the effective measurement period (Figure 14 of [ITU-T H.741.1])

Priority is associated to each generated measurement report to be used in case of measurement storage congestion

- Filtering and summarization (to reduce measurement reporting traffic).
- Duplicate sample value may either be ignored and not reported, reported as empty, or reported normally.
- Reporting a count of identified events without event details is made possible.
- Measurement report delivery schedule. Four types of delivery modes are possible: immediate push, delayed push mode (in a schedule window), pull mode (only on request from aggregation functions), delayed push and pull mode (schedule window and request from aggregation functions).
- Parameters are "delivery address(es)" and "retransmit number".

End-user privacy policies may be expressed within end-user permits. An end-user permit may contain an expiration date, a default permission level and a default content restriction list. The user permit may limit the audience measurement requests included in the configuration package.

There are three possible permission modes (i.e., external permission mode, internal permission mode and hybrid permission mode) and the TD-AMF learns of which permission mode to use from the discovery process.

Specific measurement reporting issues are described:

- Reporting of services which start or end outside measurement periods (e.g., a ServiceInstanceID is generated when a service starts even if outside of measurement period).
- Reporting surrounding restricted content (measurements stop when restricted content starts to be played and a service stop event report is generated).
- Reporting of user presence (detected presence reported only when the effective permit (if available) grants permission).
- Reporting changes due to effective permit changes (measurements and reports shall immediately reflect permission changes).
- Reporting of storage congestion (indication of measurements dropped due to storage congestion and priority is to be reported within the measurement report message).

The next chapter addresses "Security, privacy and permission mechanisms".

AM messages, if left unprotected, unverified and unauthenticated will allow an adversary to compromise the very intention of audience measurement.

The TD-AMF and AGF are required to authenticate each other directly. Before sending a request message, the TD-AMF or AGF authenticates itself to the other party using transport layer security (TLS) (IETF RFC 5246) which makes use of ITU-T X.509v3 digital certificates [ITU-T X.509].

In order to safeguard end-user privacy, it is required that all unicast AM messages be encrypted. It is recommended that all multicast AM messages be encrypted. The choices of cryptographic protocols for confidentiality are indicated in the capabilities profile and in the discovery data structure.

In order to ensure that the AM messages are not modified by an attacker, every AM message has its own expiration time. Every multicast message also has its own cryptographic digest (SHA-256) and a digital signature (RSA-1024).

In order to ensure the authenticity of AM information, the inclusion of signatures in AM reports provides non-repudiation.

In order to support privacy, it is recommended that the protection of end-user information and identity and AM message unlinkability, be supported.

Security methods and corresponding algorithms are summarized in a table for upstream and downstream AM messages to ensure authentication, confidentiality and integrity.

The chapter "End-user permission operation modes" describes with permission flow diagrams the three possible permission modes, namely:

- External permission mode in which an IPTV SP is responsible for obtaining user permits and is responsible for using those permits.
- Internal permission mode in which an AM SP is responsible for obtaining permits and is responsible for using those permits. TD-AMFs support the ability to ask for an end user's permission and store responses. Specific measurements in the received configuration package may be disallowed by the TD-AMF depending upon the end-user permissions.
- Hybrid permission mode in which an IPTV SP is responsible for obtaining permits and an AM service provider is responsible for using those permits. AM end-user permissions are part of the end-user information stored by the IPTV service provider. The IPTV SP provides the tool to allow the end users to set their AM end-user permissions for the different services it offers.

Abnormal situations may happen during the procedures of discovery, configuration, storing and reporting AM data. Some are identified here (Message high-level error, configuration message or configuration request response message error, configuration request message error, measurement report request message error, measurement report message error, storage overrun, no measurement report message transport ack, delayed push report missed, content filtering error, TD-AMF sends inappropriate but valid AM messages) and potential recovery actions are listed.

Appendix I addresses "Discovery of audience measurement services by terminal devices".

As there are several possible operational options for the aggregation functions, there declaration is necessary to allow the terminal devices to check at the AM service discovery time if they are able to operate with them or not and how best to operate.

Table I.1 from [ITU-T H.741.1] contains the elements to be included in [ITU-T H.770] for the discovery of AM services.

Appendix II is about "Considerations on implementation". This appendix addresses a number of implementation issues, namely:

- "Considerations on whether to implement AM", benefits of AM as part of IPTV architecture in comparison to traditional methods are listed (e.g., a larger audience sample, more detailed

engagement measurements, etc.) and also the AM limitations in comparison to ideal methods (e.g., AM does not measure all end-user engagements on end-user devices which support IPTV services, AM is for IPTV "TV" only, etc.).

- "Considerations for end-user permission method selection", as there are three permission modes (internal, external, hybrid), conditions that may lead to select one mode or the other are listed.

There are also diagrams to show where the user permits are exchanged and used.

Example of multiple permits in a household is given with different rights for father, mother and sons:

- "Considerations on using content filtering in configuration packages". Conditions that may lead to configuration of content filtering being used by an AM provider are listed.
- "Considerations on using different measurement triggers" (events, time-based sampling, service start). Different situations are described to show when each of these triggers are best suited.
- "Considerations for using AM message acknowledgements". AM includes an optional, flexible and low overhead acknowledgement request mechanism (response qualifier) for the multicast configuration message. Acknowledgments may be selectively configured on a set of devices which act as device samples for the greater population.
- "Considerations for configuration mode selection" among pull, push and hybrid modes. Situations for which each mode is best suited are listed.
- "Considerations regarding methods of obtaining end-user permits". Several methods may be available for AM and/or IPTV service providers to obtain end-user permits. To help select and implement a method, three processes are recommended for consideration.
- "Considerations for using multicast sub-addressing mechanisms". When using multicast messages, AM provides four mechanisms which enable addressing subsets of TD-AMFs (lower and upper thresholds in between a random number generated by the terminal device has to be to process the configuration package, device type(s), MAC addresses or match with end-user information). Conditions that may lead to any of these subset addressing are listed.
- "Considerations for requesting error message responses to multicast messages". Error message responses to multicast messages are configurable. Conditions that may lead to request error messages from a reduced set of terminal devices are listed.
- "Considerations for delivery mode selection". As there are four modes (i.e., immediate push, delayed push, pull, delayed push and pull) considerations of the situations for which each mode is best suited are given.
- "Considerations on using end-user information to filter measurement requests". Multiple end-user info qualifiers e.g., occupation="doctor" and income="over 200 000 Euros" may be associated to measurement requests to get audience information from a set of specific end-users. Conditions that may lead to the use of end-user information for filtering measurement requests are listed.

Appendix III provides "Examples of TD-AMF configurations, reports and permits".

Examples of configuration package data structure for service-common measurements are provided with corresponding end-user behaviours and measurement reports.

Examples using end-user information for filtering measurement requests in configuration packages are also given.

An example of UserPermit is given in which permission level 3 is granted for linear TV channels 150 and 153, on STB and TV, for all content genres except religious or health.

Appendix IV is about "Considerations of end-user permission levels".

4 permission levels are identified as follows:

- Permission Level 0 (default): no measurement permitted.
- Permission Level 1: End-user behaviours and device info, distinguishable end user, no end-user information, e.g., Channel 5 was watched by anonymous end user #12683304 on mobile device model "X".
- Permission Level 2: End-user behaviours and device info, distinguishable end user and anonymous end-user information, e.g., Channel 5 was watched by anonymous end user #12683304, interested in gardening, on mobile device model "X".
- Permission Level 3: End-user behaviours and device info, distinguishable end user, anonymous end-user information and identifiable subscriber or end-user information, e.g., Channel 5 was watched on mobile device model "X" being used by subscriber or end user "John Smith" who is interested in gardening.

Examples of reportable information are given for different services as permitted by the different permission levels.

Appendix V is about "Considerations regarding the unlinkability property".

It is possible to correlate an anonymous end user (either in permission level 2 or permission level 1) with other information previously or subsequently obtained about that user. To avoid such a correlation, unlinkability property for AM report submission is recommended. Indirection of AM reports is the basis to implement unlinkability which requires the use of additional network bandwidth.

The unlinkability property can be achieved using privacy enhancing technologies from two broad classes of alternatives:

- TTP (Trusted third party): Employing a trusted third party that acts as a proxy for TD-AMFs to submit AM reports.
- P2P (peer-to-peer): Collaboration among peer TD-AMFs to forward each other's AM reports to an AGF. The P2P-based alternative is preferred over the TTP-based alternative as it does not require any modifications to the AM architecture.

Appendix VI provides "Considerations for AM vendors". Analysis of measurements may lead to aggregation over device types, time, content, geography, channel, etc.

Appendix VII deals with "Audience measurement capabilities and profiles".

A table lists capabilities of TD-AMFs: transport delivery mode (unicast, multicast), cryptographic protocols, permission mode (internal, external, hybrid), configuration mode (pull, push, pull and push), measurement triggers, report delivery mode (immediate push, delayed push, pull, delayed push and pull).

Appendix VIII gives an "XML schema on the data structures for audience measurement service discovery".

An XML schema is provided for the AMServiceDiscovery record with all elements necessary for the declaration of AM services.

Appendix IX provides "XML schema instances for TD-AMF configurations, reports and permits".

These are the XML schema instances for examples of TD-AMF configurations, reports and permits defined in Appendix III. These instances are based on Appendix VIII.

12.4 ITU-T H.741.2: IPTV application event handling: Data structures of audience measurement for IPTV services

Extracted summary

Recommendation ITU-T H.741.2 specifies the data elements and structures of the payloads used in audience measurement messages.

Amendment 1 contains a new appendix I with XML schema on the data structures of audience measurement for IPTV services.

Extended summary

[ITU-T H.741.2] specifies data structures and messages to be exchanged between terminal device audience measurement function (TD-AMF) and aggregation functions.

It starts with the specification of basic data elements already from other sources, with identifier, name, format and possible values: ca:civicAddr (Civic Address), xs:date (date), xs:dateTime (date and time), etc.

Then data elements associated with a user's device, including capabilities, identification, configuration and usage are shown in a table with element identifier, description, support/type and notes or value domain, like this:

Element	Description	Support/ type (Note 3)	Notes or value domain
AMFCapabilityProfile	Container to list capabilities supported by the TD-AMF implementation.	Note 1	

Among the end user device data elements are: "AMFCapabilityProfile" (capabilities supported by TD-AMF), "ServiceInstanceID" (allocated by a TD-AMF to each specific service when it starts), "TVInformation" (information related to a TV connected to a STB), "IPTV-TVInformation" (information related to an IPTV-capable TV), "AudioAmplifierInformation" (information related to an audio system connected to a STB), "STBInformation", "MobileDeviceInformation", "PC Information", "ControlDevice" (remote control, keyboard).

The following data elements for end-user information asserted by end user and service-common elements are specified in a similar table: "PermissionLevel" (0-3), "ControlledUserInfoTypeString" (e.g., AgeRange), "ControlledUserInfoValueString" (e.g., 20-40), "ControlledUserInfoTypeDate" (e.g., birthday), "ControlledUserInfoValueDate" (e.g., 2012-09-24), "ControlledUserInfoTypeAddress" (e.g., BirthLocation), "ControlledUserInfoValueAddress" (e.g., Fr 502), "GenericUserInfoType" (e.g., interests), "GenericUserInfoValue" (e.g., gardening).

The following data elements for end-user information generated by system and service-common elements are specified in a similar table: "TDLocation", "UserPresent" (presence information from one source), "UserList" (end-user information), "ServiceProviderIdentifier", "SubscriberID", "Permit BlockedInfo" (to indicate how measurement are blocked by end-user permit: permission level, device type, channel, content class).

Service-common events which can trigger a measurement report are then specified in a similar table: "VideoResize", "VideoZoom", "VideoObscure", "AudioVolume", "ConfigurationChange", "UserChange", "UserInfoChange", "AudioLanguageChange", "CaptionLanguageChange" and "DisplayStatus".

Service-common sample set identifiers are used to indicate what is to be reported when a sample time occurs. Here are some of them: "UserPresent" (to indicate that the UserPresent data structure defined above is to be reported when sampled), "TDLocation", "DeviceInfo", etc.

The major data structures for audience measurement, making use of data elements defined above are specified:

- Data structure for error messages. It is used to report any error in a message and for this reason contains: "HighLevelErrorCode", "RootElement" (of the erroneous message) and may contain depending on the erroneous message: "ConfigPackageError", "ConfigRequestError", "ReportRequestError", "ReportError".
- Data structure for measurement requests. It consists of a header with "Measurement RequestID" and four logical parts:
 - Services to be measured. For Linear TV measurement, a "LinearTVQualifier" is specified in [ITU-T H.741.3] to select channels). "AllContentClassExceptList" allows to filter measurements across services based upon content class.
 - Measurement schedule. Several "MeasurementPeriod" may be defined with "DayOfThe Week", "StartTime" and "EndTime".
 - Measurement triggers: list of service-common or service-specific events with "priority" for congestion management, "Periodicity" for sampling after service start, with service-common sample set identifiers specified above to list what is to be reported with "priority", "Interval" (number of days) for reporting for first service start report every N days.
 - Measurement delivery with "DeliveryAddress", "RetransmitNumber", "Storage CongestionPolicy" and parameters specific to delivery modes: immediate push, delayed push ("DeliveryWindow"), pull and delayed push and pull.

A delayed push measurement reporting policy is specified to avoid network congestion by measurement reports.

- Data structure for measurement request sets. It is defined to provide an optimization mechanism to include default values for elements which have the same value in a number of measurement requests, e.g., "DefaultMeasurementPeriod", "DefaultRetransmitNumber", etc.
- Data structure for "measurement request set filter". Measurements can be requested only from end-users with end-user information matching "UserInfoTarget" defined in [ITU-T H.741.4].
- Data structure for measurement report requests. It contains only a list of "Measurement RequestID" to identify the measurement requests for which generated measurement reports are requested.
- Data structure for AMF configuration packages. It contains the following elements: "Package Version", "EffectivityDateAndTime", "UserPermitInfo" (when user permits are provided by aggregation functions) and a number of "MeasurementRequestSet" defined above.
- Data structure for "acknowledge message". It is used to report on the reception of an AM message with no error.
- Data structure for configuration package requests. It is used to ask for an AMF configuration package or to check if the current or future configuration package at the TD AMF is still valid.
- Data structure for "configuration package request response". It specifies the data structure of the response to the message containing the just above data structure. It contains the following elements: "ConfigurationPackageCheckDelay" (delay between checks for configuration update), "ImmediateMeasurementDirective" with "Code" (0= no AM, 1=no change, 2=new configuration package) and optional "AMFConfigPackage", "FutureMeasurementDirective" with "Code" and optional "AMFConfigPackage".
- Data structure for user permits. It may contain "ExpirationDate", "DefaultExpirationDate", "DefaultAllContentClassExceptList" (content classes not to be measured), "AnonUserID"

(anonymous end-user ID, to be used when permission level is below 3), "UserId" and for each "PermissionLevel" a set of "UserPermission" each for specific IPTV services identified for example by "ChannelQualifier" consumed by indicated "TerminalDeviceType".

- Data structure for measurement reports with service-common events and/or samples. The data structure consists of common elements: "MeasurementRequestID" and "MeasurementReportTriggerTime" and elements specific to measurement triggers (usually a change) and to what can be requested to be reported: "DisplayStatus", "AudioFocus", "CaptionLanguageChange", "AudioLanguageChange", "AudioVolume", "ConfigurationChange" (device configuration), "VideoObscure", "VideoZoom", "VideoResize", "EventCount", "DeviceInformation", "UserBiographicInformation", "TDLocation", "UserList", "UserPresent", "GenericUserInfo", "UserInfoChange" and "PermitBlockedInfo". Some data elements have already been defined earlier.
- Data structure for audience measurement report package. This data structure is defined to group a number of audience measurement reports. It starts with a header which may contain: "SubscriberID", "TerminalDeviceID", "StorageCongestionImpactedService" (identification of service with dropped measurement reports due to storage congestion), "ServiceStopDropped" (identification of service with dropped service stop due to storage congestion). A set of measurement reports (as defined just above) may follow this header.

12.5 ITU-T H.741.3: IPTV application event handling: Audience measurement for IPTV distributed content services

Extracted summary

Recommendation ITU-T H.741.3 specifies audience measurement for IPTV distributed content services and, in particular, linear TV services. It describes specific configuration for linear TV and metadata and data structures used in the payload of AM messages. The informative appendices discuss specific implementation considerations for linear TV-specific implementation considerations, provide examples and describe capabilities and profiles.

Extended summary

This Recommendation specifies configuration, reporting and data structures for linear TV events and samples.

Linear TV aspects with an impact on the audience measurement configuration are described:

- Channels. Either all channels or a list of channels to be measured may be configured. Alternatively, an "all channel except" list may be configured.
- Summarization and filtering. Configuration of a channel change filter time between channel change events can be used to filter out unneeded reports.
- Service navigation method. The reporting of which method was used to change channel may be configured.
- Control device. The reporting of which device was used to change channel may be configured.

Data elements specific to Linear TV, to be inserted in the data structures specified in [ITU-T H.741.2] are listed:

- ServiceIdentifier, defined in [ITU-T H.770].
- ChannelChangeFilter (minimum time in milliseconds between subsequent channel start and channel stop events to generate reports about these events).
- ControlDevice (device type used to navigate to a channel).
- StartNavMethod (method used to navigate to a channel).

- StopNavMethod (method used to navigate away from a channel).
- ViewMode (e.g., full screen, Picture-in-Picture, mosaic, etc.).

Specific Linear TV events are specified: LinearChannelStart and LinearChannelStop.

Specific Linear TV elements which can be reported: ChannelPlaying.

"LinearTVQualifier", the data element to be inserted in the "measurement request" data structure to identify what Linear TV services are to be measured, is defined in this recommendation. It indicates if navigation method ("NavMethod"), control device ("ControlDevice"), view mode ("ViewMode"), obscuration ("Obscuration") are to be reported. Other elements are "ChannelQualifier" (to identify channels to be measured) and "ChannelChangeFilter" defined above.

Specific Linear TV data elements to be inserted in measurement request set data structure are specified: "DefaultNavMethod", "DefaultControlDevice", "DefaultViewMode", "DefaultObscuration", "DefaultChannelQualifier", "DefaultChannel ChangeFilter".

Specific Linear TV data elements to be inserted in measurement report data structure are specified:

- ChannelStart with "ControlDevice", "StartNavMethod", "PreviousServiceInstanceID", "ServiceInstanceID", "ServiceIdentifier", "ViewMode", "Obscuration".
- ChannelStop "ControlDevice", "StopNavMethod", "ServiceInstanceID".
- ChannelPlaying with "ServiceIdentifier", "ServiceInstanceID".

Appendix I provides some "Implementation considerations" and in particular:

- Considerations regarding the enabling of control device reporting. Conditions that may lead to this reporting option being enabled are listed.
- Considerations regarding the enabling of navigation method reporting. Conditions that may lead to this reporting option being enabled are listed.
- Considerations for specifying channels to be measured. Three methods for specifying channels to be measured: specification by inclusion, specification by exclusion, or measurement of all channels (default).
- Considerations for using channel change filtering and how to choose the value. If reporting of transitional channels to a final channel is not desired, then it is recommended that channel change filtering be used.

Appendix II gives "Examples of configuration and reporting of the terminal device audience measurement function".

An example of an AMF configuration package is given with the following characteristics:

- For all channels except Channels 50, 53, 58 and 60. Do not measure religious content
 - Measurement reports for channel start and channel stop events when the time following an event without either subsequent event occurring is greater than two seconds.
 - Measurement all the time.
 - Report batches of events within 60 seconds of any event.
- For Channels 50, 53, 58 and 60. Do not measure religious content
 - Time sampling every five minutes. Ignore the sample if its value is the same as the previous sample's value.
 - Reporting: upon demand by aggregation functions.

An example of end-user behaviours (watching different Linear TV channels) is illustrated on a figure with time indication for generated measurement reports when an AMF is configured with the previous configuration package. Several examples of measurement report packages are given.

Another example of configuration package is given to get reports related to Picture-in-Picture (PIP) operations, including swapping the sub-picture and main picture and resizing and moving the sub-picture. An example of end-user behaviour with PIP operation is illustrated and some examples of measurement report packages about PIP operation are provided.

Appendix III is about "Audience measurement capability profiles". Capabilities of the terminal device audience measurement function are listed:

- Measurement Triggers (events and/or time sampling).
- Operational Management (Channels to be measured, Channel change filtering, Navigation method reporting, Control device reporting).

These capabilities are included in the capability data structure defined in [ITU-T H.741.2].

12.6 ITU-T H.741.4: IPTV application event handling: Transport mechanisms for audience measurement

Extracted summary

Recommendation ITU-T H.741.4 specifies the data elements and structures of the transport delivery-dependent XML and binary headers, used in audience measurement messages. Appendix I provides an analysis of AM to understand its transport protocol requirements.

Extended summary

Table 12-1 shows how messages containing data structures defined in [ITU-T H.741.2] can be delivered in unicast mode and/or in multicast mode.

Table 12-1 – Delivery mechanisms for each data structure (Table 1 of [ITU-T H.741.4])

Data structure	Unicast	Multicast
Configuration package request	X	
Configuration package request response	X	X
Configuration package	X	X
Measurement report request	X	X
Measurement report package	X	
Ack	X	
Error	X	

Messages are created to insert the data structures defined in [ITU-T H.741.2] with the following header for delivery over unicast and multicast are: message identifier ("MessageID"), message type identifier ("MessageType"), message expiration time ("ExpirationTime") and AM protocol version numbers ("ProtocolVersionMajorID", "ProtocolVersionMinorID" and "Compression" of XML payload.

For multicast delivery additional data elements are necessary: message integrity check ("Digest") and signature ("Signature") for authentication, element to request or not acknowledge or error responses ("ResponseQualifier"), sub-addressing elements to target a sub-set of TD-AMFs ("TerminalDeviceTarget", "TerminalDeviceTypeTarget", "UserInfoTarget").

Then message data structures used to delivery various data structures defined in [ITU-T H.741.2] are specified:

- Data structure for the configuration request message (Header elements and "ConfigPackage Request" defined in [ITU-T H.741.2]).

- Data structure for the unicast configuration request response message (Header elements and "ConfigPackageRequestResponse" defined in [ITU-T H.741.2]).
- Data structure for the multicast configuration request response message (Header elements, additional multicast header elements, "ConfigPackageRequestResponse" defined in [ITU-T H.741.2]).
- Data structure for the unicast configuration package message (Header elements and "ImmediateAndFutureConfiguration" defined as "ConfigPackageRequestResponse" in [ITU-T H.741.2]).
- Data structure for the multicast configuration package message (Header elements, additional multicast header elements and "ImmediateAndFutureConfiguration" defined as "ConfigPackageRequestResponse" in [ITU-T H.741.2]).
- Data structure for the unicast measurement report request message (Header elements and "MeasurementReportRequest" as defined in [ITU-T H.741.2]).
- Data structure for the multicast measurement report request message (Header elements, additional multicast header elements and "MeasurementReportRequest" as defined in [ITU-T H.741.2]).
- Data structure for the measurement report package message (Header elements and "AMReportPackage" as defined in [ITU-T H.741.2]).
- Data structure for the configuration package ack message (Header elements and "Ack" as defined in [ITU-T H.741.2]).
- Data structure for the error message (Header elements and "Error" as defined in [ITU-T H.741.2]).

Appendix I addresses "Transport protocol considerations for audience measurement".

It describes whether unicast and/or multicast protocols can be used for each message type. It provides relative message size range estimates of each message with dependencies which increase size.

It describes also the need for reliability for each message type and the impact when messages are not delivered (e.g., gap in measurements or wrong measurements).

Concerning AM message QoS needs, AM traffic may be marked as bulk class or equivalent.

Concerning AM message integrity needs, as integrity check is provided at the message level, integrity check at the transport level is not required.

Concerning AM message encryption needs, since AM messages include support for encryption, encryption at the transport level is not required.

12.7 Other Recommendations

HSTP.IPTV-AM.101 "Introduction to ITU-T H.741-series – A video engagement audience measurement standard".

[ITU-T J.706]: Target-specific content distribution is a mechanism for distributing content addressed to specific target users according to a set of distribution policies and specific interactive feedback from the platform to content providers/Ad providers. This Recommendation defines the overall architecture of the target-specific content distribution system on the platform and seeks to describe the relationship between [ITU-T J.707] and other relevant Recommendations.

[ITU-T J.707] defines the messages and protocols used to realize target-specific content distribution for integrated broadband cable networks. Target-specific content distribution is the mechanism for content distribution addressed to specific target users. This Recommendation defines message format and delivery protocols between content providers/Ad providers and the platform.

13 IPTV metadata

Metadata for IPTV services are defined in the ITU-T H.750 sub-series and currently comprises two Recommendations:

- [ITU-T H.750], *High-level specification of metadata for IPTV services*.
- [ITU-T H.751], *Common specification with IEC TC 100 on metadata for rights interoperability (or for "security")*.

13.1 ITU-T H.750: High-level specification of metadata for IPTV services

Extracted summary

Recommendation ITU-T H.750 gives the high-level specification of the metadata for IPTV services, with its elements and delivery protocols. IPTV metadata, the information on services and content processed by the service and content delivery infrastructure, provides a descriptive and structural framework for managing IPTV services. The types of metadata for IPTV are service and content metadata, user metadata, metadata for content provisioning and management, metadata aggregation management and rights and security related metadata. Aspects of discovery, delivery and transport, representation and management of metadata are covered in this Recommendation.

Extended summary

[ITU-T H.750] provides an overview of IPTV metadata, listing existing metadata standards specified by other SDO's to be the basis for metadata Recommendations to be developed by ITU-T in the IPTV area.

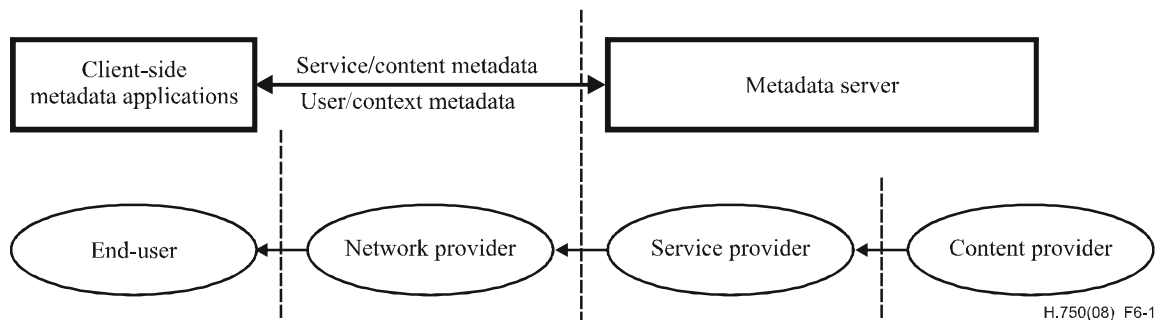

**Figure 13-1 – IPTV metadata service overview
(Figure 6-1 of [ITU-T H.750])**

It is suggested to ITU-T experts that "Existing and mature metadata standards, such as ISO/IEC 15938-5 or ETSI TS 102 822-3-1, shall be adopted or integrated to avoid reinvention of new metadata standards."

The main sources of metadata specification are TV-Anytime for content metadata and DVB for service provider/service metadata and delivery protocols.

The Recommendation identifies sets of metadata for service provider, service (or channel), content, content collection, quality monitoring, content segmentation, delivery modes, content adaptation, usage restrictions and rules, user profile or preference, audience measurement, device and network description, user interface representation, content provisioning,

Elements are listed for each metadata set with references to standards where the reader can find definition and specification. For example, "title" is an element listed in the content metadata set with references to ETSI TS 102 822-3-1, ETSI TS 102 471, UPnP CDS2 and IETF RFC 4287 where such an element is specified.

Metadata standards use the MPEG-7 description definition language (DDL) (see ISO/IEC 15938-5) to describe metadata structure as well as the XML encoding of metadata.

The Recommendation addresses also all issues related to the use of metadata, namely: identity management (content, content provider, service, service provider, user, device), discovery, delivery mode (pull or push, unicast or multicast, query/response), transport (fragmentation, container, compression), updating (change notification, versioning), security and integrity. In the same spirit, standards from other SDOs relevant to these issues are listed.

For example, on "delivery mode" issue, you can read that delivery methods can be implemented on a SIP-based service platform, or a web service-based service-oriented architecture (SOA) framework. In addition to this, references to standards are provided: ETSI TS 102 539 (push and pull modes of content description delivery for container-based and query/response-based protocols), ETSI TS 102 822-6-1 (unicast query/response delivery using the simple object access protocol (SOAP) over HTTP), ETSI TS 102 472 (metadata transport containers carrying ESG metadata instances delivered in FLUTE dynamic file delivery carousel sessions).

After this IPTV metadata overview, a number of Recommendations have been approved on different metadata aspects:

- Service provider and service metadata: [ITU-T H.770] (Mechanisms for service discovery and selection for IPTV services).
- Transport of service provider and service metadata: [ITU-T H.770] (Mechanisms for service discovery and selection for IPTV services).
- Audience measurement metadata: [ITU-T H.741.2] (IPTV application event handling: Data structures of audience measurement for IPTV services), [ITU-T H.741.3] (IPTV application event handling: Audience measurement for IPTV distributed content services).
- Transport of audience measurement metadata: [ITU-T H.741.4] (IPTV application event handling: Transport mechanisms for audience measurement).
- Rights metadata: [ITU-T H.751] (common specification with IEC TC 100 on metadata for rights interoperability (or for "security")).
- Content and content collection metadata: ETSI TS 102 822-3-1 V1.8.1 (2012-12) Broadcast and On-line Services: Search, select and rightful use of content on personal storage systems ("TV-Anytime"); Part 3: Metadata Sub-part 1: Phase 1 – Metadata schemas.

13.2 ITU-T H.751: common specification with IEC TC 100 on metadata for rights interoperability (or for "security")

Extracted summary

Recommendation ITU-T H.751 defines the common semantics and core elements of rights information interoperability (RII) for Internet protocol television (IPTV) systems and/or equipment that allow multimedia content to be legally used across different platforms.

The rights information includes rights- and security-related metadata that is described in Recommendation ITU-T H.750.

This Recommendation describes rights-related information such as content ID, permission issuer ID and permission receiver ID, which are used to bridge between rights-related metadata. It should be noted, however, that rights management and content protection technology are beyond the scope of this Recommendation.

This Recommendation is technically aligned with the specification in IEC 62698, Multimedia home server systems – Rights information interoperability for IPTV.

Extended summary

This Recommendation gives a high-level metadata description for rights information interoperability (RII). RII metadata provides descriptive and contextual classification for representing rights information using the permission framework.

RII is concerned with finding the greatest common denominators in rights expressions that include the minimum required components when trying to implement the mutual use of rights information. In other words, RII is about conveying rights information in units of groups of context expressions called permissions.

RII is not defined from a technical perspective, but rather on the basis of permission information that rights holders actually employ in the field. RII does not provide a method of encoding context expressions for permissions and the encoding method should make use of existing standardized technology.

Permissions can encode "what" (content ID), "from whom" (rights-holder ID or issuer ID) and "to whom" (receiver ID or user ID/device ID) and "under what conditions" (permission limits) using context expressions.

The permission classification identifies the following classes:

- Disclosure (for a specified player or an unspecified group of players).
- Usage purpose ("commercial", "public", "non-profit", "promotion", "education" and "other").
- Charging ("free of charge", "pay per use", "subscription" and "coupon").
- Sponsor ("No sponsor", "Advertisement model without force viewing", "Advertisement model with force viewing", etc.).
- Territory (region code, country code (ISO 3166-1) and postal code).
- Usage class with the following required elements:
 - Transmission ("broadcast", "streaming", "download" and "physical media").
 - Storage ("fixation" for content permitted to be stored in conformant devices).
 - Reuse (enable or disable secondary usage, move, copy, export, share, edit, modify and super distribution).
 - Redistribution (enable or disable).
 - Compilation (true if play-list enable, false if play-list disable and other).

Permission limits are further defined (quality, lifetime, permission management system, simultaneous outputs or exports).

Elements required for data management and export (Encryption flag, copy count, move count, transcode count and type, maximum and minimum transcode rate, expiration date, etc.) are also identified.

It makes reference mainly to IEC 62227 (Multimedia home server systems – Digital rights permission code subdivisions), which specifies permission classification for signalling and carrying disclosure information, usage purpose information, charge model information, usage class information, territory information, sponsor information, playback condition, print condition, execution condition, etc.

Appendix I is about "Security-related issues".

Appendix II is about "Syntax (encoding)". It shows the typical 23 use-cases scenarios that are described in [b-IEC 62636].

Appendix III provides a "Background to rights information interoperability".

Appendix IV specifies "Two basic technologies for enabling RII".

Appendix V title is "Rights information metadata elements corresponding to existing SCP systems".

14 IPTV multimedia application frameworks

The IPTV multimedia application frameworks found in the ITU-T H.760 sub-series of Recommendations provide a toolbox set of imperative and declarative environments that can be used to provide rich, interactive IPTV services:

- [ITU-T H.760], *Overview of Multimedia Application Frameworks for IPTV*.
- [ITU-T H.761], *Nested Context Language (NCL) and Ginga-NCL for IPTV services*.
- [ITU-T H.762], *Lightweight interactive multimedia environment (LIME) for IPTV services*.
- [ITU-T H.763.1], *Cascading style sheets for IPTV services*.
- [ITU-T H.764], *IPTV service enhanced script language*.

In addition to the Recommendations in the ITU-T H.760 sub-series, the following documents should be considered:

- HSTP-MCTB: Technical paper on media coding toolbox for IPTV.

14.1 ITU-T H.760: Overview of multimedia application frameworks for IPTV

Extracted summary

Recommendation ITU-T H.760 identifies and describes the relevant standards of multimedia application frameworks for interoperability and harmonization in IPTV services. It gives an overview of standards for declarative application frameworks as well as standards for procedural application frameworks. For declarative application frameworks, standards to be used for IPTV are described (such as HTML, CSS, DOM, ECMAScript, SVG, BML, MHEG-5 and Ginga-NCL), while procedural application frameworks are represented by GEM-based frameworks. It also contains descriptions of ISO/IEC International Standards for application frameworks, namely M3M, BIFS and LAsER. Recommendation ITU-T H.760 also has an annex on common usage of web-related technologies.

Extended summary

First, [ITU-T H.760] describes standards for declarative application frameworks. A declarative application platform is a framework on which applications written by a markup language (e.g., HTML) with or without script language (e.g., ECMAScript) can run.

Standards for declarative application frameworks include (order without preference):

- 1) Binary format for Scene (BIFS) ISO/IEC 14496-11. It is the scene description language standardized by ISO as a part of the MPEG-4 family of standards. It allows the representation of dynamic and interactive presentations, comprising two and three dimensional (2D and 3D) graphics, images, text and audiovisual material. This representation includes the description of the spatial and temporal organization of the different scene components as well as user-interaction and animations.
- 2) Binary Markup Language (BML) (see ARIB STD-B24 and [ITU-T J.201]). It is a declarative application specification for multimedia broadcasting in Japan. BML consists of XHTML 1.0, CSS 1 and CSS 2, document object model (DOM) 1 and DOM 2 and ECMA-262. It includes also additional functionalities for receivers with digital storage and for terrestrial digital broadcasting including mobile reception. It is based on the functionalities of MHEG and in particular on the following minimum set of MHEG classes: Application, Scene, Link and Action.
- 3) CEA-2014. It is a web-based protocol and framework for remote user interface (UI) on UPnP home network and over Internet. It is based on existing web rendering technologies for

consumer electronics (CE) browser with Worldwide Web Consortium (W3C) tags, XHTML 1, ECMA-262, CSS TV profile and DOM 2.

- 4) Cascading style sheet (CSS). It is a style sheet language specified by W3C that is used to describe the presentation (e.g., fonts, colours and spacing) of a document written in a markup language. CSS does not constitute by itself a multimedia framework. CSS is human readable and writable. W3C CSS TV Profile specifies subsets of W3C CSS2, e.g., colour specifications tailored to TV devices. Annex A shows different profiles including CSS.
- 5) Document object model (DOM). W3C DOM 2.0 defines a platform- and language-neutral interface that allows programs and scripts to dynamically access and update the content and structure of documents. The Core also contains specialized interfaces dedicated to XML. DOM does not constitute by itself multimedia framework. Annex A shows different profiles including DOM.
- 6) Digital video broadcasting hypertext markup language (DVB-HTML) is a standard for allowing digital televisions to access Internet content. Among other things, MHP 1.1 specifies the Internet access profile, in which applications can control the basic operations of Open Internet resident clients (web browser, e-mail and news client).
- 7) ECMAScript ISO/IEC 16262. It is a scripting programming language that is used on the web and is often referred to as JavaScript or JScript, after the two earlier implementations of the specification. ECMAScript is an object-oriented programming language for performing computations and manipulating computational objects within a host environment. The host environment provides a means to attach scripting code to events such as change of focus, page and image loading, unloading, error and abort, selection, form submission and mouse actions. ECMAScript does not constitute by itself a multimedia framework. Annex A shows different profiles including ECMAScript.
- 8) Hypertext markup language (HTML). It is the predominant markup language for web pages. It provides a means to describe the structure of text-based information in a document – by denoting certain text as links, headings, paragraphs, lists and so on – and to supplement that text with interactive forms, embedded images and other objects. XHTML is an XML-based specification where HTML is an SGML-based specification. W3C intended XHTML 1.0 to be identical to HTML 4.01 except where limitations of XML over the more complex SGML required workarounds. The differences between an HTML 4.01 and XHTML 1.0 document – in each of the corresponding document type definitions – are largely syntactic. Dynamic HTML allows a scripting language to change variables in a page's definition language, which in turn affects the look and function of otherwise "static" HTML page content, after the page has been fully loaded and during the viewing process.
- 9) Lightweight application scene representation (LASeR) and simple aggregation format. MPEG-4 Part 20 ISO/IEC 14496-20 is a specification designed for representing and delivering rich-media services to resource-constrained devices such as mobile phones. It defines two binary formats: lightweight application scene representation (LASeR), a binary format for encoding 2D scenes, including vector graphics and timed modifications of the scene; and simple aggregation format (SAF), a binary format for aggregating in a single stream LASeR content with audio/video streams. To achieve reactivity, the SAF specification defines the concept of cache unit which allows sending in advance sub-content which will be used later on in the presentation.
- 10) MHEG-5 (see [ITU-T T.170], [ITU-T T.172], [ITU-T T.175], ETSI ES 202 184 represents an application as a set of scenes that contain objects with spatio-temporal relationships, event-action associations, navigation and user interaction capabilities. Audiovisual content may consist of graphics, bitmaps, text and streams (based on the multiplex of audio and video components). Interaction can be performed via graphic elements like buttons, sliders, text

entry boxes and hypertext selections. Events can be generated by users, expiration of timers, playback of streams and other conditions.

- 11) Nested context language (NCL) is an XML application language allowing an author to declaratively describe the spatio-temporal behaviour of a multimedia presentation, associate hyperlinks (viewer interaction) with media objects, define alternatives for content and for content presentation (adaptation) and describe the layout of the presentation on multiple exhibition devices. NCL is part of the data coding specifications of the Terrestrial Brazilian Digital TV System. An NCL document (NCL application specification) only defines how media objects are structured and related, in time and space. As a glue language, it does not restrict or prescribe the media-object content types. NCL also treats an HTML document as one of its possible media objects. NCL also includes support for media objects that contain imperative code, extending the language basic model, adding decision-making features. NCL allows imperative objects with java code or Lua code. Lua is the scripting language of NCL. Lua combines simple procedural syntax with powerful data description constructs based on associative arrays and extensible semantics. Lua is dynamically typed, runs by interpreting byte-code for a register-based virtual machine.
- 12) Scalable vector graphics (SVG) (W3C SVG 1.1) is a language for describing two-dimensional graphics and graphical applications in XML. SVG allows for three types of graphic objects: vector graphic shapes (e.g., paths consisting of straight lines and curves), images and text. SVG drawings can be interactive and dynamic. Animations can be defined and triggered either declaratively (i.e., by embedding SVG animation elements in SVG content) or via scripting. SVG Basic and SVG Tiny are targeted to resource-limited devices and are part of the 3GPP platform for third generation mobile phones.
- 13) Worldwide TV markup language (WTVML) ETSI TS 102 322 is a content format for the delivery of interactive TV applications using Internet servers. A WTVML interactive television technology platform comprises a micro-browser, a markup language and a significant collection of associated software tools and services. The micro-browser and markup language are both based upon the Open Mobile Alliance WML 1.3 specification. The format combines explicit pixel-perfect control required for TV user interfaces and the dynamic layout and Internet compatibility requirements necessary for e-business and dynamic content. The format assumes a rich event model and contains explicit state and variable management, allowing the creation of sophisticated user interface effects without the use of scripting. Within an architecture consisting of a micro-browser and a gateway, the gateway processes the raw WTVML and generates compiled byte-code to be passed to the user agent to execute. Standards for procedural application frameworks are based on Globally Executable MHP (GEM) ETSI TS 102 819. It is a formally standardized Java-based platform for interactive content and applications. GEM has been adopted by ETSI, ITU, CableLabs, ARIB, ACAP and the Blu-ray Disc Association.

Advanced Common Application Platform (ACAP) is primarily based on GEM and digital television application software environment (DASE) and includes additional functionality from OCAP. There are two categories of applications: procedural (ACAP-J) (i.e., Java TV Xlet) and declarative (ACAP-X) (i.e., XHTML, style rules, scripts).

Open Cable Application Platform OCAP (ANSI/SCTE 90-1) is the set of specifications for the interactive multimedia services of digital CATV. OCAP 1.0 is based on MHP 1.0.2 and includes the extensions for the cable system in the United States.

Multimedia Home Platform (MHP) ETSI TS 102 812 is a set of specifications for multimedia broadcasting. Version 1.0 series covers the execution engine (EE) environment and version 1.1 series covers the presentation engine (PE) environment in addition to version 1.0. The MHP 1.0 specification employs Java technology for an EE environment.

Among other related standards is "MPEG multimedia middleware" (M3W). M3W ISO/IEC 23004.x provides two sets of APIs: multimedia platform APIs (handling front-end, decoder, post-processing of A/V, security management (key, signature, license and certificate) and Support platform APIs.

Annex A is about "Common usage". For a typical IPTV framework based on web-related technologies, a particular combination of these technologies defines a "profile":

- 1) BML profile: XHTML 1.0, CSS 1, CSS 2, DOM 1, DOM 2, ISO/IEC-16262 (ECMAScript).
- 2) CEA-2014: XHTML 1, CSS TV profile, DOM 2, ISO/IEC-16262 (ECMAScript).
- 3) DVB-HTML profile: XHTML 1.0, CSS 2, DOM 2, ISO/IEC-16262 (ECMAScript).
- 4) SVG profiles
 - SVG 1.1: CSS 2, DOM 1, DOM 2, ISO/IEC-16262 (ECMAScript).
 - SVG Tiny: CSS 2, uDOM, ECMA ISO/IEC-16262 (ECMAScript).

14.2 ITU-T H.761: Nested context language (NCL) and Ginga-NCL for IPTV services

Extracted summary

Recommendation ITU-T H.761 gives the specification of the nested context language (NCL) and of an NCL presentation engine called Ginga-NCL to provide interoperability and harmonization among IPTV multimedia application frameworks.

NCL is a glue language that holds media objects together in multimedia presentations, no matter which object types they are. As an example, NCL treats an HTML document as one of its possible media objects. In this way, NCL does not substitute, but embed, XHTML-based documents. The same reasoning applies to other media content and multimedia content objects and also to objects with content coded in any computer language. Ginga-NCL is an NCL presentation engine built as a component of a DTV middleware. A very special NCL object type defined in Ginga-NCL is NCLua, an imperative media-object with Lua code.

This Recommendation includes an electronic attachment containing NCL 3.0 module schemas used in the Enhanced DTV profile.

Extended summary

Nested context language (NCL) is an XML-based, glue language that holds media objects together in multimedia presentations, no matter which object types they are. As an example, NCL treats an HTML document as one of its possible media objects. In this way, NCL does not substitute, but embed, HTML-based documents. The same reasoning applies to other media content and multimedia content objects and also to objects with content coded in any computer language. Ginga-NCL is an NCL presentation environment built as a component of an IPTV middleware.

Some of NCL's highlights are: the language flexibility; its reuse facility; multi-device support (n-screen); presentation and content adaptability; API for building and modifying applications on-the-fly (live editing); and, mainly, its intrinsic ability for easily defining spatiotemporal synchronization among media assets (including viewer interactions).



Figure 14-1 – Example of an NCL Multi-device application [ITU-T H.761]

NCL applications have a strict separation between its content and its structure. NCL does not define itself any media content. Instead, it defines the glue that holds media objects together in multimedia presentations. An NCL document (NCL application specification) only defines how media objects are structured and related, in time and space. As a glue language, NCL does not restrict or prescribe the content types of its media objects. Which media objects are supported depend on the media players that are coupled to the NCL presentation environment. One of these players is the main video and main audio decoder/player, usually implemented using hardware resources in an IPTV receiver. Therefore, the main video and the main audio of a service are treated like all other media objects that may be related using NCL.

Ginga-NCL implementations are required to support HTML-based media objects. Which HTML profile is supported is an implementation choice and, therefore, it will depend on which HTML browser will act as a media player integrated to the NCL presentation engine.

Another media object that is required in a Ginga-NCL implementation is the declarative NCL media object, that is, a media object containing an NCL application. Therefore, NCL applications can be embedded in NCL parent applications, likewise HTML-based applications can be.

To extend the NCL declarative language basic model adding decision-making features that deserves the imperative paradigm, NCLua objects are part of the Ginga-NCL specification. Lua is a powerful, fast, lightweight, embeddable scripting language and was defined as the standard scripting language of NCL. NCLua media objects carry Lua code following the standardized NCLua API.

Ginga architecture is depicted in Figure 14-2. Ginga common core (Ginga-CC) is composed of media players, of procedures to obtain contents that can be delivered via diverse networks accessed by a receiver (hybrid scenarios are therefore supported) and of the conceptual display graphical model defined by the receiver platform. Ginga common core is also responsible for gathering metadata information and providing this information to NCL applications; for providing an API to communicate with DRM system; for managing context information (like user profiles and receiver profiles); and for supporting software version management (update) of Ginga's components.

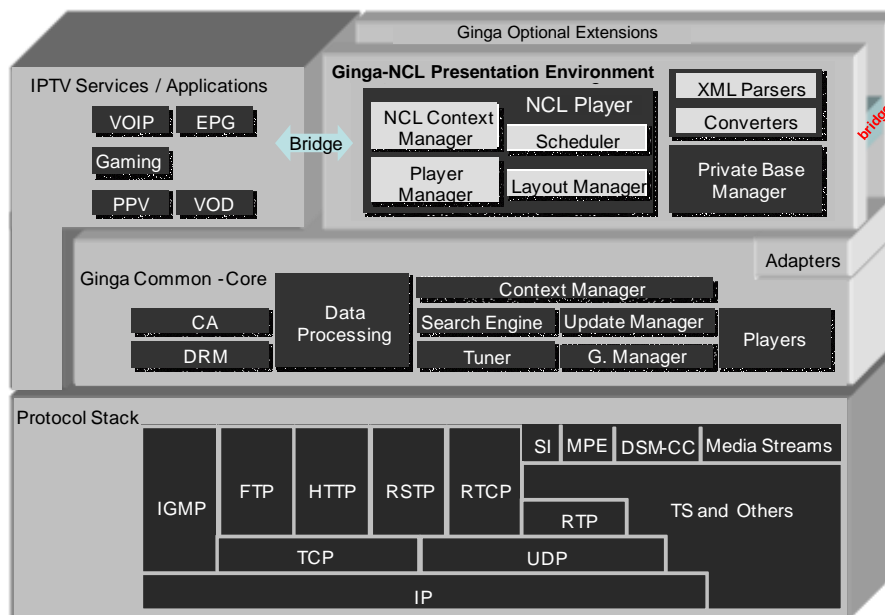

Figure 14-2 – Ginga architecture (Figure 3.1 of [ITU-T H.761])

Media player components serve application needs for decoding and presenting content types such as PNG, JPEG, MPEG and other formats, including those for content which contains declarative or imperative code, like HTML, Lua, etc. A generic media player API establishes the necessary communication between media player components and the Ginga-NCL subsystem. Thanks to this API, Ginga-NCL and the Ginga-CC are strongly coupled but independent subsystems. Ginga-CC may be substituted by other third part implementations, allowing Ginga-NCL to be integrated in other middleware specifications, extending their functionalities with NCL facilities. Players that do not follow the generic API are required to use the services provided by Adapters.

The core of Ginga-NCL subsystem is the NCL Player. This component is in charge of receiving and controlling multimedia applications written in NCL. Applications are delivered to the NCL player via the Ginga common core.

In Ginga-NCL, a declarative application can be generated or modified on the fly, using NCL editing commands. The NCL Player deals with NCL applications collected inside a data structure known as private base. A private base manager component is in charge of receiving NCL editing commands and maintaining the NCL documents being presented.

Ginga-NCL presentation engine supports multiple presentation devices through its Layout Manager module. This component is responsible for mapping all presentation regions defined in an NCL application to multiple canvases on receiver's displaying devices.

In particular, Ginga-NCL provides declarative support to IPTV specific services, such as VOD, datacasting, etc. Thus, a VoD service may, for example, play an NCL application besides the main audiovisual stream. Moreover, an IPTV service itself can be an NCL application.

Ginga has an open-source reference implementation that can be downloaded from <http://git.ginga.org.br>. Several commercial releases are derived from this reference implementation.

At <http://testsuite.gingancl.org.br>, Ginga developers and testers can find a comprehensive specification [HSTP-CONF.H761] of testing procedures for the [ITU-T H.761] Ginga-NCL presentation environment. This helps manufacturers verify the compliance of their products and give confidence that a proper interoperability level can be achieved.

For testing NCL applications, open-source NCL Players are available for Windows, Linux and MAC platforms (<http://www.gingancl.org.br/en/ferramentas>). There are also several tools to help authors

to design NCL applications. For example, one can find NCL Composer and NCL Eclipse at <http://www.ncl.org.br/en/autoria>, which are two open-source authoring tools available in the official site of the NCL language.

14.3 ITU-T H.762: Lightweight interactive multimedia environment (LIME) for IPTV services

Extracted summary

Recommendation ITU-T H.762 describes the high-level functionalities of the lightweight interactive multimedia environment (LIME) for IPTV. LIME supports functionalities in IPTV terminal devices to provide interactivity and a variety of content such as audio, video, graphics and text. Expected services include additional data such as text to enrich television programmes and two-way portal pages.

This Recommendation describes the profile called "LIME-HTML" of W3C Recommendation XHTML 1.0, the profile called "LIME-CSS" of cascading style sheets 1 (CSS1) and a part of CSS2, the profile of document object model (DOM) called "LIME-DOM" and a script language called "LIME-Script" that is a subset of ECMAScript but has functional extensions required for IPTV services. It describes the use of IP-based protocols for transport of LIME and IPTV-related services.

Extended summary

The LIME profile defined in Recommendation [ITU-T H.762] provides a lightweight solution targeted at IPTV devices ranging from TV, mobile to full- fledged devices like PCs. The profile restricts unnecessary functions while providing new extensions to support a fully functional multimedia interactivity framework.

Key design considerations include: (1) Synchronization among multiple simultaneous monomedia sources, (2) Simplification of navigation tasks by taking into account the fact that the TV remote controller lacks a spatial pointing device, (3) Rendering paradigms tailored for TV. Figure 14-3 shows the screen shot of a LIME document rendered by an IPTV terminal device.

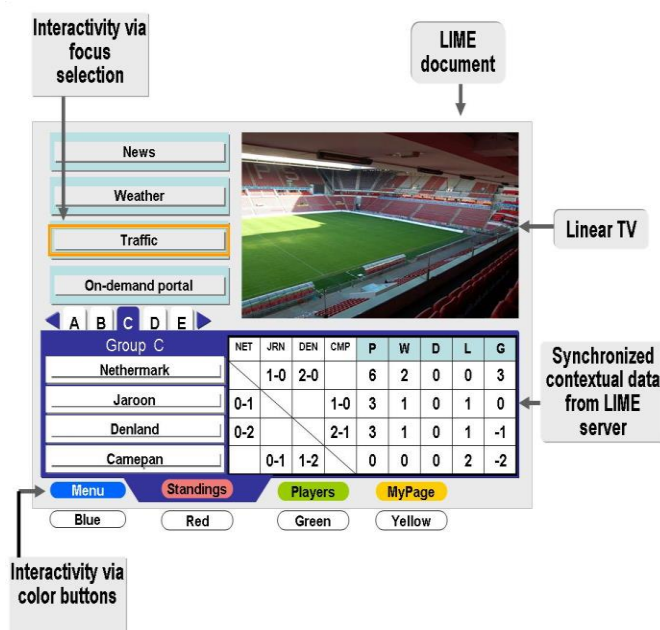

Figure 14-3 – LIME document rendered on an IPTV terminal device

An implementation example of the functions of a basic IPTV terminal device is shown in Figure 14-4.

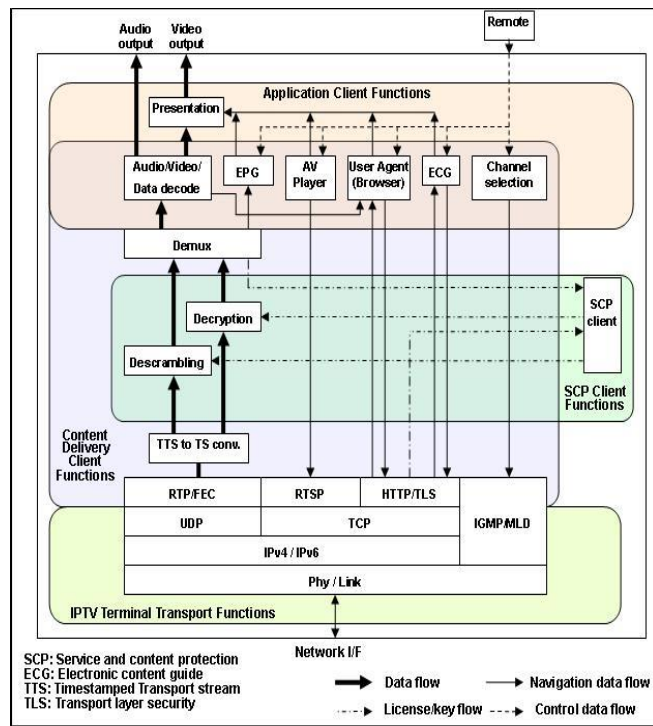

Figure 14-4 – Example of IPTV terminal device functions [ITU-T H.721]

As shown in the IPTV terminal transport functions, the terminal device is connected via IP to the network. Content delivery functions include provisions for the transmission of AV content, EPG (Electronic Program Guide) data used for linear TV service, electronic content guide (ECG) data used for video on demand service, user agent (browser) data and control data. LIME documents and related content data (e.g., monomedia files containing text, images) can be delivered from the servers of the service provider to the terminal device in two ways: (1) Embedded in the MPEG TS (transport stream) of the main service, (2) Traditional user agent (browser) interaction over HTTP.

LIME profiles

Web standards provide more functionality than typically needed by enhanced datacasting or interactive TV applications. The profile defined by LIME consists of a subset of XHTML (LIME XHTML Profile), ECMAScript (LIME-Script Profile) and CSS (LIME CSS Profile) to support appropriately enhanced data applications for TV. Additionally, some extensions are defined to address needs specific to TVs.

LIME XHTML profile

The LIME XHTML Profile consists of required elements (e.g., Body, Div, P, etc.) adopted from XHTML and new additions included in the LIME Extension module. The profile provides a lightweight, yet powerful and consistent way to produce datacasting and interactivity documents. Extensions include:

- *bevent and beitem* Used for event control. Events can be generated by pressing a button of the remote controller (e.g., to start a datacasting page). Events are also sent from the server to the terminal to trigger an action to dynamically synchronize the main content with contextual data (e.g., synchronized game statistics if the content is a sport match).
- *onfocus/onblur* attributes address the lack of a mouse.
- *streamposition, streamstatus* attributes to control playback.

LIME-Script profile

The subset of ECMAScript defined in the LIME-Script profile is limited to the following eight objects:

Global, Object, Function, Array, String, Boolean, Number, Date

LIME ECMAScript extensions include the Browser pseudo object. Main functions supported by this object are: (1) Functions to tune from EPG, (2) Communication over TCP/IP to transmit text data and set cache resources, (3) a number of operational functions.

LIME CSS profile

CSS is a declarative syntax for defining presentation rules to format and render documents. LIME CSS profile includes required properties derived from CSS2 and some extended properties to support color, aspect ratio and text plane resolution to address the TV needs. LIME CSS also includes navigation properties assuming a remote controller.

For a full list of each of the profiles described above the please refer to [ITU-T H.762].

14.4 ITU-T H.764: IPTV service enhanced script language (SESL)

Extracted summary

Recommendation ITU-T H.764 describes a script language for IPTV service, which is called IPTV SESL, to provide interoperability and harmonization among IPTV multimedia application frameworks. To provide global standard IPTV services, it is foreseeable that a combination of different standard multimedia application frameworks will be used. Therefore, this Recommendation describes the IPTV SESL, as one of those standard multimedia application frameworks, to provide interoperable use of IPTV services. It gives the core script profile as well as enhanced functionalities for IPTV services.

IPTV SESL is an object-oriented programming language based on LIME-Script of ITU-T H.762 with enhanced functionalities. The language is used in IPTV service for performing computations and manipulating computational objects within an IPTV terminal device environment. There're two primary implementations of the specification, the "Core Script Profile" part, which is conformant with the LIME-Script of ITU-T H.762, listed the objects for client-side computation and the "Extended Script Profile" part listed functional extensions required for IPTV services.

Extended summary

IPTV SESL, which is based on LIME-Script of [ITU-T H.762] with enhanced functionalities, is an object-oriented programming language for performing computations and manipulating computational objects within a host environment. It was originally designed to be a web scripting language, providing a mechanism to enliven web pages in browsers and to perform server computation as part of web-based client-server architecture. Together with the server-side scripting, it is possible to distribute computation between the client and server while providing a customised user interface for web-based applications.

In the IPTV TD, the user agent, such like a web browser, provides an IPTV SESL host environment for client-side computation including, for example, objects that represent windows, menus, etc. Further, the use agent provides a means to attach scripting code to events such as page and image loading, unloading, etc. Scripting code appears within the LIME-HTML of [ITU-T H.762] for IPTV service and the displayed page is a combination of user interface elements, together with the extended objects for IPTV service to provide web-based multimedia interaction. Figure 14-5 shows the screen shot of implementation of IPTV SESL.



Figure 14-5 – IPTV SESL implemented by IPTV terminal device

An implementation example of the functions of an IPTV terminal device with web-based user agent, which supports IPTV SESL, is shown in Figure 14-6.

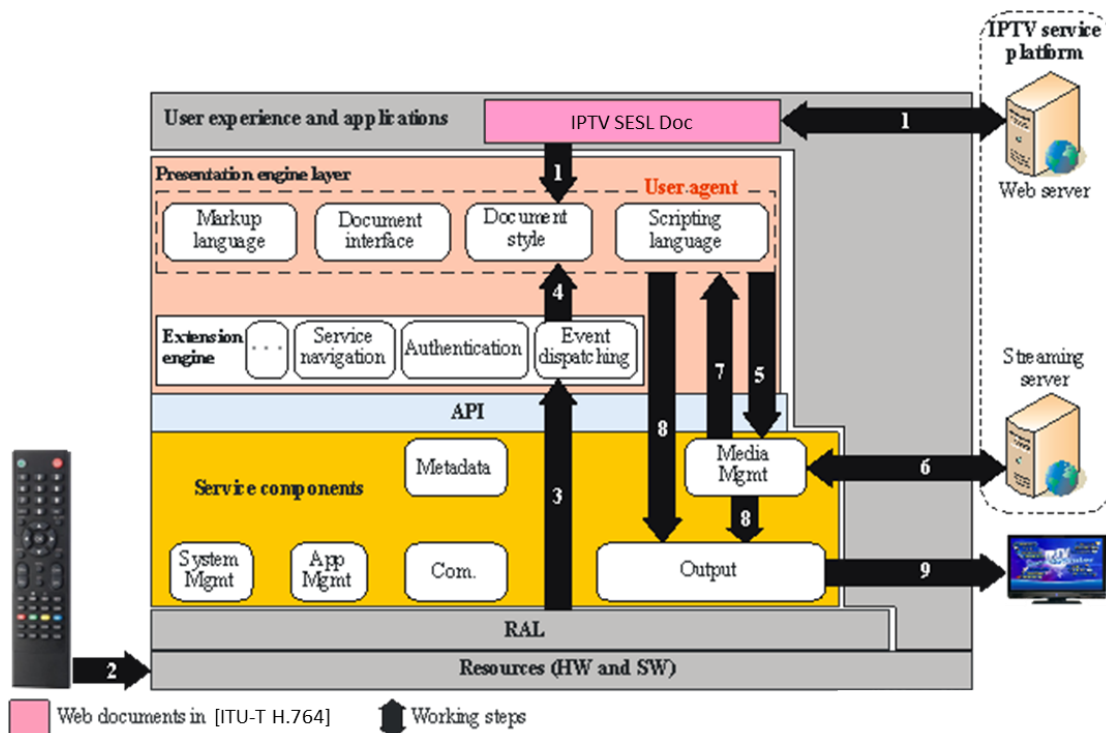

Figure 14-6 – Working flow of user interaction implemented with IPTV SESL

Step 1: The user agent downloads the web documents with IPTV SESL from the web server in the IPTV service platform to play the VoD.

Step 2: The user presses the "PAUSE" key on the remote.

Step 3: The key pressed status is sent to the "Event Dispatching" block in the extension engine through the service components layer.

Step 4: The user agent in the presentation engine layer receives the "PAUSE" key press event and executes IPTV SESL to handle the event.

Step 5: The user agent calls the media management service component.

Step 6: The media management service component communicates with the streaming server in the IPTV service platform to pause the video stream.

Step 7: The media management service component feeds back the successful communication result to the user agent.

Step 8: The media management service component refreshes the video display and the user agent refreshes the web document display according to the operation result.

Step 9: The output service component refreshes the display on the TV.

IPTV SESL profiles

IPTV SESL is designed as a web scripting language, providing a mechanism to enliven web pages in browsers and to perform server computation as part of web-based client-server architecture. It is suitable to be applied in web-based IPTV services to perform computations and provide interoperability with the end users within a host environment, which is the user agent (e.g., a browser) in the IPTV terminal device. In this Recommendation, two primary parts are defined to implement web-based IPTV service:

- The profile hereinafter called "Core Script Profile" is designed for resource restrained IPTV TD, like the basic model defined in [ITU-T H.721]. This profile is fully conformant with the LIME-Script of [ITU-T H.762].
- The profile hereinafter called "Extended Script Profile" is designed for enhanced IPTV TD, like the full-fledged model defined in [ITU-T H.722]. This profile defines the functional extensions required for IPTV services. This profile is optional, but if implemented, there are some mandatory object, methods and properties.

Core Script profile

It should be noted that not all of the manipulating computational objects defined by web script, such like ECMAScript, are necessary for implementation of the functionality defined for resource-constrained devices. Therefore, an optimized set of objects has been identified to efficiently implement that category of TDs.

The Core Script Profile of IPTV SESL are as the same as the objects whose semantics defined in the LIME Script of [ITU-T H.762]. All the built-in objects must be supplied by the implementation at the start of the execution of the user agent in the IPTV terminal device.

Extended Script profile

Since web-based IPTV also require video controlling and user interactivity, an extension is needed to the Core Script Profile for IPTV. The Extended Script Profile defined in this Recommendation provides for these additional manipulating computational objects for video and interactivity related performing computations, which may be optionally implemented by IPTV TDs. Extensions include:

- The *MediaController* object encapsulates the capabilities of the terminal device to play live channel, nPVR, VoD, music and other media types. It can provide necessary methods and properties to control a media, including the status of play, trick mode, stop and etc.
- The *Event* object is an object designed for event notification from the Service Component Layer of the IPTV TD to the web-based user agent. Events are caused by user interaction or remote server notification. The types of events include channel change, play mode change, system error and so on. With the combination of different types of Event objects, the service provider who generated the web document will easily handle the behaviour in the IPTV TD

caused by the service logic pre-programmed in the web documents to provide the corresponding service experience.

- The *Service* object can be used to implement service discovery procedure with web document. It can be accessed without using a constructor and can be called by the SPs to specify the service information used by the end users during the service procedure. By calling the object methods in the web documents, SPs can specify the necessary service information, such as the service URL for different colour keys on the remote, the service entry for linear TV with trick mode and VoD, etc.
- The *XMLHttpRequest* object implements an interface exposed by a scripting engine that allows scripts to perform HTTP client functionality (for example, submission of form data or loading data from a server). By using the *XMLHttpRequest* object, the user agent may retrieve and submit XML data directly in the background and conveniently connect an HTML presentation directly to XML data for interim updates without reloading the page.

For a full list of each of the profiles described above the please refer to [ITU-T H.764].

14.5 Other Recommendations

[ITU-T H.763.1] describes cascading style sheets (CSS) for IPTV services. The CSS profile presented in this Recommendation provides the means for describing the presentation style of documents relative to IPTV terminal devices. This profile is based on CSS 1, a part of CSS 2 and several extended properties required for IPTV services. CSS is human readable and writable and expresses style in common desktop publishing terminology.

15 IPTV service discovery up to consumption

[ITU-T H.770 series] provide specifications for service discovery and selection for IPTV services:

- [ITU-T H.770], *Mechanisms for service discovery and selection for IPTV services*.
- [ITU-T H.770] Amd.1 (2009), *Mechanisms for service discovery and selection for IPTV services: Updated Appendix I with multiple service platforms and Appendix II with requirements in other standard organizations*.
- [ITU-T H.770] Amd.2 (2010), *Mechanisms for service discovery and selection for IPTV services: Support of service discovery using Broadband Forum TR-069*.
- [ITU-T H.771], *SIP-based discovery of IPTV services*.

15.1 ITU-T H.770: Mechanisms for service discovery and selection for IPTV services

Extracted summary

Recommendation ITU-T H.770 describes the mechanisms for service provider discovery, service discovery and selection for IPTV services. The mechanisms enable IPTV terminal devices to provide the end-users with effective ways for consuming IPTV services. The expected types of IPTV services using service discovery information include linear TV and video-on-demand, etc. This Recommendation identifies service discovery metadata elements and attributes providing information concerning service providers and contents/services and its delivery protocols covering both unicast and multicast transport mechanisms.

Amendment 1 (2009) adds descriptive texts concerning service provider discovery to Appendix I and corrects errors identified in Appendix II.

Amendment 2 (2010) to Recommendation ITU-T H.770 adds new Appendix V on information for service discovery using Broadband Forum TR-069 and introduces changes in the main body of the Recommendation concerning its use.

Extended summary

[ITU-T H.770] describes the data structures (used to describe service providers and their services) and their delivery protocols to allow a user to discover them and at the end to consume a service or a content.

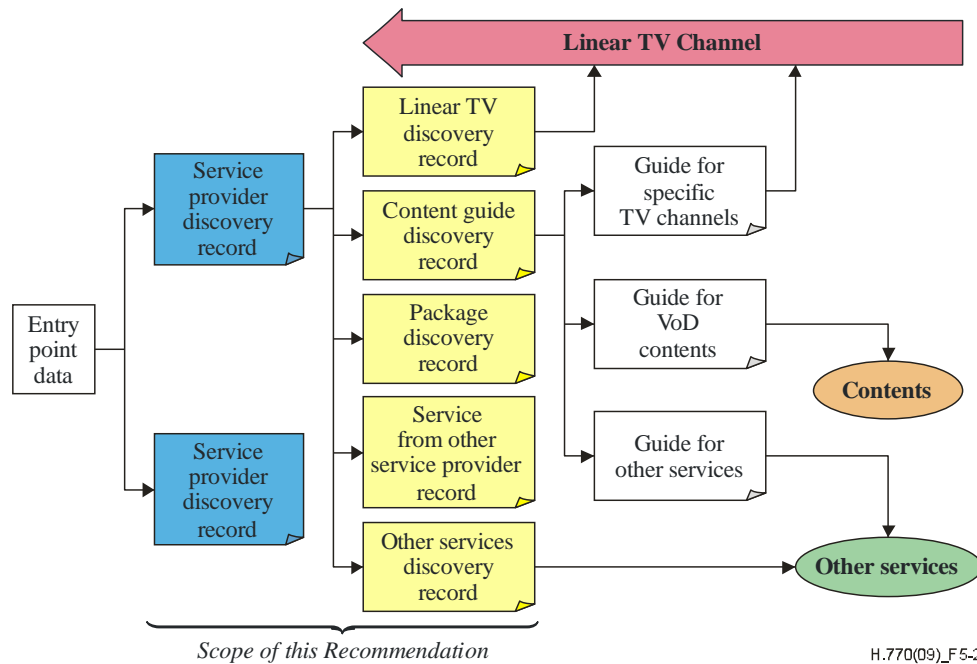

**Figure 15-1 – From entry point data to service/content acquisition
(Figure 5-2 of [ITU-T H.770])**

Each IPTV architecture has its own way to make the starting entry point(s) available to the IPTV terminal device.

The first step is to discover the service providers. All information about a service provider is stored in a "service provider discovery record". It may include:

- Record type = Service provider information (Mandatory)
- Record version (M)
- Service provider identifier (M)
- Individual service provider information version (M)
- Service provider logo URI
- Service provider name
- Service provider description
- Web portal URL
- Service offer summary (one per offering)
 - Push address (IP multicast address, port and source).
 - Pull URL.
 - Web portal URL.
 - Offer type (Linear TV, package, content guide, service from another service provider, other services).
 - Segment identifier and version (one or more segments containing a "detailed service offer").

Service provider information is encoded in XML and can optionally be compressed.

A single organization may play various roles: network provider, service platform, SCP provider, service provider.

The recommended transport mechanisms for the delivery of service provider discovery record are as follows: HTTP version 1.1 (IETF RFC 2616), HTTP over TLS (IETF RFC 2818), IGMP version 2 (IETF RFC 2236), IGMP version 3 (IETF RFC 3376), MLD version 2 (IETF RFC 3810), FLUTE (ETSI TS 102 472) and DVBSTP (ETSI TS 102 034).

From the "service provider information record", the terminal device knows the type of services (Linear TV, content guide, package) offered by each service provider available through the network provider and where to get detailed information about each service and in particular how to access them. Detailed information about a service is stored in a "service discovery record" specific to each service type. A Linear TV discovery record may include:

- Record type = Linear TV discovery record (Mandatory)
- Record version (M)
- Service provider identifier (M)
- Metadata server URL
- Portal URL
- Purchase information URL.
- Linear TV service (one or more)
 - Service identifier (M)
 - Original network Id
 - Transport stream Id
 - Service Id
 - Max bit rate
 - Service location (one or more)
 - IP multicast address, port and source, FEC base layer multicast address, FEC enhancement layer multicast address, maximum packet number in blocks, maximum FEC block duration, FEC specific information.
 - Unicast URL.
 - Audio coding
 - Video coding
 - Service availability (list of 'cells' (regions) with which the service is associated)
 - Country code.
 - Availability (true or false).
 - Region code (one or more strings for geographical regions in the country).
 - Streaming type (RTP or direct UDP)
 - Multiplex mode (MPEG-2 TS or Time-stamped MPEG-2 TS).

For linear TV discovery without SI in MPEG-2 TS, the following 'additional linear TV discovery elements/attributes' should be used:

- Type of service (coded as per the relevant SI standards: linear TV service, digital radio sound service, mosaic service, data broadcast service, etc.).
- Priority SI source (in case SI is also present): XML, SI, SI+XML.
- Service name (for display).
- Service description.

- Content guide discovery record identifier(s).
- Preferred content guide discovery record location(s).
- Service genre(s): sports, football/soccer.
- Announcement stream.
- Secondary service Id.
- Mosaic information.

The "package discovery record" provides a means for a collection of services to be marketed as, or grouped into, a single entity. It includes: record type (=package discovery record) (M), record version (M), service provider identifier (M), package identifier (M), displayable (true or false), package name, package description, preferred content guide discovery record identifier, preferred content guide discovery record location, package reference(s) (identifiers of packages included in the current package), individual service(s) (list of services forming the package), package availability (see "service availability" above).

The "content guide discovery record" provides a means to discover the locations of guides listing contents available, either live (e.g., through a linear TV offering) or via content on demand. It includes: record type (=content guide discovery record) (M), record version (M), service provider identifier (M), content guide discovery record identifier (M), content guide name, content guide provider name, content guide description, content guide locator(s) (push mode, HTTP pull mode, W3C SOAP pull mode, etc.), content guide logo URI, content guide type (guide for live programs, content on demand, both, or some other form of content), target service provider identifier (to identify the service provider whose content is described by this content guide).

A service provider can reference individual services or a complete offering provided by another service provider and describe this in a "service from other service providers" with the following elements: record type (=service from other service providers record) (M), record version, service provider identifier (M), referenced service provider identifier, service identifier(s).

A variety of other services (e.g., SMS, email, e-newspaper) may be offered by a service provider and the "other services discovery record" is used to describe them with the following elements: record type (=SMS, email, chat, e-newspaper, etc.) (M), record version, service provider identifier (M), service name, service identifier (M), service description, service locator (URI or IP addresses). Additional specific elements might be needed for each individual service type.

All records are encoded in XML and can optionally be compressed.

The recommended transport mechanisms for the delivery of all types of discovery record are the same as those listed above for the "service provider discovery record".

Annex A specifies "Service discovery profiles". The different solutions recommended for delivery protocols for the push mode lead to the definition of two profiles: profile A with DVBSTP and profile B with FLUTE.

Appendix I introduces the issue of "Multiple service platforms". It provides configuration examples in which service providers offer services through several network providers and service platforms.

Illustration is also provided for service mobility.

Appendix II addresses "Requirements in other standards organizations". It shows all the elements defined in the main body (e.g., record type, service provider name) and their status in DVB, ATIS and ITU-T (Unknown, Optional, Mandatory, Conditional).

Appendix III is about "The usage of TS with service discovery information". Service information (SI) consists of information tables defined by each standard DVB-SI ([ETSI EN 300 468]), ARIB-SI ([b-ARIB B10]) and ATSC-PSIP ([b-ATSC A/65]).

Two solutions are possible as follows:

- TS-Full SI (ETSI TS 102 034): A transport stream with embedded service information (SI) as defined by broadcasting standards organizations (e.g., ARIB, ATSC and DVB), just as in retransmission of broadcast channel captured from satellite or terrestrial broadcast. SI tables and their descriptors are different for each standards development organization.
- TS-Optional SI (ETSI TS 102 034): A transport stream with MPEG PSI (PAT and PMT tables) as defined by ISO/IEC; all other MPEG-2 and other tables are optional.

Appendix IV describes "Alternative methods for entry point handling". Alternative methods for delivery and handling of entry data are as follows (ATIS-0800017), (ETSI TS 183 063):

- Preconfigured methods.
- DHCP-based methods.
- Download methods (also known as pull mode).
- TR-069 protocol-based method.
- DNS service records (SRV)-based method.

Appendix V describes "Service discovery using TR-069". This appendix describes how to use TR-069 to discover service providers and services. Service provider information and service information are as specified in the main body.

An extension to TR-135 (Data Model for a TR-069 Enabled STB) for service provider and service discovery is specified.

15.2 Other Recommendations

Recommendation [ITU-T H.771] describes the process for IPTV service provider discovery and service discovery based on SIP [IETF RFC 3261]. The processes enable IPTV terminal device to acquire information about available IPTV service providers and IPTV services.

16 Application of IPTV technology

In addition to linear TV services, IPTV can be seen as a platform for rich, interactive services that open opportunities for service providers and users. The following application cases for IPTV are highlighted:

- [ITU-T H.780]: *Digital signage: Service requirements and IPTV-based architecture.*
- [ITU-T H.810]: *Interoperability design guidelines for personal health systems.*

16.1 ITU-T H.780: Digital signage: Service requirements and IPTV-based architecture

Extracted summary

Recommendation ITU-T H.780 describes a general framework for digital signage (DS) services based on IPTV architecture from the viewpoint of technical and service aspects. First, DS domains, a generic DS architecture and the classification of DS services are introduced. As technical IPTV specifications are close to those of DS, a brief comparison between the two services is provided (e.g., structure of a functional group and detailed media processing). Subsequently, high-level requirements concerning DS services are described. In addition, this Recommendation contains content delivery methods and details of functionalities of both server- and client-side applications for DS services.

Extended summary

Digital signage (DS) is a system that sends information, advertising and other messages to electronic devices (e.g., displays, loudspeakers) in accordance with the time of day and the location of the display, or the actions of audience. Assumed basic DS services are:

- 1) Information services (e.g., schedule of transportation, map/directory);
- 2) Advertisements/Promotion (e.g., commercial messages, details of products and services, shopping coupon);
- 3) Space decoration (e.g., ornaments/coordination samples of products);
- 4) Interactive services (e.g., service navigation such as finding a nearest restaurant).

[ITU-T H.780] describes system architecture, high-level requirements, key functionalities and sets of metadata to provide the DS services.

Figure 16-1 depicts a general digital signage architecture based on ITU-T IPTV architecture [ITU-T Y.1910]. Major technologies of IPTV services allow a DS system to use methods of contents delivery over a network.

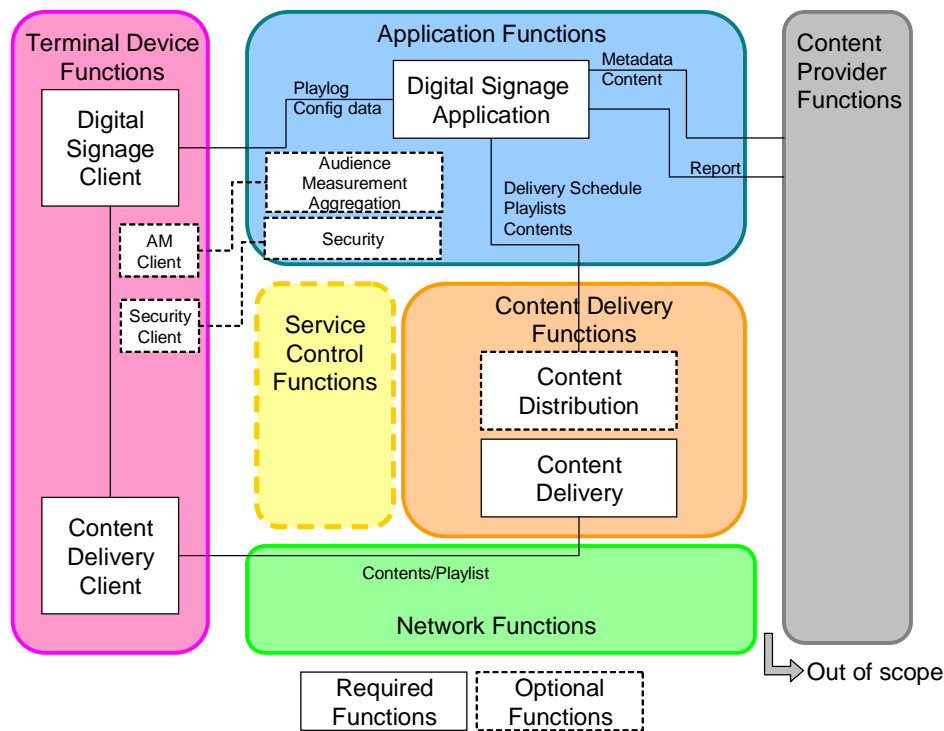

Figure 16-1 – Overview of digital signage architecture (based on [ITU-T Y.1910])

The following functional groups in the architecture are derived by grouping related functions referring to [ITU-T Y.1910]:

- Terminal device functions.
- Application functions.
- Content delivery functions.
- Network functions.
- Service control functions (optional).

Many functional blocks for the DS services, except digital signage application functions and digital signage clients, are also derived from [ITU-T Y.1910]. Explanations of each functional block are as follows:

- Digital signage application functions: manage and/or create content delivery schedules and playlists and playlist schedule (i.e., the functions that control the order and the timing of contents), ingest and distribute contents.
- Content delivery functions/ Content delivery client function.
- Digital signage client: store, decode and display contents according to the playlists.
- Content distribution functions (optional).
- Security functions/ Security client functions (optional).
- Audience measurement aggregation functions/Audience measurement client functions (optional).

Recommendation assumes the usage of various types of terminal devices as digital signage terminal devices.

- Wall screen: wall-mounted/ceiling-mounted/projector.
- Self-standing screen.
- Mobile terminal: mobile phone, smartphone or portable information terminal.

High-level requirements, which consist of mandate and optional requirements, on DS systems and services are shown as follows:

- General requirements.
- Contents management.
- Contents delivery.
- Security.
- Network.
- Terminal device/ Display.
- Management.

Following transport and control mechanisms in DS services are introduced:

- Mode of content delivery
 - Push mode: contents, playlists and playlist schedules are delivered to DS terminal devices according to the server's orders.
 - Pull mode: DS terminal devices request server-side delivery functions to send contents.
- Content delivery timing
 - Real-time delivery (streaming).
 - Pre-stored: The contents are stored in the terminal device in advance of playing. This can be advantageous for stable presentation services since it is independent of network bandwidth and quality.
 - Event-driven: high-priority contents can replace or be overlaid on the current presentation, e.g., to notify the audience of significant events.

This Recommendation selects following sets of basic elements/attributes, which are derived from IPTV relevant metadata such as TVAnytime and/or MPEG-7 specifications that are applicable to DS services:

- Content information.
- Terminal device information.

- Ambient information.
- Results of playing contents.

Appendices shows use-cases as basic DS services, codecs and data formats for digital signage service, privacy issues and terminal device interfaces.

16.2 ITU-T H.810: Interoperability design guidelines for personal health systems

Extracted summary

The Continua Design Guidelines (CDG) defines a framework of underlying standards and criteria required to ensure the interoperability of devices and data used for personal connected health. It also contains design guidelines (DGs) that further clarify the underlying standards or specifications by reducing options or by adding a missing feature to improve interoperability. These guidelines focus on the following interfaces:

- Personal Health Devices (PHD) interface – Interface between a Personal Health Device (PHD) and a Personal Health Gateway (PHG).
- Services interface – Interface between a Personal Health Gateway (PHG) and the Health & Fitness Service (HFS).
- Healthcare Information System (HIS) interface – Interface between the HFS and the Healthcare Information System (HIS).

The CDG is organized in eight parts that cover the following areas:

- ITU-T H.810 – Interoperability design guidelines for personal connected health systems: Introduction (this design guidelines document)
- ITU-T H.811 – Interoperability design guidelines for personal connected health systems: Personal Health Devices interface
- ITU-T H.812 – Interoperability design guidelines for personal connected health systems: Services interface
- ITU-T H.812.1 – Interoperability design guidelines for personal connected health systems: Services interface: Observation upload capability
- ITU-T H.812.2 – Interoperability design guidelines for personal connected health systems: Services interface: Questionnaire capability
- ITU-T H.812.3 – Interoperability design guidelines for personal connected health systems: Services interface: Capability exchange capability
- ITU-T H.812.4 – Interoperability design guidelines for personal connected health systems: Services interface: Authenticated persistent session capability
- ITU-T H.813 – Interoperability design guidelines for personal connected health systems: Healthcare Information System interface.

Extended summary

The Continua Design Guidelines (CDG) define a framework of underlying standards and criteria that are required to ensure the interoperability of components³ used for applications monitoring personal health and wellness. They also contain design guidelines (DGs) that further clarify the underlying standards or specifications by reducing options or by adding missing features to improve interoperability. These guidelines focus on the following interfaces:

³ There are two types of components, a client component (e.g., observation sender) and a service component (e.g., observation receiver). A device may implement one or more Continua certified client components, however it may also implement components not certified by Continua.

- Personal Health Devices (PHD) interface – Interface between a PHD and a Personal Health Gateway (PHG).
- Services interface – Interface between a PHG and a Health & Fitness Service (HFS).
- Healthcare Information System (HIS) interface – Interface between an HFS and a HIS.

Figure 16-2 highlights the above-mentioned interfaces in the Continua end-to-end (E2E) reference architecture.

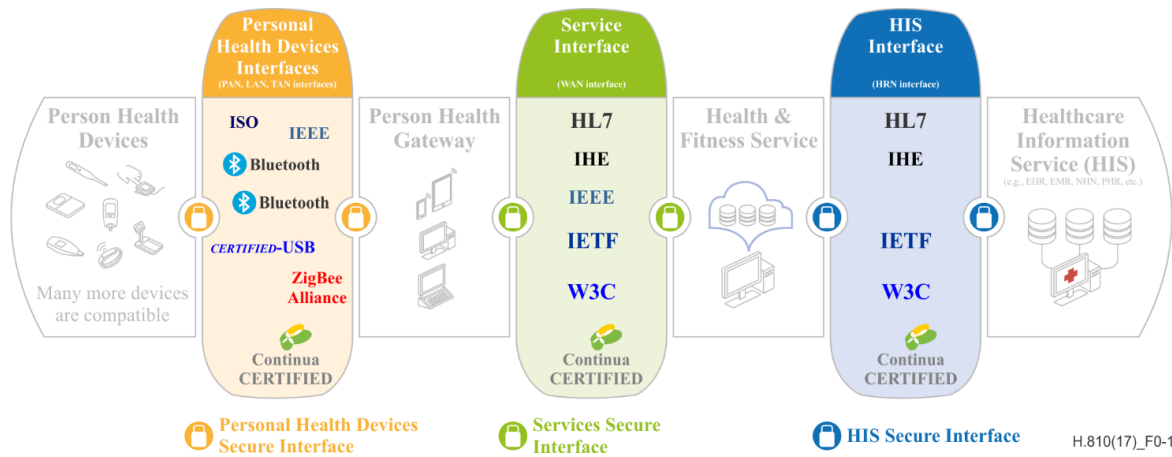

**Figure 16-2 – Continua E2E reference architecture
(Figure 0-1 of [ITU-T H.810])**

The CDG are a product of the Personal Connected Health Alliance (PCHA), which is an international not-for-profit industry organization enabling end-to-end (E2E), plug-and-play connectivity of devices and services for personal health management and healthcare delivery.

The mission of the PCHA is "to facilitate the development and adoption of personal health solutions that foster independence and empower people to better manage their health and wellness from anywhere, at any time. Making health and wellness a convenient part of daily life through personal connected health technologies". For more information visit: www.pchalliance.org.

In the DGs, references are made to specifications from Health Level 7 (HL7), Integrating the Healthcare Enterprise (IHE), ISO/IEEE, Bluetooth, ZigBee, Internet Engineering Task Force (IETF), World Wide Web Consortium (W3C), Organization for the Advancement of Structured Information Standards (OASIS) and Object Management Group (OMG).

Organization

The CDG is comprised of a series of design guidelines, which taken as a whole represent a yearly release. Table 16-1 shows the different design guidelines included in this release.

Table 16-1 – Documents conforming to the CDG (Table 0-1 of [ITU-T H.810])

Document	Area covered
[ITU-T H.810]	System Overview
[ITU-T H.811]	Personal Health Devices (PHD) interface
[ITU-T H.812]	Services interface
[ITU-T H.812.1]	Observation Upload capability
[ITU-T H.812.2]	Questionnaire capability
[ITU-T H.812.3]	Capability Exchange capability

Document	Area covered
[ITU-T H.812.4]	Authenticated Persistent Session (APS) capability
[ITU-T H.813]	Healthcare Information System (HIS) interface

[ITU-T H.810] is organized in the following manner:

- Introduction and clauses 0 to 5: Introduction and terminology – These clauses provide useful background information to help understand the structure of the CDG.
- Clause 6: System overview – This clause explains the overall end-to-end architecture and scope of the design guidelines.

White papers

This clause highlights white papers that have been published to facilitate understanding of these design guidelines and to address areas not directly covered by the CDG. These white papers can be found here: <http://www.pchalliance.org/resources> and they are also listed in the bibliography. Where relevant, additional links may be found in the appropriate clauses of the CDG.

– **Fundamentals of data exchange**

The purpose of this white paper is to provide a basic description of the data that is being exchanged between sensors, gateways and end services and the added value that Continua provides beyond the referenced standards to make implementations truly interoperable.

– **Introduction to the Continua Design Guidelines**

The purpose of this white paper is to provide a high level overview of the Continua Design Guidelines. This white paper provides an introduction to each of the standards and specifications that were selected by its members to be part of the design guidelines and the rationale behind their selection.

– **Implementation guidelines for cellular modems embedded into medical devices**

In order to aid members who wish to implement wireless connectivity directly into medical sensors by physically attaching a cellular module to the sensor, a white paper has been published to address device-specific recommendations.

Work has been carried out with leading operators, device vendors and cellular organizations such as Global System for Mobile Communications Alliance (GSMA) to provide an overview of mobile network-specific considerations that should be kept in mind when designing medical sensors with embedded modems, so that they are interoperable and optimized for use with cellular connectivity.

– **Recommendations for USB PHDC device driver interoperability**

This white paper defines a position on USB PHDC driver interoperability pertaining to the CDG. Potential problems with interoperability related to Windows USB PHDC device drivers are evaluated and recommendations are made that developers of Personal Health Gateways (PHGs) using Universal Serial Bus (USB) transport can implement. Based on the analysis of these problems, recommendations for a strategy are discussed and the handling of generic Windows drivers based on WinUSB and LibUSB are provided. This white paper does not cover application level interoperability beyond the development of USB drivers.

– **Certification programme**

A test and certification programme is designed and run by the Personal Connected Health Alliance (PCHA) to ensure that certified capabilities implemented by products conform to the standards and specifications defined in the design guidelines and underlying standards. Devices featuring the Continua logo indicate that a component implemented by a device has met the Continua conformance requirements as well as basic interoperability requirements with other CDG-compliant devices.

Devices passing this test and certification programme may use the Continua defined logo to indicate their compatibility. Details are provided in clause 6.1.4 of [ITU-T H.810].
