

International Telecommunication Union

ITU-T Technical Report

TELECOMMUNICATION
STANDARDIZATION SECTOR
OF ITU

(15 September 2017)

YSTR-M2M-DG.SEM

oneM2M – Developer guide of implementing semantics

Technical Report ITU-T YSTR-M2M-DG.SEM

oneM2M – Developer guide of implementing semantics

Summary

This Technical Report describes how developers can quickly implement applications using the semantic functionality of oneM2M release 2.

History

This document contains Version 0 of the ITU-T Technical Report on "oneM2M – Developer guide of implementing semantics" approved at the ITU-T Study Group 20 meeting held in Geneva, 4-15 September 2017.

Keywords

Developer guide, oneM2M, semantics.

© ITU 2018

All rights reserved. No part of this publication may be reproduced, by any means whatsoever, without the prior written permission of ITU.

Table of Contents

	Page
1 Scope.....	1
2 References.....	1
3 Terms and definitions	1
4 Abbreviations and acronyms	1
5 Conventions	1
6 Motivation.....	1
7 Use case	2
8 Architecture configuration.....	3
9 Semantic modelling	4
10 Procedures.....	7
10.1 Introduction	7
10.2 Call flows.....	8
11 Implementation	13
11.1 Introduction	13
11.2 Assumptions	13
11.3 Resource structure	14
11.4 Role of entities.....	15
11.5 Implementation procedures	15
Appendix I – Mapping to oneM2M base ontology.....	25
Bibliography.....	26

Technical Report ITU-T YSTR-M2M-DG.SEM

oneM2M - Developer guide of implementing semantics

1 Scope

This Technical Report provides a simple use case example for guiding developers on how to develop applications using the semantic functionalities provided by the oneM2M service platform with the scope as follows:

- objective of the use case;
- architecture of the use case mapped into a oneM2M service platform including semantic resources;
- semantic modelling of the devices and the information according to a suitable ontology;
- execution procedures for implementation of the use case with a focus on the semantic aspects; and
- implementation details of the use case using resource description framework (RDF) for representing semantic descriptions and SPARQL queries on the RDF descriptions to identify fitting resources in the semantic resource discovery.

2 References

[ITU-T Y.4500.11] Recommendation ITU-T Y.4500.11 (2018), *oneM2M - Common terminology*.

3 Terms and definitions

This Technical Report uses the terms and definitions given in [ITU-T Y.4500.11].

4 Abbreviations and acronyms

For the purposes of the present Technical Report, the abbreviations given in [ITU-T Y.4500.11] and the following apply:

ADN	Application Dedicated Node
AE	Application Entity
CSE	Common Services Entity
IN-CSE	Infrastructure Node-CSE
IoT	Internet of Things
OWL	Web Ontology Language
RDF	Resource Description Framework

5 Conventions

None.

6 Motivation

The assumption of many existing oneM2M applications is that they interact with other oneM2M applications through known resource structures. They either create the resources themselves or are configured to use specific resources. Information is typically stored in containers, often as

base64-encoded content instances, with the implicit assumption that applications have a-priori agreed on the syntax and semantics of this information.

Such an approach works well for small-scale and relatively static settings. When changes happen, the configuration will be updated manually. However, in more dynamic settings where the relevant resources frequently change, this becomes impractical. To satisfy those settings, relevant resources need to be discovered. Since Release 1, discovery of resources based on specific attributes and the use of labels has been made possible. The agreement of a fixed set of labels – which can only be combined using a logical OR operation in a discovery request – could be a viable solution.

For more heterogeneous, dynamic and larger scale scenarios, a more expressive approach for describing and discovering resources is needed. There are heterogeneous underlying technologies that can provide their information according to a different syntax, e.g., Zigbee, Z-Wave, Wi-Fi, according to different units, e.g., Celsius, Fahrenheit, Kelvin. Those technologies may measure different aspects, e.g., indoor temperature, outdoor temperature, fridge temperature, and the quality of the measurement may differ.

Another motivation of semantic annotations is to support the re-use of the same information by multiple applications. For example, in a smart city, applications may need to dynamically discover relevant resources according to multiple criteria at the same time – as outlined in the previous paragraph.

With semantic annotations, different aspects of Internet of Things (IoT) data can be described using RDF, which is a standardized semantic format. The vocabulary used for this description can be defined according to an ontology. With semantic discovery, applications can describe precisely what information they need or can deal with. This is powered by specifying a semantic filter using the SPARQL query language. The SPARQL filter is matched against the respective semantic annotation of each resource within the discovery scope, and the resource is included in the result of the discovery request only if the filter fits.

7 Use case

This clause briefly describes a use case from the perspective of services provided by the oneM2M platform. The physical device components will be introduced in this clause.

In the use case, different sensors measure temperature information, but the temperature relates to different aspects, i.e., indoor, outdoor and fridge temperature and the temperature is measured in different scales. Simply discovering temperature does not solve the problem as the temperatures relate to different aspects. Through semantic annotation and semantic discovery of resources the resources that are relevant in a particular use case can be found.

An overview of the use case is shown in Figure 7-1. The main components include:

- the temperature sensors are connected to a server;
- the server provides a set of services to enable the applications on smartphone #1 to discover and retrieve the relevant temperature information;
- the server provides a set of services to enable the applications on smartphone #2 to manage and semantically annotate the services providing temperature information.

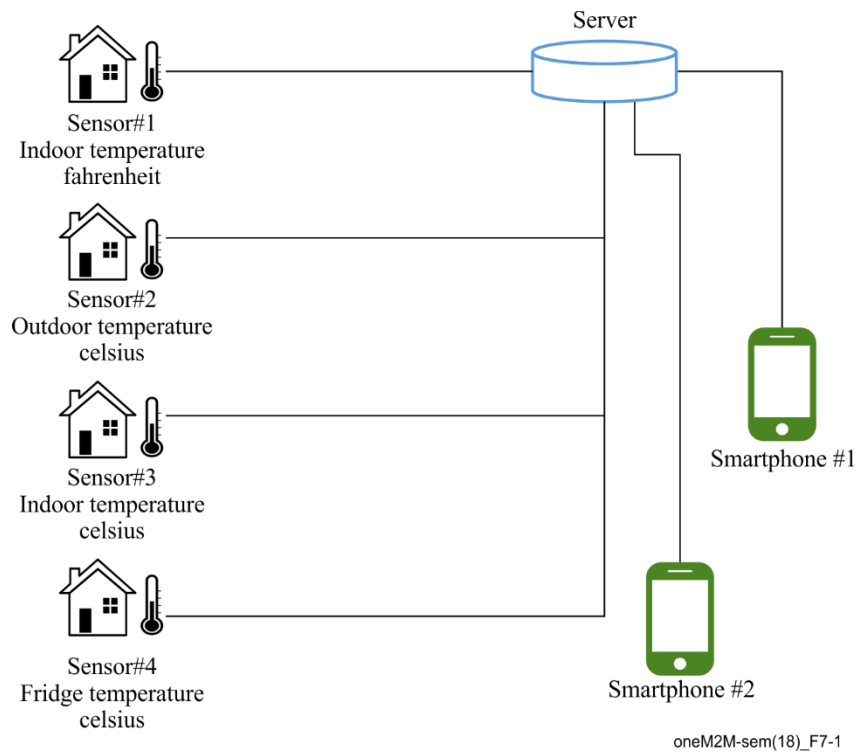

Figure 7-1 – Overview of semantic annotation and discovery use case

8 Architecture configuration

This clause describes the architecture of this use case with components represented by the oneM2M entity roles.

In the oneM2M, two basic types of entities are defined. One is an application entity (AE) and the other is a common services entity (CSE). As shown in Figure 8-1, the previous use case is modelled using oneM2M entities:

- each sensor and the smartphone hosts an AE. The AE resides in the application dedicated node (AND) is called ADN-AE;
- the server hosts an infrastructure node CSE (IN-CSE).

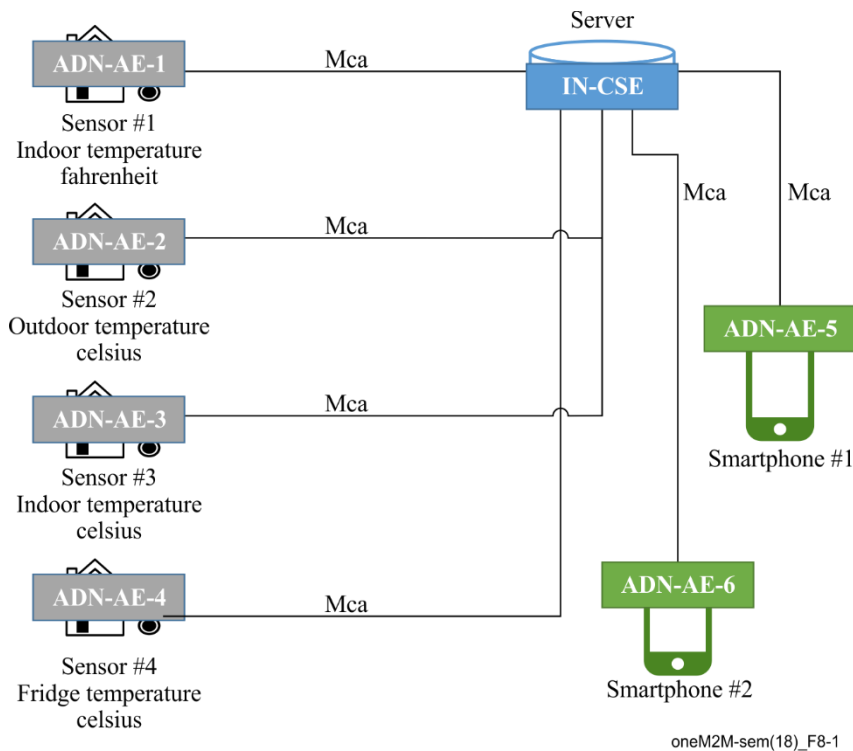

Figure 8-1 – oneM2M functional architecture of semantic annotation and discovery use case

The oneM2M defined Mca reference point is used to interface an AE and CSE. Therefore, in this use case:

- the reference point used between temperature sensor AEs and the IN-CSE or smartphone AEs and IN-CSE is Mca.

In summary, applications used in the current use case are classified as follows:

- ADN-AE-1: an application embedded in *Sensor#1* with capabilities to monitor *Sensor#1* and interact with the IN-CSE through the *Mca* reference point;
- ADN-AE-2: an application embedded in *Sensor#2* with capabilities to monitor *Sensor#2* and interact with the IN-CSE through *Mca* reference point;
- ADN-AE-3: an application embedded in *Sensor#3* with capabilities to monitor *Sensor#3* and interact with the IN-CSE through *Mca* reference point;
- ADN-AE-4: an application embedded in *Sensor#4* with capabilities to monitor *Sensor#4* and interact with the IN-CSE through *Mca* reference point;
- ADN-AE-5: a smartphone application embedded in the device smartphone #1 with capabilities to interact directly with the oneM2M service platform IN-CSE through *Mca* reference point and discover and retrieve information related to *Sensor#1*, *Sensor#2*, *Sensor#3* and *Sensor#4*.
- ADN-AE-6: a smartphone application embedded in the device smartphone #2 with capabilities to interact directly with the oneM2M service platform IN-CSE through *Mca* reference point and manage and semantically annotate resources related to *Sensor#1*, *Sensor#2*, *Sensor#3* and *Sensor#4*.

9 Semantic modelling

The semantic modelling is typically based on an ontology that specifies classes and properties, i.e., the ontology defines the vocabulary to be used for the semantic description. In Figure 9-1, a simple

ontology for the semantic annotation and discovery use case is visualized. Table 9-1 shows the actual web ontology language (OWL) ontology in an RDF representation.

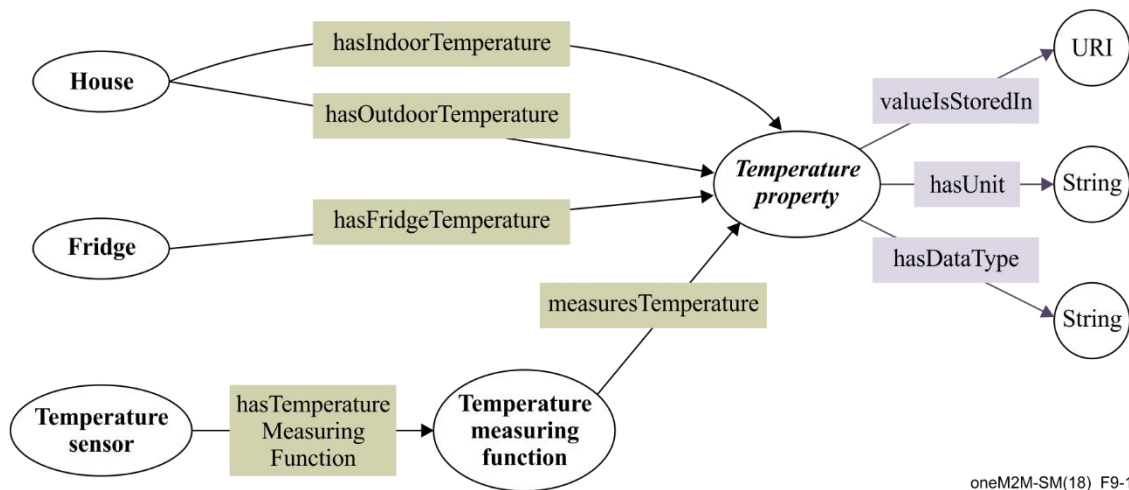

Figure 9-1 – Simple ontology for the semantic annotation and discovery use case

Table 9-1 – OWL/RDF representation of the simple ontology for the semantic annotation and discovery use case

```
<?xml version="1.0"?>
<rdf:RDF xmlns="http://www.onem2m.org/ontology/temperature_example#"
  xml:base="http://www.onem2m.org/ontology/temperature_example"
  xmlns:rdf="http://www.w3.org/1999/02/22-rdf-syntax-ns#"
  xmlns:owl="http://www.w3.org/2002/07/owl#"
  xmlns:xml="http://www.w3.org/XML/1998/namespace"
  xmlns:xsd="http://www.w3.org/2001/XMLSchema#"
  xmlns:rdfs="http://www.w3.org/2000/01/rdf-schema#">
  <owl:Ontology rdf:about="http://www.onem2m.org/ontology/temperature_example"/>

  <!-- Classes -->
  <owl:Class rdf:about="http://www.onem2m.org/ontology/temperature_example#Fridge"/>
  <owl:Class rdf:about="http://www.onem2m.org/ontology/temperature_example#House"/>
  <owl:Class
  rdf:about="http://www.onem2m.org/ontology/temperature_example#TemperatureMeasuringFunction"/>
  <owl:Class rdf:about="http://www.onem2m.org/ontology/temperature_example#TemperatureProperty"/>
  <owl:Class rdf:about="http://www.onem2m.org/ontology/temperature_example#TemperatureSensor"/>
  <!-- Object Properties -->
  <owl:ObjectProperty
  rdf:about="http://www.onem2m.org/ontology/temperature_example#hasFridgeTemperature">
    <rdfs:domain rdf:resource="http://www.onem2m.org/ontology/temperature_example#Fridge"/>
    <rdfs:range rdf:resource="http://www.onem2m.org/ontology/temperature_example#TemperatureProperty"/>
  </owl:ObjectProperty>
  <owl:ObjectProperty
  rdf:about="http://www.onem2m.org/ontology/temperature_example#hasIndoorTemperature">
```

Table 9-1 – OWL/RDF representation of the simple ontology for the semantic annotation and discovery use case

```

<rdfs:domain rdf:resource="http://www.onem2m.org/ontology/temperature_example#House"/>
<rdfs:range rdf:resource="http://www.onem2m.org/ontology/temperature_example#TemperatureProperty"/>
</owl:ObjectProperty>
<owl:ObjectProperty
rdf:about="http://www.onem2m.org/ontology/temperature_example#hasOutdoorTemperature">
  <rdfs:domain rdf:resource="http://www.onem2m.org/ontology/temperature_example#House"/>
  <rdfs:range rdf:resource="http://www.onem2m.org/ontology/temperature_example#TemperatureProperty"/>
</owl:ObjectProperty>
<owl:ObjectProperty
rdf:about="http://www.onem2m.org/ontology/temperature_example#hasTemperatureMeasuringFunction">
  <rdfs:domain rdf:resource="http://www.onem2m.org/ontology/temperature_example#TemperatureSensor"/>
  <rdfs:range
rdf:resource="http://www.onem2m.org/ontology/temperature_example#TemperatureMeasuringFunction"/>
</owl:ObjectProperty>
<owl:ObjectProperty
rdf:about="http://www.onem2m.org/ontology/temperature_example#measuresTemperature">
  <rdfs:domain
rdf:resource="http://www.onem2m.org/ontology/temperature_example#TemperatureMeasuringFunction"/>
  <rdfs:range rdf:resource="http://www.onem2m.org/ontology/temperature_example#TemperatureProperty"/>
</owl:ObjectProperty>

<!-- Data properties -->
<owl:DatatypeProperty rdf:about="http://www.onem2m.org/ontology/temperature_example#hasDatatype">
  <rdfs:domain rdf:resource="http://www.onem2m.org/ontology/temperature_example#TemperatureProperty"/>
  <rdfs:range rdf:resource="http://www.w3.org/2001/XMLSchema#string"/>
</owl:DatatypeProperty>
<owl:DatatypeProperty rdf:about="http://www.onem2m.org/ontology/temperature_example#hasUnit">
  <rdfs:domain rdf:resource="http://www.onem2m.org/ontology/temperature_example#TemperatureProperty"/>
  <rdfs:range rdf:resource="http://www.w3.org/2001/XMLSchema#string"/>
</owl:DatatypeProperty>
<owl:DatatypeProperty rdf:about="http://www.onem2m.org/ontology/temperature_example#valueIsStoredIn">
  <rdfs:domain rdf:resource="http://www.onem2m.org/ontology/temperature_example#TemperatureProperty"/>
  <rdfs:range rdf:resource="http://www.w3.org/2001/XMLSchema#anyURI"/>
</owl:DatatypeProperty>
</rdf:RDF>

```

Appendix I shows how the simple ontology for the semantic annotation and discovery use case can be mapped to the oneM2M base ontology [b-ITU-T Y.4500.12]. As a result, it is semantically integrated with the core concepts that have been identified for oneM2M itself. Such a mapping may be helpful to semantically relate to other parts of the oneM2M system, but is not required, i.e., depending on what is to be achieved, the above ontology can be used "stand-alone" as the basis for

supporting semantic annotation and discovery in a particular use case as shown in this developer guide.

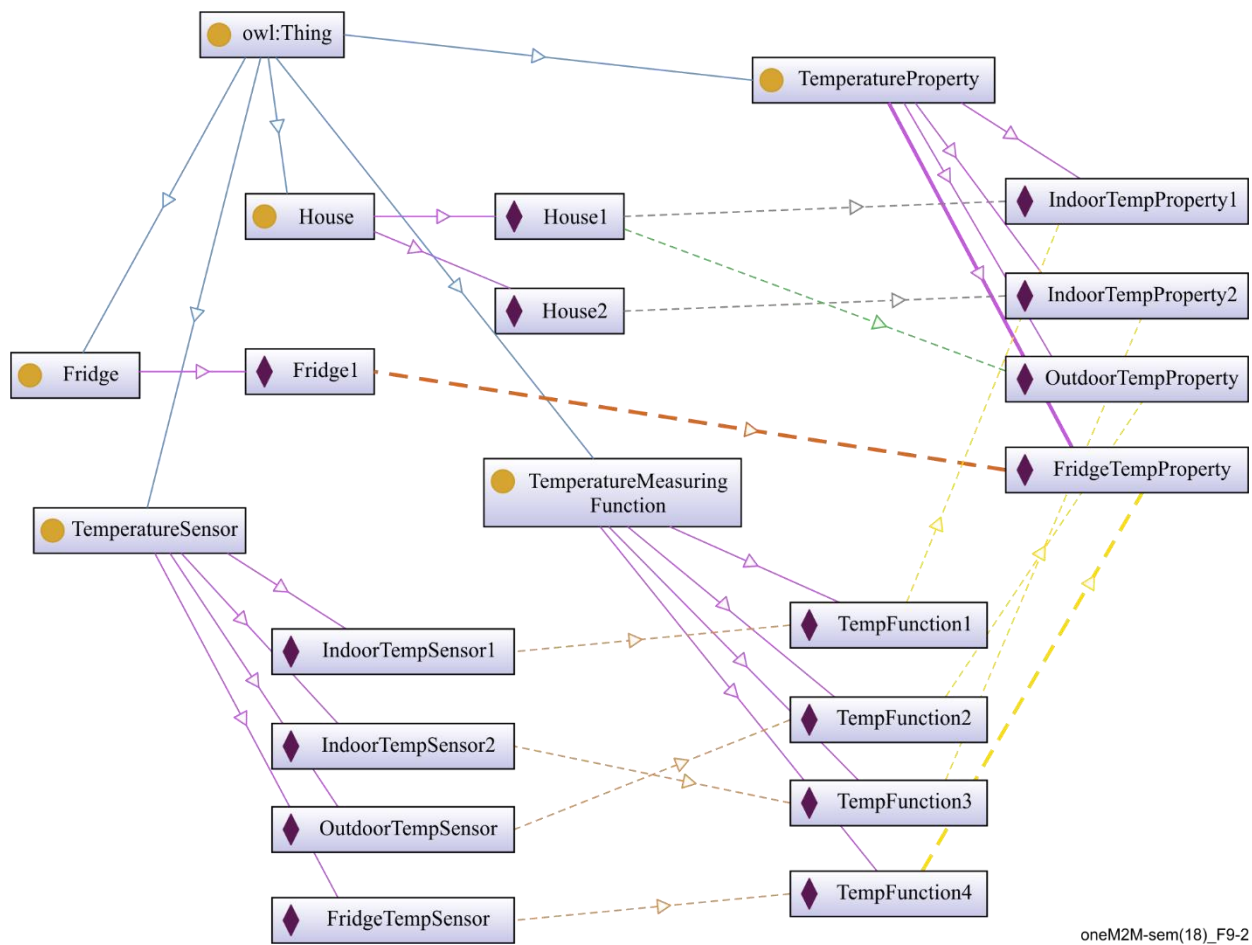

Figure 9-2 – Semantic description of the scenario according to the ontology

Figure 9-2 shows all the instances needed for modelling the semantic annotation and discovery use case, their respective types and their relations (in different colours and styles (e.g., dashed), but without annotations indicating the name of the respective relation) Each sensor will be represented by an AE and all the semantic instances related to the given sensor will be contained in the semantic descriptor. For example, IndoorTempSensor1 models the sensor, which has a function called TempFunction1, which measures IndoorProperty1, which in turn describes the indoor temperature of House1. In addition, there are some datatype properties like the unit of measurement, which are not shown in this figure.

10 Procedures

10.1 Introduction

To implement the presented use case based on oneM2M, required procedures are classified and shown below. This clause focuses on the core semantic aspects. Typical common aspects such as the creation of appropriate access control policies are not included. The interested reader is referred to other developer guides, e.g., oneM2M TR-0025 [b-oneM2M TR-0025].

- 1) **Application registration:** This procedure contains sensor application registration and smartphone application registration.
- 2) **Initial resource creation:** This procedure contains container resources creation and contentInstance resources creation.

- 3) **Semantic descriptor resource creation:** This procedure shows the creation of semantic descriptor resources by a smartphone application that is annotating the resources created earlier by the sensor applications.
- 4) **Semantic discovery of relevant sensor resources:** This procedure shows how all sensor applications that fit the semantic filter criteria specified in SPARQL are discovered by a smartphone application.
- 0) **Retrieval of semantic descriptor and sensor information:** This procedure shows how the smartphone application first retrieves the semantic descriptor resources of the discovered resource and then, based on the information contained in the semantic descriptor, retrieves the contentInstance resource containing the latest sensor reading.

10.2 Call flows

10.2.1 Application registration

Figure 10.2.1-1 depicts how the applications register with oneM2M and can be described as follows:

- 1) Sensor applications (ADN-AE1, ADN-AE2, ADN-AE3 and ADN-AE4) register with the oneM2M service platform (IN-CSE);
- 2) Smartphone applications (ADN-AE5 and ADN-AE6) register with the oneM2M service platform (IN-CSE).

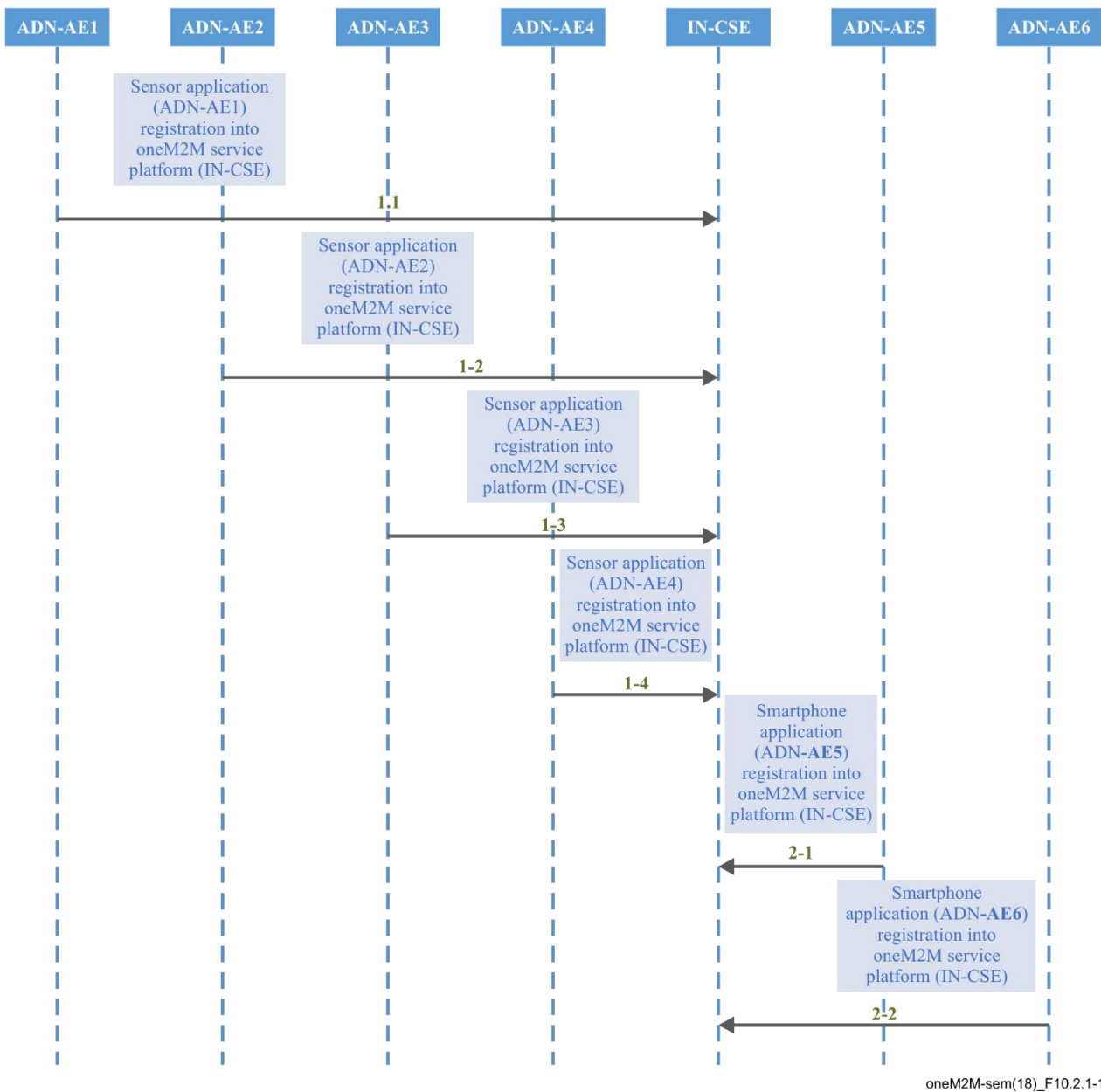
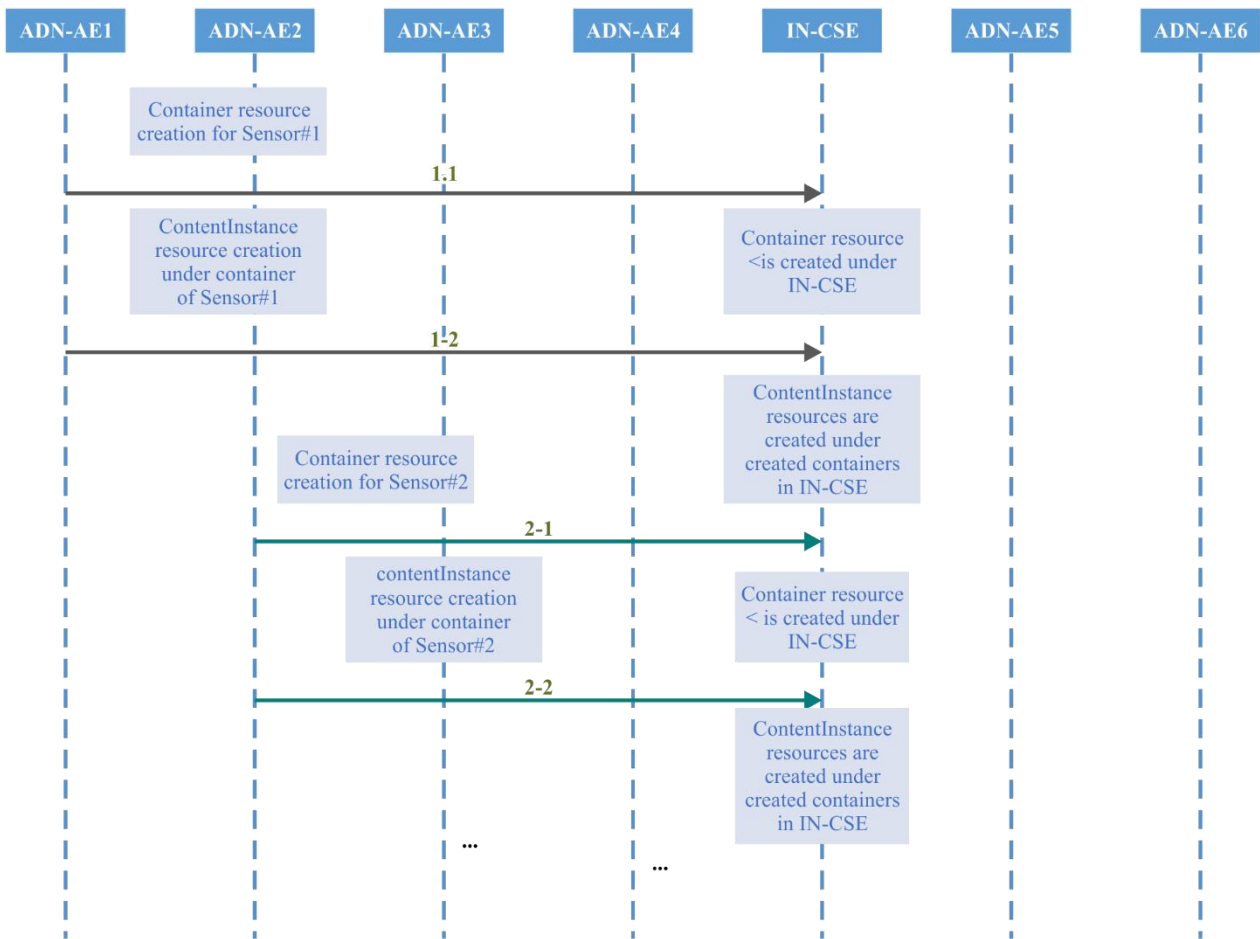

Figure 10.2.1-1 – Registration phase call flows

10.2.2 Initial resource creation

Call flows regarding the initial resource creation phase depicted in Figure 10.2.2-1 can be described as follows:

- 1) Four container resources are created in the oneM2M service platform (IN-CSE) to store the temperature values measured by Sensor#1, Sensor#2, Sensor#3 and Sensor#4 under the registered application ADN-AE1, ADN-AE2, ADN-AE3 and ADN-AE4, respectively (in Figure 10.2.2-1 this is only shown for ADN-AE1 and ADN-AE2, ADN-AE3 and ADN-AE4 are handled in exactly the same way).
- 2) ContentInstance resources are created by the applications (ADN-AE1, ADN-AE2, ADN-AE3 and ADN-AE4) under each created container and represent the measured temperatures (in Figure 10.2.2-1 this is only shown for the respective first contentInstances of ADN-AE1 and ADN-AE2, ADN-A3 and ADN-AE4 are handled in exactly the same way and contentInstances are created continuously).



oneM2M-sem(18)_F10.2.2-1

Figure 10.2.2-1 – Initial resource creation phase call flows

10.2.3 Semantic descriptor resource creation

Call flows regarding the semantic descriptor resource creation phase are depicted in Figure 10.2.3-1 and can be described as follows:

- 1) ADN-AE5 creates a semantic descriptor resource under each of the ADN resources representing a sensor application instance (i.e., ADN-AE1, ADN-AE2, ADN-AE3 and ADN-AE4). The semantic information has been provided by a human user using the smartphone application. It provides information about the sensor, the sensor measurements (e.g., unit of measurement) and what is being measured. In the given example, these are the information measured by the sensor (temperature), the unit of measurement (Celsius or Fahrenheit), and the relation to the thing for which the value is being measured (house or refrigerator).

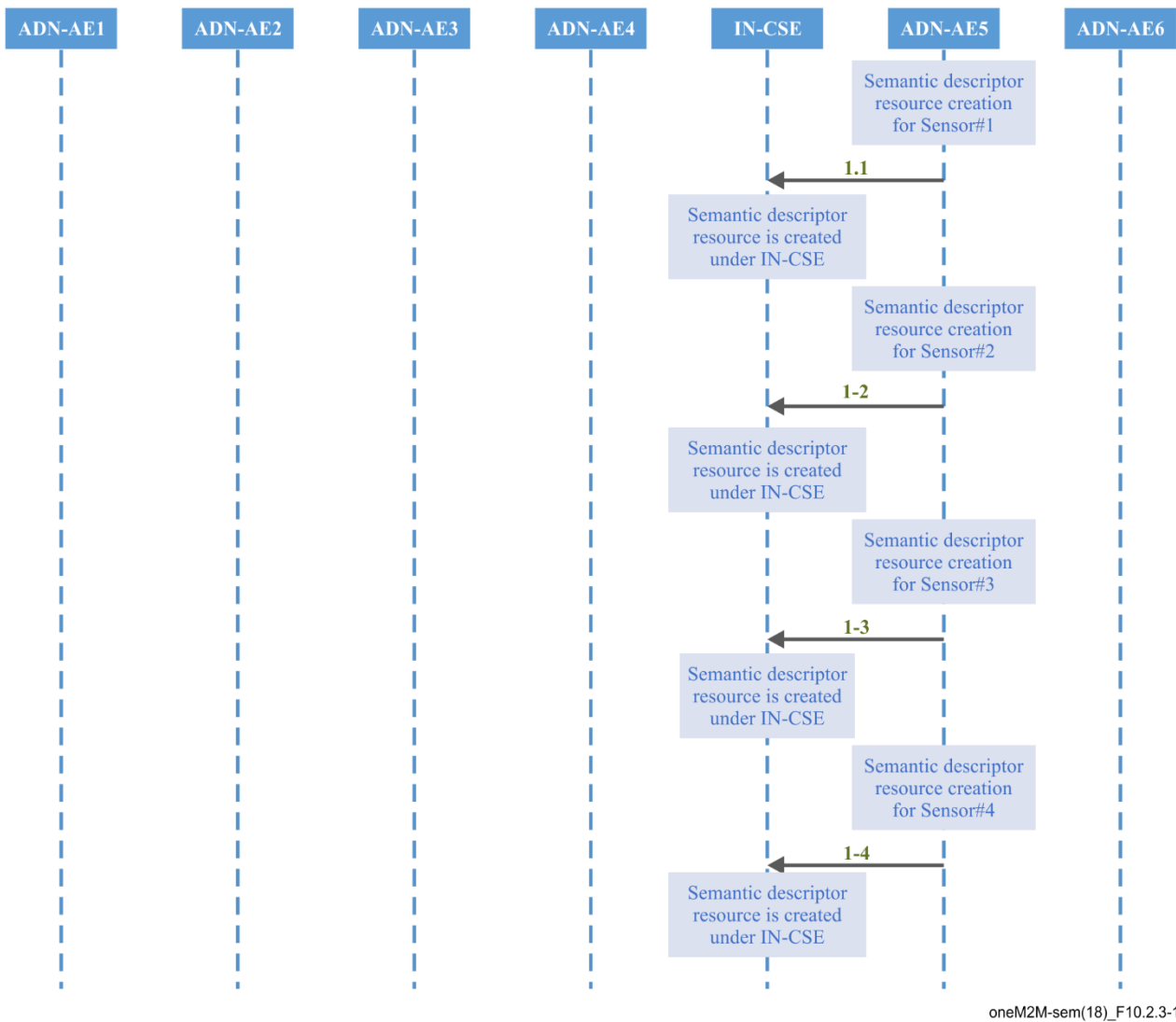
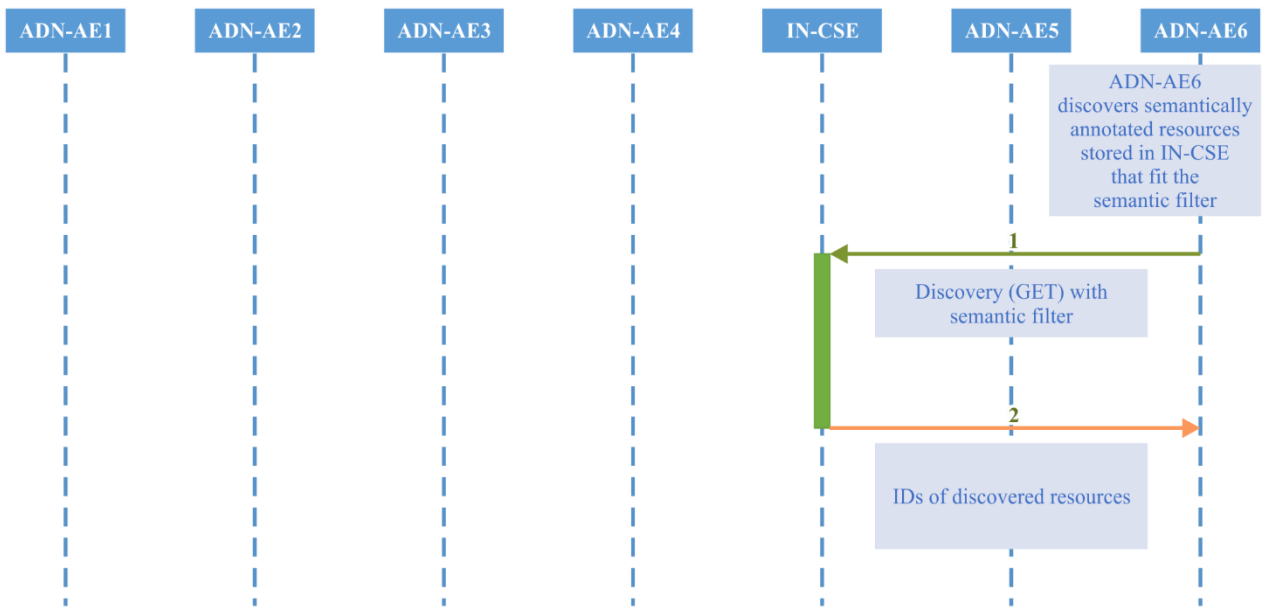

Figure 10.2.3-1 – Semantic descriptor resource creation phase call flows

10.2.4 Semantic discovery of relevant sensor resources

Call flows regarding the discovery are depicted in Figure 10.2.4-1 and can be described as follows:

- 1) Smartphone application (ADN-AE6) sends a RETRIEVE request including the parameter *filterUsage* and specific semantic filter criteria condition(s) provided in SPARQL for discovery of sensor application resources stored in the oneM2M service platform (IN-CSE).
- 2) The oneM2M service platform (IN-CSE) responds with URIs of the discovered sensor resources, if any, to the smartphone application (ADN-AE6) according to the filter criteria.



oneM2M-sem(18)_F10.2.4-1

Figure 10.2.4-1 – Semantic discovery phase call flows

10.2.5 Retrieval of semantic descriptor and sensor information

Call flows regarding the retrieval of the semantic descriptor and the contentInstance resources are depicted in Figure 10.2.5-1 and can be described as follows:

- 1) The smartphone application (ADN-AE6) sends GET requests for retrieval of the semantic descriptor child resources of the discovered sensor resources;
- 2) The oneM2M service platform (IN-CSE) returns the requested semantic descriptor child resources;
- 3) Based on the respective information contained in the retrieved semantic descriptor, the smartphone application (ADN-AE6) requests the latest content instance provided by the sensor application containing the sensor measurement;
- 4) The oneM2M service platform (IN-CSE) returns the requested content instance containing the sensor information.

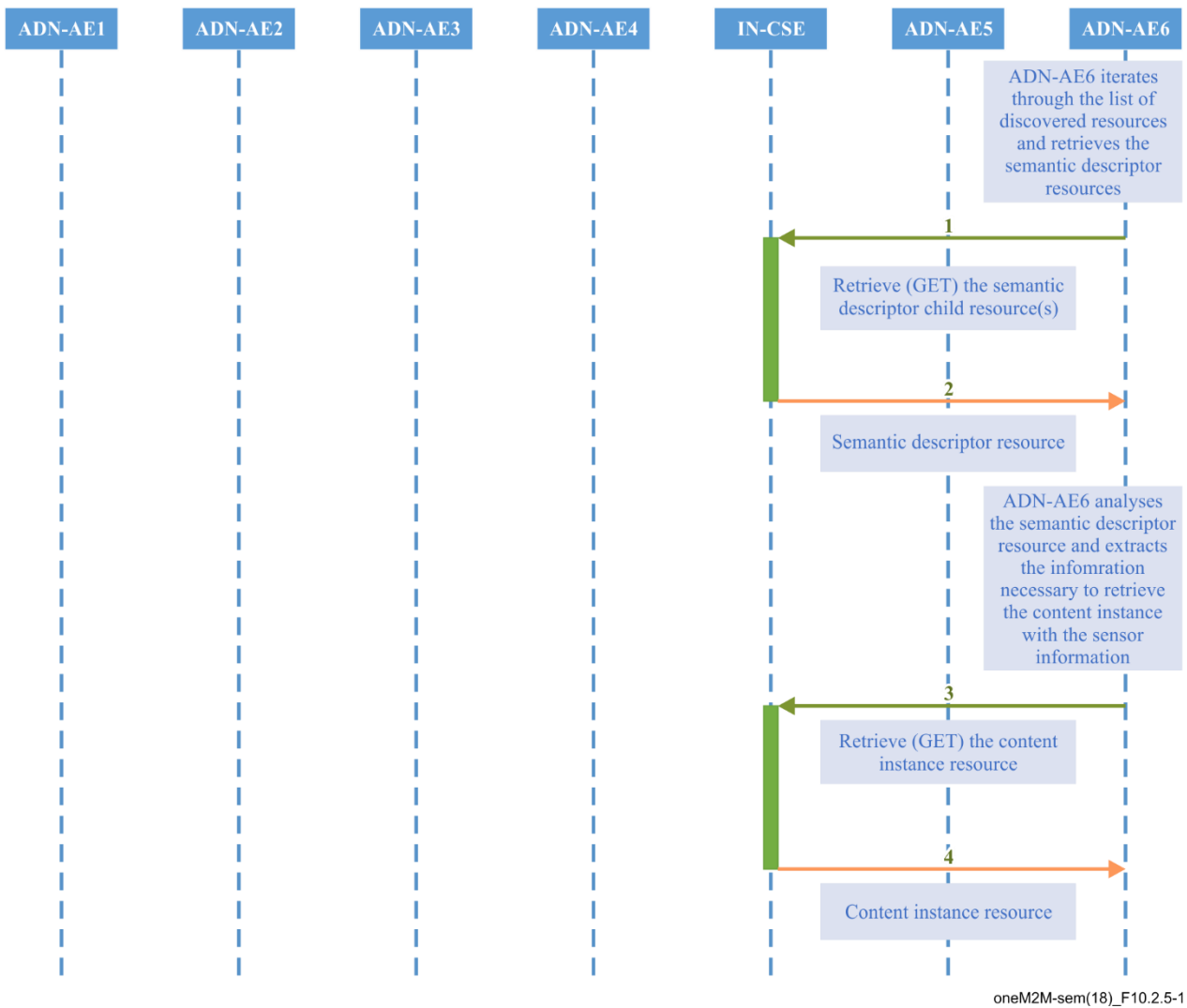

Figure 10.2.5-1 – Retrieval of semantic descriptor and sensor information phase call flows

11 Implementation

11.1 Introduction

Clause 11 presents necessary procedures required for the implementation of the semantic annotation and discovery use case, including conditions that must be met for the correct implementation of the current use case, and resource tree, etc.

11.2 Assumptions

Assumptions are presented as below in order to ensure the semantic annotation and discovery use case can be correctly implemented:

- security is not considered in the current use case;
- HTTP binding of oneM2M primitives is used in the current use case;
- XML serializations of oneM2M primitives are used in the current use case;
- all mandatory HTTP headers are presented in the HTTP requests while optional headers are selectively used in the current use case;
- all mandatory resource attributes for resources presented in the current use case are presented in the HTTP requests while optional resource attributes are selectively used in the current use case;

- all AEs in the current use case are initially registered with the IN-CSEs and the identifier of the AEs are assigned by it acting as the registrar CSE of the AE;
- all resources created in the current use case are addressable with the oneM2M resource identifier form of *hierarchical address*;
- short names for the representation of the resources and attributes are used in the current use case;
- default access control policy has already been created under IN-CSE;
- all request originators send *Blocking Requests* for accessing resources located in CSEs.

11.3 Resource structure

11.3.1 Introduction

The development of an oneM2M application includes the design of the resource trees of service capability layers, which is the IN-CSE in the current use case. The resource tree is constructed with child resources created according to the high-level procedures presented in clause 10. All the child resources shown in the resource trees are mandatorily required in order to correctly implement the semantic annotation and discovery use case.

11.3.2 Resource structure of IN-CSE

The resource tree of IN-CSE starts with a CSEBase named *server* depicted in Figure 11-1.

The root CSEBase has four direct child resources directly relevant to the semantic annotation and discovery use case, which are the tempsensorae1, tempsensorae2, tempsensorae3 and tempsensorae4 resources, representing ADN-AE1, ADN-AE2, ADN-AE3, and ADN-AE4, respectively. Each AE will have a container named temperature where the content instances (CI1 to CIN) are stored, and a semantic descriptor named SD1. As the substructure of each AE resource is exactly the same, only the substructure of tempsensorae1 is shown.

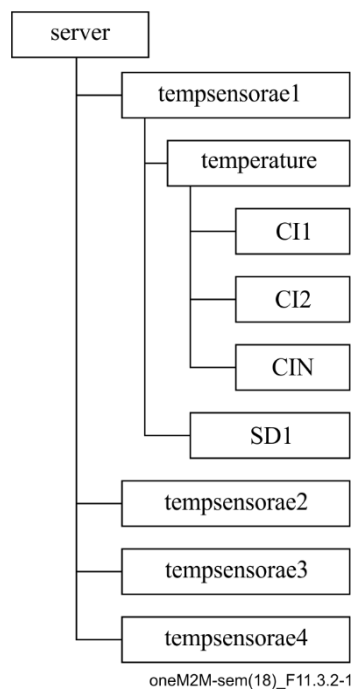

Figure 11-1 – IN-CSE resource structure

11.4 Role of entities

11.4.1 oneM2M service platform (IN-CSE)

The oneM2M service platform is modelled as an IN-CSE and is responsible for:

- handling the registration requests from all ADN-AEs in the use case;
- creating and managing the resource structures for storing sensor information and semantic annotations;
- executing semantic resource discovery.

11.4.2 Temperature sensor applications (ADN-AE1, ADN-AE2, ADN-AE3 and ADN-AE4)

Each of the temperature sensor applications are modelled as an ADN-AE and are responsible for:

- measuring the sensor information;
- registering the temperature sensors with the IN-CSE;
- creating container resources named "temperature";
- creating content instance resources under the container "temperature" that contain the temperature measurements.

11.4.3 Semantic annotation application (ADN-AE5)

The semantic annotation application, which is expected to run on a smartphone or other device with user interface is responsible for the following:

- enable the user to create semantic annotations for resources representing sensors;
- create semantic descriptor resources as child resources of sensor AE resources that contain the semantic annotations.

11.4.4 Semantic discovery application (ADN-AE6)

The semantic discovery application, which is expected to run on a user device, is responsible for the following:

- enable the user to formulate the semantic filter for the semantic discovery (in SPARQL);
- retrieve the semantic annotation for discovered resources;
- retrieve sensor measurements based on the semantic annotations.

11.5 Implementation procedures

11.5.1 Introduction

The implementation procedures in the current use case are mapped into HTTP bindings with XML serializations of oneM2M primitives according to the standard APIs describing the reference points Mca and Mcc, as defined in [b-ITU-T Y.4500.1], [b-ITU-T Y.4500.4], and the HTTP binding [b-ITU-T Y.4500.9].

In addition, *short names* for the representation of the resources and attributes are used in the implementation procedures.

11.5.2 Application registration

The following example shows how the tempsensorae1 (ADN-AE) is registered with the IN-CSE. The same is done for tempsensorae2, tempsensorae3 and tempsensorae4, which is not explicitly shown here:

```
HTTP Request:
POST /server?rcn=0 HTTP/1.1
Host: in.provider.com:7579
X-M2M-RI: 12345
```

```

X-M2M-Origin: SOrigin
Content-Type: application/xml;ty=2

<?xml version="1.0" encoding="UTF-8"?>
<m2m:ae                                xmlns:m2m="http://www.onem2m.org/xml/protocols"
xmlns:xsi="http://www.w3.org/2001/XMLSchema-instance" rn="tempsensorae1">
  <api>0.2.481.2.0001.001.000111</api>
  <lbl>semanticallyAnnotated tempSensor</lbl>
  <rr>true</rr>
</m2m:ae>

HTTP Response:
201 Created
X-M2M-RI: 12345
X-M2M-RSC: 2001
Content-Location: /server/ae-349923453

```

11.5.3 Initial resource creation

The following example shows how the temperature container child resource of tempsensorae1 is created, which will hold the content instances with the measured sensor values. The same is done for the temperature container child resources of tempsensorae2, tempsensorae3 and tempsensorae4, which is not explicitly shown here:

```

HTTP Request:
POST /server/tempsensorae1?rcn=0 HTTP/1.1
Host: in.provider.com:7579
X-M2M-RI:12346
X-M2M-Origin:SOrigin
Content-Type:application/xml;ty=3

<?xml version="1.0" encoding="UTF-8"?>
<m2m:cnt                                xmlns:m2m="http://www.onem2m.org/xml/protocols"
xmlns:xsi="http://www.w3.org/2001/XMLSchema-instance" rn="temperature">
  <lbl>container</lbl>
</m2m:cnt>

HTTP Response:
201 Created
X-M2M-RI: 12346
X-M2M-RSC: 2001
Content-Location: /server/cnt-282750912

```

The example below shows how a content instance holding a temperature value is created in the temperature container.

```

HTTP Request:
POST /server/tempsensorae1/temperature?rcn=0 HTTP/1.1
Host: in.provider.com:7579
Accept:application/xml
X-M2M-RI:12347
X-M2M-Origin:SOrigin
Content-Type:application/xml; ty=4

<?xml version="1.0" encoding="UTF-8" standalone="yes"?>
<m2m:cin                                xmlns:m2m="http://www.onem2m.org/xml/protocols"
xmlns:xsi="http://www.w3.org/2001/XMLSchema-instance">
  <con>75</con>
</m2m:cin>

HTTP Response:
201 Created
X-M2M-RI: 12347
X-M2M-RSC: 2001
Content-Location: /server/cin-234523664

```

11.5.4 Semantic descriptor resource creation

In the semantic annotation and discovery use case, a semantic annotation user application, e.g., a smartphone application, is used for semantically annotating a given resource. For this purpose, the semantic annotation application (ADN-AE5) creates a semantic descriptor child resource of the resource to be semantically annotated. The actual semantic description is represented in base64-encoded RDF/XML and can be found in the descriptor attribute of the semantic descriptor resource.

According to the scenario, there is one AE representing each temperature sensor. In the semantic description, all relevant information regarding the sensor and what it is measuring is represented, e.g., that the unit of measurement is Celsius, the temperature value is represented as an integer, the value represents the indoor temperature of a particular house and how the latest value can be retrieved. Figure 9-2 shows the complete semantic information of the scenario combined, the semantic annotations listed below each contain the relevant information for one temperature sensor. In base64-encoded form they are stored in the descriptor attributes of the respective semantic descriptor resources.

Semantic descriptor of indoor temperature sensor 1:

```
<?xml version="1.0"?>
<rdf:RDF xmlns="http://www.onem2m.org/ontology/houses_temperature_example#"
  xml:base="http://www.onem2m.org/ontology/houses_temperature_example"

  xmlns:temperature_example="http://www.onem2m.org/ontology/temperature_example#"
  xmlns:rdf="http://www.w3.org/1999/02/22-rdf-syntax-ns#"
  xmlns:owl="http://www.w3.org/2002/07/owl#"
  xmlns:xml="http://www.w3.org/XML/1998/namespace"
  xmlns:xsd="http://www.w3.org/2001/XMLSchema#"
  xmlns:rdfs="http://www.w3.org/2000/01/rdf-schema#">

  <owl:NamedIndividual
rdf:about="http://www.onem2m.org/ontology/houses_temperature_example#House1">
  <rdf:type
rdf:resource="http://www.onem2m.org/ontology/temperature_example#House"/>
  <temperature_example:hasIndoorTemperature
rdf:resource="http://www.onem2m.org/ontology/houses_temperature_example#IndoorTempProperty1"/>
  </owl:NamedIndividual>

  <owl:NamedIndividual
rdf:about="http://www.onem2m.org/ontology/houses_temperature_example#IndoorTempProperty1">
  <rdf:type
rdf:resource="http://www.onem2m.org/ontology/temperature_example#TemperatureProperty"/>
  <temperature_example:hasDatatype>xsd:int</temperature_example:hasDatatype>
  <temperature_example:hasUnit
rdf:datatype="http://www.w3.org/2001/XMLSchema#string">Fahrenheit</temperature_example:hasUnit>
  <temperature_example:valueIsStoredIn>http://
in.provider.com:7579/server/tempsensora1/temperature/latest</temperature_example:valueIsStoredIn>
  </owl:NamedIndividual>

  <owl:NamedIndividual
rdf:about="http://www.onem2m.org/ontology/houses_temperature_example#IndoorTempSensor1">
  <rdf:type
rdf:resource="http://www.onem2m.org/ontology/temperature_example#TemperatureSensor"/>
  <temperature_example:hasTemperatureMeasuringFunction
rdf:resource="http://www.onem2m.org/ontology/houses_temperature_example#TempFunction1"/>
  </owl:NamedIndividual>

  <owl:NamedIndividual
rdf:about="http://www.onem2m.org/ontology/houses_temperature_example#TempFunction1"
```

```

>
  <rdf:type
rdf:resource="http://www.onem2m.org/ontology/temperature_example#TemperatureMeasuri
ngFunction"/>
  <temperature_example:measuresTemperature
rdf:resource="http://www.onem2m.org/ontology/houses_temperature_example#IndoorTemp
roperty1"/>
  </owl:NamedIndividual>
</rdf:RDF>

```

Semantic descriptor of outdoor temperature sensor:

```

<?xml version="1.0"?>
<rdf:RDF xmlns="http://www.onem2m.org/ontology/houses_temperature_example#"
  xml:base="http://www.onem2m.org/ontology/houses_temperature_example"

  xmlns:temperature_example="http://www.onem2m.org/ontology/temperature_example#"
  xmlns:rdf="http://www.w3.org/1999/02/22-rdf-syntax-ns#"
  xmlns:owl="http://www.w3.org/2002/07/owl#"
  xmlns:xml="http://www.w3.org/XML/1998/namespace"
  xmlns:xsd="http://www.w3.org/2001/XMLSchema#"
  xmlns:rdfs="http://www.w3.org/2000/01/rdf-schema#">

  <owl:NamedIndividual
rdf:about="http://www.onem2m.org/ontology/houses_temperature_example#House1">
  <rdf:type
rdf:resource="http://www.onem2m.org/ontology/temperature_example#House"/>
  <temperature_example:hasOutdoorTemperature
rdf:resource="http://www.onem2m.org/ontology/houses_temperature_example#Outdoor
TempProperty"/>
  </owl:NamedIndividual>

  <owl:NamedIndividual
rdf:about="http://www.onem2m.org/ontology/houses_temperature_example#OutdoorTem
pProperty">
  <rdf:type
rdf:resource="http://www.onem2m.org/ontology/temperature_example#TemperaturePro
perty"/>
  <temperature_example:hasDatatype>xsd:int</temperature_example:hasDatatype>
  <temperature_example:hasUnit
rdf:datatype="http://www.w3.org/2001/XMLSchema#string">Celsius</temperature_example:ha
sUnit>

  <temperature_example:valueIsStoredIn>http://in.provider.com:7578/server/tempsensorae2/
temperature/latest</temperature_example:valueIsStoredIn>
  </owl:NamedIndividual>

  <owl:NamedIndividual
rdf:about="http://www.onem2m.org/ontology/houses_temperature_example#OutdoorTem
pSensor">
  <rdf:type
rdf:resource="http://www.onem2m.org/ontology/temperature_example#TemperatureSen
sor"/>
  <temperature_example:hasTemperatureMeasuringFunction
rdf:resource="http://www.onem2m.org/ontology/houses_temperature_example#TempFun
ction2"/>
  </owl:NamedIndividual>

  <owl:NamedIndividual
rdf:about="http://www.onem2m.org/ontology/houses_temperature_example#TempFunc
tion2">
  <rdf:type
rdf:resource="http://www.onem2m.org/ontology/temperature_example#TemperatureMea
suringFunction"/>
  <temperature_example:measuresTemperature
rdf:resource="http://www.onem2m.org/ontology/houses_temperature_example#Outdoor
TempProperty"/>
  </owl:NamedIndividual>
</rdf:RDF>

```

Semantic descriptor of indoor temperature sensor 2:

```
<?xml version="1.0"?>
<rdf:RDF xmlns="http://www.onem2m.org/ontology/houses_temperature_example#"
  xml:base="http://www.onem2m.org/ontology/houses_temperature_example"

  xmlns:temperature_example="http://www.onem2m.org/ontology/temperature_example#"
  "
  xmlns:rdf="http://www.w3.org/1999/02/22-rdf-syntax-ns#"
  xmlns:owl="http://www.w3.org/2002/07/owl#"
  xmlns:xml="http://www.w3.org/XML/1998/namespace"
  xmlns:xsd="http://www.w3.org/2001/XMLSchema#"
  xmlns:rdfs="http://www.w3.org/2000/01/rdf-schema#">

  <owl:NamedIndividual
rdf:about="http://www.onem2m.org/ontology/houses_temperature_example#House2">
  <rdf:type
rdf:resource="http://www.onem2m.org/ontology/temperature_example#House"/>
  <temperature_example:hasIndoorTemperature
rdf:resource="http://www.onem2m.org/ontology/houses_temperature_example#Indoor
TempProperty2"/>
  </owl:NamedIndividual>

  <owl:NamedIndividual
rdf:about="http://www.onem2m.org/ontology/houses_temperature_example#IndoorTem
pProperty2">
  <rdf:type
rdf:resource="http://www.onem2m.org/ontology/temperature_example#TemperaturePr
operty"/>

  <temperature_example:hasDatatype>xsd:double</temperature_example:hasDatatype>
  <temperature_example:hasUnit
rdf:datatype="http://www.w3.org/2001/XMLSchema#string">Celsius</temperature_ex
ample:hasUnit>

  <temperature_example:valueIsStoredIn>http://in.provider.com:7579/server/tempse
nsorae3/temperature/latest</temperature_example:valueIsStoredIn>
  </owl:NamedIndividual>

  <owl:NamedIndividual
rdf:about="http://www.onem2m.org/ontology/houses_temperature_example#IndoorTem
pSensor2">
  <rdf:type
rdf:resource="http://www.onem2m.org/ontology/temperature_example#TemperatureSe
nsor"/>
  <temperature_example:hasTemperatureMeasuringFunction
rdf:resource="http://www.onem2m.org/ontology/houses_temperature_example#TempFu
nction3"/>
  </owl:NamedIndividual>

  <owl:NamedIndividual
rdf:about="http://www.onem2m.org/ontology/houses_temperature_example#TempFunct
ion3">
  <rdf:type
rdf:resource="http://www.onem2m.org/ontology/temperature_example#TemperatureMe
asuringFunction"/>
  <temperature_example:measuresTemperature
rdf:resource="http://www.onem2m.org/ontology/houses_temperature_example#Indoor
TempProperty2"/>
  </owl:NamedIndividual>
</rdf:RDF>
```

Semantic descriptor of fridge temperature sensor 1:

```
<?xml version="1.0"?>
<rdf:RDF xmlns="http://www.onem2m.org/ontology/houses_temperature_example#"
  xml:base="http://www.onem2m.org/ontology/houses_temperature_example"

  xmlns:temperature_example="http://www.onem2m.org/ontology/temperature_example#"
  xmlns:rdf="http://www.w3.org/1999/02/22-rdf-syntax-ns#"
  xmlns:owl="http://www.w3.org/2002/07/owl#"
```

```

xmlns:xml="http://www.w3.org/XML/1998/namespace"
xmlns:xsd="http://www.w3.org/2001/XMLSchema#"
xmlns:rdfs="http://www.w3.org/2000/01/rdf-schema#">

  <owl:NamedIndividual
rdf:about="http://www.onem2m.org/ontology/houses_temperature_example#Fridge1">
    <rdf:type
rdf:resource="http://www.onem2m.org/ontology/temperature_example#Fridge"/>
    <temperature_example:hasFridgeTemperature
rdf:resource="http://www.onem2m.org/ontology/houses_temperature_example#FridgeTempProperty"/>
  </owl:NamedIndividual>

  <owl:NamedIndividual
rdf:about="http://www.onem2m.org/ontology/houses_temperature_example#FridgeTempProperty">
    <rdf:type
rdf:resource="http://www.onem2m.org/ontology/temperature_example#TemperatureProperty"/>
    <temperature_example:hasDatatype>xsd:double</temperature_example:hasDatatype>
    <temperature_example:hasUnit
rdf:datatype="http://www.w3.org/2001/XMLSchema#string">Celsius</temperature_example:hasUnit>

<temperature_example:valueIsStoredIn>http://in.provider.com:7579/server/tempensorae4/temperature/latest</temperature_example:valueIsStoredIn>
  </owl:NamedIndividual>

  <owl:NamedIndividual
rdf:about="http://www.onem2m.org/ontology/houses_temperature_example#FridgeTempSensor">
    <rdf:type
rdf:resource="http://www.onem2m.org/ontology/temperature_example#TemperatureSensor"/>
    <temperature_example:hasTemperatureMeasuringFunction
rdf:resource="http://www.onem2m.org/ontology/houses_temperature_example#TempFunction4"/>
  </owl:NamedIndividual>

  <owl:NamedIndividual
rdf:about="http://www.onem2m.org/ontology/houses_temperature_example#TempFunction4">
    <rdf:type
rdf:resource="http://www.onem2m.org/ontology/temperature_example#TemperatureMeasuringFunction"/>
    <temperature_example:measuresTemperature
rdf:resource="http://www.onem2m.org/ontology/houses_temperature_example#FridgeTempProperty"/>
  </owl:NamedIndividual>
</rdf:RDF>

```

The following example shows how the semantic descriptor child resource of the tempsensorae1 (ADN-AE1) is created. The semantic descriptors of tempsensorae2, tempsensorae3 and tempsensorae4 are created in the same way. Please note that the content of the descriptor attribute first needs to be base64-encoded.

```

HTTP Request:
POST /server/tempensorae1?rcn=0 HTTP/1.1
Host: in.provider.com:7579
X-M2M-RI:12349
X-M2M-Origin:SOrigin
Content-Type:application/xml;ty=24

<?xml version="1.0" encoding="UTF-8"?>
<m2m:sd
  xmlns:m2m="http://www.onem2m.org/xml/protocols"
  xmlns:xsi="http://www.w3.org/2001/XMLSchema-instance"
  rn="SD1">
  <dspt>

```

Query 1:

Natural language query: "Retrieve all the sensor related resources that measure the temperature in the unit Celsius".

```
PREFIX temp: <http://www.onem2m.org/ontology/temperature_example#>
```

```
SELECT ?sensor
  WHERE {
    ?sensor temp:hasTemperatureMeasuringFunction ?tempFunction .
    ?tempFunction temp:measuresTemperature ?property .
    ?property temp:hasUnit
    "Celsius"^^<http://www.w3.org/2001/XMLSchema#string>
  }
```

```
?sensor does not match temp:IndoorTempSensor1 → tempsensorae1 is not included in the result
```

```
?sensor matches temp:OutdoorTempSensor → tempsensorae2 is included in the result
```

```
?sensor matches temp:IndoorTempSensor2 → tempsensorae3 is included in the result
```

```
?sensor matches temp:FridgeTempSensor → tempsensorae4 is included in the result
```

Query 2:

Natural language query: "Retrieve all the sensor related resources that measure the indoor temperature of a house".

```
PREFIX temp: <http://www.onem2m.org/ontology/temperature_example#>
```

```
SELECT ?sensor
  WHERE { ?thing temp:hasIndoorTemperature ?property .
    ?tempFunction temp:measuresTemperature ?property .
    ?sensor temp:hasTemperatureMeasuringFunction ?tempFunction
  }
```

```
?sensor matches temp:IndoorTempSensor1 → tempsensorae1 is included in the result
```

```
?sensor does not match temp:OutdoorTempSensor → tempsensorae2 is not included in the result
```

```
?sensor matches temp:IndoorTempSensor2 → tempsensorae3 is included in the result
```

```
?sensor does not match temp:FridgeTempSensor → tempsensorae4 is not included in the result
```

Query 3:

Natural language query: "Retrieve all the sensor related resources that measure the indoor temperature of a house and provide the measurement in the unit Fahrenheit".

```
PREFIX temp: <http://www.onem2m.org/ontology/temperature_example#>
```

```
SELECT ?sensor
  WHERE { ?thing temp:hasIndoorTemperature ?property .
    ?property temp:hasUnit
    "Fahrenheit"^^<http://www.w3.org/2001/XMLSchema#string>.
    ?tempFunction temp:measuresTemperature ?property .
    ?sensor temp:hasTemperatureMeasuringFunction ?tempFunction
  }
```

```
?sensor matches temp:IndoorTempSensor1 → tempsensorae1 is included in the result
```

```
?sensor does not match temp:OutdoorTempSensor → tempsensorae2 is not included in the result
```

```
?sensor does not match temp:IndoorTempSensor2 → tempsensorae3 is not included in the result
```

```
?sensor does not match temp:FridgeTempSensor → tempsensorae4 is not included in the result
```

The following example shows how the semantic discovery application (ADN-AE6) on the user device can perform the complete HTTP request for Query 2, where the semantic filter in SPARQL is URI-encoded.

HTTP Request:

```
GET /server?fu=1&smf=
PREFIX%20temp%3A%20%3Chttp%3A%2F%2Fwww.onem2m.org%2Fontology%2Ftemperature_exam
ple%23%3E%20SELECT%20%3Fsensor%20WHERE%20%7B%20%3Fthing%20temp%3AhasIndoorTempe
rature%20%3Fproperty%20.%20%3FtempFunction%20temp%3AmeasuresTemperature%20%3Fpr
operty%20.%20%3Fsensor%20temp%3AhasTemperatureMeasuringFunction%20%3FtempFunci
```

```

on%7D HTTP/1.1
Host: in.provider.com:7579
Accept: application/xml
X-M2M-RI: 12355
X-M2M-Origin: SOrigin

HTTP Response:

200 OK
Accept: application/xml
X-M2M-RI: 12355
X-M2M-RSC: 2000

<?xml version="1.0" encoding="UTF-8" standalone="yes"?>
<m2m:uril xmlns:m2m="http://www.onem2m.org/xml/protocols"
xmlns:xsi="http://www.w3.org/2001/XMLSchema-instance">
  server/tempsensorael
  server/tempsensoraee3
</m2m:uril>

```

As expected tempsensorael (ADN-AE1) and tempsensoraee3 (ADN-AE3) are returned.

11.5.6 Retrieval of semantic descriptor and sensor information

As the final step, the semantic discovery application (ADN-AE6) on the user device can now retrieve the semantic descriptor itself and find out how to access the latest sensor measurement (under the assumption that the convention of using the name SD1 for the semantic descriptor was used, otherwise it needs to get the information about the semantic descriptor child resource(s) first).

HTTP Request:

```

GET /server/tempsensorael/SD1 HTTP/1.1
Host: in.provider.com:7579
Accept: application/xml
X-M2M-RI: 12645
X-M2M-Origin: SOrigin

```

HTTP Result:

```

200 OK
X-M2M-RI: 12645
X-M2M-RSC: 2000

```

```

<?xml version="1.0" encoding="UTF-8"?>
<m2m:sd
  xmlns:m2m="http://www.onem2m.org/xml/protocols"
  xmlns:xsi="http://www.w3.org/2001/XMLSchema-instance"
  rn="SD1">
<pi>cse00001</pi>
<ty>24</ty>
<ct>20170519T064158</ct>
<ri>sd-342342434</ri>
<lt>20170519T064158</lt>
<et>20190518T063022</et>
<aei>SOrigin</aei>
<dspt>PD94bWwgdMVyc2lvbj0iMS4wIj8+DQo0cmRmO1JERiB4bWxucz0iaHR0cDovL3d3dy5vbmVtM0ub3JnL29udG9sb2d5L2hvdXNlc190ZWlwZXJhdHVyZV9leGFtcGxlIyINCiAgICAgE1sOmJhc2U9Imh0dHA6Ly93d3cub25lbTJtLm9yZy9vbnRvbG9neS9ob3VzZXNfdGVtcGVyYXR1cmVfZXBhbXBsZSI NCiAgICAgE1sbnM6dGVtcGVyYXR1cmVfZXBhbXBsZT0iaHR0cDovL3d3dy5vbmVtMm0ub3JnL29udG9sb2d5L3RlbnB1cmF0dXJlX2V4YW1wbGUjIgoKICAgICB4bWxuczpyZGY9Imh0dHA6Ly93d3cudzMub3JnLzE5OTkvMDIvMjItcmRmLXN5bnRheClucyMiDQogICAgIHhtbG5zOm93bD0iaHR0cDovL3d3dy53 My5vcmcvbWAwMi8wNy9vd2wjIgoKICAgICB4bWxuczpy4bWw9Imh0dHA6Ly93d3cudzMub3JnL1hNTC8 xOTk4L25hbWVzcGFjZSINCiAgICAgE1sbnM6eHNkPSJodHRwOi8vd3d3Ln9yZy8yMDAxL1hNTF NjaGVtYSMiDQogICAgIHhtbG5zOm9kaXNpYXR1cmVfZXBhbXBsZT0iaHR0cDovL3d3dy5vbmVtMm0ub3JnL29udG9sb2d5L2hvdXNlc190ZWlwZXJhdHVyZV9leGFtc GvYXR1cmVfZXBhbXBsZT0iaHR0cDovL3d3dy5vbmVtMm0ub3JnL29udG9sb2d5L2hvdXNlc190ZWlwZXJhdHVyZV9leGFtc GvYXR1cmVfZXBhbXBsZT0iaHR0cDovL3d3dy5vbmVtMm0ub3JnL29udG9sb2d5L2hvdXNlc190ZWlwZXJhdHVyZV9leGFtc GvYXR1cmVfZXBhbXBsZT0iaHR0cDovL3d3dy5vbmVtMm0ub3JnL29udG9sb2d5L2hvdXNlc190ZWlwZXJhdHVyZV9leGFtc GvYXR1cmVfZXBhbXBsZT0iaHR0cDovL3d3dy5vbmVtMm0ub3JnL29udG9sb2d5L2hvdXNlc190ZWlwZXJhdHVyZV9leGFtc GvYXR1cmVfZXBhbXBsZT0iaHR0cDovL3d3dy5vbmVtMm0ub3JnL29udG9sb2d5L2hvdXNlc190ZWlwZXJhdHVyZV9leGFtc

```

Appendix I

Mapping to oneM2M base ontology

Figure I.1 shows the mapping of the specific concepts of the simple ontology for the semantic annotation and discovery use case to the more general concepts of the oneM2M base ontology [b-ITU-T Y.4500.12]. Thus, the semantic integration with the concepts identified for oneM2M itself is achieved.

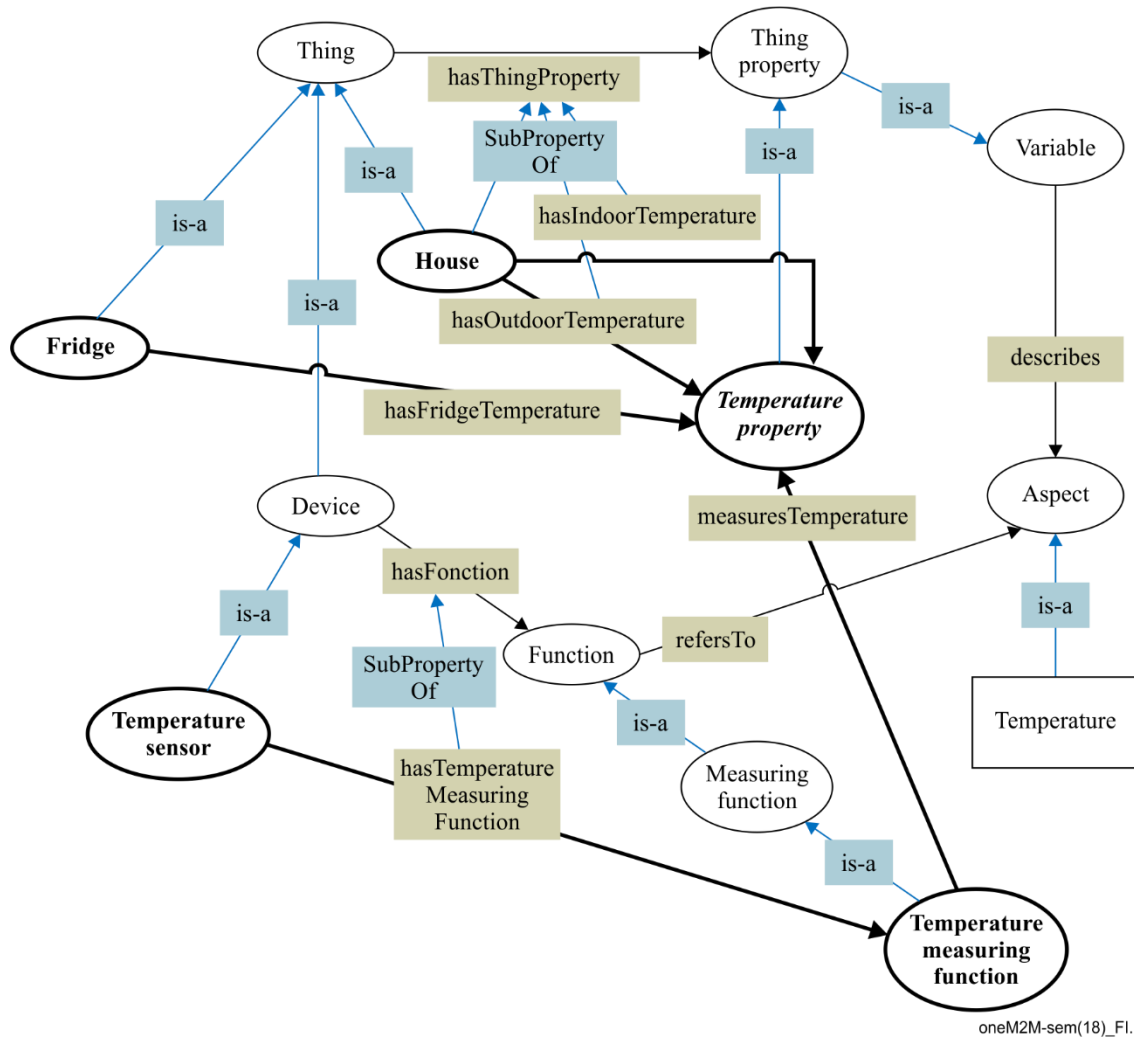

Figure I.1 – Mapping of the introduced concepts to the oneM2M base ontology

When compared to the concepts available in the complete oneM2M base ontology, it can be seen that the focus of the modelling here has been on semantic aspects. It is assumed that the functional aspects are implemented by oneM2M AEs using the Mca interface. In the case of using non-oneM2M technologies and applications for the sensors, an interworking proxy would be needed to translate between oneM2M and the native technology. Using generic interworking as described in [b-oneM2M TS-0030] with a complete modelling of the functionality according to the oneM2M base ontology (or an ontology that has been mapped to the oneM2M base ontology in a similar way as shown in Figure I.1) would allow the automatic creation of a oneM2M resource structure for the case and enable tool-support for the partially automated creation of the required interworking proxy.

Bibliography

- [b-ITU-T Y.4500.1] oneM2M Technical Specification TS-0001, *Functional Architecture*.
- [b-ITU-T Y.4500.4] oneM2M Technical Specification TS-0004, *Service Layer Core Protocol*.
- [b-ITU-T Y.4500.9] oneM2M Technical Specification TS-0009, *HTTP Protocol Binding*.
- [b-ITU-T Y.4500.12] oneM2M Technical Specification TS-0012, *Base Ontology*.
- [b-oneM2M TR-0025] oneM2M Technical Report TR-0025, *Application developer guide*.
- [b-oneM2M TS-0030] oneM2M Technical Specification TS-0030, *Generic Interworking*.
-