

I n t e r n a t i o n a l T e l e c o m m u n i c a t i o n U n i o n

ITU-T Technical Report

TELECOMMUNICATION
STANDARDIZATION SECTOR
OF ITU

(1 September 2022)

Focus Group on Vehicular Multimedia (FG-VM)

FGVM-03 Implementation aspects of vehicular multimedia

Technical Report ITU-T FGVM-03

Implementation aspects of vehicular multimedia

Summary

This Technical Report is the third output of the ITU-T Focus Group on vehicular multimedia. It has been prepared by FG-VM/WG3 during its working sessions of 2021 and 2022, according to its terms of reference to collect information about the challenges and expected requirements for implementing multimedia functionalities in a vehicle and to identify further needs of requirements and gaps in standardization.

This report represents the findings of WG3 and describes the implementation aspects of vehicular multimedia system (VMS) functionalities in vehicles, in the fields of intelligent voice interaction, the interconnection between vehicles and smartphones and connectivity. The implementation aspects include a range of technologies supporting the provision of multimedia services and infotainment applications, like connectivity, media content, human machine interface (HMI) with intelligent display and voice interaction, interaction with nomadic and in-vehicle devices. The report also includes the relevance of driving safety and user experience. It intends to provide information about the state of the art and future trends of implementing these multimedia resources, including references to relevant standards or as applicable regulations impacting the implementation aspects.

The analysis provided in the report aim to identify relevant gaps in the standardization activities, especially for emerging multimedia technologies and to propose mitigations.

Keywords

5G, aftermarket, configuration, cyber-security, driving safety, infotainment, interoperability, IPv6, protocols, testing, user experience, vehicle integration, vehicular multimedia.

Note

This is an informative ITU-T publication. Mandatory provisions, such as those found in ITU-T Recommendations, are outside the scope of this publication. This publication should only be referenced bibliographically in ITU-T Recommendations.

Change log

This Technical Report contains the following version (Highest no.) of Technical Reports that are on the implementation aspects of vehicular multimedia.

No.	Revision	Date	Revision Details
01	WG3-I-006	02 March 2021	Draft provided as input to the 3 March 2021 WG3 meeting
02	WG3-I-007	03 March 2021	Draft reviewed and updated during the 3 March 2021 WG3 meeting
03	FG-VM-WG3-TR-implementation_aspects_v03	12 March 2021	Interim version for editing purpose
04	FG-VM-WG3-TR-implementation_aspects_v04	26 March 2021	Interim version for editing purpose – Input for 30 March meeting
05	FG-VM-WG3-TR-implementation_aspects_v05	29 March 2021	Interim version for preparing March 30 th 2021, WG3 meeting – adding sections "Interoperability" and "Cybersecurity"
06	FG-VM-WG3-TR-implementation_aspects_v06	30 March 2021	Document reviewed and updated during WG3 meeting
07	FG-VM-WG3-TR-implementation_aspects_v07	12 April 2021	Release for discussion at 12 th FG-VM meeting 12-13 April
08	FG-VM-WG3-TR-implementation_aspects_v08	26 May 2021	Release for information for further development discussion at WG3 meeting 28 May
09	FG-VM-WG3-TR-implementation_aspects_v09	28 May 2021	Release discussed and updated during WG3 meeting 28 May 2021
10	FGVM-O-065_Att1.docx FG-VM-WG3-TR v10	29 June 2021	Output from FG-VM plenary meeting
11	FG-VM-WG3-TR-implementation_aspects_v11	29 Sep 2021	Input of the FG-VM plenary, FGVM-I-245
12	FG-VM-WG3-TR-implementation_aspects_v12	30 Sep 2021	Output of the FG-VM Plenary
13	FG-VM-WG3-TR-implementation_aspects_v13	15 Dec. 2021	Input of the FG-VM Plenary Dec 2021
14	FG-VM-WG3-TR-implementation_aspects_v14	20 Dec. 2021	Output of the FG-VM Plenary Dec 2021
15	FG-VM-WG3-TR-implementation_aspects_v15	12/01/2022	Input for the WG3 meeting of 13/01/2022
16	FG-VM-WG3-TR-implementation_aspects_v16	08/02/2022	Input for the WG3 meeting of 10/02/2022
17	FG-VM-WG3-TR-implementation_aspects_v17	14/02/2022	Output of the WG3 meeting of 10/02/2022
18	FG-VM-WG3-TR-implementation_aspects_v18	14/03/2022	Input for the WG3 meeting of 16/03/2022
19	FG-VM-WG3-TR-implementation_aspects_v19	26/04/2022	Input for the plenary meeting of 28/04/2022
20	FG-VM-WG3-TR-implementation_aspects_v20	06/05/2022	Output of the plenary meeting of 28/04/2022
21	FG-VM-WG3-TR3_v21	01/07/2022	Output of the WG3 meeting of 01/07/2022
22	FG-VM-WG3-TR3_v22	06/07/2022	Input of the WG3 meeting of 20/07/2022
23	FG-VM-WG3-TR3_v23	11/07/2022	Light editorial changes in section 7.2.1 - Input of the WG3 meeting of 20/07/2022
24	FG-VM-WG3-TR3-v24	26/07/2022	Output of WG3 meeting 20 July 2022, with approved contributions from Changan and Huawei
25	FG-VM-WG3-TR3-v25	27/07/2022	Clean version of FG-VM-WG3-TR3-v24

No.	Revision	Date	Revision Details
26	WG3-I-044 (Clean)	11/08/2022	Output of WG3 meeting 10/08/2022 with approved contributions – Clean version for next meeting inputs
27	WG3-I-048	17/08/2022	Output of WG3 meeting 16/08/2022 with all reviewed contributions (WG3-I-46 and 47) – Clean version for next meeting inputs
	WG3-I-049	23/08/2022	VW and Head Acoustics input correcting VA architecture in 7.2.1
	WG3-I-050	25/08/2022	Huawei contribution on several sections
28	WG3-I-051	29/08/2022	Output of WG3 meeting 25/08/2022 with all reviewed contributions – Clean version
	WG3-I-052R1	30/08/2022	Huawei contribution on 7.2.14 and 8
29	FGVM-I-283	30/08/2022	Clean version of WG3-I-052R1

Editor: Xing Chen
Changan Automobile
China

Email: chenxing@changan.com.cn

Francois Fischer
Huawei Technologies R&D
Belgium

Email: francois.fischer@huawei.com

© ITU 2022

All rights reserved. No part of this publication may be reproduced, by any means whatsoever, without the prior written permission of ITU.

Table of Contents

	Page
1	Scope..... 1
2	References..... 1
3	Definitions 4
3.1	Terms defined elsewhere 4
3.2	Terms defined in this Technical Report..... 4
4	Abbreviations and acronyms 4
5	Conventions 6
6	Vehicular multimedia functional scope 6
7	VMS implementation aspects 7
7.1	Connectivity..... 7
7.2	Human machine interface (HMI)..... 14
7.3	Media format basic set..... 22
7.4	Media service discovery 23
7.5	Media over internet..... 23
7.6	Smartphone infotainment assistant 24
7.7	Cyber-security..... 28
7.8	Privacy protection 31
7.9	Driver and user experience 32
7.10	Driver assistance and safety..... 33
7.11	In-vehicle integration..... 33
8	Conclusions..... 35
	Bibliography..... 37

Technical Report ITU-T FGVM-03

Implementation aspects of vehicular multimedia

1 Scope

This Technical Report ITU-T FGVM-03 describes the implementation aspects of vehicular multimedia system (VMS) functionalities in vehicles, in the fields of intelligent voice interaction, interconnection between vehicle and smartphones and connectivity. The implementation aspects include a range of technologies supporting the provision of multimedia services and infotainment applications, like connectivity, media content, human machine interface (HMI) with intelligent display and voice interaction, interaction with nomadic and in-vehicle device. The Technical Report also reports about the relevance of driving safety and user experience. It intends to provide information about the state of the art and future trends of implementing these multimedia resources, including references to relevant standards or as applicable regulations impacting the implementation aspects.

The analysis provided in the Technical Report aims to identify relevant gaps, in the standardization activities, especially for emerging multimedia technologies and to propose mitigations.

2 References

- [1] ISO/SAE 21434:2021, *Road vehicles – Cybersecurity engineering*.
[<https://www.iso.org/fr/standard/70918.html>]
- [2] ETSI TS 101 154v2.7.1 (2022-01), *Digital Video Broadcasting (DVB); Specification for the use of Video and Audio Coding in Broadcast and Broadband Applications*.
[https://www.etsi.org/deliver/etsi_ts/101100_101199/101154/02.07.01_60/ts_101154v020701p.pdf] and its latest version as DVB BlueBook: [https://dvb.org/wp-content/uploads/2022/02/A001r20_Use-of-Video-and-Audio-Coding-in-Broadcast-and-Broadband-Applications_Draft_TS_101-154-v281_July-2022.pdf]
- [3] ISO/IEC 23090-5:2021, *Information technology – Coded representation of immersive media – Part 5: Visual volumetric video-based coding (V3C) and video-based point cloud compression (V-PCC)*. [<https://www.iso.org/standard/73025.html>]
- [4] ISO/IEC 23090-10:2022, *Information technology – Coded representation of immersive media – Part 10: Carriage of visual volumetric video-based coding data*.
[<https://www.iso.org/standard/78991.html>]
- [5] ISO/IEC 23009-1:2019, *Information technology – Dynamic adaptive streaming over HTTP (DASH) – Part 1: Media presentation description and segment formats*.
[<https://www.iso.org/standard/75485.html>]
- [6] ETSI EN 302 755 v1.4.1 (2015-07), *Digital Video Broadcasting (DVB); Frame structure channel coding and modulation for a second generation digital terrestrial television broadcasting system (DVB-T2)*.
[http://www.etsi.org/deliver/etsi_en/302700_302799/302755/01.04.01_60/en_302755v010401p.pdf]
- [7] ETSI EN 302 307-1 v1.4.1 (2014-11), *Digital Video Broadcasting (DVB); Second generation framing structure, channel coding and modulation systems for Broadcasting, Interactive Services, News Gathering and other broadband satellite applications; Part 1: DVB-S2*. [<https://i-cas.in/documents/DVB%20S2.pdf>]
- [8] ETSI TS 102 796 V1.6.1 (2021-04), *Hybrid Broadcast Broadband TV*.
[https://www.etsi.org/deliver/etsi_ts/102700_102799/102796/01.06.01_60/ts_102796v010601p.pdf]

- [9] ETSI TS 103 285 V1.3.1 (2020-02), *Digital Video Broadcasting (DVB); MPEG-DASH Profile for Transport of ISO BMFF Based DVB Services over IP Based Networks* [https://www.etsi.org/deliver/etsi_ts/103200_103299/103285/01.03.01_60/ts_103285v010301p.pdf] and the latest DVB BlueBook: [https://dvb.org/wp-content/uploads/2019/12/a168_dvb_mpeg-dash_oct_2019.pdf]
- [10] ETSI TS 103 770 V1.1.1 (2020-11), *Digital Video Broadcasting (DVB); Service Discovery and Programme Metadata for DVB-I*. [https://www.etsi.org/deliver/etsi_ts/103700_103799/103770/01.01.01_60/ts_103770v010101p.pdf] and the latest DVB BlueBook: [https://dvb.org/wp-content/uploads/2021/06/A177r3_Service-Discovery-and-Programme-Metadata-for-DVB-I_January-2022.pdf]
- [11] DVB BlueBook C100, *Commercial Requirements for DVB-I over 5G*. [https://dvb.org/wp-content/uploads/2021/07/C100_Commercial-Requirements_DVB-I-for-5G_FINAL.pdf]
- [12] 3GPP TS 26.234 V16.2.0 (2020-12), *Transparent end-to-end Packet-switched Streaming Service (PSS); Protocols and codecs (Release 16)*. [https://www.3gpp.org/ftp/Specs/archive/26_series/26.234/26234-g20.zip]
- [13] 3GPP TS 26.346 V16.9.1 (2021-05), *Multimedia Broadcast/Multicast Service (MBMS); Protocols and codecs (Release 16)*. [https://www.3gpp.org/ftp/Specs/archive/26_series/26.346/26346-g91.zip]
- [14] 3GPP TS 26.247 V16.4.1 (2020-10), *Transparent end-to-end Packet-switched Streaming Service (PSS); Progressive Download and Dynamic Adaptive Streaming over HTTP (3GP-DASH) (Release 16)*. [https://www.3gpp.org/ftp/Specs/archive/26_series/26.247/26247-g41.zip]
- [15] 3GPP TS 26.116 V16.3.1 (2021-06) *Television (TV) over 3GPP services; Video profiles (Release 16)*. [https://www.3gpp.org/ftp/Specs/archive/26_series/26.116/26116-g31.zip]
- [16] ATSC Standard: *Link-Layer Protocol Doc. A/330:2022-3*. [<https://muygs2x2vhb2pjk6g160f1s8-wpengine.netdna-ssl.com/wp-content/uploads/2022/04/A330-2022-03-Link-Layer-Protocol.pdf>]
- [17] ATSC Standard: *Signaling, Delivery, Synchronization, and Error Protection Doc. A/331:2021*. [<https://www.atsc.org/wp-content/uploads/2021/01/A331-2021-Signaling-Delivery-Sync-FEC.pdf>]
- [18] ATSC Standard: *Service Announcement Doc. A/332:2022-3*. [<https://muygs2x2vhb2pjk6g160f1s8-wpengine.netdna-ssl.com/wp-content/uploads/2022/04/A332-2022-03-Service-Announcement.pdf>]
- [19] ATSC Standard: *Video – HEVC Doc. A/341:2022-03*. [<https://muygs2x2vhb2pjk6g160f1s8-wpengine.netdna-ssl.com/wp-content/uploads/2022/04/A341-2022-03-Video-HEVC.pdf>]
- [20] ATSC Standard: *A/342 Part 1, Audio Common Elements Doc. A/342-1:2022-3*. [<https://muygs2x2vhb2pjk6g160f1s8-wpengine.netdna-ssl.com/wp-content/uploads/2022/04/A342-1-2022-03-Audio-Common-Elements.pdf>]
- [21] ATSC Standard: *A/342 Part 2 (AC-4) System Doc. A/342-2:2022-03*. [<https://muygs2x2vhb2pjk6g160f1s8-wpengine.netdna-ssl.com/wp-content/uploads/2022/04/A342-2-2022-03-AC4-System.pdf>]
- [22] ATSC Standard: *A/342 Part 3, MPEG-H System Doc. A/342-3:2022-03*. [<https://muygs2x2vhb2pjk6g160f1s8-wpengine.netdna-ssl.com/wp-content/uploads/2022/04/A342-3-2022-03-MPEG-System.pdf>]
- [23] ISO/IEC FDIS 23090-9 *Information technology — Coded representation of immersive media – Part 9: Geometry-based point cloud compression*. [<https://www.iso.org/standard/78990.html>]
- [24] ISO/IEC DIS 23090-18 *Information technology – Coded representation of immersive media – Part 18: Carriage of geometry-based point cloud compression data*. [<https://www.iso.org/standard/80901.html>]
- [25] IETF RFC 8402, *Segment Routing Architecture*, (2018). [<https://datatracker.ietf.org/doc/rfc8402/>]

- [26] IETF RFC 8754, *IPv6 Segment Routing Header (SRH)*, (2020). [<https://datatracker.ietf.org/doc/html/rfc8754>]
- [27] IETF RFC 8986, *Segment Routing over IPv6 (SRv6) Network Programming*, (2021). [<https://datatracker.ietf.org/doc/rfc8986/>]
- [28] Recommendation ITU-T F.749.3 (2020), *Use cases and requirements for vehicular multimedia networks*. [<https://www.itu.int/rec/T-REC-F.749.3-202008-1>]
- [29] ISO 21806-1:2020, *Road vehicles – Media Oriented Systems Transport (MOST) – Part 1: General information and definitions*. [<https://www.iso.org/standard/71833.html>]
- [30] ETSI TS 103 544-1 V1.3.1 (2019-10). Publicly Available Specification (PAS); *Intelligent Transport Systems (ITS); MirrorLink; Part 1: Connectivity*. [https://www.etsi.org/deliver/etsi_ts/103500_103599/10354401/01.03.01_60/ts_10354401v010301p.pdf]
- [31] ISO 11898-1:2015 *Road vehicles – Controller area network (CAN) – Part 1: Data link layer and physical signalling*. [<https://www.iso.org/standard/63648.html>]
- [32] IEEE Standard 802.3bw-2015, *IEEE Standard for Ethernet Amendment 1: Physical Layer Specifications and Management Parameters for 100 Mb/s Operation over a Single Balanced Twisted Pair Cable (100BASE-T1)*. [<https://standards.ieee.org/ieee/802.3bw/5969/>]
- [33] IEEE Standard 802.3bp-2016, *IEEE Standard for Ethernet Amendment 4: Physical Layer Specifications and Management Parameters for 1 Gb/s Operation over a Single Twisted-Pair Copper Cable*. [<https://standards.ieee.org/ieee/802.3bp/5925/>]
- [34] IEEE 802.1AS (2006), *IEEE Standard for Local and Metropolitan Area Networks – Timing and Synchronization for Time-Sensitive Applications in Bridged Local Area Networks*. [<https://www.ieee802.org/1/files/public/docs2006/avb-garner-timing-synch-par-r09-060112.pdf>]
- [35] IEEE 802.1 Qbv-2015 - *IEEE Standard for Local and metropolitan area networks -- Bridges and Bridged Networks - Amendment 25: Enhancements for Scheduled Traffic*. [<https://ieeexplore.ieee.org/document/8613095>]
- [36] IEEE 802.1CB-2017 – *IEEE Standard for Local and metropolitan area networks--Frame Replication and Elimination for Reliability*. [<https://ieeexplore.ieee.org/document/8091139>]
- [37] Specification on SOME/IP Transport Protocol AUTOSAR CP R20-11. [https://www.autosar.org/fileadmin/user_upload/standards/classic/20-11/AUTOSAR_SWS_SOMEIPTTransportProtocol.pdf]
- [38] OMG Standards Development Organization *Data Distribution Service (DDS) Version 1.4*. [<https://www.omg.org/spec/DDS/1.4/About-DDS/>]
- [39] ETSI GR IP6 030 V1.1.1 (2020-10), *IPv6-based Vehicular Networking (V2X)*. [https://www.etsi.org/deliver/etsi_gr/IP6/001_099/030/01.01.01_60/gr_IP6030v010101p.pdf]
- [40] ISO 21210:2012, *Intelligent transport systems – Communications access for land mobiles (CALM) – IPv6 Networking*, June 2012. [<https://www.iso.org/standard/46549.html>]
- [41] 5G Automotive Association (5GAA), *5GAA Efficient Security Provisioning System*. [https://5gaa.org/wp-content/uploads/2020/05/5GAA_E-200017_ESPS_White_Paper_Final33323-ed-out.pdf]
- [42] IETF Deployment Status *draft-ietf-v6ops-ipv6-deployment-07*, [<https://datatracker.ietf.org/doc/draft-ietf-v6ops-ipv6-deployment/>]
- [43] Car 2 Car Communication Consortium, *Overview of the C2C-CC System*, (2007). [https://elib.dlr.de/48380/1/C2C-CC_manifesto_v1.1.pdf]
- [44] IETF RFC 4862, *IPv6 Stateless Address Autoconfiguration*, (2007). [<https://datatracker.ietf.org/doc/rfc4862/>]

- [45] IETF RFC 3963, *Network Mobility (NEMO) Basic Support Protocol*, (2005). [<https://datatracker.ietf.org/doc/rfc3963/>]
- [46] IETF RFC 5648, *Multiple Care-of Addresses Registration*, (2009). [<https://datatracker.ietf.org/doc/rfc5648/>]
- [47] IETF RFC 4302, *IP Authentication Header*, (2005). [<https://datatracker.ietf.org/doc/rfc4302/>]
- [48] IETF RFC 4303, *IP Encapsulating Security Payload (ESP)*, (2005). [<https://datatracker.ietf.org/doc/html/rfc4303>]
- [49] Recommendation ITU-T P.1100 (2019), *Narrowband hands-free communication in motor vehicles*. [<https://www.itu.int/rec/T-REC-P.1100-201901-l/en>]
- [50] Recommendation ITU-T P.1110 (2019), *Wideband hands-free communication in motor vehicles*. [<https://www.itu.int/rec/T-REC-P.1110-201901-l/en>]
- [51] Recommendation ITU-T P.1120 (2017), *Super-wideband and fullband stereo hands-free communication in motor vehicles*. [<https://www.itu.int/rec/T-REC-P.1120-201703-l/en>]
- [52] W3C Working Draft (2022), *Media Capability*. [<https://www.w3.org/TR/media-capabilities/>]
- [53] Technical report FGVM-01R2, Use cases and requirements for the vehicular multimedia networks. [<https://www.itu.int/pub/T-FG-VM-2020>].

3 Definitions

3.1 Terms defined elsewhere

This Technical Report uses the following terms defined elsewhere:

3.1.1 vehicle multimedia system (VMS) [28]: The VMS consists of vehicle multimedia system inputs (VM I/P), vehicle multimedia unit (VMU) and vehicle multimedia system outputs (VM O/P).

3.1.2 vehicle multimedia unit (VMU) [28]: VMU is a central processing unit that processes the received input and output audio via the speakers, video via displays, etc. VMU is not a single physical unit. It may consist of multiple electronic control units (ECUs).

3.2 Terms defined in this Technical Report

This Technical Report defines the following terms:

3.2.1 HF processing SW module: Hands free (HF) processing software (SW) module, including digital signal processing algorithms for speech signal enhancement.

NOTE – Examples are echo cancelling, echo suppression, equalization, dynamic range compression, limiters, noise reduction, beamforming and comfort noise injection.

3.2.2 smartphone infotainment assistant: An application that allows the combining of smartphone and vehicle resources and utilizing them within the car infotainment system, thus allowing the driver to use some smartphone functionalities through the vehicle human machine interface (HMI) while keeping attention to the driving task, thus avoiding distraction.

3.2.3 T-Box (Telematics-box): A functional unit in the vehicle responsible for the remote connection of the different vehicle functions, including multimedia, through a wide area network (WAN) or a local area network (LAN).

4 Abbreviations and acronyms

This Technical Report uses the following abbreviations and acronyms:

ADAS Advanced Driving Assistance System

ASR	Automatic Speech Recognition
ATSC	Advanced Television Systems Committee
BLE	Bluetooth Low Energy
BT	Bluetooth
CAN	Controller Area Network
CANFD	CAN with Flexible Data-rate
CWS	Collision Warning Systems
DASH	Dynamic Adaptive Streaming over HTTP
DDS	Data Distribution Service
DI	Diagnostic Interface
DMS	Driver Monitoring System
DVB	Digital Video Broadcasting
DRM	Digital Rights Management
ECU	Electronic Control Unit
EE	Electrical/Electronic
GNSS	Global Navigation Satellite System
HD	High Definition
HF	Hands Free
HMI	Human Machine Interface
HUD	Head Up Display
ICCE	Intelligent Car Connectivity industry Ecosystem
IMU	Inertial Measurement Unit
ISA	Intelligent Speed Assistance
LAN	Local Area Network
LIN	Local Interconnect Network
MBMS	Multimedia Broadcast / Multicast Service
MCU	Microprogrammed Control Unit
MOST	Media Oriented System Transport
MPEG	Moving Picture Expert Group
NLU	Natural Language Understanding
NR	Noise Reduction
OTA	Over-The-Air technology
PSS	Packet-switched Streaming Service
SOA	Service-Oriented Architecture
SOME/IP	Scalable service-Oriented Middleware over IP
SW	Software
T-Box	Telematics Box

TSN	Time Sensitive Networking
TTS	Text-To-Speech
USB	Universal Serial Bus
UWB	Ultra-wide band
VA	Voice Assistant
V-PCC	Video based Point Cloud Compression
WAN	Wide Area Network

5 Conventions

None.

6 Vehicular multimedia functional scope

The evolution of multimedia technologies and the uptake of driving assistance or even autonomous driving, contributes to the development of high-quality infotainment applications and services in vehicles to provide a richer and smoother user experience.

All vehicle functions are now controlled by a growing number of electronic control units (ECUs) together with increasingly complex software (SW) platforms with device virtualization, providing different vehicle functionalities. It is therefore difficult to distinguish between vehicle functionalities based on the hardware. The scope of the present report should exclude driving control functions, because their requirements include many safety relevant issues. The scope is to focus solely on infotainment functions, which may also be used to inform drivers about the driving control system status.

To represent the intended scope of the present report with regard to multimedia, and to distinguish between other vehicle functions, it is necessary to describe vehicular multimedia from a functional perspective.

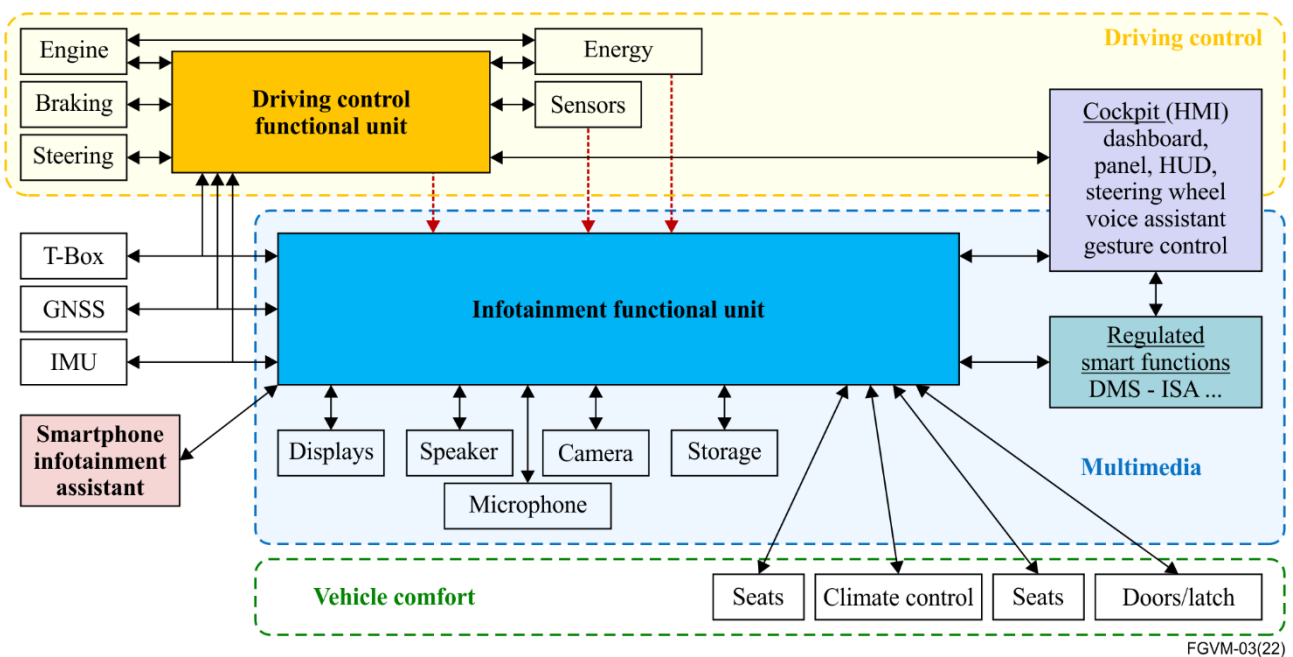

Figure 1 – Implementation aspect scope and boundaries of infotainment versus other car functions

Figure 1 shows the positioning of the infotainment functionalities compared to the driving control functionalities. The aim of the figure is to define the boundaries between the multimedia domain and the driving control domain, which are out of scope of this Technical Report.

Since driving control functionalities are safety relevant, multimedia systems do not interfere with them. But multimedia systems do aim at presenting some driving control relevant parameters to the driver, for instance the battery charging level, engine status or failure and also the status of the advanced driving assistance system (ADAS) when it becomes active (emergency breaking, lane keeping).

When presenting information from different systems to the driver, priorities are relevant to ensure the driver is not distracted by the multimedia application and can react timely to driving control issues. The infotainment functionalities are not expected to take actions on the driving control, but the driving control system can override the infotainment functionalities.

Clause 7 describes the different fields for the implementation aspects of vehicular multimedia.

7 VMS implementation aspects

7.1 Connectivity

7.1.1 Broadcast communication

For bi-directional and uni-directional broadcast communication different protocols over both terrestrial, satellite and IP over mobile communication networks could be utilized. See digital video broadcasting (DVB) specifications [6], [7], [9] and [28] clauses 7.2.3 and 7.2.4 of this Technical Report.

For media types, content navigation methods and interactivity methods for multimedia broadcasted services, standards such as DVB specification [2], hybrid broadcast broadband TV (HbbTV) specification [8] and clause 8.4.1.1 of [53] applies.

For content protection e.g., digital rights management (DRM) see [28] clause 10, and for rights management [28] clause 11.

7.1.2 Short range connectivity

Vehicular multimedia requires using devices connected to the VMU, but which do not belong to the VMU, so as to perform multimedia functionalities. A typical example is the usage of the smartphone for performing functionalities like calling, messaging, navigating, or playing media, but using the car human machine interface (HMI) and the sound systems. The smartphone and the virtual memory unit (VMU) need to use a different type of connectivity to perform these functionalities, for example Bluetooth (BT), Bluetooth low energy (BLE), USB, Wi-Fi and SparKLink.

The description of the smartphone infotainment assistant functionalities is provided in clause 7.6.

Beyond providing the relevant connectivity for infotainment, short range connectivity is also essential for digital key specified by the car connectivity consortium, allowing the utilization of smartphones as car keys.

7.1.2.1 BT (Bluetooth)

Bluetooth, also referred as Bluetooth Classic, is a low power radio technology for point-to-point device communication, targeting wireless data streaming use cases like audio streaming.

Bluetooth is commonly used to pair devices, for example, a smartphone and the VMU, utilising the secured Bluetooth pairing functionalities. Pairing the VMU with driver smartphones, enables hands-free audio streaming and calling, allowing drivers to maintain focus on their driving.

When a smartphone and a VMU is paired, Bluetooth is then used for audio streaming and for data transfer, to enable the coordination between the smartphone and the VMU.

Bluetooth can also be used to pair audio devices, like headsets, with the VMU. Smartphone infotainment assistant (see clause 7.5) functionalities can be operated through a Bluetooth connection.

The Bluetooth specifications and test documents are publicly available on the Bluetooth SIG (Special Interest Group) website: <https://www.bluetooth.com/specifications/specs/>

7.1.2.2 Bluetooth low energy

Bluetooth low energy (BLE) is a fairly recent radio technology compared to the Bluetooth Classic in providing similar data streaming but with a lower data rate, nevertheless allowing audio streaming. BLE also provides device positioning functionalities (presence, distance and direction), which can be useful to provide a dedicated feature to a smartphone according to its position outside or inside the vehicle, as well as to secure digital key operations.

Compared to Bluetooth Classic, beyond the point-to-point operations, BLE also provides broadcast and mesh networking features.

Smartphone infotainment assistant (see clause 7.5) functionalities can be operated through a BLE connection.

An overview of the Bluetooth Classic and the BLE technical features is shown in Figure 2.

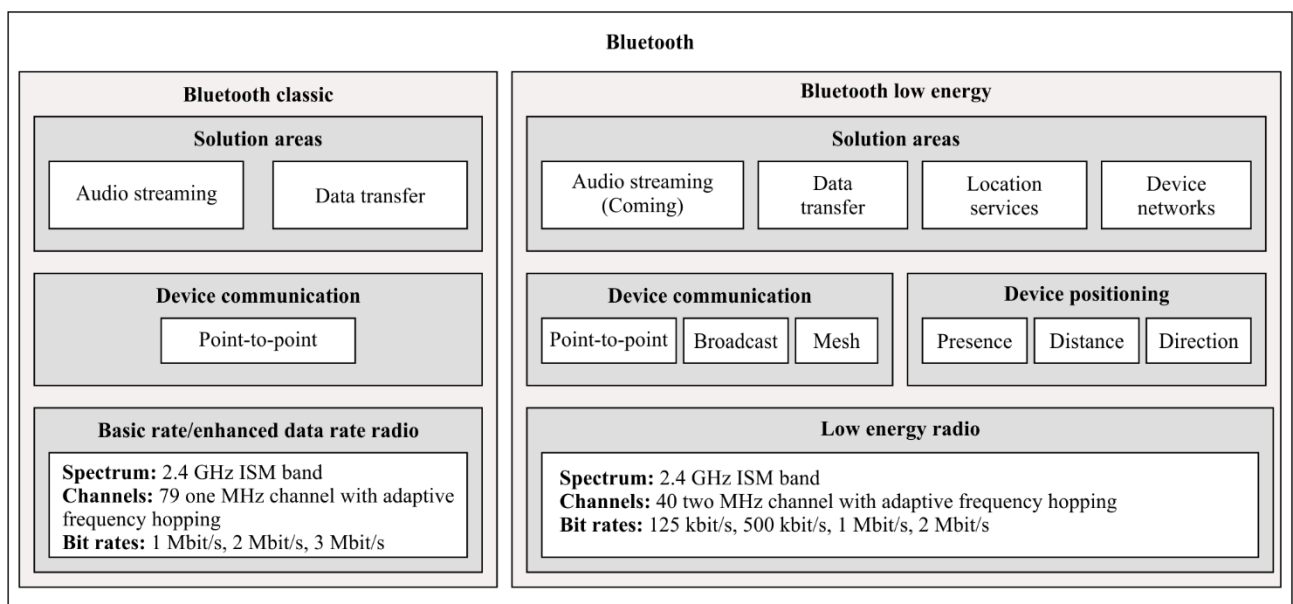

FGVM-03(22)

Figure 2 – Overview of Bluetooth classic versus BLE features

(Based on Bluetooth.com)

The BLE specifications and test documents are publicly available on the Bluetooth SIG (Special Interest Group) website: <https://www.bluetooth.com/specifications/specs/>

7.1.2.3 Bluetooth LE audio

Bluetooth SIG has now published a new set of specifications for Bluetooth LE audio, has an Auracast trademark (see: <https://www.bluetooth.com/auracast>). LE audio introduces an entirely new architecture for supporting the audio applications using Bluetooth core technology.

The Bluetooth LE audio specifications and test documents are publicly available on the Bluetooth SIG (Special Interest Group) website: <https://www.bluetooth.com/specifications/specs/>

7.1.2.4 Wi-Fi

Beyond providing connectivity for personal devices in the car, WiFi is also a suitable radio technology to perform data streaming between a smartphone and the VMU. Compared to BT and BLE, Wi-Fi will provide higher data rate enabling data streaming requiring higher data rate, for example, video.

Miracast is an industry-wide solution, allowing technology to work across device types and vendors. Connections are easy to set up and use since Miracast devices choose the appropriate settings automatically. Miracast can connect two devices using a network infrastructure or a Wi-Fi Direct. When content to be shared is stored on a Miracast-certified device, such as a smartphone to an automobile infotainment display, a Wi-Fi network connection is not required.

Wi-Fi specifications are provided by the IEEE 802.11 series of standards, see <https://www.ieee802.org/11/>

7.1.2.5 Ultra-wide band (UWB)

Ultra-wide band (UWB) connectivity technology uses wide bandwidth (0.5 to several GHz) compared to other technologies, thus increasing the data rate but also other radio performances: accuracy, power consumption or robustness. UWB can work in challenging environments such as parking and also to determine the precise device position.

UWB provides secured mean to operate the smartphone as a digital key, while measuring precisely the position of the smartphone relatively to the car and thus preventing relay attacks. The different features and performances of UWB are expected to be widely used in the transportation domain, including infotainment applications.

UWB specifications are provided by the IEEE series of standards IEEE 802.15.4, especially its latest amendment IEEE 802.15.4z-2020, see: <https://standards.ieee.org/ieee/802.15.4z/10230/>

7.1.2.6 SparkLink

The Chinese SparkLink alliance (see: <http://www.sparklink.org.cn/en/>) was established in September 2020 to prepare a new short-range communication framework providing enhanced features and capabilities:

- Low latency;
- Low jitter;
- High reliability;
- Accurate synchronization;
- Massive number of connected devices.

The low latency and accurate synchronization capabilities enables better in-vehicle sound quality and active noise reduction (NR), as well as real time interaction between car systems and displays. Massive number of connected devices allow real time control of > 100 s of devices, such as controlling battery cells for a better battery management system.

Some examples of automotive benefits of utilizing SparkLink are:

- Improving sound and active noise reduction with end-to-end low latency and accurate synchronisation;
- Screen control with unidirectional low latency and accurate synchronisation;
- Digital key with accurate positioning and high reliability;
- Battery management system with high reliability and number of connected devices (battery cells.)

7.1.3 Universal serial bus (USB)

Universal serial bus (USB) is an industry standard for a serial communication interface, including the specification of cables, connectors protocols and power supply.

USB is used for connecting smartphones to the VMUs to allow data streaming and thus using some selected smartphone functionalities with the vehicle HMI. Alternatively, smartphone infotainment assistant functionalities (see clause 7.5) can use short range radio connections.

USB specifications are provided by the IEC 62680 series of standards, see the IEC page related to IEC 62680-1.1:2015: <https://webstore.iec.ch/publication/23281>

7.1.4 Media oriented system transport (MOST)

The media oriented system transport (MOST) communication technology is specified in the ISO 21806 series of standards (see the latest update of the standards from 2002: ISO 21806-1 [29]). The technology that was initially developed at the end of the 1990s enables the transport of high quality of service (QoS) audio and video, together with packet data and real-time control to support modern automotive multimedia and similar applications. MOST is a function-oriented communication technology to network a variety of multimedia devices comprising one or more MOST nodes.

MOST buses use a daisy-chain or ring topology and synchronous or isochronous data communication. MOST transports audio, video, voice and data signals over optical fibre (MOST 150 Mbit/s), coaxial cable (MOST150) or balanced media (MOST 50 bit/s).

MOST trademark is owned by Microchip technology, see <https://www.mostcooperation.com/specifications/>.

Figure 3 shows an example of a MOST network.

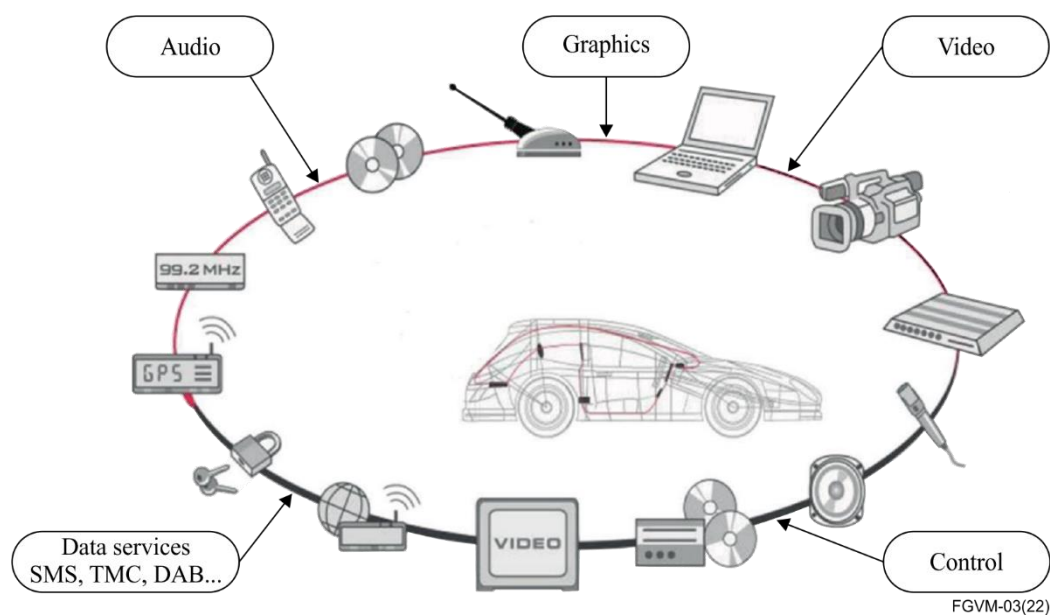

Figure 3 – Example of MOST network

(Source: ISO 21806-1 [29])

7.1.5 In-vehicle networks

With the development of intelligent connected vehicles, the in-vehicle network has gradually evolved from the traditional controller area network (CAN) / local interconnect network (LIN) BUS to CAN with flexible data-rate (CANFD) and the automotive Ethernet, in order to support greater bandwidth and rate, which realizes high-level assisted driving, over-the-air technology (OTA), big data processing and other functions.

In the aspect of vehicle Ethernet, time-sensitive networking (TSN) technology is used to solve the uncontrollable delay caused by the traditional Ethernet using the best-effort mode, and scalable service-oriented middleware over IP (SOME/IP) or data distribution service (DDS) protocol is used to realize the service oriented architecture (SOA) communication.

The graph in Figure 4 depicts an in-vehicle topological network.

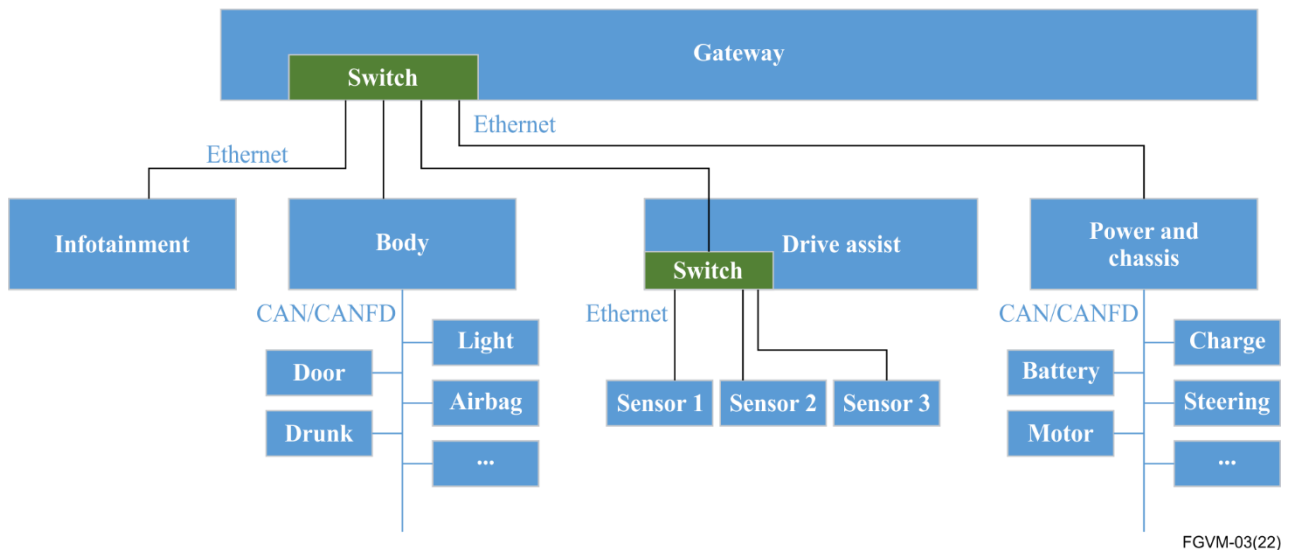

Figure 4 – In-vehicle network topological graph

CAN/CANFD bus works as a multi-master control and broadcast protocol based on ISO 11898 and is specially used to realize data exchange between automotive electronic control units (ECU). The bus communication rate is 500 kbit/s to 5 Mbit/s. CAN/CANFD bus is used to transmit control signals between controllers in vehicles, such as vehicle running status, scene reconstruction signals, etc.

The automotive Ethernet physical layer adopts IEEE 802.3bw and IEEE 802.3bp, using the UTP or STP cable.

The IEEE TSN task group has proposed a series of standards to address the transmission delay and reliability problems caused by the traditional Ethernet in vehicles (more information at <https://1.ieee802.org/tsn/>).

- Time synchronization – IEEE 802.1AS clock synchronization is based on the data link layer and applies to data transmission scenarios that require high real-time performance and high precision.
- Deterministic delay – IEEE 802.1Qbv controls the sending time of queue data by cyclic gating list to realize the function of time-aware shaper (TAS). IEEE 802.1Qbu high-priority data frames interrupt low-priority data frames in transmission and pre-empt them to ensure strict delay of high-priority data.
- Reliability – IEEE 802.1CB supports the packet replication and cancellation function of the hardware. Redundant paths on links are used for reliable back up.

There are also other sub-protocols such as Qci, Qcc and Qav in TSN. The application of Ethernet in automotive networks will be more secure and reliable with the support of TSN.

SOME/IP is an application layer protocol running on the TCP/IP layer, which is an on-board communication middleware. It provides a standard interface to the application layer, to adapt the interface differences between different vehicular multimedia operating systems.

SOME/IP protocol is a service-oriented protocol based on the service-oriented architecture (SOA), it can realize flexible deployment of the application services. The AUTOSAR standard describes the definition method of services and the invocation method of services under the SOME/IP protocol.

DDS is also an application layer protocol running on the TCP/IP layer. It is a data centric communication middleware protocol.

DDS protocol provides more than 20 kinds of QoS, through different QoS design combinations, to ensure real-time, efficient and flexible data transmission.

Table 1 – The key point of an in-vehicle network implementation

Project	Subentry	Description
CAN/CANFD	Baud rate	Defines which specific baud rate of the vehicular multimedia's CAN/CANFD transceiver should support.
	Data field length	Defines which data field length of the vehicular multimedia's CAN/CANFD message should support.
	Diagnostic	Defines the diagnostic strategy of the vehicular multimedia.
	NM	Defines what kind of network management strategy the vehicular multimedia may support.
Automotive Ethernet	Baud rate	Defines what specific baud rate of the vehicular multimedia's Ethernet PHY should support.
	Cable	Defines how to choose the UTP or the STP with different baud rate.
	IP	Defines the IP configure solution in the in-vehicle network.
	Diagnostic	Defines the diagnostic strategy of the vehicular multimedia.
	NM	Defines what kind of network management strategy the vehicular multimedia may support.
TSN	Time synchronization	Defines which crystal frequency the vehicular multimedia should support. Defines the time synchronization solution of the vehicular multimedia on the system level.
	Time aware shaper	Defines the forwarding delay of critical data.
	Frame replication and elimination for reliability	Defines which specific algorithm of replication should support.
DDS	Intra-domain transmission speed	Defines the intra-domain transmission speed of the DDS when using the vehicular multimedia.
	QoS	Defines how to choose QoS with different scenes; Defines how many QoSs should be supported when DDS is transplanted into the microprogrammed control unit (MCU.)

7.1.6 IPv6

The IP protocol stack of the VMU system provides connectivity and networking services to the devices (e.g., smartphones and tablets) present in the vehicle. The devices connect to the VMU employing the wireless technologies previously described in this Technical Report. From an IP layer implementation perspective, both IPv4 and IPv6 can be employed. While some of the requirements

described hereafter apply to both the protocol families, they are fully supported only by the IPv6, which is the focus of this clause.

IPv6 adoption worldwide has grown significantly in recent years [b14].

In many cases, national authorities and regulators have issued strategic plans and guidelines that foresee the shift to IPv6-only technologies in public networks within the 2030 timeframe [25] leading to the sunset of IPv4 in different network domains.

From a standardization standpoint, the Internet architecture board (IAB) stated in 2016 that no further support will be given to IPv4 by the IETF, while the IPv6 has to be considered as the baseline for further protocol advancements [b15]. An example of such progression is represented by the segment routing version 6 (SRv6) [25]. Even if the SRv6 in the vehicular networks is not under consideration, it is worth noting that it is the key in enabling advanced applications in the backhaul and in the transport networks. In particular, SRv6 network programming [27] extends to the base of the SRv6 behaviour and enables the advanced networking capability such as network slicing.

IPv6 is also a media-agnostic carrier. Efforts at the IETF have been directed to develop the IPv6 adaptation mechanisms for several wireless technologies, such as Bluetooth, Wi-Fi and other short-range wireless technologies.

In addition, the adoption of the IPv6 in vehicle-related applications has been already considered in different standardization works [39] and is briefly summarized in this Technical Report.

The ISO Technical Committee 204 Working Group 16 (TC204 WG16) works on the communications architecture for land mobile (CALM), a communication architecture for cooperative intelligent transport systems (ITS). The network and transport layer in the architecture of an ITS station can be based on IPv6 [40].

The IETF has been working on vehicular communications through the IPWAVE workgroup. The IPWAVE architecture foresees the use of IPv6 over IEEE 802.1operating outside the context of a basic service set (OCB).

The 5G automotive association (5GAA) is working on connected vehicles use cases. While not specifically addressing IPv6 in their reference architecture, the use of IPv6 is considered for enhancing the level of security and privacy [41]. This follows the adoption of IPv6 in the car-to-car communication consortium (CCC) architecture [43].

At the technical level, IPv6 provides an extremely wide address space, suitable to overcome the lack of publicly available IPv4 addresses. This proves useful in supporting an array of innovative applications, such as the applications addressed in this report, where hundreds of million devices may be connected simultaneously.

For vehicular networking, the following list of connectivity requirements is supported by IPv6.

1. Availability of wide, public, non-overlapping addresses. The VMU is expected to act as a proxy for the devices and applications connected. As such, it should assign an address or a set of addresses to each of the subtended items.

With IPv6, the vehicular network may be delegated by the service provider a full /56 or /64 public prefix. Depending on the preferred setup, each connected device may either receive an individual public IPv6 address, a set of individual addresses or even a sub-prefix.

2. Support of stateless address auto configuration (SLAAC) [44]. In addition to requirement no. 1, with IPv6 the connected devices are allowed to autonomously generate their address upon reception of the network prefix. This simplifies the procedures for the address assignment.
3. Media independency. IPv6 acts as the adaptation layer for the different wireless technologies employed in the vehicular network at the data link layer. For example, a smartphone connected to the Wi-Fi can communicate via IPv6 with another smartphone connected via

Bluetooth. IPv6 acts as the forwarder between the two devices through adaptation and adjustment of the frame's format across the wireless links.

4. Mobility. Service continuity is supported during trip for the devices connected to the VMU. This is achieved through mechanisms such as NEMO [45] that allow the VMU to maintain connectivity and reachability while changing points of attachment across a network, even when crossing different administrative domains (e.g., at national borders).
5. Multiple access network connectivity. A VMU may have the option to connect to multiple network domains simultaneously, for example when multiple service providers are available in a same area. In such a case, the IPv6 mobility requirement is extended to support multiple care-of address (CoA) [46].
6. Privacy and security. To achieve higher protection, the use of IPSec [47], [48] may be considered for authentication, integrity, and confidentiality. This is natively supported by IPv6 through the use of extension headers.

7.2 Human machine interface (HMI)

7.2.1 Voice assistant

7.2.1.1 Introduction

Voice assistant (VA) is an essential multimedia feature for ensuring a great user experience in vehicles. Voice assistant components provide the means to control the driver and the passenger environment in the vehicle while using only their voice, thereby eliminating the use of buttons and the display. Voice assistants are bi-directional flow of information:

- Input: the driver or the passenger voice the commands or questions to the VMU;
- Output: responses or information from the VMU as well as the execution of the commands.

Beyond providing a better user experience with vehicle cockpit, or to ease the learning of the vehicle control, while using only voice commands, the voice assistant significantly reduces driver distraction thereby increasing safety.

Voice assistant allows the control of other domains other than the vehicle, for example:

- Smartphone functions: managing calls, dictating hands free (HF) text messages,
- Home: controlling home assets like opening garage doors, setting the heating, talking with people using the home assistants,
- Cloud services: utilizing services, asking information (e.g., weather), finding the point of interest.

7.2.1.2 Voice assistant concept

Voice assistant is a service that relies on a chain of components, some of these components are shown in Figure 5.

A voice assistant system can be divided into two independent parts, represented in Figure 5 by the following two branches:

1. The voice command branch based on voice recognition procedures;
2. The voice response branch that preforms the actions requested over the voice command and which also generates the voice responses.

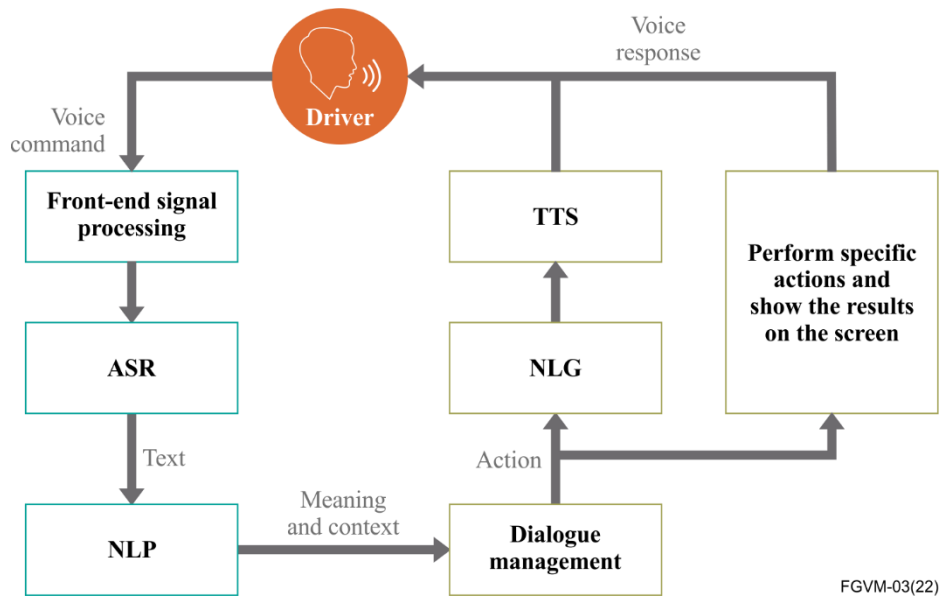

Figure 5 – Overview of the voice assistant main components
(Based on [b16])

Figure 5 shows only the main components, but advanced voice assistant implementations are very likely to include more features, especially in advanced voice assistant systems.

A list and description of the voice command features, which are likely to be used in vehicles for providing advanced and comfortable voice assistants' is provided in Table 2.

Table 2 – Voice command features

Feature	Description
Automatic speech recognition (ASR)	Word segmentation: Forward / backward maximal matching recurrent neural networks (RNN), Feature extraction: Begin and end of sentence markers, text features, Semantic annotator: Static, dynamic, string lists, etc., Rule based classifiers such as models with expected utterances, phone book access – Neural classifier: Convolutional neural network (CNN), recurrent neural network (RNN).
Natural language understanding (NLU)	Recognizes natural human speech, eliminating restriction to the predefined commands. Convenient for the driver to overlook the 'predefined' commands, but recognition rate will be lower.
Wake up by voice / wake up word	Always in listening mode with keyword activation, this removes the need for a "push to talk" button.
Language recognition (including dialects)	After speech recognition recognizes the words that are spoken, it automatically detects the spoken language and the semantic classification extracts the meaning. Various dialects are also detected automatically.
Barge-in	Allows the user to speak over spoken dialogue prompts and be recognized. Customer does not have to wait until the dialogue prompt is finished.
Multi-lingual and partial search	Recognizes multi-lingual or partial name and search database such as a phonebook, POI category, POI names, song list and so on.
One-shot voice destination entry	Recognizes the full sentence for destination entry search without the need for multiple steps.

Table 2 – Voice command features

Feature	Description
All-inclusive main menu	Enables all the commands to be spoken in a single utterance on the home screen which include all the predefined commands, including the domain specific commands.
Voice biometric	Recognizes and analyses the voice for biometric authentication. This cannot be a replacement for car keys (or remote keys) due to security reasons but can be used for comfortable features.

The features to be used by the text-to-speech component of the voice response branch are described in Table 3.

Table 3 – Voice response features

Feature	Description
Multi-lingual support	Accurate language identification and high-quality acoustic extensions provide unparalleled foreign language readouts (particularly useful for SMS readouts).
Natural language	A natural human like speech output with less resource consumption (less memory, less size of database, less consumption of the processor).
Flexible speech generation	Volume and speaking rate can be adjustable at run time for more dynamic and lively effects.
Direct phonetic input and seamless prompt insertion	Allows and offers optimal and seamless read outs of offline phonetic databases with a pre-recorded voice.
User dictionaries	Application specific lexica can be phonetically optimized for accurate readouts of exceptional pronunciations.
SSML support	Speech synthesis markup language (SSML) allows for text-to-speech (TTS) vendor independent mark-up which is correctly interpreted by the TTS engine. This can be utilized for add on features of readouts for the weather forecast.

7.2.1.3 Voice assistant implementation options

7.2.1.3.1 Local versus cloud voice processing

Cloud collaboration needed to perform procedures, which require big data set or high computing resources would provide better voice assistant performance and a higher user experience. For example, natural language processing and partially automatic speech recognition would benefit being performed in the cloud.

Advanced voice assistant systems will follow hybrid implementation of voice processing with AI, where some functionalities will be available locally in the vehicle, providing standalone voice assistant service, but complex voice processing will occur in the cloud to provide advanced cloud voice assistant services.

In case of cloud connectivity failure, the in-vehicle computing power should be dimensioned accordingly to ensure that the standalone voice assistant can provide a fair level of services.

In order to comply with the standards of data security and privacy, it is advised that the vehicle-mounted voice assistants are able to conduct their essential functions locally, including speech enhancement, wake-on-voice, automatic speech recognition (ASR), natural language understanding (NLU), speech synthesis technology as well as the functions handling the contacts or messages.

7.2.1.3.2 Advanced voice assistant functionalities

Advanced voice assistant functionalities are expected to increase the user experience and driving safety. Several categories of these functionalities are provided in Table 4.

Table 4 – Advanced functionalities

Advanced functionality	Description
Voice localization	Allows localizing the voice and identification of the speaker seat to validate the commands (e.g., driving relevant only by drivers) or proceeding with the action (e.g., open window).
Advanced noise reduction	Advanced voice recognition process to eliminate ambient noise but also to eliminate non-human voice like in-vehicle system voice – is combined with echo cancellation.
Pro-active services	Use the voice commands to perform combined actions using environment perception, e.g., "Go to work" start navigating to work, read agenda and messages, propose to book a lunch reservation, etc."
Life assistant	Extend the assistant domain from vehicle to other domains, such as home or personal devices, e.g., allow open / close garage door, set heating, read phone messages, etc.

7.2.1.4 Development and debugging logging points

Software (SW) components from several suppliers are considered to be implemented into a VMU. For design validation, tuning and debugging purposes, it is considered that a voice assistant development SW should have access to the standardized diagnostic interfaces (DI), as described in Figure 6.

This development and debugging interfaces are necessary to adjust the hands free (HF) processing SW module to the specific acoustic environment of the different vehicles. The final consumer release of the voice assistant may not include these DIs anymore.

The HF processing SW module and its DIs are defined also in ITU-T P.1100 / 1110 / 1120 (see: [49], [50] and [51]) recommendations for telephony. HF processing SW modules are suitable for telephony and also for the ASR systems.

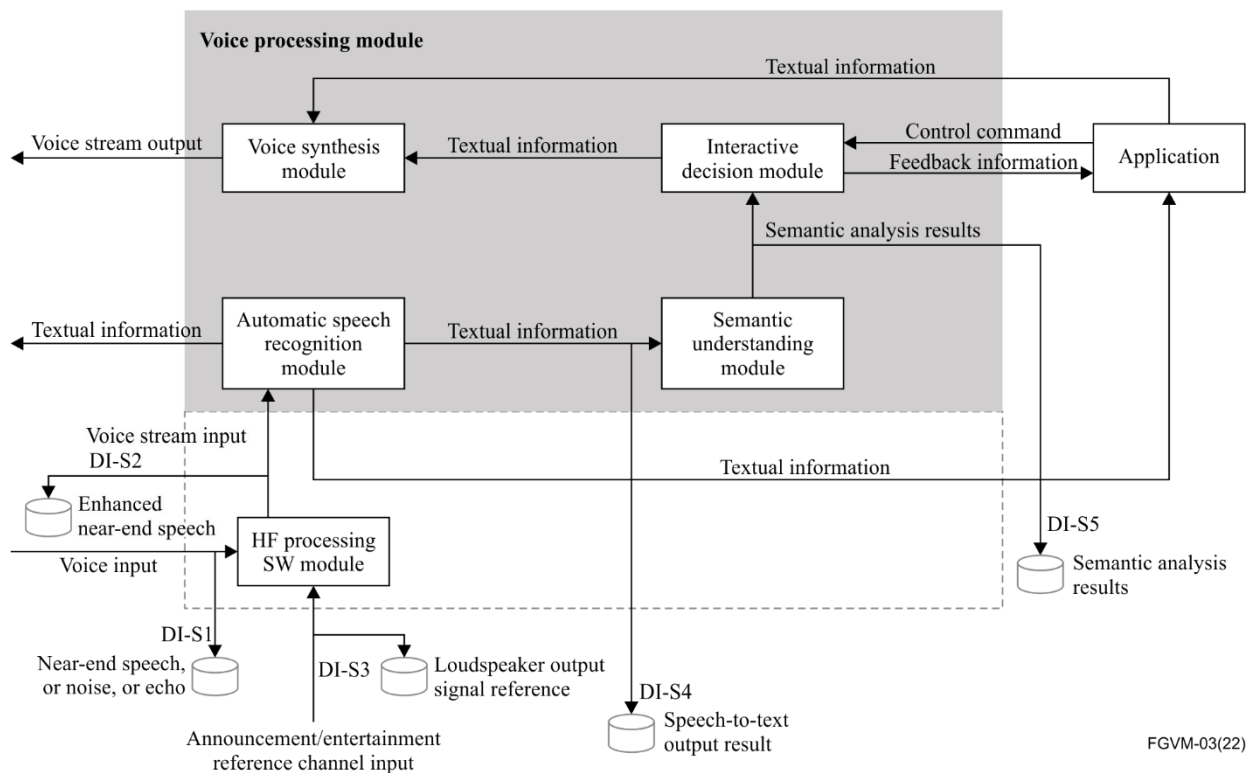

Figure 6 – Voice assistant with external HF processing SW module

NOTE – The HF processing SW module may also be implemented in the voice processing module, forming an internal HF processing SW module.

The following diagnostic interfaces (DI) should be considered for implementation, for the automatic speech recognition (ASR) HF processing SW module, in the voice assistant development SW only, and these DIs should be accessed via a tuning software (SW) on an external PC. When separate HF processing module SWs for ASR and telephony are used, both modules should have diagnostic interfaces.

DI-S1 is a logging point at the microphone input of the HF processing SW module, which should be able:

- to read digital audio data via real time audio data connection to a tuning tool;
- to write digital audio via real time audio data connection from a tuning tool into the HF processing SW module;
- to mix digital audio data and write via real time audio data connection from a tuning tool into the HF processing SW module to the microphone data stream.

DI-S2 is a logging point at the output of the HF processing SW module and it should be able:

- to read audio signals in real time via a data connection;
- to write audio signals in real time via real time data connection for all microphone channels;
- to mix digital audio data in the DI-S2 path.

The HF processing SW shall have an announcement / entertainment reference channel input. This channel serves the echo canceller with audio reference signals from the announcement sources e.g., parking distance control, navigation prompts and entertainment sources like music or radio audio to enable wake up word detection and barge-in capability. These audio signals carry important information for the driver but hamper speech recognition.

DI-S3 is a logging point at the reference channel input of the HF processing SW module and should be able:

- to read audio signals in real time and in sync to the DI-S1 via real time data connection;
- to write audio signals in real time and in sync to the DI-S1 via real time data connection.

DI-S4 is a textual logging point for the output of an automatic speech recognition module. This interface should help to fine-tune the recognition performance of user voice commands under the most difficult conditions (with background noise, no cloud service available, interfering talker). The interface should output the internal confidence of the identified words.

DI-S5 is a textual logging point for the output of the semantic understanding module. It shows the intent of the user's voice command as detected by the system on a higher abstraction level. Similar to the DI-S4, it should also provide confidence values for the detected intents.

For testing the voice recognition with safety relevant commands under the most difficult conditions both the interfaces DI-S4 and DI-S5 should be accessible for the system validation testing and tuning.

7.2.1.5 Voice and performance requirements

Audio I/O is determined by the following factors given in Table 5.

Table 5 – Performance requirements for audio I/O

Project	Subentry	Resource requirement statement	
Audio I/O	Recordings	Sampling rate	Voice input supports 16 K sample rate audio.
		Bit number	Voice input supports 16 - bit recording.
		Track	1. Input dual-channel audio in an array noise reduction mode.
			2. Input mono audio in a single-channel noise reduction mode.
		Quality evaluation	1. No DC bias, no recording truncation, etc.
			2. The index can be evaluated and evaluated in specific projects.
		De-noising processing	1. The array must support two channels of recording.
	2. The phase of the microphone with sound source positioning function should meet the quality requirements (0-8 K spectrum, phase difference < 5 degrees), which can be evaluated in specific projects.		
	Echo cancellation	1. Support echo signal returning.	
		2. Signal quality needs to meet the quality requirements which can be evaluated and tested in the project.	
	Position layout	1. The recommended microphone spacing is 4 cm - 20 cm, and the standard spacing is 8 cm.	
		2. It is advised to deploy microphones at the overhead light, and vehicle and engine positions.	
	Broadcasting	Sampling rate	Being able to broadcast ordinarily.
Bit number			
Quality evaluation			

Voice system resources is determined by the following factors given in Table 6.

Table 6 – Resource requirements for voice assistant

Resource consumption of voice system		
Available operand	≥ 9 400 DMIPS (ESR + XTTS + the standard wake-up equipment + NN dual-channel audio for noise-reduction).	
RAM for voice user interface	400 MB	
ROM for voice user interface	500 MB	
Store read / write directories	Android	Default location / SD card / directory, writable ≥ 100 MB, contained within the range of the available voice usage.
	Linux / QNX	Directory location depends on the integrator system, writable ≥ 100 MB, contained within the range of the available voice usage.

7.2.1.6 Robustness and testing aspects

Voice assistant technology is relying on speech quality and processing features. It is essential to ensure these requirements complies with the minimum requirements needed for providing fair and safe voice assistant services on any type of vehicle having the implemented voice assistant services.

Working in cooperation with the standardization bodies providing speech quality requirements should be considered in defining specific requirements for voice assistants to ensure that they provide functionalities working with a wide range of users, from different countries and under different kinds of vehicle speech environments.

Defining appropriate testing procedures should also be considered.

7.2.2 Gesture recognition control

Gesture recognition allows the control of the vehicular multimedia system. It is currently implemented in commercial car models.

Drivers of vehicles are required to have their hands on the wheel and their eyes on the road. Therefore, giving them the opportunity to control vehicular multimedia system functions safely and efficiently. One of these control modalities is given by gesture recognition, whereby specific physical gestures are associated to the semantics of a user interface. The challenge is to establish a set of distinguishable gestures for them to be reliably interpreted by the user interface, and that such gestures are easy for the user to produce without having to think too much about it.

The driving environment for gesture recognition to be of use imposes that the gesture recognition system be robust to changes of external and internal lighting environment in and around the vehicle.

It should work on a bright summer day as well as in a tunnel or a night environment.

To meet this demanding requirement robust time of flight systems have been researched, developed, and successfully implemented in vehicles, using infrared signals robust to lighting conditions.

Human user interface modalities for vehicular multimedia control include gesture recognition, based on the time-of-flight systems. Implementations are currently available in commercial car models. Future standards' developments for human user interface of vehicular multimedia systems may therefore consider this modality.

Gesture control commercial solutions are implemented in several vehicle models, following a careful verification and validation of the functionalities in operation by the automotive manufacturers of these vehicle models. New work item proposal on the standardization of the interface to gesture control for vehicular multimedia may therefore be considered for broader market uptake.

Some references to relevant publications are provided in the Bibliography section, see: [b10], [b11], [b12], [b13] and [b14.]

7.2.3 Motion sickness free

Motion sickness and ensuing discomfort¹ or acute discomfort is attributed to the movement of a vehicle in an environment, and a disconnect between the inner ear perception of the movement and the spatial information gathered by other senses.

For example, sharp turns on a mountain road, vibrations, light rays entering a vehicle with stroboscopic effect is detrimental to people subject to epilepsy, and could be one of the factors of potentially high discomfort to the occupiers of a vehicle.

Motion sickness is a recognized common condition, with an estimate of one third of humans being acutely susceptible to it, with symptoms including nausea and vomiting.

Under specific driving conditions (sharp turns) motion sickness could be increased in the case of vehicular multimedia interactions and sessions, by a sustained attention to displays [1], where the focus of the user is drawn away from the surrounding space where the vehicle movement is happening. A disconnection between attention (voluntary) sensorial information, and the body (internal ear) under physical unescapable movement constraints is a root trigger of motion sickness within the context of a vehicular multimedia.

Potential mechanisms to prevent motion sickness occurring in relation to vehicular multimedia involves a rebalancing movement awareness from the vehicle, for a user participating in a multimedia session. A technical mechanism to mitigate the split between the display focus and the movement context focus, is to re-establish a link between the multimedia session, otherwise rendered in a local onboard geometric frame of reference commonly called Eulerian, and the absolute frame of reference (fixed in the landscape of the movement) is called Lagrangian. Replacing the Eulerian view by a Lagrangian view helps to reconnect the internal ear and other sensorial perceptions².

This is shown by the observation that far away objects in the landscape, such as posters on billboards, or road signs along the road, do not cause major contributions to motion sickness onboard a vehicle in movement. Therefore, a geometric approach can be considered to virtually reproject the content from the handheld or vehicle-resident display to a virtual far-away billboard (or a drive-in cinema screen) and bring back the calculated image onto the local onboard display by another projection (e.g., along a cone), thus addressing the motion sickness factors through the geometry of the scene rendered for the vehicular multimedia session.

Future standardization work of interest towards reducing or resolving motion sickness effects, which are detrimental to the enjoyment of vehicular multimedia entertainment, might consider the following:

- i) The requirements for passenger comfort (see [b6] and [b7]), with attention to
 - Vehicle movement and its perception;
 - Visual and auditory aspects of vehicular multimedia rendering for entertainment;
 - Combination of the two factors above.
- ii) Technical approaches to mitigate or resolve motion sickness factors identified (see: [b8] and [b9])
 - Vehicle and route based;
 - Content rendering based.

¹ Sometimes motion sickness results in acute discomfort, experienced roughly by one third of humans.

² Another approach illustrating how movement awareness and multimedia can be harmoniously handled is the re-integration of dashboard data into the movement landscape, through head-up displays.

7.2.4 Auditory interaction

Auditory interaction can arouse and guide the driver's attention and provide the "presentation" of information for the driver when visual information cannot participate in the interaction. Therefore, the effectiveness of auditory interaction is particularly significant in the "presentation" of safety information. Sound signals can convey three important safety messages to drivers for collision warning systems (CWS) [b17].

- Corresponding sound signals are issued according to the degree of the danger of the event to guide the response speed of the driver;
- Location information is suggested according to the location or direction of the hazard source;
- According to the semantics needed to express the corresponding sound symbols to report the event or guide the driver to take hazard measures to avoid collision.

Each crash warning applications can use all three of these symbols, but each of these sets of symbols independently provide useful information to facilitate a fast and correct response. The use of auditory signals to attract attention for collision warning is effective because it enables the driver to perceive the situation without relying on visual cues, allowing their vision to retain its focus on the primary task. By highlighting these signals in a way that makes them prominent and easy to understand, it is possible to give an effective warning of the danger situation. A variety of acoustic signals with different characteristics can be compiled into a complete set to distinguish the severity of the same event type. This way, the driver can be informed of the incident at the same time, but also understand the severity of the incident under the cues of the audio characteristics. Various types and characteristics of acoustic warning signals can be used to express signals of different degrees of danger.

However, subtle trade-offs are made throughout the design to achieve the best effect of the auditory interaction. Obtrusive sound symbols that appear too frequently or are too loud will create a bad experience for the driver; but if the signal is not loud enough, it is easy to ignore. In addition, only some sound symbols are directly indicative, such as spoken messages, or symbolic ones (those that correspond intuitively, such as the sound of endangering the brakes). In addition, other types of sound symbols, such as pure tones, must be assigned meanings.

The main usage scenario of the sound symbols is the alarm of critical events. Due to people's intuitive aversion to sound alarms and the common situations requiring prompt attention, sound symbols are rarely used in general prompt scenarios. However, the effectiveness of sound symbols is very effective in the alarm warning scenario, especially in the differential expression of different levels of early warning statuses.

Future standardization work by the International Telecommunication Union (ITU) should be considered to address the following challenges:

- Audible cues for automotive control functions should be given immediate and higher propriety than any audio accompanying multimedia entertainment;
- Development of harmonized and standardized audible indicators is needed, such that a driver is not 'confused' by different indications in different vehicles.

7.3 Media format basic set

7.3.1 2D video format basic set

The following media formats should be considered by the VMU:

- profiles and levels for 2D video codecs as specified in ETSI TS 101 154 (DVB A001) [2]

Broadcast services over terrestrial, satellite and cellular networks employ 2D video formats:

- When DVB protocols are used [6], [7], [8], [9], [11], profiles and levels for 2D video codecs are specified in ETSI TS 101 154 (DVB A001);

- When multimedia broadcast / multicast service (MBMS) protocols are used [13], as a vehicular multimedia system (VMS), it should support the video profile operation points as specified in 3GPP TS 26.346 [13]
- When advanced television systems committee (ATSC) protocols are used [16], [17], [18], VMS should support the video profile operation points as specified in [19].

For television services over 3GPP services, the VMS shall support the video profile operation points as specified in 3GPP TS 26.116 [15].

For VMS streaming services over bidirectional cellular network; 2D video formats supported by the VMS are specified in the following specifications:

- ETSI TS 103 285 DVB-dynamic adaptive streaming over HTTP (DASH) [9];
- 3GPP-DASH as specified in 3GPP TS 26.247 [14].

7.3.2 3D format basic set

For augmented reality services, 3D formats supported by the VMS and the VMU are as follows:

- Moving picture expert group (MPEG) video-based point cloud compression (V-PCC) codec as specified in [5] can be used to convey 3D visual objects;
- The transport of V-PCC using MPEG-DASH is specified in [4].

For point cloud high definition (HD)-maps and their being generated from the cloud:

- Geometry-based point cloud compression (G-PCC) codec as specified in ISO/IEC FDIS 23090-9 [23] may be supported;
- When the G-PCC codec is supported the transport of G-PCC as specified in ISO/IEC DIS 23090-18 [24] is used.

7.3.3 Audio format basic set

For broadcast services over terrestrial, satellite and cellular networks, audio codecs to be considered by the VMS and the VMU are as follows:

- DVB audio codecs as specified in [2];
- When 3GPP MBMS protocols are supported, Enhanced aacPlus and extended AMR-WB as specified in 3GPP TS 26.346 [13];
- ATSC audio codec as specified in [20][21][22].

For VMS streaming services over bidirectional cellular network; audio codecs supported by the VMS are as follows:

- One or more of Enhanced aacPlus and extended AMR-WB over 3GPP packet-switched streaming service (PSS) services as specified in 3GPP TS 26.234 [12] and over 3GPP-DASH as specified in 3GPP TS 26.247 [14].

7.4 Media service discovery

DVB-I [10] provides the necessary mechanisms for multimedia entertainment services to be discovered and presented on a VMS. This approach provides a user experience that is comparable with the reception of television services on any consumer electronics device.

7.5 Media over internet

Playing media from the internet requires websites to know decoding and encoding abilities of the VMU. The W3C media capability standard (see: [52]) provides APIs to allow websites to get information about device decoding and encoding capabilities and to find the best match based on the device's display.

The standard aims at exposing the following sets of properties:

- API to query a device's decoding and encoding abilities of the device based on the information (codecs, profile, resolution, bitrates) describing if the playback should be smooth and power efficient;
- Information about display properties for selecting the right content;
- Real time feedback about playback for allowing websites to react to CPU/GPU usage in real time.

7.6 Smartphone infotainment assistant

7.6.1 Introduction

Convergence between the automotive and the mobile systems has accelerated during the last decade. Intelligent automotive features, especially infotainment functions, can be integrated in the vehicle eco-system, with multi-scenario collaboration and seamless connection, bringing smarter and safer experiences to users.

Nowadays, smartphones provide a wide range of infotainment functions for vehicles such as:

- navigation, including intelligent traffic management features;
- multimedia, based on local media content, streaming or web;
- music or video application and services;
- vehicle control applications provided by the OEM.

Using smartphone while driving is unsafe and also forbidden in many countries, the Digital and automotive industries have developed means to enable combining smartphone and vehicle resources and thus to allow using smartphone infotainment functions and controlling these functions with the vehicle HMI.

The car connectivity consortium has released MirrorLink specifications that specify an interface to enable remote user interaction of a mobile device via another device, especially in a vehicle HMI. The MirrorLink series of specifications are published by ETSI as a PAS, see [30].

Smartphone OS and system providers are mainly providing their own smartphone infotainment assistant solutions, including smartphone and vehicle implementations. But these infotainment solutions are proprietary, requiring dedicated proprietary SW integrations in the vehicle. If providing proprietary smartphone assistants allows the smartphone OS providers to create an application environment with their own branding and features, it also raises common problems due to multiple hardware platforms, different OS with their different versions or protocols and customizations, creating an increasingly serious situation of market fragmentation.

To solve this issue, the Intelligent Car Connectivity Industry Ecosystem (ICCE) Alliance in People's Republic of China (PRC), has developed a specification to address several challenges of the smartphone infotainment assistants. ICCE has completed or is still carrying out ongoing development of a series of specifications, test procedures, and certification processes, related to technical requirements for functions, protocols, performances, and interoperability of the interconnection system between mobile terminals and vehicle-mounted systems, as well as the corresponding test methods.

7.6.2 ICCE specification – Performance and user experience requirements

Smartphone infotainment assistants are essential to ensure safe usage of smartphone infotainment resources while driving. Thus, minimum performance requirements for the interconnection between mobile devices and in-vehicle infotainment systems, is critical to provide the appropriate level of user experience and safe driving conditions.

ICCE developed a specification to test performance and compliance for the interconnection between mobile terminals and vehicle-mounted devices, which includes test procedures and experience specifications for the relevant wired and wireless interconnections.

For representing the full user perspective with driving experience, the user activity on infotainment functions is divided into four phases: driving preparation – driving process – waiting / congestion – driving end, as described in Figure 7.

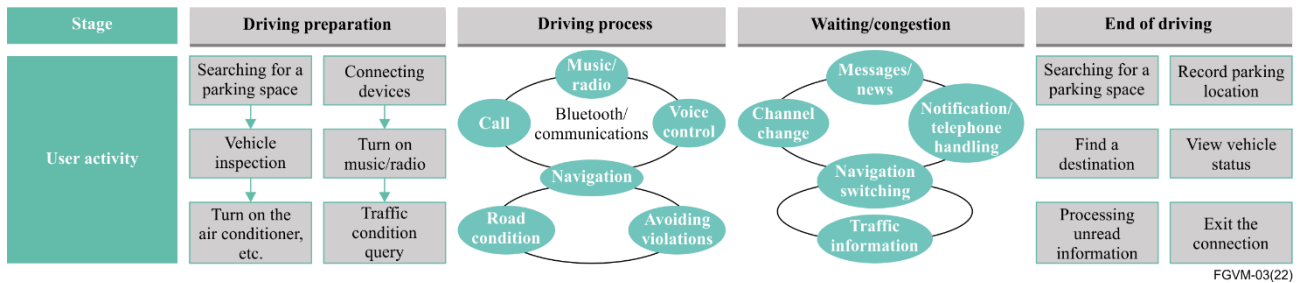

Figure 7 – ICCE representation of user driving experience

ICCE proposes, considering the four main driving phases as described below, with the following appropriate driver interactions with the infotainment devices (mobile and in-vehicle devices).

- Driving preparation phase: connection between the mobile device and the in-vehicle terminal, – mapping of applications / services on the mobile device to the vehicle;
- Driving phase: activities focusing mainly on the top three applications (navigation, call, and music) and in addition, the system provides users with a hand-free (HF) screen touch control and voice interaction (to ensure driving safely);
- Wait / congestion phase: enhanced entertainment functions such as watching videos could be used;
- End of the driving phase: users can search for parking spaces, process unread information, and obtain proactive service recommendations.

Based on the above considerations of the appropriate driver activities, ICCE test specification proposes performance requirements related to wired connections, wireless connections, projection displays, audio outputs, user operations, and voice interactions.

ICCE recommends the following performance indicators:

- Connection efficiency and stability;
- System operation smoothness;
- Display;
- Voice recognition sensitivity (also addressed in clause 7.2.1.3).

For the corresponding performance indicators, ICCE recommends the requirements listed in Table 7.

Table 7 – ICCE recommended performance requirements

Scenario	Indicators	Requirements
Wired connection	First connection completion delay	≤ 5 s
	Non-first connection completion delay	≤ 5 s
	Connection success rate	≥ 99%
	Long-term connection reliability (disconnection times)	0 (at least 8 hours)

Table 7 – ICCE recommended performance requirements

Scenario	Indicators	Requirements
Wireless connection	First discovery completion delay	≤ 1.5 s
	First discovery success rate	$> 70\%$
	Furthest discovery distance	150 cm
	First connection completion delay	≤ 5 s
	Non-first connection completion delay	≤ 5 s
	First connection success rate	$\geq 99\%$
	Long-term connection reliability (disconnection times)	0 (at least 8 hours)
	Reconnection completion delay (which is started after vehicle shutdown)	≤ 5 s
	Reconnection success rate	$\geq 99\%$
Projection display	Screen projection delay	≤ 150 ms
	Projection frame rate	FPS ≥ 55 (60 fps video source) FPS ≥ 24 (30 fps video source)
Audio output	Audio output delay	≤ 1000 ms
	No frame freezing duration for audio output	≥ 4 h
	Voice and picture synchronization delay	$T \in (-125 \text{ ms}, +45 \text{ ms}) \sim (-185 \text{ ms}, +90 \text{ ms})$ NOTE – A positive value indicates that the sound is ahead of the picture, and a negative value indicates that the sound is behind the picture.
User operations	Touch screen response delay	≤ 200 ms
	Steering wheel control response delay	≤ 200 ms
Voice interaction	Voice wakeup success rate (low noise)	$\geq 93\%$
	Voice wakeup success rate (medium noise)	$\geq 90\%$
	Voice wakeup success rate (high noise)	$\geq 85\%$
	Voice interaction response delay (entertainment category)	≤ 2600 ms
	Voice interaction response delay (call category)	≤ 2100 ms
	Voice interaction response delay (navigation category)	≤ 2500 ms
	Voice interaction success rate (entertainment category)	$\geq 85\%$
	Voice interaction success rate (call category)	$\geq 85\%$
	Voice interaction success rate (navigation category)	$\geq 85\%$

7.6.3 ICCE specification – test methods

The ICCE test specification proposes test methods to assess the requirements provided in the same specification and which is described in clause 7.6.2.

The ICCE specified test environment is as follows:

- Hardware requirements for in-vehicle infotainment systems;
- Hardware requirements for smartphones;
- Network environment requirements;
- Connectivity and delay test environment;
- Voice interaction test environment;
- Speech environment and noise simulation conventions;
- Corpus requirements for each category.

Table 8: Example of an ICCE test case for 1st connection delay shows an example of a test case to assess the "Wired first connection completion delay".

Table 8 – Example of ICCE test case for 1st connection delay

Test no.	1.1.1
Indicator	Wired first connection completion delay
Test description	This indicator is defined as the duration from the time when the mobile phone confirms the connection, to the time when the first frame is displayed on the in-vehicle screen. The smaller the delay, the better the user experience.
Preset condition	<ol style="list-style-type: none"> 1. The mobile phone is never connected to the in-vehicle device, or the information about the in-vehicle device is not saved in the system settings of the mobile phone. 2. Prepare the original USB cable of the phone to connect the phone to the in-vehicle device.
Test procedure	<ol style="list-style-type: none"> 1. Unlock the phone. 2. Find the entrance of the in-vehicle interconnection product on the in-vehicle screen and start the connection. 3. Use a USB cable to connect the phone to the in-vehicle device as prompted. Observe the phone until the discovery dialog box is displayed, click connect, and follow the instructions. 4. Record the time of the last operation before the connection is completed on the mobile phone as T1, and record the time of the first frame after the mobile phone projection is displayed on the in-vehicle device screen as T2. 5. Calculate the delay of the first frame displayed on the in-vehicle device (T) = T2 - T1. 6. Repeat the preceding operations for five times, and calculate the average value of the five times as the final result.
Test results	Passed: $T \leq 5000$ ms
Test case level	Mandatory
Test network	Connectivity and delay test environment

7.7 Cyber-security

7.7.1 The vehicle cyber-security eco-system

Today's vehicles are using a complex IT architecture including several electronic control units. Tomorrow's vehicles will have more complex IT architecture and functions using access to external data for sensing the environment and navigating autonomously through the cities. Advanced IT architectures and connectivity will offer automobile users more comfort and mobility services while increasing driving safety and reducing environmental impact. However, ACEA in its document, "ACEA Principles of Automobile Cybersecurity" (see [b3]) quotes, "The interfaces of connected vehicles present an opportunity for exploiting vulnerabilities if adequate cybersecurity mechanisms are not implemented, and cybersecurity risks are not dealt with appropriately. Attackers may compromise the user's personal data, threaten the vehicle's systems or endanger passengers." ENISA report, "ENISA good practices for security of Smart Cars" (see [b2]), defines the good practices for cybersecurity of next generation connected and automated vehicles, based on the existing standardization and regulations. ENISA report is a reference document to understand and promote vehicle cybersecurity and raise awareness on relevant threats and risks with a focus on "cybersecurity for safety".

7.7.2 Cyber security risk management for road vehicles

Cyberattacks may target different components and use various methods by constantly evolving. Protecting vehicles against cyberattacks requires applying a cybersecurity risk management procedure starting from the design phase and including the whole vehicle life cycle.

ISO/TC 22 Road vehicles, ISO/TC 22/SC 32 Electrical and electronic components and general system aspects, and ISO/TC 22/SC 32/WG 11 - Cybersecurity has developed a standard with SAE to address the vehicle cybersecurity risk management: ISO/SAE 21434 – Cybersecurity engineering" (see: [1]).

7.7.3 Cyber-security by design

7.7.3.1 Vehicle electronic control unit (ECU) cybersecurity

Today's vehicles have 10 s of electronic control units (ECU) to control different parts of functionalities like the engine, powertrain, brake, body control, suspension, multimedia, etc. Multimedia features are likely to be provided by several control units controlling the telematics, head unit, disk and so on.

AUTomotive open system architecture (AUTOSAR) is a worldwide development partnership of car manufacturers, suppliers and other companies from the electronics, semiconductors and software industries that aims to standardize the software architecture of ECUs to ensure their performance, safety and security. Automotive security is addressed in the AUTOSAR security working group (WG-SEC).

AUTOSAR framework includes elements to ensure cyber-security by design of the ECUs: SecOC standardized protocol, for securing on-board vehicle communication. Since 2020, AUTOSAR includes specifications for intrusion detection systems (IDS). See escrypt (www.escrypt.com) white paper on security, including an interview about AUTOSAR intrusion detection.

AUTOSAR Release R20-11 platform includes the following security building blocks:

- Crypto stack for access to cryptographic primitives and key management;
- Secure communication via TLS, IPSec and SecOC;
- Secure diagnostic access via the UDS services;
- Access protection to critical resources via identity and access management;
- Detection and reporting of security events via IdsM;
- Secure updates of individual applications or the whole platform;

- Authenticated software by continuing the chain of trust within the trusted platform.

7.7.3.2 Vehicle Ethernet cybersecurity

Introduction of Ethernet based E/E architecture raises new challenges for cyber security:

- Broad variety of protocols with state management;
- System prone to attacks standardised, thus well documented;
- Increased data rate;
- Open connectivity (remote and external).

Ethernet has become a widely used IT standard over the past few decades and is increasingly being used in cars as well. Due to the particularity of vehicle-mounted applications, the reliability of safety and time response is required. To ensure that data buses can work securely, independently, and cooperatively with each other, a very robust solution is needed that supports communication between Ethernet devices and smooth, seamless data exchange with traditional buses. Due to the increase in communication requirements and the abundance of external interfaces, the introduction of a broad variety of protocols will lead to the diversification of network attack entrances and forms. Similarly, with the gradual addition of smart cockpit and autonomous driving functions, sensor configurations are becoming more abundant. Highly increased data rate and payload size poses a security threat to vehicle Ethernet cybersecurity. At present, most of the attacks against Ethernet rely on the security vulnerabilities of vehicle-mounted networks. Remote and external connectivity of vehicles lead different security requirements based on the exposure of the Ethernet interface to the outer world.

A multilevel security architecture can effectively counter these external threats, a concept that prevents a hacker from wreaking havoc on an entire system by breaking through a single security barrier.

The multi-level security architecture consists of four levels to protect the system at different levels. Level 1, "encrypted network rights," severely restricts network access and makes it as difficult as possible for malicious attackers to enter the communication network. This level has been able to provide effective protection. If level 1 is compromised;

Level 2, secure vehicle-mounted communication, ensures that all security-related messages exchanged are protected from tampering by the attackers. If this level is also breached;

Level 3, data use policy, requires a specific user authentication to be performed for protection. The system performs checks in a specific user environment before further processing the sensitive message content. Finally.;

Level 4 is "Detection and defence". This level checks for anomalies in the entire communication mode. If an attack is detected, the defence mechanism ensures that the levels 1-3 security layer that was breached is restored. This multi-level architecture provides comprehensive protection against attacks on system availability, integrity, and confidentiality.

7.7.4 Regulation for vehicle cybersecurity

United Nations Economic Commission for Europe (UNECE) published on 4 March 2021 its Regulation 155 about "Uniform provisions concerning the approval of vehicles with regard to cyber security and cyber security management system" (see: [b4]). The regulation is adopted by the European Union, Japan and Republic of Korea. In the EU, this regulation is mandated in the Regulation EU 2019/2144 on type-approval requirements for motor vehicles (see: [b5]):

The EU regulation contains the **Requirement D4: Protection of vehicle against cyberattacks**.

The EU regulation 2019/2144 is applicable from June 2022 for all new types of vehicles and from 2024 for all new vehicles provided on the EU market.

UNECE regulation 155 requires vehicle manufacturers to have a compliant cyber security management system in place, applying to the development, production and postproduction phases, which shall address risks and mitigations listed in its Annex 5. This regulation also requires risk mitigation to be provided within a reasonable timeframe and monitoring to be continual.

To be compliant with the UNECE regulation 155, vehicle manufacturers shall:

- Identify and manage supplier-related risks;
- Perform exhaustive risk assessment treat / manage the identified risks appropriately;
- Protect the vehicle type against risks identified;
- Use appropriate and proportionate measures to secure dedicated environments for the storage and execution of aftermarket software, services, applications or data;
- Perform, prior to type approval, appropriate and sufficient testing to verify the effectiveness of the security measures implemented;
- Implement measures, detect and prevent cyber-attacks against vehicles and support monitoring capability for detecting threats, vulnerabilities and cyber-attacks;
- Cryptographic modules used shall be in line with the consensus standards;
- Report at least once a year to the approval authority, or technically service the outcome of the monitoring activities and relevant information on new cyber-attacks and confirm that the cyber security mitigations are still effective and that any additional actions are taken (Note – If reporting / response is not sufficient approval authority may decide to withdraw CSMS).

Annex 5 of UNECE regulation 155 contains the Threat (Part A) and Mitigation (Parts B, and C) catalogue, as described in Table 9:

Table 9 – UNECE regulation 155 – Annex 5 Threats and mitigation catalogue

Part A. Vulnerability or attack method related to the threats
Threats regarding back-end servers related to vehicles in the field
Threats to vehicles regarding their communication channels
Threats to vehicles regarding their update procedures
Threats to vehicles regarding unintended human actions facilitating a cyber attack
Threats to vehicle data / code
Potential vulnerabilities that could be exploited if not sufficiently protected or hardened
Part B. Mitigations to the threats intended for vehicles
Mitigations for "Vehicle communication channels«
Mitigations for "Update process"
Mitigations for "Unintended human actions facilitating a cyber-attack"
Mitigations for "External connectivity and connections"
Mitigations for "Potential targets of, or motivations for an attack"
Mitigations for "Potential vulnerabilities that could be exploited if not sufficiently protected or hardened"
Mitigations for "Data loss / data breach from vehicle"
Mitigations for "Physical manipulation of systems to enable an attack"
Part C Mitigations to the threats outside of vehicles
Mitigations for "Back-end servers"
Mitigations for "Unintended human actions"
Mitigations for "Physical loss of data"

7.7.5 Gaps and proposed mitigations

At present, detection and defence technologies for cybersecurity protection of in-vehicle Ethernet rely heavily on operating systems such as Linux, QNX, and Android, are currently mainly implemented in vehicle MPU systems.

Proposed mitigations:

1. Intrusion detection system (IDS)
 - Intrusion detection system (IDS) provides anomaly detecting and intrusion report creating functions. IDS can be implemented on system and network monitoring single vehicles and vehicle fleets. IDS defines all legal behaviour and can detect malformed frames and unauthorized messages. One of the legal behaviour detections is based on the intrusion detection rule. Whitelisting can be based on packet header specification, stateful behaviour of protocol timeouts and higher layer protocols like DoIP, SOME/IP, etc.
2. Isolation and access control
 - Isolation and access control are mainly located in the layers 2-4 of the OSI 7-layer model, and includes VLAN and firewall.
3. Authentication and encryption
 - Authentication and encryption methods are mainly located in the layers 2-3 and layers 5-7 of the OSI 7-layer model, and includes MACsec, IPsec, SSL / TLS / DTLS and SecOC.

7.8 Privacy protection

With the development of intelligent and networked functions, cars collect and process a large amount of data. Excessive collection, unauthorized collection and use of data, disclosure and other problems may have a serious impact on individuals, and even affect the rights and interests of the country. For example, the automatic driving function and DVR need to collect and process the videos and images outside the car, but they cannot inform and obtain the authorization consent of the subject of the personal information outside the car, which may infringe the personal information of the third party; with the development of intelligence, functions in the car are becoming more and more complex, and functions of user expressions, gestures, actions and voices are gradually increasing. At the same time, in order to meet social attributes and enhance network interactive experiences, car data will lead to the risk of uncontrolled use of personal information.

Cars face challenges in the privacy compliance, and privacy compliance capability should be considered in the design of cars. China issued the personal information protection act, from the scope of application, the basic principles of personal information processing, personal information and sensitive personal information processing rules, personal information cross-border transport rules of each participation's main body responsibility, personal information protection and power and the legal responsibility and so on has carried on the comprehensive regulation, to personal information protection, whereby the basic system for the protection of personal information has been established.

For privacy and data security management, China issued the car data safety management, several provisions (trial) have been clear about including car design, production, sales, use and operations that are involved in the process of personal information, sensitive personal information, important data, personal information and important data processing requirements.

- (1) **"Several provisions on the safety management of automobile data (Trial)"** clarified the four principles of automobile data processing, which are the principles of in-car processing, that is, unless it is necessary not to provide information outside the car;
- (2) Default non-collection principle, that is, unless it is set by the driver himself, the default setting is not in a collection state during each driving;
- (3) The applicable principle of accuracy range is to determine the coverage range and the resolution of the cameras and radars according to the requirements of data accuracy of the function services provided;
- (4) Desensitization principle, that is, as far as the possible anonymization, de-labelling and other processing.

In order to protect personal information security, the personal information processor shall satisfy or at least provide the subject of personal information with the following rights:

- (1) Right to know: Inform the organization name, contact information, scope, purpose and retention period of the personal information to obtain the consent of the subject of personal information.
- (2) Right of access: Individuals have the right to consult and copy their personal information to the personal information processor.
- (3) Right of withdrawal: For personal information processing activities based on personal consent, individuals have the right to withdraw their consent.
- (4) Deletion right: Delete personal information when the purpose of processing personal information has been realized or the consent of the individual has been withdrawn.

7.9 Driver and user experience

7.9.1 Driving safety

Driving safety is the ability to ensure the safety of the vehicle passengers as well as the other road users surrounding the vehicle, for example, the passengers from the surrounding vehicles or pedestrians.

Driving safety results from three main conditions:

- The vehicle safety, representing the ability to drive safely, resulting from all vehicle components, either passive or active, acting on the vehicle driving behaviour;
- The driver behaviour;
- The external driving environment, e.g., weather conditions, visibility, road conditions.

With regards to VMS, the two main conditions are directly relevant, however the 3rd condition can be indirectly relevant.

With regard to future autonomous driving, speech commands will be able to control safety relevant features in the car. To ensure robust and fast detection of safety relevant features, the users command shall be detected and recognized using local modules within the VMS, not relying on the cloud connection.

7.9.2 Driver ergonomics aspects

The driver behaviour is essential for driving safety, but driver attention can be disrupted by:

- The messages provided by on-board systems;
- Or interacting with those systems.

Driver distraction has increased recently due to the interaction of the driver with their smartphone.

As pointed out in [b1], "The expansion of new infotainment and in-vehicle information systems (IVIS) into vehicles in recent years has afforded drivers new activities and connectivity that can potentially impact safety. It is important to understand how these new technologies impact drivers' workload and performance."

7.9.3 Driver and user acceptance

Implementing multimedia functionalities should take into account the driver and user experience. The main question here is: how drivers and users will accept and, furthermore appreciate multimedia applications and services and what suppliers and OEMs should take into account for providing the best experience.

7.10 Driver assistance and safety

This clause provides implementation requirements about driver assistance functions or functions providing external message from safety forces, other cars or the road infrastructure (via V2X) and utilising the car HMI.

Some driver assistance functions are regulated.

- Driver monitoring system (DMS)
 - Regulated in EU – EU regulation 2019/2144 applicable from July 2022 – DDAW: Driver drowsiness and attention warning;
- Intelligent speed assistance (ISA)
 - Regulated in EU – EU regulation 2019/2144 applicable from July 2022.

7.11 In-vehicle integration

OEM have created alliances like AUTOSAR or GENIVI to handle the architecture and iteration specification.

Some architectures like GENIVI have also developed open source project based on global open source OS like Linux with specific automotive version (e.g., automotive grade Linux (AGL)).

7.11.1 Hardware (HW) and software (SW) architecture

7.11.1.1 HW architecture

The vehicular electrical/electronic (EE) architecture generally evolves from distributed architecture, domain architecture, to the central architecture.

Figure 8 gives an overview of the types of EE architectures.

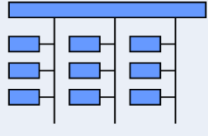
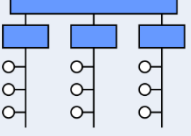
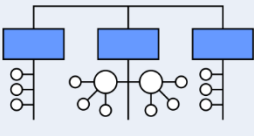
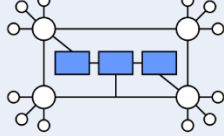
Architecture	Distributed	Domain	Central	
			Tree	Loop
Topology				
Hardware	Arbitrary distribution of functional controllers	Each functional domain has a domain controller	Central computing platform plus i/o controller	Central computing platform plus area controller (VIU)
Software	The control logic is distributed in each controller	The control logic is centralized in each domain controller according to the functional domain, and other controllers are i/o controlled	All the control logic is centralized in the central computing platform	

FGVM-03(22)

Figure 8 – Different types of EE architectures

Within central architectures, sensors and actuators are centralized by the domains, and functional logic is centralized which breaks the boundaries of the functions, forming an architecture with the characteristics of multiple central controllers (not integrated into one) plus I/O controllers. The central architecture could support the cross-domain SOA. The central architecture can also be divided into two categories, tree, and loop.

See Figure 9.

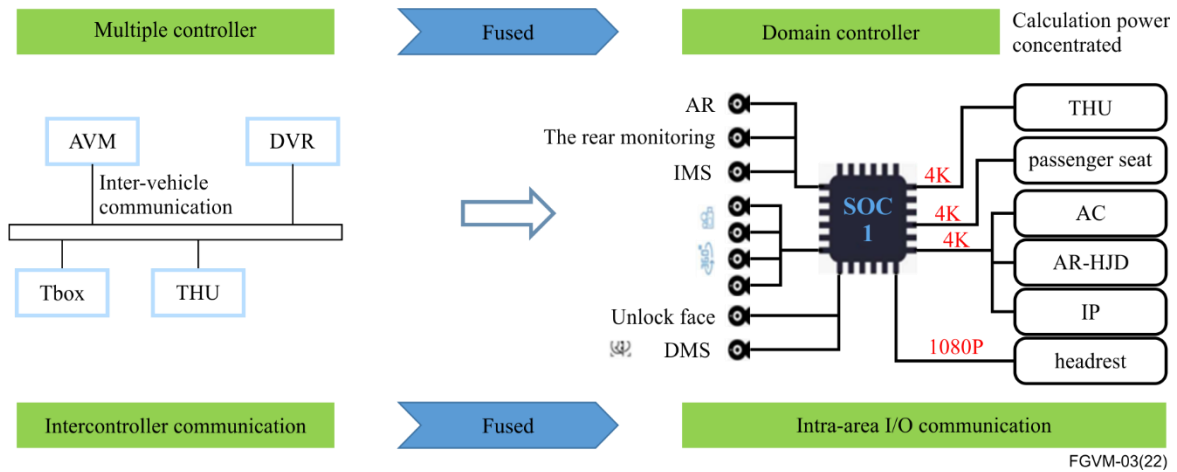

Figure 9 – Multiple controllers fused into one domain controller

7.11.1.2 SW architecture

The SW architecture should have standardized APIs, basic services, and middleware to realize the ecological isolation and HW-SW decoupling.

Figure 10 provides an overview of the software architecture.

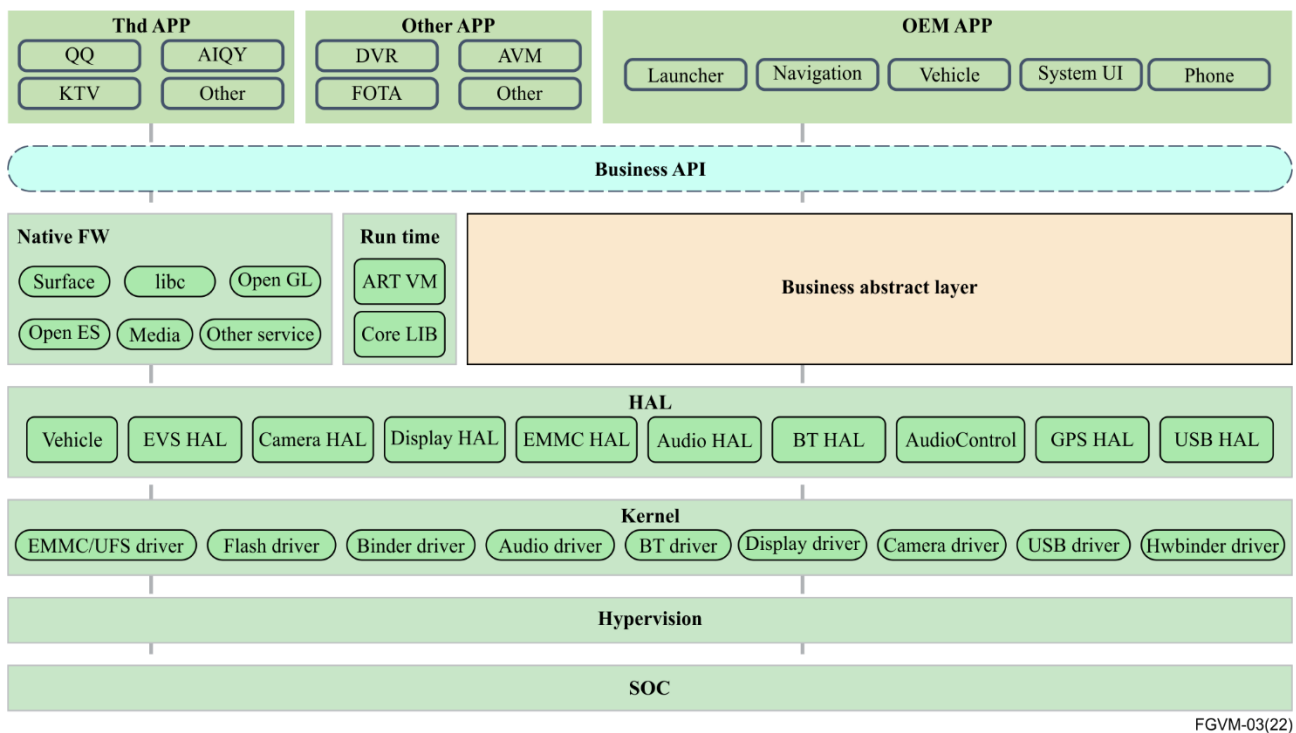

Figure 10 – SW architecture overview

7.11.2 Functional safety

VMS are systems which are not directly intended to influence the vehicle driving behaviour, like the brakes, throttle and steering. But VMS may have an indirect impact on vehicle safety while:

- Providing information to safety critical components;
- Disrupting functions of safety critical components.

Functional safety for vehicles is covered by 2 ISO standards issued by ISO/TC 22/SC 32/WG 8 (Functional Safety):

- ISO 26262-1:2018 Road vehicles – Functional safety;

– ISO/PAS 21448:2019 – Safety of the intended functionality.

For the intended functional safety, the VMS is required to make the necessary safety designs when the user is required to take over the vehicle control, such as lowering / turning off the sound, increasing the multimedia system takeover reminder so as to ensure the user's takeover is not affected by the multimedia system.

8 Conclusions

This Technical Report describes a wide range of technological fields, which are relevant for the implementation of vehicular multimedia. The next generation of vehicles are going to provide a vast choice of multimedia services and applications, interacting with a complex vehicle eco-system of sensors and actuators, including driver and passenger personal devices.

As vehicular passenger transport evolves, with new business models and societal priorities, as well as new ways of using roads and consuming energy, passenger comfort needs addressing, with candidate quality criteria to be investigated and agreed (potential standardization leading to quality levels and labels). The expected development may go through new work item proposals on sub-system architecture for passenger comfort support in vehicular multimedia.

The Technical Report has also identified some gaps and also issues that are needed to rely on sound technical specifications, to ensure providing safe, secure and user-friendly multimedia applications and services in vehicles. In some cases, the report provides some examples of requirements, which need to be developed further and enhanced in new work item(s) addressing the implementation aspects of vehicular multimedia.

The conclusions are provided as follows, in the context of the different technological domains developed in the report, identifying the issues to be considered in a new work item related to vehicular multimedia:

1. Beyond broadcast communication, the connectivity clauses shows several different communication types necessary to deliver a wide range of multimedia services. Short range communication is essential to deliver multimedia service continuity between vehicles, personal devices and home domains, also, specific vehicle networks can be used for multimedia services in combination with a regular vehicle network (CAN or Ethernet based) needing a secured interconnection with a wide area network (WAN) modem telematics box (T-Box). As many multimedia services will rely on the Internet, the IPv6 protocol is providing significant benefits for vehicular multimedia. Furthermore, standardization work is considered necessary to provide a detailed functional architecture of the connectivity for vehicular multimedia, as well as to describe requirements that are related to the connectivity performance in relationship with the expected multimedia services and quality criteria.
2. The HMI clause allows the raising of many new technology areas requiring standardization work, which is considered to provide a solid baseline for implementing competitive but harmonized HMI functionalities, which do not confuse the driver and remains user-friendly and easy to learn. The report has also identified four different key features for the latest and next generation vehicles, where new guidance and requirements must be defined in a short timeframe: Voice assistant, gesture recognition, motion sickness free and auditory interaction.
3. The three media clauses show many different types of media and procedures to enjoy the media that is played over the internet as well as the means to discover services. It is considered that further standardization work would allow the provision of recommendations about the suitability and relevance of the media types and procedures, in relationship with the expected level and quality of the multimedia services as well as the multimedia trends and evolutions.

4. The smartphone infotainment assistant clause proposes some initial recommendations on multimedia resources to ensure seamless and qualitative multimedia services combining vehicle and smartphone systems and resources. The requirement developed by the Chinese car alliance ICCE are given as good practices, but further standardization work would allow the consideration of all aspects of interoperability and service quality resulting from combined smartphone and VMU resources. Beyond defining a functional architecture of smartphone infotainment assistant, recommendations should be considered about system and data interoperability, as well as requirements on other resources like connectivity or voice assistant.
- 5 Both cyber-security and privacy protection clauses raise the importance of these topics, because multimedia using internet open services could create vulnerability. Also new HMI solutions, like voice assistant, use artificial intelligence with users' data, exposing those systems to privacy protection failures. Some regulations exist, as those provided by the UNECE, which require assessing cyber-security risks exposed by the multimedia systems. A new WI about vehicular multimedia implementation aspects should also consider providing guidance and applicable requirements for the VMU to comply with cyber-security standards and to avoid exposing the vehicle supply chain with risks about users' privacy protection.
6. Even if from a functional point of view, the VMS is not expected to control vehicle driving, it is used to command other important vehicle features, to include driving safety, like wipers. Also, the growing number of multimedia services increases the number of tasks submitted to the driver, thus raising driver distraction risks. Important features for driving safety, like driver monitoring status or intelligent speed assistance will rely on infotainment systems. A new WI must also consider providing guidance or requirements for vehicular multimedia implementations to keep driving safety features at a high level and to keep the driver vigilant by the growing complexity of the vehicles' multimedia systems. Relevance of functional safety standards and methodologies should be considered in a new WI.

The above list of conclusions shows the relevance of drafting a new vehicular multimedia implementation aspect recommendation work item, based on the many topics that are needed to be addressed with some examples of suitable recommendations being provided in clause 7.

Bibliography

- [b1] AAA Foundation for Traffic Safety (2018), *Visual and Cognitive Demands of Using Apple's CarPlay, Google's Android Auto and Five Different OEM Infotainment Systems*. <<https://aaafoundation.org/visual-cognitive-demands-apples-carplay-googles-android-auto-oem-infotainment-systems/>>
- [b2] ENISA (2019), *good practices for security of Smart Cars*. <<https://www.enisa.europa.eu/publications/smart-cars>>
- [b3] ACEA: *Principles of Automobile Cybersecurity*. <https://www.acea.be/uploads/publications/ACEA_Principles_of_Automobile_Cybersecurity.pdf>
- [b4] UN Regulation No. 155 – *Cyber security and cyber security management system* <<http://unece.org/sites/default/files/2021-03/R155e.pdf>>
- [b5] Regulation EU 2019/2144 of 27 November 2019. <<https://eur-lex.europa.eu/eli/reg/2019/2144/oj>>
- [b6] Stoffregen, T.A., Chen, Y-C. and Koslucher, F.C. (2014), *Motion control, motion sickness, and the postural dynamics of mobile devices*. *Experimental Brain Research* 232, 1389–1397. <<https://doi.org/10.1007/s00221-014-3859-3>>
- [b7] Jones, M.L.H., Sienko, K., Ebert-Hamilton, S., Kinnaird, C. et al., (2018), *Development of a Vehicle-Based Experimental Platform for Quantifying Passenger Motion Sickness during Test Track Operations*, SAE Technical Paper 2018-01-0028. <<https://doi.org/10.4271/2018-01-0028>>
- [b8] Karjanto, J., Yusof, N., M., Terken, J., Delbressine, F., Rauterberg, M. and Hassan, M. Z. (2018). *Development of On-Road Automated Vehicle Simulator for Motion Sickness Studies*. *International Journal of Driving Science*, Volume:1 Issue: 1. <https://www.researchgate.net/publication/329202354_Development_of_On-Road_Automated_Vehicle_Simulator_for_Motion_Sickness_Studies>
- [b9] Hemmerich, W., Keshavarz, B., Hecht, H. (2020), *Visually Induced Motion Sickness on the Horizon*, *Frontiers in Virtual Reality*. <<https://doi.org/10.3389/frvir.2020.582095>>
- [b10] Bahram, J., Filiberto, P., José, M. S., Xin, S., Pedro, L-C, Manuel, M-C, Rubén, F-B, and Gokul, K. (2020), *Fundamentals of automated human gesture recognition using 3D integral imaging: a tutorial*, *Advances in Optics and Photonics*. Vol.12, Issue 4, pp. 1237-1299. <<https://opg.optica.org/aop/fulltext.cfm?uri=aop-12-4-1237&id=444727>>
- [b11] Parvathy, P., Subramaniam, K., Prasanna Venkatesan, G.K.D., Karthikaikumar, P., Varghese, J. and Jayasankar, T. (2020), *Development of hand gesture recognition system using machine learning*. *Journal of Ambient Intelligence and Humanized Computing* 12, 6793–6800. <<https://doi.org/10.1007/s12652-020-02314-2>>
- [b12] D'Eusanio, A., Simoni, A., Pini, S., Borghi, G., Vezzani, R., Cucchiara, R. (2020), *Multimodal Hand Gesture Classification for the Human–Car Interaction*. *Informatics* 2020, 7(3), 31. <<https://doi.org/10.3390/informatics7030031>>

- [b13] Deleener, R., Ingelberts, H., Kuijk, M. (2015), *A delay locked loop for instantaneous time-of-flight sensing based on a CMOS demodulation detector*, 2015 IEEE SENSORS.
<<https://doi.org/10.1109/ICSENS.2015.7370519>>
- [b14] ETSI White Paper No. 35 (2020), *IPv6 Best Practices, Benefits, Transition Challenges and the Way Forward*.
<https://www.etsi.org/images/files/ETSIWhitePapers/etsi_WP35_IPv6_Best_Practices_Benefits_Transition_Challenges_and_the_Way_Forward.pdf>
- [b15] ICCE *Intelligent Car Connectivity Industry Ecosystem Alliance*, web page (in Chinese):
<<http://www.icce.cn/>>
- [b16] Allion *In-Car Voice Assistant Verification*.
<<https://www.allion.com/automotive/in-car-voice-assistant/>>
- [b17] Ken R. Catchpole, J. Denis McKeown and Deborah J. Withington (2004), *Localizable auditory warning pulses*, *Ergonomics*, 47:7, 748 - 771
-