

## 6G SYSTEM ARCHITECTURE: A SERVICE OF SERVICES VISION

Tarik Taleb<sup>1</sup>, Chafika Benzaid<sup>1</sup>, Miguel Bordallo Lopez<sup>1</sup>, Konstantin Mikhaylov<sup>1</sup>, Sasu Tarkoma<sup>1,2</sup>, Panos Kostakos<sup>1</sup>, Nurul Huda Mahmood<sup>1</sup>, Pekka Pirinen<sup>1</sup>, Marja Matinmikko-Blue<sup>1</sup>, Matti Latva-aho<sup>1</sup>, Ari Pouttu<sup>1</sup>

<sup>1</sup>University of Oulu, Finland, <sup>2</sup>University of Helsinki, Finland

NOTE: Corresponding author: Tarik Taleb, tarik.taleb@oulu.fi

**Abstract** – *The architectures of mobile networks have seen an unprecedented techno-economic transformation, fusing the telecommunications world within the cloud world, adding the spices of Software Engineering to the overall system design, and ultimately yielding the concept of Telco Cloud. This has brought significant benefits in terms of reducing expenditure and operational costs, flexibility in deployment, and a faster time to market. The key enablers are network function virtualization, software-defined networking, and edge/cloud computing. Artificial intelligence is also kicking in this arena. When all these technologies are well integrated, the creation and life-cycle management of fully programmable, flexible, service-tailored, and automated end-to-end network slices/services become possible. This will support diverse 5G and beyond 5G services, spanning from tactile IoT to pervasive robotics and immersive services. This paper introduces an unprecedented and disruptive vision for 6G that shifts the perception of future mobile networks from the old-fashioned concept of “network of networks” towards a new vision of “service of services.” The paper then introduces the functional model of the envisioned system architecture, along with its components. It then provides a high-level description of the logical architecture.*

**Keywords** – 6G networks, 6G system architecture, service of services

### 1. INTRODUCTION

As the fifth generation (5G) mobile system is being commercially deployed, the research community has shifted the focus on studying fundamental solutions for the 2030 era, i.e., the 6th Generation (6G) mobile wireless communications system. It is not clear yet what 6G will entail exactly. However, it is envisaged to include relevant technologies considered too immature for 5G or which are outside the defined scope of 5G. More specifically, 6G is expected to rethink the way in which data is collected, processed, transmitted and consumed within the wireless network. It is envisioned that we will need new Key Performance Indicator (KPI) drivers besides the current 5G technical superiority inspired KPIs. Societal megatrends including United Nations Sustainable Development Goals (UN SDGs), lowering carbon dioxide emissions, emerging new technical enablers as well as ever increasing productivity demands are critical drivers towards 2030 solutions, leading to the establishment of key value indicators (KVI) [1].

Totally new services such as telepresence and mixed reality will be made possible by high resolution imaging and sensing, accurate positioning, wearable displays, mobile robots and drones, specialized processors, and next-generation wireless networks. Current smart phones are likely to be replaced by pervasive XR experiences with lightweight glasses delivering unprecedented resolution, frame rates, and dynamic range. 6G research should look at the problem of transmitting up to 1 Tbps per user [2]. This is possible through the efficient utilization of the spectrum in the THz regime. Extended spectrum towards THz will enable merging communications and new appli-

cations such as 3D imaging and sensing. Emergence of a huge number of different types of IoT devices and applications needed in different verticals will set further diversity to system requirements. Machine type communications with real-time sensing capabilities with different maximum data rates and total capacity requirements are setting new challenges to the overall system architecture. One solution-fitting-all-problems type of thinking with rather simple network slicing approach will not be sufficient in the future landscape.

International Telecommunication Union Radiocommunication Sector (ITU-R) has not yet defined the requirements for the mobile communication system in 2030. Recently, ITU-R WP 5D, which is responsible for the overall radio system aspects of International Mobile Telecommunications (IMT) systems, comprising IMT-2000, IMT-Advanced, IMT-2020 and IMT for 2030 and beyond, started shaping 6G by formulating technology trends, which will be ready in June 2022 and vision, which will be ready in June 2023. At this early stage of 6G development, the research community should take a bold approach to look at alternative solutions for the whole system architecture and overall service delivery mechanisms underneath. It is the right time to critically challenge current 5G systems network architecture and try to find alternative models for networks operation.

The whole society will look very different in 2030 era: different sectors of our societies are increasingly relying on digital automated services transparent to humans and attempting to reach sustainability targets through the green and digital transformation. Sustainable digital solutions are needed to solve major global sustainability challenges.

The fourth industrial revolution (Industry 4.0) will be by then a reality: real-time Artificial Intelligence (AI)-driven automated processes will be everywhere, needing increasing network connectivity. Having the connectivity everywhere and all the time will be just as important as having electricity on all the time. The business ecosystem indicating who provides connectivity and other services, who owns the networks and spectrum licenses will change. Networks will be ubiquitous, and they can and will be built by different operators for different purposes. Local specialized services with various connectivity mechanisms are becoming more and more popular. At the same time, large coverage area networks are needed for reliability and service continuity. Therefore, we need to enable the growing demand for local specialized services and networks but at the same time make sure that large-area Mobile Network Operators (MNOs) will not be threatened as the global coverage relies completely on them. Hence, future needs will result in some conflicts of interests, which should be addressed in the design of future wireless networks.

In this article, we will be exploring and proposing a new paradigm for a service-driven 6G system architecture whereby a customer is in the central focus and starting point. We are not trying to justify or solve different business cases looking at MNOs' interests with respect to future emerging business cases. Our greatest interest is to picture what the delivery of varying types of services with different technical capabilities and requirements in the 2030 era would mean and that is without worrying about the legacy of current network architecture and service delivery models. Our approach is somewhat clean-slate, it does not give a complete solution for the future system but hopefully inspires for discussion and debate within the 6G research community. Without challenger ideas and courage to look beyond the foreseen horizon, there is no chance for the drastic improvements in future systems.

The remainder of this article is organized as follows. Section 2 provides an overview of the existing state-of-the-art on 6G architecture. Section 3 discusses the recent trend towards a service-based architecture. The service-centric functional model of the proposed 6G system architecture is introduced in Section 4 and the details on the key capabilities of the encompassed services are provided in sections 5 – 11. Section 12 elaborates the logical model of the envisioned Service-of-Services 6G System architecture. Finally, Section 13 outlines our concluding remarks and future work directions.

## 2. 6G ARCHITECTURE: STATE-OF-THE-ART

In this section, we provide an overview of the existing literature on the future 6G architecture, summarizing different views on potential requirements, capabilities and use cases of 6G networks, as foreseen by academia, mobile operators, equipment vendors and service providers.

### 2.1 Academia's perspectives

In addition to the 6G Flagship white papers [3], some other literature is available related to the 6G system and its architecture. Below are some state-of-the-art references from the academic research viewpoint as well as from the perspectives of different stakeholders in 6G development.

Hataria *et al.* [4] provide a comprehensive tutorial about 6G. The tutorial takes a holistic top-down view of 6G system design. Furthermore, it draws a vision for 6G and discusses seven most prominent use cases and their technical requirements. KPIs, new frequency bands and deployment scenarios are elaborated. Fundamental changes in the core and transport networks supporting 6G applications are given an overview. Also, topics such as new physical layer (PHY) techniques (e.g., waveforms, modulation methods, multiple antenna techniques), applications of AI and Machine Learning (ML) are taken into consideration. Wave propagation characteristics of 6G systems for different applications and scenarios are addressed. The challenges in building radio transceivers and performing real-time signal processing for 6G are described as well as some solutions to overcome them. A comprehensive bibliography (i.e., 246 references) is available to dig deeper into specific areas.

You *et al.* present a detailed survey of 6G wireless communication networks [5]. After the introduction to the 6G vision, performance metrics, application scenarios, and example industry verticals are discussed. Next, enabling technologies and new paradigm shifts are illustrated. Section 3.2 is devoted to network architecture discussions. First, Software Defined Networks (SDNs) and their evolution are handled. Then, Network Function Virtualization (NFV) and its evolution are covered. Dedicated sections to network slicing and its improvement, Service-Based Architecture (SBA) and its evolution, Cognitive Service Architecture (CSA), Deep Edge Node and Network (DEN2), Cell-Free (CF) architecture, and cloud/fog/edge computing follow.

The authors in [6] suggest that Intent-Based Networks (IBNs) would be a meaningful way to introduce AI into 6G wireless networks as they can effectively include efficiency, flexibility, and security while addressing network challenges. IBNs help to transform users' business intent into configuration, operation, and maintenance strategies of the networks. IBNs can also react well to massive and time-varying data demand via continuous learning and adaptivity in real time. This article surveys both the core and radio access network aspects and how the architectures, platforms and key techniques of IBNs could be utilized for 6G development.

Zhang *et al.* [7] propose a large-dimensional and autonomous 6G architecture that integrates space, air, ground, and underwater tiers and leverages AI. To improve the efficiency of network operation and maintenance and reduce operational expenditures, the authors envision 6G networks that are zero-touch and

intent-based. To realize this vision, they advocate a combination of AI capabilities with softwarization, programmability, cloudification, virtualization, and slicing features offered by SDN, NFV, and network slicing technologies.

Sergiou *et al.* [8] recommend complex systems theory as a powerful tool to be considered in 6G system design. Basic models of complex networks and especially their structural and evolutionary properties are discussed from a communication networks' perspective. Key defining characteristics of complex adaptive systems are: 1) many interacting parts, 2) evolution and co-operation, 3) emergent behavior, 4) degeneracy, 5) adaptability, 6) self-organization, 7) decentralization, 8) robustness, 9) resilience, and 10) non-linearity. Temporal networks (graphs), dynamic network analysis and evolutionary graph theory are examples of modeling tools that could respond to dynamic network operations. The European Union funded project INSPIRE-5Gplus has recently published a white paper [9] about intelligent security architecture that encompasses also beyond 5G era. The goal there is to devise and implement a fully automated end-to-end smart network and service security management framework that embodies trustworthiness in network infrastructures across multi-domains. Managing the increased complexity of 6G networks with traditional human-in-the-loop approaches will not be possible anymore, and instead technologies that fully automate the network operation will become the standard. The success of 6G will vastly depend on the quality of the Network Intelligence (NI) that will run at schedulers, controllers, and orchestrators across network domains, and manage the infrastructure. A comprehensive survey of the crossovers between deep learning and mobile and wireless networking research is presented in [10], where the authors discuss several techniques and platforms that facilitate the efficient deployment of deep learning onto mobile systems, and provide an encyclopedic review of mobile and wireless networking research based on deep learning. Furthermore, the paper also outlines several current challenges and open future directions for research.

The challenges and opportunities related to the design of an end-to-end NI native system architecture for 6G is presented in [11]. The authors of this paper advocate that instead of the common approach of plugging readily available AI models into controllers and orchestrators, AI models in an NI native 6G system architecture should be tailored to the specific network level and respond to the specific needs of network functions. On a more specific note, Chen *et al.* [12] discuss the challenges of wireless networked multi-robot systems in smart factories from a wireless networking perspective. In particular, the trends of wireless networking evolution to facilitate multi-robot smart factories, and the application of social learning to extend the resilience of precision operation in a multirobot system is highlighted.

Addressing the particular use case of Industrial IoT (IIoT) networks, Mahmood *et al.* [13] functional system architecture for a special-purpose 6G IIoT network incorporating seven functional building blocks categorized into *special-purpose functionalities* and *enabling technologies*. The former comprises wireless environment control, traffic profiling, proactive resource management and end-to-end optimization functions, whereas the latter is made up of synchronization and coordination, machine learning and artificial intelligence algorithms, and auxiliary functions. The proposed architecture aims at providing a resource-efficient and holistic solution for the complex and dynamically changing requirements imposed by future 6G industrial use cases. The In-Network Computing or Computing In the Network (COIN) is promoted as a key enabler to support the next generation of applications and services, including time-sensitive applications, extended reality and immersive media and intelligent automation and distributed intelligence [14, 15, 16, 17]. The COIN concept capitalizes on the joint computation and communication resource usage throughout the network to delegate the applications-layer processing functions to the network devices, such as switches and network interface cards [14]. NFV, SDN and data plane programmability are the basis for enabling COIN. By moving computation within the network, COIN brings the advantage of lowering end-to-end latency as well as reducing the costs due to reduced outbound traffic [17]. Albalawi *et al.* [18] propose In-Network Computing Architecture (INCA) to support the joint optimization of networking and computation within the network, empowering appropriate placement of workloads on network devices to fulfill both the application requirements and the optimization of the network resources. The authors in [19] investigate the state-of-the-art of COIN and how edge-cloud continuum should evolve to reap the capabilities of COIN for supporting 6G era applications. Pham *et al.* [20] advocate the integration of COIN with edge computing and AI to enable aerial computing in 6G. Realizing the importance of COIN, the Internet Research Task Force (IRTF) has recently initiated the computing in the network research group (COINRG<sup>1</sup>). The group aims to foster research in COIN to improve performance for the network and application, looking at different instantiations of COIN in the cloud-to-edge-to-device computing continuum.

## 2.2 Mobile operators' perspectives

Cellular network operators are generally cautious in defining 6G system contents as their focus is on 5G network deployments and operations. However, some participate in 6G research activities and discussions. For example, Orange, TIM, and Telefonica are participating in the EU Horizon2020 project Hexa-X [21]. The Next Generation Mobile Network (NGMN) Alliance has established a 6G Work Programme, and published the first version of their "6G Vision & Drivers" White Paper [22].

<sup>1</sup><https://datatracker.ietf.org/rg/coinrg>

In their white paper, network operators list, as motivations and drivers for 6G, social and environmental benefits, expanded and differentiated services (compared to 5G), and operational necessities to create and provide enhanced value. Regarding the operational necessities, network operators emphasize the need to manage complexity, drive efficiency and reduce costs. To manage growing network complexity, end-to-end system automation, including seamless ‘hyper-automation’, fully automatic lifecycle management and fully integrated AI functionality are essential. End-to-end system monitoring and data collection capability are needed to achieve 360° system visibility. Data security, privacy and anonymity functions need to be natively built in the system. System efficiency and management will play an important role as the infrastructure grows. The NGMN Alliance also raises into discussion a need for increased scope for the Standards Developing Organizations (SDOs), i.e., that SDOs and industry in general would take a holistic end-to-end view of the entire ecosystem, and not only its respective parts. In relation to 5G network architecture evolution, operators are widely participating, in addition to the 3rd Generation Partnership Project (3GPP), e.g., to Open Radio Access Network (O-RAN) alliance initiatives [23]. Recently, NGMN released a white paper on potential 6G use cases [24], where 14 generic use cases have been identified and grouped into four classes relating to enhanced human communication, enhanced human machine, enabling services, and network evolution. A high-level analysis of the identified use cases has been conducted, focusing on the assessment of their applicability, feasibility and 6G implications.

The Japanese operator NTT Docomo has published a white paper on 6G [25] discussing potential use cases and technical study areas for 5G evolution and 6G. According to Docomo, the mobile communication system has been evolving technically every decade, while the services of mobile communications have changed greatly in cycles of approximately 20 years. 5G will provide new value as a basic technology supporting industrial use cases, massive IoT and multimedia communication services, utilizing widely the AI technology. Private networks (such as “Local 5G” in Japan) will provide tailored services for industrial vertical sector customers. This development in the service domain is expected to continue through 5G evolution and 6G. Potential development trends towards 6G include 1) solving social problems, 2) communication between humans and things (e.g., wearable devices including extended Reality (XR) devices, high definition images and holograms, new five sense communications including tactile sense, IoT services), 3) expansion of communication environment (high-rise buildings, drones, flying cars, airplanes, sky and space, sea, under the sea), and 4) cyber-physical fusion.

### 2.3 Network equipment vendors’ perspectives

5G network equipment vendors (Ericsson, Nokia, Huawei) are actively contributing to discussions and research initiatives on beyond 5G/6G systems and technologies [21, 26, 27, 28, 29]. The focus in wireless systems research is increasingly shifting towards 6G as 5G network deployments are under way. However, the 5G evolution continues and enhancements to 5G are foreseen to be included in future 3GPP releases. 3GPP Rel’15 was finalized by the end of 2018, setting the framework for the 5G New Radio (NR) system. Rel’15 focused mainly on enhanced Mobile Broadband (eMBB) solutions. The support for vertical sectors is more addressed in subsequent 5G releases, including Rel’16 (completed in 2020) and Rel’17 (ongoing work). From Core Network (CN) perspective, Rel’16 and Rel’17 will provide enhanced support for Internet of Things (IoT), Time Sensitive Networks (TSNs) and non-public networks including industrial networks. Capabilities for wireline and wireless convergence, personal IoT, and AI/ML support will be further developed in Rel’18<sup>2</sup> [28]. Huawei and its subsidiary Futurewei propose the concept of New Internet Protocol (New IP), recently renamed “Future Vertical Communication Networks” (FVCN), which extends the principles of traditional IP to overcome the fixed structure of packets [30]. New IP enables new features and capabilities including flexible and semantic addressing, high-precision and deterministic service, and intrinsic security and privacy [31]. The promising features and capabilities of New IP promote it as a key enabling technology for supporting beyond 5G use cases, such as holographic type communications, haptic sensing, and high-precision communications [32, 33]. From the network equipment vendors’ perspectives, the evolved 5G network architecture forms an essential reference and baseline for the 6G network architecture design. 5G core network is cloud native and is based on micro- service architecture. It will allow flexible network slicing, service-based architecture by design and flow-based optimization. Also, RAN architecture will develop towards edge cloud-based architecture with a more flexible deployment of functions [28]. Backwards compatibility sets a kind of borderline between the 5G evolution and 6G. Introduction of any modifications that can be introduced in a backward-compatible fashion at a reasonable cost within the 5G framework to meet new performance requirements can be considered as part of the 5G evolution. On the other hand, modifications that are a fundamental shift and are incompatible with the existing 5G framework or can only be incorporated with a high cost to the network will be part of the next generation [27]. Examples of potential new use cases for the 6G system, as discussed by network vendors [26, 27, 29], include (but

<sup>2</sup><https://www.3gpp.org/release18>

not limited to) holographic communications and telepresence, “joint physical and digital worlds”, “inter-connection of physical, biological and digital worlds”, “cyber-physical service platforms”, “dynamic digital twins”, collaborative robotics, massive use of mobile robot swarms and drones, and tactile and precision healthcare.

As characteristics of the 6G system, network vendors [26, 28, 29] are discussing the following (but not limited to):

- Integrating computation, navigation and sensing with communications;
- Possibility to create a map of the environment (utilizing the very large signal bandwidth of 6G);
- Energy efficiency, with support for zero-energy devices and energy harvesting;
- Support for sustainable development, by enabling long-term viability, efficient use of resources, social inclusion for all;
- Built-in trustworthiness through availability, security and data privacy;
- Support of new air interfaces that are personalized on a device-specific basis [29];
- Significant performance improvements over 5G in KPIs (e.g., throughput, capacity, latency, and reliability) and introduction of new KPIs; e.g., precision and accuracy as measures for localization and sensing;
- Flexible network topology, 3D vertical networks, integrated access and backhaul, relay and mesh networking.

In relation to 6G network architecture and network functions, network vendors [21, 28, 29] are emphasizing the following features and/or development trends:

- Integration of computation and storage with the communication network, creating a network-compute fabric that can provide tools and services beyond connectivity, such as data services and accelerated services [26];
- Device and network programmability, allowing seamless and flexible application of new features, faster feature development, faster vulnerability fixing, and more DevOps operations;
- Fluid computing capability; providing a hybrid computing fabric that combines mist, fog, and cloud computing in a unified way [34]. As a result, applications can be deployed smoothly across this fabric, spanning the device-edge-cloud continuum;
- Enabling flexible application development through common and open APIs as well as common abstractions and simplified models;

- Massive use of AI for automated network control and management;
- Convergence of RAN and core networks; i.e., common platforms for RAN and core [26, 28];
- Heterogeneous cloud environment and dynamic relocation of service and network function execution [28];
- Emergence of subnetworks, which “consist of several devices connected to an access point and part of a 6G network” [35]. Examples could include in-body networks or swarm drones.

## 2.4 User device and measurement equipment vendors’ perspectives

5G UE vendor, Samsung, addresses in the 6G white paper [36] that connected machines will form the main user class in the 6G system. The 6G technologies have to be developed specifically to connect hundreds of billions of machines taking into account what is required for machines. Examples of connected machines include vehicles, robots, drones, home appliances, displays, smart sensors installed in various infrastructures, construction machineries, and factory equipment. As examples of new 6G services, Samsung lists 1) truly immersive extended Reality (XR), 2) high-fidelity mobile hologram, and 3) digital twins.

Samsung emphasizes the use of AI for the wireless communications, benefits of software-based implementation of network entities and openness in the network architecture. The 6G system needs to support UNSDGs as well. Moreover, 6G should provide significant performance improvements over 5G in KPIs (e.g., latency, energy efficiency, and peak data rate). In relation to 6G network architectural requirements, Samsung addresses the following:

- Offloading computation tasks from mobile devices to more powerful devices or servers in the system (“split computing”);
- Communications and computing convergence; and
- Embedding AI in multiple entities of the system, including wireless networks and services.

The use of open-source software and personal user information will increase the openness of communications systems and hence increase the attack surface. Therefore, trustworthiness will become an essential requirement in the 6G system architecture [36].

Rohde & Schwarz discusses the transition phases from 5G towards 6G in the white paper [37]. It focuses mainly on 5G evolution, explaining evolutionary steps and enhancements in various use cases and system capabilities the new 3GPP standard releases shall bring. Network architecture enhancements are briefly elaborated in the

paper. Examples of these are V2X, network automation, edge computing and RAN slicing. Service enabler architecture layer for verticals (SEAL), self-organizing network (SON) and security enhancements are also discussed as part of the 5G evolutionary steps. The paper anticipates that 6G could offer high-fidelity holograms, multisensory communications, terahertz communications and pervasive AI. It addresses privacy and security as potential technology drivers for 6G. Furthermore, sensing as a service is discussed as a possible new category for 6G applications.

## 2.5 Service providers' perspectives

Service providers such as Facebook, Google, Amazon, Microsoft, Apple, Alibaba, and alike have become important and influential players in modern society, forming complete ecosystems and network architectures around their versatile service platforms. Meta (Formerly Facebook) has its own Meta Connectivity program [38] that deals with the move to metaverse as well as rural and high-altitude connectivity. Evenstar and Magma are two notable Meta Connectivity's initiatives. Evenstar project aims at building adaptable, efficient, and metaverse-ready RAN reference designs for 4G and 5G networks in the Open RAN ecosystem. Meanwhile, Magma solution [39] is an open-source software platform providing an evolved packet core (EPC) to facilitate deployment of mobile networks in hard-to-reach areas. Another example of promoting rural internet access is Loon [40]. High-definition streaming video content providers and pay-TV companies, e.g., Netflix and HBO, are likely candidates to dedicated virtual network slices with quality-guarantees to keep their competitive edge and customers satisfied.

## 2.6 Unified European perspectives

The deliverable D1.2 of the European 6G Flagship project Hexa-X [41] summarizes the different 6G perspectives, discussing 6G vision, use cases and key societal values as a harmonized contribution of project partners ranging from vendors and operators to research institutes and universities. Hexa-X vision has three core values, setting the ambitions for the new interactions enabled by 6G. These are trustworthiness for 6G as a backbone of society, inclusiveness for 6G to be available for everyone and everywhere, and sustainability for 6G to play the largest role possible towards global development with regard to environmental, social and economic aspects. Hexa-X architecture design principles target a fully softwarized, programmable, and intelligent 6G network. Technological trends towards 2030s have been identified as: (i) convergence of communications, localization, imaging and sensing; (ii) network intelligence (AI/ML); (iii) network of computing; (iv) resilience and security; and (v) digital twin. Use cases have been defined as families under which the individual use cases have been placed. As summarized in Table 1, five families of 6G use cases have been identified: sustainable development, massive twinning, immersive telepresence for enhanced interactions, from robots

to collaborative robots (also known as cobots), and local trust zones for humans and machines. Many of these use cases are also found in the above-mentioned white papers of network vendors [26], [27] and [29].

Additionally, enabling services harnessing new capabilities include Compute-as-a-Service, AI-as-a-Service (AIaaS), flexible device type change service, energy-optimized services, Internet-of-Things, security as a service for other networks, and AI-assisted Vehicle-to-Everything (V2X).

## 3. TREND TOWARDS A SERVICE-BASED ARCHITECTURE

Tremendous efforts have been carried out towards the softwarization of mobile networks in 5G. Some level of success has been achieved in adopting IT and software engineering principles in the design of the 5G mobile system. The outcome is the 5G service-based architecture, consisting of network functions that are virtualized and instantiable on cloud platforms. Network function virtualization provides flexible, scalable, agile, and cost-effective provisioning and deployment of network services thanks to the decoupling of network function implementation from the underlying hardware [42].

Despite the achieved progress, the current design of the 5G network architecture is far from being truly cloud-native. The network slices considered in the context of 5G are still static, following three types of blueprints – each defined for a specific 5G service class (i.e., eMBB, Ultra-Reliable Low Latency Communications (URLLC), or massive IoT (mIoT)). They do not reflect, nor do they meet the frequently-changing requirements of the provisioned services and the dynamicity of the respective end users. Furthermore, network slices, in the context of 5G, are limited to the core network; the radio access network is simply shared among multiple network slices. The 5G network architecture is also designed in the operators-centric traditional fashion whereby the network is the focus and the different services are the consumers of the network. A true service consumer/service producer relationship is not reflected in the design of the 5G network architecture: the network is never a service consumer, but rather an always “connectivity” service provider. Furthermore, whilst some basic IT principles, such as micro-services, serverless, infrastructure as code, have been adopted, to some extent, in 5G architecture, the development and operations principles for Continuous Integration and Continuous Delivery (CI/CD) of network slices are entirely overlooked. To cope with the above-mentioned limitations of the 5G architecture, the 6G system architecture should, by design, address the following:

**Table 1** – Summary of Hexa-X’s 6G use case families.

Use case family	Use case
Sustainable development	E-health for all
	Institutional coverage
	Earth monitor
	Autonomous supply chains
Massive twinning	Digital Twins for manufacturing
	Immersive smart city
	Digital Twins for sustainable food production
Immersive telepresence for enhanced interactions	Fully merged cyber-physical worlds
	Mixed reality co-design
	Immersive sport event
	Merged reality game/work
From robots to cobots	Consumer robots
	AI partners
	Interacting and cooperative mobile robots
	Flexible manufacturing
Local trust zones for human & machine	Precision healthcare
	Sensor infrastructure web
	6G IoT micro-networks for smart cities
	Infrastructure-less network extensions and embedded networks
	Local coverage for temporary usage
	Small coverage, low power micro-network in networks for production & manufacturing
	Automatic public security

- **True cloud nativeness:** How shall network functions of both the control plane and user data plane be designed, not only to be able to run on any cloud platform, but also to be self-configurable according to the underlying circumstances and easily discoverable and reachable by other network functions.
- **Dynamic and fine-granular network slicing:** How can we attain true customization of the network slices with fine granularity, according to the dynamics of the underlying infrastructure, the dynamics of the provisioned services, and the spatio-temporal behavior of the end users?
- **End to end network slicing:** How can we efficiently extend the concept of network slicing, beyond the core network, towards the radio access network, and even extremely towards end-user devices?
- **Network, or rather service of inter-correlated services:** How can we truly adopt the service consumer/service producer concept in the design of the next generation network architecture whereby the network is not only a connectivity service provider, but also a consumer of other services?
- **DevOps-based networking:** What architectural changes to adopt in order to accommodate DevOps principles in extending the life-cycle management of end-to-end network slices, to ultimately attain the true zero-touch network and service management?

**4. 6G SYSTEM ARCHITECTURE: SERVICE-CENTRIC FUNCTIONAL MODEL**

In the design of our envisioned 6G System Architecture (SA), we adopt a service-centric functional model by defining the services that the 6G system shall offer to realize the envisioned new use cases, such as XR, holographic communications, digital twins, collaborative mo-

bile robots, and Beyond Visual Line of Sight (BVLoS) command and control of Unmanned Aerial Vehicles (UAVs). A combination of services is usually needed to fulfill the 6G user and application needs. This motivates our vision of seeing a 6G system as a collections of services that can be called upon on demand and communicate among themselves following the principles of SBA and cloud-native paradigms. As a result, 6G will support a fine-granular customization and exhibit a high grade of flexibility and scalability, making each network tailored and dynamically adapting to meet its intended deployment requirements.

The envisioned model provides a functional description of the services and their components, leaving more flexibility and freedom for logical network architecture design in a later phase.

**4.1 High-level concept**

The 6G system is expected to serve both human and machine type communication users. A user could also consist of a group of people or machines, or their combinations. Regardless of the user type, the user is linked with an application using 6G system services for its implementation in a potentially challenging (high speed, dynamic, etc.) operation environment. The 6G system domain model is shown in Fig. 1.

The uppermost layer of the proposed 6G system functional model is named as a *service layer*. It provides a set of key enabling services (see Fig. 1) to fulfill the versatile needs of the 6G system use cases. The 6G system service set consists of six key enabling services and one additional supporting service:

- **User context** service manages all relevant information that are needed to characterize the user situation, especially the user position and contextual data management.

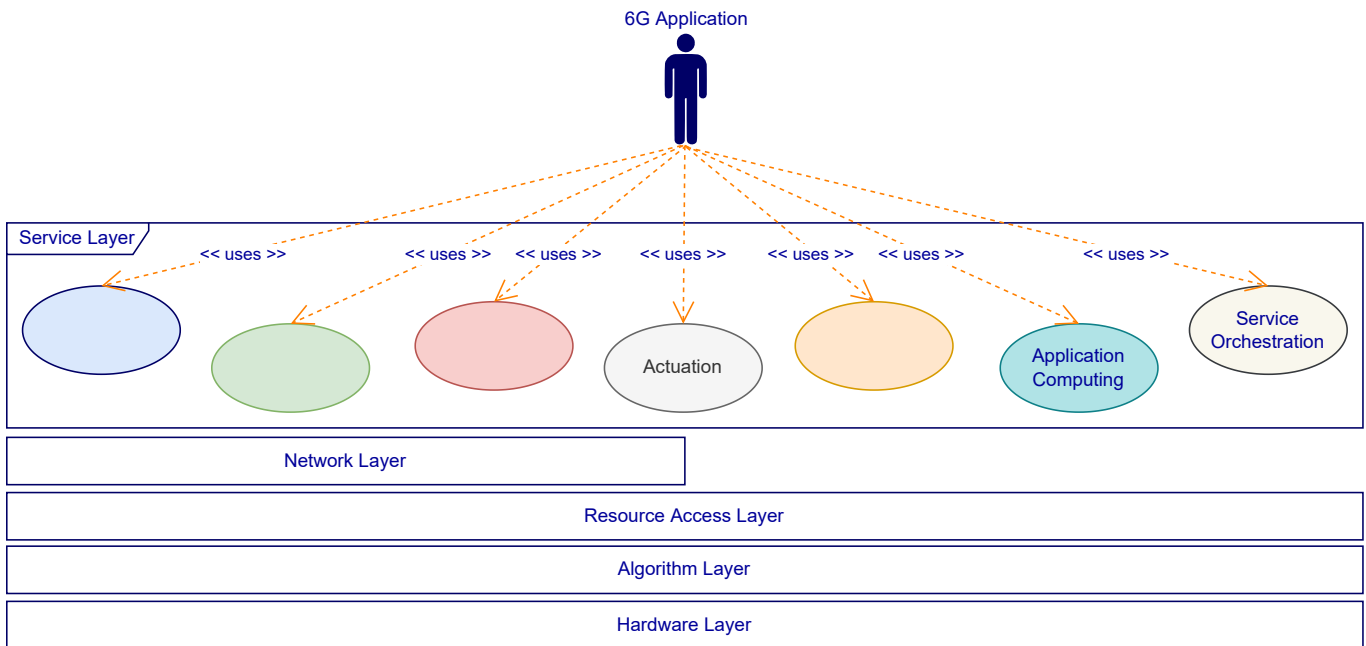

Fig. 1 – 6G system domain model.

- **Local information** service provides access to local information and means to utilize sensing and radar capabilities of the 6G wireless system to create 3D maps of the environment and characterize the environment conditions.
- **Networking** service provides basic connectivity functionality to the 6G system user and ensures service continuity during the session.
- **Actuation** service provides access to control actuators and initiate changes in the physical environment. This service can be used to change the internal states of the physical entities as well.
- **Ubiquitous intelligence** service facilitates information processing, analysis and decision-making for applications that operate in the ubiquitous environment.
- **Application computing** service provides support for application-related data processing and storage from the 6G system side, supporting also the application mobility across cloud nodes.
- **Service orchestration** service takes care of selection, use and information sharing between other 6G system services to provide a holistic service combination to satisfy the 6G user and application needs. It also includes common functionalities, such as authentication, authorization, and billing.

Each service in the service layer can be further divided into service components, i.e., functional components, to have a more detailed functional model of the 6G system services.

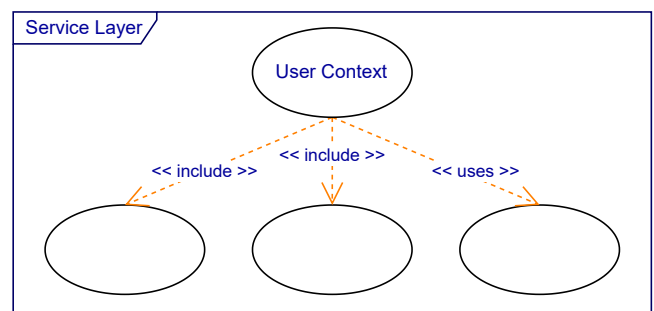

Fig. 2 – Service and service components (conceptual view).

Each service can utilize its own service components and service components owned by another service, as illustrated in Fig. 2 with marked relations `<<include>>` and `<<uses>>`, respectively. It is worth mentioning that this loose coupling between services facilitates service extensibility, allowing us to easily add new services and service capabilities. The service components are exposed and consumed, by authorized entities, through an integration fabric, following either the request-response or the publish-subscribe patterns. The integration fabric facilitates the registration and discovery of services as well as interoperation and communication between them. Further details on the capabilities of the integration fabric are provided in Section 12.

In addition to the service layer, the 6G service-centric functional model contains functions placed in four other layers to enable use of the same lower layer resources for multiple services, see Fig. 1; i.e.,

- *Network layer* provides the necessary functions to offer data transmission requested by the service layer. In some cases, network layer functionality can be by-passed.



- *Resource access layer* provides functions to select and manage resources for implementing the higher layer functionalities.
- *Algorithm layer* provides a wide range of algorithms for wireless communications, such as coding, modulation, waveform, and beamforming.
- *Hardware (HW) layer* provides the hardware (e.g., antennas) and therein related functions to physically enable transmission and reception.

## 4.2 Synergies between the services through concrete examples

A combination of services is generally needed to fulfill the 6G user and application needs. Fig. 3 shows a simplified example of how a 6G system could serve the user through provided services.

A more detailed example case is illustrated in Fig. 4. One category of potential 6G applications consists of different types of XR applications (e.g., tele-surgery or technician operating in the field). To alleviate computational requirements in the user device side, and heavy data transmission requirements in the wireless link, while still maintaining low latency from the computation engine in the network to the actual device (e.g., a Head Mounted Device (HMD)), it would be advantageous to carry out signal processing as much as possible at the edge of the network. Information from different types of sensors need to be collected e.g. to calculate user position and viewing angle, as well as to create a 3D map of the environment. Video, audio, and haptic information need to be rendered into a suitable form in real time to fulfill the user and application needs.

To provide a holistic service for the above described XR application, we would need to utilize the following basic 6G system services: networking service, local information, user context, and application computing. Additionally, service orchestration is needed for coordination and, e.g., to authenticate the user. Fig. 4 shows an example of the required information flow between the XR application and the different 6G system services.

## 5. NETWORKING SERVICE

### 5.1 General considerations and motivation

Till the 4<sup>th</sup> generation (to some extent the 5<sup>th</sup> generation), networks have always been designed in a way that they are only providers of the connectivity service. For example, Over The Top (OTT) service providers consume networks to deliver the packets of their service data. The interworking among different segments of the network has been always perceived as a “network of networks” to form a larger scale network. This traditional way of designing and perceiving networks has been the root cause

for the evolution path that the network generations took; there has been always an evolution, rather than a revolution. In the context of 6G, we hope that the perception would change towards having the network not only a connectivity service provider, but also a consumer of other services, from within the service layer as depicted in our 6G system architecture. This will certainly push for a true reflection of the service consumer/service producer concept in the entire design of the 6G system, paving the way towards the vision of 6G being a *Service of Services*, rather than the traditional and down-scoped vision of 6G being a “network of networks”. With such vision, a higher level of agile IT principles will be adopted (in addition to what has been already leveraged for network softwareization in the context of 5G), and that shall bring much further flexibility and agility in the rapid deployment and life-cycle management of 6G applications/services. The system shall be literally good for any 6G application, not only for current services, but shall also accommodate in a much flexible way, future services beyond what we are even foreseeing for 6G (as discussed in the state-of-the-art section). It shall be stressed that with this new vision of “service of services”, we do not intend excluding functionalities already developed in previous generations of the mobile communication system. We rather invite the relevant community to rethink the system architecture design in an unprecedented fashion, that would hopefully revolutionize the concept of networking.

Hereunder, we describe how the networking service functions within the envisioned 6G system architecture functional model, and highlights the potential synergies of the networking service with the other envisioned 6G SA services within the service layer.

### 5.2 Functions of the networking service

First of all, we list the different functions the networking service include. As stated earlier, the networking service provides basic connectivity functionality to the 6G system user and ensures service continuity during the session. For this purpose, and as depicted in Fig. 5, the networking service includes the following functionalities.

- **Operations, Administration and Maintenance (OAM):** This includes processes and tools to operate, administrate, manage, and maintain any of the other functionalities offered by the networking service.
- **Security & Trust (S&T):** This includes processes and tools to ensure that the connectivity service is accessed by an authorized 6G system user and an authorized 6G SA service, secure and trusty across the different segments of the underlying network infrastructure. This includes, but is not limited to, the transport network, the mobile core network, the satellite network, and the high-altitude platform network.
- **Control plane:** This includes all processes, tools, and hardware to set up and control the wired connectivity service provisioned to deliver the data of

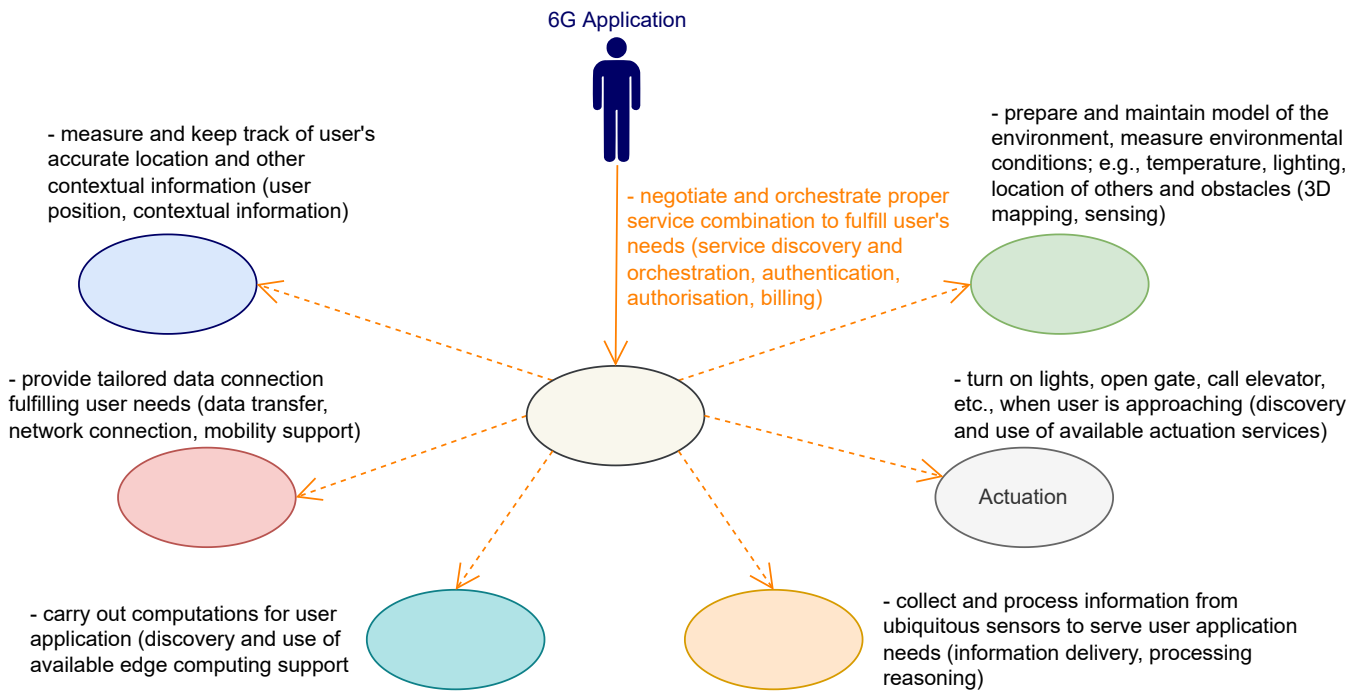

Fig. 3 – Use of 6G system services.

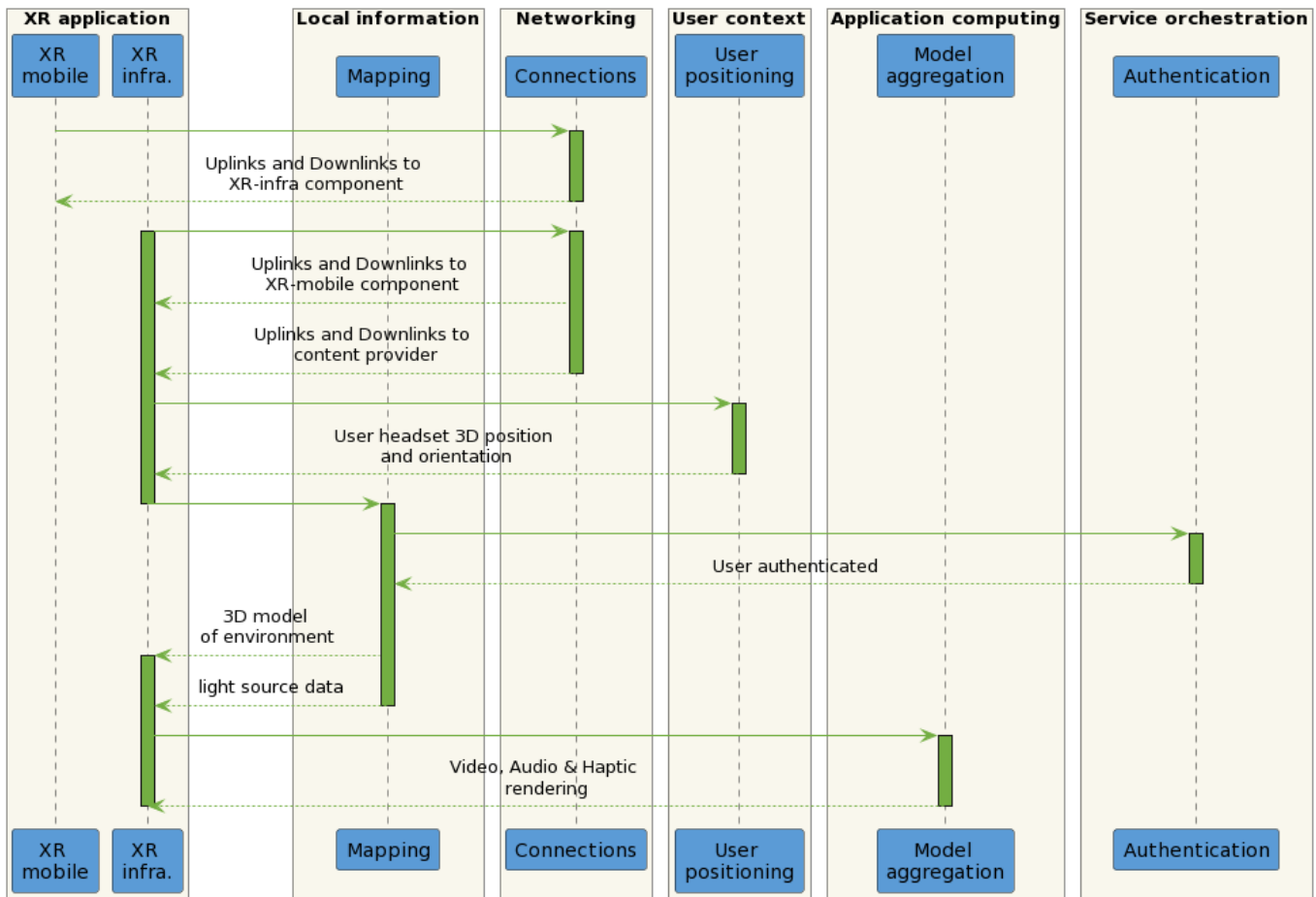

Fig. 4 – Example of possible service diagram with XR application.

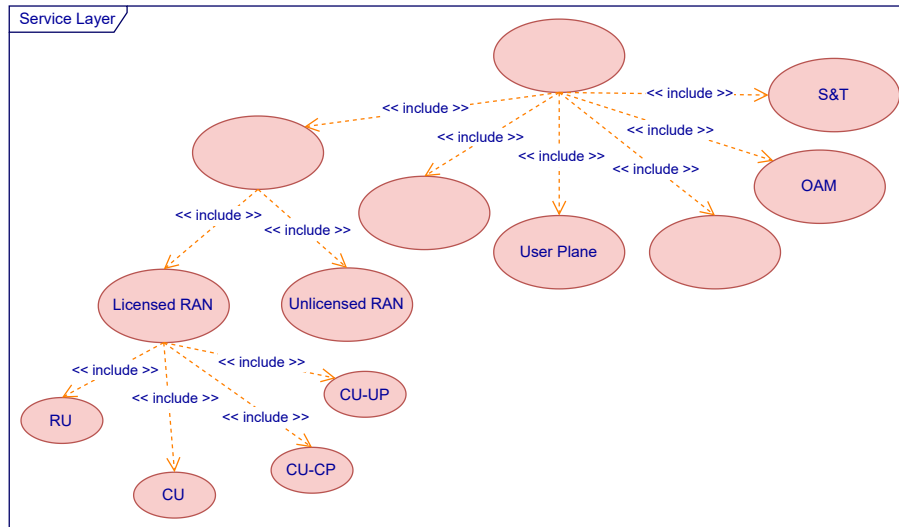

Fig. 5 – Main functionalities offered by the networking service.

the 6G system user or the data of the other 6G SA services (e.g., data of the local information service, data to the actuation service, etc.). The control plane could be of different segments of the underlying network infrastructure. This includes, but is not limited to, the transport network, the mobile core network, the satellite network, and the high-altitude platform network.

- **User data plane:** This includes all processes, tools, and hardware to enable the actual delivery of the data of the 6G system user or the data of the other 6G SA services. The user data plane could be of different segments of the underlying network infrastructure. This includes, but is not limited to, the transport network, the mobile core network, the satellite network, and the high-altitude platform network.
- **In-networking computing:** This includes all processes, tools, and hardware to enable the execution of programs, typically running on the hardware of end hosts, within hardware of the control and/or user data planes of the networking service.
- **Radio Access Networking (RAN):** This includes all processes, tools and hardware to set up and control the wireless connectivity service to wirelessly deliver the data of the 6G system user or the data of the other 6G SA services to control and user data planes of the networking service. The wireless connectivity service can be on a licensed or unlicensed radio access network. The former includes the following functionalities:
  - Remote Unit (RU)
  - Distributed Unit (DU)
  - Centralized Unit Control Plane (CU-CP)
  - Centralized Unit User Plane (CU-UP).

### 5.3 Synergies of the networking service with other 6G SA services

In the 6G Flagship project, the 6G system is perceived as a “Service of Services”, rather than the traditional way of “network of networks”. In Fig. 6, we demonstrate the possible synergies of the networking service with the other 6G SA service-layer services via an illustrative example of a 6G application. The 6G application needs a network (i.e., a network slice) for the exchange of its data between its end users and the servers hosting its logic. For the sake of simplicity, we assume the needed network shall consist of only the RAN, control plane, user plane and an OAM system to manage it.

As per the concept of network softwarization, some of the processes of the networking service’s functionalities (i.e., control plane, user plane, and OAM) may be running not on dedicated hardware, but as Virtualized Network Functions (VNFs). Depending on the virtualization technology, these VNFs are running on Virtual Machines (VMs) or within containers. These virtual resources are offered by the application computing service, putting the networking service in a “service consumer” role, consuming the “application computing” service. The virtual resources of the application computing service may be available at different physical locations. It becomes important to decide from which locations to consume these virtual resources. Such decisions can be made by the OAM sub-service of the networking service and that is for the initial deployment of the network and for its life-cycle management during the runtime. To make an accurate decision, OAM may need 1) contextual information about the end users of the target 6G application and 2) information about the environment where they currently reside. These two types of information will be provided by the user context service and the local information service, respectively.

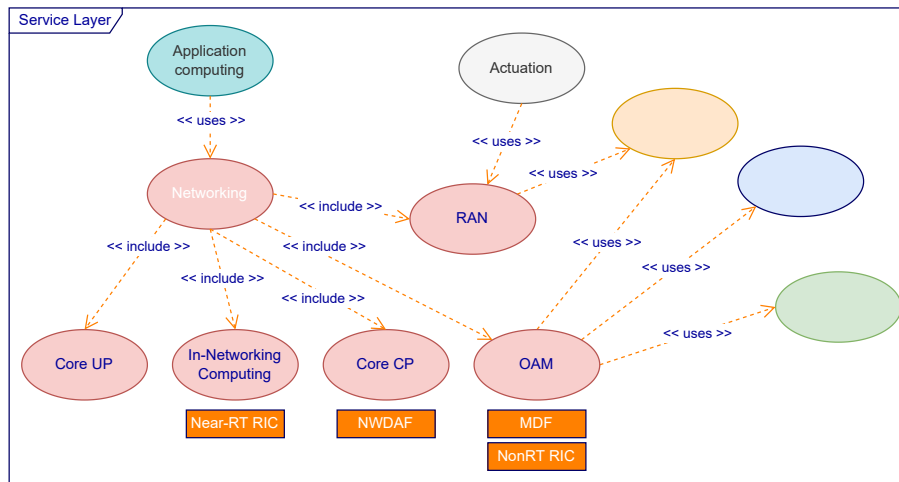

Fig. 6 – Possible synergies between the networking service and the other 6G SA service-layer services.

Leveraging AI/ML models from the ubiquitous intelligence service, OAM may be able to take optimal decisions automatically, above all during the runtime of the 6G application and its associated network.

Referring to some of the functionalities of the current 5G core network and OpenRAN, the information collected from the user context service and the local information service can be fed into the Management Data Analytics Functionality (MDAF), the Network Data Analytics Function (NWDAF) of the core control plane, and the Non/Near-Real Time RAN Intelligent Controller (Non-RT RIC/Near-RT RIC) of OPEN RAN. AI/ML models of the ubiquitous intelligence service could be carried out therein as well for the target optimization. In some scenarios, the local information received is not fine granular/up-to-date (i.e., being sensed every long period of time) or lacks important information (i.e., need for further sensed data or other type of data, to measure the size of a crowd in a location) needed for making intelligent decisions on the management of the network. In this case, OAM may call upon the actuation service to remotely actuate certain sensors or to remotely configure the periodicity at which they collect data. Some of these sensors could be embedded into the remote units (RUs) of the RAN and accordingly shall be actuated through the RAN.

## 6. APPLICATION COMPUTING SERVICE

### 6.1 General considerations and motivation

The challenge of the 6G application computing service is to enable development and deployment comparable to the flexibility of the distributed lateral web services architecture of the Internet, now with support for mobility. The density of connected devices in our environment, even on our bodies as wearables, is rapidly increasing, and clouds have become as indispensable computing service providers for all users and applications.

The flip side is that the gathering of “little data” and aggregating it into “big data” has exposed privacy risks that increase with the growing numbers of sensors in the environment. New Internet applications have frequently depended on schemes that combine the existing and future information infrastructures and human needs in new ways. In the past the connectivity provided by the Internet and cloud computing enabled the creation of search engines, video streaming services, and online stores.

We are heading towards an ultra-densely connected sensorized world with mostly practically unlimited bandwidth ubiquitous wireless communications that enables new local and user context-aware mobile applications. Together with edge computing and automated learning capabilities they may enable the adoption of novel solutions.

### 6.2 Functions of the application computing service

Fig. 7 shows the top-level organization of the **Application Computing Service**. In practice the service could be implemented as a software container in which the **Application** is executed. The application computing service offers the virtual resources for running the 6G application’s VNFs. The virtual resources may be available at different physical locations.

To fulfill the mobility and privacy needs, the application computing service needs to safely encapsulate the information the application receives from the *User* and *Local Contexts*, as well as the models it employs in each situation. In dynamic situations, **Application Caching** supports in quick access to data that would otherwise require using *Networking* to leverage a *Ubiquitous intelligence* service to upload an algorithm that again fits the context. **Application Mobility** implements the functionalities needed to migrate the container of an application to a new compute node, and could automatically learn to fit the available communications and computing resources.

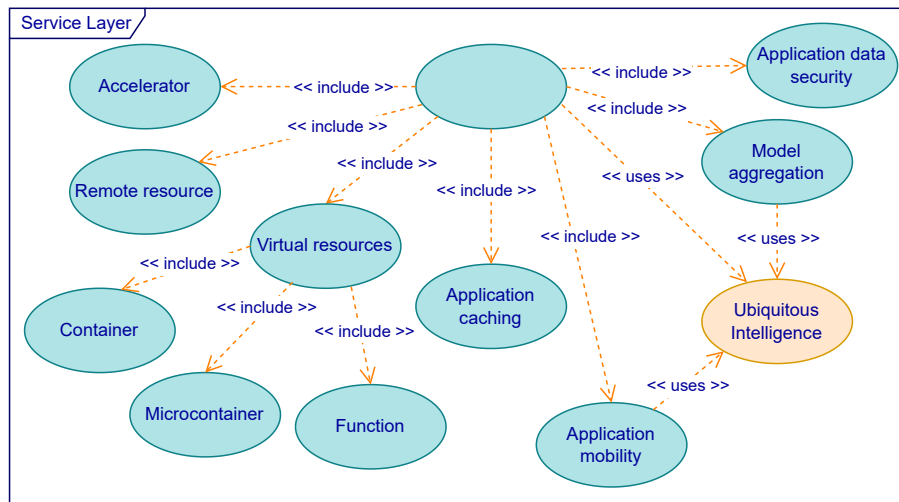

Fig. 7 – Application Computing Service.

ML models, and improves the robustness. Model aggregation could be also performed as an external AI service using the ubiquitous intelligence service, but the process might expose private data. **Application Data Security** provides authentication, integrity checking, and identity verification of both sensor data and for *Actuation*.

## 7. USER CONTEXT SERVICE

### 7.1 General considerations and motivation

Context awareness is increasingly important for the users of wireless systems. In 6G, this context awareness will be much more important. It enables the adaptation and optimization of the resources and applications to particular users and situations and constrains the relevance, availability and importance of data and information. The **User context** service’s main task is to manage all relevant information that are needed to characterize the users’ situation. This includes user positioning and localization, and also contextual data related to local information that are particularly relevant for the user, such as the environmental conditions of particular rooms, or the occupancy of different premises. User context information is collected by accessing and sharing the most current information provided by a set of sensors that are in the proximity of a user and can obtain information about them and their surroundings.

To achieve this, **User context service** should be able to leverage information of a number of sensors worn or located close to the user, and leverage their communication with other sensing system actors, but also to the personalization of the information provided by those sensors that are in the proximity of the user in a specific moment in time and that the user is subscriber to their data. These two types of sensors can then combine information in order to characterize the user and their state and conditions. The information collected is mainly referred to the utilization of sensor and communication of 6G

wireless systems to create a context, linking all local and environmental information to a particular user. The information includes contextual data related to the sensing of signals and attributes inherently related to the user, such as biosignals of motion parameters of persons or self-status and conditions in case of devices and machines, such as internal temperature battery levels. In addition, the contextual data include information about the environmental awareness of the user, such as, e.g., the personal CO2 level exposition, the time spent in locations, the level of activity that a user is experiencing, the number of people that a user has met and in some particular cases, images or video feeds obtained from fixed cameras where only the user is appearing.

Essentially, the user context service is tasked to collect all available information that is linked to a user. This specification or particularization to a particular physical place is the key driver for distinguishing the user context service as an independent one. The user context service is closely interrelated and goes often hand-in-hand with local information and 6G service design should take into account moving the relevant information from one to another using different aggregation and personalization or specification schemes. However, the user context services have some inherent particularities that affect the architecture of these services and procedures underlying them:

- **Dynamic nature of the user context:** Since user context is linked to a particular user, the data depends heavily on which sensing devices are able to obtain user data in a given time and the availability of this data depending on subscription and publication of the information. The personalization of the user information must account for adding or subtracting the information of particular sensors when the user becomes or ceases to be relevant, allowing for publication and subscription entities in a transparent manner that does not affect the service.

- **Temporal perspective and value of data:** User context has value in an instantaneous manner since it constrains and contributes to the rapid adaptation and personalization of the applications. However, the user context data is also important on a historical basis since multiple contextual conditions are only important as a temporal aggregation.
- **Heterogeneity of the sources:** The user context should be able to collect information to build user profiles by the personalization of data from multiple repositories such as local data lakes that can rapidly change as the user moves. In particular, the information could be included in a profile and become contextual when it is referring to a particular user, regardless of its real location or intended use.

## 7.2 Functions of user context service

The envisaged high-level architecture of the user context service is presented in Fig. 8. The service is composed of the following key elements:

- **Maintain user profiles** service is in charge of the storage of both the user context profiles and the data availability based on the agreements with data publishers and consumers.
- **Publish and subscribe local data** handles (i) addition, removal, or update of new data to a relevant local data lake through “Publication (Pub) and Subscription (Sub)” methods” based on a set of rules based on specific spatial patterns (e.g., the user is in the proximity of the relevant local information lake).
- **User positioning** implements the interface for accessing the user positioning and location from the fusion of multiple sources. The service is further detailed in Fig. 9.
- **Context estimation and prediction** represents the interface for estimating the user context based on current information and the prediction of the needs in the near future. Its operation is based on the collection of context data.
- **Context data collection** implements the collection of data that is specific and local to a particular user at a given time, by discovering and leveraging heterogeneous sources both public and private to the user. The service is further detailed in Fig. 10.

The role of the key elements of the **User Positioning** service is detailed below. The high-level architecture of the user positioning service is depicted in Fig. 9.

- **Positioning from different sensors** is a set of services that implement the interface to access diverse positioning options based on different sensor and system types. They include heterogeneous signals such as radars and radios and different imaging technologies such as cameras and lidars.

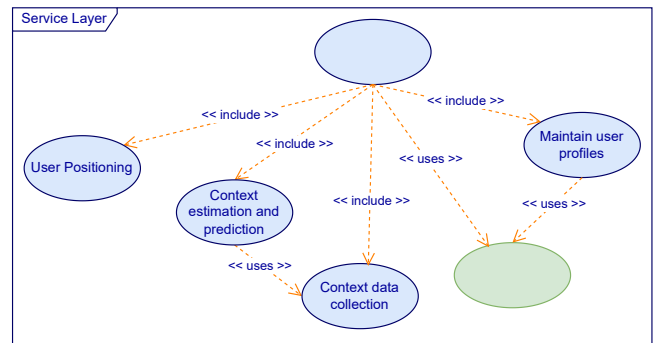

Fig. 8 – High-level architecture of the user context service.

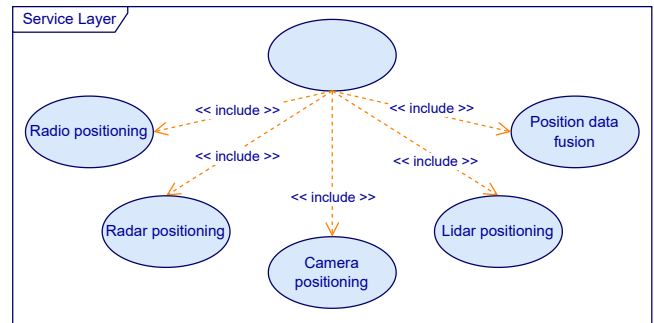

Fig. 9 – Components of the user positioning service.

- **Position data fusion** is used to aggregate and fuse positioning information provided by different available sensors.

Similarly, the role of the key elements of the **Context data collection** service is detailed below. The high-level architecture of the context data collection service is depicted in Fig. 10.

- **Identify context data sources** implement the interface to enumerate the possible sources of data that can be used to build a user context. They can include both local and private sensors.
- **Read private sensors and subscribe to local data** are used to collect the user contextual data from either private sources, or local sources in the proximity of the user.
- **User positioning**, as described before, acts a complementary service of context data collection providing for the accurate location to the user that determines the availability of the data sources.
- **Context data storage** saves the relevant contextual information for its further use.

## 7.3 Recursive definition of the service layer

In what follows, we show how the user context service can be defined and refined recursively by the definition of new sub-services and components of higher-level ones. Fig. 11 shows the example of recursive definition of user positioning by depicting more detailed components of

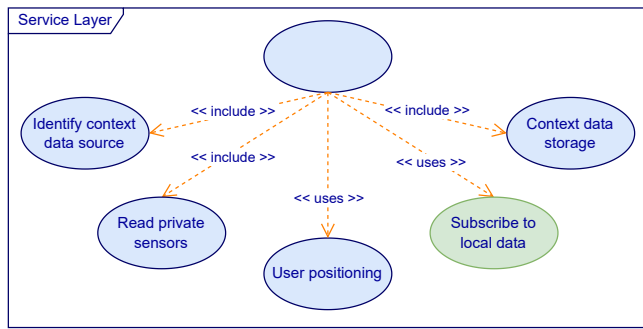

Fig. 10 – Components of the user data collection service.

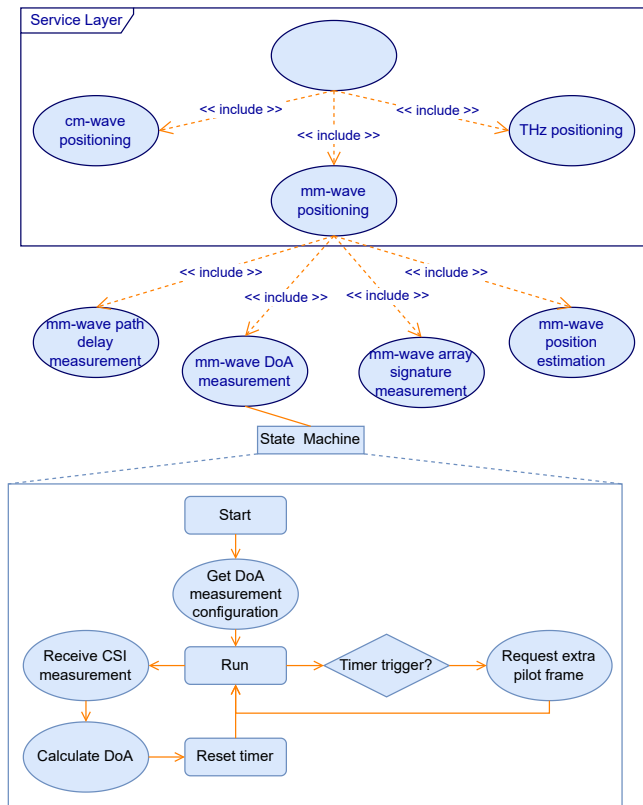

Fig. 11 – Recursive definition of radio positioning into mm-wave positioning and DoA measurement state machine.

radio-based positioning into three sub-services related to different technologies, in this case THz positioning, cm-wave positioning, and mm-wave positioning. The last one is then decomposed into other sub-services such as the estimation of the position based on mm-wave signals through the measurement of path delays, array signatures and Directions of Arrival (DoA). As a final example of the definition of the services, DoA measurement can be defined as a service based on the definition of a state machine.

## 8. LOCAL INFORMATION SERVICE

### 8.1 General considerations and motivation

Wireless information systems are increasingly being used not only to transmit data, but also as a means for dynamically sensing and mapping the environment in real time, providing timely information of the particular conditions present in a particular place.

The applications that need access to this timely information are only expected to increase with the creation of a 6G application ecosystem. **Local Information** service takes care of selecting, collecting, aggregating and sharing all the information that belongs to a certain location. The local data is collected by accessing the most current information provided by a set of sensors that are located in a certain physical place at the same moment in time.

To achieve this, **Local Information** service should be able to leverage information of a number of sensors fixed in the environment, but also the aggregation of those sensors that enter in the local range and that accept to publish their data. These two types of sensors can then combine information in order to characterize the environmental conditions. The information collected is mainly referred to the utilization of sensing and radar capabilities of 6G wireless systems to create 3D maps of the environment, linking all other contextual and environmental conditions to particular locations in these maps. The information includes the creation of fixed 2D and 3D maps, but also to the sensing of objects, persons, devices, machines or environmental conditions such as air quality or temperature. Essentially, the local information service is tasked to collect a context that is linked to a physical place. This attachment to a particular physical place is the key driver for distinguishing the local information service as an independent one. This service is closely interrelated and goes often hand-in-hand with both user context services and actuation services and 6G service design should take into account moving the relevant information from one to another. However, the local information service has some inherent particularities that affect the architecture of these services and procedures underlying them:

- **Dynamic nature of local data.** Since local information is linked to a particular place, the sensing devices and the subscribed and publishing users form a dynamic set that depends on their location. The aggregation and summarization of the local user contexts and sensors must account for simple ways of adding or subtracting particular data publishing entities in a transparent manner that does not affect the service.
- **Temporal perspective and value of data.** Local information contains fixed information such as maps that are not bound to change rapidly, but also dynamically changing elements of the environment that need the information to be timely (e.g., the position of heavy machinery). Sensors and contexts have different sensing update rates, sampling frequencies and latencies that need to be accounted for when constructing instantaneous snapshots of the information. The information has instantaneous value (situational), but also when reviewed on a historical basis it is able to compute and predict trends (e.g., rising values of CO2 or trajectories of users to anticipate their intended destinations).

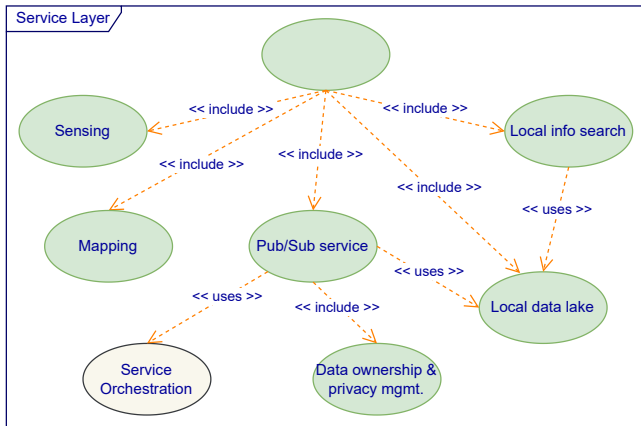

Fig. 12 – High-level architecture of the local information service.

- **Heterogeneity of the sources.** Local information should be able to collect information from multiple repositories such as local data lakes that come in very diverse formats, which come from different data modalities and that are physically stored in multiple (and possibly distant) places. In particular, the information should become local when it is referring to a particular physical place, regardless of its real location.
- **Interrelations between sensing and communication devices.** 6G devices are expected to be used for sensing, processing and communicating at the same time. The instantaneous local aggregation of new devices increases both the sensing and communication capabilities of the local information service and allows for the preprocessing of data, but schemes accounting for the function sharing and diverse learning models need to be accounted for.

## 8.2 Functions of the local information service

The envisaged high-level architecture of the local information service is presented in Fig. 12. The service is composed of the following key elements:

- **Local data lake** represents an entity that contains all the information about available information linked to a physical place (e.g., maps, environmental conditions, aggregation of user contexts, dynamically changing actors in the environment, sensor and mapping availability). Optionally, the lake can include a marketplace allowing publishers, subscribers and consumers to list their offers for the exchange of local data obtained with particular sensors owned by the entity. The standardization of the data formats, including descriptions of timeliness and accuracy, as well as the avoidance of redundant data is an important factor to allow for efficient access and transaction of local information. To access the lake, the two following key mechanisms are used.

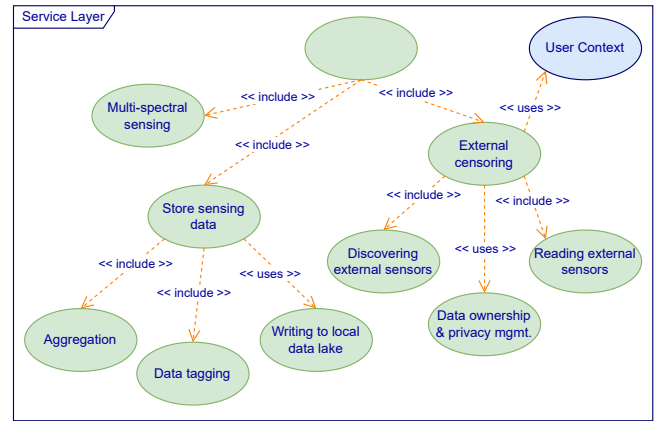

Fig. 13 – High-level architecture of the sensing service.

- **Local info search** provides a mechanism for filtering the local data available from the lake on a specific set of conditions.
  - **Pub/sub service** handles (i) addition, removal, or update of new data to the lake through “Publication (Pub)” methods, (ii) allows an interested service consumer/provider to “Subscribe (Sub)” to the information from the lake based on a set of rules based on specific temporal patterns (e.g., updates available in the local information, new information types of services added).
  - **Data ownership and privacy management’s** role is to ensure the ownership of the data accessed by imposing privacy-based restrictions on the subscribed and published data that avoid the access to unaggregated particular user contexts.
  - **Service orchestration’s** role is to enable publisher/subscriber authorization, and, optionally, provision of additional services such as interpretation of the data formats or billing for the transaction of local data.
  - **Sensing and mapping** represent interfaces for collecting the information to be contained in the **local data lakes**, allowing the service consumer to establish a connection to the sensing or mapping providers. The architecture and the key elements of both sensing and mapping services of a local information service provider are further detailed in Fig. 13 and Fig. 14, respectively.
- The role of the key elements of the **sensing** service is detailed below:
- **Multi-spectral sensing** implements the interface to collect all kinds of heterogeneous sensor data from fixed sensors located in a physical place. Once receiving a command, the sensing service might invoke periodic sensor reading from this set.



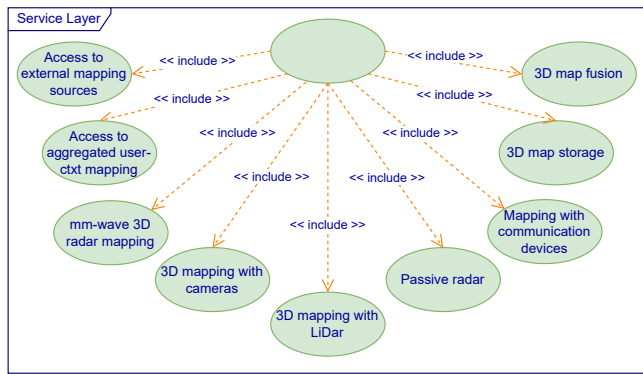

Fig. 14 – High-level architecture of the mapping service.

- **External sensing** implements an interface to access data that is not inherently attached to a physical location but that enters and leaves the local information service based on location and pub/sub availability. The interface is subdivided into two functions; (i) **discovering external sensors** is in charge of finding which sensor data is available and relevant for the local information while (ii) **reading external sensors** collect the appropriate data as published by the sensors. **Data ownership & privacy management** is used to identify the sensor, ensure its authenticity and the right for collecting the data. The external sensing functions might need to access also the **user context** service.
- **Sensing data storage** service is one of the main elements of the sensing service, which stores both instantaneous and historical series of the sensors in a systematic manner. Relevant individual sensor data is combined by invoking an **aggregation** function. The data is annotated to ensure its validity and time-liness range by performing **data tagging**. In addition, aggregated and annotated sensor data is written in its appropriate formats into the local data lake, for further access.

The **mapping** service is organized in a simpler manner. In practice this service collects and aggregates maps from different sources.

- **Sensor-based map collection functions** include the interface to collect data from multiple sources. These sources include communication devices, passive radars, lidars, cameras, mm-wave radars.
- **External map collection** functions include the access to external mapping sources stored in non-local storage or the collection of maps from the aggregation of user contexts.
- **3D map-fusion** and **storage** combine and fuse multiple maps from different sources and store them in the local data lake for further use.

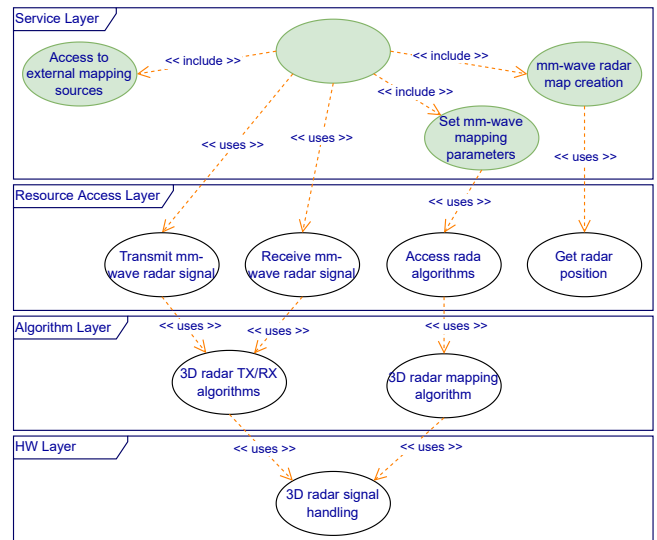

Fig. 15 – High-level architecture of the mm-wave mapping service.

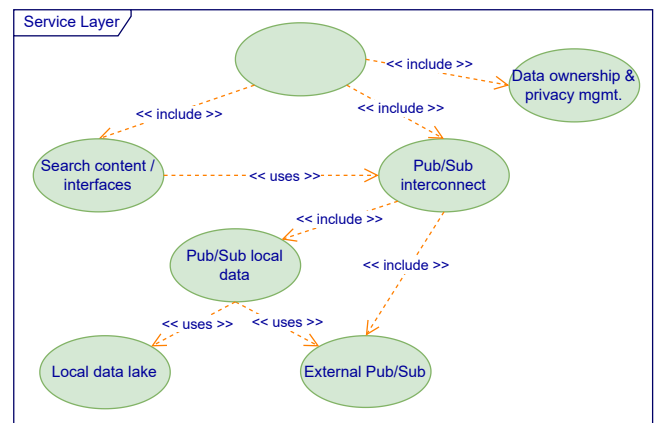

Fig. 16 – Overview of the Pub/Sub service.

### 8.3 Cross-layer resource access

We show how an element in the **local information** service (e.g., **mm-wave 3D radar mapping**) can access and use different layers of the 6G architecture. Fig. 15 illustrates how the mm-wave radar mapping services creates a new map for a specific radar by using a **get radar position** function from the resource access layer. Setting the mapping parameters for the radar is done by accessing **specific radar algorithms** that have the role of **handling the radar signals** at the HW layer. Transmission and reception of the radar signals are done in a similar manner.

### 8.4 Pub/Sub service

In our design, we advocate the loose-coupling and late binding of resources and components. This is achieved through the pub/sub service (see Fig. 16) that provides an asynchronous, many-to-many communication primitive that provides decoupling across space, time and synchronization. The pub/sub service is used by user context, actuation, service orchestration, and ubiquitous intelligence. The pub/sub service enables resource discovery and publication and subscription of data within different scopes. The service provides the glue that connects local and distributed components together at runtime.

**Table 2** – Examples of actuation contracts.

		Starting time	
Time-span	momentary	nom/ASAP	a moment/event if future
		- switch lights on now - open the door now - stop the car immediately	- switch lights on at 10 p.m. tomorrow - launch a firework at 11.59 p.m. on 31 December next year - send a taxi to pick me up once I leave the security zone of the airport
	time period/pattern	- keep lights on for the next 10 minutes - show me the news on the screen nearest to me until the program ends	- keep lights on from 10 p.m. to 11 p.m. every weekday until further notice - do not start my car if I am not near - start the cleaning robot every time I leave my house if no one is at home

## 9. ACTUATION SERVICE

### 9.1 General considerations and motivation

Already today the wireless systems are being extensively used not just to collect and convey collected data, but also to implement control over versatile modalities of a physical nature. With the promise to deliver more robust, reliable, and ubiquitous connectivity, this trend and such applications (ranging, e.g., from the prosaic control of a street lamp up to cross-ocean tactile robotic surgery control) are expected to become much more common and numerous in the 6G ecosystem. This is the key driver for distinguishing and treating the class of actuation services independently. Notably, the actuation services are closely interrelated with and often go hand-in-hand with the local information service. However, there are several principal differences, which affect the architecture of actuation services and procedures underlying them:

- **The amount of data and the direction of data flows.** The local information is first collected by the respective service (or underlying services) and then distributed to the interested clients. Often, the amount of data is thus huge capturing the change of the parameter over a long period of time. In the case of actuation, the control commands are typically issued by the interested clients.
- **Temporal perspective and value of data.** The local information would primarily contain the measurement data and other relevant information about the events and physical phenomena, which have already happened in the past. On the contrary, the actuation would always deal with the instances of time either now or in the future. The history of actuating commands thus will likely have value only for billing and legal purposes, or for system developers.
- **Scalability and availability.** The same piece of local information data can, typically, be cloned and delivered to a limitless number of interested clients. In contrast to this, a single actuator would not be able to execute two contradictory commands at the same time instance.
- **Interrelations and safety considerations.** The data falling in the wrong hands might do a lot of harm. However, the possibility of physically impacting the environment might create even more danger.

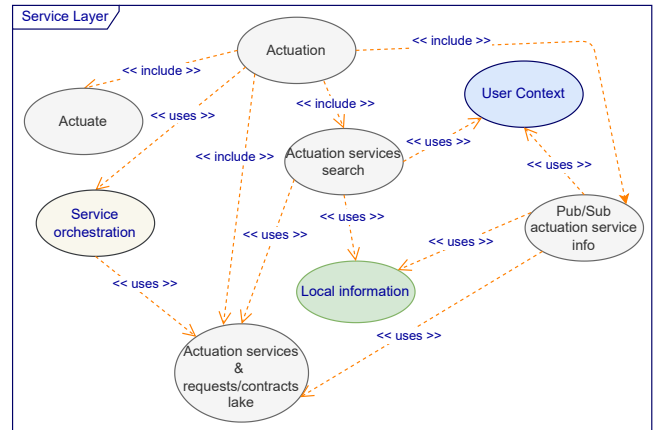

**Fig. 17** – High-level architecture of actuation service.

More than this, the safety of actuation is often context-dependent; switching off a street light on an empty street and above a person walking stairs are two different things.

Note, that in what follows **we use the term “contract” or “actuation contract” to denote a single procedure of actuation agreed by an actuation service provider and actuation service consumer.** Depending on the nature of the actuation procedure, we imply that (i) the starting time of an actuation might be either now/ASAP or some moment/event in the future, and (ii) the duration of the action might be either momentary (e.g., a one-time switch) or prolonged/periodic. Some illustrative examples of a possible contract are listed in Table 2. We also imply that in some cases the service prosumer and the service consumer might be the same entity and that a particular service might be made available by a prosumer only to a single consumer (e.g., the device owner).

### 9.2 Functions of the actuation service

The envisaged high-level architecture of the actuation service is presented in Fig. 17. The service is composed of the following key elements:

- **Actuation services & request/contracts lake** represent an entity that contains (i) all the information about available/desired actuation services (e.g., functionality, availability, costs, application programming interfaces), and (ii) information about the (“Actuate”) interface to be used to access the service provider by an interested consumer or vice versa.

Optionally, the lake can include a marketplace allowing providers to list their offers, and/or otherwise around, service consumers define the contents of the desired service while providers bid their offers. The standardization of the description language, data formats and the minimum amount of data to be utilized in the lake is of extreme importance to facilitate easy and efficient matching and decision-making by both human and machine actuation services consumers. To access the lake, the following two key mechanisms are used.

- **Actuation service search** provides a mechanism for filtering the services/service requests from the lake based on a specific set of conditions.
- **Pub/sub actuation service info** handles (i) addition, removal, or update of the new services/service requests to the lake through "Publication (Pub)" methods, (ii) allows an interested service consumer/provider to obtain information from the lake based on a set of rules (e.g., specific temporal pattern or event-based: change-of-location, change-of-price, new services added, etc.).

- **Local information** and **user context** services are used by both mechanisms discussed above to allow handling more sophisticated requests (e.g., location-based) and provide the information to service consumers/providers more efficiently.
- **Service orchestration's** role is to enable consumer/prosumer authorization and, optionally, provision of additional services such as interpretation of the data formats or billing.
- **Actuate** represents an interface, information about which is contained in the **actuation services & request/contracts lake** and allowing the service consumer to establish a connection to the actuation service provider. The architecture and the key elements of **actuate** service of an actuation service provider are further detailed in Fig. 18. Note that we imply that most often this would be the service consumer to initiate the connection.

The roles of the key elements of the actuate service are detailed below.

- **Send/schedule actuation command** implements the interface to execute the actuation or schedule its execution at some moment/period of time in the future. Once receiving a service command, the **actuate** service may invoke **service orchestration** and **validation** service to check if the command can be accepted.
- **Service orchestration** is used to identify the connected users and ensure their authenticity. Note,

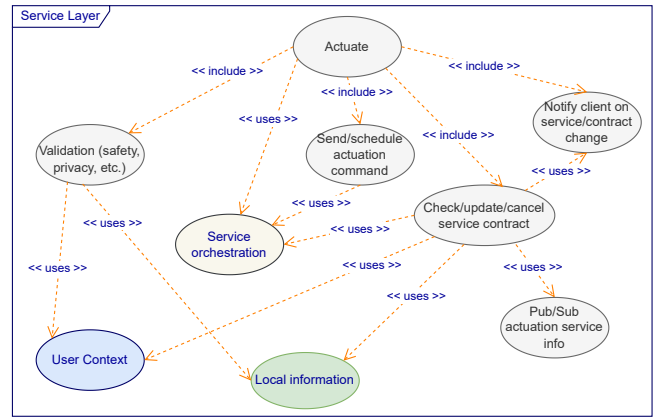

Fig. 18 – High-level architecture of the actuate service.

that the required authentication strength within **actuate** and **actuation** would likely be different: the access to the data about available services would usually require weaker authentication than the actual scheduling of an action. Optionally, **service orchestration** might also be employed for implementing billing and translation of the data formats.

- **Validation** service is the critical element of the **actuate** service, which checks the safety and appropriateness of executing the requested by the client action. Notably, to account for the possible changes in the environment, the check should be carried at least when accepting/scheduling the service, before its execution, and continuously during service execution. For implementing such checks, the **validation** service features access to the **local information** and **user context**.
- **Check/update/cancel service contract** implements a mechanism for both the service consumer and the provider to (i) obtain the information about the established contracts, and (ii) update or cancel their conditions. After modifying the contract, if the need arises, the information in the **actuation services & request/contracts lake** might be changed by the service provider accordingly through **pub/sub actuation service info** interface.
- **Notify the consumer on service/contract change** implements a mechanism to inform the client in case the actuation service contract is changed or canceled by a service provider (e.g., due to technical or safety reasons).

## 10. UBIQUITOUS INTELLIGENCE

### 10.1 General considerations and motivation

Ubiquitous intelligence pertains to the convergence of communications, sensing and localization [43] combined with decentralized learning and inference over the end-to-end environment [44] and [45]. The goals of

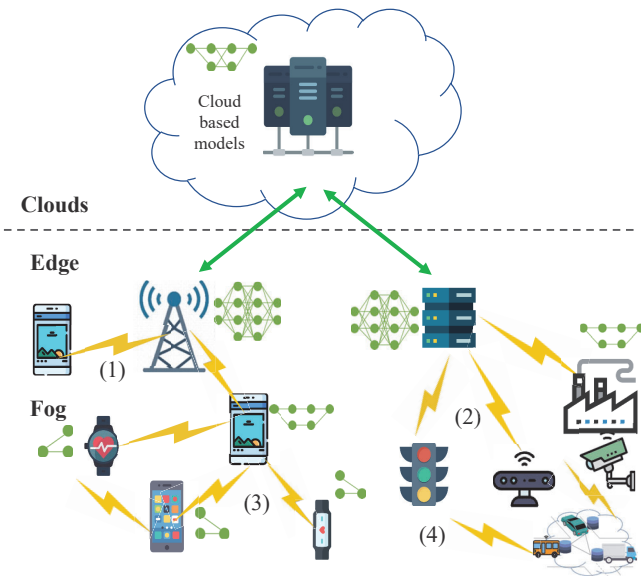

Fig. 19 – Overview of the end-to-end sensing and learning environment.

ubiquitous intelligence **are to facilitate information delivery, processing, and reasoning (learning and inference) for applications that operate in the ubiquitous environment.** The ubiquitous intelligence in 6G will serve two key purposes: a) it will support the cognitive **network** architecture capable of accommodating the requirements of the verticals, and b) it will facilitate the design and deployment of the verticals capable of **utilizing resources for learning and inference in the programmable world in real time.**

Fig. 19 presents an overview of the ubiquitous intelligence environment that is hierarchical in terms of geography and capabilities. The end-to-end environment consists of the endpoints with opportunistic interactions through fog computing and various tiers of edge and core cloud processing. In typical interactions, mobile devices (1) and industrial devices (2) send content that is processed first at the edge and then in the higher cloud levels. Learning and inference are distributed with partial models being generated and aggregated in the end-to-end environment. Consumer devices (3) and industrial devices (4) can share data and models in an opportunistic manner. The connectivity and computing infrastructure is coordinated by a set of controller components that generate and instrument the network slices, from micro-slices to end-to-end slices, and the sensing and learning pipelines over the infrastructure.

*Ubiquitous intelligence* presents a unique view in 6G, in which the network facilitates **unified virtual cognitive sensors and actuators** configured and deployed to address the specific needs of the network and applications. The 6G architecture is expected to provide native support for radio-based sensing and through versatile connectivity and computing capabilities accommodate ultra-dense sensor and actuator networks enabling hyper-local and real-time sensing, communication, machine learning and interaction.

## 10.2 Functions of the ubiquitous intelligence service

The ubiquitous intelligence service provides a unified API for the real-time discovery, interconnection, and configuration of sensor data gathering, storage, processing (learning and inference) and sharing components. The design of the service is based on decoupled asynchronous data-driven communications (pub/sub), serverless and function-based operations, and separation of concerns between the service types, such as communications, sensing, and AI.

The ubiquitous intelligence service supports the development of autonomic computing features for applications and for the network. The key autonomic properties include self-configuration, self-healing, self-protection and self-optimization. The MAPE-K (Monitor, Analyse, Plan, Execute, and Knowledge) serves as an important reference model for supporting applications and network services that have autonomic features [46].

Fig. 20 presents an overview of the ubiquitous intelligence service. The service relies on the following service elements:

- Local information for resource discovery and event delivery and processing.
- The sensing framework provides access to sensor abstractions and sensor data.
- Actuation for controlling sensors and actuators.
- User context provides access to context related information.
- The ubiquitous task controller is responsible for orchestrating sensing, inference and learning tasks for the application.
- The AI framework provides libraries and templates for machine learning including decentralized learning and inference. This framework provides support in the runtime configuration of the data processing and learning components.
- The service orchestration is responsible for resource management and coordination across the environment.

The context-awareness provided through the user context service enables adapting and optimizing the network and the network applications at runtime to better take the characteristics of the current and predictive operating environment into account. Context-awareness requires advanced sensing tasks including positioning, localization, environment mapping, location and object tracking and it enables new services including intelligent sensor data processing and hyper-personalization of services. Context-awareness will also enable the network to take

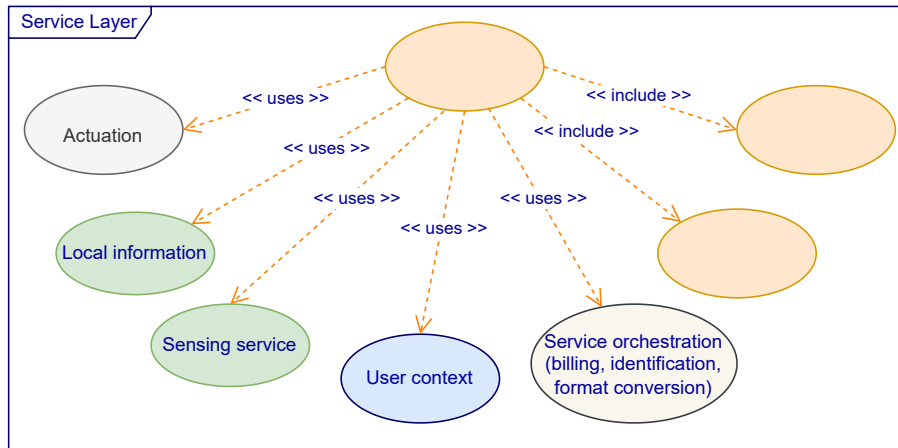

Fig. 20 – High-level architecture of the ubiquitous intelligence service.

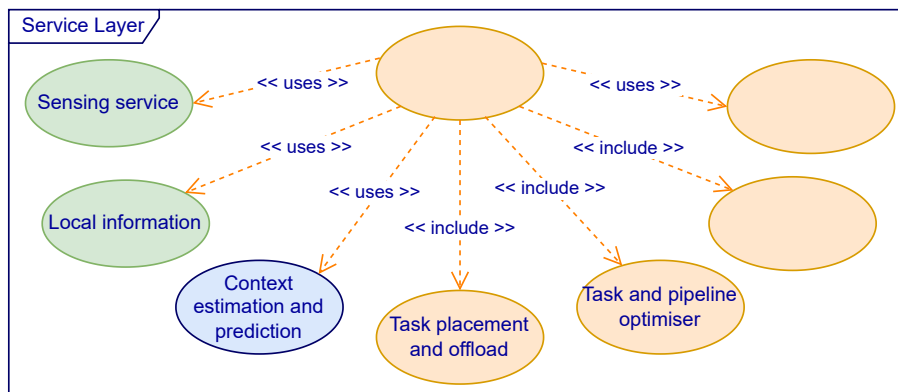

Fig. 21 – Ubiquitous task controller.

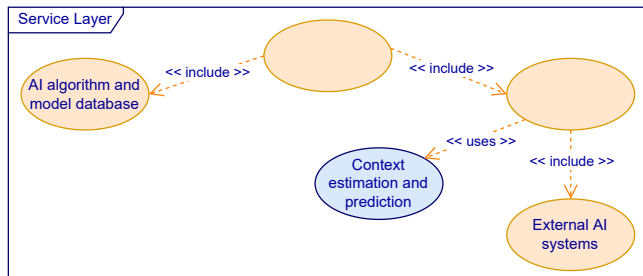

Fig. 22 – AI Framework in Ubiquitous Intelligence service.

actions and control the network and application instrumentation to optimize the network and service experience.

The following subsections elaborate further the roles of the key elements of the ubiquitous intelligence service, namely ubiquitous task controller and AI framework.

### 10.3 Orchestration and ubiquitous task controller

The 6G architecture is expected to provide native support for radio-based sensing and through versatile connectivity accommodate ultra-dense sensor and actuator networks enabling hyper-local and real-time sensing,

communication, and interaction. This orchestration needs to take place in a multidimensional structure in which we have the physical world (electromagnetic and spatial properties, sensors and actuators, meta-surfaces, etc) and the programmable world (computing and communications, interfaces to the physical world). The joint and continuous configuration of the two worlds is an important requirement for the architecture that must accommodate a high number of mobile devices that can move very fast. Thus, the **orchestration** of the sensing and AI tasks in a dynamic environment and across the traditional layers is a crucial network functionality.

The ubiquitous task controller presented in Fig. 21 is responsible for orchestrating sensing and learning tasks in the application scope in the distributed environment. The controller leverages the service orchestration API for resource management, placement and configuration. The controller uses the sensing service for managing sensor systems and the AI framework for facilitating AI algorithms. The context estimation and prediction service is used to instrument the placement of tasks and proactively react to anticipated changes in the operating environment. The controller has task placement and offloading, pipeline optimization, and handover management as sub-modules.

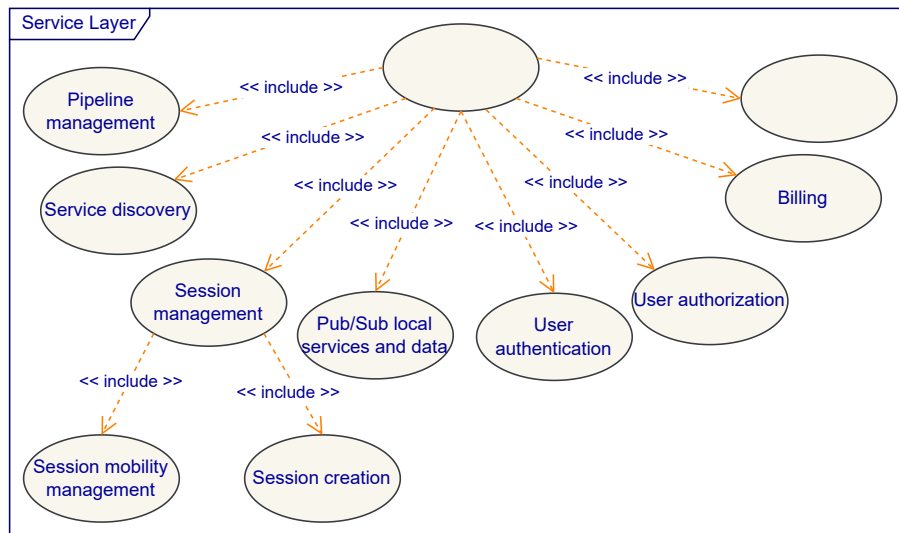

Fig. 23 – Supporting functions within the service orchestration service.

## 10.4 AI framework: Libraries and runtime support for learning and inference

Fig. 22 presents an overview of the AI framework that provides an algorithm and model database as well as a runtime AI algorithm configuration service. The AI framework will support the configuration and deployment of various ML methods, for example federated learning-based methods. The framework maintains a library of AI algorithms that can be configured and deployed. The framework provides the basic model storage and sharing mechanisms. The model storage is connected with the overall data lake solution and leverages the security and privacy features of the data lake service. Expected features include:

- Selecting an AI algorithm from the library. This includes support in the selection of privacy parameters, for example when differential privacy is utilized;
- Configuring the AI algorithm for the application given task (offline or runtime);
- Connecting the AI algorithm with the application and sensor data to build a model (offline or iterative). The sensor data processing may involve various data processing components (pipeline facilitated by service orchestration and the ubiquitous task controller);
- Sharing of model / model update with various techniques, such as federated learning.

## 11. SERVICE ORCHESTRATION

### 11.1 General considerations and motivation

The Service Orchestration (SO) service takes care of selection, use and information sharing between other 6G sys-

tem services to provide a holistic service combination to satisfy the 6G user and application needs. It also includes, or provides access to common functionalities, such as authentication, authorization, and billing. Essentially, SO can be considered a “broker” between 6G applications and a complicated set of services provided by the 6G infrastructure. The broker service may be required due to several reasons. All the services may not be available from the same service provider and therefore several contracts may need to be managed to operate/realize a single 6G application. Services or service providers may be subject to changes during the lifetime of the application, due to, e.g., mobility of the end user device. Also, some services or their components may be available through various legacy interfaces that need to be specifically selected and managed by an SO service.

Service orchestration is included as a separate service at the service layer in the architecture. In our vision, this makes it possible for this service to operate as an orchestrator or broker providing a flexible operator between 6G applications and separate services. The service elements provided through the SO service include *service discovery*, *pipeline management*, *session management* and an *access to pub/sub local data*. In addition, commonly required *billing*, *user authentication*, *user authorization* and *performance logs* are examples of services included within SO (ref. Fig. 23).

### 11.2 Orchestration frameworks

In 6G service-based architecture, service orchestration cannot be a simple one solution that can fulfill all the expectations and needs of the rich selection of various types of services. Therefore, a set of complementary frameworks or dimensions for service orchestration are proposed.

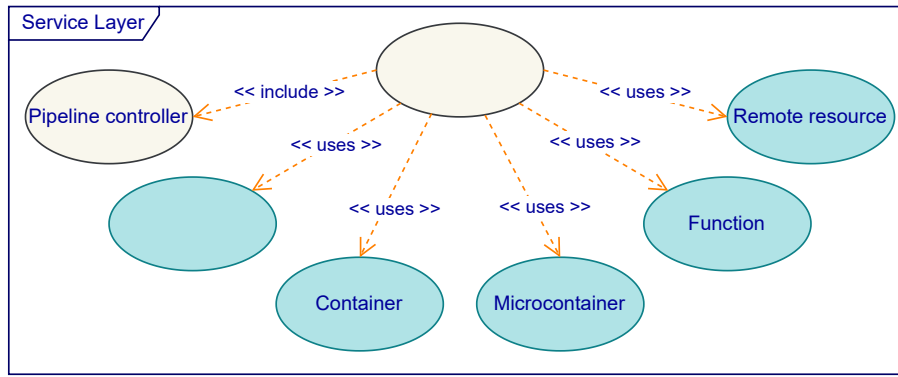

Fig. 24 – Overview of pipeline management.

The solution, or set of solutions, should be able to navigate in and between the following general frameworks in various dimensions namely, parallel/serial, distributed/centralized, long term/short term:

- **Parallel services:** Several services occurring simultaneously and serving a common purpose.
- **Serial services:** Consecutive actions are occurring to fulfill a given task.
- **Distributed services:** Multiple instances are controlling and/or performing a service simultaneously. For instance, 6G end devices, e.g., swarm of cobots, are performing a common task, e.g., observing a defined target. They all require communication and location services simultaneously and, moreover, provide their observations independent of each other.
- **Centralized services:** A service is being performed or controlled by a single entity. For instance, a 6G end device is receiving 3D-mapping information of the surroundings and operating available embedded devices and selecting its physical route based on the received map. There is a constant feedback loop between the controller and controlled service entity.
- **Long term contracts:** Services to other instances are offered and performed based on predetermined contracts.
- **Short term requests:** Services are performed “ad hoc” based on service requests received.

The cases listed above only represent the far ends of the dimensions of the orchestration frameworks. The requirements and the spectrum of use cases in the foreseen 6G infrastructure will require a flexible/fluid navigation within these dimensions indicating a broad spectrum of hybrid models between the extremes. In essence, the resources and services need to be orchestrated to form a continuum covering the whole space in the dimensions given. Furthermore, the dimensions above do not yet take into account the location of the service instances (local, edge, central, etc.) or their implementation architecture.

### 11.3 Functions of the service orchestration service

6G architecture must propose a method of how the services will be offered and distributed over cloud-based architecture to user/6G applications. We propose that this can be realized as an extreme generalization of existing cloud-based service orchestration concepts to organize and combine different general services to meet the demands of any types of 6G user applications. We call this solution Everything as a Service (EaaS). The evolution of cloud computing and other cloud services orchestration paradigms (IaaS, PaaS, SaaS, CaaS, XaaS, etc.) as explained herein, lead to EaaS. Generally, the development of cloud computing has been driven by the need to provide a more flexible and scalable computing environment to meet the ever-changing needs of the business. The service model segmentation has seen a remarkable evolution in the past three decades following advances in the innovation ecosystem. Presently, cloud services are chiefly based on the following four delivery models:

- **Infrastructure-as-a-Service (IaaS)** In this model, the service providers are chiefly responsible for the network infrastructure, hardware, storage, and servers. Virtualization services are also provided.
- **Platform-as-a-Service (PaaS)** PaaS is a service that allows you to build, deploy and run your application without having to worry about the infrastructure.
- **Software-as-a-Service (SaaS)** The resources available through the SaaS model are software applications where the infrastructure is hidden from the users.
- **Containers as a Service (CaaS)** Virtualization and micro-services.
- **Anything-as-a-Service (XaaS).** The XaaS model is a new paradigm in the cloud computing space, which is a combination of SaaS, IaaS, and PaaS. It is a new way of delivering IT services to customers.

But these are for existing cloud service architectures. For customized 6G applications, 6G architecture needs the next generation of service delivery model, exceeding even the XaaS, that is capable of providing e.g. the following features:

- Catalog of services and orchestration between those.
- Extremely large scale of 6G services.
- Fusion between services available through legacy and existing architectures as well as novel services provided by 6G roll out.
- Many players at different levels must cooperate to provide fluent services. Complex forms of trading of services must be supported.
- Move away from phone (any other end device) as a single end point of service into a smart environment.

Pipeline management functionalities are depicted in Fig. 24.

## 12. TOWARDS A LOGICAL SYSTEM ARCHITECTURE

As stated before, there has been heavy involvement of the notions of cloud computing (IaaS, PaaS, SaaS) in the design of the 5G system. The design of 5G systems has also strongly adopted many IT principles. This is manifested in the adoption of the micro-service concept, integration fabric concept, NFV, network slicing and softwarization, and SBA. These have provided some level of modularity in the operational and management independence, as well as some level of flexibility in service launch. However, there are two main points that the current design of 5G lacks, namely 1) true openness to third parties via secure and trusty interfaces and 2) extensibility whereby 5G services should be able to interact through lightweight service-based APIs.

From the above, we envision the 6G system to be truly cloud native, entirely SBA-based, and composed of a set of services, discoverable and able to provide services to other authorized services through specified APIs. Before delving into the detailed description of the logical architecture of our envisioned 6G system, we introduce the following fundamental concepts: (i) cross-domain network slicing; (ii) integration fabric; and (iii) automated closed loop.

### 12.1 Cross-domain network slicing

Generally speaking, any physical infrastructure is composed of different technological and administrative domains. Such domains can belong to different entities which may result, for instance, in different charging plans and also different management APIs. These domains can be different in the technology used, such as the RAN, edge and cloud domains. They can be also different in terms

of the entity that owns and administrates them. 6G services will have different components (i.e., VNFs) running on different domains.

In order to manage the resources in the different technological and administrative domains, there would be multiple NFV Management and Orchestration (MANO) instances, one for each domain [47, 48]. These NFV MANOs can be conceived as components of the “service orchestration” service of the overall 6G system architecture, as introduced above. Each NFV MANO consists of a NFV Orchestrator (NFVO), a VNF Manager (VNFM), and a Virtual Infrastructure Manager (VIM) [49]. The NFVO is responsible for the onboarding of network services and VNFs and for performing the life-cycle management of network services. It is also responsible for the validation and authorization of changes to the resources allocated to the VNFs. The VNFM is responsible for the life-cycle management of one or a group of VNFs. Finally, the VIM is responsible for managing the infrastructure resources. Specifically, it manages the compute, network and storage resources. Having different domains would require the need to have networks that connect all these domains. The component that is responsible for managing these networks is called the WAN (Wide Area Network) Infrastructure Manager (WIM) [50, 51]. The WIM is a special case of a VIM. While the latter manages all compute, storage and networking, the former is specialized in managing networks and stitching between network slates (i.e., the connectivity slate in Fig. 25). Its main objective is to connect the different VNFs within a single domain or to stitch among them across several technological and/or administrative domains. The underlying infrastructure may accommodate several WIMs that will be used to “stitch” the different network services that are deployed in different domains.

The virtualization layer consists in offering a unified view of the compute, storage and network. This unified view helps to aggregate and transparently run VNFs on top of the infrastructure. The network service can be composed of multiple VNFs where these VNFs can be run on VMs or on containers. Up until recently, there were specific infrastructures for Virtual Machines (VMs) and specific infrastructures for containers. Recently, ETSI defined the Container Infrastructure Service Management (CISM) function that enables MANO infrastructure to support containerized workloads and thus VMs and containers coexist on the same infrastructure [52]. Its main responsibility is to manage the infrastructure’s resources and to perform the life-cycle management of the containers running on top of the container cluster. ETSI has proposed different architectures on how this container cluster can be implemented. For instance, the containers can be run on bare metal or in VMs and a workload can also be distributed between the two. For cross-domain network slicing, we do not envision reinventing the wheel. We particularly consider the 3GPP-ETSI NFV framework proposed for managing



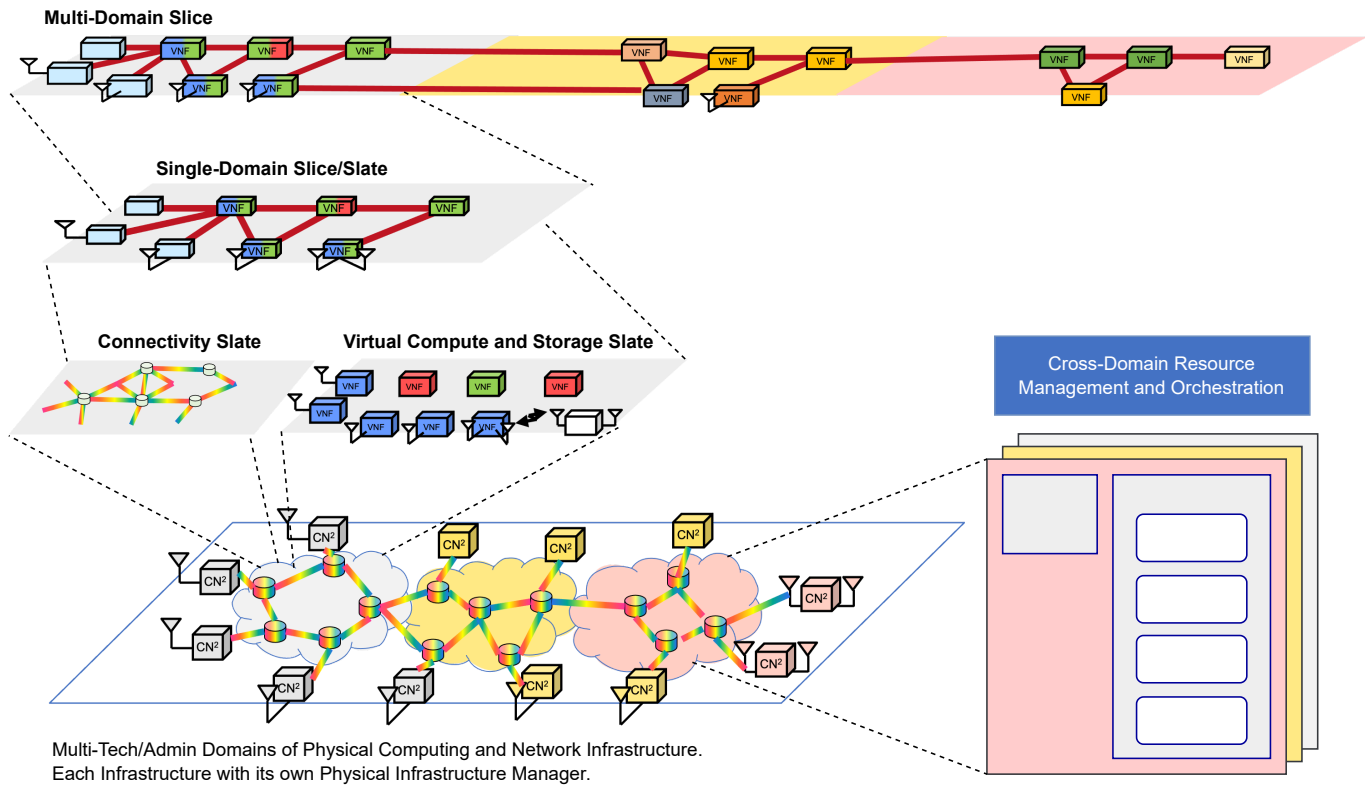

Fig. 25 – Network slicing across multiple technological and administrative domains.

network slicing in an NFV environment [53]. According to the 3GPP terminology [54], a Network Slice Instance (NSI), used by a network service, contains one or more Network Slice Subnet Instances (NSSIs), each of which is, in turn, composed of one or more network functions that can be managed as VNFs, Cloud-Native Network Functions (CNFs) and/or Physical Network Functions (PNFs). In Fig. 25, an NSSI would map onto a single-domain network slice, while a NSI may map on a multi-domain network slice (i.e., if it runs on multiple domains). In 3GPP, the management (including life cycle) of NSIs and NSSIs is under the responsibility of the Network Slice Management Function (NSMF) and the Network Slice Subnet Management Function (NSSMF), respectively. The network functions (i.e., VNFs, CNFs and PNFs) are managed and orchestrated using the Element Management (EM) and the NFV MANO functional blocks. The EM performs the Fault, Configuration, Accounting, Performance and Security (FCAPS) management of the network functions, while NFV MANO carries out the management of the virtualized infrastructure as well as the orchestration of resources required by the network services, VNFs and CNFs. Different mechanisms have been envisioned to enable the interaction between the 3GPP slicing related management functions (i.e., NSMF and NSSMF) and the NFV architecture functional blocks (i.e., EM and NFV MANO) [53].

## 12.2 Integration fabric

An integration fabric facilitates the interoperability and communication between management services, within and across domains, by providing functionalities to register, expose capabilities, discover, and invoke management services by authorized consumers (Fig. 26). Through the integration fabric, the different functions play both the roles of service consumer and service producer. It allows registration and discovery of services, which means that a service should be able to register to be added into a catalog, and using that catalog, the services can discover each other by searching for specific capabilities. It also allows the invocation of services; this invocation can be directly sent to a specific service or it can be sent to a class of services (service mesh concept). The integration fabric also offers dedicated communication channels between the different services. All of the features mentioned above are protected by an authentication and authorization service.

According to [55], the integration fabric should support both synchronous and asynchronous communications using the request-response and publish/subscribe communication models, respectively. A combination between a service mesh solution (e.g., Istio<sup>3</sup> or Linkerd<sup>4</sup>) and an event streaming platform (e.g., Apache Kafka<sup>5</sup>) allows us to implement the integration fabric functional-

<sup>3</sup><https://istio.io>

<sup>4</sup><https://linkerd.io>

<sup>5</sup><https://kafka.apache.org>

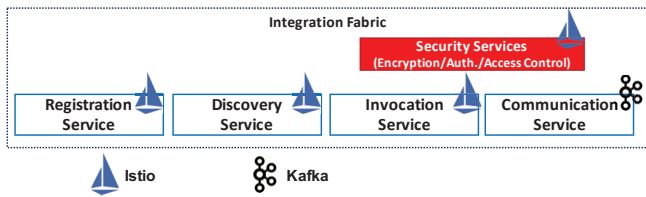

Fig. 26 – The main functionalities of a typical integration fabric.

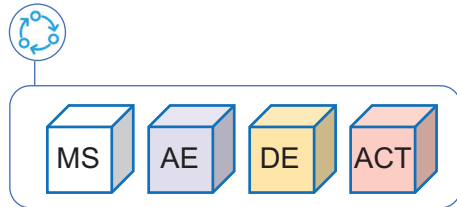

Fig. 27 – The main functionalities of a typical closed loop.

ities [56]. A mesh service manages inter-service traffic for synchronous communications while bolstering security and enabling observability. Meanwhile, an event streaming platform handles asynchronous communications between applications and services through event brokers. It provides the capabilities to ingest, store, process and react to a massive influx of real-time streams of data in a scalable and resilient manner. The use of an event streaming platform is of high value for several use cases, including real-time monitoring, analytics and reaction/prediction of security threats on the fly.

Istio is the micro-service mesh solution that has the most flexibility and features of any existing open-source service mesh solutions by far. Istio supports heterogeneous environments, including Kubernetes and VMs, and multi-domain settings. Moreover, it allows intelligent routing and load balancing between services and provides tracing, logging and monitoring features to get insights into the service mesh deployment. Finally, Istio is the incontestable leader when it comes to security features, offering a comprehensive security solution that includes throttling, powerful policy, transparent TLS encryption, strong identity, and Authentication, Authorization and Audit (AAA) tools to protect both services and data exchanged between them.

Kafka is the most popular open source distributed event streaming platform, thanks to its excellent performance, elasticity, low latency, high throughput, and fault tolerance. Kafka uses topics to store data published by a producer. The consumers access data by subscribing to the corresponding topic. Kafka can be deployed on bare-metal hardware, VMs or containers.

As illustrated in Fig. 26, we consider a combination of the functionalities of Istio and Kafka as a potential candidate to implement the integration fabric services.

### 12.3 Automated closed loop

Following the ZSM framework [55], the envisioned 6G system architecture will incorporate a number of local and global automation closed loops. We first touch upon

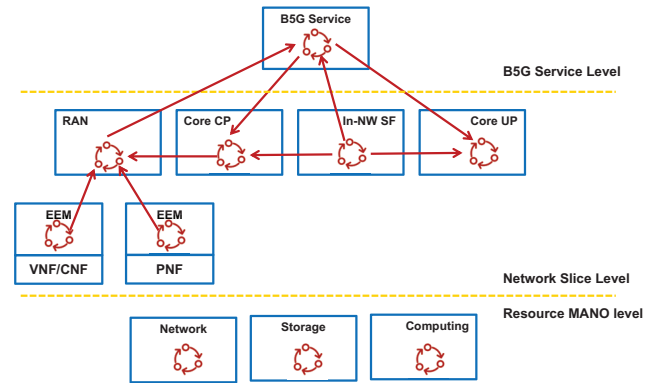

Fig. 28 – An illustrative example of coordination between closed loops at the resource MANO level, network slice level, and the 6G service level.

the concept of closed loop adopted herein. In the envisioned architecture, each closed loop is implemented using four management functions, namely: the Monitoring System (MS), the Analytics Engine (AE), the Decision Engine (DE), and the Actuation engine (ACT), as depicted in Fig. 27.

The MS is in charge of collecting, preprocessing and reporting (network, cloud/edge, service-relevant) data from the managed entity. The AE consists in algorithms that ingest the monitored data and then produce insights or alerts. These algorithms and analytics could be provisioned by the ubiquitous intelligence service of the overall 6G system architecture. For instance, such algorithms can predict the state of the 6G service, they can detect misbehaving services and attacks, and they can even identify optimizations that can greatly enhance the QoS. These algorithms consist mostly in AI and ML algorithms. The DE uses the insights gained from the analytics engine in order to derive its decisions. It can receive alerts from the AE, as it can directly ingest low level monitored data. Its main purpose is to make sure that the running 6G services keep meeting their SLAs. It can carry decisions such as service recomposition or service migration. The actuation engine translates the inferred decisions into executable actions that can be enforced on the managed entity. The ACT can trigger the deployment of specific VNFs (e.g., virtual Firewall or virtual IDS in case of security attacks) through the MANO platform or update the configuration of an already deployed network functions (i.e., CNF, VNF, and PNF). The cognition capabilities are incorporated in the closed loops by leveraging AI/ML techniques for analytics and decision-making.

The cognitive level of the closed loop can be further increased by integrating the AI/ML techniques into the MS and ACT to intelligently determine the relevant data to collect and to decide on the actions to execute, respectively. This shall allow achieving the ultimate goal of empowering a full autonomous 6G service management. The emerging distributed AI (DAI) techniques, including multi-agent reinforcement learning and federated learning, can be leveraged to accelerate the learning process of the AI/ML models used by the different closed loops. The use of DAI shall also help in fostering data privacy preser-

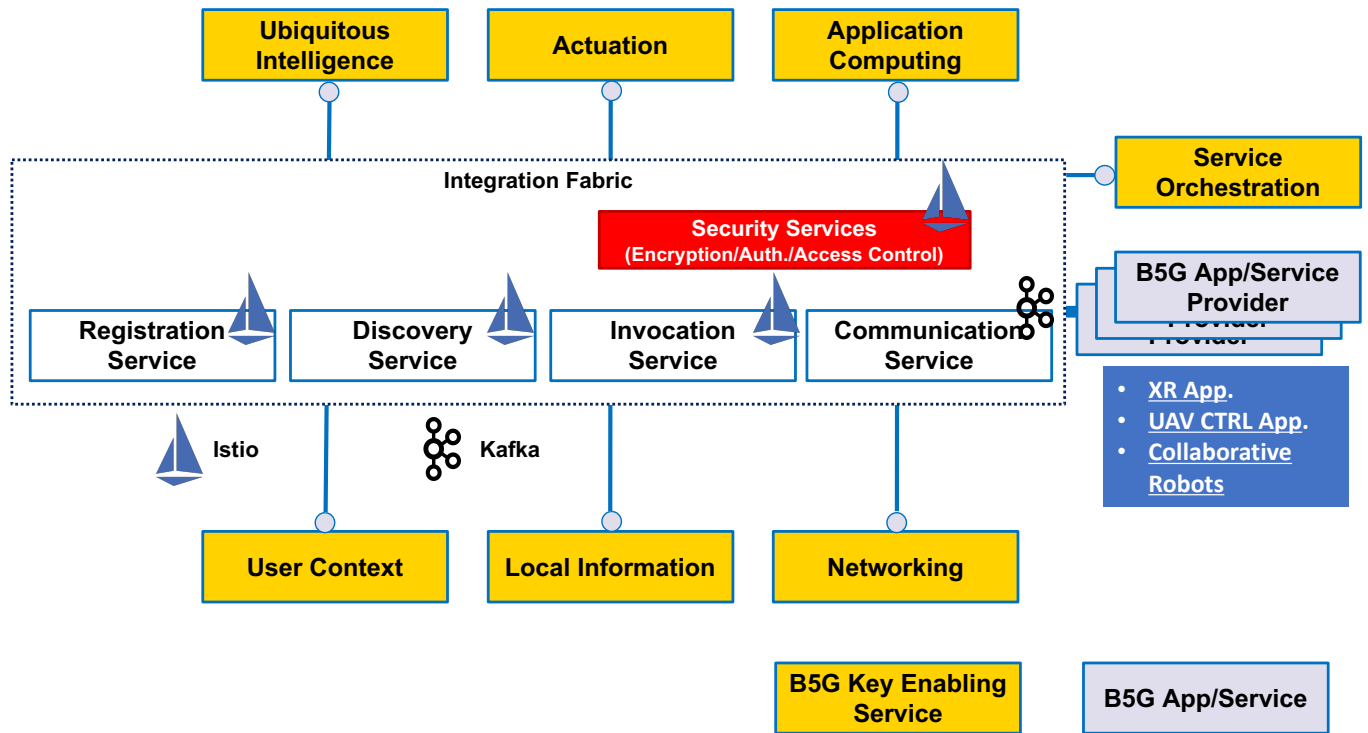

Fig. 29 – 6G system architecture envisioned as a “Service of Services”, interoperable through an integration fabric.

vation, as the information exchanged between the cooperating models is only limited to the model parameters without the need for exchanging any raw data [57, 58].

The deployed closed loops are responsible for carrying out the self-management tasks (e.g., self-configuration, self-healing, self-optimization, and self-protecting) within their scope, ranging from the resource MANO level and the network slice level to the 6G service level. Meanwhile, they can coordinate with each other to realize the service for the end user. The coordination between closed loops can be performed either *hierarchically* for delegation and escalation of goal(s) or issues, or in *peer-to-peer* for coordination of actions and sharing of information [58]. For example, as illustrated in Fig. 28, the monitoring data and/or analytics insights from the closed loops associated with the network functions incorporated into the RAN sub-slice can be used by its self-protection closed loop to identify sub-slice level security anomalies, such as the symptoms of a signaling DDoS attack [59]. This event may need to be reported to the B5G service’s self-protection closed loop, which will subsequently delegate the CN (i.e., Core CP and/or Core UP) self-protection closed loop to proactively mitigate the reported issue. A decision to scale out the network functions involved in the Core CP sub-slice (e.g., Access and Mobility Management Function (AMF) and Session Management Function (SMF)) may be taken. To perform the scaling action, a coordination with, for example, the self-optimization closed loop of the MANO may be required for ensuring optimal resource allocation and placement. In its turn, the MANO’s self-optimization

closed loop can coordinate and share its decision with the CN’s self-protection closed loop in order to consider only computing nodes that meet the desired trust level in the placement schema.

## 12.4 6G System architecture: Service of services vision

Fig. 29 illustrates the envisioned 6G system architecture whereby the six main services of the 6G system (i.e., user context, local information, networking, actuation, ubiquitous intelligence, application computing) are interconnected through an integration fabric, allowing them to register, expose their capabilities, and discover and invoke each other. The launch of a new 6G application/service or the life-cycle management of a running 6G service is also possible through this integration fabric. The integration fabric allows the 6G applications/services to consume any of the six main services of the 6G system, as well as to consume other 6G services or to provide services to them. All in all, through this integration fabric, the 6G system’s six main services as well as the 6G applications/services play both the role of “service consumer” and “service producer”. With such an integration fabric, the current limitations of the current 5G system design, namely the true openness to third parties and service extensibility, can be elevated, above all by design. This will be elaborated further when discussing Fig. 32.

In the current 5G deployment, network slices considered are static, following three types of blueprints, each defined for a specific 5G use case, eMBB, URLLC, or mMTC.

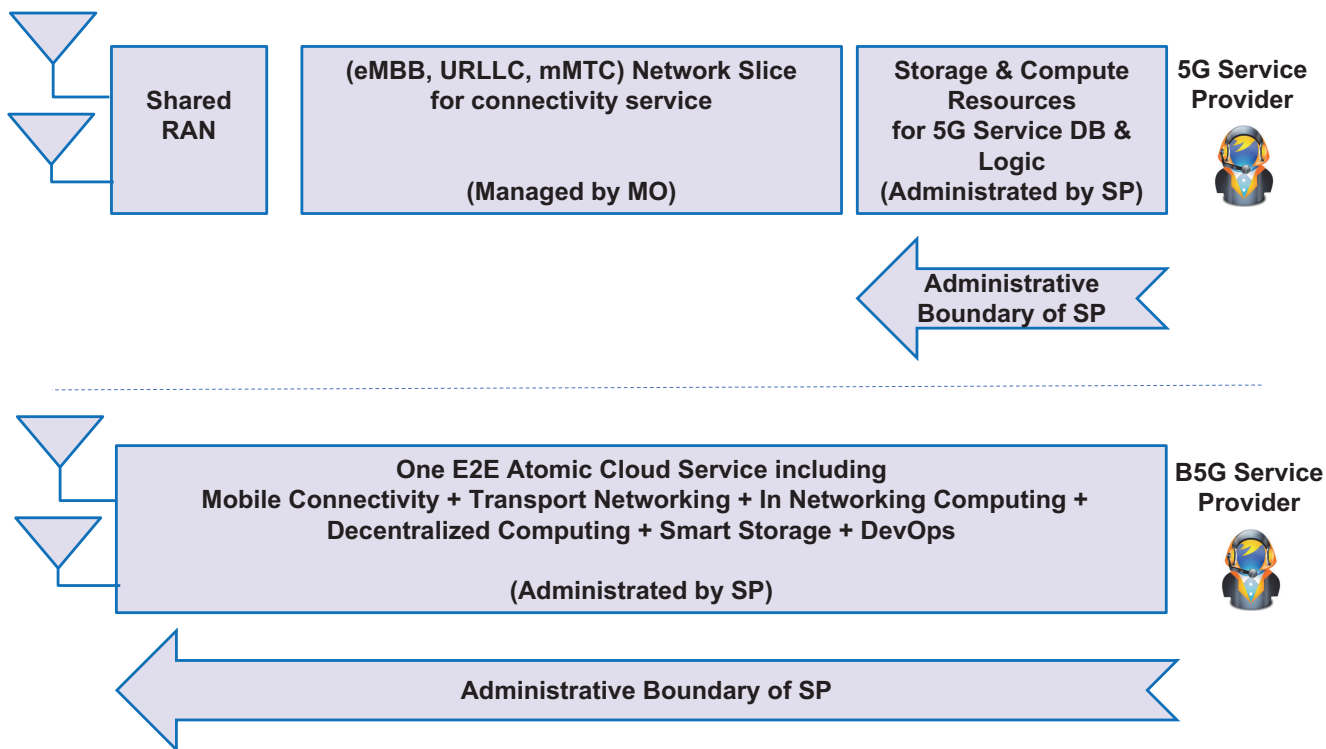

Fig. 30 – Expanding the administrative boundary of 6G service providers beyond data centers towards the last mile of connectivity.

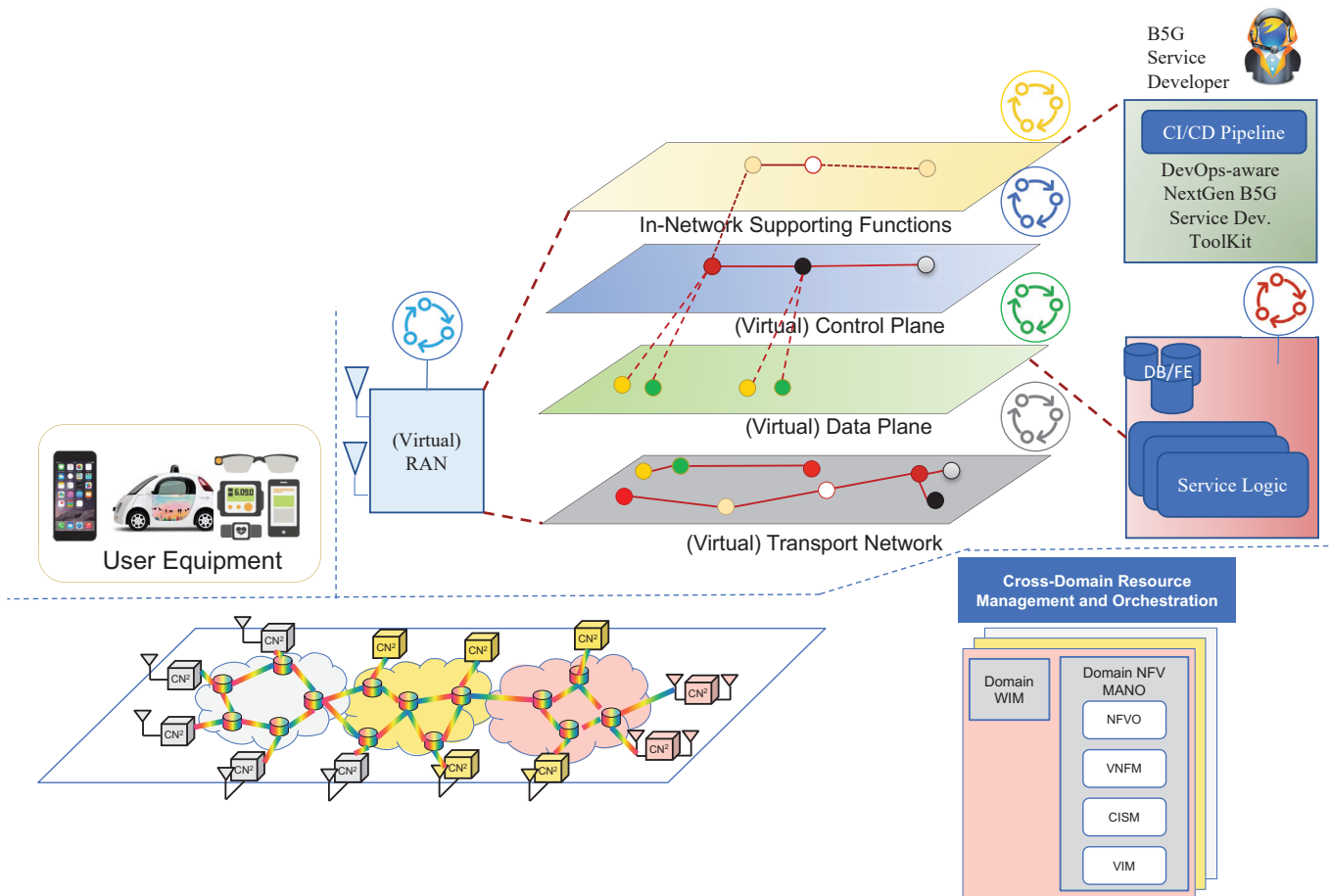

Fig. 31 – The 6G system logical architecture.

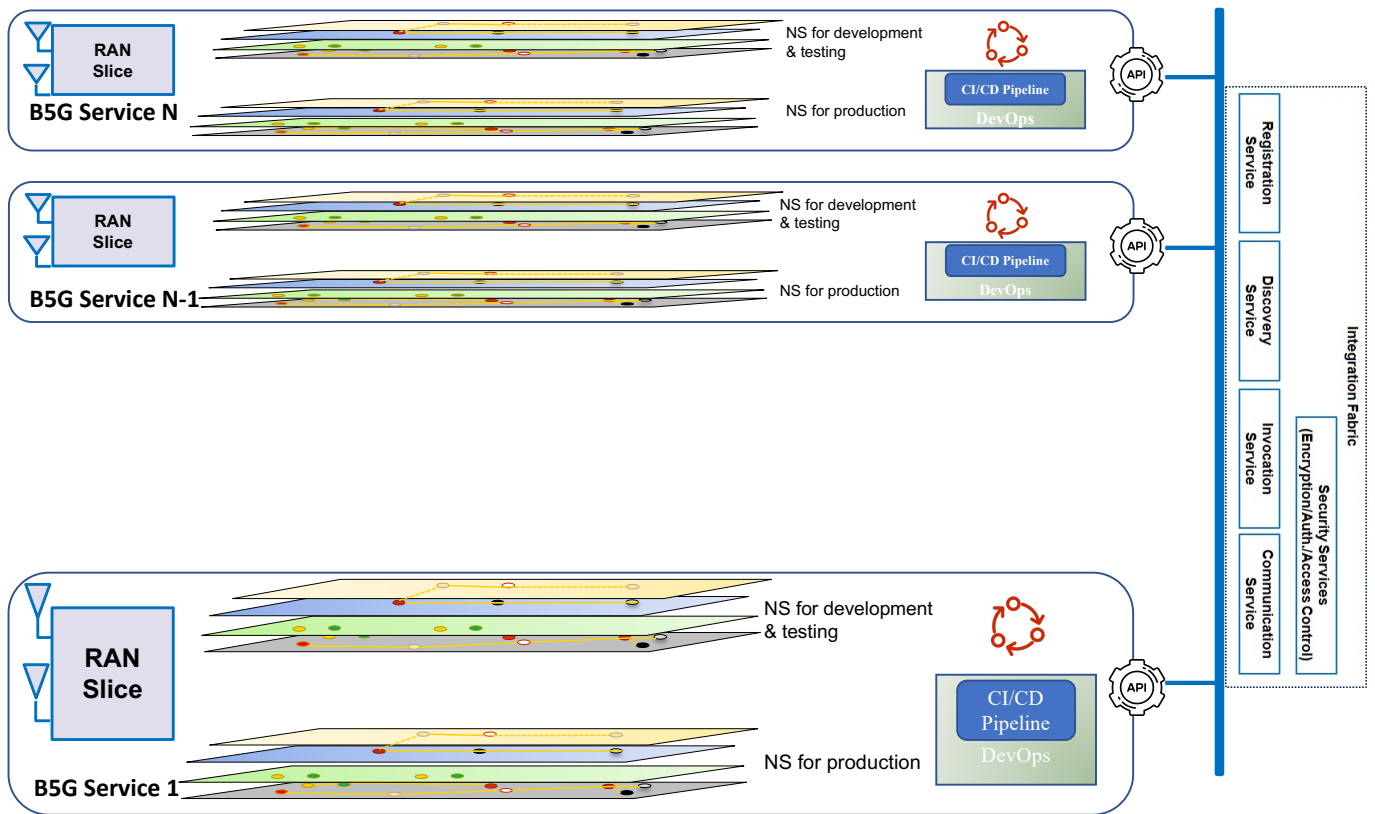

Fig. 32 – Enabling service extensibility by enabling the interoperability among 6G services through lightweight service-based APIs.

Furthermore, in 5G, network slices are limited to the core network. Indeed, when requesting a network slice, a User Plane Function (UPF) (or a set of UPFs) will be allocated, under the control of a specific AMF and SMF. The RAN remains shared among the different network slices. The network slice remains under the administration of the mobile network operator, and the service provider (i.e., consumer of the network slice) can administrate only the databases and images of its service running on a cloud platform. The connectivity service is out of its control, as illustrated in the top part of Fig. 30. With such design, true openness to third parties remains far from being attained. The optimization of the service can be carried out, but on fragmented segments of the end-to-end connection (i.e., RAN offering the last mile connectivity service, network slice offering the core connectivity service, transport network making the actual delivery of service packets, and edge/cloud hosting the service logic). End-to-end optimization of the service provisioning remains challenging on such fragmented communication path. To cope with such limitation, it is important to expand the administrative boundary of the service provider beyond data centers, hosting the logic of its service, towards the last mile, i.e., the user equipment, as depicted in the bottom part of Fig. 30. This is only possible through the offering of mobile connectivity, transport networking, decentralized computing, and smart storage as one E2E atomic cloud service, that is entirely under the administrative authority of the service provider. To allow the service provider

to carry out optimizations of its service on the fly and when needed, the service provider should be able to apply optimizations on each service offered (from the one atomic E2E service) in a closed loop fashion, enforce the decisions within the cloud and the network, leveraging in-network computing capabilities.

The 6G service provisioning can take an unprecedented level by incorporating the DevOps capabilities in the offered atomic service. This shall help 6G service providers to test the offering of their services across the end-to-end channel, involving a subset of the network slice resources for testing and development, before the final push of the 6G service to the production environment. It shall be highlighted here that while the 5G design has incorporated many interesting IT principles, leveraging the DevOps concept, widely used in IT, has been entirely overlooked and 6G design shall be an opportunity to leverage the capabilities that this concept can bring.

All in all, and as illustrated in Fig. 31, the design of the 6G system architecture stems from the intention of offering 6G service providers with 1) mobile connectivity service, 2) transport networking, 3) In Networking computing/supporting functions, 4) decentralized computing, 5) smart storage, and 6) DevOps capabilities, all as one atomic E2E service. All these services shall be running on cloud infrastructure and shall come with all the intrinsic features of cloud computing, namely on-demand deployment capability, elasticity, multi-tenancy, pay-as-you-go pricing model, etc. Following those design prin-

ciples will help in empowering service extensibility (see Fig. 32) where services can register themselves and communicate with each other through the same integration fabric. Such service extensibility allows an efficient and quick upgrade and optimization of services in a cost efficient way.

### 13. CONCLUSION

The paper presented a innovative vision of 6G being a service of services, which goes beyond the traditional vision of 6G being a network of networks by providing better flexibility, agility and cost-effectiveness in the deployment and life-cycle management of future 6G applications/services. The envisioned service-based functional 6G architecture has been described and initial steps from the functional architecture to the logical architecture have been thought of.

Potential future work could include deeper dives into the modeling of various 6G use cases, extending functional diagrams throughout lower layers (network, resource access, algorithm, hardware) and continuing logical architecture development. Also, a tighter integration of openness aspects could be a part of that. As 6G is gradually gaining more momentum worldwide, it is important to stay aware of 6G system architecture activities elsewhere in the community. This document has mainly focused on setting the top-down framework of different kinds of 6G services. Much more research on all these services is needed with tangible performance evaluations (with use case specific KPIs) to really see how well the system architecture actually works.

### ACKNOWLEDGEMENT

This research work is partially supported by the Academy of Finland 6Genesis project under Grant No. 318927 and the Academy of Finland IDEA-MILL project under Grant No. 352428.

### REFERENCES

- [1] Matti Latva-aho and Kari Leppänen (ed.) *Key drivers and research challenges for 6G ubiquitous wireless intelligence (white paper)*. Oulu, Finland: 6G Flagship, Sept. 2019. ISBN:978-952-62-2353-7.
- [2] Nandana Rajatheva, Italo Atzeni, Emil Björnson, André Bourdoux, Stefano Buzzi, Jean-Baptiste Doré, Serhat Erkucuk, Manuel Fuentes, Ke Guan, Yuzhou Hu, Xiaojing Huang, Jari Hulkkonen, Josep Miquel Jornet, Marcos Katz, Rickard Nilsson, Erdal Panayirci, Khaled Rabie, Nuwanthika Rajapaksha, MohammadJavad Salehi, Hadi Sardeddeen, Shahriar Shahabuddin, Tommy Svensson, Oskari Tervo, Antti Tölli, Qingqing Wu, and Wen Xu. *White Paper on Broadband Connectivity in 6G*. Ed. by Nandana Rajatheva. 6G Research Visions, nr. 10. Oulu, Finland: University of Oulu, June 2020, pp. 1–48. URL:<http://urn.fi/urn:isbn:9789526226798>.
- [3] *6G Channel*. <https://www.6gchannel.com/>. Accessed on July 2022.
- [4] H. Tataria, M. Shafi, A. F. Molisch, M. Dohler, H. Sjöland, and F. Tufvesson. “6G Wireless Systems: Vision, Requirements, Challenges, Insights, and Opportunities”. In: *Proc. of the IEEE* 109.7 (July 2021), pp. 1166–1199.
- [5] X. You, CX. Wang, and J. Huang *et al.* “Towards 6G Wireless Communication Networks: Vision, Enabling Technologies, and New Paradigm Shifts”. In: *Science China Information Sciences* 64 (Jan. 2021), p. 110301.
- [6] Y. Wei, M. Peng, and Y. Liu. “Intent-based networks for 6G: Insights and challenges”. In: *Digital Communications and Networks* 6.3 (Aug. 2020), pp. 270–280.
- [7] Z. Zhang *et al.* “6G Wireless Networks: Vision, Requirements, Architecture, and Key Technologies”. In: *IEEE Vehicular Technology Magazine* 14.3 (Sept. 2019), pp. 28–41.
- [8] C. Sergiou, M. Lestas, P. Antoniou, C. Liaskos, and A. Pitsillides. “Complex Systems: A Communication Networks Perspective Towards 6G”. In: *IEEE Access* 8 (May 2020), pp. 89007–89030.
- [9] C. Benzaid, P. Alemany, R. Artych, R. Asensio, G. Chollon, C. Kalalas, E. Montes de Oca, N. Pérez Palma, A. M. Zarca, H. R. Pascual, W. Soussi, T. Taleb, and A. Pastor. “INSPIRE-5Gplus’s White Paper on Intelligent Security Architecture for 5G and Beyond Networks, version 2.0.” In: (Oct. 2022).
- [10] Chaoyun Zhang, Paul Patras, and Hamed Haddadi. “Deep Learning in Mobile and Wireless Networking: A Survey”. In: *IEEE Communications Surveys and Tutorials* 21.3 (2019), pp. 2224–2287.
- [11] Albert Banchs, Marco Fiore, Andres Garcia-Saavedra, and Marco Gramaglia. “Network Intelligence in 6G: Challenges and Opportunities”. In: *Proc. 16th ACM Workshop on Mobility in the Evolving Internet Architecture (MobiArch’21)*. New Orleans, United States, Feb. 2022, pp. 7–12.
- [12] Kwang-Cheng Chen, Shih-Chun Lin, Jen-Hao Hsiao, Chun-Hung Liu, Andreas F. Molisch, and Gerhard P. Fettweis. “Wireless Networked Multirobot Systems in Smart Factories”. In: *Proceedings of the IEEE* 109.4 (Apr. 2021), pp. 468–494.
- [13] Nurul Huda Mahmood, Gilberto Berardinelli, Emil Khatib, Ramin Hashemi, Carlos Lima, and Matti Latva-aho. “A Functional Architecture for a 6G Special Purpose Industrial IoT Network”. In: *IEEE Transactions on Industrial Informatics* (2022).

[14] Ike Kunze, Klaus Wehrle, Dirk Trossen, Marie-Jose Montpetit, Xavier de Foy, David Griffin, and Miguel Rio. *Use Cases for In-Network Computing*. Internet-Draft draft-irtf-coinrg-use-cases-02. Work in Progress. Internet Engineering Task Force, Mar. 2022. 54 pp. URL: <https://datatracker.ietf.org/doc/draft-irtf-coinrg-use-cases/02/>.

[15] M. J. Montpetit. "The Network as a Computer Board: Architecture Concepts for In-Network Computing in the 6G Era". In: *Proc. of the 1st International Conference on 6G Networking (6GNet)*. July 2022, pp. 1–5.

[16] H. Wu and Y. Shen and X. Xiao and G. T. Nguyen and A. Hecker and F. H. P. Fitzek. "Accelerating Industrial IoT Acoustic Data Separation with In-Network Computing". In: *IEEE Internet of Things Journal (Early Access)* (May 2022). DOI:10.1109/JIOT.2022.3176974.

[17] S. Kianpisheh and T. Taleb. "A Survey on In-network Computing: Programmable Data Plane And Technology Specific Applications". In: *IEEE Communications Surveys & Tutorials* (2022). DOI:10.1109/COMST.2022.3213237.

[18] A. Ali Albalawi and A. Chakraborti and C. Westphal and D. Kutscher and J. He and Q. Hoole. "INCA: An Architecture for In-Network Computing". In: *Proc. of the 1st ACM CoNEXT Workshop on Emerging in-Network Computing Paradigms (ENCP'19)*. Dec. 2019, pp. 56–62.

[19] M.-J. Montpetit and N. Crespi. "Computing in the Network". In: *Shaping Future 6G Networks*. John Wiley & Sons, Ltd, 2021. Chap. 10, pp. 133–166. ISBN: 9781119765554. DOI: <https://doi.org/10.1002/9781119765554.ch10>.

[20] Q.-V. Pham and R. Ruby and F. Fang and D. C. Nguyen and Z. Yang and M. Le and Z. Ding and W.-J. Hwang. "Aerial Computing: A New Computing Paradigm, Applications, and Challenges". In: *IEEE Internet of Things Journal* 9.11 (June 2022), pp. 8339–8363.

[21] *Hexa-X Project*. <https://hexa-x.eu/hexa-x-the-joint-european-initiative-to-shape-6g/>. Accessed on July 2022.

[22] NGMN Alliance. "6G Drivers and Vision". In: (Apr. 2021).

[23] *O-RAN Alliance Home Page*. <https://www.o-ran.org/>. Accessed on July 2022.

[24] NGMN Alliance. "6G Use Cases and Analysis v1.0". In: (Feb. 2022).

[25] NTT DOCOMO, INC. "White paper on 5G Evolution and 6G (Version 4.0)". In: (Jan. 2022).

[26] Ericsson. "White paper on 6G - Connecting a Cyber-Physical World - A Research Outlook Towards 2030". In: (Feb. 2022).

[27] H. Viswanathan and P. Mogensen. "Communications in the 6G Era". In: *IEEE Access* 8 (Mar. 2020), pp. 57063–57074.

[28] V. Ziegler and H. Viswanathan and H. Flinck and M. Hoffmann and V. Räsänen and K. Hätönen. "6G Architecture to Connect the Worlds". In: *IEEE Access* 8 (Sept. 2020), pp. 173508–173520.

[29] Y. Chen and P. Zhu and G. He and X. Yan and H. Baligh and J. Wu. "From Connected People, Connected Things, to Connected Intelligence". In: *Proc. of the 2nd 6G Wireless Summit (6G SUMMIT)*. Mar. 2020, pp. 1–7.

[30] Richard Li. "Towards a New Internet for the Year 2030 and Beyond". In: *Proc. 3rd Annu. ITU IMT-2020/5G Workshop Demo Day*. 2018, pp. 1–21.

[31] Li et al., R. "New IP: A Data Packet Framework to Evolve the Internet: Invited Paper". In: *Proc. of IEEE 21st International Conference on High Performance Switching and Routing (HPRS)*. May 2020, pp. 1–8.

[32] David Zhe Lou and Noel Crespi. "Rethinking the IP Framework". In: *Shaping Future 6G Networks*. John Wiley & Sons, Ltd, 2021. Chap. 9, pp. 117–131. ISBN: 9781119765554. DOI: <https://doi.org/10.1002/9781119765554.ch9>.

[33] R. Li, U. S. Chunduri, A. Clemm, and L. Dong. "New IP: Enabling the Next Wave of Networking Innovation". In: *Design Innovation and Network Architecture for the Future Internet*. M. Boucadair and C. Jacquenet, IGI Global, Jan. 2021. Chap. 1, pp. 1–42. ISBN: 9781799876465. DOI: <https://doi.org/10.4018/978-1-7998-7646-5.ch001>.

[34] B. R. Swain and J. J. Sahoo and A. Prasad and D. T. Selvam. "Rise of Fluid Computing: A Collective Effort of Mist, Fog and Cloud". In: *International Journal of Computer Sciences and Engineering (IJCSSE)* 7.4 (Apr. 2019), pp. 62–69.

[35] 5G Americas. "White Paper on Mobile Communications Towards 2030". In: (Nov. 2021).

[36] Samsung. "6G The Next Hyper-Connected Experience for All". In: (July 2020). <https://news.samsung.com/global/samsungs-6g-white-paper-lays-out-the-companys-vision-for-the-next-generation-of-communications-technology>.

[37] N. D. Tripathi and J. H. Reed. "Rohde & Schwarz White Paper on 5G Evolution – On the Path to 6G: Expanding the Frontiers of Wireless communications (Version 01.00)". In: (Mar. 2020), p. 40.

[38] *Meta Connectivity*. <https://www.facebook.com/connectivity>. Accessed on July 2022.

[39] Facebook. "Magma Product Overview". In: *Technical Report* (2019).

[40] *Project Loon*. <https://loon.com/>. Accessed on July 2022.

- [41] Hexa-X. "D1.2 - Expanded 6G vision, use cases and societal values". In: (Apr. 2021). [https://hexa-x.eu/wp-content/uploads/2021/05/Hexa-X\\_D1.2.pdf](https://hexa-x.eu/wp-content/uploads/2021/05/Hexa-X_D1.2.pdf), p. 127.
- [42] C. Benzaid, T. Taleb, and M. Z. Farooqi. "Trust in 5G and Beyond Networks". In: *IEEE Network Magazine* 35.3 (May 2021), pp. 212–222.
- [43] C. De Lima *et al.* "Convergent Communication, Sensing and Localization in 6G Systems: An Overview of Technologies, Opportunities and Challenges". In: *IEEE Access* 9 (Jan. 2021), pp. 26902–26925.
- [44] Q. Mao, F. Hu, and Q. Hao. "Deep learning for intelligent wireless networks: A comprehensive survey". In: *IEEE Communications Surveys & Tutorials* 20.4 (June 2018), pp. 2595–2621.
- [45] S. Ali *et al.* "6G White Paper on Machine Learning in Wireless Communication Networks". In: *CoRR* abs/2004.13875 (Apr. 2020). <http://arxiv.org/abs/2004.13875>.
- [46] P. Arcaini and E. Riccobene and P. Scandurra. "Modeling and Analyzing MAPE-K Feedback Loops for Self-Adaptation". In: *Proc. of 2015 IEEE/ACM 10th International Symposium on Software Engineering for Adaptive and Self-Managing Systems*. 2015, pp. 13–23.
- [47] ETSI GR NFV-IFA 028 V3.1.1. "Network Functions Virtualisation (NFV) Release 3; Management and Orchestration; Report on Architecture Options to Support Multiple Administrative Domains". In: (Jan. 2018).
- [48] ETSI GS NFV-IFA 030 V3.6.1. "Network Functions Virtualisation (NFV) Release 3; Management and Orchestration; Multiple Administrative Domain Aspect Interfaces Specification". In: (Jan. 2022).
- [49] ETSI GS NFV-MAN 001 V1.2.1. "Network Functions Virtualisation (NFV); Management and Orchestration; Report on Management and Orchestration Framework". In: (Dec. 2021).
- [50] ETSI GS NFV-IFA 032 V3.4.1. "Network Functions Virtualisation (NFV) Release 3; Management and Orchestration; Interface and Information Model Specification for Multi-Site Connectivity Services". In: (June 2020).
- [51] ETSI GR NFV-IFA 022 V3.1.1. "Network Functions Virtualisation (NFV) Release 3; Management and Orchestration; Report on Management and Connectivity for Multi-Site Services". In: (Apr. 2018).
- [52] ETSI GR NFV-IFA 029 V3.3.1. "Report on the Enhancements of the NFV Architecture towards "Cloud-native" and "PaaS"". In: (Nov. 2019).
- [53] ETSI GR NFV-EVE 012 V3.1.1. "Report on Network Slicing Support with ETSI NFV Architecture Framework". In: Dec. 2017.
- [54] 3GPP TR 28.801 V15.1.0. "Study on Management and Orchestration of Network Slicing for Network Generation Network (Release 15)". In: Jan. 2018.
- [55] ETSI GS ZSM 002. "Zero-touch Network and Service Management (ZSM); Reference Architecture". In: (Aug. 2019).
- [56] C. Benzaid, T. Taleb, and J. Song. "AI-based Autonomous & Scalable Security Management Architecture for Secure Network Slicing in B5G". In: *IEEE Network Magazine (Early Access)* (2022), pp. 1–9. DOI:10.1109/MNET.104.2100495.
- [57] O. Hireche, C. Benzaid, and T. Taleb. "Deep Data Plane Programming and AI for Zero Trust Self-Driven Networking in Beyond 5G". In: *Elsevier J. on Computer Networks* 203 (Feb. 2022).
- [58] C. Benzaid et al. R. Asensio. "INSPIRE-5Gplus's White Paper on Evolution of 5G Cyber Threats and Security Solutions". In: (Mar. 2022).
- [59] C. Benzaid and T. Taleb. "AI for Beyond 5G Networks: A Cyber-Security Defense or Offense Enabler?" In: *IEEE Network Magazine* 34.6 (Nov. 2020), pp. 140–147.

## AUTHORS



**Tarik Taleb** (Senior Member, IEEE) is currently a professor at the Centre for Wireless Communications (CWC) – Networks and Systems Unit, Faculty of Information Technology and Electrical Engineering, The University of Oulu. He is the founder and director of the MOSAIC Lab ([www.mosaic-lab.org](http://www.mosaic-lab.org)). Between Oct. 2014 and Dec. 2021, he was a professor at the School of Electrical Engineering, Aalto University, Finland. Prior to that, he was working as a senior researcher and 3GPP Standards Expert at NEC Europe Ltd, Heidelberg, Germany. Before joining NEC and till Mar. 2009, he worked as an assistant professor at the Graduate School of Information Sciences, Tohoku University, Japan, in a lab fully funded by KDDI, the second largest mobile operator in Japan. From Oct. 2005 till Mar. 2006, he worked as a research fellow at the Intelligent Cosmos Research Institute, Sendai, Japan. He received his B. E degree in information engineering with distinction, M.Sc. and Ph.D. degrees in information sciences from Tohoku Univ, in 2001, 2003, and 2005, respectively. Prof. Taleb's research interests lie in the field of telco cloud, network softwarization and network slicing, AI-based software defined security, immersive communications, mobile multimedia streaming, and next generation mobile networking. Prof. Taleb has been also directly engaged in the development and standardization of the evolved packet system as a member of 3GPP's System Architecture working group 2.



Prof. Taleb served as the general chair of the 2019 edition of the IEEE Wireless Communications and Networking Conference (WCNC'19) held in Marrakech, Morocco. He was the guest editor in chief of the IEEE JSAC Series on Network Softwarization & Enablers. He was on the editorial board of the IEEE Transactions on Wireless Communications, IEEE Wireless Communications Magazine, IEEE Journal on Internet of Things, IEEE Transactions on Vehicular Technology, IEEE Communications Surveys & Tutorials, and a number of Wiley journals. Till Dec. 2016, he served as chair of the Wireless Communications Technical Committee, the largest in IEEE ComSoC. He also served as Vice Chair of the Satellite and Space Communications Technical Committee of IEEE ComSoC (2006 - 2010).

Prof. Taleb is the recipient of the 2021 IEEE ComSoC Wireless Communications Technical Committee Recognition Award (Dec. 2021), the 2017 IEEE ComSoC Communications Software Technical Achievement Award (Dec. 2017) for his outstanding contributions to network softwarization. He is also the (co-) recipient of the 2017 IEEE Communications Society Fred W. Ellersick Prize (May 2017), the 2009 IEEE ComSoC Asia-Pacific Best Young Researcher award (Jun. 2009), the 2008 TELECOM System Technology Award from the Telecommunications Advancement Foundation (Mar. 2008), the 2007 Funai Foundation Science Promotion Award (Apr. 2007), the 2006 IEEE Computer Society Japan Chapter Young Author Award (Dec. 2006), the Niwa Yasujirou Memorial Award (Feb. 2005), and the Young Researcher's Encouragement Award from the Japan chapter of the IEEE Vehicular Technology Society (VTS) (Oct. 2003). Some of Prof. Taleb's research work have been also awarded best paper awards at prestigious IEEE-flagged conferences.



**Chafika Benzaid** is currently a senior research fellow at the Faculty of Information Technology and Electrical Engineering, University of Oulu, Finland. Between Nov. 2018 and Dec. 2021, she has been senior researcher at the School of Electrical Engineer, Aalto University, Finland.

Prior to that, she was working as an associate professor at the Computer Science Department, University of Sciences and Technology Houari Boumediene (USTHB), Algeria. She received her engineer degree in software engineering with distinction, Magister and "Doctorat ès Sciences" degrees in programming and systems from USTHB, in 2000, 2003 and 2009, respectively. Dr Benzaid's research interest lies in the field of wireless sensor networks, software defined networking, network security, AI security, and the use of AI/ML for zero-touch security management. She is an ACM professional member. She serves/served as a TPC chair and member for several international conferences and as a reviewer for several international journals.



**Miguel Bordallo López** received his doctoral degree in computer vision in 2014 at the University of Oulu. Currently, he is an associate professor (Tenure Track) at the Center for Machine Vision and Signal Analysis at the University of Oulu and a senior scientist (AI) at VTT Technical Research Center of Finland. His research interests include real-time image-based sensing, face analysis, signal processing and AI in primary healthcare applications.



**Konstantin Mikhaylov** received a Dr.Sc. (Eng) from the University of Oulu, Finland, in 2018 and M.Sc./B.Sc. degrees from St. Petersburg State Polytechnical University, Russian Federation, in 2008 and 2006, respectively. Since 2009 he has been working in different

positions at the University of Oulu, Finland. Currently, he is an assistant professor for convergent IoT communications with the Centre for Wireless Communication of the University of Oulu. Konstantin has authored and coauthored about one hundred research papers on the different aspects of IoT connectivity and design. Ass. Prof. Mikhaylov's research interests include IoT and machine-to-machine wireless connectivity, IoT devices and systems design, performance, and applications. He is a Senior Member of IEEE.



**Sasu Tarkoma** is a professor of computer science at the University of Helsinki and Dean of the Faculty of Science. He has authored 4 textbooks and has published over 240 scientific articles. His research interests are Internet technology, distributed systems, data analytics, and mobile and ubiquitous computing. He is a Fellow of IET and EAI. He has ten granted US patents. His research has received several Best Paper awards and mentions, for example at IEEE PerCom, IEEE ICDCS, ACM CCR, and ACM OSR.



**Panos Kostakos** is a senior research fellow at the Center for Ubiquitous Computing, University of Oulu. His research is situated at the intersection of AI, information security and security orchestration, focusing on autonomous, mutable, and cognitive cybersecurity defence mechanisms. He is the leader of the research group Cyber Security Informatics (CSI).



**Nurul Huda Mahmood** is a senior researcher and adjunct professor at the Center for Wireless Communications / CWC (if already defined), University of Oulu. He is also the coordinator for wireless connectivity research area and leads critical MTC research within the 6G

Flagship research program. His current research focus is on resilient communications for the 6G era.



**Pekka Pirinen** is an adjunct professor and senior research fellow at the University of Oulu, Finland. He received his Master of Science, Licentiate of Science, and Doctor of Science in technology degrees in electrical engineering from the same university, in 1995, 1998, and 2006, respectively. Since the establishment of the Centre for Wireless Communications as a part of

the University of Oulu in 1995, he has been involved in research, management and administration in numerous international and national wireless communications research projects. His main research interests are in wireless connectivity technologies toward 6G networks.



**Marja Matinmikko-Blue** is research director of the Infotech Oulu Institute and Director of Sustainability & Regulation at 6G Flagship at the University of Oulu, Finland, where she also holds an adjunct professor position in spectrum management. Marja completed her Doctor of

Science degree in communications engineering in 2012, and Doctor of Philosophy degree in industrial engineering and management in 2018 at the University of Oulu. She has been conducting multi-disciplinary research into the technical, business, and regulatory aspects of future mobile communication systems in close collaboration with industry, academia, and regulators for over two decades. Marja has coordinated several national research project consortia that have successfully demonstrated new technology including the world's first Licensed Shared Access (LSA) spectrum sharing trials and the introduction of a new local 5G operator concept, which has become a reality in many countries. She has actively contributed to, and participated in, regulatory bodies at the national, European, and international levels. She also coordinated the preparation of twelve 6G white papers at the 6G Flagship

(the first white papers on 6G in the world) and led the development of the white paper on 6G Drivers and the UN Sustainable Development Goals. She has published 170 +scientific papers and prepared 150+ contributions to regulatory bodies.



**Matti Latva-aho** received the M.Sc., Lic.Tech. and Dr. Tech (Hons.) degrees in electrical engineering from the University of Oulu, Finland in 1992, 1996 and 1998, respectively. From 1992 to 1993, he was a research engineer at Nokia Mobile Phones, Oulu, Finland after which he joined the Centre for Wireless

Communications (CWC) at the University of Oulu. Prof. Latva-aho was Director of CWC during the years 1998-2006 and Head of Department for Communication Engineering until August 2014. Currently he is professor at the University of Oulu on wireless communications and Director for the National 6G Flagship Programme. He is also a global research fellow with Tokyo University. His research interests are related to mobile broadband communication systems and currently his group focuses on 6G systems research. Prof. Latva-aho has published over 500 conference or journal papers in the field of wireless communications. He received the Nokia Foundation Award in 2015 for his achievements in mobile communications research.



**Prof. Ari Pouttu** has scientific and engineering experience as a researcher, project manager and research manager in various domains of ICT development. The projects under his command have resulted in waveforms and system designs for military radio communica-

tion, radar systems, embedded device networks, future wireless radio communications including cellular systems, cognitive networks and navigation applications. He has published more than 70 conference or journal papers in the field of wireless communications and he holds two patents. He is the principal investigator of 5G test network (5GTN) experimental research, and vice-director of the national 6G Flagship Programme targeting 6G solutions including wireless solutions for business verticals such as energy, industry, health and automotive.