

Report ITU-R M.2531-0 (09/2023)

M Series: Mobile, radiodetermination, amateur
and related satellite services

**Operational procedures for both ship
and coast stations for automatic
connection system using digital
selective calling communications in MF
and HF bands**

Foreword

The role of the Radiocommunication Sector is to ensure the rational, equitable, efficient and economical use of the radio-frequency spectrum by all radiocommunication services, including satellite services, and carry out studies without limit of frequency range on the basis of which Recommendations are adopted.

The regulatory and policy functions of the Radiocommunication Sector are performed by World and Regional Radiocommunication Conferences and Radiocommunication Assemblies supported by Study Groups.

Policy on Intellectual Property Right (IPR)

ITU-R policy on IPR is described in the Common Patent Policy for ITU-T/ITU-R/ISO/IEC referenced in Resolution ITU-R 1. Forms to be used for the submission of patent statements and licensing declarations by patent holders are available from <http://www.itu.int/ITU-R/go/patents/en> where the Guidelines for Implementation of the Common Patent Policy for ITU-T/ITU-R/ISO/IEC and the ITU-R patent information database can also be found.

Series of ITU-R Reports

(Also available online at <https://www.itu.int/publ/R-REP/en>)

Series	Title
BO	Satellite delivery
BR	Recording for production, archival and play-out; film for television
BS	Broadcasting service (sound)
BT	Broadcasting service (television)
F	Fixed service
M	Mobile, radiodetermination, amateur and related satellite services
P	Radiowave propagation
RA	Radio astronomy
RS	Remote sensing systems
S	Fixed-satellite service
SA	Space applications and meteorology
SF	Frequency sharing and coordination between fixed-satellite and fixed service systems
SM	Spectrum management
TF	Time signals and frequency standards emissions

Note: This ITU-R Report was approved in English by the Study Group under the procedure detailed in Resolution ITU-R 1.

Electronic Publication
Geneva, 2023

© ITU 2023

All rights reserved. No part of this publication may be reproduced, by any means whatsoever, without written permission of ITU.

REPORT ITU-R M.2531-0

Operational procedures for both ship and coast stations for automatic connection system using digital selective calling communications in MF and HF bands

(2023)

Scope

This Report describes the procedure for the automatic connection system (ACS) using digital selective calling (DSC) communications on MF and HF. The implementation of ACS will ensure simple and reliable access to the required radio links for the mariner. The results of field experiment to verify the operational procedures are given in the Annex.

Keywords

ACS, DSC

Glossary of abbreviations

ACS	Automatic connection system
DSC	Digital selective calling
kHz	Kilohertz
HF	High frequency
MF	Medium frequency
MHz	Megahertz
RR	Radio Regulations
VHF	Very high frequency

Relevant ITU-R documents

Recommendation ITU-R M.493 – Digital selective-calling system for use in the maritime mobile service

Recommendation ITU-R M.541 – Operational procedures for the use of digital selective-calling equipment in the maritime mobile service

Recommendation ITU-R M.585 – Assignment and use of identities in the maritime mobile service

Recommendation ITU-R M.1082 – International maritime MF/HF radiotelephone system with automatic facilities based on digital selective calling signalling format

Recommendation ITU-R M.1171 – Radiotelephony procedures in the maritime mobile service

TABLE OF CONTENTS

	<i>Page</i>
1 General	2
2 Frequencies and method of calling for automatic connection system.....	4
2.1 Frequencies for automatic connection system.....	4
2.2 Method of calling.....	4
3 Operating procedures.....	4
3.1 Scanning	4
3.2 Calling station.....	5
3.3 Called station	5
3.4 Frequency identification and following response to a calling station	6
3.5 Selection of working frequency.....	13
4 Digital selective calling messages of automatic connection system	14
Annex – Automatic connection system field experiment	14
A1 Introduction	14
A2 Test method	14
A2.1 Test station.....	14
A2.2 Propagation prediction.....	15
A2.3 Test setup.....	16
A2.4 Frequency used for testing.....	17
A2.5 Verification method	17
A3 Test procedure	17
A4 Test result	17

1 General

The automatic connection system (ACS) means automatic connection function using digital selective calling (DSC) for coast-to-ship, ship-to-coast or ship-to-ship communication with the most appropriate working frequency (or channel) in the MF and HF bands for the maritime mobile service.

The procedures for ACS using DSC communications on MF and HF are described below. For further information, see Recommendation ITU-R M.541.

The procedure for ACS shall not interrupt a reliable watch on a 24-hour basis on appropriate DSC distress alerting frequencies unless while the equipment is transmitting.

An example of flowchart of ACS operational procedures is shown in Fig. 1.

FIGURE 1

Example of automatic connection system operational procedures

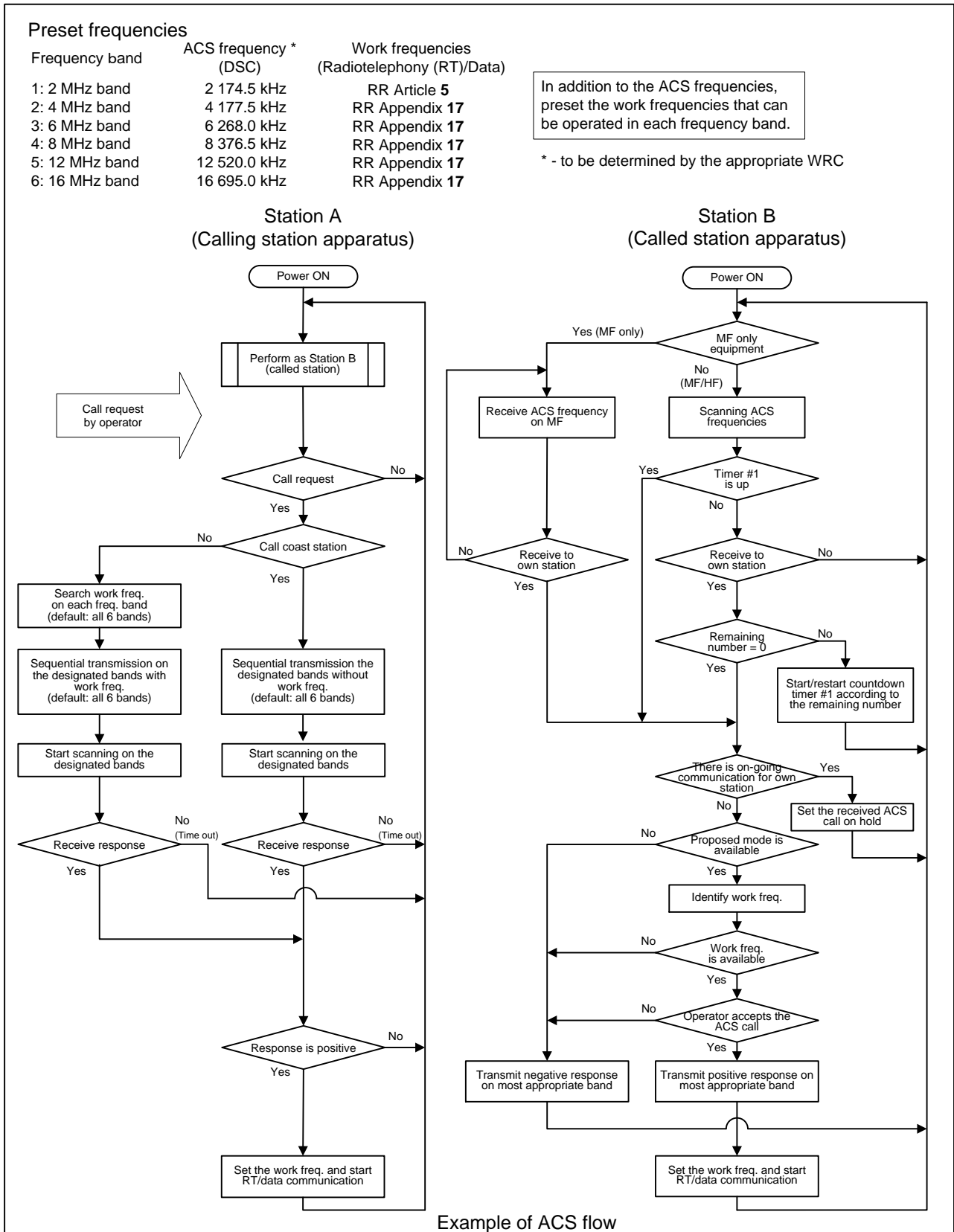

2 Frequencies and method of calling for automatic connection system

2.1 Frequencies for automatic connection system

The following worldwide harmonized frequencies, previously used by the narrow-band direct-printing for distress and safety and no longer used in the Global maritime distress and safety system, are now proposed to be used for ACS.

- 2 MHz band ACS Calling 2 174.5 kHz
- 4 MHz band ACS Calling 4 177.5 kHz
- 6 MHz band ACS Calling 6 268 kHz
- 8 MHz band ACS Calling 8 376.5 kHz
- 12 MHz band ACS Calling 12 520 kHz
- 16 MHz band ACS Calling 16 695 kHz

These frequencies are used for transmitting and receiving for both ship stations and coast stations.

2.2 Method of calling

The procedures set out in this section are applicable to the use of DSC techniques, except in cases of distress, urgency or safety, to which the provisions of the Radio Regulations (RR) Chapter VII are applicable.

The ACS call should contain information indicating the station or stations to which the call is directed, and the identification of the calling station.

The ACS call should also contain information indicating the type of subsequent communication to be set up and should include supplementary information such as a proposed working frequency or channel which is identified as the most appropriate with low noise level. This process should be repeated for each ACS frequency band.

3 Operating procedures

3.1 Scanning

The receiver designated for ACS (ACS receiver) while the equipment is in standby should:

- for MF only equipment, monitor only ACS frequency in the MF band (2 MHz band) without scanning;
- for MF/HF equipment, scan up to six ACS frequencies in MF and HF bands specified in § 2.1;
- scan all six ACS frequencies within two seconds per cycle;
- when the DSC dot pattern is detected, pause scanning on that frequency and decode receiving signal;
- resume standard scanning when the identification of the received signal is not addressed to the own station or remaining ACS sequential transmission is not completed;
- stop scanning when an acknowledgement is received;
- restart scanning ACS frequencies after completing call set up.

3.2 Calling station

The following procedures should apply at calling station of ACS:

3.2.1 The operator enters the identification (MMSI) of the called station and selects the type of subsequent communication and then initiates ACS call.

3.2.2 The ACS receiver stops scanning during the transmission of the ACS message.

3.2.3 When the called station is a ship station, the receiver searches the appropriate working frequency which is unoccupied and with low noise in each frequency band. The ACS complements the identified channels or frequencies into Message 2 for the ACS sequential transmission in each frequency band.

ACS sequential transmission to a ship station is composed as follows:

- Category of call: ACS
- Message 1 first telecommand: type of communication (e.g. J3E, F1B or Data)
- Message 1 second telecommand: number of remaining ACS sequential transmission
- Message 2: proposed working frequency which is in the same frequency band of the ACS transmission.

ACS sequential transmission to a coast station is composed as follows:

- Category of call: ACS
- Message 1 first telecommand: type of communication (e.g. J3E, F1B or Data)
- Message 1 second telecommand: number of remaining ACS sequential transmission
- Message 2: own ship's position information.

3.2.4 ACS transmits up to six ACS sequential transmissions using frequencies as specified in § 2.1. If there is a band for which no appropriate working frequency is found, the transmission is omitted for that band.

3.2.5 The ACS receiver restarts scanning after up to six ACS sequential transmissions and then waits for a response from the called station.

3.2.6 When calling station receives a response from called station within due time, the ACS receiver stops scanning.

3.2.6.1 If the response is positive, ACS tune the transmitter using the working channel or frequency and type of communication in accordance with the received positive response. The ACS receiver restarts scanning after setting up communication and operator starts communication.

3.2.6.2 If the response is negative, the ACS receiver restarts scanning, and the ACS procedure is terminated by operator.

3.2.7 When calling station does not receive a response from called station within due time or operator selects the end of ACS calling, ACS procedure is terminated.

3.3 Called station

The following procedures should apply at the called station when ACS receives call with its own identification.

3.3.1 ACS checks the number of remaining ACS sequential transmissions, calculating and updating the remaining time (Countdown Timer) according to the number of remaining ACS sequential transmissions, and records received signal conditions (e.g. receiving level, symbol error rate, noise level) for the received ACS frequency. If Countdown Timer or remaining number is zero, the procedure then goes to 3.3.3. Otherwise, the procedure goes to 3.3.2.

3.3.2 The ACS receiver continues scanning ACS frequencies. During the scanning, if a call to own station on a different ACS frequency from the same calling station is received before Countdown Timer becomes zero, the procedure goes to 3.3.1. If no call to own station on a different ACS frequency from the same calling station is received before Countdown Timer becomes zero, the scanning ends and the procedure goes to 3.3.3.

3.3.3 ACS then makes aural alarm and display that an ACS call request has been received. The system checks if there is on-going communication for own station. If all kinds of MF/HF radiocommunication (radiotelephone, data and so on) automated procedure are provided in the DSC equipment, the check can be made automatically according to the status (active or on hold) of every automated procedure. Otherwise, the check can be made by the operator manually. When there is on-going communication for own station, the received ACS call should be set as on hold and then the procedure goes to restart scanning. When there is no on-going communication for own station, the procedure goes to 3.3.4.

3.3.4 The proposed mode should be checked. If the proposed mode is unavailable for own station, a negative response should be transmitted on the most appropriate frequency as recorded in 3.3.1 and then the procedure goes to restart scanning.

The negative response is composed as follows:

- Category of call: ACS
- Message 1 first telecommand: Unable to comply
- Message 1 second telecommand: Unable to use proposed mode
- Message 2: no information.

If the proposed mode is available for own station, the frequency identification and following response should be made in accordance with 3.4.

3.3.5 When a suitable frequency has been identified and operator accept the ACS call, ACS initiate set up communication using designated working frequency and type of communication in accordance with the transmitted positive response.

3.3.6 The receiver designed for ACS restarts scanning after setting up communication.

3.3.7 The operator starts communication using the working frequency and type of communication in accordance with setting up communication.

3.4 Frequency identification and following response to a calling station

3.4.1 Response to a coast station

When the calling station is a coast station, the ACS of the called station (ship station) checks whether the working frequency (RX frequency for ship station) proposed by coast station is appropriate for the type of subsequent communication by using the receiver which is handling communication (e.g. the frequency is not busy, sufficient *S/N*).

When it is not suitable in the most appropriate frequency band as recorded in 3.3.1, ACS of the called station (ship station) checks again the proposed working frequency for the selected type of communication in the second most appropriate frequency band as recorded in 3.3.1.

When the proposed working frequency in most or second most appropriate working frequency band is suitable to use for subsequent communication, ACS notifies operator of the identified working frequency with proposed mode and the operator can decide whether to accept the ACS call.

If the operator decides to accept the ACS call, ACS responds to the calling station on the most appropriate ACS frequency as recorded in 3.3.1 including the working frequency or channel positively. Then the procedure goes to 3.3.5.

Positive response to a coast station with acceptance of the connection is composed as follows:

- Category of call: ACS
- Message 1 first telecommand: type of communication (e.g. J3E, F1B or Data)
- Message 1 second telecommand: no information
- Message 2: working frequency.

If the operator decides to reject the ACS call, ACS responds to the calling station on the most appropriate ACS frequency as recorded in 3.3.1 negatively and the procedure goes to restart scanning.

Negative response to a coast station when the operator decides to reject the call is composed is follows:

- Category of call: ACS
- Message 1 first telecommand: Unable to comply
- Message 1 second telecommand: No operator available or Operator temporarily unavailable
- Message 2: position if available, or no information.

When it is not suitable on most and second most appropriate frequency band, ACS responds to reject the connection to the calling station on the most appropriate ACS frequency as recorded in 3.3.1, and then the ACS receiver restarts scanning.

Negative response to a coast station when there is no identified working frequency is composed as follows:

- Category of call: ACS
- Message 1 first telecommand: Unable to comply
- Message 1 second telecommand: Unable to use proposed channel
- Message 2: position if available, or no information.

FIGURE 2

Flow chart for the working frequency identification and following an ACS response for the called station when calling station is a coast station and called station is ship station

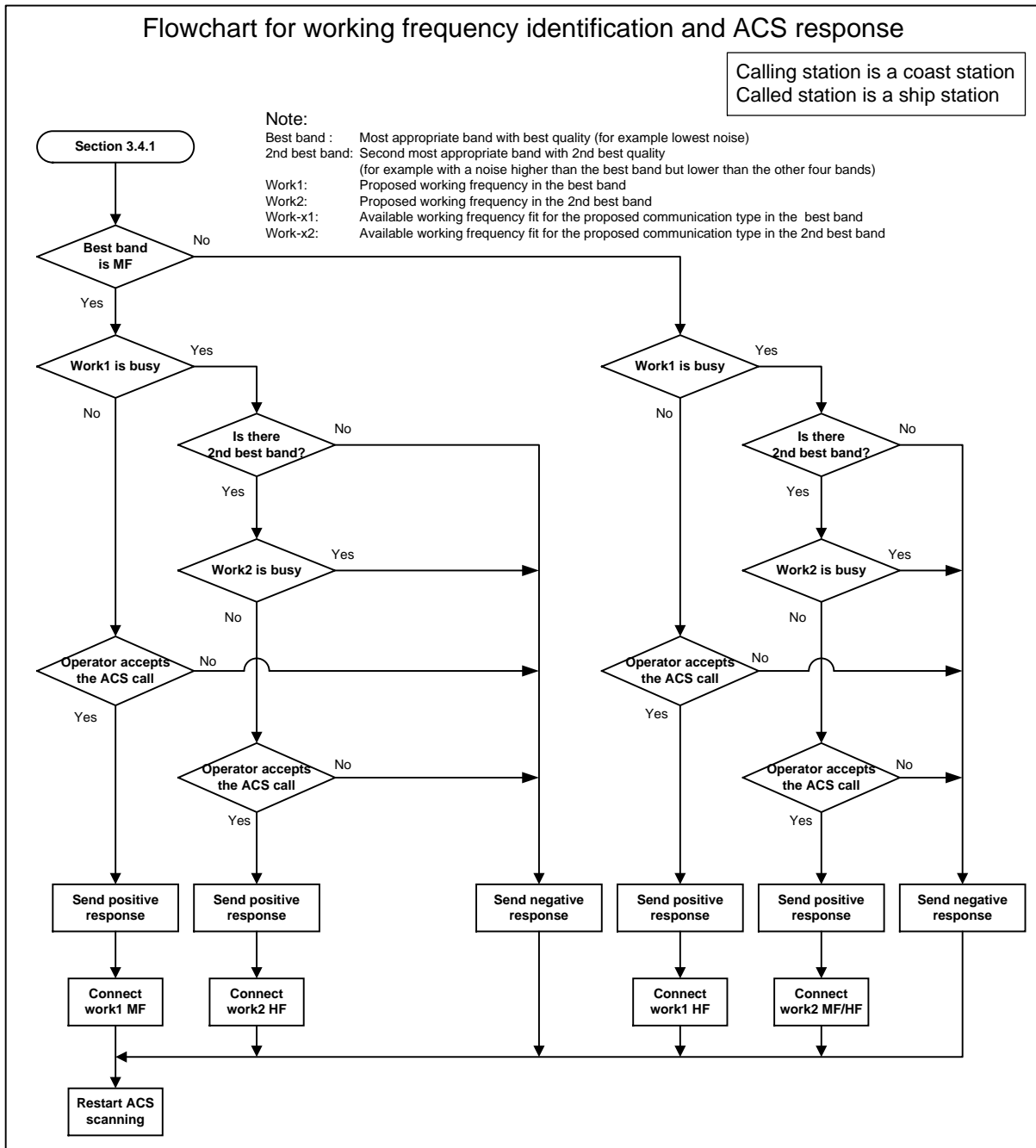

3.4.2 Response to a ship station

3.4.2.1 Response of a ship to a ship station

When the calling station is a ship station and the called station is a ship station, the ACS of the called station checks whether the proposed working frequency is suitable for the subsequent communication (e.g. the frequency is not busy) in the most appropriate frequency band recorded in 3.3.1.

When the most appropriate band is a MF band and the proposed working frequency in the MF band is not suitable, ACS checks whether the proposed working frequency is appropriate for the type of communication in the second most appropriate frequency band (i.e. a HF band) as recorded in 3.3.1.

If the proposed working frequency in the HF band is not suitable, then ACS searches the HF band for another working frequency suitable for the type of communication.

NOTE – In MF band, ACS checks only proposed working frequency because frequencies are limited in MF band, therefore ACS does not search alternative working frequency in MF band.

When the most appropriate band is an HF band and the proposed working frequency in the HF band is not suitable, ACS searches another working frequency suitable for the type of communication in the same frequency band. ACS should use the receiver which is handling communication.

When there is a suitable working frequency in the most or second most appropriate band for subsequent communication, ACS notifies operator of the identified working frequency with the proposed mode and the operator can decide whether to accept the ACS call. All frequencies in Appendix 17 of the Radio Regulations may be used manually as an alternative to ACS.

If the operator decides to accept the ACS call, ACS responds to the calling station on the most appropriate ACS frequency as recorded in 3.3.1 including working frequency or frequencies, then the procedure goes to 3.3.5.

The positive response from a ship station to a ship station with acceptance of the connection is composed as follows:

- Category of call: ACS
- Message 1 first telecommand: type of communication (e.g. J3E, F1B or Data)
- Message 1 second telecommand: no information
- Message 2: working frequency.

If the operator decides to reject the ACS call, ACS responds to the calling station on the most appropriate ACS frequency as recorded in 3.3.1 negatively and the procedure goes to restart scanning.

The negative response from a ship station to a ship station when the operator decides to reject the call is composed as follows:

- Category of call: ACS
- Message 1 first telecommand: Unable to comply
- Message 1 second telecommand: No operator available or Operator temporarily unavailable
- Message 2: position if available, or no information.

When there is no suitable working frequency in most and second most appropriate frequency bands, ACS responds to reject the connection to the calling station on the most appropriate ACS frequency as recorded in 3.3.1.

The negative response from a ship station to a ship station when there is no identified working frequency is composed as follows:

- Category of call: ACS
- Message 1 first telecommand: Unable to comply
- Message 1 second telecommand: Unable to use proposed channel
- Message 2: position if available, or no information.

When there is no identified working frequency, ACS responds to reject connection to the calling station on the most appropriate ACS frequency as recorded in 3.3.1 with the following conditions:

- When the most appropriate frequency band is MF band and the proposed working frequency is not suitable, and also there is no alternative suitable working frequency in the second most appropriate frequency band of HF; or

- When the most appropriate frequency band is HF band and the proposed working frequency is not suitable, and also there is no alternative suitable working frequency; or
- In the case of ACS for MF band only, the proposed working frequency is not suitable.

Then the ACS receiver restarts scanning.

FIGURE 3

Flow chart for working frequency identification and following an ACS response for the called station when calling station and called station are both ship stations

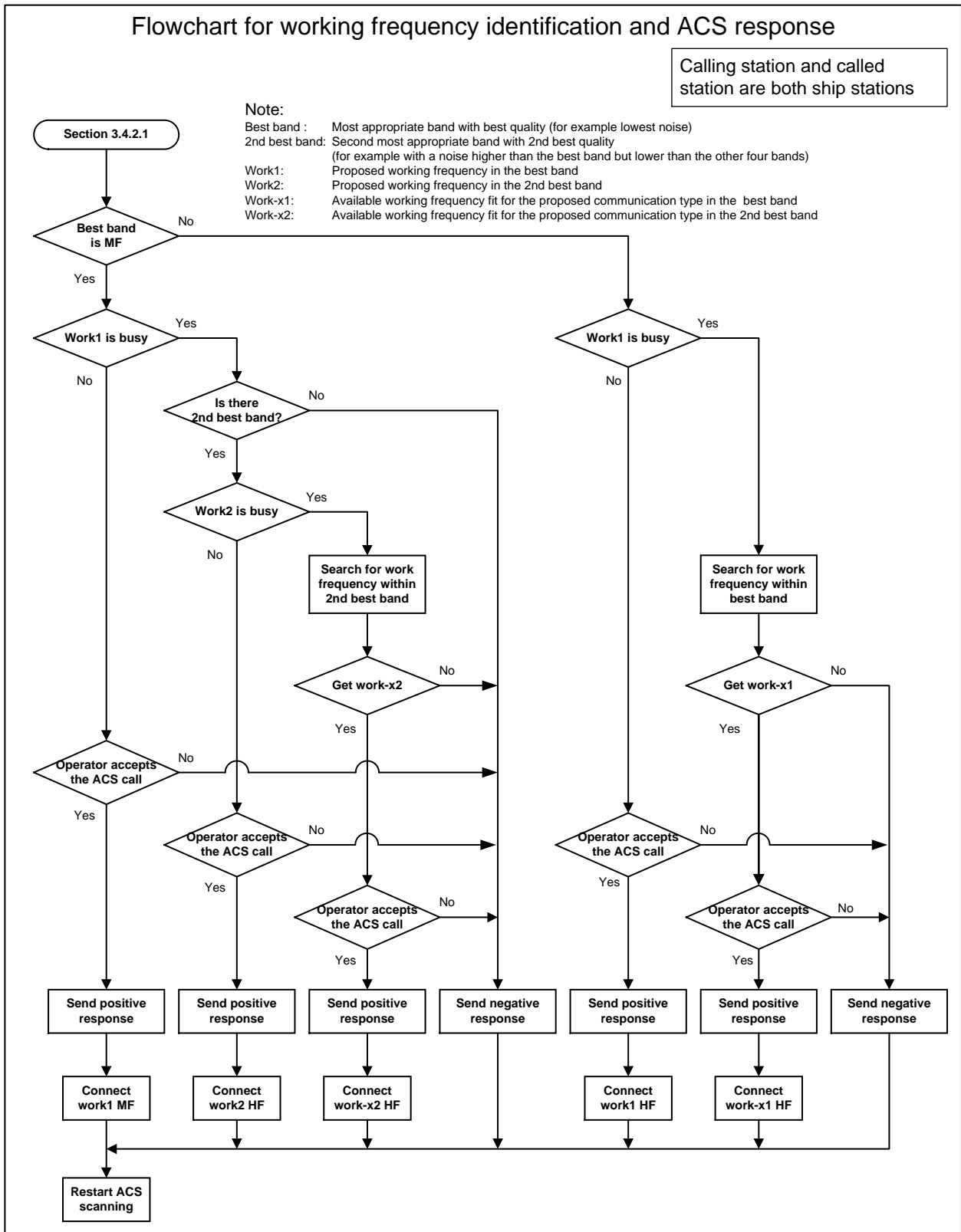

3.4.2.2 Response of a coast station to a ship station

When the calling station is a ship station and the called station is a coast station, the following procedure in Fig. 4 applies to the frequency identification and following ACS response.

When the most appropriate band is MF band, ACS searches the MF band for available working frequency (e.g. the frequency is not busy) for the proposed communication type. If no suitable frequency in the MF band is identified, ACS searches the second most appropriate band for available working frequency.

When the most appropriate band is an HF band, ACS searches the HF band for available working frequency (e.g. the frequency is not busy) for the proposed communication type.

When a suitable frequency is not identified according to Fig. 4, ACS responds to reject the connection to a calling station on the most appropriate ACS frequency as recorded in 3.3.1 and the receiver designated for ACS restarts scanning.

The negative response from a coast station to a ship station when there is no identified working frequency is composed as follows:

- Category of call: ACS
- Message 1 first telecommand: Unable to comply
- Message 1 second telecommand: busy
- Message 2: position if available, or no information.

When a suitable frequency is identified according to Figure 4, ACS notifies operator of the identified working frequency with the proposed mode, and the operator can decide whether to accept the ACS call.

If the operator decides to accept the ACS call, ACS responds to the calling station on the most appropriate ACS frequency as recorded in 3.3.1 including the working frequency or frequencies, then the procedure goes to 3.3.5.

The positive response from a coast station to a ship station with acceptance of the connection is composed as follows:

- Category of call: ACS
- Message 1 first telecommand: type of communication (e.g. J3E, F1B or Data)
- Message 1 second telecommand: no information
- Message 2: working frequency or frequencies.

If the operator decides to reject the ACS call, ACS responds to the calling station on the most appropriate ACS frequency as recorded in 3.3.1 negatively and the procedure goes to restart scanning.

The negative response from a coast station to a ship station when the operator decides to reject the call is composed as follows:

- Category of call: ACS
- Message 1 first telecommand: Unable to comply
- Message 1 second telecommand: No operator available or Operator temporarily unavailable
- Message 2: position if available, or no information.

FIGURE 4

Flow chart for the working frequency identification and following an ACS response for the called station when calling station is a ship station and called station is a coast station

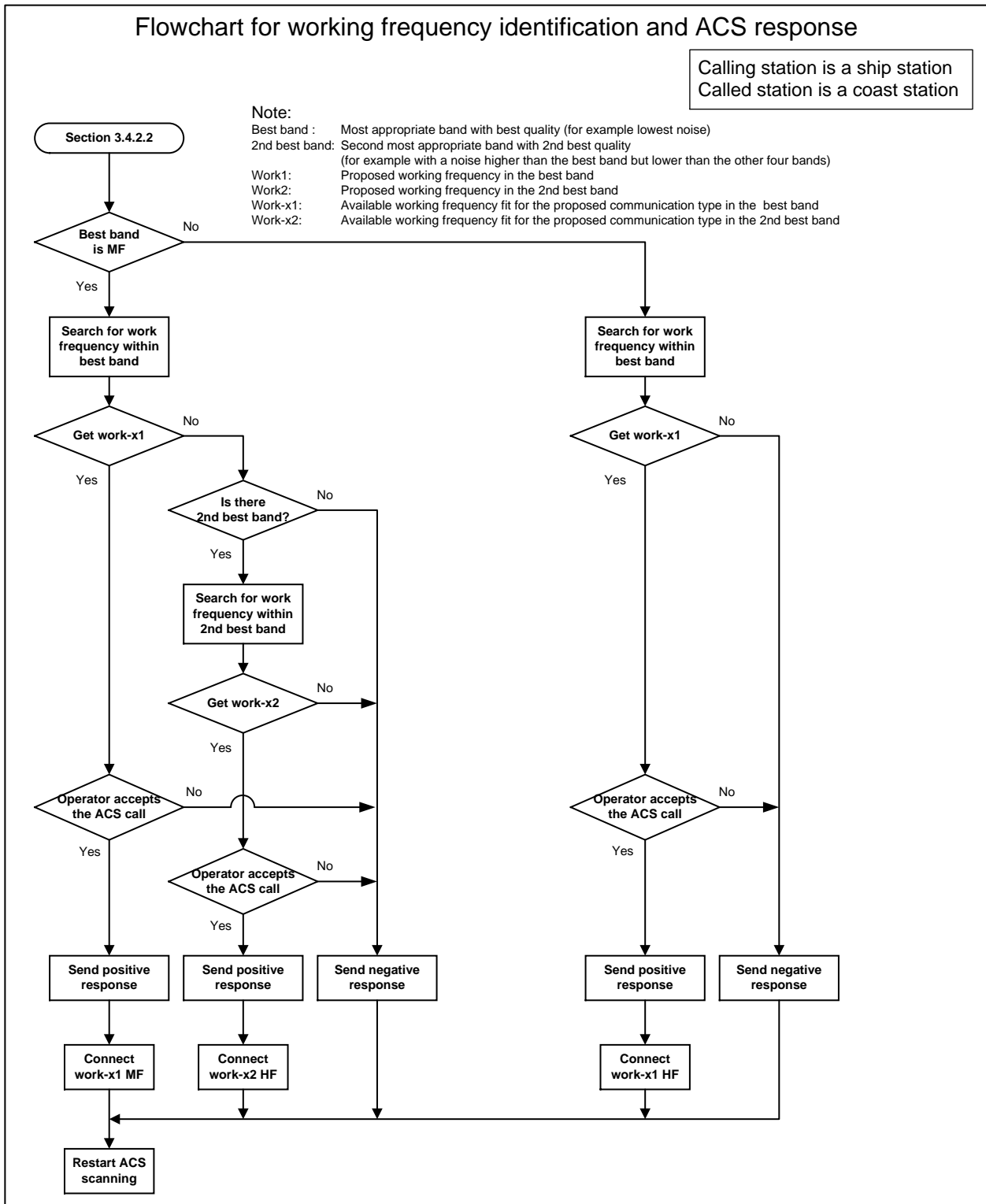

3.5 Selection of working frequency

3.5.1 The pre-setting of working frequencies in each MF/HF band is the basis for the search for the available working frequency in 3.2.3 and 3.2.4. The working frequency for subsequent communication should be selected from Appendix 17 of the RR according to the type of subsequent communication. In radiotelephony, simplex operation using single frequency is recommended for

ship-to-ship radiocommunication, however, duplex or semi-duplex operation using paired frequencies is recommended for public correspondence between coast station and ship station.

3.5.2 If the subsequent type of communication is HF radiotelephony, the working frequency should be selected in the frequencies of section 1 of the RR Appendix 17 Part B. However, the frequencies for the distress and safety traffic or frequencies for calling should be avoided.

3.5.3 In radiotelephony between the coast station and the ship station, the working frequency should be proposed always by the coast station. If the proposed working frequency is not available for the ship station called, then the ship station responds with its position information and waits for another proposal of working frequency by the coast station.

3.5.4 To minimize interference of working frequencies for duplex communications, if the last digit of MMSI of the ship station called is an even number, then it is recommended to use the working frequency of the even channel number in each frequency band of the RR Appendix 17. If the last digit of MMSI of the ship station called is an odd number, then it is recommended to use the working frequency of the odd channel number in each frequency band.

4 Digital selective calling messages of automatic connection system

ACS uses the following symbol numbers in the DSC format. For further information, see Recommendation ITU-R M.493.

Category of Call:	106 (ACS)
Second telecommand:	120 (No remaining ACS sequential transmission)
	121 (1 time remaining ACS sequential transmission)
	122 (2 times remaining ACS sequential transmission)
	123 (3 times remaining ACS sequential transmission)
	124 (4 times remaining ACS sequential transmission)
	125 (5 times remaining ACS sequential transmission).

Annex

Automatic connection system field experiment

A1 Introduction

Field experiment was carried out to confirm that the connection could be established using the ACS communication protocol, and to confirm that automatic connection establishment using ACS was effective.

A2 Test method

A2.1 Test station

For this test, the experimental radio stations were placed in Tokyo and Okinawa, Japan. The distance between the two stations is approximately 1 500 km.

FIGURE 5
Test sites

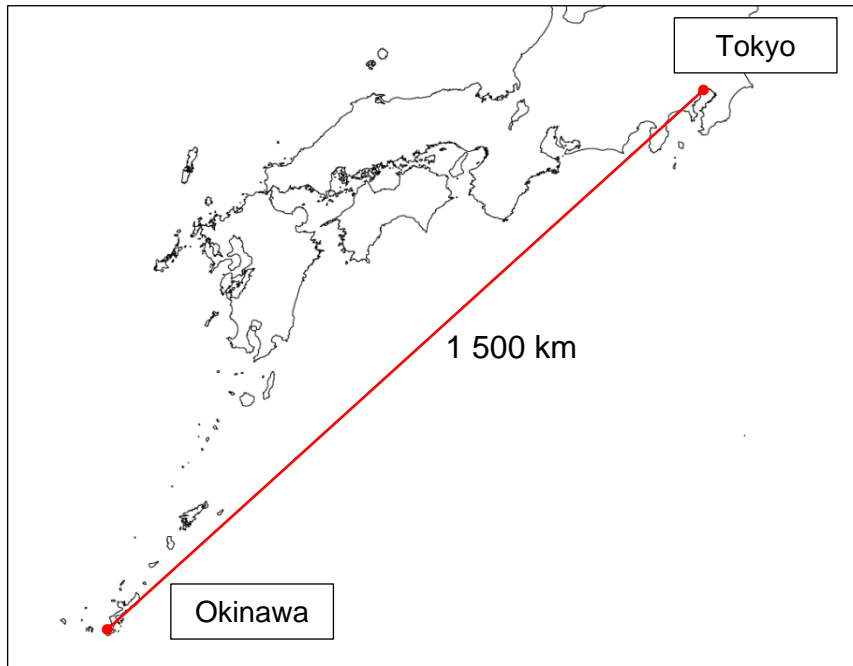

A2.2 Propagation prediction

Propagation prediction was performed by Voice of America Coverage Analysis Program prior to the field experiment. The propagation prediction is shown in Fig. 6.

FIGURE 6
Propagation prediction using Voice of America Coverage Analysis Program

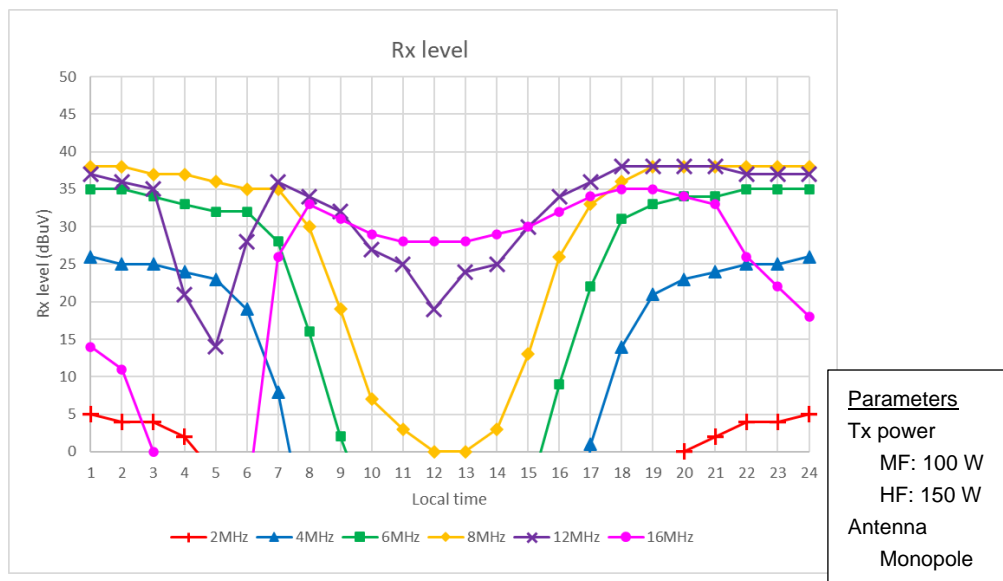

A2.3 Test setup

FIGURE 7
System configuration

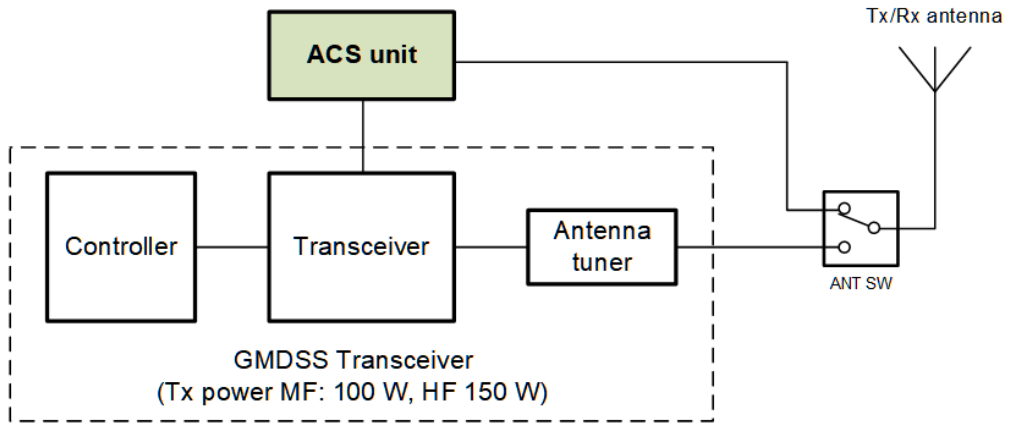
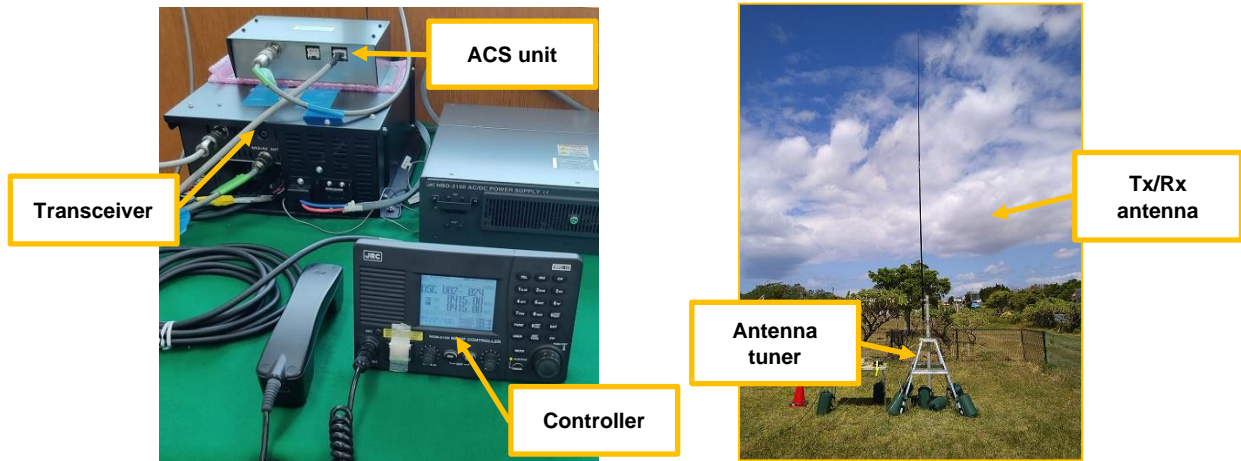

FIGURE 8
Setup (Okinawa station)



A2.4 Frequency used for testing

TABLE 1
Frequency used for testing

Frequency band (MHz)	Temporary ACS frequency for this experimental test (kHz)	Preset working frequencies for radiotelephone (kHz)*
2	2 169	2 065, 2 079, 2 082.5
4	4 208	4 146, 4 149
6	6 312.5	6 224, 6 227, 6 230
8	8 415	8 294, 8 297
12	12 577.5	12 353, 12 356, 12 362
16	16 805	16 528, 16 531, 16 534

* Carrier frequency.

A2.5 Verification method

This field experiment was carried out in March 2023. It would be better to repeat the test in different seasons, but in this test, the operation of ACS was verified by comparing the propagation predictions in March 2023 and test results.

A3 Test procedure

In accordance with the operational procedure in this document, the field experiment was carried out using the following procedure:

- a) Calling station calls the called station by using ACS.
- b) When the called station was able to receive the ACS call, record its frequency band.
- c) When a connection is established on the working frequency, confirm the communication by radiotelephone.

A4 Test result

The test was carried out several times at the following local time. Confirmed the selected frequency bands using ACS were similar to the results of the propagation prediction in § A2.2.

When it could not connect using ACS, it manually confirmed that it could not communicate using radiotelephone on any band.

Communications on the frequency selected by ACS were sometimes noisy, but in most cases readability was better than on other frequency bands, confirming the effectiveness of ACS operational procedures.

TABLE 2
Test results

Local time (JST)	Examples of frequency bands in which ACS calls were received at called station (MHz)	Examples of automatically connected radiotelephone frequency (kHz)
0800-0859	12, 16	12 356 ⁽¹⁾
0900-0959	12, 16	12 353
1200-1259	12	12 356 ⁽¹⁾
1300-1359	16	16 534 ⁽¹⁾
1400-1459	12, 16	16 534 ⁽¹⁾
1500-1559	12, 16	16 531 ⁽¹⁾
1700-1759	8, 12, 16	8 294
1900-1959	4, 6, 8, 12, 16	8 294
2300-2359	4, 6, 8, 12	8 297 ⁽¹⁾

⁽¹⁾ Channel automatically selected due to blocking of the initial channel.

Note to Table 2: To avoid interference, the operating hours of the experimental test station were limited because the Okinawa station was located at the existing coast station.
