

International Telecommunication Union

ITU-R
Radiocommunication Sector of ITU

Report ITU-R M.2373-1
(11/2018)

**Audio-visual capabilities and applications
supported by terrestrial IMT systems**

M Series
**Mobile, radiodetermination, amateur
and related satellite services**



International
Telecommunication
Union

Foreword

The role of the Radiocommunication Sector is to ensure the rational, equitable, efficient and economical use of the radio-frequency spectrum by all radiocommunication services, including satellite services, and carry out studies without limit of frequency range on the basis of which Recommendations are adopted.

The regulatory and policy functions of the Radiocommunication Sector are performed by World and Regional Radiocommunication Conferences and Radiocommunication Assemblies supported by Study Groups.

Policy on Intellectual Property Right (IPR)

ITU-R policy on IPR is described in the Common Patent Policy for ITU-T/ITU-R/ISO/IEC referenced in Resolution ITU-R 1. Forms to be used for the submission of patent statements and licensing declarations by patent holders are available from <http://www.itu.int/ITU-R/go/patents/en> where the Guidelines for Implementation of the Common Patent Policy for ITU-T/ITU-R/ISO/IEC and the ITU-R patent information database can also be found.

Series of ITU-R Reports

(Also available online at <http://www.itu.int/publ/R-REP/en>)

Series	Title
BO	Satellite delivery
BR	Recording for production, archival and play-out; film for television
BS	Broadcasting service (sound)
BT	Broadcasting service (television)
F	Fixed service
M	Mobile, radiodetermination, amateur and related satellite services
P	Radiowave propagation
RA	Radio astronomy
RS	Remote sensing systems
S	Fixed-satellite service
SA	Space applications and meteorology
SF	Frequency sharing and coordination between fixed-satellite and fixed service systems
SM	Spectrum management

Note: This ITU-R Report was approved in English by the Study Group under the procedure detailed in Resolution ITU-R 1.

Electronic Publication
Geneva, 2019

© ITU 2019

All rights reserved. No part of this publication may be reproduced, by any means whatsoever, without written permission of ITU.

REPORT ITU-R M.2373-1

**Audio-visual capabilities and applications supported
by terrestrial IMT systems**

(2015-2018)

TABLE OF CONTENTS

	<i>Page</i>
1 Introduction	3
2 Background and motivation	3
3 Related documents.....	4
4 Glossary of terms.....	4
5 User requirements and trends for audio-visual services and applications.....	5
5.1 Linear versus on-demand content.....	5
5.2 Emerging trends in user behaviour	6
5.3 Evolution of television systems	13
5.4 Virtual and Augmented reality	13
5.5 Summary of user requirements	14
6 The use of IMT in audio-visual content and service production.....	15
6.1 Audio-visual content production on remote location	15
6.2 Production studio	15
6.3 Remote editing.....	16
6.4 Stage performers	16
7 Identification of relevant use cases for the distribution of audio-visual services over IMT.....	16
7.1 User environments	16
7.2 User devices.....	17
8 Requirements for Audio-visual content provision	19
8.1 Audio-visual radio access network providers' requirements.....	20
8.2 Assessment of current IMT systems' ability to meet PSM general distribution requirements	20
8.3 Specific requirements	23
9 Characteristics of terrestrial IMT that enable audio-visual services and applications ...	23
9.1 Unicast	23

	<i>Page</i>
9.2 Supplemental Downlink (SDL)	23
9.3 eMBMS services.....	23
9.4 Beneficial further enhancements of eMBMS	24
9.5 Enhancement of the 3GPP system for TV services	24
9.6 Further technical enhancements of IMT.....	26
10 Conclusions	26
Annex 1 – List of acronyms.....	27
Annex 2 – Detailed description of LTE eMBMS features.....	30
A2.1 General description.....	30
A2.2 High level architecture.....	31
A2.3 Service framework.....	32
A2.4 Transport-only Mode	34
A2.5 Receive-only Mode.....	35
A2.6 Service discovery.....	35
A2.7 LTE downlink physical layer.....	36
A2.8 Segmentation/Concatenation across protocol layers	38
A2.9 MBSFN.....	38
A2.10 eMBMS architecture.....	39
A2.11 Synchronisation	41
A2.12 eMBMS area concepts.....	42
A2.13 eMBMS / unicast multiplexing.....	43
A2.14 User counting for MBSFN activation.....	43
A2.15 Service acquisition and continuity in multi-carrier networks.....	44
A2.16 Quality of service.....	45
A2.17 Standardization Outlook	45
Annex 3 – Demonstration trials of audio-visual over IMT.....	46
Annex 4 – Emerging transmission technologies for broadcasting/multicasting in IMT-2020	49
A4.1 Layered Division Multiplexing (LDM).....	49
A4.2 Cyclic Prefix, FFT size and High Speed Mobile Reception.....	49
A4.3 Time-Frequency Slicing (TFS).....	50
A4.4 Channel Bonding (and Statistical Multiplexing).....	50
A4.5 Non-Uniform Constellation Modulation	50
A4.6 Interleaving and Mobile Reception	50

1 Introduction

This Report examines the capabilities of IMT systems to deliver audio-visual services to consumers. The Report takes into consideration the increasing users' desire to consume such content at any time, in any place with their preferred device. It examines those user requirements as well as some of the requirements from the audio-visual content providers. It examines the use cases where IMT offers advantages over other audio-visual delivery systems, and evaluates the capabilities of the system in meeting those requirements. It also contains a discussion of desirable future enhancements to facilitate provision of audio-visual services over IMT.

The Annexes contain a detailed description of the features of IMT enhanced Multimedia Broadcast Multicast Services (eMBMS) that enable transport of content to multiple users and descriptions of demonstration trials of audio-visual over IMT.

2 Background and motivation

IMT has become an indispensable part of the daily life of consumers in many countries all over the world, and has become a common access platform for different services and applications. There is a growing demand by consumers for new services and applications in particular, for audio-visual content. Future developments of IMT are expected to enable service providers to satisfy many of these growing demands by providing audio-visual services over IMT. Today, audio-visual services over IMT (for both linear and on-demand audio-visual content) represent a small percentage of total audio-visual content consumption; however, it is expected that audio-visual over IMT will increase in the future and that it will be the major traffic contributor in IMT networks.

Mobile broadband users are demanding spontaneous access to audio-visual content and a higher-quality experience than ever before. Subscribers like to be able to consume content on multiple screens anytime, anywhere. As a result, new business models are emerging in which the line between fixed and mobile is becoming blurred. Service providers – especially over-the-top (OTT) players and content aggregators are making premium content available anytime, anywhere on a variety of devices. Mobile network operators (MNOs) are being challenged by the need to give consumers what they want, while preserving the efficiencies of their networks and creating new operative opportunities.

Through deployment of eMBMS in IMT networks, MNOs can manage network assets better by using a multicast/broadcast mode for popular content demanded by multiple subscribers, such as live TV and events. MNOs can also utilize off-peak capacity to deliver new service offerings, such as rich media caching or managed software updates. Lastly, broadcast capabilities enable MNOs to improve the quality of service (QoS) while enhancing the delivery of audio-visual content.

Offering audio-visual services over IMT already contributes to national safety and security, economies and social development by enabling a range of applications, such as social media, distance learning, health and entertainment. Other applications that benefit from unicast and multicast capabilities of IMT include e.g. early warning, dissemination of information during disaster mitigation and relief operations, public safety alerts, amber alerts and automatic upgrades of application software and operating system (for example, downloading outside peak hours).

The delivery of audio-visual services over IMT could further contribute to the reduction of the digital divide between urban areas and rural areas or certain underserved communities. Socio-economic demands are already driving requirements for access to audio-visual services and applications, for users to experience similar quality of experience (QoE), including coverage and data rates in rural and urban areas. Therefore, there is a need to provide cost-efficient coverage and capacity in rural areas, especially in developing countries.

A IMT is expected to complement traditional broadcasting systems (cable, satellite or terrestrial delivery) or other broadband services (fixed internet access or RLAN) to satisfy consumer demand

for audio-visual services, in particular with respect to personalization, portability, easy to use, and mobility.

3 Related documents

Recommendation [ITU-R BT.2020](#) – Parameter values for ultra-high definition television systems for production and international programme exchange

Recommendation [ITU-R BT.2100](#) – Image parameter values for high dynamic range television for use in production and international programme exchange

Recommendation [ITU-R F.1777](#) – System characteristics of television outside broadcast, electronic news gathering and electronic field production in the fixed service for use in sharing studies

Recommendation [ITU-R M.687](#) – International Mobile Telecommunications-2000 (IMT-2000)

Recommendation [ITU-R M.1079-2](#) – Performance and quality of service requirements for International Mobile Telecommunications-2000 (IMT-2000) access networks

Recommendation [ITU-R M.1822](#) – Framework for services supported by IMT

Recommendation [ITU-R M.1824](#) – System characteristics of television outside broadcast, electronic news gathering and electronic field production in the mobile service for use in sharing studies

Recommendation [ITU-R M.2083](#) – IMT Vision - Framework and overall objectives of the future development of IMT for 2020 and beyond

Report [ITU-R M.2410](#) – Minimum requirements related to technical performance for IMT-2020 radio interface(s)

Recommendation [ITU-T J.301](#) – Requirements for augmented reality smart television systems

Recommendation [ITU-T Q.1702](#) – Long-term vision of network aspects for systems beyond IMT-2000

Recommendation [ITU-T Q.1703](#) – Service and network capabilities framework of network aspects for systems beyond IMT-2000

CITEL Technical Notebook “Cooperation and convergence between broadcasting and mobile services using LTE networks” https://www.citel.oas.org/en/SiteAssets/About-Citel/Publications/Technical_Notebook/P2!R-3339p1_i.pdf

EBU Technical Report TR 026 “Assessment of Available Options for the Distribution of Broadcast Services”, June 2014. <https://tech.ebu.ch/docs/techreports/tr026.pdf>

EBU Technical Report TR 027 “Delivery of broadcast content over LTE networks”, July 2014.: <https://tech.ebu.ch/docs/techreports/tr027.pdf>

ECC Report 224 “Long Term Vision for the UHF broadcasting band” November 2014. <http://www.erodocdb.dk/doks/doccategoryECC.aspx?doccatid=4>

4 Glossary of terms

In this Report, the following terms are used with the following meanings:

Audio-visual content

Audio-visual content is data which represents moving pictures (or a series of still pictures), normally accompanied by related sound. Sometimes, the content can be just audio.

Linear audio-visual service

A linear audio-visual service refers to the traditional way of offering radio or TV services. Listeners and viewers “tune in” to the content organized as a scheduled sequence that may consist of e.g. news,

shows, drama or movies on TV or various types of audio content on radio. These sequences of scheduled programs are set up by content providers and cannot be changed by a listener or a viewer.

Linear services are not confined to a specific distribution technology. For example, a scheduled live stream on the Internet is to be considered as a linear service as well.

On-demand audio-visual service

On-demand audio-visual service refers to services which are actively requested by users giving them the freedom to choose when and where to consume the content. The user can select individual pieces of content and can control the timing and sequence of the consumption.

Examples of popular on-demand services are TV catch up and time-shifting. Other forms of on-demand services include downloading content to local storage for future consumption or access to audio-visual content for immediate consumption.

Hybrid service

A hybrid service consists of inter-related linear and on-demand elements. They complement each other in the sense of enriching the viewing experience. This requires a certain level of integration when producing the content.

Examples include slideshows for digital radio or second screen television.

Audio-visual service use case, use case

A use case is a combination of an audio-visual service (linear, on-demand or hybrid), the user environment in which the service is used, and a user device (see section 6 for more details).

5 User requirements and trends for audio-visual services and applications

5.1 Linear versus on-demand content

Linear content and services refers to offers which are organized as a sequence of different elements such as news, movies, episodes of series, weather information, live sports coverage, etc. Typically, editing departments of broadcasting companies are creating linear radio and TV programmes from these elements. Users can tune into a radio or TV channel, they can switch from one to another, or if they do not like what they get, they can switch off. Hence, user interaction is very limited as they can neither change the sequence nor the time at which a certain piece of content is offered.

Nonlinear or on-demand content and services refer to individual elements of the linear offer or other elements which are provided in way that users can decide themselves when, where and on which device they want to enjoy the content. On-demand content is made available in terms of data bases to which users can connect by means of apps or web browsers. Examples are the German broadcasters' Mediatheken¹, the BBC offer on iPlayer², and the CBC player³. On-demand content can also be accessed on platforms such as YouTube or Facebook. The decision about when, where and on which device consumption of on-demand content is happening is subject to the possibility of having access to content and services through an appropriate network.

¹ <http://www.ardmediathek.de/tv>.

² <https://www.bbc.co.uk/iplayer>.

³ <http://www.cbc.ca/player/>.

Traditionally, linear audio-visual services have been delivered by broadcast networks. With the rise of broadband networks (both fixed and mobile), it has become possible for users to request content in an on-demand fashion as well as continuing to consume linear services.

There are significant spikes in audio-visual consumption, due to major sporting events, breaking news, highly watched TV programs and celebrity events. Examples are the finals of soccer championships, the Oscars, concerts, royal weddings, and so on. As IMT networks' coverage and capability increase, it is expected that the amount of audio-visual content delivered to IMT user devices will also increase.

In the long term, the balance between linear and on-demand distribution is uncertain. There is evidence that younger generations are watching less linear and more on-demand audio-visual content.

Audio-visual services offered over IMT will also be an important means of getting information to citizens from local and national authorities in times of natural disasters and other emergencies. To this end, it is important that alerts can be confined to particular geographical areas. Secondly, usage of multicast/broadcast modes allows doing this efficiently.

5.2 Emerging trends in user behaviour

In the last few years, on-demand consumption of audio-visual content has grown rapidly⁴. YouTube traffic accounts for between 40% and 70% of total video traffic for almost all measured broadband networks, regardless of device type [1]. Linear audio-visual consumption remains relatively constant [2] and it appears that part of the growth of online on-demand consumption is arising from a reduction in other on-demand delivery domains (such as DVDs and CDs). Furthermore, the digitalization of television broadcasting has substantially increased the number of linear audio-visual services.

Mobile video traffic is forecast to grow by around 45% annually through 2023 to account for 73% of all mobile data traffic. Traffic from social networking is also expected to rise – increasing by 31% annually over the next 6 years. However, its relative share of traffic will decline from 12% in 2017 to around 8% in 2023, because of the stronger growth of video. Furthermore, an emerging trend with increased streaming of immersive video formats, such as 360-degree video, would also impact data traffic consumption. For example, a YouTube 360-degree video consumes four to five times as much bandwidth as a normal YouTube video at the same resolution [3].

Increasing demand for AV services is reflected also in an increase in the average amount of time spent by users watching audio-visual content on mobile devices (see Fig. 1).

⁴ The DigiWorld yearbook 2014 from IDATE indicates that linear TV still represents 90% of the world audio-visual services market, which has grown 4.2% from the previous year; while OTT (Over The Top) represents 4.4% of the market, growing 37% in 2013.

FIGURE 1

Consumption of audio-visual content by device⁵
 Source: Ericsson ConsumerLab TV & Media 2017 Study [4]

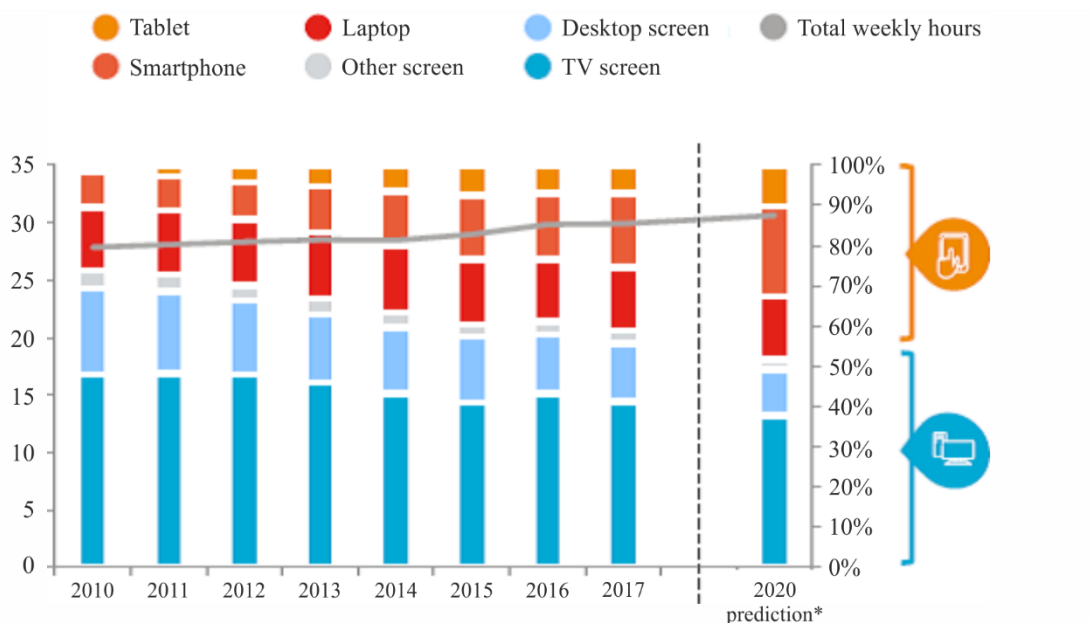

* Based on best-fit-regression analyses

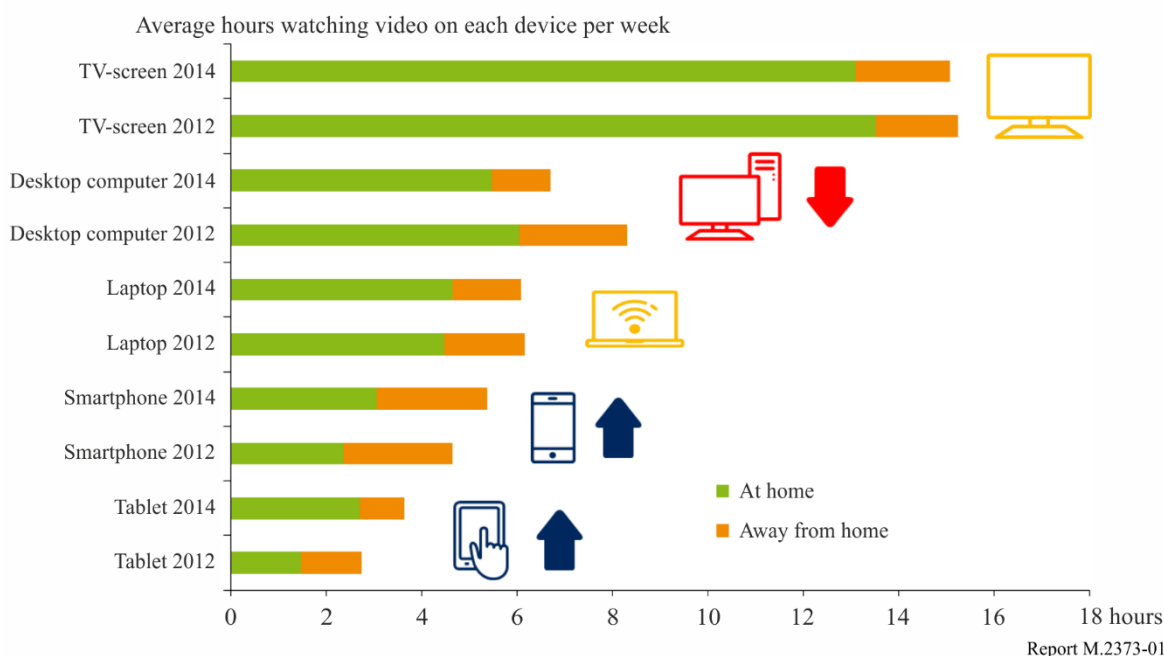

Figure 1 shows the share of total TV/video-time done on respective device screen on the right axis, and the average total number of hours per week watching TV/video on the left axis. The grey line, corresponding to the left hand vertical axis, shows how the total viewing time has changed over time. All this is based on habits and behaviour self-reported by viewers, rather than, for example, on-device measurements. Hence, the data may differ from that found in some countries through traditional broadcast audience measurement (e.g. BARB or Nielsen).

⁵ BASE: Population aged 16-69 watching TV/Video at least weekly and having Broadband at home in Brazil, Canada, China, Germany, India, Italy, Russia, South Korea, Spain, Sweden, United Kingdom and the United States of America.

It can be noted that overall viewing time is slightly up and there is an ongoing shift of viewing from fixed screens to mobile devices. The time spent watching on conventional TV screens is dropping and in the same timeframe viewing on smartphones is increasing. Also, the tablet viewing is growing, while the laptop time is fairly stable. Weekly share of time spent on TV/Video watching on mobile devices (Smartphone, laptop, tablet) has thus grown by 85% between 2010 and 2016, whereas, on fixed screens (TV, Desktops) it has gone down by 14%.

Figure 1 includes a 2020 prediction based on best-fit-regression analyses: by 2020, half of all viewing will be done on a mobile screen, an 85% increase since 2010. Almost 1/4 will be done on the smartphone alone, an increase of almost 160% since 2010. In the same time, total viewing time will have increased some 10%, reaching almost 31 hours per week by 2020.

There are also some country specific studies, for example Fig. 2 below shows that in the UK, 93% of total viewing was done on a TV set, 4% on a computer, 2% on a tablet, and 1% on a smartphone in 2014. Two years later, this proportion remains the same⁶. The Dutch Media: Tijd study shows similar results, with 91% of viewing done on TV sets in 2015. While younger age groups tend to embrace viewing on other devices, still the TV set remains dominant also for them. Among Dutch teens aged 13-19, the TV screen accounted for 70% of all viewing in 2015, followed by computer (20%), tablet (4%) and smartphone (3%).

According to Google's Consumer Barometer, nearly one out of three European adults now have access to a connected TV. For these people, TV sets are no longer limited to live or recorded TV, but also allow access to broadcaster catch-up, on demand services and online video platforms.

According to Ofcom's Media Tracker, 47% of connected TV owners used such services in 2015.

FIGURE 2
Total viewing time by device
Source: EBU Media Information Service, based on Ofcom Digital Day
Base: adults aged 16+, United Kingdom, type in % of total viewing

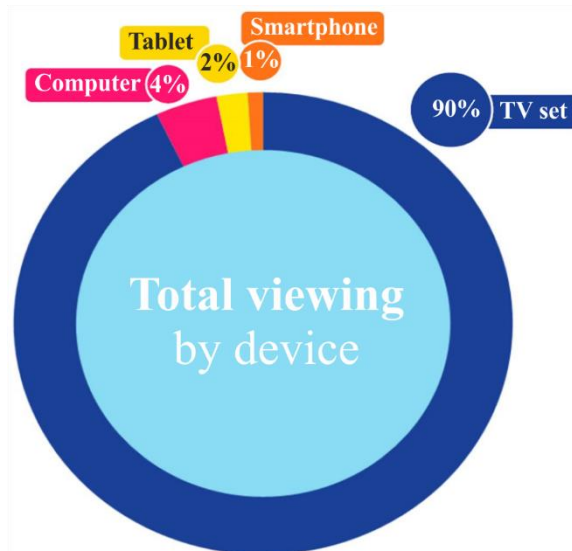

Report M.2373-02

⁶ 2016 update of the Ofcom Digital Day: <https://www.ofcom.org.uk/research-and-data/multi-sector-research/general-communications/digital-day>.

TV series and movies make up roughly half of consumers' total viewing time, which for the nine markets considered here⁷ the average weekly active viewing time in 2015 was 27 hours (this includes viewing broadcast TV, recorded TV, and downloading) [5].

Content viewing is also growing, in 2011, people estimated that they spent 2.9 hours per week watching streamed TV series, programs and movies. In 2015 it was 6 hours per week – the viewing has more than doubled (Fig. 2). This analysis is for viewers of video/TV at home, aged 16-59, that have a high-speed internet connection at home (typically enabling the users to access the Internet from any device at home, e.g. using RLANs) irrespective of how the home internet connection is delivered (i.e. they could have xDSL, Fiber, internet through Cable TV provider or even an 3G/4G/LTE home router that “converts” mobile broadband into RLAN and/or Ethernet at home; however, what is not included is if users only have mobile broadband on their smartphones).

FIGURE 3

The increase in watching on-demand TV series and movies
Source: Ericsson ConsumerLab, TV and Media 2011 and 2015 Studies
Base: At least weekly viewers of video/TV with broadband at home, aged 16–59

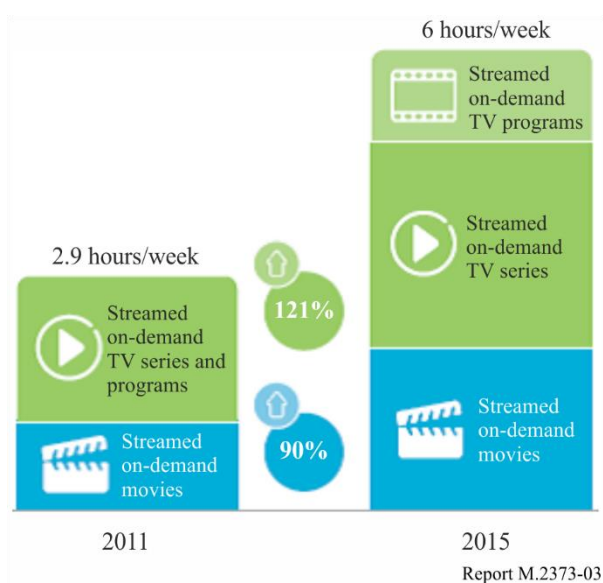

According to Ofcom's Digital Day research, in 2010 live TV represented 82% of total viewing in the UK. Between 2010 and 2014, the total viewing time increased from 3 h 32 m per day to 4 h 18 m. Although the amount of time dedicated to live TV was stable, it proportionally declined to 69% of total viewing. In the latest Digital Day survey, carried out early 2016, total viewing time was nearly stable (4h14m per day) while the proportion of live TV slightly dropped to 63% of total viewing. Combined with recorded TV and free on-demand (catch-up), broadcaster content still represents 8.6 out of every 10 minutes watched.

FIGURE 4

Total viewing time by content
Source: EBU Media Information Service, based on Ofcom Digital Day
Base: adults aged 16+, United Kingdom, type in % of total viewing

⁷ Brazil, China, Germany, South Korea, Spain, Sweden, United Kingdom and United States of America.

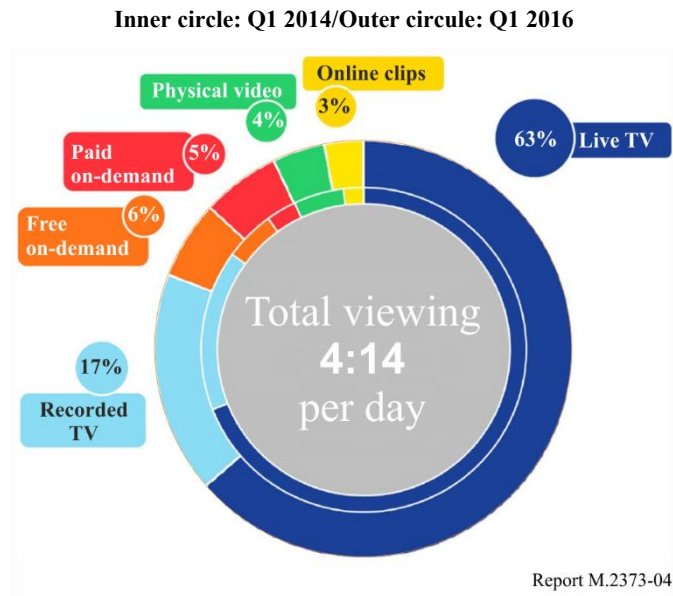

Source: Ofcom Digital Day

Consumers wishing to consume audio-visual content on a mobile device face different barriers (see Fig. 5), outside the home, which tend to limit their mobile audio-visual usage. These barriers cause many consumers to prioritize other activities (e.g. gaming, browsing) instead of watching video or wait until they are home or have RLAN coverage. The study reveals three categories of barriers, cost technology and user behaviour. Once the limiting barriers have been removed or reduced, it is likely that mobile consumption will increase.

FIGURE 5

Mobile barriers: When away from home, to what extent are the following factors limiting your consumption of TV and video content on a mobile device (Showing top 2 alternatives on a 7-graded scale).

BASE: Base 23 Markets⁸, Source: Ericsson ConsumerLab TV & Media 2014 Study

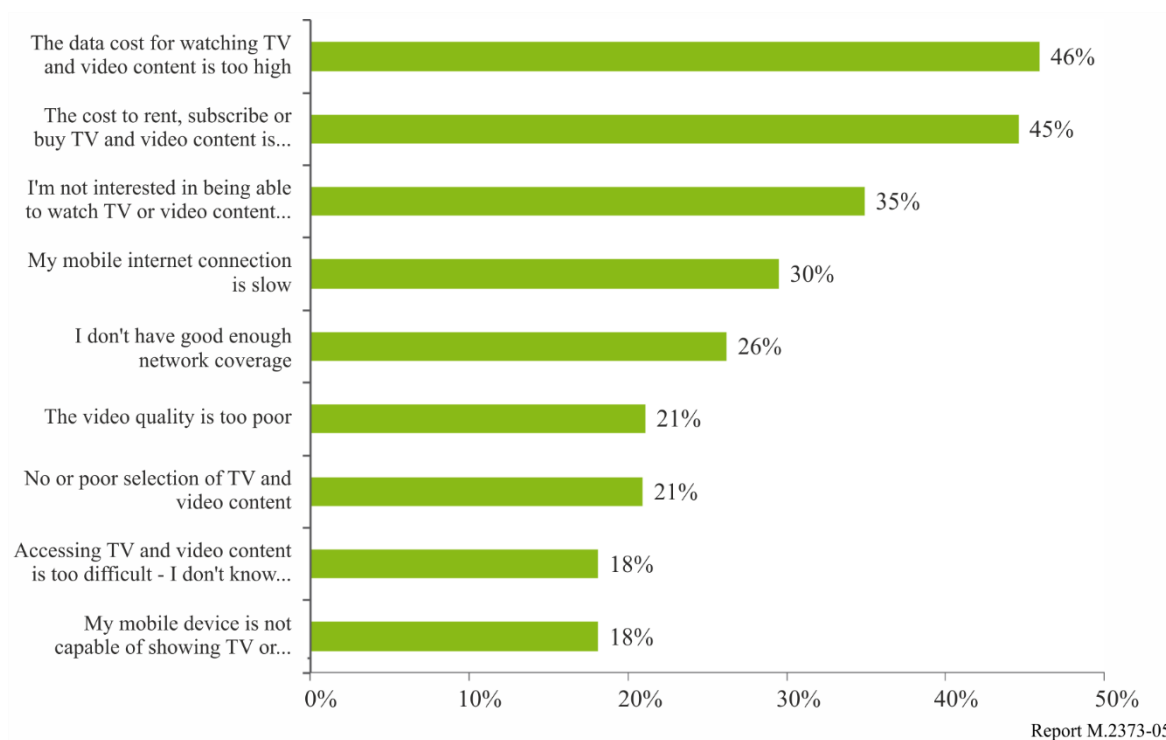

Another trend is that the user expectations of picture quality are constantly increasing (see Fig. 6). This is a natural part of the evolution of audio-visual and is likely to continue as enhancements, such as higher definition, become available.

⁸ Brazil, Canada, Chile, China, France, Germany, Greece, Indonesia, Ireland, Italy, Malaysia, Mexico, Portugal, Russia, Singapore, Spain, South Korea, Sweden, Turkey, UAE, UK and US.

FIGURE 6

Importance and willingness to pay for TV features⁹
Source: Ericsson ConsumerLab TV & Media 2016 Study

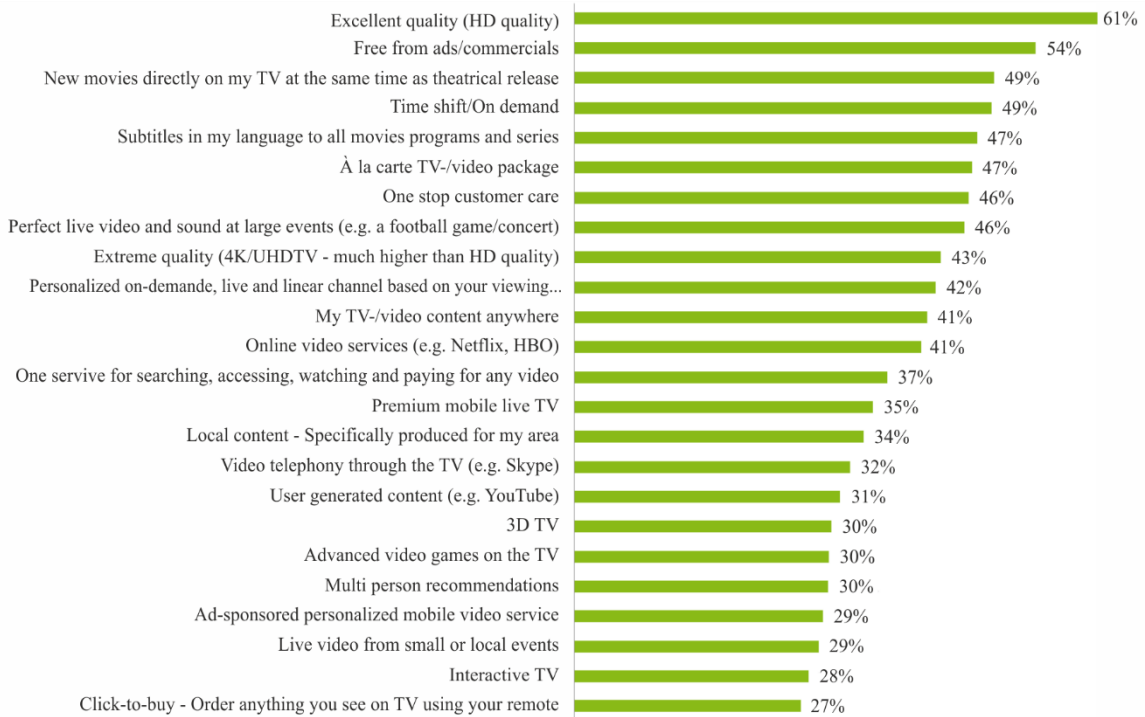

Percentage of customers that say each TV Media feature is important, by age (top 2 answers on 7-point scale), (self-reported)

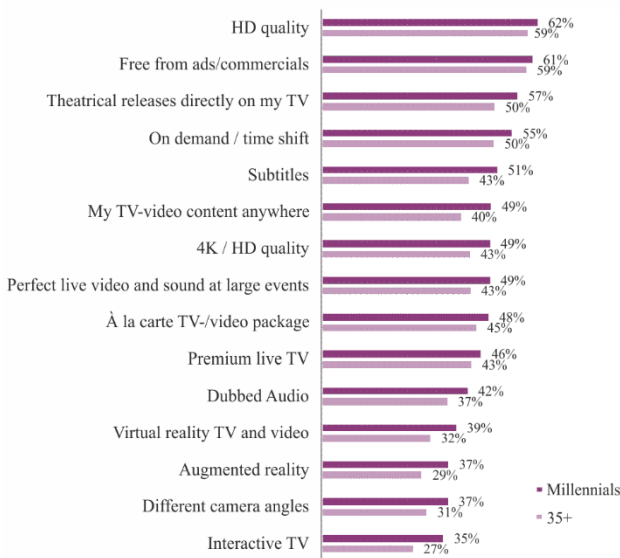

Percentage of customers that say each TV Media feature is worth paying for, by age (top 2 answers on 7-point scale), (self-reported)

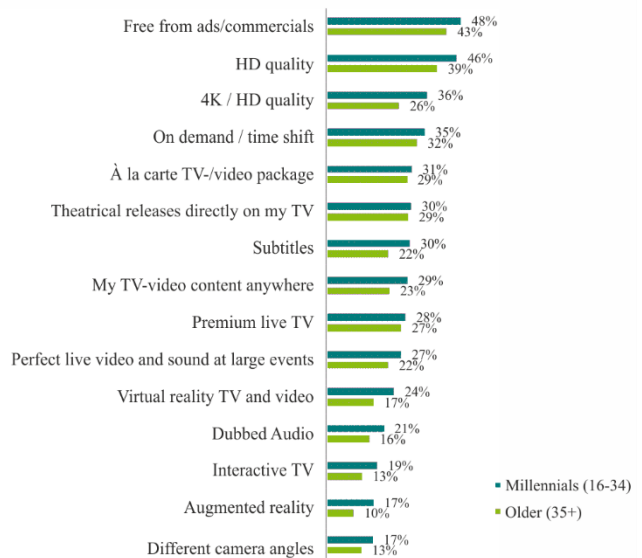

Report M.2373-06

⁹ BASE: Population aged 16-69 with broadband at home who watch any type of TV/Video at least weekly in Australia, Brazil, Canada, China, Colombia, Dominican Republic, Germany, Greece, India, Italy, Mexico, Netherlands, Poland, Portugal, Russia, South Africa, South Korea, Spain, Sweden, United Kingdom and United States of America (Interest, top two answers on 7-graded scale).

Figure 6 ranks importance and willingness to pay for the TV features – across all ages on the left, broken down by millennials (16-34 years) and 35+ on the right. In this 2016 study, ‘free from ads/commercials’ ranked as the number 1 feature worth paying for from audiences (it was number 2 in 2015). It is also worth noting the emergence of virtual reality TV and video, as well as augmented reality (cf. § 5.3).

Consumers are increasingly expecting to be able to access their services and content across all platforms and devices. This will not only extend to linear and on-demand services but include areas such as video communication, remote participation or control, cloud computing for games, safety etc. This will in turn put higher and new requirements on the delivery networks as well as the business models associated with them (roaming, data traffic, QoS).

5.3 Evolution of television systems

Broadcasters produce a wide range of content and services for distribution not only through traditional broadcast channels but also through the Internet, including IMT, and the audience has an increasing range of receiving devices for consumption of broadcast content in multiple reception environments. It is important to facilitate the distribution of broadcast content to end-users with various receiving devices in multiple reception environments (Ref.: Report ITU-R BT.2400).

As IMT continues to play an increasing role in the distribution of audio-visual broadcast, multicast and unicast signals, as well as other signals originating from broadcast content providers, collectively referred to as television, it will need to fulfil the consumer demand and requirements of advanced new and emerging systems. Report ITU-R BT.2246 gives background on all these features.

There are three new technology improvements for UHD-TV in Recommendations ITU-R BT.2020 and ITU-R BT.2100: HDR, Wider Colour Gamut (WCG) and High Frame Rate (HFR).

Ultra-high definition television (UHD-TV) represents the continuous evolution of television since it was invented in the 1930s, transforming the dim black and white screen into an ultra-high definition colour picture on large flat panel displays (Ref.: Recommendation ITU-R BT.2020).

High dynamic range television (HDR-TV) provides viewers with an enhanced visual experience by providing images that have been produced to look correct on brighter displays, that provide much brighter highlights, and that provide improved detail in dark areas (Ref.: Recommendation ITU-R BT.2100).

Wide Colour Gamut (WCG) represents a wider range of colours, as specified in Recommendation ITU-R BT.2020, and is also used in HDR-TV. Traditional TV systems could not reproduce the full range of colours visible to the human eye. Expanding the gamut of colours available to new TV systems improves the reproduction of scenes, rendering them more true to life. The texture of objects and highly saturated colours that are closer to those of real objects can be reproduced well.

High Frame Rate (HFR) represents higher temporal resolution that can reduce the perception of motion blur, stroboscopic effect, and flicker. Frame rates of up to 120 Hz are defined in Recommendation ITU-R BT.2020.

5.4 Virtual and Augmented reality

Virtual reality (VR) services give users the ability to access the sights and sounds of remotely located complex systems in real-time (Ref.: Recommendations ITU-T Q.1702 and ITU-T Q.1703). With recent progress made in rendering devices, such as head mounted displays (HMD), a significant quality of experience can be offered [6].

Augmented reality (AR) is a type of mixed reality where graphical elements are integrated into the real world in order to enhance user experience and enrich information (Ref.: Recommendation ITU-T J.301 (2014)).

The capabilities of IMT-2020 (cf. § 9) aim to support the requirements. To develop these opportunities a number of initiatives have been created, such as the Virtual Reality Industry Forum (VRIF) and the World Virtual Reality Forum (WVRF). ITU-R has also been studying advanced immersive audio-visual (AIAV) systems including VR, 360-degree video, and other immersive media technologies (Ref.: Question ITU-R 143/6).

The technologies such as AR or VR are employed by video communication. These technologies could be used in a use scenario of eMBB such as enjoying a sports game in a stadium more vividly. The use case could realize improved and seamless user experience as compared with the preceding generation systems.

AR allows users to have additional information from their environment by performing an analysis of their surroundings, deriving the semantics of the scene, augment it with additional knowledge provided by databases, and feed it back to the user within a very short time. Therefore, it requires low latency and computing/storage either at the mobile edge or on the device.

In AR services, UE can choose to offload part of the device computational load to a mobile edge application running on a mobile edge platform. UE needs to be connected to an instance of a specific application running on the mobile edge computing platform which can fulfil latency requirements of the application, and the interaction between the user and the application needs to be personalized, and continuity of the service needs to be maintained as the user moves around.

The arbitrary viewpoints visual application, as an example of VR/360° video, could be supported by the use of IMT-2020 radio interface technology, whose network realizes the characteristics of eMBB and low latency as use case scenario.

The arbitrary viewpoints visual technology could be supported by the radio link to gather data taken in some cameras, each of which tracks the same targeted object from various angles, and also by the radio link to deliver the whole gathered data to receivers to process the whole data for arbitrary viewpoints application.

It has been estimated [7] that one third of the consumers will be VR users by 2020, and, amongst current VR users, 40% use their VR headsets every single day, and roughly 60% already today watch TV and video content using their VR headsets.

5.5 Summary of user requirements

Audio-visual over IMT should be able to support the following services and applications:

- Rapid, flexible and straightforward on-demand delivery of AV content and services.
- Downloading of content for later access and use.
- Easy access to services essential for use in remote-areas e.g. tele-medicine, emergency services, disaster recovery, etc.
- Easy access to services for remote learning, also using one-to-many coaching and teaching and group presentation scenarios.
- Delivery of on-demand content; e.g. premium, free-of-charge or metadata to enhance user experience of live events such as sports events, music concerts, theatre events, carnivals, etc.
- Audio-visual services configured to ensure a high-quality viewing experience.
- Support for high definition (HD) audio-visual content as well as for higher resolution content in the future.
- Sponsored data and promotional messages.
- Allowing for bundling with other audio-visual and information sources.
- Good search mechanisms for content discovery.

6 The use of IMT in audio-visual content and service production

As described above, IMT may play an important role in the distribution of media content and services. However, it can be expected that also in the domain of AV content and service production IMT may become an important tool. There are several areas in which IMT networks may help to produce content in a cost efficient and flexible manner.

6.1 Audio-visual content production on remote location

Sporting and cultural events are important elements of the services offered by broadcasting companies around the world. Coverage of football matches or other sports competitions are highly demanded by users. Live news reports from various venues are also important for public service broadcasters. Live audio and video programmes need to be fed to production trucks at the venue or directly to production studios in the premises of broadcasting companies. On location reliable and scalable crew communication links are needed, in particular audio links. Remotely operated equipment such as cameras use reliable telemetry and control communications. These are called electronic news gathering (ENG), television outside broadcast (TVOB), electronic field production (EFP), services ancillary to programme making (SAP), and services ancillary to broadcasting (SAB). Details of service and operational requirements for video and audio SAB/SAP applications are described in Recommendation ITU-R BT.1872.

Relevant events take place inside and outside of buildings. Sometimes both situations need to be dealt with at the same time. Furthermore, audio and video content is produced under mobile conditions as well. Bicycle or car races are typical examples. The latter have to take into account high speeds (e.g. Formula 1 race cars operate at speeds of up to 360 km/h). Television outside broadcast, electronic news gathering, and electronic field production applications are described in Recommendations ITU-R F.1777 and ITU-R M.1824.

When there is neither a wired line nor a private wireless line, IMT networks are useful even though the available transmission capacity is not sufficient enough for good video quality. Requirements for ENG are specified in Recommendation ITU-R BT.1868.

Usually, a large number of microphones and several cameras are employed. They have to be carefully synchronized in time, in particular in live production.

In addition to live production IMT may become a viable communication means in movie production outside the studios. In terms of technical capabilities the same technical features are required apart from those that directly link to live transmission.

Video production, in particular in UHD quality, also includes high quality audio. However, radio and TV are independent broadcasting genres. Therefore, it must be possible to capture audio alone in order to produce radio programmes.

For news gathering applications IMT might be able to provide the necessary connectivity, in particular where network coverage and capacity are sufficient. However, business arrangements may need to be developed to ensure that journalists and the production crew have reliable access to the network, in particular in crowded areas.

6.2 Production studio

To date, most studios are using mainly wired communication infrastructure. Depending on the circumstances this is costly and inflexible. With the introduction of higher quality formats such as UHD-TV, and more complex productions using an increasing number of cameras, the wired infrastructure needs to be upgraded to cope with increasing demands in.

One of the current trends is the introduction of an all-IP production environment which would allow using standard hardware and specialised software solutions instead of dedicated, purpose-built

equipment. This opens the possibility to complement wired infrastructure by wireless components or replace it entirely in those use cases and applications where IMT is capable of meeting the service requirements.

6.3 Remote editing

High speed telecommunication networks offering reliable bandwidth and QoS allow to exploit production infrastructure distributed across different locations. Thereby better utilisation of existing production resources can be achieved which is likely to reduce production costs. Very high speed file transfer is crucial for remote editing in real-time. Elements of content which are combined to build a radio or TV service can be either stored on in-house servers or distributed in the cloud. IMT-2020 may be able to satisfy these requirements.

6.4 Stage performers

There may also be a role for IMT technology in relation to the PMSE (programme-making and special events) equipment used by live performers. This in particular includes wireless microphones, in-ear monitors, and a variety of service links. For complex stage productions the number of simultaneous links might be very high, i.e. more than 100 in the same location.

The business advantages that may emerge thanks to the application of IMT in media production include the possibility of handling live productions with high quality and high bandwidth without the need for large production vehicles. There is a clear potential for cost saving and for reducing the complexity of the workflows, provided that IMT will be able to meet the technical and operational requirements.

7 Identification of relevant use cases for the distribution of audio-visual services over IMT

Given the many ways in which audio-visual content can be consumed, some way of categorizing them can be helpful when assessing each of them. It is likely that many of the possible ways will not occur in real life and can be neglected. Others may be highly relevant and will require more detailed assessment.

In this section, different consumption patterns (“Use cases”) are identified as combinations of three independent factors:

- audio-visual service type;
- user environment; and
- user device.

Audio-visual service types are distinguished as linear and on-demand services as discussed in § 4. User environment and user device are explained below.

A use case is a unique combination of all three factors, for example on-demand service/Static user environment / Tablet user device. Many of these combinations are not likely to be relevant; others are of relevance for further study. Table 2 shows those use cases considered most relevant, along with a brief analysis of each.

7.1 User environments

Two different user environments are considered:

- *Static* – In this user environment, the user is within (or moving within) a private location that they use very regularly, for example the home, an indoor work environment (office,

workshop, etc.), or is an audio-visual display in a public location, and the user/owner has a high degree of control over the means of access to audio-visual services.

- *Dynamic* – In this user environment, the user is either nomadic or mobile in a location that they use occasionally, for example an airport, a train station or a shopping mall, or is travelling (in cars, trains, etc.), where they have limited control over the means of access to audio-visual services.

7.2 User devices

The following user devices are considered to be currently representative with regard to access to audio-visual services. It is assumed that all these devices can receive content via networks based on IMT technology. Furthermore, additional other connections (e.g. fixed/wired connections) are possible and implementation dependent. Other device types might emerge in future, and would need to be considered in future assessments.

TABLE 1

User device
Stationary TV set/video screen
Portable TV set
TV receiver/screen in a vehicle
Home audio system ('Hi-Fi')
Portable ('kitchen') radio
Radio receiver in a vehicle
Small ('pocket') radio
Desktop computer
Portable ('laptop') computer
Smartphone
Tablet

After elimination of non-relevant use cases, 19 use cases remain, as shown in Table 2.

TABLE 2

Relevant use cases

AV service type	User environment	User device	Remark
Linear	Static	Stationary TV set/video screen	This use case includes other situations where linear TV is delivered to stationary TV sets, such as public indoor spaces, outdoor public viewing, etc.
	Static	Portable TV set	Portable TV sets are often used as second sets in domestic settings (e.g. in kitchens and bedrooms).
	Static	Desktop computer	Many early online video distribution systems targeted desktop computers as the main device in the home with an IP connection.

AV service type	User environment	User device	Remark
	Static	Portable ('laptop') computer	Less convenient than smartphones and tablets, though often with larger screens In the home, laptops are often not the first choice devices for linear TV
	Static	Smartphone	Increasingly important device in the future due to its easy usability, ready availability and that the majority of users carry them all the time High relevance because e.g. in the home smartphones can be connected to a large screen.
	Static	Tablet	This is an increasingly important device due to its capabilities, easy usability and size of screen
	Dynamic	TV receiver/screen in a vehicle	Increasingly common means of video consumption
	Dynamic	Smartphone	Primarily for short programs such as news
	Dynamic	Tablet	This is an increasingly important device due to its capabilities, easy usability and size of screen
On-demand	Static	Stationary TV set/video screen	This use case could be highly relevant This use case includes other situations where on-demand TV is delivered to stationary TV sets via apps and widgets, and for uses such as public indoor information and advertising screens In the home smartphones can be connected to a large screen system
	Static	Portable TV set	This could become highly relevant as portable TV sets gain IP connectivity
	Static	Desktop computer	High relevance because of a growing market for on-demand TV services via personal computers.
	Static	Portable ('laptop') computer	High relevance because of a growing market for on-demand TV services via personal computers.
	Static	Smartphone	Increasingly important device in the future due to its easy usability, ready availability and majority of users carry them all the time
	Static	Tablet	This is an increasingly important device due to its capabilities, easy usability and size of screen

TABLE 2 (end)

AV service type	User environment	User device	Remark
	Dynamic	TV receiver/screen in a vehicle	Likely to become increasingly relevant as on-demand services become more easily accessible
	Dynamic	Portable ('laptop') computer	Nomadic access to on-demand content is increasingly prevalent.

AV service type	User environment	User device	Remark
	Dynamic	Smartphone	Widely used for short video clips (e.g. news or YouTube)
	Dynamic	Tablet	Likely to become increasingly relevant as on-demand services become more easily accessible. Already commonly used for “pre-downloaded” content

When evaluating various use cases involving IMT, the following observations regarding general trends in audio-visual services and the associated user behaviour should be borne in mind:

- Linear viewing is currently the preferred way of watching audio-visual content and it is expected that this will not change in the near future. On-demand viewing will continue to grow.
- The majority of audio-visual consumption, both linear and on-demand, currently occurs in the home. It is expected that this will not significantly change despite the increased usage of portable and mobile devices, nor with the growing adoption of innovative media services. Nevertheless, usage in dynamic user environments will increase.
- Hybrid broadcast-broadband services (e.g. tweeting while watching TV) are becoming commonplace based on broadcast platforms and fixed broadband infrastructures. In the future, hybrid services may also make use of wireless broadband.

8 Requirements for Audio-visual content provision

The provision of audio-visual content to users can be characterised by a chain of providers: firstly, content producers, then content aggregators, followed by the network operators, and finally the users of audiovisual content.

FIGURE 7
Audio-visual Content Value Chain

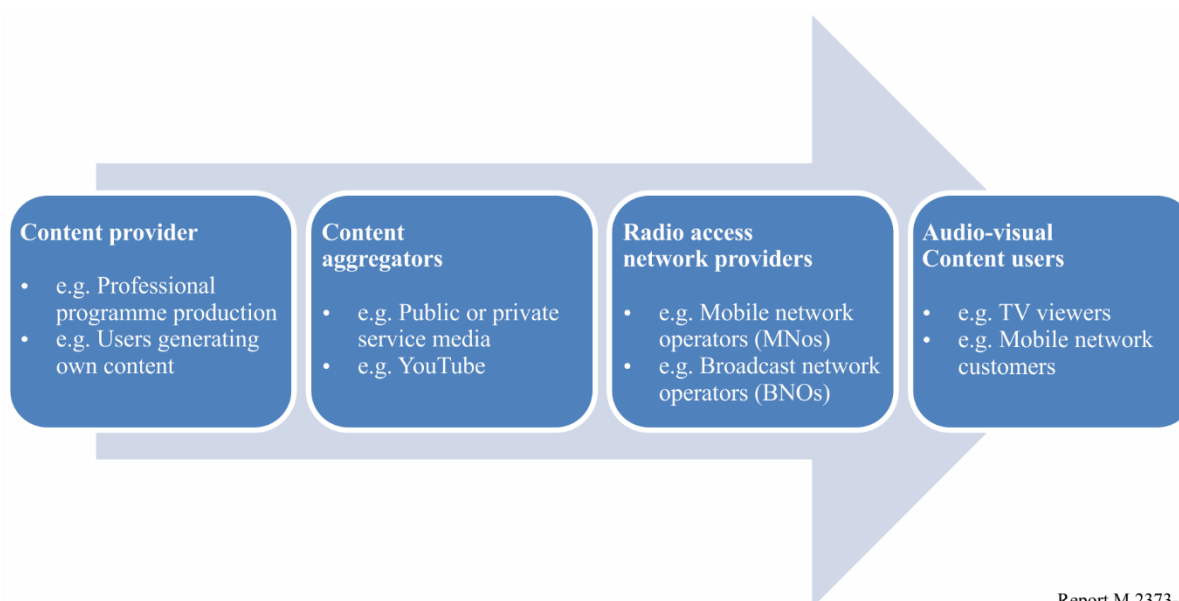

In § 8.1, some consideration is given to the operations of the radio access network providers, and this highlights some of the likely requirements of the interface between content aggregators and access providers.

In this Report, the needs of the content providers and aggregators are considered together, in § 8.2.

8.1 Audio-visual radio access network providers' requirements

For IMT service providers, audio-visual content delivery solutions need to be arranged in such a way that they enable radio access network providers to deliver multi-format and multi-screen services to users in a range of different circumstances, e.g. from stationary large screens to smartphones in high speed vehicles, as well as using agreed automated or pre-set content management procedures, allowing for efficient operations. Audio-visual content service solutions need to support standardized content formats as well as standardized interfaces between the content provider/aggregator and the radio access network provider.

Payload (involving e.g. coding, quality, resolution, frame rate, etc.) and content management procedures between content provider/aggregator and the radio access network provider need to be efficient (including energy efficiency) and support technical evolutions.

8.2 Assessment of current IMT systems' ability to meet PSM general distribution requirements

As IMT-2020 is expected to offer a flexible and dynamically adjustable network infrastructure for electronic communication of any kind, also the distribution of broadcast content and services may take advantage of coming innovations. Furthermore, if IMT-2020 technologies develop into the prevailing way of delivering any kind of electronic service it is vital for public service media organisations (PSM) to make sure that future distribution technologies will suit their needs and comply with their specific requirements.

In order to exploit the full benefits IMT-2020 may offer to the broadcast sector, broadcasters started to engage in the standardization process of IMT-2020 at ITU and in particular in 3GPP. To this end, public service broadcasters led by the EBU have submitted high-level requirements to be considered when developing future IMT-2020 technologies. These requirements are governed by the regulatory and legal obligations PSM have to adhere to. Commercial broadcasters may have partially different requirements. Figure 8 illustrates the requirements of PSM organisations.

FIGURE 8
High-level requirements of PSM organizations for IMT-2020 development

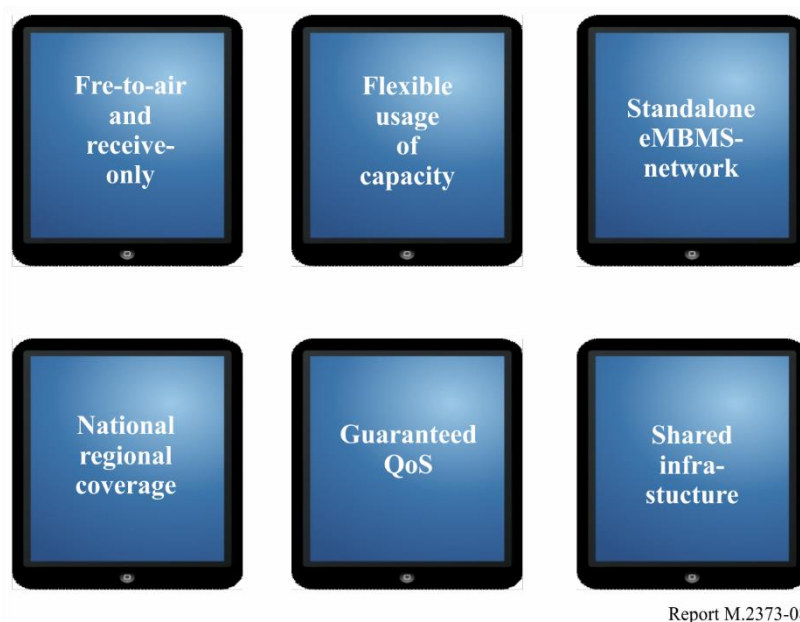

Free-to-air (FTA)¹⁰ distribution is one of the major objectives when it comes to distribution of PSM content and services. This can be implemented in a straightforward manner by making use of receive-only devices. Furthermore, efficient usage of network and spectrum resources is crucial as it is key for affordable content and service distribution. This touches upon flexible usage of spectrum carriers depending on traffic demands and other conditions. PSM organizations have to provide national, regional or local coverage depending on their respective remit. Quite often a mixture of different coverage obligations must be met.

A crucial element to meet the regulatory and economic requirements of PSM organizations is the possibility to deliver linear radio and TV programmes using dedicated standalone networks in those cases where this constitutes a viable solution. It must be possible to make available content and services provided across such networks to all users irrespective to which other network operator they may have a subscription to. In most countries, there are more than one mobile network operator. If a content provider wants to distribute his linear services to all users this would lead to redundant transmission of the same content over several networks. This would be a waste of network and spectrum resources and lead to prohibitive distribution costs for PSM organizations.

Table 3 contains the assessment of IMT-based systems that can meet the general requirements of PSM organisations with respect to distribution of their content and services.

¹⁰ Free-To-Air (FTA) means that radio or television content is distributed without any form of encryption and is available to the audience free-of-charge. In some cases there may be an obligatory license fee.

TABLE 3

Assessment of IMT ability to meet general distribution requirements

	General requirements	Assessment
1	Possibility for free-to-air or equivalent, with no additional costs for the viewers and listeners	Unencrypted content delivered via eMBMS can be received without a SIM card whereas in case it is delivered via LTE unicast a SIM card is required. The SIM card may be specifically configured by the provider to enable access only to the TV service and can also be provided for free. The associated regulatory, operational and business aspects need to be addressed.
2	Reception with devices that do not have transmitters "Receive-only Mode (ROM)"	In broadcast mode no uplink exists. Therefore, such ROM-receivers need no SIM-module as they can any way not perform an attach/registration procedure with the IMT-network. Broadcast reception mode does not prevent device implementations that possess any means for user interactivity (LAN, WLAN or even IMT-modules for unicast/multicast operation).
3	Ability to deliver services of PSM to the public without blocking or filtering the service offer, i.e. no gate keeping.	Feasible subject to commercial agreements.
4	Content and service integrity - no modification of content or service by third parties, e.g. TV content must be displayed on screen unaltered and without unauthorised overlays.	Technically feasible
5	Quality of service requirements to be defined by the content provider, such as: – QoS when the network is up and running – Availability of network: robustness, up-time, reliability	Feasible, subject to commercial agreement
6	Quality of service for each user shall be independent of the size of the audience	For unicast, subject to network capacity, as concurrent users share the available network capacity. Feasible for eMBMS.
7	Geographical extent of the service area (e.g. national, regional, local) is to be defined by the content provider.	Feasible, although the current specification of eMBMS constrains the area of the individual eMBMS single frequency network (SFN)
8	Distribution option, audio-visual over IMT needs to be viable on the market and capable of supporting at least a minimum service offer (e.g. a minimum number of programs) defined by the content provider.	Feasible
9	Ease of use - straightforward accessibility of content offer	User device dependent
10	Low barrier for access to broadcasters' content and services for people with disabilities	User device dependent
11	Ability to reach audience in emergency situations	Technically feasible Mobile networks can suffer congestion at peak times, for example, in an emergency situation. At such times, reserving a minimum capacity for certain audio-visual content may be desired.

8.3 Specific requirements

Some performance and quality of service requirements are given in Recommendations ITU-R M.1079-2 (2003) for IMT-2000 and ITU-R M.1822-0 (2007) for IMT. In addition to these general requirements, there are some specific requirements for audio-visual over IMT depending on the use case, which need to be considered, including data rate, bit error ratio, end-to-end delay (latency) and concurrent audience size. The ability to fulfil these specific requirements does not only depend on different delivery mechanism being used, but also on the specific network deployments under consideration.

9 Characteristics of terrestrial IMT that enable audio-visual services and applications

9.1 Unicast

Access to audio-visual services over IMT is provided by packet-switched streaming (PSS) resources typically dedicated to individual consumers, applying the unicast access scheme.

Capacity issues of IMT can be solved by smaller cells in bands up to few GHz complemented by RLAN capacity in license-exempted bands (best effort basis). Consumption of audio-visual content results primarily in traffic on the downlink (DL), i.e. towards the end user. Hence, an asymmetry of up to 1:10 can be observed in data demand between uplink (UL) and DL.¹¹ Symmetric frequency division duplex (FDD) assignments typically yield UL:DL ratios of 1:2 due to higher transmit power and more transmit antennas in DL direction. This can be increased by supplemental downlink (SDL) that provides additional RF bandwidth exclusively in DL direction to better match the asymmetric traffic demand. SDL is already implemented in IMT.

9.2 Supplemental Downlink (SDL)

A supplemental downlink uses unpaired spectrum to increase the downlink network capacity. This is important when the downlink traffic is much larger than the uplink traffic. The main differences between SDL and the abovementioned standalone eMBMS configuration are in that SDL can be used for unicast as well as broadcast and that it does not eliminate the need for an uplink.

SDL capacity can be used for different purposes. Besides MBB use for individual content (unicast), it can also be used to configure broadcast channels with eMBMS. As discussed in Report ITU-R M.2370, the rise of audio-visual content distributed by IMT will make traffic even more dominated by the downlink. SDL allows this asymmetry to be directly addressed and there would be no need to devote paired spectrum to the uplink. Usage of Supplemental downlink (SDL) is not possible for devices designed for SIM-free and/or Receive-only operation.

9.3 eMBMS services

eMBMS chipsets are already available. No hardware changes are required to the subscriber device hardware that implements an eMBMS-compatible chipset.

A common eMBMS service layer middleware can be utilized across all devices to simplify broadcast application development, provide consistent user experiences, and minimize interoperability testing with LTE infrastructure.

For the radio access network the deployment of eMBMS does not require hardware changes to the LTE eNBs. However, eMBMS does require an additional server in the evolved packet core (EPC) and a new software load on the eNB.

¹¹ Report ITU-R M.2370 – IMT Traffic estimates for the years 2020 to 2030.

Since new subscriber devices and specific content formats are not required, eMBMS could be deployed and be available to the entire LTE subscriber base.

9.3.1 eMBMS Multicast

In the case of audio-visual content delivered by IMT, there will be situations when many users want to watch the same content at the same time. Examples are live events of high interest like breaking news, sport events, live shows, etc.

For these cases, multicast delivery, is an appropriate access scheme to be applied. eMBMS comprises a point-to-multipoint interface specification for multicast LTE networks, both within a cell as well as within the core network. A detailed technical description of the LTE eMBMS features that are relevant for the distribution of multicast services is provided in Annex 2.

eMBMS sessions can be set up dynamically, sharing the resources with unicast sessions on a given carrier. Different types of audio-visual services could be provided through the implementation of eMBMS in parallel, such as: OTT and pay TV. When providing each type of audio-visual service, further consideration should be given to their specific requirements.

9.3.2 eMBMS Broadcast

The traditional way of delivering linear TV by means of terrestrial networks employs a broadcast mode. A signal is sent from a single transmitter to a multitude of receivers, that in contrast to unicast/multicast do not need a transmit capability in uplink direction.

eMBMS also comprises a point-to-multipoint interface specification for LTE networks operating in broadcast mode.

For broadcast transmission across multiple cells, it defines transmission via single frequency network configurations.

9.4 Beneficial further enhancements of eMBMS

The capabilities of IMT-Advanced do not fully support all requirements of AV content and service providers. Therefore, substantial effort has been made to further enhance in particular eMBMS. These enhancements are expected to become part of IMT-2020. The following elements are crucial to satisfy the needs of broadcasting companies, in particular public service broadcasters:

- Possibility to provide large scale coverage, i.e. an entire country or parts of it, by means of single frequency network based on larger inter-site distances;
- Possibility to use 100% of a carrier for eMBMS;
- Receive-only mode for terminals to enable reception of AV services without SIM-card;
- Possibility to provide free-to-air services;
- Standardized xMB interface towards the service provider;
- Transport-only mode to distribute services by means of eMBMS in the native format (e.g. DVB transport stream) without transcoding;
- Possibility to share network resources in order to distribute AV services over large areas in an efficient manner;
- Operation of standalone eMBMS networks independent of any uplink capabilities.

9.5 Enhancement of the 3GPP system for TV services

The 3GPP specifications are continuously being enhanced and this section describes the most relevant ones that have already been completed, which are in the process of being incorporated in the IMT standards.

The 3GPP enhancement for TV service support is a feature whereby 3GPP networks can provide unicast and broadcast transport, referred to as “TV transport services”, to support distribution of TV programs. TV transport services can support the three types of TV services – Free-to-air (FTA), Free-to-view (FTV), and Subscribed services. Each type of TV service has different requirements in order to meet regulatory obligations and public service and commercial broadcaster’s requirements regarding content distribution; hence many requirements captured below are optional to implement depending on the type of TV transport services an MNO chooses to offer.

The main requirements are specified in section 32 of the TS 22.101 v 14.5.0 (and onwards), which is the system wide Technical Specification (TS) [8]. See also Recommendation ITU-R M.2012-3 (§ 2.2.2.30).

3GPP Release 14 is now completed.¹² Release 14 includes enhancements for carriage of television services over eMBMS and to both smartphones and TVs in the home. Those enhancements to service layer include:

- Standardized xMB interface towards the (TV) content provider;
- Unified framework for service type negotiations and agreements with content providers;
- Enables dynamic service/session establishment;
- Extensible to other types of content and content providers (V2X etc.);
- Receive-only mode;
- Receive Only mode: enable devices without SIM card or 3GPP subscription;
- Enable Free-to-Air content broadcast over MBMS;
- Receive Only mode with independent unicast: enable interactive services feeding off of TV live broadcast;
- Transport-only mode (also referred to in TS 23.746 [9] as “MBMS Service Type 1”, or “Transport only mode”);
- Provide pass-through MBMS bearer service type;
- Enable TV broadcasters to provide the content via MBMS in the native format (e.g. DVB) without transcoding;
- Use MBMS network as common delivery platform for different content types and services;
- Shared MBMS Broadcast;
- Operators can aggregate their MBMS networks into a shared MBMS content distribution platform;
- Avoid broadcasting the same content at the same time over different networks;
- Improve coverage, bandwidth efficiency.

For this purpose, the following specifications were updated in Release 14 (available at <http://www.3gpp.org/specifications>):

- 3GPP TS 23.246 MBMS Architecture (Annex D and Annex E); see also Recommendation ITU-R M.2012-3 (§ 1.2.2.2.100);
- 3GPP TS 26.346 MBMS Protocols and Codecs; see also Recommendation ITU-R M.2012-3 (§ 1.2.2.2.222);
- 3GPP TS 26.347 MBMS APIs and URL;

¹² For a good summary of the enhanced television services over 3GPP eMBMS in Release 14, including both the eMBMS radio interface enhancements and the enhancements of the 3GPP eMBMS system architecture and media formats refer to: http://www.3gpp.org/news-events/3gpp-news/1905-embms_r14.

- 3GPP TS 29.116 xMB Interface;
- 3GPP TS 24.117 TV Service Configuration Management Object;
- 3GPP TS 24.116 Stage 3 aspects of MBMS service for Receive Only Mode.

Two new TV video profile operating points have been added to TS 26.116 in Release 15 to support HDR (High Dynamic Range – mentioned in § 5.3): H.265/HEVC Full HD HDR and H.265/HEVC UHD HDR [10] (see also Recommendation ITU-R M.2012-3, § 2.2.2.219). Furthermore, HLG (Hybrid Log Gamma) system support has been added to HDR profiles of TS 26.116 in Release 16 (in addition to the Perceptual Quantization (PQ) system support)¹³, in line with the HDR formats in Recommendation ITU-R BT.2100, which are also included in DVB, ATSC 3.0, and ARIB specifications and are gaining widespread support amongst broadcasters.

Improved audio-visual streaming rate adaptation was enabled in Release 15 on the client side, based on network/server-side information such as cached Segments, alternative Segment availability, recommended media rate and network throughput/QoS. The functionality is based on MPEG SAND in ISO/IEC 23009-5 and introduced into 3GPP DASH TS 26.247 with the definition of three modes, namely ‘Proxy Caching’, ‘Network Assistance’ and ‘Consistent QoE/QoS’ [11].

9.6 Further technical enhancements of IMT

In order to further enhance IMT to support distribution of linear and on-demand audio-visual services consideration could be given to the following areas, which are further explained in Annex 4:

- Layered Division Multiplexing (LDM)
- Additional numerologies, i.e. cyclic prefixes, FTT sizes, etc.
- Time-Frequency Slicing (TFS)
- Channel Bonding (and Statistical Multiplexing)
- Non-Uniform Constellation Modulation
- Interleaving and Mobile Reception
- Standardized interfaces
- Service layer enhancement.

10 Conclusions

IMT systems have the potential to provide high-quality audio-visual services to users. With the rise of broadband networks (both fixed and mobile) and the availability of more audio-visual content (e.g. from PSM providers), on-demand consumption has grown rapidly in past few years. Especially, younger generations are watching less linear and more on-demand audio-visual content. It is not clear whether this will continue in the future as it is seen today. Also, it cannot be predicted if the older generation will adopt similar habits as the younger generation. As IMT networks’ coverage and capability increase, it is expected that the amount of audio-visual content delivered via the terrestrial component of IMT will increase.

Provision of linear services will be enhanced by continued development of eMBMS as described in § 9 of this Report. In general, eMBMS is suitable for the provision of linear services especially if the broadcast mode is used. This Report describes some areas that need to be improved in IMT networks in the case that eMBMS is considered to replace or complement the DTTB networks.

¹³ http://www.3gpp.org/ftp/tsg_sa/TSG_SA/TSGS_81/Docs/SP-180656.zip.

On-demand services are typically unicast with the exception of some specific cases like sport events or traffic jams, which may benefit from the use the multicast mode of eMBMS. For unicast, the capacity available to IMT users in an area depends on the total radio resource available in that area. On-demand usage can also be satisfied by the use of other radio access technologies (such as RLAN) or fixed broadband connections.

Annexes:

Annex 1: List of acronyms

Annex 2: Detailed description of LTE features

Annex 3: Demonstration trials of audio-visual over IMT

Annex 4: Emerging Transmission Technologies for Broadcasting/Multicasting in IMT-2020

Annex 1

List of acronyms

AAC	Automatic congestion control
AL-FEC	Application layer forward error correction
AMR	Adaptive multi-rate
AR	Augmented reality
BLER	Block error ratio
BM-SC	Broadcast-multicast service centre
CP	Cyclic prefix
CRC	Cyclic redundancy check
DASH	Dynamic adaptive streaming over http
DL	Downlink
DL-SCH	Downlink synchronization channel
DRM	Digital rights management
DTT	Digital terrestrial television
DTTB	Digital terrestrial television broadcasting
DVB-T	Digital video broadcasting - terrestrial
eMBMS	Enhanced multimedia broadcast and multicast service
eNB	E-UTRAN Node B, evolved Node B, 'LTE base station'
EPC	Evolved packet core
EPG	Electronic program guide
E-UTRA	Evolved universal terrestrial radio access network
FDD	Frequency division duplex
FEC	Forward error correction

FFT	Fast Fourier transformation
FLUTE	Protocol for the unidirectional delivery of files over the internet, which is particularly suited to multicast networks
FRAND	Fair, reasonable and non-discriminatory
GBR	Guaranteed bit rate bearer
GPS	Global positioning system
HD	High definition
HSPA	High speed packet access
HTTP	Hypertext transfer protocol
IP	Internet Protocol
IP-OTT	IP over the Top content
LTE	Long term evolution
LTE PDCP/RLC/MAC	LTE packet data convergence protocol/radio link control/medium access control
M1	Logical interface between MBMS GW and eNBs
M2	Logical control interface between MCE and eNBs
M3	Interface between MME and MCE
MBB	Mobile broadband
MBMS	Multimedia broadcast and multicast service
MBMS CP	Multimedia broadcast and multicast service cyclic prefix
MBMS GW	MBMS gateway
MBMS SAI	MBMS service area identity
MBSFN	Multimedia broadcast and multicast service single frequency network
MCE	Multi-cell/multicast coordination entity
MCH	Multicast channel
MCS	Modulation and coding scheme
MDT	Minimization of drive tests
MIKEY	Multimedia Internet KEYing
MIMO	Multiple input multiple output
MME	Mobility management entity
MNO	Mobile network operator
MSK	MBMS service key
MSP	MCH scheduling period
MTK	MBMS traffic key
NCT	New carrier type
O&M	Operations and maintenance
OFDM	Orthogonal frequency division multiplex
PDN	Public data network
PSM	Public service media
PSS	Packet-switched streaming

P-TM	Point-to-multipoint
P-P	Point-to-point
QCI	Qos class identifier
QoE	Quality of experience: The overall acceptability of an application or service, as perceived subjectively by the end-user. It includes the complete end-to-end system effects (client, terminal, network, services, etc.) and it may be influenced by user expectations and context.
QoS	Quality of service
RRC	Radio resource control
RTCP	RTP control protocol
RTP	Real time protocol
SCTP/IP	S common transport protocol
SDL	Supplemental downlink
SFN	Single frequency network
SGmb	Reference point for the control plane between BM-SC and MBMS GW
SGi-mb	Reference point for the user plane between BM-SC and MBMS GW
SIM	GSM subscription identity module
SINR	Signal to interference + noise ratio
Sm	Reference point for the control plane between MME and MBMS GW
SRTP	Secure real-time transport protocol
SYNC	MBMS synchronisation protocol
TCP	Transmission control protocol
TDD	Time division duplex
TV	Television
TCP	Cyclic prefix length
Tu	Useful symbol time
UDP	User datagram protocol
UE	User equipment
UHD	Ultra high Definition
UL	Uplink
UP	User plane
USD	User service description
VOD	Video on demand
VR	Virtual Reality

Annex 2

Detailed description of LTE eMBMS features¹⁴

Multimedia Broadcast Multicast Services (MBMS) is the point-to-multipoint (P-MP) transmission mode defined by 3GPP in cellular systems to deliver multicast and broadcast services. In 3GPP Release 9 [12], MBMS was incorporated into the LTE system, called evolved MBMS (eMBMS), which was further enhanced in 3GPP Release 11 [13]. Sharing the advanced transmission capabilities of the LTE physical layer, eMBMS has the capability to provide high-throughput multicast/broadcast services, flexible operation frequency, and efficient coexistence with unicast services. The eMBMS services deployed in Single-Frequency-Network (SFN) mode, also called multicast/ broadcast SFN (MBSFN), can use the existing LTE infrastructure to provide service coverage over a flexible number of cells.

The LTE standard consists of a number of specification documents each covering a functional category or protocol layer. While TS 26.346 [14] defines a set of media codecs, formats and transport/application protocols to enable the deployment of MBMS user services and TS 23.246 [15] provides a high-level MBMS architecture and functional description (see also Recommendation ITU-R M.2012-3, § 1.2.2.2.100), there is no single dedicated specification document for eMBMS, the related additions are included in the appropriate documents of the LTE specifications. Section 15 of TS 36.300 [16] provides an overall technical description of the radio-level functionality (see also Recommendation ITU-R M.2012-3, § 1.2.1.3.1).

A2.1 General description

A HSPA MBMS application was standardized by 3GPP, and since Release 9 it is termed ‘evolved MBMS’ or eMBMS for short, now adapted for LTE. Notably, eMBMS is time multiplexed with unicast services, which can be used to enable interactivity for multicast services, including for future hybrid digital-TV. Currently, with regard to the LTE transmission protocol, in the time multiplexed configuration, up to 6 out of the 10 sub-frames of a radio frame can be dedicated to eMBMS in the FDD mode, or up to 5 sub-frames in the TDD mode. eMBMS can employ a single-frequency network (SFN) configuration establishing a so-called MBSFN. Cells in an MBSFN have to be adequately time synchronized. Again, eMBMS is currently built on the LTE downlink OFDM physical layer with a cyclic prefix (CP) of 16.7 μ s. This CP is extended in comparison with that typical used for the LTE unicast service¹⁵. This implies that, for two base station sites, when the distance difference between the UE and base stations is up to 5 km, no interference would occur between them, although in practice, interference from base stations more than 10 km away would have to be taken into account in the network design.

A base station cell can be associated with up to eight different MBSFN areas, allowing for overlapping national, regional, and local MBSFN service areas. Each MBSFN area supports 15 multicast channels (MCH), each of which can be configured with a different modulation and code rate to support tailored robustness under various reception conditions. Up to 29 multicast content program channels can be configured per MCH. Further details can be found in Annex 3, § A3.5.

¹⁴ Some material by permission from Jörg Huschke and Mai-Anh Phan, “An Overview of the Cellular Broadcasting Technology eMBMS in LTE,” in David Gómez-Barquero (ed.), *Next Generation Mobile Broadcasting*, Boca Raton, Florida: Taylor & Francis Group, LLC, 2013.

¹⁵ In an optional configuration, the CP could be increased to 33.3 μ s. Currently, signaling to identify which sub-frames use the CP of 33.3 μ s is missing from the standard, therefore user equipments (UEs) cannot be assumed to understand this mode yet.

On the transport layer, eMBMS employs internet protocol (IP) packets. eMBMS provides a streaming and a file download service type to the consumer device. As fast retransmissions are not supported in eMBMS for error correction purposes, increased transmission robustness can be achieved by additional forward error correction on the application layer (AL-FEC). This also achieves increased diversity in the time domain for further robustness as large AL-FEC blocks are also supported in the eMBMS mode of operation.

A very basic requirement for the terminal is the capability to find the wanted content, i.e. the TV programs. Information about how to access the multicast content is contained in the so-called user service description (USD) which can be retrieved either by a request through an LTE uplink or RLAN connection, or can be provided separately, either by using a preconfigured device or a USB stick. Access to electronic program guides (EPG) can be enabled in a similar manner.

A2.2 High level architecture

Recommendation ITU-R M.2012-3, § 2.2.2.222 incorporates 3GPP up to Release 13, which provides a significant number of enablers and functionalities to distribute real-time and non-real-time content from the MNOs Broadcast-Multicast Service Center (BM-SC) to a MBMS capable User Equipment (UE). Whereas up to Release 13, the primary focus was on enhancing the distribution functionalities from the BM-SC to the MBMS client, in Release 14 the architecture was upgraded to include an interface from the content provider to the BM-SC (the xMB interface), as well as an interface from the MBMS client to the Content Receiver application (MBMS-API) (see Fig. A2-1). In all cases, 3GPP permits the inclusion of unicast distribution of the services, for example by using MBMS-operation-on-Demand (MooD) or unicast fallback (defined in TS 26.346 [14] since Release 12). Furthermore, following typical mobile application and OTT service approaches, the content provider may establish a direct connection outside MBMS/broadcast distribution, e.g. for service configuration and updates.

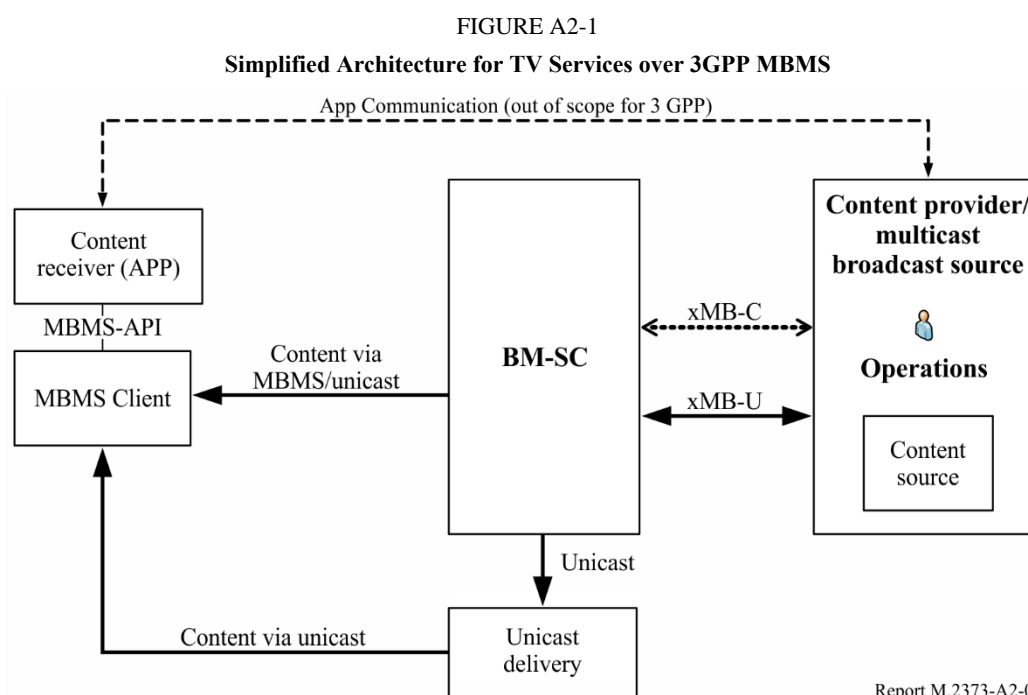

In order to simplify the access to MBMS system functionalities, a standard interface is defined and referred to as the extended MBMS interface (xMB) in order to establish connectivity between a content provider and the BM-SC. The xMB interface provides the capability for the content provider

to (i) authenticate and authorize itself to the BM-SC(s), (ii) create, modify and terminate a service, (iii) create, modify and terminate a session, (iv) query information and (v) deliver content to the BM-SC. The xMB interface also provides the capability for the BM-SC to (i) authenticate and authorize a content provider, (ii) notify the content provider of the status of an MBMS user service usage, and (iii) retrieve content from the content provider. Only authorized content providers are allowed to input media content across xMB-U. The xMB interface permits four different session types: Streaming, file, application (including DASH streaming) and transport mode. The stage-2 procedures are defined in TS 26.346 [14] and the detailed stage-3 procedures based on a RESTful design including JSON schema are defined in TS 29.116 [17].

MBMS Application Programming Interfaces (MBMS-APIs) were introduced primarily for developers of web and user applications with the objective of abstracting complex MBMS procedures by the use of simple methods and interfaces. MBMS client vendors can implement the service APIs to simplify the integration of MBMS-aware applications with MBMS User Services. In this scenario, service content can be accessed by the application through well-defined APIs: The application communicates with the MBMS client to discover and access services for rendering by existing media players. The APIs supports the distribution of existing TV services (e.g. DVB), and also provides new capabilities to support dynamic broadcast/unicast handoff, consumption reporting, etc. The APIs may be implemented within a device or as a local network interface, i.e. in the latter, the MBMS service terminates in a gateway device such as a WiFi Access Point which acts as a media server to applications residing in multiple client devices.

A2.3 Service framework

The MBMS user service addresses service layer protocols and procedures above the IP layer and includes streaming and download delivery methods. Both the download and the streaming methods deliver media data encoded in various formats, e.g. video in H.264 and audio in AMR or AAC format.

The MBMS download delivery method was originally intended to increase the efficiency of file distributions, e.g. for media files that are cached in the user equipment (UE) after reception so that user have offline access to the content at any time (within any rights management constraints defined by the service provider). The download delivery method can also be used for DASH based streaming, as explained in subsequent sections. The streaming delivery method was intended for RTP-based continuous reception and play-out used e.g. in mobile TV applications.

FIGURE A2-2

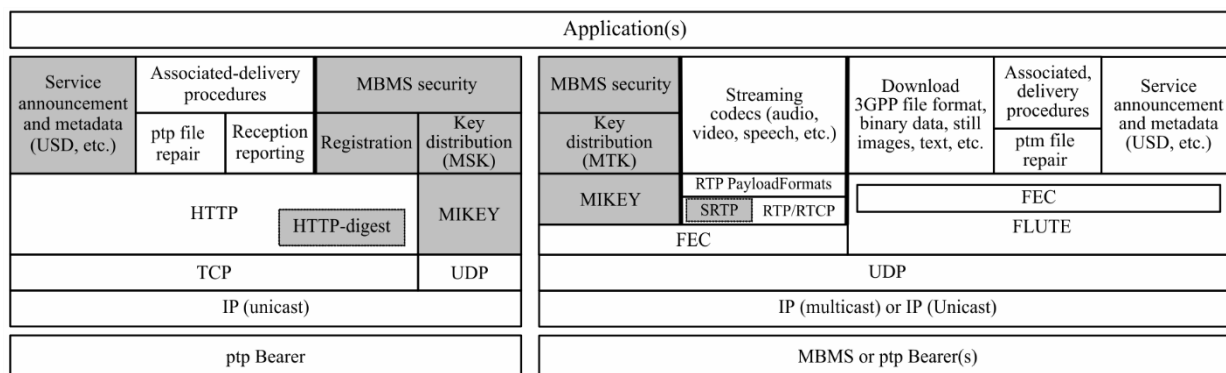
Protocol stacks used for MBMS delivery methods 26.346¹⁶

Report M.2373-A2-02

Figure A2-2 shows the protocol stacks which are used for MBMS as specified in TS 26.346 [14] (grey boxes are defined therein by reference). The left side depicts the part of the protocol stack which requires an IP unicast bearer. The right side shows the part of the protocol stack which was designed for MBMS bearers carrying UDP.

Since UDP packets can also be sent over unicast bearers, the right side of the protocol stack can also be implemented on top of a unicast bearer.

It can be seen that service announcements and other metadata can be delivered both over unicast and multicast connections. This means that a client can for instance download service announcement related information from a web page, or it receives the information via a multicast bearer. Unicast and multicast delivery of service announcement information can also be combined.

For the associated delivery procedures, certain procedures such as point-to-point file repair and reception reporting require a unicast connection whereas other procedures such as point-to-multipoint file repair (e.g. of missing packets) can be executed over a MBMS bearer.

The download delivery method can be used for file distribution services, which store the received data locally in the UE. Some recent video services on the internet appear to the end user as streaming services, but actually, they use file based transmission where the entire media file is divided into fragment files that are transmitted sequentially, using e.g. the DASH protocol [18].

In contrast, the original MBMS streaming delivery method is based on the Real Time Protocol (RTP) [19]. Meanwhile the newest trend is to implement video delivery using DASH rather than RTP. Therefore we will not discuss the RTP based MBMS streaming delivery method here. With DASH, a video stream is segmented into segment files, each one containing the data for a short playout interval, typically 1s.

During the MBMS data transfer phase, certain terminals may experience packet losses due to fading conditions or handovers. Naturally, full reliability cannot be offered in a pure unidirectional distribution scheme because the packet-loss rate can be excessive for some users. Therefore, three packet error recovery schemes are foreseen for the download delivery method. The most important one is the use of application layer forward error correction (AL-FEC) code, which allows recovery of lost packets during the MBMS data transfer phase without any server interaction. The other two recovery schemes use file repair procedures, where the first scheme is a point-to-point (P-P) repair

¹⁶ 3GPP TS 26.346 V15.0.0 (2017-12) “Multimedia Broadcast/Multicast Service (MBMS); Protocols and codecs”, section 5.5, “MBMS Protocols”.

<https://portal.3gpp.org/desktopmodules/Specifications/SpecificationDetails.aspx?specificationId=1452>.

mechanism using interactive bearers and the other one is a point-to-multipoint (P-MP) repair mechanism using MBMS bearers.

The Raptor AL-FEC code [20] was chosen as a basis for FEC protection of the files [21] and has also been adopted by DVB. The Raptor AL-FEC code generates a number of redundant FEC symbols for each source block. The FEC symbols are assembled into IP packets. A multicast signal of newly created FEC packets during the MBMS data transfer (phase 1) is of benefit for all receivers, which have not successfully reconstructed the original source block. When Raptor is used with DASH, then typically each video segment file forms a source block. Using segments covering of e.g. 1s playout time and ensuring that the transmission on the radio interface is distributed as uniformly as possible over each interval of 1s, this scheme achieves time diversity of 1s, because the Raptor code can recover any IP packet that a receiver failed to receive during that interval. In order to tolerate longer burst losses the video segment length can be increased, however, this implies an increase in end-to-end delay as well as the time it takes for a receiver to switch between separately encoded video segment streams.

During a file repair procedure, further Raptor AL-FEC packets are transmitted to the receivers. If an interactive bearer is used, the repair data is independently sent to different receivers and can even be tailored to the actual losses of that receiver. On the contrary, if the MBMS bearer is used, the same repair data is sent only once to multiple receivers and the repair data should be useful for all receivers with losses. Therefore, the rateless property of the Raptor code is very beneficial for the P-TM repair mechanism.

If a file repair procedure is used (phase 2), the MBMS client waits until the end of the transmission of files or sessions and then identifies the missing data from the MBMS download. Afterwards, it calculates a random back-off time and selects a file repair server randomly out of a list. Then, a repair request message is sent to the selected file repair server at the calculated time. The file repair server responds with a repair response message either containing the requested data (interactive bearer), redirecting the client to an MBMS download session (MBMS bearer), redirecting the client to another server, or alternatively, describing an error case. The repair data may also be sent on a MBMS bearer (possibly the same MBMS bearer as the original download) as a function of the repair process [22] [23].

A2.4 Transport-only Mode

The use of the MBMS network as a common delivery platform for different content types and services will be an important factor in achieving broad success of the 3GPP broadcast delivery platform. Based on this observation a content pass-through mode was defined in Release 14 that enables the distribution of IP packet streams and UDP Application Data Unit (ADU) flows over MBMS bearers. This for example enables TV broadcasters to deliver service content via MBMS in their native format without transcoding, such as MPEG-2 TS. Furthermore, such a mode permits the re-use of existing TV receivers, for example existing MPEG-2 TS receivers.

FIGURE A2-3
Transport-only mode

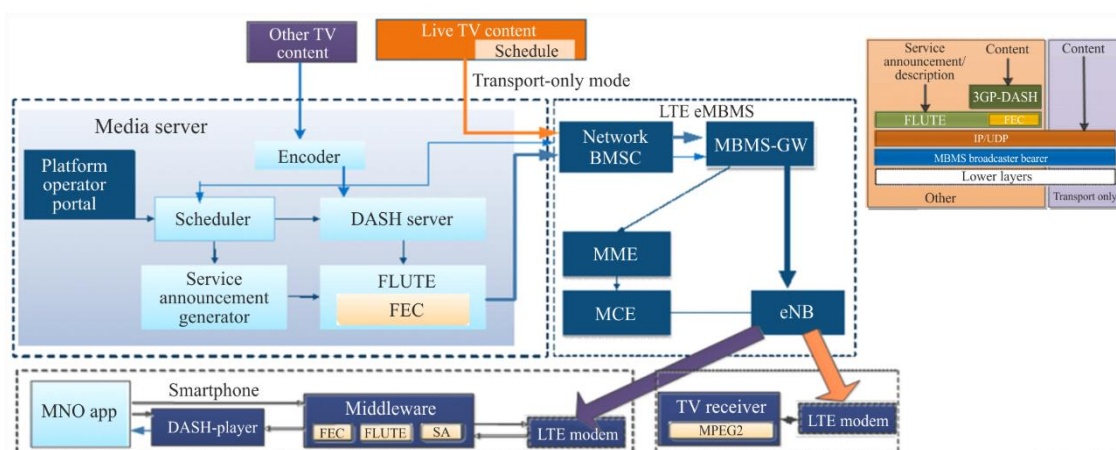

Report M.2373-A2-03

The transport-only mode is enabled by the use of the transparent delivery method which permits the distribution of any IP-based data flow through MBMS bearer services. However, the BM-SC may add additional functionalities such as the creation of MBMS User Services with their associated service layer features, such as service announcement, file repair, QoE/reception reporting and consumption reporting. The delivery protocol is extensible to enable new functionalities in future releases, such as QoS using FEC. For details refer to TS 26.346 [14].

A2.5 Receive-only Mode

One of the major extensions of the 3GPP specification is the addition of the receive-only mode. This mode enables devices without the (U)SIM card or 3GPP subscription to access a subset of 3GPP MBMS services. Receive-only mode is in particular relevant to expand the reach of MBMS into traditional TV receivers and to enable Free-to-Air content broadcast over MBMS. Obviously, services configured for this mode may also be received by regular mobile devices as enhanced and rich service offerings, possibly combined with independent unicast. The same may be enabled for stationary TV sets, for example by integrating a broadband connection to enable interactive services feeding of TV live broadcast. The receive-only mode provides the opportunity for more cost-effective data plans for mobile TV (bundled plans). Receive-only services are broadcast on the reserved range of TMGI. The reserved range uses the well-known PLMN ID 901-56, assigned by ITU-T for Receive Only Mode. The reserved range is sub-divided based on the type of service.

A2.6 Service discovery

The availability of a scheduled transmission is usually shown to the user by an application (app) that implements e.g. an Electronic Program Guide. Each transmission session is defined by a user service description (USD) which contains all information necessary for the UE to find the content data in the overall LTE signal.

Content can be protected on the application layer using standardized DRM methods such as MBMS service keys (MSK) and MBMS traffic keys (MTK). eMBMS does not make use of the LTE specific ciphering. Therefore, it is in principle possible to receive eMBMS services without a SIM card of an operator. Two preconditions are that the UE supports this operation mode and the USDs of the scheduled services are made available to the UE by other means (as mobile broadband access is not available without a SIM card), e.g. through a home RLAN. In the case that the content is encrypted by application layer DRM, the decryption keys also have to be made available to the UE in this way. NOTE – A more detailed description of service discovery is provided in Annex 9 of the EBU TR027 (reference 4 in § 3).

In addition, in 3GPP Release 14, TS 26.347 also defines a URL form for MBMS User services. The URL form is designed to refer to a single resource, just like HTTP (or FTP). Indeed the 'threads' of the world-wide web are the URL pointers that link resources together.

Using MBMS URLs in the formats that reference resources by URLs enables services using those formats to use MBMS delivery of resources. Many of those services also use 'fallback lists', where the origin format (for example, the <video> element in HTML) embeds a series of alternatives, giving, for each, a URL pointer and some information (MIME type, codecs used, and so on) about the resource at that location. Platforms not supporting the resource type, or URL type, of an alternative would skip past it, moving down the fallback list. This could, for example, enable a content distributor to offer high bitrate, high quality, content via MBMS, and a lower-quality, lower bitrate fallback over HTTP, in a backwards-compatible way.

A2.7 LTE downlink physical layer

In the following, we provide a brief introduction to the E-UTRA downlink physical layer [24] [25]. Like other multicasting standards, the E-UTRA downlink uses OFDM, because it efficiently supports flexible carrier bandwidth, allows frequency domain scheduling, is resilient to propagation delays, which is particularly beneficial for SFN configurations, and is well suited for multiple-input multiple-output (MIMO) processing.

The possibility of operating in vastly different spectrum allocations is essential. Different bandwidths are realized by varying the number of subcarriers used for transmission, while the subcarrier spacing remains unchanged. In this way operation in spectrum allocations of 1.4, 3, 5, 10, 15, and 20 MHz can be supported. Due to the fine frequency granularity offered by OFDM, a smooth migration of, for example, 2G spectrum is possible. Frequency-division duplex (FDD), time-division duplex (TDD), and combined FDD/TDD, are supported to allow for operation in paired as well as unpaired spectrum.

To minimize delays, the transmit time interval (TTI) is only 1 ms, corresponding to one sub-frame. A subframe can carry several transport blocks, each of which has a checksum attached (CRC) for error detection. Each sub-frame consists of two slots of length of 0.5 ms. Each slot consists of several OFDM symbols. A subcarrier spacing $\Delta f = 15$ kHz corresponds to a useful symbol time $T_u = 1/\Delta f \approx 66.7$ μ s. The overall OFDM symbol time is then the sum of the useful symbol time and the cyclic prefix length T_{CP} . Signals from eNBs arriving within the cyclic prefix (CP) duration of the UE synchronization point contribute useful signal energy and thereby improve the coverage.

Signals arriving outside the CP produce interference. Since the CP does not contain user data, its length is a trade-off between the time fraction available for user data and the SINR value achievable with the desired error probability. In order to cope with different propagation delays caused by different cell sizes, LTE defines two CP lengths for a typical subcarrier spacing of $\Delta f = 15$ kHz, the normal CP and an extended CP, corresponding to seven and six OFDM symbols per slot, respectively.

FIGURE A2-4
LTE symbol/slot/frame structure [26]

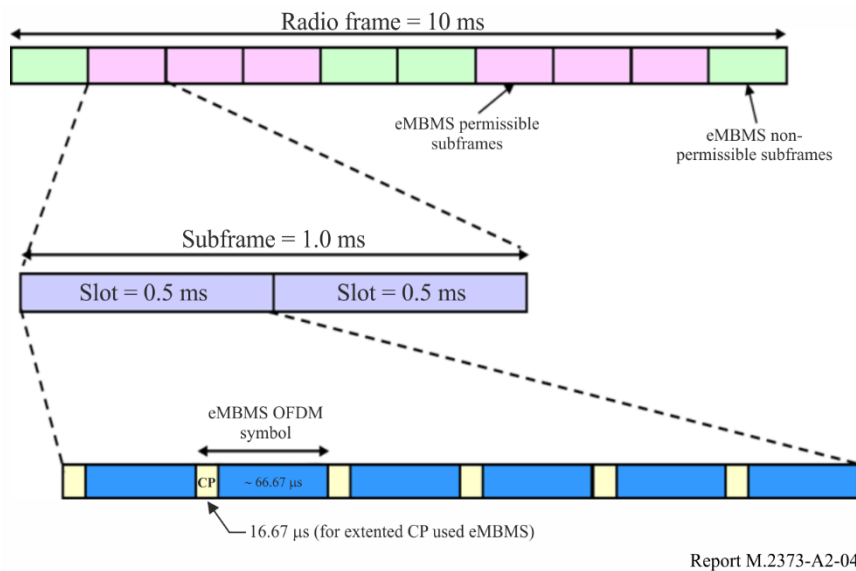

By extending the CP from $4.7 \mu\text{s}$ (normal CP for 15 kHz subcarrier spacing) to $16.7 \mu\text{s}$ (extended CP for 15 kHz subcarrier spacing), it is possible to handle very high delay spreads that can occur in a large cell with a very large radius or when several cells transmit the same signal synchronously as in the MBSFN mode described in the next section. For larger distances, the extended CP can even be increased by a factor of two resulting in $33.3 \mu\text{s}$. In order to limit the relative overhead imposed by this extended long CP, the OFDM useful symbol time is also doubled for the configuration with the long extended CP of $33.3 \mu\text{s}$. In order to maintain the same capacity with an unchanged carrier bandwidth, the subcarrier spacing is also reduced by a factor of two, resulting in 7.5 kHz subcarrier spacing. Currently, signalling to identify which sub-frames use the CP of $33.3 \mu\text{s}$ is missing from the standard, therefore UEs cannot be assumed to understand this mode yet. These parameters differ from e.g. DVB-T as LTE networks use small cells and therefore propagation delay differences are smaller, which in turn allows for smaller CP and accordingly smaller OFDM symbol sizes. This in turn allows for larger subcarrier spacing, which allows for the larger Doppler spread that result when using some of the high frequency bands defined for LTE.

Release 14 also provides upgrades on the radio. As a brief summary, the following extensions are provided:

- Assuming Single Frequency Network (SFN) operation and cellular network planning, support of larger inter-site distance: Larger cyclic prefix ($200 \mu\text{s}$) designed to cover 15 km Inter-Site-Distance (ISD), Target spectral efficiency of 2 bps/Hz with rooftop antennas, and introduction of an intermediate numerology with $33 \mu\text{s}$ CP. Note that CP is also known as guard interval in the broadcast community.
- Dedicated or mixed MBMS carrier: Mixed unicast/broadcast from same carrier, up to 100% MBMS allocation, and a self-contained system information and sync signals for dedicated carriers.
- Different types of devices: Enhanced support for rooftop reception, handheld devices and car-mounted antenna, as well as multiple numerologies (15 kHz, 7.5 kHz and 1.25 kHz) designed for different deployment/mobility scenarios.
- New subframe type: New type of MBSFN subframe without unicast control region to reduce overhead in MBMS transmissions with respect to previous releases.

- Shared MBMS Broadcast: Operators can aggregate their MBMS networks into a shared MBMS content distribution platform. This avoids broadcasting the same content at the same time over different networks and therefore improves coverage and bandwidth efficiency.

A2.8 Segmentation/Concatenation across protocol layers

Figure A2-5 shows the processing of DASH media data segments in terms of segmentation/concatenation across protocol layers including in this order the AL-FEC layer, working internally with so called symbols, the IP layer (FLUTE, UDP, IP) and finally the physical layer transport blocks (omitting for brevity the LTE PDCP/RLC/MAC layers, which are also largely irrelevant in the eMBMS context). Transport block error rate (BLER) is often used as a physical layer performance criterion. There are several factor impacting the relation between DASH segment error rate and transport block BLER, in particular the relative size of all the involved data block units on each layer, and the amount of application layer FEC repair data.

FIGURE A2-5
Segmentation/concatenation across protocol layers

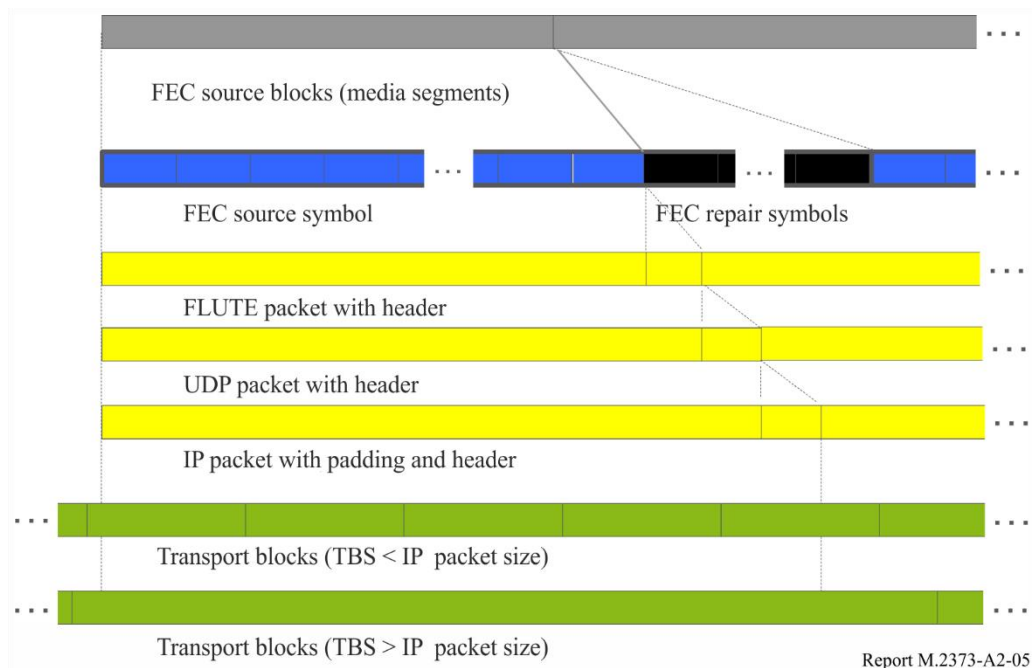

Report M.2373-A2-05

A2.9 MBSFN

If a larger number of users of a particular MBMS service are present in a cell, broadcast signal radio transmission in the cell is more suitable, which can be used either in single cell or multi-cell transmission mode. For P-TM transmission in both single-cell and multi-cell mode, a new transport channel, the multicast channel (MCH) was defined. The MCH can be time multiplexed on a sub-frame granularity of 1 ms with other transport channels such as the DL-SCH.

A multi-cell transmission essentially means that the cells transmitting the MBMS service are configured to form an MBSFN. If an MBSFN with multiple cells is established using a particular MCH, then the same MCH information is transmitted time aligned from these cells using identical transport formats, identical resource allocations and identical scrambling. From a UE point-of-view, such multi-cell MCH transmission will appear as a single MCH transmission. However, it is a channel aggregated from all cells involved in the MBSFN transmission and will typically have a large delay spread due to the differences in the propagation delay as well as residual transmit-timing differences as indicated in Fig. A2-6. In order to be able to properly demodulate the multi-cell MCH transmission,

the UE needs an estimate of the aggregated channel. For this to be possible, MCH specific reference signals are needed that are identical for all cells involved in the MBSFN, i.e. identical time/frequency locations and identical reference signal sequences are used. In the current standard MCH transmission can only use a CP of 16.7 μ s. In case sites with higher power and/or a higher tower are available, or with deployments in low frequency bands, good coverage can be achieved with even higher distance between sites, and in this case the extended CP of 33.3 μ s should be used. For this CP, there is currently a missing piece in the standard: there is no signalling which sub-frames use this CP and the UE is not required to blindly detect it. An appropriate mechanism has to be defined to make the UE known where this CP is used.

FIGURE A2-6

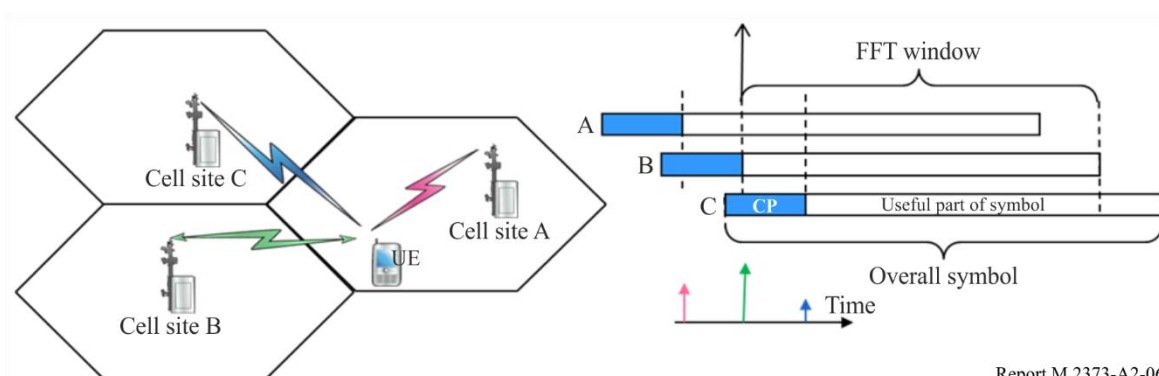
Illustration of OFDM reception of SFN transmission from 3 cell sites¹⁷

Report M.2373-A2-06

A2.10 eMBMS architecture

MBMS in LTE uses an evolved architecture in order to support MBSFNs with high flexibility, which was an important design goal of LTE from the start. Furthermore, for LTE it is desired to support MBSFN transmission and user individual services on the same carrier. The architecture needs to support the coordinated allocation of radio resources within the carrier for MBSFN transmission across all cells participating in the particular MBSFN. Figure A2-7 shows the eMBMS architecture, which is based on enhancements to the LTE Release 8 architecture. The default architecture is shown to the left. The alternative to the right is discussed along with the MCE below. The architecture defines a functional split – several functions can be co-located or even integrated in the same hardware box.

¹⁷ Section A2.5, “MBSFN”, in “Delivery of broadcast content over LTE networks”, Technical Report TR 027, EBU, July 2014. Available: https://docbox.etsi.org/Workshop/2015/201505_ETSI_EBU_WIRELESS_MEDIA_DISTRIBUTION/EBU_Technical_Report_027_Delivery_of_broadcast_content_over_LTE.pdf.

FIGURE A2-7
MBMS architecture in SAE / LTE

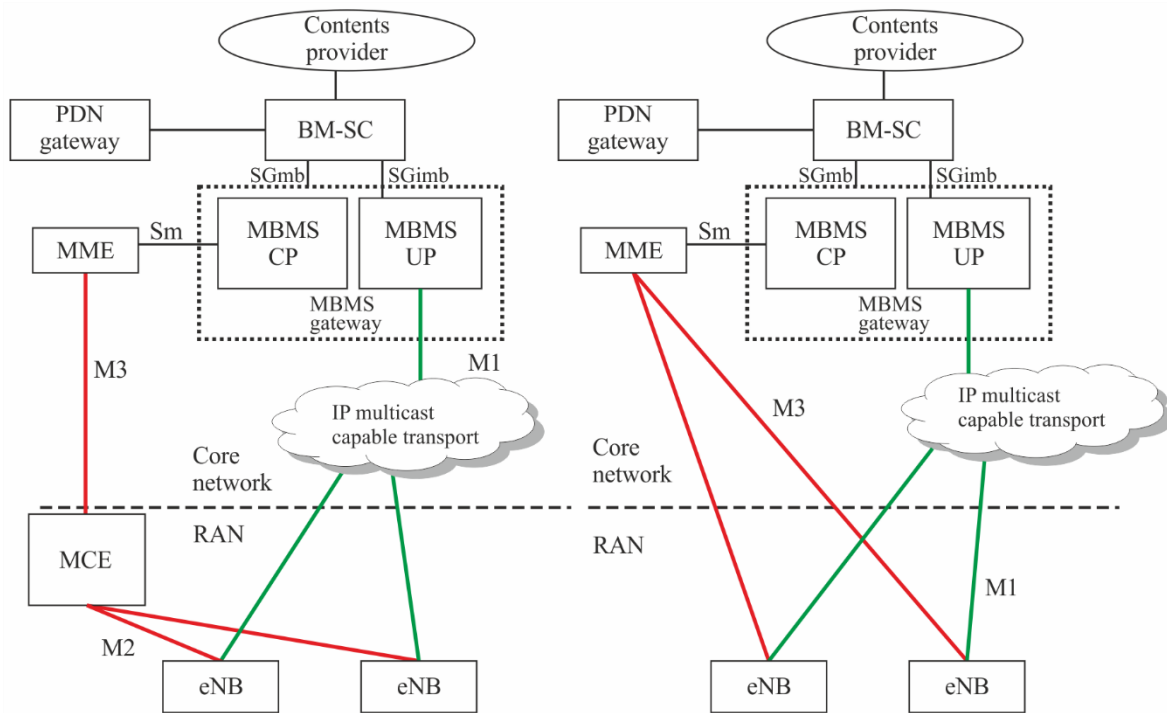

Report M.2373-A2-07

The following logical entities are defined:

- **BM-SC.** The broadcast-multicast service centre (BM-SC) controls MBMS sessions and corresponding MBMS bearers.
- **MBMS GW.** The MBMS gateway (GW) is an entity that is located between the content provider and the evolved base stations (eNode Bs, or eNBs). The control plane of the MBMS GW is involved in the MBMS session start/setup towards the LTE radio access network (RAN) via the mobility management entity (MME). The user plane (UP) is responsible for delivering the user data over the IP multicast capable transport network to the eNBs and participates in the content synchronization for MBMS services using MBSFN. The MBMS GW is part of the evolved packet core (EPC).
- **MME.** In the context of MBMS, the mobility management entity (MME) is responsible for session control signalling.
- **MCE.** The Multi-cell/multicast coordination entity (MCE) is responsible for coordinating the usage of MBSFN transmission within the same MBSFN area in the LTE RAN. Therefore, in the architecture alternative shown on the right of Fig. A2-7, where the MCE is integrated to each eNB, the necessary parameters must be consistently configured by O&M for all cells of an MBSFN area, since there is no interface for coordination between MCEs. Otherwise, an MBSFN area can only cover the cells served by the respective eNB.
- **eNB.** The eNB is the evolved base station in LTE responsible for multiplexing, framing, channel coding, modulation and transmission.

The following logical interfaces are defined:

- **M1.** Is a logical interface between the MBMS GW and the eNBs. The transport on this interface will be based on IP multi-cast. The MBMS content is transported in a frame or tunnel protocol, in order to support content synchronization and other functionalities. IP

multicast signalling is supported in the transport network layer in order to allow the eNBs to join an IP multicast group.

- **M2.** Is a logical control interface between the MCE and the eNBs. This interface is used to coordinate the setting up of an MBMS service in the eNBs for MBSFN operation. SCTP/IP is used as signalling transport i.e. point-to-point signalling is applied.
- **M3.** Interface between MME and MCE. Supports MBMS session control signalling, including the QoS attributes of each service (does not convey radio configuration data). The procedures comprise e.g. MBMS session start and stop. SCTP/IP is used as signalling transport i.e. point-to-point signalling is applied.
- It is not precluded that M3 interface can be terminated in eNBs. In this case MCE is considered as being part of eNB. Therefore M2 does not exist in this scenario. This is depicted in Fig. A2-7, which depicts two envisaged deployment alternatives. In the scenario depicted on the left, MCE is deployed in a separate node. In the scenario on the right MCE is part of the eNBs.
- **Sm.** The reference point for the control plane between MME and MBMS GW.
- **SGmb.** The reference point for the control plane between BM-SC and MBMS GW.
- **SGi-mb.** The reference point for the user plane between the BM-SC and MBMS GW.

A2.11 Synchronisation

Within a so called MBSFN area, all eNBs need to be synchronized within 1 μ s, which would facilitate 5 km propagation difference for 16.7 μ s CP. Each μ s translates to approximate 300 m. If the synchronization drifts by 1 μ s, then the distance between transmitters should not be more than 4.7 km in order to allow UE to receive the signals within the length of CP (16.7 μ s). Also, the radio frames need to be aligned. The method of achieving the required tight synchronization is not defined in the LTE specifications; this is left to the implementation of the eNBs. Typical implementations are likely to use satellite-based solutions, e.g. GPS, or possibly synchronized backhaul protocols, e.g. IEEE1588. Tight synchronisation may not only be required for MBSFN operation but also for other LTE features, e.g. TDD operation, time-domain inter-cell interference coordination or coordinated multipoint transmission (a form of very small SFN for unicast).

The MCE is responsible for configuring identical MBSFN sub-frame allocations and MCH scheduling periods (MSP) in all cells of an MBSFN area, as well as the MCH modulation and coding scheme, satisfying the guaranteed bit rate of the MBMS bearer. The MCE also defines the common order in which services are scheduled in all eNBs of an MBSFN area.

Finally, content synchronization needs to ensure that the IP packet multiplexing and mapping to transport blocks in MBSFN sub-frames is identical in all these cells, taking into account that IP packets have varying size and packet losses can occur between the BM-SC and the eNB. This is achieved by the SYNC protocol [27] where the packet flow is grouped into synchronization sequences. A separate instance of the SYNC protocol is associated with each MBMS bearer.

For each synchronization sequence, the BM-SC tries to ensure that it does not send more packets to the eNB than allowed by the guaranteed bit rate of the MBMS bearer, discarding packets if necessary. The BM-SC labels all packets of a synchronization sequence with an identical time stamp telling the eNB when to start the transmission of the first packet of that synchronization sequence.

The time stamp has to cover transfer delays between the BM-SC and all eNBs in the MBSFN area to ensure that all of them have received and buffered the packets of an MSP before any of the eNBs is allowed to transmit the first packet. The MSP is configured by the MCE, but must be an integer multiple of the synchronization sequence duration to make this concept work.

The transmission delay differences from the BM-SC to the eNBs are typically smaller than 100 ms, even with a single BM-SC and an MBMS service area involving all eNBs of a country. The SYNC protocol can handle this delay, i.e. the data will be delayed by up to 100 ms in the first eNB receiving the data first from the BM-SC, to transmit them synchronously with the last eNB when it has received the data.

A2.12 eMBMS area concepts

For the MBMS service provisioning, the MBSFN area and MBMS service area need to be distinguished. The MBMS service area defines a geographic area where a service shall be multicasted. Within the network, the operator identifies each MBMS service area by one or more MBMS service area identities (MBMS SAIs), and each MBMS SAI defines a group of cells. A cell can belong to and is therefore addressable by one or more MBMS SAIs.

An MBSFN area defines the set of cells participating in the transmission of signals for one or more services in MBSFN mode. An MBMS service area (identity) may comprise one or more complete MBSFN areas. Overlap between MBSFN areas, as well as between MBMS service areas, is supported. This also enables a smaller MBSFN area to overlap a large MBSFN area, so that e.g. regional and nation-wide MBSFN areas can coexist. Overlapping MBSFN areas can be implemented using frequency or time multiplexing. Time multiplexing means that MBSFN areas are separated by different sub-frame patterns.

The relationship between MBMS Service Areas, MBMS Service Area Identities (MBMS SAIs), and MBSFN areas is illustrated in Fig. A2-8. MBMS Service Area A consists of MBMS SAI #1 and MBMS SAI#2. MBMS SAI#1 covers MBSFN areas 1a and 1b. The MBMS services that are provided in MBSFN area 1a and 1b, belonging to the MBMS SAI #1 do not have to schedule the MBMS data synchronously. The synchronization requirement is only valid within the same MBSFN area.

Within an MBSFN area there can be reserved cells that do not contribute to the MBSFN transmission. UEs in cells at the border of an MBSFN area will suffer from a high level of interference if the neighbour cells not belonging to the MBSFN area transmit different signals in the sub-frames used by the MBSFN area. Such border cells inside the MBSFN area may therefore be configured. Such that UEs located in these cells do not expect the availability of the MBMS service, due to the lack of essential MBMS signalling. Such cells at the border can thereby serve as an interference guard zone. Thanks to the low height of the eNB antenna towers and the low transmit power, typically only a few rings of cells around an MBSFN area are needed for the guard zone, depending on the used MCS. Therefore, the sub-frames can be reused for another MBSFN area or unicast traffic already a few km or few tens of kilometres away.

FIGURE A2-8
MBMS related area concept

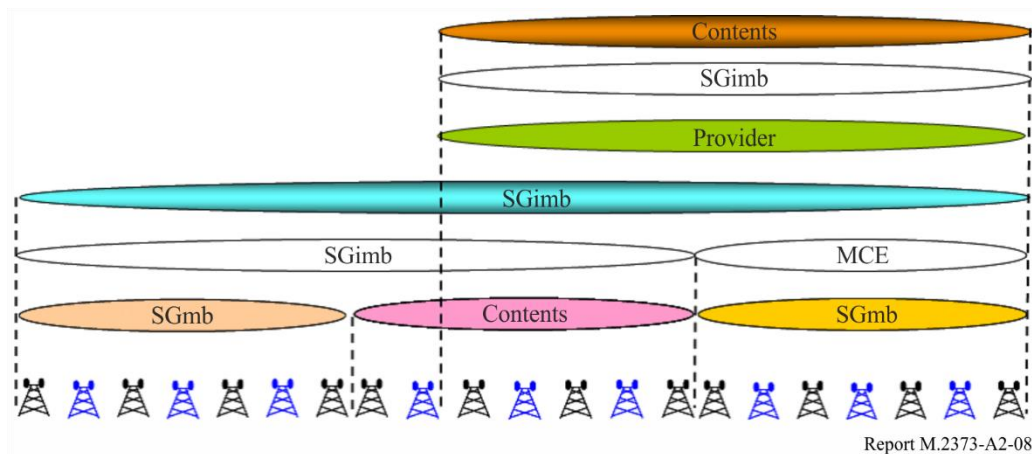

Report M.2373-A2-08

A2.13 eMBMS / unicast multiplexing

MBMS data transmission in MBSFN mode is time multiplexed with LTE unicast traffic. This is an advantage over WCDMA based MBMS transmission, where the use of MBSFN was confined to a dedicated carrier. Up to 6 of the 10 sub-frames of a radio frame are configurable for MBMS in the FDD mode and up to 5 in the TDD mode. Figure A2-9 shows which of the sub-frames can be used for MBMS transmission and which are reserved for unicast. The MBMS sub-frames use MBSFN transmission whereas in unicast sub-frames each cell can transmit different information. In FDD mode, the sub-frames that are allocated for MBMS in the downlink can be used for unicast transmission in the uplink. Sub-frames reserved for MBMS but with no content to transmit e.g. due to varying content bit rate can be used for certain transmission mode of unicast transmission. Different MBSFN sub-frame patterns must be allocated to different MBSFN areas. Due to time multiplexing, a UE can receive MBMS services and simultaneously use unicast services. This enables interactive multicast services as well as hybrid multicast/unicast delivery of content. The latter means content is delivered using eMBMS only in areas where the average number of users per cell interested in the content is high, otherwise it is delivered in unicast mode.

FIGURE A2-9

Time multiplexing of MBMS and unicast transmissions

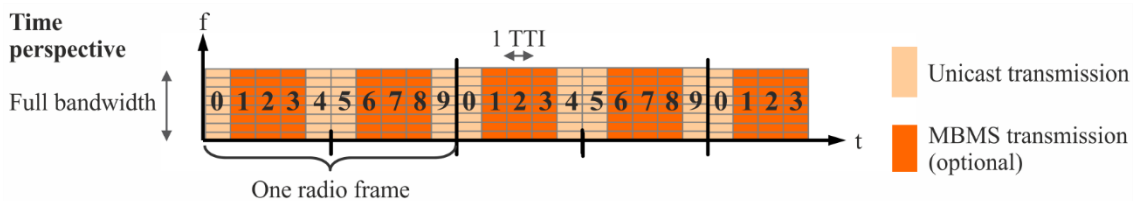

Report M.2373-A2-09

A2.14 User counting for MBSFN activation

The audience density can either be predicted from the density seen for similar content in the past (e.g. earlier episodes of the same TV series) or based on real-time user counting. The user counting procedure enables the MCE to autonomously activate/deactivate MBMS services in a predefined MBSFN area depending on user interest. The counting procedure is triggered by the MCE if the network operator has configured it to do so. Counting is possible for Release 10-compatible MBMS UEs in so called RRC_CONNECTED mode, i.e. for UEs that already have a signalling connection with the LTE network, e.g. because the UE has recently received or transmitted unicast data. The fraction of UEs that can be addressed this way is typically high enough to enable statistically

significant estimation of the total number of UEs in each cell that are interested in the considered MBMS service.

If the number of UEs responding to be interested in a service exceeds an operator-set threshold, the MCE can enable the preconfigured MBSFN area so that the service gets multicasted. The actual reception of the multicast is also possible in the RRC_IDLE mode where the UE does not have any signalling context with the network. If the threshold is not exceeded, then the number of users interested in the service is considered to be so low that delivering the service in unicast mode only in the cells with interested users is more efficient from a radio resource perspective.

If the MCE based counting procedure is not used, the set of cells to include in an MBSFN area and the services to be multicast in an MBSFN service area need to be configured manually by the network operator. The decisions need to be taken based on audience density information from the past. Such information can be gathered in the BM-SC from UE reception reports which can optionally include a cell ID of a cell that has been used for reception.

A2.15 Service acquisition and continuity in multi-carrier networks

An MBMS service that is provided via MBSFN is generally provided only on one frequency, while multiple frequencies can be deployed in a geographic area to cope with increasing unicast and MBMS traffic.

In order to provide the UE with sufficient information to find the frequency where an eMBMS service of interest is transmitted without having to scan all frequencies, in LTE Release 11 so-called MBMS assistance information is provided to the UE by both the USD (from the service layer) and the network. The USD of a service contains information in which MBMS SAIs and on which frequencies the service is provided. Each cell in the network broadcasts in its system information the MBMS SAIs of cells for its own frequency and for the frequencies used by overlapping (or neighbouring) cells. If the UE finds a match between the MBMS SAI in the USD of the service of interest and in the system information, it can deduce that the service is locally available on a certain frequency. Based on the MBMS SAI information, the UE in RRC_IDLE can prioritize this frequency as that of the only cell to monitor, and the UE in RRC_CONNECTED mode can send its MBMS interest indication to the network. This interest indication contains a list of one or more MBMS frequencies according to the UE's interest and capability of parallel MBMS reception on different frequencies, and also a priority bit. In case the cell transmitting the eMBMS service of interest is overloaded in the unicast sub-frames and a user wants to simultaneously receive the eMBMS service and other unicast services, the network can then decide based on the priority bit to keep the UE on the current cell even though the user then can experience reduced unicast performance, rather than handing over the UE to another cell which would imply the loss of the eMBMS service of interest for the user, unless the UE is capable of receiving on two cells (one per frequency) simultaneously.

A2.16 Quality of service

For unicast services, LTE provides a QoS framework. A service is associated with a QoS class identifier (QCI)¹⁸. Each QCI implies specific values of maximum transfer delay and the maximum Service Data Unit error rate. The LTE radio network then tries to ensure these QoS requirements are met, by appropriate prioritization in the UE scheduling and choice of retransmission rate, provided that the quality of the radio link enables this.

For eMBMS, the LTE sub-frames are reserved in a periodic pattern. This means eMBMS does not compete for radio resources with unicast traffic on a best-effort basis. Each service is mapped to a guaranteed bit rate bearer (GBR). The MCE allocates the required density of eMBMS sub-frames to achieve a total bit rate that supports the sum of the bitrates for all services that are multiplexed on one MCH, given the chosen modulation and coding scheme (MCS) of the MCH and AL-FEC code rate of each service. These parameters need to be configured to achieve the targeted low AL-FEC block loss rates with the targeted high geographical coverage. The BM-SC applies rate control to each service in order to not exceed the guaranteed bitrates in each synchronization sequence.

After the transmission of a file has finished, a file repair procedure can ensue where UEs not having received a sufficient number of packets to enable successful AL-FEC decoding can request delivery of additional packets. This is not useful in the case of DASH based streaming because this kind of retransmissions takes too long and would not arrive at the UE in time for the continuous playout, and the loss of a DASH segment only leads to a temporal loss of the playout. The file repair can however be very efficient for the distribution of large files and where integrity is a must.

Due to the unidirectional nature of eMBMS services, the network operator cannot easily know from the session if end-user devices have correctly received the data or the user experience of a streaming session was good.

Gathering of quality of experience (QoE) metrics from receiving MBMS clients to the BM-SC were defined for this purpose¹⁹. The service announcement information configured by the operator describes the parameters for QoE metrics. The announcements can be configured such that only samples of end-user devices report them. In the case of DASH, the QoE metrics indicates the number of lost HTTP streaming segments.

Finally, from Release 12 onwards also on the part of MBMS, LTE supports UE radio link quality reporting for network optimization, e.g. for the detection of coverage hole. This feature is called minimization of drive tests (MDT).

A2.17 Standardization Outlook

LTE is continuously further developed by 3GPP in a release cycle. A cycle takes about 1.5 years. At the end of 2014 3GPP is in the process of finalizing Release 12.

The work is organized in the form of work items. The main work items where unicast video delivery can benefit from are improvements in the areas of (distributed) multi-antenna (MIMO) methods and small cell support (including 256-QAM) for traffic hotspots. For eMBMS enhancements there is a

¹⁸ 2 Standardized QCI characteristics:

3rd Generation Partnership Project; Technical Specification Group Services and System Aspects; Policy and charging control architecture (Release 13).

Technical specification 3GPP TS 23.203 V13.3.0 (2015-03).

¹⁹ Lohmar, Sissingar, Kenenhan, Puustinen; “Delivering content with LTE Broadcast” in Ericsson Review 2013-1, 11 Feb 2013

http://www.ericsson.com/res/thecompany/docs/publications/ericsson_review/2013/er-lte-broadcast.pdf.

proposed work item to cover longer cyclic prefix to support larger inter-site-distances, support of eMBMS on dedicated carriers, i.e. using 100% of carrier resources for eMBMS, and MIMO. 3GPP RAN work items can be adopted by the 3GPP RAN plenary which meets every 3 months. Apart from the dedicated eMBMS work item proposal, discussions have started whether 3GPP should work on supporting eMBMS on the so called new carrier type (NCT) which is mainly being developed for performance increase and energy saving for unicast services, but also presents an opportunity to increase the limit of the percentage of sub-frames usable for eMBMS from 60% to 80%.

Annex 3

Demonstration trials of audio-visual over IMT

As of March 2018, thirty-nine operators are known to have been investing in eMBMS demonstrations, trials, deployments or launches and five operators have now deployed eMBMS or launched some sort of commercial service using eMBMS [28].

Two cases are described in this Annex.

Case 1: Operator trials in Melbourne

Telstra has been actively assessing LTE eMBMS (LTE-B) capability within its Technology, Networks and Products groups since 2013, through performance modelling, technology trials, live proof-of-concept activities, and internal service demonstrations. In particular, these activities have included live trials of real football and cricket events within large stadium environments (>100k seats), along with delivery of premium content associated with the ongoing games.

Telstra has conducted trials of LTE-B technology at several locations in the city of Melbourne. For example, following successful lab demonstrations, Telstra performed the first live event LTE-B trial in the world of the T20 cricket match at Melbourne Cricket Ground in Jan 2014, marking a significant step in developing the technology for commercial use. During the trial, participants used LTE-B enabled devices to access three channels of dedicated content – Channel Nine’s live coverage, a separate highlights replay service, and continuous match/player statistics – being examples of how this technology could be used in the future. Demonstration services based on HD video are currently available at the Telstra ‘experience centre’. Telstra has also enabled a world first production deployment of LTE-B in Oct 2013 in a confined area. The current focus is to continue to the trials and demonstrate the LTE broadcast technology to maintain industry awareness (user and content provider awareness), help develop the eco-system, understand requirements for spectrally efficient network design and network integration. Telstra is using the knowledge gained from these trials to further refine network planning, and to enable ongoing collaboration with manufacturers and content owners to develop devices and applications in preparation for a future commercial service launch.

Telstra launched its 3G (UMTS) network in 2006. Since then data usage on that network has grown significantly – nearly doubling year-on-year. While it is gratifying that customers are finding such benefit from the network that usage grows so strongly, the challenge for Telstra is how best to configure and expand the network to cater for that demand growth. Fortunately for network operators the IMT technology continues to evolve and provide further solutions. In 2011, Telstra further launched its 4G (LTE) network. This allowed Telstra customers to access the next generation of mobile network technology, for more efficient delivery (bps/Hz) along with higher data speeds – and at the same time added a whole extra channel for their data to be carried on. With the uptake of 4G, Telstra is now seeing traffic on its 4G network approaching a growth rate of close to doubling every

three to four months. While the 4G network is still relatively new, operators need to look for solutions that will allow them to sustain this growth month-on-month and year-on-year. This is where LTE-Broadcast is expected to play a major role. Experience shows that many customers are often seeking the same content delivered to their mobile phone at the same time. This might be a copy of the newspaper in the morning, a new operating software upgrade, or live-feed of a sporting contest. If a large number of people in a mobile network cell area request such content, it clearly becomes inefficient to deliver it using a unicast approach. Through Telstra's LTE-Broadcast trial, it has today demonstrated that it is possible to use one common stream of data, to deliver the same content to multiple users – keeping the rest of the network free for other customers.

Each wireless network is deployed on the basis of a finite amount of spectrum – and when a network is fully loaded it's usually not possible to simply add more spectrum to carry extra traffic. Thus, in the absence of any other solution, all active customers on that network will consequently experience lower speeds. Therefore, one aim of the trials conducted by Telstra was to assess the potential of LTE-B for off-loading traffic in busy areas. When a large number of people gather in one place (e.g. event arenas), a major spike in the demand for data is often observed that will stretch the capabilities of a unicast network and affect the experience of all customers. LTE-B offers network operators the ability to deliver content more effectively and provide all users the same high quality service using one single stream of data. In this way, capacity is freed up on the remainder of the network to carry other data, voice and text messages. Possible future uses of the broadcast technology, some of which have been tested in the T20 trial, include people listening to live commentary, getting real time match statistics and being able to watch replays and game highlights on their smartphone or tablet interactively.

The current focus is to continue the trials and demonstrate the LTE broadcast technology to maintain industry awareness and help develop the eco-system. A number of other live events (e.g. Spring Racing Carnival, major conferences) are currently targeted for demonstration of the LTE-B capabilities. In addition, data file download opportunities such as digital signage (e.g. billboards), content delivery to a particular industry vertical and portable LTE-B for music festivals in unconnected places are also being explored. Collaboration and sharing of experiences with operators in other countries is also seen as vitally important, along with device and chipset manufacturers, as well as the major network vendors, to further develop the LTE broadcast eco-system.

Case 2: Field test in Germany: integration of broadcast and mobile broadband in LTE/5G (IMB5)

In 2014 a research project called IMB5 started, funded by BFS (Bayerische Forschungsstiftung), with the objective to create technological models for the convergence of broadcast and mobile broadband by:

- Testing the capabilities and limitations of current LTE eMBMS for nationwide broadcast infrastructure.
- Creating an optimized system architecture for eMBMS based networks.
- Defining input for modifications of the 3GPP standardization of eMBMS.

Some further detail of the project:

Background and motivation

Today, terrestrial television (stationary and mobile reception) as well as mobile broadband use separate and different network infrastructures and are competing for scarce spectrum resources in the UHF band. The aim of the project IMB5 is therefore, with the help of theoretical and practical studies, to develop proposals how cellular phone and terrestrial television could be brought together in a new converged system. A converged system of terrestrial television and cellular communications could bring significant benefits to the consumer. Linear and on-demand broadcasting content could be

received everywhere on mobile devices via a converged single air interface. The integrated IMT uplink channel together with touch screen, microphone and camera enables new forms of interactivity via integration of spectators in live programs with image and sound. This project allows companies in the broadcasting and mobile communications business, and also media and automotive companies to come together and also, the results of this project could serve to clarify the issues in the areas of regulation and business models.

Currently, the terrestrial broadcasting coverage is nation-wide or regional. In many countries, radio and television programs of the public service broadcasters and private broadcasters are made available to the customers free of charge; in Germany the terrestrial distribution is financed by ARD, ZDF as well as the participating private broadcasters. In addition to fixed reception, portable and mobile reception of television programs is supported. The number of users is in the range of four to ten million, depending on whether laptops, secondary devices, portable receivers and multi-standard displays in motor vehicles are counted or not. However, for various reasons, the DVB-T standard is not implemented in smartphones and tablets. Currently the German mobile operators are expanding LTE-capable IMT networks. With the planned roll-out of LTE Release 9, new application areas become available eMBMS can be operated in a Multicast Broadcast Single Frequency Network (MBSFN). The parameters are optimized for LTE networks. In order to use LTE or a successor of LTE/eMBMS for wide-area TV services it is necessary to examine and improve the currently specified eMBMS-mode. The IMB5 project intends to realize this by carrying out theoretical investigations and simulations on the system and link level. In parallel, a test bed will be established to validate the current eMBMS capability in practical field tests. The results and experience gained in this project could be utilized for the development of new standards to enable the integration of broadcasting and mobile communications in a common standard and a common multimedia distribution network.

Objectives

The aim of the IMB5 project is to explore the possibilities of the currently defined eMBMS from 3GPP Release 9 to identify the existing limitations of its suitability and overcome the inadequacies for a nationwide terrestrial television infrastructure. As on-demand services are increasing, a key objective in this project is the combination of linear and on-demand content. Different scenarios will be studied to demonstrate whether eMBMS (defined in the standard mode, which provides both multicast and broadcast operation) is suitable for broadcast-specific applications. The scenarios considered are not only pure broadcasting scenarios but also a push mode in which the content is transmitted to a terminal, and the consumer can watch it at any time. Telematics services in push mode can also be used to deliver services like traffic information. Traffic control and driver information via a nationwide eMBMS coverage could result in a significant cost reduction.

A long-term goal is to define a common standard that is suitable for terrestrial television and mobile broadband. A mobile device (smartphone, tablet PC, etc.) would receive the same television and broadcasting content and in addition provide a basis to enable innovative services that require a return channel. The development of a globally applicable standardization proposal for the transmission of both linear and on-demand content, enables cost-effective mass production of uniform global receivers for the benefit of consumers, device manufacturers, network operators and content providers. In addition to the globally harmonized standard, another objective is the optimization of network structure and topology. For instance, it is crucial to distribute public service broadcast content only once per region and not once per network operator. This may provide new momentum to the transmission of broadcast content and thus help to resolve the current debate around future use of the UHF band.

In addition to the theoretical discussion of these issues, the focus of the project is a practical realization of such a network structure in the form of a field trial. Using test installations, the theoretically acquired knowledge is applied and verified in practice. In parallel, findings on incurred

costs will be fed into a cost analysis, which subsequently will be suitable for a comparison of different network structures. This is accompanied by the objective of limiting the necessary capital and operating costs of such a future integrated network on a commercially reasonable level.

Annex 4

Emerging transmission technologies for broadcasting/multicasting in IMT-2020

One of the applications for IMT-2020 systems is to deliver broadcast-type services with high to ultra-high quality video services to a large variety of devices, from handheld mobile/portable devices to high data rate fixed reception terminals with roof-top antenna. To meet these requirements, the IMT-2020 system needs to use new technologies to achieve high spectrum efficiency and flexibility. This section outlines some emerging transmission technologies for more efficient delivery of broadcasting/multicasting services in IMT-2020.

A4.1 Layered Division Multiplexing (LDM)

Layered Division Multiplexing (LDM) is a power-based non-orthogonal multiplexing (P-NOM) technology, which can multiplex two signals in overlapped spectrum resources to enable simultaneous delivery of two streams conveying independent or complementary broadcast services [29]. This can be achieved by combining spectrum overlay and signal cancellation techniques for spectrum re-use. It has been proven in extensive laboratory and field tests that LDM offers an efficient and flexible approach to deliver high quality services, e.g. HDTV and UHD-TV, simultaneously to portable indoor/mobile and fixed receivers within the same UHF channel. The performance gain from LDM over the traditional Time/Frequency Division Multiplexing (T/FDM) technologies in the latest LTE-Advanced system is in the range from 5 to 9 dB depending upon the specific deployment scenarios. Even though LDM can be used in a variety of application scenarios, the most immediate scenario is the simultaneous delivery of UHD-TV services to fixed terminals and ultra-robust HD services to mobile/portable and indoor receivers using the same UHF channel.

A technology like LDM has been adopted in 3GPP Release 14 for unicast downlink transmission, which is called Multi-User Superposition Transmission (MUST) [30]. However, for broadcast/multicast applications, the transmission parameters will be quite different. Studies show that LDM (or P-NOM) achieves significantly higher spectrum efficiency than the traditional T/FDM technologies, especially for simultaneously delivering services with different reception robustness.

A4.2 Cyclic Prefix, FFT size and High Speed Mobile Reception

In 3GPP Release 14, larger cyclic prefix (CP) length has been specified for broadcast/multicast transmissions. However, larger CP duration will reduce the spectrum efficiency, since CP only transmits redundant information. To avoid the reduced spectrum efficiency, the OFDM subcarrier spacing needs to be decreased. This will increase the system sensitivity to high speed mobile reception conditions, due to the Doppler Effect. The Doppler Effect results in Doppler noise at the receiver, where the impact depends on the RF frequency band and the receiver traveling speed.

Doppler noise will increase the system noise floor and degrade the system Signal to Noise Ratio (SNR) threshold. However, if the transmission system SNR threshold is sufficiently low, or the system noise tolerance level is high, the impact of the Doppler noise will be significantly reduced

[31]. The above-mentioned LDM technology can effectively multiplex a low SNR mobile system with a high-data-rate stationary reception system in one RF channel. The mobile system has a very low SNR threshold, in the range of 0 to 5 dB, which proves to be very robust to Doppler noise. In the UHF TV band, the speed tolerance can be up to 350 km/h for OFDM subcarrier spacing of only several hundred Hertz.

A4.3 Time-Frequency Slicing (TFS)

In the UHF band, the wavelength is relatively long. Due to multipath distortion, there are many deep fading points within the coverage area. Since the UHF TV band is quite wide, on different RF channels, the signal fading locations are different. This means, in one particular location, one might be able to receive signals from many RF channels; while for a few channels that the receiving antenna happens to locate on a signal fading point, there will be no successful signal reception.

One solution is to use the Time-Frequency Slicing (TFS) technology [32]. A very wide RF channel is used in the order of tens of MHz bandwidth. The RF channels are sorted into spectrum slices, and multiple video programs are assigned to separate spectrum slices. To further improve the performance, the spectrum slice assignments vary over time in a predefined cyclic order. This is like spectrum hopping and dynamic frequency multiplexing. The result is that a video program will be transmitted over different parts of the RF spectrum. This prevents the scenario where a deep signal fading point nulls out one particular program. It makes all programs have very short fading durations. With proper error correction code and time interleaver, all programmes can be successfully received.

A4.4 Channel Bonding (and Statistical Multiplexing)

Channel bonding provides increased spectrum flexibility [33]. Channel bonding spreads a single physical layer data stream over two or more RF channels. It enables much higher aggregated data rates required by ultra-high-quality video and data services, which exceed the capacity of a signal RF channel. This further allows the use of statistical multiplexing of multiple video programs within one physical-layer signal to achieve up to 30% cumulative service capacity increase.

A4.5 Non-Uniform Constellation Modulation

Non-Uniform Constellation (NUC) modulation that uses geometrically shaped constellations can reduce the reception SNR threshold [34]. Two dimensional NUC provides high shaping gains at the cost of higher detection complexity; while one-dimensional NUC requires lower-complexity detection with a slightly lower shaping gain.

NUC is well suited for transmissions with large constellation sizes, e.g. 64-QAM and higher, which are likely used in IMT-2020 to deliver broadcasting/multicasting services with high/ultra-high qualities.

A4.6 Interleaving and Mobile Reception

Interleaver plays an important role in mobile reception, especially in low speed pedestrian mode. A large time interleaver can significantly improve the reception performance, but it will introduce reception latency and receiver complexity. However, the broadcast service is not very sensitive to the signal processing delay, as long as the delay is not time variant to impact the real-time audio/video services. For good low speed mobile and pedestrian reception, a time interleaver of a few hundred milliseconds is required [35].

References

- [1] Ericsson Mobility Report, June 2017. <http://www.ericsson.com/mobility-report>.
- [2] DigiWorld yearbook by IDATE: key indicators of the digital economy, November 2014, http://www.idate.org/en/Forum/DigiWorld-Yearbook_40_.html.
- [3] Ericsson Mobility Report, June 2018. <http://www.ericsson.com/mobility-report>.
- [4] Ericsson ConsumerLab, “TV and Media 2017 – A consumer-driven future of media”. An Ericsson Consumer and Industry Insight Report, October 2017. Available at <https://www.ericsson.com/networked-society/consumerlab/consumer-insights/reports/tv-and-media-2017>.
- [5] Ericsson ConsumerLab, “TV and Media, 2015”, An Ericsson Consumer Insight Report, September 2015. Available at <https://www.ericsson.com/res/docs/2015/consumerlab/ericsson-consumerlab-tv-media-2015.pdf>.
- [6] TR 26.918, “Virtual Reality (VR) media services over 3GPP”. This report primarily focuses on 360 degrees video and associated audio, which support three degrees of freedom (3DOF). http://www.3gpp.org/ftp/Specs/Archive/26_series/26.918/26918-f10.zip.
- [7] Ericsson ConsumerLab, “TV and Media, 2017”, An Ericsson Consumer and Industry Insight Report, October 2017. Available: <https://www.ericsson.com/en/trends-and-insights/consumerlab/consumer-insights/reports/tv-and-media-2017>.
- [8] 3rd Generation Partnership Project; Technical Specification Group Services and System Aspects; Service aspects; Service principles (Release 14), 3GPP TS 22.101 V14.5.0 (2016-12). <https://portal.3gpp.org/desktopmodules/Specifications/SpecificationDetails.aspx?specificationId=605> (‘Releases’ tab).
- [9] 3rd Generation Partnership Project; Technical Specification Group Services and System Aspects; Study on System Architecture Enhancements to eMBMS for Television Video Service (Release 14), 3GPP TR 23.746 V14.0.0 (2016-09). <https://portal.3gpp.org/desktopmodules/Specifications/SpecificationDetails.aspx?specificationId=3061> (‘Releases’ tab).
- [10] TS 26.116 “Television (TV) over 3GPP services; Video profiles”. <https://portal.3gpp.org/desktopmodules/Specifications/SpecificationDetails.aspx?specificationId=2906>.
- [11] DASH Industry Forum, “DASH-IF Position Paper: Server and Network Assisted DASH (SAND)”, December 2016. <http://dashif.org/wp-content/uploads/2017/01/SAND-Whitepaper-Dec13-final.pdf>.
- [12] “Universal Mobile Telecommunications System (UMTS)”; LTE; Multimedia Broadcast/Multicast Service (MBMS); Architecture and functional description 3GPP TS 23.246 version 9.5.0 Release 9, 06/2010.
- [13] D. Lecompte and F. Gabin, “Evolved Multimedia Broadcast/Multicast Service (eMBMS) in LTE-Advanced: Overview and Release 11 Enhancements”, IEEE Communications Magazine, vol. 50, no. 11, pp. 68-74, Nov. 2012.
- [14] 3GPP TS 26.346, “Multimedia Broadcast/Multicast Service (MBMS); Protocols and Codes” <https://portal.3gpp.org/desktopmodules/Specifications/SpecificationDetails.aspx?specificationId=1452>.
- [15] 3GPP TS 23.246, Multimedia Broadcast/Multicast Service (MBMS) – Architecture and Functional. <https://portal.3gpp.org/desktopmodules/Specifications/SpecificationDetails.aspx?specificationId=829>.
- [16] 3GPP TS 36.300 v11.1.0, “Evolved Universal Terrestrial Radio Access (E-UTRA) and Evolved Universal Terrestrial Radio Access Network (E-UTRAN); Overall description; Stage 2”, March 2012. <https://portal.3gpp.org/desktopmodules/Specifications/SpecificationDetails.aspx?specificationId=2430>.
- [17] (3GPP TS 29.116 v14.1.0 “LTE; Representational state transfer over xMB reference point between content provider and BM-SC”).

- [18] ISO/IEC DIS 23009-1.2, "Dynamic Adaptive Streaming over http (DASH)", Nov. 2011.
- [19] H. Schulzrinne *et al.*, "RTP: A Transport Protocol for Real-Time Applications", IETF RFC 3550, July 2003.
- [20] A. Shokrollahi, "Raptor Codes", IEEE Trans. On Information Theory, vol. 52, No. 6, pp. 2551-2567, June 2006.
- [21] M. Luby, T. Gasiba, T. Stockhammer, and M. Watson, "Reliable Multimedia Download Delivery in Cellular Broadcast Networks", IEEE Trans. On Broadcasting, vol. 53, no. 1, pp. 235-246, March 2007.
- [22] T. Lohmar and M. Elisova, "Evaluation of the File Repair Operations for Multicast/Broadcast Download Deliveries", Proc. European Wireless, Nicorsia Cyprus, 2005.
- [23] T. Lohmar and J. Huschke, "Radio Resource Optimization for MBMS File Transmissions", Proc. IEEE International Symposium on Broadband Multimedia Systems and Broadcasting (BMSB), Bilbao, Spain, 2009.
- [24] E. Dahlman, S. Parkvall, J. Sköld and P. Beming, "3G Evolution: HSPA and LTE for Mobile Broadband", Academic Press, 2008.
- [25] 3GPP TR 25.814 v.7.1.0, "Physical Layer Aspects for Evolved UTRA", Oct. 2010.
- [26] A. Urie, A. Rudrapatna, C. Raman, J-M Hanriot, "Evolved Multimedia Broadcast Multicast Service in LTE: An Assessment of System Performance Under Realistic Radio Network Engineering Conditions", Bell Labs Technical Journal, Volume 18, Issue 2, pp. 57-76, September 2013.
- [27] 3GPP TS 25.446 v.10.2.0, "MBMS Synchronisation Protocol (SYNC)", Dec. 2011.
- [28] GSA, *LTE Broadcast (eMBMS) Market Update*, March 2018. Available: <https://gsacom.com/paper/lte-broadcast-embms-market-update-march-2-018/>.
- [29] L. Zhang, W. Li, Y. Wu, X. Wang, S.I. Park, H.M. Kim, J.Y. Lee, P. Angueira, and J. Montalbán, "Layered Division Multiplexing: theory and Practice," IEEE Transactions on Broadcasting, vol. 62, no. 1, Part 2, pp. 216-232, Mar. 2016.
- [30] 3GPP TR 36.859, "Study on Downlink Multiuser Superposition Transmission (MUST) for LTE," v13.0, 2016/01.
- [31] J. Montalbán, L. Zhang, U. Gil, Y. Wu, I. Angulo, K. Salehian, S.I. Park, B. Rong, Wei, Li, H.M. Kim, P. Angueira, and M. Vélez, "Cloud Transmission: System Performance and Application Scenarios," IEEE Transactions on Broadcasting, vol. 60, no. 2, pp. 170-184, June 2014.
- [32] E. Garro, J. Joan, S.I. Park, and D. Gómez-Barquero, "Layered Division Multiplexing With Multi-Radio-Frequency Channel Technologies," IEEE Transactions on Broadcasting, vol. 62, no. 2, pp. 365-374, June 2016.
- [33] L. Stadelmeier, D. Schneider, J. Zollner, and J. Giménez, "Channel Bonding for ATSC 3.0", IEEE Transactions on Broadcasting, vol. 62, no. 1, Part 2, pp. 289-297, Mar. 2016.
- [34] M. Fuentes, D. Vargas, and D. Gómez-Barquero, "Low-Complexity Demapping Algorithm for Two-Dimensional Non-Uniform Constellations," IEEE Transactions on Broadcasting, vol. 62, no. 2, pp. 375-383, June 2016.
- [35] L. Zhang, W. Li, Y. Wu, Z. Hong, K. Salehian, X. Wang, P. Angueira, J. Montalbán, M. Vélez, S.I. Park, H.M. Kim, J.Y. Lee, "Performance Characterization and Optimization of Mobile Service Delivery in LDM-Based Next Generation DTV Systems," IEEE Transactions on Broadcasting, vol. 61, no. 4, pp. 557-570, Dec. 2015.
-