

Report ITU-R BT.2408-6

(03/2023)

BT Series: Broadcasting service (television)

Guidance for operational practices in HDR television production



Foreword

The role of the Radiocommunication Sector is to ensure the rational, equitable, efficient and economical use of the radio-frequency spectrum by all radiocommunication services, including satellite services, and carry out studies without limit of frequency range on the basis of which Recommendations are adopted.

The regulatory and policy functions of the Radiocommunication Sector are performed by World and Regional Radiocommunication Conferences and Radiocommunication Assemblies supported by Study Groups.

Policy on Intellectual Property Right (IPR)

ITU-R policy on IPR is described in the Common Patent Policy for ITU-T/ITU-R/ISO/IEC referenced in Resolution ITU-R 1. Forms to be used for the submission of patent statements and licensing declarations by patent holders are available from <http://www.itu.int/ITU-R/go/patents/en> where the Guidelines for Implementation of the Common Patent Policy for ITU-T/ITU-R/ISO/IEC and the ITU-R patent information database can also be found.

Series of ITU-R Reports

(Also available online at <https://www.itu.int/publ/R-REP/en>)

Series	Title
BO	Satellite delivery
BR	Recording for production, archival and play-out; film for television
BS	Broadcasting service (sound)
BT	Broadcasting service (television)
F	Fixed service
M	Mobile, radiodetermination, amateur and related satellite services
P	Radiowave propagation
RA	Radio astronomy
RS	Remote sensing systems
S	Fixed-satellite service
SA	Space applications and meteorology
SF	Frequency sharing and coordination between fixed-satellite and fixed service systems
SM	Spectrum management
TF	Time signals and frequency standards emissions

Note: This ITU-R Report was approved in English by the Study Group under the procedure detailed in Resolution ITU-R 1.

*Electronic Publication
Geneva, 2023*

© ITU 2023

All rights reserved. No part of this publication may be reproduced, by any means whatsoever, without written permission of ITU.

REPORT ITU-R BT.2408-6

Guidance for operational practices in HDR television production

(2017-2018-04/2019-07/2019-2021-2022-2023)

Summary

This Guidance for operational practices is intended to help ensure optimum and consistent use of high dynamic range in television production using the Perceptual Quantization (PQ) and Hybrid Log-Gamma (HLG) methods specified in Recommendation ITU-R BT.2100. Additional background information on HDR is available in Report ITU-R BT.2390, while Report ITU-R BT.2446 provides guidance towards the design of methods of conversion between HDR and SDR content.

TABLE OF CONTENTS

	<i>Page</i>
Report ITU-R BT.2408-6.....	1
Policy on Intellectual Property Right (IPR).....	ii
1 Introduction	4
2 Reference levels and signal format.....	5
2.1 HDR Reference White	5
2.2 Signal levels for line-up in production	5
2.3 Bit depth.....	8
2.4 Signal range	8
2.5 Colour representation.....	9
3 Monitoring.....	9
3.1 Display of PQ signals	9
3.2 Display of HLG signals	11
4 Image brightness.....	13
4.1 Comfortable brightness of static images.....	13
4.2 Tolerance to programme brightness shifts.....	14
5 Integrating standard dynamic range and high dynamic range production.....	16
5.1 Inclusion of standard dynamic range content in high dynamic range	16
5.2 HDR to SDR down-mapping.....	23
5.3 Handling negative values in format conversion	24
5.4 Adjustments to BT.709 cameras.....	24
5.5 Use of 8-bit content	25

5.6	Mapping of SDR graphics	25
6	Conversion between PQ and HLG	26
6.1	Transcoding concepts	26
6.2	Conversion concepts using a reference condition at 1 000 cd/m ²	26
6.3	Cameras using a common OOTF at a reference peak luminance of 1 000 cd/m ²	27
6.4	Handling PQ signals with greater than 1 000 cd/m ² peak luminance.....	28
6.5	Possible colour differences when converting from PQ to HLG	28
7	Transitioning from SDR BT.709 to HDR BT.2100 production	30
7.1	HDR focused production	30
7.2	SDR focused production.....	32
7.3	SDR-HDR and HDR-SDR format conversion	35
7.4	SDR-HDR-SDR “Round-Tripping”	40
7.5	Hardware colour matrix compensation.....	40
7.6	Signal line-up.....	41
7.7	Camera painting.....	41
8	Conversion practices for camera and display RGB colorimetry	42
	Annex 1 Study to evaluate levels for PQ content	42
	Annex 2 Analysis of reference levels	45
	A2.1 Introduction.....	45
	A2.2 Analysis of reference levels.....	45
	A2.3 Diffuse white elements in live HLG encoded broadcast content.....	46
	A2.4 Diffuse white in an HDR dataset of 1 000 cd/m ² PQ encoded images.....	47
	A2.5 Discussion.....	48
	A2.6 Conclusions.....	49
	Annex 3 Two studies of skin tones, using a reflectance database and using real subjects	49
	A3.1 Study 1: using a skin tone database and an ideal model of a camera	49
	A3.2 Study 2: using human subjects and a RAW recording camera.....	52
	A3.3 Conclusions.....	54
	Annex 4 Study of facial skin tones in broadcast content	55
	A4.1 Facial skin tones in SDR news and information programmes in studio.....	55

A4.2	Comparison of facial skin tones in HLG HDR and SDR content in a music programme	56
A4.3	Conclusion	57
Annex 5	Displaying PQ – calculating the EETF	58
Annex 6	Comparison of the native looks of HDR and SDR production	61
A6.1	Differences in chromaticity and saturation	62
A6.2	Quantifying the total colour differences	65
A6.3	Comparison with the reference colour pattern data	66
Annex 7	Calculating the normalized primary matrix	68
A7.1	Conversion of normalized linear colour signals to Recommendation ITU-R BT.2100	69
A7.2	Conversion of BT.2100 to arbitrary linear colour signals for display systems ..	71
Annex 8	4K/8K UHD HDR and HD SDR simul-production and simulcast practice in China	72
A8.1	Background	72
A8.2	Basic workflows and principles	72
A8.3	Introduction of related work and research	74
A8.4	Mapping for conversion between HDR and SDR	75
A8.5	Parameter settings	75
A8.6	Converter performance consistency (LUTs usage)	76
A8.7	Signal range	77
A8.8	Consistency of international exchange	77
A8.9	Conclusions	78
Annex 9	HDR and SDR monitors in close proximity	78
A9.1	Approach used by BBC	78
A9.2	Approach used by NBCUniversal	78
Annex 10	NBCUniversal single-master HDR-SDR workflow	79
Annex 11	Conversion between 203 cd/m ² and 100 cd/m ² (BT.2035) SDR signal formats ...	82
Glossary	85

1 Introduction

Recommendation ITU-R BT.2100 (BT.2100) specifies HDR-TV image parameters for use in production and international programme exchange using the Perceptual Quantization (PQ) and Hybrid Log-Gamma (HLG) methods. Since its first publication in 2016, television programme production in high dynamic range (HDR) continues to grow and is attracting increasing interest from content creators and broadcasters wishing to benefit from the improved viewing experience that HDR offers. At the same time, standard dynamic range (SDR) and high dynamic range will need to coexist for many years to come. These operational practices propose guidance to programme makers and broadcasters based on knowledge and practical experience gained so far. A glossary of terms is included at the end of this Report.

Production in PQ is similar to standard dynamic range production. During capture, the scene may be exposed to produce the desired appearance on a reference monitor, ideally operating in the reference environment. Exposure setting may be assisted for example by setting a grey or diffuse white card to the desired signal level. It is possible for the PQ system to capture and encode information that is beyond the capabilities of a specific monitor, if that monitor cannot reach both the ideal peak luminance of 10 000 cd/m² and the full extent of the BT.2100 wide colour gamut. If the PQ signal is not actively constrained to the capability of the reference monitor in use, more information may be revealed on a subsequent display with higher peak luminance or colour gamut.

HLG has been designed to enable a straightforward migration towards HDR television production, with few changes to SDR production working practices. The compatible nature of the HLG signal allows standard dynamic range monitors to be used in non-critical monitoring areas. HDR monitors are necessary only for critical monitoring, such as when colour grading, camera shading and monitoring programme and preview outputs in a production gallery.

Just as line-up levels are useful for audio production, nominal signal levels for standard test charts are also useful for HDR television production. Nominal signal levels are given in order to facilitate camera line-up to help ensure consistency both within and between programmes, together with advice on monitoring and displaying HDR content.

Initial findings are presented on viewer tolerances to variations in image brightness, aimed in particular at avoiding viewer discomfort at junctions between programmes and other items of content, as well as when switching between programme channels.

Techniques are described for including SDR content in HDR productions, as are the principles of transcoding between PQ and HLG. Experience gained from trials with live production is documented, offering a practical guide for transitioning from SDR to HDR.

Annexes provide further technical details and background information. Annexes 1, 2, 3 and 4 present the results of studies analysing skin tones and other existing content which have been used to help inform guidance on video levels in HDR production (see § 2.2).

Annex 5 compares various approaches that can be used to map PQ signals to displays with a lower dynamic range than contained in the signal; such processes may also be required during conversion from PQ to HLG (see §§ 3.1.1 and 6.4).

Annex 6 compares the native displayed “look” of each SDR and HDR production format (see §§ 5.2 and 7.3.3).

Annex 7 gives technical details on how to calculate the normalized primary matrix (NPM) needed for conversion to and from the CIE XYZ colour space and the BT.2100 colour space (see § 8).

Annex 8 describes, as an example, practical experience with the 4K/8K UHD HDR and HD SDR simul-production and simulcast methods used in China (see § 7.2.2).

Annex 9 describes two approaches to the use of HDR and SDR monitors in situations where close proximity cannot be avoided.

Annex 10 describes a new approach, used by some broadcasters in the USA, whereby SDR shading monitors in live HDR production are operated at 203 cd/m² rather than the usual 100 cd/m² nominal peak luminance. Annex 11 describes how the resulting SDR signals may be converted to the 100 cd/m² SDR signal format for Recommendation ITU-R BT.2035 programme exchange.

2 Reference levels and signal format

During set-up, camera controls such as gain and shutter and others may be pre-adjusted to make best use of camera sensor capabilities, i.e. a balance between signal to noise ratio (SNR) and achieved sensor peak capability, and to establish a creative intent. During capture, the exposure may then be adjusted taking consideration of the reference levels listed below as well as the creative intent.

2.1 HDR Reference White

The reference level, HDR Reference White, is defined in this Report as the nominal signal level obtained from an HDR camera and a 100% reflectance white card resulting in a nominal luminance of 203 cd/m² on a PQ display or on an HLG display that has a nominal peak luminance capability of 1 000 cd/m². That is the signal level that would result from a 100% Lambertian reflector placed at the centre of interest within a scene under controlled lighting, commonly referred to as diffuse white¹. There may be brighter whites captured by the camera that are not at the centre of interest, and may therefore be brighter than the HDR Reference White.

Graphics White is defined within the scope of this Report as the equivalent in the graphics domain of a 100% reflectance white card: the signal level of a flat, white element without any specular highlights within a graphic element. It therefore has the same signal level as HDR Reference White, and graphics should be inserted based on this level.

The nominal signal level corresponding to HDR Reference White, diffuse white and Graphics White is shown in Table 1.

Signal levels for common test charts and reflectance cards with different reflectance are calculated using scene-light (the light falling on a camera sensor), from HDR Reference White. Details are given in § 2.2.

2.2 Signal levels for line-up in production

Signal levels in these operational practices are specified in terms of %PQ and %HLG. These percentages represent signal values that lie between the minimum and maximum non-linear values normalized to the range 0 to 1.

The values in Table 1 are presented as nominal recommendations for test charts and graphics for PQ production and for HLG production on a 1 000 cd/m² (nominal peak luminance) display, under controlled studio lighting². They assume no artistic adjustments have been made through camera painting controls or in post-production. In practice that may not be the case. While to facilitate

¹ Diffuse white is the white provided by a card that approximates to a perfect reflecting diffuser by being spectrally grey, not just colorimetrically grey, by minimizing specular highlights and minimizing spectral power absorptance. A “perfect reflecting diffuser” is defined as an “ideal isotropic, nonfluorescent diffuser with a spectral radiance factor equal to unity at each wavelength of interest”.

² The test chart should be illuminated by forward lights and the camera should shoot the chart from a non-specular direction.

HDR/SDR format conversion it is common practice to adhere to the reference level “HDR Reference White”, the signal levels for grey cards and skin tones (Table 2) may vary.

For PQ, the nominal luminance values are consistent on PQ reference displays. For HLG, the nominal luminance values will differ from those in Table 1 when the display’s peak luminance is lower or higher than 1 000 cd/m². The nominal signal levels in Table 1 do not change. There is a practical benefit to the use of common levels for both PQ and HLG and Table 1 reflects guidance to use common levels. However, as PQ and HLG have different capabilities, and as HLG levels are influenced by a desire to maintain a degree of compatibility with SDR displays and PQ levels are not, as experience is developed in the use of both PQ and HLG this guidance to use common levels may need to be adjusted. Annex 1 describes a study of early HDR movies graded on a 4 000 cd/m² PQ monitor. According to that study, luminance levels for indoor scenes were found to be typically about two thirds of the values indicated in Table 1, however those for outdoor scenes were found to be brighter. As producers of PQ content gain more experience, it is possible that levels in PQ indoor content may increase.

It is important to know the reflectance of greyscale charts and white cards, to ensure that cameras are aligned to deliver the appropriate signal level and consistency in production.

An 18% grey card is commonly used for camera set-up in non-live workflows as it is the closest standard reflectance card to skin tones. It may also be useful when trying to match SDR and HDR cameras as the 18% grey should not be affected by any SDR camera “knee”. However, as the 18% grey card is close to “middle grey” (i.e. halfway between black and diffuse white on a lightness scale) it is likely to be affected by camera painting in live production or colour grading in non-live production. So, the nominal signal levels for the 18% grey card will likely vary once artistic adjustments have been applied.

A 75%-HLG or 58%-PQ marker on a waveform monitor, representing the reference level, will help the camera shader ensure that objects placed at the centre of interest within a scene are placed within the appropriate signal range, and that sufficient headroom is reserved for specular highlights.

TABLE 1

Nominal levels for PQ and HLG production

Reflectance object or reference (luminance factor, %) ³	Nominal luminance, cd/m ² (for a PQ reference display, or a 1 000 cd/m ² HLG display)	Nominal signal level	
		%PQ	%HLG
Grey Card (18%) ⁽¹⁾	26	38	38
Greyscale Chart Max (83%)	162	56	71
Greyscale Chart Max (90%)	179	57	73
Reference Level: HDR Reference White (100%) ⁽¹⁾ also diffuse white and Graphics White	203	58	75

⁽¹⁾ The actual signal levels for an 18% grey card may differ significantly where camera painting controls have been applied.

⁽²⁾ The signal level of “HDR Reference White” is not directly related to the signal level of SDR “peak white”.

³ “Luminance factor” is the ratio of the luminance of the surface element in the given direction to the luminance of a perfect reflecting or transmitting diffuser identically illuminated.

In an experiment described in full in Annex 2, the levels of white objects in different types of HDR content were assessed, including an early live shoot of a baseball game, as well as a collection of HDR still photographs. In both cases, the mean white level is consistent with the HDR Reference White level as given in Table 1. However, for both types of content the spread around this mean value is significant, indicating that in practice the measured white levels can be expected to vary significantly around this target value.

When test charts are either not available or impractical, other objects such as skin tones or grass are often used to set signal levels. Approximate signal levels are given in Table 2.

The Fitzpatrick Skin Tone Scale [1] is used to classify skin types, which will vary by region. It was originally developed as a way to estimate the response of different types of skin to ultraviolet light. It may be used to provide a convenient classification method for the range of skin tones seen in television production.

Annex 3 describes how both experimental data, and a theoretical model of an ideal HDR television camera, have been used to determine the expected signal ranges for the Fitzpatrick skin types illustrated in Table 2. These ranges assume that content has been produced using the HDR Reference White signal levels specified in Table 1.

Annexes 1 and 4 report on skin tones in broadcast SDR content produced in studios in different regions. The skin tones in SDR content were found to be much different by regions. This may be mainly due to a difference in long-standing production practice for SDR rather than a difference in skin reflectance. Annex 4 also reports on a study on skin tones in HLG HDR content with camera shading compliant to the reference level of 75% HLG in comparison with SDR content, both produced independently for the same programme. The facial skin tones in the HLG content correspond to the Type 3-4 (medium skin tone) in Table 2.

Variations in these signal levels can be expected. The value for grass, for example, will depend on the type of grass planted for a given sport, changing ambient lighting conditions during the day and between daytime and evening/night-time, as well as regional and producer preferences. In Europe, Association football (soccer) grass is typically reproduced correctly with an HLG signal level of 40%, corresponding to the well-established level of 50% SDR after display-light down-mapping for a 100 cd/m² SDR display. As indicated in Table 2, these ranges can vary. For instance, in other regions grass (U.S. Football) can vary between 42.5-50% for SDR and when translated to HLG might end up lower than 40%.

Creatives making programme content may choose to encode content at differing levels, i.e. a dark indoor drama may put a grey card (and thus skin tones) at a lower level than shown in Table 1. Also, some productions may employ higher/brighter levels for outdoor scenes or for dramatic effect. However, significant deviation from the Table 1 nominal levels, in particular HDR Reference White, may lead to difficulties such as loss of important detail with static HDR to SDR down-mappers, which are usually optimised around these reference levels. When a static HDR to SDR down-mapper is used for transmission, it is therefore advisable to check for any detail loss in the derived SDR (for example in skin tones and/or displayed text) to ensure that the SDR image meets requirements and expectations.

As with the values for HDR Reference White, the nominal luminance values for PQ are the same on a PQ reference display, whereas the nominal luminance values vary for HLG depending on the display's peak luminance. Table 2 gives values for an HLG display with 1 000 cd/m² nominal peak luminance. The nominal signal levels do not change.

TABLE 2

Indicative ranges of levels for common objects in PQ and HLG production

Reflectance object	Nominal Luminance, cd/m ² (for a PQ reference display, or a 1 000 cd/m ² HLG display)	Signal level	
		%PQ	%HLG
Skin Tones (Fitzpatrick Scale)			
Type 1-2 Light skin tone ⁴	65-110	45-55	55-65
Type 3-4 Medium skin tone	40-85	40-50	45-60
Type 5-6 Dark skin tone ⁴	10-40	30-40	25-45
Grass	30-65	40-45	40-55

2.3 Bit depth

High quality HDR programmes can be produced using conventional 10-bit infrastructure and 10-bit production codecs, with similar bitrates used for standard dynamic range production.

The use of 12-bit production systems will, however, give greater headroom for downstream signal processing for both PQ and HLG.

2.4 Signal range

Recommendation ITU-R BT.2100 specifies two different signal representations, ‘narrow’ and ‘full’. Narrow range signal representations are traditionally used for television programme production. They provide headroom above the code value of the nominal peak (where the signal $E' > 1.0$) and below zero light (where the signal $E' < 0.0$) to accommodate signal overshoots and undershoots. Signals above the nominal peak are often termed ‘super-whites’ and those below zero light termed ‘sub-blacks’, although they need not be achromatic signals. Full range signal representations are more common in cinematic workflows. The movie industry has traditionally followed the computer graphics industry and placed zero light at digital code value “0”, and the code value of the nominal peak at the maximum code value for the given bit-depth. Full range signals do not, therefore, provide any headroom for signal overshoots or undershoots.

Signal overshoots and undershoots are produced by video processing techniques such as image re-sizing, filtering and compression, that are common in television production workflows. Overshoots and undershoots may also be present in the SDR signal after HDR to SDR down-mapping, particularly if the SDR super-white signal range is used to accommodate some of the highlights from the HDR source (see § 7.3.4). In order to maintain image fidelity, it is important that such overshoots and undershoots are not clipped. Any signal clipping introduces harmonic distortion, which makes the task of subsequent video compression or filtering even harder. Full range signals, which cannot accommodate signal overshoots and signal undershoots, are thus generally avoided in broadcasting systems. Furthermore, the black level of a display to represent an HLG signal should be adjusted using the Recommendation ITU-R BT.814 PLUGE signal, which is only possible if sub-blacks are present in the signal. Where HLG is used for programme production and exchange the full range signal representation should not be used.

⁴ Experimental data for Type 1, Type 5 and Type 6 skin types is limited. So there is less certainty on the signal ranges for these skin types.

The full range representation for PQ signals may, however, be useful as it provides an incremental advantage against visibility of banding/contouring and for processing. Furthermore, because the range of PQ is so large, it is rare for content to contain pixel values near the extremes of the range. Signal overshoots are therefore less likely to exist. It should be noted that full range signals may not be supported by broadcast distribution systems. For broadcast contribution, programme exchange or distribution, the full range signal representation of PQ should be used only when all parties agree. In the absence of such agreement, any PQ full range signals should be mapped to narrow range.

2.5 Colour representation

Recommendation ITU-R BT.2100 describes two luminance and colour difference signal representations, suitable for colour sub-sampling and/or source coding: the non-constant luminance $Y'C'_B C'_R$ signal format and the constant intensity $IC_T C_P$ format.

As the $IC_T C_P$ signal format is not compatible with conventional SDR monitors, and any benefits of the $IC_T C_P$ colour representation are anticipated to be less for HLG than for PQ, so the non-constant luminance $Y'C'_B C'_R$ signal format is preferred for HLG.

For PQ, the $IC_T C_P$ format has been shown to be advantageous in a number of respects (see Report ITU-R BT.2390), but compatibility with signal handling equipment must be considered before choosing to employ this format.

3 Monitoring

Ideally, critical monitoring, such as the production switcher's 'programme' and 'preview' outputs, should take place using a display that supports the full colour gamut and dynamic range of the signals. Monitors that support the BT.2100 colour space should include means to manage colours outside of their native display gamut.

3.1 Display of PQ signals

The content represented by PQ signals may be limited to the expected capabilities of the displays on which they are intended to be viewed, or they may be unlimited and represent the full level of highlights captured by the camera. In practice, monitors may not reach the full extent of the BT.2100 gamut or the 10 000 cd/m² limit of the PQ signal, resulting in the possibility that some encoded colours may not be displayable on some monitors.

Monitors that support PQ may or may not include tone-mapping to bring very high brightness signals down to the capability of that monitor. Some monitors may clip at their peak output capability (e.g. 2 000 cd/m²). Some monitors may contain tone mapping that provides a soft-clip.

For production use, monitors should generally perform a hard clip to the display capabilities, and should provide a means to identify pixels that are outside the display's capability (either in brightness or colour). If a soft-clip is desired, a Look-up-table (LUT) such as that described in § 3.1.1 can be applied to the signal to provide any desired tone mapping. Care should be taken for any content that is allowed to go outside the reference monitor colour gamut or dynamic range as that would not have been accurately presented to the operator and cannot be trusted as part of the approved or intended appearance. Reference monitors could provide a selectable overall brightness-attenuation in order to temporarily bring high brightness signals down to be within the display capability in order to provide a check on any content encoded brighter than the capability of the reference display.

If the BT.2100 PQ signal is presented to a monitor that expects a Recommendation ITU-R BT.709 (BT.709) input, the image will appear dim and washed out; colours will be desaturated and there will be some hue shifts. An external 3D LUT can provide the down-mapping function necessary to bring both colour and brightness into the BT.709 colour volume, thus allowing satisfactory display on the

BT.709 monitor. Some monitors may provide this function by means of an internally provided 3D LUT. While this allows viewing on the BT.709 monitor, the resulting images should not be used to make critical judgements of the HDR production.

If PQ signals must be monitored in an environment brighter than the reference environment (specified in Recommendation ITU-R BT.2100 as having a 5 cd/m² surround), manufacturers may provide modified brightness and display characteristics intended to compensate for the different viewing environment.

3.1.1 Mapping to displays with limited luminance range

To view the entire range of HDR content on displays with a lower dynamic range, display mapping should be performed. This can take the form of an EETF (electrical-electrical transfer function) in the display. This function provides a toe and knee to gracefully roll off the highlights and shadows providing a balance between preserving the artistic intent and maintaining details. Figure 1 is an example EETF mapping from the full 0 – 10 000 cd/m² dynamic range to various target displays.

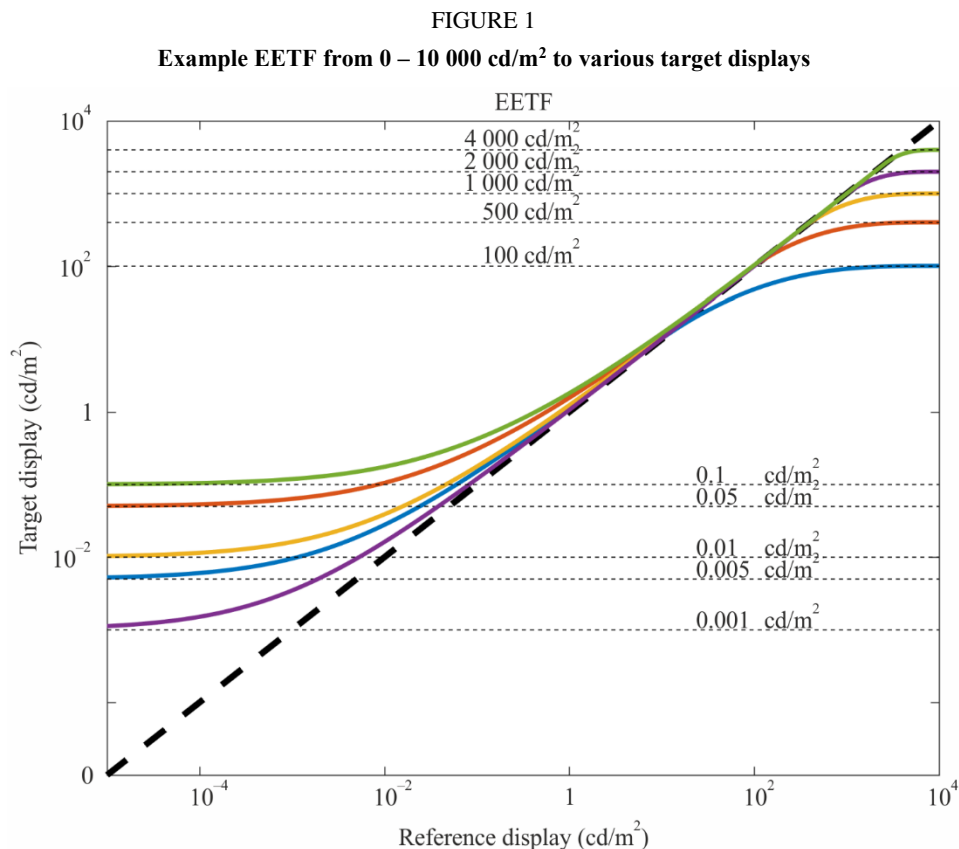

Report BT.2408-01

Annex 5 gives the specific mathematical steps to implement this tone mapping function for displays of various black and white luminance levels. Figure 2 shows the block diagram of where the EETF should be applied.

FIGURE 2
Block diagram of signal chain showing location of EETF application

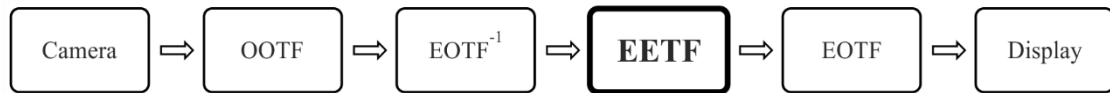

Report BT.2408-02

3.2 Display of HLG signals

Table 5 of Recommendation ITU-R BT.2100 specifies the HLG EOTF (electro-optical transfer function) for reference displays. Note 5f specifies how the display's gamma is adjusted to compensate for changes in the response of the human visual system as the eye adapts, when using HLG displays of different peak luminance. The gamma adjustment allows consistent signals to be produced from a range of displays with different peak luminance. Details can be found in § 6.2 of Report ITU-R BT.2390.

The luminance on a production monitor corresponding to nominal peak, 100%, signal level, should be adjusted to a comfortable level for the viewing environment. Nominal peak signal level does not have to be set to the peak luminance of the monitor, which may be too bright for comfortable viewing. The nominal peak luminance of 1 000 cd/m², identified in Recommendation ITU-R BT.2100, has been found to work well in typical production environments.

Note 5g of Recommendation ITU-R BT.2100 recognises that the display's gamma should further be adjusted to compensate for the adaptation state of the eye in non-reference production environments. A formula specifying the gamma adjustment is also given in § 6.2 of Report ITU-R BT.2390.

Contrast, brightness and display system gamma (α , β and γ in Table 5 of Recommendation ITU-R BT.2100) are adjusted according to the viewing environment and nominal peak luminance of the display, as appropriate.

Firstly, the monitor gamma is adjusted, according to the formula in Note 5f of Recommendation ITU-R BT.2100, to the appropriate value for the target nominal peak luminance of the display. The target nominal peak luminance may depend on the viewing environment.

Table 3 shows the gamma values for a range of typical production monitors in the reference viewing environment (5 cd/m² surround).

TABLE 3
HLG display gamma

Nominal peak luminance (cd/m ²)	Display Gamma
400	1.03
600	1.11
800	1.16
1 000	1.20
1 500	1.27
2 000	1.33

The display's nominal peak luminance is then adjusted using the user gain control (legacy "contrast" control) and a photometer, with an HDR reference white (75%HLG) window test patch (typically 1% screen area). Table 4 shows the luminance levels for a range of typical production monitors.

TABLE 4

Test patch luminance levels for different nominal peak displays

Nominal peak luminance (cd/m ²)	HDR reference white (cd/m ²)
400	101
600	138
800	172
1 000	203
1 500	276
2 000	343

In non-reference viewing environments, a further adjustment should be made to the display's system gamma to compensate for the adaptation state of the eye. Table 5 illustrates the recommended gamma adjustments for a range of common production environments, assuming a surround reflectance of approximately 60%, typical of light-coloured walls. However, for the greatest signal consistency, the reference conditions specified in Recommendation ITU-R BT.2100 should be used.

TABLE 5

Typical production environments with different surround conditions

Typical environment	Typical Illumination ¹ (Lux)	Typical luminance ² (cd/m ²)	Typical gamma adjustment
Office based production sunny day	130	25	-0.05
Office based production cloudy day	75	15	-0.04
Edit Suite	50	10	-0.02
Grading Suite	25	5	0.00
Production gallery/ Dark grading suite	3	0.5	+0.08

As a guide, a gamma adjustment of 0.03 is just visible to the expert viewer when viewed side-by-side. Thus, no additional gamma adjustment is necessary across the majority of critical television production environments.

However, a gamma adjustment is suggested for bright environments such as those sometimes used for news production, or where a colourist prefers to work in a very dark environment.

Lastly, the display black level is adjusted using the black level lift control (legacy "brightness" control) and the Recommendation ITU-R BT.814 PLUGE signal, such that the negative stripes on the test pattern disappear, whilst the positive stripes remain visible.

3.2.1 Display of HLG signals on SDR screens

For best results when displaying HLG signals on SDR screens, the SDR monitor should support the Recommendation ITU-R BT.2020 (BT.2020) colour gamut. However, for simple confirmation of the

¹ Measured perpendicular to the screen.

² Assuming ~ 60% reflectance surround.

presence or absence of a signal, BT.709 colour monitoring may be sufficient. However, BT.709 colour monitors will show a de-saturated image with visible hue shifts.

Non-critical production monitors, such as multi-view production monitors, may be SDR BT.709 displays. A three-dimensional look-up table (3D-LUT) may be included in the monitoring chain to down-convert from BT.2100 HDR signals to BT.709 SDR, minimising colour distortions on such displays. Suitable look-up tables are often included within the display monitors themselves.

4 Image brightness

Work has commenced on developing automatic objective measures for brightness, akin to those in common use for audio loudness today. Experimental results [2] show that a simple mean of displayed pixel luminances provides a good correlation with subjective brightness at 3.2 picture heights from the screen. The effectiveness of this simple objective metric suggests that real-time brightness monitoring in production is a realistic goal. This would give guidance to content producers, enabling comfortable viewing in the home, whilst allowing a range for artistic freedom. The metric could be used further to characterise long-term and short-term average brightness.

4.1 Comfortable brightness of static images

A study was performed by NHK to learn what range of luminances are judged comfortable by viewers. A number of SDR images that, on a 100 cd/m² reference monitor, varied in average luminance over a range of 10-50 cd/m², were used. The study was conducted using a relative display system that employed a 3 500 cd/m² display that was adjusted to simulate a range of display luminance levels, thus the results are relevant to the HLG system that also employs displays with relative luminance. Peak luminances of 500, 1 000, 2 000, and 2 500 cd/m² were simulated. Viewers were asked to judge whether images were “appropriate”, “too bright”, or “too dark”.

Figure 3 shows the results in the reference viewing environment (dim surround). For each simulated display peak luminance, images with average luminance less than 25% of the peak luminance being simulated were not judged as “too bright”. Images with average luminance greater than 25% of peak luminance began to be judged as “too bright” by many viewers. The judgements were essentially independent of the peak luminance being simulated on the display; this indicates that viewers’ eyes were adapting to the different display luminances. The implication of these results is that HLG images with average luminance of less than 250 cd/m² on a 1 000 cd/m² HLG monitor, would not be judged as too bright on an HLG monitor of any luminance up to at least 2 500 cd/m².

FIGURE 3

Percentage of votes for “too bright” in the reference environment (dim surround)

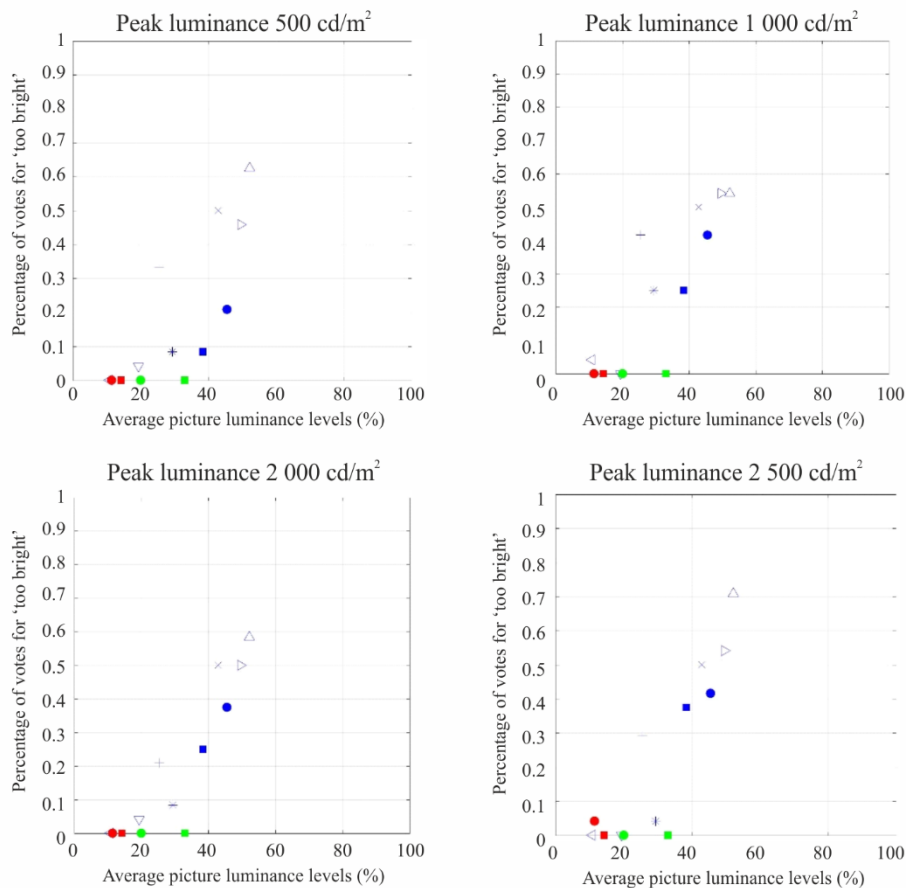

Report BT.2408-03

This is consistent with informal comments from subjects in separate tests performed by the BBC, which were targeted at measuring tolerance to brightness jumps (see § 4.2). Having seen HDR video sequences on HLG displays with peak luminance levels of 1 000 cd/m² and 4 000 cd/m², 25% of subjects commented informally that the brightest scenes were uncomfortably bright regardless of any jumps. These scenes had average luminance levels of 268 and 363 cd/m² on a 1 000 cd/m² display. Similar comments were not made about the test scenes that had average luminances of 144 and 128 cd/m² on a 1 000 cd/m² display.

Even when the static levels would be acceptable, sudden changes in brightness can be uncomfortable even when the static levels would be acceptable, so different requirements are needed to ensure viewer comfort when brightness jumps can occur.

4.2 Tolerance to programme brightness shifts

Unexpected changes in image brightness might occur between programmes, for example with interstitials. It is important to ensure that the brightness variations within HDR programmes are constrained to avoid viewer discomfort.

Subjective tests reported by the BBC investigated viewer tolerance to sudden changes in overall brightness for HDR television, using the mean pixel display luminance as a measure of brightness as described in [2]. This measure has been shown to correlate well with subjective ratings of the overall brightness, but there may occasionally be a scene with a non homogeneous spatial luminance distribution where the measure does not fully correspond to subjective brightness. For the tests, the

luminance behind the screen was 5 cd/m², and the peak screen luminance was 1 000 cd/m² [3]. Subjects were asked to rate the change in overall brightness between two still HDR images.

Figure 4 shows the overall results, with transitions from the first mean luminance A to the second mean luminance B categorised according to whether they are “not annoying”, “slightly annoying”, or “annoying”. Two regions are marked in the Figure with thick blue lines. The inner region, with mean display luminance levels of 5 to 80 cd/m², contains only one possible “slightly annoying” jump, and so could be considered a suitable range for operation that will not cause viewer discomfort. The outer region, with mean display luminance levels up to 160 cd/m², includes several slightly annoying jumps, and so could be considered an extended range for creative effect. Further experiments reported by the BBC show that this outer region can be extended down to 2.5 cd/m², and production trials with a prototype meter suggest that this extended range is appropriate.

Specific delivery requirements for luminance ranges are left to individual service providers, depending on their requirements. An example of requirement could be that the suggested ranges can be freely exceeded over a short timescale, but the mean luminance over the length of a programme is kept within an operating range of 5 to 80 cd/m². It should be noted that this range still allows for significant differences in brightness between programmes, so, for example, a “moody” or “bright” look can be achieved overall.

The results presented previously in Fig. 3 provide evidence that the eye adapts to a particular luminance level. Hence the scene-light levels corresponding to specified brightness shift tolerances are likely to be broadly applicable for HLG displays over a range of different peak luminances. This is supported by experiments reported by the BBC, which suggest that the ranges are applicable for HLG displays up to a peak luminance of 4 000 cd/m².

It should be noted that shadow detail may be lost after a transition from a bright scene to a very dark scene, even if the transition is not uncomfortable, because it takes time for the eyes to adapt. Also, a comfortable overall brightness does not ensure that the content makes good use of the available dynamic range. Further guidance may be useful to characterise best use of the dynamic range for common scene types.

FIGURE 4
Transitions from mean luminance A (cd/m²) to mean luminance B (cd/m²)
categorised by level of annoyance

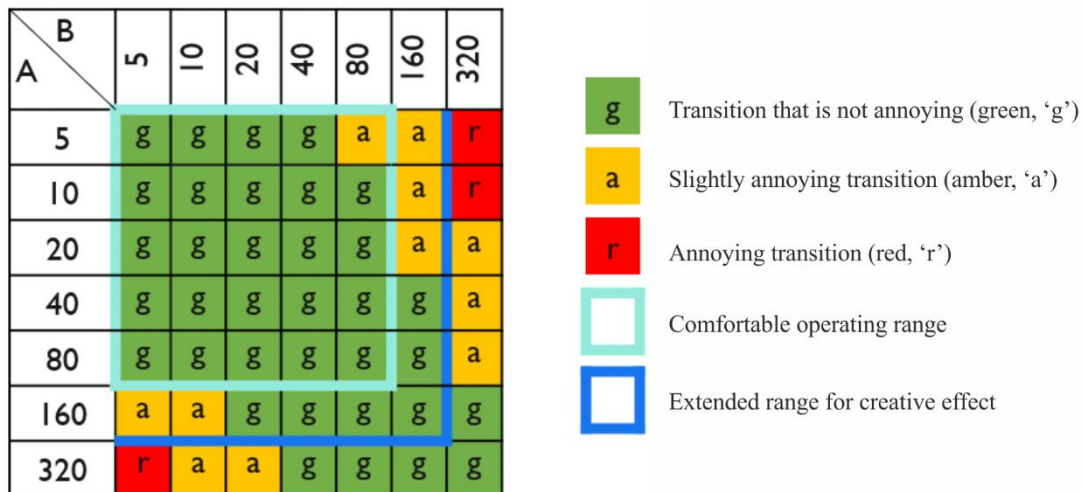

5 Integrating standard dynamic range and high dynamic range production

Definitions

Tone Mapping (TM) – Compression of the image dynamic range of content. It may be used to “down-map” (down-convert) HDR content to SDR content.

Inverse Tone Mapping (ITM) – Expansion of the image dynamic range of content. It may be used to “up-map” (up-convert) SDR content to emulate the appearance of HDR content. Also referred to as “up-mapping”.

Direct-mapping – In the context of converting SDR content to HDR content, Direct-mapping is intended to preserve the appearance of the SDR content so that the HDR version displayed on a reference HDR monitor will look similar to the original SDR version displayed on a reference SDR display. A luminance gain (e.g. 2x) and other processing will provide a better match to the luminance of a native HDR image while maintaining the SDR appearance.

Hard Clipping – When converting from HDR to SDR there are some circumstances when hard clipping rather than tone mapping (akin to soft clipping) may be more appropriate. With hard clipping all signals above a threshold are clipped to that threshold. Hard clipping is useful when the signal from an HDR camera is required to look similar to the signal delivered by an SDR camera operated without a “knee”.

Artistic Intent – A creative choice that the programme maker would like to preserve, primarily conveyed through the use of colour and tone.

Look – A characteristic of the displayed image. The native appearance of colours and tones of a particular system (for example, PQ, HLG, BT.709) as seen by the viewer.

5.1 Inclusion of standard dynamic range content in high dynamic range

SDR content may either be direct-mapped or inverse tone mapped (up-mapped) into an HDR format for inclusion in HDR programmes. Direct-mapping places SDR content into an HDR container, analogously to how content specified using BT.709 colorimetry may be placed in a BT.2020 container. This approach is intended to preserve the appearance of the SDR content when shown on an HDR display. In contrast, inverse tone mapping (up-mapping) is intended to expand the content to use more of the available HDR luminance range, and thereby leverage more of the display capabilities. Up-mapping is intended to make content captured in SDR look more as if it had been captured in HDR even though the highlights are more limited.

There are two possible approaches to both SDR direct-mapping and up-mapping depending on the application:

- Display-referred mapping is used when the goal is to preserve the colours and relative tones seen on an SDR display, when the content is shown on an HDR display; an example of which is the inclusion of SDR graded content within an HDR programme. Display-referred mappings are derived by applying the desired EOTF (Recommendation ITU-R BT.1886), scaling the displayed light signal to match the brightness of HDR content. These are known as “display-light” conversions.
- Scene-referred mapping is used when the goal is to match the colours and relative tones of a native HDR and native SDR camera; an example of which is the inter-mixing of SDR and HDR cameras within a live television production. Scene-referred mappings are based on the light falling on the camera sensor, but they include any camera characteristics, white balance, and any artistic camera adjustments. These are known as “scene-light” conversions.

The nominal signal levels described in § 2.2 may be helpful to guide midtone levels during mapping.

The following subsections describe several different methods for mapping SDR into HDR. The choice of mapping method depends on the application and should be made by implementers based on their needs and on the documented goals and characteristics of each method. Currently, there is no universal approach. The following guidance is provided.

5.1.1 Display referred mapping

Figures 5 and 6 illustrate the display-referred mapping of SDR signals into either HLG or PQ.

FIGURE 5

Method with linear scaling for “display-referred” mapping of SDR into HLG or PQ

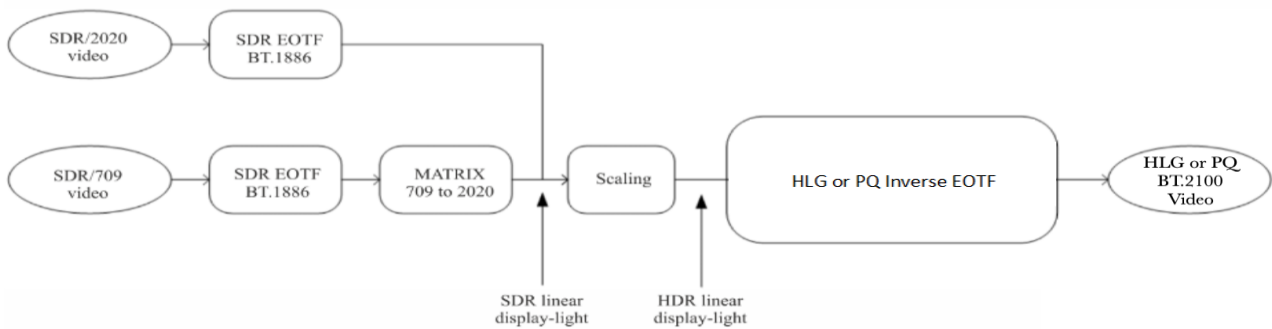
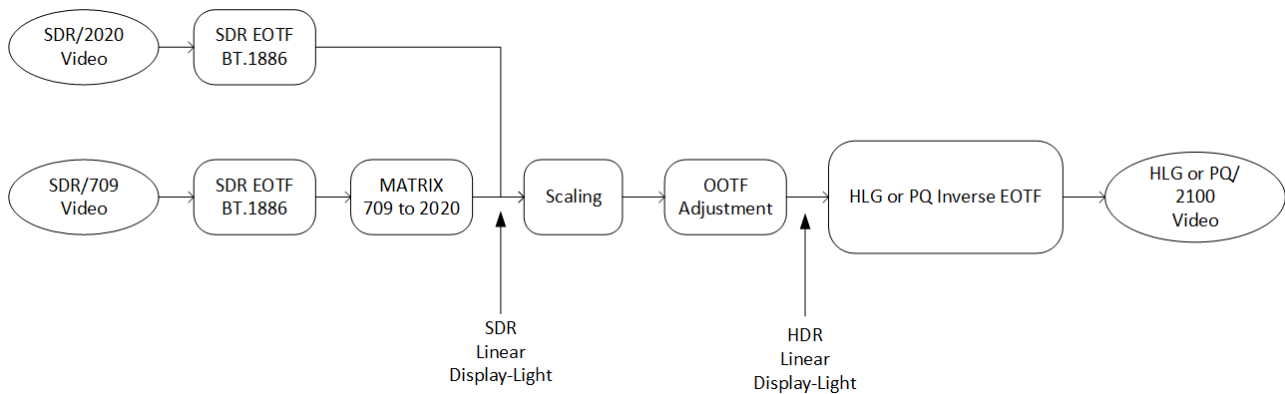

FIGURE 6

Method with OOTF adjustment for “display-referred” mapping of SDR into HLG or PQ



The SDR signal is first passed through the BT.1886 reference EOTF to derive SDR linear display light. An approximation of the electro-optical transfer function (EOTF) from Recommendation ITU-R BT.1886 may be used:

$$E = (E')^{2.40} \quad , \quad 0 \leq E' \leq 1$$

where:

E' is the non-linear signal (R', G', B') in the range [0:1]

E is the normalised linear display light in the range [0:1].

A colour space conversion from BT.709 primaries to BT.2020/BT.2100 colour primaries is performed if necessary, details of which can be found in Recommendation ITU-R BT.2087.

The linear SDR display light may then be scaled to ensure that 100% SDR maps to a similar level to HDR reference white of 203 cd/m².

Where scaling is performed,

- If the goal when direct-mapping into HDR is to mimic the appearance of SDR content displayed on a BT.1886 SDR display with peak luminance 203 cd/m², or to minimize losses when SDR material is “round-tripped” through a complementary “hybrid-linear” down mapper described in Annex 10, a 2.03× linear scaling without OOTF (opto-optical transfer function) adjustment will produce the desired results (see § 5.1.2).
- If the goal when direct-mapping into HDR is to maintain the subjective appearance of the 100 cd/m² SDR original content, for example in the SDR focused-production workflow described in § 7.2, a small “gamma” adjustment (or similar) to the OOTF should then be applied. The OOTF adjustment compensates for the subjective change in appearance of the SDR signal arising from a 2.03× linear scaling; thereby ensuring that the visibility of detail in the shadows and the appearance of skin tones in the 100 cd/m² original are maintained (see § 5.1.3.2).

Having scaled and adjusted the SDR display light, the resulting signal is passed through an HLG or PQ inverse EOTF to provide either an HLG or PQ signal.

5.1.2 Display referred mapping of SDR into PQ

The following procedure may be followed to achieve consistent midtone luminance levels when mapping standard dynamic range content into PQ.

Standard dynamic range BT.2020 content should be mapped to PQ by applying the BT.1886 display EOTF and then applying the PQ EOTF⁻¹.

$$E' = EOTF_{PQ}^{-1}[\textit{scaling} \times EOTF_{BT.1886}[V, L_W, L_B]]$$

V : Input SDR video signal level (normalized, black at $V = 0$, to white at $V = 1$)

L_W : SDR screen luminance for white = 100 cd/m²

L_B : Screen luminance for black = 0 cd/m²

E' : Output PQ video signal level (normalized [0:1])

Scaling: $EOTF_{PQ}(E'_{V=1}) / 100 \text{ cd/m}^2$

Example: for $\textit{scaling} = 2.03$, $E'_{V=1} = 0.58$ and $EOTF_{PQ}(E'_{V=1}) = 203 \text{ cd/m}^2$

A scaling factor of 2.03 is consistent with the HDR level guidance of § 2.2, as that will map the 100 cd/m² nominal peak white level of SDR to approximately the 203 cd/m² level suggested for HDR or 58%PQ. However, such a linear scaling will not maintain the subjective appearance of the SDR content on an HDR display when the original is shown in a 100 cd/m² BT.2035 environment, as it takes no account of the non-linear response of the eye. MovieLabs has found that linear scaling provides a good match to the way consumer displays scale SDR content in their “home cinema” viewing modes [4] because it mimics the linear scaling in BT.1886. Linear scaling can typically provide a closer tonal match to the scene light up-/direct-mapper which may be a useful feature for mixed SDR/HDR where intercutting of the two sources might occur.

The 2.03× linear scaling may also provide a good tonal match to HDR cameras that have not been “painted” (see § 7.7), which can be important when including archive content in live (or as live) programming.

For standard dynamic range BT.709 content the same process may be used, with the BT.709 to BT.2020 conversion matrix applied before the scaling as shown in Fig. 5 and Fig. 6.

5.1.3 Display referred mapping of SDR into HLG

5.1.3.1 Mapping without OOTF adjustment

The ‘display-referred’ method of mapping SDR content into a Hybrid Log-Gamma (HLG) container, without an OOTF adjustment, is illustrated in Fig. 7.

FIGURE 7
SDR to HLG mapping without gamma adjustment (display-referred)

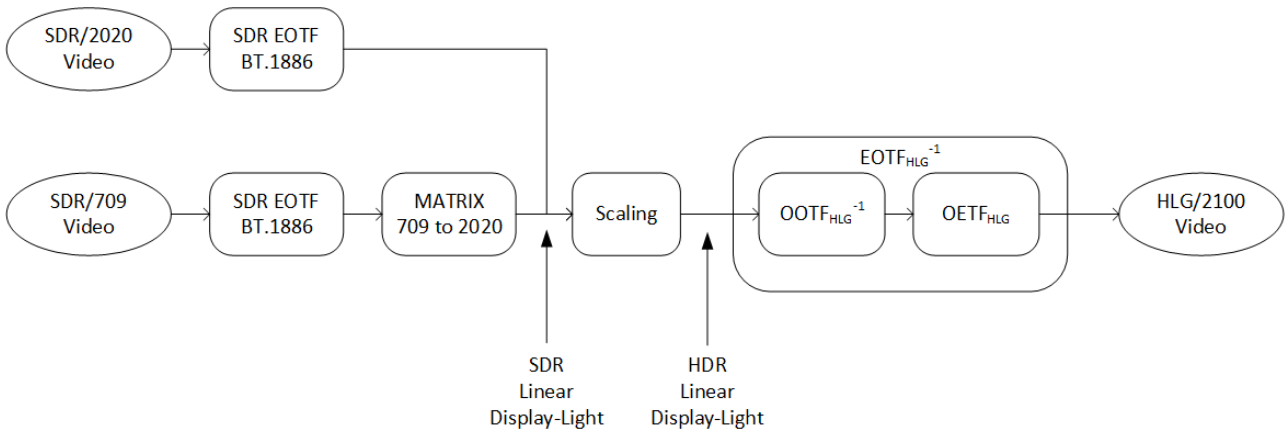

5.1.3.2 Mapping with OOTF adjustment

For the case when an OOTF “gamma” adjustment is made to the scaled SDR display light, the process is shown in Fig. 8.

To double the displayed nominal peak luminance of an SDR signal for direct-mapping into HLG, whilst maintaining the subjective appearance of viewing at 100 cd/m², a compensating adjustment to the OOTF gamma can be used. This OOTF adjustment (identified in Fig. 8 as “Gamma Adjust – Y Only”) attempts to preserve the appearance of shadows and midtones of the native SDR content at 100 cd/m², while scaling the SDR nominal peak white to 203 cd/m².

The gamma adjustment for the non-linear scaling of SDR content may be determined by using the BT.2100 Note 5f (or Footnote 2) HDR gamma formula, to calculate the equivalent ratio of system gammas for HDR Reference White of the nominal 203 cd/m² and 100 cd/m².

FIGURE 8
Model for “display-referred” mapping with OOTF “gamma” adjustment of SDR into HLG

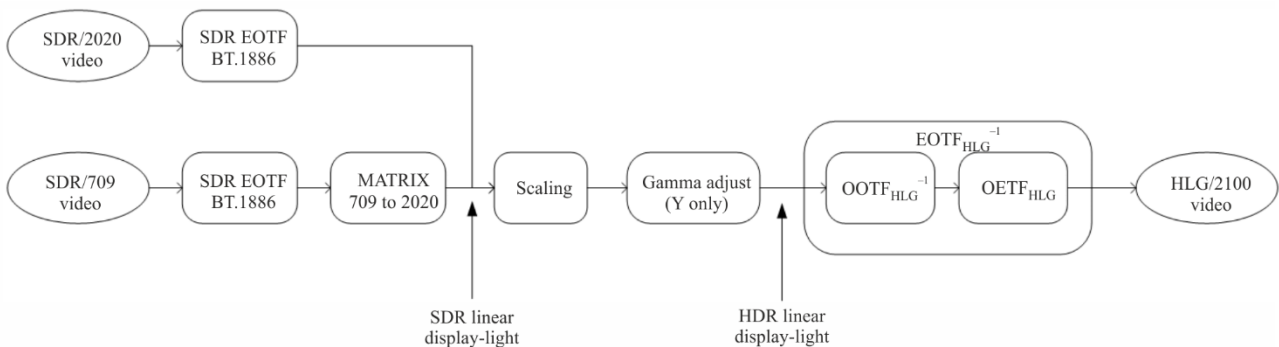

Having scaled and adjusted the SDR display light, the resulting signal is passed through an HLG inverse EOTF to provide the HLG signal.

5.1.3.3 Scaling

When (100X)%SDR signal is mapped to (100Y)%HLG signal, a scaling gain is calculated by the following equation:

$$\text{Gain} = \frac{\text{EOTF}_{\text{HLG}}(Y)}{\text{EOTF}_{\text{SDR}}(X)}$$

For example, when 100% SDR signal is mapped to 75% HLG (203 cd/m² on a 1 000 cd/m² display), the scaling gain is calculated as follows:

$$\text{Gain} = \frac{\text{EOTF}_{\text{HLG}}(0.75)}{\text{EOTF}_{\text{SDR}}(1.0)} = \frac{\text{OOTF}_{\text{HLG}}(\text{OETF}_{\text{HLG}}^{-1}(0.75))}{\text{EOTF}_{\text{SDR}}(1.0)} = \frac{0.265^{1.2}}{1.0^{2.4}} = 0.203$$

5.1.3.4 Simplification of the HLG mapping process

Through careful choice of the HLG inverse EOTF parameters, it is possible to avoid the need to scale and adjust the gamma of the SDR linear display light signal. By configuring the HLG inverse EOTF with a nominal peak luminance, L_w , of 392 cd/m², an input of 100 cd/m² from the SDR EOTF will directly deliver an HLG signal of 75%, satisfying the requirement to map 100%SDR signal to 75%HLG signal, without further scaling and gamma adjustment.

Figure 8 illustrates how, for all but the most critical applications, it is possible to simplify the conversion yet further. When applying the HLG inverse EOTF with L_w set to 392 cd/m², Note 5e of Recommendation ITU-R BT.2100 requires a gamma value of 1.03. As this is close to unity, in most applications there is no need to apply the inverse OOTF gamma to the luminance component, it can instead be applied independently to R, G and B components; greatly simplifying the mapping process. Colour distortions that usually arise through applying gamma to red, green and blue, rather than luminance, are barely visible for such low values of gamma.

FIGURE 9

Simplified (display-referred) SDR to mapping into HLG

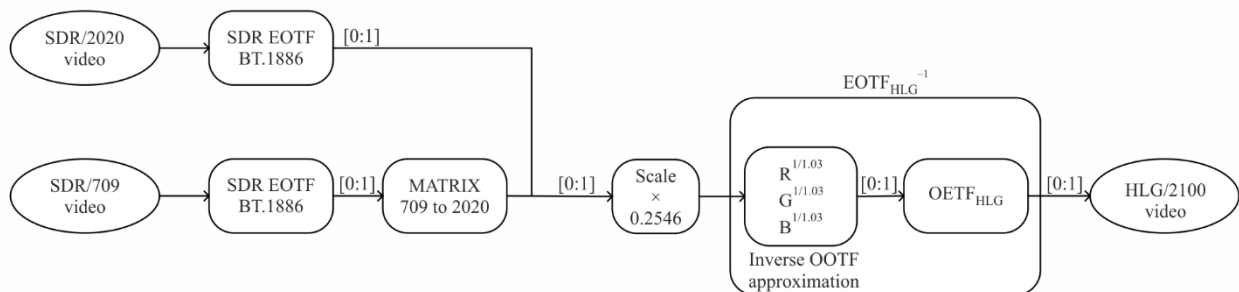

Report BT.2408-08

As normalised signals are used throughout, a different scaling is required to match the signal ranges of the SDR EOTF and HDR inverse EOTF, thereby ensuring that 100%SDR signal maps to 75% of the HLG HDR signal. Note that as the normalised signals are dimensionless, the scaler is not adjusting the peak luminance of the SDR display light, so no additional gamma compensation for the signal scaling is required. Allowing for the inverse OOTF gamma of 1.03, the correct scale factor is 0.2546.

5.1.4 Scene referred mapping

It is particularly important that the scene-referred mapping is used for matching signals from BT.709 and BT.2020 SDR cameras with signals from HLG cameras. This is because, direct from the camera (and prior to subjective adjustment), both signals represent light from the scene captured by the camera.

If the display-referred mapping were used, which maintains the appearance of SDR images on an HLG display, the signals from SDR cameras and HLG cameras would not match. This is because the displayed ‘look’ of SDR and HLG images, from cameras that implement the reference OETFs (opto-electronic transfer functions), is different (see § 7.3.3 and Annex 6).

Scene-referred mapping will also work for mapping SDR to PQ. However, because the ‘look’ of PQ and BT.2020 SDR signals is very similar, for BT.2020 SDR signals the display-referred mapping will generally work well. To best match the PQ ‘look’, BT.709 SDR camera signals could be converted to BT.2020 SDR camera signals (using an OETF-based conversion similar to that specified in Recommendation ITU-R BT.2087) before display-referred mapping is applied.

The schematic diagram of the scene-referred mapping is illustrated in Fig. 10 for both PQ and HLG. It includes an optional artistic OOTF adjustment, for example to match the ‘traditional colour reproduction’ described in § 6.5 of Report ITU-R BT.2390.

FIGURE 10
SDR to HDR mapping (scene-referred)

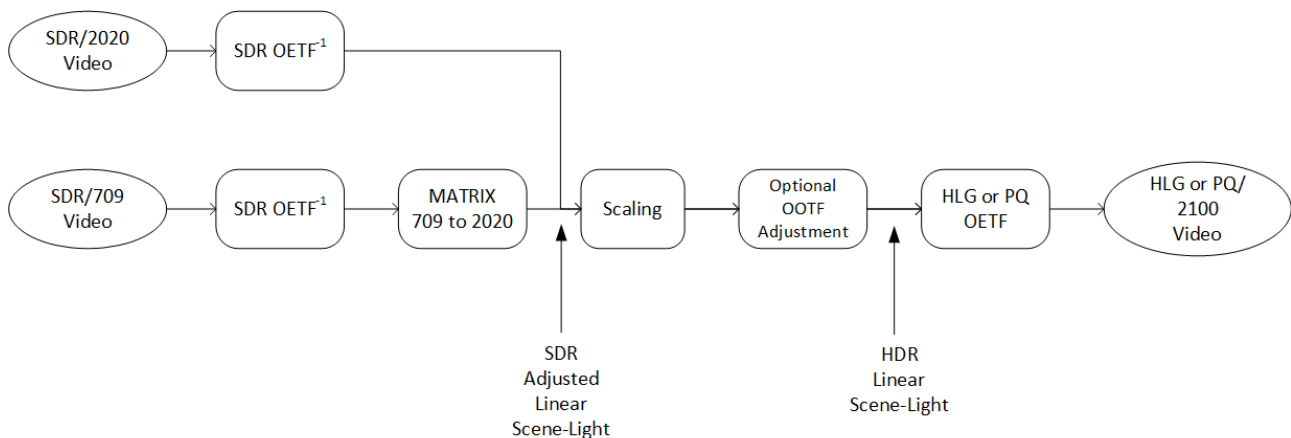

Figure 10 shows how the non-linear SDR BT.709 or BT.2020 video signal is converted to linear ‘scene light’ by applying the approximate inverse of SDR OETF, $E=(E')^2$, as described in BT.2087. When the SDR source is with the BT.709 colorimetry, the conversion is followed by the colour conversion matrix as described in Recommendation ITU-R BT.2087.

The scene light signal is then scaled so that the non-linear signal, after applying the reference PQ or HLG OETF, is at the appropriate signal level for HDR reference white: 58% PQ or 75% HLG respectively. Following any OOTF adjustment, the HLG or PQ OETFs are applied to derive the non-linear signals.

Section 5.1.4.1 describes how to calculate the scale factor for HLG, as well as how to adjust the OOTF to preserve a traditional SDR look.

5.1.4.1 Scene referred mapping of SDR into HLG

When (100X)%SDR signal is mapped to (100Y)%HLG signal, a scaling gain is calculated by the following equation:

$$\text{Gain} = \frac{\text{OETF}_{\text{HLG}}^{-1}(Y)}{\text{OETF}_{\text{SDR}}^{-1}(X)}$$

For example, when 100%SDR signal is mapped to 75%HLG signal, the scaling gain is calculated as follows:

$$\text{Gain} = \frac{\text{OETF}_{\text{HLG}}^{-1}(0.75)}{\text{OETF}_{\text{SDR}}^{-1}(1.0)} = \frac{0.265}{1.0^{2.0}} = 0.265$$

Where the SDR “look” is maintained during the conversion from SDR to HDR or the HLG camera is designed to deliver a traditional ‘look’ (see § 6.5 of Report ITU-R BT.2390), a small optional adjustment to the OOTF may then be applied to compensate for the subjective change in appearance of the SDR signal arising from a difference between HLG and SDR OOTFs. For the case when gamma adjustment is made to the scaled SDR scene light, the process is illustrated in Fig. 11.

FIGURE 11

SDR to HLG mapping with gamma adjustment (scene-referred)

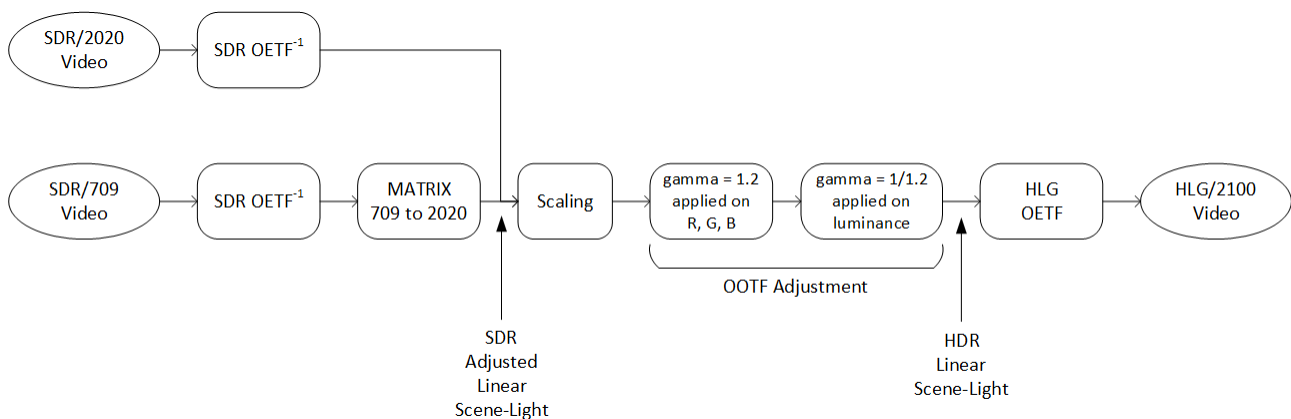

5.1.5 Comparing scene-light and display-light direct-mapping

The difference in the tonal responses of scene-light direct-mapping (which takes no account of the changed in displayed luminance between SDR and HDR) and display-light direct-mapping with a compensating OOTF adjustment, is illustrated in Fig. 12. The colour differences between the two approaches are discussed in § 7.3.3.

FIGURE 12
Comparison of scene-light and display-light direct-mapping

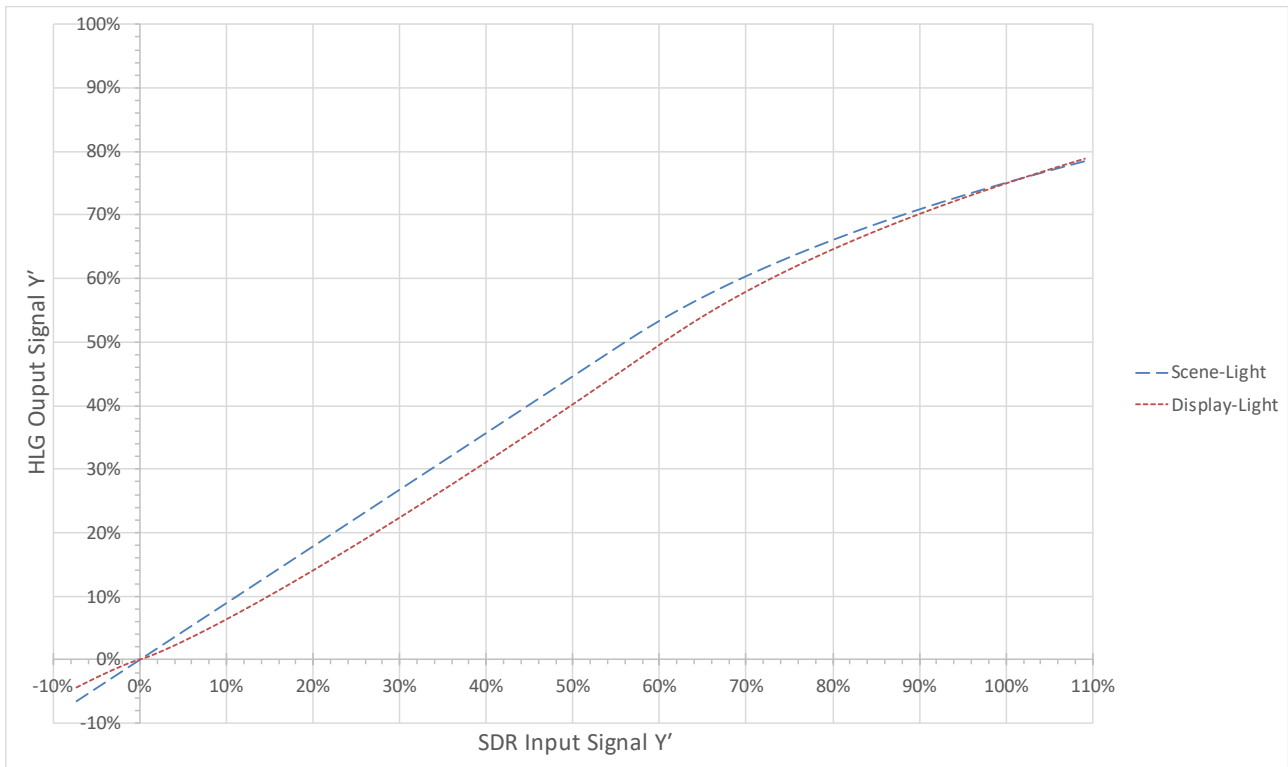

The Figure shows how the midtones are brighter in the scene-light conversion than in the display-light conversion. It is only the display-light conversion that aims to preserve the subjective appearance of the SDR signal shown on a Recommendation ITU-R BT.2035 100 cd/m² reference display.

5.2 HDR to SDR down-mapping

As with SDR to HDR conversion, HDR to SDR down-mapping can be performed using either scene-light or display-light. Scene-light conversions match the appearance of SDR cameras, but are no longer widely used for down-mapping as they change the appearance in both colour and tone of embedded graphics. Display-light down-mapping attempts to maintain the “look” of the HDR source when converted to SDR, and is usually preferred.

Report ITU-R BT.2446 describes three example methods of display-light HDR to SDR conversion (and vice-versa). Each method attempts to preserve the subjective appearance of the lowlights and midtones in the HDR image, when the tone-mapped SDR is shown on a Recommendation ITU-R BT.2035 100 cd/m² display.

The HDR to SDR down-mapper used to monitor or shade the HDR signal in production should match the characteristics of the linear or non-linear down-mapper used to create the SDR version of the programme transmission output. Table 6 Illustrates the effects that can occur when different down-mapping techniques are used.

TABLE 6

Camera shading methods and SDR down-mapped from HDR

Production			Distribution		
Camera shading method			HDR output	SDR down-mapped from HDR	
				Non-linear down-mapper	Linear down-mapper
				BT.1886 100 cd/m ² (BT.2035)	BT.1886 100 cd/m ² (BT.2035)
HDR shading			As intended	As intended	Darker midtones
SDR shading	100 cd/m ²	Non-linear down-mapper	As intended	As intended	Darker midtones
		Linear down-mapper	Brighter midtones	Brighter midtones	As intended

A linear down-mapping (.5 scaling factor) will not preserve the subjective appearance of the HDR in the SDR image when viewed on a reference 100 cd/m² SDR display. See Table A10.1 in Annex 10 for an illustration of how the linear down-mapper can be used with good effect under conditions described in BT.1886/BT.2129 where a typically higher SDR luminance level is used.

Using a non-linear scaling for down-mapping, with an additional OOTF adjustment, often in the form of a gamma adjustment, can preserve the look of lowlights and midtones while providing a good roundtrip with a non-linear gamma-adjusted up/direct-mapping (see § 5.1.3.2) when viewed on a reference 100 cd/m² SDR display.

The main difference between the two methods is in the appearance of the shadows and midtones.

In live HDR-TV production, where it is important to minimise “round-trip” losses, the HDR to SDR down-mapping will usually follow a complementary tone-curve to any SDR to HDR converters over the lower and middle signal ranges, with compressed highlights filling the upper SDR signal range (see § 7.4). So the linear down-mapper is sometimes referred to as a “hybrid-linear” down-mapper.

5.3 Handling negative values in format conversion

It is common practice for camera OETFs and display EOTFs implemented within format converters to be extended to handle negative signals by reflecting the transfer functions around the zero light and zero signal axes. Extending the transfer functions in this way can be useful for increasing the colour gamut carried by a “narrow” range signal (see § 5.4) and for processing test signals such as PLUGE.

In format conversion, however, this could lead to an increase in “round-trip” errors. So the best approach will depend on the application.

5.4 Adjustments to BT.709 cameras

It may be beneficial to include signals below black (sub-blacks) and above the SDR nominal peak white (super-whites) in the conversion process from SDR BT.709 to HDR. Such signals, which are often present in live SDR television production, effectively increase the colour gamut captured by the camera beyond the BT.709 colour primaries. More details are provided in Report ITU-R BT.2250.

The permitted SDR signal ranges vary between geographical regions. By way of an example, EBU R103 [5] allows SDR signals to span –5% to +105%. Figure 13 illustrates the maximum transmissible Y'C_BC_R colour gamut. The contours are drawn for each normalized Y at an interval of 0.1 on the CIE 1931 xy chromaticity diagram. Negative values of R', G' and B' widen the effective colour primaries. The gamut is increased in the red and the blue, and a smaller increase is also made in the

green. Allowing the $R'G'B'$ signals to extend above 100% increases the colour volume by allowing more saturated colours at higher luminance.

FIGURE 13
Extending the BT.709 camera colour gamut

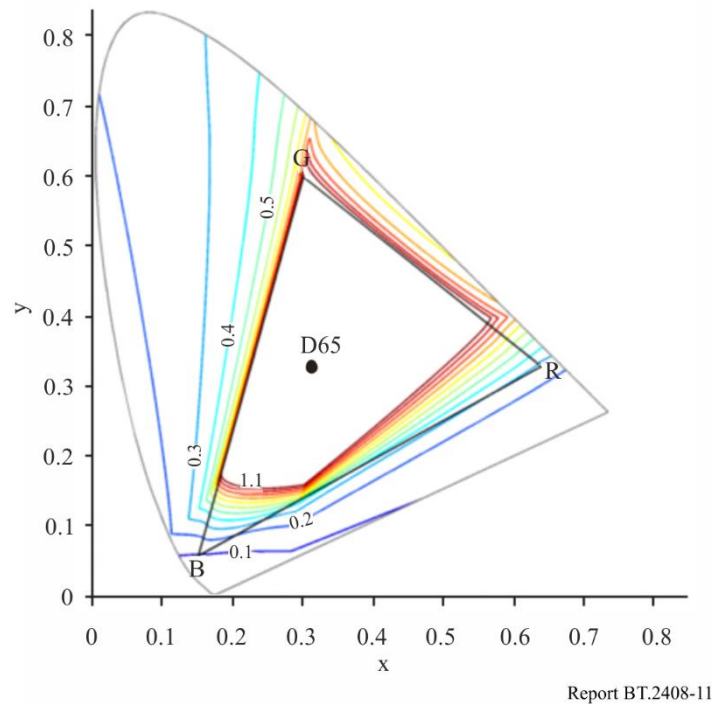

The technique can be used to ensure a closer match between BT.709 and BT.2100 cameras for colours that are close to the BT.709 colour volume boundary.

Where the SDR BT.709 camera output is only used for shading and as the input to an SDR to HDR format converter, the signal clippers can be fully relaxed to maximise the captured colour volume. Not all format converters and production infrastructure are capable of passing the sub-black and super-white signals.

5.5 Use of 8-bit content

Although a minimum of 10-bits should be used for HDR production, there may be occasions when it might not be possible to avoid including 8-bit SDR content within an HDR programme. In such cases, care should be taken if up-mapping rather than direct-mapping is used to place the content into an HDR signal container. The up-mapping process typically expands the SDR highlights. The 8-bit resolution, compounded by any 8-bit video compression, will limit the amount of highlight expansion that can be applied before banding and other artefacts become visible.

5.6 Mapping of SDR graphics

SDR graphics should be directly mapped into the HDR signal at the “Graphics White” signal level specified in Table 1 (75% HLG or 58%PQ) to avoid them appearing too bright, and thus making the underlying video appear dull in comparison. Where the desire is to maintain the colour branding of the SDR graphics, a display-light mapping should be used. Where the desire is to match signage within the captured scene (in-vision signage; e.g. a score board at a sporting event), a scene-light mapping is usually preferred.

6 Conversion between PQ and HLG

6.1 Transcoding concepts

Transcoding aims to produce identical display light when the transcoded signal is reproduced on a display of the same peak luminance as the original signal. This section describes how a PQ signal may be transcoded to an HLG signal and vice versa, although cascaded conversions are to be discouraged to avoid risking loss of quality.

Figure 14 illustrates the concept behind transcoding from the PQ signal to the HLG signal. The PQ signal is decoded by the PQ EOTF to yield a signal that represents linear display light. This signal is then encoded by the HLG inverse EOTF to produce an equivalent HLG signal. When this HLG signal is subsequently decoded by the HLG EOTF in the display, the result will be the same display light that would be produced by decoding the original PQ signal with the PQ EOTF. The HLG inverse EOTF is the HLG inverse OETF followed by the HLG OETF.

FIGURE 14

Concept of transcoding from PQ to HLG

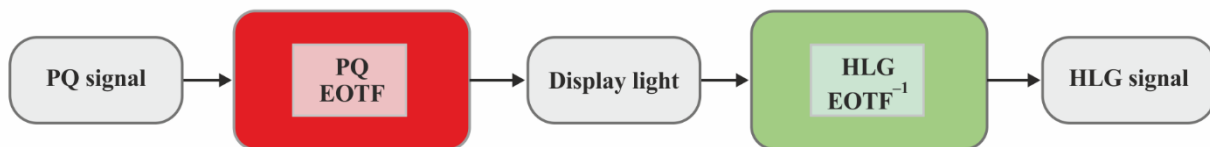

Report BT.2408-12

Figure 15 illustrates the concept behind the transcoding from the HLG signal to the PQ signal. The HLG signal is decoded by the HLG EOTF to yield a signal that represents linear display light. This signal is then encoded by the PQ inverse EOTF to produce an equivalent PQ signal. When this PQ signal is subsequently decoded by the PQ EOTF in the display, the result will be the same display light that would be produced by decoding the original HLG signal with the HLG EOTF.

FIGURE 15

Concept of transcoding from HLG to PQ

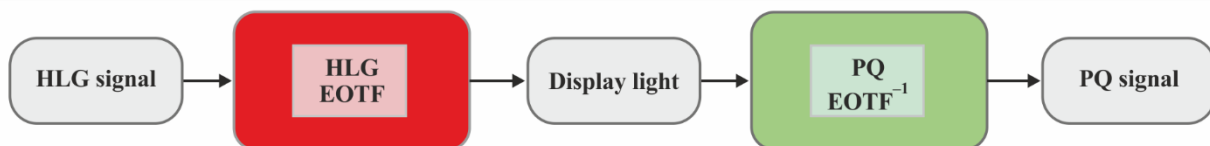

Report BT.2408-13

6.2 Conversion concepts using a reference condition at 1 000 cd/m²

The transcoding concepts in the previous section produce the same displayed light for both PQ and HLG signals only when they are viewed on displays with the same peak luminance.

However, the difference in the way that PQ and HLG signals are rendered on displays of different peak luminance complicates the conversions between PQ and HLG signals. If, for example, PQ signals, representing different peak luminances, are simply transcoded to HLG, the signal level for diffuse white will vary. Similarly, when HLG content is transcoded to PQ the brightness of diffuse white will vary depending on the assumed peak luminance of the HLG display.

To avoid such brightness changes, it is needed to convert, rather than simply transcode, the signals. Consistent brightness in the converted signals may be achieved by choosing a reference peak displayed luminance (L_w) for the HLG signal, and requiring that PQ signal be limited to the same peak luminance. With these constraints consistent brightness is achieved in the converted signals.

Therefore it is desirable that conversion between PQ and HLG should take place using the same reference peak displayed luminance for the signals used in the conversion. There is currently an industry consensus that this common peak luminance should be 1 000 cd/m².

For both transcoding and conversion a black level for the HLG EOTF also needs to be specified. The HLG black level, L_B , should be set to zero for transcoding and conversion.

With the choice of 1 000 cd/m² as the common peak luminance, the conversion outlined above is completely specified for any HLG signal to PQ and, for PQ signals not exceeding 1 000 cd/m², from PQ to HLG. Figure 16 illustrates the conversion from PQ to HLG.

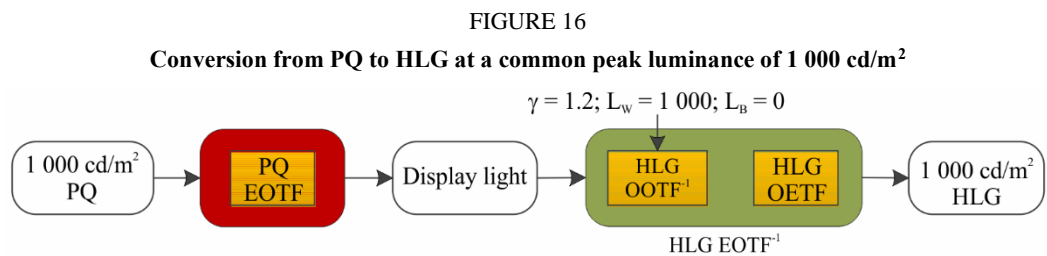

The following is an elaboration of Fig. 16 in terms of the three most fundamental transformations:

- (1) The PQ EOTF and its inverse
- (2) The HLG OETF and its inverse
- (3) The HLG OOTF and its inverse.

The HLG EOTF is derived from (2) and (3). The Figure also includes the parameters for HLG OOTF⁻¹. The resulting HLG signal will produce images identical to the original PQ images for all content that is within the colour volume of the 1 000 cd/m² HLG reference display.

Analogously, the conversion from HLG to PQ at 1 000 cd/m² is the inverse of the above as illustrated in Fig. 17.

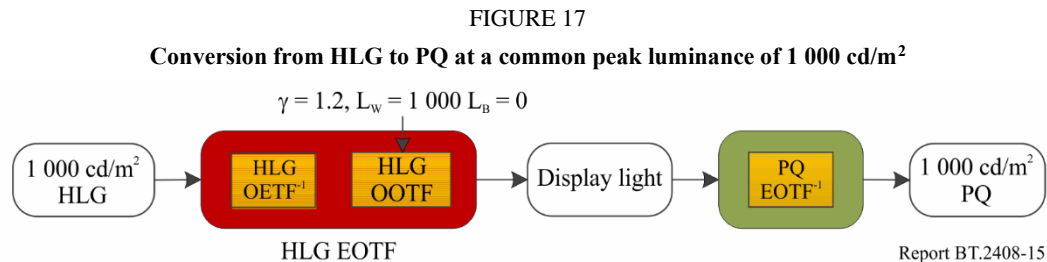

This conversion always produces a PQ image identical to HLG.

6.3 Cameras using a common OOTF at a reference peak luminance of 1 000 cd/m²

Cameras could apply a common OOTF to produce PQ and HLG signals with identical displayed images at a reference peak luminance of $L_w = 1\ 000$ cd/m².

This OOTF could be the PQ OOTF, or the HLG OOTF, and might include additional modifications applied in the camera, as illustrated in Fig. 18. PQ and HLG signals are obtained using their respective inverse EOTFs.

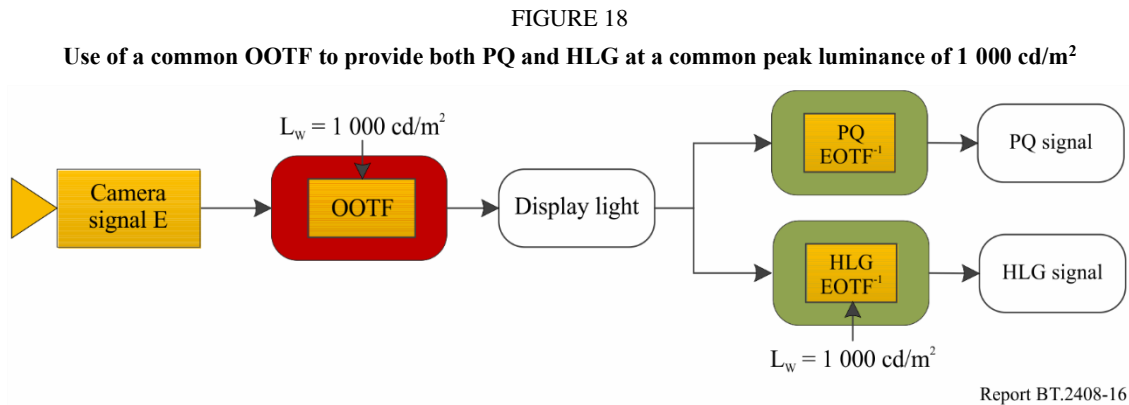

The appearance of the displayed images will be the same on displays with a peak luminance capability of 1 000 cd/m², for both the PQ and HLG signals. The appearance of the image is determined by the OOTF.

6.4 Handling PQ signals with greater than 1 000 cd/m² peak luminance

PQ signals can represent a peak luminance of up to 10 000 cd/m². In order to enable the reference conversion described above, PQ content must be limited to have a peak luminance that does not exceed 1 000 cd/m². There are, in general, three approaches to achieving this:

- (1) Clip to 1 000 cd/m²
- (2) Static mapping to 1 000 cd/m² (e.g. using an EETF curve like those described in § 3.1.1)
- (3) Dynamic mapping to 1 000 cd/m²

The first method, clipping to 1 000 cd/m², is simple to implement. While multiple round trip conversions between PQ and HLG are to be discouraged, with this method content undergoes no additional limiting/clipping in the event of multiple round-trip conversions (i.e. PQ->HLG->PQ->HLG) beyond the initial clipping.

The second method, static mapping to 1 000 cd/m² can be implemented by a LUT containing an EETF such as that described in § 3.1.1. While this avoids hard clipping of detail in the highlights, it is not invariant under blind multiple round-trip conversions.

The third method, dynamic mapping to 1 000 cd/m², utilizes adaptive processing, for example on a frame-by-frame, or scene-by-scene basis. An adaptive algorithm could vary the EETF described in § 3.1.1 based on statistics of the image content (scene maximum for example). For non-live content, dynamic mappings could be generated offline by the content producer (either manually or using algorithmic processing). Except for the initial stage of limiting the PQ signal to 1 000 cd/m², this approach could survive multiple round-trip conversions, because subsequent dynamic processing should be inactive given that the signal would already have been limited to 1 000 cd/m².

6.5 Possible colour differences when converting from PQ to HLG

In principle, the conversion of PQ images to HLG could give rise to hue shifts or desaturation on bright highly saturated areas of the picture, although such effects are believed to be rare in practice.

Mathematically, this arises because the OOTF applied in the display for HLG is a function of overall luminance rather than identical functions of R, G, and B. Consider the equations for luminance in both the display and scene domains along with the EOTF for HLG:

$$Y_D = 0.2627R_D + 0.6780G_D + 0.0593B_D$$

$$Y_S = 0.2627R_S + 0.6780G_S + 0.0593B_S$$

$$R_D = \alpha Y_S^{\gamma-1} R_S$$

$$G_D = \alpha Y_S^{\gamma-1} G_S$$

$$B_D = \alpha Y_S^{\gamma-1} B_S$$

Table 7 below summarizes the peak values that can be displayed for pure white, and for the red, green and blue primaries, for a 1 000 cd/m² PQ monitor, and for a 1 000 cd/m² nominal peak HLG monitor. The Table shows values of ‘x’ such that when the non-linear signal values $R' = G' = B' = x$ the resulting white is 1 000 cd/m². For PQ, this occurs when x is approximately 0.75; for a 1 000 cd/m² HLG display, this occurs when $x = 1.0$. For a 1 000 cd/m² PQ display, the maximum luminance of each of these colours is calculated using Y_D and is shown in the middle column of the Table. For HLG we can simplify the EOTF by normalizing scene colours within [0:1]. Thus:

$$R_D = 1000 Y_S^{\gamma-1} R_S, \text{ etc.}$$

When $x = 1$, so is the normalized scene colour and its non-linear representation, E' , for the given component. This determines $\{R_D, G_D, B_D\}$ and the resulting luminance is calculated using Y_D .

However, in production, HLG signals usually adopt the narrow range quantization levels specified in Recommendation ITU-R BT.2100. As noted in § 6.1 of Report ITU-R BT.2390, the conventional “narrow range” digital signal can support signal levels of up to 109% of nominal full scale when carried as 10-bit or 12-bit signals ($E' = 1.090$). So, the extended signal range between $E' = 1.0$ and $E' = 1.090$, sometimes referred to as “super-whites”, may be used to increase the HLG colour volume. The rightmost column in the Table shows the HLG maximum signal level required to match the displayed luminance of a 1 000 cd/m² PQ display. Thus, they also represent the HLG signal ranges necessary to precisely convert a 1 000 cd/m² PQ signal to HLG without clipping, thereby eliminating any risk of hue shifts or desaturation.

TABLE 7

Signal ranges and achievable colour volume for PQ and HLG on a 1 000 cd/m² nominal peak luminance display

Colour	BT.2100 PQ Y cd/m ² for 1 000 cd/m ² peak white		BT.2100 HLG Y cd/m ²	
	x = 0.75		x = 1.0	Max non-linear signal, E', to match PQ luminance
{x,x,x} // Peak white	1 000.0		1 000.0	R' = G' = B' = 1.000
{x,0,0} // Peak red	262.7		201.1	R' = 1.041
{0,x,0} // Peak green	678.0		627.3	G' = 1.012
{0,0,x} // Peak blue	59.3		33.7	B' = 1.086

NOTE – In practice some displays might not achieve a luminance output higher than their nominal peak value.

By exploiting the quantization levels above $E' = 1.0$, HLG is able to deliver the same 1 000 cd/m² colour volume as PQ, without clipping. This could be particularly useful when converting graded PQ content to HLG. Furthermore, the peak luminance for white on an HLG reference display is increased from 1 000 cd/m² to 1 811 cd/m². Note: the HLG OOTF system gamma is still calculated using the display's nominal peak luminance at $x = 1.0$.

7 Transitioning from SDR BT.709 to HDR BT.2100 production

During the transition from SDR to HDR production, the majority of viewers will be watching in SDR, so it is important that the SDR production is not significantly compromised by the introduction of HDR. It is, however, unlikely to be economic or practical to cover live programmes and events with totally independent HDR and SDR production facilities. As well as the cost of the two productions, there may simply be insufficient camera positions available for both HDR and SDR cameras.

Native HDR production architectures highlighting either HDR or SDR focused production are illustrated in Figs 17 and 18. Over time, as audiences adopt HDR television displays designed for BT.2100 signals, production architectures may be expected to shift from focussing on delivering primarily for SDR, to delivering primarily for HDR.

Note that in both production architectures the eye may adapt to the brighter HDR monitor, affecting the appearance of signals on the dimmer SDR screen. So, the HDR and SDR screens should be physically separated for critical assessment of the SDR signal.

7.1 HDR focused production

For optimum quality HDR pictures, both HDR and SDR cameras should be shaded using an HDR monitor, as illustrated in Fig. 19. Nominal signal levels for shading are given in § 2.2. These may vary if camera painting controls are used to deliver a particular “look”. Where the prime delivery signal is to be BT.709 for existing HD distribution, there may be compromises in the SDR feed from HDR based production, so the SDR-focused workflow described in § 7.2 may be preferred.

As the exposure latitude of HDR images is far greater than SDR, a dynamic HDR to SDR converter may be required to deliver a satisfactory SDR output. A dynamic converter is designed to optimise

the HDR to SDR tone mapping curve for any scene, thereby accommodating a wider range of exposures than might be possible with a fixed (or static) tone mapping curve.

FIGURE 19
HDR production with SDR derived by down-mapping

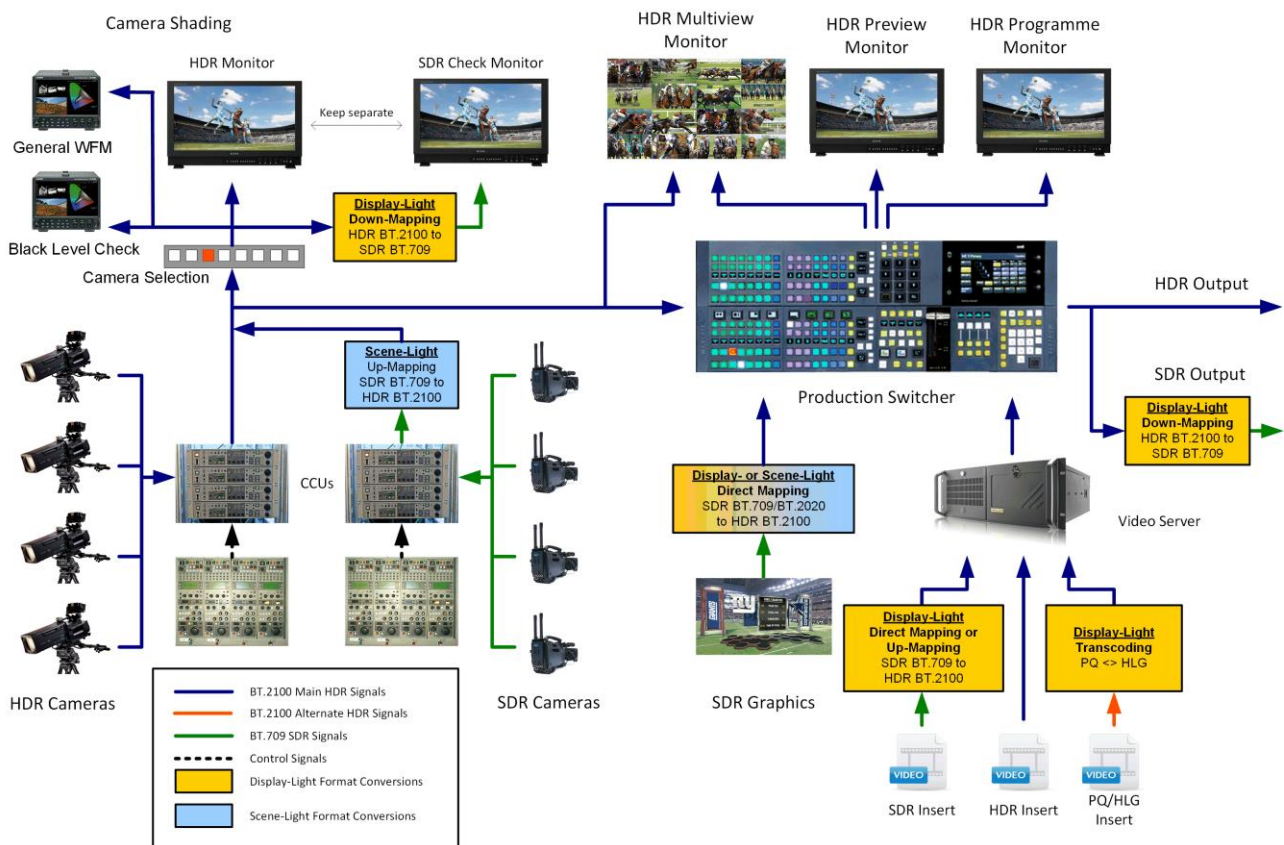

In this HDR focused production, BT.709 cameras may be included in the production by using the “scene-referred” SDR direct-mapping technique, as described in § 5. To ensure a closer match between HDR and SDR cameras, up-mapping (which expands highlights in the SDR signal) may also be used. However, as highlights are often heavily clipped by SDR cameras, only a small amount of highlight expansion is likely to be possible, so direct-mapping is often preferred. Further colour match improvements can be made by relaxing the SDR signal clippers, as described in § 5.4.

In Fig. 19, all inputs to the production switcher are HDR. This removes the need to process separate HDR and SDR feeds throughout the production chain. Graphics may be inserted as per § 5.6. Work is currently underway to determine the best practice for HDR key signals. In the interim, using an SDR key signal directly has been found to deliver satisfactory results.

The primary output from the production switcher is HDR. The SDR output is derived via display referred (display-light) down-mapping. A display-light conversion should ensure that both the SDR and HDR signals have a similar look. A dynamic down-mapper may sometimes provide a more satisfactory SDR output than a static down-mapper, but attention should be paid to graphics which may need to be inserted after dynamic down-mapping, to ensure a fixed signal level. A scene-light HDR to SDR conversion may also be included (not shown in Fig. 19) where it is important to colour match the converted PQ or HLG output to downstream SDR BT.709 cameras. However, consideration should be given to potential changes in colour saturation and tones of graded content (see § 7.3.3). Ultimately, the choice of HDR to SDR down-mapping depends on the application.

Differences in black level may be more visible in the down-mapped SDR signal than in the HDR signal, as glare from bright highlights in the HDR image can mask detail in the shadows. To help ensure a consistent black level in the HDR and down-converted SDR signals, a dedicated waveform monitor displaying the lower portion of the signal range is recommended.

7.2 SDR focused production

If the SDR production must not be compromised, both HDR and SDR cameras should be shaded using an SDR monitor fed via a display-light down-mapper. Whilst the HDR signals may not always exploit the full potential of the HDR production formats, the HDR pictures can still show significant improvement over the SDR pictures which are protected to ensure their optimal quality.

7.2.1 PQ production with SDR shading

SDR focused PQ production uses the same workflow as shown in Fig. 19 except:

- the SDR check monitor is now the shading monitor.
- the HDR shading monitor is now the check monitor.

An additional scene-light PQ to SDR BT.709 conversion may also be included for colour matching with downstream SDR BT.709 cameras.

7.2.2 HLG production with SDR shading

SDR focused HLG production can use the same workflow as shown in Fig. 19 except:

- the SDR check monitor is now the shading monitor;
- the HDR shading monitor is now the check monitor.

A common SDR focused workflow with HDR image processing is emerging utilising live HLG production and becoming the de facto, facilitated by the introduction of:

- parallel UHD (2 160 p) and HD (1 080 p) HLG outputs from cameras;
- HDR slow-motion cameras;
- improvements in the use of defined HDR to SDR down-mapping;
- LUT based HDR/SDR down-mapping in multiview monitors.

The workflow addresses the requirements for use of existing monitoring facilities, simplicity and ensuring the SDR delivery is not compromised.

UHD and HD resolution HDR camera outputs

Early trials of HDR production often employed a parallel production workflow, comprising a UHD HDR “layer” and an HD SDR “layer”. Many HDR cameras conveniently provide parallel UHD HDR and HD SDR outputs to facilitate such productions. Unfortunately, artistic or operational adjustments made by viewing one of the camera outputs do not always track in the other output. So, where both HDR and SDR programme outputs are required from a production, the SDR output is usually derived from the HDR output via a down-mapping conversion.

Whilst such a conversion is possible at UHD resolution for the main programme output, UHD conversion becomes impractical for large productions where a “host broadcaster” may have to provide very many HD resolution SDR ISO (isolated) camera feeds to RHBs (rights holding broadcasters). So, the HDR camera’s native SDR outputs were most often used for the SDR ISO lines. The same SDR outputs were also used for camera shading on an SDR monitor.

In order to ensure that the main SDR programme output derived via a down-mapper matches the SDR ISO feeds provided by the cameras’ SDR outputs, a scene-light down-mapping from the HLG signal is required. Unfortunately, a scene-light conversion does not preserve the “look” of the HDR input.

The SDR outputs derived through the scene-light conversion are more colourful, and have subjectively “punchier” midtones, than the HDR original, see § 7.3.3 and Annex 6. Moreover, where artistic adjustments are made to the cameras using the native SDR outputs, or even a scene-light down-mapped version of an HDR camera, the HDR can look “flat” and desaturated in comparison with the adjusted SDR output.

The addition of HD resolution HDR outputs from cameras has greatly improved the consistency of HDR and SDR outputs from a production as,

- It becomes practical to derive SDR camera ISO feeds and SDR shading signals from the camera’s HD (1080p) HDR output via a down-mapper, avoiding any SDR/HDR output tracking issues;
- The down-mapper can be based on display-light rather than scene-light, thereby matching the “look” of the HDR and SDR outputs and avoiding desaturated and “flat” HDR images.

HDR slow-motion

Slow-motion cameras are usually placed in key camera positions. They run at an integer multiple of the production frame-rate, but provide their output as different “phases” of the production frame-rate. A single phase is often used as a live camera position, and multiple phases recorded in parallel to provide slow-motion replays. While such cameras were limited to standard dynamic range capture, the sheer number of phases that needed recording would often prohibit the use of SDR to HDR conversion prior to recording. So, action replay servers were usually limited to SDR record and replay. As those same replay servers are often used for pre-recorded programme inserts, those would have to be limited to SDR too. Moreover, for large productions a “host broadcaster” would usually make one of the slow-motion camera’s phases available as an SDR ISO camera feed to other RHBs.

The availability of HDR slow-motion cameras has greatly reduced the number of SDR cameras used in an HDR production. It has allowed replay servers to be switched from SDR to HDR, greatly simplifying the production workflow, whilst also allowing HDR pre-recorded programme inserts. As with other HDR cameras, a single-phase from the slow-motion camera can be provided as an SDR ISO feed to other broadcasters via a display-light down-mapper.

HDR to SDR down-mapping

In any large production, SDR to HDR to SDR “round-trip” losses are a major concern. Any native SDR content included in the production should pass through the production infrastructure to SDR outputs with minimal loss. At the same time, however, programme makers may wish SDR viewers to benefit from the HDR production by reserving some of the SDR output signal range for the compressed highlights captured by the HDR cameras. Thus, it is not uncommon for SDR content directly mapped into HLG at the “HDR Reference White” level of 75% to be attenuated on the SDR output to as little as 86% (a 14% loss). The remaining signal range would carry highlights from HDR sources.

So, in order to reduce round-trip losses, SDR content would often be up-mapped rather than directly-mapped into the HDR container, complementing the tone-mapping curve in the output down-mapper. However, results from SDR up-mapping can be variable. While it may work well for carefully produced non-live content, live content often contains large areas of clipped highlights that up-map less well.

To address the problem, several down-mappers now make use of the SDR “super-white” signal range to carry the compressed highlights from the HDR cameras. By doing so, they need reserve far less of the nominal SDR signal range for those highlights, which in turn reduces the round-trip losses for directly-mapped SDR sources. EBU Recommendation R.103 [5] defines a “preferred signal range” with an upper limit of ~105%, which it is generally safe for down-mappers to use. By doing so, round-trip losses for direct-mapped SDR content may be reduced to as low as 5%.

A typical SDR-focused workflow is illustrated in simplified form in Fig. 20.

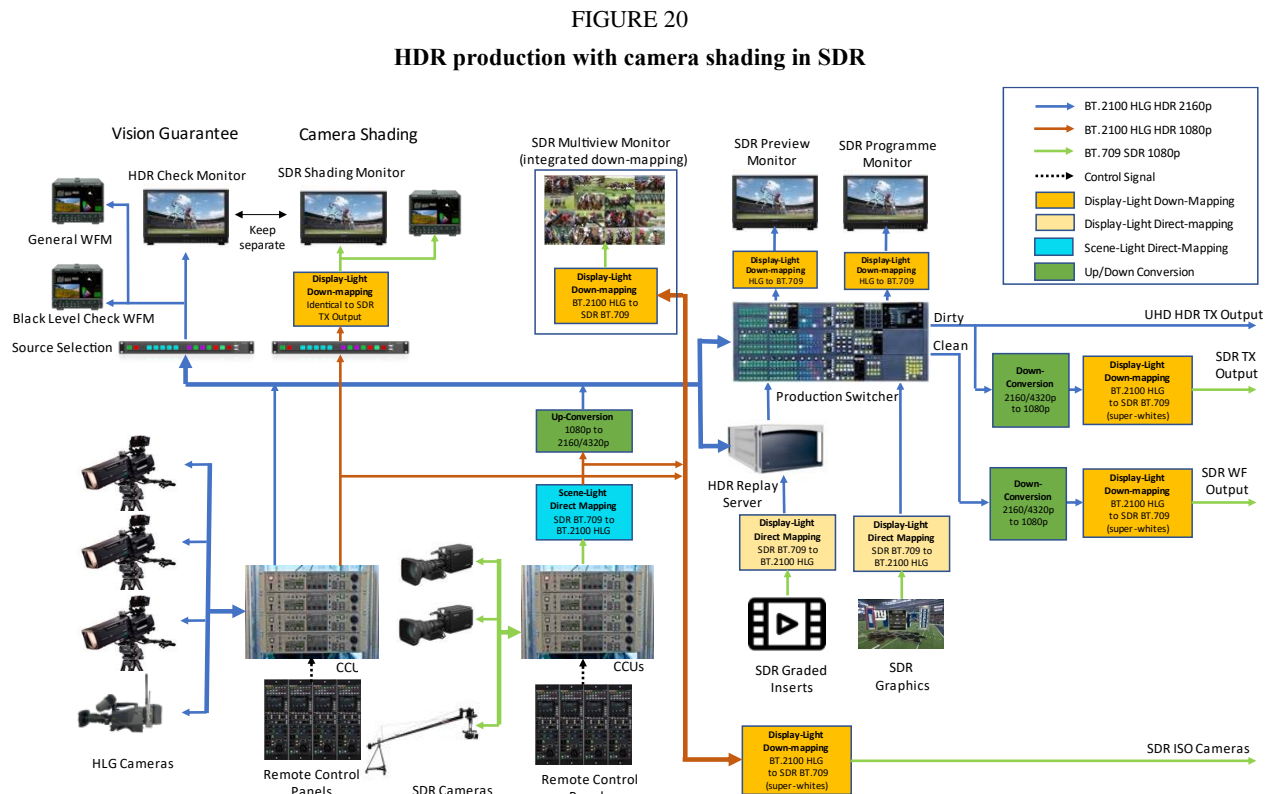

For any SDR outputs a display-light down-mapping conversion is strongly recommended, as that should ensure the same hue and saturation of images and graphics in both HDR and SDR outputs (see § 7.3.3). Most importantly, the down-mapper should be similar in nature, in particular in its treatment of shadow detail and midtones, to any down-mappers used by third-party broadcasters taking the HDR signal and deriving their own SDR versions of the programmes through a common down-mapper within their MCRs (Master Control Rooms). Suitable down-mappers are described in Report ITU-R BT.2446.

Down-mapping (tone-mapping) when converting to SDR, rather than hard clipping, will allow the SDR output to benefit from the high dynamic range production by preserving some detail in the image highlights. A down-mapper that exploits the SDR “super-white” signal range will reduce SDR>HDR>SDR round-trip losses (see §§ 7.3 and 7.4). So, these are often preferred for live productions, where round-trip losses can be a concern.

As with Fig. 19, graded content should be inserted into the programme using display-light direct-mapping or up-mapping, to preserve its original “look” and the artistic intent. However, where the HDR to SDR down-mapper exploits the SDR “super-white” region, direct-mapping is usually preferred. SDR graphics should be directly mapped into the HDR format (as per § 5.6).

During the transition to full HDR production, it will be common to include SDR BT.709 cameras within a production. In order to match the colour and tone of native HLG cameras, scene-light direct-mapping should be used. Up-mapping for live camera sources is not recommended, due to the difficulty in avoiding large areas of clipped highlights.

To ensure the highest quality SDR output, cameras are shaded using an SDR monitor fed via identical HDR to SDR down-mappers to those used on the main programme output. They may, however, be limited to HD resolution and fed via the HD HDR camera outputs.

Changes in exposure of the image may be more visible in the HDR output than the SDR output. So rapid adjustments in exposure whilst shading in SDR should be avoided.

Under controlled studio lighting, a possible option may be to shade the cameras using the HLG backwards compatible SDR picture, rather than via a dedicated HDR to SDR converter. In this case, the SDR shading monitor should be set to a display gamma of 2.2 with BT.2020 colour, to resemble a typical display-light conversion from HLG to SDR as shown on a BT.1886 (gamma 2.4) production monitor. However, under variable lighting conditions or in territories where SDR skin tones are set brighter, a dedicated HDR to SDR converter is preferred.

The SDR monitors used for camera shading should be separated from the HDR check monitor that is used to ensure that high quality HDR output is being maintained (indicated as “Vision Guarantee” in Fig. 20). In a BBC live production trial, occasional checks of the HDR output by a vision supervisor were found to be sufficient, with operators concentrating on the SDR monitors used for camera shading.

A variation of this approach used in China is shown as an example in Annex 8.

7.2.2.1 HDR and SDR monitors in close proximity

It has been noted that the close proximity of two monitors with a large brightness difference can lead to eye accommodation issues which may impact the grading or painting of the cameras. Reducing this intensity difference can assist in the production environment.

Two different approaches are described in Annex 9.

7.3 SDR-HDR and HDR-SDR format conversion

This section consists of a summary of the format conversions suggested in §§ 7.1 and 7.2. The final choice of conversion will, however, be dependent on the producer’s intent.

7.3.1 PQ conversion

Table 8 illustrates the suggested format conversions for PQ production.

TABLE 8

Suggested format conversions for PQ live production

Signal		Conversion Type		SDR to PQ		PQ to SDR		HLG to PQ
		Scene-light	Display-light	Direct-mapping	Up-mapping	Hard clip	Down-mapping	Trans-coding
Graded content	SDR graded inserts		✓	✓ ⁽¹⁾	✓ ⁽²⁾			
	HLG graded inserts		✓					✓
Cameras	SDR camera (relaxed clippers for BT.709)	✓ ⁽⁴⁾			✓			
	HLG camera	✓						✓
Graphics	SDR matching colour branding		✓	✓				
	SDR matching in-vision signage	✓		✓				
SDR output ⁽³⁾	SDR complete programme		✓				✓	
	SDR for downstream mixing with SDR cameras	✓					✓	

⁽¹⁾ Direct-mapping faithfully maintains the original SDR look.

⁽²⁾ Up-mapping adjusts the distribution of highlights of the original SDR look.

⁽³⁾ SDR Output refers to conversion from HDR to both the final programme output as well as the SDR shading/check monitor.

⁽⁴⁾ In PQ based production, the difference between display-light and scene-light conversion of BT.2020 signals is relatively minor and current practice is to use display-light conversion. Conversion from BT.709 to BT.2020 is defined in Recommendation ITU-R BT.2087.

7.3.2 HLG conversion

Table 9 illustrates the suggested format conversions for HLG production. A number of changes have been made to the table in this revision to reflect the new simplified workflow described in § 7.2.2.

TABLE 9
Suggested format conversions for HLG live production

Signal		Conversion Type		SDR to HLG		HLG to SDR		PQ to HLG
		Scene-light	Display-light	Direct-mapping	Up-mapping	Hard clip	Down-mapping	Trans-coding
Graded Content	SDR graded inserts		✓	✓ ⁽¹⁾	✓ ⁽²⁾			
	PQ graded inserts		✓					✓
Cameras	To switcher	SDR camera (relaxed clippers for BT.709)	✓		✓			
		PQ camera	✓					✓
	To shading	HDR camera with SDR shading		✓				✓
		SDR camera with HDR shading	✓			✓		
Graphics	SDR matching colour branding		✓	✓				
	SDR matching in-vision signage	✓		✓				
SDR Output ⁽³⁾	SDR complete programme		✓				✓	
	SDR for downstream mixing with SDR cameras		✓ ⁽⁴⁾				✓	

⁽¹⁾ Direct-mapping faithfully maintains the original SDR look.

⁽²⁾ Up-mapping adjusts the distribution of highlights of the original SDR look.

⁽³⁾ SDR Output refers to conversion from HDR to both the final programme output as well as the SDR shading/check monitor.

⁽⁴⁾ Display-light conversion is now preferred in order to preserve the artistic intent and match the main programme output.

7.3.3 The displayed “look” of content following format conversion

The different SDR and HDR production formats have different looks, as discussed in detail in Annex 6.

Thus, SDR to HDR and HDR to SDR format conversion may change the displayed look of content. Tables 10 and 11 summarise the look of content for HLG and PQ live production, after the format conversions specified in Tables 8 and 9.

One notable consideration is the possible change of look occurring when the input and output conversion types do not match. Scene-light HDR to SDR format conversion, necessary for downstream mixing with SDR BT.709 cameras, may cause some SDR graded content (inserted via

display-light conversion) to appear more saturated than intended for HLG HDR production, or slightly less saturated than intended for PQ HDR production. Scene-light conversion to SDR should therefore be used with care, and multiple such conversions should be avoided.

Graded content does not carry a specific SDR or HDR look, but instead has an artistic look imposed upon it by the colourist.

TABLE 10

Display look of content after format conversion for HLG Production

Signal		Input conversion type		SDR output conversion following HLG production			
		Scene-light	Display-light	Scene-light ⁽¹⁾		Display-light ⁽²⁾	
				To BT.709	To BT.2020	BT.709 and BT.2020	
Graded Content	SDR graded inserts		✓	Over saturated	Over saturated	Maintaining artistic intent ⁽⁴⁾	
	PQ graded inserts		✓	Over saturated	Over saturated	Maintaining artistic intent ⁽⁴⁾	
Cameras	To switcher	SDR BT.709 camera	✓		SDR BT.709 look	SDR BT.2020 look	HLG look ⁽³⁾
		SDR BT.2020 camera	✓		SDR BT.709 look	SDR BT.2020 look	HLG look ⁽³⁾
	To shading	HDR camera with SDR shading	✓		SDR BT.709 look	SDR BT.2020 look	HLG look ⁽³⁾
		SDR camera with HDR shading	✓		SDR BT.709 look	SDR BT.2020 look	HLG look ⁽³⁾
Graphics	SDR matching colour branding		✓	Over saturated	Over saturated	Maintaining artistic intent ⁽⁴⁾	
	SDR matching in-vision signage	✓		SDR BT.709 look	SDR BT.2020 look	HLG look ⁽³⁾	

⁽¹⁾ Scene-light conversion is used to match downstream SDR cameras but is not the preferred method for SDR output conversion.

⁽²⁾ Display-light conversion is generally the preferred SDR output method and will preserve the look of graded content and graphics that originated in SDR or PQ.

⁽³⁾ HLG, SDR BT.2020 and SDR BT.709 have different looks, as discussed in Annex 6.

⁽⁴⁾ Graded Content and Graphics content do not necessarily have the native SDR or HLG look. The "Artistic Intent" may have been to make them more saturated, have different contrast, etc.

TABLE 11

Display look of content after format conversion for PQ Production

Signal		Input conversion type		SDR output conversion following PQ production		
		Scene-light	Display-light	Scene-light ⁽¹⁾		Display-light ⁽²⁾
				To BT.709	To BT.2020	BT.709 and BT.2020
Graded Content	SDR graded inserts		✓	Slightly under saturated	Similar to artistic intent	Maintaining artistic intent ⁽⁴⁾
	HLG graded inserts		✓	Slightly under saturated	Similar to artistic intent	Maintaining artistic intent ⁽⁴⁾
Cameras	SDR camera	✓		SDR BT.709 look	SDR BT.2020 look	PQ look ⁽³⁾
	HDR camera	✓		SDR BT.709 look	SDR BT.2020 look	PQ look ⁽³⁾
Graphics	SDR matching colour branding		✓	Slightly under saturated	Similar to artistic intent	Maintaining artistic intent ⁽⁴⁾
	SDR matching in-vision signage	✓		SDR BT.709 look	SDR BT.2020 look	PQ look ⁽³⁾

(1) Scene-light output conversion may be appropriate for an SDR Output that needs to match with secondary production cameras.

(2) Display-light conversion is generally the preferred SDR output method and will preserve the look of graded content and graphics that also originated in SDR, or HLG.

(3) PQ and SDR BT.2020 have a similar look, as discussed in Annex 6 on native looks.

(4) Graded content and graphics content do not necessarily have a native SDR or PQ look. The “Artistic Intent” may have been to make them more saturated, have different contrast, etc.

7.3.4 Signal range considerations for HDR to SDR conversion

When converting signals from HDR to SDR, one approach is to hard clip the HDR signal so that signals below a given threshold (e.g. HDR Reference White) are mapped into the SDR signal range, and signals above the threshold are lost (see § 5). This approach works well when the HDR signal is tightly controlled (for example by using the production workflow described in § 7.2.2.1) to ensure that critically important image detail lies below the clipping threshold. However, to allow the SDR signal to benefit from the HDR production workflow, down-mapping (tone-mapping) is preferred.

With down-mapping, HDR highlights (for example signals above HDR Reference White) are compressed to lie within the upper portion of the SDR signal range. Signals at and below the HDR Reference White level will occupy the remaining SDR signal range. The level at which HDR Reference White is mapped to the SDR signal range is chosen to balance the overall brightness of the SDR image (including graphics) and the amount of detail that is preserved in the image highlights.

The SDR “super-white” code value range (i.e. signals above nominal peak white) is intended to accommodate signal transients and ringing which help to preserve signal fidelity after cascaded processing (e.g. filtering, video compression). In situations where it is known that these signals will not be clipped, they may also be exploited to preserve additional highlights after HDR to SDR down-mapping [5]. However, in other situations (e.g. use of some existing equipment), “super-white” and/or “sub-blacks” could be clipped. In such situations, detail that is critical to the artistic rendition of an image should not be placed in the SDR super-white region after conversion.

7.4 SDR-HDR-SDR “Round-Tripping”

As described in § 7.1, SDR signals will be converted to HDR during production and back again to SDR for distribution. This is the process known as “round-tripping”.

Ideally, the process of round-tripping would be transparent. However, in practice, this is difficult to achieve and is the subject of on-going investigation. To understand the difficulties that can arise it is helpful to consider the individual processes of up-mapping to HDR and down-mapping to SDR.

There are two main approaches to including SDR content in HDR programmes: direct-mapping and up-mapping (more information in § 5).

Conversion from HDR to SDR is also considered in § 5, where again two approaches are described: hard clipping, where the conversion can be regarded as a direct-mapping of HDR onto an SDR display, and down-mapping. In down-mapping, the HDR to SDR conversion uses a non-linearity, similar (and analogous) to the “knee” function found in cameras. This non-linear mapping reduces the dynamic range of highlights but does not completely remove them.

In both up-mapping and down-mapping, careful attention should be paid to those “diffuse” parts of the scene that can be supported in both SDR and HDR formats. However, this is made difficult by variation of the scene luminance factor corresponding to reference white (100% SDR signal) in SDR productions. SDR signals provide little “headroom” for highlights. Some SDR signals are simply clipped of most of the highlight information (e.g. live sport), but in other cases include more highlights through the use of a camera “knee” (e.g. drama or sport “beauty” shots).

The optimum techniques for up-mapping followed by down-mapping are still under investigation. However, in live production where SDR camera sources are often heavily “clipped” direct-mapping of SDR into HDR (i.e. with no expansion of image highlights) is usually preferred. In order to minimise “round-trip” losses after direct-mapping, the HDR to SDR down-mappers used in live production increasingly place the HDR image highlights within the SDR “super-white” signal range; thereby allowing HDR Reference White to be mapped to ~95% SDR signal, whilst still preserving some compressed HDR image highlights.

7.5 Hardware colour matrix compensation

Many of the existing hardware devices assume BT.709 colorimetry when converting between $R'G'B'$ and $Y'C'_B C'_R$ signal formats.

Where it is not possible to configure a device for BT.2100 colorimetry, a correction needs to be applied elsewhere. This might be in the conversion matrix on the complementary interface at the other end of the link (e.g. within a display) or, as illustrated in Fig. 21, within a look-up table performing a format conversion.

FIGURE 21

Example of colour matrix compensation within a LUT

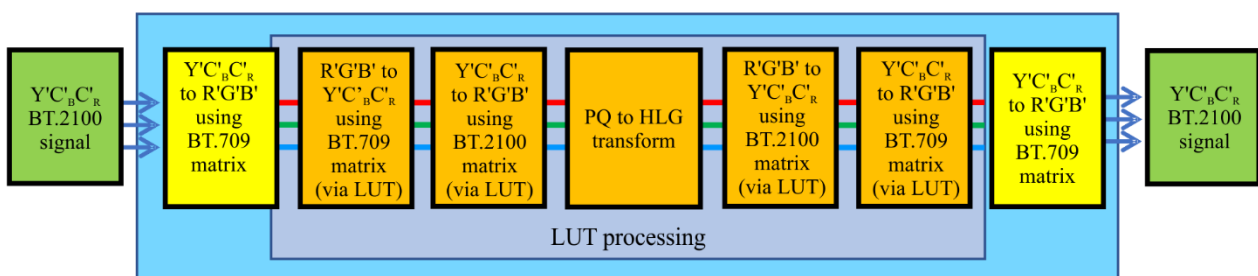

7.6 Signal line-up

Prior to any live transmission, it is common practice for broadcasters to check the end-to-end integrity of the production and contribution signal chain. Typically a signal generator producing colour bars and a lipsync test is fed into the production switcher or matrix. The video waveform and lipsync is then checked for accuracy at various points along the chain, including the broadcaster's MCR (Master Control Room).

If BT.2111 Colour Bars are used as the signal source, after any HDR to SDR conversion (e.g. to feed an SDR contribution circuit) the wide colour gamut bars within the test pattern should not be expected to land on the colour bar targets of a standard BT.709 vectorscope; as the SDR BT.709 and HDR BT.2100 colour primaries are different, the true displayed colours of the respective primary (red, green, blue) and secondary (yellow, cyan, magenta) colour bar signals are also different. The BT.709 (scene light) colour bars within the BT.2111 test pattern may also not land on the colour bar targets after scene light down-mapping, as their luminance could be affected by any tone-mapping from HDR to SDR. They should not be expected to land on the colour bar targets after display light down-mapping.

Work is currently underway to design test patterns for signal line-up that should provide a predictable output after display-light and scene-light HDR to SDR conversion.

7.7 Camera painting

Different programmes genres often require different 'looks'. The look that audiences expect for a particular genre may even vary between regions. A television drama, often shot on large format single sensor cameras in a 'RAW' format, for example, might be graded to give a look which is of an artistic nature and with colours subdued, and perhaps with less contrast too. A live sporting event such as football produced with multi sensor cameras, might be produced with images that are a little more colourful than nature and may have additional mid-tone contrast added within the CCU to deliver a 'punchy' eye-catching look.

Each production format has its own native look, determined by the OOTF. The looks vary in colour saturation and mid-tone contrast. A comparison of the native looks of HDR and SDR production formats is given in Annex 6. The native look of any given format may not necessarily match the expected look of a particular programme genre, nor the aesthetic that the programme maker wishes to achieve. Non-live programmes will, therefore, often need to be colour graded offline, and live HDR cameras will usually need to be 'painted' in real-time.

Annex 6 illustrates how HLG has been designed to deliver a look that preserves the chromaticity of the scene as imaged by the camera. SDR BT.709, BT.2020 and the PQ production formats provide a more colourful look. Moreover, although the OOTF 'gammas' of all four formats in the reference viewing environment are similar, approximately 1.2, the subjective mid-tone contrast of a BT.709 image shown on a reference display in the reference viewing environment is greater than that of either PQ or HLG.

The difference in perceived mid-tone contrast arises because of the difference in the diffuse white level of an SDR image ($\sim 100 \text{ cd/m}^2$) and that of an HDR image ($\sim 200 \text{ cd/m}^2$). As the HDR image is brighter, and the OOTF gammas are the same, when viewed in isolation the detail in the shadows of the HDR image will be more visible than in the SDR image and the mid-tones will also appear subjectively brighter. Furthermore, the BT.709 and BT.2020 OETFs have a linear portion near black, originally intended to reduce the visibility of camera sensor noise. That linear portion in the SDR OETFs also serves to further increase the perceived mid-tone contrast as it compresses detail towards the shadows. The linear portion, however, resulted in less accurate quantization of the low-light levels and so was omitted from the HLG OETF as cameras now employ more sophisticated noise reduction techniques.

Therefore, it is important when producing certain types of live (or as-live) content that HLG (and to a lesser extent PQ) cameras may be beneficially ‘painted’ to produce a ‘punchy’ and colourful look when intended by programme producers and expected by audiences.

8 Conversion practices for camera and display RGB colorimetry

Several camera and display systems, for both professional and consumer applications, use their own colour primaries, a practice that may give them certain advantages during capture or display respectively. However, content captured or displayed on such devices would still have to be transformed to or from a BT.2100 workflow, respectively. It should be noted that the transformations in this document only apply under the following conditions:

- The source and target white points are the same and should be equal to D65.
- The source and target white point brightness is the same. For scenarios where brightness is different, refer to Report ITU-R BT.2446.

Furthermore, these transformations are not applicable for camera RAW signals.

Camera and display systems are commonly defined by their normalized primary matrix, NPM, which is specified as follows:

$$\text{NPM} = \begin{bmatrix} X_R & X_G & X_B \\ Y_R & Y_G & Y_B \\ Z_R & Z_G & Z_B \end{bmatrix}, \quad (1)$$

where the elements of the matrix depend on the chromaticity coordinates, (x_R, y_R) , (x_G, y_G) , (x_B, y_B) , and (x_w, y_w) for red, green, blue, and white, respectively, that characterize each system.

The NPM is needed for the conversion process to and from the CIE XYZ colour space and the BT.2100 colour space. The specifics of the computation may be found in Annex 7.

Annex 1

Study to evaluate levels for PQ content

A study was performed to gain information that could be used to inform initial guidance on video levels for HDR production. The study used existing SDR materials from both broadcast content and home video content. The study also used PQ HDR materials, mostly from home video grades of movies that were done on a 4 000 cd/m² PQ monitor. From this study, some data on levels is shown. While much of the study employed (for convenience) Caucasian skin levels, existing data on the reflectance of the Caucasian skin was employed to change the reference from skin levels (which of course are not consistent) to use of the conventional 18% grey card.

Details

Skin tones from both broadcast content and home cinema release content were analysed. The indoor SDR broadcast content was manually segmented for well-exposed (Caucasian) skin tones and was analysed assuming a BT.1886 reference monitor with 100 cd/m² reference white and BT.709 colour primaries. A sampling of the images analysed (courtesy of SVT and FOX) is shown below:

FIGURE A1-1



Report BT.2408-A1-1

Due to the scarcity of HDR broadcast content currently available, in order to compare HDR and SDR content, the same analysis was completed utilizing HDR and SDR graded indoor scenes from cinematic content for home distribution. The cumulative histogram is given below.

FIGURE A1-2

Skin tone cumulative histogram

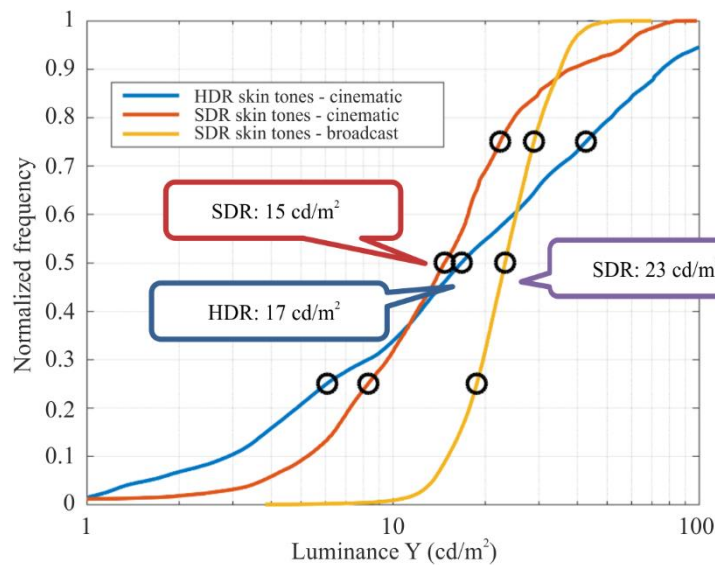

Report BT.2408-A1-2

For cinematic content for the home, HDR Caucasian skin tones are very similar to SDR skin tones (17 cd/m^2 compared to 15 cd/m^2), but the standard deviation is larger. Extrapolating from this, it is hypothesized that indoor Caucasian skin tones in HDR broadcast may average 26 cd/m^2 with a larger deviation than SDR broadcast. The 26 cd/m^2 value maps to 38% of full scale in PQ space (or 38%PQ).

Utilizing skin tones as a reference level is, of course, not satisfactory because they vary widely across ethnicities and environments. To achieve consistency, an 18% grey card may be used instead to calibrate camera exposure. To convert from Caucasian skin tone brightness and its 38%PQ level to find the %PQ level of an 18% grey card, a database of 340 measured samples of skin tones (Sun, Fairchild) was used to determine skin tone reflectance levels. This database shows that Caucasian skin tones have a reflectivity of 25% of that of a diffuse white object (white card: 100% Lambertian reflector).

FIGURE A1-3
BT.2100 reference OOTF

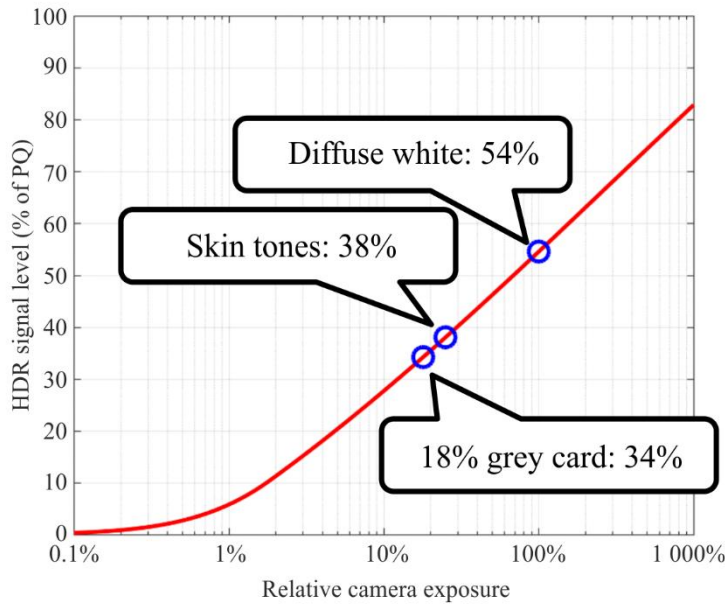

Report BT.2408-A1-3

Using the BT.2100 reference PQ OOTF, 26 cd/m² may be related to relative scene exposure. Then the 25% and 18% reflectivity relationship may be used to solve for the appropriate 18% grey card level: 17 cd/m² on a PQ reference display or 34% on the PQ scale. This is the expected luminance for a grey card anchor in HDR broadcast content for indoor scenes, for content consistent with existing practice. A diffuse white would be expected to yield 54% PQ.

By segmenting HDR indoor and outdoor scenes, it was found that outdoor skin tones were an average of 1.7 stops brighter than indoor skin tones. Assuming a 1.7 stop increase in brightness from an indoor to outdoor scene, the exposure for an 18% grey card outdoors would be set to 45% PQ.

The Table below summarizes Dolby’s findings for current content; these values could be considered tentative recommendations on settings of an 18% grey card and diffuse white objects in terms of both %PQ value and reference display brightness.

	Indoor		Outdoor	
	cd/m ²	%PQ	cd/m ²	%PQ
18% Grey Card	17	34	57	45
Diffuse White	140	54	425	66

The levels shown in this study are representative of some early HDR PQ content. More experience with HDR in broadcast is needed to settle on final values to be recommended. A major finding is that early HDR production has employed skin levels similar to those used in SDR content. The SDR skin levels are of necessity limited in order to leave room for full diffuse whites, and some trace of highlights. HDR signals have enough range that skin levels do not need such limitations. Given that in HDR production there is no need to limit the skin levels to those used in SDR production, it is possible that these may increase in brightness in subsequent productions. Thus, the values in the Table above might be considered the lower end of future operating levels.

Annex 2

Analysis of reference levels

A2.1 Introduction

The reference levels of Tables 1 and 2 of this Report are intended to provide guidance for the production of HDR content. This Annex presents a Technicolor analysis of existing content relative to several reference levels. The content chosen included frames from an HLG-based live broadcast, as well as a set of test images that were converted to PQ. The purpose of this Annex is to document how the defined reference levels relate to currently produced content, and to assess the variability in luma/luminance levels seen in current content.

A2.2 Analysis of reference levels

Several reference levels are analysed in the context of a database of 107 linear EXR images, graded for a 1 000 cd/m² display device. This dataset is included in Report ITU-R BT.2245. In this dataset the arithmetic mean luminance is 65.47 cd/m² (standard deviation 83.99 cd/m²). The geometric mean luminance is 9.17 cd/m² (standard deviation 24.74 cd/m²).

To understand how a given recommended reference level relates to the content presented in this database, the percentage of pixels that have values larger than the reference level is calculated. For each image, this percentage will be different, giving rise to a distribution of percentages. Then, a range of percentages was calculated that represents the 95% confidence interval. This means that this range of percentages represents 95% of the images in the database. To determine a confidence interval, the following equation was used:

$$CI = \bar{x} \pm z^* \frac{\sigma}{\sqrt{n}}$$

where:

- $n = 107$: number of images analysed
- x : mean number of pixels above the selected reference level
- σ : associated standard deviation.

The value of z^* is 1.96 for a 95% confidence interval. Likewise, the 99% confidence interval is computed, using a value of z^* of 2.58. The results are shown in Table A2.1.

TABLE A2.1

On a 1 000 cd/m² image dataset, the 95% and 99% confidence intervals are shown indicating the percentage of pixels that are larger than the reference luminance level

Description	Luminance (range)	95% Confidence interval	99% Confidence interval
Grey card (18%)	26	33.21% – 45.87%	32.21% – 47.88%
Greyscale chart max (83%)	162	8.89% – 16.23%	7.73% – 17.39%
Greyscale chart max (90%)	179	7.82% – 14.77%	6.72% – 15.87%
HDR Reference white	203	6.65% – 13.10%	5.62% – 14.13%
Grass	30-65	19.82% – 43.41%	18.16% – 45.37%
Ice rink	155	9.37% – 16.90%	8.18% – 19.09%
White Objects	140-425	1.79% – 18.59%	1.25% – 19.85%

Further, the same set of images were analysed to understand which luminance level marks the threshold so that 1% of the pixels lies above this level. This calculation was repeated for 5%, 10% and 20% of the pixels. The results are shown in Table A2.2.

TABLE A2.2

Luminance level marking the top $N\%$ pixels in a set of 107 HDR images

Percentile	Mean (Std) in cd/m^2
1%	321.89 (262.14)
5%	195.04 (206.15)
10%	145.03 (170.56)
20%	(145.01)

A2.3 Diffuse white elements in live HLG encoded broadcast content

Diffuse white elements³ in HLG encoded live broadcast content (“Dodgers Game”) were analysed by taking one frame every five seconds, and manually clicking in each frame on patches that appeared to represent diffuse white elements which were directly illuminated, without being over-exposed. The total number of analysed frames was 152, and the number of diffuse white points identified in this manner is 378. The content was a baseball game, interspersed with commercials, and containing scenes from a game played in daylight and a game played at night under artificial illumination.

The pixels identified in the manner described above represent values as %HLG. Statistics (mean, standard deviation, minimum and maximum RGB values) are given in the %HLG column of Table A2.3. These numbers were subsequently converted to cd/m^2 assuming a display peak luminance of 1 000 cd/m^2 , and to %PQ. These values are also reported in Table A2.3. Finally, Fig. A2-1 shows a histogram of the distribution of diffuse white levels for each of the red, green and blue channels, with the horizontal axis indicating values in %HLG.

TABLE A2.3

Analysis diffuse white of HLG encoded live broadcast content. The %HLG column was measured, while the remaining columns were derived from these measurements (152 frames, 378 points analysed)

Diffuse White	cd/m^2	%HLG	%PQ
Mean	(222.1, 204.3, 231.3)	(76.6, 75.0, 77.4)	(59.0, 58.1, 59.4)
Std	(134.7 – 373.5 123.6 – 345.4 141.0 – 386.7)	(8.3, 8.4, 8.2)	–
Min	(44.6, 44.5, 48.9)	(47.4, 47.3, 49.6)	(42.9, 42.9, 44.0)
Max	(747.1, 735.3, 789.9)	(95.6, 95.3, 96.6)	(72.0, 71.8, 72.6)

³ For the purpose of this Annex, the level of diffuse white elements is referred to as “diffuse white”.

FIGURE A2-1
Distribution of diffuse white patches in HLG live broadcast content.
 The values on the horizontal axis are in %HLG

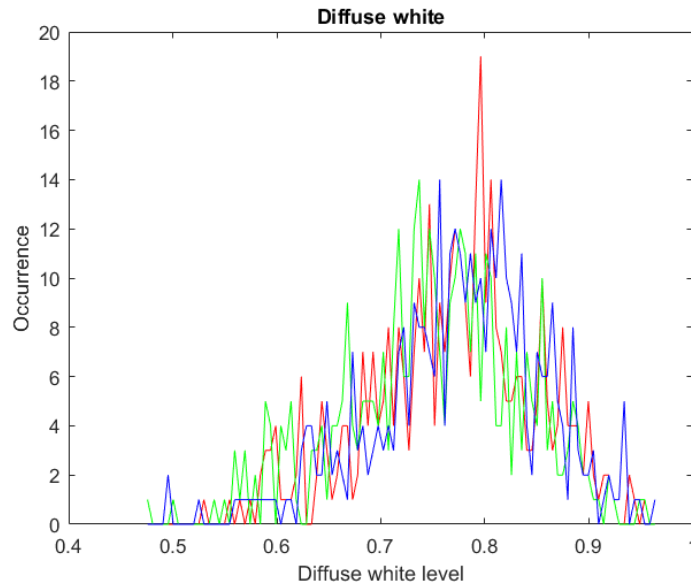

A2.4 Diffuse white in an HDR dataset of 1 000 cd/m² PQ encoded images

A dataset of 54 EXR images containing diffuse white patches was analysed using the same methodology as described in § A2.3. The dataset contains images that are graded for a 1 000 cd/m² display device. The linear EXR images were first PQ encoded. A total of 169 white patches were identified, producing the distribution shown in Fig. A2-2 and the derived statistics shown in Table A2.4. In this Table, the %PQ column was measured from the pixels that were selected, whereas the columns indicated with cd/m² and %HLG were calculated from the %PQ column.

TABLE A2.4

Analysis diffuse white of PQ encoded content. The %PQ column was measured, while the remaining columns were derived from these measurements (54 frames, 169 points analysed)

Diffuse White	cd/m ²	%HLG	%PQ
Mean	(231.8, 244.2, 193.3)	(77.1, 78.1, 73.5)	(59.5, 60.0, 57.6)
Std	(76.6 – 665.6 80.6 – 703.4 58.9 – 594.1)	–	(11.3, 11.3, 12.0)
Min	(5.6, 7.0, 6.7)	(19.7, 22.0, 21.5)	(25.6, 27.2, 27.0)
Max	(903.0, 1 000.0, 946.5)	(98.2, 100, 99.1)	(74.1, 75.2, 74.6)

FIGURE A2-2

Distribution of Diffuse White patches in a test database of 1 000 cd/m² images.
The values on the horizontal axis are in %PQ

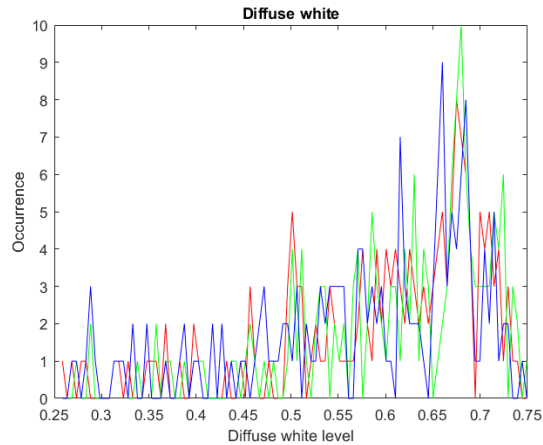

FIGURE A2-3

An image with 1.4% of its pixels above diffuse white (prior to tone mapping for display)



FIGURE A2-4

An image with 17% of its pixels with values above diffuse white (prior to tone mapping for display)



A2.5 Discussion

Two types of analyses were performed to help understand the relationship with pre-defined reference levels and content. In the first analysis, the number of pixels that have values higher than a given reference level was computed. A 95% and a 99% confidence interval was calculated, indicating the percentage of pixels that may be expected to be above the reference level.

For HDR Reference White, for example, it was determined that 99% of the images have between 5.6% and 14% of their pixels result in levels greater than 203 cd/m² in a set of 107 HDR images that were graded at 1 000 cd/m². Likewise, 95% of the same images have between 6.6% and 13% of their pixels larger than 203 cd/m².

To illustrate, compare the images shown in Figs A2-3 and A2-4, which have 1.4% and 17% of their pixels above HDR reference white, respectively. Figure A2-3 shows a clear case of an image where the extra headroom afforded by HDR technologies is spent on the highlights. Figure A2-4, on the other hand, has a significant part of the sky in the background at values above 203 cd/m².

In a second analysis, diffuse white was measured by manually identifying pixels in a set of frames/images. Over-exposed pixels were avoided, while diffuse white surfaces not receiving direct illumination were also excluded. The signal levels of white pixels were analysed. For the HLG-based live broadcast content, the mean diffuse white level was 75%HLG, which is the same as the recommended reference level in Table 1 – even if the content was produced without specifically using a target 203 cd/m² for reference level. However, the standard deviation was about 8.3% (measured in %HLG), which – for an assumed 1 000 cd/m² signal – translates to a range between around 123 and 345 cd/m² (i.e. mean \pm one standard deviation). This suggests that the diffuse white level as measured in live broadcast content varies significantly.

These results are broadly replicated with the test set of 107 HDR images which are PQ encoded. Here, the mean diffuse white level was determined to be around 60%PQ, which is close to 58%PQ as recommended in Table 1. The standard deviation was 11% (in %PQ), however, which translates to a range between around 80 and 700 cd/m² for mean \pm 1 standard deviation. The variability of diffuse white in this dataset is therefore significant, and it is larger than measured in the HLG-produced live broadcast content.

A2.6 Conclusions

The HDR Reference White level of 203 cd/m² in Table 1 of this Report is consistent with the mean diffuse white as measured in the content analysed in this Annex. However, the standard deviation of diffuse white in two different sources of content are large, indicating a significant spread of diffuse white around the mean.

Annex 3

Two studies of skin tones, using a reflectance database and using real subjects

This Annex reports two studies of skin tones, one that uses an existing database of skin reflectances and a model of an ideal camera, and one that uses real subjects and RAW camera recording. Luma values are proposed for different skin tones in HLG high dynamic range video.

A3.1 Study 1: using a skin tone database and an ideal model of a camera

A skin tone reflectance database from the US government National Institute of Standards and Technology (NIST) [6] was used for this study. The database covers a wide range of skin tones, however when comparing the 685 nm reflectances with those given elsewhere [7], it can be seen that it does not cover the full range of expected global reflectances.

The NIST database contains measures of skin reflectance of the inner forearm at a number of wavelengths. These tend to be slightly higher than the face. This dataset is shown in Fig. A3-1.

FIGURE A3-1
NIST Dataset
Each line corresponds to one skin sample

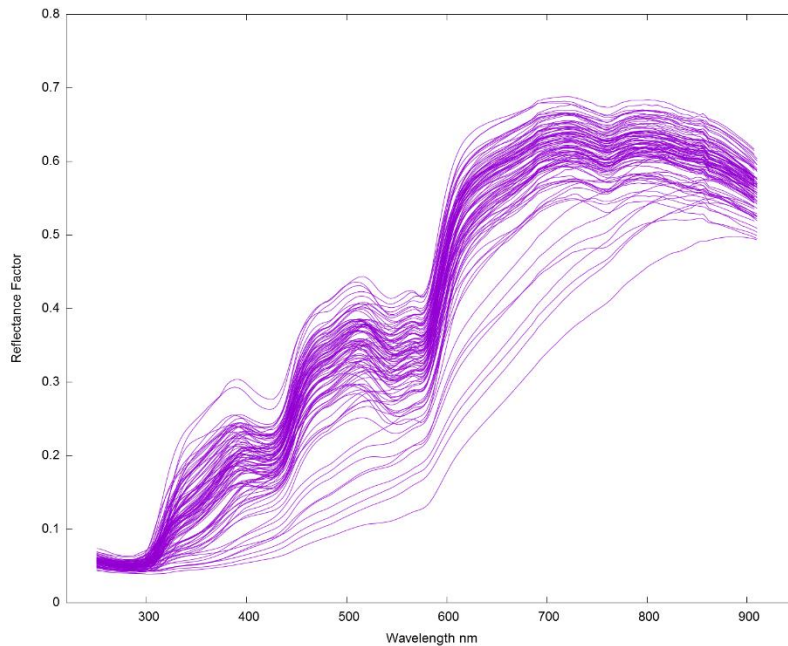

A software model of an ideal camera and lighting scenario was used (illustrated in Fig. A3-2) to generate values for Hybrid Log-Gamma (HLG) luma.

The model consists of a sample multiplied by the spectral curve of an ideal D65 illuminant [8] fed through an aperture (a fixed scalar). A set of CIE 1931 2 degree observer LMS to XYZ curves [9] are then used to convert to a known imaging format. These XYZ values are then converted to Recommendation ITU-R BT.2020/BT.2100 linear RGB values and the HLG Opto-Electronic Transfer Function (OETF) is applied. Finally, the luma value is calculated for the HLG R'G'B' values.

FIGURE A3-2
Block diagram of ideal camera model

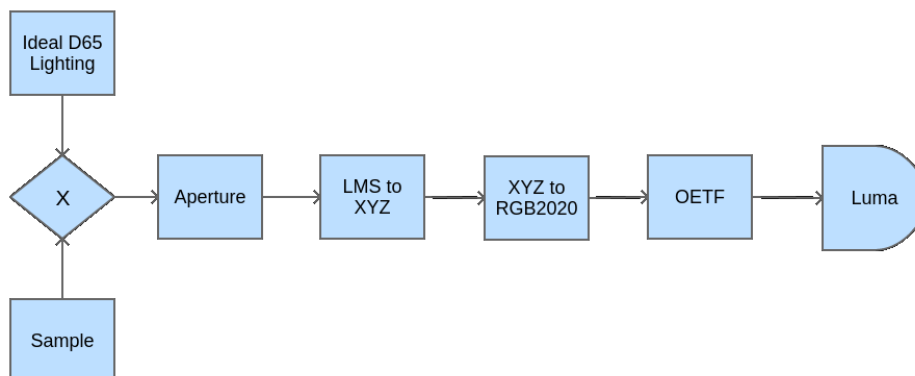

The NIST data set, ideal D65 illuminant curves and LMS to XYZ curves all used different wavelength step sizes in presenting the data, so, where data points did not align, a linear interpolation was used.

The first step in using the model was to calculate the required input aperture. By setting the input sample to a fixed value of 1.0 at all wavelengths to represent diffuse white, the aperture (a scalar) was adjusted such that the HLG luma value was equal to 0.75, the HLG signal level for HDR Reference White. This value of aperture was then used for all further samples.

The second step is to apply the model for each skin reflectance curve given in the NIST dataset. The results of this are shown in Fig. A3-3. Luma values are plotted against the skin reflectance at 685 nm to allow comparison with regional labelling from [7]. These regional labels have been added to the plot.

A further plot of skin tone reflectance against screen emittance for a 1 000 cd/m² HLG display is given in Fig. A3-4.

FIGURE A3-3

Skin tone reflectance at 685 nm against HLG Luma for ideal camera, with regional labels from [7]

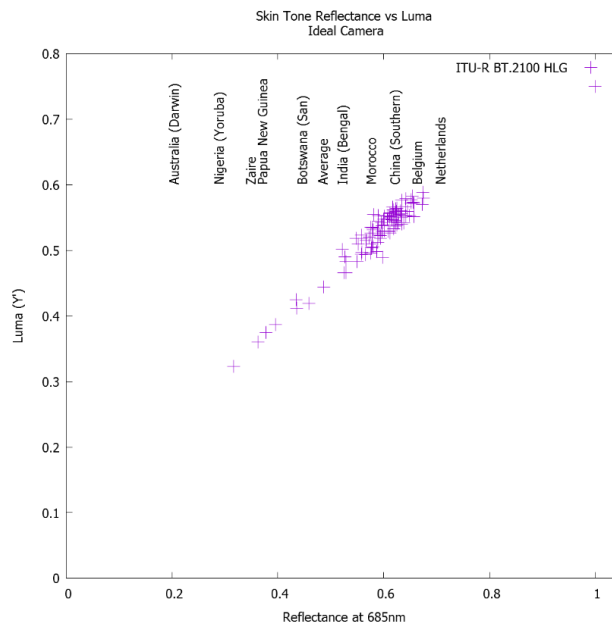
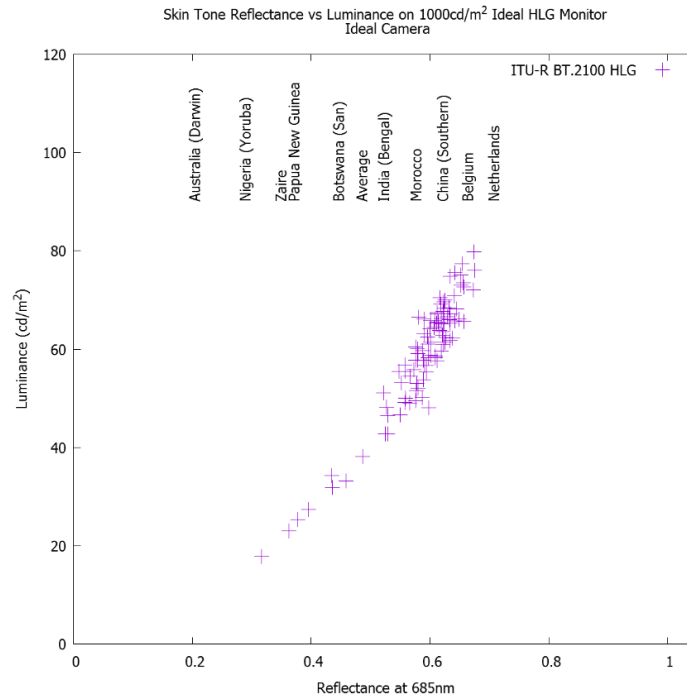

FIGURE A3-4

Skin tone reflectance at 685 nm against HLG luminance on a 1 000 cd/m² display, for ideal camera, with regional labels from [7]



A3.2 Study 2: using human subjects and a RAW recording camera

In conjunction with the European Broadcasting Union, a second experiment was conducted using real people and a DSLR RAW-recording camera. To categorise the subjects, the Fitzpatrick Skin Tone Scale [1] was used.

The first stage of the experiment was to calculate the reflectance of a small test chart that could be used in shot when photographing test subjects under practical D65 LED lighting. Using a Konika-Minolta CS2000 photospectrometer, the reflectances of the test chart white and black patches, a magnesium carbonate reference (97.5% reflectance) and a Gregory hole reference (black velvet lined box – 0% reflectance) were measured. The test chart white patch reflected 81.2% of light, the black patch 3.9%.

The processing chain for the images was designed to closely replicate the ideal camera workflow shown in Fig. A3-2. This is shown in Fig. A3-5. To convert the camera RAW file to linear XYZ, the open source package DCRaw [10] was used. This file was then processed to:

- 1 Convert the XYZ values to ITU-R BT.2020 linear RGB values and then to CIE Yu'v';
- 2 Scale Y such that the average black patch pixel value equalled 3.9% and the average white patch pixel value equalled 81.2%, then convert back to ITU-R BT.2020 linear RGB values;
- 3 Apply the HLG OETF to the R, G and B channels (using the equations found in Recommendation ITU-R BT.2100) and then calculate the Y' channel;
- 4 Crop two 50 pixel by 50 pixel areas of skin tone (forehead and cheek) and calculate the average luma value. Care was taken to ensure that the chosen areas are co-planar with the physical luminance ramp test chart.

FIGURE A3-5
Real-life human skin tone measurement

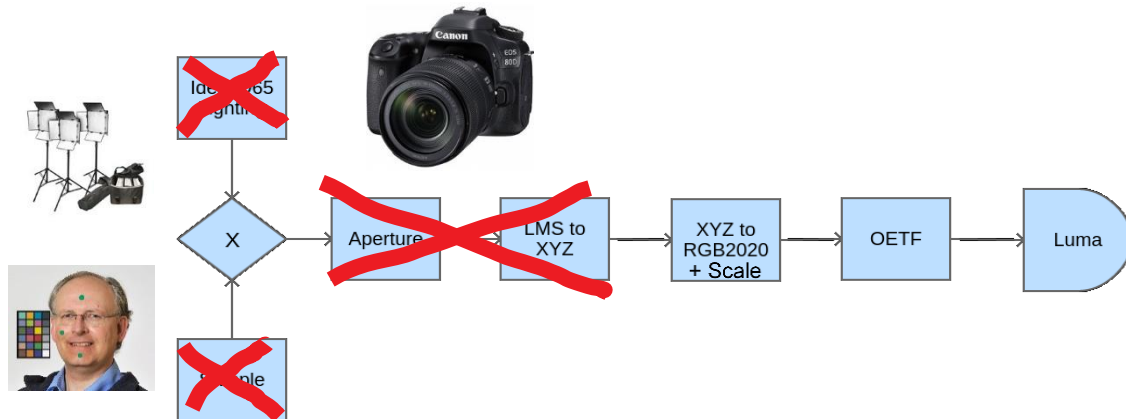

In order to match the test subject to the Fitzpatrick Scale classifications, a questionnaire from the Australian Government Radiation Protection and Nuclear Safety Agency was used [11].

The results of these photographic tests are shown in Fig. A3-6. Skin tone measurements range from approximately 26%HLG to 67%HLG dependant on skin tone. It can also be seen that there is an issue with two peoples' replies to the questionnaire. Both individuals are deeply pigmented and should either be type V or VI but have self-identified as type IV. Following discussions with these individuals, and others identifying as type IV, V or VI, it appears that there is an issue with the questions relating to tanning: people either reported that they were permanently tanned or that they never tanned, which led to changes in the result. Finally, it can be seen that there is a small difference across the face, with the forehead being more reflective than the cheek for persons with skin types II to IV.

It should be noted that the event at which measurements were taken occurred in the Northern Hemisphere during winter (so few people were currently tanned) and the attendee demographic was skewed towards categories II, III and IV.

FIGURE A3-6
HLG signal levels measured from human subjects

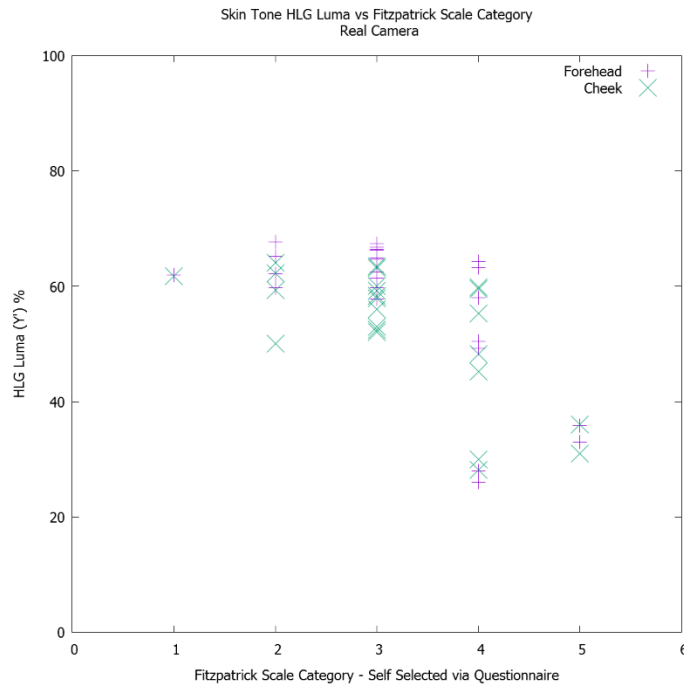

Based on these experimental results, Table A3.1 shows suggested HLG luma ranges for each skin type. In formulating the values, the two people discussed previously in this section have been re-categorised as category VI, which gives values consistent with those presented in Fig. A3-3. To accurately represent the majority of the exposed skin which does not exhibit issues with perspiration shine, the ranges are chosen to cover the majority of the cheek skin tone measurements for each category, ignoring obvious outliers. A small amount of leeway is allowed at the bottom end of the ranges for categories I-IV to allow for summer tanning. Camera zebras should be set 2 to 3% above these ranges to take account of perspiration shine. Values are chosen to be easily used by productions using waveform monitors only.

TABLE A3.1

Suggested HLG signal ranges for different skin types

Fitzpatrick skin type	HLG signal level (%HLG)
I and II	55-65
III and IV	45-60
V and VI	25-45

A3.3 Conclusions

- 1 HLG luma levels measured with the DSLR camera (Study 2) are similar to those calculated with the computer camera model (Study 1).
- 2 Results are valid when the sample is from areas of skin co-planar with the physical test chart. Due to using a single light source, there is a marked drop off in reflectance when moving away from areas of the face that are co-planar. In one instance, the side of the face reflects less light than the black test colour on the chart.

- 3 There is an issue with “forehead shine” caused by both perspiration under the studio lights and a matching of the angle of incidence and reflection such that light is reflected directly towards the camera.
- 4 The Australian Government questionnaire is designed to suggest levels of skin protection required in the southern hemisphere tropics and, therefore, is most suited to Fitzpatrick Skin Types I-IV. There is a possible mis-categorisation of two test subjects.

Annex 4

Study of facial skin tones in broadcast content

This Annex reports on studies of facial skin tones in broadcast content in Japan.

A4.1 Facial skin tones in SDR news and information programmes in studio

Eight Japanese broadcasters contributed SDR broadcast content produced under controlled lighting in studios to this study. Table A4.1 shows the overview of the content. Target areas within a face, i.e. forehead and cheeks, were clipped out from the images and their average signal levels were measured.

TABLE A4.1

SDR broadcast content produced in studio used for study

Content holders	8 Japanese broadcasters ⁽¹⁾
Programme genre	News, information, and talk shows produced in studio
Types of framing	Single shot, two-shot, and group shot
People in scenes	Male and female Japanese/Mongoloid
Target area for analysis	Forehead and cheeks ⁽²⁾
Number of sample images	387 in total
Number of faces analysed	Male: 365, female: 348, and total: 713

⁽¹⁾ Japan Broadcasting Corp., Asahi Broadcasting Corp, Nippon Television Network Corp., Tokyo Broadcasting System Television, Fuji Television Network, TV Asahi Corp., TV Tokyo Corp., and WOWOW.

⁽²⁾ Areas that exhibit the highest signal level within a face except for specular reflection and shine. A single person was charged with analysing the skin tones for consistent analysis.

Figure A4-1 shows the cumulative histogram of the facial skin tones. The average video levels (Y') and standard deviations for male, female, and total are 71.8 ($\sigma=5.2$), 77.6 ($\sigma=5.7$), and 74.6 ($\sigma=6.2$) %SDR, respectively. These video levels correspond to luminance of 45 cd/m², 55 cd/m², and 49 cd/m² on a display with the peak luminance of 100 cd/m². The luminance of facial skin tones is more than twice the 23 cd/m² reported in Annex 1 for SDR broadcast content.

FIGURE A4-1
Cumulative histogram of facial skin tones

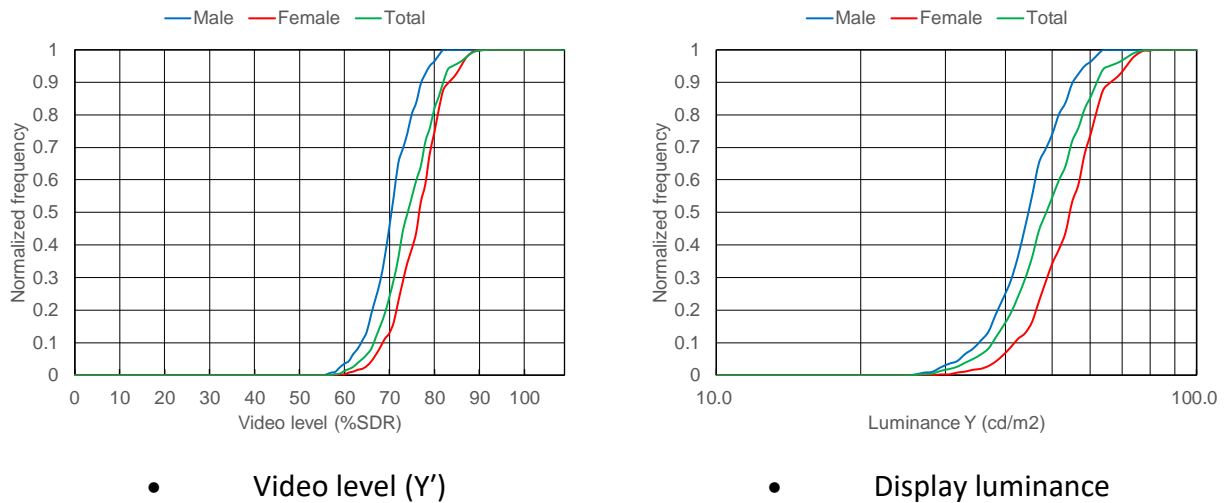

Facial skin reflectance was estimated in one of the SDR programmes, in which video level of facial skin was 81%SDR (Y'), by placing the 11-step grey scale chart at the caster's position under the same lighting and exposure conditions in the studio. From the measurement, the reflectance of the facial skin was estimated to be 31% for luminance.

A4.2 Comparison of facial skin tones in HLG HDR and SDR content in a music programme

A preliminary study was conducted on skin tones in HLG HDR content in comparison with SDR content. Both HLG and SDR content were produced independently for the same NHK music programme in a concert where musicians performed on stage under special lighting and set. In the HDR production, video engineers paid attention to the reference level of 75%HLG. 75%HLG was also used for graphics white in captions.

The facial skin tones of 11 people (musicians and hosts) from 24 scenes in each of the HLG and SDR programmes were analysed. Figure A4-2 plots average levels of each face. The facial skin tones were found to be 45-56%HLG (50%HLG on average) and 41-71 cd/m² on HLG displays with a peak luminance of 1 000 cd/m², and 61-82%SDR (70%SDR on average) and 32-63 cd/m² on SDR displays with a peak luminance of 100 cd/m².

The values for SDR correspond well to those for the SDR news and information programmes in studio described in § A4.1. Since the HLG signal level for 30% reflectance is 49%HLG when 75%HLG corresponds to 100% reflectance, the skin tones in the HLG programme well match the HDR reference level.

FIGURE A4-2

Comparison of facial skin tones in HLG and SDR content in music programme

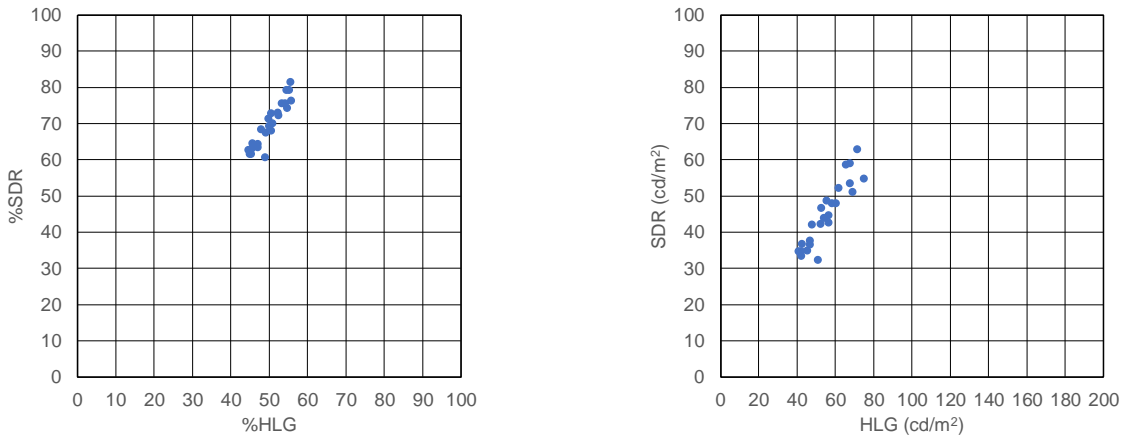

- Video level (Y')
- Display luminance

A4.3 Conclusion

Facial skin tones in SDR content in news and information programmes in studios and those in HDR and SDR content in a music programme in a concert hall were studied. The results are summarized in Table A4.2. The facial skin tones in Japanese SDR programmes were found to be much higher than those reported for European and American programmes in Annex 1. This may be mainly due to a difference in long-standing production practice for SDR rather than a difference in skin reflectance. It should also be noted that makeup also affects skin tones significantly.

The relationship in facial skin tones between HDR and SDR should provide a foundation for establishing guidelines for converting HDR content into SDR and vice versa. Although HDR production is anticipated to universally follow the HDR reference levels described in this Report, different conversion characteristics may be needed for the conversion from HDR to SDR to obtain SDR pictures with familiar facial look in different regions or countries, yet more research is desirable.

TABLE A4.2

Summary of facial skin tones in Japanese content

Programme genre		News and information in studio			Music programme in concert hall	
Format		SDR			SDR	HLG
Graphics white		100%SDR			100%SDR	75%HLG
Average skin tones	Signal level	Male	Female	Total	70%SDR	50%HLG
		72%SDR	78%SDR	75%SDR		
	Display luminance	45 cd/m ²	55 cd/m ²	49 cd/m ²	45 cd/m ²	55 cd/m ²
					on a display of 100 cd/m ² peak	
					on a display of 1 000 cd/m ² peak	

Annex 5

Displaying PQ – calculating the EETF

This Annex describes approaches to mapping HDR signals to displays with a lower dynamic range, i.e. how to calculate the necessary EETF (electrical-electrical transfer function) in order to adapt to the display, see § 3.1.1. Such mapping may also be required during conversion from PQ to HLG.

The central region of the tone mapping curve is defined as a 1:1 mapping. A ‘knee’ roll off may be calculated using a hermite spline to create a mapping that will reduce the luminance range to the capability of the display. The black level lift is controlled by an offset, b , which may be determined by a PLUGE adjustment as specified in Recommendation ITU-R BT.814. The difference between this proposal and the black level adjustment per Recommendation ITU-R BT.1886 is the addition of a tapering factor $(1 - E_2)^4$. Without such a tapering factor, a constant offset throughout the entire signal range has the effect of increasing the brightness at the high end. With Recommendation ITU-R BT.1886 this effect was limited and not problematic due to the large number of code values at the high end of the gamma curve. The perceptual uniformity of the PQ EOTF causes this effect to be unacceptable. The tapering function allows fine-tuning the lift without a significant impact on mid-tones or highlights.

In the case where the mastering display minimum black and peak white luminances are known or reasonably can be assumed, the first step in applying the EETF is to normalize the PQ values based on the mastering display black and white luminances, L_B and L_W :

$$\text{Step 1:} \quad E_1 = (E' - EOTF_{PQ}^{-1}[L_B]) / (EOTF_{PQ}^{-1}[L_W] - EOTF_{PQ}^{-1}[L_B])$$

where E' is the I, Y' or R', G', or B' PQ component and E_1 is the corresponding mastering display black and white normalized PQ component.

In the case where the mastering display minimum black and peak white luminances are not known and reasonably cannot be assumed, a value of 0 can be used for L_B and a value of 10 000 can be used for L_W , corresponding to the entire PQ encoding luminance range.

The next step is to calculate the mastering display black and white normalized PQ values, $minLum$ and $maxLum$, corresponding to the target display minimum (L_{min}) and maximum (L_{max}) luminances, including ambient, as follows:

$$minLum = (EOTF_{PQ}^{-1}[L_{min}] - EOTF_{PQ}^{-1}[L_B]) / (EOTF_{PQ}^{-1}[L_W] - EOTF_{PQ}^{-1}[L_B])$$

$$maxLum = (EOTF_{PQ}^{-1}[L_{max}] - EOTF_{PQ}^{-1}[L_B]) / (EOTF_{PQ}^{-1}[L_W] - EOTF_{PQ}^{-1}[L_B])$$

The next step is to calculate the 1:1 mapping and knee (E_2). The turning point (KneeStart or KS) for the spline is the point where the roll off will begin, as follows:

$$\text{Step 2:} \quad KS = 1.5 \maxLum - 0.5$$

$$b = minLum$$

The next step is to solve for the EETF (E_3) with given end points.

$$\text{Step 3:} \quad E_2 = E_1$$

$$\text{for } E_1 < KS$$

$$E_2 = P[E_1] \quad \text{for } KS \leq E_1 \leq 1$$

$$E_3 = E_2 + b(1 - E_2)^4 \quad \text{for } 0 \leq E_2 \leq 1$$

Hermite spline equations:

$$\text{Step 4:} \quad P[B] = (2T[B]^3 - 3T[B]^2 + 1)KS + (T[B]^3 - 2T[B]^2 + T[B])(1 - KS) + (-2T[B]^3 + 3T[B]^2)maxLum$$

$$T[A] = (A - KS) / (1 - KS)$$

The final step is to invert the normalization of the PQ values based on the mastering display black and white luminances, L_B and L_W , to obtain the target display PQ values.

$$\text{Step 5: } E_4 = E_3 (EOTF_{PQ}^{-1}[L_W] - EOTF_{PQ}^{-1}[L_B]) + EOTF_{PQ}^{-1}[L_B]$$

The EETF may be applied in many colour representations [12]. Here are some options:

1) $IC_T C_P$

$$I_2 = EETF(I_1)$$

$$C_{T2}, C_{P2} = \min\left(\frac{I_1}{I_2}, \frac{I_2}{I_1}\right) \times (C_{T1}, C_{P1})$$

2) $Y' C'_B C'_R$

$$Y'_2 = EETF(Y'_1)$$

$$C'_{B2}, C'_{R2} = \min\left(\frac{Y'_1}{Y'_2}, \frac{Y'_2}{Y'_1}\right) \times (C'_{B1}, C'_{R1})$$

3) $YRGB$

$$Y_1 = 0.2627R_1 + 0.6780G_1 + 0.0593B_1$$

$$Y_2 = EOTF_{PQ}(EETF(EOTF_{PQ}^{-1}(Y_1)))$$

$$(R_2, G_2, B_2) = \frac{Y_2}{Y_1} \times (R_1, G_1, B_1)$$

4) $R'G'B'$

$$(R'_2, G'_2, B'_2) = EETF(R'_1, G'_1, B'_1)$$

5) $maxRGB$

$$M_1 = \max(R_1, G_1, B_1)$$

$$M_2 = EOTF_{PQ}\left(EETF\left(EOTF_{PQ}^{-1}(M_1)\right)\right)$$

$$(R_2, G_2, B_2) = (M_2/M_1) \times (R_1, G_1, B_1)$$

As summarized in Table A5.1, since the $IC_T C_P$, $Y' C'_B C'_R$, and $YRGB$ methods can produce colours significantly outside the destination gamut, the degree to which these methods preserve the creative intent can be dependent on the gamut mapping used.

TABLE A5.1

Advantages of EETF application space

	$IC_T C_P$	$Y' C'_B C'_R$	$YRGB$	$R'G'B'$	$maxRGB$
Does not produce colours significantly outside the Target Colour Volume	×	×	×	✓	✓

It is possible to blend results from multiple methods. For example, with highlight compression, desaturation and hue changes can be controlled to some extent without requiring gamut mapping by using a blend of $R'G'B'$ with $maxRGB$.

The degree to which the creative intent is maintained also depends on the amount of tone and colour compression applied, with more compression producing more significant differences. See Report ITU-R BT.2446 for methods for converting between HDR and SDR.

The following is a short list expanding on the characteristics of each mapping space:

IC_TC_P

- 1 Has the potential to produce colours outside the destination gamut, which then require gamut mapping.
- 2 Since it is a perceptual colour difference space, it is a good space for gamut mapping. No need to convert to a different colour space if gamut boundary information and appropriately configurable gamut mapping algorithms are available.
- 3 Includes a desaturation function to produce a “natural” looking desaturation where the source image lightness is changed by the EETF. Natural refers to the desaturation that results from the roll-offs in the human visual system response with colours that are extremely darker or extremely lighter than the adapted luminance. A common example is walking out of a dark theatre into the sun – initially the outdoor colours will look very bright and “washed out.”
- 4 Preserves hue in *IC_TC_P* space, which should be close to preserving perceptual hue due to the design of the *IC_TC_P* space.

Y'C'_BC'_R

- 1 Has the potential to produce colours outside the destination gamut, which then require gamut mapping.
- 2 The colour space can be used for gamut mapping. No need to convert to a different colour space if gamut boundary information and appropriately configurable gamut mapping algorithms are available.
- 3 Includes a desaturation function to produce a “natural” looking desaturation where the source image lightness is changed by the EETF.
- 4 Preserves hue in the nonlinear *Y'C'_BC'_R* space, which departs in some areas from perceptual hue but can still produce acceptable results.

YRGB

- 1 Has the potential to produce colours outside the destination gamut, which then require gamut mapping.
- 2 Preserves chromaticity except for where gamut mapping is applied. Does not produce a “natural” looking desaturation of tonally compressed colours.
- 3 Problems can be avoided by using in combination with a variable desaturation and gamut mapping algorithm, although such algorithms generally perform best in hue, saturation and lightness colour spaces (requiring a colour space change).

R'G'B'

- 1 Does not produce colours outside the destination gamut.
- 2 Generally tends to produce “natural” looking colours, although saturation of extreme colours is reduced substantially and some colours may be changed in hue.
- 3 Problematic when it is desired to retain bright saturated colours, such as coloured lights at night.
- 4 Depending on the amount of compression, the saturation decrease may be excessive, and occasionally hue changes can be objectionable.
- 5 Results depend on RGB primaries used. It has been found that primaries close to the BT.2020 primaries tend to work well.

maxRGB

- 1 Does not produce colours outside the destination gamut when used to compress highlights.
- 2 Preserves chromaticity at the expense of lightness.
- 3 Can produce un-natural colours that look like artifacts, due to lightness differences being compressed without associated saturation changes. Typical examples include very bright skin tones and sunsets where luminance differences are obscured. In these cases, other methods will produce better looking results.
- 4 Does a good job maintaining bright coloured lights.
- 5 Problems can be reduced by avoiding problematic colours in the original, for example exposing so skin tones are never near the top of the range, and mastering using IC_{TCp} or $R'G'B'$ so there is some built-in saturation difference as a function of lightness for very bright colours.

Annex 6**Comparison of the native looks of HDR and SDR production**

As mentioned in § 7.3.3, when colour matching cameras in live production, it is important to note that the native displayed “look” of each SDR and HDR production format is different as, by design, they all have different OOTFs. Even though cameras usually provide “painting controls” that adjust the OOTFs to deliver the desired artistic “look”, they are often insufficient to exactly match the displayed “look” of cameras using the different formats. For that reason, when converting signals from different format cameras into a common format for live production, scene-light rather than display-light conversions are preferred, as they are agnostic to the OOTF differences.

To quantify the differences in the displayed look of the different formats, the different television production formats BT.709, BT.2020, PQ, HLG, and HLG with traditional colour reproduction (as described in § 6.5 of Report ITU-R BT.2390) are compared based on their different renderings (different displayed light) of the same scene data, i.e. their different “native looks”, as determined by their different OOTFs. For each format, the display light is obtained by passing selected reference colour pattern data (a “colour chart”) through its OOTF, where the OOTF of each format is determined by the concatenation of its respective OETF (camera side) and EOTF (display side). The reference colour data is the television colour reference pattern of [13], which describes a colour chart containing three lines of six coloured swatches as well as one line of six neutral swatches (with different reflectances). To enable an objective comparison between the different formats, the luminance of the displayed white swatch (the neutral swatch with the highest reflectance) is normalized to approximately 200 cd/m² for each format. This normalization is performed by linearly scaling the scene linear reference colour data (equivalent to adjusting the camera iris).

The differences between the display light colour charts for the different formats can be characterized by the differences in chromaticity as well as luminance between the displayed colour swatches.

The CIE 1976 uniform chromaticity scale plot [14] of the display light chromaticity values for each format shows that the chromaticity differences between the different formats can be substantially characterized as saturation differences (the differences in hue between the formats are small).

The HLG format, by design, has the lowest saturation of all formats because it preserves the chromaticity of the scene as imaged by the camera; all other formats increase saturation compared to

the scene as imaged by the camera. Earlier studies have shown that colorimetrically accurate reproduction of natural scenes does not necessarily ensure the highest perceived image quality and a reliable enhancement of perceived image quality can be produced by selectively increasing saturation values [15]. Most cameras offer a saturation adjustment in the CCU to deliver artistically pleasing images.

When ranking the formats from low to high saturation for the non-neutral colour swatches in the chart, the ranking is as follows for average and median colour swatch saturation:

Average: HLG < HLG traditional colour < PQ < BT.709 < BT.2020

Median: HLG < BT.709 < HLG traditional colour < PQ < BT.2020

In addition to the differences in saturation, there are also differences in luminance between the formats. These differences are more pronounced for relatively (or absolutely) lower luminances and can be explained by the differences in the respective OOTFs, as shown in Fig. A6-1 (where the scene luminance has been normalized on the white swatch luminance). The HLG format OOTF has a gamma 1.2 across the luminance range and, for the lower luminances, is closest to the scene light (which has a linear OOTF or a gamma of 1). The BT.709, BT.2020, and PQ formats all have a gamma 2.4 near black. It can be observed that the HDR formats (particularly HLG) preserve a higher luminance near black than the SDR formats, so the HDR formats show/preserve more detail in the dark. The SDR formats, on the other hand, produce images with a higher perceived contrast.

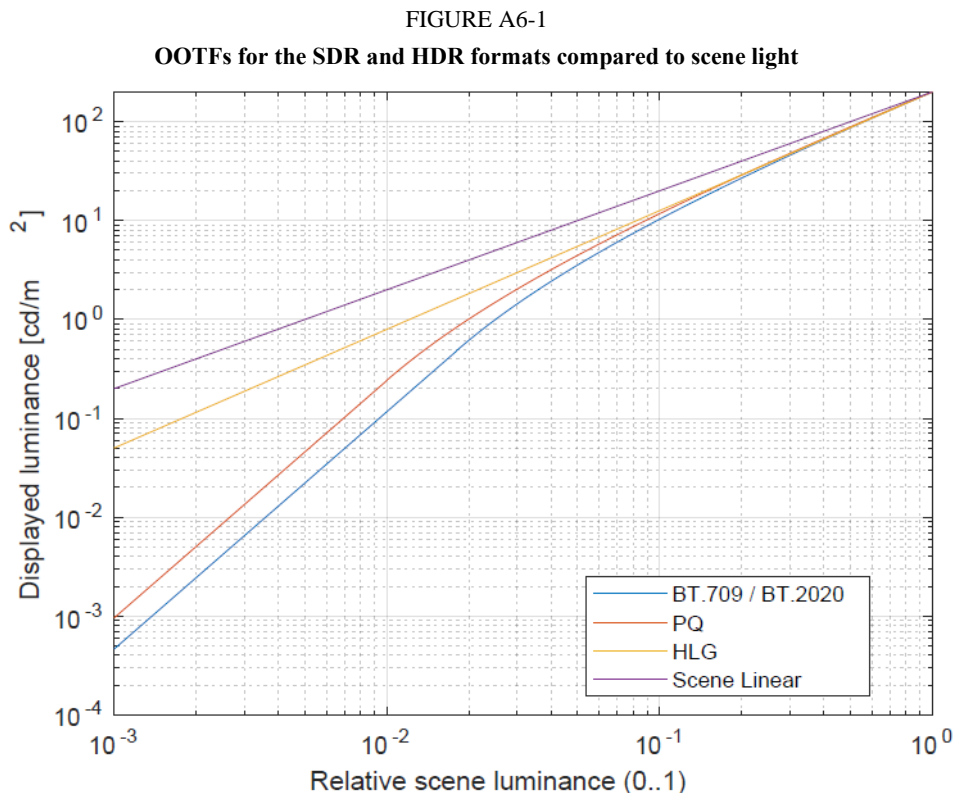

The following sub-sections provide details of the analysis of the differences in chromaticity/saturation and luminance of the different SDR and HDR formats.

A6.1 Differences in chromaticity and saturation

Colours may be characterized by their chromaticity, which is the property of colour that is independent of luminance. To visualize chromaticity and chromaticity differences, the CIE 1976

uniform chromaticity scale diagram with chromaticity coordinates u' and v' may be used [14]. Each point in the diagram can be described either directly by its coordinates, or indirectly by its hue (or hue angle) and saturation.

The hue (angle) is defined as $h_{uv} = \arctan[(v' - v'_n)/(u' - u'_n)]$ and the saturation as $s_{uv} = 13 [(u' - u'_n)^2 + (v' - v'_n)^2]^{1/2}$ where u'_n and v'_n are the coordinates of the white point, which for television is CIE D65 with coordinates (0.1978, 0.4683). Thus, the saturation corresponds to the Euclidian distance from the white point.

The uniform chromaticity diagram in Fig. A6-2 shows the display light colour swatch chromaticity for the different production formats. It can be observed that the colour swatch chromaticity for the different production formats falls approximately on a line of constant hue. Therefore, the chromaticity differences can substantially be characterized as saturation differences.

It can be observed that BT.2020 generally provides the highest saturation while, by design, HLG provides the lowest saturation. This can also be observed from the saturation values shown in Fig. A6-3. The saturation differences with BT.709 are shown in Fig. A6-4 and the saturation differences with BT.2020 are shown in Fig. A6-5.

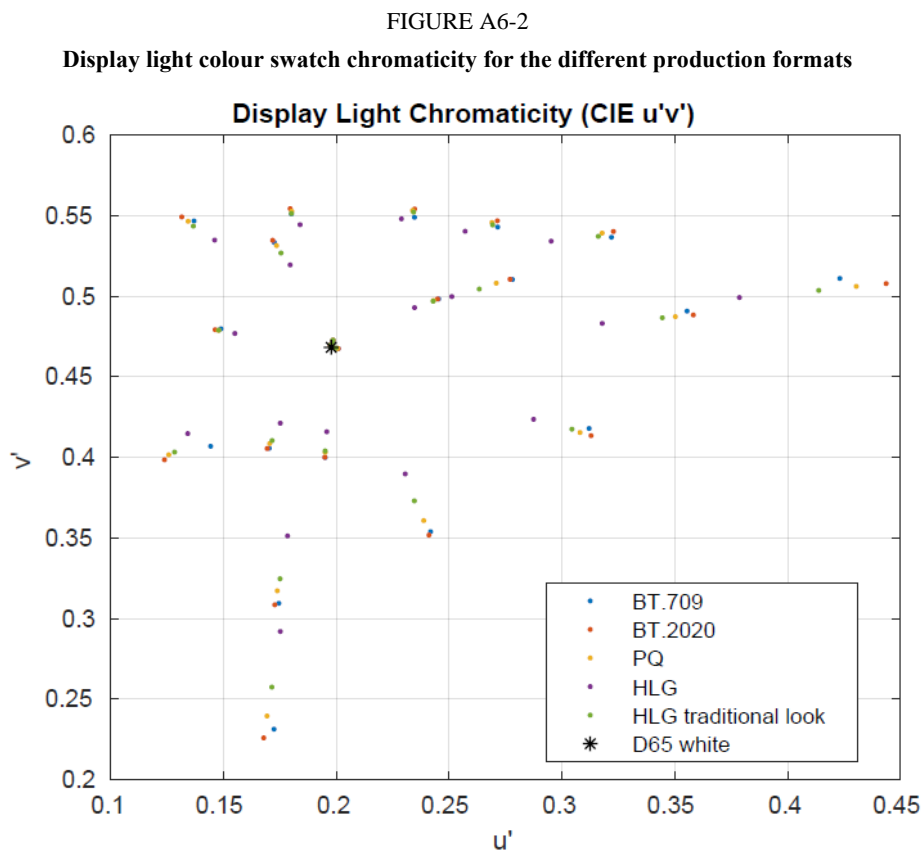

FIGURE A6-3

Display light colour swatch saturation

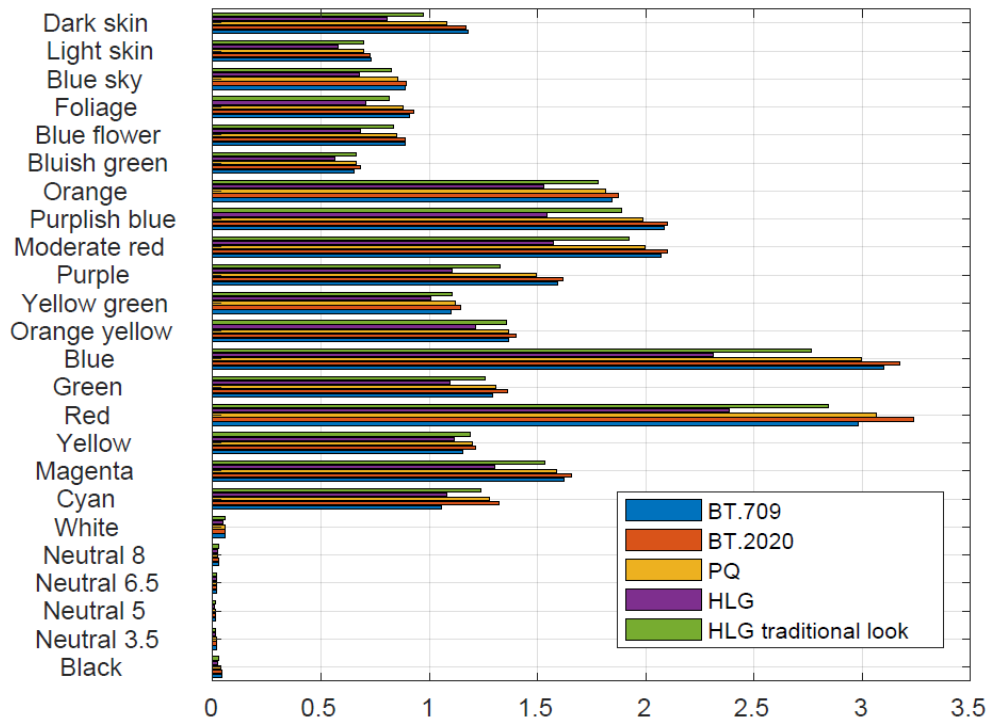

FIGURE A6-4

Display light colour swatch saturation differences with BT.709

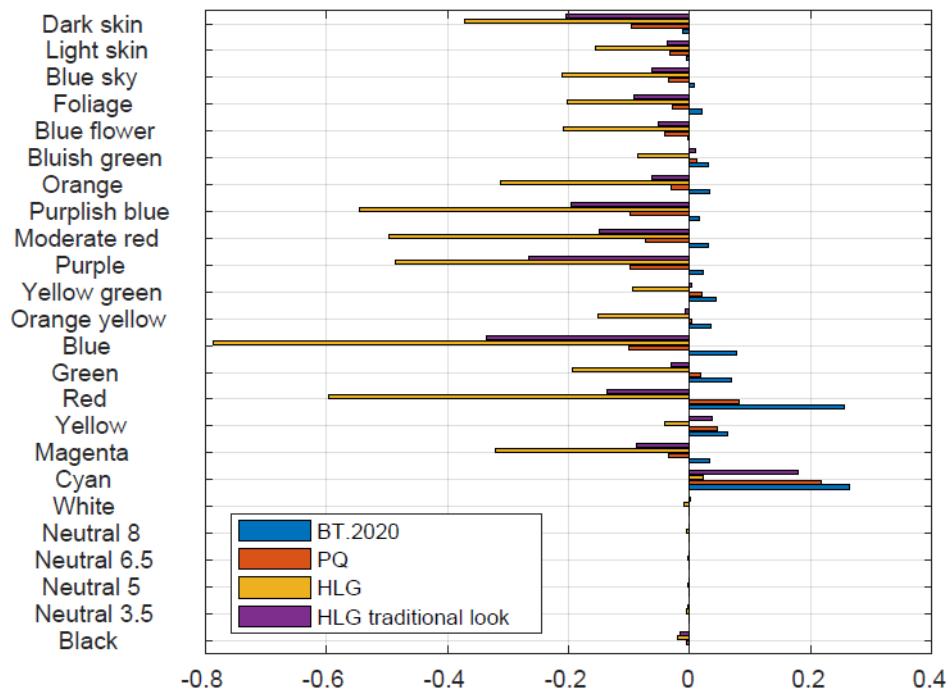
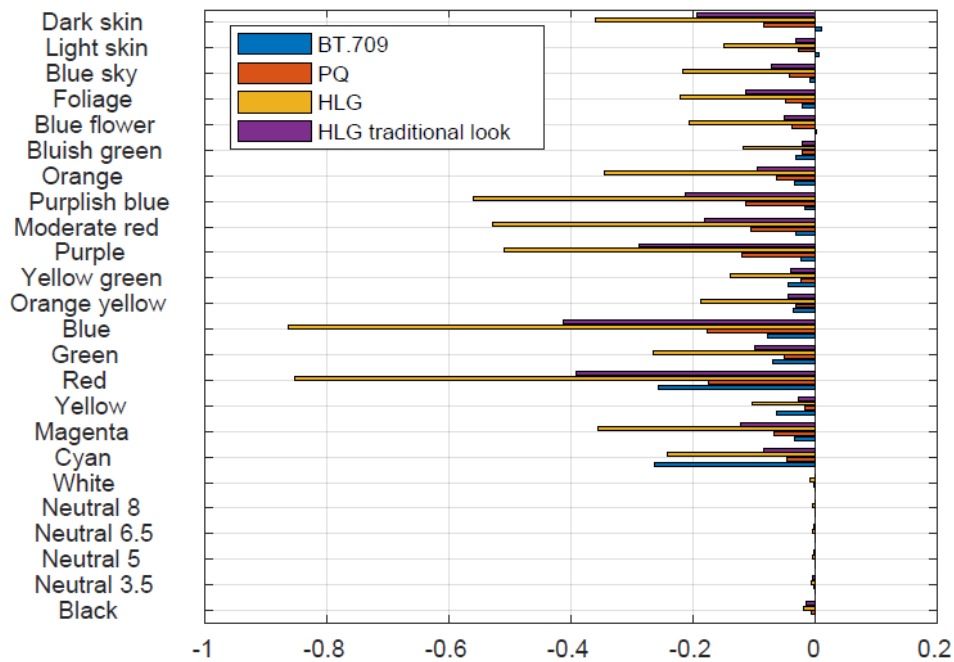

FIGURE A6-5

Display light colour swatch saturation differences with BT.2020



A6.2 Quantifying the total colour differences

While the differences in chromaticity and saturation of the colour swatches were shown in § A6.1, those differences do not take into account the luminance differences between the swatches and therefore do not represent the total colour differences. To quantify the total differences, a metric should be applied that takes into account the chromaticity differences as well as the luminance differences, such as e.g. the Delta E_{2000} metric defined by the CIE [16], or the new Delta E_{ITP} metric defined in Recommendation ITU-R BT.2124. The latter metric is applied in the following, using either the BT.709 or BT.2020 display light colour swatches as a reference.

The Delta E_{ITP} differences with BT.709 are shown in Fig. A6-6 and those with BT.2020 are shown in Fig. A6-7. It can be observed, e.g. that the differences for the highly saturated colours (such as Red and Blue) are larger than the differences with BT.709.

Note also the differences for the White/Neutral/Black colour swatches, which are luminance differences caused by the differences between the SDR and HDR OOTFs (as shown in Fig. A6-1). The relatively darker/lower scene luminances are displayed brighter in the HDR formats than in the SDR formats (so the HDR formats show/preserve additional detail in the dark).

FIGURE A6-6

Display light colour swatch Delta E_{ITP} with BT.709

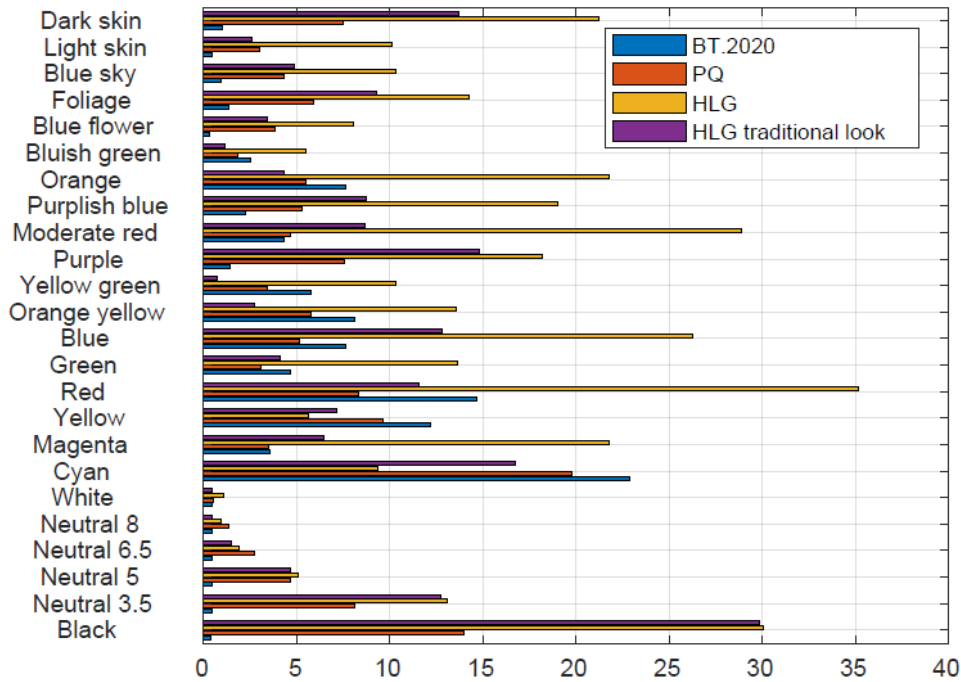
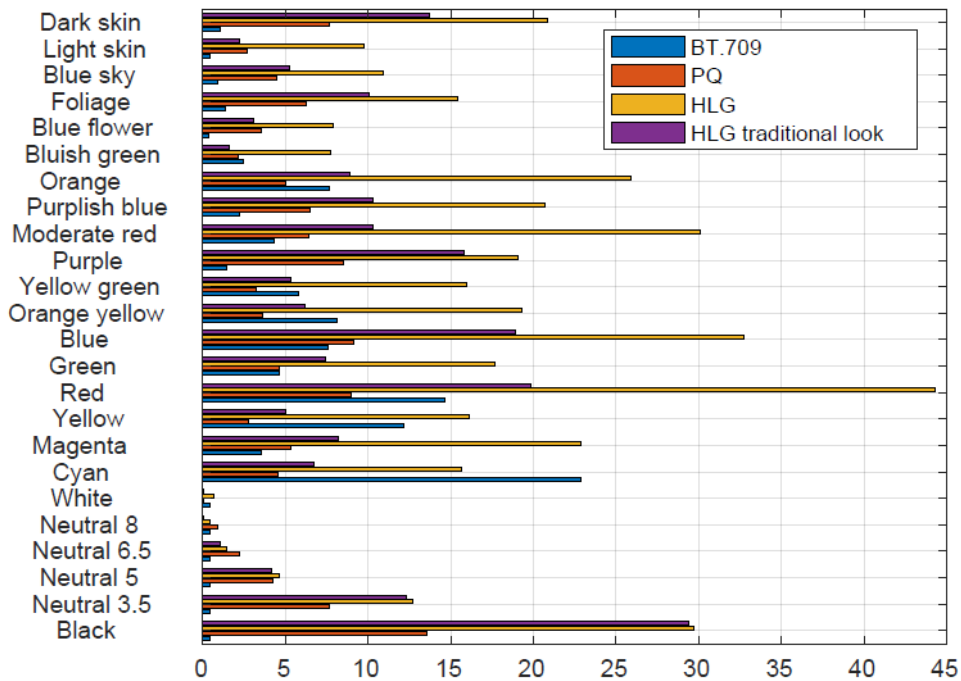

FIGURE A6-7

Display light colour swatch Delta E_{ITP} with BT.2020



A6.3 Comparison with the reference colour pattern data

Instead of using one of the production formats as a reference for comparison, the original colour pattern reference data [13] can be used as well. To do so, the reference data is linearly scaled (i.e. a linear OOTF is applied) such that the white swatch luminance is approximately 200 cd/m² as for the other formats.

The saturation differences with the scaled colour pattern reference data are shown in Fig. A6-8. For the HLG format, the saturation differences are all 0, because the HLG format preserves the chromaticity (and therefore the saturation) of the scene as imaged by the camera. Note that this does not imply that the HLG format preserves the chromaticity of the original scene, since camera image adjustments, such as white balancing, will change the chromaticity.

The Delta E_{ITP} differences with the scaled reference data are shown in Fig. A6-9. For the HLG format, the differences are purely luminance differences, caused by the difference between the relative scene luminances (linear OOTF) and the displayed luminances for the HLG format (OOTF gamma 1.2).

FIGURE A6-8

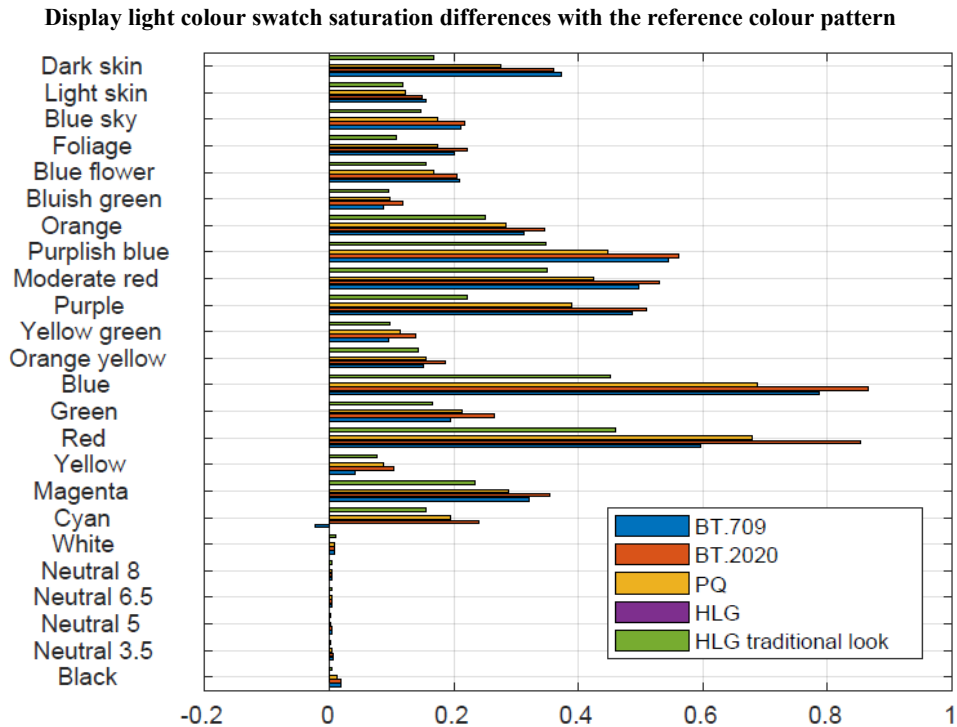
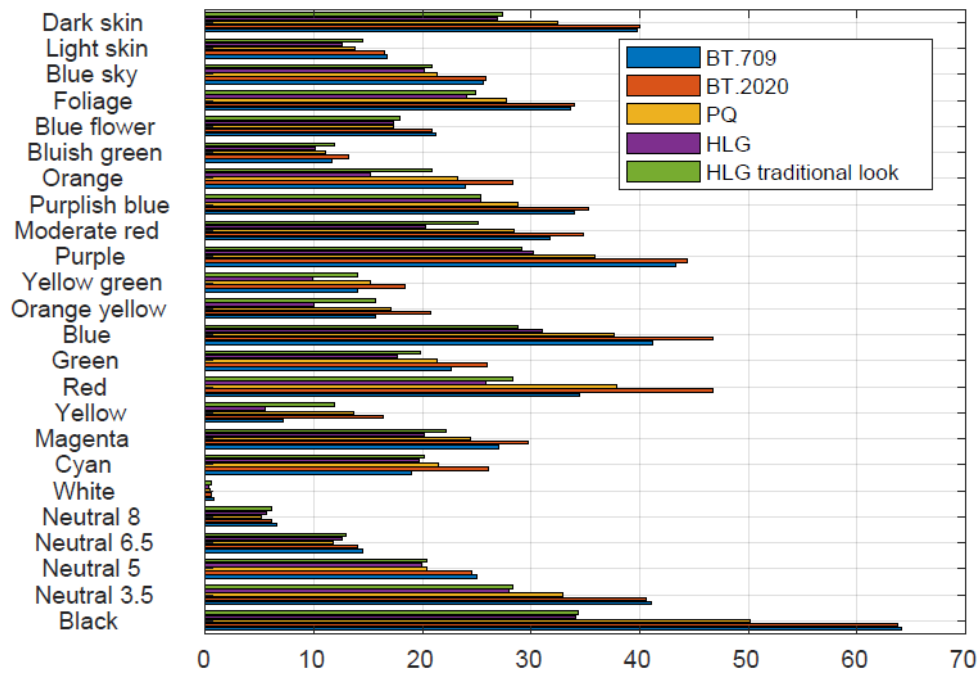

FIGURE A6-9

Display light colour swatch Delta E_{ITP} with the scaled reference colour pattern



Annex 7

Calculating the normalized primary matrix

The normalized primary matrix is needed for the conversion process to and from the CIE XYZ colour space and the BT.2100 colour space, as described in § 8.

Camera and display systems are commonly defined by their normalized primary matrix, NPM, which is specified as follows:

$$\text{NPM} = \begin{bmatrix} X_R & X_G & X_B \\ Y_R & Y_G & Y_B \\ Z_R & Z_G & Z_B \end{bmatrix}, \quad (1)$$

where the elements of the matrix depend on the chromaticity coordinates, (x_R, y_R) , (x_G, y_G) , (x_B, y_B) , and (x_w, y_w) for red, green, blue, and white, respectively, that characterize each system.

The NPM is needed for the conversion process to and from the CIE XYZ colour space and the BT.2100 colour space. Its elements could be computed as follows:

First, compute the z coordinates for all colour primaries as follows:

$$z_R = 1 - (x_R + y_R) \quad (2)$$

$$z_G = 1 - (x_G + y_G) \quad (3)$$

$$z_B = 1 - (x_B + y_B) \quad (4)$$

$$z_w = 1 - (x_w + y_w) \quad (5)$$

Then the matrix elements of NPM are derived as follows:

$$X_R = \frac{((Y_G * Z_B - Y_B * Z_G) * X_W + (X_B * Z_G - X_G * Z_B) * Y_W + (X_G * Y_B - X_B * Y_G) * Z_W) * X_R}{(X_R * (Y_G * Z_B - Y_B * Z_G) - X_G * (Y_R * Z_B - Y_B * Z_R) + X_B * (Y_R * Z_G - Y_G * Z_R)) * Y_W} \quad (6)$$

$$X_G = \frac{((Y_B * Z_R - Y_R * Z_B) * X_W + (X_R * Z_B - X_B * Z_R) * Y_W + (X_B * Y_R - X_R * Y_B) * Z_W) * X_G}{(X_R * (Y_G * Z_B - Y_B * Z_G) - X_G * (Y_R * Z_B - Y_B * Z_R) + X_B * (Y_R * Z_G - Y_G * Z_R)) * Y_W} \quad (7)$$

$$X_B = \frac{((Y_R * Z_G - Y_G * Z_R) * X_W + (X_G * Z_R - X_R * Z_G) * Y_W + (X_R * Y_G - X_G * Y_R) * Z_W) * X_B}{(X_R * (Y_G * Z_B - Y_B * Z_G) - X_G * (Y_R * Z_B - Y_B * Z_R) + X_B * (Y_R * Z_G - Y_G * Z_R)) * Y_W} \quad (8)$$

$$Y_R = \frac{((Y_G * Z_B - Y_B * Z_G) * X_W + (X_B * Z_G - X_G * Z_B) * Y_W + (X_G * Y_B - X_B * Y_G) * Z_W) * Y_R}{(X_R * (Y_G * Z_B - Y_B * Z_G) - X_G * (Y_R * Z_B - Y_B * Z_R) + X_B * (Y_R * Z_G - Y_G * Z_R)) * Y_W} \quad (9)$$

$$Y_G = \frac{((Y_B * Z_R - Y_R * Z_B) * X_W + (X_R * Z_B - X_B * Z_R) * Y_W + (X_B * Y_R - X_R * Y_B) * Z_W) * Y_G}{(X_R * (Y_G * Z_B - Y_B * Z_G) - X_G * (Y_R * Z_B - Y_B * Z_R) + X_B * (Y_R * Z_G - Y_G * Z_R)) * Y_W} \quad (10)$$

$$Y_B = \frac{((Y_R * Z_G - Y_G * Z_R) * X_W + (X_G * Z_R - X_R * Z_G) * Y_W + (X_R * Y_G - X_G * Y_R) * Z_W) * Y_B}{(X_R * (Y_G * Z_B - Y_B * Z_G) - X_G * (Y_R * Z_B - Y_B * Z_R) + X_B * (Y_R * Z_G - Y_G * Z_R)) * Y_W} \quad (11)$$

$$Z_R = \frac{((Y_G * Z_B - Y_B * Z_G) * X_W + (X_B * Z_G - X_G * Z_B) * Y_W + (X_G * Y_B - X_B * Y_G) * Z_W) * Z_R}{(X_R * (Y_G * Z_B - Y_B * Z_G) - X_G * (Y_R * Z_B - Y_B * Z_R) + X_B * (Y_R * Z_G - Y_G * Z_R)) * Y_W} \quad (12)$$

$$Z_G = \frac{((Y_B * Z_R - Y_R * Z_B) * X_W + (X_R * Z_B - X_B * Z_R) * Y_W + (X_B * Y_R - X_R * Y_B) * Z_W) * Z_G}{(X_R * (Y_G * Z_B - Y_B * Z_G) - X_G * (Y_R * Z_B - Y_B * Z_R) + X_B * (Y_R * Z_G - Y_G * Z_R)) * Y_W} \quad (13)$$

$$Z_B = \frac{((Y_R * Z_G - Y_G * Z_R) * X_W + (X_G * Z_R - X_R * Z_G) * Y_W + (X_R * Y_G - X_G * Y_R) * Z_W) * Z_B}{(X_R * (Y_G * Z_B - Y_B * Z_G) - X_G * (Y_R * Z_B - Y_B * Z_R) + X_B * (Y_R * Z_G - Y_G * Z_R)) * Y_W} \quad (14)$$

All the chromaticity values for R, G, B, and White are defined in three or four decimal digits in ITU-R texts, from which the transformation matrices or NPMs are derived. All values shown in the matrices below were calculated with high precision and then rounded to four decimal digits. It is suggested that the matrix calculations should be performed using high precision coefficient values without rounding.

A7.1 Conversion of normalized linear colour signals to Recommendation ITU-R BT.2100

In the case for conversion to the BT.2100 colour space, where the source colour space is linear, normalized within the [0:1] range, and defined by a particular NPM, conversion can be done as follows:

$$\begin{bmatrix} E_R \\ E_G \\ E_B \end{bmatrix}_{BT.2100} = \begin{bmatrix} 1.7167 & -0.3557 & -0.2534 \\ -0.6667 & 1.6165 & 0.0158 \\ 0.0176 & -0.0428 & 0.9421 \end{bmatrix} * NPM_{Source} * \begin{bmatrix} E_R \\ E_G \\ E_B \end{bmatrix}_{Source}$$

and:

$$\begin{bmatrix} E_R \\ E_G \\ E_B \end{bmatrix}_{BT.2100} = \begin{bmatrix} 1.7167 & -0.3557 & -0.2534 \\ -0.6667 & 1.6165 & 0.0158 \\ 0.0176 & -0.0428 & 0.9421 \end{bmatrix} * \begin{bmatrix} X_R & X_G & X_B \\ Y_R & Y_G & Y_B \\ Z_R & Z_G & Z_B \end{bmatrix}_{Source} * \begin{bmatrix} E_R \\ E_G \\ E_B \end{bmatrix}_{Source} \quad (15)$$

Finally, since not all colours in the source representation may be within the BT.2100 representation, an additional clipping process may be performed. The negative values may be clipped to zero. The positive values may also be clipped to the capabilities of the interface. Although both soft or hard clipping could be performed (see Report ITU-R BT.2407, in many applications hard clipping is preferred. In the scenario that hard clipping of only the negative values is performed the process would be as follows:

$$E_R = \text{Max}(0, E_R) \quad (16)$$

$$E_G = \text{Max}(0, E_G) \quad (17)$$

$$E_B = \text{Max}(0, E_B) \tag{18}$$

The above transformations could be applied in both display and scene referred workflows.

The conversion process, assuming a display referred camera workflow, as well as the final conversion to a BT.2100 representation, is shown in Fig. A7-1. For conversion to HLG, a bridge point of 1 000 cd/m² is assumed, and can therefore use the reference OOTF (see § 6.2 of Report ITU-R BT.2390).

FIGURE A7-1
Conversion of arbitrary display referred linear light signals to BT.2100 signals using a display referred workflow

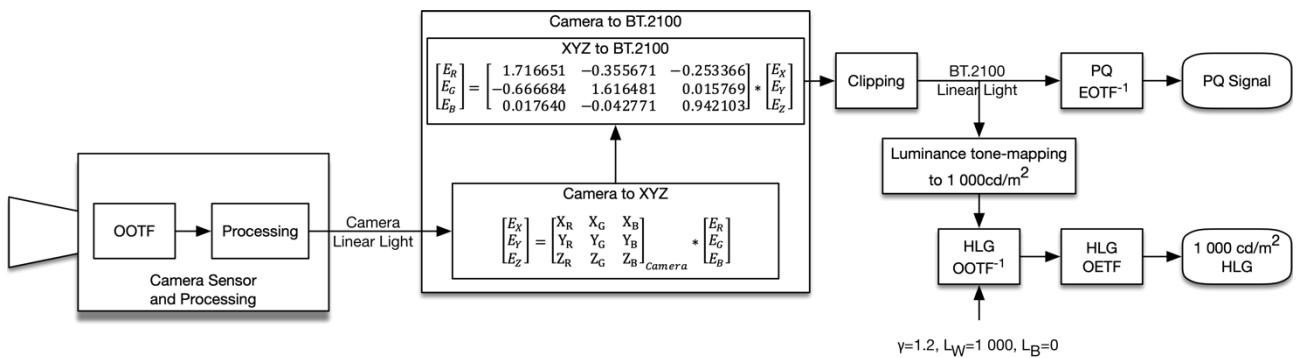

Figure A7-2 depicts the conversion process when applied on a scene referred workflow with the HLG BT.2100 signal as its output. Figure A7-3 depicts the same conversion process when applied on a scene referred workflow with the PQ BT.2100 signal as its output.

FIGURE A7-2
Conversion of arbitrary scene referred light signals to a BT.2100 HLG signal using a scene referred workflow

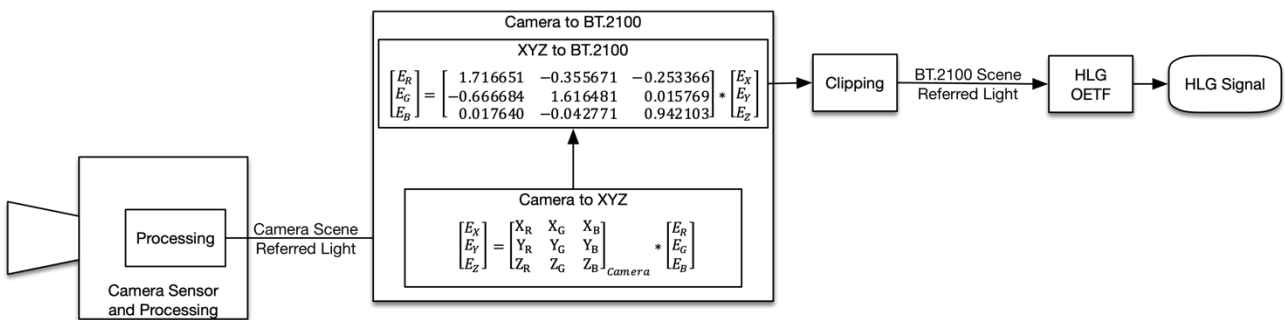
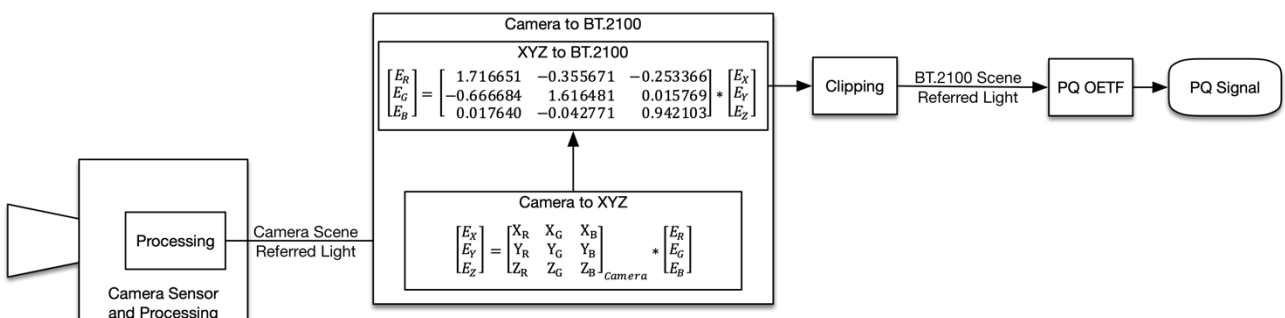

FIGURE A7-3
Conversion of arbitrary scene referred light signals to a BT.2100 PQ signal using a scene referred workflow



A7.2 Conversion of BT.2100 to arbitrary linear colour signals for display systems

Similarly, conversion from linear and normalized BT.2100 RGB primaries to the RGB primaries of an arbitrary display system can be performed as follows:

$$\begin{bmatrix} E_R \\ E_G \\ E_B \end{bmatrix}_{Display} = \text{NPM}_{Display}^{-1} * \begin{bmatrix} 0.6370 & 0.1446 & 0.1689 \\ 0.2627 & 0.6780 & 0.0593 \\ 0.0000 & 0.0281 & 1.0610 \end{bmatrix} * \begin{bmatrix} E_R \\ E_G \\ E_B \end{bmatrix}_{BT.2100}$$

and:

$$\begin{bmatrix} E_R \\ E_G \\ E_B \end{bmatrix}_{Display} = \begin{bmatrix} X_R & X_G & X_B \\ Y_R & Y_G & Y_B \\ Z_R & Z_G & Z_B \end{bmatrix}_{Display}^{-1} * \begin{bmatrix} 0.6370 & 0.1446 & 0.1689 \\ 0.2627 & 0.6780 & 0.0593 \\ 0.0000 & 0.0281 & 1.0610 \end{bmatrix} * \begin{bmatrix} E_R \\ E_G \\ E_B \end{bmatrix}_{BT.2100} \quad (19)$$

Not all colours in the original representation may be within the target representation.

The negative values may be clipped to zero. The positive values may also be clipped to the capabilities of the display. Although both soft or hard clipping could be performed, in many applications, such as when using a reference display, hard clipping is preferred. In the scenario that hard clipping of only the negative values is performed the process would be as follows:

$$E_R = \text{Max}(0, E_R) \quad (20)$$

$$E_G = \text{Max}(0, E_G) \quad (21)$$

$$E_B = \text{Max}(0, E_B) \quad (22)$$

Figure A7-4 depicts this conversion process assuming a display referred workflow for both PQ and HLG. For conversion from HLG, the nominal peak luminance of the target display (and the appropriate system gamma) is used for the HLG OOTF.

FIGURE A7-4

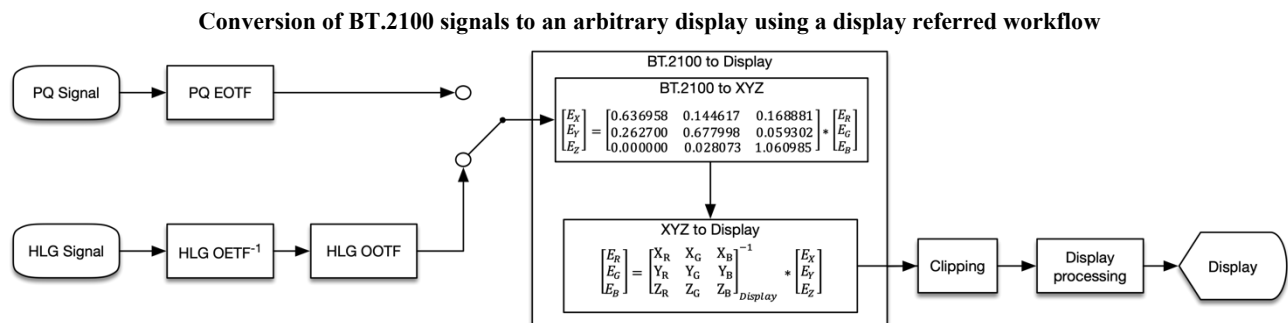

Annex 8

4K/8K UHD HDR and HD SDR simul-production and simulcast practice in China

A8.1 Background

It has become a focus of recent research as how to use UHD system to produce both UHD (Ultra High Definition) and HD (High Definition) at the same time, along with the transition from HD to UHD in media production and the broadcasting industry.

The practice of CMG⁴ UHD and HD simultaneous broadcasting (hereinafter referred to as ‘simulcasting’) began in 2018. After the launch of the first 4K channel in China, CMG attempted simulcast of certain sports events and public events. In the live broadcast of the celebration of the 70th Anniversary of the National Day in 2019, CMG carried out 4K HDR production and simulcasting on a large scale.

During the 2021 Spring Festival Gala, great experience was gained on 8K, 4K, HD simulcast. The Olympic UHD and HD Channels simulcast with the same content. To ensure this, CMG has summarized the practical experience of simulcast in recent years, released a set of relevant technical specifications, expanded relevant evaluation and research, and formed complete technical guidance for CMG simulcast.

A8.2 Basic workflows and principles

The UHD signal format of CMG is required to be 4K HLG HDR, 3840x2160/50/P or 8K HLG HDR, 7680x4320/50/P, BT.2020; and HD signal format is required to be SDR, 1920x1080/50/I, BT.709.

CMG simulcast requires 4K/8K HLG HDR production. HD specifications should be taken into consideration in the production process, and signals would be down-converted at the broadcasting end.

The production and broadcast workflow of recorded programmes is as follows:

HD SDR shading is adopted in the pre-production process, with 4K/8K HDR files recorded. For HD signals or materials, up-conversion should be completed before they are inputted into the production system.

During the post-production process, only a 4K/8K HLG HDR version will be made, with proper reference to down-conversion at fixed mapping to HD. The final programme files will be transferred into the MAMS (media assets management system) for broadcast.

The UHD channels will be broadcast directly from the MAMS. For HD channels, there are two solutions: one is to use UHD channel signals at the broadcasting end, down-converting to HD signals with fixed mapping (see Fig. A8-1); the other is to use files transcoded using dynamic down-conversion in the MAMS to broadcast (see Fig. A8-2). Dynamic down-conversion is based on global brightness equilibrium analysis.

The production and broadcast workflow of live broadcast programmes is as follows:

SDR shading is adopted in pre-production. HD signals or materials should be up-converted before entering into the production system. The finished 4K/8K HLG HDR programmes are directly used for broadcasting in UHD channels. The broadcasting signals of HD channels are down-converted from UHD channel signals at the broadcasting end (see Fig. A8-3).

⁴ CMG: China Media Group – CCTV, CNR, CRI, CGTN.

FIGURE A8-1
CMG workflow of recorded programmes (1)

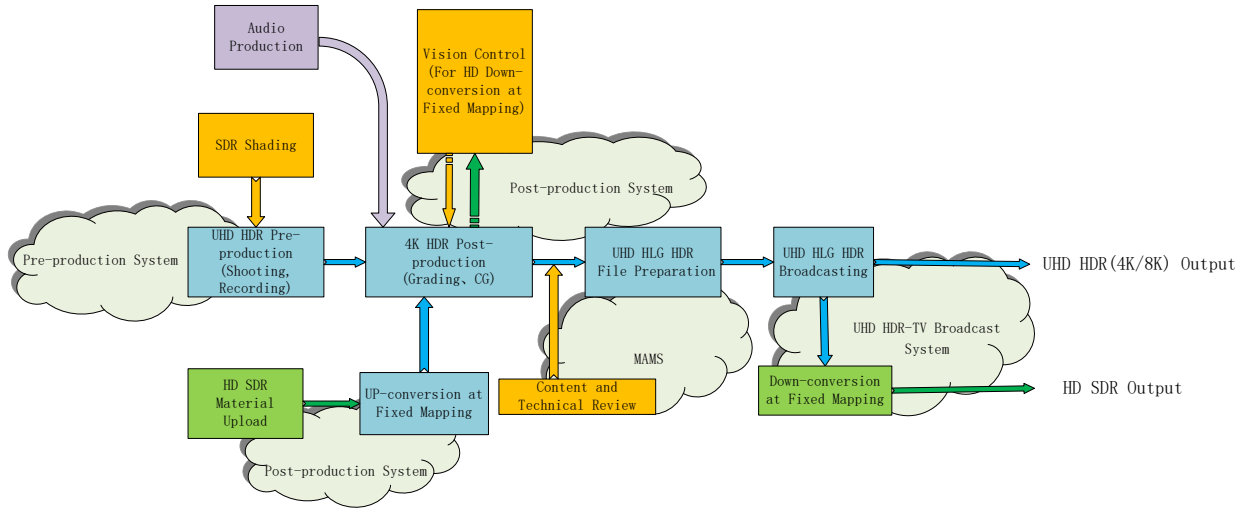

FIGURE A8-2
CMG workflow of recorded programmes (2)

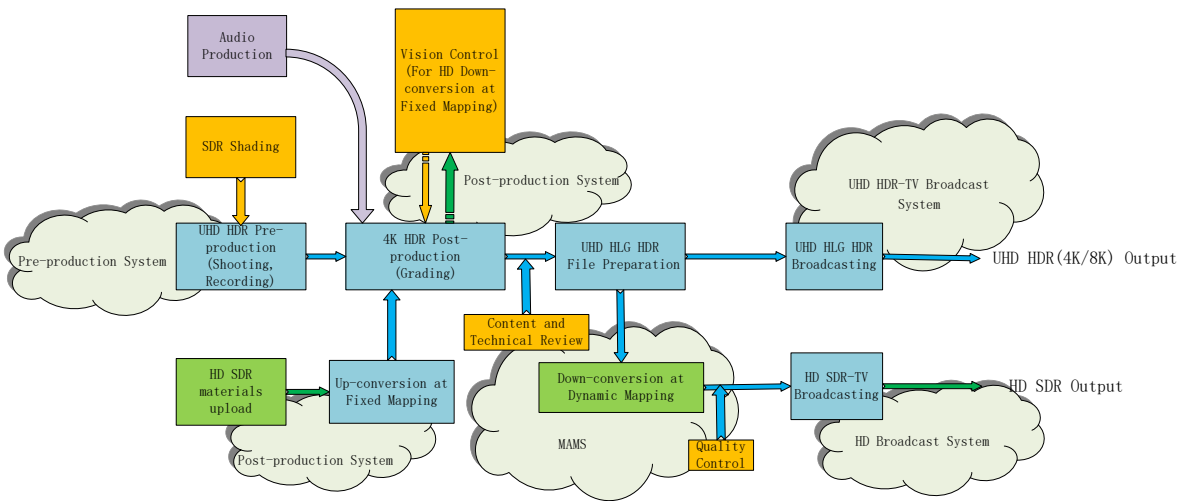
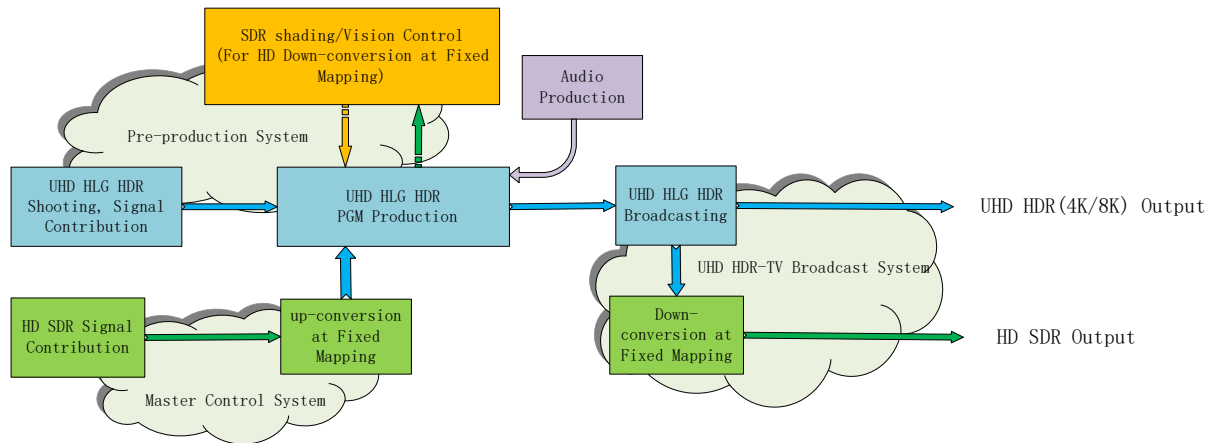

FIGURE A8-3
CMG workflow of live broadcast



Programme production is implemented based on HLG 1 000 cd/m². Considering the colour and saturation changes of images in conversion as well as comparing to actual shooting, CMG standardizes the ‘look’ of HDR images, based on which CMG then specifies the camera settings, up-converter settings and the corresponding LUTs. Furthermore, the style of down-conversion is defined with the corresponding LUTs and converter settings.

A8.3 Introduction of related work and research

The evaluation and research work is carried out around UHD and HD simulcast, mainly focusing on HDR production, workflows verification and establishment, HDR-SDR mapping and conversion, camera related research, converter related research, LUT research and testing, etc. At the same time, lighting is also included in the research.

As a result of the above works, the correctness and implementability of the technical specifications have been verified; the production method of 4K/8K HDR has been defined; the simulcast workflow has been formed; the relevant parameter settings have been specified; and the CMG simulcast system has been established. The primary research work is focused on the following aspects:

- (1) Two methods of production in 4K/8K HLG HDR system
- (2) Analysis of mapping relation between HLG and SDR conversion
- (3) Skin tone analysis
- (4) Comparison between 4K/8K cameras and HD cameras
- (5) Comparison of studio 4K/8K cameras of different manufacturers
- (6) Converter usage and comparison of different manufacturers
- (7) Influence of ‘knee’ on cameras and converters
- (8) Parameter settings of cameras and converters
- (9) CMG LUTs development and testing
- (10) Research on scene light reference (SR) and display light reference (DR) in HDR-SDR conversion
- (11) Influence of lighting characters on scene colour and skin tone
- (12) Illuminance range of scene lighting under the ultimate aperture
- (13) Ra, TLCI and SPD of commonly used studio lighting

A8.4 Mapping for conversion between HDR and SDR

In CMG's simulcast production, the mapping between HDR and SDR is 75%HLG-90%SDR. This mapping is also used in SDR shading. Tables A8.1 and A8.2 show the mapping between signal levels.

TABLE A8.1
HLG-SDR signal level mapping

HLG signal level (IRE)	HLG display luminance cd/m^2 (1 000 cd/m^2 monitor)	SDR signal level (IRE)
0	0	0
40	29.7	40
75	203	90
79	260	100
100	1000	109

Note to Table A8.1: SDR signal level is tested when the knee is OFF.

TABLE A8.2
SDR-HLG Signal level mapping

SDR signal level (IRE)	HLG signal level (IRE)	HLG display luminance cd/m^2 (1 000 cd/m^2 monitor)
0	0	0
40	40	29.7
90	75	203
100	79	260
109	82.5	324

Note to Table A8.2: SDR signal level is tested when the knee is OFF.

A8.5 Parameter settings

In order to ensure the CMG simulcast meets image requirements, settings of parameters for cameras and converters have been specified through objective tests and subjective assessments. Corresponding parameter settings are provided for cameras of different manufacturers used by CMG.

In actual shooting, cameras need to be set according to specified parameters to achieve similar image perception as far as possible (see Fig. A8-4). For SDR materials or signals to be converted, if the converter used cannot load LUTs, the specified parameters should be used for conversion. In the similar down-conversion process, 4K/8K HDR signals need to be down-converted according to the specified parameters for HD broadcast or recording. In the past two years, these parameter settings have been continuously optimized in practice.

FIGURE A8-4

Comparison of vector images taken by cameras of different manufacturers according to required parameter settings

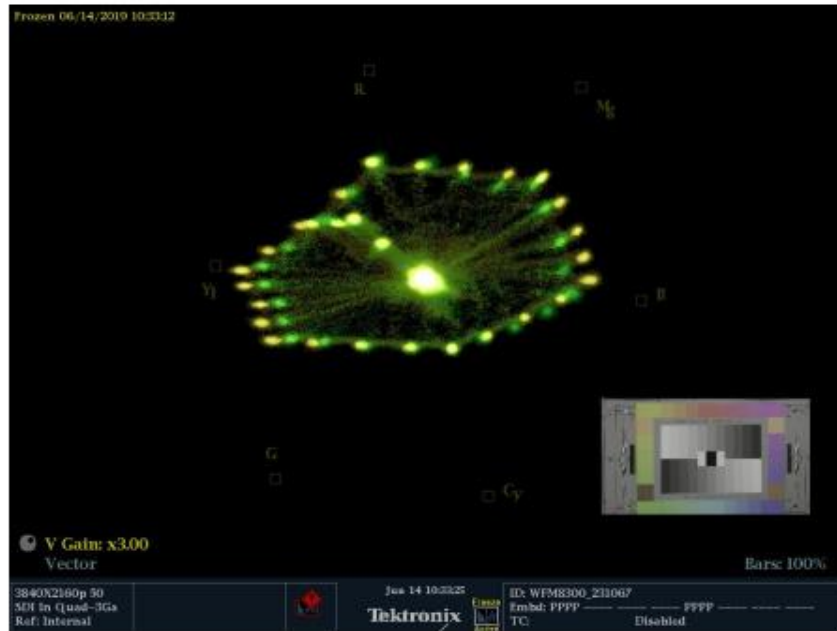

A8.6 Converter performance consistency (LUTs usage)

In the current workflow, the HDR/SDR converters play an important role. But converters of different models perform differently in terms of levels, hue, saturation, image look, etc. During the conversion process, it is impossible to exhaust the parameter settings of each model by subjectively and objectively comparing the brightness and colour consistency. It is also difficult to achieve consistency of the conversion style between different devices.

To solve this, CMG LUT sets have been developed for different converters.

LUT sets version 1 comprises 33 Cube 3D LUTs, including four sets as follows:

- HLG Scene light reference (SR) up-conversion
- HLG Scene light reference (SR) down-conversion
- HLG LIVE and HLG Native conversion
- Graphics signal conversion

LUTs are intended for LUT devices that process narrow-range video signals, but operate over the full 10-bit signal range (0 to 1 023). There are two types for each set, one offers the headroom to process super-whites, the other one is narrow-range. For SDR graphic signals, the mapping of up-conversion is 77%HLG-100%SDR, using display light reference (DR). For the rest, the mapping of up- or down-conversion of signals or materials is 75%HLG-90%SDR.

CMG LUTs mainly fit the mapping curve of the converters with fixed mapping used by CMG master control and broadcasting system, to achieve similar mapping relationship and gamut (see Figs A8-5 and A8-6). Subsequent research and development is underway for more conversion models.

FIGURE A8-5

Waveform and vector comparison between LUT and fixed parameter in down-conversion
(Yellow line is the fixed parameter Converter)

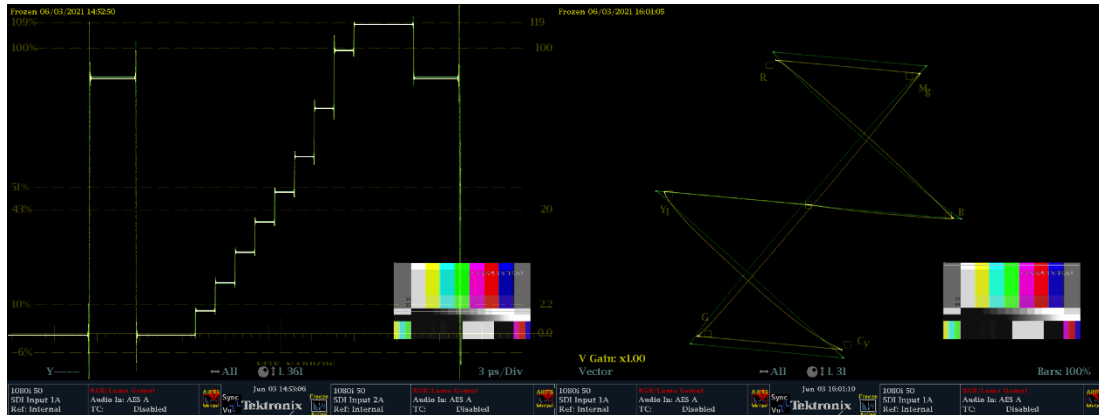
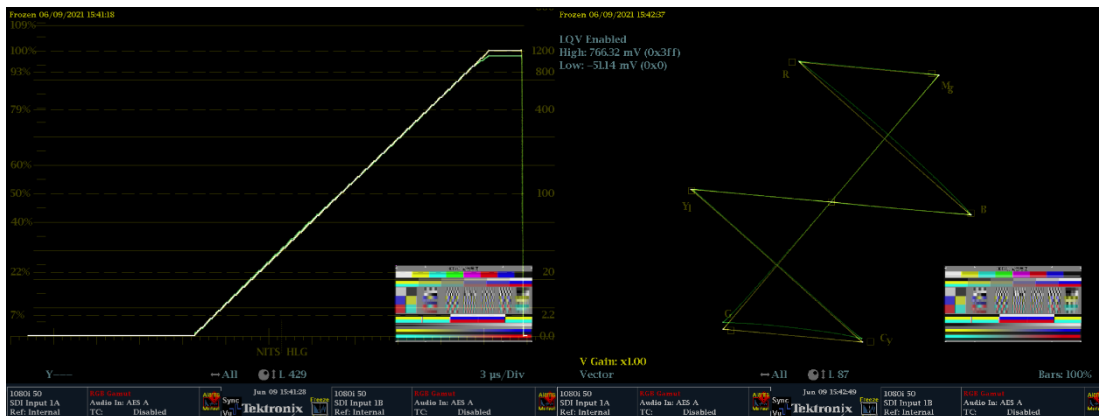

FIGURE A8-6

Waveform and vector comparison between LUT and fixed parameter in down-conversion
(Yellow line is the fixed parameter Converter)



A8.7 Signal range

Referring to § 2.4 of this Report, considering the CMG workflow and condition of devices, CMG recommends narrow range and super-white, no sub-black in the whole link. In the case of 10-bit digital coding, black level is 64, the nominal peak white level is 940, and super-white is 941-1023 (in the SDI system, super-white is 941-1019). For those devices that do not support super-white, CMG recommends clipping instead of mapping.

The use of super-white levels plays a great role in improving the dynamic range of HLG, especially on monitors and TV-sets with brightness over 1 000cd/m² for UHD HDR production and display.

A8.8 Consistency of international exchange

In the case of recorded programme, the HDR programme will usually be subject to post-production, so consistency with requirements for interchange can be assured. For live feeds, there are several methods to ensure consistency: the first is to provide 4K HDR and HD SDR signals simultaneously, so there will not be any conversions; the second is to provide 4K HDR feeds together with fixed

parameters (e.g. mapping relationship) for HDR to SDR conversion; the third is to use dynamic conversion, which is a recommended method to deal with the conversion.

A8.9 Conclusions

- 1 CMG defines the signal format, adopts HDR production for HDR/SDR simulcast and sets up the workflows for recorded programmes and live broadcast. Practice has proved that this simulcast facilitates the programme production and broadcasting efficiently, as well as guaranteeing the quality of both UHD and HD programmes.
- 2 CMG forms its own HDR image look, then defines the up- or down-conversion style, and furthermore specifies the mapping relation between HDR and SDR in simulcast.
- 3 Based on the relation between HDR and SDR in simulcast, CMG provides the parameter settings for cameras, HDR converter and corresponding LUTs.

Annex 9

HDR and SDR monitors in close proximity

Section 7 notes that two monitors with a large brightness difference used in proximity can lead to eye accommodation issues, which may impact the grading or painting of cameras.

While some broadcasters have made conscious efforts to ensure the separation of the HDR monitor being used for technical evaluation and conformance, and the operators' SDR camera shading/painting monitors, that may not always be possible. For example, in the monitor stack of a production gallery, which may comprise a mixture of SDR multiview and HDR Programme/Preview displays. So, reducing this intensity difference can be helpful.

Two different approaches are described in this Annex.

A9.1 Approach used by BBC

The BBC have found that in some situations, for example within the confined space of an outside broadcast truck, it is not practicable to achieve complete separation between the SDR and HDR monitors in the control room.

As critical monitoring is in SDR at 100 cd/m² nominal-peak luminance, to avoid camera shader operators being affected by glare from an HDR check monitor, the nominal peak luminance of the HLG HDR monitor can be lowered to reduce the disturbance, for example to 600 cd/m² (in which case HDR Reference White is displayed at 137 cd/m²) with an appropriate gamma adjustment, see § 3.2. This has the further advantage that a 1 000 cd/m² monitor adjusted this way can usually display the HLG 'super-white' signal range.

A9.2 Approach used by NBCUniversal

NBCUniversal and some other U.S. broadcasters have used an approach described in Annex 10.

Rather than decrease the nominal peak luminance of the HLG display, the nominal peak luminance of the nearby SDR display has been increased from 100 to 203 cd/m² using the latitude described in Recommendation ITU-R BT.1886 and in Report ITU-R BT.2129. In this approach, rather than targeting BT.2035 requirements, a different down-mapping LUT produces an image that is

subjectively similar to the HLG signal on a 203 cd/m² BT.1886 SDR display whilst maintaining the HDR monitor at 1 000 cd/m².

Annex 10

NBCUniversal single-master HDR-SDR workflow

During three years of production and public distribution which included the NBCUniversal production of the Tokyo and Beijing Olympics and other sports productions, NBCUniversal has shown that the combination of 1 000 cd/m² HLG display, 203 cd/m² BT.1886 SDR display and a LUT developed by Cromorama and NBCU works well together for camera shading and simultaneous production and distribution of HDR and SDR.

It has been noted that a large proportion of consumer SDR screens currently in the marketplace set to a Cinema/Movie mode often default to levels at/or close to 203 cd/m² output level. The "Hybrid-Linear" down-mapper used to create the main SDR programme linearly scales the display-light signals in a similar manner to the BT.1886 SDR EOTF. The result of the conversion can produce an excellent match between the original HDR images and the converted SDR once they are linearly rescaled on a typically higher luminance SDR consumer display configured with a BT.1886 display EOTF, and a good match on a display that uses gamma 2.2, where there will be a slight shadow and midtone stretch, see Table A10.1 below. The roundtrip (SDR->HDR->SDR) also preserves an excellent match. In both cases, original artistic intent is preserved because of optimal gain-staging of shadows, midtones and reference-white from end-to-end when viewed on most typical consumer displays.

The **NBCUniversal** workflow is identified as "CASE #2" in Table A10.1 below.

TABLE A10.1
Comparison of HDR down-mapping methods

"Single-Master" UHD HDR-SDR Monitoring						
		Case 1	Case 2	Case 3	Case 4	Case 5
			NBCUniversal workflow		Not optimal	Not recommended
A	Downmapper and SDR BT.1886 Programme Master Monitoring	HDR -> SDR "Gamma-adjusted" downmapper Optimized for 100 cd/m ² (BT.1886/BT.2035)	HDR -> SDR "Hybrid-linear" downmapper Optimized for 203 cd/m ² (BT.1886/BT.2129)	HDR -> SDR "Gamma-adjusted" downmapper Optimized for 100 cd/m ² (BT.1886/BT.2035)	HDR -> SDR "Hybrid-linear" downmapper Optimized for 203 cd/m ² (BT.1886/BT.2129)	HDR -> SDR "Hybrid-linear" downmapper Optimized for 100 cd/m ² (BT.1886/BT.2129)
B	SDR transmission downmapper	HDR -> SDR "Gamma-adjusted" downmapper Optimized for 100 cd/m ² (BT.1886/BT.2035)	HDR -> SDR "Hybrid-linear" downmapper Optimized for 203 cd/m ² (BT.1886/BT.2129)	HDR -> SDR "Hybrid-linear" downmapper Optimized for 203 cd/m ² (BT.1886/BT.2129)	HDR -> SDR "Gamma-adjusted" downmapper Optimized for 100 cd/m ² (BT.1886/BT.2035)	HDR -> SDR "Gamma-adjusted" downmapper Optimized for 100 cd/m ² (BT.1886/BT.2035)
C	SDR transmission BT.1886 display 203 cd/m ²	Slightly brighter ⁽¹⁾	Very good match ⁽³⁾	Good match ⁽⁴⁾	Slightly brighter ⁽¹⁾	Too bright ⁽²⁾
D	HDR Transmission Look	As intended	As intended	As intended ⁽⁴⁾	As intended	Slightly brighter HDR ⁽²⁾

* Columns in GRAY indicate a tone-mapping/display mismatch which may not be recommended or ideal.

- (1) A luminance difference between production display and consumer delivery can cause slightly brighter SDR shadows and midtones when viewed at more typical SDR display luminance levels. The shadow/midtone stretch in the "gamma-adjusted" tone mapper is optimized for 100 cd/m² BT.2035 viewing.
- (2) This specific tone-mapping/display luminance mismatch between Program and Transmission can cause SDR which is too bright. The "Hybrid-Linear" Tone-mapper is optimized for a 203 cd/m² SDR shading display. The "Gamma-Adjusted" tone-mapper will create slightly brighter SDR. Combining both tone-mappers and mismatched shading display luminance settings can cause SDR which is too bright.
- (3) HDR-to-SDR Conversion: When SDR BT.1886 displays are set to more typical luminance levels closer to 203 cd/m², HDR and SDR levels from black to reference white will match the original HDR content (minus highlights that are compressed into the knee above reference white). There will be a slight level reduction above reference white down-mapped from HDR in order to preserve compressed HDR highlights in the converted SDR.
- (4) The "gamma adjusted" tone-mapper attempts to compensate for darker 100 cd/m² SDR displays so that if it is used as the primary shading display, the resulting HDR should look the same as if a 203 cd/m² SDR shading display was used with the "Hybrid Linear" tone-mapper. There are subtle differences between the two tone-mapping methods in the highlight knee and color space remapping (BT.2020-to-BT.709) that will therefore produce slightly different results.

HDR highlight preservation in converted SDR for both tone-mapping methods

There will be a slight level reduction above reference white down-mapped from HDR in order to preserve compressed HDR highlights in the converted SDR.

FIGURE A10-1

Signal Flow – MovieLabs 2x Linear Scaling with complementary “Hybrid-Linear” down-mapper

Gain-Staging is ideal and preserves shadows-midtones,reference white from HDR into final SDR delivery and in roundtrip

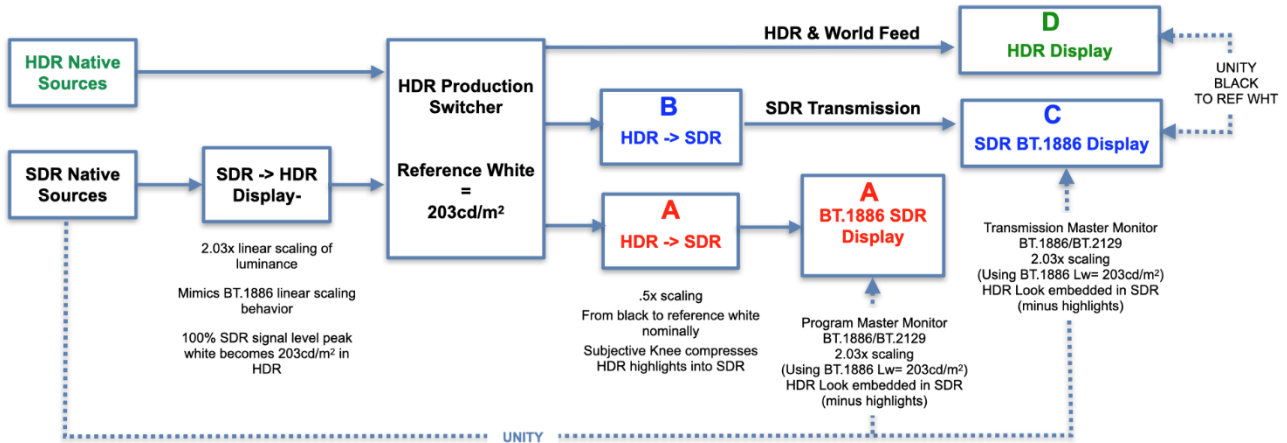

Grading an HDR distributed signal for downstream conversion optimized for 203 cd/m² SDR viewing, produces slightly darker midtones when viewed on a 100 cd/m² display based on BT.2035 recommendations but does preserve the artistic intent from the original HDR images.

A method of converting between the 203 cd/m² SDR optimized content and 100 cd/m² BT.2035 content for programme exchange is described in Annex 11. This conversion method can be used via prior agreement once the tone mapping methods and the responsibility for the conversion of HDR to SDR are discussed with the content creators.

For technical details and the free publicly available LUTs in the *NBCUniversal “Single-Master” UHD-HDR-SDR Workflow*, see reference [17].

FIGURE A10-2

HDR production (BT.1886/BT.2129 SDR 203 cd/m²) with SDR derived by “Hybrid-Linear” down-mapping

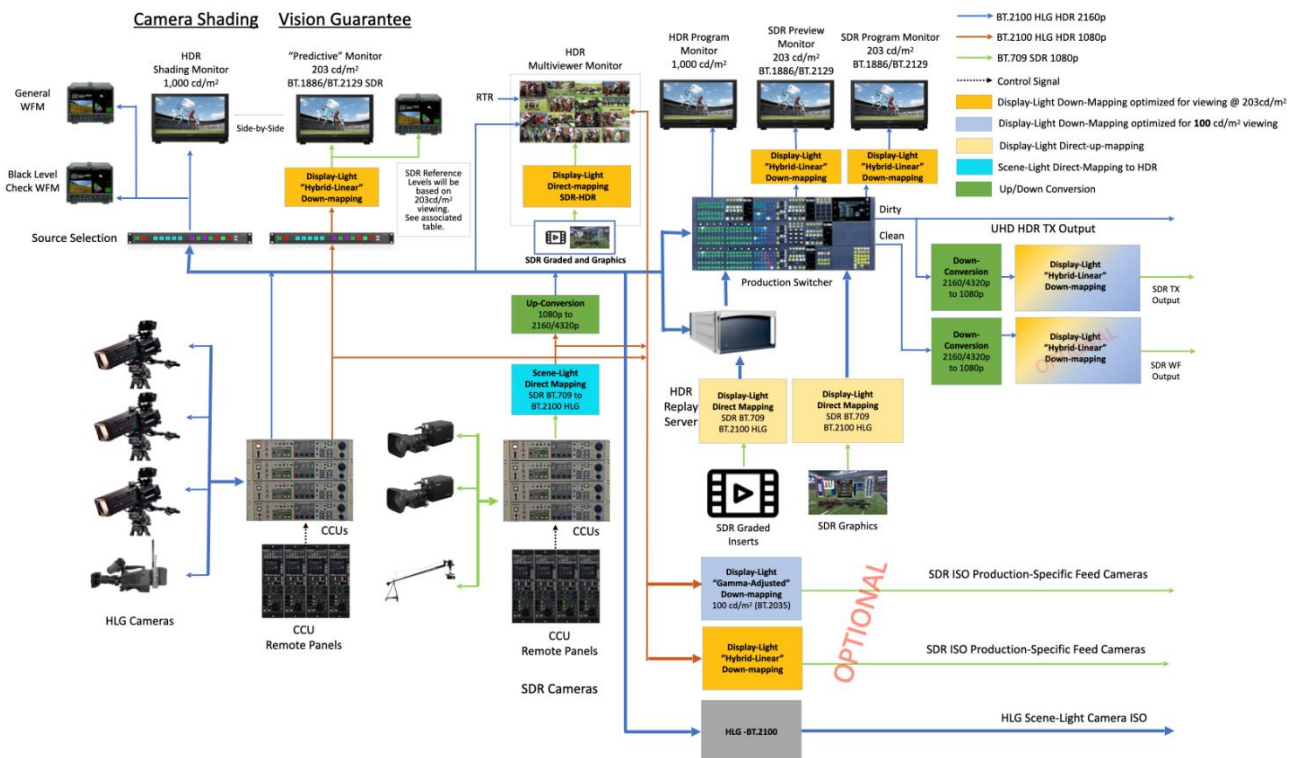

In Fig. A10-2, HDR and 203 cd/m² SDR displays can be placed side-by-side. Both the “Hybrid-Linear” scaling method and the “gamma-adjusted” method can be used for the down-mapping in TX(Transmission). “Hybrid-Linear” content will be optimized for 203 cd/m² SDR viewing (CASE #2) and “Gamma-Adjusted down mapping will be optimized for 100 cd/m² SDR viewing (CASE #5). Please examine Table A to understand the perceptual effects in each use case.

- The HDR-to-SDR “Hybrid-Linear” down-mapping LUT can be used as a “predictive LUT” to preview the transmission rendering that matches the HDR very closely with the converted SDR when viewed on a more typical higher luminance BT.1886 SDR consumer displays set at 203 cd/m² (minus highlights and some shadow detail).
- For the purposes of simplicity, both methods do not describe the complexities of the colour mapping or highlight compression (from HDR to SDR) which are based on subjective choices but can have a large impact on the preservation of detail when reducing the dynamic range from HDR to SDR.

The ‘display-referred’ method of mapping SDR content into a Hybrid Log-Gamma (HLG) container, without an OOTF adjustment, is the preferred workflow when SDR material is converted using tone mapping optimized for 203 cd/m² viewing. This method ensures minimal round-trip losses when combined with the down-mapper that matches the MovieLabs Linear up-mapping method (2.03× scaling factor).

A “Hybrid-Linear” down-mapping (~0.5 scaling factor from black to reference white) will preserve the lowlights, midtones and HDR Reference White from the HDR to SDR conversion if the nominal peak luminance of a more typical SDR consumer display luminance is used. That is because the linear scaling down to 100 cd/m² is complemented by a linear scaling in consumer displays to more typical luminance levels. This usage is described in BT.1886/BT.2129 where a latitude of 100-250 cd/m² for programme master monitoring is described.

The “Hybrid-Linear” down-mapper is an inverse of the MovieLabs direct-mapper (reversing the 2.03× linear scaling from SDR to HDR). It can be used as a “predictive” for the look of the SDR transmission on a consumer TV when it is set at 203 cd/m². For this to be optimal, SDR displays should be switched to BT.1886 and set at a peak white luminance level of 203 cd/m² which is very close to the luminance of many TVs in their default Cinema/Movie modes.

Some broadcasters are using the “Hybrid-Linear” down-mapping LUT with primary SDR shading displays set at 100 cd/m² where the SDR displays and their vision supervisors are separated from the HDR displays to avoid eye adaption issues. In that instance, the subjective appearance of the shadows and midtones between HDR and SDR will not match even after adaption.

A table is provided with suggested outcomes using five use-cases. Table A10.1 illustrates the effect of using different down-mapping methods in production and onward distribution.

Annex 11

Conversion between 203 cd/m² and 100 cd/m² (BT.2035) SDR signal formats

Where SDR signals have been derived from an HDR production using the “203 cd/m² single-stream HDR-SDR workflow” described in Annex 10, it may be desirable to convert them to the 100 cd/m² SDR signal format for programme exchange.

A similar method to that described in § 5.1.3.2 for direct-mapping of SDR into an HDR container can be used. But in this case, the intended displayed peak luminance is halved rather than doubled, and both input and output signals are SDR. The process is illustrated in Fig. A11-1.

FIGURE A11-1
Conversion of 203 cd/m² SDR signals to 100 cd/m² SDR signals

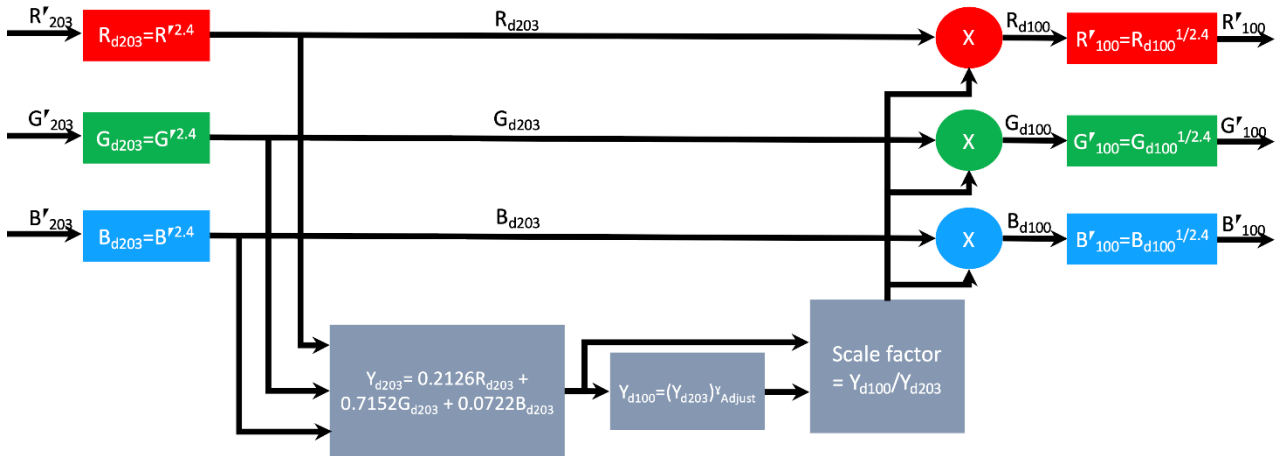

The nonlinear SDR $R'G'B'$ signal from the 203 cd/m² SDR production is first converted to a normalised linear display light using a simple power law approximation to the BT.1886 EOTF. The resulting RGB signals were intended to be displayed at a nominal peak luminance of 203 cd/m², denoted by the “d203” subscript, thus:

$$R_{d203} = R'^{2.4}$$

$$G_{d203} = G'^{2.4}$$

$$B_{d203} = B'^{2.4}$$

The normalised linear luminance signal is calculated, in this case using the BT.709 R, G, B weighting factors:

$$Y_{d203} = 0.2126 R_{d203} + 0.7152 G_{d203} + 0.0722 B_{d203}$$

The BT.2020 weighting factors are used for a BT.2020 SDR input. An appropriate signal luminance for display at a nominal peak luminance of 100 cd/m², Y_{100} , is then calculated. The 100 cd/m² luminance signal is derived by first removing the OOTF (rendering intent) for a 203 cd/m² display, to yield the scene-light signal Y_S , and then applying an appropriate OOTF (rendering intent) to Y_S for a 100 cd/m² display. In a similar manner to the SDR to HDR direct-mapping described in § 5.1.3.2 the ratio of the rendering intents (OOTF gammas) may be determined by using the BT.2100 Note 5f (or Footnote 2) HDR gamma formula, to calculate the equivalent ratio of system gammas for HDR Reference White of the nominal 203 cd/m² and 100 cd/m².

To obtain the 100 cd/m² normalised RGB signals, a scale factor based on the ratio of the Y_{d100}/Y_{d203} is applied to the linear R_{d203} , G_{d203} , B_{d203} linear light signals, which is mathematically equivalent to preserving the chromaticity of the input signal but adjusting its luminance to match Y_{d100} . The compensated non-linear R'_{100} G'_{100} B'_{100} signals for feeding a 100 cd/m² display are then obtained by applying the inverse of the approximation of the BT.1886 EOTF.

References

- [1] Fitzpatrick, T.B. (1988), “The validity and practicality of sun reactive skin types I through VI”. Arch Dermatol 124(6), pp. 869-871.
- [2] K.C. Noland, M. Pindoria and A. Cotton, “Modelling brightness perception for high dynamic range television”, *Ninth International Conference on Quality of Multimedia Experience (QoMEX)*, Erfurt, 2017.
- [3] K.C. Noland and M. Pindoria, “A Brightness Measure for High Dynamic Range Television”, IBC Conference, September 2017.
- [4] MovieLabs, “MovieLabs Best Practices for Mapping BT.709 Content to HDR10 for Consumer Distribution v1.0”, <https://movielabs.com/download/938/>.
- [5] EBU Recommendation R103 version 3.0, “Video Signal Tolerance in Digital Television Systems”, May 2020 (<https://tech.ebu.ch/docs/r/r103.pdf>).
- [6] Cooksey, C., Allen, D.W., et.al., “Reference Data Set of Human Skin Reflectance”, NIST Journal of Research, NIST, USA, Jun 2017.
- [7] Jablonski N.G., Chaplin, G., “*The evolution of human skin coloration*”, Journal of Human Evolution, Vol. 39, 2000.
- [8] ISO/CIE 11664-5:2016(en), “*Colorimetry – Part 2: CIE Standard Illuminants*”, International Organisation for Standardisation, Geneva 2016.
- [9] Colour and Vision Research Laboratory, University College London, <http://cvrl.ioo.ucl.ac.uk/>.
- [10] DCraw <https://www.cybercom.net/~dcoffin/dcraw/>.
- [11] Australian Radiation Protection and Nuclear Safety Agency, “*Fitzpatrick Skin Type*”, questionnaire to determine Fitzpatrick Skin Type <https://www.arpana.gov.au/sites/g/files/net3086/f/legacy/pubs/RadiationProtection/FitzpatrickSkinType.pdf>.
- [12] Burk, A., Smith, M., Zink, M., “Color Volume and Hue-Preservation in HDR Tone Mapping”, SMPTE Motion Imaging Journal. May 2020.
- [13] SMPTE ST 303:2002, “Color reference pattern”.
- [14] ISO/CIE 11664-5:2016, “Colorimetry — Part 5: CIE 1976 L*u*v* colour space and u', v' uniform chromaticity scale diagram”.
- [15] Elena A. Fedorovskaya and Huib de Ridder "Subjective matters: from image quality to image psychology", Proc. SPIE 8651, Human Vision and Electronic Imaging XVIII, 86510O (23 March 2013); <https://doi.org/10.1117/12.2008681>
- [16] ISO/CIE 11664-6:2014, “Colorimetry — Part 6: CIEDE2000 Colour-difference formula”.

Glossary

Following is a list of terms within Report ITU-R BT.2408 which may not have been encountered by the reader in the context of High Dynamic Range.

Camera painting – The process of adjusting the image within the camera, to balance the colours and tones to create the desired aesthetic.

Camera RAW signals – image data produced by, or internal to, a digital camera that has not been processed, except for A/D conversion and the following optional steps: linearization, dark current/frame subtraction, shading and sensitivity (flat field) correction, flare removal, white balancing (e.g. so the adopted white produces equal RGB values or no chrominance), missing colour pixel reconstruction (without colour transformations).

Camera shading – a chain of operational adjustments required to match cameras in live (or as-live) production to give and maintain the desired look, which includes selection of production format and appropriate camera present, adjustment of black level, iris/exposure and painting controls, colour balance and real-time signal level adjustment. The camera painting process may be included in this chain.

Colour branding – the intentionally applied look of graphics added to a programme designed to create or maintain a consistent and familiar appearance.

Colour correction – The process of adjusting a series of clips in post-production, so that they have a consistent appearance aligned with the production.

Colour grading – The process of further adjusting the image in post-production, to balance the colours and tones to create the desired aesthetic. Colour grading is usually performed after colour correction.

Display light – image values that result from applying the reference EOTF to the encoded image signal values.

Display-light conversion – conversion of image data performed by converting the image data to display light using the reference EOTF of the first encoding, and then applying the reference inverse EOTF for the second encoding, typically used for preserving the appearance of graded content.

Gregory hole reference – an object used as reference black with 0% reflectance, typically a box lined with black material designed to absorb light and prevent reflections of light which is viewed through a small opening.

HDR reference white – the nominal signal level obtained from an HDR camera and a 100% reflectance white card resulting in a nominal luminance of 203 cd/m² on a PQ display or on an HLG display that has a nominal peak luminance capability of 1 000 cd/m².

Lambertian reflector – a reflecting surface which reflects incident light in all directions, giving the same apparent brightness regardless of the angle of view of an observer.

Luma – a term specifying that a signal represents the monochrome information related to non-linear colour signals. The symbol for luma information is denoted as Y' .

NOTE – The term luma is used rather than the term luminance in order to signify the use of *non-linear* light transfer characteristics as opposed to the linear characteristics in the term luminance. However, in many of the ITU-R Recommendations on television systems, the term “luminance signal” is used rather than “luma” for Y' together with C'_B and C'_R .

Luminance – the photometrically weighted flow of light per unit area travelling in a given direction. It describes the amount of light that passes through, is emitted from, or is reflected from a particular area, and falls within a given solid angle. It is expressed in candelas per square meter (cd/m²).

NOTE – The relative luminance of a pixel can be approximated by a weighted sum of the *linear* colour components; the weights depend on the colour primaries and the white point.

Scene light – image values that result from applying the inverse reference OETF to the encoded image signal values.

Scene-light conversion – conversion of image data performed by converting the image data back to scene light using the inverse of the first encoding reference OETF, and then applying the reference OETF for the second encoding, typically used for matching cameras.

NOTE – The image data can be from a graded source (for example, from a camera that has been adjusted to give a particular desired appearance on a reference monitor), but scene light conversions might not preserve the colour appearance produced on the reference monitor.

Overshoots – signal excursions above nominal peak level.

Sub-blacks – in a narrow range signal, a video signal of lower than 0% black level extending down to approximately 6.8% below black level. In the case of 10-bit digital coding this range lies below value 64 (black level) extending down to value 4, while in 12-bit digital coding this range lies below value 256 extending down to value 17.

Super-white – in a narrow range signal, a video signal of greater than 100% nominal peak level extending up to 109% of nominal peak level. In the case of 10-bit digital coding this range lies above value 940 (nominal peak) extending to value 1 019, while in 12-bit digital coding this range lies above value 3 760 extending to value 4 079.

Undershoots – signal excursions below black level.
