

International Telecommunication Union

ITU-R
Radiocommunication Sector of ITU

Report ITU-R BT.2343-6
(10/2020)

**Collection of field trials of UHDTV
over DTT networks**

BT Series
Broadcasting service
(television)



International
Telecommunication
Union

Foreword

The role of the Radiocommunication Sector is to ensure the rational, equitable, efficient and economical use of the radio-frequency spectrum by all radiocommunication services, including satellite services, and carry out studies without limit of frequency range on the basis of which Recommendations are adopted.

The regulatory and policy functions of the Radiocommunication Sector are performed by World and Regional Radiocommunication Conferences and Radiocommunication Assemblies supported by Study Groups.

Policy on Intellectual Property Right (IPR)

ITU-R policy on IPR is described in the Common Patent Policy for ITU-T/ITU-R/ISO/IEC referenced in Resolution ITU-R 1. Forms to be used for the submission of patent statements and licensing declarations by patent holders are available from <http://www.itu.int/ITU-R/go/patents/en> where the Guidelines for Implementation of the Common Patent Policy for ITU-T/ITU-R/ISO/IEC and the ITU-R patent information database can also be found.

Series of ITU-R Reports

(Also available online at <http://www.itu.int/publ/R-REP/en>)

Series	Title
BO	Satellite delivery
BR	Recording for production, archival and play-out; film for television
BS	Broadcasting service (sound)
BT	Broadcasting service (television)
F	Fixed service
M	Mobile, radiodetermination, amateur and related satellite services
P	Radiowave propagation
RA	Radio astronomy
RS	Remote sensing systems
S	Fixed-satellite service
SA	Space applications and meteorology
SF	Frequency sharing and coordination between fixed-satellite and fixed service systems
SM	Spectrum management

Note: This ITU-R Report was approved in English by the Study Group under the procedure detailed in Resolution ITU-R 1.

Electronic Publication
Geneva, 2020

© ITU 2020

All rights reserved. No part of this publication may be reproduced, by any means whatsoever, without written permission of ITU.

REPORT ITU-R BT.2343-6

Collection of field trials of UHD TV over DTT networks

(2015-02/2016-10/2016-2018-04/2019-09/2019-2020)

TABLE OF CONTENTS

	<i>Page</i>
1 Introduction	3
2 Status of standardization of UHD TV	3
2.1 Standardization within ITU	3
2.2 Standardization within DVB.....	3
2.3 Standardization within TTA	3
3 Field Status of standardization of UHD TV	4
Annex – Field Experiments of UHD TV Terrestrial Transmission	10
1 Japan.....	10
1.1 Introduction.....	10
1.2 8K-UHD TV field experiments in rural area; Hitoyoshi (2 × 2 MIMO transmission system).....	10
1.3 8K-UHD TV SFN field experiments in rural area; Hitoyoshi (2 × 2 MIMO STC-SFN transmission system).....	17
1.4 8K-UHD TV field experiments with non-uniform constellation in urban area; Kinuta, Tokyo (2 × 2 MIMO transmission system)	23
1.5 4K/8K-UHD TV field experiments with advanced system in urban area; Tokyo and Nagoya.....	26
1.6 Summary	35
2 Republic of Korea.....	35
2.1 UHD TV terrestrial trial broadcasting based on DVB-T2.....	35
2.2 UHD TV terrestrial trial broadcasting based on ATSC 3.0.....	42
3 France	43
3.1 Initial experiment (2014-2018).....	43
3.2 Revised experiment (Started 2018)	48
4 Spain.....	52
4.1 UHD TV trial from Museo del Prado (Madrid) – 2014.....	52

	<i>Page</i>
4.2 Trials by the Chair of RTVE in UPM during the 2016-2019 period.....	53
5 Sweden	60
6 United Kingdom	60
7 Brazil	61
7.1 Introduction.....	61
7.2 Diagram of the PV	61
7.3 Transmission and reception station equipment.....	61
7.4 Transmission parameters	63
7.5 Field tests in Rio de Janeiro.....	65
7.6 Measurements	65
7.7 Demonstration.....	66
7.8 Conclusion	67
8 China.....	67
8.1 Introduction.....	67
8.2 Diagram of the trial.....	67
8.3 Transmission and reception station equipment.....	68
8.4 Transmission parameters	69
8.5 Field tests in Jiaying	70
8.6 Measurements	70
8.7 Conclusion	75

1 Introduction

Ultra high definition television (UHDTV) is one of the major applications of next-generation digital terrestrial broadcasting. Several countries have already started studies on digital terrestrial broadcasting transmission systems that have significantly expanded their transmission capacities by means of, for example, high multilevel modulation technology. Moreover, some countries have already carried out UHDTV field experiments on digital terrestrial broadcasting to demonstrate the feasibility of these systems. The compilation of a summary of these experiments will offer useful information to administrations and broadcasters wishing to introduce or consider UHDTV broadcasting in the future, as well as to manufacturers wishing to engage with this.

UHDTV production of big live events has already started, notably the 2014 FIFA World Cup in Brazil where three games hosted in the Epic Maracana Stadium were officially produced and distributed worldwide in 4k UHDTV. The EBU, by means of its operational branch (EUROVISION), ensured the worldwide delivery of the three games over its satellite and fibre network.

In Japan, 8K UHDTV field transmission experiments with 4096-QAM and dual-polarized multiple input multiple output (MIMO) technology were conducted in January 2014.

In the Annex, the Report presents an overview of the experiments, key technologies, and the results conducted in various countries.

The intent of this Report is to provide evidence about the suitability of terrestrial television networks to deliver UHDTV services to consumers on a large scale.

2 Status of standardization of UHDTV

2.1 Standardization within ITU

The standardization of parameters for Ultra High Definition is underway at ITU-R and different Recommendations and Reports have been published, for example:

- Recommendation ITU-R BT.2020-2 (10/2015) – Parameter values for ultra-high definition television systems for production and international programme exchange.
- Recommendation ITU-R BS.2051-2 (07/2018) – Advanced sound system for programme production.
- Report ITU-R BT.2246-6 (03/2017) – The present state of ultra-high definition television.

Other standardization activities on UHDTV are ongoing in ITU-R and ITU-T.

2.2 Standardization within DVB

The standardization process is also well underway at the DVB level, with the Standard TS 101 154 V2.5.1 published (01/2019) as DVB Blue Book A001 (7/2019) Specification for the use of Video and Audio Coding in Broadcasting and Broadband Applications.

2.3 Standardization within TTA

On August 30, 2013, the scenarios for 4K-UHDTV service were described in the Report “TTAR-07.0011: A Study on the UHDTV Service Scenarios and its Considerations”.

On May 22, 2014, the technical report “TTAR-07.0013: Terrestrial 4K UHDTV Broadcasting Service” was published.

On October 13, 2014, an interim standard – “TTAI.KO-07.0123: Transmission and Reception for Terrestrial UHDTV Broadcasting Service” – was published based on HEVC encoding, with MPEG-2 TS, and DVB-T2 serving as the standards.

On June 24, 2016, a standard – “TTAK.KO-07.0127: Transmission and Reception for Terrestrial UHDTV Broadcasting Service” – was published based on HEVC encoding, with MMTP/ROUTE IP, and ATSC 3.0 serving as the standards.

3 Field Status of standardization of UHDTV

The Annex shows details of trials conducted for UHDTV over terrestrial television networks.

The following Table summarizes the trials and indexes the Annex.

Summary of UHDTV trials on terrestrial television networks

Annex section	Country	Transmitter site	Covering	e.r.p.	DTT System	Channel bandwidth	Transmission mode	Multiplex capacity	Signal bit rate	Video encoding standard	Picture standard	Audio encoding standard	Frequency used
1.2	Japan	Hitoyoshi	City of Hitoyoshi	140W(H) 135W(V)	ISDB-T ²	6 MHz	32k <i>GI</i> = 1/32 4096-QAM, FEC 3/4 dual-polarized MIMO	91.8 Mb/s	91 Mb/s	MPEG-4 AVC/H.264,	7 680×4 320p 59.94 frame/s 8 bits/pixel	MPEG-4 AAC-LC Max. 22.2ch, Max. 1.8 Mb/s	671 MHz (Ch 46 in Japan)
1.3		Hitoyoshi Mizukami	City of Hitoyoshi	Hitoyoshi 140W(H) 135W(V) Mizukami 25W(H) 25W(V)			Space Time Coding-SFN 32k <i>GI</i> = 1/32 4096-QAM, FEC 3/4 dual-polarized MIMO	91.8 Mb/s	91 Mb/s (other bit rates also tested)	HEVC	7 680×4 320p 59.94 frame/s 10 bits/pixel		
1.4		Kinuta Tokyo	Southern area of Tokyo	93W(H) 93W(V)			16k <i>GI</i> = 1/16 4096 NUC, FEC 3/4 dual-polarized MIMO	84.2 Mb/s	76 Mb/s	MPEG-4 AVC/H.264	7 680×4 320p 59.94 frame/s 8 bits/pixel		
1.5		Shiba	Central Tokyo	2.1 kW(H) 2.1 kW(V)		6 MHz	16k <i>GI</i> = 800/16384 1024 NUC FEC 11/16 SISO and dual-polarized MIMO	32.9~65.8 Mb/s	28~56 Mb/s (+ additional 1~2 Mb/s for HDTV)	HEVC	7 680×4 320p 59.94 frame/s 10 bits/pixel	MPEG-H 3D Audio LC level 4 Max. 22.2ch + 3 objects 768 kb/s (512 kb/s to 1.4 Mb/s)	563 MHz (Ch 28 in Japan)
		Higashiyama Nabeta	City of Nagoya	Higashiyama 980 W(H) 980 W(V) Nabeta 81 W(H) 81 W(V)			605 MHz (Ch 35 in Japan)						

² Some parameters are extended from conventional ISDB-T system (System C of Recommendation ITU-R BT.1306).

Summary of UHDTV trials on terrestrial television networks

Annex section	Country	Transmitter site	Covering	e.r.p.	DTT System	Channel bandwidth	Transmission mode	Multiplex capacity	Signal bit rate	Video encoding standard	Picture standard	Audio encoding standard	Frequency used
2.1	Korea (Republic of) ³	Kwan-Ak Mountain	South Metropolitan area of Seoul	36.7 kW	DVB-T2	6 MHz	32k, extended mode, $GI = 1/16$, PP4, 256-QAM, FEC 3/4, 4/5, 5/6	< 35.0 Mb/s	Variable (some trials at 25~34 Mb/s)	HEVC Main10 Level 5.1, Max 28 Mb/s	3 840×2 160p 60 frames/s, 8 bits or 10 bits/pixel	MPEG-4 AAC-LC or Dolby AC-3, Max 5.1Ch, Max 600 kb/s	713 MHz (Ch 54 in Korea)
				12.9 kW									701 MHz (Ch 52 in Korea)
				40.0 kW									707 MHz (Ch 53 in Korea)
		Nam Mountain	Central area of Seoul	2.2 kW									713 MHz (Ch 54 in Korea)
		Yong-Moon Mountain	West Metropolitan area of Seoul	8.3 kW									707 MHz (Ch 53 in Korea)
2.2	Korea (Republic of)	Kwan-Ak Mountain	South Metropolitan area of Seoul	39.6 kW	ATSC 3.0	6 MHz	32k, NoC = 0, $GI6_1536$, PP16_2, 256-QAM, 9/15	< 30.0 Mb/s	Variable (17 Mb/s)	HEVC Main10 Level 5.1, Variable (15.5 Mb/s)	3 840×2 160p 60 frames/s, 10 bits/pixel	MPEG-H 3D Audio Max 10.2Ch,	701 MHz (Ch 52 in Korea)
													707 MHz (Ch 53 in Korea)
													762 MHz (Ch 55 in Korea)
		Nam Mountain	Central area of Seoul	18.9 kW									768 MHz (Ch 56 in Korea)
		Gwang-Gyo Mountain	Suwon (Capital city of Gyeonggi province)	7.96 kW									

³ Details for Korea in Table 1 correspond to Phase 3 of the trials. See § 2.1 for more details of Phases 1 and 2.

Summary of UHDTV trials on terrestrial television networks

Annex section	Country	Transmitter site	Covering	e.r.p.	DTT System	Channel bandwidth	Transmission mode	Multiplex capacity	Signal bit rate	Video encoding standard	Picture standard	Audio encoding standard	Frequency used
3.1	France	Eiffel Tower	City of Paris	1 kW	DVB-T2	8 MHz	32k, extended mode, $GI = 1/128$, 256-QAM, FEC2/3, PP7	40.2 Mb/s	Two programmes carried: one at 22.5 Mb/s, one at 17.5 Mb/s	HEVC	3 840×2 160p 50 frames/s 8 bits/pixel	HE-AAC 192 kb/s	514 MHz (Ch26 in Region 1)
3.2	France	Eiffel Tower	City of Paris	5 kW	DVB-T2	8 MHz	32k, extended mode, $GI = 1/32$, 256-QAM, FEC3/5, PP4 or PP6	34.2 Mb/s (PP4) 34.9 Mb/s (PP6)	Two to three programmes carried, from 10 to 17 Mb/s for UHD and from 3 to 17 Mb/s for HD-1080p	HEVC	Various combinations between 3 840×2 160p 50 frames/s 8 or 10 bits/pixel and 1 920 x 1 080p 50 frames/s 8 or 10 bits/pixel	AAC 2.0 / AC3+ with various bitrates	514 MHz (Ch26 in Region 1) / 498 MHz (Ch24 in region 1)
		Paris Est	City of Nantes	300 W									
Chenevières	City of Toulouse	40 W		500 W	32k, extended mode, $GI = 1/32$, 256-QAM, FEC2/3, PP6	38.8 Mb/s	Two programmes carried: one at 24.8 Mb/s, one at 12.4 Mb/s	Two programmes carried: one at 24.8 Mb/s, one at 12.4 Mb/s	HEVC	1 920 x 1 080p 50 frames/s 10 bits/pixel	AAC 2.0 134 kb/s		
Meaux		City of Toulouse	3 W										500 W
Chaville	City of Toulouse		3 W	500 W	32k, extended mode, $GI = 1/32$, 256-QAM, FEC2/3, PP6	38.8 Mb/s	Two programmes carried: one at 24.8 Mb/s, one at 12.4 Mb/s	Two programmes carried: one at 24.8 Mb/s, one at 12.4 Mb/s	HEVC	1 920 x 1 080p 50 frames/s 10 bits/pixel	AAC 2.0 134 kb/s		
Nantes		City of Toulouse	16 kW										500 W
Toulouse	City of Toulouse		500 W	500 W	32k, extended mode, $GI = 1/32$, 256-QAM, FEC2/3, PP6	38.8 Mb/s	Two programmes carried: one at 24.8 Mb/s, one at 12.4 Mb/s	Two programmes carried: one at 24.8 Mb/s, one at 12.4 Mb/s	HEVC	1 920 x 1 080p 50 frames/s 10 bits/pixel	AAC 2.0 134 kb/s		

Summary of UHDTV trials on terrestrial television networks

Annex section	Country	Transmitter site	Covering	e.r.p.	DTT System	Channel bandwidth	Transmission mode	Multiplex capacity	Signal bit rate	Video encoding standard	Picture standard	Audio encoding standard	Frequency used
4.1	Spain	ETSI Tele-comunicación	Ciudad Universitaria, Madrid	125 W	DVB-T2	8 MHz	32k, extended mode, $GI = 1/128$, 64-QAM, FEC5/6, PP7	36.72 Mb/s	35 Mb/s (other bit rates also tested)	HEVC	3 840×2 160p 50 frames/s 10 bits/pixel	E-AC-3 5.1	754 MHz (Ch56 in Region 1)
4.2.1	Spain	ETSI Tele-comunicación	Ciudad Universitaria, Madrid	125 W	DVB-T2	8 MHz	32k, extended mode, $GI = 1/128$, 64-QAM, FEC3/4, PP7	32.6 Mb/s	30 Mb/s	HEVC	3 840×2 160p 50 frames/s 10 bits/pixel	E-AC-3 5.1	658 MHz (Ch 44 in Region 1)
		Collserola	Barcelona	15 kW									482 MHz (Channel 22 in Region 1)
4.2.2	Spain	Torrespaña and San Fernando	Madrid	15 kW Torrespaña 75 W San Fernando	DVB-T2	8 MHz	32k, extended mode, $GI = 1/8$, 256-QAM, FEC2/3, PP2	33.4 Mb/s	30 Mb/s	HEVC	3 840×2 160p 50 frames/s 10 bits/pixel HDR 10 Dolby Vision	AC-4 and E-AC-3 5.1	562 MHz (Channel 32 in Region 1)
		Collserola and Baix Llobregat	Barcelona	10 kW Collserola 12 W Baix Llobregat									650 MHz (Channel 43 in Region 1)
		Valencina	Sevilla	9 kW									594 MHz (Channel 36 in Region 1)
4.2.3	Spain	ETSI Tele-comunicación	Ciudad Universitaria, Madrid	125 W	DVB-T2	8 MHz	32k, extended mode, $GI = 1/8$, 256-QAM, FEC2/3, PP2	33.4 Mb/s	30 Mb/s	HEVC	3 840×2 160p 100 frames/s 10 bits/pixel HDR 10 WCG	AC-4 5.1	658 MHz (Channel 44 in Region 1)
		Torrespaña and San Fernando	Madrid	15 kW Torrespaña 75 W San Fernando									562 MHz (Channel 32 in Region 1)
		Collserola and Baix Llobregat	Barcelona	10 kW Collserola 12 W Baix Llobregat									650 MHz (Channel 43 in Region 1)
		Valencina	Sevilla	9 kW									594 MHz (Channel 36 in Region 1)
		Mijas	Malaga	2 kW									514 MHz (Channel 26 in Region 1)

Summary of UHDTV trials on terrestrial television networks

Annex section	Country	Transmitter site	Covering	e.r.p.	DTT System	Channel bandwidth	Transmission mode	Multiplex capacity	Signal bit rate	Video encoding standard	Picture standard	Audio encoding standard	Frequency used
		Monte Pedroso	Santiago de Compostela	9 kW									570 MHz (Channel 33 in Region 1)
5	Sweden	Stockholm Nacka	City of Stockholm	35 kW	DVB-T2	8 MHz	32k, extended mode, $GI = 19/256$, 256-QAM, FEC 3/5, PP4	31.7 Mb/s	24 Mb/s	HEVC	3 840×2 160p 29.97 frames/s 8 bits/pixel		618 MHz (Ch 39 in Region 1)
6	UK	Crystal Palace	Greater London (serving over 4.5 million households)	40 kW	DVB-T2	8 MHz	32k, extended mode, $GI = 1/128$, 256-QAM, FEC 2/3, PP7	40.2 Mb/s	Variable (some trials at 35 Mb/s)	HEVC	Mixture of 3 840×2 160p 50 frames/s and 3 840×2 160p 59.94 frames/s		586 MHz (Ch 35 in Region 1)
		Winter Hill	North-west of England, including Manchester and Liverpool (serving 2.7 million households)	22.5 kW		8 MHz							602 MHz (Ch 37 in Region 1)
		Black Hill	Central Scotland, including Glasgow and Edinburgh (serving 1 million households)	39 kW		8 MHz							586 MHz (Ch 35 in Region 1)
7	Brazil	Mt. Sumaré	Parts of Rio de Janeiro metropolitan area	660 W(H) 660 W(V)	ISDB-T ¹	6 MHz	32k $GI = 1/32$ 4096-QAM, FEC 3/4 dual-polarized MIMO	91.8 Mb/s	85 Mb/s	HEVC	7 680×4 320p 59.94 frame/s 10 bits/pixel	MPEG-4 AAC 1.48 Mb/s	569 MHz (Ch 30 in Brazil)
8	China	Jiaxing Radio and Television Building	Jiaxing City urban and country side	10 KW	DTMB-A	8 MHz	32k $GI = 1/64$ 256APSK FEC 2/3	39.7 Mb/s	36 Mb/s	H.265	3840 × 2160p 50 frame/s	MPEG-4 AAC 384 Kbit/s	562 MHz DS-24

GI = guard intervals

Annex

Field Experiments of UHDTV Terrestrial Transmission

1 Japan

1.1 Introduction

Next-generation digital terrestrial television broadcasting will be dominated by UHDTV applications. UHDTV broadcasts consist of a huge amount of data and therefore require large-capacity transmission paths.

Japan is conducting research on large-capacity transmission technology for next-generation digital terrestrial broadcasting systems that will provide large-volume content services such as 8K. In order to transmit the 8K signal, which has a resolution 16 times greater than HDTV, it will be essential to utilize new technologies that expand transmission capacity, such as ultra-multilevel (4096-QAM), orthogonal frequency-division multiplexing (OFDM), and dual-polarized multiple-input multiple-output (MIMO).

This experiment establishes parameters for maximizing transmission capacity. However, in actual implementation, these parameters will have to be decided taking link budget, the transmission network, the receiving environment, and other factors into account.

A R&D project on an advanced digital terrestrial television broadcasting (DTTB) system is in progress under the auspices of the Ministry of Internal Affairs and Communications, Japan. The project is aiming at developing an advanced DTTB system. The system being developed in this project (hereafter referred to as advanced system) is under evaluation through field trials in large-scale experimental environments constructed in urban areas.

1.2 8K-UHDTV field experiments in rural area; Hitoyoshi (2 × 2 MIMO transmission system)

Japan has installed an experimental transmitting station in Hitoyoshi city, Kumamoto prefecture that uses dual-polarized MIMO and ultra-multilevel OFDM technologies. Two 8K field experiments were conducted there: a transmission test and field measurements at 52 points around Hitoyoshi.

Here, Japan reports the results of these experiments, including the required field strength when using 4096-QAM carrier modulation and a channel response analysis of dual-polarized MIMO transmission.

1.2.1 Transmission parameters and experiment area

Table 1 lists the specifications of the 8K field experiments in the Hitoyoshi area.

TABLE 1
Specifications of 8K field experiments in Hitoyoshi

Modulation method	OFDM
Occupied bandwidth	5.57 MHz
Transmission frequency	671.142857 MHz (UHF ch46)
Transmission power	Horizontal polarized waves: 10 W, e.r.p.: 140 W Vertical polarized waves: 10 W, e.r.p.: 135 W
Carrier modulation	4096-QAM

TABLE 1 (*end*)

FFT size (number of radiated carriers)	32k (22,465)
Guard interval ratio (guard interval duration)	1/32 (126 μ s)
Error-correcting code	Inner: LDPC, code rate = 3/4 Outer: BCH
Transmission capacity	91.8 Mb/s
Video coding	MPEG-4 AVC/H.264, HEVC
Audio coding	MPEG-4 AAC
Transmitting station	Established at NHK Hitoyoshi TV relay station
Height of transmitting antenna	632 m above sea level (21 m above ground level)

1.2.2 Transmitting and receiving station equipment

Table 2 shows the requirements for selecting the field experiment locations. The Hitoyoshi area fulfils these requirements and so it was chosen as the place to set up the experimental transmitting station.

Figure 1 shows the transmitting station and equipment and Fig. 2 shows the receiving station and equipment. An 85-inch 8K monitor was used to display the 8K signal. Both the dual-polarized transmitting antenna and the dual-polarized receiving antenna were developed.

Figure 3 is a block diagram of the modulator and demodulator used in the experiments. The input signal is coded with BCH code and low density parity check (LDPC) code, bit interleaved and mapped onto the constellation. After that, the signal is divided into two signals (one for horizontal polarization and the other for vertical) with 3D interleave (time, frequency and inter-polarization). The signals are then converted into time domain signals by inverse fast Fourier transform (IFFT) and guard intervals (G) are added.

The signals from the modulator are converted into RF signals of the same frequency by using up-converters (U/C). The signals are then amplified with a power amplifier (PA) to the desired power level and transmitted as horizontal and vertical polarized waves from a dual-polarized antenna.

The transmitted signals are received by a dual-polarized Yagi antenna. Each received signal is filtered by a band-pass filter (BPF) and input to a variable attenuator (ATT). The signals are then amplified using low noise amplifiers (LNA) and converted into IF signals with a down converter (D/C). The IF signals are then input to the demodulator.

In the demodulator, the active symbol period is extracted from the received signals, which are then converted into frequency domain signals by fast Fourier transform (FFT). The frequency domain signals are de-multiplexed, equalized by MIMO detection, 3D de-interleaved, and used to calculate the log likelihood ratio (LLR). LLRs are de-interleaved and input to the LDPC decoder. Finally, BCH decoding is applied to obtain the output signal.

In the transmission test, compressed 8K signals were transmitted over a single UHF-band channel (6 MHz bandwidth). The distance between the transmitting station and receiving station was 27 km, a typical distance for current digital terrestrial broadcasting.

TABLE 2
Location requirements for 8K field experiments

1	The place should have a vacant UHF single channel for 8K transmission.
2	To analyse the channel response of dual-polarized MIMO transmission, the experiment should be able to be conducted over a large area and over long distances (e.g. transmissions over 20 km).
3	The place should support a current DTTB system.
4	The place should be free of mutual interference from other areas.

FIGURE 1
Transmitting station and equipment

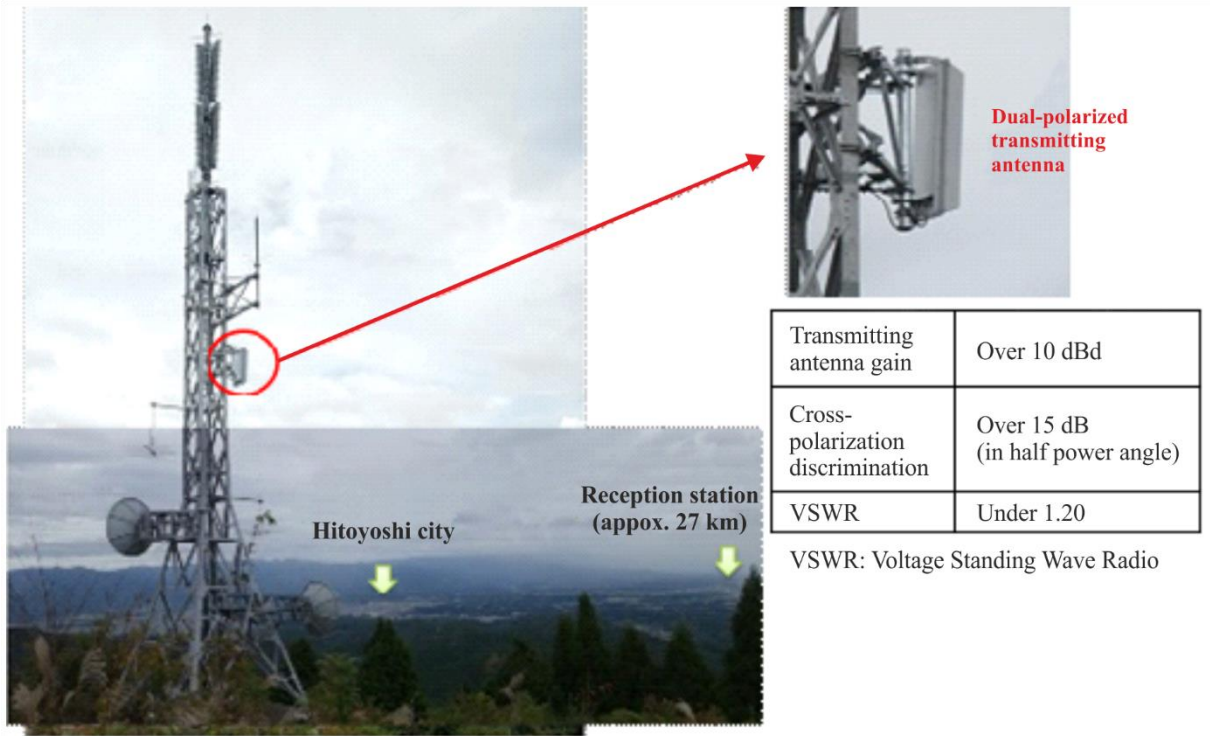

Report BT.2343-A1-01

FIGURE 2
Receiving station and equipment

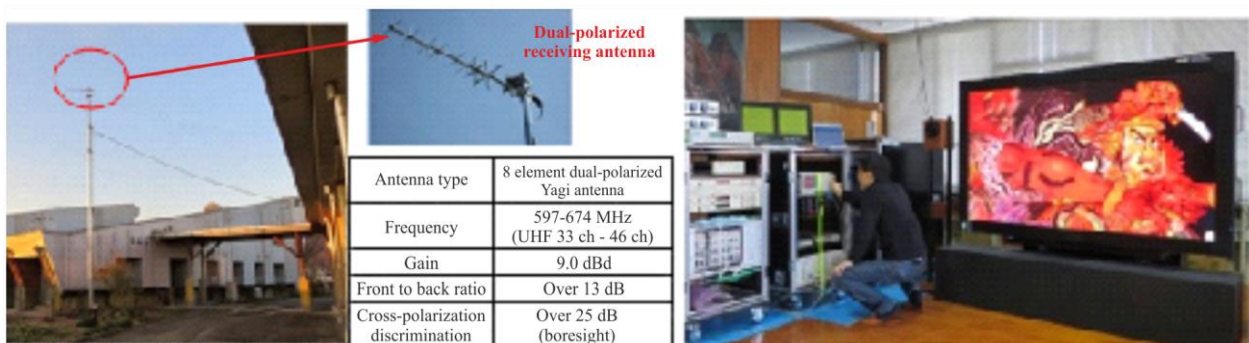

Report BT.2343-A1-02

FIGURE 3

Block diagram of 8K experiments

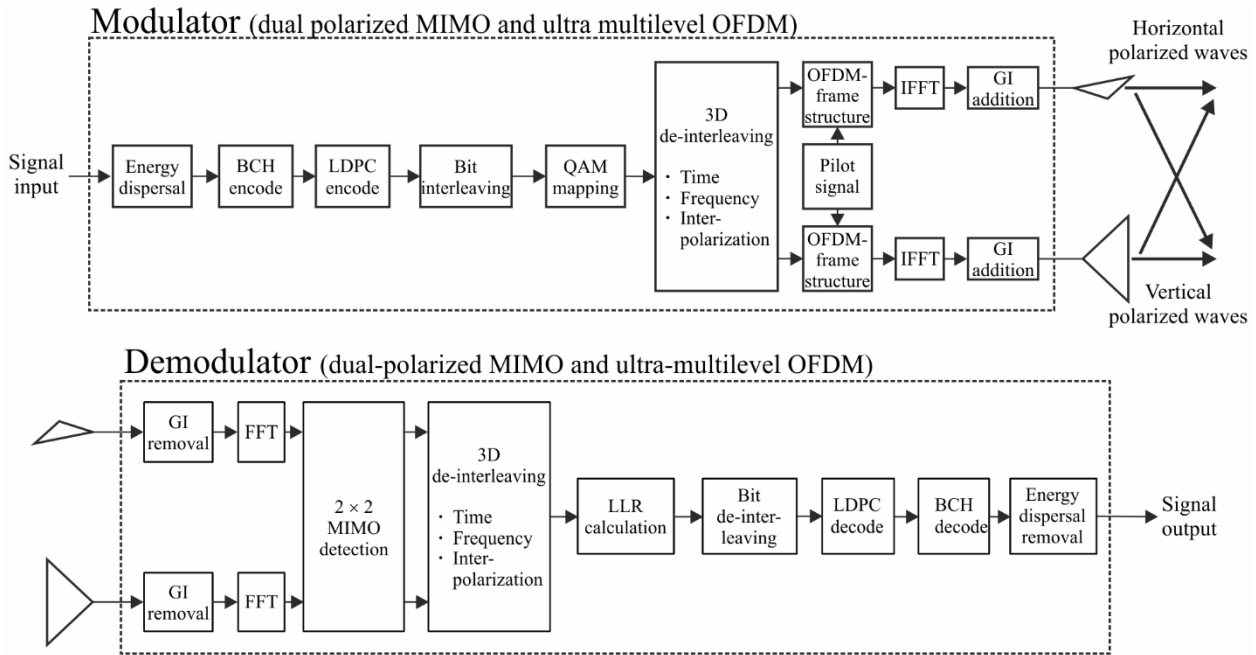

Report BT.2343-A1-03

1.2.3 Key technologies

Ultra-multilevel OFDM is a technology that applies a greater number of signal points to data symbols. Carrier modulation schemes up to 64-QAM can be used in current ISDB-T, but up to 4096-QAM can be implemented in the prototype equipment. Figure 4 shows the constellations of 64-QAM and 4096-QAM. 64-QAM can transmit six bits of data per carrier symbol, while 4096-QAM can transmit 12 bits per carrier symbol, which is twice as many as 64-QAM.

FIGURE 4

Constellations of 64-QAM (left) and 4096-QAM (right)

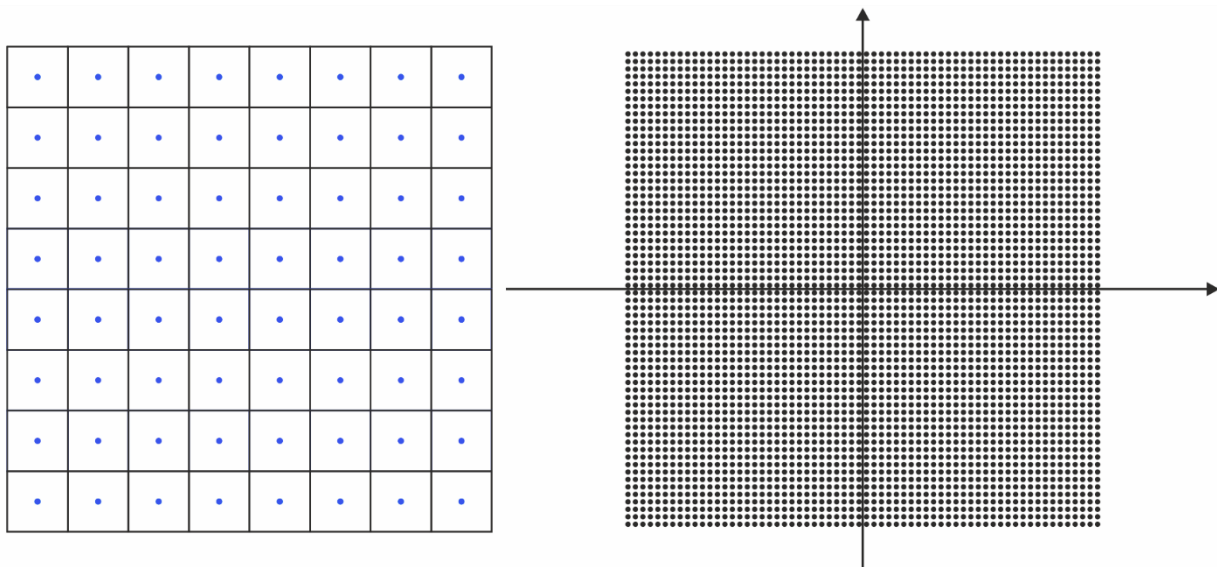

Report BT.2343-A1-04

Dual-polarized MIMO is a technology configuring MIMO with two orthogonal polarizations. This technology was used to expand the transmission capacity, and namely each of the two polarized waves transmitted different data. A dual-polarized MIMO using horizontally and vertically polarized waves can be used as the model, as shown in Fig. 5.

FIGURE 5
MIMO transmission model

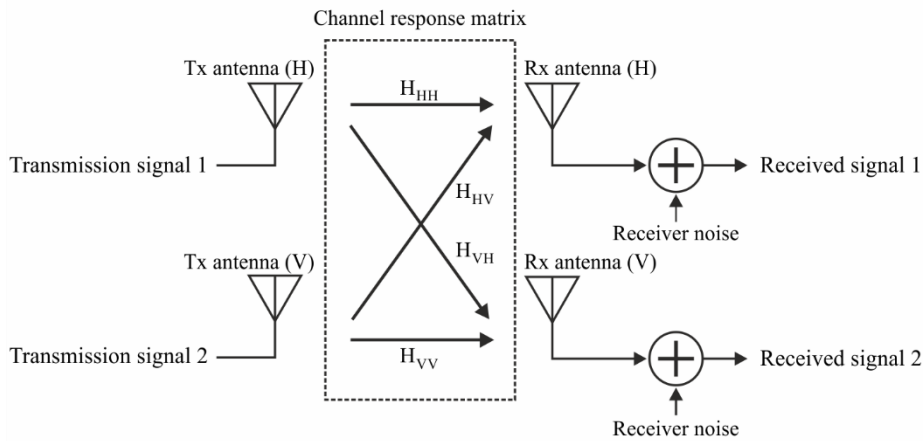

Report BT.2343-A1-05

1.2.4 Field measurement results

For the field test, 52 reception points in the Hitoyoshi area that were 1.3 km to 36.7 km from the transmitter were selected (Fig. 6). MIMO propagation measurements were conducted at all 52 points and the BER (after the BCH decoding) and receiving margin were measured at each carrier modulation at 30 points.

FIGURE 6
Location of reception points

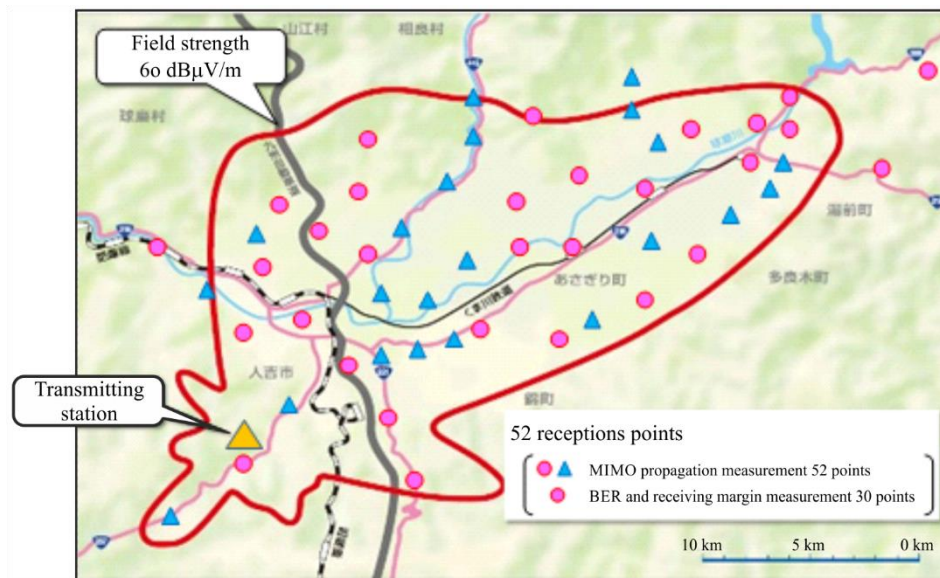

Report BT.2343-A1-06

Figure 7 plots the average field strength of the BER and receiving margin measurements at the 30 reception points. The horizontal axis is the transmission distance (km) and the vertical axis is the average field strength of both polarized waves. These results indicate that quasi error free (QEF) transmission is possible with the 4096-QAM carrier modulation scheme. In this Annex, the QEF is defined that there is no error for a measurement time of two minutes.

FIGURE 7

Average field strength vs. transmission distance

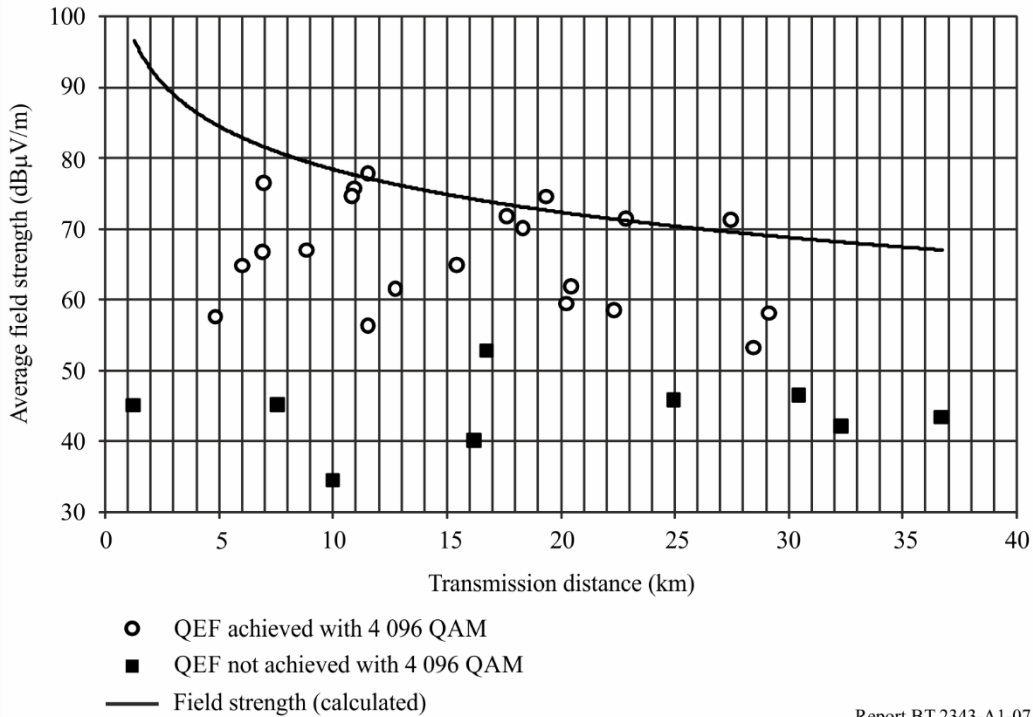

Report BT.2343-A1-07

The required field strength, which is defined as the lowest field strength for QEF transmission, was determined by decreasing the input signal level of the LNA by using the ATT.

Table 3 lists the average required field strengths, which were calculated by averaging the horizontal and vertical polarized waves. The average required field strength increased by about 5 dB as a result of quadrupling the number of signal points in the constellation.

TABLE 3

Average required field strength for QEF

Carrier modulation scheme	Average required field strength (dBµV/m)	Number of QEF points
256-QAM	42.4	23
1024-QAM	47.3	22
4096-QAM	52.3	21

The transmission characteristics were analysed at all 52 points of the MIMO propagation measurement. The propagation environment was classified into four categories: line of sight (LoS), non-line of sight (NLOS) with a strong field strength (over 60 dBµV/m), NLOS with a moderate field strength (40-60 dBµV/m), and NLOS with a weak field strength (under 40 dBµV/m).

Figure 8 shows an example of the MIMO channel responses of NLOS with a moderate field strength. An example of the distribution of the condition numbers of the four categories is presented in Fig. 9.

The analysis indicates that the MIMO propagation qualities became worse starting with LoS and followed by NLOS with a strong field strength, NLOS with a moderate field strength, and NLOS with a weak field strength. This order is attributed to the increase of the cross polarized wave components. It was also shown that the condition number increased and the distribution of the condition number spread out in the same order as above.

FIGURE 8

Example of MIMO channel responses of NLOS with a moderate field strength

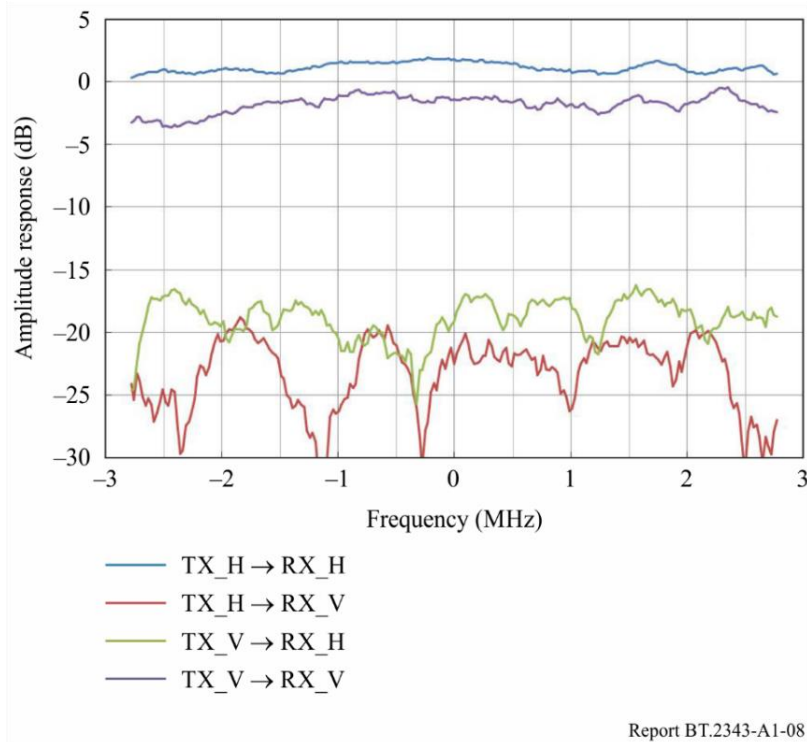

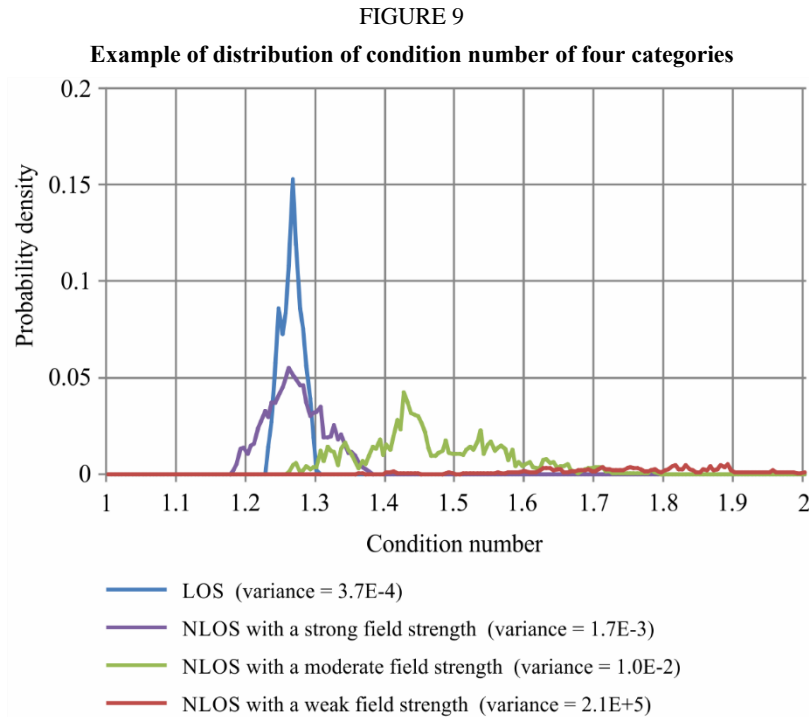

Report BT.2343-A1-09

1.3 8K-UHDTV SFN field experiments in rural area; Hitoyoshi (2 × 2 MIMO STC-SFN transmission system)

In February 2015, Japan conducted 8K-UHDTV single frequency network (SFN) field experiments using two transmission stations to form a 2 × 2 MIMO Space Time Coding (STC)-SFN system. In this field experiment, the STC method was employed to improve the reliability of high data rate transmission. In November 2016, an 8K-UHDTV field experiment using high efficiency video coding (HEVC) was conducted. It was confirmed that the video and audio were successfully received within the STC-SFN area.

1.3.1 Overview of 2 × 2 MIMO STC-SFN

Figure 10 shows the outline of a 2 × 2 MIMO STC-SFN system formed by two experimental stations, namely, the Hitoyoshi and Mizukami stations. The distance between the two stations is 38 km. Both stations use dual-polarized space division multiplexing (SDM) MIMO. The Mizukami station became operational in 2015 and was connected to the Hitoyoshi station by a transmitter to transmitter link (TTL) in the super high frequency (SHF) band.

In this field experiment, the intermediate frequency TTL (IF-TTL) method was used to transmit an OFDM signal from the Hitoyoshi station to the Mizukami station. The transmission frequencies of the two stations were precisely synchronized by rubidium (Rb) oscillator with a global positioning system (GPS) as a backup.

The 2×2 MIMO STC-SFN system used in this SFN field experiment employed STC technology as a new feature. The Hitoyoshi station transmitted a 91 Mbit/s 8K-UHDTV signal in a 6 MHz bandwidth UHF channel (channel number 46 in Japan), and the Mizukami station also transmitted using the same channel.

FIGURE 10

Outline of 2x2 MIMO STC-SFN transmission system

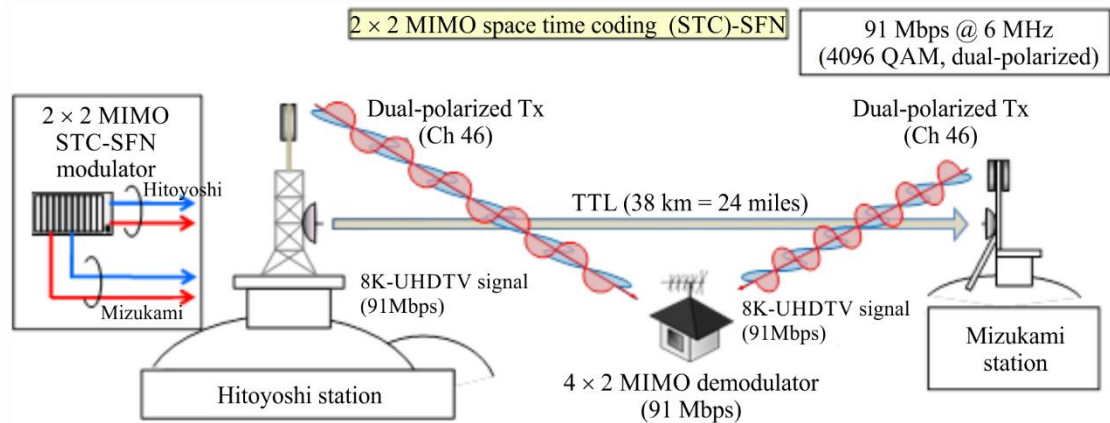

Report BT.2343-A1-10

1.3.2 Transmission parameters and equipment

Table 4 shows the parameters for MIMO transmission, and Table 5 the specifications of the Hitoyoshi and Mizukami stations. Figure 11 shows the equipment installed in each station, and Fig. 12 shows the transmission and reception antennas for the UHF channel. The transmission antennas at Hitoyoshi and Mizukami have the same characteristics.

TABLE 4

Parameters for MIMO transmission

Modulation method	OFDM
Occupied bandwidth	5.57 MHz
Carrier modulation	4096-QAM
FFT size (number of radiated carriers)	32K (22,465)
Guard interval ratio (guard interval duration)	1/32 (126 μ s)
Error-correcting code	Inner code: LDPC, coding rate $R = 3/4$ Outer code: BCH
Transmission capacity	91.8 Mbit/s

TABLE 5

Specifications of Hitoyoshi and Mizukami stations

	Hitoyoshi station	Mizukami station
Transmission frequency	671.142857 MHz (UHF ch46 in Japan)	
Transmission power	Horizontal: 10 W Vertical: 10 W	Horizontal: 3 W Vertical: 3 W
e.r.p.	Horizontal: 140 W Vertical: 135 W	Horizontal: 25 W Vertical: 25 W
Transmitting antenna height	632 m above sea level	1080 m above sea level

FIGURE 11

Equipment of MIMO experimental stations

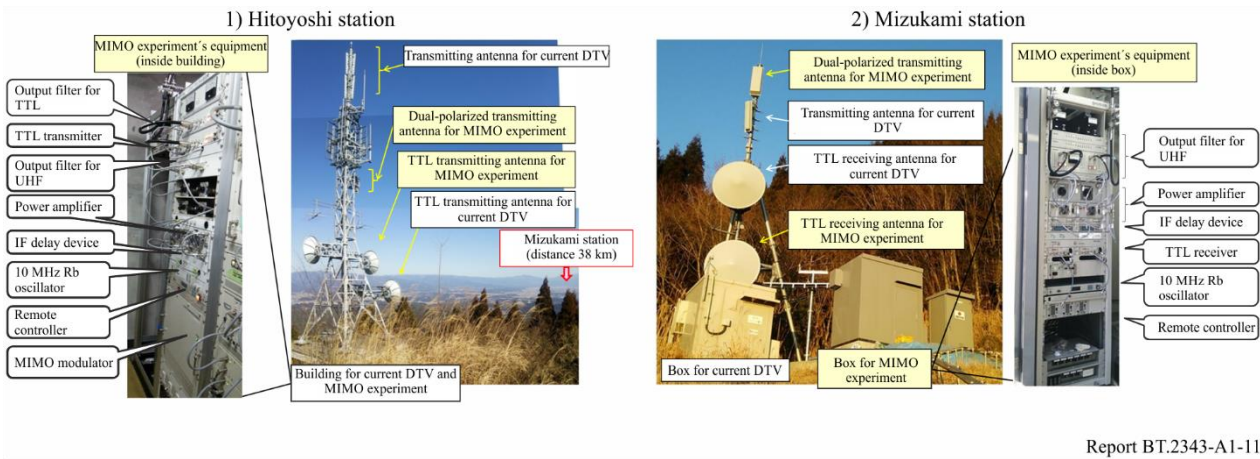

Report BT.2343-A1-11

FIGURE 12

Transmission and reception antennas for UHF

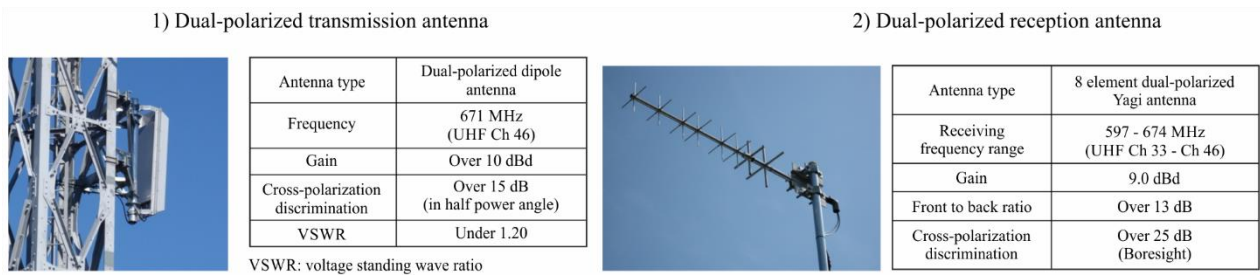

VSWR: voltage standing wave ratio

Report BT.2343-A1-12

The 2×2 MIMO STC-SFN system was developed for this experiment as shown in Fig. 13. STC is a method of encoding carrier symbols. An STC code is applied for the four carrier symbols of the two transmission antennas each of two transmission stations. Here, s is a carrier symbol of a constellation with a complex value, and “*” means the complex conjugate. The transmitted symbols s_0, s_1, s_2 and s_3 are encoded, $s_0, s_1, -s_2^*$ and s_3^* are transmitted in time t , and s_2, s_3, s_0^* and $-s_1^*$ are then transmitted in time $t+1$, from each antenna. In the transmission model, the transmitting carrier symbols are denoted as x_0, x_1, x_2 and x_3 , and the receiving carrier symbols as y_0 and y_1 . h is the channel response estimated by scattered pilot (SP), and h_{ij} is the component corresponding to the i th receiving antenna and j th transmitting antenna. In the reception model, the transmitted symbols s_0, s_1, s_2 and s_3 are obtained by decoding the received symbols y_0 and y_1 , which are received at two discrete times.

Figure 14 shows the block diagram of the 2×2 MIMO STC-SFN system modulator and demodulator used in this field trial. Figure 15 shows the SP patterns of the 2×2 MIMO STC-SFN system. To estimate the channel responses of each receiving antenna, four orthogonal SP schemes using sign inversion were investigated. These SP patterns are the extensions of those used by ISDB-T.

In order to adjust the time delay between two transmission waves, IF delay adjustment equipment with a range of $0.1 \mu\text{s} - 10 \text{ms}$ (shown in Fig. 15) was installed at both stations.

FIGURE 13
2 × 2 MIMO STC-SFN system

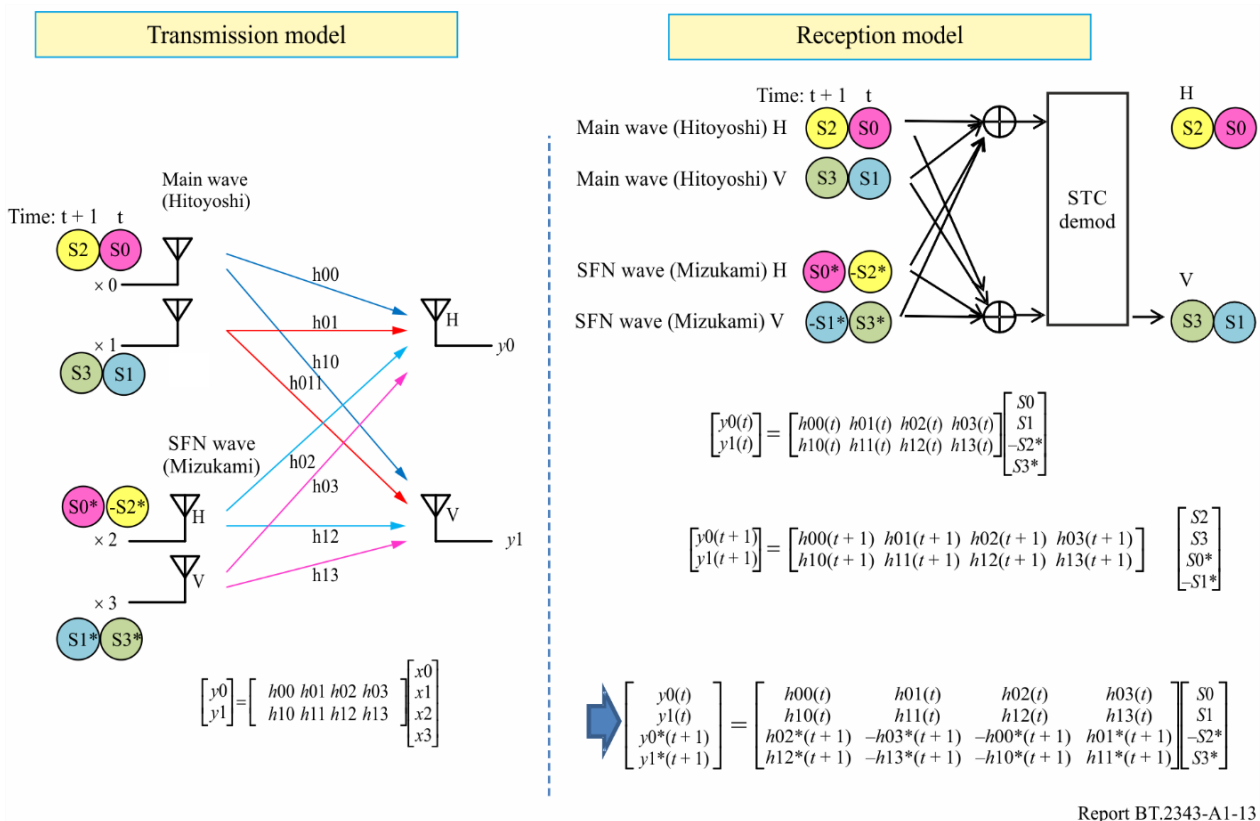
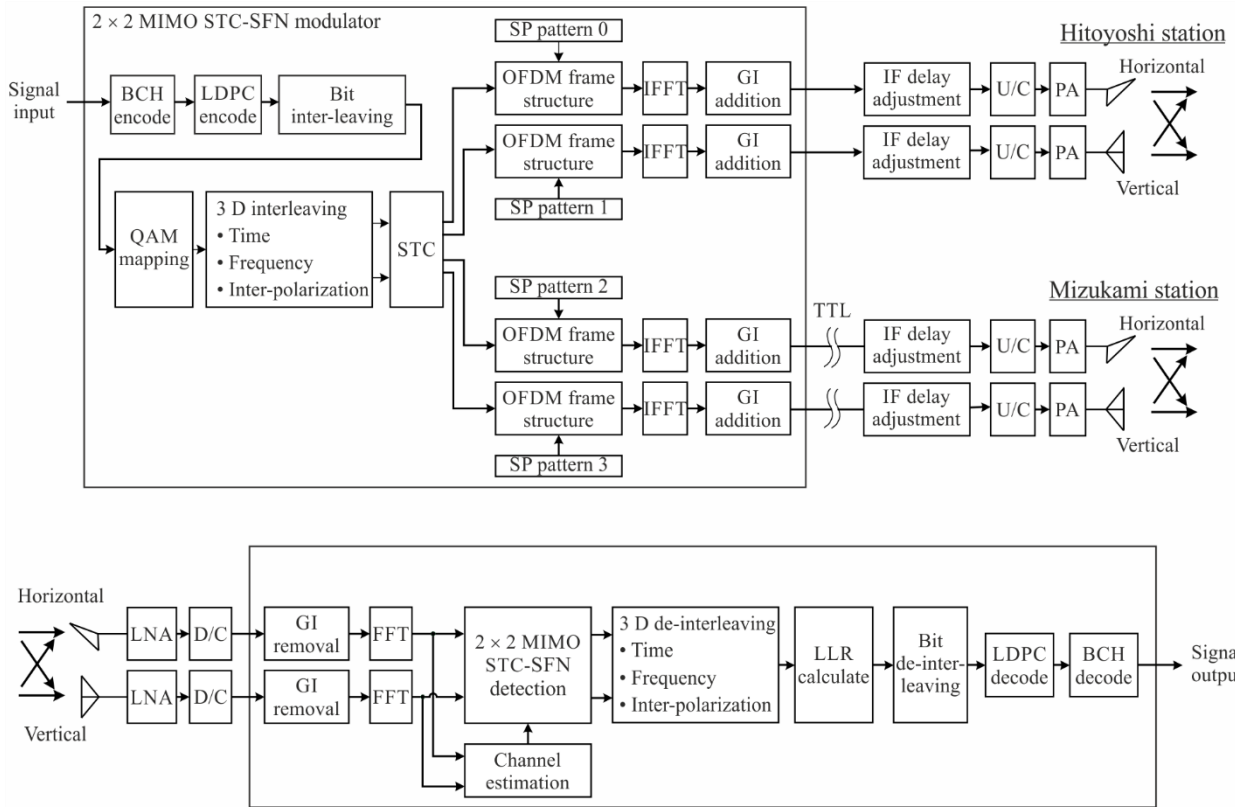

FIGURE 14

Block diagram of 2 × 2 MIMO STC-SFN system



Report BT.2343-A1-14

FIGURE 15

Scattered pilot patterns

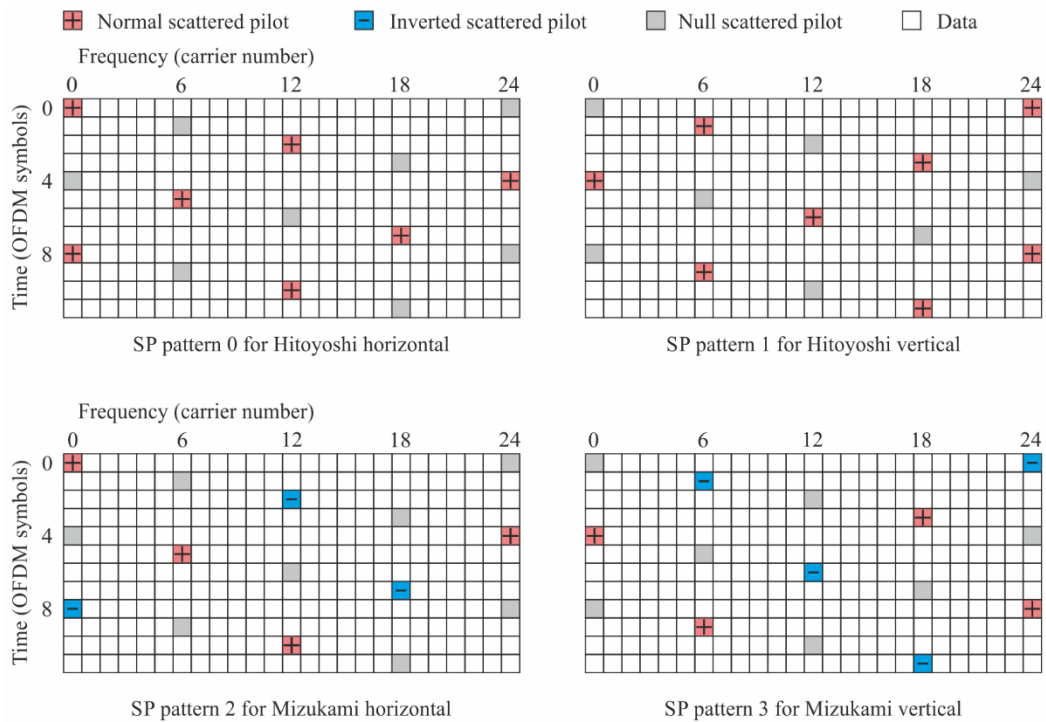

Report BT.2343-A1-15

1.3.3 Field measurements

The conventional SFN is defined as two geographically distributed stations sending exactly the same signals synchronously using the same frequency. In this conventional SFN, a deep null is generated within the reception spectrum and causes deterioration of signal quality. This problem is caused by an erasure effect, the so-called 0-dB echo effect.

To compare the differences between 2×2 MIMO STC-SFN system and conventional SFN system, transmission characteristics were measured at three points (Points A, B, and C in Fig. 16) within the area of overlap covered by both the Hitoyoshi and the Mizukami stations. Here, LoS stands for line of sight and NLOS stands for non-line of sight.

Before measurement, the transmission power and time delay at both stations was adjusted for evaluation under identical conditions. The power ratios of the main and SFN waves were adjusted to 6 dB and the time delay between the main and SFN waves to $2 \mu\text{s}$ at the receiver inputs at each test point. The power of each wave was defined as the average of the horizontal and vertical waves.

Figure 17 plots the reception powers required for both 2×2 MIMO STC-SFN and conventional SFN at all three reception points. This Figure clearly shows that the null is much shallower in the spectrum of 2×2 MIMO STC-SFN than in conventional SFN. Furthermore, the power requirement for 2×2 MIMO STC-SFN is as much as 3 dB superior to that of the conventional SFN. This decreased null and superior power requirement are clear outcomes of the application of STC technology to SFN.

An 8K-UHDTV field experiment with HEVC was conducted at Point C in Fig. 16. The 8K video compressed with HEVC and a multi-dimensional audio (22.2 channels) compressed with MPEG-4 AAC were transmitted from two experimental stations (Hitoyoshi and Mizukami) to create an STC-SFN. The received signals were demodulated and the 8K video was displayed on an 85-inch LCD display. The transmission parameters were the same as those in the previous § 1.3.2. Figure 18 shows the reception equipment for the demonstration. In this experiment, it was demonstrated that 8K-UHDTV can be successfully delivered with STC-SFN.

FIGURE 16
Measuring points

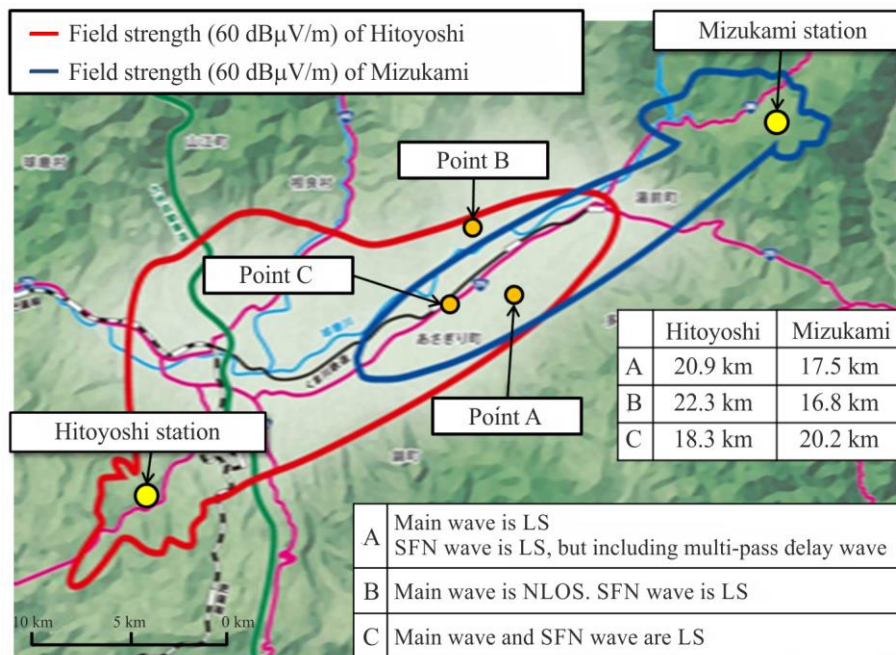

FIGURE 17

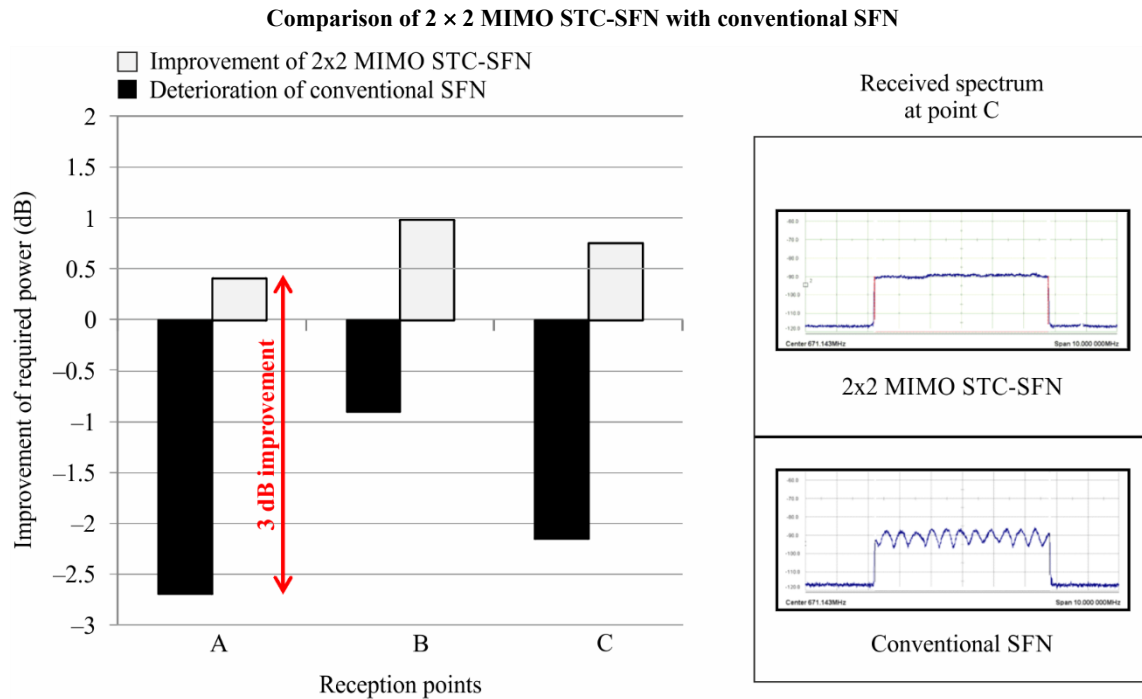

FIGURE 18

Demonstration of 8K-UHDTV transmission with STC-SFN

1.4 8K-UHDTV field experiments with non-uniform constellation in urban area; Kinuta, Tokyo (2×2 MIMO transmission system)

An 8K-UHDTV field experiment with non-uniform constellation (NUC), in which the signal points in the constellation are distributed non-uniformly, was conducted in an urban area; Kinuta, Tokyo.

1.4.1 Overview of non-uniform constellation

The NUC is a technology to improve the transmission performance by adjusting the distance between the signal points to be suited for the noise in the propagation channel. It is confirmed that the greater number of signal points in the constellation, such as 4096QAM, the larger improvement in performance is obtained. The signal points of the 4096 NUC implemented on the prototype transmission system and conventional 4096 uniform constellation (UC) are depicted in Fig. 19. In this Figure, the average power

of NUC is normalized to be the same as that of UC, and the signal points of 4096 NUC are optimized for 30 dB of carrier to noise ratio (C/N) as the expected C/N in the transmission channel.

FIGURE 19

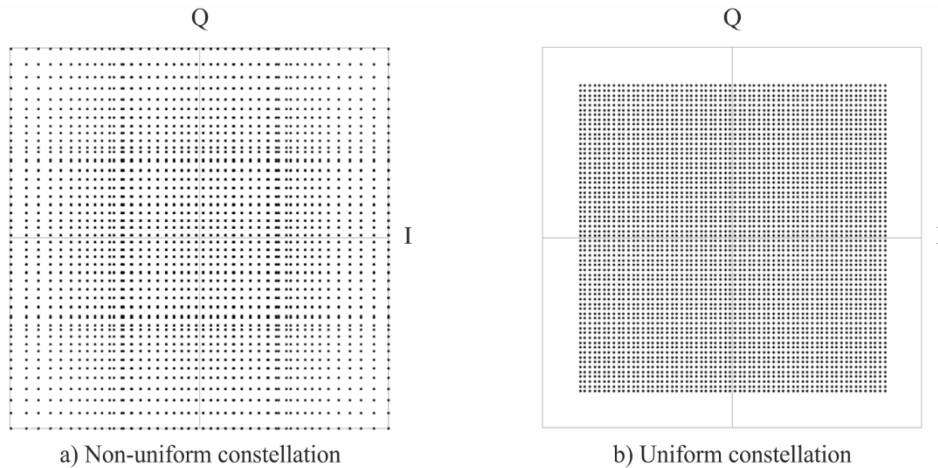

Report BT.2343-A1-19

1.4.2 Transmission parameters and equipment

An experimental station was installed on top of the NHK – Science and Technology Research Laboratories (STRL) located in southern Tokyo, and a field experiment was conducted with NUC in an urban area. The transmission parameters are listed in Table 6. The experimental station is composed of two transmitters for horizontally and vertically polarized waves. The experimental signals were received at a reception point 8 km from the transmitting point. The block diagram of the experiment is shown in Fig. 20. In this Figure, horizontal and vertical are expressed as H and V, respectively. The transmitting and receiving antennas are shown in Fig. 21. A dual-polarized dipole antenna was used for the transmitting antenna and a dual-polarized Yagi antenna was used for the receiving antenna. The view from the transmitter toward the reception point and that from the reception point toward the transmitter are shown in Fig. 22. The reception antenna was located at a LOS point, however multipath echoes reflected by the buildings on the propagation path were observed. It was confirmed that MIMO transmission with NUC can deliver 8K video stably in such an urban area. The demonstration of 8K-UHDTV reception with NUC is shown in Fig. 23.

TABLE 6

Specifications of 8K field experiments in urban area (Kinuta, Tokyo)

Modulation method	OFDM
Occupied bandwidth	5.57 MHz
Transmission frequency	581.142857 MHz (UHF ch31)
Transmission power	Horizontal polarized waves: 10 W, e.r.p.: 93 W Vertical polarized waves: 10 W, e.r.p.: 93 W
Carrier modulation	4096 NUC
FFT size (number of radiated carriers)	16k (11,233)
Guard interval ratio (guard interval duration)	1/16 (126 μ s)
Error-correcting code	Inner: LDPC, code rate = 3/4 Outer: BCH
Transmission capacity	84.2 Mb/s

TABLE 6 (end)

Video coding	MPEG-4 AVC/H.264
Audio coding	MPEG-4 AAC
Transmitting station	Established at NHK-STRL
Height of transmitting antenna	126 m above sea level (96 m above ground level)

FIGURE 20

Block diagram of 8K experiments in urban area

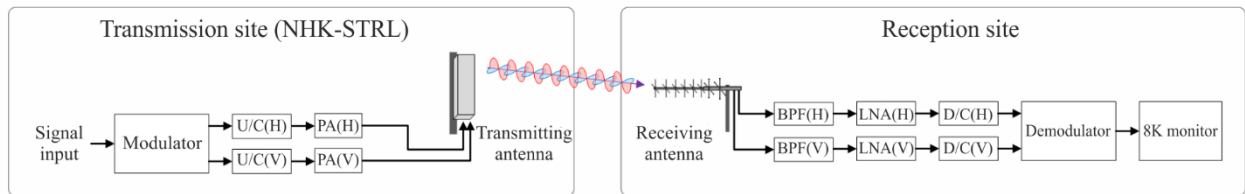

Report BT.2343-A1-20

FIGURE 21

Transmission and reception antennas for experiments in urban area



a) Transmission antenna

b) Reception antenna

Report BT.2343-A1-21

FIGURE 22

View from transmission and reception sites

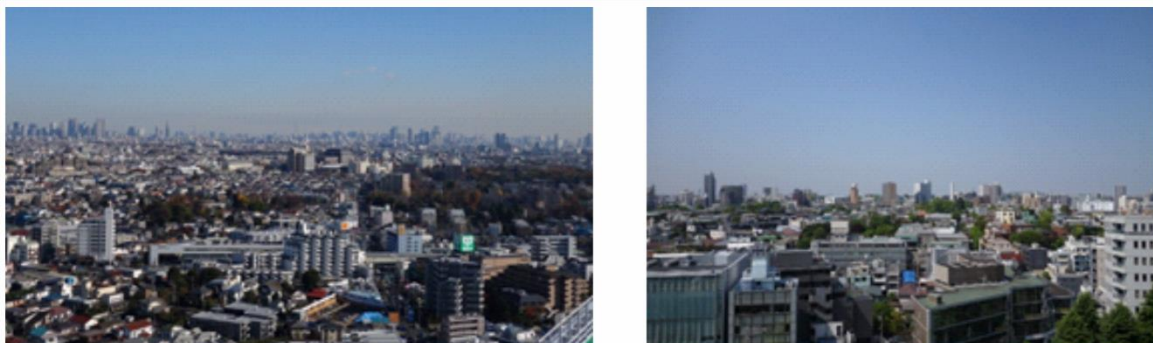

a) Transmission site toward reception site

b) Reception site toward transmission site

Report BT.2343-A1-22

FIGURE 23

Demonstration of 8K-UHDTV transmission with NUC

Report BT.2343-A1-23

1.4.3 Field measurements

The transmission performance of NUC was evaluated at three reception points in Tokyo. The improvement of NUC over UC in the C/N was investigated. The results are listed in Table 7. It was confirmed that NUC improved the transmission performance by about 1 dB in a MIMO transmission system using 4096-QAM in an urban area.

TABLE 7

Required C/N improvement of non-uniform constellation over uniform constellation

Reception point	Improvement	Transmission distance
(A) Hanegi park	0.9 dB	4.5 km
(B) NHK Broadcasting Centre	0.9 dB	8.0 km
(C) Meijijingu Gaien	1.0 dB	10.4 km

1.5 4K/8K-UHDTV field experiments with advanced system in urban area; Tokyo and Nagoya**1.5.1 Overview of advanced DTTB system**

The objective of the advancement is to provide improved transmission performance compared to ISDB-T in terms of the increased transmission capacity and the reduced C/N required. The advanced system has been designed to inherit the feature of ISDB-T, i.e. it aims to provide a 4K or 8K UHDTV service for fixed reception and an HDTV service for mobile reception simultaneously by frequency division multiplexing (FDM) within a single channel. It also uses a frequency-segmented structure that allows partial reception. The bandwidth per segment is reduced to increase the number of segments from 13 (for ISDB-T) to 35, allowing for flexible bitrate distribution between layers such as the mobile reception layer and fixed reception layer. The advanced system allows a higher spectral efficiency and/or a transmission robustness with multiple-input multiple-output (MIMO).

A prototype modulator and demodulator for the advanced system were developed and their performances were confirmed through laboratory experiments. The feasibility of the system is being verified through large-scale field trials in urban areas.

1.5.2 Transmission parameters

Field experiments were conducted with the parameters listed in Table 8. The occupied bandwidth was expanded by about 5% compared to that of ISDB-T to increase transmission capacity. The 31 and 4 segments out of 35 segments were assigned for UHDTV and HDTV services, respectively. As for

error-correcting code and carrier modulation, low density parity check (LDPC) code and NUCs were used for both UHDTV and HDTV services to enhance transmission robustness.

TABLE 8
**Parameters for field experiments of hierarchical transmission in urban area
(Tokyo and Nagoya)**

Modulation method	OFDM	
Occupied bandwidth	5.83 MHz	
Reception scenario	Fixed (Rooftop)	Mobile (Car-mounted)
Number of segments	31	4
Carrier modulation	1 024 NUC QAM	64 NUC QAM
FFT size (number of radiated carriers)	16 k (15,121)	
Guard interval ratio (guard interval duration)	800/16384 (126 μ s)	
Error-correcting code	Inner: LDPC, code rate = 11/16 Outer: BCH	Inner: LDPC, code rate = 7/16 Outer: BCH
Transmission capacity	31.4 Mb/s (SISO) 62.8 Mb/s (MIMO)	1.5 Mb/s (SISO) 3.0 Mb/s (MIMO)
Video coding	HEVC	
Video format	3840 \times 2160/60/P (4K) 7680 \times 4320/60/P (8K)	1920 \times 1080/60/P (2K)
Video bit rate	SISO: 25 Mb/s (4K) SISO: 28 Mb/s (8K)* MIMO: 56 Mb/s (8K)*	SISO: 1.0 Mb/s (2K) MIMO: 1.0 Mb/s (2K)
Audio coding	MPEG-H 3D Audio LC level 4	MPEG-4 AAC
Audio bit rate	768 kb/s (22.2ch + 3 objects)	192 kb/s (2ch)

* Pre-processed before encoding by MPEG-H HEVC with a state-of-the-art software encoder offline taking plenty of time.

1.5.3 Field measurements

To evaluate the performance of the advanced system in different propagation environments, large-scale experimental environments were constructed. Two locations (in the Tokyo and Nagoya areas) were selected to have the same scale as the main stations currently used for terrestrial broadcasting. Figure 24 shows the transmitter sites and assumed coverage areas for the experimental parameters in Table 8. Table 9 lists the specifications of the transmission stations. Each transmission station is equipped with two transmitters and two antennas for horizontally and vertically polarized waves. The directional patterns of transmitting antennas at Nabeta relay station are designed to be selectable.

FIGURE 24
Experimental environments

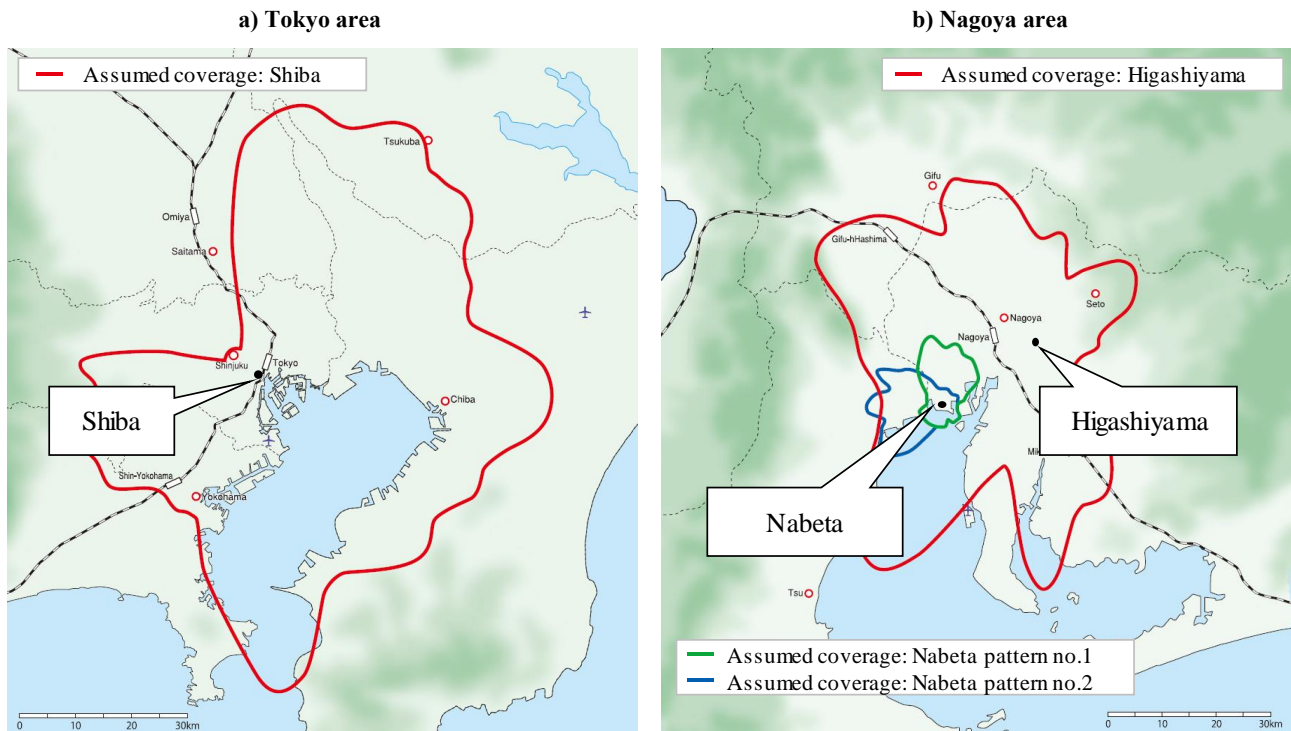

TABLE 9

Specifications of transmission stations

	Tokyo area		Nagoya area	
Transmitter site	Shiba (main station) (Minato Ward, Tokyo)		Higashiyama (main station) (Showa Ward, Nagoya, Aichi)	Nabeta (relay station) (Yatomi, Aichi)
Transmission frequency	563.143 MHz		605.143 MHz	
Polarization	Horizontal, Vertical			
Transmission power	Horizontal: 1 kW Vertical: 1 kW		Horizontal: 1 kW Vertical: 1 kW	Horizontal: 10 W Vertical: 10 W
e.r.p.	Horizontal: 2.1 kW Vertical: 2.1 kW		Horizontal: 980 W Vertical: 980 W	Horizontal: 81 W Vertical: 81 W
Transmitting antenna height	280 m above sea level		203 m above sea level	42.5 m above sea level

Transmission experiments were conducted in the two experimental urban areas. Experiments were launched in November and December 2018 in the Nagoya and Tokyo areas, respectively.

The experiments involved field trials of hierarchical transmission of UHD TV/HDTV using a single channel based on the advanced DTTB system. The UHD TV (4K or 8K) content for fixed reception and HDTV (2K) content for mobile reception shown in Table 8 were recorded in advance in a player, and the video and audio streams were played back at the experimental stations. The block diagram of transmitting and receiving system is shown in Figure 25. UHD TV and HDTV streams from the player

are multiplexed by the remultiplexer (remux) into a single IP stream and input to the advanced DTTB modulator. The frequency of two output signals from the modulator are converted and power-amplified by the transmitter. The audio of UHDTV was an object-based audio that transmitted a 22.2 channel audio encoded by MPEG-H 3D Audio and three narration objects in Japanese, English, and French. For the HDTV content, the video was encoded by HEVC and the stereo audio signals were encoded by MPEG-4 AAC.

Figure 26 shows the locations of the transmitting and receiving points in the Tokyo area. The NHK Science and Technology Research Laboratories (NHK-STRL), which is approximately 12 km away from the Shiba station, was selected as the receiving point. On the receiving side, the received spectrum was observed by a spectrum analyser, and the delay profile was confirmed by a signal analyser. The UHDTV signal output from the demodulator was decoded in real time by the HEVC decoder and displayed on a 4K/8K LCD monitor. The 22.2 channel audio was decoded in real-time by MPEG-H 3D Audio decoder, converted to 7.1 channel audio, and reproduced using a commercially available sound bar. The HDTV signal was converted from multicast to unicast, then transmitted via WiFi router, and decoded by an MMT player installed on a tablet or smartphone. Figure 27 shows the spectrum of the received signals. Figures 28 and 29 show the delay profile and constellation of the received signal of SISO transmission using horizontal polarized wave. As for the delay profile, almost no reflected waves were confirmed as shown in Fig. 28. In this experiment, it was demonstrated that UHDTV and HDTV contents can be successfully received with the advanced DTTB system.

FIGURE 25

Block diagram of transmitting and receiving system in Tokyo

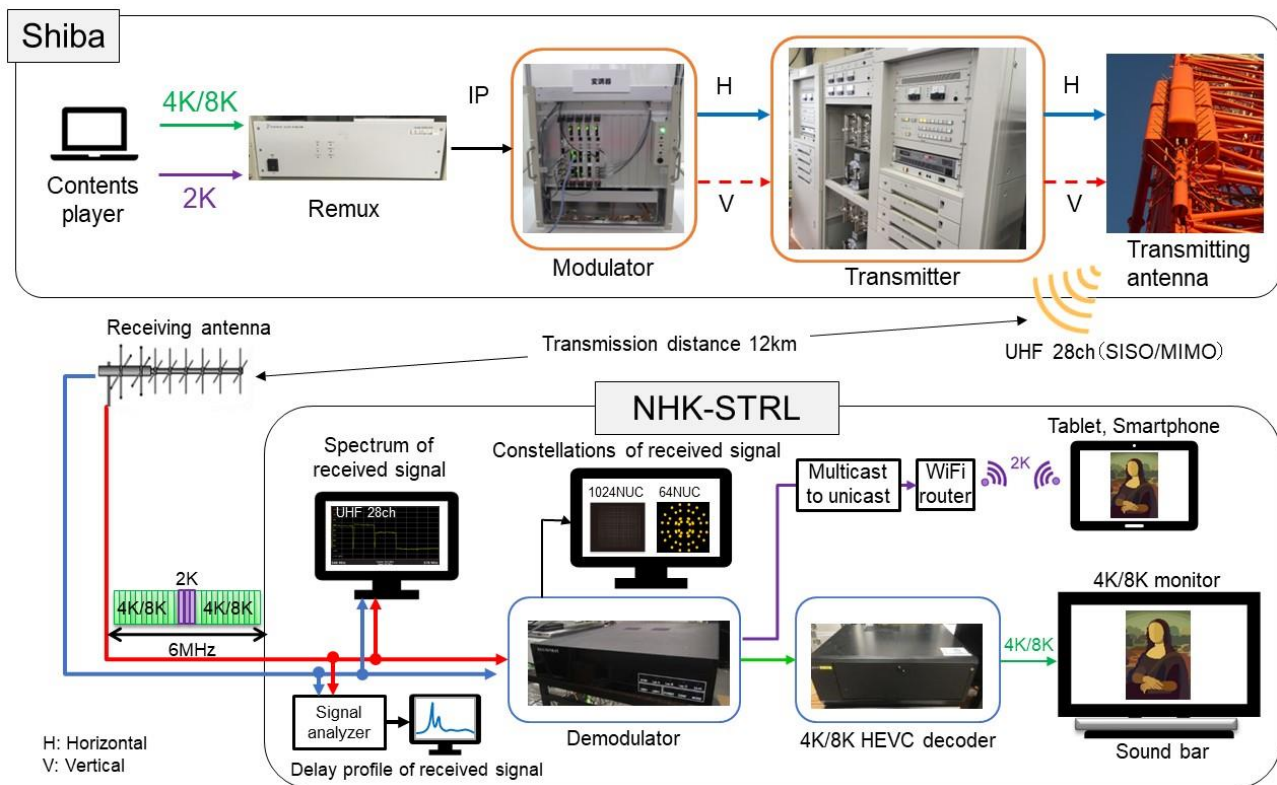

FIGURE 26
Locations of transmitting and receiving points in Tokyo

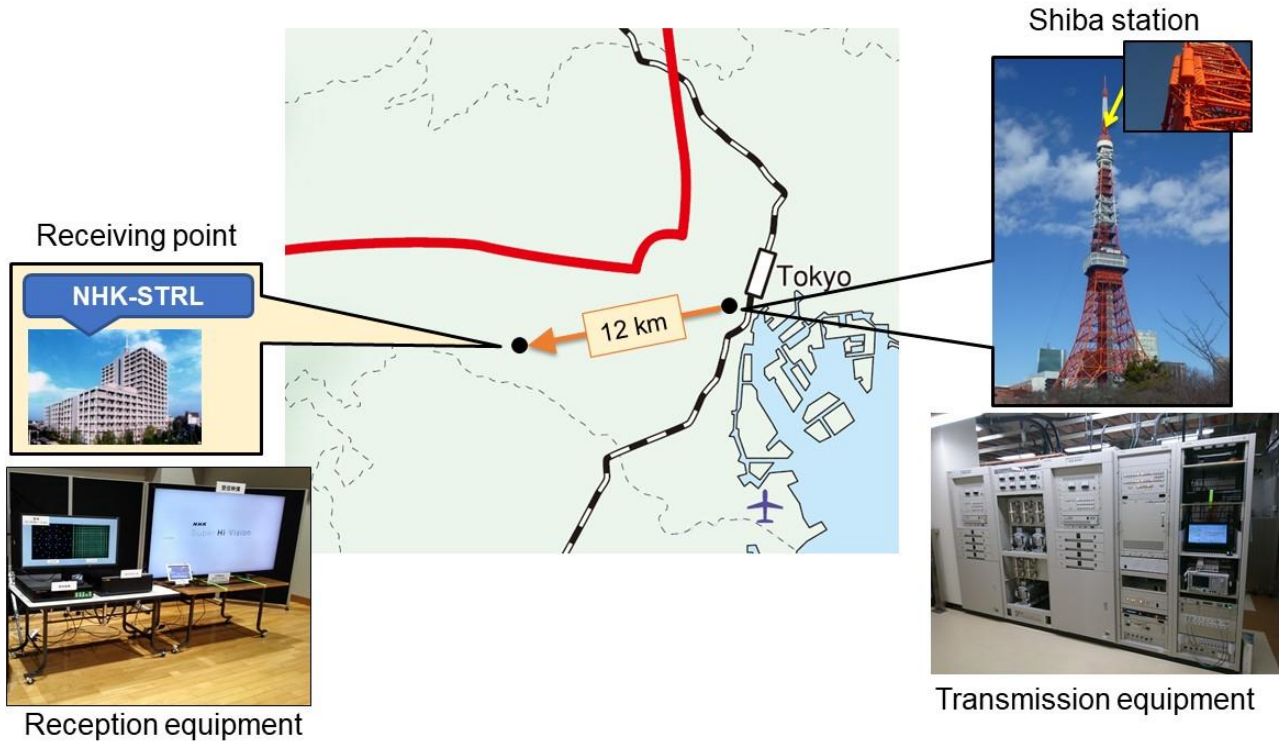
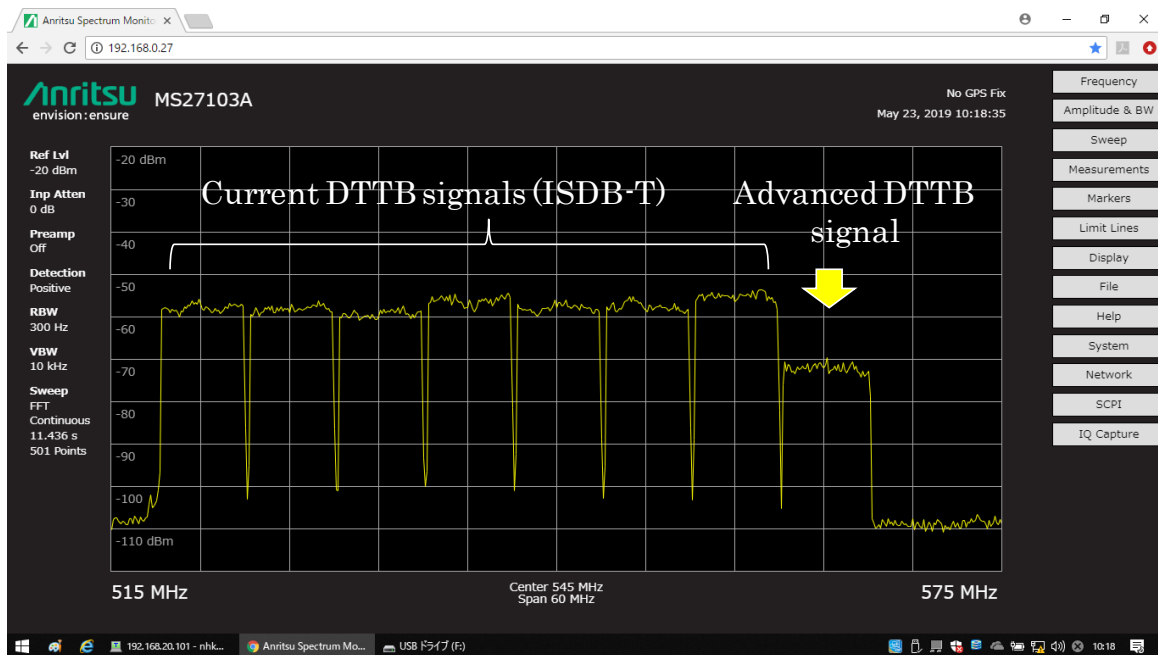

FIGURE 27
Spectrum of received signal at NHK-STRL (SISO)



Note: The advanced DTTB signal was allocated upper-adjacent to the current DTTB signals. The difference in the received power between the advanced DTTB signal and the current DTTB signals is due to the different transmitting power and the transmitting points.

FIGURE 28
Delay profile of received signal at NHK-STRL (SISO)

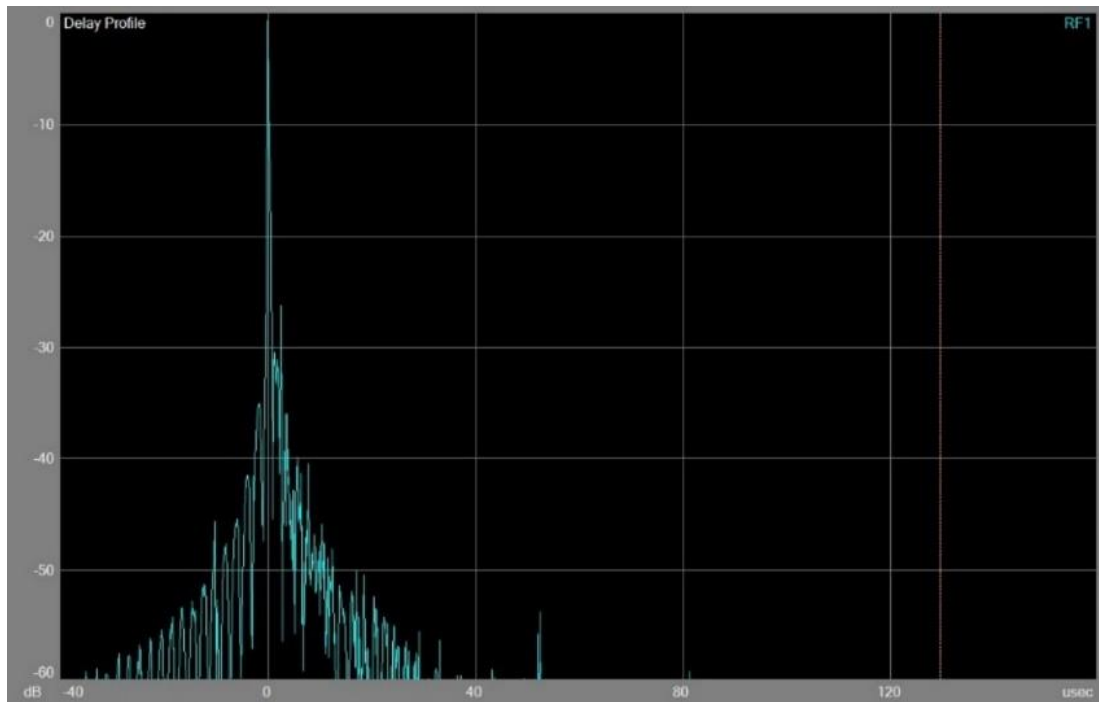
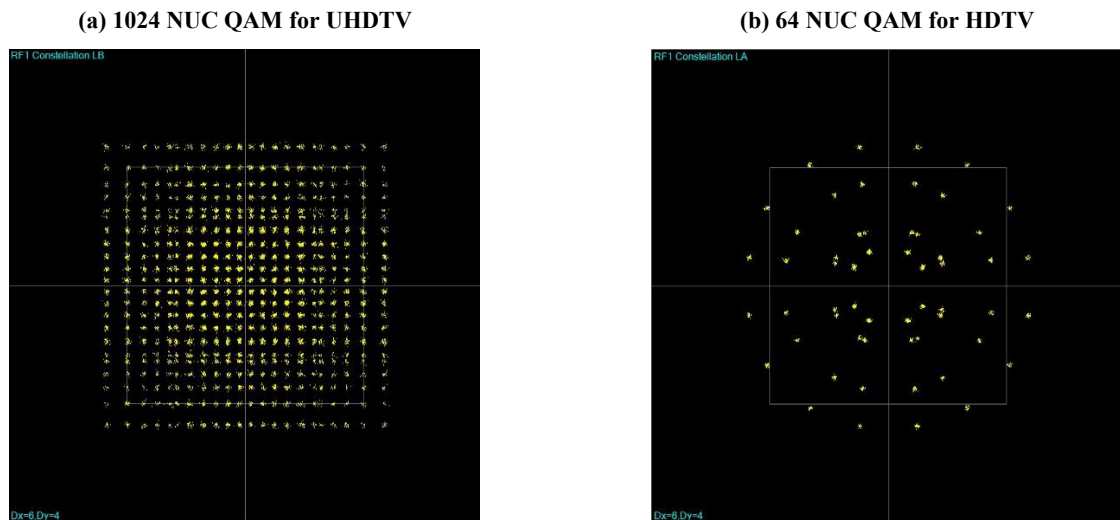

FIGURE 29
Constellations of received signal at NHK-STRL (SISO)



The block diagram of transmitting and receiving system in Nagoya is shown in Fig. 30. Figure 31 shows the locations of the transmitting and receiving points in the Nagoya area. As a receiving point, the Nagoya port building, which is approximately halfway between the Higashiyama and Nabeta experimental stations, was selected. The remultiplexer was installed at the Higashiyama station and the IP packet was sent to the two modulators installed at the Higashiyama and the Nabeta stations. A 200 Mbit/s bandwidth secured line was used as the IP line between the Higashiyama and Nabeta stations. The radio waves were emitted from the two stations to carry out the transmission experiments in a SFN environment. The modulated signals were generated at each transmission timing.

At the receiving point (the Nagoya port building), the receiving antenna was installed facing the Nabeta station. Additionally, the transmission power of the Higashiyama station was adjusted to

demonstrate severe SFN reception conditions. As an example, the desired-to-undesired signal ratio (DUR) of 3.2 dB and 1.9 dB for horizontal polarization and vertical polarization between the Nabeta station (D) and the Higashiyama station (U) was demonstrated with the reduction in the transmission power of the Higashiyama station by 5 dB for both polarizations. Regarding the delay setting of the remultiplexer, the transmitting timings of the Higashiyama and the Nabeta stations were aligned at the same time. As the Higashiyama station is geographically 500 m closer to the reception point than the Nabeta station, it was expected that the transmitted signals from the Higashiyama station would arrive 1.6 μs earlier than the signals from the Nabeta station. However, it was confirmed that the signals from the Higashiyama station arrived about 2 μs later than the signals from the Nabeta station. The delay was caused by a feedback compensation circuit installed in the transmitters at the Higashiyama station.

Figures 32, 33 and 34 show examples of the spectrum, delay profiles, and reception constellations of the received signals for MIMO transmission using horizontal and vertical polarizations. For the reception spectrum, ripples caused by the undesired signals from the Higashiyama station were confirmed. For delay profiles, horizontal to horizontal, horizontal to vertical, vertical to horizontal and vertical to vertical components are shown in blue, green, yellow and pink, respectively. The Higashiyama station is located in the direction opposite to the main lobe of the receiving antenna; therefore, many reflected signals transmitted by the Higashiyama station were observed. The demonstration of UHDTV/HDTV reception with the advanced DTTB system in the SFN environment was presented to the press. It was confirmed that even under severe SFN reception conditions, the UHDTV/HDTV video and audio could be received without any transmission errors.

FIGURE 30

Block diagram of transmitting and receiving system in Nagoya

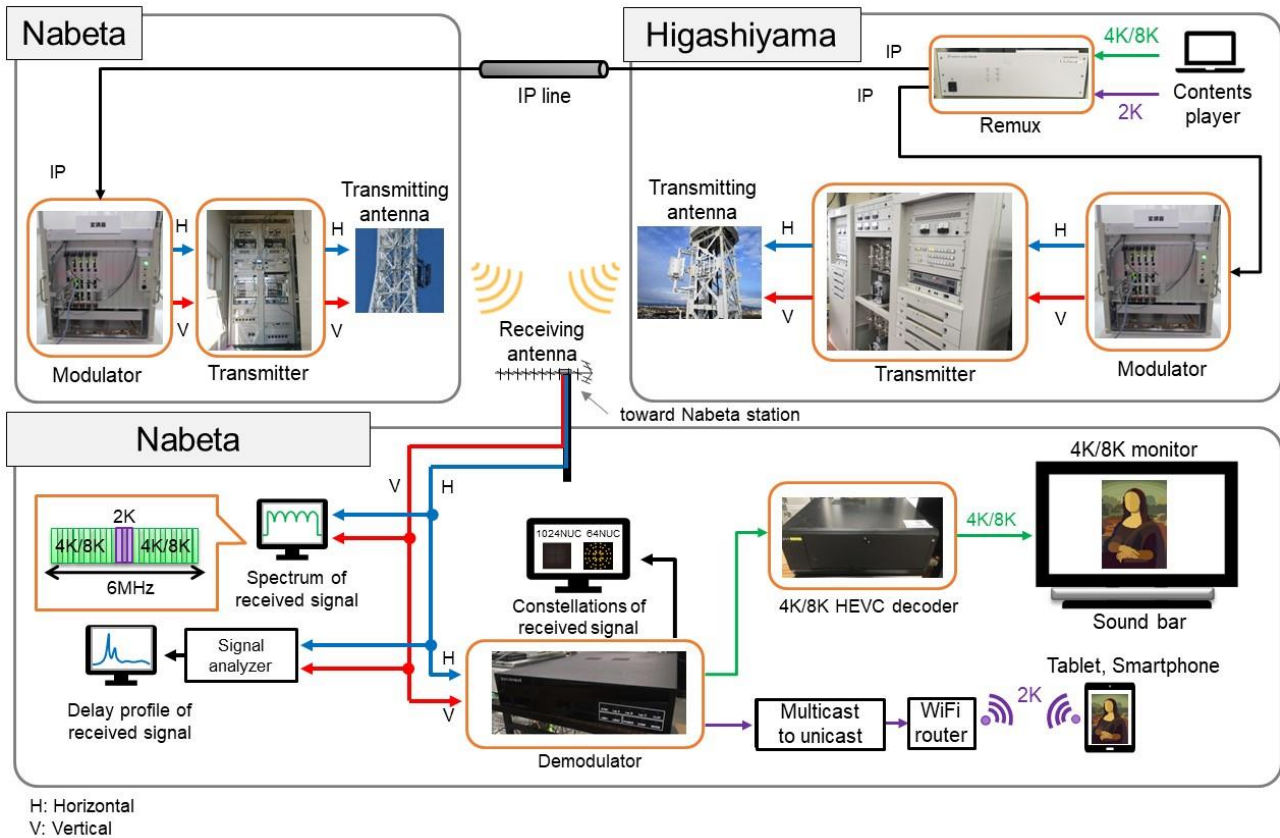

FIGURE 31
Locations of transmitting and receiving points in Nagoya

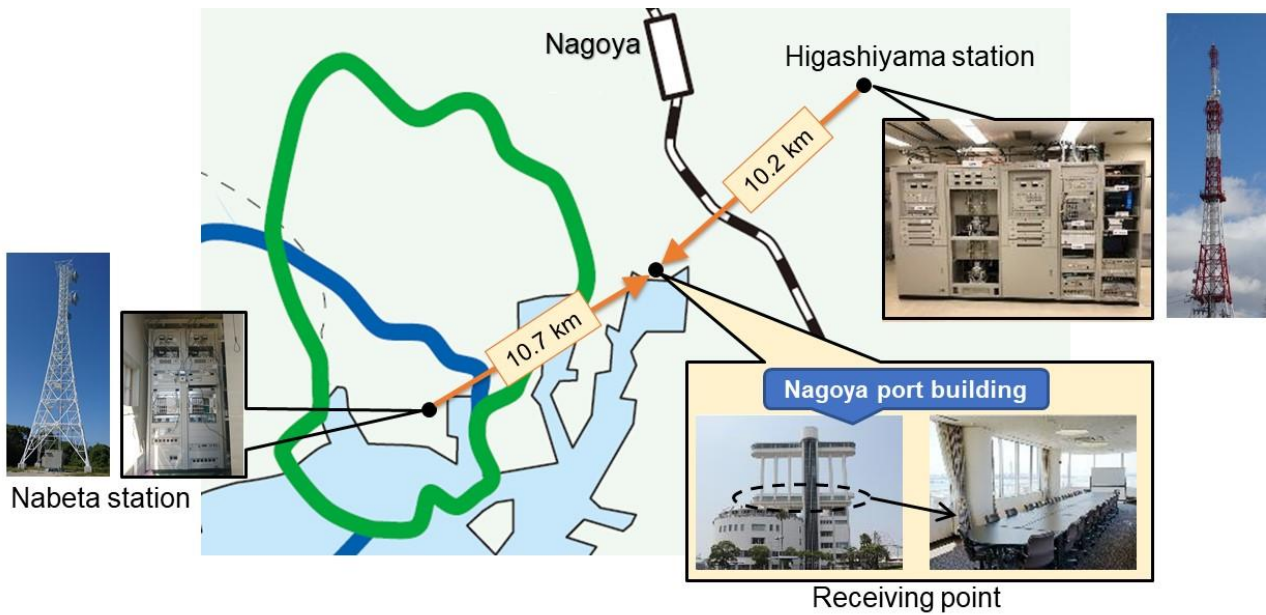

FIGURE 32
Spectrum of received signals at Nagoya port building (MIMO)

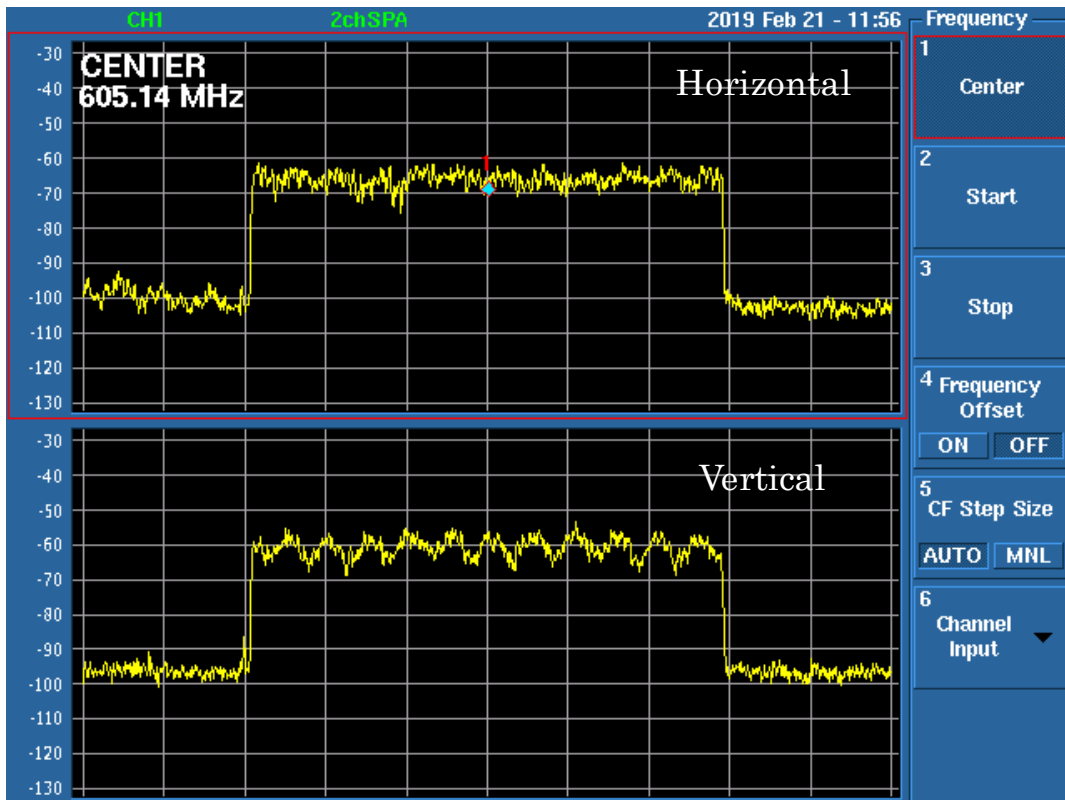

FIGURE 33
 Delay profile of received signals at Nagoya port building (MIMO)

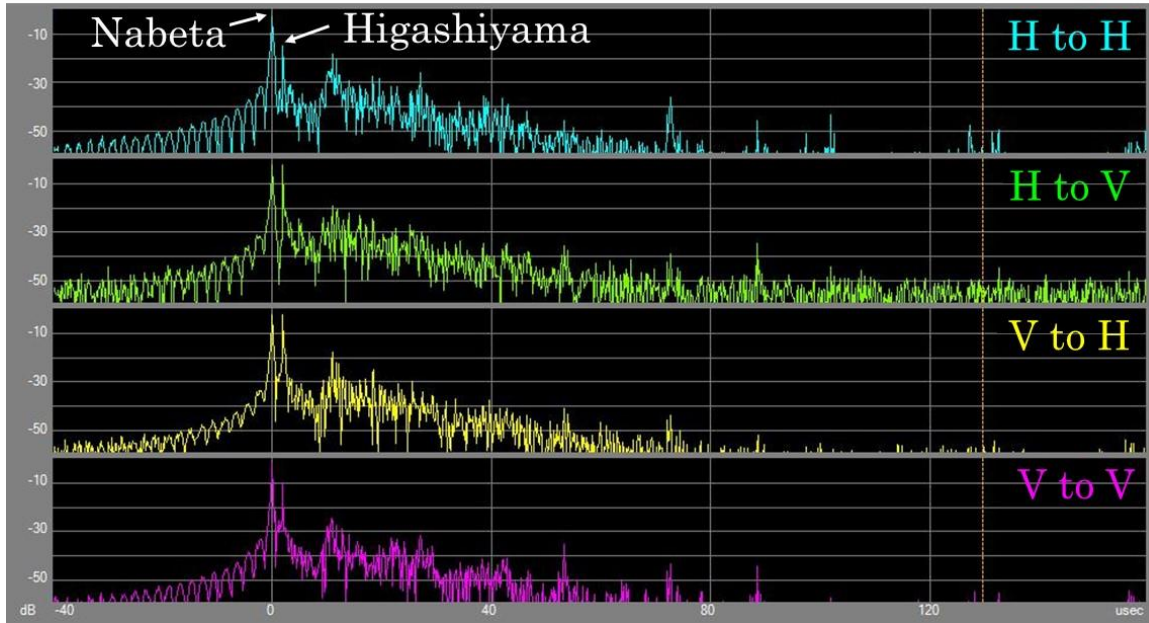
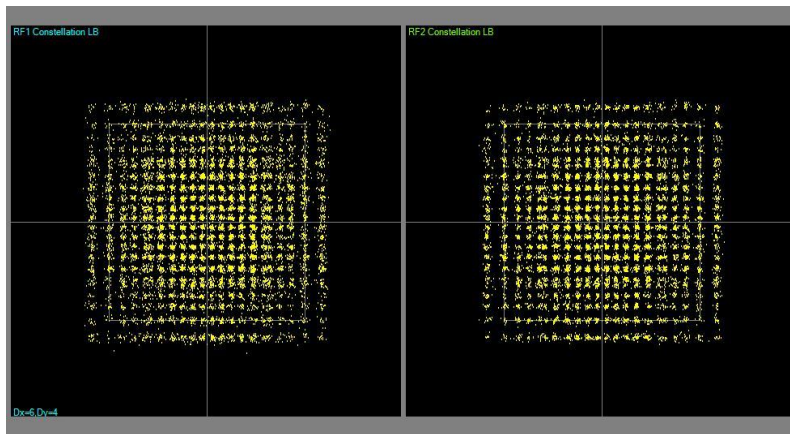

FIGURE 34
 Constellations of received signals at Nagoya port building (MIMO)

(a) 1024 NUC QAM for UHDTV (Horizontal)

(b) 1024 NUC QAM for UHDTV (Vertical)



(c) 64 NUC QAM for HDTV (Horizontal)

(d) 64 NUC QAM for HDTV (Vertical)

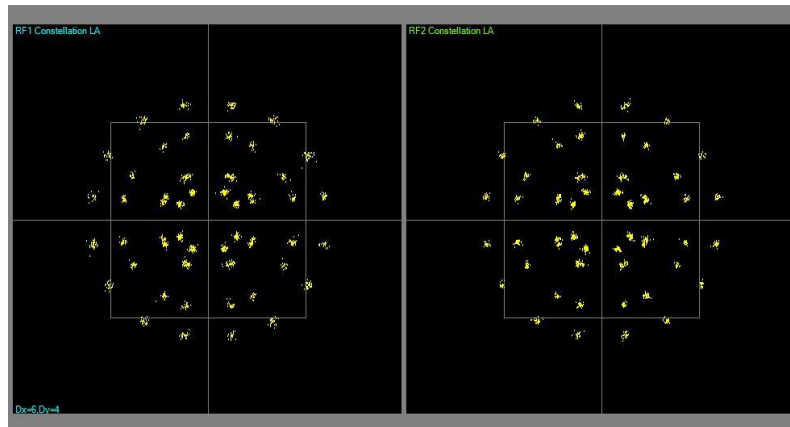

Transmission performance of the advanced system is being verified assuming a fixed rooftop reception with a reception antenna at a height of 10 metres and a mobile reception with vehicular external aerials at a height of 2 metres in the Tokyo and Nagoya areas.

The plan is to evaluate the transmission characteristics not only of single-input single-output (SISO), but also MIMO to confirm the gain in the capacity and required C/N achieved with the advanced system in actual urban reception environments.

1.6 Summary

In the field of broadcasting, 8K-UHDTV has the potential to succeed HDTV.

Japan has set up an experimental station for 8K-UHDTV transmissions at Hitoyoshi city, Kumamoto prefecture, using dual-polarized MIMO and ultra-multilevel OFDM technologies. The field experiments performed there in January 2014 were the world's first 8K-UHDTV terrestrial transmissions (91 Mbit/s) over a long distance (27 km) using a single UHF channel (6 MHz). This paper reported the results of those field experiments specific reference to the required field strength of the 256-QAM, 1024-QAM, and 4096-QAM carrier modulation and the channel response analysis of dual-polarized MIMO transmission.

Japan has added another experimental station for 2×2 MIMO STC-SFN in the same city in 2015. The new field experiment so performed showed significant improvement over conventional SFN. In 2016, an 8K-UHDTV field experiment with HEVC was conducted using the two experimental stations, and the 8K video and audio was stably received in the STC-SFN.

Another experimental station was installed in southern Tokyo, and an 8K-UHDTV field test with NUC was conducted. The experimental results showed that NUC improved the transmission performance in an urban area with the dual-polarized MIMO transmission system.

Japan has also launched an R&D project aiming at developing an advanced DTTB system and evaluating its performance through field trials in large-scale experimental environments constructed in urban areas.

These field experiments will show the feasibility of terrestrial 8K-UHDTV transmission using several key technologies, including dual-polarized MIMO, 4096-QAM carrier modulation, the 2×2 MIMO STC-SFN method, and NUC. The 8K-UHDTV system to be used in Japan will be selected on the basis of further consideration and examination of various technical possibilities and future trends.

2 Republic of Korea

2.1 UHDTV terrestrial trial broadcasting based on DVB-T2

The world's first terrestrial UHDTV trial through the DTT platform in Korea was made possible by the strong resolve of two government bodies in Korea: the Korean Communications Commission (KCC) and the Ministry of Science, ICT and Future Planning (MSIP). They granted permissions and provided support to execute the UHDTV experimental broadcast. This trial was also facilitated by the memorandum of understanding (MOU) signed in April 2012, which confirmed the cooperation of major terrestrial broadcasters in Korea, i.e. KBS, MBC, SBS and EBS, for experimental broadcasts.

Furthermore, most uncertainties regarding the implementation of 4K-UHDTV service within a 6 MHz bandwidth have been resolved and the date for launching 4K-UHDTV via terrestrial broadcast networks can be brought forward. Moreover, the capability of participating broadcasters to produce 4K-UHDTV content has been enhanced up to live production.

2.1.1 Phase 1

September 1 – December 31, 2012

KBS, on behalf of four terrestrial broadcasters, carried out the world's first terrestrial 4K broadcast at 30fps using approximately 32~35 Mbit/s. The transmission was conducted at Kwan-Ak in the south of Seoul.

2.1.2 Phase 2

May 10 – October 15, 2013

Following license renewal, KBS increased the frame rate of 4K contents from 30 to 60 fps at approximately 26~34 Mbit/s. The transmissions continued at Kwan-Ak.

The goal during these phases was to confirm the feasibility of delivering a terrestrial 4K-UHDTV contents using only 6 MHz of channel bandwidth. Thus, the HEVC compression technique, to fit high volumes of 4K video data rates into limited bandwidth, and the DVB-T2 standards, to improve the robustness of over-the-air transmission, were adopted.

Kwan-Ak Mountain Transmission Site

During Phase 1 and 2, KBS operated the Kwan-Ak site only using the parameters shown in Table 10. For the field test, 15 and 10 reception points located 5 km to 52 km, respectively, from the transmitter were selected as shown in Fig. 35.

- In Phase 1, the field test was conducted at 15 points with an almost identical radial distance of 5 km from the transmission site. We attempted to maintain an equal angle interval for each measuring point, as shown in Fig. 35(a).
- In Phase 2, the field test was conducted at 10 points at distance 10 km to 52 km from the transmission site as shown in Fig. 35(b).

FIGURE 35

Location of reception points during Phase 1 and Phase 2

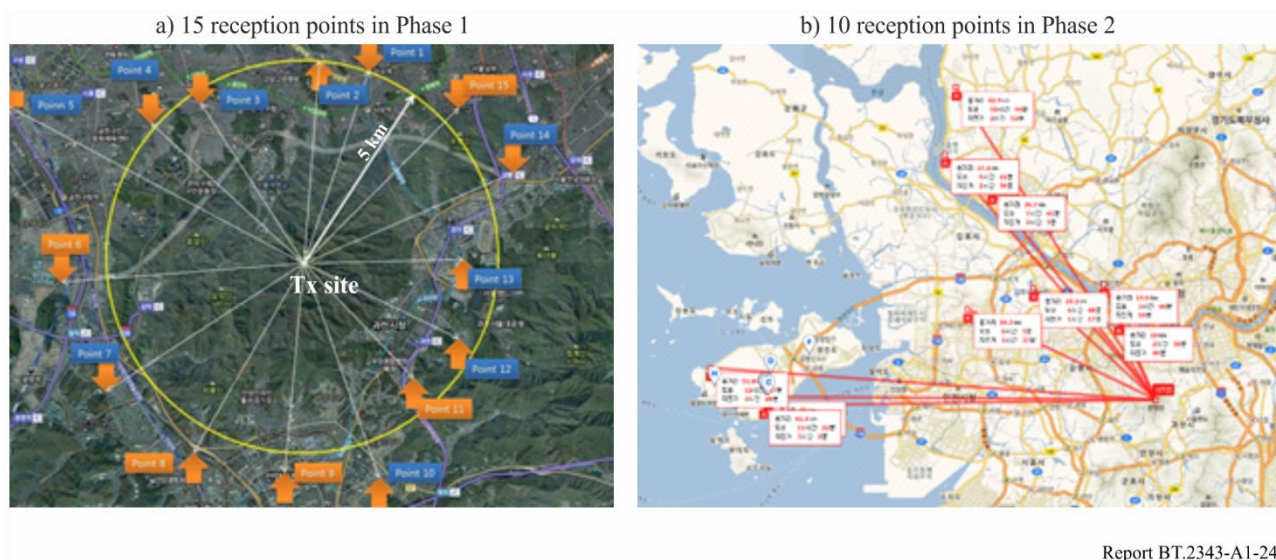

TABLE 10
Specifications of transmission system during Phase 1 and 2

	Phase 1			Phase 2	
Transmitter site	Kwan-Ak Mountain				
Covering	The Metropolitan area of Seoul				
Nominal power (Antenna gain)	100 W (6.01 dBi)				
DTT System	DVB-T2				
Transmission mode	32k, extended mode, $GI = 1/128$, PP7				
Modulation	256-QAM			64-QAM	256-QAM
Number of FEC blocks in interleaving frame	163			123	165
FEC code rate	3/4	4/5	5/6	4/5	5/6
Multiplexing capacity	32.8 Mb/s	35.0 Mb/s	36.5 Mb/s	26.5 Mb/s	36.9 Mb/s
Signal bit rate	32.0 ~ 35.0 Mb/s			26.0 ~ 34.0 Mb/s	
Video encoding standard	HEVC				
Picture standard	3 840×2 160p, 8 bits/pixel 30 fps			3 840×2 160p, 8 bits/pixel 60 fps	
Frequency used	785 MHz (Ch 66 in Korea)				

2.1.3 Phase 3

March 24, 2014 – March 31, 2015

In Phase 3, in addition to KBS, MSIP granted permission to MBC and SBS for experimental broadcast. KBS and SBS deployed a single frequency network (SFN) for live 4K-UHDTV experiments as listed in Table 11.

TABLE 11
Transmitting power and used channels of transmitter site during Phase 3

Broadcaster	KBS	MBC	SBS
Centre frequency (channel number)	713 MHz (Ch 54)	701 MHz (Ch 52)	707 MHz (Ch 53)
Kwan-Ak mountain	5 kW	2.5 kW	5 kW
Nam mountain	600 W	–	–
Yong-Moon mountain	–	–	1 kW

The detailed parameters of the 4K signal transmitted on the DTT platform are listed in Table 12. The experimental broadcast chain of KBS, including content production, encoding, microwave link, is shown in Fig. 36.

FIGURE 36

Transmission chain of the SFN deployed by KBS for 4K-UHDTV experiments in Phase 3

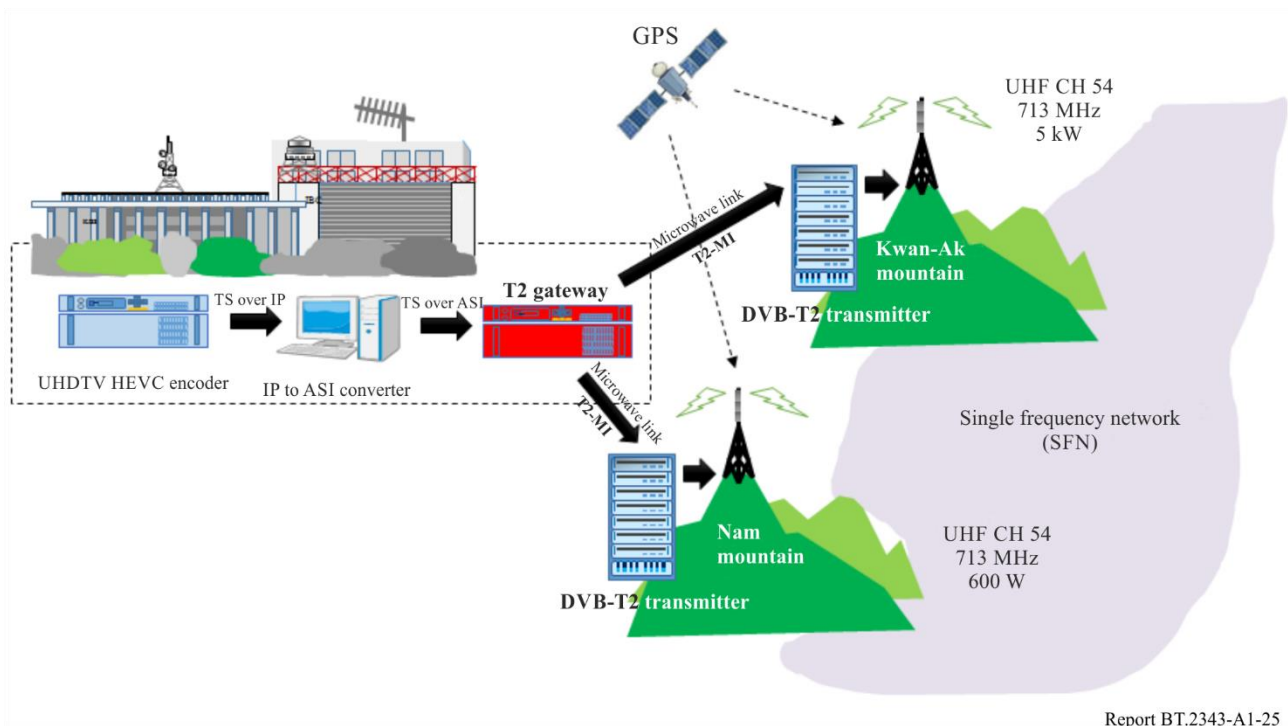

The remarkable feature of Phase 3 was that it involved live 4K-UHDTV experimental broadcasting over an SFN, which was possible due to the development of a real-time encoder for 4K-UHDTV content. KBS hence carried out the world's first live 4K terrestrial broadcast over SFN, of the 2014 Korean Basketball League (KBL) Final.

It also should be emphasized that the release of the DVB-T2 demodulator with the HEVC decoder chipset-embedded 4K-UHDTV at an affordable price has made it easier for people in Seoul to watch 4K programs through the direct reception using the antenna. That is, anyone who has a 4K-UHD TV can watch 4K contents through the DTT platform.

2014 KBL Final Match

On April 5, 2014, KBS carried out the world's first terrestrial 4K live broadcast. The target of the 4K live broadcast was the final of the KBL in Ulsan in south-eastern Korea, as shown in Fig. 37(a).

Alongside the terrestrial 4K live broadcasting, a public viewing event was also held in Seoul Station, the largest and busiest railway station in Korea. Figure 38 shows the event. The 4K UHDTVs in Fig. 37(b) had a built-in DVB-T2 tuner with the HEVC decoder, which enabled the direct reception of the 4K terrestrial signal to the station.

FIGURE 37

4K live broadcast of the 2014 KBL Final

Report BT.2343-A1-26

2014 FIFA World Cup in Brazil

In an attempt to give wider publicity to terrestrial 4K-UHDTV, the following three World Cup matches were broadcast live in 4K-UHD, as shown in Fig. 38. 4K live was fed from Brazil via AsiaSat5, a communications satellite, as shown in Fig. 38.

- Round of 16: Colombia vs. Uruguay
- The Quarterfinal: France vs. Germany
- The Final: Germany vs. Argentina

Images from Brazil were delivered in real-time through the AsiaSat5 communication satellite. The Korean Research Environment Open Network (KREONET) was used to deliver live 4K contents for public viewing events to other provinces.

In order to increase live service coverage of the 4K-UHDTV, two provinces were chosen for the public viewing, Daejeon and Jeju Island, in addition to the metropolitan area of Seoul, as shown in Fig. 39:

- Daejeon is fifth largest metropolis of Korea and approximately 167 km from Seoul. The reception system for the public viewing was set up in the lobby of the KBS's Daejeon station building.
- Jeju is 450 km south of Seoul, and is the largest island in Korea. The reception system for public viewing there was set up in the lobby of the KBS Jeju station building.

FIGURE 38

Transmission configuration established by KBS for the nationwide 4K live broadcast

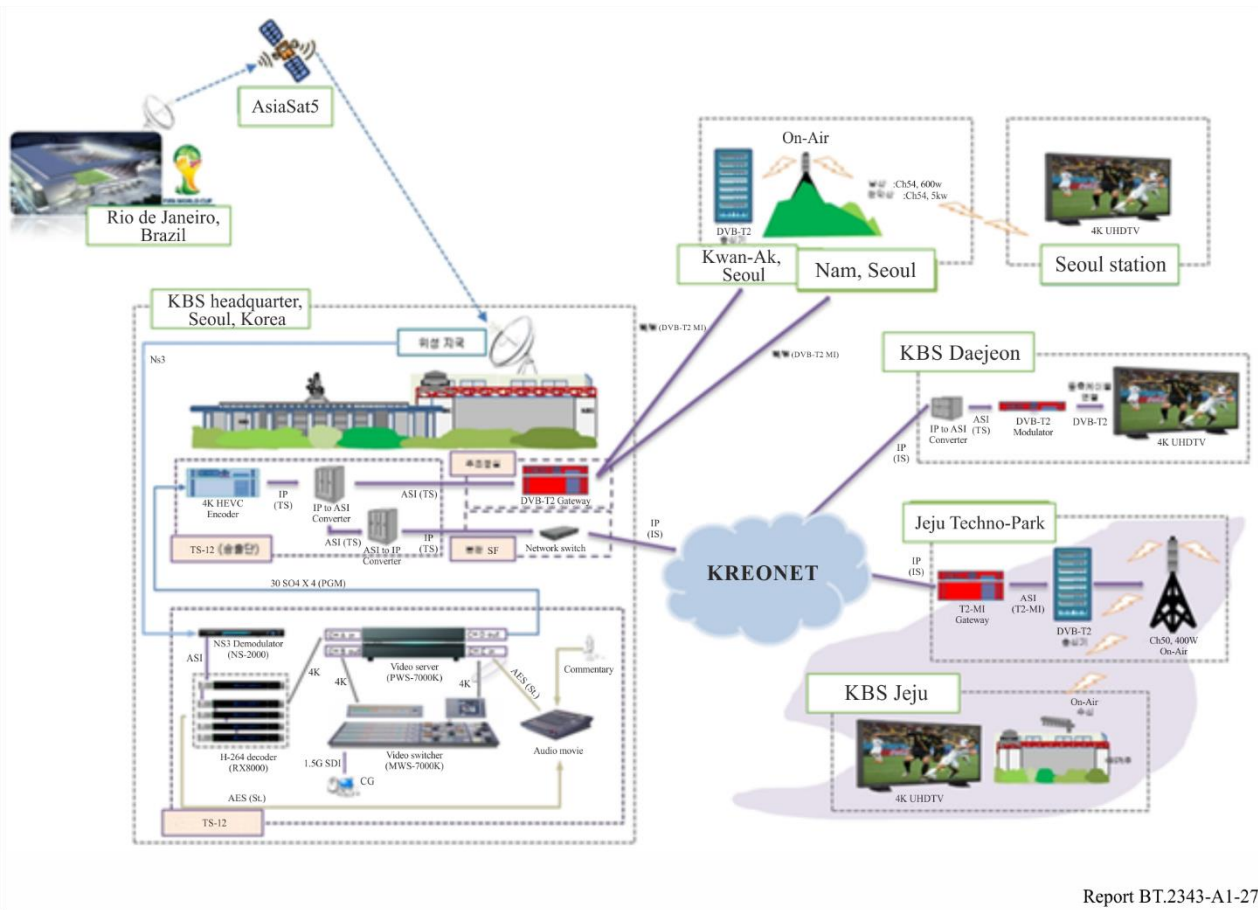

Report BT.2343-A1-27

FIGURE 39

4K live broadcast of the 2014 FIFA World Cup



Report BT.2343-A1-28

A scene of the location for public viewing at (a) the lounge in Seoul Station, (b) the lobby of the KBS Daejeon station building, and (c) the lobby of KBS's Jeju station building

2014 Incheon Asian Games

With the government's cooperation in support 4K live coverage of the 2014 Incheon Asian Games, each broadcaster picked sporting events that suited its interests:

- KBS chose men and women's volleyball (see Fig. 40).
- MBC chose track-and-field events, as well as the opening and closing ceremonies.
- SBS picked beach volleyball.

There were no public viewing events, because 4K UHD TVs with built-in DVB-T2 tuners along with the HEVC decoder had become widely available by then, and anybody in the metropolitan area of Seoul could have watched the Incheon Asian Games live on 4K UHDTV.

FIGURE 40
4K live broadcast of the 2014 Incheon Asian Games



Report BT.2343-A1-29

ITU Plenipotentiary Conference 2014 (PP-14)

During the ITU PP-14 held at the Busan Exhibition and Convention Center (BEXCO) in Busan, Korea, a local on-air demonstration was watched by several delegates from the Member States as well as Sector Members of the ITU.

A 4K stream was delivered by KREONET from Seoul to Busan, as shown in Fig. 41(a). Consequently, the same 4K contents were broadcasted in both Seoul and BEXCO. The 4K stream was fed into a transmitter installed in BEXCO, and the radio frequency (RF) signal produced by the transmitter was sent to the 4K UHDTV by covering the indoor, as shown in Fig. 41(b).

FIGURE 41
Local on-air demonstration at ITU PP-14 held in Busan, Korea



Report BT.2343-A1-30

2.2 UHDTV terrestrial trial broadcasting based on ATSC 3.0

The Republic of Korea also conducted trials based on ATSC 3.0. The results are summarized below.

2016-2017: Experimental Broadcasting Based on ATSC 3.0

On January 17, 2016, the experimental broadcasting using ATSC 3.0 transmitter was initiated. For a single frequency network (SFN), ATSC 3.0 Broadcast Gateway equipment is required, but at the time, the equipment had not been developed, so the experiment was conducted with a multiple frequency network (MFN) using only one transmission station at Kwan-Ak Mountain, as shown in Fig. 42. Through the experimental broadcasting, the technical feasibility of the ATSC 3.0 standard was examined in depth.

FIGURE 42

Transmission chain deployed by KBS for 4K-UHDTV experiments based on ATSC 3.0

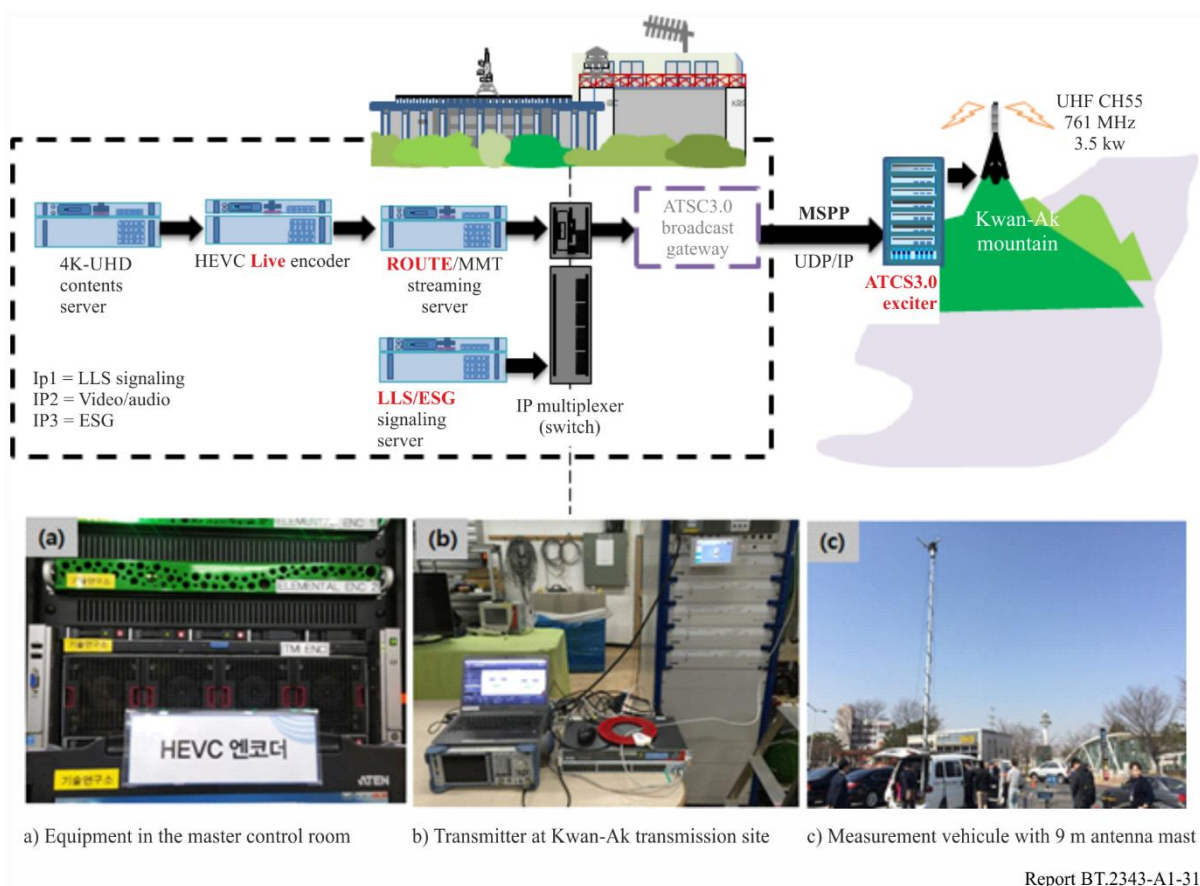

In March 2016, the first field test for the ATSC 3.0 broadcasting was conducted and terrestrial broadcasters and TV manufacturers participated in the measurement campaign for three weeks, supported by the government. Measurement results for 34 locations are shown in Fig. 43.

FIGURE 43
Measurement campaign for ATSC 3.0

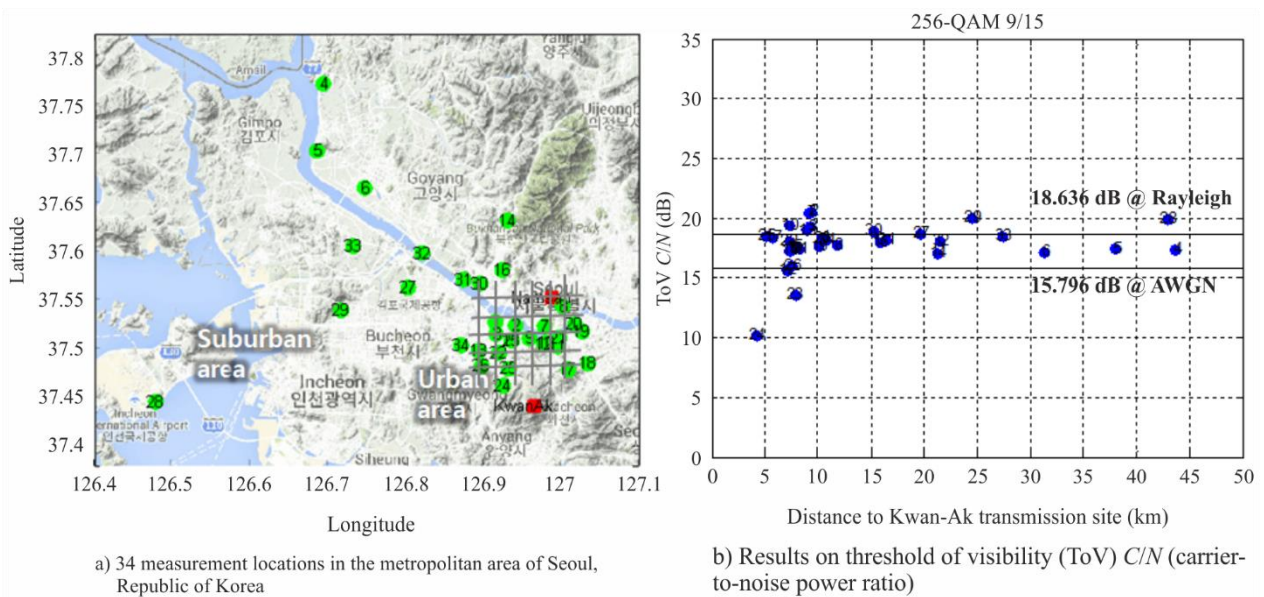

Report BT.2343-A1-32

On February 2017, the trial broadcast based on ATSC 3.0 systems was begun, and the entire broadcasting system was verified. In particular, on February 10, 2017, as shown in Fig. 44.

FIGURE 44
4K live broadcast of the FIS Freestyle Ski World Cup Finals



Report BT.2343-A1-33

3 France

3.1 Initial experiment (2014-2018)

3.1.1 Introduction

The objective of this experiment was to implement an experimental platform for transmitting linear ultra-high definition television (UHDTV) from the Eiffel Tower with a data rate of 40.215 Mb/s, aiming at testing the associated new technologies (HEVC encoding of UHD profile, DVB-T2 broadcasting and interoperability with TVs), understanding the possible technical difficulties in this context and demonstrating the corresponding services.

3.1.2 4K-UHDTV field experiment conducted in France

For maximizing the throughput during this experiment, a UHD DVB-T2 multiplex was transmitted from the Eiffel Tower (Paris) according to an MFN (Multi-frequency Network) profile with $GI = 1/128$.

The reception of DVB-T2 multiplex was possible at any point in the DTTB coverage area, having a radius of about (25 km), via a standard fixed rake antenna and a TV set equipped with a DVB-T2 tuner and HEVC chipset set up to decode the UHD programs.

3.1.2.1 System parameters and coverage area

The system parameters used in the experiment of 4K UHDTV terrestrial transmission conducted in France are presented in Table 12. The coverage of the transmitter is depicted in Fig. 45.

TABLE 12

System parameters of 4K UHDTV field experiment in France

Network topology	MFN (DTTB)
Modulation method	OFDM
Channel bandwidth / Occupied bandwidth	8 / 7.77 MHz
Transmission frequency	514.167 MHz (UHF ch26)
Transmission power	100 W, e.r.p.: 1000 W
Transmission mode	SISO
Carrier modulation	256-QAM
C/N (for Rician channel)	19.7 dB
FFT size (number of radiated carriers)	32k (27,841)
Guard interval ratio (guard interval duration)	1/128 (28 μ s)
Pilot pattern	PP7
# OFDM symbols	60
Error-correcting code	Inner: LDPC, code rate = 2/3 Outer: BCH
Data rate	40.215 Mb/s
Video coding	HEVC (2160p ⁽¹⁾ UHD-1 phase 1, 8 bit, 50 fps)
Transmitting station	Eiffel Tower
Height of transmitting antenna	313 m
Height of receiving antenna	10 m
Coverage radius	(25 km)
Minimum median field strength	55 dB μ V/m at 10 m

⁽¹⁾ 3 840×2 160 (4K)

FIGURE 45
Coverage area of 4K UHD TV field experiments in Paris (France)

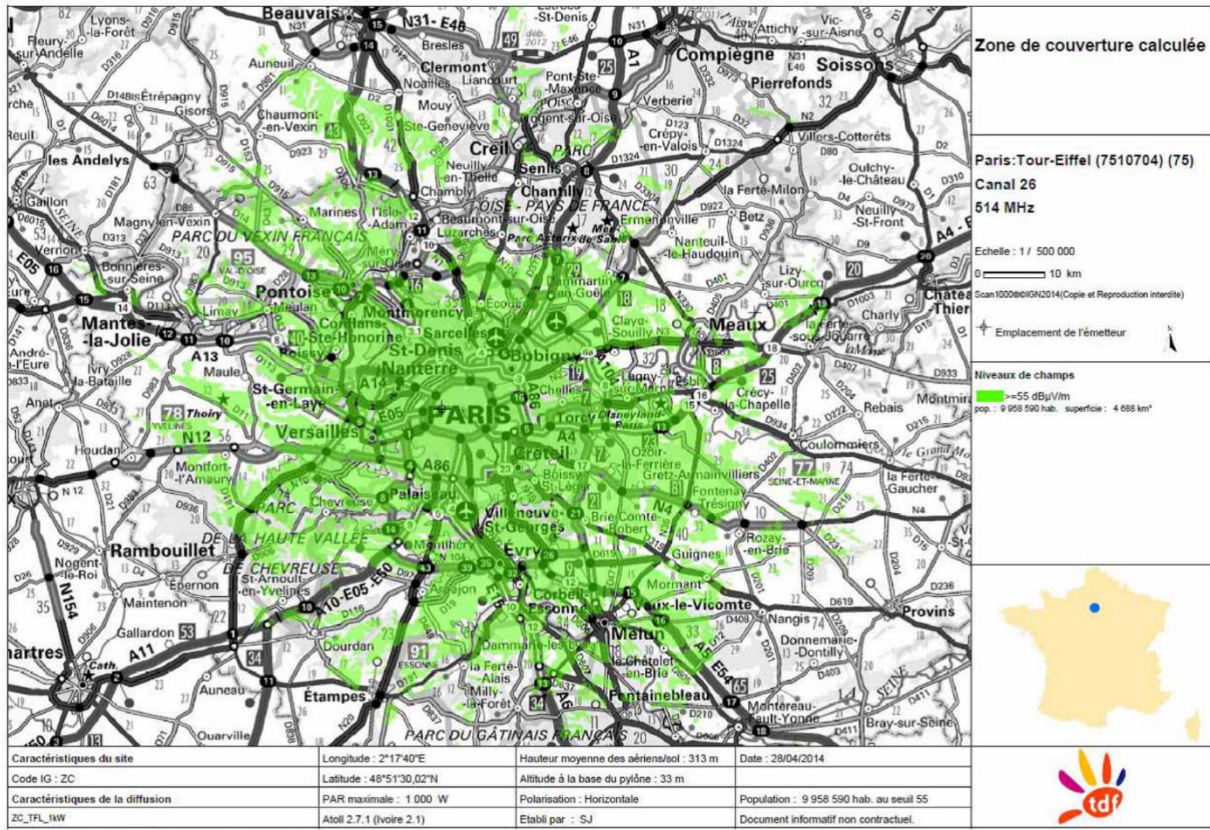

Report BT.2343-A1-34

e.r.p. = 1 kW
Coverage radius ≈ 25 km
Minimum median field strength = 55 dBμV/m

3.1.2.2 Implementation of 4K UHD TV terrestrial transmission platform

The implementation of 4K UHD TV terrestrial transmission platform was based on a set of technical links and units most of them being new and requiring specific tests to be able to run the transmission link from the starting point to the end – from the capture of UHD images to the reception on an integrated UHD-1 phase1 TV set. The technical description of the platform is depicted in Fig. 46.

FIGURE 46

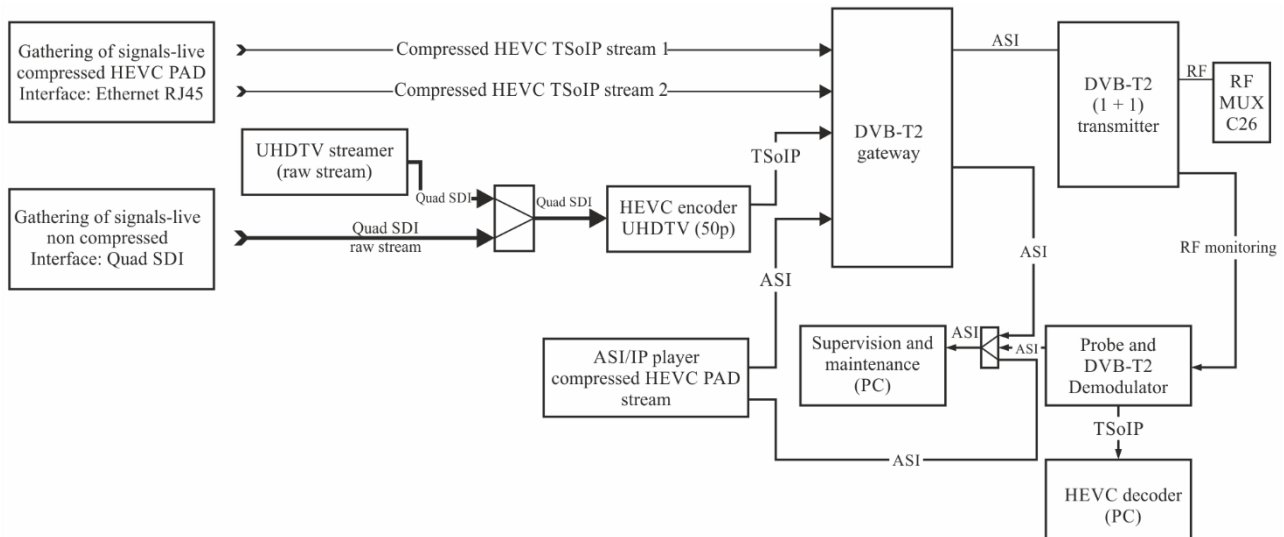
Technical description of 4K UHD TV terrestrial transmission platform

Report BT.2343-A1-35

3.1.2.3 Live 4K UHD TV terrestrial transmission of the “French Open” International tennis tournament (2014)

Live transmission as well as transmission of pre-recorded and encoded footages were performed during the experiment. Here the only focus is on live transmission of “French Open” international tennis tournament.

The implementation of 4K-UHDTV platform for live transmission (50 fps) of the “French Open” tournament was a technological challenge. The experiment has demonstrated the feasibility of such broadcasting in DVB-T2 with three different integrated UHD-TV with first embedded HEVC decoding chipset. For the duration of the tournament, two full afternoons (3 and 4 June) were dedicated for broadcasting in live on UHD Program 1 by means of four moving UHD cameras (actual UHD production). For the rest of the tournament, a fixed UHD camera installed on the main court was used for broadcasting in live on UHD program 1. A second UHD program (Program 2), pre-encoded UHD film (sea, waves with storm, fisher boats), was broadcasted on Brittany:

- UHD Program 1: 22.5 Mb/s real-time encoding for live transmission.
- UHD Program 2: 17.5 Mb/s pre-recorded and off line encoded.

These two values have been defined for several reasons:

- Off line encoding uses additional HEVC tools that are not implemented in the first generation of real time encoder (no more details from encoder manufacturers at this time) and it represents next versions that will be implemented in live encoders.
- Pre-recorded files represent the same quality of current live encoder at a different bit rate.
- 17 Mb/s represents the quality of two UHDTV channels in a SFN T2 multiplex of 36 Mb/s.
- 22 Mb/s has been set in order to show the impact of an additional 5Mb/s on UHDTV quality.

Moreover, two days were devoted to the production of UHDTV images shot by four UHDTV cameras and two HD cameras upscaled to UHD. These two days have permitted the comparison of the quality of image of UHD, HD (1 920×1 080i/25) and SD (720×576i/25) programs on the same UHDTV screen.

The block diagram of live 4K UHD TV terrestrial transmission platform is depicted in Fig. 47.

FIGURE 47

Live UHDTV terrestrial transmission of the “French Open” tournament

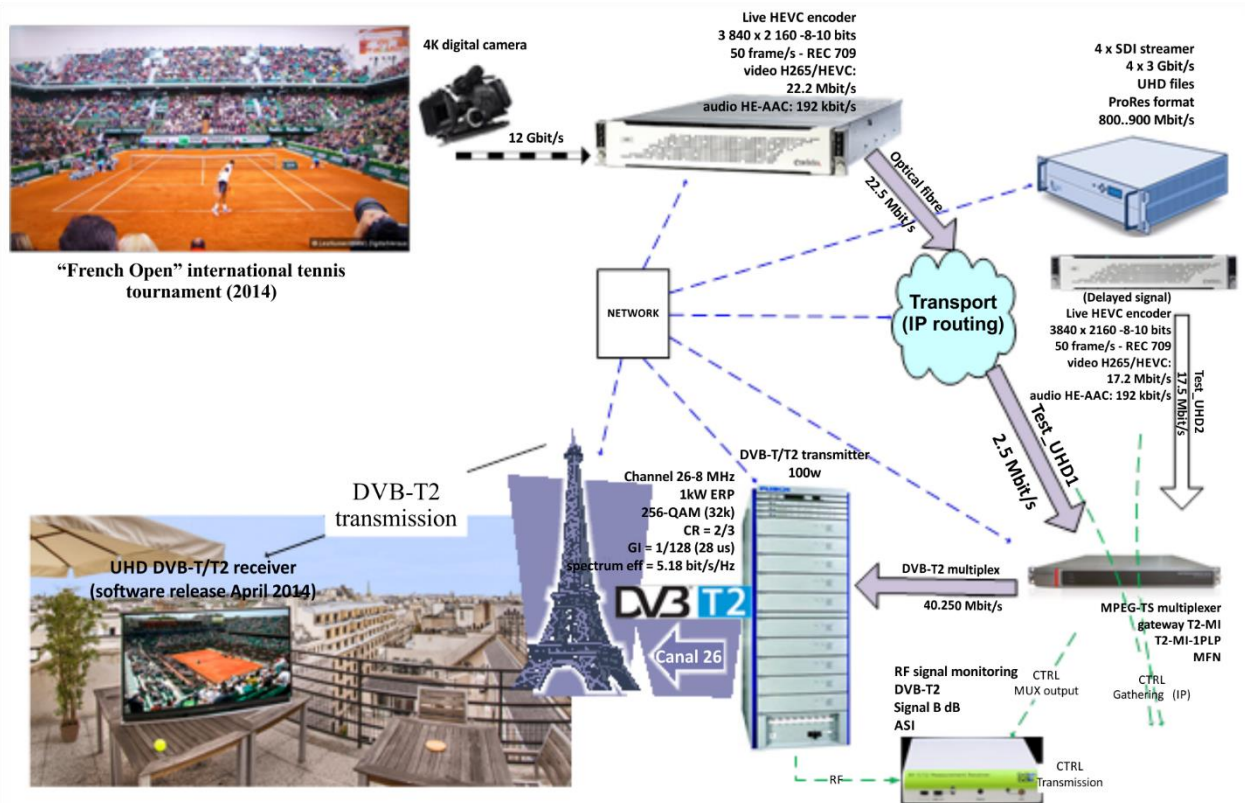

Report BT.2343-A1-36

The experiment permitted, through simulcasting DTTB including images of “French Open” tournament, to compare the perceived quality of UHD, HD and SD programs, images being presented on the same UHDTV screen.

Demonstrations were performed to have the opinion of professionals as well as home users, some of them discovering UHDTV images for the first time. They were invited to watch TV in the same conditions as in a living room sitting at a distance suitable for a UHDTV screen, which was about 1.5 times the height of the 65 inches TV display. Most of them (about 60 to 70 visitors) felt that the image quality of UHDTV programs was fairly better than that of SD and HD programs due to the fact that we could recognize people in the stands even with wide view angle, which is impossible in HD and many other feedbacks: “it is so realistic, like if we look through a window”.

3.1.3 Conclusion

This experiment was an important step towards the introduction of the terrestrial UHDTV in France, where the DTTB SD&HD platform is a major platform transmitting linear TV, with a majority of high definition (HD) programs. It demonstrated the feasibility of live 4K UHDTV terrestrial transmission based on UHDTV (phase 1) specifications and 256 QAM OFDM modulation with two programs in a DTT Multiplex for the first version of live UHDTV encoders. It also demonstrated the step of quality of UHDTV programs compared to HD programs (1 920×1 080i/25).

Consequently, it is concluded that UHDTV will surely be the successor to high definition television (HDTV). Based on this conclusion the aforementioned 4K UHDTV terrestrial transmission platform is maintained in use aiming at supporting the undergoing developments of UHDTV and preparing the introduction of the terrestrial UHDTV in France.

Moreover, based on the currently available information on the issue, from a technical and economical point of view, it can be concluded that it will be possible to transmit three UHD TV (phase 1) programs in a DVB-T2 multiplex in France by 2017.

3.2 Revised experiment (Started 2018)

The initial experiment had been running for four years when it was decided to expand its reach to lead additional tests. This decision followed the publication, by the CSA – the French broadcast sector regulator, see <https://www.csa.fr/> –, of a roadmap for the modernization of the French DTTB platform: the objectives of this roadmap³ are to study the technical and legal aspects and prepare the platform for the generalized introduction of 4K-UHD TV before the 2024 Olympic Games. The aim of this introduction is to keep the existing network infrastructure and frequency planning as they are, allowing a smooth transition for the viewers by only changing the transport and coding standards from DVB-T / H.264 / E-AC-3 to DVB-T2 / H.265 / NGA.

3.2.1 Network architecture and system parameters

The initial architecture presented in § 3.1 was based on the use of a unique site and meant to explore different implementation strategies for the transmission platform. As it is not representative of the existing network architecture, the network deployment was adapted in several stages as follows:

- On the Paris area, three additional sites were added to the Eiffel Tower initial deployment to form a SFN on channel 26. The Eiffel Tower ERP was increased to 3 kW, while an additional site, terrestrially fed (Paris-Est Chennevières) was set up at 200 W ERP; two gapfillers / on-channel repeaters were also implemented at Meaux (40 W ERP) and Chaville (3W ERP) respectively. This first stage formed the test bed for measurements around the selected system parameters (see below). The SFN delays were selected to optimize the resulting service area, while retaining the ability to adjust the SFN delay on Paris-Est Chennevières to provide levers for exploring the impact of different timings during the measurement campaign.
- The experiment was then expanded with the deployment of two additional sites in two additional cities – Nantes with a 16 kW ERP on the main transmitter covering the surrounding region and Toulouse with a 500 W ERP on a medium tower medium power site covering the city. Both sites were fed from terrestrial links.
- Finally, to cope with 700 MHz band migration constraints, the Paris SFN was switched to channel 24 (498.167 MHz centre frequency), while the Eiffel Tower ERP was increased to 5 kW to expand the coverage further.

For this experiment, a T2 gateway providing a T2-MI stream to the transmitters (except on-channel repeaters) was located at the Eiffel Tower site. The T2-MI transport was done through an IP pipe dimensioned to 50 Mb/s to cover the necessary overhead for T2-MI to IP encapsulation (~7% overhead for T2-MI over MPEG2-TS to IP) and provide a sufficient FEC protection (5-20% overhead), while leaving headroom for the testing of different DVB-T2 configurations (up to more than 40 Mb/s net bit rate). Figure 48 below depicts the network architecture after the second stage deployment.

The primary target of the experiment was to explore the behaviour of two candidate sets of DVB-T2 parameters for the switch to an all DVB-T2 landscape in France. As stated before, as the aim is to allow a smooth transition for the viewers with no network infrastructure and frequency planning modifications, those two sets were selected to match best the currently deployed DVB-T parameter

³ The CSA is currently (June 2020) in the process of reviewing this roadmap after a new public consultation on the modernization of the French DTTB platform published in December 2019 with results published in May 2020.

set for fixed reception, namely 8k FFT with 64-QAM modulation and 3/4 code rate, using a 112 μ s guard interval (Rician C/N is 18.6 dB, 24.88 Mbits/s net bit rate). Since the experiment did not allow to strictly reproduce existing coverages, the main testing was done around the SFN behaviour relating to each parameter set, specifically when echoes outside of the guard interval are present.

FIGURE 48

Revised network architecture

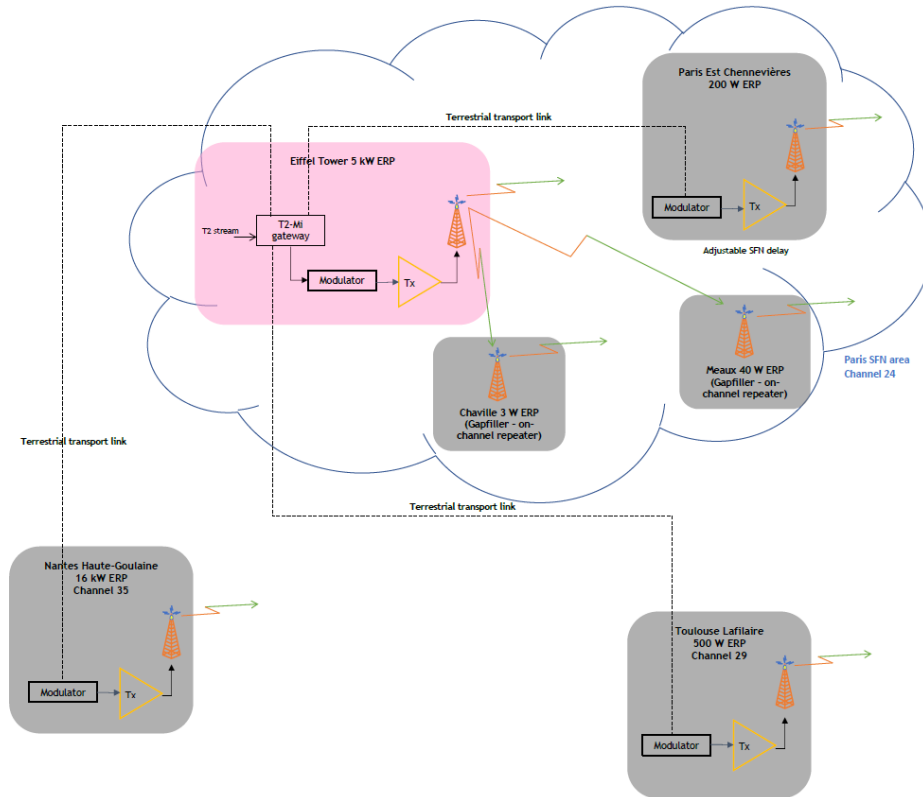

TABLE 13

DVB-T2 parameter sets for revisited field experiment in France

	1 st set (C1)	2 nd set (C'1)
Modulation method	OFDM	
Channel bandwidth / Occupied bandwidth	8 / 7.77 MHz	
Transmission mode	SISO	
Carrier modulation	256-QAM	
C/N (for Rician channel)	18.0 dB	18.6 dB
FFT size (number of radiated carriers)	32k (27,841)	
Guard interval ratio (guard interval duration)	1/32 (112 μ s)	
Pilot pattern	PP6	PP4
# OFDM symbols	58	60
Error-correcting code	Inner: 64k LDPC, code rate = 3/5 Outer: BCH	
Net bit rate	34.909 Mb/s	34.271 Mb/s

The two selected parameter sets are very close, the main difference being the choice of the pilot pattern which has a direct impact on the ability of receivers to cope with long echoes for SFN reception, to the detriment of the available net bit rate.

3.2.2 Measurements

Those two parameter sets were first qualified in laboratory tests with off-the shelf DVB-T2 / HEVC compatible products, then in the field with a measurement campaign organized to assess the real-life reception of an off-line encoded multiplex with two UHD programs (one at 12.5 Mb/s, the other one at 17.5 Mb/s). During the field measurement campaign, both the parameter set and the SFN delay on the Paris-Est Chennevières transmitter were varied on each measurement location to assess the reception quality (using a professional measurement equipment and an off-the shelf compatible TV set). A specific measurement was set-up at the Meaux gapfiller site, to check the input-output processing of the gapfiller (input/output levels, MER, impulse-response, ...).

FIGURE 49

Measurement locations and sample results on a specific location (with corresponding echo profile when varying the initial delay for the Paris-Est Chennevières transmitter)

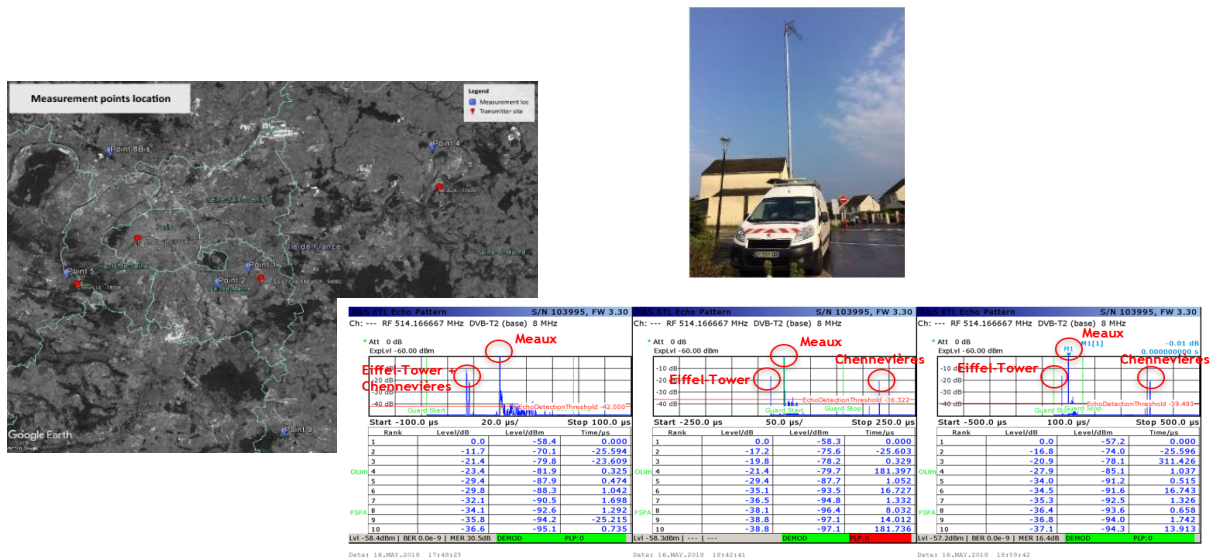

The main findings of this measurement campaign are summed-up below:

- Despite the theoretical difference in C/N between the two parameter sets, there is no noticeable difference between the two when it comes to practical reception, i.e. the effective C/N for both parameter sets is identical, at approximately 18.2 dB in a Rician environment.
- As expected, the C'1 parameter set was measured as the most tolerant set to (very) long echo delays for SFN reception with the ability to cope with echoes in the range of $-170 \mu\text{s}$ to $+280 \mu\text{s}$ from the main signal, while the C1 parameter set is only able to handle echoes in the range of -20 to $+130 \mu\text{s}$ from the main signal.
- The specific measurement set-up at the Meaux gapfiller site showed no specific difficulty in handling the retransmission of the received signal, despite the relatively low input level received from the Eiffel-Tower, with an output MER above 35 dB.

Complementary information regarding those measurements can be found in Report ITU-R BT.2467-0 Part 2.

3.2.3 Services

In addition to the specific measurement campaign, this revised experiment was used for live testing different services broadcasting:

- Renewal of the “French Open” international tennis tournament broadcast in 2018:
 - For this experiment, the DVB-T2 configuration was set to 32k extended, with a 256-QAM modulation, 2/3 code-rate, PP6 pilot pattern and 1/32 – 112 μ s – guard interval, allowing for a total 38.844 Mb/s net bit rate.
 - A main program with live UHD HDR-HLG video content along with MPEG-H audio was set-up. This main program used 24.8 Mb/s net bit rate (24.1 Mb/s main court video with 235 kb/s for AC3+ 2.0 and 435 kb/s for MPEG-H audio, with two comments and court ambiance), while a second program was available at 12.4 Mb/s (12.3 Mb/s video loop and 134 kb/s AAC 2.0 audio).
 - This experiment has permitted to assess the interoperability of existing TV sets (HDR and non HDR compatible) with the HDR-HLG content, in comparison to a previous test run on the same type of content in 2016.
 - In addition, the all IP-based transport between the headend and the transmitters proved to be efficient and permitted to validate the adopted FEC protection scheme.
- Evaluation of live HD-SDR produced contents upscaled to UHD and upgraded to HDR10 with SL-HDR2 metadata:
 - A technical platform was set-up to upscale live HD-SDR contents to 4k-UHD and HD-1080p / HDR10 with SL-HDR2 metadata
 - The live HD-SDR contents were broadcast on an existing national DTTB multiplex using DVB-T/MPEG4 (HD-1080i), while the upscaled contents were broadcast on the experimental network (using DVB-T2 parameter set C'1), on two programs: one program for 4k-UHD content with various bitrates (10, 14 and 17 Mb/s), one program for HD-1080p with various bitrates (3, 5, 10, 17 Mb/s). This set-up permitted the direct comparison between HD-1080i and 4k-UHD / HD-1080p / HDR10 variants of the same content.
 - This experiment showed the interest of upgrading to HDR even in the case of native SDR contents.
- Broadcast of a statistical multiplex of three 4k-UHD/HDR (PQ10 / HLG) using 33 Mb/s out of the 34.271 / 34.909 Mb/s maximum bitrate. The three programs were of high / medium / low complexity respectively, and off-line coded. This permitted demonstrating the ability of having at least three UHD programs in one multiplex on the future French DTTB platform. Based on the possible performance improvement of live HEVC coders and based on those results, it is expected to put four UHD programs in one multiplex by the time of the full migration of the French DTTB platform.
- Evaluation of different video resolutions / format on three programs using HEVC encoding:
 - Using the same DVB-T2 parameters as for the “French open” above (38.8 Mb/s net bit rate), three programs with the same content but different video format / bitrate were broadcasted to allow for the direct comparison between the different variants.
 - One program served as a reference with 4k-UHD / BT-2020 / 10 bits HLG at 24 Mb/s, while the other two programs varied around HD-1080p / BT-2020 / 10 bits HLG at 7 / 5 / 6 / 4 / 3 / 2.5 Mb/s.

3.2.4 Conclusion

This revised experiment has permitted to confirm the technical parameters that were foreseen for the transition of the existing DVB-T DTTB networks to DVB-T2. It has successfully permitted to contribute to the establishment of a French specification for IRD receivers for the modernised DTTB platform.

In addition, several service tests were led exploring different parameters / set-ups / ... to form a better opinion on the current status of those parameters and help shape future decisions on the subject.

This experimental platform is still on-line at the time, broadcasting the statistical multiplex of three programs as a showcase of what can be expected on a modernized French DTTB platform.

4 Spain

4.1 UHDTV trial from Museo del Prado (Madrid) – 2014

RTVE, the Spanish public service broadcaster, together with Universidad Politécnica de Madrid (UPM) and other relevant Spanish companies, undertook an Ultra High Definition TV trial in 2014. RTVE provided a documentary about the Prado Museum, titled “The Passion of the Prado”, produced using 4K resolution (3 840×2 160-pixel images) video.

Along the duration of this initiative, different encoding specifications and sets of transmission parameters were used. Meanwhile, manufacturers started to integrate the capacity to decode HEVC/H.265 video in their new flat-screens. As soon as this feature was available, it was used in the trial.

First tests were based on AVC/H.264 video encoding and 25p frame rate. After that, HEVC/H.265 at 50p fps was used to get smoother movements. Several bitrates were also tested from 20 Mb/s to 35 Mb/s. In all the cases, the transmission was based on DVB-T2 to ensure a higher spectral efficiency. Since DVB-T2 admits useful bitrates of around 50 Mb/s, the bitrate of the deployed signal (until 35 Mb/s) is low enough to integrate more programs in future tests. The trial covered the area of Ciudad Universitaria (north-west of Madrid city) from a transmitter in the Telecommunication Engineering School (ETSI de Telecomunicación – UPM).

The trial was presented in a technical event in the RTVE Institute on 24th June, 2014. The Table below shows the technical parameters involved in this demonstrator.

FIGURE 50



Report BT.2343-A1-37

Transmission standard	DVB-T2
Bandwidth	8 MHz
Frequency	754 MHz (Ch. 56 in region 1; central frequency)
Power	e.r.p.: 125 W (H)
Carrier modulation	64 QAM
FFT size	32k extended
Guard interval ratio (guard interval duration)	1/128
DVB-T2 FEC	5/6
Pilot pattern	PP7
Theoretical capacity	36.72 Mb/s
Video coding	HEVC/H.265
Audio coding	E-AC-3 5.1
Total used bitrate	35 Mb/s
Transmitting station	ETSI de Telecomunicación (UPM).

4.2 Trials by the Chair of RTVE in UPM during the 2016-2019 period

RTVE, the Spanish public service broadcaster, together with Universidad Politécnica de Madrid (UPM) and other relevant Spanish companies that form the Advisory Committee (Cellnex, Dolby, Sapec and Televisión Española) of the Chair of RTVE at UPM and Abacanto as collaborating entity, have undertaken several Ultra High Definition TV trials in the period 2016-2019.

Chair of RTVE in UPM



Advisory Committee:



Collaborating entity:



The Chair, created in January 2015, includes the strategic collaboration among the entities mentioned above in training, research, academic and dissemination activities. However, before the signing of the agreement, RTVE and UPM had already collaborated in experiences such as the first UHD trials in DTT or the first HD trials in DTT with interactive services.

Although it pursues different objectives, the broadcast is a very important part of the activities of the Chair of RTVE at UPM, which has led to the development of a significant number of UHD experiences for these last years. In this way, it has participated in several UHD trials in DTT where it has been possible not only to demonstrate that emissions in UHD are realistic and efficient, but also appreciate the advantages of the use of novel standards, such as DVB-T2, HEVC and AC-4, as different features to reach more efficiency in the use of radio spectrum and better signal with more immersivity thanks to the new features associated to the UHD signal: HDR – High Dynamic Range, HFR – High Frame Rate, WCG – Wider Colour Gamut or NGA – Next Generation Audio.

Moreover, the Chair has placed special emphasis on studying the behaviour of the different elements and components of the end to end value chain for live broadcast, from the signal acquisition to the reception. To do this, the Chair has used different platforms for delivering the content, such as Digital Terrestrial Television (DTT), satellite and Hybrid Broadcast Broadband Television (HbbTV).

Given the nature of the Chair, all experiences have been publicly presented. For this purpose, the Chair has organised workshops and has participated in events and relevant national and international trade fairs to show the results.

The three main initiatives in which the Chair has participated are described in the sections below.

4.2.1 UHDTV trial from Teatro Real (Madrid) – April 2016

On 21st April 2016, the Chair took part in the innovative live broadcast of the opera Parsifal in UHD, an initiative led by Teatro Real, RTVE and Hispasat. This live broadcast was possible thanks to the collaboration of several companies and organizations. Besides the Chair and the three entities that led the experience, other involved companies were: Kinopolis, Hurí, Ovide, EVS, Dolby, Ericsson, Samsung, Abacanto Soluciones, Sapec, Hewlett Packard Enterprise, Ateame, Albalá, Grass Valley and Crosspoint.

The 4K signal, with a frame rate of 50 images per second, was live produced by RTVE in Teatro Real and was broadcasted via Hispasat after encoding in real time the video in HEVC and the audio in E-AC-3. The final average bitrate was around 30 Mbit/s.

For this event, four reception points were contemplated to receive the signal: in Madrid the Kinopolis cinemas, Prado del Rey auditorium and ETSIT-UPM, and the Tower of Collserola in Barcelona. The Chair broadcasted on the fly the received signal with the new standard of Digital Terrestrial

Television (DVB-T2), covering a large area around Ciudad Universitaria in Madrid. The transmission frequency was 658 MHz (UHF channel 44), thanks to the temporal television broadcast license granted by the SEAD (Secretaría de Estado para el Avance Digital). Cellnex did the same from the Collserola broadcasting center, assuring the coverage in Barcelona metropolitan area. The parameters of the COFDM modulation in both DVB-T2 transmissions were: mode 32K extended, guard interval 1/128 and pilot pattern PP7. A single PLP was set with a modulation of 64QAM and FEC 3/4. With this configuration, the useful maximum bitrate was 32.6 Mbit/s.

The Table below shows the technical parameters involved in this initiative.

Characteristics of the signal	
Video	4K resolution, 50 fps, SDR
Video coding	HEVC/H265
Audio	5.1
Audio coding	E-AC-3
Bitrate total	30 Mbit/s
Characteristics of the transmission via Hispasat (satellite)	
Transmission standard	DVB-S2
Frequencies	UP: 14.408 MHz
	DOWN: 11.608 MHz
Polarity	Vertical
Symbol rate	15 Msym
Roll of	0.2
Modulation	8PSK
FEC	3/4
Characteristics of the transmission (DTT)	
Transmission standard	DVB-T2
Bandwidth	8 MHz
UHF channels	44 (Madrid), 22 (Barcelona)
Transmitting station	ETSIT UPM – Madrid ch 44
	Collserola – Barcelona ch 22
Power	E.R.P. : 125 W (H) ch 44 (ETSIT UPM)
	E.R.P. : 15 KW (H) ch 22 (Collserola)
Carrier modulation	64 QAM
FFT size	32K extended
Guard interval ratio (guard interval duration)	1/128
DVB-T2 FEC	3/4
Pilot pattern	PP7
Theoretical capacity	32.6 Mbit/s



4.2.2 UHDTV trial from Palacio Real (Madrid) – July 2017

On 5th July 2017, the Chair participated in the first live TV broadcast in Spain in 4K High Dynamic Range (HDR) technology. The 4K resolution or Ultra High Definition is one of the major technological revolutions of the audiovisual and evolves towards the HDR, a new standard of image quality that increases the brightness and balances light and dark areas.

This pilot was possible thanks to the participation of several companies that collaborated in offering the live broadcast of the Solemn Changing of the Royal Guard from the Royal Palace in Madrid. Entities as Hispasat, Ateme, Loewe, LG, Dolby, Cellnex, Albala, Abacanto, Grass Valley, Crosspoint, EVS, Moncada y Lorenzo, Canon and Hurí made possible the event, together with the collaboration of Patrimonio Nacional and Casa Real.

The 4K signal was encoded using the HEVC video standard with two metadata groups: static metadata compatible with HDR10 and dynamic metadata compatible with Dolby Vision. On the other hand, the audio was encoded using E-AC-3 (5.1) with a bitrate of 128 Kbit/s. A secondary audio PID encoded in AC-4 was used as well, with a bitrate of 48 Kbit/s. The final bitrate was around 30 Mbit/s.

The TV signal was broadcast on the 4K UHD test channel of Cellnex Telecom from the broadcasting centers of Torrespaña in Madrid (UHF channel 32), in Barcelona (UHF channel 43) and Sevilla (UHF channel 36). The parameters of the modulation in the DVB-T2 transmissions were: mode 32K extended, guard interval 1/8 and pilot pattern PP2. A single PLP was set with a modulation of 256-QAM and FEC 2/3. Using this parameter configuration, the useful maximum bitrate was 33.4 Mbit/s. In order to play the signal, it was necessary to have a TV compatible with the signal characteristics.

The Table below shows the technical parameters involved in this demonstrator.

Characteristics of the signal	
Video	4K resolution, 50 fps, HDR10 and Dolby Vision
Video coding	HEVC/H.265
Audio	5.1
Audio coding	E-AC-3 and AC-4
Bitrate total	30 Mbit/s
Characteristics of the transmission	
Transmission standard	DVB-T2
Bandwidth	8 MHz
UHF channels	32 (Madrid) , 36 (Sevilla), 43 (Barcelona)
Transmitting station	Torrespaña and San Fernando de Henares– Madrid ch 32
	Collserola and Baix Llobregat – Barcelona ch 43
	Valencina – Sevilla ch 36
Power	E.R.P.: 15 KW (H) ch 32 (Torrespaña)
	E.R.P.: 75 W (H) ch 32 (San Fernando)
	E.R.P.: 10 KW (H) ch 43 (Collserola)
	E.R.P.: 12 W (H) ch 43 (Baix Llobregat)
	E.R.P.: 9 KW (H) ch 36 (Valencina)
Carrier modulation	256-QAM
FFT size	32K extended
Guard interval ratio (guard interval duration)	1/8
DVB-T2 FEC	2/3
Pilot pattern	PP2
Theoretical capacity	33.4 Mbit/s



4.2.3 UHD-Phase 2 complete trial – October 2018

The most complete UHDTV trial, from the technical point of view, was achieved on October 4th, 2018. The event presented the first production and broadcast of UHD1-Phase 2 complete signal in Spain. It was possible thanks to the participation of the Chair of RTVE at UPM, Abacanto Soluciones, SGO, Camaleón Rental, LG and SONY.

The broadcast of the signal was made using the standard DVB-T2, and the signal had the following characteristics: 4K Ultra High Definition, High Frame Rate (HFR) up to 100 frames per second, High Dynamic Range (HDR) as HDR 10, Wider Colour Gamut (WCG) of Recommendation ITU-R BT.2020, and Next Generation Audio (NGA). HEVC and AC-4 was used for video and audio coding respectively.

The DVB-T2 signal was broadcast from the ETSIT UPM in Ciudad Universitaria (Madrid) on channel 44 of UHF band (temporarily assigned to the Chair of RTVE at UPM by the Secretaría de Estado para el Avance Digital for its experimental tests) and on the 4K UHD channels of Cellnex Telecom from the broadcasting centers of Torrespaña and San Fernando de Henares in Madrid (on UHF channel 32), Collserola and Baix Llobregat in Barcelona (on UHF channel 43), Valencina in Sevilla (on UHF channel 36), Mijas in Málaga (on UHF channel 26) and with the collaboration of Televés Corporation, Monte Pedroso in Santiago de Compostela (on UHF channel 33). The configuration used for the transmission in DVB-T2 was: mode 32K extended, guard interval 1/8 and pilot pattern PP2. A single PLP was set with a modulation of 256 QAM and FEC 2/3. With this type of configuration, the useful maximum bit rate was 33.4 Mbit/s.

The Table below shows the technical parameters of this pilot.

Characteristics of the signal	
Video	4K resolution, HFR 100 fps, HDR10 and WCG
Video coding	HEVC/H.265
Audio	5.1
Audio coding	AC-4
Bitrate total	30 Mbit/s
Characteristics of the transmission	
Transmission standard	DVB-T2
Bandwidth	8 MHz
UHF channels	26 (Malaga), 32 (Madrid), 33 (Santiago de Compostela), 36 (Sevilla), 43 (Barcelona), 44 (ETSIT UPM)
Transmitting station	Mijas – Malaga ch 26
	Torrespaña and San Fernando de Henares– Madrid ch 32
	Monte Pedroso – Santiago de Compostela ch 33
	Collserola and Baix Llobregat – Barcelona ch 43
	Valencina – Sevilla ch 36
	ETSIT UPM – Madrid ch 44
Power	E.R.P.: 2 KW (H) ch 26 (Mijas)
	E.R.P.: 15 KW (H) ch 32 (Torrespaña)
	E.R.P.: 75 W (H) ch 32 (San Fernando)
	E.R.P.: 9 KW (H) ch 33 (Santiago)
	E.R.P.: 10 KW (H) ch 43 (Collserola)
	E.R.P.: 12 W (H) ch 43 (Baix Llobregat)
	E.R.P.: 9 KW (H) ch 36 (Valencina)
	E.R.P.: 125 W (H) ch 44 (ETSIT UPM)
Carrier modulation	256-QAM
FFT size	32K extended
Guard interval ratio (guard interval duration)	1/8
DVB-T2 FEC	2/3
Pilot pattern	PP2
Theoretical capacity	33.4 Mbit/s



Currently, the Chair research activity is working in the production and broadcast of UHD2 signal (8K) using DTT with DVB-T2. Additionally, the Chair is also working in the development of services that allow the use of new generation communication networks (5G) in the professional production of remote events, making use of network edge processing, SDN and NFV capabilities to provide the required QoS.

5 Sweden

The transmission was primarily made for the Teracom customer event “TV-Puls” January 23rd 2014, but was on air the week before and two weeks after this date. Two encoded streams were alternately broadcast during this period. Stream 1 was offline encoded. Stream 2 was supplied by a manufacturer, meaning that the parameters of this stream are not known.

The 4k signal was transmitted in the DTT platform with the parameters in Table 1.

6 United Kingdom

The ready availability of 4k material for two major sporting events of great public interest in the summer of 2014 (the FIFA World Cup in Brazil, and the Commonwealth Games in Glasgow) allowed the BBC to run a series of trials concerning distribution of this material. As well as trials of streaming the content online (via DVB-DASH), the BBC’s transmission network operator, Arqiva, operated a network of three high-power DTT transmitters broadcasting a multiplex containing one UHDTV service.

The 4k signal was transmitted in the DTT platform with the parameters in Table 1.

The transmissions were successfully received and decoded for a series of public and private demonstrations in all three service area.

7 Brazil

7.1 Introduction

The next generation of television broadcasting systems has the challenge of providing content with high quality UHD TV. Research in modern high bit rate transmission systems, better coding formats and more robust reception have been performed by a number of countries.

Brazilian researches for the next generation broadcasting that contemplates all of those characteristics, began in 2014 in Rio de Janeiro, during FIFA World Cup. DVB-T2 technology was used to transmit some of the soccer matches in 4K UHD TV from TV Globo's (a Brazilian Broadcasting Company) Headquarters (HQ) to a Public Viewing at Leblon, Rio de Janeiro.

During the Rio de Janeiro Olympics in August 2016, TV Globo in collaboration with NHK (Japan Broadcasting Corporation) provided 8K UHD TV Public Viewing (PV) of the Olympic Games for the local viewers. This PV at Museum of Tomorrow was carried out by transmitting 8K UHD TV signal through terrestrial network in UHF band, from Mt. Sumaré station, using multiple-input multiple-output (MIMO) orthogonal frequency division multiplexing (OFDM) transmission technologies, utilizing dual polarization technique which was developed by NHK.

The following sections describe the details of this trial and the tests conducted at the occasion.

7.2 Diagram of the PV

The diagram of 8K transmission for this PV is shown in Fig. 51. First, the uncompressed 8K UHD TV signal provided at the International Broadcasting Centre (IBC) is received at Globo.com. Then the signal is compressed by HEVC encoding and sent to TV Globo Headquarter via optical fibre. From TV Globo HQ, the HEVC encoded signal is transmitted to Mt. Sumaré tower by station to transmitter link (STL). After Mt. Sumaré station receives this STL signal, the signal is modulated and transmitted by both horizontal and vertical polarization waves with a dual-polarized antenna. Reception antenna was installed at the Museum of Tomorrow which was the facility for the PV. Finally, the reception signal was demodulated and decoded to be displayed on a 98-inch LCD monitor.

FIGURE 51

Diagram of 8K terrestrial transmission for the PV

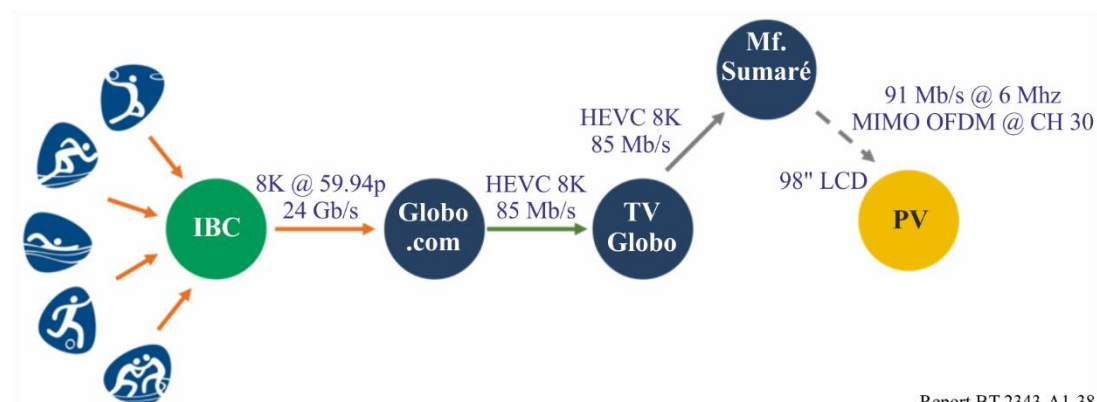

Report BT.2343-A1-38

7.3 Transmission and reception station equipment

Figure 52 shows the transmission station antenna. Transmitting antenna's characteristics are shown in Table 14. Figure 53 shows the reception station antenna. The demonstration was located at the Museum of Tomorrow, in a distance of approximately 8.5 km from the transmission's site. The receiving antenna was located at its rooftop at about 30 metres height. The characteristics of the receiving antenna are shown in Table 15.

FIGURE 52

Transmission station antenna



Report BT.2343-A1-39

TABLE 14

Transmitting antenna's characteristics

Type	Dual-Polarized Panel
Gain	11 dBd
Cross-polarization isolation	~37 dB in 569 MHz
VSWR	< 1.2

FIGURE 53

Reception station antenna



Report BT.2343-A1-40

TABLE 15

Receiving antenna's characteristics

Type	Dual-Polarized, 8-element Yagi
Gain	9 dBd
Cross-polarization isolation	~25 dB in 569 MHz

Figure 54 illustrates the block diagram of the modulator and demodulator used in this PV service. The input signal is protected with BCH code and low density parity check (LDPC) code, bit interleaved and then mapped onto the constellation. After that, the signal is divided into two signals (one for the horizontal polarization and the other for the vertical polarization) with interleaving technique (time, frequency and inter-polarization). Signals are then converted into time domain signals by Inverse fast Fourier transform (IFFT) and guard intervals (GI) are added.

In the demodulator, the active symbol period is extracted from the received signals, which are then converted into frequency domain signals by fast Fourier transform (FFT). The frequency domain signals are de-multiplexed, equalized by MIMO detection, de-interleaved, and used to calculate the log likelihood ratio (LLR). LLRs are de-interleaved and input to the LDPC decoder. Finally, BCH decoding is applied to obtain the output signal.

FIGURE 54

Modulation and demodulation scheme

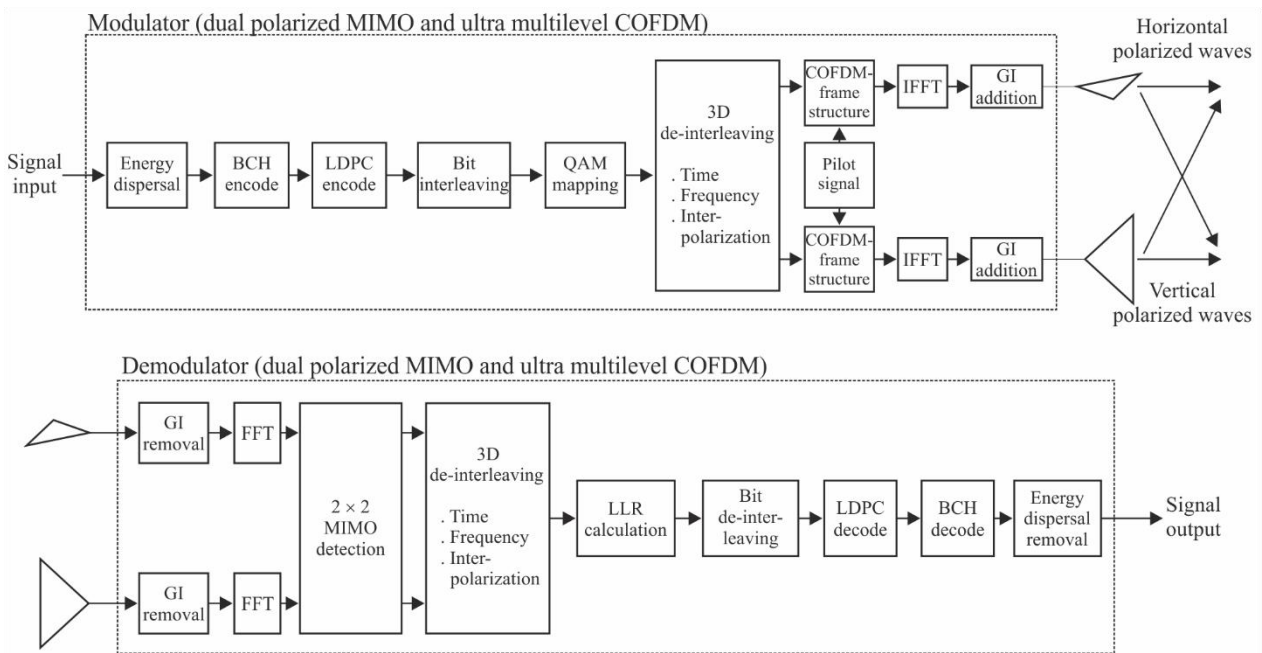

Report BT.2343-A1-41

7.4 Transmission parameters

The transmission parameters of the 8K UHDTV PV service are shown in Table 16.

TABLE 16

Transmission parameters of the 8K UHD TV PV service

Modulation method	COFDM
Occupied bandwidth	5.57 MHz
Transmission frequency	569.142857 MHz (UHF channel 30 in Brazil)
Transmission power	Horizontal polarized waves: 100 W, e.r.p.: 660 W Vertical polarized waves: 100 W, e.r.p.: 660 W
Carrier modulation	4096-QAM
FFT size (number of radiated carriers)	32k (22,465 carriers)
Guard interval ratio (guard interval duration)	1/32 (126 μ s)
Error-correcting code	Inner: LDPC, code rate = 3/4 Outer: BCH
Transmission capacity	91.8 Mb/s
Video coding	HEVC
Audio coding	MPEG-4 AAC
Transmitting station	Mt. Sumaré
Height of transmitting antenna	830 m above sea level
Receiving station	Museum of Tomorrow (approx. 8.5 km from the test transmitting station)
Height of receiving antenna	30 m above sea level (30 m above ground level)

Figure 55 shows the simulated theoretical coverage area.

FIGURE 55
Coverage area



7.5 Field tests in Rio de Janeiro

Two tests were conducted during the demonstration. The first test consisted in performing measurements across Rio de Janeiro metropolitan area to validate the theoretical coverage and to analyse the reception condition in the many diverse settings. The second test performed was a long-term measurement at a fixed point in order to evaluate the propagation conditions' behaviour at that period.

7.6 Measurements

7.6.1 Multiple point measurements

During the period of testing and demonstrating of the technology, 32 measurement points were assessed across Rio de Janeiro metropolitan area. MER, channel response, condition number and the isolation between polarizations were measured with the setup presented in Fig. 56, assembled in the van also shown in Fig. 56.

FIGURE 56
Test setup

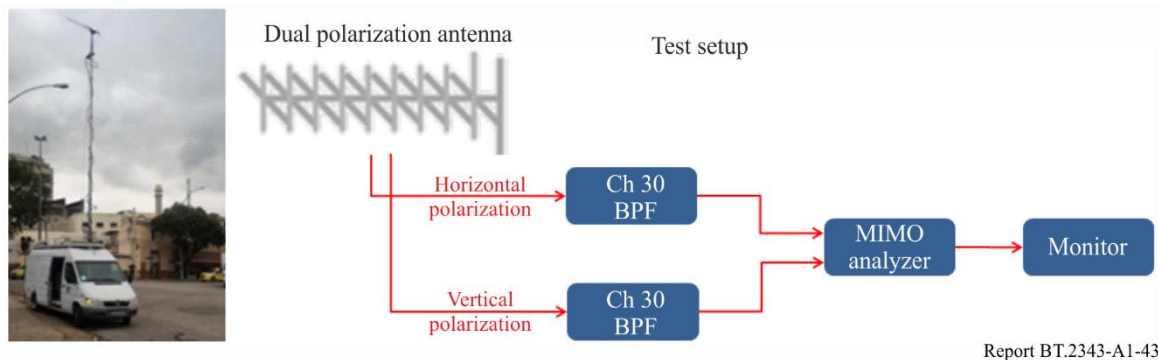

The chosen measurement points and the theoretical coverage are shown in Fig. 57.

FIGURE 57
Measurement points



The analysis of the data collected shows that, for the 32 measurements points, about 85% can receive the signal properly. The farthest point was in a distance of approximately 42 km and the measurements showed good reception conditions. Another interesting measurement point was in a distance of approximately 36 km in a propagation path over the water which also showed good conditions to receive the signal. The tests demonstrated the feasibility of 8K UHD TV digital terrestrial broadcast in a big city such as Rio de Janeiro using a modest transmitter power.

7.6.2 Single point long-term measurement

During the test period, a similar test setup was installed in a laboratory located at the fifth floor of the Rio de Janeiro State University (UERJ). The MIMO Analyser performed sequential measurements every 30 seconds for 18 days, for the purpose of recording and evaluating the channel's performance variation in a double polarization system. Figure 58 shows the measurement setup installed at the site. No significant variation on reception condition was detected during the observation period.

FIGURE 58
Measurements set up



Report BT.2343-A1-45

7.7 Demonstration

During the Rio de Janeiro Olympics, more than 30,000 people visited the 8K UHD TV PV at Museum of Tomorrow. Figure 59 shows images of the viewing session.

FIGURE 59
Public viewing at Museum of Tomorrow



Report BT.2343-A1-46

7.8 Conclusion

This trial showed the viability of 8K UHD TV over-the-air transmission using single 6 MHz channel utilizing the prototype ISDB-T next generation system developed by NHK Japan. The technical results will be an important starting point for further studies of the evolution of DTTB in Brazil.

8 China

8.1 Introduction

With the quick develop of UHD TV service in China, the terrestrial television broadcasting systems has the challenge of providing content with high quality UHD TV service. Research in modern high bit rate transmission systems, better coding formats and more robust reception have been performed by a number of countries.

On November 9, 2017, the State Administration of Press, Publication, Radio, Film and Television issued the notice on standardizing and promoting the Development of 4K Ultra HDTV service in China.

On October 1, 2018, the CCTV 4K Super HD channel of the China Central Television was officially launched, Beijing Gehua, Guangdong, Shanghai Oriental, Zhejiang, Sichuan, Guizhou, Chongqing, Jiangxi, Anhui, Shaanxi, Jiangsu, Inner Mongolia and Shenzhen Tianwei and other 13 cable TV networks simultaneously opened the 4K Ultra HD channel of the China Central Television.

In 2022, the Winter Olympics in China is planned to use 8K live broadcast.

In order to collect the experience for UHD TV in terrestrial television broadcasting systems, on August 8, 2018, National radio and television administration approved to carry out the terrestrial UHD TV trial in Jiaxing, Zhejiang Province. The trial was made by Jiaxing TV station, Tsinghua University, National engineering Lab. for DTV (Beijing) and Communication University of China.

The following sections describe the details of this trial and the tests conducted at Jiaxing.

8.2 Diagram of the trial

The diagram of Jiaxing 4K UHD TV terrestrial transmission trial is shown in Fig. 60. The uncompressed 4K UHD TV signal was generate by camera or player, then the signal is compressed by H.265 encoding, after encoder, the signal is modulated and transmitted by antenna. Reception antenna was installed at the test points (Indoor or outdoor). Finally, the reception signal was demodulated and decoded to be displayed on LCD UHD TV monitor.

FIGURE 60

Diagram of Jiaxing 4K UHDTV terrestrial transmission trial

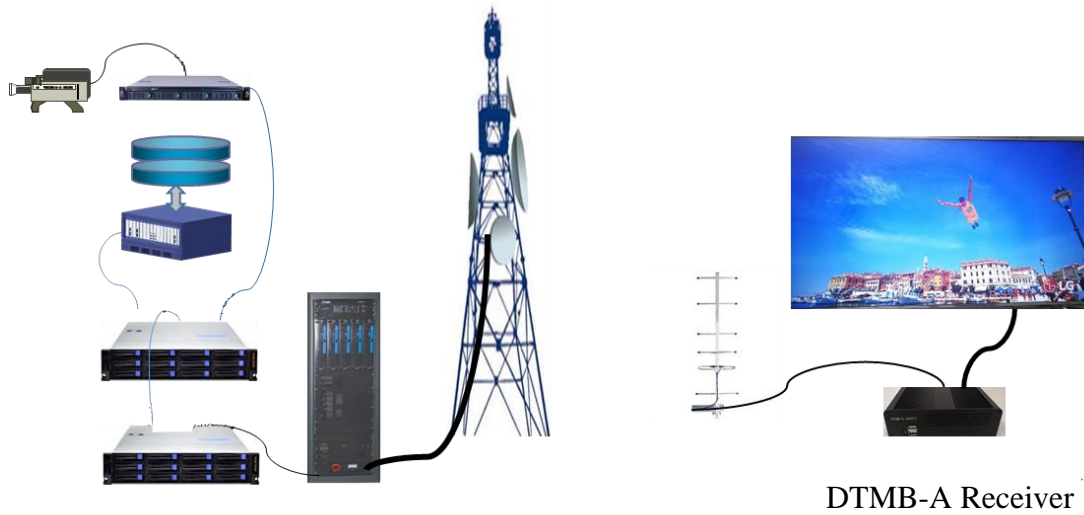

8.3 Transmission and reception station equipment

Figure 61 shows the transmission station antenna. The characteristics of transmitting antenna is shown as Table 17. Figure 62 shows the field trial reception station antenna. During the field trial, a demonstration was located at the Jiaxing radio and television center, in a distance of approximately 2.5 km from the transmission site (Jiaxing Radio and Television Building). The receiving antenna was located at its third floor. The characteristics of the receiving antenna is shown in Table 18.

FIGURE 61

Transmission station antenna



TABLE 17
Transmitting antenna's characteristics

Height above ground	145 m
Type	Horizontal
Gain	11 dBd
VSWR	< 1.2

FIGURE 62
Field trial reception station antenna

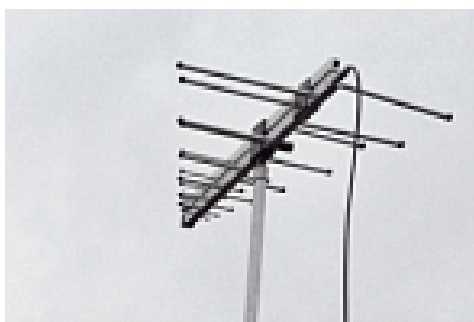

TABLE 18
Receiving antenna's characteristics

Type	Yagi antenna
Gain	5 dB
Impedance	75Ω
Interface	F

8.4 Transmission parameters

The transmission parameters of the Jiaxing 4K UHD TV terrestrial transmission trial are shown in Table 19.

TABLE 19
Transmission parameters of the Jiaxing 4K UHD TV terrestrial transmission trial

Modulation method	TDS-OFDM
Occupied bandwidth	7.56 MHz
Transmission frequency	562 MHz
Transmission power	Horizontal polarized waves: 1 000 W
Carrier modulation	256APSK
FFT size (number of radiated carriers)	32k
Guard interval ratio (guard interval duration)	1/128
Error-correcting code	Inner: LDPC, code rate = 2/3 Outer: BCH

TABLE 19 (end)

Transmission capacity	39.7 Mb/s
Video coding	H.265
Audio coding	MPEG-4 AAC
Transmitting station	Jiaxing Radio and Television Building
Height of transmitting antenna	156 m above sea level (145 m above ground level)
Receiving station	Jiaxing radio and television center (approx. 2.5 km from the test transmitting station)
Height of receiving antenna	4 m above ground level

8.5 Field tests in Jiaxing

Two tests were conducted during the trial. The first test was outdoor reception test, which was conducted at a certain distance between the radioactive roads in Jiaxing City and along Jiaxing City. The second test was an indoor reception test. The test points were distributed inside different buildings in the urban area of Jiaxing.

8.6 Measurements

8.6.1 Outdoor field trial

When select the test sites, due to actual conditions, 10 outdoor test points were selected for the outdoor fix reception test and 7 test points for the indoor test. In these test points, the receiver was checked if it can properly receive and decode the display of UHDTV programs. Through recording the receiving signal power of the test signal at the test point to have a preliminary understanding of the coverage of the Jiaxing UHDTV terrestrial broadcasting service. The test results show that the UHDTV test using DTMB-A transmission can cover most areas of Jiaxing city and its suburban areas.

The setup of the outdoor field trial is shown as Fig. 63. The pictures in some test sites are shown as Fig. 64.

FIGURE 63
Test setup

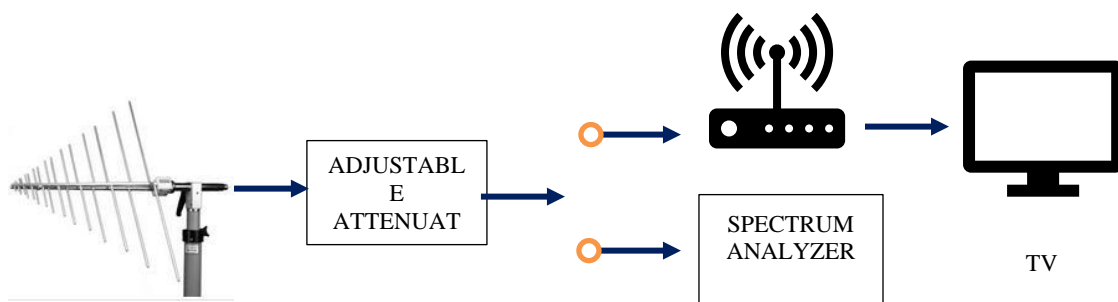

FIGURE 64
Pictures in test site
Suburban road test point



Overpass test point



Suburban TV station test point



Indoor test point



JIAXING 4K UHDTV terrestrial transmission trial test team



The chosen outdoor field trial measurement points are shown in Fig. 65. Table 20 shows the receiving signal power test results of the outdoor test point.

FIGURE 65
Measurement points of outdoor field trail



TABLE 20
Test result of outdoor reception

No.	Longitude	Latitude	Distance (km)	Receiving Signal Power (dBm)	Margin (dB)
1	E 120°40'33"	N30°53'53"	15.0	-52.9	28
2	E 120°38'56"	N31°2'0"	30.0	-65.5	13
3	E 120°39'57"	N31°5'6"	35.0	-65.5	10
4	E 120°20'50"	N30°51'46"	39.0	-72.9	2
5	E 120°19'48"	N30°44'33"	39.5	-68.4	10
6	E 120°32'3"	N30°41'35"	22.0	-65.2	11
7	E 120°43'46"	N30°32'50"	28.2	-66.6	14
8	E 120°43'18"	N30°36'47"	18.2	-50.2	31
9	E 120°56'34"	N30°48'22"	19.4	-61.8	14
10	E 120°56'3"	N30°52'43"	21.5	-70.2	4

The chosen indoor field trial measurement points are shown in Fig. 66. Table 21 shows the field strength test results of the indoor test point. The test antenna is Yagi antenna. The test position was close to the window and in the direction of the test tower in the test point. The direction of the antenna was adjusted to maximize the receiving field strength. In all test points, the receiver can work properly, the image is clear, smooth, and there is no mosaic.

FIGURE 66
Measurement points of indoor field trail

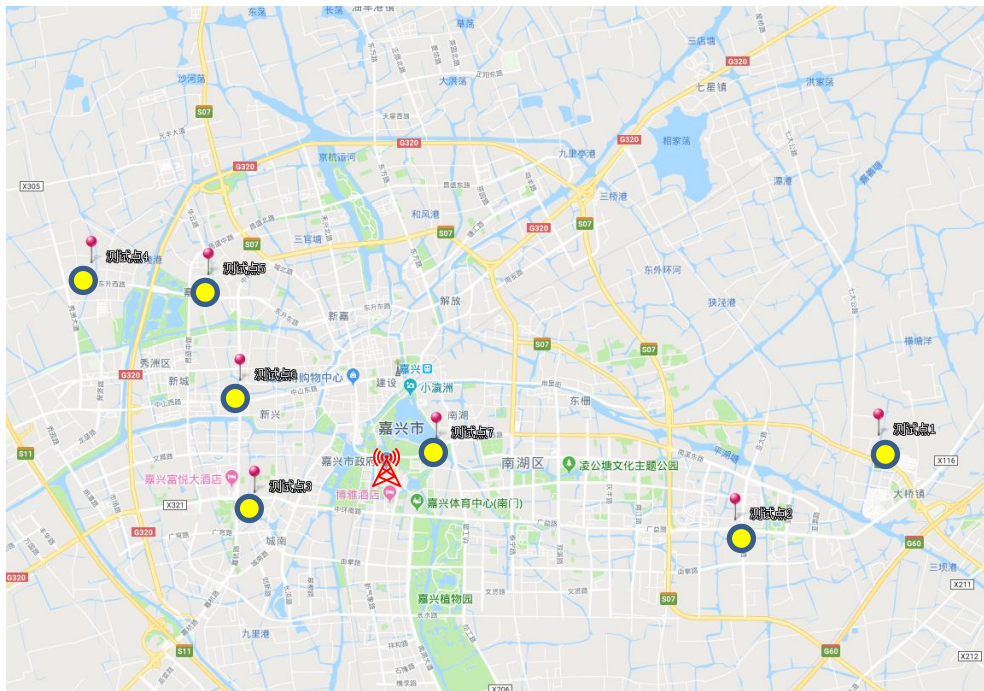

TABLE 21

Test result of indoor reception

	Longitude	Latitude	Distance (km)	Receiving Signal Power (dBm)	Margin (dB)
1	E 120°51'3"	N30°45'3"	10.8	-50.6	32
2	E 120°49'19"	N30°44'14"	8.7	-57.9	18
3	E 120°43'26"	N30°44'30"	4.2	-36	46
4	E 120°41'28"	N30°46'54"	5	-55.6	27
5	E 120°42'58"	N30°46'44"	2.5	-40.8	37
6	E 120°43'20"	N30°45'38"	2.6	-39	40
7	E 120°45'33"	N30°45'0"	3.5	-35.2	48

8.7 Conclusion

This trial showed the viability of 4K UHD TV over-the-air transmission using single 8 MHz channel utilizing DTMB-A system.

Among all the test points, the farthest distance from transmitter to the test points are as below: the north is 35 km; the west is about 39 km, the south is about 28 km, and the east is about 21 km. The seven indoor fixed receiving points are in good condition, the UHD TV signal can be received stable.

The technical results will be an important starting point for further studies of the 8K UHD TV service via terrestrial broadcasting system.