

Handbook

# A tutorial on frequency adaptive communication systems in the HF bands

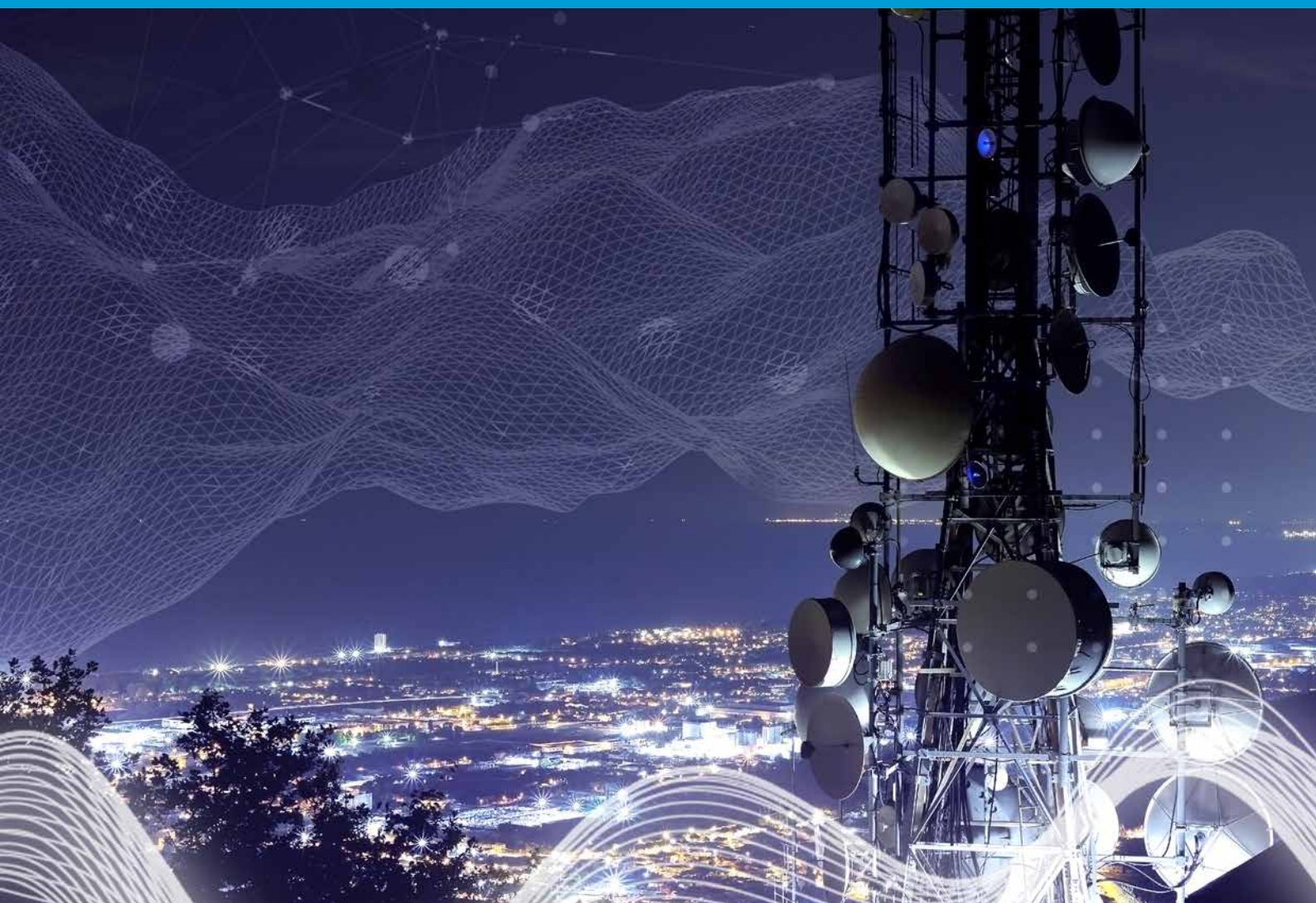



# **Handbook**

## **A tutorial on frequency adaptive communication systems in the HF bands**

**Edition of 2022**

**ITU-R**





## TABLE OF CONTENTS

	<i>Page</i>
Chapter 1 – General overview of deploying adaptive systems.....	1
1.1 Background.....	1
1.2 Deploying adaptive systems.....	1
CHAPTER 2 – Building an adaptive network.....	6
2.1 Frequency pool.....	6
2.2 Adaptive equipment use.....	8
2.3 Operation protocols.....	9
2.4 Operational considerations.....	10
Chapter 3 – Regulatory considerations.....	12
3.1 Operations.....	12
3.2 Technical limits.....	12
3.3 Sharing.....	12
Chapter 4 – Operational considerations.....	13
4.1 Comparison to static systems.....	13
4.2 Operations in the International Environment.....	14
4.3 Building networks.....	14
4.4 Monitoring.....	17



## CHAPTER 1

### General overview of deploying adaptive systems

#### 1.1 Background

Because of the unique characteristics of HF communications and the increasing requirement for stable and reliable communication, HF adaptive systems evolved. HF adaptive systems first appeared in the 1980s.

Over years of technical development, standards have been proposed and updated by organizations, practical systems have been researched and applied, and the ITU-R continually revised and updated Recommendations concerning HF adaptive systems. Of note, the United States of America developed the automatic link establishment (ALE) standard version FED-STD-1045A. As the most influential standard, it became the worldwide de facto standard for digitally initiating and sustaining HF radio communications.

With the progression of these standards, various HF adaptive systems also progressed and came to have the same general functions. These general functions are described in Recommendation ITU-R F.1110-3:

“Basically, an adaptive system has three functions:

- automatic selection of the frequency and other system parameters to be used;
- automatic operation for calling, establishing the communication (with possible switch-over to the peripheral equipment needed for the type of service to be provided), and disconnecting;
- adaptivity during the communication in order to optimize the quality of service according to the ionospheric conditions and spectrum congestion at all times.”

#### 1.2 Deploying adaptive systems

While deploying an HF adaptive system, the above functions may be implemented by using techniques or operating as follows.

##### 1.2.1 Frequency agile/adaptive – RTCE and LQA

Among adaptivity techniques, the frequency agile technique is the core method in HF adaptive communication, while real-time channel evaluation (RTCE) is the basis of and the key to this technique. The term RTCE was first proposed by Darnell in 1978:

“RTCE is the process of measuring appropriate parameters of a set of channels in real time and of employing the data thus obtained to describe quantitatively the states of those channels and hence their relative capabilities for passing a given class, or classes, of communication traffic.”

The RTCE technique contains ionospheric pulse sounding, chirp sounding (described in Recommendation ITU-R F.1337), channel evaluation and calling (CHEC) sounding and 8FSK sounding amongst others. The requirements for RTCE are both accuracy and speed, which run counter each other. The more accurate, the more parameters should be measured, such as Signal to Noise And Distortion ratio (SINAD), multiple path (MP), fading, bit error ratio (BER), Doppler shifts, statistical characteristics of noise/interference, harmonic distortion and others. In actual engineering, measuring this many parameters leads to passive real time data processing and requires a high-performance signal processor, which is obviously not economical. It has been proven that measuring SINAD, MP and BER accurately reflects the evaluation of channels.

The overall process of applying the RTCE technique in an HF adaptive system to make, assess and analyse channel measurements is called link quality analysis (LQA). LQA is often conducted before the communication or in the communication gap, and the data are stored in an LQA matrix. According to each channel's evaluation score in the LQA matrix, the best communication frequencies may be chosen in the proper order. Considering the amount of time to complete the LQA circuit, in general, 10 to 20 frequencies are stored in a frequency pool, but some adaptive systems have the capability to store and use up to several hundred frequencies.

An example of an LQA matrix is shown below.

FIGURE 1

**Connectivity and LQA memory example**

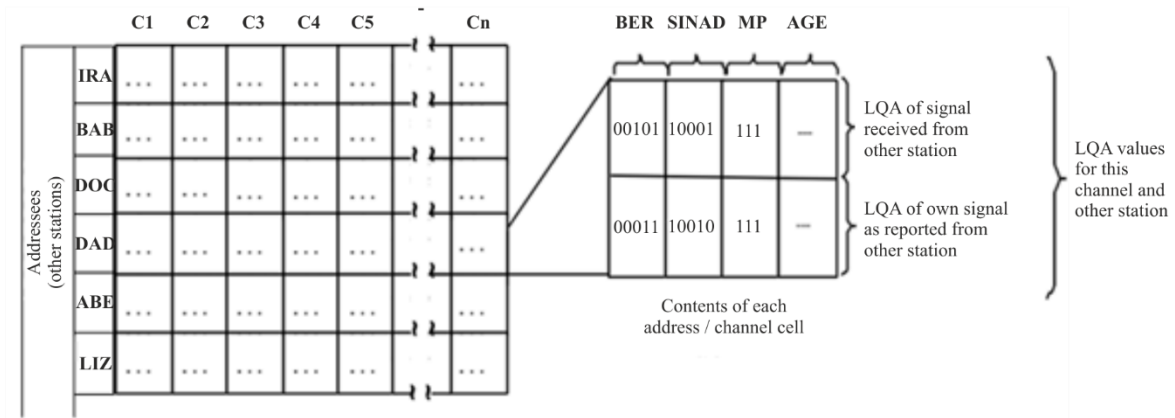

Frequency\_Adaptive\_Communication\_HF-1

*Notes to Figure 1:*

- Memory structure is shown in the matrix example for clarity; more efficient memory management techniques are encouraged because not all channels will be used by all addresses (in many situations).
- Excess memory capacity should be used to retain the latest other stations heard (that are not in the pre-programmed set) and their LQA characteristics on the channels on which the stations were heard.
- Values shown are for example only.
- Multipath (MP) tribits reserved in LQA word transmission (bits shall be set to “111”).

**1.2.2 Automatic link establishment**

Based on automatic scanning, selective calling and LQA, automatic link establishment is the best approach to an HF adaptive communication system. The operating process of ALE could be simply described as follows:

Assume that there are two stations in the link – the calling station is A and the receiving station is B. Before the link is established, both stations keep scanning their assigned channels. For the calling station, when A starts calling, a signal will be transmitted on frequencies in the LQA matrix from the best to the worst. After transmitting the calling signal, A waits for B’s response signal. If no response signal is received, A will switch to the next channel and start another call. The calling will not stop until A receive B’s response signal. For the receiving station, when B receives a calling signal, the scanning status will stop immediately, and B checks the call sign. If the call sign is not B, B keeps scanning; if it is, B sends a response signal (usually B’s call sign) on the same channel and changes status from “RECEIVING” to “STANDBY”. When A confirms it is B’s response signal, the transmitter changes status from “CALLING” to “READY”. Thus, a communication link is established.

The process above shall be completed by the control unit which is computer based. The integration of LQA, scan receiving, selective calling, transmitter and receiver controlling makes it possible to operate without manual operation.



The process of establishing a communication link can be simply indicated as follows.

FIGURE 2  
Flow chart of control unit at the Calling status

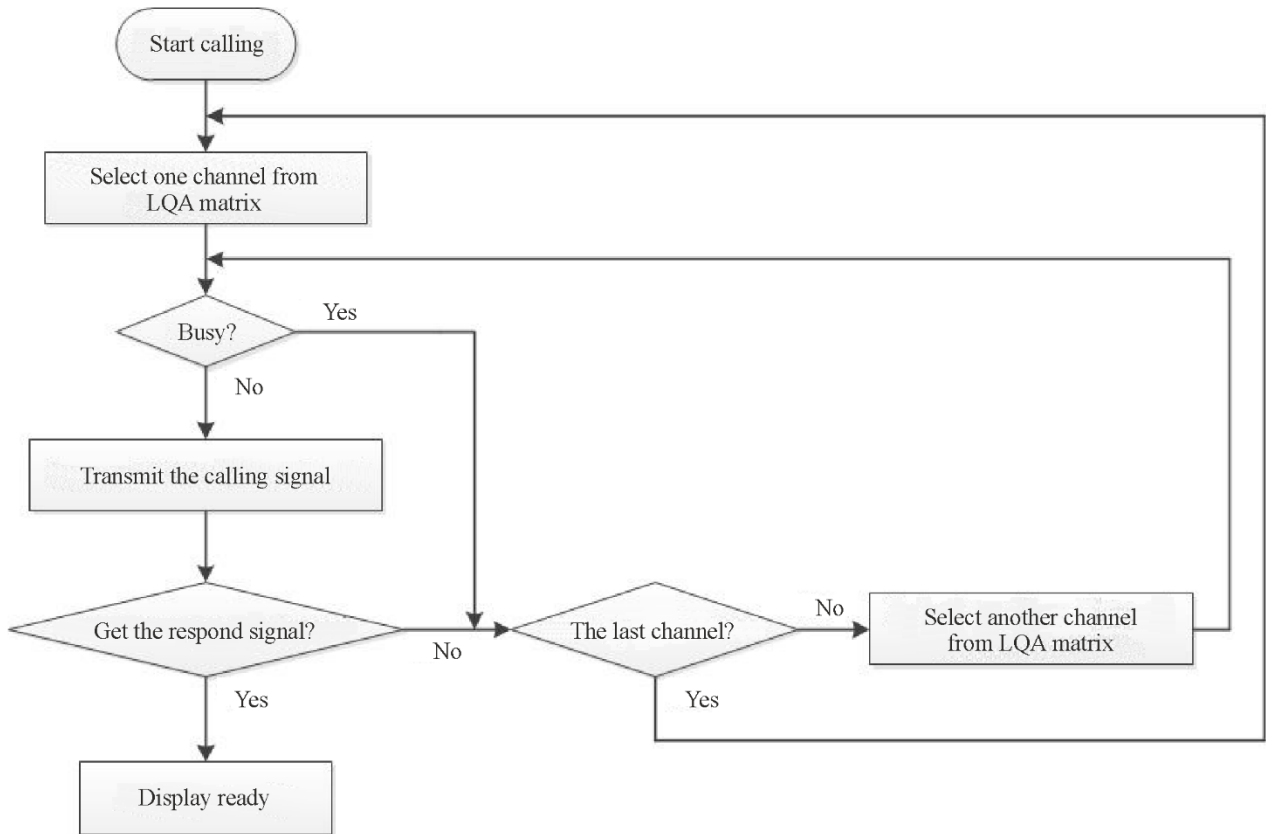
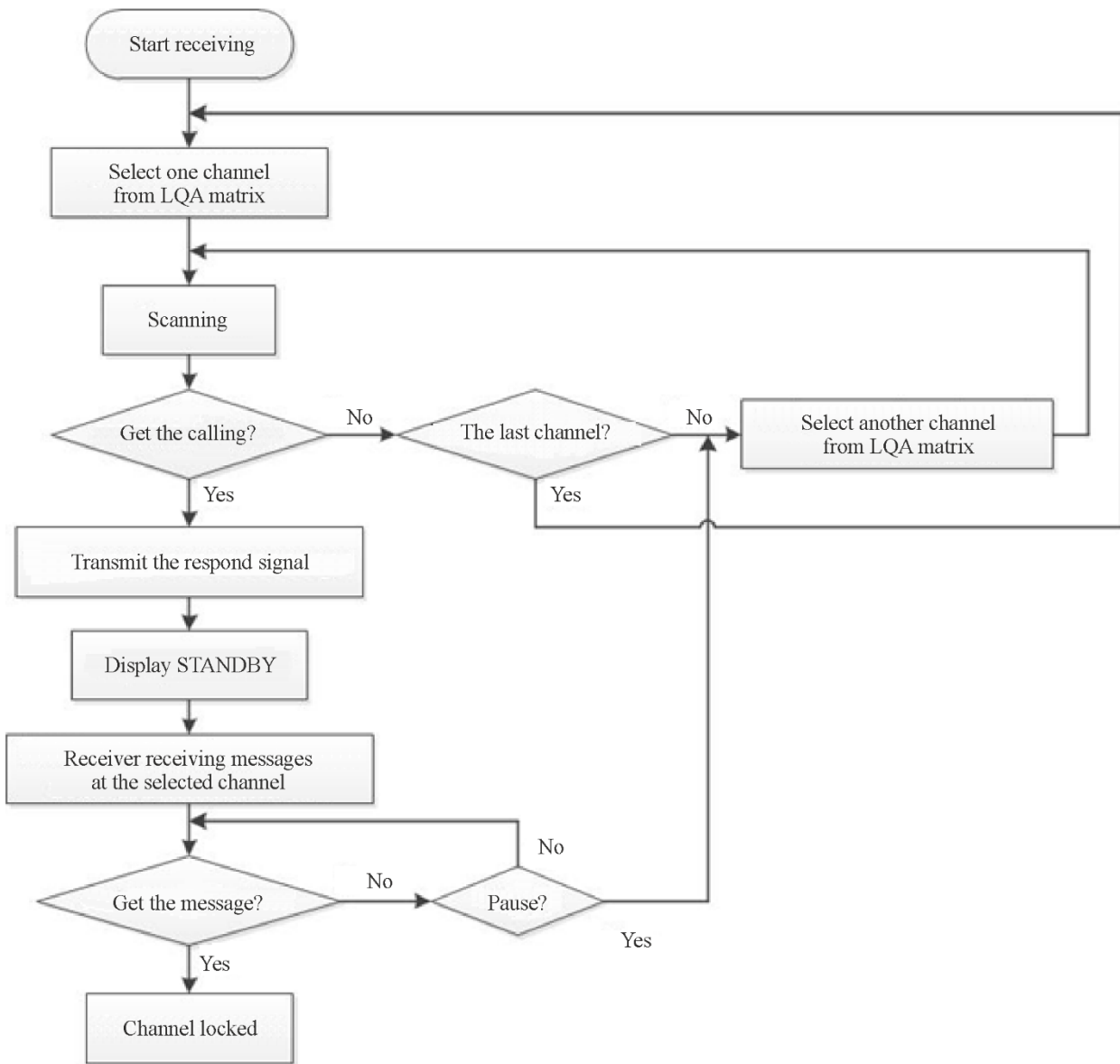

FIGURE 3

Flow chart of control unit at the Receiving status



Frequency\_Adaptive\_Communication\_HF-3

### 1.2.3 Automatic channel switching

An established link may be affected by complex environmental changes. Maintaining a high-quality communication link requires automatic channel switching. The control unit should initiate a new ALE procedure immediately if the established link breaks or degrades.

The process of switching to another channel is shown in Figure 4:

FIGURE 4

Flow chart of channel switching

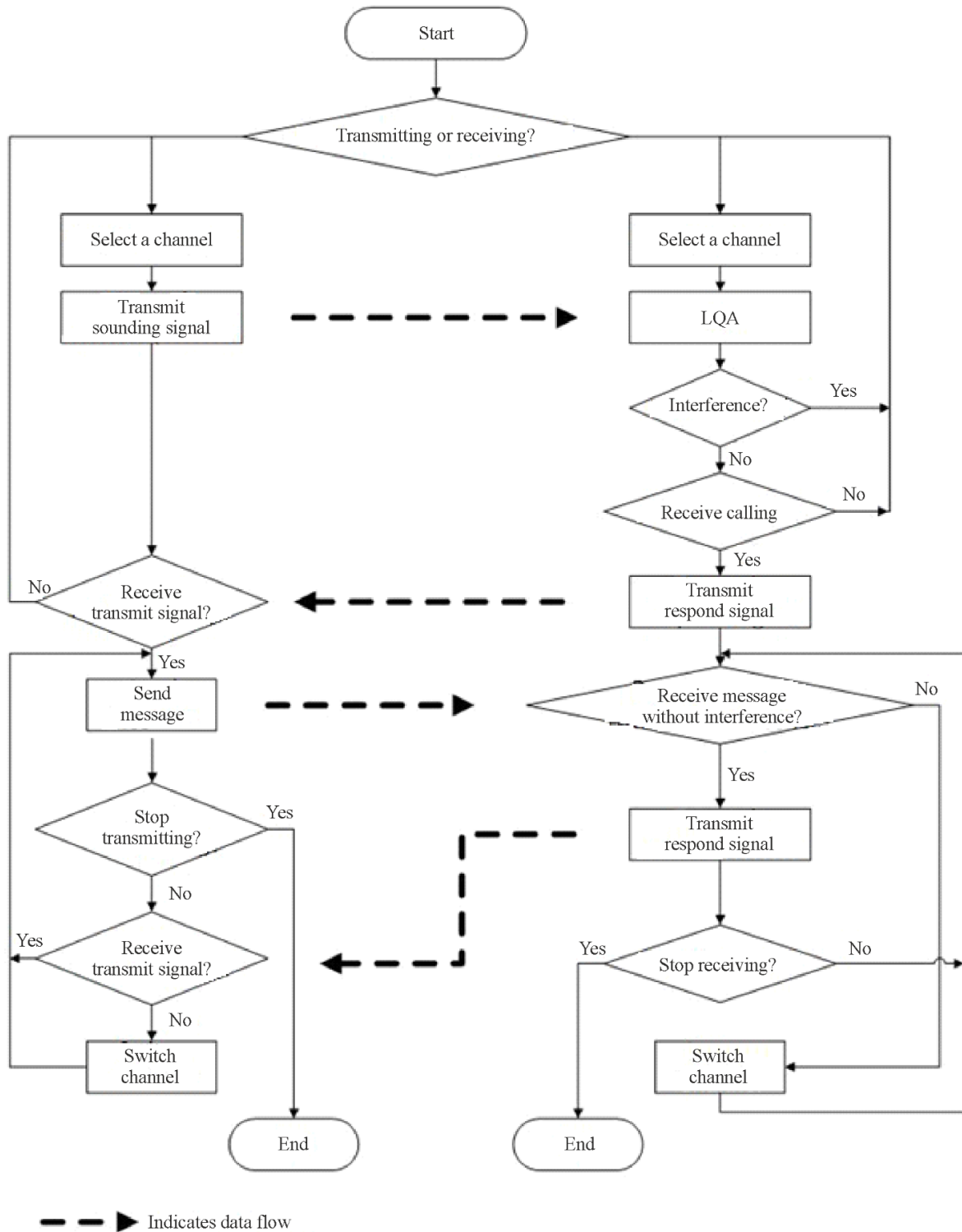

## CHAPTER 2

### Building an adaptive network

#### 2.1 Frequency pool

##### 2.1.1 General

Frequency pool planning is performed to determine the number and distribution of all available frequencies in the network. In a limited area covered by a single network, the number of available frequencies depends on the number of users, the type of user (fixed or mobile), the type of service (voice or data), and so on. Specifically, it is necessary to calculate the number of frequencies required according to the bandwidth required by the service, the number of channels required by the user, the required pass-through rate, the chain building and unbuilding time of different services and other parameters, and then plan the number of frequencies in the frequency pool.

In a wide area that needs more than one network coverage, the size of the coverage area determines the number and distribution of networks, which determines whether frequency reuse is required.

##### 2.1.2 Frequency management method

In order to adapt to the uncertain changes in the ionosphere or communication environment, and to keep the communication uninterrupted, it is necessary to select the appropriate communication frequency and update the frequency in the communication process, which requires an enduring frequency management method.

The second and third generation of ALE technology, based on the optimized frequency information obtained from the HF channel detection, determines the available working frequency group and selects a frequency in real time, within the relatively fixed working frequency group, to automatically establish the communication link. The main problem is that the channel detection system and the actual communication system are independent of each other which could introduce significant delays. If the information interaction cannot be carried out under certain conditions, the resulting frequency used in the actual communication may not be the optimal frequency in real time.

With the continuing development of HF communication technology, especially the rapid development of high-speed digital signal processing (DSP) and large-scale field programmable gate array (FPGA) technology, the combination of channel real-time detection system and HF communication system becomes possible. In the newest HF communication systems, the real-time channel detection, based on spectrum sensing, can be closely combined with the ALE process. The frequency management strategy is described as follows:

#### (1) Frequency preplanning based on medium- or long-term frequency prediction

When frequency allocation is carried out in a communication network, factors such as geographical distribution, network topology, and equipment performance should be considered. Frequency preplanning achieves this function by adopting different optimization algorithms. When building a communication network, it is usually divided by geographic region or specific task. Stations in different areas are divided into multiple resident groups, each of which selects a communication station to be responsible for sending information within the group. To establish reliable communication, frequencies need to be assigned to each group. The distribution of frequencies can be determined either by medium- or long-term frequency prediction, with an available frequency band produced by frequency prediction software.

## (2) Local noise analysis based on spectrum sensing

As HF communication is obviously affected by environmental background noise, each station requires real-time monitoring of local noise and interference by fast Fourier transform and cyclic spectrum analysis technology to exclude some of the frequencies with serious interference.

## (3) Frequency monitoring

For each station, the signal of the target station or the broadcast station are monitored and received. Through such one-way interception of signals from known geographical location, the propagation characteristics of the HF channel are analysed, and the standby frequency group is selected.

## (4) Bidirectional frequency detection

The bidirectional frequency detection of the target station can be started by timing or manual means to obtain the most direct and reliable channel quality information. The third-generation adaptive HF communication system provides a very effective link quality analysis mechanism, which does not analyse link quality by means of pre-detection, but rather to evaluate link quality by accumulating data for every communication connection. During communication, the calling station sends a call protocol data unit (PDU) on a certain frequency. After receiving the data, the called station immediately analyses the communication quality of the channel and quantifies it into a specific score. After scoring, the called station needs to send a handshake PDU to the calling station and also send the score back to the calling party. Similarly, after receiving the handshake PDU, the calling station conducts a quality analysis on the current communication link again, and a score can also be obtained on its side of the link. The final score of the current channel is obtained by adding the two scores of the calling station as a criterion for evaluating channel quality. If the current channel can meet the link requirements, the frequency can be used for normal communication. If the requirements cannot be met, the above procedure is repeated to select a channel and call again.

## (5) Memory-based frequency information processing

Memory-based frequency information processing establishes the frequency LQA matrix library for all possible target stations and updates the LQA matrix library according to the current detection results and historical information, to provide the basis for reasonable frequency selection in the future.

### 2.1.3 Dynamic frequency selection (DFS)

The existing spectrum management of HF communication adopts the method of fixed allocation of spectrum, which leads to low spectrum utilization and cannot meet the demand of HF users for spectrum resources. To address the problem of HF broadband spectrum constraints, several new HF standards and third-generation ALE (3G-ALE) synchronization systems allow HF communication system designers to use dynamic spectrum allocation strategies. By using HF dynamic frequency selection (DFS) technology, the spectrum utilization can be improved, and the capacity of HF communication systems can be increased.

In the case of many communication stations having spectrum sensing ability, the specific real-time frequency change process needs to exchange some real-time information such as frequency monitoring or detection and information about priority control. To facilitate the establishment of efficient communication in each station, it is suggested to design a DFS protocol suitable for the communication function of both parties and achieve a dialogue mechanism through a frequency selection network.

Carrier sensed multiple access (CSMA) is a network access method used on shared network topologies such as Ethernet to control access to the network, which is similar to the real time channel evaluation (RTCE) process. For CSMA, the station first listens to the channel before sending data, if the channel is occupied, the station will defer to the next time slot to listen again. CSMA's competitive access mechanism cannot fundamentally solve the collision conflict problem, especially in the case of a large number of station users where the possibility of collision is greater. Time division multiple address (TDMA) can avoid collision more effectively. Therefore, under the condition of synchronization, the TDMA access mechanism is a feasible technical approach for chain construction.

The TDMA access mechanism divides the transmission time into non-overlapping time slots. A repetition period is defined as a frame, and each channel corresponds to a time slot. Although the TDMA access mechanism can effectively avoid collisions, when the traffic volume is not balanced, it will lead to the waste of time slots and reduce the overall efficiency of the system. To improve network capacity, TDMA combined with CDMA access mechanism can be used.

The channel access strategy combining TDMA and CDMA first codes each station in advance at the physical layer, then allocates the call and reply slots to which the station belongs and also assigns spread spectrum identification codes to each station. According to the demand of traffic volume, multiple stations can be allowed to call or reply within the same time slot, and the reply time slot is allocated accordingly.

To ensure the communication needs of key stations and key regions, a prioritized frequency selection protocol will be employed where in the case of extremely bad communication conditions, priority will be given to meeting the frequency selection needs of key departments and key regions, that is, as long as there is an optimal frequency, users can choose to use it, while other users must give up this optimal channel.

Dynamic frequency management can maintain the monitoring of communication links, track changes in link conditions, and adjust frequency allocation schemes accordingly, to adapt to such changes. When a station moves its physical position a great distance or the available frequency of the station is seriously interfered with during the communication process, the current working frequency should be updated in a timely manner. The frequency management station should be able to acquire the destination location in time, re-select the communication frequency and inform each station in the network through broadcast to ensure normal communication.

## **2.2 Adaptive equipment use**

In an HF adaptive system, the main functions of the adaptive equipment are to guarantee the nominal operation of the whole system. To enable high-efficient operation of the adaptive system, the ionosphere oblique sounding system and antenna system can be well utilized.

### **2.2.1 Ionosphere oblique sounding system**

To realize a frequency adaptive HF communication system, active measures such as in-band channel sounding or frequency modulated continuous wave swept-frequency sounding is obviously better than passive spectrum monitoring. The ionosphere oblique sounding system is such an active measurement system.

The ionosphere oblique sounding system transmits HF radio signals from ground to the ionosphere obliquely upward, receives the signal reflected from the ionosphere at a certain distance, and then analyses its propagation effect to predict the characteristics of the ionosphere. Ionosphere oblique sounding can be applied to the real-time frequency selection of important communication trunk lines. The key is to make the receiver and transmitter work synchronously when changing frequency, and the receiving terminal mainly records the relationship between delay, Doppler frequency shift, and the sounding frequency during signal transmission, so as to form an oblique ionization map.

The ionosphere oblique sounding system can monitor the ionospheric condition and detect its change in real time, displaying the ionospheric condition information through the corresponding radio wave propagation and analysis software, and obtain the delay-frequency and power-frequency relationship diagram of radio wave propagation between transmitting and receiving stations. Further, the maximum usable frequency (MUF), lowest usable frequency (LUF) and other parameters of propagation at layer E, layer F1 and layer F2 are obtained. Table 1 shows typical technical parameters of an ionosphere oblique sounding system.

TABLE 1

**Parameters and performance of ionosphere oblique sounding system**

Parameters	Performance
Frequency band	3-30 MHz
Working mode	Linear or logarithmic frequency sweep
Signal type	Pulse or code
Synchronization	GPS
Sounding cycle	30 minutes
Data output	$\tau$ -f diagram, P-f diagram, LUF, layered MUF

On the basis of sounding, the information of ionosphere height, critical frequency and layer profile in the centre of the transmission link can be obtained by the inversion method. When an HF communication network coverage area has a sufficient number of ionospheric vertical sounding stations, an ionospheric oblique sounding sub-system can receive different azimuths of vertical sounding station signals, real-time computing the communication frequency, and ionospheric parameters, further obtaining parameters such as critical frequency, transmission factor, and ionosphere height. The coverage area of the transmitting station and the available operating frequency are then calculated. The sounding system can predict the next two hours, the next day, or even the next seven days of the relevant parameters, query historical data, produce an ionization map and more. Its advantage is that the sounding based on real-time measurements has higher reliability, avoids the influence of human factors, reduces the amount of manual work and makes the frequency selection of HF sky wave communication more scientific and standardized.

### 2.2.2 Antenna system

Antennas should have broadband characteristics extending over the frequency range for which adaptive operation is planned. The antennas should have radiation angles appropriate for the path length over the whole of this frequency range. Where this cannot be achieved, switching between suitable antennas for the various parts of the frequency range must be included within the adaptive control process.

Antennas used in the HF radio operations range from a simple, thin wire, half-wave dipole to large, fixed, or rotatable log-periodic antennas or rhombic antennas, covering many hectares of land. The selection of antennas depends on the number of frequencies to be covered, the RF power levels used, and the circuit reliability requirements. Whether or not the antenna has an omnidirectional or directional pattern is a function of where the stations to be contacted are located. Additional antenna system components that may be needed are transmission line (balanced or coaxial), antenna switching matrix, multicouplers, terminating devices, impedance matching networks, and high- and low-level RF patching.

Antenna switches are found where there are multiple antennas or where different antennas are to be used for different circuit paths. The switch can be adaptive electrically to meet the requirements of different operating frequencies.

## 2.3 Operation protocols

Generally, a typical HF adaptive system has operation protocols which form the protocol suite. The protocol suite deals with the process between the data link layer and the physical layer, which is responsible for connection management (e.g. 3G-ALE), traffic management (TM), data link protocols (e.g. HDL, LDL) and circuit link management (CLC), as illustrated in Figure 5.

FIGURE 5

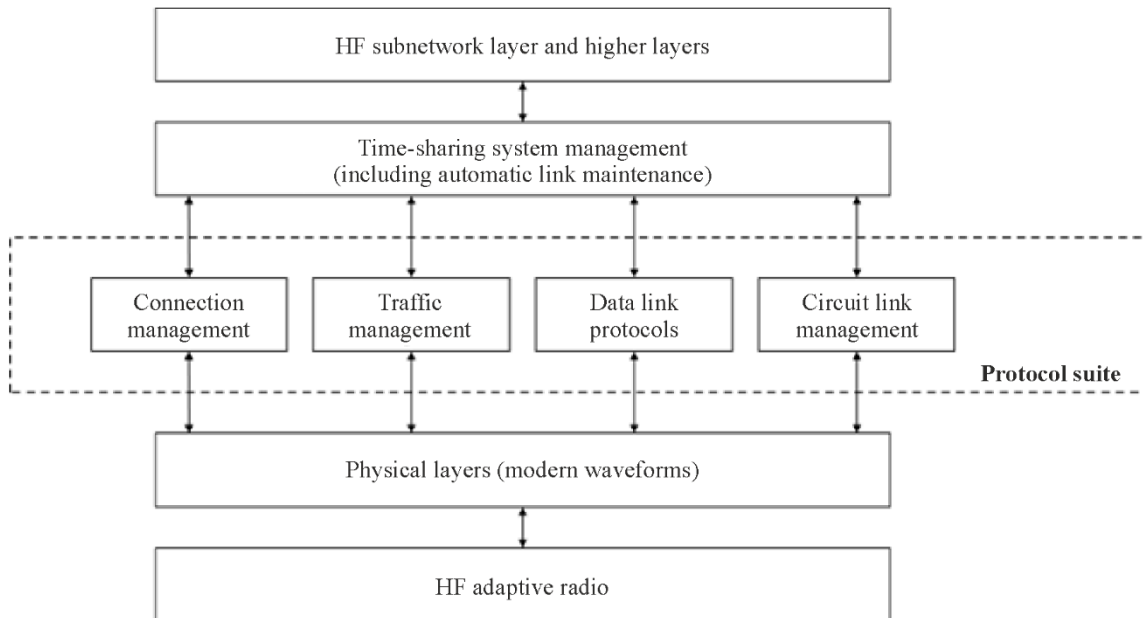

Frequency\_Adaptive\_Communication\_HF-5

The connection management protocol completes the link establishment. Its main functions include:

- (1) Control of the scanning time slot and timing;
- (2) Control of the automatic link establishment;
- (3) Completion of the detection of call channel and service channel, evaluation and selection of LQA;
- (4) Signal detection before transmission;
- (5) Call slot selection and call flow control on the call channel.

The traffic management protocol completes the interaction and management of communication services. Its main functions include:

- (1) Real-time LQA of the current service channel;
- (2) Completion of the interaction of the LQA value of the service channel;
- (3) Control link release.

Data link protocols are divided into high-speed data link protocol (HDL) and low speed data link protocol (LDL), both of which adopt variable bit rate automatic retransmission query (ARQ) technology until the data are received correctly.

The circuit connection management protocol obtains the secondary circuit connection information of each station through real-time monitoring of the channel and optimizes the automatic link control.

## 2.4 Operational considerations

To ensure the efficient operation of an HF adaptive system, it is necessary to carry out scientific and economical management and maintenance of the whole system. Considering that the transmission channel of the HF service is time-varying which relies on the ionospheric condition, the operation of HF adaptive system needs to take interference, link quality, reliability, and cost into account. These factors would affect the service experience and system performance of the HF adaptive system.



- The interference of an HF adaptive system includes internal and external interference of the HF adaptive system. The internal interference refers to the interference among different equipment in the HF adaptive system. The external interference refers to the interference between the HF adaptive system and other communication systems. It is necessary to reduce the interference in HF adaptive systems.
- The link quality of HF adaptive systems refers to the communication quality of transmission channels for various HF services. The link quality provides support for the connecting and switching of channels in the operational process of the HF adaptive system. It is essential to obtain the real-time link quality in the HF adaptive system.
- The reliability of HF adaptive systems focuses on the transmission performance of the HF adaptive system. It enables different transmission performance of HF services with specific parameters on a specific transmission channel. To achieve better service experience, the operation of HF an adaptive system needs to provide higher reliability.
- The operational cost of the HF adaptive system includes the management and maintenance expenditure of the HF adaptive system. It is essential to reduce the operational cost under efficient communication performance of HF adaptive system.

## CHAPTER 3

### Regulatory considerations

#### 3.1 Operations

While adaptive HF systems may be utilized in any radiocommunication service, such systems must be operated in accordance with the ITU Radio Regulations and applicable domestic regulations. The frequency agility of an adaptive HF system does not give regulatory authority to transmit on a frequency outside of the allocations to the radiocommunication service in which the adaptive system operates. Further, an administration may assign frequencies to stations within an adaptive HF system as a condition of licensure.

#### 3.2 Technical limits

Stations within the adaptive HF system must transmit within an allocation to the radiocommunication service with which it operates. Stations within the adaptive HF system must be authorized via an administration's licensing process and the authorizing administration may assign frequencies to be used by stations the adaptive HF system.

The ITU Radiocommunication Sector has adopted several Recommendations that licensees and administrations may consider in determining appropriate conditions of licensure for stations in an adaptive HF system. These include:

- Recommendation ITU-R F.1110, Adaptive radio systems for frequencies below about 30 MHz, which specifies the general characteristics of adaptive HF systems.
- Recommendation ITU-R F.1337, Frequency management of adaptive HF radio systems using FMCW oblique-incidence sounding, which recommends that automatic and adaptive management schemes be utilized for adaptive HF networks and describes one such technique (the use of brief sounding transmissions to determine appropriate operating frequency).
- Recommendation ITU-R F.1611, Prediction methods for adaptive HF system planning and operation, which recommends that administrations explore the use of HF performance prediction models, including, but not limited to, those contained in the current version of Recommendation ITU-R P.533, in advance of deployment to establish adaptivity bounds.
- Recommendation ITU-R F.1778, Channel access requirements for HF adaptive systems in the fixed and land mobile services, which recommends that adaptive HF systems utilize the minimum possible number of active channels out of their available frequency pools, and describes and recommends the use of dynamic frequency selection procedures.

#### 3.3 Sharing

The frequencies assigned to an adaptive HF system may or may not also be assigned, either by the same administration or by different administrations, to other stations operating in the same radiocommunication service. The nature of HF propagation is such that occasional conflicts between stations utilizing the same frequency may be expected. Properly operating adaptive HF systems with adequate frequency pools have a high, but not certain, probability of resolving many such conflicts automatically, and thus, can effectively share a frequency band with the same and other radiocommunication services.

An adaptive HF system is more likely to achieve a link with minimal interference when transmissions are kept short (minimizing the time over which a station occupies a channel). An adaptive system is also more likely to achieve a useable link when its authorized frequency pool contains several authorized frequencies within each frequency band of interest. The frequency pool will be most useful if it has frequencies in several bands potentially suitable for the intended communications path. Protocols for the adaptive selection of operating frequency can determine which of the several bands is most suited for the intended communications path at the time of transmission, taking into account propagation variations throughout the day. These protocols can also provide guidance as to which of the several authorized frequencies within the selected band is most suitable at the time of transmission, if any one frequency is more suitable than others.

## CHAPTER 4

### Operational considerations

#### 4.1 Comparison to static systems

##### 4.1.1 Static system

A generalized HF communication system incorporates both static and mobile terminals. An HF static system literally refers to static terminals in the fixed service, which require a high-quality static communication link. It operates with a defined frequency complement on a regular schedule.

Under a given communication quality and success ratio, to design and build up a high-quality static link for traditional HF communication, the following aspects must be considered:

- Frequency range;
- Modulation and shift keying type;
- Antenna type;
- Diversity reception;
- Error control;
- Minimum transmitting power.

The most important step is frequency prediction. The frequency prediction depends on the historical transmission data in the HF static system. Through analyses of the service experience on different frequencies with different link qualities, the HF static system could achieve frequency prediction.

The typical characteristic of the static system is the use of a fixed channel in the communication transmission. The frequency is stable and remains unchanged during the whole transmission process. Because the static system operates on a defined schedule, it cannot adapt to the dynamic transmission status and adjust to other channel with better quality.

##### 4.1.2 Adaptive system

Due to the fact that the HF channel quality is obviously time varying, the frequency selection is very important. For traditional static HF communication, operators on both sides of a long-distance communication link can only be successful in closing the link through complicated manual operations (selecting frequency, calling, switching channels and others) to overcome the impact of time variability to the HF channel quality. These operations are not timely in their nature and do nothing to guarantee operational accuracy in the long term. In order to make the communication process more reliable and convenient, the ALE technique is used.

ALE contains three parts which include channel evaluation, link establishment, and link maintenance. Channel evaluation completes the LQA through active detection, passive detection, and local noise estimation. Based on results of LQA, link establishment selects the optimal channel automatically for a point-to-point single call and a point to multi-point network call, through the two-way handshake protocol to establish a link. Due to the time-varying nature of the channel, in the process of communication, link maintenance continuously monitors the change of channel quality and makes use of channel switching and frequency agility to ensure continuous and reliable communication.

The ALE technique has been developed over three generations. The first generation is an independent real time detection system, applying ionosphere detection techniques to choose the optimal frequency for communication. The second generation is based on known frequency sets, using a frequency shift keying (FSK) waveform-detecting channel to achieve automatic link establishment. Building on the second-generation technique, the third generation makes use of a phase shift keying (PSK) waveform-detecting channel to establish the link, further improving the communication quality of the HF communication system.

## **4.2 Operations in the International Environment**

To enable the high-efficiency operation in the international environment, HF adaptive systems need to be operated in accordance with both the ITU Radio Regulations and the host country's domestic regulatory policy (see also Chapter 3). The HF adaptive system should take into account the compatibility, traffic communication, and transmission protocols, so as to ensure the nominal operation of the system.

Moreover, operations in the international environment should consider the interference between the HF adaptive system and other communication systems sharing the same frequency. The HF adaptive system operations should not cause harmful interference to radiocommunication systems in adjacent frequency bands. If harmful interference occurs, it is essential to solve the problem by negotiation between the affected countries.

## **4.3 Building networks**

### **4.3.1 Characteristics of HF communication networks**

Compared with other communication networks in other frequency bands, HF communication networks have the following characteristics:

- 1) Poor channel quality – In the channel of an HF system, some factors will have negative impact on signal transmission, such as multipath propagation effect, Rayleigh fading, Doppler frequency shift, etc. In addition, the HF bands are highly occupied, which usually brings in serious mutual interference and self-interference of HF systems.
- 2) Limited transmission bandwidth – The total bandwidth of HF bands is less than 30 MHz. Channel competition and collision are inevitable due to limited available time slots and transmission bandwidths, making the actual available bandwidth even scarcer.
- 3) Wide area covered – HF communication covers short distance by ground wave and long distance by ionospheric reflection. It is a wide area covered communication and its networks are wide area networks (WAN).
- 4) Dynamic change of network topology – Due to the time-varying property of HF channels, the HF communication links might change at any time, the related network topology would correspondingly change in a dynamic way, which is difficult to accurately predict.

### **4.3.2 Network type**

According to the application, scale and operating environment, the HF network topology structures fall into different types including star network, self-organizing network, hierarchical self-organizing network and so on.

**(1) Star network**

FIGURE 6

**A representation of the structure of a Star network**

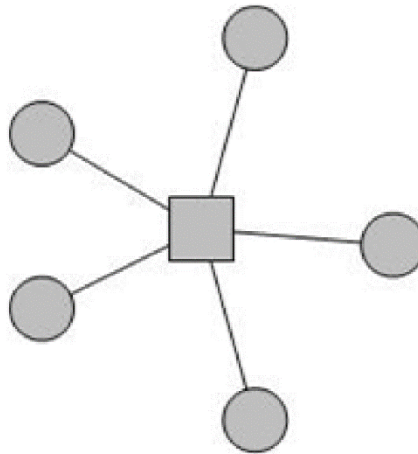

Frequency\_Adaptive\_Communication\_HF-6

In a star network, one station initiates the communication call to multiple stations. Given that collisions may occur when multiple stations respond at the same time, the time division access mode can be applied to avoid these collisions. In this mode, each network member uses the time slots and addresses which are allocated to them, which are distributed to all network members in advance. When the calling station initiates a call to all, each station will respond in its own time slot in the order of certain sequence. This results in a collision free network.

**(2) Self-organizing network**

FIGURE 7

**A representation of the structure of a Self-organizing network**

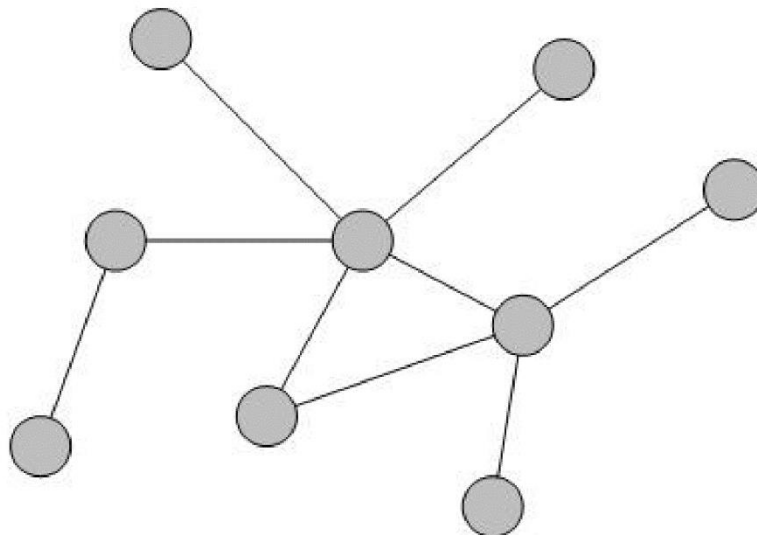

Frequency\_Adaptive\_Communication\_HF-7

In a self-organizing network, all nodes have equal status. Each node has the ability of sending, receiving and forwarding messages, which means each node operates as a terminal and as a router. All nodes are randomly distributed in the communication area and are free to move.

It is worth pointing out that, in general, for wireless self-organizing networks, the change of topology structure is mainly caused by node mobility, while in an HF network, the change of topology structure is mainly caused by the change of channel characteristics.

Generally, the above-mentioned completely self-organizing mode is rarely applied in practical experience of network building. The main reasons are as follows:

- 1) It is difficult to ensure the reliable connection between nodes, making the self-organizing network difficult to be established and operated.
- 2) Due to the relatively low transmission rate of HF channels and large differences of transmission rates among all nodes, the link maintenance will require a relatively large bandwidth and time and, as a result, the portion of the bandwidth used for efficiently transmitting data will be relatively small. Therefore, the efficiency of self-organizing networks is low.
- 3) The mobility of nodes and the time-variant property of HF channels results in a network topology structure that is always changing, thus users might suffer from a long time off the network, which means the self-organizing network will be partially paralyzed.

Based on the above reasons, the HF self-organizing network is suitable for application scenarios which are small coverage areas, mainly utilizing ground wave propagation. In such a scenario, the mobility of nodes and the time variation of HF channels can be ignored. The links between nodes are reliable and therefore it could support higher transmission rates.

Building an HF communication network in a wide area, hierarchical self-organizing network is a better solution.

**(3) Hierarchical self-organizing network**

FIGURE 8

**A representation of the structure of a Hierarchical self-organizing network**

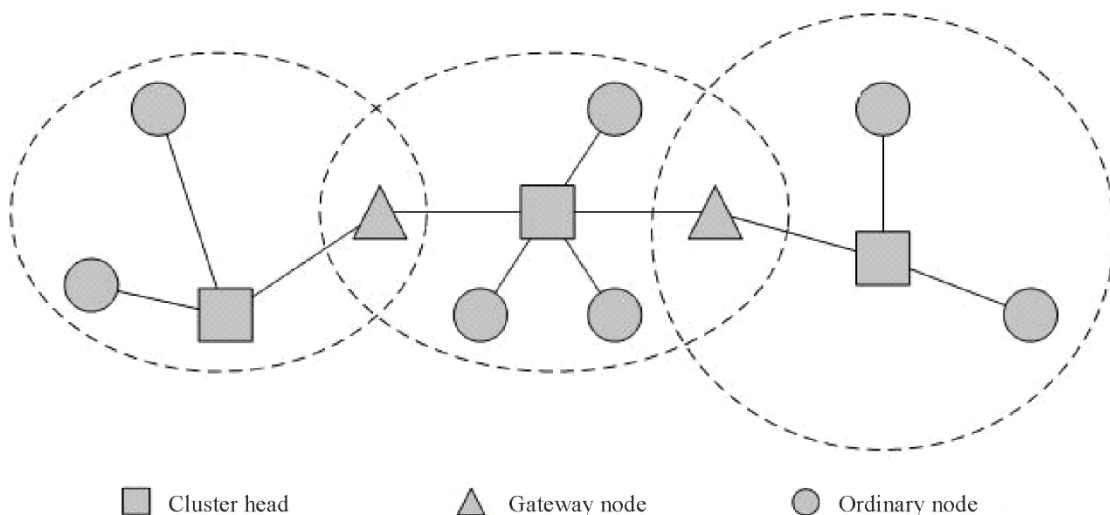

In contrast to the self-organizing network, in a hierarchical self-organizing network, the nodes are divided into several subgroups, and these subgroups are cross-linked and overlapped. The nodes are classified into three groups, cluster head, gateway node and ordinary node. The cluster head takes control of the whole subgroup; the gateway is responsible for providing links between neighbouring subgroups to exchange information; the ordinary node is an ordinary HF subscriber.

In a hierarchical self-organizing network, any node can act as one of the three types of nodes mentioned above, and could dynamically convert its identity during the networking process. The hierarchical self-organizing network is suitable for application scenarios which have wide coverage area and contain a large number of nodes. With the dynamic change of network topology structure, the topology of each node needs to be updated constantly, making the network adjust its topology structure in time to guarantee the continuity of communication. During practical HF networking process, in order to improve the efficiency and ensure a reliable connection, the cluster heads are often linked by cable, fibre or other means. The function of the gateway node is integrated into the cluster head, which mainly works to complete the conversion between the wireless network protocol and the cable network protocol. Generally, the cluster heads are fixed stations with large transmitting power, to ensure the effective coverage within the subgroup area. The wide area property of HF communication leads to multiple coverages between the subgroups, so that users can select the optimal access node among subgroups.

## 4.4 Monitoring

### 4.4.1 Overview

In general, the monitoring of HF communication systems is full duty cycle monitoring (Figure 9), including all the function modules, e.g. antenna/ antenna array, transmitter, receiver, channel status, signal analysis.

FIGURE 9

Full duty cycle monitoring of HF communication system

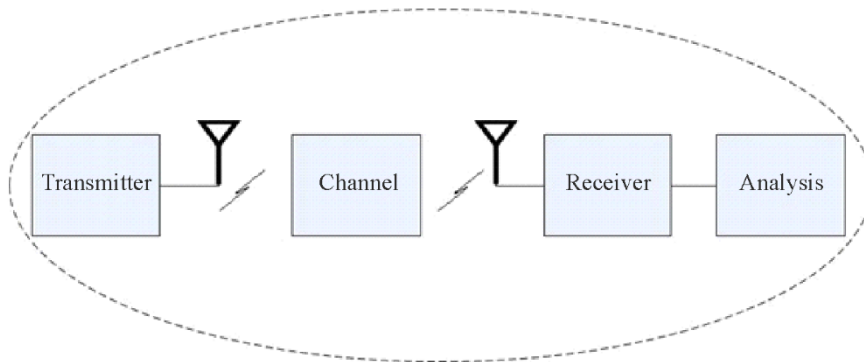

Frequency\_Adaptive\_Communication\_HF-9

### 4.4.2 The classification of monitoring

The monitoring of HF communication systems can be classified into various categories based on different characteristics.

According to geographic location, the monitoring of HF communication systems can be classified into local monitoring, remote monitoring, and hybrid monitoring (both local and remote).

- Local monitoring indicates that the distance of the operation centre and antenna/antenna-array is within a short distance range. The operators work at the local monitoring station.
- Remote monitoring indicates that the operation centre and antenna/antenna-array are separated by the great distance. The operators work at monitoring station that is far from the antenna/antenna-array. The monitoring data are transmitted to the operation centre by a wired or wireless communication link.

- Hybrid monitoring includes both local monitoring and remote monitoring.

According to monitoring content, the monitoring of HF communication systems can be classified into interference monitoring, quality of service monitoring, reliability monitoring or others.

- Interference monitoring concentrates on the interference issues among HF adaptive systems and other systems.
- Quality of service monitoring refers to the monitoring of transmission quality of channels, in order to choose the optimal frequency for the HF adaptive system.
- Reliability monitoring refers to the monitoring of link reliability for the HF adaptive system.

According to time efficiency, the monitoring of HF communication systems includes online monitoring, and offline monitoring.

- Online monitoring focuses on the real-time monitoring of the communication status of HF adaptive systems.
- Offline monitoring indicates that the monitoring is accomplished through offline analysis and processing.

### 4.4.3 Self-optimization of monitoring

In an HF communication system, the monitoring network needs to learn from historical experience to optimize the system performance. Based on the statistical analysis results of the monitoring performance, the monitoring strategy of HF communication systems can be adjusted and optimized, so as to achieve the optimal communication performance with the highest quality of service (Figure 10). Through self-optimization of monitoring, the HF communication system can improve the system performance in a timely and efficient way.

FIGURE 10

Self-optimization process of monitoring of HF communication system

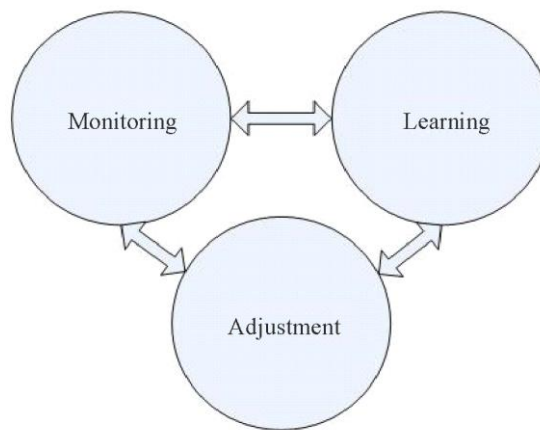

Frequency\_Adaptive\_Communication\_HF-10

### 4.4.4 Evaluation of monitoring

To deploy a highly efficient HF adaptive system, it is necessary to evaluate the operational performance by monitoring the whole system. The evaluation of monitoring for an HF adaptive system mainly concentrates on the communication status of the whole HF adaptive system. Generally, the evaluation of monitoring of an HF adaptive system includes four factors: the stability of the HF adaptive system, the efficiency of the HF adaptive system, the reliability of the HF adaptive system, and the scalability of the HF adaptive system.

- The stability of an HF adaptive system refers to the normal operation of the whole system. In response to the transmission demands of the various HF services, the system can operate in a stable way. An HF adaptive system needs to make sure that the link preparation, channel quality assessment, link establishment, information transmission of specific services, and disconnection



can be run continuously and stably. And in case of communication failure, the HF adaptive system needs to be checked and maintained in a timely manner.

- The efficiency of an HF adaptive system refers to the transmission experience of the HF adaptive system. Different HF services have different transmission needs, including the quality of transmission channel, the time-delay, bandwidth, data rate, etc. In order to provide a better experience for the users of HF services, it is necessary for the HF adaptive system to evaluate the transmission efficiency of the HF frequency band in use. So, the quality of service and efficiency should be taken into consideration for evaluation of monitoring the HF adaptive system. The system can set a different score for the transmission quality of various HF services and provides optimal experience for the users.
- The reliability of an HF adaptive system focuses on the anti-interference ability of the HF adaptive system. Considering that the HF transmission channel is time-varying, it is essential for the HF adaptive system to control the deterioration of system performance within an acceptable and tolerable range. If the packet loss is serious, the reliability of the HF adaptive system cannot be guaranteed. The evaluation of monitoring needs to consider the system reliability of the whole system, especially the evaluation of monitoring of link reliability for the HF adaptive system.
- The scalability of an HF adaptive system considers the development of the HF adaptive system, including the hardware and software scalability of the whole system. With the development and evolving of HF communication technology, the HF adaptive system needs to be continuously improved and upgraded. The evaluation of monitoring of an HF adaptive system also demands an evaluation of the scalability of the whole system.

The goal of the evaluation of monitoring of HF adaptive systems is to achieve a better transmission experience for HF services. Through appropriate and rational evaluation, the operation status of the HF adaptive system can provide a more stable and highly efficient communication quality for various HF services.

---

International  
Telecommunication  
Union  
Place des Nations  
CH-1211 Geneva 20  
Switzerland



Published in Switzerland  
Geneva, 2022  
Photo credits: Shutterstock