

ITU-EC HIPCAR Project

Enhancing Competitiveness in the Caribbean through
the Harmonization of ICT Policies, Legislation and
Regulatory Procedures

Status of Project Implementation

Presentation at the

7th Annual Conference of OOCUR

Tobago, 5 November 2009

Kerstin Ludwig

HIPCAR Project Coordinator

ITU/Telecommunication Development Bureau



Committed to connecting the world

Agenda

- Overall description of the HIPCAR project
- HIPCAR Working Groups 1-4:
 - Activities to date
 - First Consultation Workshop WGs 2&3
 - Main elements of workplan

HIPCAR Project objective

- To assist CARICOM/ACP countries in the Caribbean to harmonize their ICT policies, legislation and regulatory processes, and create an enabling environment for ICT development and connectivity
 - Aim: to enhance competitiveness and socio-economic and cultural development in the Caribbean region

Harmonization involves promoting the development of consistent and coherent ICT policies, legislation and regulations across the Caribbean that facilitate market integration, foster investment in improved ICT capabilities and services, and enhance the protection of ICT consumers' interests across the region.

Background

- An effectively functioning ICT sector is a key driver for development, growth and employment
- Global ITU/EC project: Support for the establishment of harmonized policies for the ICT market in the ACP Group of States
- Composed of *3 regional sub-projects* addressing specific needs:

Sub-projects	Acronym	Duration
1. Support for harmonization of ICT Policies in Sub-Sahara Africa	HIPSSA	3 years
2. Enhancing competitiveness in the Caribbean through the harmonization of ICT Policies, Legislation and Regulatory Procedures	HIPCAR	3 years
3. Capacity Building and ICT Policy, Regulatory and Legislative Frameworks Support for Pacific Island States	ICB4PIS	2 years
<i>Project management (ITU HQ, Geneva)</i>		4 years

- Caribbean context:
 - Caribbean Single Market & Economy (CSME)
 - Liberalization of services sector
 - CARICOM Connectivity Agenda
 - WSIS and MDGs
 - WTO Basic Telecoms Agreements
 - CARIFORUM/EU EPA



Main project partners currently active...

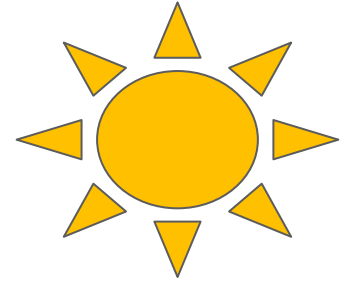

Country-level organisations

- Bodies responsible for ICT policy and regulation
- Organisations representing the ICT service industry & ICT consumers
- Organisations responsible for ICT capacity development (CoEs, etc.)

Regional & international organisations

- CARICOM Secretariat
- Caribbean Telecommunications Union (CTU)
- Caribbean Centre for Development Administration (CARICAD)
- Caribbean Association of National Telecommunications Organizations (CANTO)
- Eastern Caribbean Telecommunications Authority (ECTEL)
- European Commission



Project implementation – two phases

Phase I - **Development of regional models**

(based on int'l best practices & country experiences)

- a) ICT policy guidelines
- b) Draft model legislation to support these policies
- c) Implementation guidelines for transposing the model legislation into local laws & regulations

Phase II - **Country implementation**

Transposition of these models into national policies, laws & regulations, including implementation assistance & capacity building



Working Groups

WG 1 – ICT Legislative Framework
(Information Society Issues e.g.,
eCommerce & Cybersecurity)

WG 2 – Telecommunications Acts
(Universal Service)

WG 3 – Telecommunications Acts
(Interconnection & Licensing)

WG 4 – eGovernment

HIPCAR Working Group 1

Activities to date:

- Organization of Project Planning Meeting (Grenada, 15-16 December 2008)
- Designation of Country Focal Points & Working Group members
- Constitution of the Working Group & hiring of regional experts
- Preparation of draft Assessment Reports on the current situation in the Caribbean relating to the WGs' six work areas: eCommerce (Transactions), eCommerce (Evidence), Access to Public Information, Privacy & Data Protection, Cybercrime, and Interception of Communications
- Work undertaken by:
 - senior regional expert: Karen Stephen-Dalton
 - junior regional expert: Pricilla Banner
- Request for comments by the WG members

HIPCAR Working Groups 2 & 3

Activities to date:

- Project Planning Meeting (Grenada, 15-16 December 2008)
- Designation of CFP & WG members
- Constitution of the WGs & hiring of experts
- Preparation of draft Assessment Reports on the current situation in the Caribbean relating to the WGs' three work areas: (a) universal service, (b) interconnection & (c) licensing and their presentation to the WGs & Steering Committee
- Preparation of building blocks & proposals for draft policy guidelines and presentation to the WGs & Steering Committee
- Work undertaken by:
 - senior international expert: Sofie Maddens
 - senior regional expert: J Paul Morgan
 - senior regional expert: Kwesi Prescod
- Completion of the 1st Consultation Workshop (10 countries present, 1 country provided prior comments without participation, 1 observer, 5 operators, 4 regional organizations)



HIPCAR Working Groups 2 & 3

1st Consultation Workshop

(Port of Spain, Trinidad & Tobago, 26-29 October 2009)

Modus operandi:

- Introductory presentations by the experts
- Discussions on specific topics by sub-groups and preparation of suggestions
- Plenary discussion of sub-groups' suggestions and agreement on final proposals
- Finalization of the documents by the experts with participants;
all documents unanimously adopted
- Very positive evaluation of the event by participants

HIPCAR Working Groups 2 & 3

Outputs of 1st Consultation Workshop

- Finalized & adopted Assessment Reports on:
 - (a) Universal Access/Services,
 - (b) Access & Interconnection, and
 - (c) Licensing
- Finalized & adopted Draft Policy Guidelines covering the three areas of work (a) to (c)
- Overall consensus on “The Way Forward” (priorities for future action) and revised workplan

All documents unanimously adopted by WGs and sent to Steering Committee for consideration and action.

For more information and copies of presentations, see:
Annex I and II of this presentation and
www.itu.int/ITU-D/projects/ITU_EC_ACP/hipcar/events/2009/wg/wg2_3.html

Comments would be appreciated by 20 November 2009.

HIPCAR Working Group 4

Activities to date:

- Organization of Project Planning Meeting (Grenada, 15-16 December 2008)
- Designation of Country Focal Points & Working Group members
- Preparation of HIPCAR WG workplan & budget
- Ongoing discussions with CARICAD regarding additional CARICAD resources for joint implementation of WG activities

HIPCAR Working Groups 1-4

Way forward (re workplans):

- **WGs 1 & 4:** complete assessment reports, policy guidelines & implement 1st Consultation Workshop results in cooperation with Steering Committee
- **Follow-up to all 1st Consultation workshops:** disseminate the proposals in beneficiary countries to promote understanding & support of principles, particularly by relevant senior country authorities, seek their initial validation of proposals & of adoption and implementation process
- **2nd Consultation workshops for all WGs:** finalize policies, model legislation & guidelines for transposition into country policies, laws & regulations
- **Senior Officers Validation workshop:** confirm proposals for implementation by beneficiary countries
- **Support & participate in the country transposition process** during Phase II of the project

THANK YOU

Kerstin LUDWIG

*Project Coordinator HIPCAR
BDT/PRI/ITU-EC Project*

kerstin.ludwig@itu.int

Phone: +1 (868) 627 0281
+ 1 (868) 627 0347
Fax: +1 (868) 623 1523

ITU c/o CTU
14-17 Victoria Square
Port of Spain
Trinidad, West Indies

Sandro BAZZANELLA

*ITU-EC Project Manager
BDT/PRI/ITU-EC Project*

sandro.bazzanella@itu.int

Phone: +41 22 730 6765
Fax: +41 22 730 5484

ITU Headquarters
Place des Nations
CH-1211 Geneva 20
Switzerland

http://www.itu.int/ITU-D/projects/ITU_EC_ACP/



Committed to connecting the world

International Telecommunication Union

Committed to connecting the world



Committed to connecting the world

Annex I

ITU-EC HIPCAR Project

Assessment Reports & Policy Guidelines

Proposals of the 1st Consultation Workshop for Working Groups 2&3
to the HIPCAR Steering Committee

Trinidad and Tobago, 30 October 2009

Sofie Maddens
Senior Regulatory and Policy Advisor
Telecommunications Management Group, Inc.



Agenda

- **HIPCAR Working Groups 2 & 3**

- Objective
- Methodology
- Representation at Meeting

- **Assessment Reports**

- Working Methodology
- Overview of IBPs
- Assessment

- **Policy Guidelines**

- Working Methodology
- Guidelines

Objective

- With the support of the Project Team of international and regional experts...
 - Promote a better understanding of the issues and options relating to ICT policy development in the region, and a sharing of this understanding with other stakeholders and interested parties in the Caribbean
 - Review and discuss the Assessment Reports and Building Blocks for Policy Guidelines for the Caribbean on:
 - (a) Universal Access/Service
 - (b) Interconnection
 - (c) Licensing in a Converging Environment
 - Review Assessment Reports and Building Blocks and draft the ICT Proposed Policy Guidelines

Methodology

■ Preparatory Phase

- Preparation of Assessment Reports and Comments from Regional Experts and Working Group Members
- Preparation of Building Blocks for Policy Guidelines

■ WG Meeting

- Brief introductory presentations by the experts
- Discussions on specific topics by sub-groups and preparation of suggestions on Assessment report and Policy Guidelines
- Plenary discussion of sub-groups' suggestions and agreement on final proposals
- Finalization of documents by the experts

Representation at WGs Meeting

- 10 Countries (missing: Dominica, Dominican Republic, Guyana, Haiti, St. Kitts and Nevis)
- 4 Regional Organizations (CANTO, CARICO, CIVIC, ECTEL)
- 5 Operators
- 1 Observer

Assessment Reports



Committed to connecting the world

Methodology

- The aim of the reports is to provide an overview of the key factors as distilled from international best practices and to illustrate how they are reflected in the different Caribbean countries' legal and regulatory telecommunications frameworks
- Such an assessment will provide the basis for policy guidelines and model regulatory texts provided for under Phases 2 and 3.

Interconnection: Overview of Issues

1. Cost-Oriented, Transparent, Non-Discriminatory
2. Regulated process for interconnection
3. Method of determining dominance
4. Reference Interconnection Offer (RIO)
5. Infrastructure sharing
6. Local Loop Unbundling (LLU)
7. Mobile Termination Rates (MTRs)
8. Dispute resolution
9. International gateway access

Interconnection: Assessment

Country/ Region	1. Cost-oriented, transparent, non-discriminatory	2. Method of determining dominance	3. Regulated process for negotiation	4. RIO
Antigua and Barbuda	NONE	NONE	NONE	NONE
Bahamas	FAIR	GOOD	GOOD	GOOD
Barbados	GOOD	GOOD	GOOD	GOOD
Belize	GOOD	GOOD	GOOD	NONE
Dominica	GOOD	GOOD	GOOD	GOOD
Dominican Republic	GOOD	NONE	FAIR	GOOD
Grenada	GOOD	GOOD	GOOD	GOOD
Guyana	NONE	GOOD	NONE	NONE
Haiti	NONE	NONE	NONE	NONE
Jamaica	GOOD	GOOD	GOOD	GOOD
St. Kitts and Nevis	GOOD	GOOD	GOOD	GOOD
St. Lucia	GOOD	GOOD	GOOD	GOOD
St. Vincent and the Grenadines	GOOD	GOOD	GOOD	GOOD
Suriname	GOOD	NONE	FAIR	GOOD
Trinidad and Tobago	GOOD	GOOD	GOOD	GOOD

Interconnection: Assessment cont'd

Country/ Region	5. Infrastructure sharing	6. Local loop unbundling	7. MTR	8. Dispute resolution	9. International gateway access
Antigua and Barbuda	NONE	NONE	NONE	NONE	NONE
Bahamas	NONE	NONE	NONE	GOOD	NONE
Barbados	GOOD	NONE	NONE	GOOD	FAIR
Belize	GOOD	FAIR	NONE	FAIR	NONE
Dominica	GOOD	NONE	GOOD	GOOD	FAIR
Dominican Republic	GOOD	FAIR	NONE	GOOD	NONE
Grenada	GOOD	NONE	GOOD	GOOD	FAIR
Guyana	NONE	NONE	NONE	NONE	NONE
Haiti	NONE	NONE	NONE	NONE	NONE
Jamaica	FAIR	FAIR	NONE	FAIR	NONE
St. Kitts and Nevis	GOOD	NONE	GOOD	GOOD	FAIR
St. Lucia	GOOD	NONE	GOOD	GOOD	FAIR
St. Vincent and the Grenadines	GOOD	NONE	GOOD	GOOD	FAIR
Suriname	FAIR	FAIR	GOOD	FAIR	NONE
Trinidad and Tobago	GOOD	GOOD	NONE	GOOD	FAIR

Overview of Licensing Issues

1. Introduction to trends and key licensing issues
2. Transparency in licensing requirements and process
3. Licensing framework embraces technology neutrality and service convergence facilitation
4. Simplification of licensing process
5. Uniformity of license conditions
6. Transparency in license administration
7. Clear articulation of penalties and methods of enforcement

Licensing: Assessment

Country/ Region	1. Transparent licensing criteria	2. Licensing framework	3. Licensing of scarce resources	4. Simplified license application procedures
Antigua & Barbuda	LIMITED	NONE	NONE	LIMITED
Bahamas	GOOD	GOOD	GOOD	GOOD
Barbados	GOOD	GOOD	GOOD	FAIR
Belize	GOOD	NONE	FAIR	FAIR
Dominica	GOOD	GOOD	FAIR	FAIR
Dominican Republic	GOOD	GOOD	GOOD	FAIR
Grenada	GOOD	FAIR	FAIR	FAIR
Guyana	LIMITED	LIMITED	LIMITED	NONE
Haiti	NONE	NONE	NONE	NONE
Jamaica	GOOD	GOOD	FAIR	FAIR
St. Kitts & Nevis	GOOD	GOOD	FAIR	FAIR
St. Lucia	GOOD	GOOD	FAIR	FAIR
St. Vincent & the Grenadines	GOOD	GOOD	FAIR	FAIR
Suriname	FAIR	FAIR	FAIR	GOOD
Trinidad & Tobago	GOOD	GOOD	GOOD	FAIR

Licensing: Assessment cont'd

Country/ Region	4. License conditions	5. Transparent license administration and transitioning	6. Sanctions and enforcement
Antigua & Barbuda	LIMITED	NONE	LIMITED
Bahamas	GOOD	GOOD	GOOD
Barbados	GOOD	GOOD	GOOD
Belize	FAIR	FAIR	FAIR
Dominica	GOOD	GOOD	GOOD
Dominican Republic	GOOD	GOOD	GOOD
Grenada	FAIR	FAIR	GOOD
Guyana	FAIR	GOOD	GOOD
Haiti	NONE	NONE	NONE
Jamaica	FAIR	GOOD	GOOD
St. Kitts & Nevis	GOOD	GOOD	GOOD
St. Lucia	GOOD	GOOD	GOOD
St. Vincent & the Grenadines	GOOD	GOOD	GOOD
Suriname	FAIR	FAIR	FAIR
Trinidad & Tobago	GOOD	GOOD	GOOD

Overview of Universal Access/Service Issues

- Legal Mandate and Institutional Framework
- Scope and Enforcement of Universal Access/Service Obligations
- Financing of Universal Access/Service (UAS)
- Universal Access/Service Funds – General
- Universal Access/Service Funds – Distribution
- Universal Access/Service Funds – Management

UAS: Assessment

Country/ Region	1. Legal Mandate and Institutional Framework	2. Scope and Enforcement of UAS	3. Financing of UAS
Antigua & Barbuda	NONE	NONE	NONE
Bahamas	GOOD	GOOD	GOOD
Barbados	GOOD	FAIR	GOOD
Belize	GOOD	FAIR	FAIR
Dominica	GOOD	GOOD	GOOD
Dominican Republic	GOOD	NONE	FAIR
Grenada	GOOD	GOOD	GOOD
Guyana	NONE	NONE	NONE
Haiti	NONE	NONE	NONE
Jamaica	GOOD	GOOD	FAIR
St. Kitts & Nevis	GOOD	GOOD	GOOD
St. Lucia	GOOD	GOOD	GOOD
St. Vincent & the Grenadines	GOOD	GOOD	GOOD
Suriname	GOOD	LIMITED	LIMITED
Trinidad & Tobago	GOOD	FAIR	LIMITED

UAS: Assessment cont'd

Country/ Region	4. UAS Fund – General	5. Fund Distribution	6. Fund Management
Antigua & Barbuda	NONE	NONE	NONE
Bahamas	GOOD	GOOD	GOOD
Barbados	GOOD	FAIR	GOOD
Belize	FAIR	NONE	NONE
Dominica	GOOD	GOOD	GOOD
Dominican Republic	FAIR/GOOD	GOOD	FAIR/GOOD
Grenada	GOOD	GOOD	GOOD
Guyana	NONE	NONE	NONE
Haiti	NONE	NONE	NONE
Jamaica	FAIR	GOOD	GOOD
St. Kitts & Nevis	GOOD	GOOD	GOOD
St. Lucia	GOOD	GOOD	GOOD
St. Vincent & the Grenadines	GOOD	GOOD	GOOD
Suriname	LIMITED	NONE	NONE
Trinidad & Tobago	LIMITED	NONE	FAIR

Policy Guidelines

October 30,
2009

HIPCAR Project



Committed to connecting the world

Policy Guidelines: Methodology

- The proposals for Policy Guidelines aimed at bringing the CARICOM/CARIFORUM countries in line with international best practices in terms of access and interconnection and provide the building blocks for future model legislative texts on access and interconnection
- The proposals for Policy Guidelines were adopted by the HIPCAR Working Groups 2&3 which met in Port-of-Spain, Trinidad and Tobago, from 26 to 29 October 2009.
- The proposals for Policy Guidelines were distilled from the first phase report which gave an assessment of international and regional trends and best practices. Each Proposal contains bullets specifying key elements to be defined in future model legislation so as to capture the spirit of each policy guideline.

- **CARICOM/CARIFORUM COUNTRIES SHALL AIM TO INTRODUCE CLEAR LEGAL AND INSTITUTIONAL FRAMEWORKS TO SUPPORT OR ADDRESS THE CONCEPT OF UNIVERSAL ACCESS AND SERVICE**
- **CARICOM/CARIFORUM COUNTRIES SHALL ENSURE THAT KEY PRINCIPLES AND GOALS FOR UNIVERSAL ACCESS AND SERVICE ARE CLEARLY DEFINED IN THE HIGHEST LEGAL TOOL POSSIBLE**
- **CARICOM/CARIFORUM COUNTRIES SHALL ENSURE THAT A MULTIPRONGED APPROACH IS IN PLACE TO PROMOTE UNIVERSAL ACCESS AND SERVICE**

UAS cont'd

- **CARICOM/CARIFORUM COUNTRIES SHALL PROVIDE FOR ADEQUATE AND SUSTAINABLE FINANCIAL SOURCE(S) AND MECHANISM(S) TO SUPPORT UNIVERSAL ACCESS AND SERVICE AND SHALL ENSURE THAT ANY SUBSIDIES ARE TARGETED**
- **WHERE A UNIVERSAL ACCESS/SERVICE FUND IS ESTABLISHED, THE MANAGEMENT, PROJECT SELECTION MECHANISMS, CONTRIBUTION MECHANISMS, AND FUND DISTRIBUTION MECHANISMS ARE TRANSPARANT AND CLEARLY SET OUT**

Licensing

- **CARICOM/CARIFORUM COUNTRIES SHALL AIM TO INTRODUCE TRANSPARENT LICENSING CRITERIA, INCLUDING TERMS AND CONDITIONS OF LICENSES**
- **CARICOM/CARIFORUM COUNTRIES SHALL ENDEAVOUR TO INTRODUCE COMPETITIVE AND TECHNOLOGY NEUTRAL LICENSING FRAMEWORKS WHICH ACCOMMODATE CONVERGENCE AND FACILITATE THE INTRODUCTION OF NEW TECHNOLOGIES**
- **CARICOM/CARIFORUM COUNTRIES SHALL AIM TO INTRODUCE TRANSPARENT LICENSING CRITERIA FOR SCARCE RESOURCES, IN PARTICULAR SPECTRUM**

Licensing cont'd

- **CARICOM/CARIFORUM COUNTRIES SHALL ENDEAVOUR TO SIMPLIFY MARKET ENTRY PROCEDURES TO ENCOURAGE THE INTRODUCTION OF NEW SERVICES**
- **CARICOM/CARIFORUM COUNTRIES SHALL ENDEAVOUR TO INTRODUCE CLEAR AND TRANSPARANT LICENSE CONDITIONS WHICH ARE PROPORTIONATE AND RELEVANT OT MARKET REALITIES**

Licensing cont'd

- **CARICOM/CARIFORUM COUNTRIES SHALL ENDEAVOUR TO INTRODUCE TRANSPARANT LICENSE ADMINISTRATION AND TRANSITIONING MECHANISMS**
- **CARICOM/CARIFORUM COUNTRIES SHALL ENDEAVOUR TO INTRODUCE CLEAR AND TRANSPARANT MECHANISMS RELATING TO SANCTIONS AND ENFORCEMENT WHICH GIVE LICENSEES AN OPPORTUNITY TO STATE THEIR VIEWS AND ARE PROPORTIONATE TO THE INFRACTION**

Interconnection

- **CARICOM/CARIFORUM COUNTRIES SHALL ENSURE THAT AT LEAST DOMINANT OPERATORS, AND PERHAPS ALL OPERATORS, MUST PROVIDE INTERCONNECTION TO THEIR NETWORKS ON A COST-ORIENTED, TRANSPARANT , NON-DISCRIMINATORY, TECHNICAL AND TIMELY BASIS**

- **CARICOM/CARIFORUM COUNTRIES SHALL ENSURE THAT THERE IS A REGULATED PROCESS FOR ALL INTERCONNECTION NEGOTIATIONS, WHICH INCLUDES SPECIFIC TIMEFRAMES IN WHICH NEGOTIATIONS MUST BE COMPLETED AND APPROPRIATE ENFORCEMENT MECHANISMS WHICH PERMIT THE REGULATOR TO INTERVENE IF THE PARTIES DO NOT REACH AN AGREEMENT**

Interconnection cont'd

- CARICOM/CARIFORUM COUNTRIES SHALL ENSURE THAT WHERE OBLIGATIONS FOR DOMINANT OPERATORS OR OPERATORS WITH SIGNIFICANT MARKET POWER (SMP) DIFFER FROM OBLIGATIONS FOR NON-DOMINANT OPERATORS, THE LAW AND/OR REGULATION CLEARLY DEFINES HOW DOMINANT OR SMP STATUS IS DETERMINED, HOW AND WHICH OBLIGATIONS ARE IMPOSED, AND SUCH DETERMINATION SHOULD BE DECIDED ON A FAIR AND TRANSPARENT BASIS
- CARICOM/CARIFORUM COUNTRIES SHALL ENSURE THAT DOMINANT OPERATORS OR THOSE HAVING SIGNIFICANT MARKET POWER MUST PUBLISH A REFERENCE ACCESS AND/OR INTERCONNECTION OFFER THAT IS APPROVED BY THE REGULATOR. ALL ACCESS/INTERCONNECTION OFFERS SHALL BE APPROVED BY THE REGULATOR AND MADE PUBLICLY AVAILABLE

Interconnection cont'd

- **CARICOM/CARIFORUM COUNTRIES SHALL ADOPT MEASURES THAT HEIGHTEN COMPETITION AND STIMULATE TECHNICAL INNOVATION ON THE MARKET, THUS BOOSTING COMPETITIVE PROVISION OF A FULL RANGE OF TELECOMMUNICATION SERVICES OFFERED TO USERS, FROM SIMPLE VOICE TELEPHONY TO BROADBAND SERVICES**
- **THERE SHALL BE REGULATORY INTERVENTION ON MOBILE TERMINATION RATES (MTR) IN WHICH MOBILE OPERATORS MUST OFFER COST-ORIENTED FIXED-TO-MOBILE OR MOBILE-TO-MOBILE TERMINATION RATES**

Interconnection cont'd

- **CARICOM/CARIFORUM COUNTRIES SHALL ENSURE THAT INTERCONNECTION/ACCESS DISPUTES HAVE A SPECIFIC AND EXPEDITED PROCESS AND THAT PARTIES MAY REQUEST THE REGULATOR ADJUDICATION AT ANY TIME AND THAT APPROPRIATE ENFORCEMENT MECHANISMS ARE IN PLACE TO ALLOW THE REGULATOR TO GATHER INFORMATION AND ENFORCE DECISIONS**



Thank You!

Sofie Maddens

Senior Regulatory and Policy Advisor

sofie@tmgtelecom.com

Telecommunications Management Group, Inc.

1600 Wilson Boulevard, Suite 710

Arlington, VA 22209

USA

Tel: +1.703.224.1501

Fax: + 1.703.224.1511

www.tmgtelecom.com



Committed to connecting the world

Annex II

ITU-EC HIPCAR Project

The Way Forward & Revised Workplan

Proposals of the 1st Consultation Workshop for Working Groups 2&3
to the HIPCAR Steering Committee

Trinidad and Tobago, 30 October 2009

J Paul Morgan
Senior Regulatory and Policy Advisor





THE WAY FORWARD

**First Consultation Workshop of Working Groups 2&3 for the HIPCAR Project¹
dealing with work areas: (a) universal access/service,
(b) interconnection, and (c) licensing**

Trinidad and Tobago, 29 October 2009

**J Paul Morgan
Sofie Maddens
Kwesi Prescod**

¹ The full title of the HIPCAR Project - funded by the European Commission and ITU, in collaboration with CTU - is "Enhancing Competitiveness in the Caribbean Through the Harmonization of ICT Policies, Legislation and Regulatory Procedures".

The regional and national commitments to the WTO and the EPA impose a duty on the CARICOM/CARIFORUM States to harmonize ICT Policies, Legislation and Regulatory Procedures to meet specific objectives. In this context, timely adoption of the outcomes of the HIPCAR project by policy makers at the regional and national levels will secure compliance with these commitments.

The issue of “buy in” at the highest levels and the importance of securing ownership of the outcomes by all stakeholders were recognized at the Planning Meeting in December 2008 and again articulated at the First Consultation Workshop of WGs 2 and 3.

Extract from the Report of the Planning Meeting held in Grenada, 15-16 December 2008

Regarding stakeholder ownership and support

- *A key success factor for the Project will be to secure the political will by ministers and regulatory bodies in the region to position ICT harmonization and the Project as a high priority.*
- *Thus, engaging stakeholders at the political/policy level is essential. One option to achieve this would be to convene a meeting at this highest level to introduce the HIPCAR Project, create awareness and secure early “buy-in”.*
- *The identified national and regional focal points must play a key role in ensuring that the Project's harmonization goals are attained.*

The concerns expressed regarding ultimate buy in by the senior policy makers have been noted and it is agreed that the success of the project will be ultimately measured by the extent to which the recommendations arising out of the project are adopted by CARICOM and national governments. To secure these results activity must progress on three fronts.

1. The time table or the activities of the working groups must continue consistent with the objectives set out in the work plan (see attached)
2. The Steering Committee/CARICOM/CTU must agree on the strategy for formally introducing the project and its outcomes to the CARICOM Agenda – CARICOM must take ownership of the project outcomes.
3. National Governments must be kept informed of the project, be sensitized to its outcomes and adopt the recommendations as appropriate to their specific circumstances.

There should be no question that as a regional initiative the outcomes of the project have to be owned by CARICOM/CTU and that the strategies for getting the project on the regional agenda must be developed and initiated through those channels. In the final analysis, the Steering Committee will have to take this forward bearing in mind that both CTU and CARICOM are key members of the Committee.

As it is adoption of the recommendations by the national governments that will eventually give effect to the harmonization of policies and legalization it will be important that the portfolio ministers and ministries be kept informed of the status of the project on an ongoing basis. **The Country Focal Points (CFPs) are committed to play the key role in keeping their governments informed.**

Every opportunity should be explored for widening and strengthening the communication to the relevant ministers, particularly in those instances where the responsibility for the wider ICT applications do not coincide with the communications portfolio. The CFPs will make special efforts to brief all relevant interests in the national governments. As the countries are at differing stages in the evolution of their respective ICT policy, legislative and regulatory frameworks, there may be opportunities to introduce the principles and concepts arising out of the HIPCAR project into national policy considerations even before adoption by CARICOM. CFPs will play an important role in this regard.

There are two critical decision points which require timely policy level attention at the regional level, and thus necessitating action by CARICOM/CTU –

- 1) The deliverables of the 1st Consultation Workshops will be the Assessment Reports and the Draft Policy Guidelines. As these will form the basis for preparation of the draft Model Legislation there has to be a level of certainty regarding general acceptance of the Draft Policy Guidelines. A mechanism has to be found through CARICOM/CTU to secure a timely review and feedback on /endorsement of these Draft Policy Guidelines.
- 2) While the mode for sensitizing CARICOM will obviously be determined by the Secretariat it is suggested that a special meeting under the auspices of CARICOM/CTU/HIPCAR (invitation probably from CARICOM) with the relevant Ministers and Regulators be organized to discuss the outcomes and get commitment on/endorsement of (Senior Officials Validation Workshop) the Final Draft Policy Guidelines, Model Legislation and Implementation Guidelines.

The Steering Committee ought to agree on a strategy to secure action on policy validation (or minimally review) at the CARICOM level for the draft policy guidelines arising out of the 1st Consultation workshop and, later on, the modality for the validation of the Final Draft Policy Guidelines, Model Legislation and Implementation Guidelines.

To reinforce the efforts for national sensitization it is recommended that the ITU (Director BDT) write directly to the Ministers and Regulators providing updates on the project after the WG/SC meetings. This will complement the efforts of the CFPs.

Timely communication and information flows to Ministers, key policy makers and other stakeholders are critical to the “buy in” – the chart below shows how this might be achieved.

Communication linkages

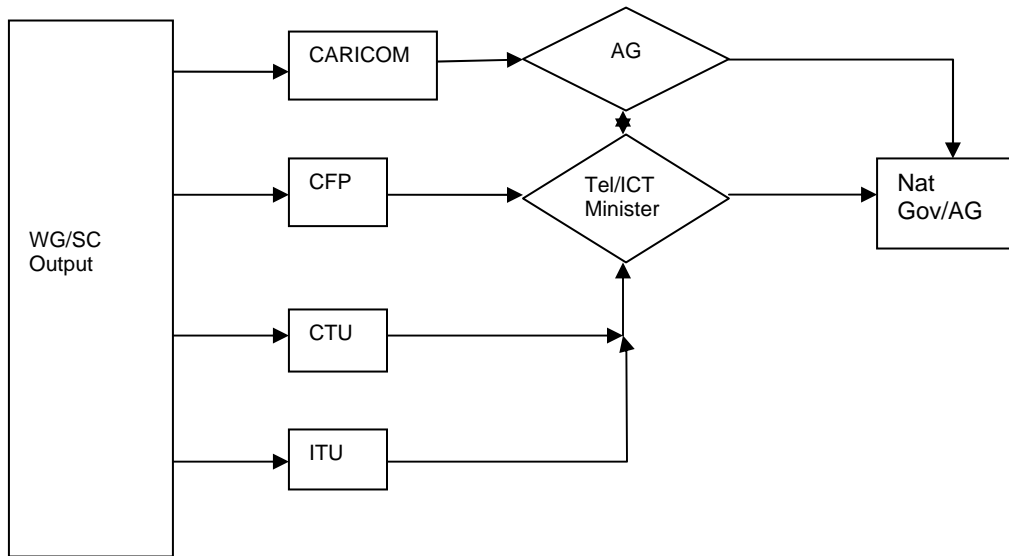

ATTACHMENT

HIPCAR Project Workplan Relating to WG 2 (Telecommunications Act – Universal Access/Service) and WG 3 (Telecommunications Act – Interconnection & Licensing) *Phase 1 – Development of Model Legislation, etc.*

Activity	Period	Outputs / Deliverables
<p>1. 2nd Steering Committee meeting (1 day) to review & approve the Critical Assessment Reports & Draft Policy Guidelines, etc. for WGs 2 & 3 (and to review the status of the other 2 Working Groups)</p>	<p>30 Oct</p>	<ul style="list-style-type: none"> • Consolidation document of comments and suggestions on the Assessment Reports and Draft Policy Guidelines • Revised Assessment Reports & Draft Policy Guidelines, etc., incorporating comments of the First Consultation Workshop & Steering Committee • Recommendations on how to achieve project sustainability / political buy-in
<p>2. Finalization of the Critical Assessment Reports and Draft Policy Guidelines, etc. <i>Policy level review/comment (CARICOM/CTU)</i></p>	<p>31 Oct – 20 Nov <i>21 Nov 09 – 31 Jan 10</i></p>	<ul style="list-style-type: none"> • 3 Final Critical Assessment Reports • 3 Final Draft Policy Guidelines <p><i>To affirm basis for preparation of model legislation</i></p>
<p>3. Preparation of first draft Model Legislation & Implementation Guidelines covering the above work areas, based on the assessment and review of existing Telecommunications Acts and aforementioned Draft Policy Guidelines. The draft Model Legislation will translate the adopted Policy Guidelines into legal text proposals. These first draft sets will be submitted for preliminary comments to the corresponding two WGs, CFPs and SC.</p>	<p>21 Nov 09 – 31 Jan 10</p>	<ul style="list-style-type: none"> • First draft of Model Legislation & Implementation Guidelines, based on the above regional assessment & draft policy guidelines. These will comprise the following: <ul style="list-style-type: none"> ○ Model legislation encompassing the above work areas ○ Guidelines for the development of regulations to implement this legislation throughout the region • Summary of best practices applied in the development and enactment of Telecoms legislation in a comparable jurisdiction, to help argue the case for the new Legislation etc.
<p>4. Second Consultation Workshop of WGs 2&3 (3.5 days) on the draft Model Legislation & Implementation Guidelines. This workshop (with time for preparation) will involve a review & finalization of the outputs /deliverables of Activity 5 by the Working Groups, Country Focal Points & Steering Committee, along with the experts.</p>	<p>1 - 4 Feb 10</p>	<ul style="list-style-type: none"> • Final draft Model Legislation & Implementation Guidelines for Regulations in the identified work areas – based on the Assessment Reports & Draft Policy Guidelines – including the rationale for the recommendations • Final briefing materials for the workshop, e.g. lecture notes, interactive exercises, guidelines on areas of divergence and rationale for any differing approaches/key provisions in the ICT legislative framework, etc. • Workshop support material, including presentations on the draft Model Legislation, Implementation Guidelines for Regulations & the related

		<ul style="list-style-type: none"> • Statement of agreement by the WG & CFP on the draft Model Legislation and Implementation Guidelines, incorporating any final recommendations they may have • Workshop report, with a summary of the participants' comments, proposals and updated draft Model Legislation & Implementation Guidelines
5. 3 rd Steering Committee meeting (2 days) to review & approve the Draft Model Legislation & Implementation Guidelines for WGs 2 & 3 (<i>and to review the status of the other 2 Working Groups</i>)	24 – 30 April	<ul style="list-style-type: none"> • Consolidation document of comments and suggestions on the first draft Model Legislation & Implementation Guidelines • Draft Final Model Legislation & Implementation Guidelines incorporating comments of the 1st and 2nd Consultation Workshops & Steering Committee • Recommendations on how to achieve project sustainability / political buy-in
6. Preparation of the Final Draft Policy Guidelines, Model Legislation and Implementation Guidelines	1 - 15 May	<ul style="list-style-type: none"> • Final consolidated document with the Draft Policy Guidelines, Model Legislation and Implementation Guidelines based on feedback at the workshops & Steering Committee
7. Senior Officials Validation Workshop (2 days) on the Final Draft Policy Guidelines, Model Legislation and Implementation Guidelines for WGs 2 & 3 (and the other two WGs). This workshop (for the region's Ministers and Attorney Generals as per the CTU's Executive Council and its General Conference of Ministers in extraordinary meeting) will involve: <ul style="list-style-type: none"> • Detailed briefing / explanations & discussions on the above documents. • Formal endorsement of the Policy Guidelines, Model Legislation and Implementation Guidelines by the senior officials – Modalities & wording of terms to be determined 	16 - 30 May (TBD)	<ul style="list-style-type: none"> • Briefing materials (as above for the Finalisation Workshop) • Formal endorsement of the Policy Guidelines, Model Legislation and Implementation Guidelines by the relevant Ministers and Attorney Generals.
8. Finalisation of the Final Draft Policy Guidelines, Model Legislation and Implementation Guidelines, with relevant amendments and regulations, identified training needs, etc. based on comments & feedback received from the Validation workshop	1 – 20 Jun	<ul style="list-style-type: none"> • Final Policy Guidelines, Model Legislation and Implementation Guidelines with amendments, regulations and specification of training needs as appropriate