



INTERNATIONAL TELECOMMUNICATION UNION

**ITU-T**

TELECOMMUNICATION  
STANDARDIZATION SECTOR  
OF ITU

**X.462**

(10/96)

SERIES X: DATA NETWORKS AND OPEN SYSTEM  
COMMUNICATION

Message Handling Systems

---

**Information technology – Message Handling  
Systems (MHS) management: Logging  
information**

ITU-T Recommendation X.462

(Previously “CCITT Recommendation”)

---

ITU-T X-SERIES RECOMMENDATIONS  
DATA NETWORKS AND OPEN SYSTEM COMMUNICATION

PUBLIC DATA NETWORKS	X.1-X.199
Services and facilities	X.1-X.19
Interfaces	X.20-X.49
Transmission, signalling and switching	X.50-X.89
Network aspects	X.90-X.149
Maintenance	X.150-X.179
Administrative arrangements	X.180-X.199
OPEN SYSTEM INTERCONNECTION	X.200-X.299
Model and notation	X.200-X.209
Service definitions	X.210-X.219
Connection-mode protocol specifications	X.220-X.229
Connectionless-mode protocol specification	X.230-X.239
PICS proformas	X.240-X.259
Protocol Identification	X.260-X.269
Security Protocols	X.270-X.279
Layer Managed Objects	X.280-X.289
Conformance testing	X.290-X.299
INTERWORKING BETWEEN NETWORKS	X.300-X.399
General	X.300-X.349
Satellite data transmission systems	X.350-X.399
<b>MESSAGE HANDLING SYSTEMS</b>	<b>X.400-X.499</b>
DIRECTORY	X.500-X.599
OSI NETWORKING AND SYSTEM ASPECTS	X.600-X.699
Networking	X.600-X.629
Efficiency	X.630-X.649
Naming, Addressing and Registration	X.650-X.679
Abstract Syntax Notation One (ASN.1)	X.680-X.699
OSI MANAGEMENT	X.700-X.799
Systems Management framework and architecture	X.700-X.709
Management Communication Service and Protocol	X.710-X.719
Structure of Management Information	X.720-X.729
Management functions	X.730-X.799
SECURITY	X.800-X.849
OSI APPLICATIONS	X.850-X.899
Commitment, Concurrency and Recovery	X.850-X.859
Transaction processing	X.860-X.879
Remote operations	X.880-X.899
OPEN DISTRIBUTED PROCESSING	X.900-X.999

*For further details, please refer to ITU-T List of Recommendations.*

## FOREWORD

ITU (International Telecommunication Union) is the United Nations Specialized Agency in the field of telecommunications. The ITU Telecommunication Standardization Sector (ITU-T) is a permanent organ of the ITU. Some 179 member countries, 84 telecom operating entities, 145 scientific and industrial organizations and 38 international organizations participate in ITU-T which is the body which sets world telecommunications standards (Recommendations).

The approval of Recommendations by the Members of ITU-T is covered by the procedure laid down in WTSC Resolution No. 1 (Helsinki, 1993). In addition, the World Telecommunication Standardization Conference (WTSC), which meets every four years, approves Recommendations submitted to it and establishes the study programme for the following period.

In some areas of information technology which fall within ITU-T's purview, the necessary standards are prepared on a collaborative basis with ISO and IEC. The text of ITU-T Recommendation X.462 was approved on 5th of October 1996. The identical text is also published as ISO/IEC International Standard 11588-3.

---

### NOTE

In this Recommendation, the expression "Administration" is used for conciseness to indicate both a telecommunication administration and a recognized operating agency.

© ITU 1997

All rights reserved. No part of this publication may be reproduced or utilized in any form or by any means, electronic or mechanical, including photocopying and microfilm, without permission in writing from the ITU.

## CONTENTS

	<i>Page</i>
SECTION 1 – INTRODUCTION .....	1
1 Scope .....	1
2 Normative references .....	1
3 Definitions .....	3
4 Abbreviations .....	4
5 Conventions .....	5
SECTION 2 – MHS LOGGING PRINCIPLES .....	5
6 Requirements .....	5
7 Service definitions .....	7
8 Logging model .....	15
9 Creation conditions .....	16
SECTION 3 – MANAGEMENT INFORMATION MODEL .....	20
10 Definition of managed object classes .....	20
11 Definitions of packages .....	25
12 Definition of attributes .....	40
13 Definition of attribute groups .....	60
14 Definition of Notifications .....	60
15 Definition of actions .....	61
16 Definition of parameters .....	61
17 Name bindings .....	63
SECTION 4 – CONFORMANCE STATEMENTS .....	65
18 Conformance statements .....	65
Annex A – ASN.1 definitions .....	69
Annex B – Relation with ITU-T Rec. X.742   ISO/IEC 10164-10 .....	84
Annex C – Examples of use of settlement log information .....	86
Model 1 .....	86
Model 2 .....	88

## **Summary**

This Recommendation | International Standard presents the information that needs to be recorded in order to manage a message handling system using the OSI management framework.



**INTERNATIONAL STANDARD****ITU-T RECOMMENDATION****INFORMATION TECHNOLOGY – MESSAGE HANDLING SYSTEMS (MHS)  
MANAGEMENT: LOGGING INFORMATION****SECTION 1 – INTRODUCTION****1 Scope**

MHS Logging is the collection of information relating to the use of MHS resources when providing MHS services in an MIS management domain.

Three aspects of MHS Logging are considered in this Recommendation | International Standard:

- a) MHS Events logging management;
- b) MHS Customer accounting management;
- c) MHS Settlement accounting management.

MHS Events logging is the collection of information relating to the use of MHS entities (UA, AU, MTA and MS), within an MIS management domain, when acting upon messages, probes and reports. MHS Events logging information is the basic information that is used to provide others MHS management services, for example Customer accounting management and Settlement accounting management.

MHS Customer accounting is the collection, for the purpose of billing, of information related to the use of MHS resources by a Customer within an MIS management domain.

MHS Settlement accounting is the collection, for the purpose of reconciliation of accounts, of information related to the use of MHS resources by an Interworking MD.

This Specification:

- a) Establishes the requirements for MHS Logging;
- b) Defines the services provided for the purpose of MHS Logging;
- c) Defines relationships with other system management functions;
- d) Establishes models that relate the services to the managed objects;
- e) Defines object classes, packages, attributes types, operations and notifications types;
- f) Specifies conformance requirements.

This Specification does not:

- a) Specify accounting metering;
- b) Specify how Customer accounting and Settlement accounting information can be derived from MHS events logging information.

The information captured relates to open systems resource usage at the Application layer. It does not capture resource usage at lower layers. For example, it does not capture network layer cost between MDs nor between MD and client systems for the transfer of messages.

**2 Normative references**

The following Recommendations and International Standards contain provisions which, through reference in this text, constitute provisions of this Recommendation | International Standard. At the time of publication, the editions indicated were valid. All Recommendations and Standards are subject to revision, and parties to agreements based on this Recommendation | International Standard are encouraged to investigate the possibility of applying the most recent

## ISO/IEC 11588-3 : 1997 (E)

edition of the Recommendations and Standards listed below. Members of the IEC and ISO maintain registers of currently valid International Standards. The Telecommunication Standardization Bureau of the ITU maintains a list of currently valid ITU-T Recommendations.

### 2.1 Identical Recommendations | International Standards

- ITU-T Recommendation X.200 (1994) | ISO/IEC 7498-1:1994, *Information technology – Open Systems Interconnection – Basic Reference Model: The Basic Model.*
- ITU-T Recommendation X.402 (1995) | ISO/IEC 10021-2:1996, *Information technology – Message Handling Systems (MHS): Overall architecture.*
- ITU-T Recommendation X.411 (1995) | ISO/IEC 10021-4:1997, *Information technology – Message Handling Systems (MHS): Message transfer system: Abstract service definition and procedures.*
- ITU-T Recommendation X.460 (1995) | ISO/IEC 11588-1:1996, *Information technology – Message Handling Systems (MHS) management: Model and architecture.*
- ITU-T Recommendation X.464<sup>1)</sup> | ISO/IEC 11588-4...<sup>1)</sup>, *Information technology – Message Handling Systems (MHS) management: Security Management Functions.*
- ITU-T Recommendation X.501 (1993) | ISO/IEC 9594-2:1995, *Information technology – Open Systems Interconnection – The Directory: Models.*
- ITU-T Recommendation X.509 (1993) | ISO/IEC 9594-8:1995, *Information technology – Open Systems Interconnection – The Directory: Authentication framework.*
- CCITT Recommendation X.701 (1992) | ISO/IEC 10040:1992, *Information technology – Open Systems Interconnection – Systems management overview.*
- CCITT Recommendation X.720 (1992) | ISO/IEC 10165-1:1993, *Information technology – Open Systems Interconnection – Structure of management information: Management information model.*
- CCITT Recommendation X.721 (1992) | ISO/IEC 10165-2:1992, *Information technology – Open Systems Interconnection – Structure of management information: Definition of management information.*
- CCITT Recommendation X.722 (1992) | ISO/IEC 10165-4:1992, *Information technology – Open Systems Interconnection – Structure of management information: Guidelines for the definition of managed objects.*
- CCITT Recommendation X.734 (1992) | ISO/IEC 10164-5:1993, *Information technology – Open Systems Interconnection – Systems management: Event report management function.*
- CCITT Recommendation X.735 (1992) | ISO/IEC 10164-6:1993, *Information technology – Open Systems Interconnection – Systems management – Log control function.*
- ITU-T Recommendation X.742 (1995) | ISO/IEC 10164-10:1995, *Information technology – Open Systems Interconnection – Systems management: Usage metering function for accounting purposes.*

### 2.2 Paired Recommendations | International Standards equivalent in technical content

- ITU-T Recommendation F. 400/X.400 (1993), *Message handling services: Message handling system and service overview.*  
ISO/IEC 10021-1:1990, *Information technology – Text communication – Message-Oriented Text Interchange Systems (MOTIS) – Part 1: System and Service Overview.*
- CCITT Recommendation X.700 (1992), *Management framework for Open Systems Interconnection (OSI) for CCITT applications.*  
ISO/IEC 7498-4:1989, *Information processing systems – Open Systems Interconnection – Basic Reference Model – Part 4: Management framework.*

### 2.3 Additionnal references

- CCITT Recommendation Q.36 (1988), *Customer recognition of foreign tones.*
- ITU-T Recommendation M. 3010 (1996), *Principles for a telecommunications management network.*
- ITU-T Recommendation M. 3100 (1995), *Generic network information model.*

---

<sup>1)</sup> Presently at the stage of draft.



### 3 Definitions

For the purposes of this Recommendation | International Standard, the following definitions apply.

- 3.1 accounting:** The action of collecting information on the operations performed within a system and the effects thereof.
- 3.2 customer:** A Customer is a corporation, organization or individual with telecommunications needs to be satisfied.
- 3.3 customer accounting:** The reconciliation of accounts between MHS service provider and MHS service user. The charging policy used may be subject to a bilateral agreement.
- 3.4 indirect MIS-user:** An indirect MIS-User is a Customer or an interworkingMD. An Indirect MIS-User cannot reach the Management Information System directly. Access to management information is provided through a generic set of services: the Service Request Management Services (SRMS).
- 3.5 interworkingMD:** Interconnected management domain. A MHS management domain that has settlement arrangements with the managed MHS management domain.
- An Indirect MIS-user is an entity, like Customer or InterworkingMD.
- 3.6 MD manager:** An MD manager is an MHS system manager who is additionally responsible for the management of an ADMD or a PRMD.
- 3.7 MHS system manager:** An MHS system manager is a corporation, organization or individual which is responsible for the management of the resources of an MHS system.
- 3.8 processingError Managed object:** A Managed object with the processing error flag set to TRUE.
- 3.9 settlement:** The reconciliation of accounts between MHS service providers. The settlement policy used is subject to a bilateral agreement.

This Recommendation | International Standard makes use of the following term defined in ITU-T Rec. X.700 and ISO/IEC 7498-4:

- managed object.

**3.10** This Recommendation | International Standard makes use of the following terms defined in ITU-T Rec. X.701 | ISO/IEC 10040:

- a) agent role;
- b) agent;
- c) managed object class;
- d) manager;
- e) manager role;
- f) notification.

**3.11** This Recommendation | International Standard makes use of the following terms defined in ITU-T Rec. X.400 and ISO/IEC 10021-1:

- a) access unit;
- b) administration management domain;
- c) delivery;
- d) delivery report;
- e) distribution list;
- f) distribution list expansion;
- g) encoded information type;
- h) conversion;
- i) management domain;
- j) message;
- k) message store;
- l) message transfer agent;

## ISO/IEC 11588-3 : 1997 (E)

- m) O/R name;
- n) originator;
- o) physical delivery access unit;
- p) probe;
- q) recipient;
- r) transfer;
- s) user agent.

**3.12** This Recommendation | International Standard makes use of the following terms defined in ITU-T Rec. X.402 | ISO/IEC 10021-2:

- a) Message Administration Service Element;
- b) Message Delivery Service Element;
- c) Message Retrieval Service Element;
- d) Message Submission Service Element;
- e) Message Transfer Service Element.

**3.13** This Recommendation | International Standard makes use of the following terms defined in ITU-T Rec. X.460 | ISO/IEC 11588-1:

- a) MHS management domain;
- b) MHS system;
- c) MIS management domain;
- d) MIS-User.

## 4 Abbreviations

For the purposes of this Recommendation | International Standard, the following abbreviations apply:

ADMD	Administration Management Domain
ASN.1	Abstract Syntax Notation One
AU	Access Unit
CMIP	Common Management Information Protocol
CMIS	Common Management Information Service
DL	Distribution List
DMI	Definition of Management Information
DN	Distinguished Name
EIT	Encoded Information Type
GDMO	Guidelines for the Definition of Managed Objects
MASE	Message Administration Service Element
MD	MHS Management Domain
MDSE	Message Delivery Service Element
MHS	Message Handling System
MIB	Management Information Base
MIS	Management Information System
MO	Managed Object
MRSE	Message Retrieval Service Element
MS	Message Store
MSSE	Message Submission Service Element
MTA	Message Transfer Agent
MTSE	Message Transfer Service Element

PDAU	Physical Delivery Access Unit
PDU	Protocol Data Unit
RDN	Relative Distinguished Name
SMI	Structure of Management Information
SRMS	Service Request Management Service
UA	User Agent

**5 Conventions**

In clause 10, the managed object class templates are grouped in subclauses according to their logical organization in the naming tree of Figure 4. This may lead to clauses having only one subclause, but this is deemed necessary in order to keep in line with the structure of the MIB. The first two layers of the structure have been kept separate so as not to have only one subclause in clause 10.

In clause 11, the package templates are grouped in subclauses according to their logical organization in their respective managed object class template, as defined in clause 10. The conditional packages are placed in subclauses of the corresponding mandatory packages. This may lead to clauses having only one subclause, but this is deemed necessary in order to keep in line with the structure of the MIB.

**SECTION 2 – MHS LOGGING PRINCIPLES**

**6 Requirements**

Three types of users may express requirements on MHS Logging Information:

- a) MHS system manager;
- b) MD manager;
- c) Customer,

Table 1 describes the specific requirements of each type of MHS Accounting Management user.

**Table 1 – User requirements**

Requirements	Users		
	MHS system manager	MD manager	Customer
MHS events logging	x	x	
Customer accounting data collection	x	x	
Customer access to Customer information			x
Settlement data collection		x	
Exchange of Settlement information		x	

**6.1 MHS events logging purposes**

MHS events logging services shall enable to store in logs:

- a) interactions between various components within the managed part of the MHS;
- b) actions on messages performed by the MTS-provider within the managed part of the MHS.

The content of MHS events logs shall be available for MHS management functions (e.g. Settlement accounting and Customer accounting).

**6.2 Customer accounting purposes**

**6.2.1 Customer accounting data collection**

Customer accounting services shall enable the use of the MHS service by a Customer to be measured. Following facilities shall be offered for the control of Customer accounting data collection:

- a) creation of an accounting data collection;
- b) deletion of an accounting data collection;
- c) modification of data collection characteristics.

NOTE – The content of the Customer Accounting Record is not defined in this Recommendation | International Standard. Such information may be subject to a charging policy agreements between the Customer and the MHS service provider. Such policies are currently under study and the standardization of Customer Accounting Records is therefore left to further study.

**6.2.2 Customer access to Customer accounting information**

Customer accounting services shall enable a Customer to request access to the accounting information. This information may be constrained to read-only access rights on behalf of the Customer. Condition of availability to the Customer of such information may be subject to negotiation with the MIS provider.

**6.3 Settlement purposes**

**6.3.1 Settlement cost element model**

The information collected for Settlement accounting purposes are those cost elements relating to the processing of messages, as identified in Figure 1.

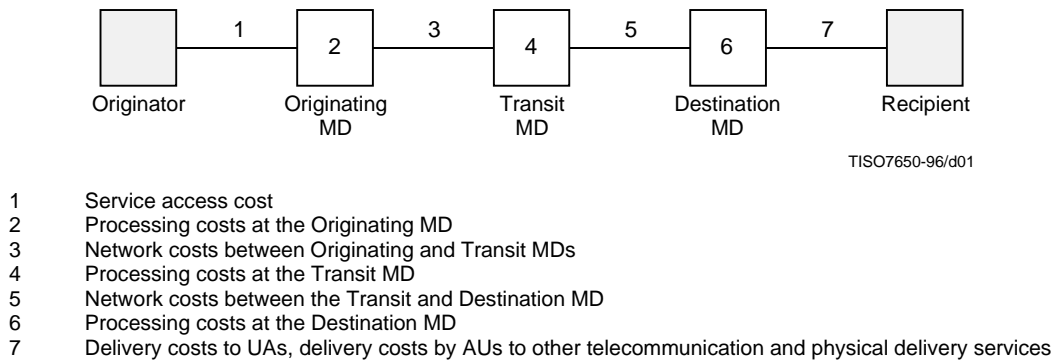

**Figure 1 – Cost element model**

**6.3.2 Settlement data collection**

Settlement accounting services enable settlement information to be collected. The following facilities shall be offered for the control of Settlement accounting data collection:

- a) creation of a Settlement data collection;
- b) deletion of a Settlement data collection;
- c) modification of Settlement data collection characteristics.

**6.3.3 Exchange of Settlement information**

Settlement accounting services shall provide mechanisms for the exchange of settlement information between InterworkingMDs. The condition of availability of such information may be subject to negotiation with each InterworkingMD.

**6.3.4 Information collected**

The accounting information is collected by MDs that perform service on behalf of the originator/ recipient of a message. The destination MD collects information associated with the delivery of the message to a recipient. The originating MD collects information associated with message submission (e.g. service access charge). Any MD along the path collects informations associated to actions which are subject to accounting, such as distribution list expansion, redirection, and conversion.

Settlement among MDs requires the collection of the following information:

- a) Information related to the message processing at the originating MD:
  - 1) Originating Customer requested;
  - 2) Additional processing.
- b) Information related to the message processing at zero, one, or more transit MDs:
  - 1) Originating Customer requested;
  - 2) Third party requested.
- c) Information related to the message processing, including delivery costs at the destination MD:
  - 1) Originating Customer requested;
  - 2) Recipient requested.

**7 Service definitions**

Two types of service users are identified in this Recommendation | International Standard: MIS-Users and Indirect MIS-users.

Table 2 describes services and functions provided to these service users.

**Table 2 – Services and functions provided to accounting service user**

Services	Functions	Provided to MIS-users	Provided to Customers	Provided to interworkingMD
Service request	<ul style="list-style-type: none"> <li>• Indirect MIS-user Event report</li> <li>• Indirect MIS-user Service request</li> </ul>		x x	x x
Settlement account request	<ul style="list-style-type: none"> <li>• Settlement account request</li> <li>• Settlement log retrieval</li> </ul>			x x
Customer account request	<ul style="list-style-type: none"> <li>• Customer account request</li> <li>• Customer accounting log retrieval</li> </ul>		x x	
Settlement accounting	<ul style="list-style-type: none"> <li>• Settlement accounting log</li> </ul>	x		
Customer accounting	<ul style="list-style-type: none"> <li>• Customer accounting log</li> </ul>	x		
MHS event logging	<ul style="list-style-type: none"> <li>• MHS events log</li> </ul>	x		
NOTES 1 The Service request services are generic services which shall not be realized in the generic form but specialized for specific purposes. For instance, the Settlement account request and Customer account request functions defined in this Recommendation   International Standard are derived from the Service request services. 2 The exchange of accounting information with Customers may but need not be provided through the Customer account request services. 3 The exchange of settlement information between MDs may but need not be provided through the settlement account request services.				

**7.1 Service request management services**

The SRMS enable the exchange of information between an Indirect MIS-user and the MIS-provider. The SRMS enable an Indirect MIS-user to request a service, eventually to negotiate request parameters, and to control and monitor the performance of a request, as shown in Figure 2.

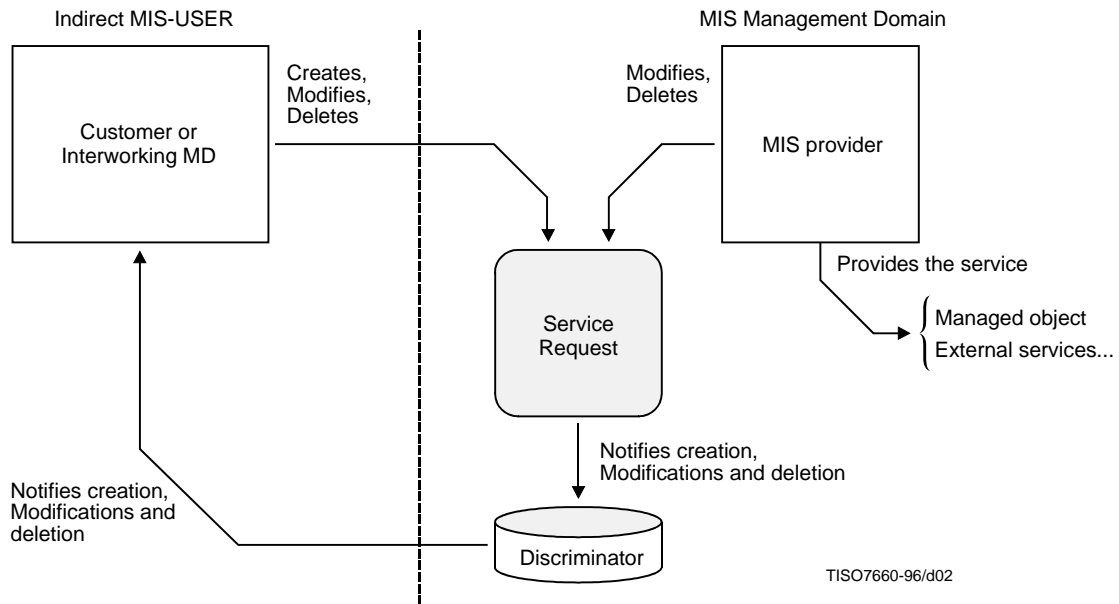

**Figure 2 – Model for the service request**

NOTE – The use of such services is not limited to accounting management purposes. For instance, it may be used in Performance management to request performance reports.

**7.1.1 Indirect MIS-user event report function**

**7.1.1.1 Function description**

This function enables the Indirect MIS-user to receive event reports. The Indirect MIS-user may define the characteristics that a potential event report must have before being sent (discriminator construct).

**7.1.1.2 Parameters**

Parameters are defined in CCITT Rec. X.734 | ISO/IEC 10164-5, clause 8.1.2: Event forwarding discriminator.

**7.1.1.3 Behaviour**

The Event forwarding discriminator object (customerEFD or interworkingMD-EFD) is used to represent the criteria that shall be satisfied by potential events reports before the event report is forwarded to the Indirect MIS-user.

Each event that may be reported to the Indirect MIS-user is sent to the Indirect MIS-user if it satisfies the current discriminator construct.

The Indirect MIS-user may modify the discriminator construct and he may suspend or resume the EventForwardingDiscriminator’s activity.

**7.1.1.4 References**

CCITT Rec. X.734 | ISO/IEC10164-5.

**7.1.1.5 Service primitives**

Table 3 describes services primitives associated with this function.

**Table 3 – Indirect MIS-user event report function service primitives**

Primitives	Service SMASE	CMISE	Objects
Modification of discriminator attributes	PT-SET	M-SET	customerEFD, interworkingMD-EFD
Suspension of the discriminator activity	PT-SET	M-SET	customerEFD, interworkingMD-EFD
Resumption of the discriminator activity	M-SET	M-SET	customerEFD, interworkingMD-EFD

## 7.1.2 Indirect MIS-user service request function

### 7.1.2.1 Function description

The Service request function enables the Indirect MIS-user to control and monitor the performance of a request and eventually to negotiate request parameters.

### 7.1.2.2 Parameters

The following parameters are defined for this service:

- contactInstance;
- serviceRequestID;
- status;
- limitValidityDate;
- startUpDate.

#### 7.1.2.2.1 contactInstance

This attribute contains the identification of the Indirect MIS-user.

#### 7.1.2.2.2 serviceRequestID

This attribute is used to identify the requested function.

#### 7.1.2.2.3 status

This attribute contains the status of the Service request in progress. A request may have the following status:

- indirect-MIS-User agreement on the request;
- MIS-provider agreement on the request;
- request in progress;
- request processed.

#### 7.1.2.2.4 limitValidityDate

This attribute provides the means to the Indirect MIS-user and MIS-provider to exchange information about the validity period of the Service request.

#### 7.1.2.2.5 startUpDate

This attribute provides the means for the Indirect MIS-user to set the date and time at which he wishes the function to be made available. This attribute provides the means for the MIS-provider to inform the Indirect MIS-user that this date is not acceptable, then giving another date.

### 7.1.2.3 Behaviour

This function is provided through a serviceRequest managed object class. Specific serviceRequest objects (for instance the acctRequest object defined in this Recommendation | International Standard) are subclasses of the serviceRequest managed object class.

The performance of a Service request can be split into four steps:

- a) creation of a serviceRequest managed object instance;
- b) negotiation of attribute values;
- c) performance of the request;
- d) deletion of the serviceRequest managed object instance.

The Indirect MIS-user exercises control over the notifications that may be forwarded to him with the "Indirect MIS-user Event report function".

#### 7.1.2.3.1 Creation of service request

The Indirect MIS-user requests the creation of an instance of a subclass of the serviceRequest managed object class. The performance of the creation is reported to the Indirect MIS-user as an object creation report. The status attribute is set to: "Customer agreement on the request" at initialization time.

**7.1.2.3.2 Negotiation**

The MIS-provider modifies, if needed, the values of negotiated attributes (e.g. limitValidityDate, startUpDate) and sets the status attribute to: "provider agreement on the request". All changes on attribute values including the status attribute are reported to the Indirect MIS-user as Attribute change value notifications.

Then, the Indirect MIS-user modify, if needed, the values of negotiated attributes and sets again the status attribute to: "Customer agreement on the request".

This procedure is renewed until a compromise is found. Then the MIS-provider sets the status attribute to: "request in progress". If no compromise is found, the Indirect MIS-user cancels the request by deleting the Service request object.

**7.1.2.3.3 Performance of the request**

The MIS-provider performs the request and sets the status attribute value to: "request processed". A specific attribute may be used to provide the result to the Indirect MIS-user. All changes on attribute values including the status attribute are reported to the Indirect MIS-user as Attribute change value notifications.

**7.1.2.3.4 Normal deletion of the request**

The MIS-provider or the Indirect MIS-user may delete the requested service instance after the Service request has been provided. The performance of the deletion is reported to the Indirect MIS-user as an object deletion report.

**7.1.2.3.5 Abnormal deletion of the request**

At any time between the creation and the normal end of the negotiation, the Indirect MIS-user may cancel the service request by deleting the serviceRequest instance. The performance of the deletion is reported to the Indirect MIS-user as an object deletion report.

**7.1.2.4 Service primitives**

Table 4 describes services primitives associated with this function.

**Table 4 – Indirect MIS-user event report function service primitives**

Primitives	Service SMASE	CMISE	Objects
Initiation of a Service request	PT-CREATE	M-CREATE	Subclass of serviceRequest
Modification of a Service request	PT-SET	M-SET	Subclass of serviceRequest
Retrieval of Service request attributes	PT-GET	M-GET	Subclass of serviceRequest
Deletion of a Service request	PT-DELETE	M-DELETE	Subclass of serviceRequest
Event report filtering	Indirect MIS-user event report service	M-EVENT-REPORT	customerEFD or interworkingMD-EFD

**7.2 Settlement account request function**

**7.2.1 Settlement accounting log function**

**7.2.1.1 Function description**

This function enables an MIS-user to:

- a) create, delete, and modify a data collection for settlement accounting;
- b) retrieve settlement records.

**7.2.1.2 Parameters**

Parameters correspond to the attributes of the settlementAcctLog managed object.

**7.2.1.3 References**

CCITT Rec. X.735 | ISO/IEC 10164-6.



### 7.2.1.4 Service primitives

Table 5 describes services primitives associated with this function.

**Table 5 – Settlement accounting log function service primitives**

Primitives	Service SMASE	CMISE	Objects
Initiation of data collection	PT-CREATE	M-CREATE	settlementAcctLog
Modification of a data collection	PT-SET	M-SET	settlementAcctLog
Deletion of a data collection	PT-DELETE	M-DELETE	settlementAcctLog
Retrieval of settlement records	PT-GET	M-GET	settlementAcctRecord

## 7.2.2 Settlement account request function

### 7.2.2.1 Function description

The Settlement account request function enables an interworkingMD to request the availability of a settlementAcctLog. This function is derived from the generic Service request function defined in this Recommendation | International Standard.

### 7.2.2.2 Parameters

The following parameters are defined for this service, in addition to those described for the Service request function:

- logStartTime;
- logStopTime;
- logId;
- settlementPolicy.

#### 7.2.2.2.1 logStartTime

This parameter represents the starting time for logging of settlement accounting information.

#### 7.2.2.2.2 logStopTime

This parameter represents the stopping time for logging of settlement accounting information.

#### 7.2.2.2.3 logID

This log identifier is provided by the MIS provider in response to the Settlement account request.

#### 7.2.2.2.4 settlementPolicy

This parameter identifies which policy is used for Settlement accounting purposes. The default value defined for this parameter references "The General Accounting Principles Applicable to Message Handling Services" defined in Recommendation D.36.

## 7.2.2.3 Behaviour

### 7.2.2.3.1 Negotiation

The negotiation between the interworking MD and the MIS-provider is as described in the Service request behaviour. Values of limitValidityDate, startUpDate, logStartTime and logStopTime attributes may be negotiated between the InterworkingMD and the MIS-provider:

- logStartTime should be less or equal than startUpDate;
- logStopTime should be greater than logStartTime.

### 7.2.2.3.2 Performance of the request

When startUpDate is reached, the MIS-provider supplies a logging identifier as follows:

- if logStartTime is equal to startUpDate, the MIS-provider provides the log identifier of an empty settlementAcctLog;

**ISO/IEC 11588-3 : 1997 (E)**

- if logStartTime is less than startUpDate, the MIS-provider provides the log identifier of a settlementAcctLog which contains all settlementAcctRecord logged since logStartTime, up to startUpDate (if this time is less than logStopTime) or logStopTime (if this time is less than the StartUpDate).

No additional settlementAcctRecord shall be added to the log after logStopTime.

**7.2.2.4 Service primitives**

Table 6 describes services primitives associated with this function.

**Table 6 – Settlement accounting log function service primitives**

Primitives	Service SMASE	CMISE	Objects
Initiation of a Settlement account request	PT-CREATE	M-CREATE	settlementAcctRequest
Modification of a Settlement account request	PT-SET	M-SET	settlementAcctRequest
Retrieval of Settlement account request attributes	PT-GET	M-GET	settlementAcctRequest
Deletion of a Settlement account request	PT-DELETE	M-DELETE	settlementAcctRequest
Event report filtering	E-MIS-user event report function	M-EVENT-REPORT	interworkingMD-EFD

**7.2.3 Settlement log retrieval function**

A Settlement account request shall have successfully been performed before a call to this function can be made.

**7.2.3.1 Function description**

This function enables the interworkingMD to retrieve attributes from a settlementAcctLog object and to retrieve attributes from settlementAcctRecord objects.

**7.2.3.2 Parameters**

Parameters correspond to the attributes of a settlementAcctLog managed object.

**7.2.3.3 References**

CCITT Rec. X.735 | ISO/IEC 10164-6.

**7.2.3.4 Service primitives**

Table 7 describes services primitives associated with this function.

**Table 7 – Settlement log retrieval function service primitives**

Primitives	Service SMASE	CMISE	Objects
Retrieval of Settlement log attributes	PT-GET	M-GET	settlementAcctLog
Retrieval of Settlement log records	PT-GET	M-GET	settlementAcctRecord

**7.3 Customer accounting services**

**7.3.1 Customer accounting log function**

**7.3.1.1 Function description**

This function enables an MIS-user to:

- a) create, delete, and modify a data collection for Customer accounting;
- b) retrieve customer acctRecord.

The content of a customerAcctRecord is not defined in this Recommendation | International Standard. Such information may be subject to a Customer accounting policy agreements between the Customer and the MIS-provider and is therefore not subject to standardization.

### 7.3.1.2 Parameters

Parameters correspond to the attributes of the customerAcctLog managed object.

### 7.3.1.3 References

CCITT Rec. X.735 | ISO/IEC 10164-6.

### 7.3.1.4 Service primitives

Table 8 describes services primitives associated with this function.

**Table 8 – Customer accounting log function service primitives**

Primitives	Service SMASE	CMISE	Objects
Initiation of data collection	PT-CREATE	M-CREATE	customerAcctLog
Modification of a data collection	PT-SET	M-SET	customerAcctLog
Deletion of a data collection	PT-DELETE	M-DELETE	customerAcctLog
Retrieval of customer accounting records	PT-GET	M-GET	customerAcctRecord

## 7.3.2 Customer account request function

### 7.3.2.1 Function description

The Customer account request function enables a Customer to request the availability of a customerAcctLog managed object. This function is derived from the generic Service request function defined in this Recommendation | International Standard.

### 7.3.2.2 Parameters

The following parameters are defined for this service, in addition to those described for the Service request function:

- logStartTime;
- logStopTime;
- logId;
- customerAcctPolicy.

#### 7.3.2.2.1 logStartTime

This parameter represents the starting time for logging of Customer accounting information.

#### 7.3.2.2.2 logStopTime

This parameter represents the stopping time for logging of Customer accounting information.

#### 7.3.2.2.3 logId

This log identifier is provided by the MIS provider in response to the Customer account request.

#### 7.3.2.2.4 customerAcctPolicy

This parameter identifies which policy is used for Customer accounting purposes.

NOTE – The definition of possible values of this parameter is out of the scope of this Recommendation | International Standard.

### 7.3.2.3 Behaviour

#### 7.3.2.3.1 Negotiation

The negotiation between the Customer and the MIS-user is as described in the Service request behaviour. Values of limitValidityDate, startUpDate, logStartTime and logStopTime attributes may be negotiated between the Customer and the MIS-provider:

- logStartTime should be less or equal than startUpDate;
- logStopTime should be greater than logStartTime.

**7.3.2.3.2 Performance of the request**

When startUpDate is reached, the MIS-provider supplies a logging identifier as follow:

- if logStartTime is equal to startUpDate, the MIS-provider provides the log identifier of a customerAcctLog object which contains customerAcctRecord objects;
- if logStartTime is less than startUpDate, the MIS-provider provides the log identifier of a customerAcctLog which contains all customerAcctRecord logged since logStartTime up to startUpDate (if this time is less than logStopTime) or logStopTime (if this time is less than StartUpDate).

No additional customerAcctRecord instances shall be added to the customerAcctLog object after logStopTime.

**7.3.2.4 Service primitives**

Table 9 describes services primitives associated with this function.

**Table 9 – Customer account request function service primitives**

Primitives	Service SMASE	CMISE	Objects
Initiation of a Customer account request	PT-CREATE	M-CREATE	customerAcctRequest
Modification of a Customer account request	PT-SET	M-SET	customerAcctRequest
Retrieval of Customer account request attributes	PT-GET	M-GET	customerAcctRequest
Deletion of a Customer account request	PT-DELETE	M-DELETE	customerAcctRequest
Event report filtering	E-MIS-user event report function	M-EVENT-REPORT	interworkingMD-EFD

**7.3.3 Customer log retrieval function**

The Customer account request function must have successfully been used before a call to this function can be made.

**7.3.3.1 Function description**

This function enables a Customer to retrieve attributes from a customerAcctLog object and to retrieve attributes from a number of customerAcctRecord objects.

**7.3.3.2 Parameters**

Parameters correspond to the attributes of a customerAccountLog managed object.

**7.3.3.3 References**

CCITT Rec. X.735 | ISO/IEC 10164-6.

**7.3.3.4 Service primitives**

Table 10 describes services primitives associated with this function.

**Table 10 – Customer log retrieval function service primitives**

Primitives	Service SMASE	CMISE	Objects
Retrieval of Customer accounting log attributes	PT-GET	M-GET	customerAcctLog
Retrieval of Customer accounting log records	PT-GET	M-GET	customerAcctRecord

**7.4 MHS events logging services**

**7.4.1 MHS events log function**

**7.4.1.1 Function description**

This function enables an MIS-user to retrieve attributes from mhsEventLog and to retrieve MHS events records.

### 7.4.1.2 Parameters

Parameters correspond to the attributes of the mhsEventLog managed object.

### 7.4.1.3 References

CCITT Rec. X.735 | ISO/IEC 10164-6.

### 7.4.1.4 Service primitives

Table 11 describes services primitives associated with this function.

**Table 11 – MHS events log function service primitives**

Primitives	Service SMASE	CMISE	Objects
Retrieval of log attributes	PT-GET	M-GET	mhsEventLog
Retrieval of events	PT-GET	M-GET	bindEventRecord messageEventRecord

## 8 Logging model

The functional model of MHS logging is based on the OSI managed objects, functions, and services as defined by OSI management information model CCITT Rec. X.700 and ISO/IEC 7498-4.

To provide the MHS Events logging services, each MHS entity (e.g. MTA, MS, AU and UA) maintains at least one instance of object class mhsEventLog. Each log instance records the resources used by individual entities in processing messages. These logs are entity-specific.

To provide the Customer accounting services to a Customer, at least one customerAcctLog instance is maintained for that Customer.

To provide the Settlement accounting services to a MD, at least one settlementAcctLog is maintained for that MD.

Conditions under which a log is created are specified in 9.1.

Conditions under which a record is placed in the logs are specified in 9.2.

### 8.1 Class hierarchy

The entity-specific and MIS management domain-specific logs are MHS managed object whose class definitions are derived from the log object class defined in CCITT Rec. X.721 | ISO/IEC 10165-2. Information in the logs are organized in log records. These are instances of record object classes whose are derived from the eventRecord object class defined in CCITT Rec. X.721 | ISO/IEC 10165-2.

Figure 3 shows the inheritance tree of the object classes defined in this Recommendation | International Standard.

NOTE – The messageEventRecord subtypes are organized around their respective port type in a MHS system. This is not because the records are tied in any way to the ports, but rather because information in the various MHS reference documents are usually presented according to the port they are related to. In this way, all events occurring at a given port, produce the same object class. The particularities of the event are recorded using conditional packages in the relevant object. In a way, it is as if the last branch of the inheritance process was achieved using conditional packages instead of the usual inheritance mechanisms. This was done so that the information regarding events occurring at a particular port would stay grouped together, like in the other reference documents on MHS.

### 8.2 Name hierarchy

The containment relationship defined in CCITT Rec. X.720 | ISO/IEC 10165-1 is used for naming instances of logs and records.

The following diagram shows the name hierarchy for log and record instances. Multiple instances of the same class are illustrated by suspension points ("...") following the named object.

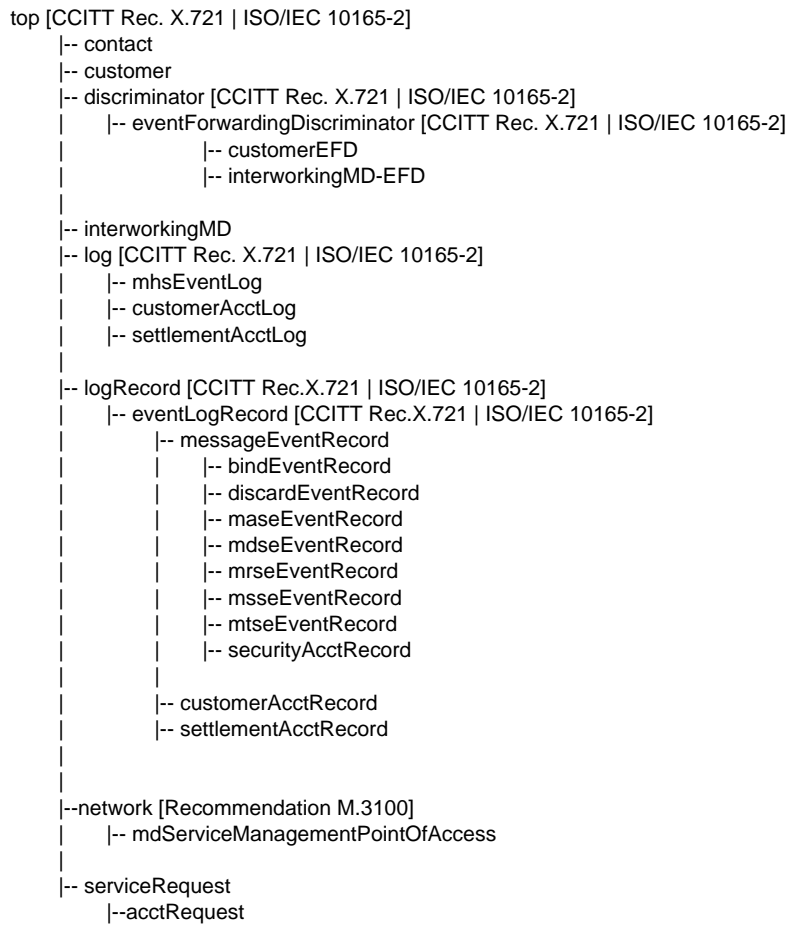

**Figure 3 – Object Inheritance Diagram**

The name binding in GDMO notation is specified in clause 17 and is shown here in Figure 4.

**NOTES**

- 1 This naming tree is not complete and should not be taken as normative.
- 2 This specification of the logs and records does not define how these objects are implemented. An implementation may use only one database table to capture all information required by various logs and yet offer standard interfaces through which users can retrieve information as if individual logs existed.
- 3 The logs are designed to provide a view of what is happening in the system from a specific component’s point of view. In a co-located entity, there may be only one log with different access functions, depending which part of the co-located entity is looking at it. Or an implementor might decide to provide a separate log for each part of the co-located entity. It is not the intent of this Recommendation | International Standard to dictate which approach should be used, or if one is better than all the others. This is left for the implementor to decide. But the individual integrity of the various views must be preserved. Operations on the log by one part of the co-located entity must not restrict the view from another part without an agreement of the two parts to do so. As an example of this, in a co-located UA-MS where the mhsEventLog is implemented as a single log with two views, the UA part cannot delete the log as this would also destroy the MS’s log and therefore violate integrity. Unless, of course, the MS happened to also request deletion of the log, in which case there would be no problem. How such situations are resolved is left for the implementor to decide as it will depend greatly on the way the logs and the views associated with them have been implemented. But in any case, operations on one view must not disturb the other(s).

**9 Creation conditions**

**9.1 Log creation conditions**

It is outside the scope of this Recommendation | International Standard to specify the conditions under which settlementAcctLog and customerAcctLog creation/deletion functions are invoked. The mhsEventLog shall be created when conditions demand that MHS events be logged. All these conditions are determined by the accounting policy. Creation or deletion of log managed objects can be the result of a management operation or of a non-standardized operation.

```

misManagementDomain
|-- mdServiceManagementPointOfAccess
|   |-- interworkingMD ...
|   |   |-- acctRequest
|   |   |-- contact
|   |   |-- interworkingMD-EFD
|   |   |-- settlementAcctLog
|   |       |-- settlementAcctRecord ...
|   |-- customer ...
|   |   |-- acctRequest
|   |   |-- contact
|   |   |-- customerEFD
|   |   |-- customerAcctLog
|   |       |-- customerAcctRecord ...
|-- mta ...
|   |-- mhsEventLog
|   |   |-- bindEventRecord ...
|   |   |-- discardEventRecord ...
|   |   |-- maseEventRecord ...
|   |   |-- mdseEventRecord ...
|   |   |-- msseEventRecord ...
|   |   |-- mtseEventRecord ...
|   |   |-- securityAcctRecord ...
|-- ms ...
|   |-- mhsEventLog
|   |   |-- bindEventRecord ...
|   |   |-- maseEventRecord ...
|   |   |-- mdseEventRecord ...
|   |   |-- msseEventRecord ...
|   |   |-- mrseEventRecord ...
|   |   |-- securityAcctRecord ...
|-- ua ...
|   |-- mhsEventLog
|   |   |-- bindEventRecord ...
|   |   |-- maseEventRecord ...
|   |   |-- mdseEventRecord ...
|   |   |-- msseEventRecord ...
|   |   |-- mrseEventRecord ...
|   |   |-- securityAcctRecord ...
|-- au ...
|   |-- mhsEventLog
|   |   |-- bindEventRecord ...
|   |   |-- maseEventRecord ...
|   |   |-- mdseEventRecord ...
|   |   |-- msseEventRecord ...
|   |   |-- mrseEventRecord ...
|   |   |-- securityAcctRecord ...

```

**Figure 4 – Name binding**

## 9.2 Record creation conditions

This clause lists conditions under which records are created in the entity-specific logs (i.e. mhsEvent log) and the MIS management domain-specific logs (i.e. customerAcct log and settlementAcct log).

### 9.2.1 Entity-specific record creation events

The records in entity-specific logs are created as follows:

- a) A BindEvent record is created when a Bind is completed (whether successfully or unsuccessfully). The record creation occurs even if the Bind was not realized through OSI protocols. Errors occurring in the underlying communication system shall be dealt with by that system's own MIS.
- b) An UnBindEvent record is created when an UnBind is completed. The record creation occurs even if the UnBind was not realized through OSI protocols.

- c) A messageEvent record is created when an MHS abstract operation is completed (whether successfully or unsuccessfully). The record creation occurs even if the MHS abstract operation was not realized through OSI protocols. Errors occurring in the underlying communication system shall be dealt with by that system's own MIS.
- d) A discardEvent record is created whenever a MTA determines that the MTS cannot deliver a message or report. The discardEvent record is also created whenever the MTA determines that the MTS cannot affirm a probe.
- e) A securityAcct record is created when a security event is detected as required by the security policy in force.

NOTE 1 – Items c) and d) imply that, for each message, probe, or report, processed by an MTA, at least one of the mtseEvent record, mdseEvent record or a discardEvent record is created. In case of multi-recipients message, probe or report more than one such records may be created.

Tables 12a and 12b specify events that trigger the creation of records in mhsEvent log. Table 12a describes successful interactions, Table 12b describes error events. Tables 12a and 12b specify the events (first column) that trigger the entities (first row) to create log records. An empty table entry shows that no record is created in that entity for that corresponding event. Non-empty table entry shows that one record shall be created. The entry is the clause number in which the class of the created record is defined.

In the case of co-located entities, some situations may not give rise to the generation of MHS Abstract operations, but rather to the activation of some internal mechanism. In such cases the implementation shall record internal activities where they are equivalent to Message Submission, Probe Submission, Message Delivery and Report Delivery operations. Internal activities which correspond to the equivalent of other standardized MHS Abstract operations described in Tables 12a and 12b may but need not to be recorded.

NOTE 2 – Other internal events may be recorded but are not standardized.

If a probe or a message is split (e.g. for transfer out to multiple MTAs), one mhsEventRecord shall be generated for each message-transfer-out event.

**Table 12a – Entity-Specific non-error events record creation**

*The following events are defined in ITU-T Rec. X.411 | ISO/IEC 10021-4 clause 8*

Event	mta	ua	ms	au
MTS-bind (from MTS-user or MTS) successful completion	10.6.1	10.6.1	10.6.1	10.6.1
MTS-unbind (from MTS-user or MTS)	10.6.1	10.6.1	10.6.1	10.6.1
Message Submission operation successful completion	10.6.7	10.6.7	10.6.7	10.6.7
Probe Submission operation successful completion	10.6.7	10.6.7	10.6.7	10.6.7
Cancel Deferred Delivery operation successful completion	10.6.7	10.6.7	10.6.7	10.6.7
Submission Control operation successful completion	10.6.7	10.6.7	10.6.7	10.6.7
Message Delivery operation successful completion	10.6.4	10.6.4	10.6.4	10.6.4
Report Delivery operation successful completion	10.6.4	10.6.4	10.6.4	10.6.4
Delivery Control operation successful completion	10.6.4	10.6.4	10.6.4	10.6.4
Register operation successful completion	10.6.3	10.6.3	10.6.3	10.6.3
Change credentials (from MTS-user) operation successful completion	10.6.3	10.6.3	10.6.3	10.6.3

*The following events are defined in ITU-T Rec. X.411 | ISO/IEC 10021-4 clause 12*

Event	mta	ua	ms	au
MTA-bind (to or from another MTA) operation successful completion	10.6.1			
MTA-unbind (to or from another MTA)	10.6.1			
Message Transfer out (to another MTA) operation successful completion	10.6.8			
Probe Transfer out (to another MTA) operation successful completion	10.6.8			
Report Transfer out (to another MTA) operation successful completion	10.6.8			
Message transfer in (from another MTA) operation successful completion	10.6.8			
Probe Transfer in (from another MTA) operation successful completion	10.6.8			
Report Transfer in (from another MTA) operation successful completion	10.6.8			



The following events are defined in ITU-T Rec. X.413 / ISO/IEC 10021-5 clauses 7 and 8 and also from ITU-T Rec. X.411 / ISO/IEC 10021-4 clause 8

Event	mta	ua	ms	au
MS-bind successful completion		10.6.1	10.6.1	
MS-unbind		10.6.1	10.6.1	
Summarize operation successful completion		10.6.6	10.6.6	
List operation successful completion		10.6.6	10.6.6	
Fetch operation successful completion		10.6.6	10.6.6	
Delete operation successful completion		10.6.6	10.6.6	
Register-MS operation successful completion		10.6.6	10.6.6	
Alert operation successful completion		10.6.6	10.6.6	
Message-Indirect-Submission (to MS) operation successful completion		10.6.7	10.6.7	
Probe-Indirect-Submission (to MS) operation successful completion		10.6.7	10.6.7	
Cancel Deferred Delivery (to MS) operation successful completion		10.6.7	10.6.7	
Submission Control (to MS) operation successful completion		10.6.7	10.6.7	
Delivery Control (to MS) operation successful completion		10.6.4	10.6.4	
Register (to MS) operation successful completion		10.6.3	10.6.3	
Change credentials (from UA) operation successful completion		10.6.3	10.6.3	
Change credentials (from MS) operation successful completion		10.6.3	10.6.3	

**Table 12b – Entity-specific errors events record creation**

The following events are defined in ITU-T Rec. X.411 / ISO/IEC 10021-4 clause 8

Event	mta	ua	ms	au
MTS-bind (from MTS-user or MTS) error	10.6.1	10.6.1	10.6.1	10.6.1
Message Submission operation error	10.6.7	10.6.7	10.6.7	10.6.7
Probe Submission operation error	10.6.7	10.6.7	10.6.7	10.6.7
Cancel Deferred Delivery operation error	10.6.7	10.6.7	10.6.7	10.6.7
Submission Control operation error	10.6.7	10.6.7	10.6.7	10.6.7
Message Delivery operation error	10.6.4	10.6.4	10.6.4	10.6.4
Report Delivery operation error	10.6.4	10.6.4	10.6.4	10.6.4
Delivery Control operation error	10.6.4	10.6.4	10.6.4	10.6.4
Register operation error	10.6.3	10.6.3	10.6.3	10.6.3
Change Credentials (from MTS-user) operation error	10.6.3	10.6.3	10.6.3	10.6.3

The following events are defined in ITU-T Rec. X.411 / ISO/IEC 10021-4 clause 14

Event	mta	ua	ms	au
MTA-bind (to or from another MTA) error	10.6.1			
Non-delivery decision of a Message or a Report (Discard event)	10.6.2			
Non-affirmation of a Probe decision (Discard event)	10.6.2			

The following events are defined in ITU-T Rec. X.413 | ISO/IEC 10021-5 clauses 7 and 8 and also from ITU-T Rec. X.411 | ISO/IEC 10021-4 clause 8

Event	mta	ua	ms	au
MS-bind error		10.6.1	10.6.1	
Summarize operation error		10.6.6	10.6.6	
List operation error		10.6.6	10.6.6	
Fetch operation error		10.6.6	10.6.6	
Delete operation error		10.6.6	10.6.6	
Register-MS operation error		10.6.6	10.6.6	
Alert operation error		10.6.6	10.6.6	
Message-Indirect-Submission (to MS) operation error		10.6.7	10.6.7	
Probe-Indirect-Submission (to MS) operation error		10.6.7	10.6.7	
Cancel Deferred Delivery (to MS) operation error		10.6.7	10.6.7	
Submission Control (to MS) operation error		10.6.7	10.6.7	
Delivery Control (to MS) operation error		10.6.4	10.6.4	
Register (to MS) operation error		10.6.3	10.6.3	
Change Credentials (from UA) operation error		10.6.3	10.6.3	
Change Credentials (from MS) operation error		10.6.3	10.6.3	
NOTES				
1 On receipt of an event, two objects may be created: one at the MTA and one at either the UA, the MS, or the AU, whichever is most appropriate for the event.				
2 Records of the internal processes of a MS or a UA are for further study.				

### 9.2.2 MIS management domain-specific record creation

All records in MIS management domain-specific logs are created based on accounting policy established among domains involved. As a result, the events that trigger the creation of records in MIS management domain-specific logs is not standardized.

## SECTION 3 – MANAGEMENT INFORMATION MODEL

### 10 Definition of managed object classes

The following definitions are given using the GDMO notation defined in CCITT Rec. X.722 | ISO/IEC 10165-4.

#### 10.1 acctRequest

This managed object is used to represent the generic Service request described in 7.1. Conditional packages provide specific instances with capabilities for either the Settlement account service of 7.2 or the Customer account service of 7.3.

NOTE – In digression with what was stated in clause 5, this subclause has been kept at the upper level of structure within clause 10 because the object is subordinate to more than one other defined in this Recommendation | International Standard (see Figure 4).

**acctRequest MANAGED OBJECT CLASS**

**DERIVED FROM** serviceRequest;

**CHARACTERIZED BY** acctRequestPackage;

**CONDITIONAL PACKAGES**

**customerAcctRequestPackage**

**PRESENT IF** "the object is created to represent a Customer accounting request";

**settlementAcctRequestPackage**

**PRESENT IF** "the object is created to represent a Settlement accounting request";

**REGISTERED AS** { MhsAcctObjectIdentifiers.id-moc-acctRequest };

## 10.2 contact

The Contact managed object class refers to a person or organization having responsibility for one or more managed object instances.

NOTE – In digression with what was stated in clause 5, this subclause has been kept at the upper level of structure within clause 10 because the object is subordinate to more than one other defined in this Recommendation | International Standard (see Figure 4).

### contact MANAGED OBJECT CLASS

DERIVED FROM "Rec. X.721 | ISO/IEC 10165-2":top;

CHARACTERIZED BY

commonCreationDeletionPackage,  
contactPackage,  
"Rec. M3100":locationNamePackage;

REGISTERED AS { MhsAcctObjectIdentifiers.id-moc-contact };

## 10.3 customer

The Customer managed object class describes a Customer of an MD.

### customer MANAGED OBJECT CLASS

DERIVED FROM "Rec. X.721 | ISO/IEC 10165-2":top;

CHARACTERIZED BY commonCreationDeletionPackage, customerPackage;

REGISTERED AS { MhsAcctObjectIdentifiers.id-moc-customer };

### 10.3.1 customerAcctLog

This object enables, for each Customer of an MD, to record accounting information. An instance, at least, of this log shall be created for each customer who has subscribed to the Customer Accounting service.

#### customerAcctLog MANAGED OBJECT CLASS

DERIVED FROM "Rec. X.721 | ISO/IEC 10165-2":log;

CHARACTERIZED BY commonCreationDeletionPackage;

REGISTERED AS { MhsAcctObjectIdentifiers.id-moc-customerAcctLog };

#### 10.3.1.1 customerAcctRecord

This object enables to record customer accounting information. One record shall be created for each transaction with the customer.

NOTE – The structure of the information contained within such records is for further study.

#### customerAcctRecord MANAGED OBJECT CLASS

DERIVED FROM "Rec. X.721 | ISO/IEC 10165-2":eventLogRecord;

REGISTERED AS { MhsAcctObjectIdentifiers.id-moc-customerAcctRecord };

### 10.3.2 customerEFD

This managed object is used to represent the criteria that shall be satisfied by potential events reports before the event report is forwarded to a Customer.

#### customerEFD MANAGED OBJECT CLASS

DERIVED FROM "Rec. X.721 | ISO/IEC 10165-2":eventForwardingDiscriminator;

CHARACTERIZED BY customerEFDPackage;

REGISTERED AS { MhsAcctObjectIdentifiers.id-moc-customerEFD };

## 10.4 interworkingMD

The interworkingMD managed object class refers to a MHS management domain that has settlement arrangements with the managed MHS management domain.

### interworkingMD MANAGED OBJECT CLASS

DERIVED FROM "Rec. X.721 | ISO/IEC 10165-2":top;

CHARACTERIZED BY

commonCreationDeletionPackage,  
interworkingMDPackage;

REGISTERED AS { MhsAcctObjectIdentifiers.id-moc-interworkingMD };

#### 10.4.1 interworkingMD-EFD

This managed object is used to represent the criteria that shall be satisfied by potential events reports before the event report is forwarded to an interworkingMD.

**interworkingMD-EFD MANAGED OBJECT CLASS**

**DERIVED FROM "Rec. X.721 | ISO/IEC 10165-2":eventForwardingDiscriminator;**

**CHARACTERIZED BY**

**commonCreationDeletionPackage,  
interworkingMD-EFDPackage;**

**REGISTERED AS { MhsAcctObjectIdentifiers.id-moc-interworkingMD-EFD };**

#### 10.4.2 settlementAcctLog

This object enables, for each InterworkingMD of an MD, to record accounting information. An instance, at least, of this log shall be created for each InterworkingMD.

**settlementAcctLog MANAGED OBJECT CLASS**

**DERIVED FROM "Rec. X.721|ISO/IEC 10165-2":log;**

**CHARACTERIZED BY**

**commonCreationDeletionPackage;**

**REGISTERED AS { MhsAcctObjectIdentifiers.id-moc-settlementAcctLog };**

##### 10.4.2.1 settlementAcctRecord

Information captured in the settlementAcctRecord enables to support the "estimated accounting method" and the "exact accounting method" specified in Recommendation D.36. Information captured is sufficient to produce the "account statement" specified in Annex D/D.36.

NOTE – The comments next to the attributes refer to components of the formulae in 6.1/D.36 and 6.2.2.1/D.36.

**settlementAcctRecord MANAGED OBJECT CLASS**

**DERIVED FROM "Rec. X.721 | ISO/IEC 10165-2":eventLogRecord;**

**CHARACTERIZED BY settlementAcctRecordPackage;**

**CONDITIONAL PACKAGES**

**originatingDomainTransferOutPackage**

**PRESENT IF "subject message is transferred out by the originating domain",**

**transitDomainTransferOutPackage**

**PRESENT IF "subject message is transferred out by the transit domain",**

**destinationDomainDeliveryPackage**

**PRESENT IF "subject message is delivered",**

**d36-commonAttributesPackage**

**PRESENT IF**

**"the settlementAcctPolicy attribute references D.36",**

**d36-deliveryViaAccessUnitPackage**

**PRESENT IF**

**"the settlementAcctPolicy attribute references D.36 and the record is created regarding a message being delivered via one or many delivery services (fax, PDS, telex, etc.);"**

**d36-directDeliveryPackage**

**PRESENT IF**

**"the settlementAcctPolicy attribute references D.36 and the record is created regarding a message being delivered to UAs belonging to the ADMD or to PRMDs that are clients of the ADMD.";**

**REGISTERED AS { MhsAcctObjectIdentifiers.id-moc-settlementAcctRecord };**

#### 10.5 mdServiceManagementPointOfAccess

The mdServiceManagementPointOfAccess object class provides a point of access to a subset of MHS management services and MHS management information. Such services and information may be provided to MIS-users, Customers and Interworking management domains of an MD.

**mdServiceManagementPointOfAccess MANAGED OBJECT CLASS**

**DERIVED FROM "Rec. M.3100":Network;**

**CHARACTERIZED BY mdServiceManagementPointOfAccessPackage;**

**REGISTERED AS { MhsAcctObjectIdentifiers.id-moc-mdServiceMgtPOA };**

## 10.6 mhsEventLog

This object enables to record bindAcctRecord, MASEAcctRecord, messageAcctRecord, changeAutoRecord, MRSEAcctRecord and alertRecord.

```
mhsEventLog MANAGED OBJECT CLASS
  DERIVED FROM "Rec. X.721 | ISO/IEC 10165-2":log;
  CHARACTERIZED BY commonCreationDeletionPackage;
REGISTERED AS { MhsAcctObjectIdentifiers.id-moc-mhsEventLog };
```

### 10.6.1 bindEventRecord

This record enables to capture information related to a Bind or Unbind abstract operation.

```
bindEventRecord MANAGED OBJECT CLASS
  DERIVED FROM messageEventRecord;
  CHARACTERIZED BY bindEventRecordPackage;
  CONDITIONAL PACKAGES
    commonBindArgumentsPackage
      PRESENT IF "the record is created following an abstract-bind operation",
    mtsBindArgumentsPackage
      PRESENT IF "the record is created following a MTSBind abstract-bind operation",
    mtaBindArgumentsPackage
      PRESENT IF "the record is created following a MTABind abstract-bind operation",
REGISTERED AS { MhsAcctObjectIdentifiers.id-moc-bindEventRecord };
```

### 10.6.2 discardEventRecord

This enables to capture information related to one internal operation which causes a message, report, or probe to be discarded. Records of this class are kept in the mhsEventLog.

```
discardEventRecord MANAGED OBJECT CLASS
  DERIVED FROM messageEventRecord;
  CHARACTERIZED BY discardEventRecordPackage, processingPackage;
  CONDITIONAL PACKAGES
    messageTransferPackage
      PRESENT IF "the record is created due to a non-delivery operation on a message",
    reportTransferPackage
      PRESENT IF "the record is created due to a non-delivery operation on a report",
    probeTransferPackage
      PRESENT IF "the record is created due to an affirmation or non-affirmation operation on a probe";
REGISTERED AS { MhsAcctObjectIdentifiers.id-moc-discardEventRecord };
```

### 10.6.3 maseEventRecord

This enables to capture accounting information related to one operation via the administration port of a MS. Records of this class are kept in mhsEventLog.

```
maseEventRecord MANAGED OBJECT CLASS
  DERIVED FROM messageEventRecord;
  CHARACTERIZED BY maseEventRecordPackage;
  CONDITIONAL PACKAGES
    registerPackage
      PRESENT IF "the record is created due to register operation",
    changeCredentialPackage
      PRESENT IF "the record is created due to change credential operation";
REGISTERED AS { MhsAcctObjectIdentifiers.id-moc-maseEventRecord };
```

### 10.6.4 mdseEventRecord

This enables to capture accounting information related to one operation via the message-delivery-port of a UA, MTA, MS (, or AU). Records of this class are kept in mhsEventLog.

```
mdseEventRecord MANAGED OBJECT CLASS
  DERIVED FROM messageEventRecord;
  CHARACTERIZED BY mdseEventRecordPackage;
  CONDITIONAL PACKAGES
    messageDeliveryPackage
      PRESENT IF "the record is created due to message delivery operation",
```

**messageDeliveryEnvelopePackage**  
 PRESENT IF "messageDeliveryPackage is present and  
                   MHS Events Attributes and Envelopes logging function is supported",  
**reportDeliveryPackage**  
 PRESENT IF "the record is created due to report delivery operation",  
**reportDeliveryEnvelopePackage**  
 PRESENT IF "reportDeliveryPackage is present and  
                   MHS Events Attributes and Envelopes logging function is supported",  
**deliveryControlPackage**  
 PRESENT IF "the record is created due to delivery control operation",  
**processingPackage**  
 PRESENT IF "the record is created inside an MTA due to a message delivery or a  
                   report delivery operation";

REGISTERED AS { MhsAcctObjectIdentifiers.id-moc-mdseEventRecord };

#### 10.6.5 messageEventRecord

This enables to capture information relating to an event, e.g. when an abstract operation defined in X.400-Series of Recommendations is performed. Information captured may be used for, but not limited to, financial accounting management and security management purposes.

**messageEventRecord** MANAGED OBJECT CLASS  
 DERIVED FROM "Rec. X.721|ISO/IEC 10165-2":eventLogRecord;  
 CHARACTERIZED BY messageEventRecordPackage;  
 CONDITIONAL PACKAGE  
   **tracePackage**  
     PRESENT IF "it is necessary to record trace information on the message.";

REGISTERED AS { MhsAcctObjectIdentifiers.id-moc-messageEventRecord };

#### 10.6.6 mrseEventRecord

This enables to capture accounting information related to one operation via the message-retrieval-port of a MS. Records of this class are kept in mhsEventLog.

**mrseEventRecord** MANAGED OBJECT CLASS  
 DERIVED FROM messageEventRecord;  
 CHARACTERIZED BY mrseEventRecordPackage;  
 CONDITIONAL PACKAGES  
   **summarizePackage**  
     PRESENT IF "the record is created due to summarize operation",  
   **listPackage**  
     PRESENT IF "the record is created due to list operation",  
   **fetchPackage**  
     PRESENT IF "the record is created due to fetch operation",  
   **deletePackage**  
     PRESENT IF "the record is created due to delete operation",  
   **registerMSPackage**  
     PRESENT IF "the record is created due to register MS operation",  
   **alertPackage**  
     PRESENT IF "the record is created due to alert operation";

REGISTERED AS { MhsAcctObjectIdentifiers.id-moc-mrseEventRecord };

#### 10.6.7 msseEventRecord

This enables to capture accounting information related to one operation via the message-submission-port of a UA, MTA, MS (, or AU). Records of this class are kept in mhsEventLog.

**msseEventRecord** MANAGED OBJECT CLASS  
 DERIVED FROM messageEventRecord;  
 CHARACTERIZED BY msseEventRecordPackage;  
 CONDITIONAL PACKAGES  
   **probeSubmissionPackage**  
     PRESENT IF "the record is created due to probe submission operation",  
   **probeSubmissionEnvelopePackage**  
     PRESENT IF "probeSubmissionPackage is present and  
                   MHS Events Attributes and Envelopes logging function is supported",  
   **messageSubmissionPackage**  
     PRESENT IF "the record is created due to message submission operation",

**messageSubmissionEnvelopePackage**  
**PRESENT IF**"messageSubmissionPackage is present and  
MHS Events Attributes and Envelopes logging function is supported",  
**cancelDeferredDeliveryPackage**  
**PRESENT IF**"the record is created due to cancel deferred-delivery operation",  
**submissionControlPackage**  
**PRESENT IF**"the record is created due to submission control operation";

**REGISTERED AS** { MhsAcctObjectIdentifiers.id-moc-msseEventRecord };

### 10.6.8 mtseEventRecord

This enables to capture accounting information related to one operation via the message-transfer-port of a MTA. Records of this class are kept in mhsEventLog.

**mtseEventRecord** **MANAGED OBJECT CLASS**  
**DERIVED FROM** messageEventRecord;  
**CHARACTERIZED BY**  
mtseEventRecordPackage,  
processingPackage;  
**CONDITIONAL PACKAGES**  
messageTransferPackage  
**PRESENT IF** "the record is created due to message-transfer operation",  
reportTransferPackage  
**PRESENT IF** "the record is created due to report-transfer operation",  
probeTransferPackage  
**PRESENT IF** "the record is created due to a probe-transfer operation";

**REGISTERED AS** { MhsAcctObjectIdentifiers.id-moc-mtseEventRecord };

### 10.6.9 securityAcctRecord

This managed object enables to record security features of an event that a domain's management policy might want to charge for.

**securityAcctRecord** **MANAGED OBJECT CLASS**  
**DERIVED FROM** messageEventRecord;  
**CHARACTERIZED BY** securityAcctRecordPackage;

**REGISTERED AS** { MhsAcctObjectIdentifiers.id-moc-securityAcctRecord };

## 10.7 misManagementDomain

The misManagementDomain object class enables to represent an MIS Management Domain.

**misManagementDomain** **MANAGED OBJECT CLASS**  
**DERIVED FROM** "Rec. M3010":Network;

**REGISTERED AS** { MhsAcctObjectIdentifiers.id-moc-misManagementDomain };

## 10.8 serviceRequest

The serviceRequest managed object provides the mean for an Indirect MIS-user to ask for a special service that is not directly accessible through the interoperable interface. It contains the basic attributes that allow an Indirect MIS-user to request and negotiate dates of application of a requested service.

**serviceRequest** **MANAGED OBJECT CLASS**  
**DERIVED FROM** "Rec. X.721 | ISO/IEC 10165-2":top;  
**CHARACTERIZED BY** serviceRequestPackage;

**REGISTERED AS** { MhsAcctObjectIdentifiers.id-moc-serviceRequest };

## 11 Definitions of packages

This clause specifies packages definitions for the managed object class definitions of clause 10.

## 11.1 acctRequestPackage

This package lists the attributes of a acctRequest managed object.

**acctRequestPackage PACKAGE**

**ATTRIBUTES**

logStartTime GET-REPLACE,  
logStopTime GET-REPLACE,  
"Rec. X.721 | ISO/IEC 10165-2":logId GET-REPLACE;

**REGISTERED AS { MhsAcctObjectIdentifiers.id-package-acctRequest };**

### 11.1.1 customerAcctRequestPackage

This packages lists the specific attributes of a customer-oriented acctRequest managed object.

**customerAcctRequestPackage PACKAGE**

**BEHAVIOUR customerAcctRequestPackageBehaviour;**

**ATTRIBUTES**

customerAcctPolicy GET;

**REGISTERED AS { MhsAcctObjectIdentifiers.id-package-customerAcctRequest };**

**customerAcctRequestPackageBehaviour BEHAVIOUR**

**DEFINED AS**

"The customerAcctRequest managed object provides the mean for a Customer to ask for Customer accounting information for a period of time. A log identifier is provided in response.";

### 11.1.2 settlementAcctRequestPackage

This packages lists the specific attributes of a settlement-oriented acctRequest managed object.

**settlementAcctRequestPackage PACKAGE**

**BEHAVIOUR settlementAcctRequestPackageBehaviour;**

**ATTRIBUTES**

settlementPolicy GET;

**REGISTERED AS { MhsAcctObjectIdentifiers.id-package-settlementAcctRequest };**

**settlementAcctRequestPackageBehaviour BEHAVIOUR**

**DEFINED AS**

"The SettlementAcctRequest managed object provides the mean for an interworkingADMD to ask for Settlement accounting information for a period of time. A log identifier is provided in response.";

## 11.2 bindEventRecordPackage

This packages lists the attributes of a bindEventRecord managed object.

**bindEventRecordPackage PACKAGE**

**BEHAVIOUR bindEventRecordPackageBehaviour;**

**REGISTERED AS { MhsAcctObjectIdentifiers.id-package-bindEventRecord };**

**bindEventRecordPackageBehaviour BEHAVIOUR**

**DEFINED AS**

"This record is created to keep information related to binding and unbinding operations. The eventType attribute stores what kind of operation generated the record.";

### 11.2.1 commonBindArgumentPackage

This packages lists the common attributes of a bindEventRecord managed object created following a Bind abstract operation.

**commonBindArgumentsPackage PACKAGE**

**BEHAVIOUR commonBindArgumentsPackageBehaviour;**

**ATTRIBUTES**

-- Arguments

initiatorName GET,

initiatorCredentials GET,

securityContext GET,

--

-- Results



```

responderCredentials GET,
--
-- Errors
bindingError GET;
--

```

**REGISTERED AS { MhsAcctObjectIdentifiers.id-package-commonBindArguments };**

**commonBindArgumentsPackageBehaviour BEHAVIOUR**

**DEFINED AS**

"This package contains those attributes which are common to all the binding abstract operations, whether MS-Bind, MTS-Bind or MTA-Bind.";

### 11.2.2 mtaBindArgumentsPackage

This package lists the specific attributes of a bindEventRecord managed object created following a MTA-Bind abstract operation.

**mtaBindArgumentsPackage PACKAGE**

**BEHAVIOUR mtaBindArgumentsPackageBehaviour;**

**ATTRIBUTES**

```

-- Results
responderName GET;
--

```

**REGISTERED AS { MhsAcctObjectIdentifiers.id-package-mtaBindArguments };**

**mtaBindArgumentsPackageBehaviour BEHAVIOUR**

**DEFINED AS**

"This package contains those attributes which are specific to the MTA-Bind abstract operation.";

### 11.2.3 mtsBindArgumentsPackage

This package lists the specific attributes of a bindEventRecord managed object created following a MTS-Bind abstract operation.

**mtsBindArgumentsPackage PACKAGE**

**BEHAVIOUR mtsBindArgumentsPackageBehaviour;**

**ATTRIBUTES**

```

-- Results
responderName GET;
--

```

**REGISTERED AS { MhsAcctObjectIdentifiers.id-package-mtsBindArguments };**

**mtsBindArgumentsPackageBehaviour BEHAVIOUR**

**DEFINED AS**

"This package contains those attributes which are specific to the MTS-Bind abstract operation.";

## 11.3 commonCreationDeletionPackage

This package contains updated versions of the basic operations that can be applied to managed objects.

**commonCreationDeletionPackage PACKAGE**

**BEHAVIOUR commonCreationDeletionBehaviour;**

**NOTIFICATIONS**

```

objectCreation,
objectDeletion;

```

**REGISTERED AS { MhsAcctObjectIdentifiers.id-package-commonCreationDeletion };**

**commonCreationDeletionBehaviour BEHAVIOUR**

**DEFINED AS**

"This package extends upon the Rec. X.721 | ISO/IEC 10165-2 objectCreation and objectDeletion notifications by specifying the values sent with the notification.";

## 11.4 contactPackage

This package lists the attributes of a contact managed object.

**contactPackage PACKAGE**

**BEHAVIOUR** contactPackageBehaviour;

**ATTRIBUTES**

contactId GET,  
contactName GET-REPLACE,  
contactCompany GET-REPLACE,  
contactFunction GET-REPLACE,  
contactDetails GET-REPLACE,  
electronicMailAddress, GET-REPLACE,  
telephoneNumberList GET-REPLACE ADD-REMOVE,  
facsimileTelephoneNumberList GET-REPLACE ADD-REMOVE;

**REGISTERED AS** { MhsAcctObjectIdentifiers.id-package-contact };

**contactPackageBehaviour BEHAVIOUR**

**DEFINED AS**

"A value for the contactId attribute shall be provided when the object is created. This value cannot be modified.";

## 11.5 customerEFDPackage

This package lists the attributes of a customerEFD managed object.

**customerEFDPackage PACKAGE**

**BEHAVIOUR** customerEFDPackageBehaviour;

**REGISTERED AS** { MhsAcctObjectIdentifiers.id-package-customerEFD };

**customerEFDPackageBehaviour BEHAVIOUR**

**DEFINED AS**

"The Customer may modify the discriminator construct, or suspend / resume the EventforwardingDiscriminator activity.";

## 11.6 customerPackage

This package lists the attributes of a customer managed object.

**customerPackage PACKAGE**

**BEHAVIOUR** customerPackageBehaviour;

**ATTRIBUTES**

customerId GET,  
customerName GET-REPLACE;

**REGISTERED AS** { MhsAcctObjectIdentifiers.id-package-customer };

**customerPackageBehaviour BEHAVIOUR**

**DEFINED AS**

"A value for the customerId attribute shall be provided when the object is created. This value cannot be modified.";

## 11.7 discardEventRecordPackage

This package lists the common attributes of a messageEventRecord managed object related to the internal processing that occurred on a message, probe, or report inside a MHS entity.

**discardEventRecordPackage PACKAGE**

**BEHAVIOUR** discardEventRecordPackageBehaviour;

**ATTRIBUTES**

recipientsOnResponsibilityList GET, -- identifies recipients whose perRecipientIndicator responsibility  
-- bit is set to "responsible" (see Figure 4/X.411, Part 5 of 7)

"Rec. X.721 | ISO/IEC 10165-2":eventType PERMITTED VALUES MhsAcctAsn1Module.DiscardOperations;  
-- to indicate Affirmation, Non-Affirmation, or Non-Delivery operation --

**REGISTERED AS** { MhsAcctObjectIdentifiers.id-package-discardEventRecord };

**discardEventRecordPackageBehaviour BEHAVIOUR****DEFINED AS**

"In managed objects of this class, the messageTransferEnvelope, probeTransferEnvelope, or reportTransferEnvelope attribute shall show the state such an envelope at the time the error creating the discardEventRecord occurred. In addition, if the error is being reported in respect of a subset of the recipients, there is no requirement to split the message before creating the messageTransferEnvelope, probeTransferEnvelope, or reportTransferEnvelope attribute. The recipientsOnResponsibilityList attribute shall be used in such a situation to indicate which recipients caused the error to occur.";

**11.8 interworkingMD-EFDPackage**

This package lists the attributes of a interworkingMD-EFD managed object.

**interworkingMD-EFDPackage PACKAGE**

**BEHAVIOUR** interworkingMD-EFDPackagebehaviour;

**REGISTERED AS** { MhsAcctObjectIdentifiers.id-package-interworkingMD-EFD };

**interworkingADMDLogPkgBehaviour BEHAVIOUR****DEFINED AS**

"The interworkingMD may modify the discriminator construct, suspend or resume the eventForwardingDiscriminator activity.";

**11.9 interworkingMDPackage**

This package lists the attributes of a interworkingMD managed object.

**interworkingMDPackage PACKAGE**

**BEHAVIOUR** interworkingMDPackageBehaviour;

**ATTRIBUTES**

interworkingMDId GET,  
interworkingMDName GET-REPLACE,  
globalDomainId GET;

**REGISTERED AS** { MhsAcctObjectIdentifiers.id-package-interworkingMD };

**interworkingMDPackageBehaviour BEHAVIOUR****DEFINED AS**

"A value for the interworkingMDId attribute shall be provided when the object is created. This value can't be modified.";

**11.10 maseEventRecordPackage**

This package lists the common attributes of a messageEventRecord managed object created following an abstract operation at the administration port of a MHS entity.

**maseEventRecordPackage PACKAGE****ATTRIBUTES**

"Rec. X.721 | ISO/IEC 10165-2":eventType PERMITTED VALUES

MhsAcctAsn1Module.AdminstrationPortOperations;

-- to indicate register or change-credential operation --

**REGISTERED AS** { MhsAcctObjectIdentifiers.id-package-maseEventRecord };

**11.10.1 changeCredentialPackage**

This package lists the specific attributes of a maseEventRecord managed object created following a Charge-Credential abstract operation.

**changeCredentialPackage PACKAGE**

**BEHAVIOUR** changeCredentialPackageBehaviour;

**ATTRIBUTES**

oldCredentials GET,  
newCredentials GET,  
administrationError PERMITTED VALUES MhsAcctAsn1Module.ChangeCredentialsErrors;

**REGISTERED AS** { MhsAcctObjectIdentifiers.id-package-changeCredential };

**changeCredentialPackageBehaviour BEHAVIOUR****DEFINED AS**

"This package contains the attributes of the Change-Credentials abstract operation.";

### 11.10.2 registerPackage

This package lists the specific attributes of a maseEventRecord managed object created following a Register abstract operation.

```

registerPackage PACKAGE
    BEHAVIOUR registerPackageBehaviour;
    ATTRIBUTES
        userName GET,
        userAddress GET,
        deliverableEncodedInformationTypes GET,
        deliverableMaximumContentLength GET,
        defaultDeliveryControls GET,
        deliverableContentTypes GET,
        labelsAndRedirections GET,
        administrationError PERMITTED VALUES MhsAcctAsn1Module.RegisterErrors;

REGISTERED AS { MhsAcctObjectIdentifiers.id-package-register };

registerPackageBehaviour BEHAVIOUR
    DEFINED AS
        "This package contains the attributes of the Register abstract operation.";
    
```

### 11.11 mdseEventRecordPackage

This package lists the common attributes of a messageEventRecord managed object created following an abstract operation at the Message-Delivery port of a MHS entity.

```

mdseEventRecordPackage PACKAGE
    ATTRIBUTES
        originatorName GET,
        "Rec. X.721 | ISO/IEC 10165-2":eventType PERMITTED VALUES
MhsAcctAsn1Module.DeliveryPortOperations;
    -- to indicate message delivery, report delivery or delivery control operation --

REGISTERED AS { MhsAcctObjectIdentifiers.id-package-mdseEventRecord };
    
```

#### 11.11.1 deliveryControlPackage

This package lists the specific attributes of a mdseEventRecord managed object created following a Delivery-Control abstract operation.

```

deliveryControlPackage PACKAGE
    BEHAVIOUR deliveryControlPackageBehaviour;
    ATTRIBUTES
        deliveryControls GET,
        deliveryError PERMITTED VALUES MhsAcctAsn1Module.DeliveryControlErrors;

REGISTERED AS { MhsAcctObjectIdentifiers.id-package-deliveryControl };

deliveryControlPackageBehaviour BEHAVIOUR
    DEFINED AS "Captures accounting information on a delivery control";
    
```

#### 11.11.2 messageDeliveryPackage

This package lists the specific attributes of a mdseEventRecord managed object created following a Message-Delivery abstract operation.

```

messageDeliveryPackage PACKAGE
    BEHAVIOUR messageDeliveryPackageBehaviour;
    ATTRIBUTES
        thisRecipientName GET,
    -- The following ones are extracted from messageDeliveryEnvelope
        priority GET,
        contentType GET,
        MTSIdentifier GET,
        messageContentSize GET,    -- This one not extracted but inferred
    -- Operation results
    
```

proofOfDelivery GET,  
 recipientCertificate GET,  
 deliveryError PERMITTED VALUES MhsAcctAsn1Module.MessageDeliveryErrors;

REGISTERED AS { MhsAcctObjectIdentifiers.id-package-messageDelivery };

messageDeliveryPackageBehaviour BEHAVIOUR  
 DEFINED AS

"Captures accounting information on a message delivery. All but one of the attributes are directly taken from the event itself or from the messageDeliveryEnvelope field. Only the messageContentSize must be calculated to indicate the length, in octets, of the 'content' field in the messageDeliveryEnvelope attribute of the managed object, if present.";

### 11.11.3 messageDeliveryEnvelopePackage

This package lists a specific attribute of a mdseEventRecord managed object created following a Message-Delivery abstract operation in non-co-located entities.

messageDeliveryEnvelopePackage PACKAGE  
 BEHAVIOUR messageDeliveryEnvelopePackageBehaviour;  
 ATTRIBUTES  
 messageDeliveryEnvelope GET;

REGISTERED AS { MhsAcctObjectIdentifiers.id-package-messageDeliveryEnvelope };

messageDeliveryEnvelopePackageBehaviour BEHAVIOUR  
 DEFINED AS

"This attribute was isolated so that co-located entities would not have to actually generate a whole envelope just to meet the requirements of Logging Information.";

### 11.11.4 reportDeliveryPackage

This package lists the specific attributes of a mdseEventRecord managed object created following a Report-Delivery abstract operation.

reportDeliveryPackage PACKAGE  
 BEHAVIOUR reportDeliveryPackageBehaviour;  
 ATTRIBUTES  
 actualRecipientName GET,  
 contentType GET,  
 subjectSubmissionIdentifier GET,  
 MTSIdentifier GET,  
 deliveryError PERMITTED VALUES MhsAcctAsn1Module.ReportDeliveryErrors;

REGISTERED AS { MhsAcctObjectIdentifiers.id-package-reportDelivery };

reportDeliveryPackageBehaviour BEHAVIOUR  
 DEFINED AS "Captures accounting information on a report delivery";

### 11.11.5 reportDeliveryEnvelopePackage

This package lists a specific attribute of a mdseEventRecord managed object created following a Report-Delivery abstract operation in non-co-located entities.

reportDeliveryEnvelopePackage PACKAGE  
 BEHAVIOUR reportDeliveryEnvelopePackageBehaviour;  
 ATTRIBUTES  
 reportDeliveryEnvelope GET;

REGISTERED AS { MhsAcctObjectIdentifiers.id-package-reportDeliveryEnvelope };

reportDeliveryEnvelopePackageBehaviour BEHAVIOUR  
 DEFINED AS

"This attribute was isolated so that co-located entities would not have to actually generate a whole envelope just to meet the requirements of Logging Information.";

## 11.12 mdServiceManagementPointOfAccessPackage

This package lists the attributes of a mdServiceManagementPointOfAccess managed object.

mdServiceManagementPointOfAccessPackage PACKAGE  
 ATTRIBUTES  
 globalDomainId GET;

REGISTERED AS { MhsAcctObjectIdentifiers.id-package-mdServiceMgtPOA };

### 11.13 messageEventRecordPackage

This package lists the common attributes to all messageEventRecord managed objects. The eventType attribute is reproduced here in a comment as a reminder of its presence in the managed object class through the inheritance mechanism.

**messageEventRecordPackage PACKAGE**

**BEHAVIOUR** messageEventRecordPackageBehaviour;

**ATTRIBUTES**

-- "Rec. X.721 | ISO/IEC 10165-2":eventType GET,  
 consumerOfOperation GET,  
 supplierOfOperation GET,  
 serviceFlag GET, -- indicates if this is a service message (no charge) --  
 operationStatus GET; -- indicates if the operation is progress, OK, in error --

**REGISTERED AS** { MhsAcctObjectIdentifiers.id-package-messageEventRecord };

**messageEventRecordPackageBehaviour BEHAVIOUR**

**DEFINED AS**

"The eventType attribute (which is inherited from the "Rec. X.721 | ISO/IEC 10165-2":eventLogRecord managed object class) has its range of values restricted in the various subclasses of this managed object class. In all those subclasses, it remains a read-only attribute."

#### 11.13.1 tracePackage

This package contains the trace information which documents the passage of the message, probe, or report through the MIS.

**tracePackage PACKAGE**

**ATTRIBUTES**

trace GET,  
 internalTrace GET;

**REGISTERED AS** { MhsAcctObjectIdentifiers.id-package-trace };

### 11.14 mrseEventRecordPackage

This package lists the common attributes of a messageEventRecord managed object created following an abstract operation at the Message-Retrieval port of a MHS entity.

**mrseEventRecordPackage PACKAGE**

**ATTRIBUTES**

"Rec. X.721 | ISO/IEC 10165-2":eventType **PERMITTED VALUES**

MhsAcctAsn1Module.RetrievalPortOperations;

-- to indicate summarize, list, fetch, delete, register MS or alert operation --

**REGISTERED AS** { MhsAcctObjectIdentifiers.id-package-mrseEventRecord };

#### 11.14.1 alertPackage

This package lists the specific attributes of a mrseEventRecord managed object created following an Alert abstract operation.

**alertPackage PACKAGE**

**BEHAVIOUR** alertPackageBehaviour;

**ATTRIBUTES**

alertArgument GET,  
 alertResult GET,  
 retrievalError **PERMITTED VALUES** MhsAcctAsn1Module.AlertErrors;

**REGISTERED AS** { MhsAcctObjectIdentifiers.id-package-alert };

**alertPackageBehaviour BEHAVIOUR**

**DEFINED AS**

"This package contains the attributes of the Alert abstract operation.";

**11.14.2 deletePackage**

This package lists the specific attributes of a mrseEventRecord managed object created following a Delete abstract operation.

```
deletePackage PACKAGE
    BEHAVIOUR deletePackageBehaviour;
    ATTRIBUTES
        deleteArgument GET,
        deleteResult GET,
        retrievalError PERMITTED VALUES MhsAcctAsn1Module.DeleteErrors;

REGISTERED AS { MhsAcctObjectIdentifiers.id-package-delete };

deletePackageBehaviour BEHAVIOUR
    DEFINED AS
        "This package contains the attributes of the Delete abstract operation.";
```

**11.14.3 fetchPackage**

This package lists the specific attributes of a mrseEventRecord managed object created following a Fetch abstract operation.

```
fetchPackage PACKAGE
    BEHAVIOUR fetchPackageBehaviour;
    ATTRIBUTES
        fetchArgument GET,
        fetchResult GET,
        retrievalError PERMITTED VALUES MhsAcctAsn1Module.FetchErrors;

REGISTERED AS { MhsAcctObjectIdentifiers.id-package-fetch };

fetchPackageBehaviour BEHAVIOUR
    DEFINED AS
        "This package contains the attributes of the Fetch abstract operation.";
```

**11.14.4 listPackage**

This package lists the specific attributes of a mrseEventRecord managed object created following a List abstract operation.

```
listPackage PACKAGE
    BEHAVIOUR listPackageBehaviour;
    ATTRIBUTES
        listArgument GET,
        listResult GET,
        retrievalError PERMITTED VALUES MhsAcctAsn1Module.ListErrors;

REGISTERED AS { MhsAcctObjectIdentifiers.id-package-list };

listPackageBehaviour BEHAVIOUR
    DEFINED AS
        "This package contains the attributes of the List abstract operation.";
```

**11.14.5 registerMSPackage**

This package lists the specific attributes of a mrseEventRecord managed object created following a Register-MS abstract operation.

```
registerMSPackage PACKAGE
    BEHAVIOUR registerMSPackageBehaviour;
    ATTRIBUTES
        registerMSArgument GET,
        registerMSResult GET,
        retrievalError PERMITTED VALUES MhsAcctAsn1Module.RegisterMSErrors;

REGISTERED AS { MhsAcctObjectIdentifiers.id-package-registerMS };

registerMSPackageBehaviour BEHAVIOUR
    DEFINED AS
        "This package contains the attributes of the Register-MS abstract operation.";
```

### 11.14.6 summarizePackage

This package lists the specific attributes of a mrseEventRecord managed object created following a Sumarize abstract operation.

```
summarizePackage PACKAGE
  BEHAVIOUR summarizePackageBehaviour;
  ATTRIBUTES
    summarizeArgument GET,
    summarizeResult GET,
    retrievalError PERMITTED VALUES MhsAcctAsn1Module.SummarizeErrors;

REGISTERED AS { MhsAcctObjectIdentifiers.id-package-summarize };

summarizePackageBehaviour BEHAVIOUR
  DEFINED AS
    "This package contains the attributes of the Summarize abstract operation.";
```

### 11.15 msseEventRecordPackage

This package lists the common attributes of a messageEventRecord managed object created following an abstract operation at the Message-Submission port of a MHS entity.

```
msseEventRecordPackage PACKAGE
  ATTRIBUTES
    "Rec. X.721 | ISO/IEC 10165-2":eventType PERMITTED VALUES
MhsAcctAsn1Module.SubmissionPortOperations;
    -- to indicate message submission, probe submission, cancel deferred delivery or
    -- submission control operation --

REGISTERED AS { MhsAcctObjectIdentifiers.id-package-msseEventRecord };
```

#### 11.15.1 cancelDeferredDeliveryPackage

This package lists the specific attributes of a msseEventRecord managed object created following a Cancel-Deferred-Delivery abstract operation.

```
cancelDeferredDeliveryPackage PACKAGE
  BEHAVIOUR cancelDeferredDeliveryBehaviour;
  ATTRIBUTES
    MTSIdentifier GET,
    submissionError PERMITTED VALUES MhsAcctAsn1Module.CancelDeferredDeliverySubmissionErrors;

REGISTERED AS { MhsAcctObjectIdentifiers.id-package-cancelDeferredDelivery };

cancelDeferredDeliveryBehaviour BEHAVIOUR
  DEFINED AS "Captures accounting information on a cancel deferred delivery submission";
```

#### 11.15.2 messageSubmissionPackage

This package lists the specific attributes of a msseEventRecord managed object created following a Message-Submission abstract operation.

```
messageSubmissionPackage PACKAGE
  BEHAVIOUR messageSubmissionPackageBehaviour;
  ATTRIBUTES
    originatorName GET,
    priority GET,
    contentType GET,
    messageContentSize GET,
    -- Operation Result
    contentIdentifier GET,
    MTSIdentifier GET,
    SubmissionTime GET,
    originatingMTACertificate GET,
    proofOfSubmission GET,
    submissionError PERMITTED VALUES MhsAcctAsn1Module.MessageSubmissionErrors;

REGISTERED AS { MhsAcctObjectIdentifiers.id-package-messageSubmission };

messageSubmissionPackageBehaviour BEHAVIOUR
  DEFINED AS "Captures accounting information on a message submission";
```



**11.15.3 messageSubmissionEnvelopePackage**

This package lists a specific attribute of a msseEventRecord managed object created following a Message-Submission abstract operation in non-co-located entities.

```
messageSubmissionEnvelopePackage PACKAGE
    BEHAVIOUR messageSubmissionEnvelopePackageBehaviour;
    ATTRIBUTES
        messageSubmissionEnvelope GET;
REGISTERED AS { MhsAcctObjectIdentifiers.id-package-messageSubmissionEnvelope };
messageSubmissionEnvelopePackageBehaviour BEHAVIOUR
    DEFINED AS
        "This attribute was isolated so that co-located entities would not have to actually generate a whole envelope just to meet the requirements of Logging Information.";
```

**11.15.4 probeSubmissionPackage**

This package lists the specific attributes of a msseEventRecord managed object created following a Probe-Submission abstract operation.

```
probeSubmissionPackage PACKAGE
    BEHAVIOUR probeSubmissionPackageBehaviour;
    ATTRIBUTES
        originatorName GET,
        contentType GET,
        -- Operation result
        MTSIdentifier GET,
        SubmissionTime GET,
        contentIdentifier GET,
        submissionError PERMITTED VALUES MhsAcctAsn1Module.ProbeSubmissionErrors;
REGISTERED AS { MhsAcctObjectIdentifiers.id-package-probeSubmission };
probeSubmissionPackageBehaviour BEHAVIOUR
    DEFINED AS "Captures accounting information on a probe submission";
```

**11.15.5 probeSubmissionEnvelopePackage**

This package lists a specific attribute of a msseEventRecord managed object created following a Probe-Submission abstract operation in non-co-located entities.

```
probeSubmissionEnvelopePackage PACKAGE
    BEHAVIOUR probeSubmissionEnvelopePackageBehaviour;
    ATTRIBUTES
        probeSubmissionEnvelope GET;
REGISTERED AS { MhsAcctObjectIdentifiers.id-package-probeSubmissionEnvelope };
probeSubmissionEnvelopePackageBehaviour BEHAVIOUR
    DEFINED AS
        "This attribute was isolated so that co-located entities would not have to actually generate a whole envelope just to meet the requirements of Logging Information.";
```

**11.15.6 submissionControlPackage**

This package lists the specific attributes of a msseEventRecord managed object created following a Submission-Control abstract operation.

```
submissionControlPackage PACKAGE
    BEHAVIOUR submissionControlPackageBehaviour;
    ATTRIBUTES
        submissionControls GET,
        submissionError PERMITTED VALUES MhsAcctAsn1Module.SubmissionControlErrors;
REGISTERED AS { MhsAcctObjectIdentifiers.id-package-submissionControl };
submissionControlPackageBehaviour BEHAVIOUR
    DEFINED AS "Captures accounting information on a submission control operation";
```

## 11.16 mtseEventRecordPackage

This package lists the common attributes of a messageEventRecord managed object created following an abstract operation at the Message-Transmission port of a MHS entity.

### mtseEventRecordPackage PACKAGE

BEHAVIOUR mtseEventRecordPackageBehaviour;  
 ATTRIBUTES

recipientsOnResponsibilityList GET, -- identifies recipients whose perRecipientIndicator responsibility  
 -- bit is set to "responsible" (see Figure 4/X.411, Part 5 of 7)

"Rec. X.721 | ISO/IEC 10165-2":eventType PERMITTED VALUES

### MhsAcctAsn1Module.TransferPortOperations;

-- to indicate message transfer, probe transfer or report transfer operation --

REGISTERED AS { MhsAcctObjectIdentifiers.id-package-mtseEventRecord };

### mtseEventRecordPackageBehaviour BEHAVIOUR

DEFINED AS "The originatorName attribute's value can be instantly extracted from the probeTransferEnvelope or the messageTransferEnvelope. In the case of the report transfer operation, the attribute shall be given the value of the first OR-name in the Originator-and-DL-expansion-history field of the reportTransferEnvelope (see X.411, 8.3.1.2.1.3), if that field is present. If that field is not present, then the Report-destination-name (see X.411, 12.2.1.3.1.2) shall be used in its stead.";

### 11.16.1 messageTransferPackage

This package lists the specific attributes of a mtseEventRecord managed object created following a Message-Transfer abstract operation.

### messageTransferPackage PACKAGE

BEHAVIOUR messageTransferPackageBehaviour;  
 ATTRIBUTES

MTSIdentifier GET,  
 originatorName GET,  
 priority GET,  
 contentType GET,  
 messageContentSize GET, -- before conversion --  
 messageTransferEnvelope GET;

REGISTERED AS { MhsAcctObjectIdentifiers.id-package-messageTransfer };

### messageTransferPackageBehaviour BEHAVIOUR

DEFINED AS "Captures accounting information on a message transfer.";

### 11.16.2 probeTransferPackage

This package lists the specific attributes of a mtseEventRecord managed object created following a Probe-Transfer abstract operation.

### probeTransferPackage PACKAGE

BEHAVIOUR probeTransferPackageBehaviour;  
 ATTRIBUTES

MTSIdentifier GET,  
 originatorName GET,  
 contentType GET,  
 probeTransferEnvelope GET;

REGISTERED AS { MhsAcctObjectIdentifiers.id-package-probeTransfer };

### probeTransferPackageBehaviour BEHAVIOUR

DEFINED AS "Captures accounting information on a probe transfer";

### 11.16.3 reportTransferPackage

This package lists the specific attributes of a mtseEventRecord managed object created following a Report-Transfer abstract operation.

### reportTransferPackage PACKAGE

BEHAVIOUR reportTransferPackageBehaviour;  
 ATTRIBUTES

reportIdentifier GET,  
 subjectIdentifier GET,

contentType GET,  
reportTransferEnvelope GET,

REGISTERED AS { MhsAcctObjectIdentifiers.id-package-reportTransfer };

reportTransferPackageBehaviour BEHAVIOUR  
DEFINED AS "Captures accounting information on a report transfer";

### 11.17 processingPackage

This package contains attributes used to list the internal processing that happened on a message, probe, or report inside the MTA.

processingPackage PACKAGE  
BEHAVIOUR processingPackageBehaviour;  
ATTRIBUTES  
processingErrorFlag GET,  
processingSummary GET,  
processingDetails GET;

REGISTERED AS { MhsAcctObjectIdentifiers.id-package-processing };

processingPackageBehaviour BEHAVIOUR  
DEFINED AS  
"This package contains attributes used to list the internal processing that happened on a message, probe, or report inside the MTA";

### 11.18 securityAcctRecordPackage

This package lists the attributes of a securityAcctRecord managed object.

securityAcctRecordPackage PACKAGE  
BEHAVIOUR securityAcctRecordPackageBehaviour;  
ATTRIBUTES  
authenticationCheck GET,  
authenticationGeneration GET,  
bindAuthenticationCheck GET,  
bindToken GET,  
certificate GET,  
contentConfidentialityAlgorithmIdentifier GET,  
contentIntegrityCheck GET,  
decipherment GET,  
encipherment GET,  
globalDomainId GET,  
initiatorCredentials GET,  
messageOriginAuthenticationCheck GET,  
messageSecurityLabel GET,  
messageToken GET,  
msBindAuthenticationCheck GET,  
newCredentials GET,  
oldCredentials GET,  
operationTime GET,  
originatorCertificate GET,  
permissibleSecurityContext GET,  
probeOriginAuthenticationCheck GET,  
proofOfDelivery GET,  
proofOfDeliveryRequest GET,  
proofOfSubmission GET,  
proofOfSubmissionRequest GET,  
recipientCertificate GET,  
reportingMTACertificate GET,  
reportOriginAuthenticationCheck GET,  
securityContext GET,  
securityError GET,  
securityProblem GET,  
signatureCheck GET,  
signatureGeneration GET,  
userSecurityLabel GET;

REGISTERED AS { MhsAcctObjectIdentifiers.id-package-securityAcctRecord };

securityAcctRecordPackageBehaviour BEHAVIOUR  
DEFINED AS

"This object is only present if there is a security policy in use in the MD. ";

### 11.19 serviceRequestPackage

This package lists the attributes of a serviceRequest managed object.

serviceRequestPackage PACKAGE  
BEHAVIOUR serviceRequestPackageBehaviour;  
ATTRIBUTES

contactInstance GET-REPLACE,  
serviceRequestId GET,  
status GET-REPLACE,  
limitValidityDate GET-REPLACE,  
startUpDate GET-REPLACE;

REGISTERED AS { MhsAcctObjectIdentifiers.id-package-serviceRequest };

serviceRequestPackageBehaviour BEHAVIOUR  
DEFINED AS

"When an instance of the Service Request managed object class is created, the contactInstance and ServiceRequestID attribute values shall be supplied. The contactInstance attribute shall contain the name of a managed object that already exists.

The performance of the creation of a ServiceRequest object is reported to the Indirect MIS-user as an object creation report.

All changes on attributes values of a ServiceRequest object are reported to the Indirect MIS-user as Attribute change value notifications.

The performance of the deletion of a ServiceRequest object is reported to the Indirect MIS-user as an object deletion report.";

### 11.20 settlementAcctRecordPackage

This package lists the common attributes of a settlementAcctRecord managed object.

settlementAcctRecordPackage PACKAGE  
ATTRIBUTES

entryExitMtaNames GET,  
MTSIdentifier GET,  
encodedInformationTypes GET,  
envelopeType GET,  
priority GET,  
messageContentSize GET, -- *PI's content in octets, when message enters domain* --  
processingComponentRate GET; -- *see page 27 of D.36* --

REGISTERED AS { MhsAcctObjectIdentifiers.id-package-settlementAcctRecord };

#### 11.20.1 d36-commonAttributesPackage

This package lists the common attributes of a settlementAcctRecord managed object under the settlement policy described in Recommendation D.36.

d36-commonAttributesPackage PACKAGE  
ATTRIBUTES

MTSIdentifier GET,  
originatingADMD GET,  
destinationADMD GET, -- *MTA names*  
messageSize GET, -- *PIe*  
totalNumberOfORAddresses GET, -- *a*  
currency GET; -- *R*

REGISTERED AS { MhsAcctObjectIdentifiers.id-package-d36-commonAttributes };

#### 11.20.2 d36-deliveryViaAccessUnitPackage

This package lists the specific attributes of a settlementAcctRecord managed object under the settlement policy described in Recommendation D.36 when processing a delivery via an AU.

d36-deliveryViaAccessUnitPackage PACKAGE  
BEHAVIOUR deliveryViaAccessUnitPackageBehaviour;

**ATTRIBUTES**

**numberOfMessagesPerDeliveryServiceType** GET, -- *x(i)*  
**componentRatesPerOctetPerDeliveryServiceType** GET, -- *D(i)*  
**accessRatePerDeliveryServiceType** GET, -- *E(i)*  
**deliveryServiceTypes** GET; -- *i*

**REGISTERED AS** { MhsAcctObjectIdentifiers.id-package-d36-deliveryViaAccessUnit };

**deliveryViaAccessUnitPackageBehaviour** BEHAVIOUR

**DEFINED AS** "Used when the concerned message is delivered by the ADMD via an access unit.";

**11.20.3 d36-directDeliveryPackage**

This package lists the specific attributes of a settlementAcctRecord managed object under the settlement policy described in Recommendation D.36 when processing a delivery via an AU.

**d36-directDeliveryPackage** PACKAGE

**BEHAVIOUR** directDeliveryPackageBehaviour;

**ATTRIBUTES**

**numberOfAddressedUAs** GET, -- *b*  
**numberOfAddressedPRMDs** GET, -- *c*  
**deliveryComponentRateToUa** GET, -- *D*  
**deliveryComponentRateToPRMD** GET; -- *D'*

**REGISTERED AS** { MhsAcctObjectIdentifiers.id-package-d36-directDelivery };

**directDeliveryPackageBehaviour** BEHAVIOUR

**DEFINED AS** "Used when the concerned message is directly delivered by the ADMD.";

**11.20.4 destinationDomainDeliveryPackage**

This package lists the specific attributes of a settlementAcctRecord managed object regarding the destination domain of a delivered message.

**destinationDomainDeliveryPackage** PACKAGE

**BEHAVIOUR** destinationDomainDeliveryPackageBehaviour;

**ATTRIBUTES**

**destinationDomainDeliveryList** GET;

**REGISTERED AS** { MhsAcctObjectIdentifiers.id-package-destinationDomainDelivery };

**destinationDomainDeliveryPackageBehaviour** BEHAVIOUR

**DEFINED AS** "Captures accounting information on a destination domain after it delivers message(s) via AU, to UA and to MS";

**11.20.5 originatingDomainTransferOutPackage**

This package lists the specific attributes of a settlementAcctRecord managed object regarding the originating domain of a transferred message.

**originatingDomainTransferOutPackage** PACKAGE

**BEHAVIOUR** transferOutPackageBehaviour;

**ATTRIBUTES**

**serviceAccessCharge** GET,  
-- *Note – To use monetary unit or other units like type of access is for further study* --  
**originatingDomainTransferOutList** GET;

**REGISTERED AS** { MhsAcctObjectIdentifiers.id-package-originatingDomainTransferOut };

**transferOutPackageBehaviour** BEHAVIOUR

**DEFINED AS** "Captures accounting information on an originating domain";

**11.20.6 transitDomainTransferOutPackage**

This package lists the specific attributes of a settlementAcctRecord managed object regarding the transit domain of a delivered message

**transitDomainTransferOutPackage** PACKAGE

**BEHAVIOUR** transitDomainTransferOutPackageBehaviour;

**ATTRIBUTES**

**transitDomainTransferOutList** GET;

**REGISTERED AS** { MhsAcctObjectIdentifiers.id-package-transitDomainTransferOut };

transitDomainTransferOutPackageBehaviour BEHAVIOUR

DEFINED AS "Captures accounting information on a transit domain after it transfers out a message";

## 12 Definition of attributes

### 12.1 Access Rate Per Delivery Service Type

This attribute is part of the settlement record and is described in Recommendation. D.36.

accessRatePerDeliveryServiceType ATTRIBUTE

WITH ATTRIBUTE SYNTAX MhsAcctAsn1Module.AccessRatePerDeliveryServiceType;

REGISTERED AS { MhsAcctObjectIdentifiers.id-attribute-accessRatePerDeliveryServiceType };

### 12.2 Actual Recipient Name

This attribute enables to store the corresponding parameter of a Report Delivery abstract-operation. This attribute may have one of the possible values of an **actual-recipient-name** abstract service parameter defined in ITU-T Rec. X.411 | ISO/IEC 10021-4.

actualRecipientName ATTRIBUTE

WITH ATTRIBUTE SYNTAX MhsAcctAsn1Module.ActualRecipientName;

REGISTERED AS { MhsAcctObjectIdentifiers.id-attribute-actualRecipientName };

### 12.3 Administration Error

This attribute enables to store an error occurring at the administration port of an MHS entity.

administrationError ATTRIBUTE

WITH ATTRIBUTE SYNTAX MhsAcctAsn1Module.AdministrationError;

REGISTERED AS { MhsAcctObjectIdentifiers.id-attribute-administrationError };

### 12.4 Alert Argument

This attribute enables to store the corresponding MS Alert abstract-operation argument. This attribute may have one of the possible values of an **alert-argument** abstract service parameter defined in ITU-T Rec. X.413 | ISO/IEC 10021-5.

alertArgument ATTRIBUTE

WITH ATTRIBUTE SYNTAX MhsAcctAsn1Module.AlertArgument;

REGISTERED AS { MhsAcctObjectIdentifiers.id-attribute-alertArgument };

### 12.5 Alert Result

This attribute enables to store the corresponding MS Alert abstract-operation result. This attribute may have one of the possible values of an **alert-result** abstract service parameter defined in ITU-T Rec. X.413 | ISO/IEC 10021-5.

alertResult ATTRIBUTE

WITH ATTRIBUTE SYNTAX MhsAcctAsn1Module.AlertResult;

REGISTERED AS { MhsAcctObjectIdentifiers.id-attribute-alertResult };

### 12.6 Authentication Check

The use of this attribute, as part of the security Accounting Record is described in ITU-T Rec. X.464 | ISO/IEC 11588-4.

authenticationCheck ATTRIBUTE

WITH ATTRIBUTE SYNTAX MhsAcctAsn1Module.AuthenticationCheck;

REGISTERED AS { MhsAcctObjectIdentifiers.id-attribute-authenticationCheck };

## 12.7 Authentication Generation

The use of this attribute, as part of the security Accounting Record is described in ITU-T Rec. X.464 | ISO/IEC 11588-4.

**authenticationGeneration ATTRIBUTE**  
**WITH ATTRIBUTE SYNTAX MhsAcctAsn1Module.AuthenticationGeneration;**  
**REGISTERED AS { MhsAcctObjectIdentifiers.id-attribute-authenticationGeneration };**

## 12.8 Available Attribute Types

This attribute enables to store the corresponding parameter of an MS-Bind abstract-operation. This attribute may have one of the possible values of an **available-attribute-types** abstract service parameter defined in ITU-T Rec. X.413 | ISO/IEC 10021-5.

**availableAttributeTypes ATTRIBUTE**  
**WITH ATTRIBUTE SYNTAX MhsAcctAsn1Module.AvailableAttributeTypes;**  
**REGISTERED AS { MhsAcctObjectIdentifiers.id-attribute-availableAttributeTypes };**

## 12.9 Bind Authentication Check

The use of this attribute, as part of the security Accounting Record is described in ITU-T Rec. X.464 | ISO/IEC 11588-4.

**bindAuthenticationCheck ATTRIBUTE**  
**WITH ATTRIBUTE SYNTAX MhsAcctAsn1Module.BindAuthenticationCheck;**  
**REGISTERED AS { MhsAcctObjectIdentifiers.id-attribute-bindAuthenticationCheck };**

## 12.10 Binding Error

This attribute enables to store an error occurring during a bind abstract operation.

**bindingError ATTRIBUTE**  
**WITH ATTRIBUTE SYNTAX MhsAcctAsn1Module.BindingError;**  
**REGISTERED AS { MhsAcctObjectIdentifiers.id-attribute-bindingError };**

## 12.11 Bind Token

This attribute enables to store the corresponding parameter of an MHS abstract operation. This attribute may have one of the possible values of a **bind-token** abstract service parameter defined in ITU-T Rec. X.411 | ISO/IEC 10021-4. The use of this attribute, as part of the security Accounting Record, is described in ITU-T Rec. X.464 | ISO/IEC 11588-4.

**bindToken ATTRIBUTE**  
**WITH ATTRIBUTE SYNTAX MhsAcctAsn1Module.BindToken;**  
**REGISTERED AS { MhsAcctObjectIdentifiers.id-attribute-bindToken };**

## 12.12 Certificate

This attribute enables to store the corresponding parameter of an MHS abstract operation. This attribute may have one of the possible values of a **certificate** abstract service parameter defined in ITU-T Rec. X.411 | ISO/IEC 10021-4. The use of this attribute, as part of the security Accounting Record, is described in ITU-T Rec. X.464 | ISO/IEC 11588-4.

**certificate ATTRIBUTE**  
**WITH ATTRIBUTE SYNTAX MhsAcctAsn1Module.Certificate;**  
**REGISTERED AS { MhsAcctObjectIdentifiers.id-attribute-certificate };**

## 12.13 Component Rates per Octets per Delivery Service Type

This attribute is part of the settlement record and is described in Recommendation D.36.

**componentRatesPerOctetsPerDeliveryServiceType ATTRIBUTE**  
**WITH ATTRIBUTE SYNTAX MhsAcctAsn1Module.ComponentRatesPerOctetsPerDeliveryServiceType;**  
**REGISTERED AS { MhsAcctObjectIdentifiers.id-attribute-componentRatesPerOctetsPerDeliveryServiceType };**

### 12.14 Consumer of Operation

This attribute enables to store the identification of the consumer of an operation.

**consumerOfOperation ATTRIBUTE**

**WITH ATTRIBUTE SYNTAX MhsAcctAsn1Module.ObjectInstance;**

**REGISTERED AS { MhsAcctObjectIdentifiers.id-attribute-consumerOfOperation };**

### 12.15 Contact Company

This attribute enables to store the company name of the contact represented by the Contact managed object instance.

**contactCompany ATTRIBUTE**

**WITH ATTRIBUTE SYNTAX MhsAcctAsn1Module.ContactCompany;**

**REGISTERED AS { MhsAcctObjectIdentifiers.id-attribute-contactCompany };**

### 12.16 Contact Details

This attribute enables to store the details of the contact represented by the Contact managed object instance.

**contactDetails ATTRIBUTE**

**WITH ATTRIBUTE SYNTAX MhsAcctAsn1Module.ContactDetails;**

**REGISTERED AS { MhsAcctObjectIdentifiers.id-attribute-contactDetails };**

### 12.17 Contact Function

This attribute enables to store the function of the contact represented by the Contact managed object instance.

**contactFunction ATTRIBUTE**

**WITH ATTRIBUTE SYNTAX MhsAcctAsn1Module.ContactFunction;**

**REGISTERED AS { MhsAcctObjectIdentifiers.id-attribute-contactFunction };**

### 12.18 Contact ID

This attribute enables to identify a Contact managed object instance within the containment hierarchy.

**contactId ATTRIBUTE**

**WITH ATTRIBUTE SYNTAX MhsAcctAsn1Module.ContactId;**

**REGISTERED AS { MhsAcctObjectIdentifiers.id-attribute-contactId };**

### 12.19 Contact Instance

This attribute enables to store the Relative distinguished name of a Contact managed object instance.

**contactInstance ATTRIBUTE**

**WITH ATTRIBUTE SYNTAX MhsAcctAsn1Module.ObjectInstance;**

**REGISTERED AS { MhsAcctObjectIdentifiers.id-attribute-contactInstance };**

### 12.20 Contact Name

This attribute enables to store the name of the contact represented by the Contact managed object instance.

**contactName ATTRIBUTE**

**WITH ATTRIBUTE SYNTAX MhsAcctAsn1Module.ContactName;**

**REGISTERED AS { MhsAcctObjectIdentifiers.id-attribute-contactName };**



### 12.21 Content Confidentiality Algorithm Identifier

This attribute enables to store the corresponding parameter of an MHS abstract operation. This attribute may have one of the possible values of a **content-confidentiality-algorithm-identifier** abstract service parameter defined in ITU-T Rec. X.411 | ISO/IEC 10021-4. The use of this attribute, as part of the security Accounting Record is described in ITU-T Rec. X.464 | ISO/IEC 11588-4.

**contentConfidentialityAlgorithmIdentifier ATTRIBUTE**  
**WITH ATTRIBUTE SYNTAX MhsAcctAsn1Module.ContentConfidentialityAlgorithmIdentifier;**  
**REGISTERED AS { MhsAcctObjectIdentifiers.id-attribute-contentConfidentialityAlgorithmIdentifier };**

### 12.22 Content Identifier

This attribute enables to store the corresponding parameter of an MHS abstract-operation. This attribute may have one of the possible values of a **content-identifier** abstract service parameter defined in ITU-T Rec. X.411 | ISO/IEC 10021-4.

**contentIdentifier ATTRIBUTE**  
**WITH ATTRIBUTE SYNTAX MhsAcctAsn1Module.ContentIdentifier;**  
**REGISTERED AS { MhsAcctObjectIdentifiers.id-attribute-contentIdentifier};**

### 12.23 Content Integrity Check

This attribute is used for security purposes. The reader is referred to ITU-T Rec. X.464 | ISO/IEC 11588-4.

**contentIntegrityCheck ATTRIBUTE**  
**WITH ATTRIBUTE SYNTAX MhsAcctAsn1Module.ContentIntegrityCheck;**  
**REGISTERED AS { MhsAcctObjectIdentifiers.id-attribute-contentIntegrityCheck };**

### 12.24 Content Type

This attribute enables to store the corresponding parameter of an MHS abstract-operation. This attribute may have one of the possible values of a **content-type** abstract service parameter defined in ITU-T Rec. X.411 | ISO/IEC 10021-4.

**contentType ATTRIBUTE**  
**WITH ATTRIBUTE SYNTAX MhsAcctAsn1Module.ContentType;**  
**MATCHES FOR EQUALITY;**  
**REGISTERED AS { MhsAcctObjectIdentifiers.id-attribute-contentType };**

### 12.25 Currency

This attribute is part of the settlement record and is described in Recommendation D.36.

**currency ATTRIBUTE**  
**WITH ATTRIBUTE SYNTAX MhsAcctAsn1Module.Currency;**  
**REGISTERED AS { MhsAcctObjectIdentifiers.id-attribute-currency };**

### 12.26 customerAcct Policy

This attribute enables to store the Customer accounting policy enforced in the MIS management domain.

**customerAcctPolicy ATTRIBUTE**  
**WITH ATTRIBUTE SYNTAX MhsAcctAsn1Module.CustomerAcctPolicy;**  
**REGISTERED AS { MhsAcctObjectIdentifiers.id-attribute-customerAcctPolicy };**

### 12.27 Customer ID

This attribute enables to identify a Customer managed object instance within the containment hierarchy.

**customerId ATTRIBUTE**  
**WITH ATTRIBUTE SYNTAX MhsAcctAsn1Module.CustomerId;**  
**REGISTERED AS { MhsAcctObjectIdentifiers.id-attribute-customerId };**

### 12.28 Customer Name

This attribute enables to store the name of the Customer represented by a Customer managed object instance.

**customerName ATTRIBUTE**  
WITH ATTRIBUTE SYNTAX **MhsAcctAsn1Module.CustomerName;**  
**REGISTERED AS { MhsAcctObjectIdentifiers.id-attribute-customerName };**

### 12.29 Decipherment

The use of this attribute, as part of the security Accounting Record, is described in ITU-T Rec. X.464 | ISO/IEC 11588-4.

**decipherment ATTRIBUTE**  
WITH ATTRIBUTE SYNTAX **MhsAcctAsn1Module.Decipherment;**  
**REGISTERED AS { MhsAcctObjectIdentifiers.id-attribute-decipherment };**

### 12.30 Default Delivery Controls

This attribute enables to store the corresponding parameter of a Register abstract operation. This attribute may have one of the possible values of a **default-delivery-controls** abstract service parameter defined in ITU-T Rec. X.411 | ISO/IEC 10021-4.

**defaultDeliveryControls ATTRIBUTE**  
WITH ATTRIBUTE SYNTAX **MhsAcctAsn1Module.DefaultDeliveryControls;**  
**REGISTERED AS { MhsAcctObjectIdentifiers.id-attribute-defaultDeliveryControls };**

### 12.31 Delete Argument

This attribute enables to store the corresponding MS Delete abstract-operation argument. This attribute may have one of the possible values of a **delete-argument** abstract service parameter defined in ITU-T Rec. X.413 | ISO/IEC 10021-5.

**deleteArgument ATTRIBUTE**  
WITH ATTRIBUTE SYNTAX **MhsAcctAsn1Module.DeleteArgument;**  
**REGISTERED AS { MhsAcctObjectIdentifiers.id-attribute-deleteArgument };**

### 12.32 Delete Result

This attribute enables to store the corresponding MS Delete abstract-operation result. This attribute may have one of the possible values of a **delete-result** abstract service parameter defined in ITU-T Rec. X.413 | ISO/IEC 10021-5.

**deleteResult ATTRIBUTE**  
WITH ATTRIBUTE SYNTAX **MhsAcctAsn1Module.DeleteResult;**  
**REGISTERED AS { MhsAcctObjectIdentifiers.id-attribute-deleteResult };**

### 12.33 Deliverable Content Types

This attribute enables to store the corresponding parameter of a Register abstract operation. This attribute may have one of the possible values of a **deliverable-content-types** abstract service parameter defined in ITU-T Rec. X.411 | ISO/IEC 10021-4.

**deliverableContentTypes ATTRIBUTE**  
WITH ATTRIBUTE SYNTAX **MhsAcctAsn1Module.DeliverableContentTypes;**  
**REGISTERED AS { MhsAcctObjectIdentifiers.id-attribute-deliverableContentTypes };**

### 12.34 Deliverable Encoded Information Types

This attribute enables to store the corresponding parameter of a Register abstract operation. This attribute may have one of the possible values of a **deliverable-encoded-information-types** abstract service parameter defined in ITU-T Rec. X.411 | ISO/IEC 10021-4.

**deliverableEncodedInformationTypes ATTRIBUTE**  
WITH ATTRIBUTE SYNTAX **MhsAcctAsn1Module.EncodedInformationTypes;**  
**REGISTERED AS { MhsAcctObjectIdentifiers.id-attribute-deliverableEncodedInformationTypes };**

**12.35 Deliverable Maximum Content Length**

This attribute enables to store the corresponding parameter of a Register abstract operation. This attribute may have one of the possible values of a **deliverable-maximum-content-length** abstract service parameter defined in ITU-T Rec. X.411 | ISO/IEC 10021-4.

**deliverableMaximumContentLength ATTRIBUTE**  
 WITH ATTRIBUTE SYNTAX **MhsAcctAsn1Module.ContentLength;**  
**REGISTERED AS { MhsAcctObjectIdentifiers.id-attribute-deliverableMaximumContentLength };**

**12.36 Delivery Component Rate to PRMD**

This attribute is part of the settlement record and is described in Recommendation D.36.

**deliveryComponentRateToPrmd ATTRIBUTE**  
 WITH ATTRIBUTE SYNTAX **MhsAcctAsn1Module.DeliveryComponentRateToPrmd;**  
**REGISTERED AS { MhsAcctObjectIdentifiers.id-attribute-deliveryComponentRateToPrmd };**

**12.37 Delivery Component Rate To UA**

This attribute is part of the settlement record and is described in Recommendation D.36.

**deliveryComponentRateToUa ATTRIBUTE**  
 WITH ATTRIBUTE SYNTAX **MhsAcctAsn1Module.DeliveryComponentRateToUa;**  
**REGISTERED AS { MhsAcctObjectIdentifiers.id-attribute-deliveryComponentRateToUa };**

**12.38 Delivery Controls**

This attribute enables to store the corresponding parameter of a Delivery-control abstract operation. This attribute may have one of the possible values of a **delivery-controls** abstract service parameter defined in ITU-T Rec. X.411 | ISO/IEC 10021-4.

**deliveryControls ATTRIBUTE**  
 WITH ATTRIBUTE SYNTAX **MhsAcctAsn1Module.DeliveryControls;**  
**REGISTERED AS { MhsAcctObjectIdentifiers.id-attribute-deliveryControls };**

**12.39 Delivery Error**

This attribute enables to store an error occurring at the MTS Delivery port.

**deliveryError ATTRIBUTE**  
 WITH ATTRIBUTE SYNTAX **MhsAcctAsn1Module.DeliveryError;**  
**PARAMETERS**  
**securityError;**  
**REGISTERED AS { MhsAcctObjectIdentifiers.id-attribute-deliveryError };**

**12.40 Delivery Service Types**

This attribute is part of the settlement record and is described in Recommendation D.36.

**deliveryServiceTypes ATTRIBUTE**  
 WITH ATTRIBUTE SYNTAX **MhsAcctAsn1Module.DeliveryServiceTypes;**  
**REGISTERED AS { MhsAcctObjectIdentifiers.id-attribute-deliveryServiceTypes };**

**12.41 DestinationADMD**

This attribute is part of the settlement record and is described in Recommendation D.36.

**destinationAdmd ATTRIBUTE**  
 WITH ATTRIBUTE SYNTAX **MhsAcctAsn1Module.DestinationADMD;**  
**REGISTERED AS { MhsAcctObjectIdentifiers.id-attribute-destinationAdmd };**

#### 12.42 Destination Domain Delivery List

This attribute is part of the settlement record and is described in Recommendation D.36.

**destinationDomainDeliveryList ATTRIBUTE**  
**WITH ATTRIBUTE SYNTAX MhsAcctAsn1Module.DestinationDomainDeliveryList;**  
**REGISTERED AS { MhsAcctObjectIdentifiers.id-attribute-destinationDomainDeliveryList };**

#### 12.43 Electronic Mail Address

This attribute enables to store the e-mail address of the person in charge of the contact represented by a Contact managed object instance.

**electronicMailAddress ATTRIBUTE**  
**WITH ATTRIBUTE SYNTAX MhsAcctAsn1Module.ElectronicMailAddress;**  
**REGISTERED AS { MhsAcctObjectIdentifiers.id-attribute-electronicMailAddress };**

#### 12.44 Encipherment

The use of this attribute, as part of the security Accounting Record is described in ITU-T Rec. X.464 | ISO/IEC 11588-4.

**encipherment ATTRIBUTE**  
**WITH ATTRIBUTE SYNTAX MhsAcctAsn1Module.Encipherment;**  
**REGISTERED AS { MhsAcctObjectIdentifiers.id-attribute-encipherment };**

#### 12.45 Encoded Information Types

This attribute enables to store the corresponding parameter of an MHS abstract-operation. This attribute may have one of the possible values of an **encoded-information-types** abstract service parameter defined in ITU-T Rec. X.411 | ISO/IEC 10021-4.

**encodedInformationTypes ATTRIBUTE**  
**WITH ATTRIBUTE SYNTAX MhsAcctAsn1Module.EncodedInformationTypes;**  
**REGISTERED AS { MhsAcctObjectIdentifiers.id-attribute-encodedInformationTypes };**

#### 12.46 Entry Exit MTA Names

This attribute is part of the settlement record and is described in Recommendation D.36.

**entryExitMtaNames ATTRIBUTE**  
**WITH ATTRIBUTE SYNTAX MhsAcctAsn1Module.EntryExitMTANames;**  
**REGISTERED AS { MhsAcctObjectIdentifiers.id-attribute-entryExitMtaNames };**

#### 12.47 Envelope Type

This attribute is part of the settlement record and is described in Recommendation D.36.

**envelopeType ATTRIBUTE**  
**WITH ATTRIBUTE SYNTAX MhsAcctAsn1Module.EnvelopeType;**  
**REGISTERED AS { MhsAcctObjectIdentifiers.id-attribute-envelopeType };**

#### 12.48 Facsimile Telephone Number List

This attribute enables to store the fax numbers associated with the contact represented by a Contact managed object instance.

**facsimileTelephoneNumberList ATTRIBUTE**  
**WITH ATTRIBUTE SYNTAX MhsAcctAsn1Module.TelephoneNumberList;**  
**REGISTERED AS { MhsAcctObjectIdentifiers.id-attribute-faxTelephoneNumberList };**

### 12.49 Fetch Argument

This attribute enables to store the corresponding MS Fetch abstract-operation argument. This attribute may have one of the possible values of a **fetch-argument** abstract service parameter defined in ITU-T Rec. X.413 | ISO/IEC 10021-5.

**fetchArgument ATTRIBUTE**

WITH ATTRIBUTE SYNTAX **MhsAcctAsn1Module.FetchArgument;**

REGISTERED AS { **MhsAcctObjectIdentifiers.id-attribute-fetchArgument** };

### 12.50 Fetch Result

This attribute enables to store the corresponding MS Fetch abstract-operation result. This attribute may have one of the possible values of a **fetch-result** abstract service parameter defined in ITU-T Rec. X.413 | ISO/IEC 10021-5.

**fetchResult ATTRIBUTE**

WITH ATTRIBUTE SYNTAX **MhsAcctAsn1Module.FetchResult;**

REGISTERED AS { **MhsAcctObjectIdentifiers.id-attribute-fetchResult** };

### 12.51 Global Domain ID

This attribute enables to store the corresponding parameter of an MHS abstract-operation. This attribute may have one of the possible values of a **global-domain-identifier** abstract service parameter defined in ITU-T Rec. X.411 | ISO/IEC 10021-4. The use of this attribute, as part of the security Accounting Record, is described in ITU-T Rec. X.464 | ISO/IEC 11588-4.

**globalDomainId ATTRIBUTE**

WITH ATTRIBUTE SYNTAX **MhsAcctAsn1Module.GlobalDomainIdentifier;**

REGISTERED AS { **MhsAcctObjectIdentifiers.id-attribute-globalDomainId** };

### 12.52 InitiatorCredentials

This attribute enables to store the corresponding parameter of an MHS abstract-operation. This attribute may have one of the possible values of a **credentials** abstract service parameter defined in ITU-T Rec. X.411 | ISO/IEC 10021-4. The use of this attribute, as part of the security Accounting Record, is described in ITU-T Rec. X.464 | ISO/IEC 11588-4.

**initiatorCredentials ATTRIBUTE**

WITH ATTRIBUTE SYNTAX **MhsAcctAsn1Module.InitiatorCredentials;**

REGISTERED AS { **MhsAcctObjectIdentifiers.id-attribute-initiatorCredentials** };

### 12.53 Initiator Name

This attribute enables to store the corresponding parameter of a Bind abstract-operation. This attribute may have one of the possible values of an **OR-name** abstract service parameter defined in ITU-T Rec. X.411 | ISO/IEC 10021-4.

**initiatorName ATTRIBUTE**

WITH ATTRIBUTE SYNTAX **MhsAcctAsn1Module.ObjectName;**

REGISTERED AS { **MhsAcctObjectIdentifiers.id-attribute-initiatorName** };

### 12.54 Internal Trace

This attribute enables to store the corresponding parameter of an MHS abstract-operation. This attribute may have one of the possible values of an **OR-name** abstract service parameter defined in ITU-T Rec. X.411 | ISO/IEC 10021-4.

**internalTrace ATTRIBUTE**

WITH ATTRIBUTE SYNTAX **MhsAcctAsn1Module.InternalTrace;**

REGISTERED AS { **MhsAcctObjectIdentifiers.id-attribute-internalTrace** };

### 12.55 InterworkingMD ID

This attribute enables to identify an InterworkingMD managed object instance within the containment hierarchy.

**interworkingMDId ATTRIBUTE**

**WITH ATTRIBUTE SYNTAX MhsAcctAsn1Module.InterworkingMDId;**

**REGISTERED AS { MhsAcctObjectIdentifiers.id-attribute-interworkingAdmdId };**

### 12.56 InterworkingMD Name

This attribute enables to store the name of the InterworkingMD represented by an InterworkingMD managed object instance.

**interworkingMDName ATTRIBUTE**

**WITH ATTRIBUTE SYNTAX MhsAcctAsn1Module.InterworkingMDName;**

**REGISTERED AS { MhsAcctObjectIdentifiers.id-attribute-interworkingAdmdName };**

### 12.57 Labels and Redirections

This attribute enables to store the corresponding parameter of an MHS abstract-operation. This attribute may have one of the possible values of a **labels-and-redirections** abstract service parameter defined in ITU-T Rec. X.411 | ISO/IEC 10021-4.

**labelsAndRedirections ATTRIBUTE**

**WITH ATTRIBUTE SYNTAX MhsAcctAsn1Module.LabelsAndRedirections;**

**REGISTERED AS { MhsAcctObjectIdentifiers.id-attribute-labelsAndRedirections };**

### 12.58 Limit Validity Date

This attribute enables to provide information on the validity period of a Service request.

**limitValidityDate ATTRIBUTE**

**WITH ATTRIBUTE SYNTAX MhsAcctAsn1Module.LimitValidityDate;**

**REGISTERED AS { MhsAcctObjectIdentifiers.id-attribute-limitValidityDate };**

### 12.59 List Argument

This attribute enables to store the corresponding MS List abstract-operation argument. This attribute may have one of the possible values of a **list-argument** abstract service parameter defined in ITU-T Rec. X.413 | ISO/IEC 10021-5.

**listArgument ATTRIBUTE**

**WITH ATTRIBUTE SYNTAX MhsAcctAsn1Module.ListArgument;**

**REGISTERED AS { MhsAcctObjectIdentifiers.id-attribute-listArgument };**

### 12.60 List Result

This attribute enables to store the corresponding MS List abstract-operation result. This attribute may have one of the possible values of a **list-result** abstract service parameter defined in ITU-T Rec. X.413 | ISO/IEC 10021-5.

**listResult ATTRIBUTE**

**WITH ATTRIBUTE SYNTAX MhsAcctAsn1Module.ListResult;**

**REGISTERED AS { MhsAcctObjectIdentifiers.id-attribute-listResult };**

### 12.61 Log Start Time

This attribute enables to store the time at which logging shall be started.

**logStartTime ATTRIBUTE**

**WITH ATTRIBUTE SYNTAX MhsAcctAsn1Module.Time;**

**REGISTERED AS { MhsAcctObjectIdentifiers.id-attribute-logStartTime };**

### 12.62 Log Stop Time

This attribute enables to store the time at which logging shall be stopped.

**logStopTime ATTRIBUTE**  
WITH ATTRIBUTE SYNTAX **MhsAcctAsn1Module.Time;**  
**REGISTERED AS { MhsAcctObjectIdentifiers.id-attribute-logStopTime };**

### 12.63 Message Content Size

This attribute indicates the size of the content of a message in octets.

**messageContentSize ATTRIBUTE**  
WITH ATTRIBUTE SYNTAX **MhsAcctAsn1Module.MessageContentSize;**  
**REGISTERED AS { MhsAcctObjectIdentifiers.id-attribute-messageContentSize };**

### 12.64 Message Delivery Envelope

This attribute enables to store the corresponding parameter of a Message Delivery abstract-operation. This attribute may have one of the possible values of a **message-delivery-envelope** abstract service parameter defined in ITU-T Rec. X.411 | ISO/IEC 10021-4.

**messageDeliveryEnvelope ATTRIBUTE**  
WITH ATTRIBUTE SYNTAX **MhsAcctAsn1Module.MessageDeliveryEnvelope;**  
**REGISTERED AS { MhsAcctObjectIdentifiers.id-attribute-messageDeliveryEnvelope };**

### 12.65 MTS Identifier

This attribute enables to store the corresponding parameter of an MHS abstract-operation. This attribute may have one of the possible values of an **MTS-identifier** abstract service parameter defined in ITU-T Rec. X.411 | ISO/IEC 10021-4.

**MTSIdentifier ATTRIBUTE**  
WITH ATTRIBUTE SYNTAX **MhsAcctAsn1Module.MTSIdentifier;**  
**REGISTERED AS { MhsAcctObjectIdentifiers.id-attribute-MTSIdentifier };**

### 12.66 Message Origin Authentication Check

The use of this attribute, as part of the security Accounting Record is described in ITU-T Rec. X.464 | ISO/IEC 11588-4.

**messageOriginAuthenticationCheck ATTRIBUTE**  
WITH ATTRIBUTE SYNTAX **MhsAcctAsn1Module.MessageOriginAuthenticationCheck;**  
**REGISTERED AS { MhsAcctObjectIdentifiers.id-attribute-messageOriginAuthenticationCheck };**

### 12.67 Message Security Label

This attribute enables to store the corresponding parameter of an MHS abstract-operation. This attribute may have one of the possible values of a **message-security-label** abstract service parameter defined in ITU-T Rec. X.411 | ISO/IEC 10021-4. The use of this attribute, as part of the security Accounting Record, is described in ITU-T Rec. X.464 | ISO/IEC 11588-4.

**messageSecurityLabel ATTRIBUTE**  
WITH ATTRIBUTE SYNTAX **MhsAcctAsn1Module.MessageSecurityLabel;**  
**REGISTERED AS { MhsAcctObjectIdentifiers.id-attribute-messageSecurityLabel };**

### 12.68 Message Size

This attribute enables to store the size of a message in octets.

**messageSize ATTRIBUTE**  
WITH ATTRIBUTE SYNTAX **MhsAcctAsn1Module.MessageSize;**  
**REGISTERED AS { MhsAcctObjectIdentifiers.id-attribute-messageSize };**

### 12.69 Message Submission Envelope

This attribute enables to store the corresponding parameter of a Message Submission abstract-operation. This attribute may have one of the possible values of a **message-submission-envelope** abstract service parameter defined in ITU-T Rec. X.411 | ISO/IEC 10021-4.

**messageSubmissionEnvelope ATTRIBUTE**

**WITH ATTRIBUTE SYNTAX MhsAcctAsn1Module.MessageSubmissionEnvelope;**

**REGISTERED AS { MhsAcctObjectIdentifiers.id-attribute-messageSubmissionEnvelope };**

### 12.70 Submission Time

This attribute enables to store the corresponding parameter of an MHS abstract-operation. This attribute may have one of the possible values of a **time** abstract service parameter defined in ITU-T Rec. X.411 | ISO/IEC 10021-4.

**submissionTime ATTRIBUTE**

**WITH ATTRIBUTE SYNTAX MhsAcctAsn1Module.Time;**

**REGISTERED AS { MhsAcctObjectIdentifiers.id-attribute-submissionTime};**

### 12.71 Message Token

This attribute enables to store the corresponding parameter of an MHS abstract-operation. This attribute may have one of the possible values of a **message-token** abstract service parameter defined in ITU-T Rec. X.411 | ISO/IEC 10021-4. The use of this attribute, as part of the security Accounting Record, is described in ITU-T Rec. X.464 | ISO/IEC 11588-4.

**messageToken ATTRIBUTE**

**WITH ATTRIBUTE SYNTAX MhsAcctAsn1Module.MessageToken;**

**REGISTERED AS { MhsAcctObjectIdentifiers.id-attribute-messageToken };**

### 12.72 Message Transfer Envelope

This attribute enables to store the corresponding parameter of a Message Transfer abstract-operation. This attribute may have one of the possible values of a **message-Transfer-envelope** abstract service parameter defined in ITU-T Rec. X.411 | ISO/IEC 10021-4.

**messageTransferEnvelope ATTRIBUTE**

**WITH ATTRIBUTE SYNTAX MhsAcctAsn1Module.MessageTransferEnvelope;**

**REGISTERED AS { MhsAcctObjectIdentifiers.id-attribute-messageTransferEnvelope };**

### 12.73 MS-Bind Authentication Check

The use of this attribute, as part of the security Accounting Record, is described in ITU-T Rec. X.464 | ISO/IEC 11588-4.

**msBindAuthenticationCheck ATTRIBUTE**

**WITH ATTRIBUTE SYNTAX MhsAcctAsn1Module.MsBindAuthenticationCheck;**

**REGISTERED AS { MhsAcctObjectIdentifiers.id-attribute-msBindAuthenticationCheck };**

### 12.74 New Credentials

This attribute enables to store the corresponding parameter of a Change Credentials abstract-operation. This attribute may have one of the possible values of a **credentials** abstract service parameter defined in ITU-T Rec. X.411 | ISO/IEC 10021-4. The use of this attribute, as part of the security Accounting Record, is described in ITU-T Rec. X.464 | ISO/IEC 11588-4.

**newCredentials ATTRIBUTE**

**WITH ATTRIBUTE SYNTAX MhsAcctAsn1Module.Credentials;  
MATCHES FOR EQUALITY;**

**REGISTERED AS { MhsAcctObjectIdentifiers.id-attribute-newCredentials };**



**12.75 Number of Addressed PRMDs**

This attribute enables to store the number of PRMDs that received this message directly from this ADMD.

**numberOfAddressedPrmds ATTRIBUTE**  
**WITH ATTRIBUTE SYNTAX MhsAcctAsn1Module.NumberOfAddressedPrmds;**  
**REGISTERED AS { MhsAcctObjectIdentifiers.id-attribute-numberOfAddressedPrmds };**

**12.76 Number of Addressed UAs**

This attribute enables to store the number of UAs that received this message directly from this ADMD.

**numberOfAddressedUas ATTRIBUTE**  
**WITH ATTRIBUTE SYNTAX MhsAcctAsn1Module.NumberOfAddressedUas;**  
**REGISTERED AS { MhsAcctObjectIdentifiers.id-attribute-numberOfAddressedUas };**

**12.77 Number of Messages per Delivery Service Type**

This attribute enables to store, for each delivery service type, the number of messages that were sent to it by this ADMD.

**numberOfMessagesPerDeliveryServiceType ATTRIBUTE**  
**WITH ATTRIBUTE SYNTAX MhsAcctAsn1Module.NumberOfMessagesPerDeliveryServiceType;**  
**REGISTERED AS { MhsAcctObjectIdentifiers.id-attribute-numberOfMessagesPerDeliveryServiceType };**

**12.78 Old Credentials**

This attribute enables to store the corresponding parameter of a Change Credentials abstract-operation. This attribute may have one of the possible values of a **credentials** abstract service parameter defined in ITU-T Rec. X.411 | ISO/IEC 10021-4. The use of this attribute, as part of the security Accounting Record, is described in ITU-T Rec. X.464 | ISO/IEC 11588-4.

**oldCredentials ATTRIBUTE**  
**WITH ATTRIBUTE SYNTAX MhsAcctAsn1Module.Credentials;**  
**MATCHES FOR EQUALITY;**  
**REGISTERED AS { MhsAcctObjectIdentifiers.id-attribute-oldCredentials };**

**12.79 Operation Status**

This attribute indicates if the operation is in progress, has terminated successfully or returned an error code.

**operationStatus ATTRIBUTE**  
**WITH ATTRIBUTE SYNTAX MhsAcctAsn1Module.OperationStatus;**  
**REGISTERED AS { MhsAcctObjectIdentifiers.id-attribute-operationStatus };**

**12.80 Operation Time**

This attribute enables to store the time at which the operation was performed. The use of this attribute, as part of the security Accounting Record is described in ITU-T Rec. X.464 | ISO/IEC 11588-4.

**operationTime ATTRIBUTE**  
**WITH ATTRIBUTE SYNTAX MhsAcctAsn1Module.OperationTime;**  
**REGISTERED AS { MhsAcctObjectIdentifiers.id-attribute-operationTime };**

**12.81 Originating Domain Transfer out List**

This attribute enables to store the MDs that the message was transferred to.

**originatingDomainTransferOutList ATTRIBUTE**  
**WITH ATTRIBUTE SYNTAX MhsAcctAsn1Module.OriginatingDomainTransferOutList;**  
**REGISTERED AS { MhsAcctObjectIdentifiers.id-attribute-originatingDomainTransferOutList };**

### 12.82 Originating Admd

This attribute enables to store the originating ADMD in a settlement record (using Recommendation D.36).

**originatingAdmd ATTRIBUTE**  
**WITH ATTRIBUTE SYNTAX MhsAcctAsn1Module.OriginatingADMD;**  
**REGISTERED AS { MhsAcctObjectIdentifiers.id-attribute-originatingAdmd };**

### 12.83 Originating MTA Certificate

This attribute enables to store the corresponding parameter of an MHS abstract-operation. This attribute may have one of the possible values of an **originating-MTA-certificate** abstract service parameter defined in ITU-T Rec. X.411 | ISO/IEC 10021-4.

**originatingMTACertificate ATTRIBUTE**  
**WITH ATTRIBUTE SYNTAX MhsAcctAsn1Module.OriginatingMTACertificate;**  
**REGISTERED AS { MhsAcctObjectIdentifiers.id-attribute-originatingMTACertificate};**

### 12.84 Originator Certificate

This attribute enables to store the corresponding parameter of an MHS abstract-operation. This attribute may have one of the possible values of an **originating-certificate** abstract service parameter defined in ITU-T Rec. X.411 | ISO/IEC 10021-4. The use of this attribute, as part of the security Accounting Record, is described in ITU-T Rec. X.464 | ISO/IEC 11588-4.

**originatorCertificate ATTRIBUTE**  
**WITH ATTRIBUTE SYNTAX MhsAcctAsn1Module.OriginatorCertificate;**  
**REGISTERED AS { MhsAcctObjectIdentifiers.id-attribute-originatorCertificate };**

### 12.85 Originator Name

This attribute enables to store the corresponding parameter of an MHS abstract-operation. This attribute may have one of the possible values of an **OR-name** abstract service parameter defined in ITU-T Rec. X.411 | ISO/IEC 10021-4.

**originatorName ATTRIBUTE**  
**WITH ATTRIBUTE SYNTAX MhsAcctAsn1Module.OriginatorName;**  
**MATCHES FOR EQUALITY;**  
**REGISTERED AS { MhsAcctObjectIdentifiers.id-attribute-originatorName };**

### 12.86 Permissible Security Context

The use of this attribute, as part of the security Accounting Record, is described in ITU-T Rec. X.464 | ISO/IEC 11588-4.

**permissibleSecurityContext ATTRIBUTE**  
**WITH ATTRIBUTE SYNTAX MhsAcctAsn1Module.PermissibleSecurityContext;**  
**REGISTERED AS { MhsAcctObjectIdentifiers.id-attribute-permissibleSecurityContext };**

### 12.87 Priority

This attribute enables to store the corresponding parameter of an MHS abstract-operation. This attribute may have one of the possible values of a **priority** abstract service parameter defined in ITU-T Rec. X.411 | ISO/IEC 10021-4.

**priority ATTRIBUTE**  
**WITH ATTRIBUTE SYNTAX MhsAcctAsn1Module.Priority;**  
**REGISTERED AS { MhsAcctObjectIdentifiers.id-attribute-priority };**

### 12.88 Probe Origin Authentication Check

The use of this attribute, as part of the security Accounting Record, is described in ITU-T Rec. X.464 | ISO/IEC 11588-4.

**probeOriginAuthenticationCheck ATTRIBUTE**  
**WITH ATTRIBUTE SYNTAX MhsAcctAsn1Module.ProbeOriginAuthenticationCheck;**  
**REGISTERED AS { MhsAcctObjectIdentifiers.id-attribute-probeOriginAuthenticationCheck };**

### 12.89 Probe Submission Envelope

This attribute enables to store the corresponding parameter of a Probe Submission abstract-operation. This attribute may have one of the possible values of a **probe-submission-envelope** abstract service parameter defined in ITU-T Rec. X.411 | ISO/IEC 10021-4.

**probeSubmissionEnvelope ATTRIBUTE**  
 WITH ATTRIBUTE SYNTAX **MhsAcctAsn1Module.ProbeSubmissionEnvelope;**  
**REGISTERED AS { MhsAcctObjectIdentifiers.id-attribute-probeSubmissionEnvelope };**

### 12.90 Probe Transfer Envelope

This attribute enables to store the corresponding parameter of a Probe Transfer abstract-operation. This attribute may have one of the possible values of a **probe-transfer-envelope** abstract service parameter defined in ITU-T Rec. X.411 | ISO/IEC 10021-4.

**probeTransferEnvelope ATTRIBUTE**  
 WITH ATTRIBUTE SYNTAX **MhsAcctAsn1Module.ProbeTransferEnvelope;**  
**REGISTERED AS { MhsAcctObjectIdentifiers.id-attribute-probeTransferEnvelope };**

### 12.91 Processing Component Rate

This attribute enables to store component rate associated to the processing message.

**processingComponentRate ATTRIBUTE**  
 WITH ATTRIBUTE SYNTAX **MhsAcctAsn1Module.ProcessingComponentRate;**  
**REGISTERED AS { MhsAcctObjectIdentifiers.id-attribute-processingComponentRate };**

### 12.92 Processing Details

This attribute enables to store information about the processing that occurred on a message, probe, or report while inside an MTA and which is indicated in the processingSummary attribute.

**processingDetails ATTRIBUTE**  
 WITH ATTRIBUTE SYNTAX **MhsAcctAsn1Module.ProcessingDetails;**  
**REGISTERED AS { MhsAcctObjectIdentifiers.id-attribute-processingDetails };**

### 12.93 Processing Error Flag

This attribute enables to indicate whether the managed object was created following an internal error in the MHS entity.

**processingErrorFlag ATTRIBUTE**  
 WITH ATTRIBUTE SYNTAX **MhsAcctAsn1Module.ProcessingErrorFlag;**  
**REGISTERED AS { MhsAcctObjectIdentifiers.id-attribute-processingErrorFlag };**

### 12.94 Processing Summary

This attribute enables to store the processing that occurred on a message, probe, or report while inside an MTA.

**processingSummary ATTRIBUTE**  
 WITH ATTRIBUTE SYNTAX **MhsAcctAsn1Module.ProcessingSummary;**  
**REGISTERED AS { MhsAcctObjectIdentifiers.id-attribute-processingSummary };**

### 12.95 Proof of Delivery

This attribute enables to store the corresponding parameter of an MHS abstract-operation. This attribute may have one of the possible values of a **proof-of-delivery** abstract service parameter defined in ITU-T Rec. X.411 | ISO/IEC 10021-4. The use of this attribute, as part of the security Accounting Record, is described in ITU-T Rec. X.464 | ISO/IEC 11588-4.

**proofOfDelivery ATTRIBUTE**  
 WITH ATTRIBUTE SYNTAX **MhsAcctAsn1Module.ProofOfDelivery;**  
**REGISTERED AS { MhsAcctObjectIdentifiers.id-attribute-proofOfDelivery };**

### 12.96 Proof of Delivery Request

This attribute enables to store the corresponding parameter of an MHS abstract-operation. This attribute may have one of the possible values of a **proof-of-delivery-request** abstract service parameter defined in ITU-T Rec. X.411 | ISO/IEC 10021-4. The use of this attribute, as part of the security Accounting Record, is described in ITU-T Rec. X.464 | ISO/IEC 11588-4.

**proofOfDeliveryRequest ATTRIBUTE**

**WITH ATTRIBUTE SYNTAX MhsAcctAsn1Module.ProofOfDeliveryRequest;**

**REGISTERED AS { MhsAcctObjectIdentifiers.id-attribute-proofOfDeliveryRequest };**

### 12.97 Proof of Submission

This attribute enables to store the corresponding parameter of an MHS abstract-operation. This attribute may have one of the possible values of a **proof-of-submission** abstract service parameter defined in ITU-T Rec. X.411 | ISO/IEC 10021-4. The use of this attribute, as part of the security Accounting Record, is described in ITU-T Rec. X.464 | ISO/IEC 11588-4.

**proofOfSubmission ATTRIBUTE**

**WITH ATTRIBUTE SYNTAX MhsAcctAsn1Module.ProofOfSubmission;**

**REGISTERED AS { MhsAcctObjectIdentifiers.id-attribute-proofOfSubmission };**

### 12.98 Proof of Submission Request

This attribute enables to store the corresponding parameter of an MHS abstract-operation. This attribute may have one of the possible values of a **proof-of-submission-request** abstract service parameter defined in ITU-T Rec. X.411 | ISO/IEC 10021-4. The use of this attribute, as part of the security Accounting Record, is described in ITU-T Rec. X.464 | ISO/IEC 11588-4.

**proofOfSubmissionRequest ATTRIBUTE**

**WITH ATTRIBUTE SYNTAX MhsAcctAsn1Module.ProofOfSubmissionRequest;**

**REGISTERED AS { MhsAcctObjectIdentifiers.id-attribute-proofOfSubmissionRequest };**

### 12.99 Recipient Certificate

This attribute enables to store the corresponding parameter of an MHS abstract-operation. This attribute may have one of the possible values of a **recipient-certificate** abstract service parameter defined in ITU-T Rec. X.411 | ISO/IEC 10021-4. The use of this attribute, as part of the security Accounting Record, is described in ITU-T Rec. X.464 | ISO/IEC 11588-4.

**recipientCertificate ATTRIBUTE**

**WITH ATTRIBUTE SYNTAX MhsAcctAsn1Module.RecipientCertificate;**

**REGISTERED AS { MhsAcctObjectIdentifiers.id-attribute-recipientCertificate };**

### 12.100 Recipients on Responsibility List

This attribute enables to store the recipients whose perRecipientIndicator responsibility bit is set to “responsible” (see Figure 4 of ITU-T Rec. X.411 | ISO/IEC 10021-4).

**recipientsOnResponsibilityList ATTRIBUTE**

**WITH ATTRIBUTE SYNTAX MhsAcctAsn1Module.RecipientsOnResponsibilityList;**

**REGISTERED AS { MhsAcctObjectIdentifiers.id-attribute-recipientsOnResponsibilityList };**

### 12.101 Register MS Argument

This attribute enables to store the corresponding Register-MS abstract-operation argument. This attribute may have one of the possible values of a **Register-MS-argument** abstract service parameter defined in ITU-T Rec. X.413 | ISO/IEC 10021-5.

**registerMSArgument ATTRIBUTE**

**WITH ATTRIBUTE SYNTAX MhsAcctAsn1Module.Register-MSArgument;**

**REGISTERED AS { MhsAcctObjectIdentifiers.id-attribute-registerMSArgument };**

### 12.102 Register MS Result

This attribute enables to store the corresponding Register-MS abstract-operation result. This attribute may have one of the possible values of a **Register-MS-result** abstract service parameter defined in ITU-T Rec. X.413 | ISO/IEC 10021-5.

**registerMSResult ATTRIBUTE**  
 WITH ATTRIBUTE SYNTAX **MhsAcctAsn1Module.Register-MSResult;**  
**REGISTERED AS { MhsAcctObjectIdentifiers.id-attribute-registerMSResult };**

### 12.103 Report Delivery Envelope

This attribute enables to store the corresponding parameter of a Report Delivery abstract-operation. This attribute may have one of the possible values of a **Report-delivery-envelope** abstract service parameter defined in ITU-T Rec. X.411 | ISO/IEC 10021-4.

**reportDeliveryEnvelope ATTRIBUTE**  
 WITH ATTRIBUTE SYNTAX **MhsAcctAsn1Module.ReportDeliveryEnvelope;**  
**REGISTERED AS { MhsAcctObjectIdentifiers.id-attribute-reportDeliveryEnvelope };**

### 12.104 Report Identifier

This attribute enables to store the corresponding parameter of an MHS abstract-operation. This attribute may have one of the possible values of an **MTS-identifier** abstract service parameter defined in ITU-T Rec. X.411 | ISO/IEC 10021-4.

**reportIdentifier ATTRIBUTE**  
 WITH ATTRIBUTE SYNTAX **MhsAcctAsn1Module.ReportIdentifier;**  
**REGISTERED AS { MhsAcctObjectIdentifiers.id-attribute-reportIdentifier };**

### 12.105 Reporting MTA Certificate

This attribute enables to store the corresponding parameter of an MHS abstract-operation. This attribute may have one of the possible values of a **reporting-MTA-certificate** abstract service parameter defined in ITU-T Rec. X.411 | ISO/IEC-10021-4. The use of this attribute, as part of the security Accounting Record, is described in ITU-T Rec. X.464 | ISO/IEC 11588-4.

**reportingMtaCertificate ATTRIBUTE**  
 WITH ATTRIBUTE SYNTAX **MhsAcctAsn1Module.ReportingMtaCertificate;**  
**REGISTERED AS { MhsAcctObjectIdentifiers.id-attribute-reportingMtaCertificate };**

### 12.106 Report Origin Authentication Check

The use of this attribute, as part of the security Accounting Record, is described in ITU-T Rec. X.464 | ISO/IEC 11588-4.

**reportOriginAuthenticationCheck ATTRIBUTE**  
 WITH ATTRIBUTE SYNTAX **MhsAcctAsn1Module.ReportOriginAuthenticationCheck;**  
**REGISTERED AS { MhsAcctObjectIdentifiers.id-attribute-reportOriginAuthenticationCheck };**

### 12.107 Report Transfer Envelope

This attribute enables to store the corresponding parameter of a Report Transfer abstract-operation. This attribute may have one of the possible values of a **report-transfer-envelope** abstract service parameter defined in ITU-T Rec. X.411 | ISO/IEC 10021-4.

**reportTransferEnvelope ATTRIBUTE**  
 WITH ATTRIBUTE SYNTAX **MhsAcctAsn1Module.ReportTransferEnvelope;**  
**REGISTERED AS { MhsAcctObjectIdentifiers.id-attribute-reportTransferEnvelope };**

### 12.108 Responder Credentials

This attribute enables to store the corresponding parameter of a Bind abstract-operation. This attribute may have one of the possible values of a **credentials** abstract service parameter defined in ITU-T Rec. X.411 | ISO/IEC 10021-4.

**responderCredentials ATTRIBUTE**  
WITH ATTRIBUTE SYNTAX **MhsAcctAsn1Module.ResponderCredentials;**  
**REGISTERED AS { MhsAcctObjectIdentifiers.id-attribute-responderCredentials };**

### 12.109 Responder Name

This attribute enables to store the corresponding parameter of a Bind abstract-operation. This attribute may have one of the possible values of an **OR-name** abstract service parameter defined in ITU-T Rec. X.411 | ISO/IEC 10021-4.

**responderName ATTRIBUTE**  
WITH ATTRIBUTE SYNTAX **MhsAcctAsn1Module.ObjectName;**  
**REGISTERED AS { MhsAcctObjectIdentifiers.id-attribute-responderName };**

### 12.110 Retrieval Error

This attribute enables to store an error occurring at the retrieval port.

**retrievalError ATTRIBUTE**  
WITH ATTRIBUTE SYNTAX **MhsAcctAsn1Module.RetrievalError;**  
**PARAMETERS**  
attributeError,  
autoActionRequestError,  
deleteError,  
fetchRestrictionError,  
rangeError,  
sequenceNumberError,  
serviceError;  
**REGISTERED AS { MhsAcctObjectIdentifiers.id-attribute-retrievalError };**

### 12.111 Security Context

This attribute enables to store the corresponding parameter of a Bind abstract-operation. This attribute may have one of the possible values of a **security-context** abstract service parameter defined in ITU-T Rec. X.411 | ISO/IEC 10021-4. The use of this attribute, as part of the security Accounting Record, is described in ITU-T Rec. X.464 | ISO/IEC 11588-4.

**securityContext ATTRIBUTE**  
WITH ATTRIBUTE SYNTAX **MhsAcctAsn1Module.SecurityContext;**  
**REGISTERED AS { MhsAcctObjectIdentifiers.id-attribute-securityContext };**

### 12.112 Security Error

This attribute enables to store a security error. The use of this attribute, as part of the security Accounting Record, is described in ITU-T Rec. X.464 | ISO/IEC 11588-4.

**securityError ATTRIBUTE**  
WITH ATTRIBUTE SYNTAX **MhsAcctAsn1Module.SecurityError;**  
**REGISTERED AS { MhsAcctObjectIdentifiers.id-attribute-securityError };**

### 12.113 Security Problem

This attribute enables to store the corresponding parameter of a Bind abstract-operation. This attribute may have one of the possible values of a **security-problem** abstract service parameter defined in ITU-T Rec. X.411 | ISO/IEC 10021-4. The use of this attribute, as part of the security Accounting Record, is described in ITU-T Rec. X.464 | ISO/IEC 11588-4.

**securityProblem ATTRIBUTE**  
WITH ATTRIBUTE SYNTAX **MhsAcctAsn1Module.SecurityProblem;**  
**REGISTERED AS { MhsAcctObjectIdentifiers.id-attribute-securityProblem };**

**12.114 Service Access Charge**

This attribute enables to store the cost of accessing the MTS service.

**serviceAccessCharge ATTRIBUTE**  
**WITH ATTRIBUTE SYNTAX MhsAcctAsn1Module.ServiceAccessCharge;**  
**REGISTERED AS { MhsAcctObjectIdentifiers.id-attribute-serviceAccessCharge };**

**12.115 Service Flag**

This attribute enables to tell whether this message is a service message (no charge) or not.

**serviceFlag ATTRIBUTE**  
**WITH ATTRIBUTE SYNTAX MhsAcctAsn1Module.ServiceFlag;**  
**REGISTERED AS { MhsAcctObjectIdentifiers.id-attribute-serviceFlag };**

**12.116 Service Request ID**

This attribute enables to identify a ServiceRequest managed object instance within the containment hierarchy.

**serviceRequestId ATTRIBUTE**  
**WITH ATTRIBUTE SYNTAX MhsAcctAsn1Module.ServiceRequestId;**  
**REGISTERED AS { MhsAcctObjectIdentifiers.id-attribute-serviceRequestId };**

**12.117 Settlement Policy**

This attribute enables to store the Settlement policy enforced in the MIS management domain.

**settlementPolicy ATTRIBUTE**  
**WITH ATTRIBUTE SYNTAX MhsAcctAsn1Module.SettlementPolicy;**  
**REGISTERED AS { MhsAcctObjectIdentifiers.id-attribute-settlementPolicy };**

**12.118 Signature Check**

The use of this attribute, as part of the security Accounting Record, is described in ITU-T Rec. X.464 | ISO/IEC 11588-4.

**signatureCheck ATTRIBUTE**  
**WITH ATTRIBUTE SYNTAX MhsAcctAsn1Module.SignatureCheck;**  
**REGISTERED AS { MhsAcctObjectIdentifiers.id-attribute-signatureCheck };**

**12.119 Signature Generation**

The use of this attribute, as part of the security Accounting Record, is described in ITU-T Rec. X.464 | ISO/IEC 11588-4.

**signatureGeneration ATTRIBUTE**  
**WITH ATTRIBUTE SYNTAX MhsAcctAsn1Module.SignatureGeneration;**  
**REGISTERED AS { MhsAcctObjectIdentifiers.id-attribute-signatureGeneration };**

**12.120 Start-Up Date**

This attribute enables to store the date and time since which a service has been working without interruption.

**startUpDate ATTRIBUTE**  
**WITH ATTRIBUTE SYNTAX MhsAcctAsn1Module.StartUpDate;**  
**REGISTERED AS { MhsAcctObjectIdentifiers.id-attribute-startUpDate };**

**12.121 Status**

This attribute enables to store the status of a Service request in progress.

**status ATTRIBUTE**  
**WITH ATTRIBUTE SYNTAX MhsAcctAsn1Module.Status;**  
**REGISTERED AS { MhsAcctObjectIdentifiers.id-attribute-status };**

### 12.122 Subject Identifier

This attribute enables to store the corresponding parameter of an MHS abstract-operation. This attribute may have one of the possible values of an **MTS-Identifier** abstract service parameter defined in ITU-T Rec. X.411 | ISO/IEC 10021-4.

**subjectIdentifier** ATTRIBUTE

WITH ATTRIBUTE SYNTAX **MhsAcctAsn1Module.SubjectIdentifier**;  
MATCHES FOR EQUALITY;

REGISTERED AS { **MhsAcctObjectIdentifiers.id-attribute-subjectIdentifier** };

### 12.123 Subject Submission Identifier

This attribute enables to store the corresponding parameter of an MHS abstract-operation. This attribute may have one of the possible values of an **MTS-Identifier** abstract service parameter defined in ITU-T Rec. X.411 | ISO/IEC 10021-4.

**subjectSubmissionIdentifier** ATTRIBUTE

WITH ATTRIBUTE SYNTAX **MhsAcctAsn1Module.SubjectSubmissionIdentifier**;  
MATCHES FOR EQUALITY;

REGISTERED AS { **MhsAcctObjectIdentifiers.id-attribute-subjectSubmissionIdentifier** };

### 12.124 Submission Controls

This attribute enables to store the corresponding Submission control abstract-operation parameter. This attribute may have one of the possible values of a **submission-Controls** abstract service parameter defined in ITU-T Rec. X.413 | ISO/IEC 10021-5.

**submissionControls** ATTRIBUTE

WITH ATTRIBUTE SYNTAX **MhsAcctAsn1Module.SubmissionControls**;

REGISTERED AS { **MhsAcctObjectIdentifiers.id-attribute-submissionControls** };

### 12.125 Submission Error

This attribute enables to store an error occurring at the submission port.

**submissionError** ATTRIBUTE

WITH ATTRIBUTE SYNTAX **MhsAcctAsn1Module.SubmissionError**;  
PARAMETERS  
**improperlySpecifiedRecipients**,  
**securityError**;

REGISTERED AS { **MhsAcctObjectIdentifiers.id-attribute-submissionError** };

### 12.126 Summarize Argument

This attribute enables to store the corresponding Summarize abstract-operation argument. This attribute may have one of the possible values of a **summarize-argument** abstract service parameter defined in ITU-T Rec. X.413 | ISO/IEC 10021-5.

**summarizeArgument** ATTRIBUTE

WITH ATTRIBUTE SYNTAX **MhsAcctAsn1Module.SummarizeArgument**;

REGISTERED AS { **MhsAcctObjectIdentifiers.id-attribute-summarizeArgument** };

### 12.127 Summarize Result

This attribute enables to store the corresponding Summarize abstract-operation result. This attribute may have one of the possible values of a **summarize-result** abstract service parameter defined in ITU-T Rec. X.413 | ISO/IEC 10021-5.

**summarizeResult** ATTRIBUTE

WITH ATTRIBUTE SYNTAX **MhsAcctAsn1Module.SummarizeResult**;

REGISTERED AS { **MhsAcctObjectIdentifiers.id-attribute-summarizeResult** };



**12.128 Supplier of Operation**

This attribute enables to store the identification of the supplier of an operation.

**supplierOfOperation ATTRIBUTE**  
**WITH ATTRIBUTE SYNTAX MhsAcctAsn1Module.ObjectInstance;**  
**REGISTERED AS { MhsAcctObjectIdentifiers.id-attribute-supplierOfOperation };**

**12.129 Telephone Number List**

This attribute enables to store the telephone numbers associated with the contact represented by a Contact managed object instance.

**telephoneNumberList ATTRIBUTE**  
**WITH ATTRIBUTE SYNTAX MhsAcctAsn1Module.TelephoneNumberList;**  
**REGISTERED AS { MhsAcctObjectIdentifiers.id-attribute-telephoneNumberList };**

**12.130 This Recipient Name**

This attribute enables to store the corresponding parameter of an MHS abstract-operation. This attribute may have one of the possible values of an **OR-Name** abstract service parameter defined in ITU-T Rec. X.411 | ISO/IEC 10021-4.

**thisRecipientName ATTRIBUTE**  
**WITH ATTRIBUTE SYNTAX MhsAcctAsn1Module.ThisRecipientName;**  
**REGISTERED AS { MhsAcctObjectIdentifiers.id-attribute-thisRecipientName };**

**12.131 Total Number of O/R Addresses**

This attribute enables to store the total number of O/R addresses contained in the message. This attribute is used for settlement purposes as outlined in Recommendation D.36.

**totalNumberOfORAddresses ATTRIBUTE**  
**WITH ATTRIBUTE SYNTAX MhsAcctAsn1Module.TotalNumberOfORAddresses;**  
**REGISTERED AS { MhsAcctObjectIdentifiers.id-attribute-totalNumberOfORAddresses };**

**12.132 Trace**

This attribute enables for security audit purposes. The reader is referred to ITU-T Rec. X.464 | ISO/IEC 11588-4.

**trace ATTRIBUTE**  
**WITH ATTRIBUTE SYNTAX MhsAcctAsn1Module.Trace;**  
**REGISTERED AS { MhsAcctObjectIdentifiers.id-attribute-trace };**

**12.133 Transit Domain Transfer out List**

This attribute enables to store the MDs that the message was transferred to.

**transitDomainTransferOutList ATTRIBUTE**  
**WITH ATTRIBUTE SYNTAX MhsAcctAsn1Module.TransitDomainTransferOutList;**  
**REGISTERED AS { MhsAcctObjectIdentifiers.id-attribute-transitDomainTransferOutList };**

**12.134 User Address**

This attribute enables to store the corresponding parameter of a change credentials abstract-operation. This attribute may have one of the possible values of a **user-address** abstract service parameter defined in ITU-T Rec. X.411 | ISO/IEC 10021-4.

**userAddress ATTRIBUTE**  
**WITH ATTRIBUTE SYNTAX MhsAcctAsn1Module.UserAddress;**  
**REGISTERED AS { MhsAcctObjectIdentifiers.id-attribute-userAddress };**

### 12.135 User Name

This attribute enables to store the corresponding parameter of a change credentials abstract-operation. This attribute may have one of the possible values of an **ORName** abstract service parameter defined in ITU-T Rec. X.411 | ISO/IEC 10021-4.

**userName ATTRIBUTE**

**WITH ATTRIBUTE SYNTAX MhsAcctAsn1Module.UserName;**

**REGISTERED AS { MhsAcctObjectIdentifiers.id-attribute-userName };**

### 12.136 User Security Label

This attribute enables to store the corresponding parameter of a Bind abstract-operation. This attribute may have one of the possible values of a **security-label** abstract service parameter defined in ITU-T Rec. X.411 | ISO/IEC 10021-4. The use of this attribute, as part of the security Accounting Record, is described in ITU-T Rec. X.464 | ISO/IEC 11588-4.

**userSecurityLabel ATTRIBUTE**

**WITH ATTRIBUTE SYNTAX MhsAcctAsn1Module.UserSecurityLabel;**

**REGISTERED AS { MhsAcctObjectIdentifiers.id-attribute-userSecurityLabel };**

## 13 Definition of attribute groups

No attribute groups are defined for accounting management functions.

## 14 Definition of Notifications

### 14.1 objectCreation

This notification is sent whenever a managed object containing the commonCreationDeletionPackage is created.

**objectCreation NOTIFICATION**

**BEHAVIOUR objectCreationBehaviour;**

**WITH INFORMATION SYNTAX MhsAcctAsn1Module.CommonCreationAndDeletionInfo;**

**REGISTERED AS { MhsAcctObjectIdentifiers.id-notification-objectCreation };**

**objectCreationBehaviour BEHAVIOUR**

**DEFINED AS**

**"Generated whenever an instance of the class is created.**

**If creation occurred as a result of internal operation, the value 'resourceOperation' shall be used. If creation occurred in response to a management operation, the value 'managementOperation' shall be used. A value of 'unknown' shall be used if it is not possible to determine the source of the operation. No other optional parameter shall be used."**;

### 14.2 objectDeletion

This notification is sent whenever a managed object containing the commonCreateionDeletionPackage is deleted.

**objectDeletion NOTIFICATION**

**BEHAVIOUR objectDeletionBehaviour;**

**WITH INFORMATION SYNTAX MhxAcctAsn1Module.CommonCreationAndDeletionInfo;**

**REGISTERED AS { MhsAcctObjectIdentifiers.id-notification-objectDeletion };**

**objectDeletionBehaviour BEHAVIOUR**

**DEFINED AS**

**"Generated whenever an instance of the class is deleted.**

**If deletion occurred as a result of internal operation, the value 'resourceOperation' shall be used. If deletion occurred in response to a management operation, the value 'managementOperation' shall be used. A value of 'unknown' shall be used if it is not possible to determine the source of the operation. No other optional parameters shall be used."**;

## 15 Definition of actions

No actions are defined for accounting management functions.

## 16 Definition of parameters

This clause describes the error parameters associated with the `bindingError` attribute of the `commonBindArgumentPackage`. At the time of writing, the `CONTEXT` construct of each parameter cannot be specified as the referenced notifications were not specified using GDMO.

### 16.1 `attributeError`

The parameter addresses the `Attribute-Error` error returned by some MHS abstract operations.

```
attributeError PARAMETER
  CONTEXT SPECIFIC-ERROR;
  WITH SYNTAX MhsAcctAsn1Module.AttributeError;
  BEHAVIOUR attributeErrorBehaviour;
REGISTERED AS { MhsAcctObjectIdentifiers.id-parameter-attributeError };
```

```
attributeErrorBehaviour BEHAVIOUR
  DEFINED AS
```

```
"The value of the parameter is only pertinent if the parameter is associated with a retrievalError
attribute that has a value referencing the attribute-error abstract error defined in ITU-T Rec. X.413 |
ISO/IEC 10021-5";
```

### 16.2 `autoActionRequestError`

The parameter addresses the `Auto-Action-Request-Error` error returned by some MHS abstract operations.

```
autoActionRequestError PARAMETER
  CONTEXT SPECIFIC-ERROR;
  WITH SYNTAX MhsAcctAsn1Module.AutoActionRequestError;
  BEHAVIOUR autoActionRequestBehaviour;
REGISTERED AS { MhsAcctObjectIdentifiers.id-parameter-autoActionRequestError };
```

```
autoActionRequestBehaviour BEHAVIOUR
  DEFINED AS
```

```
"The value of the parameter is only pertinent if the parameter is associated with a retrievalError attribute
that has a value referencing the auto-action-request-error abstract error defined in ITU-T Rec. X.413 |
ISO/IEC 10021-5";
```

### 16.3 `deleteError`

The parameter addresses the `Delete-Error` error returned by some MHS abstract operations.

```
deleteError PARAMETER
  CONTEXT SPECIFIC-ERROR;
  WITH SYNTAX MhsAcctAsn1Module.DeleteError;
  BEHAVIOUR deleteErrorBehaviour;
REGISTERED AS { MhsAcctObjectIdentifiers.id-parameter-deleteError };
```

```
deleteErrorBehaviour BEHAVIOUR
  DEFINED AS
```

```
"The value of the parameter is only pertinent if the parameter is associated with a retrievalError attribute
that has a value referencing the delete-error abstract error defined in ITU-T Rec. X.413 | ISO/IEC 10021-5";
```

### 16.4 `fetchRestrictionError`

The parameter addresses the `Fetch-Restriction-Error` error returned by some MHS abstract operations.

```
fetchRestrictionError PARAMETER
  CONTEXT SPECIFIC-ERROR;
  WITH SYNTAX MhsAcctAsn1Module.FetchRestrictionError;
  BEHAVIOUR fetchRestrictionErrorBehaviour;
REGISTERED AS { MhsAcctObjectIdentifiers.id-parameter-fetchRestrictionError };
```

**fetchRestrictionErrorBehaviour BEHAVIOUR**

**DEFINED AS**

"The value of the parameter is only pertinent if the parameter is associated with a retrievalError attribute that has a value referencing the fetch-restriction-error abstract error defined in ITU-T Rec. X.413 | ISO/IEC 10021-5";

**16.5 improperlySpecifiedRecipients**

The parameter addresses the Improperly-Specified-Recipients error returned by some MHS abstract operations.

**improperlySpecifiedRecipients PARAMETER**

**CONTEXT SPECIFIC-ERROR;**

**WITH SYNTAX MhsAcctAsn1Module.ImproperlySpecifiedRecipients;**

**BEHAVIOUR improperlySpecifiedRecipientsBehaviour;**

**REGISTERED AS { MhsAcctObjectIdentifiers.id-parameter-improperlySpecifiedRecipients };**

**improperlySpecifiedRecipientsBehaviour BEHAVIOUR**

**DEFINED AS**

"The value of the parameter is only pertinent if the parameter is associated with a submissionError attribute that has a value referencing the recipient-improperly-specified abstract error defined in ITU-T Rec. X.411 | ISO/IEC 10021-4";

**16.6 rangeError**

The parameter addresses the Range-Error error returned by some MHS abstract operations.

**rangeError PARAMETER**

**CONTEXT SPECIFIC-ERROR;**

**WITH SYNTAX MhsAcctAsn1Module.RangeError;**

**BEHAVIOUR rangeErrorBehaviour;**

**REGISTERED AS { MhsAcctObjectIdentifiers.id-parameter-rangeError };**

**rangeErrorBehaviour BEHAVIOUR**

**DEFINED AS**

"The value of the parameter is only pertinent if the parameter is associated with a retrievalError attribute that has a value referencing the range-error abstract error defined in ITU-T Rec. X.413 | ISO/IEC 10021-5";

**16.7 securityError**

The parameter addresses the Security-Error error returned by some MHS abstract operations.

**securityError PARAMETER**

**CONTEXT SPECIFIC-ERROR;**

**WITH SYNTAX MhsAcctAsn1Module.SecurityProblem;**

**BEHAVIOUR securityErrorBehaviour;**

**REGISTERED AS { MhsAcctObjectIdentifiers.id-parameter-securityError };**

**securityErrorBehaviour BEHAVIOUR**

**DEFINED AS**

"The value of the parameter is only pertinent if the parameter is associated with a submissionError or deliveryError attribute that has a value referencing the security-error abstract error defined in ITU-T Rec. X.411 | ISO/IEC 10021-4";

**16.8 sequenceNumberError**

The parameter addresses the Sequence-Number-Error error returned by some MHS abstract operations.

**sequenceNumberError PARAMETER**

**CONTEXT SPECIFIC-ERROR;**

**WITH SYNTAX MhsAcctAsn1Module.SequenceNumberError;**

**BEHAVIOUR sequenceNumberErrorBehaviour;**

**REGISTERED AS { MhsAcctObjectIdentifiers.id-parameter-sequenceNumberError };**

**sequenceNumberErrorBehaviour BEHAVIOUR**

**DEFINED AS**

"The value of the parameter is only pertinent if the parameter is associated with a retrievalError attribute that has a value referencing the sequence-number-error abstract error defined in ITU-T Rec. X.413 | ISO/IEC 10021-5";

## 16.9 serviceError

The parameter addresses the Service-Error error returned by some MHS abstract operations.

### serviceError PARAMETER

CONTEXT SPECIFIC-ERROR;  
WITH SYNTAX MhsAcctAsn1Module.ServiceError;  
BEHAVIOUR serviceErrorBehaviour;

REGISTERED AS { MhsAcctObjectIdentifiers.id-parameter-serviceError };

### serviceErrorBehaviour BEHAVIOUR

#### DEFINED AS

"The value of the parameter is only pertinent if the parameter is associated with a retrievalError attribute that has a value referencing the service-error abstract error defined in ITU-T Rec. X.413 | ISO/IEC 10021-5";

## 17 Name bindings

This clause formalizes the naming hierarchy outlined in 8.1.

### NOTES

1 The record-log relationships are already covered by the logRecord-log name binding defined in 7.3 of ITU-T Rec. X.721 | ISO/IEC 10165-2.

2 The log-system relationships are already covered by the log-system name binding defined in 7.2 of ITU-T Rec. X.721 | ISO/IEC 10165-2.

### 17.1 acctRequest-customer

This template formalizes the relationship between the customer and the acctRequest managed objects.

#### acctRequest-customer NAME BINDING

SUBORDINATE OBJECT CLASS acctRequest;  
NAMED BY SUPERIOR OBJECT CLASS customer;  
WITH ATTRIBUTE serviceRequestId;  
CREATE WITH-REFERENCE-OBJECT;  
DELETE ONLY-IF-NO-CONTAINED-OBJECTS;

REGISTERED AS { MhsAcctObjectIdentifiers.id-name-binding-acctRequest-customer };

### 17.2 acctRequest-interworkingMD

#### acctRequest-interworkingMD NAME BINDING

SUBORDINATE OBJECT CLASS acctRequest;  
NAMED BY SUPERIOR OBJECT CLASS interworkingMD;  
WITH ATTRIBUTE serviceRequestId;  
CREATE WITH-REFERENCE-OBJECT;  
DELETE ONLY-IF-NO-CONTAINED-OBJECTS;

REGISTERED AS { MhsAcctObjectIdentifiers.id-name-binding-acctRequest-interworkingMD };

### 17.3 contact-customer

This template formalizes the relationship between the customer and the contact managed objects.

#### contact-customer NAME BINDING

SUBORDINATE OBJECT CLASS contact;  
NAMED BY SUPERIOR OBJECT CLASS customer;  
WITH ATTRIBUTE contactId;  
CREATE WITH-REFERENCE-OBJECT;  
DELETE ONLY-IF-NO-CONTAINED-OBJECTS;

REGISTERED AS { MhsAcctObjectIdentifiers.id-name-binding-contact-customer };

#### 17.4 contact-interworkingMD

This template formalizes the relationship between the interworkingMD and the contact managed objects.

```
contact-interworkingMD NAME BINDING
    SUBORDINATE OBJECT CLASS contact;
    NAMED BY SUPERIOR OBJECT CLASS interworkingMD;
    WITH ATTRIBUTE contactId;
    CREATE WITH-REFERENCE-OBJECT;
    DELETE ONLY-IF-NO-CONTAINED-OBJECTS;
REGISTERED AS { MhsAcctObjectIdentifiers.id-name-binding-contact-interworkingMD };
```

#### 17.5 customer-mdServiceManagementPointOfAccess

This template formalizes the relationship between the mdServiceManagementPointOfAccess and the managed objects.

```
customer-mdServiceManagementPointOfAccess NAME BINDING
    SUBORDINATE OBJECT CLASS customer;
    NAMED BY SUPERIOR OBJECT CLASS mdServiceManagementPointOfAccess;
    WITH ATTRIBUTE customerId;
    CREATE WITH-REFERENCE-OBJECT;
    DELETE ONLY-IF-NO-CONTAINED-OBJECTS;
REGISTERED AS { MhsAcctObjectIdentifiers.id-name-binding-customer-mdServiceManagementPointOfAccess };
```

#### 17.6 customerAcctLog-customer

This template formalizes the relationship between the customer and the customerAcctLog managed objects.

```
customerAcctLog-customer NAME BINDING
    SUBORDINATE OBJECT CLASS customerAcctLog AND SUBCLASSES;
    NAMED BY SUPERIOR OBJECT CLASS customer;
    WITH ATTRIBUTE "Rec. X.721 | ISO/IEC 10165-2":logId;
    CREATE WITH-REFERENCE-OBJECT;
    DELETE ONLY-IF-NO-CONTAINED-OBJECTS;
REGISTERED AS { MhsAcctObjectIdentifiers.id-name-binding-customerAcctLog-customer };
```

#### 17.7 customerEFD-customer

This template formalizes the relationship between the customer and the customerEFD managed objects.

```
customerEFD-customer NAME BINDING
    SUBORDINATE OBJECT CLASS customerEFD;
    NAMED BY SUPERIOR OBJECT CLASS customer;
    WITH ATTRIBUTE "Rec. X.721 | ISO/IEC 10165-2":discriminator;
    CREATE WITH-REFERENCE-OBJECT;
    DELETE ONLY-IF-NO-CONTAINED-OBJECTS;
REGISTERED AS { MhsAcctObjectIdentifiers.id-name-binding-customerEFD-customer };
```

#### 17.8 interworkingMD-EFD-interworkingMD

This template formalizes the relationship between the interworkingMD and the interworkingMD-EFD managed objects.

```
interworkingMD-EFD-interworkingMD NAME BINDING
    SUBORDINATE OBJECT CLASS interworkingMD-EFD;
    NAMED BY SUPERIOR OBJECT CLASS interworkingMD;
    WITH ATTRIBUTE "Rec. X.721 | ISO/IEC 10165-2":discriminator;
    CREATE WITH-REFERENCE-OBJECT;
    DELETE ONLY-IF-NO-CONTAINED-OBJECTS;
REGISTERED AS { MhsAcctObjectIdentifiers.id-name-binding-interworkingMD-EFD-interworkingMD };
```

**17.9 interworkingMD-mdServiceManagementPointOfAccess**

This template formalizes the relationship between the mdServiceManagementPointOfAccess and the interworkingMD managed objects.

**interworkingMD-mdServiceManagementPointOfAccess NAME BINDING**

**SUBORDINATE OBJECT CLASS interworkingMD;**  
**NAMED BY SUPERIOR OBJECT CLASS mdServiceManagementPointOfAccess;**  
**WITH ATTRIBUTE interworkingMId;**  
**CREATE WITH-REFERENCE-OBJECT;**  
**DELETE ONLY-IF-NO-CONTAINED-OBJECTS;**

**REGISTERED AS { MhsAcctObjectIdentifiers.id-name-binding-interworkingMD-mdServiceManagementPointOfAccess };**

**17.10 mdServiceManagementPointOfAccess-misManagementDomain**

This template formalizes the relationship between the mhsEventLog and the maseEventRecord managed objects.

**mdServiceManagementPointOfAccess-md NAME BINDING**

**SUBORDINATE OBJECT CLASS mdServiceManagementPointOfAccess;**  
**NAMED BY SUPERIOR OBJECT CLASS md;**  
**WITH ATTRIBUTE "Rec. M.3100":networkId;**  
**CREATE WITH-REFERENCE-OBJECT;**  
**DELETE ONLY-IF-NO-CONTAINED-OBJECTS;**

**REGISTERED AS { MhsAcctObjectIdentifiers.id-name-binding-mdServiceManagementPointOfAccess-misManagementDomain };**

**17.11 settlementAcctLog-interworkingMD**

This template formalizes the relationship between the interworkingMD and the settlementAcctLog managed objects.

**settlementAcctLog-interworkingMD NAME BINDING**

**SUBORDINATE OBJECT CLASS settlementAcctLog AND SUBCLASSES;**  
**NAMED BY SUPERIOR OBJECT CLASS interworkingMD;**  
**WITH ATTRIBUTE "Rec. X.721 | ISO/IEC 10165-2":logId;**  
**CREATE WITH-REFERENCE-OBJECT;**  
**DELETE ONLY-IF-NO-CONTAINED-OBJECTS;**

**REGISTERED AS { MhsAcctObjectIdentifiers.id-name-binding-settlementAcctLog-interworkingMD };**

**SECTION 4 – CONFORMANCE STATEMENTS****18 Conformance statements**

There are three conformance classes:

- the basic MHS logging class;
- the conditional MHS Logging class; and
- the optional MHS logging class.

A system claiming conformance to this Recommendation | Standard shall comply with the requirements of the basic MHS logging conformance class and may additionally comply with one or more other classes. Table 13 provides a summary of conformance classes.

**Table 13 – Conformance classes and optional functions**

Conformance class	Functions	Status	Managed objects
Basic MHS logging conformance class	MHS Error Events logging	M	mta, ua, ms, au, mhsEventLog, bindEventRecord, discardEventRecord, maseEventRecord, mdseEventRecord, mrseEventRecord, msseEventRecord
Conditional MHS logging conformance class	MHS Security Events logging	C	securityAcctRecord
Optional MHS logging conformance class	MHS Events Attributes logging	O	bindEventRecord, maseEventRecord, mdseEventRecord, mtseEventRecord, mrseEventRecord, msseEventRecord
	MHS Events Attributes and Envelopes logging	O	bindEventRecord, maseEventRecord, mdseEventRecord, mtseEventRecord, mrseEventRecord, msseEventRecord
	Customer Account logging	O	mdServiceManagementPointOf Access, customer, customerAcctLog, customerAcctRecord
	Settlement logging	O	mdServiceManagementPointOf Access, interworkingMD, settlementAcctLog, settlementAcctRecord
	Customer Account Request	O	mdServiceManagementPointOf Access, customer, customerEFD, acctRequest
	Settlement Account Request	O	mdServiceManagementPointOf Access, interworkingMD, interworkingMD-EFD, acctRequest
M Mandatory O Optional			

**18.1 Statement requirements**

The following shall be stated when claiming conformance:

- a) the optional MHS Logging functions for which conformance is claimed;
- b) the OSI management application-context for which conformance is claimed.

**18.2 Basic MHS logging conformance class**

A system claiming conformance to the Basic MHS logging conformance class shall support the system management function for the logging of MHS Error events. These error events and the clause numbers in which the corresponding MHS Event Records are defined are listed in Table 12b.



**18.2.1 Static conformance**

A system shall:

- a) support the managed objects classes which correspond to the MHS entity type (UA, MS, MTA, UA or any combination) for which conformance is claimed;
- b) support the MHSEventLog managed object class;
- c) support the MHSEventRecord managed objects classes listed in the rows of Table 12b which correspond to the MHS entity (UA, MS, MTA, UA or any combination) for which conformance is claimed;
- d) support the role of manager or agent or both, with respect to this MHS Logging Information.

**18.3 Conditional MHS logging conformance class**

Support for the securityAcct record managed object class shall be mandatory if the system claims to support this (Recommendation | International Standard) and claims to support the MHS security function defined in ITU-T Rec. X.411 | ISO/IEC 10021-4.

**18.3.1 MHS Security Events logging function**

A system claiming conformance to the MHS Security Events logging function shall support the system management function for the logging of MHS security events.

**18.3.1.1 Static conformance**

A system shall:

- a) support the securityAcctRecord managed object class;
- b) support the role of manager or agent or both, with respect to this MHS Logging Information.

**18.4 Optional MHS logging conformance class**

A system claiming conformance to Optional MHS logging conformance class shall state to which optional function conformance is claimed.

**18.4.1 MHS Events Attributes logging function**

A system claiming conformance to the MHS Events Attributes logging function shall support the system management function for the logging of MHS events attributes. These events and the clause numbers in which the corresponding MHS Event Records are defined are listed in Table 12a.

**18.4.1.1 Static conformance**

A system shall:

- a) support the mandatory packages of MHSEventRecord managed objects classes listed in the rows of Table 12a which correspond to the MHS entity (UA, MS, MTA, UA or any combination) for which conformance is claimed;
- b) support the role of manager or agent or both, with respect to this MHS Logging Information.

**18.4.2 MHS Events Attributes and envelopes logging function**

A system claiming conformance to the MHS Events Attributes and envelopes logging function shall support the system management function for the logging of MHS events attributes and MHS events optional envelopes. These events and the clause numbers in which the corresponding MHS Event Records are defined are listed in Table 12a.

**18.4.2.1 Static conformance**

A system shall:

- a) support the MHS Events Attributes logging function;
- b) support the optional envelope packages of the MHSEventRecord managed objects classes listed in the rows of Table 12b which correspond to the MHS entity (UA, MS, MTA, UA or any combination) for which conformance is claimed;
- c) support the role of manager or agent or both, with respect to this MHS Logging Information.

### 18.4.3 Customer Account logging function

A system claiming conformance to the Customer Account logging function shall support the system management function for the logging of Customer Accounting information.

#### 18.4.3.1 Static conformance

A system shall:

- a) support the mdServiceManagementPointOfAccess, customer, customerAcctLog, customerAcctRecord managed objects classes;
- b) support the role of manager or agent or both, with respect to this MHS Logging Information.

### 18.4.4 Settlement logging function

A system claiming conformance to the Settlement logging function shall support the system management function for the logging of Settlement information.

#### 18.4.4.1 Static conformance

A system shall:

- a) support the mdServiceManagementPointOfAccess, interworkingMD, settlementAcctLog, settlementAcctRecord managed objects classes;
- b) support the role of manager or agent or both, with respect to this MHS Logging Information.

### 18.4.5 Customer account request function

A system claiming conformance to the Customer account request function shall support the system management function for this service request.

#### 18.4.5.1 Static conformance

A system shall:

- a) support the mdServiceManagementPointOfAccess, customer, customerEFD, acctRequest managed objects classes;
- b) support the role of manager or agent or both, with respect to this MHS Logging Information.

### 18.4.6 Settlement account request function

A system claiming conformance to the Settlement account request function shall support the system management function for this service request.

#### 18.4.6.1 Static conformance

A system shall:

- a) support the mdServiceManagementPointOfAccess, interworkingMD, interworkingMD-EFD, acctRequest managed objects classes;
- b) support the role of manager or agent or both, with respect to this MHS Logging Information.

## Annex A

## ASN.1 definitions

(This annex forms an integral part of this Recommendation | International Standard)

## A.1 ObjectIdentifiers

This subclause contains the ASN.1 module that defines the object identifiers referenced by the “REGISTERED AS” statements of the GDMO templates in clauses 10 to 17.

```
MhsAcctObjectIdentifiers {
    joint-iso-itu-t
    mhs (6)
    management (9)
    accounting (3)
    modules (8)
    object-identifiers ( 0 ) }
```

DEFINITIONS IMPLICIT TAGS ::=

BEGIN

*-- Prologue**-- EXPORTS everything*IMPORTS *-- nothing -- ;*

ID ::= OBJECT IDENTIFIER

*-- MHS management (definitive)*mhs-management ID ::= { joint-iso-itu-t mhs (6) management (9) } *-- this is definitive**-- Document IDs*

id-model	ID ::= {mhs-management 1}	<i>-- Model And Architecture</i>
id-information	ID ::= {mhs-management 2}	<i>-- Information</i>
id-accounting	ID ::= {mhs-management 3}	<i>-- Accounting Manag. Func.</i>
id-security	ID ::= {mhs-management 4}	<i>-- Security Manag. Func.</i>
id-configuration	ID ::= {mhs-management 5}	<i>-- Configuration Manag. Func.</i>
id-fault	ID ::= {mhs-management 6}	<i>-- Fault Manag. Func.</i>
id-performance	ID ::= {mhs-management 7}	<i>-- Performance Manag. Func.</i>
id-mta	ID ::= {mhs-management 8}	<i>-- MTA Entity</i>
id-ua	ID ::= {mhs-management 9}	<i>-- UA Entity</i>
id-ms	ID ::= {mhs-management 10}	<i>-- MS Entity</i>
id-au	ID ::= {mhs-management 11}	<i>-- AU Entity</i>

*-- Template types*

id-moc	ID ::= {id-accounting 0}	<i>-- Managed Object Class templates</i>
id-package	ID ::= {id-accounting 1}	<i>-- Package templates</i>
id-attribute	ID ::= {id-accounting 2}	<i>-- Attribute templates</i>
id-attribute-group	ID ::= {id-accounting 3}	<i>-- Attribute Group templates</i>
id-notification	ID ::= {id-accounting 4}	<i>-- Notification templates</i>
id-action	ID ::= {id-accounting 5}	<i>-- Action templates</i>
id-parameter	ID ::= {id-accounting 6}	<i>-- Parameter templates</i>
id-name-binding	ID ::= {id-accounting 7}	<i>-- Name Binding templates</i>
id-modules	ID ::= {id-accounting 8}	<i>-- Modules – Not definitive</i>

-- *Managed Object Classes*

id-moc-acctRequest	ID ::= {id-moc 0}
id-moc-bindEventRecord	ID ::= {id-moc 1}
id-moc-contact	ID ::= {id-moc 2}
id-moc-customer	ID ::= {id-moc 3}
id-moc-customerAcctLog	ID ::= {id-moc 4}
id-moc-customerAcctRecord	ID ::= {id-moc 5}
id-moc-customerEFD	ID ::= {id-moc 6}
id-moc-discardEventRecord	ID ::= {id-moc 7}
id-moc-interworkingMD	ID ::= {id-moc 8}
id-moc-interworkingMD-EFD	ID ::= {id-moc 9}
id-moc-maseEventRecord	ID ::= {id-moc 10}
id-moc-mdseEventRecord	ID ::= {id-moc 11}
id-moc-mdServiceMgtPOA	ID ::= {id-moc 12}
id-moc-messageEventRecord	ID ::= {id-moc 13}
id-moc-mhsEventLog	ID ::= {id-moc 14}
id-moc-misManagementDomain	ID ::= {id-moc 15}
id-moc-mrseEventRecord	ID ::= {id-moc 16}
id-moc-msseEventRecord	ID ::= {id-moc 17}
id-moc-mtseEventRecord	ID ::= {id-moc 18}
id-moc-securityAcctRecord	ID ::= {id-moc 19}
id-moc-serviceRequest	ID ::= {id-moc 20}
id-moc-settlementAcctRecord	ID ::= {id-moc 21}
id-moc-settlementAcctLog	ID ::= {id-moc 22}

-- *Packages*

id-package-acctRequest	ID ::= {id-package 0}
id-package-alert	ID ::= {id-package 1}
id-package-bindEventRecord	ID ::= {id-package 2}
id-package-cancelDeferredDelivery	ID ::= {id-package 3}
id-package-changeCredential	ID ::= {id-package 4}
id-package-commonBindArguments	ID ::= {id-package 5}
id-package-commonCreationDeletion	ID ::= {id-package 6}
id-package-contact	ID ::= {id-package 7}
id-package-customer	ID ::= {id-package 8}
id-package-customerAcctRequest	ID ::= {id-package 9}
id-package-customerEFD	ID ::= {id-package 10}
id-package-d36-commonAttributes	ID ::= {id-package 11}
id-package-d36-deliveryViaAccessUnit	ID ::= {id-package 12}
id-package-d36-directDelivery	ID ::= {id-package 13}
id-package-delete	ID ::= {id-package 14}
id-package-deliveryControl	ID ::= {id-package 15}
id-package-destinationDomainDelivery	ID ::= {id-package 16}
id-package-discardEventRecord	ID ::= {id-package 17}
id-package-fetch	ID ::= {id-package 18}
id-package-interworkingMD	ID ::= {id-package 19}
id-package-interworkingMD-EFD	ID ::= {id-package 20}
id-package-list	ID ::= {id-package 21}
id-package-maseEventRecord	ID ::= {id-package 22}
id-package-mdseEventRecord	ID ::= {id-package 23}
id-package-mdServiceMgtPOA	ID ::= {id-package 24}
id-package-messageDelivery	ID ::= {id-package 25}
id-package-messageDeliveryEnvelope	ID ::= {id-package 26}
id-package-messageEventRecord	ID ::= {id-package 27}
id-package-messageSubmission	ID ::= {id-package 28}
id-package-messageSubmissionEnvelope	ID ::= {id-package 29}
id-package-messageTransfer	ID ::= {id-package 30}
id-package-mrseEventRecord	ID ::= {id-package 31}
id-package-msBindArguments	ID ::= {id-package 32}
id-package-msseEventRecord	ID ::= {id-package 33}
id-package-mtaBindArguments	ID ::= {id-package 34}
id-package-mtsBindArguments	ID ::= {id-package 35}
id-package-mtseEventControl	ID ::= {id-package 36}
id-package-originatingDomainTransferOut	ID ::= {id-package 37}
id-package-probeSubmission	ID ::= {id-package 38}

id-package-probeSubmissionEnvelope	ID ::= {id-package 39}
id-package-probeTransfer	ID ::= {id-package 40}
id-package-processing	ID ::= {id-package 41}
id-package-register	ID ::= {id-package 42}
id-package-registerMS	ID ::= {id-package 43}
id-package-reportDelivery	ID ::= {id-package 44}
id-package-reportDeliveryEnvelope	ID ::= {id-package 45}
id-package-reportTransfer	ID ::= {id-package 46}
id-package-securityAcctRecord	ID ::= {id-package 47}
id-package-serviceRequest	ID ::= {id-package 48}
id-package-settlementAcctLog	ID ::= {id-package 49}
id-package-settlementAcctRecord	ID ::= {id-package 50}
id-package-settlementAcctRequest	ID ::= {id-package 51}
id-package-submissionControl	ID ::= {id-package 52}
id-package-summarize	ID ::= {id-package 53}
id-package-trace	ID ::= {id-package 54}
id-package-transitDomainTransferOut	ID ::= {id-package 55}
-- <i>Attributes</i>	
id-attribute-accessRatePerDeliveryServiceType	ID ::= {id-attribute 0}
id-attribute-actualRecipientName	ID ::= {id-attribute 1}
id-attribute-administrationError	ID ::= {id-attribute 2}
id-attribute-alertArgument	ID ::= {id-attribute 3}
id-attribute-alertResult	ID ::= {id-attribute 4}
id-attribute-authenticationCheck	ID ::= {id-attribute 5}
id-attribute-authenticationGeneration	ID ::= {id-attribute 6}
id-attribute-bindAuthenticationCheck	ID ::= {id-attribute 7}
id-attribute-bindingError	ID ::= {id-attribute 8}
id-attribute-bindToken	ID ::= {id-attribute 9}
id-attribute-certificate	ID ::= {id-attribute 10}
id-attribute-componentRatesPerOctetsPerDeliveryServiceType	ID ::= {id-attribute 11}
id-attribute-consumerOfOperation	ID ::= {id-attribute 12}
id-attribute-contactCompany	ID ::= {id-attribute 13}
id-attribute-contactDetails	ID ::= {id-attribute 14}
id-attribute-contactFunction	ID ::= {id-attribute 15}
id-attribute-contactId	ID ::= {id-attribute 16}
id-attribute-contactInstance	ID ::= {id-attribute 17}
id-attribute-contactName	ID ::= {id-attribute 18}
id-attribute-contentConfidentialityAlgorithmIdentifier	ID ::= {id-attribute 19}
id-attribute-contentIdentifier	ID ::= {id-attribute 20}
id-attribute-contentIntegrityCheck	ID ::= {id-attribute 21}
id-attribute-contentType	ID ::= {id-attribute 22}
id-attribute-currency	ID ::= {id-attribute 23}
id-attribute-customerAcctPolicy	ID ::= {id-attribute 24}
id-attribute-customerId	ID ::= {id-attribute 25}
id-attribute-customerName	ID ::= {id-attribute 26}
id-attribute-decipherment	ID ::= {id-attribute 27}
id-attribute-defaultDeliveryControls	ID ::= {id-attribute 28}
id-attribute-deleteArgument	ID ::= {id-attribute 29}
id-attribute-deleteResult	ID ::= {id-attribute 30}
id-attribute-deliverableContentTypes	ID ::= {id-attribute 31}
id-attribute-deliverableEncodedInformationTypes	ID ::= {id-attribute 32}
id-attribute-deliverableMaximumContentLength	ID ::= {id-attribute 33}
id-attribute-deliveryComponentRateToPrmd	ID ::= {id-attribute 34}
id-attribute-deliveryComponentRateToUa	ID ::= {id-attribute 35}
id-attribute-deliveryControls	ID ::= {id-attribute 36}
id-attribute-deliveryError	ID ::= {id-attribute 37}
id-attribute-deliveryServiceTypes	ID ::= {id-attribute 38}
id-attribute-destinationAdmd	ID ::= {id-attribute 39}
id-attribute-destinationDomainDeliveryList	ID ::= {id-attribute 40}
id-attribute-electronicMailAddress	ID ::= {id-attribute 41}
id-attribute-encipherment	ID ::= {id-attribute 42}
id-attribute-encodedInformationTypes	ID ::= {id-attribute 43}
id-attribute-entryExitMtaNames	ID ::= {id-attribute 44}
id-attribute-envelopeType	ID ::= {id-attribute 45}
id-attribute-faxTelephoneNumberList	ID ::= {id-attribute 46}

id-attribute-fetchArgument	ID ::= {id-attribute 47}
id-attribute-fetchResult	ID ::= {id-attribute 48}
id-attribute-globalDomainId	ID ::= {id-attribute 49}
id-attribute-initiatorCredentials	ID ::= {id-attribute 50}
id-attribute-initiatorName	ID ::= {id-attribute 51}
id-attribute-internalTrace	ID ::= {id-attribute 52}
id-attribute-interworkingMDId	ID ::= {id-attribute 53}
id-attribute-interworkingMDName	ID ::= {id-attribute 54}
id-attribute-labelsAndRedirections	ID ::= {id-attribute 55}
id-attribute-limitValidityDate	ID ::= {id-attribute 56}
id-attribute-listArgument	ID ::= {id-attribute 57}
id-attribute-listResult	ID ::= {id-attribute 58}
id-attribute-logStartTime	ID ::= {id-attribute 59}
id-attribute-logStopTime	ID ::= {id-attribute 60}
id-attribute-messageContentSize	ID ::= {id-attribute 61}
id-attribute-messageDeliveryEnvelope	ID ::= {id-attribute 62}
id-attribute-MTSIdentifier	ID ::= {id-attribute 63}
id-attribute-messageOriginAuthenticationCheck	ID ::= {id-attribute 64}
id-attribute-messageSecurityLabel	ID ::= {id-attribute 65}
id-attribute-messageSize	ID ::= {id-attribute 66}
id-attribute-messageSubmissionEnvelope	ID ::= {id-attribute 67}
id-attribute-submissionTime	ID ::= {id-attribute 68}
id-attribute-messageToken	ID ::= {id-attribute 69}
id-attribute-messageTransferEnvelope	ID ::= {id-attribute 70}
id-attribute-msBindAuthenticationCheck	ID ::= {id-attribute 71}
id-attribute-newCredentials	ID ::= {id-attribute 72}
id-attribute-numberOfAddressedPrmds	ID ::= {id-attribute 73}
id-attribute-numberOfAddressedUas	ID ::= {id-attribute 74}
id-attribute-numberOfMessagesPerDeliveryServiceType	ID ::= {id-attribute 75}
id-attribute-oldCredentials	ID ::= {id-attribute 76}
id-attribute-operationStatus	ID ::= {id-attribute 77}
id-attribute-operationTime	ID ::= {id-attribute 78}
id-attribute-originalMtaCertification	ID ::= {id-attribute 79}
id-attribute-originatingDomainTransferOutList	ID ::= {id-attribute 80}
id-attribute-originatingAdmd	ID ::= {id-attribute 81}
id-attribute-originatingMTACertificate	ID ::= {id-attribute 82}
id-attribute-originatorCertificate	ID ::= {id-attribute 83}
id-attribute-originatorName	ID ::= {id-attribute 84}
id-attribute-permissibleSecurityContext	ID ::= {id-attribute 85}
id-attribute-priority	ID ::= {id-attribute 86}
id-attribute-probeOriginAuthenticationCheck	ID ::= {id-attribute 87}
id-attribute-probeSubmissionEnvelope	ID ::= {id-attribute 88}
id-attribute-probeTransferEnvelope	ID ::= {id-attribute 89}
id-attribute-processingComponentRate	ID ::= {id-attribute 90}
id-attribute-processingDetails	ID ::= {id-attribute 91}
id-attribute-processingErrorFlag	ID ::= {id-attribute 92}
id-attribute-processingSummary	ID ::= {id-attribute 93}
id-attribute-proofOfDelivery	ID ::= {id-attribute 94}
id-attribute-proofOfDeliveryRequest	ID ::= {id-attribute 95}
id-attribute-proofOfSubmission	ID ::= {id-attribute 96}
id-attribute-proofOfSubmissionRequest	ID ::= {id-attribute 97}
id-attribute-recipientCertificate	ID ::= {id-attribute 98}
id-attribute-recipientOnResponsibilityList	ID ::= {id-attribute 99}
id-attribute-registerMSArgument	ID ::= {id-attribute 100}
id-attribute-registerMSResult	ID ::= {id-attribute 101}
id-attribute-reportDeliveryEnvelope	ID ::= {id-attribute 102}
id-attribute-reportIdentifier	ID ::= {id-attribute 103}
id-attribute-reportingMtaCertificate	ID ::= {id-attribute 104}
id-attribute-reportOriginAuthenticationCheck	ID ::= {id-attribute 105}
id-attribute-reportTransferEnvelope	ID ::= {id-attribute 106}
id-attribute-responderCredentials	ID ::= {id-attribute 107}
id-attribute-responderName	ID ::= {id-attribute 108}
id-attribute-retrievalError	ID ::= {id-attribute 109}
id-attribute-securityContext	ID ::= {id-attribute 110}
id-attribute-securityError	ID ::= {id-attribute 111}
id-attribute-securityProblem	ID ::= {id-attribute 112}

<b>id-attribute-serviceAccessCharge</b>	<b>ID ::= {id-attribute 113}</b>
<b>id-attribute-serviceFlag</b>	<b>ID ::= {id-attribute 114}</b>
<b>id-attribute-serviceRequestId</b>	<b>ID ::= {id-attribute 115}</b>
<b>id-attribute-settlementPolicy</b>	<b>ID ::= {id-attribute 116}</b>
<b>id-attribute-signatureCheck</b>	<b>ID ::= {id-attribute 117}</b>
<b>id-attribute-signatureGeneration</b>	<b>ID ::= {id-attribute 118}</b>
<b>id-attribute-startUpDate</b>	<b>ID ::= {id-attribute 119}</b>
<b>id-attribute-status</b>	<b>ID ::= {id-attribute 120}</b>
<b>id-attribute-subjectIdentifier</b>	<b>ID ::= {id-attribute 121}</b>
<b>id-attribute-subjectSubmissionIdentifier</b>	<b>ID ::= {id-attribute 122}</b>
<b>id-attribute-submissionControls</b>	<b>ID ::= {id-attribute 123}</b>
<b>id-attribute-submissionError</b>	<b>ID ::= {id-attribute 124}</b>
<b>id-attribute-summarizeArgument</b>	<b>ID ::= {id-attribute 125}</b>
<b>id-attribute-summarizeResult</b>	<b>ID ::= {id-attribute 126}</b>
<b>id-attribute-supplierOfOperation</b>	<b>ID ::= {id-attribute 127}</b>
<b>id-attribute-telephoneNumberList</b>	<b>ID ::= {id-attribute 128}</b>
<b>id-attribute-thisRecipientName</b>	<b>ID ::= {id-attribute 129}</b>
<b>id-attribute-totalNumberOfORAddresses</b>	<b>ID ::= {id-attribute 130}</b>
<b>id-attribute-trace</b>	<b>ID ::= {id-attribute 131}</b>
<b>id-attribute-transitDomainTransferOutList</b>	<b>ID ::= {id-attribute 132}</b>
<b>id-attribute-userAddress</b>	<b>ID ::= {id-attribute 133}</b>
<b>id-attribute-userName</b>	<b>ID ::= {id-attribute 134}</b>
<b>id-attribute-userSecurityLabel</b>	<b>ID ::= {id-attribute 135}</b>
<i>-- Attribute Groups</i>	
<i>-- none are defined</i>	
<i>-- Notifications</i>	
<b>id-notification-objectCreation</b>	<b>ID ::= {id-notification 0}</b>
<b>id-notification-objectDeletion</b>	<b>ID ::= {id-notification 1}</b>
<i>-- Actions</i>	
<i>-- none are defined</i>	
<i>-- Parameters</i>	
<b>id-parameter-attributeError</b>	<b>ID ::= {id-parameter 0}</b>
<b>id-parameter-autoActionRequestError</b>	<b>ID ::= {id-parameter 1}</b>
<b>id-parameter-deleteError</b>	<b>ID ::= {id-parameter 2}</b>
<b>id-parameter-fetchRestrictionError</b>	<b>ID ::= {id-parameter 3}</b>
<b>id-parameter-improperlySpecifiedRecipients</b>	<b>ID ::= {id-parameter 4}</b>
<b>id-parameter-rangeError</b>	<b>ID ::= {id-parameter 5}</b>
<b>id-parameter-securityError</b>	<b>ID ::= {id-parameter 6}</b>
<b>id-parameter-sequenceNumberError</b>	<b>ID ::= {id-parameter 7}</b>
<b>id-parameter-serviceError</b>	<b>ID ::= {id-parameter 8}</b>
<i>-- Name Bindings</i>	
<b>id-name-binding-acctRequest-customer</b>	<b>ID ::= {id-name-binding 0}</b>
<b>id-name-binding-acctRequest-interworkingMD</b>	<b>ID ::= {id-name-binding 1}</b>
<b>id-name-binding-contact-customer</b>	<b>ID ::= {id-name-binding 2}</b>
<b>id-name-binding-contact-interworkingMD</b>	<b>ID ::= {id-name-binding 3}</b>
<b>id-name-binding-customer-mdServiceManagementPointOfAccess</b>	<b>ID ::= {id-name-binding 4}</b>
<b>id-name-binding-customerAcctLog-customer</b>	<b>ID ::= {id-name-binding 5}</b>
<b>id-name-binding-customerEFD-customer</b>	<b>ID ::= {id-name-binding 6}</b>
<b>id-name-binding-interworkingMD-EFD-interworkingMD</b>	<b>ID ::= {id-name-binding 7}</b>
<b>id-name-binding-interworkingMD-mdServiceManagementPointOfAccess</b>	<b>ID ::= {id-name-binding 8}</b>
<b>id-name-binding-mdServiceManagementPointOfAccess-misManagementDomain</b>	<b>ID ::= {id-name-binding 9}</b>
<b>id-name-binding-settlementAcctLog-interworkingMD</b>	<b>ID ::= {id-name-binding 10}</b>

END -- of MhsAcctObjectIdentifiers

**A.2 ASN.1 notations**

This clause contains the ASN.1 module that defines the attribute syntaxes referenced by the attributes in clause “Attributes”.

```
MhsAcctAsn1Module {  joint-iso-itu-t
                    mhs (6)
                    management (9)
                    accounting (3)
                    modules (8)
                    asn1-module ( 1 ) }
```

**DEFINITIONS IMPLICIT TAGS ::=**

**BEGIN**

-- *Prologue*

-- *EXPORTS everything*

**IMPORTS**

-- *MTS abstract service parameters*

```
AdministrationDomainName,
ActualRecipientName,
BindTokenEncryptedData,
BindTokenSignedData,
ContentConfidentialityAlgorithmIdentifier,
ContentIdentifier,
ContentIntegrityCheck,
ContentLength,
ContentType,
Credentials,

DefaultDeliveryControls,
DeferredDeliveryTime,
DeliveryControls,
EncodedInformationTypes,
ExplicitConversion,

GlobalDomainIdentifier,
InitiatorCredentials,

LabelAndRedirection,

MessageDeliveryEnvelope,
MessageOriginAuthenticationCheck,
MessageSecurityLabel,
MessageSubmissionEnvelope,
MessageToken,
MTAName,
MTSIdentifier,
NonDeliveryReasonCode,
NonDeliveryDiagnosticCode,
ObjectName,
ORAddressAndOptionalDirectoryName,
ORName,
OriginatingMTACertificate.
OriginatorCertificate,
OriginatorName,

Priority,
ProbeOriginAuthenticationCheck,
ProbeSubmissionEnvelope,
ProofOfDelivery,
ProofOfDeliveryRequest,
ProofOfSubmission,
ProofOfSubmissionRequest,
RecipientCertificate,
RedirectionReason,
ReportDeliveryEnvelope,
ReportingMTACertificate,
ReportOriginAuthenticationCheck,
ResponderCredentials,
```



**SecurityContext,**  
**SecurityProblem,**  
**SubjectSubmissionIdentifier,**  
**SubmissionControls,**  
**Time,**  
**ThisRecipientName,**  
**UserAddress,**  
**UserName,**

**FROM MTSAbstractService { joint-iso-ccitt mhs-motis (6) mts (3) modules (0) mts-abstract-service (0) version-1994 (0) }**  
*-- MTA abstract service parameters*

**InternalTraceInformation,**  
**MTSIdentifier,**  
**MessageTransferEnvelope,**  
**ProbeTransferEnvelope,**  
**ReportIdentifier,**  
**ReportTransferEnvelope,**  
**SubjectIdentifier,**  
**TraceInformation**

**FROM MTAAbstractService { joint-iso-ccitt mhs-motis (6) mts (3) modules (0) mta-abstract-service (2) version-1994 (0) }**  
*-- MS abstract service*

**AlertArgument,**  
**AlertResult,**  
**AttributeProblem,**  
**AttributeType,**  
**AutoActionRequestProblem,**  
**AutoActionType,**  
**DeleteArgument,**  
**DeleteProblem,**  
**DeleteResult,**  
**FetchArgument,**  
**FetchRestrictionProblem,**  
**FetchResult,**  
**ListArgument,**  
**ListResult,**  
**MS-EITs,**  
**RangeProblem,**  
**Register-MSArgument,**  
**Register-MSResult,**  
**Restrictions,**  
**SequenceNumber,**  
**SequenceNumberProblem,**  
**ServiceProblem,**  
**SummarizeArgument,**  
**SummarizeResult**

**FROM MSAbstractService { joint-iso-ccitt mhs-motis (6) mts (3) modules (0) abstract-service (1) version-1994 (0) }**  
*-- MTS upper bounds*

**ub-content-types,**  
**ub-labels-and-redirections,**  
**ub-recipients**

**FROM MTSUpperBounds { joint-iso-ccitt mhs-motis (6) mts (3) modules (0) upper-bounds (3) version-1994 (0) }**  
*-- MS upper bounds*

**ub-attributes-supported,**  
**ub-auto-actions,**  
**ub-auto-registrations,**  
**ub-default-registrations,**  
**ub-messages,**  
**ub-per-entry**

FROM MSUpperBounds {joint-iso-ccitt mhs-motis (6) mts (3) modules (0) upper-bounds (3) }

EventTypeId,  
ObjectInstance

FROM CMIP-1 {joint-iso-ccitt ms (9) cmip (1) modules (0) protocol (3) }

-- X.721 DMI

SimpleNameType

FROM Attribute-ASN1Module {joint-iso-ccitt ms (9) smi (3) part2 (2) asn1Module (2) 1};

-- In the context of MHS management, the following values are defined for the EventTypeId data type.

affirmation	EventTypeId ::= localForm : 1
alert	EventTypeId ::= localForm : 2
cancel-deferred-delivery	EventTypeId ::= localForm : 3
change-credentials	EventTypeId ::= localForm : 4
delete	EventTypeId ::= localForm : 5
delivery-control	EventTypeId ::= localForm : 6
fetch	EventTypeId ::= localForm : 7
list	EventTypeId ::= localForm : 8
message-delivery	EventTypeId ::= localForm : 9
message-indirect-submission	EventTypeId ::= localForm : 10
message-submission	EventTypeId ::= localForm : 11
message-transfer-in	EventTypeId ::= localForm : 12
message-transfer-out	EventTypeId ::= localForm : 13
ms-bind	EventTypeId ::= localForm : 14
ms-unbind	EventTypeId ::= localForm : 15
mta-bind	EventTypeId ::= localForm : 16
mta-unbind	EventTypeId ::= localForm : 17
mts-bind	EventTypeId ::= localForm : 18
mts-unbind	EventTypeId ::= localForm : 19
non-affirmation	EventTypeId ::= localForm : 20
non-delivery	EventTypeId ::= localForm : 21
probe-indirect-submission	EventTypeId ::= localForm : 22
probe-submission	EventTypeId ::= localForm : 23
probe-transfer-in	EventTypeId ::= localForm : 24
probe-transfer-out	EventTypeId ::= localForm : 25
register	EventTypeId ::= localForm : 26
register-ms	EventTypeId ::= localForm : 27
report-delivery	EventTypeId ::= localForm : 28
report-transfer-in	EventTypeId ::= localForm : 29
report-transfer-out	EventTypeId ::= localForm : 30
submission-control	EventTypeId ::= localForm : 31
summarize	EventTypeId ::= localForm : 32

AdministrationPortOperations ::= EventTypeId (

change-credentials |  
register )

BindingOperations ::= EventTypeId (

ms-bind |  
ms-unbind |  
mta-bind |  
mta-unbind |  
mts-bind |  
mts-unbind )

DeliveryPortOperations ::= EventTypeId (

delivery-control |  
message-delivery |  
report-delivery )

DiscardOperations ::= EventTypeId (

affirmation |  
non-affirmation |  
non-delivery )

**RetrievalPortOperations ::= EventTypeId (**  
 alert |  
 delete |  
 fetch |  
 list |  
 register-ms |  
 summarize )

**SubmissionPortOperations ::= EventTypeId (**  
 message-submission |  
 probe-submission |  
 cancel-deferred-delivery |  
 submission-control )

**TransferPortOperations ::= EventTypeId (**  
 message-transfer-in |  
 message-transfer-out |  
 probe-transfer-in |  
 probe-transfer-out |  
 report-transfer-in |  
 report-transfer-out )

**OperationStatus ::= INTEGER {**  
 in-progress (0),  
 ok (1),  
 error (2) }

**ServiceFlag ::= BOOLEAN**

-- *Contact attributes*

**ContactId ::= SimpleNameType**  
**ContactName ::= UniversalString**  
**ContactCompany ::= UniversalString**  
**ContactFunction ::= UniversalString**  
**ContactDetails ::= UniversalString**  
**ElectronicMailAddress ::= ORAddressAndOptionalDirectoryName**  
**TelephoneNumbersList ::= SET OF TelephoneNumber**  
**TelephoneNumbers ::= UniversalString**

-- *Customer attributes*

**CustomerId ::= SimpleNameType**  
**CustomerName ::= UniversalString**

-- *InterworkingMD attributes*

**InterworkingMDId ::= SimpleNameType**  
**InterworkingMDName ::= UniversalString**

-- *Service request attributes*

**ServiceRequestId ::= SimpleNameType**

**Status ::= INTEGER {**  
 indirect-mIS-user-agreement-on-the-request (0),  
 MIS-provider-agreement-on-the-request (1),  
 request-in-progress (2),  
 request-processed (3) }

**LimitValidityDate ::= Time**

**StartUpDate ::= Time**

-- *Accounting policies*

**CustomerAcctPolicy ::= CHOICE {**  
 globalForm OBJECT IDENTIFIER,  
 localForm INTEGER }

```
SettlementPolicy ::= CHOICE {
    globalForm OBJECT IDENTIFIER,
    localForm INTEGER}
```

-- In the context of MHS management, the following values are defined for the  
-- SettlementPolicy data type.

**d36 SettlementPolicy ::= localForm : 0**

-- In the following descriptions, a number of redefinition of material defined in other  
-- modules occurs. This was made inevitable for either one of two reasons:  
-- Reason 1: There is no specific type to be imported for the concerned attribute.  
-- This often occurs when parameters are of the format "SET SIZE (...) OF ...".  
-- In those cases, the corresponding description has been copied textually in  
-- module, with a specific mention of its origin. Though this introduces maintenance  
-- difficulties, no better solution has been found.  
-- Reason 2: The corresponding type is unavailable. For instance, the various  
-- operation errors already have assigned numbers, but the module in which this  
-- is done (MTSAccessProtocol { joint-iso-ccitt mhs-motis (6) protocols (0) modules (0)  
-- mts-access-protocol (1) } in ITU-T Rec. X.419 | ISO/IEC 10021-6) does not export  
-- them, so they are not available for use in this module. Correspondingly, there  
-- are no single "error" type to import from ITU-T Rec. X.411 | ISO/IEC 10021-4 not  
-- ITU-T Rec. X.413 | ISO/IEC 10021-5, this is why they were reproduced here.  
-- Though this introduces maintenance difficulties, no better solution has been found.  
-- Binding Types

```
BindingError ::= CHOICE {
    [0] INTEGER {
        busy (0),
        authentication-error (2),
        unacceptable-dialogue-mode (3),
        unacceptable-security-context (4)},
    [1] MSBindError }
```

-- Submission Port Types

```
SubmissionError ::= INTEGER {
    submission-control-violated (1),
    element-of-service-not-subscribed (2),
    deferred-delivery-cancellation-rejected (3),
    originator-invalid (4),
    recipient-improperly-specified (5), -- has parameters
    message-submission-identifier-invalid (6),
    inconsistent-request (7),
    security-error (8), -- has parameters
    unsupported-critical-function (9),
    remote-bind-error (10) }
```

```
CancelDeferredDeliverySubmissionErrors ::= SubmissionError (
    deferred-delivery-cancellation-rejected |
    message-submission-identifier-invalid |
    remote-bind-error )
```

```
MessageSubmissionErrors ::= SubmissionError (
    submission-control-violated |
    element-of-service-not-subscribed |
    originator-invalid |
    recipient-improperly-specified |
    inconsistent-request |
    security-error |
    unsupported-critical-function |
    remote-bind-error )
```

**ProbeSubmissionErrors ::= SubmissionError (**  
     **submission-control-violated |**  
     **element-of-service-not-subscribed |**  
     **originator-invalid |**  
     **recipient-improperly-specified |**  
     **inconsistent-request |**  
     **security-error |**  
     **unsupported-critical-function |**  
     **remote-bind-error )**

**SubmissionControlErrors ::= SubmissionError (**  
     **security-error |**  
     **remote-bind-error )**

-- *definition copied from [ITU-T Rec. X.411 | ISO/IEC 10021-4] Figure 2 --*

**ImproperlySpecifiedRecipients ::= SEQUENCE SIZE (1..ub-recipients) OF ORAddressAndOptionalDirectoryName**  
 -- *Delivery Port Types*

**DeliveryError ::= INTEGER {**  
     **delivery-control-violation (1),**  
     **control-violates-registration (2),**  
     **security-error (3), -- has parameters**  
     **unsupported-critical-function (4) }**

**MessageDeliveryErrors ::= DeliveryError (**  
     **delivery-control-violation |**  
     **security-error |**  
     **unsupported-critical-function )**

**ReportDeliveryErrors ::= MessageDeliveryErrors**

**DeliveryControlErrors ::= DeliveryError (**  
     **control-violates-registration |**  
     **security-error )**

-- *Retrieval Port Types*

**RetrievalError ::= INTEGER {**  
     -- *Most of these have parameters*  
     **attribute-error (1),**  
     **auto-action-request-error (2),**  
     **delete-error (3),**  
     **fetch-restriction-error (4),**  
     **invalid-parameter-error (5),**  
     **range-error (6),**  
     **security-error (7),**  
     **sequence-number-error (8),**  
     **service-error (9) }**

**SummarizeErrors ::= RetrievalError (**  
     **attribute-error |**  
     **invalid-parameter-error |**  
     **range-error |**  
     **security-error |**  
     **sequence-number-error |**  
     **service-error )**

**ListErrors ::= SummarizeErrors**

**FetchErrors ::= RetrievalError (**  
     **INCLUDES SummarizeErrors |**  
     **fetch-restriction-error )**

**DeleteErrors ::= RetrievalError (**  
     **delete-error |**  
     **invalid-parameter-error |**  
     **range-error |**  
     **security-error |**  
     **sequence-number-error |**  
     **service-error )**

**RegisterMSErrors ::= RetrievalError (**  
     **attribute-error |**  
     **auto-action-request-error |**  
     **invalid-parameter-error |**  
     **security-error |**  
     **service-error )**

**AlertErrors ::= RetrievalError ( security-error )**  
 -- definitions copied from [ITU-T Rec. X.413 | ISO/IEC 10021-5] Annex B --

**AttributeError ::= SET {**  
     **problems [0] SET SIZE (1..ub-per-entry) OF SET {**  
         **problem [0] AttributeProblem,**  
         **type [1] AttributeType,**  
         **value [3] { ... } }**

**AutoActionRequestError ::= SET {**  
     **problems [0] SET SIZE (1..ub-auto-registrations) OF SET {**  
         **problem [0] AutoActionRequestProblem,**  
         **type [1] AutoActionType}}**

**DeleteError ::= SET {**  
     **problems [0] SET SIZE (1..ub-messages) OF SET {**  
         **problem [0] DeleteProblem,**  
         **sequence-number [1] SequenceNumber}}**

**FetchRestrictionError ::= SET {**  
     **problems [0] SET SIZE (1..ub-default-registrations) OF SET {**  
         **problem [3] FetchRestrictionProblem,**  
         **restriction CHOICE {**  
             **content-type [0] ContentType,**  
             **eit [1] MS-EITs,**  
             **content-length [2] ContentLength}}**

**RangeError ::= SET {**  
     **problem [0] RangeProblem}**

**SequenceNumberError ::= SET {**  
     **problems [1] SET SIZE (1..ub-messages) OF SET {**  
         **problem [0] SequenceNumberProblem,**  
         **sequence-number [1] SequenceNumber}}**

**ServiceError ::= SET {**  
     **problem [0] ServiceProblem}**

-- Administration Port Types

**AdministrationError ::= INTEGER {**  
     **register-rejected (1),**  
     **new-credentials-unacceptable (2),**  
     **old-credentials-incorrectly-specified (3),**  
     **remote-bind-error (10) }**

**RegisterErrors ::= AdministrationErrors (**  
     **register-rejected |**  
     **remote-bind-error )**

**ChangeCredentialsErrors ::= AdministrationError (**  
     **new-credentials-unacceptable |**  
     **old-credentials-incorrectly-specified |**  
     **remote-bind-error )**

-- two definitions copied from [ITU-T Rec. X.411 | ISO/IEC 10021-4] Figure 2 --

**DeliverableContentTypes ::= SET SIZE (1 .. ub-content-types) OF ContentType**  
**LabelsAndRedirections ::= SET SIZE (1 .. ub-labels-and-redirections) OF LabelAndRedirection**  
 -- Security-related types

**AuthenticationCheck ::= INTEGER {**  
     **validated (1),**  
     **failed (2) }**

**BindAuthenticationCheck ::= AuthenticationCheck**

**AuthenticationGeneration ::= INTEGER {**  
     **generated (1),**  
     **non-generated (2) }**

**Decipherment ::= INTEGER {**  
     **success (1),**  
     **failure (2) }**

**SignatureCheck ::= INTEGER {**  
     **valid (1),**  
     **failed (2) }**

**SignatureGeneration ::= INTEGER {**  
     **generated (1),**  
     **non-generated (2) }**

-- *Information contained in the notifications*

**CommonCreationAndDeletionInfo ::= INTEGER {**  
     **unknown (0),**  
     **ressourceOperation(1),**  
     **managementOperation(2) }**

-- *These are types for the processing history-related attributes*

**ProcessingErrorFlag ::= BOOLEAN**

**ProcessingSummary ::= BIT STRING {**  
     **idle (0),**  
     **processed (1),**  
     **rejected (2),**  
     **name-resolution (3),**  
     **dl-expansion (4),**  
     **redirection (5),**  
     **deferred-delivery (6),**  
     **conversion (7),**  
     **securityContextCheck (8) }**

-- *at most one of idle, processed, and rejected bits shall be 'one':*  
 -- *idle bit 'one' means the MPR is waiting to be processed;*  
 -- *processed bit 'one' means the MPR was successfully processed;*  
 -- *rejected bit 'one' means that the MTS was not able to deliver the message*  
 -- *or the report or affirm the probe.*  
 -- *idle, processed, and rejected bits 'zero' means the MPR is*  
 -- *currently under process.*  
 -- *A 'name-resolution', 'redirection', 'deferred-delivery',*  
 -- *'conversion' or 'securityContextCheck' bit one means the corresponding*  
 -- *function was performed on the MPR.*  
 -- *if idle bit is set to 'one' (MPR idle), dl-expansion, redirection,*  
 -- *deferred-delivery and conversion bits shall be set to 'zero'.*

**ProcessingDetails ::= SEQUENCE OF ProcessingDetail**

**ProcessingDetail ::= CHOICE {**  
     **name-resolution [3] NameResolutionProcessingInfo,**  
     **dl-expansion [4] DLExpansionProcessingInfo,**  
     **redirection [5] RedirectionProcessingInfo,**  
     **deferred-delivery [6] DeferralOfDeliveryProcessingInfo,**  
     **conversion [7] ConversionProcessingInfo,**  
     **securityContextCheck [8] SecurityProcessingInfo }**

-- *These come from X.411: MTS Abstract Service*

**ProcessingError ::= SET {**  
     **non-delivery-reason [0] NonDeliveryReasonCode OPTIONAL,**  
     **non-delivery-diagnostics [1] NonDeliveryDiagnosticCode OPTIONAL,**  
     **supplementary-info [2] SupplementaryError }**

**ISO/IEC 11588-3 : 1997 (E)**

**SupplementaryError ::= UniversalString**

**ConversionProcessingInfo ::= SET OF EMailFromToEIT**

**EMailFromToEIT ::= CHOICE {**  
    **explicitConversion**       **[0] ExplicitConversion,**  
    **genericConversion**       **[1] GenericConversion }**

**GenericConversion ::= OBJECT IDENTIFIER**

**DLExpansionProcessingInfo ::= SEQUENCE {**  
    **dlORName**    **ORAddressAndOptionalDirectoryName,**  
    **actions**       **Actions }**

**Actions ::= BIT STRING {**  
    **owner-report (0),**  
    **originator-on-previous-dl (1),**  
    **secure-dl-operation (2) }**

**RedirectionProcessingInfo ::= SET {**  
    **redirection-reason**       **[0] RedirectionReason,**  
    **original**               **[1] ORName OPTIONAL,**  
    **redirected-to**           **[2] ORName OPTIONAL }**

**DeferralOfDeliveryProcessingInfo ::= DeferredDeliveryTime**  
    -- *Imported from X.411*

**SecurityProcessingInfo ::= SET {**  
    **action**               **[0] SecurityAction,**  
    **security-policy**       **[1] OBJECT IDENTIFIER OPTIONAL }**

**SecurityAction ::= BIT STRING {**  
    **unspecified (0),**  
    **origin-authentication (1),**  
    **security-label-check (2) }**

**NameResolutionProcessingInfo ::= DirectoryNameAndOptionalORAddress**

**DirectoryNameAndOptionalORAddress ::= ORName**

**DeliveryServiceType ::= INTEGER {**  
    **mhs-delivery (0),**  
    **physical-delivery (1),**  
    **telex-delivery (2),**  
    **teletex-delivery (3),**  
    **g3-facsimile-delivery (4),**  
    **g4-facsimile-delivery (5),**  
    **videotex-delivery (6),**  
    **telephone-delivery (7),**  
    **other-delivery (8) }**

**MessageContentSize ::= INTEGER**

**RecipientsOnResponsibilityList ::= RecipientName**

**RecipientName ::= SET OF ORAddressAndOptionalDirectoryName**

**BindToken ::= CHOICE {**  
    **signed**       **[0] BindTokenSignedData,**  
    **encrypted**    **[1] BindTokenEncryptedData }**

**Encipherment ::= INTEGER {**  
    **encrypted (1),**  
    **clear (2) }**

**MsBindAuthenticationCheck ::= AuthenticationCheck**

**OperationTime ::= Time**

**PermissibleSecurityContext ::= SET OF SecurityContext**  
    -- *related to ITU-T Rec. D.36*



**AccessRatePerDeliveryServiceType ::= SET OF REAL**  
**ComponentRatesPerOctetsPerDeliveryServiceType ::= SET OF REAL**  
**Currency ::= PrintableString**  
**DeliveryComponentRateToPrmd ::= REAL**  
**DeliveryComponentRateToUa ::= REAL**  
**DestinationADMD ::= AdministrationDomainName**  
**MessageSize ::= INTEGER**  
**NumberOfAddressedPRMDs ::= INTEGER**  
**NumberOfAddressedUas ::= INTEGER**  
**NumberOfMessagesPerDeliveryServiceType ::= SET OF INTEGER**  
**OriginatingADMD ::= AdministrationDomainName**  
**ProcessingComponentRate ::= REAL**  
**TotalNumberOfORAddresses ::= INTEGER**  
**ConversionStatistics ::= SEQUENCE {**  
     oldEit    EncodedInformationTypes,  
     newEit    EncodedInformationTypes}  
**DestinationDomainDeliveryList ::= SET OF DeliveredRecipientField**  
**DeliveredRecipientField ::= SET {**  
     recipient-name        – ORAddressAndOptionalDirectoryName,  
     message-delivery-time – Time,  
     delivery-service     – [1] DeliveryService OPTIONAL,  
     -- absence means no delivery cost incurred  
     conversion-statistics – [2] ConversionStatistics OPTIONAL, -- absence means no conversion cost incurred --  
     edirector-name       – [5] ORAddressAndOptionalDirectoryName OPTIONAL }  
**DeliveryService ::= SET {**  
     delivery-service-type        DeliveryServiceType,  
     per-message-component-rate   [1] PerMessageComponentRate OPTIONAL,  
     per-octet-component-rate     [2] PerOctetComponentRate OPTIONAL }  
**PerMessageComponentRate ::= INTEGER**  
**PerOctetComponentRate ::= INTEGER**  
**OriginatingDomainTransferOutList ::= SET OF TransferRecipientField**  
**ServiceAccessCharge ::= INTEGER**  
**TransitDomainTransferOutList ::= SET OF TransferRecipientField**  
**TransferRecipientField ::= MtaName**  
**EntryExitMTANames ::= SEQUENCE OF MTAName**  
**EnvelopeType ::= INTEGER {**  
     message-delivery-envelope (0),  
     message-submission-envelope (1),  
     message-transfer-envelope (2),  
     probe-submission-envelope (3),  
     probe-transfer-envelope (4),  
     report-delivery-envelope (5),  
     report-transfer-envelope (6)}  
**InternalTrace ::= InternalTraceInformation**  
**Trace ::= TraceInformation**

END

## Annex B

### Relation with ITU-T Rec. X.742 | ISO/IEC 10164-10

(This annex does not form an integral part of this Recommendation | International Standard)

This is the result of a discussion between ITU-T SG7 Q14/5 and Q13/7 experts on the matter of aligning ITU-T Rec. X.462 | ISO/IEC 11588-3 and ITU-T Rec. X.742 | ISO/IEC 10164-10. This annex is a summary of the changes that were requested to be made to ITU-T Rec. X.742 | ISO/IEC 10164-10 for it to better fit the model of the MHS Management Logging Information.

ITU-T Rec. X.742 | ISO/IEC 10164-10 standardizes a process through which usage metering data is gathered and placed into records. It does not standardize the content of those records as it will vary between applications. The data are gathered by a “usage metering data” managed object which operates under the supervision of a “usage metering control” managed object. The data are stored in records which are subclasses of the eventRecord managed object class found in CCITT Rec. X.721 | ISO/IEC 10165-2.

ITU-T Rec. X.742 | ISO/IEC 10164-10 places some constraints on the structure of the information inside the stored records. This Recommendation | International Standard do not claim conformance to that latter part. That structure was rejected because it was deemed more important to stay as close as possible to the information structure that can be found in the ITU-T Rec. X.400-Series | ISO/IEC 10021. A comment was addressed to ITU-T SG7 Q13/7 so that they have separate conformance statements for their general model and their more specific record structure.

This Recommendation | International Standard standardizes the logging information which could be collected in a standardized form as defined by ITU-T Rec. X.742 | ISO/IEC 10164-10 but not mandated to be. This Recommendation | International Standard specifies the precise content of the logged information in the various records of MHS event logs.

Figure B.1 illustrates an example on how ITU-T Rec. X.742 | ISO/IEC 10164-10 would integrate with this Recommendation | International Standard. The centre box is a part of the MHS Management Model defined in ITU-T Rec. X.460 | ISO/IEC 11588-1 with some of the component partially exploded to show the Usage Metering Function and the logging information managed objects working together so as to provide a reliable logging service.

This example illustrates the MTA agent entity which is the network element control point (as defined in ITU-T Rec. X.460 | ISO/IEC 11588-1) for the MTA. In this example, the MTA is the network element being monitored by the usage metering data object under the control of the meter control object. Information collected by the process is stored in the mhsEvent log as mhsEvent records.

This example also illustrates the Accounting entity which provides the customer accounting service for the whole of the MHS. In this example, the MHS is being monitored by the usage metering data object under the control of the meter control object. Information collected by the process is stored in the CustomerAccounting log as CustomerAccounting records. In this case, the MHS abstract object represents the computed version of the data collected from the various mhsEvent logs of underlying agents.

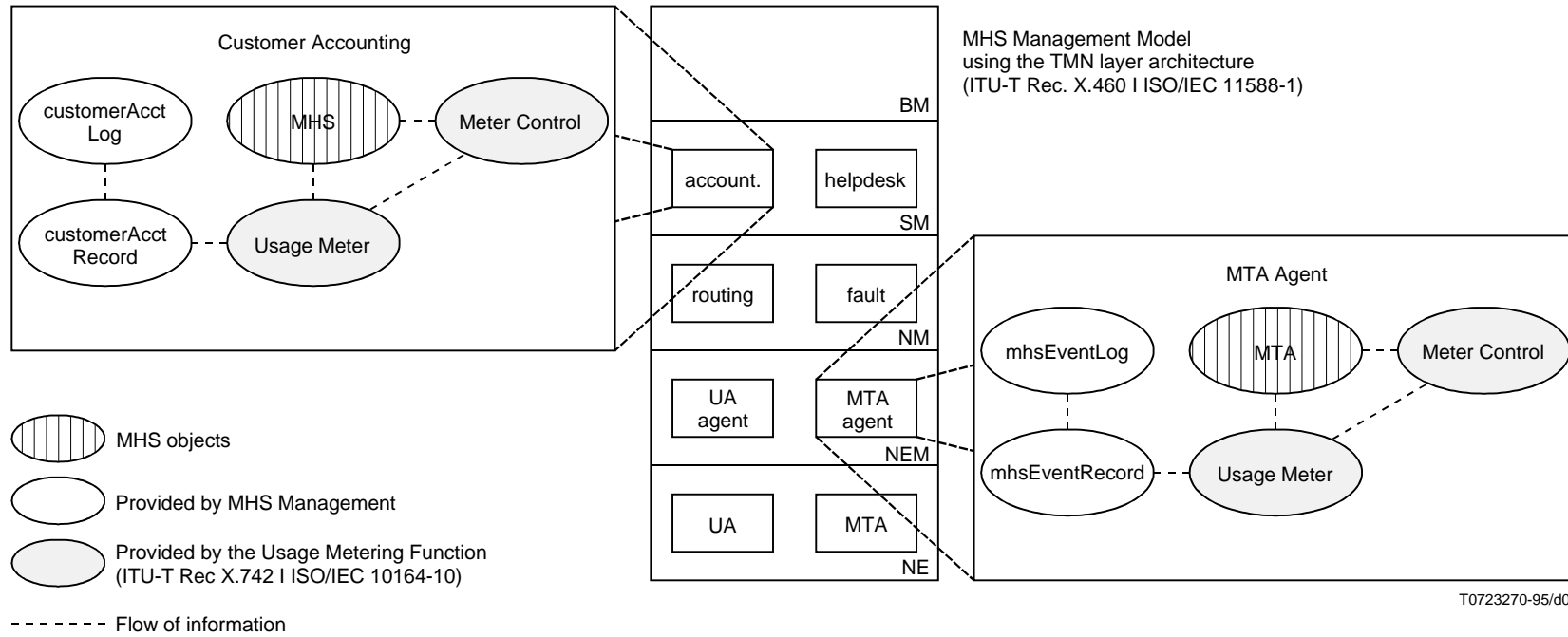

Figure B.1 – Example of Interaction between Logging Information and Rec. X.742 | ISO/IEC 10164-10 for Customer accounting and MTA logging

Annex C

Examples of use of settlement log information

(This annex does not form an integral part of this Recommendation | International Standard)

Model 1

This model illustrates how an ADMD, responsible for billing a client (the domain’s user or the domain’s PRMD), constructs its billing information from settlementAcctLogs maintained by ADMDs involved.

The ADMD responsible for billing would directly 'read' logs maintained by other domains that act on the message. For example, in the case of a message that passes from domain A to domain B and then to C, domain A would read domain B and domain C settlementAcctLogs.

Another model to construct billing information is for further study.

In Figure C.1, each ADMD is modelled as a single MTA. The MTA names and ADMD names are A, B and C respectively. '1' and '2' are PRMDs. Originator is a subscriber of '1'. Recipients are subscriber of '2' and the user of AU '3'.

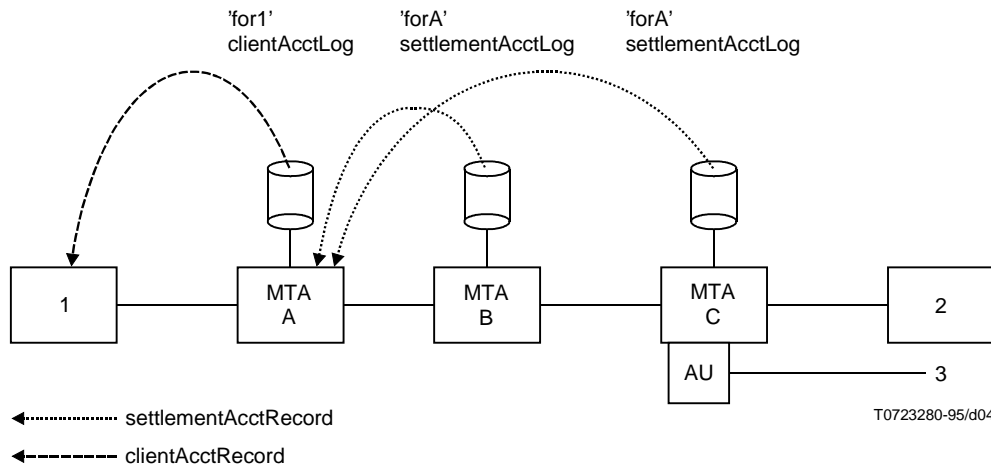

Figure C.1 – Use of Settlement Log Model

**Example 1:** Originator '1' of PRMD '1' sends recipient '2' of PRMD '2'. ADMDs A, B and C agree that A is responsible to bill the PRMD '1'. No dl expansion nor conversion is performed. Exact accounting method is used.

Part a: IPM Message accounting

Message arrives at MTA A from 1, is transferred to MTA B, then MTA C, then is transferred to 2.

Each MTA maintains a log of class mhsEventLog. Each MTA creates records of messageEventRecord class and places them in their respective logs in the following events:

- a) MTA A creates one record in the message-transfer-in and one record in the message-transfer-out;
- b) MTA B creates one record in the message-transfer-in and one record in the message-transfer-out;
- c) MTA C creates one record in the message-transfer-in and one record in the message-transfer-out.

Records of class settlementAcctRecord are produced as follows:

- ADMD C produces settlementAcctRecords and places them in settlementAcctLog named 'forA'. Information in these records is derived from messageEventRecords in MTA C’s mhsEventLog.
- ADMD B produces settlementAcctRecords and places them in settlementAcctLog named 'forA'. Information in these records is derived from messageEventRecords in MTA B’s mhsEventLog.
- ADMD A does not need to maintain a settlementAcctLog.

ADMD A reads 'forA' log of C and 'forA' log of B to produce accounting information. Such information can be placed in clientAcctLog named 'for1'.

**Part b: IPM Notification accounting**

Notification arrives at MTA C from PRMD '2', is transferred to MTA B, then MTA A, then is transferred to PRMD '1'.

Records of class messageEventRecord are created in the following events:

- a) MTA C creates a messageEventRecord in the event of message-transfer-in;
- b) MTA C creates a messageEventRecord in the event of message-transfer-out;
- c) MTA B creates a messageEventRecord in the event of message-transfer-out;
- d) MTA B creates a messageEventRecord in the event of message-transfer-in;
- e) MTA A creates a messageEventRecord in the event of message-transfer-out;
- f) MTA A creates a messageEventRecord in the event of message-transfer-in.

Records of settlementAcctRecord are produced as follows:

- ADMD C produces settlementAcctRecords on settlementAcctLog named 'forA'. Information in these records is derived from messageEventRecords in MTA C's mhsEventLog.
- ADMD B produces settlementAcctRecords and places them in settlementAcctLog named 'forA'. Information in these records is derived from information contained in its own mhsEventLog.
- ADMD A does not produce any settlementAcctRecord.

ADMD A reads 'forA' log of C and 'forA' log of B. Information read is used to produce exact accounting information. Such information can be placed in ADMD A's clientAcctLog named 'for1'. ADMD A does not need to maintain settlementAcctLog.

**Example 2:** Originator '1' sends to '2' with Reverse Charge Accounting. ADMDs A, B and C agree that C is responsible for billing.

Message arrives at MTA A from 1, is transferred to MTA B, then MTA C, then is transferred to 2. Reverse charging is requested for the message.

Records of messageEventRecord class are created in the following events:

- a) MTA A creates a messageEventRecord in the event of message-transfer-out;
- b) MTA A creates a messageEventRecord in the event of message-transfer-in;
- c) MTA B creates a messageEventRecord in the event of message-transfer-out;
- d) MTA B creates a messageEventRecord in the event of message-transfer-in;
- e) MTA C creates a messageEventRecord in the event of message-transfer-out;
- f) MTA C creates a messageEventRecord in the event of message-transfer-in.

Records of settlementAcctRecord are produced as follows:

- ADMD A creates settlementAcctRecord on settlementAcctLog named 'forC'. Information in the records is derived from messageEventRecords in MTA A's msgEventLog.
- ADMD B creates settlementAcctRecord on settlementAcctLog named for 'forC'. Information in the records is derived from transfer out messageEventRecord in MTA B's msgEventLog.

ADMD C reads A's 'forC' and B's 'forC' logs. Information read can be used to produce exact accounting information. This information can be placed in ADMD C's clientAcctLog named 'for2'. ADMD C does not need to maintain a settlementAcctLog.

**Example 3:** Originator '1' sends to AU recipient 3. ADMDs A, B and C agree that A is responsible for billing using exact accounting. Conversion is done at B. Special AU delivery is done at C.

Message arrives at MTA A from subscriber 1, is transferred to MTA B, then MTA C, then is transferred via the Access Unit to recipient 3.

Records of messageEventRecord class are created as follows:

- a) MTA A creates a messageEventRecord in the event of message-transfer-out;
- b) MTA A creates a messageEventRecord in the event of message-transfer-in;
- c) MTA B creates a messageEventRecord in the event of message-transfer-out;
- d) MTA B creates a messageEventRecord in the event of message-transfer-in;
- e) MTA C creates a messageEventRecord in the event of ...

In addition, MTA B creates conversionEventRecord in the event of conversion.

Records of settlementAcctRecord are produced as follows:

- ADMD A creates settlementAcctRecord in settlementAcctLog named 'forC'. Information in the records is derived from messageEventRecords.
- ADMD B creates settlementAcctRecord in settlementAcctLog named 'forC'. Information in the records is derived from messageEventRecords.

ADMD C reads 'forC' of A and 'forC' of B. Information read is used to produce the exact accounting information. That information can be placed in clientAcctLog 'for2'. ADMD C is not required to maintain a settlementAcctLog.

### Model 2

This model illustrates how an ADMD, responsible for billing a client (the domain's user or the domain's PRMD), constructs its billing information from settlementAcctLogs maintained by ADMDs involved.

In this model, an ADMD 'reads' the settlementAcctLog of its adjacent ADMD towards which it has transferred a message. Using the settlementAcctRecords and its own messageEventRecords, it constructs the settlementAcctRecords to be read by the ADMD from which the message comes.

Consider the case where a message passes from ADMD A to ADMD B where it was split into two; one goes to ADMD C and one goes to ADMD D. In this case, ADMD B would read ADMD C's and ADMD D's settlementAcctLogs. Using the read settlementAcctRecords and its own messageEventRecords, ADMD B constructs its own settlementAcctRecords and places them in its own settlementAcctLog to be read by ADMD A.

In Figure C.2, each ADMD is modelled as a single MTA. The MTA names and ADMD names are A, B and C respectively. '1' and '2' are PRMDs. Originator is a subscriber of '1'. Recipients are subscriber of '2' and the user of AU '3'.

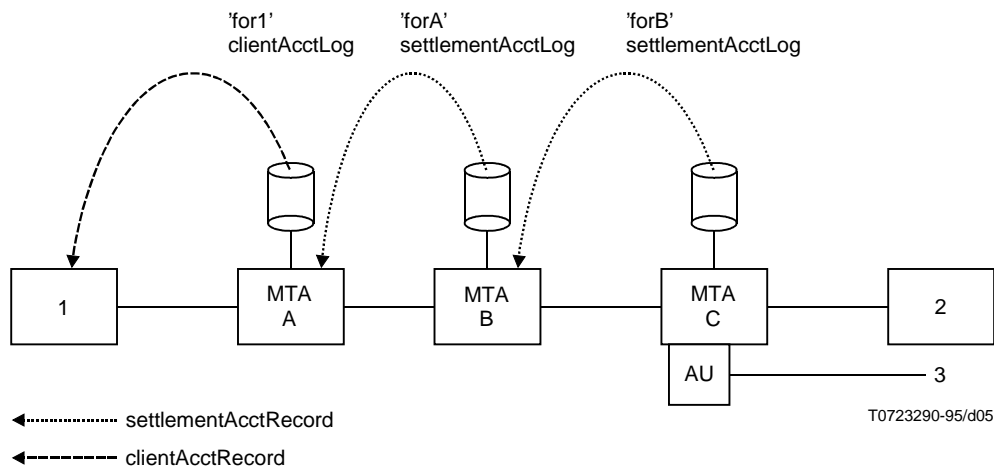

Figure C.2 – Use of Settlement Log Model 2

**Example 1:** Originator '1' of PRMD '1' sends a message to recipient '2' of PRMD '2'. ADMDs A is responsible to bill the PRMD '1'. No dl expansion nor conversion is performed. Exact accounting method is used.

**Part a: IPM Message accounting**

Message arrives at MTA A from 1, is transferred to MTA B, then MTA C, then is transferred to 2.

Each MTA maintains a log of class mhsEventLog. Each MTA creates records of messageEventRecord class and places them in their respective logs in the following events:

- a) MTA A creates one record in the message-transfer-in and one record in the message-transfer-out;
- b) MTA B creates one record in the message-transfer-in and one record in the message-transfer-out;
- c) MTA C creates one record in the message-transfer-in and one record in the message-transfer-out.

Records of class settlementAcctRecord are produced as follows:

- ADMD C produces settlementAcctRecords and places them in settlementAcctLog named 'forB'. Information in these records is derived from messageEventRecords in MTA C's mhsEventLog.
- ADMD B produces settlementAcctRecords and places them in settlementAcctLog named 'forA'. Information in these records is derived from information contained in settlementAcctRecords in MTA C's settlementAcctLog and information in its own mhsEventLog.
- ADMD C does not maintain a settlementAcctLog.

ADMD A produces clientAcctRecords and places them in clientAcctLog named 'for1'. Information in these records is derived from information contained in messageEventRecords in MTA B's settlementAcctLog and information in its own mhsEventLog.

**Part b: IPM Notification accounting**

Notification arrives at MTA C from PRMD '2', is transferred to MTA B, then MTA A, then is transferred to PRMD '1'.

Records of class messageEventRecord are created in the following events:

- a) MTA C creates a messageEventRecord in the event of message-transfer-in;
- b) MTA C creates a messageEventRecord in the event of message-transfer-out;
- c) MTA B creates a messageEventRecord in the event of message-transfer-out;
- d) MTA B creates a messageEventRecord in the event of message-transfer-in;
- e) MTA A creates a messageEventRecord in the event of message-transfer-out;
- f) MTA A creates a messageEventRecord in the event of message-transfer-in.

Records of settlementAcctRecord are produced as follows:

- ADMD C creates settlementAcctRecords in settlementAcctLog named 'forB'. Information in these records is derived from messageEventRecords in MTA C's mhsEventLog.
- ADMD B produces settlementAcctRecords and places them in settlementAcctLog named 'forA'. These records contained information derived from ADMD C's settlementAcctRecords and its own messageEventRecords.
- ADMD A does not produce any settlementAcctRecord.

ADMD A reads 'forA' log of B. Information read is used to produce exact accounting information. Such information can be placed in ADMD A's clientAcctLog named 'for1'.

**Example 2:** Originator '1' sends to '2' with Reverse Charge Accounting. ADMD C is responsible for billing.

Message arrives at MTA A from 1, is transferred to MTA B, then MTA C, then is transferred to 2. Reverse charging is requested for the message.

Records of messageEventRecord class are created in the following events:

- a) MTA A creates a messageEventRecord in the event of message-transfer-out;
- b) MTA A creates a messageEventRecord in the event of message-transfer-in;
- c) MTA B creates a messageEventRecord in the event of message-transfer-out;
- d) MTA B creates a messageEventRecord in the event of message-transfer-in;
- e) MTA C creates a messageEventRecord in the event of message-transfer-out;
- f) MTA C creates a messageEventRecord in the event of message-transfer-in.

## ISO/IEC 11588-3 : 1997 (E)

Records of settlementAcctRecord are produced as follows:

- ADMD A produces settlementAcctRecord on settlementAcctLog named 'forB'. Information in the records is derived from messageEventRecords in MTA A's msgEventLog.
- ADMD B creates settlementAcctRecord on settlementAcctLog named 'forC'. Information in the records is derived from information contained in its own msgEventLog and that in ADMD A's settlementAcctLog.
- ADMD C does not produce any settlementAcctRecord.

ADMD C reads B's 'forC' log. Information read can be used to produce exact accounting information. This information can be placed in ADMD C's clientAcctLog named 'for2'.

**Example 3:** Originator '1' sends to AU recipient 3. ADMDs A, B and C agree that A is responsible for billing using exact accounting. Conversion is done at B. Special AU delivery is done at C.

Message arrives at MTA A from subscriber 1, is transferred to MTA B, then MTA C, then is transferred via the Access Unit to recipient 3.

Records of messageEventRecord class are created as follows:

- a) MTA A creates a messageEventRecord in the event of message-transfer-out;
- b) MTA A creates a messageEventRecord in the event of message-transfer-in;
- c) MTA B creates a messageEventRecord in the event of message-transfer-out;
- d) MTA B creates a conversionEventRecord in the event of conversion (explicit/implicit);
- e) MTA B creates a messageEventRecord in the event of message-transfer-in;
- f) MTA C creates a messageEventRecord in the event of ...

In addition, MTA B creates conversionEventRecord in the event of conversion.

Records of settlementAcctRecord are produced as follows:

- ADMD C produces settlementAcctRecord in settlementAcctLog named 'forB'. Information in the records is derived from messageEventRecords.
- ADMD B produces settlementAcctRecord in settlementAcctLog named 'forA'. Information in the records is derived from that contained in its own msgEventLog and that contained in ADMD C's settlementAcctLog.
- ADMD A does not produce any settlementAcctRecords.

ADMD A reads settlementAcctLog named 'forB' in ADMD B. Information read is used to produce the exact accounting information. That information can be placed in clientAcctLog 'for 1'.



## ITU-T RECOMMENDATIONS SERIES

- Series A Organization of the work of the ITU-T
- Series B Means of expression
- Series C General telecommunication statistics
- Series D General tariff principles
- Series E Telephone network and ISDN
- Series F Non-telephone telecommunication services
- Series G Transmission systems and media
- Series H Transmission of non-telephone signals
- Series I Integrated services digital network
- Series J Transmission of sound-programme and television signals
- Series K Protection against interference
- Series L Construction, installation and protection of cables and other elements of outside plant
- Series M Maintenance: international transmission systems, telephone circuits, telegraphy, facsimile and leased circuits
- Series N Maintenance: international sound-programme and television transmission circuits
- Series O Specifications of measuring equipment
- Series P Telephone transmission quality
- Series Q Switching and signalling
- Series R Telegraph transmission
- Series S Telegraph services terminal equipment
- Series T Terminal equipments and protocols for telematic services
- Series U Telegraph switching
- Series V Data communication over the telephone network
- Series X Data networks and open system communication**
- Series Z Programming languages