

# Standardization in ITU-T Study Group 15 and Q13/15

Networks, Technologies and Infrastructures for Transport,  
Access and Home:  
Network synchronization and time distribution performance

*Stefano Ruffini (Q13 Rapporteur)*

*Silvana Rodrigues (Q13 Associate Rapporteur)*

# SG15 mandate

SG15 is responsible for the development of **standards** on:

**optical transport  
network**

**systems**

**instrumentation  
and  
measurement  
techniques**

**access network**

**equipment**

**maintenance**

**management**

**test**

**home network and  
power utility network  
infrastructures**

**optical fibres and cables and  
their related installation**

**control plane technologies**

to enable the evolution toward intelligent transport networks, including the support of smart-grid applications.



# SG15 Working Parties

- **WP1/15:** Transport aspects of access, home and smart grid networks
- **WP2/15:** Optical technologies and physical infrastructures
- **WP3/15:** Transport network characteristics

# WP1 – Broadband Access

**G.FAST**

Broadband access  
up to 2 Gbps

**G.mgfast**

Next generation  
G.fast targeting 5-10 Gbps

**DTA**

G.fast dynamic time assignment  
(DTA) – downstream/upstream  
bit-rates responsive to  
customer traffic



Continue collaboration with



**G.RoF**

Radio over fiber  
for mobile fronthaul



**NG-PON2**

Next generation of  
converged fiber access  
going to higher speeds



Visible Light  
Communication  
for home networking



Powerline  
communication  
(PLC)

**G.Hn**

G.hn home networking over  
indoor phone, power,  
and coax wires >2 Gbps

# WP2 – Optical Technologies

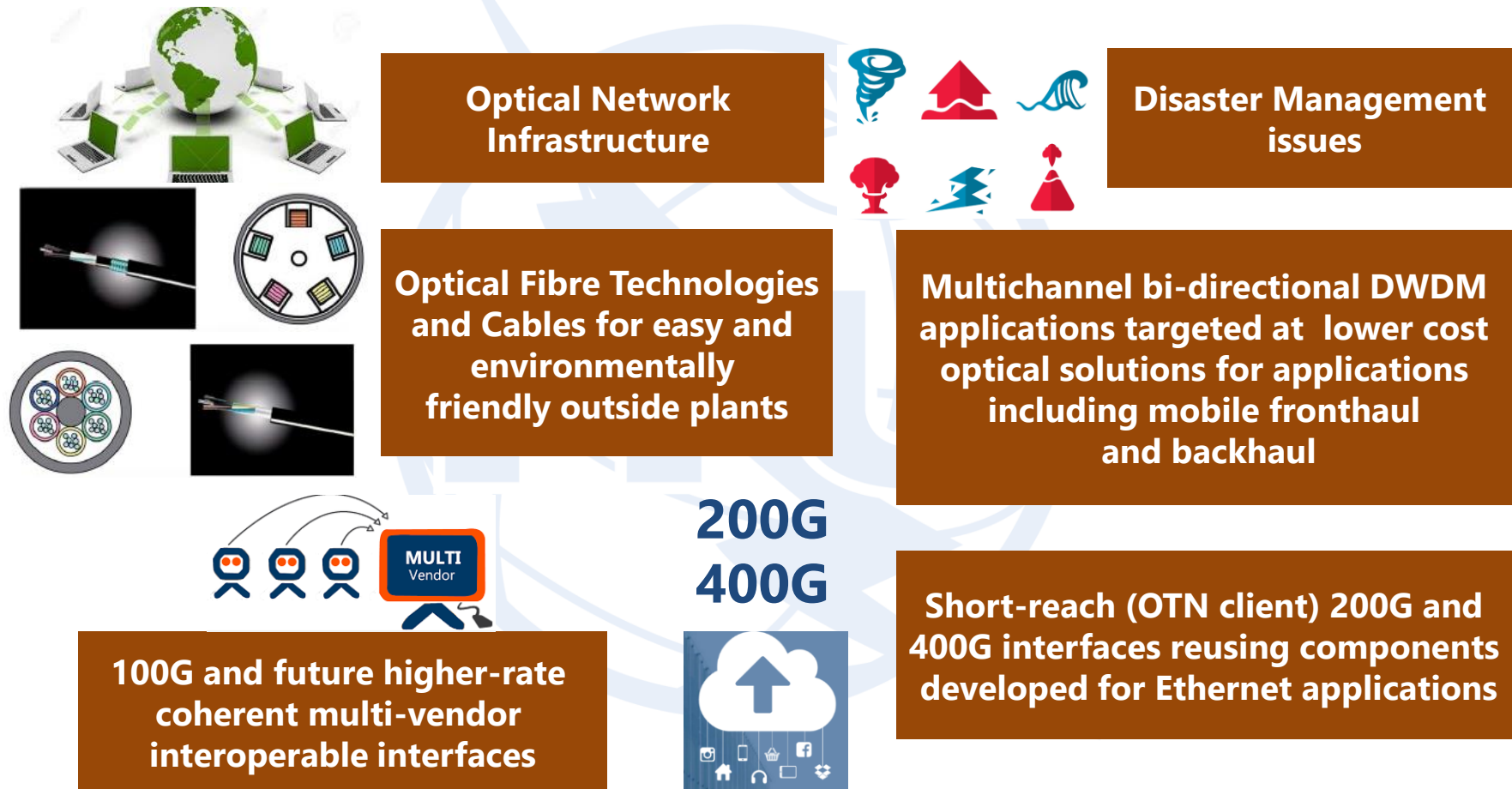

# WP3 – Optical Transport Networks

**5G**

Transport and synchronization supporting 5G mobile fronthaul and backhaul

Optical Transport Networks

Synchronization of packet networks and future OTN networks, e.g., beyond 100G



Architecture and other Transport SDN Aspects



Network survivability (protection and restoration)

**BEYOND 100G**

New “B100G” OTN interfaces, including the use of coherent G.698.2 interfaces under development



Management aspects of control and transport planes



Equipment & management specifications for OTN, Ethernet and MPLS-TP



Core Information model enhancement for management of synchronization and optical media

# Meetings

- Past meetings since 2017
  - Geneva, 19 – 30 June 2017
  - Geneva, 29 January – 9 February 2018
  - Geneva, 8-19 October 2018
  - Geneva, 1 – 12 July 2019
  - Geneva, 27 January – 7 February 2020
- Future SG15 meeting
  - Geneva, 7-18 September 2020

2017-2020  
Study Period

# Q13: Introduction

- Network synchronization and time distribution performance
  - Networks Timing Needs (e.g., OTN)
  - End Applications Timing Needs (e.g. 5G Base Stations)
- Distribution of Time-Phase and Frequency
  - Methods (e.g., over physical layer, via packets, GNSS)
  - Architectures
  - Clocks
  - IEEE 1588 profiles
  - Performance, Redundancy, Reliability, etc.
- Networks
  - From SDH to Ethernet, IP-MPLS, OTN, xPON, ... -> MTN
- Recommendations
  - G.826x series (distribution of frequency synchronziation)
  - G.827x series (Distribution fo time synchronzation)
  - G.781, G.781.1 (Sync Layer Functions)
  - «Historical» (G.803, G.810, G.811, G.812, G.813, G.823, G.824, G.825...)

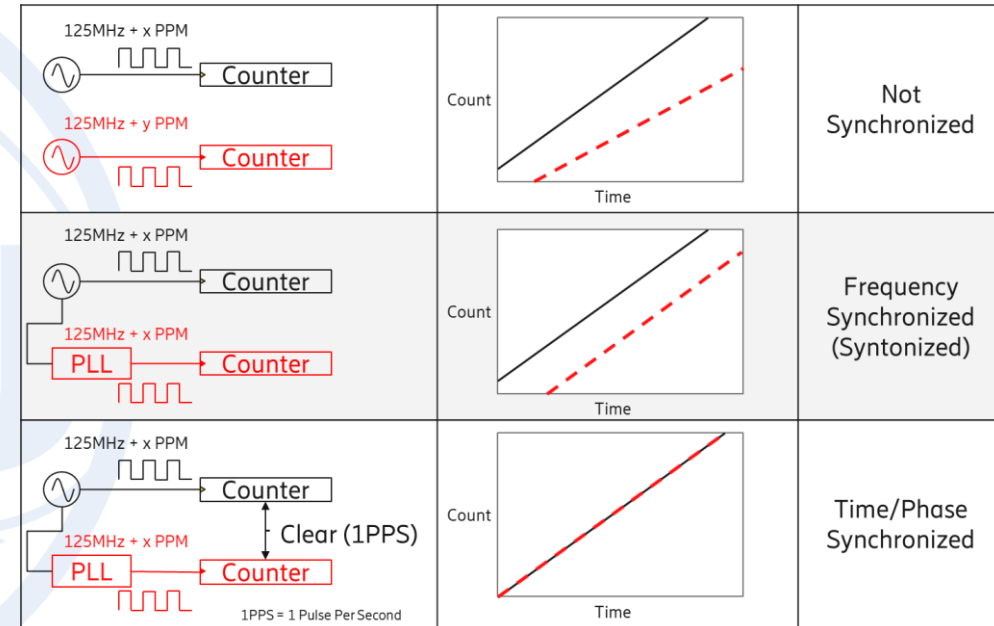



# Q13 Recommendations

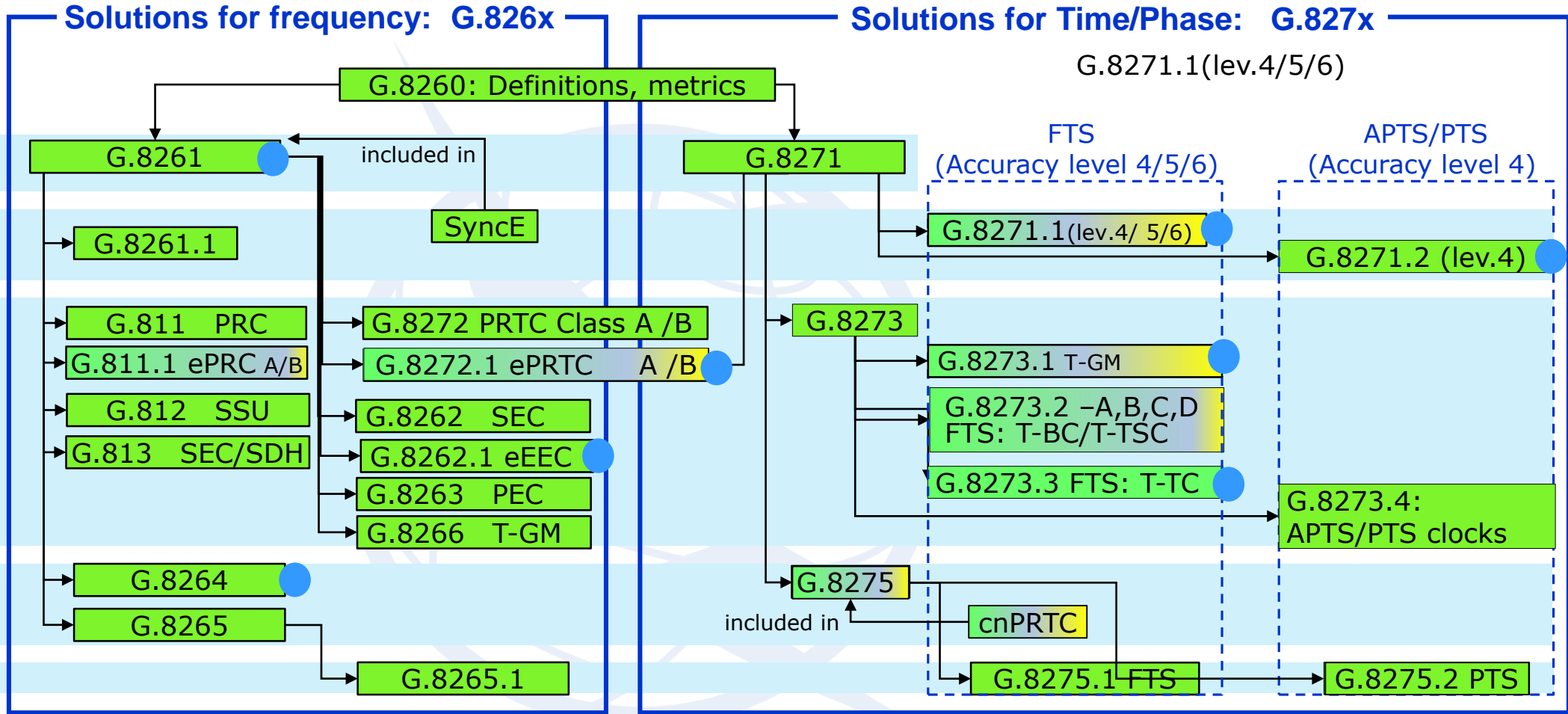

Synchronization	Layer Functions	G.781	G.781.1
Interfaces	G.703	Technical Report	G.Supp.GNSS
OAM	G.Suppl.SyncOAM	Simulation Background	G.Supp.sim

## Related recommendations

Legend:  
Agreed ongoing

New Rec/Rev/  
 Amd  
 09-2020



# Ongoing Studies: Fronthaul (G.8271.1)

- Under analysis guidelines for network dimensioning
- Use of G.8273.2 Clock Class C is generally assumed
- Use of enhanced Synchronous Ethernet
- Initial assumptions : short clock chain (e.g.,  $M < 3-5$  )

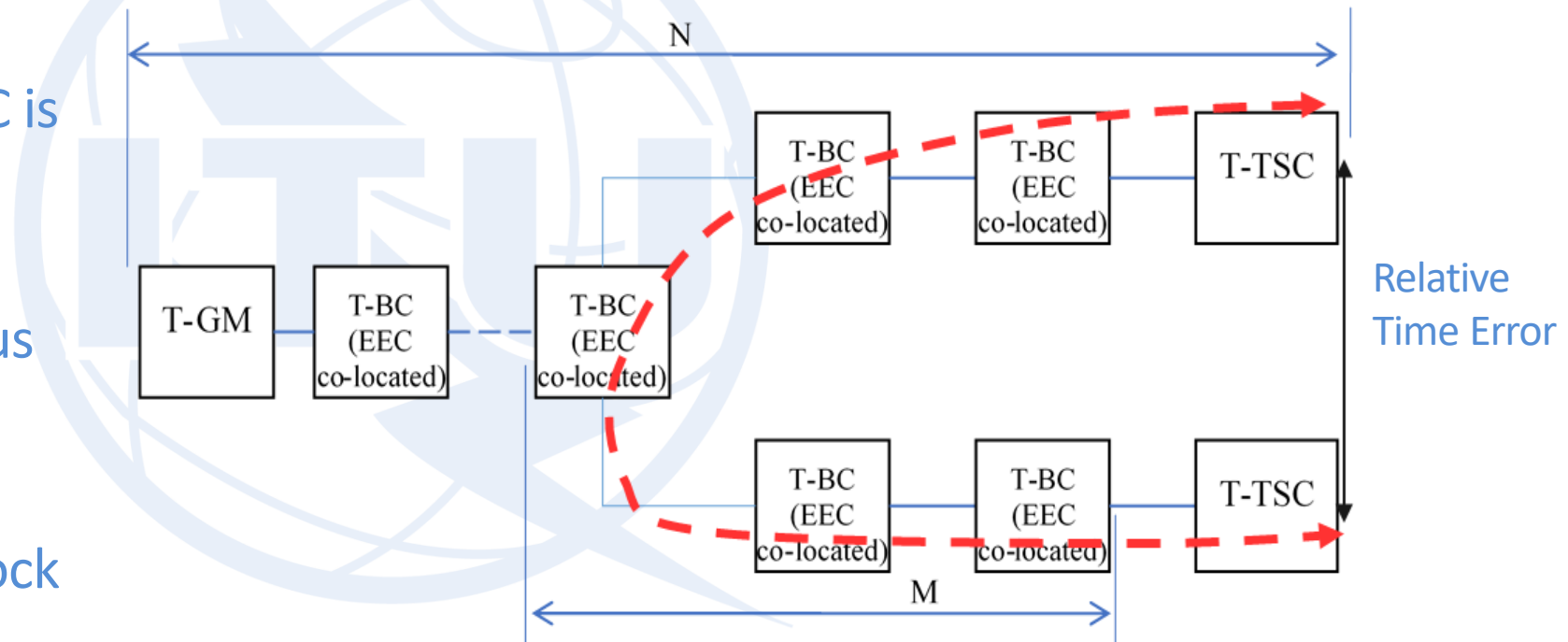

# What is Next ?

- MTN, Metro Transport Network  
(based on FlexE for 5G transport network)

- Sync Requirements
- Sync Architecture
- PTP and syncE distribution
- Clocks

- Complete work on Profile Interworking

- Complete work on cnPRTC (Coherent PRTC)

- Requirements
- Methods (high accuracy profile?)

- Address New Sync Requirements

- Emerging needs in mobile networks  
(positioning or even use cases with  
less stringent requirements);
- Future needs ?

*The coherent network PRTC connects primary reference clocks at the highest core or regional network level. This provides the ability to maintain network-wide ePRTC time accuracy, even during periods of regional or network-wide GNSS loss (G.8275)*

