

Arturas Medeisis ITU Expert (VGTU, Lithuania)
István Bozsoki, BDT, ITU

SPECTRUM MANAGEMENT TRENDS: TOWARDS 2020

Radio spectrum - a most crucial resource to ensure **stable operation and further development of wireless communication services** and applications: from high-tech interstellar science research to humble garage door openers

TIME TO CRANK EFFICIENCY OF SPECTRUM USE,
TIME TO SHARE IT EVEN MORE...

Radio Spectrum Management IN THE AGE OF SHARING

ADVANCE COPY

Report



Telecommunication Development Sector



PRESENTATION OUTLINE

- ✘ Role of Spectrum Management (SM)
- ✘ Institutional best practices of SM
- ✘ Forward-looking planning of frequencies
- ✘ Novel licensing approaches
- ✘ Economic aspects of SM
- ✘ Interference monitoring and enforcement
- ✘ International harmonisation

PRESENTATION OUTLINE

Role of Spectrum Management (SM)

- ✘ Institutional best practices of SM
- ✘ Forward-looking planning of frequencies
- ✘ Novel licensing approaches
- ✘ Economic aspects of SM
- ✘ Interference monitoring and enforcement
- ✘ International harmonisation

ROLE OF SPECTRUM MANAGEMENT

Features	Natural Resource			
	Spectrum	Land	Oil	Water
Is the resource varied?	YES	YES	Not very	Not very
Is it scarce?	YES	YES	YES	YES
Can it be made more productive?	YES	YES	YES	NO
Is it renewable?	YES	Partially	NO	YES
Can it be stored for later use?	NO	NO	YES	YES
Can it be exported?	NO	NO	YES	YES
Can it be traded?	YES	YES	YES	YES

BROADBAND PENETRATION ACROSS THE GLOBE

Broadband may be seen as **key driving force** for development of consumer wireless service.

Figure shows percentage of penetration, source: ITU

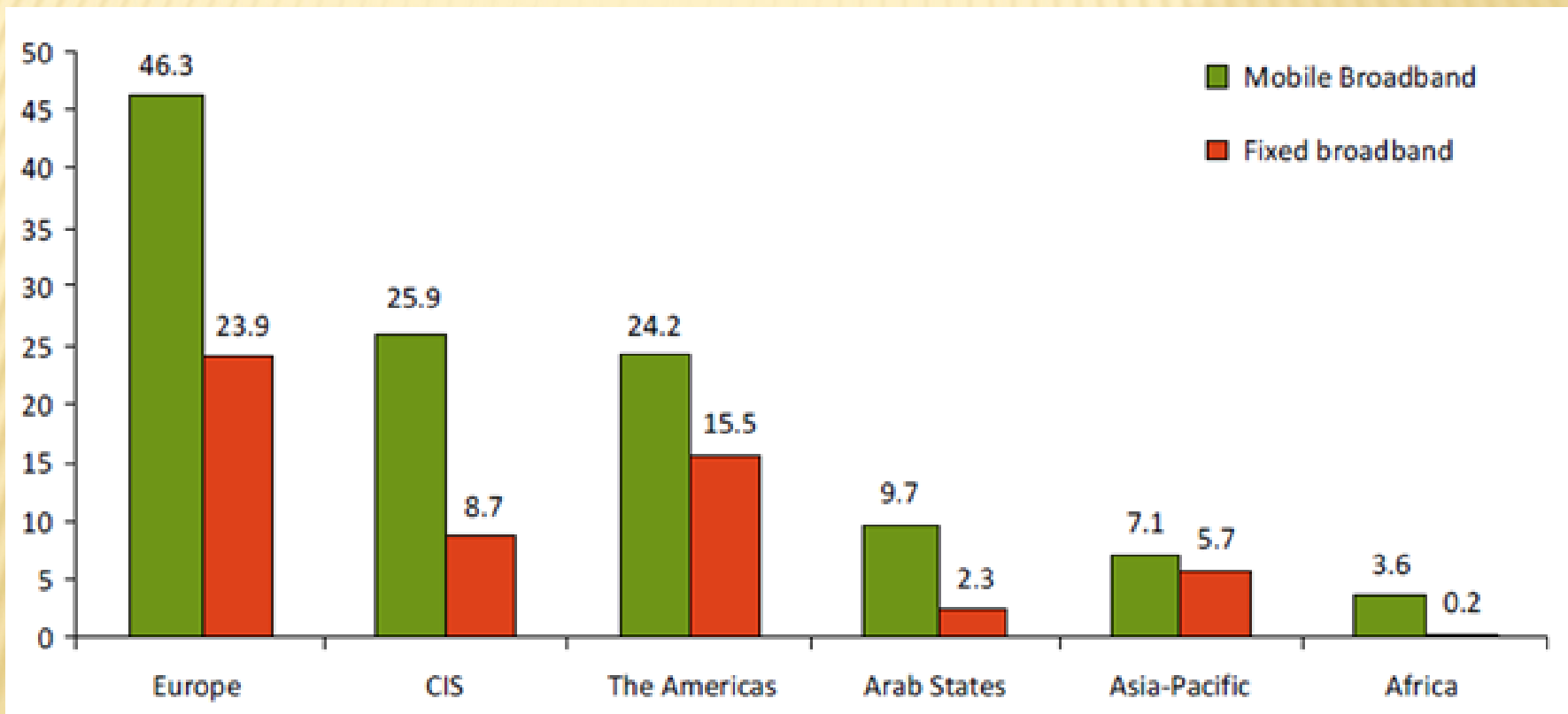

FORECASTED EXPLOSION OF WIRELESS DATA

Future traffic is going to be driven by predominant smartphone and mobile PC/tablet market segments.

Source: Ericsson/The Economist (Oct. 2012)

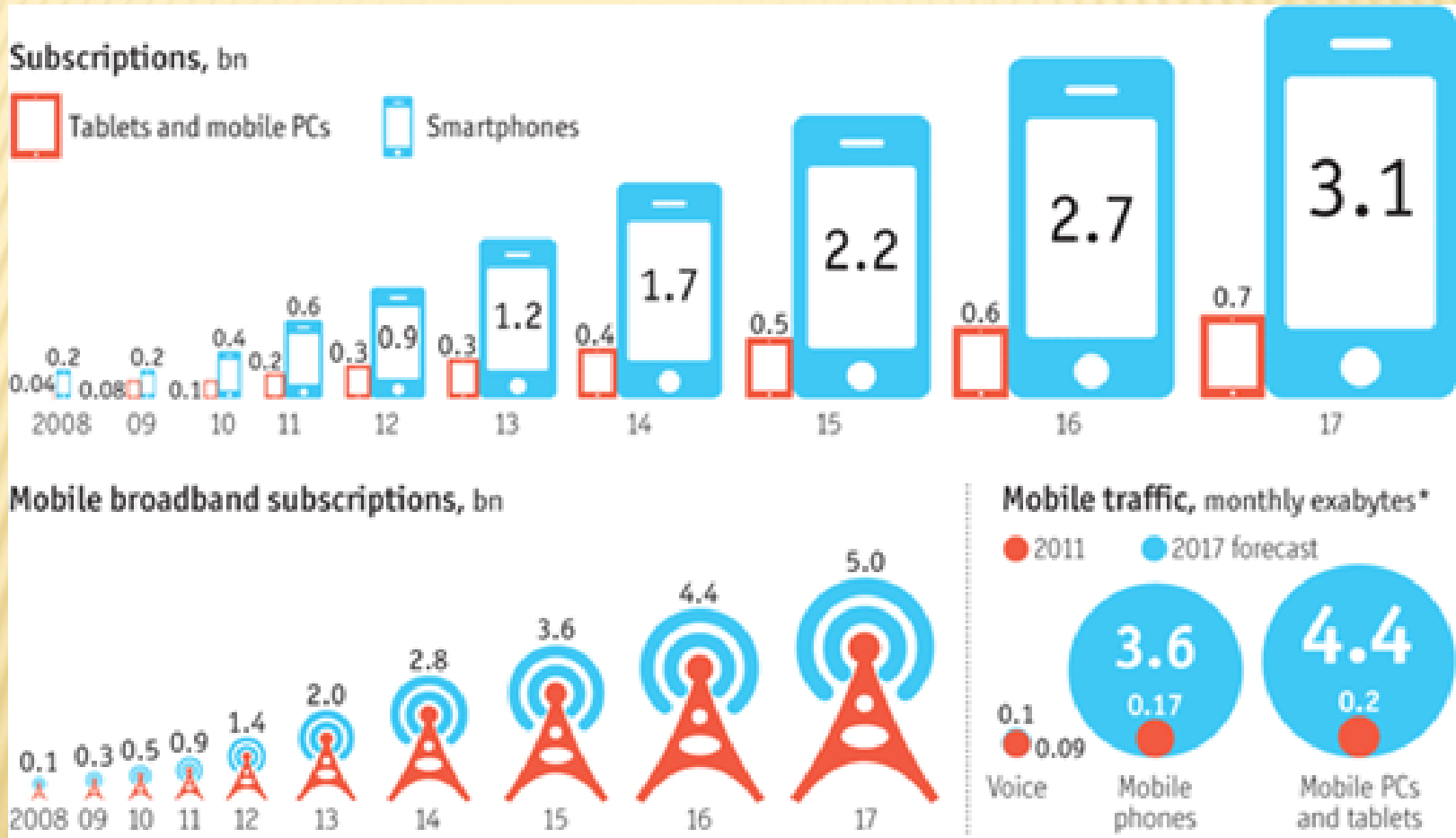

PRESENTATION OUTLINE

- ✘ Role of Spectrum Management (SM)

Institutional best practices of SM

- ✘ Forward-looking planning of frequencies
- ✘ Novel licensing approaches
- ✘ Economic aspects of SM
- ✘ Interference monitoring and enforcement
- ✘ International harmonisation

INSTITUTIONAL BEST PRACTICES (I)

- × **Setting up efficient SM organization:**
 - + Achieving streamlined and efficient SM on both short-term and long-term basis, **allocating spectrum in an economic and efficient manner**, and by relying on market forces, economic incentives and technical innovations
- × **Transparency of SM operations:**
 - + Promoting transparent, non-discriminatory, economically efficient and **effective SM policies**, that provide regulatory certainty
- × **Technological neutrality and flexible spectrum use:**
 - + Promoting wireless innovation, by creating conditions for the **development of new services**, reducing investment risks and stimulating competition among different technologies, including facilitating entry into market of **new competitors**

ROLE OF SM: VISION TOWARDS 2020

- ✘ Radio spectrum shall continue playing ever **more vital role in provisioning of broad variety of radiocommunications services** - public, private and governmental alike
- ✘ Especially the continued growth of public **demand for mobile broadband services** shall be putting **pressure on spectrum managers**, requiring them to find solutions to ensure unrestricted long term growth of those services, through **allocating new bands** and finding innovative ways of **more efficient utilisation of spectrum**

INSTITUTIONAL BEST PRACTICES (II)

- × **Timely availability and efficient use of spectrum:**
 - + Facilitating timely introduction of **new applications and technology**, while protecting existing services from harmful interference; ensuring most efficient use of radio spectrum
- × **International harmonization:**
 - + Aligning domestic spectrum policies with internationally recommended, in order to achieve **faster take-up of new bands** and economies of scale
- × **Affordable and fair spectrum access:**
 - + Reducing financial barriers for new wireless entrants to the market and promoting **development of wireless technologies**, especially in less developed areas
 - + Ensuring that all wireless players have **equitable and fair access** to spectrum resources

MANDATE OF MODERN NRA

Increasing trend towards seeing ICT policy and regulation as integral part of overall national infrastructure provisioning platform.

Source: ITU, based on data from 158 countries

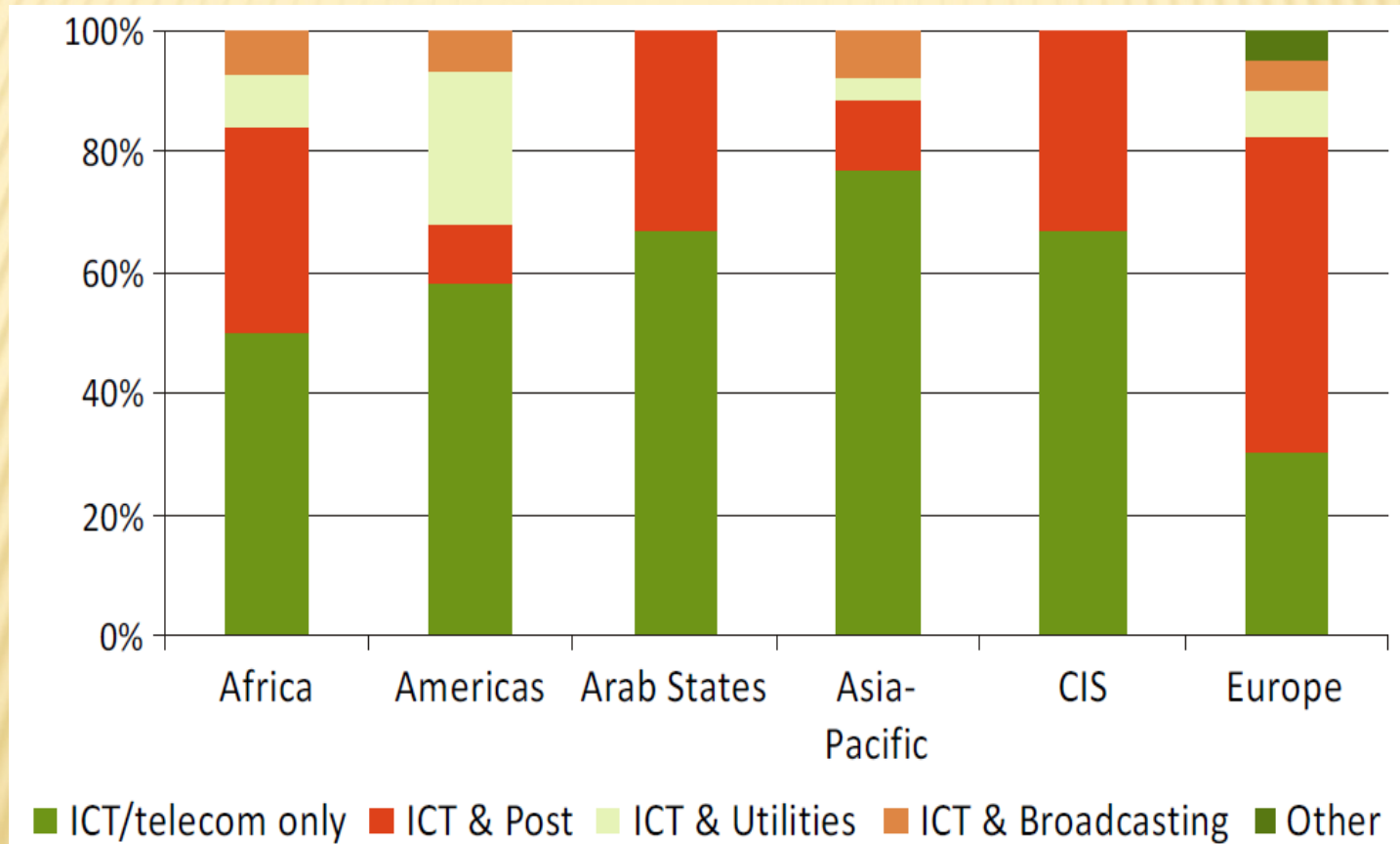

TYPICAL AUTOMATED SPECTRUM MANAGEMENT SYSTEM (ASMS)

ASMS is today a critical constituent element of a lean and efficient SM organisation.

NRAs will be able to increasingly use public web interfaces to their ASMS with the aim of providing broad set of spectrum use data for transparency purposes and making use of self-service opportunities.

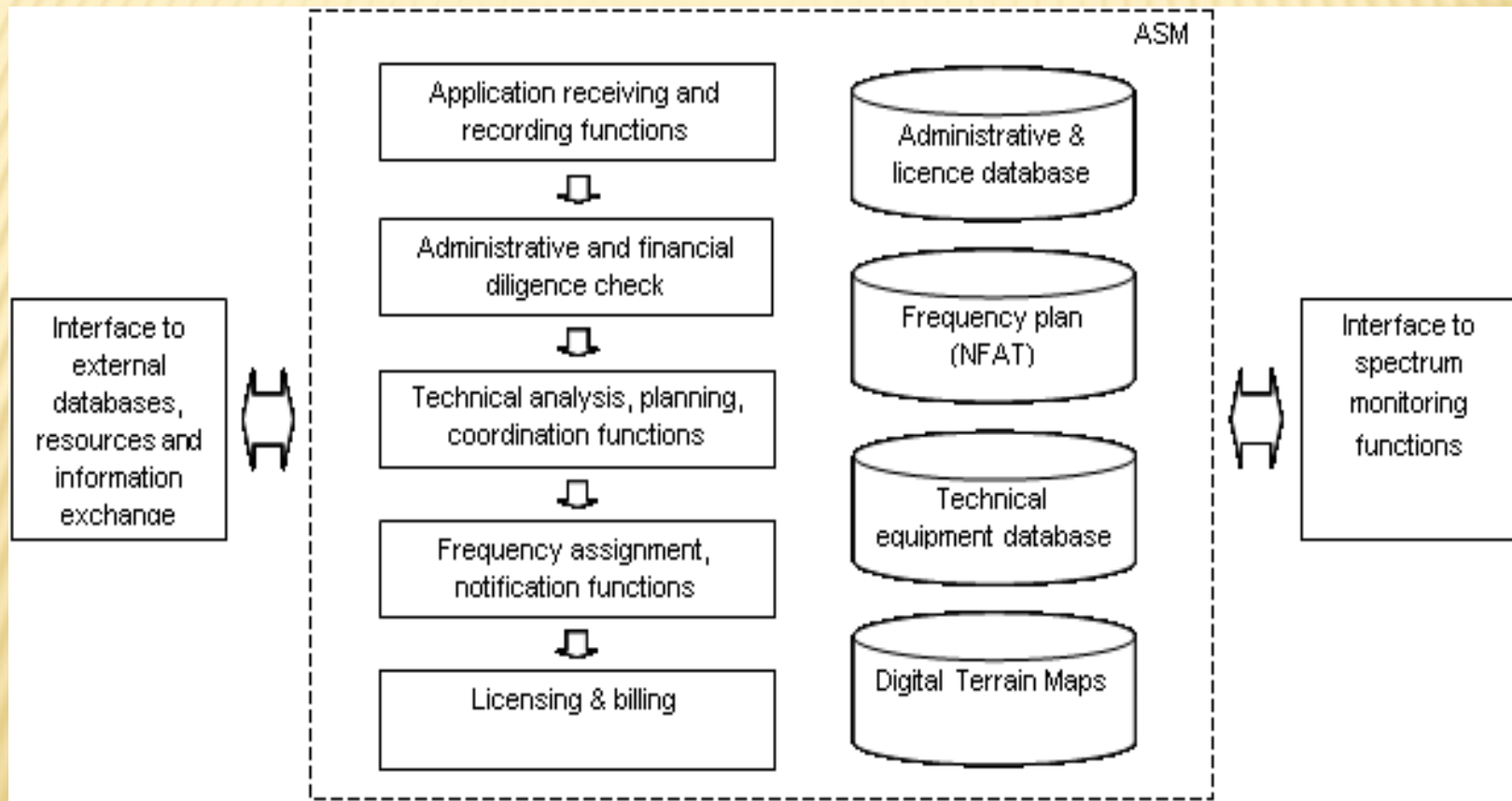

SM ORGANISATION TOWARDS 2020

- ✘ To stay current with time, modern NRA will be an **independent professional organization**, operating within a lean structure of national SM governance and using automated tools with increased **transparency**
- ✘ It will be increasingly important to study and where found appropriate, implement **recommendations from ITU** and learn from elsewhere as regards best SM practices to ensure transparency and soundness of operations, while maintaining **confidence and respect of the wireless industry** stakeholders
- ✘ The key to efficient spectrum utilisation will be in developing system of **incentives for market players**

PRESENTATION OUTLINE

- ✘ Role of Spectrum Management (SM)
- ✘ Institutional best practices of SM

Forward-looking planning of frequencies

- ✘ Novel licensing approaches
- ✘ Economic aspects of SM
- ✘ Interference monitoring and enforcement
- ✘ International harmonisation

PLANNING OF FREQUENCY USE

- ✘ **Market consultations and self-regulation** as means of deciding the most economical way to utilise spectrum are gaining importance
- ✘ Yet **centralised planning** will retain its role where broader objectives of spectrum allocation and use efficiency may be at stake

SM method	% of spectrum allocated in the UK (source: Ofcom)	
	Year 2000	Year 2010
Administrative	96 %	22 %
Market	0 %	71 %
Commons	4 %	7 %

IMPACT OF NEW TECHNOLOGIES

- ✘ Advanced wireless technologies increasingly possess features of **dynamic re-configurability** and “intelligent” spectrum access agility
- ✘ This leads to new spectrum use concepts such as **Dynamic Spectrum Access** or White Space utilisation

FREQUENCY PLANNING TOWARDS 2020

- ✘ Existing administrative national and international frequency planning processes shall retain their relevance especially as regards any **re-alignment of spectrum allocations** at the level of ITU Radio Regulations and establishment of regional plans for **harmonised frequency use** by broadcasting and other services
- ✘ Nevertheless, the proportion of **flexible allocations** allowing markets to self-determine the best utilisation of spectrum will continue to grow, empowered by emergence of **new technologies** such as Geolocation databases and Cognitive Radio, which may be expected to gain widespread use by the end of the decade

PRESENTATION OUTLINE

- ✘ Role of Spectrum Management (SM)
- ✘ Institutional best practices of SM
- ✘ Forward-looking planning of frequencies

Novel licensing approaches

- ✘ Economic aspects of SM
- ✘ Interference monitoring and enforcement
- ✘ International harmonisation

SPECTRUM LICENSING

- ✘ The borderline between traditional polarised approaches of **exclusive licensing vs. licence-exempt use** is gradually becoming diluted by appearance of novel compromising solutions that promote various forms and degrees of organised sharing of spectrum:
 - + Light-licensing
 - + Authorised Shared Access/Licensed Shared Access
 - + Pluralistic Licensing, etc.

DIFFERENT DIMENSIONS OF SPECTRUM LICENSING

The pyramid depicts the hierarchical view of **spectrum access licensing forms**, complemented by reference to other commonly used terms that refer to identical, yet sometime subtly different licensing types.

Source: adapted from US PCAST report 2012.

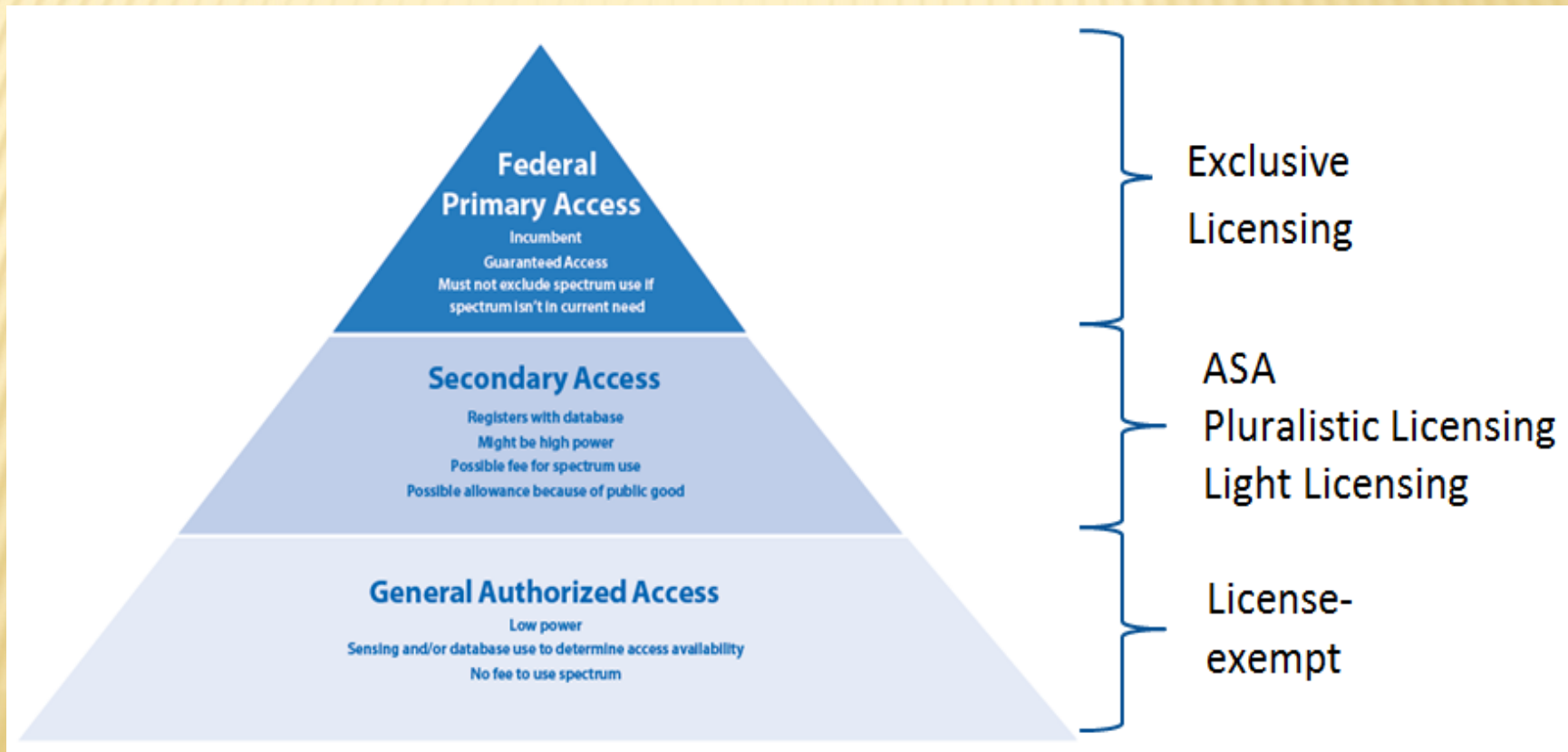

LICENSED SHARED ACCESS CONCEPT

Licensed Shared Access (LSA, similar to ASA, Authorised Shared Access) envisions possibility of **centrally controlled dynamic sharing of spectrum**. This concept is especially suited for adaptable spectrum consumption by future “Heterogeneous Networks” (HetNets)

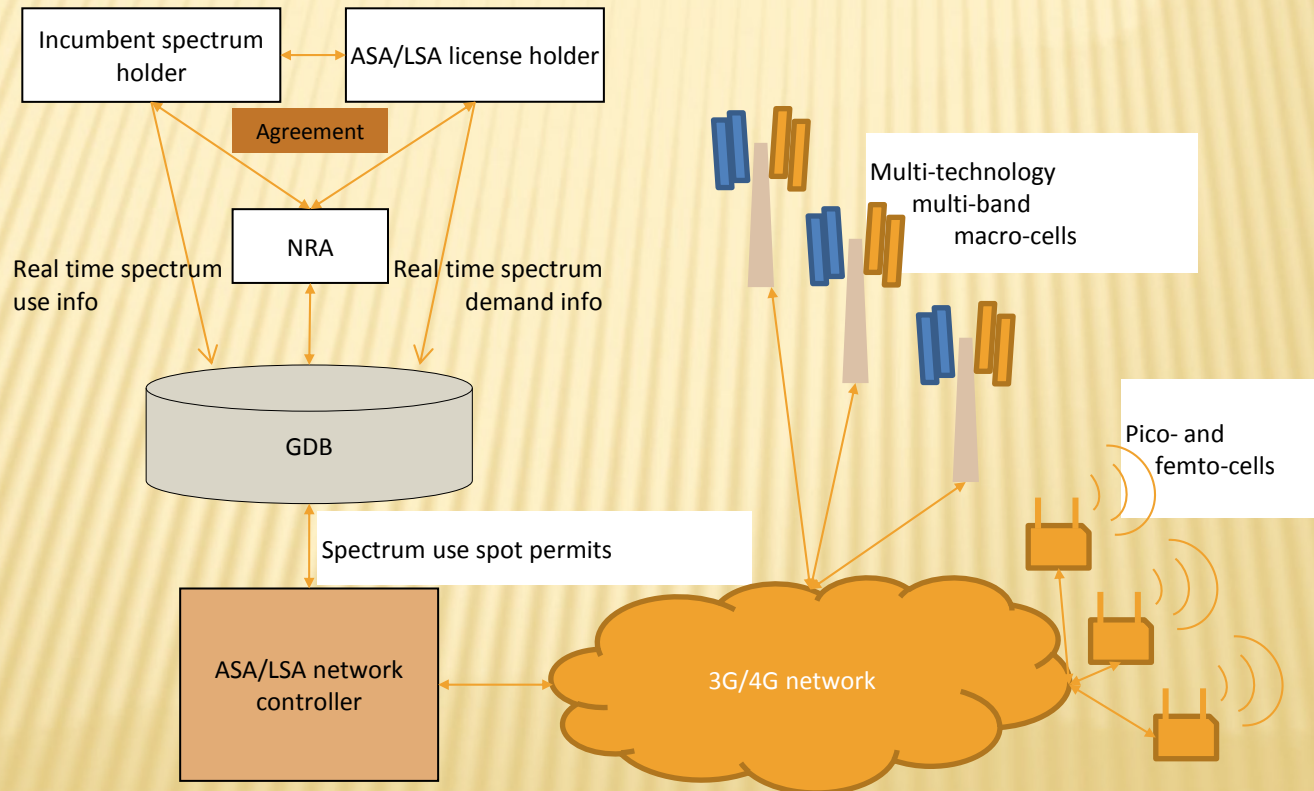

LICENSING TOWARDS 2020

- ✘ NRAs shall retain principal use of both **auctions** and “**beauty contests**” as main tools for awarding of *operating* licenses
- ✘ Similarly, the existing *radio apparatus licensing/authorization* schemes will all retain their value and use depending on the circumstances of specific bands and services
- ✘ Moreover, the NRAs’ authorization toolbox shall be enriched by further additions of licensing schemes that will allow **various arrangements** and degrees of shared use of spectrum resource

PRESENTATION OUTLINE

- ✘ Role of Spectrum Management (SM)
- ✘ Institutional best practices of SM
- ✘ Forward-looking planning of frequencies
- ✘ Novel licensing approaches

Economic aspects of SM

- ✘ Interference monitoring and enforcement
- ✘ International harmonisation

ECONOMIC ASPECTS OF SM

- ✘ Various **economic SM** tools are by now well established and tested
- ✘ Can be invoked in **three different stages** of the spectrum use cycle:
 - + to increase efficiency of **initial spectrum distribution** in the licensing process (cf. auctions)
 - + to increase efficiency of **spectrum use by the license holder** (cf. Administrative Incentive Pricing)
 - + to increase timeliness and efficiency of **re-distribution** of inefficiently used spectrum (cf. AIP)

SPECTRUM RE-FARMING IN FRANCE

One of global success stories in applying economic tools to increase efficiency of spectrum use, **French administration** succeeded in timely re-allocation of more than 1 GHz of spectrum over a decade since 1998

Source: ANFR, 2011

System	Spectrum amount	Tranfered from
GSM 900	50 MHz	Defense
GSM 1800	150 MHz	Defense
UMTS 2 GHz	140 MHz	Defense (partly)
Wifi 2.4 GHz	83 MHz	Defense
Wifi 5 GHz	455 MHz	Defense, Meteo, Space, Telecom (shared)
LTE 2,6 GHz	190 MHz	Defense
LTE 800 MHz	32 MHz 40 MHz	Defense Broadcasting
Total MHz	1140 MHz	

ECONOMIC METHODS TOWARDS 2020

- ✘ Economic tools and methods will continue providing crucial basis for **transparent award of frequencies** in highly contested bands and for subsequently creating incentives for **most efficient utilisation** of spectrum resource
- ✘ The **auctions** are likely to get more widespread use, especially for flexibly termed frequency assignments (spectrum usage rights)

PRESENTATION OUTLINE

- ✘ Role of Spectrum Management (SM)
- ✘ Institutional best practices of SM
- ✘ Forward-looking planning of frequencies
- ✘ Novel licensing approaches
- ✘ Economic aspects of SM

Interference monitoring and enforcement

- ✘ International harmonisation

MONITORING AND ENFORCEMENT

- ✘ Monitoring, market-supervision and enforcement become increasingly integrated fields of operation
- ✘ Most NRAs today will have some **monitoring facilities** at or near their headquarters as well as a set of regional stations spread throughout the country
- ✘ It is important that each station becomes a generic hub for control and enforcement functions, whereas one or more teams of inspectors would carry out regular inspections of:
 - + **Licensed radio stations:** prior and at regular intervals during their operation
 - + **Vendors of radio equipment** in order to control whether they put on the market suitable (type approved) equipment
 - + Assessment of **interference complaints**

TYPICAL MONITORING SET-UP IN A LARGER COUNTRY

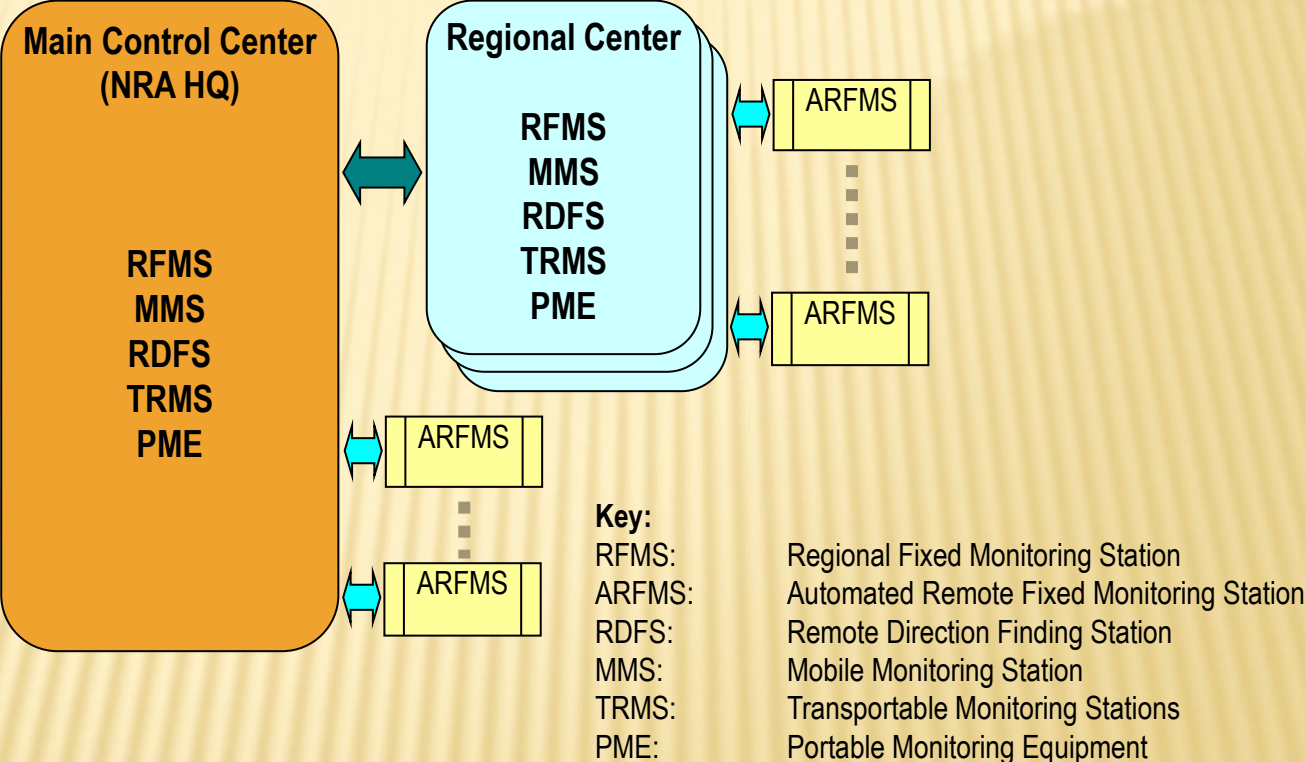

MARKET SELF-REGULATION

- ✘ Due to explosive growth in trade and proliferation of wireless uses and consumer devices, in some cases (frequency bands) regulators see benefits in promoting **self-control by the markets**
- ✘ This trend is exemplified by gradual change from **ex ante regulation** (i.e. strict regulation and controlling beforehand) to **ex post regulation** (i.e. letting market forces work and only intervening in cases of reported problems)

MONITORING & ENFORCEMENT TRENDS

- ✘ Radio monitoring will remain **important operational function** of NRAs also in the future, however its technical and staff complement may see change due to changing efficiency and increasing automation of radio monitoring equipment, including “cloud” monitoring by dispersed nodes
- ✘ **Market self-regulation** is likely to be an increasing trend, especially for the highly congested bands used by a limited set of professional operators
- ✘ In the latter cases the NRAs will still retain the **overall important oversight role**, such:
 - + Wireless equipment market inspection
 - + Agents for consumer protection, e.g. impartial market supervision and auditing of quality of public wireless services delivered to end-users

PRESENTATION OUTLINE

- ✘ Role of Spectrum Management (SM)
- ✘ Institutional best practices of SM
- ✘ Forward-looking planning of frequencies
- ✘ Novel licensing approaches
- ✘ Economic aspects of SM
- ✘ Interference monitoring and enforcement

International harmonisation

INTERNATIONAL HARMONISATION

- ✘ Remains an ever important issue even after a century of efforts in this area, since the 1906 signing of Radio Telegraph Convention aiming to align **international use of radio frequencies**
- ✘ Two main avenues:
 - + **International harmonisation** of radio spectrum allocations and use on global (ITU) and regional (CITEL, CEPT, ATU, APT) levels
 - + **Cross-border agreements** for efficient utilisation of frequencies between countries

HARMONISATION OF ALLOCATIONS

- ✘ Today faces a challenge of finding a balance between **degree of harmonisation vs. degree of technological neutrality**, while reaching towards the overall objective of most efficient spectrum utilisation and highest socio-economic benefit:
 - + Importance of continued **international collaboration** with active involvement of all relevant stakeholders
 - + Harnessing the enabling new agility and **re-configurability features** of modern wireless technologies

CROSS-BORDER AGREEMENTS

- ✘ Well established practice that most optimal approach is to set out ***a priori* bi- or multi-lateral coordination agreements** on frequency use in border areas in order to:
 - + Ensure equal distribution, and
 - + Speed up the day-to-day frequency assignments in border areas
- ✘ **New technologies create new challenges**, such as it is not enough to agree on a single channel raster, but provide options for different bandwidth, partitioning of CDMA access codes, special OFDMA signals and sub-carriers, etc, etc.

HARMONISATION TOWARDS 2020

- ✘ International harmonisation will become even more important with the **ever growing globalisation** of business, trade and peoples' mobility
- ✘ Recent examples with WiMAX and LTE developments show that multi-band operability is not a panacea and mass market momentum and economies of scale could only be achieved by **harmonising frequency bands**. To this end the **ITU and regional organisations** will retain their vital role as mediators for harmonised spectrum use
- ✘ The use of **cross-border agreements** will remain the key for ensuring efficient spectrum use in border areas

SUMMARY AND CONCLUSIONS

- ✘ SM remains a vibrant sphere of activities that makes an important constituent part of **ICT industry functioning and innovation**
- ✘ Some of the most general trends for SM towards the year 2020:
 - + Radio spectrum shall continue playing ever more **vital role**, such as to accommodate unrelenting growth of public demand for broadband services
 - + The key to further increasing efficiency of overall spectrum utilisation would be through **better sharing, enabled by continued international collaboration and innovation in SM**
 - + Proportion of flexible allocations allowing **markets to self-determine best utilisation of spectrum** will continue to grow, helped by emergence of new empowering technologies such as Geolocation databases and Cognitive Radio
 - + The NRAs' **authorization toolbox** shall benefit of wider use of licensing schemes that create market incentives and allow various degrees of shared use of spectrum resource, such as light-licensing, ASA/LSA etc.

Thank you !