

RECOMMENDATION ITU-R SM.328-9

SPECTRA AND BANDWIDTH OF EMISSIONS

(Question ITU-R 76/1)

(1948-1951-1953-1956-1959-1963-1966-1970-1974-1978-1982-1986-1990-1994-1997)

The ITU Radiocommunication Assembly,

considering

- a) that in the interest of an efficient use of the radio spectrum, it is essential to establish for each class of emission rules governing the spectrum emitted by a transmitting station;
- b) that, for the determination of an emitted spectrum of optimum width, the whole transmission circuit as well as all its technical working conditions, including other circuits and radio services sharing the band, and particularly propagation phenomena, must be taken into account;
- c) that the concepts of “necessary bandwidth” and “occupied bandwidth”, defined in Nos. 146 (S1.152) and 147 (S1.153) of the Radio Regulations (RR), are useful for specifying the spectral properties of a given emission, or class of emission, in the simplest possible manner;
- d) that, however, these definitions do not suffice when consideration of the complete problem of radio spectrum economy and efficiency is involved; and that an endeavour should be made to establish rules limiting, on the one hand, the bandwidth occupied by an emission to the most efficient value in each case and, on the other hand, the amplitudes of the components emitted in the outer parts of the spectrum so as to decrease interference to adjacent channels;
- e) that with regard to the efficient use of the radio-frequency spectrum necessary bandwidths for individual classes of emission must be known, that in some cases the formulae listed in Recommendation ITU-R SM.1138, can only be used as a guide and that the necessary bandwidth for certain classes of emissions is to be evaluated corresponding to a specified transmission standard and a quality requirement;
- f) that the occupied bandwidth and the x dB bandwidth enable operating agencies, national and international organizations, to carry out measurements of the bandwidth actually occupied by a given emission and thus to ascertain, by comparison with the necessary bandwidth, that such an emission does not occupy an excessive bandwidth for the service to be provided and is, therefore, not likely to create interference beyond the limits laid down for this class of emission;
- g) that, in addition to limiting the bandwidth occupied by an emission to the most efficient value in each case, rules should be established to limit the amplitudes of the components emitted in the outer parts of the spectrum by reconciling the following requirements:
 - the necessity for limiting the interference caused to adjacent channels to a strict minimum;
 - the technical and practical possibilities of transmitter and receiver design, and modulation technique;
 - the limitation of shaping or distortion of the signal to a permissible value;
- h) that, although some problems of spacing between channels or interference can be dealt with in an approximate but simple manner, merely by use of the data for the necessary bandwidth (for a given class of emission), the occupied bandwidth or the x dB bandwidth (for a given emission), and the spectrum emitted outside the necessary bandwidth, interference problems can be dealt with accurately only if complete knowledge is available, either of the Fourier transform of the signal or of the function representing its energy spectrum for all frequencies in the radio-frequency spectrum;
- j) that in several cases, the use of systems employing necessary bandwidths much greater than the baseband bandwidth (e.g. systems which employ high modulation index FM or other bandwidth expansion techniques) potentially increase the number of users sharing a band, because the susceptibility of receivers to interference may be reduced sufficiently to more than compensate for the reduction in the number of channels available, thus increasing the efficiency of radio spectrum use,

recommends

1 Definitions

that the following definitions and explanatory notes should be used when dealing with bandwidth, channel spacing and interference problems:

1.1 Baseband

The band of frequencies occupied by one signal, or a number of multiplexed signals, which is intended to be conveyed by a line or a radio transmission system.

NOTE 1 – In the case of radiocommunication, the baseband signal constitutes the signal modulating the transmitter.

1.2 Baseband bandwidth

The width of the band of frequencies occupied by one signal, or a number of multiplexed signals, which is intended to be conveyed by a line or a radio transmission system.

1.3 Necessary bandwidth

For a given class of emission, the width of the frequency band which is just sufficient to ensure the transmission of information at the rate and with the quality required under specified conditions RR No. 146 (S1.152).

1.4 Bandwidth expansion ratio

The ratio of the necessary bandwidth to baseband bandwidth.

1.5 Out-of-band spectrum (of an emission)

The part of the power density spectrum (or the power spectrum when the spectrum consists of discrete components) of an emission which is outside the necessary bandwidth and which results from the modulation process, with the exception of spurious emissions.

1.6 Out-of-band emission

Emission on a frequency or frequencies immediately outside the necessary bandwidth which results from the modulation process, but excluding spurious emissions (RR No. 138 (S1.144)).

NOTE 1 – Non-linearity in amplitude modulated transmitters (including single-sideband transmitters) may result in out-of-band emissions which are immediately adjacent to the necessary bandwidth, due to odd order intermodulation products. The acceptable levels of intermodulation distortion are specified in Recommendation ITU-R SM.326.

1.7 Spurious emission

Emission on a frequency or frequencies which are outside the necessary bandwidth and the level of which may be reduced without affecting the corresponding transmission of information. Spurious emissions include harmonic emissions, parasitic emissions, intermodulation products and frequency conversion products, but exclude out-of-band emissions (RR No. 139 (S1.145)).

1.8 Unwanted emissions

Consist of spurious emissions and out-of-band emissions (RR No. 140 (S1.146)).

1.9 The terms associated with the definitions given in § 1.6, 1.7 and 1.8 above are expressed in the working languages as shown in Table 1.

TABLE 1

English	French	Spanish
Out-of-band emission	Emission hors bande	Emisión fuera de banda
Spurious emission	Rayonnement non essentiel	Emisión no esencial
Unwanted emissions	Rayonnements non désirés	Emisiones no deseadas

1.10 Permissible out-of-band spectrum (of an emission)

For a given class of emission, the permissible level of the power density (or the power of discrete components) at frequencies above and below the limits of the necessary bandwidth.

NOTE 1 – The permissible power density (or power) may be specified in the form of a limiting curve giving the power density (or power), expressed in decibels relative to the specified reference level, for frequencies outside the necessary bandwidth. The abscissa of the initial point of the limiting curve should coincide with the limiting frequencies of the necessary bandwidth. Descriptions of limiting curves for various classes of emissions are given in § 3 below.

1.11 Out-of-band power (of an emission)

The total power emitted at the frequencies of the out-of-band spectrum.

1.12 Permissible out-of-band power

For a given class of emission, the permissible level of mean power emitted at frequencies above and below the limits of necessary bandwidth.

NOTE 1 – The permissible level of out-of-band power should be determined for each class of emission and specified as a percentage β of total mean power radiated derived from the limiting curve fixed individually for each class of emission.

1.13 Occupied bandwidth

The width of a frequency band such that, below the lower and above the upper frequency limits, the mean powers emitted are each equal to a specified percentage $\beta/2$ of the total mean power of a given emission.

Unless otherwise specified by the Radiocommunication Assembly for the appropriate class of emission, the value of $\beta/2$ should be taken as 0.5% (RR No. 147 (S1.153)).

NOTE 1 – The value of β could be determined by calculating the sum of the percentages of the total mean power above and below the necessary bandwidth. The occupied bandwidth is optimum when it equals the necessary bandwidth.

1.14 x dB bandwidth

The width of a frequency band such that beyond its lower and upper limits any discrete spectrum component or continuous spectral power density is at least x dB lower than a predetermined 0 dB reference level.

1.15 Assigned frequency band

The frequency band within which the emission of a station is authorized; the width of the band equals the necessary bandwidth plus twice the absolute value of the frequency tolerance. Where space stations are concerned, the assigned frequency band includes twice the maximum Doppler shift that may occur in relation to any point of the Earth's surface (RR No. 141 (S1.147)).

1.16 Assigned frequency

The centre of the frequency band assigned to a station (RR No. 142 (S1.148)).

1.17 Characteristic frequency

A frequency which can be easily identified and measured in a given emission.

A carrier frequency may, for example, be designated as the characteristic frequency (RR No. 143 (S1.149)).

1.18 Reference frequency

A frequency having a fixed and specified position with respect to the assigned frequency. The displacement of this frequency with respect to the assigned frequency has the same absolute value and sign that the displacement of the characteristic frequency has with respect to the centre of the frequency band occupied by the emission (RR No. 144 (S1.150)).

1.19 Frequency tolerance

The maximum permissible departure by the centre frequency of the frequency band occupied by an emission from the assigned frequency or, by the characteristic frequency of an emission from the reference frequency.

The frequency tolerance is expressed in parts in 10^6 or in hertz (RR No. 145 (S1.151)).

1.20 Build-up time of a telegraph signal

The time during which the telegraph current passes from one-tenth to nine-tenths (or *vice versa*) of the value reached in the steady state; for asymmetric signals, the build-up times at the beginning and end of a signal can be different.

1.21 Relative build-up time of a telegraph signal

Ratio of the build-up time of a telegraph signal defined in § 1.20 to the half-amplitude pulse duration.

2 Emission of a transmitter, optimum from the standpoint of spectrum economy

that an emission should be considered optimum from the standpoint of spectrum economy when its occupied bandwidth coincides with the necessary bandwidth for the class of emission concerned and when the out-of-band spectrum envelope is inscribed within the appropriate limiting curve given in § 3 below for various classes of emission.

To facilitate monitoring, an emission optimum from the standpoint of spectrum economy may be regarded as an emission whose x dB bandwidth stands in a fixed relationship to the necessary bandwidth for the corresponding class of emission, this relationship being determined by the x dB level and the parameters of the limiting curve for the out-of-band spectrum (see the examples given in Annex 1).

An optimum bandwidth from the standpoint of spectrum economy may not be optimum from the standpoint of spectrum efficiency in a sharing situation.

3 Limitations of the emitted spectra

that administrations should endeavour, with the minimum practicable delay, to limit the emitted spectra to those shown below for various classes of emission.

NOTE 1 – The modulation rate (Bd), B , used in the following text is the maximum speed used by the corresponding transmitter. For a transmitter operating at a speed lower than this maximum speed, the build-up time should be increased to keep the occupied bandwidth at a minimum, to comply with RR No. 307 (S3.9).

3.1 Classes of emission A1A and A1B with fluctuations

When large short-period variations of the received field are present, the specifications given below for single-channel, amplitude-modulated, continuous-wave telegraphy (Class A1A and A1B), represent the desirable performance obtainable from a transmitter with an adequate input filter and sufficiently linear amplifiers following the stage in which keying occurs.

3.1.1 Necessary bandwidth

The necessary bandwidth is equal to five times the modulation rate in baud. Components at the edges of the band shall be at least 3 dB below the levels of the same components of a spectrum representing a series of equal rectangular dots and spaces at the same modulation rate.

This relative level of –3 dB corresponds to an absolute level of 27 dB below the mean power of the continuous emission (see Recommendation ITU-R SM.326, Table 1).

3.1.2 Shape of the spectrum envelope

The amplitude of the spectrum envelope relative to the amplitude of the continuous emission is shown in Fig. 3 as a function of the order of the sideband components, assuming that the envelope of the RF signal is a square wave. In this figure, the order n , of the sideband component is given by:

$$n = \frac{2f}{B} \quad (1)$$

where:

f : frequency separation from the centre of the spectrum (Hz)

B : modulation rate (Bd).

3.1.3 Occupied bandwidth

The occupied bandwidth, L (Hz) for an out-of-band power ratio $\beta = 0.01$ may be calculated from the following empirical formula:

$$L = \left(\frac{1}{0.05 + \alpha} - 1 \right) B \quad (2)$$

where:

α : relative build-up time of the shortest pulse of a telegraph signal as defined in § 1.21

B : modulation rate (Bd).

The maximum divergence between the results obtained by using this formula and the results of accurate calculations is $2B$ when $\alpha < 0.02$; and B when $\alpha \geq 0.02$. This has also been confirmed by measurements. Equation (1) may therefore be used for the indirect measurement of occupied bandwidth of A1A and A1B emissions.

3.1.4 Out-of-band spectrum

If frequency is plotted as the abscissa in logarithmic units and if the power densities are plotted as ordinates (dB) the curve representing the out-of-band spectrum should lie below two straight lines starting at point $(+5 B/2, -27 \text{ dB})$ or at point $(-5 B/2, -27 \text{ dB})$ defined above, with a slope of 30 dB/octave and finishing at point $(+5 B, -57 \text{ dB})$ or $(-5 B, -57 \text{ dB})$, respectively. Thereafter, the same curve should lie below the level -57 dB .

The permissible amounts of out-of-band power, above and below the frequency limits of the necessary bandwidth, are each approximately 0.5% of the total mean power radiated.

3.1.5 Build-up time of the signal

The build-up time of the emitted signal depends essentially on the shape of the signal at the input to the transmitter, on the characteristics of the filter to which the signal is applied, and on any linear or non-linear effects which may take place in the transmitter itself (assuming that the antenna has no influence on the shape of the signal). As a first approximation, it may be assumed that an out-of-band spectrum close to the limiting curve defined in § 3.1.4 corresponds to a build-up time of about 20% of the initial duration of the telegraph dot, i.e. about $1/5 B$.

3.1.6 Adjacent-channel interference

Interference to adjacent channels depends on a large number of parameters and its rigorous calculation is difficult. Since it is not necessary to calculate the values of interference with great precision, semi-empirical equations and graphs can be used.

3.2 Classes of emission A1A and A1B without fluctuations

For amplitude-modulated, continuous-wave telegraphy, when short-period variations of the received field strength do not affect transmission quality, the necessary bandwidth can be reduced to three times the modulation rate (Bd).

3.3 Shaping of the telegraph signal by means of filters

Increasing the build-up time of the telegraph signal to the maximum value compatible with the proper operation of the receiving equipment is a suitable means of reducing occupied bandwidth.

The minimum value of the ratio, T , of the 6 dB passband of such filters to half the modulation rate (Bd), is largely dependent on the synchronization requirements of the receiver terminal equipment, the frequency stability of both the transmitter and receiver and, in the case of actual traffic, also on the propagation conditions. The minimum value may vary from 2, when synchronization and stability are extremely good, to 15 when the frequency drift is appreciable and teletype equipment is used.

Minimum overshoot filters preferably should be used in order to fully utilize the transmitter power.

The table below shows, as a function of T , the percentage or time during which the signal element is not within 1% for a minimum overshoot filter:

TABLE 2

$\frac{\text{Length of flat portion}}{\text{Length of signal element}}$	0% (sinusoidal signal)	50%	90%	100% (rectangular signal)
T	1.6	3.2	16	∞

Since the ratio T is predetermined, it may be necessary to use a filter consisting of several sections to sufficiently reduce the components in the outer parts of the spectrum.

3.4 Classes of emission A2A and A2B

For single-channel telegraphy, in which both the carrier frequency and the modulating oscillations are keyed, the percentage of modulation not exceeding 100% and the modulation frequency being higher than the modulation rate ($f > B$), the specifications given below represent the desirable performance that can be obtained from a transmitter with a fairly simple input filter and approximately linear stages.

3.4.1 Necessary bandwidth

The necessary bandwidth is equal to twice the modulating frequency f plus five times the modulation rate (Bd).

3.4.2 Out-of-band spectrum

If the frequency is plotted as the abscissa in logarithmic units and the power densities are plotted as ordinates (dB) the curve representing the out-of-band spectrum should lie below two straight lines starting at point $(+ (f + 5 B/2), -24 \text{ dB})$, or at point $(- (f + 5 B/2), -24 \text{ dB})$, with a slope of 12 dB/octave, and finishing at point $(+ (f + 5 B), -36 \text{ dB})$ or $(- (f + 5 B), -36 \text{ dB})$, respectively. Thereafter, the same curve should be below the level -36 dB .

The reference level, 0 dB, corresponds to that of the carrier in a continuous emission with modulating oscillation.

The permissible amounts of out-of-band power above and below the frequency limits of the necessary bandwidth are each approximately 0.5% of the total mean power radiated.

3.5 Amplitude-modulated radiotelephone emission, excluding emissions for sound broadcasting

The occupied bandwidth and out-of-band radiation of amplitude-modulated emissions carrying analogue signals depend, to a varying degree, on several factors such as:

- type of modulating signal;
- the input signal level determines the modulation loading of the transmitter;
- the passband which results from the filters used in the audio-frequency stages and in the intermediate and final modulating stages of the transmitter;
- the magnitude of the harmonic distortion and intermodulation components at the frequencies of the out-of-band spectrum.

The spectrum limits described in this section for radiotelephone emissions have been deduced from various measurements. The peak envelope power of the transmitter is first determined using the method described in Recommendation ITU-R SM.326, § 3.1.3, and the transmitter is adjusted for an acceptable distortion for the class of service.

Measurements have been made using several different modulating signals substituted for the two audio tones. It has been found that white or weighted noise, with the bandwidth limited by filtering to the desired bandwidth of the information to be transmitted in normal service, is a satisfactory substitute for a speech signal in making practical measurements.

In the out-of-band emission curves defined in § 3.5.1 and 3.5.2, the ordinates represent the energy intercepted by a receiver of 3 kHz bandwidth, the central frequency of which is tuned to the frequency plotted on the abscissa, normalized to the energy which is intercepted by the same receiver when tuned to the central frequency of the occupied band.

However, a receiver with 3 kHz bandwidth cannot provide detailed information in the frequency region close to the edge of the occupied band. It has been found that point-by-point measurements with a receiver having an effective bandwidth of 100 to 250 Hz or with a spectrum analyser with a similar filter bandwidth are more useful in analysing the fine structure of the spectrum.

To make these measurements, the attenuation-frequency characteristics of the filter limiting the transmitted bandwidth should first be determined. The transmitter is then supplied with a source of white noise or weighted noise, limited to a bandwidth somewhat larger than the filter bandwidth.

In applying the input signal to transmitter, care should be taken that, at the output, the peaks of the signal do not exceed the peak envelope power of the transmitter or the level corresponding to a modulation factor of 100%, whichever is applicable, for more than a specific small percentage of time. This percentage will depend on the class of emission (see Annex 4, § 1).

3.5.1 Class of emission A3E double-sideband telephony

3.5.1.1 Necessary bandwidth

The necessary bandwidth F is, in practice, equal to twice the highest modulation frequency, M , which it is desired to transmit with a specified small attenuation.

3.5.1.2 Power within the necessary band

The statistical distribution of power within the necessary band is determined by the relative power level of the different speech frequency components applied at the input to the transmitter or, when more than one telephony channel is used, by the number of active channels and the relative power level of the speech frequency components, applied at the input to each channel.

When no privacy equipment is connected to the transmitter, the power distribution of the different speech frequency components in each channel may be assumed to correspond to the curve given in Fig. 21. This curve is not applicable to sound broadcasting.

If the transmitter is used in connection with a frequency inversion privacy equipment, the same data can be used with appropriate frequency inversion of the resulting spectrum.

If a band-splitting privacy equipment is used, it may be assumed that the statistical distribution of power is uniform within the frequency band.

3.5.1.3 Out-of-band spectrum

If frequency is plotted as the abscissa in logarithmic units and if the power densities are plotted as ordinates (dB) the curve representing the out-of-band spectrum should lie below two straight lines starting at point $(+0.5 F, 0 \text{ dB})$ or at point $(-0.5 F, 0 \text{ dB})$, and finishing at point $(+0.7 F, -20 \text{ dB})$ or $(-0.7 F, -20 \text{ dB})$, respectively. Beyond these points and down to the level -60 dB , this curve should lie below two straight lines starting from the latter points and having a slope of 12 dB/octave . Thereafter, the same curve should lie below the level -60 dB .

The reference level, 0 dB , corresponds to the power density that would exist if the total power, excluding the power of the carrier, were distributed uniformly over the necessary bandwidth.

3.5.1.4 Relationships between the 0 dB reference level for determining the out-of-band spectrum and the levels of other spectral components of the emission

3.5.1.4.1 Relationship between the 0 dB reference level and the level corresponding to maximum spectral power density

The 0 dB reference level defined in § 3.5.1.3 is about 5 dB below the level corresponding to the maximum power density in either sideband when the transmitter is modulated with white noise weighted in accordance with the curve mentioned in § 3.5.1.2 and shown in Annex 2.

The value of 5 dB is valid for a modulation frequency bandwidth with an upper frequency limit of 3 kHz or 3.4 kHz .

3.5.1.4.2 Relationship between the 0 dB reference level and the carrier level

The ratio α_B (dB) of the 0 dB reference level to the carrier level is given by the equation:

$$\alpha_B = 10 \log \left(\frac{m_{rms}^2}{2} \frac{B_{eff}}{F} \right) \quad (3)$$

where:

m_{rms} : r.m.s. modulation factor of the transmitter,

B_{eff} : effective noise bandwidth of the analyser

F : necessary bandwidth for the emission.

Hence the reference level depends on:

- the power of the sideband P_s , given by the formula:

$$P_s = \frac{m_{rms}^2}{2} P_c \quad (4)$$

where P_c is the carrier power,

- the necessary bandwidth F ,
- the effective noise bandwidth B_{eff} of the analysing instrument used.

Figure 1 shows the ratio α_B calculated from equation (3) as a function of the necessary bandwidth for different values of the r.m.s. modulation factor.

FIGURE 1

The ratio α_B (dB), between the 0 dB reference level for the limiting curve of the out-of-band spectrum for class of emission A3E and the level of the carrier, as a function of the necessary bandwidth F (kHz), for an effective noise bandwidth of the analysing instrument of 100 Hz with the r.m.s. modulation factor (m_{rms}) of the transmitter as a parameter

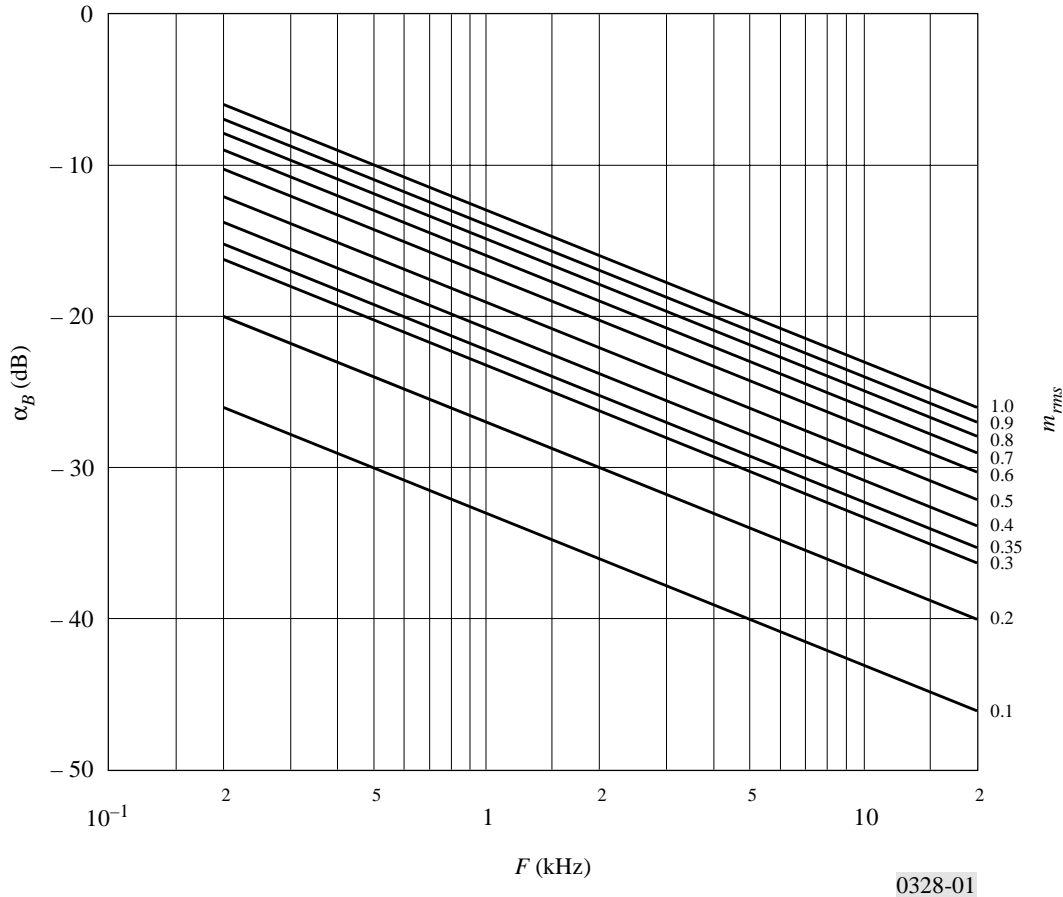

For certain practical applications, for example in monitoring stations, an r.m.s. modulation factor of the transmitter of 35% may be assumed in cases where the actual modulation factor cannot be determined precisely. Equation (3) may then be simplified as follows:

$$\alpha_B = 10 \log \left(\frac{B_{eff}}{F} \right) - 12.1 \tag{5}$$

Fig. 2 shows the ratio α_B calculated from the simplified formula (5) as a function of the necessary bandwidth for different values of the effective noise bandwidth.

3.5.2 Single-sideband, classes of emission R3E, H3E and J3E (reduced, full or suppressed carrier) and independent-sideband class of emission B8E

3.5.2.1 Necessary bandwidth

3.5.2.1.1 For classes of emission R3E and H3E, the necessary bandwidth F is, in practice, equal to the value of the highest audio frequency, f_2 , which it is desired to transmit with a specified small attenuation.

FIGURE 2

The ratio α_B (dB), between 0 dB reference level for the limiting curve of the out-of-band spectrum for class of emission A3E and the level of the carrier as a function of the necessary bandwidth F (kHz), for an r.m.s. modulation factor of 35% with the effective noise bandwidth (B_{eff}) of the analysing instrument as a parameter

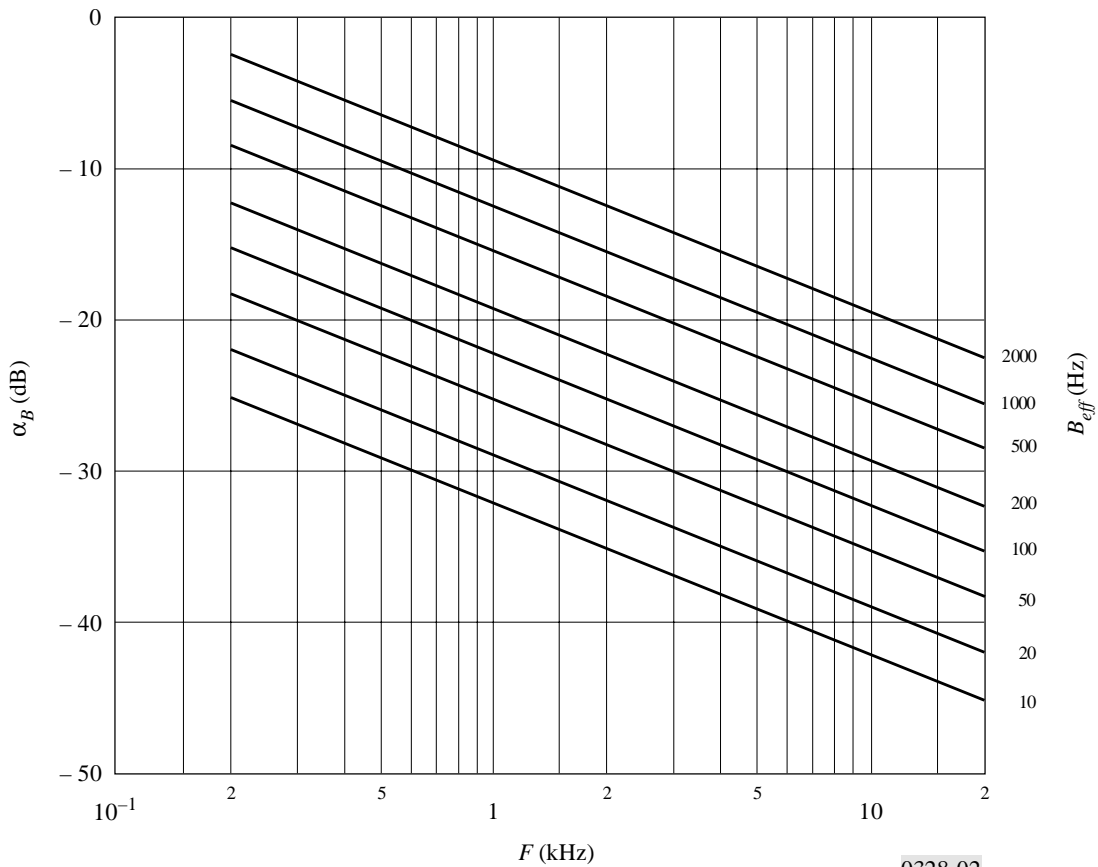

0328-02

3.5.2.1.2 For class of emission J3E, the necessary bandwidth F is, in practice, equal to the difference between the highest, f_2 , and lowest, f_1 , of the audio frequencies which it is desired to transmit with a specified small attenuation.

3.5.2.1.3 For class of emission B8E, the necessary bandwidth F is, in practice, equal to the difference between the two radio frequencies most remote from the assigned frequency, which correspond to the two extreme audio frequencies to be transmitted with a specified small attenuation in the two outer channels of the emission.

3.5.2.2 Power within the necessary band

For considerations with regard to the power in the necessary band, reference is made to § 3.5.1.2.

3.5.2.3 Out-of-band spectrum for class of emission B8E; four telephony channels simultaneously active

The out-of-band power is dependent on the number and position of the active channels. The curves described below are only appropriate when four telephone channels are active simultaneously. When some channels are idle, the out-of-band power is less.

If frequency is plotted as the abscissa in logarithmic units, the reference frequency being supposed to coincide with the centre of the necessary band, and if the power densities are plotted as ordinates (dB) the curve representing the out-of-band spectrum should lie below two straight lines starting at point $(+0.5 F, 0 \text{ dB})$ or at point $(-0.5 F, 0 \text{ dB})$ and finishing at point $(+0.7 F, -30 \text{ dB})$ or $(-0.7 F, -30 \text{ dB})$ respectively. Beyond the latter points and down to the level -60 dB , this curve should lie below two straight lines starting from the latter points and having a slope of 12 dB/octave . Thereafter, the same curve should lie below the level -60 dB .

The reference level, 0 dB, corresponds to the power density that would exist if the total power, excluding the power of the reduced carrier, were distributed uniformly over the necessary bandwidth.

3.6 Amplitude-modulated emissions for sound broadcasting

The spectrum limits described in this section for amplitude-modulated emissions for sound broadcasting have been deduced from measurements performed on transmitters which were modulated by weighted noise to an r.m.s. modulation factor of 35% in the absence of any dynamic compression of the signal amplitudes (see Annex 4 § 2).

3.6.1 Class of emission A3E, double-sideband sound broadcasting

3.6.1.1 Necessary bandwidth

The necessary bandwidth F is in practice equal to twice the highest modulation frequency, M , which it is desired to transmit with a specified small attenuation.

3.6.1.2 Power within the necessary band

The statistical distribution of power within the necessary band is determined by the relative power level of the different audio-frequency components applied at the input to the transmitter.

The power distribution in the audio-frequency band of an average broadcast programme can be assumed to correspond to the curves given in Fig. 23. In practice, these curves will not be exceeded for more than 5% to 10% of the programme transmission time.

3.6.1.3 Out-of-band spectrum

If frequency is plotted as the abscissa in logarithmic units and if the power densities are plotted as ordinates (dB) the curve representing the out-of-band spectrum should lie below two straight lines starting at point $(+0.5 F, 0 \text{ dB})$ or at point $(-0.5 F, 0 \text{ dB})$ and finishing at point $(+0.7 F, -35 \text{ dB})$ or $(-0.7 F, -35 \text{ dB})$ respectively. Beyond these points and down to the level of -60 dB , this curve should lie below two straight lines starting from the latter points and having a slope of 12 dB/octave. Thereafter, the same curve should lie below the level -60 dB .

The reference level, 0 dB, corresponds to the power density that would exist if the total power, excluding the power of the carrier, were distributed uniformly over the necessary bandwidth (see § 3.6.1.4).

The ordinate of the curve so defined represents the average power intercepted by an analyser with an r.m.s. noise bandwidth of 100 Hz, the frequency of which is tuned to the frequency plotted on the abscissa.

3.6.1.4 Relationship between the 0 dB reference level for determining the out-of-band spectrum and the levels of other spectral components of the emission

3.6.1.4.1 Relationship between the 0 dB reference level and the level corresponding to maximum spectral power density

The 0 dB reference level defined in § 3.6.1.3 is 8-10 dB below the level corresponding to the maximum power density in either sideband when the transmitter is modulated with white noise weighted in accordance with the curves mentioned in § 3.6.1.2.

The value of 8 dB is valid for a modulation frequency bandwidth with an upper frequency limit of 4.5 kHz or 6 kHz. The value of 10 dB is applicable when the upper frequency limit is 10 kHz.

3.6.1.4.2 Relationship between the 0 dB reference level and the carrier level

See § 3.5.1.4.2, which is also applicable in the case of sound broadcasting.

3.6.2 Class of emission J3E, single-sideband sound broadcasting

Refer to RR Appendix 45 (S.11), Part B (HF Broadcasting).

3.7 Class of emission F1B

For class of emission F1B, frequency-shift telegraphy, with or without fluctuations due to propagation:

3.7.1 Necessary bandwidth

If the frequency shift, or the difference between mark and space frequencies is $2D$ and if m is the modulation index, $2D/B$, the necessary bandwidth is given by one of the following formulae, the choice depending on the value of m :

$$\begin{array}{ll} 2.6 D + 0.55 B & \text{within 10\% for } 1.5 < m < 5.5 \\ 2.1 D + 1.9 B & \text{within 2\% for } 5.5 \leq m \leq 20. \end{array}$$

3.7.2 Shape of the spectrum envelope

The shape of the RF spectrum for class of emission F1B is described in § 3.7.2.1 to 3.7.2.3 below for various shapes of the telegraph signal.

3.7.2.1 Telegraph signal consisting of reversals with zero build-up time

The amplitude of the spectrum envelope relative to the amplitude of the continuous emission ($A(n)$) is shown in Fig. 3 (solid lines) as a function of the order of the sideband component for a telegraph signal consisting of reversals with zero build-up time and equal mark and space durations.

The linear or asymptotic parts of the solid curves shown in Fig. 3 may be approximated with the aid of the formula:

$$A(n) = \frac{2m}{\pi n^2} \quad (6)$$

where:

n : order of the sideband component

$$n = 2f/B$$

f : frequency separation from the centre of the spectrum (Hz)

B : modulation rate (Bd)

m : modulation index

$$m = 2D/B$$

D : peak frequency deviation or half the frequency shift (Hz).

3.7.2.2 Periodic telegraph signals with finite build-up time

The amplitude, $A(x)$ of the envelope of the spectrum produced by a telegraph signal consisting of reversals with a finite build-up time and equal mark and space durations is given by the following empirical formula:

$$A(x) = E \frac{2}{\pi} \frac{1}{m} x^{-u} (x^2 - 1)^{-1} \quad \text{for } x > 1 \quad (7)$$

where:

$$x = f/D$$

E : amplitude of the continuous emission

$$u = \sqrt{5 D \tau}$$

τ : build-up time of signal(s) of the telegraph signal, as defined in § 1.20

f , D and m : as defined in § 3.7.2.1 above.

In equation (7), the shape of the spectrum envelope depends only on the product $D \tau$ and that for a given value of this product the amplitude, $A(x)$, of the envelope is inversely proportional to the modulation index m . This is illustrated in Fig. 4, where the product $m A(x)$ is shown as a function of x for various values of $D \tau$.

FIGURE 3

Envelopes of RF spectra for a telegraph signal consisting of reversals

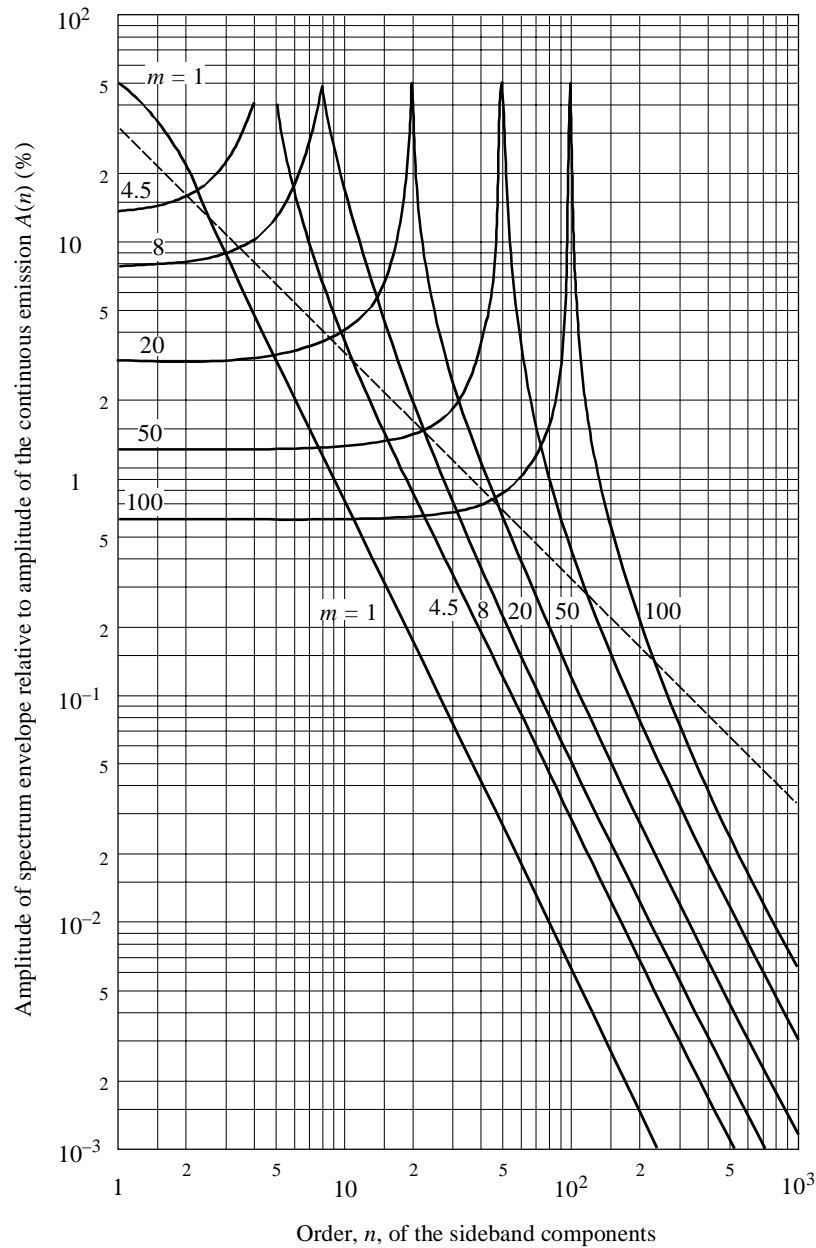

0328-03

It has been shown that the effect of the build-up time on the shape of the spectrum envelope is small for values of $D \tau$ which are less than 0.15 or are between 1 and 5. When the mark and space durations are unequal, the shape of the spectrum envelope depends largely on the product of $D \tau$ and the duration of the shortest signal element, but is always similar to that produced by a signal consisting of reversals with the same build-up time.

In Fig. 5 the results of measurements made on various spectra are compared with those obtained by calculating the corresponding values from equation (7). The agreement is satisfactory for values of x greater than 1.2, but decreases for decreasing values of the product $D \tau$.

FIGURE 4
Spectrum distribution of F1B emission calculated from the empirical formula (7)

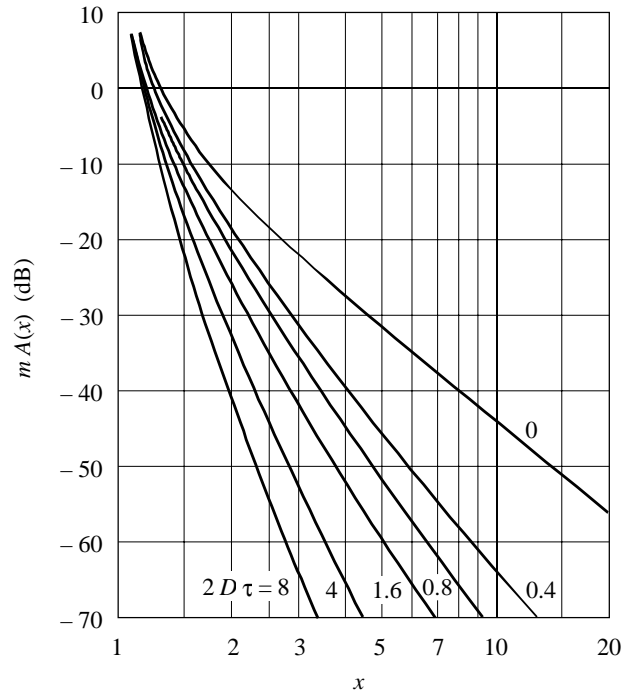

0328-04

3.7.2.3 Non-periodic telegraph signal with finite build-up time

When the signal is non-periodic, as may be the case under actual traffic conditions, the spectrum distribution should be represented in the form of a power density spectrum.

The average power density per unit of bandwidth, $p(x)$, is given by the empirical formula:

$$p(x) = \frac{P_0}{B} \frac{4}{\pi^2} \frac{1}{m^2} x^{-2u} (x^2 - 1)^{-2} \tag{8}$$

where:

- P_0 : total power of the emission
- B, m, x and u : as defined in §§ 3.7.2.1 and 3.7.2.2.

Also in this case, the shape of the spectrum envelope depends only on the product of frequency shift and build-up time.

3.7.3 Out-of-band power and occupied bandwidth

The out-of-band power, P' , as defined in § 1.11 may be determined by integrating the power density given by equation (8) between two frequency limits.

Fig. 6 shows the values of bandwidth, L , calculated in terms of m and $2D\tau$, for $\beta = 0.01$ and $\beta = 0.001$, where β is the out-of-band power ratio P'/P_0 .

The occupied bandwidth L (Hz) for $\beta = 0.01$ may also be calculated from the empirical equation:

$$L = 2D + D \left(3 - 4\sqrt{\bar{\alpha}} \right) m^{-0.6} \tag{9}$$

where $\bar{\alpha}$ is the relative build-up time of the shortest pulse of the telegraph signal, as defined in § 1.21.

The occupied bandwidth so calculated is hardly affected by the shape of the telegraph signal, whereas the out-of-band spectrum depends largely on this shape.

FIGURE 5
Spectra of F1B emissions

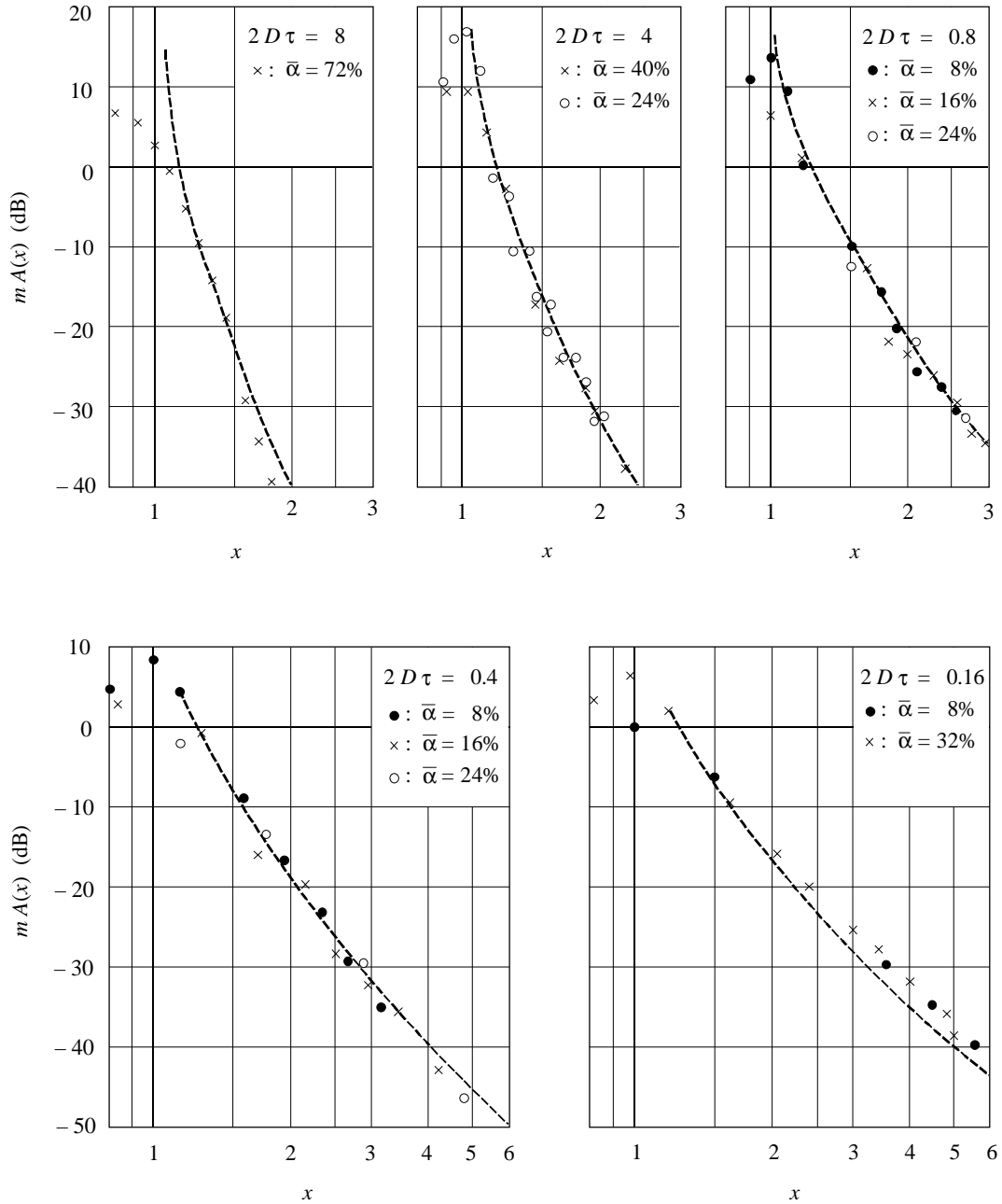

----- Calculated from the empirical formula (7)

• o x Measured values

$\bar{\alpha}$: relative build-up time (%)

FIGURE 6

Bandwidth calculation from the empirical formula (8)

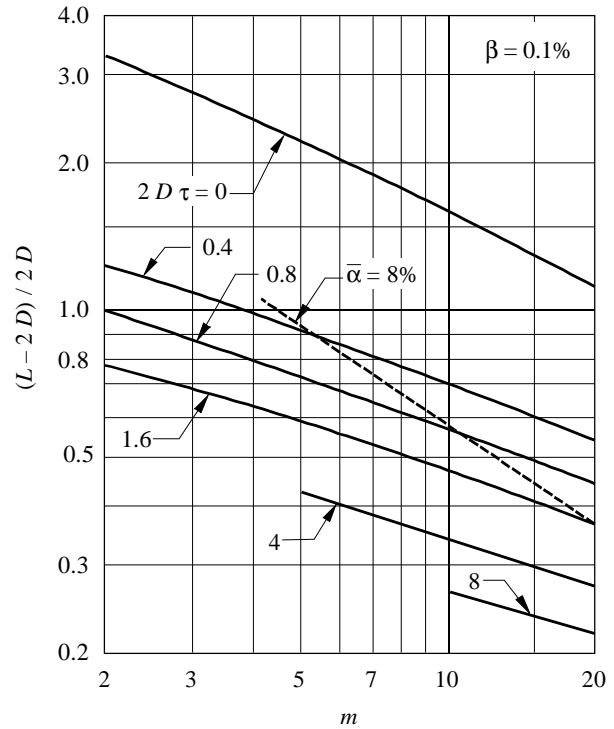
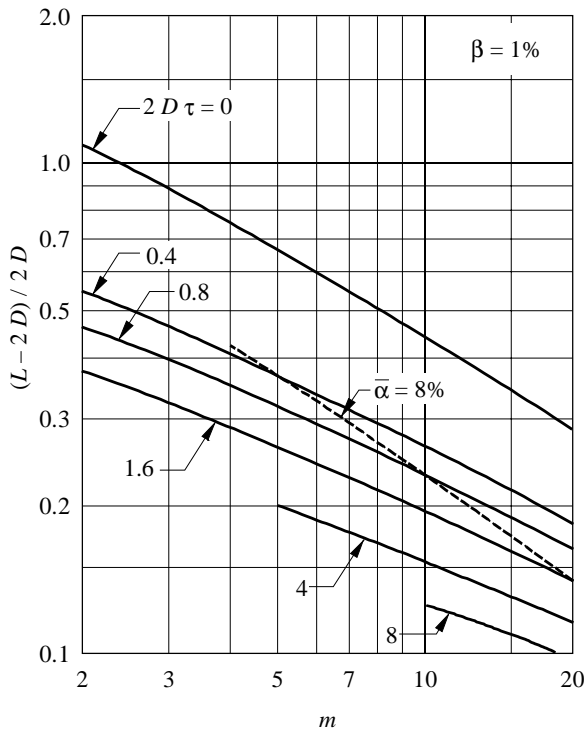
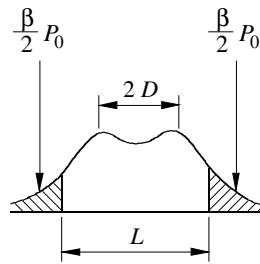

0328-06

The maximum divergence between the results obtained by using equation (9) and those obtained by exact calculations, is as follows:

- 3% for $\bar{\alpha} = 0$; $2 \leq m \leq 20$
- 9% for $\bar{\alpha} = 0.08$; $1.4 \leq m \leq 20$
- 10% for $\bar{\alpha} = 0.24$; $2 \leq m \leq 20$.

The list above shows the limits within which equation (9) can be used with reasonable accuracy. The percentages indicated apply to the lower limit of m . They are less for the higher limit.

Finally, Fig. 7 shows the results of calculations and measurements of occupied bandwidth employing different methods.

3.7.4 Shaping of the telegraph signal by means of filters

See § 3.3. However, the use of minimum overshoot filters is not essential, when the transmitter is required to operate at more than two frequencies, for example in the case of four-frequency diplex.

FIGURE 7
Comparison of the results of calculations and measurements
of occupied bandwidth

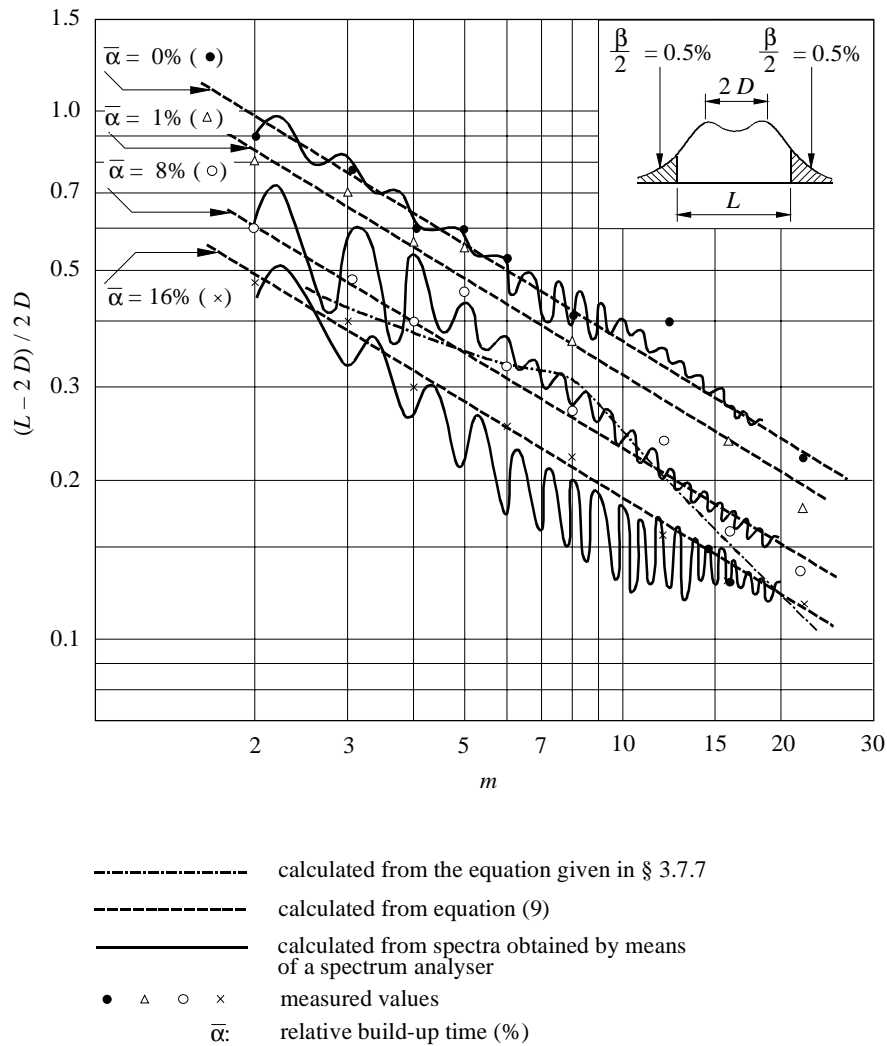

0328-07

3.7.5 Adjacent-channel interference

See § 3.1.6.

3.7.6 Build-up time of the signal

An out-of-band spectrum close to the limiting curve described in § 3.7.8 corresponds to a build-up time equal to about 8% of the initial duration of the telegraph dot, i.e. about $1/12 B$, provided that an adequate filter is used for signal shaping.

3.7.7 Bandwidth occupied, for unshaped signals

For the purpose of comparison with the formulae in § 3.7.1, it may be mentioned that, for a sequence of equal and rectangular (zero build-up time) mark and space signals, the occupied bandwidth is given by the following formulae:

$$2.6 D + 1.4 B \quad \text{within 2\% for } 2 \leq m \leq 8$$

$$2.2 D + 3.1 B \quad \text{within 2\% for } 8 \leq m \leq 20.$$

3.7.8 Out-of-band spectrum

If frequency is plotted as the abscissa in logarithmic units and if the power densities are plotted as ordinates (dB), the curve representing the out-of-band spectrum should lie below two straight lines of constant slope in decibels per octave, starting from the two points situated at the frequencies limiting the necessary bandwidth, and finishing at the level -60 dB. Thereafter, the same curve should lie below the level -60 dB. The starting ordinates of the two straight lines and their slopes are given in Table 3, as a function of the modulation index, m .

TABLE 3

Modulation index	Starting ordinates (dB)	Slope (dB octave)
$1.5 \leq m < 6$	-15	$13 + 1.8 m$
$6 \leq m < 8$	-18	$19 + 0.8 m$
$8 \leq m \leq 20$	-20	$19 + 0.8 m$

The reference level, 0 dB, corresponds to the mean power of the emission.

The permissible amounts of out-of-band power, above and below the frequency limits of the necessary bandwidth, are each approximately 0.5% of the total mean power radiated.

The curve representing the out-of-band spectrum for modulation indexes $0.5 \leq m \leq 1.5$ should lie below the points with the coordinates given in Table 4.

TABLE 4

Formula for calculating B_x at levels X (dB)				
-20	-30	-40	-50	-60
$3 \sqrt{m} \cdot B$	$4.1 \sqrt{m} \cdot B$	$5.8 \sqrt{m} \cdot B$	$8.1 \sqrt{m} \cdot B$	$11 \sqrt{m} \cdot B$

m : modulation index

B : modulation rate.

For each point of the limiting spectrum curve, the abscissa is the relative bandwidth $\pm B_x/2B$, and the ordinate is the relative level X . The reference level 0 dB is the level of the unmodulated carrier.

3.8 Frequency-modulated emissions for sound broadcasting

3.8.1 Class of emission F3E, monophonic sound broadcasting

3.8.1.1 Necessary bandwidth

The necessary bandwidth can be calculated by the formula, provided in Recommendation ITU-R SM.1138:

$$B_n = 2M + 2DK \quad (10)$$

where:

B_n : necessary bandwidth

M : highest modulation frequency

D : maximum deviation of the RF carrier

K : factor, equals 1 if the condition $D \gg M$ is met.

3.8.1.2 Out-of-band spectrum of class F3E emissions modulated by noise

The curve representing the out-of-band spectrum should lie below the points with the coordinates given in Table 5.

TABLE 5

Formula for calculating B_x at levels X (dB)					Effective modulation index m'
-20	-30	-40	-50	-60	
$6 m' M$	$(6.7 m' + 2) M$	$(7.8 m' + 3) M$	$(8.4 m' + 4.4) M$	$(9 m' + 6) M$	$0.5 \leq m' \leq 1.3$
$6 m' M$	$(7 m' + 2) M$	$(7.8 m' + 4) M$	$(8.4 m' + 6) M$	$(8.8 m' + 8) M$	$m' > 1.3$

$m' = D/pM$: effective modulation index

D : peak frequency deviation

p : peak factor

M : maximum modulation frequency.

For each point of the limiting spectrum curve the abscissa is the relative bandwidth $\pm B_x/2 M$, and the ordinate is the relative level X . The reference level 0 dB is the level of the maximum spectral power density within a sideband.

3.8.2 Classes of emission F8E and F9E, stereophonic sound broadcasting

3.8.2.1 Necessary bandwidth

Since generally the condition that $D \gg M$ is not met, sufficient information for the determination of the factor K is not available and the formula mentioned in § 3.8.1.1 is recommended as a guide.

Measurement results have shown that the RF bandwidth of stereophonic FM sound-broadcast emissions are smaller than one would expect from calculations using the formula with a factor $K = 1$.

Sufficient information is not available for the determination of a reliable formula and for reasons of simplification and international uniformity it is desirable that measurements for determining the necessary bandwidth be made as seldom as possible.

For the present, the necessary bandwidth for F8E and F9E emissions should be determined by measurement, taking into consideration the requirement that transmission and quality standards must be specified.

3.9 Frequency-modulated multi-channel emissions employing frequency division multiplex

The output signal of a frequency-modulated multichannel transmitter using frequency division multiplex can be simulated by a signal which is frequency-modulated with white noise. This applies also to the output signal of a transmitter with a limited number of channels if band-splitting privacy devices are used in each of the channels.

It is difficult, however, to make a theoretical analysis of the spectrum of a signal which is frequency-modulated with white noise, unless the frequency deviation is either very large or very small, compared with the maximum frequency of the band-limited white noise.

However, emissions with modulation indices between the limits mentioned above are important in actual communication systems.

3.9.1 Necessary bandwidth

See Recommendation ITU-R SM.853, § 1: Necessary bandwidth, multi-channel FDM-FM.

3.9.2 Shape of the spectrum envelope

For larger values of the frequency deviation the envelope of the spectrum may be derived from the following equation:

$$p(f) = \frac{2}{\sqrt{2}} (P_0 / 2 D_p) e^{-(f/D_p)^2} \quad (11)$$

Measurements have been carried out in order to find an empirical equation which could be applied for median values of the frequency deviation. The empirical equation may be considered as an extension of equation (11). Curves derived from the empirical equation are shown in Fig. 8.

FIGURE 8
Power spectral distribution for $D_p/M > 0.5$

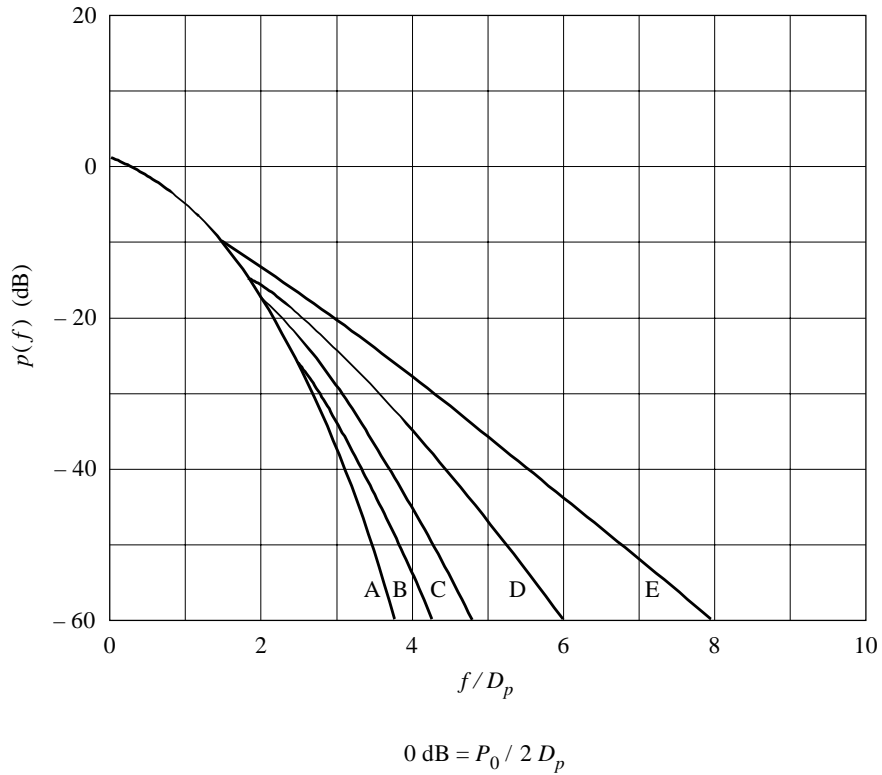

- Curves A: $D_p/M > 2.5$
- B: $D_p/M = 1.8$
- C: $D_p/M = 1.0$
- D: $D_p/M = 0.7$
- E: $D_p/M = 0.5$

The following symbols are used in Figs. 8 to 12:

- M : maximum frequency of the band limited noise
- D_0 : r.m.s. frequency deviation, i.e. the r.m.s. value of the difference between the instantaneous frequency and its arithmetic mean
- $D_p = D_0\sqrt{2}$: i.e. the peak frequency deviation when the white noise modulating signal is replaced by a sinusoidal signal having the same power
- f : frequency separation from the centre of the spectrum
- P_0 : total power of the emission
- P' : power outside the frequencies $-f$ and $+f$ in the spectrum, i.e. the out-of-band power
- β : out-of-band power ratio P'/P_0 , as mentioned in § 1.12
- $p(f)$: power density of the spectrum at frequency f

For small values of the frequency deviation, the distribution of the power density may be calculated from equation (12):

$$p(f) = \frac{1}{2} (P_0 / 2 D_p) (D_p / M) \left[\frac{1}{(\pi^2 / 16) (D_p / M)^2 + (f / D_p)^2} \right] \tag{12}$$

However, this equation is valid only for that part of the spectrum which lies within the frequency limits defined by plus and minus the maximum frequency of the noise signal.

Measurements have demonstrated that the spectra beyond these limits decay almost linearly. Therefore the slopes of the spectra were determined and used to complete the curves representing the spectral distribution (see Fig. 9).

FIGURE 9
Power spectral distribution for $D_p / M < 0.5$

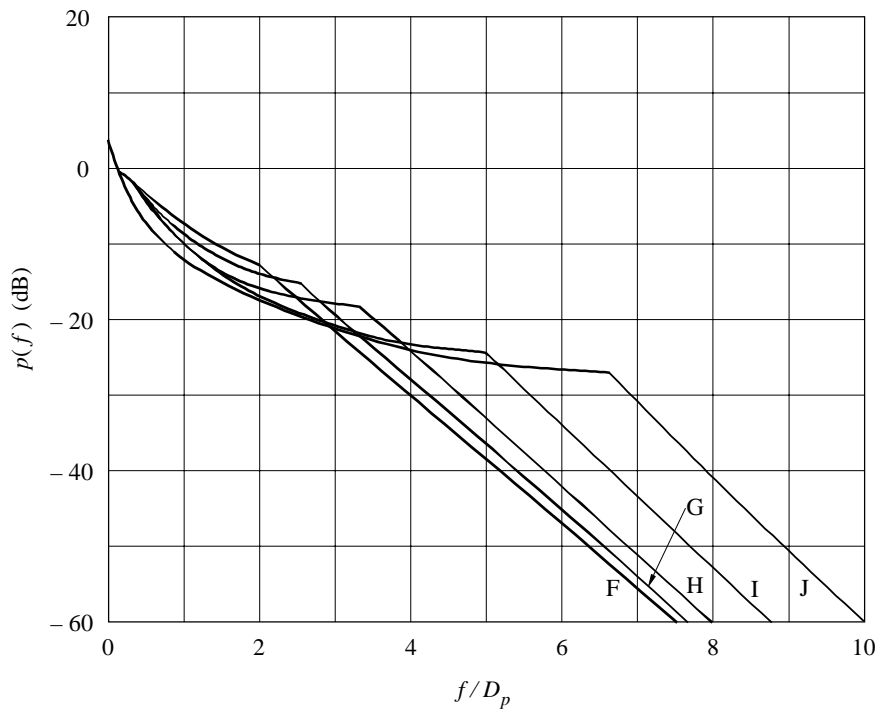

- Curves F: $D_p / M = 0.5$
- G: $D_p / M = 0.4$
- H: $D_p / M = 0.3$
- I: $D_p / M = 0.2$
- J: $D_p / M = 0.15$

0328-09

It should be noted, however, that these slopes do not continue without limit. Because of the noise generated internally within the transmitter, the spectrum has a lower bound, or floor, the level of which depends upon the type of radio-frequency output stage.

3.9.3 Out-of-band power and bandwidth

Curves giving the out-of-band power of emissions with median values of frequency deviation are shown in Fig. 10. These curves have been derived from the empirical equation mentioned in the first paragraph of § 3.9.2.

FIGURE 10
Out-of-band power of the spectra for $D_p/M > 0.5$

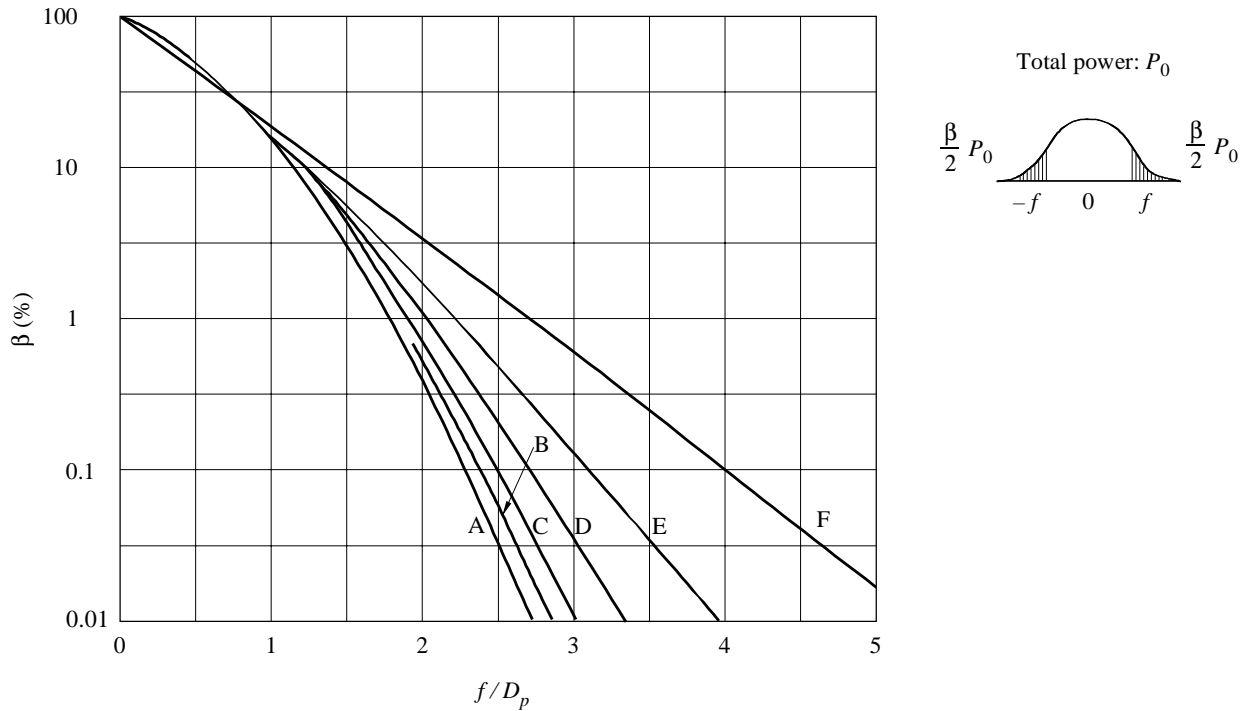

- Curves A: $D_p/M > 2.5$
 B: $D_p/M = 1.8$
 C: $D_p/M = 1.4$
 D: $D_p/M = 1.2$
 E: $D_p/M = 0.7$
 F: $D_p/M = 0.5$

0328-10

Curves relating to emissions with a small frequency deviation are given in Fig. 11. This figure has been obtained from Fig. 9 by graphical integration.

Fig. 12 has been obtained from Figs. 10 and 11 and shows the normalized bandwidth for different values of the out-of-band radiation. The irregularities in the vicinity of the points given by $D_p/M = 0.5$ may be attributed to the fact that Figs. 8 and 9 were deduced using different approaches, starting from the two extreme cases of modulation index.

Experimental data has been plotted in Fig. 12, and clearly demonstrate the validity of Figs. 8 to 12.

FIGURE 11
Out-of-band power of the spectra for $D_p/M < 0.5$

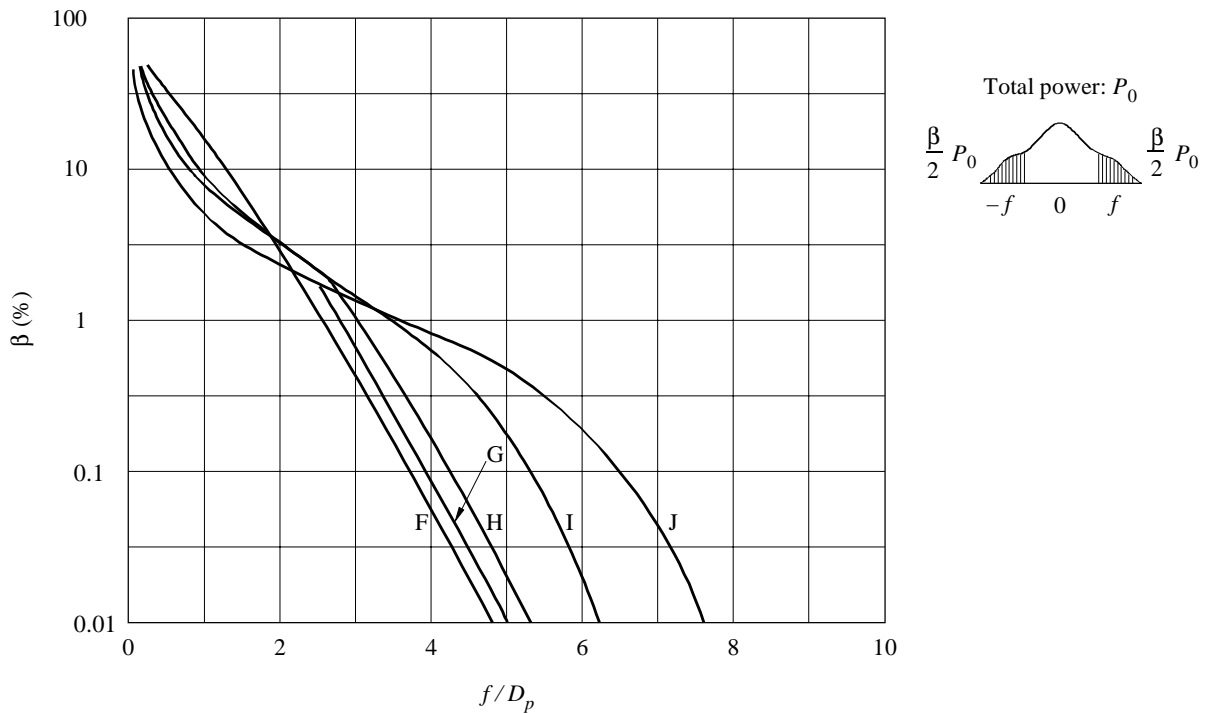

- Curves F: $D_p/M = 0.5$
- G: $D_p/M = 0.4$
- H: $D_p/M = 0.3$
- I: $D_p/M = 0.2$
- J: $D_p/M = 0.15$

0328-11

3.10 Single-sideband and independent-sideband amplitude-modulated emissions for telephony and multi-channel voice-frequency telegraphy

3.10.1 Introduction

The occupied bandwidth and out-of-band radiation of amplitude-modulated emissions carrying analogue signals depend, to a varying degree, on several factors such as:

- type of modulating signal;
- the input signal level determines the modulation loading of the transmitter;
- the passband which results from the filters used in the audio-frequency stages and in the intermediate and final modulating stages of the transmitter;
- the magnitude of the harmonic distortion and intermodulation components at the frequencies of the out-of-band spectrum.

The results of measurements are also dependent upon the passband of the selective measuring device employed and on its dynamic characteristics, such as the integration time of the meter, or any other devices used in conjunction with the selective measuring device.

FIGURE 12
 Bandwidth, in terms of D_p , for specific percentages of the out-of-band power

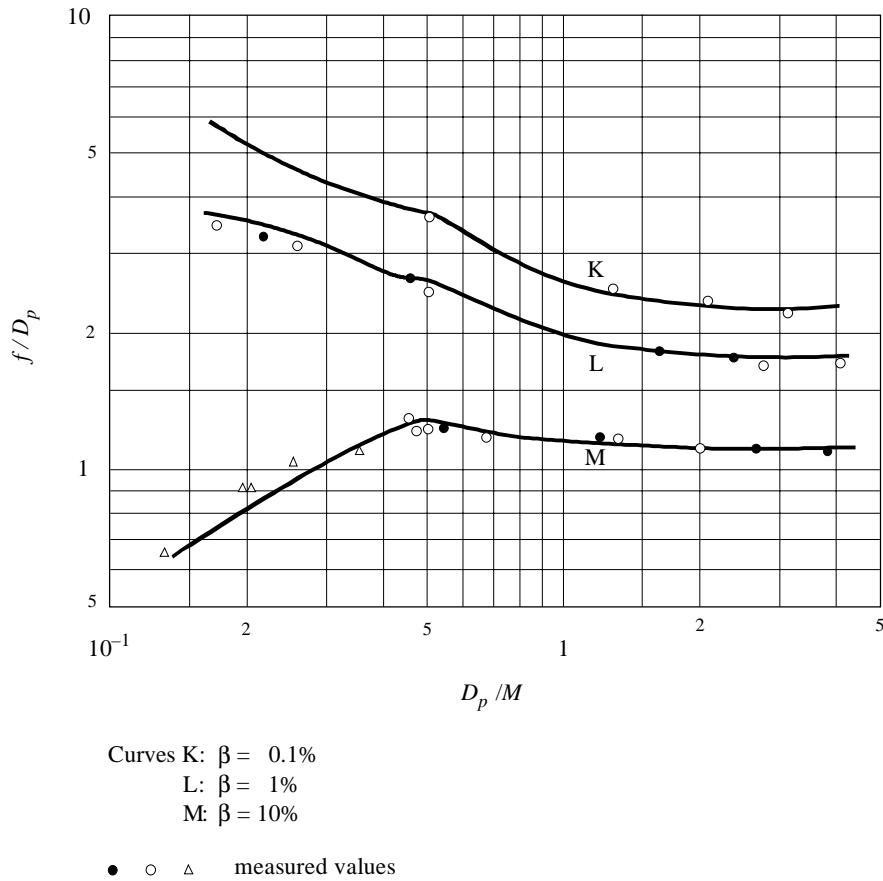

0328-12

3.10.2 Shape of the spectrum envelope for class J3E and class J7B emissions modulated with white noise

This section deals with the results of measurements made by several administrations on different designs of transmitters for classes of emission J3E and J7B.

The major characteristics of the transmitters and the test conditions relating to the measurements are summarized in Table 6.

TABLE 6

**Transmitter characteristics and measurement test conditions
for J3E and J7B emissions**

Item No.	1	2	3	4	5
Class of emission	J3E	J3E	J3E	J3E; J7B	J3E
<i>Transmitter characteristics:</i>					
– peak envelope power P_p (two tones) ⁽¹⁾ (kW)	Different values	0.150	Various transmitters 2.5-30		Various transmitters Several kW to some tens of kW
– third order intermodulation distortion α_3 ⁽¹⁾ (dB)	Different values	About –40	Different values		
<i>Type of modulating signal:</i>					
– bandwidth	White noise Slightly smaller than B_p ⁽²⁾	White noise Limited only by B_p ⁽²⁾	White noise Limited only by B_p ⁽²⁾	White noise Weighted noise	White noise
<i>Input signal level</i> ⁽¹⁾ adjusted to a value such that:					
– at the input, P_m (noise) =	P_m (two tones)		P_m (two tones)		
– at the output, P_m (noise) =				$0.25 P_p$ (two noise)	
– at the output, P_p (noise) =		P_p (two tones)			
<i>Type of measuring device:</i>					
– passband (Hz)		Spectrum analyser 300	Spectrum analyser		Spectrum analyser $\leq 0.05 F$ ⁽²⁾
Shape of spectrum	See Fig. 14				See § 3.10.2.5

⁽¹⁾ In all tests, the transmitter is first modulated with two sinusoidal signals of equal amplitude. Next, the peak envelope power, P_p (two tones), and the third order intermodulation distortion level, α_3 , are determined in accordance with the methods given in Recommendation ITU-R SM.326. Finally, the two sinusoidal signals are replaced by a noise signal, the level of which is adjusted to obtain one of the conditions mentioned under “input signal level”, where P_m denotes mean power and P_p denotes peak envelope power.

⁽²⁾ B_p is the passband resulting from the filters in the transmitter, and F is the necessary bandwidth.

The results of the measurements may be summarized as follows:

3.10.2.1 The tests described in item 1 of Table 6

Assuming that the transmitter is operated under the conditions mentioned in item 1 of Table 6 and also assuming that the out-of-band radiation is mainly caused by intermodulation in the radio-frequency stages following the final modulator, the following may be concluded:

- the centre part of the radio-frequency spectrum exhibits a substantially rectangular form and is superimposed on a curve showing the out-of-band radiation which extends symmetrically with respect to the centre frequency (see Fig. 14);
- the difference α_N between the level of the flat portion of the top of the spectrum and the level at which the out-of-band radiation starts is generally equal to the level of the third order intermodulation component α_3 (see Fig. 15);
- the slope (dB/Hz) of the curve representing the out-of-band radiation, is inversely proportional to the bandwidth B of the noise signal at the input;

- the slope is constant, at least in the neighbourhood of the limits of the bandwidth, and has a value between 10 and 20 dB per bandwidth B , dependent on the character of the distortion (see Fig. 16);
- the bandwidth occupied by the emission is equal to the width of the main spectrum, provided that α_3 is at least 20 dB.

The above conclusions are expected to be also valid in those cases where the modulating signal is similar to white noise, such as radiotelephone emissions using a band-splitting privacy device and multi-channel voice-frequency radio-telegraph emissions.

FIGURE 13

Spectrum envelope of class J3E emission modulated with two sinusoidal signals

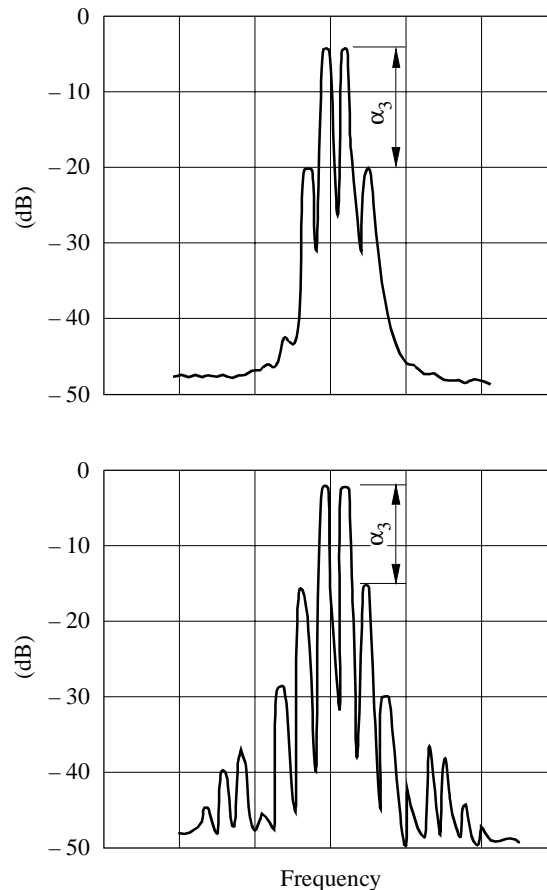

α_3 : third order intermodulation level

0328-13

3.10.2.2 The tests described in item 2 of Table 6

The results, particularly with respect to the level at which the out-of-band radiation starts, correspond very closely to those obtained from the measurements described in item 1 of Table 6 and in item 1 of Table 7.

3.10.2.3 The tests described in item 3 of Table 6

The transmitters used in these tests, although of different design and power rating, used triodes in the final stage which were capable of being driven into grid current.

In one series of tests, the transmitters were fairly heavily loaded in order to determine the possible influence of grid current. Under this condition the third order intermodulation distortion level α_3 , was rather poor and there appeared to be a fairly large difference between the value of α_3 and the level α_N in the power spectrum at which the out-of-band radiation starts.

In a second series of tests, α_N and α_3 were determined as a function of the modulation input level. For the lower values of this level the relation $\alpha_3 = \alpha_N$, was approximately satisfied.

Furthermore, it has been observed that under the modulating conditions mentioned in item 3 of Table 5, the mean power of the noise-modulated radio-frequency signal was about 1 dB greater than the mean power of the radio-frequency signal modulated with two sinusoidal signals. This causes the peak envelope power to be exceeded for a considerable percentage of the time. This condition does not correspond to the practices generally adopted in actual traffic and further experiments seem to indicate that it might be necessary to adjust the level of the noise signal to a value which is 2-3 dB lower than that used in the tests just mentioned.

FIGURE 14
Spectrum envelope of class J3E emission modulated with white noise

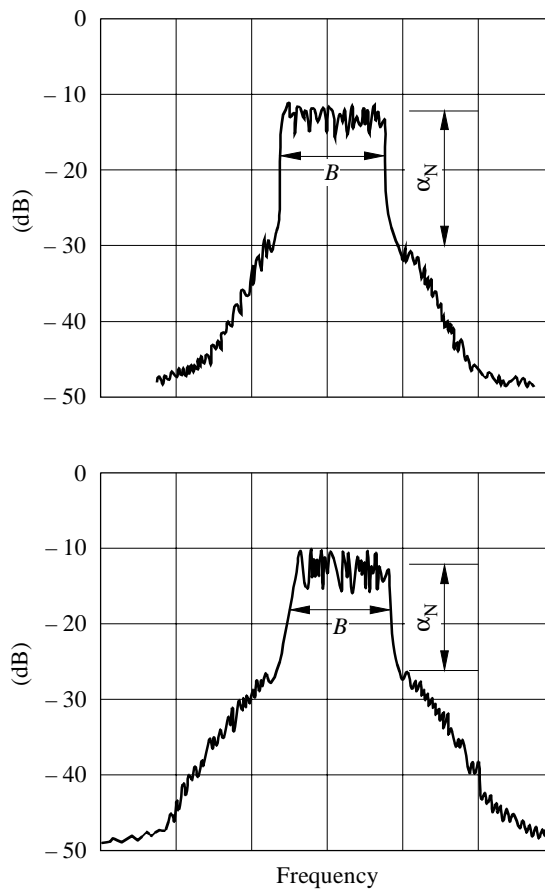

α_N : see text
 B: bandwidth of noise signal

0328-14

3.10.2.4 The tests described in item 4 of Table 6

The adjustment of the input signal level mentioned in item 4 of Table 5 applies to both transmitters for class of emission J3E and transmitters for class of emission J7B. In this case the following relationship is satisfied with respect to the power of the radio-frequency signal:

$$P_m \text{ (noise)} = 0.5 P_m \text{ (two tones)} = 0.25 P_p \text{ (two tones)} \quad (13)$$

Under this condition the envelope of the noise-modulated signal will not exceed the level corresponding to the rated peak envelope power for more than about 2% of the time.

If, with a transmitter for class of emission J3E, the noise signal is weighted, the same adjustment can be used.

FIGURE 15
The value of α_N shown in Fig. 14 for different values of α_3

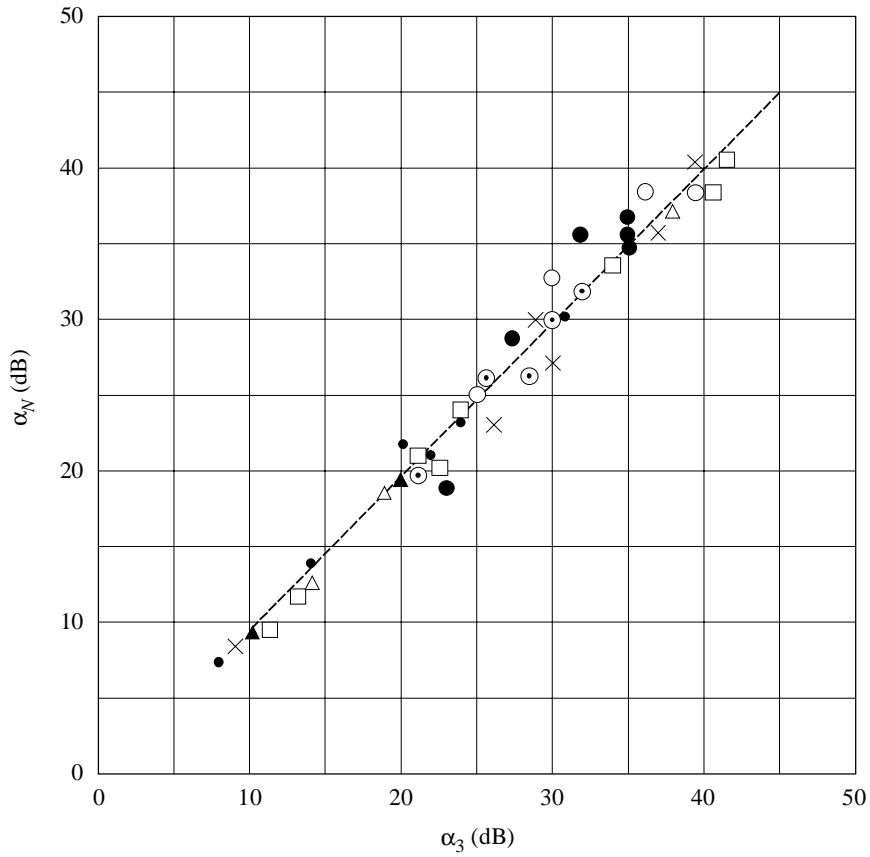

0328-15

FIGURE 16
The value of the slope in the vicinity of the bandwidth for different values of α_3

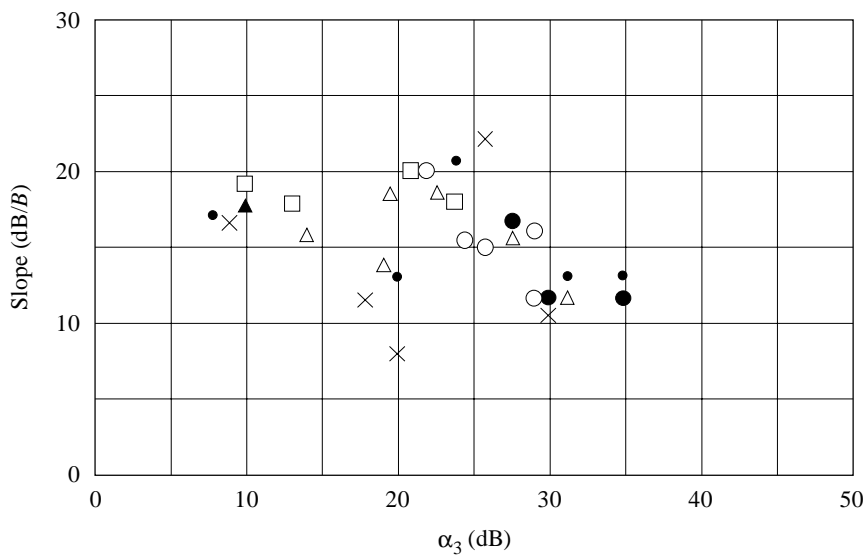

0328-16

3.10.2.5 The tests described in item 5 of Table 6

If frequency is plotted as the abscissa in logarithmic units, the reference frequency being assumed to coincide with the centre of the necessary bandwidth F , and if the power densities are plotted as ordinates (dB) the curves representing the out-of-band spectra produced by a number of transmitters of different power rating for class of emission J3E lie below two straight lines, starting at point $(+0.5 F, 0 \text{ dB})$, or at point $(-0.5 F, 0 \text{ dB})$, and finishing at point $(+0.6 F, -30 \text{ dB})$ or $(-0.6 F, -30 \text{ dB})$, respectively. Beyond the latter points and down to the level -60 dB , the curves lie below two straight lines, starting from the latter point and having a slope of 12 dB/octave .

3.10.3 Shape of the spectrum envelope for class B8E and class R7J emissions modulated with white noise

This section deals with the results of measurements made by several administrations on transmitters of different design for classes of emission B8E and R7J.

The major characteristics of the transmitters and the test condition relating to the measurements are summarized in Table 7.

TABLE 7

**Transmitter characteristics and measurement test conditions
for B8E and R7J emissions**

Item No.	1	2	3
Class of emission	B8E	B8E	B8E; R7J
<i>Transmitter characteristics:</i>		Various transmitters Several kW up to some tens of kW	Various transmitters Different values
– peak envelope power P_p (two tones) ⁽¹⁾ (kW)	20		
– third order intermodulation distortion α_3 ⁽¹⁾ (dB)	≤ -35		
– number of channels active during the measurement	2, in lower sideband	2 and 4	
– bandwidth of speech channel (Hz)	3 000		
– carrier suppression (dB) relative to peak envelope power	-50		
<i>Type of modulating signal:</i>	White noise 30 Hz-20 kHz $\pm 1 \text{ dB}$	White noise	White noise 100 Hz-6 kHz per sideband
<i>Input signal level</i> ⁽¹⁾ adjusted to a value such that:			
– at the output, P_m (noise) =	$0.25 P_p$ (two tones)		$0.25 P_p$ (two tones)
<i>Type of measuring device:</i>	True r.m.s. selective measurement device	Spectrum analyser	Spectrum analyser
– passband (Hz)	Curves C: 3 800 D: 100	$\leq 0.05 F$ ⁽²⁾	
Shape of spectrum	See Fig. 17	See § 3.10.3.2	

⁽¹⁾ In all tests, the transmitter is first modulated with two sinusoidal signals of equal amplitude. Next, the peak envelope power, P_p (two tones), and the third order intermodulation distortion level, α_3 , are determined in accordance with the methods given in Recommendation ITU-R SM.326. Finally, the two sinusoidal signals are replaced by a noise signal, the level of which is adjusted to obtain one of the conditions mentioned under “input signal level”, where P_m denotes mean power and P_p denotes peak envelope power

⁽²⁾ B_p is the passband resulting from the filters in the transmitter, and F is the necessary bandwidth.

The results of the measurements may be summarized as follows:

3.10.3.1 The tests described in item 1 of Table 7

Only the lower sideband was used, the upper sideband being suppressed to at least -60 dB by means of the filter incorporated in the transmitter. The carrier was suppressed to approximately -50 dB (class J3E) and the audio-frequency bandwidth was approximately 6 000 Hz.

The bandwidth of the noise signal was limited only by the filter characteristic of the transmitter (see curve A of Fig. 17). In this connection it should be noted that, if the radio-frequency spectrum produced by only one speech channel were to be determined, the bandwidth of the test signal should be limited before it is applied to the transmitter, since its overall bandwidth is considerably larger than the width of one speech channel.

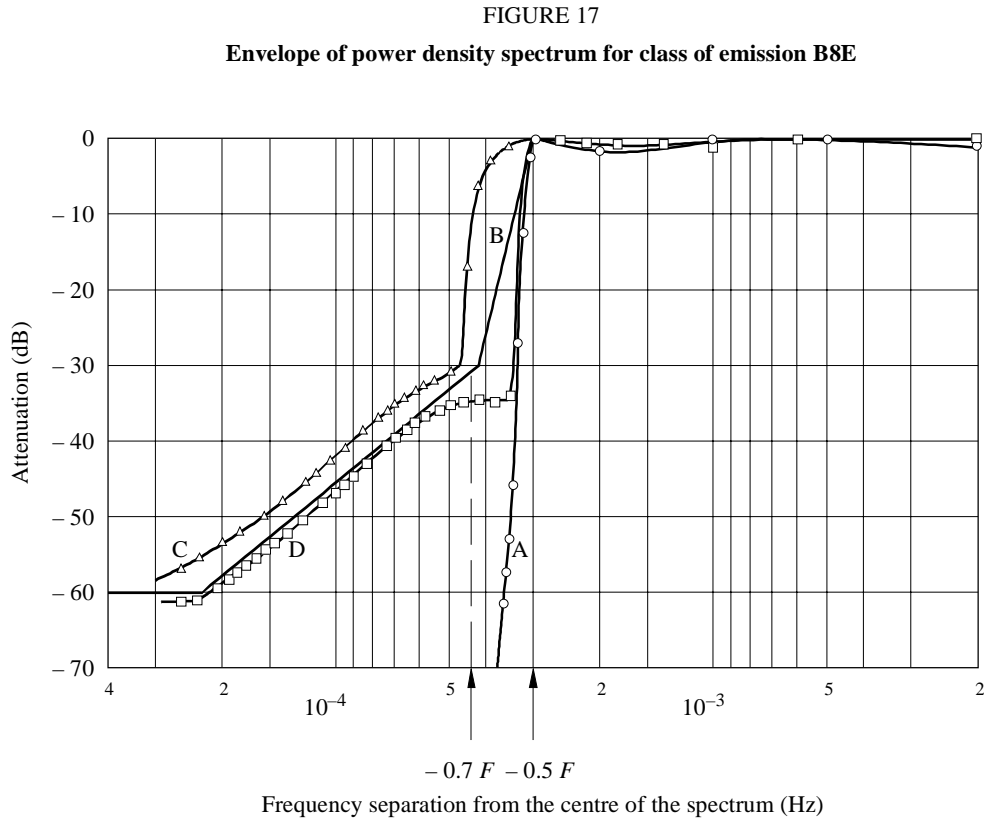

F : necessary bandwidth (6 000 Hz)

Curves A: filter characteristic of the transmitter

B: limiting curve specified in § 3.5.2.3

C: measured with an analyser having a passband of 3 800 Hz

D: measured with an analyser having a passband of about 100 Hz

0328-17

One series of measurements was carried out using an analyser with a bandwidth of about 100 Hz. An analyser with a bandwidth of 3.8 kHz and a very steep attenuation slope was employed for the other series.

The results are shown in Fig. 17 curves D and C respectively. These curves represent the envelopes of the spectra of the lower sideband, measured in the lower radio-frequency range. Curves similar to those given in Fig. 17 were obtained for the higher frequency range.

If the spectrum measured with the aid of narrow-band equipment is, as in the present case, just within the limiting curve B, the spectrum analysed by means of wideband receivers will exceed this limit. As wideband measuring equipment does not take account of the fine structure of the spectrum, particularly in the region where its slope is steep, the use of narrow-band devices for such measurements is recommended.

It can be further concluded from Fig. 17 that the out-of-band radiation starts at a level nearly equal to the level of third order intermodulation components, *viz.* at -35 dB. The out-of-band radiation remains almost constant in the immediate vicinity of the limits of the bandwidth; for frequencies remote from these limits the curve gradually decays, at first proportional to frequency, then reaching an ultimate slope of about 12 dB/octave. In Fig. 18 a linear frequency scale has been used at the abscissa to illustrate more clearly the envelope of the spectrum mentioned above.

FIGURE 18
Curve D of Fig. 17 shown on a linear frequency scale

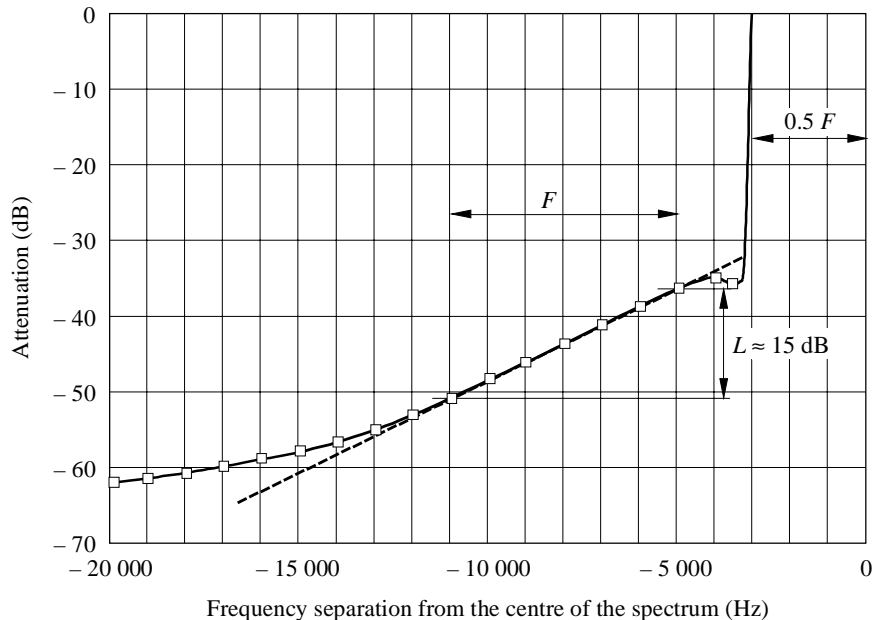

L : linear region equal to about the necessary bandwidth F

0328-18

3.10.3.2 The tests described in item 2 of Table 7

If frequency is plotted as the abscissa in logarithmic units, the reference frequency being assumed to coincide with the centre of the necessary bandwidth F , and if the power densities are plotted as ordinates (dB) the curves representing the out-of-band spectra produced by a number of transmitters of different power rating for class of emission B8E (two channels or four channels simultaneously active) lie below two straight lines starting at point $(+0.5 F, 0 \text{ dB})$ or at point $(-0.5 F, 0 \text{ dB})$, and finishing at point $(+0.55 F, -30 \text{ dB})$ or $(-0.55 F, -30 \text{ dB})$, respectively. Beyond the latter points and down to the level -60 dB, the curves lie below two straight lines starting from the latter points and having a slope of 12 dB/octave.

3.10.3.3 The tests described in item 3 of Table 7

The test equipment was arranged to facilitate intermodulation distortion measurements to be made either by the two-tone method or the white-noise method, so that comparisons could be made between the two methods. When using the white-noise method, the white noise generator output was passed through filters to limit the noise bandwidth to the maximum bandwidth normally expected on traffic *i.e.* 100-6000 Hz per sideband. A band stop filter provided a slot in which "in-band" distortion products could be measured using a 30 Hz filter in the spectrum analyser. A band-stop filter with a minimum bandwidth of 500 Hz at 3 dB and a 60 dB shape factor of 3.5 to 1 was found necessary to permit adequate resolution by the 30 Hz spectrum analyser filter when measuring distortion ratios approaching 50 dB.

The majority of the white-noise loading tests were made with a mean output power level of -6 dB relative to peak envelope power rating which confirms the relationship mentioned in § 3.10.2.4, equation (13).

The tests confirm and extend the earlier conclusions and establish the use of a white-noise signal as a valid substitute for the modulating signal of two types of multiplex emissions, B8E and R7E, in common use. Further, the tests disclose a useful and stable experimental relationship between in-band intermodulation distortion and out-of-band radiation. However, there was no clear agreement between two-tone intermodulation distortion ratios and equivalent white-noise loading distortion.

3.11 Class of emission G1B (single channel phase modulation telegraphy)

3.11.1 Necessary bandwidth

The necessary bandwidth can be calculated by the following formula:

$$B_n = K B$$

where:

B : modulation rate (Bd)

$K = 5$, for radio links with fading

$K = 3$, for radio links without fading.

3.11.2 Out-of-band spectrum

The curve representing the out-of-band spectrum should lie below the points with the coordinates given in Table 8.

TABLE 8

Formula for calculating B_x at levels X (dB)				
-20	-30	-40	-50	-60
$3 B$	$7 B$	$13 B$	$23 B$	$41 B$

For each point of the limiting spectrum curve, the abscissa is the relative frequency $\pm B_x/2B$, and the ordinate is the relative level X . The reference level 0 dB is the level of the unmodulated carrier.

4 Approximation of out-of-band spectra envelopes for analytical calculations

Formula for approximating out-of-band spectra envelopes by power functions (straight lines in double logarithmic scale, see § 3.1.4, 3.4.2, 3.5.1.3, 3.5.2.3, 3.6.1.3 and 3.7.8 above) and by exponential functions are given in § 3.4.2.2 of the ITU Spectrum Monitoring Handbook (Geneva, 1995). For converting the slope of straight lines in double-logarithmic scale (power function), expressed in N_{oct} (dB/octave) and N_{dec} (dB/decade), the following equation should be used:

$$N_{dec} = 3.33 N_{oct}$$

ANNEX 1

Examples of spectra illustrating the definitions of out-of-band power, necessary bandwidth and x dB bandwidth.

Abscissae: frequency

Ordinates: power per unit frequency.

NOTE 1 – Symmetrical spectra are assumed.

NOTE 2 – The dotted lines denote the permissible limiting curve for the out-of-band spectrum.

FIGURE 19
Evaluation of spectra, by comparing out-of-band power and band limitation

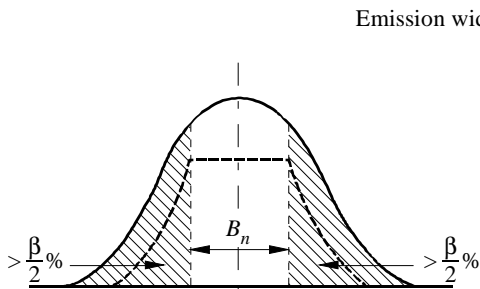
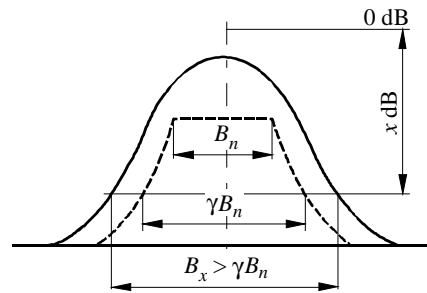
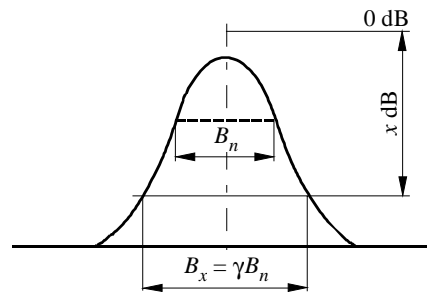
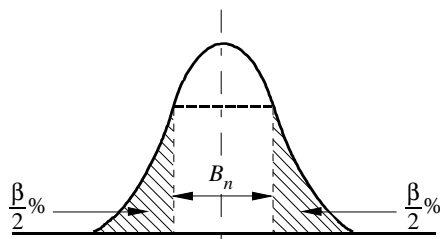

FIGURE 20
Evaluation of spectra by means of the x dB bandwidth



Emission corresponding to "optimum"



Emission narrower than "optimum"

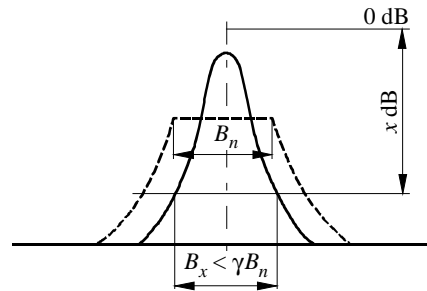
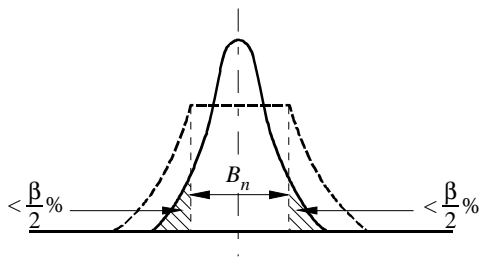

B_n : necessary bandwidth

B_x : x dB bandwidth

x : value of measurement level (dB)

γ : required relationship between x dB bandwidth and necessary bandwidth, determined by the x dB level and the parameters of the limiting curve for the out-of-band spectrum

$\frac{\beta}{2}$: half of the permissible out-of-band power

ANNEX 2

(See ITU-T Recommendation G.227)

FIGURE 21

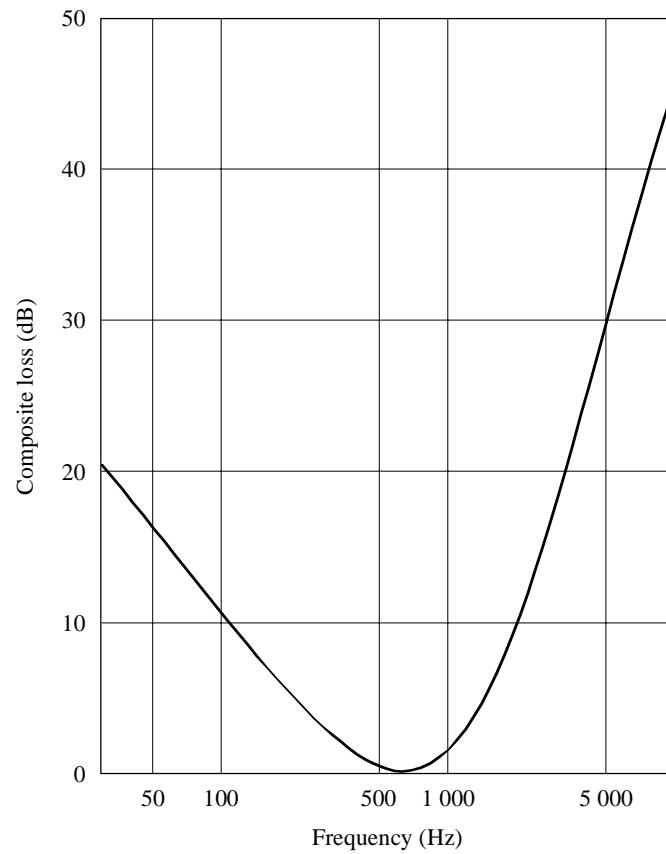
**Relative response curve of the shaping network
of the conventional telephone signal generator**

0328-21

FIGURE 22
Shaping network of the conventional telephone signal generator

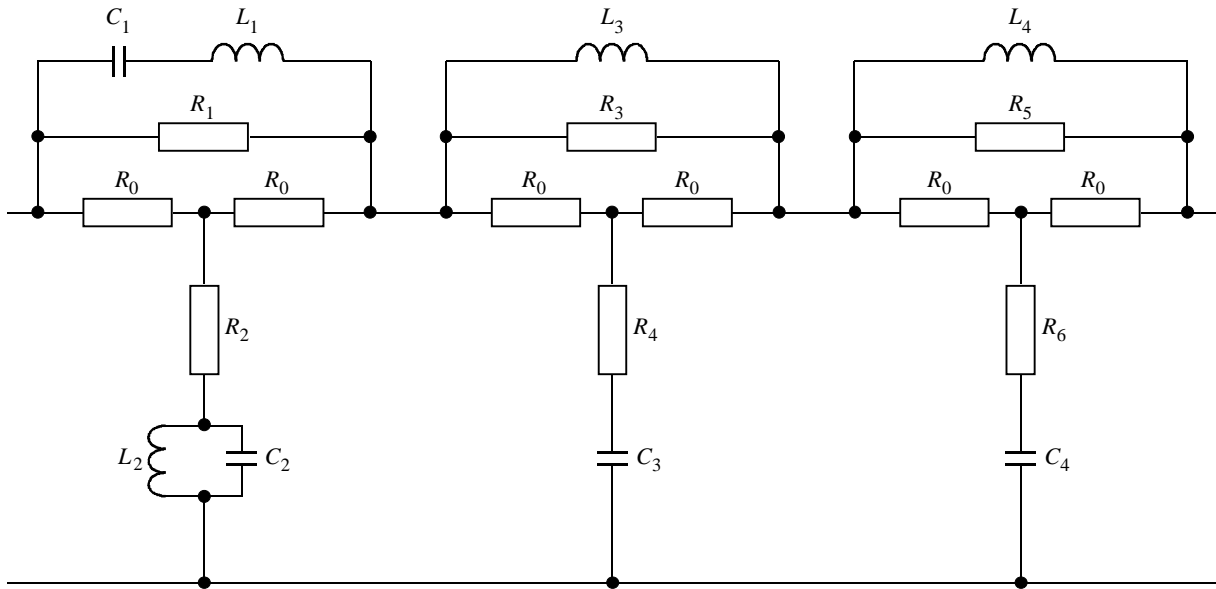

Section 1

$$\frac{R_1}{R_0} = 45$$

$$\frac{R_2}{R_0} = 0.0222$$

$$\frac{R_3}{R_0} = 10$$

$$\frac{R_4}{R_0} = 0.1$$

$$\frac{R_5}{R_0} = 22$$

$$\frac{R_6}{R_0} = 0.0455$$

Section 2

$$\frac{L_1 \omega_0}{R_0} = 0.5$$

$$\frac{L_2 \omega_0}{R_0} = 2$$

$$\frac{L_3 \omega_0}{R_0} = 0.5$$

$$\frac{L_4 \omega_0}{R_0} = 1.11$$

Section 3

$$R_0 C_1 \omega_0 = 2$$

$$R_0 C_2 \omega_0 = 0.5$$

$$R_0 C_3 \omega_0 = 0.5$$

$$R_0 C_4 \omega_0 = 1.11$$

$$\omega_0 = 2\pi \times 10^3 \times \text{s}^{-1}$$

R_0 : characteristic impedance of network

Tolerance of components: $\pm 1\%$

Extract from Recommendation ITU-R BS.559, § 1.3

1 Noise signal for modulating the signal generators

Two conditions must be fulfilled by the standardized signal to simulate programme modulation:

- its spectral constitution must correspond to that of a representative broadcast programme;
- its dynamic range must be small to result in a constant unequivocal reading on the instrument.

The amplitude distribution of modern dance music was taken as a basis, as it is a type of programme with a considerable proportion of high audio-frequencies, which occur most frequently. However, the dynamic range of this type of programme is too wide and does not fulfil, therefore, the second requirement mentioned above. A signal which is appropriate for this purpose is a standardized coloured noise signal, the spectral amplitude distribution of which is fairly close to that of modern dance music (see curve A of Fig. 23, which is measured using one-third octave filters).

FIGURE 23

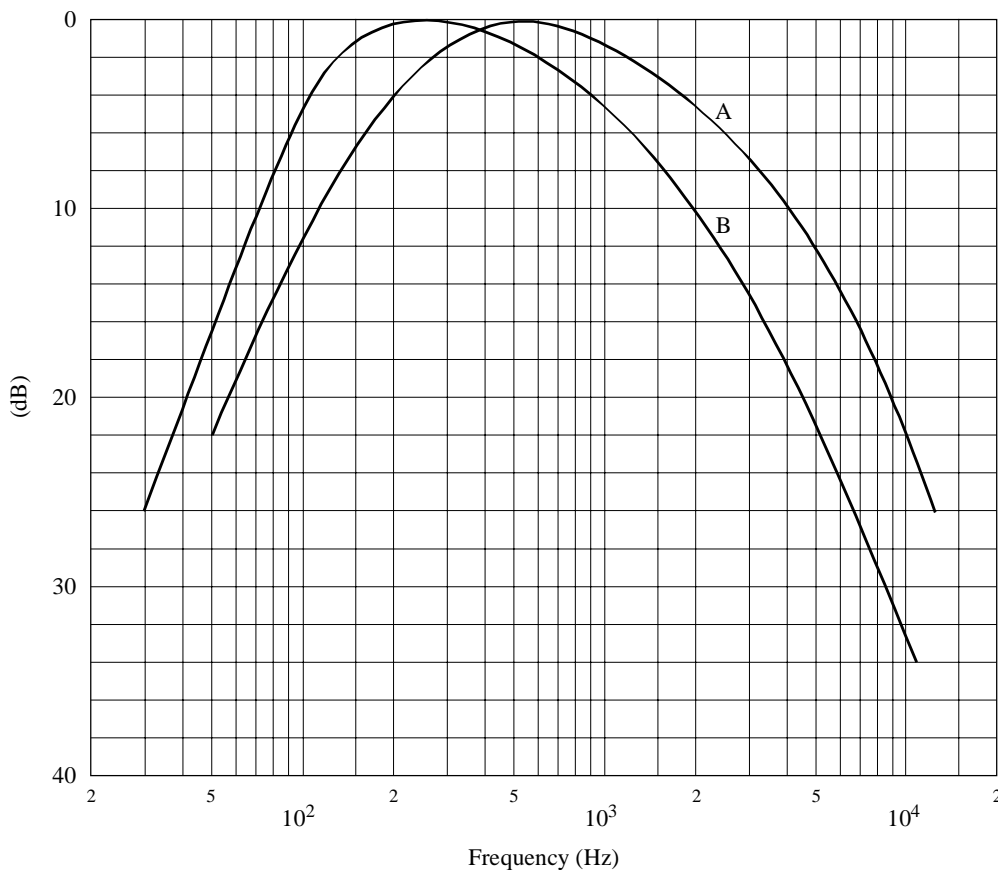

Curves A: frequency spectrum of standardized noise (measured with one-third octave filters)
 B: frequency response characteristic of filter-circuit

0328-23

This standardized coloured noise signal may be obtained from a white-noise generator by means of a passive filter circuit as shown in Fig. 24. The frequency-response characteristic of this filter is reproduced as curve B of Fig. 23. (It should be noted that the difference between curves A and B of Fig. 23 is due to the fact that curve A is based on measurements with one-third octave filters which pass greater amounts of energy as the bandwidth of the filter increases with frequency.)

The spectrum beyond the required bandwidth of the standardized coloured noise should be restricted by a low-pass filter having a cut-off frequency and a slope such that the bandwidth of the modulating signal is approximately equal to half the standardized bandwidth of emission. The audio-frequency amplitude/frequency characteristic of the modulating stage of the signal generator shall not vary by more than 2 dB up to the cut-off frequency of the low-pass filter.

FIGURE 24

Filter circuit

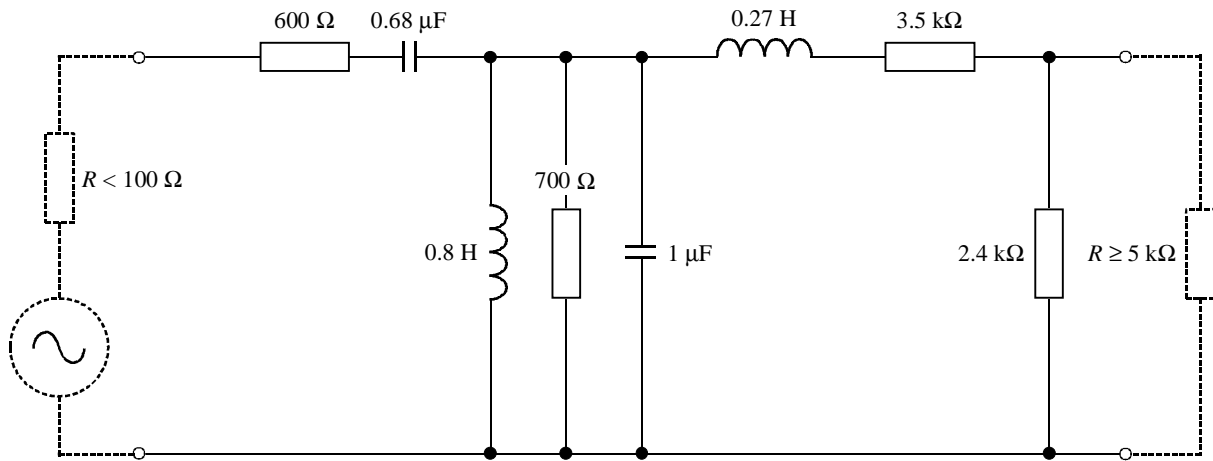

0328-24

ANNEX 4

Type of modulation signal and adjustment of the input signal level

1 Class of emission A3E, telephony

As the statistical distribution of the noise amplitude is almost independent of bandwidth and is not significantly altered when a linear weighting network is used, the following procedure is suitable for simulating the loading of a transmitter under actual traffic conditions.

The transmitter is first modulated with a sinusoidal signal to a modulation factor of 100%. Next, the sinusoidal signal is replaced by a noise signal, the level of which is adjusted until the r.m.s. voltage after linear demodulation of the radio-frequency signal is equal to 35% of the r.m.s. voltage which was produced by the sinusoidal signal.

With this adjustment, which applies equally to a modulating signal consisting of white noise or of weighted noise, the envelope of the noise-modulated signal will not exceed the level corresponding to a modulation factor of 100% for more than about 0.01% of the time, according to the curve shown in Fig. 25.

The levels should preferably be measured at the output of the transmitter, as explained above, in order to avoid errors due to different values of the noise bandwidth, which may occur when the noise level is determined at the input or at the output of the band-limiting filters used in the transmitter.

2 Class of emission A3EGN, sound broadcasting

The adjustment procedure described in § 1 above may also be applied to transmitters for sound broadcasting, except that in this case, the noise is weighted in accordance with the curves mentioned in § 3.6.1.2, and shown in Fig. 23.

FIGURE 25

Time Φ (%) during which the instantaneous value of the white noise exceeds the threshold voltage $\pm u$, as a function of the ratio x

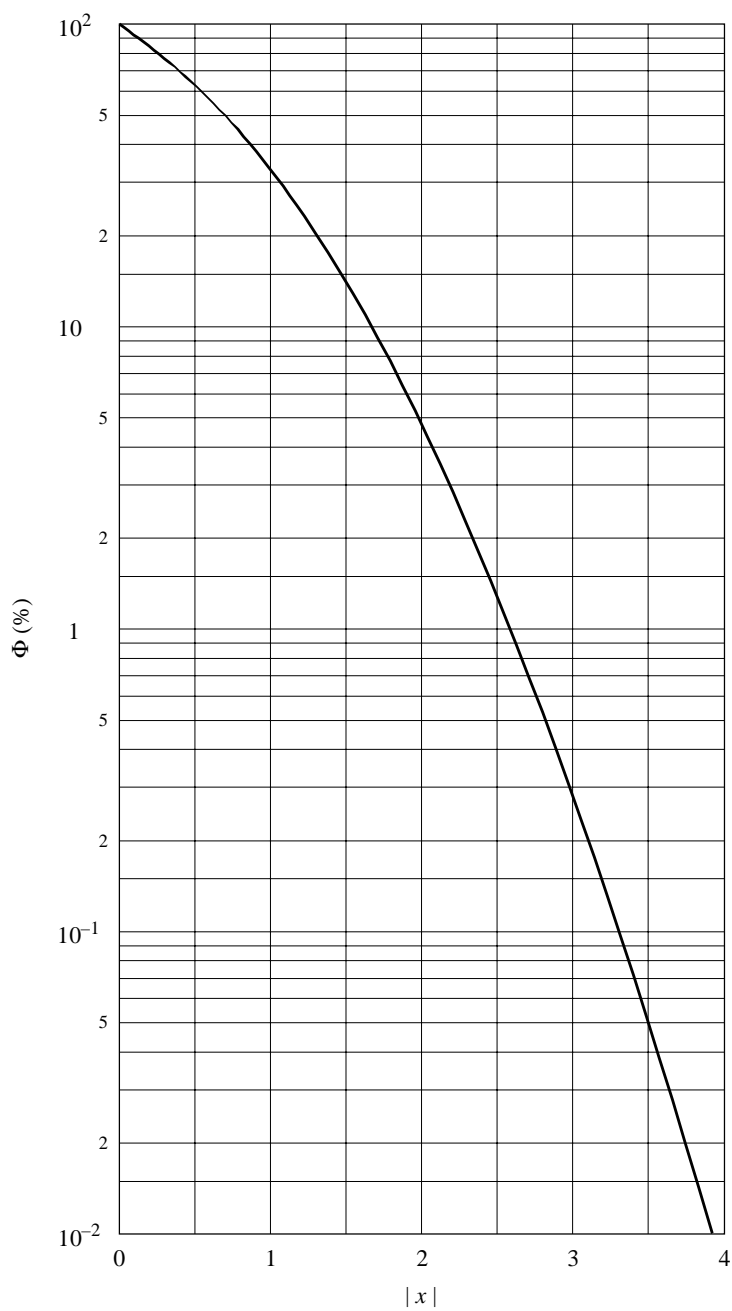

x is given by $|x| = |u| / U_{rms}$
 where:

U_{rms} : r.m.s. noise voltage
 u : threshold level