

International Telecommunication Union

ITU-R
Radiocommunication Sector of ITU

Recommendation ITU-R SM.2096-0
(08/2016)

**Test procedure for measuring direction
finder sensitivity in the VHF/UHF
frequency range**

SM Series
Spectrum management

Foreword

The role of the Radiocommunication Sector is to ensure the rational, equitable, efficient and economical use of the radio-frequency spectrum by all radiocommunication services, including satellite services, and carry out studies without limit of frequency range on the basis of which Recommendations are adopted.

The regulatory and policy functions of the Radiocommunication Sector are performed by World and Regional Radiocommunication Conferences and Radiocommunication Assemblies supported by Study Groups.

Policy on Intellectual Property Right (IPR)

ITU-R policy on IPR is described in the Common Patent Policy for ITU-T/ITU-R/ISO/IEC referenced in Annex 1 of Resolution ITU-R 1. Forms to be used for the submission of patent statements and licensing declarations by patent holders are available from <http://www.itu.int/ITU-R/go/patents/en> where the Guidelines for Implementation of the Common Patent Policy for ITU-T/ITU-R/ISO/IEC and the ITU-R patent information database can also be found.

Series of ITU-R Recommendations

(Also available online at <http://www.itu.int/publ/R-REC/en>)

Series	Title
BO	Satellite delivery
BR	Recording for production, archival and play-out; film for television
BS	Broadcasting service (sound)
BT	Broadcasting service (television)
F	Fixed service
M	Mobile, radiodetermination, amateur and related satellite services
P	Radiowave propagation
RA	Radio astronomy
RS	Remote sensing systems
S	Fixed-satellite service
SA	Space applications and meteorology
SF	Frequency sharing and coordination between fixed-satellite and fixed service systems
SM	Spectrum management
SNG	Satellite news gathering
TF	Time signals and frequency standards emissions
V	Vocabulary and related subjects

Note: This ITU-R Recommendation was approved in English under the procedure detailed in Resolution ITU-R 1.

Electronic Publication
Geneva, 2016

© ITU 2016

All rights reserved. No part of this publication may be reproduced, by any means whatsoever, without written permission of ITU.

RECOMMENDATION ITU-R SM.2096-0

**Test procedure for measuring direction finder sensitivity
in the VHF/UHF frequency range**

(2016)

Scope

The sensitivity of direction finding systems is an important consideration to regulatory authorities and others who have to locate emitters. It is often difficult to compare different systems due to a number of factors, such as the system architecture, typical use/purpose, size, installation requirements, and other issues. To facilitate comparison between direction finding (DF) systems, this Recommendation provides guidance on a standard method of testing DF sensitivity and reporting of the results.

Keywords

DF sensitivity, measurement, test site, open-air-test-site, OATS

Related ITU Recommendations, Reports

Recommendation ITU-R SM.854

Recommendation ITU-R SM.2060

Recommendation ITU-R SM.2061

Recommendation ITU-R SM.2097-0

Report ITU-R SM.2125

NOTE – In every case the latest edition of the Recommendation/Report in force should be used.

The ITU Radiocommunication Assembly,

considering

- a) that ITU-R published the typical specifications for direction finding (DF) sensitivity in the ITU Handbook on Spectrum Monitoring (Edition 2011);
- b) that the Handbook refers to Report ITU-R SM.2125 – Parameters of and measurement procedures on H/V/UHF monitoring receivers and stations, which defines DF sensitivity and provides relevant test procedures;
- c) that the specification of DF sensitivity strongly depends on the test procedures applied;
- d) that DF sensitivity may influence the suitability of a direction finder to fulfil certain monitoring tasks such as mobile or fixed use, or its ability to measure digital wideband signals, especially when used in typical operating environments;
- e) that a defined set of test procedures for DF sensitivity must be independent of the DF design;
- f) that a well-defined set of test procedures for DF sensitivity, if adopted by all manufacturers of DF intended for civil radio monitoring, will have the advantage for the users of such DF, that an easier and more objective assessment of products from different manufacturers is possible;
- g) that performance data in specifications of DF systems usually show the performance under ideal test conditions or one specific condition,

recommends

- 1 that the test procedure in Annex 1 should be used to determine and report the DF sensitivity;
- 2 that for each DF sensitivity performance specification, the test procedure and test conditions should be indicated by the manufacturer.

Annex 1

Test procedure for measuring direction finder sensitivity in the VHF/UHF frequency range

1 Introduction

This Recommendation describes a general test procedure to evaluate the DF sensitivity of radio direction-finding systems. The aim of this document is to provide a definition of DF sensitivity and a standard method to conduct testing, so that administrations can have some basis for comparison of DF systems based on their requirements.

The sensitivity of a direction finding system is defined as the minimum signal field strength ($\mu\text{V}/\text{m}$) at the DF antenna that results in a suitable DF accuracy when receiving weak signals.

The method described in this recommendation is used to determine the “system sensitivity” in a defined set of test conditions simulated on a test range under ideal/controlled propagation conditions, and can be used, for example, for calibration purposes.

2 Principle of measurement

The measurement will be conducted under simplified conditions, thus permitting great simplicity of the tests and easy repeatability of the results at any time and at any site. Considering the objective to simplify the measurement, effects of modulation type (including phase and time variant signals), signal duty cycle, bandwidth, signal polarization, signal duration, noise, effects from other signals and external uncontrollable conditions such as multi-wave/multipath propagation conditions, are intentionally ignored to reduce the complexity and duration of the test procedure. The measurement takes place in an otherwise reflection-free environment such as an open-air-test-site (OATS) or an anechoic chamber.¹ Measurements in an OATS shall be conducted under sufficiently low levels of external noise.

3 Measurement set up

The measurement setup is shown in Fig. 1. To ensure a well-defined propagation scenario, the environment of the DF and transmitting antennas should be free of reflecting obstacles and interferences as indicated in Recommendation ITU-R SM.2060.

¹ OATS definition can be found in a number of standards documents such as ANSI C63.7, CISPR or EN55 022. The OATS is considered as line-of sight with no interference signal, no reflection and far-field (Fraunhofer Region).

The test frequency selection, the distances between the DF antenna and the transmitting antennas, as well as the height of all antennas involved should be in line with Recommendation ITU-R SM.2060. Frequencies with sufficiently low external noise levels should be selected as test frequencies for measurement in an OATS.

The attenuator of the DF system should be set to the minimum attenuation.

The bandwidth of the DF system should be set to 1 kHz for the narrowband unmodulated signal (if the DF system does not support this setting, choose the nearest value which is higher than the default parameter value).

The integration time of the DF system should be set to 1 second for the narrowband unmodulated signal (if the DF system does not support this setting, choose the nearest value which is lower than the default parameter value).

Set the default 0 degree bearing of the DF system directly facing the transmitting antenna by adjusting the angle of the turn table.

Other settings should be the optimal settings for the DF system. All the relevant settings should be specified in the data sheet.

All test equipment (including transmitter, transmitting antennas and turntable) should be calibrated.

4 Measurement procedure

Adjust the signal level of the test transmitter to make sure that the DF antenna receives a strong signal with SNR of at least 20 dB. Record the angle of arrival θ_0 (it must be stable).

Note the signal level of the transmitter and perform a field measurement at the position of the direction-finding antenna E_0 ($\mu\text{V/m}$).

In the next step, measure the DF bearing fluctuation (RMS value) after incrementally reducing the signal level of the test transmitter until DF bearing fluctuation reaches a certain value (nominal 3 degrees RMS).

The RMS value for DF bearing fluctuation should be calculated described as follows:

$$\delta = \sqrt{\frac{\sum(\theta_{mes} - \theta_0)^2}{N}}$$

where:

- δ : RMS value between the measurement at the sensitivity limit and the measurement at the high level with at least 20 dB SNR (degrees)
- θ_0 : azimuth measured with a strong signal with at least 20 dB SNR
- θ_{mes} : azimuth measured for each level of the signal generator (degrees)
- N : number of readings of the azimuth for each level of the signal generator.

A minimum of 10 consecutive readings of the azimuth for each level of the signal generator should be used. In order to allow for automated measurements, out of these readings, 10% could be discarded to exclude outliers, e.g. from short duration interferers.

Record the signal level of the transmitter and the field strength at the position of the direction-finding antenna $E(\mu\text{V/m})$.

Change the test frequency and repeat the above procedure until all the frequencies are completed.²

The final result is presented as a table or chart indicating the field strength for each measurement frequency as indicated in Table 1. It should be noted that the recommended measurement procedure is focused on narrowband unmodulated signals. However, it would be agreed that different types of signals are measured according to specific test conditions. If such specific test conditions are applied, it should be indicated in the test reports. All measurement parameters should be compliant with the Spectrum Monitoring Handbook (Bandwidth, etc.), with results specified in $\mu\text{V/m}$ so they are comparable.

FIGURE 1
DF sensitivity measurement setup for a direction finding system at an OATS

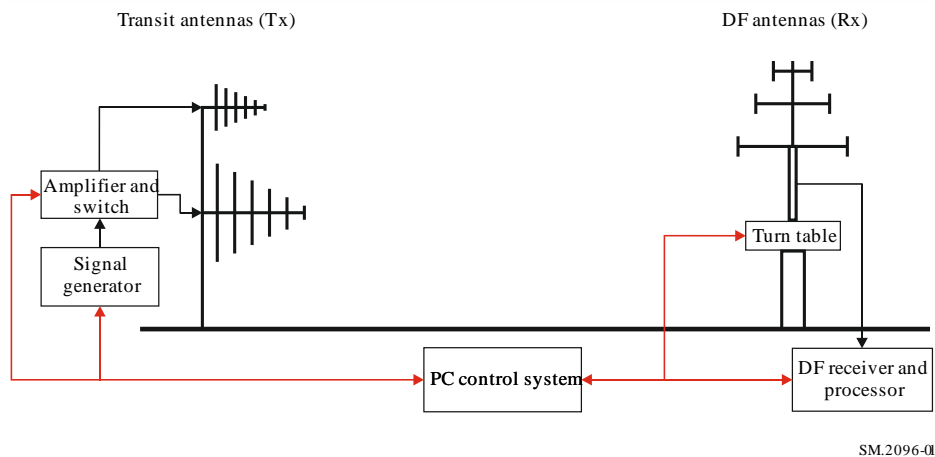

TABLE 1
Sample test data table

Signal modulation: _____ Signal polarization: _____

Frequency (MHz)	True Azimuth θ_0 (degree)	Field Strength E ($\mu\text{V/m}$)
1		
2		
3		
...

Example for a specification in a data sheet of DF sensitivity:

Frequency	f_1	f_2	f_3	...	f_N
DF sensitivity	DF sensitivity at f_1	DF sensitivity at f_2	DF sensitivity at f_3	...	DF sensitivity at f_N

² This kind of repeated testing can be efficiently conducted using software to control the transmitter and DF system, and collect and report the results. The test efficiency can be improved dramatically.