



Recommendation ITU-R SM.1879-1
(09/2011)

**The impact of power line high data
rate telecommunication systems on
radiocommunication systems
below 30 MHz and between
80 and 470 MHz**

SM Series
Spectrum management

Foreword

The role of the Radiocommunication Sector is to ensure the rational, equitable, efficient and economical use of the radio-frequency spectrum by all radiocommunication services, including satellite services, and carry out studies without limit of frequency range on the basis of which Recommendations are adopted.

The regulatory and policy functions of the Radiocommunication Sector are performed by World and Regional Radiocommunication Conferences and Radiocommunication Assemblies supported by Study Groups.

Policy on Intellectual Property Right (IPR)

ITU-R policy on IPR is described in the Common Patent Policy for ITU-T/ITU-R/ISO/IEC referenced in Annex 1 of Resolution ITU-R 1. Forms to be used for the submission of patent statements and licensing declarations by patent holders are available from <http://www.itu.int/ITU-R/go/patents/en> where the Guidelines for Implementation of the Common Patent Policy for ITU-T/ITU-R/ISO/IEC and the ITU-R patent information database can also be found.

Series of ITU-R Recommendations

(Also available online at <http://www.itu.int/publ/R-REC/en>)

Series	Title
BO	Satellite delivery
BR	Recording for production, archival and play-out; film for television
BS	Broadcasting service (sound)
BT	Broadcasting service (television)
F	Fixed service
M	Mobile, radiodetermination, amateur and related satellite services
P	Radiowave propagation
RA	Radio astronomy
RS	Remote sensing systems
S	Fixed-satellite service
SA	Space applications and meteorology
SF	Frequency sharing and coordination between fixed-satellite and fixed service systems
SM	Spectrum management
SNG	Satellite news gathering
TF	Time signals and frequency standards emissions
V	Vocabulary and related subjects

Note: This ITU-R Recommendation was approved in English under the procedure detailed in Resolution ITU-R 1.

Electronic Publication
Geneva, 2011

© ITU 2011

All rights reserved. No part of this publication may be reproduced, by any means whatsoever, without written permission of ITU.

RECOMMENDATION ITU-R SM.1879-1*

**The impact of power line high data rate telecommunication systems
on radiocommunication systems below 30 MHz
and between 80 and 470 MHz**

(Question ITU-R 221/1)

(01/2011-09/2011)

Scope

This Recommendation addresses the impact of power line telecommunication (PLT) systems on radiocommunication services and provides as guidance a summary of the protection criteria for radiocommunication services below 30 MHz and between 80 and 470 MHz with regard to interference by an aggregate of PLT systems including examples of some national regulations.

The ITU Radiocommunication Assembly,

considering

- a) that there is increasing demand for broadband home networking and broadband connection to the Internet throughout the world;
- b) that power line telecommunication (PLT) systems may provide a means of connectivity by the introduction of radio-frequency (RF) signals onto the electrical power supply network;
- c) that although these systems have no frequency allocation in the Radio Regulations as they are not a radiocommunication service, RF energy will leak and radiate;
- d) that such systems may cause interference to the radiocommunication services operating up to 470 MHz and beyond, which provide an extensive range of scientific, public and government services;
- e) that some radiocommunication services have established criteria to assess the impact of interference from extraneous sources of RF energy that produce unwanted radiation in the frequency bands allocated to those services;
- f) that use of the radio spectrum requires definition of the maximum allowable error performance and availability degradations to radiocommunication systems caused by various sources of interference,

noting

- a) that detailed studies relevant to the impact of devices using PLT technology on radiocommunication services are documented in Reports ITU-R SM.2158 and ITU-R SM.2212;
- b) that Recommendation ITU-R P.372 describes levels of some types of radio noise;
- c) that intrinsic receiver noise and external radio noise, including atmospheric, man-made and galactic noise, determine how well radiocommunication services function;
- d) that radiation from power lines and PLT systems increase the level of man-made radio noise, causing an increase in the external radio noise environment;

* This Recommendation should be brought to the attention of Radiocommunication Study Group 6.

- e) that the increase in external radio noise results in an increase in the minimum usable field strength and degradation of the quality, reliability, or both, of the fixed, mobile and broadcasting services;
- f) that the reception environment of the radio astronomy service requires protection from interference or extraneous sources of noise, or both;
- g) that some PLT systems incorporate adaptive power control and notching techniques designed to avoid frequencies used by certain radiocommunication services;
- h) that ITU-T Recommendation G.9960 (2010) defines a spectrum mask for PLT systems to use the frequencies up to 80 MHz,

recognizing

- a) the obligations on administrations to ensure the continued availability of the RF spectrum and guard against harmful interference;
- b) that protection of radiocommunication services from radiated disturbances from telecommunication networks is specifically called for in No. 15.12 of the Radio Regulations,

recommends

- 1 that administrations should take all necessary possible precautions to implement limits, measures and procedures to ensure that radiocommunication services are protected from interference caused by power line telecommunication systems;
- 2 that the information contained in this Recommendation should be taken into account as guidance by administrations when considering their own national rules and regulations regarding the use of PLT.

Annex 1

Protection criteria of radiocommunication services operating below 30 MHz and between 80 and 470 MHz

This Annex provides a summary of the protection criteria of radiocommunication services operating below 30 MHz and between 80 and 470 MHz with regard to interference by an aggregate of power line telecommunication systems. Details on interference considerations below 80 MHz are contained in Report ITU-R SM.2158 on the Impact of power line telecommunication systems on radiocommunication systems operating in the LF, MF, HF and VHF bands below 80 MHz (references are given in the first column of Table 1 and in Report ITU-R SM.2212 on the Impact of PLT systems on radiocommunication systems operating in the VHF and UHF bands between 80 and 470 MHz (references are given in the first column of Table 2).

Reports ITU-R SM.2158 and ITU-R SM.2212 contain detailed studies and measurement tests as well as studies on mitigation techniques considered within ITU-R. It is to be noted that assumptions and measurement conditions fundamentally affect the results of these studies.

TABLE 1
**Summary table of protection criteria for radiocommunication
 services operating below 30 MHz***

Part of Report ITU-R SM.2158	Service/application	(Approximate) frequency bands (MHz)	Protection criteria
3.1	Broadcasting	2 (and below), 3, 4, 5, 6, 7, 9, 12, 13, 15, 17, 19, 21, 26	Increase in the total noise floor due to PLT less than 0.5 dB
3.2	Amateur	1.8, 3.5, 5, 7, 10, 14, 18, 21, 24, 28	Increase in the total noise floor due to PLT less than 0.5 dB
3.3	Aeronautical mobile	2, 3, 4, 5, 6, 8, 10, 11, 13, 15, 18, 22, 23	Increase in the total noise floor due to PLT less than 0.5 dB
3.3	Aeronautical radionavigation	0.19-0.535	Aggregate level of -107 dBm/Hz at the aircraft antenna
3.6	Radiolocation	5, 8, 9.2, 12, 13, 16, 24.5, 25	-147 dBm/500 Hz at a receiving antenna in the main beam of the antenna Recommendation ITU-R M.1874
3.8	Radio astronomy	13.36-13.41 25.55-25.67	-55.2 dB(μ V/m)/0.05 MHz -53.2 dB(μ m)/0.12 MHz at a receiving antenna location Report ITU-R RA.2131 and Recommendation ITU-R RA.769

* Where services or frequency bands are not specified in Table 1, an increase in the total noise floor due to PLT of less than 0.5 dB should be taken as the protection criteria.

TABLE 2
**Summary table of protection criteria for radiocommunication services/applications
 operating between about 80 MHz and 470 MHz****

Part of Report ITU-R SM.2212	Service/application	(Approximate) frequency bands (MHz)	Protection criteria (at the receiving antenna)
3.1	Broadcasting	76-108, 174-240	Increase in the total receiving system noise power due to PLT not to exceed 1 % (for application of the above value see Recommendations ITU-R BS./BT.1895 and BO.1773)
3.2	Amateur and amateur-satellite	144-148 220-225 (Region 2 only) 420-450	Strength from PLT and its harmonics not to exceed 6 dB(μ V/m) in 120 kHz at 3 m

TABLE 2 (end)

Part of Report ITU-R SM.2212	Service/application	(Approximate) frequency bands (MHz)	Protection criteria (at the receiving antenna)
3.3	Aeronautical mobile (R) Aeronautical mobile (OR)	108-117.975 117.975-137 132-137 138-143.6	-165 dBm/Hz (airborne) -177 dBm/Hz (ground) -170 dBm/Hz (airborne) -181 dBm/Hz (ground) See Note** See Note**
3.4	Maritime mobile	156.4875-156.5625 156.7625-156.8375 161.9625-161.9875 162.0125-162.0375 216-220 456-459 460-470	See Note**
3.5	Radiodetermination: – Aeronautical radionavigation – Radiolocation	– 108-112 112-117.975 200-225 223-225 328.6-335.4 420-460 138-144 216-220 430-450	– -177 dBm/Hz (airborne) -171 dBm/Hz (airborne) See Note** See Note** -168 dBm/Hz (airborne) See Note** See Note** See Note** See Note**
3.7	Radio astronomy	150.05-153 322-328.6 406.1-410	-48.2 dB(μ V/m)/2.95 MHz -43.2 dB(μ V/m)/6.6 MHz (cont.) -58.2 dB(μ V/m)/10 kHz (line) -43.2 dB(μ V/m)/3.9 MHz at a receiving antenna location Report ITU-R RA.2131 and Recommendation ITU-R RA.769
3.8	Mobile-satellite	137-138 148-150.05 161.9625-161.9875 162.0125-162.0375 235-322 312-315 335.4-399.9 387-390 399.9-400.05 400.15-401 406-406.1	$\Delta T/T$ criterion of 1% (to be used in analogy to Recommendation ITU-R S.1432) See Recommendation ITU-R M.1478 NOTE – Special protection required for Cospas-Sarsat (406-406.1 MHz, see Nos. 5.266 and 5.267 of the Radio Regulations)
3.9	Radionavigation-satellite	149-9-150.05 399.9-400.05	$\Delta T/T$ criterion of 1% (to be used in analogy to Recommendation ITU-R S.1432)

** Where services or frequency bands are not specified in Table 2, an increase in the total noise floor due to PLT of less than 0.05 dB should be taken as the protection criteria.

Annex 2

Examples of national regulations

Some administrations have adopted or are in the process of adopting national regulations including technical and operational restrictions that may have been derived using different parameters and/or methodologies, taking into account, in particular, specific national deployment scenarios and technical characteristics, as well as other considerations. Examples can be found in the following Appendices to this Annex. These Appendices are provided for information.

Appendix 1 to Annex 2

United States of America

Regulation of RF emissions from power line communication systems in the United States of America

1 Introduction

In October 2004, the United States of America adopted new rules for access broadband over power line (access BPL) systems, a new type of carrier current technology that provides access to high speed broadband services using electric utility companies' power lines. [1], [2]

These rules recognized the need to ensure that RF energy from BPL signals on power lines does not cause harmful interference to licensed radio services.

2 Definition of BPL

The following definitions of BPL were adopted:

Access BPL: A carrier current system operating as an unintentional radiator using frequencies between 1 705 kHz and 80 MHz on medium voltage (MV) or low voltage (LV) lines to provide broadband communications and located on the supply side of the utility service's points of interconnection with customer premises.

MV wires carry between 1 000 and 40 000 V from a substation and may be overhead or underground; LV wires carry "low voltage" e.g. 240/120 V from a distribution transformer to a customer premise.

In Home BPL: A carrier current system operating as an unintentional radiator using frequencies between 1 705 kHz and 80 MHz on LV lines that are not owned, operated or controlled by an electric service provider. This includes closed networks within a customer premise and includes customer premise networks forming connections with access BPL systems.

3 Emission limits

In the United States of America, a single set of frequency-dependent radiated emission limits below 30 MHz. In the range 1 705 kHz to 30 MHz, the limit is 30 $\mu\text{V}/\text{m}$ at a measurement distance of 30 m.

Above 30 MHz, there is a distinction between Class A radiated emission limits (intended to protect commercial/industrial environments) and Class B radiated emission limits (intended to protect residential environments). Thus, for example, in the band 30-88 MHz, the Class A limit is 90 $\mu\text{V}/\text{m}$ at a measurement distance of 10 m; the Class B limit is 100 $\mu\text{V}/\text{m}$ at a distance of 3 m. Class A provides for ~ 10 dB (or $\sim 10 \times$) more power than Class B.

Those existing radiated emission limits apply to BPL below 30 MHz, and that above 30 MHz, Class A radiated emission limits should apply on MV wires and Class B radiated emissions rules apply on LV wires.

There are no conducted emission limits for BPL (including no limits in AM broadcast bands).

4 Special frequency protections

Certain frequency bands were determined to require special interference protection and a variety of frequency band exclusions, geographical exclusion zones and consultation requirements were adopted.

4.1 Frequency band exclusions

On overhead MV lines access BPL systems may not use (“place carrier frequencies in”) certain designated bands between 2 MHz and 22 MHz as well as 74.8-75.2 MHz. These are bands allocated to aeronautical mobile (R) and radionavigation services that are used to provide aeronautical safety of life services. This requirement does not apply to LV wires, nor to underground wires (LV or MV). A total of 1 731 kHz falls within the excluded bands, or 2% of the spectrum within the 1.7-80 MHz band.

4.2 Geographical exclusion zones

The rules prohibit access BPL operators from using the frequency band 2.1735-2.1905 MHz (global maritime distress band) within 1 km of about 110 designated United States Coast Guard and maritime radio stations. They also prohibit access BPL from using 73.0-74.6 MHz (VLBA radio astronomy frequencies) within 65 km of one radio astronomy observatory (this limit applies only to overhead MV) or within 47 km of the RA observatory (this limit applies to underground MV and overhead LV lines).

4.3 Consultation area requirements

Access BPL operators are required to give 30 day’s advance notice of all installations in the following bands and locations as follows:

- on 1.7-30 MHz, if within 4 km of monitoring stations and about 60 aeronautical and land HF radio stations;
- on 1.7-80 MHz, if within 4 km of about 16 radio astronomy sites;
- on 1.7-80 MHz, if within 1 km of United States Department of Commerce facilities in Boulder, Colorado;
- on 1.7-30 MHz, if within 37 km of three specified radar receive sites.

4.4 Consultation area notice requirements

For planned operations within the consultation areas defined above, access BPL operators must supply the following information:

1. name of the access BPL operator;
2. frequencies of the access BPL operation;
3. postal zip codes served by the access BPL operation;
4. the manufacturer of and type of access BPL equipment being deployed (i.e. FCC ID for certified equipment and make and model for verified equipment);
5. point of contact information (both telephone and e-mail address);
6. the proposed or actual date of initiation of access BPL operation.

Notice must be provided to designated consultation area contacts 30 days prior to initiation of any access BPL deployment.

4.5 Public safety licensee notice requirements

Access BPL systems are required to notify the public safety agencies in their local areas, e.g. state and local police, fire and emergency medical agencies.

The requirements are the same as for consultation areas, including subsequent notice of the activation of any major extensions of the BPL system or any changes in its operating characteristics, such as transmitting frequencies. Local public safety agencies already have designated frequency coordinators for their mobile communication systems, and these are the persons to be notified.

5 Interference mitigation

United States regulations do not rely on emission limits alone to protect against interference. Interference mitigation techniques are key elements of the new BPL policies. These techniques include complaint procedures, adaptive interference techniques and database requirements.

5.1 Interference complaint procedures

Procedures already existed for responding to interference complaints, and they remain unchanged.

The complainant must first take reasonable steps to confirm that interference exists, and is caused by a BPL system. The BPL operator must be notified, and he must then investigate within a reasonable time. The BPL operator has 24 h to investigate complaints from public safety licensees. If the complaint cannot be resolved the licensee can then file a complaint with the appropriate national administration agency.

5.2 Adaptive interference techniques

System operators are not required to use specific mitigation techniques but rather are subject to a more general requirement that their systems not cause interference. Interference mitigation techniques may include notching, frequency shifting or power reduction.

Within 18 months, new access BPL equipment must be able to implement adaptive interference mitigation techniques. If notching is used, notches will need to be at least 20 dB below applicable emission limits, below 30 MHz. Above 30 MHz, notches will need to be at least 10 dB below applicable emissions limits.

Equipment will need a “last resort” remote-controllable RF transmission shut-down feature for deactivation of any unit found to cause harmful interference.

Equipment will also need to comply with applicable emission limits upon power-up following a fault condition, or during a start-up operation after a shut-off procedure.

5.3 Access BPL database requirements

The BPL industry was required to establish a publicly accessible access BPL database within six months of the effective date of the new rules. A database manager has been selected to operate the database.

The database contains the same data as required for consultation areas. BPL operators must notify the database manager within 30 days prior to initiation of service and again upon commencement of service. The database must be updated within three business days of notice from BPL operator. The database manager has no role in any interference complaint/investigation. The database is to be staffed during normal business hours.

6 Measurement guidelines

Some existing radiated emission measurement requirements were reconfirmed, and some new measurement guidelines for both access BPL and in-home BPL were adopted.

6.1 Existing measurement requirements

Radiated emissions testing must be done *in situ*, at three typical installations. Separate testing must be done for underground and overhead wiring. Existing requirements for detector types, bandwidths and extrapolation factors all remain unchanged. Antenna types remain unchanged (but differ above and below 30 MHz). Conducted emissions testing is not required for access BPL devices.

6.2 New/modified measurement requirements

Emission levels must be tested along overhead lines in addition to along radials. Testing must be performed at distances of 0, 1/4, 1/2, 3/4, and 1 wavelength down the line from the BPL injection point on the power line.

Measurements should normally be performed at a horizontal separation distance of 10 m from the overhead line. If necessary, due to ambient emissions, measurements may be performed at a distance of 3 m. Procedures for distance corrections were specified.

In addition to testing radials around the building, testing must be performed at three positions along the overhead line connecting to the building (i.e. the service wire). It is recommended that these measurements be performed starting at a distance 10 m down the line from the connection to the building.

Regarding testing height, testing can either be done at varying heights between 1 and 4 m and the highest reading must be used, or 5 dB may be added to the 1 m measurement.

For underground lines, measurements should normally be performed at a separation distance of 10 m from the in-ground power transformer that contains the BPL device(s). If necessary, due to ambient emissions, measurements may be performed a distance of 3 m. Underground installations are to be tested along radials around the perimeter of the in-ground power transformer.

7 Equipment authorization

In the United States of America, equipment that radiates RF energy is subject to an equipment authorization process. There are two forms of equipment authorization, verification (self-compliance confirmation) and certification (third-party compliance confirmation). Certification will be required for BPL devices, after an initial 18 month-period when verification will be used. After the 18 month-start-up period, all new or modified access BPL equipment manufactured, sold or installed must be certified, but previously deployed and verified equipment may remain in use.

8 Conclusion

Regulations for BPL were adopted in the United States of America that depend on a combination of radiated emission limits and interference mitigation procedures intended to protect against harmful interference. There are no limits on conducted emission levels. Using this approach, it was determined that properly designed BPL systems, operating in accordance with existing radiated emission limits, pose little interference hazard.

References

- [1] Amendment of Part 15 regarding new requirements and measurement guidelines for access broadband over power line systems, Report and Order in ET Docket No. 04-37, FCC 04-245, released October 28, 2004; http://hraunfoss.fcc.gov/edocs_public/attachmatch/FCC-04-245A1.pdf.
- [2] Amendment of Part 15 regarding new requirements and measurement guidelines for access broadband over power line systems; carrier current systems, including broadband over power line systems Memorandum Opinion and Order in ET Docket No. 04-37, FCC-06-113 released 07/08/2006; http://hraunfoss.fcc.gov/edocs_public/attachmatch/FCC-06-113A1.pdf.

Appendix 2 to Annex 2

Germany

The presented CEPT ECC Recommendation is applied by Germany in case of interference originated from PLT.

Special attention is given to the recommended limits of the disturbance field strength as given in the Table of Annex 2 of the ECC Recommendation. These field-strength limits are recommended for assessing the level of the disturbance emission generated by a wire-line network at the location of the victim at the frequency of the (disturbed) wanted signal.

ECC Recommendation (05)04

Criteria for the assessment of radio interferences caused by radiated disturbances from wire-line telecommunication networks**Recommendation adopted by the Working Group
“Spectrum Engineering” (SE)****Introduction**

In individual cases radiated disturbances from wire-line telecommunication networks can cause (harmful) interference¹ to radiocommunication applications even if the relevant part of the network meets all relevant EMC requirements. The elimination of such interference cases becomes particularly difficult if also the individual radiocommunication application meets the provisions of its harmonized EMC and functional standards and is operating within the coverage area of the relevant radiocommunication system.

In order to resolve such individual interference cases to the best interests of both parties involved, CEPT recommends that it is useful to have a set of common criteria to assess such cases of radio interference. CEPT administrations are encouraged to use these criteria as a guideline for eliminating individual interference cases.

It is considered appropriate that this Recommendation be reviewed every three years, in the light of changing technologies and regulatory requirements. This review should involve consultation with the relevant technical and working groups within CEPT, ETSI and CENELEC.

“The European conference of Postal and Telecommunications Administrations,

considering

- a) that the radio-frequency spectrum is a common resource and that it is essential to minimize unnecessary interference by making the best use of the most modern and cost-effective techniques;
- b) that harmonized standards for radiocommunication equipment and other electrical/electronic apparatus are established in order that such products, systems and installations operate as intended in the majority of application cases and under normal operation conditions;
- c) that meeting the requirements of harmonized EMC standards may not prevent an individual apparatus, system, installation or network from causing harmful radio interference under certain operation and environmental conditions;
- d) that protection from radiated disturbances from telecommunication networks is specifically called for in RR No. 15.12² and provided for in Council Directive 89/336/EEC³;
- e) that Article 6 (Art. 4.2 new EMC Directive, see Note 3) of the Council Directive 89/336/EEC provides special measures with regard to the taking into service and use of apparatus

¹ For ITU definitions on interference and harmful interference see RR Articles 1.166 and 1.169.

² “RR No. 15.12: Administrations shall take all practicable and necessary steps to ensure that the operation of electrical apparatus or installations of any kind, including power and telecommunication distribution networks, but excluding equipment used for industrial, scientific and medical applications, does not cause harmful interference to a radiocommunication service and, in particular, to a radionavigation or any other safety service operating in accordance with the provisions of these Regulations”.

³ It is expected that the new version of the EMC Directive will be in force in 2007.

taken for a specific site in order to overcome an existing or predicted electromagnetic compatibility problem;

f) an assessment of disturbances from wire-line telecommunication networks in accordance with the provisions of harmonized standards or other EMC specifications only is not sufficient to resolve in an appropriate manner individual cases of harmful radio interference;

g) that the ECC Report 24 “PLT, DSL, cable communications (including cable TV), LANs and their effect on radio services” addresses the compatibility between data communication systems and radiocommunication services. It also describes in detail the various radiocommunication services potentially affected by unwanted radiation from telecommunication networks and it describes the associated protection requirements. The ECC Report 24 also provides evaluation of radiation limit examples and examples of measurements;

h) that CEPT and ETSI have developed a Memorandum of Understanding describing the mutual responsibilities of the two bodies. The MoU text is available from ERO, further information available from ETSI⁴;

i) that the R&TTE Directive 1999/05/EC, in force since 8 April 2000, has been implemented in EU Member States and also followed by most other CEPT member countries;

j) that further steps should be taken to harmonize the resolution of interference cases through a more formalized framework;

k) that the European Commission is preparing a Recommendation on broadband communications through power-lines⁵;

l) that the European Commission has issued the standardization mandate M/313 under EMC Directive 89/336/EEC to CEN, CENELEC and ETSI to produce harmonized EMC standards for telecommunication networks. This mandate concerns the preparation of harmonized standards covering EMC aspects of wire-line telecommunication networks and their in-house extensions. These standards should cover the types of networks, which are currently operational or which are under development, including, but not limited to those using power lines, coaxial cables and classical telephone wires,

recommends

1 that when examining cases of interference complaints, caused by radiated disturbances of wire-line telecommunication networks, CEPT Administrations or National Authorities consider the use of the framework described in Annex 1 as a guideline for the process of resolving these interference cases in a transparent, proportionate and non-discriminatory way;

2 that the set of criteria for the assessment of interference, which includes reference field strength limits, as given in the Annex 2, should be used in order to investigate the case and to address all necessary measures to resolve the interference in a proportionate, non-discriminatory and transparent manner.”

Annexes: 2

⁴ http://portal.etsi.org/erm/hta/emc/clc_agree_emc.asp.

⁵ This Recommendation was in draft form as of August 2004.

Annex 1 to ECC Recommendation (05)04

Guidelines for the assessment of radio interference cases caused by disturbing radiations generated by wire-line telecommunication networks

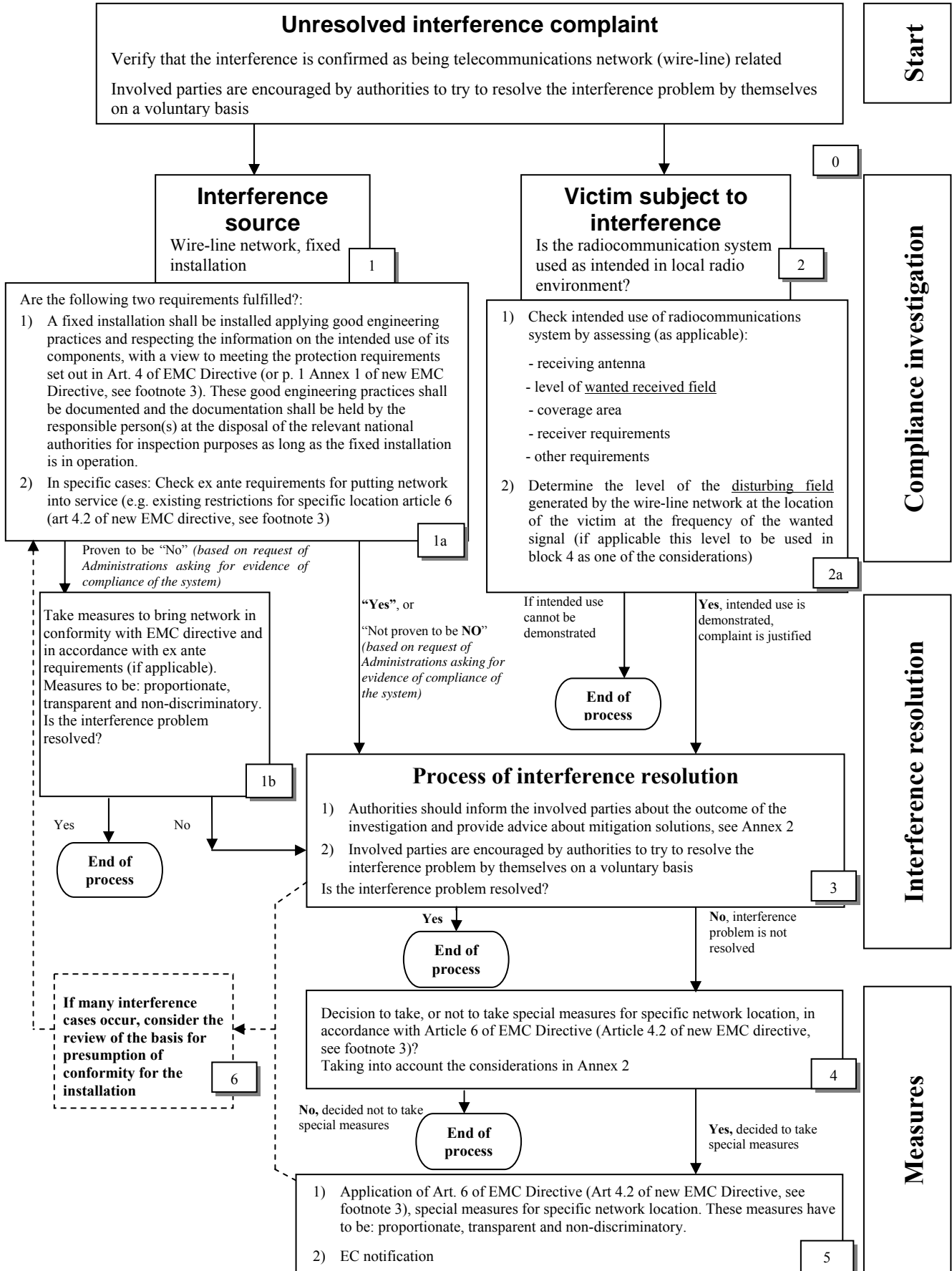

Addendum to Annex 1 of ECC Recommendation (05)04

Explanation of flowchart in Annex 1 to ECC Recommendation (05)04

0	<p>Starting point</p> <p>The process starts with an unresolved interference case complaint involving a radiocommunication system and a wire-line network. Involved parties are encouraged by authorities to try to resolve the interference problem by themselves on a voluntary basis.</p>
1	<p>Gathering information about the interference source</p> <ul style="list-style-type: none"> • Determine if the wire-line telecommunications network causes the interference. • Request evidence of presumption of conformity of the network. Wire-line telecommunication networks are considered to be fixed installations and can only be put into service if they comply with the essential requirements of the EMC Directive.
	<p>1a The following requirements have to be assessed by the national authority:</p> <ul style="list-style-type: none"> • A fixed installation shall be established applying good engineering practices and respecting the information on the intended use of its components, with a view to meeting the protection requirements set out in Art. 4 of EMC Directive (P. 1 of Annex 1 of new EMC Directive, see Footnote 3). Those good engineering practices shall be documented and the documentation shall be held by the responsible person(s) at the disposal of the relevant national authorities for inspection purposes as long as the fixed installation is in operation. • In addition, <i>ex ante</i> requirements might be applicable for a specific location, e.g. if prior EMC Directive's Art. 6 procedure (Art. 4.2 of new EMC Directive, see Footnote 3) was used to forbid the putting into service or use of a wire-line network in an certain area in order to overcome an existing or predicted EMC problem in that area.
	<p>1b If network is NOT in conformity with EMC directive:</p> <ul style="list-style-type: none"> • Wire-line communications networks are considered to be fixed installations and can only be put into service if they comply with the essential requirements of the EMC Directive. So the network must be brought in conformity with the EMC Directive. Measures should be: <ul style="list-style-type: none"> – proportionate; – transparent; – non-discriminatory.
2	<p>Gathering information about the radiocommunication system which suffers interference</p> <p>Is the radiocommunication system used as intended in local radio environment?:</p> <ul style="list-style-type: none"> • Investigate the radiocommunication system. • Obtain information and evidence of compliance of the radiocommunication system with the relevant requirements.

2a	<p>1) Check intended use of radiocommunication system by assessing (as applicable):</p> <ul style="list-style-type: none"> • Receiving antenna. • Receiver requirements. • Coverage area. • Level of wanted received field. • Distance between the source and victim. • Does the victim radiocommunication system suffer from a structural defect or other inner malfunction? • Are the operating conditions in accordance with the specification? • Do the operating conditions (such as location and type of antenna) fulfil the minimum relevant requirements for reliable signal reception? • Other requirements that are applicable.
	<p>2) Determine the level of the disturbing field generated by the wire-line network at the location of the victim at the frequency of the wanted signal (if applicable this level to be used in Block 4 as one of the considerations).</p>
3	<p>Process of interference resolution:</p> <ul style="list-style-type: none"> – Authorities should inform the involved parties about the outcome of the investigation and provide advice about mitigation solutions, Annex 2 refers. – Involved parties are encouraged by authorities to try to resolve the interference problem by themselves on a voluntary basis.
4	<p>Process of taking a decision to take or not to take special measures for this specific location of the network (in accordance with Art. 6 of EMC Directive, Art. 4 of new EMC Directive), taking into account the considerations given in Annex 2 like:</p> <ul style="list-style-type: none"> – the importance of the radiocommunication service; – the importance of the network; – technical aspects; – economic aspects and other aspects.
5	<p>Taking specific measures on the basis of Art. 6 of EMC Directive, Art. 4 of new EMC Directive (see Footnote 3).</p> <p>Special measures for a specific location of a network have to be:</p> <ul style="list-style-type: none"> – proportionate; – transparent; – non-discriminatory. <p>Special measures should be notified to the European Commission. Those that have been recognized as justified must be contained in an appropriate notice made by the Commission in the Official Journal of the European Union.</p>
6	<p>If many interference cases occur, administrations are urged to consider the review of the basis for the presumption of network conformity.</p>

Annex 2 to ECC Recommendation (05)04

Mitigation techniques and considerations, including limits of the disturbance field strength, applicable to blocks 3 and 4 of flowchart in Annex 1 to ECC Recommendation (05)04

Mitigation techniques (Ref. Block 3, Annex 1)

Some examples of possible mitigation techniques are:

- Change of receiving antennas and/or their siting for the victim radiocommunication system
NOTE – Other antenna types or a better antenna siting could be an efficient mitigation technique. However this may not always be possible in a given location and could involve significant costs if the antenna site is high above the ground.
- Change in the geometrical structure of the wire-line network.
- Frequency notching by the operator of wire-line network
NOTE – The notching of specific frequencies may not be possible with some modulation schemes. Notching is an effective technique to mitigate specific cases of interference. If there are multiple cases of interference, multiple notches will seriously reduce the bandwidth available to the network operator.
- Use more repeaters in the wire-line network to reduce peak power
NOTE – This will tend to increase the bandwidth used by a network operator in a locality as many repeaters employ a frequency-shift. A wire-line telecommunications network operator will wish to minimize the number of repeaters on economic grounds.
- For the case of power line communication systems, other techniques such as the use of filters and signal terminations, differential mode signal injection, adaptive filtering and power control can be considered.

Criteria to decide whether special measures should be taken (Ref. Block 4, Annex 1)

These special measures refer to Art. 6 of the EMC directive (Art 4.2 of new EMC directive, see Footnote 3) which are meant to overcome an existing or predicted electromagnetic compatibility problem at a specific site regardless of the fulfillment by the involved equipment (interference source and victim) of the requirements of the EMC Directive.

Criteria to decide whether special measure should be taken should contain the following aspects:

1 Technical aspects

- Level of the disturbance field strength generated by the network at the location of the victim at the frequency of the (disturbed) wanted signal. Examples of practical measurement procedures⁶: for each scenario and network different measurement methods should be used as appropriate, for example: in-situ measurements of the disturbance emission or conducted disturbance measurements.

⁶ CENELEC TLC/prTS50271; RegTP 322 MV 05.

- Recommended field strength level for assessing the level of the disturbance emission generated by the wire-line network at the location of the victim at the frequency of the (disturbed) wanted signal is stated in the following table:

Frequency f (MHz)	Limit of the interfering electric field strength in dB(μ V/m) (peak detector) at the location of the victim and at the distance of 3 metre from the source	Measurement bandwidth
0.009 to 0.15	$40 - 20 \cdot \log_{10}(f/\text{MHz})$	200 Hz
0.15 to 1	$40 - 20 \cdot \log_{10}(f/\text{MHz})$	9 kHz
Above 1 to 30	$40 - 8.8 \cdot \log_{10}(f/\text{MHz})$	9 kHz
Above 30 to 1 000	27(1)	120 kHz
Above 1 000 to 3 000	40(2)	1 MHz

⁽¹⁾ This corresponds to an effective radiated power of 20 dBpW.

⁽²⁾ This corresponds to an effective radiated power of 33 dBpW.

- National administrations could decide to take special measures regardless of the level of disturbing field if it is justified by the importance of the victim radiocommunication service, e.g. for safety and/or emergency services (see Section 2 of this Annex).
- Field strength measurements at the interference site will show if a decrease in the unwanted field strength might improve the interference scenario.

2 Economic and political aspects

- Burden of costs to achieve compatibility for the victim and interferer
(NOTE – Administrations should have to take account of the proportionalities of the costs).
- Importance of the victim service (safety related services etc.)
Setting more stringent parameters or limits for particular devices or frequency bands.
NOTE – This is a political rather than an economic aspect. The need to protect special services (e.g. safety related services) should not be influenced by an economic argument.
- Alternative delivery of the service
NOTE – This is a political decision. Freedom of access to existing sources may potentially be restricted if alternative delivery is by a non-radio medium. An alternative delivery of a service will also have an economic impact for the operator and the user of this service.
- Number of interference complaints
NOTE – The number of interference complaints may be far below the number of interference events. A user subject to interference may not recognize the cause as interference from a wire-line network. As a result an interference complaint is not made to the administration. Administrations are expected to intervene only when interference complaints are notified.
- Perspectives for the future – New radio technologies
NOTE – New technologies may not improve the interference scenario. New technologies are usually introduced for economic reasons.
- New users to take account of existing users (“First come – first served” principle)
NOTE – This principle provides a general protection of existing services. However administrations have to assess if this general principle has to be maintained under all circumstances.

3 Regulatory aspects

– Responsibility

NOTE – The responsibilities of the interferer and the victim have to be identified.

- Administrations may invoke coordination procedures between the affected parties to solve a case of interference.

4 Assessment of all criteria and circumstances

Administrations should assess all criteria in a balanced and proportional way. Especially in a “Conflict of standards” case, administrations are expected to avoid any unnecessary burden for the victim service.

Appendix 3 to Annex 2

Japanese regulations for the power line high data rate telecommunication systems

The following are the Japanese rules and regulations for PLT that were enforced on 4 October 2006. The derivation of the limits is also described briefly.

1 Fundamental principle

The access low-voltage power line system (single phase) in Japan has a line grounded. So, experimental installation of access PLTs revealed that considerably high electromagnetic fields were generated by the PLTs. Hence, only in-house PLTs are allowed in Japan.

In a house, there are a large number of electrical and electronic equipment that emit conducted disturbances (voltage/current) on the power lines in the HF band, generating unwanted electromagnetic fields outside the house. Hence, the fundamental principle of the Japanese PLT limits is to reduce the level of PLT conducted disturbances to those of information technology equipment and other household appliances. Consequently, electromagnetic fields generated by PLTs do not significantly increase ambient noise levels around the house.

It may be possible to specify the PLT limits in terms of the field strength measured around a house equipped with PLTs. However, such limits cause a great difficulty to manufacturers in designing PLTs, because there are a large variety of PLT installation conditions and housing structures.

Furthermore, they require a lot of time and energy of radio regulatory agencies for making measurements of the field strength around houses. Since the leakage fields from the PLT are generated by disturbance currents (common-mode) flowing on the power lines, the Japanese limits for the HF band apply to the common-mode current measured at the mains port of a PLT with specified measurement methods.

2 Equipment allowed to be used: In-house PLT equipment only

PLT equipment which is intended to transmit RF signals in the frequency range from 2 MHz up to 30 MHz over low-voltage power lines (100 or 200 V, single phase) installed in houses. Access broadband PLT is not allowed in Japan.

3 Limits

3.1 Conducted emission at the mains port

The common-mode current shall be measured in communication mode of the PLT under test (EUT: Equipment Under Test) at a best signal transmission rate, while in idle mode the unsymmetrical voltage shall be measured as specified in CISPR 22 Fifth Edition (2005-04). The limits are listed in Table 3 with the following remarks.

For the communication mode:

1. the limits were newly established for the signal band (2-30 MHz);
2. the limits for frequencies below 2 MHz are derived from the CISPR 22 Class B limits by applying a conversion factor of -30 dB (nearly equal to $-20 \log 25 \Omega$);
3. the compliance test shall use an impedance stabilization network (ISN1) developed for an LCL of 16 dB with common- and differential-mode impedances of 25 and 100 Ω , respectively.

For the idle mode:

1. the limits to be applied are the same as the CISPR 22 Class B limits. Compliance test shall use an artificial mains network (AMN) having 50 Ω /50 μ H as specified in CISPR 16-1-2 Edition 1.1 (2004-06).

TABLE 3
PLT limits for the mains port

Measurement port	Measurement conditions	
	Communication mode	Idle mode
Mains port	0.15 MHz~0.5 MHz <QP> 36 to 26 dB(μ A) <Av> 26 to 16 dB(μ A) ISN1 used	0.15 MHz~0.5 MHz <QP> 66 to 56 dB(μ V) <Av> 56 to 46 dB(μ V) AMN used
	0.5 MHz~2 MHz <QP> 26 dB(μ A) <Av> 16 dB(μ A) ISN1 used	0.5 MHz~5 MHz <QP> 56 dB(μ V) <Av> 46 dB(μ V) AMN used
	2 MHz~15 MHz <QP> 30 dB(μ A) <Av> 20 dB(μ A) ISN1 used	5 MHz~15 MHz <QP> 60 dB(μ V) <Av> 50 dB(μ V) AMN used
	15 MHz~30 MHz <QP> 20 dB(μ A) <Av> 10 dB(μ A) ISN1 used	15 MHz~30 MHz <QP> 60 dB(μ V) <Av> 50 dB(μ V) AMN used

3.2 Conducted emission at the telecommunication port

The limits are the same as the CISPR 22 Class B limits as listed in Table 4. Compliance test shall use an impedance stabilization network (ISN2) specified in CISPR 22.

However, these limits are not applied for the time being.

TABLE 4
PLT limits for the telecommunication port

Measurement port	Measurement conditions	
	Communication mode	Idle mode
Telecommunication port	0.15 MHz~0.5 MHz <QP> 40 to 30 dB(μ A) <Av> 30 to 20 dB(μ A) ISN2 used	
	0.5 MHz~30 MHz <QP> 30 dB(μ A) <Av> 20 dB(μ A) ISN2 used	

3.3 Radiated emission

The limits are the same as the CISPR 22 Class B limits as listed in Table 5.

TABLE 5
PLT limits for radiated emission

Measurement distance	Measurement conditions	
	Communication	Non-communication
10 m apart from the EUT	30 MHz~230 MHz <QP> 30 dB(μ V/m)	
	230 MHz~1 000 MHz <QP> 37 dB(μ V/m)	

References (informative)

1. CISPR 16-1-2 Edition 1.1 (2004-06): Specification for radio disturbance and immunity measuring apparatus and methods.
2. CISPR 22 Fifth edition (2005-04): Information technology equipment – Radio disturbance characteristics – Limits and methods of measurement.

4 Derivation of the limits

4.1 Procedures

Firstly, preliminary derivation of the PLT limits was made on a theoretical basis using a simple house model equipped with a couple of PLTs that is illustrated in Fig. 1.

Then, PLT modems complying with the above draft limits were produced by manufacturers for field experiments using actual dwelling houses.

Finally, measurements of leakage fields were performed outside the houses in which PLT modems were actually installed. The measurement results were compared with the ambient noise levels in order to determine the official PLT limits.

4.2 PLT installation model and draft limits

A typical Japanese two-story house was assumed as illustrated in Fig. 1. A PLT modem was placed on a horizontal power wire (20 m in length) on each floor as well as on a vertical wire (5.6 m in length) connecting the floors.

With reference to Fig. 1, the maximum allowable common-mode current on the mains wires, $I_{com}(\max)$ in dB(μ A), could be derived from equation (1):

$$I_{com}(\max) = Ep + L + A - Z + K \quad (\text{dB}(\mu\text{A})) \quad (1)$$

for the quasi-peak value, where:

Ep: permissible r.m.s. strength of the leakage field at neighbouring houses (dB(μ V/m))

It was decided that the leakage field around a house installed with PLTs, *Ep*, should be reduced to the ambient noise levels. The draft limits were derived referring to the noise levels described in Recommendation ITU-R P.372-8.

L: propagation attenuation of the leakage field (dB)

The values were estimated by numerical analysis using an MoM code that was carried out for various ground conditions and wire installation conditions.

A: attenuation caused by the walls and roofs of a house equipped with PLTs (dB)

The values were estimated by numerical analysis using an FDTD code that was carried out for a wooden house as well as for a reinforced concrete house.

Z: conversion factor from the PLT common-mode current to the EM field generated at a specified distance *R* (dB(Ω /m))

The values were estimated by numerical analysis using an MoM code that was carried out for various ground conditions and wire installation conditions.

K: conversion factor from the r.m.s. value of the current to the quasi-peak value (dB)

The ratio of the quasi-peak to r.m.s. values was assumed to be 10 dB.

R: separation distance (m) of a neighbouring house from the house equipped with PLTs, which was set to be 10 m for business areas and 30 m for rural areas.

From equation (1) with the various parameter values described above, the draft limits were derived for the PLT common-mode current, that is:

$$I_{com}(\max) = 30 \text{ dB}(\mu\text{A})$$

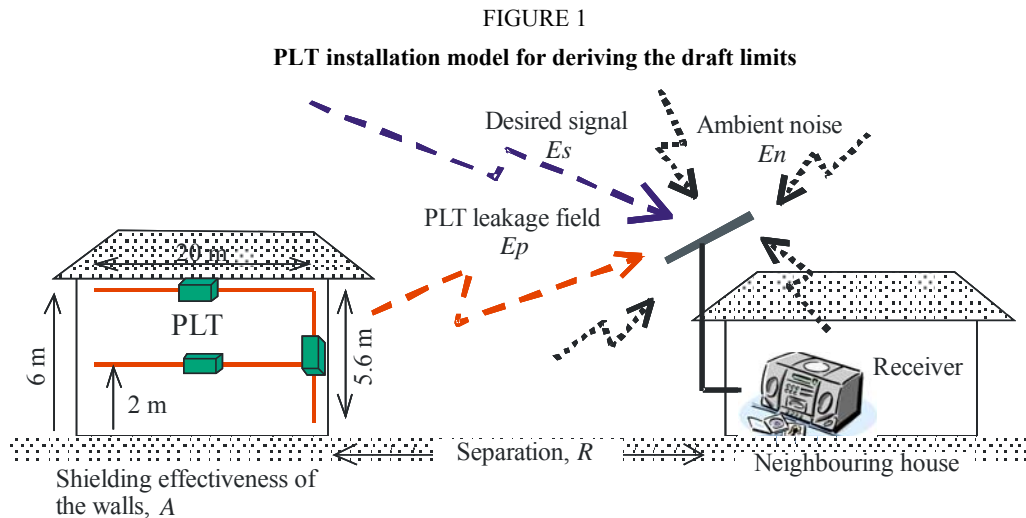

4.3 Japanese PLT limits

PLT modems complying with the above draft limits were produced by manufacturers for field experiments using actual dwelling houses. From these experiments, it was found that the draft limit of 30 dB(μ A) might produce radiated fields exceeding ambient noise levels at neighbouring houses in residential areas.

Hence, the official limits were reduced from the draft ones by 10 dB especially in the frequency range from 15 MHz to 30 MHz to yield almost the same levels as actual ambient noises.

Thus, the Japanese QP limits for the PLT common-mode current were decided to be:

- 30 dB(μ A) (for 2 MHz to 15 MHz);
- 20 dB(μ A) (for 15 MHz to 30 MHz) as tabulated in Table 3.

5 Measurement conditions for the PLT common-mode current

Radiated disturbances from PLTs are mostly produced by common-mode currents that are converted to from signal currents (differential-mode) on the power line cables. Thus, the power line characteristics such as LCL and common-/differential-mode impedances are key factors for considering the PLT limits and measurement procedures. Since they greatly vary with time and location in actual dwelling houses, a large number of measurements were made at wall sockets in typical houses in Japan.

It was decided from experimental data that compliance of a PLT modem with the limits should be examined using an impedance stabilization network (ISN1 referred to in Table 3) having an LCL of 16 dB with common- and differential-mode impedances of 25 and 100 Ω , respectively.

Appendix 4 to Annex 2

Federative Republic of Brazil

Brazilian regulation on power line high data rate telecommunication systems

1 Introduction

On 8 April 2009, ANATEL⁷ approved Resolution 527 on broadband PLT. The rules consider the implementation of general and specific requirements so as to enable the coexistence of PLT systems with HF licensed systems on the frequency band of 1 705 kHz to 50 MHz.

It is important to note that PLT systems will operate in Brazil on a non-interference basis.

2 General requirements

The following tables contain the maximum radiated emission limits permitted for the PLT systems to operate.

TABLE 6

**Maximum radiated emission limits caused by PLT systems
operating in low voltage* lines**

Frequency band (MHz)	Field strength ($\mu\text{V/m}$)	Measuring distance (m)
1.705-30	30	30
30-50	100	3

* Low voltage: below 1 kV.

TABLE 7

**Maximum radiated emission limits caused by PLT systems
operating in medium voltage* lines**

Frequency band (MHz)	Field strength ($\mu\text{V/m}$)	Measuring distance (m)
1.705-30	30	30
30-50	90	10

* Medium voltage: between 1 kV and 69 kV.

⁷ Agência Nacional de Telecomunicações (www.anatel.gov.br) is the Telecommunication regulatory agency in Brazil.

In addition, the PLT systems must have the following technical characteristics:

- a) embedded interference mitigation techniques that allow to reduce remotely the signal strength;
- b) for frequencies below 30 MHz, when using filters to avoid interference in a range of specific frequencies, the filters must be able to mitigate unwanted radiation within this range at a level of at least 20 dB below the limits specified in Tables 6 and 7;
- c) for frequencies above to 30 MHz, when using filters to avoid interference in a range of specific frequencies, the filters must be able to mitigate unwanted radiation within this range at a level of at least 10 dB below the limits specified in Tables 6 and 7;
- d) maintain settings for mitigating interference, even when there is a power failure;
- e) allow remote shutdown of the unit causing harmful interference, if another mitigation technique does not reach the expected outcome.

3 Measurements

Measurements should be made using CISPR 16-1-1 quasi-peak detector according to Recommendation ITU-T K.60 measurement procedure. Radiated emission testing must be done in a typical field installation, from the injection point and along the line.

4 Specific requirements

4.1 Frequency band exclusions

Exclusion bands are imposed for aeronautical mobile frequencies, as this service is used for long-range communications with aircraft covering the entire country.

In Brazil, amateur radio services are often used in distress situations. Therefore, additional exclusion bands for this service were adopted.

4.2 Exclusion zones

Exclusion zones were set for coast stations so as to protect critical maritime mobile service distress frequencies. The size of this zone was calculated according to PLT radiated emission limits and the sensitivity of maritime mobile reception equipment used in Brazil. Other fixed stations can be protected on a similar basis.

4.3 Preventive action

Public safety users, when in the fulfillment of their constitutional missions, may notify the PLT operator the region and the frequency band that will be temporarily used. The operator must implement the adequate adjustments in order to prevent possible interferences to public safety systems.

4.4 Coordination process

If after the commencement of operation PLT system the existence of some harmful interference caused by the PLT system is detected, the following procedures apply:

- a) if the interfered station operates in primary basis, the PLT station should immediately cease its transmission and make the necessary adjustments to eliminate interference;

- b) if the interfered station also operates in secondary basis, the parties concerned must coordinate use of radio frequencies in order to eliminate the interference.

5 Conclusion

The set of constraints imposed on PLT systems must prevent harmful interference to licensed radiocommunication services and in the meantime permit PLT systems to provide throughput rates high enough to meet the demand of most of broadband access users.

Appendix 5 to Annex 2

Republic of Korea

1 Limits

1.1 Limits for conducted emission at power ports

- Conducted emission is measured at AC power port when PLT transmission is off.
- Criteria is same as information technology equipment (same as CISPR 22).
- Measurement bandwidth is in accordance with CISPR guidance.

1.2 Limits for radiated disturbance

TABLE 8

Limits for radiated disturbance

Frequency range (MHz)	Quasi-peak limits (dB(μV/m))	
	Class A (10 m)	Class B (10 m) ⁽¹⁾
0.009 ~ 0.45	$47 - 20 \log f^{(2)(3)}$	
0.45 ~ 30	$54^{(2)(3)}$	
30 ~ 230	40	30
230 ~ 1 000	47	37

⁽¹⁾ If the ambient signal field strength is high, 3 m measurement distance could be used in case of the size of equipment of test being less than $1 \times 1 \times 1(\text{m}^3)$. The limits should be corrected by addition of 10.5. If there is any dispute about the test results, the test result performed at a distance of 10 m is preferable.

⁽²⁾ Measuring distance of 3 m should be applied in case of limits for radiated disturbance in frequency range 9 kHz to 30 MHz.

⁽³⁾ PLT shall conform with the operation prohibition band notified by the Korea Communications Commission regarding Article 58, paragraph of Radio Wave Act.

1.3 The prohibited frequency band as use of PLT

The PLT disturbance shall conform to the limits shown in Table 9 according to the frequency bands:

TABLE 9
The prohibited frequency band as use of PLT

Protecting services	Frequency bands	Limits
AM broadcasting	526.5-1 605.5 kHz	6.3 μ V/m at 3 m distance
Amateur	1 800-2 000 kHz, 3 500-4 000 kHz, 7 000-7 300 kHz, 10 100-10 150 kHz, 14 000-14 350 kHz, 18 068-18 168 kHz, 21 000-21 450 kHz, 24 890-24 990 kHz, 28 000-29 700 kHz	16 μ V/m at 3 m distance
Aeronautical and maritime safety	2 850-3 025 kHz, 3 400-3 500 kHz, 6 525-6 685 kHz, 8 815-8 965 kHz, 10 005-10 100 kHz, 13 260-13 360 kHz, 17 900-17 970 kHz, 2 173.5-2 190.5 kHz, 4 176.5-4 178.5 kHz, 8 413.5-8 415.5 kHz, 27 819.9-27 824.9 kHz	16 μ V/m at 3 m distance (The limit is applied when the PLT systems are operated in outside a room)
Maritime	450 kHz – 30 MHz	16 μ V/m at 3 m distance (This limit is applied when the PLT systems are installed within a radius of 1 km from a maritime base station)

2 Measurement method of radiated disturbance

2.1 Measurement methods in frequency range 9 kHz to 30 MHz

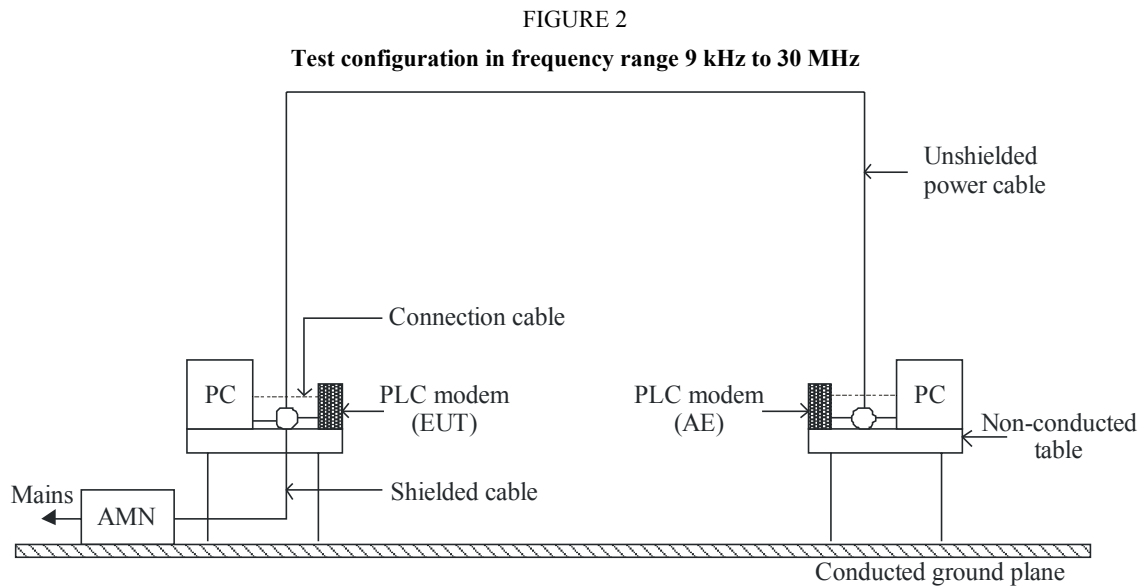

SM1879-02

Note 1 – Power line communication modem which can carry out independent communication is tested without a personal computer.

Note 2 – For cable connection between personal computer and PLT modem, the method offered by the manufacturer of the power line communication modem shall be used.

FIGURE 3
Measurement setup for testing of PLT

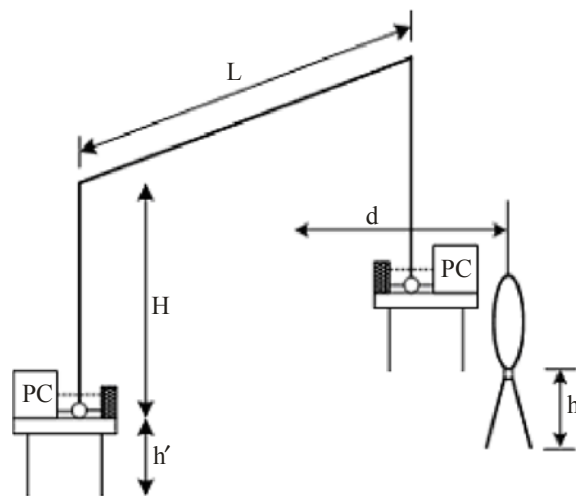

Measurement setup from the front of PLT setup

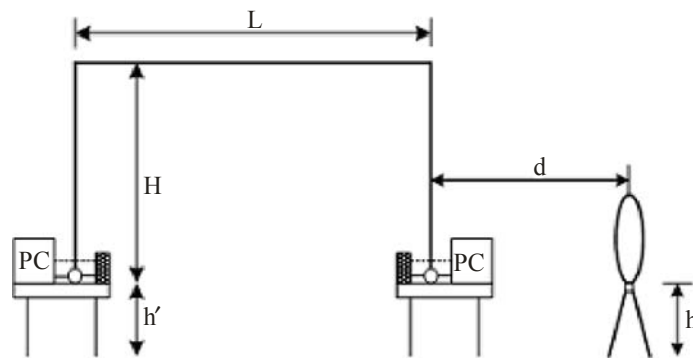

Measurement setup from the side of PLT setup

SM.1879-03

1. As shown in the figure, the loop antenna is placed on the tripod of 1 m height after organizing power line communication system. However, it is possible to change the installation position of EUT and auxiliary equipment.
2. The horizontal length of the power line (L) should be more than 3 m while the height (H) is more than 3 m.
3. The height of installation on power line communication modem and personal computer should be 0.8 m.
4. The height of the measuring antenna should be 1 m from the ground. The distance from the most exterior unshielded power line to the receiving antenna should be 3 m.
5. Materials which support power line, power line communication modem and personal computer should be non-conductive.
6. Cable for equipments which are used by hand (keyboard, mouse, etc.) should be placed where it can be used commonly.
7. Other table-top equipment should be placed as shown in Fig. 4.
8. The arrangement of power line communication EUT shown in Fig. 3 should be applied in the frequency range 9 kHz – 30 MHz.

2.2 Measurement methods in frequency range 30 MHz to 1 000 MHz

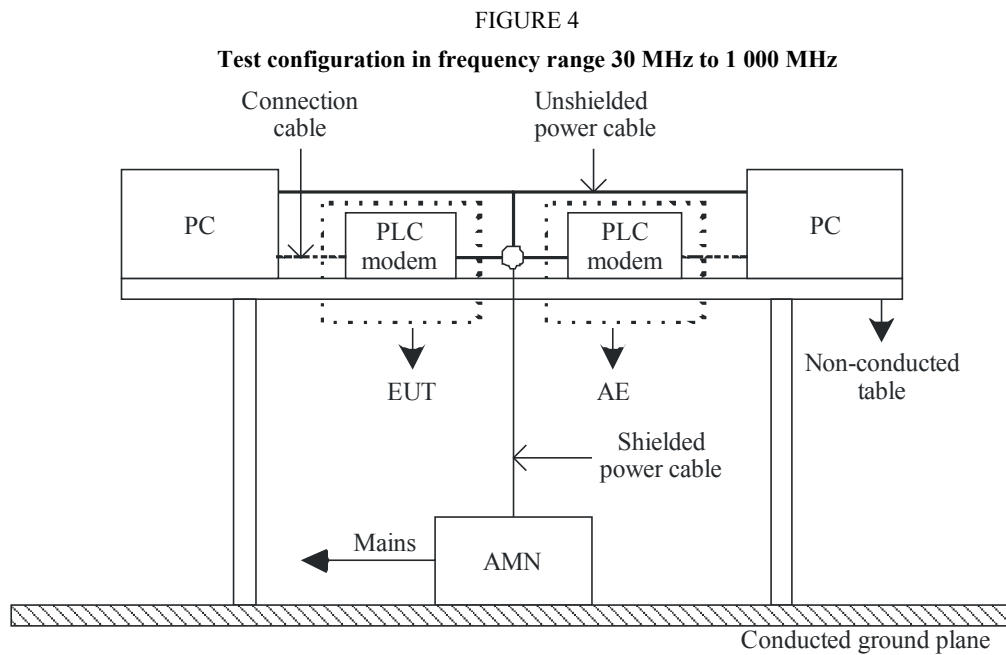

SM.1879-04

Note 1 – Power line communication modem which can carry out independent communication is tested without a personal computer.

Note 2 – Cable connection between personal computer and power line communication modem should be done with the method offered by the manufacture of power line communication modem.