

RECOMMENDATION ITU-R M.625-3*

DIRECT-PRINTING TELEGRAPH EQUIPMENT EMPLOYING AUTOMATIC IDENTIFICATION IN THE MARITIME MOBILE SERVICE**

(Question ITU-R 5/8)

(1986-1990-1992-1995)

Summary

The Recommendation provides in Annex 1 characteristics of direct-printing telegraph equipment employing a 7-unit ARQ method for selective communication, a 7-unit FEC method for broadcast mode and automatic identification to be used for newly developed equipment to provide compatibility with existing equipment conforming to Recommendation ITU-R M.476.

The ITU Radiocommunication Assembly,

considering

- a) that there is a requirement to interconnect ship stations or ship stations and coast stations, equipped with start-stop apparatus employing the ITU-T International Telegraph Alphabet No. 2, by means of radiotelegraph circuits;
- b) that direct-printing telegraph equipment in the maritime mobile service is used for:
 - telex and/or telegraph service between a ship station and a subscriber of the (international) telex network;
 - telegraph service between a ship station and a coast station or between two ship stations;
 - telegraph service between a ship station and an extended station (ship owner) via a coast station;
 - telegraph service in a broadcast mode from a coast station, or a ship station, to one or more ship stations;
- c) that the broadcast mode cannot take advantage of an ARQ method, as a return path is not used;
- d) that for the broadcast mode a forward error-correcting (FEC) method should be used;
- e) that the period for synchronization and phasing should be as short as possible;
- f) that most of the ship stations do not readily permit the simultaneous use of radio transmitter and receiver;
- g) that a direct-printing telegraph system employing error-detecting and error-correcting methods in accordance with Recommendation ITU-R M.476, is in actual operation;
- h) that the increased use of direct-printing telegraph equipment has emphasized the importance of an unambiguous identification of both stations when a circuit is established or re-established;
- j) that unambiguous identification could be accomplished by the exchange of self-identification signals between the ARQ equipments at the 7-unit level;
- k) that Appendix 43 of the Radio Regulations (RR), Recommendation ITU-R M.585 and ITU-T Recommendations E.210 and F.120 provide for a comprehensive system of assigning maritime mobile service identities;

* This Recommendation should be brought to the attention of the International Maritime Organization (IMO) and the Telecommunication Standardization Bureau of the ITU.

** Newly developed equipment should conform to the present Recommendation which provides for compatibility with existing equipment built in accordance with Recommendation ITU-R M.476.

l) that, in the interest of having a unique identity assigned to each ship station for distress and safety and other telecommunication purposes, the address capability should allow the use of maritime mobile service identities in accordance with the provisions of Appendix 43 of the RR;

m) that equipment built in accordance with Recommendation ITU-R M.476 cannot provide for the use of maritime mobile service identities mentioned in § k);

n) that there is a need to provide for compatibility to the extent possible with equipments built in accordance with Recommendation ITU-R M.476; however, unambiguous identification of both stations cannot be achieved when circuits are established with equipments built in accordance with Recommendation ITU-R M.476,

recommends

1 that for direct-printing telegraph circuits in the maritime mobile service, a 7-unit ARQ method should be employed;

2 that for the direct-printing telegraph service in the broadcast mode, a 7-unit forward acting error-correcting method, using time diversity, should be employed;

3 that equipment designed in accordance with § 1 and 2 should employ automatic identification and have the characteristics given in Annex 1.

ANNEX 1

CONTENTS

	Page
1 General (mode A (ARQ) and mode B (FEC)).....	4
2 Conversion tables.....	4
2.1 General.....	4
2.2 Traffic information signals.....	4
2.3 Service information signals.....	4
2.4 Identification and check-sum numbers and signals.....	6
2.5 Check-sum signal derivation.....	6
3 Characteristics, mode A (ARQ).....	7
3.1 General.....	7
3.2 Master and slave arrangements.....	7
3.3 The information sending station (ISS).....	7
3.4 The information receiving station (IRS).....	7
3.5 Phasing procedure.....	8
3.6 Automatic identification.....	9
3.7 Traffic flow.....	11
3.8 Rephasing procedure.....	12
3.9 Summary of service blocks and service information signals.....	14
4 Characteristics, mode B (FEC).....	14
4.1 General.....	14
4.2 The sending station (CBSS and SBSS).....	14
4.3 The receiving station (CBRS and SBRS).....	15
4.4 Phasing procedure.....	15
4.5 Selecting calling procedure (selective B-mode).....	15
4.6 Traffic flow.....	15

Appendix 1 – SDL diagrams (mode A)	27
Appendix 2 – Phasing procedure with automatic identification in the case of a 7-signal call identity (calling station)	31
Appendix 3 – Rephasing procedure with automatic identification in the case of a 7-signal call identity (calling station)	34
Appendix 4 – Phasing procedure without automatic identification in the case of a 4-signal call identity (calling station)	37
Appendix 5 – Rephasing procedure without automatic identification in the case of a 4-signal call identity (calling station)	38
Appendix 6 – Phasing procedure with automatic identification in the case of a 7-signal call identity (called station)	39
Appendix 7 – Rephasing procedure with automatic identification in the case of a 7-signal call identity (called station)	42
Appendix 8 – Phasing procedure without automatic identification in the case of a 4-signal call identity (called station)	45
Appendix 9 – Rephasing procedure without automatic identification in the case of a 4-signal call identity (called station)	46
Appendix 10 – Traffic flow in the case of a 4-signal call identity and in the case of a 7-signal call identity (station is in the ISS position)	47
Appendix 11 – Traffic flow in the case of a 4-signal call identity and in the case of a 7-signal call identity (station is in the IRS position)	50
Appendix 12 – State overview diagrams	52
Sheet 1 – Phasing procedure with automatic identification in the case of a 7-signal call identity (calling station) and traffic flow if the station is in the ISS position.....	52
Sheet 2 – Rephasing procedure with automatic identification in the case of a 7-signal call identity (calling station) and traffic flow if the station is in the ISS position.....	53
Sheet 3 – Phasing procedure without automatic identification in the case of a 4-signal call identity (calling station) and traffic flow if the station is in the ISS position.....	54
Sheet 4 – Rephasing procedure without automatic identification in the case of a 4-signal call identity (calling station) and traffic flow if the station is in the ISS position.....	55
Sheet 5 – Phasing procedure with automatic identification in the case of a 7-signal call identity (called station) and traffic flow if the station is in the IRS position	56
Sheet 6 – Rephasing procedure with automatic identification in the case of a 7-signal call identity (called station) and traffic flow if the station is in the IRS position	57
Sheet 7 – Phasing procedure without automatic identification in the case of a 4-signal call identity (called station) and traffic flow if the station is in the IRS position	58
Sheet 8 – Rephasing procedure without automatic identification in the case of a 4-signal call identity (called station) and traffic flow if the station is in the IRS position	59

1 General (mode A (ARQ) and mode B (FEC))

1.1 The system in both Mode A (ARQ) and Mode B (FEC) is a single-channel synchronous system using the 7-unit constant ratio error-detecting code as listed in § 2.2 and 2.3.

1.2 FSK modulation is used on the radio link at 100 Bd. The equipment clock controlling the modulation rate should have an accuracy of 30 parts in 10^6 or better.

1.3 The class of emission is F1B or J2B with a frequency shift on the radio link of 170 Hz. When frequency shift is effected by applying audio signals to the input of a single-sideband transmitter, the centre frequency of the audio spectrum applied to the transmitter should be 1 700 Hz.

1.4 The radio-frequency tolerance of the transmitter and the receiver should be in accordance with Recommendation ITU-R SM.1137. It is desirable that the receiver employs the minimum practicable bandwidth (see also Report ITU-R M.585).

NOTE 1 – The receiver 6 dB bandwidth should preferably be between 270 and 340 Hz.

1.5 For direct connection to the international telex network, the line input and output signals should be in accordance with the 5-unit start-stop International Telegraph Alphabet No. 2, at a modulation rate of 50 Bd.

1.6 Equipment designed in accordance with this Recommendation is likely to contain high speed digital circuitry. Special care should be taken to avoid interference to other equipment and to minimize susceptibility to interference from other equipment or electrical lines on board ship (see also Recommendation ITU-R M.218).

1.7 When operating in mode A (ARQ), the called station employs a constant time interval between the end of the received signal and the start of the transmitted signal (t_E in Fig. 1). In the case of long propagation distances it is essential to have this t_E as short as practicable. However, in the case of short distances it may be desirable to introduce a longer time interval, e.g. 20-40 ms, to accommodate receiver desensitization at the calling station. This time interval can be introduced at the called station either in the ARQ equipment or in the radio equipment.

2 Conversion tables

2.1 General

Several kinds of “signals” are used in the system, such as:

- traffic information signals,
- service information signals (control signals, idle signals, signal repetition),
- identification signals,
- check-sum signals.

2.2 Traffic information signals

These signals are used during communication to convey the message information which is passed from an information sending station to one or more information receiving stations. Table 1 lists the traffic information signals which may be used.

2.3 Service information signals

These signals are used to control the procedures taking place over the radio circuit and do not form part of the transmitted messages. Service information signals are not normally printed or displayed. Table 2 lists the service information signals which may be used.

TABLE 1

Combination No.	Traffic information signals		International Telegraph Alphabet No. 2 Code ⁽¹⁾	Transmitted 7-unit signal ⁽²⁾
	Letter-case	Figure case	Bit position ⁽³⁾ 1 2 3 4 5	Bit position ⁽³⁾ 1 2 3 4 5 6 7
1	A	—	ZZAAA	BBBYYB
2	B	?	ZAAZZ	YBYYBB
3	C	:	AZZZA	BYBBYY
4	D	☒ ⁽⁴⁾	ZAAZA	BBYYBY
5	E	3	ZAAAA	YBBYBY
6	F	(5)	ZAZZA	BBYBBY
7	G	(5)	AZAZZ	BYBYBY
8	H	(5)	AAZAZ	BYBYBB
9	I	8	AZZAA	BYBBYY
10	J	⌚ (Audible signal)	ZZAZA	BBBYBY
11	K	(ZZZZA	YBBBBY
12	L)	AZAAZ	BYYYBB
13	M	.	AAZZZ	BYBBBY
14	N	,	AAZZA	BYBBYB
15	O	9	AAAZZ	BYYYBB
16	P	0	AZZAZ	BYBBYB
17	Q	1	ZZAZZ	YBBYBY
18	R	4	AZAZA	BYBYBY
19	S	'	ZAZAA	BBBYBY
20	T	5	AAAAZ	YYBYBB
21	U	7	ZZZAA	YBBYYB
22	V	=	AZZZZ	YYBBBY
23	W	2	ZZAAZ	BBYYBY
24	X	/	ZAZZZ	YBYBBY
25	Y	6	ZAZAZ	BBYBYB
26	Z	+	ZAAAZ	BBYYBB
27	←	(Carriage return)	AAAZA	YYYBBB
28	≡	(Line feed)	AZAAA	YYBBYB
29	↓	(Letter shift)	ZZZZZ	YBYBBY
30	↑	(Figure shift)	ZZAZZ	YBBYBY
31	△	(Space)	AAZAA	YYBBYB
32	□	No information	AAAAA	YBYBYB

- (1) A represents start polarity, Z represents stop polarity (see also Recommendation ITU-R M.490).
- (2) B represents the higher emitted frequency and Y the lower (see also Recommendation ITU-R M.490).
- (3) The bit in bit position 1 is transmitted first; B = 0, Y = 1.
- (4) The pictorial representation shown is a schematic of ☒ which may also be used when equipment allows (ITU-T Recommendation F.1, § C9).
- (5) At present unassigned (see ITU-T Recommendation F.1, § C8). Reception of these signals, however, should not initiate a request for repetition.

TABLE 2

Mode A (ARQ)	Transmitted signal	Mode B (FEC)
Control signal 1 (CS1)	BYBYBB	Idle signal β Phasing signal 1, Idle signal α Phasing signal 2
Control signal 2 (CS2)	YBYBYB	
Control signal 3 (CS3)	BYYBBY	
Control signal 4 (CS4)	BYBYBY	
Control signal 5 (CS5)	BYYBYB	
Idle signal β	BBYYBB	
Idle signal α	BBBYYY	
Signal repetition (RQ)	YBBYYB	

2.4 Identification and check-sum numbers and signals

Identification and check-sum numbers and signals are used in the automatic identification procedure in order to provide a means by which, during the establishment or re-establishment of a radio circuit, the stations concerned are clearly and unambiguously identified to each other. The relationship between the transmitted identification signals and their equivalent numbers is shown in Table 3a; Table 3b indicates the conversion from check-sum numbers to the transmitted check-sum signals.

TABLE 3a

Identification signal (IS)	Equivalent number (N)
A	19
B	11
C	6
D	18
E	13
F	8
I	15
K	3
M	4
O	14
P	5
Q	2
R	16
S	9
T	10
U	12
V	0
X	1
Y	7
Z	17

TABLE 3b

Check-sum number (CN)	Check-sum signal (CK)
0	V
1	X
2	Q
3	K
4	M
5	P
6	C
7	Y
8	F
9	S
10	T
11	B
12	U
13	E
14	O
15	I
16	R
17	Z
18	D
19	A

2.5 Check-sum signal derivation

These identification signals IS1, IS2, IS3, IS4, IS5, IS6 and IS7 are converted into their equivalent numbers N1, N2, N3, N4, N5, N6 and N7 respectively, in accordance with Table 3a. The three numbers N1, N2 and N3 are added and the sum is translated into one check-sum number CN1 using modulo 20-addition. This process is repeated for the numbers N3, N4 and N5 resulting in a check-sum number CN2 and for the numbers N5, N6 and N7 resulting in a check-sum number CN3, as follows:

$$N1 \oplus N2 \oplus N3 = CN1$$

$$N3 \oplus N4 \oplus N5 = CN2$$

$$N5 \oplus N6 \oplus N7 = CN3$$

where \oplus denotes modulo 20-addition.

The last conversion is from check-sum numbers CN1, CN2 and CN3 into “check-sum signal 1”, “check-sum signal 2” and “check-sum signal 3” respectively, in accordance with Table 3b.

Example:

The seven identification signals of station 364775427 are: P E A R D B Y (see Recommendation ITU-R M.491).

The check-sum derivation will be as follows:

P E A R D B Y → 5 13 19 16 18 11 7

$$5 \oplus 13 \oplus 19 = 17 \text{ (37-20)}$$

$$19 \oplus 16 \oplus 18 = 13 \text{ (53-20-20)}$$

$$18 \oplus 11 \oplus 7 = 16 \text{ (36-20)}$$

17 13 16 → Z E R

where \oplus denotes modulo 20-addition.

Result:

CK1 becomes “Z” (combination No. 26, see Table 1)

CK2 becomes “E” (combination No. 5, see Table 1)

CK3 becomes “R” (combination No. 18, see Table 1)

3 Characteristics, mode A (ARQ)

3.1 General

The system operates in a synchronous mode transmitting blocks of three signals from an information sending station (ISS) towards an information receiving station (IRS). A control signal is transmitted from the IRS to the ISS after reception of each block indicating correct reception or requesting retransmission of the block. These stations can interchange their functions.

3.2 Master and slave arrangements

3.2.1 The station that initiates the establishment of the radio circuit (the calling station) becomes the “master” station, and the station being called will be the “slave” station. This situation remains unchanged during the entire time that the established radio circuit is maintained, regardless of which station, at any given time, is the information sending station (ISS) or the information receiving station (IRS).

3.2.2 The clock in the master station controls the timing of the entire circuit (see circuit timing diagram, Fig. 1). This clock should have an accuracy of 30 parts in 10^6 or better.

3.2.3 The basic timing cycle is 450 ms and consists for each station of a transmission period followed by a transmission pause during which reception is effected.

3.2.4 The master station transmit timing is controlled by the clock in the master station.

3.2.5 The clock controlling the timing of the slave station is phase-locked to the signal received from the master station, i.e. the time interval between the end of the received signal and the start of the transmitted signal (t_E in Fig. 1) is constant (see also § 1.7).

3.2.6 The master station receive timing is phase-locked to the signal received from the slave station.

3.3 The information sending station (ISS)

3.3.1 The ISS groups the information to be transmitted into blocks of three signals (3×7 signal elements).

3.3.2 The ISS sends a block in 210 ms (3×70 ms) after which a transmission pause of 240 ms becomes effective.

3.4 The information receiving station (IRS)

3.4.1 After the reception of each block the IRS sends one signal of 70 ms duration (7-signal elements), after which a transmission pause of 380 ms becomes effective.

FIGURE 1
Basic timing diagram

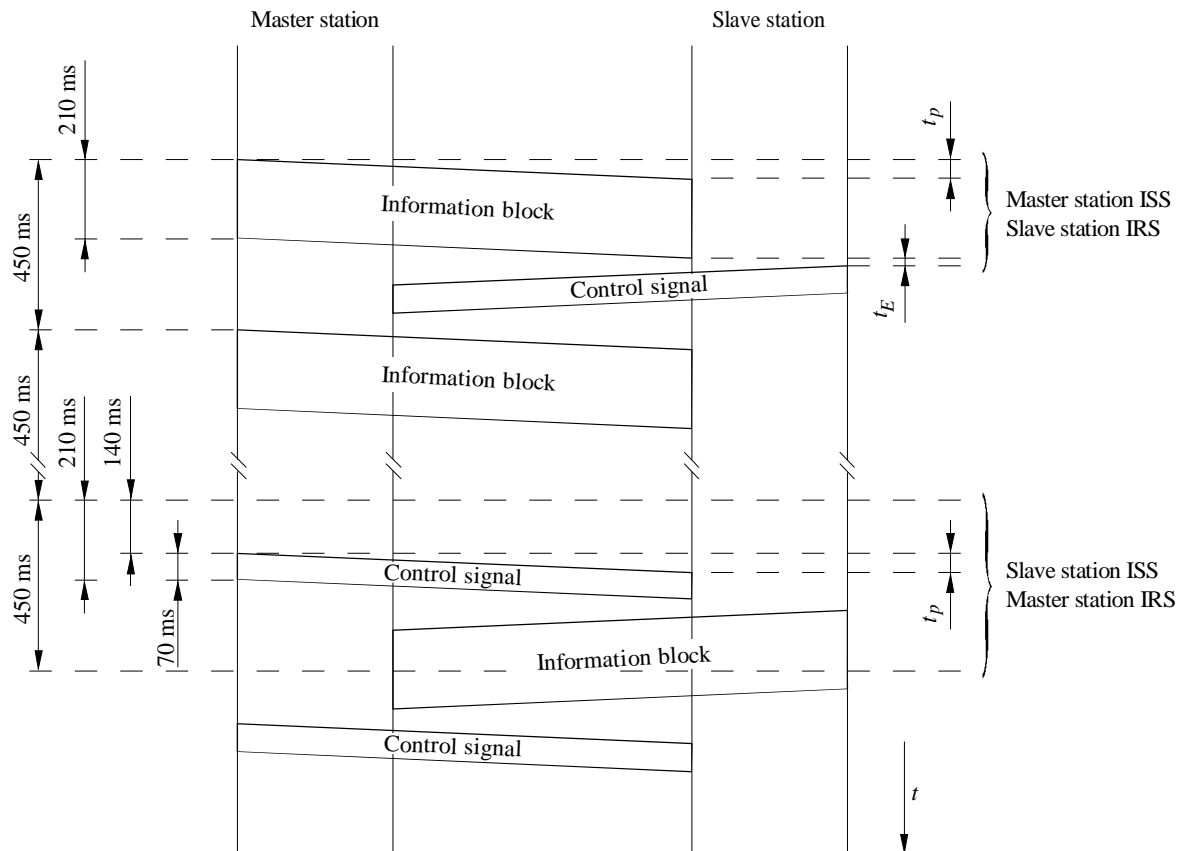

t_p : (one-way) propagation time
 t_E : equipment delay (see also § 1.7)

D01

3.5 Phasing procedure

3.5.1 When no circuit is established, both stations are in the “stand-by” condition. In this condition neither of the stations is designated master, slave, ISS or IRS.

3.5.2 The “call signal” contains either four or seven identification signals as applicable. The identification signals are listed in Table 3a. The composition of these “call signals” should be in accordance with Recommendation ITU-R M.491.

3.5.2.1 The equipment should be capable of operating with both 4-signal and 7-signal identity procedures and automatically employing the appropriate procedure for either, as indicated by the composition of the “call signal” received from a calling station or by the number of digits (4, 5 or 9) supplied to the equipment of a calling station to identify the station to be called.

3.5.3 The “call signal” (Note 1) contains:

- in “call block 1”: in the first, second and third character places respectively: the first identification signal, the service information signal “signal repetition” and the second identification signal of the called station;
- in “call block 2”: in the first, second and third character places respectively, either:
 - in the case of a 4-signal call identity: the third and the fourth identification signals of the called station and “signal repetition”; or
 - in the case of a 7-signal call identity: “signal repetition”, and the third and fourth identification signals of the called station;

- in the case of a 7-signal call identity in “call block 3”: the last three identification signals of the called station.

NOTE 1 – A station using a two block call signal shall be assigned a number in accordance with RR Nos. 2088, 2134 and 2143 to 2146.

A station capable of using a three block call signal, shall employ the maritime identification digits required in accordance with RR Appendix 43 when communicating with stations also capable of using a three block call signal.

3.5.4 The station required to establish the circuit becomes the master station and sends the “call signal” until it receives an appropriate control signal; however, if the circuit has not been established within 128 cycles (128×450 ms), the station changes into the “stand-by” condition and waits for a time of at least 128 cycles before sending the same “call signal” again.

3.5.5 The called station becomes the slave station and changes from the “stand-by” to the IRS condition:

- in the case of a 4-signal call identity following the consecutive reception of “call block 1” and “call block 2”, after which it sends “control signal 1” until the first information block has been received;
- in the case of a 7-signal call identity following the reception of the three call blocks in succession after which it sends “control signal 4” until “identification block 1” has been received.

3.5.6 On receipt of two consecutive identical signals “control signal 1” or “control signal 2” the calling station changes to the ISS condition and proceeds directly with the transmission of traffic information (see § 3.7) without automatic identification.

NOTE 1 – Equipment built in accordance with Recommendation ITU-R M.476 sends “control signal 1” or “control signal 2” on receipt of the appropriate “call signal”.

3.5.7 On receipt of “control signal 3” during the phasing procedure, the calling station immediately changes to the “stand-by” condition, and waits 128 cycles before sending the same “call signal” again.

NOTE 1 – Equipment built in accordance with Recommendation ITU-R M.476 may send “control signal 3” on receipt of the appropriate “call signal”, if the called station is rephasing and was in the ISS condition at the moment of interruption.

3.5.8 On receipt of “control signal 5” during the phasing procedure, the calling station starts the “end-of-communication” procedure in accordance with § 3.7.14, and waits at least 128 cycles before sending the same “call signal” again. During this waiting time the station is in the “stand-by” condition.

3.6 Automatic identification

Only applicable in the case of a 7-signal call identity.

3.6.1 On receipt of “control signal 4” the calling station changes to the ISS condition and starts the identification procedure. During the identification cycle, information is exchanged about the identities of both stations; the ISS transmits its identification blocks and the IRS returns the check-sum signals derived from its identity in accordance with § 2.5. On receipt of each check-sum signal, the calling station compares this signal with the appropriate check-sum signal locally derived from the identification signals transmitted in the call blocks. If they are identical, the calling station continues with the following procedure, otherwise the procedure of § 3.6.12 is followed.

3.6.2 The ISS sends “identification block 1” containing its own first identification signal, “idle signal α ” and its second identification signal in the first, second and third character places respectively.

3.6.3 On receipt of “identification block 1” the called station sends “check-sum signal 1”, derived from its identity.

3.6.4 On receipt of “check-sum signal 1” the calling station sends “identification block 2” containing the first, second and third character places respectively, “idle signal α ”, its third identification signal and its fourth identification signal.

3.6.5 On receipt of “identification block 2” the called station sends “check-sum signal 2”, derived from its identity.

3.6.6 On receipt of “check-sum signal 2” the calling station sends “identification block 3” containing its fifth, sixth and seventh identification signals in the first, second and third character places respectively.

3.6.7 On receipt of “identification block 3” the called station sends “check-sum signal 3”, derived from its identity.

3.6.8 On receipt of the last check-sum signal the calling station sends the “end-of-identification block” containing three “signal repetition” signals.

3.6.9 On receipt of the “end-of-identification block” the called station sends, either:

- “control signal 1”, thus starting the traffic flow in accordance with § 3.7; or
- “control signal 3”, if the called station is required to start the traffic flow in the ISS condition (in accordance with § 3.7.11).

3.6.10 On receipt of “control signal 1” the calling station ends the identification cycle and starts the traffic flow by transmitting “information block 1” in accordance with § 3.7.

3.6.11 On receipt of “control signal 3” the calling station ends the identification cycle and starts the traffic flow with the change-over procedure in accordance with § 3.7.11.

3.6.12 If any received check-sum signal is not identical to the locally derived check-sum signal, the calling station retransmits the previous identification block. On receipt of this identification block, the called station sends the appropriate check-sum signal once more.

On receipt of this check-sum signal the calling station compares again. If they are still not identical, and the received check-sum signal is the same as the previous one, the calling station initiates the “end of communication” procedure in accordance with § 3.7.14; otherwise the calling station transmits the previous identification block again. Any identification block should not be retransmitted more than four times due to reception of wrong check-sum signals, after which, if the required check-sum signal is still not received, the calling station reverts to the “stand-by” condition.

3.6.13 If, due to mutilated reception, the calling station does not receive:

- “control signal 4”, it continues transmitting the “call signal”;
- “check-sum signal 1”, it retransmits “identification block 1”;
- “check-sum signal 2”, it retransmits “identification block 2”;
- “check-sum signal 3”, it retransmits “identification block 3”;
- “control signal 1” or “control signal 3”, it retransmits the “end-of-identification block”,

taking into account the time limit mentioned in § 3.6.18.

3.6.14 If, due to mutilated reception, the called station does not receive a block during the identification cycle, it transmits a “signal repetition”, taking into account the time limit mentioned in § 3.6.18.

3.6.15 If during the identification cycle the calling station receives a “signal repetition”, it retransmits the previous block.

3.6.16 If, due to retransmission of an identification block by the calling station, the identification signals as received by the called station are not identical, the called station sends “signal repetition” until two identical consecutive identification blocks are received after which the corresponding check-sum signal is transmitted, taking into account the time limit mentioned in § 3.6.18.

3.6.17 If during the identification cycle the called station receives the “end-of-communication block” (containing three “idle signals α ”), it sends a “control signal 1” and reverts to the “stand-by” condition.

3.6.18 When reception of signals during the identification cycle is continuously mutilated, both stations revert to the “stand-by” condition after 32 cycles of continuous repetition.

3.6.19 Each station should retain the identity of the other station for the duration of the connection (see § 3.7.1) and this information should be accessible locally, e.g. by means of a display or on a separate output circuit for external use. However, this identity information should not appear on the output line to the network.

3.7 Traffic flow

3.7.1 At all times after the start of the traffic flow and until the station reverts to the “stand-by” condition, the station should retain the following information:

- whether it is in the master or slave condition;
- the identity of the other station (when applicable);
- whether it is in the ISS or IRS condition;
- whether the traffic flow is in the letter case or figure case condition.

3.7.2 The ISS transmits the traffic information in blocks, each block consisting of three signals. If necessary, “idle signals β ” are used to complete or to fill information blocks when no traffic information is available.

3.7.3 The ISS retains the transmitted information block in memory until the appropriate control signal confirming correct reception by the IRS has been received.

3.7.4 For internal use, the IRS numbers the received information blocks alternately “information block 1” and “information block 2” dependent on the first transmitted control signal. The numbering is interrupted at the reception of, either:

- an information block in which one or more signals are mutilated; or
- an information block containing at least one “signal repetition”.

3.7.5 The IRS sends “control signal 1” at the reception of, either:

- an unmutated “information block 2”; or
- a mutilated “information block 1”; or
- an “information block 1” containing at least one “signal repetition”.

3.7.6 The IRS sends “control signal 2” at the reception of, either:

- an unmutated “information block 1”; or
- a mutilated “information block 2”; or
- an “information block 2” containing at least one “signal repetition”.

3.7.7 For internal use, the ISS numbers successive information blocks alternately “information block 1” and “information block 2”. The first block should be numbered “information block 1” or “information block 2” dependent on whether the received control signal is a “control signal 1” or a “control signal 2”. The numbering is interrupted at the reception of, either:

- a request for repetition; or
- a mutilated control signal; or
- a “control signal 3”.

3.7.8 On receipt of “control signal 1” the ISS sends “information block 1”.

3.7.9 On receipt of “control signal 2” the ISS sends “information block 2”.

3.7.10 On receipt of a mutilated control signal the ISS sends a block containing three “signal repetitions”.

3.7.11 Change-over procedure

3.7.11.1 If the ISS is required to initiate a change in the direction of the traffic flow, the station sends the signal sequence (“ \uparrow ” combination No. 30), “+” (combination No. 26), “?” (combination No. 2) followed, if necessary, by one or more “idle signals β ” to complete the information block.

3.7.11.2 On receipt of the signal sequence (“+”, “?” (combination No. 26 and combination No. 2)) with the traffic flow in the figure case condition, the IRS sends “control signal 3” until an information block containing the signals “idle signal β ”, “idle signal α ”, “idle signal β ” has been received.

NOTE 1 – The presence of “idle signals β ” between the signals “+” and “?” should not inhibit the response of the IRS.

3.7.11.3 If the IRS is required to initiate a change in the direction of the traffic flow, it sends “control signal 3”.

3.7.11.4 On receipt of “control signal 3” the ISS sends an information block containing “idle signal β ”, “idle signal α ” and “idle signal β ” in the first, second and third character places respectively.

3.7.11.5 On receipt of the information block containing the service information signals “idle signal β ”, “idle signal α ” and “idle signal β ”, the IRS changes to ISS and sends, either:

- an information block containing three “signal repetitions”, if it is the slave station; or
- one “signal repetition”, if it is the master station,

until either “control signal 1” or “control signal 2” is received, taking into account the time limit mentioned in § 3.7.12.1.

3.7.11.6 The ISS changes to IRS after the reception of, either:

- an information block containing three “signal repetitions” if it is the master station; or
- one “signal repetition” if it is the slave station,

and sends either “control signal 1” or “control signal 2” depending on whether the preceding control signal was “control signal 2” or “control signal 1”, respectively, after which the traffic flow starts in the appropriate direction.

3.7.12 Time-out procedure

3.7.12.1 When reception of information blocks or of control signals is continuously mutilated, both stations revert to the “rephase” condition after 32 cycles of continuous repetition, in accordance with § 3.8.

3.7.13. Answer-back procedure

3.7.13.1 If the ISS is required to request terminal identification, the station sends the signals “ \uparrow ” (combination No. 30) and “ \boxtimes ” (combination No. 4) followed, if necessary, by one or more “idle signals β ” to complete the information block.

3.7.13.2 On receipt of an information block containing the traffic information signal “ \boxtimes ” (combination No. 4) with the traffic flow in the figure case condition, the IRS:

- changes the direction of the traffic flow in accordance with § 3.7.11;
- transmits the traffic information signals derived from the teleprinter answer-back code generator;
- transmits, after completion of the answer-back code, or in the absence of an answer-back code, two information blocks of three “idle signals β ”;
- changes the direction of the traffic flow in accordance with § 3.7.11, and reverts to IRS.

3.7.14 End-of-communication procedure

3.7.14.1 If the ISS is required to terminate the established circuit, it sends the “end-of-communication block” containing three “idle signals α ”, until the appropriate “control signal 1” or “control signal 2” has been received; however, the number of transmissions of the “end-of-communication block” is limited to four, after which the ISS reverts to the “stand-by” condition.

3.7.14.2 On receipt of the “end-of-communication block” the IRS sends the appropriate control signal indicating correct reception of this block, and reverts to the “stand-by” condition.

3.7.14.3 On receipt of the control signal that confirms the unmutated reception of the “end-of-communication block”, the ISS reverts to the “stand-by” condition.

3.7.14.4 If the IRS is required to terminate the established circuit, it has first to change over to the ISS condition, in accordance with § 3.7.11, before the termination can take place.

3.8 Rephasing procedure

3.8.1 If during the traffic flow, reception of information blocks or control signals is continuously mutilated, both stations change to the “rephase” condition after 32 cycles of continuous repetition. Rephasing is the automatic re-establishment of the previous circuit immediately following interruption of that circuit as a result of continuous repetition (see § 3.7.12).

NOTE 1 – Some coast stations do not provide for rephasing. Therefore, it should be possible to disable the rephasing procedure.

3.8.2 After changing to the “rephase” condition the master station immediately initiates the rephasing procedure. This procedure is the same as the phasing procedure; however, in the case of a 7-signal call identity, instead of “control signal 4” the rephasing slave station will transmit “control signal 5” after the reception of the appropriate “call signal” transmitted by the rephasing master station.

3.8.3 When “control signal 5” is received by the master station, automatic identification takes place along the same lines as laid down in § 3.6. However, on receipt of the “end-of-identification block”, containing three “signal repetitions”:

3.8.3.1 If, at the time of interruption, the slave station was in the IRS condition, it sends either:

- “control signal 1” if the last correctly received block before the interruption occurred as an “information block 2”;
or
- “control signal 2” if the last correctly received block before the interruption occurred was an “information block 1”.

3.8.3.2 If, at the time of interruption, the slave station was in the ISS condition, it sends “control signal 3”, to initiate change-over to the IRS condition. When the change-over is completed, i.e. after correct reception of the block containing three “signal repetitions” by the master station, the master station sends either:

- “control signal 1” if the last correctly received block before the interruption occurred was an “information block 2”;
or
- “control signal 2” if the last correctly received block before the interruption occurred was an “information block 1”.

3.8.4 On receipt of “control signal 4”, during the rephasing procedure the master station sends one “end-of-communication block” containing three “idle signals α ” after which it continues with the rephasing attempt.

3.8.5 On receipt of each identification block, the slave station compares the received identification signals with the previously stored identity of the master station and:

- if the signals are identical, the slave station continues with the procedure by sending the appropriate check-sum signal;
- if the signals are not identical, the slave station initiates the “end-of-communication” procedure in accordance with § 3.7.14 and remains in the “rephase” condition.

3.8.6 On receipt of a block containing three “idle signals α ”, the slave station sends one “control signal 1” and remains in the “rephase” condition.

3.8.7 In the case of a 4-signal call identity, the rephasing master station:

- upon receipt of two consecutive signals “control signal 1” or “control signal 2” resumes directly with the transmission of traffic information if the slave station was in the IRS condition, or initiates the change-over procedure in accordance with § 3.7.11.1 if the slave station was in the ISS condition;
- upon receipt of two consecutive signals “control signal 3” proceeds directly with the change-over procedure in accordance with § 3.7.11.4 if the slave station was in the ISS condition.

3.8.8 In the case of a 4-signal call identity, the slave station on receipt of the appropriate “call signal” sends:

- if, at the time of interruption, the slave station was in the IRS condition, either:
 - “control signal 1” if it had correctly received “information block 2” before the interruption occurred; or
 - “control signal 2” if it had correctly received “information block 1” before the interruption occurred;
- if, at the time of interruption, the slave station was in the ISS condition, “control signal 3” to initiate change-over to the ISS condition.

3.8.9 If rephasing has not been accomplished within the time-out interval of 32 cycles, both stations revert to the “stand-by” condition and no further rephasing attempts are made.

3.9 Summary of service blocks and service information signals

3.9.1 Service blocks

$X_1 - RQ - X_2$: “Call block 1” containing the 1st and 2nd identification signals.

$X_3 - X_4 - RQ$: “Call block 2” for a 4-signal call identity containing the 3rd and 4th identification signals.

$RQ - X_3 - X_4$: “Call block 2” for a 7-signal call identity containing the 3rd and 4th identification signals.

$X_5 - X_6 - X_7$: “Call block 3” for a 7-signal call identity containing the 5th, 6th and 7th identification signals.

$Y_1 - \alpha - Y_2$: “Identification block 1” containing self-identification signals 1 and 2 and request for the 1st check-sum signal.

$\alpha - Y_3 - Y_4$: “Identification block 2” containing self-identification signals 3 and 4 and request for the 2nd check-sum signal.

$Y_5 - Y_6 - Y_7$: “Identification block 3” containing self-identification signals 5, 6 and 7 and request for the 3rd check-sum signal.

$RQ - RQ - RQ$: If occurring within the automatic identification procedure, indicates the end of that procedure and requests the appropriate control signal.

During the traffic flow, indicates request for repetition of the last control signal or in the change-over procedure response to $\beta - \alpha - \beta$.

$\beta - \alpha - \beta$: Block to change the direction of the traffic flow.

$\alpha - \alpha - \alpha$: Block to initiate the end-of-communication procedure.

3.9.2 Service information signals

CS1 : Request for “information block 1” or “call signal” has been correctly received during phasing/rephasing (only in the case of a 4-signal call identity).

CS2 : Request for “information block 2”.

CS3 : IRS requests change of traffic flow direction.

CS4 : “Call signal” has been correctly received during phasing.

CS5 : “Call signal” has been correctly received during rephasing.

RQ : Request for retransmission of the last identification or information block or in the change-over procedure, response to $\beta - \alpha - \beta$.

4 Characteristics, mode B (FEC)

4.1 General

The system operates in a synchronous mode, transmitting an uninterrupted stream of signals from a station sending in the collective B-mode (CBSS) to a number of stations receiving in the collective B-mode (CBRS), or from a station sending in the selective B-mode (SBSS) to one or more selected stations receiving in the selective B-mode (SBRS).

4.2 The sending station (CBSS and SBSS)

The sending station, both in collective and in selective B-mode, sends each signal twice: the first transmission (DX) of a specific signal is followed by the transmission of four other signals, after which the retransmission (RX) of the first signal takes place, allowing for time-diversity reception at 280 ms (4×70 ms) time space (see Fig. 2).

FIGURE 2
Time-diversity transmission

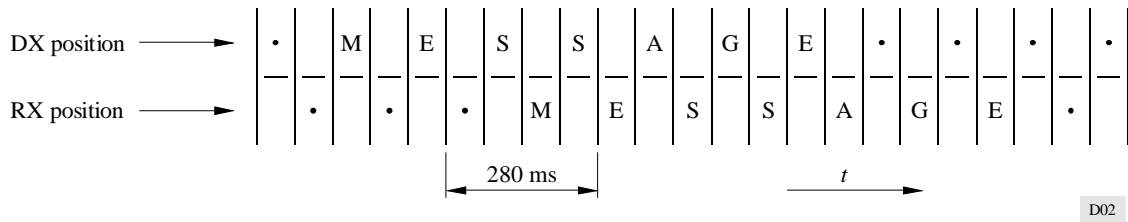

4.3 The receiving station (CBRS and SBRS)

The receiving station, both in collective and selective B-mode, checks both signals (DX and RX), and uses the unmutated one. When both signals appear as unmutated but different, then both signals should be considered as mutilated.

4.4 Phasing procedure

4.4.1 When no circuit is established, both stations are in the “stand-by” condition and no sending or receiving condition is assigned to either of the stations.

4.4.2 The station required to transmit information becomes the sending station and sends alternately “phasing signal 2” and “phasing signal 1”, whereby “phasing signal 2” is transmitted in the DX position and “phasing signal 1” in the RX position. At least sixteen of these signal pairs should be transmitted.

4.4.3 On receipt of the signal sequence “phasing signal 1”-“phasing signal 2”, or of the signal sequence “phasing signal 2”-“phasing signal 1”, in which “phasing signal 2” determines the DX position and “phasing signal 1” determines the RX position, and at least two further phasing signals in the appropriate position, the station changes to the CBRS condition and offers continuous stop-polarity to the line output terminal until either the traffic information signal “←” (combination No. 27) or “≡” (combination No. 28) is received.

4.5 Selecting calling procedure (selective B-mode)

4.5.1 After the transmission of the required number of phasing signals, the SBSS sends the “call signal”, which consists of six transmissions of a sequence, each consisting of the identification signals of the station to be selected followed by an “idle signal β”. This transmission takes place using time-diversity in accordance with § 4.2.

4.5.2 The SBSS sends the “call signal” and all further information signals in a 3B/4Y ratio, i.e. inverted with respect to the information signals in Tables 1 and 2 and the identification signals in Table 3a.

4.5.3 The “call signal” contains either four, or seven identification signals as applicable. The identification signals are listed in Table 3a. The composition of these “call signals” should be in accordance with Recommendation ITU-R M.491.

4.5.4 Following unmutated reception of one complete signal sequence representing its inverted identification signals, the CBRS changes to the SBRS condition and continues offering stop-polarity to the line output terminal until either the traffic information signal; “←” (combination No. 27) or “≡” (combination No. 28) is received.

4.5.5 The station in the SBRS condition accepts the subsequent information signals received with the 3B/4Y ratio, all other stations reverting to the “stand-by” condition.

4.6 Traffic flow

4.6.1 Immediately prior to the transmission of the first traffic signals the sending station transmits the information signals “←” (combination No. 27) and “≡” (combination No. 28), and starts transmitting traffic.

4.6.2 A CBSS sends, during breaks in the information flow, “phasing signals 1” and “phasing signals 2” in the RX and DX positions respectively. At least one sequence of four consecutive phasing signal pairs should occur for every 100 signals sent in the DX position during traffic flow.

4.6.3 A SBSS sends, during breaks in the information flow, “idle signals β ”.

4.6.4 On receipt of either the traffic combination signal “←” (combination No. 27) or “≡” (combination No. 28), the receiving station starts printing the received traffic information signals.

NOTE 1 – The term “printing” is used in § 4.6.4 and 4.6.5 to denote the transfer of traffic signals to the output device.

4.6.5 The receiving station checks both signals received in the DX and RX position:

- printing an unmutated DX or RX signal; or
- printing a “ Δ ” (combination No. 31), or alternatively an “error character” (to be user-defined) if both DX and RX signals are mutilated or appear unmutated but are different.

4.6.6 A receiving station reverts to the “stand-by” condition if, during a predetermined time, the percentage of mutilated signals received has reached a predetermined value.

4.6.7 End-of-transmission

4.6.7.1 A station sending in the B-mode (CBSS or SBSS) should terminate the transmission by sending at least 2 s of consecutive “idle signals α ”, immediately after the last transmitted traffic information signals after which the station reverts to the “stand-by” condition.

4.6.7.2 The receiving station reverts to the “stand-by” condition not less than 210 ms after receipt of at least two consecutive “idle signals α ” in the DX position.

FIGURE 3
 Phasing procedure with automatic identification
 in the case of a 7-signal call identity (mode A)

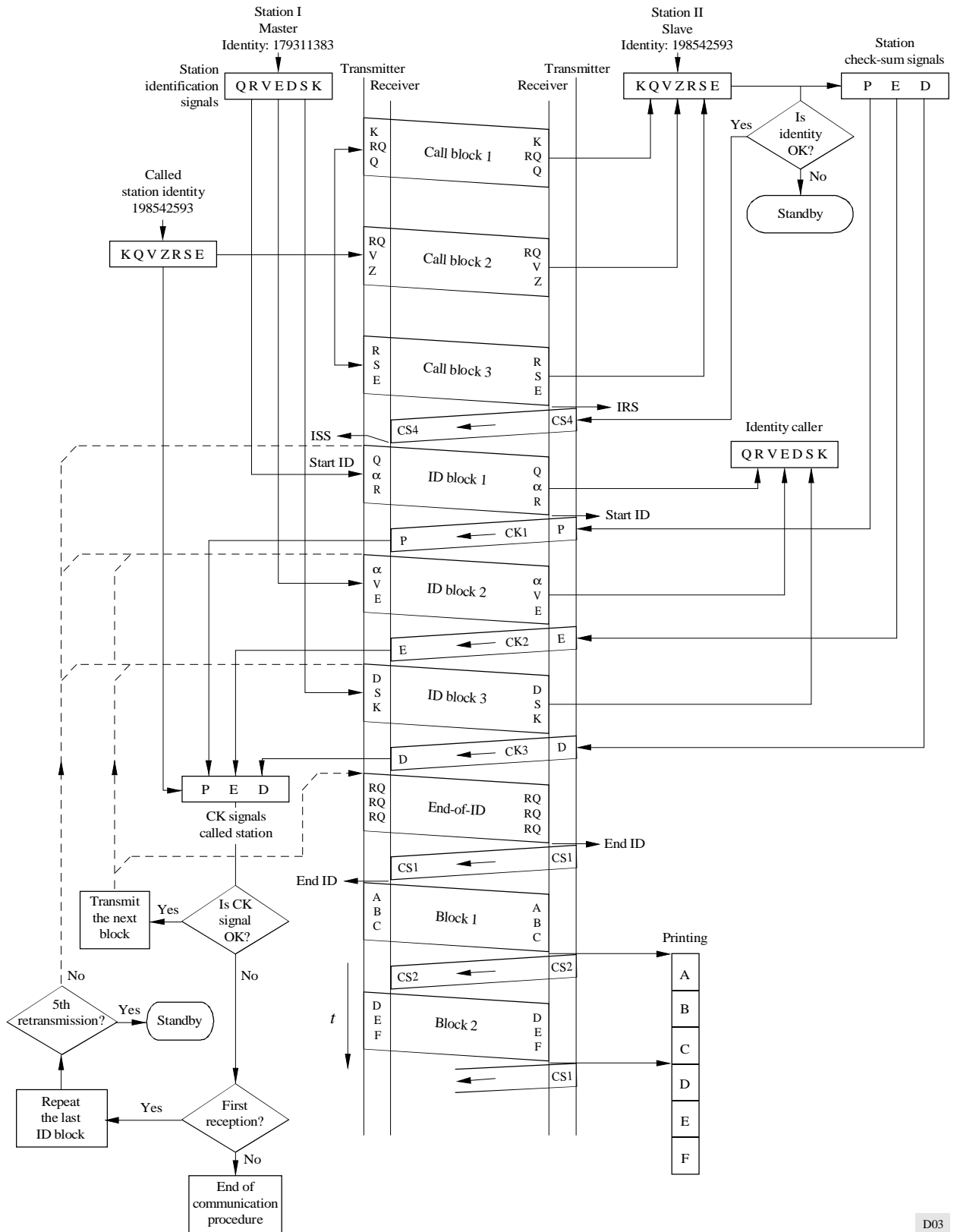

FIGURE 4
 Rephasing procedure with automatic identification in the case
 of a 7-signal call identity (station II was ISS)

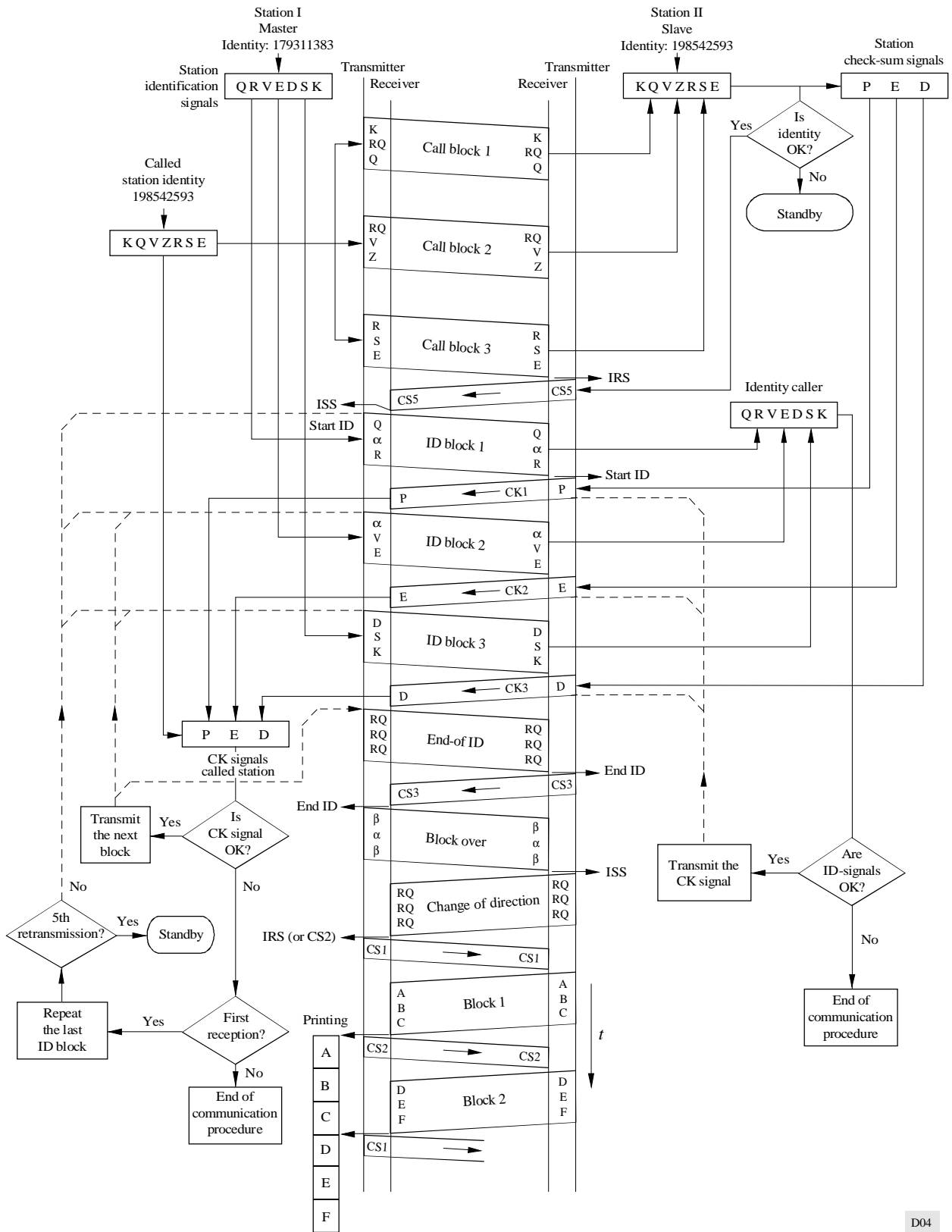

FIGURE 5
Traffic flow with change-over procedure and end-of-communication

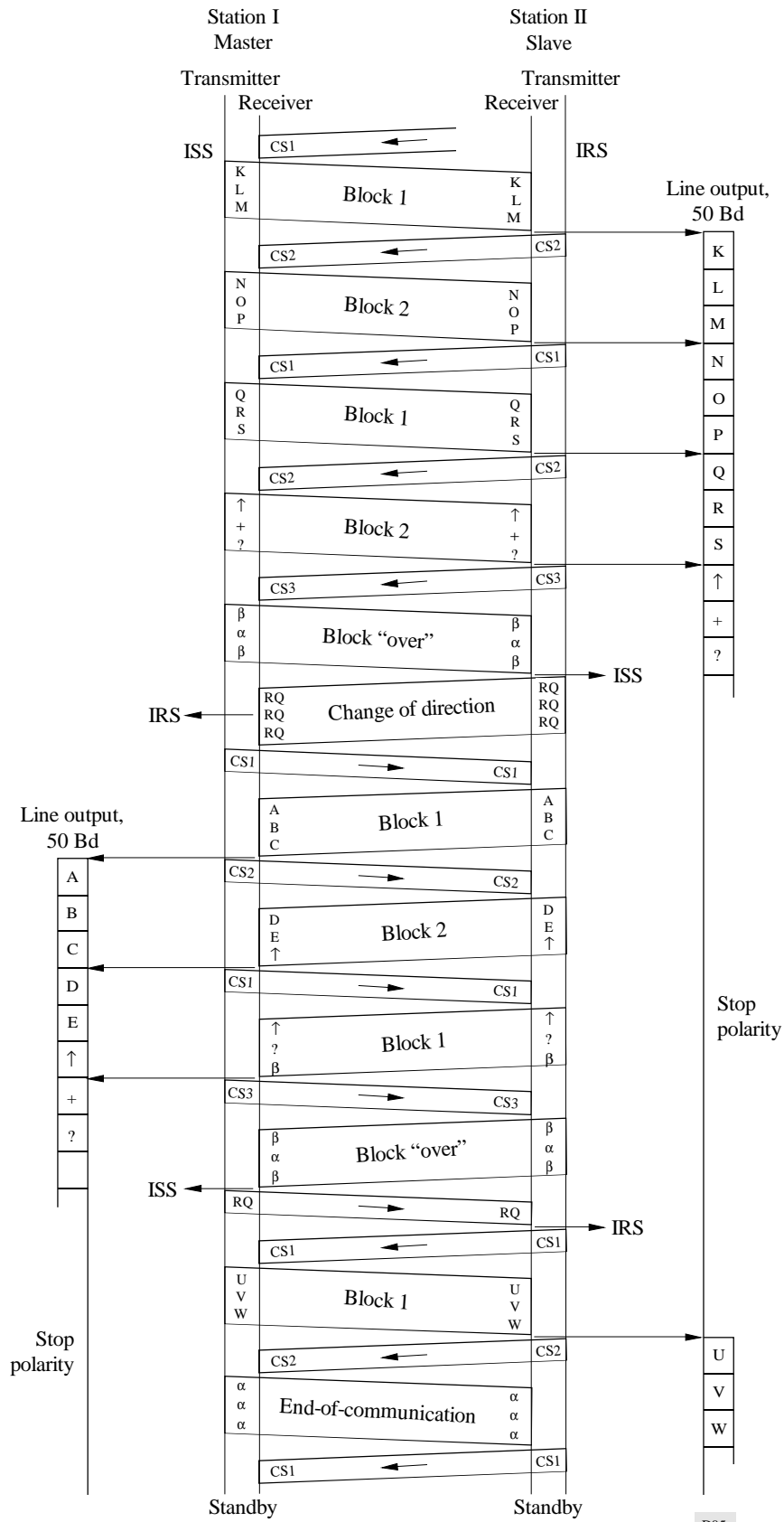

FIGURE 6
**Phasing procedure with automatic identification in the condition
of mutilated reception in the case of a 7-signal call identity**

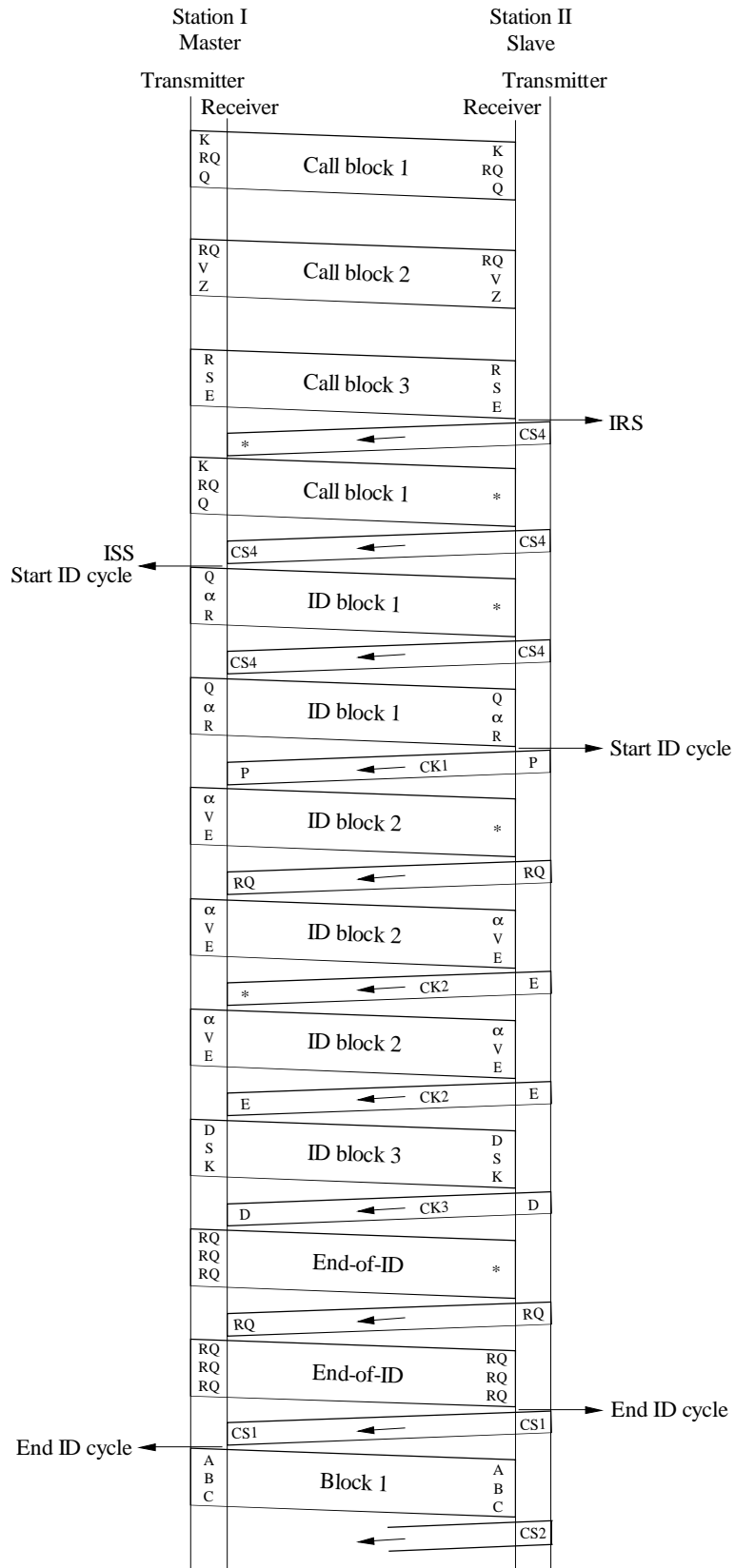
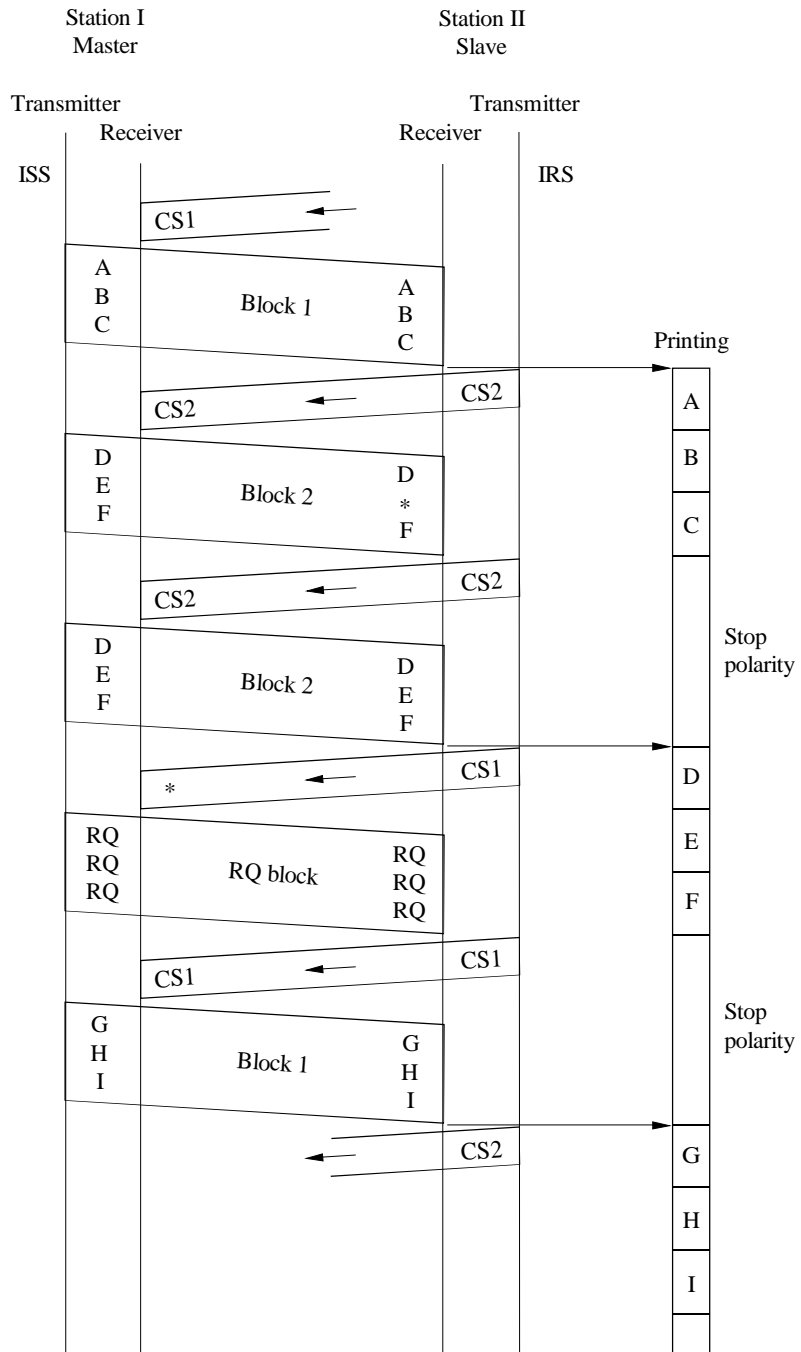

FIGURE 7
Traffic flow in the condition of mutilated reception



* Detected error

D07

FIGURE 8
Phasing procedure in the case of a 4-signal call identity

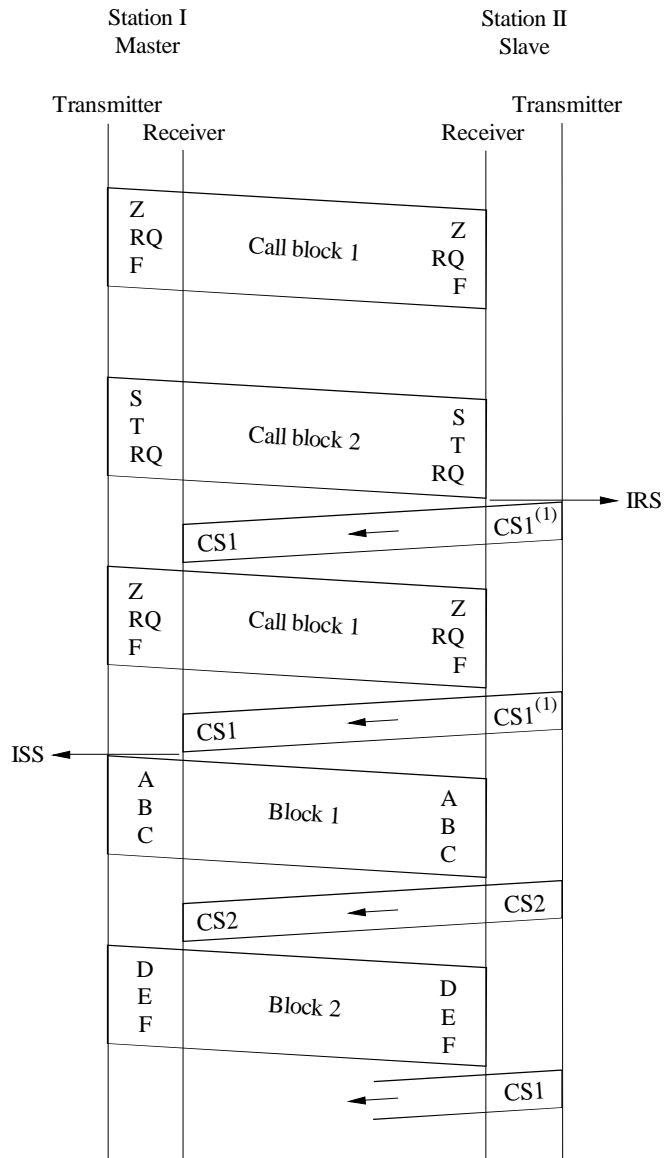

⁽¹⁾ With some equipment built in accordance with Recommendation ITU-R M. 476 this could be CS2.

FIGURE 9
**Phasing procedure in the condition of mutilated reception
 in the case of a 4-signal call identity**

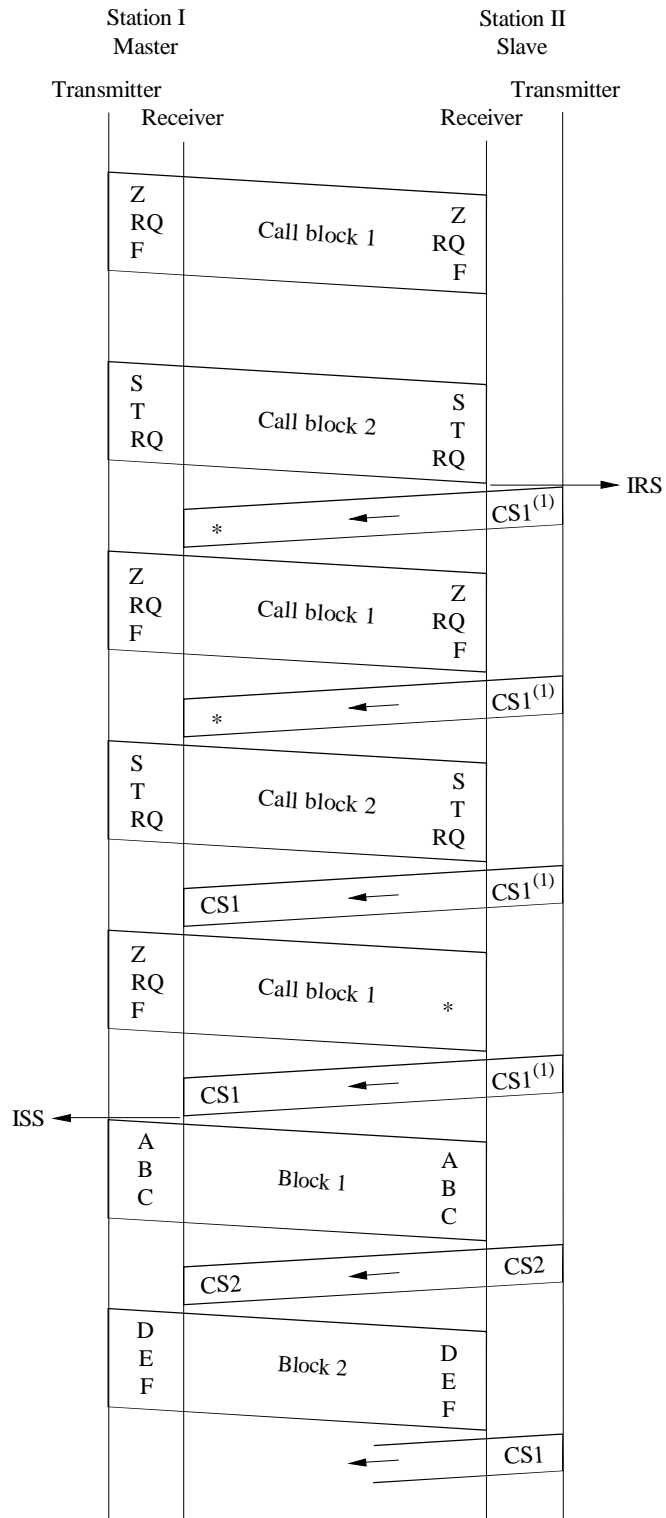

* Detected error
⁽¹⁾ With some equipment built in accordance with Recommendation ITU-R M.476 this could be CS2.

FIGURE 10
Collective B-mode operation

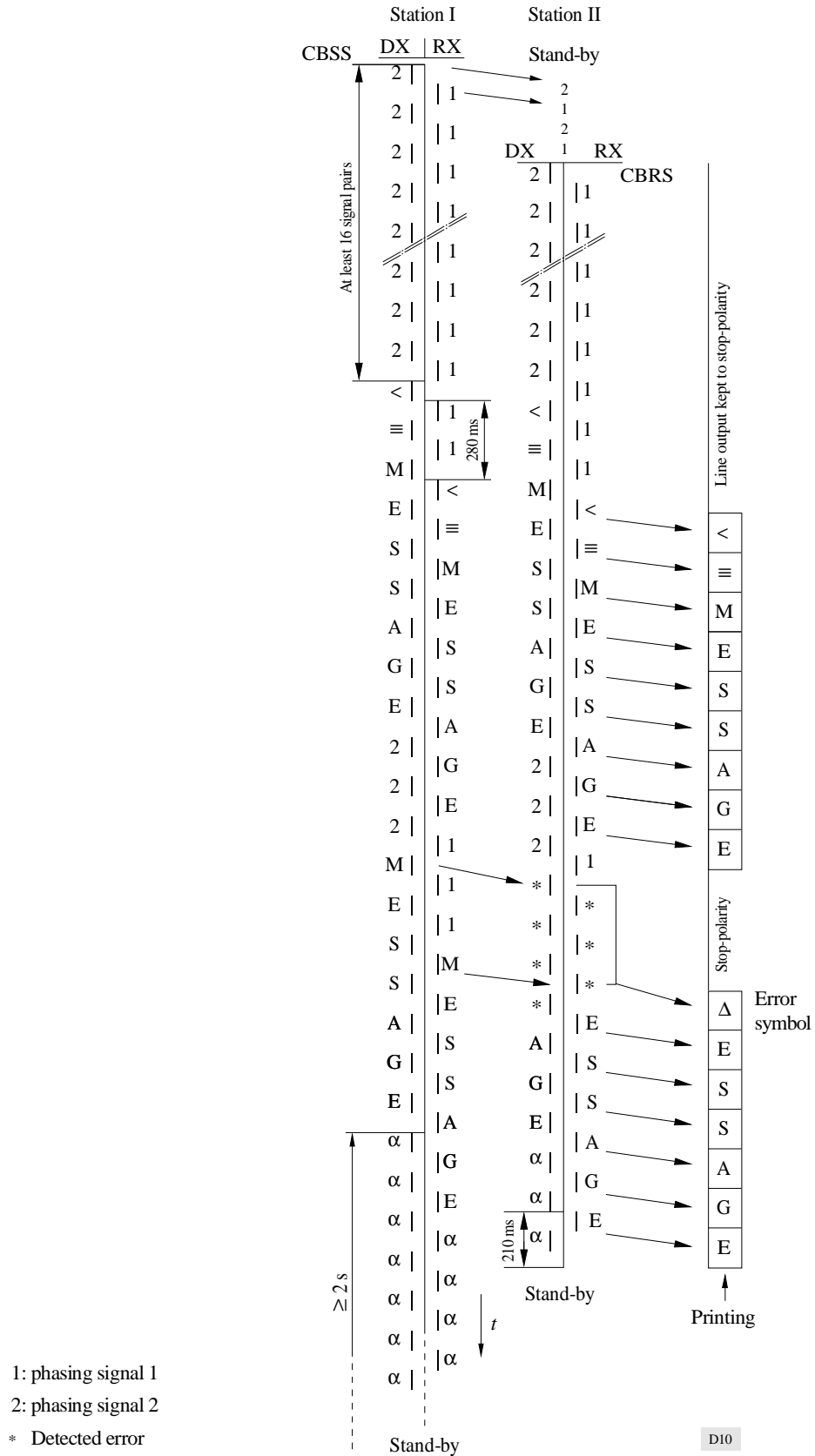

FIGURE 11
Selective B-mode operation in the case of a 4-signal call identity

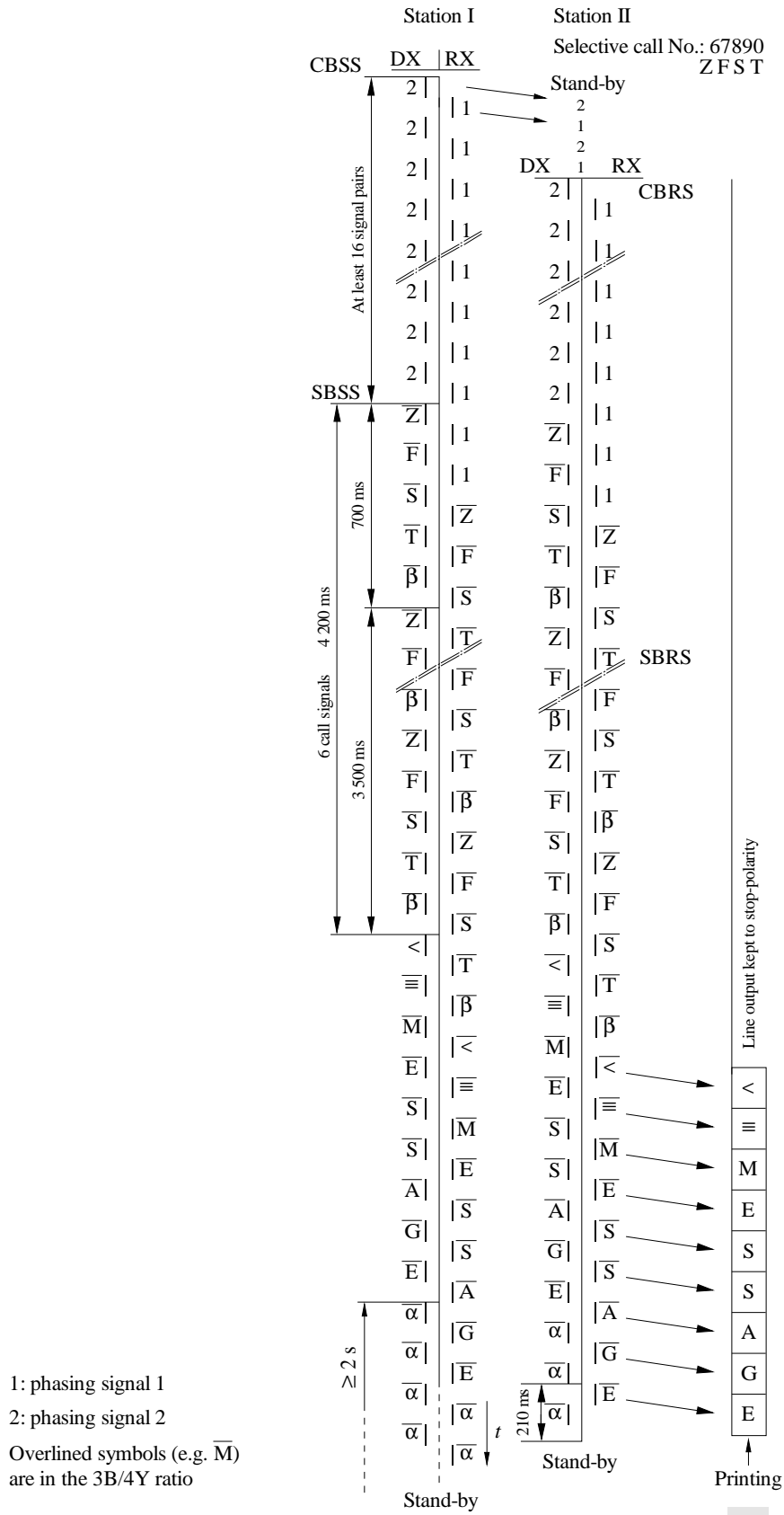
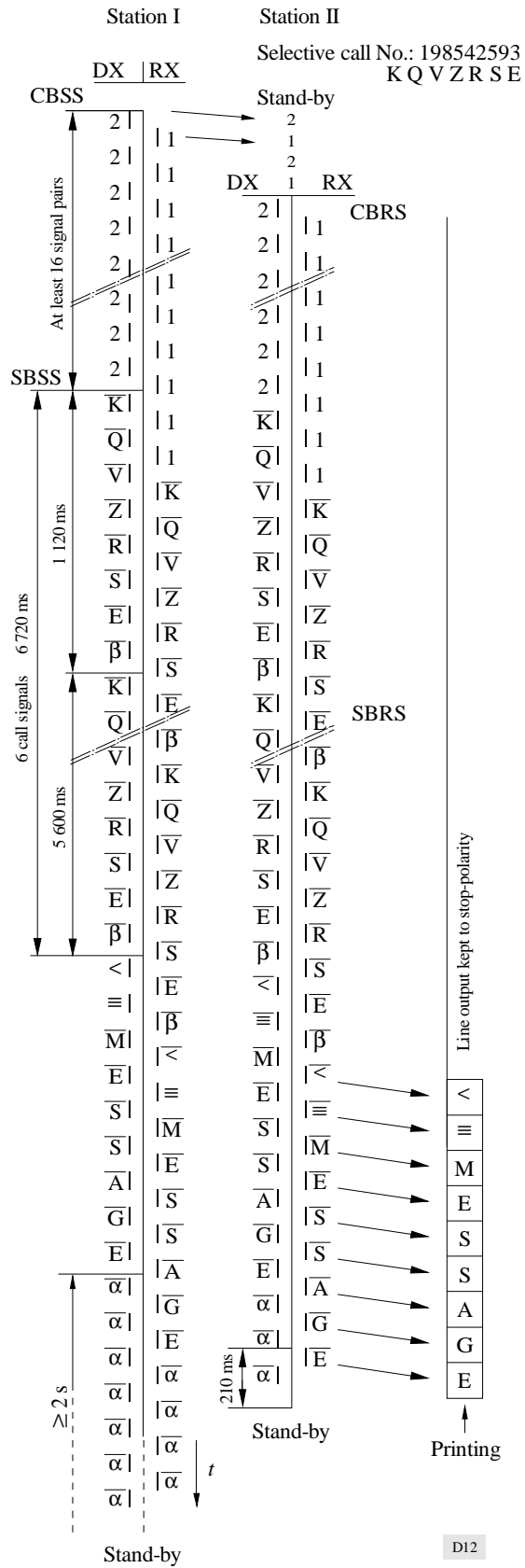

FIGURE 12
Selective B-mode operation in the case of a 7-signal call identity



APPENDICES TO ANNEX 1

APPENDIX 1

SDL diagrams (mode A)

1 General

The specification and description language (SDL) is described in ITU-T Recommendation Z.100.

The following graphical symbols have been used*:

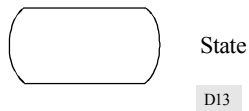

- A “state” is a condition in which the action of a process is suspended awaiting an input.

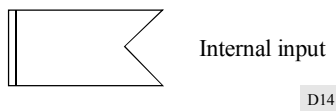
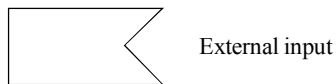

- An “input” is an incoming signal which is recognized by a process.

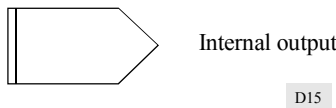

- An “output” is an action which generates a signal which in turn acts as an input elsewhere.

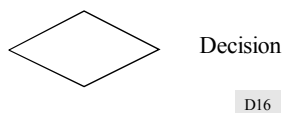

* *Note by the Secretariat:*

A “connector” is represented by the following graphical symbol:



where:

- n : connector reference
- x : number of the sheet
- y : number of the Appendix (omitted when it occurs in the same Appendix).
- z : number of occurrences.

- A “decision” is an action which asks a question to which the answer can be obtained at that instant and chooses one of several paths to continue the sequence.



- A “task” is any action which is neither a decision nor an output.

2 Phasing procedure with automatic identification in the case of a 7-signal call identity (calling station)

2.1 The SDL diagrams are given in Appendix 2.

2.2 The following supervisory counters are used in the diagrams:

Counter	Time-out	State	Sheet
n_0	128 cycles	02, 03, 04	1
n_1	128 cycles	00	1
n_2	32 cycles	05, 06, 07, 08	2, 3

3 Rephasing procedure with automatic identification in the case of a 4-signal call identity (calling station)

3.1 The SDL diagrams are given in Appendix 3.

3.2 The following supervisory counters are used in the diagrams:

Counter	Time-out	State	Sheet
n_5	32 cycles	00, 02, 03, 04	1
		05, 06, 07, 08	2, 3
n_1	128 cycles		1
n_2	32 cycles	05, 06, 07, 08	2, 3

4 Phasing procedure without automatic identification in the case of a 4-signal call identity (calling station)

4.1 The SDL diagrams are given in Appendix 4.

4.2 The following supervisory counters are used in the diagrams:

Counter	Time-out	State	Sheet
n_0	128 cycles	02, 03	1
n_1	128 cycles	00	1

5 Rephasing procedure without automatic identification in the case of a 4-signal call identity (calling station)

5.1 The SDL diagrams are given in Appendix 5.

5.2 The following supervisory counters are used in the diagrams:

Counter	Time-out	State	Sheet
n ₅	32 cycles	00, 02, 03	1
n ₁	128 cycles		1

6 Phasing procedure with automatic identification in the case of a 7-signal call identity (called station)

6.1 The SDL diagrams are given in Appendix 6.

6.2 The following supervisory counters are used in the diagrams:

Counter	Time-out	State	Sheet
n ₂	32 cycles	05, 06, 07, 08	2, 3

7 Rephasing procedure with automatic identification in the case of a 7-signal call identity (called station)

7.1 The SDL diagrams are given in Appendix 7.

7.2 The following supervisory counters are used in the diagrams:

Counter	Time-out	State	Sheet
n ₅	32 cycles	00, 01, 02, 03, 04	1
		05, 06, 07, 08	2, 3
n ₂	32 cycles	05, 06, 07, 08	2, 3

8 Phasing procedure without automatic identification in the case of a 4-signal call identity (called station)

8.1 The SDL diagrams are given in Appendix 8.

9 Rephasing procedure without automatic identification in the case of a 4-signal call identity (called station)

9.1 The SDL diagrams are given in Appendix 9.

9.2 The following supervisory counters are used in the diagrams:

Counter	Time-out	State	Sheet
n ₅	32 cycles	00, 01, 03	1

10 Traffic flow in the case of a 4-signal call identity and in the case of a 7-signal call identity (station is in the ISS position)

10.1 The SDL diagrams are given in Appendix 10.

10.2 The following supervisory counters are used in the diagrams:

Counter	Time-out	State	Sheet
n ₃	32 cycles	09, 10, 13	1, 3
n ₄	4 cycles	11, 12	2
n ₁	128 cycles	12	2
n ₅	32 cycles	11, 12, 13, 14	2, 3

11 Traffic flow in the case of a 4-signal call identity and in the case of a 7-signal call identity (station is in the IRS position)

11.1 The SDL diagrams are given in Appendix 11.

11.2 The following supervisory counters are used in the diagrams:

Counter	Time-out	State	Sheet
n ₃	32 cycles	09, 10, 11	1, 2
n ₅	32 cycles	09, 10, 11, 12	1, 2

APPENDIX 2

Phasing procedure with automatic identification in the case of a 7-signal call identity (calling station)

Sheet 1 (of 3)

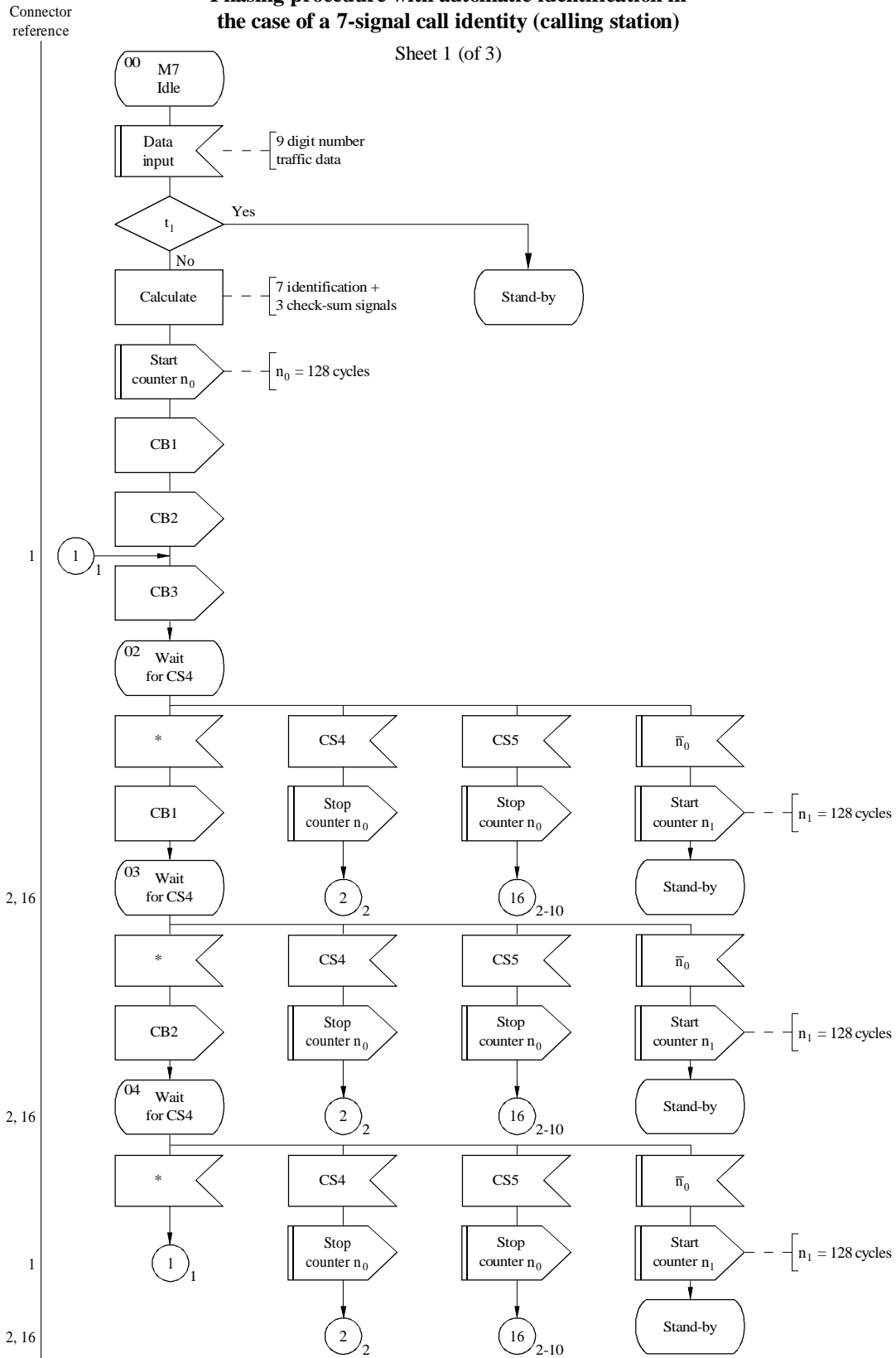

t_1 : call identity the same as the one before and $n_1 > 0$?
 * Detected error, invalid signal or no signal at all

APPENDIX 2
Sheet 2 (of 3)

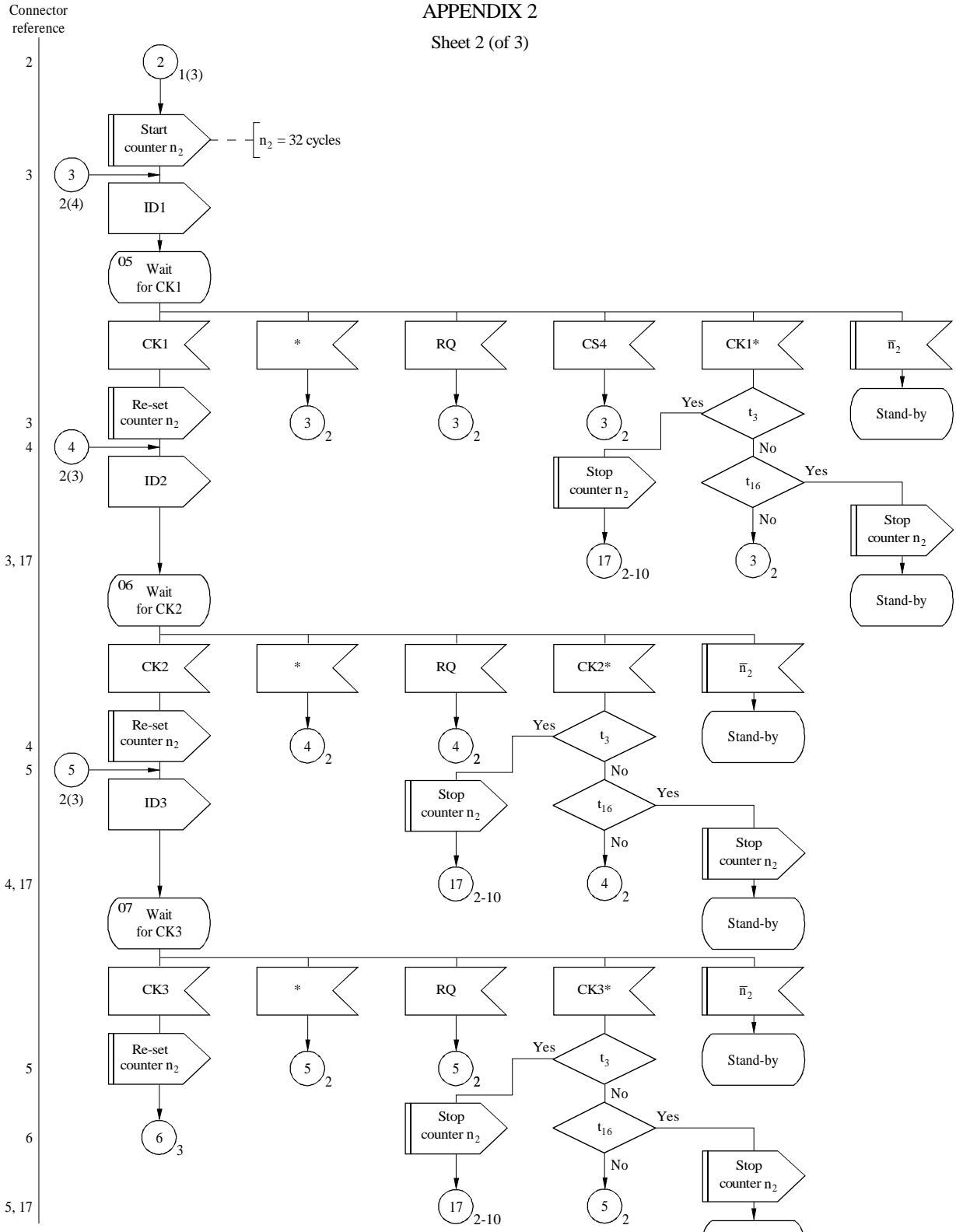

t_{16} : fourth reception of a wrong check-sum signal?
 t_3 : same wrong check-sum signal one cycle before?
 CKn* : wrong check-sum signal
 * Detected error, invalid signal or no signal at all

APPENDIX 2

Sheet 3 (of 3)

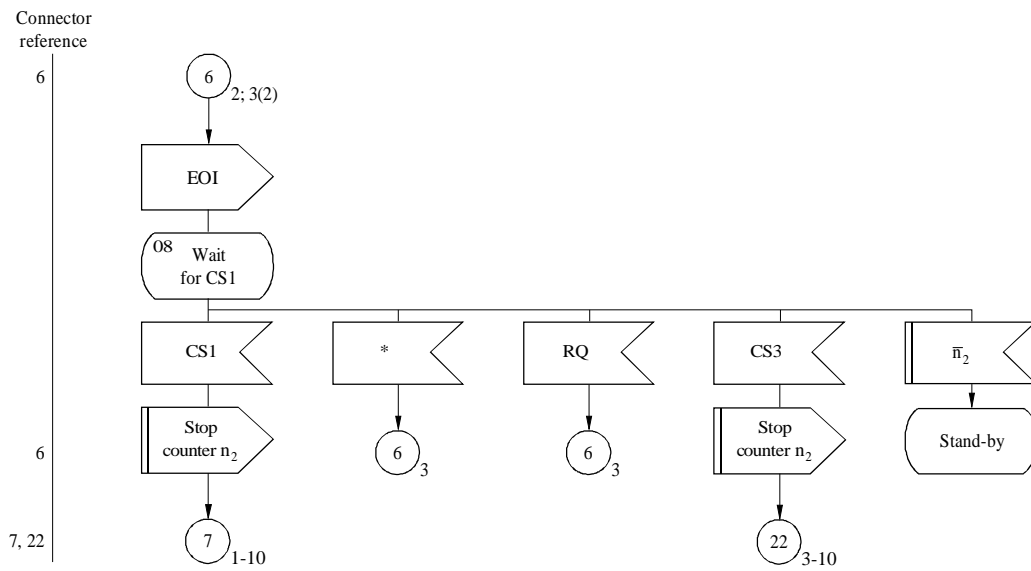

* Detected error, invalid signal or no signal at all

D20

APPENDIX 3
**Rephasing procedure with automatic identification in
the case of a 7-signal call identity
(calling station)**

Sheet 1 (of 3)

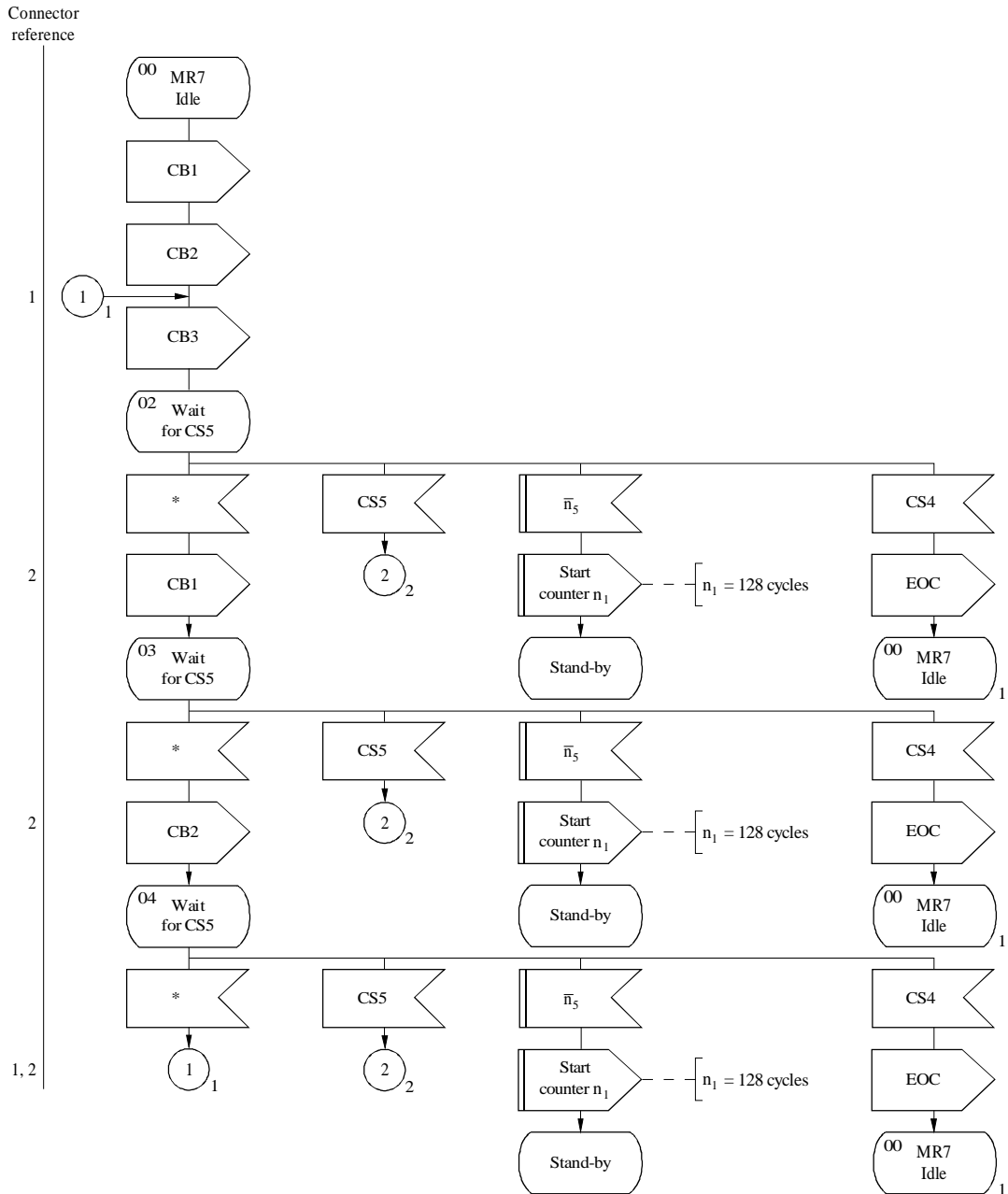

* Detected error, invalid signal or no signal at all

APPENDIX 3
Sheet 2 (of 3)

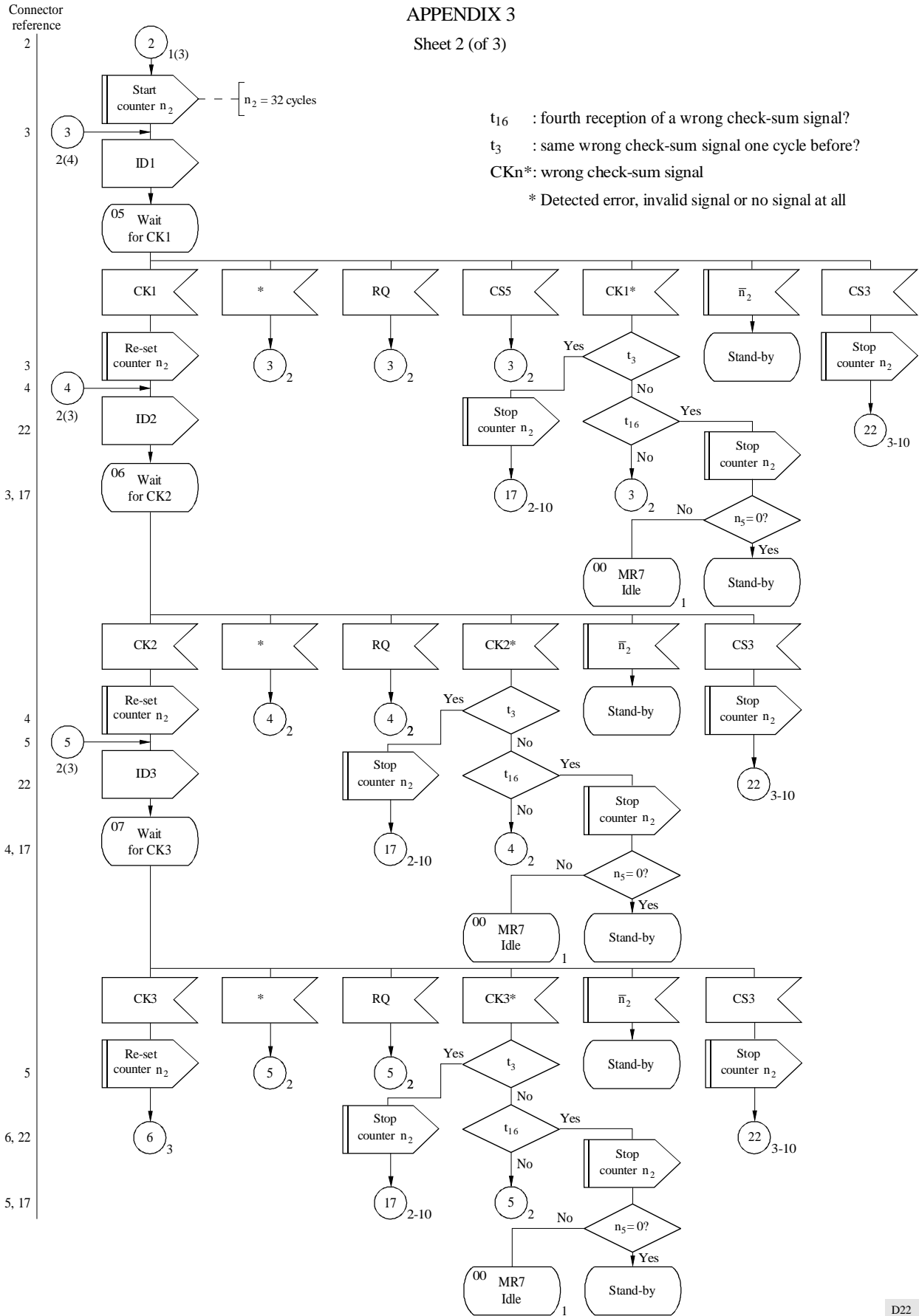

APPENDIX 3

Sheet 3 (of 3)

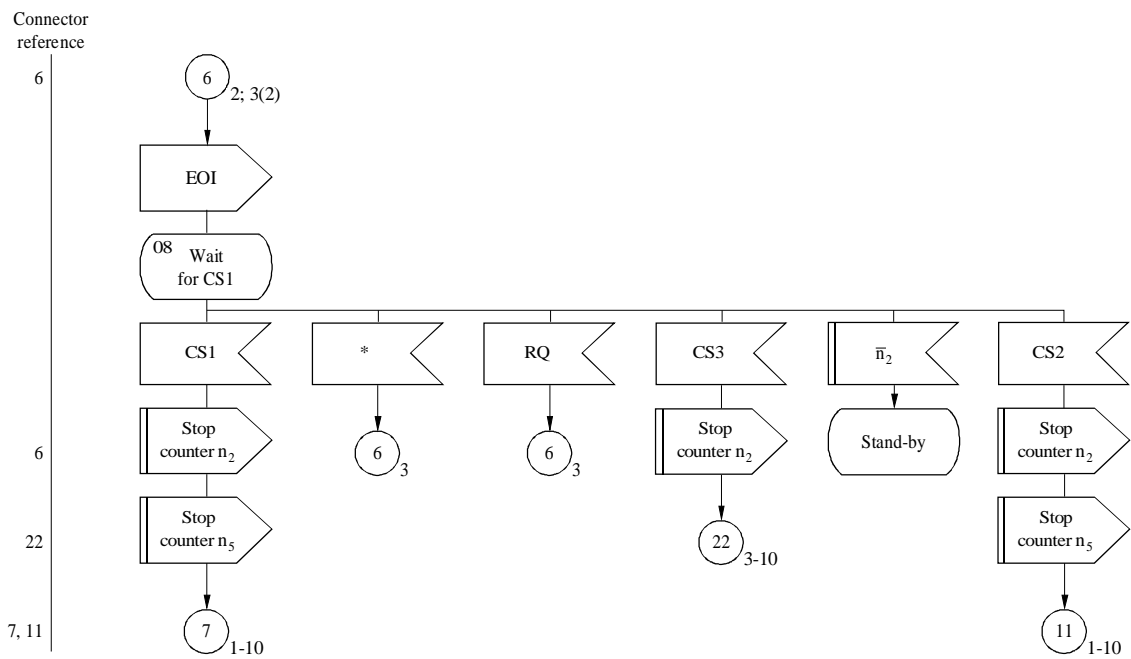

* Detected error, invalid signal or no signal at all

D23

APPENDIX 4

Phasing procedure without automatic identification in the case of a 4-signal call identity (calling station)

Sheet 1 (of 1)

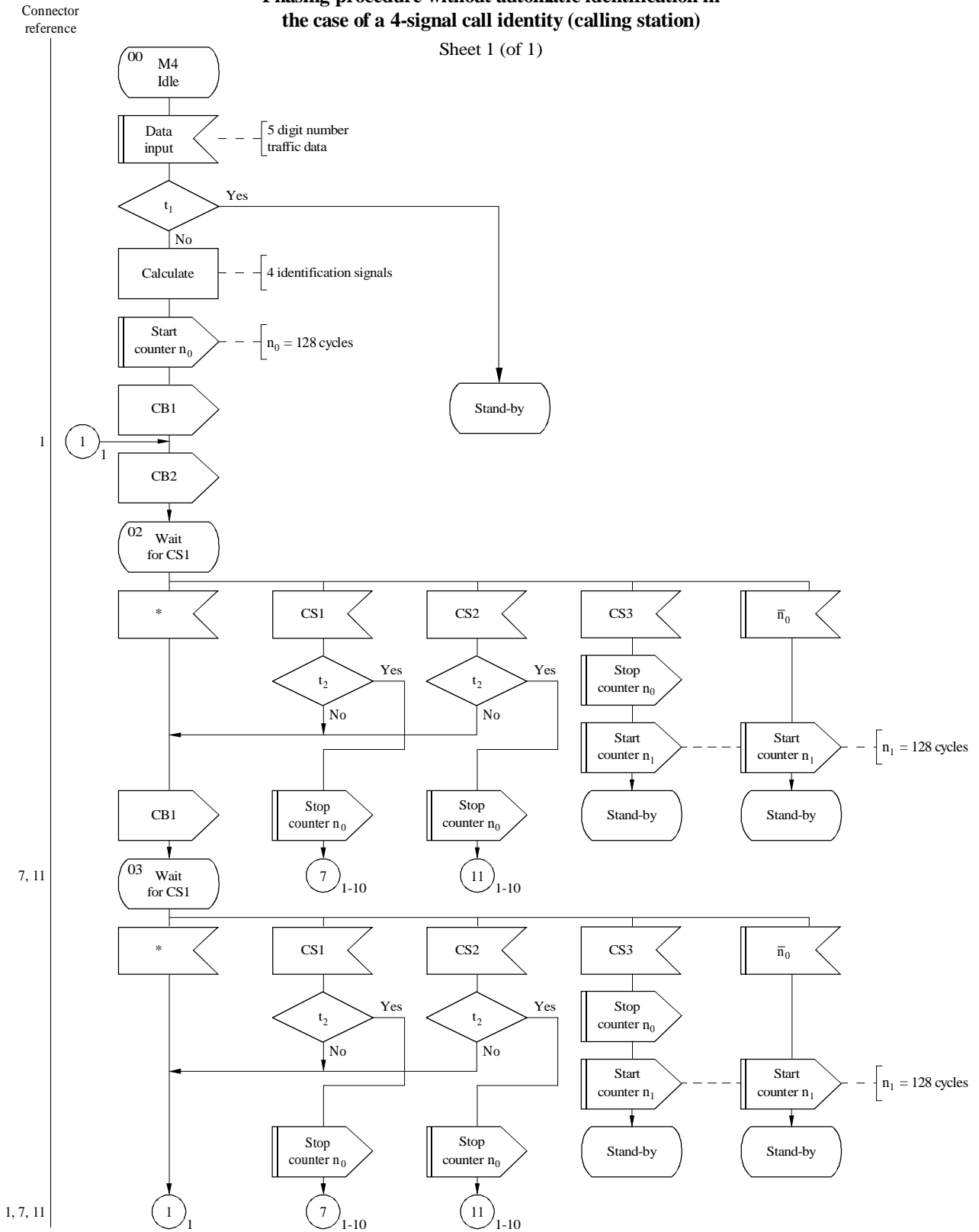

t_1 : call identity the same as the one before and $n_1 > 0$?

t_2 : same control signal one cycle before?

* Detected error, invalid signal or no signal at all

APPENDIX 5
**Rephasing procedure without automatic identification in
the case of a 4-signal call identity
(calling station)**

Sheet 1 (of 1)

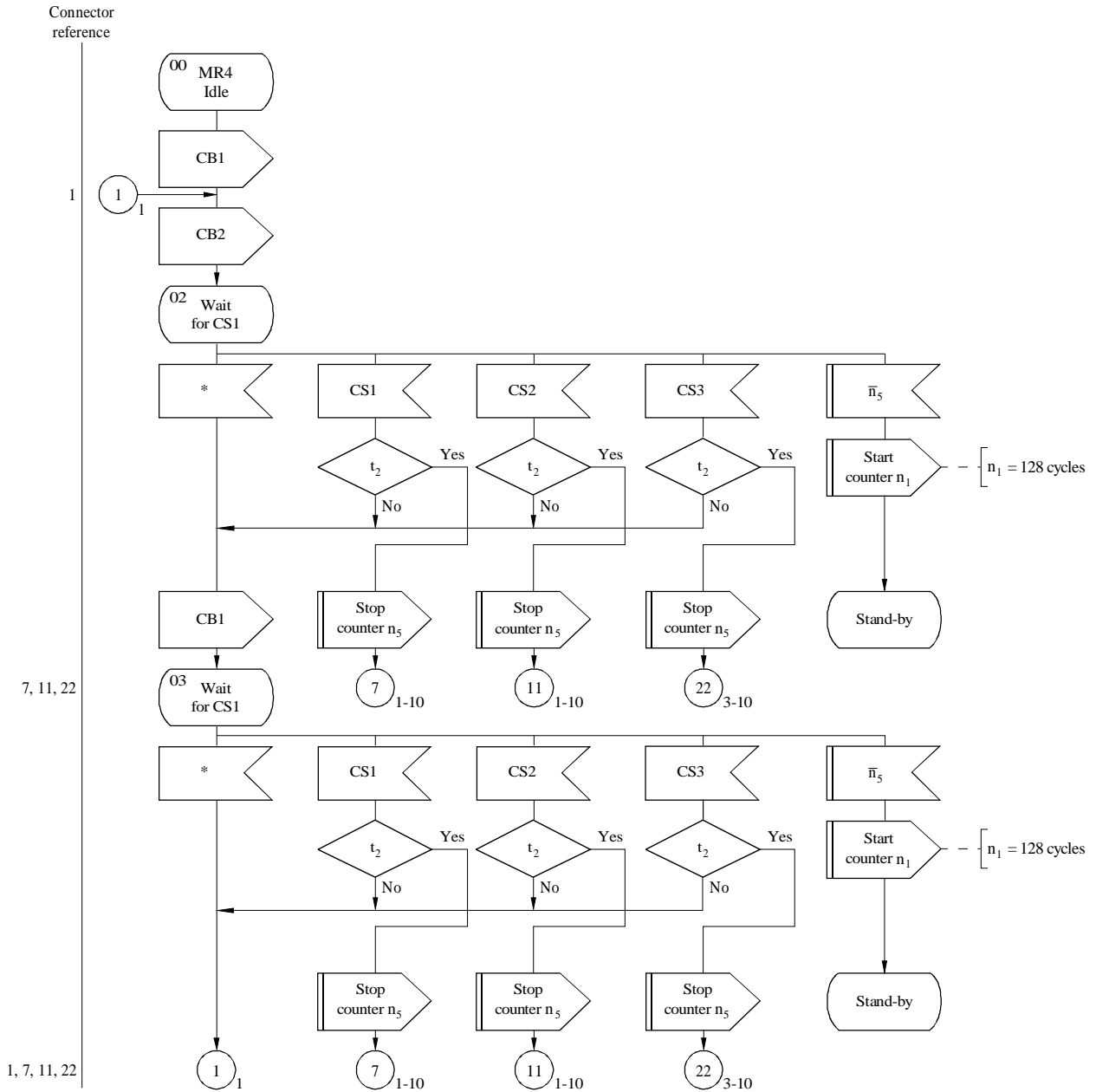

t_2 : same control signal one cycle before?
* Detected error, invalid signal or no signal at all

APPENDIX 6
**Phasing procedure with automatic identification in
the case of a 7-signal call identity
(called station)**

Sheet 1 (of 3)

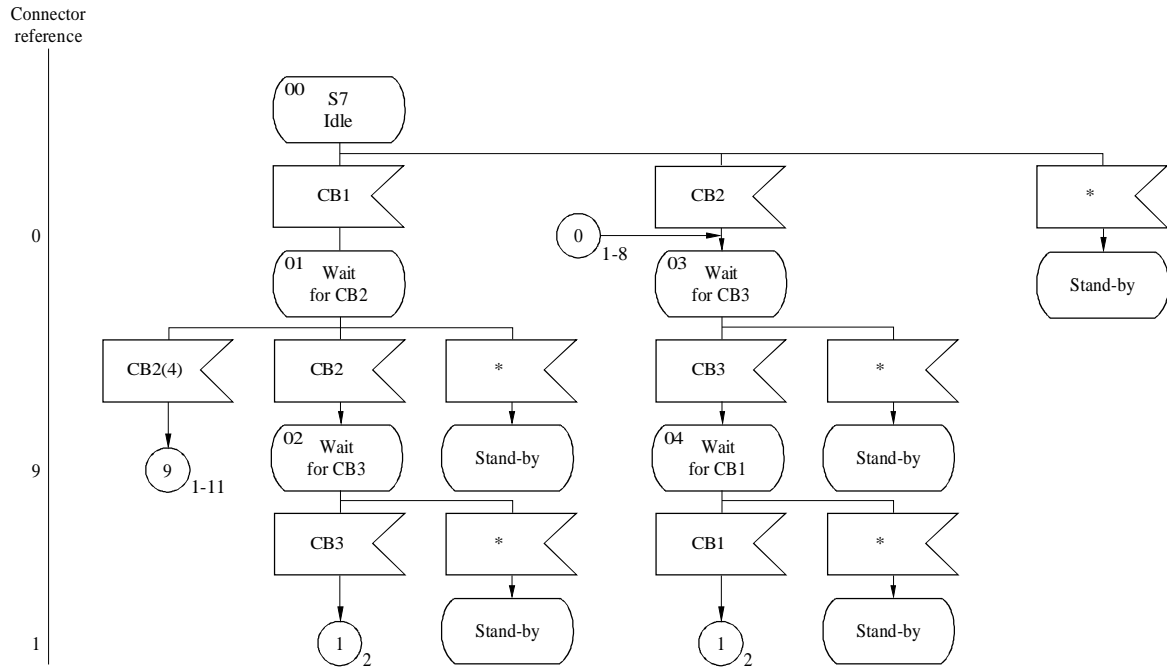

* Detected error, invalid signal or no signal at all

APPENDIX 6
Sheet 2 (of 3)

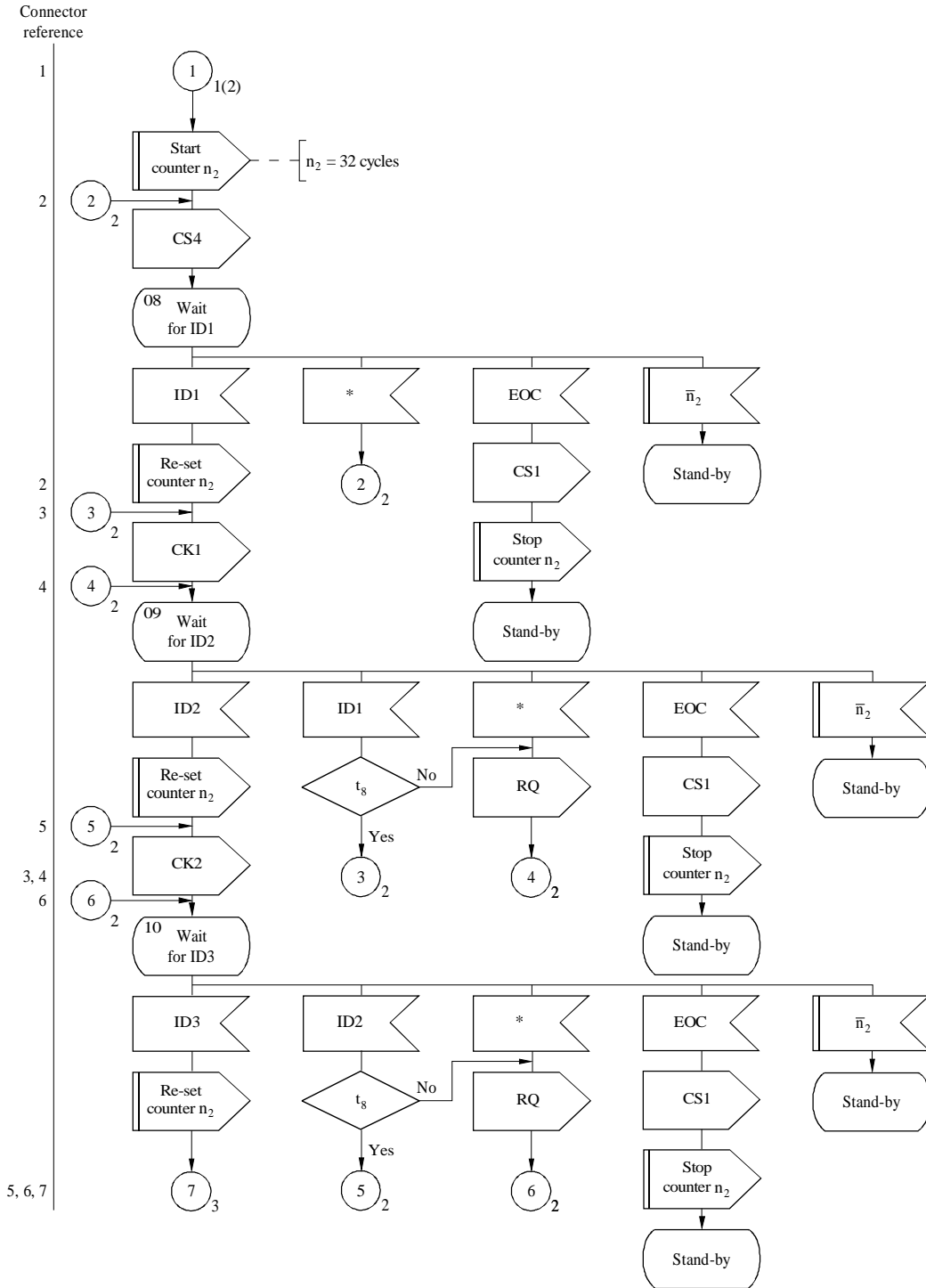

t₃: same ID-block one cycle before?

* Detected error, invalid signal or no signal at all

APPENDIX 6
Sheet 3 (of 3)

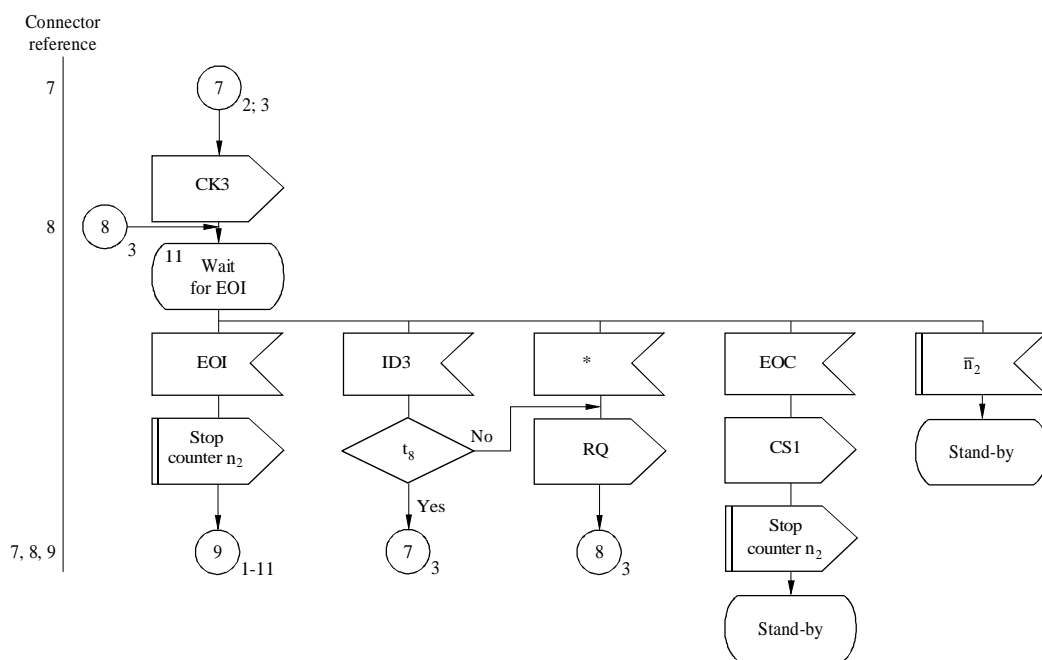

t₃: same ID-block one cycle before?

* Detected error, invalid signal or no signal at all

APPENDIX 7
**Rephasing procedure with automatic identification in
the case of a 7-signal call identity
(called station)**

Sheet 1 (of 3)

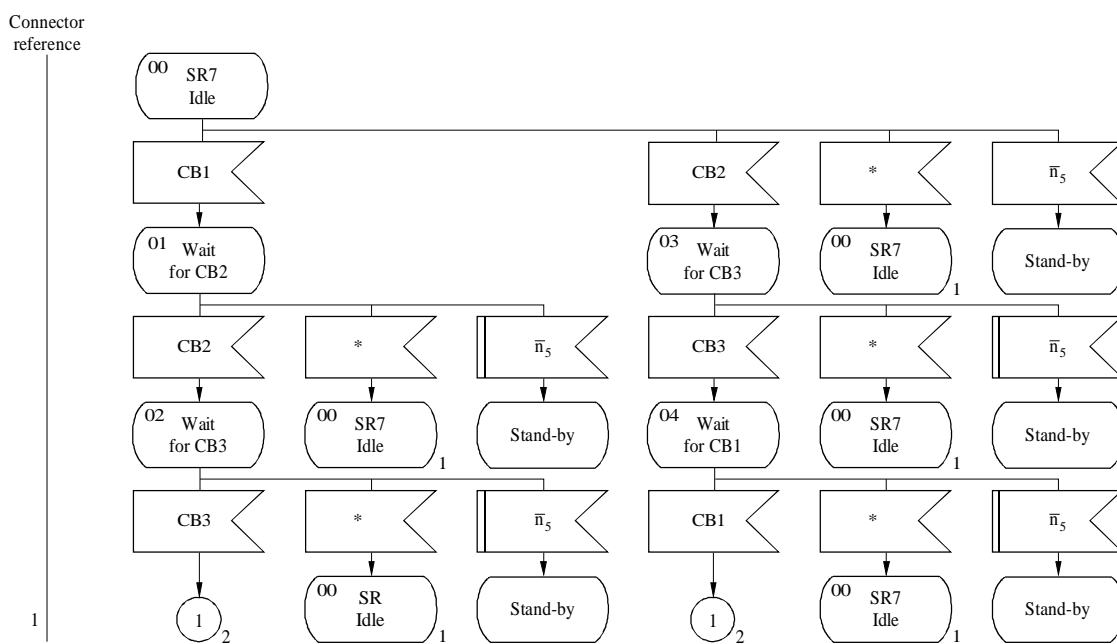

* Detected error, invalid signal or no signal at all

D29

APPENDIX 7
Sheet 2 (of 3)

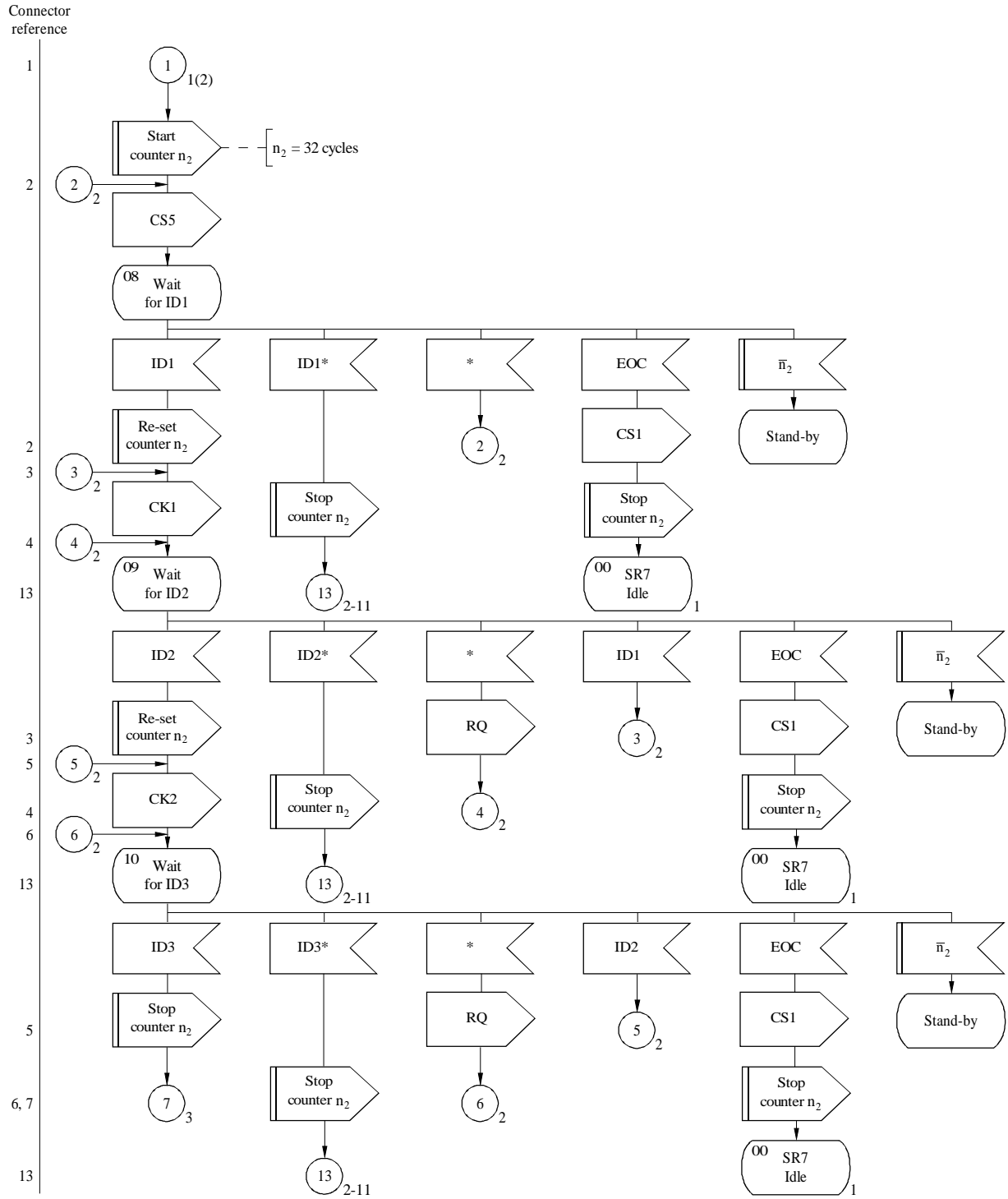

IDn* : wrong identification signal(s)

* Detected error, invalid signal or no signal at all

APPENDIX 7
Sheet 3 (of 3)

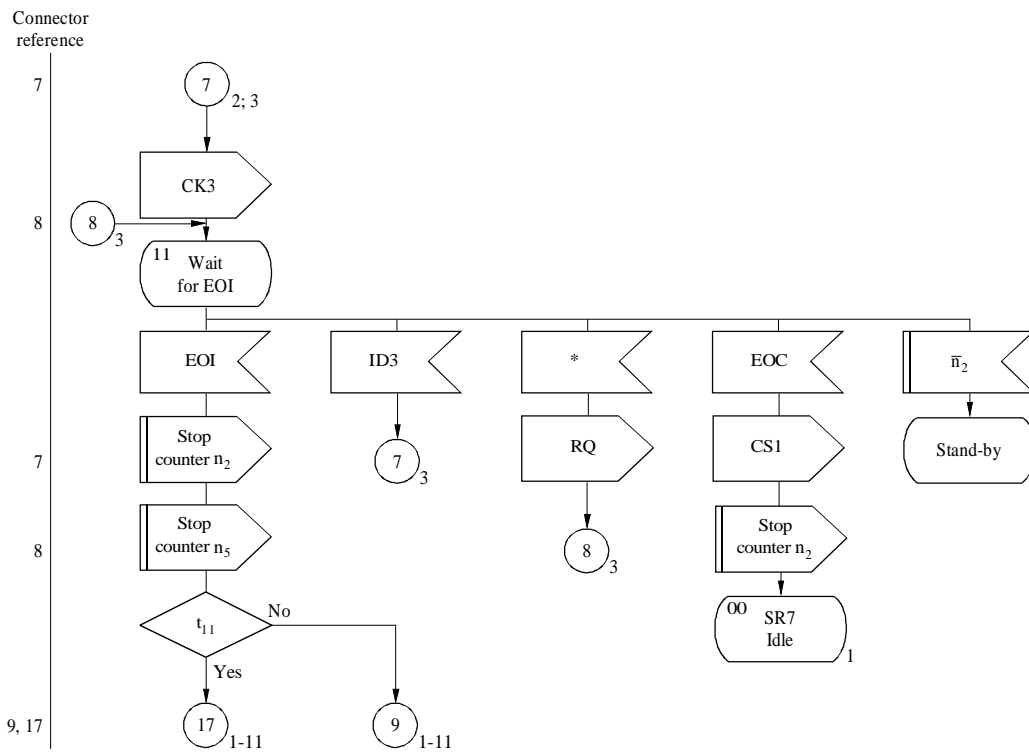

t₁₁: block 2 was the last received block at the moment the interruption occurred?

* Detected error, invalid signal or no signal at all

APPENDIX 8
**Phasing procedure without automatic identification in
the case of a 4-signal call identity
(called station)**

Sheet 1 (of 1)

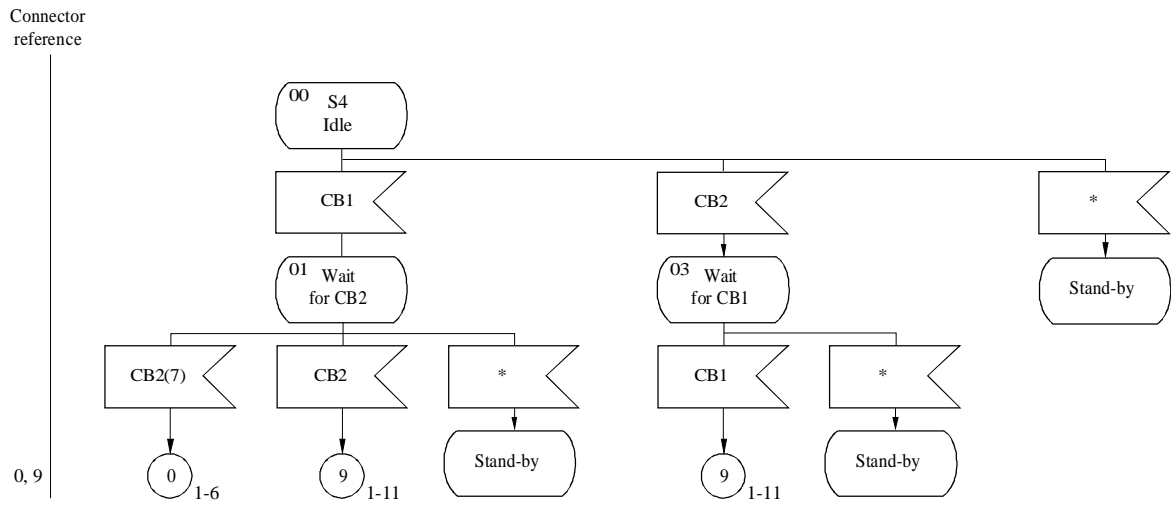

* Detected error, invalid signal or no signal at all

APPENDIX 9
**Rephasing procedure with automatic identification in
the case of a 4-signal call identity
(called station)**

Sheet 1 (of 1)

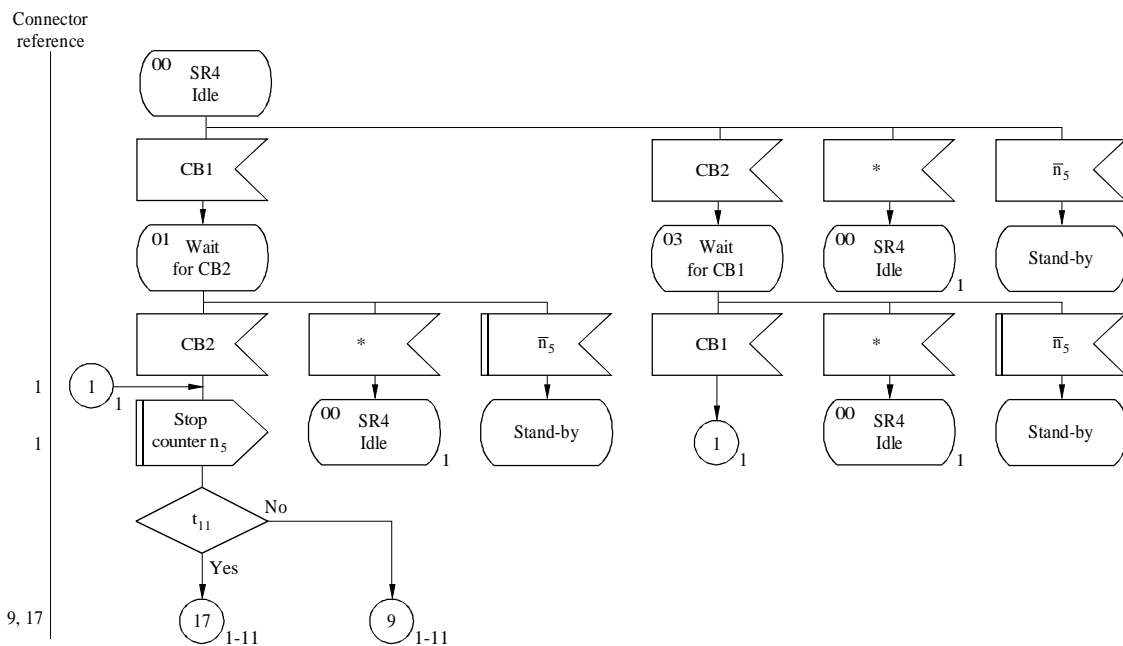

t_{11} : block 2 was the last received block at the moment the interruption occurred?

* Detected error, invalid signal or no signal at all

APPENDIX 10

Traffic flow in the case of a 4-signal call identity and in the case of a 7-signal call identity (station is in the ISS position)

Sheet 1 (of 3)

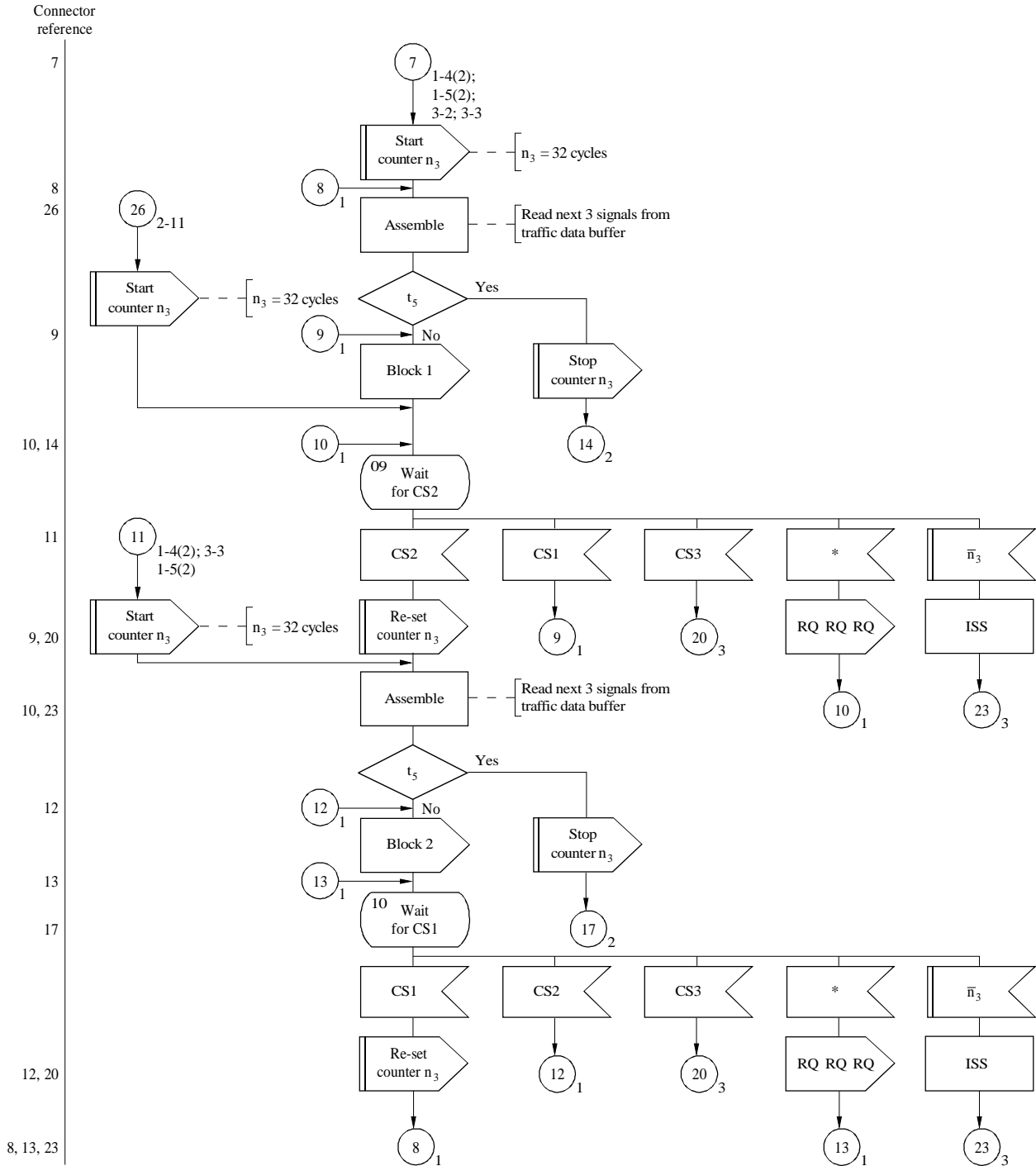

t_5 : data block contains message "end-of-communication"?

ISS: notice: station is ISS at the moment the interruption occurred

* Detected error, invalid signal or no signal at all

APPENDIX 10

Sheet 2 (of 3)

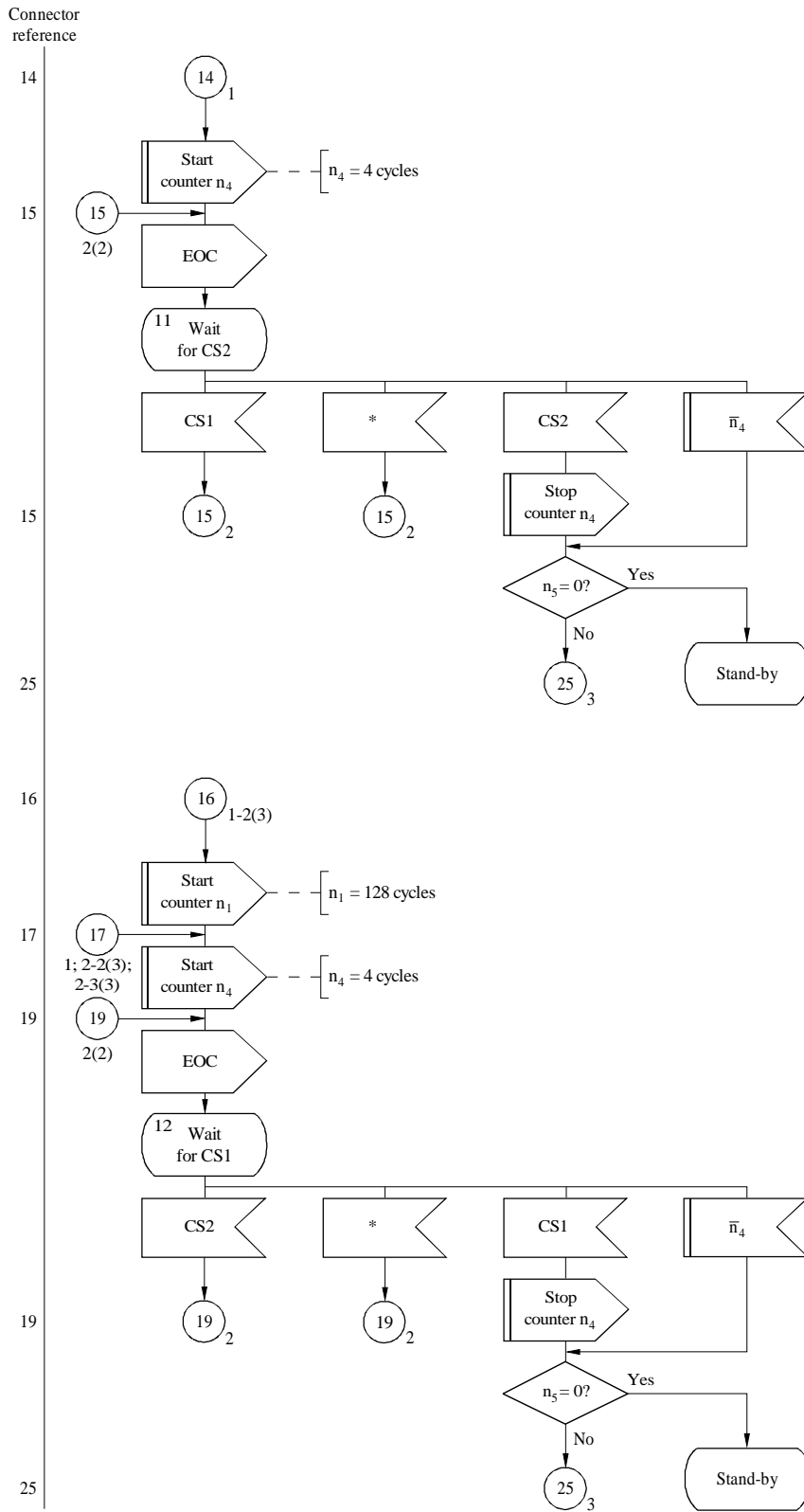

* Detected error, invalid signal or no signal at all

APPENDIX 10
Sheet 3 (of 3)

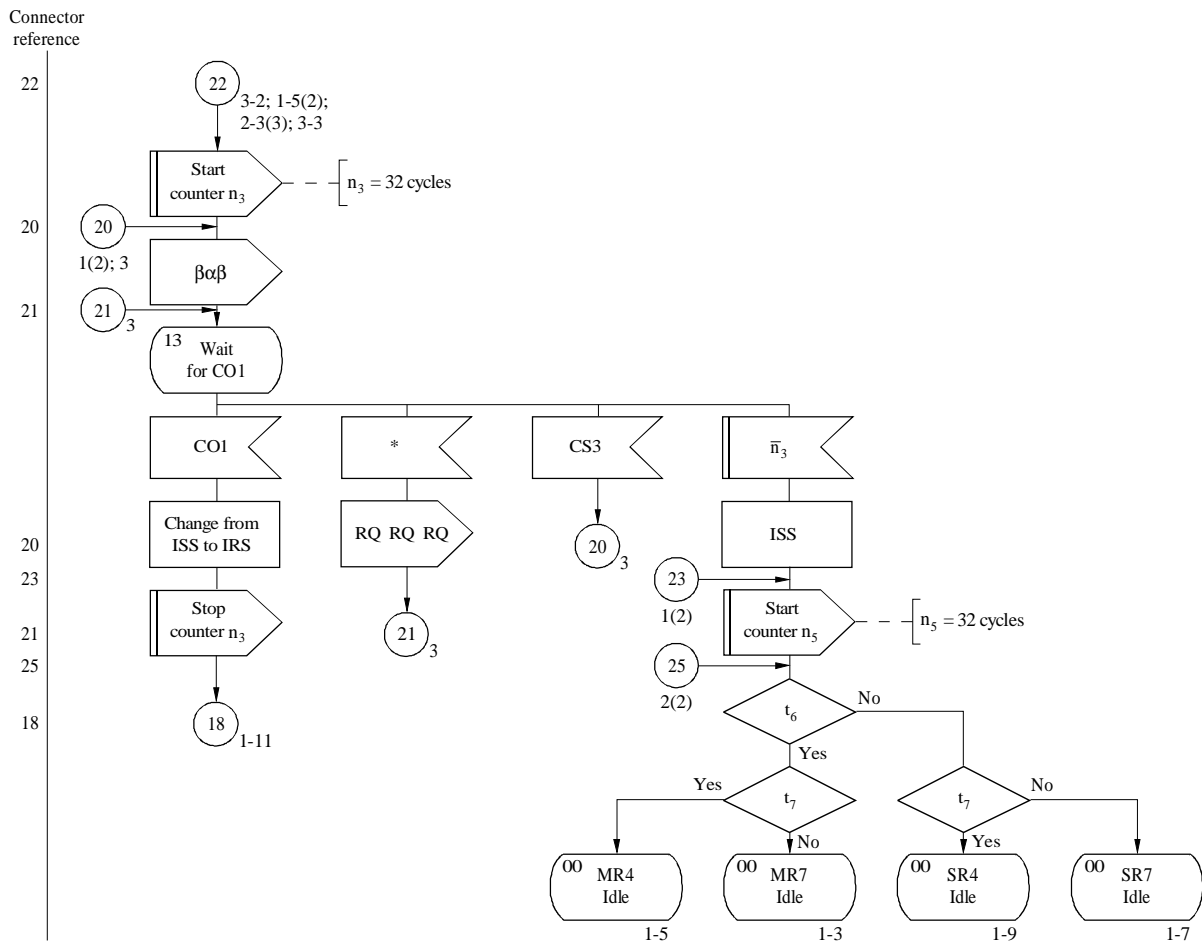

t_6 : station is master station?

t_7 : station working in the case of a 4-position call identity?

ISS : notice: station is ISS at the moment the interruption occurred

CO1: if ISS is:
 - master then "RQ RQ RQ"
 - slave then "RQ"

* Detected error, invalid signal or no signal at all

APPENDIX 11

Traffic flow in the case of a 4-signal call identity and in the case of a 7-signal call identity (station is in the IRS position)

Sheet 1 (of 2)

Connector reference
18
9
17
10
11
13
11, 17
13, 14
16
12
13
12
13, 14
10
16

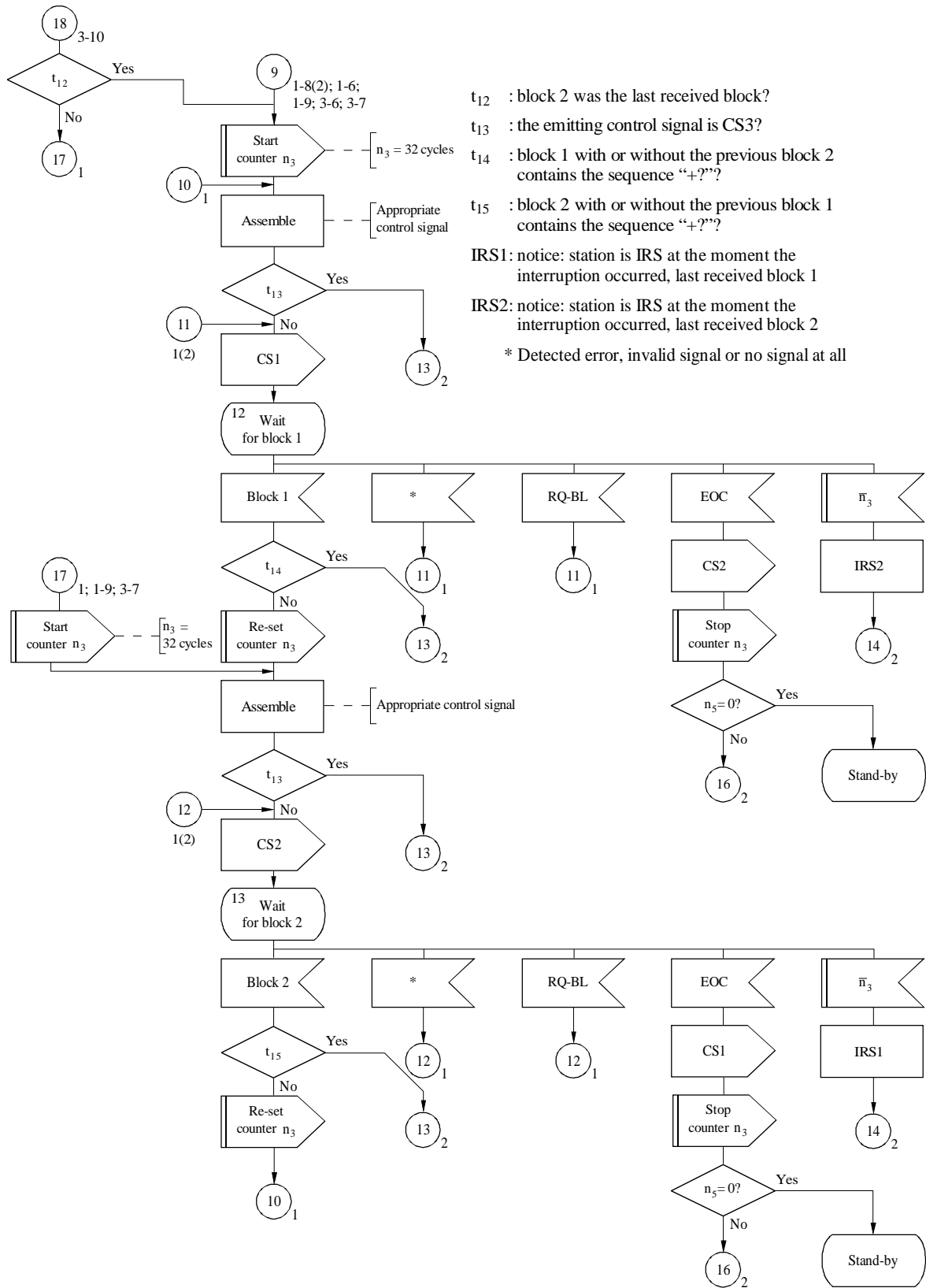

- t_{12} : block 2 was the last received block?
- t_{13} : the emitting control signal is CS3?
- t_{14} : block 1 with or without the previous block 2 contains the sequence "+??"
- t_{15} : block 2 with or without the previous block 1 contains the sequence "+??"
- IRS1: notice: station is IRS at the moment the interruption occurred, last received block 1
- IRS2: notice: station is IRS at the moment the interruption occurred, last received block 2
- * Detected error, invalid signal or no signal at all

APPENDIX 11

Sheet 2 (of 2)

Connector reference

13

13

14

16

26

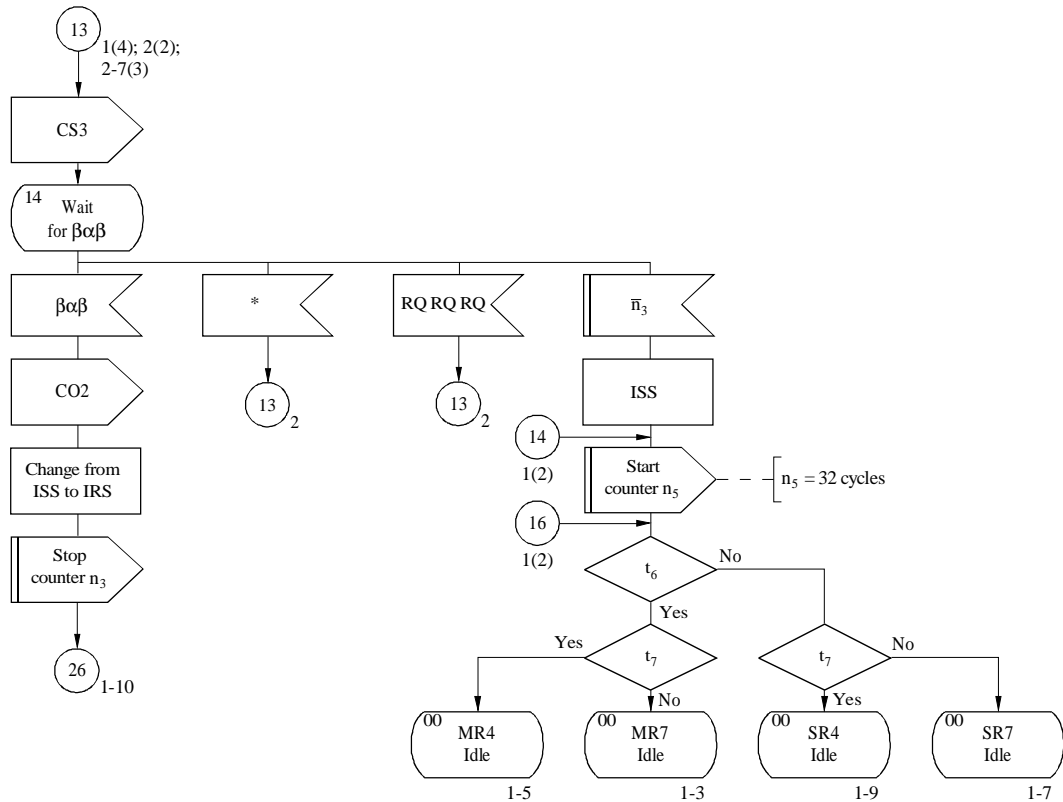

t_6 : station is master station?

t_7 : station working in the case of a 4-signal call identity?

CO2: if IRS is:
 – master then “RQ”
 – slave then “RQ RQ RQ”

* Detected error, invalid signal or no signal at all

APPENDIX 12

**Phasing procedure with automatic identification
in the case of a 7-signal call identity (calling station) and traffic flow if the station
is in the ISS position (state overview diagram)**

Sheet 1 (of 8)

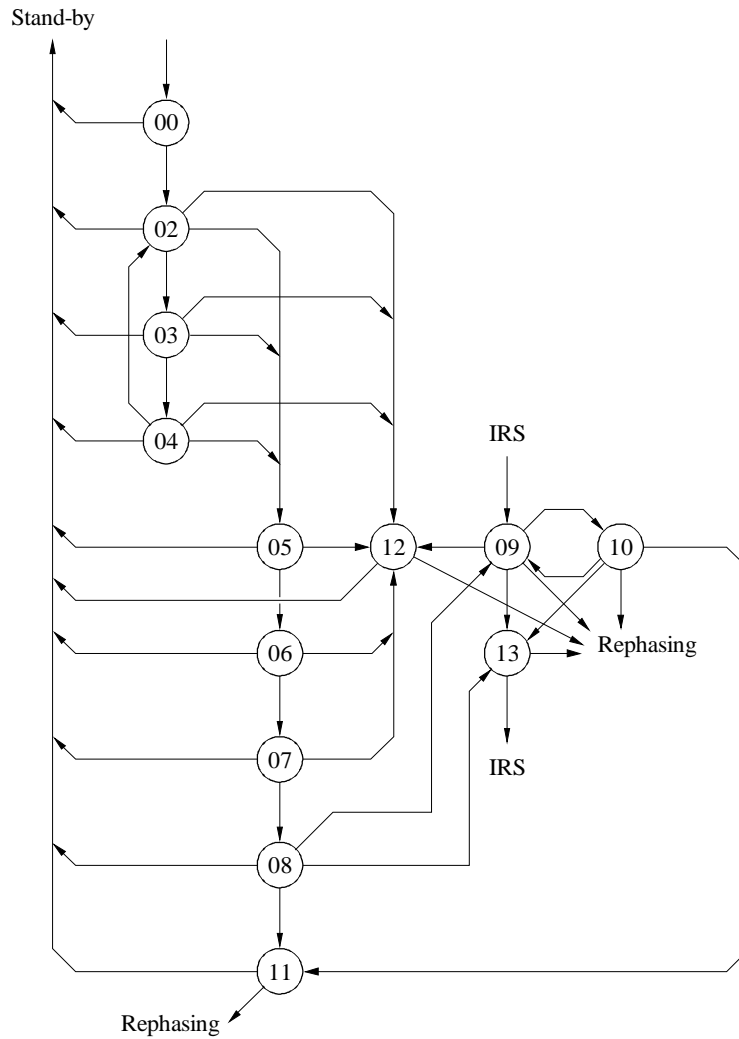

State number	State description	Sheet reference	Counters running	Supervisory counters
00	M7 idle	1-2	n ₁	n ₀ = 128 cycles
02	Wait for CS4	1-2	n ₀	n ₁ = 128 cycles
03	Wait for CS4	1-2	n ₀	n ₂ = 32 cycles
04	Wait for CS4	1-2	n ₀	n ₃ = 32 cycles
05	Wait for CK1	2-2	n ₂	n ₄ = 4 cycles
06	Wait for CK2	2-2	n ₂	
07	Wait for CK3	2-2	n ₂	
08	Wait for CS1	3-2	n ₂	
09	Wait for CS2	1-10	n ₃	
10	Wait for CS1	1-10	n ₃	
11	Wait for CS2	2-10	n ₄	
12	Wait for CS1	2-10	n ₁ , n ₄	
13	Wait for change-over	3-10	n ₃	

APPENDIX 12

**Rephasing procedure with automatic identification
in the case of a 7-signal call identity (calling station) and traffic flow if the station
is in the ISS position (state overview diagram)**

Sheet 2 (of 8)

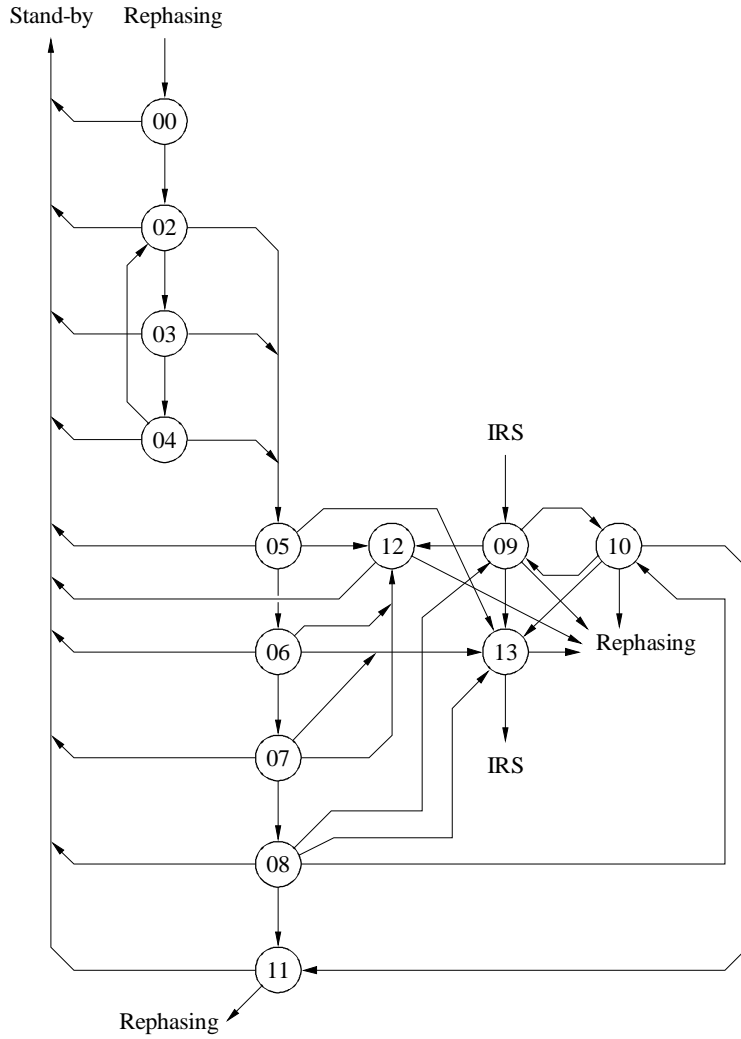

State number	State description	Sheet reference	Counters running	Supervisory counters
00	MR7 idle	1-3	n_5	$n_1 = 128$ cycles
02	Wait for CS5	1-3	n_5	$n_2 = 32$ cycles
03	Wait for CS5	1-3	n_5	$n_3 = 32$ cycles
04	Wait for CS5	1-3	n_5	$n_4 = 4$ cycles
05	Wait for CK1	2-3	n_2, n_5	$n_5 = 32$ cycles
06	Wait for CK2	2-3	n_2, n_5	
07	Wait for CK3	2-3	n_2, n_5	
08	Wait for CS1	3-3	n_2, n_5	
09	Wait for CS2	1-10	n_3, n_5	
10	Wait for CS1	1-10	n_3, n_5	
11	Wait for CS2	2-10	n_4, n_5	
12	Wait for CS1	2-10	n_1, n_4, n_5	
13	Wait for change-over	3-10	n_3, n_5	

APPENDIX 12

**Phasing procedure without automatic identification
in the case of a 4-signal call identity (calling station) and traffic flow if the station
is in the ISS position (state overview diagram)**

Sheet 3 (of 8)

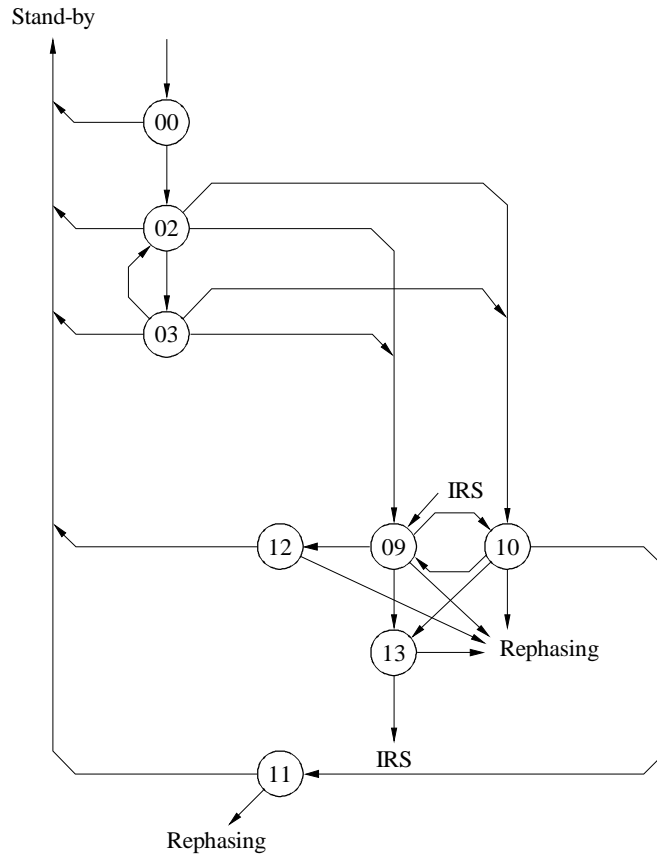

State number	State description	Sheet reference	Counters running	Supervisory counters
00	M4 idle	1- 4	n ₁	n ₀ = 128 cycles
02	Wait for CS1	1- 4	n ₀	n ₁ = 128 cycles
03	Wait for CS1	1- 4	n ₀	n ₃ = 32 cycles
09	Wait for CS2	1-10	n ₃	n ₄ = 4 cycles
10	Wait for CS1	1-10	n ₃	
11	Wait for CS2	2-10	n ₄	
12	Wait for CS1	2-10	n ₁ , n ₄	
13	Wait for change-over	3-10	n ₃	

APPENDIX 12

**Rephasing procedure without automatic identification
in the case of a 4-signal call identity (calling station) and traffic flow if the station
is in the ISS position (state overview diagram)**

Sheet 4 (of 8)

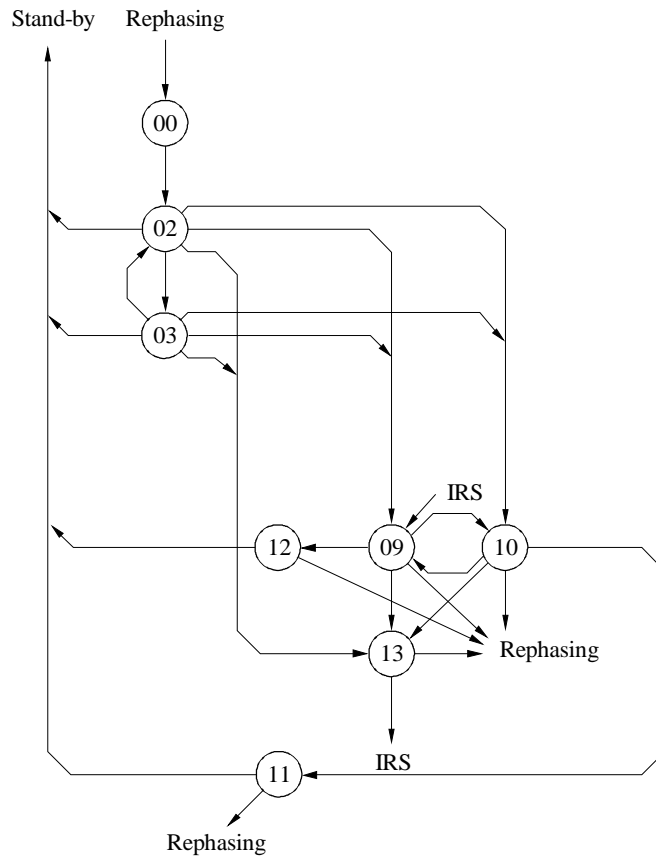

State number	State description	Sheet reference	Counters running	Supervisory counters
00	M4 idle	1-5	n ₅	n ₁ = 128 cycles
02	Wait for CS1	1-5	n ₅	n ₃ = 32 cycles
03	Wait for CS1	1-5	n ₅	n ₄ = 4 cycles
09	Wait for CS2	1-10	n ₃	n ₅ = 32 cycles
10	Wait for CS1	1-10	n ₃	
11	Wait for CS2	2-10	n ₄	
12	Wait for CS1	2-10	n ₁ , n ₄	
13	Wait for change-over	3-10	n ₃	

APPENDIX 12

**Phasing procedure with automatic identification
in the case of a 7-signal call identity (called station) and traffic flow if the station
is in the IRS position (state overview diagram)**

Sheet 5 (of 8)

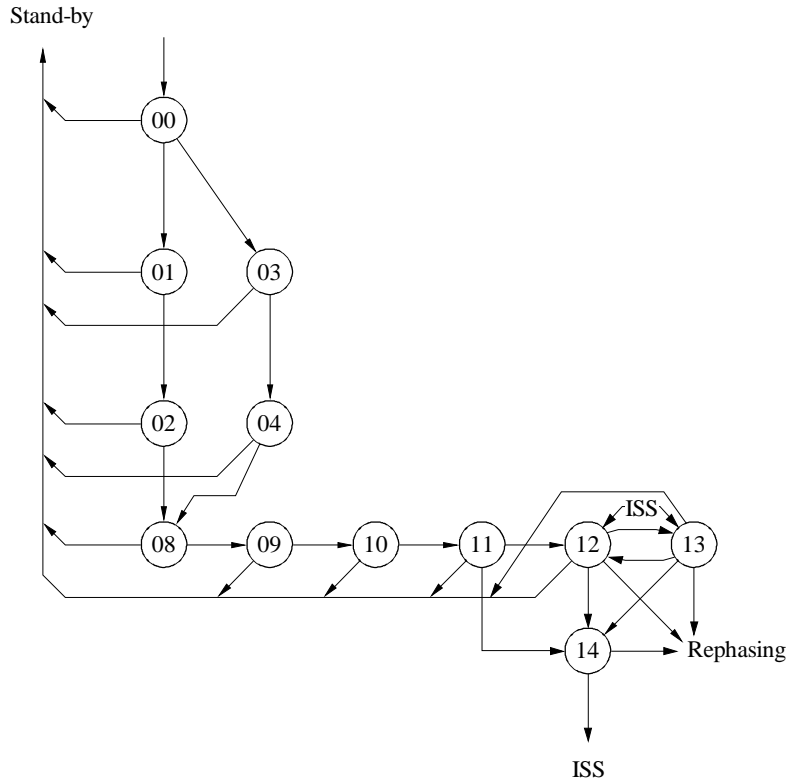

State number	State description	Sheet reference	Counters running	Supervisory counters
00	S7 idle	1-6		$n_2 = 32$ cycles
01	Wait for CB2	1-6		$n_3 = 32$ cycles
02	Wait for CB3	1-6		
03	Wait for CB3	1-6		
04	Wait for CB1	1-6		
08	Wait for ID1	2-6	n_2	
09	Wait for ID2	2-6	n_2	
10	Wait for ID3	2-6	n_2	
11	Wait for EOI	3-6	n_2	
12	Wait for block 1	1-11	n_3	
13	Wait for block 2	1-11	n_3	
14	Wait for $\beta\alpha\beta$	2-11	n_3	

APPENDIX 12

**Rephasing procedure with automatic identification
in the case of a 7-signal call identity (called station) and traffic flow if the station
is in the IRS position (state overview diagram)**

Sheet 6 (of 8)

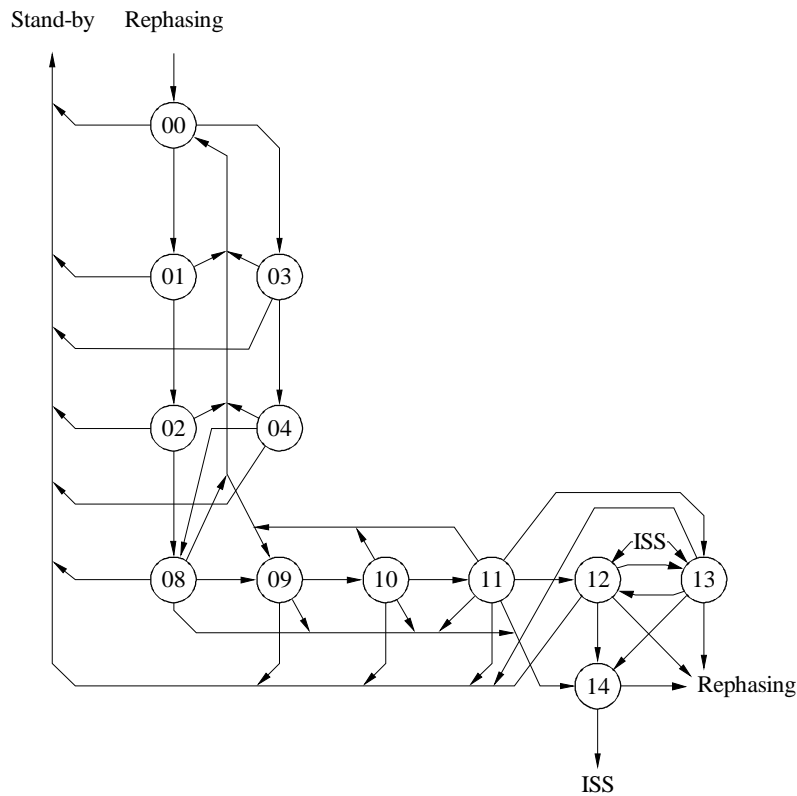

State number	State description	Sheet reference	Counters running	Supervisory counters
00	SR7 idle	1-7	n ₅	n ₂ = 32 cycles
01	Wait for CB2	1-7	n ₅	n ₃ = 32 cycles
02	Wait for CB3	1-7	n ₅	n ₅ = 32 cycles
03	Wait for CB3	1-7	n ₅	
04	Wait for CB1	1-7	n ₅	
08	Wait for ID1	2-7	n ₂ , n ₅	
09	Wait for ID2	2-7	n ₂ , n ₅	
10	Wait for ID3	2-7	n ₂ , n ₅	
11	Wait for EOI	3-7	n ₂ , n ₅	
12	Wait for block 1	1-11	n ₃ , n ₅	
13	Wait for block 2	1-11	n ₃ , n ₅	
14	Wait for β α β	2-11	n ₃ , n ₅	

APPENDIX 12

**Phasing procedure without automatic identification
in the case of a 4-signal call identity (called station) and traffic flow if the station
is in the IRS position (state overview diagram)**

Sheet 7 (of 8)

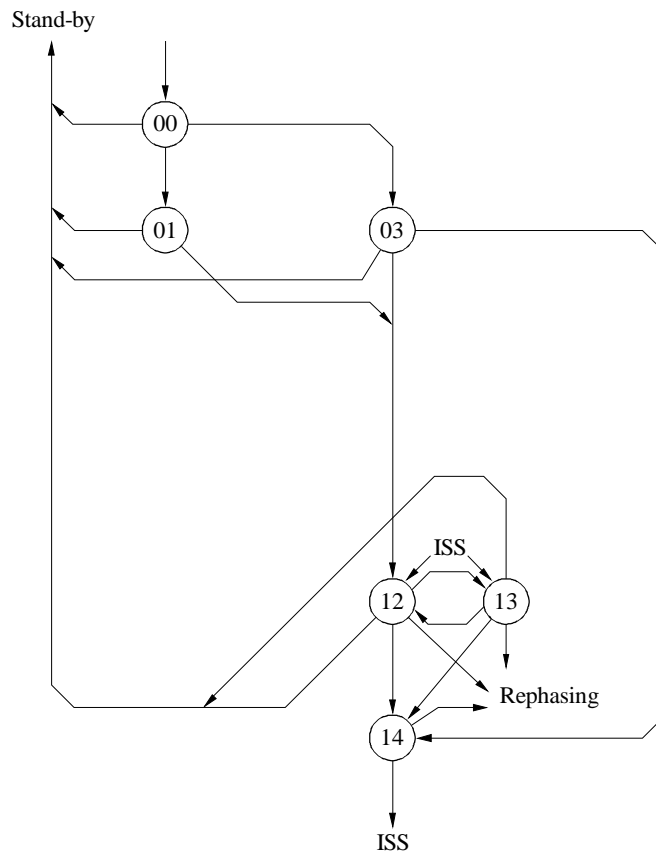

State number	State description	Sheet reference	Counters running	Supervisory counters
00	S4 idle	1-8		$n_3 = 32$ cycles
01	Wait for CB2	1-8		
03	Wait for CB1	1-8		
12	Wait for block 1	1-11	n_3	
13	Wait for block 2	1-11	n_3	
14	Wait for $\beta\alpha\beta$	2-11	n_3	

APPENDIX 12

**Rephasing procedure without automatic identification
in the case of a 4-signal call identity (called station) and traffic flow if the station
is in the IRS position (state overview diagram)**

Sheet 8 (of 8)

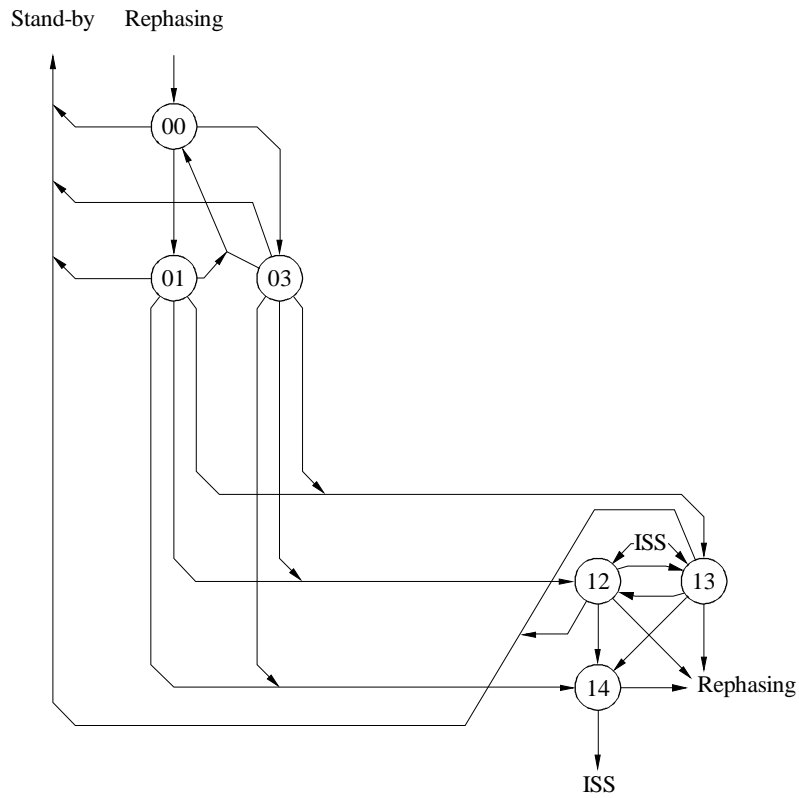

State number	State description	Sheet reference	Counters running	Supervisory counters
00	SR4 idle	1-9	n ₅	n ₂ = 32 cycles
01	Wait for CB2	1-9	n ₅	n ₃ = 32 cycles
03	Wait for CB1	1-9	n ₅	n ₅ = 32 cycles
12	Wait for block 1	1-11	n ₃ , n ₅	
13	Wait for block 2	1-11	n ₃ , n ₅	
14	Wait for βαβ	2-11	n ₃ , n ₅	

D46