



Recommendation ITU-R M.493-15
(01/2019)

**Digital selective-calling system for use in
the maritime mobile service**

M Series
**Mobile, radiodetermination, amateur
and related satellite services**

Foreword

The role of the Radiocommunication Sector is to ensure the rational, equitable, efficient and economical use of the radio-frequency spectrum by all radiocommunication services, including satellite services, and carry out studies without limit of frequency range on the basis of which Recommendations are adopted.

The regulatory and policy functions of the Radiocommunication Sector are performed by World and Regional Radiocommunication Conferences and Radiocommunication Assemblies supported by Study Groups.

Policy on Intellectual Property Right (IPR)

ITU-R policy on IPR is described in the Common Patent Policy for ITU-T/ITU-R/ISO/IEC referenced in Resolution ITU-R 1. Forms to be used for the submission of patent statements and licensing declarations by patent holders are available from <http://www.itu.int/ITU-R/go/patents/en> where the Guidelines for Implementation of the Common Patent Policy for ITU-T/ITU-R/ISO/IEC and the ITU-R patent information database can also be found.

Series of ITU-R Recommendations

(Also available online at <http://www.itu.int/publ/R-REC/en>)

Series	Title
BO	Satellite delivery
BR	Recording for production, archival and play-out; film for television
BS	Broadcasting service (sound)
BT	Broadcasting service (television)
F	Fixed service
M	Mobile, radiodetermination, amateur and related satellite services
P	Radiowave propagation
RA	Radio astronomy
RS	Remote sensing systems
S	Fixed-satellite service
SA	Space applications and meteorology
SF	Frequency sharing and coordination between fixed-satellite and fixed service systems
SM	Spectrum management
SNG	Satellite news gathering
TF	Time signals and frequency standards emissions
V	Vocabulary and related subjects

Note: This ITU-R Recommendation was approved in English under the procedure detailed in Resolution ITU-R 1.

Electronic Publication
Geneva, 2019

© ITU 2019

All rights reserved. No part of this publication may be reproduced, by any means whatsoever, without written permission of ITU.

RECOMMENDATION ITU-R M.493-15*

Digital selective-calling system for use in the maritime mobile service

(1974-1978-1982-1986-1990-1992-1994-1995-1997-1997-2000-2004-2007-2009-2015-2019)

Scope

This Recommendation describes the digital selective-calling (DSC) system for use in the maritime mobile service covering general purpose and simplified versions of DSC equipment. A description of a generalized user interface as well as an automated procedure for the operation of shipborne equipment are also included.

Keywords

Alert, announcement, class, digital selective calling, distress, global maritime distress and safety system, maritime

Abbreviations/Glossary

AIS	Automatic identification system
ARQ	Automatic repeat request
DSC	Digital selective calling
ECC	Error check character
EPIRB	Emergency position-indicating radiobeacon
EOS	End of sequence
FEC	Forward error correction
GMDSS	Global maritime distress and safety system
HF	High frequency (band number 7, 3-30 MHz)
IEC	International Electrotechnical Commission
IMO	International Maritime Organization
MF	Medium frequency (band number 6; 300-3 000 kHz)
MID	Maritime identification digits
MMSI	Maritime mobile service identity
MOB	Man overboard
MSC	Maritime safety committee
n/a	This field is not included in this call
NM	Nautical mile (1 NM = 1852 m)
RT	Radiotelephony
RX	Retransmission
Rx	Receive
SOLAS	International Convention for the Safety of Life at Sea

* This Recommendation should be brought to the attention of the International Maritime Organization (IMO).

TP	Telephony
TTY	Direct Printing
Tx	Transmit
UTC	Coordinated universal time
VHF	Very high frequency (band number 8, 30-300 MHz)

Related ITU Recommendations, Reports

Recommendation ITU-R M.476 – Direct-printing telegraph equipment in the maritime mobile service

Recommendation ITU-R M.541 – Operational procedures for the use of digital selective-calling equipment in the maritime mobile service

Recommendation ITU-R M.585 – Assignment and use of identities in the maritime mobile service

Recommendation ITU-R M.586 – Automated VHF/UHF maritime mobile telephone system

Recommendation ITU-R M.625 – Direct-printing telegraph equipment employing automatic identification in the maritime mobile service

Recommendation ITU-R M.689 – International maritime VHF radiotelephone system with automatic facilities based on DSC signalling format

Recommendation ITU-R M.821 – Optional expansion of the digital selective-calling system for use in the maritime mobile service

Recommendation ITU-R M.822 – Calling-channel loading for digital selective calling (DSC) for the maritime mobile service

Recommendation ITU R M.825 – Characteristics of a transponder system using digital selective calling techniques for use with vessel traffic services and ship-to-ship identification

Recommendation ITU-R M.1080 – Digital selective calling system enhancement for multiple equipment installations

Recommendation ITU R M.1081 – Automatic HF facsimile and data system for maritime mobile users

Recommendation ITU-R M.1082 – International maritime MF/HF radiotelephone system with automatic facilities based on digital selective calling signalling format

Recommendation ITU-R M.1084 – Interim solutions for improved efficiency in the use of the band 156-174 MHz by stations in the maritime mobile service

Recommendation ITU-R M.1371 – Technical characteristics for an automatic identification system using time-division multiple access in the VHF maritime mobile band

Report ITU-R M.1159 – Characteristics of an automatic identification system for VHF and UHF transmitting stations in the maritime mobile service

Report ITU-R M.1161 – Use of MF/HF DSC for automatic connection of calls in the maritime-mobile service MF and HF bands to the public switched network

The ITU Radiocommunication Assembly,

considering

a) that selective-calling in the shore-to-ship, ship-to-ship and ship-to-shore directions would expedite the handling of traffic in the maritime mobile service;

b) that the International Maritime Organization (IMO) has listed a number of operational requirements that should be taken into account when designing a general purpose selective-calling system;

- c) that Chapter IV of the International Convention for the Safety of Life at Sea (SOLAS), 1974, as amended, requires the use of digital selective calling (DSC) for distress alerting and safety calling in the global maritime distress and safety system (GMDSS);
- d) that the narrow-band direct printing systems should comply with Recommendation ITU-R M.625;
- e) that the DSC system should be applicable to the maritime mobile service, both for international and national needs;
- f) that it is desirable that the DSC system fulfils the requirements of all types of vessels desiring to use it;
- g) that after experience gained, a need exists to reduce unnecessary alarms and simplify operation of shipborne equipment;
- h) that in certain applications there may be a need to disable DSC automatic channel switching when there is a requirement for vessels to maintain continuous radio watch on a specific radio telephony channel (e.g. port traffic control, bridge-to-bridge communications),

recommends

- 1 that devices or equipment which use DSC channels/frequencies should be in full compliance with one of the defined classes within this Recommendation;
- 2 that DSC equipment should be designed in response to the operational requirements specified within Recommendation ITU-R M.541;
- 3 that where there is a need for a general purpose DSC system, the system should be designed in accordance with the characteristics given in Annex 1;
- 4 that where there is a need for simplified versions of DSC equipment, they should be designed in accordance with Annex 2;
- 5 that shipborne DSC equipment should be designed to provide a simplified user interface, following the examples of good practice set out in Annexes 3 and 4;
- 6 that in a GMDSS coast radio station installation, sufficient geographical separation should be provided between the DSC distress channel receiver antennas and any transmitting antennas within the installation. This is to avoid any de-sensitization of the DSC distress channel receivers if any transmitter is used at full power on any designated transmit frequency other than the DSC distress frequencies.

Annex 1

General purpose equipment characteristics

1 General

1.1 The system is a synchronous system using characters composed from a ten-bit error-detecting code as listed in Table A1-1.

1.1.1 The first seven bits of the ten-bit code of Table A1-1 are information bits. Bits 8, 9 and 10 indicate, in the form of a binary number, the number of B elements that occur in the seven information bits, a Y element being a binary number 1 and a B element a binary number 0. For example, a BYY sequence for bits 8, 9 and 10 indicates 3 ($0 \times 4 + 1 \times 2 + 1 \times 1$) B elements in the associated seven information bit sequence; and a YYB sequence indicates 6 ($1 \times 4 + 1 \times 2 + 0 \times 1$) B elements in the associated seven information bit sequence. The order of transmission for the information bits is least significant bit first but for the check bits it is most significant bit first.

1.2 Time diversity is provided in the call sequence as follows:

1.2.1 Apart from the phasing characters, each character is transmitted twice in a time-spread mode; the first transmission (DX) of a specific character is followed by the transmission of four other characters before the re-transmission (RX) of that specific character takes place, allowing for a time-diversity reception interval of:

- 400 ms for HF and MF channels, and
- $33\frac{1}{3}$ ms for VHF radio-telephone channels.

1.3 The classes of emission, frequency shifts and modulation rates are as follows:

1.3.1 F1B or J2B 170 Hz and modulation rate of $100 \text{ (bit/s)} * (1 \pm 30 * 10^{-6})$ for use on HF and MF DSC calling channels. When frequency-shift keying is effected by applying audio signals to the input of single-sideband transmitters (J2B), the centre of the audio-frequency spectrum offered to the transmitter is 1 700 Hz. When a DSC call is transmitted on HF and MF working channels for public correspondence, the class of emission is J2B. In this case, audio tones with frequencies $1\,700 \text{ Hz} \pm 85 \text{ Hz}$ and modulation rate $100 \text{ (bit/s)} * (1 \pm 30 * 10^{-6})$ are used in order for the DSC call to be transmitted.

1.3.2 Frequency modulation with a pre-emphasis of 6 dB/octave (phase modulation) with frequency-shift of the modulating sub-carrier for use on VHF channels:

- frequency-shift between 1 300 and 2 100 Hz; the sub-carrier being at 1 700 Hz;
- the frequency tolerance of the 1 300 and 2 100 Hz tones is $\pm 10 \text{ Hz}$;
- the modulation rate is $1\,200 \text{ (bit/s)} * (1 \pm 30 * 10^{-6})$;
- the index of modulation is $2.0 \pm 10\%$.

1.3.3 The radio-frequency tolerances of new designs of both transmitters and receivers in the MF and HF bands should be:

- coast station: $\pm 10 \text{ Hz}$,
- ship station: $\pm 10 \text{ Hz}$,
- receiver bandwidth: should not exceed 300 Hz.

1.4 The higher frequency corresponds to the B-state and the lower frequency corresponds to the Y-state of the signal elements.

1.5 The information in the call is presented as a sequence of seven-bit combinations constituting a primary code.

1.5.1 The seven information bits of the primary code express a symbol number from 00 to 127, as shown in Table A1-1, and where:

- the symbols from 00 to 99 are used to code two decimal figures according to Table A1-2;
- the symbols from 100 to 127 are used to code service commands (see Table A1-3).

1.6 Where the distress alert repetitions described in § 11 apply, the following conditions are considered necessary:

1.6.1 the transmitter encoder must provide repetitive transmission of the call sequence in accordance with § 11; and

1.6.2 the receiver decoder should provide maximum utilization of the received signal, including use of the error-check character and by using an iterative decoding process with adequate memory provision.

1.7 When the transmission of a DSC distress alert is automatically repeated, ships' DSC equipment must be capable of automatically receiving a subsequent distress acknowledgement (see Recommendation ITU-R M.541).

TABLE A1-1

Ten-bit error-detecting code

Symbol No.	Emitted signal and bit position 12345678910	Symbol No.	Emitted signal and bit position 12345678910	Symbol No.	Emitted signal and bit position 12345678910
00	BBBBBBYYY	43	YYBYBYBBY	86	BYYBYBYBY
01	YBBBBBBYB	44	BBYBYBYBB	87	YYYBYBYBY
02	BYBBBBBYB	45	YBYBYBBY	88	BBYBYBYBB
03	YYBBBBBYB	46	BYYBYBBY	89	YBBYBYBY
04	BBYBBBBYB	47	YYYYBYBYB	90	BYBYBYBY
05	YBYBBBBYB	48	BBBBYBYBY	91	YYBYBYBY
06	BYYBBBBYB	49	YBBYBYBYB	92	BBYYBYBY
07	YYYBBBBYB	50	BYBBYBYBB	93	YBYBYBYBY
08	BBYBBBBYB	51	YYBBYBBY	94	BYYBYBYBY
09	YBBYBBYBY	52	BBYBYBYBB	95	YYYYBYBY
10	BYBYBBYBY	53	YBYBYBBY	96	BBBBYYBY
11	YYBYBBYBB	54	BYYBYBBY	97	YBBBBYYBB
12	BBYBBYBY	55	YYBYBYBYB	98	BYBBBBYYB
13	YBYBBYBB	56	BBYBYBYBB	99	YBBBBYBY
14	BYYBBYBB	57	YBBYBBY	100	BBYBBYYBB
15	YYYYBBBY	58	BYBYBBY	101	YBYBBYBY
16	BBBBYBBYB	59	YYBYBYBYB	102	BYYBYBY
17	YBBYBBYBY	60	BBYYBYBY	103	YYBYBYBY
18	BYBBYBBYB	61	YBYBYBYB	104	BBYBYYYBB
19	YBBYBBYBB	62	BYYBYBYB	105	YBBYBYBY
20	BBYBYBYBY	63	YYYYYBBY	106	BYBYBYBY
21	YBYBYBYBB	64	BBBBBYYYB	107	YBYBYBYBY
22	BYYBYBYBB	65	YBBBBYYBY	108	BBYBYBY
23	YYYBYBBYY	66	BYBBYBYBY	109	YBYBYBYBY
24	BBYBYBYBY	67	YBBBBYYBB	110	BYYBYBYBY
25	YBBYBYBYB	68	BBYBBYBY	111	YYYYBYBY
26	BYBYBYBYB	69	YBYBBYBYB	112	BBBBYYYYB
27	YYBYBBYY	70	BYYBBYBYB	113	YBBBBYYBY
28	BBYYBYBYB	71	YYBBYBY	114	BYBBYYBY
29	YBYBYBBYY	72	BBYBBYBY	115	YBBYYBYBY
30	BYYBYBBYY	73	YBYBBYBYB	116	BBYBYBY
31	YYYYBBBYB	74	BYBYBYBYB	117	YBYBYBYBY
32	BBBBBYBYB	75	YYBYBYBY	118	BYYBYBYBY
33	YBBBBYBYBY	76	BBYBYBYBYB	119	YYBYYYBY
34	BYBBYBYBY	77	YBYBBYBY	120	BBYYYYBY
35	YYBBYBYBB	78	BYYBYBY	121	YBBYYBYBY
36	BBYBYBYBY	79	YYYYBYBYB	122	BYBYBYBY
37	YBYBYBYBB	80	BBBBYBYBY	123	YBYYYBY
38	BYYBYBYBB	81	YBBYBYBYB	124	BBYYYYBY
39	YYBYBYBY	82	BYBBYBYBB	125	YBYYYBY
40	BBYBYBYBY	83	YYBYBYBY	126	BYYYYBY
41	YBYBYBYBB	84	BBYBYBYBB	127	YYYYYYBB
42	BYBYBYBYB	85	YBYBYBYBY		

B = 0

Y = 1

Order of bit transmission: bit 1 first.

TABLE A1-2

Packing table for decimal numbers into ten-bit characters

The digits for the									
Thousands of millions D2	Hundreds of millions D1	Tens of millions D2	Millions D1	Hundreds of thousands D2	Tens of thousands D1	Thousands D2	Hundreds D1	Tens D2	Units D1
Character 5		Character 4		Character 3		Character 2		Character 1	

NOTE 1 – Character 1 is the last character transmitted.

The digit sequence D2-D1 varies from 00 to 99 inclusive in each character (character 1 to 5 inclusive). The character that represents a particular two-decimal figure is transmitted as the symbol number (see Table A1-1) that is identical to that particular two-decimal figure.

When the number consists of an odd number of decimal digits, a zero shall be added in front of the most significant position to provide an integral number of ten-bit characters.

TABLE A1-3

Use of symbol Nos 100 to 127

Symbol No.	Phasing and unique functions	Format specifier ⁽¹⁾	Category ⁽¹⁾	Nature of distress ⁽¹⁾	First telecommand ⁽¹⁾	Second telecommand ⁽¹⁾
100			Routine	Fire, explosion	F3E/G3E All modes TP	No reason given ⁽²⁾
101				Flooding	F3E/G3E duplex TP	Congestion at maritime switching centre
102		Geographical area		Collision		Busy ⁽²⁾
103		⁽³⁾	⁽³⁾	Grounding	Polling	Queue indication ⁽²⁾
104	Phasing RX-0 position			Listing, in danger of capsizing	Unable to comply	Station barred ⁽²⁾
105	Phasing RX-1 position			Sinking	End of call ⁽⁴⁾	No operator available ⁽²⁾
106	Phasing RX-2 position		⁽⁶⁾	Disabled and adrift	Data	Operator temporarily unavailable ⁽²⁾
107	Phasing RX-3 position			Undesignated distress		Equipment disabled ⁽²⁾
108	Phasing RX-4 position		Safety	Abandoning ship		Unable to use proposed channel ⁽²⁾
109	Phasing RX-5 position			Piracy/armed robbery attack	J3E TP	Unable to use proposed mode ⁽²⁾
110	Phasing RX-6 position	⁽⁵⁾	Urgency	Man overboard	Distress acknowledgement	Ships and aircraft of States not parties to an armed conflict

TABLE A1-3 (*end*)

Symbol No.	Phasing and unique functions	Format specifier ⁽¹⁾	Category ⁽¹⁾	Nature of distress ⁽¹⁾	First telecommand ⁽¹⁾	Second telecommand ⁽¹⁾
111	Phasing RX-7 position				⁽⁶⁾	Medical transports (as defined in 1949 Geneva Conventions and additional Protocols) ^A
112		Distress	Distress	EPIRB emission ^B	Distress alert relay	Pay-phone/public call office ^C
113					F1B/J2B TTY-FEC	Facsimile/data according to Recommendation ITU-R M.1081
114		Ships having common interest				
115					F1B/J2B TTY-ARQ	⁽⁶⁾
116		All ships ⁽⁷⁾			⁽⁶⁾	⁽⁶⁾
117	Ack. RQ (EOS)				⁽⁶⁾	⁽⁶⁾
118					Test	⁽⁶⁾
119					⁽⁶⁾	⁽⁶⁾
120		Individual stations			⁽⁶⁾	⁽⁶⁾
121		Reserved for national non-calling purposes e.g. Report ITU-R M.1159			Ship position or location registration updating	⁽⁶⁾
122	Ack. BQ (EOS)				⁽⁶⁾	⁽⁶⁾
123		Individual station semi-automatic/automatic service ^C			⁽⁶⁾	⁽⁶⁾
124		⁽⁵⁾			⁽⁶⁾	⁽⁶⁾
125	Phasing DX position				⁽⁶⁾	⁽⁶⁾
126	*				No information	No information
127	EOS				⁽⁶⁾	⁽⁶⁾

TP: Telephony

TTY: Direct printing

ARQ: Recommendations ITU-R M.476 or ITU-R M.625 equipment

- ⁽¹⁾ Unassigned symbols should be rejected. The DSC equipment should take no action.
- ⁽²⁾ Currently unassigned when used with first telecommands other than symbol No. 104 – for future use.
- ⁽³⁾ Used for selective call to a group of ships in a specified VTS area (Rec. ITU-R M.825). Reception of calls having format specifier 103, for (or) category shall not activate any alarms on shipborne DSC controller. Should not be used in any future expansion.
- ⁽⁴⁾ Only used for semi-automatic/automatic service.
- ⁽⁵⁾ Used in the automatic VHF/UHF service (Rec. ITU-R M.586). Should not be used in any future expansion.
- ⁽⁶⁾ Should not be used in any future expansion.
- ⁽⁷⁾ MF/HF used only for distress alert acknowledgment and coast station receive (see Table A1-4).

Notes relative to Table A1-3 (cont.):

A –NOTE – The telecommands for “Ships and aircraft of States not parties to an armed conflict” and “Medical transports (as defined in 1949 Geneva Conventions and additional Protocols)” are laid down in binding conventions and protocols which should not be touched by any change to Rec. ITU-R M.493.

B –NOTE – The VHF emergency position indicating radiobeacon (EPIRB) can be used to comply with an IMO carriage requirement – prior to deletion it should be deleted from the relevant chapter of SOLAS – this would require a new work item.

C –NOTE – The deletion of certain telecommands is a major change in the system, such as codes for the connection the fixed network information about the worldwide implementation should be sought by sending a circular letter to administrations. The result and further requests for the deletion should be brought to the attention of the IMO Correspondence Group for the revision of the GMDSS.

“*” Symbol transmitted in place of unused message information.

2 Technical format of a call sequence

2.1 The technical format of the call sequence is:

Dot patter See § 3	Phasing sequence See § 3	Call content See Tables A1-4.1 to A1-4.1.10.2	Closing sequence See §§ 9, 10 and Fig. 1
-----------------------	-----------------------------	-----------------------------------------------------	------------------------------------------------

2.2 Examples of typical call sequences and the construction of the transmission format are given in Figs 1 to 3 (see § 16.8).

2.3 The flow charts illustrating the operation of the DSC system are shown in Figs 4 and 5 (see § 16.8).

3 Dot pattern and phasing

3.1 The phasing sequence provides information to the receiver to permit correct bit phasing and unambiguous determination of the positions of the characters within a call sequence (see Note 1).

NOTE 1 – Acquisition of character synchronization should be achieved by means of character recognition rather than, for example, by recognizing a change in the dot pattern, in order to reduce false synchronization caused by a bit error in the dot pattern.

3.2 The phasing sequence consists of specific characters in the DX and RX positions transmitted alternatively. Six DX characters are transmitted.

3.2.1 The phasing character in the DX position is symbol No. 125 of Table A1-1.

3.2.2 The phasing characters in the RX position specify the start of the information sequence (i.e. the format specifier) and consist of the symbol Nos. 111, 110, 109, 108, 107, 106, 105 and 104 of Table A1-1, consecutively.

3.3 Phasing is considered to be achieved when two DXs and one RX, or two RXs and one DX, or three RXs in the appropriate DX or RX positions, respectively, are successfully received. These three phasing characters may be detected in either consecutive or non-consecutive positions but in both cases all bits of the phasing sequence should be examined for a correct 3-character pattern. A call should be rejected only if a correct pattern is not found anywhere within the phasing sequence.

3.4 To provide appropriate conditions for earlier bit synchronization and to allow for scanning methods to monitor several HF and MF frequencies by ship stations, the phasing sequence should be preceded by a dot pattern (i.e. alternating B-Y or Y-B sequence bit synchronization signals) with duration of:

3.4.1 200 bits

At HF and MF for:

- distress alerts;
- distress acknowledgements;
- distress alert relays addressed to a geographic area;
- distress alert relay acknowledgements addressed to all ships;
- all calls addressed to a ship station other than those specified in § 3.4.2.

3.4.2 20 bits

At HF and MF for:

- all acknowledgements to individual calls having format specifiers 120 and 123;
- all calling to coast stations.

At VHF for all calls.

4 Format specifier

4.1 The format specifier characters which are transmitted twice in both the DX and RX positions (see Fig. 1) are:

- symbol No. 112 for a “distress” alert; or
- symbol No. 116 for an “all ships” call; or
- symbol No. 114 for a selective call to a group of ships having a common interest (e.g. belonging to one particular country, or to a single ship owner, etc.); or
- symbol No. 120 for a selective call to a particular individual station; or
- symbol No. 102 for a selective call to a group of ships in a particular geographic area; or
- symbol No. 123 for a selective call to a particular individual station using the semi-automatic/automatic service.

4.2 It is considered that receiver decoders must detect the format specifier character twice for “distress” alerts and “all ships” calls to effectively eliminate false alerting. For other calls, the address characters provide additional protection against false alerting and, therefore, single detection of the format specifier character is considered satisfactory (see Table A1-3).

5 Address

5.1 “Distress” alerts and “all ships” calls do not have addresses since these calls are implicitly addressed to all stations (ship stations and coast stations).

5.2 For a selective call directed to an individual ship, to a coast station or to a group of stations having a common interest, the address consists of the characters corresponding to the station’s maritime identity as defined in Recommendation ITU-R M.585. The sequence consists of characters coded in accordance with Table A1-2 (see Note 1).

NOTE 1 – According to Recommendation ITU-R M.585 and RR Article 19, maritime mobile service identities are formed of a series of nine digits, consisting of three digits of the maritime identification digits (MID) and six more digits.

These identities are included in the address and self-identification parts of the call sequence and are transmitted as five characters $C_5C_4C_3C_2C_1$, comprising the ten digits of:

$$(X_1, X_2) (X_3, X_4) (X_5, X_6) (X_7, X_8) \text{ and } (X_9, X_{10})$$

respectively, whereas digit X_{10} is always the digit 0 unless the equipment is also designed in accordance with Recommendation ITU-R M.1080.

Example:

MID $X_4 X_5 X_6 X_7 X_8 X_9$ being the ship station identity is transmitted by the DSC equipment as:

$$(M, I) (D, X_4) (X_5, X_6) (X_7, X_8) (X_9, 0)$$

5.3 For a selective call directed to a group of ships in a particular geographic area a numerical geographic coordinates address consisting of ten digits (i.e. 5 characters), is constructed as follows (see Fig. 6 and Note 1):

NOTE 1 – In order to comply with commonly accepted practice, the order of entry and read-out should be: first latitude and then longitude.

- 1 the designated geographic area will be a rectangle in Mercator projection;
- 2 the upper left-hand (i.e. North-West) corner of the rectangle is the reference point for the area;
- 3 the first digit indicates the azimuth sector in which the reference point is located, as follows:
 - quadrant NE is indicated by the digit “0”,
 - quadrant NW is indicated by the digit “1”,
 - quadrant SE is indicated by the digit “2”,
 - quadrant SW is indicated by the digit “3”;
- 4 the second and third digits indicate the latitude of the reference point in tens and units of degrees;
- 5 the fourth, fifth and sixth digits indicate the longitude of the reference point in hundreds, tens and units of degrees;
- 6 the seventh and eighth digits indicate the vertical (i.e. North-to-South) side of the rectangle, $\Delta\varphi$, in tens and units of degrees;
- 7 the ninth and tenth digits indicate the horizontal (i.e. West-to-East) side of the rectangle, $\Delta\lambda$, in tens and units of degrees.

6 Category

The “category” information is coded as shown in Table A1-3 and defines the degree of priority of the call sequence.

6.1 For a “distress” alert the priority is defined by the format specifier and no category information is included in the call sequence.

For distress alert relays, distress alert relay acknowledgements and distress acknowledgements the category is distress.

6.2 For safety related calls, the “category” information specifies:

- urgency; or
- safety.

6.3 For other calls, the “category” information specifies:

- routine.

7 Self-identification

7.1 The maritime identity as defined in Recommendation ITU-R M.585, coded as indicated in § 5.2 and its Note 1, is used for self-identification.

8 Messages

The messages that are included in a call sequence contain the following message elements, which are listed in the order in which they would appear in each message. All message formats are explicitly defined in Tables A1-4.1 through A1-4.11:

8.1 For a “distress” alert (see Table A1-4.1) the distress information is contained in four messages in the following order:

8.1.1 Message 1

Message 1 is the “nature of distress” message, coded as shown in Table A1-3, i.e.:

- 100 fire, explosion;
- 101 flooding;
- 102 collision;
- 103 grounding;
- 104 listing, in danger of capsizing;
- 105 sinking;
- 106 disabled and adrift;
- 107 undesignated distress;
- 108 abandoning ship;
- 109 piracy/armed robbery attack;
- 110 man overboard;
- 112 VHF emergency position-indicating radiobeacon (EPIRB) emission.

8.1.2 Message 2

Message 2 is the “distress coordinates” message, consisting of ten digits indicating the location of the vessel in distress, coded on the principles described in Table A1-2, in pairs starting from the first and second digits (see Note 1 to § 5.3):

- The first digit indicates the quadrant in which the incident has occurred, as follows:
 - quadrant NE is indicated by the digit “0”,
 - quadrant NW is indicated by the digit “1”,
 - quadrant SE is indicated by the digit “2”,
 - quadrant SW is indicated by the digit “3”.
- The next four figures indicate the latitude in degrees and minutes.
- The next five figures indicate the longitude in degrees and minutes.

- If “distress coordinates” cannot be included, or if the position information has not been updated for 23½ h, the 10 digits following the “nature of distress” should be automatically transmitted as the digit 9 repeated 10 times.

8.1.3 Message 3

Message 3 is the time indication coordinated universal time (UTC) when the coordinates were valid consisting of four digits coded on the principles described in Table A1-2, in pairs starting from the first and second digits.

- The first two digits indicate the time in hours.
- The third and fourth digits indicate the part of the hours in minutes.
- If the time cannot be included the four time indicating digits should be transmitted automatically as “8 8 8 8”.

8.1.4 Message 4

Message 4 is a single character to indicate the type of communication (telephone or FEC teleprinter) which is preferred by the station in distress for subsequent exchange of distress traffic. This character is coded as shown in Table A1-3 first telecommand.

8.2 Distress alert relay, distress alert relay acknowledgement, distress acknowledgement

For a distress alert relay, distress alert relay acknowledgement, distress acknowledgement (see Tables A1-4.2, A1-4.3 and A1-4.4) the distress information is contained in five messages in the following order:

8.2.1 Message 0

Message 0 is the maritime identity of the unit in distress as defined in Recommendation ITU-R M.585.

8.2.2 Message 1

Message 1 is the “nature of distress” message, coded as shown in Table A1-3, i.e.:

- 100 fire, explosion;
- 101 flooding;
- 102 collision;
- 103 grounding;
- 104 listing, in danger of capsizing;
- 105 sinking;
- 106 disabled and adrift;
- 107 undesignated distress;
- 108 abandoning ship;
- 109 piracy/armed robbery attack;
- 110 man overboard;
- 112 VHF emergency position-indicating radiobeacon (EPIRB) emission.

8.2.3 Message 2

Message 2 is the “distress coordinates” message, consisting of ten digits indicating the location of the vessel in distress, coded on the principles described in Table A1-2, in pairs starting from the first and second digits (see Note 1 to § 5.3):

- The first digit indicates the quadrant in which the incident has occurred, as follows:
 - quadrant NE is indicated by the digit “0”,
 - quadrant NW is indicated by the digit “1”,
 - quadrant SE is indicated by the digit “2”,
 - quadrant SW is indicated by the digit “3”.
- The next four figures indicate the latitude in degrees and minutes.
- The next five figures indicate the longitude in degrees and minutes.

If “distress coordinates” cannot be included, or if the position information has not been updated for 23½ h, the 10 digits following the “nature of distress” should be automatically transmitted as the digit 9 repeated 10 times.

8.2.4 Message 3

Message 3 is the time indication (UTC) when the coordinates were valid consisting of four digits coded on the principles described in Table A1-2, in pairs starting from the first and second digits.

- The first two digits indicate the time in hours.
- The third and fourth digits indicate the part of the hours in minutes.
- If the time cannot be included the four time indicating digits should be transmitted automatically as “8 8 8 8”.

8.2.5 Message 4

Message 4 is a single character to indicate the type of communication (telephone or FEC teleprinter) which is preferred by the station in distress for subsequent exchange of distress traffic. This character is coded as shown in Table A1-3 first telecommand.

8.3 Other types of calls

For other types of calls (see Table A1-4.5 through A1-4.11 and Figs 3 and 4) messages are included in the following order:

8.3.1 Message 1

Message 1 is the “telecommand” information and consists of two characters (first and second telecommand) coded as shown in Table A1-3:

- if no information additional to that conveyed by the first telecommand character is required, then the second telecommand signal should be symbol No. 126 (no information) (see Table A1-3);
- if no telecommand information is used, symbol No. 126 is transmitted twice;
- if the telecommand 1 is “F3E/G3E duplex TP” (symbol 101) in a request, which can be complied with, the telecommand 1 “F3E/G3E all modes TP” (symbol 100) should be used in the acknowledgement.

8.3.2 Message 2

Message 2 may contain two “channel or frequency message” elements, each of which basically consists of three characters, “character 1”, “character 2” and “character 3”, indicating the proposed working frequency (in the F1B/J2B mode the assigned frequency should be used) in multiples of 100 Hz or the channel number (coded in accordance with Table A1-5) or the ship’s position. The first frequency element (the Rx field) in the call indicates the called station receive frequency and the second frequency element (the Tx field) indicates the called station transmit frequency. In

acknowledgements the Rx and Tx fields indicate the receive and transmit frequency of the acknowledging station respectively (see also Fig. 2 and Note 1).

NOTE 1 – If only one channel or frequency message element is used, this indicates the called station receive channel or frequency or a two-frequency (paired) channel. A second channel or frequency message element may be used to designate the called station transmit channel or frequency. If the calling station indicates only the called station receive frequency (for broadcast mode transmissions) then the symbol No. 126 repeated three times (see Note 2) should be transmitted instead of the called station transmit channel or frequency message element. If no “channel or frequency message” elements are used, the symbol No. 126 is transmitted six times. For calls using the semi-automatic/automatic VHF service (see Table A1-4.10.1) then only one “channel or frequency message” element is transmitted which indicates the paired channel number. In the absence of this element the symbol No. 126 should be transmitted three times.

NOTE 2 – In the F1B/J2B mode (FEC or ARQ), if using seven-digit frequency as the working frequency, Message 2 may contain two frequency message elements as mentioned above, but each of which consists of four characters, “character 0”, “character 1”, “character 2” and “character 3” in multiples of 10 Hz (coded in accordance with Table A1-5). Additionally if the calling station indicates only the called station receive frequency of seven-digit (for broadcast mode transmissions) then the symbol No. 126 repeated four times should be transmitted instead of the called station transmit frequency message element.

8.3.2.1 Frequency information

The frequency (in the F1B/J2B mode the assigned frequency should be used) in multiples of 100 Hz or 10 Hz (see Note 2 above) may only be indicated as such when the frequency is below 30 MHz. The three characters provide for the required six decimal digits. Character 1 represents the units (U) and tens (T) of 100 Hz, character 2 the hundreds (H) and thousands (M) and character 3 the tens of thousands (TM) and hundreds of thousands (HM) of 100 Hz. For MF/HF DSC, use frequency selection mode, vice channel selection mode, to ensure international interoperability. Also, when using seven-digit frequencies, the four characters provide for the required seven decimal digits. Character 0 represents the units (U1) and tens (T1) of 10 Hz, character 1 the units (U) and tens (T) of 1 kHz, character 2 the hundreds (H) and thousands (M) and character 3 the tens of thousands (TM) of 1 kHz. However note that this four characters information is only for use of seven-digit frequencies in the F1B/J2B, i.e. it does not affect the messages for the J3E TP mode and for the F1B/J2B mode using six-digit frequencies to ensure interoperability.

8.3.2.2 Channel information

8.3.2.2.1 HF and MF channels

If the HM digit is 3, this indicates that the number represented by the digits TM, M, H, T, U, T1 and U1 is the HF/MF working channel number (either single frequency or two frequency channels). This mode should only be used for decoding received calls, to ensure interoperability with older equipment.

8.3.2.2.2 VHF channels

If the HM digit is 9, this indicates that the number represented by the values of the digits M, H, T and U is the VHF working channel number. If the M digit is 1, this indicates that the ship stations transmitting frequency is being used as a simplex channel frequency for both ship and coast stations. If the M digit is 2, this indicates that the coast stations transmitting frequency is being used as a simplex channel frequency for both ship and coast stations.

8.3.2.3 Ship's position information

For MF/HF calls, message 2 may contain the ship's position, consisting of the digit 5 repeated two times and ten digits (five characters) indicating this position, coded in accordance with § 8.1.2 (see Table A1-6).

For position requests message 2 consists of 6 no information symbols (symbol No. 126).

In acknowledgements to a call requesting ship's position (see Fig. 3d)) message 2 consists of twelve digits (six symbols), the first of which should be coded in accordance with § 8.1.2 followed by one symbol No. 126.

8.3.3 Message 3

Message 3 follows message 2 in this case and contains the time (UTC) when the coordinates were valid, coded as indicated in § 8.1.3.

Message 3 follows message 2 when using the DSC system for calls initiated by ship stations requiring a semi-automatic or automatic connection (see Table A1-4.10.1 and A1-4.10.2) and contains the public switched network number (e.g. telephone number). In this case the format specifier used is symbol No. 123.

This number is coded by up to nine symbols in a manner similar to that shown in Table A1-2, except that the first character transmitted should be either symbol No. 105 or No. 106 to indicate whether the network number contains an odd or even number of significant digits. As an example, the number 0012345 would be coded as symbol numbers 105 00 01 23 45 whereas the number 00123456 should be coded as symbol numbers 106 00 12 34 56.

8.4 Distress alert relay

For "distress alert relay" including shore-to-ship alerts, "distress alert relay acknowledgement" and "distress acknowledgement" calls, the message formats are indicated in Tables A1-4.3, A1-4.4 and A1-4.2 respectively.

When sending a distress alert on behalf of another ship which is unable to send its own alert, and where the identity of the station in distress is unknown, the distress alert relay call should contain the symbol No. 126 transmitted five times for the "identification of the station in distress".

8.5 Test calls

Test calls on the distress and safety frequencies for MF and HF and VHF channel 70 may be conducted using the test call sequence in Table A1-4.7.

8.6 Distress self-cancel operation

Distress acknowledgments where the transmitting ID and ship in distress ID are the same, the message should be interpreted as a self-cancel operation. This should be displayed on all receiving stations.

9 End of sequence

The "end of sequence" (EOS) character is transmitted three times in the DX position and once in the RX position (see Fig. 1b)). It is one of the three unique characters corresponding to symbol Nos. 117, 122 and 127 as follows:

- symbol No. 117 if the call requires acknowledgement (Acknowledge RQ), used for individual and automatic/semiautomatic calls only;
- symbol No. 122 if the sequence is an answer to a call that requires acknowledgement (Acknowledge BQ), used for individual and automatic/semiautomatic calls and all distress alert relay acknowledgements;
- symbol No. 127 for all other calls.

10 Error-check character

10.1 The error-check character (ECC) is the final character transmitted and it serves to check the entire sequence for the presence of errors which are undetected by the ten-unit error-detecting code and the time diversity employed.

10.2 The seven information bits of the ECC shall be equal to the least significant bit of the modulo-2 sums of the corresponding bits of all information characters (i.e. even vertical parity). The format specifier and the EOS characters are considered to be information characters. The phasing characters and the retransmission (RX) characters shall not be considered to be information characters. Only one format specifier character and one EOS character should be used in constructing the ECC. The ECC shall also be sent in the DX and RX positions.

10.3 Automatic acknowledgement transmissions should not start unless the ECC is received and decoded correctly. A received ECC which does not match that calculated from the received information characters may be ignored if this was due to an error detected in the ten-unit error-detecting code of the information characters which was correctable by use of the time diversity code.

10.4 The receiver decoder should provide maximum utilization of the received signal, including use of the error-check character.

11 Distress alert attempt

11.1 Distress alerts may be transmitted as a single frequency or a multi-frequency call attempt preceded by a dot pattern. MF/HF equipment should be capable of using both single and multi-frequency call attempts. Where a distress alert attempt contains more than one consecutive distress alert on the same frequency (see Recommendation ITU-R M.541), these consecutive alerts should be transmitted with no gap between the end of one call and the start of the dot pattern of the following call to enable bit synchronization to be maintained (see Fig. 1c)). Multi-frequency call attempts should always include at least the MF and HF 8 MHz band DSC distress and safety frequencies.

11.2 A distress alert should be activated only by means of a dedicated distress button which should be clearly identified and be protected against inadvertent operation. For a fixed station the protection should be a spring loaded lid or cover. For a handheld VHF the protection should be a cover or a lid which should be rapidly self-closing when unattended. The initiation of a distress alert should at least require two independent actions.

11.3 Calls with format specifier “distress” or category “distress”, “urgency” and “safety” should be initiated manually only. This applies also for ships equipped for automatic DSC operation. For automatic repetition of distress alerts see Recommendation ITU-R M.541.

11.4 Immediately following a distress alert a DSC expansion message giving enhanced position resolution according to Recommendation ITU-R M.821 should be transmitted in the following manner.

For a single frequency distress alert attempt the expansion message should be transmitted immediately after the last of five consecutive distress alerts.

For a multi-frequency distress alert attempt the expansion message should be transmitted immediately after each distress alert.

12 Shipborne human machine interface

12.1 Shipborne audible alarm

Shipborne alarms should start softly and increase in volume if not silenced by the operator. This will give the operator the opportunity to acknowledge the alarm without interrupting the ship's current communications. It should be possible for the operator to disable all audible alarms except those of category (see 6) distress and urgency.

Distress calls should have an alarm consisting of a repetition of the 2 200 Hz tone for 250 ms followed by a 1 300 Hz tone for 250 ms (two-tone alarm). This alarm occurs at the initiation of the received distress DSC automated procedure. The characteristics of this alarm should not be able to be altered.

Urgency calls should have an alarm consisting of a repetition of the 2 200 Hz tone for 250 ms followed by 250 ms period of silence. This alarm occurs at the initiation of the received non-distress DSC automated procedure when the category of the initiating DSC message is "urgency". The characteristics of this alarm should not be able to be altered.

For HF and MF distress calls, the alarm should activate only when a distress alert, distress acknowledgement, or a distress alert relay is received and the distress position is within 500 NM (926 km) of the receiving vessel's position, or if the distress position is in the polar areas (latitude greater than 70° N or 70° S). The alarm should also activate when the call is received and the distance between the vessel in distress and the receiving vessel cannot be determined.

NOTE 1 – Disabling of audible alarm does not affect handling of call.

For geographic area calls, the alarm appropriate to the category should activate when the receiving station's position is within the area specified by the call or the receiving station's position is not known. The alarm should not be activated where duplicate distress alert relay calls are received within one hour. A duplicate distress alert relay call is one having format specifier all ships or geographic area that contains identical message information, as defined in § 8.1 and an identical distress maritime mobile service identity (MMSI).

12.2 Inactivity timer

During normal operation, the equipment should include an inactivity timer to return the DSC system display to default or standby mode if the operator is in a menu where DSC call reception is disabled and does not make any selections or changes for 10 min.

12.3 Display

The presentation of information on the display should support readability from typical user positions when operating the equipment under all ambient light conditions and operational requirements likely to be experienced on the bridge of a ship¹.

It should have the means to display, in plain language, the information contained in the received call. For Class A DSC equipment, the display should have a minimum of 160 characters in two or more lines.

12.4 Maritime mobile service identity

DSC equipment should not transmit any DSC call until own ship's MMSI allocated to the ship by the relevant administration has been configured and stored in the DSC equipment. Once stored, it should

¹ See IMO MSC. 191(79) for further details.

only be possible for an authorised user to change the MMSI with advice/cooperation from the manufacturer.

The DSC equipment should display own ship's MMSI on start-up unless the MMSI has not been configured. If the MMSI has not been configured, the equipment will display a warning that the unit will not transmit any DSC calls until own ship's MMSI is entered. The equipment should stay in this state until the operator confirms he has read the display and input own ship's MMSI.

The MMSI should be readily displayed on the human machine interface when the DSC equipment is on.

12.5 Automatic channel switching function on VHF

Automatic switching to a subsequent communications channel on receipt of a DSC call may be implemented on VHF equipment. Prior to an automatic switch to the proposed frequency or channel, the user should accept the change, which should be carried out after the acknowledgement.

Automatic switching to a subsequent communications channel on receipt of a DSC call might in some cases disrupt important ongoing communications. Where such capability exists, a means for disabling that function should therefore be provided for all calls other than individual station calls of category distress or urgency. The DSC equipment should provide visual indication that the automatic switching function is disabled.

12.6 Data interface

DSC equipment should be provided with facilities for exchange of data from shipborne navigational equipment or systems, or other shipborne equipment as necessary in accordance with IEC 61162 series for purposes including automatic position updating.

12.7 Position updating

DSC equipment should accept valid IEC 61162 position information including the time at which the position was determined, from an external source utilizing the data interface described in § 12.6, for automatic update of own ship's DSC position.

The DSC Class D and E Equipment should, and the DSC Class A equipment may also be provided with an integral electronic position fixing device. In which case, the DSC equipment should automatically switch to the internal source if the external IEC 61162 position information is not valid or not available. Antennas for integral electronic position fixing devices should be mounted externally, such that they are provided with an unobstructed view of the sky.

If the automatic position update is not available, a displayed and audible reminder to manually update the position should occur when a) no position information is provided during start up and b) before the position information is 4 hours old. The displayed reminder should remain until position updating has been carried out. Any position information not updated for more than 23½ hours should automatically be erased.

Own ship's DSC position information and the source of that information (external, internal, or manually entered) should be displayed on the DSC equipment.

12.8 Geographic area entry

DSC equipment should be provided with means for transforming a geographical area specified by the user as a centre point and a range to the corresponding Mercator area call format specified in § 5.3. The centre point should default to the ships position information and the range should default to

500 NM (926 km). The transformation of the entered range and centre-point should result in the minimum rectangular area that encompasses the entered data.

12.9 Medical transport and neutral ships and aircraft

The capability of using second telecommands “Ships and aircraft of States not parties to an armed conflict” and “Medical Transports” should not be available by default but only after changing relevant parameters in the setup menu.

12.10 Group calls (Ships having common interest)/individual call

When the MMSI in the menu for an individual call starts with “0” followed by the three digits of a MID the format specifier for individual call 120 should/may change to a group call specifier 114 automatically, as well as the settings of the call.

13 Handheld human machine interface

13.1 Audible alarms

All calls to the handheld VHF should activate an audible alarm.

Distress calls should have an alarm consisting of a repetition of the 2 200 Hz tone for 250 ms followed by a 1 300 Hz tone for 250 ms (two-tone alarm). This alarm occurs at the initiation of the received distress DSC automated procedure. The characteristics of this alarm should not be able to be altered.

Urgency calls should have an alarm consisting of a repetition of the 2 200 Hz tone for 250 ms followed by 250 ms period of silence. This alarm occurs at the initiation of the received non-distress DSC automated procedure when the category of the initiating DSC message is “urgency”. The characteristics of this alarm should not be able to be altered.

It should be possible for the operator to disable all audible alarms except those of category distress and urgency.

NOTE 1 – Disabling of audible alarm does not affect handling of call.

13.2 Inactivity timer

During normal operation, the handheld equipment should include an inactivity timer to return the DSC system display to default or standby mode if the operator is in a menu where DSC call reception is disabled and does not make any selections or changes for a number of minutes. The range of minutes should be adjustable from 1 to 10 in the configuration of the handheld VHF.

13.3 Display

The presentation of information on the display of the handheld VHF should support readability from typical user positions under all ambient light conditions and operational requirements². It should have the means to display, in plain language, the information contained in the received call.

13.4 Maritime mobile service identity/Maritime identity

Handheld DSC equipment should not transmit any DSC call until the MMSI or maritime identity allocated to the handheld VHF by the relevant administration has been configured and stored in

² See IMO MSC. 191(79) for further details.

the DSC equipment. Once stored, it should not be possible for the user to reprogram the identifier without advice from the manufacturer.

The DSC equipment should display the identifier on start-up unless an identifier has not been configured. If the identifier has not been configured, the equipment will display a warning that the unit will not transmit any DSC calls until an identifier is entered. The equipment should stay in this state until the operator confirms he has read the display and input an identifier.

The identifier should be displayed in standby mode and available to be displayed in the menu system of the handheld VHF.

13.5 Automatic channel switching

Automatic switching to a subsequent communications channel on receipt of a DSC call may be implemented on VHF equipment. Prior to an automatic switch to the proposed frequency or channel, the user should accept the change, which should be carried out after the acknowledgement.

Automatic switching to a subsequent communications channel on receipt of a DSC call might in some cases disrupt important ongoing communications. Where such capability exists, a means for disabling that function should therefore be provided for all calls.

The handheld VHF should revert to automatic channel switching after a power off and power ON sequence has been carried out.

14 Handheld VHF digital selective calling equipment with electronic position fixing systems (Class H)

The DSC equipment must provide an internal electronic position fixing device and use those capabilities.

15 Position request operation for Class D, E and H

The Position Request Acknowledgement function should be capable of being deactivated by the user in order to ensure privacy. However, after transmission of a distress alert, the position request acknowledgment of that particular radio should be activated automatically and then stay active until reset by the user. The Position Request Acknowledgement should be sent automatically by the equipment if requested. This would ensure that search and rescue entities are able to request the position of the vessel in distress even after a Distress Acknowledgement has been received by the equipment.

16 Man overboard devices using VHF digital selective calling (Class M)

16.1 Open and closed loop

Man overboard (MOB) devices using VHF DSC must be capable of operating as an open loop/all station device (see § 16.7) or as a closed loop/designated station device (see § 16.8) only, as described in this Recommendation.

16.2 General requirements

MOB devices shall be:

- fitted with an internal electronic position fixing device, a transceiver operating on VHF DSC channel 70 and an automatic identification system (AIS) transmitter operating in accordance with Recommendation ITU-R M.1371 (for MOB-devices);
- fitted with visual indicators to designate operation of the device and reception of DSC acknowledgment messages; and
- capable of manual and automatic activation and manual deactivation.

16.3 Identification number

- MOB devices shall be programmed with an appropriate identification number, coded in accordance with Recommendation ITU-R M.585.
- It shall not be possible for the user to change the MOB device's identification number.
- The MOB device's identification number shall be prominently and permanently marked on the exterior of the device.

16.4 Measures to avoid false alerts

Manufacturers shall implement measures to avoid false alerts from MOB devices, such as two simple, independent actions needed to start the transmissions:

- where one has to be manual such as an arming function or the protection of a switch by a removable cover;
- and the other which may be an automatic activation such as a water detection system.

Prior to release of the initial transmission a delay for a period not to exceed 30 seconds should be implemented, to allow users to deactivate the MOB device in the case of inadvertent activation. During this period an audible and visual indication has to be provided. These indications are to be activated also at follow up alerts. Equipment designed for intrinsically safe use should provide as a minimum a visual indication.

16.5 Distress self-cancel operation

MOB devices shall be capable of transmitting a distress self-cancel message, as described in § 8.6 and Table A1-4.2 which shall only be used in the following circumstances. The action of switching off a MOB device that has previously sent a distress alert as specified in Table A1-4.1 and that has not been acknowledged, shall cause the MOB device to transmit the distress self-cancel message.

16.6 Action on receipt of acknowledgment messages

If a DSC distress alert acknowledgement message, formatted in accordance with Table A1-4.2 as response to a DSC distress alert message, or a DSC distress alert relay acknowledgment message, formatted in accordance with Table A1-4.4 as response to a DSC distress alert relay message, is received by the MOB device, the DSC transmitter shall be switched off. The MOB device shall indicate reception of the acknowledgment message. The MOB device shall indicate reception of the acknowledgment message.

16.7 Open loop man overboard devices

Messages from and to open loop MOB devices using VHF DSC are defined in Tables A1-4.1 and A1-4.2. On initial activation, the open loop MOB device shall transmit a DSC message formatted as a distress alert as specified in Table A1-4.1. The nature of distress field shall be set to symbol 110 (man overboard) and the subsequent communications field set to symbol 126 (no information).

The position (message 2) and time (message 3) fields in the initial DSC message shall be replaced by the digits 9 and 8 respectively, in accordance with §§ 8.2.3 and 8.2.4.

As soon as the internal electronic position fixing device is able to provide an accurate position and time, the open loop MOB device transmits a further distress alert with the position and time from the position fixing device automatically inserted into the message. The position expansion sequence of Recommendation ITU-R M.821 shall be used. The AIS transmitter begins transmitting MOB messages at this time. The messages will continue until the MOB device is manually switched off or the battery is exhausted.

After this transmission, the DSC receiver in the open loop MOB device shall turn on and monitor the DSC channel for acknowledgment messages for 30 minutes.

If a DSC Distress Alert Acknowledgment message is not received, the open loop MOB device shall operate with a duty cycle of at least one message every 5 minutes for a period of 30 minutes. The actual transmitter duty cycle shall be a randomly selected time of between 4.9 and 5.1 minutes.

After 30 minutes have elapsed without an acknowledgment message being received, the open loop MOB device's duty cycle should then change to 10 minutes. The actual transmitter duty cycle shall be a randomly selected time of between 9.9 and 10.1 minutes. This will continue until an acknowledgment message is received, the batteries are exhausted or the MOB device is switched off. After each transmission, the DSC receiver shall turn on and monitor the DSC channel for an acknowledgment message for 5 minutes.

16.8 Closed loop man overboard devices

Messages from and to closed loop MOB devices using VHF DSC are defined in Tables A1-4.3 and A1-4.4.

On initial activation, the closed loop MOB device shall transmit a DSC message formatted as a distress alert relay on behalf of another ship, as specified in Table A1-4.3 with the nature of distress set to 110 (MOB) and the subsequent communications field set to symbol 126 (no information). The destination maritime identity may be either an individual station or a group. The position (message 2) and time (message 3) fields in the initial DSC message shall be replaced by the digits 9 and 8 respectively, in accordance with §§ 8.2.3 and 8.2.4.

As soon as the internal electronic position fixing device is able to provide an accurate position and time, the closed loop MOB device shall transmit a further distress alert relay on behalf of another ship with the position and time from the position fixing device automatically inserted into the message. The position expansion sequence of Recommendation ITU-R M.821 shall be used. The AIS transmitter begins transmitting MOB messages at this time. The messages will continue until the MOB device is manually switched off or the battery is exhausted.

After this transmission, the DSC receiver in the closed loop MOB device shall turn on and monitor the DSC channel for acknowledgment messages for 30 minutes. If a DSC distress alert relay acknowledgment message is not received, the closed loop MOB device shall operate with a duty cycle of at least one message every 5 minutes. The actual transmitter duty cycle shall be a randomly selected time of between 4.9 and 5.1 minutes. If, after a 12 minute period, a DSC distress alert relay acknowledgment message has not been received, the MOB device shall then switch from closed loop to open loop mode by transmitting a DSC message coded as an all ships distress alert as specified in Table A1-4.1. The nature of distress field shall be set to symbol 110 (man overboard) and the subsequent communications field set to symbol 126 (no information). Position and time shall be automatically inserted from the internal electronic position fixing device. After this transmission, the DSC receiver shall turn on and monitor the DSC channel for acknowledgment messages for 5 minutes.

If a DSC distress alert acknowledgment message is not received, the MOB device shall operate with a duty cycle of at least one distress alert every 5 minutes for a period of 30 minutes, i.e. at least one transmission every 5 minutes for a 30 minute period. The actual transmitter duty cycle shall be a randomly selected time of between 4.9 and 5.1 minutes. After each transmission, the DSC receiver shall turn on and monitor the DSC channel for acknowledgment messages for 5 minutes.

After 30 minutes have elapsed without an acknowledgment message being received, the MOB device's duty cycle should then change to 10 minutes. The actual transmitter duty cycle shall be a randomly selected time of between 9.9 and 10.1 minutes. This will continue until an acknowledgment message is received, the batteries are exhausted or the MOB device is switched off. After each transmission, the DSC receiver shall turn on and monitor the DSC channel for acknowledgment messages for 5 minutes.

FIGURE 2

Examples of a calling sequence and reply sequences for typical individual calls

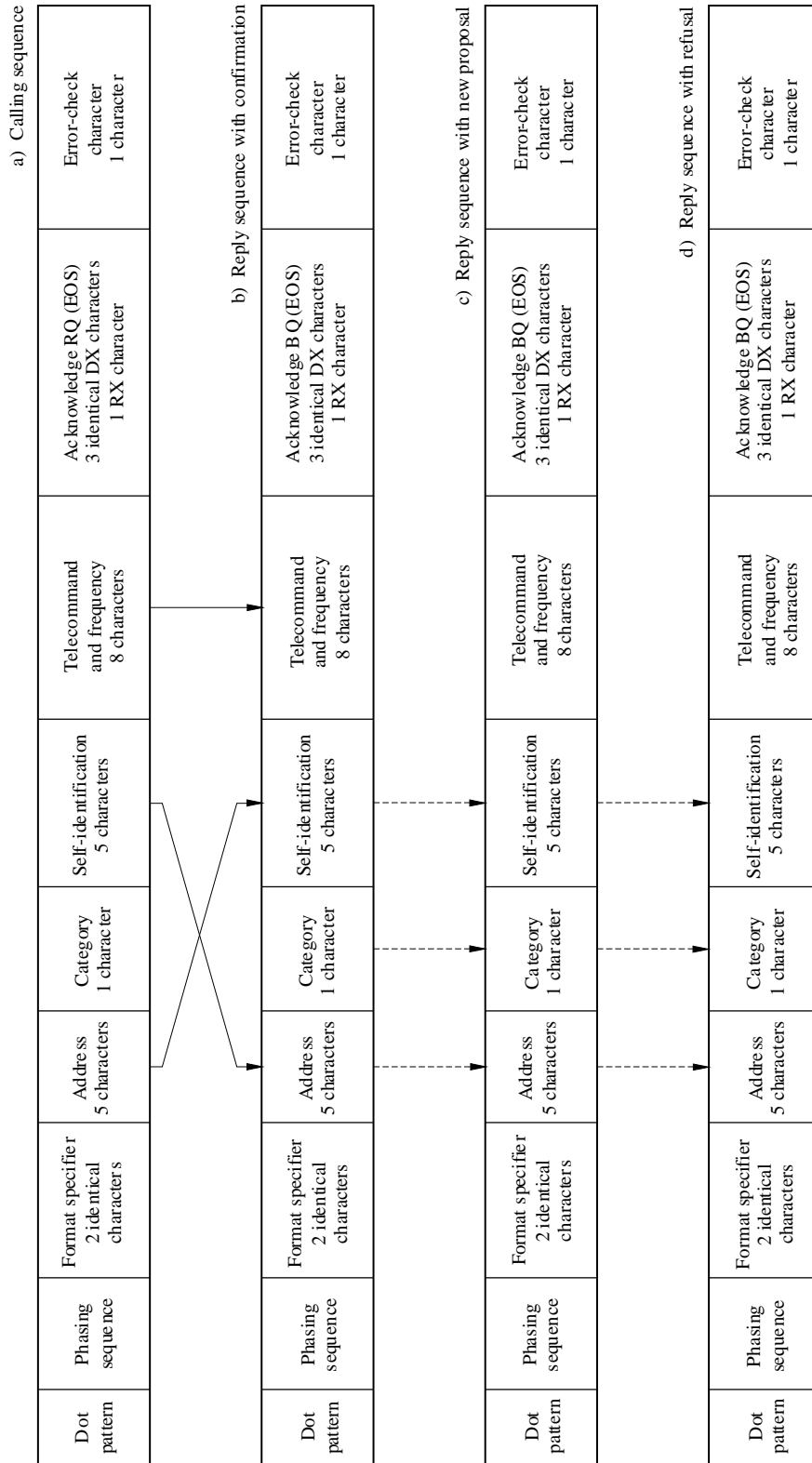
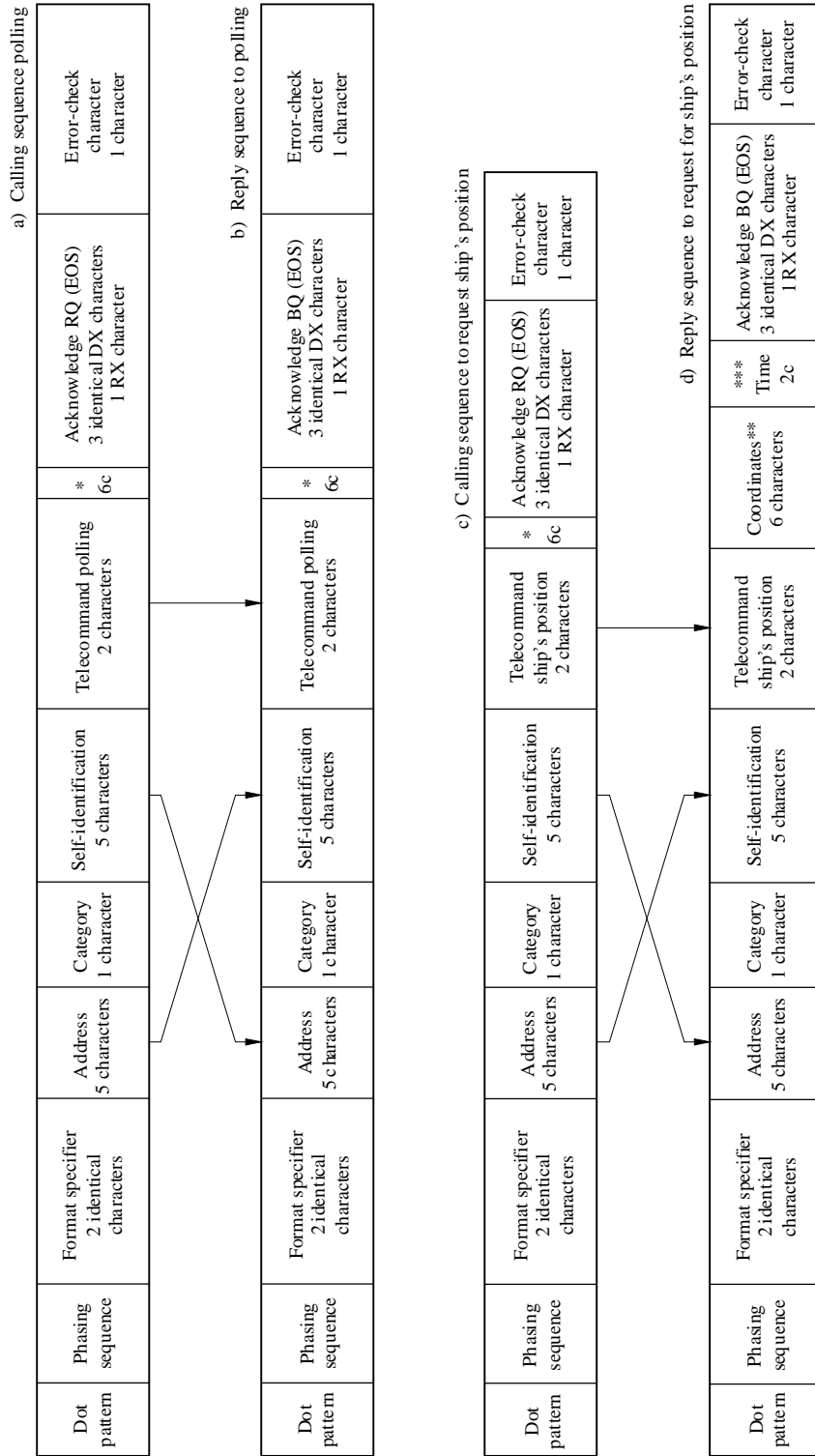

FIGURE 3

Calling sequences and reply sequences for polling and ship's position



M.0493-03

FIGURE 4

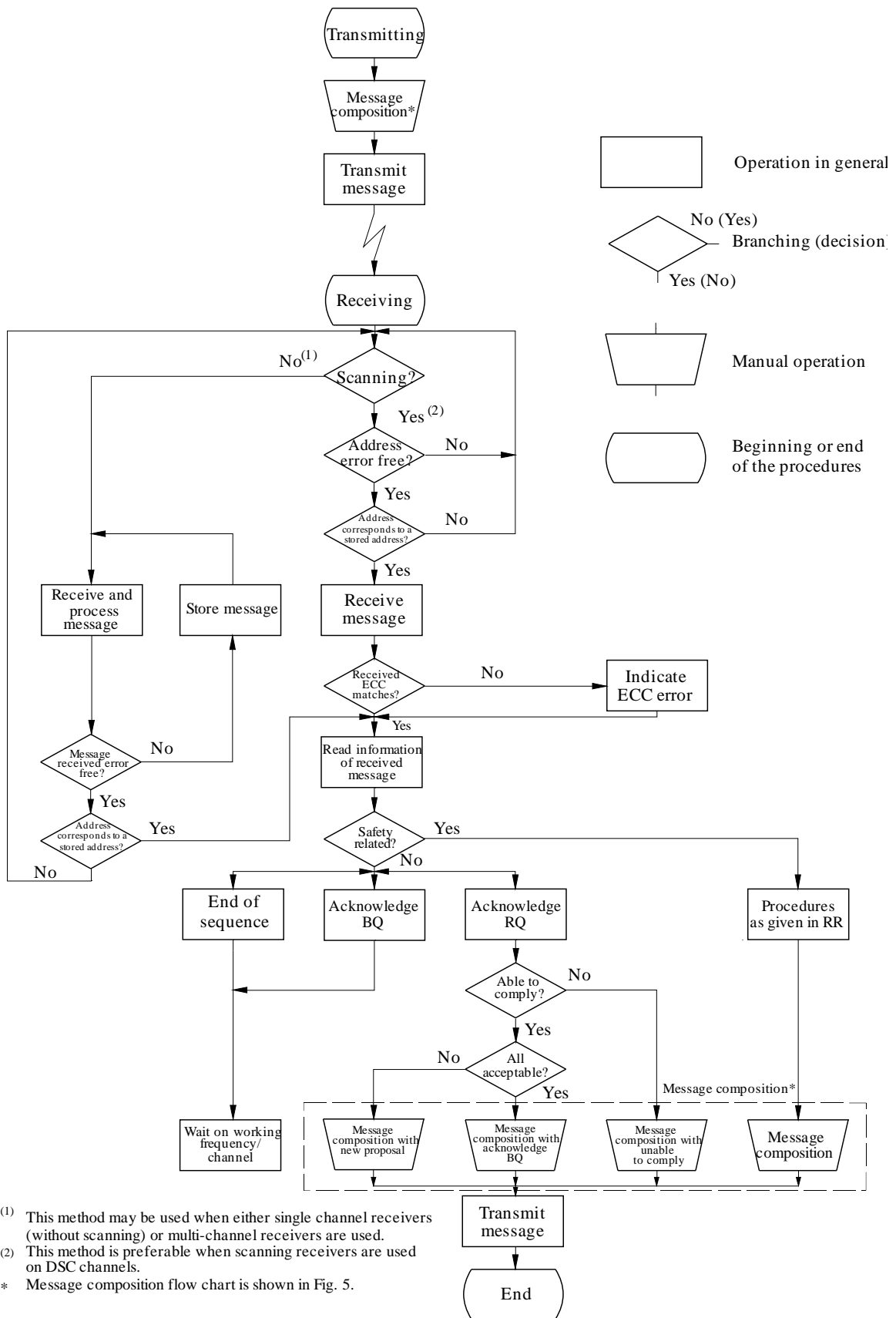

FIGURE 5
Example of message composition flow chart

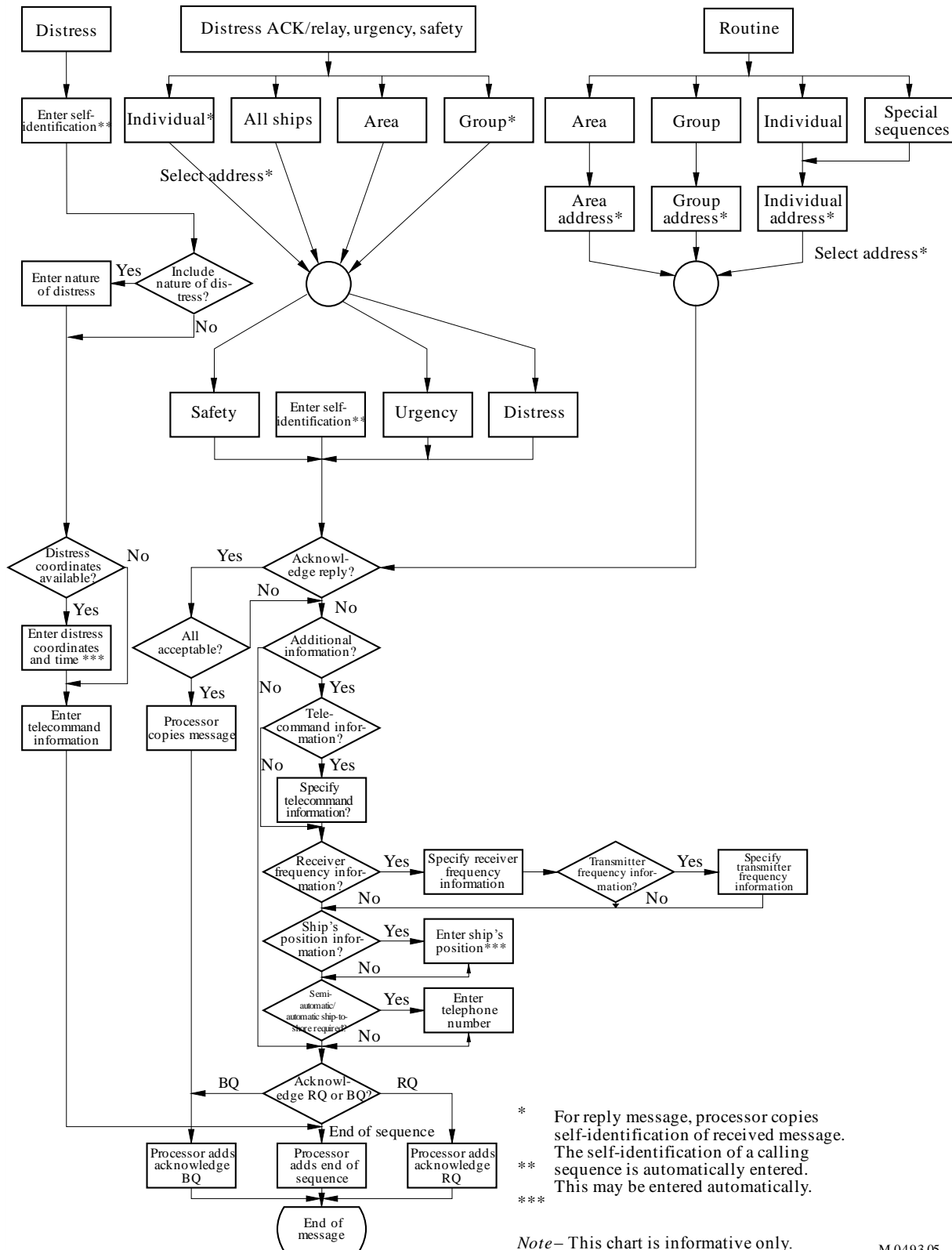
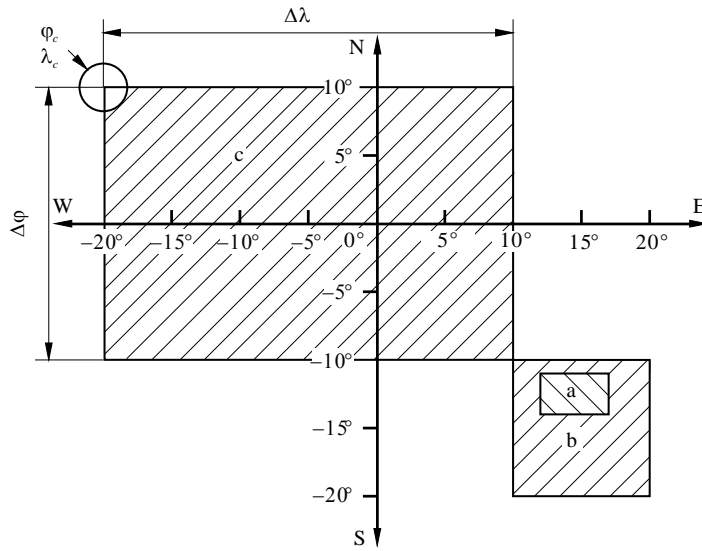

FIGURE 6
Geographic coordinates



a) $\phi_a = -11^\circ$ (South) $\lambda_a = 12^\circ$ (East) $\Delta\phi = 3^\circ$ $\Delta\lambda = 5^\circ$

Format specifier	2	1	1	0	1	2	0	3	0	5	Category
	Sector		ϕ_a	λ_a		$\Delta\phi$		$\Delta\lambda$			

b) $\phi_b = -10^\circ$ (South) $\lambda_b = 10^\circ$ (East) $\Delta\phi = 10^\circ$ $\Delta\lambda = 10^\circ$

Format specifier	2	1	0	0	1	0	1	0	1	0	Category
------------------	---	---	---	---	---	---	---	---	---	---	----------

c) $\phi_c = 10^\circ$ (North) $\lambda_c = -20^\circ$ (West) $\Delta\phi = 20^\circ$ $\Delta\lambda = 30^\circ$

Format specifier	1	1	0	0	2	0	2	0	3	0	Category
------------------	---	---	---	---	---	---	---	---	---	---	----------

Legend for Tables A1-4.1 to A1-4.11

Symbol/expression	Meaning
●	Required
■	Required for backward compatibility
—	Not allowed
Symbols 100-127	Symbols in accordance with Table A1-3
Area	Coded in accordance with Annex 1, § 5.3
Frequency	Coded in accordance with Annex 1, § 8.2.2
MMSI	Coded in accordance with Annex 1, § 5.2
ID	Coded in accordance with Annex 1, § 5.2
Pos1	Coded in accordance with Annex 1, § 8.1.2
Pos2	Coded in accordance with Annex 1, § 8.3.2.3
Pos3	Coded in accordance with Annex 1, § 8.3.2.3
Pos4	Coded in accordance with Annex 1, § 8.3.2.3
Pos5	Coded in accordance with Recommendation ITU-R M.821
UTC	Coded in accordance with Annex 1, § 8.1.3
n/a	This field is not included in this call
ECC	Coded in accordance with Annex 1, § 10.2
EOS	Coded in accordance with Annex 1, § 9
expan1	Expansion sequence 1
expan2	Expansion sequence 2
expan3	Expansion sequence 3
	Does not apply

NOTE 1 – For Class A all functions are identical for VHF and MF.

TABLE A1-4.1

Distress alerts

Frequency band	Type	Applicable to												Technical format of call sequence								Rec. ITU-R M.821 expansion sequence* (9)	
		Ship station Class A		Ship station Class D		Ship station Class E		Hand-held Class H		MOB Device Class M Open loop		Coast station		Format specifier (2 identical)	Self-ID (5)	Message				EOS (1)	ECC (1)		EOS (2 identical)
		Tx	Rx	Tx	Rx	Tx	Rx	Tx	Rx	Tx	Rx	Tx	Rx			1	2	3	4				
																Nature of distress (1)	Distress coordinates (5)	Time (2)	Subsequent communications (1)				
VHF	Distress (RT)	●	●	●	●			●	●	●	—	—	●	112	Self-ID	100 to 110	Pos1	UTC	100**	127	ECC	127	expan1
	Distress (EPIRB)	—	●	—	●			—	●	—	—	—	●	112	Self-ID	112	Pos1	UTC	126	127	ECC	127	expan1
MF/HF	Distress (RT)	●	●			●	●					—	●	112	Self-ID	100 to 110	Pos1	UTC	109	127	ECC	127	expan1
	Distress (FEC)	●	●			—	●					—	●	112	Self-ID	100 to 110	Pos1	UTC	113	127	ECC	127	expan1

* Expansion sequence see Table A1-4.11

** For class M, this field is set to 126

TABLE A1-4.2
Distress acknowledgements

Frequency band	Type	Applicable to												Technical format of call sequence												
		Ship station Class A		Ship station Class D		Ship station Class E		Hand-held Class H		MOB Device Class M open loop		Coast station		Format specifier (2 identical)	Category (1)	Self-ID (5)	Tele-command (1)	Message					EOS (1)	ECC (1)	EOS (2 identical)	
		Tx	Rx	Tx	Rx	Tx	Rx	Tx	Rx	Tx	Rx	Tx	Rx					0	1	2	3	4				
VHF	Distress acknowledgement (RT)	•	•	—	•			—	•	—	•	•	•	•	116	112	Self-ID	110	Distress ID	100 - 110	Pos1	UTC	100**	127	ECC	127
	Distress acknowledgement (EPIRB)	•	•	—	•			—	•	—	—	•	•	116	112	Self-ID	110	Distress ID	112	Pos1	UTC	126	127	ECC	127	
	Distress self-cancel	•	•	•	•			•	•	•	—	—	•	116	112	Self-ID	110	Self-ID	100 - 110	Pos1	UTC	100**	127	ECC	127	

Rec. ITU-R M.821 expansion sequence* (9)
expan1
expan1
expan1

* Expansion sequence see Table A1-4.11

** For class M, this field is set to 126

TABLE A1-4.2 (end)

Distress acknowledgements

Frequency band	Type	Applicable to												Technical format of call sequence											Rec. ITU-R M.821 expansion sequence* (9)	
		Ship station Class A		Ship station Class D		Ship station Class E		Hand-held Class H		MOB Device Class M open loop		Coast station		Format specifier (2 identical)	Category (1)	Self-ID (5)	Tele-command (1)	Message					EOS (1)	ECC (1)		EOS (2 identical)
		Tx	Rx	Tx	Rx	Tx	Rx	Tx	Rx	Tx	Rx	Tx	Rx					0	1	2	3	4				
																		Distress ID (5)	Nature of distress (1)	Distress coordinates (5)	Time (2)	Subsequent communications (1)				
MF	Distress acknowledgement (RT)	•	•			—	•					•	•	116	112	Self-ID	110	Distress ID	100 - 110	Pos1	UTC	109	127	ECC	127	expan1
	Distress acknowledgement (FEC)	•	•			—	•					•	•	116	112	Self-ID	110	Distress ID	100 - 110	Pos1	UTC	113	127	ECC	127	expan1
	Distress self-cancel	•	•			•	•					—	•	116	112	Self-ID	110	Self-ID	100 - 110	Pos1	UTC	109	127	ECC	127	expan1
HF	Distress acknowledgement (RT)	—	•			—	•					•	•	116	112	Self-ID	110	Distress ID	100 - 110	Pos1	UTC	109	127	ECC	127	expan1
	Distress acknowledgement (FEC)	—	•			—	•					•	•	116	112	Self-ID	110	Distress ID	100 - 110	Pos1	UTC	113	127	ECC	127	expan1
	Distress self-cancel	•	•			•	•					—	•	116	112	Self-ID	110	Self-ID	100 - 110	Pos1	UTC	109	127	ECC	127	expan1

The message should match the received distress alert information, except for manually generated distress acknowledgements by coast stations.

* Expansion sequence see Table A1-4.11

TABLE A1-4.3
Distress alert relays

Frequency band	Type	Applicable to												Technical format of call sequence										Rec. ITU-R M.821 expansion sequence* (9)			
		Ship station Class A		Ship station Class D		Ship station Class E		Hand-held Class H		MOB Device Class M Closed Loop		Coast station		Format specifier (2 identical)	Address (5)	Category (1)	Self-ID (5)	Tele-command (1)	Message						EOS (1)	ECC (1)	EOS (2 identical)
		Tx	Rx	Tx	Rx	Tx	Rx	Tx	Rx	Tx	Rx	Tx	Rx						Distress ID (5)	Nature of distress (1)	Distress coordinates (5)	Time (2)	Subsequent communications (1)				
VHF	Individual (RT)	●	●	—	●	■	■	—	—	—	—	●	●	120	ID	112	Self-ID	112	Distress ID	100 - 110	Pos1	UTC	100	117	ECC	117	expan2
	Individual (EPIRB)	●	●	—	●	■	■	—	—	—	—	●	●	120	ID	112	Self-ID	112	Distress ID	112	Pos1	UTC	126	117	ECC	117	expan2
	Individual (Man Overboard Beacon)	—	●	—	●	■	■	—	—	●	—	—	●	120	ID	112	Self-ID	112	Distress ID	110	Pos1	UTC	126	117	ECC	117	expan2
	Group (Man Overboard Beacon)	—	●	—	●	■	■	—	—	●	—	—	●	114	ID	112	Self-ID	112	Distress ID	110	Pos1	UTC	126	127	ECC	127	expan1
	Geographic area (RT)	—	■	—	■	■	■	—	—	—	—	—	■	102	Area	112	Self-ID	112	Distress ID	100 - 110	Pos1	UTC	100	127	ECC	127	expan1
	Geographic area (EPIRB)	—	■	—	■	■	■	—	—	—	—	—	■	102	Area	112	Self-ID	112	Distress ID	112	Pos1	UTC	126	127	ECC	127	expan1
	All ships (RT)	●	●	—	●	■	■	—	—	—	—	●	●	116	n/a	112	Self-ID	112	Distress ID	100 - 110	Pos1	UTC	100	127	ECC	127	expan1
	All ships (EPIRB)	●	●	—	●	■	■	—	—	—	—	●	●	116	n/a	112	Self-ID	112	Distress ID	112	Pos1	UTC	126	127	ECC	127	expan1

* Expansion sequence see Table A1-4.11

TABLE A1-4.3 (end)

Distress alert relays

Frequency band	Type	Applicable to												Technical format of call sequence										Rec. ITU-R M.821 expansion sequence* (9)				
		Ship station Class A		Ship station Class D		Ship station Class E		Hand-held Class H		MOB Device Class M Open and Closed Loop		Coast station		Format specifier (2 identical)	Address (5)	Category (1)	Self-ID (5)	Tele-command (1)	Message						EOS (1)	ECC (1)	EOS (2 identical)	
		Tx	Rx	Tx	Rx	Tx	Rx	Tx	Rx	Tx	Rx	Tx	Rx						0	1	2	3	4					
														Distress ID (5)	Nature of distress (1)	Distress coordinates (5)	Time (2)	Subsequent communications (1)										
MF/HF	Individual (RT)	●	●			—	●						●	●	120	MMSI	112	Self-ID	112	Distress ID	100 - 110	Pos1	UTC	109	117	ECC	117	expan2
	Individual (FEC)	●	●			—	●						●	●	120	MMSI	112	Self-ID	112	Distress ID	100 - 110	Pos1	UTC	113	117	ECC	117	expan2
	Geographic area (RT)	●	●			—	●						●	●	102	Zone	112	Self-ID	112	Distress ID	100 - 110	Pos1	UTC	109	127	ECC	127	expan1
	Geographic area (FEC)	●	●			—	●						●	●	102	Zone	112	Self-ID	112	Distress ID	100 - 110	Pos1	UTC	113	127	ECC	127	expan1
	All ships (RT)	—	■			—	■						—	■	116	n/a	112	Self-ID	112	Distress ID	100 - 110	Pos1	UTC	109	127	ECC	127	expan1
	All ships (FEC)	—	■			—	■						—	■	116	n/a	112	Self-ID	112	Distress ID	100 - 110	Pos1	UTC	113	127	ECC	127	expan1

The message should match the received distress alert information, except for manually generated distress alert relays observed or notified by non-DSC means.

* Expansion sequence see Table A1-4.11

TABLE A1-4.4
Distress alert relay acknowledgements

Frequency band	Type	Applicable to												Technical format of call sequence											Rec. ITU-R M.821 expansion sequence* (9)			
		Ship station Class A		Ship station Class D		Ship station Class E		Hand-held Class H		MOB Device Class M Closed Loop		Coast station		Format specifier (2 identical)	Address (5)	Category (1)	Self-ID (5)	Tele command (1)	Message					EOS (1)		ECC (1)	EOS (2 identical)	
		Tx	Rx	Tx	Rx	Tx	Rx	Tx	Rx	Tx	Rx	Tx	Rx						0	1	2	3	4					
																			Distress ID (5)	Nature of distress (1)	Distress coordinates (5)	Time (2)	Subsequent communications (1)					
VHF	Individual (RT)	●	●	●	●			—	●	—	●	●	●	120	ID	112	Self-ID	112	Distress ID	100 - 110	Pos1	UTC	100	122	ECC	122	expan3	
	DROBOSE to a Group (RT)	●	●	●	●			—	●	—	●	●	●	114	ID	112	Self-ID	112	Distress ID	110	Pos1	UTC	126	122	ECC	122	expan3	
	Individual (EPIRB)	●	●	●	●			—	—	—	—	●	●	120	ID	112	Self-ID	112	Distress ID	112	Pos1	UTC	126	122	ECC	122	expan3	
	Individual (MoB)	●	●	●	●			—	—	—	—	●	●	120	ID	112	Self-ID	112	Distress ID	110	Pos1	UTC	126	122	ECC	122	Expan3	
	All ships (RT)	—	●	—	●			—	—	—	—	●	●	116	n/a	112	Self-ID	112	Distress ID	100 - 110	Pos1	UTC	100	122	ECC	122	expan3	
	All ships (EPIRB)	—	●	—	●			—	—	—	—	●	●	116	n/a	112	Self-ID	112	Distress ID	112	Pos1	UTC	126	122	ECC	122	expan3	
MF/HF	Individual (RT)	●	●			●	●						●	●	120	ID	112	Self-ID	112	Distress ID	100 - 110	Pos1	UTC	109	122	ECC	122	expan3
	Individual (FEC)	●	●			—	●						●	●	120	ID	112	Self-ID	112	Distress ID	100 - 110	Pos1	UTC	113	122	ECC	122	expan3
	All ships (RT)	—	■			—	●						●	●	116	n/a	112	Self-ID	112	Distress ID	100 - 110	Pos1	UTC	109	122	ECC	122	expan3
	All ships (FEC)	—	■			—	●						●	●	116	n/a	112	Self-ID	112	Distress ID	100 - 110	Pos1	UTC	113	122	ECC	122	expan3

The message should match the received distress alert relay call information.

* Expansion sequence see Table A1-4.11

TABLE A1-4.5

Urgency and safety calls – All ships

Frequency band	Type	Applicable to												Technical format of call sequence								
		Ship station Class A		Ship station Class D		Ship station Class E		Hand-held Class H		MOB Device Class M Open and Closed Loop		Coast station		Format specifier (2 identical)	Category (1)	Self-ID (5)	Message			EOS (1)	ECC (1)	EOS (2 identical)
		Tx	Rx	Tx	Rx	Tx	Rx	Tx	Rx	Tx	Rx	Tx	Rx				1		2			
																	1 st tele-command (1)	2 nd tele-command (1)				
VHF	All modes RT	●	●	●	●	■	■	—	●	—	—	●	●	116	108 or 110	Self-ID	100	126	Frequency	127	ECC	127
	Duplex RT ⁽¹⁾	—	■	—	■	■	■	—	■	—	—	—	■	116	108 or 110	Self-ID	101	126	Frequency	127	ECC	127
	Medical transports	●	●	—	—	■	■	—	—	—	—	—	●	116	110	Self-ID	100	111	Frequency	127	ECC	127
	Ships and aircraft (Res. 18)	●	●	—	—	■	■	—	—	—	—	—	●	116	110	Self-ID	100	110	Frequency	127	ECC	127
MF/HF	J3E RT	—	—	■	■	■	■	■	■	■	■	—	■	116	108 or 110	Self-ID	109	126	Frequency	127	ECC	127
	F1B FEC	—	—	■	■	■	■	■	■	■	■	—	■	116	108 or 110	Self-ID	113	126	Frequency	127	ECC	127

(1) See § 8.3.1

TABLE A1-4.6
Urgency and safety – Geographic area calls

Frequency band	Type	Applicable to												Technical format of call sequence										
		Ship station Class A		Ship station Class D		Ship station Class E		Hand-held Class H		MOB Device Class M Open and Closed Loop		Coast station		Format specifier (2 identical)	Address (5)	Category (1)	Self-ID (5)	Message			EOS (1)	ECC (1)	EOS (2 identical)	
		1		2		Frequency (6) or (8)																		
		1 st tele-command (1)	2 nd tele-command (1)																					
Tx	Rx	Tx	Rx	Tx	Rx	Tx	Rx	Tx	Rx	Tx	Rx													
MF/HF	J3E (RT)	●	●			●	●						●	●	102	Area	108 or 110	Self-ID	109	126	Frequency	127	ECC	127
	F1B (FEC)	●	●			—	—						●	●	102	Area	108 or 110	Self-ID	113	126	Frequency	127	ECC	127
	Medical transports	●	●			—	—						—	●	102	Area	110	Self-ID	109 or 113	111	Frequency	127	ECC	127
	Ships and aircraft (Res. 18)	●	●			—	—						—	●	102	Area	110	Self-ID	109 or 113	110	Frequency	127	ECC	127

TABLE A1-4.7

Urgency and safety – Individual calls and their acknowledgements

Frequency band	Type	Applicable to												Technical format of call sequence										Rec. ITU-R M.821 expansion sequence* (9)	
		Ship station Class A		Ship station Class D		Ship station Class E		Hand-held Class H		MOB Device Class M Open and Closed Loop		Coast station		Format specifier (2 identical)	Address (5)	Category (1)	Self-ID (5)	Message			EOS (1)	ECC (1)	EOS (2 identical)		
		Tx	Rx	Tx	Rx	Tx	Rx	Tx	Rx	Tx	Rx	Tx	Rx					1	2	3					
																		1 st tele-command (1)	2 nd tele-command (1)	Frequency or pos number (6) or (8)					Time (2)
VHF	All modes RT	●	●	—	●			—	●	—	—	●	●	120	ID	108 or 110	Self-ID	100	126	Frequency	n/a	117	ECC	117	—
	Duplex RT ⁽¹⁾	—	■	—	—			—	—	—	—	—	■	120	ID	108 or 110	Self-ID	101	126	Frequency	n/a	117	ECC	117	—
	RT acknowledgement	●	●	●	—			●	—	—	—	●	●	120	ID	108 or 110	Self-ID	100	126	Frequency	n/a	122	ECC	122	—
	Unable to comply acknowledgement	●	●	●	—			●	—	—	—	●	●	120	ID	108 or 110	Self-ID	104	100 - 109	Frequency	n/a	122	ECC	122	—
	Position request	●	●	●	●			●	●	—	—	●	—	120	ID	108	Self-ID	121	126	Pos3	n/a	117	ECC	117	—
	Position acknowledgement	●	●	●	●			●	●	—	—	—	●	120	ID	108	Self-ID	121	126	Pos4	UTC	122	ECC	122	expan3
	Test	●	●	●	●			●	●	●	—	●	●	120	ID	108	Self-ID	118	126	126	n/a	117	ECC	117	—
	Test acknowledgement	●	●	●	●			●	●	—	●	●	●	120	ID	108	Self-ID	118	126	126	n/a	122	ECC	122	—

* Expansion sequence see Table A1-4.11

TABLE A1-4.7 (end)

Urgency and safety – Individual calls and their acknowledgements

Frequency band	Type	Applicable to												Technical format of call sequence										Rec. ITU-R M.821 expansion sequence* (9)		
		Ship station Class A		Ship station Class D		Ship station Class E		Hand-held Class H		MOB Device Class M Open and Closed Loop		Coast station		Format specifier (2 identical)	Address (5)	Category (1)	Self-ID (5)	Message				EOS (1)	ECC (1)		EOS (2 identical)	
		Tx	Rx	Tx	Rx	Tx	Rx	Tx	Rx	Tx	Rx	Tx	Rx					1		2	3					
																		1 st tele-command (1)	2 nd tele-command (1)	Frequency or pos number (6) or (8)	Time (2)					
MF/HF	J3E RT	●	●			—	●						●	●	120	ID	108 or 110	Self-ID	109	126	Frequency	n/a	117	ECC	117	—
	J3E RT with pos number	●	—			—	—						—	●	120	ID	108 or 110	Self-ID	109	126	Pos2	n/a	117	ECC	117	—
	J3E RT acknowledgement	●	●			●	—						●	●	120	ID	108 or 110	Self-ID	109	126	Frequency	n/a	122	ECC	122	—
	F1B FEC or ARQ	●	●			—	—						●	●	120	ID	108 or 110	Self-ID	113 or 115	126	Frequency	n/a	117	ECC	117	—
	F1B FEC or ARQ with pos number	●	—			—	—						—	●	120	ID	108 or 110	Self-ID	113 or 115	126	Pos2	n/a	117	ECC	117	—
	F1B FEC or ARQ acknowledgement	●	●			—	—						●	●	120	ID	108 or 110	Self-ID	113 or 115	126	Frequency	n/a	122	ECC	122	—
	Unable to comply acknowledgement	●	●			●	—						●	●	120	ID	108 or 110	Self-ID	104	100 - 109	Frequency	n/a	122	ECC	122	—
	Position request	●	●			●	●						●	—	120	ID	108	Self-ID	121	126	Pos3	n/a	117	ECC	117	—
	Position acknowledgement	●	●			●	●						—	●	120	ID	108	Self-ID	121	126	Pos4	UTC	122	ECC	122	expans3
	Test	●	●			●	●						●	●	120	ID	108	Self-ID	118	126	126	n/a	117	ECC	117	—
	Test acknowledgement	●	●			●	●						●	●	120	ID	108	Self-ID	118	126	126	n/a	122	ECC	122	—

(1) See § 8.3.1

* Expansion sequence see Table A1-4.11

TABLE A1-4.8
Routine group calls

Frequency band	Type	Applicable to												Technical format of call sequence									
		Ship station Class A		Ship station Class D		Ship station Class E		Hand-held Class H		MOB Device Class M Open and Closed Loop		Coast station		Format specifier (2 identical)	Address (5)	Category (1)	Self-ID (5)	Message			EOS (1)	ECC (1)	EOS (2 identical)
		Tx	Rx	Tx	Rx	Tx	Rx	Tx	Rx	Tx	Rx	Tx	Rx					1		2			
																		1 st tele-command (1)	2 nd tele-command (1)				
VHF	All mode RT	●	●	●	●	■	■	●	●	—	—	●	●	114	MMSI	100	Self-ID	100	126	Frequency	127	ECC	127
	Duplex RT ⁽¹⁾	—	■	—	—	■	■	—	—	—	—	—	■	114	MMSI	100	Self-ID	101	126	Frequency	127	ECC	127
MF/HF	J3E RT	●	●	■	■	●	●	■	■	■	■	■	■	114	MMSI	100	Self-ID	109	126	Frequency	127	ECC	127
	F1B FEC	●	●	■	■	—	—	■	■	■	■	■	■	114	MMSI	100	Self-ID	113	126	Frequency	127	ECC	127

⁽¹⁾ See § 8.3.1.

TABLE A1-4.9

Routine individual calls and their acknowledgements

Frequency band	Type	Applicable to												Technical format of call sequence									
		Ship station Class A		Ship station Class D		Ship station Class E		Hand-held Class H		MOB Device Class M Open and Closed Loop		Coast station		Format specifier (2 identical)	Address (5)	Category (1)	Self-ID (5)	Message			EOS (1)	ECC (1)	EOS (2 identical)
		Tx	Rx	Tx	Rx	Tx	Rx	Tx	Rx	Tx	Rx	Tx	Rx					1		2			
																		1 st tele-command (1)	2 nd tele-command (1)				
VHF	All mode RT	●	●	●	●			●	●	—	—	●	●	120	ID	100	Self-ID	100	126	Frequency	117	ECC	117
	Duplex RT ⁽¹⁾	—	■	—	—			—	—	—	—	—	■	120	ID	100	Self-ID	101	126	Frequency	117	ECC	117
	RT acknowledgement	●	●	●	●			●	●	—	—	●	●	120	ID	100	Self-ID	100	126	Frequency	122	ECC	122
	Data	●	●	—	—			—	—	—	—	●	●	120	ID	100	Self-ID	106	126	Frequency	117	ECC	117
	Data acknowledgement	●	●	—	—			—	—	—	—	●	●	120	ID	100	Self-ID	106	126	Frequency	122	ECC	122
	Unable to comply acknowledgement	●	●	●	●			●	●	—	—	●	●	120	ID	100	Self-ID	104	100 to 109	Frequency	122	ECC	122
	Polling	—	●	—	—			—	—	—	—	●	■	120	ID	100	Self-ID	103	126	126	117	ECC	117
	Polling acknowledgement	●	—	—	—			—	—	—	—	■	●	120	ID	100	Self-ID	103	126	126	122	ECC	122

TABLE A1-4.9 (end)

Routine individual calls and their acknowledgements

Frequency band	Type	Applicable to										Technical format of call sequence											
		Ship station Class A		Ship station Class D		Ship station Class E		Hand-held Class H		MOB Device Class M Open and Closed Loop		Coast station		Format specifier (2 identical)	Address (5)	Category (1)	Self-ID (5)	Message			EOS (1)	ECC (1)	EOS (2 identical)
		1		2		3																	
		Tx	Rx	Tx	Rx	Tx	Rx	Tx	Rx	Tx	Rx	1 st tele-command (1)	2 nd tele-command (1)					Frequency or pos number (6 or 8)					
MF/HF	J3E RT	●	●			●	●					●	●	120	ID	100	Self-ID	109	126	Frequency	117	ECC	117
	J3E RT with pos number	●	—			●	—					—	●	120	ID	100	Self-ID	109	126	Pos2	117	ECC	117
	J3E RT acknowledgement	●	●			●	●					●	●	120	ID	100	Self-ID	109	126	Frequency	122	ECC	122
	F1B FEC, ARQ or data	●	●			—	—					●	●	120	ID	100	Self-ID	113, 115, 106	126	Frequency	117	ECC	117
	FEC, ARQ or data with pos number	●	—			—	—					—	●	120	ID	100	Self-ID	113, 115, 106	126	Pos2	117	ECC	117
	F1B FEC, ARQ or data acknowledgement	●	●			—	—					●	●	120	ID	100	Self-ID	113, 115, 106	126	Frequency	122	ECC	122
	Unable to comply acknowledgement	●	●			●	●					●	●	120	ID	100	Self-ID	104	100 - 109	Frequency	122	ECC	122
	Polling	—	●			—	—					●	■	120	ID	100	Self-ID	103	126	126	117	ECC	117
	Polling acknowledgement	●	—			—	—					■	●	120	ID	100	Self-ID	103	126	126	122	ECC	122

⁽¹⁾ See § 8.3.1.

TABLE A1-4.10.1
Semi/auto VHF (optional)

Type	Applicable to												Technical format of call sequence										
	Ship station Class A		Ship station Class D		Ship station Class E		Hand-held Class H		MOB Device Class M Open and Closed Loop		Coast station		Format specifier (2 identical)	Address (5)	Category (1)	Self-ID (5)	Message				EOS (1)	ECC (1)	EOS (2 identical)
	Tx	Rx	Tx	Rx	Tx	Rx	Tx	Rx	Tx	Rx	Tx	Rx					1		2	3			
																	1 st tele-command (1)	2 nd tele-command (1)	Frequency (3)	Number (2-9)			
Request	●	●	●	●			—	—	—	—	●	●	123	ID	100	Self-ID	100, 101, 106	126	Frequency	Number	117	ECC	117
Able to comply acknowledgement	●	●	●	●			—	—	—	—	●	●	123	ID	100	Self-ID	100, 101, 106	126	Frequency	Number	122	ECC	122
Start of call (on working channel)	●	—	●	—			—	—	—	—	—	●	123	ID	100	Self-ID	100, 101, 106	126	Frequency	Number	127	ECC	127
Unable to comply acknowledgement	●	●	●	●			—	—	—	—	●	●	123	ID	100	Self-ID	104	100 - 109	Frequency	Number	122	ECC	122
End of call request (on working channel)	●	—	●	—			—	—	—	—	—	●	123	ID	100	Self-ID	105	126	Frequency	Number	117	ECC	117
End of call acknowledgement (on working channel) ⁽¹⁾	—	●	—	●			—	—	—	—	●	—	123	ID	100	Self-ID	105	126	Duration	Number	122	ECC	122

⁽¹⁾ Upon call completion the coast station may send the end of call acknowledgement without a request from the ship station. The EOS symbol being 127.

NOTE 1 – See Recommendation ITU-R M.689.

NOTE 2 – For Class D symbol 123 does not need to be displayed.

TABLE A1-4.10.2
Semi/auto MF/HF (optional)

Type J3E RT or F1B FEC/ARQ	Applicable to												Technical format of call sequence											
	Ship station Class A		Ship station Class D		Ship station Class E		Hand-held Class H		MOB Device Class M Open and Closed Loop		Coast station		Format specifier (2 identical)	Address (5)	Category (1)	Self-ID (5)	Message			EOS (1)	ECC (1)	EOS (2 identical)		
											1	2					3							
	Tx	Rx	Tx	Rx	Tx	Rx	Tx	Rx	Tx	Rx	1 st tele command (1)	2 nd tele-command (1)					Frequency or pos number (6 or 8)	Number (2-9)						
Request coast station	—	●			—	●						●	—	123	ID	100	Self-ID	109, 113, 115	126	Frequency	Number	117	ECC	117
Request ship station	●	—			●	—						—	●	123	ID	100	Self-ID	109, 113, 115	126	126 or Pos2	Number	117	ECC	117
Able to comply acknowledgement	●	●			●	●						●	●	123	ID	100	Self-ID	109, 113, 115	126	Frequency	Number	122	ECC	122
Signal strength test by ship (on working channel) ⁽¹⁾	●	—			●	—						—	●	123	ID	100	Self-ID	109, 113, 115	126	Frequency	Number	117	ECC	117
Coast station acknowledgement with new working frequency ⁽¹⁾	—	●			—	●						●	—	123	ID	100	Self-ID	109, 113, 115	126	New frequency	Number	122	ECC	122
Call start: Coast station acknowledgement with same working frequency ⁽¹⁾	—	●			—	●						●	—	123	ID	100	Self-ID	109, 113, 115	126	Same frequency	Number	122	ECC	122
Unable to comply	●	●			●	●						●	●	123	ID	100	Self-ID	104	100 - 109	Frequency	Number	122	ECC	122
End of call request (on working channel)	●	—			●	—						—	●	123	ID	100	Self-ID	105	126	Frequency	Number	117	ECC	117
End of call acknowledgement (on working channel) ⁽²⁾	—	●			—	●						●	—	123	ID	100	Self-ID	105	126	Duration	Number	122	ECC	122

⁽¹⁾ This call involves signal strength testing. The ship requests call by sending the coast station its position. Once the ship or coast station is able to comply the ship station sends test DSCs on the working frequency. If the coast station acknowledges with a new working frequency, the ship station sends a test DSC on the new frequency. When the coast station acknowledges with an unchanged frequency, the subsequent communication may begin.

⁽²⁾ Upon call completion the coast station may send the end of call acknowledgement without a request from the ship station. The EOS symbol being 127.

NOTE 1 – See Recommendation ITU-R M.1082.

NOTE 2 – For Class E symbol 123 does not need to be displayed.

TABLE A1-4.11
Expansion sequences

Rec. ITU-R M.821 expansion sequence					
Type	Expansion data specifier (1)	Enhanced position resolution (4)	EOS (1)	ECC (1)	EOS (2 identical)
expan1	100	Pos5	127	ECC	127
expan2	100	Pos5	117	ECC	117
expan3	100	Pos5	122	ECC	122

TABLE A1-5
Frequency or channel information

Frequency	0 1 2	X X X	X X X	X X X	X X X	X X X	(N/A)	The frequency in multiples of 100 Hz as indicated by the figures for the digits HM, TM, M, H, T, U. This should be used for MF, HF equipment except when using seven-digit frequencies.	
Channels	3	X	X	X	X	X	(N/A)	The HF/MF working channel number indicated by the values of the digits TM, M, H, T and U. This should be used for backward compatibility in receive only mode.	
Frequency	4 4 4	0 1 2	X X X	X X X	X X X	X X X	X X X	X X X	The frequency in multiples of 10 Hz as indicated by the figures for the digits TM, M, H, T, U, T1 and U1. This should be used for MF, HF equipment when using seven-digit frequencies.
Channels	8	X	X	X	X	X	(N/A)	Only used for Recommendation ITU-R M.586 equipment.	
	9	0	X ⁽¹⁾	X	X	X	(N/A)	The VHF working channel number indicated by the values of the digits M, H, T and U.	
	HM	TM	M	H	T	U	T1	U1	
	Character 3	Character 2		Character 1 ⁽²⁾		Character 0			

⁽¹⁾ If the M digit is 1 this indicates that the ship stations transmitting frequency is being used as a simplex channel frequency for both ship and coast stations. If the M digit is 2 this indicates that the coast stations transmitting frequency is being used as a simplex channel frequency for both ship and coast stations. If the M digit is 0, this indicates the frequency being used is in accordance with RR Appendix 18 for both single and two frequency channels.

⁽²⁾ Character 1 is the last character transmitted except when using seven-digit frequencies.

TABLE A1-6
Position information (Annex 1, § 8.3.2.3)

	Quadrant digit NE = 0 NO = 1 SE = 2 SO = 3	Latitude				Longitude				
		Tens of degrees	Units of degrees	Tens of minutes	Units of minutes	Hundreds of degrees	Tens of degrees	Units of degrees	Tens of minutes	Units of minutes
55	X	X	X	X	X	X	X	X	X	X
Character 6	Character 5		Character 4		Character 3		Character 2		Character 5 ⁽¹⁾	

Character 1 is the last character transmitted.

Annex 2

Equipment classes

1 Equipment classes only apply to shipborne equipment

Class A equipment, which includes all the facilities defined in Annex 1, will comply with the IMO GMDSS carriage requirements for MF/HF installations and/or VHF installations.

Class D equipment is intended to provide minimum facilities for VHF DSC distress, urgency and safety as well as routing calling and reception, not necessarily in full accordance with IMO GMDSS carriage requirements for VHF installations.

Class E equipment is intended to provide minimum facilities for MF and/or HF DSC distress, urgency and safety as well as routine calling and reception, not necessarily in full accordance with IMO GMDSS carriage requirements for MF/HF installations.

Class H handheld equipment is intended to provide minimum facilities for VHF DSC distress, urgency and safety as well as routine calling and reception, not necessarily in full accordance with IMO GMDSS carriage requirements for VHF installations.

Class M Man overboard equipment is intended to activate a Distress alarm on a predefined ship or for a predefined group of ships (closed loop) or all ships (open loop) in the vicinity. This equipment does not provide any voice capability and is not an IMO GMDSS carriage requirement.

Class A equipment may support the optional semi-automatic/automatic service in accordance with Recommendations ITU-R M.689, ITU-R M.1082 and Tables A1-4.10.1 and A1-4.10.2 and are encouraged to do so.

Class D and Class E equipment may also support the optional semi-automatic/automatic service.

NOTE 1 – Class C, F and G equipment as defined in earlier versions of this Recommendation (e.g. Recommendations ITU-R M.493-5 (Geneva, 1992) and ITU-R M.493-7 (Geneva, 1995)) did not provide vital minimum DSC functions (transmitting and receiving distress alerts) and have therefore been withdrawn.

NOTE 2 – Class D Handheld as defined in Recommendation ITU-R M.493-13 (Geneva, 2009) has been redefined as new VHF Handheld Class H with a clear set of functionalities to be provided.

NOTE 3 – Class B has been deleted because there is no demand in the market to support such equipment and the scope of application was requested by the administrations in preparation of Recommendation ITU-R M.493-15.

Annex 3

User interface for simplified operation of shipborne equipment

1 General

The user interface for operation of the DSC equipment should be so designed that it will be easy for the operator onboard the ship to operate the equipment and to compose and initiate the types of DSC messages provided for by the equipment. The equipment software should allow the operator to only compose the types of DSC messages which are specified in Tables A1-4.1 to A1-4.11. These Tables indicate which DSC messages are applicable for each class of DSC equipment, messages defined

in Tables A1-4.10.1 (Semi/auto VHF (optional)) and A1-4.10.2 (Semi/auto MF/HF (optional)) should not be selectable from the top level menu.

2 Definitions

2.1 Automated procedure: the term given to describe the set of actions necessary to complete the objective of an initiating DSC message or non-DSC communication event. Four DSC automated procedures are designed to process these. They are the receiving of distress DSC messages, the receiving of non-distress DSC messages, the sending of distress DSC alert attempts and the sending of non-distress DSC messages. In addition a fifth procedure is designed to handle non-DSC communication events.

These automated procedures are called:

- Received distress automated procedure
- Sending distress automated procedure
- Received non-distress automated procedure
- Sending non-distress automated procedure
- Communications automated procedure.

2.2 default: a value selected or an action taken by the equipment software in the absence of any operator input.

2.3 DROBOSE: distress alert relay on behalf of someone else.

2.4 engaged: the term used to indicate that the equipment is busy handling an automated procedure.

2.5 factory default: a default value that is set by the manufacturer such that the field or behaviour is defined prior to any operator intervention.

2.6 standby: the term used to indicate that the equipment is not handling an automated procedure, either active or on hold, but is able to receive DSC messages.

2.7 top level: top level means that items, buttons, or functions are present and visible without requiring any action by the operator (such as scrolling, opening up menus, or removing any obscuring covers, etc.).

3 Controls

3.1 Dedicated distress button to initiate the sending of the distress alert attempt. This button should have at least two independent actions. Lifting of the protective lid is considered the first action. Pressing the distress button is considered as the second independent action. This button should be red in colour and marked “DISTRESS”. Where a non-transparent protective lid or cover is used, it should also be marked “DISTRESS”. The cover should be protected against inadvertent operation with a spring loaded lid or cover permanently attached to the equipment by e.g. hinges. It should not be necessary for the user to remove seals or to break the lid or cover in order to operate the distress button. This button should be used only for this purpose and it should be able to perform this function at all times. Use of the button without any previous operator actions to compose the alert should initiate the default distress alert attempt. The “default distress alert attempt” consists of “undesigned” for the nature of distress, radiotelephony for the communication mode, and on HF the transmission of the attempt uses the multi-frequency method including all six bands.

The distress button should have priority over all DSC procedures.

3.2 The following controls, buttons or functions should be provided and visible at the top level while the equipment is in standby:

Distress function for composing distress alert attempts other than the default distress alert attempt where the operator is able to:

- select the nature of distress (the factory default should be undesignated distress);
- on HF select the communication mode (the factory default should be telephone);
- on HF select the method and frequencies of transmission (the factory default should be the multi-frequency method on all six bands);
- check the content of the position and time of position information and to manually enter this information if not correct;

prior to initiating the sending of the distress alert attempt with the dedicated distress button.

Call function for composing non-distress DSC messages.

Distress alert relay on behalf of someone else function for composing and relaying the occurrence of a distress event obtained by non-DSC means.

3.3 The following controls, buttons or functions should be provided and be visible as noted:

Cancel/esc/exit/or equivalent for returning to a previous menu level from any state of the equipment.

Enter/accept/next/touch/press or equivalent for

accepting a menu item; or

going to the next step.

4 Display of messages in plain language

The headings and content of messages should be shown in plain language, for example:

- “radiotelephone” instead of J3E;
- “busy” instead of “telecommand 2: 102”.

5 Transmission of digital selective calling messages

5.1 DSC message composition features

The facilities for choosing and composing DSC messages should be so arranged that it is possible for the operator quickly and precisely to:

compose the content of the DSC message;

review and correct, if needed, the content before transmitting the DSC message.

5.2 Operational guidance to the operator

The operator should only be able to compose the types of DSC messages which are specified in Tables A1-4.1 through A1-4.11.

The equipment should automatically propose the next step for composing the DSC message, for example, when pressing the enter/accept/next/touch/press button or equivalent, if not visible from the context or on the display.

5.3 Defaults

Where options for the items in the DSC message exist (see Annex 1, Tables A1-4.1 to A1-4.11), the factory default values should be as follows:

After the operator selects the option to compose a non-distress DSC message:

- if the operator has the option to select a format (destination address) the default format should be “individual (120)”;
- if the format (destination address) is either individual (120), a group of ships (114), or a semi-automatic phone call (123), the default MMSI should be some internal indicator that the MMSI is invalid and needs to be entered before transmission can occur;
- if the format (destination address) is an area (102), the default area should be a circle of radius 500 nautical miles centred on the ship;
- if the operator has the option to select a category (priority) the default category should be “routine” unless the routine priority is not allowed (such as in an area or all-ships DSC message) in which case it should be “safety”;
- if the operator has the option to select the type of subsequent communication the default value should be radiotelephony;
- if the operator has the option to select a frequency or channel for the subsequent communication the default value should be a non-distress frequency or channel consistent with the means of subsequent communication and on MF/HF in the same band as the DSC message transmission;
 - on MF/HF if the operator has the option to select the frequency of the DSC transmission, default value should be 2 177 kHz;
 - on MF if the operator has the option to select the frequency of the DSC transmission, default value should be 2 177 kHz;
 - on HF if the operator has the option to select the frequency of the DSC transmission, default value should be in the 8 MHz band;
- all other parameters, for example the position, self ID, time of position, and end of sequence character, should be automatically entered by the equipment;
- the category should not be “remembered” when the call composition option is selected at a later time but should be reset to the factory default; this requirement does not mean the equipment is unable to provide the operator with the option to send pre-composed, customized DSC messages with a single action;
- for example, if there is only a single “call” button, menu selection, or equivalent for initiating a non-distress DSC message, the default DSC message should have format “individual” and category “routine”.

After the operator selects the option to compose a distress alert relay on behalf of someone else (DROBOSE):

- if the operator has the option to select a format (destination address) the default format should be “individual (120)”;
- if the format (destination address) is individual (120), the default MMSI should be some internal indicator that the MMSI is invalid and needs to be entered before transmission can occur;
- if the format (destination address) is an area (102), the default area should be a circle of radius 500 nautical miles centred on the ship;
- the default nature of distress should be “undesignated (107)”;
- the default MMSI for the vessel in distress should be “unknown (five 126 s)”;

- the default position and time of position should be unknown;
- the default means of subsequent communication should be radiotelephony:
 - on MF/HF the default band of the DSC transmission should be on the 2 MHz band;
 - on MF the default band of the DSC transmission should be on the 2 MHz band;
 - on HF the default band of the DSC transmission should be on the 8 MHz band;
- all other parameters, for example the, self- ID, the distress alert relay telecommand 1 parameter, the category (distress), and end of sequence character should be automatically entered by the equipment;
- the format, MMSI of the vessel in distress, the nature of distress, the position and time of position should not be “remembered” when the DROBOSE composition option is selected at a later time but should be reset to the defaults.

5.4 Other items

If the called station is a ship station or a group of ship stations the equipment should request input of a channel number (frequency in case of MF). The equipment should assist the operator by suggesting a suitable inter-ship channel; on VHF for example channel 6.

Automated HF subsequent communication channel selection for non-distress DSC messages. There is a simplex set and duplex set (contains the distress channels) for HF for both voice (3 000 Hz) and data (500 Hz) communication modes. Selection of the appropriate channel from these sets should follow the following steps:

- The band of the communication channel should be the band of the DSC message.
- The telecommand 1 parameter determines the choice of voice or data channels.
- DSC messages directed to a coast station (i.e. MMSI commencing 00) should let the coast station decide.
- All other DSC messages should select a channel from the simplex frequencies.

Use of the distress channels should be avoided and for routine communications use of the distress channels should not be allowed.

Annex 4

Automated procedures for simplified operation in shipborne equipment

1 General

The equipment software should allow the operator to only compose the types of DSC messages which are specified in Tables A1-4.1 to A1-4.11. These tables indicate which DSC messages are applicable for each class of DSC equipment.

Automated procedures are the incorporation of ITU-R recommended DSC operational procedures into equipment software.

The equipment should initiate (start) one of five automated procedures whenever the equipment becomes engaged in a new communication event. Four of these automated procedures handle events initiated by sent and received DSC messages and the fifth automated procedure handles

radiotelephony established by non-DSC means. One of these five automated procedures is initiated by:

- a) sending a distress alert,
- b) receiving a DSC message containing distress information,
- c) sending an individually addressed distress alert relay containing distress information,
- d) sending distress alert relay on behalf of someone else,
- e) sending a DSC message containing no distress information,
- f) receiving a DSC message containing no distress information,
- g) engaging in traffic initiated by non-DSC means.

Once initiated by any of the events listed in a)-g), the automated procedure should handle all the tasks required to satisfy the objectives of the initiating event. These tasks should include the handling of any subsequent DSC messages that may be pertinent (relevant) to the objectives of the automated procedure and appropriately updating the automated procedure, providing the operator with any possible options, and keeping the operator informed of the progress until either the operator terminates the automated procedure or conditions warrant that the automated procedure self terminates. Automated procedures should be able to be run in parallel. Whereas all DSC automated procedures continuously monitor the watch receiver only one active automated procedure has control of the transmitter and general receiver. The reception of any DSC message not pertinent to an automated procedure should not disrupt that procedure but should be appropriately allocated to the appropriate ongoing automated procedure or initiate a new automated procedure.

2 Definitions

2.1 acknowledged: when used to describe an automated procedure it indicates that the objective of the initial DSC message has been achieved.

2.2 active: the term used to describe an automated procedure which has control of the general receiver and transmitter and is thus able to engage in subsequent communications and receive DSC messages on both the watch receiver and general receiver.

2.3 automated procedure: the term given to describe the set of actions necessary to complete the objective of an initiating DSC message or non-DSC communication event. Four DSC automated procedures are designed to process these. They are the receiving of distress DSC messages, the receiving of non-distress DSC messages, the sending of distress DSC alert attempts and the sending of non-distress DSC messages. In addition a fifth procedure is designed to handle non-DSC communication events.

These automated procedures are called:

- Received distress automated procedure
- Sending distress automated procedure
- Received non-distress automated procedure
- Sending non-distress automated procedure
- Communications automated procedure.

2.4 critical errors: a set of information characters obtained from one or more received DSC messages is considered to have critical errors if the automated procedure needs information characters from that set in order to proceed or perform any task, but the required information characters are in error (for example, an acknowledgement cannot be composed to an individual DSC message that has errors in the sender's MMSI).

- 2.5 default:** a value selected or an action taken by the equipment software in the absence of any operator input.
- 2.6 distress digital selective calling message:** A DSC message or acknowledgement containing the distress information.
- 2.7 distress event:** a unique distress situation identified by two (VHF) or three (MF/HF) parameters of the distress information; the MMSI of the vessel in distress and the nature of distress and on MF/HF the mode of subsequent communication. If a MOB device triggered the distress event then multiple distress alerts from different MOB devices should be handled as one event and within the same automated procedure.
- 2.8 distress information:** the symbols within a DSC message describing a distress situation consisting of the MMSI of the vessel in distress, the nature of distress, the position of the vessel in distress, the UTC time of that position, and the mode of subsequent communication.
- 2.9 DROBOSE:** distress alert relay on behalf of someone else.
- 2.10 DX/RX:** a notation used to describe the time diversity structure of DSC messages (see Fig. 1). One has to be careful not to confuse the “RX” notation when used to indicate the symbol position in the DSC message structure (as in § 4.1 of Annex 1) with its use to indicate reception (as in § 8.3.2 of Annex 1).
- 2.11 engaged:** the term used to indicate that the equipment is busy handling an automated procedure.
- 2.12 factory default:** A default value that is set by the manufacturer such that the field or behaviour is defined prior to any operator intervention.
- 2.13 general receiver:** this unit is the receiver part of the transceiver used for the reception of all subsequent communications and on HF the reception of non-distress DSC acknowledgements. It is important to distinguish this unit from the watch receiver (see below).
- 2.14 identical:** a set of information characters is considered identical to another set of information characters if all pairs of corresponding information characters are equal or, if a pair of corresponding information characters is not equal, one of the pair is in error.
- 2.15 information characters:** the set of symbols in the DSC message that contain the items of interest for the recipient and is used to compute the ECC symbol that terminates the message. These symbols are repeated in the DX/RX time diversity pattern.
- 2.16 initial digital selective calling message:** the DSC message that starts an automated procedure.
- 2.17 non-distress digital selective calling message:** DSC messages and acknowledgments that do not contain the distress information.
- 2.18 objective:** when in reference to a DSC message or automated procedure it is the goal or intent of the item; usually this goal or intent is to establish subsequent communications or request information.
- 2.19 on hold:** the term used to describe an automated procedure which does not have access to the transmitter and general receiver and therefore cannot engage in subsequent communications and is only able to receive DSC messages on the watch receiver.
- 2.20 operator options:** are any choices the operator can make while the automated procedure is engaged.
- 2.21 parallel event handling:** the background process of handling a received DSC message that is not pertinent to the active automated procedure.

2.22 pertinent to the automated procedure: an expression used primarily with reference to DSC messages to indicate that the message has something to do with the procedure and is therefore “handled” by the procedure. A DSC message is pertinent to an automated procedure if the set of information characters in the DSC message has the correct values.

2.23 standby: the term used to indicate that the equipment is not handling an automated procedure, either active or on hold, but is able to receive DSC messages.

2.24 two-tone alarm: an alarm consisting of a repetition of the 2 200 Hz tone for 250 ms followed by a 1 300 Hz tone for 250 ms. This alarm occurs at the initiation of the received distress DSC automated procedure. The characteristics of this alarm should not be able to be altered.

2.25 urgency alarm: an alarm consisting of a repetition of the 2 200 Hz tone for 250 ms followed by 250 ms period of silence. This alarm occurs at the initiation of the received non-distress DSC automated procedure when the category of the initiating DSC message is “urgency”. The characteristics of this alarm should not be able to be altered.

2.26 watch receiver: this unit is the separate receiver in DSC radios that continuously monitors the DSC distress frequencies on MF/HF, 2 187.5 kHz on MF, and channel 70 on VHF. On MF/HF it is sometimes referred to as the scanning receiver.

3 Tasks of automated procedures

3.1 Tasks common to all automated procedures handling DSC messages

3.1.1 Handling alarms

The sounding of any alarm should simultaneously display the reason for the alarm and the means to silence it.

Alarms should sound appropriate to the automated procedure when a received DSC message either initiates or acknowledges the automated procedure with the two-tone alarm being reserved for the initiation of the received distress procedure, and the urgency alarm being reserved for the initiation of the received non-distress procedure when the category of the initiating DSC message is “urgency”.

Only the **first** occurrence of a received DSC message should sound the alarms.

All received DSC messages that do not sound an alarm as specified in § 3.1.1 should sound a brief, self-terminating alarm to inform the operator of the reception.

3.1.2 Displaying stages of the automated procedure

The automated procedure should display the stages and/or activity in order to indicate the progress of the procedure.

3.1.3 Tuning the radio

Tuning of the general receiver and transmitter for reception or transmission of required acknowledgments, repeat transmissions, distress alert relays, or subsequent communications should be handled automatically.

Any automated tuning action that could potentially disrupt ongoing subsequent communications should provide the operator with at least a 10 s warning. The operator should then be provided with the opportunity to pause the action. In the absence of operator intervention the automated action should proceed.

3.1.4 Displaying operator options

Options should only be provided at those times the option is appropriate.

3.1.5 Handling DSC messages not pertinent to the active procedure

The received DSC message is either allocated to the correct automated procedure running in the background on hold or initiates a new automated procedure on hold.

3.1.6 Displaying warnings

Warnings should be displayed when the operator attempts to do anything that does not follow the guidelines given by ITU and IMO. The operator should have the option to go back to the stage of the automated procedure where the action was taken that caused the warning.

3.1.7 Handling DSC messages containing errors

A DSC message with errors is pertinent to an automated procedure if the set of information characters in the DSC message is **identical** as defined in the “definitions” section to the set of information characters normally used to determine pertinence.

Automated procedures initiated by DSC messages with critical errors should sound the same alarm they would sound if the DSC message were received error free but the alarm should self-terminate.

Automated procedures are encouraged to utilize subsequent DSC messages pertinent to the automated procedure to reduce the number of receive errors in the set of information characters that are important to the automated procedure. In no case should the reception of subsequent DSC messages increase the number of errors in the set of information characters important to the automated procedure.

No automated procedure should allow the transmission of further DSC messages with errors.

If critical errors prevent an automated procedure from setting up an operator option or performing any automated action, that option should be disabled or that action not performed.

Automated procedures should not be considered acknowledged until all the critical errors in the set of acknowledgement information characters have been received correctly or corrected by repeat reception.

Information that is normally displayed that contains errors should be displayed to the full extent possible; for example, digits in the MMSI or position information that are received correctly should be displayed in their correct positions and those that are not should be indicated by some special error symbol.

3.1.8 Transmission of digital selective calling messages

Transmission of DSC messages should use a prioritized wait scheme. If the channel is not free, and the DSC message is a distress alert, the alert should be transmitted as soon as the channel becomes free or after 10 s on MF or HF or 1 s on VHF, whichever occurs first. For all other DSC messages, the automated procedure should wait for the channel to become free and then delay transmission of the DSC message for a specified wait time. Distress DSC messages (except for alerts), urgency, safety, routine and test DSC messages should wait one, two, three, and four “fixed” units of time plus a random addition described below, respectively, before attempting to transmit. Transmission occurs if and only if the channel is still free after this wait time has elapsed, otherwise the process is repeated. The fixed “unit” of time should be 100 ms on MF and HF and 50 ms on VHF. The randomly generated component should be some positive integer with resolution in milliseconds between zero and the fixed interval. On MF/HF the channel is considered free if the receiver hardware or DSP software is unable to recognize the DSC tones.

3.1.9 Automated termination

Automated procedures should have an automated termination timer whose factory default values can be changed by the operator. It should be possible to disable this timer. Unacknowledged sending distress automated procedures should not have a termination timer, however after acknowledgement a termination timer is optional.

At least 10 s prior to automatic termination, a warning with a discrete audible alarm should be displayed giving the operator the opportunity to stop the termination.

3.2 Tasks specific to certain automated procedures

3.2.1 Tasks of automated procedures initiated by receiving non-distress digital selective calling messages

3.2.1.1 Display of elapsed time

The elapsed time since receiving the initiating DSC message should be displayed or after any requested acknowledgment has been sent, the elapsed time since sending the acknowledgement should be displayed. Sending repeat acknowledgments should not affect the time display.

3.2.1.2 Handling acknowledgments

If the equipment has been set up to automatically acknowledge individually addressed polling, position request, or test DSC messages, no alarm should sound and the automated procedure should self-terminate.

Acknowledgement options should only be made available to the operator when the received DSC message requests an acknowledgement.

When acknowledgments are requested the automated procedure should provide the operator with up to three possible acknowledgement options based upon the received DSC message as follows:

Able to comply: This option should be provided if the frequencies and mode of subsequent communication are provided by the received DSC message and the equipment is capable of handling the requested communications, or if the received DSC message is a polling, position request, or test that has not been automatically acknowledged.

Able to comply with a mode or frequency change: This option should be provided if the received DSC message requests subsequent communications.

Unable to comply: This option should be provided if the received DSC message contains subsequent communications or is a position request. The sending of this acknowledgement indicates a refusal and should terminate the automated procedure.

The automated procedure should **automatically compose the acknowledgement** messages based upon the received DSC message as shown in Fig. 2 and Fig. 3.

“**Able to comply**” acknowledgments should be composed in entirety by the automated procedure.

“**Able to comply with a mode or frequency change**” acknowledgments should only require the entry/selection of a new mode and/or frequency.

“**Unable to comply**” acknowledgments to DSC messages containing subsequent communications should only require the entry/selection of one of the ten telecommand 2 “reason” symbols specified in Table A1-3.

“**Unable to comply**” acknowledgments to position requests if implemented should only require a single action by the operator to send. The procedure should automatically place the “no information symbol” in the position and time messages of the acknowledgement.

The operator should be able to resend a duplicate of the first acknowledgement in automated procedures that have subsequent communications.

3.2.2 Tasks of automated procedures initiated by sending a non-distress digital selective calling message

3.2.2.1 Display of elapsed time

The elapsed time since sending the initial DSC message should be displayed or after the automated procedure has received a requested acknowledgment, the elapsed time since acknowledgement should be displayed. Receiving repeat acknowledgments should not affect the time display.

3.2.2.2 Resending the initial digital selective calling message

If no acknowledgement is requested the option to resend the initial DSC message should remain available until the procedure is terminated.

If an acknowledgement is requested the option to resend the initial DSC message should remain available until the acknowledgment has been received.

3.2.2.3 Handling the reception of a delayed acknowledgement

If an acknowledgement appropriate to this automated procedure is received but the operator has terminated the automated procedure prematurely, the appropriate automated procedure should be reconstructed based on the acknowledgement and the operator informed of the situation.

3.2.3 Tasks of automated procedures initiated by receiving a distress digital selective calling message or sending a distress alert relay on behalf of someone else

3.2.3.1 Display of elapsed time

The elapsed time since receiving the initial DSC message should be displayed or after the automated procedure has been acknowledged, the elapsed time since acknowledgement should be displayed. Receiving repeat acknowledgments should not affect the time display.

3.2.3.2 Determining operator options

On HF the operator should have the option to set the general receiver and transmitter to any one of the six distress frequencies of subsequent communication.

The option to send a distress alert relay should always be available until the automated procedure is terminated.

3.2.3.3 Distress alert acknowledgments and distress alert relay acknowledgement options

These options should not be made available until a DSC message has been received that can respond to the acknowledgement.

These options should be available immediately after reception of the appropriate DSC messages and **not** wait until certain conditions for their use, such as time limits, are fulfilled.

Once these options are available, they should remain available until the automated procedure is terminated.

3.2.3.4 Digital selective calling message composition

The automated procedure should automatically compose distress alert relays, distress alert acknowledgments and distress alert relay acknowledgments based upon the received DSC messages.

The distress information should be taken from the distress DSC message which has the latest UTC time stamp.

Distress alert acknowledgements and distress alert relay acknowledgements should require no data entry by the operator except on HF where the frequency of the DSC message may be selected.

Distress alert relays should only allow the entry of the addressing mode (format) and destination address and on HF, the mode of subsequent communication and the frequency of the DSC message.

On HF the automated procedure should indicate those frequencies on which DSC messages pertinent to the automated procedure have been received as the preferred choices, however the operator should be allowed to choose any of the six distress frequencies.

3.2.3.5 Tuning of the radio after acknowledgment on HF

The automated tuning should cease upon reception or sending of a distress alert acknowledgement or a distress alert relay acknowledgment addressed to multiple stations. However, the operator should be provided with sufficient information to manually tune to the working frequencies of the most recently received DSC message.

3.2.3.6 Handling individually addressed distress alert relays

The sending or receiving of individually addressed distress alert relays should initiate their own automated procedure separate from the automated procedure that may be handling distress DSC messages concerning the same distress event. In the case of an event triggered by MOB devices then multiple alerts from different MOB devices should be handled as one event and within the same automated procedure.

The option to send a distress alert acknowledgement should never be available during this automated procedure.

3.2.3.7 Handling group addressed distress alert relays

In the case of an event triggered by MOB devices then multiple alerts from different MOB devices should be handled as one event and within the same automated procedure.

3.2.3.8 Handling digital selective calling messages with critical errors

If the subsequent communication parameter of the distress information is received in error, radiotelephone should be assumed and an indication that the parameter was received in error should be made known to the operator.

3.2.3.9 Handling the self-addressed distress alert acknowledgement

If the MMSI of the sender of a distress alert acknowledgement is the same as the MMSI of the vessel in distress, the automated procedure should recognize the message as an attempt to cancel the distress alert and inform the operator accordingly.

3.2.3.10 Extended digital selective calling sentences

The automated procedure should be able to successfully receive and decode single frequency alert attempts that have extended sentence information at the end of some or all of the individual alerts.

3.2.3.11 MF/HF only scanning for distress digital selective calling messages

The received distress automated procedure should scan all six distress DSC channels if not already doing so.

3.2.4 Tasks of automated procedures initiated by sending a distress alert attempt

3.2.4.1 Display of elapsed time

The time remaining to the sending of the next distress alert attempt should be displayed prior to acknowledgment by DSC.

The elapsed time since acknowledgement should be displayed after acknowledgment by DSC. Receiving repeat acknowledgments should not affect the time display.

3.2.4.2 Resending of the distress alert attempt

The unacknowledged distress alert attempt should be automatically resent after a 3.5 to 4.5 min wait.

The automatic resending of the distress alert attempt should automatically terminate after acknowledgment by DSC.

Resent distress alert attempts should contain updated position and time of position information.

3.2.4.3 Determining operator options

The option to manually resend the distress alert attempt at any time should remain available until the distress alert has been acknowledged by DSC.

On HF the operator should have the option to change the frequencies of the distress alert attempt and the option to select between the single frequency or multi-frequency method.

The option to pause the countdown to the next distress alert attempt should be available prior to acknowledgment by DSC.

The option to cancel the distress alert should be available prior to acknowledgment by DSC.

The option to terminate the procedure should only be available after acknowledgment by DSC.

3.2.4.4 The distress alert cancel procedure

The *cancel procedure* consists of the *cancel operation* on all bands utilized by the distress alert attempts (on VHF and MF there is only one *cancel operation* whereas on MF/HF there may be up to six). The *cancel operation* consists of a DSC cancel message (a self-addressed distress alert acknowledgement) followed by a *voice cancel* on the corresponding frequency of subsequent communication. The phrase “*voice cancel*” refers to the part of the cancel done over the subsequent communication frequencies whether it is by radiotelephony or on MF and MF/HF by data.

Upon selection of the cancel option the sending distress automated procedure should provide an explanation of the *cancel procedure* to the operator and provide the option to either continue or return and not do the cancel.

If the operator selects to proceed with the *cancel procedure* the sending distress automated procedure should pause the countdown to the next automated sending of the distress alert attempt and wait (if necessary) until any alert within an attempt is transmitted to completion before allowing the operator to initiate the first *cancel operation*.

The operator options during the *cancel procedure* should be to terminate the cancel procedure and to start the *cancel operation*.

If the *cancel procedure* is terminated before the first *cancel operation* is started, the sending distress automated procedure should resume from where it left off. However, once the *cancel operation* is started, the option to terminate the *cancel procedure* should not be available until the *cancel procedure* is completed.

The status of the *cancel procedure* should be displayed.

The operator should be provided with the appropriate text for the *voice cancel* at the time of the *voice cancel*.

The *cancel operation* should be able to be repeated on any band but a warning should be provided that the cancel has already been done on this band.

3.2.4.5 Special considerations for MF/HF

The status of each of the bands should be displayed;

Once one band is cancelled the option to end the *cancel procedure* should not be available until ALL utilized bands are cancelled;

When the *cancel procedure* is completed, the sending distress automated procedure should be considered acknowledged and the fact that a cancel was performed should be displayed.

3.2.4.6 MF/HF only scanning for distress alert acknowledgements

The sending distress automated procedure should scan all six distress DSC channels if not already doing so.

3.2.5 Radiotelephone communications automated procedure

The equipment should also be provided with a communications function for radiotelephony that is compatible with the DSC automated procedures described in this Annex. This automated procedure should have:

- the ability to switch between being active or being on hold at the discretion of the operator,
- the ability to be terminated at the discretion of the operator,
- the ability to select the channels for the communications

3.2.6 Other non-digital selective calling automated procedures

Any other non-DSC functionality that is included in the equipment should:

- be able to be activated or placed on hold at the discretion of the operator,
- never control the watch receiver such that DSC automated procedures, either active or on hold, are unable to receive DSC messages on the watch receiver,
- be able to be terminated by the operator.

3.3 Tasks concerning multiple automated procedures

3.3.1 Number of simultaneous automated procedures

Facilities should be provided to handle a minimum of seven simultaneous automated procedures including a reserve of one. The initiation of the reserve automated procedure should:

- warn the operator that the equipment cannot handle another automated procedure and that one automated procedure should be terminated,
- prevent the operator from initiating any new automated procedures except for the sending of a distress alert and,
- warn the operator that the reception of an additional DSC message that would initiate an automated procedure if the equipment were in standby will result in the automatic and immediate termination of an inactive automated procedure where,
- the automatic and immediate termination should be based upon age and priority.

3.3.2 Sending distress automated procedure

When initiating a sending distress automated procedure, automatic immediate termination of all other automated procedures (if any) is encouraged but not required.

3.3.3 Operator options

The operator should be able to freely navigate between the automated procedures except when engaged in an unacknowledged sending distress automated procedure.

When the operator makes any one of the automated procedures on hold active, the automated procedure that was active (if any) should automatically go on hold.

3.3.4 Unacknowledged poll, test, or position request automated procedures received on hold

If any of these automated procedures is set to automatically acknowledge, it should automatically acknowledge and self-terminate as soon as all remaining automated procedures are on hold.

3.4 Warnings

Warnings should be provided when the *operator* attempts to do the following:

- send a distress alert relay before three minutes have elapsed since the automated procedure started,
 - send a non-individually addressed distress alert relay,
 - send a distress alert acknowledgement (requires coast station permission),
 - send an all stations (116 format) distress alert relay acknowledgement (should be sent by coast station only),
 - send an acknowledgement to a DSC message containing no distress information that is not individually addressed,
 - cancel a distress alert,
 - send any DSC message after the objective of the automated procedure has been obtained,
 - terminate the automated procedure before the objective has been reached,
 - terminate the automated procedure if engaged in subsequent communications.
-