



**Recommendation ITU-R M.2150-0**  
(02/2021)

**Detailed specifications of the terrestrial  
radio interfaces of International Mobile  
Telecommunications-2020 (IMT-2020)**

**M Series**  
**Mobile, radiodetermination, amateur  
and related satellite services**

## Foreword

The role of the Radiocommunication Sector is to ensure the rational, equitable, efficient and economical use of the radio-frequency spectrum by all radiocommunication services, including satellite services, and carry out studies without limit of frequency range on the basis of which Recommendations are adopted.

The regulatory and policy functions of the Radiocommunication Sector are performed by World and Regional Radiocommunication Conferences and Radiocommunication Assemblies supported by Study Groups.

## Policy on Intellectual Property Right (IPR)

ITU-R policy on IPR is described in the Common Patent Policy for ITU-T/ITU-R/ISO/IEC referenced in Resolution ITU-R 1. Forms to be used for the submission of patent statements and licensing declarations by patent holders are available from <http://www.itu.int/ITU-R/go/patents/en> where the Guidelines for Implementation of the Common Patent Policy for ITU-T/ITU-R/ISO/IEC and the ITU-R patent information database can also be found.

### Series of ITU-R Recommendations

(Also available online at <http://www.itu.int/publ/R-REC/en>)

Series	Title
<b>BO</b>	Satellite delivery
<b>BR</b>	Recording for production, archival and play-out; film for television
<b>BS</b>	Broadcasting service (sound)
<b>BT</b>	Broadcasting service (television)
<b>F</b>	Fixed service
<b>M</b>	<b>Mobile, radiodetermination, amateur and related satellite services</b>
<b>P</b>	Radiowave propagation
<b>RA</b>	Radio astronomy
<b>RS</b>	Remote sensing systems
<b>S</b>	Fixed-satellite service
<b>SA</b>	Space applications and meteorology
<b>SF</b>	Frequency sharing and coordination between fixed-satellite and fixed service systems
<b>SM</b>	Spectrum management
<b>SNG</b>	Satellite news gathering
<b>TF</b>	Time signals and frequency standards emissions
<b>V</b>	Vocabulary and related subjects

*Note: This ITU-R Recommendation was approved in English under the procedure detailed in Resolution ITU-R 1.*

Electronic Publication  
Geneva, 2021

© ITU 2021

All rights reserved. No part of this publication may be reproduced, by any means whatsoever, without written permission of ITU.

## RECOMMENDATION ITU-R M.2150-0

**Detailed specifications of the terrestrial radio interfaces of  
International Mobile Telecommunications-2020 (IMT-2020)**

(2021)

**Scope**

This Recommendation identifies and provides the detailed specifications of the radio interfaces for the terrestrial component of International Mobile Telecommunications-2020 (IMT-2020) and provides the detailed radio interface specifications.

These radio interface specifications detail the feature and parameters of IMT-2020. IMT-2020 enables worldwide compatibility, international roaming, and access to the services under diverse usage scenarios, including enhanced mobile broadband (eMBB), massive machine type communications (mMTC) and ultra-reliable and low latency communications (URLLC).

**Keywords**

IMT, IMT-2020, Radio interface specifications, Enhanced Mobile Broadband (eMBB), massive Machine Type Communications (mMTC), Ultra-Reliable and Low Latency Communications (URLLC)

**Abbreviations/Glossary**

3GPP	3 <sup>rd</sup> Generation Partnership Project
AAS	Active antenna system
ARQ	Automatic repeat request
CA	Carrier aggregation
CoMP	Coordinated multipoint
CSI-RS	Channel state information reference symbol
DC	Dual connectivity
DFTS	Discrete Fourier transform-spread
DMRS	Demodulation reference signal
DRB	Data radio bearer
DRX	Discontinuous reception
eMBB	enhanced mobile broadband
EMC	Electromagnetic compatibility
FEC	Forward error correction
FSTD	Frequency switched transmit diversity
GCS	Global core specifications
GNSS	Global navigation satellite system
GPS	Global positioning system
H-ARQ	Hybrid – ARQ
ICIC	Inter-cell interference coordination
IMT	International Mobile Telecommunications

LTE	Long term evolution
LWA	LTE-WLAN aggregation
MAC	Medium access control
MBMS	Multimedia broadcast/multicast service
MBSFN	Multicast/broadcast over single frequency network
MCG	Master cell group
MIMO	Multiple input multiple output
MME	Mobility management entity
mMTC	massive machine type communications
MTC	Machine-type communication
NB-IOT	Narrowband internet of things
NR	New radio
OAM	Operation and maintenance
OFDM	Orthogonal frequency-division multiplexing
OFDMA	Orthogonal frequency-division multiple access
OTDOA	Observed time difference of arrival
PAPR	Peak-to-average power ratio
PDCCP	Packet data convergence protocol
PDU	Protocol data unit
PHY	Physical layer
PPDR	Public protection and disaster relief
PRB	Physical resource block
ProSe	Proximity-based services
QoS	Quality of service
RIT	Radio interface technologies
RLC	Radio link control
RN	Relay node
RRC	Radio resource control
RRM	Radio resource management
SCG	Secondary cell group
SDP	Session description protocol
SDU	Service data unit
SFBC	Space-frequency block coding
SIP	Session initiation protocol
SON	Self-organizing networks
SRB	Signalling radio bearer

SRIT	Set of radio interface technologies
TAG	Timing advance group
TB	Transport block
TTI	Transmission time interval
UE	User equipment
URLLC	Ultra-reliable and low latency communications

Additional terms may be found in document 3GPP TR 21.905 "Vocabulary for 3GPP Specifications".

#### **Related documentation: ITU Recommendations, Reports, Document and Handbook<sup>1</sup>**

Recommendation ITU-R M.1036	Frequency arrangements for implementation of the terrestrial component of International Mobile Telecommunications (IMT) in the bands identified for IMT in the Radio Regulations (RR)
Recommendation ITU-R M.1224	Vocabulary of Terms for International Mobile Telecommunications (IMT)
Recommendation ITU-R M.1579	Global circulation of IMT terrestrial terminals
Recommendation ITU-R M.1822	Framework for services supported by IMT
Recommendation ITU-R M.2015	Frequency arrangements for public protection and disaster relief radiocommunication systems in accordance with Resolution <b>646 (Rev.WRC-15)</b>
Recommendation ITU-R M.2083	IMT Vision – Framework and overall objectives of the future development of IMT for 2020 and beyond
Report ITU-R M.2291	The use of International Mobile Telecommunications for broadband public protection and disaster relief application
Report ITU-R M.2320	Future technology trends of terrestrial IMT systems
Report ITU-R M.2334	Passive and active antenna systems for base stations of IMT systems
Report ITU-R M.2370	IMT traffic estimations for the years 2020 to 2030
Report ITU-R M.2375	Architecture and topology of IMT networks
Report ITU-R M.2376	Technical feasibility of IMT in bands above 6 GHz
Report ITU-R M.2410	Minimum requirements related to technical performance for IMT-2020 radio interface(s)
Report ITU-R M.2411	Requirements, evaluation criteria and submission templates for the development of IMT-2020
Report ITU-R M.2412	Guidelines for evaluation of radio interface technologies for IMT-2020
Report ITU-R M.2441	Emerging usage of the terrestrial component of International Mobile Telecommunication (IMT)

---

<sup>1</sup> The latest edition of the Recommendation/Report in force should be used.

Report ITU-R M.2483	The outcome of the evaluation, consensus building and decision of the IMT-2020 process (steps 4-7), including characteristics of IMT-2020 radio interfaces
Resolution ITU-R 50	Role of the Radiocommunication Sector in the ongoing development of IMT
Resolution ITU-R 56	Naming for International Mobile Telecommunications
Resolution ITU-R 65	Principles for the process of future development of IMT for 2020 and beyond
Document IMT-2020/2	Submission, evaluation process and consensus building for IMT-2020
Handbook on Global Trends in International Mobile Telecommunication.	

The ITU Radiocommunication Assembly,

*considering*

- a) that IMT systems are mobile broadband systems including IMT-2000, IMT-Advanced and IMT-2020;
- b) that IMT-2020 systems include the new capabilities of IMT that go beyond those of IMT-2000 and IMT-Advanced<sup>2</sup>, and will interwork with and complement existing IMT-systems and their enhancements;
- c) that IMT-2020 systems and beyond are envisaged to expand and support diverse usage scenarios and applications;
- d) that IMT-2020 systems provide access to a wide range of advanced communication applications supported by mobile and fixed networks;
- e) that ITU has contributed to standardization and harmonized use of IMT, which has provided telecommunication services on a global scale and global operation and economies of scale are key requirements for the success of mobile telecommunication systems;
- f) that IMT-2020 systems support low to high mobility applications and a wide range of data rates in accordance with user and service demands in multiple user environments;
- g) that the usage scenarios of IMT-2020 include enhanced Mobile Broadband, ultra-reliable and low latency communication and massive machine-type communication;
- h) that IMT-2020 systems support the machine type communications to realize the Internet of Things connecting a vast range of smart appliances, machines and other objects, beside supporting human communications;
- i) that IMT-2020 systems support ultra-reliable and low latency communications which are necessary in particular use cases;
- j) that IMT-2020 also has capabilities for high-quality multimedia applications within a wide range of services and platforms providing a significant improvement in performance, quality of service and user experience;

---

<sup>2</sup> Recommendations ITU-R M.1457, ITU-R M.2012 and ITU-R M.2150 are three separate, independent, and self-contained Recommendations, each one with a specific scope. All Recommendations will evolve independently, and there could be some overlap reflected by commonality in content among the three documents.

- k) that the key features of IMT-2020 are indicated in Recommendation ITU-R M.2083, and that the key requirements related to the minimum technical performance of IMT-2020 radio interface(s) are described in Report ITU-R M.2410 and the guidelines for evaluation of radio interface technologies for IMT-2020 are provided in Report ITU-R M.2412;
- l) that the capabilities of IMT-2020 systems are being continuously enhanced in line with technology developments;
- m) that IMT systems support Public Protection and Disaster Relief (PPDR);
- n) that IMT systems support the necessity of priority services;
- o) that due to the large effective bandwidths required to support the very high data rates needed for the various services offered, allowances must be made for either much larger single carrier bandwidths (even as spectral efficiencies increase) or aggregation of RF carriers;
- p) that IMT-2020 systems support wide contiguous spectrum bands, and thus expands the application of IMT;
- q) that IMT systems provide various specific applications to facilitate development of the digital economy, e.g. e-manufacturing, e-agriculture, e-health, intelligent transport systems, smart city and traffic control, etc., which could bring requirements beyond current capabilities of IMT systems,

*noting*

- a) that Report ITU-R M.2483 contains the outcome of the evaluation, consensus building and decision of the IMT-2020 process (Steps 4 to 7), including the characteristics of the IMT-2020 radio interfaces;
- b) that the detailed specifications indicated in the *recommends* 2 might include technical details which could be interpreted as “frequency arrangements for implementation of the terrestrial component of International Mobile Telecommunications” (partially due to different terminology usage);
- c) that it is understood that technical details referred to in *noting b)* above are only intended to be interpreted as those necessary for “proper design and technical operation of the IMT system, and the establishment of minimum RF characteristics and minimum performance requirements”,

*recognizing*

- a) that Resolution ITU-R 65 on the “Principles for the process of future development of IMT for 2020 and beyond” outlines the essential criteria and principles used in the process of developing the Recommendations and Reports for IMT-2020, including Recommendation(s) for the radio interface specification;
- b) that frequency arrangements for IMT are addressed in the other ITU-R Recommendations and Reports, detailed in the related documentation section above,

*recommends*

- 1** that the terrestrial radio interfaces for IMT-2020 should be:
- “3GPP 5G-SRIT”<sup>3</sup>;
  - “3GPP 5G-RIT”<sup>4</sup>;

---

<sup>3</sup> Developed by 3GPP Proponent as “5G, Release 15 and beyond – LTE+NR SRIT”.

<sup>4</sup> Developed by 3GPP Proponent as “5G, Release 15 and beyond – NR RIT”.

– “5Gi”<sup>5</sup>;

2 that the information provided or referenced in Annexes 1, 2 and 3 should be used according to the terrestrial radio interfaces referred to in *recommends* 1 above as the complete set of standards for the detailed specifications of the terrestrial radio interfaces of IMT-2020.

---

<sup>5</sup> Developed by TSDSI as “5Gi RIT”.



## Annex 1

### Specification of the 3GPP 5G – SRIT<sup>6</sup> radio interface technology

#### TABLE OF CONTENTS

	<i>Page</i>
Background.....	7
1.1 Overview of the radio interface technology .....	8
1.2 Detailed specification of the radio interface technology .....	47

#### Background

IMT-2020 is a system with global development activity and the IMT-2020 terrestrial radio interface specifications identified in this Recommendation have been developed by the ITU in collaboration with the global core specifications (GCS) Proponents and the Transposing Organizations. It is noted from Document IMT-2020/20, that:

- The GCS Proponent must be one of the Radio interface technologies (RIT)/set of radio interface technologies (SRIT) Proponents for the relevant technology, and must have legal authority to grant to ITU-R the relevant legal usage rights to the relevant specifications provided within a GCS corresponding to a technology in Recommendation ITU-R M.[IMT-2020.SPECS].
- A Transposing Organization must have been authorized by the relevant GCS Proponent to produce transposed standards for a particular technology, and must have the relevant legal usage rights.

It is further noted that GCS Proponents and Transposing Organizations must also qualify appropriately under the auspices of Resolution ITU-R 9 and the ITU-R “Guidelines for the contribution of material of other organizations to the work of the Study Groups and for inviting other organizations to take part in the study of specific matters (Resolution ITU-R 9)”.

The ITU has provided the global and overall framework and requirements and has developed the Global Core Specification jointly with the GCS Proponent. The detailed standardization has been undertaken within the recognized Transposing Organizations which operate in concert with the GCS Proponent. This Recommendation therefore makes extensive use of references to externally developed specifications.

This approach was considered to be the most appropriate solution to enable completion of this Recommendation within the aggressive schedules set by the ITU and by the needs of administrations, operators and manufacturers.

This Recommendation has therefore been constructed to take full advantage of this method of work and to allow the global standardization timescales to be maintained. The main body of this Recommendation has been developed by the ITU, with each Annex containing references pointing to the location of the more detailed information.

This Annex 1 contains the detailed information developed by the ITU and “3GPP” (the GCS Proponent) and ARIB, ATIS, CCSA, ETSI, TSDSI, TTA, TTC (the transposing organizations).

---

<sup>6</sup> Developed by 3GPP Proponent as “5G, Release 15 and beyond – LTE+NR SRIT”.

Such use of referencing enables timely completion and update of the high-level elements of this Recommendation, with change control procedures, transposition, and public enquiry procedures being undertaken within the external organization. This information has generally been adopted unchanged, recognizing the need to minimize duplication of work, and the need to facilitate and support an ongoing maintenance and update process.

This general agreement, noting that the detailed information of the radio interface should to a large extent be achieved by reference to the work of external organizations, highlights not only the ITU's significant role as a catalyst in stimulating, coordinating and facilitating the development of advanced telecommunications technologies, but also its forward-looking and flexible approach to the development of this and other telecommunications standards for the 21<sup>st</sup> century.

A more detailed understanding of the process for the development of the first release of this Recommendation may be found in Document IMT-2020/20.

## **1.1 Overview of the radio interface technology**

The IMT-2020 specifications, known as 5G, have been developed by 3GPP and consist of long-term evolution (LTE) and new radio (NR) Releases 15 and beyond. In 3GPP terminology, the term Evolved-UMTS Terrestrial Radio Access (E-UTRA) is also used to signify the LTE radio interface.

5G is a set of radio interface technologies (RITs) consisting of E-UTRA/LTE as one component RIT and NR as the other component RIT. Both components are designed for operation in IMT spectrum.

5G fulfils all technical performance requirements in all five selected test environments: Indoor Hotspot – enhanced Mobile Broadband (eMBB), Dense Urban – eMBB, Rural – eMBB, Urban Macro – Ultra Reliable Low Latency Communication (URLLC) and Urban Macro – massive Machine Type Communication (mMTC).

Also, 5G fulfils the service and the spectrum requirements. Both component RITs, NR and E-UTRA/LTE, utilize the frequency bands below 6 GHz identified for International Mobile Telecommunication (IMT) in the ITU Radio Regulations. In addition, the NR component RIT can also utilize the frequency bands above 6 GHz, i.e. above 24.25 GHz, identified for IMT in the ITU Radio Regulations.

The complete set of standards for the terrestrial radio interface of IMT-2020 identified as 5G includes not only the key characteristics of IMT-2020 but also the additional capabilities of 5G both of which are continuing to be enhanced.

The 3GPP 5G System (5GS) also includes specifications for its non-radio aspects, such as the core network elements (the EPC Network and 5GC Network), security, codecs, network management, etc. These non-radio specifications are not included in the so-called "Global Core Specifications (GCS)" of IMT-2020.

### **1.1.1 Overview of the component RIT: E-UTRA/LTE**

The E-UTRA/LTE Component RIT is based on releases 15 and 16 of LTE, and it is the evolution of the previous releases, encompassing both FDD and TDD. The E-UTRA/LTE RIT uses either 1) FDD operation and therefore is applicable for the operation with paired spectrum, or 2) TDD operation and therefore is applicable for the operation with unpaired spectrum. Both full-duplex and half-duplex FDD are supported. Aggregation of TDD and FDD spectrum is supported.

Transmission bandwidths up to 640 MHz are supported, yielding peak data rates up to roughly 32 Gbit/s in the downlink (DL) and 13.6 Gbit/s in the uplink (UL).

The downlink transmission scheme is based on conventional OFDM to provide a high degree of robustness against channel frequency selectivity while still allowing for low-complexity receiver implementations also at very large bandwidths.

The uplink transmission scheme is based on Discrete Fourier Transform-Spread OFDM (DFTS-OFDM). The use of this transmission scheme for the uplink is motivated by the lower Peak-to-Average Power Ratio (PAPR) of the transmitted signal compared to conventional OFDM. This allows for more efficient usage of the power amplifier in the User Equipment (UE), which translates into an increased coverage and/or reduced terminal power consumption. The uplink numerology (subcarrier spacing and symbol duration) is aligned with the downlink numerology. The Narrow-Band Internet of Things (NB-IoT) UL allows the allocation of a single-tone in addition to multi-tone DFTS-OFDM with the possibility of a lower subcarrier spacing in addition to the normal subcarrier spacing.

Channel coding is based on rate-1/3 turbo coding and is complemented by Hybrid-Automatic Repeat Request (HARQ) with soft combining to handle decoding errors at the receiver side. Data modulation supports Quadrature Phase Shift Keying (QPSK), 16QAM, 64QAM and 256QAM for both the downlink and the uplink. In downlink, 1024QAM is supported. NB-IoT supports QPSK on DL and UL, and additionally  $\pi/2$ -BPSK and  $\pi/4$ -QPSK are supported in uplink when a single-tone is allocated. NB-IoT DL channel coding is based on tail biting convolutional code. For eMTC,  $\pi/2$ -BPSK is supported when two tones are allocated.

The E-UTRA/LTE RIT supports bandwidths from approximately 1.4 MHz to 640 MHz. NB-IoT supports 200 kHz bandwidth. Carrier aggregation, i.e. the simultaneous transmission of multiple component carriers in parallel to/from the same terminal/eNB, is used to support bandwidths greater than 20 MHz. Component carriers do not have to be contiguous in frequency and can even be located in different frequency bands in order to enable exploitation of fragmented spectrum allocations by means of spectrum aggregation.

Carrier Aggregation (CA) supports the functionality to aggregate TDD bands with different uplink and downlink allocations as well as the functionality to support multiple timing advances. Carrier Aggregation also supports aggregating FDD and TDD component carriers. Dual Connectivity (DC) allows aggregating component carriers of different eNBs that are connected via a non-ideal backhaul.

Channel-dependent scheduling in both the time and frequency domains is supported for both downlink and uplink with the base-station scheduler being responsible for (dynamically) selecting the transmission resource as well as the data rate. The basic operation is dynamic scheduling, where the base-station scheduler takes a decision for each 1 ms Transmission Time Interval (TTI), but there is also a possibility for semi-persistent scheduling. Apart from the basic TTI of 1ms, E-UTRA/LTE supports shortened TTI of 2/3 OFDM symbols (142  $\mu$ s) and one slot (500  $\mu$ s). Semi-persistent scheduling enables transmission resources and data rates to be semi-statically allocated to a given User Equipment (UE) for a longer time period than one TTI in order to reduce the control-signalling overhead. For better uplink coverage, TTI bundling allows UEs to transmit in four consecutive TTIs. NB-IoT and enhanced MTC (eMTC) allow for widespread coverage extension by means of scheduling multiple TTIs (up to several thousands).

Multi-antenna transmission schemes are an integral part of E-UTRA/LTE RIT. Multi-antenna precoding with dynamic rank adaptation supports both spatial multiplexing (single-user Multiple Input Multiple Output (MIMO)) and beam-forming. Beam-forming by means of 2-dimensional antenna arrays can exploit the horizontal as well as the vertical spatial domains. Spatial multiplexing with up to eight layers in the downlink and four layers in the uplink is supported. Multi-user MIMO, where multiple users are assigned the same time-frequency resources, is also supported. Coordinated MultiPoint (CoMP) operation is also supported, where multiple transmission points or reception points are coordinated in their transmission or reception,

respectively. The coordinated transmission points can belong to the same cell, to different cells of the same eNB or to different cells of different eNBs. A discovery reference signal can be used to identify transmission points or cells for CoMP and/or Carrier aggregation operation. Finally, transmit diversity based on Space-Frequency Block Coding (SFBC) or a combination of SFBC and Frequency Switched Transmit Diversity (FSTD) is supported.

Inter-cell interference coordination (ICIC), where neighbouring cells exchange information aiding the scheduling in order to reduce interference, is supported for the E-UTRA/LTE RIT. ICIC can be used for homogenous deployments with non-overlapping cells of similar transmission power, as well as for heterogeneous deployments where a higher-power cell overlays one or several lower-power cells. In order to increase the potential of cell range expansion, functionality exists for terminal-side interference mitigation of reference and synchronization signals as well as the broadcast channel. A terminal-side mitigation of inter-cell interference caused by the data channel is supported with network assistance. A network-side interference mitigation technique is supported, which is based on the ability to turn on and off secondary cells.

Relaying functionality is included in E-UTRA/LTE RIT. A relay node (RN) appears as a conventional e-Node B to UEs but is wirelessly backhauled to the remaining part of the radio-access network using the LTE Release 10 radio-interface technology. E-UTRA/LTE RIT also supports sidelink communication via Proximity based Services (ProSe) UE-to-Network Relay.

E-UTRA/LTE RIT supports various types of machine-type communication. In order to better address the low-cost segment, a low-complexity terminal (Category 0) is supported, which has approximately 50% reduced modem complexity as compared to the least complex 'normal' UE (Category 1). Another 50% complexity reduction was made possible with eMTC (Category M1) and even more with NB-IoT (Category NB1). eMTC optionally supports half duplex (HD) operation and NB-IoT supports only HD. In addition, eMTC and NB-IoT extended the original LTE coverage area by ~15 dB and ~20 dB respectively. The narrow NB-IoT channel bandwidth of 200 kHz makes it possible to operate in re-farmed GSM channels or in LTE guardbands. In order to improve UE power consumption, a power saving State was introduced and extended Discontinuous Reception (eDRX) cycles range up to 10.24 seconds in connected mode and 43.69 minutes in idle mode. For eMTC and NB-IoT, it is possible to configure an additional uplink and an additional downlink carrier for traffic which is dedicated to a particular User Equipment, whilst common transmissions such as synchronization signals, and uplink transmissions during cell access, occur on the same carrier for all UEs. In 3GPP Rel-16, spectral efficiency is increased further for massive-MTC transmissions and reduced energy consumption for massive-MTC devices enabled e.g. uplink transmission using preconfigured resources in idle mode (allowing the device to skip random access procedures) and multi-transport-block scheduling in both the DL and UL transmission directions (reducing the control signalling overhead).

Sidelink transmissions are defined for ProSe Direct Discovery and ProSe Direct Communication between UEs. ProSe Direct Communication is targeting only Public Safety applications and allows terminals to communicate with each other directly without routing the data via the eNB. ProSe Direct Discovery allows discovering other terminals in close proximity. Direct communication is also supported when a terminal is out of LTE network coverage. Vehicular communication services can be provided by PC5 interface and/or Uu interface. Support of vehicle-to-everything (V2X) services via PC5 interface is provided by V2X sidelink communication.

E-UTRA/LTE RIT supports also Multicast Broadcast Multimedia Service (MBMS), allowing for multiple cells to jointly transmit multicast/broadcast data forming a single frequency network. Multiple subcarrier spacings and cyclic prefixes are supported, targeting different use cases (e.g. handheld, car-mounted, rooftop) and different inter-site distances (up to 100km ISD). E-UTRA/LTE RIT supports both mixed unicast/MBMS carriers and dedicated MBMS carriers.

In order to enhance mobility robustness and performance, additional LTE mobility enhancements are introduced in 3GPP Rel-16. User data interruption is reduced during handover to 0 ms by dual-active-protocol-stack handover. In addition, the robustness during handover is improved by conditional handover.

### 1.1.1.1 Network architecture

The radio-access network of E-UTRA/LTE RIT has a flat architecture with a single type of node, the eNodeB, which is responsible for all radio-related functions in one or several cells. The eNodeB is connected to the core network via the S1 interface, more specifically to the serving gateway (S-GW) by means of the user-plane part, S1-u, and to the Mobility Management Entity (MME) by means of the control-plane part, S1-c. One eNodeB can connect to multiple MMEs/S-GWs for the purpose of load sharing and redundancy. MMEs/S-GWs can be (re)selected for support of separate dedicated core networks that are designed to meet the requirements of a certain group of devices/customers.

The X2 interface, connecting eNodeBs to each other, is mainly used to support active-mode mobility. This interface may also be used for multi-cell Radio Resource Management (RRM) functions such as ICIC or CoMP. The X2 interface is also used to support lossless mobility between neighbouring cells by means of packet forwarding. The architecture is shown in Fig. 1.

FIGURE 1  
Radio-access network interfaces

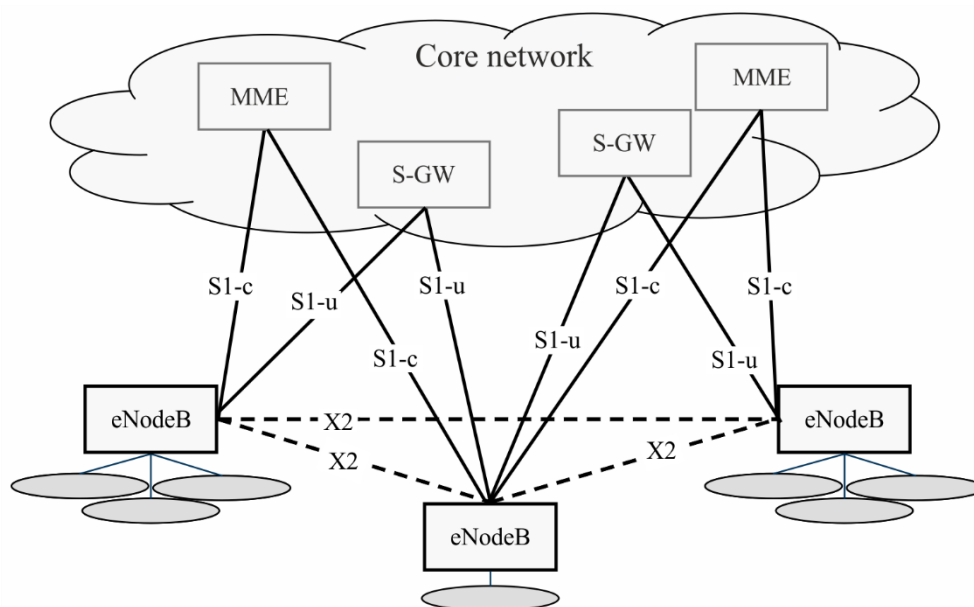

M.2150-01

### 1.1.1.2 Layer 2 protocol architecture

Layer 2 (L2) consists of several sub-layers: Packet Data Convergence Protocol (PDCP), Radio Link Control (RLC) and Medium Access Control (MAC). The downlink and uplink protocol structures are illustrated in Fig. 2 and Fig. 3, respectively. L2 provides one or more Radio Bearers to higher layers to which Internet Protocol (IP) packets are mapped according to their Quality-of-Service (QoS) requirements. L2/MAC Protocol Data Units (PDUs), also referred to as transport blocks, are created according to instantaneous scheduling decisions and delivered to the physical layer on one or several transport channels (one transport channel of the same type per component carrier).

FIGURE 2  
Downlink L2 protocol structure

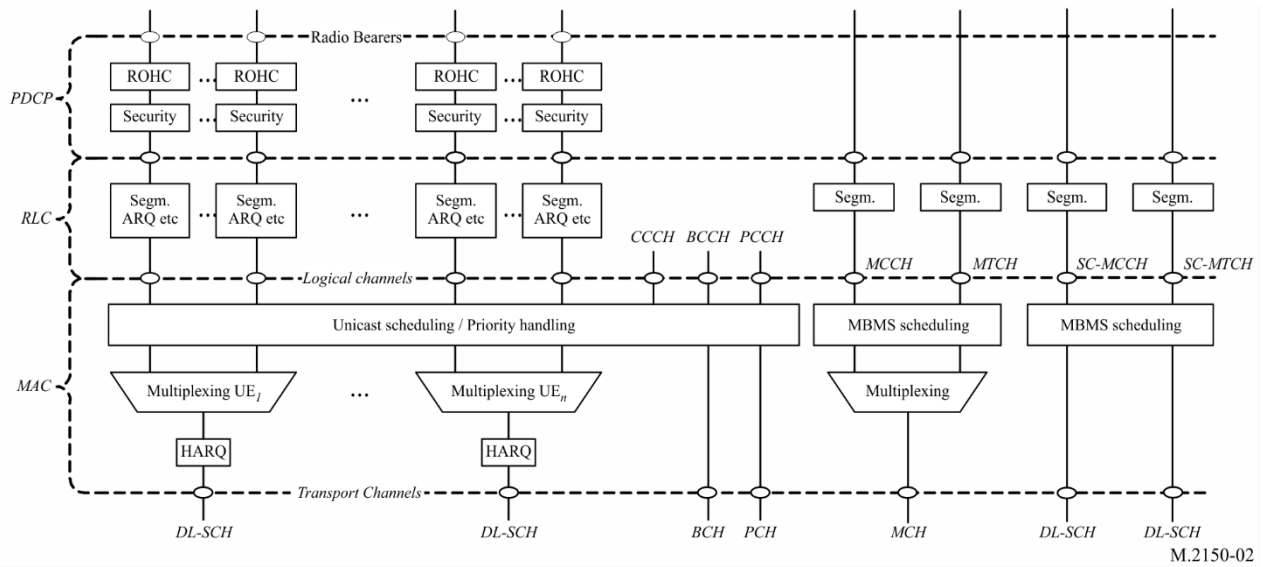

M.2150-02

FIGURE 3  
Uplink L2 protocol structure

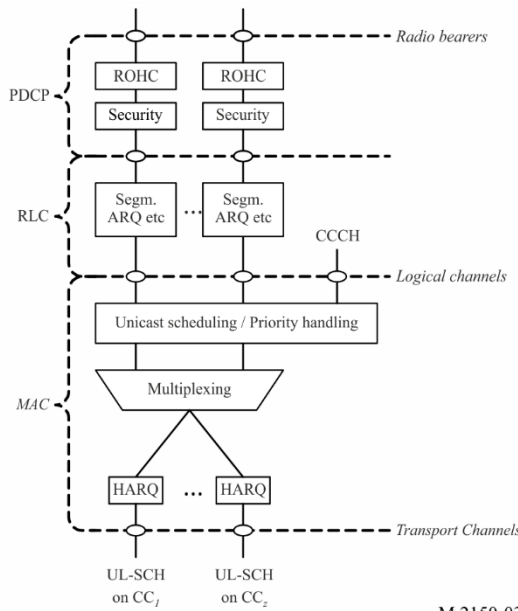

M.2150-03

Radio bearers are categorized into two groups: Data Radio Bearers (DRB) for UP data and Signalling Radio Bearers (SRB) for CP data.

In DC, a data radio bearer can be configured as Master Cell Group (MCG) bearer, Secondary Cell Group (SCG) bearer or a split bearer. The MCG bearer is served by the Master eNB (MeNB), SCG bearer by the Secondary eNB (SeNB) and the split bearer is served by both eNBs. For a split bearer, a common PDCP entity is located in the MeNB, but there are two RLC entities, one terminating in the MeNB and one in the SeNB. From Rel-15 onwards, a data packet of a data radio bearer can be duplicated increasing robustness.

### 1.1.1.2.1 Packet Data Convergence Protocol (PDCP)

Except for NB-IoT, the main services and functions of the PDCP sublayer for the User Plane (UP) include:

- Header compression and decompression of IP data flows using ROHC.
- Transfer of user data.
- In-sequence delivery of upper layer PDUs in the PDCP re-establishment procedure for RLC Acknowledged Mode (AM).
- For split bearers in Dual Connectivity (only supported in RLC AM mode): PDCP PDU routing for transmission and PDCP PDU reordering for reception.
- Duplicate detection of lower layer Service Data Units (SDUs) in the PDCP re-establishment procedure for RLC AM.
- Retransmission of PDCP SDUs at handover and, for split bearers in DC and LWA bearers, of PDCP PDUs at PDCP data-recovery procedure, for RLC AM.
- Ciphering and deciphering.
- Timer-based SDU discard in uplink.

For NB-IoT UEs when AS security is activated, the main services and functions of the PDCP sublayer for the user plane include:

- Header compression and decompression: ROHC only;
- Transfer of user data;
- In-sequence delivery of upper layer PDUs in the PDCP re-establishment procedure for RLC AM;
- Duplicate detection of lower layer SDUs in the PDCP re-establishment procedure for RLC AM;
- Ciphering and deciphering;
- Timer-based SDU discard in uplink.

The main services and functions of the PDCP for the CP include:

- Ciphering and integrity protection and verification.
- Transfer of control plane data.

For an NB-IoT UE that supports Control Plane Cellular Internet of Things (CIoT) EPS optimizations only, PDCP is bypassed. For a NB-IoT UE that supports both Control Plane CIoT EPS optimizations and User Plane CIoT EPS optimizations PDCP is not used until AS security is activated.

PDCP uses the services provided by the RLC sub-layer. There is one PDCP entity per radio bearer configured for each UE.

### 1.1.1.2.2 Radio Link Control (RLC)

Radio Link Control (RLC) is responsible for:

- Transfer of upper layer PDUs.
- Error correction through ARQ (only for AM data transfer).
- Concatenation, segmentation and reassembly of RLC SDUs (only for Unacknowledged Mode (UM) and AM data transfer).
- Resegmentation of RLC data PDUs (only for AM data transfer).
- Reordering of RLC data PDUs (only for UM and AM data transfer).

- Duplicate detection (only for UM and AM data transfer).
- Protocol error detection (only for AM data transfer).
- RLC SDU discard (only for UM and AM data transfer).
- RLC re-establishment, except for a NB-IoT UE that only uses CP CIoT EPS optimizations.

Depending on the mode-of-operation, an RLC entity may provide all, a subset of, or none of the services above. The RLC can operate in three different modes:

- Transparent mode (TM), where the RLC is completely transparent and is in essence bypassed. This configuration is used for control-plane broadcast channels such as Broadcast Control Channel (BCCH), Common Control Channel (CCCH) and Paging Control Channel (PCCH) only where the information should reach multiple users.
- Unacknowledged mode (UM), where the RLC provides all the functionality above except error correction, is used when error-free delivery is not required, for example for Multicast Control Channel (MCCH) and Multicast Traffic Channel (MTCH) using Multimedia Broadcast over a Single Frequency Network (MBSFN) and for Voice-over-IP (VoIP).
- Acknowledged mode (AM), where the RLC provides all the services above, is the main mode-of-operation for TCP/IP packet data transmission on the Downlink Shared Channel (DL-SCH). Segmentation/reassembly, in-sequence delivery and retransmissions of erroneous data are all supported.

The RLC offers services to the PDCP in the form of *radio bearers* and uses services from the MAC layer in the form of *logical channels*. There is one RLC entity per radio bearer configured for each UE.

#### 1.1.1.2.3 Medium Access Control (MAC)

The MAC layer is responsible for:

- Mapping between logical channels and transport channels.
- Multiplexing/demultiplexing of MAC SDUs belonging to one or different logical channels into/from transport blocks delivered to/from the physical layer on transport channels.
- Scheduling information reporting.
- Error correction through N-process stop-and-wait hybrid-ARQ (HARQ) with synchronous (for the uplink) and asynchronous (for the downlink) retransmissions.
- Priority handling between logical channels of one UE.
- Priority handling between UEs by means of dynamic scheduling.
- Multimedia Broadcast/Multicast Service (MBMS) identification.
- Transport format selection.
- Padding.

The ProSe specific services and functions of the MAC sublayer include:

- Radio resource selection;
- Packet filtering for Prose Direct Communication.

In case of DC, the UE is configured with two independent MAC entities, one for MCG and one for SCG.

The MAC offers services to the RLC in the form of logical channels. A logical channel is defined by the type of information it carries and is generally classified as a control channel, used for transmission of control and configuration information necessary for operating an E-UTRA/LTE



RIT system, or as a traffic channel, used for the user data. The set of logical-channel types specified for E-UTRA/LTE RIT includes:

- Broadcast Control Channel (BCCH), used for broadcasting system control information.
- Bandwidth Reduced Broadcast Control Channel (BR-BCCH), used for broadcasting system control information to bandwidth limited eMTC UEs.
- Paging Control Channel (PCCH), a downlink channel used for paging when the network is not aware of the location of the UE and for system information change notifications.
- Common Control Channel (CCCH), used for transmission of control information between UEs and network when the UE has no Radio Resource Control (RRC) connection.
- Dedicated Control Channel (DCCH), used for transmission of control information to/from a mobile terminal when the UE has a RRC connection.
- Multicast Control Channel (MCCH), used for transmission of control information required for reception of the MTCH.
- Single-Cell Multicast Control Channel (SC-MCCH), used for transmission of control information required for reception of MBMS using Single-Cell Point-to-Multipoint (SC-PTM).
- Sidelink Broadcast Channel (SBCH) used for broadcasting sidelink system information from one UE to one or more other UE(s). This channel is used only by ProSe Direct Communication capable UEs.
- Dedicated Traffic Channel (DTCH), used for transmission of user data to/from a mobile terminal. This is the logical channel type used for transmission of all uplink and non-MBSFN downlink user data. DTCH is not supported for an NB-IoT UE that only uses CP CIoT EPS optimizations.
- Multicast Traffic Channel (MTCH), used for downlink transmission of MBMS services.
- Single-Cell Multicast Traffic Channel (SC-MTCH), used for downlink transmission of MBMS services using SC-PTM.
- Sidelink Traffic Channel (STCH) is a point-to-multipoint channel, for transfer of user information from one UE to other UEs. This channel is used only by Prose Direct Communication capable UEs.

For a NB-IoT UE that only uses CP CIoT EPS optimizations there is only one dedicated logical channel per UE.

From the physical layer, the MAC layer uses services in the form of Transport Channels. A transport channel is defined by how and with what characteristics the information is transmitted over the radio interface. Data on a transport channel is organized into transport blocks. In each Transmission Time Interval (TTI), at most one or two (in case of spatial multiplexing) transport blocks are transmitted per component carrier.

Associated with each transport block is a Transport Format (TF), specifying how the transport block is to be transmitted over the radio interface. The transport format includes information about the transport-block size, the modulation scheme, and the antenna mapping. The scheduler is responsible for (dynamically) determining the uplink as well as downlink transport format in each TTI.

The following transport-channel types are defined:

- The Broadcast Channel (BCH) has a fixed transport format, provided by the specifications. It is used for transmission of parts of the BCCH system information, more specifically the so-called Master Information Block (MIB).

- Paging Channel (PCH) is used for transmission of paging information from the PCCH logical channel. The PCH supports DRX to allow the mobile terminal to save battery power by waking up to receive the PCH only at predefined time instants.
  - The downlink Shared Channel (DL-SCH) is the main transport-channel type used for transmission of downlink data in E-UTRA/LTE RIT. The DL-SCH supports dynamic rate adaptation and channel-dependent scheduling, HARQ with soft combining, and spatial multiplexing. It also supports DRX to reduce mobile-terminal power consumption while still providing an always-on experience.
- The DL-SCH is also used for transmission of the parts of the BCCH system information not mapped to the BCH. For transmission to a terminal using multiple component carriers, the UE receives one DL-SCH per component carrier.
- The Multicast Channel (MCH) is used to support MBMS. It is characterized by a semi-static transport format and semi-persistent scheduling. In case of multi-cell transmission using MBSFN, the scheduling and transport format configuration is coordinated among the cells involved in the MBSFN transmission.
  - The Uplink Shared Channel (UL-SCH) is the uplink counterpart to the DL-SCH, i.e. it is the uplink transport channel used for transmission of uplink data.
  - The Random Access Channel (RACH) is also defined as an uplink transport channel although it does not carry transport blocks. The RACH is used in the uplink to respond to the paging message or to initiate the move to the RRC\_CONNECTED state according to terminal data transmission needs.
  - The Sidelink Broadcast Channel (SL-BCH) uses a pre-defined transport format.
  - The Sidelink Discovery Channel (SL-DCH) supports both UE autonomous resource selection and scheduled resource allocation by eNodeB; it uses a fixed size, pre-defined format periodic broadcast transmission.
  - The Sidelink Shared Channel (SL-SCH) supports both UE autonomous resource selection and scheduled resource allocation by eNodeB; it supports HARQ combining and dynamic link adaptation by varying the transmit power, modulation and coding.

The mapping between logical channels, transport channels and physical channels is illustrated in Fig. 4 for the downlink, Fig. 5 for the uplink, Fig. 6 for the sidelink, Fig. 7 for the NB-IoT downlink and Fig. 8 for the NB-IoT uplink.

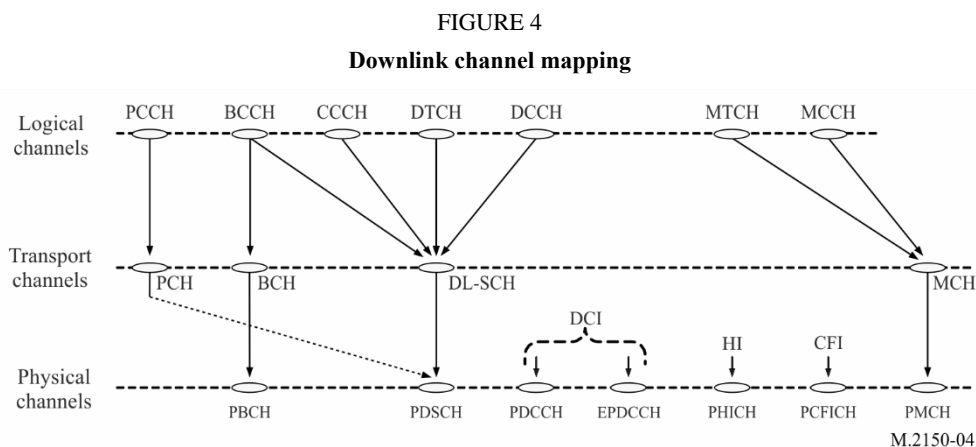

FIGURE 5

**Uplink channel mapping**

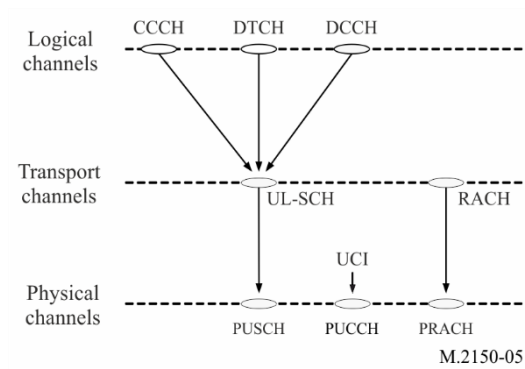

FIGURE 6

**Sidelink channel mapping**

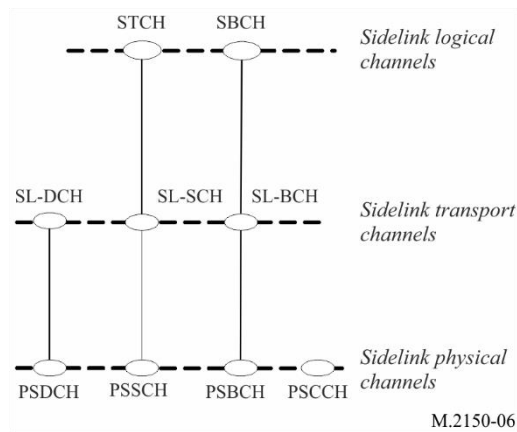

FIGURE 7

**NB-IoT DL channel mapping**

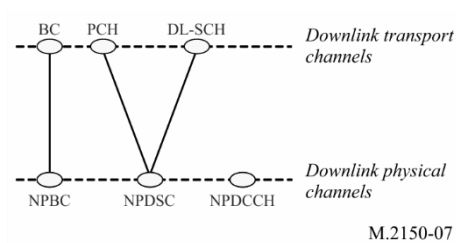
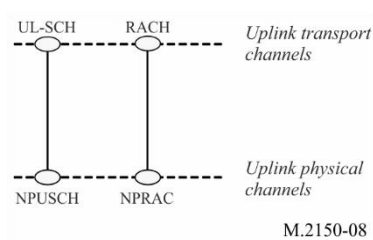

FIGURE 8

**NB-IoT UL channel mapping**



**1.1.1.3 Physical layer**

The physical layer is responsible for:

- modulation and demodulation of physical channels;
- error detection on the transport channel and indication to higher layers;
- forward Error Correction (FEC) encoding and decoding of transport channels;
- rate matching of the coded transport channel to physical channels;
- mapping of the coded transport channel onto physical channels according to Fig. 4 (downlink) and Fig. 5 (uplink);
- Hybrid-ARQ soft-combining;
- frequency and time synchronization;
- power weighting of physical channels;
- multi-antenna processing and beamforming;
- characteristic measurements and indication to higher layers; and
- RF processing.

A simplified overview of the processing for the DL-SCH is given in Fig. 9.

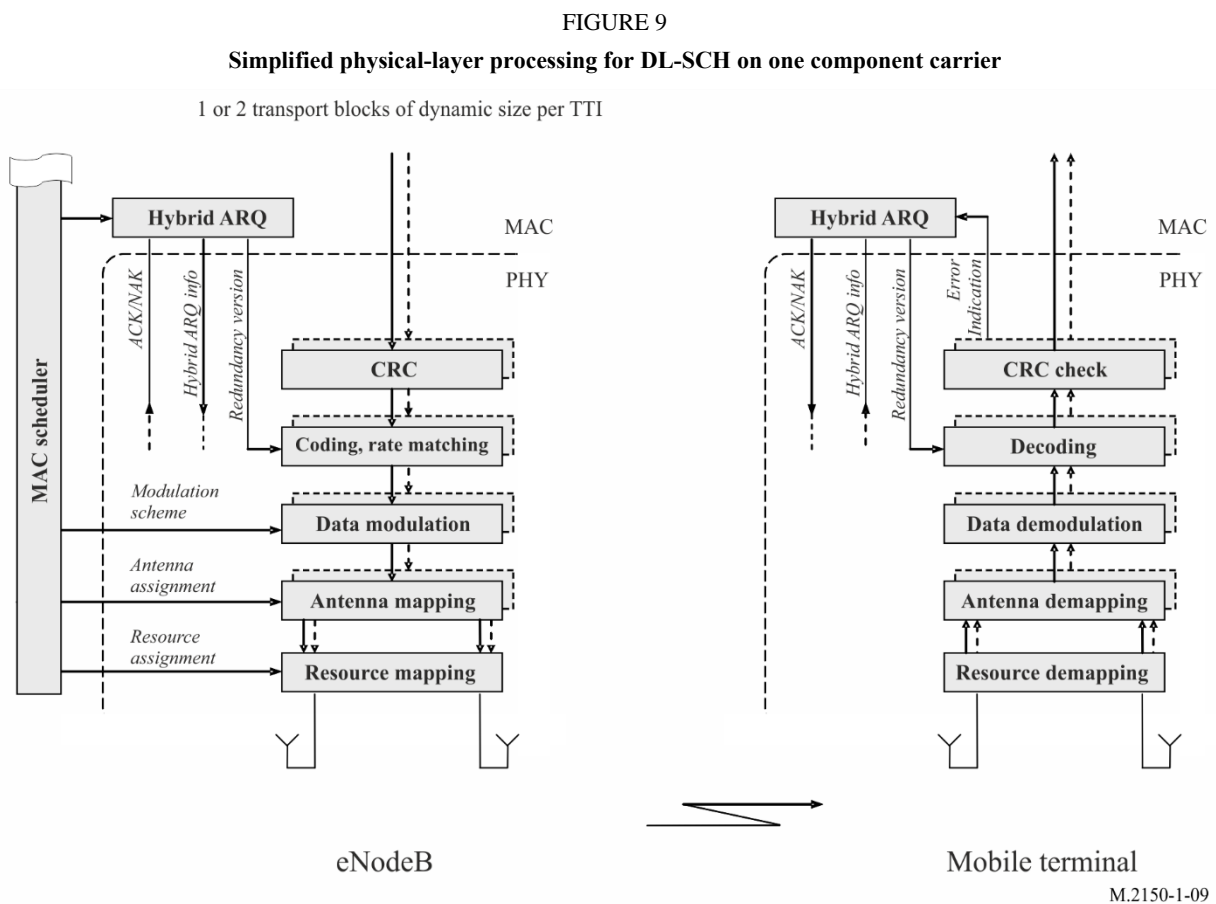

### 1.1.1.3.1 Physical channels

The following different types of physical channels are defined for the downlink:

- Physical Downlink Shared Channel (PDSCH): used for transmission of user and control plane data services.
- Physical Multicast Channel (PMCH): used for transmission of control and user-plane broadcast services during MBSFN subframes.

- Physical Downlink Control Channel (PDCCH): used for transmission of control information such as resource allocation, transport format and HARQ related information.
- Enhanced Physical Downlink Control Channel (EPDCCH): used for transmission of control information such as resource allocation, transport format and HARQ related information.
- MTC physical downlink control channel (MPDCCH): used for transmission of control information in bandwidth-reduced operation and/or using coverage extension mode.
- Physical Broadcast Channel (PBCH): used for conveying cell and/or system specific information.
- Physical Control Format Indicator Channel (PCFICH): used to indicate to the UE the control format (number of symbols comprising PDCCH, PHICH) of the current subframe.
- Physical Hybrid ARQ Indicator Channel (PHICH): used to convey the ACK/NAK information for UL (PUSCH) transmissions received at the eNodeB.

Three different types of physical channels are defined for the uplink:

- Physical Random Access Channel (PRACH): used to convey a preamble which is used to trigger a random-access procedure in the eNodeB.
- Physical Uplink Shared Channel (PUSCH): used to convey both user data and upper layer control information.
- Physical Uplink Control Channel (PUCCH): used to convey control information (scheduling requests, CQI, PMI, RI, HARQ ACK/NAK for PDSCH, etc.).

The following types of physical channels are defined for the sidelink:

- Physical sidelink broadcast channel (PSBCH): used to carry system and synchronization related information, transmitted from the UE.
- Physical sidelink discovery channel (PSDCH): used to carry ProSe Direct Discovery message from the UE.
- Physical sidelink control channel (PSCCH): used to carry control from a UE for ProSe Direct Communication.
- Physical sidelink shared channel (PSSCH): used to carry traffic from a UE for ProSe Direct Communication.

The following types of physical channels are defined for NB-IoT:

- Narrowband Physical broadcast channel (NPBCH) : used to carry the BCH for NB-IoT UEs. Used for conveying cell and/or system specific information using a transport block mapped to sixty four subframes within a 640 ms interval.
- Narrowband Physical downlink shared channel (NPDSCH): used to carry the DL-SCH and PCH for NB-IoT UEs.
- Narrowband Physical downlink control channel (NPDCCH): used to inform the NB-IoT UE about the resource allocation of PCH and DL-SCH. Carries the uplink scheduling grant for the NB-IoT UE. Carries the direct indication information.
- Narrowband Physical uplink shared channel (NPUSCH): used to carry the UL-SCH and Hybrid ARQ ACK/NAKs in response to downlink transmission for the NB-IoT UE.
- Narrowband Physical random access channel (NPRACH): used to carry the random access preamble for the NB-IoT UE.

#### 1.1.1.3.2 Time-domain structure and duplex schemes

Figure 10 illustrates the high-level time-domain structure for transmission, with each (radio) frame of length 10 ms consisting of ten equally sized subframes of length 1 ms. Each subframe consists of

two equally sized slots of length  $T_{\text{slot}} = 0.5 \text{ ms}$  with each slot consisting of a number of OFDM symbols including cyclic prefix. For MBSFN transmission, slots of 1 ms and 3 ms are additionally defined.

FIGURE 10  
*E-UTRA/LTE RIT* time-domain structure

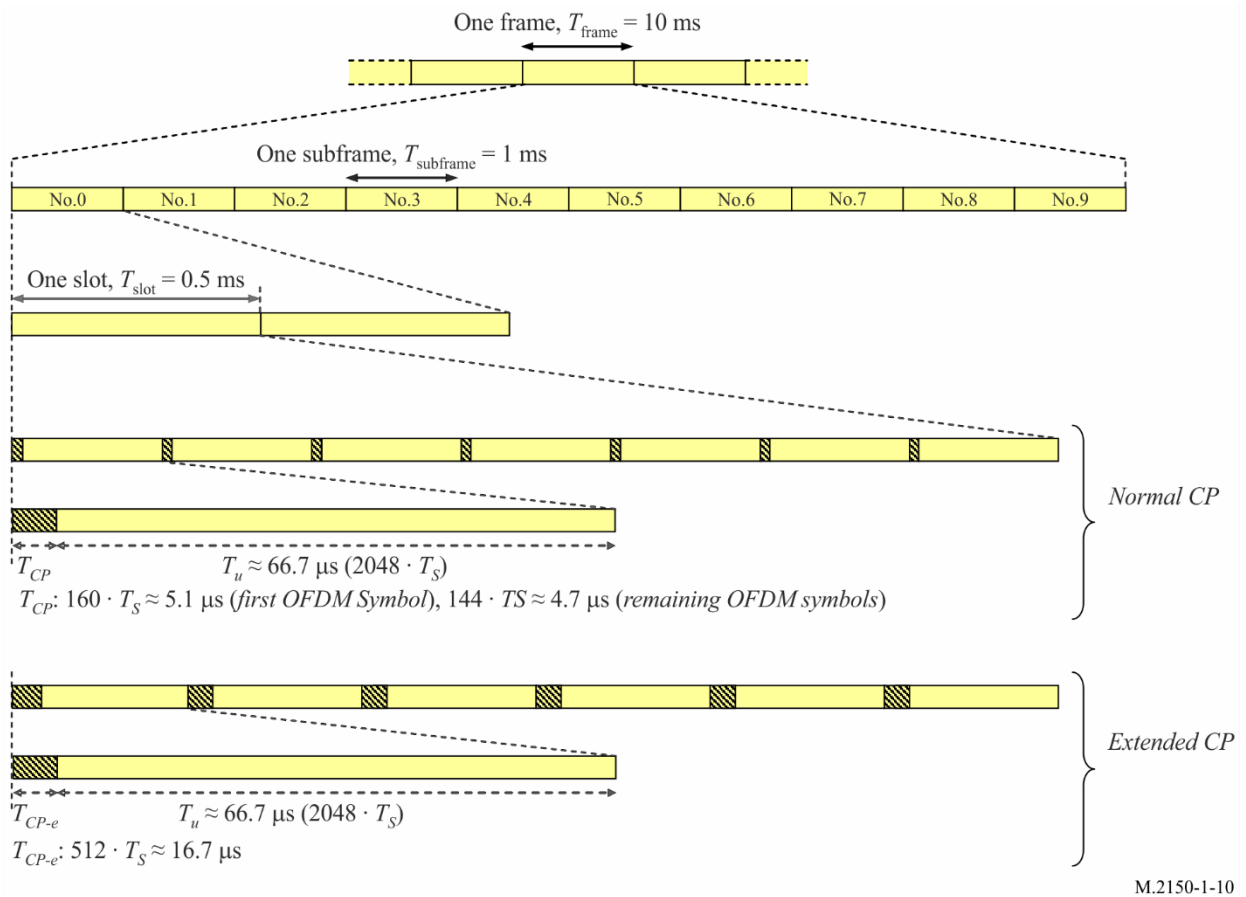

The E-UTRA/LTE RIT can operate in both FDD and TDD modes as illustrated in Fig. 11. Although the time-domain structure is, in most respects, the same for FDD and TDD there are some differences between the two duplex modes, most notably the presence of a special subframe in the case of TDD. The special subframe is used to provide the necessary guard time for downlink-to-uplink switching.

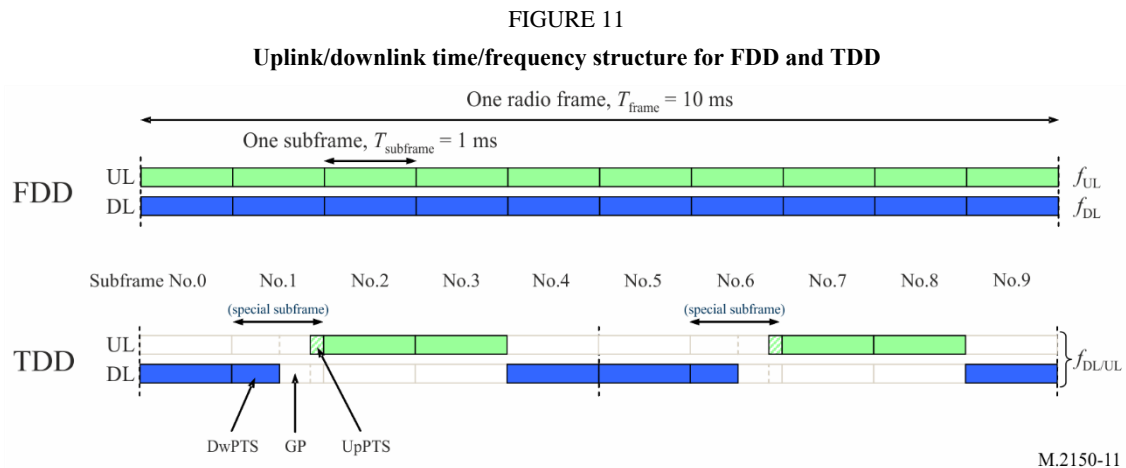

For FDD operation (upper part of Fig. 11), there are two carrier frequencies for each component carrier, one for uplink transmission ( $f_{UL}$ ) and one for downlink transmission ( $f_{DL}$ ). During each frame, there are thus ten uplink subframes and ten downlink subframes and uplink and downlink transmission can occur simultaneously within a cell. Half-duplex operation at the UE side is supported by the scheduler ensuring non-simultaneous reception and transmission at the UE.

For TDD operation (lower part of Fig. 11), there is only a single carrier frequency per component carrier and uplink and downlink transmissions are always separated in time also on a cell basis. As seen in the figure, some subframes are allocated for uplink transmissions and some subframes for downlink transmission with the switch between downlink and uplink occurring in the special subframe. The special subframe is split into three parts: a downlink part (DwPTS), a guard period (GP) where the switch occurs, and an uplink part (UpPTS). The DwPTS is in essence treated as a normal downlink subframe, although the amount of data that it is possible to transmit is smaller due to the reduced length of the DwPTS. The UpPTS can be used for channel sounding or random access. The DwPTS, GP, and UpPTS have configurable individual lengths to support different deployment scenarios, and a total length of 1 ms.

Different asymmetries in terms of the amount of resources allocated for uplink and downlink transmission, respectively, are provided through seven different downlink/uplink configurations as shown in Fig. 12. Where carrier aggregation is employed, the downlink/uplink configuration is identical across component carriers in the same band and may be the same or different across component carriers in different bands.

Coexistence between the E-UTRA/LTE RIT and other (IMT-2000) TDD systems such as TD-SCDMA is catered for by aligning the switch points between the two systems and selecting the appropriate special subframe configuration and uplink-downlink asymmetry.

FIGURE 12

Uplink-downlink asymmetries supported by the E-UTRA/LTE RIT

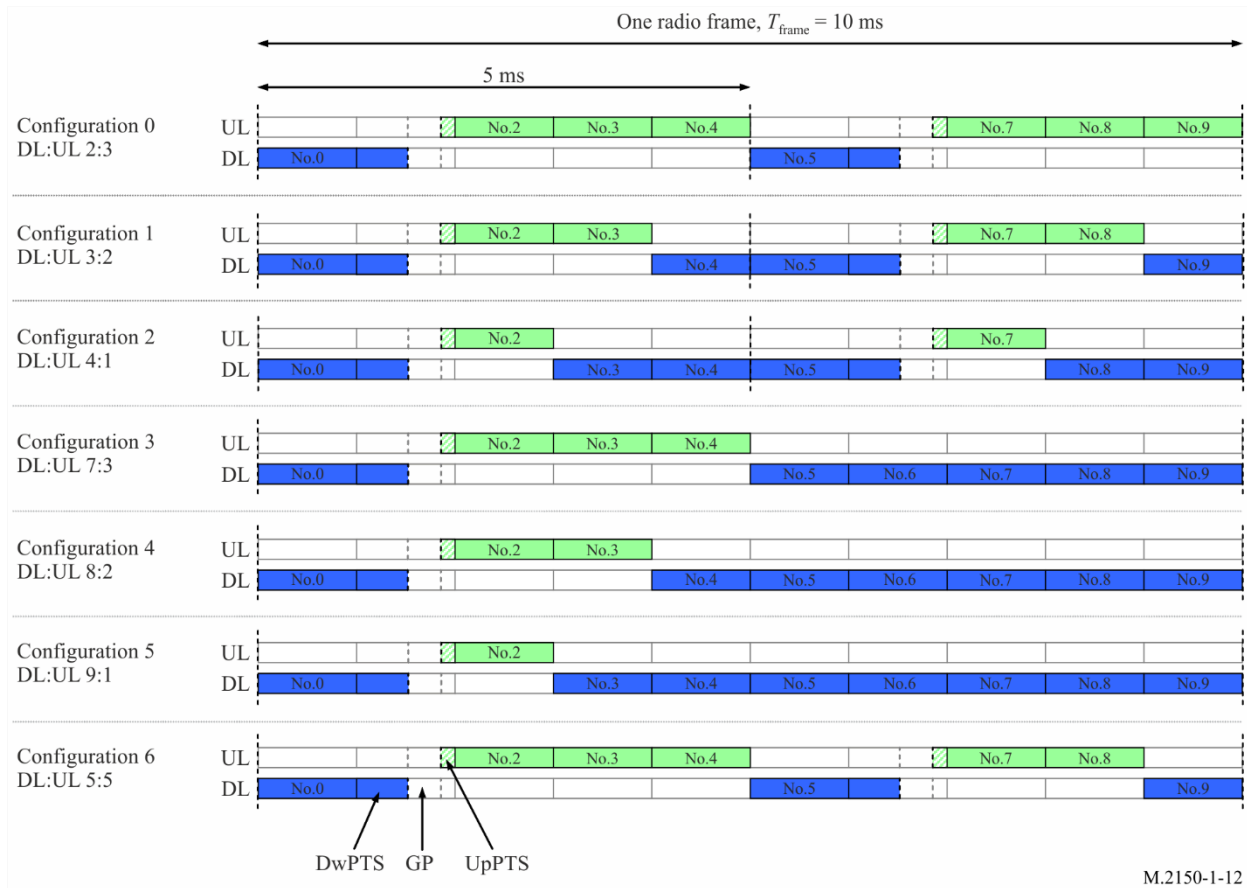

Sidelink transmissions use the same frame structure as the frame structure that is defined for uplink and downlink when UEs are in network coverage. However, the sidelink transmissions are restricted to a subset of the uplink resources in time and frequency domain.

The physical channel structure is similar to uplink transmissions and the same basic transmission scheme as the UL transmission scheme is used. However, sidelink is limited to single cluster transmissions and it uses a one symbol gap at the end of each sidelink subframe.

### 1.1.1.3.3 Physical layer processing

To the transport block(s) to be transmitted on a DL-SCH or UL-SCH, a Cyclic Redundancy Check is attached, followed by rate-1/3 Turbo coding for error correction (tail biting convolutional code for NPDSCH). Rate matching is used not only to match the number of coded bits to the amount of resources allocated for the DL-SCH/UL-SCH transmission, but also to generate the different redundancy versions as controlled by the HARQ protocol. When spatial multiplexing is employed, the processing is duplicated for the two transport blocks. After rate matching, the coded bits are modulated (QPSK, 16QAM, 64QAM, 256QAM, and 1024QAM in DL, and QPSK, 16QAM, 64QAM, 256QAM in UL). In the case of multi-antenna transmission, the modulation symbols are mapped to multiple layers and precoded before being mapped to the different antenna ports. Alternatively, transmit diversity can be applied. Finally, the (precoded) modulation symbols are mapped to the time-frequency resources allocated for the transmission.

Downlink transmission is based on conventional OFDM with a cyclic prefix. The subcarrier spacing is  $\Delta f = 15 \text{ kHz}$  and two cyclic prefix lengths are supported: normal cyclic prefix  $\approx 4.7 \mu\text{s}$  and extended cyclic prefix  $\approx 16.7 \mu\text{s}$ . In the frequency domain, the number of resource blocks can range from 6 to 100 per component carrier (for channel bandwidths ranging from 1.4 to 20 MHz



respectively), where a resource block is 180 kHz in the frequency domain. There can be up to 32 component carriers transmitted in parallel implying an overall bandwidth up to 640 MHz. In inband mode NB-IoT allocates a single resource block. In standalone mode, NB-IoT uses a channel bandwidth of 200 kHz.

Uplink transmission is based on Discrete Fourier Transform (DFT) Spread OFDM (DFTS-OFDM). DFTS-OFDM can be seen as a DFT precoder, followed by conventional OFDM with the same numerology as in the downlink. The NB-IoT UL allows allocation of a single-tone with  $\Delta f = 3.75$  kHz or  $\Delta f = 15$  kHz subcarrier spacing. Multiple DFT precoding sizes, corresponding to transmission with different scheduled bandwidths, can be used.

The remaining downlink transport channels (PCH, BCH, MCH) are based on the same general physical-layer processing as DL-SCH, although with some restrictions in the set of features used. MCH supports additional subcarrier spacings of 0.370, 1.25, 2.5 and 7.5 kHz are supported, with cyclic prefixes up to 300  $\mu$ s.

#### 1.1.1.3.4 Multi-antenna transmission

A wide range of multi-antenna transmission schemes are supported in the downlink:

- Single-antenna transmission using a single cell-specific reference signal.
- Closed-loop spatial multiplexing, also known as codebook-based beam-forming or precoding, of up to four layers using cell-specific reference signals. Feedback reports from the terminal are used to assist the eNodeB in selecting a suitable precoding matrix.
- Open-loop spatial multiplexing, also known as large-delay cyclic delay diversity, of up to four layers using cell-specific reference signals.
- Spatial multiplexing of up to eight layers using UE-specific reference signals. The eNodeB may use feedback reports or exploit channel reciprocity to set the beam-forming weights.
- Transmit diversity based on Space-Frequency Block Coding (SFBC) or a combination of SFBC and Frequency Switched Transmit Diversity (FSTD).
- Multi-user MIMO where multiple terminals are assigned overlapping time-frequency resources.
- Non-precoded Channel State Information Reference Symbol (CSI-RS) operation is supported, which comprises schemes where different CSI-RS ports have the same wide beam width and direction and hence generally cell wide coverage.
- Beamformed CSI-RS operation is supported, which comprises schemes where (at least at a given time/frequency) CSI-RS ports have narrow beam widths and hence not cell wide coverage, and (at least from the eNB perspective) at least some CSI-RS port-resource combinations have different beam directions.
- Downlink Coordinated MultiPoint (DL-CoMP) operation where multiple transmission points are coordinated.

The following multi-antenna transmission schemes are supported in the uplink:

- Single-antenna transmission.
- Precoding supporting rank-adaptive spatial multiplexing with one up to four layers.
- Uplink Coordinated MultiPoint (UL-CoMP) operation where multiple reception points are coordinated.

#### 1.1.1.3.5 Link adaptation and power control

According to the radio channel conditions, the Modulation and Coding Scheme (MCS) can be adapted flexibly. The same modulation and coding is applied to all resource units assigned to the

same transport block within a TTI. Uplink power control determines the average power over a DFTS-OFDM symbol in which the physical channel is transmitted.

#### 1.1.1.3.6 L1/L2 control signalling

Downlink Control Information (DCI) is transmitted on either a PDCCH or an EPDCCH. In bandwidth-reduced operation and/or when using coverage extension mode, a DCI is transmitted on an MPDCCH. For NB-IoT, a DCI is transmitted on NPDCCH.

The PDCCH is transmitted in the first one to three OFDM symbols of each downlink subframe in each component carrier with the number of OFDM symbols being indicated on the PCFICH. Downlink and uplink scheduling grants (consisting of UE identity, time-frequency resources and transport format) and HARQ acknowledgements are transmitted on the PDCCH and PHICH, respectively. Each grant is transmitted on a separate PDCCH using QPSK modulation and cell-specific reference signals.

The EPDCCH/MPDCCH is transmitted in pairs of Physical Resource Blocks (PRBs) multiplexed in frequency with the PDSCH; it carries downlink and uplink scheduling grants (consisting of UE identity, time-frequency resources and transport format). The EPDCCH/MPDCCH uses QPSK modulation and demodulation reference signals, and it may use either frequency-localized or frequency-distributed transmission.

For NB-IoT, the NPDCCH is transmitted in all available OFDM symbols of pairs of PRBs, with no multiplexing with NPDSCH; it carries downlink and uplink scheduling grants (consisting of UE identity, time-frequency resources and transport format). The NPDCCH uses QPSK modulation and narrowband reference signals.

Sidelink resource allocation can be transmitted on the PDCCH/EPDCCH.

Uplink control information (UCI), consisting of CSI, scheduling requests and hybrid-ARQ acknowledgements, is transmitted at the band edges of the primary uplink component carrier. Alternatively, parts of the control signalling can be multiplexed with data on PUSCH. To support downlink CoMP transmission, a UE may be configured with multiple CSI processes.

#### 1.1.1.3.7 MBSFN operation

Multicast/Broadcast over Single Frequency Network (MBSFN) transmission, where the same signal is transmitted from multiple, time-synchronized cells, is supported by the MCH transport channel. One component carrier can support simultaneous unicast and broadcast support through time-domain multiplexing of MCH and DL-SCH transmissions.

### 1.1.2 Overview of the Component RIT: NR

The NR RIT as one component RIT represents the releases 15 and 16 of NR, which uses either 1) FDD operation and therefore is applicable for operation with paired spectrum or 2) TDD operation and therefore is applicable for operation with unpaired spectrum. Channel bandwidths up to 400 MHz and Carrier Aggregation over 16 component carriers are supported, yielding peak data rates up to roughly 140 Gbit/s in the downlink and 65 Gbit/s in the uplink.

#### 1.1.2.1 Overall architecture

An NG-RAN node, is either:

- A gNB, providing NR user plane and control plane protocol terminations towards the UE;  
or
- An ng-eNB, providing E-UTRA user plane and control plane protocol terminations towards the UE.

NG-RAN nodes are interconnected by means of the interface named Xn. The gNBs and ng-eNBs are also connected by means of the NG interfaces to the 5GC, more specifically to the Access and Mobility Management Function (AMF) by means of the NG-C interface and to the User Plane Function (UPF) by means of the NG-U interface.

The NG-RAN architecture is illustrated in Fig. 13.

FIGURE 13  
Overall Architecture

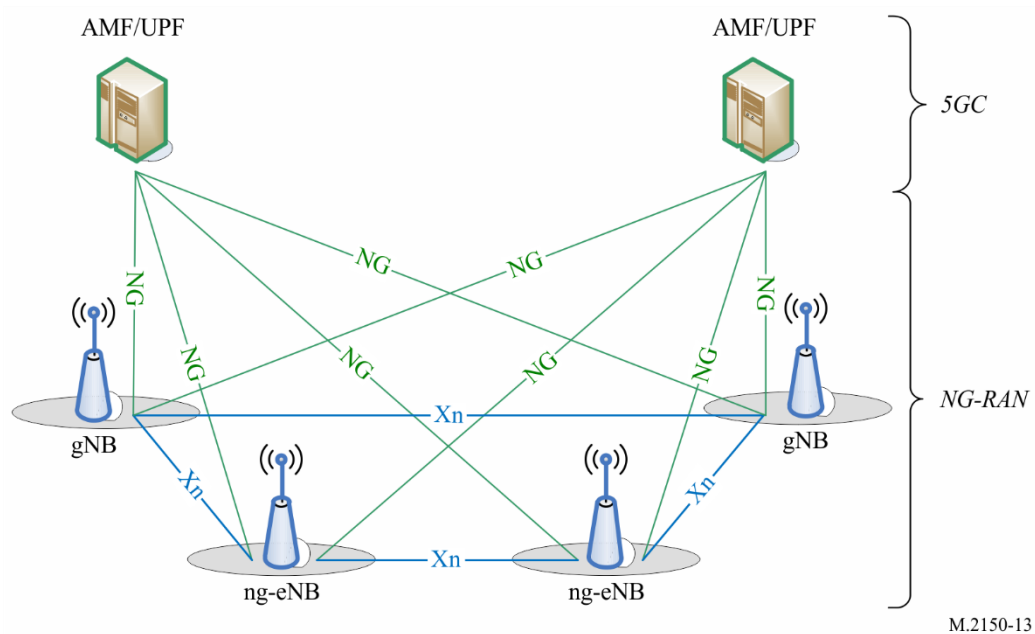

### 1.1.2.2 Radio protocol architecture

#### 1.1.2.2.1 User Plane (UP)

Figure 14 shows the protocol stack for the User Plane, where Service Data Adaptation Protocol (SDAP), PDCP, RLC and MAC sublayers (terminated in gNB on the network side) perform the functions listed in § 1.1.2.5.

FIGURE 14  
User Plane protocol stack

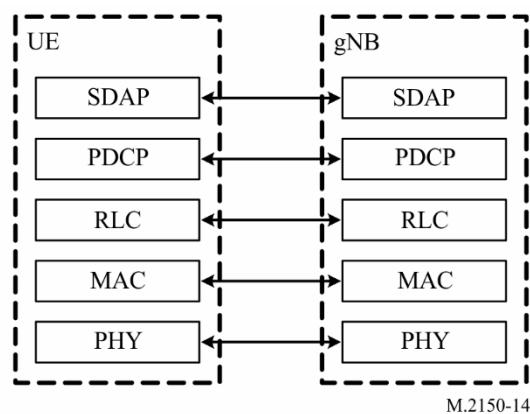

### 1.1.2.2.2 Control Plane

Figure 15 shows the protocol stack for the control plane, where:

- PDCP, RLC and MAC sublayers (terminated in gNB on the network side) perform the functions listed in § 1.1.2.5;
- RRC (terminated in gNB on the network side) performs the functions listed in § 1.1.2.6;
- Non-Access Stratum (NAS) control protocol (terminated in AMF on the network side) performs the functions listed in 3GPP TS 23.501, for instance: authentication, mobility management, security control.

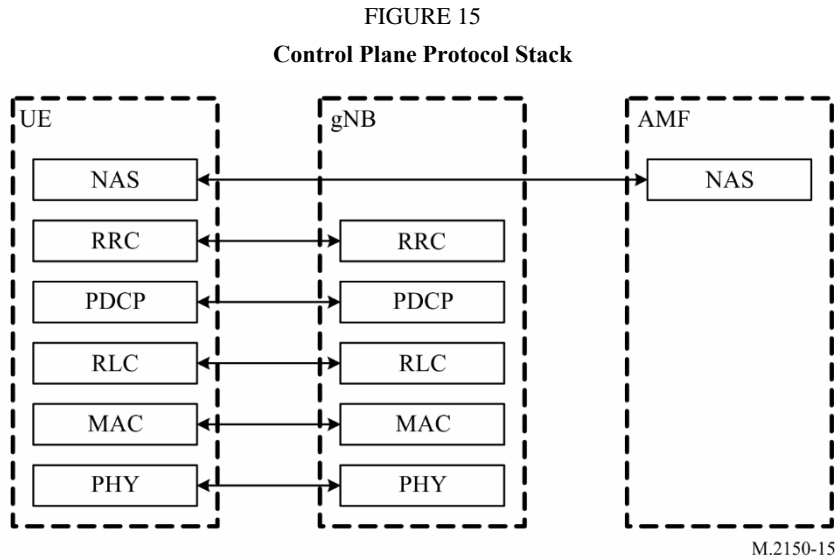

### 1.1.2.2.3 Integrated Access and Backhaul (IAB) architecture

From NR Rel-16, Integrated access and backhaul (IAB) enables wireless relaying in NG-RAN. The relaying node, referred to as the IAB-node, supports access and backhauling via NR. The terminating node of NR backhauling on the network side is referred to as the IAB-donor, which represents a gNB with additional functionality to support IAB. Backhauling can occur via a single or via multiple hops. The IAB architecture is shown in Fig. 16.

FIGURE 16

IAB architecture; a) IAB-node using SA mode with 5GCN; b) IAB-node using EN-DC

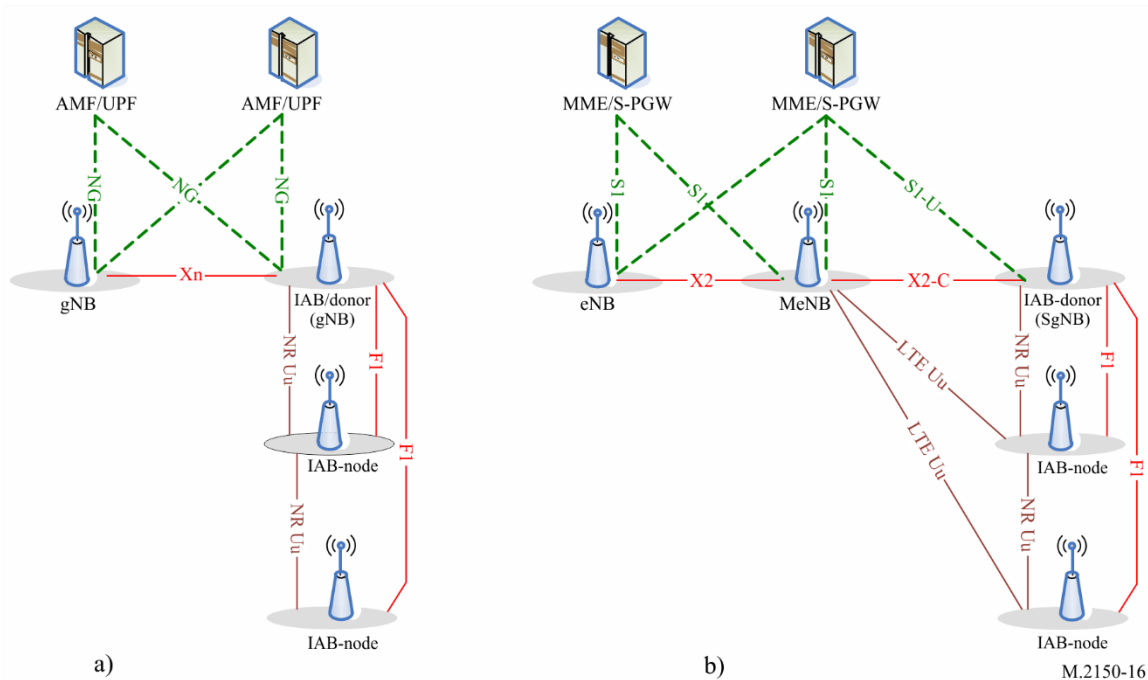

### 1.1.2.3 Multi-Radio Dual Connectivity (MR-DC)

NG-RAN supports Multi-Radio Dual Connectivity (MR-DC) operation whereby a UE in the RRC\_CONNECTED state is configured to utilise radio resources provided by two distinct schedulers, located in two different NG-RAN nodes connected via a non-ideal backhaul, one providing NR access and the other one providing either E-UTRA or NR access.

#### 1.1.2.3.1 MR-DC with the EPC

E-UTRAN supports MR-DC via E-UTRA-NR Dual Connectivity (EN-DC), in which a UE is connected to one eNB that acts as a Master Node (MN) and one en-gNB that acts as a Secondary Node (SN). The eNB is connected to the EPC via the S1 interface and to the en-gNB via the X2 interface. The en-gNB might also be connected to the EPC via the S1-U interface and other en-gNBs via the X2-U interface.

The EN-DC architecture is illustrated in Fig. 17 below.

FIGURE 17  
EN-DC overall architecture

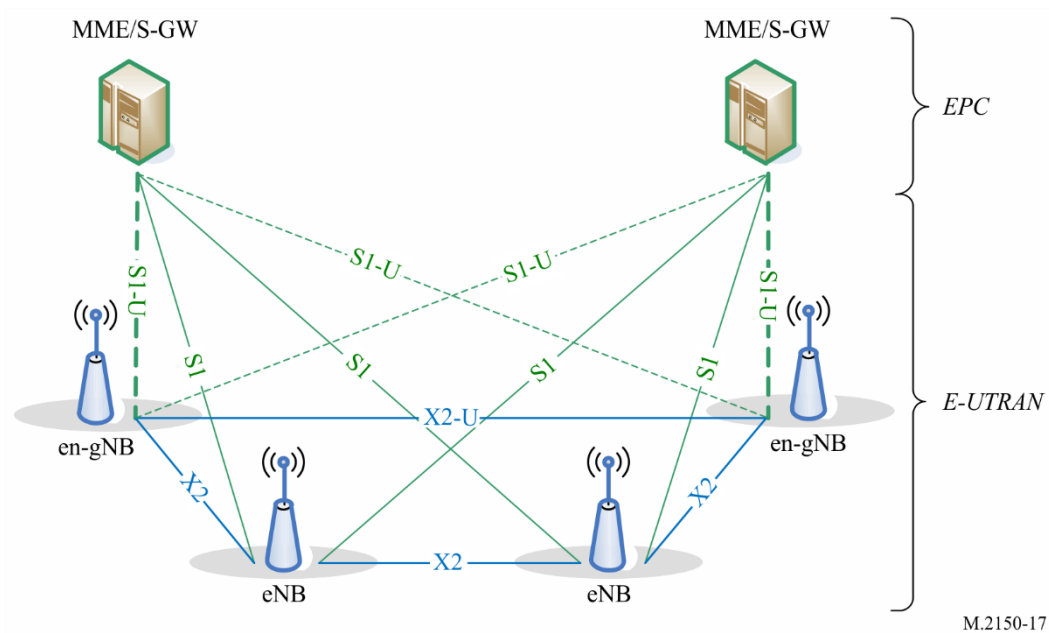

### 1.1.2.3.2 MR-DC with the 5GC

#### 1.1.2.3.2.1 E-UTRA-NR Dual Connectivity

NG-RAN supports NG-RAN E-UTRA-NR Dual Connectivity (NGEN-DC), in which a UE is connected to one ng-eNB that acts as a MN and one gNB that acts as a SN. The ng-eNB is connected to the 5GC and the gNB is connected to the ng-eNB via the Xn interface.

#### 1.1.2.3.2.2 NR-E-UTRA Dual Connectivity

NG-RAN supports NR-E-UTRA Dual Connectivity (NE-DC), in which a UE is connected to one gNB that acts as a MN and one ng-eNB that acts as a SN. The gNB is connected to 5GC and the ng-eNB is connected to the gNB via the Xn interface.

#### 1.1.2.3.2.3 NR-NR Dual Connectivity

NG-RAN supports NR-NR Dual Connectivity (NR-DC), in which a UE is connected to one gNB that acts as a MN and another gNB that acts as a SN. The master gNB is connected to the 5GC via the NG interface and to the secondary gNB via the Xn interface. The secondary gNB might also be connected to the 5GC via the NG-U interface.

### 1.1.2.4 Physical layer

#### 1.1.2.4.1 Waveform, numerology and frame structure

The downlink transmission waveform is conventional OFDM using a cyclic prefix. The uplink transmission waveform is conventional OFDM using a cyclic prefix with a transform precoding function performing DFT spreading that can be disabled or enabled.

FIGURE 18

Transmitter block diagram for CP-OFDM with optional DFT-spreading

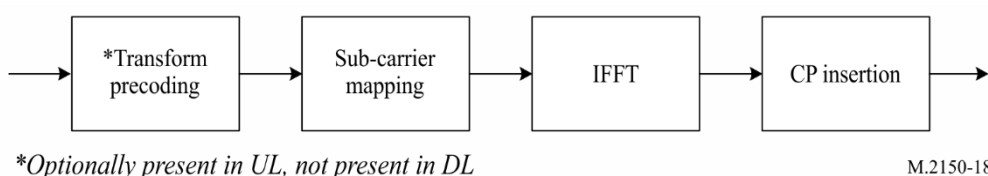

M.2150-18

The numerology is based on exponentially scalable sub-carrier spacing  $\Delta f = 2^\mu \times 15$  kHz with  $\mu = \{0,1,3,4\}$  for Primary Synchronization Signal (PSS), Secondary Synchronization Signal (SSS) and PBCH and  $\mu = \{0,1,2,3\}$  for other channels. Normal Cyclic Prefix (CP) is supported for all sub-carrier spacings, Extended CP is supported for  $\mu = 2$ . 12 consecutive sub-carriers form a Physical Resource Block (PRB). Up to 275 PRBs are supported on a carrier.

TABLE 1-1

Supported transmission numerologies

$\mu$	$\Delta f = 2^\mu \times 15$ [kHz]	Cyclic prefix	Supported for data	Supported for synch
0	15	Normal	Yes	Yes
1	30	Normal	Yes	Yes
2	60	Normal, Extended	Yes	No
3	120	Normal	Yes	Yes
4	240	Normal	No	Yes

The UE may be configured with one or more bandwidth parts on a given component carrier, of which only one can be active at a time, as described in § 1.2.5.10. The active bandwidth part defines the UE's operating bandwidth within the cell's operating bandwidth. For initial access, and until the UE's configuration in a cell is received, the initial bandwidth part detected from system information is used.

Downlink and uplink transmissions are organized into frames of 10 ms duration, consisting of ten 1 ms subframes. Each frame is divided into two equally-sized half-frames of five subframes. The slot duration is 14 symbols with Normal CP and 12 symbols with Extended CP, and scales in time as a function sub-carrier spacing in use so that there is always an integral number of slots in a subframe.

Timing Advance (TA) is used to adjust the uplink frame timing relative to the downlink frame timing.

FIGURE 19

Uplink-downlink timing relation

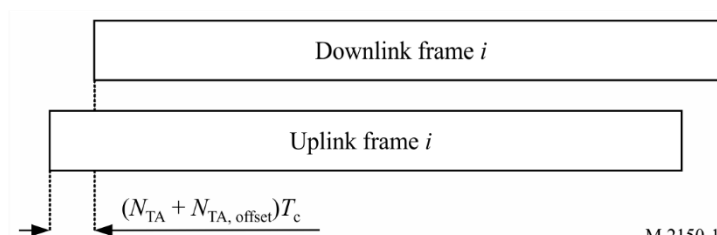

M.2150-19

Operation on both paired and unpaired spectrum is supported.

### 1.1.2.4.2 Downlink

#### 1.1.2.4.2.1 Downlink transmission scheme

A closed loop Demodulation Reference Signal (DMRS) based spatial multiplexing is supported for Physical Downlink Shared Channel (PDSCH). Up to 8 and 12 orthogonal DL DMRS ports are supported for type 1 and type 2 DMRS respectively. Up to 8 orthogonal DL DMRS ports per UE are supported for Single-User MIMO (SU-MIMO) and up to 4 orthogonal DL DMRS ports per UE are supported for Multi-User MIMO (MU-MIMO). The number of SU-MIMO code words is one for 1 to 4 layers transmissions and two for 5 to 8 layers transmissions.

The DMRS and corresponding PDSCH are transmitted using the same precoding matrix and the UE does not need to know the precoding matrix to demodulate the transmission. The transmitter may use different precoder matrix for different parts of the transmission bandwidth, resulting in frequency selective precoding. The UE may also assume that the same precoding matrix is used across a set of Physical Resource Blocks (PRBs) denoted Precoding Resource Block Group (PRG).

Transmission durations from 2 to 14 symbols in a slot with a single PDSCH is supported.

Aggregation of multiple slots with Transport Block (TB) repetition is supported.

From Rel-16, enhancements for DL/UL MIMO are introduced, including enhancements on multi-Transmission Reception Points (TRPs) or multi-panel transmission improving reliability and robustness with both ideal and non-ideal backhaul.

#### 1.1.2.4.2.2 Physical-layer processing for physical downlink shared channel

The downlink physical-layer processing of transport channels consists of the following steps:

- TB CRC attachment;
- code block segmentation and code block CRC attachment;
- channel coding: Low Density Parity Check (LDPC) coding;
- physical-layer hybrid-ARQ processing;
- rate matching;
- scrambling;
- modulation: QPSK, 16QAM, 64QAM and 256QAM;
- layer mapping;
- mapping to assigned resources and antenna ports.

The UE may assume that at least one symbol with demodulation reference signal is present on each layer in which PDSCH is transmitted to a UE, and up to three additional DMRS symbols can be configured by higher layers.

Phase tracking RS may be transmitted on additional symbols to aid receiver phase tracking.

#### 1.1.2.4.2.3 Physical downlink control channels

The Physical Downlink Control Channel (PDCCH) can be used to schedule DL transmissions on PDSCH and UL transmissions on PUSCH, where the Downlink Control Information (DCI) on PDCCH includes:

- downlink assignments containing at least modulation and coding format, resource allocation, and HARQ information related to DL-SCH;
- uplink scheduling grants containing at least modulation and coding format, resource allocation, and HARQ information related to UL-SCH.



In addition to scheduling, PDCCH can be used for

- activation and deactivation of configured PUSCH transmission with configured grant;
- activation and deactivation of PDSCH semi-persistent transmission;
- notifying one or more UEs of the slot format;
- notifying one or more UEs of the PRB(s) and OFDM symbol(s) where the UE may assume no transmission is intended for the UE;
- transmission of Transmit Power Control (TPC) commands for PUCCH and PUSCH;
- transmission of one or more TPC commands for Sounding Reference Signal (SRS) transmissions by one or more UEs;
- Switching a UE's active bandwidth part;
- Initiating a random access procedure.

A UE monitors a set of PDCCH candidates in the configured monitoring occasions in one or more configured Control Resource Sets (CORESETs) according to the corresponding search space configurations.

A CORESET consists of a set of PRBs with a time duration of 1 to 3 OFDM symbols. The resource units Resource Element Groups (REGs) and Control Channel Elements (CCEs) are defined within a CORESET with each CCE consisting a set of REGs. Control channels are formed by aggregation of CCEs. Different code rates for the control channels are realized by aggregating different number of CCEs. Interleaved and non-interleaved CCE-to-REG mapping are supported in a CORESET.

Polar coding is used for PDCCH.

Each resource element group carrying PDCCH carries its own DMRS.

QPSK modulation is used for PDCCH.

#### **1.1.2.4.2.4 Synchronization signal and PBCH block**

The Synchronization Signal and PBCH block (SSB) consists of primary and secondary synchronization signals (PSS, SSS), each occupying 1 symbol and 127 subcarriers, and PBCH spanning across three OFDM symbols and 240 subcarriers, but on one symbol leaving an unused part in the middle for SSS as show in Fig. 20. The possible time locations of SSBs within a half-frame are determined by sub-carrier spacing, and the periodicity of the half-frames where SSBs are transmitted is configured by the network. During a half-frame, different SSBs may be transmitted in different spatial directions (i.e. using different beams, spanning the coverage area of a cell).

Within the frequency span of a carrier, multiple SSBs can be transmitted. The Physical Cell Identifiers (PCIs) of SSBs transmitted in different frequency locations do not have to be unique, i.e. different SSBs in the frequency domain can have different PCIs. However, when an SSB is associated with a Remaining Minimum System Information (RMSI), the SSB corresponds to an individual cell, which has a unique NR Cell Global Identifier (NCGI). Such an SSB is referred to as a Cell-Defining SSB (CD-SSB). A PCell is always associated to a CD-SSB located on the synchronization raster.

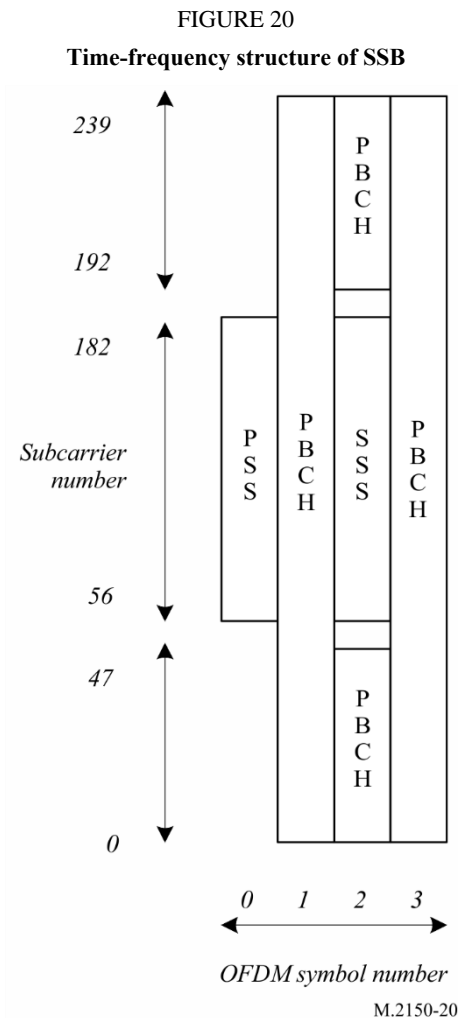

Polar coding is used for the PBCH.

The UE may assume a band-specific sub-carrier spacing for the SSB unless a network has configured the UE to assume a different sub-carrier spacing.

PBCH symbols carry their own frequency-multiplexed DMRS.

QPSK modulation is used for PBCH.

#### 1.1.2.4.2.5 Physical layer procedures

##### 1.1.2.4.2.5.1 Link adaptation

Link adaptation (Adaptive Modulation and Coding (AMC)) with various modulation schemes and channel coding rates is applied to the PDSCH. The same coding and modulation is applied to all groups of resource blocks belonging to the same L2 Protocol Data Unit (PDU) scheduled for one user within one transmission duration and within a MIMO codeword.

For channel state estimation purposes, the UE may be configured to measure CSI-RS and estimate the downlink channel state based on the CSI-RS measurements. The UE reports the estimated channel state back to the gNB to be used in link adaptation.

##### 1.1.2.4.2.5.2 Power control

Downlink power control can be used.

### 1.1.2.4.2.5.3 Cell search

Cell search is the procedure by which a UE acquires time and frequency synchronization with a cell and detects the Cell ID of that cell. NR cell search is based on the primary and secondary synchronization signals, and PBCH DMRS, located on the synchronization raster.

### 1.1.2.4.2.5.4 HARQ

Asynchronous Incremental Redundancy Hybrid ARQ is supported. The gNB provides the UE with the HARQ-ACK feedback timing either dynamically in the DCI or semi-statically in an RRC configuration.

The UE may be configured to receive code block group-based transmissions where retransmissions may be scheduled to carry only a sub-set of all the code blocks of a TB.

### 1.1.2.4.2.5.5 Reception of SIB1

The Master Information Block (MIB) on the PBCH provides the UE with parameters (e.g. CORESET#0 configuration) for monitoring of the PDCCH for scheduling PDSCH that carries the System Information Block 1 (SIB1). The PBCH may also indicate that there is no associated SIB1, in which case the UE may be pointed to another frequency from where to search for an SSB that is associated with a SIB1 as well as a frequency range where the UE may assume no SSB associated with SIB1 is present. The indicated frequency range is confined within a contiguous spectrum allocation of the same operator in which SSB is detected.

## 1.1.2.4.3 Uplink

### 1.1.2.4.3.1 Uplink transmission scheme

Two transmission schemes are supported for PUSCH: codebook-based transmission and non-codebook-based transmission.

For codebook-based transmission, the gNB provides the UE with a transmit precoding matrix indication in the DCI. The UE uses the indication to select the PUSCH transmit precoder from the codebook. For non-codebook-based transmission, the UE determines its PUSCH precoder based on the wideband SRS Resource Indicator (SRI) field from the DCI.

A closed loop DMRS based spatial multiplexing is supported for PUSCH. For a given UE, up to four-layer transmissions are supported. The number of codewords is one. When transform precoding is used, only a single MIMO layer transmission is supported.

Transmission durations from 1 to 14 symbols in a slot with a single PUSCH is supported.

Aggregation of multiple slots with TB repetition is supported.

Two types of frequency hopping are supported, intra-slot frequency hopping, and in case of slot aggregation, inter-slot frequency hopping.

The PUSCH may be scheduled with DCI on the PDCCH, or a semi-static configured grant may be provided over RRC, where two types of operation are supported:

- The first PUSCH is triggered with a DCI, with subsequent PUSCH transmissions following the RRC configuration and scheduling received on the DCI, or
- The PUSCH is triggered by data arrival in the UE's transmit buffer and the PUSCH transmissions follow the RRC configuration.

### 1.1.2.4.3.2 Physical-layer processing for physical uplink shared channel

The uplink physical-layer processing of transport channels consists of the following steps:

- Transport Block CRC attachment;
- code block segmentation and Code Block CRC attachment;
- channel coding: LDPC coding;
- physical-layer HARQ processing;
- rate matching;
- scrambling;
- modulation:  $\pi/2$  BPSK (with transform precoding only), QPSK, 16QAM, 64QAM and 256QAM;
- layer mapping, transform precoding (enabled/disabled by configuration), and pre-coding;
- mapping to assigned resources and antenna ports.

The UE transmits at least one symbol with Demodulation Reference Signal on each layer on each frequency hop in which the PUSCH is transmitted, and up to 3 additional DMRS symbols can be configured by higher layers.

Phase tracking RS may be transmitted on additional symbols to aid receiver phase tracking.

#### 1.1.2.4.3.3 Physical uplink control channel

The physical uplink control channel (PUCCH) carries the Uplink Control Information (UCI) from the UE to the gNB. Five formats of PUCCH exist, depending on the duration of PUCCH and the UCI payload size.

- format #0: short PUCCH of 1 or 2 symbols with small UCI payloads of up to two bits with UE multiplexing capacity of up to 6 UEs with 1-bit payload in the same PRB;
- format #1: long PUCCH of 4-14 symbols with small UCI payloads of up to two bits with UE multiplexing capacity of up to 84 UEs without frequency hopping and 36 UEs with frequency hopping in the same PRB;
- format #2: short PUCCH of 1 or 2 symbols with large UCI payloads of more than two bits with no UE multiplexing capability in the same PRBs;
- format #3: long PUCCH of 4-14 symbols with large UCI payloads with no UE multiplexing capability in the same PRBs;
- format #4: long PUCCH of 4-14 symbols with moderate UCI payloads with multiplexing capacity of up to 4 UEs in the same PRBs.

The short PUCCH format of up to two UCI bits is based on sequence selection, while the short PUCCH format of more than two UCI bits frequency-multiplexes the UCI and the DMRS. The long PUCCH formats time-multiplex the UCI and DMRS. Frequency hopping is supported for long PUCCH formats and for short PUCCH formats of duration of two symbols. Long PUCCH formats can be repeated over multiple slots.

UCI multiplexing in the PUSCH is supported when UCI and PUSCH transmissions coincide in time, either due to transmission of a UL-SCH transport block or due to triggering of A-CSI transmission without UL-SCH transport block:

- UCI carrying HARQ-ACK feedback with 1 or 2 bits is multiplexed by puncturing the PUSCH;
- In all other cases the UCI is multiplexed by rate matching the PUSCH.

UCI consists of the following information:

- CSI;
- ACK/NAK;
- Scheduling request.

QPSK and  $\pi/2$  BPSK modulation can be used for long PUCCH with more than 2 bits of information, QPSK is used for a short PUCCH with more than 2 bits of information and BPSK and QPSK modulation can be used for a long PUCCH with up to two information bits.

Transform precoding is applied to a long PUCCH.

Channel coding used for uplink control information is described in Table 1-2.

TABLE 1-2

**Channel coding for uplink control information**

Uplink control information size including CRC, if present	Channel code
1	Repetition code
2	Simplex code
3-11	Reed Muller code
>11	Polar code

#### 1.1.2.4.3.4 Random access

Random access preamble sequences of two different lengths are supported. The long sequence length 839 is applied with subcarrier spacings of 1.25 and 5 kHz, and the short sequence length 139 is applied with subcarrier spacings of 15, 30, 60 and 120 kHz. Long sequences support unrestricted sets and restricted sets of Type A and Type B, while short sequences support unrestricted sets only.

Multiple PRACH preamble formats are defined with one or more PRACH OFDM symbols, and different cyclic prefixes and guard times. The PRACH preamble configuration to use is provided to the UE in the system information.

The UE calculates the PRACH transmit power for the retransmission of the preamble based on the most recent estimated pathloss and the power ramping counter value.

The system information provides information for the UE to determine the association between the SSB and the RACH resources. The Reference Signal Received Power (RSRP) threshold for SSB selection for RACH resource association is configurable by the network.

#### 1.1.2.4.3.5 Physical layer procedures

##### 1.1.2.4.3.5.1 Link adaptation

Four types of link adaptation are supported as follows:

- adaptive transmission bandwidth;
- adaptive transmission duration;
- transmission power control;
- adaptive modulation and channel coding rate.

For channel state estimation purposes, the UE may be configured to transmit SRS that the gNB may use to estimate the uplink channel state, and then use the estimate in link adaptation.

#### 1.1.2.4.3.5.2 Uplink power control

The gNB determines the desired uplink transmit power and provides uplink transmit power control commands to the UE. The UE uses the provided uplink transmit power control commands to adjust its transmit power.

#### 1.1.2.4.3.5.3 Uplink timing control

The gNB determines the desired Timing Advance setting and provides that to the UE. The UE uses the provided TA to determine its uplink transmit timing relative to the UE's observed downlink receive timing.

#### 1.1.2.4.3.5.4 HARQ

Asynchronous Incremental Redundancy Hybrid ARQ is supported. The gNB schedules each uplink transmission and retransmission using the uplink grant on the DCI.

The UE may be configured to transmit code block group-based transmissions where retransmissions may be scheduled to carry only a sub-set of all the code blocks of a transport block.

#### 1.1.2.4.4 Carrier Aggregation (CA)

In Carrier Aggregation (CA), two or more Component Carriers (CCs) are aggregated. A UE may simultaneously receive or transmit on one or multiple CCs depending on its capabilities:

- A UE with single timing advance capability for CA can simultaneously receive and/or transmit on multiple CCs corresponding to multiple serving cells sharing the same timing advance (multiple serving cells grouped in one Timing Advance Group (TAG));
- A UE with multiple timing advance capability for CA can simultaneously receive and/or transmit on multiple CCs corresponding to multiple serving cells with different timing advances (multiple serving cells grouped in multiple TAGs). NG-RAN ensures that each TAG contains at least one serving cell;
- A non-CA capable UE can receive on a single CC and transmit on a single CC corresponding to one serving cell only (one serving cell in one TAG).

CA is supported for both contiguous and non-contiguous CCs. When CA is deployed, frame timing and System Frame Number (SFN) are aligned across cells that can be aggregated. The maximum number of configured CCs for a UE is 16 for DL and 16 for UL. From Rel-16, cells with unaligned frame boundary can also be aggregated.

#### 1.1.2.4.5 Supplementary uplink

In conjunction with a UL/DL carrier pair (FDD band) or a bidirectional carrier (TDD band), a UE may be configured with additional, Supplementary Uplink (SUL). SUL differs from the aggregated uplink in that the UE may be scheduled to transmit either on the supplementary uplink or on the uplink of the carrier being supplemented, but not on both at the same time.

#### 1.1.2.4.6 Transport channels

The physical layer offers information transfer services to MAC and higher layers. The physical layer transport services are described by how and with what characteristics data are transferred over the radio interface.

Downlink transport channel types are:

- 1 Broadcast Channel (BCH) characterised by:
  - fixed, pre-defined transport format;

- requirement to be broadcast in the entire coverage area of the cell, either as a single message or by beamforming different BCH instances.
- 2 Downlink Shared Channel (DL-SCH) characterised by:
- support for HARQ;
  - support for dynamic link adaptation by varying the modulation, coding and transmit power;
  - possibility to be broadcast in the entire cell;
  - possibility to use beamforming;
  - support for both dynamic and semi-static resource allocation;
  - support for UE discontinuous reception (DRX) to enable UE power saving.
- 3 Paging Channel (PCH) characterised by:
- support for UE discontinuous reception (DRX) to enable UE power saving (DRX cycle is indicated by the network to the UE);
  - requirement to be broadcast in the entire coverage area of the cell, either as a single message or by beamforming different PCH instances;
  - mapped to physical resources which can be used dynamically also for traffic/other control channels.

Uplink transport channel types are:

- 1 Uplink Shared Channel (UL-SCH) characterised by:
- possibility to use beamforming;
  - support for dynamic link adaptation by varying the transmit power and potentially modulation and coding;
  - support for HARQ;
  - support for both dynamic and semi-static resource allocation.
- 2 Random Access Channel(s) (RACH) characterised by:
- limited control information;
  - collision risk.

Sidelink transport channel types are:

- 1 Sidelink broadcast channel (SL-BCH) characterised by:
- pre-defined transport format.
- 2 Sidelink shared channel (SL-SCH) characterised by:
- support for unicast transmission, groupcast transmission and broadcast transmission;
  - support for both UE autonomous resource selection and scheduled resource allocation by NG-RAN;
  - support for both dynamic and semi-static resource allocation when UE is allocated resources by the NG-RAN;
  - support for HARQ;
  - support for dynamic link adaptation by varying the transmit power, modulation and coding.

### 1.1.2.5 Layer 2

#### 1.1.2.5.1 Overview

The layer 2 of NR is split into the following sublayers: Medium Access Control (MAC), Radio Link Control (RLC), Packet Data Convergence Protocol (PDCP) and Service Data Adaptation Protocol (SDAP). Figures 21 and 22 depict the Layer 2 architecture for downlink and uplink, where:

- the physical layer offers to the MAC sublayer transport channels;
- the MAC sublayer offers to the RLC sublayer logical channels;
- the RLC sublayer offers to the PDCP sublayer RLC channels;
- the PDCP sublayer offers to the SDAP sublayer radio bearers;
- the SDAP sublayer offers to 5GC QoS flows;
- control channels (BCCH, PCCH are not depicted for clarity).

NOTE – The gNB may not be able to guarantee that a L2 buffer overflow will never occur. If such overflow occurs, the UE may discard packets from the L2 buffer.

FIGURE 21  
Downlink layer 2 structure

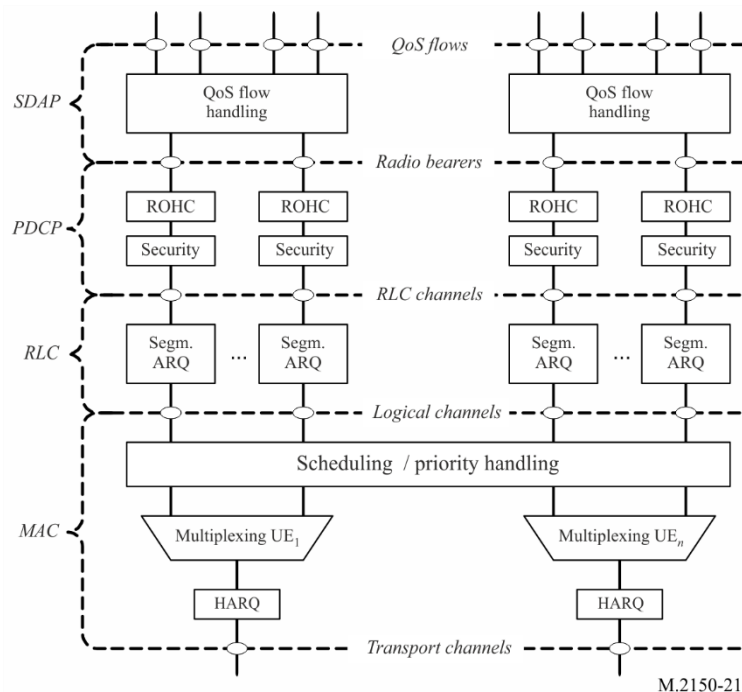
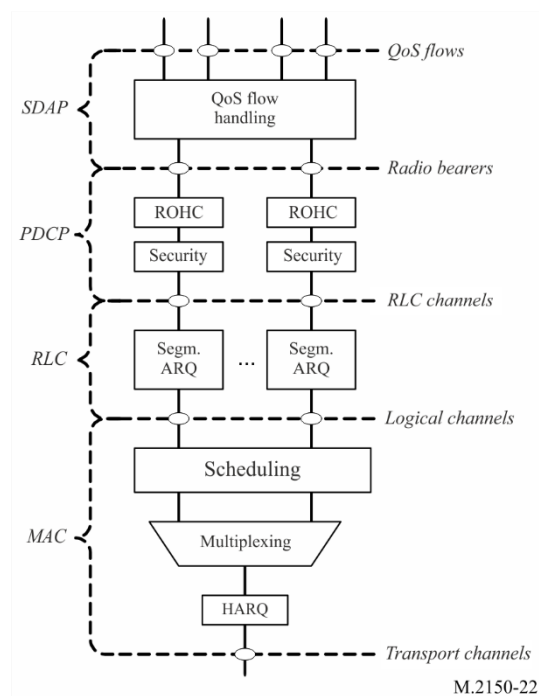



FIGURE 22  
Uplink layer 2 structure



Similar to LTE, Radio bearers are categorized into two groups: DRBs for UP data and SRBs for CP data.

### 1.1.2.5.2 MAC sublayer

#### 1.1.2.5.2.1 Services and functions

The main services and functions of the MAC sublayer are:

- mapping between logical channels and transport channels;
- multiplexing/demultiplexing of MAC SDUs belonging to one or different logical channels into/from transport blocks (TB) delivered to/from the physical layer on transport channels;
- scheduling information reporting;
- error correction through HARQ (one HARQ entity per cell in case of CA);
- priority handling between UEs by means of dynamic scheduling;
- priority handling between logical channels of one UE by means of logical channel prioritisation;
- padding.

A single MAC entity can support multiple numerologies, transmission timings and cells. Mapping restrictions in logical channel prioritisation control which numerology(ies), cell(s), and transmission timing(s) a logical channel can use.

#### 1.1.2.5.2.2 Logical Channels

Different kinds of data transfer services as offered by MAC. Each logical channel type is defined by what type of information is transferred. Logical channels are classified into two groups: Control Channels and Traffic Channels. Control channels are used for the transfer of control plane information only:

- Broadcast Control Channel (BCCH): a downlink channel for broadcasting system control information.
- Paging Control Channel (PCCH): a downlink channel that carries paging messages.
- Common Control Channel (CCCH): channel for transmitting control information between UEs and network. This channel is used for UEs having no RRC connection with the network.
- Dedicated Control Channel (DCCH): a point-to-point bi-directional channel that transmits dedicated control information between a UE and the network. Used by UEs having an RRC connection.

Traffic channels are used for the transfer of user plane information only:

- Dedicated Traffic Channel (DTCH): point-to-point channel, dedicated to one UE, for the transfer of user information. A DTCH can exist in both uplink and downlink.

#### **1.1.2.5.2.3 Mapping to transport channels**

In Downlink, the following connections between logical channels and transport channels exist:

- BCCH can be mapped to BCH;
- BCCH can be mapped to DL-SCH;
- PCCH can be mapped to PCH;
- CCCH can be mapped to DL-SCH;
- DCCH can be mapped to DL-SCH;
- DTCH can be mapped to DL-SCH.

In Uplink, the following connections between logical channels and transport channels exist:

- CCCH can be mapped to UL-SCH;
- DCCH can be mapped to UL-SCH;
- DTCH can be mapped to UL-SCH.

#### **1.1.2.5.2.4 HARQ**

The HARQ functionality ensures delivery between peer entities at Layer 1. A single HARQ process supports one TB when the physical layer is not configured for downlink/uplink spatial multiplexing, and when the physical layer is configured for downlink/uplink spatial multiplexing, a single HARQ process supports one or multiple TBs.

#### **1.1.2.5.3 RLC sublayer**

##### **1.1.2.5.3.1 Transmission modes**

The RLC sublayer supports three transmission modes:

- Transparent Mode (TM);
- Unacknowledged Mode (UM);
- Acknowledged Mode (AM).

The RLC configuration is per logical channel with no dependency on numerologies and/or transmission durations, and ARQ can operate on any of the numerologies and/or transmission durations the logical channel is configured with.

For SRB0, paging and broadcast system information, TM mode is used. For other SRBs AM mode used. For DRBs, either UM or AM mode are used.

#### **1.1.2.5.3.2 Services and functions**

The main services and functions of the RLC sublayer depend on the transmission mode and include:

- transfer of upper layer PDUs;
- sequence numbering independent of the one in PDCP (UM and AM);
- error Correction through ARQ (AM only);
- segmentation (AM and UM) and re-segmentation (AM only) of RLC SDUs;
- reassembly of SDU (AM and UM);
- duplicate Detection (AM only);
- RLC SDU discard (AM and UM);
- RLC re-establishment;
- protocol error detection (AM only).

#### **1.1.2.5.3.3 ARQ**

The ARQ within the RLC sublayer has the following characteristics:

- ARQ retransmits RLC SDUs or RLC SDU segments based on RLC status reports;
- polling for RLC status report is used when needed by RLC;
- the RLC receiver can also trigger a RLC status report after detecting a missing RLC SDU or RLC SDU segment.

#### **1.1.2.5.4 PDCP sublayer**

##### **1.1.2.5.4.1 Services and functions**

The main services and functions of the PDCP sublayer are:

- transfer of data (user plane or control plane);
- maintenance of PDCP SNs;
- header compression and decompression using the ROHC protocol;
- ciphering and deciphering;
- integrity protection and integrity verification;
- timer based SDU discard;
- for split bearers, routing;
- duplication;
- reordering and in-order delivery;
- out-of-order delivery;
- duplicate discarding.

Since PDCP does not allow COUNT to wrap around in DL and UL, it is up to the network to prevent this from happening (e.g. by using a release and add of the corresponding radio bearer or a full configuration).

### 1.1.2.5.5 SDAP Sublayer

The main services and functions of SDAP are:

- mapping between a QoS flow and a data radio bearer;
- marking QoS Flow ID (QFI) in both DL and UL packets.

A single protocol entity of SDAP is configured for each individual PDU session.

### 1.1.2.5.6 L2 data flow

An example of the Layer 2 Data Flow is depicted on Fig. 23, where a transport block is generated by MAC by concatenating two RLC PDUs from  $RB_x$  and one RLC PDU from  $RB_y$ . The two RLC PDUs from  $RB_x$  each corresponds to one IP packet ( $n$  and  $n+1$ ) while the RLC PDU from  $RB_y$  is a segment of an IP packet ( $m$ ).

FIGURE 23  
Data flow example

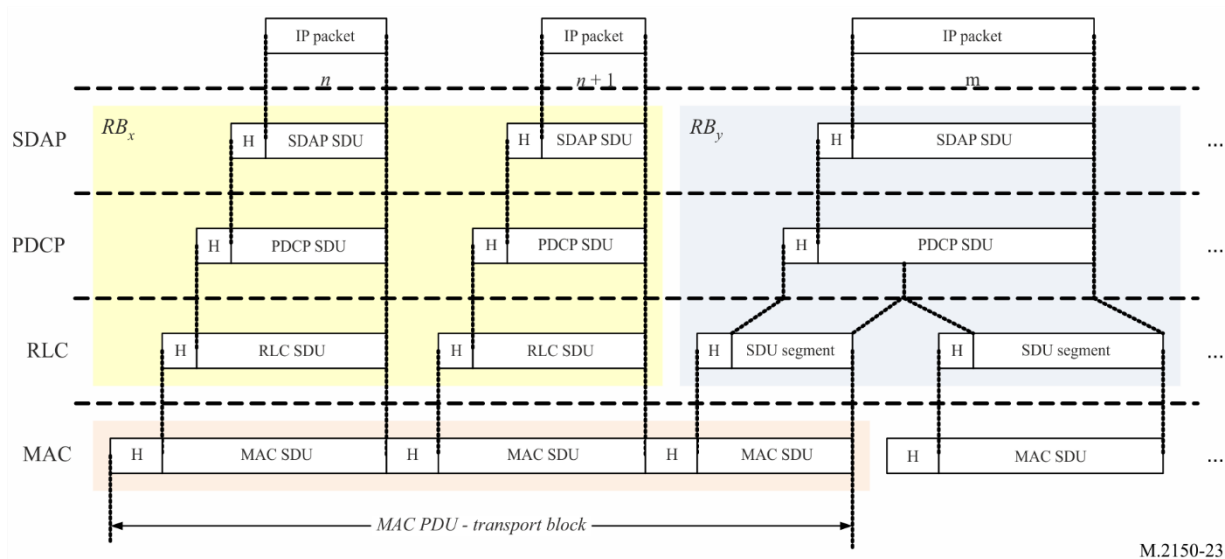

M.2150-23

NOTE – H depicts the headers and subheaders.

### 1.1.2.5.7 Carrier Aggregation (CA)

With CA, the multi-carrier nature of the physical layer is only exposed to the MAC layer for which one HARQ entity is required per serving cell as depicted on Figs 24 and 25 below:

- In both uplink and downlink, there is one independent HARQ entity per serving cell and one transport block is generated per assignment/grant per serving cell in the absence of spatial multiplexing. Each transport block and its potential HARQ retransmissions are mapped to a single serving cell.

FIGURE 24  
Layer 2 structure for DL with CA configured

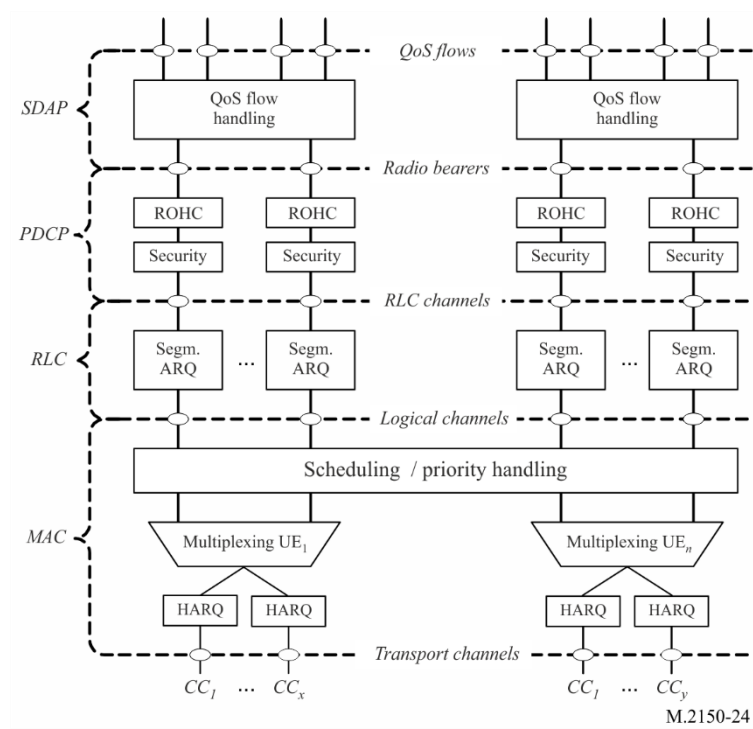
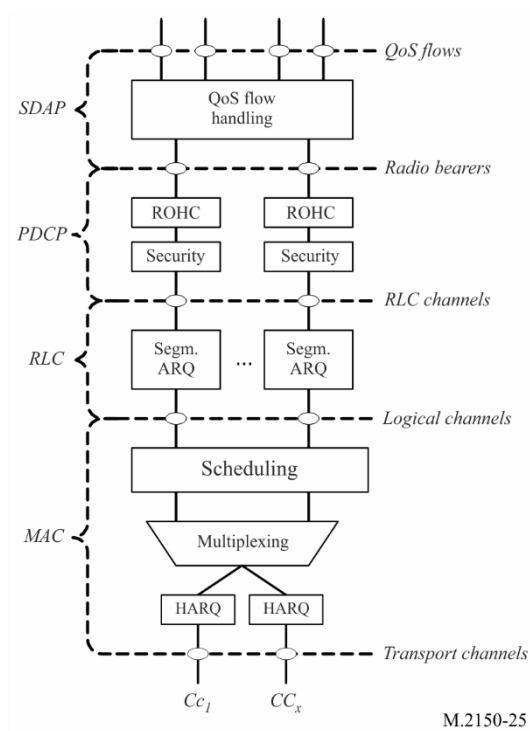

FIGURE 25  
Layer 2 structure for UL with CA configured



### 1.1.2.5.8 Dual Connectivity (DC)

When the UE is configured with a SCG, the UE is configured with two MAC entities: one MAC entity for the MCG and one MAC entity for the SCG.

### 1.1.2.5.9 Supplementary uplink

In case of Supplementary Uplink (SUL), the UE is configured with two ULs for one DL of the same cell, and uplink transmissions on those two ULs are controlled by the network to avoid overlapping PUSCH/PUCCH transmissions in time. Overlapping transmissions on PUSCH are avoided through scheduling while overlapping transmissions on PUCCH are avoided through configuration (PUCCH can only be configured for only one of the two ULs of the cell). In addition, initial access is supported in each of the uplink.

### 1.1.2.5.10 Bandwidth Adaptation (BA)

With Bandwidth Adaptation (BA), the receive and transmit bandwidth of a UE need not be as large as the bandwidth of the cell and can be adjusted: the width can be ordered to change (e.g. to shrink during period of low activity to save power); the location can move in the frequency domain (e.g. to increase scheduling flexibility); and the subcarrier spacing can be ordered to change (e.g. to allow different services). A subset of the total cell bandwidth of a cell is referred to as a Bandwidth Part (BWP) and BA is achieved by configuring the UE with BWP(s) and telling the UE which of the configured BWPs is currently the active one.

Figure 26 below describes a scenario where three different BWPs are configured:

- BWP<sub>1</sub> with a width of 40 MHz and subcarrier spacing of 15 kHz;
- BWP<sub>2</sub> with a width of 10 MHz and subcarrier spacing of 15 kHz;
- BWP<sub>3</sub> with a width of 20 MHz and subcarrier spacing of 60 kHz.

FIGURE 26

#### BA example

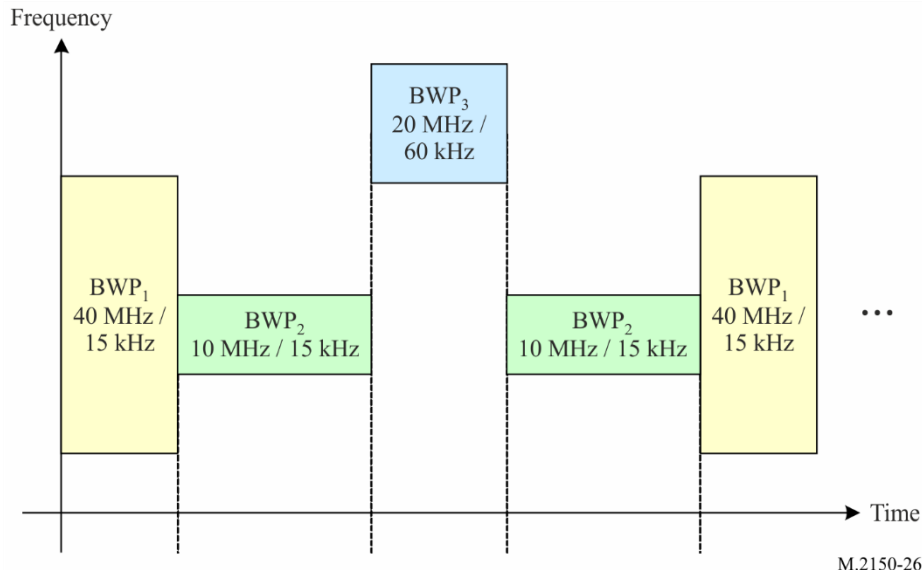

### 1.1.2.6 Radio Resources Control (RRC)

#### 1.1.2.6.1 Services and functions

The main services and functions of the RRC sublayer include:

- broadcast of System Information related to AS and NAS;
- paging initiated by 5GC or NG-RAN;
- establishment, maintenance and release of an RRC connection between the UE and NG-RAN including:

- addition, modification and release of Carrier Aggregation;
- addition, modification and release of Dual Connectivity in NR or between E-UTRA and NR.
- security functions including key management;
- establishment, configuration, maintenance and release of Signalling Radio Bearers (SRBs) and Data Radio Bearers (DRBs);
- Mobility functions including:
  - handover and context transfer;
  - UE cell selection and reselection and control of cell selection and reselection;
  - inter-RAT mobility.
- QoS management functions;
- UE measurement reporting and control of the reporting;
- detection of and recovery from radio link failure;
- NAS message transfer to/from NAS from/to UE.

In order to enhance mobility robustness and performance, additional NR mobility enhancements are introduced in 3GPP Rel-16. User data interruption is reduced during handover to 0 ms by dual-active-protocol-stack handover. In addition, the robustness during handover is improved by a conditional handover.

#### 1.1.2.6.2 Protocol States

RRC supports the following states which can be characterised as follows:

- RRC\_IDLE:
  - Public Land Mobile Network (PLMN) selection;
  - broadcast of system information;
  - cell re-selection mobility;
  - paging for mobile terminated data is initiated by 5GC;
  - DRX for core network paging configured by NAS.
- RRC\_INACTIVE:
  - PLMN selection;
  - broadcast of system information;
  - cell re-selection mobility;
  - paging is initiated by NG-RAN (RAN paging);
  - RAN-based notification area (RNA) is managed by NG-RAN;
  - DRX for RAN paging configured by NG-RAN;
  - 5GC - NG-RAN connection (both CP and UP) is established for UE;
  - the UE AS context is stored in NG-RAN and the UE;
  - NG-RAN knows the RNA which the UE belongs to.
- RRC\_CONNECTED:
  - 5GC - NG-RAN connection (both CP and UP) is established for UE;
  - the UE AS context is stored in NG-RAN and the UE;

- NG-RAN knows the cell which the UE belongs to;
- transfer of unicast data to/from the UE;
- network controlled mobility including measurements.

### 1.1.3 Support of verticals

The E-UTRA/LTE and NR component RITs support a diverse set of mobile broadband (eMBB) services and other so-called “verticals”, including URLLC, Industrial IoT, Automotive/V2X, Private Networks (NPN), and others. NR RIT supports in-band coexistence with NB-IoT and eMTC.

For optimal support of specific verticals, the NR RIT has been designed, or enhanced, with certain key features, or set of features. Taking few verticals as examples, a short summary of relevant NR RIT capabilities is provided below.

#### 1.1.3.1 Ultra-Reliable and Low Latency Communications (URLLC) and Industrial IoT (IIoT)

For support of URLLC services, some of the main features supported by the NR RIT are:

- Logical Channel Priority (LCP) restrictions
- Packet duplication with DC or CA
- New QCI table for block error rate  $10^{-5}$
- Physical layer short transmission time interval (TTI)

From Rel-16 onwards, URLLC and IIoT use cases are further facilitated by:

- NR PDCP duplication enhancements,
- Prioritization/multiplexing enhancements,
- NR Time Sensitive Communications (TSC) related enhancements, e.g. Ethernet header compression, and
- Precise time information delivery

#### 1.1.3.2 Vehicle-to-everything (V2X)

From Rel-16, NR RIT includes support of Vehicle-to-everything (V2X), mainly by means of NR sidelink communication over the PC5 interface, partly leveraging what was defined for E-UTRA V2X sidelink communication.

The architecture supporting the PC5 interface is illustrated in Fig. 27, for the overall NG-RAN (showing both NR and -EUTRA). Sidelink transmission and reception over the PC5 interface are supported when the UE is inside NG-RAN coverage, irrespective of which RRC state the UE is in, and when the UE is outside NG-RAN coverage.



FIGURE 27  
NG-RAN architecture supporting the PC5 interface

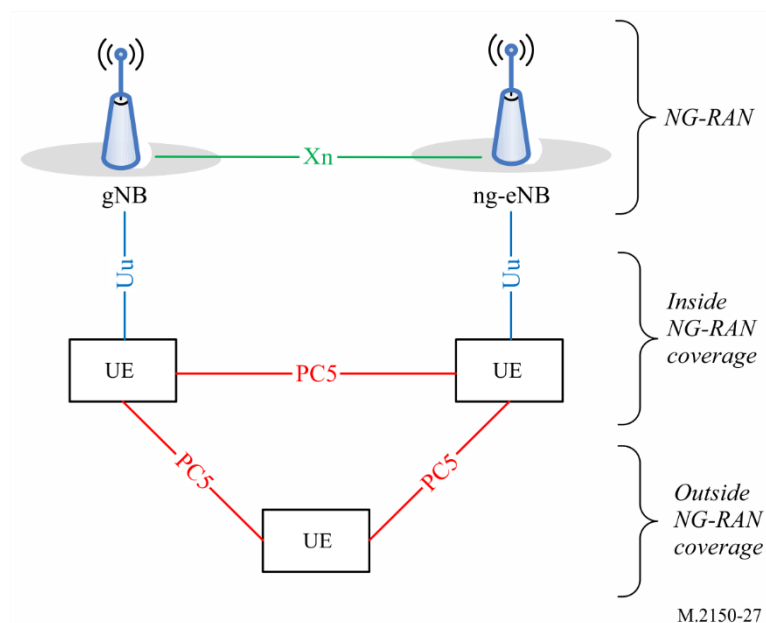

M.2150-27

NR sidelink communication can support three types of transmission modes (in the access stratum):

- Unicast, characterized by:
  - support of at least one PC5-RRC connection between peer UEs;
  - transmission and reception of control information and user traffic between peer UEs in sidelink;
  - support of sidelink feedback, for HARQ and link adaptation;
  - support of RLC AM;
  - Detection of radio link failure for the PC5 unicast connection;
- Groupcast, characterized by:
  - transmission and reception of user traffic among UEs belonging to a group in sidelink;
  - support of distance/range based sidelink HARQ feedback;
  - support of connection-less groupcast, and application managed groupcast
- Broadcast, characterized by transmission and reception of broadcast user traffic among UEs in sidelink.
  - NR sidelink communication may also be used to support other services than V2X, depending on service requirements.

## 1.2 Detailed specification of the radio interface technology

Detailed specifications described in this Annex are developed around a “Global Core Specification” (GCS)<sup>7</sup>, which is related to externally developed materials incorporated by specific references for a specific technology. The process and use of the GCS, references, and related notifications and certifications are found as Document IMT-2020/20.

<sup>7</sup> A “GCS” (Global Core Specification) is the set of specifications that defines a single RIT, an SRIT, or a component RIT within an SRIT.

The IMT-2020 standards contained in this section are derived from the global core specification for 3GPP 5G-SRIT contained at IMT-2020 Global Core Specifications. The following notes apply to the sections below:

- 1) The identified Transposing Organizations<sup>8</sup> should make their reference material available from their website.
- 2) This information was supplied by the Transposing Organizations and relates to their own deliverables of the transposed global core specification.

Section 1.2.1 contains titles and synopses of the Global Core Specification of IMT-2020 radio interface technology entitled 3GPP 5G-SRIT and the related hyperlinks to the transposed standards.

The specific 3GPP specifications of the Global Core Specifications (GCS) for IMT-2020 and 5G that are being transposed in § 1.2.1 are summarized in Table 1-3:

---

<sup>8</sup> The following identified Transposing Organizations have provided their transposed sets of standards information contained in this section:

- Association of Radio Industries and Businesses (ARIB)
- Alliance for Telecommunications Industry Solutions (ATIS)
- China Communications Standards Association (CCSA)
- European Telecommunications Standards Institute (ETSI)
- Telecommunications Standards Development Society, India (TSDSI)
- Telecommunications Technology Association (TTA)
- Telecommunication Technology Committee (TTC).

TABLE 1-3  
**3GPP specifications in § 1.2.1 that are to be transposed**

See Note a) and Note b) below the Table.								
PART A								
List of Specifications								
36.100 Series	36.200 Series	36.300 Series	36.400 Series	37.xxx Series	38.100 Series	38.200 Series	38.300 Series	38.400 Series
TS 36.101	TS 36.201	TS 36.300	TS 36.401	TS 37.104	TS 38.101-1	TS 38.201	TS 38.300	TS 38.401
TS 36.104	TS 36.211	TS 36.302	TS 36.410	TS 37.105	TS 38.101-2	TS 38.202	TS 38.304	TS 38.410
TS 36.106	TS 36.212	TS 36.304	TS 36.411	TS 37.113	TS 38.101-3	TS 38.211	TS 38.305	TS 38.411
TS 36.111	TS 36.213	TS 36.305	TS 36.412	TS 37.114	TS 38.104	TS 38.212	TS 38.306	TS 38.412
TS 36.113	TS 36.214	TS 36.306	TS 36.413	TS 37.320	TS 38.113	TS 38.213	TS 38.307	TS 38.413
TS 36.116	TS 36.216	TS 36.307	TS 36.414	TS 37.324	TS 38.124	TS 38.214	TS 38.314	TS 38.414
TS 36.124		TS 36.314	TS 36.420	TS 37.340	TS 38.133	TS 38.215	TS 38.321	TS 38.415
TS 36.133		TS 36.321	TS 36.421	TS 37.355			TS 38.322	TS 38.420
		TS 36.322	TS 36.422	TS 37.460			TS 38.323	TS 38.421
		TS 36.323	TS 36.423	TS 37.461			TS 38.331	TS 38.422
		TS 36.331	TS 36.424	TS 37.462			TS 38.340	TS 38.423
		TS 36.355	TS 36.425	TS 37.466				TS 38.424
		TS 36.360	TS 36.440	TS 37.470				TS 38.425
		TS 36.361	TS 36.441	TS 37.471				TS 38.425
			TS 36.442	TS 37.472				TS 38.455
			TS 36.443	TS 37.473				TS 38.460
			TS 36.444					TS 38.461
			TS 36.445					TS 38.462
			TS 36.455					TS 38.463
			TS 36.456					TS 38.470
			TS 36.457					TS 38.471
			TS 36.458					TS 38.472
			TS 36.459					TS 38.473
			TS 36.461					TS 38.474
			TS 36.462					
			TS 36.463					
			TS 36.464					
			TS 36.465					
PART B								
Specification versions to be used								
The specific versions of the 3GPP specifications that are to be used for the transpositions of those specifications listed in Table 1-3 are provided in the link below:								
<a href="#">Click here for the direct link to the GCS material.</a>								

Specifically, the following is noted for Table 1-3:

Notes on specification versions to be utilized for the Global Core Specifications (GCS):

**Note a)** In conjunction with Table 1-3, the published specification versions for Release 15 *and* Release 16 resulting from 3GPP TSG RAN #88-e meeting shall be utilized as the specific GCS version. If a RAN #88-e designated specification is not provided, the latest available 3GPP published specifications before 29 July 2020, shall be utilized as the specific GCS version.

**Note b)** Furthermore, these specific GCS versions in alignment with Note a) above are to be utilized in the transpositions of those specifications listed in Table 1-3 into the corresponding standards by the designated *Transposing Organizations* indicated in the Certification B provided by the 3GPP GCS Proponent to ITU-R under the IMT-2020 process. See Table 1-3, Part B.

## 1.2.1 Titles and synopses of the global core specification and the transposed standards

### 1.2.1.1 Introduction

The standards documents referenced below, as transposed from the relevant 3GPP specifications, are provided by the identified *Transposing Organizations* as the transposed sets of standards for the terrestrial radio interface of IMT-2020 identified as 5G and includes not only the key characteristics of IMT-2020 but also the additional capabilities of 5G both of which are continuing to be enhanced.

### 1.2.1.2 Radio Layer 1

#### 1.2.1.2.1 TS 36.201

##### Evolved Universal Terrestrial Radio Access (E-UTRA); LTE physical layer; General description

This document provides a general description of the physical layer of the E-UTRA radio interface. This document also describes the document structure of the 3GPP E-UTRA physical layer specifications, i.e. TS 36.200 series. The TS 36.200 series specifies the Uu point for the LTE mobile system, and defines the minimum level of specifications required for basic connections in terms of mutual connectivity and compatibility.

SDO	Document No.	Version	Status	Issued date	Location
<b>Release 15</b>					
ARIB	ARIB STD-T120-36.201		15.3.0	Published 28.09.2020	<a href="http://www.arib.or.jp/english/html/overview/doc/T120_T23_v2_00/2_T120/ARIB-STD-T120/Rel15/36/A36201-f30.pdf">http://www.arib.or.jp/english/html/overview/doc/T120_T23_v2_00/2_T120/ARIB-STD-T120/Rel15/36/A36201-f30.pdf</a>
ATIS	ATIS.3GPP.36.201V1530		15.3.0	Published 08.09.2020	<a href="http://www.atis.org/3gpp-documents/Rel15">http://www.atis.org/3gpp-documents/Rel15</a>
CCSA	CCSA.36.201V1530		15.3.0	Published 03.04.2020	<a href="http://www.ccsa.org.cn:9001/portalsFile/downloadOldFile?type=17&amp;oldFileUrl=Rel15/TS%2036.201%20V15.3.0.docx">http://www.ccsa.org.cn:9001/portalsFile/downloadOldFile?type=17&amp;oldFileUrl=Rel15/TS%2036.201%20V15.3.0.docx</a>
ETSI	ETSI TS 136 201		15.3.0	Published 14.04.2020	<a href="http://www.etsi.org/deliver/etsi_ts/136200_136299/136201/15.03.00_60/ts_136201v150300p.pdf">http://www.etsi.org/deliver/etsi_ts/136200_136299/136201/15.03.00_60/ts_136201v150300p.pdf</a>
TSDSI	TSDSI STD T1.3GPP 36.201-15.3.0 V1.0.0		15.3.0	Published 06.10.2020	<a href="https://members.tdsi.in/index.php/s/TJ5e7eMFzoNENaw">https://members.tdsi.in/index.php/s/TJ5e7eMFzoNENaw</a>
TTA	TTAT.3G-36.201V15.3.0		15.3.0	Published 11.09.2020	<a href="http://www.tta.or.kr/data/ttasDown.jsp?where=14688&amp;pk_num=TTAT.3G-36.201V15.3.0">http://www.tta.or.kr/data/ttasDown.jsp?where=14688&amp;pk_num=TTAT.3G-36.201V15.3.0</a>
<b>Release 16</b>					
ARIB	ARIB STD-T120-36.201		16.0.0	Published 28.09.2020	<a href="http://www.arib.or.jp/english/html/overview/doc/T120_T23_v2_00/2_T120/ARIB-STD-T120/Rel16/36/A36201-g00.pdf">http://www.arib.or.jp/english/html/overview/doc/T120_T23_v2_00/2_T120/ARIB-STD-T120/Rel16/36/A36201-g00.pdf</a>
ATIS	ATIS.3GPP.36.201V1600		16.0.0	Published 08.09.2020	<a href="http://www.atis.org/3gpp-documents/Rel16">http://www.atis.org/3gpp-documents/Rel16</a>
CCSA	CCSA.36.201V1600		16.0.0	Published 14.07.2020	<a href="http://www.ccsa.org.cn:9001/portalsFile/downloadOldFile?type=17&amp;oldFileUrl=Rel16/TS%2036.201%20V16.0.0.docx">http://www.ccsa.org.cn:9001/portalsFile/downloadOldFile?type=17&amp;oldFileUrl=Rel16/TS%2036.201%20V16.0.0.docx</a>
ETSI	ETSI TS 136 201		16.0.0	Published 20.07.2020	<a href="http://www.etsi.org/deliver/etsi_ts/136200_136299/136201/16.00.00_60/ts_136201v160000p.pdf">http://www.etsi.org/deliver/etsi_ts/136200_136299/136201/16.00.00_60/ts_136201v160000p.pdf</a>
TSDSI	TSDSI STD T1.3GPP 36.201-16.0.0 V1.0.0		16.0.0	Published 06.10.2020	<a href="https://members.tdsi.in/index.php/s/rNFgxpDc5zbTma">https://members.tdsi.in/index.php/s/rNFgxpDc5zbTma</a>
TTA	TTAT.3G-36.201V16.0.0		16.0.0	Published 11.09.2020	<a href="http://www.tta.or.kr/data/ttasDown.jsp?where=14688&amp;pk_num=TTAT.3G-36.201V16.0.0">http://www.tta.or.kr/data/ttasDown.jsp?where=14688&amp;pk_num=TTAT.3G-36.201V16.0.0</a>

#### 1.2.1.2.2 TS 36.211

##### Evolved Universal Terrestrial Radio Access (E-UTRA); Physical channels and modulation

This document describes the physical channels and modulation for E-UTRA.

SDO	Document No.	Version	Status	Issued date	Location
<b>Release 15</b>					
ARIB	ARIB STD-T120-36.211		15.10.0	Published 28.09.2020	<a href="http://www.arib.or.jp/english/html/overview/doc/T120_T23_v2_00/2_T120/ARIB-STD-T120/Rel15/36/A36211-fa0.pdf">http://www.arib.or.jp/english/html/overview/doc/T120_T23_v2_00/2_T120/ARIB-STD-T120/Rel15/36/A36211-fa0.pdf</a>
ATIS	ATIS.3GPP.36.211V15100		15.10.0	Published 08.09.2020	<a href="http://www.atis.org/3gpp-documents/Rel15">http://www.atis.org/3gpp-documents/Rel15</a>
CCSA	CCSA.36.211V15100		15.10.0	Published 14.07.2020	<a href="http://www.ccsa.org.cn:9001/portalsFile/downloadOldFile?type=17&amp;oldFileUrl=Rel15/TS%2036.211%20V15.10.0.zip">http://www.ccsa.org.cn:9001/portalsFile/downloadOldFile?type=17&amp;oldFileUrl=Rel15/TS%2036.211%20V15.10.0.zip</a>

ETSI	ETSI TS 136 211	15.10.0	Published	24.09.2020	<a href="http://www.etsi.org/deliver/etsi_ts/136200_136299/136211/15.10.00_60/ts_136211v151000p.pdf">http://www.etsi.org/deliver/etsi_ts/136200_136299/136211/15.10.00_60/ts_136211v151000p.pdf</a>
TSDSI	TSDSI STD T1.3GPP 36.211-15.10.0 V1.0.0	15.10.0	Published	06.10.2020	<a href="https://members.tdsi.in/index.php/s/Y7DfAZtMaXYMgAt">https://members.tdsi.in/index.php/s/Y7DfAZtMaXYMgAt</a>
TTA	TTAT.3G-36.211V15.10.0	15.10.0	Published	11.09.2020	<a href="http://www.tta.or.kr/data/ttasDown.jsp?where=14688&amp;pk_num=TTAT.3G-36.211V15.10.0">http://www.tta.or.kr/data/ttasDown.jsp?where=14688&amp;pk_num=TTAT.3G-36.211V15.10.0</a>
<b>Release 16</b>					
ARIB	ARIB STD-T120-36.211	16.2.0	Published	28.09.2020	<a href="http://www.arib.or.jp/english/html/overview/doc/T120_T23_v2_00/2_T120/ARIB-STD-T120/Rel16/36/A36211-g20.pdf">http://www.arib.or.jp/english/html/overview/doc/T120_T23_v2_00/2_T120/ARIB-STD-T120/Rel16/36/A36211-g20.pdf</a>
ATIS	ATIS.3GPP.36.211V1620	16.2.0	Published	08.09.2020	<a href="http://www.atis.org/3gpp-documents/Rel16">http://www.atis.org/3gpp-documents/Rel16</a>
CCSA	CCSA.36.211V1620	16.2.0	Published	14.07.2020	<a href="http://www.ccsa.org.cn:9001/portalsFile/downloadOldFile?type=17&amp;oldFileUrl=Rel16/TS%2036.211%20V16.2.0.zip">http://www.ccsa.org.cn:9001/portalsFile/downloadOldFile?type=17&amp;oldFileUrl=Rel16/TS%2036.211%20V16.2.0.zip</a>
ETSI	ETSI TS 136 211	16.2.0	Published	24.09.2020	<a href="http://www.etsi.org/deliver/etsi_ts/136200_136299/136211/16.02.00_60/ts_136211v160200p.pdf">http://www.etsi.org/deliver/etsi_ts/136200_136299/136211/16.02.00_60/ts_136211v160200p.pdf</a>
TSDSI	TSDSI STD T1.3GPP 36.211-16.2.0 V1.0.0	16.2.0	Published	06.10.2020	<a href="https://members.tdsi.in/index.php/s/fyS5edKyZmQoS9D">https://members.tdsi.in/index.php/s/fyS5edKyZmQoS9D</a>
TTA	TTAT.3G-36.211V16.2.0	16.2.0	Published	11.09.2020	<a href="http://www.tta.or.kr/data/ttasDown.jsp?where=14688&amp;pk_num=TTAT.3G-36.211V16.2.0">http://www.tta.or.kr/data/ttasDown.jsp?where=14688&amp;pk_num=TTAT.3G-36.211V16.2.0</a>

**1.2.1.2.3 TS 36.212**

**Evolved Universal Terrestrial Radio Access (E-UTRA); Multiplexing and channel coding**

This document specifies the coding, multiplexing and mapping to physical channels for E-UTRA.

<b>Release 15</b>					
ARIB	ARIB STD-T120-36.212	15.10.0	Published	28.09.2020	<a href="http://www.arib.or.jp/english/html/overview/doc/T120_T23_v2_00/2_T120/ARIB-STD-T120/Rel15/36/A36212-fa0.pdf">http://www.arib.or.jp/english/html/overview/doc/T120_T23_v2_00/2_T120/ARIB-STD-T120/Rel15/36/A36212-fa0.pdf</a>
ATIS	ATIS.3GPP.36.212V15100	15.10.0	Published	08.09.2020	<a href="http://www.atis.org/3gpp-documents/Rel15">http://www.atis.org/3gpp-documents/Rel15</a>
CCSA	CCSA.36.212V15100	15.10.0	Published	14.07.2020	<a href="http://www.ccsa.org.cn:9001/portalsFile/downloadOldFile?type=17&amp;oldFileUrl=Rel15/TS%2036.212%20V15.10.0.docx">http://www.ccsa.org.cn:9001/portalsFile/downloadOldFile?type=17&amp;oldFileUrl=Rel15/TS%2036.212%20V15.10.0.docx</a>
ETSI	ETSI TS 136 212	15.10.0	Published	20.07.2020	<a href="http://www.etsi.org/deliver/etsi_ts/136200_136299/136212/15.10.00_60/ts_136212v151000p.pdf">http://www.etsi.org/deliver/etsi_ts/136200_136299/136212/15.10.00_60/ts_136212v151000p.pdf</a>
TSDSI	TSDSI STD T1.3GPP 36.212-15.10.0 V1.0.0	15.10.0	Published	06.10.2020	<a href="https://members.tdsi.in/index.php/s/S3o2JNcamg7AMtA">https://members.tdsi.in/index.php/s/S3o2JNcamg7AMtA</a>
TTA	TTAT.3G-36.212V15.10.0	15.10.0	Published	11.09.2020	<a href="http://www.tta.or.kr/data/ttasDown.jsp?where=14688&amp;pk_num=TTAT.3G-36.212V15.10.0">http://www.tta.or.kr/data/ttasDown.jsp?where=14688&amp;pk_num=TTAT.3G-36.212V15.10.0</a>
<b>Release 16</b>					
ARIB	ARIB STD-T120-36.212	16.2.0	Published	28.09.2020	<a href="http://www.arib.or.jp/english/html/overview/doc/T120_T23_v2_00/2_T120/ARIB-STD-T120/Rel16/36/A36212-g20.pdf">http://www.arib.or.jp/english/html/overview/doc/T120_T23_v2_00/2_T120/ARIB-STD-T120/Rel16/36/A36212-g20.pdf</a>
ATIS	ATIS.3GPP.36.212V1620	16.2.0	Published	08.09.2020	<a href="http://www.atis.org/3gpp-documents/Rel16">http://www.atis.org/3gpp-documents/Rel16</a>
CCSA	CCSA.36.212V1620	16.2.0	Published	14.07.2020	<a href="http://www.ccsa.org.cn:9001/portalsFile/downloadOldFile?type=17&amp;oldFileUrl=Rel16/TS%2036.212%20V16.2.0.docx">http://www.ccsa.org.cn:9001/portalsFile/downloadOldFile?type=17&amp;oldFileUrl=Rel16/TS%2036.212%20V16.2.0.docx</a>
ETSI	ETSI TS 136 212	16.2.0	Published	20.07.2020	<a href="http://www.etsi.org/deliver/etsi_ts/136200_136299/136212/16.02.00_60/ts_136212v160200p.pdf">http://www.etsi.org/deliver/etsi_ts/136200_136299/136212/16.02.00_60/ts_136212v160200p.pdf</a>
TSDSI	TSDSI STD T1.3GPP 36.212-16.2.0 V1.0.0	16.2.0	Published	06.10.2020	<a href="https://members.tdsi.in/index.php/s/bXZiLxjNP5o4CP4">https://members.tdsi.in/index.php/s/bXZiLxjNP5o4CP4</a>
TTA	TTAT.3G-36.212V16.2.0	16.2.0	Published	11.09.2020	<a href="http://www.tta.or.kr/data/ttasDown.jsp?where=14688&amp;pk_num=TTAT.3G-36.212V16.2.0">http://www.tta.or.kr/data/ttasDown.jsp?where=14688&amp;pk_num=TTAT.3G-36.212V16.2.0</a>

**1.2.1.2.4 TS 36.213**

**Evolved Universal Terrestrial Radio Access (E-UTRA); Physical layer procedures**

This document specifies and establishes the characteristics of the physical layer procedures for E-UTRA.

SDO	Document No.	Version	Status	Issued date	Location
<b>Release 15</b>					
ARIB	ARIB STD-T120-36.213	15.10.0	Published	28.09.2020	<a href="http://www.arib.or.jp/english/html/overview/doc/T120_T23_v2_00/2_T120/ARIB-STD-T120/Rel15/36/A36213-fa0.pdf">http://www.arib.or.jp/english/html/overview/doc/T120_T23_v2_00/2_T120/ARIB-STD-T120/Rel15/36/A36213-fa0.pdf</a>
ATIS	ATIS.3GPP.36.213V15100	15.10.0	Published	08.09.2020	<a href="http://www.atis.org/3gpp-documents/Rel15">http://www.atis.org/3gpp-documents/Rel15</a>
CCSA	CCSA.36.213V15100	15.10.0	Published	14.07.2020	<a href="http://www.ccsa.org.cn:9001/portalsFile/downloadOldFile?type=17&amp;oldFileUrl=Rel15/TS%2036.213%20V15.10.0.zip">http://www.ccsa.org.cn:9001/portalsFile/downloadOldFile?type=17&amp;oldFileUrl=Rel15/TS%2036.213%20V15.10.0.zip</a>
ETSI	ETSI TS 136 213	15.10.0	Published	24.09.2020	<a href="http://www.etsi.org/deliver/etsi_ts/136200_136299/136213/15.10.00_60/ts_136213v151000p.pdf">http://www.etsi.org/deliver/etsi_ts/136200_136299/136213/15.10.00_60/ts_136213v151000p.pdf</a>
TSDSI	TSDSI STD T1.3GPP 36.213-15.10.0 V1.0.0	15.10.0	Published	06.10.2020	<a href="https://members.tdsi.in/index.php/s/w4YN2dzoRGQ5Pfp">https://members.tdsi.in/index.php/s/w4YN2dzoRGQ5Pfp</a>
TTA	TTAT.3G-36.213V15.10.0	15.10.0	Published	11.09.2020	<a href="http://www.tta.or.kr/data/ttasDown.jsp?where=14688&amp;pk_num=TTAT.3G-36.213V15.10.0">http://www.tta.or.kr/data/ttasDown.jsp?where=14688&amp;pk_num=TTAT.3G-36.213V15.10.0</a>
<b>Release 16</b>					
ARIB	ARIB STD-T120-36.213	16.2.0	Published	28.09.2020	<a href="http://www.arib.or.jp/english/html/overview/doc/T120_T23_v2_00/2_T120/ARIB-STD-T120/Rel16/36/A36213-g20.pdf">http://www.arib.or.jp/english/html/overview/doc/T120_T23_v2_00/2_T120/ARIB-STD-T120/Rel16/36/A36213-g20.pdf</a>
ATIS	ATIS.3GPP.36.213V1620	16.2.0	Published	08.09.2020	<a href="http://www.atis.org/3gpp-documents/Rel16">http://www.atis.org/3gpp-documents/Rel16</a>

SDO	Document No.	Version	Status	Issued date	Location	
CCSA	CCSA.36.213V1620		16.2.0	Published	14.07.2020	<a href="http://www.ccsa.org.cn:9001/portalsFile/downloadOldFile?type=17&amp;oldFileUrl=Rel16/TS%2036.213%20V16.2.0.zip">http://www.ccsa.org.cn:9001/portalsFile/downloadOldFile?type=17&amp;oldFileUrl=Rel16/TS%2036.213%20V16.2.0.zip</a>
ETSI	ETSI TS 136 213		16.2.0	Published	24.09.2020	<a href="http://www.etsi.org/deliver/etsi_ts/136200_136299/136213/16.02.00_60/ts_136213v160200p.pdf">http://www.etsi.org/deliver/etsi_ts/136200_136299/136213/16.02.00_60/ts_136213v160200p.pdf</a>
TSDSI	TSDSI STD T1.3GPP 36.213-16.2.0 V1.0.0		16.2.0	Published	06.10.2020	<a href="https://members.tdsi.in/index.php/s/W3BGwDgd3wYCYX5">https://members.tdsi.in/index.php/s/W3BGwDgd3wYCYX5</a>
TTA	TTAT.3G-36.213V16.2.0		16.2.0	Published	11.09.2020	<a href="http://www.tta.or.kr/data/ttasDown.jsp?where=14688&amp;pk_num=TTAT.3G-36.213V16.2.0">http://www.tta.or.kr/data/ttasDown.jsp?where=14688&amp;pk_num=TTAT.3G-36.213V16.2.0</a>

### 1.2.1.2.5 TS 36.214

#### Evolved Universal Terrestrial Radio Access (E-UTRA); Physical layer; Measurements

This document contains the description and definition of the measurements done at the UE and network in order to support operation in idle mode and connected mode in E-UTRA.

SDO	Document No.	Version	Status	Issued date	Location	
<b>Release 15</b>						
ARIB	ARIB STD-T120-36.214		15.5.0	Published	28.09.2020	<a href="http://www.arib.or.jp/english/html/overview/doc/T120_T23_v2_00/2_T120/ARIB-STD-T120/Rel15/36/A36214-f50.pdf">http://www.arib.or.jp/english/html/overview/doc/T120_T23_v2_00/2_T120/ARIB-STD-T120/Rel15/36/A36214-f50.pdf</a>
ATIS	ATIS.3GPP.36.214V1550		15.5.0	Published	08.09.2020	<a href="http://www.atis.org/3gpp-documents/Rel15">http://www.atis.org/3gpp-documents/Rel15</a>
CCSA	CCSA.36.214V1550		15.5.0	Published	06.01.2020	<a href="http://www.ccsa.org.cn:9001/portalsFile/downloadOldFile?type=17&amp;oldFileUrl=Rel15/TS%2036.214%20V15.5.0.docx">http://www.ccsa.org.cn:9001/portalsFile/downloadOldFile?type=17&amp;oldFileUrl=Rel15/TS%2036.214%20V15.5.0.docx</a>
ETSI	ETSI TS 136 214		15.5.0	Published	17.01.2020	<a href="http://www.etsi.org/deliver/etsi_ts/136200_136299/136214/15.05.00_60/ts_136214v150500p.pdf">http://www.etsi.org/deliver/etsi_ts/136200_136299/136214/15.05.00_60/ts_136214v150500p.pdf</a>
TSDSI	TSDSI STD T1.3GPP 36.214-15.5.0 V1.0.0		15.5.0	Published	06.10.2020	<a href="https://members.tdsi.in/index.php/s/5paPZBtz47S9qWG">https://members.tdsi.in/index.php/s/5paPZBtz47S9qWG</a>
TTA	TTAT.3G-36.214V15.5.0		15.5.0	Published	11.09.2020	<a href="http://www.tta.or.kr/data/ttasDown.jsp?where=14688&amp;pk_num=TTAT.3G-36.214V15.5.0">http://www.tta.or.kr/data/ttasDown.jsp?where=14688&amp;pk_num=TTAT.3G-36.214V15.5.0</a>
<b>Release 16</b>						
ARIB	ARIB STD-T120-36.214		16.1.0	Published	28.09.2020	<a href="http://www.arib.or.jp/english/html/overview/doc/T120_T23_v2_00/2_T120/ARIB-STD-T120/Rel16/36/A36214-g10.pdf">http://www.arib.or.jp/english/html/overview/doc/T120_T23_v2_00/2_T120/ARIB-STD-T120/Rel16/36/A36214-g10.pdf</a>
ATIS	ATIS.3GPP.36.214V1610		16.1.0	Published	08.09.2020	<a href="http://www.atis.org/3gpp-documents/Rel16">http://www.atis.org/3gpp-documents/Rel16</a>
CCSA	CCSA.36.214V1610		16.1.0	Published	14.07.2020	<a href="http://www.ccsa.org.cn:9001/portalsFile/downloadOldFile?type=17&amp;oldFileUrl=Rel16/TS%2036.214%20V16.1.0.docx">http://www.ccsa.org.cn:9001/portalsFile/downloadOldFile?type=17&amp;oldFileUrl=Rel16/TS%2036.214%20V16.1.0.docx</a>
ETSI	ETSI TS 136 214		16.1.0	Published	20.07.2020	<a href="http://www.etsi.org/deliver/etsi_ts/136200_136299/136214/16.01.00_60/ts_136214v160100p.pdf">http://www.etsi.org/deliver/etsi_ts/136200_136299/136214/16.01.00_60/ts_136214v160100p.pdf</a>
TSDSI	TSDSI STD T1.3GPP 36.214-16.1.0 V1.0.0		16.1.0	Published	06.10.2020	<a href="https://members.tdsi.in/index.php/s/grYc7eLTmd4Dy6p">https://members.tdsi.in/index.php/s/grYc7eLTmd4Dy6p</a>
TTA	TTAT.3G-36.214V16.1.0		16.1.0	Published	11.09.2020	<a href="http://www.tta.or.kr/data/ttasDown.jsp?where=14688&amp;pk_num=TTAT.3G-36.214V16.1.0">http://www.tta.or.kr/data/ttasDown.jsp?where=14688&amp;pk_num=TTAT.3G-36.214V16.1.0</a>

### 1.2.1.2.6 TS 36.216

#### Evolved Universal Terrestrial Radio Access (E-UTRA); Physical layer for relaying operation

This document describes the characteristics of eNodeB – relay node transmissions.

SDO	Document No.	Version	Status	Issued date	Location	
<b>Release 15</b>						
ARIB	ARIB STD-T120-36.216		15.0.0	Published	28.09.2020	<a href="http://www.arib.or.jp/english/html/overview/doc/T120_T23_v2_00/2_T120/ARIB-STD-T120/Rel15/36/A36216-f00.pdf">http://www.arib.or.jp/english/html/overview/doc/T120_T23_v2_00/2_T120/ARIB-STD-T120/Rel15/36/A36216-f00.pdf</a>
ATIS	ATIS.3GPP.36.216V1500		15.0.0	Published	08.09.2020	<a href="http://www.atis.org/3gpp-documents/Rel15">http://www.atis.org/3gpp-documents/Rel15</a>
CCSA	CCSA.36.216V1500		15.0.0	Published	14.07.2020	<a href="http://www.ccsa.org.cn:9001/portalsFile/downloadOldFile?type=17&amp;oldFileUrl=Rel16/TS%2036.216V15.0.0.docx">http://www.ccsa.org.cn:9001/portalsFile/downloadOldFile?type=17&amp;oldFileUrl=Rel16/TS%2036.216V15.0.0.docx</a>
ETSI	ETSI TS 136 216		15.0.0	Published	13.07.2018	<a href="http://www.etsi.org/deliver/etsi_ts/136200_136299/136216/15.00.00_60/ts_136216v150000p.pdf">http://www.etsi.org/deliver/etsi_ts/136200_136299/136216/15.00.00_60/ts_136216v150000p.pdf</a>
TSDSI	TSDSI STD T1.3GPP 36.216-15.0.0 V1.0.0		15.0.0	Published	06.10.2020	<a href="https://members.tdsi.in/index.php/s/jcqMsxTx8j5DXcd">https://members.tdsi.in/index.php/s/jcqMsxTx8j5DXcd</a>
TTA	TTAT.3G-36.216V15.0.0		15.0.0	Published	11.09.2020	<a href="http://www.tta.or.kr/data/ttasDown.jsp?where=14688&amp;pk_num=TTAT.3G-36.216V15.0.0">http://www.tta.or.kr/data/ttasDown.jsp?where=14688&amp;pk_num=TTAT.3G-36.216V15.0.0</a>
<b>Release 16</b>						
ARIB	ARIB STD-T120-36.216		16.0.0	Published	28.09.2020	<a href="http://www.arib.or.jp/english/html/overview/doc/T120_T23_v2_00/2_T120/ARIB-STD-T120/Rel16/36/A36216-g00.pdf">http://www.arib.or.jp/english/html/overview/doc/T120_T23_v2_00/2_T120/ARIB-STD-T120/Rel16/36/A36216-g00.pdf</a>
ATIS	ATIS.3GPP.36.216V1600		16.0.0	Published	08.09.2020	<a href="http://www.atis.org/3gpp-documents/Rel16">http://www.atis.org/3gpp-documents/Rel16</a>
CCSA	CCSA.36.216V1600		16.0.0	Published	14.07.2020	<a href="http://www.ccsa.org.cn:9001/portalsFile/downloadOldFile?type=17&amp;oldFileUrl=Rel16/TS%2036.216V16.0.0.docx">http://www.ccsa.org.cn:9001/portalsFile/downloadOldFile?type=17&amp;oldFileUrl=Rel16/TS%2036.216V16.0.0.docx</a>
ETSI	ETSI TS 136 216		16.0.0	Published	20.07.2020	<a href="http://www.etsi.org/deliver/etsi_ts/136200_136299/136216/16.00.00_60/ts_136216v160000p.pdf">http://www.etsi.org/deliver/etsi_ts/136200_136299/136216/16.00.00_60/ts_136216v160000p.pdf</a>

TSDSI	TSDSI STD T1.3GPP 36.216-16.0.0 V1.0.0	16.0.0	Published	06.10.2020	<a href="https://members.tdsi.in/index.php/s/Cte6XjCgzyQ4y7S">https://members.tdsi.in/index.php/s/Cte6XjCgzyQ4y7S</a>
TTA	TTAT.3G-36.216V16.0.0	16.0.0	Published	11.09.2020	<a href="http://www.tta.or.kr/data/ttasDown.jsp?where=14688&amp;pk_num=TTAT.3G-36.216V16.0.0">http://www.tta.or.kr/data/ttasDown.jsp?where=14688&amp;pk_num=TTAT.3G-36.216V16.0.0</a>

### 1.2.1.2.7 TS 38.201

#### NR; Physical layer; General description

This document provides a general description of the physical layer of NR radio interface. This document also describes the document structure of the 3GPP physical layer specifications, i.e. TS 38.200 series.

SDO	Document No.	Version	Status	Issued date	Location	
<b>Release 15</b>						
ARIB	ARIB STD-T120-38.201		15.0.0	Published	28.09.2020	<a href="http://www.arib.or.jp/english/html/overview/doc/T120_T23_v2_00/2_T120/ARIB-STD-T120/Rel15/38/A38201-f00.pdf">http://www.arib.or.jp/english/html/overview/doc/T120_T23_v2_00/2_T120/ARIB-STD-T120/Rel15/38/A38201-f00.pdf</a>
ATIS	ATIS.3GPP.38.201V1500		15.0.0	Published	08.09.2020	<a href="http://www.atis.org/3gpp-documents/Rel15">http://www.atis.org/3gpp-documents/Rel15</a>
CCSA	CCSA.38.201V1500		15.0.0	Published	03.01.2018	<a href="http://www.ccsa.org.cn:9001/portalsFile/downloadOldFile?type=17&amp;oldFileUrl=Rel15/TS%2038.201%20V15.0.0.doc">http://www.ccsa.org.cn:9001/portalsFile/downloadOldFile?type=17&amp;oldFileUrl=Rel15/TS%2038.201%20V15.0.0.doc</a>
ETSI	ETSI TS 138 201		15.0.0	Published	18.09.2018	<a href="http://www.etsi.org/deliver/etsi_ts/138200_138299/138201/15.00.00_60/ts_138201v150000p.pdf">http://www.etsi.org/deliver/etsi_ts/138200_138299/138201/15.00.00_60/ts_138201v150000p.pdf</a>
TSDSI	TSDSI STD T1.3GPP 38.201-15.0.0 V1.0.0		15.0.0	Published	06.10.2020	<a href="https://members.tdsi.in/index.php/s/XNXHNmtmtp7QWG">https://members.tdsi.in/index.php/s/XNXHNmtmtp7QWG</a>
TTA	TTAT.3G-38.201V15.0.0		15.0.0	Published	11.09.2020	<a href="http://www.tta.or.kr/data/ttasDown.jsp?where=14688&amp;pk_num=TTAT.3G-38.201V15.0.0">http://www.tta.or.kr/data/ttasDown.jsp?where=14688&amp;pk_num=TTAT.3G-38.201V15.0.0</a>
<b>Release 16</b>						
ARIB	ARIB STD-T120-38.201		16.0.0	Published	28.09.2020	<a href="http://www.arib.or.jp/english/html/overview/doc/T120_T23_v2_00/2_T120/ARIB-STD-T120/Rel16/38/A38201-g00.pdf">http://www.arib.or.jp/english/html/overview/doc/T120_T23_v2_00/2_T120/ARIB-STD-T120/Rel16/38/A38201-g00.pdf</a>
ATIS	ATIS.3GPP.38.201V1600		16.0.0	Published	08.09.2020	<a href="http://www.atis.org/3gpp-documents/Rel16">http://www.atis.org/3gpp-documents/Rel16</a>
CCSA	CCSA.38.201V1600		16.0.0	Published	11.01.2020	<a href="http://www.ccsa.org.cn:9001/portalsFile/downloadOldFile?type=17&amp;oldFileUrl=Rel16/TS%2038.201%20V16.0.0.doc">http://www.ccsa.org.cn:9001/portalsFile/downloadOldFile?type=17&amp;oldFileUrl=Rel16/TS%2038.201%20V16.0.0.doc</a>
ETSI	ETSI TS 138 201		16.0.0	Published	21.09.2020	<a href="http://www.etsi.org/deliver/etsi_ts/138200_138299/138201/16.00.00_60/ts_138201v160000p.pdf">http://www.etsi.org/deliver/etsi_ts/138200_138299/138201/16.00.00_60/ts_138201v160000p.pdf</a>
TSDSI	TSDSI STD T1.3GPP 38.201-16.0.0 V1.0.0		16.0.0	Published	06.10.2020	<a href="https://members.tdsi.in/index.php/s/N96FRkwqQ6HzHte">https://members.tdsi.in/index.php/s/N96FRkwqQ6HzHte</a>
TTA	TTAT.3G-38.201V16.0.0		16.0.0	Published	11.09.2020	<a href="http://www.tta.or.kr/data/ttasDown.jsp?where=14688&amp;pk_num=TTAT.3G-38.201V16.0.0">http://www.tta.or.kr/data/ttasDown.jsp?where=14688&amp;pk_num=TTAT.3G-38.201V16.0.0</a>

### 1.2.1.2.8 TS 38.202

#### NR; Services provided by the physical layer

This document is a technical specification of the services provided by the physical layer of 5G-NR to upper layers.

SDO	Document No.	Version	Status	Issued date	Location	
<b>Release 15</b>						
ARIB	ARIB STD-T120-38.202		15.6.0	Published	28.09.2020	<a href="http://www.arib.or.jp/english/html/overview/doc/T120_T23_v2_00/2_T120/ARIB-STD-T120/Rel15/38/A38202-f60.pdf">http://www.arib.or.jp/english/html/overview/doc/T120_T23_v2_00/2_T120/ARIB-STD-T120/Rel15/38/A38202-f60.pdf</a>
ATIS	ATIS.3GPP.38.202V1560		15.6.0	Published	08.09.2020	<a href="http://www.atis.org/3gpp-documents/Rel15">http://www.atis.org/3gpp-documents/Rel15</a>
CCSA	CCSA.38.202V1560		15.6.0	Published	11.01.2020	<a href="http://www.ccsa.org.cn:9001/portalsFile/downloadOldFile?type=17&amp;oldFileUrl=Rel15/TS%2038.202%20V15.6.0.docx">http://www.ccsa.org.cn:9001/portalsFile/downloadOldFile?type=17&amp;oldFileUrl=Rel15/TS%2038.202%20V15.6.0.docx</a>
ETSI	ETSI TS 138 202		15.6.0	Published	21.01.2020	<a href="http://www.etsi.org/deliver/etsi_ts/138200_138299/138202/15.06.00_60/ts_138202v150600p.pdf">http://www.etsi.org/deliver/etsi_ts/138200_138299/138202/15.06.00_60/ts_138202v150600p.pdf</a>
TSDSI	TSDSI STD T1.3GPP 38.202-15.6.0 V1.0.0		15.6.0	Published	06.10.2020	<a href="https://members.tdsi.in/index.php/s/qNiqDsCrQC3b6aq">https://members.tdsi.in/index.php/s/qNiqDsCrQC3b6aq</a>
TTA	TTAT.3G-38.202V15.6.0		15.6.0	Published	11.09.2020	<a href="http://www.tta.or.kr/data/ttasDown.jsp?where=14688&amp;pk_num=TTAT.3G-38.202V15.6.0">http://www.tta.or.kr/data/ttasDown.jsp?where=14688&amp;pk_num=TTAT.3G-38.202V15.6.0</a>
<b>Release 16</b>						
ARIB	ARIB STD-T120-38.202		16.1.0	Published	28.09.2020	<a href="http://www.arib.or.jp/english/html/overview/doc/T120_T23_v2_00/2_T120/ARIB-STD-T120/Rel16/38/A38202-g10.pdf">http://www.arib.or.jp/english/html/overview/doc/T120_T23_v2_00/2_T120/ARIB-STD-T120/Rel16/38/A38202-g10.pdf</a>
ATIS	ATIS.3GPP.38.202V1610		16.1.0	Published	08.09.2020	<a href="http://www.atis.org/3gpp-documents/Rel16">http://www.atis.org/3gpp-documents/Rel16</a>
CCSA	CCSA.38.202V1610		16.1.0	Published	14.07.2020	<a href="http://www.ccsa.org.cn:9001/portalsFile/downloadOldFile?type=17&amp;oldFileUrl=Rel16/TS%2038.202%20V16.1.0.docx">http://www.ccsa.org.cn:9001/portalsFile/downloadOldFile?type=17&amp;oldFileUrl=Rel16/TS%2038.202%20V16.1.0.docx</a>
ETSI	ETSI TS 138 202		16.1.0	Published	20.07.2020	<a href="http://www.etsi.org/deliver/etsi_ts/138200_138299/138202/16.01.00_60/ts_138202v160100p.pdf">http://www.etsi.org/deliver/etsi_ts/138200_138299/138202/16.01.00_60/ts_138202v160100p.pdf</a>
TSDSI	TSDSI STD T1.3GPP 38.202-16.1.0 V1.0.0		16.1.0	Published	06.10.2020	<a href="https://members.tdsi.in/index.php/s/g8qy2m6ZLzobWGA">https://members.tdsi.in/index.php/s/g8qy2m6ZLzobWGA</a>
TTA	TTAT.3G-38.202V16.1.0		16.1.0	Published	11.09.2020	<a href="http://www.tta.or.kr/data/ttasDown.jsp?where=14688&amp;pk_num=TTAT.3G-38.202V16.1.0">http://www.tta.or.kr/data/ttasDown.jsp?where=14688&amp;pk_num=TTAT.3G-38.202V16.1.0</a>

## 1.2.1.2.9 TS 38.211

## NR; Physical channels and modulation

This document describes the physical channels and signals for 5G-NR.

SDO	Document No.	Version	Status	Issued date	Location	
<b>Release 15</b>						
ARIB	ARIB STD-T120-38.211		15.8.0	Published	28.09.2020	<a href="http://www.arib.or.jp/english/html/overview/doc/T120_T23_v2_00/2_T120/ARIB-STD-T120/Rel15/38/A38211-f80.pdf">http://www.arib.or.jp/english/html/overview/doc/T120_T23_v2_00/2_T120/ARIB-STD-T120/Rel15/38/A38211-f80.pdf</a>
ATIS	ATIS.3GPP.38.211V1580		15.8.0	Published	08.09.2020	<a href="http://www.atis.org/3gpp-documents/Rel15">http://www.atis.org/3gpp-documents/Rel15</a>
CCSA	CCSA.38.211V1580		15.8.0	Published	11.01.2020	<a href="http://www.ccsa.org.cn:9001/portalsFile/downloadOldFile?type=17&amp;oldFileUrl=Rel15/TS%2038.211%20V15.8.0.docx">http://www.ccsa.org.cn:9001/portalsFile/downloadOldFile?type=17&amp;oldFileUrl=Rel15/TS%2038.211%20V15.8.0.docx</a>
ETSI	ETSI TS 138 211		15.8.0	Published	21.01.2020	<a href="http://www.etsi.org/deliver/etsi_ts/138200_138299/138211/15.08.00_60/ts_138211v150800p.pdf">http://www.etsi.org/deliver/etsi_ts/138200_138299/138211/15.08.00_60/ts_138211v150800p.pdf</a>
TSDSI	TSDSI STD T1.3GPP 38.211-15.8.0 V1.0.0		15.8.0	Published	06.10.2020	<a href="https://members.tdsi.in/index.php/s/RqwCnMYeJzxCpNc">https://members.tdsi.in/index.php/s/RqwCnMYeJzxCpNc</a>
TTA	TTAT.3G-38.211V15.8.0		15.8.0	Published	11.09.2020	<a href="http://www.tta.or.kr/data/ttasDown.jsp?where=14688&amp;pk_num=TTAT.3G-38.211V15.8.0">http://www.tta.or.kr/data/ttasDown.jsp?where=14688&amp;pk_num=TTAT.3G-38.211V15.8.0</a>
<b>Release 16</b>						
ARIB	ARIB STD-T120-38.211		16.2.0	Published	28.09.2020	<a href="http://www.arib.or.jp/english/html/overview/doc/T120_T23_v2_00/2_T120/ARIB-STD-T120/Rel16/38/A38211-g20.pdf">http://www.arib.or.jp/english/html/overview/doc/T120_T23_v2_00/2_T120/ARIB-STD-T120/Rel16/38/A38211-g20.pdf</a>
ATIS	ATIS.3GPP.38.211V1620		16.2.0	Published	08.09.2020	<a href="http://www.atis.org/3gpp-documents/Rel16">http://www.atis.org/3gpp-documents/Rel16</a>
CCSA	CCSA.38.211V1620		16.2.0	Published	14.07.2020	<a href="http://www.ccsa.org.cn:9001/portalsFile/downloadOldFile?type=17&amp;oldFileUrl=Rel16/TS%2038.211%20V16.2.0.docx">http://www.ccsa.org.cn:9001/portalsFile/downloadOldFile?type=17&amp;oldFileUrl=Rel16/TS%2038.211%20V16.2.0.docx</a>
ETSI	ETSI TS 138 211 1		6.2.0	Published	20.07.2020	<a href="http://www.etsi.org/deliver/etsi_ts/138200_138299/138212/16.02.00_60/ts_138211v160200p.pdf">http://www.etsi.org/deliver/etsi_ts/138200_138299/138212/16.02.00_60/ts_138211v160200p.pdf</a>
TSDSI	TSDSI STD T1.3GPP 38.211-16.2.0 V1.0.0		16.2.0	Published	06.10.2020	<a href="https://members.tdsi.in/index.php/s/QR9pxK6p4MyHgP2">https://members.tdsi.in/index.php/s/QR9pxK6p4MyHgP2</a>
TTA	TTAT.3G-38.211V16.2.0		16.2.0	Published	11.09.2020	<a href="http://www.tta.or.kr/data/ttasDown.jsp?where=14688&amp;pk_num=TTAT.3G-38.211V16.2.0">http://www.tta.or.kr/data/ttasDown.jsp?where=14688&amp;pk_num=TTAT.3G-38.211V16.2.0</a>

## 1.2.1.2.10 TS 38.212

## NR; Multiplexing and channel coding

This document specifies the coding, multiplexing and mapping to physical channels for 5G NR.

SDO	Document No.	Version	Status	Issued date	Location	
<b>Release 15</b>						
ARIB	ARIB STD-T120-38.212		15.9.0	Published	28.09.2020	<a href="http://www.arib.or.jp/english/html/overview/doc/T120_T23_v2_00/2_T120/ARIB-STD-T120/Rel15/38/A38212-f90.pdf">http://www.arib.or.jp/english/html/overview/doc/T120_T23_v2_00/2_T120/ARIB-STD-T120/Rel15/38/A38212-f90.pdf</a>
ATIS	ATIS.3GPP.38.212V1590		15.9.0	Published	08.09.2020	<a href="http://www.atis.org/3gpp-documents/Rel15">http://www.atis.org/3gpp-documents/Rel15</a>
CCSA	CCSA.38.212V1590		15.9.0	Published	14.07.2020	<a href="http://www.ccsa.org.cn:9001/portalsFile/downloadOldFile?type=17&amp;oldFileUrl=Rel15/TS%2038.212%20V15.9.0.docx">http://www.ccsa.org.cn:9001/portalsFile/downloadOldFile?type=17&amp;oldFileUrl=Rel15/TS%2038.212%20V15.9.0.docx</a>
ETSI	ETSI TS 138 212		15.9.0	Published	20.07.2020	<a href="http://www.etsi.org/deliver/etsi_ts/138200_138299/138212/15.09.00_60/ts_138212v150900p.pdf">http://www.etsi.org/deliver/etsi_ts/138200_138299/138212/15.09.00_60/ts_138212v150900p.pdf</a>
TSDSI	TSDSI STD T1.3GPP 38.212-15.9.0 V1.0.0		15.9.0	Published	06.10.2020	<a href="https://members.tdsi.in/index.php/s/ZpT9Pc6P6KYTF97">https://members.tdsi.in/index.php/s/ZpT9Pc6P6KYTF97</a>
TTA	TTAT.3G-38.212V15.9.0		15.9.0	Published	11.09.2020	<a href="http://www.tta.or.kr/data/ttasDown.jsp?where=14688&amp;pk_num=TTAT.3G-38.212V15.9.0">http://www.tta.or.kr/data/ttasDown.jsp?where=14688&amp;pk_num=TTAT.3G-38.212V15.9.0</a>
<b>Release 16</b>						
ARIB	ARIB STD-T120-38.212		16.2.0	Published	28.09.2020	<a href="http://www.arib.or.jp/english/html/overview/doc/T120_T23_v2_00/2_T120/ARIB-STD-T120/Rel16/38/A38212-g20.pdf">http://www.arib.or.jp/english/html/overview/doc/T120_T23_v2_00/2_T120/ARIB-STD-T120/Rel16/38/A38212-g20.pdf</a>
ATIS	ATIS.3GPP.38.212V1620		16.2.0	Published	08.09.2020	<a href="http://www.atis.org/3gpp-documents/Rel16">http://www.atis.org/3gpp-documents/Rel16</a>
CCSA	CCSA.38.212V1620		16.2.0	Published	20.07.2020	<a href="http://www.ccsa.org.cn:9001/portalsFile/downloadOldFile?type=17&amp;oldFileUrl=Rel16/TS%2038.212%20V16.2.0.docx">http://www.ccsa.org.cn:9001/portalsFile/downloadOldFile?type=17&amp;oldFileUrl=Rel16/TS%2038.212%20V16.2.0.docx</a>
ETSI	ETSI TS 138 212		16.2.0	Published	30.07.2020	<a href="http://www.etsi.org/deliver/etsi_ts/138200_138299/138212/16.02.00_60/ts_138212v160200p.pdf">http://www.etsi.org/deliver/etsi_ts/138200_138299/138212/16.02.00_60/ts_138212v160200p.pdf</a>
TSDSI	TSDSI STD T1.3GPP 38.212-16.2.0 V1.0.0		16.2.0	Published	06.10.2020	<a href="https://members.tdsi.in/index.php/s/km4eQMZxsmrpeXB">https://members.tdsi.in/index.php/s/km4eQMZxsmrpeXB</a>
TTA	TTAT.3G-38.212V16.2.0		16.2.0	Published	11.09.2020	<a href="http://www.tta.or.kr/data/ttasDown.jsp?where=14688&amp;pk_num=TTAT.3G-38.212V16.2.0">http://www.tta.or.kr/data/ttasDown.jsp?where=14688&amp;pk_num=TTAT.3G-38.212V16.2.0</a>



**1.2.1.2.11 TS 38.213****NR; Physical layer procedures for control**

This document specifies and establishes the characteristics of the physical layer procedures for control operations in 5G-NR.

SDO	Document No.	Version	Status	Issued date	Location	
<b>Release 15</b>						
ARIB	ARIB STD-T120-38.213		15.10.0	Published	28.09.2020	<a href="http://www.arib.or.jp/english/html/overview/doc/T120_T23_v2_00/2_T120/ARIB-STD-T120/Rel15/38/A38213-fa0.pdf">http://www.arib.or.jp/english/html/overview/doc/T120_T23_v2_00/2_T120/ARIB-STD-T120/Rel15/38/A38213-fa0.pdf</a>
ATIS	ATIS.3GPP.38.213V15100		15.10.0	Published	08.09.2020	<a href="http://www.atis.org/3gpp-documents/Rel15">http://www.atis.org/3gpp-documents/Rel15</a>
CCSA	CCSA.38.213V15100		15.10.0	Published	17.07.2020	<a href="http://www.ccsa.org.cn:9001/portalsFile/downloadOldFile?type=17&amp;oldFileUrl=Rel15/TS%2038.213%20V15.10.0.docx">http://www.ccsa.org.cn:9001/portalsFile/downloadOldFile?type=17&amp;oldFileUrl=Rel15/TS%2038.213%20V15.10.0.docx</a>
ETSI	ETSI TS 138 213		15.10.0	Published	23.07.2020	<a href="http://www.etsi.org/deliver/etsi_ts/138200_138299/138213/15.10.00_60/ts_138213v151000p.pdf">http://www.etsi.org/deliver/etsi_ts/138200_138299/138213/15.10.00_60/ts_138213v151000p.pdf</a>
TSDSI	TSDSI STD T1.3GPP 38.213-15.10.0 V1.0.0		15.10.0	Published	06.10.2020	<a href="https://members.tdsi.in/index.php/s/cfqCbrPm5A59dot">https://members.tdsi.in/index.php/s/cfqCbrPm5A59dot</a>
TTA	TTAT.3G-38.213V15.10.0		15.10.0	Published	11.09.2020	<a href="http://www.tta.or.kr/data/ttasDown.jsp?where=14688&amp;pk_num=TTAT.3G-38.213V15.10.0">http://www.tta.or.kr/data/ttasDown.jsp?where=14688&amp;pk_num=TTAT.3G-38.213V15.10.0</a>
<b>Release 16</b>						
ARIB	ARIB STD-T120-38.213		16.2.0	Published	28.09.2020	<a href="http://www.arib.or.jp/english/html/overview/doc/T120_T23_v2_00/2_T120/ARIB-STD-T120/Rel16/38/A38213-g20.pdf">http://www.arib.or.jp/english/html/overview/doc/T120_T23_v2_00/2_T120/ARIB-STD-T120/Rel16/38/A38213-g20.pdf</a>
ATIS	ATIS.3GPP.38.213V1620		16.2.0	Published	08.09.2020	<a href="http://www.atis.org/3gpp-documents/Rel16">http://www.atis.org/3gpp-documents/Rel16</a>
CCSA	CCSA.38.213V1620		16.2.0	Published	20.07.2020	<a href="http://www.ccsa.org.cn:9001/portalsFile/downloadOldFile?type=17&amp;oldFileUrl=Rel16/TS%2038.213%20V16.2.0.docx">http://www.ccsa.org.cn:9001/portalsFile/downloadOldFile?type=17&amp;oldFileUrl=Rel16/TS%2038.213%20V16.2.0.docx</a>
ETSI	ETSI TS 138 213		16.2.0	Published	30.07.2020	<a href="http://www.etsi.org/deliver/etsi_ts/138200_138299/138213/16.02.00_60/ts_138213v160200p.pdf">http://www.etsi.org/deliver/etsi_ts/138200_138299/138213/16.02.00_60/ts_138213v160200p.pdf</a>
TSDSI	TSDSI STD T1.3GPP 38.213-16.2.0 V1.0.0		16.2.0	Published	06.10.2020	<a href="https://members.tdsi.in/index.php/s/g7cADGP4c2MdkXx">https://members.tdsi.in/index.php/s/g7cADGP4c2MdkXx</a>
TTA	TTAT.3G-38.213V16.2.0		16.2.0	Published	11.09.2020	<a href="http://www.tta.or.kr/data/ttasDown.jsp?where=14688&amp;pk_num=TTAT.3G-38.213V16.2.0">http://www.tta.or.kr/data/ttasDown.jsp?where=14688&amp;pk_num=TTAT.3G-38.213V16.2.0</a>

**1.2.1.2.12 TS 38.214****NR; Physical layer procedures for data**

This document specifies and establishes the characteristics of the physicals layer procedures of data channels for 5G-NR.

SDO	Document No.	Version	Status	Issued date	Location	
<b>Release 15</b>						
ARIB	ARIB STD-T120-38.214		15.10.0	Published	28.09.2020	<a href="http://www.arib.or.jp/english/html/overview/doc/T120_T23_v2_00/2_T120/ARIB-STD-T120/Rel15/38/A38214-fa0.pdf">http://www.arib.or.jp/english/html/overview/doc/T120_T23_v2_00/2_T120/ARIB-STD-T120/Rel15/38/A38214-fa0.pdf</a>
ATIS	ATIS.3GPP.38.214V15100		15.10.0	Published	08.09.2020	<a href="http://www.atis.org/3gpp-documents/Rel15">http://www.atis.org/3gpp-documents/Rel15</a>
CCSA	CCSA.38.214V15100		15.10.0	Published	17.07.2020	<a href="http://www.ccsa.org.cn:9001/portalsFile/downloadOldFile?type=17&amp;oldFileUrl=Rel15/TS%2038.214%20V15.10.0.docx">http://www.ccsa.org.cn:9001/portalsFile/downloadOldFile?type=17&amp;oldFileUrl=Rel15/TS%2038.214%20V15.10.0.docx</a>
ETSI	ETSI TS 138 214		15.10.0	Published	23.07.2020	<a href="http://www.etsi.org/deliver/etsi_ts/138200_138299/138214/15.10.00_60/ts_138214v151000p.pdf">http://www.etsi.org/deliver/etsi_ts/138200_138299/138214/15.10.00_60/ts_138214v151000p.pdf</a>
TSDSI	TSDSI STD T1.3GPP 38.214-15.10.0 V1.0.0		15.10.0	Published	06.10.2020	<a href="https://members.tdsi.in/index.php/s/QepiRBMZYrGcXx8">https://members.tdsi.in/index.php/s/QepiRBMZYrGcXx8</a>
TTA	TTAT.3G-38.214V15.10.0		15.10.0	Published	11.09.2020	<a href="http://www.tta.or.kr/data/ttasDown.jsp?where=14688&amp;pk_num=TTAT.3G-38.214V15.10.0">http://www.tta.or.kr/data/ttasDown.jsp?where=14688&amp;pk_num=TTAT.3G-38.214V15.10.0</a>
<b>Release 16</b>						
ARIB	ARIB STD-T120-38.214		16.2.0	Published	28.09.2020	<a href="http://www.arib.or.jp/english/html/overview/doc/T120_T23_v2_00/2_T120/ARIB-STD-T120/Rel16/38/A38214-g20.pdf">http://www.arib.or.jp/english/html/overview/doc/T120_T23_v2_00/2_T120/ARIB-STD-T120/Rel16/38/A38214-g20.pdf</a>
ATIS	ATIS.3GPP.38.214V1620		16.2.0	Published	08.09.2020	<a href="http://www.atis.org/3gpp-documents/Rel16">http://www.atis.org/3gpp-documents/Rel16</a>
CCSA	CCSA.38.214V1620		16.2.0	Published	20.07.2020	<a href="http://www.ccsa.org.cn:9001/portalsFile/downloadOldFile?type=17&amp;oldFileUrl=Rel16/TS%2038.214%20V16.2.0.docx">http://www.ccsa.org.cn:9001/portalsFile/downloadOldFile?type=17&amp;oldFileUrl=Rel16/TS%2038.214%20V16.2.0.docx</a>
ETSI	ETSI TS 138 214		16.2.0	Published	30.07.2020	<a href="http://www.etsi.org/deliver/etsi_ts/138200_138299/138214/16.02.00_60/ts_138214v160200p.pdf">http://www.etsi.org/deliver/etsi_ts/138200_138299/138214/16.02.00_60/ts_138214v160200p.pdf</a>
TSDSI	TSDSI STD T1.3GPP 38.214-16.2.0 V1.0.0		16.2.0	Published	06.10.2020	<a href="https://members.tdsi.in/index.php/s/kFSHAZxNiYQGmxf">https://members.tdsi.in/index.php/s/kFSHAZxNiYQGmxf</a>
TTA	TTAT.3G-38.214V16.2.0		16.2.0	Published	11.09.2020	<a href="http://www.tta.or.kr/data/ttasDown.jsp?where=14688&amp;pk_num=TTAT.3G-38.214V16.2.0">http://www.tta.or.kr/data/ttasDown.jsp?where=14688&amp;pk_num=TTAT.3G-38.214V16.2.0</a>

### 1.2.1.2.13 TS 38.215

#### NR; Physical layer measurements

This document describes the physical layer measurements for NR.

SDO	Document No.	Version	Status	Issued date	Location	
<b>Release 15</b>						
ARIB	ARIB STD-T120-38.215		15.7.0	Published	28.09.2020	<a href="http://www.arib.or.jp/english/html/overview/doc/T120_T23_v2_00/2_T120/ARIB-STD-T120/Rel15/38/A38215-f70.pdf">http://www.arib.or.jp/english/html/overview/doc/T120_T23_v2_00/2_T120/ARIB-STD-T120/Rel15/38/A38215-f70.pdf</a>
ATIS	ATIS.3GPP.38.215V1570		15.7.0	Published	08.09.2020	<a href="http://www.atis.org/3gpp-documents/Rel15">http://www.atis.org/3gpp-documents/Rel15</a>
CCSA	CCSA.38.215V1570		15.7.0	Published	14.07.2020	<a href="http://www.ccsa.org.cn:9001/portalsFile/downloadOldFile?type=17&amp;oldFileUrl=Rel15/TS%2038.215%20V15.7.0.docx">http://www.ccsa.org.cn:9001/portalsFile/downloadOldFile?type=17&amp;oldFileUrl=Rel15/TS%2038.215%20V15.7.0.docx</a>
ETSI	ETSI TS 138 215		15.7.0	Published	20.07.2020	<a href="http://www.etsi.org/deliver/etsi_ts/138200_138299/138215/15.07.00_60/ts_138215v150700p.pdf">http://www.etsi.org/deliver/etsi_ts/138200_138299/138215/15.07.00_60/ts_138215v150700p.pdf</a>
TSDSI	TSDSI STD T1.3GPP 38.215-15.7.0 V1.0.0		15.7.0	Published	06.10.2020	<a href="https://members.tdsi.in/index.php/s/4PMqJQM8LcoJCWn">https://members.tdsi.in/index.php/s/4PMqJQM8LcoJCWn</a>
TTA	TTAT.3G-38.215V15.7.0		15.7.0	Published	11.09.2020	<a href="http://www.tta.or.kr/data/ttasDown.jsp?where=14688&amp;pk_num=TTAT.3G-38.215V15.7.0">http://www.tta.or.kr/data/ttasDown.jsp?where=14688&amp;pk_num=TTAT.3G-38.215V15.7.0</a>
<b>Release 16</b>						
ARIB	ARIB STD-T120-38.215		16.2.0	Published	28.09.2020	<a href="http://www.arib.or.jp/english/html/overview/doc/T120_T23_v2_00/2_T120/ARIB-STD-T120/Rel16/38/A38215-g20.pdf">http://www.arib.or.jp/english/html/overview/doc/T120_T23_v2_00/2_T120/ARIB-STD-T120/Rel16/38/A38215-g20.pdf</a>
ATIS	ATIS.3GPP.38.215V1620		16.2.0	Published	08.09.2020	<a href="http://www.atis.org/3gpp-documents/Rel16">http://www.atis.org/3gpp-documents/Rel16</a>
CCSA	CCSA.38.215V1620		16.2.0	Published	14.07.2020	<a href="http://www.ccsa.org.cn:9001/portalsFile/downloadOldFile?type=17&amp;oldFileUrl=Rel16/TS%2038.215%20V16.2.0.docx">http://www.ccsa.org.cn:9001/portalsFile/downloadOldFile?type=17&amp;oldFileUrl=Rel16/TS%2038.215%20V16.2.0.docx</a>
ETSI	ETSI TS 138 215		16.2.0	Published	20.07.2020	<a href="http://www.etsi.org/deliver/etsi_ts/138200_138299/138215/16.02.00_60/ts_138215v160200p.pdf">http://www.etsi.org/deliver/etsi_ts/138200_138299/138215/16.02.00_60/ts_138215v160200p.pdf</a>
TSDSI	TSDSI STD T1.3GPP 38.215-16.2.0 V1.0.0		16.2.0	Published	06.10.2020	<a href="https://members.tdsi.in/index.php/s/NKqZomA38qbdY2o">https://members.tdsi.in/index.php/s/NKqZomA38qbdY2o</a>
TTA	TTAT.3G-38.215V16.2.0		16.2.0	Published	11.09.2020	<a href="http://www.tta.or.kr/data/ttasDown.jsp?where=14688&amp;pk_num=TTAT.3G-38.215V16.2.0">http://www.tta.or.kr/data/ttasDown.jsp?where=14688&amp;pk_num=TTAT.3G-38.215V16.2.0</a>

### 1.2.1.3 Radio Layers 2 & 3

#### 1.2.1.3.1 TS 36.300

#### Evolved Universal Terrestrial Radio Access (E-UTRA) and Evolved Universal Terrestrial Radio Access Network (E-UTRAN); Overall description; Stage 2

This document provides an overview and overall description of the E-UTRAN radio interface protocol architecture. Details of the radio interface protocols are specified in companion specifications of the 36 series.

SDO	Document No.	Version	Status	Issued date	Location	
<b>Release 15</b>						
ARIB	ARIB STD-T120-36.300		15.10.0	Published	28.09.2020	<a href="http://www.arib.or.jp/english/html/overview/doc/T120_T23_v2_00/2_T120/ARIB-STD-T120/Rel15/36/A36300-fa0.pdf">http://www.arib.or.jp/english/html/overview/doc/T120_T23_v2_00/2_T120/ARIB-STD-T120/Rel15/36/A36300-fa0.pdf</a>
ATIS	ATIS.3GPP.36.300V15100		15.10.0	Published	08.09.2020	<a href="http://www.atis.org/3gpp-documents/Rel15">http://www.atis.org/3gpp-documents/Rel15</a>
CCSA	CCSA.36.300V15100		15.10.0	Published	24.07.2020	<a href="http://www.ccsa.org.cn:9001/portalsFile/downloadOldFile?type=17&amp;oldFileUrl=Rel15/TS%2036.300%20V15.10.0.docx">http://www.ccsa.org.cn:9001/portalsFile/downloadOldFile?type=17&amp;oldFileUrl=Rel15/TS%2036.300%20V15.10.0.docx</a>
ETSI	ETSI TS 136 300		15.10.0	Published	31.07.2020	<a href="http://www.etsi.org/deliver/etsi_ts/136300_136399/136300/15.10.00_60/ts_136300v151000p.pdf">http://www.etsi.org/deliver/etsi_ts/136300_136399/136300/15.10.00_60/ts_136300v151000p.pdf</a>
TSDSI	TSDSI STD T1.3GPP 36.300-15.10.0 V1.0.0		15.10.0	Published	06.10.2020	<a href="https://members.tdsi.in/index.php/s/zq5NxBpnbG8EN9B">https://members.tdsi.in/index.php/s/zq5NxBpnbG8EN9B</a>
TTA	TTAT.3G-36.300V15.10.0		15.10.0	Published	11.09.2020	<a href="http://www.tta.or.kr/data/ttasDown.jsp?where=14688&amp;pk_num=TTAT.3G-36.300V15.10.0">http://www.tta.or.kr/data/ttasDown.jsp?where=14688&amp;pk_num=TTAT.3G-36.300V15.10.0</a>
<b>Release 16</b>						
ARIB	ARIB STD-T120-36.300		16.2.0	Published	28.09.2020	<a href="http://www.arib.or.jp/english/html/overview/doc/T120_T23_v2_00/2_T120/ARIB-STD-T120/Rel16/36/A36300-g20.pdf">http://www.arib.or.jp/english/html/overview/doc/T120_T23_v2_00/2_T120/ARIB-STD-T120/Rel16/36/A36300-g20.pdf</a>
ATIS	ATIS.3GPP.36.300V1620		16.2.0	Published	08.09.2020	<a href="http://www.atis.org/3gpp-documents/Rel16">http://www.atis.org/3gpp-documents/Rel16</a>
CCSA	CCSA.36.300V1620		16.2.0	Published	24.07.2020	<a href="http://www.ccsa.org.cn:9001/portalsFile/downloadOldFile?type=17&amp;oldFileUrl=Rel16/TS%2036.300%20V16.2.0.docx">http://www.ccsa.org.cn:9001/portalsFile/downloadOldFile?type=17&amp;oldFileUrl=Rel16/TS%2036.300%20V16.2.0.docx</a>
ETSI	ETSI TS 136 300		16.2.0	Published	31.07.2020	<a href="http://www.etsi.org/deliver/etsi_ts/136300_136399/136300/16.02.00_60/ts_136300v160200p.pdf">http://www.etsi.org/deliver/etsi_ts/136300_136399/136300/16.02.00_60/ts_136300v160200p.pdf</a>
TSDSI	TSDSI STD T1.3GPP 36.300-16.2.0 V1.0.0		16.2.0	Published	06.10.2020	<a href="https://members.tdsi.in/index.php/s/Tw4KsKibEP23JEn">https://members.tdsi.in/index.php/s/Tw4KsKibEP23JEn</a>
TTA	TTAT.3G-36.300V16.2.0		16.2.0	Published	11.09.2020	<a href="http://www.tta.or.kr/data/ttasDown.jsp?where=14688&amp;pk_num=TTAT.3G-36.300V16.2.0">http://www.tta.or.kr/data/ttasDown.jsp?where=14688&amp;pk_num=TTAT.3G-36.300V16.2.0</a>

**1.2.1.3.2 TS 36.302****Evolved Universal Terrestrial Radio Access (E-UTRA); Services provided by the physical layer**

This document is a technical specification of the services provided by the physical layer of E-UTRA to upper layers.

SDO	Document No.	Version	Status	Issued date	Location
<b>Release 15</b>					
ARIB	ARIB STD-T120-36.302		15.3.0	Published 28.09.2020	<a href="http://www.arib.or.jp/english/html/overview/doc/T120_T23_v2_00/2_T120/ARIB-STD-T120/Rel15/36/A36302-f30.pdf">http://www.arib.or.jp/english/html/overview/doc/T120_T23_v2_00/2_T120/ARIB-STD-T120/Rel15/36/A36302-f30.pdf</a>
ATIS	ATIS.3GPP.36.302V1530		15.3.0	Published 08.09.2020	<a href="http://www.atis.org/3gpp-documents/Rel15">http://www.atis.org/3gpp-documents/Rel15</a>
CCSA	CCSA.36.302V1530		15.3.0	Published 24.07.2020	<a href="http://www.ccsa.org.cn:9001/portalsFile/downloadOldFile?type=17&amp;oldFileUrl=Rel15/TS%2036.302%20V15.3.0.docx">http://www.ccsa.org.cn:9001/portalsFile/downloadOldFile?type=17&amp;oldFileUrl=Rel15/TS%2036.302%20V15.3.0.docx</a>
ETSI	ETSI TS 136 302		15.3.0	Published 31.07.2020	<a href="http://www.etsi.org/deliver/etsi_ts/136300_136399/136302/15.03.00_60/ts_136302v150300p.pdf">http://www.etsi.org/deliver/etsi_ts/136300_136399/136302/15.03.00_60/ts_136302v150300p.pdf</a>
TSDSI	TSDSI STD T1.3GPP 36.302-15.3.0 V1.0.0		15.3.0	Published 06.10.2020	<a href="https://members.tdsi.in/index.php/s/cwDCA7K772aMqcB">https://members.tdsi.in/index.php/s/cwDCA7K772aMqcB</a>
TTA	TTAT.3G-36.302V15.3.0		15.3.0	Published 11.09.2020	<a href="http://www.tta.or.kr/data/ttasDown.jsp?where=14688&amp;pk_num=TTAT.3G-36.302V15.3.0">http://www.tta.or.kr/data/ttasDown.jsp?where=14688&amp;pk_num=TTAT.3G-36.302V15.3.0</a>
<b>Release 16</b>					
ARIB	ARIB STD-T120-36.302		16.1.0	Published 28.09.2020	<a href="http://www.arib.or.jp/english/html/overview/doc/T120_T23_v2_00/2_T120/ARIB-STD-T120/Rel16/36/A36302-g10.pdf">http://www.arib.or.jp/english/html/overview/doc/T120_T23_v2_00/2_T120/ARIB-STD-T120/Rel16/36/A36302-g10.pdf</a>
ATIS	ATIS.3GPP.36.302V1610		16.1.0	Published 08.09.2020	<a href="http://www.atis.org/3gpp-documents/Rel16">http://www.atis.org/3gpp-documents/Rel16</a>
CCSA	CCSA.36.302V1610		16.1.0	Published 24.07.2020	<a href="http://www.ccsa.org.cn:9001/portalsFile/downloadOldFile?type=17&amp;oldFileUrl=Rel16/TS%2036.302%20V16.1.0.docx">http://www.ccsa.org.cn:9001/portalsFile/downloadOldFile?type=17&amp;oldFileUrl=Rel16/TS%2036.302%20V16.1.0.docx</a>
ETSI	ETSI TS 136 302		16.1.0	Published 30.07.2020	<a href="http://www.etsi.org/deliver/etsi_ts/136300_136399/136302/16.01.00_60/ts_136302v160100p.pdf">http://www.etsi.org/deliver/etsi_ts/136300_136399/136302/16.01.00_60/ts_136302v160100p.pdf</a>
TSDSI	TSDSI STD T1.3GPP 36.302-16.1.0 V1.0.0		16.1.0	Published 06.10.2020	<a href="https://members.tdsi.in/index.php/s/CzsjbiJL6YjCQoR">https://members.tdsi.in/index.php/s/CzsjbiJL6YjCQoR</a>
TTA	TTAT.3G-36.302V16.1.0		16.1.0	Published 11.09.2020	<a href="http://www.tta.or.kr/data/ttasDown.jsp?where=14688&amp;pk_num=TTAT.3G-36.302V16.1.0">http://www.tta.or.kr/data/ttasDown.jsp?where=14688&amp;pk_num=TTAT.3G-36.302V16.1.0</a>

**1.2.1.3.3 TS 36.304****Evolved Universal Terrestrial Radio Access (E-UTRA); User Equipment (UE) procedures in idle mode**

This document specifies the Access Stratum (AS) part of the Idle Mode procedures applicable to a UE. This document specifies the model for the functional division between the NAS and AS in a UE. This document applies to all UEs that support at least E-UTRA, including multi-RAT UEs as described in 3GPP specifications, in the following cases: (i) When the UE is camped on an E-UTRA cell; (ii) When the UE is searching for a cell to camp on.

SDO	Document No.	Version	Status	Issued date	Location
<b>Release 15</b>					
ARIB	ARIB STD-T120-36.304		15.6.0	Published 28.09.2020	<a href="http://www.arib.or.jp/english/html/overview/doc/T120_T23_v2_00/2_T120/ARIB-STD-T120/Rel15/36/A36304-f60.pdf">http://www.arib.or.jp/english/html/overview/doc/T120_T23_v2_00/2_T120/ARIB-STD-T120/Rel15/36/A36304-f60.pdf</a>
ATIS	ATIS.3GPP.36.304V1560		15.6.0	Published 08.09.2020	<a href="http://www.atis.org/3gpp-documents/Rel15">http://www.atis.org/3gpp-documents/Rel15</a>
CCSA	CCSA.36.304V1560		15.6.0	Published 24.07.2020	<a href="http://www.ccsa.org.cn:9001/portalsFile/downloadOldFile?type=17&amp;oldFileUrl=Rel15/TS%2036.304%20V15.6.0.docx">http://www.ccsa.org.cn:9001/portalsFile/downloadOldFile?type=17&amp;oldFileUrl=Rel15/TS%2036.304%20V15.6.0.docx</a>
ETSI	ETSI TS 136 304		15.6.0	Published 31.07.2020	<a href="http://www.etsi.org/deliver/etsi_ts/136300_136399/136304/15.06.00_60/ts_136304v150600p.pdf">http://www.etsi.org/deliver/etsi_ts/136300_136399/136304/15.06.00_60/ts_136304v150600p.pdf</a>
TSDSI	TSDSI STD T1.3GPP 36.304-15.6.0 V1.0.0		15.6.0	Published 06.10.2020	<a href="https://members.tdsi.in/index.php/s/QmedDoPc2QiSewc">https://members.tdsi.in/index.php/s/QmedDoPc2QiSewc</a>
TTA	TTAT.3G-36.304V15.6.0		15.6.0	Published 11.09.2020	<a href="http://www.tta.or.kr/data/ttasDown.jsp?where=14688&amp;pk_num=TTAT.3G-36.304V15.6.0">http://www.tta.or.kr/data/ttasDown.jsp?where=14688&amp;pk_num=TTAT.3G-36.304V15.6.0</a>
<b>Release 16</b>					
ARIB	ARIB STD-T120-36.304		16.1.0	Published 28.09.2020	<a href="http://www.arib.or.jp/english/html/overview/doc/T120_T23_v2_00/2_T120/ARIB-STD-T120/Rel16/36/A36304-g10.pdf">http://www.arib.or.jp/english/html/overview/doc/T120_T23_v2_00/2_T120/ARIB-STD-T120/Rel16/36/A36304-g10.pdf</a>
ATIS	ATIS.3GPP.36.304V1610		16.1.0	Published 08.09.2020	<a href="http://www.atis.org/3gpp-documents/Rel16">http://www.atis.org/3gpp-documents/Rel16</a>
CCSA	CCSA.36.304V1610		16.1.0	Published 24.07.2020	<a href="http://www.ccsa.org.cn:9001/portalsFile/downloadOldFile?type=17&amp;oldFileUrl=Rel16/TS%2036.304%20V16.1.0.docx">http://www.ccsa.org.cn:9001/portalsFile/downloadOldFile?type=17&amp;oldFileUrl=Rel16/TS%2036.304%20V16.1.0.docx</a>
ETSI	ETSI TS 136 304		16.1.0	Published 31.07.2020	<a href="http://www.etsi.org/deliver/etsi_ts/136300_136399/136304/16.01.00_60/ts_136304v160100p.pdf">http://www.etsi.org/deliver/etsi_ts/136300_136399/136304/16.01.00_60/ts_136304v160100p.pdf</a>
TSDSI	TSDSI STD T1.3GPP 36.304-16.1.0 V1.0.0		16.1.0	Published 06.10.2020	<a href="https://members.tdsi.in/index.php/s/kMZ4RpR5Btiq4jE">https://members.tdsi.in/index.php/s/kMZ4RpR5Btiq4jE</a>
TTA	TTAT.3G-36.304V16.1.0		16.1.0	Published 11.09.2020	<a href="http://www.tta.or.kr/data/ttasDown.jsp?where=14688&amp;pk_num=TTAT.3G-36.304V16.1.0">http://www.tta.or.kr/data/ttasDown.jsp?where=14688&amp;pk_num=TTAT.3G-36.304V16.1.0</a>

### 1.2.1.3.4 TS 36.305

#### Evolved Universal Terrestrial Radio Access Network (E-UTRAN); Stage 2 functional specification of User Equipment (UE) positioning in E-UTRAN

This document specifies the stage 2 of the UE positioning function of E-UTRAN, which provides the mechanisms to support or assist the calculation of the geographical position of a UE. The purpose of this stage 2 specification is to define the E-UTRAN UE Positioning architecture, functional entities and operations to support positioning methods. This description is confined to the E-UTRAN Access Stratum. This stage 2 specification covers the E-UTRAN positioning methods, state descriptions, and message flows to support UE positioning.

SDO	Document No.	Version	Status	Issued date	Location	
<b>Release 15</b>						
ARIB	ARIB STD-T120-36.305		15.5.0	Published	28.09.2020	<a href="http://www.arib.or.jp/english/html/overview/doc/T120_T23_v2_00/2_T120/ARIB-STD-T120/Rel15/36/A36305-f50.pdf">http://www.arib.or.jp/english/html/overview/doc/T120_T23_v2_00/2_T120/ARIB-STD-T120/Rel15/36/A36305-f50.pdf</a>
ATIS	ATIS.3GPP.36.305V1550		15.5.0	Published	08.09.2020	<a href="http://www.atis.org/3gpp-documents/Rel15">http://www.atis.org/3gpp-documents/Rel15</a>
CCSA	CCSA.36.305V1550		15.5.0	Published	24.07.2020	<a href="http://www.ccsa.org.cn:9001/portalsFile/downloadOldFile?type=17&amp;oldFileUrl=Rel15/TS%2036.305%20V15.5.0.docx">http://www.ccsa.org.cn:9001/portalsFile/downloadOldFile?type=17&amp;oldFileUrl=Rel15/TS%2036.305%20V15.5.0.docx</a>
ETSI	ETSI TS 136 305		15.5.0	Published	31.07.2020	<a href="http://www.etsi.org/deliver/etsi_ts/136300_136399/136305/15.05.00_60/ts_136305v150500p.pdf">http://www.etsi.org/deliver/etsi_ts/136300_136399/136305/15.05.00_60/ts_136305v150500p.pdf</a>
TSDSI	TSDSI STD T1.3GPP 36.305-15.5.0 V1.0.0		15.5.0	Published	06.10.2020	<a href="https://members.tdsi.in/index.php/s/HXRJ3fxtcr2RK8b">https://members.tdsi.in/index.php/s/HXRJ3fxtcr2RK8b</a>
TTA	TTAT.3G-36.305V15.5.0		15.5.0	Published	11.09.2020	<a href="http://www.tta.or.kr/data/ttasDown.jsp?where=14688&amp;pk_num=TTAT.3G-36.305V15.5.0">http://www.tta.or.kr/data/ttasDown.jsp?where=14688&amp;pk_num=TTAT.3G-36.305V15.5.0</a>
<b>Release 16</b>						
ARIB	ARIB STD-T120-36.305		16.1.0	Published	28.09.2020	<a href="http://www.arib.or.jp/english/html/overview/doc/T120_T23_v2_00/2_T120/ARIB-STD-T120/Rel16/36/A36305-g10.pdf">http://www.arib.or.jp/english/html/overview/doc/T120_T23_v2_00/2_T120/ARIB-STD-T120/Rel16/36/A36305-g10.pdf</a>
ATIS	ATIS.3GPP.36.305V1610		16.1.0	Published	08.09.2020	<a href="http://www.atis.org/3gpp-documents/Rel16">http://www.atis.org/3gpp-documents/Rel16</a>
CCSA	CCSA.36.305V1610		16.1.0	Published	24.07.2020	<a href="http://www.ccsa.org.cn:9001/portalsFile/downloadOldFile?type=17&amp;oldFileUrl=Rel16/TS%2036.305%20V16.1.0.docx">http://www.ccsa.org.cn:9001/portalsFile/downloadOldFile?type=17&amp;oldFileUrl=Rel16/TS%2036.305%20V16.1.0.docx</a>
ETSI	ETSI TS 136 305		16.1.0	Published	30.07.2020	<a href="http://www.etsi.org/deliver/etsi_ts/136300_136399/136305/16.01.00_60/ts_136305v160100p.pdf">http://www.etsi.org/deliver/etsi_ts/136300_136399/136305/16.01.00_60/ts_136305v160100p.pdf</a>
TSDSI	TSDSI STD T1.3GPP 36.305-16.1.0 V1.0.0		16.1.0	Published	06.10.2020	<a href="https://members.tdsi.in/index.php/s/KBd4JDDZSLNSGDs">https://members.tdsi.in/index.php/s/KBd4JDDZSLNSGDs</a>
TTA	TTAT.3G-36.305V16.1.0		16.1.0	Published	11.09.2020	<a href="http://www.tta.or.kr/data/ttasDown.jsp?where=14688&amp;pk_num=TTAT.3G-36.305V16.1.0">http://www.tta.or.kr/data/ttasDown.jsp?where=14688&amp;pk_num=TTAT.3G-36.305V16.1.0</a>

### 1.2.1.3.5 TS 36.306

#### Evolved Universal Terrestrial Radio Access (E-UTRA); User Equipment (UE) radio access capabilities

This document defines the E-UTRA UE Radio Access Capability Parameters.

SDO	Document No.	Version	Status	Issued date	Location	
<b>Release 15</b>						
ARIB	ARIB STD-T120-36.306		15.9.0	Published	28.09.2020	<a href="http://www.arib.or.jp/english/html/overview/doc/T120_T23_v2_00/2_T120/ARIB-STD-T120/Rel15/36/A36306-f90.pdf">http://www.arib.or.jp/english/html/overview/doc/T120_T23_v2_00/2_T120/ARIB-STD-T120/Rel15/36/A36306-f90.pdf</a>
ATIS	ATIS.3GPP.36.306V1590		15.9.0	Published	08.09.2020	<a href="http://www.atis.org/3gpp-documents/Rel15">http://www.atis.org/3gpp-documents/Rel15</a>
CCSA	CCSA.36.306V1590		15.9.0	Published	24.07.2020	<a href="http://www.ccsa.org.cn:9001/portalsFile/downloadOldFile?type=17&amp;oldFileUrl=Rel15/TS%2036.306%20V15.9.0.docx">http://www.ccsa.org.cn:9001/portalsFile/downloadOldFile?type=17&amp;oldFileUrl=Rel15/TS%2036.306%20V15.9.0.docx</a>
ETSI	ETSI TS 136 306		15.9.0	Published	31.07.2020	<a href="http://www.etsi.org/deliver/etsi_ts/136300_136399/136306/15.09.00_60/ts_136306v150900p.pdf">http://www.etsi.org/deliver/etsi_ts/136300_136399/136306/15.09.00_60/ts_136306v150900p.pdf</a>
TSDSI	TSDSI STD T1.3GPP 36.306-15.9.0 V1.0.0		15.9.0	Published	06.10.2020	<a href="https://members.tdsi.in/index.php/s/oNDz9c6tNWFkBoX">https://members.tdsi.in/index.php/s/oNDz9c6tNWFkBoX</a>
TTA	TTAT.3G-36.306V15.9.0		15.9.0	Published	11.09.2020	<a href="http://www.tta.or.kr/data/ttasDown.jsp?where=14688&amp;pk_num=TTAT.3G-36.306V15.9.0">http://www.tta.or.kr/data/ttasDown.jsp?where=14688&amp;pk_num=TTAT.3G-36.306V15.9.0</a>
<b>Release 16</b>						
ARIB	ARIB STD-T120-36.306		16.1.0	Published	28.09.2020	<a href="http://www.arib.or.jp/english/html/overview/doc/T120_T23_v2_00/2_T120/ARIB-STD-T120/Rel16/36/A36306-g10.pdf">http://www.arib.or.jp/english/html/overview/doc/T120_T23_v2_00/2_T120/ARIB-STD-T120/Rel16/36/A36306-g10.pdf</a>
ATIS	ATIS.3GPP.36.306V1610		16.1.0	Published	08.09.2020	<a href="http://www.atis.org/3gpp-documents/Rel16">http://www.atis.org/3gpp-documents/Rel16</a>
CCSA	CCSA.36.306V1610		16.1.0	Published	24.07.2020	<a href="http://www.ccsa.org.cn:9001/portalsFile/downloadOldFile?type=17&amp;oldFileUrl=Rel16/TS%2036.306%20V16.1.0.docx">http://www.ccsa.org.cn:9001/portalsFile/downloadOldFile?type=17&amp;oldFileUrl=Rel16/TS%2036.306%20V16.1.0.docx</a>
ETSI	ETSI TS 136 306		16.1.0	Published	30.07.2020	<a href="http://www.etsi.org/deliver/etsi_ts/136300_136399/136306/16.01.00_60/ts_136306v160100p.pdf">http://www.etsi.org/deliver/etsi_ts/136300_136399/136306/16.01.00_60/ts_136306v160100p.pdf</a>
TSDSI	TSDSI STD T1.3GPP 36.306-16.1.0 V1.0.0		16.1.0	Published	06.10.2020	<a href="https://members.tdsi.in/index.php/s/9B7PK48mjN6xb5D">https://members.tdsi.in/index.php/s/9B7PK48mjN6xb5D</a>
TTA	TTAT.3G-36.306V16.1.0		16.1.0	Published	11.09.2020	<a href="http://www.tta.or.kr/data/ttasDown.jsp?where=14688&amp;pk_num=TTAT.3G-36.306V16.1.0">http://www.tta.or.kr/data/ttasDown.jsp?where=14688&amp;pk_num=TTAT.3G-36.306V16.1.0</a>

**1.2.1.3.6 TS 36.307****Evolved Universal Terrestrial Radio Access (E-UTRA); Requirements on User Equipments (UEs) supporting a release-independent frequency band**

This document specifies requirements on UEs supporting a frequency band that is independent of release. TSG-RAN has agreed that the standardization of new frequency bands may be independent of a release. However, in order to implement a UE that conforms to a particular release but supports a band of operation that is specified in a later release, it is necessary to specify some extra requirements. All frequency bands are fully specified in this release of the specifications. This document does not contain any requirements for UEs supporting frequency bands independent of release.

SDO	Document No.	Version	Status	Issued date	Location
<b>Release 15</b>					
ARIB	ARIB STD-T120-36.307		15.6.0	Published 28.09.2020	<a href="http://www.arib.or.jp/english/html/overview/doc/T120_T23_v2_00/2_T120/ARIB-STD-T120/Rel15/36/A36307-f60.pdf">http://www.arib.or.jp/english/html/overview/doc/T120_T23_v2_00/2_T120/ARIB-STD-T120/Rel15/36/A36307-f60.pdf</a>
ATIS	ATIS.3GPP.36.307V1560		15.6.0	Published 08.09.2020	<a href="http://www.atis.org/3gpp-documents/Rel15">http://www.atis.org/3gpp-documents/Rel15</a>
CCSA	CCSA.36.307V1560		15.6.0	Published 04.10.2019	<a href="http://www.ccsa.org.cn:9001/portalsFile/downloadOldFile?type=17&amp;oldFileUrl=Rel15/TS%2036.307%20V15.6.0.docx">http://www.ccsa.org.cn:9001/portalsFile/downloadOldFile?type=17&amp;oldFileUrl=Rel15/TS%2036.307%20V15.6.0.docx</a>
ETSI	ETSI TS 136 307		15.6.0	Published 17.10.2019	<a href="http://www.etsi.org/deliver/etsi_ts/136300_136399/136307/15.06.00_60/ts_136307v150600p.pdf">http://www.etsi.org/deliver/etsi_ts/136300_136399/136307/15.06.00_60/ts_136307v150600p.pdf</a>
TSDSI	TSDSI STD T1.3GPP 36.307-15.6.0 V1.0.0		15.6.0	Published 06.10.2020	<a href="https://members.tdsi.in/index.php/s/eQ82dHHytdPKskQ">https://members.tdsi.in/index.php/s/eQ82dHHytdPKskQ</a>
TTA	TTAT.3G-36.307V15.6.0		15.6.0	Published 11.09.2020	<a href="http://www.tta.or.kr/data/ttasDown.jsp?where=14688&amp;pk_num=TTAT.3G-36.307V15.6.0">http://www.tta.or.kr/data/ttasDown.jsp?where=14688&amp;pk_num=TTAT.3G-36.307V15.6.0</a>
<b>Release 16</b>					
ARIB	ARIB STD-T120-36.307		16.2.0	Published 28.09.2020	<a href="http://www.arib.or.jp/english/html/overview/doc/T120_T23_v2_00/2_T120/ARIB-STD-T120/Rel16/36/A36307-g20.pdf">http://www.arib.or.jp/english/html/overview/doc/T120_T23_v2_00/2_T120/ARIB-STD-T120/Rel16/36/A36307-g20.pdf</a>
ATIS	ATIS.3GPP.36.307V1620		16.2.0	Published 08.09.2020	<a href="http://www.atis.org/3gpp-documents/Rel16">http://www.atis.org/3gpp-documents/Rel16</a>
CCSA	CCSA.36.307V1620		16.2.0	Published 17.07.2020	<a href="http://www.ccsa.org.cn:9001/portalsFile/downloadOldFile?type=17&amp;oldFileUrl=Rel16/TS%2036.307%20V16.2.0.docx">http://www.ccsa.org.cn:9001/portalsFile/downloadOldFile?type=17&amp;oldFileUrl=Rel16/TS%2036.307%20V16.2.0.docx</a>
ETSI	ETSI TS 136 307		16.2.0	Published 23.07.2020	<a href="http://www.etsi.org/deliver/etsi_ts/136300_136399/136307/16.02.00_60/ts_136307v160200p.pdf">http://www.etsi.org/deliver/etsi_ts/136300_136399/136307/16.02.00_60/ts_136307v160200p.pdf</a>
TSDSI	TSDSI STD T1.3GPP 36.307-16.2.0 V1.0.0		16.2.0	Published 06.10.2020	<a href="https://members.tdsi.in/index.php/s/Hg5STtSpLXCarvi">https://members.tdsi.in/index.php/s/Hg5STtSpLXCarvi</a>
TTA	TTAT.3G-36.307V16.2.0		16.2.0	Published 11.09.2020	<a href="http://www.tta.or.kr/data/ttasDown.jsp?where=14688&amp;pk_num=TTAT.3G-36.307V16.2.0">http://www.tta.or.kr/data/ttasDown.jsp?where=14688&amp;pk_num=TTAT.3G-36.307V16.2.0</a>

**1.2.1.3.7 TS 36.314****Evolved Universal Terrestrial Radio Access (E-UTRA); Layer 2 – Measurements**

This document contains the description and definition of the measurements performed by E-UTRAN that are transferred over the standardized interfaces in order to support E-UTRA radio link operations, radio resource management (RRM), network operations and maintenance (OAM), and self-organizing networks (SON).

SDO	Document No.	Version	Status	Issued date	Location
<b>Release 15</b>					
ARIB	ARIB STD-T120-36.314		15.2.0	Published 28.09.2020	<a href="http://www.arib.or.jp/english/html/overview/doc/T120_T23_v2_00/2_T120/ARIB-STD-T120/Rel15/36/A36314-f20.pdf">http://www.arib.or.jp/english/html/overview/doc/T120_T23_v2_00/2_T120/ARIB-STD-T120/Rel15/36/A36314-f20.pdf</a>
ATIS	ATIS.3GPP.36.314V1520		15.2.0	Published 08.09.2020	<a href="http://www.atis.org/3gpp-documents/Rel15">http://www.atis.org/3gpp-documents/Rel15</a>
CCSA	CCSA.36.314V1520		15.2.0	Published 11.01.2019	<a href="http://www.ccsa.org.cn:9001/portalsFile/downloadOldFile?type=17&amp;oldFileUrl=Rel15/TS%2036.314%20V15.2.0.doc">http://www.ccsa.org.cn:9001/portalsFile/downloadOldFile?type=17&amp;oldFileUrl=Rel15/TS%2036.314%20V15.2.0.doc</a>
ETSI	ETSI TS 136 314		15.2.0	Published 17.04.2019	<a href="http://www.etsi.org/deliver/etsi_ts/136300_136399/136314/15.02.00_60/ts_136314v150200p.pdf">http://www.etsi.org/deliver/etsi_ts/136300_136399/136314/15.02.00_60/ts_136314v150200p.pdf</a>
TSDSI	TSDSI STD T1.3GPP 36.314-15.2.0 V1.0.0		15.2.0	Published 06.10.2020	<a href="https://members.tdsi.in/index.php/s/5QmYq3a9BaHpdH9">https://members.tdsi.in/index.php/s/5QmYq3a9BaHpdH9</a>
TTA	TTAT.3G-36.314V15.2.0		15.2.0	Published 11.09.2020	<a href="http://www.tta.or.kr/data/ttasDown.jsp?where=14688&amp;pk_num=TTAT.3G-36.314V15.2.0">http://www.tta.or.kr/data/ttasDown.jsp?where=14688&amp;pk_num=TTAT.3G-36.314V15.2.0</a>
<b>Release 16</b>					
ARIB	ARIB STD-T120-36.314		16.0.0	Published 28.09.2020	<a href="http://www.arib.or.jp/english/html/overview/doc/T120_T23_v2_00/2_T120/ARIB-STD-T120/Rel16/36/A36314-g00.pdf">http://www.arib.or.jp/english/html/overview/doc/T120_T23_v2_00/2_T120/ARIB-STD-T120/Rel16/36/A36314-g00.pdf</a>
ATIS	ATIS.3GPP.36.314V1600		16.0.0	Published 08.09.2020	<a href="http://www.atis.org/3gpp-documents/Rel16">http://www.atis.org/3gpp-documents/Rel16</a>
CCSA	CCSA.36.314V1600		16.0.0	Published 24.07.2020	<a href="http://www.ccsa.org.cn:9001/portalsFile/downloadOldFile?type=17&amp;oldFileUrl=Rel16/TS%2036.314%20V16.0.0.doc">http://www.ccsa.org.cn:9001/portalsFile/downloadOldFile?type=17&amp;oldFileUrl=Rel16/TS%2036.314%20V16.0.0.doc</a>
ETSI	ETSI TS 136 314		16.0.0	Published 31.07.2020	<a href="http://www.etsi.org/deliver/etsi_ts/136300_136399/136314/16.00.00_60/ts_136314v160000p.pdf">http://www.etsi.org/deliver/etsi_ts/136300_136399/136314/16.00.00_60/ts_136314v160000p.pdf</a>
TSDSI	TSDSI STD T1.3GPP 36.314-16.0.0 V1.0.0		16.0.0	Published 06.10.2020	<a href="https://members.tdsi.in/index.php/s/5BcnS8fdPrk3kpn">https://members.tdsi.in/index.php/s/5BcnS8fdPrk3kpn</a>

TTA TTAT.3G-36.314V16.0.0 16.0.0 Published 11.09.2020 [http://www.tta.or.kr/data/ttasDown.jsp?where=14688&pk\\_num=TTAT.3G-36.314V16.0.0](http://www.tta.or.kr/data/ttasDown.jsp?where=14688&pk_num=TTAT.3G-36.314V16.0.0)

### 1.2.1.3.8 TS 36.321

#### Evolved Universal Terrestrial Radio Access (E-UTRA); Medium Access Control (MAC) protocol specification

This document specifies the E-UTRA Medium Access Control (MAC) protocol.

SDO	Document No.	Version	Status	Issued date	Location
<b>Release 15</b>					
ARIB	ARIB STD-T120-36.321		15.9.0	Published 28.09.2020	<a href="http://www.arib.or.jp/english/html/overview/doc/T120_T23_v2_00/2_T120/ARIB-STD-T120/Rel15/36/A36321-f90.pdf">http://www.arib.or.jp/english/html/overview/doc/T120_T23_v2_00/2_T120/ARIB-STD-T120/Rel15/36/A36321-f90.pdf</a>
ATIS	ATIS.3GPP.36.321V1590		15.9.0	Published 08.09.2020	<a href="http://www.atis.org/3gpp-documents/Rel15">http://www.atis.org/3gpp-documents/Rel15</a>
CCSA	CCSA.36.321V1590		15.9.0	Published 24.07.2020	<a href="http://www.ccsa.org.cn:9001/portalsFile/downloadOldFile?type=17&amp;oldFileUrl=Rel15/TS%2036.321%20V15.9.0.docx">http://www.ccsa.org.cn:9001/portalsFile/downloadOldFile?type=17&amp;oldFileUrl=Rel15/TS%2036.321%20V15.9.0.docx</a>
ETSI	ETSI TS 136 321		15.9.0	Published 31.07.2020	<a href="http://www.etsi.org/deliver/etsi_ts/136300_136399/136321/15.09.00_60/ts_136321v150900p.pdf">http://www.etsi.org/deliver/etsi_ts/136300_136399/136321/15.09.00_60/ts_136321v150900p.pdf</a>
TSDSI	TSDSI STD T1.3GPP 36.321-15.9.0 V1.0.0		15.9.0	Published 06.10.2020	<a href="https://members.tdsi.in/index.php/s/ezX8m4naxmEj24N">https://members.tdsi.in/index.php/s/ezX8m4naxmEj24N</a>
TTA	TTAT.3G-36.321V15.9.0		15.9.0	Published 11.09.2020	<a href="http://www.tta.or.kr/data/ttasDown.jsp?where=14688&amp;pk_num=TTAT.3G-36.321V15.9.0">http://www.tta.or.kr/data/ttasDown.jsp?where=14688&amp;pk_num=TTAT.3G-36.321V15.9.0</a>
<b>Release 16</b>					
ARIB	ARIB STD-T120-36.321		16.1.0	Published 28.09.2020	<a href="http://www.arib.or.jp/english/html/overview/doc/T120_T23_v2_00/2_T120/ARIB-STD-T120/Rel16/36/A36321-g10.pdf">http://www.arib.or.jp/english/html/overview/doc/T120_T23_v2_00/2_T120/ARIB-STD-T120/Rel16/36/A36321-g10.pdf</a>
ATIS	ATIS.3GPP.36.321V1610		16.1.0	Published 08.09.2020	<a href="http://www.atis.org/3gpp-documents/Rel16">http://www.atis.org/3gpp-documents/Rel16</a>
CCSA	CCSA.36.321V1610		16.1.0	Published 24.07.2020	<a href="http://www.ccsa.org.cn:9001/portalsFile/downloadOldFile?type=17&amp;oldFileUrl=Rel16/TS%2036.321%20V16.1.0.docx">http://www.ccsa.org.cn:9001/portalsFile/downloadOldFile?type=17&amp;oldFileUrl=Rel16/TS%2036.321%20V16.1.0.docx</a>
ETSI	ETSI TS 136 321		16.1.0	Published 31.07.2020	<a href="http://www.etsi.org/deliver/etsi_ts/136300_136399/136321/16.01.00_60/ts_136321v160100p.pdf">http://www.etsi.org/deliver/etsi_ts/136300_136399/136321/16.01.00_60/ts_136321v160100p.pdf</a>
TSDSI	TSDSI STD T1.3GPP 36.321-16.1.0 V1.0.0		16.1.0	Published 06.10.2020	<a href="https://members.tdsi.in/index.php/s/n6DMeNHHgmJw8YT">https://members.tdsi.in/index.php/s/n6DMeNHHgmJw8YT</a>
TTA	TTAT.3G-36.321V16.1.0		16.1.0	Published 11.09.2020	<a href="http://www.tta.or.kr/data/ttasDown.jsp?where=14688&amp;pk_num=TTAT.3G-36.321V16.1.0">http://www.tta.or.kr/data/ttasDown.jsp?where=14688&amp;pk_num=TTAT.3G-36.321V16.1.0</a>

### 1.2.1.3.9 TS 36.322

#### Evolved Universal Terrestrial Radio Access (E-UTRA); Radio Link Control (RLC) protocol specification

This document specifies the E-UTRA Radio Link Control (RLC) protocol.

SDO	Document No.	Version	Status	Issued date	Location
<b>Release 15</b>					
ARIB	ARIB STD-T120-36.322		15.4.0	Published 28.09.2020	<a href="http://www.arib.or.jp/english/html/overview/doc/T120_T23_v2_00/2_T120/ARIB-STD-T120/Rel15/36/A36322-f40.pdf">http://www.arib.or.jp/english/html/overview/doc/T120_T23_v2_00/2_T120/ARIB-STD-T120/Rel15/36/A36322-f40.pdf</a>
ATIS	ATIS.3GPP.36.322V1540		15.4.0	Published 08.09.2020	<a href="http://www.atis.org/3gpp-documents/Rel15">http://www.atis.org/3gpp-documents/Rel15</a>
CCSA	CCSA.36.322V1540		15.4.0	Published 24.07.2020	<a href="http://www.ccsa.org.cn:9001/portalsFile/downloadOldFile?type=17&amp;oldFileUrl=Rel15/TS%2036.322%20V15.4.0.docx">http://www.ccsa.org.cn:9001/portalsFile/downloadOldFile?type=17&amp;oldFileUrl=Rel15/TS%2036.322%20V15.4.0.docx</a>
ETSI	ETSI TS 136 322		15.4.0	Published 31.07.2020	<a href="http://www.etsi.org/deliver/etsi_ts/136300_136399/136322/15.04.00_60/ts_136322v150400p.pdf">http://www.etsi.org/deliver/etsi_ts/136300_136399/136322/15.04.00_60/ts_136322v150400p.pdf</a>
TSDSI	TSDSI STD T1.3GPP 36.322-15.4.0 V1.0.0		15.4.0	Published 06.10.2020	<a href="https://members.tdsi.in/index.php/s/aX4PCAK4LzzaByX">https://members.tdsi.in/index.php/s/aX4PCAK4LzzaByX</a>
TTA	TTAT.3G-36.322V15.4.0		15.4.0	Published 11.09.2020	<a href="http://www.tta.or.kr/data/ttasDown.jsp?where=14688&amp;pk_num=TTAT.3G-36.322V15.4.0">http://www.tta.or.kr/data/ttasDown.jsp?where=14688&amp;pk_num=TTAT.3G-36.322V15.4.0</a>
<b>Release 16</b>					
ARIB	ARIB STD-T120-36.322		16.0.0	Published 28.09.2020	<a href="http://www.arib.or.jp/english/html/overview/doc/T120_T23_v2_00/2_T120/ARIB-STD-T120/Rel16/36/A36322-g00.pdf">http://www.arib.or.jp/english/html/overview/doc/T120_T23_v2_00/2_T120/ARIB-STD-T120/Rel16/36/A36322-g00.pdf</a>
ATIS	ATIS.3GPP.36.322V1600		16.0.0	Published 08.09.2020	<a href="http://www.atis.org/3gpp-documents/Rel16">http://www.atis.org/3gpp-documents/Rel16</a>
CCSA	CCSA.36.322V1600		16.0.0	Published 24.07.2020	<a href="http://www.ccsa.org.cn:9001/portalsFile/downloadOldFile?type=17&amp;oldFileUrl=Rel16/TS%2036.322%20V16.0.0.docx">http://www.ccsa.org.cn:9001/portalsFile/downloadOldFile?type=17&amp;oldFileUrl=Rel16/TS%2036.322%20V16.0.0.docx</a>
ETSI	ETSI TS 136 322		16.0.0	Published 31.07.2020	<a href="http://www.etsi.org/deliver/etsi_ts/136300_136399/136322/16.00.00_60/ts_136322v160000p.pdf">http://www.etsi.org/deliver/etsi_ts/136300_136399/136322/16.00.00_60/ts_136322v160000p.pdf</a>
TSDSI	TSDSI STD T1.3GPP 36.322-16.0.0 V1.0.0		16.0.0	Published 06.10.2020	<a href="https://members.tdsi.in/index.php/s/RjPMqccxkMFt2gL">https://members.tdsi.in/index.php/s/RjPMqccxkMFt2gL</a>
TTA	TTAT.3G-36.322V16.0.0		16.0.0	Published 11.09.2020	<a href="http://www.tta.or.kr/data/ttasDown.jsp?where=14688&amp;pk_num=TTAT.3G-36.322V16.0.0">http://www.tta.or.kr/data/ttasDown.jsp?where=14688&amp;pk_num=TTAT.3G-36.322V16.0.0</a>

**1.2.1.3.10 TS 36.323****Evolved Universal Terrestrial Radio Access (E-UTRA); Packet Data Convergence Protocol (PDCP) specification**

This document specifies the E-UTRA Packet Data Convergence Protocol (PDCP).

SDO	Document No.	Version	Status	Issued date	Location	
<b>Release 15</b>						
ARIB	ARIB STD-T120-36.323		15.6.0	Published	28.09.2020	<a href="http://www.arib.or.jp/english/html/overview/doc/T120_T23_v2_00/2_T120/ARIB-STD-T120/Rel15/36/A36323-f60.pdf">http://www.arib.or.jp/english/html/overview/doc/T120_T23_v2_00/2_T120/ARIB-STD-T120/Rel15/36/A36323-f60.pdf</a>
ATIS	ATIS.3GPP.36.323V1560		15.6.0	Published	08.09.2020	<a href="http://www.atis.org/3gpp-documents/Rel15">http://www.atis.org/3gpp-documents/Rel15</a>
CCSA	CCSA.36.323V1560		15.6.0	Published	24.07.2020	<a href="http://www.ccsa.org.cn:9001/portalsFile/downloadOldFile?type=17&amp;oldFileUrl=Rel15/TS%2036.323%20V15.6.0.docx">http://www.ccsa.org.cn:9001/portalsFile/downloadOldFile?type=17&amp;oldFileUrl=Rel15/TS%2036.323%20V15.6.0.docx</a>
ETSI	ETSI TS 136 323		15.6.0	Published	31.07.2020	<a href="http://www.etsi.org/deliver/etsi_ts/136300_136399/136323/15.06.00_60/ts_136323v150600p.pdf">http://www.etsi.org/deliver/etsi_ts/136300_136399/136323/15.06.00_60/ts_136323v150600p.pdf</a>
TSDSI	TSDSI STD T1.3GPP 36.323-15.6.0 V1.0.0		15.6.0	Published	06.10.2020	<a href="https://members.tdsi.in/index.php/s/4dWRrYRBbNB4T2B">https://members.tdsi.in/index.php/s/4dWRrYRBbNB4T2B</a>
TTA	TTAT.3G-36.323V15.6.0		15.6.0	Published	11.09.2020	<a href="http://www.tta.or.kr/data/ttasDown.jsp?where=14688&amp;pk_num=TTAT.3G-36.323V15.6.0">http://www.tta.or.kr/data/ttasDown.jsp?where=14688&amp;pk_num=TTAT.3G-36.323V15.6.0</a>
<b>Release 16</b>						
ARIB	ARIB STD-T120-36.323		16.1.0	Published	28.09.2020	<a href="http://www.arib.or.jp/english/html/overview/doc/T120_T23_v2_00/2_T120/ARIB-STD-T120/Rel16/36/A36323-g10.pdf">http://www.arib.or.jp/english/html/overview/doc/T120_T23_v2_00/2_T120/ARIB-STD-T120/Rel16/36/A36323-g10.pdf</a>
ATIS	ATIS.3GPP.36.323V1610		16.1.0	Published	08.09.2020	<a href="http://www.atis.org/3gpp-documents/Rel16">http://www.atis.org/3gpp-documents/Rel16</a>
CCSA	CCSA.36.323V1610		16.1.0	Published	24.07.2020	<a href="http://www.ccsa.org.cn:9001/portalsFile/downloadOldFile?type=17&amp;oldFileUrl=Rel16/TS%2036.323%20V16.1.0.docx">http://www.ccsa.org.cn:9001/portalsFile/downloadOldFile?type=17&amp;oldFileUrl=Rel16/TS%2036.323%20V16.1.0.docx</a>
ETSI	ETSI TS 136 323		16.1.0	Published	30.07.2020	<a href="http://www.etsi.org/deliver/etsi_ts/136300_136399/136323/16.01.00_60/ts_136323v160100p.pdf">http://www.etsi.org/deliver/etsi_ts/136300_136399/136323/16.01.00_60/ts_136323v160100p.pdf</a>
TSDSI	TSDSI STD T1.3GPP 36.323-16.1.0 V1.0.0		16.1.0	Published	06.10.2020	<a href="https://members.tdsi.in/index.php/s/WXzm27ketNcKgoR">https://members.tdsi.in/index.php/s/WXzm27ketNcKgoR</a>
TTA	TTAT.3G-36.323V16.1.0		16.1.0	Published	11.09.2020	<a href="http://www.tta.or.kr/data/ttasDown.jsp?where=14688&amp;pk_num=TTAT.3G-36.323V16.1.0">http://www.tta.or.kr/data/ttasDown.jsp?where=14688&amp;pk_num=TTAT.3G-36.323V16.1.0</a>

**1.2.1.3.11 TS 36.331****Evolved Universal Terrestrial Radio Access (E-UTRA); Radio Resource Control (RRC); Protocol specification**

This document specifies the Radio Resource Control protocol for the radio interface between UE and E-UTRAN as well as for the radio interface between RN and E-UTRAN. The scope of this document also includes: (i) the radio related information transported in a transparent container between source eNodeB and target eNodeB upon inter eNodeB handover; (ii) the radio related information transported in a transparent container between a source or target eNodeB and another system upon inter RAT handover.

SDO	Document No.	Version	Status	Issued date	Location	
<b>Release 15</b>						
ARIB	ARIB STD-T120-36.331		15.10.0	Published	28.09.2020	<a href="http://www.arib.or.jp/english/html/overview/doc/T120_T23_v2_00/2_T120/ARIB-STD-T120/Rel15/36/A36331-fa0.pdf">http://www.arib.or.jp/english/html/overview/doc/T120_T23_v2_00/2_T120/ARIB-STD-T120/Rel15/36/A36331-fa0.pdf</a>
ATIS	ATIS.3GPP.36.331V15100		15.10.0	Published	08.09.2020	<a href="http://www.atis.org/3gpp-documents/Rel15">http://www.atis.org/3gpp-documents/Rel15</a>
CCSA	CCSA.36.331V15100		15.10.0	Published	24.07.2020	<a href="http://www.ccsa.org.cn:9001/portalsFile/downloadOldFile?type=17&amp;oldFileUrl=Rel15/TS%2036.331%20V15.10.0.docx">http://www.ccsa.org.cn:9001/portalsFile/downloadOldFile?type=17&amp;oldFileUrl=Rel15/TS%2036.331%20V15.10.0.docx</a>
ETSI	ETSI TS 136 331		15.10.0	Published	31.07.2020	<a href="http://www.etsi.org/deliver/etsi_ts/136300_136399/136331/15.10.00_60/ts_136331v151000p.pdf">http://www.etsi.org/deliver/etsi_ts/136300_136399/136331/15.10.00_60/ts_136331v151000p.pdf</a>
TSDSI	TSDSI STD T1.3GPP 36.331-15.10.0 V1.0.0		15.10.0	Published	06.10.2020	<a href="https://members.tdsi.in/index.php/s/TWZ8oG2x57sjXCK">https://members.tdsi.in/index.php/s/TWZ8oG2x57sjXCK</a>
TTA	TTAT.3G-36.331V15.10.0		15.10.0	Published	11.09.2020	<a href="http://www.tta.or.kr/data/ttasDown.jsp?where=14688&amp;pk_num=TTAT.3G-36.331V15.10.0">http://www.tta.or.kr/data/ttasDown.jsp?where=14688&amp;pk_num=TTAT.3G-36.331V15.10.0</a>
<b>Release 16</b>						
ARIB	ARIB STD-T120-36.331		16.1.1	Published	28.09.2020	<a href="http://www.arib.or.jp/english/html/overview/doc/T120_T23_v2_00/2_T120/ARIB-STD-T120/Rel16/36/A36331-g11.pdf">http://www.arib.or.jp/english/html/overview/doc/T120_T23_v2_00/2_T120/ARIB-STD-T120/Rel16/36/A36331-g11.pdf</a>
ATIS	ATIS.3GPP.36.331V1611		16.1.1	Published	08.09.2020	<a href="http://www.atis.org/3gpp-documents/Rel16">http://www.atis.org/3gpp-documents/Rel16</a>
CCSA	CCSA.36.331V1611		16.1.1	Published	26.07.2020	<a href="http://www.ccsa.org.cn:9001/portalsFile/downloadOldFile?type=17&amp;oldFileUrl=Rel16/TS%2036.331%20V16.1.1.docx">http://www.ccsa.org.cn:9001/portalsFile/downloadOldFile?type=17&amp;oldFileUrl=Rel16/TS%2036.331%20V16.1.1.docx</a>
ETSI	ETSI TS 136 331		16.1.1	Published	31.07.2020	<a href="http://www.etsi.org/deliver/etsi_ts/136300_136399/136331/16.01.01_60/ts_136331v160101p.pdf">http://www.etsi.org/deliver/etsi_ts/136300_136399/136331/16.01.01_60/ts_136331v160101p.pdf</a>
TSDSI	TSDSI STD T1.3GPP 36.331-16.1.1 V1.0.0		16.1.1	Published	06.10.2020	<a href="https://members.tdsi.in/index.php/s/57SMo8DNRw7yYKs">https://members.tdsi.in/index.php/s/57SMo8DNRw7yYKs</a>
TTA	TTAT.3G-36.331V16.1.1		16.1.1	Published	11.09.2020	<a href="http://www.tta.or.kr/data/ttasDown.jsp?where=14688&amp;pk_num=TTAT.3G-36.331V16.1.1">http://www.tta.or.kr/data/ttasDown.jsp?where=14688&amp;pk_num=TTAT.3G-36.331V16.1.1</a>

**1.2.1.3.12 TS 36.355****Evolved Universal Terrestrial Radio Access (E-UTRA); LTE Positioning Protocol (LPP)**

This document contains the definition of the LTE Positioning Protocol (LPP).

SDO	Document No.	Version	Status	Issued date	Location	
<b>Release 15</b>						
ARIB	ARIB STD-T120-36.355		15.6.0	Published	28.09.2020	<a href="http://www.arib.or.jp/english/html/overview/doc/T120_T23_v2_00/2_T120/ARIB-STD-T120/Rel15/36/A36355-f60.pdf">http://www.arib.or.jp/english/html/overview/doc/T120_T23_v2_00/2_T120/ARIB-STD-T120/Rel15/36/A36355-f60.pdf</a>
ATIS	ATIS.3GPP.36.355V1560		15.6.0	Published	08.09.2020	<a href="http://www.atis.org/3gpp-documents/Rel15">http://www.atis.org/3gpp-documents/Rel15</a>
CCSA	CCSA.36.355V1560		15.6.0	Published	08.01.2020	<a href="http://www.ccsa.org.cn:9001/portalsFile/downloadOldFile?type=17&amp;oldFileUrl=Rel15/TS%2036.355%20V15.6.0.docx">http://www.ccsa.org.cn:9001/portalsFile/downloadOldFile?type=17&amp;oldFileUrl=Rel15/TS%2036.355%20V15.6.0.docx</a>
ETSI	ETSI TS 136 355		15.6.0	Published	17.01.2020	<a href="http://www.etsi.org/deliver/etsi_ts/136300_136399/136355/15.06.00_60/ts_136355v150600p.pdf">http://www.etsi.org/deliver/etsi_ts/136300_136399/136355/15.06.00_60/ts_136355v150600p.pdf</a>
TSDSI	TSDSI STD T1.3GPP 36.355-15.6.0 V1.0.0		15.6.0	Published	06.10.2020	<a href="https://members.tdsi.in/index.php/s/f2pmS6dSwAGMXfm">https://members.tdsi.in/index.php/s/f2pmS6dSwAGMXfm</a>
TTA	TTAT.3G-36.355V15.6.0		15.6.0	Published	11.09.2020	<a href="http://www.tta.or.kr/data/ttasDown.jsp?where=14688&amp;pk_num=TTAT.3G-36.355V15.6.0">http://www.tta.or.kr/data/ttasDown.jsp?where=14688&amp;pk_num=TTAT.3G-36.355V15.6.0</a>
<b>Release 16</b>						
ARIB	ARIB STD-T120-36.355		16.0.0	Published	28.09.2020	<a href="http://www.arib.or.jp/english/html/overview/doc/T120_T23_v2_00/2_T120/ARIB-STD-T120/Rel16/36/A36355-g00.pdf">http://www.arib.or.jp/english/html/overview/doc/T120_T23_v2_00/2_T120/ARIB-STD-T120/Rel16/36/A36355-g00.pdf</a>
ATIS	ATIS.3GPP.36.355V1600		16.0.0	Published	08.09.2020	<a href="http://www.atis.org/3gpp-documents/Rel16">http://www.atis.org/3gpp-documents/Rel16</a>
CCSA	CCSA.36.355V1600		16.0.0	Published	24.07.2020	<a href="http://www.ccsa.org.cn:9001/portalsFile/downloadOldFile?type=17&amp;oldFileUrl=Rel16/TS%2036.355%20V16.0.0.docx">http://www.ccsa.org.cn:9001/portalsFile/downloadOldFile?type=17&amp;oldFileUrl=Rel16/TS%2036.355%20V16.0.0.docx</a>
ETSI	ETSI TS 136 355		16.0.0	Published	31.07.2020	<a href="http://www.etsi.org/deliver/etsi_ts/136300_136399/136355/16.00.00_60/ts_136355v160000p.pdf">http://www.etsi.org/deliver/etsi_ts/136300_136399/136355/16.00.00_60/ts_136355v160000p.pdf</a>
TSDSI	TSDSI STD T1.3GPP 36.355-16.0.0 V1.0.0		16.0.0	Published	06.10.2020	<a href="https://members.tdsi.in/index.php/s/ANXCtGtwpDrZf8B">https://members.tdsi.in/index.php/s/ANXCtGtwpDrZf8B</a>
TTA	TTAT.3G-36.355V16.0.0		16.0.0	Published	11.09.2020	<a href="http://www.tta.or.kr/data/ttasDown.jsp?where=14688&amp;pk_num=TTAT.3G-36.355V16.0.0">http://www.tta.or.kr/data/ttasDown.jsp?where=14688&amp;pk_num=TTAT.3G-36.355V16.0.0</a>

**1.2.1.3.13 TS 36.360****Evolved Universal Terrestrial Radio Access (E-UTRA); LTE-WLAN Aggregation Adaptation Protocol (LWAAP) specification**

This document specifies the E-UTRA LTE-WLAN Aggregation Adaptation Protocol (LWAAP).

SDO	Document No.	Version	Status	Issued date	Location	
<b>Release 15</b>						
ARIB	ARIB STD-T120-36.360		15.0.0	Published	28.09.2020	<a href="http://www.arib.or.jp/english/html/overview/doc/T120_T23_v2_00/2_T120/ARIB-STD-T120/Rel15/36/A36360-f00.pdf">http://www.arib.or.jp/english/html/overview/doc/T120_T23_v2_00/2_T120/ARIB-STD-T120/Rel15/36/A36360-f00.pdf</a>
ATIS	ATIS.3GPP.36.360V1500		15.0.0	Published	08.09.2020	<a href="http://www.atis.org/3gpp-documents/Rel15">http://www.atis.org/3gpp-documents/Rel15</a>
CCSA	CCSA.36.360V1500		15.0.0	Published	09.07.2018	<a href="http://www.ccsa.org.cn:9001/portalsFile/downloadOldFile?type=17&amp;oldFileUrl=Rel15/TS%2036.360%20V15.0.0.doc">http://www.ccsa.org.cn:9001/portalsFile/downloadOldFile?type=17&amp;oldFileUrl=Rel15/TS%2036.360%20V15.0.0.doc</a>
ETSI	ETSI TS 136 360		15.0.0	Published	16.07.2018	<a href="http://www.etsi.org/deliver/etsi_ts/136300_136399/136360/15.00.00_60/ts_136360v150000p.pdf">http://www.etsi.org/deliver/etsi_ts/136300_136399/136360/15.00.00_60/ts_136360v150000p.pdf</a>
TSDSI	TSDSI STD T1.3GPP 36.360-15.0.0 V1.0.0		15.0.0	Published	06.10.2020	<a href="https://members.tdsi.in/index.php/s/W3F5oEyY8jYZH8f">https://members.tdsi.in/index.php/s/W3F5oEyY8jYZH8f</a>
TTA	TTAT.3G-36.360V15.0.0		15.0.0	Published	11.09.2020	<a href="http://www.tta.or.kr/data/ttasDown.jsp?where=14688&amp;pk_num=TTAT.3G-36.360V15.0.0">http://www.tta.or.kr/data/ttasDown.jsp?where=14688&amp;pk_num=TTAT.3G-36.360V15.0.0</a>
TTC	TS-3GA-36.360(Rel15) v15.0.0		15.0.0	Published	28.09.2018	<a href="https://www.ttc.or.jp/st/docs/3gpps2018/TS/TS-3GA-36.360(Rel15)v15.0.0.pdf">https://www.ttc.or.jp/st/docs/3gpps2018/TS/TS-3GA-36.360(Rel15)v15.0.0.pdf</a>
<b>Release 16</b>						
ARIB	ARIB STD-T120-36.360		16.0.0	Published	28.09.2020	<a href="http://www.arib.or.jp/english/html/overview/doc/T120_T23_v2_00/2_T120/ARIB-STD-T120/Rel16/36/A36360-g00.pdf">http://www.arib.or.jp/english/html/overview/doc/T120_T23_v2_00/2_T120/ARIB-STD-T120/Rel16/36/A36360-g00.pdf</a>
ATIS	ATIS.3GPP.36.360V1600		16.0.0	Published	08.09.2020	<a href="http://www.atis.org/3gpp-documents/Rel16">http://www.atis.org/3gpp-documents/Rel16</a>
CCSA	CCSA.36.360V1600		16.0.0	Published	24.07.2020	<a href="http://www.ccsa.org.cn:9001/portalsFile/downloadOldFile?type=17&amp;oldFileUrl=Rel16/TS%2036.360%20V16.0.0.doc">http://www.ccsa.org.cn:9001/portalsFile/downloadOldFile?type=17&amp;oldFileUrl=Rel16/TS%2036.360%20V16.0.0.doc</a>
ETSI	ETSI TS 136 360		16.0.0	Published	31.07.2020	<a href="http://www.etsi.org/deliver/etsi_ts/136300_136399/136360/16.00.00_60/ts_136360v160000p.pdf">http://www.etsi.org/deliver/etsi_ts/136300_136399/136360/16.00.00_60/ts_136360v160000p.pdf</a>
TSDSI	TSDSI STD T1.3GPP 36.360-16.0.0 V1.0.0		16.0.0	Published	06.10.2020	<a href="https://members.tdsi.in/index.php/s/eHY2dSadTCysDZp">https://members.tdsi.in/index.php/s/eHY2dSadTCysDZp</a>
TTA	TTAT.3G-36.360V16.0.0		16.0.0	Published	11.09.2020	<a href="http://www.tta.or.kr/data/ttasDown.jsp?where=14688&amp;pk_num=TTAT.3G-36.360V16.0.0">http://www.tta.or.kr/data/ttasDown.jsp?where=14688&amp;pk_num=TTAT.3G-36.360V16.0.0</a>
TTC	TS-3GA-36.360(Rel16) v16.0.0		16.0.0	Published	02.10.2020	<a href="https://www.ttc.or.jp/st/docs/3gpps2020/TS/TS-3GA-36_360_Rel16v16_0_0.pdf">https://www.ttc.or.jp/st/docs/3gpps2020/TS/TS-3GA-36_360_Rel16v16_0_0.pdf</a>



**1.2.1.3.14 TS 36.361****Evolved Universal Terrestrial Radio Access (E-UTRA); LTE/WLAN Radio Level Integration Using IPsec Tunnel (LWIP) encapsulation; Protocol specification**

This document specifies the LWIP Encapsulation Protocol.

SDO	Document No.	Version	Status	Issued date	Location	
<b>Release 15</b>						
ARIB	ARIB STD-T120-36.361		15.0.0	Published	28.09.2020	<a href="http://www.arib.or.jp/english/html/overview/doc/T120_T23_v2_00/2_T120/ARIB-STD-T120/Rel15/36/A36361-f00.pdf">http://www.arib.or.jp/english/html/overview/doc/T120_T23_v2_00/2_T120/ARIB-STD-T120/Rel15/36/A36361-f00.pdf</a>
ATIS	ATIS.3GPP.36.361V1500		15.0.0	Published	08.09.2020	<a href="http://www.atis.org/3gpp-documents/Rel15">http://www.atis.org/3gpp-documents/Rel15</a>
CCSA	CCSA.36.361V1500		15.0.0	Published	09.07.2018	<a href="http://www.ccsa.org.cn:9001/portalsFile/downloadOldFile?type=17&amp;oldFileUrl=Rel15/TS%2036.361%20V15.0.0.doc">http://www.ccsa.org.cn:9001/portalsFile/downloadOldFile?type=17&amp;oldFileUrl=Rel15/TS%2036.361%20V15.0.0.doc</a>
ETSI	ETSI TS 136 361		15.0.0	Published	16.07.2018	<a href="http://www.etsi.org/deliver/etsi_ts/136300_136399/136361/15.00.00_60/ts_136361v150000p.pdf">http://www.etsi.org/deliver/etsi_ts/136300_136399/136361/15.00.00_60/ts_136361v150000p.pdf</a>
TSDSI	TSDSI STD T1.3GPP 36.361-15.0.0 V1.0.0		15.0.0	Published	06.10.2020	<a href="https://members.tdsi.in/index.php/s/FMT7KpL9YbN92ZX">https://members.tdsi.in/index.php/s/FMT7KpL9YbN92ZX</a>
TTA	TTAT.3G-36.361V15.0.0		15.0.0	Published	11.09.2020	<a href="http://www.tta.or.kr/data/ttasDown.jsp?where=14688&amp;pk_num=TTAT.3G-36.361V15.0.0">http://www.tta.or.kr/data/ttasDown.jsp?where=14688&amp;pk_num=TTAT.3G-36.361V15.0.0</a>
TTC	TS-3GA-36.361(Rel15) v15.0.0		15.0.0	Published	28.09.2018	<a href="https://www.ttc.or.jp/st/docs/3gpps2018/TS/TS-3GA-36.361(Rel15)v15.0.0.pdf">https://www.ttc.or.jp/st/docs/3gpps2018/TS/TS-3GA-36.361(Rel15)v15.0.0.pdf</a>
<b>Release 16</b>						
ARIB	ARIB STD-T120-36.361		16.0.0	Published	28.09.2020	<a href="http://www.arib.or.jp/english/html/overview/doc/T120_T23_v2_00/2_T120/ARIB-STD-T120/Rel16/36/A36361-g00.pdf">http://www.arib.or.jp/english/html/overview/doc/T120_T23_v2_00/2_T120/ARIB-STD-T120/Rel16/36/A36361-g00.pdf</a>
ATIS	ATIS.3GPP.36.361V1600		16.0.0	Published	08.09.2020	<a href="http://www.atis.org/3gpp-documents/Rel16">http://www.atis.org/3gpp-documents/Rel16</a>
CCSA	CCSA.36.361V1600		16.0.0	Published	24.07.2020	<a href="http://www.ccsa.org.cn:9001/portalsFile/downloadOldFile?type=17&amp;oldFileUrl=Rel16/TS%2036.361%20V16.0.0.doc">http://www.ccsa.org.cn:9001/portalsFile/downloadOldFile?type=17&amp;oldFileUrl=Rel16/TS%2036.361%20V16.0.0.doc</a>
ETSI	ETSI TS 136 361		16.0.0	Published	31.07.2020	<a href="http://www.etsi.org/deliver/etsi_ts/136300_136399/136361/16.00.00_60/ts_136361v160000p.pdf">http://www.etsi.org/deliver/etsi_ts/136300_136399/136361/16.00.00_60/ts_136361v160000p.pdf</a>
TSDSI	TSDSI STD T1.3GPP 36.361-16.0.0 V1.0.0		16.0.0	Published	06.10.2020	<a href="https://members.tdsi.in/index.php/s/A3bNCzCf7t9Q5f7">https://members.tdsi.in/index.php/s/A3bNCzCf7t9Q5f7</a>
TTA	TTAT.3G-36.361V16.0.0		16.0.0	Published	11.09.2020	<a href="http://www.tta.or.kr/data/ttasDown.jsp?where=14688&amp;pk_num=TTAT.3G-36.361V16.0.0">http://www.tta.or.kr/data/ttasDown.jsp?where=14688&amp;pk_num=TTAT.3G-36.361V16.0.0</a>
TTC	TS-3GA-36.361(Rel16) v16.0.0		16.0.0	Published	02.10.2020	<a href="https://www.ttc.or.jp/st/docs/3gpps2020/TS/TS-3GA-36_361_Rel16v16_0_0.pdf">https://www.ttc.or.jp/st/docs/3gpps2020/TS/TS-3GA-36_361_Rel16v16_0_0.pdf</a>

**1.2.1.3.15 TS 37.320****Universal Terrestrial Radio Access (UTRA) and Evolved Universal Terrestrial Radio Access (E-UTRA); Radio measurement collection for Minimization of Drive Tests (MDT); Overall description; Stage 2**

This document provides an overview and overall description of the minimization of drive tests functionality. The document describes functions and procedures to support collection of UE-specific measurements for MDT using Control Plane architecture, for both UTRAN and E-UTRAN. Details of the signalling procedures for single-RAT operation are specified in the appropriate radio interface protocol specification. Network operation and overall control of MDT is described in OAM specifications.

SDO	Document No.	Version	Status	Issued date	Location	
<b>Release 15</b>						
ARIB	ARIB STD-T120-37.320		15.0.0	Published	28.09.2020	<a href="http://www.arib.or.jp/english/html/overview/doc/T120_T23_v2_00/2_T120/ARIB-STD-T120/Rel15/37/A37320-f00.pdf">http://www.arib.or.jp/english/html/overview/doc/T120_T23_v2_00/2_T120/ARIB-STD-T120/Rel15/37/A37320-f00.pdf</a>
ATIS	ATIS.3GPP.37.320V1500		15.0.0	Published	08.09.2020	<a href="http://www.atis.org/3gpp-documents/Rel15">http://www.atis.org/3gpp-documents/Rel15</a>
CCSA	CCSA.37.320V1500		15.0.0	Published	06.07.2018	<a href="http://www.ccsa.org.cn:9001/portalsFile/downloadOldFile?type=17&amp;oldFileUrl=Rel15/TS%2037.320%20V15.0.0.doc">http://www.ccsa.org.cn:9001/portalsFile/downloadOldFile?type=17&amp;oldFileUrl=Rel15/TS%2037.320%20V15.0.0.doc</a>
ETSI	ETSI TS 137 320		15.0.0	Published	17.07.2018	<a href="http://www.etsi.org/deliver/etsi_ts/137300_137399/137320/15.00.00_60/ts_137320v150000p.pdf">http://www.etsi.org/deliver/etsi_ts/137300_137399/137320/15.00.00_60/ts_137320v150000p.pdf</a>
TSDSI	TSDSI STD T1.3GPP 37.320-15.0.0 V1.0.0		15.0.0	Published	06.10.2020	<a href="https://members.tdsi.in/index.php/s/ZonFpABk5TG4HSc">https://members.tdsi.in/index.php/s/ZonFpABk5TG4HSc</a>
TTA	TTAT.3G-37.320V15.0.0		15.0.0	Published	11.09.2020	<a href="http://www.tta.or.kr/data/ttasDown.jsp?where=14688&amp;pk_num=TTAT.3G-37.320V15.0.0">http://www.tta.or.kr/data/ttasDown.jsp?where=14688&amp;pk_num=TTAT.3G-37.320V15.0.0</a>
<b>Release 16</b>						
ARIB	ARIB STD-T120-37.320		16.1.0	Published	28.09.2020	<a href="http://www.arib.or.jp/english/html/overview/doc/T120_T23_v2_00/2_T120/ARIB-STD-T120/Rel16/37/A37320-g10.pdf">http://www.arib.or.jp/english/html/overview/doc/T120_T23_v2_00/2_T120/ARIB-STD-T120/Rel16/37/A37320-g10.pdf</a>
ATIS	ATIS.3GPP.37.320V1610		16.1.0	Published	08.09.2020	<a href="http://www.atis.org/3gpp-documents/Rel16">http://www.atis.org/3gpp-documents/Rel16</a>
CCSA	CCSA.37.320V1610		16.1.0	Published	24.07.2020	<a href="http://www.ccsa.org.cn:9001/portalsFile/downloadOldFile?type=17&amp;oldFileUrl=Rel16/TS%2037.320%20V16.1.0.doc">http://www.ccsa.org.cn:9001/portalsFile/downloadOldFile?type=17&amp;oldFileUrl=Rel16/TS%2037.320%20V16.1.0.doc</a>

ETSI	ETSI TS 137 320	16.1.0	Published	31.07.2020	<a href="http://www.etsi.org/deliver/etsi_ts/137300_137399/137320/16.01.00_60/ts_137320v160100p.pdf">http://www.etsi.org/deliver/etsi_ts/137300_137399/137320/16.01.00_60/ts_137320v160100p.pdf</a>
TSDSI	TSDSI STD T1.3GPP 37.320-16.1.0 V1.0.0	16.1.0	Published	06.10.2020	<a href="https://members.tdsi.in/index.php/s/Hm8dwf2YdJqExMw">https://members.tdsi.in/index.php/s/Hm8dwf2YdJqExMw</a>
TTA	TTAT.3G-37.320V16.1.0	16.1.0	Published	11.09.2020	<a href="http://www.tta.or.kr/data/ttasDown.jsp?where=14688&amp;pk_num=TTAT.3G-37.320V16.1.0">http://www.tta.or.kr/data/ttasDown.jsp?where=14688&amp;pk_num=TTAT.3G-37.320V16.1.0</a>

### 1.2.1.3.16 TS 37.324

#### Evolved Universal Terrestrial Radio Access (E-UTRA) and NR; Service Data Adaptation Protocol (SDAP) specification

This document specifies the Service Data Adaptation Protocol (SDAP) for a UE with connection to the 5G-CN.

SDO	Document No.	Version	Status	Issued date	Location
<b>Release 15</b>					
ARIB	ARIB STD-T120-37.324	15.1.0	Published	28.09.2020	<a href="http://www.arib.or.jp/english/html/overview/doc/T120_T23_v2_00/2_T120/ARIB-STD-T120/Rel15/37/A37324-f10.pdf">http://www.arib.or.jp/english/html/overview/doc/T120_T23_v2_00/2_T120/ARIB-STD-T120/Rel15/37/A37324-f10.pdf</a>
ATIS	ATIS.3GPP.37.324V1510	15.1.0	Published	08.09.2020	<a href="http://www.atis.org/3gpp-documents/Rel15">http://www.atis.org/3gpp-documents/Rel15</a>
CCSA	CCSA.37.324V1510	15.1.0	Published	25.09.2018	<a href="http://www.ccsa.org.cn:9001/portalsFile/downloadOldFile?type=17&amp;oldFileUrl=Rel15/TS%2037.324%20V15.1.0.doc">http://www.ccsa.org.cn:9001/portalsFile/downloadOldFile?type=17&amp;oldFileUrl=Rel15/TS%2037.324%20V15.1.0.doc</a>
ETSI	ETSI TS 137 324	15.1.0	Published	28.09.2018	<a href="http://www.etsi.org/deliver/etsi_ts/137300_137399/137324/15.01.00_60/ts_137324v150100p.pdf">http://www.etsi.org/deliver/etsi_ts/137300_137399/137324/15.01.00_60/ts_137324v150100p.pdf</a>
TSDSI	TSDSI STD T1.3GPP 37.324-15.1.0 V1.0.0	15.1.0	Published	06.10.2020	<a href="https://members.tdsi.in/index.php/s/Z8Bc2kg4rztgbBR">https://members.tdsi.in/index.php/s/Z8Bc2kg4rztgbBR</a>
TTA	TTAT.3G-37.324V15.1.0	15.1.0	Published	11.09.2020	<a href="http://www.tta.or.kr/data/ttasDown.jsp?where=14688&amp;pk_num=TTAT.3G-37.324V15.1.0">http://www.tta.or.kr/data/ttasDown.jsp?where=14688&amp;pk_num=TTAT.3G-37.324V15.1.0</a>
<b>Release 16</b>					
ARIB	ARIB STD-T120-37.324	16.1.0	Published	28.09.2020	<a href="http://www.arib.or.jp/english/html/overview/doc/T120_T23_v2_00/2_T120/ARIB-STD-T120/Rel16/37/A37324-g10.pdf">http://www.arib.or.jp/english/html/overview/doc/T120_T23_v2_00/2_T120/ARIB-STD-T120/Rel16/37/A37324-g10.pdf</a>
ATIS	ATIS.3GPP.37.324V1610	16.1.0	Published	08.09.2020	<a href="http://www.atis.org/3gpp-documents/Rel16">http://www.atis.org/3gpp-documents/Rel16</a>
CCSA	CCSA.37.324V1610	16.1.0	Published	24.07.2020	<a href="http://www.ccsa.org.cn:9001/portalsFile/downloadOldFile?type=17&amp;oldFileUrl=Rel16/TS%2037.324%20V16.1.0.docx">http://www.ccsa.org.cn:9001/portalsFile/downloadOldFile?type=17&amp;oldFileUrl=Rel16/TS%2037.324%20V16.1.0.docx</a>
ETSI	ETSI TS 137 324	16.1.0	Published	18.09.2020	<a href="http://www.etsi.org/deliver/etsi_ts/137300_137399/137324/16.01.00_60/ts_137324v160100p.pdf">http://www.etsi.org/deliver/etsi_ts/137300_137399/137324/16.01.00_60/ts_137324v160100p.pdf</a>
TSDSI	TSDSI STD T1.3GPP 37.324-16.1.0 V1.0.0	16.1.0	Published	06.10.2020	<a href="https://members.tdsi.in/index.php/s/TGitSs2dd2yWpS5">https://members.tdsi.in/index.php/s/TGitSs2dd2yWpS5</a>
TTA	TTAT.3G-37.324V16.1.0	16.1.0	Published	11.09.2020	<a href="http://www.tta.or.kr/data/ttasDown.jsp?where=14688&amp;pk_num=TTAT.3G-37.324V16.1.0">http://www.tta.or.kr/data/ttasDown.jsp?where=14688&amp;pk_num=TTAT.3G-37.324V16.1.0</a>

### 1.2.1.3.17 TS 37.340

#### NR; Multi-connectivity; Overall description; Stage-2

This document provides an overview of the multi-connectivity operation using E-UTRA and NR radio access technologies. Details of the network and radio interface protocols are specified in companion specifications of the 36 and 38 series.

SDO	Document No.	Version	Status	Issued date	Location
<b>Release 15</b>					
ARIB	ARIB STD-T120-37.340	15.9.0	Published	28.09.2020	<a href="http://www.arib.or.jp/english/html/overview/doc/T120_T23_v2_00/2_T120/ARIB-STD-T120/Rel15/37/A37340-f90.pdf">http://www.arib.or.jp/english/html/overview/doc/T120_T23_v2_00/2_T120/ARIB-STD-T120/Rel15/37/A37340-f90.pdf</a>
ATIS	ATIS.3GPP.37.340V1590	15.9.0	Published	08.09.2020	<a href="http://www.atis.org/3gpp-documents/Rel15">http://www.atis.org/3gpp-documents/Rel15</a>
CCSA	CCSA.37.340V1590	15.9.0	Published	24.07.2020	<a href="http://www.ccsa.org.cn:9001/portalsFile/downloadOldFile?type=17&amp;oldFileUrl=Rel15/TS%2037.340%20V15.9.0.docx">http://www.ccsa.org.cn:9001/portalsFile/downloadOldFile?type=17&amp;oldFileUrl=Rel15/TS%2037.340%20V15.9.0.docx</a>
ETSI	ETSI TS 137 340	15.9.0	Published	31.07.2020	<a href="http://www.etsi.org/deliver/etsi_ts/137300_137399/137340/15.09.00_60/ts_137340v150900p.pdf">http://www.etsi.org/deliver/etsi_ts/137300_137399/137340/15.09.00_60/ts_137340v150900p.pdf</a>
TSDSI	TSDSI STD T1.3GPP 37.340-15.9.0 V1.0.0	15.9.0	Published	06.10.2020	<a href="https://members.tdsi.in/index.php/s/4Qb7j9ApeYokyYF">https://members.tdsi.in/index.php/s/4Qb7j9ApeYokyYF</a>
TTA	TTAT.3G-37.340V15.9.0	15.9.0	Published	11.09.2020	<a href="http://www.tta.or.kr/data/ttasDown.jsp?where=14688&amp;pk_num=TTAT.3G-37.340V15.9.0">http://www.tta.or.kr/data/ttasDown.jsp?where=14688&amp;pk_num=TTAT.3G-37.340V15.9.0</a>
<b>Release 16</b>					
ARIB	ARIB STD-T120-37.340	16.2.0	Published	28.09.2020	<a href="http://www.arib.or.jp/english/html/overview/doc/T120_T23_v2_00/2_T120/ARIB-STD-T120/Rel16/37/A37340-g20.pdf">http://www.arib.or.jp/english/html/overview/doc/T120_T23_v2_00/2_T120/ARIB-STD-T120/Rel16/37/A37340-g20.pdf</a>
ATIS	ATIS.3GPP.37.340V1620	16.2.0	Published	08.09.2020	<a href="http://www.atis.org/3gpp-documents/Rel16">http://www.atis.org/3gpp-documents/Rel16</a>
CCSA	CCSA.37.340V1620	16.2.0	Published	24.07.2020	<a href="http://www.ccsa.org.cn:9001/portalsFile/downloadOldFile?type=17&amp;oldFileUrl=Rel16/TS%2037.340%20V16.2.0.docx">http://www.ccsa.org.cn:9001/portalsFile/downloadOldFile?type=17&amp;oldFileUrl=Rel16/TS%2037.340%20V16.2.0.docx</a>
ETSI	ETSI TS 137 340	16.2.0	Published	18.09.2020	<a href="http://www.etsi.org/deliver/etsi_ts/137300_137399/137340/16.02.00_60/ts_137340v160200p.pdf">http://www.etsi.org/deliver/etsi_ts/137300_137399/137340/16.02.00_60/ts_137340v160200p.pdf</a>
TSDSI	TSDSI STD T1.3GPP 37.340-16.2.0 V1.0.0	16.2.0	Published	06.10.2020	<a href="https://members.tdsi.in/index.php/s/rcbRRsELjxnm73a">https://members.tdsi.in/index.php/s/rcbRRsELjxnm73a</a>

TTA TTAT.3G-37.340V16.2.0 16.2.0 Published 11.09.2020 [http://www.tta.or.kr/data/ttasDown.jsp?where=14688&pk\\_num=TTAT.3G-37.340V16.2.0](http://www.tta.or.kr/data/ttasDown.jsp?where=14688&pk_num=TTAT.3G-37.340V16.2.0)

### 1.2.1.3.18 TS 37.355

#### LTE Positioning Protocol (LPP)

This document contains the definition of the LTE Positioning Protocol (LPP) for the radio access technologies E-UTRA/LTE and NR.

SDO	Document No.	Version	Status	Issued date	Location
<b>Release 15</b>					
ARIB	ARIB STD-T120-37.355		15.0.0	Published 28.09.2020	<a href="http://www.arib.or.jp/english/html/overview/doc/T120_T23_v2_00/2_T120/ARIB-STD-T120/Rel15/37/A37355-f00.pdf">http://www.arib.or.jp/english/html/overview/doc/T120_T23_v2_00/2_T120/ARIB-STD-T120/Rel15/37/A37355-f00.pdf</a>
ATIS	ATIS.3GPP.37.355V1500		15.0.0	Published 08.09.2020	<a href="http://www.atis.org/3gpp-documents/Rel15">http://www.atis.org/3gpp-documents/Rel15</a>
CCSA	CCSA.37.355V1500		15.0.0	Published 21.12.2019	<a href="http://www.ccsa.org.cn:9001/portalsFile/downloadOldFile?type=17&amp;oldFileUrl=Rel15/TS%2037.355%20V15.0.0.docx">http://www.ccsa.org.cn:9001/portalsFile/downloadOldFile?type=17&amp;oldFileUrl=Rel15/TS%2037.355%20V15.0.0.docx</a>
ETSI	ETSI TS 137 355		15.0.0	Published 16.01.2020	<a href="http://www.etsi.org/deliver/etsi_ts/137300_137399/137355/15.00.00_60/ts_137355v150000p.pdf">http://www.etsi.org/deliver/etsi_ts/137300_137399/137355/15.00.00_60/ts_137355v150000p.pdf</a>
TSDSI	TSDSI STD T1.3GPP 37.355-15.0.0 V1.0.0		15.0.0	Published 06.10.2020	<a href="https://members.tdsi.in/index.php/s/sKCWFBteSQo6QbY">https://members.tdsi.in/index.php/s/sKCWFBteSQo6QbY</a>
TTA	TTAT.3G-37.355V15.0.0		15.0.0	Published 11.09.2020	<a href="http://www.tta.or.kr/data/ttasDown.jsp?where=14688&amp;pk_num=TTAT.3G-37.355V15.0.0">http://www.tta.or.kr/data/ttasDown.jsp?where=14688&amp;pk_num=TTAT.3G-37.355V15.0.0</a>
<b>Release 16</b>					
ARIB	ARIB STD-T120-37.355		16.1.0	Published 28.09.2020	<a href="http://www.arib.or.jp/english/html/overview/doc/T120_T23_v2_00/2_T120/ARIB-STD-T120/Rel16/37/A37355-g10.pdf">http://www.arib.or.jp/english/html/overview/doc/T120_T23_v2_00/2_T120/ARIB-STD-T120/Rel16/37/A37355-g10.pdf</a>
ATIS	ATIS.3GPP.37.355V1610		16.1.0	Published 08.09.2020	<a href="http://www.atis.org/3gpp-documents/Rel16">http://www.atis.org/3gpp-documents/Rel16</a>
CCSA	CCSA.37.355V1610		16.1.0	Published 24.07.2020	<a href="http://www.ccsa.org.cn:9001/portalsFile/downloadOldFile?type=17&amp;oldFileUrl=Rel16/TS%2037.355%20V16.1.0.docx">http://www.ccsa.org.cn:9001/portalsFile/downloadOldFile?type=17&amp;oldFileUrl=Rel16/TS%2037.355%20V16.1.0.docx</a>
ETSI	ETSI TS 137 355		16.1.0	Published 31.07.2020	<a href="http://www.etsi.org/deliver/etsi_ts/137300_137399/137355/16.01.00_60/ts_137355v160100p.pdf">http://www.etsi.org/deliver/etsi_ts/137300_137399/137355/16.01.00_60/ts_137355v160100p.pdf</a>
TSDSI	TSDSI STD T1.3GPP 37.355-16.1.0 V1.0.0		16.1.0	Published 06.10.2020	<a href="https://members.tdsi.in/index.php/s/nzpHnNfo33WQSyK">https://members.tdsi.in/index.php/s/nzpHnNfo33WQSyK</a>
TTA	TTAT.3G-37.355V16.1.0		16.1.0	Published 11.09.2020	<a href="http://www.tta.or.kr/data/ttasDown.jsp?where=14688&amp;pk_num=TTAT.3G-37.355V16.1.0">http://www.tta.or.kr/data/ttasDown.jsp?where=14688&amp;pk_num=TTAT.3G-37.355V16.1.0</a>

### 1.2.1.3.19 TS 38.300

#### NR; NR and NG-RAN Overall description; Stage-2

This document provides an overview and overall description of the NG-RAN and focuses on the radio interface protocol architecture of NR connected to 5GC (E-UTRA connected to 5GC is covered in the 36 series). Details of the radio interface protocols are specified in companion specifications of the 38 series.

SDO	Document No.	Version	Status	Issued date	Location
<b>Release 15</b>					
ARIB	ARIB STD-T120-38.300		15.10.0	Published 28.09.2020	<a href="http://www.arib.or.jp/english/html/overview/doc/T120_T23_v2_00/2_T120/ARIB-STD-T120/Rel15/38/A38300-fa0.pdf">http://www.arib.or.jp/english/html/overview/doc/T120_T23_v2_00/2_T120/ARIB-STD-T120/Rel15/38/A38300-fa0.pdf</a>
ATIS	ATIS.3GPP.38.300V15100		15.10.0	Published 08.09.2020	<a href="http://www.atis.org/3gpp-documents/Rel15">http://www.atis.org/3gpp-documents/Rel15</a>
CCSA	CCSA.38.300V15100		15.10.0	Published 24.07.2020	<a href="http://www.ccsa.org.cn:9001/portalsFile/downloadOldFile?type=17&amp;oldFileUrl=Rel15/TS%2038.300%20V15.10.0.docx">http://www.ccsa.org.cn:9001/portalsFile/downloadOldFile?type=17&amp;oldFileUrl=Rel15/TS%2038.300%20V15.10.0.docx</a>
ETSI	ETSI TS 138 300		15.10.0	Published 31.07.2020	<a href="http://www.etsi.org/deliver/etsi_ts/138300_138399/138300/15.10.00_60/ts_138300v151000p.pdf">http://www.etsi.org/deliver/etsi_ts/138300_138399/138300/15.10.00_60/ts_138300v151000p.pdf</a>
TSDSI	TSDSI STD T1.3GPP 38.300-15.10.0 V1.0.0		15.10.0	Published 06.10.2020	<a href="https://members.tdsi.in/index.php/s/s4tRSxrLgYBCQjk">https://members.tdsi.in/index.php/s/s4tRSxrLgYBCQjk</a>
TTA	TTAT.3G-38.300V15.10.0		15.10.0	Published 11.09.2020	<a href="http://www.tta.or.kr/data/ttasDown.jsp?where=14688&amp;pk_num=TTAT.3G-38.300V15.10.0">http://www.tta.or.kr/data/ttasDown.jsp?where=14688&amp;pk_num=TTAT.3G-38.300V15.10.0</a>
<b>Release 16</b>					
ARIB	ARIB STD-T120-38.300		16.2.0	Published 28.09.2020	<a href="http://www.arib.or.jp/english/html/overview/doc/T120_T23_v2_00/2_T120/ARIB-STD-T120/Rel16/38/A38300-g20.pdf">http://www.arib.or.jp/english/html/overview/doc/T120_T23_v2_00/2_T120/ARIB-STD-T120/Rel16/38/A38300-g20.pdf</a>
ATIS	ATIS.3GPP.38.300V1620		16.2.0	Published 08.09.2020	<a href="http://www.atis.org/3gpp-documents/Rel16">http://www.atis.org/3gpp-documents/Rel16</a>
CCSA	CCSA.38.300V1620		16.2.0	Published 24.07.2020	<a href="http://www.ccsa.org.cn:9001/portalsFile/downloadOldFile?type=17&amp;oldFileUrl=Rel16/TS%2038.300%20V16.2.0.docx">http://www.ccsa.org.cn:9001/portalsFile/downloadOldFile?type=17&amp;oldFileUrl=Rel16/TS%2038.300%20V16.2.0.docx</a>
ETSI	ETSI TS 138 300		16.2.0	Published 31.07.2020	<a href="http://www.etsi.org/deliver/etsi_ts/138300_138399/138300/16.02.00_60/ts_138300v160200p.pdf">http://www.etsi.org/deliver/etsi_ts/138300_138399/138300/16.02.00_60/ts_138300v160200p.pdf</a>
TSDSI	TSDSI STD T1.3GPP 38.300-16.2.0 V1.0.0		16.2.0	Published 06.10.2020	<a href="https://members.tdsi.in/index.php/s&gt;NamaWsAcBqF4mts">https://members.tdsi.in/index.php/s&gt;NamaWsAcBqF4mts</a>
TTA	TTAT.3G-38.300V16.2.0		16.2.0	Published 11.09.2020	<a href="http://www.tta.or.kr/data/ttasDown.jsp?where=14688&amp;pk_num=TTAT.3G-38.300V16.2.0">http://www.tta.or.kr/data/ttasDown.jsp?where=14688&amp;pk_num=TTAT.3G-38.300V16.2.0</a>

**1.2.1.3.20 TS 38.304****NR; User Equipment (UE) procedures in idle mode and in RRC Inactive state**

This document specifies the Access Stratum (AS) part of the UE procedures in RRC\_IDLE state (also called Idle mode) and RRC\_INACTIVE state. The non-access stratum (NAS) part of Idle mode procedures and processes is specified in TS 23.122.

This document specifies the model for the functional division between the NAS and AS in a UE.

This document applies to all UEs that support at least NR Radio Access, including multi-RAT UEs as described in 3GPP specifications, in the following cases:

- When the UE is camped on a NR cell;
- When the UE is searching for a cell to camp on;

NOTE – When the UE is camped on or searching for a cell to camp on belonging to other RATs, the UE behaviour is described in the specifications of the other RATs.

SDO	Document No.	Version	Status	Issued date	Location	
<b>Release 15</b>						
ARIB	ARIB STD-T120-38.304		15.7.0	Published	28.09.2020	<a href="http://www.arib.or.jp/english/html/overview/doc/T120_T23_v2_00/2_T120/ARIB-STD-T120/Rel15/38/A38304-f70.pdf">http://www.arib.or.jp/english/html/overview/doc/T120_T23_v2_00/2_T120/ARIB-STD-T120/Rel15/38/A38304-f70.pdf</a>
ATIS	ATIS.3GPP.38.304V1570		15.7.0	Published	08.09.2020	<a href="http://www.atis.org/3gpp-documents/Rel15">http://www.atis.org/3gpp-documents/Rel15</a>
CCSA	CCSA.38.304V1570		15.7.0	Published	24.07.2020	<a href="http://www.ccsa.org.cn:9001/portalsFile/downloadOldFile?type=17&amp;oldFileUrl=Rel15/TS%2038.304%20V15.7.docx">http://www.ccsa.org.cn:9001/portalsFile/downloadOldFile?type=17&amp;oldFileUrl=Rel15/TS%2038.304%20V15.7.docx</a>
ETSI	ETSI TS 138 304		15.7.0	Published	31.07.2020	<a href="http://www.etsi.org/deliver/etsi_ts/138300_138399/138304/15.07.00_60/ts_138304v150700p.pdf">http://www.etsi.org/deliver/etsi_ts/138300_138399/138304/15.07.00_60/ts_138304v150700p.pdf</a>
TSDSI	TSDSI STD T1.3GPP 38.304-15.7.0 V1.0.0		15.7.0	Published	06.10.2020	<a href="https://members.tdsi.in/index.php/s/W7omnjRzJTj2LS">https://members.tdsi.in/index.php/s/W7omnjRzJTj2LS</a>
TTA	TTAT.3G-38.304V15.7.0		15.7.0	Published	11.09.2020	<a href="http://www.tta.or.kr/data/ttasDown.jsp?where=14688&amp;pk_num=TTAT.3G-38.304V15.7.0">http://www.tta.or.kr/data/ttasDown.jsp?where=14688&amp;pk_num=TTAT.3G-38.304V15.7.0</a>
<b>Release 16</b>						
ARIB	ARIB STD-T120-38.304		16.1.0	Published	28.09.2020	<a href="http://www.arib.or.jp/english/html/overview/doc/T120_T23_v2_00/2_T120/ARIB-STD-T120/Rel16/38/A38304-g10.pdf">http://www.arib.or.jp/english/html/overview/doc/T120_T23_v2_00/2_T120/ARIB-STD-T120/Rel16/38/A38304-g10.pdf</a>
ATIS	ATIS.3GPP.38.304V1610		16.1.0	Published	08.09.2020	<a href="http://www.atis.org/3gpp-documents/Rel16">http://www.atis.org/3gpp-documents/Rel16</a>
CCSA	CCSA.38.304V1610		16.1.0	Published	24.07.2020	<a href="http://www.ccsa.org.cn:9001/portalsFile/downloadOldFile?type=17&amp;oldFileUrl=Rel16/TS%2038.304%20V16.1.0.docx">http://www.ccsa.org.cn:9001/portalsFile/downloadOldFile?type=17&amp;oldFileUrl=Rel16/TS%2038.304%20V16.1.0.docx</a>
ETSI	ETSI TS 138 304		16.1.0	Published	31.07.2020	<a href="http://www.etsi.org/deliver/etsi_ts/138300_138399/138304/16.01.00_60/ts_138304v160100p.pdf">http://www.etsi.org/deliver/etsi_ts/138300_138399/138304/16.01.00_60/ts_138304v160100p.pdf</a>
TSDSI	TSDSI STD T1.3GPP 38.304-16.1.0 V1.0.0		16.1.0	Published	06.10.2020	<a href="https://members.tdsi.in/index.php/s/eeYJoNaByYRGxkH">https://members.tdsi.in/index.php/s/eeYJoNaByYRGxkH</a>
TTA	TTAT.3G-38.304V16.1.0		16.1.0	Published	11.09.2020	<a href="http://www.tta.or.kr/data/ttasDown.jsp?where=14688&amp;pk_num=TTAT.3G-38.304V16.1.0">http://www.tta.or.kr/data/ttasDown.jsp?where=14688&amp;pk_num=TTAT.3G-38.304V16.1.0</a>

**1.2.1.3.21 TS 38.305****NG Radio Access Network (NG-RAN); Stage 2 functional specification of User Equipment (UE) positioning in NG-RAN**

This document specifies the stage 2 of the UE Positioning function of NG-RAN which provides the mechanisms to support or assist the calculation of the geographical position of a UE. UE position knowledge can be used, for example, in support of Radio Resource Management functions, as well as location-based services for operators, subscribers, and third-party service providers. The purpose of this stage 2 specification is to define the NG-RAN UE Positioning architecture, functional entities and operations to support positioning methods. This description is confined to the NG-RAN Access Stratum. It does not define or describe how the results of the UE position calculation can be utilised in the Core Network (e.g. LCS) or in NG-RAN (e.g. RRM).

UE Positioning may be considered as a network-provided enabling technology consisting of standardised service capabilities that enable the provision of location applications. The application(s) may be service provider specific. The description of the numerous and varied possible location applications which are

enabled by this technology is outside the scope of this document. However, clarifying examples of how the functionality being described may be used to provide specific location services may be included.

This stage 2 specification covers the NG-RAN positioning methods, state descriptions, and message flows to support UE Positioning.

SDO	Document No.	Version	Status	Issued date	Location	
<b>Release 15</b>						
ARIB	ARIB STD-T120-38.305		15.6.0	Published	28.09.2020	<a href="http://www.arib.or.jp/english/html/overview/doc/T120_T23_v2_00/2_T120/ARIB-STD-T120/Rel15/38/A38305-f60.pdf">http://www.arib.or.jp/english/html/overview/doc/T120_T23_v2_00/2_T120/ARIB-STD-T120/Rel15/38/A38305-f60.pdf</a>
ATIS	ATIS.3GPP.38.305V1560		15.6.0	Published	08.09.2020	<a href="http://www.atis.org/3gpp-documents/Rel15">http://www.atis.org/3gpp-documents/Rel15</a>
CCSA	CCSA.38.305V1560		15.6.0	Published	24.07.2020	<a href="http://www.ccsa.org.cn:9001/portalsFile/downloadOldFile?type=17&amp;oldFileUrl=Rel15/TS%2038.305%20V15.6.0.docx">http://www.ccsa.org.cn:9001/portalsFile/downloadOldFile?type=17&amp;oldFileUrl=Rel15/TS%2038.305%20V15.6.0.docx</a>
ETSI	ETSI TS 138 305		15.6.0	Published	31.07.2020	<a href="http://www.etsi.org/deliver/etsi_ts/138300_138399/138305/15.06.00_60/ts_138305v150600p.pdf">http://www.etsi.org/deliver/etsi_ts/138300_138399/138305/15.06.00_60/ts_138305v150600p.pdf</a>
TSDSI	TSDSI STD T1.3GPP 38.305-15.6.0 V1.0.0		15.6.0	Published	06.10.2020	<a href="https://members.tdsi.in/index.php/s/QZBNjzm78xFGNP">https://members.tdsi.in/index.php/s/QZBNjzm78xFGNP</a>
TTA	TTAT.3G-38.305V15.6.0		15.6.0	Published	11.09.2020	<a href="http://www.tta.or.kr/data/ttasDown.jsp?where=14688&amp;pk_num=TTAT.3G-38.305V15.6.0">http://www.tta.or.kr/data/ttasDown.jsp?where=14688&amp;pk_num=TTAT.3G-38.305V15.6.0</a>
<b>Release 16</b>						
ARIB	ARIB STD-T120-38.305		16.1.0	Published	28.09.2020	<a href="http://www.arib.or.jp/english/html/overview/doc/T120_T23_v2_00/2_T120/ARIB-STD-T120/Rel16/38/A38305-g10.pdf">http://www.arib.or.jp/english/html/overview/doc/T120_T23_v2_00/2_T120/ARIB-STD-T120/Rel16/38/A38305-g10.pdf</a>
ATIS	ATIS.3GPP.38.305V1610		16.1.0	Published	08.09.2020	<a href="http://www.atis.org/3gpp-documents/Rel16">http://www.atis.org/3gpp-documents/Rel16</a>
CCSA	CCSA.38.305V1610		16.1.0	Published	24.07.2020	<a href="http://www.ccsa.org.cn:9001/portalsFile/downloadOldFile?type=17&amp;oldFileUrl=Rel16/TS%2038.305%20V16.1.0.docx">http://www.ccsa.org.cn:9001/portalsFile/downloadOldFile?type=17&amp;oldFileUrl=Rel16/TS%2038.305%20V16.1.0.docx</a>
ETSI	ETSI TS 138 305		16.1.0	Published	30.07.2020	<a href="http://www.etsi.org/deliver/etsi_ts/138300_138399/138305/16.01.00_60/ts_138305v160100p.pdf">http://www.etsi.org/deliver/etsi_ts/138300_138399/138305/16.01.00_60/ts_138305v160100p.pdf</a>
TSDSI	TSDSI STD T1.3GPP 38.305-16.1.0 V1.0.0		16.1.0	Published	06.10.2020	<a href="https://members.tdsi.in/index.php/s/kFpRkDFr8Hpcjk2">https://members.tdsi.in/index.php/s/kFpRkDFr8Hpcjk2</a>
TTA	TTAT.3G-38.305V16.1.0		16.1.0	Published	11.09.2020	<a href="http://www.tta.or.kr/data/ttasDown.jsp?where=14688&amp;pk_num=TTAT.3G-38.305V16.1.0">http://www.tta.or.kr/data/ttasDown.jsp?where=14688&amp;pk_num=TTAT.3G-38.305V16.1.0</a>

### 1.2.1.3.22 TS 38.306

#### NR; User Equipment (UE) radio access capabilities

This document defines the NR UE Radio Access Capability Parameters.

SDO	Document No.	Version	Status	Issued date	Location	
<b>Release 15</b>						
ARIB	ARIB STD-T120-38.306		15.10.0	Published	28.09.2020	<a href="http://www.arib.or.jp/english/html/overview/doc/T120_T23_v2_00/2_T120/ARIB-STD-T120/Rel15/38/A38306-fa0.pdf">http://www.arib.or.jp/english/html/overview/doc/T120_T23_v2_00/2_T120/ARIB-STD-T120/Rel15/38/A38306-fa0.pdf</a>
ATIS	ATIS.3GPP.38.306V15100		15.10.0	Published	08.09.2020	<a href="http://www.atis.org/3gpp-documents/Rel15">http://www.atis.org/3gpp-documents/Rel15</a>
CCSA	CCSA.38.306V15100		15.10.0	Published	24.07.2020	<a href="http://www.ccsa.org.cn:9001/portalsFile/downloadOldFile?type=17&amp;oldFileUrl=Rel15/TS%2038.306%20V15.10.0.docx">http://www.ccsa.org.cn:9001/portalsFile/downloadOldFile?type=17&amp;oldFileUrl=Rel15/TS%2038.306%20V15.10.0.docx</a>
ETSI	ETSI TS 138 306		15.10.0	Published	31.07.2020	<a href="http://www.etsi.org/deliver/etsi_ts/138300_138399/138306/15.10.00_60/ts_138306v151000p.pdf">http://www.etsi.org/deliver/etsi_ts/138300_138399/138306/15.10.00_60/ts_138306v151000p.pdf</a>
TSDSI	TSDSI STD T1.3GPP 38.306-15.10.0 V1.0.0		15.10.0	Published	06.10.2020	<a href="https://members.tdsi.in/index.php/s/YiYEbnxRN9ekGnL">https://members.tdsi.in/index.php/s/YiYEbnxRN9ekGnL</a>
TTA	TTAT.3G-38.306V15.10.0		15.10.0	Published	11.09.2020	<a href="http://www.tta.or.kr/data/ttasDown.jsp?where=14688&amp;pk_num=TTAT.3G-38.306V15.10.0">http://www.tta.or.kr/data/ttasDown.jsp?where=14688&amp;pk_num=TTAT.3G-38.306V15.10.0</a>
<b>Release 16</b>						
ARIB	ARIB STD-T120-38.306		16.1.0	Published	28.09.2020	<a href="http://www.arib.or.jp/english/html/overview/doc/T120_T23_v2_00/2_T120/ARIB-STD-T120/Rel16/38/A38306-g10.pdf">http://www.arib.or.jp/english/html/overview/doc/T120_T23_v2_00/2_T120/ARIB-STD-T120/Rel16/38/A38306-g10.pdf</a>
ATIS	ATIS.3GPP.38.306V1610		16.1.0	Published	08.09.2020	<a href="http://www.atis.org/3gpp-documents/Rel16">http://www.atis.org/3gpp-documents/Rel16</a>
CCSA	CCSA.38.306V1610		16.1.0	Published	24.07.2020	<a href="http://www.ccsa.org.cn:9001/portalsFile/downloadOldFile?type=17&amp;oldFileUrl=Rel16/TS%2038.306%20V16.1.0.docx">http://www.ccsa.org.cn:9001/portalsFile/downloadOldFile?type=17&amp;oldFileUrl=Rel16/TS%2038.306%20V16.1.0.docx</a>
ETSI	ETSI TS 138 306		16.1.0	Published	30.07.2020	<a href="http://www.etsi.org/deliver/etsi_ts/138300_138399/138306/16.01.00_60/ts_138306v160100p.pdf">http://www.etsi.org/deliver/etsi_ts/138300_138399/138306/16.01.00_60/ts_138306v160100p.pdf</a>
TSDSI	TSDSI STD T1.3GPP 38.306-16.1.0 V1.0.0		16.1.0	Published	06.10.2020	<a href="https://members.tdsi.in/index.php/s/6cZdRwZGci8ztCc">https://members.tdsi.in/index.php/s/6cZdRwZGci8ztCc</a>
TTA	TTAT.3G-38.306V16.1.0		16.1.0	Published	11.09.2020	<a href="http://www.tta.or.kr/data/ttasDown.jsp?where=14688&amp;pk_num=TTAT.3G-38.306V16.1.0">http://www.tta.or.kr/data/ttasDown.jsp?where=14688&amp;pk_num=TTAT.3G-38.306V16.1.0</a>

**1.2.1.3.23 TS 38.307****NR; Requirements on User Equipments (UEs) supporting a release-independent frequency band**

This document specifies requirements for UEs supporting release independent features such as additional NR operating bands and power classes on top of TS 38.101 and TS 38.133.

SDO	Document No.	Version	Status	Issued date	Location	
<b>Release 15</b>						
ARIB	ARIB STD-T120-38.307		15.6.0	Published	28.09.2020	<a href="http://www.arib.or.jp/english/html/overview/doc/T120_T23_v2_00/2_T120/ARIB-STD-T120/Rel15/38/A38307-f60.pdf">http://www.arib.or.jp/english/html/overview/doc/T120_T23_v2_00/2_T120/ARIB-STD-T120/Rel15/38/A38307-f60.pdf</a>
ATIS	ATIS.3GPP.38.307V1560		15.6.0	Published	08.09.2020	<a href="http://www.atis.org/3gpp-documents/Rel15">http://www.atis.org/3gpp-documents/Rel15</a>
CCSA	CCSA.38.307V1560		15.6.0	Published	17.07.2020	<a href="http://www.ccsa.org.cn:9001/portalsFile/downloadOldFile?type=17&amp;oldFileUrl=Rel15/TS%2038.307%20V15.6.0.docx">http://www.ccsa.org.cn:9001/portalsFile/downloadOldFile?type=17&amp;oldFileUrl=Rel15/TS%2038.307%20V15.6.0.docx</a>
ETSI	ETSI TS 138 307		15.6.0	Published	23.07.2020	<a href="http://www.etsi.org/deliver/etsi_ts/138300_138399/138307/15.06.00_60/ts_138307v150600p.pdf">http://www.etsi.org/deliver/etsi_ts/138300_138399/138307/15.06.00_60/ts_138307v150600p.pdf</a>
TSDSI	TSDSI STD T1.3GPP 38.307-15.6.0 V1.0.0		15.6.0	Published	06.10.2020	<a href="https://members.tdsi.in/index.php/s/ncsf55EHbge96d3">https://members.tdsi.in/index.php/s/ncsf55EHbge96d3</a>
TTA	TTAT.3G-38.307V15.6.0		15.6.0	Published	11.09.2020	<a href="http://www.tta.or.kr/data/ttasDown.jsp?where=14688&amp;pk_num=TTAT.3G-38.307V15.6.0">http://www.tta.or.kr/data/ttasDown.jsp?where=14688&amp;pk_num=TTAT.3G-38.307V15.6.0</a>
<b>Release 16</b>						
ARIB	ARIB STD-T120-38.307		16.3.0	Published	28.09.2020	<a href="http://www.arib.or.jp/english/html/overview/doc/T120_T23_v2_00/2_T120/ARIB-STD-T120/Rel16/38/A38307-g30.pdf">http://www.arib.or.jp/english/html/overview/doc/T120_T23_v2_00/2_T120/ARIB-STD-T120/Rel16/38/A38307-g30.pdf</a>
ATIS	ATIS.3GPP.38.307V1630		16.3.0	Published	08.09.2020	<a href="http://www.atis.org/3gpp-documents/Rel16">http://www.atis.org/3gpp-documents/Rel16</a>
CCSA	CCSA.38.307V1630		16.3.0	Published	17.07.2020	<a href="http://www.ccsa.org.cn:9001/portalsFile/downloadOldFile?type=17&amp;oldFileUrl=Rel16/TS%2038.307%20V16.3.0.docx">http://www.ccsa.org.cn:9001/portalsFile/downloadOldFile?type=17&amp;oldFileUrl=Rel16/TS%2038.307%20V16.3.0.docx</a>
ETSI	ETSI TS 138 307		16.3.0	Published	23.07.2020	<a href="http://www.etsi.org/deliver/etsi_ts/138300_138399/138307/16.03.00_60/ts_138307v160300p.pdf">http://www.etsi.org/deliver/etsi_ts/138300_138399/138307/16.03.00_60/ts_138307v160300p.pdf</a>
TSDSI	TSDSI STD T1.3GPP 38.307-16.3.0 V1.0.0		16.3.0	Published	06.10.2020	<a href="https://members.tdsi.in/index.php/s/meo464Cb4aejXpt">https://members.tdsi.in/index.php/s/meo464Cb4aejXpt</a>
TTA	TTAT.3G-38.307V16.3.0		16.3.0	Published	11.09.2020	<a href="http://www.tta.or.kr/data/ttasDown.jsp?where=14688&amp;pk_num=TTAT.3G-38.307V16.3.0">http://www.tta.or.kr/data/ttasDown.jsp?where=14688&amp;pk_num=TTAT.3G-38.307V16.3.0</a>

**1.2.1.3.24 TS 38.314****NR; Layer 2 measurements**

This document contains the description and definition of the measurements performed by NR or the UE that are transferred over the standardised interfaces in order to support NR radio link operations, radio resource management (RRM), network operations and maintenance (OAM), minimization of drive tests (MDT) and self-organising networks (SON).

Only the differences relative to TS 28.552 are specified in this specification.

SDO	Document No.	Version	Status	Issued date	Location	
<b>Release 16</b>						
ARIB	ARIB STD-T120-38.314		16.0.0	Published	28.09.2020	<a href="http://www.arib.or.jp/english/html/overview/doc/T120_T23_v2_00/2_T120/ARIB-STD-T120/Rel16/38/A38314-g00.pdf">http://www.arib.or.jp/english/html/overview/doc/T120_T23_v2_00/2_T120/ARIB-STD-T120/Rel16/38/A38314-g00.pdf</a>
ATIS	ATIS.3GPP.38.314V1600		16.0.0	Published	08.09.2020	<a href="http://www.atis.org/3gpp-documents/Rel16">http://www.atis.org/3gpp-documents/Rel16</a>
CCSA	CCSA.38.314V1600		16.0.0	Published	24.07.2020	<a href="http://www.ccsa.org.cn:9001/portalsFile/downloadOldFile?type=17&amp;oldFileUrl=Rel16/TS%2038.314%20V16.0.0.docx">http://www.ccsa.org.cn:9001/portalsFile/downloadOldFile?type=17&amp;oldFileUrl=Rel16/TS%2038.314%20V16.0.0.docx</a>
ETSI	ETSI TS 138 314		16.0.0	Published	31.07.2020	<a href="http://www.etsi.org/deliver/etsi_ts/138300_138399/138314/16.00.00_60/ts_138314v160000p.pdf">http://www.etsi.org/deliver/etsi_ts/138300_138399/138314/16.00.00_60/ts_138314v160000p.pdf</a>
TSDSI	TSDSI STD T1.3GPP 38.314-16.0.0 V1.0.0		16.0.0	Published	06.10.2020	<a href="https://members.tdsi.in/index.php/s/HyeZZm43gwP3Aao">https://members.tdsi.in/index.php/s/HyeZZm43gwP3Aao</a>
TTA	TTAT.3G-38.314V16.0.0		16.0.0	Published	11.09.2020	<a href="http://www.tta.or.kr/data/ttasDown.jsp?where=14688&amp;pk_num=TTAT.3G-38.314V16.0.0">http://www.tta.or.kr/data/ttasDown.jsp?where=14688&amp;pk_num=TTAT.3G-38.314V16.0.0</a>

**1.2.1.3.25 TS 38.321****NR; Medium Access Control (MAC) protocol specification**

This document specifies the NR MAC protocol.

SDO	Document No.	Version	Status	Issued date	Location	
<b>Release 15</b>						
ARIB	ARIB STD-T120-38.321		15.9.0	Published	28.09.2020	<a href="http://www.arib.or.jp/english/html/overview/doc/T120_T23_v2_00/2_T120/ARIB-STD-T120/Rel15/38/A38321-f90.pdf">http://www.arib.or.jp/english/html/overview/doc/T120_T23_v2_00/2_T120/ARIB-STD-T120/Rel15/38/A38321-f90.pdf</a>
ATIS	ATIS.3GPP.38.321V1590		15.9.0	Published	08.09.2020	<a href="http://www.atis.org/3gpp-documents/Rel15">http://www.atis.org/3gpp-documents/Rel15</a>
CCSA	CCSA.38.321V1590		15.9.0	Published	24.07.2020	<a href="http://www.ccsa.org.cn:9001/portalsFile/downloadOldFile?type=17&amp;oldFileUrl=Rel15/TS%2038.321%20V15.9.0.docx">http://www.ccsa.org.cn:9001/portalsFile/downloadOldFile?type=17&amp;oldFileUrl=Rel15/TS%2038.321%20V15.9.0.docx</a>
ETSI	ETSI TS 138 321		15.9.0	Published	31.07.2020	<a href="http://www.etsi.org/deliver/etsi_ts/138300_138399/138321/15.09.00_60/ts_138321v150900p.pdf">http://www.etsi.org/deliver/etsi_ts/138300_138399/138321/15.09.00_60/ts_138321v150900p.pdf</a>
TSDSI	TSDSI STD T1.3GPP 38.321-15.9.0 V1.0.0		15.9.0	Published	06.10.2020	<a href="https://members.tdsi.in/index.php/s/CzkDn8dTJQ43NrX">https://members.tdsi.in/index.php/s/CzkDn8dTJQ43NrX</a>
TTA	TTAT.3G-38.321V15.9.0		15.9.0	Published	11.09.2020	<a href="http://www.tta.or.kr/data/ttasDown.jsp?where=14688&amp;pk_num=TTAT.3G-38.321V15.9.0">http://www.tta.or.kr/data/ttasDown.jsp?where=14688&amp;pk_num=TTAT.3G-38.321V15.9.0</a>
<b>Release 16</b>						
ARIB	ARIB STD-T120-38.321		16.1.0	Published	28.09.2020	<a href="http://www.arib.or.jp/english/html/overview/doc/T120_T23_v2_00/2_T120/ARIB-STD-T120/Rel16/38/A38321-g10.pdf">http://www.arib.or.jp/english/html/overview/doc/T120_T23_v2_00/2_T120/ARIB-STD-T120/Rel16/38/A38321-g10.pdf</a>
ATIS	ATIS.3GPP.38.321V1610		16.1.0	Published	08.09.2020	<a href="http://www.atis.org/3gpp-documents/Rel16">http://www.atis.org/3gpp-documents/Rel16</a>
CCSA	CCSA.38.321V1610		16.1.0	Published	24.07.2020	<a href="http://www.ccsa.org.cn:9001/portalsFile/downloadOldFile?type=17&amp;oldFileUrl=Rel16/TS%2038.321%20V16.1.0.docx">http://www.ccsa.org.cn:9001/portalsFile/downloadOldFile?type=17&amp;oldFileUrl=Rel16/TS%2038.321%20V16.1.0.docx</a>
ETSI	ETSI TS 138 321		16.1.0	Published	30.07.2020	<a href="http://www.etsi.org/deliver/etsi_ts/138300_138399/138321/16.01.00_60/ts_138321v160100p.pdf">http://www.etsi.org/deliver/etsi_ts/138300_138399/138321/16.01.00_60/ts_138321v160100p.pdf</a>
TSDSI	TSDSI STD T1.3GPP 38.321-16.1.0 V1.0.0		16.1.0	Published	06.10.2020	<a href="https://members.tdsi.in/index.php/s/WQQ7eTbaggiGC5f">https://members.tdsi.in/index.php/s/WQQ7eTbaggiGC5f</a>
TTA	TTAT.3G-38.321V16.1.0		16.1.0	Published	11.09.2020	<a href="http://www.tta.or.kr/data/ttasDown.jsp?where=14688&amp;pk_num=TTAT.3G-38.321V16.1.0">http://www.tta.or.kr/data/ttasDown.jsp?where=14688&amp;pk_num=TTAT.3G-38.321V16.1.0</a>

**1.2.1.3.26 TS 38.322****NR; Radio Link Control (RLC) protocol specification**

This document specifies the NR Radio Link Control (RLC) protocol for the UE – NR radio interface.

SDO	Document No.	Version	Status	Issued date	Location	
<b>Release 15</b>						
ARIB	ARIB STD-T120-38.322		15.5.0	Published	28.09.2020	<a href="http://www.arib.or.jp/english/html/overview/doc/T120_T23_v2_00/2_T120/ARIB-STD-T120/Rel15/38/A38322-f50.pdf">http://www.arib.or.jp/english/html/overview/doc/T120_T23_v2_00/2_T120/ARIB-STD-T120/Rel15/38/A38322-f50.pdf</a>
ATIS	ATIS.3GPP.38.322V1550		15.5.0	Published	08.09.2020	<a href="http://www.atis.org/3gpp-documents/Rel15">http://www.atis.org/3gpp-documents/Rel15</a>
CCSA	CCSA.38.322V1550		15.5.0	Published	09.04.2019	<a href="http://www.ccsa.org.cn:9001/portalsFile/downloadOldFile?type=17&amp;oldFileUrl=Rel15/TS%2038.322%20V15.5.0.docx">http://www.ccsa.org.cn:9001/portalsFile/downloadOldFile?type=17&amp;oldFileUrl=Rel15/TS%2038.322%20V15.5.0.docx</a>
ETSI	ETSI TS 138 322		15.5.0	Published	10.05.2019	<a href="http://www.etsi.org/deliver/etsi_ts/138300_138399/138322/15.05.00_60/ts_138322v150500p.pdf">http://www.etsi.org/deliver/etsi_ts/138300_138399/138322/15.05.00_60/ts_138322v150500p.pdf</a>
TSDSI	TSDSI STD T1.3GPP 38.322-15.5.0 V1.0.0		15.5.0	Published	06.10.2020	<a href="https://members.tdsi.in/index.php/s/24K2wCxxq8oFbCbN">https://members.tdsi.in/index.php/s/24K2wCxxq8oFbCbN</a>
TTA	TTAT.3G-38.322V15.5.0		15.5.0	Published	11.09.2020	<a href="http://www.tta.or.kr/data/ttasDown.jsp?where=14688&amp;pk_num=TTAT.3G-38.322V15.5.0">http://www.tta.or.kr/data/ttasDown.jsp?where=14688&amp;pk_num=TTAT.3G-38.322V15.5.0</a>
<b>Release 16</b>						
ARIB	ARIB STD-T120-38.322		16.1.0	Published	28.09.2020	<a href="http://www.arib.or.jp/english/html/overview/doc/T120_T23_v2_00/2_T120/ARIB-STD-T120/Rel16/38/A38322-g10.pdf">http://www.arib.or.jp/english/html/overview/doc/T120_T23_v2_00/2_T120/ARIB-STD-T120/Rel16/38/A38322-g10.pdf</a>
ATIS	ATIS.3GPP.38.322V1610		16.1.0	Published	08.09.2020	<a href="http://www.atis.org/3gpp-documents/Rel16">http://www.atis.org/3gpp-documents/Rel16</a>
CCSA	CCSA.38.322V1610		16.1.0	Published	24.07.2020	<a href="http://www.ccsa.org.cn:9001/portalsFile/downloadOldFile?type=17&amp;oldFileUrl=Rel16/TS%2038.322%20V16.1.0.docx">http://www.ccsa.org.cn:9001/portalsFile/downloadOldFile?type=17&amp;oldFileUrl=Rel16/TS%2038.322%20V16.1.0.docx</a>
ETSI	ETSI TS 138 322		16.1.0	Published	31.07.2020	<a href="http://www.etsi.org/deliver/etsi_ts/138300_138399/138322/16.01.00_60/ts_138322v160100p.pdf">http://www.etsi.org/deliver/etsi_ts/138300_138399/138322/16.01.00_60/ts_138322v160100p.pdf</a>
TSDSI	TSDSI STD T1.3GPP 38.322-16.1.0 V1.0.0		16.1.0	Published	06.10.2020	<a href="https://members.tdsi.in/index.php/s/fbZegak9q9Y5THr">https://members.tdsi.in/index.php/s/fbZegak9q9Y5THr</a>
TTA	TTAT.3G-38.322V16.1.0		16.1.0	Published	11.09.2020	<a href="http://www.tta.or.kr/data/ttasDown.jsp?where=14688&amp;pk_num=TTAT.3G-38.322V16.1.0">http://www.tta.or.kr/data/ttasDown.jsp?where=14688&amp;pk_num=TTAT.3G-38.322V16.1.0</a>

**1.2.1.3.27 TS 38.323****NR; Packet Data Convergence Protocol (PDCP) specification**

This document provides the description of the Packet Data Convergence Protocol (PDCP).

SDO	Document No.	Version	Status	Issued date	Location	
<b>Release 15</b>						
ARIB	ARIB STD-T120-38.323		15.6.0	Published	28.09.2020	<a href="http://www.arib.or.jp/english/html/overview/doc/T120_T23_v2_00/2_T120/ARIB-STD-T120/Rel15/38/A38323-f60.pdf">http://www.arib.or.jp/english/html/overview/doc/T120_T23_v2_00/2_T120/ARIB-STD-T120/Rel15/38/A38323-f60.pdf</a>
ATIS	ATIS.3GPP.38.323V1560		15.6.0	Published	08.09.2020	<a href="http://www.atis.org/3gpp-documents/Rel15">http://www.atis.org/3gpp-documents/Rel15</a>
CCSA	CCSA.38.323V1560		15.6.0	Published	28.06.2019	<a href="http://www.ccsa.org.cn:9001/portalsFile/downloadOldFile?type=17&amp;oldFileUrl=Rel15/TS%2038.323%20V15.6.0.docx">http://www.ccsa.org.cn:9001/portalsFile/downloadOldFile?type=17&amp;oldFileUrl=Rel15/TS%2038.323%20V15.6.0.docx</a>
ETSI	ETSI TS 138 323		15.6.0	Published	25.07.2019	<a href="http://www.etsi.org/deliver/etsi_ts/138300_138399/138323/15.06.00_60/ts_138323v150600p.pdf">http://www.etsi.org/deliver/etsi_ts/138300_138399/138323/15.06.00_60/ts_138323v150600p.pdf</a>
TSDSI	TSDSI STD T1.3GPP 38.323-15.6.0 V1.0.0		15.6.0	Published	06.10.2020	<a href="https://members.tdsi.in/index.php/s/egq7i5QTpnreMrJ">https://members.tdsi.in/index.php/s/egq7i5QTpnreMrJ</a>
TTA	TTAT.3G-38.323V15.6.0		15.6.0	Published	11.09.2020	<a href="http://www.tta.or.kr/data/ttasDown.jsp?where=14688&amp;pk_num=TTAT.3G-38.323V15.6.0">http://www.tta.or.kr/data/ttasDown.jsp?where=14688&amp;pk_num=TTAT.3G-38.323V15.6.0</a>
<b>Release 16</b>						
ARIB	ARIB STD-T120-38.323		16.1.0	Published	28.09.2020	<a href="http://www.arib.or.jp/english/html/overview/doc/T120_T23_v2_00/2_T120/ARIB-STD-T120/Rel16/38/A38323-g10.pdf">http://www.arib.or.jp/english/html/overview/doc/T120_T23_v2_00/2_T120/ARIB-STD-T120/Rel16/38/A38323-g10.pdf</a>
ATIS	ATIS.3GPP.38.323V1610		16.1.0	Published	08.09.2020	<a href="http://www.atis.org/3gpp-documents/Rel16">http://www.atis.org/3gpp-documents/Rel16</a>
CCSA	CCSA.38.323V1610		16.1.0	Published	24.07.2020	<a href="http://www.ccsa.org.cn:9001/portalsFile/downloadOldFile?type=17&amp;oldFileUrl=Rel16/TS%2038.323%20V16.1.0.docx">http://www.ccsa.org.cn:9001/portalsFile/downloadOldFile?type=17&amp;oldFileUrl=Rel16/TS%2038.323%20V16.1.0.docx</a>
ETSI	ETSI TS 138 323		16.1.0	Published	30.07.2020	<a href="http://www.etsi.org/deliver/etsi_ts/138300_138399/138323/16.01.00_60/ts_138323v160100p.pdf">http://www.etsi.org/deliver/etsi_ts/138300_138399/138323/16.01.00_60/ts_138323v160100p.pdf</a>
TSDSI	TSDSI STD T1.3GPP 38.323-16.1.0 V1.0.0		16.1.0	Published	06.10.2020	<a href="https://members.tdsi.in/index.php/s/2SRYdCb8XGas3kS">https://members.tdsi.in/index.php/s/2SRYdCb8XGas3kS</a>
TTA	TTAT.3G-38.323V16.1.0		16.1.0	Published	11.09.2020	<a href="http://www.tta.or.kr/data/ttasDown.jsp?where=14688&amp;pk_num=TTAT.3G-38.323V16.1.0">http://www.tta.or.kr/data/ttasDown.jsp?where=14688&amp;pk_num=TTAT.3G-38.323V16.1.0</a>

**1.2.1.3.28 TS 38.331****NR; Radio Resource Control (RRC); Protocol specification**

This document specifies the Radio Resource Control protocol for the radio interface between UE and NG-RAN.

The scope of this document also includes:

- the radio related information transported in a transparent container between source gNB and target gNB upon inter gNB handover;
- the radio related information transported in a transparent container between a source or target gNB and another system upon inter RAT handover.
- the radio related information transported in a transparent container between a source eNB and target gNB during E-UTRA-NR Dual Connectivity.

SDO	Document No.	Version	Status	Issued date	Location	
<b>Release 15</b>						
ARIB	ARIB STD-T120-38.331		15.10.0	Published	28.09.2020	<a href="http://www.arib.or.jp/english/html/overview/doc/T120_T23_v2_00/2_T120/ARIB-STD-T120/Rel15/38/A38331-fa0.pdf">http://www.arib.or.jp/english/html/overview/doc/T120_T23_v2_00/2_T120/ARIB-STD-T120/Rel15/38/A38331-fa0.pdf</a>
ATIS	ATIS.3GPP.38.331V15100		15.10.0	Published	08.09.2020	<a href="http://www.atis.org/3gpp-documents/Rel15">http://www.atis.org/3gpp-documents/Rel15</a>
CCSA	CCSA.38.331V15100		15.10.0	Published	24.07.2020	<a href="http://www.ccsa.org.cn:9001/portalsFile/downloadOldFile?type=17&amp;oldFileUrl=Rel15/TS%2038.331%20V15.10.0.docx">http://www.ccsa.org.cn:9001/portalsFile/downloadOldFile?type=17&amp;oldFileUrl=Rel15/TS%2038.331%20V15.10.0.docx</a>
ETSI	ETSI TS 138 331		15.10.0	Published	30.07.2020	<a href="http://www.etsi.org/deliver/etsi_ts/138300_138399/138331/15.10.00_60/ts_138331v151000p.pdf">http://www.etsi.org/deliver/etsi_ts/138300_138399/138331/15.10.00_60/ts_138331v151000p.pdf</a>
TSDSI	TSDSI STD T1.3GPP 38.331-15.10.0 V1.0.0		15.10.0	Published	06.10.2020	<a href="https://members.tdsi.in/index.php/s/L3ELMSr5maHX5oC">https://members.tdsi.in/index.php/s/L3ELMSr5maHX5oC</a>
TTA	TTAT.3G-38.331V15.10.0		15.10.0	Published	11.09.2020	<a href="http://www.tta.or.kr/data/ttasDown.jsp?where=14688&amp;pk_num=TTAT.3G-38.331V15.10.0">http://www.tta.or.kr/data/ttasDown.jsp?where=14688&amp;pk_num=TTAT.3G-38.331V15.10.0</a>
<b>Release 16</b>						
ARIB	ARIB STD-T120-38.331		16.1.0	Published	28.09.2020	<a href="http://www.arib.or.jp/english/html/overview/doc/T120_T23_v2_00/2_T120/ARIB-STD-T120/Rel16/38/A38331-g10.pdf">http://www.arib.or.jp/english/html/overview/doc/T120_T23_v2_00/2_T120/ARIB-STD-T120/Rel16/38/A38331-g10.pdf</a>
ATIS	ATIS.3GPP.38.331V1610		16.1.0	Published	08.09.2020	<a href="http://www.atis.org/3gpp-documents/Rel16">http://www.atis.org/3gpp-documents/Rel16</a>
CCSA	CCSA.38.331V1610		16.1.0	Published	24.07.2020	<a href="http://www.ccsa.org.cn:9001/portalsFile/downloadOldFile?type=17&amp;oldFileUrl=Rel16/TS%2038.331%20V16.1.0.docx">http://www.ccsa.org.cn:9001/portalsFile/downloadOldFile?type=17&amp;oldFileUrl=Rel16/TS%2038.331%20V16.1.0.docx</a>
ETSI	ETSI TS 138 331		16.1.0	Published	30.07.2020	<a href="http://www.etsi.org/deliver/etsi_ts/138300_138399/138331/16.01.00_60/ts_138331v160100p.pdf">http://www.etsi.org/deliver/etsi_ts/138300_138399/138331/16.01.00_60/ts_138331v160100p.pdf</a>



TSDSI	TSDSI STD T1.3GPP 38.331-16.1.0 V1.0.0	16.1.0	Published	06.10.2020	<a href="https://members.tsdSI.in/index.php/s/9RJxfOP7ZKK5wbX">https://members.tsdSI.in/index.php/s/9RJxfOP7ZKK5wbX</a>
TTA	TTAT.3G-38.331V16.1.0	16.1.0	Published	11.09.2020	<a href="http://www.tta.or.kr/data/ttasDown.jsp?where=14688&amp;pk_num=TTAT.3G-38.331V16.1.0">http://www.tta.or.kr/data/ttasDown.jsp?where=14688&amp;pk_num=TTAT.3G-38.331V16.1.0</a>

### 1.2.1.3.29 TS 38.340

#### NR; Backhaul Adaptation Protocol (BAP) specification

This document provides description of the Backhaul Adaptation Protocol (BAP).

SDO	Document No.	Version	Status	Issued date	Location	
<b>Release 16</b>						
ARIB	ARIB STD-T120-38.340		16.1.0	Published	28.09.2020	<a href="http://www.arib.or.jp/english/html/overview/doc/T120_T23_v2_00/2_T120/ARIB-STD-T120/Rel16/38/A38340-g10.pdf">http://www.arib.or.jp/english/html/overview/doc/T120_T23_v2_00/2_T120/ARIB-STD-T120/Rel16/38/A38340-g10.pdf</a>
ATIS	ATIS.3GPP.38.340V1610		16.1.0	Published	08.09.2020	<a href="http://www.atis.org/3gpp-documents/Rel16">http://www.atis.org/3gpp-documents/Rel16</a>
CCSA	CCSA.38.340V1610		16.1.0	Published	24.07.2020	<a href="http://www.ccsa.org.cn:9001/portalsFile/downloadOldFile?type=17&amp;oldFileUrl=Rel16/TS%2038.340%20V16.1.0.docx">http://www.ccsa.org.cn:9001/portalsFile/downloadOldFile?type=17&amp;oldFileUrl=Rel16/TS%2038.340%20V16.1.0.docx</a>
ETSI	ETSI TS 138 340		16.1.0	Published	30.07.2020	<a href="http://www.etsi.org/deliver/etsi_ts/138300_138399/138340/16.01.00_60/ts_138340v160100p.pdf">http://www.etsi.org/deliver/etsi_ts/138300_138399/138340/16.01.00_60/ts_138340v160100p.pdf</a>
TSDSI	TSDSI STD T1.3GPP 38.340-16.1.0 V1.0.0		16.1.0	Published	06.10.2020	<a href="https://members.tsdSI.in/index.php/s/3tRPzsoksc6Q3GS">https://members.tsdSI.in/index.php/s/3tRPzsoksc6Q3GS</a>
TTA	TTAT.3G-38.340V16.1.0		16.1.0	Published	11.09.2020	<a href="http://www.tta.or.kr/data/ttasDown.jsp?where=14688&amp;pk_num=TTAT.3G-38.340V16.1.0">http://www.tta.or.kr/data/ttasDown.jsp?where=14688&amp;pk_num=TTAT.3G-38.340V16.1.0</a>

### 1.2.1.4 Architecture

#### 1.2.1.4.1 TS 36.401

#### Evolved Universal Terrestrial Radio Access Network (E-UTRAN); Architecture description

This document describes the overall architecture of the E-UTRAN, including internal interfaces and assumptions on the radio, S1 and X2 interfaces.

SDO	Document No.	Version	Status	Issued date	Location	
<b>Release 15</b>						
ATIS	ATIS.3GPP.36.401V1510		15.1.0	Published	08.09.2020	<a href="http://www.atis.org/3gpp-documents/Rel15">http://www.atis.org/3gpp-documents/Rel15</a>
CCSA	CCSA.36.401V1510		15.1.0	Published	08.01.2019	<a href="http://www.ccsa.org.cn:9001/portalsFile/downloadOldFile?type=17&amp;oldFileUrl=Rel15/TS%2036.401%20V15.1.0.doc">http://www.ccsa.org.cn:9001/portalsFile/downloadOldFile?type=17&amp;oldFileUrl=Rel15/TS%2036.401%20V15.1.0.doc</a>
ETSI	ETSI TS 136 401		15.1.0	Published	17.04.2019	<a href="http://www.etsi.org/deliver/etsi_ts/136400_136499/136401/15.01.00_60/ts_136401v150100p.pdf">http://www.etsi.org/deliver/etsi_ts/136400_136499/136401/15.01.00_60/ts_136401v150100p.pdf</a>
TSDSI	TSDSI STD T1.3GPP 36.401-15.1.0 V1.0.0		15.1.0	Published	06.10.2020	<a href="https://members.tsdSI.in/index.php/s/keKTFKqYJxrPbkC">https://members.tsdSI.in/index.php/s/keKTFKqYJxrPbkC</a>
TTA	TTAT.3G-36.401V15.1.0		15.1.0	Published	11.09.2020	<a href="http://www.tta.or.kr/data/ttasDown.jsp?where=14688&amp;pk_num=TTAT.3G-36.401V15.1.0">http://www.tta.or.kr/data/ttasDown.jsp?where=14688&amp;pk_num=TTAT.3G-36.401V15.1.0</a>
TTC	TS-3GA-36.401(Rel15) v15.1.0		15.1.0	Published	29.03.2019	<a href="https://www.ttc.or.jp/st/docs/3gpps2019/TS/TS-3GA-36.401(Rel15)v15.1.0.pdf">https://www.ttc.or.jp/st/docs/3gpps2019/TS/TS-3GA-36.401(Rel15)v15.1.0.pdf</a>
<b>Release 16</b>						
ATIS	ATIS.3GPP.36.401V1600		16.0.0	Published	08.09.2020	<a href="http://www.atis.org/3gpp-documents/Rel16">http://www.atis.org/3gpp-documents/Rel16</a>
CCSA	CCSA.36.401V1600		16.0.0	Published	16.07.2020	<a href="http://www.ccsa.org.cn:9001/portalsFile/downloadOldFile?type=17&amp;oldFileUrl=Rel16/TS%2036.401%20V16.0.0.doc">http://www.ccsa.org.cn:9001/portalsFile/downloadOldFile?type=17&amp;oldFileUrl=Rel16/TS%2036.401%20V16.0.0.doc</a>
ETSI	ETSI TS 136 401		16.0.0	Published	21.07.2020	<a href="http://www.etsi.org/deliver/etsi_ts/136400_136499/136401/16.00.00_60/ts_136401v160000p.pdf">http://www.etsi.org/deliver/etsi_ts/136400_136499/136401/16.00.00_60/ts_136401v160000p.pdf</a>
TSDSI	TSDSI STD T1.3GPP 36.401-16.0.0 V1.0.0		16.0.0	Published	06.10.2020	<a href="https://members.tsdSI.in/index.php/s/ekXa3HgJwqHjY9">https://members.tsdSI.in/index.php/s/ekXa3HgJwqHjY9</a>
TTA	TTAT.3G-36.401V16.0.0		16.0.0	Published	11.09.2020	<a href="http://www.tta.or.kr/data/ttasDown.jsp?where=14688&amp;pk_num=TTAT.3G-36.401V16.0.0">http://www.tta.or.kr/data/ttasDown.jsp?where=14688&amp;pk_num=TTAT.3G-36.401V16.0.0</a>
TTC	TS-3GA-36.401(Rel16) v16.0.0		16.0.0	Published	02.10.2020	<a href="https://www.ttc.or.jp/st/docs/3gpps2020/TS/TS-3GA-36_401_Rel16v16_0_0.pdf">https://www.ttc.or.jp/st/docs/3gpps2020/TS/TS-3GA-36_401_Rel16v16_0_0.pdf</a>

#### 1.2.1.4.2 TS 36.410

#### Evolved Universal Terrestrial Radio Access Network (E-UTRAN); S1 general aspects and principles

This document is an introduction to the 3GPP TS 36.41x series of technical specifications that define the S1 interface for the interconnection of the eNodeB component of the Evolved Universal Terrestrial Radio Access Network (E-UTRAN) to the Core Network of the EPS system.

SDO	Document No.	Version	Status	Issued date	Location	
<b>Release 15</b>						
ATIS	ATIS.3GPP.36.410V1500		15.0.0	Published	08.09.2020	<a href="http://www.atis.org/3gpp-documents/Rel15">http://www.atis.org/3gpp-documents/Rel15</a>
CCSA	CCSA.36.410V1500		15.0.0	Published	22.06.2018	<a href="http://www.ccsa.org.cn:9001/portalsFile/downloadOldFile?type=17&amp;oldFileUrl=Rel15/TS%2036.410%20V15.0.0.doc">http://www.ccsa.org.cn:9001/portalsFile/downloadOldFile?type=17&amp;oldFileUrl=Rel15/TS%2036.410%20V15.0.0.doc</a>
ETSI	ETSI TS 136 410		15.0.0	Published	04.07.2018	<a href="http://www.etsi.org/deliver/etsi_ts/136400_136499/136410/15.00.00_60/ts_136410v150000p.pdf">http://www.etsi.org/deliver/etsi_ts/136400_136499/136410/15.00.00_60/ts_136410v150000p.pdf</a>
TSDSI	TSDSI STD T1.3GPP 36.410-15.0.0 V1.0.0		15.0.0	Published	06.10.2020	<a href="https://members.tdsi.in/index.php/s/wLNHBt3xXET4Rk3">https://members.tdsi.in/index.php/s/wLNHBt3xXET4Rk3</a>
TTA	TTAT.3G-36.410V15.0.0		15.0.0	Published	11.09.2020	<a href="http://www.tta.or.kr/data/ttasDown.jsp?where=14688&amp;pk_num=TTAT.3G-36.410V15.0.0">http://www.tta.or.kr/data/ttasDown.jsp?where=14688&amp;pk_num=TTAT.3G-36.410V15.0.0</a>
TTC	TS-3GA-36.410(Rel15) v15.0.0		15.0.0	Published	28.09.2018	<a href="https://www.ttc.or.jp/st/docs/3gpps2018/TS/TS-3GA-36.410(Rel15)v15.0.0.pdf">https://www.ttc.or.jp/st/docs/3gpps2018/TS/TS-3GA-36.410(Rel15)v15.0.0.pdf</a>
<b>Release 16</b>						
ATIS	ATIS.3GPP.36.410V1600		16.0.0	Published	08.09.2020	<a href="http://www.atis.org/3gpp-documents/Rel16">http://www.atis.org/3gpp-documents/Rel16</a>
CCSA	CCSA.36.410V1600		16.0.0	Published	16.07.2020	<a href="http://www.ccsa.org.cn:9001/portalsFile/downloadOldFile?type=17&amp;oldFileUrl=Rel16/TS%2036.410%20V16.0.0.doc">http://www.ccsa.org.cn:9001/portalsFile/downloadOldFile?type=17&amp;oldFileUrl=Rel16/TS%2036.410%20V16.0.0.doc</a>
ETSI	ETSI TS 136 410		16.0.0	Published	21.07.2020	<a href="http://www.etsi.org/deliver/etsi_ts/136400_136499/136410/16.00.00_60/ts_136410v160000p.pdf">http://www.etsi.org/deliver/etsi_ts/136400_136499/136410/16.00.00_60/ts_136410v160000p.pdf</a>
TSDSI	TSDSI STD T1.3GPP 36.410-16.0.0 V1.0.0		16.0.0	Published	06.10.2020	<a href="https://members.tdsi.in/index.php/s/yjep3ZKHsSgJSbL">https://members.tdsi.in/index.php/s/yjep3ZKHsSgJSbL</a>
TTA	TTAT.3G-36.410V16.0.0		16.0.0	Published	11.09.2020	<a href="http://www.tta.or.kr/data/ttasDown.jsp?where=14688&amp;pk_num=TTAT.3G-36.410V16.0.0">http://www.tta.or.kr/data/ttasDown.jsp?where=14688&amp;pk_num=TTAT.3G-36.410V16.0.0</a>
TTC	TS-3GA-36.410(Rel16) v16.0.0		16.0.0	Published	02.10.2020	<a href="https://www.ttc.or.jp/st/docs/3gpps2020/TS/TS-3GA-36.410_Rel16v16.0.0.pdf">https://www.ttc.or.jp/st/docs/3gpps2020/TS/TS-3GA-36.410_Rel16v16.0.0.pdf</a>

### 1.2.1.4.3 TS 36.411

#### Evolved Universal Terrestrial Radio Access Network (E-UTRAN); S1 layer 1

This document specifies the standards allowed to implement layer 1 on the S1 interface. The specification of transmission delay requirements and O&M requirements are not in the scope of this document. In the following, “layer 1” and “physical layer” are assumed to be synonymous.

SDO	Document No.	Version	Status	Issued date	Location	
<b>Release 15</b>						
ATIS	ATIS.3GPP.36.411V1500		15.0.0	Published	08.09.2020	<a href="http://www.atis.org/3gpp-documents/Rel15">http://www.atis.org/3gpp-documents/Rel15</a>
CCSA	CCSA.36.411V1500		15.0.0	Published	22.06.2018	<a href="http://www.ccsa.org.cn:9001/portalsFile/downloadOldFile?type=17&amp;oldFileUrl=Rel15/TS%2036.411%20V15.0.0.doc">http://www.ccsa.org.cn:9001/portalsFile/downloadOldFile?type=17&amp;oldFileUrl=Rel15/TS%2036.411%20V15.0.0.doc</a>
ETSI	ETSI TS 136 411		15.0.0	Published	04.07.2018	<a href="http://www.etsi.org/deliver/etsi_ts/136400_136499/136411/15.00.00_60/ts_136411v150000p.pdf">http://www.etsi.org/deliver/etsi_ts/136400_136499/136411/15.00.00_60/ts_136411v150000p.pdf</a>
TSDSI	TSDSI STD T1.3GPP 36.411-15.0.0 V1.0.0		15.0.0	Published	06.10.2020	<a href="https://members.tdsi.in/index.php/s/PckqmjFsPC5dGj4">https://members.tdsi.in/index.php/s/PckqmjFsPC5dGj4</a>
TTA	TTAT.3G-36.411V15.0.0		15.0.0	Published	11.09.2020	<a href="http://www.tta.or.kr/data/ttasDown.jsp?where=14688&amp;pk_num=TTAT.3G-36.411V15.0.0">http://www.tta.or.kr/data/ttasDown.jsp?where=14688&amp;pk_num=TTAT.3G-36.411V15.0.0</a>
TTC	TS-3GA-36.411(Rel15) v15.0.0		15.0.0	Published	28.09.2018	<a href="https://www.ttc.or.jp/st/docs/3gpps2018/TS/TS-3GA-36.411(Rel15)v15.0.0.pdf">https://www.ttc.or.jp/st/docs/3gpps2018/TS/TS-3GA-36.411(Rel15)v15.0.0.pdf</a>
<b>Release 16</b>						
ATIS	ATIS.3GPP.36.411V1600		16.0.0	Published	08.09.2020	<a href="http://www.atis.org/3gpp-documents/Rel16">http://www.atis.org/3gpp-documents/Rel16</a>
CCSA	CCSA.36.411V1600		16.0.0	Published	16.07.2020	<a href="http://www.ccsa.org.cn:9001/portalsFile/downloadOldFile?type=17&amp;oldFileUrl=Rel16/TS%2036.411%20V16.0.0.doc">http://www.ccsa.org.cn:9001/portalsFile/downloadOldFile?type=17&amp;oldFileUrl=Rel16/TS%2036.411%20V16.0.0.doc</a>
ETSI	ETSI TS 136 411		16.0.0	Published	21.07.2020	<a href="http://www.etsi.org/deliver/etsi_ts/136400_136499/136411/16.00.00_60/ts_136411v160000p.pdf">http://www.etsi.org/deliver/etsi_ts/136400_136499/136411/16.00.00_60/ts_136411v160000p.pdf</a>
TSDSI	TSDSI STD T1.3GPP 36.411-16.0.0 V1.0.0		16.0.0	Published	06.10.2020	<a href="https://members.tdsi.in/index.php/s/3CXRFYt7DZHE7Nw">https://members.tdsi.in/index.php/s/3CXRFYt7DZHE7Nw</a>
TTA	TTAT.3G-36.411V16.0.0		16.0.0	Published	11.09.2020	<a href="http://www.tta.or.kr/data/ttasDown.jsp?where=14688&amp;pk_num=TTAT.3G-36.411V16.0.0">http://www.tta.or.kr/data/ttasDown.jsp?where=14688&amp;pk_num=TTAT.3G-36.411V16.0.0</a>
TTC	TS-3GA-36.411(Rel16) v16.0.0		16.0.0	Published	02.10.2020	<a href="https://www.ttc.or.jp/st/docs/3gpps2020/TS/TS-3GA-36.411_Rel16v16.0.0.pdf">https://www.ttc.or.jp/st/docs/3gpps2020/TS/TS-3GA-36.411_Rel16v16.0.0.pdf</a>

### 1.2.1.4.4 TS 36.412

#### Evolved Universal Terrestrial Radio Access Network (E-UTRAN); S1 signalling transport

This document specifies the standards for signalling transport to be used across S1 interface. S1 interface is a logical interface between the eNodeB and the E-UTRAN core network. This document describes how the S1-AP signalling messages are transported over S1.

SDO	Document No.	Version	Status	Issued date	Location
-----	--------------	---------	--------	-------------	----------

<b>Release 15</b>						
ATIS	ATIS.3GPP.36.412V1500	15.0.0	Published	08.09.2020	<a href="http://www.atis.org/3gpp-documents/Rel15">http://www.atis.org/3gpp-documents/Rel15</a>	
CCSA	CCSA.36.412V1500	15.0.0	Published	22.06.2018	<a href="http://www.ccsa.org.cn:9001/portalsFile/downloadOldFile?type=17&amp;oldFileUrl=Rel15/TS%2036.412%20V15.0.0.doc">http://www.ccsa.org.cn:9001/portalsFile/downloadOldFile?type=17&amp;oldFileUrl=Rel15/TS%2036.412%20V15.0.0.doc</a>	
ETSI	ETSI TS 136 412	15.0.0	Published	04.07.2018	<a href="http://www.etsi.org/deliver/etsi_ts/136400_136499/136412/15.00.00_60/ts_136412v150000p.pdf">http://www.etsi.org/deliver/etsi_ts/136400_136499/136412/15.00.00_60/ts_136412v150000p.pdf</a>	
TSDSI	TSDSI STD T1.3GPP 36.412-15.0.0 V1.0.0	15.0.0	Published	06.10.2020	<a href="https://members.tdsi.in/index.php/s/3CxGHsojZ4fBy94">https://members.tdsi.in/index.php/s/3CxGHsojZ4fBy94</a>	
TTA	TTAT.3G-36.412V15.0.0	15.0.0	Published	11.09.2020	<a href="http://www.tta.or.kr/data/ttasDown.jsp?where=14688&amp;pk_num=TTAT.3G-36.412V15.0.0">http://www.tta.or.kr/data/ttasDown.jsp?where=14688&amp;pk_num=TTAT.3G-36.412V15.0.0</a>	
TTC	TS-3GA-36.412(Rel15) v15.0.0	15.0.0	Published	28.09.2018	<a href="https://www.ttc.or.jp/st/docs/3gpps2018/TS/TS-3GA-36.412(Rel15)v15.0.0.pdf">https://www.ttc.or.jp/st/docs/3gpps2018/TS/TS-3GA-36.412(Rel15)v15.0.0.pdf</a>	
<b>Release 16</b>						
ATIS	ATIS.3GPP.36.412V1600	16.0.0	Published	08.09.2020	<a href="http://www.atis.org/3gpp-documents/Rel16">http://www.atis.org/3gpp-documents/Rel16</a>	
CCSA	CCSA.36.412V1600	16.0.0	Published	01.04.2020	<a href="http://www.ccsa.org.cn:9001/portalsFile/downloadOldFile?type=17&amp;oldFileUrl=Rel16/TS%2036.412%20V16.0.0.doc">http://www.ccsa.org.cn:9001/portalsFile/downloadOldFile?type=17&amp;oldFileUrl=Rel16/TS%2036.412%20V16.0.0.doc</a>	
ETSI	ETSI TS 136 412	16.0.0	Published	21.09.2020	<a href="http://www.etsi.org/deliver/etsi_ts/136400_136499/136412/16.00.00_60/ts_136412v160000p.pdf">http://www.etsi.org/deliver/etsi_ts/136400_136499/136412/16.00.00_60/ts_136412v160000p.pdf</a>	
TSDSI	TSDSI STD T1.3GPP 36.412-16.0.0 V1.0.0	16.0.0	Published	06.10.2020	<a href="https://members.tdsi.in/index.php/s/cw7yJaBMg3baAbQ">https://members.tdsi.in/index.php/s/cw7yJaBMg3baAbQ</a>	
TTA	TTAT.3G-36.412V16.0.0	16.0.0	Published	11.09.2020	<a href="http://www.tta.or.kr/data/ttasDown.jsp?where=14688&amp;pk_num=TTAT.3G-36.412V16.0.0">http://www.tta.or.kr/data/ttasDown.jsp?where=14688&amp;pk_num=TTAT.3G-36.412V16.0.0</a>	
TTC	TS-3GA-36.412(Rel16) v16.0.0	16.0.0	Published	02.10.2020	<a href="https://www.ttc.or.jp/st/docs/3gpps2020/TS/TS-3GA-36_412_Rel16v16_0_0.pdf">https://www.ttc.or.jp/st/docs/3gpps2020/TS/TS-3GA-36_412_Rel16v16_0_0.pdf</a>	

**1.2.1.4.5 TS 36.413**

**Evolved Universal Terrestrial Radio Access Network (E-UTRAN); S1 Application Protocol (S1AP)**

This document specifies the E-UTRAN radio network layer signalling protocol for the S1 interface. The S1 Application Protocol (S1AP) supports the functions of S1 interface by signalling procedures defined in this document.

SDO	Document No.	Version	Status	Issued date	Location
<b>Release 15</b>					
ATIS	ATIS.3GPP.36.413V1590	15.9.0	Published	08.09.2020	<a href="http://www.atis.org/3gpp-documents/Rel15">http://www.atis.org/3gpp-documents/Rel15</a>
CCSA	CCSA.36.413V1590	15.9.0	Published	16.07.2020	<a href="http://www.ccsa.org.cn:9001/portalsFile/downloadOldFile?type=17&amp;oldFileUrl=Rel15/TS%2036.413%20V15.9.0.doc">http://www.ccsa.org.cn:9001/portalsFile/downloadOldFile?type=17&amp;oldFileUrl=Rel15/TS%2036.413%20V15.9.0.doc</a>
ETSI	ETSI TS 136 413	15.9.0	Published	21.07.2020	<a href="http://www.etsi.org/deliver/etsi_ts/136400_136499/136413/15.09.00_60/ts_136413v150900p.pdf">http://www.etsi.org/deliver/etsi_ts/136400_136499/136413/15.09.00_60/ts_136413v150900p.pdf</a>
TSDSI	TSDSI STD T1.3GPP 36.413-15.9.0 V1.0.0	15.9.0	Published	06.10.2020	<a href="https://members.tdsi.in/index.php/s/EoLfFgcPcG7Hbet">https://members.tdsi.in/index.php/s/EoLfFgcPcG7Hbet</a>
TTA	TTAT.3G-36.413V15.9.0	15.9.0	Published	11.09.2020	<a href="http://www.tta.or.kr/data/ttasDown.jsp?where=14688&amp;pk_num=TTAT.3G-36.413V15.9.0">http://www.tta.or.kr/data/ttasDown.jsp?where=14688&amp;pk_num=TTAT.3G-36.413V15.9.0</a>
TTC	TS-3GA-36.413(Rel15) v15.9.0	15.9.0	Published	02.10.2020	<a href="https://www.ttc.or.jp/st/docs/3gpps2020/TS/TS-3GA-36_413_Rel15v15_9_0.pdf">https://www.ttc.or.jp/st/docs/3gpps2020/TS/TS-3GA-36_413_Rel15v15_9_0.pdf</a>
<b>Release 16</b>					
ATIS	ATIS.3GPP.36.413V1620	16.2.0	Published	08.09.2020	<a href="http://www.atis.org/3gpp-documents/Rel16">http://www.atis.org/3gpp-documents/Rel16</a>
CCSA	CCSA.36.413V1620	16.2.0	Published	16.07.2020	<a href="http://www.ccsa.org.cn:9001/portalsFile/downloadOldFile?type=17&amp;oldFileUrl=Rel16/TS%2036.413%20V16.2.0.doc">http://www.ccsa.org.cn:9001/portalsFile/downloadOldFile?type=17&amp;oldFileUrl=Rel16/TS%2036.413%20V16.2.0.doc</a>
ETSI	ETSI TS 136 413	16.2.0	Published	21.07.2020	<a href="http://www.etsi.org/deliver/etsi_ts/136400_136499/136413/16.02.00_60/ts_136413v160200p.pdf">http://www.etsi.org/deliver/etsi_ts/136400_136499/136413/16.02.00_60/ts_136413v160200p.pdf</a>
TSDSI	TSDSI STD T1.3GPP 36.413-16.2.0 V1.0.0	16.2.0	Published	06.10.2020	<a href="https://members.tdsi.in/index.php/s/Cb4HynLKoaHrMRt">https://members.tdsi.in/index.php/s/Cb4HynLKoaHrMRt</a>
TTA	TTAT.3G-36.413V16.2.0	16.2.0	Published	11.09.2020	<a href="http://www.tta.or.kr/data/ttasDown.jsp?where=14688&amp;pk_num=TTAT.3G-36.413V16.2.0">http://www.tta.or.kr/data/ttasDown.jsp?where=14688&amp;pk_num=TTAT.3G-36.413V16.2.0</a>
TTC	TS-3GA-36.413(Rel16) v16.2.0	16.2.0	Published	02.10.2020	<a href="https://www.ttc.or.jp/st/docs/3gpps2020/TS/TS-3GA-36_413_Rel16v16_2_0.pdf">https://www.ttc.or.jp/st/docs/3gpps2020/TS/TS-3GA-36_413_Rel16v16_2_0.pdf</a>

**1.2.1.4.6 TS 36.414**

**Evolved Universal Terrestrial Radio Access Network (E-UTRAN); S1 data transport**

This document specifies the standards for user data transport protocols and related signalling protocols to establish user plane transport bearers over the S1 interface.

SDO	Document No.	Version	Status	Issued date	Location
<b>Release 15</b>					

## 74

### Rec. ITU-R M.2150-0

ATIS	ATIS.3GPP.36.414V1500	15.0.0	Published	08.09.2020	<a href="http://www.atis.org/3gpp-documents/Rel15">http://www.atis.org/3gpp-documents/Rel15</a>
CCSA	CCSA.36.414V1500	15.0.0	Published	22.06.2018	<a href="http://www.ccsa.org.cn:9001/portalsFile/downloadOldFile?type=17&amp;oldFileUrl=Rel15/TS%2036.414%20V15.0.0.doc">http://www.ccsa.org.cn:9001/portalsFile/downloadOldFile?type=17&amp;oldFileUrl=Rel15/TS%2036.414%20V15.0.0.doc</a>
ETSI	ETSI TS 136 414	15.0.0	Published	04.07.2018	<a href="http://www.etsi.org/deliver/etsi_ts/136400_136499/136414/15.00.00_60/ts_136414v150000p.pdf">http://www.etsi.org/deliver/etsi_ts/136400_136499/136414/15.00.00_60/ts_136414v150000p.pdf</a>
TSDSI	TSDSI STD T1.3GPP 36.414-15.0.0 V1.0.0	15.0.0	Published	06.10.2020	<a href="https://members.tdsi.in/index.php/s/rBbRyPf5gQZrJsm">https://members.tdsi.in/index.php/s/rBbRyPf5gQZrJsm</a>
TTA	TTAT.3G-36.414V15.0.0	15.0.0	Published	11.09.2020	<a href="http://www.tta.or.kr/data/ttasDown.jsp?where=14688&amp;pk_num=TTAT.3G-36.414V15.0.0">http://www.tta.or.kr/data/ttasDown.jsp?where=14688&amp;pk_num=TTAT.3G-36.414V15.0.0</a>
TTC	TS-3GA-36.414(Rel15) v15.0.0	15.0.0	Published	28.09.2018	<a href="https://www.ttc.or.jp/st/docs/3gpps2018/TS/TS-3GA-36.414(Rel15)v15.0.0.pdf">https://www.ttc.or.jp/st/docs/3gpps2018/TS/TS-3GA-36.414(Rel15)v15.0.0.pdf</a>

#### Release 16

ATIS	ATIS.3GPP.36.414V1600	16.0.0	Published	08.09.2020	<a href="http://www.atis.org/3gpp-documents/Rel16">http://www.atis.org/3gpp-documents/Rel16</a>
CCSA	CCSA.36.414V1600	16.0.0	Published	16.07.2020	<a href="http://www.ccsa.org.cn:9001/portalsFile/downloadOldFile?type=17&amp;oldFileUrl=Rel16/TS%2036.414%20V16.0.0.doc">http://www.ccsa.org.cn:9001/portalsFile/downloadOldFile?type=17&amp;oldFileUrl=Rel16/TS%2036.414%20V16.0.0.doc</a>
ETSI	ETSI TS 136 414	16.0.0	Published	21.07.2020	<a href="http://www.etsi.org/deliver/etsi_ts/136400_136499/136414/16.00.00_60/ts_136414v160000p.pdf">http://www.etsi.org/deliver/etsi_ts/136400_136499/136414/16.00.00_60/ts_136414v160000p.pdf</a>
TSDSI	TSDSI STD T1.3GPP 36.414-16.0.0 V1.0.0	16.0.0	Published	06.10.2020	<a href="https://members.tdsi.in/index.php/s/y6R7BGNQqMJZY22">https://members.tdsi.in/index.php/s/y6R7BGNQqMJZY22</a>
TTA	TTAT.3G-36.414V16.0.0	16.0.0	Published	11.09.2020	<a href="http://www.tta.or.kr/data/ttasDown.jsp?where=14688&amp;pk_num=TTAT.3G-36.414V16.0.0">http://www.tta.or.kr/data/ttasDown.jsp?where=14688&amp;pk_num=TTAT.3G-36.414V16.0.0</a>
TTC	TS-3GA-36.414(Rel16) v16.0.0	16.0.0	Published	02.10.2020	<a href="https://www.ttc.or.jp/st/docs/3gpps2020/TS/TS-3GA-36_414_Rel16v16_0_0.pdf">https://www.ttc.or.jp/st/docs/3gpps2020/TS/TS-3GA-36_414_Rel16v16_0_0.pdf</a>

### 1.2.1.4.7 TS 36.420

#### Evolved Universal Terrestrial Radio Access Network (E-UTRAN); X2 general aspects and principles

This document is an introduction to the TSG RAN TS 36.42x series of UMTS technical specifications that define the X2 interface. It is an interface for the interconnection of two E-UTRAN NodeB (eNodeB) components within the Evolved Universal Terrestrial Radio Access Network (E-UTRAN) architecture.

SDO	Document No.	Version	Status	Issued date	Location
<b>Release 15</b>					
ATIS	ATIS.3GPP.36.420V1520	15.2.0	Published	08.09.2020	<a href="http://www.atis.org/3gpp-documents/Rel15">http://www.atis.org/3gpp-documents/Rel15</a>
CCSA	CCSA.36.420V1520	15.2.0	Published	09.01.2020	<a href="http://www.ccsa.org.cn:9001/portalsFile/downloadOldFile?type=17&amp;oldFileUrl=Rel15/TS%2036.420%20V15.2.0.doc">http://www.ccsa.org.cn:9001/portalsFile/downloadOldFile?type=17&amp;oldFileUrl=Rel15/TS%2036.420%20V15.2.0.doc</a>
ETSI	ETSI TS 136 420	15.2.0	Published	17.01.2020	<a href="http://www.etsi.org/deliver/etsi_ts/136400_136499/136420/15.02.00_60/ts_136420v150200p.pdf">http://www.etsi.org/deliver/etsi_ts/136400_136499/136420/15.02.00_60/ts_136420v150200p.pdf</a>
TSDSI	TSDSI STD T1.3GPP 36.420-15.2.0 V1.0.0	15.2.0	Published	06.10.2020	<a href="https://members.tdsi.in/index.php/s/9PK4K3jApf6tYW7">https://members.tdsi.in/index.php/s/9PK4K3jApf6tYW7</a>
TTA	TTAT.3G-36.420V15.2.0	15.2.0	Published	11.09.2020	<a href="http://www.tta.or.kr/data/ttasDown.jsp?where=14688&amp;pk_num=TTAT.3G-36.420V15.2.0">http://www.tta.or.kr/data/ttasDown.jsp?where=14688&amp;pk_num=TTAT.3G-36.420V15.2.0</a>
TTC	TS-3GA-36.420(Rel15) v15.2.0	15.2.0	Published	16.04.2020	<a href="https://www.ttc.or.jp/st/docs/3gpps2020/TS/TS-3GA-36_420_Rel15v15_2_0.pdf">https://www.ttc.or.jp/st/docs/3gpps2020/TS/TS-3GA-36_420_Rel15v15_2_0.pdf</a>
<b>Release 16</b>					
ATIS	ATIS.3GPP.36.420V1600	16.0.0	Published	08.09.2020	<a href="http://www.atis.org/3gpp-documents/Rel16">http://www.atis.org/3gpp-documents/Rel16</a>
CCSA	CCSA.36.420V1600	16.0.0	Published	17.07.2020	<a href="http://www.ccsa.org.cn:9001/portalsFile/downloadOldFile?type=17&amp;oldFileUrl=Rel16/TS%2036.420%20V16.0.0.doc">http://www.ccsa.org.cn:9001/portalsFile/downloadOldFile?type=17&amp;oldFileUrl=Rel16/TS%2036.420%20V16.0.0.doc</a>
ETSI	ETSI TS 136 420	16.0.0	Published	23.07.2020	<a href="http://www.etsi.org/deliver/etsi_ts/136400_136499/136420/16.00.00_60/ts_136420v160000p.pdf">http://www.etsi.org/deliver/etsi_ts/136400_136499/136420/16.00.00_60/ts_136420v160000p.pdf</a>
TSDSI	TSDSI STD T1.3GPP 36.420-16.0.0 V1.0.0	16.0.0	Published	06.10.2020	<a href="https://members.tdsi.in/index.php/s/7mpQW2MFtKHGc8b">https://members.tdsi.in/index.php/s/7mpQW2MFtKHGc8b</a>
TTA	TTAT.3G-36.420V16.0.0	16.0.0	Published	11.09.2020	<a href="http://www.tta.or.kr/data/ttasDown.jsp?where=14688&amp;pk_num=TTAT.3G-36.420V16.0.0">http://www.tta.or.kr/data/ttasDown.jsp?where=14688&amp;pk_num=TTAT.3G-36.420V16.0.0</a>
TTC	TS-3GA-36.420(Rel16) v16.0.0	16.0.0	Published	02.10.2020	<a href="https://www.ttc.or.jp/st/docs/3gpps2020/TS/TS-3GA-36_420_Rel16v16_0_0.pdf">https://www.ttc.or.jp/st/docs/3gpps2020/TS/TS-3GA-36_420_Rel16v16_0_0.pdf</a>

### 1.2.1.4.8 TS 36.421

#### Evolved Universal Terrestrial Radio Access Network (E-UTRAN); X2 layer 1

This document specifies the standards allowed to implement Layer 1 on the X2 interface. The specification of transmission delay requirements and O & M requirements are not in the scope of this document. In the following “Layer 1” and “Physical Layer” are assumed to be synonymous.

SDO	Document No.	Version	Status	Issued date	Location
<b>Release 15</b>					
ATIS	ATIS.3GPP.36.421V1500	15.0.0	Published	08.09.2020	<a href="http://www.atis.org/3gpp-documents/Rel15">http://www.atis.org/3gpp-documents/Rel15</a>

CCSA	CCSA.36.421V1500	15.0.0	Published	22.06.2018	<a href="http://www.ccsa.org.cn:9001/portalsFile/downloadOldFile?type=17&amp;oldFileUrl=Rel15/TS%2036.421%20V15.0.0.doc">http://www.ccsa.org.cn:9001/portalsFile/downloadOldFile?type=17&amp;oldFileUrl=Rel15/TS%2036.421%20V15.0.0.doc</a>
ETSI	ETSI TS 136 421	15.0.0	Published	04.07.2018	<a href="http://www.etsi.org/deliver/etsi_ts/136400_136499/136421/15.00.00_60/ts_136421v150000p.pdf">http://www.etsi.org/deliver/etsi_ts/136400_136499/136421/15.00.00_60/ts_136421v150000p.pdf</a>
TSDSI	TSDSI STD T1.3GPP 36.421-15.0.0 V1.0.0	15.0.0	Published	06.10.2020	<a href="https://members.tdsi.in/index.php/s/oHQTHbiE4GnTJcF">https://members.tdsi.in/index.php/s/oHQTHbiE4GnTJcF</a>
TTA	TTAT.3G-36.421V15.0.0	15.0.0	Published	11.09.2020	<a href="http://www.tta.or.kr/data/ttasDown.jsp?where=14688&amp;pk_num=TTAT.3G-36.421V15.0.0">http://www.tta.or.kr/data/ttasDown.jsp?where=14688&amp;pk_num=TTAT.3G-36.421V15.0.0</a>
TTC	TS-3GA-36.421(Rel15) v15.0.0	15.0.0	Published	28.09.2018	<a href="https://www.ttc.or.jp/st/docs/3gpps2018/TS/TS-3GA-36.421(Rel15)v15.0.0.pdf">https://www.ttc.or.jp/st/docs/3gpps2018/TS/TS-3GA-36.421(Rel15)v15.0.0.pdf</a>

**Release 16**

ATIS	ATIS.3GPP.36.421V1600	16.0.0	Published	08.09.2020	<a href="http://www.atis.org/3gpp-documents/Rel16">http://www.atis.org/3gpp-documents/Rel16</a>
CCSA	CCSA.36.421V1600	16.0.0	Published	16.07.2020	<a href="http://www.ccsa.org.cn:9001/portalsFile/downloadOldFile?type=17&amp;oldFileUrl=Rel16/TS%2036.421%20V16.0.0.doc">http://www.ccsa.org.cn:9001/portalsFile/downloadOldFile?type=17&amp;oldFileUrl=Rel16/TS%2036.421%20V16.0.0.doc</a>
ETSI	ETSI TS 136 421	16.0.0	Published	21.07.2020	<a href="http://www.etsi.org/deliver/etsi_ts/136400_136499/136421/16.00.00_60/ts_136421v160000p.pdf">http://www.etsi.org/deliver/etsi_ts/136400_136499/136421/16.00.00_60/ts_136421v160000p.pdf</a>
TSDSI	TSDSI STD T1.3GPP 36.421-16.0.0 V1.0.0	16.0.0	Published	06.10.2020	<a href="https://members.tdsi.in/index.php/s/DGRSem7PLiDpeSi">https://members.tdsi.in/index.php/s/DGRSem7PLiDpeSi</a>
TTA	TTAT.3G-36.421V16.0.0	16.0.0	Published	11.09.2020	<a href="http://www.tta.or.kr/data/ttasDown.jsp?where=14688&amp;pk_num=TTAT.3G-36.421V16.0.0">http://www.tta.or.kr/data/ttasDown.jsp?where=14688&amp;pk_num=TTAT.3G-36.421V16.0.0</a>
TTC	TS-3GA-36.421(Rel16) v16.0.0	16.0.0	Published	02.10.2020	<a href="https://www.ttc.or.jp/st/docs/3gpps2020/TS/TS-3GA-36_421_Rel16v16_0_0.pdf">https://www.ttc.or.jp/st/docs/3gpps2020/TS/TS-3GA-36_421_Rel16v16_0_0.pdf</a>

**1.2.1.4.9 TS 36.422**

**Evolved Universal Terrestrial Radio Access Network (E-UTRAN); X2 signalling transport**

This document specifies the standards for Signalling Transport to be used across X2 interface. X2 interface is a logical interface between eNodeBs. This document describes how the X2-AP signalling messages are transported over X2.

SDO	Document No.	Version	Status	Issued date	Location
<b>Release 15</b>					
ATIS	ATIS.3GPP.36.422V1510	15.1.0	Published	08.09.2020	<a href="http://www.atis.org/3gpp-documents/Rel15">http://www.atis.org/3gpp-documents/Rel15</a>
CCSA	CCSA.36.422V1510	15.1.0	Published	08.01.2019	<a href="http://www.ccsa.org.cn:9001/portalsFile/downloadOldFile?type=17&amp;oldFileUrl=Rel15/TS%2036.422%20V15.1.0.doc">http://www.ccsa.org.cn:9001/portalsFile/downloadOldFile?type=17&amp;oldFileUrl=Rel15/TS%2036.422%20V15.1.0.doc</a>
ETSI	ETSI TS 136 422	15.1.0	Published	17.04.2019	<a href="http://www.etsi.org/deliver/etsi_ts/136400_136499/136422/15.01.00_60/ts_136422v150100p.pdf">http://www.etsi.org/deliver/etsi_ts/136400_136499/136422/15.01.00_60/ts_136422v150100p.pdf</a>
TSDSI	TSDSI STD T1.3GPP 36.422-15.1.0 V1.0.0	15.1.0	Published	06.10.2020	<a href="https://members.tdsi.in/index.php/s/zSdFHNCjNAKXAnH">https://members.tdsi.in/index.php/s/zSdFHNCjNAKXAnH</a>
TTA	TTAT.3G-36.422V15.1.0	15.1.0	Published	11.09.2020	<a href="http://www.tta.or.kr/data/ttasDown.jsp?where=14688&amp;pk_num=TTAT.3G-36.422V15.1.0">http://www.tta.or.kr/data/ttasDown.jsp?where=14688&amp;pk_num=TTAT.3G-36.422V15.1.0</a>
TTC	TS-3GA-36.422(Rel15) v15.1.0	15.1.0	Published	29.03.2019	<a href="https://www.ttc.or.jp/st/docs/3gpps2019/TS/TS-3GA-36.422(Rel15)v15.1.0.pdf">https://www.ttc.or.jp/st/docs/3gpps2019/TS/TS-3GA-36.422(Rel15)v15.1.0.pdf</a>

**Release 16**

ATIS	ATIS.3GPP.36.422V1600	16.0.0	Published	08.09.2020	<a href="http://www.atis.org/3gpp-documents/Rel16">http://www.atis.org/3gpp-documents/Rel16</a>
CCSA	CCSA.36.422V1600	16.0.0	Published	01.04.2020	<a href="http://www.ccsa.org.cn:9001/portalsFile/downloadOldFile?type=17&amp;oldFileUrl=Rel16/TS%2036.422%20V16.0.0.doc">http://www.ccsa.org.cn:9001/portalsFile/downloadOldFile?type=17&amp;oldFileUrl=Rel16/TS%2036.422%20V16.0.0.doc</a>
ETSI	ETSI TS 136 422	16.0.0	Published	21.09.2020	<a href="http://www.etsi.org/deliver/etsi_ts/136400_136499/136422/16.00.00_60/ts_136422v160000p.pdf">http://www.etsi.org/deliver/etsi_ts/136400_136499/136422/16.00.00_60/ts_136422v160000p.pdf</a>
TSDSI	TSDSI STD T1.3GPP 36.422-16.0.0 V1.0.0	16.0.0	Published	06.10.2020	<a href="https://members.tdsi.in/index.php/s/CHtjSZz72n3PFLR">https://members.tdsi.in/index.php/s/CHtjSZz72n3PFLR</a>
TTA	TTAT.3G-36.422V16.0.0	16.0.0	Published	11.09.2020	<a href="http://www.tta.or.kr/data/ttasDown.jsp?where=14688&amp;pk_num=TTAT.3G-36.422V16.0.0">http://www.tta.or.kr/data/ttasDown.jsp?where=14688&amp;pk_num=TTAT.3G-36.422V16.0.0</a>
TTC	TS-3GA-36.422(Rel16) v16.0.0	16.0.0	Published	02.10.2020	<a href="https://www.ttc.or.jp/st/docs/3gpps2020/TS/TS-3GA-36_422_Rel16v16_0_0.pdf">https://www.ttc.or.jp/st/docs/3gpps2020/TS/TS-3GA-36_422_Rel16v16_0_0.pdf</a>

**1.2.1.4.10 TS 36.423**

**Evolved Universal Terrestrial Radio Access Network (E-UTRAN); X2 Application Protocol (X2AP)**

This document specifies the radio network layer signalling procedures of the control plane between eNodeBs in E-UTRAN. X2AP supports the functions of X2 interface by signalling procedures defined in this document.

SDO	Document No.	Version	Status	Issued date	Location
<b>Release 15</b>					
ATIS	ATIS.3GPP.36.423V15100	15.10.0	Published	08.09.2020	<a href="http://www.atis.org/3gpp-documents/Rel15">http://www.atis.org/3gpp-documents/Rel15</a>
CCSA	CCSA.36.423V15100	15.10.0	Published	17.07.2020	<a href="http://www.ccsa.org.cn:9001/portalsFile/downloadOldFile?type=17&amp;oldFileUrl=Rel15/TS%2036.423%20V15.10.doc">http://www.ccsa.org.cn:9001/portalsFile/downloadOldFile?type=17&amp;oldFileUrl=Rel15/TS%2036.423%20V15.10.doc</a>
ETSI	ETSI TS 136 423	15.10.0	Published	23.07.2020	<a href="http://www.etsi.org/deliver/etsi_ts/136400_136499/136423/15.10.00_60/ts_136423v151000p.pdf">http://www.etsi.org/deliver/etsi_ts/136400_136499/136423/15.10.00_60/ts_136423v151000p.pdf</a>

TSDSI	TSDSI STD T1.3GPP 36.423-15.10.0 V1.0.0	15.10.0	Published	06.10.2020	<a href="https://members.tdsi.in/index.php/s/AdfcFm8DpD3o8nG">https://members.tdsi.in/index.php/s/AdfcFm8DpD3o8nG</a>
TTA	TTAT.3G-36.423V15.10.0	15.10.0	Published	11.09.2020	<a href="http://www.tta.or.kr/data/ttasDown.jsp?where=14688&amp;pk_num=TTAT.3G-36.423V15.10.0">http://www.tta.or.kr/data/ttasDown.jsp?where=14688&amp;pk_num=TTAT.3G-36.423V15.10.0</a>
TTC	TS-3GA-36.423(Rel15) v15.10.0	15.10.0	Published	02.10.2020	<a href="https://www.ttc.or.jp/st/docs/3gpps2020/TS/TS-3GA-36_423_Rel15v15_10_0.pdf">https://www.ttc.or.jp/st/docs/3gpps2020/TS/TS-3GA-36_423_Rel15v15_10_0.pdf</a>

**Release 16**

ATIS	ATIS.3GPP.36.423V1620	16.2.0	Published	08.09.2020	<a href="http://www.atis.org/3gpp-documents/Rel16">http://www.atis.org/3gpp-documents/Rel16</a>
CCSA	CCSA.36.423V1620	16.2.0	Published	17.07.2020	<a href="http://www.ccsa.org.cn:9001/portalsFile/downloadOldFile?type=17&amp;oldFileUrl=Rel16/TS%2036.423%20V16.2.0.doc">http://www.ccsa.org.cn:9001/portalsFile/downloadOldFile?type=17&amp;oldFileUrl=Rel16/TS%2036.423%20V16.2.0.doc</a>
ETSI	ETSI TS 136 423	16.2.0	Published	23.07.2020	<a href="http://www.etsi.org/deliver/etsi_ts/136400_136499/136423/16.02.00_60/ts_136423v160200p.pdf">http://www.etsi.org/deliver/etsi_ts/136400_136499/136423/16.02.00_60/ts_136423v160200p.pdf</a>
TSDSI	TSDSI STD T1.3GPP 36.423-16.2.0 V1.0.0	16.2.0	Published	06.10.2020	<a href="https://members.tdsi.in/index.php/s/FHzmHf6aApLetDk">https://members.tdsi.in/index.php/s/FHzmHf6aApLetDk</a>
TTA	TTAT.3G-36.423V16.2.0	16.2.0	Published	11.09.2020	<a href="http://www.tta.or.kr/data/ttasDown.jsp?where=14688&amp;pk_num=TTAT.3G-36.423V16.2.0">http://www.tta.or.kr/data/ttasDown.jsp?where=14688&amp;pk_num=TTAT.3G-36.423V16.2.0</a>
TTC	TS-3GA-36.423(Rel16) v16.2.0	16.2.0	Published	02.10.2020	<a href="https://www.ttc.or.jp/st/docs/3gpps2020/TS/TS-3GA-36_423_Rel16v16_2_0.pdf">https://www.ttc.or.jp/st/docs/3gpps2020/TS/TS-3GA-36_423_Rel16v16_2_0.pdf</a>

**1.2.1.4.11 TS 36.424****Evolved Universal Terrestrial Radio Access Network (E-UTRAN); X2 data transport**

This document specifies the standards for user data transport protocols and related signalling protocols to establish user plane transport bearers over the X2 interface.

SDO	Document No.	Version	Status	Issued date	Location
<b>Release 15</b>					
ATIS	ATIS.3GPP.36.424V1510	15.1.0	Published	08.09.2020	<a href="http://www.atis.org/3gpp-documents/Rel15">http://www.atis.org/3gpp-documents/Rel15</a>
CCSA	CCSA.36.424V1510	15.1.0	Published	09.01.2020	<a href="http://www.ccsa.org.cn:9001/portalsFile/downloadOldFile?type=17&amp;oldFileUrl=Rel15/TS%2036.424%20V15.1.0.doc">http://www.ccsa.org.cn:9001/portalsFile/downloadOldFile?type=17&amp;oldFileUrl=Rel15/TS%2036.424%20V15.1.0.doc</a>
ETSI	ETSI TS 136 424	15.1.0	Published	17.01.2020	<a href="http://www.etsi.org/deliver/etsi_ts/136400_136499/136424/15.01.00_60/ts_136424v150100p.pdf">http://www.etsi.org/deliver/etsi_ts/136400_136499/136424/15.01.00_60/ts_136424v150100p.pdf</a>
TSDSI	TSDSI STD T1.3GPP 36.424-15.1.0 V1.0.0	15.1.0	Published	06.10.2020	<a href="https://members.tdsi.in/index.php/s/kpf94ny3RKq3eRD">https://members.tdsi.in/index.php/s/kpf94ny3RKq3eRD</a>
TTA	TTAT.3G-36.424V15.1.0	15.1.0	Published	11.09.2020	<a href="http://www.tta.or.kr/data/ttasDown.jsp?where=14688&amp;pk_num=TTAT.3G-36.424V15.1.0">http://www.tta.or.kr/data/ttasDown.jsp?where=14688&amp;pk_num=TTAT.3G-36.424V15.1.0</a>
TTC	TS-3GA-36.424(Rel15) v15.1.0	15.1.0	Published	16.04.2020	<a href="https://www.ttc.or.jp/st/docs/3gpps2020/TS/TS-3GA-36_424_Rel15v15_1_0.pdf">https://www.ttc.or.jp/st/docs/3gpps2020/TS/TS-3GA-36_424_Rel15v15_1_0.pdf</a>
<b>Release 16</b>					
ATIS	ATIS.3GPP.36.424V1600	16.0.0	Published	08.09.2020	<a href="http://www.atis.org/3gpp-documents/Rel16">http://www.atis.org/3gpp-documents/Rel16</a>
CCSA	CCSA.36.424V1600	16.0.0	Published	16.07.2020	<a href="http://www.ccsa.org.cn:9001/portalsFile/downloadOldFile?type=17&amp;oldFileUrl=Rel16/TS%2036.424%20V16.0.0.doc">http://www.ccsa.org.cn:9001/portalsFile/downloadOldFile?type=17&amp;oldFileUrl=Rel16/TS%2036.424%20V16.0.0.doc</a>
ETSI	ETSI TS 136 424	16.0.0	Published	21.07.2020	<a href="http://www.etsi.org/deliver/etsi_ts/136400_136499/136424/16.00.00_60/ts_136424v160000p.pdf">http://www.etsi.org/deliver/etsi_ts/136400_136499/136424/16.00.00_60/ts_136424v160000p.pdf</a>
TSDSI	TSDSI STD T1.3GPP 36.424-16.0.0 V1.0.0	16.0.0	Published	06.10.2020	<a href="https://members.tdsi.in/index.php/s/HexHwXSIXoWdT2">https://members.tdsi.in/index.php/s/HexHwXSIXoWdT2</a>
TTA	TTAT.3G-36.424V16.0.0	16.0.0	Published	11.09.2020	<a href="http://www.tta.or.kr/data/ttasDown.jsp?where=14688&amp;pk_num=TTAT.3G-36.424V16.0.0">http://www.tta.or.kr/data/ttasDown.jsp?where=14688&amp;pk_num=TTAT.3G-36.424V16.0.0</a>
TTC	TS-3GA-36.424(Rel16) v16.0.0	16.0.0	Published	02.10.2020	<a href="https://www.ttc.or.jp/st/docs/3gpps2020/TS/TS-3GA-36_424_Rel16v16_0_0.pdf">https://www.ttc.or.jp/st/docs/3gpps2020/TS/TS-3GA-36_424_Rel16v16_0_0.pdf</a>

**1.2.1.4.12 TS 36.425****Evolved Universal Terrestrial Radio Access Network (E-UTRAN); X2 interface user plane protocol**

This document specifies the X2 user plane protocol being used over the X2 interface.

SDO	Document No.	Version	Status	Issued date	Location
<b>Release 15</b>					
ATIS	ATIS.3GPP.36.425V1500	15.0.0	Published	08.09.2020	<a href="http://www.atis.org/3gpp-documents/Rel15">http://www.atis.org/3gpp-documents/Rel15</a>
CCSA	CCSA.36.425V1500	15.0.0	Published	22.06.2018	<a href="http://www.ccsa.org.cn:9001/portalsFile/downloadOldFile?type=17&amp;oldFileUrl=Rel15/TS%2036.425%20V15.0.0.doc">http://www.ccsa.org.cn:9001/portalsFile/downloadOldFile?type=17&amp;oldFileUrl=Rel15/TS%2036.425%20V15.0.0.doc</a>
ETSI	ETSI TS 136 425	15.0.0	Published	04.07.2018	<a href="http://www.etsi.org/deliver/etsi_ts/136400_136499/136425/15.00.00_60/ts_136425v150000p.pdf">http://www.etsi.org/deliver/etsi_ts/136400_136499/136425/15.00.00_60/ts_136425v150000p.pdf</a>
TSDSI	TSDSI STD T1.3GPP 36.425-15.0.0 V1.0.0	15.0.0	Published	06.10.2020	<a href="https://members.tdsi.in/index.php/s/gTrKqLPwwFo8tE2">https://members.tdsi.in/index.php/s/gTrKqLPwwFo8tE2</a>
TTA	TTAT.3G-36.425V15.0.0	15.0.0	Published	11.09.2020	<a href="http://www.tta.or.kr/data/ttasDown.jsp?where=14688&amp;pk_num=TTAT.3G-36.425V15.0.0">http://www.tta.or.kr/data/ttasDown.jsp?where=14688&amp;pk_num=TTAT.3G-36.425V15.0.0</a>
TTC	TS-3GA-36.425(Rel15) v15.0.0	15.0.0	Published	28.09.2018	<a href="https://www.ttc.or.jp/st/docs/3gpps2018/TS/TS-3GA-36.425(Rel15)v15.0.0.pdf">https://www.ttc.or.jp/st/docs/3gpps2018/TS/TS-3GA-36.425(Rel15)v15.0.0.pdf</a>

**Release 16**

SDO	Document No.	Version	Status	Issued date	Location
ATIS	ATIS.3GPP.36.425V1600	16.0.0	Published	08.09.2020	<a href="http://www.atis.org/3gpp-documents/Rel16">http://www.atis.org/3gpp-documents/Rel16</a>
CCSA	CCSA.36.425V1600	16.0.0	Published	16.07.2020	<a href="http://www.ccsa.org.cn:9001/portalsFile/downloadOldFile?type=17&amp;oldFileUrl=Rel16/TS%2036.425%20V16.0.0.doc">http://www.ccsa.org.cn:9001/portalsFile/downloadOldFile?type=17&amp;oldFileUrl=Rel16/TS%2036.425%20V16.0.0.doc</a>
ETSI	ETSI TS 136 425	16.0.0	Published	21.07.2020	<a href="http://www.etsi.org/deliver/etsi_ts/136400_136499/136425/16.00.00_60/ts_136425v160000p.pdf">http://www.etsi.org/deliver/etsi_ts/136400_136499/136425/16.00.00_60/ts_136425v160000p.pdf</a>
TSDSI	TSDSI STD T1.3GPP 36.425-16.0.0 V1.0.0	16.0.0	Published	06.10.2020	<a href="https://members.tdsi.in/index.php/s/RzRNx4Tcqqs2tH">https://members.tdsi.in/index.php/s/RzRNx4Tcqqs2tH</a>
TTA	TTAT.3G-36.425V16.0.0	16.0.0	Published	11.09.2020	<a href="http://www.tta.or.kr/data/ttasDown.jsp?where=14688&amp;pk_num=TTAT.3G-36.425V16.0.0">http://www.tta.or.kr/data/ttasDown.jsp?where=14688&amp;pk_num=TTAT.3G-36.425V16.0.0</a>
TTC	TS-3GA-36.425(Rel16) v16.0.0	16.0.0	Published	02.10.2020	<a href="https://www.ttc.or.jp/st/docs/3gpps2020/TS/TS-3GA-36_425_Rel16v16_0_0.pdf">https://www.ttc.or.jp/st/docs/3gpps2020/TS/TS-3GA-36_425_Rel16v16_0_0.pdf</a>

**1.2.1.4.13 TS 36.440****Evolved Universal Terrestrial Radio Access Network (E-UTRAN); General aspects and principles for interfaces supporting Multimedia Broadcast Multicast Service (MBMS) within E-UTRAN**

This document describes the overall architecture of the interface for the provision of MBMS in the E-UTRAN. This includes also a description of the general aspects, assumptions and principles guiding the architecture and interface. The MBMS functions to be provided within that architecture are summarized. It introduces the TSG RAN TS 36.44x series of UMTS technical specifications that define the different interfaces introduced for MBMS provision in E-UTRAN.

SDO	Document No.	Version	Status	Issued date	Location
<b>Release 15</b>					
ATIS	ATIS.3GPP.36.440V1500	15.0.0	Published	08.09.2020	<a href="http://www.atis.org/3gpp-documents/Rel15">http://www.atis.org/3gpp-documents/Rel15</a>
CCSA	CCSA.36.440V1500	15.0.0	Published	25.09.2018	<a href="http://www.ccsa.org.cn:9001/portalsFile/downloadOldFile?type=17&amp;oldFileUrl=Rel15/TS%2036.440%20V15.0.0.doc">http://www.ccsa.org.cn:9001/portalsFile/downloadOldFile?type=17&amp;oldFileUrl=Rel15/TS%2036.440%20V15.0.0.doc</a>
ETSI	ETSI TS 136 440	15.0.0	Published	28.09.2018	<a href="http://www.etsi.org/deliver/etsi_ts/136400_136499/136440/15.00.00_60/ts_136440v150000p.pdf">http://www.etsi.org/deliver/etsi_ts/136400_136499/136440/15.00.00_60/ts_136440v150000p.pdf</a>
TSDSI	TSDSI STD T1.3GPP 36.440-15.0.0 V1.0.0	15.0.0	Published	06.10.2020	<a href="https://members.tdsi.in/index.php/s/3Jm8Z92BtjqmArd">https://members.tdsi.in/index.php/s/3Jm8Z92BtjqmArd</a>
TTA	TTAT.3G-36.440V15.0.0	15.0.0	Published	11.09.2020	<a href="http://www.tta.or.kr/data/ttasDown.jsp?where=14688&amp;pk_num=TTAT.3G-36.440V15.0.0">http://www.tta.or.kr/data/ttasDown.jsp?where=14688&amp;pk_num=TTAT.3G-36.440V15.0.0</a>
TTC	TS-3GA-36.440(Rel15) v15.0.0	15.0.0	Published	21.12.2018	<a href="https://www.ttc.or.jp/st/docs/3gpps2018/TS/TS-3GA-36.440(Rel15)v15.0.0.pdf">https://www.ttc.or.jp/st/docs/3gpps2018/TS/TS-3GA-36.440(Rel15)v15.0.0.pdf</a>
<b>Release 16</b>					
ATIS	ATIS.3GPP.36.440V1600	16.0.0	Published	08.09.2020	<a href="http://www.atis.org/3gpp-documents/Rel16">http://www.atis.org/3gpp-documents/Rel16</a>
CCSA	CCSA.36.440V1600	16.0.0	Published	16.07.2020	<a href="http://www.ccsa.org.cn:9001/portalsFile/downloadOldFile?type=17&amp;oldFileUrl=Rel16/TS%2036.440%20V16.0.0.doc">http://www.ccsa.org.cn:9001/portalsFile/downloadOldFile?type=17&amp;oldFileUrl=Rel16/TS%2036.440%20V16.0.0.doc</a>
ETSI	ETSI TS 136 440	16.0.0	Published	21.07.2020	<a href="http://www.etsi.org/deliver/etsi_ts/136400_136499/136440/16.00.00_60/ts_136440v160000p.pdf">http://www.etsi.org/deliver/etsi_ts/136400_136499/136440/16.00.00_60/ts_136440v160000p.pdf</a>
TSDSI	TSDSI STD T1.3GPP 36.440-16.0.0 V1.0.0	16.0.0	Published	06.10.2020	<a href="https://members.tdsi.in/index.php/s/DMwSp2Y5nGQMkXM">https://members.tdsi.in/index.php/s/DMwSp2Y5nGQMkXM</a>
TTA	TTAT.3G-36.440V16.0.0	16.0.0	Published	11.09.2020	<a href="http://www.tta.or.kr/data/ttasDown.jsp?where=14688&amp;pk_num=TTAT.3G-36.440V16.0.0">http://www.tta.or.kr/data/ttasDown.jsp?where=14688&amp;pk_num=TTAT.3G-36.440V16.0.0</a>
TTC	TS-3GA-36.440(Rel16) v16.0.0	16.0.0	Published	02.10.2020	<a href="https://www.ttc.or.jp/st/docs/3gpps2020/TS/TS-3GA-36_440_Rel16v16_0_0.pdf">https://www.ttc.or.jp/st/docs/3gpps2020/TS/TS-3GA-36_440_Rel16v16_0_0.pdf</a>

**1.2.1.4.14 TS 36.441****Evolved Universal Terrestrial Radio Access Network (E-UTRAN); Layer 1 for interfaces supporting Multimedia Broadcast Multicast Service (MBMS) within E-UTRAN**

This document specifies the standards allowed to implement layer 1 on the interfaces supporting Multimedia Broadcast Multicast Service (MBMS) within E-UTRAN. In the following, “layer 1” and “physical layer” are assumed to be synonymous.

SDO	Document No.	Version	Status	Issued date	Location
<b>Release 15</b>					
ATIS	ATIS.3GPP.36.441V1500	15.0.0	Published	08.09.2020	<a href="http://www.atis.org/3gpp-documents/Rel15">http://www.atis.org/3gpp-documents/Rel15</a>
CCSA	CCSA.36.441V1500	15.0.0	Published	25.09.2018	<a href="http://www.ccsa.org.cn:9001/portalsFile/downloadOldFile?type=17&amp;oldFileUrl=Rel15/TS%2036.441%20V15.0.0.doc">http://www.ccsa.org.cn:9001/portalsFile/downloadOldFile?type=17&amp;oldFileUrl=Rel15/TS%2036.441%20V15.0.0.doc</a>
ETSI	ETSI TS 136 441	15.0.0	Published	28.09.2018	<a href="http://www.etsi.org/deliver/etsi_ts/136400_136499/136441/15.00.00_60/ts_136441v150000p.pdf">http://www.etsi.org/deliver/etsi_ts/136400_136499/136441/15.00.00_60/ts_136441v150000p.pdf</a>
TSDSI	TSDSI STD T1.3GPP 36.441-15.0.0 V1.0.0	15.0.0	Published	06.10.2020	<a href="https://members.tdsi.in/index.php/s/qKjT5XfHNPpB3MG">https://members.tdsi.in/index.php/s/qKjT5XfHNPpB3MG</a>
TTA	TTAT.3G-36.441V15.0.0	15.0.0	Published	11.09.2020	<a href="http://www.tta.or.kr/data/ttasDown.jsp?where=14688&amp;pk_num=TTAT.3G-36.441V15.0.0">http://www.tta.or.kr/data/ttasDown.jsp?where=14688&amp;pk_num=TTAT.3G-36.441V15.0.0</a>

## 78

### Rec. ITU-R M.2150-0

SDO	Document No.	Version	Status	Issued date	Location
TTC	TS-3GA-36.441(Rel15) v15.0.0	15.0.0	Published	21.12.2018	<a href="https://www.ttc.or.jp/st/docs/3gpps2018/TS/TS-3GA-36.441(Rel15)v15.0.0.pdf">https://www.ttc.or.jp/st/docs/3gpps2018/TS/TS-3GA-36.441(Rel15)v15.0.0.pdf</a>
<b>Release 16</b>					
ATIS	ATIS.3GPP.36.441V1600	16.0.0	Published	08.09.2020	<a href="http://www.atis.org/3gpp-documents/Rel16">http://www.atis.org/3gpp-documents/Rel16</a>
CCSA	CCSA.36.441V1600	16.0.0	Published	16.07.2020	<a href="http://www.ccsa.org.cn:9001/portalsFile/downloadOldFile?type=17&amp;oldFileUrl=Rel16/TS%2036.441%20V16.0.0.doc">http://www.ccsa.org.cn:9001/portalsFile/downloadOldFile?type=17&amp;oldFileUrl=Rel16/TS%2036.441%20V16.0.0.doc</a>
ETSI	ETSI TS 136 441	16.0.0	Published	21.07.2020	<a href="http://www.etsi.org/deliver/etsi_ts/136400_136499/136441/16.00.00_60/ts_136441v160000p.pdf">http://www.etsi.org/deliver/etsi_ts/136400_136499/136441/16.00.00_60/ts_136441v160000p.pdf</a>
TSDSI	TSDSI STD T1.3GPP 36.441-16.0.0 V1.0.0	16.0.0	Published	06.10.2020	<a href="https://members.tdsi.in/index.php/s/enp8P2MA YEW R4B7">https://members.tdsi.in/index.php/s/enp8P2MA YEW R4B7</a>
TTA	TTAT.3G-36.441V16.0.0	16.0.0	Published	11.09.2020	<a href="http://www.tta.or.kr/data/ttasDown.jsp?where=14688&amp;pk_num=TTAT.3G-36.441V16.0.0">http://www.tta.or.kr/data/ttasDown.jsp?where=14688&amp;pk_num=TTAT.3G-36.441V16.0.0</a>
TTC	TS-3GA-36.441(Rel16) v16.0.0	16.0.0	Published	02.10.2020	<a href="https://www.ttc.or.jp/st/docs/3gpps2020/TS/TS-3GA-36_441_Rel16v16_0_0.pdf">https://www.ttc.or.jp/st/docs/3gpps2020/TS/TS-3GA-36_441_Rel16v16_0_0.pdf</a>

### 1.2.1.4.15 TS 36.442

#### Evolved Universal Terrestrial Radio Access Network (E-UTRAN); Signalling Transport for interfaces supporting Multimedia Broadcast Multicast Service (MBMS) within E-UTRAN

This document specifies the standards for signalling transport to be used across M2 and M3 interfaces. M2 interface is a logical interface between the eNodeB and the MCE. M3 interface is a logical interface between the MCE and the MME. This document describes how the M2-AP signalling messages are transported over M2, and how the M3-AP signalling messages are transported over M3.

SDO	Document No.	Version	Status	Issued date	Location
<b>Release 15</b>					
ATIS	ATIS.3GPP.36.442V1500	15.0.0	Published	08.09.2020	<a href="http://www.atis.org/3gpp-documents/Rel15">http://www.atis.org/3gpp-documents/Rel15</a>
CCSA	CCSA.36.442V1_500	15.0.0	Published	25.09.2018	<a href="http://www.ccsa.org.cn:9001/portalsFile/downloadOldFile?type=17&amp;oldFileUrl=Rel15/TS%2036.442%20V15.0.0.doc">http://www.ccsa.org.cn:9001/portalsFile/downloadOldFile?type=17&amp;oldFileUrl=Rel15/TS%2036.442%20V15.0.0.doc</a>
ETSI	ETSI TS 136 442 15.0.0	15.0.0	Published	28.09.2018	<a href="http://www.etsi.org/deliver/etsi_ts/136400_136499/136442/15.00.00_60/ts_136442v150000p.pdf">http://www.etsi.org/deliver/etsi_ts/136400_136499/136442/15.00.00_60/ts_136442v150000p.pdf</a>
TSDSI	TSDSI STD T1.3GPP 36.442-15.0.0 V1.0.0	15.0.0	Published	06.10.2020	<a href="https://members.tdsi.in/index.php/s/SdqLi2EkrJRE43Q">https://members.tdsi.in/index.php/s/SdqLi2EkrJRE43Q</a>
TTA	TTAT.3G-36.442V15.0.0	15.0.0	Published	11.09.2020	<a href="http://www.tta.or.kr/data/ttasDown.jsp?where=14688&amp;pk_num=TTAT.3G-36.442V15.0.0">http://www.tta.or.kr/data/ttasDown.jsp?where=14688&amp;pk_num=TTAT.3G-36.442V15.0.0</a>
TTC	TS-3GA-36.442(Rel15) v15.0.0	15.0.0	Published	21.12.2018	<a href="https://www.ttc.or.jp/st/docs/3gpps2018/TS/TS-3GA-36.442(Rel15)v15.0.0.pdf">https://www.ttc.or.jp/st/docs/3gpps2018/TS/TS-3GA-36.442(Rel15)v15.0.0.pdf</a>
<b>Release 16</b>					
ATIS	ATIS.3GPP.36.442V1600	16.0.0	Published	08.09.2020	<a href="http://www.atis.org/3gpp-documents/Rel16">http://www.atis.org/3gpp-documents/Rel16</a>
CCSA	CCSA.36.442V1600	16.0.0	Published	16.07.2020	<a href="http://www.ccsa.org.cn:9001/portalsFile/downloadOldFile?type=17&amp;oldFileUrl=Rel16/TS%2036.442%20V16.0.0.doc">http://www.ccsa.org.cn:9001/portalsFile/downloadOldFile?type=17&amp;oldFileUrl=Rel16/TS%2036.442%20V16.0.0.doc</a>
ETSI	ETSI TS 136 442	16.0.0	Published	21.07.2020	<a href="http://www.etsi.org/deliver/etsi_ts/136400_136499/136442/16.00.00_60/ts_136442v160000p.pdf">http://www.etsi.org/deliver/etsi_ts/136400_136499/136442/16.00.00_60/ts_136442v160000p.pdf</a>
TSDSI	TSDSI STD T1.3GPP 36.442-16.0.0 V1.0.0	16.0.0	Published	06.10.2020	<a href="https://members.tdsi.in/index.php/s/CXyeK6nEpoFWC4o">https://members.tdsi.in/index.php/s/CXyeK6nEpoFWC4o</a>
TTA	TTAT.3G-36.442V16.0.0	16.0.0	Published	11.09.2020	<a href="http://www.tta.or.kr/data/ttasDown.jsp?where=14688&amp;pk_num=TTAT.3G-36.442V16.0.0">http://www.tta.or.kr/data/ttasDown.jsp?where=14688&amp;pk_num=TTAT.3G-36.442V16.0.0</a>
TTC	TS-3GA-36.442(Rel16) v16.0.0	16.0.0	Published	02.10.2020	<a href="https://www.ttc.or.jp/st/docs/3gpps2020/TS/TS-3GA-36_442_Rel16v16_0_0.pdf">https://www.ttc.or.jp/st/docs/3gpps2020/TS/TS-3GA-36_442_Rel16v16_0_0.pdf</a>

### 1.2.1.4.16 TS 36.443

#### Evolved Universal Terrestrial Radio Access Network (E-UTRAN); M2 Application Protocol (M2AP)

This document specifies the E-UTRAN radio network layer signalling protocol for the M2 interface. The M2 Application Protocol (M2AP) supports the functions of M2 interface by signalling procedures defined in this document.

SDO	Document No.	Version	Status	Issued date	Location
<b>Release 15</b>					
ATIS	ATIS.3GPP.36.443V1500	15.0.0	Published	08.09.2020	<a href="http://www.atis.org/3gpp-documents/Rel15">http://www.atis.org/3gpp-documents/Rel15</a>
CCSA	CCSA.36.443V1500	15.0.0	Published	25.09.2018	<a href="http://www.ccsa.org.cn:9001/portalsFile/downloadOldFile?type=17&amp;oldFileUrl=Rel15/TS%2036.443%20V15.0.0.doc">http://www.ccsa.org.cn:9001/portalsFile/downloadOldFile?type=17&amp;oldFileUrl=Rel15/TS%2036.443%20V15.0.0.doc</a>
ETSI	ETSI TS 136 443	15.0.0	Published	28.09.2018	<a href="http://www.etsi.org/deliver/etsi_ts/136400_136499/136443/15.00.00_60/ts_136443v150000p.pdf">http://www.etsi.org/deliver/etsi_ts/136400_136499/136443/15.00.00_60/ts_136443v150000p.pdf</a>
TSDSI	TSDSI STD T1.3GPP 36.443-15.0.0 V1.0.0	15.0.0	Published	06.10.2020	<a href="https://members.tdsi.in/index.php/s/witLz5XMM3CFHxp">https://members.tdsi.in/index.php/s/witLz5XMM3CFHxp</a>



TTA	TTAT.3G-36.443V15.0.0	15.0.0	Published	11.09.2020	<a href="http://www.tta.or.kr/data/ttasDown.jsp?where=14688&amp;pk_num=TTAT.3G-36.443V15.0.0">http://www.tta.or.kr/data/ttasDown.jsp?where=14688&amp;pk_num=TTAT.3G-36.443V15.0.0</a>
TTC	TS-3GA-36.443(Rel15) v15.0.0	15.0.0	Published	21.12.2018	<a href="https://www.ttc.or.jp/st/docs/3gpps2018/TS/TS-3GA-36.443(Rel15)v15.0.0.pdf">https://www.ttc.or.jp/st/docs/3gpps2018/TS/TS-3GA-36.443(Rel15)v15.0.0.pdf</a>
<b>Release 16</b>					
ATIS	ATIS.3GPP.36.443V1600	16.0.0	Published	08.09.2020	<a href="http://www.atis.org/3gpp-documents/Rel16">http://www.atis.org/3gpp-documents/Rel16</a>
CCSA	CCSA.36.443V1600	16.0.0	Published	31.03.2020	<a href="http://www.ccsa.org.cn:9001/portalsFile/downloadOldFile?type=17&amp;oldFileUrl=Rel16/TS%2036.443%20V16.0.0.doc">http://www.ccsa.org.cn:9001/portalsFile/downloadOldFile?type=17&amp;oldFileUrl=Rel16/TS%2036.443%20V16.0.0.doc</a>
ETSI	ETSI TS 136 443	16.0.0	Published	21.09.2020	<a href="http://www.etsi.org/deliver/etsi_ts/136400_136499/136443/16.00.00_60/ts_136443v160000p.pdf">http://www.etsi.org/deliver/etsi_ts/136400_136499/136443/16.00.00_60/ts_136443v160000p.pdf</a>
TSDSI	TSDSI STD T1.3GPP 36.443-16.0.0 V1.0.0	16.0.0	Published	06.10.2020	<a href="https://members.tdsi.in/index.php/s/FYfjn77KfHjJnk9">https://members.tdsi.in/index.php/s/FYfjn77KfHjJnk9</a>
TTA	TTAT.3G-36.443V16.0.0	16.0.0	Published	11.09.2020	<a href="http://www.tta.or.kr/data/ttasDown.jsp?where=14688&amp;pk_num=TTAT.3G-36.443V16.0.0">http://www.tta.or.kr/data/ttasDown.jsp?where=14688&amp;pk_num=TTAT.3G-36.443V16.0.0</a>
TTC	TS-3GA-36.443(Rel16) v16.0.0	16.0.0	Published	02.10.2020	<a href="https://www.ttc.or.jp/st/docs/3gpps2020/TS/TS-3GA-36_443_Rel16v16_0_0.pdf">https://www.ttc.or.jp/st/docs/3gpps2020/TS/TS-3GA-36_443_Rel16v16_0_0.pdf</a>

**1.2.1.4.17 TS 36.444**

**Evolved Universal Terrestrial Radio Access Network (E-UTRAN); M3 Application Protocol (M3AP)**

This document specifies the E-UTRAN radio network layer signalling protocol for the M3 interface. The M3 Application Protocol (M3AP) supports the functions of M3 interface by signalling procedures defined in this document.

SDO	Document No.	Version	Status	Issued date	Location
<b>Release 15</b>					
ATIS	ATIS.3GPP.36.444V1500	15.0.0	Published	08.09.2020	<a href="http://www.atis.org/3gpp-documents/Rel15">http://www.atis.org/3gpp-documents/Rel15</a>
CCSA	CCSA.36.444V1500	15.0.0	Published	25.09.2018	<a href="http://www.ccsa.org.cn:9001/portalsFile/downloadOldFile?type=17&amp;oldFileUrl=Rel15/TS%2036.444%20V15.0.0.doc">http://www.ccsa.org.cn:9001/portalsFile/downloadOldFile?type=17&amp;oldFileUrl=Rel15/TS%2036.444%20V15.0.0.doc</a>
ETSI	ETSI TS 136 444	15.0.0	Published	28.09.2018	<a href="http://www.etsi.org/deliver/etsi_ts/136400_136499/136444/15.00.00_60/ts_136444v150000p.pdf">http://www.etsi.org/deliver/etsi_ts/136400_136499/136444/15.00.00_60/ts_136444v150000p.pdf</a>
TSDSI	TSDSI STD T1.3GPP 36.444-15.0.0 V1.0.0	15.0.0	Published	06.10.2020	<a href="https://members.tdsi.in/index.php/s/Wc5skLztjkprFKr">https://members.tdsi.in/index.php/s/Wc5skLztjkprFKr</a>
TTA	TTAT.3G-36.444V15.0.0	15.0.0	Published	11.09.2020	<a href="http://www.tta.or.kr/data/ttasDown.jsp?where=14688&amp;pk_num=TTAT.3G-36.444V15.0.0">http://www.tta.or.kr/data/ttasDown.jsp?where=14688&amp;pk_num=TTAT.3G-36.444V15.0.0</a>
TTC	TS-3GA-36.444(Rel15) v15.0.0	15.0.0	Published	21.12.2018	<a href="https://www.ttc.or.jp/st/docs/3gpps2018/TS/TS-3GA-36.444(Rel15)v15.0.0.pdf">https://www.ttc.or.jp/st/docs/3gpps2018/TS/TS-3GA-36.444(Rel15)v15.0.0.pdf</a>
<b>Release 16</b>					
ATIS	ATIS.3GPP.36.444V1600	16.0.0	Published	08.09.2020	<a href="http://www.atis.org/3gpp-documents/Rel16">http://www.atis.org/3gpp-documents/Rel16</a>
CCSA	CCSA.36.444V1600	16.0.0	Published	16.07.2020	<a href="http://www.ccsa.org.cn:9001/portalsFile/downloadOldFile?type=17&amp;oldFileUrl=Rel16/TS%2036.444%20V16.0.0.doc">http://www.ccsa.org.cn:9001/portalsFile/downloadOldFile?type=17&amp;oldFileUrl=Rel16/TS%2036.444%20V16.0.0.doc</a>
ETSI	ETSI TS 136 444	16.0.0	Published	21.07.2020	<a href="http://www.etsi.org/deliver/etsi_ts/136400_136499/136444/16.00.00_60/ts_136444v160000p.pdf">http://www.etsi.org/deliver/etsi_ts/136400_136499/136444/16.00.00_60/ts_136444v160000p.pdf</a>
TSDSI	TSDSI STD T1.3GPP 36.444-16.0.0 V1.0.0	16.0.0	Published	06.10.2020	<a href="https://members.tdsi.in/index.php/s/fp3fn2q65LM88gG">https://members.tdsi.in/index.php/s/fp3fn2q65LM88gG</a>
TTA	TTAT.3G-36.444V16.0.0	16.0.0	Published	11.09.2020	<a href="http://www.tta.or.kr/data/ttasDown.jsp?where=14688&amp;pk_num=TTAT.3G-36.444V16.0.0">http://www.tta.or.kr/data/ttasDown.jsp?where=14688&amp;pk_num=TTAT.3G-36.444V16.0.0</a>
TTC	TS-3GA-36.444(Rel16) v16.0.0	16.0.0	Published	02.10.2020	<a href="https://www.ttc.or.jp/st/docs/3gpps2020/TS/TS-3GA-36_444_Rel16v16_0_0.pdf">https://www.ttc.or.jp/st/docs/3gpps2020/TS/TS-3GA-36_444_Rel16v16_0_0.pdf</a>

**1.2.1.4.18 TS 36.445**

**Evolved Universal Terrestrial Radio Access Network (E-UTRAN); M1 data transport**

This document specifies the standards for user data transport protocols over the E-UTRAN M1 interface.

SDO	Document No.	Version	Status	Issued date	Location
<b>Release 15</b>					
ATIS	ATIS.3GPP.36.445V1500	15.0.0	Published	08.09.2020	<a href="http://www.atis.org/3gpp-documents/Rel15">http://www.atis.org/3gpp-documents/Rel15</a>
CCSA	CCSA.36.445V1500	15.0.0	Published	25.09.2018	<a href="http://www.ccsa.org.cn:9001/portalsFile/downloadOldFile?type=17&amp;oldFileUrl=Rel15/TS%2036.445%20V15.0.0.doc">http://www.ccsa.org.cn:9001/portalsFile/downloadOldFile?type=17&amp;oldFileUrl=Rel15/TS%2036.445%20V15.0.0.doc</a>
ETSI	ETSI TS 136 445	15.0.0	Published	28.09.2018	<a href="http://www.etsi.org/deliver/etsi_ts/136400_136499/136445/15.00.00_60/ts_136445v150000p.pdf">http://www.etsi.org/deliver/etsi_ts/136400_136499/136445/15.00.00_60/ts_136445v150000p.pdf</a>
TSDSI	TSDSI STD T1.3GPP 36.445-15.0.0 V1.0.0	15.0.0	Published	06.10.2020	<a href="https://members.tdsi.in/index.php/s/MdCjGc9BERPXbaA">https://members.tdsi.in/index.php/s/MdCjGc9BERPXbaA</a>
TTA	TTAT.3G-36.445V15.0.0	15.0.0	Published	11.09.2020	<a href="http://www.tta.or.kr/data/ttasDown.jsp?where=14688&amp;pk_num=TTAT.3G-36.445V15.0.0">http://www.tta.or.kr/data/ttasDown.jsp?where=14688&amp;pk_num=TTAT.3G-36.445V15.0.0</a>
TTC	TS-3GA-36.445(Rel15) v15.0.0	15.0.0	Published	21.12.2018	<a href="https://www.ttc.or.jp/st/docs/3gpps2018/TS/TS-3GA-36.445(Rel15)v15.0.0.pdf">https://www.ttc.or.jp/st/docs/3gpps2018/TS/TS-3GA-36.445(Rel15)v15.0.0.pdf</a>
<b>Release 16</b>					

**80****Rec. ITU-R M.2150-0**

ATIS	ATIS.3GPP.36.445V1600	16.0.0	Published	08.09.2020	<a href="http://www.atis.org/3gpp-documents/Rel16">http://www.atis.org/3gpp-documents/Rel16</a>
CCSA	CCSA.36.445V1600	16.0.0	Published	16.07.2020	<a href="http://www.ccsa.org.cn:9001/portalsFile/downloadOldFile?type=17&amp;oldFileUrl=Rel15/TS%2036.445%20V16.0.0.doc">http://www.ccsa.org.cn:9001/portalsFile/downloadOldFile?type=17&amp;oldFileUrl=Rel15/TS%2036.445%20V16.0.0.doc</a>
ETSI	ETSI TS 136 445	16.0.0	Published	21.07.2020	<a href="http://www.etsi.org/deliver/etsi_ts/136400_136499/136445/16.00.00_60/ts_136445v160000p.pdf">http://www.etsi.org/deliver/etsi_ts/136400_136499/136445/16.00.00_60/ts_136445v160000p.pdf</a>
TSDSI	TSDSI STD T1.3GPP 36.445-16.0.0 V1.0.0	16.0.0	Published	06.10.2020	<a href="https://members.tdsi.in/index.php/s/HEBzkYbBZw2KnPQ">https://members.tdsi.in/index.php/s/HEBzkYbBZw2KnPQ</a>
TTA	TTAT.3G-36.445V16.0.0	16.0.0	Published	11.09.2020	<a href="http://www.tta.or.kr/data/ttasDown.jsp?where=14688&amp;pk_num=TTAT.3G-36.445V16.0.0">http://www.tta.or.kr/data/ttasDown.jsp?where=14688&amp;pk_num=TTAT.3G-36.445V16.0.0</a>
TTC	TS-3GA-36.445(Rel16) v16.0.0	16.0.0	Published	02.10.2020	<a href="https://www.ttc.or.jp/st/docs/3gpps2020/TS/TS-3GA-36_445_Rel16v16_0_0.pdf">https://www.ttc.or.jp/st/docs/3gpps2020/TS/TS-3GA-36_445_Rel16v16_0_0.pdf</a>

**1.2.1.4.19 TS 36.455****Evolved Universal Terrestrial Radio Access (E-UTRA); LTE Positioning Protocol A (LPPa)**

This document specifies the control plane radio network layer signalling procedures between eNodeB and E-SMLC. LPPa supports the concerned functions by signalling procedures defined in this document.

SDO	Document No.	Version	Status	Issued date	Location
<b>Release 15</b>					
ATIS	ATIS.3GPP.36.455V1521	15.2.1	Published	08.09.2020	<a href="http://www.atis.org/3gpp-documents/Rel15">http://www.atis.org/3gpp-documents/Rel15</a>
CCSA	CCSA.36.455V1521	15.2.1	Published	14.01.2019	<a href="http://www.ccsa.org.cn:9001/portalsFile/downloadOldFile?type=17&amp;oldFileUrl=Rel15/TS%2036.455%20V15.2.1.doc">http://www.ccsa.org.cn:9001/portalsFile/downloadOldFile?type=17&amp;oldFileUrl=Rel15/TS%2036.455%20V15.2.1.doc</a>
ETSI	ETSI TS 136 455	15.2.1	Published	17.04.2019	<a href="http://www.etsi.org/deliver/etsi_ts/136400_136499/136455/15.02.01_60/ts_136455v150201p.pdf">http://www.etsi.org/deliver/etsi_ts/136400_136499/136455/15.02.01_60/ts_136455v150201p.pdf</a>
TSDSI	TSDSI STD T1.3GPP 36.455-15.2.1 V1.0.0	15.2.1	Published	06.10.2020	<a href="https://members.tdsi.in/index.php/s/yHwzCP7d52qtnnJ">https://members.tdsi.in/index.php/s/yHwzCP7d52qtnnJ</a>
TTA	TTAT.3G-36.455V15.2.1	15.2.1	Published	11.09.2020	<a href="http://www.tta.or.kr/data/ttasDown.jsp?where=14688&amp;pk_num=TTAT.3G-36.455V15.2.1">http://www.tta.or.kr/data/ttasDown.jsp?where=14688&amp;pk_num=TTAT.3G-36.455V15.2.1</a>
TTC	TS-3GA-36.455(Rel15) v15.2.1	15.2.1	Published	29.03.2019	<a href="https://www.ttc.or.jp/st/docs/3gpps2019/TS/TS-3GA-36.455(Rel15)v15.2.1.pdf">https://www.ttc.or.jp/st/docs/3gpps2019/TS/TS-3GA-36.455(Rel15)v15.2.1.pdf</a>
<b>Release 16</b>					
ATIS	ATIS.3GPP.36.455V1600	16.0.0	Published	08.09.2020	<a href="http://www.atis.org/3gpp-documents/Rel16">http://www.atis.org/3gpp-documents/Rel16</a>
CCSA	CCSA.36.455V1600	16.0.0	Published	16.07.2020	<a href="http://www.ccsa.org.cn:9001/portalsFile/downloadOldFile?type=17&amp;oldFileUrl=Rel15/TS%2036.455%20V16.0.0.doc">http://www.ccsa.org.cn:9001/portalsFile/downloadOldFile?type=17&amp;oldFileUrl=Rel15/TS%2036.455%20V16.0.0.doc</a>
ETSI	ETSI TS 136 455	16.0.0	Published	21.09.2020	<a href="http://www.etsi.org/deliver/etsi_ts/136400_136499/136455/16.00.00_60/ts_136455v160000p.pdf">http://www.etsi.org/deliver/etsi_ts/136400_136499/136455/16.00.00_60/ts_136455v160000p.pdf</a>
TSDSI	TSDSI STD T1.3GPP 36.455-16.0.0 V1.0.0	16.0.0	Published	06.10.2020	<a href="https://members.tdsi.in/index.php/s/MTTTeNBSbNGtgwd">https://members.tdsi.in/index.php/s/MTTTeNBSbNGtgwd</a>
TTA	TTAT.3G-36.455V16.0.0	16.0.0	Published	11.09.2020	<a href="http://www.tta.or.kr/data/ttasDown.jsp?where=14688&amp;pk_num=TTAT.3G-36.455V16.0.0">http://www.tta.or.kr/data/ttasDown.jsp?where=14688&amp;pk_num=TTAT.3G-36.455V16.0.0</a>
TTC	TS-3GA-36.455(Rel16) v16.0.0	16.0.0	Published	02.10.2020	<a href="https://www.ttc.or.jp/st/docs/3gpps2020/TS/TS-3GA-36_455_Rel16v16_0_0.pdf">https://www.ttc.or.jp/st/docs/3gpps2020/TS/TS-3GA-36_455_Rel16v16_0_0.pdf</a>

**1.2.1.4.20 TS 36.456****Evolved Universal Terrestrial Radio Access Network (E-UTRAN); SLM interface general aspects and principles**

This document is an introduction to the 3GPP TS 36.45x series of technical specifications that define the SLM interface for the interconnection of the Evolved Serving Mobile Location Centre (E-SMLC) to the Location Measurement Unit (LMU) components of the Evolved Universal Terrestrial Radio Access Network (E-UTRAN).

SDO	Document No.	Version	Status	Issued date	Location
<b>Release 15</b>					
ATIS	ATIS.3GPP.36.456V1500	15.0.0	Published	08.09.2020	<a href="http://www.atis.org/3gpp-documents/Rel15">http://www.atis.org/3gpp-documents/Rel15</a>
CCSA	CCSA.36.456V1500	15.0.0	Published	22.06.2018	<a href="http://www.ccsa.org.cn:9001/portalsFile/downloadOldFile?type=17&amp;oldFileUrl=Rel15/TS%2036.456%20V15.0.0.doc">http://www.ccsa.org.cn:9001/portalsFile/downloadOldFile?type=17&amp;oldFileUrl=Rel15/TS%2036.456%20V15.0.0.doc</a>
ETSI	ETSI TS 136 456	15.0.0	Published	04.07.2018	<a href="http://www.etsi.org/deliver/etsi_ts/136400_136499/136456/15.00.00_60/ts_136456v150000p.pdf">http://www.etsi.org/deliver/etsi_ts/136400_136499/136456/15.00.00_60/ts_136456v150000p.pdf</a>
TSDSI	TSDSI STD T1.3GPP 36.456-15.0.0 V1.0.0	15.0.0	Published	06.10.2020	<a href="https://members.tdsi.in/index.php/s/o3sdASpA7tyGaSp">https://members.tdsi.in/index.php/s/o3sdASpA7tyGaSp</a>
TTA	TTAT.3G-36.456V15.0.0	15.0.0	Published	11.09.2020	<a href="http://www.tta.or.kr/data/ttasDown.jsp?where=14688&amp;pk_num=TTAT.3G-36.456V15.0.0">http://www.tta.or.kr/data/ttasDown.jsp?where=14688&amp;pk_num=TTAT.3G-36.456V15.0.0</a>
TTC	TS-3GA-36.456(Rel15) v15.0.0	15.0.0	Published	28.09.2018	<a href="https://www.ttc.or.jp/st/docs/3gpps2018/TS/TS-3GA-36.456(Rel15)v15.0.0.pdf">https://www.ttc.or.jp/st/docs/3gpps2018/TS/TS-3GA-36.456(Rel15)v15.0.0.pdf</a>

**Release 16**

ATIS	ATIS.3GPP.36.456V1600	16.0.0	Published	08.09.2020	<a href="http://www.atis.org/3gpp-documents/Rel16">http://www.atis.org/3gpp-documents/Rel16</a>
CCSA	CCSA.36.456V1600	16.0.0	Published	16.07.2020	<a href="http://www.ccsa.org.cn:9001/portalsFile/downloadOldFile?type=17&amp;oldFileUrl=Rel16/TS%2036.456%20V16.0.0.doc">http://www.ccsa.org.cn:9001/portalsFile/downloadOldFile?type=17&amp;oldFileUrl=Rel16/TS%2036.456%20V16.0.0.doc</a>
ETSI	ETSI TS 136 456	16.0.0	Published	21.07.2020	<a href="http://www.etsi.org/deliver/etsi_ts/136400_136499/136456/16.00.00_60/ts_136456v160000p.pdf">http://www.etsi.org/deliver/etsi_ts/136400_136499/136456/16.00.00_60/ts_136456v160000p.pdf</a>
TSDSI	TSDSI STD T1.3GPP 36.456-16.0.0 V1.0.0	16.0.0	Published	06.10.2020	<a href="https://members.tdsi.in/index.php/s/GtMXxWeAM5osqkr">https://members.tdsi.in/index.php/s/GtMXxWeAM5osqkr</a>
TTA	TTAT.3G-36.456V16.0.0	16.0.0	Published	11.09.2020	<a href="http://www.tta.or.kr/data/ttasDown.jsp?where=14688&amp;pk_num=TTAT.3G-36.456V16.0.0">http://www.tta.or.kr/data/ttasDown.jsp?where=14688&amp;pk_num=TTAT.3G-36.456V16.0.0</a>
TTC	TS-3GA-36.456(Rel16) v16.0.0	16.0.0	Published	02.10.2020	<a href="https://www.ttc.or.jp/st/docs/3gpps2020/TS/TS-3GA-36_456_Rel16v16_0_0.pdf">https://www.ttc.or.jp/st/docs/3gpps2020/TS/TS-3GA-36_456_Rel16v16_0_0.pdf</a>

**1.2.1.4.21 TS 36.457****Evolved Universal Terrestrial Radio Access Network (E-UTRAN); SLM interface layer 1**

This document specifies the standards allowed to implement layer 1 on the SLM interface.

SDO	Document No.	Version	Status	Issued date	Location
<b>Release 15</b>					
ATIS	ATIS.3GPP.36.457V1500	15.0.0	Published	08.09.2020	<a href="http://www.atis.org/3gpp-documents/Rel15">http://www.atis.org/3gpp-documents/Rel15</a>
CCSA	CCSA.36.457V1500	15.0.0	Published	22.06.2018	<a href="http://www.ccsa.org.cn:9001/portalsFile/downloadOldFile?type=17&amp;oldFileUrl=Rel15/TS%2036.457%20V15.0.0.doc">http://www.ccsa.org.cn:9001/portalsFile/downloadOldFile?type=17&amp;oldFileUrl=Rel15/TS%2036.457%20V15.0.0.doc</a>
ETSI	ETSI TS 136 457	15.0.0	Published	04.07.2018	<a href="http://www.etsi.org/deliver/etsi_ts/136400_136499/136457/15.00.00_60/ts_136457v150000p.pdf">http://www.etsi.org/deliver/etsi_ts/136400_136499/136457/15.00.00_60/ts_136457v150000p.pdf</a>
TSDSI	TSDSI STD T1.3GPP 36.457-15.0.0 V1.0.0	15.0.0	Published	06.10.2020	<a href="https://members.tdsi.in/index.php/s/frGMbayaG4qekcz">https://members.tdsi.in/index.php/s/frGMbayaG4qekcz</a>
TTA	TTAT.3G-36.457V15.0.0	15.0.0	Published	11.09.2020	<a href="http://www.tta.or.kr/data/ttasDown.jsp?where=14688&amp;pk_num=TTAT.3G-36.457V15.0.0">http://www.tta.or.kr/data/ttasDown.jsp?where=14688&amp;pk_num=TTAT.3G-36.457V15.0.0</a>
TTC	TS-3GA-36.457(Rel15) v15.0.0	15.0.0	Published	28.09.2018	<a href="https://www.ttc.or.jp/st/docs/3gpps2018/TS/TS-3GA-36.457(Rel15)v15.0.0.pdf">https://www.ttc.or.jp/st/docs/3gpps2018/TS/TS-3GA-36.457(Rel15)v15.0.0.pdf</a>

**Release 16**

ATIS	ATIS.3GPP.36.457V1600	16.0.0	Published	08.09.2020	<a href="http://www.atis.org/3gpp-documents/Rel16">http://www.atis.org/3gpp-documents/Rel16</a>
CCSA	CCSA.36.457V1600	16.0.0	Published	16.07.2020	<a href="http://www.ccsa.org.cn:9001/portalsFile/downloadOldFile?type=17&amp;oldFileUrl=Rel16/TS%2036.457%20V16.0.0.doc">http://www.ccsa.org.cn:9001/portalsFile/downloadOldFile?type=17&amp;oldFileUrl=Rel16/TS%2036.457%20V16.0.0.doc</a>
ETSI	ETSI TS 136 457	16.0.0	Published	21.07.2020	<a href="http://www.etsi.org/deliver/etsi_ts/136400_136499/136457/16.00.00_60/ts_136457v160000p.pdf">http://www.etsi.org/deliver/etsi_ts/136400_136499/136457/16.00.00_60/ts_136457v160000p.pdf</a>
TSDSI	TSDSI STD T1.3GPP 36.457-16.0.0 V1.0.0	16.0.0	Published	06.10.2020	<a href="https://members.tdsi.in/index.php/s/WfDtPTxwia8HRDw">https://members.tdsi.in/index.php/s/WfDtPTxwia8HRDw</a>
TTA	TTAT.3G-36.457V16.0.0	16.0.0	Published	11.09.2020	<a href="http://www.tta.or.kr/data/ttasDown.jsp?where=14688&amp;pk_num=TTAT.3G-36.457V16.0.0">http://www.tta.or.kr/data/ttasDown.jsp?where=14688&amp;pk_num=TTAT.3G-36.457V16.0.0</a>
TTC	TS-3GA-36.457(Rel16) v16.0.0	16.0.0	Published	02.10.2020	<a href="https://www.ttc.or.jp/st/docs/3gpps2020/TS/TS-3GA-36_457_Rel16v16_0_0.pdf">https://www.ttc.or.jp/st/docs/3gpps2020/TS/TS-3GA-36_457_Rel16v16_0_0.pdf</a>

**1.2.1.4.22 TS 36.458****Evolved Universal Terrestrial Radio Access Network (E-UTRAN); SLM interface signalling transport**

This document specifies the standards for signalling transport to be used across the SLM interface. The SLM interface is a logical interface between the LMU and the E-SMLC in the E-UTRAN core network. This document describes how the SLMAP signalling messages are transported over SLM.

SDO	Document No.	Version	Status	Issued date	Location
<b>Release 15</b>					
ATIS	ATIS.3GPP.36.458V1500	15.0.0	Published	08.09.2020	<a href="http://www.atis.org/3gpp-documents/Rel15">http://www.atis.org/3gpp-documents/Rel15</a>
CCSA	CCSA.36.458V1500	15.0.0	Published	22.06.2018	<a href="http://www.ccsa.org.cn:9001/portalsFile/downloadOldFile?type=17&amp;oldFileUrl=Rel15/TS%2036.458%20V15.0.0.doc">http://www.ccsa.org.cn:9001/portalsFile/downloadOldFile?type=17&amp;oldFileUrl=Rel15/TS%2036.458%20V15.0.0.doc</a>
ETSI	ETSI TS 136 458	15.0.0	Published	04.07.2018	<a href="http://www.etsi.org/deliver/etsi_ts/136400_136499/136458/15.00.00_60/ts_136458v150000p.pdf">http://www.etsi.org/deliver/etsi_ts/136400_136499/136458/15.00.00_60/ts_136458v150000p.pdf</a>
TSDSI	TSDSI STD T1.3GPP 36.458-15.0.0 V1.0.0	15.0.0	Published	06.10.2020	<a href="https://members.tdsi.in/index.php/s/GC5wiixejnwf7s">https://members.tdsi.in/index.php/s/GC5wiixejnwf7s</a>
TTA	TTAT.3G-36.458V15.0.0	15.0.0	Published	11.09.2020	<a href="http://www.tta.or.kr/data/ttasDown.jsp?where=14688&amp;pk_num=TTAT.3G-36.458V15.0.0">http://www.tta.or.kr/data/ttasDown.jsp?where=14688&amp;pk_num=TTAT.3G-36.458V15.0.0</a>
TTC	TS-3GA-36.458(Rel15) v15.0.0	15.0.0	Published	28.09.2018	<a href="https://www.ttc.or.jp/st/docs/3gpps2018/TS/TS-3GA-36.458(Rel15)v15.0.0.pdf">https://www.ttc.or.jp/st/docs/3gpps2018/TS/TS-3GA-36.458(Rel15)v15.0.0.pdf</a>

**Release 16**

ATIS	ATIS.3GPP.36.458V1600	16.0.0	Published	08.09.2020	<a href="http://www.atis.org/3gpp-documents/Rel16">http://www.atis.org/3gpp-documents/Rel16</a>
CCSA	CCSA.36.458V1600	16.0.0	Published	16.07.2020	<a href="http://www.ccsa.org.cn:9001/portalsFile/downloadOldFile?type=17&amp;oldFileUrl=Rel16/TS%2036.458%20V16.0.0.doc">http://www.ccsa.org.cn:9001/portalsFile/downloadOldFile?type=17&amp;oldFileUrl=Rel16/TS%2036.458%20V16.0.0.doc</a>

## 82

## Rec. ITU-R M.2150-0

ETSI	ETSI TS 136 458	16.0.0	Published	21.07.2020	<a href="http://www.etsi.org/deliver/etsi_ts/136400_136499/136458/16.00.00_60/ts_136458v160000p.pdf">http://www.etsi.org/deliver/etsi_ts/136400_136499/136458/16.00.00_60/ts_136458v160000p.pdf</a>
TSDSI	TSDSI STD T1.3GPP 36.458-16.0.0 V1.0.0	16.0.0	Published	06.10.2020	<a href="https://members.tdsi.in/index.php/s/4LdWnKHwzkbncb">https://members.tdsi.in/index.php/s/4LdWnKHwzkbncb</a>
TTA	TTAT.3G-36.458V16.0.0	16.0.0	Published	11.09.2020	<a href="http://www.tta.or.kr/data/ttasDown.jsp?where=14688&amp;pk_num=TTAT.3G-36.458V16.0.0">http://www.tta.or.kr/data/ttasDown.jsp?where=14688&amp;pk_num=TTAT.3G-36.458V16.0.0</a>
TTC	TS-3GA-36.458(Rel16) v16.0.0	16.0.0	Published	02.10.2020	<a href="https://www.ttc.or.jp/st/docs/3gpps2020/TS/TS-3GA-36_458_Rel16v16_0_0.pdf">https://www.ttc.or.jp/st/docs/3gpps2020/TS/TS-3GA-36_458_Rel16v16_0_0.pdf</a>

### 1.2.1.4.23 TS 36.459

#### Evolved Universal Terrestrial Radio Access Network (E-UTRAN); SLM interface Application Protocol (SLM-AP)

This document specifies the E-UTRAN radio network layer signalling protocol for the SLM interface. The SLM Application Protocol (SLM-AP) supports the functions of the SLM interface by signalling procedures defined in this document.

SDO	Document No.	Version	Status	Issued date	Location
<b>Release 15</b>					
ATIS	ATIS.3GPP.36.459V1500	15.0.0	Published	08.09.2020	<a href="http://www.atis.org/3gpp-documents/Rel15">http://www.atis.org/3gpp-documents/Rel15</a>
CCSA	CCSA.36.459V1500	15.0.0	Published	22.06.2018	<a href="http://www.ccsa.org.cn:9001/portalsFile/downloadOldFile?type=17&amp;oldFileUrl=Rel15/TS%2036.459%20V15.0.0.doc">http://www.ccsa.org.cn:9001/portalsFile/downloadOldFile?type=17&amp;oldFileUrl=Rel15/TS%2036.459%20V15.0.0.doc</a>
ETSI	ETSI TS 136 459	15.0.0	Published	04.07.2018	<a href="http://www.etsi.org/deliver/etsi_ts/136400_136499/136459/15.00.00_60/ts_136459v150000p.pdf">http://www.etsi.org/deliver/etsi_ts/136400_136499/136459/15.00.00_60/ts_136459v150000p.pdf</a>
TSDSI	TSDSI STD T1.3GPP 36.459-15.0.0 V1.0.0	15.0.0	Published	06.10.2020	<a href="https://members.tdsi.in/index.php/s/N2wpD2iCw92r37Q">https://members.tdsi.in/index.php/s/N2wpD2iCw92r37Q</a>
TTA	TTAT.3G-36.459V15.0.0	15.0.0	Published	11.09.2020	<a href="http://www.tta.or.kr/data/ttasDown.jsp?where=14688&amp;pk_num=TTAT.3G-36.459V15.0.0">http://www.tta.or.kr/data/ttasDown.jsp?where=14688&amp;pk_num=TTAT.3G-36.459V15.0.0</a>
TTC	TS-3GA-36.459(Rel15) v15.0.0	15.0.0	Published	28.09.2018	<a href="https://www.ttc.or.jp/st/docs/3gpps2018/TS/TS-3GA-36.459(Rel15)v15.0.0.pdf">https://www.ttc.or.jp/st/docs/3gpps2018/TS/TS-3GA-36.459(Rel15)v15.0.0.pdf</a>
<b>Release 16</b>					
ATIS	ATIS.3GPP.36.459V1600	16.0.0	Published	08.09.2020	<a href="http://www.atis.org/3gpp-documents/Rel16">http://www.atis.org/3gpp-documents/Rel16</a>
CCSA	CCSA.36.459V1600	16.0.0	Published	16.07.2020	<a href="http://www.ccsa.org.cn:9001/portalsFile/downloadOldFile?type=17&amp;oldFileUrl=Rel16/TS%2036.459%20V16.0.0.doc">http://www.ccsa.org.cn:9001/portalsFile/downloadOldFile?type=17&amp;oldFileUrl=Rel16/TS%2036.459%20V16.0.0.doc</a>
ETSI	ETSI TS 136 459	16.0.0	Published	21.07.2020	<a href="http://www.etsi.org/deliver/etsi_ts/136400_136499/136459/16.00.00_60/ts_136459v160000p.pdf">http://www.etsi.org/deliver/etsi_ts/136400_136499/136459/16.00.00_60/ts_136459v160000p.pdf</a>
TSDSI	TSDSI STD T1.3GPP 36.459-16.0.0 V1.0.0	16.0.0	Published	06.10.2020	<a href="https://members.tdsi.in/index.php/s/WpS6xsiExFwW9MT">https://members.tdsi.in/index.php/s/WpS6xsiExFwW9MT</a>
TTA	TTAT.3G-36.459V16.0.0	16.0.0	Published	11.09.2020	<a href="http://www.tta.or.kr/data/ttasDown.jsp?where=14688&amp;pk_num=TTAT.3G-36.459V16.0.0">http://www.tta.or.kr/data/ttasDown.jsp?where=14688&amp;pk_num=TTAT.3G-36.459V16.0.0</a>
TTC	TS-3GA-36.459(Rel16) v16.0.0	16.0.0	Published	02.10.2020	<a href="https://www.ttc.or.jp/st/docs/3gpps2020/TS/TS-3GA-36_459_Rel16v16_0_0.pdf">https://www.ttc.or.jp/st/docs/3gpps2020/TS/TS-3GA-36_459_Rel16v16_0_0.pdf</a>

### 1.2.1.4.24 TS 36.461

#### Evolved Universal Terrestrial Radio Access Network (E-UTRAN) and Wireless LAN (WLAN); Xw layer 1

This document specifies the standards allowed to implement Layer 1 on the Xw interface. The specification of transmission delay requirements and O&M requirements are not in the scope of this document.

SDO	Document No.	Version	Status	Issued date	Location
<b>Release 15</b>					
ARIB	ARIB STD-T120-36.461	15.0.0	Published	28.09.2020	<a href="http://www.arib.or.jp/english/html/overview/doc/T120_T23_v2_00/2_T120/ARIB-STD-T120/Rel15/36/A36461-f00.pdf">http://www.arib.or.jp/english/html/overview/doc/T120_T23_v2_00/2_T120/ARIB-STD-T120/Rel15/36/A36461-f00.pdf</a>
ATIS	ATIS.3GPP.36.461V1500	15.0.0	Published	08.09.2020	<a href="http://www.atis.org/3gpp-documents/Rel15">http://www.atis.org/3gpp-documents/Rel15</a>
CCSA	CCSA.36.461V1500	15.0.0	Published	22.06.2018	<a href="http://www.ccsa.org.cn:9001/portalsFile/downloadOldFile?type=17&amp;oldFileUrl=Rel15/TS%2036.461%20V15.0.0.doc">http://www.ccsa.org.cn:9001/portalsFile/downloadOldFile?type=17&amp;oldFileUrl=Rel15/TS%2036.461%20V15.0.0.doc</a>
ETSI	ETSI TS 136 461	15.0.0	Published	04.07.2018	<a href="http://www.etsi.org/deliver/etsi_ts/136400_136499/136461/15.00.00_60/ts_136461v150000p.pdf">http://www.etsi.org/deliver/etsi_ts/136400_136499/136461/15.00.00_60/ts_136461v150000p.pdf</a>
TSDSI	TSDSI STD T1.3GPP 36.461-15.0.0 V1.0.0	15.0.0	Published	06.10.2020	<a href="https://members.tdsi.in/index.php/s/DNAy2doqCc3gQD3">https://members.tdsi.in/index.php/s/DNAy2doqCc3gQD3</a>
TTA	TTAT.3G-36.461V15.0.0	15.0.0	Published	11.09.2020	<a href="http://www.tta.or.kr/data/ttasDown.jsp?where=14688&amp;pk_num=TTAT.3G-36.461V15.0.0">http://www.tta.or.kr/data/ttasDown.jsp?where=14688&amp;pk_num=TTAT.3G-36.461V15.0.0</a>
<b>Release 16</b>					
ARIB	ARIB STD-T120-36.461	16.0.0	Published	28.09.2020	<a href="http://www.arib.or.jp/english/html/overview/doc/T120_T23_v2_00/2_T120/ARIB-STD-T120/Rel16/36/A36461-g00.pdf">http://www.arib.or.jp/english/html/overview/doc/T120_T23_v2_00/2_T120/ARIB-STD-T120/Rel16/36/A36461-g00.pdf</a>
ATIS	ATIS.3GPP.36.461V1600	16.0.0	Published	08.09.2020	<a href="http://www.atis.org/3gpp-documents/Rel16">http://www.atis.org/3gpp-documents/Rel16</a>
CCSA	CCSA.36.461V1600	16.0.0	Published	17.07.2020	<a href="http://www.ccsa.org.cn:9001/portalsFile/downloadOldFile?type=17&amp;oldFileUrl=Rel16/TS%2036.461%20V16.0.0.doc">http://www.ccsa.org.cn:9001/portalsFile/downloadOldFile?type=17&amp;oldFileUrl=Rel16/TS%2036.461%20V16.0.0.doc</a>

ETSI	ETSI TS 136 461	16.0.0	Published	23.07.2020	<a href="http://www.etsi.org/deliver/etsi_ts/136400_136499/136461/16.00.00_60/ts_136461v160000p.pdf">http://www.etsi.org/deliver/etsi_ts/136400_136499/136461/16.00.00_60/ts_136461v160000p.pdf</a>
TSDSI	TSDSI STD T1.3GPP 36.461-16.0.0 V1.0.0	16.0.0	Published	06.10.2020	<a href="https://members.tdsi.in/index.php/s/g6c2TKsZTeZEZDx">https://members.tdsi.in/index.php/s/g6c2TKsZTeZEZDx</a>
TTA	TTAT.3G-36.461V16.0.0	16.0.0	Published	11.09.2020	<a href="http://www.tta.or.kr/data/ttasDown.jsp?where=14688&amp;pk_num=TTAT.3G-36.461V16.0.0">http://www.tta.or.kr/data/ttasDown.jsp?where=14688&amp;pk_num=TTAT.3G-36.461V16.0.0</a>

**1.2.1.4.25 TS 36.462**

**Evolved Universal Terrestrial Radio Access Network (E-UTRAN) and Wireless LAN (WLAN); Xw signalling transport**

This document specifies the standards for Signalling Transport to be used across the Xw interface. The Xw interface is a logical interface between the eNB and the WLAN Termination (WT). This document describes how the Xw-AP signalling messages are transported over Xw.

SDO	Document No.	Version	Status	Issued date	Location
<b>Release 15</b>					
ARIB	ARIB STD-T120-36.462	15.0.0	Published	28.09.2020	<a href="http://www.arib.or.jp/english/html/overview/doc/T120_T23_v2_00/2_T120/ARIB-STD-T120/Rel15/36/A36462-f00.pdf">http://www.arib.or.jp/english/html/overview/doc/T120_T23_v2_00/2_T120/ARIB-STD-T120/Rel15/36/A36462-f00.pdf</a>
ATIS	ATIS.3GPP.36.462V1500	15.0.0	Published	08.09.2020	<a href="http://www.atis.org/3gpp-documents/Rel15">http://www.atis.org/3gpp-documents/Rel15</a>
CCSA	CCSA.36.462V1500	15.0.0	Published	22.06.2018	<a href="http://www.ccsa.org.cn:9001/portalsFile/downloadOldFile?type=17&amp;oldFileUrl=Rel15/TS%2036.462%20V15.0.0.doc">http://www.ccsa.org.cn:9001/portalsFile/downloadOldFile?type=17&amp;oldFileUrl=Rel15/TS%2036.462%20V15.0.0.doc</a>
ETSI	ETSI TS 136 462	15.0.0	Published	04.07.2018	<a href="http://www.etsi.org/deliver/etsi_ts/136400_136499/136462/15.00.00_60/ts_136462v150000p.pdf">http://www.etsi.org/deliver/etsi_ts/136400_136499/136462/15.00.00_60/ts_136462v150000p.pdf</a>
TSDSI	TSDSI STD T1.3GPP 36.462-15.0.0 V1.0.0	15.0.0	Published	06.10.2020	<a href="https://members.tdsi.in/index.php/s/H9iiG9iA3ZAskQz">https://members.tdsi.in/index.php/s/H9iiG9iA3ZAskQz</a>
TTA	TTAT.3G-36.462V15.0.0	15.0.0	Published	11.09.2020	<a href="http://www.tta.or.kr/data/ttasDown.jsp?where=14688&amp;pk_num=TTAT.3G-36.462V15.0.0">http://www.tta.or.kr/data/ttasDown.jsp?where=14688&amp;pk_num=TTAT.3G-36.462V15.0.0</a>
<b>Release 16</b>					
ARIB	ARIB STD-T120-36.462	16.0.0	Published	28.09.2020	<a href="http://www.arib.or.jp/english/html/overview/doc/T120_T23_v2_00/2_T120/ARIB-STD-T120/Rel16/36/A36462-g00.pdf">http://www.arib.or.jp/english/html/overview/doc/T120_T23_v2_00/2_T120/ARIB-STD-T120/Rel16/36/A36462-g00.pdf</a>
ATIS	ATIS.3GPP.36.462V1600	16.0.0	Published	08.09.2020	<a href="http://www.atis.org/3gpp-documents/Rel16">http://www.atis.org/3gpp-documents/Rel16</a>
CCSA	CCSA.36.462V1600	16.0.0	Published	16.07.2020	<a href="http://www.ccsa.org.cn:9001/portalsFile/downloadOldFile?type=17&amp;oldFileUrl=Rel16/TS%2036.462%20V16.0.0.doc">http://www.ccsa.org.cn:9001/portalsFile/downloadOldFile?type=17&amp;oldFileUrl=Rel16/TS%2036.462%20V16.0.0.doc</a>
ETSI	ETSI TS 136 462	16.0.0	Published	21.07.2020	<a href="http://www.etsi.org/deliver/etsi_ts/136400_136499/136462/16.00.00_60/ts_136462v160000p.pdf">http://www.etsi.org/deliver/etsi_ts/136400_136499/136462/16.00.00_60/ts_136462v160000p.pdf</a>
TSDSI	TSDSI STD T1.3GPP 36.462-16.0.0 V1.0.0	16.0.0	Published	06.10.2020	<a href="https://members.tdsi.in/index.php/s/G7XwpExMFLAZH4L">https://members.tdsi.in/index.php/s/G7XwpExMFLAZH4L</a>
TTA	TTAT.3G-36.462V16.0.0	16.0.0	Published	11.09.2020	<a href="http://www.tta.or.kr/data/ttasDown.jsp?where=14688&amp;pk_num=TTAT.3G-36.462V16.0.0">http://www.tta.or.kr/data/ttasDown.jsp?where=14688&amp;pk_num=TTAT.3G-36.462V16.0.0</a>

**1.2.1.4.26 TS 36.463**

**Evolved Universal Terrestrial Radio Access Network (E-UTRAN) and Wireless Local Area Network (WLAN); Xw application protocol (XwAP)**

This document specifies the signalling procedures of the control plane between an eNB and WLAN Termination (WT). The Xw Application Protocol (XwAP) supports the functions of Xw interface by signalling procedures defined in this document.

SDO	Document No.	Version	Status	Issued date	Location
<b>Release 15</b>					
ARIB	ARIB STD-T120-36.463	15.0.0	Published	28.09.2020	<a href="http://www.arib.or.jp/english/html/overview/doc/T120_T23_v2_00/2_T120/ARIB-STD-T120/Rel15/36/A36463-f00.pdf">http://www.arib.or.jp/english/html/overview/doc/T120_T23_v2_00/2_T120/ARIB-STD-T120/Rel15/36/A36463-f00.pdf</a>
ATIS	ATIS.3GPP.36.463V1500	15.0.0	Published	08.09.2020	<a href="http://www.atis.org/3gpp-documents/Rel15">http://www.atis.org/3gpp-documents/Rel15</a>
CCSA	CCSA.36.463V1500	15.0.0	Published	22.06.2018	<a href="http://www.ccsa.org.cn:9001/portalsFile/downloadOldFile?type=17&amp;oldFileUrl=Rel16/TS%2036.463%20V15.0.0.doc">http://www.ccsa.org.cn:9001/portalsFile/downloadOldFile?type=17&amp;oldFileUrl=Rel16/TS%2036.463%20V15.0.0.doc</a>
ETSI	ETSI TS 136 463	15.0.0	Published	04.07.2018	<a href="http://www.etsi.org/deliver/etsi_ts/136400_136499/136463/15.00.00_60/ts_136463v150000p.pdf">http://www.etsi.org/deliver/etsi_ts/136400_136499/136463/15.00.00_60/ts_136463v150000p.pdf</a>
TSDSI	TSDSI STD T1.3GPP 36.463-15.0.0 V1.0.0	15.0.0	Published	06.10.2020	<a href="https://members.tdsi.in/index.php/s/MFem6KcmqnCDwpe">https://members.tdsi.in/index.php/s/MFem6KcmqnCDwpe</a>
TTA	TTAT.3G-36.463V15.0.0	15.0.0	Published	11.09.2020	<a href="http://www.tta.or.kr/data/ttasDown.jsp?where=14688&amp;pk_num=TTAT.3G-36.463V15.0.0">http://www.tta.or.kr/data/ttasDown.jsp?where=14688&amp;pk_num=TTAT.3G-36.463V15.0.0</a>
<b>Release 16</b>					
ARIB	ARIB STD-T120-36.463	16.0.0	Published	28.09.2020	<a href="http://www.arib.or.jp/english/html/overview/doc/T120_T23_v2_00/2_T120/ARIB-STD-T120/Rel16/36/A36463-g00.pdf">http://www.arib.or.jp/english/html/overview/doc/T120_T23_v2_00/2_T120/ARIB-STD-T120/Rel16/36/A36463-g00.pdf</a>
ATIS	ATIS.3GPP.36.463V1600	16.0.0	Published	08.09.2020	<a href="http://www.atis.org/3gpp-documents/Rel16">http://www.atis.org/3gpp-documents/Rel16</a>
CCSA	CCSA.36.463V1600	16.0.0	Published	16.07.2020	<a href="http://www.ccsa.org.cn:9001/portalsFile/downloadOldFile?type=17&amp;oldFileUrl=Rel16/TS%2036.463%20V16.0.0.doc">http://www.ccsa.org.cn:9001/portalsFile/downloadOldFile?type=17&amp;oldFileUrl=Rel16/TS%2036.463%20V16.0.0.doc</a>
ETSI	ETSI TS 136 463	16.0.0	Published	21.07.2020	<a href="http://www.etsi.org/deliver/etsi_ts/136400_136499/136463/16.00.00_60/ts_136463v160000p.pdf">http://www.etsi.org/deliver/etsi_ts/136400_136499/136463/16.00.00_60/ts_136463v160000p.pdf</a>
TSDSI	TSDSI STD T1.3GPP 36.463-16.0.0 V1.0.0	16.0.0	Published	06.10.2020	<a href="https://members.tdsi.in/index.php/s/L4dbZFLbtrH4HtA">https://members.tdsi.in/index.php/s/L4dbZFLbtrH4HtA</a>

TTA TTAT.3G-36.463V16.0.0 16.0.0 Published 11.09.2020 [http://www.tta.or.kr/data/ttasDown.jsp?where=14688&pk\\_num=TTAT.3G-36.463V16.0.0](http://www.tta.or.kr/data/ttasDown.jsp?where=14688&pk_num=TTAT.3G-36.463V16.0.0)

#### 1.2.1.4.27 TS 36.464

### Evolved Universal Terrestrial Radio Access Network (E-UTRAN) and Wireless Local Area Network (WLAN); Xw data transport

This document specifies the standards for user data transport protocols and related signalling protocols to establish user plane transport bearers over the Xw interface for LTE/WLAN Aggregation (LWA).

#### Release 15

ARIB	ARIB STD-T120-36.464	15.0.0	Published	28.09.2020	<a href="http://www.arib.or.jp/english/html/overview/doc/T120_T23_v2_00/2_T120/ARIB-STD-T120/Rel15/36/A36464-f00.pdf">http://www.arib.or.jp/english/html/overview/doc/T120_T23_v2_00/2_T120/ARIB-STD-T120/Rel15/36/A36464-f00.pdf</a>
ATIS	ATIS.3GPP.36.464V1500	15.0.0	Published	08.09.2020	<a href="http://www.atis.org/3gpp-documents/Rel15">http://www.atis.org/3gpp-documents/Rel15</a>
CCSA	CCSA.36.464V1500	15.0.0	Published	22.06.2018	<a href="http://www.ccsa.org.cn:9001/portalsFile/downloadOldFile?type=17&amp;oldFileUrl=Rel15/TS%2036.464%20V15.0.0.doc">http://www.ccsa.org.cn:9001/portalsFile/downloadOldFile?type=17&amp;oldFileUrl=Rel15/TS%2036.464%20V15.0.0.doc</a>
ETSI	ETSI TS 136 464	15.0.0	Published	04.07.2018	<a href="http://www.etsi.org/deliver/etsi_ts/136400_136499/136464/15.00.00_60/ts_136464v150000p.pdf">http://www.etsi.org/deliver/etsi_ts/136400_136499/136464/15.00.00_60/ts_136464v150000p.pdf</a>
TSDSI	TSDSI STD T1.3GPP 36.464-15.0.0 V1.0.0	15.0.0	Published	06.10.2020	<a href="https://members.tdsi.in/index.php/s/mwyWy73GX5A45m3">https://members.tdsi.in/index.php/s/mwyWy73GX5A45m3</a>
TTA	TTAT.3G-36.464V15.0.0	15.0.0	Published	11.09.2020	<a href="http://www.tta.or.kr/data/ttasDown.jsp?where=14688&amp;pk_num=TTAT.3G-36.464V15.0.0">http://www.tta.or.kr/data/ttasDown.jsp?where=14688&amp;pk_num=TTAT.3G-36.464V15.0.0</a>

#### Release 16

ARIB	ARIB STD-T120-36.464	16.0.0	Published	28.09.2020	<a href="http://www.arib.or.jp/english/html/overview/doc/T120_T23_v2_00/2_T120/ARIB-STD-T120/Rel16/36/A36464-g00.pdf">http://www.arib.or.jp/english/html/overview/doc/T120_T23_v2_00/2_T120/ARIB-STD-T120/Rel16/36/A36464-g00.pdf</a>
ATIS	ATIS.3GPP.36.464V1600	16.0.0	Published	08.09.2020	<a href="http://www.atis.org/3gpp-documents/Rel16">http://www.atis.org/3gpp-documents/Rel16</a>
CCSA	CCSA.36.464V1600	16.0.0	Published	16.07.2020	<a href="http://www.ccsa.org.cn:9001/portalsFile/downloadOldFile?type=17&amp;oldFileUrl=Rel16/TS%2036.464%20V16.0.0.doc">http://www.ccsa.org.cn:9001/portalsFile/downloadOldFile?type=17&amp;oldFileUrl=Rel16/TS%2036.464%20V16.0.0.doc</a>
ETSI	ETSI TS 136 464	16.0.0	Published	21.07.2020	<a href="http://www.etsi.org/deliver/etsi_ts/136400_136499/136464/16.00.00_60/ts_136464v160000p.pdf">http://www.etsi.org/deliver/etsi_ts/136400_136499/136464/16.00.00_60/ts_136464v160000p.pdf</a>
TSDSI	TSDSI STD T1.3GPP 36.464-16.0.0 V1.0.0	16.0.0	Published	06.10.2020	<a href="https://members.tdsi.in/index.php/s/MFNqYFSH8zGkzfc">https://members.tdsi.in/index.php/s/MFNqYFSH8zGkzfc</a>
TTA	TTAT.3G-36.464V16.0.0	16.0.0	Published	11.09.2020	<a href="http://www.tta.or.kr/data/ttasDown.jsp?where=14688&amp;pk_num=TTAT.3G-36.464V16.0.0">http://www.tta.or.kr/data/ttasDown.jsp?where=14688&amp;pk_num=TTAT.3G-36.464V16.0.0</a>

#### 1.2.1.4.28 TS 36.465

### Evolved Universal Terrestrial Radio Access Network (E-UTRAN) and Wireless Local Area Network (WLAN); Xw interface user plane protocol

This document specifies the Xw user plane protocol being used over the Xw interface for LTE/WLAN Aggregation (LWA).

SDO	Document No.	Version	Status	Issued date	Location
<b>Release 15</b>					
ARIB	ARIB STD-T120-36.465	15.0.0	Published	28.09.2020	<a href="http://www.arib.or.jp/english/html/overview/doc/T120_T23_v2_00/2_T120/ARIB-STD-T120/Rel15/36/A36465-f00.pdf">http://www.arib.or.jp/english/html/overview/doc/T120_T23_v2_00/2_T120/ARIB-STD-T120/Rel15/36/A36465-f00.pdf</a>
ATIS	ATIS.3GPP.36.465V1500	15.0.0	Published	08.09.2020	<a href="http://www.atis.org/3gpp-documents/Rel15">http://www.atis.org/3gpp-documents/Rel15</a>
CCSA	CCSA.36.465V1500	15.0.0	Published	22.06.2018	<a href="http://www.ccsa.org.cn:9001/portalsFile/downloadOldFile?type=17&amp;oldFileUrl=Rel15/TS%2036.465%20V15.0.0.doc">http://www.ccsa.org.cn:9001/portalsFile/downloadOldFile?type=17&amp;oldFileUrl=Rel15/TS%2036.465%20V15.0.0.doc</a>
ETSI	ETSI TS 136 465	15.0.0	Published	04.07.2018	<a href="http://www.etsi.org/deliver/etsi_ts/136400_136499/136465/15.00.00_60/ts_136465v150000p.pdf">http://www.etsi.org/deliver/etsi_ts/136400_136499/136465/15.00.00_60/ts_136465v150000p.pdf</a>
TSDSI	TSDSI STD T1.3GPP 36.465-15.0.0 V1.0.0	15.0.0	Published	06.10.2020	<a href="https://members.tdsi.in/index.php/s/e4Br8i7KAjNkSTB">https://members.tdsi.in/index.php/s/e4Br8i7KAjNkSTB</a>
TTA	TTAT.3G-36.465V15.0.0	15.0.0	Published	11.09.2020	<a href="http://www.tta.or.kr/data/ttasDown.jsp?where=14688&amp;pk_num=TTAT.3G-36.465V15.0.0">http://www.tta.or.kr/data/ttasDown.jsp?where=14688&amp;pk_num=TTAT.3G-36.465V15.0.0</a>
<b>Release 16</b>					
ARIB	ARIB STD-T120-36.465	16.0.0	Published	28.09.2020	<a href="http://www.arib.or.jp/english/html/overview/doc/T120_T23_v2_00/2_T120/ARIB-STD-T120/Rel16/36/A36465-g00.pdf">http://www.arib.or.jp/english/html/overview/doc/T120_T23_v2_00/2_T120/ARIB-STD-T120/Rel16/36/A36465-g00.pdf</a>
ATIS	ATIS.3GPP.36.465V1600	16.0.0	Published	08.09.2020	<a href="http://www.atis.org/3gpp-documents/Rel16">http://www.atis.org/3gpp-documents/Rel16</a>
CCSA	CCSA.36.465V16	16.0.0	Published	16.07.2020	<a href="http://www.ccsa.org.cn:9001/portalsFile/downloadOldFile?type=17&amp;oldFileUrl=Rel16/TS%2036.465%20V16.0.0.doc">http://www.ccsa.org.cn:9001/portalsFile/downloadOldFile?type=17&amp;oldFileUrl=Rel16/TS%2036.465%20V16.0.0.doc</a>
ETSI	ETSI TS 136 465	16.0.0	Published	21.07.2020	<a href="http://www.etsi.org/deliver/etsi_ts/136400_136499/136465/16.00.00_60/ts_136465v160000p.pdf">http://www.etsi.org/deliver/etsi_ts/136400_136499/136465/16.00.00_60/ts_136465v160000p.pdf</a>
TSDSI	TSDSI STD T1.3GPP 36.465-16.0.0 V1.0.0	16.0.0	Published	06.10.2020	<a href="https://members.tdsi.in/index.php/s/si9g3X7gKpXAqM2">https://members.tdsi.in/index.php/s/si9g3X7gKpXAqM2</a>
TTA	TTAT.3G-36.465V16.0.0	16.0.0	Published	11.09.2020	<a href="http://www.tta.or.kr/data/ttasDown.jsp?where=14688&amp;pk_num=TTAT.3G-36.465V16.0.0">http://www.tta.or.kr/data/ttasDown.jsp?where=14688&amp;pk_num=TTAT.3G-36.465V16.0.0</a>

### 1.2.1.4.29 TS 37.460

#### Iuant interface: General aspects and principles

This document is an introduction to the 3GPP TS 37.46x series of Technical Specifications that define the Iuant Interface. The Iuant interface is applicable for UTRAN, E-UTRAN and NG-RAN. In this specification UTRAN, E-UTRAN and NG-RAN are denoted as "RAN", whereas the corresponding network entities Node B, eNB, en-gNB and NG-RAN node are denoted as "RAN Node". The logical Iuant interface is an interface internal to the RAN Node and defined to reside between the implementation specific O&M function and the RET antennas and between the implementation specific O&M function and the TMA control unit function.

SDO	Document No.	Version	Status	Issued date	Location
<b>Release 15</b>					
ARIB	ARIB STD-T120-37.460		15.2.0	Published 28.09.2020	<a href="http://www.arib.or.jp/english/html/overview/doc/T120_T23_v2_00/2_T120/ARIB-STD-T120/Rel15/37/A37460-f20.pdf">http://www.arib.or.jp/english/html/overview/doc/T120_T23_v2_00/2_T120/ARIB-STD-T120/Rel15/37/A37460-f20.pdf</a>
ATIS	ATIS.3GPP.37.460V1520		15.2.0	Published 08.09.2020	<a href="http://www.atis.org/3gpp-documents/Rel15">http://www.atis.org/3gpp-documents/Rel15</a>
CCSA	CCSA.37.460V1520		15.2.0	Published 09.01.2020	<a href="http://www.ccsa.org.cn:9001/portalsFile/downloadOldFile?type=17&amp;oldFileUrl=Rel15/TS%2037.460%20V15.2.0.doc">http://www.ccsa.org.cn:9001/portalsFile/downloadOldFile?type=17&amp;oldFileUrl=Rel15/TS%2037.460%20V15.2.0.doc</a>
ETSI	ETSI TS 137 460		15.2.0	Published 17.01.2020	<a href="http://www.etsi.org/deliver/etsi_ts/137400_137499/137460/15.02.00_60/ts_137460v150200p.pdf">http://www.etsi.org/deliver/etsi_ts/137400_137499/137460/15.02.00_60/ts_137460v150200p.pdf</a>
TSDSI	TSDSI STD T1.3GPP 37.460-15.2.0 V1.0.0		15.2.0	Published 06.10.2020	<a href="https://members.tdsi.in/index.php/s/C3SDXoFzkzmPeeM">https://members.tdsi.in/index.php/s/C3SDXoFzkzmPeeM</a>
TTA	TTAT.3G-37.460V15.2.0		15.2.0	Published 11.09.2020	<a href="http://www.tta.or.kr/data/ttasDown.jsp?where=14688&amp;pk_num=TTAT.3G-37.460V15.2.0">http://www.tta.or.kr/data/ttasDown.jsp?where=14688&amp;pk_num=TTAT.3G-37.460V15.2.0</a>
<b>Release 16</b>					
ARIB	ARIB STD-T120-37.460		16.0.0	Published 28.09.2020	<a href="http://www.arib.or.jp/english/html/overview/doc/T120_T23_v2_00/2_T120/ARIB-STD-T120/Rel16/37/A37460-g00.pdf">http://www.arib.or.jp/english/html/overview/doc/T120_T23_v2_00/2_T120/ARIB-STD-T120/Rel16/37/A37460-g00.pdf</a>
ATIS	ATIS.3GPP.37.460V1600		16.0.0	Published 08.09.2020	<a href="http://www.atis.org/3gpp-documents/Rel16">http://www.atis.org/3gpp-documents/Rel16</a>
CCSA	CCSA.37.460V1600		16.0.0	Published 17.07.2020	<a href="http://www.ccsa.org.cn:9001/portalsFile/downloadOldFile?type=17&amp;oldFileUrl=Rel16/TS%2037.460%20V16.0.0.doc">http://www.ccsa.org.cn:9001/portalsFile/downloadOldFile?type=17&amp;oldFileUrl=Rel16/TS%2037.460%20V16.0.0.doc</a>
ETSI	ETSI TS 137 460		16.0.0	Published 15.09.2020	<a href="http://www.etsi.org/deliver/etsi_ts/137400_137499/137460/16.00.00_60/ts_137460v160000p.pdf">http://www.etsi.org/deliver/etsi_ts/137400_137499/137460/16.00.00_60/ts_137460v160000p.pdf</a>
TSDSI	TSDSI STD T1.3GPP 37.460-16.0.0 V1.0.0		16.0.0	Published 06.10.2020	<a href="https://members.tdsi.in/index.php/s/3HG7csB4NabyzNQ">https://members.tdsi.in/index.php/s/3HG7csB4NabyzNQ</a>
TTA	TTAT.3G-37.460V16.0.0		16.0.0	Published 11.09.2020	<a href="http://www.tta.or.kr/data/ttasDown.jsp?where=14688&amp;pk_num=TTAT.3G-37.460V16.0.0">http://www.tta.or.kr/data/ttasDown.jsp?where=14688&amp;pk_num=TTAT.3G-37.460V16.0.0</a>

### 1.2.1.4.30 TS 37.461

#### Iuant interface: Layer 1

This document specifies the standards allowed to implement layer 1 on the Iuant interface for UTRA, E-UTRA and NR.

The specification of transmission delay requirements and O&M requirements are not in the scope of this document.

SDO	Document No.	Version	Status	Issued date	Location
<b>Release 15</b>					
ARIB	ARIB STD-T120-37.461		15.4.0	Published 28.09.2020	<a href="http://www.arib.or.jp/english/html/overview/doc/T120_T23_v2_00/2_T120/ARIB-STD-T120/Rel15/37/A37461-f40.pdf">http://www.arib.or.jp/english/html/overview/doc/T120_T23_v2_00/2_T120/ARIB-STD-T120/Rel15/37/A37461-f40.pdf</a>
ATIS	ATIS.3GPP.37.461V1540		15.4.0	Published 08.09.2020	<a href="http://www.atis.org/3gpp-documents/Rel15">http://www.atis.org/3gpp-documents/Rel15</a>
CCSA	CCSA.37.461V1540		15.4.0	Published 20.04.2019	<a href="http://www.ccsa.org.cn:9001/portalsFile/downloadOldFile?type=17&amp;oldFileUrl=Rel15/TS%2037.461%20V15.4.0.doc">http://www.ccsa.org.cn:9001/portalsFile/downloadOldFile?type=17&amp;oldFileUrl=Rel15/TS%2037.461%20V15.4.0.doc</a>
ETSI	ETSI TS 137 461		15.4.0	Published 15.05.2019	<a href="http://www.etsi.org/deliver/etsi_ts/137400_137499/137461/15.04.00_60/ts_137461v150400p.pdf">http://www.etsi.org/deliver/etsi_ts/137400_137499/137461/15.04.00_60/ts_137461v150400p.pdf</a>
TSDSI	TSDSI STD T1.3GPP 37.461-15.4.0 V1.0.0		15.4.0	Published 06.10.2020	<a href="https://members.tdsi.in/index.php/s/pkmKkZQZ5qE5dGT">https://members.tdsi.in/index.php/s/pkmKkZQZ5qE5dGT</a>
TTA	TTAT.3G-37.461V15.4.0		15.4.0	Published 11.09.2020	<a href="http://www.tta.or.kr/data/ttasDown.jsp?where=14688&amp;pk_num=TTAT.3G-37.461V15.4.0">http://www.tta.or.kr/data/ttasDown.jsp?where=14688&amp;pk_num=TTAT.3G-37.461V15.4.0</a>
<b>Release 16</b>					
ARIB	ARIB STD-T120-37.461		16.0.0	Published 28.09.2020	<a href="http://www.arib.or.jp/english/html/overview/doc/T120_T23_v2_00/2_T120/ARIB-STD-T120/Rel16/37/A37461-g00.pdf">http://www.arib.or.jp/english/html/overview/doc/T120_T23_v2_00/2_T120/ARIB-STD-T120/Rel16/37/A37461-g00.pdf</a>
ATIS	ATIS.3GPP.37.461V1600		16.0.0	Published 08.09.2020	<a href="http://www.atis.org/3gpp-documents/Rel16">http://www.atis.org/3gpp-documents/Rel16</a>
CCSA	CCSA.37.461V1600		16.0.0	Published 17.07.2020	<a href="http://www.ccsa.org.cn:9001/portalsFile/downloadOldFile?type=17&amp;oldFileUrl=Rel16/TS%2037.461%20V16.0.0.doc">http://www.ccsa.org.cn:9001/portalsFile/downloadOldFile?type=17&amp;oldFileUrl=Rel16/TS%2037.461%20V16.0.0.doc</a>
ETSI	ETSI TS 137 461		16.0.0	Published 15.09.2020	<a href="http://www.etsi.org/deliver/etsi_ts/137400_137499/137461/16.00.00_60/ts_137461v160000p.pdf">http://www.etsi.org/deliver/etsi_ts/137400_137499/137461/16.00.00_60/ts_137461v160000p.pdf</a>

TSDSI	TSDSI STD T1.3GPP 37.461-16.0.0 V1.0.0	16.0.0	Published	06.10.2020	<a href="https://members.tdsi.in/index.php/s/LCXXKrtEprG9PYWg">https://members.tdsi.in/index.php/s/LCXXKrtEprG9PYWg</a>
TTA	TTAT.3G-37.461V16.0.0	16.0.0	Published	11.09.2020	<a href="http://www.tta.or.kr/data/ttasDown.jsp?where=14688&amp;pk_num=TTAT.3G-37.461V16.0.0">http://www.tta.or.kr/data/ttasDown.jsp?where=14688&amp;pk_num=TTAT.3G-37.461V16.0.0</a>

### 1.2.1.4.31 TS 37.462

#### Iuant interface: Signalling transport

This document specifies the signalling transport related to RETAP and TMAAP signalling to be used across the Iuant interface for UTRAN, E-UTRAN and NG-RAN. In this specification UTRAN, E-UTRAN and NG-RAN are denoted as "RAN", whereas the corresponding network entities Node B, eNB, en-gNB and NG-RAN node are denoted as "RAN Node". The logical Iuant interface is an interface internal to the RAN Node and defined to reside between the implementation specific O&M function and the RET antennas and between the implementation specific O&M function and the TMA control unit function.

SDO	Document No.	Version	Status	Issued date	Location	
<b>Release 15</b>						
ARIB	ARIB STD-T120-37.462		15.2.0	Published	28.09.2020	<a href="http://www.arib.or.jp/english/html/overview/doc/T120_T23_v2_00/2_T120/ARIB-STD-T120/Rel15/37/A37462-f20.pdf">http://www.arib.or.jp/english/html/overview/doc/T120_T23_v2_00/2_T120/ARIB-STD-T120/Rel15/37/A37462-f20.pdf</a>
ATIS	ATIS.3GPP.37.462V1520		15.2.0	Published	08.09.2020	<a href="http://www.atis.org/3gpp-documents/Rel15">http://www.atis.org/3gpp-documents/Rel15</a>
CCSA	CCSA.37.462V1520		15.2.0	Published	09.01.2020	<a href="http://www.ccsa.org.cn:9001/portalsFile/downloadOldFile?type=17&amp;oldFileUrl=Rel15/TS%2037.462%20V15.2.0.doc">http://www.ccsa.org.cn:9001/portalsFile/downloadOldFile?type=17&amp;oldFileUrl=Rel15/TS%2037.462%20V15.2.0.doc</a>
ETSI	ETSI TS 137 462		15.2.0	Published	17.01.2020	<a href="http://www.etsi.org/deliver/etsi_ts/137400_137499/137462/15.02.00_60/ts_137462v150200p.pdf">http://www.etsi.org/deliver/etsi_ts/137400_137499/137462/15.02.00_60/ts_137462v150200p.pdf</a>
TSDSI	TSDSI STD T1.3GPP 37.462-15.2.0 V1.0.0		15.2.0	Published	06.10.2020	<a href="https://members.tdsi.in/index.php/s/KNsFOxJcdmeTETQ">https://members.tdsi.in/index.php/s/KNsFOxJcdmeTETQ</a>
TTA	TTAT.3G-37.462V15.2.0		15.2.0	Published	11.09.2020	<a href="http://www.tta.or.kr/data/ttasDown.jsp?where=14688&amp;pk_num=TTAT.3G-37.462V15.2.0">http://www.tta.or.kr/data/ttasDown.jsp?where=14688&amp;pk_num=TTAT.3G-37.462V15.2.0</a>
<b>Release 16</b>						
ARIB	ARIB STD-T120-37.462		16.0.0	Published	28.09.2020	<a href="http://www.arib.or.jp/english/html/overview/doc/T120_T23_v2_00/2_T120/ARIB-STD-T120/Rel16/37/A37462-g00.pdf">http://www.arib.or.jp/english/html/overview/doc/T120_T23_v2_00/2_T120/ARIB-STD-T120/Rel16/37/A37462-g00.pdf</a>
ATIS	ATIS.3GPP.37.462V1600		16.0.0	Published	08.09.2020	<a href="http://www.atis.org/3gpp-documents/Rel16">http://www.atis.org/3gpp-documents/Rel16</a>
CCSA	CCSA.37.462V1600		16.0.0	Published	20.07.2020	<a href="http://www.ccsa.org.cn:9001/portalsFile/downloadOldFile?type=17&amp;oldFileUrl=Rel16/TS%2037.462%20V16.0.0.doc">http://www.ccsa.org.cn:9001/portalsFile/downloadOldFile?type=17&amp;oldFileUrl=Rel16/TS%2037.462%20V16.0.0.doc</a>
ETSI	ETSI TS 137 462		16.0.0	Published	17.09.2020	<a href="http://www.etsi.org/deliver/etsi_ts/137400_137499/137462/16.00.00_60/ts_137462v160000p.pdf">http://www.etsi.org/deliver/etsi_ts/137400_137499/137462/16.00.00_60/ts_137462v160000p.pdf</a>
TSDSI	TSDSI STD T1.3GPP 37.462-16.0.0 V1.0.0		16.0.0	Published	06.10.2020	<a href="https://members.tdsi.in/index.php/s/oCmRJwDcXTn8c4b">https://members.tdsi.in/index.php/s/oCmRJwDcXTn8c4b</a>
TTA	TTAT.3G-37.462V16.0.0		16.0.0	Published	11.09.2020	<a href="http://www.tta.or.kr/data/ttasDown.jsp?where=14688&amp;pk_num=TTAT.3G-37.462V16.0.0">http://www.tta.or.kr/data/ttasDown.jsp?where=14688&amp;pk_num=TTAT.3G-37.462V16.0.0</a>

### 1.2.1.4.32 TS 37.466

#### Iuant interface: Application part

This document is an introduction to the 3GPP TS 37.46x series of Technical Specifications that define the Iuant Interface. The Iuant interface is applicable for UTRAN, E-UTRAN and NG-RAN. In this specification UTRAN, E-UTRAN and NG-RAN are denoted as "RAN", whereas the corresponding network entities Node B, eNB, en-gNB and NG-RAN node are denoted as "RAN Node". The logical Iuant interface is an interface internal to the RAN Node and defined to reside between the implementation specific O&M function and the RET antennas together with the TMAs control unit function of the RAN Node.



This document is applicable for UTRAN, E-UTRAN and NG-RAN and specifies the *Remote Electrical Tilting Application Part (RETAP)* and the *Tower Mounted Amplifier Application Part (TMAAP)*. In this specification UTRAN, E-UTRAN and NG-RAN are denoted as "RAN", whereas the corresponding network entities Node B, eNB, en-gNB and NG-RAN node are denoted as "RAN Node". RETAP supports the functions of the Iuant interface between the implementation specific O&M transport function and the RET Antenna Control unit function, TMAAP supports the functions of the Iuant interface between the implementation specific O&M transport function and the TMA control function.

SDO	Document No.	Version	Status	Issued date	Location	
<b>Release 15</b>						
ARIB	ARIB STD-T120-37.466		15.5.0	Published	28.09.2020	<a href="http://www.arib.or.jp/english/html/overview/doc/T120_T23_v2_00/2_T120/ARIB-STD-T120/Rel15/37/A37466-f50.pdf">http://www.arib.or.jp/english/html/overview/doc/T120_T23_v2_00/2_T120/ARIB-STD-T120/Rel15/37/A37466-f50.pdf</a>
ATIS	ATIS.3GPP.37.466V1550		15.5.0	Published	08.09.2020	<a href="http://www.atis.org/3gpp-documents/Rel15">http://www.atis.org/3gpp-documents/Rel15</a>
CCSA	CCSA.37.466V1550		15.5.0	Published	09.01.2020	<a href="http://www.ccsa.org.cn:9001/portalsFile/downloadOldFile?type=17&amp;oldFileUrl=Rel15/TS%2037.466%20V15.5.0.doc">http://www.ccsa.org.cn:9001/portalsFile/downloadOldFile?type=17&amp;oldFileUrl=Rel15/TS%2037.466%20V15.5.0.doc</a>
ETSI	ETSI TS 137 466		15.5.0	Published	17.01.2020	<a href="http://www.etsi.org/deliver/etsi_ts/137400_137499/137466/15.05.00_60/ts_137466v150500p.pdf">http://www.etsi.org/deliver/etsi_ts/137400_137499/137466/15.05.00_60/ts_137466v150500p.pdf</a>
TSDSI	TSDSI STD T1.3GPP 37.466-15.5.0 V1.0.0		15.5.0	Published	06.10.2020	<a href="https://members.tdsi.in/index.php/s/EeHNBLpXRMtgdTW">https://members.tdsi.in/index.php/s/EeHNBLpXRMtgdTW</a>
TTA	TTAT.3G-37.466V15.5.0		15.5.0	Published	11.09.2020	<a href="http://www.tta.or.kr/data/ttasDown.jsp?where=14688&amp;pk_num=TTAT.3G-37.466V15.5.0">http://www.tta.or.kr/data/ttasDown.jsp?where=14688&amp;pk_num=TTAT.3G-37.466V15.5.0</a>
<b>Release 16</b>						
ARIB	ARIB STD-T120-37.466		16.0.0	Published	28.09.2020	<a href="http://www.arib.or.jp/english/html/overview/doc/T120_T23_v2_00/2_T120/ARIB-STD-T120/Rel16/37/A37466-g00.pdf">http://www.arib.or.jp/english/html/overview/doc/T120_T23_v2_00/2_T120/ARIB-STD-T120/Rel16/37/A37466-g00.pdf</a>
ATIS	ATIS.3GPP.37.466V1600		16.0.0	Published	08.09.2020	<a href="http://www.atis.org/3gpp-documents/Rel16">http://www.atis.org/3gpp-documents/Rel16</a>
CCSA	CCSA.37.466V1600		16.0.0	Published	28.07.2020	<a href="http://www.ccsa.org.cn:9001/portalsFile/downloadOldFile?type=17&amp;oldFileUrl=Rel16/TS%2037.466%20V16.0.0.doc">http://www.ccsa.org.cn:9001/portalsFile/downloadOldFile?type=17&amp;oldFileUrl=Rel16/TS%2037.466%20V16.0.0.doc</a>
ETSI	ETSI TS 137 466		16.0.0	Published	18.09.2020	<a href="http://www.etsi.org/deliver/etsi_ts/137400_137499/137466/16.00.00_60/ts_137466v160000p.pdf">http://www.etsi.org/deliver/etsi_ts/137400_137499/137466/16.00.00_60/ts_137466v160000p.pdf</a>
TSDSI	TSDSI STD T1.3GPP 37.466-16.0.0 V1.0.0		16.0.0	Published	06.10.2020	<a href="https://members.tdsi.in/index.php/s/e8qXqTXA69FcGtH">https://members.tdsi.in/index.php/s/e8qXqTXA69FcGtH</a>
TTA	TTAT.3G-37.466V16.0.0		16.0.0	Published	11.09.2020	<a href="http://www.tta.or.kr/data/ttasDown.jsp?where=14688&amp;pk_num=TTAT.3G-37.466V16.0.0">http://www.tta.or.kr/data/ttasDown.jsp?where=14688&amp;pk_num=TTAT.3G-37.466V16.0.0</a>

### 1.2.1.4.33 TS 37.470

#### W1 interface; General aspects and principles

This document is an introduction to the 3GPP TS 37.4xx series of technical specifications that define the W1 interface. The W1 interface provides means for interconnecting a ng-eNB-CU and a ng-eNB-DU of a ng-eNB within a NG-RAN.

SDO	Document No.	Version	Status	Issued date	Location	
<b>Release 16</b>						
ARIB	ARIB STD-T120-37.470		16.2.0	Published	28.09.2020	<a href="http://www.arib.or.jp/english/html/overview/doc/T120_T23_v2_00/2_T120/ARIB-STD-T120/Rel16/37/A37470-g20.pdf">http://www.arib.or.jp/english/html/overview/doc/T120_T23_v2_00/2_T120/ARIB-STD-T120/Rel16/37/A37470-g20.pdf</a>
ATIS	ATIS.3GPP.37.470V1620		16.2.0	Published	08.09.2020	<a href="http://www.atis.org/3gpp-documents/Rel16">http://www.atis.org/3gpp-documents/Rel16</a>
CCSA	CCSA.37.470V1620		16.2.0	Published	17.07.2020	<a href="http://www.ccsa.org.cn:9001/portalsFile/downloadOldFile?type=17&amp;oldFileUrl=Rel16/TS%2037.370%20V16.2.0.doc">http://www.ccsa.org.cn:9001/portalsFile/downloadOldFile?type=17&amp;oldFileUrl=Rel16/TS%2037.370%20V16.2.0.doc</a>
ETSI	ETSI TS 137 470		16.2.0	Published	15.09.2020	<a href="http://www.etsi.org/deliver/etsi_ts/137400_137499/137470/16.02.00_60/ts_137470v160200p.pdf">http://www.etsi.org/deliver/etsi_ts/137400_137499/137470/16.02.00_60/ts_137470v160200p.pdf</a>
TSDSI	TSDSI STD T1.3GPP 37.470-16.2.0 V1.0.0		16.2.0	Published	06.10.2020	<a href="https://members.tdsi.in/index.php/s/5gdiKqeMnXOfK2X">https://members.tdsi.in/index.php/s/5gdiKqeMnXOfK2X</a>
TTA	TTAT.3G-37.470V16.2.0		16.2.0	Published	11.09.2020	<a href="http://www.tta.or.kr/data/ttasDown.jsp?where=14688&amp;pk_num=TTAT.3G-37.470V16.2.0">http://www.tta.or.kr/data/ttasDown.jsp?where=14688&amp;pk_num=TTAT.3G-37.470V16.2.0</a>

### 1.2.1.4.34 TS 37.471

#### W1 interface; Layer 1

This document specifies the standards allowed to implement Layer 1 on the W1 interface. The W1 interface provides means for interconnecting a ng-eNB-CU and a ng-eNB-DU of a ng-eNB within a NG-RAN.

The specification of transmission delay requirements and O&M requirements are not in the scope of this document.

In the following 'Layer 1' and 'Physical Layer' are assumed to be synonymous.

SDO	Document No.	Version	Status	Issued date	Location
<b>Release 16</b>					
ARIB	ARIB STD-T120-37.471		16.1.0	Published 28.09.2020	<a href="http://www.arib.or.jp/english/html/overview/doc/T120_T23_v2_00/2_T120/ARIB-STD-T120/Rel16/37/A37471-g10.pdf">http://www.arib.or.jp/english/html/overview/doc/T120_T23_v2_00/2_T120/ARIB-STD-T120/Rel16/37/A37471-g10.pdf</a>
ATIS	ATIS.3GPP.37.471V1610		16.1.0	Published 08.09.2020	<a href="http://www.atis.org/3gpp-documents/Rel16">http://www.atis.org/3gpp-documents/Rel16</a>
CCSA	CCSA.37.471V1610		16.1.0	Published 31.03.2020	<a href="http://www.ccsa.org.cn:9001/portalsFile/downloadOldFile?type=17&amp;oldFileUrl=Rel16/TS%2037.471%20V16.1.0.doc">http://www.ccsa.org.cn:9001/portalsFile/downloadOldFile?type=17&amp;oldFileUrl=Rel16/TS%2037.471%20V16.1.0.doc</a>
ETSI	ETSI TS 137 471		16.1.0	Published 21.09.2020	<a href="http://www.etsi.org/deliver/etsi_ts/137400_137499/137471/16.01.00_60/ts_137471v160100p.pdf">http://www.etsi.org/deliver/etsi_ts/137400_137499/137471/16.01.00_60/ts_137471v160100p.pdf</a>
TSDSI	TSDSI STD T1.3GPP 37.471-16.1.0 V1.0.0		16.1.0	Published 06.10.2020	<a href="https://members.tdsi.in/index.php/s/YypzZHQEjmZYYjS">https://members.tdsi.in/index.php/s/YypzZHQEjmZYYjS</a>
TTA	TTAT.3G-37.471V16.1.0		16.1.0	Published 11.09.2020	<a href="http://www.tta.or.kr/data/ttasDown.jsp?where=14688&amp;pk_num=TTAT.3G-37.471V16.1.0">http://www.tta.or.kr/data/ttasDown.jsp?where=14688&amp;pk_num=TTAT.3G-37.471V16.1.0</a>

### 1.2.1.4.35 TS 37.472

#### W1 interface; Signalling transport

This document specifies the standards for Signalling Transport to be used across the W1 interface. The W1 interface provides means for interconnecting a ng-eNB-CU and a ng-eNB-DU of a ng-eNB within a NG-RAN. This document describes how the W1AP signalling messages are transported over W1.

SDO	Document No.	Version	Status	Issued date	Location
<b>Release 16</b>					
ARIB	ARIB STD-T120-37.472		16.1.0	Published 28.09.2020	<a href="http://www.arib.or.jp/english/html/overview/doc/T120_T23_v2_00/2_T120/ARIB-STD-T120/Rel16/37/A37472-g10.pdf">http://www.arib.or.jp/english/html/overview/doc/T120_T23_v2_00/2_T120/ARIB-STD-T120/Rel16/37/A37472-g10.pdf</a>
ATIS	ATIS.3GPP.37.472V1610		16.1.0	Published 08.09.2020	<a href="http://www.atis.org/3gpp-documents/Rel16">http://www.atis.org/3gpp-documents/Rel16</a>
CCSA	CCSA.37.472V1610		16.1.0	Published 17.07.2020	<a href="http://www.ccsa.org.cn:9001/portalsFile/downloadOldFile?type=17&amp;oldFileUrl=Rel16/TS%2037.472%20V16.1.0.doc">http://www.ccsa.org.cn:9001/portalsFile/downloadOldFile?type=17&amp;oldFileUrl=Rel16/TS%2037.472%20V16.1.0.doc</a>
ETSI	ETSI TS 137 472		16.1.0	Published 15.09.2020	<a href="http://www.etsi.org/deliver/etsi_ts/137400_137499/137472/16.01.00_60/ts_137472v160100p.pdf">http://www.etsi.org/deliver/etsi_ts/137400_137499/137472/16.01.00_60/ts_137472v160100p.pdf</a>
TSDSI	TSDSI STD T1.3GPP 37.472-16.1.0 V1.0.0		16.1.0	Published 06.10.2020	<a href="https://members.tdsi.in/index.php/s/ecrHinLENfpwjE7">https://members.tdsi.in/index.php/s/ecrHinLENfpwjE7</a>
TTA	TTAT.3G-37.472V16.1.0		16.1.0	Published 11.09.2020	<a href="http://www.tta.or.kr/data/ttasDown.jsp?where=14688&amp;pk_num=TTAT.3G-37.472V16.1.0">http://www.tta.or.kr/data/ttasDown.jsp?where=14688&amp;pk_num=TTAT.3G-37.472V16.1.0</a>

### 1.2.1.4.36 TS 37.473

#### W1 interface; Application Protocol (W1AP)

This document specifies the 5G radio network layer signalling protocol for the W1 interface. The W1 interface provides means for interconnecting a ng-eNB-CU and a ng-eNB-DU of a ng-eNB within an NG-RAN. The W1 Application Protocol (W1AP) supports the functions of W1 interface by signalling procedures defined in this document. W1AP is developed in accordance with the general principles stated in TS 38.401 and TS 37.470.

SDO	Document No.	Version	Status	Issued date	Location
<b>Release 16</b>					
ARIB	ARIB STD-T120-37.473		16.2.0	Published 28.09.2020	<a href="http://www.arib.or.jp/english/html/overview/doc/T120_T23_v2_00/2_T120/ARIB-STD-T120/Rel16/37/A37473-g20.pdf">http://www.arib.or.jp/english/html/overview/doc/T120_T23_v2_00/2_T120/ARIB-STD-T120/Rel16/37/A37473-g20.pdf</a>
ATIS	ATIS.3GPP.37.473V1620		16.2.0	Published 08.09.2020	<a href="http://www.atis.org/3gpp-documents/Rel16">http://www.atis.org/3gpp-documents/Rel16</a>
CCSA	CCSA.37.473V1620		16.2.0	Published 17.07.2020	<a href="http://www.ccsa.org.cn:9001/portalsFile/downloadOldFile?type=17&amp;oldFileUrl=Rel16/TS%2037.473%20V16.2.0.doc">http://www.ccsa.org.cn:9001/portalsFile/downloadOldFile?type=17&amp;oldFileUrl=Rel16/TS%2037.473%20V16.2.0.doc</a>
ETSI	ETSI TS 137 473		16.2.0	Published 15.09.2020	<a href="http://www.etsi.org/deliver/etsi_ts/137400_137499/137473/16.02.00_60/ts_137473v160200p.pdf">http://www.etsi.org/deliver/etsi_ts/137400_137499/137473/16.02.00_60/ts_137473v160200p.pdf</a>
TSDSI	TSDSI STD T1.3GPP 37.473-16.2.0 V1.0.0		16.2.0	Published 06.10.2020	<a href="https://members.tdsi.in/index.php/s/zi7XfEtayYzXDxa">https://members.tdsi.in/index.php/s/zi7XfEtayYzXDxa</a>
TTA	TTAT.3G-37.473V16.2.0		16.2.0	Published 11.09.2020	<a href="http://www.tta.or.kr/data/ttasDown.jsp?where=14688&amp;pk_num=TTAT.3G-37.473V16.2.0">http://www.tta.or.kr/data/ttasDown.jsp?where=14688&amp;pk_num=TTAT.3G-37.473V16.2.0</a>

**1.2.1.4.37 TS 38.401****NG-RAN; Architecture description**

This document describes the overall architecture of the NG-RAN, including interfaces NG, Xn and F1 interfaces and their interaction with the radio interface.

SDO	Document No.	Version	Status	Issued date	Location
<b>Release 15</b>					
ATIS	ATIS.3GPP.38.401V1580		15.8.0	Published 08.09.2020	<a href="http://www.atis.org/3gpp-documents/Rel15">http://www.atis.org/3gpp-documents/Rel15</a>
CCSA	CCSA.38.401V1580		15.8.0	Published 17.07.2020	<a href="http://www.ccsa.org.cn:9001/portalsFile/downloadOldFile?type=17&amp;oldFileUrl=Rel15/TS%2038.401%20V15.8.0.doc">http://www.ccsa.org.cn:9001/portalsFile/downloadOldFile?type=17&amp;oldFileUrl=Rel15/TS%2038.401%20V15.8.0.doc</a>
ETSI	ETSI TS 138 401		15.8.0	Published 23.07.2020	<a href="http://www.etsi.org/deliver/etsi_ts/138400_138499/138401/15.08.00_60/ts_138401v150800p.pdf">http://www.etsi.org/deliver/etsi_ts/138400_138499/138401/15.08.00_60/ts_138401v150800p.pdf</a>
TSDSI	TSDSI STD T1.3GPP 38.401-15.8.0 V1.0.0		15.8.0	Published 06.10.2020	<a href="https://members.tdsi.in/index.php/s/49928WsQckdCzFi">https://members.tdsi.in/index.php/s/49928WsQckdCzFi</a>
TTA	TTAT.3G-38.401V15.8.0		15.8.0	Published 11.09.2020	<a href="http://www.tta.or.kr/data/ttasDown.jsp?where=14688&amp;pk_num=TTAT.3G-38.401V15.8.0">http://www.tta.or.kr/data/ttasDown.jsp?where=14688&amp;pk_num=TTAT.3G-38.401V15.8.0</a>
TTC	TS-3GA-38.401(Rel15) v15.8.0		15.8.0	Published 02.10.2020	<a href="https://www.ttc.or.jp/st/docs/3gpps2020/TS/TS-3GA-38_401_Rel15v15_8_0.pdf">https://www.ttc.or.jp/st/docs/3gpps2020/TS/TS-3GA-38_401_Rel15v15_8_0.pdf</a>
<b>Release 16</b>					
ATIS	ATIS.3GPP.38.401V1620		16.2.0	Published 08.09.2020	<a href="http://www.atis.org/3gpp-documents/Rel16">http://www.atis.org/3gpp-documents/Rel16</a>
CCSA	CCSA.38.401V1620		16.2.0	Published 17.07.2020	<a href="http://www.ccsa.org.cn:9001/portalsFile/downloadOldFile?type=17&amp;oldFileUrl=Rel16/TS%2038.401%20V16.2.0.doc">http://www.ccsa.org.cn:9001/portalsFile/downloadOldFile?type=17&amp;oldFileUrl=Rel16/TS%2038.401%20V16.2.0.doc</a>
ETSI	ETSI TS 138 401		16.2.0	Published 23.07.2020	<a href="http://www.etsi.org/deliver/etsi_ts/138400_138499/138401/16.02.00_60/ts_138401v160200p.pdf">http://www.etsi.org/deliver/etsi_ts/138400_138499/138401/16.02.00_60/ts_138401v160200p.pdf</a>
TSDSI	TSDSI STD T1.3GPP 38.401-16.2.0 V1.0.0		16.2.0	Published 06.10.2020	<a href="https://members.tdsi.in/index.php/s/kT7gro63ESF85Yi">https://members.tdsi.in/index.php/s/kT7gro63ESF85Yi</a>
TTA	TTAT.3G-38.401V16.2.0		16.2.0	Published 11.09.2020	<a href="http://www.tta.or.kr/data/ttasDown.jsp?where=14688&amp;pk_num=TTAT.3G-38.401V16.2.0">http://www.tta.or.kr/data/ttasDown.jsp?where=14688&amp;pk_num=TTAT.3G-38.401V16.2.0</a>
TTC	TS-3GA-38.401(Rel16) v16.2.0		16.2.0	Published 02.10.2020	<a href="https://www.ttc.or.jp/st/docs/3gpps2020/TS/TS-3GA-38_401_Rel16v16_2_0.pdf">https://www.ttc.or.jp/st/docs/3gpps2020/TS/TS-3GA-38_401_Rel16v16_2_0.pdf</a>

**1.2.1.4.38 TS 38.410****NG-RAN; NG general aspects and principles**

This document is an introduction to the 3GPP TS 38.41x series of technical specifications that define the NG interface for the interconnection of an NG-RAN node to the 5GC (5G Core Network).

SDO	Document No.	Version	Status	Issued date	Location
<b>Release 15</b>					
ATIS	ATIS.3GPP.38.410V1520		15.2.0	Published 08.09.2020	<a href="http://www.atis.org/3gpp-documents/Rel15">http://www.atis.org/3gpp-documents/Rel15</a>
CCSA	CCSA.38.410V1520		15.2.0	Published 08.01.2019	<a href="http://www.ccsa.org.cn:9001/portalsFile/downloadOldFile?type=17&amp;oldFileUrl=Rel15/TS%2038.410%20V15.2.0.doc">http://www.ccsa.org.cn:9001/portalsFile/downloadOldFile?type=17&amp;oldFileUrl=Rel15/TS%2038.410%20V15.2.0.doc</a>
ETSI	ETSI TS 138 410		15.2.0	Published 24.04.2019	<a href="http://www.etsi.org/deliver/etsi_ts/138400_138499/138410/15.02.00_60/ts_138410v150200p.pdf">http://www.etsi.org/deliver/etsi_ts/138400_138499/138410/15.02.00_60/ts_138410v150200p.pdf</a>
TSDSI	TSDSI STD T1.3GPP 38.410-15.2.0 V1.0.0		15.2.0	Published 06.10.2020	<a href="https://members.tdsi.in/index.php/s/gGtM3ESsZ8ZztZj">https://members.tdsi.in/index.php/s/gGtM3ESsZ8ZztZj</a>
TTA	TTAT.3G-38.410V15.2.0		15.2.0	Published 11.09.2020	<a href="http://www.tta.or.kr/data/ttasDown.jsp?where=14688&amp;pk_num=TTAT.3G-38.410V15.2.0">http://www.tta.or.kr/data/ttasDown.jsp?where=14688&amp;pk_num=TTAT.3G-38.410V15.2.0</a>
TTC	TS-3GA-38.410(Rel15) v15.2.0		15.2.0	Published 02.10.2020	<a href="https://www.ttc.or.jp/st/docs/3gpps2020/TS/TS-3GA-38_410_Rel15v15_2_0.pdf">https://www.ttc.or.jp/st/docs/3gpps2020/TS/TS-3GA-38_410_Rel15v15_2_0.pdf</a>
<b>Release 16</b>					
ATIS	ATIS.3GPP.38.410V1620		16.2.0	Published 08.09.2020	<a href="http://www.atis.org/3gpp-documents/Rel16">http://www.atis.org/3gpp-documents/Rel16</a>
CCSA	CCSA.38.410V1620		16.2.0	Published 17.07.2020	<a href="http://www.ccsa.org.cn:9001/portalsFile/downloadOldFile?type=17&amp;oldFileUrl=Rel16/TS%2038.410%20V16.2.0.doc">http://www.ccsa.org.cn:9001/portalsFile/downloadOldFile?type=17&amp;oldFileUrl=Rel16/TS%2038.410%20V16.2.0.doc</a>
ETSI	ETSI TS 138 410		16.2.0	Published 21.07.2020	<a href="http://www.etsi.org/deliver/etsi_ts/138400_138499/138410/16.02.00_60/ts_138410v160200p.pdf">http://www.etsi.org/deliver/etsi_ts/138400_138499/138410/16.02.00_60/ts_138410v160200p.pdf</a>
TSDSI	TSDSI STD T1.3GPP 38.410-16.2.0 V1.0.0		16.2.0	Published 06.10.2020	<a href="https://members.tdsi.in/index.php/s/mDjXgTGR2j6jNDw">https://members.tdsi.in/index.php/s/mDjXgTGR2j6jNDw</a>
TTA	TTAT.3G-38.410V16.2.0		16.2.0	Published 11.09.2020	<a href="http://www.tta.or.kr/data/ttasDown.jsp?where=14688&amp;pk_num=TTAT.3G-38.410V16.2.0">http://www.tta.or.kr/data/ttasDown.jsp?where=14688&amp;pk_num=TTAT.3G-38.410V16.2.0</a>
TTC	TS-3GA-38.410(Rel16) v16.2.0		16.2.0	Published 02.10.2020	<a href="https://www.ttc.or.jp/st/docs/3gpps2020/TS/TS-3GA-38_410_Rel16v16_2_0.pdf">https://www.ttc.or.jp/st/docs/3gpps2020/TS/TS-3GA-38_410_Rel16v16_2_0.pdf</a>

**1.2.1.4.39 TS 38.411****NG-RAN; NG layer 1**

This document specifies the standards allowed to implement layer 1 on the NG interface.

The specification of transmission delay requirements and O&M requirements are not in the scope of this document.

SDO	Document No.	Version	Status	Issued date	Location
<b>Release 15</b>					
ATIS	ATIS.3GPP.38.411V1500		15.0.0	Published 08.09.2020	<a href="http://www.atis.org/3gpp-documents/Rel15">http://www.atis.org/3gpp-documents/Rel15</a>
CCSA	CCSA.38.411V1500		15.0.0	Published 22.06.2018	<a href="http://www.ccsa.org.cn:9001/portalsFile/downloadOldFile?type=17&amp;oldFileUrl=Rel15/TS%2038.411%20V15.0.0.doc">http://www.ccsa.org.cn:9001/portalsFile/downloadOldFile?type=17&amp;oldFileUrl=Rel15/TS%2038.411%20V15.0.0.doc</a>
ETSI	ETSI TS 138 411		15.0.0	Published 04.07.2018	<a href="http://www.etsi.org/deliver/etsi_ts/138400_138499/138411/15.00.00_60/ts_138411v150000p.pdf">http://www.etsi.org/deliver/etsi_ts/138400_138499/138411/15.00.00_60/ts_138411v150000p.pdf</a>
TSDSI	TSDSI STD T1.3GPP 38.411-15.0.0 V1.0.0		15.0.0	Published 06.10.2020	<a href="https://members.tdsi.in/index.php/s/pci27QRkyfDdJey">https://members.tdsi.in/index.php/s/pci27QRkyfDdJey</a>
TTA	TTAT.3G-38.411V15.0.0		15.0.0	Published 11.09.2020	<a href="http://www.tta.or.kr/data/ttasDown.jsp?where=14688&amp;pk_num=TTAT.3G-38.411V15.0.0">http://www.tta.or.kr/data/ttasDown.jsp?where=14688&amp;pk_num=TTAT.3G-38.411V15.0.0</a>
TTC	TS-3GA-38.411(Rel15) v15.0.0		15.0.0	Published 28.09.2018	<a href="https://www.ttc.or.jp/st/docs/3gpps2018/TS/TS-3GA-38.411(Rel15)v15.0.0.pdf">https://www.ttc.or.jp/st/docs/3gpps2018/TS/TS-3GA-38.411(Rel15)v15.0.0.pdf</a>
<b>Release 16</b>					
ATIS	ATIS.3GPP.38.411V1600		16.0.0	Published 08.09.2020	<a href="http://www.atis.org/3gpp-documents/Rel16">http://www.atis.org/3gpp-documents/Rel16</a>
CCSA	CCSA.38.411V1600		16.0.0	Published 16.07.2020	<a href="http://www.ccsa.org.cn:9001/portalsFile/downloadOldFile?type=17&amp;oldFileUrl=Rel16/TS%2038.411%20V16.0.0.doc">http://www.ccsa.org.cn:9001/portalsFile/downloadOldFile?type=17&amp;oldFileUrl=Rel16/TS%2038.411%20V16.0.0.doc</a>
ETSI	ETSI TS 138 411		16.0.0	Published 21.07.2020	<a href="http://www.etsi.org/deliver/etsi_ts/138400_138499/138411/16.00.00_60/ts_138411v160000p.pdf">http://www.etsi.org/deliver/etsi_ts/138400_138499/138411/16.00.00_60/ts_138411v160000p.pdf</a>
TSDSI	TSDSI STD T1.3GPP 38.411-16.0.0 V1.0.0		16.0.0	Published 06.10.2020	<a href="https://members.tdsi.in/index.php/s/LC9RL5RnBHnEdPE">https://members.tdsi.in/index.php/s/LC9RL5RnBHnEdPE</a>
TTA	TTAT.3G-38.411V16.0.0		16.0.0	Published 11.09.2020	<a href="http://www.tta.or.kr/data/ttasDown.jsp?where=14688&amp;pk_num=TTAT.3G-38.411V16.0.0">http://www.tta.or.kr/data/ttasDown.jsp?where=14688&amp;pk_num=TTAT.3G-38.411V16.0.0</a>
TTC	TS-3GA-38.411(Rel16) v16.0.0		16.0.0	Published 02.10.2020	<a href="https://www.ttc.or.jp/st/docs/3gpps2020/TS/TS-3GA-38_411_Rel16v16_0_0.pdf">https://www.ttc.or.jp/st/docs/3gpps2020/TS/TS-3GA-38_411_Rel16v16_0_0.pdf</a>

**1.2.1.4.40 TS 38.412****NG-RAN; NG signalling transport**

This document specifies the standards for signalling transport to be used across NG interface. NG interface is a logical interface between the NG-RAN and the 5GC. This document describes how the NGAP signalling messages are transported over NG.

SDO	Document No.	Version	Status	Issued date	Location
<b>Release 15</b>					
ATIS	ATIS.3GPP.38.412V1540		15.4.0	Published 08.09.2020	<a href="http://www.atis.org/3gpp-documents/Rel15">http://www.atis.org/3gpp-documents/Rel15</a>
CCSA	CCSA.38.412V1540		15.4.0	Published 09.01.2020	<a href="http://www.ccsa.org.cn:9001/portalsFile/downloadOldFile?type=17&amp;oldFileUrl=Rel15/TS%2038.412%20V15.4.0.doc">http://www.ccsa.org.cn:9001/portalsFile/downloadOldFile?type=17&amp;oldFileUrl=Rel15/TS%2038.412%20V15.4.0.doc</a>
ETSI	ETSI TS 138 412		15.4.0	Published 17.01.2020	<a href="http://www.etsi.org/deliver/etsi_ts/138400_138499/138412/15.04.00_60/ts_138412v150400p.pdf">http://www.etsi.org/deliver/etsi_ts/138400_138499/138412/15.04.00_60/ts_138412v150400p.pdf</a>
TSDSI	TSDSI STD T1.3GPP 38.412-15.4.0 V1.0.0		15.4.0	Published 06.10.2020	<a href="https://members.tdsi.in/index.php/s/xdi5zaWeYKfNEpF">https://members.tdsi.in/index.php/s/xdi5zaWeYKfNEpF</a>
TTA	TTAT.3G-38.412V15.4.0		15.4.0	Published 11.09.2020	<a href="http://www.tta.or.kr/data/ttasDown.jsp?where=14688&amp;pk_num=TTAT.3G-38.412V15.4.0">http://www.tta.or.kr/data/ttasDown.jsp?where=14688&amp;pk_num=TTAT.3G-38.412V15.4.0</a>
TTC	TS-3GA-38.412(Rel15) v15.4.0		15.4.0	Published 16.04.2020	<a href="https://www.ttc.or.jp/st/docs/3gpps2020/TS/TS-3GA-38_412_Rel15v15_4_0.pdf">https://www.ttc.or.jp/st/docs/3gpps2020/TS/TS-3GA-38_412_Rel15v15_4_0.pdf</a>
<b>Release 16</b>					
ATIS	ATIS.3GPP.38.412V1600		16.0.0	Published 08.09.2020	<a href="http://www.atis.org/3gpp-documents/Rel16">http://www.atis.org/3gpp-documents/Rel16</a>
CCSA	CCSA.38.412V1600		16.0.0	Published 01.04.2020	<a href="http://www.ccsa.org.cn:9001/portalsFile/downloadOldFile?type=17&amp;oldFileUrl=Rel16/TS%2038.412%20V16.0.0.doc">http://www.ccsa.org.cn:9001/portalsFile/downloadOldFile?type=17&amp;oldFileUrl=Rel16/TS%2038.412%20V16.0.0.doc</a>
ETSI	ETSI TS 138 412		16.0.0	Published 21.09.2020	<a href="http://www.etsi.org/deliver/etsi_ts/138400_138499/138412/16.00.00_60/ts_138412v160000p.pdf">http://www.etsi.org/deliver/etsi_ts/138400_138499/138412/16.00.00_60/ts_138412v160000p.pdf</a>
TSDSI	TSDSI STD T1.3GPP 38.412-16.0.0 V1.0.0		16.0.0	Published 06.10.2020	<a href="https://members.tdsi.in/index.php/s/NsRRj7QxYBrKCZ8">https://members.tdsi.in/index.php/s/NsRRj7QxYBrKCZ8</a>
TTA	TTAT.3G-38.412V16.0.0		16.0.0	Published 11.09.2020	<a href="http://www.tta.or.kr/data/ttasDown.jsp?where=14688&amp;pk_num=TTAT.3G-38.412V16.0.0">http://www.tta.or.kr/data/ttasDown.jsp?where=14688&amp;pk_num=TTAT.3G-38.412V16.0.0</a>
TTC	TS-3GA-38.412(Rel16) v16.0.0		16.0.0	Published 02.10.2020	<a href="https://www.ttc.or.jp/st/docs/3gpps2020/TS/TS-3GA-38_412_Rel16v16_0_0.pdf">https://www.ttc.or.jp/st/docs/3gpps2020/TS/TS-3GA-38_412_Rel16v16_0_0.pdf</a>

**1.2.1.4.41 TS 38.413****NG-RAN; NG Application Protocol (NGAP)**

This document specifies the radio network layer signalling protocol for the NG interface. The NG Application Protocol (NGAP) supports the functions of the NG interface by signalling procedures defined in this document. NGAP is developed in accordance with the general principles stated in TS 38.401 and TS 38.410.

SDO	Document No.	Version	Status	Issued date	Location
<b>Release 15</b>					
ATIS	ATIS.3GPP.38.413V1580		15.8.0	Published 08.09.2020	<a href="http://www.atis.org/3gpp-documents/Rel15">http://www.atis.org/3gpp-documents/Rel15</a>
CCSA	CCSA.38.413V1580		15.8.0	Published 17.07.2020	<a href="http://www.ccsa.org.cn:9001/portalsFile/downloadOldFile?type=17&amp;oldFileUrl=Rel15/TS%2038.413%20V15.8.0.doc">http://www.ccsa.org.cn:9001/portalsFile/downloadOldFile?type=17&amp;oldFileUrl=Rel15/TS%2038.413%20V15.8.0.doc</a>
ETSI	ETSI TS 138 413		15.8.0	Published 23.07.2020	<a href="http://www.etsi.org/deliver/etsi_ts/138400_138499/138413/15.08.00_60/ts_138413v150800p.pdf">http://www.etsi.org/deliver/etsi_ts/138400_138499/138413/15.08.00_60/ts_138413v150800p.pdf</a>
TSDSI	TSDSI STD T1.3GPP 38.413-15.8.0 V1.0.0		15.8.0	Published 06.10.2020	<a href="https://members.tdsi.in/index.php/s/B7jGFsLMRw8km4p">https://members.tdsi.in/index.php/s/B7jGFsLMRw8km4p</a>
TTA	TTAT.3G-38.413V15.8.0		15.8.0	Published 11.09.2020	<a href="http://www.tta.or.kr/data/ttasDown.jsp?where=14688&amp;pk_num=TTAT.3G-38.413V15.8.0">http://www.tta.or.kr/data/ttasDown.jsp?where=14688&amp;pk_num=TTAT.3G-38.413V15.8.0</a>
TTC	TS-3GA-38.413(Rel15) v15.8.0		15.8.0	Published 02.10.2020	<a href="https://www.ttc.or.jp/st/docs/3gpps2020/TS/TS-3GA-38_413_Rel15v15_8_0.pdf">https://www.ttc.or.jp/st/docs/3gpps2020/TS/TS-3GA-38_413_Rel15v15_8_0.pdf</a>
<b>Release 16</b>					
ATIS	ATIS.3GPP.38.413V1620		16.2.0	Published 08.09.2020	<a href="http://www.atis.org/3gpp-documents/Rel16">http://www.atis.org/3gpp-documents/Rel16</a>
CCSA	CCSA.38.413V1620		16.2.0	Published 17.07.2020	<a href="http://www.ccsa.org.cn:9001/portalsFile/downloadOldFile?type=17&amp;oldFileUrl=Rel16/TS%2038.413%20V16.2.0.doc">http://www.ccsa.org.cn:9001/portalsFile/downloadOldFile?type=17&amp;oldFileUrl=Rel16/TS%2038.413%20V16.2.0.doc</a>
ETSI	ETSI TS 138 413		16.2.0	Published 23.07.2020	<a href="http://www.etsi.org/deliver/etsi_ts/138400_138499/138413/16.02.00_60/ts_138413v160200p.pdf">http://www.etsi.org/deliver/etsi_ts/138400_138499/138413/16.02.00_60/ts_138413v160200p.pdf</a>
TSDSI	TSDSI STD T1.3GPP 38.413-16.2.0 V1.0.0		16.2.0	Published 06.10.2020	<a href="https://members.tdsi.in/index.php/s/OKLffEDRYGw98yb">https://members.tdsi.in/index.php/s/OKLffEDRYGw98yb</a>
TTA	TTAT.3G-38.413V16.2.0		16.2.0	Published 11.09.2020	<a href="http://www.tta.or.kr/data/ttasDown.jsp?where=14688&amp;pk_num=TTAT.3G-38.413V16.2.0">http://www.tta.or.kr/data/ttasDown.jsp?where=14688&amp;pk_num=TTAT.3G-38.413V16.2.0</a>
TTC	TS-3GA-38.413(Rel16) v16.2.0		16.2.0	Published 02.10.2020	<a href="https://www.ttc.or.jp/st/docs/3gpps2020/TS/TS-3GA-38_413_Rel16v16_2_0.pdf">https://www.ttc.or.jp/st/docs/3gpps2020/TS/TS-3GA-38_413_Rel16v16_2_0.pdf</a>

**1.2.1.4.42 TS 38.414****NG-RAN; NG data transport**

This document specifies the standards for user data transport protocols and related signalling protocols to establish user plane transport bearers over the NG interface.

SDO	Document No.	Version	Status	Issued date	Location
<b>Release 15</b>					
ATIS	ATIS.3GPP.38.414V1530		15.3.0	Published 08.09.2020	<a href="http://www.atis.org/3gpp-documents/Rel15">http://www.atis.org/3gpp-documents/Rel15</a>
CCSA	CCSA.38.414V1530		15.3.0	Published 17.07.2020	<a href="http://www.ccsa.org.cn:9001/portalsFile/downloadOldFile?type=17&amp;oldFileUrl=Rel15/TS%2038.414%20V15.3.0.doc">http://www.ccsa.org.cn:9001/portalsFile/downloadOldFile?type=17&amp;oldFileUrl=Rel15/TS%2038.414%20V15.3.0.doc</a>
ETSI	ETSI TS 138 414		15.3.0	Published 23.07.2020	<a href="http://www.etsi.org/deliver/etsi_ts/138400_138499/138414/15.03.00_60/ts_138414v150300p.pdf">http://www.etsi.org/deliver/etsi_ts/138400_138499/138414/15.03.00_60/ts_138414v150300p.pdf</a>
TSDSI	TSDSI STD T1.3GPP 38.414-15.3.0 V1.0.0		15.3.0	Published 06.10.2020	<a href="https://members.tdsi.in/index.php/s/EnTDLLT6W5RLrHq">https://members.tdsi.in/index.php/s/EnTDLLT6W5RLrHq</a>
TTA	TTAT.3G-38.414V15.3.0		15.3.0	Published 11.09.2020	<a href="http://www.tta.or.kr/data/ttasDown.jsp?where=14688&amp;pk_num=TTAT.3G-38.414V15.3.0">http://www.tta.or.kr/data/ttasDown.jsp?where=14688&amp;pk_num=TTAT.3G-38.414V15.3.0</a>
TTC	TS-3GA-38.414(Rel15) v15.3.0		15.3.0	Published 02.10.2020	<a href="https://www.ttc.or.jp/st/docs/3gpps2020/TS/TS-3GA-38_414_Rel15v15_3_0.pdf">https://www.ttc.or.jp/st/docs/3gpps2020/TS/TS-3GA-38_414_Rel15v15_3_0.pdf</a>
<b>Release 16</b>					
ATIS	ATIS.3GPP.38.414V1600		16.0.0	Published 08.09.2020	<a href="http://www.atis.org/3gpp-documents/Rel16">http://www.atis.org/3gpp-documents/Rel16</a>
CCSA	CCSA.38.414V1600		16.0.0	Published 17.07.2020	<a href="http://www.ccsa.org.cn:9001/portalsFile/downloadOldFile?type=17&amp;oldFileUrl=Rel16/TS%2038.414%20V16.0.0.doc">http://www.ccsa.org.cn:9001/portalsFile/downloadOldFile?type=17&amp;oldFileUrl=Rel16/TS%2038.414%20V16.0.0.doc</a>
ETSI	ETSI TS 138 414		16.0.0	Published 23.07.2020	<a href="http://www.etsi.org/deliver/etsi_ts/138400_138499/138414/16.00.00_60/ts_138414v160000p.pdf">http://www.etsi.org/deliver/etsi_ts/138400_138499/138414/16.00.00_60/ts_138414v160000p.pdf</a>
TSDSI	TSDSI STD T1.3GPP 38.414-16.0.0 V1.0.0		16.0.0	Published 06.10.2020	<a href="https://members.tdsi.in/index.php/s/mSbYzQ6QqWEGdrD">https://members.tdsi.in/index.php/s/mSbYzQ6QqWEGdrD</a>
TTA	TTAT.3G-38.414V16.0.0		16.0.0	Published 11.09.2020	<a href="http://www.tta.or.kr/data/ttasDown.jsp?where=14688&amp;pk_num=TTAT.3G-38.414V16.0.0">http://www.tta.or.kr/data/ttasDown.jsp?where=14688&amp;pk_num=TTAT.3G-38.414V16.0.0</a>
TTC	TS-3GA-38.414(Rel16) v16.0.0		16.0.0	Published 02.10.2020	<a href="https://www.ttc.or.jp/st/docs/3gpps2020/TS/TS-3GA-38_414_Rel16v16_0_0.pdf">https://www.ttc.or.jp/st/docs/3gpps2020/TS/TS-3GA-38_414_Rel16v16_0_0.pdf</a>

### 1.2.1.4.43 TS 38.415

#### NG-RAN; PDU session user plane protocol

This document specifies the PDU Session user plane protocol being used over the NG-U, Xn-U and N9 interfaces. Applicability to other interfaces is not precluded.

SDO	Document No.	Version	Status	Issued date	Location	
<b>Release 15</b>						
ATIS	ATIS.3GPP.38.415V1520		15.2.0	Published	08.09.2020	<a href="http://www.atis.org/3gpp-documents/Rel15">http://www.atis.org/3gpp-documents/Rel15</a>
CCSA	CCSA.38.415V1520		15.2.0	Published	08.01.2019	<a href="http://www.ccsa.org.cn:9001/portalsFile/downloadOldFile?type=17&amp;oldFileUrl=Rel15/TS%2038.415%20V15.2.0.doc">http://www.ccsa.org.cn:9001/portalsFile/downloadOldFile?type=17&amp;oldFileUrl=Rel15/TS%2038.415%20V15.2.0.doc</a>
ETSI	ETSI TS 138 415		15.2.0	Published	24.04.2019	<a href="http://www.etsi.org/deliver/etsi_ts/138400_138499/138415/15.02.00_60/ts_138415v150200p.pdf">http://www.etsi.org/deliver/etsi_ts/138400_138499/138415/15.02.00_60/ts_138415v150200p.pdf</a>
TSDSI	TSDSI STD T1.3GPP 38.415-15.2.0 V1.0.0		15.2.0	Published	06.10.2020	<a href="https://members.tdsi.in/index.php/s/myphsmk2nXMxD7x">https://members.tdsi.in/index.php/s/myphsmk2nXMxD7x</a>
TTA	TTAT.3G-38.415V15.2.0		15.2.0	Published	11.09.2020	<a href="http://www.tta.or.kr/data/ttasDown.jsp?where=14688&amp;pk_num=TTAT.3G-38.415V15.2.0">http://www.tta.or.kr/data/ttasDown.jsp?where=14688&amp;pk_num=TTAT.3G-38.415V15.2.0</a>
TTC	TS-3GA-38.415(Rel15) v15.2.0		15.2.0	Published	29.03.2019	<a href="https://www.ttc.or.jp/st/docs/3gpps2019/TS/TS-3GA-38.415(Rel15)v15.2.0.pdf">https://www.ttc.or.jp/st/docs/3gpps2019/TS/TS-3GA-38.415(Rel15)v15.2.0.pdf</a>
<b>Release 16</b>						
ATIS	ATIS.3GPP.38.415V1610		16.1.0	Published	08.09.2020	<a href="http://www.atis.org/3gpp-documents/Rel16">http://www.atis.org/3gpp-documents/Rel16</a>
CCSA	CCSA.38.415V1610		16.1.0	Published	17.07.2020	<a href="http://www.ccsa.org.cn:9001/portalsFile/downloadOldFile?type=17&amp;oldFileUrl=Rel16/TS%2038.415%20V16.1.0.doc">http://www.ccsa.org.cn:9001/portalsFile/downloadOldFile?type=17&amp;oldFileUrl=Rel16/TS%2038.415%20V16.1.0.doc</a>
ETSI	ETSI TS 138 415		16.1.0	Published	23.07.2020	<a href="http://www.etsi.org/deliver/etsi_ts/138400_138499/138415/16.01.00_60/ts_138415v160100p.pdf">http://www.etsi.org/deliver/etsi_ts/138400_138499/138415/16.01.00_60/ts_138415v160100p.pdf</a>
TSDSI	TSDSI STD T1.3GPP 38.415-16.1.0 V1.0.0		16.1.0	Published	06.10.2020	<a href="https://members.tdsi.in/index.php/s/xC6AKfMNXetNxxc">https://members.tdsi.in/index.php/s/xC6AKfMNXetNxxc</a>
TTA	TTAT.3G-38.415V16.1.0		16.1.0	Published	11.09.2020	<a href="http://www.tta.or.kr/data/ttasDown.jsp?where=14688&amp;pk_num=TTAT.3G-38.415V16.1.0">http://www.tta.or.kr/data/ttasDown.jsp?where=14688&amp;pk_num=TTAT.3G-38.415V16.1.0</a>
TTC	TS-3GA-38.415(Rel16) v16.1.0		16.1.0	Published	02.10.2020	<a href="https://www.ttc.or.jp/st/docs/3gpps2020/TS/TS-3GA-38_415_Rel16v16_1_0.pdf">https://www.ttc.or.jp/st/docs/3gpps2020/TS/TS-3GA-38_415_Rel16v16_1_0.pdf</a>

### 1.2.1.4.44 TS 38.420

#### NG-RAN; Xn general aspects and principles

This document is an introduction to the TSG RAN TS 38.42x series of Technical Specifications that define the Xn interface. It is an interface for the interconnection of two NG-RAN nodes within the NG-RAN architecture (TS 38.401).

SDO	Document No.	Version	Status	Issued date	Location	
<b>Release 15</b>						
ATIS	ATIS.3GPP.38.420V1520		15.2.0	Published	08.09.2020	<a href="http://www.atis.org/3gpp-documents/Rel15">http://www.atis.org/3gpp-documents/Rel15</a>
CCSA	CCSA.38.420V1520		15.2.0	Published	08.01.2019	<a href="http://www.ccsa.org.cn:9001/portalsFile/downloadOldFile?type=17&amp;oldFileUrl=Rel15/TS%2038.420%20V15.2.0.doc">http://www.ccsa.org.cn:9001/portalsFile/downloadOldFile?type=17&amp;oldFileUrl=Rel15/TS%2038.420%20V15.2.0.doc</a>
ETSI	ETSI TS 138 420		15.2.0	Published	24.04.2019	<a href="http://www.etsi.org/deliver/etsi_ts/138400_138499/138420/15.02.00_60/ts_138420v150200p.pdf">http://www.etsi.org/deliver/etsi_ts/138400_138499/138420/15.02.00_60/ts_138420v150200p.pdf</a>
TSDSI	TSDSI STD T1.3GPP 38.420-15.2.0 V1.0.0		15.2.0	Published	06.10.2020	<a href="https://members.tdsi.in/index.php/s/kSZScp7FYKtPx6i">https://members.tdsi.in/index.php/s/kSZScp7FYKtPx6i</a>
TTA	TTAT.3G-38.420V15.2.0		15.2.0	Published	11.09.2020	<a href="http://www.tta.or.kr/data/ttasDown.jsp?where=14688&amp;pk_num=TTAT.3G-38.420V15.2.0">http://www.tta.or.kr/data/ttasDown.jsp?where=14688&amp;pk_num=TTAT.3G-38.420V15.2.0</a>
TTC	TS-3GA-38.420(Rel15) v15.2.0		15.2.0	Published	29.03.2019	<a href="https://www.ttc.or.jp/st/docs/3gpps2019/TS/TS-3GA-38.420(Rel15)v15.2.0.pdf">https://www.ttc.or.jp/st/docs/3gpps2019/TS/TS-3GA-38.420(Rel15)v15.2.0.pdf</a>
<b>Release 16</b>						
ATIS	ATIS.3GPP.38.420V1600		16.0.0	Published	08.09.2020	<a href="http://www.atis.org/3gpp-documents/Rel16">http://www.atis.org/3gpp-documents/Rel16</a>
CCSA	CCSA.38.420V1600		16.0.0	Published	16.07.2020	<a href="http://www.ccsa.org.cn:9001/portalsFile/downloadOldFile?type=17&amp;oldFileUrl=Rel16/TS%2038.420%20V16.0.0.doc">http://www.ccsa.org.cn:9001/portalsFile/downloadOldFile?type=17&amp;oldFileUrl=Rel16/TS%2038.420%20V16.0.0.doc</a>
ETSI	ETSI TS 138 420		16.0.0	Published	21.07.2020	<a href="http://www.etsi.org/deliver/etsi_ts/138400_138499/138420/16.00.00_60/ts_138420v160000p.pdf">http://www.etsi.org/deliver/etsi_ts/138400_138499/138420/16.00.00_60/ts_138420v160000p.pdf</a>
TSDSI	TSDSI STD T1.3GPP 38.420-16.0.0 V1.0.0		16.0.0	Published	06.10.2020	<a href="https://members.tdsi.in/index.php/s/CZARyijncBKfLZQ">https://members.tdsi.in/index.php/s/CZARyijncBKfLZQ</a>
TTA	TTAT.3G-38.420V16.0.0		16.0.0	Published	11.09.2020	<a href="http://www.tta.or.kr/data/ttasDown.jsp?where=14688&amp;pk_num=TTAT.3G-38.420V16.0.0">http://www.tta.or.kr/data/ttasDown.jsp?where=14688&amp;pk_num=TTAT.3G-38.420V16.0.0</a>
TTC	TS-3GA-38.420(Rel16) v16.0.0		16.0.0	Published	02.10.2020	<a href="https://www.ttc.or.jp/st/docs/3gpps2020/TS/TS-3GA-38_420_Rel16v16_0_0.pdf">https://www.ttc.or.jp/st/docs/3gpps2020/TS/TS-3GA-38_420_Rel16v16_0_0.pdf</a>

**1.2.1.4.45 TS 38.421****NG-RAN; Xn layer 1**

This document specifies the standards allowed to implement layer 1 on the Xn interface.

The specification of transmission delay requirements and O&M requirements are not in the scope of this document.

SDO	Document No.	Version	Status	Issued date	Location	
<b>Release 15</b>						
ATIS	ATIS.3GPP.38.421V1510		15.1.0	Published	08.09.2020	<a href="http://www.atis.org/3gpp-documents/Rel15">http://www.atis.org/3gpp-documents/Rel15</a>
CCSA	CCSA.38.421V1510		15.1.0	Published	02.10.2019	<a href="http://www.ccsa.org.cn:9001/portalsFile/downloadOldFile?type=17&amp;oldFileUrl=Rel15/TS%2038.421%20V15.1.0.doc">http://www.ccsa.org.cn:9001/portalsFile/downloadOldFile?type=17&amp;oldFileUrl=Rel15/TS%2038.421%20V15.1.0.doc</a>
ETSI	ETSI TS 138 421		15.1.0	Published	16.10.2019	<a href="http://www.etsi.org/deliver/etsi_ts/138400_138499/138421/15.01.00_60/ts_138421v150100p.pdf">http://www.etsi.org/deliver/etsi_ts/138400_138499/138421/15.01.00_60/ts_138421v150100p.pdf</a>
TSDSI	TSDSI STD T1.3GPP 38.421-15.1.0 V1.0.0		15.1.0	Published	06.10.2020	<a href="https://members.tdsi.in/index.php/s/CsmLZaoiiNNX2Ar">https://members.tdsi.in/index.php/s/CsmLZaoiiNNX2Ar</a>
TTA	TTAT.3G-38.421V15.1.0		15.1.0	Published	11.09.2020	<a href="http://www.tta.or.kr/data/ttasDown.jsp?where=14688&amp;pk_num=TTAT.3G-38.421V15.1.0">http://www.tta.or.kr/data/ttasDown.jsp?where=14688&amp;pk_num=TTAT.3G-38.421V15.1.0</a>
TTC	TS-3GA-38.421(Rel15) v15.1.0		15.1.0	Published	20.12.2019	<a href="https://www.ttc.or.jp/st/docs/3gpps2019/TS/TS-3GA-38.421(Rel15)v15.1.0.pdf">https://www.ttc.or.jp/st/docs/3gpps2019/TS/TS-3GA-38.421(Rel15)v15.1.0.pdf</a>
<b>Release 16</b>						
ATIS	ATIS.3GPP.38.421V1600		16.0.0	Published	08.09.2020	<a href="http://www.atis.org/3gpp-documents/Rel16">http://www.atis.org/3gpp-documents/Rel16</a>
CCSA	CCSA.38.421V1600		16.0.0	Published	16.07.2020	<a href="http://www.ccsa.org.cn:9001/portalsFile/downloadOldFile?type=17&amp;oldFileUrl=Rel16/TS%2038.421%20V16.0.0.doc">http://www.ccsa.org.cn:9001/portalsFile/downloadOldFile?type=17&amp;oldFileUrl=Rel16/TS%2038.421%20V16.0.0.doc</a>
ETSI	ETSI TS 138 421		16.0.0	Published	21.07.2020	<a href="http://www.etsi.org/deliver/etsi_ts/138400_138499/138421/16.00.00_60/ts_138421v160000p.pdf">http://www.etsi.org/deliver/etsi_ts/138400_138499/138421/16.00.00_60/ts_138421v160000p.pdf</a>
TSDSI	TSDSI STD T1.3GPP 38.421-16.0.0 V1.0.0		16.0.0	Published	06.10.2020	<a href="https://members.tdsi.in/index.php/s/NMCfe3NmrFAX5rk">https://members.tdsi.in/index.php/s/NMCfe3NmrFAX5rk</a>
TTA	TTAT.3G-38.421V16.0.0		16.0.0	Published	11.09.2020	<a href="http://www.tta.or.kr/data/ttasDown.jsp?where=14688&amp;pk_num=TTAT.3G-38.421V16.0.0">http://www.tta.or.kr/data/ttasDown.jsp?where=14688&amp;pk_num=TTAT.3G-38.421V16.0.0</a>
TTC	TS-3GA-38.421(Rel16) v16.0.0		16.0.0	Published	02.10.2020	<a href="https://www.ttc.or.jp/st/docs/3gpps2020/TS/TS-3GA-38_421_Rel16v16_0_0.pdf">https://www.ttc.or.jp/st/docs/3gpps2020/TS/TS-3GA-38_421_Rel16v16_0_0.pdf</a>

**1.2.1.4.46 TS 38.422****NG-RAN; Xn signalling transport**

This document specifies the standards for signalling transport to be used across Xn interface. The Xn interface provides means for interconnecting two NG-RAN nodes. The Xn interface is a logical interface between two nodes of the NG-RAN. This document describes how the XnAP signalling messages are transported over Xn.

SDO	Document No.	Version	Status	Issued date	Location	
<b>Release 15</b>						
ATIS	ATIS.3GPP.38.422V1540		15.4.0	Published	08.09.2020	<a href="http://www.atis.org/3gpp-documents/Rel15">http://www.atis.org/3gpp-documents/Rel15</a>
CCSA	CCSA.38.422V1540		15.4.0	Published	09.01.2020	<a href="http://www.ccsa.org.cn:9001/portalsFile/downloadOldFile?type=17&amp;oldFileUrl=Rel15/TS%2038.422%20V15.4.0.doc">http://www.ccsa.org.cn:9001/portalsFile/downloadOldFile?type=17&amp;oldFileUrl=Rel15/TS%2038.422%20V15.4.0.doc</a>
ETSI	ETSI TS 138 422		15.4.0	Published	17.01.2020	<a href="http://www.etsi.org/deliver/etsi_ts/138400_138499/138422/15.04.00_60/ts_138422v150400p.pdf">http://www.etsi.org/deliver/etsi_ts/138400_138499/138422/15.04.00_60/ts_138422v150400p.pdf</a>
TSDSI	TSDSI STD T1.3GPP 38.422-15.4.0 V1.0.0		15.4.0	Published	06.10.2020	<a href="https://members.tdsi.in/index.php/s/5XwBzWnpynSDqXb">https://members.tdsi.in/index.php/s/5XwBzWnpynSDqXb</a>
TTA	TTAT.3G-38.422V15.4.0		15.4.0	Published	11.09.2020	<a href="http://www.tta.or.kr/data/ttasDown.jsp?where=14688&amp;pk_num=TTAT.3G-38.422V15.4.0">http://www.tta.or.kr/data/ttasDown.jsp?where=14688&amp;pk_num=TTAT.3G-38.422V15.4.0</a>
TTC	TS-3GA-38.422(Rel15) v15.4.0		15.4.0	Published	16.04.2020	<a href="https://www.ttc.or.jp/st/docs/3gpps2020/TS/TS-3GA-38_422_Rel15v15_4_0.pdf">https://www.ttc.or.jp/st/docs/3gpps2020/TS/TS-3GA-38_422_Rel15v15_4_0.pdf</a>
<b>Release 16</b>						
ATIS	ATIS.3GPP.38.422V1600		16.0.0	Published	08.09.2020	<a href="http://www.atis.org/3gpp-documents/Rel16">http://www.atis.org/3gpp-documents/Rel16</a>
CCSA	CCSA.38.422V1600		16.0.0	Published	01.04.2020	<a href="http://www.ccsa.org.cn:9001/portalsFile/downloadOldFile?type=17&amp;oldFileUrl=Rel16/TS%2038.422%20V16.0.0.doc">http://www.ccsa.org.cn:9001/portalsFile/downloadOldFile?type=17&amp;oldFileUrl=Rel16/TS%2038.422%20V16.0.0.doc</a>
ETSI	ETSI TS 138 422		16.0.0	Published	21.09.2020	<a href="http://www.etsi.org/deliver/etsi_ts/138400_138499/138422/16.00.00_60/ts_138422v160000p.pdf">http://www.etsi.org/deliver/etsi_ts/138400_138499/138422/16.00.00_60/ts_138422v160000p.pdf</a>
TSDSI	TSDSI STD T1.3GPP 38.422-16.0.0 V1.0.0		16.0.0	Published	06.10.2020	<a href="https://members.tdsi.in/index.php/s/fgLr9n7GJDjmdRE">https://members.tdsi.in/index.php/s/fgLr9n7GJDjmdRE</a>
TTA	TTAT.3G-38.422V16.0.0		16.0.0	Published	11.09.2020	<a href="http://www.tta.or.kr/data/ttasDown.jsp?where=14688&amp;pk_num=TTAT.3G-38.422V16.0.0">http://www.tta.or.kr/data/ttasDown.jsp?where=14688&amp;pk_num=TTAT.3G-38.422V16.0.0</a>
TTC	TS-3GA-38.422(Rel16) v16.0.0		16.0.0	Published	02.10.2020	<a href="https://www.ttc.or.jp/st/docs/3gpps2020/TS/TS-3GA-38_422_Rel16v16_0_0.pdf">https://www.ttc.or.jp/st/docs/3gpps2020/TS/TS-3GA-38_422_Rel16v16_0_0.pdf</a>

## 1.2.1.4.47 TS 38.423

## NG-RAN; Xn Application Protocol (XnAP)

This document specifies the radio network layer signalling procedures of the control plane between NG-RAN nodes in NG-RAN. XnAP supports the functions of the Xn interface by signalling procedures defined in this document. XnAP is developed in accordance with the general principles stated in TS 38.401 and TS 38.420.

SDO	Document No.	Version	Status	Issued date	Location
<b>Release 15</b>					
ATIS	ATIS.3GPP.38.423V1580		15.8.0	Published 08.09.2020	<a href="http://www.atis.org/3gpp-documents/Rel15">http://www.atis.org/3gpp-documents/Rel15</a>
CCSA	CCSA.38.423V1580		15.8.0	Published 17.07.2020	<a href="http://www.ccsa.org.cn:9001/portalsFile/downloadOldFile?type=17&amp;oldFileUrl=Rel15/TS%2038.423%20V15.8.0.doc">http://www.ccsa.org.cn:9001/portalsFile/downloadOldFile?type=17&amp;oldFileUrl=Rel15/TS%2038.423%20V15.8.0.doc</a>
ETSI	ETSI TS 138 423		15.8.0	Published 23.07.2020	<a href="http://www.etsi.org/deliver/etsi_ts/138400_138499/138423/15.08.00_60/ts_138423v150800p.pdf">http://www.etsi.org/deliver/etsi_ts/138400_138499/138423/15.08.00_60/ts_138423v150800p.pdf</a>
TSDSI	TSDSI STD T1.3GPP 38.423-15.8.0 V1.0.0		15.8.0	Published 06.10.2020	<a href="https://members.tdsi.in/index.php/s/jrCbmrFD2XBHRZD">https://members.tdsi.in/index.php/s/jrCbmrFD2XBHRZD</a>
TTA	TTAT.3G-38.423V15.8.0		15.8.0	Published 11.09.2020	<a href="http://www.tta.or.kr/data/ttasDown.jsp?where=14688&amp;pk_num=TTAT.3G-38.423V15.8.0">http://www.tta.or.kr/data/ttasDown.jsp?where=14688&amp;pk_num=TTAT.3G-38.423V15.8.0</a>
TTC	TS-3GA-38.423(Rel15) v15.8.0		15.8.0	Published 02.10.2020	<a href="https://www.ttc.or.jp/st/docs/3gpps2020/TS/TS-3GA-38_423_Rel15v15_8_0.pdf">https://www.ttc.or.jp/st/docs/3gpps2020/TS/TS-3GA-38_423_Rel15v15_8_0.pdf</a>
<b>Release 16</b>					
ATIS	ATIS.3GPP.38.423V1620		16.2.0	Published 08.09.2020	<a href="http://www.atis.org/3gpp-documents/Rel16">http://www.atis.org/3gpp-documents/Rel16</a>
CCSA	CCSA.38.423V1620		16.2.0	Published 17.07.2020	<a href="http://www.ccsa.org.cn:9001/portalsFile/downloadOldFile?type=17&amp;oldFileUrl=Rel16/TS%2038.423%20V16.2.0.doc">http://www.ccsa.org.cn:9001/portalsFile/downloadOldFile?type=17&amp;oldFileUrl=Rel16/TS%2038.423%20V16.2.0.doc</a>
ETSI	ETSI TS 138 423		16.2.0	Published 23.07.2020	<a href="http://www.etsi.org/deliver/etsi_ts/138400_138499/138423/16.02.00_60/ts_138423v160200p.pdf">http://www.etsi.org/deliver/etsi_ts/138400_138499/138423/16.02.00_60/ts_138423v160200p.pdf</a>
TSDSI	TSDSI STD T1.3GPP 38.423-16.2.0 V1.0.0		16.2.0	Published 06.10.2020	<a href="https://members.tdsi.in/index.php/s/2gKxqCeJt8r7fmE">https://members.tdsi.in/index.php/s/2gKxqCeJt8r7fmE</a>
TTA	TTAT.3G-38.423V16.2.0		16.2.0	Published 11.09.2020	<a href="http://www.tta.or.kr/data/ttasDown.jsp?where=14688&amp;pk_num=TTAT.3G-38.423V16.2.0">http://www.tta.or.kr/data/ttasDown.jsp?where=14688&amp;pk_num=TTAT.3G-38.423V16.2.0</a>
TTC	TS-3GA-38.423(Rel16) v16.2.0		16.2.0	Published 02.10.2020	<a href="https://www.ttc.or.jp/st/docs/3gpps2020/TS/TS-3GA-38_423_Rel16v16_2_0.pdf">https://www.ttc.or.jp/st/docs/3gpps2020/TS/TS-3GA-38_423_Rel16v16_2_0.pdf</a>

## 1.2.1.4.48 TS 38.424

## NG-RAN; Xn data transport

This document specifies the standards for user data transport protocols and related signalling protocols to establish user plane transport bearers over the Xn interface.

SDO	Document No.	Version	Status	Issued date	Location
<b>Release 15</b>					
ATIS	ATIS.3GPP.38.424V1520		15.2.0	Published 08.09.2020	<a href="http://www.atis.org/3gpp-documents/Rel15">http://www.atis.org/3gpp-documents/Rel15</a>
CCSA	CCSA.38.424V1520		15.2.0	Published 13.07.2019	<a href="http://www.ccsa.org.cn:9001/portalsFile/downloadOldFile?type=17&amp;oldFileUrl=Rel15/TS%2038.424%20V15.2.0.doc">http://www.ccsa.org.cn:9001/portalsFile/downloadOldFile?type=17&amp;oldFileUrl=Rel15/TS%2038.424%20V15.2.0.doc</a>
ETSI	ETSI TS 138 424		15.2.0	Published 23.07.2019	<a href="http://www.etsi.org/deliver/etsi_ts/138400_138499/138424/15.02.00_60/ts_138424v150200p.pdf">http://www.etsi.org/deliver/etsi_ts/138400_138499/138424/15.02.00_60/ts_138424v150200p.pdf</a>
TSDSI	TSDSI STD T1.3GPP 38.424-15.2.0 V1.0.0		15.2.0	Published 06.10.2020	<a href="https://members.tdsi.in/index.php/s/ToekLawe9q7yiHM">https://members.tdsi.in/index.php/s/ToekLawe9q7yiHM</a>
TTA	TTAT.3G-38.424V15.2.0		15.2.0	Published 11.09.2020	<a href="http://www.tta.or.kr/data/ttasDown.jsp?where=14688&amp;pk_num=TTAT.3G-38.424V15.2.0">http://www.tta.or.kr/data/ttasDown.jsp?where=14688&amp;pk_num=TTAT.3G-38.424V15.2.0</a>
TTC	TS-3GA-38.424(Rel15) v15.2.0		15.2.0	Published 11.10.2019	<a href="https://www.ttc.or.jp/st/docs/3gpps2019/TS/TS-3GA-38.424(Rel15)v15.2.0.pdf">https://www.ttc.or.jp/st/docs/3gpps2019/TS/TS-3GA-38.424(Rel15)v15.2.0.pdf</a>
<b>Release 16</b>					
ATIS	ATIS.3GPP.38.424V1600		16.0.0	Published 08.09.2020	<a href="http://www.atis.org/3gpp-documents/Rel16">http://www.atis.org/3gpp-documents/Rel16</a>
CCSA	CCSA.38.424V1600		16.0.0	Published 16.07.2020	<a href="http://www.ccsa.org.cn:9001/portalsFile/downloadOldFile?type=17&amp;oldFileUrl=Rel16/TS%2038.424%20V16.0.0.doc">http://www.ccsa.org.cn:9001/portalsFile/downloadOldFile?type=17&amp;oldFileUrl=Rel16/TS%2038.424%20V16.0.0.doc</a>
ETSI	ETSI TS 138 424		16.0.0	Published 21.07.2020	<a href="http://www.etsi.org/deliver/etsi_ts/138400_138499/138424/16.00.00_60/ts_138424v160000p.pdf">http://www.etsi.org/deliver/etsi_ts/138400_138499/138424/16.00.00_60/ts_138424v160000p.pdf</a>
TSDSI	TSDSI STD T1.3GPP 38.424-16.0.0 V1.0.0		16.0.0	Published 06.10.2020	<a href="https://members.tdsi.in/index.php/s/Kkx4fK4wagjtmDD">https://members.tdsi.in/index.php/s/Kkx4fK4wagjtmDD</a>
TTA	TTAT.3G-38.424V16.0.0		16.0.0	Published 11.09.2020	<a href="http://www.tta.or.kr/data/ttasDown.jsp?where=14688&amp;pk_num=TTAT.3G-38.424V16.0.0">http://www.tta.or.kr/data/ttasDown.jsp?where=14688&amp;pk_num=TTAT.3G-38.424V16.0.0</a>
TTC	TS-3GA-38.424(Rel16) v16.0.0		16.0.0	Published 02.10.2020	<a href="https://www.ttc.or.jp/st/docs/3gpps2020/TS/TS-3GA-38_424_Rel16v16_0_0.pdf">https://www.ttc.or.jp/st/docs/3gpps2020/TS/TS-3GA-38_424_Rel16v16_0_0.pdf</a>



**1.2.1.4.49 TS 38.425****NG-RAN; NR user plane protocol**

This document specifies the NR user plane protocol functions used within NG-RAN and, for EN-DC, within E-UTRAN. NR user plane protocol functions may reside in nodes terminating either the X2-U (for EN-DC) or the Xn-U or the F1-U interface.

SDO	Document No.	Version	Status	Issued date	Location
<b>Release 15</b>					
ATIS	ATIS.3GPP.38.425V1560		15.6.0	Published 08.09.2020	<a href="http://www.atis.org/3gpp-documents/Rel15">http://www.atis.org/3gpp-documents/Rel15</a>
CCSA	CCSA.38.425V1560		15.6.0	Published 13.07.2019	<a href="http://www.ccsa.org.cn:9001/portalsFile/downloadOldFile?type=17&amp;oldFileUrl=Rel15/TS%2038.425%20V15.6.0.doc">http://www.ccsa.org.cn:9001/portalsFile/downloadOldFile?type=17&amp;oldFileUrl=Rel15/TS%2038.425%20V15.6.0.doc</a>
ETSI	ETSI TS 138 425		15.6.0	Published 23.07.2019	<a href="http://www.etsi.org/deliver/etsi_ts/138400_138499/138425/15.06.00_60/ts_138425v150600p.pdf">http://www.etsi.org/deliver/etsi_ts/138400_138499/138425/15.06.00_60/ts_138425v150600p.pdf</a>
TSDSI	TSDSI STD T1.3GPP 38.425-15.6.0 V1.0.0		15.6.0	Published 06.10.2020	<a href="https://members.tdsi.in/index.php/s/r4PwfcexAPxDrgN">https://members.tdsi.in/index.php/s/r4PwfcexAPxDrgN</a>
TTA	TTAT.3G-38.425V15.6.0		15.6.0	Published 11.09.2020	<a href="http://www.tta.or.kr/data/ttasDown.jsp?where=14688&amp;pk_num=TTAT.3G-38.425V15.6.0">http://www.tta.or.kr/data/ttasDown.jsp?where=14688&amp;pk_num=TTAT.3G-38.425V15.6.0</a>
TTC	TS-3GA-38.425(Rel15) v15.6.0		15.6.0	Published 11.10.2019	<a href="https://www.ttc.or.jp/st/docs/3gpps2019/TS/TS-3GA-38.425(Rel15)v15.6.0.pdf">https://www.ttc.or.jp/st/docs/3gpps2019/TS/TS-3GA-38.425(Rel15)v15.6.0.pdf</a>
<b>Release 16</b>					
ATIS	ATIS.3GPP.38.425V1610		16.1.0	Published 08.09.2020	<a href="http://www.atis.org/3gpp-documents/Rel16">http://www.atis.org/3gpp-documents/Rel16</a>
CCSA	CCSA.38.425V1610		16.1.0	Published 16.07.2020	<a href="http://www.ccsa.org.cn:9001/portalsFile/downloadOldFile?type=17&amp;oldFileUrl=Rel16/TS%2038.425%20V16.1.0.doc">http://www.ccsa.org.cn:9001/portalsFile/downloadOldFile?type=17&amp;oldFileUrl=Rel16/TS%2038.425%20V16.1.0.doc</a>
ETSI	ETSI TS 138 425		16.1.0	Published 21.07.2020	<a href="http://www.etsi.org/deliver/etsi_ts/138400_138499/138425/16.01.00_60/ts_138425v160100p.pdf">http://www.etsi.org/deliver/etsi_ts/138400_138499/138425/16.01.00_60/ts_138425v160100p.pdf</a>
TSDSI	TSDSI STD T1.3GPP 38.425-16.1.0 V1.0.0		16.1.0	Published 06.10.2020	<a href="https://members.tdsi.in/index.php/s/8nKqTg4JDA56sqq">https://members.tdsi.in/index.php/s/8nKqTg4JDA56sqq</a>
TTA	TTAT.3G-38.425V16.1.0		16.1.0	Published 11.09.2020	<a href="http://www.tta.or.kr/data/ttasDown.jsp?where=14688&amp;pk_num=TTAT.3G-38.425V16.1.0">http://www.tta.or.kr/data/ttasDown.jsp?where=14688&amp;pk_num=TTAT.3G-38.425V16.1.0</a>
TTC	TS-3GA-38.425(Rel16) v16.1.0		16.1.0	Published 02.10.2020	<a href="https://www.ttc.or.jp/st/docs/3gpps2020/TS/TS-3GA-38_425_Rel16v16_1_0.pdf">https://www.ttc.or.jp/st/docs/3gpps2020/TS/TS-3GA-38_425_Rel16v16_1_0.pdf</a>

**1.2.1.4.50 TS 38.455****NG-RAN; NR Positioning Protocol A (NRPPa)**

This document specifies the control plane radio network layer signalling procedures between a NG-RAN node and the LMF. NRPPa supports the concerned functions by signalling procedures defined in this document.

SDO	Document No.	Version	Status	Issued date	Location
<b>Release 15</b>					
ATIS	ATIS.3GPP.38.455V1521		15.2.1	Published 08.09.2020	<a href="http://www.atis.org/3gpp-documents/Rel15">http://www.atis.org/3gpp-documents/Rel15</a>
CCSA	CCSA.38.455V1521		15.2.1	Published 14.01.2019	<a href="http://www.ccsa.org.cn:9001/portalsFile/downloadOldFile?type=17&amp;oldFileUrl=Rel15/TS%2038.455%20V15.2.1.doc">http://www.ccsa.org.cn:9001/portalsFile/downloadOldFile?type=17&amp;oldFileUrl=Rel15/TS%2038.455%20V15.2.1.doc</a>
ETSI	ETSI TS 138 455		15.2.1	Published 24.04.2019	<a href="http://www.etsi.org/deliver/etsi_ts/138400_138499/138455/15.02.01_60/ts_138455v150201p.pdf">http://www.etsi.org/deliver/etsi_ts/138400_138499/138455/15.02.01_60/ts_138455v150201p.pdf</a>
TSDSI	TSDSI STD T1.3GPP 38.455-15.2.1 V1.0.0		15.2.1	Published 06.10.2020	<a href="https://members.tdsi.in/index.php/s/KP5C8bxQK9ocn7t">https://members.tdsi.in/index.php/s/KP5C8bxQK9ocn7t</a>
TTA	TTAT.3G-38.455V15.2.1		15.2.1	Published 11.09.2020	<a href="http://www.tta.or.kr/data/ttasDown.jsp?where=14688&amp;pk_num=TTAT.3G-38.455V15.2.1">http://www.tta.or.kr/data/ttasDown.jsp?where=14688&amp;pk_num=TTAT.3G-38.455V15.2.1</a>
TTC	TS-3GA-38.455(Rel15) v15.2.1		15.2.1	Published 29.03.2019	<a href="https://www.ttc.or.jp/st/docs/3gpps2019/TS/TS-3GA-38.455(Rel15)v15.2.1.pdf">https://www.ttc.or.jp/st/docs/3gpps2019/TS/TS-3GA-38.455(Rel15)v15.2.1.pdf</a>
<b>Release 16</b>					
ATIS	ATIS.3GPP.38.455V1600		16.0.0	Published 08.09.2020	<a href="http://www.atis.org/3gpp-documents/Rel16">http://www.atis.org/3gpp-documents/Rel16</a>
CCSA	CCSA.38.455V1600		16.0.0	Published 16.07.2020	<a href="http://www.ccsa.org.cn:9001/portalsFile/downloadOldFile?type=17&amp;oldFileUrl=Rel16/TS%2038.455%20V16.0.0.doc">http://www.ccsa.org.cn:9001/portalsFile/downloadOldFile?type=17&amp;oldFileUrl=Rel16/TS%2038.455%20V16.0.0.doc</a>
ETSI	ETSI TS 138 455		16.0.0	Published 18.09.2020	<a href="http://www.etsi.org/deliver/etsi_ts/138400_138499/138455/16.00.00_60/ts_138455v160000p.pdf">http://www.etsi.org/deliver/etsi_ts/138400_138499/138455/16.00.00_60/ts_138455v160000p.pdf</a>
TSDSI	TSDSI STD T1.3GPP 38.455-16.0.0 V1.0.0		16.0.0	Published 06.10.2020	<a href="https://members.tdsi.in/index.php/s/qGHcgch9Q8qanfW">https://members.tdsi.in/index.php/s/qGHcgch9Q8qanfW</a>
TTA	TTAT.3G-38.455V16.0.0		16.0.0	Published 11.09.2020	<a href="http://www.tta.or.kr/data/ttasDown.jsp?where=14688&amp;pk_num=TTAT.3G-38.455V16.0.0">http://www.tta.or.kr/data/ttasDown.jsp?where=14688&amp;pk_num=TTAT.3G-38.455V16.0.0</a>
TTC	TS-3GA-38.455(Rel16) v16.0.0		16.0.0	Published 02.10.2020	<a href="https://www.ttc.or.jp/st/docs/3gpps2020/TS/TS-3GA-38_455_Rel16v16_0_0.pdf">https://www.ttc.or.jp/st/docs/3gpps2020/TS/TS-3GA-38_455_Rel16v16_0_0.pdf</a>

**1.2.1.4.51 TS 38.460****NG-RAN; E1 general aspects and principles**

This document is an introduction to the 3GPP TS 38.46x series of technical specifications that define the E1 interface. The E1 interface provides means for interconnecting a gNB-CU-CP and a gNB-CU-UP of a gNB-CU within an NG-RAN, or for interconnecting a gNB-CU-CP and a gNB-CU-UP of an en-gNB within an E-UTRAN.

SDO	Document No.	Version	Status	Issued date	Location	
<b>Release 15</b>						
ATIS	ATIS.3GPP.38.460V1540		15.4.0	Published	08.09.2020	<a href="http://www.atis.org/3gpp-documents/Rel15">http://www.atis.org/3gpp-documents/Rel15</a>
CCSA	CCSA.38.460V1540		15.4.0	Published	11.07.2019	<a href="http://www.ccsa.org.cn:9001/portalsFile/downloadOldFile?type=17&amp;oldFileUrl=Rel15/TS%2038.460%20V15.4.0.doc">http://www.ccsa.org.cn:9001/portalsFile/downloadOldFile?type=17&amp;oldFileUrl=Rel15/TS%2038.460%20V15.4.0.doc</a>
ETSI	ETSI TS 138 460		15.4.0	Published	23.07.2019	<a href="http://www.etsi.org/deliver/etsi_ts/138400_138499/138460/15.04.00_60/ts_138460v150400p.pdf">http://www.etsi.org/deliver/etsi_ts/138400_138499/138460/15.04.00_60/ts_138460v150400p.pdf</a>
TSDSI	TSDSI STD T1.3GPP 38.460-15.4.0 V1.0.0		15.4.0	Published	06.10.2020	<a href="https://members.tdsi.in/index.php/s/DBXnLypdf5T4QQq">https://members.tdsi.in/index.php/s/DBXnLypdf5T4QQq</a>
TTA	TTAT.3G-38.460V15.4.0		15.4.0	Published	11.09.2020	<a href="http://www.tta.or.kr/data/ttasDown.jsp?where=14688&amp;pk_num=TTAT.3G-38.460V15.4.0">http://www.tta.or.kr/data/ttasDown.jsp?where=14688&amp;pk_num=TTAT.3G-38.460V15.4.0</a>
TTC	TS-3GA-38.460(Rel15) v15.4.0		15.4.0	Published	11.10.2019	<a href="https://www.ttc.or.jp/st/docs/3gpps2019/TS/TS-3GA-38.460(Rel15)v15.4.0.pdf">https://www.ttc.or.jp/st/docs/3gpps2019/TS/TS-3GA-38.460(Rel15)v15.4.0.pdf</a>
<b>Release 16</b>						
ATIS	ATIS.3GPP.38.460V1610		16.1.0	Published	08.09.2020	<a href="http://www.atis.org/3gpp-documents/Rel16">http://www.atis.org/3gpp-documents/Rel16</a>
CCSA	CCSA.38.460V1610		16.1.0	Published	17.07.2020	<a href="http://www.ccsa.org.cn:9001/portalsFile/downloadOldFile?type=17&amp;oldFileUrl=Rel16/TS%2038.460%20V16.1.0.doc">http://www.ccsa.org.cn:9001/portalsFile/downloadOldFile?type=17&amp;oldFileUrl=Rel16/TS%2038.460%20V16.1.0.doc</a>
ETSI	ETSI TS 138 460		16.1.0	Published	21.07.2020	<a href="http://www.etsi.org/deliver/etsi_ts/138400_138499/138460/16.01.00_60/ts_138460v160100p.pdf">http://www.etsi.org/deliver/etsi_ts/138400_138499/138460/16.01.00_60/ts_138460v160100p.pdf</a>
TSDSI	TSDSI STD T1.3GPP 38.460-16.1.0 V1.0.0		16.1.0	Published	06.10.2020	<a href="https://members.tdsi.in/index.php/s/cKLEwFmpHM493L9">https://members.tdsi.in/index.php/s/cKLEwFmpHM493L9</a>
TTA	TTAT.3G-38.460V16.1.0		16.1.0	Published	11.09.2020	<a href="http://www.tta.or.kr/data/ttasDown.jsp?where=14688&amp;pk_num=TTAT.3G-38.460V16.1.0">http://www.tta.or.kr/data/ttasDown.jsp?where=14688&amp;pk_num=TTAT.3G-38.460V16.1.0</a>
TTC	TS-3GA-38.460(Rel16) v16.1.0		16.1.0	Published	02.10.2020	<a href="https://www.ttc.or.jp/st/docs/3gpps2020/TS/TS-3GA-38_460_Rel16v16_1_0.pdf">https://www.ttc.or.jp/st/docs/3gpps2020/TS/TS-3GA-38_460_Rel16v16_1_0.pdf</a>

**1.2.1.4.52 TS 38.461****NG-RAN; E1 layer 1**

This document specifies the standards allowed to implement layer 1 on the E1 interface.

The specification of transmission delay requirements and O&M requirements are not in the scope of this document.

SDO	Document No.	Version	Status	Issued date	Location	
<b>Release 15</b>						
ATIS	ATIS.3GPP.38.461V1510		15.1.0	Published	08.09.2020	<a href="http://www.atis.org/3gpp-documents/Rel15">http://www.atis.org/3gpp-documents/Rel15</a>
CCSA	CCSA.38.461V1510		15.1.0	Published	02.10.2019	<a href="http://www.ccsa.org.cn:9001/portalsFile/downloadOldFile?type=17&amp;oldFileUrl=Rel15/TS%2038.461%20V15.1.0.doc">http://www.ccsa.org.cn:9001/portalsFile/downloadOldFile?type=17&amp;oldFileUrl=Rel15/TS%2038.461%20V15.1.0.doc</a>
ETSI	ETSI TS 138 461		15.1.0	Published	16.10.2019	<a href="http://www.etsi.org/deliver/etsi_ts/138400_138499/138461/15.01.00_60/ts_138461v150100p.pdf">http://www.etsi.org/deliver/etsi_ts/138400_138499/138461/15.01.00_60/ts_138461v150100p.pdf</a>
TSDSI	TSDSI STD T1.3GPP 38.461-15.1.0 V1.0.0		15.1.0	Published	06.10.2020	<a href="https://members.tdsi.in/index.php/s/j9qk4ARG94X66Y8">https://members.tdsi.in/index.php/s/j9qk4ARG94X66Y8</a>
TTA	TTAT.3G-38.461V15.1.0		15.1.0	Published	11.09.2020	<a href="http://www.tta.or.kr/data/ttasDown.jsp?where=14688&amp;pk_num=TTAT.3G-38.461V15.1.0">http://www.tta.or.kr/data/ttasDown.jsp?where=14688&amp;pk_num=TTAT.3G-38.461V15.1.0</a>
TTC	TS-3GA-38.461(Rel15) v15.1.0		15.1.0	Published	20.12.2019	<a href="https://www.ttc.or.jp/st/docs/3gpps2019/TS/TS-3GA-38.461(Rel15)v15.1.0.pdf">https://www.ttc.or.jp/st/docs/3gpps2019/TS/TS-3GA-38.461(Rel15)v15.1.0.pdf</a>
<b>Release 16</b>						
ATIS	ATIS.3GPP.38.461V1600		16.0.0	Published	08.09.2020	<a href="http://www.atis.org/3gpp-documents/Rel16">http://www.atis.org/3gpp-documents/Rel16</a>
CCSA	CCSA.38.461V1600		16.0.0	Published	16.07.2020	<a href="http://www.ccsa.org.cn:9001/portalsFile/downloadOldFile?type=17&amp;oldFileUrl=Rel16/TS%2038.461%20V16.0.0.doc">http://www.ccsa.org.cn:9001/portalsFile/downloadOldFile?type=17&amp;oldFileUrl=Rel16/TS%2038.461%20V16.0.0.doc</a>
ETSI	ETSI TS 138 461		16.0.0	Published	21.07.2020	<a href="http://www.etsi.org/deliver/etsi_ts/138400_138499/138461/16.00.00_60/ts_138461v160000p.pdf">http://www.etsi.org/deliver/etsi_ts/138400_138499/138461/16.00.00_60/ts_138461v160000p.pdf</a>
TSDSI	TSDSI STD T1.3GPP 38.461-16.0.0 V1.0.0		16.0.0	Published	06.10.2020	<a href="https://members.tdsi.in/index.php/s/meWGYCTEEGFAtjT">https://members.tdsi.in/index.php/s/meWGYCTEEGFAtjT</a>
TTA	TTAT.3G-38.461V16.0.0		16.0.0	Published	11.09.2020	<a href="http://www.tta.or.kr/data/ttasDown.jsp?where=14688&amp;pk_num=TTAT.3G-38.461V16.0.0">http://www.tta.or.kr/data/ttasDown.jsp?where=14688&amp;pk_num=TTAT.3G-38.461V16.0.0</a>
TTC	TS-3GA-38.461(Rel16) v16.0.0		16.0.0	Published	02.10.2020	<a href="https://www.ttc.or.jp/st/docs/3gpps2020/TS/TS-3GA-38_461_Rel16v16_0_0.pdf">https://www.ttc.or.jp/st/docs/3gpps2020/TS/TS-3GA-38_461_Rel16v16_0_0.pdf</a>

**1.2.1.4.53 TS 38.462****NG-RAN; E1 signalling transport**

This document specifies the standards for Signalling Transport to be used across the E1 interface. The E1 interface provides means for the interconnection of gNB-CU-CP and gNB-CU-UP within the NG-RAN architecture (TS 38.401).

SDO	Document No.	Version	Status	Issued date	Location
<b>Release 15</b>					
ATIS	ATIS.3GPP.38.462V1561		15.6.1	Published 08.09.2020	<a href="http://www.atis.org/3gpp-documents/Rel15">http://www.atis.org/3gpp-documents/Rel15</a>
CCSA	CCSA.38.462V1561		15.6.1	Published 08.04.2020	<a href="http://www.ccsa.org.cn:9001/portalsFile/downloadOldFile?type=17&amp;oldFileUrl=Rel15/TS%2038.462%20V15.6.1.doc">http://www.ccsa.org.cn:9001/portalsFile/downloadOldFile?type=17&amp;oldFileUrl=Rel15/TS%2038.462%20V15.6.1.doc</a>
ETSI	ETSI TS 138 462		15.6.1	Published 15.04.2020	<a href="http://www.etsi.org/deliver/etsi_ts/138400_138499/138462/15.06.01_60/ts_138462v150601p.pdf">http://www.etsi.org/deliver/etsi_ts/138400_138499/138462/15.06.01_60/ts_138462v150601p.pdf</a>
TSDSI	TSDSI STD T1.3GPP 38.462-15.6.1 V1.0.0		15.6.1	Published 06.10.2020	<a href="https://members.tdsi.in/index.php/s/DWYQRqYSFBHy6QF">https://members.tdsi.in/index.php/s/DWYQRqYSFBHy6QF</a>
TTA	TTAT.3G-38.462V15.6.1		15.6.1	Published 11.09.2020	<a href="http://www.tta.or.kr/data/ttasDown.jsp?where=14688&amp;pk_num=TTAT.3G-38.462V15.6.1">http://www.tta.or.kr/data/ttasDown.jsp?where=14688&amp;pk_num=TTAT.3G-38.462V15.6.1</a>
TTC	TS-3GA-38.462(Rel15) v15.6.1		15.6.1	Published 16.07.2020	<a href="https://www.ttc.or.jp/st/docs/3gpps2020/TS/TS-3GA-38_462_Rel15v15_6_1.pdf">https://www.ttc.or.jp/st/docs/3gpps2020/TS/TS-3GA-38_462_Rel15v15_6_1.pdf</a>
<b>Release 16</b>					
ATIS	ATIS.3GPP.38.462V1600		16.0.0	Published 08.09.2020	<a href="http://www.atis.org/3gpp-documents/Rel16">http://www.atis.org/3gpp-documents/Rel16</a>
CCSA	CCSA.38.462V1600		16.0.0	Published 16.07.2020	<a href="http://www.ccsa.org.cn:9001/portalsFile/downloadOldFile?type=17&amp;oldFileUrl=Rel16/TS%2038.462%20V16.0.0.doc">http://www.ccsa.org.cn:9001/portalsFile/downloadOldFile?type=17&amp;oldFileUrl=Rel16/TS%2038.462%20V16.0.0.doc</a>
ETSI	ETSI TS 138 462		16.0.0	Published 21.07.2020	<a href="http://www.etsi.org/deliver/etsi_ts/138400_138499/138462/16.00.00_60/ts_138462v160000p.pdf">http://www.etsi.org/deliver/etsi_ts/138400_138499/138462/16.00.00_60/ts_138462v160000p.pdf</a>
TSDSI	TSDSI STD T1.3GPP 38.462-16.0.0 V1.0.0		16.0.0	Published 06.10.2020	<a href="https://members.tdsi.in/index.php/s/4aSeqcst6Dc3EkA">https://members.tdsi.in/index.php/s/4aSeqcst6Dc3EkA</a>
TTA	TTAT.3G-38.462V16.0.0		16.0.0	Published 11.09.2020	<a href="http://www.tta.or.kr/data/ttasDown.jsp?where=14688&amp;pk_num=TTAT.3G-38.462V16.0.0">http://www.tta.or.kr/data/ttasDown.jsp?where=14688&amp;pk_num=TTAT.3G-38.462V16.0.0</a>
TTC	TS-3GA-38.462(Rel16) v16.0.0		16.0.0	Published 02.10.2020	<a href="https://www.ttc.or.jp/st/docs/3gpps2020/TS/TS-3GA-38_462_Rel16v16_0_0.pdf">https://www.ttc.or.jp/st/docs/3gpps2020/TS/TS-3GA-38_462_Rel16v16_0_0.pdf</a>

**1.2.1.4.54 TS 38.463****NG-RAN; E1 Application Protocol (E1AP)**

This document specifies the 5G radio network layer signalling protocol for the E1 interface. The E1 interface provides means for interconnecting a gNB-CU-CP and a gNB-CU-UP of a gNB within an NG-RAN, or for interconnecting a gNB-CU-CP and a gNB-CU-UP of an en-gNB within an E-UTRAN. The E1 Application Protocol (E1AP) supports the functions of E1 interface by signalling procedures defined in this document. E1AP is developed in accordance to the general principles stated in TS 38.401 and TS 38.460.

SDO	Document No.	Version	Status	Issued date	Location
<b>Release 15</b>					
ATIS	ATIS.3GPP.38.463V1570		15.7.0	Published 08.09.2020	<a href="http://www.atis.org/3gpp-documents/Rel15">http://www.atis.org/3gpp-documents/Rel15</a>
CCSA	CCSA.38.463V1570		15.7.0	Published 17.07.2020	<a href="http://www.ccsa.org.cn:9001/portalsFile/downloadOldFile?type=17&amp;oldFileUrl=Rel15/TS%2038.463%20V15.7.0.doc">http://www.ccsa.org.cn:9001/portalsFile/downloadOldFile?type=17&amp;oldFileUrl=Rel15/TS%2038.463%20V15.7.0.doc</a>
ETSI	ETSI TS 138 463		15.7.0	Published 23.07.2020	<a href="http://www.etsi.org/deliver/etsi_ts/138400_138499/138463/15.07.00_60/ts_138463v150700p.pdf">http://www.etsi.org/deliver/etsi_ts/138400_138499/138463/15.07.00_60/ts_138463v150700p.pdf</a>
TSDSI	TSDSI STD T1.3GPP 38.463-15.7.0 V1.0.0		15.7.0	Published 06.10.2020	<a href="https://members.tdsi.in/index.php/s/XeBQLpBJKwND7EF">https://members.tdsi.in/index.php/s/XeBQLpBJKwND7EF</a>
TTA	TTAT.3G-38.463V15.7.0		15.7.0	Published 11.09.2020	<a href="http://www.tta.or.kr/data/ttasDown.jsp?where=14688&amp;pk_num=TTAT.3G-38.463V15.7.0">http://www.tta.or.kr/data/ttasDown.jsp?where=14688&amp;pk_num=TTAT.3G-38.463V15.7.0</a>
TTC	TS-3GA-38.463(Rel15) v15.7.0		15.7.0	Published 02.10.2020	<a href="https://www.ttc.or.jp/st/docs/3gpps2020/TS/TS-3GA-38_463_Rel15v15_7_0.pdf">https://www.ttc.or.jp/st/docs/3gpps2020/TS/TS-3GA-38_463_Rel15v15_7_0.pdf</a>
<b>Release 16</b>					
ATIS	ATIS.3GPP.38.463V1620		16.2.0	Published 08.09.2020	<a href="http://www.atis.org/3gpp-documents/Rel16">http://www.atis.org/3gpp-documents/Rel16</a>
CCSA	CCSA.38.463V1620		16.2.0	Published 17.07.2020	<a href="http://www.ccsa.org.cn:9001/portalsFile/downloadOldFile?type=17&amp;oldFileUrl=Rel16/TS%2038.463%20V16.2.0.doc">http://www.ccsa.org.cn:9001/portalsFile/downloadOldFile?type=17&amp;oldFileUrl=Rel16/TS%2038.463%20V16.2.0.doc</a>
ETSI	ETSI TS 138 463		16.2.0	Published 23.07.2020	<a href="http://www.etsi.org/deliver/etsi_ts/138400_138499/138463/16.02.00_60/ts_138463v160200p.pdf">http://www.etsi.org/deliver/etsi_ts/138400_138499/138463/16.02.00_60/ts_138463v160200p.pdf</a>
TSDSI	TSDSI STD T1.3GPP 38.463-16.2.0 V1.0.0		16.2.0	Published 06.10.2020	<a href="https://members.tdsi.in/index.php/s/KjFkjg6fJwqqF94">https://members.tdsi.in/index.php/s/KjFkjg6fJwqqF94</a>
TTA	TTAT.3G-38.463V16.2.0		16.2.0	Published 11.09.2020	<a href="http://www.tta.or.kr/data/ttasDown.jsp?where=14688&amp;pk_num=TTAT.3G-38.463V16.2.0">http://www.tta.or.kr/data/ttasDown.jsp?where=14688&amp;pk_num=TTAT.3G-38.463V16.2.0</a>
TTC	TS-3GA-38.463(Rel16) v16.2.0		16.2.0	Published 02.10.2020	<a href="https://www.ttc.or.jp/st/docs/3gpps2020/TS/TS-3GA-38_463_Rel16v16_2_0.pdf">https://www.ttc.or.jp/st/docs/3gpps2020/TS/TS-3GA-38_463_Rel16v16_2_0.pdf</a>

**1.2.1.4.55 TS 38.470****NG-RAN; F1 general aspects and principles**

This document is an introduction to the 3GPP TS 38.47x series of technical specifications that define the F1 interface. The F1 interface provides means for interconnecting a gNB-CU and a gNB-DU of a gNB within an NG-RAN, or for interconnecting a gNB-CU and a gNB-DU of an en-gNB within an E-UTRAN.

SDO	Document No.	Version	Status	Issued date	Location	
<b>Release 15</b>						
ATIS	ATIS.3GPP.38.470V1570		15.7.0	Published	08.09.2020	<a href="http://www.atis.org/3gpp-documents/Rel15">http://www.atis.org/3gpp-documents/Rel15</a>
CCSA	CCSA.38.470V1570		15.7.0	Published	09.01.2020	<a href="http://www.ccsa.org.cn:9001/portalsFile/downloadOldFile?type=17&amp;oldFileUrl=Rel15/TS%2038.470%20V15.7.0.doc">http://www.ccsa.org.cn:9001/portalsFile/downloadOldFile?type=17&amp;oldFileUrl=Rel15/TS%2038.470%20V15.7.0.doc</a>
ETSI	ETSI TS 138 470		15.7.0	Published	17.01.2020	<a href="http://www.etsi.org/deliver/etsi_ts/138400_138499/138470/15.07.00_60/ts_138470v150700p.pdf">http://www.etsi.org/deliver/etsi_ts/138400_138499/138470/15.07.00_60/ts_138470v150700p.pdf</a>
TSDSI	TSDSI STD T1.3GPP 38.470-15.7.0 V1.0.0		15.7.0	Published	06.10.2020	<a href="https://members.tdsi.in/index.php/s/B3AZ44kRtHtYz72">https://members.tdsi.in/index.php/s/B3AZ44kRtHtYz72</a>
TTA	TTAT.3G-38.470V15.7.0		15.7.0	Published	11.09.2020	<a href="http://www.tta.or.kr/data/ttasDown.jsp?where=14688&amp;pk_num=TTAT.3G-38.470V15.7.0">http://www.tta.or.kr/data/ttasDown.jsp?where=14688&amp;pk_num=TTAT.3G-38.470V15.7.0</a>
TTC	TS-3GA-38.470(Rel15) v15.7.0		15.7.0	Published	16.04.2020	<a href="https://www.ttc.or.jp/st/docs/3gpps2020/TS/TS-3GA-38_470_Rel15v15_7_0.pdf">https://www.ttc.or.jp/st/docs/3gpps2020/TS/TS-3GA-38_470_Rel15v15_7_0.pdf</a>
<b>Release 16</b>						
ATIS	ATIS.3GPP.38.470V1620		16.2.0	Published	08.09.2020	<a href="http://www.atis.org/3gpp-documents/Rel16">http://www.atis.org/3gpp-documents/Rel16</a>
CCSA	CCSA.38.470V1620		16.2.0	Published	16.07.2020	<a href="http://www.ccsa.org.cn:9001/portalsFile/downloadOldFile?type=17&amp;oldFileUrl=Rel16/TS%2038.470%20V16.2.0.doc">http://www.ccsa.org.cn:9001/portalsFile/downloadOldFile?type=17&amp;oldFileUrl=Rel16/TS%2038.470%20V16.2.0.doc</a>
ETSI	ETSI TS 138 470		16.2.0	Published	21.07.2020	<a href="http://www.etsi.org/deliver/etsi_ts/138400_138499/138470/16.02.00_60/ts_138470v160200p.pdf">http://www.etsi.org/deliver/etsi_ts/138400_138499/138470/16.02.00_60/ts_138470v160200p.pdf</a>
TSDSI	TSDSI STD T1.3GPP 38.470-16.2.0 V1.0.0		16.2.0	Published	06.10.2020	<a href="https://members.tdsi.in/index.php/s/jtezbgyvPydRTE8">https://members.tdsi.in/index.php/s/jtezbgyvPydRTE8</a>
TTA	TTAT.3G-38.470V16.2.0		16.2.0	Published	11.09.2020	<a href="http://www.tta.or.kr/data/ttasDown.jsp?where=14688&amp;pk_num=TTAT.3G-38.470V16.2.0">http://www.tta.or.kr/data/ttasDown.jsp?where=14688&amp;pk_num=TTAT.3G-38.470V16.2.0</a>
TTC	TS-3GA-38.470(Rel16) v16.2.0		16.2.0	Published	02.10.2020	<a href="https://www.ttc.or.jp/st/docs/3gpps2020/TS/TS-3GA-38_470_Rel16v16_2_0.pdf">https://www.ttc.or.jp/st/docs/3gpps2020/TS/TS-3GA-38_470_Rel16v16_2_0.pdf</a>

**1.2.1.4.56 TS 38.471****NG-RAN; F1 layer 1**

This document specifies the standards allowed to implement Layer 1 on the F1 interface. The F1 interface provides means for interconnecting a gNB-CU and a gNB-DU of a gNB within an NG-RAN, or for interconnecting a gNB-CU and a gNB-DU of an en-gNB within an E-UTRAN.

The specification of transmission delay requirements and O&M requirements are not in the scope of this document.

SDO	Document No.	Version	Status	Issued date	Location	
<b>Release 15</b>						
ATIS	ATIS.3GPP.38.471V1500		15.0.0	Published	08.09.2020	<a href="http://www.atis.org/3gpp-documents/Rel15">http://www.atis.org/3gpp-documents/Rel15</a>
CCSA	CCSA.38.471V1500		15.0.0	Published	21.12.2019	<a href="http://www.ccsa.org.cn:9001/portalsFile/downloadOldFile?type=17&amp;oldFileUrl=Rel16/TS%2038.471%20V15.0.0.doc">http://www.ccsa.org.cn:9001/portalsFile/downloadOldFile?type=17&amp;oldFileUrl=Rel16/TS%2038.471%20V15.0.0.doc</a>
ETSI	ETSI TS 138 471		15.0.0	Published	18.09.2018	<a href="http://www.etsi.org/deliver/etsi_ts/138400_138499/138471/15.00.00_60/ts_138471v150000p.pdf">http://www.etsi.org/deliver/etsi_ts/138400_138499/138471/15.00.00_60/ts_138471v150000p.pdf</a>
TSDSI	TSDSI STD T1.3GPP 38.471-15.0.0 V1.0.0		15.0.0	Published	06.10.2020	<a href="https://members.tdsi.in/index.php/s/rtBfWwinpnbZHqs">https://members.tdsi.in/index.php/s/rtBfWwinpnbZHqs</a>
TTA	TTAT.3G-38.471V15.0.0		15.0.0	Published	11.09.2020	<a href="http://www.tta.or.kr/data/ttasDown.jsp?where=14688&amp;pk_num=TTAT.3G-38.471V15.0.0">http://www.tta.or.kr/data/ttasDown.jsp?where=14688&amp;pk_num=TTAT.3G-38.471V15.0.0</a>
TTC	TS-3GA-38.471(Rel15) v15.0.0		15.0.0	Published	28.09.2018	<a href="https://www.ttc.or.jp/st/docs/3gpps2018/TS/TS-3GA-38.471(Rel15)v15.0.0.pdf">https://www.ttc.or.jp/st/docs/3gpps2018/TS/TS-3GA-38.471(Rel15)v15.0.0.pdf</a>
<b>Release 16</b>						
ATIS	ATIS.3GPP.38.471V1600		16.0.0	Published	08.09.2020	<a href="http://www.atis.org/3gpp-documents/Rel16">http://www.atis.org/3gpp-documents/Rel16</a>
CCSA	CCSA.38.471V1600		16.0.0	Published	31.03.2020	<a href="http://www.ccsa.org.cn:9001/portalsFile/downloadOldFile?type=17&amp;oldFileUrl=Rel16/TS%2038.471%20V16.0.0.doc">http://www.ccsa.org.cn:9001/portalsFile/downloadOldFile?type=17&amp;oldFileUrl=Rel16/TS%2038.471%20V16.0.0.doc</a>
ETSI	ETSI TS 138 471		16.0.0	Published	21.07.2020	<a href="http://www.etsi.org/deliver/etsi_ts/138400_138499/138471/16.00.00_60/ts_138471v160000p.pdf">http://www.etsi.org/deliver/etsi_ts/138400_138499/138471/16.00.00_60/ts_138471v160000p.pdf</a>
TSDSI	TSDSI STD T1.3GPP 38.471-16.0.0 V1.0.0		16.0.0	Published	06.10.2020	<a href="https://members.tdsi.in/index.php/s/4Reniqk2F3nHA3o">https://members.tdsi.in/index.php/s/4Reniqk2F3nHA3o</a>
TTA	TTAT.3G-38.471V16.0.0		16.0.0	Published	11.09.2020	<a href="http://www.tta.or.kr/data/ttasDown.jsp?where=14688&amp;pk_num=TTAT.3G-38.471V16.0.0">http://www.tta.or.kr/data/ttasDown.jsp?where=14688&amp;pk_num=TTAT.3G-38.471V16.0.0</a>
TTC	TS-3GA-38.471(Rel16) v16.0.0		16.0.0	Published	02.10.2020	<a href="https://www.ttc.or.jp/st/docs/3gpps2020/TS/TS-3GA-38_471_Rel16v16_0_0.pdf">https://www.ttc.or.jp/st/docs/3gpps2020/TS/TS-3GA-38_471_Rel16v16_0_0.pdf</a>

**1.2.1.4.57 TS 38.472****NG-RAN; F1 signalling transport**

This document specifies the standards for Signalling Transport to be used across the F1 interface. The F1 interface provides means for interconnecting a gNB-CU and a gNB-DU of a gNB within an NG-RAN, or for interconnecting a gNB-CU and a gNB-DU of an en-gNB within an E-UTRAN. This document describes how the F1AP signalling messages are transported over F1.

SDO	Document No.	Version	Status	Issued date	Location
<b>Release 15</b>					
ATIS	ATIS.3GPP.38.472V1560		15.6.0	Published 08.09.2020	<a href="http://www.atis.org/3gpp-documents/Rel15">http://www.atis.org/3gpp-documents/Rel15</a>
CCSA	CCSA.38.472V1560		15.6.0	Published 09.01.2020	<a href="http://www.ccsa.org.cn:9001/portalsFile/downloadOldFile?type=17&amp;oldFileUrl=Rel15/TS%2038.472%20V15.6.0.doc">http://www.ccsa.org.cn:9001/portalsFile/downloadOldFile?type=17&amp;oldFileUrl=Rel15/TS%2038.472%20V15.6.0.doc</a>
ETSI	ETSI TS 138 472		15.6.0	Published 17.01.2020	<a href="http://www.etsi.org/deliver/etsi_ts/138400_138499/138472/15.06.00_60/ts_138472v150600p.pdf">http://www.etsi.org/deliver/etsi_ts/138400_138499/138472/15.06.00_60/ts_138472v150600p.pdf</a>
TSDSI	TSDSI STD T1.3GPP 38.472-15.6.0 V1.0.0		15.6.0	Published 06.10.2020	<a href="https://members.tdsi.in/index.php/s/NAC5end68xJpAMn">https://members.tdsi.in/index.php/s/NAC5end68xJpAMn</a>
TTA	TTAT.3G-38.472V15.6.0		15.6.0	Published 11.09.2020	<a href="http://www.tta.or.kr/data/ttasDown.jsp?where=14688&amp;pk_num=TTAT.3G-38.472V15.6.0">http://www.tta.or.kr/data/ttasDown.jsp?where=14688&amp;pk_num=TTAT.3G-38.472V15.6.0</a>
TTC	TS-3GA-38.472(Rel15) v15.6.0		15.6.0	Published 16.04.2020	<a href="https://www.ttc.or.jp/st/docs/3gpps2020/TS/TS-3GA-38_472_Rel15v15_6_0.pdf">https://www.ttc.or.jp/st/docs/3gpps2020/TS/TS-3GA-38_472_Rel15v15_6_0.pdf</a>
<b>Release 16</b>					
ATIS	ATIS.3GPP.38.472V1600		16.0.0	Published 08.09.2020	<a href="http://www.atis.org/3gpp-documents/Rel16">http://www.atis.org/3gpp-documents/Rel16</a>
CCSA	CCSA.38.472V1600		16.0.0	Published 31.03.2020	<a href="http://www.ccsa.org.cn:9001/portalsFile/downloadOldFile?type=17&amp;oldFileUrl=Rel16/TS%2038.472%20V16.0.0.doc">http://www.ccsa.org.cn:9001/portalsFile/downloadOldFile?type=17&amp;oldFileUrl=Rel16/TS%2038.472%20V16.0.0.doc</a>
ETSI	ETSI TS 138 472		16.0.0	Published 21.09.2020	<a href="http://www.etsi.org/deliver/etsi_ts/138400_138499/138472/16.00.00_60/ts_138472v160000p.pdf">http://www.etsi.org/deliver/etsi_ts/138400_138499/138472/16.00.00_60/ts_138472v160000p.pdf</a>
TSDSI	TSDSI STD T1.3GPP 38.472-16.0.0 V1.0.0		16.0.0	Published 06.10.2020	<a href="https://members.tdsi.in/index.php/s/Q4WJi9Ng2w6WF74">https://members.tdsi.in/index.php/s/Q4WJi9Ng2w6WF74</a>
TTA	TTAT.3G-38.472V16.0.0		16.0.0	Published 11.09.2020	<a href="http://www.tta.or.kr/data/ttasDown.jsp?where=14688&amp;pk_num=TTAT.3G-38.472V16.0.0">http://www.tta.or.kr/data/ttasDown.jsp?where=14688&amp;pk_num=TTAT.3G-38.472V16.0.0</a>
TTC	TS-3GA-38.472(Rel16) v16.0.0		16.0.0	Published 02.10.2020	<a href="https://www.ttc.or.jp/st/docs/3gpps2020/TS/TS-3GA-38_472_Rel16v16_0_0.pdf">https://www.ttc.or.jp/st/docs/3gpps2020/TS/TS-3GA-38_472_Rel16v16_0_0.pdf</a>

**1.2.1.4.58 TS 38.473****NG-RAN; F1 Application Protocol (F1AP)**

This document specifies the 5G radio network layer signalling protocol for the F1 interface. The F1 interface provides means for interconnecting a gNB-CU and a gNB-DU of a gNB within an NG-RAN, or for interconnecting a gNB-CU and a gNB-DU of an en-gNB within an E-UTRAN. The F1 Application Protocol (F1AP) supports the functions of F1 interface by signalling procedures defined in this document. F1AP is developed in accordance with the general principles stated in TS 38.401 and TS 38.470.

SDO	Document No.	Version	Status	Issued date	Location
<b>Release 15</b>					
ATIS	ATIS.3GPP.38.473V15100		15.10.0	Published 08.09.2020	<a href="http://www.atis.org/3gpp-documents/Rel15">http://www.atis.org/3gpp-documents/Rel15</a>
CCSA	CCSA.38.473V15100		15.10.0	Published 16.07.2020	<a href="http://www.ccsa.org.cn:9001/portalsFile/downloadOldFile?type=17&amp;oldFileUrl=Rel15/TS%2038.473%20V15.10.0.doc">http://www.ccsa.org.cn:9001/portalsFile/downloadOldFile?type=17&amp;oldFileUrl=Rel15/TS%2038.473%20V15.10.0.doc</a>
ETSI	ETSI TS 138 473		15.10.0	Published 21.07.2020	<a href="http://www.etsi.org/deliver/etsi_ts/138400_138499/138473/15.10.00_60/ts_138473v151000p.pdf">http://www.etsi.org/deliver/etsi_ts/138400_138499/138473/15.10.00_60/ts_138473v151000p.pdf</a>
TSDSI	TSDSI STD T1.3GPP 38.473-15.10.0 V1.0.0		15.10.0	Published 06.10.2020	<a href="https://members.tdsi.in/index.php/s/kWAFW8bMTN9MYkA">https://members.tdsi.in/index.php/s/kWAFW8bMTN9MYkA</a>
TTA	TTAT.3G-38.473V15.10.0		15.10.0	Published 11.09.2020	<a href="http://www.tta.or.kr/data/ttasDown.jsp?where=14688&amp;pk_num=TTAT.3G-38.473V15.10.0">http://www.tta.or.kr/data/ttasDown.jsp?where=14688&amp;pk_num=TTAT.3G-38.473V15.10.0</a>
TTC	TS-3GA-38.473(Rel15) v15.10.0		15.10.0	Published 02.10.2020	<a href="https://www.ttc.or.jp/st/docs/3gpps2020/TS/TS-3GA-38_473_Rel15v15_10_0.pdf">https://www.ttc.or.jp/st/docs/3gpps2020/TS/TS-3GA-38_473_Rel15v15_10_0.pdf</a>
<b>Release 16</b>					
ATIS	ATIS.3GPP.38.473V1620		16.2.0	Published 08.09.2020	<a href="http://www.atis.org/3gpp-documents/Rel16">http://www.atis.org/3gpp-documents/Rel16</a>
CCSA	CCSA.38.473V1620		16.2.0	Published 16.07.2020	<a href="http://www.ccsa.org.cn:9001/portalsFile/downloadOldFile?type=17&amp;oldFileUrl=Rel16/TS%2038.473%20V16.2.0.doc">http://www.ccsa.org.cn:9001/portalsFile/downloadOldFile?type=17&amp;oldFileUrl=Rel16/TS%2038.473%20V16.2.0.doc</a>
ETSI	ETSI TS 138 473		16.2.0	Published 21.07.2020	<a href="http://www.etsi.org/deliver/etsi_ts/138400_138499/138473/16.02.00_60/ts_138473v160200p.pdf">http://www.etsi.org/deliver/etsi_ts/138400_138499/138473/16.02.00_60/ts_138473v160200p.pdf</a>
TSDSI	TSDSI STD T1.3GPP 38.473-16.2.0 V1.0.0		16.2.0	Published 06.10.2020	<a href="https://members.tdsi.in/index.php/s/EdspBPRdwWXrHL4">https://members.tdsi.in/index.php/s/EdspBPRdwWXrHL4</a>
TTA	TTAT.3G-38.473V16.2.0		16.2.0	Published 11.09.2020	<a href="http://www.tta.or.kr/data/ttasDown.jsp?where=14688&amp;pk_num=TTAT.3G-38.473V16.2.0">http://www.tta.or.kr/data/ttasDown.jsp?where=14688&amp;pk_num=TTAT.3G-38.473V16.2.0</a>
TTC	TS-3GA-38.473(Rel16) v16.2.0		16.2.0	Published 02.10.2020	<a href="https://www.ttc.or.jp/st/docs/3gpps2020/TS/TS-3GA-38_473_Rel16v16_2_0.pdf">https://www.ttc.or.jp/st/docs/3gpps2020/TS/TS-3GA-38_473_Rel16v16_2_0.pdf</a>

## 1.2.1.4.59 TS 38.474

## NG-RAN; F1 data transport

This document specifies the standards for user data transport protocols and related signalling protocols to establish user plane transport bearers over the F1 interface. The F1 interface provides means for interconnecting a gNB-CU and a gNB-DU of a gNB within an NG-RAN, or for interconnection a gNB-CU and a gNB-DU of an en-gNB within an E-UTRAN.

SDO	Document No.	Version	Status	Issued date	Location	
<b>Release 15</b>						
ATIS	ATIS.3GPP.38.474V1530		15.3.0	Published	08.09.2020	<a href="http://www.atis.org/3gpp-documents/Rel15">http://www.atis.org/3gpp-documents/Rel15</a>
CCSA	CCSA.38.474V1530		15.3.0	Published	02.10.2019	<a href="http://www.ccsa.org.cn:9001/portalsFile/downloadOldFile?type=17&amp;oldFileUrl=Rel15/TS%2038.474%20V15.3.0.doc">http://www.ccsa.org.cn:9001/portalsFile/downloadOldFile?type=17&amp;oldFileUrl=Rel15/TS%2038.474%20V15.3.0.doc</a>
ETSI	ETSI TS 138 474		15.3.0	Published	16.10.2019	<a href="http://www.etsi.org/deliver/etsi_ts/138400_138499/138474/15.03.00_60/ts_138474v150300p.pdf">http://www.etsi.org/deliver/etsi_ts/138400_138499/138474/15.03.00_60/ts_138474v150300p.pdf</a>
TSDSI	TSDSI STD T1.3GPP 38.474-15.3.0 V1.0.0		15.3.0	Published	06.10.2020	<a href="https://members.tdsi.in/index.php/s/taQLMy7bSPZoHir">https://members.tdsi.in/index.php/s/taQLMy7bSPZoHir</a>
TTA	TTAT.3G-38.474V15.3.0		15.3.0	Published	11.09.2020	<a href="http://www.tta.or.kr/data/ttasDown.jsp?where=14688&amp;pk_num=TTAT.3G-38.474V15.3.0">http://www.tta.or.kr/data/ttasDown.jsp?where=14688&amp;pk_num=TTAT.3G-38.474V15.3.0</a>
TTC	TS-3GA-38.474(Rel15) v15.3.0		15.3.0	Published	20.12.2019	<a href="https://www.ttc.or.jp/st/docs/3gpps2019/TS/TS-3GA-38.474(Rel15)v15.3.0.pdf">https://www.ttc.or.jp/st/docs/3gpps2019/TS/TS-3GA-38.474(Rel15)v15.3.0.pdf</a>
<b>Release 16</b>						
ATIS	ATIS.3GPP.38.474V1600		16.0.0	Published	08.09.2020	<a href="http://www.atis.org/3gpp-documents/Rel16">http://www.atis.org/3gpp-documents/Rel16</a>
CCSA	CCSA.38.474V1600		16.0.0	Published	17.07.2020	<a href="http://www.ccsa.org.cn:9001/portalsFile/downloadOldFile?type=17&amp;oldFileUrl=Rel16/TS%2038.474%20V16.0.0.doc">http://www.ccsa.org.cn:9001/portalsFile/downloadOldFile?type=17&amp;oldFileUrl=Rel16/TS%2038.474%20V16.0.0.doc</a>
ETSI	ETSI TS 138 474		16.0.0	Published	23.07.2020	<a href="http://www.etsi.org/deliver/etsi_ts/138400_138499/138474/16.00.00_60/ts_138474v160000p.pdf">http://www.etsi.org/deliver/etsi_ts/138400_138499/138474/16.00.00_60/ts_138474v160000p.pdf</a>
TSDSI	TSDSI STD T1.3GPP 38.474-16.0.0 V1.0.0		16.0.0	Published	06.10.2020	<a href="https://members.tdsi.in/index.php/s/xaNrDWy9sJ4TsLW">https://members.tdsi.in/index.php/s/xaNrDWy9sJ4TsLW</a>
TTA	TTAT.3G-38.474V16.0.0		16.0.0	Published	11.09.2020	<a href="http://www.tta.or.kr/data/ttasDown.jsp?where=14688&amp;pk_num=TTAT.3G-38.474V16.0.0">http://www.tta.or.kr/data/ttasDown.jsp?where=14688&amp;pk_num=TTAT.3G-38.474V16.0.0</a>
TTC	TS-3GA-38.474(Rel16) v16.0.0		16.0.0	Published	02.10.2020	<a href="https://www.ttc.or.jp/st/docs/3gpps2020/TS/TS-3GA-38_474_Rel16v16_0_0.pdf">https://www.ttc.or.jp/st/docs/3gpps2020/TS/TS-3GA-38_474_Rel16v16_0_0.pdf</a>

## 1.2.1.5 Radio-frequency aspects

## 1.2.1.5.1 TS 36.101

## Evolved Universal Terrestrial Radio Access (E-UTRA); User Equipment (UE) radio transmission and reception

This document establishes the minimum RF characteristics and minimum performance requirements for E-UTRA User Equipment (UE).

SDO	Document No.	Version	Status	Issued date	Location	
<b>Release 15</b>						
ARIB	ARIB STD-T120-36.101		15.11.0	Published	28.09.2020	<a href="http://www.arib.or.jp/english/html/overview/doc/T120_T23_v2_00/2_T120/ARIB-STD-T120/Rel15/36/A36101-fb0.pdf">http://www.arib.or.jp/english/html/overview/doc/T120_T23_v2_00/2_T120/ARIB-STD-T120/Rel15/36/A36101-fb0.pdf</a>
ATIS	ATIS.3GPP.36.101V15110		15.11.0	Published	08.09.2020	<a href="http://www.atis.org/3gpp-documents/Rel15">http://www.atis.org/3gpp-documents/Rel15</a>
CCSA	CCSA.36.101V15110		15.11.0	Published	16.07.2020	<a href="http://www.ccsa.org.cn:9001/portalsFile/downloadOldFile?type=17&amp;oldFileUrl=Rel15/TS%2036.101%20V15.11.0.zip">http://www.ccsa.org.cn:9001/portalsFile/downloadOldFile?type=17&amp;oldFileUrl=Rel15/TS%2036.101%20V15.11.0.zip</a>
ETSI	ETSI TS 136 101		15.11.0	Published	13.08.2020	<a href="http://www.etsi.org/deliver/etsi_ts/136100_136199/136101/15.11.00_60/ts_136101v151100p.pdf">http://www.etsi.org/deliver/etsi_ts/136100_136199/136101/15.11.00_60/ts_136101v151100p.pdf</a>
TSDSI	TSDSI STD T1.3GPP 36.101-15.11.0 V1.0.0		15.11.0	Published	06.10.2020	<a href="https://members.tdsi.in/index.php/s/LJOr8EfMsEaWjp6">https://members.tdsi.in/index.php/s/LJOr8EfMsEaWjp6</a>
TTA	TTAT.3G-36.101V15.11.0		15.11.0	Published	11.09.2020	<a href="http://www.tta.or.kr/data/ttasDown.jsp?where=14688&amp;pk_num=TTAT.3G-36.101V15.11.0">http://www.tta.or.kr/data/ttasDown.jsp?where=14688&amp;pk_num=TTAT.3G-36.101V15.11.0</a>
<b>Release 16</b>						
ARIB	ARIB STD-T120-36.101		16.6.0	Published	28.09.2020	<a href="http://www.arib.or.jp/english/html/overview/doc/T120_T23_v2_00/2_T120/ARIB-STD-T120/Rel16/36/A36101-g60.pdf">http://www.arib.or.jp/english/html/overview/doc/T120_T23_v2_00/2_T120/ARIB-STD-T120/Rel16/36/A36101-g60.pdf</a>
ATIS	ATIS.3GPP.36.101V1660		16.6.0	Published	08.09.2020	<a href="http://www.atis.org/3gpp-documents/Rel16">http://www.atis.org/3gpp-documents/Rel16</a>
CCSA	CCSA.36.101V1660		16.6.0	Published	16.07.2020	<a href="http://www.ccsa.org.cn:9001/portalsFile/downloadOldFile?type=17&amp;oldFileUrl=Rel16/TS%2036.101%20V16.6.0.zip">http://www.ccsa.org.cn:9001/portalsFile/downloadOldFile?type=17&amp;oldFileUrl=Rel16/TS%2036.101%20V16.6.0.zip</a>
ETSI	ETSI TS 136 101		16.6.0	Published	13.08.2020	<a href="http://www.etsi.org/deliver/etsi_ts/136100_136199/136101/16.06.00_60/ts_136101v160600p.pdf">http://www.etsi.org/deliver/etsi_ts/136100_136199/136101/16.06.00_60/ts_136101v160600p.pdf</a>
TSDSI	TSDSI STD T1.3GPP 36.101-16.6.0 V1.0.0		16.6.0	Published	06.10.2020	<a href="https://members.tdsi.in/index.php/s/N6x6E5mEsr7ZqYB">https://members.tdsi.in/index.php/s/N6x6E5mEsr7ZqYB</a>
TTA	TTAT.3G-36.101V16.6.0		16.6.0	Published	11.09.2020	<a href="http://www.tta.or.kr/data/ttasDown.jsp?where=14688&amp;pk_num=TTAT.3G-36.101V16.6.0">http://www.tta.or.kr/data/ttasDown.jsp?where=14688&amp;pk_num=TTAT.3G-36.101V16.6.0</a>

**1.2.1.5.2 TS 36.104****Evolved Universal Terrestrial Radio Access (E-UTRA); Base Station (BS) radio transmission and reception**

This document establishes the minimum RF characteristics and minimum performance requirements of E-UTRA Base Station (BS).

SDO	Document No.	Version	Status	Issued date	Location	
<b>Release 15</b>						
ARIB	ARIB STD-T120-36.104		15.9.0	Published	28.09.2020	<a href="http://www.arib.or.jp/english/html/overview/doc/T120_T23_v2_00/2_T120/ARIB-STD-T120/Rel15/36/A36104-f90.pdf">http://www.arib.or.jp/english/html/overview/doc/T120_T23_v2_00/2_T120/ARIB-STD-T120/Rel15/36/A36104-f90.pdf</a>
ATIS	ATIS.3GPP.36.104V1590		15.9.0	Published	08.09.2020	<a href="http://www.atis.org/3gpp-documents/Rel15">http://www.atis.org/3gpp-documents/Rel15</a>
CCSA	CCSA.36.104V1590		15.9.0	Published	16.07.2020	<a href="http://www.ccsa.org.cn:9001/portalsFile/downloadOldFile?type=17&amp;oldFileUrl=Rel15/TS%2036.104%20V15.9.0.docx">http://www.ccsa.org.cn:9001/portalsFile/downloadOldFile?type=17&amp;oldFileUrl=Rel15/TS%2036.104%20V15.9.0.docx</a>
ETSI	ETSI TS 136 104		15.9.0	Published	21.07.2020	<a href="http://www.etsi.org/deliver/etsi_ts/136100_136199/136104/15.09.00_60/ts_136104v150900p.pdf">http://www.etsi.org/deliver/etsi_ts/136100_136199/136104/15.09.00_60/ts_136104v150900p.pdf</a>
TSDSI	TSDSI STD T1.3GPP 36.104-15.9.0 V1.0.0		15.9.0	Published	06.10.2020	<a href="https://members.tdsi.in/index.php/s/29ixHHm2Ytpe4ic">https://members.tdsi.in/index.php/s/29ixHHm2Ytpe4ic</a>
TTA	TTAT.3G-36.104V15.9.0		15.9.0	Published	11.09.2020	<a href="http://www.tta.or.kr/data/ttasDown.jsp?where=14688&amp;pk_num=TTAT.3G-36.104V15.9.0">http://www.tta.or.kr/data/ttasDown.jsp?where=14688&amp;pk_num=TTAT.3G-36.104V15.9.0</a>
<b>Release 16</b>						
ARIB	ARIB STD-T120-36.104		16.6.0	Published	28.09.2020	<a href="http://www.arib.or.jp/english/html/overview/doc/T120_T23_v2_00/2_T120/ARIB-STD-T120/Rel16/36/A36104-g60.pdf">http://www.arib.or.jp/english/html/overview/doc/T120_T23_v2_00/2_T120/ARIB-STD-T120/Rel16/36/A36104-g60.pdf</a>
ATIS	ATIS.3GPP.36.104V1660		16.6.0	Published	08.09.2020	<a href="http://www.atis.org/3gpp-documents/Rel16">http://www.atis.org/3gpp-documents/Rel16</a>
CCSA	CCSA.36.104V1660		16.6.0	Published	16.07.2020	<a href="http://www.ccsa.org.cn:9001/portalsFile/downloadOldFile?type=17&amp;oldFileUrl=Rel16/TS%2036.104%20V16.6.0.docx">http://www.ccsa.org.cn:9001/portalsFile/downloadOldFile?type=17&amp;oldFileUrl=Rel16/TS%2036.104%20V16.6.0.docx</a>
ETSI	ETSI TS 136 104		16.6.0	Published	29.07.2020	<a href="http://www.etsi.org/deliver/etsi_ts/136100_136199/136104/16.06.00_60/ts_136104v160600p.pdf">http://www.etsi.org/deliver/etsi_ts/136100_136199/136104/16.06.00_60/ts_136104v160600p.pdf</a>
TSDSI	TSDSI STD T1.3GPP 36.104-16.6.0 V1.0.0		16.6.0	Published	06.10.2020	<a href="https://members.tdsi.in/index.php/s/DfwWN2Pw3QBBzLZ">https://members.tdsi.in/index.php/s/DfwWN2Pw3QBBzLZ</a>
TTA	TTAT.3G-36.104V16.6.0		16.6.0	Published	11.09.2020	<a href="http://www.tta.or.kr/data/ttasDown.jsp?where=14688&amp;pk_num=TTAT.3G-36.104V16.6.0">http://www.tta.or.kr/data/ttasDown.jsp?where=14688&amp;pk_num=TTAT.3G-36.104V16.6.0</a>

**1.2.1.5.3 TS 36.106****Evolved Universal Terrestrial Radio Access (E-UTRA); FDD repeater radio transmission and reception**

This document establishes the minimum RF characteristics of E-UTRA FDD Repeater.

SDO	Document No.	Version	Status	Issued date	Location	
<b>Release 15</b>						
ATIS	ATIS.3GPP.36.106V1500		15.0.0	Published	08.09.2020	<a href="http://www.atis.org/3gpp-documents/Rel15">http://www.atis.org/3gpp-documents/Rel15</a>
CCSA	CCSA.36.106V1500		15.0.0	Published	17.01.2018	<a href="http://www.ccsa.org.cn:9001/portalsFile/downloadOldFile?type=17&amp;oldFileUrl=Rel15/TS%2036.106%20V15.0.0.doc">http://www.ccsa.org.cn:9001/portalsFile/downloadOldFile?type=17&amp;oldFileUrl=Rel15/TS%2036.106%20V15.0.0.doc</a>
ETSI	ETSI TS 136 106		15.0.0	Published	18.09.2018	<a href="http://www.etsi.org/deliver/etsi_ts/136100_136199/136106/15.00.00_60/ts_136106v150000p.pdf">http://www.etsi.org/deliver/etsi_ts/136100_136199/136106/15.00.00_60/ts_136106v150000p.pdf</a>
TSDSI	TSDSI STD T1.3GPP 36.106-15.0.0 V1.0.0		15.0.0	Published	06.10.2020	<a href="https://members.tdsi.in/index.php/s/RysS4xxksTACLk8">https://members.tdsi.in/index.php/s/RysS4xxksTACLk8</a>
TTA	TTAT.3G-36.106V15.0.0		15.0.0	Published	11.09.2020	<a href="http://www.tta.or.kr/data/ttasDown.jsp?where=14688&amp;pk_num=TTAT.3G-36.106V15.0.0">http://www.tta.or.kr/data/ttasDown.jsp?where=14688&amp;pk_num=TTAT.3G-36.106V15.0.0</a>
<b>Release 16</b>						
ATIS	ATIS.3GPP.36.106V1600		16.0.0	Published	08.09.2020	<a href="http://www.atis.org/3gpp-documents/Rel16">http://www.atis.org/3gpp-documents/Rel16</a>
CCSA	CCSA.36.106V1600		16.0.0	Published	16.07.2020	<a href="http://www.ccsa.org.cn:9001/portalsFile/downloadOldFile?type=17&amp;oldFileUrl=Rel16/TS%2036.106%20V16.0.0.doc">http://www.ccsa.org.cn:9001/portalsFile/downloadOldFile?type=17&amp;oldFileUrl=Rel16/TS%2036.106%20V16.0.0.doc</a>
ETSI	ETSI TS 136 106		16.0.0	Published	21.07.2020	<a href="http://www.etsi.org/deliver/etsi_ts/136100_136199/136106/16.00.00_60/ts_136106v160000p.pdf">http://www.etsi.org/deliver/etsi_ts/136100_136199/136106/16.00.00_60/ts_136106v160000p.pdf</a>
TSDSI	TSDSI STD T1.3GPP 36.106-16.0.0 V1.0.0		16.0.0	Published	06.10.2020	<a href="https://members.tdsi.in/index.php/s/AWoP6N4JdK22fPi">https://members.tdsi.in/index.php/s/AWoP6N4JdK22fPi</a>
TTA	TTAT.3G-36.106V16.0.0		16.0.0	Published	11.09.2020	<a href="http://www.tta.or.kr/data/ttasDown.jsp?where=14688&amp;pk_num=TTAT.3G-36.106V16.0.0">http://www.tta.or.kr/data/ttasDown.jsp?where=14688&amp;pk_num=TTAT.3G-36.106V16.0.0</a>

**1.2.1.5.4 TS 36.111****Location Measurement Unit (LMU) performance specification; Network based positioning systems in Evolved Universal Terrestrial Radio Access Network (E-UTRAN)**

This document establishes the Location Measurement Unit (LMU) minimum UTDOA positioning requirement for the FDD and TDD mode of E-UTRAN.

**102****Rec. ITU-R M.2150-0**

SDO	Document No.	Version	Status	Issued date	Location	
<b>Release 15</b>						
ARIB	ARIB STD-T120-36.111		15.0.0	Published	28.09.2020	<a href="http://www.arib.or.jp/english/html/overview/doc/T120_T23_v2_00/2_T120/ARIB-STD-T120/Rel15/36/A36111-f00.pdf">http://www.arib.or.jp/english/html/overview/doc/T120_T23_v2_00/2_T120/ARIB-STD-T120/Rel15/36/A36111-f00.pdf</a>
ATIS	ATIS.3GPP.36.111V1500		15.0.0	Published	08.09.2020	<a href="http://www.atis.org/3gpp-documents/Rel15">http://www.atis.org/3gpp-documents/Rel15</a>
CCSA	CCSA.36.111V1500		15.0.0	Published	24.10.2018	<a href="http://www.ccsa.org.cn:9001/portalsFile/downloadOldFile?type=17&amp;oldFileUrl=Rel15/TS%2036.111%20V15.0.0.doc">http://www.ccsa.org.cn:9001/portalsFile/downloadOldFile?type=17&amp;oldFileUrl=Rel15/TS%2036.111%20V15.0.0.doc</a>
ETSI	ETSI TS 136 111		15.0.0	Published	12.11.2018	<a href="http://www.etsi.org/deliver/etsi_ts/136100_136199/136111/15.00.00_60/ts_136111v150000p.pdf">http://www.etsi.org/deliver/etsi_ts/136100_136199/136111/15.00.00_60/ts_136111v150000p.pdf</a>
TSDSI	TSDSI STD T1.3GPP 36.111-15.0.0 V1.0.0		15.0.0	Published	06.10.2020	<a href="https://members.tdsi.in/index.php/s/9gsiAgXd2obYC9e">https://members.tdsi.in/index.php/s/9gsiAgXd2obYC9e</a>
TTA	TTAT.3G-36.111V15.0.0		15.0.0	Published	11.09.2020	<a href="http://www.tta.or.kr/data/ttasDown.jsp?where=14688&amp;pk_num=TTAT.3G-36.111V15.0.0">http://www.tta.or.kr/data/ttasDown.jsp?where=14688&amp;pk_num=TTAT.3G-36.111V15.0.0</a>
<b>Release 16</b>						
ARIB	ARIB STD-T120-36.111		16.0.0	Published	28.09.2020	<a href="http://www.arib.or.jp/english/html/overview/doc/T120_T23_v2_00/2_T120/ARIB-STD-T120/Rel16/36/A36111-g00.pdf">http://www.arib.or.jp/english/html/overview/doc/T120_T23_v2_00/2_T120/ARIB-STD-T120/Rel16/36/A36111-g00.pdf</a>
ATIS	ATIS.3GPP.36.111V1600		16.0.0	Published	08.09.2020	<a href="http://www.atis.org/3gpp-documents/Rel16">http://www.atis.org/3gpp-documents/Rel16</a>
CCSA	CCSA.36.111V1600		16.0.0	Published	16.07.2020	<a href="http://www.ccsa.org.cn:9001/portalsFile/downloadOldFile?type=17&amp;oldFileUrl=Rel16/TS%2036.111%20V16.0.0.doc">http://www.ccsa.org.cn:9001/portalsFile/downloadOldFile?type=17&amp;oldFileUrl=Rel16/TS%2036.111%20V16.0.0.doc</a>
ETSI	ETSI TS 136 111		16.0.0	Published	21.07.2020	<a href="http://www.etsi.org/deliver/etsi_ts/136100_136199/136111/16.00.00_60/ts_136111v160000p.pdf">http://www.etsi.org/deliver/etsi_ts/136100_136199/136111/16.00.00_60/ts_136111v160000p.pdf</a>
TSDSI	TSDSI STD T1.3GPP 36.111-16.0.0 V1.0.0		16.0.0	Published	06.10.2020	<a href="https://members.tdsi.in/index.php/s/NWadC5dNboZ2bnz">https://members.tdsi.in/index.php/s/NWadC5dNboZ2bnz</a>
TTA	TTAT.3G-36.111V16.0.0		16.0.0	Published	11.09.2020	<a href="http://www.tta.or.kr/data/ttasDown.jsp?where=14688&amp;pk_num=TTAT.3G-36.111V16.0.0">http://www.tta.or.kr/data/ttasDown.jsp?where=14688&amp;pk_num=TTAT.3G-36.111V16.0.0</a>

**1.2.1.5.5 TS 36.113****Evolved Universal Terrestrial Radio Access (E-UTRA); Base Station (BS) and repeater ElectroMagnetic Compatibility (EMC)**

This document covers the assessment of E-UTRA base stations, repeaters and associated ancillary equipment in respect of Electromagnetic Compatibility (EMC). This document specifies the applicable test conditions, performance assessment and performance criteria for E-UTRA base stations, repeaters and associated ancillary equipment in one of the following categories: (i) base stations of E-UTRA meeting the requirements of TS 36.104, with conformance demonstrated by compliance to TS 36.141; (ii) repeaters of FDD E-UTRA meeting the requirements of TS 36.106, with conformance demonstrated by compliance to TS 36.143. The environment classification used in this document refers to the environment classification used in IEC 61000-6-1 and IEC 61000-6-3. The EMC requirements have been selected to ensure an adequate level of compatibility for apparatus at residential, commercial and light industrial environments. The levels, however, do not cover extreme cases which may occur in any location but with low probability of occurrence.

SDO	Document No.	Version	Status	Issued date	Location	
<b>Release 15</b>						
ARIB	ARIB STD-T120-36.113		15.4.0	Published	28.09.2020	<a href="http://www.arib.or.jp/english/html/overview/doc/T120_T23_v2_00/2_T120/ARIB-STD-T120/Rel15/36/A36113-f40.pdf">http://www.arib.or.jp/english/html/overview/doc/T120_T23_v2_00/2_T120/ARIB-STD-T120/Rel15/36/A36113-f40.pdf</a>
ATIS	ATIS.3GPP.36.113V1540		15.4.0	Published	08.09.2020	<a href="http://www.atis.org/3gpp-documents/Rel15">http://www.atis.org/3gpp-documents/Rel15</a>
CCSA	CCSA.36.113V1540		15.4.0	Published	03.10.2019	<a href="http://www.ccsa.org.cn:9001/portalsFile/downloadOldFile?type=17&amp;oldFileUrl=Rel15/TS%2036.113%20V15.4.0.doc">http://www.ccsa.org.cn:9001/portalsFile/downloadOldFile?type=17&amp;oldFileUrl=Rel15/TS%2036.113%20V15.4.0.doc</a>
ETSI	ETSI TS 136 113		15.4.0	Published	17.10.2019	<a href="http://www.etsi.org/deliver/etsi_ts/136100_136199/136113/15.04.00_60/ts_136113v150400p.pdf">http://www.etsi.org/deliver/etsi_ts/136100_136199/136113/15.04.00_60/ts_136113v150400p.pdf</a>
TSDSI	TSDSI STD T1.3GPP 36.113-15.4.0 V1.0.0		15.4.0	Published	06.10.2020	<a href="https://members.tdsi.in/index.php/s/EZY3yixL8takEMD">https://members.tdsi.in/index.php/s/EZY3yixL8takEMD</a>
TTA	TTAT.3G-36.113V15.4.0		15.4.0	Published	11.09.2020	<a href="http://www.tta.or.kr/data/ttasDown.jsp?where=14688&amp;pk_num=TTAT.3G-36.113V15.4.0">http://www.tta.or.kr/data/ttasDown.jsp?where=14688&amp;pk_num=TTAT.3G-36.113V15.4.0</a>
<b>Release 16</b>						
ARIB	ARIB STD-T120-36.113		16.2.0	Published	28.09.2020	<a href="http://www.arib.or.jp/english/html/overview/doc/T120_T23_v2_00/2_T120/ARIB-STD-T120/Rel16/36/A36113-g20.pdf">http://www.arib.or.jp/english/html/overview/doc/T120_T23_v2_00/2_T120/ARIB-STD-T120/Rel16/36/A36113-g20.pdf</a>
ATIS	ATIS.3GPP.36.113V1620		16.2.0	Published	08.09.2020	<a href="http://www.atis.org/3gpp-documents/Rel16">http://www.atis.org/3gpp-documents/Rel16</a>
CCSA	CCSA.36.113V1620		16.2.0	Published	03.10.2019	<a href="http://www.ccsa.org.cn:9001/portalsFile/downloadOldFile?type=17&amp;oldFileUrl=Rel16/TS%2036.113%20V16.2.0.docx">http://www.ccsa.org.cn:9001/portalsFile/downloadOldFile?type=17&amp;oldFileUrl=Rel16/TS%2036.113%20V16.2.0.docx</a>
ETSI	ETSI TS 136 113		16.2.0	Published	21.09.2020	<a href="http://www.etsi.org/deliver/etsi_ts/136100_136199/136113/16.02.00_60/ts_136113v160200p.pdf">http://www.etsi.org/deliver/etsi_ts/136100_136199/136113/16.02.00_60/ts_136113v160200p.pdf</a>
TSDSI	TSDSI STD T1.3GPP 36.113-16.2.0 V1.0.0		16.2.0	Published	06.10.2020	<a href="https://members.tdsi.in/index.php/s/wpkcqfpYb5yYsPB">https://members.tdsi.in/index.php/s/wpkcqfpYb5yYsPB</a>
TTA	TTAT.3G-36.113V16.2.0		16.2.0	Published	11.09.2020	<a href="http://www.tta.or.kr/data/ttasDown.jsp?where=14688&amp;pk_num=TTAT.3G-36.113V16.2.0">http://www.tta.or.kr/data/ttasDown.jsp?where=14688&amp;pk_num=TTAT.3G-36.113V16.2.0</a>



**1.2.1.5.6 TS 36.116****Evolved Universal Terrestrial Radio Access (E-UTRA); Relay radio transmission and reception**

This document establishes the minimum RF characteristics and minimum performance requirements of E-UTRA Relay.

SDO	Document No.	Version	Status	Issued date	Location
<b>Release 15</b>					
ATIS	ATIS.3GPP.36.116V1500		15.0.0	Published 08.09.2020	<a href="http://www.atis.org/3gpp-documents/Rel15">http://www.atis.org/3gpp-documents/Rel15</a>
CCSA	CCSA.36.116V1500		15.0.0	Published 25.10.2018	<a href="http://www.ccsa.org.cn:9001/portalsFile/downloadOldFile?type=17&amp;oldFileUrl=Rel15/TS%2036.116%20V15.0.0.doc">http://www.ccsa.org.cn:9001/portalsFile/downloadOldFile?type=17&amp;oldFileUrl=Rel15/TS%2036.116%20V15.0.0.doc</a>
ETSI	ETSI TS 136 116		15.0.0	Published 12.11.2018	<a href="http://www.etsi.org/deliver/etsi_ts/136100_136199/136116/15.00.00_60/ts_136116v150000p.pdf">http://www.etsi.org/deliver/etsi_ts/136100_136199/136116/15.00.00_60/ts_136116v150000p.pdf</a>
TSDSI	TSDSI STD T1.3GPP 36.116-15.0.0 V1.0.0		15.0.0	Published 06.10.2020	<a href="https://members.tdsi.in/index.php/s/j3WGg2XmZrL6mTx">https://members.tdsi.in/index.php/s/j3WGg2XmZrL6mTx</a>
TTA	TTAT.3G-36.116V15.0.0		15.0.0	Published 11.09.2020	<a href="http://www.tta.or.kr/data/ttasDown.jsp?where=14688&amp;pk_num=TTAT.3G-36.116V15.0.0">http://www.tta.or.kr/data/ttasDown.jsp?where=14688&amp;pk_num=TTAT.3G-36.116V15.0.0</a>
<b>Release 16</b>					
ATIS	ATIS.3GPP.36.116V1600		16.0.0	Published 08.09.2020	<a href="http://www.atis.org/3gpp-documents/Rel16">http://www.atis.org/3gpp-documents/Rel16</a>
CCSA	CCSA.36.116V1600		16.0.0	Published 16.07.2020	<a href="http://www.ccsa.org.cn:9001/portalsFile/downloadOldFile?type=17&amp;oldFileUrl=Rel16/TS%2036.116%20V16.0.0.doc">http://www.ccsa.org.cn:9001/portalsFile/downloadOldFile?type=17&amp;oldFileUrl=Rel16/TS%2036.116%20V16.0.0.doc</a>
ETSI	ETSI TS 136 116		16.0.0	Published 21.07.2020	<a href="http://www.etsi.org/deliver/etsi_ts/136100_136199/136116/16.00.00_60/ts_136116v160000p.pdf">http://www.etsi.org/deliver/etsi_ts/136100_136199/136116/16.00.00_60/ts_136116v160000p.pdf</a>
TSDSI	TSDSI STD T1.3GPP 36.116-16.0.0 V1.0.0		16.0.0	Published 06.10.2020	<a href="https://members.tdsi.in/index.php/s/oH5nyKqMWNnPMYw">https://members.tdsi.in/index.php/s/oH5nyKqMWNnPMYw</a>
TTA	TTAT.3G-36.116V16.0.0		16.0.0	Published 11.09.2020	<a href="http://www.tta.or.kr/data/ttasDown.jsp?where=14688&amp;pk_num=TTAT.3G-36.116V16.0.0">http://www.tta.or.kr/data/ttasDown.jsp?where=14688&amp;pk_num=TTAT.3G-36.116V16.0.0</a>

**1.2.1.5.7 TS 36.124****Evolved Universal Terrestrial Radio Access (E-UTRA); Electromagnetic compatibility (EMC) requirements for mobile terminals and ancillary equipment**

This document establishes the essential EMC requirements for “3<sup>rd</sup> generation” digital cellular mobile terminal equipment and ancillary accessories in combination with a 3GPP E-UTRA user equipment (UE). This document specifies the applicable EMC tests, the methods of measurement, the frequency range, the limits and the minimum performance criteria for all types of E-UTRA UEs and their accessories. Requirements for the radiated emission from the enclosure port of integral antenna equipment and ancillaries have been included. The immunity requirements have been selected to ensure an adequate level of compatibility for apparatus in residential, commercial, light industrial and vehicular environments. The levels, however, do not cover extreme cases, which may occur in any location but with low probability of occurrence. Compliance of radio equipment to the requirements of this document does not signify compliance to any requirement related to the use of the equipment (i.e. licensing requirements). Compliance to the requirements of this document does not signify compliance to any safety requirement. However, any temporary or permanent unsafe condition caused by EMC is considered as non-compliance.

SDO	Document No.	Version	Status	Issued date	Location
<b>Release 15</b>					
ARIB	ARIB STD-T120-36.124		15.2.0	Published 28.09.2020	<a href="http://www.arib.or.jp/english/html/overview/doc/T120_T23_v2_00/2_T120/ARIB-STD-T120/Rel15/36/A36124-f20.pdf">http://www.arib.or.jp/english/html/overview/doc/T120_T23_v2_00/2_T120/ARIB-STD-T120/Rel15/36/A36124-f20.pdf</a>
ATIS	ATIS.3GPP.36.124V1520		15.2.0	Published 08.09.2020	<a href="http://www.atis.org/3gpp-documents/Rel15">http://www.atis.org/3gpp-documents/Rel15</a>
CCSA	CCSA.36.124V1520		15.2.0	Published 06.04.2018	<a href="http://www.ccsa.org.cn:9001/portalsFile/downloadOldFile?type=17&amp;oldFileUrl=Rel15/TS%2036.124%20V15.2.0.doc">http://www.ccsa.org.cn:9001/portalsFile/downloadOldFile?type=17&amp;oldFileUrl=Rel15/TS%2036.124%20V15.2.0.doc</a>
ETSI	ETSI TS 136 124		15.2.0	Published 18.09.2018	<a href="http://www.etsi.org/deliver/etsi_ts/136100_136199/136124/15.02.00_60/ts_136124v150200p.pdf">http://www.etsi.org/deliver/etsi_ts/136100_136199/136124/15.02.00_60/ts_136124v150200p.pdf</a>
TSDSI	TSDSI STD T1.3GPP 36.124-15.2.0 V1.0.0		15.2.0	Published 06.10.2020	<a href="https://members.tdsi.in/index.php/s/MWrpPoxsReSZQ6D">https://members.tdsi.in/index.php/s/MWrpPoxsReSZQ6D</a>
TTA	TTAT.3G-36.124V15.2.0		15.2.0	Published 11.09.2020	<a href="http://www.tta.or.kr/data/ttasDown.jsp?where=14688&amp;pk_num=TTAT.3G-36.124V15.2.0">http://www.tta.or.kr/data/ttasDown.jsp?where=14688&amp;pk_num=TTAT.3G-36.124V15.2.0</a>
<b>Release 16</b>					
ARIB	ARIB STD-T120-36.124		16.1.0	Published 28.09.2020	<a href="http://www.arib.or.jp/english/html/overview/doc/T120_T23_v2_00/2_T120/ARIB-STD-T120/Rel16/36/A36124-g10.pdf">http://www.arib.or.jp/english/html/overview/doc/T120_T23_v2_00/2_T120/ARIB-STD-T120/Rel16/36/A36124-g10.pdf</a>
ATIS	ATIS.3GPP.36.124V1610		16.1.0	Published 08.09.2020	<a href="http://www.atis.org/3gpp-documents/Rel16">http://www.atis.org/3gpp-documents/Rel16</a>

## 104

## Rec. ITU-R M.2150-0

CCSA	CCSA.36.124V1610	16.1.0	Published	03.07.2019	<a href="http://www.ccsa.org.cn:9001/portalsFile/downloadOldFile?type=17&amp;oldFileUrl=Rel16/TS%2036.124%20V16.1.0.docx">http://www.ccsa.org.cn:9001/portalsFile/downloadOldFile?type=17&amp;oldFileUrl=Rel16/TS%2036.124%20V16.1.0.docx</a>
ETSI	ETSI TS 136 124	16.1.0	Published	21.09.2020	<a href="http://www.etsi.org/deliver/etsi_ts/136100_136199/136124/16.01.00_60/ts_136124v160100p.pdf">http://www.etsi.org/deliver/etsi_ts/136100_136199/136124/16.01.00_60/ts_136124v160100p.pdf</a>
TSDSI	TSDSI STD T1.3GPP 36.124-16.1.0 V1.0.0	16.1.0	Published	06.10.2020	<a href="https://members.tdsi.in/index.php/s/N6x9G2LjEGBaPBQ">https://members.tdsi.in/index.php/s/N6x9G2LjEGBaPBQ</a>
TTA	TTAT.3G-36.124V16.1.0	16.1.0	Published	11.09.2020	<a href="http://www.tta.or.kr/data/ttasDown.jsp?where=14688&amp;pk_num=TTAT.3G-36.124V16.1.0">http://www.tta.or.kr/data/ttasDown.jsp?where=14688&amp;pk_num=TTAT.3G-36.124V16.1.0</a>

### 1.2.1.5.8 TS 36.133

#### Evolved Universal Terrestrial Radio Access (E-UTRA); Requirements for support of radio resource management

This document specifies requirements for support of Radio Resource Management for the FDD and TDD modes of E-UTRA. These requirements include requirements on measurements in UTRAN and the UE as well as requirements on node dynamical behaviour and interaction, in terms of delay and response characteristics.

SDO	Document No.	Version	Status	Issued date	Location
<b>Release 15</b>					
ARIB	ARIB STD-T120-36.133	15.10.0	Published	28.09.2020	<a href="http://www.arib.or.jp/english/html/overview/doc/T120_T23_v2_00/2_T120/ARIB-STD-T120/Rel15/36/A36133-fa0.pdf">http://www.arib.or.jp/english/html/overview/doc/T120_T23_v2_00/2_T120/ARIB-STD-T120/Rel15/36/A36133-fa0.pdf</a>
ATIS	ATIS.3GPP.36.133V15100	15.10.0	Published	08.09.2020	<a href="http://www.atis.org/3gpp-documents/Rel15">http://www.atis.org/3gpp-documents/Rel15</a>
CCSA	CCSA.36.133V15100	15.10.0	Published	17.07.2020	<a href="http://www.ccsa.org.cn:9001/portalsFile/downloadOldFile?type=17&amp;oldFileUrl=Rel15/TS%2036.133%20V15.10.0.zip">http://www.ccsa.org.cn:9001/portalsFile/downloadOldFile?type=17&amp;oldFileUrl=Rel15/TS%2036.133%20V15.10.0.zip</a>
ETSI	ETSI TS 136 133	15.10.0	Published	23.09.2020	<a href="http://www.etsi.org/deliver/etsi_ts/136100_136199/136133/15.10.00_60/ts_136133v151000p.pdf">http://www.etsi.org/deliver/etsi_ts/136100_136199/136133/15.10.00_60/ts_136133v151000p.pdf</a>
TSDSI	TSDSI STD T1.3GPP 36.133-15.10.0 V1.0.0	15.10.0	Published	06.10.2020	<a href="https://members.tdsi.in/index.php/s/73KWQfo3JEp35pk">https://members.tdsi.in/index.php/s/73KWQfo3JEp35pk</a>
TTA	TTAT.3G-36.133V15.10.0	15.10.0	Published	11.09.2020	<a href="http://www.tta.or.kr/data/ttasDown.jsp?where=14688&amp;pk_num=TTAT.3G-36.133V15.10.0">http://www.tta.or.kr/data/ttasDown.jsp?where=14688&amp;pk_num=TTAT.3G-36.133V15.10.0</a>
<b>Release 16</b>					
ARIB	ARIB STD-T120-36.133	16.6.0	Published	28.09.2020	<a href="http://www.arib.or.jp/english/html/overview/doc/T120_T23_v2_00/2_T120/ARIB-STD-T120/Rel16/36/A36133-g60.pdf">http://www.arib.or.jp/english/html/overview/doc/T120_T23_v2_00/2_T120/ARIB-STD-T120/Rel16/36/A36133-g60.pdf</a>
ATIS	ATIS.3GPP.36.133V1660	16.6.0	Published	08.09.2020	<a href="http://www.atis.org/3gpp-documents/Rel16">http://www.atis.org/3gpp-documents/Rel16</a>
CCSA	CCSA.36.133V1660	16.6.0	Published	17.07.2020	<a href="http://www.ccsa.org.cn:9001/portalsFile/downloadOldFile?type=17&amp;oldFileUrl=Rel16/TS%2036.133%20V16.6.0.zip">http://www.ccsa.org.cn:9001/portalsFile/downloadOldFile?type=17&amp;oldFileUrl=Rel16/TS%2036.133%20V16.6.0.zip</a>
ETSI	ETSI TS 136 133	16.6.0	Published	23.09.2020	<a href="http://www.etsi.org/deliver/etsi_ts/136100_136199/136133/16.06.00_60/ts_136133v160600p.pdf">http://www.etsi.org/deliver/etsi_ts/136100_136199/136133/16.06.00_60/ts_136133v160600p.pdf</a>
TSDSI	TSDSI STD T1.3GPP 36.133-16.6.0 V1.0.0	16.6.0	Published	06.10.2020	<a href="https://members.tdsi.in/index.php/s/mYWgqpid2eefBqj">https://members.tdsi.in/index.php/s/mYWgqpid2eefBqj</a>
TTA	TTAT.3G-36.133V16.6.0	16.6.0	Published	11.09.2020	<a href="http://www.tta.or.kr/data/ttasDown.jsp?where=14688&amp;pk_num=TTAT.3G-36.133V16.6.0">http://www.tta.or.kr/data/ttasDown.jsp?where=14688&amp;pk_num=TTAT.3G-36.133V16.6.0</a>

### 1.2.1.5.9 TS 37.104

#### NE, E-UTRA, UTRA and GSM/EDGE; Multi-Standard Radio (MSR) Base Station (BS) radio transmission and reception

This document establishes the minimum RF characteristics of E-UTRA, UTRA and GSM/EDGE Multi-Standard Radio (MSR) Base Station (BS). Requirements for multi-RAT and single-RAT operation of MSR BS are covered in this document. The requirements in this document for E-UTRA and UTRA single-RAT operation of MSR BS are also applicable to E-UTRA and UTRA multi-carrier capable single-RAT BS. Requirements for GSM BS that are only single-RAT capable are not covered.

SDO	Document No.	Version	Status	Issued date	Location
<b>Release 15</b>					
ATIS	ATIS.3GPP.37.104V15110	15.11.0	Published	08.09.2020	<a href="http://www.atis.org/3gpp-documents/Rel15">http://www.atis.org/3gpp-documents/Rel15</a>
CCSA	CCSA.37.104V15110	15.11.0	Published	16.07.2020	<a href="http://www.ccsa.org.cn:9001/portalsFile/downloadOldFile?type=17&amp;oldFileUrl=Rel16/TS%2037.104%20V15.11.0.doc">http://www.ccsa.org.cn:9001/portalsFile/downloadOldFile?type=17&amp;oldFileUrl=Rel16/TS%2037.104%20V15.11.0.doc</a>
ETSI	ETSI TS 137 104	15.11.0	Published	17.09.2020	<a href="http://www.etsi.org/deliver/etsi_ts/137100_137199/137104/15.11.00_60/ts_137104v151100p.pdf">http://www.etsi.org/deliver/etsi_ts/137100_137199/137104/15.11.00_60/ts_137104v151100p.pdf</a>
TSDSI	TSDSI STD T1.3GPP 37.104-15.11.0 V1.0.0	15.11.0	Published	06.10.2020	<a href="https://members.tdsi.in/index.php/s/kXWMzjjgAZKQZDq">https://members.tdsi.in/index.php/s/kXWMzjjgAZKQZDq</a>
TTA	TTAT.3G-37.104V15.11.0	15.11.0	Published	11.09.2020	<a href="http://www.tta.or.kr/data/ttasDown.jsp?where=14688&amp;pk_num=TTAT.3G-37.104V15.11.0">http://www.tta.or.kr/data/ttasDown.jsp?where=14688&amp;pk_num=TTAT.3G-37.104V15.11.0</a>
<b>Release 16</b>					
ATIS	ATIS.3GPP.37.104V1660	16.6.0	Published	08.09.2020	<a href="http://www.atis.org/3gpp-documents/Rel16">http://www.atis.org/3gpp-documents/Rel16</a>
CCSA	CCSA.37.104V1660	16.6.0	Published	16.07.2020	<a href="http://www.ccsa.org.cn:9001/portalsFile/downloadOldFile?type=17&amp;oldFileUrl=Rel16/TS%2037.104%20V16.6.0.doc">http://www.ccsa.org.cn:9001/portalsFile/downloadOldFile?type=17&amp;oldFileUrl=Rel16/TS%2037.104%20V16.6.0.doc</a>
ETSI	ETSI TS 137 104	16.6.0	Published	15.09.2020	<a href="http://www.etsi.org/deliver/etsi_ts/137100_137199/137104/16.06.00_60/ts_137104v160600p.pdf">http://www.etsi.org/deliver/etsi_ts/137100_137199/137104/16.06.00_60/ts_137104v160600p.pdf</a>

TSDSI	TSDSI STD T1.3GPP 37.104-16.6.0 V1.0.0	16.6.0	Published	06.10.2020	<a href="https://members.tsdSI.in/index.php/s/eW9PPjm47btokJH">https://members.tsdSI.in/index.php/s/eW9PPjm47btokJH</a>
TTA	TTAT.3G-37.104V16.6.0	16.6.0	Published	11.09.2020	<a href="http://www.tta.or.kr/data/ttasDown.jsp?where=14688&amp;pk_num=TTAT.3G-37.104V16.6.0">http://www.tta.or.kr/data/ttasDown.jsp?where=14688&amp;pk_num=TTAT.3G-37.104V16.6.0</a>

### 1.2.1.5.10 TS 37.105

#### Active Antenna System (AAS) Base Station (BS) transmission and reception

This document establishes the RF characteristics, the RF minimum requirements and minimum performance requirements for E-UTRA AAS Base Station (BS), the FDD mode of UTRA AAS Base Station (BS), the 1,28 Mchip/s TDD mode of UTRA AAS Base Station (BS) in single RAT and any MSR AAS Base Station (BS) implementation of these RATs.

SDO	Document No.	Version	Status	Issued date	Location	
<b>Release 15</b>						
ATIS	ATIS.3GPP.37.105V1590		15.9.0	Published	08.09.2020	<a href="http://www.atis.org/3gpp-documents/Rel15">http://www.atis.org/3gpp-documents/Rel15</a>
CCSA	CCSA.37.105V1590		15.9.0	Published	17.07.2020	<a href="http://www.ccsa.org.cn:9001/portalsFile/downloadOldFile?type=17&amp;oldFileUrl=Rel15/TS%2037.105%20V15.9.0.docx">http://www.ccsa.org.cn:9001/portalsFile/downloadOldFile?type=17&amp;oldFileUrl=Rel15/TS%2037.105%20V15.9.0.docx</a>
ETSI	ETSI TS 137 105		15.9.0	Published	15.09.2020	<a href="http://www.etsi.org/deliver/etsi_ts/137100_137199/137105/15.09.00_60/ts_137105v150900p.pdf">http://www.etsi.org/deliver/etsi_ts/137100_137199/137105/15.09.00_60/ts_137105v150900p.pdf</a>
TSDSI	TSDSI STD T1.3GPP 37.105-15.9.0 V1.0.0		15.9.0	Published	06.10.2020	<a href="https://members.tsdSI.in/index.php/s/QWgbdftz98gzfRQ">https://members.tsdSI.in/index.php/s/QWgbdftz98gzfRQ</a>
TTA	TTAT.3G-37.105V15.9.0		15.9.0	Published	11.09.2020	<a href="http://www.tta.or.kr/data/ttasDown.jsp?where=14688&amp;pk_num=TTAT.3G-37.105V15.9.0">http://www.tta.or.kr/data/ttasDown.jsp?where=14688&amp;pk_num=TTAT.3G-37.105V15.9.0</a>
<b>Release 16</b>						
ATIS	ATIS.3GPP.37.105V1640		16.4.0	Published	08.09.2020	<a href="http://www.atis.org/3gpp-documents/Rel16">http://www.atis.org/3gpp-documents/Rel16</a>
CCSA	CCSA.37.105V1640		16.4.0	Published	17.07.2020	<a href="http://www.ccsa.org.cn:9001/portalsFile/downloadOldFile?type=17&amp;oldFileUrl=Rel16/TS%2037.105%20V16.4.0.docx">http://www.ccsa.org.cn:9001/portalsFile/downloadOldFile?type=17&amp;oldFileUrl=Rel16/TS%2037.105%20V16.4.0.docx</a>
ETSI	ETSI TS 137 105		16.4.0	Published	15.09.2020	<a href="http://www.etsi.org/deliver/etsi_ts/137100_137199/137105/16.04.00_60/ts_137105v160400p.pdf">http://www.etsi.org/deliver/etsi_ts/137100_137199/137105/16.04.00_60/ts_137105v160400p.pdf</a>
TSDSI	TSDSI STD T1.3GPP 37.105-16.4.0 V1.0.0		16.4.0	Published	06.10.2020	<a href="https://members.tsdSI.in/index.php/s/fQ9mNDXTbYaztXX">https://members.tsdSI.in/index.php/s/fQ9mNDXTbYaztXX</a>
TTA	TTAT.3G-37.105V16.4.0		16.4.0	Published	11.09.2020	<a href="http://www.tta.or.kr/data/ttasDown.jsp?where=14688&amp;pk_num=TTAT.3G-37.105V16.4.0">http://www.tta.or.kr/data/ttasDown.jsp?where=14688&amp;pk_num=TTAT.3G-37.105V16.4.0</a>

### 1.2.1.5.11 TS 37.113

#### NR, E-UTRA, UTRA and GSM/EDGE; Multi-Standard Radio (MSR) Base Station (BS) Electromagnetic Compatibility (EMC)

This document covers the assessment of E-UTRA, UTRA and GSM/EDGE Multi-Standard Radio (MSR) Base Stations and associated ancillary equipment in respect of Electromagnetic Compatibility (EMC). This document specifies the applicable test conditions, performance assessment and performance criteria for E-UTRA, UTRA and GSM/EDGE Base Stations and associated ancillary equipment in one of the following categories: (i) Multi-Standard Radio (MSR) Base Stations for E-UTRA, UTRA and GSM/EDGE meeting the requirements of TS 37.104, with conformance demonstrated by compliance to TS 37.141; (ii) Base Stations for E-UTRA meeting the requirements of TS 36.104, with conformance demonstrated by compliance to TS 36.141; (iii) Base Stations for UTRA FDD meeting the requirements of TS 25.104, with conformance demonstrated by compliance to TS 25.141; (iv) Base Stations for UTRA TDD meeting the requirements of TS 25.105, with conformance demonstrated by compliance to TS 25.142; (v) Base Stations for GSM/EDGE meeting the requirements of TS 45.005, with conformance demonstrated by compliance to TS 51.021. The environment classification used in this document refers to the environment classification used in IEC 61000-6-1 and IEC 61000-6-3.

The EMC requirements have been selected to ensure an adequate level of compatibility for apparatus at residential, commercial and light industrial environments. The levels, however, do not cover extreme cases which may occur in any location but with low probability of occurrence.

SDO	Document No.	Version	Status	Issued date	Location
<b>Release 15</b>					
ATIS	ATIS.3GPP.37.113V1590		15.9.0	Published 08.09.2020	<a href="http://www.atis.org/3gpp-documents/Rel15">http://www.atis.org/3gpp-documents/Rel15</a>
CCSA	CCSA.37.113V1590		15.9.0	Published 17.07.2020	<a href="http://www.ccsa.org.cn:9001/portalsFile/downloadOldFile?type=17&amp;oldFileUrl=Rel16/TS%2037.113%20V15.9.0.docx">http://www.ccsa.org.cn:9001/portalsFile/downloadOldFile?type=17&amp;oldFileUrl=Rel16/TS%2037.113%20V15.9.0.docx</a>
ETSI	ETSI TS 137 113		15.9.0	Published 15.09.2020	<a href="http://www.etsi.org/deliver/etsi_ts/137100_137199/137113/15.09.00_60/ts_137113v150900p.pdf">http://www.etsi.org/deliver/etsi_ts/137100_137199/137113/15.09.00_60/ts_137113v150900p.pdf</a>
TSDSI	TSDSI STD T1.3GPP 37.113-15.9.0 V1.0.0		15.9.0	Published 06.10.2020	<a href="https://members.tdsi.in/index.php/s/55oazWMctnJLcG3">https://members.tdsi.in/index.php/s/55oazWMctnJLcG3</a>
TTA	TTAT.3G-37.113V15.9.0		15.9.0	Published 11.09.2020	<a href="http://www.tta.or.kr/data/ttasDown.jsp?where=14688&amp;pk_num=TTAT.3G-37.113V15.9.0">http://www.tta.or.kr/data/ttasDown.jsp?where=14688&amp;pk_num=TTAT.3G-37.113V15.9.0</a>
<b>Release 16</b>					
ATIS	ATIS.3GPP.37.113V1600		16.0.0	Published 08.09.2020	<a href="http://www.atis.org/3gpp-documents/Rel16">http://www.atis.org/3gpp-documents/Rel16</a>
CCSA	CCSA.37.113V1600		16.0.0	Published 17.07.2020	<a href="http://www.ccsa.org.cn:9001/portalsFile/downloadOldFile?type=17&amp;oldFileUrl=Rel16/TS%2037.113%20V16.0.0.docx">http://www.ccsa.org.cn:9001/portalsFile/downloadOldFile?type=17&amp;oldFileUrl=Rel16/TS%2037.113%20V16.0.0.docx</a>
ETSI	ETSI TS 137 113		16.0.0	Published 15.09.2020	<a href="http://www.etsi.org/deliver/etsi_ts/137100_137199/137113/16.00.00_60/ts_137113v160000p.pdf">http://www.etsi.org/deliver/etsi_ts/137100_137199/137113/16.00.00_60/ts_137113v160000p.pdf</a>
TSDSI	TSDSI STD T1.3GPP 37.113-16.0.0 V1.0.0		16.0.0	Published 06.10.2020	<a href="https://members.tdsi.in/index.php/s/9HTfzowsBzGzHP8">https://members.tdsi.in/index.php/s/9HTfzowsBzGzHP8</a>
TTA	TTAT.3G-37.113V16.0.0		16.0.0	Published 11.09.2020	<a href="http://www.tta.or.kr/data/ttasDown.jsp?where=14688&amp;pk_num=TTAT.3G-37.113V16.0.0">http://www.tta.or.kr/data/ttasDown.jsp?where=14688&amp;pk_num=TTAT.3G-37.113V16.0.0</a>

### 1.2.1.5.12 TS 37.114

#### Active Antenna System (AAS) Base Station (BS) Electromagnetic Compatibility (EMC)

This document covers the assessment of E-UTRA, UTRA and Multi-Standard Radio (MSR) Active Antenna Systems Base Stations in respect of Electromagnetic Compatibility (EMC).

This document specifies the applicable test conditions, performance assessment and performance criteria for E-UTRA and UTRA Base Stations and associated ancillary equipment in one of the following categories:

- Active Antenna System Base Station for E-UTRA, UTRA and MSR meeting the requirements of 3GPP TS 37.105, with conformance demonstrated by compliance to 3GPP TS 37.145.

The scope of this document is AAS BS with TAB connectors for every transceiver unit at the Transceiver Array Boundary. Requirement, procedures and values of an AAS Base Station without TAB connectors are not included in this document and are FFS.

The environment classification used in this document refers to the residential, commercial and light industrial environment classification used in IEC 61000-6-1 and IEC 61000-6-3.

The EMC requirements have been selected to ensure an adequate level of compatibility for apparatus at residential, commercial and light industrial environments. The levels, however, do not cover extreme cases which may occur in any location but with low probability of occurrence.

SDO	Document No.	Version	Status	Issued date	Location
<b>Release 15</b>					
ATIS	ATIS.3GPP.37.114V1590		15.9.0	Published 08.09.2020	<a href="http://www.atis.org/3gpp-documents/Rel15">http://www.atis.org/3gpp-documents/Rel15</a>
CCSA	CCSA.37.114V1590		15.9.0	Published 17.07.2020	<a href="http://www.ccsa.org.cn:9001/portalsFile/downloadOldFile?type=17&amp;oldFileUrl=Rel15/TS%2037.114%20V15.9.0.docx">http://www.ccsa.org.cn:9001/portalsFile/downloadOldFile?type=17&amp;oldFileUrl=Rel15/TS%2037.114%20V15.9.0.docx</a>
ETSI	ETSI TS 137 114		15.9.0	Published 15.09.2020	<a href="http://www.etsi.org/deliver/etsi_ts/137100_137199/137114/15.09.00_60/ts_137114v150900p.pdf">http://www.etsi.org/deliver/etsi_ts/137100_137199/137114/15.09.00_60/ts_137114v150900p.pdf</a>
TSDSI	TSDSI STD T1.3GPP 37.114-15.9.0 V1.0.0		15.9.0	Published 06.10.2020	<a href="https://members.tdsi.in/index.php/s/fb7dpSMGiM7f82H">https://members.tdsi.in/index.php/s/fb7dpSMGiM7f82H</a>
TTA	TTAT.3G-37.114V15.9.0		15.9.0	Published 11.09.2020	<a href="http://www.tta.or.kr/data/ttasDown.jsp?where=14688&amp;pk_num=TTAT.3G-37.114V15.9.0">http://www.tta.or.kr/data/ttasDown.jsp?where=14688&amp;pk_num=TTAT.3G-37.114V15.9.0</a>
<b>Release 16</b>					

ATIS	ATIS.3GPP.37.114V1600	16.0.0	Published	08.09.2020	<a href="http://www.atis.org/3gpp-documents/Rel16">http://www.atis.org/3gpp-documents/Rel16</a>
CCSA	CCSA.37.114V1600	16.0.0	Published	17.07.2020	<a href="http://www.ccsa.org.cn:9001/portalsFile/downloadOldFile?type=17&amp;oldFileUrl=Rel16/TS%2037.114%20V16.0.0.docx">http://www.ccsa.org.cn:9001/portalsFile/downloadOldFile?type=17&amp;oldFileUrl=Rel16/TS%2037.114%20V16.0.0.docx</a>
ETSI	ETSI TS 137 114	16.0.0	Published	15.09.2020	<a href="http://www.etsi.org/deliver/etsi_ts/137100_137199/137114/16.00.00_60/ts_137114v160000p.pdf">http://www.etsi.org/deliver/etsi_ts/137100_137199/137114/16.00.00_60/ts_137114v160000p.pdf</a>
TSDSI	TSDSI STD T1.3GPP 37.114-16.0.0 V1.0.0	16.0.0	Published	06.10.2020	<a href="https://members.tdsi.in/index.php/s/cgij55wt4LKsgs">https://members.tdsi.in/index.php/s/cgij55wt4LKsgs</a>
TTA	TTAT.3G-37.114V16.0.0	16.0.0	Published	11.09.2020	<a href="http://www.tta.or.kr/data/ttasDown.jsp?where=14688&amp;pk_num=TTAT.3G-37.114V16.0.0">http://www.tta.or.kr/data/ttasDown.jsp?where=14688&amp;pk_num=TTAT.3G-37.114V16.0.0</a>

**1.2.1.5.13 TS 38.101-1**

**NR; User Equipment (UE) radio transmission and reception; Part 1: Range 1 Standalone**

This document establishes the minimum RF requirements for NR User Equipment (UE) operating on frequency Range 1.

SDO	Document No.	Version	Status	Issued date	Location
<b>Release 15</b>					
ARIB	ARIB STD-T120-38.101-1	15.10.0	Published	28.09.2020	<a href="http://www.arib.or.jp/english/html/overview/doc/T120_T23_v2_00/2_T120/ARIB-STD-T120/Rel15/38/A38101-1-fa0.pdf">http://www.arib.or.jp/english/html/overview/doc/T120_T23_v2_00/2_T120/ARIB-STD-T120/Rel15/38/A38101-1-fa0.pdf</a>
ATIS	ATIS.3GPP.38.101-1V15100	15.10.0	Published	08.09.2020	<a href="http://www.atis.org/3gpp-documents/Rel15">http://www.atis.org/3gpp-documents/Rel15</a>
CCSA	CCSA.38.101-1V15100	15.10.0	Published	17.07.2020	<a href="http://www.ccsa.org.cn:9001/portalsFile/downloadOldFile?type=17&amp;oldFileUrl=Rel15/TS%2038.101-">http://www.ccsa.org.cn:9001/portalsFile/downloadOldFile?type=17&amp;oldFileUrl=Rel15/TS%2038.101-</a>
ETSI	ETSI TS 138 101-1	15.10.0	Published	23.07.2020	<a href="http://www.etsi.org/deliver/etsi_ts/138100_138199/13810101/15.10.00_60/ts_13810101v151000p.pdf">http://www.etsi.org/deliver/etsi_ts/138100_138199/13810101/15.10.00_60/ts_13810101v151000p.pdf</a>
TSDSI	TSDSI STD T1.3GPP 38.101-1-15.10.0	15.10.0	Published	06.10.2020	<a href="https://members.tdsi.in/index.php/s/BtPHPzJBKMackJo">https://members.tdsi.in/index.php/s/BtPHPzJBKMackJo</a>
TTA	TTAT.3G-38.101-1V15.10.0	15.10.0	Published	11.09.2020	<a href="http://www.tta.or.kr/data/ttasDown.jsp?where=14688&amp;pk_num=TTAT.3G-38.101-1V15.10.0">http://www.tta.or.kr/data/ttasDown.jsp?where=14688&amp;pk_num=TTAT.3G-38.101-1V15.10.0</a>
<b>Release 16</b>					
ARIB	ARIB STD-T120-38.101-1	16.4.0	Published	28.09.2020	<a href="http://www.arib.or.jp/english/html/overview/doc/T120_T23_v2_00/2_T120/ARIB-STD-T120/Rel16/38/A38101-1-g40.pdf">http://www.arib.or.jp/english/html/overview/doc/T120_T23_v2_00/2_T120/ARIB-STD-T120/Rel16/38/A38101-1-g40.pdf</a>
ATIS	ATIS.3GPP.38.101-1V1640	16.4.0	Published	08.09.2020	<a href="http://www.atis.org/3gpp-documents/Rel16">http://www.atis.org/3gpp-documents/Rel16</a>
CCSA	CCSA.38.101-1V1640	16.4.0	Published	17.07.2020	<a href="http://www.ccsa.org.cn:9001/portalsFile/downloadOldFile?type=17&amp;oldFileUrl=Rel16/TS%2038.101-1%20V16.4.0.docx">http://www.ccsa.org.cn:9001/portalsFile/downloadOldFile?type=17&amp;oldFileUrl=Rel16/TS%2038.101-1%20V16.4.0.docx</a>
ETSI	ETSI TS 138 101-1	16.4.0	Published	23.07.2020	<a href="http://www.etsi.org/deliver/etsi_ts/138100_138199/13810101/16.04.00_60/ts_13810101v160400p.pdf">http://www.etsi.org/deliver/etsi_ts/138100_138199/13810101/16.04.00_60/ts_13810101v160400p.pdf</a>
TSDSI	TSDSI STD T1.3GPP 38.101-1-16.4.0 V1.0.0	16.4.0	Published	06.10.2020	<a href="https://members.tdsi.in/index.php/s/eLo4x6gpgqHknnKi">https://members.tdsi.in/index.php/s/eLo4x6gpgqHknnKi</a>
TTA	TTAT.3G-38.101-1V16.4.0	16.4.0	Published	11.09.2020	<a href="http://www.tta.or.kr/data/ttasDown.jsp?where=14688&amp;pk_num=TTAT.3G-38.101-1V16.4.0">http://www.tta.or.kr/data/ttasDown.jsp?where=14688&amp;pk_num=TTAT.3G-38.101-1V16.4.0</a>

**1.2.1.5.14 TS 38.101-2**

**NR; User Equipment (UE) radio transmission and reception; Part 2: Range 2 Standalone**

This document establishes the minimum RF requirements for NR User Equipment (UE) operating on frequency Range 2.

SDO	Document No.	Version	Status	Issued date	Location
<b>Release 15</b>					
ARIB	ARIB STD-T120-38.101-2	15.10.0	Published	28.09.2020	<a href="http://www.arib.or.jp/english/html/overview/doc/T120_T23_v2_00/2_T120/ARIB-STD-T120/Rel15/38/A38101-2-fa0.pdf">http://www.arib.or.jp/english/html/overview/doc/T120_T23_v2_00/2_T120/ARIB-STD-T120/Rel15/38/A38101-2-fa0.pdf</a>
ATIS	ATIS.3GPP.38.101-2V15100	15.10.0	Published	08.09.2020	<a href="http://www.atis.org/3gpp-documents/Rel15">http://www.atis.org/3gpp-documents/Rel15</a>
CCSA	CCSA.38.101-2V15100	15.10.0	Published	17.07.2020	<a href="http://www.ccsa.org.cn:9001/portalsFile/downloadOldFile?type=17&amp;oldFileUrl=Rel16/TS%2038.101-">http://www.ccsa.org.cn:9001/portalsFile/downloadOldFile?type=17&amp;oldFileUrl=Rel16/TS%2038.101-</a>
ETSI	ETSI TS 138 101-2	15.10.0	Published	23.07.2020	<a href="http://www.etsi.org/deliver/etsi_ts/138100_138199/13810102/15.10.00_60/ts_13810102v151000p.pdf">http://www.etsi.org/deliver/etsi_ts/138100_138199/13810102/15.10.00_60/ts_13810102v151000p.pdf</a>
TSDSI	TSDSI STD T1.3GPP 38.101-2-15.10.0	15.10.0	Published	06.10.2020	<a href="https://members.tdsi.in/index.php/s/RJSDnP96ZH3LbpP">https://members.tdsi.in/index.php/s/RJSDnP96ZH3LbpP</a>
TTA	TTAT.3G-38.101-2V15.10.0	15.10.0	Published	11.09.2020	<a href="http://www.tta.or.kr/data/ttasDown.jsp?where=14688&amp;pk_num=TTAT.3G-38.101-2V15.10.0">http://www.tta.or.kr/data/ttasDown.jsp?where=14688&amp;pk_num=TTAT.3G-38.101-2V15.10.0</a>
<b>Release 16</b>					
ARIB	ARIB STD-T120-38.101-2	16.4.0	Published	28.09.2020	<a href="http://www.arib.or.jp/english/html/overview/doc/T120_T23_v2_00/2_T120/ARIB-STD-T120/Rel16/38/A38101-2-g40.pdf">http://www.arib.or.jp/english/html/overview/doc/T120_T23_v2_00/2_T120/ARIB-STD-T120/Rel16/38/A38101-2-g40.pdf</a>
ATIS	ATIS.3GPP.38.101-2V1640	16.4.0	Published	08.09.2020	<a href="http://www.atis.org/3gpp-documents/Rel16">http://www.atis.org/3gpp-documents/Rel16</a>
CCSA	CCSA.38.101-2V1640	16.4.0	Published	17.07.2020	<a href="http://www.ccsa.org.cn:9001/portalsFile/downloadOldFile?type=17&amp;oldFileUrl=Rel16/TS%2038.101-2%20V16.4.0.docx">http://www.ccsa.org.cn:9001/portalsFile/downloadOldFile?type=17&amp;oldFileUrl=Rel16/TS%2038.101-2%20V16.4.0.docx</a>
ETSI	ETSI TS 138 101-2	16.4.0	Published	23.07.2020	<a href="http://www.etsi.org/deliver/etsi_ts/138100_138199/13810102/16.04.00_60/ts_13810102v160400p.pdf">http://www.etsi.org/deliver/etsi_ts/138100_138199/13810102/16.04.00_60/ts_13810102v160400p.pdf</a>
TSDSI	TSDSI STD T1.3GPP 38.101-2-16.4.0 V1.0.0	16.4.0	Published	06.10.2020	<a href="https://members.tdsi.in/index.php/s/BgRqXdipT9WA3Q">https://members.tdsi.in/index.php/s/BgRqXdipT9WA3Q</a>

TTA TTAT.3G-38.101-2V16.4.0 16.4.0 Published 11.09.2020 [http://www.tta.or.kr/data/ttasDown.jsp?where=14688&pk\\_num=TTAT.3G-38.101-2V16.4.0](http://www.tta.or.kr/data/ttasDown.jsp?where=14688&pk_num=TTAT.3G-38.101-2V16.4.0)

### 1.2.1.5.15 TS 38.101-3

#### NR; User Equipment (UE) radio transmission and reception; Part 3: Range 1 and Range 2 Interworking operation with other radios

This document establishes the minimum RF requirements for NR User Equipment (UE) Interworking operation with other radios. This includes but is not limited to additional requirements for carrier aggregation or NR dual connectivity between Range 1 and Range 2 and additional requirements due to NR non-standalone (NSA) operation mode with E-UTRA.

SDO	Document No.	Version	Status	Issued date	Location	
<b>Release 15</b>						
ARIB	ARIB STD-T120-38.101-3		15.10.0	Published	28.09.2020	<a href="http://www.arib.or.jp/english/html/overview/doc/T120_T23_v2_00/2_T120/ARIB-STD-T120/Rel15/38/A38101-3-fa0.pdf">http://www.arib.or.jp/english/html/overview/doc/T120_T23_v2_00/2_T120/ARIB-STD-T120/Rel15/38/A38101-3-fa0.pdf</a>
ATIS	ATIS.3GPP.38.101-3V15100		15.10.0	Published	08.09.2020	<a href="http://www.atis.org/3gpp-documents/Rel15">http://www.atis.org/3gpp-documents/Rel15</a>
CCSA	CCSA.38.101-3V15100		15.10.0	Published	17.07.2020	<a href="http://www.ccsa.org.cn:9001/portalsFile/downloadOldFile?type=17&amp;oldFileUrl=Rel15/TS%2038.101-">http://www.ccsa.org.cn:9001/portalsFile/downloadOldFile?type=17&amp;oldFileUrl=Rel15/TS%2038.101-</a>
ETSI	ETSI TS 138 101-3		15.10.0	Published	23.07.2020	<a href="http://www.etsi.org/deliver/etsi_ts/138100_138199/13810103/15.10.00_60/ts_13810103v151000p.pdf">http://www.etsi.org/deliver/etsi_ts/138100_138199/13810103/15.10.00_60/ts_13810103v151000p.pdf</a>
TSDSI	TSDSI STD T1.3GPP 38.101-3-15.10.0		15.10.0	Published	06.10.2020	<a href="https://members.tdsi.in/index.php/s/5D5XPXAST4p9b2D">https://members.tdsi.in/index.php/s/5D5XPXAST4p9b2D</a>
TTA	TTAT.3G-38.101-3V15.10.0		15.10.0	Published	11.09.2020	<a href="http://www.tta.or.kr/data/ttasDown.jsp?where=14688&amp;pk_num=TTAT.3G-38.101-3V15.10.0">http://www.tta.or.kr/data/ttasDown.jsp?where=14688&amp;pk_num=TTAT.3G-38.101-3V15.10.0</a>
<b>Release 16</b>						
ARIB	ARIB STD-T120-38.101-3		16.4.0	Published	28.09.2020	<a href="http://www.arib.or.jp/english/html/overview/doc/T120_T23_v2_00/2_T120/ARIB-STD-T120/Rel16/38/A38101-3-g40.pdf">http://www.arib.or.jp/english/html/overview/doc/T120_T23_v2_00/2_T120/ARIB-STD-T120/Rel16/38/A38101-3-g40.pdf</a>
ATIS	ATIS.3GPP.38.101-3V1640		16.4.0	Published	08.09.2020	<a href="http://www.atis.org/3gpp-documents/Rel16">http://www.atis.org/3gpp-documents/Rel16</a>
CCSA	CCSA.38.101-3V1640		16.4.0	Published	17.07.2020	<a href="http://www.ccsa.org.cn:9001/portalsFile/downloadOldFile?type=17&amp;oldFileUrl=Rel16/TS%2038.101-3%20V16.4.0.docx">http://www.ccsa.org.cn:9001/portalsFile/downloadOldFile?type=17&amp;oldFileUrl=Rel16/TS%2038.101-3%20V16.4.0.docx</a>
ETSI	ETSI TS 138 101-3		16.4.0	Published	23.07.2020	<a href="http://www.etsi.org/deliver/etsi_ts/138100_138199/13810103/16.04.00_60/ts_13810103v160400p.pdf">http://www.etsi.org/deliver/etsi_ts/138100_138199/13810103/16.04.00_60/ts_13810103v160400p.pdf</a>
TSDSI	TSDSI STD T1.3GPP 38.101-3-16.4.0 V1.0.0		16.4.0	Published	06.10.2020	<a href="https://members.tdsi.in/index.php/s/QB5aC7Z4WJAetxz">https://members.tdsi.in/index.php/s/QB5aC7Z4WJAetxz</a>
TTA	TTAT.3G-38.101-3V16.4.0		16.4.0	Published	11.09.2020	<a href="http://www.tta.or.kr/data/ttasDown.jsp?where=14688&amp;pk_num=TTAT.3G-38.101-3V16.4.0">http://www.tta.or.kr/data/ttasDown.jsp?where=14688&amp;pk_num=TTAT.3G-38.101-3V16.4.0</a>

### 1.2.1.5.16 TS 38.104

#### NR; Base Station (BS) radio transmission and reception

This document establishes the minimum RF characteristics and minimum performance requirements of NR and NB-IoT operation in NR in-band Base Station (BS).

SDO	Document No.	Version	Status	Issued date	Location	
<b>Release 15</b>						
ARIB	ARIB STD-T120-38.104		15.10.0	Published	28.09.2020	<a href="http://www.arib.or.jp/english/html/overview/doc/T120_T23_v2_00/2_T120/ARIB-STD-T120/Rel15/38/A38104-fa0.pdf">http://www.arib.or.jp/english/html/overview/doc/T120_T23_v2_00/2_T120/ARIB-STD-T120/Rel15/38/A38104-fa0.pdf</a>
ATIS	ATIS.3GPP.38.104V15100		15.10.0	Published	08.09.2020	<a href="http://www.atis.org/3gpp-documents/Rel15">http://www.atis.org/3gpp-documents/Rel15</a>
CCSA	CCSA.38.104V15100		15.10.0	Published	17.07.2020	<a href="http://www.ccsa.org.cn:9001/portalsFile/downloadOldFile?type=17&amp;oldFileUrl=Rel15/TS%2038.104%20V15.10.0.docx">http://www.ccsa.org.cn:9001/portalsFile/downloadOldFile?type=17&amp;oldFileUrl=Rel15/TS%2038.104%20V15.10.0.docx</a>
ETSI	ETSI TS 138 104		15.10.0	Published	23.07.2020	<a href="http://www.etsi.org/deliver/etsi_ts/138100_138199/138104/15.10.00_60/ts_138104v151000p.pdf">http://www.etsi.org/deliver/etsi_ts/138100_138199/138104/15.10.00_60/ts_138104v151000p.pdf</a>
TSDSI	TSDSI STD T1.3GPP 38.104-15.10.0 V1.0.0		15.10.0	Published	06.10.2020	<a href="https://members.tdsi.in/index.php/s/XcpPemcEFqDQq2e">https://members.tdsi.in/index.php/s/XcpPemcEFqDQq2e</a>
TTA	TTAT.3G-38.104V15.10.0		15.10.0	Published	11.09.2020	<a href="http://www.tta.or.kr/data/ttasDown.jsp?where=14688&amp;pk_num=TTAT.3G-38.104V15.10.0">http://www.tta.or.kr/data/ttasDown.jsp?where=14688&amp;pk_num=TTAT.3G-38.104V15.10.0</a>
<b>Release 16</b>						
ARIB	ARIB STD-T120-38.104		16.4.0	Published	28.09.2020	<a href="http://www.arib.or.jp/english/html/overview/doc/T120_T23_v2_00/2_T120/ARIB-STD-T120/Rel16/38/A38104-g40.pdf">http://www.arib.or.jp/english/html/overview/doc/T120_T23_v2_00/2_T120/ARIB-STD-T120/Rel16/38/A38104-g40.pdf</a>
ATIS	ATIS.3GPP.38.104V1640		16.4.0	Published	08.09.2020	<a href="http://www.atis.org/3gpp-documents/Rel16">http://www.atis.org/3gpp-documents/Rel16</a>
CCSA	CCSA.38.104V1640		16.4.0	Published	17.07.2020	<a href="http://www.ccsa.org.cn:9001/portalsFile/downloadOldFile?type=17&amp;oldFileUrl=Rel16/TS%2038.104%20V16.4.0.docx">http://www.ccsa.org.cn:9001/portalsFile/downloadOldFile?type=17&amp;oldFileUrl=Rel16/TS%2038.104%20V16.4.0.docx</a>
ETSI	ETSI TS 138 104		16.4.0	Published	23.07.2020	<a href="http://www.etsi.org/deliver/etsi_ts/138100_138199/138104/16.04.00_60/ts_138104v160400p.pdf">http://www.etsi.org/deliver/etsi_ts/138100_138199/138104/16.04.00_60/ts_138104v160400p.pdf</a>
TSDSI	TSDSI STD T1.3GPP 38.104-16.4.0 V1.0.0		16.4.0	Published	06.10.2020	<a href="https://members.tdsi.in/index.php/s/KgWpay6a6SP8X8n">https://members.tdsi.in/index.php/s/KgWpay6a6SP8X8n</a>
TTA	TTAT.3G-38.104V16.4.0		16.4.0	Published	11.09.2020	<a href="http://www.tta.or.kr/data/ttasDown.jsp?where=14688&amp;pk_num=TTAT.3G-38.104V16.4.0">http://www.tta.or.kr/data/ttasDown.jsp?where=14688&amp;pk_num=TTAT.3G-38.104V16.4.0</a>

**1.2.1.5.17 TS 38.113****NR; Base Station (BS) ElectroMagnetic Compatibility (EMC)**

This document covers the assessment of NR Base Station (BS) and ancillary equipment in respect of Electromagnetic Compatibility (EMC).

This document specifies the applicable test conditions, performance assessment and performance criteria for base stations and associated ancillary equipment in the following categories:

- BS equipped with antenna connectors or *TAB connectors* which are possible to be terminated during EMC testing, meeting the *BS type 1-C* and *BS type 1-H* RF requirements of TS 38.104, with conformance demonstrated by compliance to TS 38.141-1.
- BS not equipped with antenna connectors nor *TAB connectors*, i.e. with antenna elements radiating during the EMC testing, meeting the *BS type 1-O* and *BS type 2-O* RF requirements of TS 38.104, with conformance demonstrated by compliance to TS 38.141-2.

The scope of this document is twofold:

- Requirements, procedures and values of a BS with antenna connectors or *TAB connectors*,
- Requirements, procedures and values of a BS without antenna connectors, nor *TAB connectors*.

The environment classification used in this document refers to the residential, commercial and light industrial environment classification used in IEC 61000-6-1 and IEC 61000-6-3.

The EMC requirements have been selected to ensure an adequate level of compatibility for apparatus at residential, commercial and light industrial environments. The levels, however, do not cover extreme cases which may occur in any location but with low probability of occurrence.

SDO	Document No.	Version	Status	Issued date	Location	
<b>Release 15</b>						
ARIB	ARIB STD-T120-38.113		15.10.0	Published	28.09.2020	<a href="http://www.arib.or.jp/english/html/overview/doc/T120_T23_v2_00/2_T120/ARIB-STD-T120/Rel15/38/A38113-fa0.pdf">http://www.arib.or.jp/english/html/overview/doc/T120_T23_v2_00/2_T120/ARIB-STD-T120/Rel15/38/A38113-fa0.pdf</a>
ATIS	ATIS.3GPP.38.113V15100		15.10.0	Published	08.09.2020	<a href="http://www.atis.org/3gpp-documents/Rel15">http://www.atis.org/3gpp-documents/Rel15</a>
CCSA	CCSA.38.113V15100		15.10.0	Published	17.07.2020	<a href="http://www.ccsa.org.cn:9001/portalsFile/downloadOldFile?type=17&amp;oldFileUrl=Rel15/TS%2038.113%20V15.10.0.docx">http://www.ccsa.org.cn:9001/portalsFile/downloadOldFile?type=17&amp;oldFileUrl=Rel15/TS%2038.113%20V15.10.0.docx</a>
ETSI	ETSI TS 138 113		15.10.0	Published	23.07.2020	<a href="http://www.etsi.org/deliver/etsi_ts/138100_138199/138113/15.10.00_60/ts_138113v1510000p.pdf">http://www.etsi.org/deliver/etsi_ts/138100_138199/138113/15.10.00_60/ts_138113v1510000p.pdf</a>
TSDSI	TSDSI STD T1.3GPP 38.113-15.10.0 V1.0.0		15.10.0	Published	06.10.2020	<a href="https://members.tdsi.in/index.php/s/ZoPrJFoZbFkQHEQ">https://members.tdsi.in/index.php/s/ZoPrJFoZbFkQHEQ</a>
TTA	TTAT.3G-38.113V15.10.0		15.10.0	Published	11.09.2020	<a href="http://www.tta.or.kr/data/ttasDown.jsp?where=14688&amp;pk_num=TTAT.3G-38.113V15.10.0">http://www.tta.or.kr/data/ttasDown.jsp?where=14688&amp;pk_num=TTAT.3G-38.113V15.10.0</a>
<b>Release 16</b>						
ARIB	ARIB STD-T120-38.113		16.0.0	Published	28.09.2020	<a href="http://www.arib.or.jp/english/html/overview/doc/T120_T23_v2_00/2_T120/ARIB-STD-T120/Rel16/38/A38113-g00.pdf">http://www.arib.or.jp/english/html/overview/doc/T120_T23_v2_00/2_T120/ARIB-STD-T120/Rel16/38/A38113-g00.pdf</a>
ATIS	ATIS.3GPP.38.113V1600		16.0.0	Published	08.09.2020	<a href="http://www.atis.org/3gpp-documents/Rel16">http://www.atis.org/3gpp-documents/Rel16</a>
CCSA	CCSA.38.113V1600		16.0.0	Published	17.07.2020	<a href="http://www.ccsa.org.cn:9001/portalsFile/downloadOldFile?type=17&amp;oldFileUrl=Rel16/TS%2038.113%20V16.0.0.docx">http://www.ccsa.org.cn:9001/portalsFile/downloadOldFile?type=17&amp;oldFileUrl=Rel16/TS%2038.113%20V16.0.0.docx</a>
ETSI	ETSI TS 138 113		16.0.0	Published	24.09.2020	<a href="http://www.etsi.org/deliver/etsi_ts/138100_138199/138113/16.00.00_60/ts_138113v160000p.pdf">http://www.etsi.org/deliver/etsi_ts/138100_138199/138113/16.00.00_60/ts_138113v160000p.pdf</a>
TSDSI	TSDSI STD T1.3GPP 38.113-16.0.0 V1.0.0		16.0.0	Published	06.10.2020	<a href="https://members.tdsi.in/index.php/s/bQqnMbAtXbEyyBc">https://members.tdsi.in/index.php/s/bQqnMbAtXbEyyBc</a>
TTA	TTAT.3G-38.113V16.0.0		16.0.0	Published	11.09.2020	<a href="http://www.tta.or.kr/data/ttasDown.jsp?where=14688&amp;pk_num=TTAT.3G-38.113V16.0.0">http://www.tta.or.kr/data/ttasDown.jsp?where=14688&amp;pk_num=TTAT.3G-38.113V16.0.0</a>

**1.2.1.5.18 TS 38.124****NR; Electromagnetic compatibility (EMC) requirements for mobile terminals and ancillary equipment**

This document establishes the essential EMC requirements for "3<sup>rd</sup> generation" digital cellular mobile terminal equipment and ancillary accessories in combination with a 3GPP NR user equipment (UE).

The equipment conforming to the requirements laid out in this document and used in its intended electromagnetic environment in accordance with the manufacturer's instructions

- shall not generate electromagnetic disturbances at a level which may interfere with the intended operation of other equipment;
- has an adequate level of intrinsic immunity to electromagnetic disturbances to operate as intended;

This document specifies the applicable EMC tests, methods of measurement, frequency ranges, applicable limits and minimum performance criteria for all types of NR UE(s) and their accessories. NR base station equipment operating within network infrastructure is outside the scope of this document. However, this document does cover mobile and portable equipment that is intended to be operated in a fixed location while connected to the AC mains. NR base station equipment operating within network infrastructure is covered by the technical specification TS 38.113.

Requirements for the radiated emission from the enclosure port of integral antenna equipment and ancillaries are included in this document. Technical specifications for conducted emissions from the antenna connector are found in the 3GPP specifications for the radio interface, e.g. TS 38.xyz, for the effective use of the radio spectrum.

Requirements for the radiated emissions from the enclosure port and ancillaries cover two cases:

- UE equipment supporting operations in a frequency range for which antenna connectors are available (i.e. for operations in Frequency Range 1 as defined in e.g. TS 38.101-1 for the radio interface)
- UE equipment supporting operations in a frequency range for which only integral antennas may be available (i.e. for operations in Frequency Range 2 as defined in e.g. TS 38.101-2 for the radio interface)

The immunity requirements are selected to ensure an adequate level of compatibility for apparatus in residential, commercial, light industrial and vehicular environments. The levels, however, do not cover extreme cases, which may occur in any location but with low probability of occurrence.

Compliance of radio equipment to the requirements of this document does not signify compliance to any requirement related to the use of the equipment (i.e. licensing requirements).

Compliance to the requirements of this document does not signify compliance to any safety requirement. However, any temporary or permanent unsafe condition caused by EMC is considered as non-compliance.

SDO	Document No.	Version	Status	Issued date	Location
<b>Release 15</b>					
ARIB	ARIB STD-T120-38.124		15.3.0	Published 28.09.2020	<a href="http://www.arib.or.jp/english/html/overview/doc/T120_T23_v2_00/2_T120/ARIB-STD-T120/Rel15/38/A38124-f30.pdf">http://www.arib.or.jp/english/html/overview/doc/T120_T23_v2_00/2_T120/ARIB-STD-T120/Rel15/38/A38124-f30.pdf</a>
ATIS	ATIS.3GPP.38.124V1530		15.3.0	Published 08.09.2020	<a href="http://www.atis.org/3gpp-documents/Rel15">http://www.atis.org/3gpp-documents/Rel15</a>
CCSA	CCSA.38.124V1530		15.3.0	Published 21.07.2020	<a href="http://www.ccsa.org.cn:9001/portalsFile/downloadOldFile?type=17&amp;oldFileUrl=Rel15/TS%2038.124%20V15.3.0.docx">http://www.ccsa.org.cn:9001/portalsFile/downloadOldFile?type=17&amp;oldFileUrl=Rel15/TS%2038.124%20V15.3.0.docx</a>
ETSI	ETSI TS 138 124		15.3.0	Published 14.09.2020	<a href="http://www.etsi.org/deliver/etsi_ts/138100_138199/138124/15.03.00_60/ts_138124v150300p.pdf">http://www.etsi.org/deliver/etsi_ts/138100_138199/138124/15.03.00_60/ts_138124v150300p.pdf</a>



TSDSI	TSDSI STD T1.3GPP 38.124-15.3.0 V1.0.0	15.3.0	Published	06.10.2020	<a href="https://members.tdsi.in/index.php/s/iXn5C8kqB3Jc3tS">https://members.tdsi.in/index.php/s/iXn5C8kqB3Jc3tS</a>
TTA	TTAT.3G-38.124V15.3.0	15.3.0	Published	11.09.2020	<a href="http://www.tta.or.kr/data/ttasDown.jsp?where=14688&amp;pk_num=TTAT.3G-38.124V15.3.0">http://www.tta.or.kr/data/ttasDown.jsp?where=14688&amp;pk_num=TTAT.3G-38.124V15.3.0</a>
<b>Release 16</b>					
ARIB	ARIB STD-T120-38.124	16.0.0	Published	28.09.2020	<a href="http://www.arib.or.jp/english/html/overview/doc/T120_T23_v2_00/2_T120/ARIB-STD-T120/Rel16/38/A38124-g00.pdf">http://www.arib.or.jp/english/html/overview/doc/T120_T23_v2_00/2_T120/ARIB-STD-T120/Rel16/38/A38124-g00.pdf</a>
ATIS	ATIS.3GPP.38.124V1600	16.0.0	Published	08.09.2020	<a href="http://www.atis.org/3gpp-documents/Rel16">http://www.atis.org/3gpp-documents/Rel16</a>
CCSA	CCSA.38.124V1600	16.0.0	Published	21.07.2020	<a href="http://www.ccsa.org.cn:9001/portalsFile/downloadOldFile?type=17&amp;oldFileUrl=Rel16/TS%2038.124%20V16.0.0.docx">http://www.ccsa.org.cn:9001/portalsFile/downloadOldFile?type=17&amp;oldFileUrl=Rel16/TS%2038.124%20V16.0.0.docx</a>
ETSI	ETSI TS 138 124	16.0.0	Published	30.07.2020	<a href="http://www.etsi.org/deliver/etsi_ts/138100_138199/138124/16.00.00_60/ts_138124v160000p.pdf">http://www.etsi.org/deliver/etsi_ts/138100_138199/138124/16.00.00_60/ts_138124v160000p.pdf</a>
TSDSI	TSDSI STD T1.3GPP 38.124-16.0.0 V1.0.0	16.0.0	Published	06.10.2020	<a href="https://members.tdsi.in/index.php/s/Lq2JCmtTPZkDoMn">https://members.tdsi.in/index.php/s/Lq2JCmtTPZkDoMn</a>
TTA	TTAT.3G-38.124V16.0.0	16.0.0	Published	11.09.2020	<a href="http://www.tta.or.kr/data/ttasDown.jsp?where=14688&amp;pk_num=TTAT.3G-38.124V16.0.0">http://www.tta.or.kr/data/ttasDown.jsp?where=14688&amp;pk_num=TTAT.3G-38.124V16.0.0</a>

1.2.1.5.19 TS 38.133

**NR; Requirements for support of radio resource management**

This document specifies requirements for support of Radio Resource Management for the FDD and TDD modes of New Radio (NR). These requirements include requirements on measurements in NR and the UE as well as requirements on node dynamical behaviour and interaction, in terms of delay and response characteristics.

SDO	Document No.	Version	Status	Issued date	Location
<b>Release 15</b>					
ARIB	ARIB STD-T120-38.133	15.10.0	Published	28.09.2020	<a href="http://www.arib.or.jp/english/html/overview/doc/T120_T23_v2_00/2_T120/ARIB-STD-T120/Rel15/38/A38133-fa0.pdf">http://www.arib.or.jp/english/html/overview/doc/T120_T23_v2_00/2_T120/ARIB-STD-T120/Rel15/38/A38133-fa0.pdf</a>
ATIS	ATIS.3GPP.38.133V15100	15.10.0	Published	08.09.2020	<a href="http://www.atis.org/3gpp-documents/Rel15">http://www.atis.org/3gpp-documents/Rel15</a>
CCSA	CCSA.38.133V15100	15.10.0	Published	17.07.2020	<a href="http://www.ccsa.org.cn:9001/portalsFile/downloadOldFile?type=17&amp;oldFileUrl=Rel15/TS%2038.133%20V15.10.0.zip">http://www.ccsa.org.cn:9001/portalsFile/downloadOldFile?type=17&amp;oldFileUrl=Rel15/TS%2038.133%20V15.10.0.zip</a>
ETSI	ETSI TS 138 133	15.10.0	Published	25.09.2020	<a href="http://www.etsi.org/deliver/etsi_ts/138100_138199/138133/15.10.00_60/ts_138133v151000p.pdf">http://www.etsi.org/deliver/etsi_ts/138100_138199/138133/15.10.00_60/ts_138133v151000p.pdf</a>
TSDSI	TSDSI STD T1.3GPP 38.133-15.10.0 V1.0.0	15.10.0	Published	06.10.2020	<a href="https://members.tdsi.in/index.php/s/fK2NHEZd9kgsbdr">https://members.tdsi.in/index.php/s/fK2NHEZd9kgsbdr</a>
TTA	TTAT.3G-38.133V15.10.0	15.10.0	Published	11.09.2020	<a href="http://www.tta.or.kr/data/ttasDown.jsp?where=14688&amp;pk_num=TTAT.3G-38.133V15.10.0">http://www.tta.or.kr/data/ttasDown.jsp?where=14688&amp;pk_num=TTAT.3G-38.133V15.10.0</a>
<b>Release 16</b>					
ARIB	ARIB STD-T120-38.133	16.4.0	Published	28.09.2020	<a href="http://www.arib.or.jp/english/html/overview/doc/T120_T23_v2_00/2_T120/ARIB-STD-T120/Rel16/38/A38133-g40.pdf">http://www.arib.or.jp/english/html/overview/doc/T120_T23_v2_00/2_T120/ARIB-STD-T120/Rel16/38/A38133-g40.pdf</a>
ATIS	ATIS.3GPP.38.133V1640	16.4.0	Published	08.09.2020	<a href="http://www.atis.org/3gpp-documents/Rel16">http://www.atis.org/3gpp-documents/Rel16</a>
CCSA	CCSA.38.133V1640	16.4.0	Published	17.07.2020	<a href="http://www.ccsa.org.cn:9001/portalsFile/downloadOldFile?type=17&amp;oldFileUrl=Rel16/TS%2038.133%20V16.4.0.zip">http://www.ccsa.org.cn:9001/portalsFile/downloadOldFile?type=17&amp;oldFileUrl=Rel16/TS%2038.133%20V16.4.0.zip</a>
ETSI	ETSI TS 138 133	16.4.0	Published	14.08.2020	<a href="http://www.etsi.org/deliver/etsi_ts/138100_138199/138133/16.04.00_60/ts_138133v160400p.pdf">http://www.etsi.org/deliver/etsi_ts/138100_138199/138133/16.04.00_60/ts_138133v160400p.pdf</a>
TSDSI	TSDSI STD T1.3GPP 38.133-16.4.0 V1.0.0	16.4.0	Published	06.10.2020	<a href="https://members.tdsi.in/index.php/s/5AJwoZ8jRcPK4SY">https://members.tdsi.in/index.php/s/5AJwoZ8jRcPK4SY</a>
TTA	TTAT.3G-38.133V16.4.0	16.4.0	Published	11.09.2020	<a href="http://www.tta.or.kr/data/ttasDown.jsp?where=14688&amp;pk_num=TTAT.3G-38.133V16.4.0">http://www.tta.or.kr/data/ttasDown.jsp?where=14688&amp;pk_num=TTAT.3G-38.133V16.4.0</a>

### 1.2.2 Other specifications

Other specifications addressing radio and device testing, but not part of the GCS, are listed in this Section.

Information on system and core network specifications can be found in the 3GPP web site for a complete system perspective. These system and core network specifications address the network, terminal, and service aspects required to provide an integrated mobility solution including aspects such as user services, connectivity, interoperability, mobility and roaming, security, codecs and media, operations and maintenance, charging, etc.

All the 3GPP specifications can be found at the following link: <https://www.3gpp.org/specifications/specification-numbering>. 3GPP specifications are reviewed and updated after each Technical Specification Group Plenary meeting (held every year in March, June, September and December).

#### 1.2.2.1 TS 36.112

##### **Location Measurement Unit (LMU) conformance specification; Network based positioning systems in Evolved Universal Terrestrial Radio Access Network (E-UTRAN)**

This document establishes the conformance requirements for E-UTRAN Location Measurement Units (LMU) operating in the FDD or TDD mode.

#### 1.2.2.2 TS 36.117

##### **Evolved Universal Terrestrial Radio Access (E-UTRA); Relay conformance testing**

This document specifies the Radio Frequency (RF) test methods and conformance requirements for E-UTRA Relay. These have been derived from and are consistent with the E-UTRA Relay specifications defined in TS 36.116.

#### 1.2.2.3 TS 36.141

##### **Evolved Universal Terrestrial Radio Access (E-UTRA); Base Station (BS) conformance testing**

This document specifies the Radio Frequency (RF) test methods and conformance requirements for E-UTRA Base Stations (BS) operating either in the FDD mode (used in paired bands) or the TDD mode (used in unpaired bands). These have been derived from and are consistent with the E-UTRA Base Station (BS) specifications defined in TS 36 104.

#### 1.2.2.4 TS 36.143

##### **Evolved Universal Terrestrial Radio Access (E-UTRA); FDD repeater conformance testing**

This document specifies the Radio Frequency (RF) test methods and conformance requirements for E-UTRA FDD Repeater. These have been derived from and are consistent with the E-UTRA FDD repeater specifications defined in TS 36.106.

#### 1.2.2.5 TS 36.171

##### **Evolved Universal Terrestrial Radio Access (E-UTRA); Requirements for Support of Assisted Global Navigation Satellite System (A-GNSS)**

This document establishes the minimum performance requirements for A-GNSS (including A-GPS) for FDD or TDD mode of E-UTRA for the User Equipment (UE).

### **1.2.2.6 TS 37.141**

#### **E-UTRA, UTRA and GSM/EDGE; Multi-Standard Radio (MSR) Base Station (BS) conformance testing**

This document specifies the Radio Frequency (RF) test methods and conformance requirements for E-UTRA, UTRA and GSM/EDGE Multi-Standard Radio (MSR) Base Station (BS).

### **1.2.2.7 TS 37.144**

#### **User Equipment (UE) and Mobile Station (MS) GSM, UTRA and E-UTRA over the air performance requirements**

This document establishes over the air antenna minimum requirements for user equipment (UE) and mobile station (MS).

Handheld UE requirements are defined for roaming bands for the speech position (beside the head and beside the head and hand) and hand phantom browsing mode position. Laptop mounted equipment requirements are defined for roaming bands for the data transfer position (laptop ground plane phantom). Laptop embedded equipment requirements are defined for roaming bands for the data transfer position (free space).

All bands are potential roaming bands, and the requirements for roaming bands shall therefore be fulfilled for all bands supported by a UE/MS.

Requirements for operating bands are dependent on how the network has been built and are thus operator specific and cannot be specified here. Recommended performance values for operating bands (Annex B) are however included in this specification for information. It should be recognised that the ability to meet the recommended performance values depends on the number of frequency bands supported by the UE/MS.

### **1.2.2.8 TS 37.145-1**

#### **Active Antenna System (AAS) Base Station (BS) conformance testing; Part 1: conducted conformance testing**

This document specifies the Radio Frequency (RF) test methods and conformance requirements for Single RAT E-UTRA, UTRA and Multi-Standard Radio (MSR) UTRA and EUTRA Active Antenna System (AAS) Base Station (BS). These have been derived from, and are consistent with the E-UTRA, UTRA AAS BS specification defined in 3GPP TS 25.104. The technical specification is in two parts: part 1 (this document) covers conducted requirements and part 2 covers radiated requirements.

**1.2.2.9 TS 37.145-2****Active Antenna System (AAS) Base Station (BS) conformance testing; Part 2: radiated conformance testing**

This document specifies the Radio Frequency (RF) test methods and conformance requirements for Single RAT E-UTRA, UTRA and Multi-Standard Radio (MSR) UTRA and EUTRA Active Antenna System (AAS) Base Station (BS). These have been derived from, and are consistent with the E-UTRA, UTRA AAS BS specification defined in 3GPP TS 25.104. The technical specification is in two parts, part 1 covers conducted requirements and part 2 (this document) covers radiated requirements.

**1.2.2.10 TS 37.171****Universal Terrestrial Radio Access (UTRA) and Evolved UTRA (E-UTRA); User Equipment (UE) performance requirements for RAT-Independent Positioning Enhancements**

This document establishes the minimum performance requirements for RAT-Independent Positioning Enhancements (e.g. MBS positioning technology) for FDD or TDD mode of UTRA and E-UTRA for the User Equipment (UE).

**1.2.2.11 TS 38.101-4****NR; User Equipment (UE) radio transmission and reception; Part 4: Performance requirements**

This document establishes the minimum performance requirements for NR User Equipment (UE).

**1.2.2.12 TS 38.141-1****NR; Base Station (BS) conformance testing Part 1: Conducted conformance testing**

This document specifies the Radio Frequency (RF) test methods and conformance requirements for NR Base Station (BS) *Type 1-C* and *Type 1-H*. These have been derived from and are consistent with the conducted requirements for *BS Type 1-C* and *BS Type 1-H* in NR BS specification defined in TS 38.104.

- A *BS type 1-C* only has conducted requirements, so it requires compliance to this specification only.
- A *BS type 1-H* has both conducted and radiated requirements, so it requires compliance to the applicable requirements of this specification and TS 38.141-2.
- *BS type 1-O* and *BS type 2-O* have only radiated requirements, so they require compliance to TS 38.141-2 only.

**1.2.2.13 TS 38.141-2****NR; Base Station (BS) conformance testing Part 2: Radiated conformance testing**

This document specifies the Radio Frequency (RF) test methods and conformance requirements for NR Base Station (BS) *type 1-H*, *BS type 1-O* and *BS type 2-O*. These have been derived from and are consistent with the radiated requirements for *BS type 1-H*, *BS type 1-O* and *BS type 2-O* in BS specification defined in TS 38.104.

- A *BS type 1-C* only has conducted requirements, so it does not require compliance to this specification.
- A *BS type 1-H* has both conducted and radiated requirements, so it requires compliance to the applicable requirements of this specification and TS 38.141-1.

- *BS type 1-O* and *BS type 2-O* have only radiated requirements, so they require compliance to this specification only.

#### **1.2.2.14 TS 38.171**

##### **NR; Requirements for support of Assisted Global Navigation Satellite System (A-GNSS)**

This document establishes the minimum requirements for both UE based and UE assisted FDD or TDD A-GNSS terminals which have NG-RAN access via gNB (in SA NR, NR-DC or NE-DC NR operation mode) or via ng-eNB (in EN-DC operation mode) and which are supporting A-GNSS in 5GS via LPP between UE and LMF as described in TS 38.305.

#### **1.2.2.15 TS 36.508**

##### **Evolved Universal Terrestrial Radio Access (E-UTRA) and Evolved Packet Core (EPC); Common test environments for User Equipment (UE) conformance testing**

This document contains definitions of reference conditions and test signals, default parameters, reference radio bearer configurations used in radio bearer interoperability testing, common radio bearer configurations for other test purposes, common requirements for test equipment and generic set-up procedures for use in conformance tests for the 3<sup>rd</sup> Generation E-UTRAN User Equipment (UE).

#### **1.2.2.16 TS 36.509**

##### **Evolved Universal Terrestrial Radio Access (E-UTRA) and Evolved Packet Core (EPC); Special conformance testing functions for User Equipment (UE)**

This document defines for User Equipment (UE) in E-UTRA FDD or TDD mode those special functions and their activation/deactivation methods that are required in UE for conformance testing purposes.

This document also describes the operation of these special functions for UEs supporting E-UTRA FDD or TDD mode, when operating in UTRA FDD and TDD mode, in GSM/GPRS mode, and in CDMA2000 mode.

#### **1.2.2.17 TS 36.521-1**

##### **Evolved Universal Terrestrial Radio Access (E-UTRA); User Equipment (UE) conformance specification; Radio transmission and reception; Part 1: Conformance testing**

This document specifies the measurement procedures for the conformance test of the user equipment (UE) that contain transmitting characteristics, receiving characteristics and performance requirements as part of the 3G Long Term Evolution (3G LTE). Conformance test for the support of RRM (Radio Resource Management) are specified in TS 36.521-3.

The requirements are listed in different clauses only if the corresponding parameters deviate. More generally, tests are only applicable to those mobiles that are intended to support the appropriate functionality. To indicate the circumstances in which tests apply, this is noted in the “definition and applicability” part of the test.

For example, only Release 8 and later UE declared to support LTE shall be tested for this functionality. In the event that for some tests different conditions apply for different releases, this is indicated within the text of the test itself.

### 1.2.2.18 TS 36.521-2

#### **Evolved Universal Terrestrial Radio Access (E-UTRA); User Equipment (UE) conformance specification; Radio transmission and reception; Part 2: Implementation Conformance Statement (ICS)**

This document provides the ICS proforma for 3G Evolved Universal Terrestrial Radio Access (E-UTRA) User Equipment (UE), in compliance with the relevant requirements, and in accordance with the relevant guidance given in ISO/IEC 9646-1 and ISO/IEC 9646-7.

This document specifies the recommended applicability statement for the test cases included in 3GPP TS 36.521-1 and 3GPP TS 36.521-3. These applicability statements are based on the features implemented in the UE.

Special conformance testing functions can be found in 3GPP TS 36.509 and the common test environments are included in 3GPP TS 36.508.

This document is valid for UE implemented according to 3GPP releases starting from Release 8 up to the Release indicated on the cover page of this document.

### 1.2.2.19 TS 36.521-3

#### **Evolved Universal Terrestrial Radio Access (E-UTRA); User Equipment (UE) conformance specification; Radio transmission and reception; Part 3: Radio Resource Management (RRM) conformance testing**

This document specifies the measurement procedures for the conformance test of the user equipment (UE) that contain requirements for support of RRM (Radio Resource Management) as part of the 3G Long Term Evolution (3G LTE).

The requirements are listed in different clauses only if the corresponding parameters deviate. More generally, tests are only applicable to those mobiles that are intended to support the appropriate functionality. To indicate the circumstances in which tests apply, this is noted in the “test applicability” part of the test.

For example, only Release 8 and later UE declared to support LTE shall be tested for this functionality. In the event that for some tests different conditions apply for different releases, this is indicated within the text of the test itself.

### 1.2.2.20 TS 36.523-1

#### **Evolved Universal Terrestrial Radio Access (E-UTRA) and Evolved Packet Core (EPC); User Equipment (UE) conformance specification; Part 1: Protocol conformance specification**

This document specifies the protocol conformance testing for the 3<sup>rd</sup> Generation E-UTRAN User Equipment (UE).

This is the first part of a multi-part test specification. The following information can be found in this part:

- the overall test structure;
- the test configurations;
- the conformance requirement and reference to the core specifications;
- the test purposes; and
- a brief description of the test procedure, the specific test requirements and short message exchange table.

The following information relevant to testing could be found in accompanying specifications:

- the default setting of the test parameters (TS 36.508);
- the applicability of each test case (TS 36.523-2).

A detailed description of the expected sequence of messages could be found in the 3<sup>rd</sup> part of this test specification.

The Implementation Conformance Statement (ICS) pro-forma could be found in the 2<sup>nd</sup> part of this document.

This document is valid for UE implemented according to 3GPP releases starting from Release 8 up to the Release indicated on the cover page of this document.

#### **1.2.2.21 TS 36.523-2**

##### **Evolved Universal Terrestrial Radio Access (E-UTRA) and Evolved Packet Core (EPC); User Equipment (UE) conformance specification; Part 2: Implementation Conformance Statement (ICS) proforma specification**

This document provides the ICS proforma for 3<sup>rd</sup> Generation User Equipment (UE), in compliance with the relevant EPS (E-UTRA/EPC) requirements, and in accordance with the relevant guidance given in ISO/IEC 9646-1 and ISO/IEC 9646-7.

This document also specifies a recommended applicability statement for the test cases included in TS 36.523-1. These applicability statements are based on the features implemented in the UE.

Special conformance testing functions can be found in TS 36.509 and the common test environments are included in 3GPP TS 36.508.

This document is valid for UE complying with EPS (E-UTRA/EPC) and implemented according to 3GPP releases starting from Release 8 up to the Release indicated on the cover page of this document.

#### **1.2.2.22 TS 36.523-3**

##### **Evolved Universal Terrestrial Radio Access (E-UTRA) and Evolved Packet Core (EPC); User Equipment (UE) conformance specification; Part 3: Test suites**

This document specifies the protocol and signalling conformance testing in TTCN-3 for the 3GPP UE at the UE-E-UTRAN radio interface.

The following TTCN test specification and design considerations can be found in this document:

- the test system architecture;
- the overall test suite structure;
- the test models and ASP definitions;
- the test methods and usage of communication ports definitions;
- the test configurations;
- the design principles and assumptions;
- TTCN styles and conventions;
- the partial PIXIT proforma;
- the test suites.

The Abstract Test Suites designed in the document are based on the test cases specified in prose (3GPP TS 36.523-1). The applicability of the individual test cases is specified in the test ICS proforma specification (3GPP TS 36.523-2).

This document is valid for UE implemented according to 3GPP Rel-9 upwards.

### 1.2.2.23 TS 36.579-1

#### **Mission Critical (MC) services over LTE; Part 1: Common test environment**

This document defines the common test environment required for testing Client and Server implementations for compliance to the Mission Critical Services over LTE protocol requirements defined by 3GPP.

It contains definitions of reference conditions and test signals, default messages and other parameters, generic procedures, and common requirements for test equipment with the goal for facilitating testing in general and test procedures specification in particular. Various parts of its content are referred to from other parts of the Mission Critical Services over LTE protocol conformance testing specification e.g. TS 36.579-2 and TS 36.579-3.

This document does not define the common test environment required for testing the implementation of the underlying LTE protocols, i.e. the LTE bearers used for transport of the Mission Critical Services signalling and media. This is defined in TS 36.508 and referred to from this document whenever needed.

In regard to default messages or other information elements contents, this document refers to content defined in requirements specifications specified by 3GPP or other organisations. In the case of Session Initiation Protocol (SIP) and Session Description Protocol (SDP) information elements this document refers to those specified in TS 34.229-1 and explicitly specifies only those relevant for the purposes of the Mission Critical Services over LTE protocol conformance testing.

In this release of the specification only Mission Critical Push To Talk (MCPTT) Services are considered. Future releases may include other Mission Critical Services.

### 1.2.2.24 TS 36.579-2

#### **Mission Critical (MC) services over LTE; Part 2: Mission Critical Push To Talk (MCPTT) User Equipment (UE) Protocol conformance specification**

This document specifies the protocol conformance testing for testing a MCPTT Client for compliance to the Mission Critical Push To Talk (MCPTT) over LTE protocol requirements defined by 3GPP.

In particular this document contains:

- the overall test structure;
- the test configurations;
- the conformance requirement and reference to the core specifications;
- the test purposes; and
- a brief description of the test procedure, the specific test requirements and short message exchange table.

This document is valid for MCPTT Clients implemented according to 3GPP releases starting from Release 13 up to the Release indicated on the cover page of this document.

The following information relevant to testing specified in this document could be found in accompanying specifications:

- default setting of the test parameters TS 36.579-1;
- Implementation Conformance Statement (ICS) TS 36.579-4 and Implementation eXtra Information for Testing (IXIT) TS 36.579-5;
- the applicability of each test case TS 36.579-4.



The test cases are expected to be executed through the 3GPP radio interface. This document does not specify the protocol conformance testing for the EPS (LTE) bearers which carry the MCPTT data sent or received by the MCPTT Client and which are required to be supported by the UE in which the MCPTT Client is installed. This is defined in TS 36.523-1.

#### **1.2.2.25 TS 36.579-3**

##### **Mission Critical (MC) services over LTE; Part 3: Mission Critical Push To Talk (MCPTT) Server Application conformance specification**

This document specifies the protocol conformance testing for testing a MCPTT Server for compliance to the Mission Critical Push To Talk (MCPTT) over LTE protocol requirements defined by 3GPP. This document addresses only MCPTT Server-Client, and, MCPTT Server-Server communication scenarios. It does not cover e.g. MCPTT Server-EPS, MCPTT Server-SIP Core, etc. scenarios which involve interfaces which implementation may widely vary.

In particular this specification contains:

- the overall test structure;
- the test configurations;
- the conformance requirement and reference to the core specifications;
- the test purposes; and
- a brief description of the test procedure, the specific test requirements and short message exchange table.

This document is valid for MCPTT Servers implemented according to 3GPP releases starting from Release 13 up to the Release indicated on the cover page of this document.

The following information relevant to testing specified in this document could be found in accompanying specifications:

- default setting of the test parameters TS 36.579-1;
- Implementation Conformance Statement (ICS) TS 36.579-4 and Implementation eXtra Information for Testing (IXIT) TS 36.579-5;
- the applicability of each test case TS 36.579-4.

This document does not specify the protocol conformance testing for the EPS (LTE) bearers which carry the MCPTT data sent or received by the MCPTT Server. The specification of such testing is out of the scope of RAN5.

#### **1.2.2.26 TS 36.579-4**

##### **Mission Critical (MC) services over LTE; Part 4: Test Applicability and Implementation Conformance Statement (ICS) proforma specification**

This document provides the Implementation Conformance Statement (ICS) proforma for testing Client or Server implementations for compliance to the Mission Critical Services over LTE protocol requirements defined by 3GPP, and in accordance with the relevant guidance given in ISO/IEC 9646-1 and ISO/IEC 9646-7.

This document specifies the recommended applicability statement for the test cases included in 3GPP TS 36.579-2 and 3GPP TS 36.579-3. These applicability statements are based on the features implemented in the Client or the Server respectively.

This document is valid for Mission Critical Services Servers and Clients implemented according to 3GPP releases starting from Release 13 up to the Release indicated on the cover page of this document.

This document does not specify applicability or ICS for protocol conformance testing for the EPS (LTE) bearers which carry the Mission Critical Services data sent or received by the Client and/or the Server. These are defined in TS 36.523-2.

#### **1.2.2.27 TS 36.579-5**

##### **Mission Critical (MC) services over LTE; Part 5: Abstract test suite (ATS)**

This document specifies the protocol and signalling conformance testing in TTCN-3 for the Mission Critical services over LTE signalling and protocol requirements defined by 3GPP.

The following TTCN test specification and design considerations can be found in this document:

- the test system architecture;
- the overall test suite structure;
- the test models and ASP definitions;
- the test methods and usage of communication ports definitions;
- the test configurations;
- the design principles and assumptions;
- TTCN styles and conventions;
- the partial Implementation eXtra Information for Testing (IXIT) proforma;
- the test suites.

The Abstract Test Suites designed in the document are based on the test cases specified in 3GPP TS 36.579-2. The test cases specified in 3GPP TS 36.579-3 are out of scope of this document.

The applicability of the individual test cases is specified in the test ICS proforma specification in 3GPP TS 36.579-4). Where appropriate the Abstract Test Suites belonging to this specification may refer to other Abstract Test Suites e.g. 3GPP TS 36.523-3 for test requirements related to the EPS (LTE) bearers which carry the Mission Critical services data.

This document is valid for TTCN development for Mission Critical services clients' conformance tests according to 3GPP Releases starting from Release 13 up to the Release indicated on the cover page of this document.

#### **1.2.2.28 TS 36.579-6**

##### **Mission Critical (MC) services over LTE; Part 6: Mission Critical Video (MCVideo) User Equipment (UE) Protocol conformance specification**

This document specifies the protocol conformance testing for testing a MCVideo Client for compliance to the Mission Critical Video (MCVideo) over LTE protocol requirements defined by 3GPP.

In particular this document contains:

- the overall test structure;
- the test configurations;
- the conformance requirement and reference to the core specifications;
- the test purposes; and
- a brief description of the test procedure, the specific test requirements and short message exchange table.

This document is valid for MCVideo Clients implemented according to 3GPP releases starting from Release 13 up to the Release indicated on the cover page of this document.

The following information relevant to testing specified in this document could be found in accompanying specifications:

- default setting of the test parameters TS 36.579-1;
- Implementation Conformance Statement (ICS) TS 36.579-4 and Implementation eXtra Information for Testing (IXIT) TS 36.579-5;
- the applicability of each test case TS 36.579-4.

The test cases are expected to be executed through the 3GPP radio interface. This document does not specify the protocol conformance testing for the EPS (LTE) bearers which carry the MCVideo data sent or received by the MCVideo Client and which are required to be supported by the UE in which the MCVideo Client is installed. This is defined in TS 36.523-1.

#### **1.2.2.29 TS 36.579-7**

##### **Mission Critical (MC) services over LTE; Part 7: Mission Critical Data (MCDData) User Equipment (UE) Protocol conformance specification**

This document specifies the protocol conformance testing for testing a MCDData Client for compliance to the Mission Critical Video (MCDData) over LTE protocol requirements defined by 3GPP.

In particular this document contains:

- the overall test structure;
- the test configurations;
- the conformance requirement and reference to the core specifications;
- the test purposes; and
- a brief description of the test procedure, the specific test requirements and short message exchange table.

This document is valid for MCDData Clients implemented according to 3GPP releases starting from Release 13 up to the Release indicated on the cover page of this document.

The following information relevant to testing specified in this document could be found in accompanying specifications:

- default setting of the test parameters TS 36.579-1;
- Implementation Conformance Statement (ICS) TS 36.579-4 and Implementation eXtra Information for Testing (IXIT) TS 36.579-5;
- the applicability of each test case TS 36.579-4.

The test cases are expected to be executed through the 3GPP radio interface. This document does not specify the protocol conformance testing for the EPS (LTE) bearers which carry the MCDData data sent or received by the MCDData Client and which are required to be supported by the UE in which the MCDData Client is installed. This is defined in TS 36.523-1.

### 1.2.2.30 TS 37.571-1

#### **Universal Terrestrial Radio Access (UTRA) and Evolved UTRA (E-UTRA) and Evolved Packet Core (EPC); User Equipment (UE) conformance specification for UE positioning; Part 1: Conformance test specification**

This document specifies the procedures for the conformance test of the measurement requirements for FDD mode of UTRA and FDD or TDD mode of E-UTRA for the User Equipment (UE) that supports one or more of the defined positioning methods. These positioning methods are for UTRA: Assisted Global Positioning System (A-GPS), Assisted Global Navigation Satellite Systems (A-GNSS) and for E-UTRA: Assisted Global Navigation Satellite System (A-GNSS), Observed Time Difference of Arrival (OTDOA), Enhanced Cell ID (ECID).

Tests are only applicable to those mobiles that are intended to support the appropriate functionality. To indicate the circumstances in which tests apply, this is noted in the “Test applicability” part of the test.

The Implementation Conformance Statement (ICS) pro-forma could be found in the 3<sup>rd</sup> part of this document.

### 1.2.2.31 TS 37.571-2

#### **Universal Terrestrial Radio Access (UTRA) and Evolved UTRA (E-UTRA) and Evolved Packet Core (EPC); User Equipment (UE) conformance specification for UE positioning; Part 2: Protocol conformance**

This document specifies the protocol conformance testing for the 3<sup>rd</sup> Generation UTRAN and E-UTRAN User Equipment (UE) supporting UE positioning.

This is the second part of a multi-part test specification. The following information can be found in this part:

- the overall protocol conformance test structure;
- the protocol conformance test configurations;
- the conformance requirement and reference to the core specifications;
- the test purposes; and
- a brief description of the test procedure, the specific test requirements and short message exchange table.

The Implementation Conformance Statement (ICS) pro-forma could be found in the 3<sup>rd</sup> part of this document.

This document is valid for UE supporting UE positioning implemented according to 3GPP releases starting from Release 99 up to the Release indicated on the cover page of this document.

### 1.2.2.32 TS 37.571-3

#### **Universal Terrestrial Radio Access (UTRA) and Evolved UTRA (E-UTRA) and Evolved Packet Core (EPC); User Equipment (UE) conformance specification for UE positioning; Part 3: Implementation Conformance Statement (ICS)**

This document provides the ICS proforma for 3<sup>rd</sup> Generation UTRAN and E-UTRAN User Equipment (UE) supporting UE positioning, in compliance with the relevant requirements, and in accordance with the relevant guidance given in ISO/IEC 9646-1 and ISO/IEC 9646-7.

This document also specifies a recommended applicability statement for the test cases included in 3GPP TS 37.571-1 and 3GPP TS 37.571-2. These applicability statements are based on the features implemented in the UE.

Special conformance testing functions can be found in 3GPP TS 34.109 for UTRA and 3GPP TS 36.509 for E-UTRA. The common test environments are included in 3GPP TS 34.108 for UTRA and in 3GPP TS 36.508 for E-UTRA.

This document is valid for UE supporting UE positioning implemented according to 3GPP releases starting from Release 99 up to the Release indicated on the cover page of this document.

#### **1.2.2.33 TS 37.571-4**

##### **Universal Terrestrial Radio Access (UTRA) and Evolved UTRA (E-UTRA) and Evolved Packet Core (EPC); User Equipment (UE) conformance specification for UE positioning; Part 4: Test suites**

This document specifies the protocol and signalling conformance testing in TTCN for the UE:

- A-GPS at the UTRA Uu interface;
- LTE positioning at the LTE-Uu interface;
- A-GNSS at the UTRA Uu interface.

The following TTCN test specification and design considerations can be found in this document:

- Test system architecture;
- Test models and ASP definitions;
- Test methods and usage of communication ports definitions;
- Test configurations;
- Design principles and assumptions;
- TTCN styles and conventions;
- Partial PIXIT proforma;
- Test suites in TTCN-2 and TTCN-3;
- The Test Suites designed and implemented in this document are based on the test specifications in prose in 3GPP TS 37.571-2;
- The applicability of the individual test cases is specified in the test ICS proforma specification in 3GPP TS 37.571-3.

#### **1.2.2.34 TS 37.571-5**

##### **Universal Terrestrial Radio Access (UTRA) and Evolved UTRA (E-UTRA) and Evolved Packet Core (EPC); User Equipment (UE) conformance specification for UE positioning; Part 5: Test scenarios and assistance data**

This document specifies the test scenarios and assistance data required for the conformance test for FDD or TDD mode of UTRA and E-UTRA for the User Equipment (UE) that supports one or more of the defined positioning methods. For UTRA these are Assisted Global Positioning System (A-GPS) and Assisted Global Navigation Satellite System (A-GNSS). For E-UTRA these are A-GNSS, Observed Time Difference of Arrival (OTDOA) and Enhanced Cell ID (ECID).

#### **1.2.2.35 TS 38.508-1**

##### **5GS; User Equipment (UE) conformance specification; Part 1: Common test environment**

This document defines the test environment for the 5G System.

This specification covers all aspects, including NG-RAN, 5GC and interworking between 5GS and EPS used for conformance tests of User Equipment (UE).

**1.2.2.36 TS 38.508-2****5GS; User Equipment (UE) conformance specification; Part 2: Common Implementation Conformance Statement (ICS) proforma**

This document provides the Implementation Conformance Statement (ICS) proforma for 5G New Radio (NR) User Equipment (UE), in compliance with the relevant requirements.

Special conformance testing functions can be found in 3GPP TS 38.509 and 3GPP TS 36.509 and the common test environments are included in 3GPP TS 38.508-1 and 3GPP TS 36.508.

This document is valid for UE implemented according to 3GPP Releases starting from Release 15 up to the Release indicated on the cover page of this document.

**1.2.2.37 TS 38.509****5GS; Special conformance testing functions for User Equipment (UE)**

This document defines for User Equipment (UE) those special functions and their activation/deactivation methods that are required in the UE for conformance testing purposes when the UE is connected to the 5G System (5GS) via its radio interface(s).

The document also describes the operation of these special functions when the 5GS capable UEs are connected via a non-5GS system e.g. E-UTRA FDD or TDD system.

Depending on the 5GS system's architecture some relevant for the UE for conformance testing special functions may be defined in TS 36.509.

**1.2.2.38 TS 38.521-1****NR; User Equipment (UE) conformance specification; Radio transmission and reception; Part 1: Range 1 standalone**

This document specifies the measurement procedures for the conformance test of the user equipment (UE) that contain RF characteristics for frequency Range 1 as part of the 5G-NR.

The requirements are listed in different clauses only if the corresponding parameters deviate. More generally, tests are only applicable to those mobiles that are intended to support the appropriate functionality. To indicate the circumstances in which tests apply, this is noted in the "*definition and applicability*" part of the test.

For example, only Release 15 and later UE declared to support 5G-NR shall be tested for this functionality. In the event that for some tests different conditions apply for different releases, this is indicated within the text of the test itself.

**1.2.2.39 TS 38.521-2****NR; User Equipment (UE) conformance specification; Radio transmission and reception; Part 2: Range 2 standalone**

This document specifies the measurement procedures for the conformance test of the user equipment (UE) that contain RF characteristics for frequency Range 2 as part of the 5G-NR.

The requirements are listed in different clauses only if the corresponding parameters deviate. More generally, tests are only applicable to those mobiles that are intended to support the appropriate functionality. To indicate the circumstances in which tests apply, this is noted in the "*definition and applicability*" part of the test.

For example, only Release 15 and later UE declared to support 5G-NR shall be tested for this functionality. In the event that for some tests different conditions apply for different releases, this is indicated within the text of the test itself.

#### **1.2.2.40 TS 38.521-3**

##### **NR; User Equipment (UE) conformance specification; Radio transmission and reception; Part 3: Range 1 and Range 2 Interworking operation with other radios**

This document specifies the measurement procedures for the conformance test of the user equipment (UE) that contain RF characteristics for carrier aggregation between Range 1 and Range 2 and additional requirements due to NR non-standalone (NSA) operation mode with E-UTRA.

The requirements are listed in different clauses only if the corresponding parameters deviate. More generally, tests are only applicable to those mobiles that are intended to support the appropriate functionality. To indicate the circumstances in which tests apply, this is noted in the "*definition and applicability*" part of the test.

For example, only Release 15 and later UE declared to support 5G-NR shall be tested for this functionality. In the event that for some tests different conditions apply for different releases, this is indicated within the text of the test itself.

#### **1.2.2.41 TS 38.521-4**

##### **NR; User Equipment (UE) conformance specification; Radio transmission and reception; Part 4: Performance**

This document specifies the measurement procedures for the conformance test of the user equipment (UE) that contain performance requirements as part of 5G-NR.

The requirements are listed in different clauses only if the corresponding parameters deviate. More generally, tests are only applicable to those mobiles that are intended to support the appropriate functionality. To indicate the circumstances in which tests apply, this is noted in the "*definition and applicability*" part of the test.

For example, only Release 15 and later UE declared to support 5G-NR shall be tested for this functionality. In the event that for some tests different conditions apply for different releases, this is indicated within the text of the test itself.

#### **1.2.2.42 TS 38.522**

##### **NR; User Equipment (UE) conformance specification; Applicability of radio transmission, radio reception and radio resource management test cases**

This document provides the Implementation Conformance Statement (ICS) proforma for 5G New Radio (NR) User Equipment (UE), in compliance with the relevant requirements.

This document specifies the recommended applicability statement for the test cases included in 3GPP TS 38.521-1, TS 38.521-2, TS 38.521-3, TS 38.521-4 and TS 38.533. These applicability statements are based on the features implemented in the UE.

Special conformance testing functions can be found in 3GPP TS 38.509 and the common test environments are included in 3GPP TS 38.508-1. Common implementation conformance statement (ICS) proforma can be found in 3GPP TS 38.508-2.

### 1.2.2.43 TS 38.523-1

#### **5GS; User Equipment (UE) conformance specification; Part 1: Protocol**

This document specifies the protocol conformance testing for the 3GPP UE connecting to the 5G System (5GS) via its radio interface(s).

The following information can be found in this document (first part of a multi-part test specification):

- the overall test structure;
- the test configurations;
- the conformance requirement and references to the core specifications;
- the test purposes; and
- a brief description of the test procedure, the specific test requirements and short message exchange table.

The applicability of the individual test cases is specified in the ICS proforma specification (3GPP TS 38.523-2). The Test Suites are specified in part 3 (3GPP TS 38.523-3).

### 1.2.2.44 TS 38.523-2

#### **5GS; User Equipment (UE) conformance specification; Part 2: Applicability of protocol test cases**

This document provides the applicability of protocol test cases proforma for 5G New Radio (NR) User Equipment (UE), in compliance with the relevant requirements.

This document specifies the recommended applicability statement for the test cases included in 3GPP TS 38.523-1 and 3GPP TS 38.523-3. These applicability statements are based on the features implemented in the UE.

Special conformance testing functions can be found in 3GPP TS 38.509 and 3GPP TS 36.509 and the common test environments are included in 3GPP TS 38.508-1 and 3GPP TS 36.508.

### 1.2.2.45 TS 38.523-3

#### **5GS; User Equipment (UE) conformance specification; Part 3: Protocol Test Suites**

This document specifies the protocol and signalling conformance testing in TTCN-3 for the 3GPP UE connecting to the 5G System (5GS) via its radio interface(s).

The following TTCN test specification and design considerations can be found in this document:

- the test system architecture;
- the overall test suite structure;
- the test models and ASP definitions;
- the test methods and usage of communication ports definitions;
- the test configurations;
- the design principles and assumptions;
- TTCN styles and conventions;
- the partial PIXIT proforma;
- the test suites.

The Test Suites designed in the document are based on the test cases specified in prose in 3GPP TS 38.523-1. The applicability of the individual test cases is specified in 3GPP TS 38.523-2.



#### 1.2.2.46 TS 38.533

##### **NR; User Equipment (UE) conformance specification; Radio Resource Management (RRM)**

This document specifies the measurement procedures for the conformance test of the user equipment (UE) that contain requirements for support of RRM (Radio Resource Management) as part of the 5G New Radio (5G-NR). This document covers NR Range 1, NR Range 2 and Interworking.

The requirements are listed in different clauses only if the corresponding parameters deviate. More generally, tests are only applicable to those mobiles that are intended to support the appropriate functionality. To indicate the circumstances in which tests apply, this is noted in the “*test applicability*” part of the test.

#### 1.2.2.47 TS 34.229-1

##### **Internet Protocol (IP) multimedia call control protocol based on Session Initiation Protocol (SIP) and Session Description Protocol (SDP); User Equipment (UE) conformance specification; Part 1: Protocol conformance specification**

This document specifies the protocol conformance testing for the User Equipment (UE) supporting the Internet Protocol (IP) multimedia call control protocol based on Session Initiation Protocol (SIP) and Session Description Protocol (SDP).

This is the first part of a multi-part test specification. The following information can be found in this part:

- the overall test structure;
- the test configurations;
- the conformance requirement and reference to the core specifications;
- the test purposes; and
- a brief description of the test procedure, the specific test requirements and short message exchange table.

The following information relevant to testing can be found in accompanying specifications:

- the applicability of each test case.

#### 1.2.2.48 TS 34.229-2

##### **Internet Protocol (IP) multimedia call control protocol based on Session Initiation Protocol (SIP) and Session Description Protocol (SDP); User Equipment (UE) conformance specification; Part 2: Implementation Conformance Statement (ICS) specification**

This document provides the Implementation Conformance Statement (ICS) proforma for 3<sup>rd</sup> Generation User Equipment (UE) supporting the Internet Protocol (IP) multimedia call control protocol based on Session Initiation Protocol (SIP) and Session Description Protocol (SDP), in compliance with the relevant requirements, and in accordance with the relevant guidance given in ISO/IEC 9646-7 and ETSI ETS 300 406.

#### 1.2.2.49 TS 34.229-3

##### **Internet Protocol (IP) multimedia call control protocol based on Session Initiation Protocol (SIP) and Session Description Protocol (SDP); User Equipment (UE) conformance specification; Part 3: Abstract test suite (ATS)**

This document specifies the protocol conformance testing in TTCN for the 3GPP User Equipment (UE) at the Gm interface.

This document is the 3<sup>rd</sup> part of a multi-part test specification, 3GPP TS 34.229. The following TTCN test specification and design considerations can be found in this document

- the overall test suite structure;
- the testing architecture;
- the test methods and PCO definitions;
- the test configurations;
- the design principles, assumptions, and used interfaces to the TTCN tester (System Simulator);
- TTCN styles and conventions;
- the partial PIXIT proforma;
- the TTCN files for the mentioned protocols tests.

The Abstract Test Suites designed in the document are based on the test cases specified in prose (3GPP TS 34.229-1).

#### **1.2.2.50 TS 34.229-5**

##### **Internet Protocol (IP) multimedia call control protocol based on Session Initiation Protocol (SIP) and Session Description Protocol (SDP); User Equipment (UE) conformance specification; Part 5: Protocol conformance specification using 5G System (5GS)**

This document specifies the protocol conformance testing for the User Equipment (UE) supporting the Internet Protocol (IP) multimedia call control protocol based on Session Initiation Protocol (SIP) and Session Description Protocol (SDP) when using the 5G System (5GS).

This is the fifth part of a multi-part test specification. The following information can be found in this part:

- the overall test structure;
- the test configurations;
- the conformance requirement and reference to the core specifications;
- the test purposes; and
- the test procedure.

The following information relevant to testing can be found in accompanying specifications:

- Implementation Conformance Statement (ICS) pro-forma and the applicability of each test case.

## Annex 2

### Specification of the 3GPP 5G – RIT<sup>1</sup> radio interface technology

#### TABLE OF CONTENTS

	<i>Page</i>
<a href="#">Background</a>	129
<a href="#">2.1 Overview of the radio interface technology</a>	130
<a href="#">2.2 Detailed specification of the radio interface technology</a>	152

#### **Background**

IMT-2020 is a system with global development activity and the IMT-2020 terrestrial radio interface specifications identified in this Recommendation have been developed by the ITU in collaboration with the GCS Proponents and the Transposing Organizations. It is noted from Document IMT-2020/20, that:

- The GCS Proponent must be one of the RIT/SRIT Proponents for the relevant technology, and must have legal authority to grant to ITU-R the relevant legal usage rights to the relevant specifications provided within a GCS corresponding to a technology in Recommendation ITU-R M.[IMT-2020.SPECS].
- A Transposing Organization must have been authorized by the relevant GCS Proponent to produce transposed standards for a particular technology and must have the relevant legal usage rights.

It is further noted that GCS Proponents and Transposing Organizations must also qualify appropriately under the auspices of Resolution ITU-R 9 and the ITU-R “Guidelines for the contribution of material of other organizations to the work of the Study Groups and for inviting other organizations to take part in the study of specific matters (Resolution ITU-R 9)”.

The ITU has provided the global and overall framework and requirements and has developed the Global Core Specification jointly with the GCS Proponent. The detailed standardization has been undertaken within the recognized Transposing Organizations which operate in concert with the GCS Proponent. This Recommendation therefore makes extensive use of references to externally developed specifications.

This approach was considered to be the most appropriate solution to enable completion of this Recommendation within the aggressive schedules set by the ITU and by the needs of administrations, operators and manufacturers.

This Recommendation has therefore been constructed to take full advantage of this method of work and to allow the global standardization timescales to be maintained. The main body of this Recommendation has been developed by the ITU, with each Annex containing references pointing to the location of the more detailed information.

This Annex 2 contains the detailed information developed by the ITU and “3GPP” (the GCS Proponent) and ARIB, ATIS, CCSA, ETSI, TSDSI, TTA, TTC (the Transposing Organizations).

Such use of referencing enables timely completion and update of the high-level elements of this Recommendation, with change control procedures, transposition, and public enquiry procedures

---

<sup>1</sup> Developed by 3GPP Proponent as “5G, Release 15 and beyond – NR RIT”.

being undertaken within the external organization. This information has generally been adopted unchanged, recognizing the need to minimize duplication of work, and the need to facilitate and support an ongoing maintenance and update process.

This general agreement, noting that the detailed information of the radio interface should to a large extent be achieved by reference to the work of external organizations, highlights not only the ITU's significant role as a catalyst in stimulating, coordinating and facilitating the development of advanced telecommunications technologies, but also its forward-looking and flexible approach to the development of this and other telecommunications standards for the 21<sup>st</sup> century.

A more detailed understanding of the process for the development of the first release of this Recommendation may be found in Document IMT-2020/20.

## **2.1 Overview of the radio interface technology**

The IMT-2020 specifications known as 5G have been developed by 3GPP and encompass NR Releases 15 and beyond.

New Radio (NR) is designed for operation in IMT spectrum and fulfils all technical performance requirements in all five selected test environments: Indoor Hotspot – enhanced Mobile Broadband (eMBB), Dense Urban – eMBB, Rural – eMBB, Urban Macro – Ultra Reliable Low Latency Communication (URLLC) and Urban Macro – massive Machine Type Communication (mMTC).

Also, NR fulfils the service and the spectrum requirements. NR utilizes the frequency bands below 6 GHz identified for International Mobile Telecommunication (IMT) in the ITU Radio Regulations. In addition, NR can also utilize the frequency bands above 6 GHz, i.e. above 24.25 GHz, identified for IMT in the ITU Radio Regulations.

The complete set of standards for the terrestrial radio interface of IMT-2020 identified as 3GPP 5G – RIT. NR – includes not only the key characteristics of IMT-2020 but also the additional capabilities of NR both of which are continuing to be enhanced.

The 3GPP 5G System (5GS) also includes specifications for its non-radio aspects, such as the core network elements (the Enhanced Packet Core (EPC) Network and 5G Core (5GC) Network), security, codecs, network management, etc. These non-radio specifications are not included in the so-called "Global Core Specifications (GCS)" of IMT-2020.

### **2.1.1 Overview of the system aspects of the NR RIT**

The NR RIT represents the releases 15 and 16 of NR, which uses either 1) FDD operation and therefore is applicable for operation with paired spectrum or 2) TDD operation and therefore is applicable for operation with unpaired spectrum. Channel bandwidths up to 400 MHz and Carrier Aggregation over 16 component carriers are supported, yielding peak data rates up to roughly 140 Gbit/s in the downlink and 65 Gbit/s in the uplink.

#### **2.1.1.1 Overall architecture**

The NG Radio Access Network (NG-RAN) includes NG-RAN nodes that support multiple radio access (e.g. NR, MR-DC of NR and E-UTRA<sup>2</sup>, etc). The RIT considers the gNB as an NG-RAN node providing NR user plane and control plane protocol terminations towards the UE and connected via the NG interface to the 5GC, and the ng-eNB as NG-RAN node for Multi-Radio Dual Connectivity only.

---

<sup>2</sup> In 3GPP terminology, the term Evolved-UMTS Terrestrial Radio Access (E-UTRA) is also used to signify the LTE radio interface.

NG-RAN nodes are interconnected by means of the interface named Xn. The gNBs and ng-eNBs are also connected by means of the NG interfaces to the 5GC, more specifically to the Access and Mobility Management Function (AMF) by means of the NG-C interface and to the User Plane Function (UPF) by means of the NG-U interface.

The NG-RAN architecture is illustrated in Fig. 28 below.

FIGURE 28  
Overall Architecture

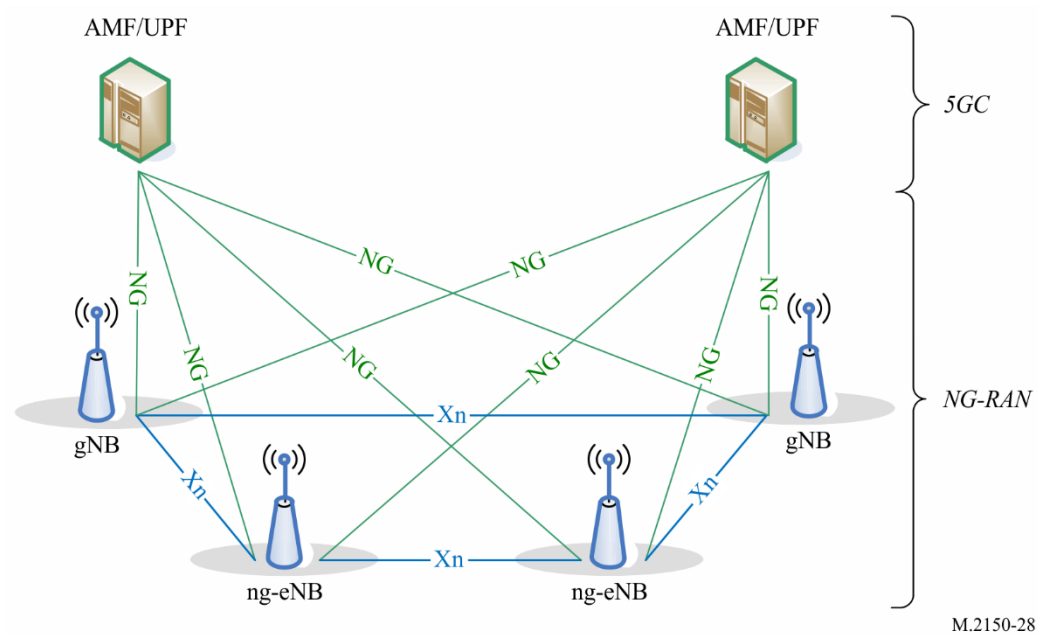

### 2.1.1.2 Radio protocol architecture

#### 2.1.1.2.1 User Plane (UP)

Figure 29 shows the protocol stack for the User Plane, where Service Data Adaptation Protocol (SDAP), PDCP, RLC and MAC sublayers (terminated in gNB on the network side) perform the functions listed in § 2.1.1.5.

FIGURE 29  
User Plane protocol stack

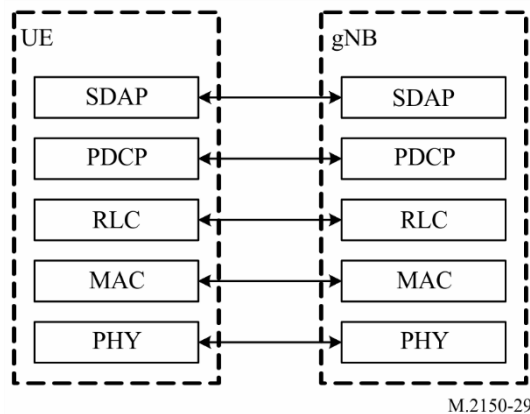

### 2.1.1.2.2 Control Plane

Figure 30 below shows the protocol stack for the control plane, where:

- PDCP, RLC and MAC sublayers (terminated in gNB on the network side) perform the functions listed in § 2.1.1.5;
- RRC (terminated in gNB on the network side) performs the functions listed in § 2.1.1.6;
- Non-Access Stratum (NAS) control protocol (terminated in AMF on the network side) performs the functions listed in 3GPP TS 23.501, for instance: authentication, mobility management, security control.

FIGURE 30  
Control Plane protocol stack

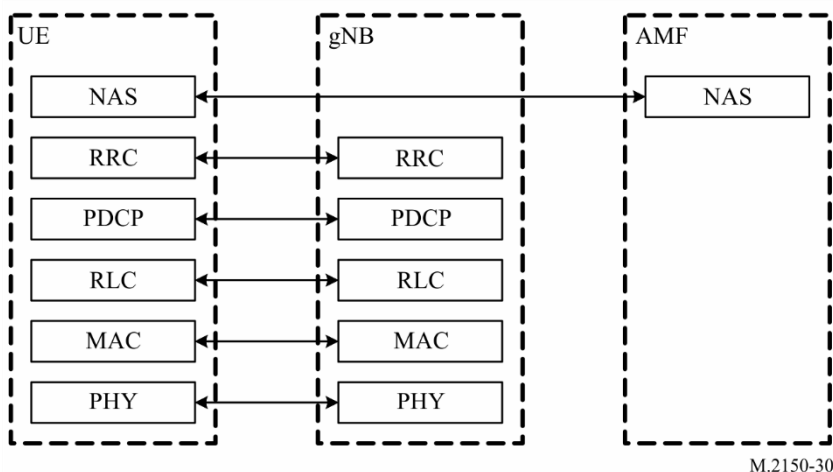

M.2150-30

### 2.1.1.2.3 Integrated access and Backhaul (IAB) architecture

From NR Rel-16, Integrated access and backhaul (IAB) enables wireless relaying in NG-RAN. The relaying node, referred to as the IAB-node, supports access and backhauling via NR. The terminating node of NR backhauling on the network side is referred to as the IAB-donor, which represents a gNB with additional functionality to support IAB. Backhauling can occur via a single or via multiple hops. The IAB architecture is shown in Fig. 31.

FIGURE 31

IAB architecture; a) IAB-node using SA mode with 5GCN; b) IAB-node using EN-DC

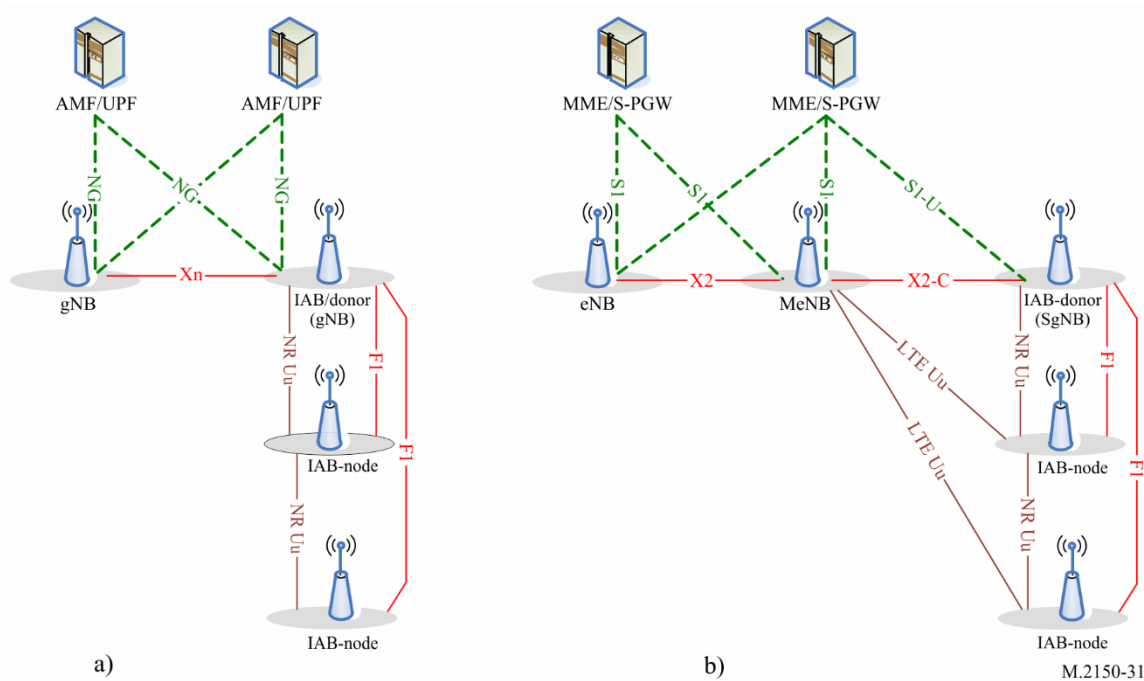

**2.1.1.3 Multi-Radio Dual Connectivity (MR-DC)**

NG-RAN supports Multi-Radio Dual Connectivity (MR-DC) operation whereby a UE in the RRC\_CONNECTED state is configured to utilise radio resources provided by two distinct schedulers, located in two different NG-RAN nodes connected via a non-ideal backhaul, one providing NR access and the other one providing either E-UTRA or NR access. In MR-DC, one NG-RAN node acts as a Master Node (MN) and another NG-RAN node acts as a Secondary Node (SN).

NR may also be used as part of MR-DC configuration when combined with E-UTRA, within either an NG-RAN or E-UTRAN. For the case of NR-NR Dual Connectivity (NR-DC), a UE is connected to one gNB that acts as a MN and another gNB that acts as a SN. The master gNB is connected to the 5GC via the NG interface and to the secondary gNB via the Xn interface. The secondary gNB might also be connected to the 5GC via the NG-U interface.

**2.1.1.4 Physical layer**

**2.1.1.4.1 Waveform, numerology and frame structure**

The downlink transmission waveform is conventional OFDM using a cyclic prefix. The uplink transmission waveform is conventional OFDM using a cyclic prefix with a transform precoding function performing DFT spreading that can be disabled or enabled.

FIGURE 32

Transmitter block diagram for CP-OFDM with optional DFT-spreading

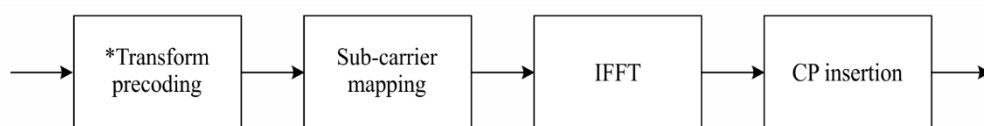

*\*Optionally present in UL, not present in DL*

The numerology is based on exponentially scalable sub-carrier spacing  $\Delta f = 2^\mu \times 15$  kHz with  $\mu=\{0,1,3,4\}$  for Primary Synchronization Signal (PSS), Secondary Synchronization Signal (SSS) and PBCH and  $\mu=\{0,1,2,3\}$  for other channels. Normal Cyclic Prefix (CP) is supported for all sub-carrier spacings, Extended CP is supported for  $\mu=2$ . 12 consecutive sub-carriers form a Physical Resource Block (PRB). Up to 275 PRBs are supported on a carrier.

TABLE 2-1

## Supported transmission numerologies

$\mu$	$\Delta f = 2^\mu \times 15$ [kHz]	Cyclic prefix	Supported for data	Supported for synch
0	15	Normal	Yes	Yes
1	30	Normal	Yes	Yes
2	60	Normal, Extended	Yes	No
3	120	Normal	Yes	Yes
4	240	Normal	No	Yes

The UE may be configured with one or more bandwidth parts on a given component carrier, of which only one can be active at a time, as described in § 2.1.1.5.10. The active bandwidth part defines the UE's operating bandwidth within the cell's operating bandwidth. For initial access, and until the UE's configuration in a cell is received, the initial bandwidth part detected from system information is used.

Downlink and uplink transmissions are organized into frames of 10 ms duration, consisting of ten 1 ms subframes. Each frame is divided into two equally sized half-frames of five subframes. The slot duration is 14 symbols with Normal CP and 12 symbols with Extended CP, and scales in time as a function sub-carrier spacing in use so that there is always an integral number of slots in a subframe.

Timing Advance (TA) is used to adjust the uplink frame timing relative to the downlink frame timing.

FIGURE 33

## Uplink-downlink timing relation

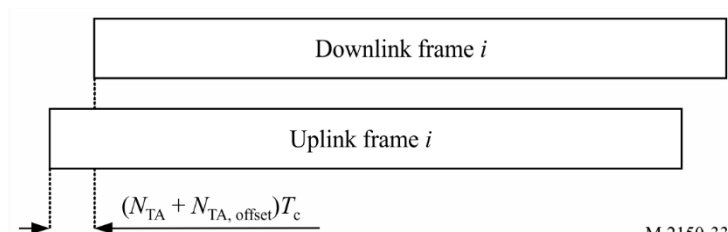

M.2150-33

Operation on both paired and unpaired spectrum is supported.

## 2.1.1.4.2 Downlink

## 2.1.1.4.2.1 Downlink transmission scheme

A closed loop Demodulation Reference Signal (DMRS) based spatial multiplexing is supported for Physical Downlink Shared Channel (PDSCH). Up to 8 and 12 orthogonal DL DMRS ports are supported for type 1 and type 2 DMRS respectively. Up to 8 orthogonal DL DMRS ports per UE are supported for Single-User MIMO (SU-MIMO) and up to 4 orthogonal DL DMRS ports per UE



are supported for Multi-User MIMO (MU-MIMO). The number of SU-MIMO code words is one for 1-4 layers transmissions and two for 5-8 layers transmissions.

The DMRS and corresponding PDSCH are transmitted using the same precoding matrix and the UE does not need to know the precoding matrix to demodulate the transmission. The transmitter may use different precoder matrix for different parts of the transmission bandwidth, resulting in frequency selective precoding. The UE may also assume that the same precoding matrix is used across a set of Physical Resource Blocks (PRBs) denoted Precoding Resource Block Group (PRG).

Transmission durations from 2 to 14 symbols in a slot with a single PDSCH is supported.

Aggregation of multiple slots with Transport Block (TB) repetition is supported.

From Rel-16, enhancements for DL/UL MIMO are introduced, including enhancements on multi-Transmission Reception Points (TRPs) or multi-panel transmission improving reliability and robustness with both ideal and non-ideal backhaul.

#### **2.1.1.4.2.2 Physical-layer processing for physical downlink shared channel**

The downlink physical-layer processing of transport channels consists of the following steps:

- TB CRC attachment;
- code block segmentation and code block CRC attachment;
- channel coding: Low Density Parity Check (LDPC) coding;
- physical-layer hybrid-ARQ processing;
- rate matching;
- scrambling;
- modulation: QPSK, 16QAM, 64QAM and 256QAM;
- layer mapping;
- mapping to assigned resources and antenna ports.

The UE may assume that at least one symbol with demodulation reference signal is present on each layer in which PDSCH is transmitted to a UE, and up to three additional DMRS symbols can be configured by higher layers.

Phase tracking RS may be transmitted on additional symbols to aid receiver phase tracking.

#### **2.1.1.4.2.3 Physical downlink control channels**

The Physical Downlink Control Channel (PDCCH) can be used to schedule DL transmissions on PDSCH and UL transmissions on PUSCH, where the Downlink Control Information (DCI) on PDCCH includes:

- downlink assignments containing at least modulation and coding format, resource allocation, and HARQ information related to DL-SCH;
- uplink scheduling grants containing at least modulation and coding format, resource allocation, and HARQ information related to UL-SCH.

In addition to scheduling, PDCCH can be used for

- activation and deactivation of configured PUSCH transmission with configured grant;
- activation and deactivation of PDSCH semi-persistent transmission;
- notifying one or more UEs of the slot format;
- notifying one or more UEs of the PRB(s) and OFDM symbol(s) where the UE may assume no transmission is intended for the UE;

- transmission of Transmit Power Control (TPC) commands for PUCCH and PUSCH;
- transmission of one or more TPC commands for Sounding Reference Signal (SRS) transmissions by one or more UEs;
- Switching a UE's active bandwidth part;
- Initiating a random access procedure.

A UE monitors a set of PDCCH candidates in the configured monitoring occasions in one or more configured Control Resource Sets (CORESETs) according to the corresponding search space configurations.

A CORESET consists of a set of PRBs with a time duration of 1 to 3 OFDM symbols. The resource units Resource Element Groups (REGs) and Control Channel Elements (CCEs) are defined within a CORESET with each CCE consisting a set of REGs. Control channels are formed by aggregation of CCEs. Different code rates for the control channels are realized by aggregating different number of CCEs. Interleaved and non-interleaved CCE-to-REG mapping are supported in a CORESET.

Polar coding is used for PDCCH.

Each resource element group carrying PDCCH carries its own DMRS.

QPSK modulation is used for PDCCH.

#### **2.1.1.4.2.4 Synchronization signal and PBCH block**

The Synchronization Signal and PBCH block (SSB) consists of primary and secondary synchronization signals (PSS, SSS), each occupying 1 symbol and 127 subcarriers, and PBCH spanning across three OFDM symbols and 240 subcarriers, but on one symbol leaving an unused part in the middle for SSS as show in Fig. 34. The possible time locations of SSBs within a half-frame are determined by sub-carrier spacing, and the periodicity of the half-frames where SSBs are transmitted is configured by the network. During a half-frame, different SSBs may be transmitted in different spatial directions (i.e. using different beams, spanning the coverage area of a cell).

Within the frequency span of a carrier, multiple SSBs can be transmitted. The Physical Cell Identifiers (PCIs) of SSBs transmitted in different frequency locations do not have to be unique, i.e. different SSBs in the frequency domain can have different PCIs. However, when an SSB is associated with a Remaining Minimum System Information (RMSI), the SSB corresponds to an individual cell, which has a unique NR Cell Global Identifier (NCGI). Such an SSB is referred to as a Cell-Defining SSB (CD-SSB). A PCell is always associated to a CD-SSB located on the synchronization raster.

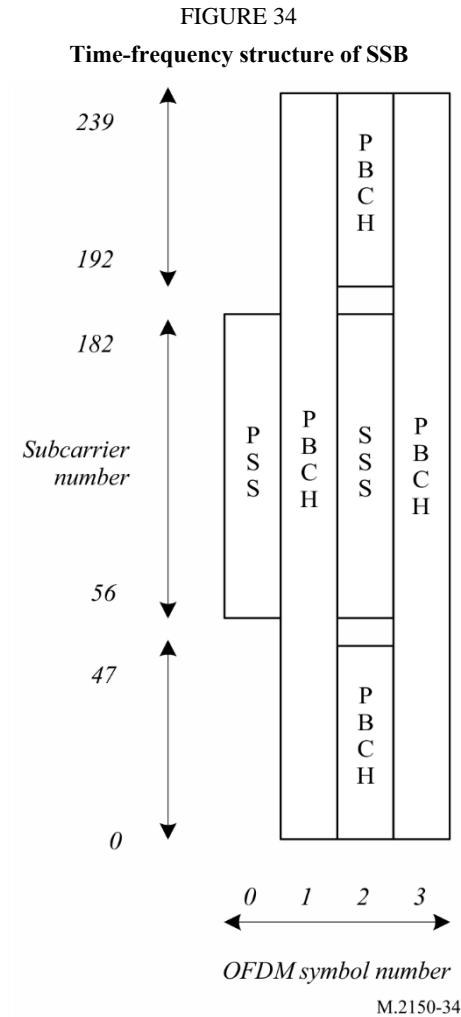

Polar coding is used for the PBCH.

The UE may assume a band-specific sub-carrier spacing for the SSB unless a network has configured the UE to assume a different sub-carrier spacing.

PBCH symbols carry their own frequency-multiplexed DMRS.

QPSK modulation is used for PBCH.

#### 2.1.1.4.2.5 Physical layer procedures

##### 2.1.1.4.2.5.1 Link adaptation

Link adaptation (Adaptive Modulation and Coding (AMC)) with various modulation schemes and channel coding rates is applied to the PDSCH. The same coding and modulation is applied to all groups of resource blocks belonging to the same L2 Protocol Data Unit (PDU) scheduled for one user within one transmission duration and within a MIMO codeword.

For channel state estimation purposes, the UE may be configured to measure CSI-RS and estimate the downlink channel state based on the CSI-RS measurements. The UE reports the estimated channel state back to the gNB to be used in link adaptation.

##### 2.1.1.4.2.5.2 Power control

Downlink power control can be used.

### 2.1.1.4.2.5.3 Cell search

Cell search is the procedure by which a UE acquires time and frequency synchronization with a cell and detects the Cell ID of that cell. NR cell search is based on the primary and secondary synchronization signals, and PBCH DMRS, located on the synchronization raster.

### 2.1.1.4.2.5.4 HARQ

Asynchronous Incremental Redundancy Hybrid ARQ is supported. The gNB provides the UE with the HARQ-ACK feedback timing either dynamically in the DCI or semi-statically in an RRC configuration.

The UE may be configured to receive code block group-based transmissions where retransmissions may be scheduled to carry only a sub-set of all the code blocks of a TB.

### 2.1.1.4.2.5.5 Reception of SIB1

The Master Information Block (MIB) on the PBCH provides the UE with parameters (e.g. CORESET#0 configuration) for monitoring of the PDCCH for scheduling PDSCH that carries the System Information Block 1 (SIB1). The PBCH may also indicate that there is no associated SIB1, in which case the UE may be pointed to another frequency from where to search for an SSB that is associated with a SIB1 as well as a frequency range where the UE may assume no SSB associated with SIB1 is present. The indicated frequency range is confined within a contiguous spectrum allocation of the same operator in which SSB is detected.

## 2.1.1.4.3 Uplink

### 2.1.1.4.3.1 Uplink transmission scheme

Two transmission schemes are supported for PUSCH: codebook-based transmission and non-codebook-based transmission.

For codebook-based transmission, the gNB provides the UE with a transmit precoding matrix indication in the DCI. The UE uses the indication to select the PUSCH transmit precoder from the codebook. For non-codebook-based transmission, the UE determines its PUSCH precoder based on the wideband SRS Resource Indicator (SRI) field from the DCI.

A closed loop DMRS based spatial multiplexing is supported for PUSCH. For a given UE, up to four-layer transmissions are supported. The number of codewords is one. When transform precoding is used, only a single MIMO layer transmission is supported.

Transmission durations from 1 to 14 symbols in a slot with a single PUSCH is supported.

Aggregation of multiple slots with TB repetition is supported.

Two types of frequency hopping are supported, intra-slot frequency hopping, and in case of slot aggregation, inter-slot frequency hopping.

The PUSCH may be scheduled with DCI on the PDCCH, or a semi-static configured grant may be provided over RRC, where two types of operation are supported:

- The first PUSCH is triggered with a DCI, with subsequent PUSCH transmissions following the RRC configuration and scheduling received on the DCI, or
- The PUSCH is triggered by data arrival in the UE's transmit buffer and the PUSCH transmissions follow the RRC configuration.

### 2.1.1.4.3.2 Physical-layer processing for physical uplink shared channel

The uplink physical-layer processing of transport channels consists of the following steps:

- Transport Block CRC attachment;

- code block segmentation and Code Block CRC attachment;
- channel coding: LDPC coding;
- physical-layer HARQ processing;
- rate matching;
- scrambling;
- modulation:  $\pi/2$  BPSK (with transform precoding only), QPSK, 16QAM, 64QAM and 256QAM;
- layer mapping, transform precoding (enabled/disabled by configuration), and pre-coding;
- mapping to assigned resources and antenna ports.

The UE transmits at least one symbol with Demodulation Reference Signal on each layer on each frequency hop in which the PUSCH is transmitted, and up to three additional DMRS symbols can be configured by higher layers.

Phase tracking RS may be transmitted on additional symbols to aid receiver phase tracking.

#### 2.1.1.4.3.3 Physical uplink control channel

The physical uplink control channel (PUCCH) carries the Uplink Control Information (UCI) from the UE to the gNB. Five formats of PUCCH exist, depending on the duration of PUCCH and the UCI payload size.

- format #0: short PUCCH of 1 or 2 symbols with small UCI payloads of up to two bits with UE multiplexing capacity of up to 6 UEs with 1-bit payload in the same PRB;
- format #1: long PUCCH of 4 to 14 symbols with small UCI payloads of up to two bits with UE multiplexing capacity of up to 84 UEs without frequency hopping and 36 UEs with frequency hopping in the same PRB;
- format #2: short PUCCH of 1 or 2 symbols with large UCI payloads of more than two bits with no UE multiplexing capability in the same PRBs;
- format #3: long PUCCH of 4 to 14 symbols with large UCI payloads with no UE multiplexing capability in the same PRBs;
- format #4: long PUCCH of 4 to 14 symbols with moderate UCI payloads with multiplexing capacity of up to 4 UEs in the same PRBs.

The short PUCCH format of up to two UCI bits is based on sequence selection, while the short PUCCH format of more than two UCI bits frequency-multiplexes the UCI and the DMRS. The long PUCCH formats time-multiplex the UCI and DMRS. Frequency hopping is supported for long PUCCH formats and for short PUCCH formats of duration of two symbols. Long PUCCH formats can be repeated over multiple slots.

UCI multiplexing in the PUSCH is supported when UCI and PUSCH transmissions coincide in time, either due to transmission of a UL-SCH transport block or due to triggering of A-CSI transmission without UL-SCH transport block:

- UCI carrying HARQ-ACK feedback with 1 or 2 bits is multiplexed by puncturing the PUSCH;
- In all other cases the UCI is multiplexed by rate matching the PUSCH.

UCI consists of the following information:

- CSI;
- ACK/NAK;
- Scheduling request.

QPSK and  $\pi/2$  BPSK modulation can be used for long PUCCH with more than 2 bits of information, QPSK is used for a short PUCCH with more than 2 bits of information and BPSK and QPSK modulation can be used for a long PUCCH with up to 2 information bits.

Transform precoding is applied to a long PUCCH.

Channel coding used for uplink control information is described in Table 2-2.

TABLE 2-2

**Channel coding for uplink control information**

<b>Uplink Control Information size including CRC, if present</b>	<b>Channel code</b>
1	Repetition code
2	Simplex code
3-11	Reed Muller code
>11	Polar code

#### **2.1.1.4.3.4 Random access**

Random access preamble sequences of two different lengths are supported. The long sequence length 839 is applied with subcarrier spacings of 1.25 and 5 kHz, and the short sequence length 139 is applied with subcarrier spacings of 15, 30, 60 and 120 kHz. Long sequences support unrestricted sets and restricted sets of Type A and Type B, while short sequences support unrestricted sets only.

Multiple PRACH preamble formats are defined with one or more PRACH OFDM symbols, and different cyclic prefixes and guard times. The PRACH preamble configuration to use is provided to the UE in the system information.

The UE calculates the PRACH transmit power for the retransmission of the preamble based on the most recent estimated pathloss and the power ramping counter value.

The system information provides information for the UE to determine the association between the SSB and the RACH resources. The Reference Signal Received Power (RSRP) threshold for SSB selection for RACH resource association is configurable by the network.

#### **2.1.1.4.3.5 Physical layer procedures**

##### **2.1.1.4.3.5.1 Link adaptation**

Four types of link adaptation are supported as follows:

- adaptive transmission bandwidth;
- adaptive transmission duration;
- transmission power control;
- adaptive modulation and channel coding rate.

For channel state estimation purposes, the UE may be configured to transmit SRS that the gNB may use to estimate the uplink channel state, and then use the estimate in link adaptation.

##### **2.1.1.4.3.5.2 Uplink power control**

The gNB determines the desired uplink transmit power and provides uplink transmit power control commands to the UE. The UE uses the provided uplink transmit power control commands to adjust its transmit power.

### 2.1.1.4.3.5.3 Uplink timing control

The gNB determines the desired Timing Advance setting and provides that to the UE. The UE uses the provided TA to determine its uplink transmit timing relative to the UE's observed downlink receive timing.

### 2.1.1.4.3.5.4 HARQ

Asynchronous Incremental Redundancy Hybrid ARQ is supported. The gNB schedules each uplink transmission and retransmission using the uplink grant on the DCI.

The UE may be configured to transmit code block group-based transmissions where retransmissions may be scheduled to carry only a sub-set of all the code blocks of a transport block.

### 2.1.1.4.4 Carrier Aggregation (CA)

In Carrier Aggregation (CA), two or more Component Carriers (CCs) are aggregated. A UE may simultaneously receive or transmit on one or multiple CCs depending on its capabilities:

- a UE with single timing advance capability for CA can simultaneously receive and/or transmit on multiple CCs corresponding to multiple serving cells sharing the same timing advance (multiple serving cells grouped in one Timing Advance Group (TAG));
- a UE with multiple timing advance capability for CA can simultaneously receive and/or transmit on multiple CCs corresponding to multiple serving cells with different timing advances (multiple serving cells grouped in multiple TAGs). NG-RAN ensures that each TAG contains at least one serving cell;
- a non-CA capable UE can receive on a single CC and transmit on a single CC corresponding to one serving cell only (one serving cell in one TAG).

CA is supported for both contiguous and non-contiguous CCs. When CA is deployed, frame timing and System Frame Number (SFN) are aligned across cells that can be aggregated. The maximum number of configured CCs for a UE is 16 for DL and 16 for UL. From Rel-16, cells with unaligned frame boundary can also be aggregated.

### 2.1.1.4.5 Supplementary uplink

In conjunction with a UL/DL carrier pair (FDD band) or a bidirectional carrier (TDD band), a UE may be configured with additional, Supplementary Uplink (SUL). SUL differs from the aggregated uplink in that the UE may be scheduled to transmit either on the supplementary uplink or on the uplink of the carrier being supplemented, but not on both at the same time.

### 2.1.1.4.6 Transport channels

The physical layer offers information transfer services to MAC and higher layers. The physical layer transport services are described by how and with what characteristics data are transferred over the radio interface.

Downlink transport channel types are:

- 1 Broadcast Channel (BCH) characterised by:
  - fixed, pre-defined transport format;
  - requirement to be broadcast in the entire coverage area of the cell, either as a single message or by beamforming different BCH instances.
- 2 Downlink Shared Channel (DL-SCH) characterised by:
  - support for HARQ;
  - support for dynamic link adaptation by varying the modulation, coding and transmit power;

- possibility to be broadcast in the entire cell;
  - possibility to use beamforming;
  - support for both dynamic and semi-static resource allocation;
  - support for UE discontinuous reception (DRX) to enable UE power saving.
- 3 Paging Channel (PCH) characterised by:
- support for UE discontinuous reception (DRX) to enable UE power saving (DRX cycle is indicated by the network to the UE);
  - requirement to be broadcast in the entire coverage area of the cell, either as a single message or by beamforming different PCH instances;
  - mapped to physical resources which can be used dynamically also for traffic/other control channels.

Uplink transport channel types are:

- 1 Uplink Shared Channel (UL-SCH) characterised by:
- possibility to use beamforming;
  - support for dynamic link adaptation by varying the transmit power and potentially modulation and coding;
  - support for HARQ;
  - support for both dynamic and semi-static resource allocation.
- 2 Random Access Channel(s) (RACH) characterised by:
- limited control information;
  - collision risk.

Sidelink transport channel types are:

- 1 Sidelink broadcast channel (SL-BCH) characterised by:
- pre-defined transport format.
- 2 Sidelink shared channel (SL-SCH) characterised by:
- support for unicast transmission, groupcast transmission and broadcast transmission;
  - support for both UE autonomous resource selection and scheduled resource allocation by NG-RAN;
  - support for both dynamic and semi-static resource allocation when UE is allocated resources by the NG-RAN;
  - support for HARQ;
  - support for dynamic link adaptation by varying the transmit power, modulation and coding.

### 2.1.1.5 Layer 2

#### 2.1.1.5.1 Overview

The layer 2 of NR is split into the following sublayers: Medium Access Control (MAC), Radio Link Control (RLC), Packet Data Convergence Protocol (PDCP) and Service Data Adaptation Protocol (SDAP). Figures 35 and 36 depict the Layer 2 architecture for downlink and uplink, where:

- the physical layer offers to the MAC sublayer transport channels;
- the MAC sublayer offers to the RLC sublayer logical channels;
- the RLC sublayer offers to the PDCP sublayer RLC channels;
- the PDCP sublayer offers to the SDAP sublayer radio bearers;



- the SDAP sublayer offers to 5GC QoS flows;
- control channels (BCCH, PCCH are not depicted for clarity).

NOTE – The gNB may not be able to guarantee that a L2 buffer overflow will never occur. If such overflow occurs, the UE may discard packets from the L2 buffer.

FIGURE 35  
Downlink layer 2 structure

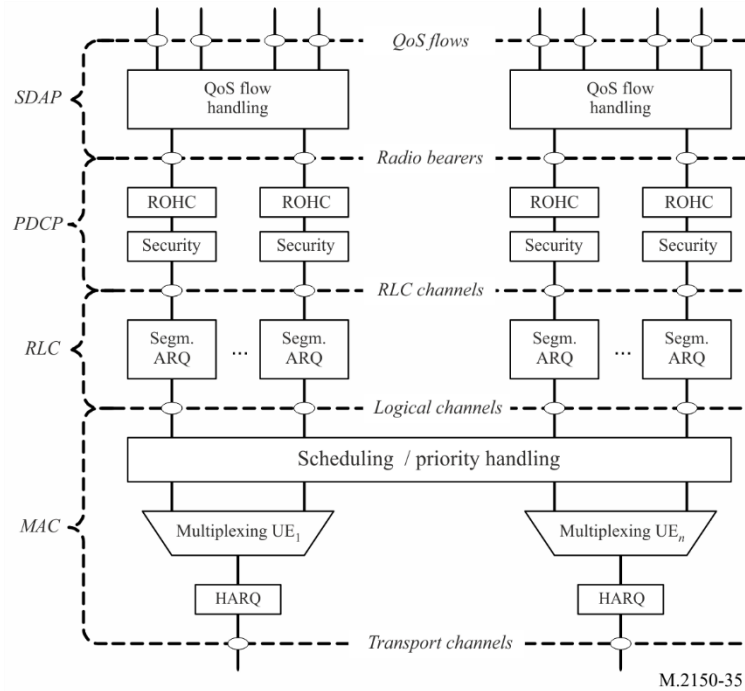
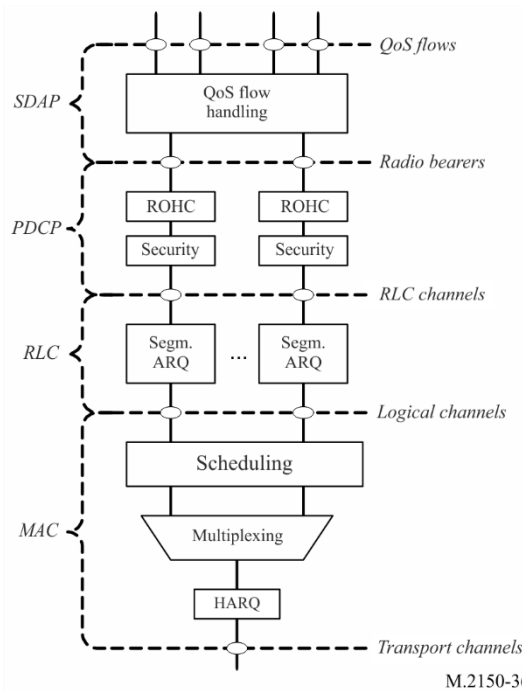

FIGURE 36  
Uplink layer 2 structure



Similar to LTE, Radio bearers are categorized into two groups: DRBs for UP data and SRBs for CP data.

### 2.1.1.5.2 MAC Sublayer

#### 2.1.1.5.2.1 Services and Functions

The main services and functions of the MAC sublayer are:

- mapping between logical channels and transport channels;
- multiplexing/demultiplexing of MAC SDUs belonging to one or different logical channels into/from transport blocks (TB) delivered to/from the physical layer on transport channels;
- scheduling information reporting;
- error correction through HARQ (one HARQ entity per cell in case of CA);
- priority handling between UEs by means of dynamic scheduling;
- priority handling between logical channels of one UE by means of logical channel prioritisation;
- padding.

A single MAC entity can support multiple numerologies, transmission timings and cells. Mapping restrictions in logical channel prioritisation control which numerology(ies), cell(s), and transmission timing(s) a logical channel can use.

#### 2.1.1.5.2.2 Logical channels

Different kinds of data transfer services as offered by MAC. Each logical channel type is defined by what type of information is transferred. Logical channels are classified into two groups: control channels and traffic channels. Control channels are used for the transfer of control plane information only:

- Broadcast Control Channel (BCCH): a downlink channel for broadcasting system control information.
- Paging Control Channel (PCCH): a downlink channel that carries paging messages.
- Common Control Channel (CCCH): channel for transmitting control information between UEs and network. This channel is used for UEs having no RRC connection with the network.
- Dedicated Control Channel (DCCH): a point-to-point bi-directional channel that transmits dedicated control information between a UE and the network. Used by UEs having an RRC connection.

Traffic channels are used for the transfer of user plane information only:

- Dedicated Traffic Channel (DTCH): point-to-point channel, dedicated to one UE, for the transfer of user information. A DTCH can exist in both uplink and downlink.

#### 2.1.1.5.2.3 Mapping to Transport Channels

In Downlink, the following connections between logical channels and transport channels exist:

- BCCH can be mapped to BCH;
- BCCH can be mapped to DL-SCH;
- PCCH can be mapped to PCH;
- CCCH can be mapped to DL-SCH;
- DCCH can be mapped to DL-SCH;

- DTCH can be mapped to DL-SCH.

In Uplink, the following connections between logical channels and transport channels exist:

- CCCH can be mapped to UL-SCH;
- DCCH can be mapped to UL-SCH;
- DTCH can be mapped to UL-SCH.

#### **2.1.1.5.2.4 HARQ**

The HARQ functionality ensures delivery between peer entities at Layer 1. A single HARQ process supports one TB when the physical layer is not configured for downlink/uplink spatial multiplexing, and when the physical layer is configured for downlink/uplink spatial multiplexing, a single HARQ process supports one or multiple TBs.

#### **2.1.1.5.3 RLC sublayer**

##### **2.1.1.5.3.1 Transmission modes**

The RLC sublayer supports three transmission modes:

- Transparent Mode (TM);
- Unacknowledged Mode (UM);
- Acknowledged Mode (AM).

The RLC configuration is per logical channel with no dependency on numerologies and/or transmission durations, and ARQ can operate on any of the numerologies and/or transmission durations the logical channel is configured with.

For SRB0, paging and broadcast system information, TM mode is used. For other SRBs AM mode is used. For DRBs, either UM or AM mode are used.

##### **2.1.1.5.3.2 Services and functions**

The main services and functions of the RLC sublayer depend on the transmission mode and include:

- transfer of upper layer PDUs;
- sequence numbering independent of the one in PDCP (UM and AM);
- error Correction through ARQ (AM only);
- segmentation (AM and UM) and re-segmentation (AM only) of RLC SDUs;
- reassembly of SDU (AM and UM);
- duplicate Detection (AM only);
- RLC SDU discard (AM and UM);
- RLC re-establishment;
- protocol error detection (AM only).

##### **2.1.1.5.3.3 ARQ**

The ARQ within the RLC sublayer has the following characteristics:

- ARQ retransmits RLC SDUs or RLC SDU segments based on RLC status reports;
- polling for RLC status report is used when needed by RLC;
- the RLC receiver can also trigger a RLC status report after detecting a missing RLC SDU or RLC SDU segment.

#### 2.1.1.5.4 PDCP sublayer

##### 2.1.1.5.4.1 Services and functions

The main services and functions of the PDCP sublayer are:

- transfer of data (user plane or control plane);
- maintenance of PDCP SNs;
- header compression and decompression using the ROHC protocol;
- ciphering and deciphering;
- integrity protection and integrity verification;
- timer based SDU discard;
- for split bearers, routing;
- duplication;
- reordering and in-order delivery;
- out-of-order delivery;
- duplicate discarding.

Since PDCP does not allow COUNT to wrap around in DL and UL, it is up to the network to prevent this from happening (e.g. by using a release and add of the corresponding radio bearer or a full configuration).

##### 2.1.1.5.5 SDAP Sublayer

The main services and functions of SDAP are:

- mapping between a QoS flow and a data radio bearer;
- marking QoS Flow ID (QFI) in both DL and UL packets.

A single protocol entity of SDAP is configured for each individual PDU session.

##### 2.1.1.5.6 L2 data flow

An example of the Layer 2 Data Flow is depicted on Fig. 37, where a transport block is generated by MAC by concatenating two RLC PDUs from  $RB_x$  and one RLC PDU from  $RB_y$ . The two RLC PDUs from  $RB_x$  each corresponds to one IP packet ( $n$  and  $n+1$ ) while the RLC PDU from  $RB_y$  is a segment of an IP packet ( $m$ ).

FIGURE 37  
Data flow example

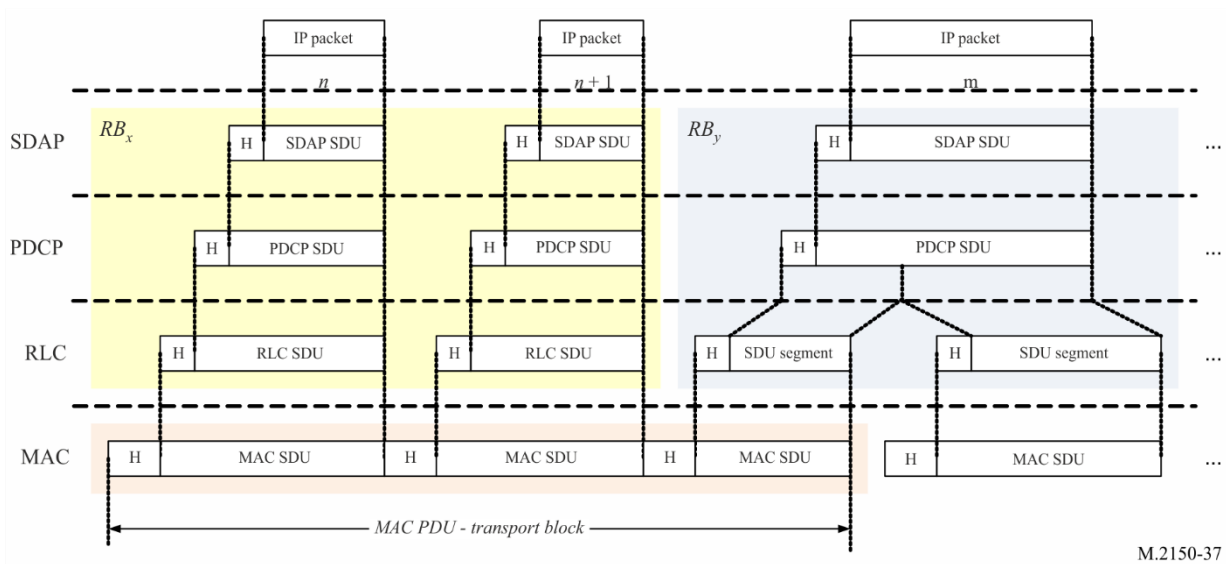

M.2150-37

NOTE – H depicts the headers and subheaders.

### 2.1.1.5.7 Carrier Aggregation (CA)

With CA, the multi-carrier nature of the physical layer is only exposed to the MAC layer for which one HARQ entity is required per serving cell as depicted on Figs 38 and 39 below:

- In both uplink and downlink, there is one independent HARQ entity per serving cell and one transport block is generated per assignment/grant per serving cell in the absence of spatial multiplexing. Each transport block and its potential HARQ retransmissions are mapped to a single serving cell.

FIGURE 38

### Layer 2 structure for DL with CA configured

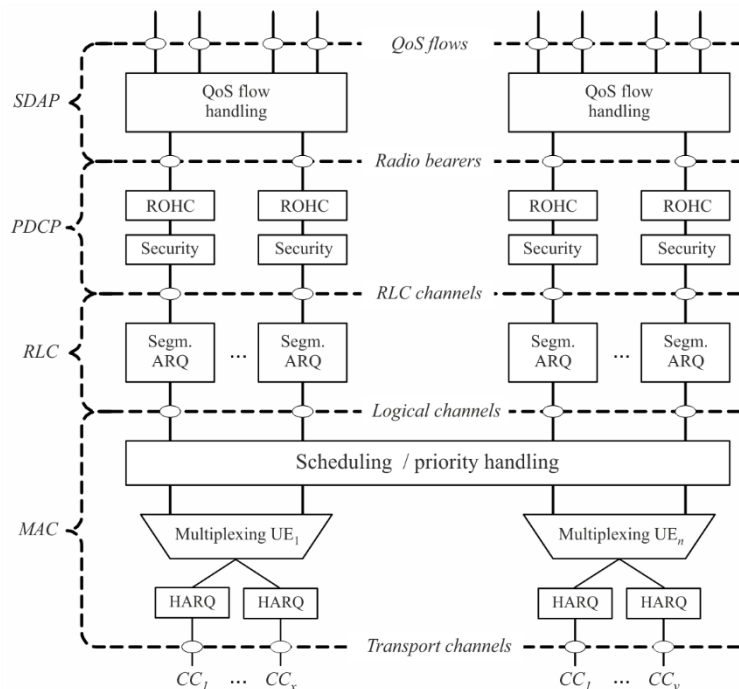

M.2150-38

FIGURE 39

## Layer 2 structure for UL with CA configured

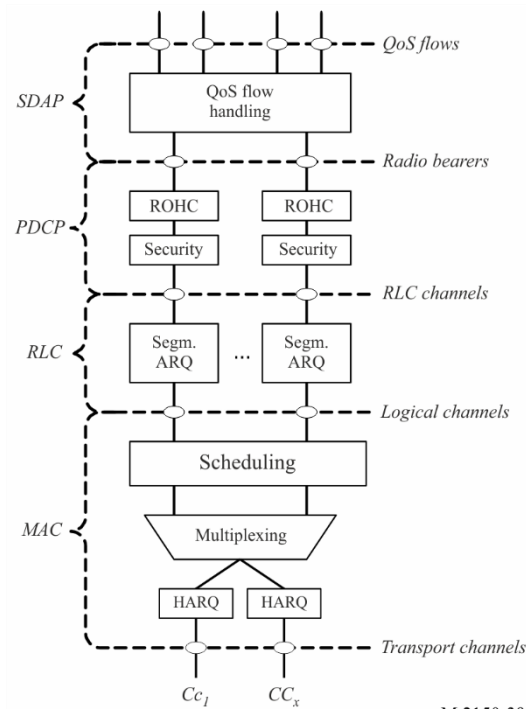

M.2150-39

**2.1.1.5.8 Dual Connectivity (DC)**

When the UE is configured with a SCG, the UE is configured with two MAC entities: one MAC entity for the MCG and one MAC entity for the SCG.

**2.1.1.5.9 Supplementary uplink**

In case of Supplementary Uplink (SUL), the UE is configured with two ULs for one DL of the same cell, and uplink transmissions on those two ULs are controlled by the network to avoid overlapping PUSCH/PUCCH transmissions in time. Overlapping transmissions on PUSCH are avoided through scheduling while overlapping transmissions on PUCCH are avoided through configuration (PUCCH can only be configured for only one of the two ULs of the cell). In addition, initial access is supported in each of the uplink.

**2.1.1.5.10 Bandwidth Adaptation (BA)**

With Bandwidth Adaptation, the receive and transmit bandwidth of a UE need not be as large as the bandwidth of the cell and can be adjusted: the width can be ordered to change (e.g. to shrink during period of low activity to save power); the location can move in the frequency domain (e.g. to increase scheduling flexibility); and the subcarrier spacing can be ordered to change (e.g. to allow different services). A subset of the total cell bandwidth of a cell is referred to as a Bandwidth Part (BWP) and BA is achieved by configuring the UE with BWP(s) and telling the UE which of the configured BWPs is currently the active one.

Figure 40 below describes a scenario where three different BWPs are configured:

- BWP<sub>1</sub> with a width of 40 MHz and subcarrier spacing of 15 kHz;
- BWP<sub>2</sub> with a width of 10 MHz and subcarrier spacing of 15 kHz;
- BWP<sub>3</sub> with a width of 20 MHz and subcarrier spacing of 60 kHz.

FIGURE 40  
BA example

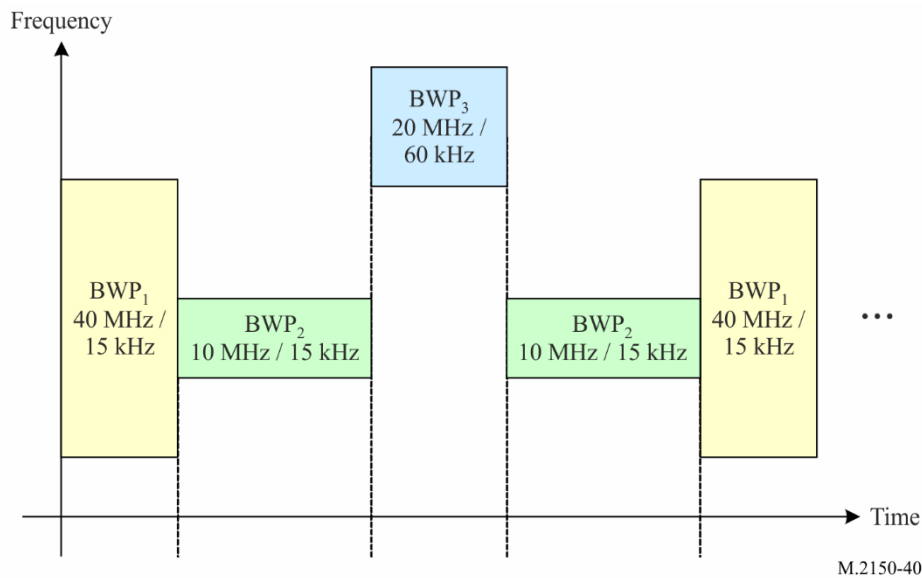

## 2.1.1.6 Radio Resources Control (RRC)

### 2.1.1.6.1 Services and functions

The main services and functions of the RRC sublayer include:

- broadcast of System Information related to AS and NAS;
- paging initiated by 5GC or NG-RAN;
- establishment, maintenance and release of an RRC connection between the UE and NG-RAN including:
  - addition, modification and release of Carrier Aggregation;
  - addition, modification and release of Dual Connectivity in NR or between E-UTRA and NR;
- security functions including key management;
- establishment, configuration, maintenance and release of Signalling Radio Bearers (SRBs) and Data Radio Bearers (DRBs);
- Mobility functions including:
  - handover and context transfer;
  - UE cell selection and reselection and control of cell selection and reselection;
  - inter-RAT mobility;
- QoS management functions;
- UE measurement reporting and control of the reporting;
- detection of and recovery from radio link failure;
- NAS message transfer to/from NAS from/to UE.

In order to enhance mobility robustness and performance, additional NR mobility enhancements are introduced in 3GPP Rel-16. User data interruption is reduced during handover to 0 ms by dual-active-protocol-stack handover. In addition, the robustness during handover is improved by a conditional handover.

### 2.1.1.6.2 Protocol states

RRC supports the following states which can be characterised as follows:

- RRC\_IDLE:
  - Public Land Mobile Network (PLMN) selection;
  - broadcast of system information;
  - cell re-selection mobility;
  - paging for mobile terminated data is initiated by 5GC;
  - DRX for core network paging configured by NAS.
- RRC\_INACTIVE:
  - PLMN selection;
  - broadcast of system information;
  - cell re-selection mobility;
  - paging is initiated by NG-RAN (RAN paging);
  - RAN-based notification area (RNA) is managed by NG-RAN;
  - DRX for RAN paging configured by NG-RAN;
  - 5GC - NG-RAN connection (both CP and UP) is established for UE;
  - the UE AS context is stored in NG-RAN and the UE;
  - NG-RAN knows the RNA which the UE belongs to.
- RRC\_CONNECTED:
  - 5GC - NG-RAN connection (both CP and UP) is established for UE;
  - the UE AS context is stored in NG-RAN and the UE;
  - NG-RAN knows the cell which the UE belongs to;
  - transfer of unicast data to/from the UE;
  - network controlled mobility including measurements.

### 2.1.2 Support of verticals

The NR RIT supports a diverse set of mobile broadband (eMBB) services and other so-called “verticals”, including URLLC, Industrial IoT, Automotive/V2X, Private Networks (NPN), and others. NR RIT supports in-band coexistence with NB-IoT and eMTC.

For optimal support of specific verticals, the NR RIT has been designed, or enhanced, with certain key features, or set of features. Taking few verticals as examples, a short summary of relevant NR RIT capabilities is provided below.

#### 2.1.2.1 Ultra-Reliable and Low Latency Communications (URLLC) and Industrial IoT (IIoT)

For support of Ultra-Reliable and Low Latency Communications services, some of the main features supported by the NR RIT are:

- Logical Channel Priority (LCP) restrictions
- Packet duplication with DC or CA
- New QCI table for block error rate  $10^{-5}$
- Physical layer short transmission time interval (TTI).



From Rel-16 onwards, URLLC and Industrial IoT use cases are further facilitated by NR PDCP duplication enhancements:

- Prioritization/multiplexing enhancements
- NR Time Sensitive Communications (TSC) related enhancements, e.g. Ethernet header compression, and
- Precise time information delivery.

### 2.1.2.2 Vehicle-to-everything (V2X)

From Rel-16, NR RIT includes support of Vehicle-to-everything (V2X), mainly by means of NR sidelink communication over the PC5 interface, partly leveraging what was defined for E-UTRA V2X sidelink communication.

The architecture supporting the PC5 interface is illustrated in Fig. 41, for the overall NG-RAN (showing both NR and EUTRA). Sidelink transmission and reception over the PC5 interface are supported when the UE is inside NG-RAN coverage, irrespective of which RRC state the UE is in, and when the UE is outside NG-RAN coverage.

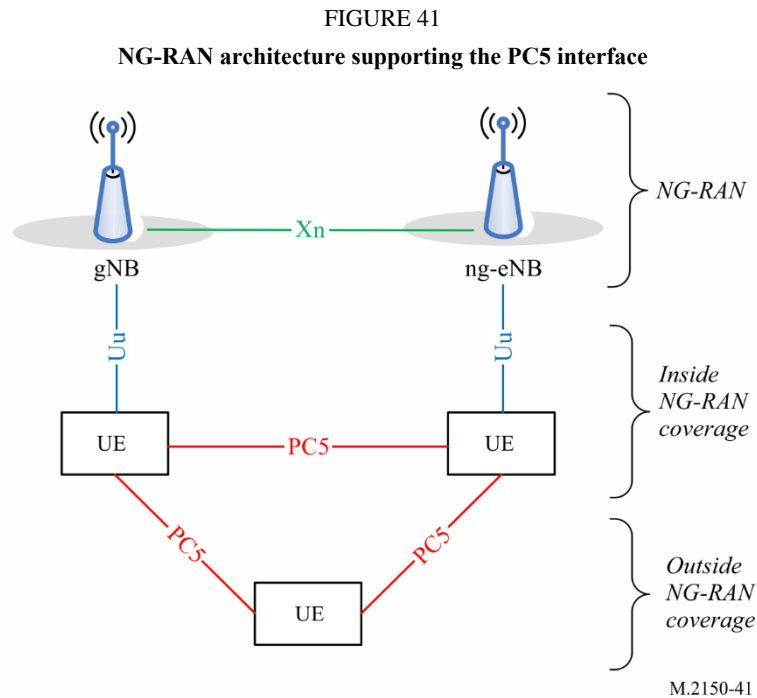

NR sidelink communication can support three types of transmission modes (in the access stratum):

- Unicast, characterized by:
  - support of at least one PC5-RRC connection between peer UEs;
  - transmission and reception of control information and user traffic between peer UEs in sidelink;
  - support of sidelink feedback, for HARQ and link adaptation;
  - support of RLC AM;
  - Detection of radio link failure for the PC5 unicast connection.
- Groupcast, characterized by:
  - transmission and reception of user traffic among UEs belonging to a group in sidelink;

- support of distance/range based sidelink HARQ feedback;
  - support of connection-less groupcast, and application managed groupcast.
- Broadcast, characterized by transmission and reception of broadcast user traffic among UEs in sidelink.

NR sidelink communication may also be used to support other services than V2X, depending on service requirements.

## 2.2 Detailed specification of the radio interface technology

Detailed specifications described in this Annex are developed around a “Global Core Specification” (GCS)<sup>3</sup>, which is related to externally developed materials incorporated by specific references for a specific technology. The process and use of the GCS, references, and related notifications and certifications are found as Document IMT-2020/20.

The IMT-2020 standards contained in this section are derived from the global core specification for 3GPP 5G-RIT contained at IMT-2020 Global Core Specifications. The following notes apply to the sections below:

- 1) The identified Transposing Organizations<sup>4</sup> should make their reference material available from their website.
- 2) This information was supplied by the Transposing Organizations and relates to their own deliverables of the transposed global core specification.

Section 2.2.1 contains titles and synopses of the Global Core Specification of IMT-2020 radio interface technology entitled 3GPP 5G-RIT and the related hyperlinks to the transposed standards.

The specific 3GPP specifications of the Global Core Specifications (GCS) for IMT-2020 and 5G that are being transposed in § 2.2.1 are summarized in Table 2-3:

---

<sup>3</sup> A “GCS” (Global Core Specification) is the set of specifications that defines a single RIT, an SRIT, or a component RIT within an SRIT.

<sup>4</sup> The following identified Transposing Organizations have provided their transposed sets of standards information contained in this section:

- Association of Radio Industries and Businesses (ARIB)
- Alliance for Telecommunications Industry Solutions (ATIS)
- China Communications Standards Association (CCSA)
- European Telecommunications Standards Institute (ETSI)
- Telecommunications Standards Development Society, India (TSDSI)
- Telecommunications Technology Association (TTA)
- Telecommunication Technology Committee (TTC).

TABLE 2-3  
**3GPP specifications in § 2.2.1 that are to be transposed**

See Note a) and Note b) below the table.				
PART A				
List of Specifications				
37.xxx Series	38.100 Series	38.200 Series	38.300 Series	38.400 Series
TS 37.104	TS 38.101-1	TS 38.201	TS 38.300	TS 38.401
TS 37.105	TS 38.101-2	TS 38.202	TS 38.304	TS 38.410
TS 37.113	TS 38.101-3	TS 38.211	TS 38.305	TS 38.411
TS 37.114	TS 38.104	TS 38.212	TS 38.306	TS 38.412
TS 37.320	TS 38.113	TS 38.213	TS 38.307	TS 38.413
TS 37.324	TS 38.124	TS 38.214	TS 38.314	TS 38.414
TS 37.340	TS 38.133	TS 38.215	TS 38.321	TS 38.415
TS 37.355			TS 38.322	TS 38.420
TS 37.460			TS 38.323	TS 38.421
TS 37.461			TS 38.331	TS 38.422
TS 37.462			TS 38.340	TS 38.423
TS 37.466				TS 38.424
TS 37.470				TS 38.425
TS 37.471				TS 38.455
TS 37.472				TS 38.460
TS 37.473				TS 38.461
				TS 38.462
				TS 38.463
				TS 38.470
				TS 38.471
				TS 38.472
				TS 38.473
				TS 38.474
PART B				
Specification versions to be used				
The specific versions of the 3GPP specifications that are to be used for the transpositions of those specifications listed in Table 2-3 are provided in the link below: <a href="#">Click here for the direct link to the GCS material</a>				

Specifically, the following is noted for Table 2-3:

Notes on specification versions to be utilized for the Global Core Specifications (GCS):

Note a) In conjunction with Table 2-3, the published specification versions for Release 15 and Release 16 resulting from 3GPP TSG RAN #88-e meeting shall be utilized as the specific GCS version. If a RAN #88-e designated specification is not provided, the latest available 3GPP published specifications before 29 July 2020, shall be utilized as the specific GCS version.

Note b) Furthermore, these specific GCS versions in alignment with Note a) above are to be utilized in the transpositions of those specifications listed in Table 2-3 into the corresponding standards by the designated Transposing Organizations indicated in the Certification B provided by the 3GPP GCS Proponent to ITU-R under the IMT-2020 process. See Table 2-3, Part B.

## 2.2.1 Titles and synopses of the global core specification and the transposed standards

### 2.2.1.1 Introduction

The standards documents referenced below, as transposed from the relevant 3GPP specifications, are provided by the identified *Transposing Organizations* as the transposed sets of standards for the terrestrial radio interface of IMT-2020 identified as 5G and includes not only the key characteristics of IMT-2020 but also the additional capabilities of 5G both of which are continuing to be enhanced.

### 2.2.1.2 Radio Layer 1

#### 2.2.1.2.1 TS 38.201

##### NR; Physical layer; General description

This document provides a general description of the physical layer of NR radio interface. This document also describes the document structure of the 3GPP physical layer specifications, i.e. TS 38.200 series.

SDO	Document No.	Version	Status	Issued date	Location
<b>Release 15</b>					
ARIB	ARIB STD-T120-38.201		15.0.0	Published 28.09.2020	<a href="http://www.arib.or.jp/english/html/overview/doc/T120_T23_v2_00/2_T120/ARIB-STD-T120/Rel15/38/A38201-f00.pdf">http://www.arib.or.jp/english/html/overview/doc/T120_T23_v2_00/2_T120/ARIB-STD-T120/Rel15/38/A38201-f00.pdf</a>
ATIS	ATIS.3GPP.38.201V1500		15.0.0	Published 08.09.2020	<a href="http://www.atis.org/3gpp-documents/Rel15">http://www.atis.org/3gpp-documents/Rel15</a>
CCSA	CCSA.38.201V1500		15.0.0	Published 03.01.2018	<a href="http://www.ccsa.org.cn:9001/portalsFile/downloadOldFile?type=17&amp;oldFileUrl=Rel15/TS%2038.201%20V15.0.0.doc">http://www.ccsa.org.cn:9001/portalsFile/downloadOldFile?type=17&amp;oldFileUrl=Rel15/TS%2038.201%20V15.0.0.doc</a>
ETSI	ETSI TS 138 201		15.0.0	Published 18.09.2018	<a href="http://www.etsi.org/deliver/etsi_ts/138200_138299/138201/15.00.00_60/ts_138201v150000p.pdf">http://www.etsi.org/deliver/etsi_ts/138200_138299/138201/15.00.00_60/ts_138201v150000p.pdf</a>
TSDSI	TSDSI STD T1.3GPP 38.201-15.0.0 V1.0.0		15.0.0	Published 06.10.2020	<a href="https://members.tdsi.in/index.php/s/XNXHNmtdmtp7QWG">https://members.tdsi.in/index.php/s/XNXHNmtdmtp7QWG</a>
TTA	TTAT.3G-38.201V15.0.0		15.0.0	Published 11.09.2020	<a href="http://www.tta.or.kr/data/ttasDown.jsp?where=14688&amp;pk_num=TTAT.3G-38.201V15.0.0">http://www.tta.or.kr/data/ttasDown.jsp?where=14688&amp;pk_num=TTAT.3G-38.201V15.0.0</a>
<b>Release 16</b>					
ARIB	ARIB STD-T120-38.201		16.0.0	Published 28.09.2020	<a href="http://www.arib.or.jp/english/html/overview/doc/T120_T23_v2_00/2_T120/ARIB-STD-T120/Rel16/38/A38201-g00.pdf">http://www.arib.or.jp/english/html/overview/doc/T120_T23_v2_00/2_T120/ARIB-STD-T120/Rel16/38/A38201-g00.pdf</a>
ATIS	ATIS.3GPP.38.201V1600		16.0.0	Published 08.09.2020	<a href="http://www.atis.org/3gpp-documents/Rel16">http://www.atis.org/3gpp-documents/Rel16</a>
CCSA	CCSA.38.201V1600		16.0.0	Published 11.01.2020	<a href="http://www.ccsa.org.cn:9001/portalsFile/downloadOldFile?type=17&amp;oldFileUrl=Rel16/TS%2038.201%20V16.0.0.doc">http://www.ccsa.org.cn:9001/portalsFile/downloadOldFile?type=17&amp;oldFileUrl=Rel16/TS%2038.201%20V16.0.0.doc</a>
ETSI	ETSI TS 138 201		16.0.0	Published 21.09.2020	<a href="http://www.etsi.org/deliver/etsi_ts/138200_138299/138201/16.00.00_60/ts_138201v160000p.pdf">http://www.etsi.org/deliver/etsi_ts/138200_138299/138201/16.00.00_60/ts_138201v160000p.pdf</a>
TSDSI	TSDSI STD T1.3GPP 38.201-16.0.0 V1.0.0		16.0.0	Published 06.10.2020	<a href="https://members.tdsi.in/index.php/s/N96FRkwqQ6HzHte">https://members.tdsi.in/index.php/s/N96FRkwqQ6HzHte</a>
TTA	TTAT.3G-38.201V16.0.0		16.0.0	Published 11.09.2020	<a href="http://www.tta.or.kr/data/ttasDown.jsp?where=14688&amp;pk_num=TTAT.3G-38.201V16.0.0">http://www.tta.or.kr/data/ttasDown.jsp?where=14688&amp;pk_num=TTAT.3G-38.201V16.0.0</a>

#### 2.2.1.2.2 TS 38.202

##### NR; Services provided by the physical layer

This document is a technical specification of the services provided by the physical layer of 5G-NR to upper layers.

SDO	Document No.	Version	Status	Issued date	Location
<b>Release 15</b>					
ARIB	ARIB STD-T120-38.202		15.6.0	Published 28.09.2020	<a href="http://www.arib.or.jp/english/html/overview/doc/T120_T23_v2_00/2_T120/ARIB-STD-T120/Rel15/38/A38202-f60.pdf">http://www.arib.or.jp/english/html/overview/doc/T120_T23_v2_00/2_T120/ARIB-STD-T120/Rel15/38/A38202-f60.pdf</a>
ATIS	ATIS.3GPP.38.202V1560		15.6.0	Published 08.09.2020	<a href="http://www.atis.org/3gpp-documents/Rel15">http://www.atis.org/3gpp-documents/Rel15</a>
CCSA	CCSA.38.202V1560		15.6.0	Published 11.01.2020	<a href="http://www.ccsa.org.cn:9001/portalsFile/downloadOldFile?type=17&amp;oldFileUrl=Rel15/TS%2038.202%20V15.6.0.docx">http://www.ccsa.org.cn:9001/portalsFile/downloadOldFile?type=17&amp;oldFileUrl=Rel15/TS%2038.202%20V15.6.0.docx</a>
ETSI	ETSI TS 138 202		15.6.0	Published 21.01.2020	<a href="http://www.etsi.org/deliver/etsi_ts/138200_138299/138202/15.06.00_60/ts_138202v150600p.pdf">http://www.etsi.org/deliver/etsi_ts/138200_138299/138202/15.06.00_60/ts_138202v150600p.pdf</a>

TSDSI	TSDSI STD T1.3GPP 38.202-15.6.0 V1.0.0	15.6.0	Published	06.10.2020	<a href="https://members.tdsi.in/index.php/s/qNiqDsCrQC3b6aq">https://members.tdsi.in/index.php/s/qNiqDsCrQC3b6aq</a>
TTA	TTAT.3G-38.202V15.6.0	15.6.0	Published	11.09.2020	<a href="http://www.tta.or.kr/data/ttasDown.jsp?where=14688&amp;pk_num=TTAT.3G-38.202V15.6.0">http://www.tta.or.kr/data/ttasDown.jsp?where=14688&amp;pk_num=TTAT.3G-38.202V15.6.0</a>
<b>Release 16</b>					
ARIB	ARIB STD-T120-38.202	16.1.0	Published	28.09.2020	<a href="http://www.arib.or.jp/english/html/overview/doc/T120_T23_v2_00/2_T120/ARIB-STD-T120/Rel16/38/A38202-g10.pdf">http://www.arib.or.jp/english/html/overview/doc/T120_T23_v2_00/2_T120/ARIB-STD-T120/Rel16/38/A38202-g10.pdf</a>
ATIS	ATIS.3GPP.38.202V1610	16.1.0	Published	08.09.2020	<a href="http://www.atis.org/3gpp-documents/Rel16">http://www.atis.org/3gpp-documents/Rel16</a>
CCSA	CCSA.38.202V1610	16.1.0	Published	14.07.2020	<a href="http://www.ccsa.org.cn:9001/portalsFile/downloadOldFile?type=17&amp;oldFileUrl=Rel16/TS%2038.202%20V16.1.0.docx">http://www.ccsa.org.cn:9001/portalsFile/downloadOldFile?type=17&amp;oldFileUrl=Rel16/TS%2038.202%20V16.1.0.docx</a>
ETSI	ETSI TS 138 202	16.1.0	Published	20.07.2020	<a href="http://www.etsi.org/deliver/etsi_ts/138200_138299/138202/16.01.00_60/ts_138202v160100p.pdf">http://www.etsi.org/deliver/etsi_ts/138200_138299/138202/16.01.00_60/ts_138202v160100p.pdf</a>
TSDSI	TSDSI STD T1.3GPP 38.202-16.1.0 V1.0.0	16.1.0	Published	06.10.2020	<a href="https://members.tdsi.in/index.php/s/g8qy2m6ZLzobWGA">https://members.tdsi.in/index.php/s/g8qy2m6ZLzobWGA</a>
TTA	TTAT.3G-38.202V16.1.0	16.1.0	Published	11.09.2020	<a href="http://www.tta.or.kr/data/ttasDown.jsp?where=14688&amp;pk_num=TTAT.3G-38.202V16.1.0">http://www.tta.or.kr/data/ttasDown.jsp?where=14688&amp;pk_num=TTAT.3G-38.202V16.1.0</a>

**2.2.1.2.3 TS 38.211**

**NR; Physical channels and modulation**

This document describes the physical channels and signals for 5G-NR.

SDO	Document No.	Version	Status	Issued date	Location
<b>Release 15</b>					
ARIB	ARIB STD-T120-38.211	15.8.0	Published	28.09.2020	<a href="http://www.arib.or.jp/english/html/overview/doc/T120_T23_v2_00/2_T120/ARIB-STD-T120/Rel15/38/A38211-f80.pdf">http://www.arib.or.jp/english/html/overview/doc/T120_T23_v2_00/2_T120/ARIB-STD-T120/Rel15/38/A38211-f80.pdf</a>
ATIS	ATIS.3GPP.38.211V1580	15.8.0	Published	08.09.2020	<a href="http://www.atis.org/3gpp-documents/Rel15">http://www.atis.org/3gpp-documents/Rel15</a>
CCSA	CCSA.38.211V1580	15.8.0	Published	11.01.2020	<a href="http://www.ccsa.org.cn:9001/portalsFile/downloadOldFile?type=17&amp;oldFileUrl=Rel15/TS%2038.211%20V15.8.0.docx">http://www.ccsa.org.cn:9001/portalsFile/downloadOldFile?type=17&amp;oldFileUrl=Rel15/TS%2038.211%20V15.8.0.docx</a>
ETSI	ETSI TS 138 211	15.8.0	Published	21.01.2020	<a href="http://www.etsi.org/deliver/etsi_ts/138200_138299/138211/15.08.00_60/ts_138211v150800p.pdf">http://www.etsi.org/deliver/etsi_ts/138200_138299/138211/15.08.00_60/ts_138211v150800p.pdf</a>
TSDSI	TSDSI STD T1.3GPP 38.211-15.8.0 V1.0.0	15.8.0	Published	06.10.2020	<a href="https://members.tdsi.in/index.php/s/RqwCnMYeJzxCpNc">https://members.tdsi.in/index.php/s/RqwCnMYeJzxCpNc</a>
TTA	TTAT.3G-38.211V15.8.0	15.8.0	Published	11.09.2020	<a href="http://www.tta.or.kr/data/ttasDown.jsp?where=14688&amp;pk_num=TTAT.3G-38.211V15.8.0">http://www.tta.or.kr/data/ttasDown.jsp?where=14688&amp;pk_num=TTAT.3G-38.211V15.8.0</a>
<b>Release 16</b>					
ARIB	ARIB STD-T120-38.211	16.2.0	Published	28.09.2020	<a href="http://www.arib.or.jp/english/html/overview/doc/T120_T23_v2_00/2_T120/ARIB-STD-T120/Rel16/38/A38211-g20.pdf">http://www.arib.or.jp/english/html/overview/doc/T120_T23_v2_00/2_T120/ARIB-STD-T120/Rel16/38/A38211-g20.pdf</a>
ATIS	ATIS.3GPP.38.211V1620	16.2.0	Published	08.09.2020	<a href="http://www.atis.org/3gpp-documents/Rel16">http://www.atis.org/3gpp-documents/Rel16</a>
CCSA	CCSA.38.211V1620	16.2.0	Published	14.07.2020	<a href="http://www.ccsa.org.cn:9001/portalsFile/downloadOldFile?type=17&amp;oldFileUrl=Rel16/TS%2038.211%20V16.2.0.docx">http://www.ccsa.org.cn:9001/portalsFile/downloadOldFile?type=17&amp;oldFileUrl=Rel16/TS%2038.211%20V16.2.0.docx</a>
ETSI	ETSI TS 138 211	16.2.0	Published	20.07.2020	<a href="http://www.etsi.org/deliver/etsi_ts/138200_138299/138211/16.02.00_60/ts_138211v160200p.pdf">http://www.etsi.org/deliver/etsi_ts/138200_138299/138211/16.02.00_60/ts_138211v160200p.pdf</a>
TSDSI	TSDSI STD T1.3GPP 38.211-16.2.0 V1.0.0	16.2.0	Published	06.10.2020	<a href="https://members.tdsi.in/index.php/s/QR9pxK6p4MyHgP2">https://members.tdsi.in/index.php/s/QR9pxK6p4MyHgP2</a>
TTA	TTAT.3G-38.211V16.2.0	16.2.0	Published	11.09.2020	<a href="http://www.tta.or.kr/data/ttasDown.jsp?where=14688&amp;pk_num=TTAT.3G-38.211V16.2.0">http://www.tta.or.kr/data/ttasDown.jsp?where=14688&amp;pk_num=TTAT.3G-38.211V16.2.0</a>

**2.2.1.2.4 TS 38.212**

**NR; Multiplexing and channel coding**

This document specifies the coding, multiplexing and mapping to physical channels for 5G NR.

SDO	Document No.	Version	Status	Issued date	Location
<b>Release 15</b>					
ARIB	ARIB STD-T120-38.212	15.9.0	Published	28.09.2020	<a href="http://www.arib.or.jp/english/html/overview/doc/T120_T23_v2_00/2_T120/ARIB-STD-T120/Rel15/38/A38212-f90.pdf">http://www.arib.or.jp/english/html/overview/doc/T120_T23_v2_00/2_T120/ARIB-STD-T120/Rel15/38/A38212-f90.pdf</a>
ATIS	ATIS.3GPP.38.212V1590	15.9.0	Published	08.09.2020	<a href="http://www.atis.org/3gpp-documents/Rel15">http://www.atis.org/3gpp-documents/Rel15</a>
CCSA	CCSA.38.212V1590	15.9.0	Published	14.07.2020	<a href="http://www.ccsa.org.cn:9001/portalsFile/downloadOldFile?type=17&amp;oldFileUrl=Rel15/TS%2038.212%20V15.9.0.docx">http://www.ccsa.org.cn:9001/portalsFile/downloadOldFile?type=17&amp;oldFileUrl=Rel15/TS%2038.212%20V15.9.0.docx</a>
ETSI	ETSI TS 138 212	15.9.0	Published	20.07.2020	<a href="http://www.etsi.org/deliver/etsi_ts/138200_138299/138212/15.09.00_60/ts_138212v150900p.pdf">http://www.etsi.org/deliver/etsi_ts/138200_138299/138212/15.09.00_60/ts_138212v150900p.pdf</a>
TSDSI	TSDSI STD T1.3GPP 38.212-15.9.0 V1.0.0	15.9.0	Published	06.10.2020	<a href="https://members.tdsi.in/index.php/s/ZpT9Pc6P6KYTF97">https://members.tdsi.in/index.php/s/ZpT9Pc6P6KYTF97</a>
TTA	TTAT.3G-38.212V15.9.0	15.9.0	Published	11.09.2020	<a href="http://www.tta.or.kr/data/ttasDown.jsp?where=14688&amp;pk_num=TTAT.3G-38.212V15.9.0">http://www.tta.or.kr/data/ttasDown.jsp?where=14688&amp;pk_num=TTAT.3G-38.212V15.9.0</a>
<b>Release 16</b>					
ARIB	ARIB STD-T120-38.212	16.2.0	Published	28.09.2020	<a href="http://www.arib.or.jp/english/html/overview/doc/T120_T23_v2_00/2_T120/ARIB-STD-T120/Rel16/38/A38212-g20.pdf">http://www.arib.or.jp/english/html/overview/doc/T120_T23_v2_00/2_T120/ARIB-STD-T120/Rel16/38/A38212-g20.pdf</a>
ATIS	ATIS.3GPP.38.212V1620	16.2.0	Published	08.09.2020	<a href="http://www.atis.org/3gpp-documents/Rel16">http://www.atis.org/3gpp-documents/Rel16</a>

## 156

SDO	Document No.	Version	Status	Issued date	Location
CCSA	CCSA.38.212V1620		16.2.0	Published 20.07.2020	<a href="http://www.ccsa.org.cn:9001/portalsFile/downloadOldFile?type=17&amp;oldFileUrl=Rel16/TS%2038.212%20V16.2.0.docx">http://www.ccsa.org.cn:9001/portalsFile/downloadOldFile?type=17&amp;oldFileUrl=Rel16/TS%2038.212%20V16.2.0.docx</a>
ETSI	ETSI TS 138 212		16.2.0	Published 30.07.2020	<a href="http://www.etsi.org/deliver/etsi_ts/138200_138299/138212/16.02.00_60/ts_138212v160200p.pdf">http://www.etsi.org/deliver/etsi_ts/138200_138299/138212/16.02.00_60/ts_138212v160200p.pdf</a>
TSDSI	TSDSI STD T1.3GPP 38.212-16.2.0 V1.0.0		16.2.0	Published 06.10.2020	<a href="https://members.tdsi.in/index.php/s/km4eQMZxsmrpeXB">https://members.tdsi.in/index.php/s/km4eQMZxsmrpeXB</a>
TTA	TTAT.3G-38.212V16.2.0		16.2.0	Published 11.09.2020	<a href="http://www.tta.or.kr/data/ttasDown.jsp?where=14688&amp;pk_num=TTAT.3G-38.212V16.2.0">http://www.tta.or.kr/data/ttasDown.jsp?where=14688&amp;pk_num=TTAT.3G-38.212V16.2.0</a>

## Rec. ITU-R M.2150-0

### 2.2.1.2.5 TS 38.213

#### NR; Physical layer procedures for control

This document specifies and establishes the characteristics of the physical layer procedures for control operations in 5G-NR.

SDO	Document No.	Version	Status	Issued date	Location
<b>Release 15</b>					
ARIB	ARIB STD-T120-38.213		15.10.0	Published 28.09.2020	<a href="http://www.arib.or.jp/english/html/overview/doc/T120_T23_v2_00/2_T120/ARIB-STD-T120/Rel15/38/A38213-fa0.pdf">http://www.arib.or.jp/english/html/overview/doc/T120_T23_v2_00/2_T120/ARIB-STD-T120/Rel15/38/A38213-fa0.pdf</a>
ATIS	ATIS.3GPP.38.213V15100		15.10.0	Published 08.09.2020	<a href="http://www.atis.org/3gpp-documents/Rel15">http://www.atis.org/3gpp-documents/Rel15</a>
CCSA	CCSA.38.213V15100		15.10.0	Published 17.07.2020	<a href="http://www.ccsa.org.cn:9001/portalsFile/downloadOldFile?type=17&amp;oldFileUrl=Rel15/TS%2038.213%20V15.10.0.docx">http://www.ccsa.org.cn:9001/portalsFile/downloadOldFile?type=17&amp;oldFileUrl=Rel15/TS%2038.213%20V15.10.0.docx</a>
ETSI	ETSI TS 138 213		15.10.0	Published 23.07.2020	<a href="http://www.etsi.org/deliver/etsi_ts/138200_138299/138213/15.10.00_60/ts_138213v151000p.pdf">http://www.etsi.org/deliver/etsi_ts/138200_138299/138213/15.10.00_60/ts_138213v151000p.pdf</a>
TSDSI	TSDSI STD T1.3GPP 38.213-15.10.0 V1.0.0		15.10.0	Published 06.10.2020	<a href="https://members.tdsi.in/index.php/s/cfqCbrPm5A59dot">https://members.tdsi.in/index.php/s/cfqCbrPm5A59dot</a>
TTA	TTAT.3G-38.213V15.10.0		15.10.0	Published 11.09.2020	<a href="http://www.tta.or.kr/data/ttasDown.jsp?where=14688&amp;pk_num=TTAT.3G-38.213V15.10.0">http://www.tta.or.kr/data/ttasDown.jsp?where=14688&amp;pk_num=TTAT.3G-38.213V15.10.0</a>
<b>Release 16</b>					
ARIB	ARIB STD-T120-38.213		16.2.0	Published 28.09.2020	<a href="http://www.arib.or.jp/english/html/overview/doc/T120_T23_v2_00/2_T120/ARIB-STD-T120/Rel16/38/A38213-g20.pdf">http://www.arib.or.jp/english/html/overview/doc/T120_T23_v2_00/2_T120/ARIB-STD-T120/Rel16/38/A38213-g20.pdf</a>
ATIS	ATIS.3GPP.38.213V1620		16.2.0	Published 08.09.2020	<a href="http://www.atis.org/3gpp-documents/Rel16">http://www.atis.org/3gpp-documents/Rel16</a>
CCSA	CCSA.38.213V1620		16.2.0	Published 20.07.2020	<a href="http://www.ccsa.org.cn:9001/portalsFile/downloadOldFile?type=17&amp;oldFileUrl=Rel16/TS%2038.213%20V16.2.0.docx">http://www.ccsa.org.cn:9001/portalsFile/downloadOldFile?type=17&amp;oldFileUrl=Rel16/TS%2038.213%20V16.2.0.docx</a>
ETSI	ETSI TS 138 213		16.2.0	Published 30.07.2020	<a href="http://www.etsi.org/deliver/etsi_ts/138200_138299/138213/16.02.00_60/ts_138213v160200p.pdf">http://www.etsi.org/deliver/etsi_ts/138200_138299/138213/16.02.00_60/ts_138213v160200p.pdf</a>
TSDSI	TSDSI STD T1.3GPP 38.213-16.2.0 V1.0.0		16.2.0	Published 06.10.2020	<a href="https://members.tdsi.in/index.php/s/g7cADGP4c2MdkXx">https://members.tdsi.in/index.php/s/g7cADGP4c2MdkXx</a>
TTA	TTAT.3G-38.213V16.2.0		16.2.0	Published 11.09.2020	<a href="http://www.tta.or.kr/data/ttasDown.jsp?where=14688&amp;pk_num=TTAT.3G-38.213V16.2.0">http://www.tta.or.kr/data/ttasDown.jsp?where=14688&amp;pk_num=TTAT.3G-38.213V16.2.0</a>

### 2.2.1.2.6 TS 38.214

#### NR; Physical layer procedures for data

This document specifies and establishes the characteristics of the physical layer procedures of data channels for 5G-NR.

SDO	Document No.	Version	Status	Issued date	Location
<b>Release 15</b>					
ARIB	ARIB STD-T120-38.214		15.10.0	Published 28.09.2020	<a href="http://www.arib.or.jp/english/html/overview/doc/T120_T23_v2_00/2_T120/ARIB-STD-T120/Rel15/38/A38214-fa0.pdf">http://www.arib.or.jp/english/html/overview/doc/T120_T23_v2_00/2_T120/ARIB-STD-T120/Rel15/38/A38214-fa0.pdf</a>
ATIS	ATIS.3GPP.38.214V15100		15.10.0	Published 08.09.2020	<a href="http://www.atis.org/3gpp-documents/Rel15">http://www.atis.org/3gpp-documents/Rel15</a>
CCSA	CCSA.38.214V15100		15.10.0	Published 17.07.2020	<a href="http://www.ccsa.org.cn:9001/portalsFile/downloadOldFile?type=17&amp;oldFileUrl=Rel15/TS%2038.214%20V15.10.0.docx">http://www.ccsa.org.cn:9001/portalsFile/downloadOldFile?type=17&amp;oldFileUrl=Rel15/TS%2038.214%20V15.10.0.docx</a>
ETSI	ETSI TS 138 214		15.10.0	Published 23.07.2020	<a href="http://www.etsi.org/deliver/etsi_ts/138200_138299/138214/15.10.00_60/ts_138214v151000p.pdf">http://www.etsi.org/deliver/etsi_ts/138200_138299/138214/15.10.00_60/ts_138214v151000p.pdf</a>
TSDSI	TSDSI STD T1.3GPP 38.214-15.10.0 V1.0.0		15.10.0	Published 06.10.2020	<a href="https://members.tdsi.in/index.php/s/QepiRBMZYrGcXx8">https://members.tdsi.in/index.php/s/QepiRBMZYrGcXx8</a>
TTA	TTAT.3G-38.214V15.10.0		15.10.0	Published 11.09.2020	<a href="http://www.tta.or.kr/data/ttasDown.jsp?where=14688&amp;pk_num=TTAT.3G-38.214V15.10.0">http://www.tta.or.kr/data/ttasDown.jsp?where=14688&amp;pk_num=TTAT.3G-38.214V15.10.0</a>
<b>Release 16</b>					
ARIB	ARIB STD-T120-38.214		16.2.0	Published 28.09.2020	<a href="http://www.arib.or.jp/english/html/overview/doc/T120_T23_v2_00/2_T120/ARIB-STD-T120/Rel16/38/A38214-g20.pdf">http://www.arib.or.jp/english/html/overview/doc/T120_T23_v2_00/2_T120/ARIB-STD-T120/Rel16/38/A38214-g20.pdf</a>
ATIS	ATIS.3GPP.38.214V1620		16.2.0	Published 08.09.2020	<a href="http://www.atis.org/3gpp-documents/Rel16">http://www.atis.org/3gpp-documents/Rel16</a>
CCSA	CCSA.38.214V1620		16.2.0	Published 20.07.2020	<a href="http://www.ccsa.org.cn:9001/portalsFile/downloadOldFile?type=17&amp;oldFileUrl=Rel16/TS%2038.214%20V16.2.0.docx">http://www.ccsa.org.cn:9001/portalsFile/downloadOldFile?type=17&amp;oldFileUrl=Rel16/TS%2038.214%20V16.2.0.docx</a>
ETSI	ETSI TS 138 214		16.2.0	Published 30.07.2020	<a href="http://www.etsi.org/deliver/etsi_ts/138200_138299/138214/16.02.00_60/ts_138214v160200p.pdf">http://www.etsi.org/deliver/etsi_ts/138200_138299/138214/16.02.00_60/ts_138214v160200p.pdf</a>
TSDSI	TSDSI STD T1.3GPP 38.214-16.2.0 V1.0.0		16.2.0	Published 06.10.2020	<a href="https://members.tdsi.in/index.php/s/kFSHAZxNiYQGmxf">https://members.tdsi.in/index.php/s/kFSHAZxNiYQGmxf</a>
TTA	TTAT.3G-38.214V16.2.0		16.2.0	Published 11.09.2020	<a href="http://www.tta.or.kr/data/ttasDown.jsp?where=14688&amp;pk_num=TTAT.3G-38.214V16.2.0">http://www.tta.or.kr/data/ttasDown.jsp?where=14688&amp;pk_num=TTAT.3G-38.214V16.2.0</a>

### 2.2.1.2.7 TS 38.215

#### NR; Physical layer measurements

This document describes the physical layer measurements for NR.

SDO	Document No.	Version	Status	Issued date	Location	
<b>Release 15</b>						
ARIB	ARIB STD-T120-38.215		15.7.0	Published	28.09.2020	<a href="http://www.arib.or.jp/english/html/overview/doc/T120_T23_v2_00/2_T120/ARIB-STD-T120/Rel15/38/A38215-f70.pdf">http://www.arib.or.jp/english/html/overview/doc/T120_T23_v2_00/2_T120/ARIB-STD-T120/Rel15/38/A38215-f70.pdf</a>
ATIS	ATIS.3GPP.38.215V1570		15.7.0	Published	08.09.2020	<a href="http://www.atis.org/3gpp-documents/Rel15">http://www.atis.org/3gpp-documents/Rel15</a>
CCSA	CCSA.38.215V1570		15.7.0	Published	14.07.2020	<a href="http://www.ccsa.org.cn:9001/portalsFile/downloadOldFile?type=17&amp;oldFileUrl=Rel15/TS%2038.215%20V15.7.0.docx">http://www.ccsa.org.cn:9001/portalsFile/downloadOldFile?type=17&amp;oldFileUrl=Rel15/TS%2038.215%20V15.7.0.docx</a>
ETSI	ETSI TS 138 215		15.7.0	Published	20.07.2020	<a href="http://www.etsi.org/deliver/etsi_ts/138200_138299/138215/15.07.00_60/ts_138215v150700p.pdf">http://www.etsi.org/deliver/etsi_ts/138200_138299/138215/15.07.00_60/ts_138215v150700p.pdf</a>
TSDSI	TSDSI STD T1.3GPP 38.215-15.7.0 V1.0.0		15.7.0	Published	06.10.2020	<a href="https://members.tdsi.in/index.php/s/4PMqJQM8LcoJCWn">https://members.tdsi.in/index.php/s/4PMqJQM8LcoJCWn</a>
TTA	TTAT.3G-38.215V15.7.0		15.7.0	Published	11.09.2020	<a href="http://www.tta.or.kr/data/ttasDown.jsp?where=14688&amp;pk_num=TTAT.3G-38.215V15.7.0">http://www.tta.or.kr/data/ttasDown.jsp?where=14688&amp;pk_num=TTAT.3G-38.215V15.7.0</a>
<b>Release 16</b>						
ARIB	ARIB STD-T120-38.215		16.2.0	Published	28.09.2020	<a href="http://www.arib.or.jp/english/html/overview/doc/T120_T23_v2_00/2_T120/ARIB-STD-T120/Rel16/38/A38215-g20.pdf">http://www.arib.or.jp/english/html/overview/doc/T120_T23_v2_00/2_T120/ARIB-STD-T120/Rel16/38/A38215-g20.pdf</a>
ATIS	ATIS.3GPP.38.215V1620		16.2.0	Published	08.09.2020	<a href="http://www.atis.org/3gpp-documents/Rel16">http://www.atis.org/3gpp-documents/Rel16</a>
CCSA	CCSA.38.215V1620		16.2.0	Published	14.07.2020	<a href="http://www.ccsa.org.cn:9001/portalsFile/downloadOldFile?type=17&amp;oldFileUrl=Rel16/TS%2038.215%20V16.2.0.docx">http://www.ccsa.org.cn:9001/portalsFile/downloadOldFile?type=17&amp;oldFileUrl=Rel16/TS%2038.215%20V16.2.0.docx</a>
ETSI	ETSI TS 138 215		16.2.0	Published	20.07.2020	<a href="http://www.etsi.org/deliver/etsi_ts/138200_138299/138215/16.02.00_60/ts_138215v160200p.pdf">http://www.etsi.org/deliver/etsi_ts/138200_138299/138215/16.02.00_60/ts_138215v160200p.pdf</a>
TSDSI	TSDSI STD T1.3GPP 38.215-16.2.0 V1.0.0		16.2.0	Published	06.10.2020	<a href="https://members.tdsi.in/index.php/s/NKqZomA38qbdY2o">https://members.tdsi.in/index.php/s/NKqZomA38qbdY2o</a>
TTA	TTAT.3G-38.215V16.2.0		16.2.0	Published	11.09.2020	<a href="http://www.tta.or.kr/data/ttasDown.jsp?where=14688&amp;pk_num=TTAT.3G-38.215V16.2.0">http://www.tta.or.kr/data/ttasDown.jsp?where=14688&amp;pk_num=TTAT.3G-38.215V16.2.0</a>

### 2.2.1.3 Radio Layers 2 & 3

#### 2.2.1.3.1 TS 37.320

#### Universal Terrestrial Radio Access (UTRA) and Evolved Universal Terrestrial Radio Access (E-UTRA); Radio measurement collection for Minimization of Drive Tests (MDT); Overall description; Stage 2

This document provides an overview and overall description of the minimization of drive tests functionality. The document describes functions and procedures to support collection of UE-specific measurements for MDT using Control Plane architecture, for both UTRAN and E-UTRAN. Details of the signalling procedures for single-RAT operation are specified in the appropriate radio interface protocol specification. Network operation and overall control of MDT is described in OAM specifications.

SDO	Document No.	Version	Status	Issued date	Location	
<b>Release 15</b>						
ARIB	ARIB STD-T120-37.320		15.0.0	Published	28.09.2020	<a href="http://www.arib.or.jp/english/html/overview/doc/T120_T23_v2_00/2_T120/ARIB-STD-T120/Rel15/37/A37320-f00.pdf">http://www.arib.or.jp/english/html/overview/doc/T120_T23_v2_00/2_T120/ARIB-STD-T120/Rel15/37/A37320-f00.pdf</a>
ATIS	ATIS.3GPP.37.320V1500		15.0.0	Published	08.09.2020	<a href="http://www.atis.org/3gpp-documents/Rel15">http://www.atis.org/3gpp-documents/Rel15</a>
CCSA	CCSA.37.320V1500		15.0.0	Published	06.07.2018	<a href="http://www.ccsa.org.cn:9001/portalsFile/downloadOldFile?type=17&amp;oldFileUrl=Rel15/TS%2037.320%20V15.0.0.doc">http://www.ccsa.org.cn:9001/portalsFile/downloadOldFile?type=17&amp;oldFileUrl=Rel15/TS%2037.320%20V15.0.0.doc</a>
ETSI	ETSI TS 137 320		15.0.0	Published	17.07.2018	<a href="http://www.etsi.org/deliver/etsi_ts/137300_137399/137320/15.00.00_60/ts_137320v150000p.pdf">http://www.etsi.org/deliver/etsi_ts/137300_137399/137320/15.00.00_60/ts_137320v150000p.pdf</a>
TSDSI	TSDSI STD T1.3GPP 37.320-15.0.0 V1.0.0		15.0.0	Published	06.10.2020	<a href="https://members.tdsi.in/index.php/s/ZonFpABk5TG4HSc">https://members.tdsi.in/index.php/s/ZonFpABk5TG4HSc</a>
TTA	TTAT.3G-37.320V15.0.0		15.0.0	Published	11.09.2020	<a href="http://www.tta.or.kr/data/ttasDown.jsp?where=14688&amp;pk_num=TTAT.3G-37.320V15.0.0">http://www.tta.or.kr/data/ttasDown.jsp?where=14688&amp;pk_num=TTAT.3G-37.320V15.0.0</a>
<b>Release 16</b>						
ARIB	ARIB STD-T120-37.320		16.1.0	Published	28.09.2020	<a href="http://www.arib.or.jp/english/html/overview/doc/T120_T23_v2_00/2_T120/ARIB-STD-T120/Rel16/37/A37320-g10.pdf">http://www.arib.or.jp/english/html/overview/doc/T120_T23_v2_00/2_T120/ARIB-STD-T120/Rel16/37/A37320-g10.pdf</a>
ATIS	ATIS.3GPP.37.320V1610		16.1.0	Published	08.09.2020	<a href="http://www.atis.org/3gpp-documents/Rel16">http://www.atis.org/3gpp-documents/Rel16</a>
CCSA	CCSA.37.320V1610		16.1.0	Published	24.07.2020	<a href="http://www.ccsa.org.cn:9001/portalsFile/downloadOldFile?type=17&amp;oldFileUrl=Rel16/TS%2037.320%20V16.1.0.doc">http://www.ccsa.org.cn:9001/portalsFile/downloadOldFile?type=17&amp;oldFileUrl=Rel16/TS%2037.320%20V16.1.0.doc</a>
ETSI	ETSI TS 137 320		16.1.0	Published	31.07.2020	<a href="http://www.etsi.org/deliver/etsi_ts/137300_137399/137320/16.01.00_60/ts_137320v160100p.pdf">http://www.etsi.org/deliver/etsi_ts/137300_137399/137320/16.01.00_60/ts_137320v160100p.pdf</a>

**158****Rec. ITU-R M.2150-0**

TSDSI	TSDSI STD T1.3GPP 37.320-16.1.0 V1.0.0	16.1.0	Published	06.10.2020	<a href="https://members.tdsi.in/index.php/s/Hm8dwf2YdJqExMw">https://members.tdsi.in/index.php/s/Hm8dwf2YdJqExMw</a>
TTA	TTAT.3G-37.320V16.1.0	16.1.0	Published	11.09.2020	<a href="http://www.tta.or.kr/data/ttasDown.jsp?where=14688&amp;pk_num=TTAT.3G-37.320V16.1.0">http://www.tta.or.kr/data/ttasDown.jsp?where=14688&amp;pk_num=TTAT.3G-37.320V16.1.0</a>

**2.2.1.3.2 TS 37.324****Evolved Universal Terrestrial Radio Access (E-UTRA) and NR; Service Data Adaptation Protocol (SDAP) specification**

This document specifies the Service Data Adaptation Protocol (SDAP) for a UE with connection to the 5G-CN.

SDO	Document No.	Version	Status	Issued date	Location	
<b>Release 15</b>						
ARIB	ARIB STD-T120-37.324		15.1.0	Published	28.09.2020	<a href="http://www.arib.or.jp/english/html/overview/doc/T120_T23_v2_00/2_T120/ARIB-STD-T120/Rel15/37/A37324-f10.pdf">http://www.arib.or.jp/english/html/overview/doc/T120_T23_v2_00/2_T120/ARIB-STD-T120/Rel15/37/A37324-f10.pdf</a>
ATIS	ATIS.3GPP.37.324V1510		15.1.0	Published	08.09.2020	<a href="http://www.atis.org/3gpp-documents/Rel15">http://www.atis.org/3gpp-documents/Rel15</a>
CCSA	CCSA.37.324V1510		15.1.0	Published	25.09.2018	<a href="http://www.ccsa.org.cn:9001/portalsFile/downloadOldFile?type=17&amp;oldFileUrl=Rel15/TS%2037.324%20V15.1.0.doc">http://www.ccsa.org.cn:9001/portalsFile/downloadOldFile?type=17&amp;oldFileUrl=Rel15/TS%2037.324%20V15.1.0.doc</a>
ETSI	ETSI TS 137 324		15.1.0	Published	28.09.2018	<a href="http://www.etsi.org/deliver/etsi_ts/137300_137399/137324/15.01.00_60/ts_137324v150100p.pdf">http://www.etsi.org/deliver/etsi_ts/137300_137399/137324/15.01.00_60/ts_137324v150100p.pdf</a>
TSDSI	TSDSI STD T1.3GPP 37.324-15.1.0 V1.0.0		15.1.0	Published	06.10.2020	<a href="https://members.tdsi.in/index.php/s/Z8Bc2kg4rztgbBR">https://members.tdsi.in/index.php/s/Z8Bc2kg4rztgbBR</a>
TTA	TTAT.3G-37.324V15.1.0		15.1.0	Published	11.09.2020	<a href="http://www.tta.or.kr/data/ttasDown.jsp?where=14688&amp;pk_num=TTAT.3G-37.324V15.1.0">http://www.tta.or.kr/data/ttasDown.jsp?where=14688&amp;pk_num=TTAT.3G-37.324V15.1.0</a>
<b>Release 16</b>						
ARIB	ARIB STD-T120-37.324		16.1.0	Published	28.09.2020	<a href="http://www.arib.or.jp/english/html/overview/doc/T120_T23_v2_00/2_T120/ARIB-STD-T120/Rel16/37/A37324-g10.pdf">http://www.arib.or.jp/english/html/overview/doc/T120_T23_v2_00/2_T120/ARIB-STD-T120/Rel16/37/A37324-g10.pdf</a>
ATIS	ATIS.3GPP.37.324V1610		16.1.0	Published	08.09.2020	<a href="http://www.atis.org/3gpp-documents/Rel16">http://www.atis.org/3gpp-documents/Rel16</a>
CCSA	CCSA.37.324V1610		16.1.0	Published	24.07.2020	<a href="http://www.ccsa.org.cn:9001/portalsFile/downloadOldFile?type=17&amp;oldFileUrl=Rel16/TS%2037.324%20V16.1.0.docx">http://www.ccsa.org.cn:9001/portalsFile/downloadOldFile?type=17&amp;oldFileUrl=Rel16/TS%2037.324%20V16.1.0.docx</a>
ETSI	ETSI TS 137 324		16.1.0	Published	18.09.2020	<a href="http://www.etsi.org/deliver/etsi_ts/137300_137399/137324/16.01.00_60/ts_137324v160100p.pdf">http://www.etsi.org/deliver/etsi_ts/137300_137399/137324/16.01.00_60/ts_137324v160100p.pdf</a>
TSDSI	TSDSI STD T1.3GPP 37.324-16.1.0 V1.0.0		16.1.0	Published	06.10.2020	<a href="https://members.tdsi.in/index.php/s/TGItSs2dd2yWpS5">https://members.tdsi.in/index.php/s/TGItSs2dd2yWpS5</a>
TTA	TTAT.3G-37.324V16.1.0		16.1.0	Published	11.09.2020	<a href="http://www.tta.or.kr/data/ttasDown.jsp?where=14688&amp;pk_num=TTAT.3G-37.324V16.1.0">http://www.tta.or.kr/data/ttasDown.jsp?where=14688&amp;pk_num=TTAT.3G-37.324V16.1.0</a>

**2.2.1.3.3 TS 37.340****NR; Multi-connectivity; Overall description; Stage-2**

This document provides an overview of the multi-connectivity operation using E-UTRA and NR radio access technologies. Details of the network and radio interface protocols are specified in companion specifications of the 36 and 38 series.

SDO	Document No.	Version	Status	Issued date	Location	
<b>Release 15</b>						
ARIB	ARIB STD-T120-37.340		15.9.0	Published	28.09.2020	<a href="http://www.arib.or.jp/english/html/overview/doc/T120_T23_v2_00/2_T120/ARIB-STD-T120/Rel15/37/A37340-f90.pdf">http://www.arib.or.jp/english/html/overview/doc/T120_T23_v2_00/2_T120/ARIB-STD-T120/Rel15/37/A37340-f90.pdf</a>
ATIS	ATIS.3GPP.37.340V1590		15.9.0	Published	08.09.2020	<a href="http://www.atis.org/3gpp-documents/Rel15">http://www.atis.org/3gpp-documents/Rel15</a>
CCSA	CCSA.37.340V1590		15.9.0	Published	24.07.2020	<a href="http://www.ccsa.org.cn:9001/portalsFile/downloadOldFile?type=17&amp;oldFileUrl=Rel15/TS%2037.340%20V15.9.0.docx">http://www.ccsa.org.cn:9001/portalsFile/downloadOldFile?type=17&amp;oldFileUrl=Rel15/TS%2037.340%20V15.9.0.docx</a>
ETSI	ETSI TS 137 340		15.9.0	Published	31.07.2020	<a href="http://www.etsi.org/deliver/etsi_ts/137300_137399/137340/15.09.00_60/ts_137340v150900p.pdf">http://www.etsi.org/deliver/etsi_ts/137300_137399/137340/15.09.00_60/ts_137340v150900p.pdf</a>
TSDSI	TSDSI STD T1.3GPP 37.340-15.9.0 V1.0.0		15.9.0	Published	06.10.2020	<a href="https://members.tdsi.in/index.php/s/4Qb7j9ApeYokyYF">https://members.tdsi.in/index.php/s/4Qb7j9ApeYokyYF</a>
TTA	TTAT.3G-37.340V15.9.0		15.9.0	Published	11.09.2020	<a href="http://www.tta.or.kr/data/ttasDown.jsp?where=14688&amp;pk_num=TTAT.3G-37.340V15.9.0">http://www.tta.or.kr/data/ttasDown.jsp?where=14688&amp;pk_num=TTAT.3G-37.340V15.9.0</a>
<b>Release 16</b>						
ARIB	ARIB STD-T120-37.340		16.2.0	Published	28.09.2020	<a href="http://www.arib.or.jp/english/html/overview/doc/T120_T23_v2_00/2_T120/ARIB-STD-T120/Rel16/37/A37340-g20.pdf">http://www.arib.or.jp/english/html/overview/doc/T120_T23_v2_00/2_T120/ARIB-STD-T120/Rel16/37/A37340-g20.pdf</a>
ATIS	ATIS.3GPP.37.340V1620		16.2.0	Published	08.09.2020	<a href="http://www.atis.org/3gpp-documents/Rel16">http://www.atis.org/3gpp-documents/Rel16</a>
CCSA	CCSA.37.340V1620		16.2.0	Published	24.07.2020	<a href="http://www.ccsa.org.cn:9001/portalsFile/downloadOldFile?type=17&amp;oldFileUrl=Rel16/TS%2037.340%20V16.2.0.docx">http://www.ccsa.org.cn:9001/portalsFile/downloadOldFile?type=17&amp;oldFileUrl=Rel16/TS%2037.340%20V16.2.0.docx</a>
ETSI	ETSI TS 137 340		16.2.0	Published	18.09.2020	<a href="http://www.etsi.org/deliver/etsi_ts/137300_137399/137340/16.02.00_60/ts_137340v160200p.pdf">http://www.etsi.org/deliver/etsi_ts/137300_137399/137340/16.02.00_60/ts_137340v160200p.pdf</a>
TSDSI	TSDSI STD T1.3GPP 37.340-16.2.0 V1.0.0		16.2.0	Published	06.10.2020	<a href="https://members.tdsi.in/index.php/s/rcbRRsELjxnm73a">https://members.tdsi.in/index.php/s/rcbRRsELjxnm73a</a>
TTA	TTAT.3G-37.340V16.2.0		16.2.0	Published	11.09.2020	<a href="http://www.tta.or.kr/data/ttasDown.jsp?where=14688&amp;pk_num=TTAT.3G-37.340V16.2.0">http://www.tta.or.kr/data/ttasDown.jsp?where=14688&amp;pk_num=TTAT.3G-37.340V16.2.0</a>



### 2.2.1.3.4 TS 37.355

#### LTE Positioning Protocol (LPP)

This document contains the definition of the LTE Positioning Protocol (LPP) for the radio access technologies E-UTRA/LTE and NR.

SDO	Document No.	Version	Status	Issued date	Location
<b>Release 15</b>					
ARIB	ARIB STD-T120-37.355		15.0.0	Published 28.09.2020	<a href="http://www.arib.or.jp/english/html/overview/doc/T120_T23_v2_00/2_T120/ARIB-STD-T120/Rel15/37/A37355-f00.pdf">http://www.arib.or.jp/english/html/overview/doc/T120_T23_v2_00/2_T120/ARIB-STD-T120/Rel15/37/A37355-f00.pdf</a>
ATIS	ATIS.3GPP.37.355V1500		15.0.0	Published 08.09.2020	<a href="http://www.atis.org/3gpp-documents/Rel15">http://www.atis.org/3gpp-documents/Rel15</a>
CCSA	CCSA.37.355V1500		15.0.0	Published 21.12.2019	<a href="http://www.ccsa.org.cn:9001/portalsFile/downloadOldFile?type=17&amp;oldFileUrl=Rel15/TS%2037.355%20V15.0.0.docx">http://www.ccsa.org.cn:9001/portalsFile/downloadOldFile?type=17&amp;oldFileUrl=Rel15/TS%2037.355%20V15.0.0.docx</a>
ETSI	ETSI TS 137 355		15.0.0	Published 16.01.2020	<a href="http://www.etsi.org/deliver/etsi_ts/137300_137399/137355/15.00.00_60/ts_137355v150000p.pdf">http://www.etsi.org/deliver/etsi_ts/137300_137399/137355/15.00.00_60/ts_137355v150000p.pdf</a>
TSDSI	TSDSI STD T1.3GPP 37.355-15.0.0 V1.0.0		15.0.0	Published 06.10.2020	<a href="https://members.tdsi.in/index.php/s/sKCWFBteSQo6QbY">https://members.tdsi.in/index.php/s/sKCWFBteSQo6QbY</a>
TTA	TTAT.3G-37.355V15.0.0		15.0.0	Published 11.09.2020	<a href="http://www.tta.or.kr/data/ttasDown.jsp?where=14688&amp;pk_num=TTAT.3G-37.355V15.0.0">http://www.tta.or.kr/data/ttasDown.jsp?where=14688&amp;pk_num=TTAT.3G-37.355V15.0.0</a>
<b>Release 16</b>					
ARIB	ARIB STD-T120-37.355		16.1.0	Published 28.09.2020	<a href="http://www.arib.or.jp/english/html/overview/doc/T120_T23_v2_00/2_T120/ARIB-STD-T120/Rel16/37/A37355-g10.pdf">http://www.arib.or.jp/english/html/overview/doc/T120_T23_v2_00/2_T120/ARIB-STD-T120/Rel16/37/A37355-g10.pdf</a>
ATIS	ATIS.3GPP.37.355V1610		16.1.0	Published 08.09.2020	<a href="http://www.atis.org/3gpp-documents/Rel16">http://www.atis.org/3gpp-documents/Rel16</a>
CCSA	CCSA.37.355V1610		16.1.0	Published 24.07.2020	<a href="http://www.ccsa.org.cn:9001/portalsFile/downloadOldFile?type=17&amp;oldFileUrl=Rel16/TS%2037.355%20V16.1.0.docx">http://www.ccsa.org.cn:9001/portalsFile/downloadOldFile?type=17&amp;oldFileUrl=Rel16/TS%2037.355%20V16.1.0.docx</a>
ETSI	ETSI TS 137 355		16.1.0	Published 31.07.2020	<a href="http://www.etsi.org/deliver/etsi_ts/137300_137399/137355/16.01.00_60/ts_137355v160100p.pdf">http://www.etsi.org/deliver/etsi_ts/137300_137399/137355/16.01.00_60/ts_137355v160100p.pdf</a>
TSDSI	TSDSI STD T1.3GPP 37.355-16.1.0 V1.0.0		16.1.0	Published 06.10.2020	<a href="https://members.tdsi.in/index.php/s/nzpHnNfo33WQSyK">https://members.tdsi.in/index.php/s/nzpHnNfo33WQSyK</a>
TTA	TTAT.3G-37.355V16.1.0		16.1.0	Published 11.09.2020	<a href="http://www.tta.or.kr/data/ttasDown.jsp?where=14688&amp;pk_num=TTAT.3G-37.355V16.1.0">http://www.tta.or.kr/data/ttasDown.jsp?where=14688&amp;pk_num=TTAT.3G-37.355V16.1.0</a>

### 2.2.1.3.5 TS 38.300

#### NR; NR and NG-RAN Overall description; Stage-2

This document provides an overview and overall description of the NG-RAN and focuses on the radio interface protocol architecture of NR connected to 5GC (E-UTRA connected to 5GC is covered in the 36 series). Details of the radio interface protocols are specified in companion specifications of the 38 series.

SDO	Document No.	Version	Status	Issued date	Location
<b>Release 15</b>					
ARIB	ARIB STD-T120-38.300		15.10.0	Published 28.09.2020	<a href="http://www.arib.or.jp/english/html/overview/doc/T120_T23_v2_00/2_T120/ARIB-STD-T120/Rel15/38/A38300-fa0.pdf">http://www.arib.or.jp/english/html/overview/doc/T120_T23_v2_00/2_T120/ARIB-STD-T120/Rel15/38/A38300-fa0.pdf</a>
ATIS	ATIS.3GPP.38.300V15100		15.10.0	Published 08.09.2020	<a href="http://www.atis.org/3gpp-documents/Rel15">http://www.atis.org/3gpp-documents/Rel15</a>
CCSA	CCSA.38.300V15100		15.10.0	Published 24.07.2020	<a href="http://www.ccsa.org.cn:9001/portalsFile/downloadOldFile?type=17&amp;oldFileUrl=Rel15/TS%2038.300%20V15.10.0.docx">http://www.ccsa.org.cn:9001/portalsFile/downloadOldFile?type=17&amp;oldFileUrl=Rel15/TS%2038.300%20V15.10.0.docx</a>
ETSI	ETSI TS 138 300		15.10.0	Published 31.07.2020	<a href="http://www.etsi.org/deliver/etsi_ts/138300_138399/138300/15.10.00_60/ts_138300v151000p.pdf">http://www.etsi.org/deliver/etsi_ts/138300_138399/138300/15.10.00_60/ts_138300v151000p.pdf</a>
TSDSI	TSDSI STD T1.3GPP 38.300-15.10.0 V1.0.0		15.10.0	Published 06.10.2020	<a href="https://members.tdsi.in/index.php/s/s4tRSxrLgYBCQjk">https://members.tdsi.in/index.php/s/s4tRSxrLgYBCQjk</a>
TTA	TTAT.3G-38.300V15.10.0		15.10.0	Published 11.09.2020	<a href="http://www.tta.or.kr/data/ttasDown.jsp?where=14688&amp;pk_num=TTAT.3G-38.300V15.10.0">http://www.tta.or.kr/data/ttasDown.jsp?where=14688&amp;pk_num=TTAT.3G-38.300V15.10.0</a>
<b>Release 16</b>					
ARIB	ARIB STD-T120-38.300		16.2.0	Published 28.09.2020	<a href="http://www.arib.or.jp/english/html/overview/doc/T120_T23_v2_00/2_T120/ARIB-STD-T120/Rel16/38/A38300-g20.pdf">http://www.arib.or.jp/english/html/overview/doc/T120_T23_v2_00/2_T120/ARIB-STD-T120/Rel16/38/A38300-g20.pdf</a>
ATIS	ATIS.3GPP.38.300V1620		16.2.0	Published 08.09.2020	<a href="http://www.atis.org/3gpp-documents/Rel16">http://www.atis.org/3gpp-documents/Rel16</a>
CCSA	CCSA.38.300V1620		16.2.0	Published 24.07.2020	<a href="http://www.ccsa.org.cn:9001/portalsFile/downloadOldFile?type=17&amp;oldFileUrl=Rel16/TS%2038.300%20V16.2.0.docx">http://www.ccsa.org.cn:9001/portalsFile/downloadOldFile?type=17&amp;oldFileUrl=Rel16/TS%2038.300%20V16.2.0.docx</a>
ETSI	ETSI TS 138 300		16.2.0	Published 31.07.2020	<a href="http://www.etsi.org/deliver/etsi_ts/138300_138399/138300/16.02.00_60/ts_138300v160200p.pdf">http://www.etsi.org/deliver/etsi_ts/138300_138399/138300/16.02.00_60/ts_138300v160200p.pdf</a>
TSDSI	TSDSI STD T1.3GPP 38.300-16.2.0 V1.0.0		16.2.0	Published 06.10.2020	<a href="https://members.tdsi.in/index.php/s&gt;NamaWsAcbqF4mts">https://members.tdsi.in/index.php/s&gt;NamaWsAcbqF4mts</a>
TTA	TTAT.3G-38.300V16.2.0		16.2.0	Published 11.09.2020	<a href="http://www.tta.or.kr/data/ttasDown.jsp?where=14688&amp;pk_num=TTAT.3G-38.300V16.2.0">http://www.tta.or.kr/data/ttasDown.jsp?where=14688&amp;pk_num=TTAT.3G-38.300V16.2.0</a>

### 2.2.1.3.6 TS 38.304

#### NR; User Equipment (UE) procedures in idle mode and in RRC Inactive state

This document specifies the Access Stratum (AS) part of the UE procedures in RRC\_IDLE state (also called Idle mode) and RRC\_INACTIVE state. The non-access stratum (NAS) part of Idle mode procedures and processes is specified in TS 23.122.

This document specifies the model for the functional division between the NAS and AS in a UE.

This document applies to all UEs that support at least NR Radio Access, including multi-RAT UEs as described in 3GPP specifications, in the following cases:

- When the UE is camped on a NR cell;
- When the UE is searching for a cell to camp on;

NOTE: When the UE is camped on or searching for a cell to camp on belonging to other RATs, the UE behaviour is described in the specifications of the other RATs.

SDO	Document No.	Version	Status	Issued date	Location	
<b>Release 15</b>						
ARIB	ARIB STD-T120-38.304		15.7.0	Published	28.09.2020	<a href="http://www.arib.or.jp/english/html/overview/doc/T120_T23_v2_00/2_T120/ARIB-STD-T120/Rel15/38/A38304-f70.pdf">http://www.arib.or.jp/english/html/overview/doc/T120_T23_v2_00/2_T120/ARIB-STD-T120/Rel15/38/A38304-f70.pdf</a>
ATIS	ATIS.3GPP.38.304V1570		15.7.0	Published	08.09.2020	<a href="http://www.atis.org/3gpp-documents/Rel15">http://www.atis.org/3gpp-documents/Rel15</a>
CCSA	CCSA.38.304V1570		15.7.0	Published	24.07.2020	<a href="http://www.ccsa.org.cn:9001/portalsFile/downloadOldFile?type=17&amp;oldFileUrl=Rel15/TS%2038.304%20V15.7.docx">http://www.ccsa.org.cn:9001/portalsFile/downloadOldFile?type=17&amp;oldFileUrl=Rel15/TS%2038.304%20V15.7.docx</a>
ETSI	ETSI TS 138 304		15.7.0	Published	31.07.2020	<a href="http://www.etsi.org/deliver/etsi_ts/138300_138399/138304/15.07.00_60/ts_138304v150700p.pdf">http://www.etsi.org/deliver/etsi_ts/138300_138399/138304/15.07.00_60/ts_138304v150700p.pdf</a>
TSDSI	TSDSI STD T1.3GPP 38.304-15.7.0 V1.0.0		15.7.0	Published	06.10.2020	<a href="https://members.tdsi.in/index.php/s/W7omnjRzJTxx2LS">https://members.tdsi.in/index.php/s/W7omnjRzJTxx2LS</a>
TTA	TTAT.3G-38.304V15.7.0		15.7.0	Published	11.09.2020	<a href="http://www.tta.or.kr/data/ttasDown.jsp?where=14688&amp;pk_num=TTAT.3G-38.304V15.7.0">http://www.tta.or.kr/data/ttasDown.jsp?where=14688&amp;pk_num=TTAT.3G-38.304V15.7.0</a>
<b>Release 16</b>						
ARIB	ARIB STD-T120-38.304		16.1.0	Published	28.09.2020	<a href="http://www.arib.or.jp/english/html/overview/doc/T120_T23_v2_00/2_T120/ARIB-STD-T120/Rel16/38/A38304-g10.pdf">http://www.arib.or.jp/english/html/overview/doc/T120_T23_v2_00/2_T120/ARIB-STD-T120/Rel16/38/A38304-g10.pdf</a>
ATIS	ATIS.3GPP.38.304V1610		16.1.0	Published	08.09.2020	<a href="http://www.atis.org/3gpp-documents/Rel16">http://www.atis.org/3gpp-documents/Rel16</a>
CCSA	CCSA.38.304V1610		16.1.0	Published	24.07.2020	<a href="http://www.ccsa.org.cn:9001/portalsFile/downloadOldFile?type=17&amp;oldFileUrl=Rel16/TS%2038.304%20V16.1.0.docx">http://www.ccsa.org.cn:9001/portalsFile/downloadOldFile?type=17&amp;oldFileUrl=Rel16/TS%2038.304%20V16.1.0.docx</a>
ETSI	ETSI TS 138 304		16.1.0	Published	31.07.2020	<a href="http://www.etsi.org/deliver/etsi_ts/138300_138399/138304/16.01.00_60/ts_138304v160100p.pdf">http://www.etsi.org/deliver/etsi_ts/138300_138399/138304/16.01.00_60/ts_138304v160100p.pdf</a>
TSDSI	TSDSI STD T1.3GPP 38.304-16.1.0 V1.0.0		16.1.0	Published	06.10.2020	<a href="https://members.tdsi.in/index.php/s/eeYJoNaByYRGxkH">https://members.tdsi.in/index.php/s/eeYJoNaByYRGxkH</a>
TTA	TTAT.3G-38.304V16.1.0		16.1.0	Published	11.09.2020	<a href="http://www.tta.or.kr/data/ttasDown.jsp?where=14688&amp;pk_num=TTAT.3G-38.304V16.1.0">http://www.tta.or.kr/data/ttasDown.jsp?where=14688&amp;pk_num=TTAT.3G-38.304V16.1.0</a>

### 2.2.1.3.7 TS 38.305

#### NG Radio Access Network (NG-RAN); Stage 2 functional specification of User Equipment (UE) positioning in NG-RAN

This document specifies the stage 2 of the UE Positioning function of NG-RAN which provides the mechanisms to support or assist the calculation of the geographical position of a UE. UE position knowledge can be used, for example, in support of Radio Resource Management functions, as well as location-based services for operators, subscribers, and third-party service providers. The purpose of this stage 2 specification is to define the NG-RAN UE Positioning architecture, functional entities and operations to support positioning methods. This description is confined to the NG-RAN Access Stratum. It does not define or describe how the results of the UE position calculation can be utilised in the Core Network (e.g. LCS) or in NG-RAN (e.g. RRM).

UE Positioning may be considered as a network-provided enabling technology consisting of standardised service capabilities that enable the provision of location applications. The application(s) may be service provider specific. The description of the numerous and varied possible location applications which are enabled by this technology is outside the scope of this document. However, clarifying examples of how the functionality being described may be used to provide specific location services may be included.

This stage 2 specification covers the NG-RAN positioning methods, state descriptions, and message flows to support UE Positioning.

SDO	Document No.	Version	Status	Issued date	Location
<b>Release 15</b>					
ARIB	ARIB STD-T120-38.305		15.6.0	Published 28.09.2020	<a href="http://www.arib.or.jp/english/html/overview/doc/T120_T23_v2_00/2_T120/ARIB-STD-T120/Rel15/38/A38305-f60.pdf">http://www.arib.or.jp/english/html/overview/doc/T120_T23_v2_00/2_T120/ARIB-STD-T120/Rel15/38/A38305-f60.pdf</a>
ATIS	ATIS.3GPP.38.305V1560		15.6.0	Published 08.09.2020	<a href="http://www.atis.org/3gpp-documents/Rel15">http://www.atis.org/3gpp-documents/Rel15</a>
CCSA	CCSA.38.305V1560		15.6.0	Published 24.07.2020	<a href="http://www.ccsa.org.cn:9001/portalsFile/downloadOldFile?type=17&amp;oldFileUrl=Rel15/TS%2038.305%20V15.6.0.docx">http://www.ccsa.org.cn:9001/portalsFile/downloadOldFile?type=17&amp;oldFileUrl=Rel15/TS%2038.305%20V15.6.0.docx</a>
ETSI	ETSI TS 138 305		15.6.0	Published 31.07.2020	<a href="http://www.etsi.org/deliver/etsi_ts/138300_138399/138305/15.06.00_60/ts_138305v150600p.pdf">http://www.etsi.org/deliver/etsi_ts/138300_138399/138305/15.06.00_60/ts_138305v150600p.pdf</a>
TSDSI	TSDSI STD T1.3GPP 38.305-15.6.0 V1.0.0		15.6.0	Published 06.10.2020	<a href="https://members.tdsi.in/index.php/s/QZBNjzm78xFGNP">https://members.tdsi.in/index.php/s/QZBNjzm78xFGNP</a>
TTA	TTAT.3G-38.305V15.6.0		15.6.0	Published 11.09.2020	<a href="http://www.tta.or.kr/data/ttasDown.jsp?where=14688&amp;pk_num=TTAT.3G-38.305V15.6.0">http://www.tta.or.kr/data/ttasDown.jsp?where=14688&amp;pk_num=TTAT.3G-38.305V15.6.0</a>
<b>Release 16</b>					
ARIB	ARIB STD-T120-38.305		16.1.0	Published 28.09.2020	<a href="http://www.arib.or.jp/english/html/overview/doc/T120_T23_v2_00/2_T120/ARIB-STD-T120/Rel16/38/A38305-g10.pdf">http://www.arib.or.jp/english/html/overview/doc/T120_T23_v2_00/2_T120/ARIB-STD-T120/Rel16/38/A38305-g10.pdf</a>
ATIS	ATIS.3GPP.38.305V1610		16.1.0	Published 08.09.2020	<a href="http://www.atis.org/3gpp-documents/Rel16">http://www.atis.org/3gpp-documents/Rel16</a>
CCSA	CCSA.38.305V1610		16.1.0	Published 24.07.2020	<a href="http://www.ccsa.org.cn:9001/portalsFile/downloadOldFile?type=17&amp;oldFileUrl=Rel16/TS%2038.305%20V16.1.0.docx">http://www.ccsa.org.cn:9001/portalsFile/downloadOldFile?type=17&amp;oldFileUrl=Rel16/TS%2038.305%20V16.1.0.docx</a>
ETSI	ETSI TS 138 305		16.1.0	Published 30.07.2020	<a href="http://www.etsi.org/deliver/etsi_ts/138300_138399/138305/16.01.00_60/ts_138305v160100p.pdf">http://www.etsi.org/deliver/etsi_ts/138300_138399/138305/16.01.00_60/ts_138305v160100p.pdf</a>
TSDSI	TSDSI STD T1.3GPP 38.305-16.1.0 V1.0.0		16.1.0	Published 06.10.2020	<a href="https://members.tdsi.in/index.php/s/kFpRkDFr8Hpcjk2">https://members.tdsi.in/index.php/s/kFpRkDFr8Hpcjk2</a>
TTA	TTAT.3G-38.305V16.1.0		16.1.0	Published 11.09.2020	<a href="http://www.tta.or.kr/data/ttasDown.jsp?where=14688&amp;pk_num=TTAT.3G-38.305V16.1.0">http://www.tta.or.kr/data/ttasDown.jsp?where=14688&amp;pk_num=TTAT.3G-38.305V16.1.0</a>

### 2.2.1.3.8 TS 38.306

#### NR; User Equipment (UE) radio access capabilities

This document defines the NR UE Radio Access Capability Parameters.

SDO	Document No.	Version	Status	Issued date	Location
<b>Release 15</b>					
ARIB	ARIB STD-T120-38.306		15.10.0	Published 28.09.2020	<a href="http://www.arib.or.jp/english/html/overview/doc/T120_T23_v2_00/2_T120/ARIB-STD-T120/Rel15/38/A38306-fa0.pdf">http://www.arib.or.jp/english/html/overview/doc/T120_T23_v2_00/2_T120/ARIB-STD-T120/Rel15/38/A38306-fa0.pdf</a>
ATIS	ATIS.3GPP.38.306V15100		15.10.0	Published 08.09.2020	<a href="http://www.atis.org/3gpp-documents/Rel15">http://www.atis.org/3gpp-documents/Rel15</a>
CCSA	CCSA.38.306V15100		15.10.0	Published 24.07.2020	<a href="http://www.ccsa.org.cn:9001/portalsFile/downloadOldFile?type=17&amp;oldFileUrl=Rel15/TS%2038.306%20V15.10.0.docx">http://www.ccsa.org.cn:9001/portalsFile/downloadOldFile?type=17&amp;oldFileUrl=Rel15/TS%2038.306%20V15.10.0.docx</a>
ETSI	ETSI TS 138 306		15.10.0	Published 31.07.2020	<a href="http://www.etsi.org/deliver/etsi_ts/138300_138399/138306/15.10.00_60/ts_138306v151000p.pdf">http://www.etsi.org/deliver/etsi_ts/138300_138399/138306/15.10.00_60/ts_138306v151000p.pdf</a>
TSDSI	TSDSI STD T1.3GPP 38.306-15.10.0 V1.0.0		15.10.0	Published 06.10.2020	<a href="https://members.tdsi.in/index.php/s/YiYEbnxRN9ekGnL">https://members.tdsi.in/index.php/s/YiYEbnxRN9ekGnL</a>
TTA	TTAT.3G-38.306V15.10.0		15.10.0	Published 11.09.2020	<a href="http://www.tta.or.kr/data/ttasDown.jsp?where=14688&amp;pk_num=TTAT.3G-38.306V15.10.0">http://www.tta.or.kr/data/ttasDown.jsp?where=14688&amp;pk_num=TTAT.3G-38.306V15.10.0</a>
<b>Release 16</b>					
ARIB	ARIB STD-T120-38.306		16.1.0	Published 28.09.2020	<a href="http://www.arib.or.jp/english/html/overview/doc/T120_T23_v2_00/2_T120/ARIB-STD-T120/Rel16/38/A38306-g10.pdf">http://www.arib.or.jp/english/html/overview/doc/T120_T23_v2_00/2_T120/ARIB-STD-T120/Rel16/38/A38306-g10.pdf</a>
ATIS	ATIS.3GPP.38.306V1610		16.1.0	Published 08.09.2020	<a href="http://www.atis.org/3gpp-documents/Rel16">http://www.atis.org/3gpp-documents/Rel16</a>
CCSA	CCSA.38.306V1610		16.1.0	Published 24.07.2020	<a href="http://www.ccsa.org.cn:9001/portalsFile/downloadOldFile?type=17&amp;oldFileUrl=Rel16/TS%2038.306%20V16.1.0.docx">http://www.ccsa.org.cn:9001/portalsFile/downloadOldFile?type=17&amp;oldFileUrl=Rel16/TS%2038.306%20V16.1.0.docx</a>
ETSI	ETSI TS 138 306		16.1.0	Published 30.07.2020	<a href="http://www.etsi.org/deliver/etsi_ts/138300_138399/138306/16.01.00_60/ts_138306v160100p.pdf">http://www.etsi.org/deliver/etsi_ts/138300_138399/138306/16.01.00_60/ts_138306v160100p.pdf</a>
TSDSI	TSDSI STD T1.3GPP 38.306-16.1.0 V1.0.0		16.1.0	Published 06.10.2020	<a href="https://members.tdsi.in/index.php/s/6cZdRwZGci8ztCc">https://members.tdsi.in/index.php/s/6cZdRwZGci8ztCc</a>
TTA	TTAT.3G-38.306V16.1.0		16.1.0	Published 11.09.2020	<a href="http://www.tta.or.kr/data/ttasDown.jsp?where=14688&amp;pk_num=TTAT.3G-38.306V16.1.0">http://www.tta.or.kr/data/ttasDown.jsp?where=14688&amp;pk_num=TTAT.3G-38.306V16.1.0</a>

### 2.2.1.3.9 TS 38.307

#### NR; Requirements on User Equipments (UEs) supporting a release-independent frequency band

This document specifies requirements for UEs supporting release independent features such as additional NR operating bands and power classes on top of TS 38.101 and TS 38.133.

SDO	Document No.	Version	Status	Issued date	Location
-----	--------------	---------	--------	-------------	----------

**Release 15**

ARIB	ARIB STD-T120-38.307	15.6.0	Published	28.09.2020	<a href="http://www.arib.or.jp/english/html/overview/doc/T120_T23_v2_00/2_T120/ARIB-STD-T120/Rel15/38/A38307-f60.pdf">http://www.arib.or.jp/english/html/overview/doc/T120_T23_v2_00/2_T120/ARIB-STD-T120/Rel15/38/A38307-f60.pdf</a>
ATIS	ATIS.3GPP.38.307V1560	15.6.0	Published	08.09.2020	<a href="http://www.atis.org/3gpp-documents/Rel15">http://www.atis.org/3gpp-documents/Rel15</a>
CCSA	CCSA.38.307V1560	15.6.0	Published	17.07.2020	<a href="http://www.ccsa.org.cn:9001/portalsFile/downloadOldFile?type=17&amp;oldFileUrl=Rel15/TS%2038.307%20V15.6.0.docx">http://www.ccsa.org.cn:9001/portalsFile/downloadOldFile?type=17&amp;oldFileUrl=Rel15/TS%2038.307%20V15.6.0.docx</a>
ETSI	ETSI TS 138 307	15.6.0	Published	23.07.2020	<a href="http://www.etsi.org/deliver/etsi_ts/138300_138399/138307/15.06.00_60/ts_138307v150600p.pdf">http://www.etsi.org/deliver/etsi_ts/138300_138399/138307/15.06.00_60/ts_138307v150600p.pdf</a>
TSDSI	TSDSI STD T1.3GPP 38.307-15.6.0 V1.0.0	15.6.0	Published	06.10.2020	<a href="https://members.tdsi.in/index.php/s/ncsf55EHbge96d3">https://members.tdsi.in/index.php/s/ncsf55EHbge96d3</a>
TTA	TTAT.3G-38.307V15.6.0	15.6.0	Published	11.09.2020	<a href="http://www.tta.or.kr/data/ttasDown.jsp?where=14688&amp;pk_num=TTAT.3G-38.307V15.6.0">http://www.tta.or.kr/data/ttasDown.jsp?where=14688&amp;pk_num=TTAT.3G-38.307V15.6.0</a>

**Release 16**

ARIB	ARIB STD-T120-38.307	16.3.0	Published	28.09.2020	<a href="http://www.arib.or.jp/english/html/overview/doc/T120_T23_v2_00/2_T120/ARIB-STD-T120/Rel16/38/A38307-g30.pdf">http://www.arib.or.jp/english/html/overview/doc/T120_T23_v2_00/2_T120/ARIB-STD-T120/Rel16/38/A38307-g30.pdf</a>
ATIS	ATIS.3GPP.38.307V1630	16.3.0	Published	08.09.2020	<a href="http://www.atis.org/3gpp-documents/Rel16">http://www.atis.org/3gpp-documents/Rel16</a>
CCSA	CCSA.38.307V1630	16.3.0	Published	17.07.2020	<a href="http://www.ccsa.org.cn:9001/portalsFile/downloadOldFile?type=17&amp;oldFileUrl=Rel16/TS%2038.307%20V16.3.0.docx">http://www.ccsa.org.cn:9001/portalsFile/downloadOldFile?type=17&amp;oldFileUrl=Rel16/TS%2038.307%20V16.3.0.docx</a>
ETSI	ETSI TS 138 307	16.3.0	Published	23.07.2020	<a href="http://www.etsi.org/deliver/etsi_ts/138300_138399/138307/16.03.00_60/ts_138307v160300p.pdf">http://www.etsi.org/deliver/etsi_ts/138300_138399/138307/16.03.00_60/ts_138307v160300p.pdf</a>
TSDSI	TSDSI STD T1.3GPP 38.307-16.3.0 V1.0.0	16.3.0	Published	06.10.2020	<a href="https://members.tdsi.in/index.php/s/meo464Cb4aejXpt">https://members.tdsi.in/index.php/s/meo464Cb4aejXpt</a>
TTA	TTAT.3G-38.307V16.3.0	16.3.0	Published	11.09.2020	<a href="http://www.tta.or.kr/data/ttasDown.jsp?where=14688&amp;pk_num=TTAT.3G-38.307V16.3.0">http://www.tta.or.kr/data/ttasDown.jsp?where=14688&amp;pk_num=TTAT.3G-38.307V16.3.0</a>

**2.2.1.3.10 TS 38.314****NR; Layer 2 measurements**

This document contains the description and definition of the measurements performed by NR or the UE that are transferred over the standardised interfaces in order to support NR radio link operations, radio resource management (RRM), network operations and maintenance (OAM), minimization of drive tests (MDT) and self-organising networks (SON).

Only the differences relative to TS 28.552 are specified in this specification.

SDO	Document No.	Version	Status	Issued date	Location
<b>Release 16</b>					
ARIB	ARIB STD-T120-38.314	16.0.0	Published	28.09.2020	<a href="http://www.arib.or.jp/english/html/overview/doc/T120_T23_v2_00/2_T120/ARIB-STD-T120/Rel16/38/A38314-g00.pdf">http://www.arib.or.jp/english/html/overview/doc/T120_T23_v2_00/2_T120/ARIB-STD-T120/Rel16/38/A38314-g00.pdf</a>
ATIS	ATIS.3GPP.38.314V1600	16.0.0	Published	08.09.2020	<a href="http://www.atis.org/3gpp-documents/Rel16">http://www.atis.org/3gpp-documents/Rel16</a>
CCSA	CCSA.38.314V1600	16.0.0	Published	24.07.2020	<a href="http://www.ccsa.org.cn:9001/portalsFile/downloadOldFile?type=17&amp;oldFileUrl=Rel16/TS%2038.314%20V16.0.0.docx">http://www.ccsa.org.cn:9001/portalsFile/downloadOldFile?type=17&amp;oldFileUrl=Rel16/TS%2038.314%20V16.0.0.docx</a>
ETSI	ETSI TS 138 314	16.0.0	Published	31.07.2020	<a href="http://www.etsi.org/deliver/etsi_ts/138300_138399/138314/16.00.00_60/ts_138314v160000p.pdf">http://www.etsi.org/deliver/etsi_ts/138300_138399/138314/16.00.00_60/ts_138314v160000p.pdf</a>
TSDSI	TSDSI STD T1.3GPP 38.314-16.0.0 V1.0.0	16.0.0	Published	06.10.2020	<a href="https://members.tdsi.in/index.php/s/HyeZZm43gwP3Aao">https://members.tdsi.in/index.php/s/HyeZZm43gwP3Aao</a>
TTA	TTAT.3G-38.314V16.0.0	16.0.0	Published	11.09.2020	<a href="http://www.tta.or.kr/data/ttasDown.jsp?where=14688&amp;pk_num=TTAT.3G-38.314V16.0.0">http://www.tta.or.kr/data/ttasDown.jsp?where=14688&amp;pk_num=TTAT.3G-38.314V16.0.0</a>

**2.2.1.3.11 TS 38.321****NR; Medium Access Control (MAC) protocol specification**

This document specifies the NR MAC protocol.

SDO	Document No.	Version	Status	Issued date	Location
<b>Release 15</b>					
ARIB	ARIB STD-T120-38.321	15.9.0	Published	28.09.2020	<a href="http://www.arib.or.jp/english/html/overview/doc/T120_T23_v2_00/2_T120/ARIB-STD-T120/Rel15/38/A38321-f90.pdf">http://www.arib.or.jp/english/html/overview/doc/T120_T23_v2_00/2_T120/ARIB-STD-T120/Rel15/38/A38321-f90.pdf</a>
ATIS	ATIS.3GPP.38.321V1590	15.9.0	Published	08.09.2020	<a href="http://www.atis.org/3gpp-documents/Rel15">http://www.atis.org/3gpp-documents/Rel15</a>
CCSA	CCSA.38.321V1 590	15.9.0	Published	24.07.2020	<a href="http://www.ccsa.org.cn:9001/portalsFile/downloadOldFile?type=17&amp;oldFileUrl=Rel15/TS%2038.321%20V15.9.0.docx">http://www.ccsa.org.cn:9001/portalsFile/downloadOldFile?type=17&amp;oldFileUrl=Rel15/TS%2038.321%20V15.9.0.docx</a>
ETSI	ETSI TS 138 321 15.9.0	Published		31.07.2020	<a href="http://www.etsi.org/deliver/etsi_ts/138300_138399/138321/15.09.00_60/ts_138321v150900p.pdf">http://www.etsi.org/deliver/etsi_ts/138300_138399/138321/15.09.00_60/ts_138321v150900p.pdf</a>
TSDSI	TSDSI STD T1.3GPP 38.321-15.9.0 V1.0.0	15.9.0	Published	06.10.2020	<a href="https://members.tdsi.in/index.php/s/CzkDn8dTJQ43NrX">https://members.tdsi.in/index.php/s/CzkDn8dTJQ43NrX</a>
TTA	TTAT.3G-38.321V15.9.0	15.9.0	Published	11.09.2020	<a href="http://www.tta.or.kr/data/ttasDown.jsp?where=14688&amp;pk_num=TTAT.3G-38.321V15.9.0">http://www.tta.or.kr/data/ttasDown.jsp?where=14688&amp;pk_num=TTAT.3G-38.321V15.9.0</a>

**Release 16**

ARIB	ARIB STD-T120-38.321	16.1.0	Published	28.09.2020	<a href="http://www.arib.or.jp/english/html/overview/doc/T120_T23_v2_00/2_T120/ARIB-STD-T120/Rel16/38/A38321-g10.pdf">http://www.arib.or.jp/english/html/overview/doc/T120_T23_v2_00/2_T120/ARIB-STD-T120/Rel16/38/A38321-g10.pdf</a>
ATIS	ATIS.3GPP.38.321V1610	16.1.0	Published	08.09.2020	<a href="http://www.atis.org/3gpp-documents/Rel16">http://www.atis.org/3gpp-documents/Rel16</a>
CCSA	CCSA.38.321V1610	16.1.0	Published	24.07.2020	<a href="http://www.ccsa.org.cn:9001/portalsFile/downloadOldFile?type=17&amp;oldFileUrl=Rel16/TS%2038.321%20V16.1.0.docx">http://www.ccsa.org.cn:9001/portalsFile/downloadOldFile?type=17&amp;oldFileUrl=Rel16/TS%2038.321%20V16.1.0.docx</a>
ETSI	ETSI TS 138 321	16.1.0	Published	30.07.2020	<a href="http://www.etsi.org/deliver/etsi_ts/138300_138399/138321/16.01.00_60/ts_138321v160100p.pdf">http://www.etsi.org/deliver/etsi_ts/138300_138399/138321/16.01.00_60/ts_138321v160100p.pdf</a>
TSDSI	TSDSI STD T1.3GPP 38.321-16.1.0 V1.0.0	16.1.0	Published	06.10.2020	<a href="https://members.tdsi.in/index.php/s/WQQ7eTbaggiGC5f">https://members.tdsi.in/index.php/s/WQQ7eTbaggiGC5f</a>
TTA	TTAT.3G-38.321V16.1.0	16.1.0	Published	11.09.2020	<a href="http://www.tta.or.kr/data/ttasDown.jsp?where=14688&amp;pk_num=TTAT.3G-38.321V16.1.0">http://www.tta.or.kr/data/ttasDown.jsp?where=14688&amp;pk_num=TTAT.3G-38.321V16.1.0</a>

**2.2.1.3.12 TS 38.322****NR; Radio Link Control (RLC) protocol specification**

This document specifies the NR Radio Link Control (RLC) protocol for the UE – NR radio interface.

SDO	Document No.	Version	Status	Issued date	Location
<b>Release 15</b>					
ARIB	ARIB STD-T120-38.322	15.5.0	Published	28.09.2020	<a href="http://www.arib.or.jp/english/html/overview/doc/T120_T23_v2_00/2_T120/ARIB-STD-T120/Rel15/38/A38322-f50.pdf">http://www.arib.or.jp/english/html/overview/doc/T120_T23_v2_00/2_T120/ARIB-STD-T120/Rel15/38/A38322-f50.pdf</a>
ATIS	ATIS.3GPP.38.322V1550	15.5.0	Published	08.09.2020	<a href="http://www.atis.org/3gpp-documents/Rel15">http://www.atis.org/3gpp-documents/Rel15</a>
CCSA	CCSA.38.322V1550	15.5.0	Published	09.04.2019	<a href="http://www.ccsa.org.cn:9001/portalsFile/downloadOldFile?type=17&amp;oldFileUrl=Rel15/TS%2038.322%20V15.5.0.docx">http://www.ccsa.org.cn:9001/portalsFile/downloadOldFile?type=17&amp;oldFileUrl=Rel15/TS%2038.322%20V15.5.0.docx</a>
ETSI	ETSI TS 138 322	15.5.0	Published	10.05.2019	<a href="http://www.etsi.org/deliver/etsi_ts/138300_138399/138322/15.05.00_60/ts_138322v150500p.pdf">http://www.etsi.org/deliver/etsi_ts/138300_138399/138322/15.05.00_60/ts_138322v150500p.pdf</a>
TSDSI	TSDSI STD T1.3GPP 38.322-15.5.0 V1.0.0	15.5.0	Published	06.10.2020	<a href="https://members.tdsi.in/index.php/s/24K2wCxq8oFbCnB">https://members.tdsi.in/index.php/s/24K2wCxq8oFbCnB</a>
TTA	TTAT.3G-38.322V15.5.0	15.5.0	Published	11.09.2020	<a href="http://www.tta.or.kr/data/ttasDown.jsp?where=14688&amp;pk_num=TTAT.3G-38.322V15.5.0">http://www.tta.or.kr/data/ttasDown.jsp?where=14688&amp;pk_num=TTAT.3G-38.322V15.5.0</a>
<b>Release 16</b>					
ARIB	ARIB STD-T120-38.322	16.1.0	Published	28.09.2020	<a href="http://www.arib.or.jp/english/html/overview/doc/T120_T23_v2_00/2_T120/ARIB-STD-T120/Rel16/38/A38322-g10.pdf">http://www.arib.or.jp/english/html/overview/doc/T120_T23_v2_00/2_T120/ARIB-STD-T120/Rel16/38/A38322-g10.pdf</a>
ATIS	ATIS.3GPP.38.322V1610	16.1.0	Published	08.09.2020	<a href="http://www.atis.org/3gpp-documents/Rel16">http://www.atis.org/3gpp-documents/Rel16</a>
CCSA	CCSA.38.322V1610	16.1.0	Published	24.07.2020	<a href="http://www.ccsa.org.cn:9001/portalsFile/downloadOldFile?type=17&amp;oldFileUrl=Rel16/TS%2038.322%20V16.1.0.docx">http://www.ccsa.org.cn:9001/portalsFile/downloadOldFile?type=17&amp;oldFileUrl=Rel16/TS%2038.322%20V16.1.0.docx</a>
ETSI	ETSI TS 138 322	16.1.0	Published	31.07.2020	<a href="http://www.etsi.org/deliver/etsi_ts/138300_138399/138322/16.01.00_60/ts_138322v160100p.pdf">http://www.etsi.org/deliver/etsi_ts/138300_138399/138322/16.01.00_60/ts_138322v160100p.pdf</a>
TSDSI	TSDSI STD T1.3GPP 38.322-16.1.0 V1.0.0	16.1.0	Published	06.10.2020	<a href="https://members.tdsi.in/index.php/s/fbZegak9q9Y5THr">https://members.tdsi.in/index.php/s/fbZegak9q9Y5THr</a>
TTA	TTAT.3G-38.322V16.1.0	16.1.0	Published	11.09.2020	<a href="http://www.tta.or.kr/data/ttasDown.jsp?where=14688&amp;pk_num=TTAT.3G-38.322V16.1.0">http://www.tta.or.kr/data/ttasDown.jsp?where=14688&amp;pk_num=TTAT.3G-38.322V16.1.0</a>

**2.2.1.3.13 TS 38.323****NR; Packet Data Convergence Protocol (PDCP) specification**

This document provides the description of the Packet Data Convergence Protocol (PDCP).

SDO	Document No.	Version	Status	Issued date	Location
<b>Release 15</b>					
ARIB	ARIB STD-T120-38.323	15.6.0	Published	28.09.2020	<a href="http://www.arib.or.jp/english/html/overview/doc/T120_T23_v2_00/2_T120/ARIB-STD-T120/Rel15/38/A38323-f60.pdf">http://www.arib.or.jp/english/html/overview/doc/T120_T23_v2_00/2_T120/ARIB-STD-T120/Rel15/38/A38323-f60.pdf</a>
ATIS	ATIS.3GPP.38.323V1560	15.6.0	Published	08.09.2020	<a href="http://www.atis.org/3gpp-documents/Rel15">http://www.atis.org/3gpp-documents/Rel15</a>
CCSA	CCSA.38.323V1560	15.6.0	Published	28.06.2019	<a href="http://www.ccsa.org.cn:9001/portalsFile/downloadOldFile?type=17&amp;oldFileUrl=Rel15/TS%2038.323%20V15.6.0.docx">http://www.ccsa.org.cn:9001/portalsFile/downloadOldFile?type=17&amp;oldFileUrl=Rel15/TS%2038.323%20V15.6.0.docx</a>
ETSI	ETSI TS 138 323	15.6.0	Published	25.07.2019	<a href="http://www.etsi.org/deliver/etsi_ts/138300_138399/138323/15.06.00_60/ts_138323v150600p.pdf">http://www.etsi.org/deliver/etsi_ts/138300_138399/138323/15.06.00_60/ts_138323v150600p.pdf</a>
TSDSI	TSDSI STD T1.3GPP 38.323-15.6.0 V1.0.0	15.6.0	Published	06.10.2020	<a href="https://members.tdsi.in/index.php/s/egg7i5QTpnreMrJ">https://members.tdsi.in/index.php/s/egg7i5QTpnreMrJ</a>
TTA	TTAT.3G-38.323V15.6.0	15.6.0	Published	11.09.2020	<a href="http://www.tta.or.kr/data/ttasDown.jsp?where=14688&amp;pk_num=TTAT.3G-38.323V15.6.0">http://www.tta.or.kr/data/ttasDown.jsp?where=14688&amp;pk_num=TTAT.3G-38.323V15.6.0</a>
<b>Release 16</b>					
ARIB	ARIB STD-T120-38.323	16.1.0	Published	28.09.2020	<a href="http://www.arib.or.jp/english/html/overview/doc/T120_T23_v2_00/2_T120/ARIB-STD-T120/Rel16/38/A38323-g10.pdf">http://www.arib.or.jp/english/html/overview/doc/T120_T23_v2_00/2_T120/ARIB-STD-T120/Rel16/38/A38323-g10.pdf</a>
ATIS	ATIS.3GPP.38.323V1610	16.1.0	Published	08.09.2020	<a href="http://www.atis.org/3gpp-documents/Rel16">http://www.atis.org/3gpp-documents/Rel16</a>
CCSA	CCSA.38.323V1610	16.1.0	Published	24.07.2020	<a href="http://www.ccsa.org.cn:9001/portalsFile/downloadOldFile?type=17&amp;oldFileUrl=Rel16/TS%2038.323%20V16.1.0.docx">http://www.ccsa.org.cn:9001/portalsFile/downloadOldFile?type=17&amp;oldFileUrl=Rel16/TS%2038.323%20V16.1.0.docx</a>

ETSI	ETSI TS 138 323	16.1.0	Published	30.07.2020	<a href="http://www.etsi.org/deliver/etsi_ts/138300_138399/138323/16.01.00_60/ts_138323v160100p.pdf">http://www.etsi.org/deliver/etsi_ts/138300_138399/138323/16.01.00_60/ts_138323v160100p.pdf</a>
TSDSI	TSDSI STD T1.3GPP 38.323-16.1.0 V1.0.0	16.1.0	Published	06.10.2020	<a href="https://members.tdsi.in/index.php/s/2SRydCb8XGas3kS">https://members.tdsi.in/index.php/s/2SRydCb8XGas3kS</a>
TTA	TTAT.3G-38.323V16.1.0	16.1.0	Published	11.09.2020	<a href="http://www.tta.or.kr/data/ttasDown.jsp?where=14688&amp;pk_num=TTAT.3G-38.323V16.1.0">http://www.tta.or.kr/data/ttasDown.jsp?where=14688&amp;pk_num=TTAT.3G-38.323V16.1.0</a>

### 2.2.1.3.14 TS 38.331

#### NR; Radio Resource Control (RRC); Protocol specification

This document specifies the Radio Resource Control protocol for the radio interface between UE and NG-RAN.

The scope of this document also includes:

- the radio related information transported in a transparent container between source gNB and target gNB upon inter gNB handover;
- the radio related information transported in a transparent container between a source or target gNB and another system upon inter RAT handover.
- the radio related information transported in a transparent container between a source eNB and target gNB during E-UTRA-NR Dual Connectivity.

SDO	Document No.	Version	Status	Issued date	Location
<b>Release 15</b>					
ARIB	ARIB STD-T120-38.331	15.10.0	Published	28.09.2020	<a href="http://www.arib.or.jp/english/html/overview/doc/T120_T23_v2_00/2_T120/ARIB-STD-T120/Rel15/38/A38331-fa0.pdf">http://www.arib.or.jp/english/html/overview/doc/T120_T23_v2_00/2_T120/ARIB-STD-T120/Rel15/38/A38331-fa0.pdf</a>
ATIS	ATIS.3GPP.38.331V15100	15.10.0	Published	08.09.2020	<a href="http://www.atis.org/3gpp-documents/Rel15">http://www.atis.org/3gpp-documents/Rel15</a>
CCSA	CCSA.38.331V15100	15.10.0	Published	24.07.2020	<a href="http://www.ccsa.org.cn:9001/portalsFile/downloadOldFile?type=17&amp;oldFileUrl=Rel15/TS%2038.331%20V15.10.0.docx">http://www.ccsa.org.cn:9001/portalsFile/downloadOldFile?type=17&amp;oldFileUrl=Rel15/TS%2038.331%20V15.10.0.docx</a>
ETSI	ETSI TS 138 331	15.10.0	Published	30.07.2020	<a href="http://www.etsi.org/deliver/etsi_ts/138300_138399/138331/15.10.00_60/ts_138331v151000p.pdf">http://www.etsi.org/deliver/etsi_ts/138300_138399/138331/15.10.00_60/ts_138331v151000p.pdf</a>
TSDSI	TSDSI STD T1.3GPP 38.331-15.10.0 V1.0.0	15.10.0	Published	06.10.2020	<a href="https://members.tdsi.in/index.php/s/L3ELMSr5maHX5oC">https://members.tdsi.in/index.php/s/L3ELMSr5maHX5oC</a>
TTA	TTAT.3G-38.331V15.10.0	15.10.0	Published	11.09.2020	<a href="http://www.tta.or.kr/data/ttasDown.jsp?where=14688&amp;pk_num=TTAT.3G-38.331V15.10.0">http://www.tta.or.kr/data/ttasDown.jsp?where=14688&amp;pk_num=TTAT.3G-38.331V15.10.0</a>
<b>Release 16</b>					
ARIB	ARIB STD-T120-38.331	16.1.0	Published	28.09.2020	<a href="http://www.arib.or.jp/english/html/overview/doc/T120_T23_v2_00/2_T120/ARIB-STD-T120/Rel16/38/A38331-g10.pdf">http://www.arib.or.jp/english/html/overview/doc/T120_T23_v2_00/2_T120/ARIB-STD-T120/Rel16/38/A38331-g10.pdf</a>
ATIS	ATIS.3GPP.38.331V1610	16.1.0	Published	08.09.2020	<a href="http://www.atis.org/3gpp-documents/Rel16">http://www.atis.org/3gpp-documents/Rel16</a>
CCSA	CCSA.38.331V1610	16.1.0	Published	24.07.2020	<a href="http://www.ccsa.org.cn:9001/portalsFile/downloadOldFile?type=17&amp;oldFileUrl=Rel16/TS%2038.331%20V16.1.0.docx">http://www.ccsa.org.cn:9001/portalsFile/downloadOldFile?type=17&amp;oldFileUrl=Rel16/TS%2038.331%20V16.1.0.docx</a>
ETSI	ETSI TS 138 331	16.1.0	Published	30.07.2020	<a href="http://www.etsi.org/deliver/etsi_ts/138300_138399/138331/16.01.00_60/ts_138331v160100p.pdf">http://www.etsi.org/deliver/etsi_ts/138300_138399/138331/16.01.00_60/ts_138331v160100p.pdf</a>
TSDSI	TSDSI STD T1.3GPP 38.331-16.1.0 V1.0.0	16.1.0	Published	06.10.2020	<a href="https://members.tdsi.in/index.php/s/9RJxfOP7ZKK5wbX">https://members.tdsi.in/index.php/s/9RJxfOP7ZKK5wbX</a>
TTA	TTAT.3G-38.331V16.1.0	16.1.0	Published	11.09.2020	<a href="http://www.tta.or.kr/data/ttasDown.jsp?where=14688&amp;pk_num=TTAT.3G-38.331V16.1.0">http://www.tta.or.kr/data/ttasDown.jsp?where=14688&amp;pk_num=TTAT.3G-38.331V16.1.0</a>

### 2.2.1.3.15 TS 38.340

#### NR; Backhaul Adaptation Protocol (BAP) specification

This document provides description of the Backhaul Adaptation Protocol (BAP).

SDO	Document No.	Version	Status	Issued date	Location
<b>Release 16</b>					
ARIB	ARIB STD-T120-38.340	16.1.0	Published	28.09.2020	<a href="http://www.arib.or.jp/english/html/overview/doc/T120_T23_v2_00/2_T120/ARIB-STD-T120/Rel16/38/A38340-g10.pdf">http://www.arib.or.jp/english/html/overview/doc/T120_T23_v2_00/2_T120/ARIB-STD-T120/Rel16/38/A38340-g10.pdf</a>
ATIS	ATIS.3GPP.38.340V1610	16.1.0	Published	08.09.2020	<a href="http://www.atis.org/3gpp-documents/Rel16">http://www.atis.org/3gpp-documents/Rel16</a>
CCSA	CCSA.38.340V1610	16.1.0	Published	24.07.2020	<a href="http://www.ccsa.org.cn:9001/portalsFile/downloadOldFile?type=17&amp;oldFileUrl=Rel16/TS%2038.340%20V16.1.0.docx">http://www.ccsa.org.cn:9001/portalsFile/downloadOldFile?type=17&amp;oldFileUrl=Rel16/TS%2038.340%20V16.1.0.docx</a>
ETSI	ETSI TS 138 340	16.1.0	Published	30.07.2020	<a href="http://www.etsi.org/deliver/etsi_ts/138300_138399/138340/16.01.00_60/ts_138340v160100p.pdf">http://www.etsi.org/deliver/etsi_ts/138300_138399/138340/16.01.00_60/ts_138340v160100p.pdf</a>
TSDSI	TSDSI STD T1.3GPP 38.340-16.1.0 V1.0.0	16.1.0	Published	06.10.2020	<a href="https://members.tdsi.in/index.php/s/3tRPzsoksc6Q3GS">https://members.tdsi.in/index.php/s/3tRPzsoksc6Q3GS</a>
TTA	TTAT.3G-38.340V16.1.0	16.1.0	Published	11.09.2020	<a href="http://www.tta.or.kr/data/ttasDown.jsp?where=14688&amp;pk_num=TTAT.3G-38.340V16.1.0">http://www.tta.or.kr/data/ttasDown.jsp?where=14688&amp;pk_num=TTAT.3G-38.340V16.1.0</a>

## 2.2.1.4 Architecture

### 2.2.1.4.1 TS 37.460

#### Iuant interface: General aspects and principles

This document is an introduction to the 3GPP TS 37.46x series of Technical Specifications that define the Iuant Interface. The Iuant interface is applicable for UTRAN, E-UTRAN and NG-RAN. In this specification UTRAN, E-UTRAN and NG-RAN are denoted as "RAN", whereas the corresponding network entities Node B, eNB, en-gNB and NG-RAN node are denoted as "RAN Node". The logical Iuant interface is an interface internal to the RAN Node and defined to reside between the implementation specific O&M function and the RET antennas and between the implementation specific O&M function and the TMA control unit function.

SDO	Document No.	Version	Status	Issued date	Location	
<b>Release 15</b>						
ARIB	ARIB STD-T120-37.460		15.2.0	Published	28.09.2020	<a href="http://www.arib.or.jp/english/html/overview/doc/T120_T23_v2_00/2_T120/ARIB-STD-T120/Rel15/37/A37460-f20.pdf">http://www.arib.or.jp/english/html/overview/doc/T120_T23_v2_00/2_T120/ARIB-STD-T120/Rel15/37/A37460-f20.pdf</a>
ATIS	ATIS.3GPP.37.460V1520		15.2.0	Published	08.09.2020	<a href="http://www.atis.org/3gpp-documents/Rel15">http://www.atis.org/3gpp-documents/Rel15</a>
CCSA	CCSA.37.460V1520		15.2.0	Published	09.01.2020	<a href="http://www.ccsa.org.cn:9001/portalsFile/downloadOldFile?type=17&amp;oldFileUrl=Rel15/TS%2037.460%20V15.2.0.doc">http://www.ccsa.org.cn:9001/portalsFile/downloadOldFile?type=17&amp;oldFileUrl=Rel15/TS%2037.460%20V15.2.0.doc</a>
ETSI	ETSI TS 137 460		15.2.0	Published	17.01.2020	<a href="http://www.etsi.org/deliver/etsi_ts/137400_137499/137460/15.02.00_60/ts_137460v150200p.pdf">http://www.etsi.org/deliver/etsi_ts/137400_137499/137460/15.02.00_60/ts_137460v150200p.pdf</a>
TSDSI	TSDSI STD T1.3GPP 37.460-15.2.0 V1.0.0		15.2.0	Published	06.10.2020	<a href="https://members.tdsi.in/index.php/s/C3SDXoFzkzmPeeM">https://members.tdsi.in/index.php/s/C3SDXoFzkzmPeeM</a>
TTA	TTAT.3G-37.460V15.2.0		15.2.0	Published	11.09.2020	<a href="http://www.tta.or.kr/data/ttasDown.jsp?where=14688&amp;pk_num=TTAT.3G-37.460V15.2.0">http://www.tta.or.kr/data/ttasDown.jsp?where=14688&amp;pk_num=TTAT.3G-37.460V15.2.0</a>
<b>Release 16</b>						
ARIB	ARIB STD-T120-37.460		16.0.0	Published	28.09.2020	<a href="http://www.arib.or.jp/english/html/overview/doc/T120_T23_v2_00/2_T120/ARIB-STD-T120/Rel16/37/A37460-g00.pdf">http://www.arib.or.jp/english/html/overview/doc/T120_T23_v2_00/2_T120/ARIB-STD-T120/Rel16/37/A37460-g00.pdf</a>
ATIS	ATIS.3GPP.37.460V1600		16.0.0	Published	08.09.2020	<a href="http://www.atis.org/3gpp-documents/Rel16">http://www.atis.org/3gpp-documents/Rel16</a>
CCSA	CCSA.37.460V1600		16.0.0	Published	17.07.2020	<a href="http://www.ccsa.org.cn:9001/portalsFile/downloadOldFile?type=17&amp;oldFileUrl=Rel16/TS%2037.460%20V16.0.0.doc">http://www.ccsa.org.cn:9001/portalsFile/downloadOldFile?type=17&amp;oldFileUrl=Rel16/TS%2037.460%20V16.0.0.doc</a>
ETSI	ETSI TS 137 460		16.0.0	Published	15.09.2020	<a href="http://www.etsi.org/deliver/etsi_ts/137400_137499/137460/16.00.00_60/ts_137460v160000p.pdf">http://www.etsi.org/deliver/etsi_ts/137400_137499/137460/16.00.00_60/ts_137460v160000p.pdf</a>
TSDSI	TSDSI STD T1.3GPP 37.460-16.0.0 V1.0.0		16.0.0	Published	06.10.2020	<a href="https://members.tdsi.in/index.php/s/3HG7csB4NabyzNQ">https://members.tdsi.in/index.php/s/3HG7csB4NabyzNQ</a>
TTA	TTAT.3G-37.460V16.0.0		16.0.0	Published	11.09.2020	<a href="http://www.tta.or.kr/data/ttasDown.jsp?where=14688&amp;pk_num=TTAT.3G-37.460V16.0.0">http://www.tta.or.kr/data/ttasDown.jsp?where=14688&amp;pk_num=TTAT.3G-37.460V16.0.0</a>

### 2.2.1.4.2 TS 37.461

#### Iuant interface: Layer 1

This document specifies the standards allowed to implement layer 1 on the Iuant interface for UTRA, E-UTRA and NR.

The specification of transmission delay requirements and O&M requirements are not in the scope of this document.

SDO	Document No.	Version	Status	Issued date	Location	
<b>Release 15</b>						
ARIB	ARIB STD-T120-37.461		15.4.0	Published	28.09.2020	<a href="http://www.arib.or.jp/english/html/overview/doc/T120_T23_v2_00/2_T120/ARIB-STD-T120/Rel15/37/A37461-f40.pdf">http://www.arib.or.jp/english/html/overview/doc/T120_T23_v2_00/2_T120/ARIB-STD-T120/Rel15/37/A37461-f40.pdf</a>
ATIS	ATIS.3GPP.37.461V1540		15.4.0	Published	08.09.2020	<a href="http://www.atis.org/3gpp-documents/Rel15">http://www.atis.org/3gpp-documents/Rel15</a>
CCSA	CCSA.37.461V1540		15.4.0	Published	20.04.2019	<a href="http://www.ccsa.org.cn:9001/portalsFile/downloadOldFile?type=17&amp;oldFileUrl=Rel15/TS%2037.461%20V15.4.0.doc">http://www.ccsa.org.cn:9001/portalsFile/downloadOldFile?type=17&amp;oldFileUrl=Rel15/TS%2037.461%20V15.4.0.doc</a>
ETSI	ETSI TS 137 461		15.4.0	Published	15.05.2019	<a href="http://www.etsi.org/deliver/etsi_ts/137400_137499/137461/15.04.00_60/ts_137461v150400p.pdf">http://www.etsi.org/deliver/etsi_ts/137400_137499/137461/15.04.00_60/ts_137461v150400p.pdf</a>
TSDSI	TSDSI STD T1.3GPP 37.461-15.4.0 V1.0.0		15.4.0	Published	06.10.2020	<a href="https://members.tdsi.in/index.php/s/pkmKkZQZ5qE5dGT">https://members.tdsi.in/index.php/s/pkmKkZQZ5qE5dGT</a>
TTA	TTAT.3G-37.461V15.4.0		15.4.0	Published	11.09.2020	<a href="http://www.tta.or.kr/data/ttasDown.jsp?where=14688&amp;pk_num=TTAT.3G-37.461V15.4.0">http://www.tta.or.kr/data/ttasDown.jsp?where=14688&amp;pk_num=TTAT.3G-37.461V15.4.0</a>
<b>Release 16</b>						
ARIB	ARIB STD-T120-37.461		16.0.0	Published	28.09.2020	<a href="http://www.arib.or.jp/english/html/overview/doc/T120_T23_v2_00/2_T120/ARIB-STD-T120/Rel16/37/A37461-g00.pdf">http://www.arib.or.jp/english/html/overview/doc/T120_T23_v2_00/2_T120/ARIB-STD-T120/Rel16/37/A37461-g00.pdf</a>
ATIS	ATIS.3GPP.37.461V1600		16.0.0	Published	08.09.2020	<a href="http://www.atis.org/3gpp-documents/Rel16">http://www.atis.org/3gpp-documents/Rel16</a>

## 166

## Rec. ITU-R M.2150-0

CCSA	CCSA.37.461V1600	16.0.0	Published	17.07.2020	<a href="http://www.ccsa.org.cn:9001/portalsFile/downloadOldFile?type=17&amp;oldFileUrl=Rel16/TS%2037.461%20V16.0.0.doc">http://www.ccsa.org.cn:9001/portalsFile/downloadOldFile?type=17&amp;oldFileUrl=Rel16/TS%2037.461%20V16.0.0.doc</a>
ETSI	ETSI TS 137 461	16.0.0	Published	15.09.2020	<a href="http://www.etsi.org/deliver/etsi_ts/137400_137499/137461/16.00.00_60/ts_137461v160000p.pdf">http://www.etsi.org/deliver/etsi_ts/137400_137499/137461/16.00.00_60/ts_137461v160000p.pdf</a>
TSDSI	TSDSI STD T1.3GPP 37.461-16.0.0 V1.0.0	16.0.0	Published	06.10.2020	<a href="https://members.tdsi.in/index.php/s/LCXXKrtEprG9PYWg">https://members.tdsi.in/index.php/s/LCXXKrtEprG9PYWg</a>
TTA	TTAT.3G-37.461V16.0.0	16.0.0	Published	11.09.2020	<a href="http://www.tta.or.kr/data/ttasDown.jsp?where=14688&amp;pk_num=TTAT.3G-37.461V16.0.0">http://www.tta.or.kr/data/ttasDown.jsp?where=14688&amp;pk_num=TTAT.3G-37.461V16.0.0</a>

### 2.2.1.4.3 TS 37.462

#### Iuant interface: Signalling transport

This document specifies the signalling transport related to RETAP and TMAAP signalling to be used across the Iuant interface for UTRAN, E-UTRAN and NG-RAN. In this specification UTRAN, E-UTRAN and NG-RAN are denoted as "RAN", whereas the corresponding network entities Node B, eNB, en-gNB and NG-RAN node are denoted as "RAN Node". The logical Iuant interface is an interface internal to the RAN Node and defined to reside between the implementation specific O&M function and the RET antennas and between the implementation specific O&M function and the TMA control unit function.

SDO	Document No.	Version	Status	Issued date	Location
<b>Release 15</b>					
ARIB	ARIB STD-T120-37.462	15.2.0	Published	28.09.2020	<a href="http://www.arib.or.jp/english/html/overview/doc/T120_T23_v2_00/2_T120/ARIB-STD-T120/Rel15/37/A37462-f20.pdf">http://www.arib.or.jp/english/html/overview/doc/T120_T23_v2_00/2_T120/ARIB-STD-T120/Rel15/37/A37462-f20.pdf</a>
ATIS	ATIS.3GPP.37.462V1520	15.2.0	Published	08.09.2020	<a href="http://www.atis.org/3gpp-documents/Rel15">http://www.atis.org/3gpp-documents/Rel15</a>
CCSA	CCSA.37.462V1520	15.2.0	Published	09.01.2020	<a href="http://www.ccsa.org.cn:9001/portalsFile/downloadOldFile?type=17&amp;oldFileUrl=Rel15/TS%2037.462%20V15.2.0.doc">http://www.ccsa.org.cn:9001/portalsFile/downloadOldFile?type=17&amp;oldFileUrl=Rel15/TS%2037.462%20V15.2.0.doc</a>
ETSI	ETSI TS 137 462	15.2.0	Published	17.01.2020	<a href="http://www.etsi.org/deliver/etsi_ts/137400_137499/137462/15.02.00_60/ts_137462v150200p.pdf">http://www.etsi.org/deliver/etsi_ts/137400_137499/137462/15.02.00_60/ts_137462v150200p.pdf</a>
TSDSI	TSDSI STD T1.3GPP 37.462-15.2.0 V1.0.0	15.2.0	Published	06.10.2020	<a href="https://members.tdsi.in/index.php/s/KNsFOxJcdmeTETQ">https://members.tdsi.in/index.php/s/KNsFOxJcdmeTETQ</a>
TTA	TTAT.3G-37.462V15.2.0	15.2.0	Published	11.09.2020	<a href="http://www.tta.or.kr/data/ttasDown.jsp?where=14688&amp;pk_num=TTAT.3G-37.462V15.2.0">http://www.tta.or.kr/data/ttasDown.jsp?where=14688&amp;pk_num=TTAT.3G-37.462V15.2.0</a>
<b>Release 16</b>					
ARIB	ARIB STD-T120-37.462	16.0.0	Published	28.09.2020	<a href="http://www.arib.or.jp/english/html/overview/doc/T120_T23_v2_00/2_T120/ARIB-STD-T120/Rel16/37/A37462-g00.pdf">http://www.arib.or.jp/english/html/overview/doc/T120_T23_v2_00/2_T120/ARIB-STD-T120/Rel16/37/A37462-g00.pdf</a>
ATIS	ATIS.3GPP.37.462V1600	16.0.0	Published	08.09.2020	<a href="http://www.atis.org/3gpp-documents/Rel16">http://www.atis.org/3gpp-documents/Rel16</a>
CCSA	CCSA.37.462V1600	16.0.0	Published	20.07.2020	<a href="http://www.ccsa.org.cn:9001/portalsFile/downloadOldFile?type=17&amp;oldFileUrl=Rel16/TS%2037.462%20V16.0.0.doc">http://www.ccsa.org.cn:9001/portalsFile/downloadOldFile?type=17&amp;oldFileUrl=Rel16/TS%2037.462%20V16.0.0.doc</a>
ETSI	ETSI TS 137 462	16.0.0	Published	17.09.2020	<a href="http://www.etsi.org/deliver/etsi_ts/137400_137499/137462/16.00.00_60/ts_137462v160000p.pdf">http://www.etsi.org/deliver/etsi_ts/137400_137499/137462/16.00.00_60/ts_137462v160000p.pdf</a>
TSDSI	TSDSI STD T1.3GPP 37.462-16.0.0 V1.0.0	16.0.0	Published	06.10.2020	<a href="https://members.tdsi.in/index.php/s/oCmRjWdCXtn8c4b">https://members.tdsi.in/index.php/s/oCmRjWdCXtn8c4b</a>
TTA	TTAT.3G-37.462V16.0.0	16.0.0	Published	11.09.2020	<a href="http://www.tta.or.kr/data/ttasDown.jsp?where=14688&amp;pk_num=TTAT.3G-37.462V16.0.0">http://www.tta.or.kr/data/ttasDown.jsp?where=14688&amp;pk_num=TTAT.3G-37.462V16.0.0</a>

### 2.2.1.4.4 TS 37.466

#### Iuant interface: Application part

This document is an introduction to the 3GPP TS 37.46x series of Technical Specifications that define the Iuant Interface. The Iuant interface is applicable for UTRAN, E-UTRAN and NG-RAN. In this specification UTRAN, E-UTRAN and NG-RAN are denoted as "RAN", whereas the corresponding network entities Node B, eNB, en-gNB and NG-RAN node are denoted as "RAN Node". The logical Iuant interface is an interface internal to the RAN Node and defined to reside between the implementation specific O&M function and the RET antennas together with the TMAs control unit function of the RAN Node.

This document is applicable for UTRAN, E-UTRAN and NG-RAN and specifies the *Remote Electrical Tilting Application Part (RETAP)* and the *Tower Mounted Amplifier Application Part (TMAAP)*. In this specification UTRAN, E-UTRAN and NG-RAN are denoted as "RAN", whereas the corresponding network entities Node B, eNB, en-gNB and NG-RAN node are denoted as "RAN Node". RETAP supports the functions of the Iuant interface between the implementation specific O&M transport function and the RET Antenna Control unit function, TMAAP supports the functions of the Iuant interface between the implementation specific O&M transport function and the TMA control function.



SDO	Document No.	Version	Status	Issued date	Location
<b>Release 15</b>					
ARIB	ARIB STD-T120-37.466		15.5.0	Published 28.09.2020	<a href="http://www.arib.or.jp/english/html/overview/doc/T120_T23_v2_00/2_T120/ARIB-STD-T120/Rel15/37/A37466-f50.pdf">http://www.arib.or.jp/english/html/overview/doc/T120_T23_v2_00/2_T120/ARIB-STD-T120/Rel15/37/A37466-f50.pdf</a>
ATIS	ATIS.3GPP.37.466V1550		15.5.0	Published 08.09.2020	<a href="http://www.atis.org/3gpp-documents/Rel15">http://www.atis.org/3gpp-documents/Rel15</a>
CCSA	CCSA.37.466V1550		15.5.0	Published 09.01.2020	<a href="http://www.ccsa.org.cn:9001/portalsFile/downloadOldFile?type=17&amp;oldFileUrl=Rel15/TS%2037.466%20V15.5.0.doc">http://www.ccsa.org.cn:9001/portalsFile/downloadOldFile?type=17&amp;oldFileUrl=Rel15/TS%2037.466%20V15.5.0.doc</a>
ETSI	ETSI TS 137 466		15.5.0	Published 17.01.2020	<a href="http://www.etsi.org/deliver/etsi_ts/137400_137499/137466/15.05.00_60/ts_137466v150500p.pdf">http://www.etsi.org/deliver/etsi_ts/137400_137499/137466/15.05.00_60/ts_137466v150500p.pdf</a>
TSDSI	TSDSI STD T1.3GPP 37.466-15.5.0 V1.0.0		15.5.0	Published 06.10.2020	<a href="https://members.tdsi.in/index.php/s/EeHNBLpXRMtgdtW">https://members.tdsi.in/index.php/s/EeHNBLpXRMtgdtW</a>
TTA	TTAT.3G-37.466V15.5.0		15.5.0	Published 11.09.2020	<a href="http://www.tta.or.kr/data/ttasDown.jsp?where=14688&amp;pk_num=TTAT.3G-37.466V15.5.0">http://www.tta.or.kr/data/ttasDown.jsp?where=14688&amp;pk_num=TTAT.3G-37.466V15.5.0</a>
<b>Release 16</b>					
ARIB	ARIB STD-T120-37.466		16.0.0	Published 28.09.2020	<a href="http://www.arib.or.jp/english/html/overview/doc/T120_T23_v2_00/2_T120/ARIB-STD-T120/Rel16/37/A37466-g00.pdf">http://www.arib.or.jp/english/html/overview/doc/T120_T23_v2_00/2_T120/ARIB-STD-T120/Rel16/37/A37466-g00.pdf</a>
ATIS	ATIS.3GPP.37.466V1600		16.0.0	Published 08.09.2020	<a href="http://www.atis.org/3gpp-documents/Rel16">http://www.atis.org/3gpp-documents/Rel16</a>
CCSA	CCSA.37.466V1600		16.0.0	Published 28.07.2020	<a href="http://www.ccsa.org.cn:9001/portalsFile/downloadOldFile?type=17&amp;oldFileUrl=Rel16/TS%2037.466%20V16.0.0.doc">http://www.ccsa.org.cn:9001/portalsFile/downloadOldFile?type=17&amp;oldFileUrl=Rel16/TS%2037.466%20V16.0.0.doc</a>
ETSI	ETSI TS 137 466		16.0.0	Published 18.09.2020	<a href="http://www.etsi.org/deliver/etsi_ts/137400_137499/137466/16.00.00_60/ts_137466v160000p.pdf">http://www.etsi.org/deliver/etsi_ts/137400_137499/137466/16.00.00_60/ts_137466v160000p.pdf</a>
TSDSI	TSDSI STD T1.3GPP 37.466-16.0.0 V1.0.0		16.0.0	Published 06.10.2020	<a href="https://members.tdsi.in/index.php/s/e8qXqTXA69FcGtH">https://members.tdsi.in/index.php/s/e8qXqTXA69FcGtH</a>
TTA	TTAT.3G-37.466V16.0.0		16.0.0	Published 11.09.2020	<a href="http://www.tta.or.kr/data/ttasDown.jsp?where=14688&amp;pk_num=TTAT.3G-37.466V16.0.0">http://www.tta.or.kr/data/ttasDown.jsp?where=14688&amp;pk_num=TTAT.3G-37.466V16.0.0</a>

### 2.2.1.4.5 TS 37.470

#### W1 interface; General aspects and principles

This document is an introduction to the 3GPP TS 37.4xx series of technical specifications that define the W1 interface. The W1 interface provides means for interconnecting a ng-eNB-CU and a ng-eNB-DU of a ng-eNB within a NG-RAN.

SDO	Document No.	Version	Status	Issued date	Location
<b>Release 16</b>					
ARIB	ARIB STD-T120-37.470		16.2.0	Published 28.09.2020	<a href="http://www.arib.or.jp/english/html/overview/doc/T120_T23_v2_00/2_T120/ARIB-STD-T120/Rel16/37/A37470-g20.pdf">http://www.arib.or.jp/english/html/overview/doc/T120_T23_v2_00/2_T120/ARIB-STD-T120/Rel16/37/A37470-g20.pdf</a>
ATIS	ATIS.3GPP.37.470V1620		16.2.0	Published 08.09.2020	<a href="http://www.atis.org/3gpp-documents/Rel16">http://www.atis.org/3gpp-documents/Rel16</a>
CCSA	CCSA.37.470V1620		16.2.0	Published 17.07.2020	<a href="http://www.ccsa.org.cn:9001/portalsFile/downloadOldFile?type=17&amp;oldFileUrl=Rel16/TS%2037.370%20V16.2.0.doc">http://www.ccsa.org.cn:9001/portalsFile/downloadOldFile?type=17&amp;oldFileUrl=Rel16/TS%2037.370%20V16.2.0.doc</a>
ETSI	ETSI TS 137 470		16.2.0	Published 15.09.2020	<a href="http://www.etsi.org/deliver/etsi_ts/137400_137499/137470/16.02.00_60/ts_137470v160200p.pdf">http://www.etsi.org/deliver/etsi_ts/137400_137499/137470/16.02.00_60/ts_137470v160200p.pdf</a>
TSDSI	TSDSI STD T1.3GPP 37.470-16.2.0 V1.0.0		16.2.0	Published 06.10.2020	<a href="https://members.tdsi.in/index.php/s/5gdiKqeMnXOfK2X">https://members.tdsi.in/index.php/s/5gdiKqeMnXOfK2X</a>
TTA	TTAT.3G-37.470V16.2.0		16.2.0	Published 11.09.2020	<a href="http://www.tta.or.kr/data/ttasDown.jsp?where=14688&amp;pk_num=TTAT.3G-37.470V16.2.0">http://www.tta.or.kr/data/ttasDown.jsp?where=14688&amp;pk_num=TTAT.3G-37.470V16.2.0</a>

### 2.2.1.4.6 TS 37.471

#### W1 interface; Layer 1

This document specifies the standards allowed to implement Layer 1 on the W1 interface. The W1 interface provides means for interconnecting a ng-eNB-CU and a ng-eNB-DU of a ng-eNB within a NG-RAN.

The specification of transmission delay requirements and O&M requirements are not in the scope of this document.

In the following 'Layer 1' and 'Physical Layer' are assumed to be synonymous.

SDO	Document No.	Version	Status	Issued date	Location
<b>Release 16</b>					
ARIB	ARIB STD-T120-37.471		16.1.0	Published 28.09.2020	<a href="http://www.arib.or.jp/english/html/overview/doc/T120_T23_v2_00/2_T120/ARIB-STD-T120/Rel16/37/A37471-g10.pdf">http://www.arib.or.jp/english/html/overview/doc/T120_T23_v2_00/2_T120/ARIB-STD-T120/Rel16/37/A37471-g10.pdf</a>
ATIS	ATIS.3GPP.37.471V1610		16.1.0	Published 08.09.2020	<a href="http://www.atis.org/3gpp-documents/Rel16">http://www.atis.org/3gpp-documents/Rel16</a>
CCSA	CCSA.37.471V1610		16.1.0	Published 31.03.2020	<a href="http://www.ccsa.org.cn:9001/portalsFile/downloadOldFile?type=17&amp;oldFileUrl=Rel16/TS%2037.471%20V16.1.0.doc">http://www.ccsa.org.cn:9001/portalsFile/downloadOldFile?type=17&amp;oldFileUrl=Rel16/TS%2037.471%20V16.1.0.doc</a>

## 168

## Rec. ITU-R M.2150-0

ETSI	ETSI TS 137 471	16.1.0	Published	21.09.2020	<a href="http://www.etsi.org/deliver/etsi_ts/137400_137499/137471/16.01.00_60/ts_137471v160100p.pdf">http://www.etsi.org/deliver/etsi_ts/137400_137499/137471/16.01.00_60/ts_137471v160100p.pdf</a>
TSDSI	TSDSI STD T1.3GPP 37.471-16.1.0 V1.0.0	16.1.0	Published	06.10.2020	<a href="https://members.tdsi.in/index.php/s/YypzZHQEjmZYYjS">https://members.tdsi.in/index.php/s/YypzZHQEjmZYYjS</a>
TTA	TTAT.3G-37.471V16.1.0	16.1.0	Published	11.09.2020	<a href="http://www.tta.or.kr/data/ttasDown.jsp?where=14688&amp;pk_num=TTAT.3G-37.471V16.1.0">http://www.tta.or.kr/data/ttasDown.jsp?where=14688&amp;pk_num=TTAT.3G-37.471V16.1.0</a>

### 2.2.1.4.7 TS 37.472

#### W1 interface; Signalling transport

This document specifies the standards for Signalling Transport to be used across the W1 interface. The W1 interface provides means for interconnecting a ng-eNB-CU and a ng-eNB-DU of a ng-eNB within a NG-RAN. This document describes how the W1AP signalling messages are transported over W1.

SDO	Document No.	Version	Status	Issued date	Location
<b>Release 16</b>					
ARIB	ARIB STD-T120-37.472	16.1.0	Published	28.09.2020	<a href="http://www.arib.or.jp/english/html/overview/doc/T120_T23_v2_00/2_T120/ARIB-STD-T120/Rel16/37/A37472-g10.pdf">http://www.arib.or.jp/english/html/overview/doc/T120_T23_v2_00/2_T120/ARIB-STD-T120/Rel16/37/A37472-g10.pdf</a>
ATIS	ATIS.3GPP.37.472V1610	16.1.0	Published	08.09.2020	<a href="http://www.atis.org/3gpp-documents/Rel16">http://www.atis.org/3gpp-documents/Rel16</a>
CCSA	CCSA.37.472V1610	16.1.0	Published	17.07.2020	<a href="http://www.ccsa.org.cn:9001/portalsFile/downloadOldFile?type=17&amp;oldFileUrl=Rel16/TS%2037.472%20V16.1.0.doc">http://www.ccsa.org.cn:9001/portalsFile/downloadOldFile?type=17&amp;oldFileUrl=Rel16/TS%2037.472%20V16.1.0.doc</a>
ETSI	ETSI TS 137 472	16.1.0	Published	15.09.2020	<a href="http://www.etsi.org/deliver/etsi_ts/137400_137499/137472/16.01.00_60/ts_137472v160100p.pdf">http://www.etsi.org/deliver/etsi_ts/137400_137499/137472/16.01.00_60/ts_137472v160100p.pdf</a>
TSDSI	TSDSI STD T1.3GPP 37.472-16.1.0 V1.0.0	16.1.0	Published	06.10.2020	<a href="https://members.tdsi.in/index.php/s/ecrHinLENfpwjE7">https://members.tdsi.in/index.php/s/ecrHinLENfpwjE7</a>
TTA	TTAT.3G-37.472V16.1.0	16.1.0	Published	11.09.2020	<a href="http://www.tta.or.kr/data/ttasDown.jsp?where=14688&amp;pk_num=TTAT.3G-37.472V16.1.0">http://www.tta.or.kr/data/ttasDown.jsp?where=14688&amp;pk_num=TTAT.3G-37.472V16.1.0</a>

### 2.2.1.4.8 TS 37.473

#### W1 interface; Application Protocol (W1AP)

This document specifies the 5G radio network layer signalling protocol for the W1 interface. The W1 interface provides means for interconnecting a ng-eNB-CU and a ng-eNB-DU of a ng-eNB within an NG-RAN. The W1 Application Protocol (W1AP) supports the functions of W1 interface by signalling procedures defined in this document. W1AP is developed in accordance with the general principles stated in TS 38.401 and TS 37.470.

SDO	Document No.	Version	Status	Issued date	Location
<b>Release 16</b>					
ARIB	ARIB STD-T120-37.473	16.2.0	Published	28.09.2020	<a href="http://www.arib.or.jp/english/html/overview/doc/T120_T23_v2_00/2_T120/ARIB-STD-T120/Rel16/37/A37473-g20.pdf">http://www.arib.or.jp/english/html/overview/doc/T120_T23_v2_00/2_T120/ARIB-STD-T120/Rel16/37/A37473-g20.pdf</a>
ATIS	ATIS.3GPP.37.473V1620	16.2.0	Published	08.09.2020	<a href="http://www.atis.org/3gpp-documents/Rel16">http://www.atis.org/3gpp-documents/Rel16</a>
CCSA	CCSA.37.473V1620	16.2.0	Published	17.07.2020	<a href="http://www.ccsa.org.cn:9001/portalsFile/downloadOldFile?type=17&amp;oldFileUrl=Rel16/TS%2037.473%20V16.2.0.doc">http://www.ccsa.org.cn:9001/portalsFile/downloadOldFile?type=17&amp;oldFileUrl=Rel16/TS%2037.473%20V16.2.0.doc</a>
ETSI	ETSI TS 137 473	16.2.0	Published	15.09.2020	<a href="http://www.etsi.org/deliver/etsi_ts/137400_137499/137473/16.02.00_60/ts_137473v160200p.pdf">http://www.etsi.org/deliver/etsi_ts/137400_137499/137473/16.02.00_60/ts_137473v160200p.pdf</a>
TSDSI	TSDSI STD T1.3GPP 37.473-16.2.0 V1.0.0	16.2.0	Published	06.10.2020	<a href="https://members.tdsi.in/index.php/s/zi7XfEtayYzXDxa">https://members.tdsi.in/index.php/s/zi7XfEtayYzXDxa</a>
TTA	TTAT.3G-37.473V16.2.0	16.2.0	Published	11.09.2020	<a href="http://www.tta.or.kr/data/ttasDown.jsp?where=14688&amp;pk_num=TTAT.3G-37.473V16.2.0">http://www.tta.or.kr/data/ttasDown.jsp?where=14688&amp;pk_num=TTAT.3G-37.473V16.2.0</a>

### 2.2.1.4.9 TS 38.401

#### NG-RAN; Architecture description

This document describes the overall architecture of the NG-RAN, including interfaces NG, Xn and F1 interfaces and their interaction with the radio interface.

SDO	Document No.	Version	Status	Issued date	Location
<b>Release 15</b>					
ATIS	ATIS.3GPP.38.401V1580	15.8.0	Published	08.09.2020	<a href="http://www.atis.org/3gpp-documents/Rel15">http://www.atis.org/3gpp-documents/Rel15</a>
CCSA	CCSA.38.401V1580	15.8.0	Published	17.07.2020	<a href="http://www.ccsa.org.cn:9001/portalsFile/downloadOldFile?type=17&amp;oldFileUrl=Rel15/TS%2038.401%20V15.8.0.doc">http://www.ccsa.org.cn:9001/portalsFile/downloadOldFile?type=17&amp;oldFileUrl=Rel15/TS%2038.401%20V15.8.0.doc</a>
ETSI	ETSI TS 138 401	15.8.0	Published	23.07.2020	<a href="http://www.etsi.org/deliver/etsi_ts/138400_138499/138401/15.08.00_60/ts_138401v150800p.pdf">http://www.etsi.org/deliver/etsi_ts/138400_138499/138401/15.08.00_60/ts_138401v150800p.pdf</a>

TSDSI	TSDSI STD T1.3GPP 38.401-15.8.0 V1.0.0	15.8.0	Published	06.10.2020	<a href="https://members.tdsi.in/index.php/s/49928WsQekdCzFi">https://members.tdsi.in/index.php/s/49928WsQekdCzFi</a>
TTA	TTAT.3G-38.401V15.8.0	15.8.0	Published	11.09.2020	<a href="http://www.tta.or.kr/data/ttasDown.jsp?where=14688&amp;pk_num=TTAT.3G-38.401V15.8.0">http://www.tta.or.kr/data/ttasDown.jsp?where=14688&amp;pk_num=TTAT.3G-38.401V15.8.0</a>
TTC	TS-3GA-38.401(Rel15)v15.8.0	15.8.0	Published	02.10.2020	<a href="https://www.ttc.or.jp/st/docs/3gpps2020/TS/TS-3GA-38_401_Rel15v15_8_0.pdf">https://www.ttc.or.jp/st/docs/3gpps2020/TS/TS-3GA-38_401_Rel15v15_8_0.pdf</a>
<b>Release 16</b>					
ATIS	ATIS.3GPP.38.401V1620	16.2.0	Published	08.09.2020	<a href="http://www.atis.org/3gpp-documents/Rel16">http://www.atis.org/3gpp-documents/Rel16</a>
CCSA	CCSA.38.401V1620	16.2.0	Published	17.07.2020	<a href="http://www.ccsa.org.cn:9001/portalsFile/downloadOldFile?type=17&amp;oldFileUrl=Rel16/TS%2038.401%20V16.2.0.doc">http://www.ccsa.org.cn:9001/portalsFile/downloadOldFile?type=17&amp;oldFileUrl=Rel16/TS%2038.401%20V16.2.0.doc</a>
ETSI	ETSI TS 138 401	16.2.0	Published	23.07.2020	<a href="http://www.etsi.org/deliver/etsi_ts/138400_138499/138401/16.02.00_60/ts_138401v160200p.pdf">http://www.etsi.org/deliver/etsi_ts/138400_138499/138401/16.02.00_60/ts_138401v160200p.pdf</a>
TSDSI	TSDSI STD T1.3GPP 38.401-16.2.0 V1.0.0	16.2.0	Published	06.10.2020	<a href="https://members.tdsi.in/index.php/s/kT7gro63ESF85Yi">https://members.tdsi.in/index.php/s/kT7gro63ESF85Yi</a>
TTA	TTAT.3G-38.401V16.2.0	16.2.0	Published	11.09.2020	<a href="http://www.tta.or.kr/data/ttasDown.jsp?where=14688&amp;pk_num=TTAT.3G-38.401V16.2.0">http://www.tta.or.kr/data/ttasDown.jsp?where=14688&amp;pk_num=TTAT.3G-38.401V16.2.0</a>
TTC	TS-3GA-38.401(Rel16)v16.2.0	16.2.0	Published	02.10.2020	<a href="https://www.ttc.or.jp/st/docs/3gpps2020/TS/TS-3GA-38_401_Rel16v16_2_0.pdf">https://www.ttc.or.jp/st/docs/3gpps2020/TS/TS-3GA-38_401_Rel16v16_2_0.pdf</a>

### 2.2.1.4.10 TS 38.410

#### NG-RAN; NG general aspects and principles

This document is an introduction to the 3GPP TS 38.41x series of technical specifications that define the NG interface for the interconnection of an NG-RAN node to the 5GC (5G Core Network).

SDO	Document No.	Version	Status	Issued date	Location
<b>Release 15</b>					
ATIS	ATIS.3GPP.38.410V1520	15.2.0	Published	08.09.2020	<a href="http://www.atis.org/3gpp-documents/Rel15">http://www.atis.org/3gpp-documents/Rel15</a>
CCSA	CCSA.38.410V1520	15.2.0	Published	08.01.2019	<a href="http://www.ccsa.org.cn:9001/portalsFile/downloadOldFile?type=17&amp;oldFileUrl=Rel15/TS%2038.410%20V15.2.0.doc">http://www.ccsa.org.cn:9001/portalsFile/downloadOldFile?type=17&amp;oldFileUrl=Rel15/TS%2038.410%20V15.2.0.doc</a>
ETSI	ETSI TS 138 410	15.2.0	Published	24.04.2019	<a href="http://www.etsi.org/deliver/etsi_ts/138400_138499/138410/15.02.00_60/ts_138410v150200p.pdf">http://www.etsi.org/deliver/etsi_ts/138400_138499/138410/15.02.00_60/ts_138410v150200p.pdf</a>
TSDSI	TSDSI STD T1.3GPP 38.410-15.2.0 V1.0.0	15.2.0	Published	06.10.2020	<a href="https://members.tdsi.in/index.php/s/gGtM3ESsZ8ZztZj">https://members.tdsi.in/index.php/s/gGtM3ESsZ8ZztZj</a>
TTA	TTAT.3G-38.410V15.2.0	15.2.0	Published	11.09.2020	<a href="http://www.tta.or.kr/data/ttasDown.jsp?where=14688&amp;pk_num=TTAT.3G-38.410V15.2.0">http://www.tta.or.kr/data/ttasDown.jsp?where=14688&amp;pk_num=TTAT.3G-38.410V15.2.0</a>
TTC	TS-3GA-38.410(Rel15)v15.2.0	15.2.0	Published	02.10.2020	<a href="https://www.ttc.or.jp/st/docs/3gpps2020/TS/TS-3GA-38_410_Rel15v15_2_0.pdf">https://www.ttc.or.jp/st/docs/3gpps2020/TS/TS-3GA-38_410_Rel15v15_2_0.pdf</a>
<b>Release 16</b>					
ATIS	ATIS.3GPP.38.410V1620	16.2.0	Published	08.09.2020	<a href="http://www.atis.org/3gpp-documents/Rel16">http://www.atis.org/3gpp-documents/Rel16</a>
CCSA	CCSA.38.410V1620	16.2.0	Published	17.07.2020	<a href="http://www.ccsa.org.cn:9001/portalsFile/downloadOldFile?type=17&amp;oldFileUrl=Rel16/TS%2038.410%20V16.2.0.doc">http://www.ccsa.org.cn:9001/portalsFile/downloadOldFile?type=17&amp;oldFileUrl=Rel16/TS%2038.410%20V16.2.0.doc</a>
ETSI	ETSI TS 138 410	16.2.0	Published	21.07.2020	<a href="http://www.etsi.org/deliver/etsi_ts/138400_138499/138410/16.02.00_60/ts_138410v160200p.pdf">http://www.etsi.org/deliver/etsi_ts/138400_138499/138410/16.02.00_60/ts_138410v160200p.pdf</a>
TSDSI	TSDSI STD T1.3GPP 38.410-16.2.0 V1.0.0	16.2.0	Published	06.10.2020	<a href="https://members.tdsi.in/index.php/s/mDjXgTGR2j6jNDw">https://members.tdsi.in/index.php/s/mDjXgTGR2j6jNDw</a>
TTA	TTAT.3G-38.410V16.2.0	16.2.0	Published	11.09.2020	<a href="http://www.tta.or.kr/data/ttasDown.jsp?where=14688&amp;pk_num=TTAT.3G-38.410V16.2.0">http://www.tta.or.kr/data/ttasDown.jsp?where=14688&amp;pk_num=TTAT.3G-38.410V16.2.0</a>
TTC	TS-3GA-38.410(Rel16)v16.2.0	16.2.0	Published	02.10.2020	<a href="https://www.ttc.or.jp/st/docs/3gpps2020/TS/TS-3GA-38_410_Rel16v16_2_0.pdf">https://www.ttc.or.jp/st/docs/3gpps2020/TS/TS-3GA-38_410_Rel16v16_2_0.pdf</a>

### 2.2.1.4.11 TS 38.411

#### NG-RAN; NG layer 1

This document specifies the standards allowed to implement layer 1 on the NG interface.

The specification of transmission delay requirements and O&M requirements are not in the scope of this document.

SDO	Document No.	Version	Status	Issued date	Location
<b>Release 15</b>					
ATIS	ATIS.3GPP.38.411V1500	15.0.0	Published	08.09.2020	<a href="http://www.atis.org/3gpp-documents/Rel15">http://www.atis.org/3gpp-documents/Rel15</a>
CCSA	CCSA.38.411V1500	15.0.0	Published	22.06.2018	<a href="http://www.ccsa.org.cn:9001/portalsFile/downloadOldFile?type=17&amp;oldFileUrl=Rel15/TS%2038.411%20V15.0.0.doc">http://www.ccsa.org.cn:9001/portalsFile/downloadOldFile?type=17&amp;oldFileUrl=Rel15/TS%2038.411%20V15.0.0.doc</a>
ETSI	ETSI TS 138 411	15.0.0	Published	04.07.2018	<a href="http://www.etsi.org/deliver/etsi_ts/138400_138499/138411/15.00.00_60/ts_138411v150000p.pdf">http://www.etsi.org/deliver/etsi_ts/138400_138499/138411/15.00.00_60/ts_138411v150000p.pdf</a>
TSDSI	TSDSI STD T1.3GPP 38.411-15.0.0 V1.0.0	15.0.0	Published	06.10.2020	<a href="https://members.tdsi.in/index.php/s/pci27QRkyfDdJey">https://members.tdsi.in/index.php/s/pci27QRkyfDdJey</a>
TTA	TTAT.3G-38.411V15.0.0	15.0.0	Published	11.09.2020	<a href="http://www.tta.or.kr/data/ttasDown.jsp?where=14688&amp;pk_num=TTAT.3G-38.411V15.0.0">http://www.tta.or.kr/data/ttasDown.jsp?where=14688&amp;pk_num=TTAT.3G-38.411V15.0.0</a>

## 170

## Rec. ITU-R M.2150-0

TTC	TS-3GA-38.411(Rel15)v15.0.0	15.0.0	Published	28.09.2018	<a href="https://www.ttc.or.jp/st/docs/3gpps2018/TS/TS-3GA-38.411(Rel15)v15.0.0.pdf">https://www.ttc.or.jp/st/docs/3gpps2018/TS/TS-3GA-38.411(Rel15)v15.0.0.pdf</a>
<b>Release 16</b>					
ATIS	ATIS.3GPP.38.411V1600	16.0.0	Published	08.09.2020	<a href="http://www.atis.org/3gpp-documents/Rel16">http://www.atis.org/3gpp-documents/Rel16</a>
CCSA	CCSA.38.411V1600	16.0.0	Published	16.07.2020	<a href="http://www.ccsa.org.cn:9001/portalsFile/downloadOldFile?type=17&amp;oldFileUrl=Rel16/TS%2038.411%20V16.0.0.doc">http://www.ccsa.org.cn:9001/portalsFile/downloadOldFile?type=17&amp;oldFileUrl=Rel16/TS%2038.411%20V16.0.0.doc</a>
ETSI	ETSI TS 138 411	16.0.0	Published	21.07.2020	<a href="http://www.etsi.org/deliver/etsi_ts/138400_138499/138411/16.00.00_60/ts_138411v160000p.pdf">http://www.etsi.org/deliver/etsi_ts/138400_138499/138411/16.00.00_60/ts_138411v160000p.pdf</a>
TSDSI	TSDSI STD T1.3GPP 38.411-16.0.0 V1.0.0	16.0.0	Published	06.10.2020	<a href="https://members.tdsi.in/index.php/s/LC9RL5RnBHnEdPE">https://members.tdsi.in/index.php/s/LC9RL5RnBHnEdPE</a>
TTA	TTAT.3G-38.411V16.0.0	16.0.0	Published	11.09.2020	<a href="http://www.tta.or.kr/data/ttasDown.jsp?where=14688&amp;pk_num=TTAT.3G-38.411V16.0.0">http://www.tta.or.kr/data/ttasDown.jsp?where=14688&amp;pk_num=TTAT.3G-38.411V16.0.0</a>
TTC	TS-3GA-38.411(Rel16)v16.0.0	16.0.0	Published	02.10.2020	<a href="https://www.ttc.or.jp/st/docs/3gpps2020/TS/TS-3GA-38_411_Rel16v16_0_0.pdf">https://www.ttc.or.jp/st/docs/3gpps2020/TS/TS-3GA-38_411_Rel16v16_0_0.pdf</a>

### 2.2.1.4.12 TS 38.412

#### NG-RAN; NG signalling transport

This document specifies the standards for signalling transport to be used across NG interface. NG interface is a logical interface between the NG-RAN and the 5GC. This document describes how the NGAP signalling messages are transported over NG.

SDO	Document No.	Version	Status	Issued date	Location
<b>Release 15</b>					
ATIS	ATIS.3GPP.38.412V1540	15.4.0	Published	08.09.2020	<a href="http://www.atis.org/3gpp-documents/Rel15">http://www.atis.org/3gpp-documents/Rel15</a>
CCSA	CCSA.38.412V1540	15.4.0	Published	09.01.2020	<a href="http://www.ccsa.org.cn:9001/portalsFile/downloadOldFile?type=17&amp;oldFileUrl=Rel15/TS%2038.412%20V15.4.0.doc">http://www.ccsa.org.cn:9001/portalsFile/downloadOldFile?type=17&amp;oldFileUrl=Rel15/TS%2038.412%20V15.4.0.doc</a>
ETSI	ETSI TS 138 412	15.4.0	Published	17.01.2020	<a href="http://www.etsi.org/deliver/etsi_ts/138400_138499/138412/15.04.00_60/ts_138412v150400p.pdf">http://www.etsi.org/deliver/etsi_ts/138400_138499/138412/15.04.00_60/ts_138412v150400p.pdf</a>
TSDSI	TSDSI STD T1.3GPP 38.412-15.4.0 V1.0.0	15.4.0	Published	06.10.2020	<a href="https://members.tdsi.in/index.php/s/xdi5zaWeYKfNEpF">https://members.tdsi.in/index.php/s/xdi5zaWeYKfNEpF</a>
TTA	TTAT.3G-38.412V15.4.0	15.4.0	Published	11.09.2020	<a href="http://www.tta.or.kr/data/ttasDown.jsp?where=14688&amp;pk_num=TTAT.3G-38.412V15.4.0">http://www.tta.or.kr/data/ttasDown.jsp?where=14688&amp;pk_num=TTAT.3G-38.412V15.4.0</a>
TTC	TS-3GA-38.412(Rel15)v15.4.0	15.4.0	Published	16.04.2020	<a href="https://www.ttc.or.jp/st/docs/3gpps2020/TS/TS-3GA-38_412_Rel15v15_4_0.pdf">https://www.ttc.or.jp/st/docs/3gpps2020/TS/TS-3GA-38_412_Rel15v15_4_0.pdf</a>
<b>Release 16</b>					
ATIS	ATIS.3GPP.38.412V1600	16.0.0	Published	08.09.2020	<a href="http://www.atis.org/3gpp-documents/Rel16">http://www.atis.org/3gpp-documents/Rel16</a>
CCSA	CCSA.38.412V1600	16.0.0	Published	01.04.2020	<a href="http://www.ccsa.org.cn:9001/portalsFile/downloadOldFile?type=17&amp;oldFileUrl=Rel16/TS%2038.412%20V16.0.0.doc">http://www.ccsa.org.cn:9001/portalsFile/downloadOldFile?type=17&amp;oldFileUrl=Rel16/TS%2038.412%20V16.0.0.doc</a>
ETSI	ETSI TS 138 412	16.0.0	Published	21.09.2020	<a href="http://www.etsi.org/deliver/etsi_ts/138400_138499/138412/16.00.00_60/ts_138412v160000p.pdf">http://www.etsi.org/deliver/etsi_ts/138400_138499/138412/16.00.00_60/ts_138412v160000p.pdf</a>
TSDSI	TSDSI STD T1.3GPP 38.412-16.0.0 V1.0.0	16.0.0	Published	06.10.2020	<a href="https://members.tdsi.in/index.php/s/NsRRj7QxYBrKCZ8">https://members.tdsi.in/index.php/s/NsRRj7QxYBrKCZ8</a>
TTA	TTAT.3G-38.412V16.0.0	16.0.0	Published	11.09.2020	<a href="http://www.tta.or.kr/data/ttasDown.jsp?where=14688&amp;pk_num=TTAT.3G-38.412V16.0.0">http://www.tta.or.kr/data/ttasDown.jsp?where=14688&amp;pk_num=TTAT.3G-38.412V16.0.0</a>
TTC	TS-3GA-38.412(Rel16)v16.0.0	16.0.0	Published	02.10.2020	<a href="https://www.ttc.or.jp/st/docs/3gpps2020/TS/TS-3GA-38_412_Rel16v16_0_0.pdf">https://www.ttc.or.jp/st/docs/3gpps2020/TS/TS-3GA-38_412_Rel16v16_0_0.pdf</a>

### 2.2.1.4.13 TS 38.413

#### NG-RAN; NG Application Protocol (NGAP)

This document specifies the radio network layer signalling protocol for the NG interface. The NG Application Protocol (NGAP) supports the functions of the NG interface by signalling procedures defined in this document. NGAP is developed in accordance with the general principles stated in TS 38.401 and TS 38.410.

SDO	Document No.	Version	Status	Issued date	Location
<b>Release 15</b>					
ATIS	ATIS.3GPP.38.413V1580	15.8.0	Published	08.09.2020	<a href="http://www.atis.org/3gpp-documents/Rel15">http://www.atis.org/3gpp-documents/Rel15</a>
CCSA	CCSA.38.413V1580	15.8.0	Published	17.07.2020	<a href="http://www.ccsa.org.cn:9001/portalsFile/downloadOldFile?type=17&amp;oldFileUrl=Rel15/TS%2038.413%20V15.8.0.doc">http://www.ccsa.org.cn:9001/portalsFile/downloadOldFile?type=17&amp;oldFileUrl=Rel15/TS%2038.413%20V15.8.0.doc</a>
ETSI	ETSI TS 138 413	15.8.0	Published	23.07.2020	<a href="http://www.etsi.org/deliver/etsi_ts/138400_138499/138413/15.08.00_60/ts_138413v150800p.pdf">http://www.etsi.org/deliver/etsi_ts/138400_138499/138413/15.08.00_60/ts_138413v150800p.pdf</a>
TSDSI	TSDSI STD T1.3GPP 38.413-15.8.0 V1.0.0	15.8.0	Published	06.10.2020	<a href="https://members.tdsi.in/index.php/s/B7jGFsLMRw8km4p">https://members.tdsi.in/index.php/s/B7jGFsLMRw8km4p</a>
TTA	TTAT.3G-38.413V15.8.0	15.8.0	Published	11.09.2020	<a href="http://www.tta.or.kr/data/ttasDown.jsp?where=14688&amp;pk_num=TTAT.3G-38.413V15.8.0">http://www.tta.or.kr/data/ttasDown.jsp?where=14688&amp;pk_num=TTAT.3G-38.413V15.8.0</a>

SDO	Document No.	Version	Status	Issued date	Location
TTC	TS-3GA-38.413(Rel15)v15.8.0	15.8.0	Published	02.10.2020	<a href="https://www.ttc.or.jp/st/docs/3gpps2020/TS/TS-3GA-38_413_Rel15v15_8_0.pdf">https://www.ttc.or.jp/st/docs/3gpps2020/TS/TS-3GA-38_413_Rel15v15_8_0.pdf</a>
<b>Release 16</b>					
ATIS	ATIS.3GPP.38.413V1620	16.2.0	Published	08.09.2020	<a href="http://www.atis.org/3gpp-documents/Rel16">http://www.atis.org/3gpp-documents/Rel16</a>
CCSA	CCSA.38.413V1620	16.2.0	Published	17.07.2020	<a href="http://www.ccsa.org.cn:9001/portalsFile/downloadOldFile?type=17&amp;oldFileUrl=Rel16/TS%2038.413%20V16.2.0.doc">http://www.ccsa.org.cn:9001/portalsFile/downloadOldFile?type=17&amp;oldFileUrl=Rel16/TS%2038.413%20V16.2.0.doc</a>
ETSI	ETSI TS 138 413	16.2.0	Published	23.07.2020	<a href="http://www.etsi.org/deliver/etsi_ts/138400_138499/138413/16.02.00_60/ts_138413v160200p.pdf">http://www.etsi.org/deliver/etsi_ts/138400_138499/138413/16.02.00_60/ts_138413v160200p.pdf</a>
TSDSI	TSDSI STD T1.3GPP 38.413-16.2.0 V1.0.0	16.2.0	Published	06.10.2020	<a href="https://members.tdsi.in/index.php/s/QLffEDRYGw98yb">https://members.tdsi.in/index.php/s/QLffEDRYGw98yb</a>
TTA	TTAT.3G-38.413V16.2.0	16.2.0	Published	11.09.2020	<a href="http://www.tta.or.kr/data/ttasDown.jsp?where=14688&amp;pk_num=TTAT.3G-38.413V16.2.0">http://www.tta.or.kr/data/ttasDown.jsp?where=14688&amp;pk_num=TTAT.3G-38.413V16.2.0</a>
TTC	TS-3GA-38.413(Rel16)v16.2.0	16.2.0	Published	02.10.2020	<a href="https://www.ttc.or.jp/st/docs/3gpps2020/TS/TS-3GA-38_413_Rel16v16_2_0.pdf">https://www.ttc.or.jp/st/docs/3gpps2020/TS/TS-3GA-38_413_Rel16v16_2_0.pdf</a>

**2.2.1.4.14 TS 38.414**

**NG-RAN; NG data transport**

This document specifies the standards for user data transport protocols and related signalling protocols to establish user plane transport bearers over the NG interface.

SDO	Document No.	Version	Status	Issued date	Location
<b>Release 15</b>					
ATIS	ATIS.3GPP.38.414V1530	15.3.0	Published	08.09.2020	<a href="http://www.atis.org/3gpp-documents/Rel15">http://www.atis.org/3gpp-documents/Rel15</a>
CCSA	CCSA.38.414V1530	15.3.0	Published	17.07.2020	<a href="http://www.ccsa.org.cn:9001/portalsFile/downloadOldFile?type=17&amp;oldFileUrl=Rel15/TS%2038.414%20V15.3.0.doc">http://www.ccsa.org.cn:9001/portalsFile/downloadOldFile?type=17&amp;oldFileUrl=Rel15/TS%2038.414%20V15.3.0.doc</a>
ETSI	ETSI TS 138 414	15.3.0	Published	23.07.2020	<a href="http://www.etsi.org/deliver/etsi_ts/138400_138499/138414/15.03.00_60/ts_138414v150300p.pdf">http://www.etsi.org/deliver/etsi_ts/138400_138499/138414/15.03.00_60/ts_138414v150300p.pdf</a>
TSDSI	TSDSI STD T1.3GPP 38.414-15.3.0 V1.0.0	15.3.0	Published	06.10.2020	<a href="https://members.tdsi.in/index.php/s/EnTDLLT6W5RLrHq">https://members.tdsi.in/index.php/s/EnTDLLT6W5RLrHq</a>
TTA	TTAT.3G-38.414V15.3.0	15.3.0	Published	11.09.2020	<a href="http://www.tta.or.kr/data/ttasDown.jsp?where=14688&amp;pk_num=TTAT.3G-38.414V15.3.0">http://www.tta.or.kr/data/ttasDown.jsp?where=14688&amp;pk_num=TTAT.3G-38.414V15.3.0</a>
TTC	TS-3GA-38.414(Rel15)v15.3.0	15.3.0	Published	02.10.2020	<a href="https://www.ttc.or.jp/st/docs/3gpps2020/TS/TS-3GA-38_414_Rel15v15_3_0.pdf">https://www.ttc.or.jp/st/docs/3gpps2020/TS/TS-3GA-38_414_Rel15v15_3_0.pdf</a>
<b>Release 16</b>					
ATIS	ATIS.3GPP.38.414V1600	16.0.0	Published	08.09.2020	<a href="http://www.atis.org/3gpp-documents/Rel16">http://www.atis.org/3gpp-documents/Rel16</a>
CCSA	CCSA.38.414V1600	16.0.0	Published	17.07.2020	<a href="http://www.ccsa.org.cn:9001/portalsFile/downloadOldFile?type=17&amp;oldFileUrl=Rel16/TS%2038.414%20V16.0.0.doc">http://www.ccsa.org.cn:9001/portalsFile/downloadOldFile?type=17&amp;oldFileUrl=Rel16/TS%2038.414%20V16.0.0.doc</a>
ETSI	ETSI TS 138 414	16.0.0	Published	23.07.2020	<a href="http://www.etsi.org/deliver/etsi_ts/138400_138499/138414/16.00.00_60/ts_138414v160000p.pdf">http://www.etsi.org/deliver/etsi_ts/138400_138499/138414/16.00.00_60/ts_138414v160000p.pdf</a>
TSDSI	TSDSI STD T1.3GPP 38.414-16.0.0 V1.0.0	16.0.0	Published	06.10.2020	<a href="https://members.tdsi.in/index.php/s/mSbYzO6OqWEGdrD">https://members.tdsi.in/index.php/s/mSbYzO6OqWEGdrD</a>
TTA	TTAT.3G-38.414V16.0.0	16.0.0	Published	11.09.2020	<a href="http://www.tta.or.kr/data/ttasDown.jsp?where=14688&amp;pk_num=TTAT.3G-38.414V16.0.0">http://www.tta.or.kr/data/ttasDown.jsp?where=14688&amp;pk_num=TTAT.3G-38.414V16.0.0</a>
TTC	TS-3GA-38.414(Rel16)v16.0.0	16.0.0	Published	02.10.2020	<a href="https://www.ttc.or.jp/st/docs/3gpps2020/TS/TS-3GA-38_414_Rel16v16_0_0.pdf">https://www.ttc.or.jp/st/docs/3gpps2020/TS/TS-3GA-38_414_Rel16v16_0_0.pdf</a>

**2.2.1.4.15 TS 38.415**

**NG-RAN; PDU session user plane protocol**

This document specifies the PDU Session user plane protocol being used over the NG-U, Xn-U and N9 interfaces. Applicability to other interfaces is not precluded.

SDO	Document No.	Version	Status	Issued date	Location
<b>Release 15</b>					
ATIS	ATIS.3GPP.38.415V1520	15.2.0	Published	08.09.2020	<a href="http://www.atis.org/3gpp-documents/Rel15">http://www.atis.org/3gpp-documents/Rel15</a>
CCSA	CCSA.38.415V1520	15.2.0	Published	08.01.2019	<a href="http://www.ccsa.org.cn:9001/portalsFile/downloadOldFile?type=17&amp;oldFileUrl=Rel15/TS%2038.415%20V15.2.0.doc">http://www.ccsa.org.cn:9001/portalsFile/downloadOldFile?type=17&amp;oldFileUrl=Rel15/TS%2038.415%20V15.2.0.doc</a>
ETSI	ETSI TS 138 415	15.2.0	Published	24.04.2019	<a href="http://www.etsi.org/deliver/etsi_ts/138400_138499/138415/15.02.00_60/ts_138415v150200p.pdf">http://www.etsi.org/deliver/etsi_ts/138400_138499/138415/15.02.00_60/ts_138415v150200p.pdf</a>
TSDSI	TSDSI STD T1.3GPP 38.415-15.2.0 V1.0.0	15.2.0	Published	06.10.2020	<a href="https://members.tdsi.in/index.php/s/myppHsmk2nXMxD7x">https://members.tdsi.in/index.php/s/myppHsmk2nXMxD7x</a>
TTA	TTAT.3G-38.415V15.2.0	15.2.0	Published	11.09.2020	<a href="http://www.tta.or.kr/data/ttasDown.jsp?where=14688&amp;pk_num=TTAT.3G-38.415V15.2.0">http://www.tta.or.kr/data/ttasDown.jsp?where=14688&amp;pk_num=TTAT.3G-38.415V15.2.0</a>
TTC	TS-3GA-38.415(Rel15)v15.2.0	15.2.0	Published	29.03.2019	<a href="https://www.ttc.or.jp/st/docs/3gpps2019/TS/TS-3GA-38.415(Rel15)v15.2.0.pdf">https://www.ttc.or.jp/st/docs/3gpps2019/TS/TS-3GA-38.415(Rel15)v15.2.0.pdf</a>
<b>Release 16</b>					

## 172

SDO	Document No.	Version	Status	Issued date	Location
ATIS	ATIS.3GPP.38.415V1610	16.1.0	Published	08.09.2020	<a href="http://www.atis.org/3gpp-documents/Rel16">http://www.atis.org/3gpp-documents/Rel16</a>
CCSA	CCSA.38.415V1610	16.1.0	Published	17.07.2020	<a href="http://www.ccsa.org.cn:9001/portalsFile/downloadOldFile?type=17&amp;oldFileUrl=Rel16/TS%2038.415%20V16.1.0.doc">http://www.ccsa.org.cn:9001/portalsFile/downloadOldFile?type=17&amp;oldFileUrl=Rel16/TS%2038.415%20V16.1.0.doc</a>
ETSI	ETSI TS 138 415	16.1.0	Published	23.07.2020	<a href="http://www.etsi.org/deliver/etsi_ts/138400_138499/138415/16.01.00_60/ts_138415v160100p.pdf">http://www.etsi.org/deliver/etsi_ts/138400_138499/138415/16.01.00_60/ts_138415v160100p.pdf</a>
TSDSI	TSDSI STD T1.3GPP 38.415-16.1.0 V1.0.0	16.1.0	Published	06.10.2020	<a href="https://members.tdsi.in/index.php/s/xC6AKfMNxetNxxc">https://members.tdsi.in/index.php/s/xC6AKfMNxetNxxc</a>
TTA	TTAT.3G-38.415V16.1.0	16.1.0	Published	11.09.2020	<a href="http://www.tta.or.kr/data/ttasDown.jsp?where=14688&amp;pk_num=TTAT.3G-38.415V16.1.0">http://www.tta.or.kr/data/ttasDown.jsp?where=14688&amp;pk_num=TTAT.3G-38.415V16.1.0</a>
TTC	TS-3GA-38.415(Rel16)v16.1.0	16.1.0	Published	02.10.2020	<a href="https://www.ttc.or.jp/st/docs/3gpps2020/TS/TS-3GA-38_415_Rel16v16_1_0.pdf">https://www.ttc.or.jp/st/docs/3gpps2020/TS/TS-3GA-38_415_Rel16v16_1_0.pdf</a>

## Rec. ITU-R M.2150-0

### 2.2.1.4.16 TS 38.420

#### NG-RAN; Xn general aspects and principles

This document is an introduction to the TSG RAN TS 38.42x series of Technical Specifications that define the Xn interface. It is an interface for the interconnection of two NG-RAN nodes within the NG-RAN architecture (TS 38.401).

SDO	Document No.	Version	Status	Issued date	Location
<b>Release 15</b>					
ATIS	ATIS.3GPP.38.420V1520	15.2.0	Published	08.09.2020	<a href="http://www.atis.org/3gpp-documents/Rel15">http://www.atis.org/3gpp-documents/Rel15</a>
CCSA	CCSA.38.420V1520	15.2.0	Published	08.01.2019	<a href="http://www.ccsa.org.cn:9001/portalsFile/downloadOldFile?type=17&amp;oldFileUrl=Rel15/TS%2038.420%20V15.2.0.doc">http://www.ccsa.org.cn:9001/portalsFile/downloadOldFile?type=17&amp;oldFileUrl=Rel15/TS%2038.420%20V15.2.0.doc</a>
ETSI	ETSI TS 138 420	15.2.0	Published	24.04.2019	<a href="http://www.etsi.org/deliver/etsi_ts/138400_138499/138420/15.02.00_60/ts_138420v150200p.pdf">http://www.etsi.org/deliver/etsi_ts/138400_138499/138420/15.02.00_60/ts_138420v150200p.pdf</a>
TSDSI	TSDSI STD T1.3GPP 38.420-15.2.0 V1.0.0	15.2.0	Published	06.10.2020	<a href="https://members.tdsi.in/index.php/s/kSZScp7FYKtPx6i">https://members.tdsi.in/index.php/s/kSZScp7FYKtPx6i</a>
TTA	TTAT.3G-38.420V15.2.0	15.2.0	Published	11.09.2020	<a href="http://www.tta.or.kr/data/ttasDown.jsp?where=14688&amp;pk_num=TTAT.3G-38.420V15.2.0">http://www.tta.or.kr/data/ttasDown.jsp?where=14688&amp;pk_num=TTAT.3G-38.420V15.2.0</a>
TTC	TS-3GA-38.420(Rel15)v15.2.0	15.2.0	Published	29.03.2019	<a href="https://www.ttc.or.jp/st/docs/3gpps2019/TS/TS-3GA-38.420(Rel15)v15.2.0.pdf">https://www.ttc.or.jp/st/docs/3gpps2019/TS/TS-3GA-38.420(Rel15)v15.2.0.pdf</a>
<b>Release 16</b>					
ATIS	ATIS.3GPP.38.420V1600	16.0.0	Published	08.09.2020	<a href="http://www.atis.org/3gpp-documents/Rel16">http://www.atis.org/3gpp-documents/Rel16</a>
CCSA	CCSA.38.420V1600	16.0.0	Published	16.07.2020	<a href="http://www.ccsa.org.cn:9001/portalsFile/downloadOldFile?type=17&amp;oldFileUrl=Rel16/TS%2038.420%20V16.0.0.doc">http://www.ccsa.org.cn:9001/portalsFile/downloadOldFile?type=17&amp;oldFileUrl=Rel16/TS%2038.420%20V16.0.0.doc</a>
ETSI	ETSI TS 138 420	16.0.0	Published	21.07.2020	<a href="http://www.etsi.org/deliver/etsi_ts/138400_138499/138420/16.00.00_60/ts_138420v160000p.pdf">http://www.etsi.org/deliver/etsi_ts/138400_138499/138420/16.00.00_60/ts_138420v160000p.pdf</a>
TSDSI	TSDSI STD T1.3GPP 38.420-16.0.0 V1.0.0	16.0.0	Published	06.10.2020	<a href="https://members.tdsi.in/index.php/s/CZARvijncBKfLZQ">https://members.tdsi.in/index.php/s/CZARvijncBKfLZQ</a>
TTA	TTAT.3G-38.420V16.0.0	16.0.0	Published	11.09.2020	<a href="http://www.tta.or.kr/data/ttasDown.jsp?where=14688&amp;pk_num=TTAT.3G-38.420V16.0.0">http://www.tta.or.kr/data/ttasDown.jsp?where=14688&amp;pk_num=TTAT.3G-38.420V16.0.0</a>
TTC	TS-3GA-38.420(Rel16)v16.0.0	16.0.0	Published	02.10.2020	<a href="https://www.ttc.or.jp/st/docs/3gpps2020/TS/TS-3GA-38_420_Rel16v16_0_0.pdf">https://www.ttc.or.jp/st/docs/3gpps2020/TS/TS-3GA-38_420_Rel16v16_0_0.pdf</a>

### 2.2.1.4.17 TS 38.421

#### NG-RAN; Xn layer 1

This document specifies the standards allowed to implement layer 1 on the Xn interface.

The specification of transmission delay requirements and O&M requirements are not in the scope of this document.

SDO	Document No.	Version	Status	Issued date	Location
<b>Release 15</b>					
ATIS	ATIS.3GPP.38.421V1510	15.1.0	Published	08.09.2020	<a href="http://www.atis.org/3gpp-documents/Rel15">http://www.atis.org/3gpp-documents/Rel15</a>
CCSA	CCSA.38.421V1510	15.1.0	Published	02.10.2019	<a href="http://www.ccsa.org.cn:9001/portalsFile/downloadOldFile?type=17&amp;oldFileUrl=Rel15/TS%2038.421%20V15.1.0.doc">http://www.ccsa.org.cn:9001/portalsFile/downloadOldFile?type=17&amp;oldFileUrl=Rel15/TS%2038.421%20V15.1.0.doc</a>
ETSI	ETSI TS 138 421	15.1.0	Published	16.10.2019	<a href="http://www.etsi.org/deliver/etsi_ts/138400_138499/138421/15.01.00_60/ts_138421v150100p.pdf">http://www.etsi.org/deliver/etsi_ts/138400_138499/138421/15.01.00_60/ts_138421v150100p.pdf</a>
TSDSI	TSDSI STD T1.3GPP 38.421-15.1.0 V1.0.0	15.1.0	Published	06.10.2020	<a href="https://members.tdsi.in/index.php/s/CsmLZaoiiNNX2Ar">https://members.tdsi.in/index.php/s/CsmLZaoiiNNX2Ar</a>
TTA	TTAT.3G-38.421V15.1.0	15.1.0	Published	11.09.2020	<a href="http://www.tta.or.kr/data/ttasDown.jsp?where=14688&amp;pk_num=TTAT.3G-38.421V15.1.0">http://www.tta.or.kr/data/ttasDown.jsp?where=14688&amp;pk_num=TTAT.3G-38.421V15.1.0</a>
TTC	TS-3GA-38.421(Rel15)v15.1.0	15.1.0	Published	20.12.2019	<a href="https://www.ttc.or.jp/st/docs/3gpps2019/TS/TS-3GA-38.421(Rel15)v15.1.0.pdf">https://www.ttc.or.jp/st/docs/3gpps2019/TS/TS-3GA-38.421(Rel15)v15.1.0.pdf</a>
<b>Release 16</b>					
ATIS	ATIS.3GPP.38.421V1600	16.0.0	Published	08.09.2020	<a href="http://www.atis.org/3gpp-documents/Rel16">http://www.atis.org/3gpp-documents/Rel16</a>
CCSA	CCSA.38.421V1600	16.0.0	Published	16.07.2020	<a href="http://www.ccsa.org.cn:9001/portalsFile/downloadOldFile?type=17&amp;oldFileUrl=Rel16/TS%2038.421%20V16.0.0.doc">http://www.ccsa.org.cn:9001/portalsFile/downloadOldFile?type=17&amp;oldFileUrl=Rel16/TS%2038.421%20V16.0.0.doc</a>

ETSI	ETSI TS 138 421	16.0.0	Published	21.07.2020	<a href="http://www.etsi.org/deliver/etsi_ts/138400_138499/138421/16.00.00_60/ts_138421v160000p.pdf">http://www.etsi.org/deliver/etsi_ts/138400_138499/138421/16.00.00_60/ts_138421v160000p.pdf</a>
TSDSI	TSDSI STD T1.3GPP 38.421-16.0.0 V1.0.0	16.0.0	Published	06.10.2020	<a href="https://members.tdsi.in/index.php/s/NMCfe3NmrFAx5rk">https://members.tdsi.in/index.php/s/NMCfe3NmrFAx5rk</a>
TTA	TTAT.3G-38.421V16.0.0	16.0.0	Published	11.09.2020	<a href="http://www.tta.or.kr/data/ttasDown.jsp?where=14688&amp;pk_num=TTAT.3G-38.421V16.0.0">http://www.tta.or.kr/data/ttasDown.jsp?where=14688&amp;pk_num=TTAT.3G-38.421V16.0.0</a>
TTC	TS-3GA-38.421(Rel16)v16.0.0	16.0.0	Published	02.10.2020	<a href="https://www.ttc.or.jp/st/docs/3gpps2020/TS/TS-3GA-38_421_Rel16v16_0_0.pdf">https://www.ttc.or.jp/st/docs/3gpps2020/TS/TS-3GA-38_421_Rel16v16_0_0.pdf</a>

### 2.2.1.4.18 TS 38.422

#### NG-RAN; Xn signalling transport

This document specifies the standards for signalling transport to be used across Xn interface. The Xn interface provides means for interconnecting two NG-RAN nodes. The Xn interface is a logical interface between two nodes of the NG-RAN. This document describes how the XnAP signalling messages are transported over Xn.

SDO	Document No.	Version	Status	Issued date	Location
<b>Release 15</b>					
ATIS	ATIS.3GPP.38.422V1540	15.4.0	Published	08.09.2020	<a href="http://www.atis.org/3gpp-documents/Rel15">http://www.atis.org/3gpp-documents/Rel15</a>
CCSA	CCSA.38.422V1540	15.4.0	Published	09.01.2020	<a href="http://www.ccsa.org.cn:9001/portalsFile/downloadOldFile?type=17&amp;oldFileUrl=Rel15/TS%2038.422%20V15.4.0.doc">http://www.ccsa.org.cn:9001/portalsFile/downloadOldFile?type=17&amp;oldFileUrl=Rel15/TS%2038.422%20V15.4.0.doc</a>
ETSI	ETSI TS 138 422	15.4.0	Published	17.01.2020	<a href="http://www.etsi.org/deliver/etsi_ts/138400_138499/138422/15.04.00_60/ts_138422v150400p.pdf">http://www.etsi.org/deliver/etsi_ts/138400_138499/138422/15.04.00_60/ts_138422v150400p.pdf</a>
TSDSI	TSDSI STD T1.3GPP 38.422-15.4.0 V1.0.0	15.4.0	Published	06.10.2020	<a href="https://members.tdsi.in/index.php/s/5XwBzWnpynSDqXb">https://members.tdsi.in/index.php/s/5XwBzWnpynSDqXb</a>
TTA	TTAT.3G-38.422V15.4.0	15.4.0	Published	11.09.2020	<a href="http://www.tta.or.kr/data/ttasDown.jsp?where=14688&amp;pk_num=TTAT.3G-38.422V15.4.0">http://www.tta.or.kr/data/ttasDown.jsp?where=14688&amp;pk_num=TTAT.3G-38.422V15.4.0</a>
TTC	TS-3GA-38.422(Rel15)v15.4.0	15.4.0	Published	16.04.2020	<a href="https://www.ttc.or.jp/st/docs/3gpps2020/TS/TS-3GA-38_422_Rel15v15_4_0.pdf">https://www.ttc.or.jp/st/docs/3gpps2020/TS/TS-3GA-38_422_Rel15v15_4_0.pdf</a>
<b>Release 16</b>					
ATIS	ATIS.3GPP.38.422V1600	16.0.0	Published	08.09.2020	<a href="http://www.atis.org/3gpp-documents/Rel16">http://www.atis.org/3gpp-documents/Rel16</a>
CCSA	CCSA.38.422V1600	16.0.0	Published	01.04.2020	<a href="http://www.ccsa.org.cn:9001/portalsFile/downloadOldFile?type=17&amp;oldFileUrl=Rel16/TS%2038.422%20V16.0.0.doc">http://www.ccsa.org.cn:9001/portalsFile/downloadOldFile?type=17&amp;oldFileUrl=Rel16/TS%2038.422%20V16.0.0.doc</a>
ETSI	ETSI TS 138 422	16.0.0	Published	21.09.2020	<a href="http://www.etsi.org/deliver/etsi_ts/138400_138499/138422/16.00.00_60/ts_138422v160000p.pdf">http://www.etsi.org/deliver/etsi_ts/138400_138499/138422/16.00.00_60/ts_138422v160000p.pdf</a>
TSDSI	TSDSI STD T1.3GPP 38.422-16.0.0 V1.0.0	16.0.0	Published	06.10.2020	<a href="https://members.tdsi.in/index.php/s/fgLr9n7GJDjmdRE">https://members.tdsi.in/index.php/s/fgLr9n7GJDjmdRE</a>
TTA	TTAT.3G-38.422V16.0.0	16.0.0	Published	11.09.2020	<a href="http://www.tta.or.kr/data/ttasDown.jsp?where=14688&amp;pk_num=TTAT.3G-38.422V16.0.0">http://www.tta.or.kr/data/ttasDown.jsp?where=14688&amp;pk_num=TTAT.3G-38.422V16.0.0</a>
TTC	TS-3GA-38.422(Rel16)v16.0.0	16.0.0	Published	02.10.2020	<a href="https://www.ttc.or.jp/st/docs/3gpps2020/TS/TS-3GA-38_422_Rel16v16_0_0.pdf">https://www.ttc.or.jp/st/docs/3gpps2020/TS/TS-3GA-38_422_Rel16v16_0_0.pdf</a>

### 2.2.1.4.19 TS 38.423

#### NG-RAN; Xn Application Protocol (XnAP)

This document specifies the radio network layer signalling procedures of the control plane between NG-RAN nodes in NG-RAN. XnAP supports the functions of the Xn interface by signalling procedures defined in this document. XnAP is developed in accordance with the general principles stated in TS 38.401 and TS 38.420.

SDO	Document No.	Version	Status	Issued date	Location
<b>Release 15</b>					
ATIS	ATIS.3GPP.38.423V1580	15.8.0	Published	08.09.2020	<a href="http://www.atis.org/3gpp-documents/Rel15">http://www.atis.org/3gpp-documents/Rel15</a>
CCSA	CCSA.38.423V1580	15.8.0	Published	17.07.2020	<a href="http://www.ccsa.org.cn:9001/portalsFile/downloadOldFile?type=17&amp;oldFileUrl=Rel15/TS%2038.423%20V15.8.0.doc">http://www.ccsa.org.cn:9001/portalsFile/downloadOldFile?type=17&amp;oldFileUrl=Rel15/TS%2038.423%20V15.8.0.doc</a>
ETSI	ETSI TS 138 423	15.8.0	Published	23.07.2020	<a href="http://www.etsi.org/deliver/etsi_ts/138400_138499/138423/15.08.00_60/ts_138423v150800p.pdf">http://www.etsi.org/deliver/etsi_ts/138400_138499/138423/15.08.00_60/ts_138423v150800p.pdf</a>
TSDSI	TSDSI STD T1.3GPP 38.423-15.8.0 V1.0.0	15.8.0	Published	06.10.2020	<a href="https://members.tdsi.in/index.php/s/jrCbmrFD2XBHRZD">https://members.tdsi.in/index.php/s/jrCbmrFD2XBHRZD</a>
TTA	TTAT.3G-38.423V15.8.0	15.8.0	Published	11.09.2020	<a href="http://www.tta.or.kr/data/ttasDown.jsp?where=14688&amp;pk_num=TTAT.3G-38.423V15.8.0">http://www.tta.or.kr/data/ttasDown.jsp?where=14688&amp;pk_num=TTAT.3G-38.423V15.8.0</a>
TTC	TS-3GA-38.423(Rel15)v15.8.0	15.8.0	Published	02.10.2020	<a href="https://www.ttc.or.jp/st/docs/3gpps2020/TS/TS-3GA-38_423_Rel15v15_8_0.pdf">https://www.ttc.or.jp/st/docs/3gpps2020/TS/TS-3GA-38_423_Rel15v15_8_0.pdf</a>
<b>Release 16</b>					
ATIS	ATIS.3GPP.38.423V1620	16.2.0	Published	08.09.2020	<a href="http://www.atis.org/3gpp-documents/Rel16">http://www.atis.org/3gpp-documents/Rel16</a>
CCSA	CCSA.38.423V1620	16.2.0	Published	17.07.2020	<a href="http://www.ccsa.org.cn:9001/portalsFile/downloadOldFile?type=17&amp;oldFileUrl=Rel16/TS%2038.423%20V16.2.0.doc">http://www.ccsa.org.cn:9001/portalsFile/downloadOldFile?type=17&amp;oldFileUrl=Rel16/TS%2038.423%20V16.2.0.doc</a>
ETSI	ETSI TS 138 423	16.2.0	Published	23.07.2020	<a href="http://www.etsi.org/deliver/etsi_ts/138400_138499/138423/16.02.00_60/ts_138423v160200p.pdf">http://www.etsi.org/deliver/etsi_ts/138400_138499/138423/16.02.00_60/ts_138423v160200p.pdf</a>

## 174

## Rec. ITU-R M.2150-0

TSDSI	TSDSI STD T1.3GPP 38.423-16.2.0 V1.0.0	16.2.0	Published	06.10.2020	<a href="https://members.tdsi.in/index.php/s/2gKxqCeJt8r7fmE">https://members.tdsi.in/index.php/s/2gKxqCeJt8r7fmE</a>
TTA	TTAT.3G-38.423V16.2.0	16.2.0	Published	11.09.2020	<a href="http://www.tta.or.kr/data/ttasDown.jsp?where=14688&amp;pk_num=TTAT.3G-38.423V16.2.0">http://www.tta.or.kr/data/ttasDown.jsp?where=14688&amp;pk_num=TTAT.3G-38.423V16.2.0</a>
TTC	TS-3GA-38.423(Rel16)v16.2.0	16.2.0	Published	02.10.2020	<a href="https://www.ttc.or.jp/st/docs/3gpps2020/TS/TS-3GA-38_423_Rel16v16_2_0.pdf">https://www.ttc.or.jp/st/docs/3gpps2020/TS/TS-3GA-38_423_Rel16v16_2_0.pdf</a>

### 2.2.1.4.20 TS 38.424

#### NG-RAN; Xn data transport

This document specifies the standards for user data transport protocols and related signalling protocols to establish user plane transport bearers over the Xn interface.

SDO	Document No.	Version	Status	Issued date	Location	
<b>Release 15</b>						
ATIS	ATIS.3GPP.38.424V1520		15.2.0	Published	08.09.2020	<a href="http://www.atis.org/3gpp-documents/Rel15">http://www.atis.org/3gpp-documents/Rel15</a>
CCSA	CCSA.38.424V1520		15.2.0	Published	13.07.2019	<a href="http://www.ccsa.org.cn:9001/portalsFile/downloadOldFile?type=17&amp;oldFileUrl=Rel15/TS%2038.424%20V15.2.0.doc">http://www.ccsa.org.cn:9001/portalsFile/downloadOldFile?type=17&amp;oldFileUrl=Rel15/TS%2038.424%20V15.2.0.doc</a>
ETSI	ETSI TS 138 424		15.2.0	Published	23.07.2019	<a href="http://www.etsi.org/deliver/etsi_ts/138400_138499/138424/15.02.00_60/ts_138424v150200p.pdf">http://www.etsi.org/deliver/etsi_ts/138400_138499/138424/15.02.00_60/ts_138424v150200p.pdf</a>
TSDSI	TSDSI STD T1.3GPP 38.424-15.2.0 V1.0.0		15.2.0	Published	06.10.2020	<a href="https://members.tdsi.in/index.php/s/ToekLawe9q7yiHM">https://members.tdsi.in/index.php/s/ToekLawe9q7yiHM</a>
TTA	TTAT.3G-38.424V15.2.0		15.2.0	Published	11.09.2020	<a href="http://www.tta.or.kr/data/ttasDown.jsp?where=14688&amp;pk_num=TTAT.3G-38.424V15.2.0">http://www.tta.or.kr/data/ttasDown.jsp?where=14688&amp;pk_num=TTAT.3G-38.424V15.2.0</a>
TTC	TS-3GA-38.424(Rel15)v15.2.0		15.2.0	Published	11.10.2019	<a href="https://www.ttc.or.jp/st/docs/3gpps2019/TS/TS-3GA-38.424(Rel15)v15.2.0.pdf">https://www.ttc.or.jp/st/docs/3gpps2019/TS/TS-3GA-38.424(Rel15)v15.2.0.pdf</a>
<b>Release 16</b>						
ATIS	ATIS.3GPP.38.424V1600		16.0.0	Published	08.09.2020	<a href="http://www.atis.org/3gpp-documents/Rel16">http://www.atis.org/3gpp-documents/Rel16</a>
CCSA	CCSA.38.424V1600		16.0.0	Published	16.07.2020	<a href="http://www.ccsa.org.cn:9001/portalsFile/downloadOldFile?type=17&amp;oldFileUrl=Rel16/TS%2038.424%20V16.0.0.doc">http://www.ccsa.org.cn:9001/portalsFile/downloadOldFile?type=17&amp;oldFileUrl=Rel16/TS%2038.424%20V16.0.0.doc</a>
ETSI	ETSI TS 138 424		16.0.0	Published	21.07.2020	<a href="http://www.etsi.org/deliver/etsi_ts/138400_138499/138424/16.00.00_60/ts_138424v160000p.pdf">http://www.etsi.org/deliver/etsi_ts/138400_138499/138424/16.00.00_60/ts_138424v160000p.pdf</a>
TSDSI	TSDSI STD T1.3GPP 38.424-16.0.0 V1.0.0		16.0.0	Published	06.10.2020	<a href="https://members.tdsi.in/index.php/s/Kkx4fK4wagjtmDD">https://members.tdsi.in/index.php/s/Kkx4fK4wagjtmDD</a>
TTA	TTAT.3G-38.424V16.0.0		16.0.0	Published	11.09.2020	<a href="http://www.tta.or.kr/data/ttasDown.jsp?where=14688&amp;pk_num=TTAT.3G-38.424V16.0.0">http://www.tta.or.kr/data/ttasDown.jsp?where=14688&amp;pk_num=TTAT.3G-38.424V16.0.0</a>
TTC	TS-3GA-38.424(Rel16)v16.0.0		16.0.0	Published	02.10.2020	<a href="https://www.ttc.or.jp/st/docs/3gpps2020/TS/TS-3GA-38_424_Rel16v16_0_0.pdf">https://www.ttc.or.jp/st/docs/3gpps2020/TS/TS-3GA-38_424_Rel16v16_0_0.pdf</a>

### 2.2.1.4.21 TS 38.425

#### NG-RAN; NR user plane protocol

This document specifies the NR user plane protocol functions used within NG-RAN and, for EN-DC, within E-UTRAN. NR user plane protocol functions may reside in nodes terminating either the X2-U (for EN-DC) or the Xn-U or the F1-U interface.

SDO	Document No.	Version	Status	Issued date	Location	
<b>Release 15</b>						
ATIS	ATIS.3GPP.38.425V1560		15.6.0	Published	08.09.2020	<a href="http://www.atis.org/3gpp-documents/Rel15">http://www.atis.org/3gpp-documents/Rel15</a>
CCSA	CCSA.38.425V1560		15.6.0	Published	13.07.2019	<a href="http://www.ccsa.org.cn:9001/portalsFile/downloadOldFile?type=17&amp;oldFileUrl=Rel15/TS%2038.425%20V15.6.0.doc">http://www.ccsa.org.cn:9001/portalsFile/downloadOldFile?type=17&amp;oldFileUrl=Rel15/TS%2038.425%20V15.6.0.doc</a>
ETSI	ETSI TS 138 425		15.6.0	Published	23.07.2019	<a href="http://www.etsi.org/deliver/etsi_ts/138400_138499/138425/15.06.00_60/ts_138425v150600p.pdf">http://www.etsi.org/deliver/etsi_ts/138400_138499/138425/15.06.00_60/ts_138425v150600p.pdf</a>
TSDSI	TSDSI STD T1.3GPP 38.425-15.6.0 V1.0.0		15.6.0	Published	06.10.2020	<a href="https://members.tdsi.in/index.php/s/r4PwfcexAPxDrgN">https://members.tdsi.in/index.php/s/r4PwfcexAPxDrgN</a>
TTA	TTAT.3G-38.425V15.6.0		15.6.0	Published	11.09.2020	<a href="http://www.tta.or.kr/data/ttasDown.jsp?where=14688&amp;pk_num=TTAT.3G-38.425V15.6.0">http://www.tta.or.kr/data/ttasDown.jsp?where=14688&amp;pk_num=TTAT.3G-38.425V15.6.0</a>
TTC	TS-3GA-38.425(Rel15)v15.6.0		15.6.0	Published	11.10.2019	<a href="https://www.ttc.or.jp/st/docs/3gpps2019/TS/TS-3GA-38.425(Rel15)v15.6.0.pdf">https://www.ttc.or.jp/st/docs/3gpps2019/TS/TS-3GA-38.425(Rel15)v15.6.0.pdf</a>
<b>Release 16</b>						
ATIS	ATIS.3GPP.38.425V1610		16.1.0	Published	08.09.2020	<a href="http://www.atis.org/3gpp-documents/Rel16">http://www.atis.org/3gpp-documents/Rel16</a>
CCSA	CCSA.38.425V1610		16.1.0	Published	16.07.2020	<a href="http://www.ccsa.org.cn:9001/portalsFile/downloadOldFile?type=17&amp;oldFileUrl=Rel16/TS%2038.425%20V16.1.0.doc">http://www.ccsa.org.cn:9001/portalsFile/downloadOldFile?type=17&amp;oldFileUrl=Rel16/TS%2038.425%20V16.1.0.doc</a>
ETSI	ETSI TS 138 425		16.1.0	Published	21.07.2020	<a href="http://www.etsi.org/deliver/etsi_ts/138400_138499/138425/16.01.00_60/ts_138425v160100p.pdf">http://www.etsi.org/deliver/etsi_ts/138400_138499/138425/16.01.00_60/ts_138425v160100p.pdf</a>
TSDSI	TSDSI STD T1.3GPP 38.425-16.1.0 V1.0.0		16.1.0	Published	06.10.2020	<a href="https://members.tdsi.in/index.php/s/8nKqTg4JDA56sqg">https://members.tdsi.in/index.php/s/8nKqTg4JDA56sqg</a>
TTA	TTAT.3G-38.425V16.1.0		16.1.0	Published	11.09.2020	<a href="http://www.tta.or.kr/data/ttasDown.jsp?where=14688&amp;pk_num=TTAT.3G-38.425V16.1.0">http://www.tta.or.kr/data/ttasDown.jsp?where=14688&amp;pk_num=TTAT.3G-38.425V16.1.0</a>



TTC TS-3GA-38.425(Rel16)v16.1.0 16.1.0 Published 02.10.2020 [https://www.ttc.or.jp/st/docs/3gpps2020/TS/TS-3GA-38\\_425\\_Rel16v16\\_1\\_0.pdf](https://www.ttc.or.jp/st/docs/3gpps2020/TS/TS-3GA-38_425_Rel16v16_1_0.pdf)

#### 2.2.1.4.22 TS 38.455

#### NG-RAN; NR Positioning Protocol A (NRPPa)

This document specifies the control plane radio network layer signalling procedures between a NG-RAN node and the LMF. NRPPa supports the concerned functions by signalling procedures defined in this document.

SDO	Document No.	Version	Status	Issued date	Location	
<b>Release 15</b>						
ATIS	ATIS.3GPP.38.455V1521		15.2.1	Published	08.09.2020	<a href="http://www.atis.org/3gpp-documents/Rel15">http://www.atis.org/3gpp-documents/Rel15</a>
CCSA	CCSA.38.455V1521		15.2.1	Published	14.01.2019	<a href="http://www.ccsa.org.cn:9001/portalsFile/downloadOldFile?type=17&amp;oldFileUrl=Rel15/TS%2038.455%20V15.2.1.doc">http://www.ccsa.org.cn:9001/portalsFile/downloadOldFile?type=17&amp;oldFileUrl=Rel15/TS%2038.455%20V15.2.1.doc</a>
ETSI	ETSI TS 138 455		15.2.1	Published	24.04.2019	<a href="http://www.etsi.org/deliver/etsi_ts/138400_138499/138455/15.02.01_60/ts_138455v150201p.pdf">http://www.etsi.org/deliver/etsi_ts/138400_138499/138455/15.02.01_60/ts_138455v150201p.pdf</a>
TSDSI	TSDSI STD T1.3GPP 38.455-15.2.1 V1.0.0		15.2.1	Published	06.10.2020	<a href="https://members.tdsi.in/index.php/s/KP5C8bxQK9ocn7t">https://members.tdsi.in/index.php/s/KP5C8bxQK9ocn7t</a>
TTA	TTAT.3G-38.455V15.2.1		15.2.1	Published	11.09.2020	<a href="http://www.tta.or.kr/data/ttasDown.jsp?where=14688&amp;pk_num=TTAT.3G-38.455V15.2.1">http://www.tta.or.kr/data/ttasDown.jsp?where=14688&amp;pk_num=TTAT.3G-38.455V15.2.1</a>
TTC	TS-3GA-38.455(Rel15)v15.2.1		15.2.1	Published	29.03.2019	<a href="https://www.ttc.or.jp/st/docs/3gpps2019/TS/TS-3GA-38.455(Rel15)v15.2.1.pdf">https://www.ttc.or.jp/st/docs/3gpps2019/TS/TS-3GA-38.455(Rel15)v15.2.1.pdf</a>
<b>Release 16</b>						
ATIS	ATIS.3GPP.38.455V1600		16.0.0	Published	08.09.2020	<a href="http://www.atis.org/3gpp-documents/Rel16">http://www.atis.org/3gpp-documents/Rel16</a>
CCSA	CCSA.38.455V1600		16.0.0	Published	16.07.2020	<a href="http://www.ccsa.org.cn:9001/portalsFile/downloadOldFile?type=17&amp;oldFileUrl=Rel16/TS%2038.455%20V16.0.0.doc">http://www.ccsa.org.cn:9001/portalsFile/downloadOldFile?type=17&amp;oldFileUrl=Rel16/TS%2038.455%20V16.0.0.doc</a>
ETSI	ETSI TS 138 455		16.0.0	Published	18.09.2020	<a href="http://www.etsi.org/deliver/etsi_ts/138400_138499/138455/16.00.00_60/ts_138455v160000p.pdf">http://www.etsi.org/deliver/etsi_ts/138400_138499/138455/16.00.00_60/ts_138455v160000p.pdf</a>
TSDSI	TSDSI STD T1.3GPP 38.455-16.0.0 V1.0.0		16.0.0	Published	06.10.2020	<a href="https://members.tdsi.in/index.php/s/qGHcgch9Q8qanfW">https://members.tdsi.in/index.php/s/qGHcgch9Q8qanfW</a>
TTA	TTAT.3G-38.455V16.0.0		16.0.0	Published	11.09.2020	<a href="http://www.tta.or.kr/data/ttasDown.jsp?where=14688&amp;pk_num=TTAT.3G-38.455V16.0.0">http://www.tta.or.kr/data/ttasDown.jsp?where=14688&amp;pk_num=TTAT.3G-38.455V16.0.0</a>
TTC	TS-3GA-38.455(Rel16)v16.0.0		16.0.0	Published	02.10.2020	<a href="https://www.ttc.or.jp/st/docs/3gpps2020/TS/TS-3GA-38_455_Rel16v16_0_0.pdf">https://www.ttc.or.jp/st/docs/3gpps2020/TS/TS-3GA-38_455_Rel16v16_0_0.pdf</a>

#### 2.2.1.4.23 TS 38.460

#### NG-RAN; E1 general aspects and principles

This document is an introduction to the 3GPP TS 38.46x series of technical specifications that define the E1 interface. The E1 interface provides means for interconnecting a gNB-CU-CP and a gNB-CU-UP of a gNB-CU within an NG-RAN, or for interconnecting a gNB-CU-CP and a gNB-CU-UP of an en-gNB within an E-UTRAN.

SDO	Document No.	Version	Status	Issued date	Location	
<b>Release 15</b>						
ATIS	ATIS.3GPP.38.460V1540		15.4.0	Published	08.09.2020	<a href="http://www.atis.org/3gpp-documents/Rel15">http://www.atis.org/3gpp-documents/Rel15</a>
CCSA	CCSA.38.460V1540		15.4.0	Published	11.07.2019	<a href="http://www.ccsa.org.cn:9001/portalsFile/downloadOldFile?type=17&amp;oldFileUrl=Rel15/TS%2038.460%20V15.4.0.doc">http://www.ccsa.org.cn:9001/portalsFile/downloadOldFile?type=17&amp;oldFileUrl=Rel15/TS%2038.460%20V15.4.0.doc</a>
ETSI	ETSI TS 138 460		15.4.0	Published	23.07.2019	<a href="http://www.etsi.org/deliver/etsi_ts/138400_138499/138460/15.04.00_60/ts_138460v150400p.pdf">http://www.etsi.org/deliver/etsi_ts/138400_138499/138460/15.04.00_60/ts_138460v150400p.pdf</a>
TSDSI	TSDSI STD T1.3GPP 38.460-15.4.0 V1.0.0		15.4.0	Published	06.10.2020	<a href="https://members.tdsi.in/index.php/s/DBXnLypdf5T4QQq">https://members.tdsi.in/index.php/s/DBXnLypdf5T4QQq</a>
TTA	TTAT.3G-38.460V15.4.0		15.4.0	Published	11.09.2020	<a href="http://www.tta.or.kr/data/ttasDown.jsp?where=14688&amp;pk_num=TTAT.3G-38.460V15.4.0">http://www.tta.or.kr/data/ttasDown.jsp?where=14688&amp;pk_num=TTAT.3G-38.460V15.4.0</a>
TTC	TS-3GA-38.460(Rel15)v15.4.0		15.4.0	Published	11.10.2019	<a href="https://www.ttc.or.jp/st/docs/3gpps2019/TS/TS-3GA-38.460(Rel15)v15.4.0.pdf">https://www.ttc.or.jp/st/docs/3gpps2019/TS/TS-3GA-38.460(Rel15)v15.4.0.pdf</a>
<b>Release 16</b>						
ATIS	ATIS.3GPP.38.460V1610		16.1.0	Published	08.09.2020	<a href="http://www.atis.org/3gpp-documents/Rel16">http://www.atis.org/3gpp-documents/Rel16</a>
CCSA	CCSA.38.460V1610		16.1.0	Published	17.07.2020	<a href="http://www.ccsa.org.cn:9001/portalsFile/downloadOldFile?type=17&amp;oldFileUrl=Rel16/TS%2038.460%20V16.1.0.doc">http://www.ccsa.org.cn:9001/portalsFile/downloadOldFile?type=17&amp;oldFileUrl=Rel16/TS%2038.460%20V16.1.0.doc</a>
ETSI	ETSI TS 138 460		16.1.0	Published	21.07.2020	<a href="http://www.etsi.org/deliver/etsi_ts/138400_138499/138460/16.01.00_60/ts_138460v160100p.pdf">http://www.etsi.org/deliver/etsi_ts/138400_138499/138460/16.01.00_60/ts_138460v160100p.pdf</a>
TSDSI	TSDSI STD T1.3GPP 38.460-16.1.0 V1.0.0		16.1.0	Published	06.10.2020	<a href="https://members.tdsi.in/index.php/s/cKLEwFmpHM493L9">https://members.tdsi.in/index.php/s/cKLEwFmpHM493L9</a>
TTA	TTAT.3G-38.460V16.1.0		16.1.0	Published	11.09.2020	<a href="http://www.tta.or.kr/data/ttasDown.jsp?where=14688&amp;pk_num=TTAT.3G-38.460V16.1.0">http://www.tta.or.kr/data/ttasDown.jsp?where=14688&amp;pk_num=TTAT.3G-38.460V16.1.0</a>
TTC	TS-3GA-38.460(Rel16)v16.1.0		16.1.0	Published	02.10.2020	<a href="https://www.ttc.or.jp/st/docs/3gpps2020/TS/TS-3GA-38_460_Rel16v16_1_0.pdf">https://www.ttc.or.jp/st/docs/3gpps2020/TS/TS-3GA-38_460_Rel16v16_1_0.pdf</a>

**2.2.1.4.24 TS 38.461****NG-RAN; E1 layer 1**

This document specifies the standards allowed to implement layer 1 on the E1 interface.

The specification of transmission delay requirements and O&M requirements are not in the scope of this document.

SDO	Document No.	Version	Status	Issued date	Location	
<b>Release 15</b>						
ATIS	ATIS.3GPP.38.461V1510		15.1.0	Published	08.09.2020	<a href="http://www.atis.org/3gpp-documents/Rel15">http://www.atis.org/3gpp-documents/Rel15</a>
CCSA	CCSA.38.461V1510		15.1.0	Published	02.10.2019	<a href="http://www.ccsa.org.cn:9001/portalsFile/downloadOldFile?type=17&amp;oldFileUrl=Rel15/TS%2038.461%20V15.1.0.doc">http://www.ccsa.org.cn:9001/portalsFile/downloadOldFile?type=17&amp;oldFileUrl=Rel15/TS%2038.461%20V15.1.0.doc</a>
ETSI	ETSI TS 138 461		15.1.0	Published	16.10.2019	<a href="http://www.etsi.org/deliver/etsi_ts/138400_138499/138461/15.01.00_60/ts_138461v150100p.pdf">http://www.etsi.org/deliver/etsi_ts/138400_138499/138461/15.01.00_60/ts_138461v150100p.pdf</a>
TSDSI	TSDSI STD T1.3GPP 38.461-15.1.0 V1.0.0		15.1.0	Published	06.10.2020	<a href="https://members.tdsi.in/index.php/s/j9qk4ARG94X66Y8">https://members.tdsi.in/index.php/s/j9qk4ARG94X66Y8</a>
TTA	TTAT.3G-38.461V15.1.0		15.1.0	Published	11.09.2020	<a href="http://www.tta.or.kr/data/ttasDown.jsp?where=14688&amp;pk_num=TTAT.3G-38.461V15.1.0">http://www.tta.or.kr/data/ttasDown.jsp?where=14688&amp;pk_num=TTAT.3G-38.461V15.1.0</a>
TTC	TS-3GA-38.461(Rel15)v15.1.0		15.1.0	Published	20.12.2019	<a href="https://www.ttc.or.jp/st/docs/3gpps2019/TS/TS-3GA-38.461(Rel15)v15.1.0.pdf">https://www.ttc.or.jp/st/docs/3gpps2019/TS/TS-3GA-38.461(Rel15)v15.1.0.pdf</a>
<b>Release 16</b>						
ATIS	ATIS.3GPP.38.461V1600		16.0.0	Published	08.09.2020	<a href="http://www.atis.org/3gpp-documents/Rel16">http://www.atis.org/3gpp-documents/Rel16</a>
CCSA	CCSA.38.461V1600		16.0.0	Published	16.07.2020	<a href="http://www.ccsa.org.cn:9001/portalsFile/downloadOldFile?type=17&amp;oldFileUrl=Rel16/TS%2038.461%20V16.0.0.doc">http://www.ccsa.org.cn:9001/portalsFile/downloadOldFile?type=17&amp;oldFileUrl=Rel16/TS%2038.461%20V16.0.0.doc</a>
ETSI	ETSI TS 138 461		16.0.0	Published	21.07.2020	<a href="http://www.etsi.org/deliver/etsi_ts/138400_138499/138461/16.00.00_60/ts_138461v160000p.pdf">http://www.etsi.org/deliver/etsi_ts/138400_138499/138461/16.00.00_60/ts_138461v160000p.pdf</a>
TSDSI	TSDSI STD T1.3GPP 38.461-16.0.0 V1.0.0		16.0.0	Published	06.10.2020	<a href="https://members.tdsi.in/index.php/s/meWGYCTEEGFAjT">https://members.tdsi.in/index.php/s/meWGYCTEEGFAjT</a>
TTA	TTAT.3G-38.461V16.0.0		16.0.0	Published	11.09.2020	<a href="http://www.tta.or.kr/data/ttasDown.jsp?where=14688&amp;pk_num=TTAT.3G-38.461V16.0.0">http://www.tta.or.kr/data/ttasDown.jsp?where=14688&amp;pk_num=TTAT.3G-38.461V16.0.0</a>
TTC	TS-3GA-38.461(Rel16)v16.0.0		16.0.0	Published	02.10.2020	<a href="https://www.ttc.or.jp/st/docs/3gpps2020/TS/TS-3GA-38_461_Rel16v16_0_0.pdf">https://www.ttc.or.jp/st/docs/3gpps2020/TS/TS-3GA-38_461_Rel16v16_0_0.pdf</a>

**2.2.1.4.25 TS 38.462****NG-RAN; E1 signalling transport**

This document specifies the standards for Signalling Transport to be used across the E1 interface. The E1 interface provides means for the interconnection of gNB-CU-CP and gNB-CU-UP within the NG-RAN architecture (TS 38.401).

SDO	Document No.	Version	Status	Issued date	Location	
<b>Release 15</b>						
ATIS	ATIS.3GPP.38.462V1561		15.6.1	Published	08.09.2020	<a href="http://www.atis.org/3gpp-documents/Rel15">http://www.atis.org/3gpp-documents/Rel15</a>
CCSA	CCSA.38.462V1561		15.6.1	Published	08.04.2020	<a href="http://www.ccsa.org.cn:9001/portalsFile/downloadOldFile?type=17&amp;oldFileUrl=Rel15/TS%2038.462%20V15.6.1.doc">http://www.ccsa.org.cn:9001/portalsFile/downloadOldFile?type=17&amp;oldFileUrl=Rel15/TS%2038.462%20V15.6.1.doc</a>
ETSI	ETSI TS 138 462		15.6.1	Published	15.04.2020	<a href="http://www.etsi.org/deliver/etsi_ts/138400_138499/138462/15.06.01_60/ts_138462v150601p.pdf">http://www.etsi.org/deliver/etsi_ts/138400_138499/138462/15.06.01_60/ts_138462v150601p.pdf</a>
TSDSI	TSDSI STD T1.3GPP 38.462-15.6.1 V1.0.0		15.6.1	Published	06.10.2020	<a href="https://members.tdsi.in/index.php/s/DWyQRqYSFBHy6QF">https://members.tdsi.in/index.php/s/DWyQRqYSFBHy6QF</a>
TTA	TTAT.3G-38.462V15.6.1		15.6.1	Published	11.09.2020	<a href="http://www.tta.or.kr/data/ttasDown.jsp?where=14688&amp;pk_num=TTAT.3G-38.462V15.6.1">http://www.tta.or.kr/data/ttasDown.jsp?where=14688&amp;pk_num=TTAT.3G-38.462V15.6.1</a>
TTC	TS-3GA-38.462(Rel15)v15.6.1		15.6.1	Published	16.07.2020	<a href="https://www.ttc.or.jp/st/docs/3gpps2020/TS/TS-3GA-38_462_Rel15v15_6_1.pdf">https://www.ttc.or.jp/st/docs/3gpps2020/TS/TS-3GA-38_462_Rel15v15_6_1.pdf</a>
<b>Release 16</b>						
ATIS	ATIS.3GPP.38.462V1600		16.0.0	Published	08.09.2020	<a href="http://www.atis.org/3gpp-documents/Rel16">http://www.atis.org/3gpp-documents/Rel16</a>
CCSA	CCSA.38.462V1600		16.0.0	Published	16.07.2020	<a href="http://www.ccsa.org.cn:9001/portalsFile/downloadOldFile?type=17&amp;oldFileUrl=Rel16/TS%2038.462%20V16.0.0.doc">http://www.ccsa.org.cn:9001/portalsFile/downloadOldFile?type=17&amp;oldFileUrl=Rel16/TS%2038.462%20V16.0.0.doc</a>
ETSI	ETSI TS 138 462		16.0.0	Published	21.07.2020	<a href="http://www.etsi.org/deliver/etsi_ts/138400_138499/138462/16.00.00_60/ts_138462v160000p.pdf">http://www.etsi.org/deliver/etsi_ts/138400_138499/138462/16.00.00_60/ts_138462v160000p.pdf</a>
TSDSI	TSDSI STD T1.3GPP 38.462-16.0.0 V1.0.0		16.0.0	Published	06.10.2020	<a href="https://members.tdsi.in/index.php/s/4aSeqcst6Dc3EkA">https://members.tdsi.in/index.php/s/4aSeqcst6Dc3EkA</a>
TTA	TTAT.3G-38.462V16.0.0		16.0.0	Published	11.09.2020	<a href="http://www.tta.or.kr/data/ttasDown.jsp?where=14688&amp;pk_num=TTAT.3G-38.462V16.0.0">http://www.tta.or.kr/data/ttasDown.jsp?where=14688&amp;pk_num=TTAT.3G-38.462V16.0.0</a>
TTC	TS-3GA-38.462(Rel16)v16.0.0		16.0.0	Published	02.10.2020	<a href="https://www.ttc.or.jp/st/docs/3gpps2020/TS/TS-3GA-38_462_Rel16v16_0_0.pdf">https://www.ttc.or.jp/st/docs/3gpps2020/TS/TS-3GA-38_462_Rel16v16_0_0.pdf</a>

**2.2.1.4.26 TS 38.463****NG-RAN; E1 Application Protocol (E1AP)**

This document specifies the 5G radio network layer signalling protocol for the E1 interface. The E1 interface provides means for interconnecting a gNB-CU-CP and a gNB-CU-UP of a gNB within an NG-RAN, or for interconnecting a gNB-CU-CP and a gNB-CU-UP of an en-gNB within an E-UTRAN. The E1 Application Protocol (E1AP) supports the functions of E1 interface by signalling procedures defined in this document. E1AP is developed in accordance to the general principles stated in TS 38.401 and TS 38.460.

SDO	Document No.	Version	Status	Issued date	Location	
<b>Release 15</b>						
ATIS	ATIS.3GPP.38.463V1570		15.7.0	Published	08.09.2020	<a href="http://www.atis.org/3gpp-documents/Rel15">http://www.atis.org/3gpp-documents/Rel15</a>
CCSA	CCSA.38.463V1570		15.7.0	Published	17.07.2020	<a href="http://www.ccsa.org.cn:9001/portalsFile/downloadOldFile?type=17&amp;oldFileUrl=Rel15/TS%2038.463%20V15.7.0.doc">http://www.ccsa.org.cn:9001/portalsFile/downloadOldFile?type=17&amp;oldFileUrl=Rel15/TS%2038.463%20V15.7.0.doc</a>
ETSI	ETSI TS 138 463		15.7.0	Published	23.07.2020	<a href="http://www.etsi.org/deliver/etsi_ts/138400_138499/138463/15.07.00_60/ts_138463v150700p.pdf">http://www.etsi.org/deliver/etsi_ts/138400_138499/138463/15.07.00_60/ts_138463v150700p.pdf</a>
TSDSI	TSDSI STD T1.3GPP 38.463-15.7.0 V1.0.0		15.7.0	Published	06.10.2020	<a href="https://members.tdsi.in/index.php/s/XeBQLpBJKwND7EF">https://members.tdsi.in/index.php/s/XeBQLpBJKwND7EF</a>
TTA	TTAT.3G-38.463V15.7.0		15.7.0	Published	11.09.2020	<a href="http://www.tta.or.kr/data/ttasDown.jsp?where=14688&amp;pk_num=TTAT.3G-38.463V15.7.0">http://www.tta.or.kr/data/ttasDown.jsp?where=14688&amp;pk_num=TTAT.3G-38.463V15.7.0</a>
TTC	TS-3GA-38.463(Rel15)v15.7.0		15.7.0	Published	02.10.2020	<a href="https://www.ttc.or.jp/st/docs/3gpps2020/TS/TS-3GA-38_463_Rel15v15_7_0.pdf">https://www.ttc.or.jp/st/docs/3gpps2020/TS/TS-3GA-38_463_Rel15v15_7_0.pdf</a>
<b>Release 16</b>						
ATIS	ATIS.3GPP.38.463V1620		16.2.0	Published	08.09.2020	<a href="http://www.atis.org/3gpp-documents/Rel16">http://www.atis.org/3gpp-documents/Rel16</a>
CCSA	CCSA.38.463V1620		16.2.0	Published	17.07.2020	<a href="http://www.ccsa.org.cn:9001/portalsFile/downloadOldFile?type=17&amp;oldFileUrl=Rel16/TS%2038.463%20V16.2.0.doc">http://www.ccsa.org.cn:9001/portalsFile/downloadOldFile?type=17&amp;oldFileUrl=Rel16/TS%2038.463%20V16.2.0.doc</a>
ETSI	ETSI TS 138 463		16.2.0	Published	23.07.2020	<a href="http://www.etsi.org/deliver/etsi_ts/138400_138499/138463/16.02.00_60/ts_138463v160200p.pdf">http://www.etsi.org/deliver/etsi_ts/138400_138499/138463/16.02.00_60/ts_138463v160200p.pdf</a>
TSDSI	TSDSI STD T1.3GPP 38.463-16.2.0 V1.0.0		16.2.0	Published	06.10.2020	<a href="https://members.tdsi.in/index.php/s/KjFkjg6fJwqqF94">https://members.tdsi.in/index.php/s/KjFkjg6fJwqqF94</a>
TTA	TTAT.3G-38.463V16.2.0		16.2.0	Published	11.09.2020	<a href="http://www.tta.or.kr/data/ttasDown.jsp?where=14688&amp;pk_num=TTAT.3G-38.463V16.2.0">http://www.tta.or.kr/data/ttasDown.jsp?where=14688&amp;pk_num=TTAT.3G-38.463V16.2.0</a>
TTC	TS-3GA-38.463(Rel16)v16.2.0		16.2.0	Published	02.10.2020	<a href="https://www.ttc.or.jp/st/docs/3gpps2020/TS/TS-3GA-38_463_Rel16v16_2_0.pdf">https://www.ttc.or.jp/st/docs/3gpps2020/TS/TS-3GA-38_463_Rel16v16_2_0.pdf</a>

**2.2.1.4.27 TS 38.470****NG-RAN; F1 general aspects and principles**

This document is an introduction to the 3GPP TS 38.47x series of technical specifications that define the F1 interface. The F1 interface provides means for interconnecting a gNB-CU and a gNB-DU of a gNB within an NG-RAN, or for interconnecting a gNB-CU and a gNB-DU of an en-gNB within an E-UTRAN.

SDO	Document No.	Version	Status	Issued date	Location	
<b>Release 15</b>						
ATIS	ATIS.3GPP.38.470V1570		15.7.0	Published	08.09.2020	<a href="http://www.atis.org/3gpp-documents/Rel15">http://www.atis.org/3gpp-documents/Rel15</a>
CCSA	CCSA.38.470V1570		15.7.0	Published	09.01.2020	<a href="http://www.ccsa.org.cn:9001/portalsFile/downloadOldFile?type=17&amp;oldFileUrl=Rel15/TS%2038.470%20V15.7.0.doc">http://www.ccsa.org.cn:9001/portalsFile/downloadOldFile?type=17&amp;oldFileUrl=Rel15/TS%2038.470%20V15.7.0.doc</a>
ETSI	ETSI TS 138 470		15.7.0	Published	17.01.2020	<a href="http://www.etsi.org/deliver/etsi_ts/138400_138499/138470/15.07.00_60/ts_138470v150700p.pdf">http://www.etsi.org/deliver/etsi_ts/138400_138499/138470/15.07.00_60/ts_138470v150700p.pdf</a>
TSDSI	TSDSI STD T1.3GPP 38.470-15.7.0 V1.0.0		15.7.0	Published	06.10.2020	<a href="https://members.tdsi.in/index.php/s/B3AZ44kRtHtYz72">https://members.tdsi.in/index.php/s/B3AZ44kRtHtYz72</a>
TTA	TTAT.3G-38.470V15.7.0		15.7.0	Published	11.09.2020	<a href="http://www.tta.or.kr/data/ttasDown.jsp?where=14688&amp;pk_num=TTAT.3G-38.470V15.7.0">http://www.tta.or.kr/data/ttasDown.jsp?where=14688&amp;pk_num=TTAT.3G-38.470V15.7.0</a>
TTC	TS-3GA-38.470(Rel15)v15.7.0		15.7.0	Published	16.04.2020	<a href="https://www.ttc.or.jp/st/docs/3gpps2020/TS/TS-3GA-38_470_Rel15v15_7_0.pdf">https://www.ttc.or.jp/st/docs/3gpps2020/TS/TS-3GA-38_470_Rel15v15_7_0.pdf</a>
<b>Release 16</b>						
ATIS	ATIS.3GPP.38.470V1620		16.2.0	Published	08.09.2020	<a href="http://www.atis.org/3gpp-documents/Rel16">http://www.atis.org/3gpp-documents/Rel16</a>
CCSA	CCSA.38.470V1620		16.2.0	Published	16.07.2020	<a href="http://www.ccsa.org.cn:9001/portalsFile/downloadOldFile?type=17&amp;oldFileUrl=Rel16/TS%2038.470%20V16.2.0.doc">http://www.ccsa.org.cn:9001/portalsFile/downloadOldFile?type=17&amp;oldFileUrl=Rel16/TS%2038.470%20V16.2.0.doc</a>
ETSI	ETSI TS 138 470		16.2.0	Published	21.07.2020	<a href="http://www.etsi.org/deliver/etsi_ts/138400_138499/138470/16.02.00_60/ts_138470v160200p.pdf">http://www.etsi.org/deliver/etsi_ts/138400_138499/138470/16.02.00_60/ts_138470v160200p.pdf</a>
TSDSI	TSDSI STD T1.3GPP 38.470-16.2.0 V1.0.0		16.2.0	Published	06.10.2020	<a href="https://members.tdsi.in/index.php/s/jtezbgyvcPydRTE8">https://members.tdsi.in/index.php/s/jtezbgyvcPydRTE8</a>
TTA	TTAT.3G-38.470V16.2.0		16.2.0	Published	11.09.2020	<a href="http://www.tta.or.kr/data/ttasDown.jsp?where=14688&amp;pk_num=TTAT.3G-38.470V16.2.0">http://www.tta.or.kr/data/ttasDown.jsp?where=14688&amp;pk_num=TTAT.3G-38.470V16.2.0</a>
TTC	TS-3GA-38.470(Rel16)v16.2.0		16.2.0	Published	02.10.2020	<a href="https://www.ttc.or.jp/st/docs/3gpps2020/TS/TS-3GA-38_470_Rel16v16_2_0.pdf">https://www.ttc.or.jp/st/docs/3gpps2020/TS/TS-3GA-38_470_Rel16v16_2_0.pdf</a>

**2.2.1.4.28 TS 38.471****NG-RAN; F1 layer 1**

This document specifies the standards allowed to implement Layer 1 on the F1 interface. The F1 interface provides means for interconnecting a gNB-CU and a gNB-DU of a gNB within an NG-RAN, or for interconnecting a gNB-CU and a gNB-DU of an en-gNB within an E-UTRAN.

The specification of transmission delay requirements and O&M requirements are not in the scope of this document.

SDO	Document No.	Version	Status	Issued date	Location
<b>Release 15</b>					
ATIS	ATIS.3GPP.38.471V1500		15.0.0	Published 08.09.2020	<a href="http://www.atis.org/3gpp-documents/Rel15">http://www.atis.org/3gpp-documents/Rel15</a>
CCSA	CCSA.38.471V1500		15.0.0	Published 21.12.2019	<a href="http://www.ccsa.org.cn:9001/portalsFile/downloadOldFile?type=17&amp;oldFileUrl=Rel16/TS%2038.471%20V15.0.0.doc">http://www.ccsa.org.cn:9001/portalsFile/downloadOldFile?type=17&amp;oldFileUrl=Rel16/TS%2038.471%20V15.0.0.doc</a>
ETSI	ETSI TS 138 471		15.0.0	Published 18.09.2018	<a href="http://www.etsi.org/deliver/etsi_ts/138400_138499/138471/15.00.00_60/ts_138471v150000p.pdf">http://www.etsi.org/deliver/etsi_ts/138400_138499/138471/15.00.00_60/ts_138471v150000p.pdf</a>
TSDSI	TSDSI STD T1.3GPP 38.471-15.0.0 V1.0.0		15.0.0	Published 06.10.2020	<a href="https://members.tdsi.in/index.php/s/rtBfWwinpnbZHqs">https://members.tdsi.in/index.php/s/rtBfWwinpnbZHqs</a>
TTA	TTAT.3G-38.471V15.0.0		15.0.0	Published 11.09.2020	<a href="http://www.tta.or.kr/data/ttasDown.jsp?where=14688&amp;pk_num=TTAT.3G-38.471V15.0.0">http://www.tta.or.kr/data/ttasDown.jsp?where=14688&amp;pk_num=TTAT.3G-38.471V15.0.0</a>
TTC	TS-3GA-38.471(Rel15)v15.0.0		15.0.0	Published 28.09.2018	<a href="https://www.ttc.or.jp/st/docs/3gpps2018/TS/TS-3GA-38.471(Rel15)v15.0.0.pdf">https://www.ttc.or.jp/st/docs/3gpps2018/TS/TS-3GA-38.471(Rel15)v15.0.0.pdf</a>
<b>Release 16</b>					
ATIS	ATIS.3GPP.38.471V1600		16.0.0	Published 08.09.2020	<a href="http://www.atis.org/3gpp-documents/Rel16">http://www.atis.org/3gpp-documents/Rel16</a>
CCSA	CCSA.38.471V1600		16.0.0	Published 31.03.2020	<a href="http://www.ccsa.org.cn:9001/portalsFile/downloadOldFile?type=17&amp;oldFileUrl=Rel16/TS%2038.471%20V16.0.0.doc">http://www.ccsa.org.cn:9001/portalsFile/downloadOldFile?type=17&amp;oldFileUrl=Rel16/TS%2038.471%20V16.0.0.doc</a>
ETSI	ETSI TS 138 471		16.0.0	Published 21.07.2020	<a href="http://www.etsi.org/deliver/etsi_ts/138400_138499/138471/16.00.00_60/ts_138471v160000p.pdf">http://www.etsi.org/deliver/etsi_ts/138400_138499/138471/16.00.00_60/ts_138471v160000p.pdf</a>
TSDSI	TSDSI STD T1.3GPP 38.471-16.0.0 V1.0.0		16.0.0	Published 06.10.2020	<a href="https://members.tdsi.in/index.php/s/4Reniqk2F3nHA3o">https://members.tdsi.in/index.php/s/4Reniqk2F3nHA3o</a>
TTA	TTAT.3G-38.471V16.0.0		16.0.0	Published 11.09.2020	<a href="http://www.tta.or.kr/data/ttasDown.jsp?where=14688&amp;pk_num=TTAT.3G-38.471V16.0.0">http://www.tta.or.kr/data/ttasDown.jsp?where=14688&amp;pk_num=TTAT.3G-38.471V16.0.0</a>
TTC	TS-3GA-38.471(Rel16)v16.0.0		16.0.0	Published 02.10.2020	<a href="https://www.ttc.or.jp/st/docs/3gpps2020/TS/TS-3GA-38_471_Rel16v16_0_0.pdf">https://www.ttc.or.jp/st/docs/3gpps2020/TS/TS-3GA-38_471_Rel16v16_0_0.pdf</a>

**2.2.1.4.29 TS 38.472****NG-RAN; F1 signalling transport**

This document specifies the standards for Signalling Transport to be used across the F1 interface. The F1 interface provides means for interconnecting a gNB-CU and a gNB-DU of a gNB within an NG-RAN, or for interconnecting a gNB-CU and a gNB-DU of an en-gNB within an E-UTRAN. This document describes how the F1AP signalling messages are transported over F1.

SDO	Document No.	Version	Status	Issued date	Location
<b>Release 15</b>					
ATIS	ATIS.3GPP.38.472V1560		15.6.0	Published 08.09.2020	<a href="http://www.atis.org/3gpp-documents/Rel15">http://www.atis.org/3gpp-documents/Rel15</a>
CCSA	CCSA.38.472V1560		15.6.0	Published 09.01.2020	<a href="http://www.ccsa.org.cn:9001/portalsFile/downloadOldFile?type=17&amp;oldFileUrl=Rel15/TS%2038.472%20V15.6.0.doc">http://www.ccsa.org.cn:9001/portalsFile/downloadOldFile?type=17&amp;oldFileUrl=Rel15/TS%2038.472%20V15.6.0.doc</a>
ETSI	ETSI TS 138 472		15.6.0	Published 17.01.2020	<a href="http://www.etsi.org/deliver/etsi_ts/138400_138499/138472/15.06.00_60/ts_138472v150600p.pdf">http://www.etsi.org/deliver/etsi_ts/138400_138499/138472/15.06.00_60/ts_138472v150600p.pdf</a>
TSDSI	TSDSI STD T1.3GPP 38.472-15.6.0 V1.0.0		15.6.0	Published 06.10.2020	<a href="https://members.tdsi.in/index.php/s/NAC5end68xJpAMn">https://members.tdsi.in/index.php/s/NAC5end68xJpAMn</a>
TTA	TTAT.3G-38.472V15.6.0		15.6.0	Published 11.09.2020	<a href="http://www.tta.or.kr/data/ttasDown.jsp?where=14688&amp;pk_num=TTAT.3G-38.472V15.6.0">http://www.tta.or.kr/data/ttasDown.jsp?where=14688&amp;pk_num=TTAT.3G-38.472V15.6.0</a>
TTC	TS-3GA-38.472(Rel15)v15.6.0		15.6.0	Published 16.04.2020	<a href="https://www.ttc.or.jp/st/docs/3gpps2020/TS/TS-3GA-38_472_Rel15v15_6_0.pdf">https://www.ttc.or.jp/st/docs/3gpps2020/TS/TS-3GA-38_472_Rel15v15_6_0.pdf</a>
<b>Release 16</b>					
ATIS	ATIS.3GPP.38.472V1600		16.0.0	Published 08.09.2020	<a href="http://www.atis.org/3gpp-documents/Rel16">http://www.atis.org/3gpp-documents/Rel16</a>
CCSA	CCSA.38.472V1600		16.0.0	Published 31.03.2020	<a href="http://www.ccsa.org.cn:9001/portalsFile/downloadOldFile?type=17&amp;oldFileUrl=Rel16/TS%2038.472%20V16.0.0.doc">http://www.ccsa.org.cn:9001/portalsFile/downloadOldFile?type=17&amp;oldFileUrl=Rel16/TS%2038.472%20V16.0.0.doc</a>
ETSI	ETSI TS 138 472		16.0.0	Published 21.09.2020	<a href="http://www.etsi.org/deliver/etsi_ts/138400_138499/138472/16.00.00_60/ts_138472v160000p.pdf">http://www.etsi.org/deliver/etsi_ts/138400_138499/138472/16.00.00_60/ts_138472v160000p.pdf</a>
TSDSI	TSDSI STD T1.3GPP 38.472-16.0.0 V1.0.0		16.0.0	Published 06.10.2020	<a href="https://members.tdsi.in/index.php/s/Q4WJi9Ng2w6WF74">https://members.tdsi.in/index.php/s/Q4WJi9Ng2w6WF74</a>
TTA	TTAT.3G-38.472V16.0.0		16.0.0	Published 11.09.2020	<a href="http://www.tta.or.kr/data/ttasDown.jsp?where=14688&amp;pk_num=TTAT.3G-38.472V16.0.0">http://www.tta.or.kr/data/ttasDown.jsp?where=14688&amp;pk_num=TTAT.3G-38.472V16.0.0</a>

TTC TS-3GA-38.472(Rel16)v16.0.0 16.0.0 Published 02.10.2020 [https://www.ttc.or.jp/st/docs/3gpps2020/TS/TS-3GA-38\\_472\\_Rel16v16\\_0\\_0.pdf](https://www.ttc.or.jp/st/docs/3gpps2020/TS/TS-3GA-38_472_Rel16v16_0_0.pdf)

**2.2.1.4.30 TS 38.473**

**NG-RAN; F1 Application Protocol (F1AP)**

This document specifies the 5G radio network layer signalling protocol for the F1 interface. The F1 interface provides means for interconnecting a gNB-CU and a gNB-DU of a gNB within an NG-RAN, or for interconnecting a gNB-CU and a gNB-DU of an en-gNB within an E-UTRAN. The F1 Application Protocol (F1AP) supports the functions of F1 interface by signalling procedures defined in this document. F1AP is developed in accordance with the general principles stated in TS 38.401 and TS 38.470.

SDO	Document No.	Version	Status	Issued date	Location
<b>Release 15</b>					
ATIS	ATIS.3GPP.38.473V15100		15.10.0	Published 08.09.2020	<a href="http://www.atis.org/3gpp-documents/Rel15">http://www.atis.org/3gpp-documents/Rel15</a>
CCSA	CCSA.38.473V15100		15.10.0	Published 16.07.2020	<a href="http://www.ccsa.org.cn:9001/portalsFile/downloadOldFile?type=17&amp;oldFileUrl=Rel15/TS%2038.473%20V15.10.0.doc">http://www.ccsa.org.cn:9001/portalsFile/downloadOldFile?type=17&amp;oldFileUrl=Rel15/TS%2038.473%20V15.10.0.doc</a>
ETSI	ETSI TS 138 473		15.10.0	Published 21.07.2020	<a href="http://www.etsi.org/deliver/etsi_ts/138400_138499/138473/15.10.00_60/ts_138473v151000p.pdf">http://www.etsi.org/deliver/etsi_ts/138400_138499/138473/15.10.00_60/ts_138473v151000p.pdf</a>
TSDSI	TSDSI STD T1.3GPP 38.473-15.10.0 V1.0.0		15.10.0	Published 06.10.2020	<a href="https://members.tsdsi.in/index.php/s/kWAFW8bMTN9MYkA">https://members.tsdsi.in/index.php/s/kWAFW8bMTN9MYkA</a>
TTA	TTAT.3G-38.473V15.10.0		15.10.0	Published 11.09.2020	<a href="http://www.tta.or.kr/data/ttasDown.jsp?where=14688&amp;pk_num=TTAT.3G-38.473V15.10.0">http://www.tta.or.kr/data/ttasDown.jsp?where=14688&amp;pk_num=TTAT.3G-38.473V15.10.0</a>
TTC	TS-3GA-38.473(Rel15)v15.10.0		15.10.0	Published 02.10.2020	<a href="https://www.ttc.or.jp/st/docs/3gpps2020/TS/TS-3GA-38_473_Rel15v15_10_0.pdf">https://www.ttc.or.jp/st/docs/3gpps2020/TS/TS-3GA-38_473_Rel15v15_10_0.pdf</a>
<b>Release 16</b>					
ATIS	ATIS.3GPP.38.473V1620		16.2.0	Published 08.09.2020	<a href="http://www.atis.org/3gpp-documents/Rel16">http://www.atis.org/3gpp-documents/Rel16</a>
CCSA	CCSA.38.473V1620		16.2.0	Published 16.07.2020	<a href="http://www.ccsa.org.cn:9001/portalsFile/downloadOldFile?type=17&amp;oldFileUrl=Rel16/TS%2038.473%20V16.2.0.doc">http://www.ccsa.org.cn:9001/portalsFile/downloadOldFile?type=17&amp;oldFileUrl=Rel16/TS%2038.473%20V16.2.0.doc</a>
ETSI	ETSI TS 138 473		16.2.0	Published 21.07.2020	<a href="http://www.etsi.org/deliver/etsi_ts/138400_138499/138473/16.02.00_60/ts_138473v160200p.pdf">http://www.etsi.org/deliver/etsi_ts/138400_138499/138473/16.02.00_60/ts_138473v160200p.pdf</a>
TSDSI	TSDSI STD T1.3GPP 38.473-16.2.0 V1.0.0		16.2.0	Published 06.10.2020	<a href="https://members.tsdsi.in/index.php/s/EdspBPRdwWXrHL4">https://members.tsdsi.in/index.php/s/EdspBPRdwWXrHL4</a>
TTA	TTAT.3G-38.473V16.2.0		16.2.0	Published 11.09.2020	<a href="http://www.tta.or.kr/data/ttasDown.jsp?where=14688&amp;pk_num=TTAT.3G-38.473V16.2.0">http://www.tta.or.kr/data/ttasDown.jsp?where=14688&amp;pk_num=TTAT.3G-38.473V16.2.0</a>
TTC	TS-3GA-38.473(Rel16)v16.2.0		16.2.0	Published 02.10.2020	<a href="https://www.ttc.or.jp/st/docs/3gpps2020/TS/TS-3GA-38_473_Rel16v16_2_0.pdf">https://www.ttc.or.jp/st/docs/3gpps2020/TS/TS-3GA-38_473_Rel16v16_2_0.pdf</a>

**2.2.1.4.31 TS 38.474**

**NG-RAN; F1 data transport**

This document specifies the standards for user data transport protocols and related signalling protocols to establish user plane transport bearers over the F1 interface. The F1 interface provides means for interconnecting a gNB-CU and a gNB-DU of a gNB within an NG-RAN, or for interconnection a gNB-CU and a gNB-DU of an en-gNB within an E-UTRAN.

SDO	Document No.	Version	Status	Issued date	Location
<b>Release 15</b>					
ATIS	ATIS.3GPP.38.474V1530		15.3.0	Published 08.09.2020	<a href="http://www.atis.org/3gpp-documents/Rel15">http://www.atis.org/3gpp-documents/Rel15</a>
CCSA	CCSA.38.474V1530		15.3.0	Published 02.10.2019	<a href="http://www.ccsa.org.cn:9001/portalsFile/downloadOldFile?type=17&amp;oldFileUrl=Rel15/TS%2038.474%20V15.3.0.doc">http://www.ccsa.org.cn:9001/portalsFile/downloadOldFile?type=17&amp;oldFileUrl=Rel15/TS%2038.474%20V15.3.0.doc</a>
ETSI	ETSI TS 138 474		15.3.0	Published 16.10.2019	<a href="http://www.etsi.org/deliver/etsi_ts/138400_138499/138474/15.03.00_60/ts_138474v150300p.pdf">http://www.etsi.org/deliver/etsi_ts/138400_138499/138474/15.03.00_60/ts_138474v150300p.pdf</a>
TSDSI	TSDSI STD T1.3GPP 38.474-15.3.0 V1.0.0		15.3.0	Published 06.10.2020	<a href="https://members.tsdsi.in/index.php/s/taQLMy7bSPZoHir">https://members.tsdsi.in/index.php/s/taQLMy7bSPZoHir</a>
TTA	TTAT.3G-38.474V15.3.0		15.3.0	Published 11.09.2020	<a href="http://www.tta.or.kr/data/ttasDown.jsp?where=14688&amp;pk_num=TTAT.3G-38.474V15.3.0">http://www.tta.or.kr/data/ttasDown.jsp?where=14688&amp;pk_num=TTAT.3G-38.474V15.3.0</a>
TTC	TS-3GA-38.474(Rel15)v15.3.0		15.3.0	Published 20.12.2019	<a href="https://www.ttc.or.jp/st/docs/3gpps2019/TS/TS-3GA-38.474(Rel15)v15.3.0.pdf">https://www.ttc.or.jp/st/docs/3gpps2019/TS/TS-3GA-38.474(Rel15)v15.3.0.pdf</a>

SDO	Document No.	Version	Status	Issued date	Location	
<b>Release 16</b>						
ATIS	ATIS.3GPP.38.474V1600		16.0.0	Published	08.09.2020	<a href="http://www.atis.org/3gpp-documents/Rel16">http://www.atis.org/3gpp-documents/Rel16</a>
CCSA	CCSA.38.474V1600		16.0.0	Published	17.07.2020	<a href="http://www.ccsa.org.cn:9001/portalsFile/downloadOldFile?type=17&amp;oldFileUrl=Rel16/TS%2038.474%20V16.0.0.doc">http://www.ccsa.org.cn:9001/portalsFile/downloadOldFile?type=17&amp;oldFileUrl=Rel16/TS%2038.474%20V16.0.0.doc</a>
ETSI	ETSI TS 138 474		16.0.0	Published	23.07.2020	<a href="http://www.etsi.org/deliver/etsi_ts/138400_138499/138474/16.00.00_60/ts_138474v160000p.pdf">http://www.etsi.org/deliver/etsi_ts/138400_138499/138474/16.00.00_60/ts_138474v160000p.pdf</a>
TSDSI	TSDSI STD T1.3GPP 38.474-16.0.0 V1.0.0		16.0.0	Published	06.10.2020	<a href="https://members.tdsi.in/index.php/s/xaNrDWy9sJ4TsLW">https://members.tdsi.in/index.php/s/xaNrDWy9sJ4TsLW</a>
TTA	TTAT.3G-38.474V16.0.0		16.0.0	Published	11.09.2020	<a href="http://www.tta.or.kr/data/ttasDown.jsp?where=14688&amp;pk_num=TTAT.3G-38.474V16.0.0">http://www.tta.or.kr/data/ttasDown.jsp?where=14688&amp;pk_num=TTAT.3G-38.474V16.0.0</a>
TTC	TS-3GA-38.474(Rel16)v16.0.0		16.0.0	Published	02.10.2020	<a href="https://www.ttc.or.jp/st/docs/3gpps2020/TS/TS-3GA-38_474_Rel16v16_0_0.pdf">https://www.ttc.or.jp/st/docs/3gpps2020/TS/TS-3GA-38_474_Rel16v16_0_0.pdf</a>

## 2.2.1.5 Radio-frequency aspects

### 2.2.1.5.1 TS 37.104

#### NR, E-UTRA, UTRA and GSM/EDGE; Multi-Standard Radio (MSR) Base Station (BS) radio transmission and reception

This document establishes the minimum RF characteristics of E-UTRA, UTRA and GSM/EDGE Multi-Standard Radio (MSR) Base Station (BS). Requirements for multi-RAT and single-RAT operation of MSR BS are covered in this document. The requirements in this document for E-UTRA and UTRA single-RAT operation of MSR BS are also applicable to E-UTRA and UTRA multi-carrier capable single-RAT BS. Requirements for GSM BS that are only single-RAT capable are not covered.

SDO	Document No.	Version	Status	Issued date	Location	
<b>Release 15</b>						
ATIS	ATIS.3GPP.37.104V15110		15.11.0	Published	08.09.2020	<a href="http://www.atis.org/3gpp-documents/Rel15">http://www.atis.org/3gpp-documents/Rel15</a>
CCSA	CCSA.37.104V15110		15.11.0	Published	16.07.2020	<a href="http://www.ccsa.org.cn:9001/portalsFile/downloadOldFile?type=17&amp;oldFileUrl=Rel16/TS%2037.104%20V15.11.0.doc">http://www.ccsa.org.cn:9001/portalsFile/downloadOldFile?type=17&amp;oldFileUrl=Rel16/TS%2037.104%20V15.11.0.doc</a>
ETSI	ETSI TS 137 104		15.11.0	Published	17.09.2020	<a href="http://www.etsi.org/deliver/etsi_ts/137100_137199/137104/15.11.00_60/ts_137104v151100p.pdf">http://www.etsi.org/deliver/etsi_ts/137100_137199/137104/15.11.00_60/ts_137104v151100p.pdf</a>
TSDSI	TSDSI STD T1.3GPP 37.104-15.11.0 V1.0.0		15.11.0	Published	06.10.2020	<a href="https://members.tdsi.in/index.php/s/kXWMzjgAZKQZDq">https://members.tdsi.in/index.php/s/kXWMzjgAZKQZDq</a>
TTA	TTAT.3G-37.104V15.11.0		15.11.0	Published	11.09.2020	<a href="http://www.tta.or.kr/data/ttasDown.jsp?where=14688&amp;pk_num=TTAT.3G-37.104V15.11.0">http://www.tta.or.kr/data/ttasDown.jsp?where=14688&amp;pk_num=TTAT.3G-37.104V15.11.0</a>
<b>Release 16</b>						
ATIS	ATIS.3GPP.37.104V1660		16.6.0	Published	08.09.2020	<a href="http://www.atis.org/3gpp-documents/Rel16">http://www.atis.org/3gpp-documents/Rel16</a>
CCSA	CCSA.37.104V1660		16.6.0	Published	16.07.2020	<a href="http://www.ccsa.org.cn:9001/portalsFile/downloadOldFile?type=17&amp;oldFileUrl=Rel16/TS%2037.104%20V16.6.0.doc">http://www.ccsa.org.cn:9001/portalsFile/downloadOldFile?type=17&amp;oldFileUrl=Rel16/TS%2037.104%20V16.6.0.doc</a>
ETSI	ETSI TS 137 104		16.6.0	Published	15.09.2020	<a href="http://www.etsi.org/deliver/etsi_ts/137100_137199/137104/16.06.00_60/ts_137104v160600p.pdf">http://www.etsi.org/deliver/etsi_ts/137100_137199/137104/16.06.00_60/ts_137104v160600p.pdf</a>
TSDSI	TSDSI STD T1.3GPP 37.104-16.6.0 V1.0.0		16.6.0	Published	06.10.2020	<a href="https://members.tdsi.in/index.php/s/eW9PPjm47btokJH">https://members.tdsi.in/index.php/s/eW9PPjm47btokJH</a>
TTA	TTAT.3G-37.104V16.6.0		16.6.0	Published	11.09.2020	<a href="http://www.tta.or.kr/data/ttasDown.jsp?where=14688&amp;pk_num=TTAT.3G-37.104V16.6.0">http://www.tta.or.kr/data/ttasDown.jsp?where=14688&amp;pk_num=TTAT.3G-37.104V16.6.0</a>

### 2.2.1.5.2 TS 37.105

#### Active Antenna System (AAS) Base Station (BS) transmission and reception

This document establishes the RF characteristics, the RF minimum requirements and minimum performance requirements for E-UTRA AAS Base Station (BS), the FDD mode of UTRA AAS Base Station (BS), the 1,28 Mchip/s TDD mode of UTRA AAS Base Station (BS) in single RAT and any MSR AAS Base Station (BS) implementation of these RATs.

SDO	Document No.	Version	Status	Issued date	Location	
<b>Release 15</b>						
ATIS	ATIS.3GPP.37.105V1590		15.9.0	Published	08.09.2020	<a href="http://www.atis.org/3gpp-documents/Rel15">http://www.atis.org/3gpp-documents/Rel15</a>
CCSA	CCSA.37.105V1590		15.9.0	Published	17.07.2020	<a href="http://www.ccsa.org.cn:9001/portalsFile/downloadOldFile?type=17&amp;oldFileUrl=Rel15/TS%2037.105%20V15.9.0.docx">http://www.ccsa.org.cn:9001/portalsFile/downloadOldFile?type=17&amp;oldFileUrl=Rel15/TS%2037.105%20V15.9.0.docx</a>
ETSI	ETSI TS 137 105		15.9.0	Published	15.09.2020	<a href="http://www.etsi.org/deliver/etsi_ts/137100_137199/137105/15.09.00_60/ts_137105v150900p.pdf">http://www.etsi.org/deliver/etsi_ts/137100_137199/137105/15.09.00_60/ts_137105v150900p.pdf</a>
TSDSI	TSDSI STD T1.3GPP 37.105-15.9.0 V1.0.0		15.9.0	Published	06.10.2020	<a href="https://members.tdsi.in/index.php/s/QWgbdfz98gzfRQ">https://members.tdsi.in/index.php/s/QWgbdfz98gzfRQ</a>

TTA	TTAT.3G-37.105V15.9.0	15.9.0	Published	11.09.2020	<a href="http://www.tta.or.kr/data/ttasDown.jsp?where=14688&amp;pk_num=TTAT.3G-37.105V15.9.0">http://www.tta.or.kr/data/ttasDown.jsp?where=14688&amp;pk_num=TTAT.3G-37.105V15.9.0</a>
<b>Release 16</b>					
ATIS	ATIS.3GPP.37.105V1640	16.4.0	Published	08.09.2020	<a href="http://www.atis.org/3gpp-documents/Rel16">http://www.atis.org/3gpp-documents/Rel16</a>
CCSA	CCSA.37.105V1640	16.4.0	Published	17.07.2020	<a href="http://www.ccsa.org.cn:9001/portalsFile/downloadOldFile?type=17&amp;oldFileUrl=Rel16/TS%2037.105%20V16.4.0.docx">http://www.ccsa.org.cn:9001/portalsFile/downloadOldFile?type=17&amp;oldFileUrl=Rel16/TS%2037.105%20V16.4.0.docx</a>
ETSI	ETSI TS 137 105	16.4.0	Published	15.09.2020	<a href="http://www.etsi.org/deliver/etsi_ts/137100_137199/137105/16.04.00_60/ts_137105v160400p.pdf">http://www.etsi.org/deliver/etsi_ts/137100_137199/137105/16.04.00_60/ts_137105v160400p.pdf</a>
TSDSI	TSDSI STD T1.3GPP 37.105-16.4.0 V1.0.0	16.4.0	Published	06.10.2020	<a href="https://members.tdsi.in/index.php/s/fQ9mNDXTbYaztXX">https://members.tdsi.in/index.php/s/fQ9mNDXTbYaztXX</a>
TTA	TTAT.3G-37.105V16.4.0	16.4.0	Published	11.09.2020	<a href="http://www.tta.or.kr/data/ttasDown.jsp?where=14688&amp;pk_num=TTAT.3G-37.105V16.4.0">http://www.tta.or.kr/data/ttasDown.jsp?where=14688&amp;pk_num=TTAT.3G-37.105V16.4.0</a>

### 2.2.1.5.3 TS 37.113

#### NR, E-UTRA, UTRA and GSM/EDGE; Multi-Standard Radio (MSR) Base Station (BS) Electromagnetic Compatibility (EMC)

This document covers the assessment of E-UTRA, UTRA and GSM/EDGE Multi-Standard Radio (MSR) Base Stations and associated ancillary equipment in respect of Electromagnetic Compatibility (EMC). This document specifies the applicable test conditions, performance assessment and performance criteria for E-UTRA, UTRA and GSM/EDGE Base Stations and associated ancillary equipment in one of the following categories: (i) Multi-Standard Radio (MSR) Base Stations for E-UTRA, UTRA and GSM/EDGE meeting the requirements of TS 37.104, with conformance demonstrated by compliance to TS 37.141; (ii) Base Stations for E-UTRA meeting the requirements of TS 36.104, with conformance demonstrated by compliance to TS 36.141; (iii) Base Stations for UTRA FDD meeting the requirements of TS 25.104, with conformance demonstrated by compliance to TS 25.141; (iv) Base Stations for UTRA TDD meeting the requirements of TS 25.105, with conformance demonstrated by compliance to TS 25.142; (v) Base Stations for GSM/EDGE meeting the requirements of TS 45.005, with conformance demonstrated by compliance to TS 51.021. The environment classification used in this document refers to the environment classification used in IEC 61000-6-1 and IEC 61000-6-3.

The EMC requirements have been selected to ensure an adequate level of compatibility for apparatus at residential, commercial and light industrial environments. The levels, however, do not cover extreme cases which may occur in any location but with low probability of occurrence.

SDO	Document No.	Version	Status	Issued date	Location
<b>Release 15</b>					
ATIS	ATIS.3GPP.37.113V1590	15.9.0	Published	08.09.2020	<a href="http://www.atis.org/3gpp-documents/Rel15">http://www.atis.org/3gpp-documents/Rel15</a>
CCSA	CCSA.37.113V1590	15.9.0	Published	17.07.2020	<a href="http://www.ccsa.org.cn:9001/portalsFile/downloadOldFile?type=17&amp;oldFileUrl=Rel16/TS%2037.113%20V15.9.0.docx">http://www.ccsa.org.cn:9001/portalsFile/downloadOldFile?type=17&amp;oldFileUrl=Rel16/TS%2037.113%20V15.9.0.docx</a>
ETSI	ETSI TS 137 113	15.9.0	Published	15.09.2020	<a href="http://www.etsi.org/deliver/etsi_ts/137100_137199/137113/15.09.00_60/ts_137113v150900p.pdf">http://www.etsi.org/deliver/etsi_ts/137100_137199/137113/15.09.00_60/ts_137113v150900p.pdf</a>
TSDSI	TSDSI STD T1.3GPP 37.113-15.9.0 V1.0.0	15.9.0	Published	06.10.2020	<a href="https://members.tdsi.in/index.php/s/55oazWMctnJLcG3">https://members.tdsi.in/index.php/s/55oazWMctnJLcG3</a>
TTA	TTAT.3G-37.113V15.9.0	15.9.0	Published	11.09.2020	<a href="http://www.tta.or.kr/data/ttasDown.jsp?where=14688&amp;pk_num=TTAT.3G-37.113V15.9.0">http://www.tta.or.kr/data/ttasDown.jsp?where=14688&amp;pk_num=TTAT.3G-37.113V15.9.0</a>
<b>Release 16</b>					
ATIS	ATIS.3GPP.37.113V1600	16.0.0	Published	08.09.2020	<a href="http://www.atis.org/3gpp-documents/Rel16">http://www.atis.org/3gpp-documents/Rel16</a>
CCSA	CCSA.37.113V1600	16.0.0	Published	17.07.2020	<a href="http://www.ccsa.org.cn:9001/portalsFile/downloadOldFile?type=17&amp;oldFileUrl=Rel16/TS%2037.113%20V16.0.0.docx">http://www.ccsa.org.cn:9001/portalsFile/downloadOldFile?type=17&amp;oldFileUrl=Rel16/TS%2037.113%20V16.0.0.docx</a>
ETSI	ETSI TS 137 113	16.0.0	Published	15.09.2020	<a href="http://www.etsi.org/deliver/etsi_ts/137100_137199/137113/16.00.00_60/ts_137113v160000p.pdf">http://www.etsi.org/deliver/etsi_ts/137100_137199/137113/16.00.00_60/ts_137113v160000p.pdf</a>
TSDSI	TSDSI STD T1.3GPP 37.113-16.0.0 V1.0.0	16.0.0	Published	06.10.2020	<a href="https://members.tdsi.in/index.php/s/9HTfzowsBzGzHP8">https://members.tdsi.in/index.php/s/9HTfzowsBzGzHP8</a>
TTA	TTAT.3G-37.113V16.0.0	16.0.0	Published	11.09.2020	<a href="http://www.tta.or.kr/data/ttasDown.jsp?where=14688&amp;pk_num=TTAT.3G-37.113V16.0.0">http://www.tta.or.kr/data/ttasDown.jsp?where=14688&amp;pk_num=TTAT.3G-37.113V16.0.0</a>

### 2.2.1.5.4 TS 37.114

#### Active Antenna System (AAS) Base Station (BS) Electromagnetic Compatibility (EMC)

This document covers the assessment of E-UTRA, UTRA and Multi-Standard Radio (MSR) Active Antenna Systems Base Stations in respect of Electromagnetic Compatibility (EMC).

This document specifies the applicable test conditions, performance assessment and performance criteria for E-UTRA and UTRA Base Stations and associated ancillary equipment in one of the following categories:

- Active Antenna System Base Station for E-UTRA, UTRA and MSR meeting the requirements of 3GPP TS 37.105, with conformance demonstrated by compliance to 3GPP TS 37.145.

The scope of this document is AAS BS with TAB connectors for every transceiver unit at the Transceiver Array Boundary. Requirement, procedures and values of an AAS Base Station without TAB connectors are not included in this document and are FFS.

The environment classification used in this document refers to the residential, commercial and light industrial environment classification used in IEC 61000-6-1 and IEC 61000-6-3.

The EMC requirements have been selected to ensure an adequate level of compatibility for apparatus at residential, commercial and light industrial environments. The levels, however, do not cover extreme cases which may occur in any location but with low probability of occurrence.

SDO	Document No.	Version	Status	Issued date	Location
<b>Release 15</b>					
ATIS	ATIS.3GPP.37.114V1590		15.9.0	Published 08.09.2020	<a href="http://www.atis.org/3gpp-documents/Rel15">http://www.atis.org/3gpp-documents/Rel15</a>
CCSA	CCSA.37.114V1590		15.9.0	Published 17.07.2020	<a href="http://www.ccsa.org.cn:9001/portalsFile/downloadOldFile?type=17&amp;oldFileUrl=Rel15/TS%2037.114%20V15.9.0.docx">http://www.ccsa.org.cn:9001/portalsFile/downloadOldFile?type=17&amp;oldFileUrl=Rel15/TS%2037.114%20V15.9.0.docx</a>
ETSI	ETSI TS 137 114		15.9.0	Published 15.09.2020	<a href="http://www.etsi.org/deliver/etsi_ts/137100_137199/137114/15.09.00_60/ts_137114v150900p.pdf">http://www.etsi.org/deliver/etsi_ts/137100_137199/137114/15.09.00_60/ts_137114v150900p.pdf</a>
TSDSI	TSDSI STD T1.3GPP 37.114-15.9.0 V1.0.0		15.9.0	Published 06.10.2020	<a href="https://members.tdsi.in/index.php/s/fb7dpSMGiM7f82H">https://members.tdsi.in/index.php/s/fb7dpSMGiM7f82H</a>
TTA	TTAT.3G-37.114V15.9.0		15.9.0	Published 11.09.2020	<a href="http://www.tta.or.kr/data/ttasDown.jsp?where=14688&amp;pk_num=TTAT.3G-37.114V15.9.0">http://www.tta.or.kr/data/ttasDown.jsp?where=14688&amp;pk_num=TTAT.3G-37.114V15.9.0</a>
<b>Release 16</b>					
ATIS	ATIS.3GPP.37.114V1600		16.0.0	Published 08.09.2020	<a href="http://www.atis.org/3gpp-documents/Rel16">http://www.atis.org/3gpp-documents/Rel16</a>
CCSA	CCSA.37.114V1600		16.0.0	Published 17.07.2020	<a href="http://www.ccsa.org.cn:9001/portalsFile/downloadOldFile?type=17&amp;oldFileUrl=Rel16/TS%2037.114%20V16.0.0.docx">http://www.ccsa.org.cn:9001/portalsFile/downloadOldFile?type=17&amp;oldFileUrl=Rel16/TS%2037.114%20V16.0.0.docx</a>
ETSI	ETSI TS 137 114		16.0.0	Published 15.09.2020	<a href="http://www.etsi.org/deliver/etsi_ts/137100_137199/137114/16.00.00_60/ts_137114v160000p.pdf">http://www.etsi.org/deliver/etsi_ts/137100_137199/137114/16.00.00_60/ts_137114v160000p.pdf</a>
TSDSI	TSDSI STD T1.3GPP 37.114-16.0.0 V1.0.0		16.0.0	Published 06.10.2020	<a href="https://members.tdsi.in/index.php/s/cgij55wt4LKsgs">https://members.tdsi.in/index.php/s/cgij55wt4LKsgs</a>
TTA	TTAT.3G-37.114V16.0.0		16.0.0	Published 11.09.2020	<a href="http://www.tta.or.kr/data/ttasDown.jsp?where=14688&amp;pk_num=TTAT.3G-37.114V16.0.0">http://www.tta.or.kr/data/ttasDown.jsp?where=14688&amp;pk_num=TTAT.3G-37.114V16.0.0</a>

### 2.2.1.5.5 TS 38.101-1

#### NR; User Equipment (UE) radio transmission and reception; Part 1: Range 1 Standalone

This document establishes the minimum RF requirements for NR User Equipment (UE) operating on frequency Range 1.

SDO	Document No.	Version	Status	Issued date	Location
<b>Release 15</b>					
ARIB	ARIB STD-T120-38.101-1		15.10.0	Published 28.09.2020	<a href="http://www.arib.or.jp/english/html/overview/doc/T120_T23_v2_00/2_T120/ARIB-STD-T120/Rel15/38/A38101-1-fa0.pdf">http://www.arib.or.jp/english/html/overview/doc/T120_T23_v2_00/2_T120/ARIB-STD-T120/Rel15/38/A38101-1-fa0.pdf</a>
ATIS	ATIS.3GPP.38.101-1V15100		15.10.0	Published 08.09.2020	<a href="http://www.atis.org/3gpp-documents/Rel15">http://www.atis.org/3gpp-documents/Rel15</a>
CCSA	CCSA.38.101-1V15100		15.10.0	Published 17.07.2020	<a href="http://www.ccsa.org.cn:9001/portalsFile/downloadOldFile?type=17&amp;oldFileUrl=Rel15/TS%2038.101-1V15100.docx">http://www.ccsa.org.cn:9001/portalsFile/downloadOldFile?type=17&amp;oldFileUrl=Rel15/TS%2038.101-1V15100.docx</a>
ETSI	ETSI TS 138 101-1		15.10.0	Published 23.07.2020	<a href="http://www.etsi.org/deliver/etsi_ts/138100_138199/138101/15.10.00_60/ts_138101v151000p.pdf">http://www.etsi.org/deliver/etsi_ts/138100_138199/138101/15.10.00_60/ts_138101v151000p.pdf</a>
TSDSI	TSDSI STD T1.3GPP 38.101-1-15.10.0		15.10.0	Published 06.10.2020	<a href="https://members.tdsi.in/index.php/s/BtPHPzJBKMackJo">https://members.tdsi.in/index.php/s/BtPHPzJBKMackJo</a>
TTA	TTAT.3G-38.101-1V15.10.0		15.10.0	Published 11.09.2020	<a href="http://www.tta.or.kr/data/ttasDown.jsp?where=14688&amp;pk_num=TTAT.3G-38.101-1V15.10.0">http://www.tta.or.kr/data/ttasDown.jsp?where=14688&amp;pk_num=TTAT.3G-38.101-1V15.10.0</a>
<b>Release 16</b>					
ARIB	ARIB STD-T120-38.101-1		16.4.0	Published 28.09.2020	<a href="http://www.arib.or.jp/english/html/overview/doc/T120_T23_v2_00/2_T120/ARIB-STD-T120/Rel16/38/A38101-1-g40.pdf">http://www.arib.or.jp/english/html/overview/doc/T120_T23_v2_00/2_T120/ARIB-STD-T120/Rel16/38/A38101-1-g40.pdf</a>
ATIS	ATIS.3GPP.38.101-1V1640		16.4.0	Published 08.09.2020	<a href="http://www.atis.org/3gpp-documents/Rel16">http://www.atis.org/3gpp-documents/Rel16</a>
CCSA	CCSA.38.101-1V1640		16.4.0	Published 17.07.2020	<a href="http://www.ccsa.org.cn:9001/portalsFile/downloadOldFile?type=17&amp;oldFileUrl=Rel16/TS%2038.101-1%20V16.4.0.docx">http://www.ccsa.org.cn:9001/portalsFile/downloadOldFile?type=17&amp;oldFileUrl=Rel16/TS%2038.101-1%20V16.4.0.docx</a>
ETSI	ETSI TS 138 101-1		16.4.0	Published 23.07.2020	<a href="http://www.etsi.org/deliver/etsi_ts/138100_138199/138101/16.04.00_60/ts_138101v160400p.pdf">http://www.etsi.org/deliver/etsi_ts/138100_138199/138101/16.04.00_60/ts_138101v160400p.pdf</a>



TSDSI	TSDSI STD T1.3GPP 38.101-1-16.4.0 V1.0.0	16.4.0	Published	06.10.2020	<a href="https://members.tdsi.in/index.php/s/eLo4x6gpgqHknnKi">https://members.tdsi.in/index.php/s/eLo4x6gpgqHknnKi</a>
TTA	TTAT.3G-38.101-1V16.4.0	16.4.0	Published	11.09.2020	<a href="http://www.tta.or.kr/data/ttasDown.jsp?where=14688&amp;pk_num=TTAT.3G-38.101-1V16.4.0">http://www.tta.or.kr/data/ttasDown.jsp?where=14688&amp;pk_num=TTAT.3G-38.101-1V16.4.0</a>

### 2.2.1.5.6 TS 38.101-2

#### NR; User Equipment (UE) radio transmission and reception; Part 2: Range 2 Standalone

This document establishes the minimum RF requirements for NR User Equipment (UE) operating on frequency Range 2.

SDO	Document No.	Version	Status	Issued date	Location	
<b>Release 15</b>						
ARIB	ARIB STD-T120-38.101-2		15.10.0	Published	28.09.2020	<a href="http://www.arib.or.jp/english/html/overview/doc/T120_T23_v2_00/2_T120/ARIB-STD-T120/Rel15/38/A38101-2-fa0.pdf">http://www.arib.or.jp/english/html/overview/doc/T120_T23_v2_00/2_T120/ARIB-STD-T120/Rel15/38/A38101-2-fa0.pdf</a>
ATIS	ATIS.3GPP.38.101-2V15100		15.10.0	Published	08.09.2020	<a href="http://www.atis.org/3gpp-documents/Rel15">http://www.atis.org/3gpp-documents/Rel15</a>
CCSA	CCSA.38.101-2V15100		15.10.0	Published	17.07.2020	<a href="http://www.ccsa.org.cn:9001/portalsFile/downloadOldFile?type=17&amp;oldFileUrl=Rel16/TS%2038.101-">http://www.ccsa.org.cn:9001/portalsFile/downloadOldFile?type=17&amp;oldFileUrl=Rel16/TS%2038.101-</a>
ETSI	ETSI TS 138 101-2		15.10.0	Published	23.07.2020	<a href="http://www.etsi.org/deliver/etsi_ts/138100_138199/13810102/15.10.00_60/ts_13810102v151000p.pdf">http://www.etsi.org/deliver/etsi_ts/138100_138199/13810102/15.10.00_60/ts_13810102v151000p.pdf</a>
TSDSI	TSDSI STD T1.3GPP 38.101-2-15.10.0		15.10.0	Published	06.10.2020	<a href="https://members.tdsi.in/index.php/s/RJSDnP96ZH3LbpP">https://members.tdsi.in/index.php/s/RJSDnP96ZH3LbpP</a>
TTA	TTAT.3G-38.101-2V15.10.0		15.10.0	Published	11.09.2020	<a href="http://www.tta.or.kr/data/ttasDown.jsp?where=14688&amp;pk_num=TTAT.3G-38.101-2V15.10.0">http://www.tta.or.kr/data/ttasDown.jsp?where=14688&amp;pk_num=TTAT.3G-38.101-2V15.10.0</a>
<b>Release 16</b>						
ARIB	ARIB STD-T120-38.101-2		16.4.0	Published	28.09.2020	<a href="http://www.arib.or.jp/english/html/overview/doc/T120_T23_v2_00/2_T120/ARIB-STD-T120/Rel16/38/A38101-2-g40.pdf">http://www.arib.or.jp/english/html/overview/doc/T120_T23_v2_00/2_T120/ARIB-STD-T120/Rel16/38/A38101-2-g40.pdf</a>
ATIS	ATIS.3GPP.38.101-2V1640		16.4.0	Published	08.09.2020	<a href="http://www.atis.org/3gpp-documents/Rel16">http://www.atis.org/3gpp-documents/Rel16</a>
CCSA	CCSA.38.101-2V1640		16.4.0	Published	17.07.2020	<a href="http://www.ccsa.org.cn:9001/portalsFile/downloadOldFile?type=17&amp;oldFileUrl=Rel16/TS%2038.101-2%20V16.4.0.docx">http://www.ccsa.org.cn:9001/portalsFile/downloadOldFile?type=17&amp;oldFileUrl=Rel16/TS%2038.101-2%20V16.4.0.docx</a>
ETSI	ETSI TS 138 101-2		16.4.0	Published	23.07.2020	<a href="http://www.etsi.org/deliver/etsi_ts/138100_138199/13810102/16.04.00_60/ts_13810102v160400p.pdf">http://www.etsi.org/deliver/etsi_ts/138100_138199/13810102/16.04.00_60/ts_13810102v160400p.pdf</a>
TSDSI	TSDSI STD T1.3GPP 38.101-2-16.4.0 V1.0.0		16.4.0	Published	06.10.2020	<a href="https://members.tdsi.in/index.php/s/BgRqgXdipT9WA3Q">https://members.tdsi.in/index.php/s/BgRqgXdipT9WA3Q</a>
TTA	TTAT.3G-38.101-2V16.4.0		16.4.0	Published	11.09.2020	<a href="http://www.tta.or.kr/data/ttasDown.jsp?where=14688&amp;pk_num=TTAT.3G-38.101-2V16.4.0">http://www.tta.or.kr/data/ttasDown.jsp?where=14688&amp;pk_num=TTAT.3G-38.101-2V16.4.0</a>

### 2.2.1.5.7 TS 38.101-3

#### NR; User Equipment (UE) radio transmission and reception; Part 3: Range 1 and Range 2 Interworking operation with other radios

This document establishes the minimum RF requirements for NR User Equipment (UE) Interworking operation with other radios. This includes but is not limited to additional requirements for carrier aggregation or NR dual connectivity between Range 1 and Range 2 and additional requirements due to NR non-standalone (NSA) operation mode with E-UTRA.

SDO	Document No.	Version	Status	Issued date	Location	
<b>Release 15</b>						
ARIB	ARIB STD-T120-38.101-3		15.10.0	Published	28.09.2020	<a href="http://www.arib.or.jp/english/html/overview/doc/T120_T23_v2_00/2_T120/ARIB-STD-T120/Rel15/38/A38101-3-fa0.pdf">http://www.arib.or.jp/english/html/overview/doc/T120_T23_v2_00/2_T120/ARIB-STD-T120/Rel15/38/A38101-3-fa0.pdf</a>
ATIS	ATIS.3GPP.38.101-3V15100		15.10.0	Published	08.09.2020	<a href="http://www.atis.org/3gpp-documents/Rel15">http://www.atis.org/3gpp-documents/Rel15</a>
CCSA	CCSA.38.101-3V15100		15.10.0	Published	17.07.2020	<a href="http://www.ccsa.org.cn:9001/portalsFile/downloadOldFile?type=17&amp;oldFileUrl=Rel15/TS%2038.101-">http://www.ccsa.org.cn:9001/portalsFile/downloadOldFile?type=17&amp;oldFileUrl=Rel15/TS%2038.101-</a>
ETSI	ETSI TS 138 101-3		15.10.0	Published	23.07.2020	<a href="http://www.etsi.org/deliver/etsi_ts/138100_138199/13810103/15.10.00_60/ts_13810103v151000p.pdf">http://www.etsi.org/deliver/etsi_ts/138100_138199/13810103/15.10.00_60/ts_13810103v151000p.pdf</a>
TSDSI	TSDSI STD T1.3GPP 38.101-3-15.10.0		15.10.0	Published	06.10.2020	<a href="https://members.tdsi.in/index.php/s/5D5XPXAST4p9b2D">https://members.tdsi.in/index.php/s/5D5XPXAST4p9b2D</a>
TTA	TTAT.3G-38.101-3V15.10.0		15.10.0	Published	11.09.2020	<a href="http://www.tta.or.kr/data/ttasDown.jsp?where=14688&amp;pk_num=TTAT.3G-38.101-3V15.10.0">http://www.tta.or.kr/data/ttasDown.jsp?where=14688&amp;pk_num=TTAT.3G-38.101-3V15.10.0</a>
<b>Release 16</b>						
ARIB	ARIB STD-T120-38.101-3		16.4.0	Published	28.09.2020	<a href="http://www.arib.or.jp/english/html/overview/doc/T120_T23_v2_00/2_T120/ARIB-STD-T120/Rel16/38/A38101-3-g40.pdf">http://www.arib.or.jp/english/html/overview/doc/T120_T23_v2_00/2_T120/ARIB-STD-T120/Rel16/38/A38101-3-g40.pdf</a>
ATIS	ATIS.3GPP.38.101-3V1640		16.4.0	Published	08.09.2020	<a href="http://www.atis.org/3gpp-documents/Rel16">http://www.atis.org/3gpp-documents/Rel16</a>
CCSA	CCSA.38.101-3V1640		16.4.0	Published	17.07.2020	<a href="http://www.ccsa.org.cn:9001/portalsFile/downloadOldFile?type=17&amp;oldFileUrl=Rel16/TS%2038.101-3%20V16.4.0.docx">http://www.ccsa.org.cn:9001/portalsFile/downloadOldFile?type=17&amp;oldFileUrl=Rel16/TS%2038.101-3%20V16.4.0.docx</a>
ETSI	ETSI TS 138 101-3		16.4.0	Published	23.07.2020	<a href="http://www.etsi.org/deliver/etsi_ts/138100_138199/13810103/16.04.00_60/ts_13810103v160400p.pdf">http://www.etsi.org/deliver/etsi_ts/138100_138199/13810103/16.04.00_60/ts_13810103v160400p.pdf</a>
TSDSI	TSDSI STD T1.3GPP 38.101-3-16.4.0 V1.0.0		16.4.0	Published	06.10.2020	<a href="https://members.tdsi.in/index.php/s/QB5aC7Z4WJAetxz">https://members.tdsi.in/index.php/s/QB5aC7Z4WJAetxz</a>
TTA	TTAT.3G-38.101-3V16.4.0		16.4.0	Published	11.09.2020	<a href="http://www.tta.or.kr/data/ttasDown.jsp?where=14688&amp;pk_num=TTAT.3G-38.101-3V16.4.0">http://www.tta.or.kr/data/ttasDown.jsp?where=14688&amp;pk_num=TTAT.3G-38.101-3V16.4.0</a>

**2.2.1.5.8 TS 38.104****NR; Base Station (BS) radio transmission and reception**

This document establishes the minimum RF characteristics and minimum performance requirements of NR and NB-IoT operation in NR in-band Base Station (BS).

SDO	Document No.	Version	Status	Issued date	Location	
<b>Release 15</b>						
ARIB	ARIB STD-T120-38.104		15.10.0	Published	28.09.2020	<a href="http://www.arib.or.jp/english/html/overview/doc/T120_T23_v2_00/2_T120/ARIB-STD-T120/Rel15/38/A38104-fa0.pdf">http://www.arib.or.jp/english/html/overview/doc/T120_T23_v2_00/2_T120/ARIB-STD-T120/Rel15/38/A38104-fa0.pdf</a>
ATIS	ATIS.3GPP.38.104V15100		15.10.0	Published	08.09.2020	<a href="http://www.atis.org/3gpp-documents/Rel15">http://www.atis.org/3gpp-documents/Rel15</a>
CCSA	CCSA.38.104V15100		15.10.0	Published	17.07.2020	<a href="http://www.ccsa.org.cn:9001/portalsFile/downloadOldFile?type=17&amp;oldFileUrl=Rel15/TS%2038.104%20V15.10.0.docx">http://www.ccsa.org.cn:9001/portalsFile/downloadOldFile?type=17&amp;oldFileUrl=Rel15/TS%2038.104%20V15.10.0.docx</a>
ETSI	ETSI TS 138 104		15.10.0	Published	23.07.2020	<a href="http://www.etsi.org/deliver/etsi_ts/138100_138199/138104/15.10.00_60/ts_138104v151000p.pdf">http://www.etsi.org/deliver/etsi_ts/138100_138199/138104/15.10.00_60/ts_138104v151000p.pdf</a>
TSDSI	TSDSI STD T1.3GPP 38.104-15.10.0 V1.0.0		15.10.0	Published	06.10.2020	<a href="https://members.tdsi.in/index.php/s/XcpPemcEFqDOq2e">https://members.tdsi.in/index.php/s/XcpPemcEFqDOq2e</a>
TTA	TTAT.3G-38.104V15.10.0		15.10.0	Published	11.09.2020	<a href="http://www.tta.or.kr/data/ttasDown.jsp?where=14688&amp;pk_num=TTAT.3G-38.104V15.10.0">http://www.tta.or.kr/data/ttasDown.jsp?where=14688&amp;pk_num=TTAT.3G-38.104V15.10.0</a>
<b>Release 16</b>						
ARIB	ARIB STD-T120-38.104		16.4.0	Published	28.09.2020	<a href="http://www.arib.or.jp/english/html/overview/doc/T120_T23_v2_00/2_T120/ARIB-STD-T120/Rel16/38/A38104-g40.pdf">http://www.arib.or.jp/english/html/overview/doc/T120_T23_v2_00/2_T120/ARIB-STD-T120/Rel16/38/A38104-g40.pdf</a>
ATIS	ATIS.3GPP.38.104V1640		16.4.0	Published	08.09.2020	<a href="http://www.atis.org/3gpp-documents/Rel16">http://www.atis.org/3gpp-documents/Rel16</a>
CCSA	CCSA.38.104V1640		16.4.0	Published	17.07.2020	<a href="http://www.ccsa.org.cn:9001/portalsFile/downloadOldFile?type=17&amp;oldFileUrl=Rel16/TS%2038.104%20V16.4.0.docx">http://www.ccsa.org.cn:9001/portalsFile/downloadOldFile?type=17&amp;oldFileUrl=Rel16/TS%2038.104%20V16.4.0.docx</a>
ETSI	ETSI TS 138 104		16.4.0	Published	23.07.2020	<a href="http://www.etsi.org/deliver/etsi_ts/138100_138199/138104/16.04.00_60/ts_138104v160400p.pdf">http://www.etsi.org/deliver/etsi_ts/138100_138199/138104/16.04.00_60/ts_138104v160400p.pdf</a>
TSDSI	TSDSI STD T1.3GPP 38.104-16.4.0 V1.0.0		16.4.0	Published	06.10.2020	<a href="https://members.tdsi.in/index.php/s/KgWpay6a6SP8X8n">https://members.tdsi.in/index.php/s/KgWpay6a6SP8X8n</a>
TTA	TTAT.3G-38.104V16.4.0		16.4.0	Published	11.09.2020	<a href="http://www.tta.or.kr/data/ttasDown.jsp?where=14688&amp;pk_num=TTAT.3G-38.104V16.4.0">http://www.tta.or.kr/data/ttasDown.jsp?where=14688&amp;pk_num=TTAT.3G-38.104V16.4.0</a>

**2.2.1.5.9 TS 38.113****NR; Base Station (BS) ElectroMagnetic Compatibility (EMC)**

This document covers the assessment of NR Base Station (BS) and ancillary equipment in respect of Electromagnetic Compatibility (EMC).

This document specifies the applicable test conditions, performance assessment and performance criteria for base stations and associated ancillary equipment in the following categories:

- BS equipped with antenna connectors or *TAB connectors* which are possible to be terminated during EMC testing, meeting the *BS type 1-C* and *BS type 1-H* RF requirements of TS 38.104, with conformance demonstrated by compliance to TS 38.141-1.
- BS not equipped with antenna connectors nor *TAB connectors*, i.e. with antenna elements radiating during the EMC testing, meeting the *BS type 1-O* and *BS type 2-O* RF requirements of TS 38.104, with conformance demonstrated by compliance to TS 38.141-2.

The scope of this document is twofold:

- Requirements, procedures and values of a BS with antenna connectors or *TAB connectors*,
- Requirements, procedures and values of a BS without antenna connectors, nor *TAB connectors*.

The environment classification used in this document refers to the residential, commercial and light industrial environment classification used in IEC 61000-6-1 and IEC 61000-6-3.

The EMC requirements have been selected to ensure an adequate level of compatibility for apparatus at residential, commercial and light industrial environments. The levels, however, do not cover extreme cases which may occur in any location but with low probability of occurrence.

SDO	Document No.	Version	Status	Issued date	Location	
<b>Release 15</b>						
ARIB	ARIB STD-T120-38.113		15.10.0	Published	28.09.2020	<a href="http://www.arib.or.jp/english/html/overview/doc/T120_T23_v2_00/2_T120/ARIB-STD-T120/Rel15/38/A38113-fa0.pdf">http://www.arib.or.jp/english/html/overview/doc/T120_T23_v2_00/2_T120/ARIB-STD-T120/Rel15/38/A38113-fa0.pdf</a>
ATIS	ATIS.3GPP.38.113V15100		15.10.0	Published	08.09.2020	<a href="http://www.atis.org/3gpp-documents/Rel15">http://www.atis.org/3gpp-documents/Rel15</a>
CCSA	CCSA.38.113V15100		15.10.0	Published	17.07.2020	<a href="http://www.ccsa.org.cn:9001/portalsFile/downloadOldFile?type=17&amp;oldFileUrl=Rel15/TS%2038.113%20V15.10.0.docx">http://www.ccsa.org.cn:9001/portalsFile/downloadOldFile?type=17&amp;oldFileUrl=Rel15/TS%2038.113%20V15.10.0.docx</a>
ETSI	ETSI TS 138 113		15.10.0	Published	23.07.2020	<a href="http://www.etsi.org/deliver/etsi_ts/138100_138199/138113/15.10.00_60/ts_138113v151000p.pdf">http://www.etsi.org/deliver/etsi_ts/138100_138199/138113/15.10.00_60/ts_138113v151000p.pdf</a>
TSDSI	TSDSI STD T1.3GPP 38.113-15.10.0 V1.0.0		15.10.0	Published	06.10.2020	<a href="https://members.tdsi.in/index.php/s/ZoPrJFoZbFkOHEQ">https://members.tdsi.in/index.php/s/ZoPrJFoZbFkOHEQ</a>
TTA	TTAT.3G-38.113V15.10.0		15.10.0	Published	11.09.2020	<a href="http://www.tta.or.kr/data/ttasDown.jsp?where=14688&amp;pk_num=TTAT.3G-38.113V15.10.0">http://www.tta.or.kr/data/ttasDown.jsp?where=14688&amp;pk_num=TTAT.3G-38.113V15.10.0</a>
<b>Release 16</b>						
ARIB	ARIB STD-T120-38.113		16.0.0	Published	28.09.2020	<a href="http://www.arib.or.jp/english/html/overview/doc/T120_T23_v2_00/2_T120/ARIB-STD-T120/Rel16/38/A38113-g00.pdf">http://www.arib.or.jp/english/html/overview/doc/T120_T23_v2_00/2_T120/ARIB-STD-T120/Rel16/38/A38113-g00.pdf</a>
ATIS	ATIS.3GPP.38.113V1600		16.0.0	Published	08.09.2020	<a href="http://www.atis.org/3gpp-documents/Rel16">http://www.atis.org/3gpp-documents/Rel16</a>
CCSA	CCSA.38.113V1600		16.0.0	Published	17.07.2020	<a href="http://www.ccsa.org.cn:9001/portalsFile/downloadOldFile?type=17&amp;oldFileUrl=Rel16/TS%2038.113%20V16.0.0.docx">http://www.ccsa.org.cn:9001/portalsFile/downloadOldFile?type=17&amp;oldFileUrl=Rel16/TS%2038.113%20V16.0.0.docx</a>
ETSI	ETSI TS 138 113		16.0.0	Published	24.09.2020	<a href="http://www.etsi.org/deliver/etsi_ts/138100_138199/138113/16.00.00_60/ts_138113v160000p.pdf">http://www.etsi.org/deliver/etsi_ts/138100_138199/138113/16.00.00_60/ts_138113v160000p.pdf</a>
TSDSI	TSDSI STD T1.3GPP 38.113-16.0.0 V1.0.0		16.0.0	Published	06.10.2020	<a href="https://members.tdsi.in/index.php/s/bQqnMbAtXbEyyBc">https://members.tdsi.in/index.php/s/bQqnMbAtXbEyyBc</a>
TTA	TTAT.3G-38.113V16.0.0		16.0.0	Published	11.09.2020	<a href="http://www.tta.or.kr/data/ttasDown.jsp?where=14688&amp;pk_num=TTAT.3G-38.113V16.0.0">http://www.tta.or.kr/data/ttasDown.jsp?where=14688&amp;pk_num=TTAT.3G-38.113V16.0.0</a>

### 2.2.1.5.10 TS 38.124

#### NR; Electromagnetic compatibility (EMC) requirements for mobile terminals and ancillary equipment

This document establishes the essential EMC requirements for "3<sup>rd</sup> generation" digital cellular mobile terminal equipment and ancillary accessories in combination with a 3GPP NR user equipment (UE).

The equipment conforming to the requirements laid out in this document and used in its intended electromagnetic environment in accordance with the manufacturer's instructions

- shall not generate electromagnetic disturbances at a level which may interfere with the intended operation of other equipment;
- has an adequate level of intrinsic immunity to electromagnetic disturbances to operate as intended;

This document specifies the applicable EMC tests, methods of measurement, frequency ranges, applicable limits and minimum performance criteria for all types of NR UE(s) and their accessories. NR base station equipment operating within network infrastructure is outside the scope of this document. However, this document does cover mobile and portable equipment that is intended to be operated in a fixed location while connected to the AC mains. NR base station equipment operating within network infrastructure is covered by the technical specification TS 38.113.

Requirements for the radiated emission from the enclosure port of integral antenna equipment and ancillaries are included in this document. Technical specifications for conducted emissions from the antenna connector are found in the 3GPP specifications for the radio interface, e.g. TS 38.xyz, for the effective use of the radio spectrum.

Requirements for the radiated emissions from the enclosure port and ancillaries cover two cases:

- UE equipment supporting operations in a frequency range for which antenna connectors are available (i.e. for operations in Frequency Range 1 as defined in e.g. TS 38.101-1 for the radio interface);

- UE equipment supporting operations in a frequency range for which only integral antennas may be available (i.e. for operations in Frequency Range 2 as defined in e.g. TS 38.101-2 for the radio interface).

The immunity requirements are selected to ensure an adequate level of compatibility for apparatus in residential, commercial, light industrial and vehicular environments. The levels, however, do not cover extreme cases, which may occur in any location but with low probability of occurrence.

Compliance of radio equipment to the requirements of this document does not signify compliance to any requirement related to the use of the equipment (i.e. licensing requirements).

Compliance to the requirements of this document does not signify compliance to any safety requirement. However, any temporary or permanent unsafe condition caused by EMC is considered as non-compliance.

SDO	Document No.	Version	Status	Issued date	Location	
<b>Release 15</b>						
ARIB	ARIB STD-T120-38.124		15.3.0	Published	28.09.2020	<a href="http://www.arib.or.jp/english/html/overview/doc/T120_T23_v2_00/2_T120/ARIB-STD-T120/Rel15/38/A38124-f30.pdf">http://www.arib.or.jp/english/html/overview/doc/T120_T23_v2_00/2_T120/ARIB-STD-T120/Rel15/38/A38124-f30.pdf</a>
ATIS	ATIS.3GPP.38.124V1530		15.3.0	Published	08.09.2020	<a href="http://www.atis.org/3gpp-documents/Rel15">http://www.atis.org/3gpp-documents/Rel15</a>
CCSA	CCSA.38.124V1530		15.3.0	Published	21.07.2020	<a href="http://www.ccsa.org.cn:9001/portalsFile/downloadOldFile?type=17&amp;oldFileUrl=Rel15/TS%2038.124%20V15.3.0.docx">http://www.ccsa.org.cn:9001/portalsFile/downloadOldFile?type=17&amp;oldFileUrl=Rel15/TS%2038.124%20V15.3.0.docx</a>
ETSI	ETSI TS 138 124		15.3.0	Published	14.09.2020	<a href="http://www.etsi.org/deliver/etsi_ts/138100_138199/138124/15.03.00_60/ts_138124v150300p.pdf">http://www.etsi.org/deliver/etsi_ts/138100_138199/138124/15.03.00_60/ts_138124v150300p.pdf</a>
TSDSI	TSDSI STD T1.3GPP 38.124-15.3.0 V1.0.0		15.3.0	Published	06.10.2020	<a href="https://members.tdsi.in/index.php/s/iXn5C8kqB3Jc3tS">https://members.tdsi.in/index.php/s/iXn5C8kqB3Jc3tS</a>
TTA	TTAT.3G-38.124V15.3.0		15.3.0	Published	11.09.2020	<a href="http://www.tta.or.kr/data/ttasDown.jsp?where=14688&amp;pk_num=TTAT.3G-38.124V15.3.0">http://www.tta.or.kr/data/ttasDown.jsp?where=14688&amp;pk_num=TTAT.3G-38.124V15.3.0</a>
<b>Release 16</b>						
ARIB	ARIB STD-T120-38.124		16.0.0	Published	28.09.2020	<a href="http://www.arib.or.jp/english/html/overview/doc/T120_T23_v2_00/2_T120/ARIB-STD-T120/Rel16/38/A38124-g00.pdf">http://www.arib.or.jp/english/html/overview/doc/T120_T23_v2_00/2_T120/ARIB-STD-T120/Rel16/38/A38124-g00.pdf</a>
ATIS	ATIS.3GPP.38.124V1600		16.0.0	Published	08.09.2020	<a href="http://www.atis.org/3gpp-documents/Rel16">http://www.atis.org/3gpp-documents/Rel16</a>
CCSA	CCSA.38.124V1600		16.0.0	Published	21.07.2020	<a href="http://www.ccsa.org.cn:9001/portalsFile/downloadOldFile?type=17&amp;oldFileUrl=Rel16/TS%2038.124%20V16.0.0.docx">http://www.ccsa.org.cn:9001/portalsFile/downloadOldFile?type=17&amp;oldFileUrl=Rel16/TS%2038.124%20V16.0.0.docx</a>
ETSI	ETSI TS 138 124		16.0.0	Published	30.07.2020	<a href="http://www.etsi.org/deliver/etsi_ts/138100_138199/138124/16.00.00_60/ts_138124v160000p.pdf">http://www.etsi.org/deliver/etsi_ts/138100_138199/138124/16.00.00_60/ts_138124v160000p.pdf</a>
TSDSI	TSDSI STD T1.3GPP 38.124-16.0.0 V1.0.0		16.0.0	Published	06.10.2020	<a href="https://members.tdsi.in/index.php/s/Lq2JCmtTPZkDoMn">https://members.tdsi.in/index.php/s/Lq2JCmtTPZkDoMn</a>
TTA	TTAT.3G-38.124V16.0.0		16.0.0	Published	11.09.2020	<a href="http://www.tta.or.kr/data/ttasDown.jsp?where=14688&amp;pk_num=TTAT.3G-38.124V16.0.0">http://www.tta.or.kr/data/ttasDown.jsp?where=14688&amp;pk_num=TTAT.3G-38.124V16.0.0</a>

### 2.2.1.5.11 TS 38.133

#### NR; Requirements for support of radio resource management

This document specifies requirements for support of Radio Resource Management for the FDD and TDD modes of New Radio (NR). These requirements include requirements on measurements in NR and the UE as well as requirements on node dynamical behaviour and interaction, in terms of delay and response characteristics.

SDO	Document No.	Version	Status	Issued date	Location	
<b>Release 15</b>						
ARIB	ARIB STD-T120-38.133		15.10.0	Published	28.09.2020	<a href="http://www.arib.or.jp/english/html/overview/doc/T120_T23_v2_00/2_T120/ARIB-STD-T120/Rel15/38/A38133-fa0.pdf">http://www.arib.or.jp/english/html/overview/doc/T120_T23_v2_00/2_T120/ARIB-STD-T120/Rel15/38/A38133-fa0.pdf</a>
ATIS	ATIS.3GPP.38.133V15100		15.10.0	Published	08.09.2020	<a href="http://www.atis.org/3gpp-documents/Rel15">http://www.atis.org/3gpp-documents/Rel15</a>
CCSA	CCSA.38.133V15100		15.10.0	Published	17.07.2020	<a href="http://www.ccsa.org.cn:9001/portalsFile/downloadOldFile?type=17&amp;oldFileUrl=Rel15/TS%2038.133%20V15.10.0.zip">http://www.ccsa.org.cn:9001/portalsFile/downloadOldFile?type=17&amp;oldFileUrl=Rel15/TS%2038.133%20V15.10.0.zip</a>
ETSI	ETSI TS 138 133		15.10.0	Published	25.09.2020	<a href="http://www.etsi.org/deliver/etsi_ts/138100_138199/138133/15.10.00_60/ts_138133v151000p.pdf">http://www.etsi.org/deliver/etsi_ts/138100_138199/138133/15.10.00_60/ts_138133v151000p.pdf</a>
TSDSI	TSDSI STD T1.3GPP 38.133-15.10.0 V1.0.0		15.10.0	Published	06.10.2020	<a href="https://members.tdsi.in/index.php/s/fK2NHEZd9kgsbdr">https://members.tdsi.in/index.php/s/fK2NHEZd9kgsbdr</a>
TTA	TTAT.3G-38.133V15.10.0		15.10.0	Published	11.09.2020	<a href="http://www.tta.or.kr/data/ttasDown.jsp?where=14688&amp;pk_num=TTAT.3G-38.133V15.10.0">http://www.tta.or.kr/data/ttasDown.jsp?where=14688&amp;pk_num=TTAT.3G-38.133V15.10.0</a>
<b>Release 16</b>						
ARIB	ARIB STD-T120-38.133		16.4.0	Published	28.09.2020	<a href="http://www.arib.or.jp/english/html/overview/doc/T120_T23_v2_00/2_T120/ARIB-STD-T120/Rel16/38/A38133-g40.pdf">http://www.arib.or.jp/english/html/overview/doc/T120_T23_v2_00/2_T120/ARIB-STD-T120/Rel16/38/A38133-g40.pdf</a>
ATIS	ATIS.3GPP.38.133V1640		16.4.0	Published	08.09.2020	<a href="http://www.atis.org/3gpp-documents/Rel16">http://www.atis.org/3gpp-documents/Rel16</a>
CCSA	CCSA.38.133V1640		16.4.0	Published	17.07.2020	<a href="http://www.ccsa.org.cn:9001/portalsFile/downloadOldFile?type=17&amp;oldFileUrl=Rel16/TS%2038.133%20V16.4.0.zip">http://www.ccsa.org.cn:9001/portalsFile/downloadOldFile?type=17&amp;oldFileUrl=Rel16/TS%2038.133%20V16.4.0.zip</a>

### Rec. ITU-R M.2150-0

ETSI	ETSI TS 138 133	16.4.0	Published	14.08.2020	<a href="http://www.etsi.org/deliver/etsi_ts/138100_138199/138133/16.04.00_60/ts_138133v160400p.pdf">http://www.etsi.org/deliver/etsi_ts/138100_138199/138133/16.04.00_60/ts_138133v160400p.pdf</a>
TSDSI	TSDSI STD T1.3GPP 38.133-16.4.0 V1.0.0	16.4.0	Published	06.10.2020	<a href="https://members.tsdsi.in/index.php/s/5AJwoZ8jRcPK4SY">https://members.tsdsi.in/index.php/s/5AJwoZ8jRcPK4SY</a>
TTA	TTAT.3G-38.133V16.4.0	16.4.0	Published	11.09.2020	<a href="http://www.tta.or.kr/data/ttasDown.jsp?where=14688&amp;pk_num=TTAT.3G-38.133V16.4.0">http://www.tta.or.kr/data/ttasDown.jsp?where=14688&amp;pk_num=TTAT.3G-38.133V16.4.0</a>

### 2.2.2 Other specifications

Other specifications addressing radio and device testing, but not part of the GCS, are listed in this section.

Information on system and core network specifications can be found in the 3GPP web site for a complete system perspective. These system and core network specifications address the network, terminal, and service aspects required to provide an integrated mobility solution including aspects such as user services, connectivity, interoperability, mobility and roaming, security, codecs and media, operations and maintenance, charging, etc.

All the 3GPP specifications can be found at the following link: <https://www.3gpp.org/specifications/specification-numbering>. 3GPP specifications are reviewed and updated after each Technical Specification Group Plenary meeting (held every year in March, June, September and December).

#### 2.2.2.1 TS 37.141

##### **E-UTRA, UTRA and GSM/EDGE; Multi-Standard Radio (MSR) Base Station (BS) conformance testing**

This document specifies the Radio Frequency (RF) test methods and conformance requirements for E-UTRA, UTRA and GSM/EDGE Multi-Standard Radio (MSR) Base Station (BS).

#### 2.2.2.2 TS 37.144

##### **User Equipment (UE) and Mobile Station (MS) GSM, UTRA and E-UTRA over the air performance requirements**

This document establishes over the air antenna minimum requirements for user equipment (UE) and mobile station (MS).

Handheld UE requirements are defined for roaming bands for the speech position (beside the head and beside the head and hand) and hand phantom browsing mode position. Laptop mounted equipment requirements are defined for roaming bands for the data transfer position (laptop ground plane phantom). Laptop embedded equipment requirements are defined for roaming bands for the data transfer position (free space).

All bands are potential roaming bands, and the requirements for roaming bands shall therefore be fulfilled for all bands supported by a UE/MS.

Requirements for operating bands are dependent on how the network has been built and are thus operator specific and cannot be specified here. Recommended performance values for operating bands (Annex B) are however included in this specification for information. It should be recognised that the ability to meet the recommended performance values depends on the number of frequency bands supported by the UE/MS.

#### 2.2.2.3 TS 37.145-1

##### **Active Antenna System (AAS) Base Station (BS) conformance testing; Part 1: conducted conformance testing**

This document specifies the Radio Frequency (RF) test methods and conformance requirements for Single RAT E-UTRA, UTRA and Multi-Standard Radio (MSR) UTRA and EUTRA Active Antenna System (AAS) Base Station (BS). These have been derived from, and are consistent with the E-UTRA, UTRA AAS BS specification defined in 3GPP TS 25.104. The technical specification is in two parts: part 1 (this document) covers conducted requirements and part 2 covers radiated requirements.

#### 2.2.2.4 TS 37.145-2

##### **Active Antenna System (AAS) Base Station (BS) conformance testing; Part 2: radiated conformance testing**

This document specifies the Radio Frequency (RF) test methods and conformance requirements for Single RAT E-UTRA, UTRA and Multi-Standard Radio (MSR) UTRA and EUTRA Active Antenna System (AAS) Base Station (BS). These have been derived from, and are consistent with the E-UTRA, UTRA AAS BS specification defined in 3GPP TS 25.104. The technical specification is in two parts, part 1 covers conducted requirements and part 2 (this document) covers radiated requirements.

#### 2.2.2.5 TS 37.171

##### **Universal Terrestrial Radio Access (UTRA) and Evolved UTRA (E-UTRA); User Equipment (UE) performance requirements for RAT-Independent Positioning Enhancements**

This document establishes the minimum performance requirements for RAT-Independent Positioning Enhancements (e.g. MBS positioning technology) for FDD or TDD mode of UTRA and E-UTRA for the User Equipment (UE).

#### 2.2.2.6 TS 38.101-4

##### **NR; User Equipment (UE) radio transmission and reception; Part 4: Performance requirements**

This document establishes the minimum performance requirements for NR User Equipment (UE).

#### 2.2.2.7 TS 38.141-1

##### **NR; Base Station (BS) conformance testing Part 1: Conducted conformance testing**

This document specifies the Radio Frequency (RF) test methods and conformance requirements for NR Base Station (BS) *Type 1-C* and *Type 1-H*. These have been derived from, and are consistent with the conducted requirements for *BS Type 1-C* and *BS Type 1-H* in NR BS specification defined in TS 38.104.

- A *BS type 1-C* only has conducted requirements, so it requires compliance to this specification only.
- A *BS type 1-H* has both conducted and radiated requirements, so it requires compliance to the applicable requirements of this specification and TS 38.141-2.
- *BS type 1-O* and *BS type 2-O* have only radiated requirements, so they require compliance to TS 38.141-2 only.

#### 2.2.2.8 TS 38.141-2

##### **NR; Base Station (BS) conformance testing Part 2: Radiated conformance testing**

This document specifies the Radio Frequency (RF) test methods and conformance requirements for NR Base Station (BS) *type 1-H*, *BS type 1-O* and *BS type 2-O*. These have been derived from, and are consistent with the radiated requirements for *BS type 1-H*, *BS type 1-O* and *BS type 2-O* in BS specification defined in TS 38.104.

- A *BS type 1-C* only has conducted requirements, so it does not require compliance to this specification.
- A *BS type 1-H* has both conducted and radiated requirements, so it requires compliance to the applicable requirements of this specification and TS 38.141-1.

- *BS type 1-O* and *BS type 2-O* have only radiated requirements, so they require compliance to this specification only.

#### 2.2.2.9 TS 38.171

##### **NR; Requirements for support of Assisted Global Navigation Satellite System (A-GNSS)**

This document establishes the minimum requirements for both UE based and UE assisted FDD or TDD A-GNSS terminals which have NG-RAN access via gNB (in SA NR, NR-DC or NE-DC NR operation mode) or via ng-eNB (in EN-DC operation mode) and which are supporting A-GNSS in 5GS via LPP between UE and LMF as described in TS 38.305.

#### 2.2.2.10 TS 37.571-1

##### **Universal Terrestrial Radio Access (UTRA) and Evolved UTRA (E-UTRA) and Evolved Packet Core (EPC); User Equipment (UE) conformance specification for UE positioning; Part 1: Conformance test specification**

This document specifies the procedures for the conformance test of the measurement requirements for FDD mode of UTRA and FDD or TDD mode of E-UTRA for the User Equipment (UE) that supports one or more of the defined positioning methods. These positioning methods are for UTRA: Assisted Global Positioning System (A-GPS), Assisted Global Navigation Satellite Systems (A-GNSS) and for E-UTRA: Assisted Global Navigation Satellite System (A-GNSS), Observed Time Difference of Arrival (OTDOA), Enhanced Cell ID (ECID).

Tests are only applicable to those mobiles that are intended to support the appropriate functionality. To indicate the circumstances in which tests apply, this is noted in the “Test applicability” part of the test.

The Implementation Conformance Statement (ICS) pro-forma could be found in the 3<sup>rd</sup> part of this document.

#### 2.2.2.11 TS 37.571-2

##### **Universal Terrestrial Radio Access (UTRA) and Evolved UTRA (E-UTRA) and Evolved Packet Core (EPC); User Equipment (UE) conformance specification for UE positioning; Part 2: Protocol conformance**

This document specifies the protocol conformance testing for the 3<sup>rd</sup> Generation UTRAN and E-UTRAN User Equipment (UE) supporting UE positioning.

This is the second part of a multi-part test specification. The following information can be found in this part:

- the overall protocol conformance test structure;
- the protocol conformance test configurations;
- the conformance requirement and reference to the core specifications;
- the test purposes; and
- a brief description of the test procedure, the specific test requirements and short message exchange table.

The Implementation Conformance Statement (ICS) pro-forma could be found in the 3<sup>rd</sup> part of this document.

This document is valid for UE supporting UE positioning implemented according to 3GPP releases starting from Release 99 up to the Release indicated on the cover page of this document.



### 2.2.2.12 TS 37.571-3

#### **Universal Terrestrial Radio Access (UTRA) and Evolved UTRA (E-UTRA) and Evolved Packet Core (EPC); User Equipment (UE) conformance specification for UE positioning; Part 3: Implementation Conformance Statement (ICS)**

This document provides the ICS proforma for 3<sup>rd</sup> Generation UTRAN and E-UTRAN User Equipment (UE) supporting UE positioning, in compliance with the relevant requirements, and in accordance with the relevant guidance given in ISO/IEC 9646-1 and ISO/IEC 9646-7.

This document also specifies a recommended applicability statement for the test cases included in 3GPP TS 37.571-1 and 3GPP TS 37.571-2. These applicability statements are based on the features implemented in the UE.

Special conformance testing functions can be found in 3GPP TS 34.109 for UTRA and 3GPP TS 36.509 for E-UTRA. The common test environments are included in 3GPP TS 34.108 for UTRA and in 3GPP TS 36.508 for E-UTRA.

This document is valid for UE supporting UE positioning implemented according to 3GPP releases starting from Release 99 up to the Release indicated on the cover page of this document.

### 2.2.2.13 TS 37.571-4

#### **Universal Terrestrial Radio Access (UTRA) and Evolved UTRA (E-UTRA) and Evolved Packet Core (EPC); User Equipment (UE) conformance specification for UE positioning; Part 4: Test suites**

This document specifies the protocol and signalling conformance testing in TTCN for the UE:

- A-GPS at the UTRA Uu interface;
- LTE positioning at the LTE-Uu interface;
- A-GNSS at the UTRA Uu interface.

The following TTCN test specification and design considerations can be found in this document:

- Test system architecture;
- Test models and ASP definitions;
- Test methods and usage of communication ports definitions;
- Test configurations;
- Design principles and assumptions;
- TTCN styles and conventions;
- Partial PIXIT proforma;
- Test suites in TTCN-2 and TTCN-3;
- The Test Suites designed and implemented in this document are based on the test specifications in prose in 3GPP TS 37.571-2;
- The applicability of the individual test cases is specified in the test ICS proforma specification in 3GPP TS 37.571-3.

**2.2.2.14 TS 37.571-5****Universal Terrestrial Radio Access (UTRA) and Evolved UTRA (E-UTRA) and Evolved Packet Core (EPC); User Equipment (UE) conformance specification for UE positioning; Part 5: Test scenarios and assistance data**

This document specifies the test scenarios and assistance data required for the conformance test for FDD or TDD mode of UTRA and E-UTRA for the User Equipment (UE) that supports one or more of the defined positioning methods. For UTRA these are Assisted Global Positioning System (A-GPS) and Assisted Global Navigation Satellite System (A-GNSS). For E-UTRA these are A-GNSS, Observed Time Difference of Arrival (OTDOA) and Enhanced Cell ID (ECID).

**2.2.2.15 TS 38.508-1****5GS; User Equipment (UE) conformance specification; Part 1: Common test environment**

This document defines the test environment for the 5G System.

This specification covers all aspects, including NG-RAN, 5GC and interworking between 5GS and EPS used for conformance tests of User Equipment (UE).

**2.2.2.16 TS 38.508-2****5GS; User Equipment (UE) conformance specification; Part 2: Common Implementation Conformance Statement (ICS) proforma**

This document provides the Implementation Conformance Statement (ICS) proforma for 5G New Radio (NR) User Equipment (UE), in compliance with the relevant requirements.

Special conformance testing functions can be found in 3GPP TS 38.509 and 3GPP TS 36.509 and the common test environments are included in 3GPP TS 38.508-1 and 3GPP TS 36.508.

This document is valid for UE implemented according to 3GPP Releases starting from Release 15 up to the Release indicated on the cover page of this document.

**2.2.2.17 TS 38.509****5GS; Special conformance testing functions for User Equipment (UE)**

This document defines for User Equipment (UE) those special functions and their activation/deactivation methods that are required in the UE for conformance testing purposes when the UE is connected to the 5G System (5GS) via its radio interface(s).

The document also describes the operation of these special functions when the 5GS capable UEs are connected via a non-5GS system e.g. E-UTRA FDD or TDD system.

Depending on the 5GS system's architecture some relevant for the UE for conformance testing special functions may be defined in TS 36.509.

**2.2.2.18 TS 38.521-1****NR; User Equipment (UE) conformance specification; Radio transmission and reception; Part 1: Range 1 standalone**

This document specifies the measurement procedures for the conformance test of the user equipment (UE) that contain RF characteristics for frequency Range 1 as part of the 5G-NR.

The requirements are listed in different clauses only if the corresponding parameters deviate. More generally, tests are only applicable to those mobiles that are intended to support the appropriate functionality. To indicate the circumstances in which tests apply, this is noted in the "definition and applicability" part of the test.

For example, only Release 15 and later UE declared to support 5G-NR shall be tested for this functionality. In the event that for some tests different conditions apply for different releases, this is indicated within the text of the test itself.

#### **2.2.2.19 TS 38.521-2**

##### **NR; User Equipment (UE) conformance specification; Radio transmission and reception; Part 2: Range 2 standalone**

This document specifies the measurement procedures for the conformance test of the user equipment (UE) that contain RF characteristics for frequency Range 2 as part of the 5G-NR.

The requirements are listed in different clauses only if the corresponding parameters deviate. More generally, tests are only applicable to those mobiles that are intended to support the appropriate functionality. To indicate the circumstances in which tests apply, this is noted in the "definition and applicability" part of the test.

For example, only Release 15 and later UE declared to support 5G-NR shall be tested for this functionality. In the event that for some tests different conditions apply for different releases, this is indicated within the text of the test itself.

#### **2.2.2.20 TS 38.521-3**

##### **NR; User Equipment (UE) conformance specification; Radio transmission and reception; Part 3: Range 1 and Range 2 Interworking operation with other radios**

This document specifies the measurement procedures for the conformance test of the user equipment (UE) that contain RF characteristics for carrier aggregation between Range 1 and Range 2 and additional requirements due to NR non-standalone (NSA) operation mode with E-UTRA.

The requirements are listed in different clauses only if the corresponding parameters deviate. More generally, tests are only applicable to those mobiles that are intended to support the appropriate functionality. To indicate the circumstances in which tests apply, this is noted in the "*definition and applicability*" part of the test.

For example, only Release 15 and later UE declared to support 5G-NR shall be tested for this functionality. In the event that for some tests different conditions apply for different releases, this is indicated within the text of the test itself.

#### **2.2.2.21 TS 38.521-4**

##### **NR; User Equipment (UE) conformance specification; Radio transmission and reception; Part 4: Performance**

This document specifies the measurement procedures for the conformance test of the user equipment (UE) that contain performance requirements as part of 5G-NR.

The requirements are listed in different clauses only if the corresponding parameters deviate. More generally, tests are only applicable to those mobiles that are intended to support the appropriate functionality. To indicate the circumstances in which tests apply, this is noted in the "*definition and applicability*" part of the test.

For example, only Release 15 and later UE declared to support 5G-NR shall be tested for this functionality. In the event that for some tests different conditions apply for different releases, this is indicated within the text of the test itself.

#### 2.2.2.22 TS 38.522

##### **NR; User Equipment (UE) conformance specification; Applicability of radio transmission, radio reception and radio resource management test cases**

This document provides the Implementation Conformance Statement (ICS) proforma for 5G New Radio (NR) User Equipment (UE), in compliance with the relevant requirements.

This document specifies the recommended applicability statement for the test cases included in 3GPP TS 38.521-1, TS 38.521-2, TS 38.521-3, TS 38.521-4 and TS 38.533. These applicability statements are based on the features implemented in the UE.

Special conformance testing functions can be found in 3GPP TS 38.509 and the common test environments are included in 3GPP TS 38.508-1. Common implementation conformance statement (ICS) proforma can be found in 3GPP TS 38.508-2.

#### 2.2.2.23 TS 38.523-1

##### **5GS; User Equipment (UE) conformance specification; Part 1: Protocol**

This document specifies the protocol conformance testing for the 3GPP UE connecting to the 5G System (5GS) via its radio interface(s).

The following information can be found in this document (first part of a multi-part test specification):

- the overall test structure;
- the test configurations;
- the conformance requirement and references to the core specifications;
- the test purposes; and
- a brief description of the test procedure, the specific test requirements and short message exchange table.

The applicability of the individual test cases is specified in the ICS proforma specification (3GPP TS 38.523-2). The Test Suites are specified in part 3 (3GPP TS 38.523-3).

#### 2.2.2.24 TS 38.523-2

##### **5GS; User Equipment (UE) conformance specification; Part 2: Applicability of protocol test cases**

This document provides the applicability of protocol test cases proforma for 5G New Radio (NR) User Equipment (UE), in compliance with the relevant requirements.

This document specifies the recommended applicability statement for the test cases included in 3GPP TS 38.523-1 and 3GPP TS 38.523-3. These applicability statements are based on the features implemented in the UE.

Special conformance testing functions can be found in 3GPP TS 38.509 and 3GPP TS 36.509 and the common test environments are included in 3GPP TS 38.508-1 and 3GPP TS 36.508.

#### 2.2.2.25 TS 38.523-3

##### **5GS; User Equipment (UE) conformance specification; Part 3: Protocol Test Suites**

This document specifies the protocol and signalling conformance testing in TTCN-3 for the 3GPP UE connecting to the 5G System (5GS) via its radio interface(s).

The following TTCN test specification and design considerations can be found in this document:

- the test system architecture;

- the overall test suite structure;
- the test models and ASP definitions;
- the test methods and usage of communication ports definitions;
- the test configurations;
- the design principles and assumptions;
- TTCN styles and conventions;
- the partial PIXIT proforma;
- the test suites.

The Test Suites designed in the document are based on the test cases specified in prose in 3GPP TS 38.523-1. The applicability of the individual test cases is specified in 3GPP TS 38.523-2.

#### **2.2.2.26 TS 38.533**

##### **NR; User Equipment (UE) conformance specification; Radio Resource Management (RRM)**

This document specifies the measurement procedures for the conformance test of the user equipment (UE) that contain requirements for support of RRM (Radio Resource Management) as part of the 5G New Radio (5G-NR). This document covers NR Range 1, NR Range 2 and Interworking.

The requirements are listed in different clauses only if the corresponding parameters deviate. More generally, tests are only applicable to those mobiles that are intended to support the appropriate functionality. To indicate the circumstances in which tests apply, this is noted in the “*test applicability*” part of the test.

#### **2.2.2.27 TS 34.229-1**

##### **Internet Protocol (IP) multimedia call control protocol based on Session Initiation Protocol (SIP) and Session Description Protocol (SDP); User Equipment (UE) conformance specification; Part 1: Protocol conformance specification**

This document specifies the protocol conformance testing for the User Equipment (UE) supporting the Internet Protocol (IP) multimedia call control protocol based on Session Initiation Protocol (SIP) and Session Description Protocol (SDP).

This is the first part of a multi-part test specification. The following information can be found in this part:

- the overall test structure;
- the test configurations;
- the conformance requirement and reference to the core specifications;
- the test purposes; and
- a brief description of the test procedure, the specific test requirements and short message exchange table.

The following information relevant to testing can be found in accompanying specifications:

- the applicability of each test case.

#### 2.2.2.28 TS 34.229-2

##### **Internet Protocol (IP) multimedia call control protocol based on Session Initiation Protocol (SIP) and Session Description Protocol (SDP); User Equipment (UE) conformance specification; Part 2: Implementation Conformance Statement (ICS) specification**

This document provides the Implementation Conformance Statement (ICS) proforma for 3<sup>rd</sup> Generation User Equipment (UE) supporting the Internet Protocol (IP) multimedia call control protocol based on Session Initiation Protocol (SIP) and Session Description Protocol (SDP), in compliance with the relevant requirements, and in accordance with the relevant guidance given in ISO/IEC 9646-7 and ETSI ETS 300 406.

#### 2.2.2.29 TS 34.229-3

##### **Internet Protocol (IP) multimedia call control protocol based on Session Initiation Protocol (SIP) and Session Description Protocol (SDP); User Equipment (UE) conformance specification; Part 3: Abstract test suite (ATS)**

This document specifies the protocol conformance testing in TTCN for the 3GPP User Equipment (UE) at the Gm interface.

This document is the 3<sup>rd</sup> part of a multi-part test specification, 3GPP TS 34.229. The following TTCN test specification and design considerations can be found in this document:

- the overall test suite structure;
- the testing architecture;
- the test methods and PCO definitions;
- the test configurations;
- the design principles, assumptions, and used interfaces to the TTCN tester (System Simulator);
- TTCN styles and conventions;
- the partial PIXIT proforma;
- the TTCN files for the mentioned protocols tests.

The Abstract Test Suites designed in the document are based on the test cases specified in prose (3GPP TS 34.229-1).

#### 2.2.2.30 TS 34.229-5

##### **Internet Protocol (IP) multimedia call control protocol based on Session Initiation Protocol (SIP) and Session Description Protocol (SDP); User Equipment (UE) conformance specification; Part 5: Protocol conformance specification using 5G System (5GS)**

This document specifies the protocol conformance testing for the User Equipment (UE) supporting the Internet Protocol (IP) multimedia call control protocol based on Session Initiation Protocol (SIP) and Session Description Protocol (SDP) when using the 5G System (5GS).

This is the fifth part of a multi-part test specification. The following information can be found in this part:

- the overall test structure;
- the test configurations;
- the conformance requirement and reference to the core specifications;
- the test purposes; and
- the test procedure.

The following information relevant to testing can be found in accompanying specifications:

- Implementation Conformance Statement (ICS) pro-forma and the applicability of each test case.

### Annex 3

## Specification of the 5Gi<sup>1</sup> radio interface technology

### TABLE OF CONTENTS

	<i>Page</i>
Background .....	198
3.1 Overview of the radio interface technology .....	199
3.2 Detailed specification of the radio interface technology .....	217

#### Background

IMT-2020 is a system with global development activity and the IMT-2020 terrestrial radio interface specifications identified in this Recommendation have been developed by the ITU in collaboration with the GCS Proponents and the Transposing Organizations. It is noted from Document IMT-2020/20, that:

- The GCS Proponent must be one of the RIT/SRIT Proponents for the relevant technology, and must have legal authority to grant to ITU-R the relevant legal usage rights to the relevant specifications provided within a GCS corresponding to a technology in Recommendation ITU-R M.[IMT-2020.SPECS].
- A Transposing Organization must have been authorized by the relevant GCS Proponent to produce transposed standards for a particular technology and must have the relevant legal usage rights.

It is further noted that GCS Proponents and Transposing Organizations must also qualify appropriately under the auspices of Resolution ITU-R 9 and the ITU-R “Guidelines for the contribution of material of other organizations to the work of the Study Groups and for inviting other organizations to take part in the study of specific matters (Resolution ITU-R 9)”.

The ITU has provided the global and overall framework and requirements and has developed the Global Core Specification jointly with the GCS Proponent. The detailed standardization has been undertaken within the recognized Transposing Organizations which operate in concert with the GCS Proponent. This Recommendation therefore makes extensive use of references to externally developed specifications.

This approach was considered to be the most appropriate solution to enable completion of this Recommendation within the aggressive schedules set by the ITU and by the needs of administrations, operators and manufacturers.

This Recommendation has therefore been constructed to take full advantage of this method of work and to allow the global standardization timescales to be maintained. The main body of this Recommendation has been developed by the ITU, with each Annex containing references pointing to the location of the more detailed information.

---

<sup>1</sup> Developed by TSDSI as “5Gi RIT”.



This Annex 3 contains the detailed information developed by the ITU and “TSDSI” (the GCS Proponent and Transposing Organizations).

Such use of referencing enables timely completion and update of the high-level elements of this Recommendation, with change control procedures, transposition, and public enquiry procedures being undertaken within the external organization. This information has generally been adopted unchanged, recognizing the need to minimize duplication of work, and the need to facilitate and support an ongoing maintenance and update process.

This general agreement, noting that the detailed information of the radio interface should to a large extent be achieved by reference to the work of external organizations, highlights not only the ITU’s significant role as a catalyst in stimulating, coordinating and facilitating the development of advanced telecommunications technologies, but also its forward-looking and flexible approach to the development of this and other telecommunications standards for the 21<sup>st</sup> century.

A more detailed understanding of the process for the development of the first release of this Recommendation may be found in Document IMT-2020/20.

### **3.1 Overview of the radio interface technology**

TSDSI RIT is a versatile radio interface that fulfils all the technical performance requirements of IMT 2020 across all the different test environments. This RIT focuses on connecting the next generation of devices and providing services across various sectors. In particular, this RIT focuses on:

- 1 Enhanced spectral efficiency and broadband access;
- 2 Low latency communication;
- 3 Support millions of IOT devices;
- 4 Power efficiency;
- 5 High speed connectivity;
- 6 Large Coverage (in particular for Rural areas);
- 7 Support multiple frequency bands including mmWave spectrum.

While, the current specifications provide a robust RIT, the specification also provides a framework on which future enhancements can be supported, providing a future-proof technology. In the following sections, we provide a basic description of the RIT. The complete details of the RIT can be found in the specification documents.

### 3.1.1 System and protocol architecture

The overall RAN protocol architecture is shown in Fig. 42.

FIGURE 42  
Control-plane and user-plane protocol stack (AMF is not part of the RAN)

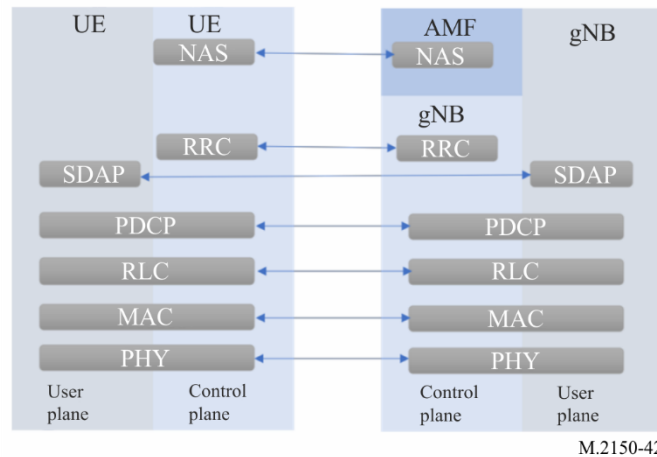

- 1 Physical layer is responsible for coding (decoding), modulation (demodulation), rate adaptation, multi-antenna processing and appropriate waveform generation.
- 2 Medium-Access Control (MAC) layer is responsible for scheduling, hybrid-ARQ and multiplexing of logical channels. Physical layer interacts with MAC using transport channels.
- 3 Radio-link Control (RLC) layer is responsible for packet segmentation and handling retransmissions. MAC layer interfaces with RLC layer using logical channels.
- 4 Packet Data Convergence Protocol (PDCP) layer provides in-sequence delivery of packets, ciphering functionality and integrity protection. RLC interacts with PDCP using RLC channels
- 5 Service Data Application Protocol (SDAP) layer is primarily responsible for managing radio bearers and maintaining QoS requirements.
- 6 Radio Resource Control (RRC) layer is responsible for handling RAN control-plane procedures, transmission of configuration and system parameters.

### 3.1.2 Physical layer

#### 3.1.2.1 Waveform and frame structure

TSDSI RIT offers a flexible waveform and frame structure to support applications with various requirements. The underlying waveform is based on Orthogonal Frequency Division Multiplexing (OFDM) with cyclic prefix (CP). In uplink, in addition to OFDM, DFT spreading can also be applied to reduce the cubic metric. The waveforms support multiple sub-carrier spacings to accommodate transmission at mmWave frequencies and also achieve lower latency transmissions. The supported sub-carrier spacings and the supported frequency ranges are shown in Table 3-1 below. Here FR1 indicates sub-6 GHz bands while FR2 indicates mmWave bands.

TABLE 3-1  
Allowed SCS

$\mu$	$\Delta f = 2^\mu \times 15 \text{ KHz}$	CP	Frequency
0	15	Normal	FR1
1	30	Normal	FR1
2	60	Normal / Extended	FR1/FR2
3	120	Normal	FR2
4	240	Normal	FR2

OFDMA based time-frequency grid is used for packing multiple users, synchronization and reference signals. Slot (see Fig. 43) is a fundamental unit of scheduling in the TSDSI RIT and always consists of 14 OFDM symbols. Slots make up subframes (1 ms duration), ten of which in turn make up a frame (10 ms duration).

FIGURE 43  
Frame structure in the time domain

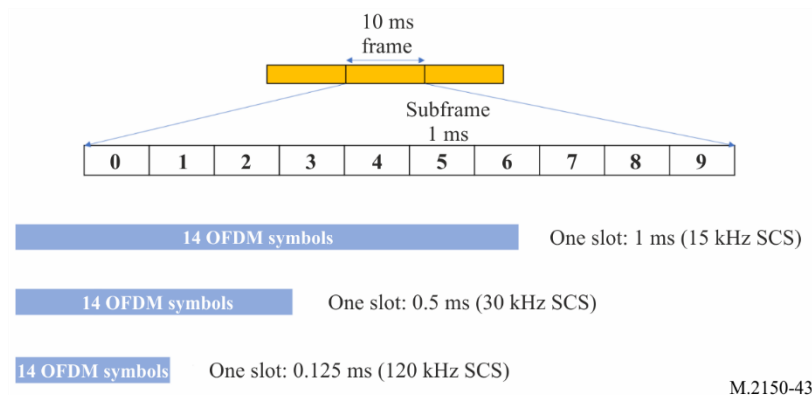

In the frequency domain, the finest granularity of resource allocation is the RE (resource elements) which have a bandwidth of the SCS being used. Twelve RE make a physical resource block and the RIT supports a maximum of 275 PRB on a carrier. The RIT supports multiple bandwidths and different carrier frequencies. Both paired and un-paired spectrum are supported by the RIT.

### 3.1.2.2 Downlink

#### 3.1.2.2.1 Downlink Data Channel

The downlink transport block (TB) processing consists of the following steps:

- 1 TB CRC attachment
- 2 Code-block segmentation
- 3 LDPC channel coding
- 4 Rate matching, interleaving and scrambling
- 5 Modulation (QPSK, 16 QAM, 64 QAM, 256 QAM)
- 6 Layer mapping
- 7 Mapping to antenna ports

For single user MIMO, up to 4 layers are supported by one TB and up to 8 layers are supported by two TBs. Demodulation reference signals (DMRS) are incorporated in the frequency grid for channel estimation by the UE. Up to 12 orthogonal DMRS ports are supported in the downlink and can be used for estimating the precoding matrix being used. A user can be allocated any number of PRB's within his BWP and 2- 14 OFDM symbols in the time domain in a slot.

### 3.1.2.2.2 Control channels

The physical downlink control channel (PDCCH) provides the following information to the UE:

- DL resources of PDSCH, HARQ and related information required for PDSCH demodulation and decoding;
- UL scheduling grant for PUSCH and HARQ.

Other information related to slot format, pre-emption, UL power control, SRS etc.

The PDCCH consists of control resource sets (CORESETS). The characteristics of a CORESET are:

- Up to three OFDM symbols in time;
- Always contained within the active bandwidth part (BWP) of a UE;
- Occupies any position within a slot;
- Consists of control channel elements (CCE). 1 CCE is 6 resource element groups (REGs) where 1 REG is one resource block in 1 OFDM symbol. The CCE-to-REG mapping can be either interleaved or non-interleaved;
- 1, 2, 4, 8, or 16 aggregation level of CCEs are possible;
- Contains PDCCH DMRS for demodulation;
- PDCCH can be beamformed.

The payload transmitted on a PDCCH is Downlink Control Information (DCI). The characteristics of DCI are:

- QPSK modulated symbols;
- Polar coding;
- 24-bit CRC.

The PDCCH is blindly decoded by the UEs. To reduce the number of blind decoding's, search spaces are provided. The search space can be device specific (to a particular UE) or common (for a group of UEs).

### 3.1.2.2.3 Synchronization and Initial Cell Access

#### 3.1.2.2.3.1 SS/PBCH

The synchronization signals and PBCH (SSB) block spans four OFDM symbols and 240 subcarriers. They are used for frequency locking and downlink time sync. The numerology and time domain location are dependent on the carrier frequency.

The PSS and SSS intrinsically hold the ID of the cell, and the PBCH carries the Master Information Block (MIB). The PBCH also has an associated DMRS and is polar encoded.

SSB is transmitted as bursts of 5ms. Each burst can contain up to 8 SSB in FR1 and 64 SSB in FR2. The gNB may transmit each SSB of a burst in a different direction using multiple beams.

### 3.1.2.2.3.2 Cell Search

The UE searches for SSB centred at a frequency raster which is much sparser than the channel raster enabling faster detection. If the UE detects multiple SSBs, it chooses the beam with maximum power.

### 3.1.2.2.3.3 SIB/MSI

The MIB along with SystemInformationBlock1 forms the minimum system information which is transmitted periodically. The MIB is transmitted in PBCH and it provides the CORESET0 info to decode the SIB1. Additional SIBs are transmitted on the request of UE or if triggered by the network

## 3.1.2.3 Uplink

### 3.1.2.3.1 Data channels

The uplink transport block (TB) processing consists of the following steps:

- 1 TB CRC attachment;
- 2 Code-block segmentation and CRC attachment;
- 3 LDPC channel coding;
- 4 Rate matching;
- 5 Modulation (shaped  $\pi/2$  BPSK, QPSK, 16 QAM, 64 QAM, 256 QAM);
- 6 Layer mapping and transform precoding;
- 7 Mapping to antenna ports.

The entire uplink transmission is scheduled by DCI or semi-statically scheduled by RRC. In the uplink, the entire 14 symbols can be used for transmission of data. Demodulation reference signals (DMRS) are incorporated in the frequency grid for channel estimation by the UE. The UE has at least one DMRS in each layer and up to three additional DMRS can be configured. Codebook and non-codebook-based MIMO transmissions are supported. The gNB provides the precoder information via DCI for the codebook transmission.

### 3.1.2.3.2 Control channels

The uplink control information (UCI) consists of the following:

- HARQ for PDSCH;
- Channel state information (CSI);
- Scheduling request (SR).

The UCI is transmitted either on the physical uplink control channel (PUCCH) or on the PUSCH. PUCCH formats are of two types; short and long.

Short PUCCH format consists of formats 0 and 2 which can occupy up to two OFDM symbols.

TABLE 3-2  
Short PUCCH formats

Format	Characteristics
0	<ul style="list-style-type: none"> <li>– Transmits at most 2 bits</li> <li>– Low PAPR sequence</li> <li>– HARQ/SR</li> </ul>
2	<ul style="list-style-type: none"> <li>– Transmits more than 2 bits</li> <li>– HARQ/CSI/SR</li> <li>– Reed Muller/Polar code</li> <li>– QPSK modulation</li> </ul>

Long PUCCH format consists of 1, 3 and 4 which can occupy 4 to 14 OFDM symbols.

TABLE 3-3  
Long PUCCH formats

Format	Characteristics
1	<ul style="list-style-type: none"> <li>– At most 2 bits</li> <li>– BPSK/QPSK</li> <li>– Low PAPR sequence</li> </ul>
3	<ul style="list-style-type: none"> <li>– More than 2 bits</li> <li>– Reed Muller/Polar code</li> <li>– DMRS included</li> </ul>
4	<ul style="list-style-type: none"> <li>– More than 2 bits</li> <li>– Same as PUCCH format 3 but code-multiplexing of multiple devices in the same resource is allowed</li> <li>– DMRS included</li> </ul>

In case of transmission on PUSCH, the UCI is multiplexed with the data.

### 3.1.2.3.3 Random access

The RACH process synchronizes the UE to the gNB in time in the UL direction by estimating the timing advance needed for the UE. ZC sequences are used for the initial random access procedure. RACH occasions occur in different frequency and time locations and have multiple formats and sequence lengths. Each occasion has 64 possible preambles formats and can be used for various deployments. The format and occasion of PRACH is conveyed by the SIB1 message. In addition, for beam management, a notion of PRACH-SSB association that conveys the beam ID with maximum power to the gNB is also introduced.

### 3.1.2.4 MIMO Capabilities

The RIT supports deployments of large-scale massive MIMO systems to enhance coverage as well as capacity. It can support both TDD and FDD configurations in quite a flexible manner. The

MIMO features support is crucial for both sub6GHz bands and mmWave bands. The specification is in general a beam-based technology to support both these spectrum bands.

For the downlink transmissions, the DMRS is designed to support up to 12 users via MU-MIMO techniques in the downlink via 12 orthogonal DMRS ports. Specifically, a maximum of 8 orthogonal DL DMRS ports per UE are allowed in the Single-User MIMO (SU-MIMO) mode of operation and a maximum of 4 orthogonal DL DMRS ports per UE are supported for Multi-User MIMO (MU-MIMO) mode. The number of SU-MIMO code words is one for 1 to 4 layers transmissions and two for 5 to 8 layers transmissions.

The specification supports both codebook-based and non-codebook-based precoding mechanisms for MIMO transmissions. For codebook-based mechanisms, two kinds of CSI feedback mechanisms are supported, mainly Type-I and Type-II aka low-resolution and high-resolution CSI feedback. Efforts are made to ensure the feedback from the users is minimized and yet achieve significant gains in the downlink transmission in MU-MIMO mode.

For the case of uplink, closed loop DMRS based spatial multiplexing is supported. For a given user, a maximum of up to four-layer transmissions are supported while the number of codewords is limited to one. When transform precoding is used i.e. DFT-s-OFDM transmission, only a single MIMO layer transmission is supported.

The specification also supports multiple transmission-reception points such as in the case of coordinated multiple point transmission, multiple antenna panel transmissions among others. These support use cases such as avoiding blockages in higher frequencies and enhance reliability.

### 3.1.2.5 Support for URLLC

The RIT supports ultra-reliable and low latency communications which is useful in many industry verticals such as smart factories, industry automation, smart cities among others. The reliability level that can be achieved is 99.9999% and very low latency is supported. The control plane and user plane latencies are ensured to be less than 10 ms and 1 ms respectively. Some main technical features that are part of the RIT to support this feature are:

- 1 Shaped Pi/2 BPSK modulation scheme to support higher reliability even at low SNRs;
- 2 Mini-slot (less than 1 full slot) transmissions to support fast transmissions and faster ACK/NACK feedback mechanisms;
- 3 Different numerologies to support smaller slot durations to aid URLLC transmissions;
- 4 Repetitions across slots, slot aggregation, higher aggregation levels for control channel, a separate MCS/CQI table;
- 5 Traffic pre-emption to allow URLLC data packets through;
- 6 Restrictions on logical channel priorities;
- 7 Supporting packet duplication via dual connectivity and carrier aggregation;
- 8 Ethernet header compression to reduce the latency among others.

As can be seen, the features are across various protocol layers to ensure a true low latency mechanism.

### 3.1.2.6 HARQ

HARQ functionality ensures delivery of packets between peer entities at Physical layer. When the Physical layer is not configured for downlink/uplink spatial multiplexing, HARQ process supports only one TB. When the Physical layer is configured, HARQ process supports one or more TBs.

### 3.1.2.7 Supplementary Uplink (SUL)

In case of supplementary Uplink (SUL), UE will be configured with two Uplinks (2 ULs) for one Downlink of the same cell. The uplink transmissions on both ULs are controlled by the network to avoid overlapping of transmissions in PUSCH/PUCCH in time.

Note:

- Overlapping transmissions on PUSCH are avoided through scheduling;
- Overlapping transmissions on PUCCH are avoided through configuration (PUCCH can only be configured for only one of the two ULs of the cell).

In addition to these, initial access is supported on each of the uplink.

### 3.1.2.8 Carrier Aggregation (CA)

In TSDSI RIT, with carrier aggregation multi carrier nature of physical layer is exposed to MAC layer where transmissions through multiple carriers can be aggregated for which one HARQ entity is required for each serving cell.

In both uplink and downlink, there is one independent HARQ entity for each serving cell and one transport block is generated per assignment per serving cell in the absence of spatial multiplexing. Note that each transport block and its HARQ retransmissions are mapped to a single serving cell.

### 3.1.2.9 Bandwidth Adaptation (BW)

In TSDSI RIT the receive and transmit bandwidth of a UE need not be as large as the bandwidth of the cell. With bandwidth adaptation, the bandwidth of the UE can be adjusted i.e. as an example the following parameters can be adjusted to achieve adaptability.

- 1 Bandwidth can be ordered to change i.e. it can be adjusted according to the activity of the user in order to meet power constraints;
- 2 Location can move in frequency domain in order to increase scheduling flexibility;
- 3 Subcarrier spacing can be ordered to change to allow different services.

A subset of the total cell bandwidth is referred to as Bandwidth part (BWP). The Bandwidth adaptation is achieved by configuring UE with BWPs and letting the UE know which BWPs is currently the active one. Note that a maximum of only four bandwidths can be specified in DL and UL.

### 3.1.2.10 Support for Higher Power Efficiency

#### 3.1.2.10.1 Network

When there is no active data transfer between the network and the UE, the network saves power by remaining on for some duration and sleeping for the rest. The on duration consists of transmission of SSB with PBCH, RMSI and paging signal which needs to be monitored by UEs. During the sleep duration, there is no transmission or reception to/from the UE.

#### 3.1.2.10.2 UE

The UE can be in any one of the states at the given time:

- 1 Idle;
- 2 Inactive;
- 3 Active.

During the idle/inactive modes, the UE does not perform any active data communication with the network. It uses the discontinuous reception (DRX) cycle to save power consumption. The DRX



cycle consists of an ‘on’ duration and ‘off’ duration which is signalled by the network to the UE. During the ‘off’ duration, there UE sleeps (there is no transmission or reception). During ‘on’ duration, the UE performs SSB monitoring, paging monitoring and radio resource management (RRM) measurement. This is to ensure that the UE synchronised in downlink with its network and also keeps a track of when it needs to wake up for active data transfer. Once it receives a paging message, the UE wakes up. It starts the inactivity timer and remains active until the time expires. There are two types of DRX cycles;

- 1 long DRX cycle; and
- 2 short DRX cycle (within the ‘off’ duration of the long DRX cycle).

The following documents provide details of the RF interface and the physical layer:

- T3.9038.211 NR; Physical channels and modulation;
- T3.9038.212 NR; Multiplexing and channel coding;
- T3.9038.213 NR; Physical layer procedures for control;
- T3.9038.214 NR; Physical layer procedures for data;
- T3.9038.101-1 NR; User Equipment (UE) radio transmission and reception; Part 1: Range 1 Standalone;
- T3.9038.101-2 NR; User Equipment (UE) radio transmission and reception; Part 2: Range 2 Standalone;
- T3.9038.104 NR; Base Station (BS) radio transmission and reception.

### **3.1.3 Layer 2**

#### **3.1.3.1 Overview**

Layer 2 of TSDSI RIT has the following sublayers

- 1 SDAP (Service Data Adaptation Protocol);
- 2 PDCP (Packet Data Convergence Protocol);
- 3 RLC (Radio Link Control);
- 4 MAC (Medium Access Control).

The architecture of TSDSI RIT with Layer 2 and Layer 3 is depicted in Fig. 44.

FIGURE 44

Architecture of TSDSI RIT logical layer

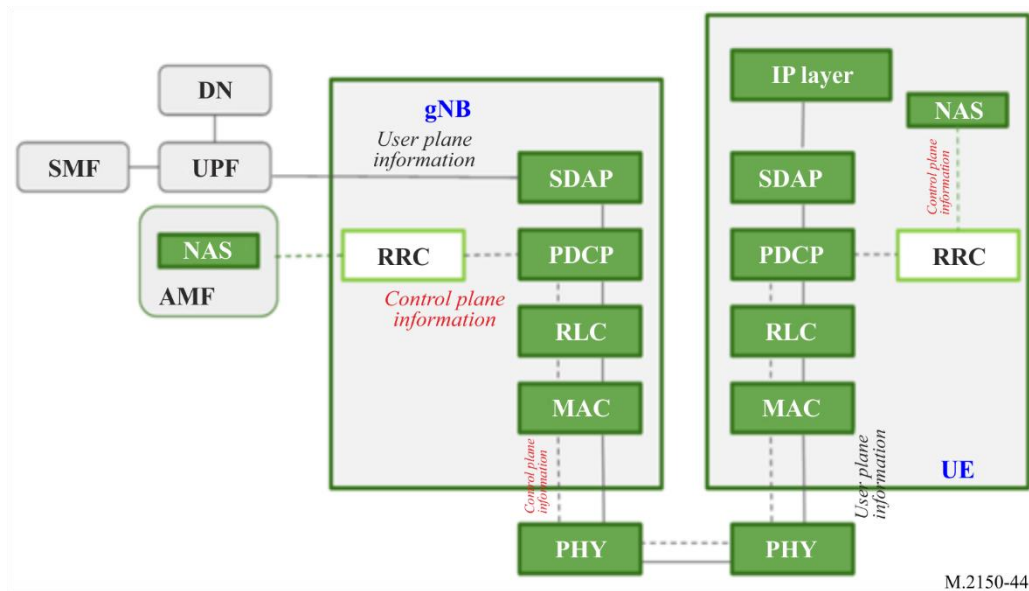

Control Plane information from RRC (Layer 3) flows through PDCP, RLC, MAC sublayers of Layer 2 stack, whereas user plane data from UPF (CN) flows through SDAP, PDCP, RLC, MAC sublayers of Layer 2 stack. SDAP receives data from Core Network through QoS flows. SDAP offers data to PDCP via Radio Bearers. PDCP offers data to RLC via RLC channels/logical channels. RLC offers data to MAC via logical channels. MAC offers data to the Physical layer via Transport channels. The downlink and uplink architectures for user plane data flow are depicted in Figs 45 and 46.

FIGURE 45

Downlink user plane architecture of Layer 2

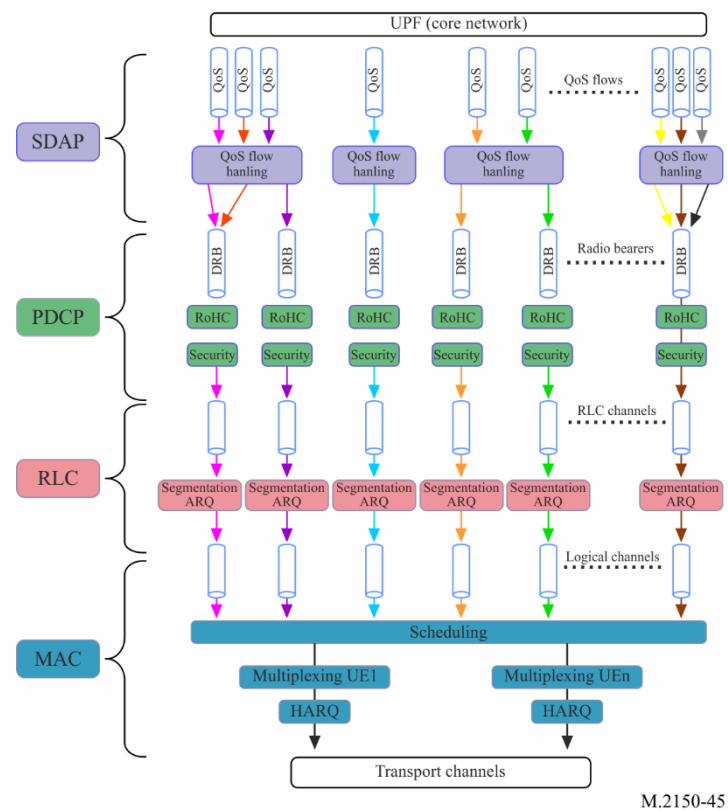

M.2150-45

FIGURE 46

Uplink user plane architecture of Layer 2

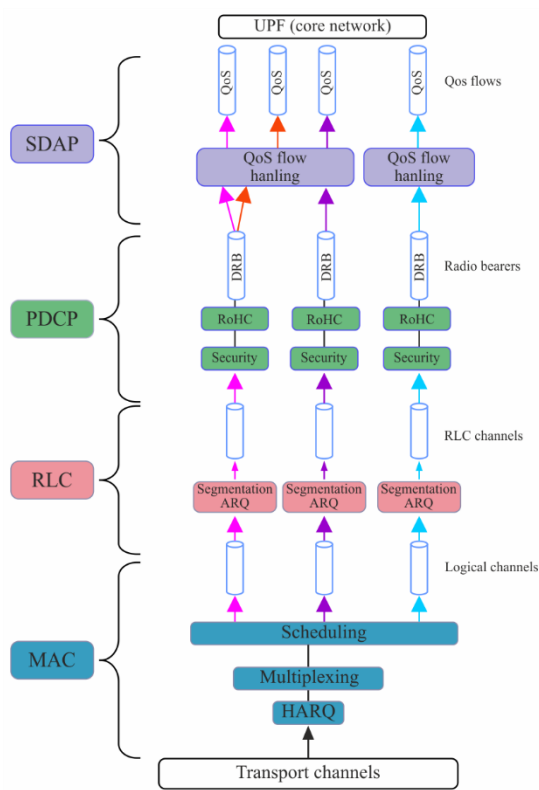

M.2150-46

### 3.1.3.2 Channels

#### 3.1.3.2.1 QoS flows

SDAP offers data to Core Network via QoS (Quality of Service) flows.

Data is separated into QoS flows based on the QoS requirements.

#### 3.1.3.2.2 Radio bearers

PDCCP offers data to SDAP via Radio Bearers. There are two types of radio bearers.

- 1 SRB (Signalling Radio Bearer)
- 2 DRB (Data Radio Bearer)

SRBs are used for transfer of signalling information/Control Plane data.

DRBs are used for transfer of Data plane information/User Plane data.

#### 3.1.3.2.3 Logical channels

There are two kinds of logical channels.

Control Channels:

- 1 Traffic Channels

Control channels are used for transfer of control plane information. Traffic channels are used for transfer of user plane information. Each of the logical channels is defined by what type of information is being transferred by or to the MAC Layer.

Control Channels:

- 1 BCCH (Broadcast Control Channel): It is a downlink channel used for broadcasting system control information
- 2 PCCH (Paging Control Channel): It is a downlink channel used for carrying paging messages
- 3 CCCH (Common Control Channel): For UEs having no RRC connection with the network, this channel is used for transmitting control information between UEs and network (RAN)
- 4 DCCH (Dedicated Control Channel): After RRC connection establishment, DCCH is a point-to-point bi-directional channel that transmits dedicated control information between a UE and the network.

Traffic Channels:

- 1 DTCH (Dedicated Traffic Channel): It is a bi-directional channel which establishes a point-to-point communication between UE and network used for transfer of data plane information/user information.

### 3.1.3.2.4 Mapping of logical channels to Transport Channels

The mapping of logical channels to the downlink transport channels is given in Fig. 47.

FIGURE 47  
Downlink mapping of logical to transport channels  
(Logical channels)

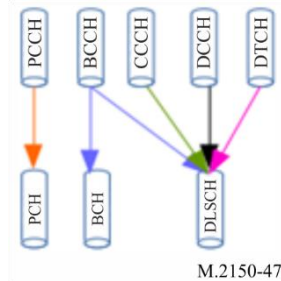

In Downlink:

- 1 PCCH is mapped to PCH;
- 2 Part of BCCH information is sent through BCH and part of BCCH is sent through DLSCH;
- 3 CCCH is mapped to DLSCH;
- 4 DCCH is mapped to DLSCH;
- 5 DTCH is mapped to DLSCH.

The mapping of logical channels to the downlink transport channels is given in Fig. 48.

FIGURE 48  
Uplink mapping of transport to logical channels

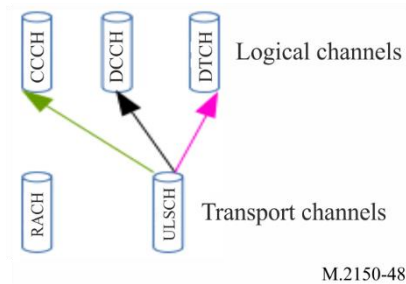

In Uplink:

- 1 CCCH is mapped to ULSCH;
- 2 DCCH is mapped to ULSCH;
- 3 DTCH is mapped to ULSCH.

### 3.1.3.2.5 Sublayers

#### 3.1.3.2.5.1 SDAP

Key Functions:

- 1 Mapping between a QoS flow and a data radio bearer;
- 2 Marking QoS flow ID (QFI) in both DL and UL packets.

The typical downlink and uplink architectures of SDAP are depicted in Figs 49 and 50.

FIGURE 49

SDAP downlink architecture

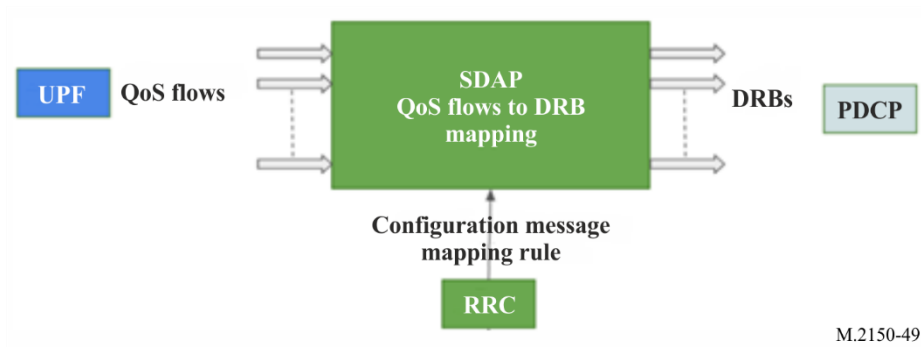
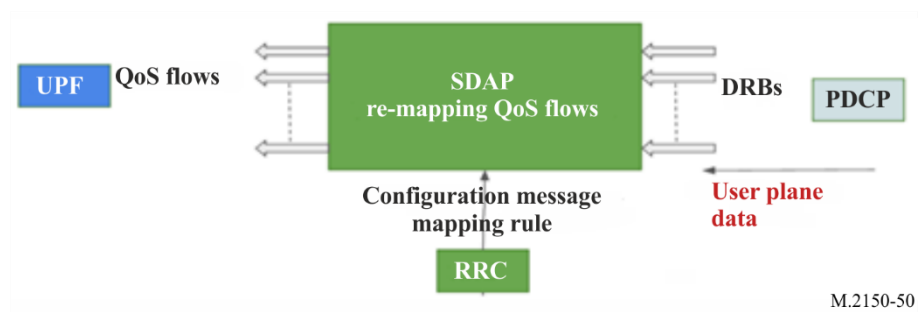

FIGURE 50

SDAP uplink architecture



### 3.1.3.2.5.2 PDCP

Key functions:

- 1 Addition and Removal and sequence number;
- 2 Header compression and de-compression;
- 3 Ciphering and de-ciphering;
- 4 Integrity Protection;
- 5 Duplicate detection and reordering of packets (if in-order delivery is requested by upper layers).

The typical downlink and uplink architectures of PDCP are depicted in Figs 51 and 52.

FIGURE 51  
Downlink architecture of PDCP  
PDCP\_DL\_gNB

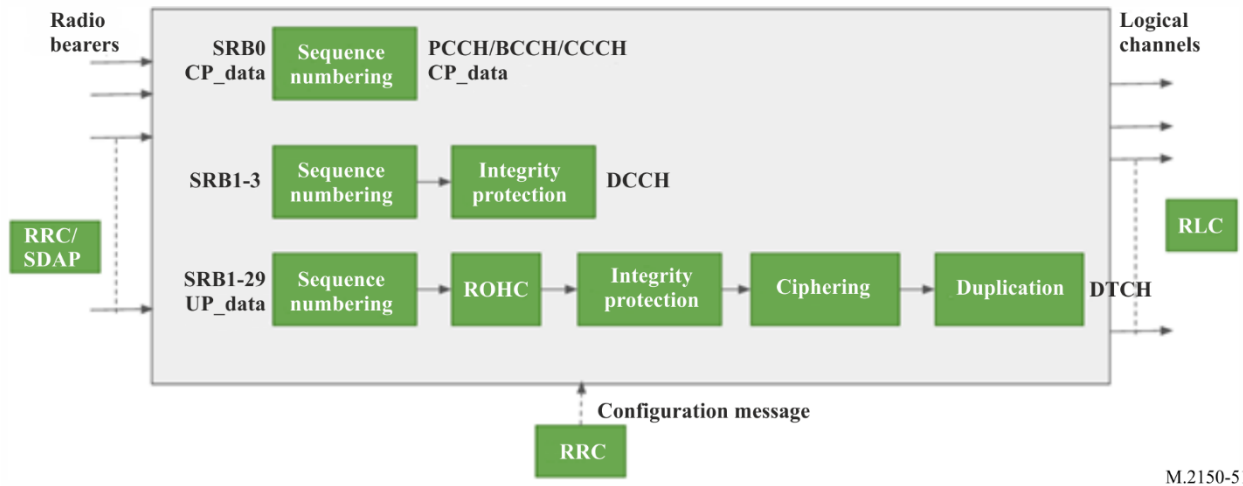

M.2150-51

FIGURE 52  
Uplink architecture of PDCP  
PDCP\_UL\_gNB

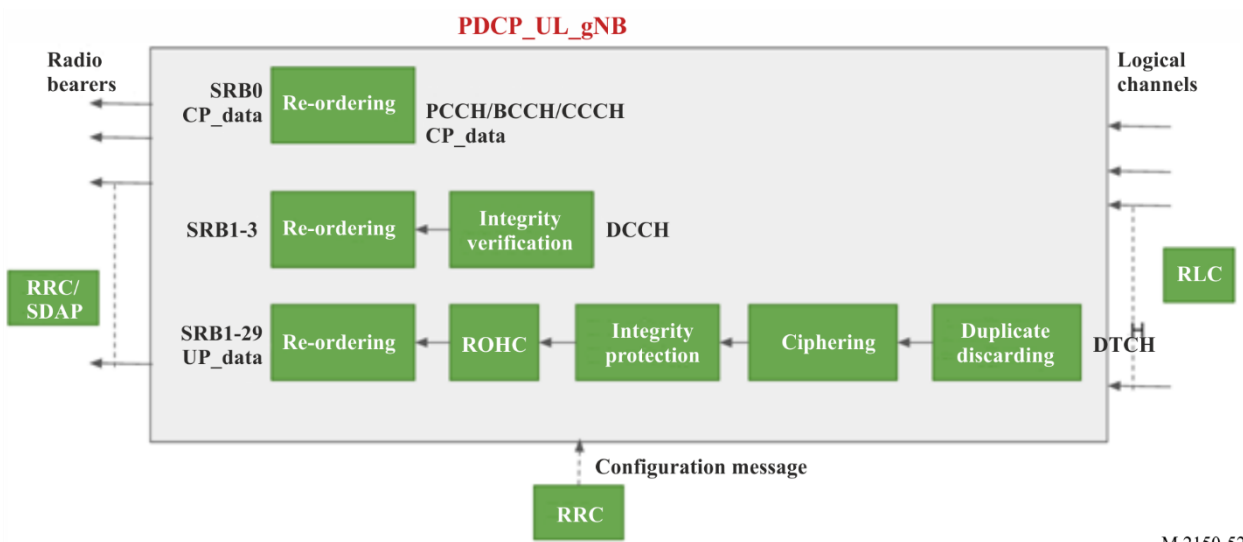

M.2150-52

### 3.1.3.2.5.3 RLC

Key functions:

- 1 Transfer of upper layer PDUs;
- 2 Sequence numbering independent of the one in PDCP;
- 3 Error Correction through ARQ;
- 4 Segmentation and re-segmentation.

The typical downlink and uplink architectures of RLC are depicted in Figs 53 and 54.

FIGURE 53

## Downlink architecture of RLC

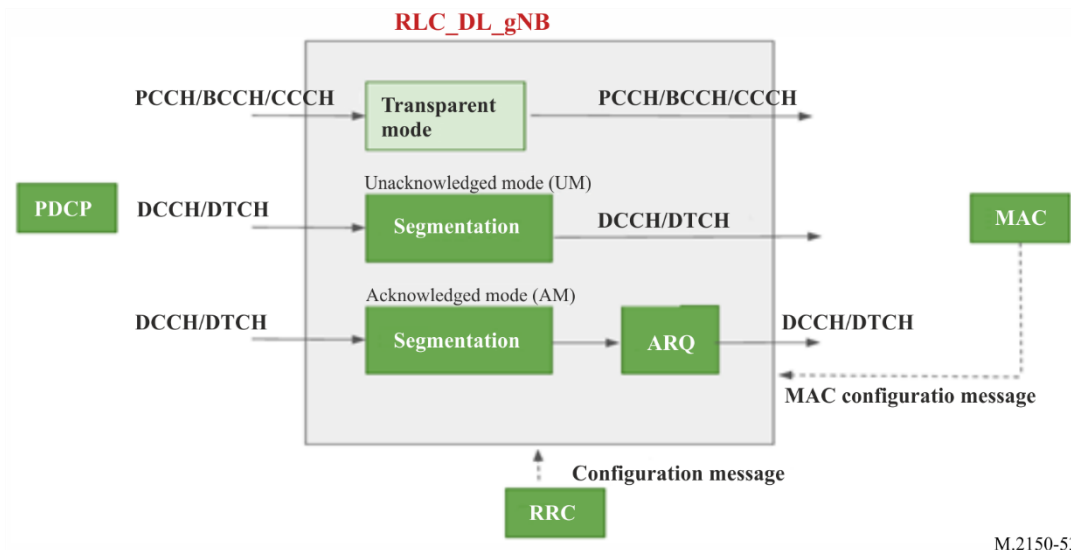
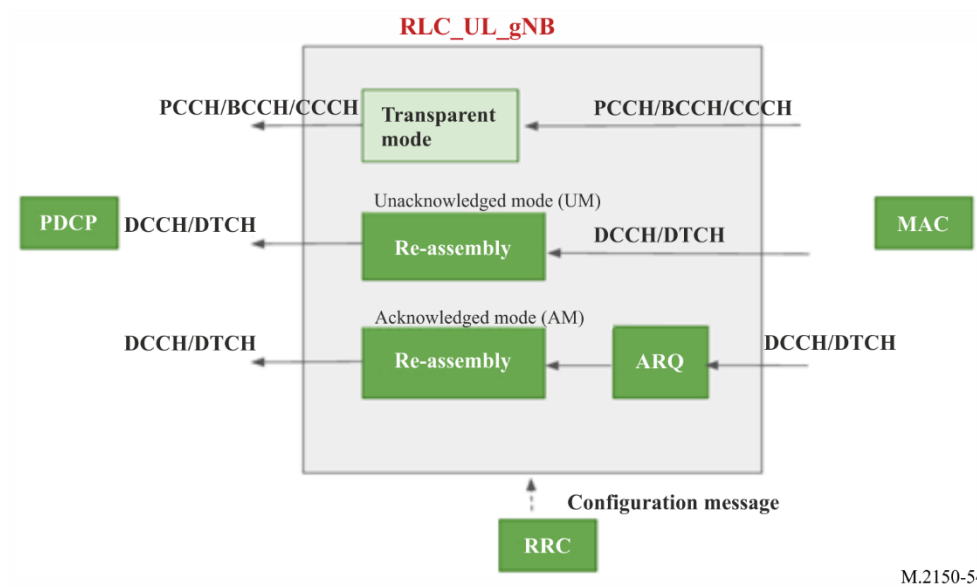

FIGURE 54

## Uplink architecture of RLC



## 3.1.3.2.5.4 MAC

Key functions:

- 1 Mapping between logical channels and transport channels;
- 2 Multiplexing/demultiplexing of MAC SDUs belonging to one or different logical channels into/from transport blocks (TB) delivered to/from the physical layer on transport channels;
- 3 Scheduling Information Reporting;
- 4 Error correction through HARQ;
- 5 Priority handling between UEs by means of dynamic scheduling;
- 6 Priority handling between logical channels of one UE by means of logical channel prioritization;
- 7 Padding.



### 3.1.3.3 Data flow

A simple model depicting the hierarchy of user data flow in Layer 2 is given in Fig. 55.

FIGURE 55  
Hierarchy of user data flow in layer 2

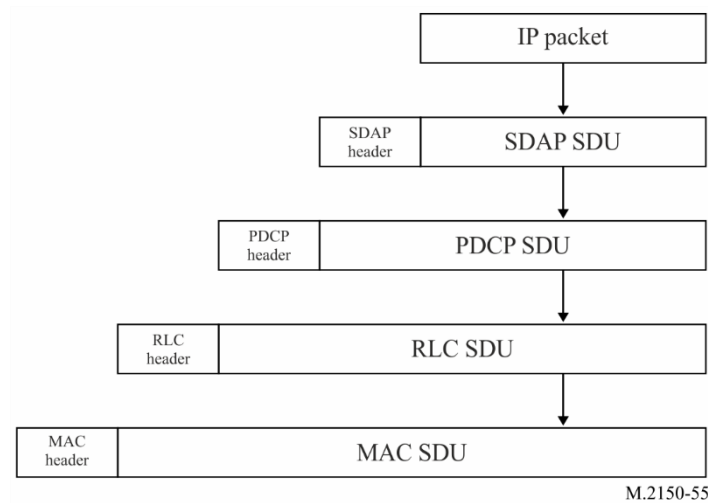

The following documents provide details about the layers described above:

- T3.9038.321 NR; Medium Access Control (MAC) protocol specification
- T3.9038.322 NR; Radio Link Control (RLC) protocol specification
- T3.9038.323 NR; Packet Data Convergence Protocol (PDCP) specification
- T3.9037.324 Evolved Universal Terrestrial Radio Access (E-UTRA) and NR; Service Data Adaptation Protocol (SDAP) specification

### 3.1.4 Radio Resources Control (RRC)

The overview of the functions and services of RRC are given below:

- Paging transmission, initiated by Core network or RAN.
- Broadcast of system information.
- Security functions including generation and maintaining security keys.
- RRC connection establishment, maintenance, release between UE and RAN which includes the CA and dual connectivity.
- SRB (Signalling Radio Bearer) and DRB (Data Radio bearer) establishment, maintenance, configuration and release.
- Radio Link Failure functions, which includes detection and recovery procedures.
- Mobility related functions, includes the handover procedures and cell selection procedures.
- UE measurements maintenance and reporting of those measurements to the RAN.
- QOS Management procedures.
- Transfer of NAS messages.

The protocol states supported by RRC are:

- RRC IDLE
- RRC INACTIVE
- RRC ACTIVE

The characteristics of each of the different states are given as follows.

#### 3.1.4.1 RRC IDLE:

- System Information broadcast and reception.
- Public Land Mobile Network (PLMN) selection.
- Cell selection and re-selection.
- Paging for mobile terminated data is initiated by the Core Network.
- DRX for core network paging.
- Performing UE Measurements and reporting.

#### 3.1.4.2 RRC INACTIVE:

- PLMN selection.
- Broadcast and reception of System information.
- Cell re-selection.
- Paging initiated by RAN.
- RNA (RAN based Notification Area) is maintained.
- Connection between NG-C and CP for control plane data, NG-U and UP for user plane data is maintained.
- UE AS context is stored in NG-RAN and UE
- DRX for RAN paging.
- Performing UE Measurements and reporting.

#### 3.1.4.3 RRC ACTIVE:

- Establishment of NGRAN and CORE, UP and CP connections for a user.
- UE AS context is stored in NG-RAN and UE.
- Cell re-selection.
- Transfer and Reception of UE unicast messages.
- Performing UE Measurements and reporting.
- NG-RAN knows the cell UE belongs to.
- Mobility functionalities.

More details about the RRC layer can be found in the following documents:

- T3.9038.331 NR; Radio Resource Control (RRC); Protocol specification
- T3.9038.304 NR; User Equipment (UE) procedures in idle mode and in RRC Inactive state

#### 3.1.5 RIT support for mMTC

The specifications support mMTC applications via a narrow band technology named as NB-IoT. NB-IoT supports 200 kHz bandwidth with 1 PRB scheduling. It significantly enhances the coverage by means of scheduling multiple TTIs for every physical channel transmission. It supports mainly three modes of transmissions – in-band, guard band and standalone and is flexible due to this reason.

In NB-IoT, Uplink transmission is based on Discrete Fourier Transform (DFT) Spread OFDM (DFTS-OFDM). DFTS-OFDM can be seen as a DFT precoder, followed by conventional OFDM with the same numerology as in the downlink. The Narrow-Band Internet of Things (NB-IoT) UL allows the allocation of a single-tone in addition to multi-tone DFTS-OFDM with the possibility of

a lower subcarrier spacing in addition to the normal subcarrier spacing. The NB-IoT UL allows allocation of a single-tone with  $Df = 3.75$  kHz or  $Df = 15$  kHz subcarrier spacing. In the DL, only conventional OFDM is supported with 15 kHz sub-carrier spacing.

NB-IoT supports QPSK on DL and UL, and additionally  $\pi/2$ -BPSK,  $\pi/4$ -QPSK are supported in uplink when a single-tone is allocated and spectrum shaped  $\pi/2$  BPSK modulation when multiple tones are allocated. The UE capability signalling and activation/de-activation of shaped  $\pi/2$  BPSK modulation is supported by RRC signalling.

The following types of physical channels are defined for NB-IoT:

- Narrowband Physical broadcast channel (NPBCH): used to carry the broadcast channel information for NB-IoT UEs. This channel carries cell and/or system specific information.
- Narrowband Physical downlink shared channel (NPDSCH): used to carry the data payloads and paging information for NB-IoT UEs.
- Narrowband Physical downlink control channel (NPDCCH): used to inform the NB-IoT UE about the resource allocation NPDSCH. It also carries the uplink scheduling grant for the NB-IoT UE.
- Narrowband Physical uplink shared channel (NPUSCH): used to carry the uplink data payloads from the user and Hybrid ARQ ACK/NAKs in response to downlink transmission for the NB-IoT UE.
- Narrowband Physical random access channel (NPRACH): used to carry the random access preamble for the NB-IoT UE

Power efficiency is supported for the IoT devices via long sleep and DRX cycles. For NB-IoT, an extended DRX cycle of 10.24s is supported in RRC Connected. In RRC Idle, the maximum DRX cycle is 2.91 hours. For PSM, the maximum PSM time is 310 hours which ensures a long battery life for the UE.

Details about NB-IoT can be found in the following specifications:

- T3.9036.211 Evolved Universal Terrestrial Radio Access (E-UTRA); Physical channels and modulation
- T3.9036.212 Evolved Universal Terrestrial Radio Access (E-UTRA); Multiplexing and channel coding
- T3.9036.213 Evolved Universal Terrestrial Radio Access (E-UTRA); Physical layer procedures
- T3.9036.101 Evolved Universal Terrestrial Radio Access (E-UTRA); User Equipment (UE) radio transmission and reception
- T3.9036.104 Evolved Universal Terrestrial Radio Access (E-UTRA); Base Station (BS) radio transmission and reception

### 3.2 Detailed specification of the radio interface technology

Detailed specifications described in this Annex are developed around a “Global Core Specification” (GCS), which is related to externally developed materials incorporated by specific references for a specific technology. The process and use of the GCS, references, and related notifications and certifications are found as Document IMT-2020/20.

The IMT-2020 standards contained in this section are derived from the global core specification for 5Gi contained at IMT-2020 Global Core Specifications. The following notes apply to the sections below:

- 1) The identified Transposing Organizations<sup>2</sup> should make their reference material available from their website.
- 2) This information was supplied by the Transposing Organizations and relates to their own deliverables of the transposed global core specification.

Section 3.2.1 contains titles and synopses of the Global Core Specification of the IMT-2020 radio interface technology entitled 5Gi and the related hyperlinks to the transposed standards.

The specific TSDSI specifications of the Global Core Specifications (GCS) for IMT-2020 and 5Gi that are being transposed in § 3.2.1 are summarized in Table 3-4:

---

<sup>2</sup> The following identified Transposing Organizations have provided their transposed sets of standards information contained in this section:

- Telecommunications Standards Development Society, India (TSDSI).

TABLE 3-4  
TSDSI specifications in § 3.2.1 that are to be transposed

See Note a) and Note b) below the table.				
Part A <sup>3</sup> : List of specifications				
TSDSI Specifications list				
T3.9036.101	T3.9036.323	T3.9036.457	T3.9038.101-1	T3.9038.401
T3.9036.104	T3.9036.331	T3.9036.458	T3.9038.101-2	T3.9038.410
T3.9036.106	T3.9036.355	T3.9036.459	T3.9038.101-3	T3.9038.411
T3.9036.111	T3.9036.360	T3.9036.461	T3.9038.104	T3.9038.412
T3.9036.113	T3.9036.361	T3.9036.462	T3.9038.113	T3.9038.413
T3.9036.116		T3.9036.463	T3.9038.124	T3.9038.414
T3.9036.124	T3.9036.401	T3.9036.464	T3.9038.133	T3.9038.415
T3.9036.133	T3.9036.410	T3.9036.465		T3.9038.420
	T3.9036.411		T3.9038.201	T3.9038.421
T3.9036.201	T3.9036.412	T3.9037.104	T3.9038.202	T3.9038.422
T3.9036.211	T3.9036.413	T3.9037.105	T3.9038.211	T3.9038.423
T3.9036.212	T3.9036.414	T3.9037.113	T3.9038.212	T3.9038.424
T3.9036.213	T3.9036.420	T3.9037.114	T3.9038.213	T3.9038.425
T3.9036.214	T3.9036.421	T3.9037.320	T3.9038.214	T3.9038.455
T3.9036.216	T3.9036.422	T3.9037.324	T3.9038.215	T3.9038.460
	T3.9036.423	T3.9037.340		T3.9038.461
T3.9036.300	T3.9036.424	T3.9037.355	T3.9038.300	T3.9038.462
T3.9036.302	T3.9036.425	T3.9037.460	T3.9038.304	T3.9038.463
T3.9036.304	T3.9036.440	T3.9037.461	T3.9038.305	T3.9038.470
T3.9036.305	T3.9036.441	T3.9037.462	T3.9038.306	T3.9038.471
T3.9036.306	T3.9036.442	T3.9037.466	T3.9038.307	T3.9038.472
T3.9036.307	T3.9036.443	T3.9037.470	T3.9038.314	T3.9038.473
T3.9036.314	T3.9036.444	T3.9037.471	T3.9038.321	T3.9038.474
T3.9036.321	T3.9036.445	T3.9037.472	T3.9038.322	
T3.9036.322	T3.9036.455	T3.9037.473	T3.9038.323	
	T3.9036.456		T3.9038.331	
			T3.9038.340	
Part B: Specifications versions to be used.				
The specific versions of the TSDSI specifications that are to be used for the transpositions of those specifications listed in Table 3-4 are provided in the link below: <a href="#">Click here for the direct link to the GCS material.</a>				

<sup>3</sup> The NB-IoT technology for this GCS is supported using T3.9036.1XX, T3.9036.2XX, T3.9036.3XX, and T3.9036.4XX series specifications.

Specifically, the following is noted for Table 3-4:

Notes on specification versions to be utilized for the Global Core Specifications (GCS):

**Note a)** In conjunction with Table 3-4, the published TSDSI specifications versions as of 3 August 2020, shall be utilized as the basis for the specific GCS version.

**Note b)** Furthermore, these specific GCS versions in alignment with Note a) above are to be utilized in the transpositions of those specifications listed in Table 3-4 into the corresponding standards by the designated Transposing Organizations indicated in the Certification B provided by the TSDSI GCS Proponent to ITU-R under the IMT-2020 process. See Table 3-4, Part B.

### **3.2.1 Titles and synopses of the global core specification and the transposed standards**

#### **3.2.1.1 Introduction**

The standards documents referenced below, as transposed from the relevant TSDSI specifications, are provided by the identified Transposing Organizations as the transposed sets of standards for the terrestrial radio interface of IMT-2020 identified as **5Gi** and includes not only the key characteristics of IMT-2020 but also the additional capabilities of 5Gi both of which are continuing to be enhanced.

**3.2.1.2 Radio Layer 1****3.2.1.2.1 T3.9036.201****Evolved Universal Terrestrial Radio Access (E-UTRA); LTE physical layer; General description**

This document provides a general description of the physical layer of the E-UTRA radio interface.

SDO	Document No.	Version	Status	Issued date	Location
<b>Version 1</b>					
TSDSI	TSDSI STD T3.9036.201-15.2.0	V1.0.1	Published	01.10.2020	<a href="https://members.tdsi.in/index.php/s/gKBAGbGqDS8Amre">https://members.tdsi.in/index.php/s/gKBAGbGqDS8Amre</a>

**3.2.1.2.2 T3.9036.211****Evolved Universal Terrestrial Radio Access (E-UTRA); Physical channels and modulation**

This document describes the physical channels and modulation for E-UTRA.

SDO	Document No.	Version	Status	Issued date	Location
<b>Version 1</b>					
TSDSI	TSDSI STD T3.9036.211-15.6.0	V1.0.1	Published	01.10.2020	<a href="https://members.tdsi.in/index.php/s/KSRStKxJgAixpf">https://members.tdsi.in/index.php/s/KSRStKxJgAixpf</a>

**3.2.1.2.3 T3.9036.212****Evolved Universal Terrestrial Radio Access (E-UTRA); Multiplexing and channel coding**

This document specifies the coding, multiplexing and mapping to physical channels for E-UTRA.

SDO	Document No.	Version	Status	Issued date	Location
<b>Version 1</b>					
TSDSI	TSDSI STD T3.9036.212-15.6.0	V1.0.1	Published	01.10.2020	<a href="https://members.tdsi.in/index.php/s/6XTfGASGn2MxEkq">https://members.tdsi.in/index.php/s/6XTfGASGn2MxEkq</a>

**3.2.1.2.4 T3.9036.213****Evolved Universal Terrestrial Radio Access (E-UTRA); Physical layer procedures**

This document specifies and establishes the characteristics of the physical layer procedures for E-UTRA.

SDO	Document No.	Version	Status	Issued date	Location
<b>Version 1</b>					
TSDSI	TSDSI STD T3.9036.213-15.6.0 V1.0.1	V1.0.1	Published	01.10.2020	<a href="https://members.tdsi.in/index.php/s/Zr8T2YebTaSEjc8">https://members.tdsi.in/index.php/s/Zr8T2YebTaSEjc8</a>

**3.2.1.2.5 T3.9036.214****Evolved Universal Terrestrial Radio Access (E-UTRA); Physical layer; Measurements**

This document contains the description and definition of the measurements done at the UE and network in order to support operation in idle mode and connected mode in E-UTRA.

SDO	Document No.	Version	Status	Issued date	Location
<b>Version 1</b>					
TSDSI	TSDSI STD T3.9036.214-15.3.0 V1.0.1	V1.0.1	Published	01.10.2020	<a href="https://members.tdsi.in/index.php/s/cAF7AeeXoy47DNm">https://members.tdsi.in/index.php/s/cAF7AeeXoy47DNm</a>

**3.2.1.2.6 T3.9036.216****Evolved Universal Terrestrial Radio Access (E-UTRA); Physical layer for relaying operation**

This document describes the characteristics of eNodeB – relay node transmissions.

SDO	Document No.	Version	Status	Issued date	Location
<b>Version 1</b>					
TSDSI	TSDSI STD T3.9036.216-15.0.0 V1.0.0	V1.0.0	Published	01.10.2020	<a href="https://members.tdsi.in/index.php/s/qm2gA5NWyCCKxMK">https://members.tdsi.in/index.php/s/qm2gA5NWyCCKxMK</a>

**3.2.1.2.7 T3.9038.201**

NR; Physical layer; General description

This document provides a general description of the physical layer of the radio interface. This document also describes the document structure of the physical layer specifications, i.e. T3.9038.200 series.

SDO	Document No.	Version	Status	Issued date	Location
<b>Version 1</b>					
TSDSI	TSDSI STD T3.9038.201-15.0.0 V1.0.1	V1.0.1	Published	01.10.2020	<a href="https://members.tdsi.in/index.php/s/MPp4LiaJg8RYQX8">https://members.tdsi.in/index.php/s/MPp4LiaJg8RYQX8</a>



**3.2.1.2.8 T3.9038.202****NR; Services provided by the physical layer**

This document is a technical specification of the services provided by the physical layer of radio interface to upper layers.

SDO	Document No.	Version	Status	Issued date	Location
<b>Version 1</b>					
TSDSI	TSDSI STD T3.9038.202-15.4.0 V1.0.0	V1.0.0	Published	01.10.2020	<a href="https://members.tdsi.in/index.php/s/A4expLrZW3kMWp5">https://members.tdsi.in/index.php/s/A4expLrZW3kMWp5</a>

**3.2.1.2.9 T3.9038.211****NR; Physical channels and modulation**

This document describes the physical channels and signals for the radio interface.

SDO	Document No.	Version	Status	Issued date	Location
<b>Version 1</b>					
TSDSI	TSDSI STD T3.9038.211-15.5.0 V1.0.1	V1.0.1	Published	01.10.2020	<a href="https://members.tdsi.in/index.php/s/dt7kfjBZ7x6jxa2">https://members.tdsi.in/index.php/s/dt7kfjBZ7x6jxa2</a>

**3.2.1.2.10 T3.9038.212****NR; Multiplexing and channel coding**

This document specifies the coding, multiplexing and mapping to physical channels for the radio interface.

SDO	Document No.	Version	Status	Issued date	Location
<b>Version 1</b>					
TSDSI	TSDSI STD T3.9038.212-15.5.0 V1.0.1	V1.0.1	Published	01.10.2020	<a href="https://members.tdsi.in/index.php/s/BPoNcifiSn57Ysw">https://members.tdsi.in/index.php/s/BPoNcifiSn57Ysw</a>

**3.2.1.2.11 T3.9038.213****NR; Physical layer procedures for control**

This document specifies and establishes the characteristics of the physical layer procedures for control operations in the radio interface technology.

SDO	Document No.	Version	Status	Issued date	Location
<b>Version 1</b>					
TSDSI	TSDSI STD T3.9038.213-15.5.0 V1.0.1	V1.0.1	Published	01.10.2020	<a href="https://members.tdsi.in/index.php/s/E9nnLdTkJ4pCEXS">https://members.tdsi.in/index.php/s/E9nnLdTkJ4pCEXS</a>

**3.2.1.2.12 T3.9038.214****NR; Physical layer procedures for data**

This document specifies and establishes the characteristics of the physical layer procedures of data channels for radio interface.

SDO	Document No.	Version	Status	Issued date	Location
<b>Version 1</b>					
TSDSI	TSDSI STD T3.9038.214-15.5.0 V1.0.1	V1.0.1	Published	01.10.2020	<a href="https://members.tdsi.in/index.php/s/fB9WYoMjmsC8RES">https://members.tdsi.in/index.php/s/fB9WYoMjmsC8RES</a>

**3.2.1.2.13 T3.9038.215****NR; Physical layer measurements**

This document describes the physical layer measurements for radio interface.

SDO	Document No.	Version	Status	Issued date	Location
<b>Version 1</b>					
TSDSI	TSDSI STD T3.9038.215-15.4.0 V1.0.1	V1.0.1	Published	01.10.2020	<a href="https://members.tdsi.in/index.php/s/pQb7JJtEmsZFSfR">https://members.tdsi.in/index.php/s/pQb7JJtEmsZFSfR</a>

**3.2.1.3 Radio Layers 2 & 3****3.2.1.3.1 T3.9036.300****Evolved Universal Terrestrial Radio Access (E-UTRA) and Evolved Universal Terrestrial Radio Access Network (E-UTRAN); Overall description; Stage 2**

This document provides an overview and overall description of the E-UTRAN radio interface protocol architecture. Details of the radio interface protocols are specified in companion specifications of the 36 series.

SDO	Document No.	Version	Status	Issued date	Location
<b>Version 1</b>					
TSDSI	TSDSI STD T3.9036.300-15.6.0 V1.0.1	V1.0.1	Published	01.10.2020	<a href="https://members.tdsi.in/index.php/s/FY5DJwbSmWyFB8F">https://members.tdsi.in/index.php/s/FY5DJwbSmWyFB8F</a>

**3.2.1.3.2 T3.9036.302****Evolved Universal Terrestrial Radio Access (E-UTRA); Services provided by the physical layer**

This document is a technical specification of the services provided by the physical layer of E-UTRA to upper layers.

SDO	Document No.	Version	Status	Issued date	Location
<b>Version 1</b>					
TSDSI	TSDSI STD T3.9036.302-15.2.0 V1.0.0	V1.0.0	Published	01.10.2020	<a href="https://members.tdsi.in/index.php/s/TZCrBtaPRE8xixA">https://members.tdsi.in/index.php/s/TZCrBtaPRE8xixA</a>

**3.2.1.3.3 T3.9036.304****Evolved Universal Terrestrial Radio Access (E-UTRA); User Equipment (UE) procedures in idle mode**

This document specifies the Access Stratum (AS) part of the Idle Mode procedures applicable to a UE. This document specifies the model for the functional division between the NAS and AS in a UE. This document applies to all UEs that support at least E-UTRA, including multi-RAT UEs as described in the specifications, in the following cases: (i) When the UE is camped on an E-UTRA cell; (ii) When the UE is searching for a cell to camp on.

SDO	Document No.	Version	Status	Issued date	Location
<b>Version 1</b>					
TSDSI	TSDSI STD T3.9036.304-15.4.0 V1.0.1	V1.0.1	Published	01.10.2020	<a href="https://members.tdsi.in/index.php/s/sJ469b4s9Bak58M">https://members.tdsi.in/index.php/s/sJ469b4s9Bak58M</a>

**3.2.1.3.4 T3.9036.305****Evolved Universal Terrestrial Radio Access Network (E-UTRAN); Stage 2 functional specification of User Equipment (UE) positioning in E-UTRAN**

This document specifies the stage 2 of the UE positioning function of E-UTRAN, which provides the mechanisms to support or assist the calculation of the geographical position of a UE. The purpose of this stage 2 specification is to define the E-UTRAN UE Positioning architecture, functional entities and operations to support positioning methods. This description is confined to the E-UTRAN Access Stratum. This stage 2 specification covers the E-UTRAN positioning methods, state descriptions, and message flows to support UE positioning.

SDO	Document No.	Version	Status	Issued date	Location
<b>Version 1</b>					
TSDSI	TSDSI STD T3.9036.305-15.4.0 V1.0.0	V1.0.0	Published	01.10.2020	<a href="https://members.tdsi.in/index.php/s/nMaJt9ZeNNy8ZjQ">https://members.tdsi.in/index.php/s/nMaJt9ZeNNy8ZjQ</a>

**3.2.1.3.5 T3.9036.306****Evolved Universal Terrestrial Radio Access (E-UTRA); User Equipment (UE) radio access capabilities**

This document defines the E-UTRA UE Radio Access Capability Parameters.

SDO	Document No.	Version	Status	Issued date	Location
<b>Version 1</b>					
TSDSI	TSDSI STD T3.9036.306-15.5.0 V1.0.1	V1.0.1	Published	01.10.2020	<a href="https://members.tdsi.in/index.php/s/FPj2WiM4Be5XBCE">https://members.tdsi.in/index.php/s/FPj2WiM4Be5XBCE</a>

**3.2.1.3.6 T3.9036.307****Evolved Universal Terrestrial Radio Access (E-UTRA); Requirements on User Equipments (UEs) supporting a release-independent frequency band**

This document specifies requirements on UEs supporting a frequency band that is independent of release. In order to implement a UE that conforms to a particular release but supports a band of operation that is specified in a later release, it is necessary to specify some extra requirements. All frequency bands are fully specified in this release of the specifications. This document does not contain any requirements for UEs supporting frequency bands independent of release.

SDO	Document No.	Version	Status	Issued date	Location
<b>Version 1</b>					
TSDSI	TSDSI STD T3.9036.307-15.5.0	V1.0.0	Published	01.10.2020	<a href="https://members.tdsi.in/index.php/s/xd5z59aHSD98c8K">https://members.tdsi.in/index.php/s/xd5z59aHSD98c8K</a>

**3.2.1.3.7 T3.9036.314****Evolved Universal Terrestrial Radio Access (E-UTRA); Layer 2 – Measurements**

This document contains the description and definition of the measurements performed by E-UTRAN that are transferred over the standardized interfaces in order to support E-UTRA radio link operations, radio resource management (RRM), network operations and maintenance (OAM), and self-organizing networks (SON).

SDO	Document No.	Version	Status	Issued date	Location
<b>Version 1</b>					
TSDSI	TSDSI STD T3.9036.314-15.2.0	V1.0.0	Published	01.10.2020	<a href="https://members.tdsi.in/index.php/s/PMEzjpWmFngSmNJ">https://members.tdsi.in/index.php/s/PMEzjpWmFngSmNJ</a>

**3.2.1.3.8 T3.9036.321****Evolved Universal Terrestrial Radio Access (E-UTRA); Medium Access Control (MAC) protocol specification**

This document specifies the E-UTRA Medium Access Control (MAC) protocol.

SDO	Document No.	Version	Status	Issued date	Location
<b>Version 1</b>					
TSDSI	TSDSI STD T3.9036.321-15.6.0	V1.0.1	Published	01.10.2020	<a href="https://members.tdsi.in/index.php/s/2f7z6PDG4KosmnC">https://members.tdsi.in/index.php/s/2f7z6PDG4KosmnC</a>

**3.2.1.3.9 T3.9036.322****Evolved Universal Terrestrial Radio Access (E-UTRA); Radio Link Control (RLC) protocol specification**

This document specifies the E-UTRA Radio Link Control (RLC) protocol.

SDO	Document No.	Version	Status	Issued date	Location
-----	--------------	---------	--------	-------------	----------

**Version 1**

TSDSI TSDSI STD T3.9036.322-15.2.0 V1.0.1 V1.0.1 Published 01.10.2020 <https://members.tdsi.in/index.php/s/96HWsLnDibom45f>

**3.2.1.3.10 T3.9036.323****Evolved Universal Terrestrial Radio Access (E-UTRA); Packet Data Convergence Protocol (PDCP) specification**

This document specifies the E-UTRA Packet Data Convergence Protocol (PDCP).

SDO	Document No.	Version	Status	Issued date	Location
-----	--------------	---------	--------	-------------	----------

**Version 1**

TSDSI	TSDSI STD T3.9036.323-15.4.0 V1.0.1	V1.0.1	Published	01.10.2020	<a href="https://members.tdsi.in/index.php/s/Mnq3qsqOrPS7kqd">https://members.tdsi.in/index.php/s/Mnq3qsqOrPS7kqd</a>
-------	-------------------------------------	--------	-----------	------------	---

**3.2.1.3.11 T3.9036.331****Evolved Universal Terrestrial Radio Access (E-UTRA); Radio Resource Control (RRC); Protocol specification**

This document specifies the Radio Resource Control protocol for the radio interface between UE and E-UTRAN as well as for the radio interface between RN and E-UTRAN. The scope of this document also includes: (i) the radio related information transported in a transparent container between source eNodeB and target eNodeB upon inter eNodeB handover; (ii) the radio related information transported in a transparent container between a source or target eNodeB and another system upon inter RAT handover.

SDO	Document No.	Version	Status	Issued date	Location
-----	--------------	---------	--------	-------------	----------

**Version 1**

TSDSI	TSDSI STD T3.9036.331-15.6.0 V1.0.1	V1.0.1	Published	01.10.2020	<a href="https://members.tdsi.in/index.php/s/5EnKrHJ4f8McDpM">https://members.tdsi.in/index.php/s/5EnKrHJ4f8McDpM</a>
-------	-------------------------------------	--------	-----------	------------	---

**3.2.1.3.12 T3.9036.355****Evolved Universal Terrestrial Radio Access (E-UTRA); LTE Positioning Protocol (LPP)**

This document contains the definition of the LTE Positioning Protocol (LPP).

SDO	Document No.	Version	Status	Issued date	Location
-----	--------------	---------	--------	-------------	----------

**Version 1**

TSDSI	TSDSI STD T3.9036.355-15.4.0 V1.0.0	V1.0.0	Published	01.10.2020	<a href="https://members.tdsi.in/index.php/s/ziCMTR6M7WxcqR7">https://members.tdsi.in/index.php/s/ziCMTR6M7WxcqR7</a>
-------	-------------------------------------	--------	-----------	------------	---

**3.2.1.3.13 T3.9036.360****Evolved Universal Terrestrial Radio Access (E-UTRA); LTE-WLAN Aggregation Adaptation Protocol (LWAAP) specification**

This document specifies the E-UTRA LTE-WLAN Aggregation Adaptation Protocol (LWAAP).

SDO	Document No.	Version	Status	Issued date	Location
-----	--------------	---------	--------	-------------	----------

**Version 1**

TSDSI TSDSI STD T3.9036.360-15.0.0 V1.0.0 V1.0.0 Published 01.10.2020 <https://members.tdsi.in/index.php/s/z5eXkrQaSWYKOHF>

### 3.2.1.3.14 T3.9036.361

#### **Evolved Universal Terrestrial Radio Access (E-UTRA); LTE/WLAN Radio Level Integration Using IPsec Tunnel (LWIP) encapsulation; Protocol specification**

This document specifies the LWIP Encapsulation Protocol.

SDO	Document No.	Version	Status	Issued date	Location
-----	--------------	---------	--------	-------------	----------

##### Version 1

TSDSI	TSDSI STD T3.9036.361-15.0.0 V1.0.0	V1.0.0	Published	01.10.2020	<a href="https://members.tdsi.in/index.php/s/qXBnDp4rFqw9cmY">https://members.tdsi.in/index.php/s/qXBnDp4rFqw9cmY</a>
-------	-------------------------------------	--------	-----------	------------	---

### 3.2.1.3.15 T3.9037.320

#### **Universal Terrestrial Radio Access (UTRA) and Evolved Universal Terrestrial Radio Access (E-UTRA); Radio measurement collection for Minimization of Drive Tests (MDT); Overall description; Stage 2**

This document provides an overview and overall description of the minimization of drive tests functionality. The document describes functions and procedures to support collection of UE-specific measurements for MDT using Control Plane architecture, for both UTRAN and E-UTRAN. Details of the signalling procedures for single-RAT operation are specified in the appropriate radio interface protocol specification. Network operation and overall control of MDT is described in OAM specifications.

SDO	Document No.	Version	Status	Issued date	Location
-----	--------------	---------	--------	-------------	----------

##### Version 1

TSDSI	TSDSI STD T3.9037.320-15.0.0 V1.0.0	V1.0.0	Published	01.10.2020	<a href="https://members.tdsi.in/index.php/s/H4Tgk23SCabNWwS">https://members.tdsi.in/index.php/s/H4Tgk23SCabNWwS</a>
-------	-------------------------------------	--------	-----------	------------	---

### 3.2.1.3.16 T3.9037.324

#### **Evolved Universal Terrestrial Radio Access (E-UTRA) and NR; Service Data Adaptation Protocol (SDAP) specification**

This document specifies the Service Data Adaptation Protocol (SDAP) for a UE with connection to the core network.

SDO	Document No.	Version	Status	Issued date	Location
-----	--------------	---------	--------	-------------	----------

##### Version 1

TSDSI	TSDSI STD T3.9037.324-15.1.0 V1.0.0	V1.0.0	Published	01.10.2020	<a href="https://members.tdsi.in/index.php/s/o3zHFn32262BY7d">https://members.tdsi.in/index.php/s/o3zHFn32262BY7d</a>
-------	-------------------------------------	--------	-----------	------------	---

### 3.2.1.3.17 T3.9037.340

#### **NR; Multi-connectivity; Overall description; Stage-2**

This document provides an overview of the multi-connectivity operation. Details of the network and radio interface protocols are specified in companion specifications of the 36 and 38 series.

SDO	Document No.	Version	Status	Issued date	Location
-----	--------------	---------	--------	-------------	----------

**Version 1**

TS/DSI	TS/DSI STD T3.9037.340-15.5.0 V1.0.1	V1.0.1	Published	01.10.2020	<a href="https://members.tdsi.in/index.php/s/fptmsjgxFdC2Z22">https://members.tdsi.in/index.php/s/fptmsjgxFdC2Z22</a>
--------	--------------------------------------	--------	-----------	------------	---

**3.2.1.3.18 T3.9037.355****LTE Positioning Protocol (LPP)**

This document contains the definition of the LTE Positioning Protocol (LPP) for the radio access technologies.

<b>SDO</b>	<b>Document No.</b>	<b>Version</b>	<b>Status</b>	<b>Issued date</b>	<b>Location</b>
------------	---------------------	----------------	---------------	--------------------	-----------------

**Version 1**

TS/DSI	TS/DSI STD T3.9037.355-15.0.0 V1.0.0	V1.0.0	Published	01.10.2020	<a href="https://members.tdsi.in/index.php/s/a5X2kj4ORDfwpRD">https://members.tdsi.in/index.php/s/a5X2kj4ORDfwpRD</a>
--------	--------------------------------------	--------	-----------	------------	---

**3.2.1.3.19 T3.9038.300****NR; NR and NG-RAN Overall description; Stage-2**

This document provides an overview and overall description of the RAN. Details of the radio interface protocols are specified in companion specifications of the 38 series.

<b>SDO</b>	<b>Document No.</b>	<b>Version</b>	<b>Status</b>	<b>Issued date</b>	<b>Location</b>
------------	---------------------	----------------	---------------	--------------------	-----------------

**Version 1**

TS/DSI	TS/DSI STD T3.9038.300-15.5.0 V1.0.1	V1.0.1	Published	01.10.2020	<a href="https://members.tdsi.in/index.php/s/RtRg3TYe36o7pjN">https://members.tdsi.in/index.php/s/RtRg3TYe36o7pjN</a>
--------	--------------------------------------	--------	-----------	------------	---

**3.2.1.3.20 T3.9038.304****NR; User Equipment (UE) procedures in idle mode and in RRC Inactive state**

This document specifies the Access Stratum (AS) part of the UE procedures in RRC\_IDLE state (also called Idle mode) and RRC\_INACTIVE state.

<b>SDO</b>	<b>Document No.</b>	<b>Version</b>	<b>Status</b>	<b>Issued date</b>	<b>Location</b>
------------	---------------------	----------------	---------------	--------------------	-----------------

**Version 1**

TS/DSI	TS/DSI STD T3.9038.304-15.3.0 V1.0.1	V1.0.1	Published	01.10.2020	<a href="https://members.tdsi.in/index.php/s/kGF2c4baMpxNZrk">https://members.tdsi.in/index.php/s/kGF2c4baMpxNZrk</a>
--------	--------------------------------------	--------	-----------	------------	---

**3.2.1.3.21 T3.9038.305****NG Radio Access Network (NG-RAN); Stage 2 functional specification of User Equipment (UE) positioning in NG-RAN**

This document specifies the stage 2 of the UE Positioning function of the RAN which provides the mechanisms to support or assist the calculation of the geographical position of a UE.

<b>SDO</b>	<b>Document No.</b>	<b>Version</b>	<b>Status</b>	<b>Issued date</b>	<b>Location</b>
------------	---------------------	----------------	---------------	--------------------	-----------------

**Version 1**

TSDSI TSDSI STD T3.9038.305-15.3.0 V1.0.0 V1.0.0 Published 01.10.2020 <https://members.tdsi.in/index.php/s/Gb2EQaCArcngocw>

### 3.2.1.3.22 T3.9038.306

#### NR; User Equipment (UE) radio access capabilities

This document defines the UE Radio Access Capability Parameters.

SDO	Document No.	Version	Status	Issued date	Location
-----	--------------	---------	--------	-------------	----------

##### Version 1

TSDSI	TSDSI STD T3.9038.306-15.5.0 V1.0.1	V1.0.1	Published	01.10.2020	<a href="https://members.tdsi.in/index.php/s/RyzbXAoQSGa2qHK">https://members.tdsi.in/index.php/s/RyzbXAoQSGa2qHK</a>
-------	-------------------------------------	--------	-----------	------------	---

### 3.2.1.3.23 T3.9038.307

#### NR; Requirements on User Equipments (UEs) supporting a release-independent frequency band

This document specifies requirements for UEs supporting release independent features such as additional radio operating bands and power classes.

SDO	Document No.	Version	Status	Issued date	Location
-----	--------------	---------	--------	-------------	----------

##### Version 1

TSDSI	TSDSI STD T3.9038.307-15.2.0 V1.0.0	V1.0.0	Published	01.10.2020	<a href="https://members.tdsi.in/index.php/s/xYCAcALRbwCqbB9">https://members.tdsi.in/index.php/s/xYCAcALRbwCqbB9</a>
-------	-------------------------------------	--------	-----------	------------	---

### 3.2.1.3.24 T3.9038.314

#### NR; Layer 2 measurements

This document contains the description and definition of the measurements performed by the radio or the UE that are transferred over the standardised interfaces in order to support radio link operations, radio resource management (RRM), network operations and maintenance (OAM), minimization of drive tests (MDT) and self-organising networks (SON).

SDO	Document No.	Version	Status	Issued date	Location
-----	--------------	---------	--------	-------------	----------

##### Version 1

TSDSI	TSDSI STD T3.9038.314-16.0.0 V1.0.0	V1.0.0	Published	01.10.2020	<a href="https://members.tdsi.in/index.php/s/bzKyHfzYt6e3Cow">https://members.tdsi.in/index.php/s/bzKyHfzYt6e3Cow</a>
-------	-------------------------------------	--------	-----------	------------	---

### 3.2.1.3.25 T3.9038.321

#### NR; Medium Access Control (MAC) protocol specification

This document specifies the MAC protocol.

SDO	Document No.	Version	Status	Issued date	Location
-----	--------------	---------	--------	-------------	----------

##### Version 1

TSDSI	TSDSI STD T3.9038.321-15.5.0 V1.0.1	V1.0.1	Published	01.10.2020	<a href="https://members.tdsi.in/index.php/s/npFE8EjixT2Wrc8">https://members.tdsi.in/index.php/s/npFE8EjixT2Wrc8</a>
-------	-------------------------------------	--------	-----------	------------	---



**3.2.1.3.26 T3.9038.322****NR; Radio Link Control (RLC) protocol specification**

This document specifies the Radio Link Control (RLC) protocol.

SDO	Document No.	Version	Status	Issued date	Location
<b>Version 1</b>					
TSDSI	TSDSI STD T3.9038.322-15.5.0 V1.0.1	V1.0.1	Published	01.10.2020	<a href="https://members.tdsi.in/index.php/s/2idWFeG3WFFXWSk">https://members.tdsi.in/index.php/s/2idWFeG3WFFXWSk</a>

**3.2.1.3.27 T3.9038.323****NR; Packet Data Convergence Protocol (PDCP) specification**

This document provides the description of the Packet Data Convergence Protocol (PDCP).

SDO	Document No.	Version	Status	Issued date	Location
<b>Version 1</b>					
TSDSI	TSDSI STD T3.9038.323-15.5.0 V1.0.0	V1.0.0	Published	01.10.2020	<a href="https://members.tdsi.in/index.php/s/GJRCSgaDB9iBMH">https://members.tdsi.in/index.php/s/GJRCSgaDB9iBMH</a>

**3.2.1.3.28 T3.9038.331****NR; Radio Resource Control (RRC); Protocol specification**

This document specifies the Radio Resource Control protocol for the radio interface between the UE and the RAN.

SDO	Document No.	Version	Status	Issued date	Location
<b>Version 1</b>					
TSDSI	TSDSI STD T3.9038.331-15.5.1 V1.0.1	V1.0.1	Published	01.10.2020	<a href="https://members.tdsi.in/index.php/s/tTDDnpxdgNsvyA7">https://members.tdsi.in/index.php/s/tTDDnpxdgNsvyA7</a>

**3.2.1.3.29 T3.9038.340****NR; Backhaul Adaptation Protocol (BAP) specification**

This document provides description of the Backhaul Adaptation Protocol (BAP).

SDO	Document No.	Version	Status	Issued date	Location
<b>Version 1</b>					
TSDSI	TSDSI STD T3.9038.340-16.0.0 V1.0.0	V1.0.0	Published	01.10.2020	<a href="https://members.tdsi.in/index.php/s/WGsTFmziY7ZyFpK">https://members.tdsi.in/index.php/s/WGsTFmziY7ZyFpK</a>

### 3.2.1.4 Architecture

#### 3.2.1.4.1 T3.9036.401

##### Evolved Universal Terrestrial Radio Access Network (E-UTRAN); Architecture description

This document describes the overall architecture of the E-UTRAN, including internal interfaces and assumptions on the radio, S1 and X2 interfaces.

SDO	Document No.	Version	Status	Issued date	Location
<b>Version 1</b>					
TSDSI	TSDSI STD T3.9036.401-15.1.0 V1.0.1	V1.0.1	Published	01.10.2020	<a href="https://members.tdsi.in/index.php/s/yZTmXqQqMBQD74o">https://members.tdsi.in/index.php/s/yZTmXqQqMBQD74o</a>

#### 3.2.1.4.2 T3.9036.410

##### Evolved Universal Terrestrial Radio Access Network (E-UTRAN); S1 general aspects and principles

This document is an introduction to the TSDSI T3.9036.41x series of technical specifications that define the S1 interface for the interconnection of the eNodeB component of the Evolved Universal Terrestrial Radio Access Network (E UTRAN) to the Core Network of the EPS system.

SDO	Document No.	Version	Status	Issued date	Location
<b>Version 1</b>					
TSDSI	TSDSI STD T3.9036.410-15.0.0 V1.0.0	V1.0.0	Published	01.10.2020	<a href="https://members.tdsi.in/index.php/s/e2xMdKCzGfD3kJ6">https://members.tdsi.in/index.php/s/e2xMdKCzGfD3kJ6</a>

#### 3.2.1.4.3 T3.9036.411

##### Evolved Universal Terrestrial Radio Access Network (E-UTRAN); S1 layer 1

This document specifies the standards allowed to implement layer 1 on the S1 interface. The specification of transmission delay requirements and O&M requirements are not in the scope of this document. In the following, “layer 1” and “physical layer” are assumed to be synonymous.

SDO	Document No.	Version	Status	Issued date	Location
<b>Version 1</b>					
TSDSI	TSDSI STD T3.9036.411-15.0.0 V1.0.0	V1.0.0	Published	01.10.2020	<a href="https://members.tdsi.in/index.php/s/KBCfaLAZi8LnJSb">https://members.tdsi.in/index.php/s/KBCfaLAZi8LnJSb</a>

#### 3.2.1.4.4 T3.9036.412

##### Evolved Universal Terrestrial Radio Access Network (E-UTRAN); S1 signalling transport

This document specifies the standards for signalling transport to be used across S1 interface. S1 interface is a logical interface between the eNodeB and the E-UTRAN core network. This document describes how the S1-AP signalling messages are transported over S1.

SDO	Document No.	Version	Status	Issued date	Location
<b>Version 1</b>					
TSDSI	TSDSI STD T3.9036.412-15.0.0 V1.0.0	V1.0.0	Published	01.10.2020	<a href="https://members.tdsi.in/index.php/s/Cb8ZGFxY6aaFZtk">https://members.tdsi.in/index.php/s/Cb8ZGFxY6aaFZtk</a>

**3.2.1.4.5 T3.9036.413****Evolved Universal Terrestrial Radio Access Network (E-UTRAN); S1 Application Protocol (S1AP)**

This document specifies the E-UTRAN radio network layer signalling protocol for the S1 interface. The S1 Application Protocol (S1AP) supports the functions of S1 interface by signalling procedures defined in this document.

SDO	Document No.	Version	Status	Issued date	Location
<b>Version 1</b>					
TSDSI	TSDSI STD T3.9036.413-15.6.0	V1.0.0	Published	01.10.2020	<a href="https://members.tdsi.in/index.php/s/wAG7Xe88dZHTzGW">https://members.tdsi.in/index.php/s/wAG7Xe88dZHTzGW</a>

**3.2.1.4.6 T3.9036.414****Evolved Universal Terrestrial Radio Access Network (E-UTRAN); S1 data transport**

This document specifies the standards for user data transport protocols and related signalling protocols to establish user plane transport bearers over the S1 interface.

SDO	Document No.	Version	Status	Issued date	Location
<b>Version 1</b>					
TSDSI	TSDSI STD T3.9036.414-15.0.0	V1.0.0	Published	01.10.2020	<a href="https://members.tdsi.in/index.php/s/M7pKGDWTLGsZiR9">https://members.tdsi.in/index.php/s/M7pKGDWTLGsZiR9</a>

**3.2.1.4.7 T3.9036.420****Evolved Universal Terrestrial Radio Access Network (E-UTRAN); X2 general aspects and principles**

This document is an introduction to the T3.9036.42x series of UMTS technical specifications that define the X2 interface. It is an interface for the interconnection of two E-UTRAN NodeB (eNodeB) components within the Evolved Universal Terrestrial Radio Access Network (EUTRAN) architecture.

SDO	Document No.	Version	Status	Issued date	Location
<b>Version 1</b>					
TSDSI	TSDSI STD T3.9036.420-15.1.0	V1.0.0	Published	01.10.2020	<a href="https://members.tdsi.in/index.php/s/4M6NfGAzykKkC3k">https://members.tdsi.in/index.php/s/4M6NfGAzykKkC3k</a>

**3.2.1.4.8 T3.9036.421****Evolved Universal Terrestrial Radio Access Network (E-UTRAN); X2 layer 1**

This document specifies the standards allowed to implement Layer 1 on the X2 interface. The specification of transmission delay requirements and O & M requirements are not in the scope of this document. In the following “Layer 1” and “Physical Layer” are assumed to be synonymous.

SDO	Document No.	Version	Status	Issued date	Location
<b>Version 1</b>					
TSDSI	TSDSI STD T3.9036.421-15.0.0	V1.0.0	Published	01.10.2020	<a href="https://members.tdsi.in/index.php/s/5nLXnbC67QJNHQ8">https://members.tdsi.in/index.php/s/5nLXnbC67QJNHQ8</a>

**3.2.1.4.9 T3.9036.422****Evolved Universal Terrestrial Radio Access Network (E-UTRAN); X2 signalling transport**

This document specifies the standards for Signalling Transport to be used across X2 interface. X2 interface is a logical interface between eNodeBs. This document describes how the X2-AP signalling messages are transported over X2.

SDO	Document No.	Version	Status	Issued date	Location
<b>Version 1</b>					
TSDSI	TSDSI STD T3.9036.422-15.1.0	V1.0.0	Published	01.10.2020	<a href="https://members.tdsi.in/index.php/s/3Bi4fQ246AdsNXj">https://members.tdsi.in/index.php/s/3Bi4fQ246AdsNXj</a>

**3.2.1.4.10 T3.9036.423****Evolved Universal Terrestrial Radio Access Network (E-UTRAN); X2 Application Protocol (X2AP)**

This document specifies the radio network layer signalling procedures of the control plane between eNodeBs in E-UTRAN. X2AP supports the functions of X2 interface by signalling procedures defined in this document.

SDO	Document No.	Version	Status	Issued date	Location
<b>Version 1</b>					
TSDSI	TSDSI STD T3.9036.423-15.6.0	V1.0.0	Published	01.10.2020	<a href="https://members.tdsi.in/index.php/s/bZk4CQ58jRdHcwc">https://members.tdsi.in/index.php/s/bZk4CQ58jRdHcwc</a>

**3.2.1.4.11 T3.9036.424****Evolved Universal Terrestrial Radio Access Network (E-UTRAN); X2 data transport**

This document specifies the standards for user data transport protocols and related signalling protocols to establish user plane transport bearers over the X2 interface.

SDO	Document No.	Version	Status	Issued date	Location
<b>Version 1</b>					
TSDSI	TSDSI STD T3.9036.424-15.0.0	V1.0.0	Published	01.10.2020	<a href="https://members.tdsi.in/index.php/s/aFdbgW4BPY4Cet">https://members.tdsi.in/index.php/s/aFdbgW4BPY4Cet</a>

**3.2.1.4.12 T3.9036.425****Evolved Universal Terrestrial Radio Access Network (E-UTRAN); X2 interface user plane protocol**

This document specifies the X2 user plane protocol being used over the X2 interface.

SDO	Document No.	Version	Status	Issued date	Location
<b>Version 1</b>					
TSDSI	TSDSI STD T3.9036.425-15.0.0	V1.0.0	Published	01.10.2020	<a href="https://members.tdsi.in/index.php/s/ws5Ja7oTGXgbYNj">https://members.tdsi.in/index.php/s/ws5Ja7oTGXgbYNj</a>

**3.2.1.4.13 T3.9036.440****Evolved Universal Terrestrial Radio Access Network (E-UTRAN); General aspects and principles for interfaces supporting Multimedia Broadcast Multicast Service (MBMS) within E-UTRAN**

This document describes the overall architecture of the interface for the provision of MBMS in the E-UTRAN. This also includes a description of the general aspects, assumptions and principles guiding the architecture and interface.

SDO	Document No.	Version	Status	Issued date	Location
<b>Version 1</b>					
TSDSI	TSDSI STD T3.9036.440-15.0.0	V1.0.0	Published	01.10.2020	<a href="https://members.tdsi.in/index.php/s/3nMsTgP4f4pqfsf">https://members.tdsi.in/index.php/s/3nMsTgP4f4pqfsf</a>

**3.2.1.4.14 T3.9036.441****Evolved Universal Terrestrial Radio Access Network (E-UTRAN); Layer 1 for interfaces supporting Multimedia Broadcast Multicast Service (MBMS) within E-UTRAN**

This document specifies the standards allowed to implement layer 1 on the interfaces supporting Multimedia Broadcast Multicast Service (MBMS) within E-UTRAN. In the following, “layer 1” and “physical layer” are assumed to be synonymous.

SDO	Document No.	Version	Status	Issued date	Location
<b>Version 1</b>					
TSDSI	TSDSI STD T3.9036.441-15.0.0	V1.0.0	Published	01.10.2020	<a href="https://members.tdsi.in/index.php/s/PAbHSPj3qYfpgAJ">https://members.tdsi.in/index.php/s/PAbHSPj3qYfpgAJ</a>

**3.2.1.4.15 T3.9036.442****Evolved Universal Terrestrial Radio Access Network (E-UTRAN); Signalling Transport for interfaces supporting Multimedia Broadcast Multicast Service (MBMS) within E-UTRAN**

This document specifies the standards for signalling transport to be used across M2 and M3 interfaces. M2 interface is a logical interface between the eNodeB and the MCE. M3 interface is a logical interface between the MCE and the MME. This document describes how the M2-AP signalling messages are transported over M2, and how the M3-AP signalling messages are transported over M3.

SDO	Document No.	Version	Status	Issued date	Location
<b>Version 1</b>					
TSDSI	TSDSI STD T3.9036.442-15.0.0	V1.0.0	Published	01.10.2020	<a href="https://members.tdsi.in/index.php/s/3gZ4pfYxkFfysrF">https://members.tdsi.in/index.php/s/3gZ4pfYxkFfysrF</a>

**3.2.1.4.16 T3.9036.443****Evolved Universal Terrestrial Radio Access Network (E-UTRAN); M2 Application Protocol (M2AP)**

This document specifies the E-UTRAN radio network layer signalling protocol for the M2 interface. The M2 Application Protocol (M2AP) supports the functions of M2 interface by signalling procedures defined in this document.

SDO	Document No.	Version	Status	Issued date	Location
<b>Version 1</b>					
TSDSI	TSDSI STD T3.9036.443-15.0.0	V1.0.0	Published	01.10.2020	<a href="https://members.tdsi.in/index.php/s/xCyfH8KgcPnpA66">https://members.tdsi.in/index.php/s/xCyfH8KgcPnpA66</a>

**3.2.1.4.17 T3.9036.444****Evolved Universal Terrestrial Radio Access Network (E-UTRAN); M3 Application Protocol (M3AP)**

This document specifies the E-UTRAN radio network layer signalling protocol for the M3 interface. The M3 Application Protocol (M3AP) supports the functions of M3 interface by signalling procedures defined in this document.

SDO	Document No.	Version	Status	Issued date	Location
<b>Version 1</b>					
TSDSI	TSDSI STD T3.9036.444-15.0.0	V1.0.0	Published	01.10.2020	<a href="https://members.tdsi.in/index.php/s/4gwZQ3NEj5bxqrt">https://members.tdsi.in/index.php/s/4gwZQ3NEj5bxqrt</a>

**3.2.1.4.18 T3.9036.445****Evolved Universal Terrestrial Radio Access Network (E-UTRAN); M1 data transport**

This document specifies the standards for user data transport protocols over the E-UTRAN M1 interface.

SDO	Document No.	Version	Status	Issued date	Location
<b>Version 1</b>					
TSDSI	TSDSI STD T3.9036.445-15.0.0	V1.0.0	Published	01.10.2020	<a href="https://members.tdsi.in/index.php/s/J7tQw4zMq5tJDLA">https://members.tdsi.in/index.php/s/J7tQw4zMq5tJDLA</a>

**3.2.1.4.19 T3.9036.455****Evolved Universal Terrestrial Radio Access (E-UTRA); LTE Positioning Protocol A (LPPa)**

This document specifies the control plane radio network layer signalling procedures between eNodeB and E-SMLC. LPPa supports the concerned functions by signalling procedures defined in this document.

SDO	Document No.	Version	Status	Issued date	Location
<b>Version 1</b>					
TSDSI	TSDSI STD T3.9036.455-15.2.1	V1.0.0	Published	01.10.2020	<a href="https://members.tdsi.in/index.php/s/44qtwBrbWTWNmg">https://members.tdsi.in/index.php/s/44qtwBrbWTWNmg</a>

**3.2.1.4.20 T3.9036.456****Universal Terrestrial Radio Access (UTRA) and Evolved Universal Terrestrial Radio Access (E-UTRA); SLM interface general aspects and principles**

This document is an introduction to the technical specifications that define the SLM interface for the interconnection of the Evolved Serving Mobile Location Centre (E-SMLC) to the Location Measurement Unit (LMU) components of the Evolved Universal Terrestrial Radio Access Network (E-UTRAN).

SDO	Document No.	Version	Status	Issued date	Location
<b>Version 1</b>					
TSDSI	TSDSI STD T3.9036.456-15.0.0 V1.0.0	V1.0.0	Published	01.10.2020	<a href="https://members.tdsi.in/index.php/s/SsWwPrEZmGTMe2Y">https://members.tdsi.in/index.php/s/SsWwPrEZmGTMe2Y</a>

**3.2.1.4.21 T3.9036.457****Universal Terrestrial Radio Access (UTRA) and Evolved Universal Terrestrial Radio Access (E-UTRA); SLM interface layer 1**

This document specifies the standards allowed to implement layer 1 on the SLM interface.

SDO	Document No.	Version	Status	Issued date	Location
<b>Version 1</b>					
TSDSI	TSDSI STD T3.9036.457-15.0.0 V1.0.0	V1.0.0	Published	01.10.2020	<a href="https://members.tdsi.in/index.php/s/cgwBY8M8pbaXX6e">https://members.tdsi.in/index.php/s/cgwBY8M8pbaXX6e</a>

**3.2.1.4.22 T3.9036.458****Universal Terrestrial Radio Access (UTRA) and Evolved Universal Terrestrial Radio Access (E-UTRA); SLM interface signalling transport**

This document specifies the standards for signalling transport to be used across the SLM interface. The SLM interface is a logical interface between the LMU and the E-SMLC in the E-UTRAN core network. This document describes how the SLMAP signalling messages are transported over SLM.

SDO	Document No.	Version	Status	Issued date	Location
<b>Version 1</b>					
TSDSI	TSDSI STD T3.9036.458-15.0.0 V1.0.0	V1.0.0	Published	01.10.2020	<a href="https://members.tdsi.in/index.php/s/w64bBQzdf6En9H4">https://members.tdsi.in/index.php/s/w64bBQzdf6En9H4</a>

**3.2.1.4.23 T3.9036.459****Universal Terrestrial Radio Access (UTRA) and Evolved Universal Terrestrial Radio Access (E-UTRA); SLM interface Application Protocol (SLMAP)**

This document specifies the E-UTRAN radio network layer signalling protocol for the SLM interface. The SLM Application Protocol (SLMAP) supports the functions of the SLM interface by signalling procedures defined in this document.

SDO	Document No.	Version	Status	Issued date	Location
<b>Version 1</b>					
TSDSI	TSDSI STD T3.9036.459-15.0.0	V1.0.0	Published	01.10.2020	<a href="https://members.tdsi.in/index.php/s/F6xzLD28q2TRerG">https://members.tdsi.in/index.php/s/F6xzLD28q2TRerG</a>

### 3.2.1.4.24 T3.9036.461

#### Evolved Universal Terrestrial Radio Access Network (E-UTRAN) and Wireless LAN (WLAN); Xw layer 1

This document specifies the standards allowed to implement Layer 1 on the Xw interface. The specification of transmission delay requirements and O&M requirements are not in the scope of this document.

SDO	Document No.	Version	Status	Issued date	Location
<b>Version 1</b>					
TSDSI	TSDSI STD T3.9036.461-15.0.0	V1.0.0	Published	01.10.2020	<a href="https://members.tdsi.in/index.php/s/irx3Yz5kBMxbl6p">https://members.tdsi.in/index.php/s/irx3Yz5kBMxbl6p</a>

### 3.2.1.4.25 T3.9036.462

#### Evolved Universal Terrestrial Radio Access Network (E-UTRAN) and Wireless LAN (WLAN); Xw signalling transport

This document specifies the standards for Signalling Transport to be used across the Xw interface. The Xw interface is a logical interface between the eNB and the WLAN Termination (WT). This document describes how the Xw-AP signalling messages are transported over Xw.

SDO	Document No.	Version	Status	Issued date	Location
<b>Version 1</b>					
TSDSI	TSDSI STD T3.9036.462-15.0.0	V1.0.0	Published	01.10.2020	<a href="https://members.tdsi.in/index.php/s/9k59Fo34CqtHALm">https://members.tdsi.in/index.php/s/9k59Fo34CqtHALm</a>

### 3.2.1.4.26 T3.9036.463

#### Evolved Universal Terrestrial Radio Access Network (E-UTRAN) and Wireless Local Area Network (WLAN); Xw application protocol (XwAP)

This document specifies the signalling procedures of the control plane between an eNB and WLAN Termination (WT). The Xw Application Protocol (XwAP) supports the functions of Xw interface by signalling procedures defined in this document.

SDO	Document No.	Version	Status	Issued date	Location
<b>Version 1</b>					
TSDSI	TSDSI STD T3.9036.463-15.0.0	V1.0.0	Published	01.10.2020	<a href="https://members.tdsi.in/index.php/s/DzQATYF6nLqkmeK">https://members.tdsi.in/index.php/s/DzQATYF6nLqkmeK</a>



**3.2.1.4.27 T3.9036.464****Evolved Universal Terrestrial Radio Access Network (E-UTRAN) and Wireless Local Area Network (WLAN); Xw data transport**

This document specifies the standards for user data transport protocols and related signalling protocols to establish user plane transport bearers over the Xw interface for LTE/WLAN Aggregation (LWA).

SDO	Document No.	Version	Status	Issued date	Location
<b>Version 1</b>					
TSDSI	TSDSI STD T3.9036.464-15.0.0	V1.0.0	Published	01.10.2020	<a href="https://members.tdsi.in/index.php/s/kjKnDSAcDdFWsDN">https://members.tdsi.in/index.php/s/kjKnDSAcDdFWsDN</a>

**3.2.1.4.28 T3.9036.465****Evolved Universal Terrestrial Radio Access Network (E-UTRAN) and Wireless Local Area Network (WLAN); Xw interface user plane protocol**

This document specifies the Xw user plane protocol being used over the Xw interface for LTE/WLAN Aggregation (LWA).

SDO	Document No.	Version	Status	Issued date	Location
<b>Version 1</b>					
TSDSI	TSDSI STD T3.9036.465-15.0.0	V1.0.0	Published	01.10.2020	<a href="https://members.tdsi.in/index.php/s/ErKQaYorG5FaRHF">https://members.tdsi.in/index.php/s/ErKQaYorG5FaRHF</a>

**3.2.1.4.29 T3.9037.460****Iuant interface: General aspects and principles**

This document is an introduction to the Technical Specifications that define the Iuant Interface.

SDO	Document No.	Version	Status	Issued date	Location
<b>Version 1</b>					
TSDSI	TSDSI STD T3.9037.460-15.1.0	V1.0.0	Published	01.10.2020	<a href="https://members.tdsi.in/index.php/s/F3GzKM4r3iCLRxD">https://members.tdsi.in/index.php/s/F3GzKM4r3iCLRxD</a>

**3.2.1.4.30 T3.9037.461****Iuant interface: Layer 1**

This document specifies the standards allowed to implement layer 1 on the Iuant interface. The specification of transmission delay requirements and O&M requirements are not in the scope of this document.

SDO	Document No.	Version	Status	Issued date	Location
<b>Version 1</b>					
TSDSI	TSDSI STD T3.9037.461-15.4.0	V1.0.0	Published	01.10.2020	<a href="https://members.tdsi.in/index.php/s/bBT3npZLrdmikT8">https://members.tdsi.in/index.php/s/bBT3npZLrdmikT8</a>

**3.2.1.4.31 T3.9037.462****Iuant interface: Signalling transport**

This document specifies the signalling transport related to RETAP and TMAAP signalling to be used across the Iuant interface.

SDO	Document No.	Version	Status	Issued date	Location
<b>Version 1</b>					
TSDSI	TSDSI STD T3.9037.462-15.1.0 V1.0.0	V1.0.0	Published	01.10.2020	<a href="https://members.tdsi.in/index.php/s/2WbEGtKaXWLxFOa">https://members.tdsi.in/index.php/s/2WbEGtKaXWLxFOa</a>

**3.2.1.4.32 T3.9037.466****Iuant interface: Application part**

This document is an introduction to the Technical Specifications that define the Iuant Interface applications.

SDO	Document No.	Version	Status	Issued date	Location
<b>Version 1</b>					
TSDSI	TSDSI STD T3.9037.466-15.4.0 V1.0.0	V1.0.0	Published	01.10.2020	<a href="https://members.tdsi.in/index.php/s/kNdSZJdkpLX8pgd">https://members.tdsi.in/index.php/s/kNdSZJdkpLX8pgd</a>

**3.2.1.4.33 T3.9037.470****W1 interface; General aspects and principles**

This document is an introduction to the technical specifications that define the W1 interface.

SDO	Document No.	Version	Status	Issued date	Location
<b>Version 1</b>					
TSDSI	TSDSI STD T3.9037.470-16.0.0 V1.0.0	V1.0.0	Published	01.10.2020	<a href="https://members.tdsi.in/index.php/s/jNqb9jOz3jAka7p">https://members.tdsi.in/index.php/s/jNqb9jOz3jAka7p</a>

**3.2.1.4.34 T3.9037.471****W1 interface; Layer 1**

This document specifies the standards allowed to implement Layer 1 on the W1 interface.

SDO	Document No.	Version	Status	Issued date	Location
<b>Version 1</b>					
TSDSI	TSDSI STD T3.9037.471-16.0.0 V1.0.0	V1.0.0	Published	01.10.2020	<a href="https://members.tdsi.in/index.php/s/TWMeNnxyWHs73SC">https://members.tdsi.in/index.php/s/TWMeNnxyWHs73SC</a>

**3.2.1.4.35 T3.9037.472****W1 interface; Signalling transport**

This document specifies the standards for Signalling Transport to be used across the W1 interface.

SDO	Document No.	Version	Status	Issued date	Location
<b>Version 1</b>					
TSDSI	TSDSI STD T3.9037.472-16.0.0 V1.0.0	V1.0.0	Published	01.10.2020	<a href="https://members.tdsi.in/index.php/s/t3aqrwRoSYcc6YH">https://members.tdsi.in/index.php/s/t3aqrwRoSYcc6YH</a>

### 3.2.1.4.36 T3.9037.473

#### W1 interface; Application Protocol (W1AP)

This document specifies the radio network layer signalling protocol for the W1 interface.

SDO	Document No.	Version	Status	Issued date	Location
<b>Version 1</b>					
TSDSI	TSDSI STD T3.9037.473-16.0.0 V1.0.0	V1.0.0	Published	01.10.2020	<a href="https://members.tdsi.in/index.php/s/Hm4xFD7BzjbNfQb">https://members.tdsi.in/index.php/s/Hm4xFD7BzjbNfQb</a>

### 3.2.1.4.37 T3.9038.401

#### NG-RAN; Architecture description

This document describes the overall architecture of the NG-RAN, including interfaces NG, Xn and F1 interfaces and their interaction with the radio interface.

SDO	Document No.	Version	Status	Issued date	Location
<b>Version 1</b>					
TSDSI	TSDSI STD T3.9038.401-15.5.0 V1.0.1	V1.0.1	Published	01.10.2020	<a href="https://members.tdsi.in/index.php/s/JQwsbgercBXNCWk">https://members.tdsi.in/index.php/s/JQwsbgercBXNCWk</a>

### 3.2.1.4.38 T3.9038.410

#### NG-RAN; NG general aspects and principles

This document is an introduction to the technical specifications that define the NG interface for the interconnection of an NG-RAN node to the core network.

SDO	Document No.	Version	Status	Issued date	Location
<b>Version 1</b>					
TSDSI	TSDSI STD T3.9038.410-15.2.0 V1.0.0	V1.0.0	Published	01.10.2020	<a href="https://members.tdsi.in/index.php/s/zaYSKaL25gotbdq">https://members.tdsi.in/index.php/s/zaYSKaL25gotbdq</a>

### 3.2.1.4.39 T3.9038.411

#### NG-RAN; NG layer 1

This document specifies the standards allowed to implement layer 1 on the NG interface.

The specification of transmission delay requirements and O&M requirements are not in the scope of this document.

SDO	Document No.	Version	Status	Issued date	Location
-----	--------------	---------	--------	-------------	----------

**Version 1**

TSDSI	TSDSI STD T3.9038.411-15.0.0 V1.0.0	V1.0.0	Published	01.10.2020	<a href="https://members.tdsi.in/index.php/s/nYsQcp3HiDfNdia">https://members.tdsi.in/index.php/s/nYsQcp3HiDfNdia</a>
-------	-------------------------------------	--------	-----------	------------	---

**3.2.1.4.40 T3.9038.412****NG-RAN; NG signalling transport**

This document specifies the standards for signalling transport to be used across NG interface. NG interface is a logical interface between the NG-RAN and the core network. This document describes how the NGAP signalling messages are transported over NG.

<b>SDO</b>	<b>Document No.</b>	<b>Version</b>	<b>Status</b>	<b>Issued date</b>	<b>Location</b>
------------	---------------------	----------------	---------------	--------------------	-----------------

**Version 1**

TSDSI	TSDSI STD T3.9038.412-15.1.0 V1.0.0	V1.0.0	Published	01.10.2020	<a href="https://members.tdsi.in/index.php/s/DxPYPJSGkFybaNY">https://members.tdsi.in/index.php/s/DxPYPJSGkFybaNY</a>
-------	-------------------------------------	--------	-----------	------------	---

**3.2.1.4.41 T3.9038.413****NG-RAN; NG Application Protocol (NGAP)**

This document specifies the radio network layer signalling protocol for the NG interface. The NG Application Protocol (NGAP) supports the functions of the NG interface by signalling procedures defined in this document. NGAP is developed in accordance to the general principles stated in T3.9038.401 and T3.9038.410.

<b>SDO</b>	<b>Document No.</b>	<b>Version</b>	<b>Status</b>	<b>Issued date</b>	<b>Location</b>
------------	---------------------	----------------	---------------	--------------------	-----------------

**Version 1**

TSDSI	TSDSI STD T3.9038.413-15.3.0 V1.0.0	V1.0.0	Published	01.10.2020	<a href="https://members.tdsi.in/index.php/s/JHNTRNW9HNrEiEP">https://members.tdsi.in/index.php/s/JHNTRNW9HNrEiEP</a>
-------	-------------------------------------	--------	-----------	------------	---

**3.2.1.4.42 T3.9038.414****NG-RAN; NG data transport**

This document specifies the standards for user data transport protocols and related signalling protocols to establish user plane transport bearers over the NG interface.

<b>SDO</b>	<b>Document No.</b>	<b>Version</b>	<b>Status</b>	<b>Issued date</b>	<b>Location</b>
------------	---------------------	----------------	---------------	--------------------	-----------------

**Version 1**

TSDSI	TSDSI STD T3.9038.414-15.1.0 V1.0.0	V1.0.0	Published	01.10.2020	<a href="https://members.tdsi.in/index.php/s/tYyGwtdqipYjfzs">https://members.tdsi.in/index.php/s/tYyGwtdqipYjfzs</a>
-------	-------------------------------------	--------	-----------	------------	---

**3.2.1.4.43 T3.9038.415****NG-RAN; PDU session user plane protocol**

This document specifies the PDU Session user plane protocol being used over the NG-U, Xn-U and N9 interfaces. Applicability to other interfaces is not precluded.

SDO	Document No.	Version	Status	Issued date	Location
<b>Version 1</b>					
TSDSI	TSDSI STD T3.9038.415-15.2.0	V1.0.0	Published	01.10.2020	<a href="https://members.tdsi.in/index.php/s/TSG2tD56c4Z88wX">https://members.tdsi.in/index.php/s/TSG2tD56c4Z88wX</a>

### 3.2.1.4.44 T3.9038.420

#### NG-RAN; Xn general aspects and principles

This document is an introduction to the Technical Specifications that define the Xn interface. It is an interface for the interconnection of two NG-RAN nodes within the NG-RAN architecture (T3.9038.401).

SDO	Document No.	Version	Status	Issued date	Location
<b>Version 1</b>					
TSDSI	TSDSI STD T3.9038.420-15.2.0	V1.0.0	Published	01.10.2020	<a href="https://members.tdsi.in/index.php/s/TbNqGWeyirc5dfs">https://members.tdsi.in/index.php/s/TbNqGWeyirc5dfs</a>

### 3.2.1.4.45 T3.9038.421

#### NG-RAN; Xn layer 1

This document specifies the standards allowed to implement layer 1 on the Xn interface.

The specification of transmission delay requirements and O&M requirements are not in the scope of this document.

SDO	Document No.	Version	Status	Issued date	Location
<b>Version 1</b>					
TSDSI	TSDSI STD T3.9038.421-15.0.0	V1.0.0	Published	01.10.2020	<a href="https://members.tdsi.in/index.php/s/qYz4H4ZyHCGTXoM">https://members.tdsi.in/index.php/s/qYz4H4ZyHCGTXoM</a>

### 3.2.1.4.46 T3.9038.422

#### NG-RAN; Xn signalling transport

This document specifies the standards for signalling transport to be used across Xn interface. The Xn interface provides means for interconnecting two NG-RAN nodes. The Xn interface is a logical interface between two nodes of the NG-RAN. This document describes how the XnAP signalling messages are transported over Xn.

SDO	Document No.	Version	Status	Issued date	Location
<b>Version 1</b>					
TSDSI	TSDSI STD T3.9038.422-15.2.0	V1.0.0	Published	01.10.2020	<a href="https://members.tdsi.in/index.php/s/tqxkYL6zxyFAAWC">https://members.tdsi.in/index.php/s/tqxkYL6zxyFAAWC</a>

**3.2.1.4.47 T3.9038.423****NG-RAN; Xn Application Protocol (XnAP)**

This document specifies the radio network layer signalling procedures of the control plane between NG-RAN nodes in NG-RAN. XnAP supports the functions of the Xn interface by signalling procedures defined in this document. XnAP is developed in accordance to the general principles stated in T3.9038.401 and T3.9038.420.

SDO	Document No.	Version	Status	Issued date	Location
<b>Version 1</b>					
TSDSI	TSDSI STD T3.9038.423-15.3.0	V1.0.0	Published	01.10.2020	<a href="https://members.tdsi.in/index.php/s/WxZYXtb5cyingGr">https://members.tdsi.in/index.php/s/WxZYXtb5cyingGr</a>

**3.2.1.4.48 T3.9038.424****NG-RAN; Xn data transport**

This document specifies the standards for user data transport protocols and related signalling protocols to establish user plane transport bearers over the Xn interface.

SDO	Document No.	Version	Status	Issued date	Location
<b>Version 1</b>					
TSDSI	TSDSI STD T3.9038.424-15.1.0	V1.0.0	Published	01.10.2020	<a href="https://members.tdsi.in/index.php/s/cFfPDfsY55GX5ic">https://members.tdsi.in/index.php/s/cFfPDfsY55GX5ic</a>

**3.2.1.4.49 T3.9038.425****NG-RAN; NR user plane protocol**

This document specifies the user plane protocol functions used within NG-RAN and, for EN-DC, within E-UTRAN. User plane protocol functions may reside in nodes terminating either the X2-U (for EN-DC) or the Xn-U or the F1-U interface.

SDO	Document No.	Version	Status	Issued date	Location
<b>Version 1</b>					
TSDSI	TSDSI STD T3.9038.425-15.5.0	V1.0.0	Published	01.10.2020	<a href="https://members.tdsi.in/index.php/s/fNR3MexmS7jb4mG">https://members.tdsi.in/index.php/s/fNR3MexmS7jb4mG</a>

**3.2.1.4.50 T3.9038.455****NG-RAN; NR Positioning Protocol A (NRPPa)**

This document specifies the control plane radio network layer signalling procedures between a NG-RAN node and the LMF. NRPPa supports the concerned functions by signalling procedures defined in this document.

SDO	Document No.	Version	Status	Issued date	Location
<b>Version 1</b>					
TSDSI	TSDSI STD T3.9038.455-15.2.1	V1.0.0	Published	01.10.2020	<a href="https://members.tdsi.in/index.php/s/aCZbitPZfXnms3F">https://members.tdsi.in/index.php/s/aCZbitPZfXnms3F</a>

**3.2.1.4.51 T3.9038.460****NG-RAN; E1 general aspects and principles**

This document is an introduction to the technical specifications that define the E1 interface. The E1 interface provides means for interconnecting a gNB-CU-CP and a gNB-CU-UP of a gNB-CU within an NG-RAN, or for interconnecting a gNB-CU-CP and a gNB-CU-UP of an en-gNB within an E-UTRAN.

SDO	Document No.	Version	Status	Issued date	Location
<b>Version 1</b>					
TSDSI	TSDSI STD T3.9038.460-15.3.0 V1.0.0	V1.0.0	Published	01.10.2020	<a href="https://members.tdsi.in/index.php/s/kFwosYKZpCDpFs5">https://members.tdsi.in/index.php/s/kFwosYKZpCDpFs5</a>

**3.2.1.4.52 T3.9038.461****NG-RAN; E1 layer 1**

This document specifies the standards allowed to implement layer 1 on the E1 interface.

The specification of transmission delay requirements and O&M requirements are not in the scope of this document.

SDO	Document No.	Version	Status	Issued date	Location
<b>Version 1</b>					
TSDSI	TSDSI STD T3.9038.461-15.0.0 V1.0.0	V1.0.0	Published	01.10.2020	<a href="https://members.tdsi.in/index.php/s/QQtjxbajpZzXsR">https://members.tdsi.in/index.php/s/QQtjxbajpZzXsR</a>

**3.2.1.4.53 T3.9038.462****NG-RAN; E1 signalling transport**

This document specifies the standards for Signalling Transport to be used across the E1 interface.

SDO	Document No.	Version	Status	Issued date	Location
<b>Version 1</b>					
TSDSI	TSDSI STD T3.9038.462-15.3.0 V1.0.0	V1.0.0	Published	01.10.2020	<a href="https://members.tdsi.in/index.php/s/984NWGDpjfmsdR3">https://members.tdsi.in/index.php/s/984NWGDpjfmsdR3</a>

**3.2.1.4.54 T3.9038.463****NG-RAN; E1 Application Protocol (E1AP)**

This document specifies the radio network layer signalling protocol for the E1 interface.

SDO	Document No.	Version	Status	Issued date	Location
<b>Version 1</b>					
TSDSI	TSDSI STD T3.9038.463-15.3.0 V1.0.0	V1.0.0	Published	01.10.2020	<a href="https://members.tdsi.in/index.php/s/DfctiCRgqgB89rG">https://members.tdsi.in/index.php/s/DfctiCRgqgB89rG</a>

**3.2.1.4.55 T3.9038.470****NG-RAN; F1 general aspects and principles**

This document is an introduction to the technical specifications that define the F1 interface.

SDO	Document No.	Version	Status	Issued date	Location
<b>Version 1</b>					
TSDSI	TSDSI STD T3.9038.470-15.5.0 V1.0.0	V1.0.0	Published	01.10.2020	<a href="https://members.tdsi.in/index.php/s/4KrPwiMA3Abs9RA">https://members.tdsi.in/index.php/s/4KrPwiMA3Abs9RA</a>

**3.2.1.4.56 T3.9038.471****NG-RAN; F1 layer 1**

This document specifies the standards allowed to implement Layer 1 on the F1 interface.

SDO	Document No.	Version	Status	Issued date	Location
<b>Version 1</b>					
TSDSI	TSDSI STD T3.9038.471-15.0.0 V1.0.0	V1.0.0	Published	01.10.2020	<a href="https://members.tdsi.in/index.php/s/rttDSB5ywD7SKay">https://members.tdsi.in/index.php/s/rttDSB5ywD7SKay</a>

**3.2.1.4.57 T3.9038.472****NG-RAN; F1 signalling transport**

This document specifies the standards for Signalling Transport to be used across the F1 interface.

SDO	Document No.	Version	Status	Issued date	Location
<b>Version 1</b>					
TSDSI	TSDSI STD T3.9038.472-15.3.0 V1.0.0	V1.0.0	Published	01.10.2020	<a href="https://members.tdsi.in/index.php/s/WLNfJEGBeS2KasJ">https://members.tdsi.in/index.php/s/WLNfJEGBeS2KasJ</a>

**3.2.1.4.58 T3.9038.473****NG-RAN; F1 Application Protocol (F1AP)**

This document specifies the radio network layer signalling protocol for the F1 interface.

SDO	Document No.	Version	Status	Issued date	Location
<b>Version 1</b>					
TSDSI	TSDSI STD T3.9038.473-15.5.0 V1.0.0	V1.0.0	Published	01.10.2020	<a href="https://members.tdsi.in/index.php/s/6FtEN9cfcP2jAWP">https://members.tdsi.in/index.php/s/6FtEN9cfcP2jAWP</a>



**3.2.1.4.59 T3.9038.474****NG-RAN; F1 data transport**

This document specifies the standards for user data transport protocols and related signalling protocols to establish user plane transport bearers over the F1 interface.

SDO	Document No.	Version	Status	Issued date	Location
<b>Version 1</b>					
TSDSI	TSDSI STD T3.9038.474-15.2.0	V1.0.0	Published	01.10.2020	<a href="https://members.tdsi.in/index.php/s/mJyeF66RJdJpAag">https://members.tdsi.in/index.php/s/mJyeF66RJdJpAag</a>

**3.2.1.5 Radio-frequency aspects****3.2.1.5.1 T3.9036.101****Evolved Universal Terrestrial Radio Access (E-UTRA); User Equipment (UE) radio transmission and reception**

This document establishes the minimum RF characteristics and minimum performance requirements for E-UTRA User Equipment (UE).

SDO	Document No.	Version	Status	Issued date	Location
<b>Version 1</b>					
TSDSI	TSDSI STD T3.9036.101-15.7.0	V1.0.1	Published	01.10.2020	<a href="https://members.tdsi.in/index.php/s/SeeXLcaPriPxXNJ">https://members.tdsi.in/index.php/s/SeeXLcaPriPxXNJ</a>

**3.2.1.5.2 T3.9036.104****Evolved Universal Terrestrial Radio Access (E-UTRA); Base Station (BS) radio transmission and reception**

This document establishes the minimum RF characteristics and minimum performance requirements of E-UTRA Base Station (BS).

SDO	Document No.	Version	Status	Issued date	Location
<b>Version 1</b>					
TSDSI	TSDSI STD T3.9036.104-15.7.0	V1.0.1	Published	01.10.2020	<a href="https://members.tdsi.in/index.php/s/DcemEbQz2qYcw8a">https://members.tdsi.in/index.php/s/DcemEbQz2qYcw8a</a>

**3.2.1.5.3 T3.9036.106****Evolved Universal Terrestrial Radio Access (E-UTRA); FDD repeater radio transmission and reception**

This document establishes the minimum RF characteristics of E-UTRA FDD Repeater.

SDO	Document No.	Version	Status	Issued date	Location
<b>Version 1</b>					
TSDSI	TSDSI STD T3.9036.106-15.0.0	V1.0.0	Published	01.10.2020	<a href="https://members.tdsi.in/index.php/s/rYJs8HyfbRHP6Bx">https://members.tdsi.in/index.php/s/rYJs8HyfbRHP6Bx</a>

**3.2.1.5.4 T3.9036.111****Location Measurement Unit (LMU) performance specification; Network based positioning systems in Evolved Universal Terrestrial Radio Access Network (E-UTRAN)**

This document establishes the Location Measurement Unit (LMU) minimum UTDOA positioning requirement for the FDD and TDD mode of E-UTRAN.

SDO	Document No.	Version	Status	Issued date	Location
<b>Version 1</b>					
TSDSI	TSDSI STD T3.9036.111-15.0.0	V1.0.0	Published	01.10.2020	<a href="https://members.tdsi.in/index.php/s/NJcxdxMSPaHXFgN">https://members.tdsi.in/index.php/s/NJcxdxMSPaHXFgN</a>

**3.2.1.5.5 T3.9036.113****Evolved Universal Terrestrial Radio Access (E-UTRA); Base Station (BS) and repeater ElectroMagnetic Compatibility (EMC)**

This document covers the assessment of E-UTRA base stations, repeaters and associated ancillary equipment in respect of Electromagnetic Compatibility (EMC).

SDO	Document No.	Version	Status	Issued date	Location
<b>Version 1</b>					
TSDSI	TSDSI STD T3.9036.113-15.3.0	V1.0.0	Published	01.10.2020	<a href="https://members.tdsi.in/index.php/s/soQ2A4Hgqf7rz9m">https://members.tdsi.in/index.php/s/soQ2A4Hgqf7rz9m</a>

**3.2.1.5.6 T3.9036.116****Evolved Universal Terrestrial Radio Access (E-UTRA); Relay radio transmission and reception**

This document establishes the minimum RF characteristics and minimum performance requirements of E-UTRA Relay.

SDO	Document No.	Version	Status	Issued date	Location
<b>Version 1</b>					
TSDSI	TSDSI STD T3.9036.116-15.0.0	V1.0.0	Published	01.10.2020	<a href="https://members.tdsi.in/index.php/s/NtgEWRRXnX6iRCe">https://members.tdsi.in/index.php/s/NtgEWRRXnX6iRCe</a>

**3.2.1.5.7 T3.9036.124**

Evolved Universal Terrestrial Radio Access (E-UTRA); Electromagnetic compatibility (EMC) requirements for mobile terminals and ancillary equipment.

This document establishes the essential EMC requirements for “3<sup>rd</sup> generation” digital cellular mobile terminal equipment and ancillary accessories in combination with a E-UTRA user equipment (UE). This document specifies the applicable EMC tests, the methods of measurement, the frequency range, the limits and the minimum performance criteria for all types of E-UTRA UEs and their accessories. Requirements for the radiated emission from the enclosure port of integral antenna equipment and ancillaries have been included. The immunity requirements have been selected to ensure an adequate level of compatibility for apparatus in residential, commercial, light industrial and vehicular environments. The levels,

however, do not cover extreme cases, which may occur in any location but with low probability of occurrence. Compliance of radio equipment to the requirements of this document does not signify compliance to any requirement related to the use of the equipment (i.e. licensing requirements). Compliance to the requirements of this document does not signify compliance to any safety requirement. However, any temporary or permanent unsafe condition caused by EMC is considered as non-compliance.

SDO	Document No.	Version	Status	Issued date	Location
<b>Version 1</b>					
TSDSI	TSDSI STD T3.9036.124-15.2.0	V1.0.0	V1.0.0	Published 01.10.2020	<a href="https://members.tdsi.in/index.php/s/97toS29aTrjiddF">https://members.tdsi.in/index.php/s/97toS29aTrjiddF</a>

### 3.2.1.5.8 T3.9036.133

#### **Evolved Universal Terrestrial Radio Access (E-UTRA); Requirements for support of radio resource management**

This document specifies requirements for support of Radio Resource Management for the FDD and TDD modes of E-UTRA. These requirements include requirements on measurements in UTRAN and the UE as well as requirements on node dynamical behaviour and interaction, in terms of delay and response characteristics.

SDO	Document No.	Version	Status	Issued date	Location
<b>Version 1</b>					
TSDSI	TSDSI STD T3.9036.133-15.7.0	V1.0.1	V1.0.1	Published 01.10.2020	<a href="https://members.tdsi.in/index.php/s/55Ke6D2bnzzdEnF">https://members.tdsi.in/index.php/s/55Ke6D2bnzzdEnF</a>

### 3.2.1.5.9 T3.9037.104

#### **NR, E-UTRA, UTRA and GSM/EDGE; Multi-Standard Radio (MSR) Base Station (BS) radio transmission and reception**

This document establishes the minimum RF characteristics of E-UTRA, UTRA and GSM/EDGE Multi-Standard Radio (MSR) Base Station (BS). Requirements for multi-RAT and single-RAT operation of MSR BS are covered in this document. The requirements in this document for E-UTRA and UTRA single-RAT operation of MSR BS are also applicable to E-UTRA and UTRA multi-carrier capable single-RAT BS. Requirements for GSM BS that are only single-RAT capable are not covered.

SDO	Document No.	Version	Status	Issued date	Location
<b>Version 1</b>					
TSDSI	TSDSI STD T3.9037.104-15.6.0	V1.0.0	V1.0.0	Published 01.10.2020	<a href="https://members.tdsi.in/index.php/s/ESF9jKwC68eYEEL">https://members.tdsi.in/index.php/s/ESF9jKwC68eYEEL</a>

### 3.2.1.5.10 T3.9037.105

#### **Active Antenna System (AAS) Base Station (BS) transmission and reception**

This document establishes the RF characteristics, the RF minimum requirements and minimum performance requirements for E-UTRA AAS Base Station (BS), the FDD mode of UTRA AAS Base Station (BS), the 1,28 Mchip/s TDD mode of UTRA AAS Base Station (BS) in single RAT and any MSR AAS Base Station (BS) implementation of these RATs.

SDO	Document No.	Version	Status	Issued date	Location
<b>Version 1</b>					
TSDSI	TSDSI STD T3.9037.105-15.5.0	V1.0.0	Published	01.10.2020	<a href="https://members.tdsi.in/index.php/s/gwRgCLxjWmfyMSi">https://members.tdsi.in/index.php/s/gwRgCLxjWmfyMSi</a>

### 3.2.1.5.11 T3.9037.113

#### **NR, E-UTRA, UTRA and GSM/EDGE; Multi-Standard Radio (MSR) Base Station (BS) Electromagnetic Compatibility (EMC)**

This document covers the assessment of E-UTRA, UTRA and GSM/EDGE Multi-Standard Radio (MSR) Base Stations and associated ancillary equipment in respect of Electromagnetic Compatibility (EMC).

SDO	Document No.	Version	Status	Issued date	Location
<b>Version 1</b>					
TSDSI	TSDSI STD T3.9037.113-15.5.0	V1.0.0	Published	01.10.2020	<a href="https://members.tdsi.in/index.php/s/kwNd4QbNYMDKC9r">https://members.tdsi.in/index.php/s/kwNd4QbNYMDKC9r</a>

### 3.2.1.5.12 T3.9037.114

#### **Active Antenna System (AAS) Base Station (BS) Electromagnetic Compatibility (EMC)**

This document covers the assessment of E-UTRA, UTRA and Multi-Standard Radio (MSR) Active Antenna Systems Base Stations in respect of Electromagnetic Compatibility (EMC).

SDO	Document No.	Version	Status	Issued date	Location
<b>Version 1</b>					
TSDSI	TSDSI STD T3.9037.114-15.4.0	V1.0.0	Published	01.10.2020	<a href="https://members.tdsi.in/index.php/s/EGXbF9K3grqKtzK">https://members.tdsi.in/index.php/s/EGXbF9K3grqKtzK</a>

### 3.2.1.5.13 T3.9038.101-1

#### **NR; User Equipment (UE) radio transmission and reception; Part 1: Range 1 Standalone**

This document establishes the minimum RF requirements for User Equipment (UE) operating on frequency Range 1.

SDO	Document No.	Version	Status	Issued date	Location
<b>Version 1</b>					
TSDSI	TSDSI STD T3.9038.101-1-15.5.0	V1.0.1	Published	01.10.2020	<a href="https://members.tdsi.in/index.php/s/TCQSJbpzWri4EgG">https://members.tdsi.in/index.php/s/TCQSJbpzWri4EgG</a>

### 3.2.1.5.14 T3.9038.101-2

#### **NR; User Equipment (UE) radio transmission and reception; Part 2: Range 2 Standalone**

This document establishes the minimum RF requirements for User Equipment (UE) operating on frequency Range 2.

SDO	Document No.	Version	Status	Issued date	Location
<b>Version 1</b>					

TSDSI TSDSI STD T3.9038.101-2-15.5.0 V1.0.1 V1.0.1 Published 01.10.2020 <https://members.tdsi.in/index.php/s/NEy8HwxaAoROMzy>

### 3.2.1.5.15 T3.9038.101-3

#### NR; User Equipment (UE) radio transmission and reception; Part 3: Range 1 and Range 2 Interworking operation with other radios

This document establishes the minimum RF requirements for User Equipment (UE) Interworking operation with other radios. This includes but is not limited to additional requirements for carrier aggregation or dual connectivity between Range 1 and Range 2 and additional requirements due to non-standalone (NSA) operation mode with E-UTRA.

SDO	Document No.	Version	Status	Issued date	Location
-----	--------------	---------	--------	-------------	----------

#### Version 1

TSDSI	TSDSI STD T3.9038.101-3-15.5.0 V1.0.0	V1.0.0	Published	01.10.2020	<a href="https://members.tdsi.in/index.php/s/CwHFSqGZL9eSZfd">https://members.tdsi.in/index.php/s/CwHFSqGZL9eSZfd</a>
-------	---------------------------------------	--------	-----------	------------	---

### 3.2.1.5.16 T3.9038.104

#### NR; Base Station (BS) radio transmission and reception

This document establishes the minimum RF characteristics and minimum performance requirements of the radio interface and NB-IoT operation in in-band Base Station (BS).

SDO	Document No.	Version	Status	Issued date	Location
-----	--------------	---------	--------	-------------	----------

#### Version 1

TSDSI	TSDSI STD T3.9038.104-15.5.0 V1.0.0	V1.0.0	Published	01.10.2020	<a href="https://members.tdsi.in/index.php/s/On3AZZ9XWegA87q">https://members.tdsi.in/index.php/s/On3AZZ9XWegA87q</a>
-------	-------------------------------------	--------	-----------	------------	---

### 3.2.1.5.17 T3.9038.113

#### NR; Base Station (BS) ElectroMagnetic Compatibility (EMC)

This document covers the assessment of Base Station (BS) and ancillary equipment in respect of Electromagnetic Compatibility (EMC).

This document specifies the applicable test conditions, performance assessment and performance criteria for base stations and associated ancillary equipment in the following categories:

- BS equipped with antenna connectors or TAB connectors which are possible to be terminated during EMC testing, meeting the BS type 1-C and BS type 1-H RF requirements of T3.9038.104.
- BS not equipped with antenna connectors nor TAB connectors, i.e. with antenna elements radiating during the EMC testing, meeting the BS type 1-O and BS type 2-O RF requirements of T3.9038.104.

SDO	Document No.	Version	Status	Issued date	Location
-----	--------------	---------	--------	-------------	----------

#### Version 1

TSDSI	TSDSI STD T3.9038.113-15.5.0 V1.0.0	V1.0.0	Published	01.10.2020	<a href="https://members.tdsi.in/index.php/s/CaXtozdzkAjeZdc">https://members.tdsi.in/index.php/s/CaXtozdzkAjeZdc</a>
-------	-------------------------------------	--------	-----------	------------	---

**3.2.1.5.18 T3.9038.124****NR; Electromagnetic compatibility (EMC) requirements for mobile terminals and ancillary equipment**

This document establishes the essential EMC requirements for "3<sup>rd</sup> generation" digital cellular mobile terminal equipment and ancillary accessories in combination with a user equipment (UE).

The equipment conforming to the requirements laid out in this document and used in its intended electromagnetic environment in accordance with the manufacturer's instructions:

- shall not generate electromagnetic disturbances at a level which may interfere with the intended operation of other equipment;
- has an adequate level of intrinsic immunity to electromagnetic disturbances to operate as intended.

This document specifies the applicable EMC tests, methods of measurement, frequency ranges, applicable limits and minimum performance criteria for all types of UE(s) and their accessories. Base station equipment operating within network infrastructure is outside the scope of this document. However, this document does cover mobile and portable equipment that is intended to be operated in a fixed location while connected to the AC mains. Base station equipment operating within network infrastructure is covered by the technical specification T3.9038.113.

Requirements for the radiated emission from the enclosure port of integral antenna equipment and ancillaries are included in this document. Technical specifications for conducted emissions from the antenna connector are found in the specifications for the radio interface, e.g. T3.9038.xyz, for the effective use of the radio spectrum.

Requirements for the radiated emissions from the enclosure port and ancillaries cover two cases:

- UE equipment supporting operations in a frequency range for which antenna connectors are available (i.e. for operations in Frequency Range 1 as defined in e.g. T3.9038.101-1 for the radio interface);
- UE equipment supporting operations in a frequency range for which only integral antennas may be available (i.e. for operations in Frequency Range 2 as defined in e.g. T3.9038.101-2 for the radio interface).

The immunity requirements are selected to ensure an adequate level of compatibility for apparatus in residential, commercial, light industrial and vehicular environments. The levels, however, do not cover extreme cases, which may occur in any location but with low probability of occurrence.

Compliance of radio equipment to the requirements of this document does not signify compliance to any requirement related to the use of the equipment (i.e. licensing requirements).

Compliance to the requirements of this document does not signify compliance to any safety requirement. However, any temporary or permanent unsafe condition caused by EMC is considered as non-compliance.

SDO	Document No.	Version	Status	Issued date	Location
Version 1					
TSDSI	TSDSI STD T3.9038.124-15.2.0 V1.0.0	V1.0.0	Published	01.10.2020	<a href="https://members.tdsi.in/index.php/s/tdkFWfwqHytEBB">https://members.tdsi.in/index.php/s/tdkFWfwqHytEBB</a>

**3.2.1.5.19 T3.9038.133****NR; Requirements for support of radio resource management**

This document specifies requirements for support of Radio Resource Management for the FDD and TDD modes of the radio interface.

SDO	Document No.	Version	Status	Issued date	Location
<b>Version 1</b>					
TSDSI	TSDSI STD T3.9038.133-15.5.0 V1.0.1	V1.0.1	Published	01.10.2020	<a href="https://members.tdsi.in/index.php/s/qjcfpj2DYL3yY3X">https://members.tdsi.in/index.php/s/qjcfpj2DYL3yY3X</a>

---