



**Recommendation ITU-R M.2010-2**  
**(02/2023)**

**Characteristics of a digital system,  
referred to as navigational data for  
broadcasting maritime safety and  
security related information from  
shore-to-ship in the 500 kHz band**

**M Series**  
**Mobile, radiodetermination, amateur  
and related satellite services**

## Foreword

The role of the Radiocommunication Sector is to ensure the rational, equitable, efficient and economical use of the radio-frequency spectrum by all radiocommunication services, including satellite services, and carry out studies without limit of frequency range on the basis of which Recommendations are adopted.

The regulatory and policy functions of the Radiocommunication Sector are performed by World and Regional Radiocommunication Conferences and Radiocommunication Assemblies supported by Study Groups.

## Policy on Intellectual Property Right (IPR)

ITU-R policy on IPR is described in the Common Patent Policy for ITU-T/ITU-R/ISO/IEC referenced in Resolution ITU-R 1. Forms to be used for the submission of patent statements and licensing declarations by patent holders are available from <http://www.itu.int/ITU-R/go/patents/en> where the Guidelines for Implementation of the Common Patent Policy for ITU-T/ITU-R/ISO/IEC and the ITU-R patent information database can also be found.

### Series of ITU-R Recommendations

(Also available online at <http://www.itu.int/publ/R-REC/en>)

Series	Title
<b>BO</b>	Satellite delivery
<b>BR</b>	Recording for production, archival and play-out; film for television
<b>BS</b>	Broadcasting service (sound)
<b>BT</b>	Broadcasting service (television)
<b>F</b>	Fixed service
<b>M</b>	<b>Mobile, radiodetermination, amateur and related satellite services</b>
<b>P</b>	Radiowave propagation
<b>RA</b>	Radio astronomy
<b>RS</b>	Remote sensing systems
<b>S</b>	Fixed-satellite service
<b>SA</b>	Space applications and meteorology
<b>SF</b>	Frequency sharing and coordination between fixed-satellite and fixed service systems
<b>SM</b>	Spectrum management
<b>SNG</b>	Satellite news gathering
<b>TF</b>	Time signals and frequency standards emissions
<b>V</b>	Vocabulary and related subjects

*Note: This ITU-R Recommendation was approved in English under the procedure detailed in Resolution ITU-R 1.*

*Electronic Publication*  
Geneva, 2023

© ITU 2023

All rights reserved. No part of this publication may be reproduced, by any means whatsoever, without written permission of ITU.

## RECOMMENDATION ITU-R M.2010-2

**Characteristics of a digital system, referred to as navigational data for  
broadcasting maritime safety and security related information  
from shore-to-ship in the 500 kHz band**

(2012-2019-2023)

**Scope**

The Recommendation describes an MF radio system, referred to as navigational data (NAVDAT), for use in the maritime mobile service, operating in the 500 kHz band for digital broadcasting of maritime safety and security related information from shore-to-ship. The operational characteristics and system architecture of this radio system are included in Annexes 1 and 2. Technical characteristics and transmission structure are detailed in Annexes 3 and 4. Message file structure and a broadcast mode are introduced in Annexes 5 and 6. The list of subject messages is in Annex 7.

**Keywords**

500 kHz, broadcasting, NAVDAT

**Abbreviations/Glossary**

BER	Bit error rate
BPSK	Binary phase shift keying
BW	Bandwidth
CDU	Control and display unit
CRC	Cyclic redundancy check
DRM	Digital Radio Mondiale
DS	Data stream
ECDIS	Electronic chart and display information system
GF	Galois Field or finite field
GMDSS	Global maritime distress and safety system
GNSS	Global navigation satellite system
HF	High frequency
IMO	International Maritime Organization
ITU	International Telecommunication Union
LDPC	Low density parity-check
MER	Modulation error ratio
MF	Medium frequency
MIS	Modulation information stream
MMSI	Maritime mobile service identity
NAVDAT	Navigational data (the system name)
NAVTEX	Navigational telex (the system name)
NM	Nautical mile (1 852 metres)
OFDM	Orthogonal frequency division multiplexing
PEP	Peak envelope power
PRBS	Pseudo-random binary sequence

QAM	Quadrature amplitude modulation
rms	Root mean square
RS	Reed-Solomon codes
SAR	Search and rescue
SDR	Software defined radio
SFN	Single frequency network
SIM	System of information and management
S/N or SNR	Signal-to-noise ratio
TIS	Transmitter information stream
WRC	World radiocommunication conference

### Related ITU Recommendations, Reports

Recommendation ITU-R P.368 – Ground-wave propagation prediction method for frequencies between 10 kHz and 30 MHz

Recommendation ITU-R P.372 – Radio noise

Recommendation ITU-R M.493 – Digital selective-calling system for use in the maritime mobile service

Recommendation ITU-R M.585 – Assignment and use of identities in the maritime mobile service

Recommendation ITU-R BS.1514 – System for digital sound broadcasting in the broadcasting bands below 30 MHz

Recommendation ITU-R M.2058 – Characteristics of a digital system, referred to as navigational data for broadcasting maritime safety and security related information from shore-to-ship in the maritime HF frequency band

Report ITU-R M.2201 – Utilization of the 495-505 kHz band by the maritime mobile service for the digital broadcasting of safety and security related information from shore-to-ships

Report ITU-R M.2443 – NAVDAT Guidelines

The ITU Radiocommunication Assembly,

*considering*

- a) that high speed data broadcast from shore-to-ships enhances operational efficiency and maritime safety;
- b) that the navigational telex NAVTEX system has limited capacity;
- c) that the e-Navigation system of the International Maritime Organization (IMO) increases the demand for data transmission from shore-to-ship;
- d) that the 500 kHz band provides good coverage for digital systems,

*noting*

- a) that Report ITU-R M.2201 provides the basis for the NAVDAT system;
- b) that Recommendation ITU-R M.2058 describes the NAVDAT system operating in HF band;
- c) that the NAVDAT system uses two international frequencies: 500 kHz in MF band and 4 226 kHz in HF band;
- d) that the NAVDAT system may use other allocated frequencies in the maritime MF and HF bands for national or regional broadcasts;

*e)* that the digital radio mondiale (DRM) system referenced in Annex 6 has been incorporated in Recommendation ITU-R BS.1514,

*recommends*

- 1** that the operational characteristics for the broadcasting of maritime safety and security related information should be in accordance with Annex 1;
- 2** that the system architecture of the broadcasting system for maritime safety and security related information should be in accordance with Annex 2;
- 3** that the technical characteristics and modem protocols for digital data transmission from shore-to-ships in the 500 kHz band should be in accordance with Annexes 3 and 4;
- 4** that the data stream of the system and the message structure should be in accordance with Annex 5;
- 5** that the single frequency network (SFN) mode of operation as described in Annex 6 should be used;
- 6** that information on subject message as given in Annex 7 should be used;
- 7** that Annex 8 should be used to determine the minimum height of antenna towers in the shore infrastructure to support NAVDAT transmission modes and the associated bandwidths.

## TABLE OF CONTENTS

	<i>Page</i>
Policy on Intellectual Property Right (IPR) .....	ii
Annex 1 Operational characteristics .....	6
1 Type of messages and files .....	6
2 Broadcast modes .....	6
2.1 General broadcast.....	6
2.2 Selective broadcast.....	6
2.3 Dedicated message.....	6
3 Broadcast priority .....	7
Annex 2 System architecture.....	7
1 The broadcast chain.....	7
1.1 System of information and management.....	8
1.2 Shore network .....	10
1.3 Shore transmitter description .....	10
1.4 Transmission channel: Radio coverage estimation.....	13
Annex 3 NAVDAT technical characteristics .....	14
1 Modulation principle.....	14
1.1 Introduction .....	14
1.2 Principle.....	15
1.3 Orthogonal frequency division multiplexing parameters .....	16
1.4 Channel bandwidth .....	17
1.5 Modulation .....	17
1.6 Synchronization.....	19
1.7 Energy dispersal.....	21
1.8 Spectral occupancy of RF signal.....	22
1.9 Sequence for receiving scanning possibility .....	22
2 Estimated usable data rate .....	23
3 NAVDAT transmitter performance specification.....	25
4 NAVDAT ship receiver .....	25
4.1 NAVDAT ship receiver description .....	25

5	Minimum NAVDAT ship receiver performance specifications .....	31
	Annex 4 Transmission structure.....	32
1	Frame structure.....	32
2	Synchronization head.....	33
3	Modulation information stream.....	34
3.1	Structure.....	34
3.2	Encoding.....	35
4	Transmitter information stream.....	35
4.1	Structure.....	35
4.2	Encoding.....	37
4.3	Position .....	38
5	Data stream .....	39
5.1	Structure.....	39
5.2	Encoding.....	41
6	Low-density parity-check codes.....	43
7	Cyclic redundancy check .....	44
	Annex 5 Message file structure .....	44
	Annex 6 Single frequency network for simultaneous broadcasting from multiple NAVDAT locations (taken from Digital Radio Mondiale) .....	46
1	Explanation of Digital Radio Mondiale .....	46
1.1	Single frequency network operating mode.....	46
	Annex 7 NAVDAT subject message codes.....	47
	Annex 8 Implementation of NAVDAT shore infrastructure.....	50
A8.1	Purpose of this Annex .....	50
A8.2	Antenna characteristics of radio towers of various heights .....	50
A8.3	Antenna requirements for NAVTEX and NAVDAT systems .....	51
A8.4	NAVDAT estimated data rates for various transmission modes .....	52



## Annex 1

### Operational characteristics

The NAVDAT system uses a time-slot allocation similar to the NAVTEX system which could be coordinated by IMO in the same manner.

That NAVDAT system can also work on a SFN as described in Annex 6. In this case transmitters are frequency synchronized and the transmit data must be the same for all transmitters.

The NAVDAT 500 kHz digital system offers a broadcast transmission of any kind of message from shore-to-ships with possibility of encryption.

#### 1 Type of messages and files

Any broadcasting message should be provided by a secure and controlled source.

Message types broadcast can include, but are not limited to, the following:

- safety of navigation;
- security;
- piracy;
- search and rescue;
- meteorological messages;
- piloting or harbour messages;
- vessel traffic system files transfer;
- electronic chart update packages.

See Annex 7 which gives the message subjects and their encoding.

#### 2 Broadcast modes

##### 2.1 General broadcast

These messages are broadcasted for the attention of all ships.

##### 2.2 Selective broadcast

These messages are broadcasted for the attention of a group of ships<sup>1</sup> or in a specific navigation area. (see also Annex 3 § 4.1.9.)

##### 2.3 Dedicated message

These messages are addressed to one ship, using the maritime mobile service identity.

---

<sup>1</sup> The group call identification format of the ship station is defined in part 1 of Annex 1 of Recommendation ITU-R M.585.



### 3 Broadcast priority

NAVDAT is capable of prioritizing messages (refer to the NAVDAT documents published by IMO) (see also Table 19).

## Annex 2

### System architecture

#### 1 The broadcast chain

The NAVDAT system is organized upon five vectors performing the following functions:

- System of information and management (SIM):
  - collects and controls all kinds of information;
  - creates message files to be transmitted;
  - creates transmitting programme according to message files priority and need of repetition;
  - monitors the operating status and broadcast quality of the shore transmitter;
  - controls the operating parameters of shore transmitter.
- Shore network:
  - assures the transportation of the message files and monitor data from sources to the transmitters.
- Shore transmitter:
  - receives the message files from SIM;
  - translates message files to orthogonal frequency division multiplexing (OFDM) signal;
  - transmits RF signal to the antenna for broadcast to ships;
  - monitors operating status and reports to the SIM.
- Transmission channel:
  - Transports the 500 kHz RF signal.
- Ship receiver:
  - demodulates the RF OFDM signal;
  - reconstructs the message files;
  - sorts and makes the message files available for the dedicated equipment according to the message files applications, or displays the contents of the message files.

Figures 1 and 2 show the diagram of the broadcast chain.

FIGURE 1  
NAVDAT 500 kHz broadcast chain block diagram

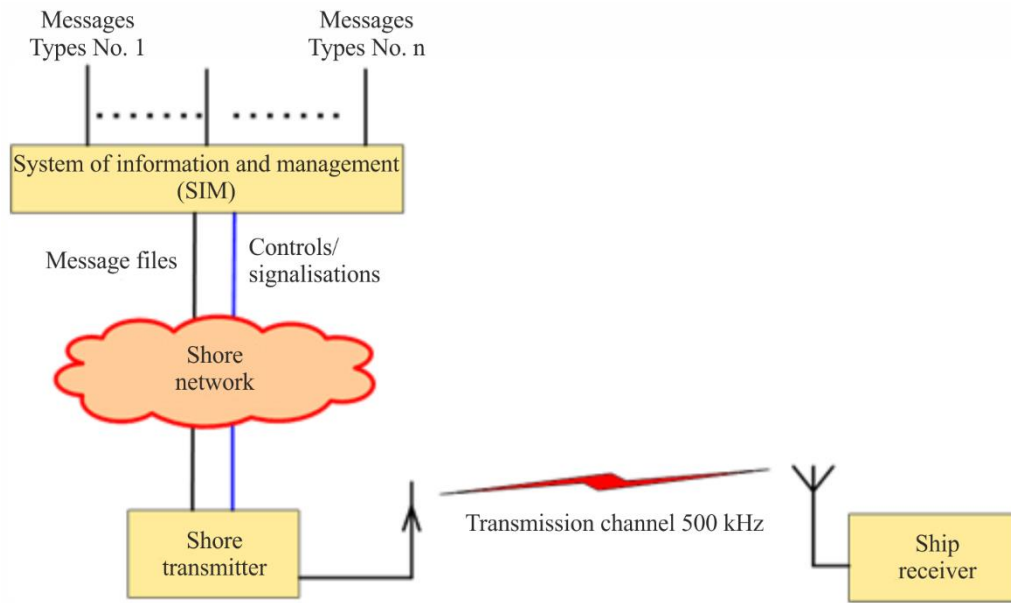

M.2010-01

FIGURE 2  
Global NAVDAT broadcast chain

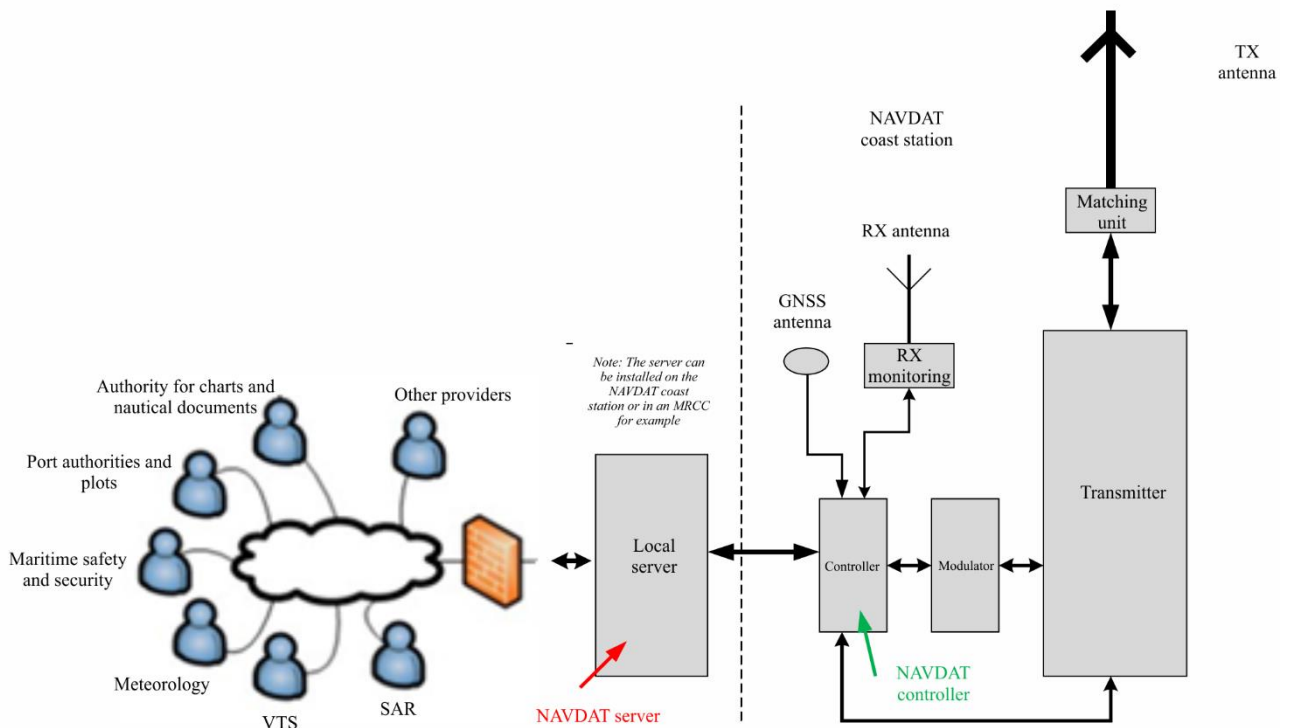

M.2010-02

### 1.1 System of information and management

The SIM term includes:

- all the sources that deliver file messages (e.g. meteorological office, safety and security organizations, etc.);
- the file multiplexer which is an application running on a server;
- the file multiplexer manager;
- the shore transmitter manager.

All the sources are connected to the file multiplexer through a network.

Figure 3 shows the general diagram of the SIM.

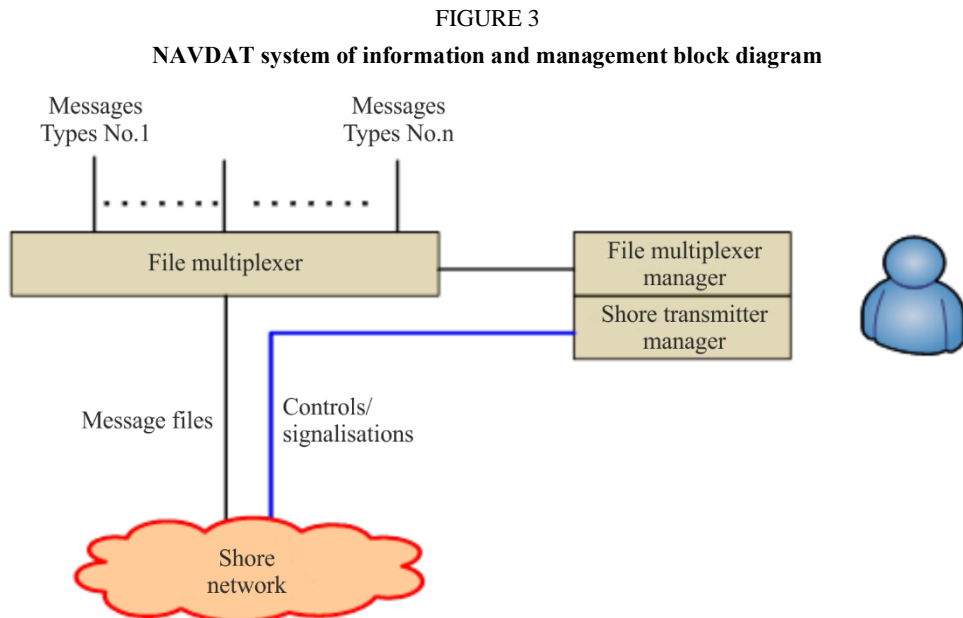

M.2010-03

### 1.1.1 File multiplexer

The file multiplexer:

- takes delivery of the message files from the data sources;
- encrypts the message files if asked;
- formats the file messages with recipient information, priority status and time validity;
- sends the message files to the transmitter.

### 1.1.2 File multiplexer manager

The file multiplexer manager is a man machine interface that enables the user to, among other tasks:

- have a look at the message files coming from any source;
- specify the priority and periodicity of the any message file;
- specify the recipient of any message file;
- manage the file message encryption.

Some of these functionalities may be automated. As an example, the priority and the periodicity of a message may be selected according to the source it comes from or the source may specify the priority in the message.

### 1.1.3 Shore transmitter manager

The shore station manager is a man machine interface connected to the transmitter through the network; it makes it possible to supervise the transmitter status indications such as:

- transmit acknowledgment;
- alarms;
- effective RF transmit power;
- synchronization report;
- quality of transmission;

and to change the transmitter parameters, such as:

- RF transmit power;
- OFDM parameters (pilot subcarriers, modulation, error coding, etc.);
- transmission schedule.

## 1.2 Shore network

The shore network can use a broadband link, a low data rate link or a local file sharing.

## 1.3 Shore transmitter description

A coastal transmitting station consists of this minimum configuration:

- one controller, which is a local server with access protection;
- one OFDM modulator;
- one RF generator;
- one RF power amplifier;
- one transmit antenna with matching unit;
- one global navigation satellite system (GNSS) receiver or atomic clock for synchronization;
- one monitoring receiver with its antenna.

### 1.3.1 Shore system architecture

Figure 4 shows the block diagram of a 500 kHz digital transmitter.

FIGURE 4  
NAVDAT 500 kHz transmitter functional block diagram

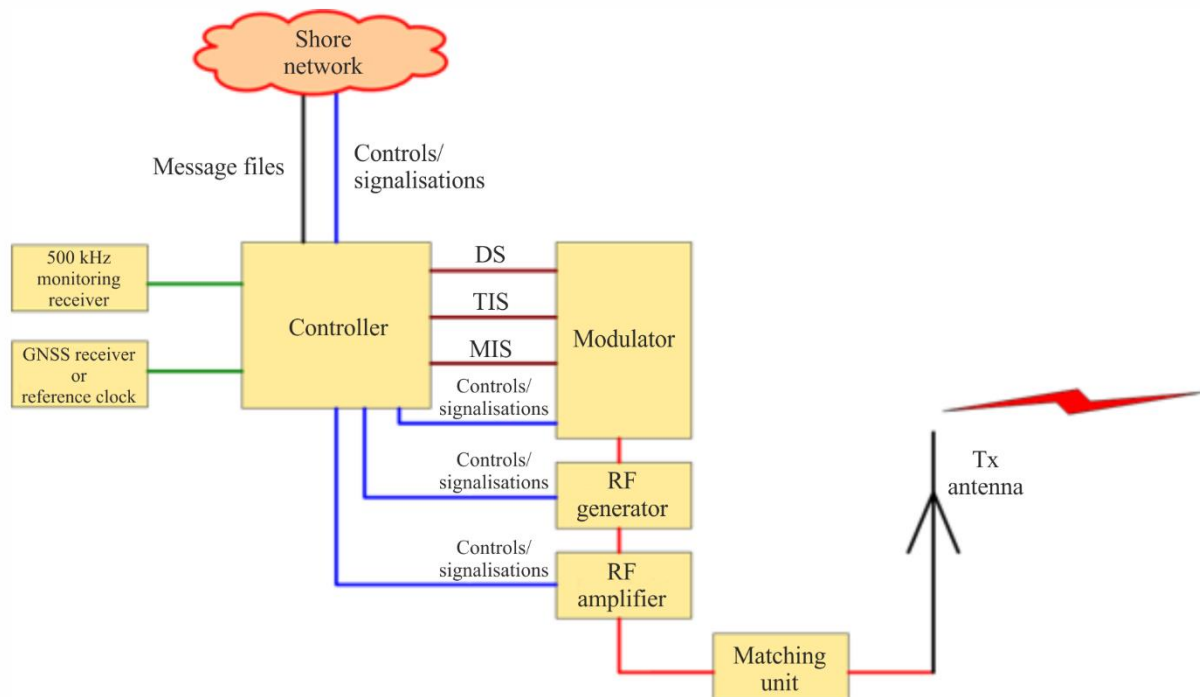

M.2010-04

### 1.3.2 Controller

This unit receives and transmits some pieces of information:

- message files from SIM;
- GNSS or reference clock for synchronization;
- 500 kHz signal from monitoring receiver;
- modulator, 500 kHz signal RF generator, RF power amplifier control signals and monitoring;
- monitor signal from the RF signal generator and RF power amplifier.

The function of the controller is:

- to check if the frequency band 495-505 kHz is free before transmission;
- to synchronize all signals on the coast station from synchronization clock;
- to control the transmission parameters, time and schedule;
- to format the message files to be transmitted (split files into packets).

### 1.3.3 Modulator

Figure 5 shows the diagram of the modulator.

FIGURE 5  
NAVDAT 500 kHz modulator functional block diagram

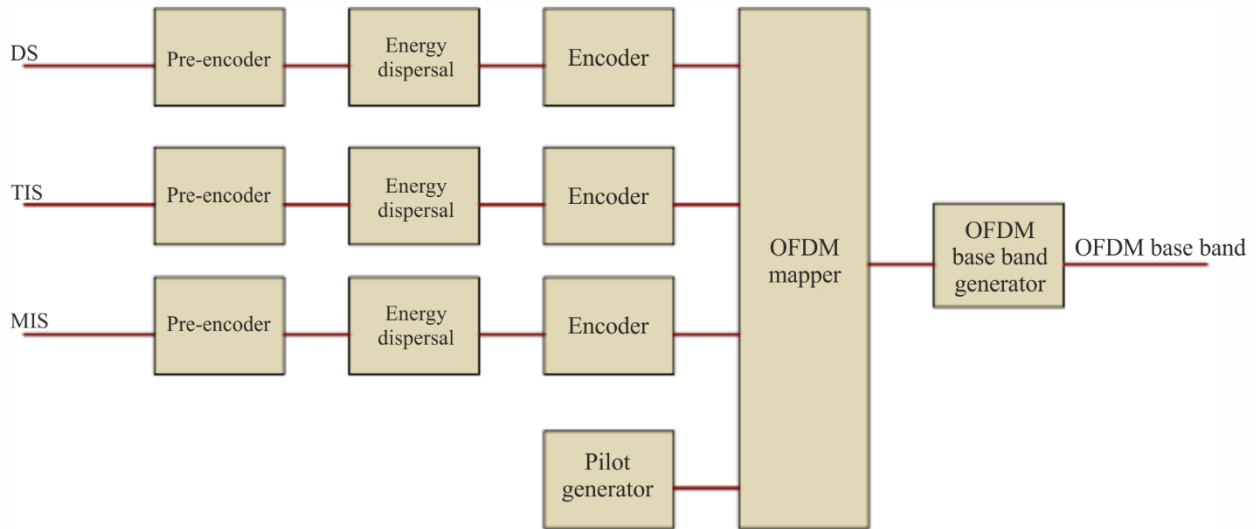

M.2010-05

### 1.3.3.1 Input streams

In order to operate, the modulator needs three input streams:

- modulation information stream (MIS);
- transmitter information stream (TIS);
- data stream (DS).

These streams are transcoded and then placed on the OFDM signal by the cell mapper.

#### 1.3.3.1.1 Modulation information stream

This stream is used to provide information about:

- the channel bandwidth (1, 3, 5 or 10 kHz);
- the modulation for transmission information stream and data stream (4, 16 or 64-QAM).

This MIS stream is always coded on 4-QAM subcarriers for good demodulation into the receiver.

#### 1.3.3.1.2 Transmitter information stream

This stream is used to provide information to the receiver about:

- error coding for data stream (should be different for surface wave propagation at daytime, mode A, and for surface + sky wave propagation at night-time, mode B);
- identifier of the transmitter;
- time.

This TIS stream can be coded on 4 or 16-QAM.

#### 1.3.3.1.3 Data stream

It contains the message files to transmit (these message files were previously formatted by the file multiplexer).

### 1.3.3.2 Error encoding

The error correction scheme determines the robustness of the coding. The code rate is the ratio between useful and raw data rate. It illustrates the transmission efficiency and can vary between 0.5 and 0.75 depending on the error correction schemes and modulation patterns.

### 1.3.3.3 Orthogonal frequency division multiplexing generation

The three streams (MIS, TIS and DS) are formatted:

- encoding;
- energy dispersal.

A cell mapper organizes the OFDM cells with the formatted streams and the pilot cells. The pilot cells are transmitted for the receiver to estimate the radio channel and synchronize on the RF signal.

An OFDM signal generator creates the OFDM base band according to the output of the cell mapper.

### 1.3.4 500 kHz RF generator

A 500 kHz RF generator transposes the base band signal to 500 kHz RF output carrier.

An amplifier brings the RF signal to the desired power.

### 1.3.5 RF power amplifier

The function of this stage is to amplify the 500 kHz signal from the generator output to the necessary level to obtain the desired radio coverage.

The OFDM transmission introduces a crest factor on the RF signal. This crest factor must be less than 10 dB at the RF amplifier output for a correct modulation error rate (MER).

The rms RF power of the transmitter must be adapted to the overall efficiency of the antenna and the desired radio coverage.

The output RF power of a shore transmitter may be adjusted up to 10 kW rms.

### 1.3.6 Transmit antenna with matching unit

The RF amplifier is connected to the transmit antenna through the impedance matching unit.

### 1.3.7 Global navigation satellite receiver and a backup atomic reference clock

The clock is used to synchronize the local controller and configure a high-precision reference clock when working in SFN mode.

### 1.3.8 Monitoring receiver

The monitoring receiver checks that the frequency band 495-505 kHz is free before transmission and offers possibility to check the transmission. A remote receiver is recommended to ensure the local signal reception quality.

## 1.4 Transmission channel: Radio coverage estimation

The coverage could be calculated based on the most recent version of Recommendations ITU-R P.368 and ITU-R P.372 via appropriate simulation software. See Reports ITU-R M.2201 and ITU-R M.2443 for examples.

### 1.4.1 Propagation channel

The ITU has defined several criteria concerning the propagation channel from which four modes can be defined:



- Mode A: Gaussian channels with minor fading. Use with surface wave propagation.
- Mode B: Time and frequency selective channels, with longer delay spread. Use with mixed surface wave and sky wave propagation.
- Mode C: As mode B, but with higher Doppler spread. Use with sky wave propagation with multi-hops (not used for 500 kHz MF NAVDAT).
- Mode D: As mode B, but with severe delay and Doppler spread. Use with sky wave with multi hops on several ionospheric layers (not used for 500 kHz MF NAVDAT).

Only modes A and B are to be used for 500 kHz with surface wave propagation.

The NAVDAT in MF frequency band has two modes of propagation:

Mode A: Surface wave propagation with vertical polarization. Normal mode during the daytime. In this mode the coverages can be calculated with the “GRWAVE” or “LFMF-SmoothEarth” software in connection with the most recent version of Recommendation ITU-R P.368, and NOISEDAT software in connection with the most recent version of Recommendation ITU-R P.372.

Mode B: Propagation by combination of surface wave and sky wave. This mode can be used during the night-time.

In daytime, the ionospheric layer D is absorbent. During this period, the mode A will therefore be used.

At sunset the layer D disappears and it's better to use the mode B during the night period.

The station's radio coverage is closely related to the overall performance of the transmit antenna.

## Annex 3

### NAVDAT technical characteristics

#### 1 Modulation principle

The system uses OFDM which is a modulation technology for digital transmissions.

##### 1.1 Introduction

The bandwidth of the radio transmission channel is divided in the frequency domain to form subcarriers.

The radio transmission channel occupancy is organized in the time to form OFDM symbols.

An OFDM cell is equivalent to one subcarrier in one OFDM symbol.

FIGURE 6  
OFDM introduction

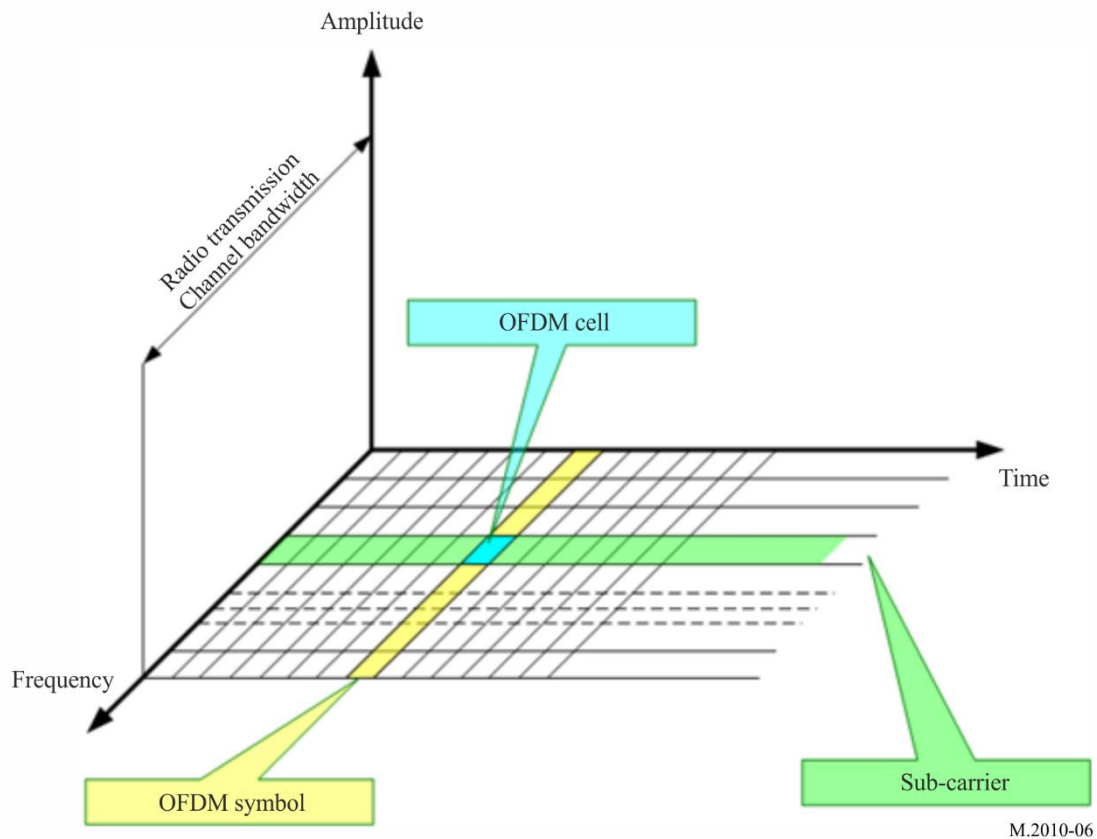

## 1.2 Principle

The OFDM uses a large number of closely spaced (either 41.666 Hz (mode A) or 46.875 Hz (mode B) in Table 1) orthogonal subcarriers to obtain high spectral efficiency to transmit data. These subcarriers are frequency-spaced ( $F_u = 1/T_u$ ), where  $T_u$  is the OFDM symbol duration of the useful part.

The phases of subcarriers are orthogonal one to each other to enhance signal diversity caused by the multipath, especially in long distance.

A guard interval ( $T_d$ ) is inserted in the OFDM symbol to reduce multipath effect, thus reducing the inter-symbol interference.

The OFDM symbol duration is  $T_s = T_u + T_d$

The OFDM symbols are then concatenated to make an OFDM frame.

The OFDM frame duration is  $T_f$ .

FIGURE 7  
Spectral representation of an OFDM frame

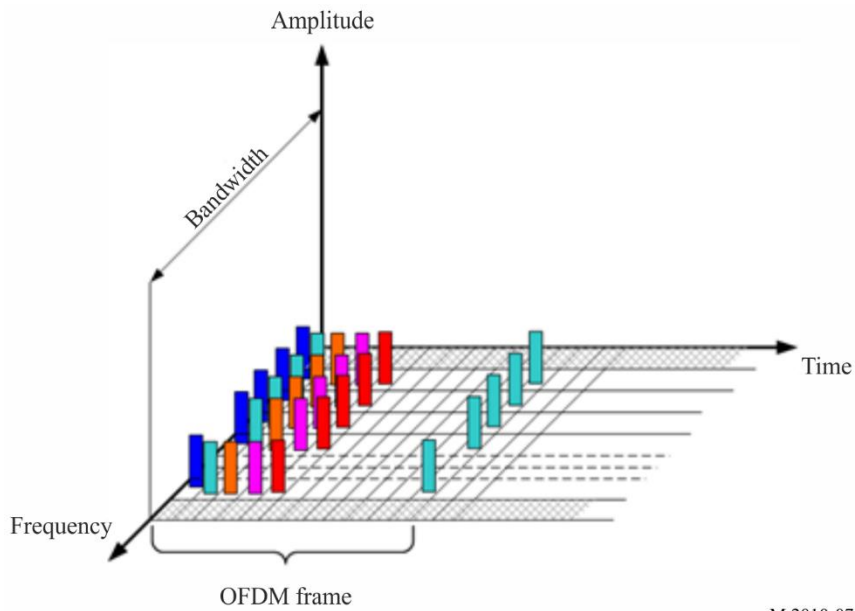

M.2010-07

FIGURE 8  
Temporal representation of an OFDM frame

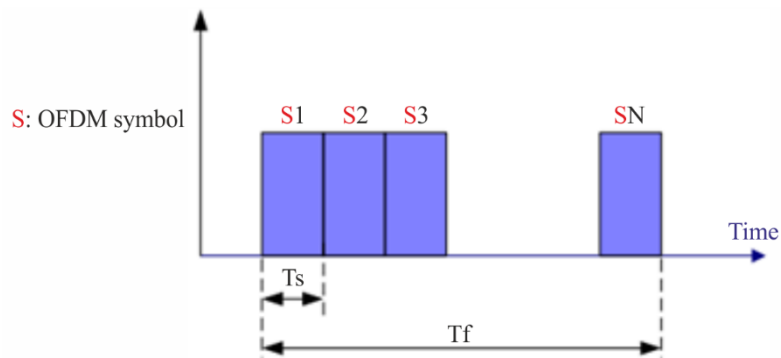

M.2010-08

### 1.3 Orthogonal frequency division multiplexing parameters

OFDM parameter values are listed in Table 1.

TABLE 1  
OFDM parameter values

Propagation mode	$T_u$ (ms)	$1 / T_u$ (Hz)	$T_d$ (ms)	$T_s = T_u + T_d$ (ms)	$N_s$	$T_f$ (ms)
A: surface wave	24	41.666	2.66	26.66	15	400
B: surface wave + sky wave	21.33	46.875	5.33	26.66	15	400

$T_u$ : duration of the useful part of an OFDM symbol

$1/T_u$ : carrier spacing

$T_d$ : duration of the guard interval

- $T_s$ : duration of an OFDM symbol
- $N_s$ : the number of symbols per frame
- $T_f$ : duration of the transmission frame.

**1.4 Channel bandwidth**

NAVDAT digital broadcast defines different channel bandwidths and determines subcarrier numbers corresponding to different spectrum occupancy rates. Table 2 presents the channel bandwidth value and subcarrier numbers.

TABLE 2  
Relationship between channel bandwidth and OFDM sub-carrier numbers

Propagation mode	Case	1	2	3	4
	Channel bandwidth	1 kHz	3 kHz	5 kHz	10 kHz
A: surface wave	Number of subcarriers	23	69	115	229
	Number of subcarriers	K -11 to 11	K -34 to 34	K -57 to 57	K -114 to 114
B: surface wave + sky wave	Number of subcarriers	19	61	103	207
	Number of subcarriers	K -9 to 9	K -30 to 30	K -51 to 51	K -103 to 103

**1.5 Modulation**

Every subcarrier is modulated in amplitude and phase (QAM: Quadrature amplitude modulation). Modulation patterns can be either 64 states (6 bits, 64-QAM), 16 states (4 bits, 16-QAM), or 4 states (2 bits, 4-QAM).

The modulation pattern depends on the desired robustness of the signal.

FIGURE 9  
Binary phase shift keying modulation constellation

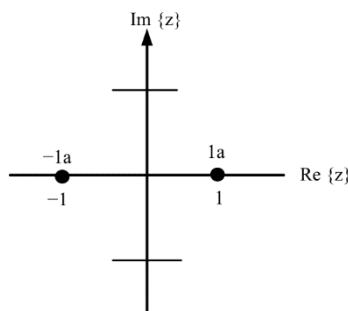

FIGURE 10  
4-QAM constellation

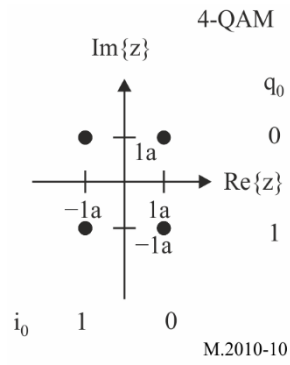

FIGURE 11  
16-QAM constellation

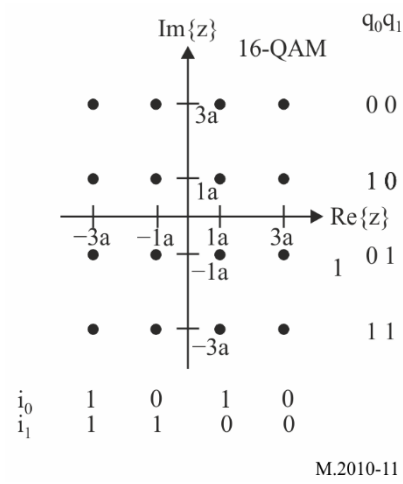
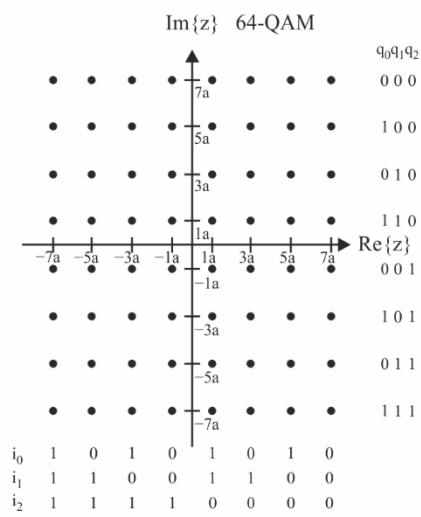

FIGURE 12  
64-QAM constellation



### 1.6 Synchronization

In order to allow a good demodulation of each subcarrier, the radio transmission channel response must be determined for each subcarrier and the equalization should be applied. For this, some of the subcarriers of the OFDM symbols may carry pilot signals.

The pilot signals allow the receiver to:

- detect if a signal is received;
- estimate the frequency offset;
- estimate the radio transmission channel.

The number of pilot signals depends on the desired robustness of the signal.

The pilot cells have a power gain of factor 2 in BPSK modulation.

FIGURE 13  
Pilot OFDM signal

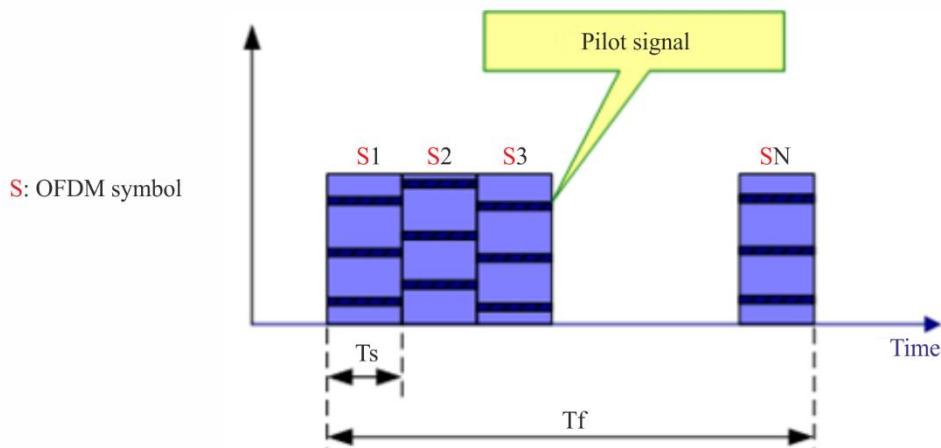

M.2010-13

The pilot signal location in each OFDM symbol in a frame can be shown as follows:

FIGURE 14  
The pilot signal location in mode A

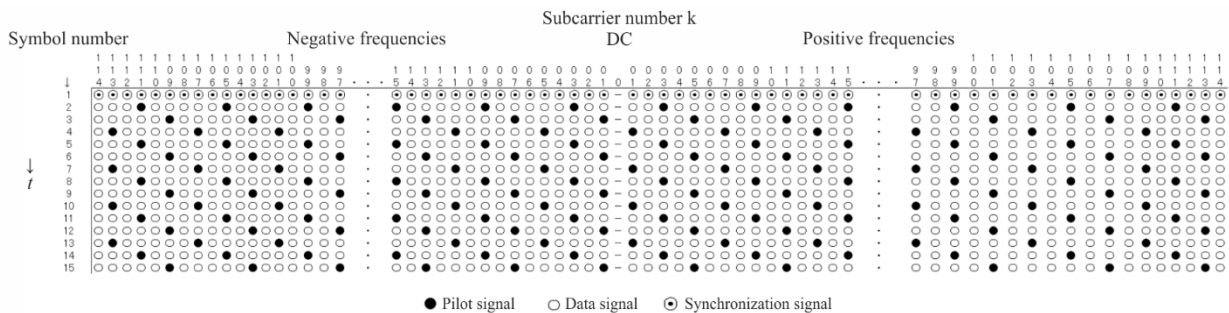

M.2010-14

FIGURE 15  
The pilot signal location in mode B

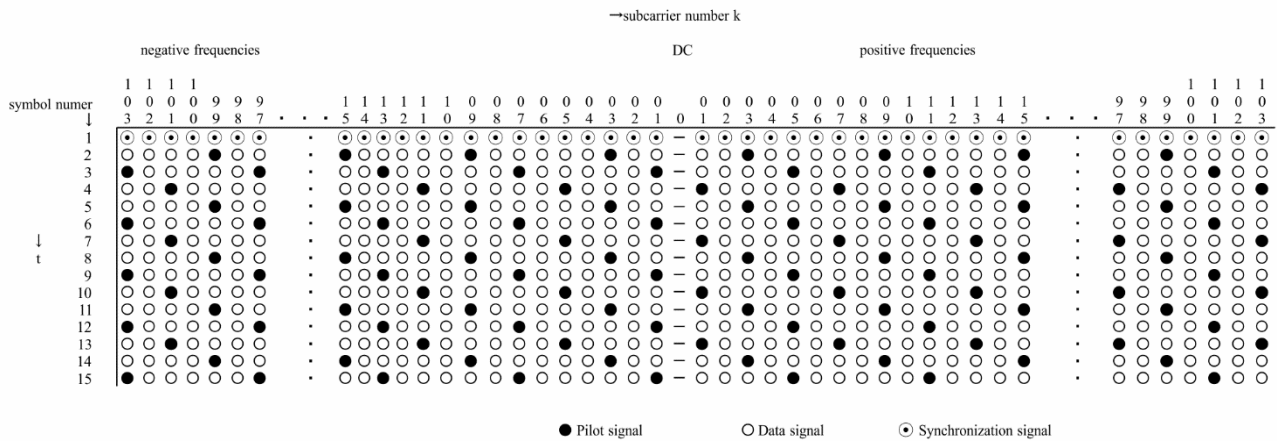

M.2010-15

Here,  $t$  is the direction of time domain,  $f$  is the direction of frequency domain. The first symbol of each OFDM head frame should be filled by a sequence of synchronization signals that make up the synchronization head (refer to Tables 9 and 10), all of which are used as a time reference to provide synchronization for the receiver. The black cell and the white cell represent the pilot signal and the data signal, respectively. The pilot signal value which is modulated in 2-QAM (BPSK) in an OFDM symbol is shown in Tables 3 and 4.

TABLE 3  
Pilot sequence (mode A)

Number of subcarriers	Pilot sequence
229	-1 1 -1 1 -1 1 1 1 -1 1 1 1 1 -1 -1 -1 1 1 -1 -1 -1 1 1 1 -1 -1 -1 -1 -1 -1 1 -1 1 -1 1 1 1
115	-1 1 -1 1 -1 1 1 1 -1 1 1 1 1 -1 -1 -1 1 1 -1 -1
69	-1 1 -1 1 -1 1 1 1 -1 1 1 1
23	-1 1 -1 1

TABLE 4  
Pilot sequence (mode B)

Number of subcarriers	Pilot sequence
207	-1 1 -1 1 -1 1 1 1 -1 1 1 1 1 -1 -1 -1 1 1 -1 -1 -1 1 1 1 -1 -1 -1 -1 -1 1 -1 -1 1 -1 1 -1 -1
103	-1 1 -1 1 -1 1 1 1 -1 1 1 1 1 -1 -1 -1 1
61	-1 1 -1 1 -1 1 1 1 -1 1
19	-1 1 -1 1

In the first symbol of each OFDM head frame, any subcarriers are used as time reference for the receiver to synchronize.



FIGURE 16  
Synchronization symbol

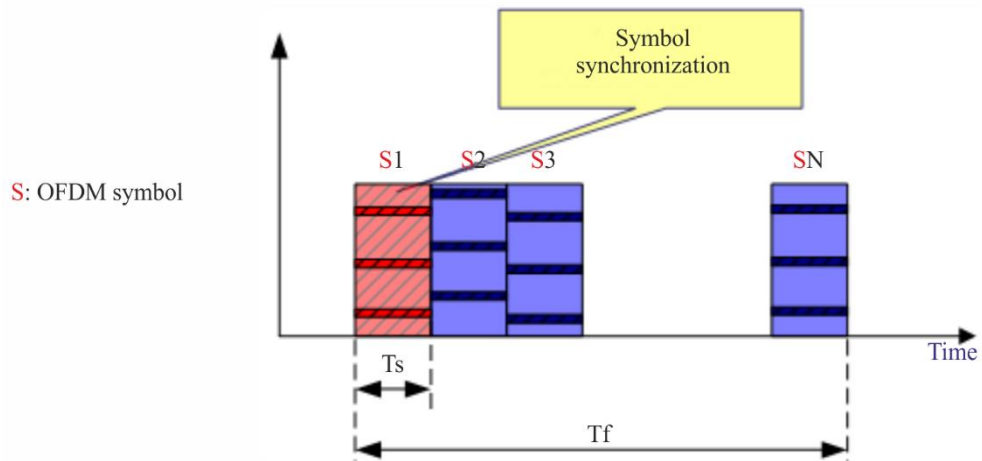

M.2010-16

### 1.7 Energy dispersal

The purpose of the energy dispersal is to avoid the transmission of signal patterns resulted in an unwanted regularity. The individual inputs of energy dispersal scramblers should be scrambled by a modulo-2 with a pseudo-random binary sequence (PRBS), prior to channel encoding. The PRBS is defined as the output of the feedback shift register of Fig. 17. It should use a polynomial of degree 9, defined by:

$$P(X) = X^9 + X^5 + 1$$

FIGURE 17  
Pseudo-random binary sequence generator

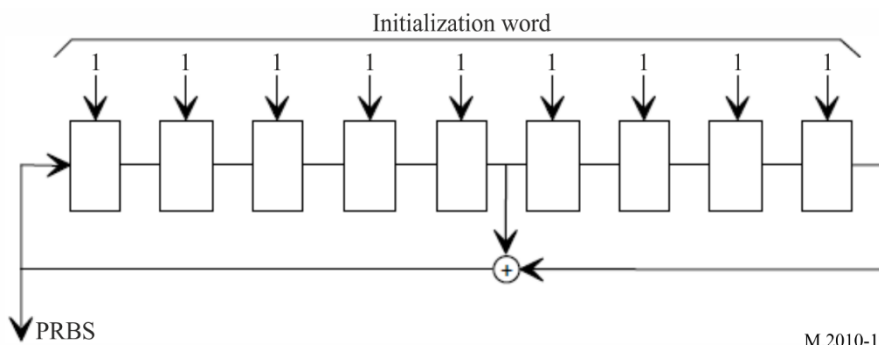

M.2010-17

## 1.8 Spectral occupancy of RF signal

FIGURE 18

Spectral emission mask of NAVDAT RF signal with bandwidth  $F = 10$  kHz  
Emission masks for 5 kHz, 3 kHz and 1 kHz should fit within the mask for 10 kHz

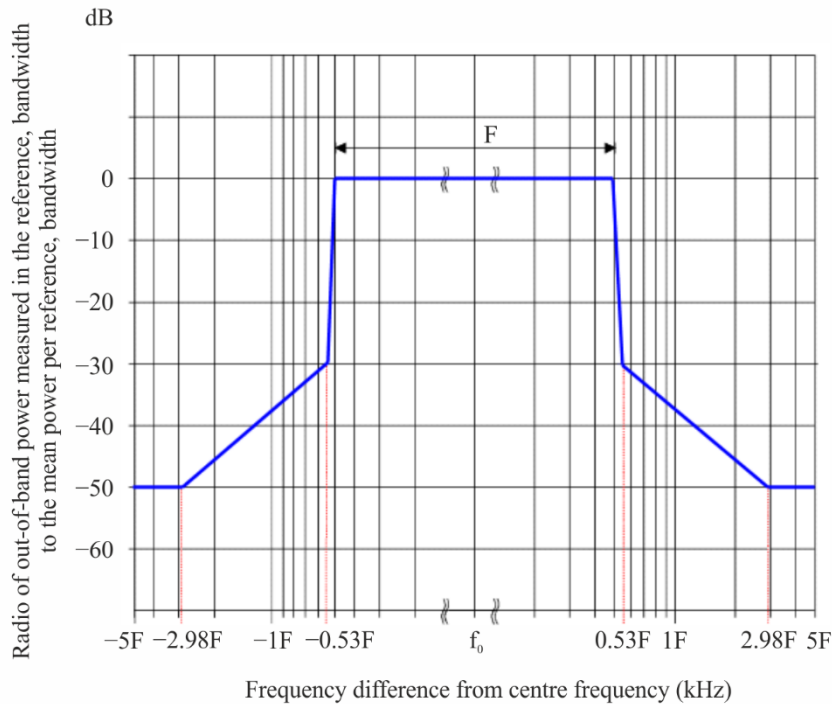

M.2010-18

## 1.9 Sequence for receiving scanning possibility

To allow reception of national or regional frequencies assigned to the NAVDAT system, the receiver uses a scan function.

Frequencies should then be scanned to monitor the reception of the pre-signal transmitted by the station before broadcast.

To ensure proper operation of the receiver scan function, the transmitters of active National or Regional NAVDAT coast stations should transmit, before the NAVDAT broadcast, a sequence of known data during 400 ms repeated 8 times for a total duration of 3.2 seconds.

To ease receiver demodulation of the NAVDAT broadcast, known data is using the same bandwidth and the same constellation as the subsequent NAVDAT broadcast. Known data uses a 1 length super-frame pattern.

To enable evaluation of BER, DS stream is filled with PRBS (Pseudo-Random Binary Sequence) data using the polynomial:

$$P(X) = X^{20} + X^{17} + 1$$

Each cell of the shift register should be pre-set to a logical 1 at the beginning of the sequence and the start of the PRBS sequence is synchronized with the beginning of each frame.

Any text message included inside the known data must be in National and as well in English language.

FIGURE 19  
Transmission structure for scan facility



M.2010-19

FIGURE 20  
Frame structure

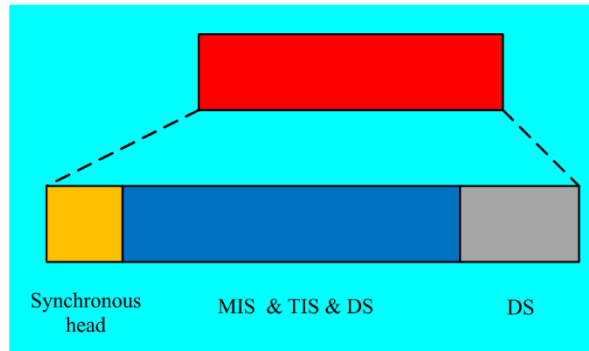

M.2010-20

The frame structure is described in Annex 4.

## 2 Estimated usable data rate

In the 10 kHz channel bandwidth with 500 kHz propagation, the raw data rate available for the DS is typically around 25 kbit/s with 16-QAM signal.

The number of subcarriers that hold data can be varied in order to adjust the channel protection. Higher channel protection (protection against multipath, fading, delay, etc.) results in a lower number of useful subcarriers.

Error coding must then be applied to the raw data rate to obtain the useful data rate. With a code rate of 0.5 to 0.75, the useful data rate is then between 5 and 27 kbit/s.

A higher code rate provides a higher useful data rate, but the radio coverage is accordingly reduced.

With the different modulation and code rate, the useful data rate is shown as below.

TABLE 5  
Data rate

Mode	Spectrum occupancy (kHz)	Modulation (nQAM)	Code rate	Estimated data rate (kbit/s)
0	10	4-QAM	0.5	6.36
1	10	4-QAM	0.75	9.56
2	10	16-QAM	0.5	12.72
3	10	16-QAM	0.75	19.12
4	10	64-QAM	0.5	19.08
5	10	64-QAM	0.75	28.68

TABLE 5 (end)

Mode	Spectrum occupancy (kHz)	Modulation (nQAM)	Code rate	Estimated data rate (kbit/s)
6	5	4-QAM	0.5	2.89
7	5	4-QAM	0.75	4.35
8	5	16-QAM	0.5	5.78
9	5	16-QAM	0.75	8.69
10	5	64-QAM	0.5	8.67
11	5	64-QAM	0.75	13.04
12	3	4-QAM	0.5	1.67
13	3	4-QAM	0.75	2.52
14	3	16-QAM	0.5	3.35
15	3	16-QAM	0.75	5.03
16	3	64-QAM	0.5	5.02
17	3	64-QAM	0.75	7.55
18	1	4-QAM	0.5	0.55
19	1	4-QAM	0.75	0.84
20	1	16-QAM	0.5	1.12
21	1	16-QAM	0.75	1.68
22	1	64-QAM	0.5	1.67
23	1	64-QAM	0.75	2.52

TABLE 6

## Data rate for mode B

Mode	Spectrum occupancy (kHz)	Modulation (nQAM)	Code rate	Estimated data rate (kbit/s)
0	10	4-QAM	0.5	5.705
1	10	4-QAM	0.75	8.578
2	10	16-QAM	0.5	11.41
3	10	16-QAM	0.75	17.155
4	10	64-QAM	0.5	17.115
5	10	64-QAM	0.75	25.733
6	5	4-QAM	0.5	2.67
7	5	4-QAM	0.75	4.025
8	5	16-QAM	0.5	5.34
9	5	16-QAM	0.75	8.05
10	5	64-QAM	0.5	8.01
11	5	64-QAM	0.75	12.075
12	3	4-QAM	0.5	1.46
13	3	4-QAM	0.75	2.21
14	3	16-QAM	0.5	2.92

TABLE 6 (end)

Mode	Spectrum occupancy (k Hz)	Modulation (nQAM)	Code rate	Estimated data rate (kbit/s)
15	3	16-QAM	0.75	4.42
16	3	64-QAM	0.5	4.38
17	3	64-QAM	0.75	6.63
18	1	4-QAM	0.5	0.22
19	1	4-QAM	0.75	0.35
20	1	16-QAM	0.5	0.44
21	1	16-QAM	0.75	0.70
22	1	64-QAM	0.5	0.66
23	1	64-QAM	0.75	1.05

### 3 NAVDAT transmitter performance specification

TABLE 7

#### Minimum international NAVDAT MF transmitter performance specification

Parameters	Required results
Frequency band	495 to 505 kHz
Carrier frequency error	Within $\pm 2.5$ Hz of the nominal frequency
Spectrum mask	Comply with the requirements of Fig. 18
Transmitter third-order intermodulation rejection ratio	$\geq 40$ dBc
Transmitter emission spurious (all power range)	$-50$ dB without exceeding the absolute level of 50 mW (17 dBm)

*Note:* The transmitter may also cover the HF band. Refer to Rec. ITU-R M.2058 for technical specification. The transmitter may also cover the MF band 415 to 526.5 kHz for future National NAVDAT frequencies. The Emission class used is W7D.

### 4 NAVDAT ship receiver

#### 4.1 NAVDAT ship receiver description

The ship receiver block diagram is shown in Fig. 22.

A typical NAVDAT digital receiver is composed of several basic blocks:

- Reception antenna and GNSS antenna;
- RF front end;
- Demodulator;
- File demultiplexer;
- Controller;
- Control and display unit (CDU);

- Data interface;
- Power supply.

The NAVDAT ship receiver can receive and decode the main MF channel (500 kHz) and the main international HF channel (4 226 kHz) at the same time with 2 complete independent channels.

The first channel should constantly listen to 500 kHz and the second channel should constantly listen to 4 226 kHz.

A third channel should scan all the other NAVDAT frequencies (regional in MF and attributed HF frequencies). The design of this third channel allows reception and decoding future potential national, regional or local transmitters using MF or HF channels:

- 1 The maritime MF band from 415 to 526.5 kHz (except 500 kHz).
- 2 The channels assigned to NAVDAT: 6 337.5, 8 443, 12 663.5, 16 909.5 and 22 450.5 kHz (except 4 226 kHz).
- 3 The frequency bands assigned to wideband digital transmissions of RR Appendix 17: 4, 6, 8, 12, 16, 19, 22 and 26 MHz.

The decoding of frequencies received by scanning can be demodulated in real time or with a time delay.

The choice of frequencies to be scanned should be based on information on the NAVDAT stations declared and stored by the receiver (table updated via message 63).

The receiver should first determine the NAVAREA and METAREA zone in which the vessel is located (from its position) with the possibility by the operator to add some NAVDAT stations outside of this NAVAREA / METAREA.

From the table, the receiver should determine the future allocated slots and the frequencies used.

These frequencies should then be scanned to monitor the reception of the pre-signal transmitted by the station before broadcast.

The receiving antenna is common to the three channels. It is recommended that the antenna be equipped with two outputs for sharing with another MF/HF receiver.

Figure 21 describes a generic block diagram of a software defined radio (SDR) receiver.

The design of NAVDAT receivers is left to the initiative of each manufacturer.

FIGURE 21  
Model of generic software defined radio NAVDAT receiver

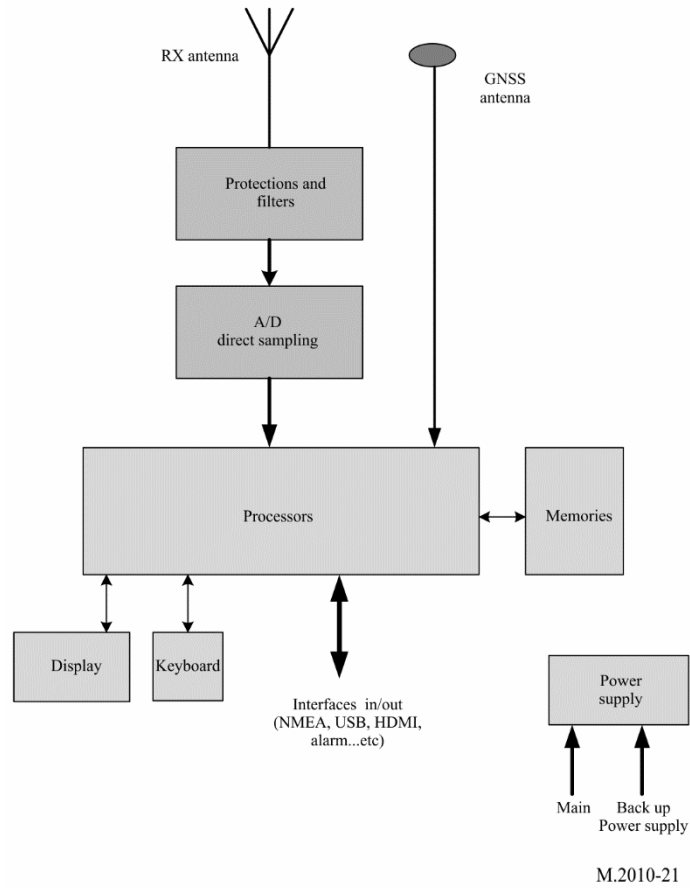
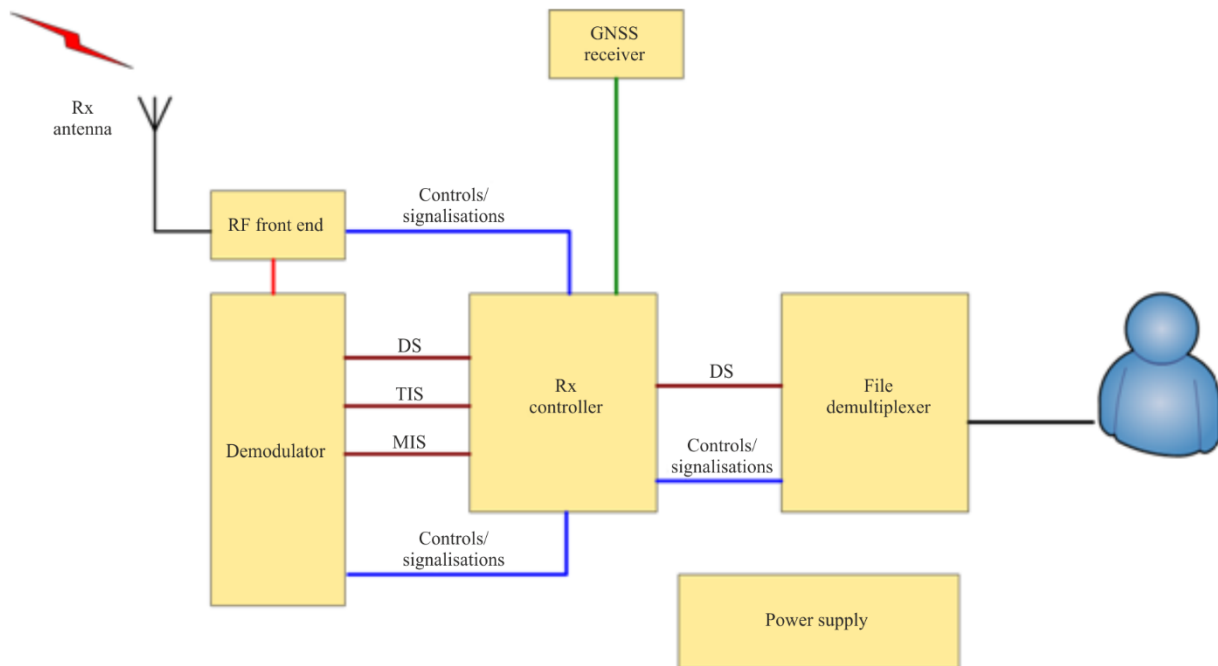

FIGURE 22  
NAVDAT receiver logical diagram





#### 4.1.1 Receiving antenna and global navigation satellite system antenna

The omnidirectional receiving antenna system should have a minimum band from 415 kHz to 27.5 MHz to allow reception of MF and HF bands. It may be a H-field antenna (recommended on a EMC noisy ship) or a vertical E-field antenna.

A GNSS antenna connected to an internal GNSS receiver, (or connection to an existing GNSS receiver onboard), is also needed in order to obtain ship's position and time.

#### 4.1.2 RF front end

The RF front end includes the RF filter, RF amplifier and base band output.

High sensitivity and high dynamic range are necessary with protection against strong RF fields from ship transmitting antennas or lighting.

The passband of the input filters must allow reception of the maritime MF band from 415 to 526.5 kHz and for all maritime HF bands.

It is recommended to place a notch filter on the MF broadcasting band (from 526.5 kHz).

The receiver design can either be conventional or SDR type with at least three channels.

#### 4.1.3 Demodulator

This stage demodulates the base band OFDM signal and recreates the data stream that holds the transmitted message files.

It implements:

- time/frequency synchronization;
- channel estimation;
- automatic modulation recovery;
- error correction.

The NAVDAT receiver should be able to detect the following modulation parameters automatically:

- 4, 16 or 64-QAM;
- type of error coding.

In addition to the DS, it reports the information filled in the TIS and MIS. Furthermore, it reports complementary information about the channel such as:

- estimated SNR;
- BER;
- MER.

#### 4.1.4 File demultiplexer

The file demultiplexer:

- receives the message files from the controller;
- verifies that the message files are marked for its attention (type of broadcast mode);
- decrypts the message files if needed/able;
- makes the message files available for the terminal application that will use the message files;
- deletes the out-of-date message files.

Depending on the final application, the message file can be:

- stored on an onboard server accessible through the ship network;

- display on the receiver CDU directly;
- sent directly to the final application.

#### **4.1.5 Controller**

The controller:

- extracts the message files from the DS (merge packets into files);
- interprets the TIS and MIS and the other pieces of information given by the demodulator;
- collects the following information from the file demultiplexer:
  - total number of decoded message files;
  - number of available message files;
  - error event (e.g. decrypt errors).

#### **4.1.6 Control and display unit**

The receiver can provide a display and control unit, the function of this unit is:

- display the special information and by configuring the interface to be connected to a dedicated equipment application (e.g. e-navigation) and manage the licensed contents of the ship (e.g. ship identification, encryption);
- display and check the receiving parameters;
- display the message content according to the application classification of the message file.

This CDU may be a special application running on an external computer, and the receiver may be a black-box device.

#### **4.1.7 Data interface**

The receiver gets the data from external devices such as GNSS through the data interface. The controller classifies the message files according to their applications and provides the message files to the application devices through the data interface.

The receiver should provide a configurable data interface that complies with the requirements of the IEC 61162 series. This data interface is for the purposes of connection to other onboard equipment. It is also recommended to provide Ethernet and USB interfaces for high-speed transmission of files and provide connectivity for printers.

When required the receiver should include an interface for alert management in accordance with the IMO performance standards for bridge alert management (IMO resolution MSC.302(87)).

#### **4.1.8 Power supply**

The connection to the ship's power supply must be protected against surges and EMI.

#### **4.1.9 Receiver ID**

It should be possible to configure the receiver with:

- The identity (MMSI) of the vessel (according to Recommendation ITU-R M.585).
- The group identity (MMSI) (according to Recommendation ITU-R M.585).
- Additional lists of identities (MMSI's) may be provided.

See Table 21 and note.

#### 4.1.10 Stored tables

The receiver should have the possibility of storing information in different memorized tables which can be updated by the reception of the message 63. This message should be authenticated by the shore authority.

For example:

- 1 The list of coast stations with:
  - Area
  - Country
  - Longitude
  - Latitude
  - Name
  - Slots
  - Frequency used.

This stored table is queried when the identities (MMSI) of the stations received are received and the complete parameters of the received NAVDAT coast station should be displayed in plain text.

- 2 The list of subject messages:  
Table with subject message 01 to 63.

All the tables in memory can be updated by receiving the message 63.

#### 4.1.11 Storage

##### 4.1.11.1 Non-volatile files message memory

For each frequency provided it should be possible to record at least 100 message files in non-volatile memory. It should not be possible for the user to erase file messages from the memory. When the memory is full, the oldest file message must be replaced by the new messages.

The user should be able to mark the individual files of a message from permanent retention. These file messages can occupy up to 25% of available memory and should not be overwritten by new files. When no longer needed, the user must be able to delete the tag on these files, which can be overwritten normally.

Duplicate message could be recognized by the equipment and should not be stored.

The storage capacity of this memory should not be less than 1 GB.

##### 4.1.11.2 Programmable control memories

Information identifying the transmitter service area and the designator of each type of message in programmable memory should not be erased by interruptions in the power supply of less than 24 h.

The equipment should be able to store at least the time, transmitter identification, message type and message content. The storage capacity should not be less than 1 GB.

When the power supply is unexpectedly interrupted, the equipment should protect the stored data and software parameters.

The equipment should be able to display, delete and query stored messages, and be able to output messages manually or automatically to appropriate ship equipment (such as the electronic chart and display information system (ECDIS)).

#### 4.1.12 Alert

The receipt of a search and rescue (SAR) related information message should give a continuous audible alarm. It should only be possible to reset this alarm manually. The position information contained in the SAR messages may be transmitted to other navigation equipment (e.g. ECDIS, electronic navigational chart plotter).

#### 4.1.13 Test facilities

The equipment should be provided with a facility to test that the radio receiver, the display and the non-volatile memory are functioning correctly and to display self-test results. In case of using a specific antenna it also must be checked by this process.

#### 4.1.14 Updates

The software/firmware of the equipment should be able to be updated. The update should be performed by using the appropriate interface or reception of message 63 (update receiver software). This function is necessary to follow the evolutions of the GMDSS master plan for the new NAVDAT stations as well as for the future revisions of the ITU recommendations.

#### 4.1.15 Scan function

As indicated in § 4.1 the ship's NAVDAT receiver permanently monitors the frequencies 500 and 4 226 kHz and can simultaneously decode the signals received on these two frequencies.

To allow reception of national or regional frequencies assigned to the NAVDAT system, the receiver uses a scan function on the following maritime frequency bands:

- The MF band from 415 to 526.5 kHz (except 500 kHz).
- The channels assigned to NAVDAT in RR Appendix 17: 6 337.5, 8 443, 12 663.5, 16 909.5 and 22 450.5 kHz (except 4 226 kHz).
- The frequency bands assigned to wideband digital transmissions of Appendix 17 in the bands 4, 6, 8, 12, 16, 19, 22 and 26 MHz.

The receiver should search its stored NAVDAT station table (updated via message code 63) for all frequencies that can be sequentially scanned in relation to allocated slots (time reference).

The signals received on the frequency selected by scan can be decoded in real time or in time shifted according to the resources of the NAVDAT receiver computer at this moment.

To ensure proper operation of the receiver scan function, the transmitters of active National or Regional NAVDAT coast stations should broadcast, before the NAVDAT frames, a known data repeated 8 times for a total duration of 3.2 seconds (see § 1.9 and Fig. 19 in Annex 3).

This should allow the receiver to detect the transmission and tune in to the frequency, measure its SNR, identify the station and its NAVAREA / METAREA area.

## 5 Minimum NAVDAT ship receiver performance specifications

These assumed ship receiver specifications are set out below with the objective to obtain minimum SNR for a good OFDM demodulation (4-QAM, 16-QAM or 64-QAM).

The ship's NAVDAT receiver must receive the two international NAVDAT frequencies: 500 kHz and 4 226 kHz, but also the MF and HF frequency bands in scan mode (see Table 8).

TABLE 8

## NAVDAT ship receiver minimum performance specifications

Parameters	Requirements
<b>Total frequency band</b>	415 to 526.5 kHz and 4 to 27.5 MHz maritime band
Main MF frequency (centre frequency)	500 kHz
Main HF frequency (centre frequency)	4 226 kHz
<b>MF maritime band</b>	415 to 526.5 kHz
<b>HF maritime bands</b>	Maritime HF bands RR Appendix 17
Adjacent channel protection	> 40 dB @ 5 kHz
Noise factor	< 10 dB (< 20 dB for MF band)
Usable sensitivity for BER = $10^{-4}$ after error correction	< -95 dBm
Dynamic	> 80 dB
Minimal usable RF field (with adapted receiving antenna)	20 dB( $\mu$ V/m)

## Annex 4

## Transmission structure

## 1 Frame structure

NAVDAT head frame structure contains synchronization head (the first symbol), MIS, TIS, and DS (data stream) shown as follow.

FIGURE 23  
NAVDAT Frame structure

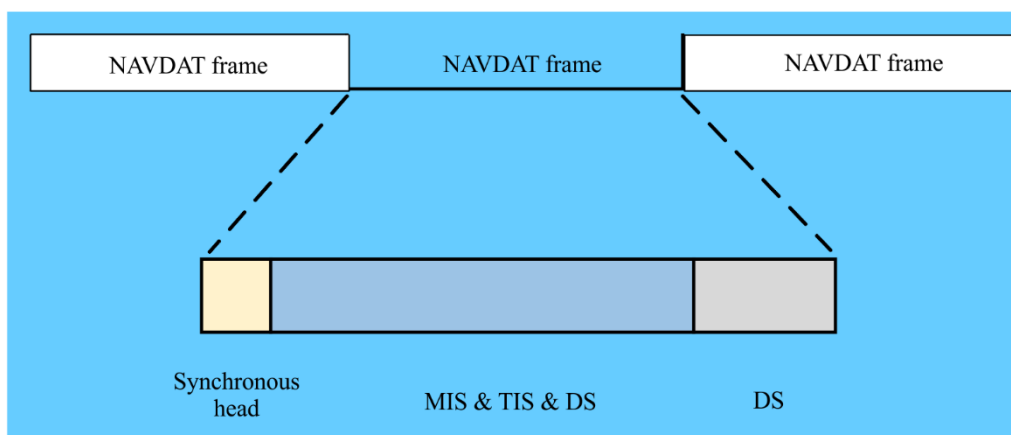

Head frame length is 400 ms.

Standard frame structure does not include DS stream without Synchronization head, MIS or TIS. Standard frame length is 400 ms. A sequence of one head frame and N-1 standard frame constitutes a super-frame of the length of N. The NAVDAT broadcast should use a super-frame pattern of the length of 5.

**2 Synchronization head**

Synchronization head is the first OFDM symbol of each head frame for the receiver to synchronize and for the information on every subcarrier is shown in Tables 9 and 10.

TABLE 9  
Synchronization head sequence in mode A

Bandwidth and number of subcarriers	Synchronization head sequence
229 (10 kHz)	-1 1 1 1 1 1 1 1 -1 1 1 -1 -1 1 -1 1 1 1 1 1 -1 -1 1 -1 1 -1 -1 -1 1 1 1 1 -1 1 -1 -1 -1 -1 1 1 1 -1 1 1 1 1 -1 -1 -1 1 1 1 -1 1 -1 -1 1 1 -1 1 1 -1 -1 -1 1 -1 1 -1 -1 -1 -1 -1 -1 1 -1 1 1 -1 -1 -1 -1 1 -1 -1 -1 1 -1 1 1 1 -1 -1 1 1 -1 -1 -1 1 1 -1 1 -1 -1 1 1 -1 1 -1 -1 1 -1 1 -1 1 -1 0 -1 -1 -1 -1 -1 1 -1 -1 -1 -1 -1 -1 -1 1 -1 -1 1 1 1 -1 -1 1 1 1 -1 1 1 -1 1 -1 1 1 1 -1 1 -1 1 -1 -1 -1 -1 -1 1 1 -1 -1 -1 -1 -1 1 1 1 1 -1 1 -1 1 1 1 1 -1 1 1 1 1 -1 -1 -1 -1 1 1 1 -1 -1 1 1 1 -1 1 1 1 -1 1 1 -1 1 -1 1 1 1 -1 -1 1 -1 -1 -1 -1 -1 1 -1 1 -1 1 -1 1 -1 1 1
115 (5 kHz)	1 -1 1 1 -1 -1 -1 1 -1 1 -1 -1 1 -1 -1 1 -1 -1 -1 -1 1 -1 -1 1 -1 -1 -1 1 -1 1 1 -1 -1 1 -1 -1 1 1 -1 -1 -1 1 1 -1 1 -1 -1 1 -1 1 -1 0 1 -1 -1 -1 1 -1 -1 -1 -1 -1 1 -1 -1 -1 1 1 -1 -1 1 1 1 1 -1 -1 1 1 -1 1 -1 1 -1 1 1 -1 1 -1 -1 -1 -1 -1 -1 -1 1 1 - 1 -1 -1 -1 -1 1 1 1 1 1 -1
69 (3 kHz)	1 -1 -1 1 -1 -1 -1 1 -1 1 1 1 -1 -1 1 -1 -1 -1 1 1 -1 1 -1 -1 1 -1 -1 1 1 0 - 1 -1 -1 -1 1 -1 -1 -1 -1 1 -1 -1 -1 1 1 -1 -1 1 1 1 1 -1 -1 1 1 -1 1 -1 1 1 1 1
23 (1 kHz)	1 -1 1 -1 -1 1 -1 1 -1 1 1 0 1 -1 -1 -1 1 -1 -1 -1 -1 -1 1

TABLE 10  
Synchronisation head sequence in mode B

Bandwidth and number of subcarriers	Synchronization head sequence
207 (10 kHz)	-1 1 1 1 1 1 1 1 -1 1 1 -1 -1 1 -1 1 1 1 1 1 -1 -1 1 -1 1 -1 -1 -1 1 1 1 1 -1 1 -1 -1 -1 1 1 1 -1 1 1 1 1 -1 -1 -1 1 1 1 -1 1 -1 -1 1 1 -1 1 1 -1 1 1 -1 -1 -1 1 -1 1 -1 -1 -1 1 -1 1 1 -1 -1 -1 -1 1 1 -1 -1 -1 1 -1 1 1 1 -1 -1 1 1 -1 -1 -1 1 1 -1 1 -1 1 1 -1 1 -1 -1 1 -1 1 -1 1 -1 0 -1 -1 -1 -1 -1 1 -1 -1 -1 1 1 -1 -1 1 1 -1 -1 1 1 1 -1 -1 1 1 1 -1 1 1 -1 1 -1 1 1 1 -1 1 -1 1 -1 -1 -1 -1 -1 -1 1 1 -1 -1 -1 -1 -1 1 1 1 1 -1 1 -1 1 1 1 1 -1 1 1 1 1 -1 -1 -1 -1 1 1 1 -1 -1 1 1 1 -1 1 1 1 -1 1 1 -1 1 1 1 -1 -1 1 1 -1 -1 1 -1 -1 -1 -1 1 -1 1 -1 1 -1 1 -1 1 1
103 (5 kHz)	1 -1 1 1 -1 -1 -1 1 -1 1 -1 -1 1 -1 -1 1 -1 -1 -1 -1 1 -1 -1 1 -1 -1 -1 1 -1 1 1 -1 -1 1 -1 -1 1 1 -1 -1 -1 1 1 -1 1 -1 -1 1 -1 1 -1 0 1 -1 -1 -1 1 -1 -1 -1 -1 -1 1 -1 -1 -1 1 1 -1 -1 1 1 1 1 -1 -1 1 1 -1 1 -1 1 1 1 -1 1 -1 1 -1 -1 -1 -1 -1 -1 1 1 - 1 -1 -1 -1 -1 1 1 1 1 1 -1
61 (3 kHz)	1 -1 -1 1 -1 -1 -1 1 -1 1 1 1 -1 -1 1 -1 -1 -1 1 1 -1 1 -1 -1 1 -1 -1 1 1 0 - 1 -1 -1 -1 1 -1 -1 -1 -1 1 -1 -1 -1 1 1 -1 -1 1 1 1 1 -1 -1 1 1 -1 1 -1 1 1 1 1 1
19 (1 kHz)	1 -1 1 -1 -1 1 -1 1 -1 1 1 0 1 -1 -1 -1 1 -1 -1 -1 -1 -1 1

For the different channel bandwidth, the OFDM symbol index corresponding to the synchronization header is shown in Table 11.

TABLE 11  
Index of the synchronization head symbols

Mode	Ns	Index of the OFDM symbol per frame
A	15	1
B	15	1

### 3 Modulation information stream

#### 3.1 Structure

MIS is used to provide the information about channel spectrum occupancy as well as TIS and DS modulation:

- information of spectrum occupancy 2 bits;
- information of TIS modulation 1 bits;
- information of DS modulation 2 bits;
- Cyclic redundancy check (CRC) 8 bits;
- Reserved 3 bits (default: 0).

TABLE 12  
Information of spectrum occupancy

Case (refer to Table 2 above)	Patterns of bits	Channel bandwidth (kHz)
1	00	1
2	01	3
3	10	5
4	11	10

TABLE 13  
Information of transmitter information stream modulation

Patterns of bit	Modulation
0	4-QAM
1	16-QAM





TABLE 15 (*end*)

Patterns of bits	Transmission mode		
	Spectrum occupancy (kHz)	Code rate	Modulation
01001	3	0.75	4-QAM
01010	3	0.5	16-QAM
01011	3	0.75	16-QAM
01100	3	0.5	64-QAM
01101	3	0.75	64-QAM
10000	5	0.5	4-QAM
10001	5	0.75	4-QAM
10010	5	0.5	16-QAM
10011	5	0.75	16-QAM
10100	5	0.5	64-QAM
10101	5	0.75	64-QAM
11000	10	0.5	4-QAM
11001	10	0.75	4-QAM
11010	10	0.5	16-QAM
11011	10	0.75	16-QAM
11100	10	0.5	64-QAM
11101	10	0.75	64-QAM

TABLE 16

**Identifier of the transmitter**

Coding	Identifier of the transmitter
I	8 bits ASCII
D	8 bits ASCII
NAV/MET AREA	5 bits
STATION NUMBER	11 bits
Total	32 bits

The encoding of the **I** and **D** header should be in 8-bit ASCII.

The coding of the areas should be done in binary on 5 bits (maximum 31 areas).

The station number allocated for a frequency should be coded on 11 bits (maximum of 2 047 stations by area).

Total of 32 bits should thus be used for the identification of each pair station/frequency.



### 4.3 Position

There are 100 (MIS:48, TIS:152) carriers for MIS and TIS transmission. Tables 19 and 20 give the position of these carriers.

TABLE 19

**Position of the modulation information stream and transmitter information stream carriers for 10 kHz, 5 kHz and 3 kHz in mode A and B, and 1 kHz in mode A**

Symbol	Carrier number
2	-10, -8, -6, -4, -2, 2, 4, 6, 8,10
3	-10, -8, -6, -4, -2, 2, 4, 6, 8,10
4	-10, -8, -6, -4, -2, 2, 4, 6, 8,10
5	-10, -8, -6, -4, -2, 2, 4, 6, 8,10
6	-10, -8, -6, -4, -2, 2, 4, 6, 8,10
7	-10, -8, -6, -4, -2, 2, 4, 6, 8,10
8	-10, -8, -6, -4, -2, 2, 4, 6, 8,10
9	-10, -8, -6, -4, -2, 2, 4, 6, 8,10
10	-10, -8, -6, -4, -2, 2, 4, 6, 8,10
11	-10, -8, -6, -4, -2, 2, 4, 6, 8,10

TABLE 20

**For 1 kHz bandwidth in mode B**

Symbol	Carrier number
2	-8, -6, -4, -2, 2, 4, 6, 8
3	-8, -6, -4, -2, 2, 4, 6, 8
4	-8, -6, -4, -2, 2, 4, 6, 8
5	-8, -6, -4, -2, 2, 4, 6, 8
6	-8, -6, -4, -2, 2, 4, 6, 8
7	-8, -6, -4, -2, 2, 4, 6, 8
8	-8, -6, -4, -2, 2, 4, 6, 8
9	-8, -6, -4, -2, 2, 4, 6, 8
10	-8, -6, -4, -2, 2, 4, 6, 8
11	-8, -6, -4, -2, 2, 4, 6, 8
12	-8, -6, -4, -2, 2, 4, 6, 8
13	-8, -6, -4, -2, 2, 4, 6, 8
14	-4, -2, 2, 4

## 5 Data stream

### 5.1 Structure

Data stream generally consist of either text information or files of information. A generalized packet delivery allows the delivery of text information and files for various services in the same data stream. And services can be carried by a series of single packets.

The structure of a packet is as follows:

- Head 32 bits
- Data field n bytes
- CRC 16 bits.

The head is made up as follows:

- Data length 12 bits
- toggle bit 1 bit
- first flag 1 bit
- last flag 1 bit
- packet ID 10 bits
- padded packet indicator 1 bit
- reserved 6 bits.

**Data length:** This 12-bit indicates the length of a packet in bytes.

**Toggle bit:** This bit should be maintained in the same state as long as packets from the same text message or file are being transmitted. When a packet from a different text message or file is sent for the first time, this bit should be inverted with respect to its previous state. If a text message or file, which may consist of several packets, is repeated, then this bit should remain unchanged.

**First flag, Last flag:** These flags are used to identify particular packets which form a succession of packets. The flags are assigned as follows:

TABLE 21  
Coding of first flag and last flag

First flag	Last flag	The packet is
0	0	an intermediate packet
0	1	the last packet of a data unit
1	0	the first packet of a data unit
1	1	the one and only packet of a data unit

**Packet ID:** This 8-bit field indicates the packet ID of this packet.

**Padded Packet Indicator:** This 1-bit flag indicates whether the data field carries padding or not, as follows:

0: no padding is present: all data bytes in the data field are useful;

1: padding is present: the first two bytes give the number of useful data bytes in the data field.

**Reserved:** This 6-bit field is reserved for future use.

**Data field:** It contains the useful data intended for a particular service. It can be text information or file information (see also Table 26).

The first information in the Data Field is Broadcast mode, which is defined in Table 22.

TABLE 22  
Broadcast mode

MODE	Pattern of bit	Coding	Comments
General	00	36 bits	
Selective ship	01	36 bits	MMSI of the ship
Group of ships	10	36 bits	Group of ship's ID (main or secondary)
Selective area	11	512 bits	Geographic coordinates of the defined area

Note:

In the case of selective broadcast over a specific area, this geographical area is defined as follows:

The zone number assigned by the server (maximum 99) + space

The area is determined by four geographical points in degrees minutes seconds (DMS) starting from the highest point and turning clockwise (Latitude followed by Longitude).

The sign + indicates North and East

The sign - indicates South and West

For example, for a zone 1 (Z01)

Position 1      47°42'22" N and 137°28'59" E

Position 2:     37°50'24" N and 139°00'10" E

Position 3:     32°04'57" N and 129°29'05" E

Position 4:     33°04'56" N and 127°30'28" E

Giving: Z01 +474222+1372859+375024+1390010+320457+1292905+330456+1273028

The server converts this text in binary:

```
01011010 00110000 00110001 00100000 00101011 00110100 00110111 00110100 00110010
00110010 00110010 00101011 00110001 00110011 00110111 00110010 00111000 00110101
00111001 00101011 00110011 00110111 00110101 00110000 00110010 00110100 00101011
00110001 00110011 00111001 00110000 00110000 00110001 00110000 00101011 00110011
00110010 00110000 00110100 00110101 00110111 00101011 00110001 00110010 00111001
00110010 00111001 00110000 00110101 00101011 00110011 00110011 00110000 00110100
00110101 00110110 00101011 00110001 00110010 00110111 00110011 00110000 00110010
00111000
```

Total 512 bits.

The second information defines the priority of the message: Routine, safety, urgency or distress according to Table 23.

TABLE 23

**Priority of the message**

Coding	Priority
00	Routine
01	Safety
10	Urgency
11	Distress

The third information gives the number of the message from 1 to 999 coded on 10 bits

Example: 1 = 0000000001

999 = 1111100111

The fourth piece of information specifies the subject of the message according to Table 27 in Annex 7 (from 1 to 63) coded on 6 bits:

1 = 000001

63 = 111111

**CRC:** This 16-bit CRC should be calculated on the header and the data field.

## 5.2 Encoding

NAVDAT data stream is encoded by low-density parity-check (LDPC), and different encoding parameters will be adopted in different modes (see Table 15). The following Tables give the LDPC parameters in 10 kHz, 5 kHz, 3 kHz and 1 kHz for modes A and B.

TABLE 24

**LDPC parameters of data stream for mode A**

Bandwidth (kHz)	Number of subcarriers	Number of pilots	Number of data subcarriers	Modulation	TIS and MIS	Information bits	Channel coding	Information rate (kbits)
10	228*14	38*14	190*14	4-QAM	100	2560*2	(2560,5120)	6.36
10	228*14	38*14	190*14	4-QAM	100	2560*2	(3840,5120)	9.56
10	228*14	38*14	190*14	16-QAM	100	2560*4	(2560,5120)	12.72
10	228*14	38*14	190*14	16-QAM	100	2560*4	(3840,5120)	19.12
10	228*14	38*14	190*14	64-QAM	100	2560*6	(2560,5120)	19.08
10	228*14	38*14	190*14	64-QAM	100	2560*6	(3840,5120)	28.68
5	114*14	271	1325	4-QAM	100	1224*2	(1224,2448)	3.02
5	114*14	271	1325	4-QAM	100	1224*2	(1836,2448)	4.55
5	114*14	271	1325	16-QAM	100	1224*4	(1224,2448)	6.04
5	114*14	271	1325	16-QAM	100	1224*4	(1836,2448)	9.10
5	114*14	271	1325	64-QAM	100	1224*6	(1224,2448)	9.06
5	114*14	271	1325	64-QAM	100	1224*6	(1836,2448)	13.65
3	68*14	159	793	4-QAM	100	692*2	(692,1384)	1.69
3	68*14	159	793	4-QAM	100	692*2	(1038,1384)	2.555
3	68*14	159	793	16-QAM	100	692*4	(692,1384)	3.38

TABLE 24 (end)

Bandwidth (kHz)	Number of subcarriers	Number of pilots	Number of data subcarriers	Modulation	TIS and MIS	Information bits	Channel coding	Information rate (kbits)
3	68*14	159	793	16-QAM	100	692*4	(1038,1384)	5.11
3	68*14	159	793	64-QAM	100	692*6	(692,1384)	5.07
3	68*14	159	793	64-QAM	100	692*6	(1038,1384)	7.665
1	22*14	4*14	252	4-QAM	100	152*2	(152,304)	0.34
1	22*14	4*14	252	4-QAM	100	152*2	(228,304)	0.53
1	22*14	4*14	252	16-QAM	100	152*4	(152,304)	0.68
1	22*14	4*14	252	16-QAM	100	152*4	(228,304)	1.06
1	22*14	4*14	252	64-QAM	100	152*6	(152,304)	1.095
1	22*14	4*14	252	64-QAM	100	152*6	(228,304)	1.59

TABLE 25

**LDPC parameters of data stream for mode B**

Bandwidth (kHz)	Number of subcarriers	Number of pilots	Number of data subcarriers	Modulation	TIS and MIS	Information bits	Channel coding	Information rate (kbit/s)
10	206*14	485	2399	4-QAM	100	2298*2	(2298,4596)	5.705
10	206*14	485	2399	4-QAM	100	2298*2	(3447,4596)	8.578
10	206*14	485	2399	16-QAM	100	2298*4	(2298,4596)	11.41
10	206*14	485	2399	16-QAM	100	2298*4	(3447,4596)	17.155
10	206*14	485	2399	64-QAM	100	2298*6	(2298,4596)	17.115
10	206*14	485	2399	64-QAM	100	2298*6	(3447,4596)	25.733
5	102*14	243	1185	4-QAM	100	1084*2	(1084,2168)	2.67
5	102*14	243	1185	4-QAM	100	1084*2	(1626,2168)	4.025
5	102*14	243	1185	16-QAM	100	1084*4	(1084,2168)	5.34
5	102*14	243	1185	16-QAM	100	1084*4	(1626,2168)	8.05
5	102*14	243	1185	64-QAM	100	1084*6	(1084,2168)	8.01
5	102*14	243	1185	64-QAM	100	1084*6	(1626,2168)	12.075
3	60*14	10*14	700	4-QAM	100	600*2	(600,1200)	1.46
3	60*14	10*14	700	4-QAM	100	600*2	(900,1200)	2.21
3	60*14	10*14	700	16-QAM	100	600*4	(600,1200)	2.92
3	60*14	10*14	700	16-QAM	100	600*4	(900,1200)	4.42
3	60*14	10*14	700	64-QAM	100	600*6	(600,1200)	4.38
3	60*14	10*14	700	64-QAM	100	600*6	(900,1200)	6.63
1	18*14	47	205	4-QAM	100	104*2	(104,208)	0.22
1	18*14	47	205	4-QAM	100	104*2	(156,208)	0.35
1	18*14	47	205	16-QAM	100	104*4	(104,208)	0.44





$$\begin{bmatrix} 3 & -1 & -1 & -1 & 120 & -1 & 11 & -1 & 133 & -1 & -1 & 19 & 126 & -1 & -1 & -1 & 143 & 142 & -1 & -1 & 116 & 144 & -1 & 18 & 1 & 0 & -1 & -1 & -1 & -1 & -1 & -1 \\ -1 & 12 & 13 & -1 & -1 & 157 & -1 & 112 & -1 & -1 & 87 & -1 & -1 & -1 & 32 & -1 & -1 & -1 & 52 & 94 & 118 & -1 & 86 & -1 & -1 & 0 & 0 & -1 & -1 & -1 & -1 & -1 \\ 76 & -1 & -1 & 75 & -1 & -1 & 74 & -1 & -1 & 28 & -1 & -1 & -1 & 94 & 138 & -1 & -1 & 13 & 73 & 119 & -1 & -1 & 4 & 90 & -1 & -1 & 0 & 0 & -1 & -1 & -1 & -1 \\ -1 & -1 & -1 & -1 & -1 & 14 & -1 & 61 & 51 & -1 & -1 & -1 & -1 & 117 & -1 & 93 & -1 & 103 & -1 & 2 & 5 & 60 & 153 & -1 & 0 & -1 & -1 & 0 & 0 & -1 & -1 & -1 \\ -1 & 23 & -1 & 106 & 7 & -1 & -1 & -1 & -1 & 143 & 16 & -1 & 101 & -1 & -1 & -1 & 126 & -1 & 122 & -1 & 111 & -1 & 29 & 120 & -1 & -1 & -1 & -1 & 0 & 0 & -1 & -1 \\ 39 & -1 & 21 & -1 & -1 & 0 & -1 & -1 & 0 & -1 & -1 & 124 & -1 & -1 & 0 & -1 & 70 & -1 & 109 & -1 & 0 & 24 & -1 & 116 & -1 & -1 & -1 & -1 & -1 & 0 & 0 & -1 \\ -1 & 159 & -1 & -1 & 57 & -1 & -1 & 27 & -1 & 48 & -1 & 0 & 76 & -1 & -1 & 7 & -1 & 95 & -1 & 18 & -1 & 38 & -1 & 80 & -1 & -1 & -1 & -1 & -1 & -1 & 0 & 0 \\ -1 & -1 & 43 & 0 & -1 & -1 & 25 & -1 & -1 & -1 & 50 & -1 & -1 & 3 & -1 & 0 & -1 & 42 & 150 & 0 & -1 & 143 & 0 & -1 & 1 & -1 & -1 & -1 & -1 & -1 & -1 & 0 \end{bmatrix}$$

Encoded DS bits sequence should be interleaved in time and frequency before mapping.

## 7 Cyclic redundancy check

For the bit error detection in DS, the 16-bit cyclic redundancy check should be calculated at the end of each DS. The generator polynomial should be  $G_{16}(x) = x^{16} + x^{12} + x^5 + 1$ .

For MIS and TIS, the 8-bit cyclic redundancy check should be calculated, and the generator polynomial should be  $G_8(x) = x^8 + x^4 + x^3 + x^2 + 1$ .

## Annex 5

### Message file structure

Figure 24 shows an example of how a data group is built for a message file. In the first step, a header is created to describe the body (a message file). The header contains the file's management data. Afterwards, the header as well as the body are split into equally sized segments (only the last segment of each item may be smaller). A segment header is attached to a segment, and each segment is mapped into one data group. Then each data group with its header is mapped directly to a data unit. The data unit is split into packets for transportation. "FF" and "LF" represent the state of the "first flag" and "last flag" bits for each packet.

FIGURE 24  
Message file structure

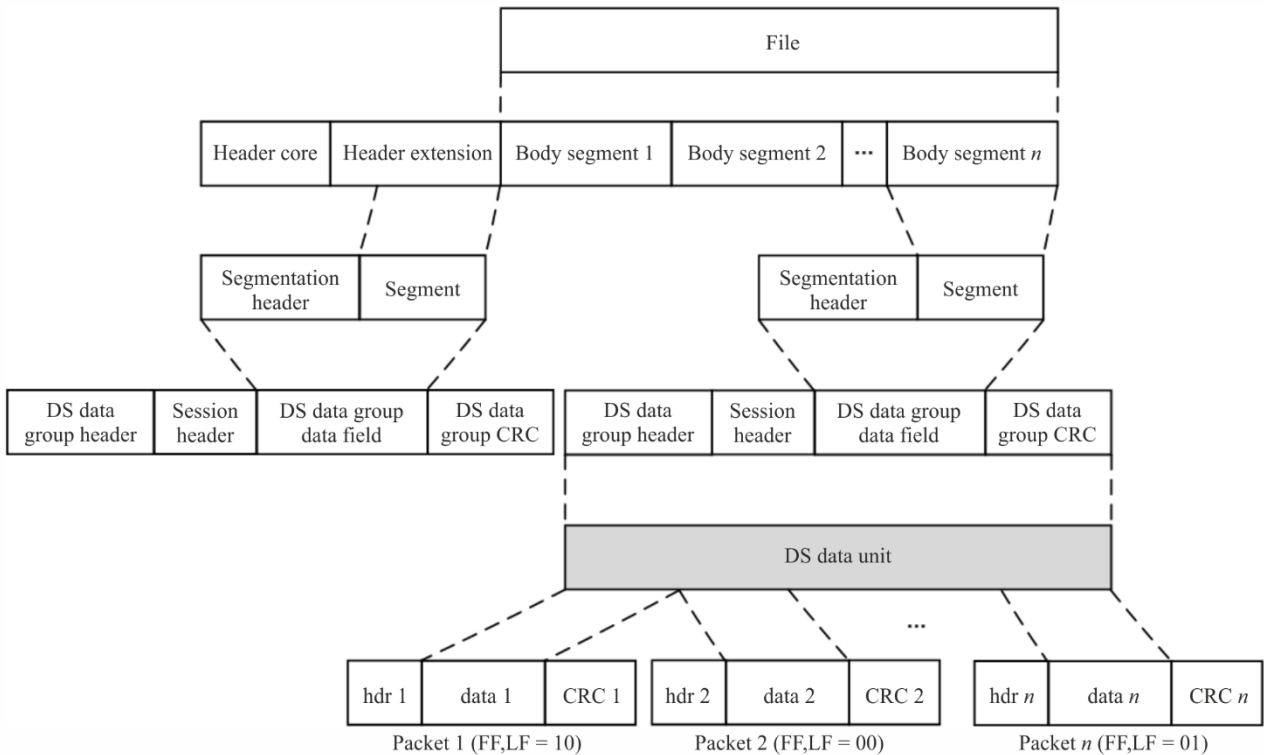

M.2010-24

TABLE 26

The structure of the message head

Parameter	Number of bits	Description
Broadcast mode	2	00 General broadcast 01 Selective ship 10 Group of ship 11 Selective area
Detail of Broadcast modes 00, 01 and 10	36	1 When broadcast mode = 00 All bits are = to 0 2 While the Broadcast mode is 01 or 10, the identity is defined on 9 bits according to Rec. ITU-R M.493 Each digit consists of 4 bits and the number of bits is 36.
Detail of Broadcast mode 11	512	The area is defined by four geographical positions on 512 bits (See Table 22 and note)
Priority (Level of message)	2	00 Routine 01 Safety 10 Urgency 11 Distress
Subject of message	6	Refer to Table 27
Numbering of the message	10	1 to 999
Broadcast count	4	Used for multiple broadcast of the same file (1 to 15)

TABLE 26 (*end*)

Parameter	Number of bits	Description
Length of data	24	The total length of the data in bytes, and valid range = 1~16777216
Total packets	10	The total packets of the data segment, and valid range = 1~1024
Length of file	16	The total length of the message file in bytes, and valid range = 1~65535
Reserved	16	Reserved for future use (= 0)
CRC	16	The CRC calculation ranges from the Broadcast mode to the end of the reserved field

Note:

The body of the broadcast message contains the following information:

The subject of the message.

The origin of the message (authority that wrote the message).

The date when the message was written (Year, Month, Day and Hour/ minutes)

The message reference number (it is the numbering of the message). The NAVDAT server must be informed of this number when submitting the message. It will be used for the “Broadcast count” function.

## Annex 6

### Single frequency network for simultaneous broadcasting from multiple NAVDAT locations (taken from Digital Radio Mondiale)

#### 1 Explanation of Digital Radio Mondiale

The international digital radio broadcast standard DRM is used for digital radio broadcasting at MF and HF. DRM is a proven technology that provides superior coverage, improves signal fidelity (through digital error correction coding), eliminates multi-path interference (including sky-wave interference) and thus extends coverage from sky-wave propagated signals. DRM broadcasts are implemented in both 16-QAM and 64-QAM modulation modes, depending on coverage requirements, transmitter location, power and antenna height.

##### 1.1 Single frequency network operating mode

The NAVDAT system is capable of supporting what is called SFN operation. This is the case where a number of transmitters transmit on the same frequency, and at the same time, identical data signals. Generally, these transmitters are arranged to have overlapping coverage areas, within which a radio should receive signals from more than one transmitter. Provided that these signals arrive within a time difference of less than the guard interval, they should provide positive signal reinforcement. Thus, the service coverage should be improved at that location compared to that obtained if there was only

a single transmitter providing service to that location. By careful design, and using a number of transmitters in a SFN, a region or country may be completely covered using a single frequency, and in this application, a single time slot, thus drastically improving spectrum efficiency and release broadcast slots.

In a single frequency network all the individual transmitters must be exactly time synchronized. Every transmitter must broadcast absolutely identical OFDM symbol at the same time.

Time synchronization of all transmitted packets in the transport stream of the final data multiplex is ensured by the time signal 1 pps (pulse per second), which is acquired from the GNSS system.

The frequency stability of transmitters should be better than 2 Hz.

The basic parameter that defines the size of the SFN area is the guard interval  $T_g$ .

In OFDM modulation method, its great robustness against inter-symbol interference as an effect of multipath reception (an impact of time delayed signals – echoes) consists in largely extending the very short bit time interval  $T_b$  in the serial original data stream.

This guard interval must be carefully configured according to the position of the transmitters in relation with the coverage areas.

When building an SFN network, particular attention will be paid so that the flux of the MIS, TIS and DS are preferably generated by a common server.

## Annex 7

### NAVDAT subject message codes

This list of subject messages codes is given only for information.

Refer to the documents published by IMO.

TABLE 27

List of NAVDAT subject message codes

Maritime Safety Information (MSI)				
Subject message code	Type of message	Coding	can be rejected	
			YES	NO
<b>Navigational warnings</b>				
1	Sub-area warning	000001		X
2	Coastal warning	000010		X
3	Local warning (only on national NAVDAT services)	000011		X
4	Drifting hazards (including derelict ships, ice, mines, containers, other large items over 6 metres in length, etc.)	000100		X
5	Reserved	000101		
6	Reserved	000110		

TABLE 27 (continued)

Maritime Safety Information (MSI)				
Subject message code	Type of message	Coding	can be rejected	
			YES	NO
7	No message on hand	000111		X
<b>Navigational warnings</b> (following) – Positioning system <i>Significant malfunctioning of radio-navigation services and shore-based maritime safety information radio or satellite services</i>				
8	GNSS and RNSS	001000		X
9	LORAN and E LORAN/ Chayka and e Chayka	001001		X
10	Differential correction information	001010		X
11	Operating anomalies identified within ECDIS including ENC issues	001011		
12	Areas where search and rescue (SAR) and anti-pollution operations are being carried out (for avoidance of such areas)	001100		X
13	Reserved	001101		
14	Reserved	001110		
<b>Navigational warnings</b> (following) – Act of piracy and arm robbery				
15	Acts of piracy and armed robbery against ships	001111		X
16	Chart of piracy attacks	010000		X
17	Reserved	010001		
<b>Navigational warnings</b> (following) – Tsunamis and other natural phenomena warnings				
18	Tsunami warning/Abnormal changes to sea level	010010		X
19	Reserved	010011		
<b>Navigational warnings</b> (following) – Security In accordance with the requirements of the international Ship and port facility Security Code				
20	Security-related information	010100		X
21	Chart of security level areas	010101		X
22	Reserved	010110		
23	Reserved	010111		
<b>Navigational warnings</b> (following) – HEALTH Implementation of the International Health Regulation – IHR				
24	World Health Organization (WHO) health advisory information	011000		X
25	Pandemic warning	011001		X
26	Reserved	011010		
Meteorological				
27	Meteorological warning (Including tropical cyclone, storm, gale warning)	011011		X
28	Meteorological synopses (including weather chart)	011100	X	
29	Meteorological forecast	011101	X	
30	Current and tide	011110	X	

TABLE 27 (continued)

<b>Maritime Safety Information (MSI)</b>				
<b>Subject message code</b>	<b>Type of message</b>	<b>Coding</b>	<b>can be rejected</b>	
			<b>YES</b>	<b>NO</b>
31	Wave height and direction	011111	X	
32	Reserved	100000		X
33	Reserved	100001		X
<b>Ice Report</b>				
34	Ice chart	100010	X	
35	Iceberg	100011	X	
36	Polar Road Information	100100	X	
37	Icebreaker patrol information	100101	X	
<b>Search and Rescue related information</b>				
38	Distress alert relay to all ships (MAYDAY RELAY)	100110		X
39	Ship overdue (description and/or picture of the missing ship)	100111		X
40	SAR coordination (to ships involved in the SAR operation)	101000		X
41	SAR pattern (to ships involved in the SAR operation)	101001		X
42	Reserved	101010		
43	Reserved	101011		
<b>Other safety-related information</b>				
	<b>Pilot service</b>			
44	Pilot service information	101100	X	
	<b>Tug services</b>			
45	Tug service information	101101	X	
	<b>Port support service</b>			
46	Time and height of the tide	101110	X	
47	Local port information	101111	X	
48	Hydrographic and environmental information	110000	X	
	<b>Vessel Traffic Service (VTS)</b>			
49	VTS information	110001	X	
50	Reserved	110010		
51	Reserved	110011		
	<b>Pollution</b>			
52	Pollution information	110100		
53	Pollution chart	110101		
<b>Other information</b>				
	<b>AIS and LRIT messages</b>			
55	AIS	110111	X	
56	LRIT	111000	X	

TABLE 27 (*end*)

<b>Maritime Safety Information (MSI)</b>				
<b>Subject message code</b>	<b>Type of message</b>	<b>Coding</b>	<b>can be rejected</b>	
			<b>YES</b>	<b>NO</b>
	<b>Nautical chart and publications service</b>			
57	Electronic nautical chart and publications corrections	111001	X	
58	Electronic Nautical chart and publications update	111010	X	
	<b>Fishing information (only on national NAVDAT services)</b>			
59	Regulations	111011	X	
60	Special maps	111100	X	
61	Fishing Quota information	111101	X	
	<b>Encrypted message</b>			
62	Receiving an encrypted message	111110		
63	Update receiver software	111111		X

Information is grouped by subject in the NAVDAT broadcast and each subject group is allocated a subject message code from 1 to 63.

The subject message code is used by the receiver to identify the different classes of messages as listed in this table (from memorized information tables).

The software/firmware of the receiver should be able to be updated. The update should be performed by using an appropriate interface or reception of message 63 (update receiver software).

This function is necessary to follow the evolutions of the GMDSS master plan for new NAVDAT stations as well as for the future revisions of the ITU Recommendations.

## **Annex 8**

### **Implementation of NAVDAT shore infrastructure**

#### **A8.1 Purpose of this Annex**

This Annex provides guidance for implementation of MF NAVDAT (495-505 kHz) on shore facilities, which may integrate NAVTEX to support the NAVTEX/NAVDAT transition.

#### **A8.2 Antenna characteristics of radio towers of various heights**

Antenna characteristics of radio towers of various heights are shown in Fig. 25 below<sup>2</sup>.

---

<sup>2</sup> Reference Data for Radio Engineers, Howard W. Sams & Co., Inc., Fifth Edition.



FIGURE 25

Antenna impedance characteristics of radio towers of various heights

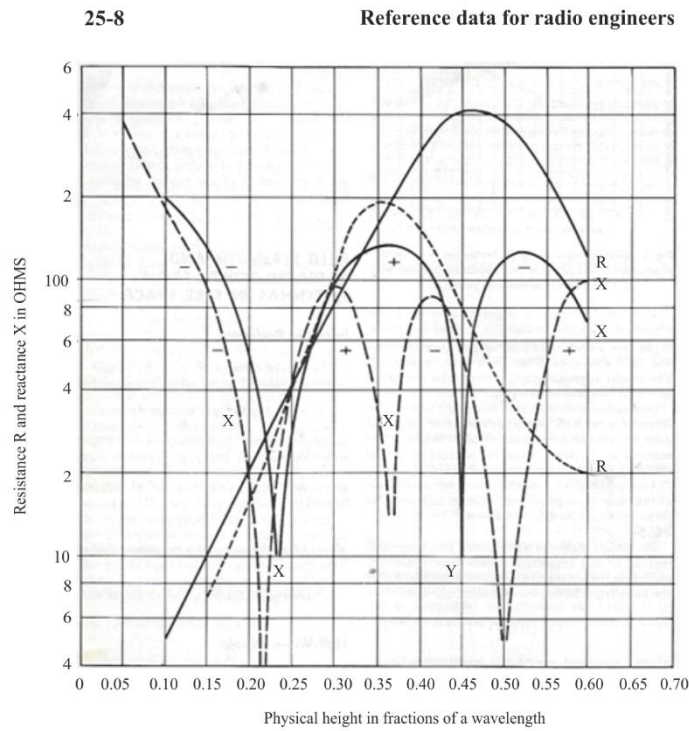

M.2010-25

Figure 25 describes resistance and reactance components of impedance between tower base and ground of vertical radiators as given by Chamberlain and Lodge. Solid lines show average results for five guyed towers; dashed lines show average results for three self-supporting towers. Courtesy of Proceedings of the IRE, in the public domain.

### A8.3 Antenna requirements for NAVTEX and NAVDAT systems

The antenna requirements for NAVTEX and NAVDAT are different, but it is possible to transmit both NAVTEX and NAVDAT from the same transmitter and tower that is designed and configured for NAVDAT. This would provide a backward compatible system to serve in the transition period. For digital systems such as NAVDAT, a low-Q ( $Q = X/R$ , where  $Q = 1$  or less) antenna is ideal to provide linear phase shift across the transmission bandwidth. Low-Q is achieved when the reactance Y is less than the resistance R such as in the vicinity of 0.25 wavelength antenna height as shown above. For NAVTEX and NAVDAT, this occurs at a height of approximately 150 m for both guyed and self-supporting towers.

**A8.4 NAVDAT estimated data rates for various transmission modes**

Lower tower heights, e.g. 90 m (0.15 wavelengths), can be impedance matched to the transmitter using a series matching inductor. This would result in a Q of 13, according to Fig. 25, where  $Q = X/R = 130/10 = 13$ . Although this is acceptable for NAVTEX, which is a narrow-band analog system, its application for NAVDAT should be carefully evaluated. Tables 5 and 6 describe the various NAVDAT transmission modes and the associated spectrum occupancy. For NAVDAT transmission, the 3 dB bandwidth of the antenna tower should be at least three times the spectrum occupancy to avoid inter-symbol interference caused by nonlinear group delay within the occupied bandwidth. For the 90-metre tower example above, the Q of 13 provides a 3 dB bandwidth of  $500 \text{ kHz}/13 = 38.4 \text{ kHz}$ , which is adequate to support the NAVDAT transmission modes 0-23.

---