



Recommendation ITU-R M.1850-2
(10/2014)

**Detailed specifications of the radio
interfaces for the satellite component
of International Mobile
Telecommunications-2000
(IMT-2000)**

M Series
**Mobile, radiodetermination, amateur
and related satellite services**

Foreword

The role of the Radiocommunication Sector is to ensure the rational, equitable, efficient and economical use of the radio-frequency spectrum by all radiocommunication services, including satellite services, and carry out studies without limit of frequency range on the basis of which Recommendations are adopted.

The regulatory and policy functions of the Radiocommunication Sector are performed by World and Regional Radiocommunication Conferences and Radiocommunication Assemblies supported by Study Groups.

Policy on Intellectual Property Right (IPR)

ITU-R policy on IPR is described in the Common Patent Policy for ITU-T/ITU-R/ISO/IEC referenced in Annex 1 of Resolution ITU-R 1. Forms to be used for the submission of patent statements and licensing declarations by patent holders are available from <http://www.itu.int/ITU-R/go/patents/en> where the Guidelines for Implementation of the Common Patent Policy for ITU-T/ITU-R/ISO/IEC and the ITU-R patent information database can also be found.

Series of ITU-R Recommendations

(Also available online at <http://www.itu.int/publ/R-REC/en>)

Series	Title
BO	Satellite delivery
BR	Recording for production, archival and play-out; film for television
BS	Broadcasting service (sound)
BT	Broadcasting service (television)
F	Fixed service
M	Mobile, radiodetermination, amateur and related satellite services
P	Radiowave propagation
RA	Radio astronomy
RS	Remote sensing systems
S	Fixed-satellite service
SA	Space applications and meteorology
SF	Frequency sharing and coordination between fixed-satellite and fixed service systems
SM	Spectrum management
SNG	Satellite news gathering
TF	Time signals and frequency standards emissions
V	Vocabulary and related subjects

Note: This ITU-R Recommendation was approved in English under the procedure detailed in Resolution ITU-R 1.

Electronic Publication
Geneva, 2014

© ITU 2014

All rights reserved. No part of this publication may be reproduced, by any means whatsoever, without written permission of ITU.

RECOMMENDATION ITU-R M.1850-2

**Detailed specifications of the radio interfaces for the satellite component of
International Mobile Telecommunications-2000 (IMT-2000)***

(2010-2012-2014)

Scope

This Recommendation identifies the IMT-2000 satellite radio interface specifications, originally based on the key characteristics identified in the output of activities outside ITU.

These satellite radio interfaces support the features and design parameters of IMT-2000, including the capability to ensure worldwide compatibility, international roaming, and access to high-speed data services.

CONTENTS

	<i>Page</i>
1 Introduction	2
2 Related Recommendations	2
3 Considerations	4
3.1 Radio interfaces for the satellite component of IMT-2000.....	4
3.2 Incorporation of externally developed specification material	4
3.3 Satellite component interfaces	5
4 Recommendations (satellite component).....	7
4.1 Core network interface	7
4.2 Satellite/terrestrial terminal interface	8
4.3 Satellite radio interface specifications	8
5 Recommendations on unwanted emission limits from the terminals of IMT-2000 satellite systems	159
Annex 1 – Abbreviations	159

* The recommended detailed specifications of the radio interfaces of IMT-2000 are contained in the core global specifications which form part of this Recommendation by means of references to uniform resource locators (URLs) at the ITU Website. For those cases where recognized external organizations have converted these core global specifications or parts thereof into their own approved standards, a reference to the corresponding external text is included in this Recommendation by means of URLs at their Websites. Such references do not give the external texts the status, as stand-alone texts, of ITU Recommendations. Any reference to an external text is accurate at the time of approval of this Recommendation. Since the external text may be revised, users of this Recommendation are advised to contact the source of the external text to determine whether the reference is still current. This Recommendation will be subject to periodic updates that will be coordinated with the appropriate recognized external organizations responsible for the Pageexternal texts that are referenced.

1 Introduction¹

IMT-2000s are third generation mobile systems which provide access, by means of one or more radio links, to a wide range of telecommunications services supported by the fixed telecommunication networks (e.g. PSTN/ISDN/Internet protocol (IP)), and to other services which are specific to mobile users.

A range of mobile terminal types is encompassed, linking to terrestrial and/or satellite-based networks, and the terminals may be designed for mobile or fixed use.

Key features of IMT-2000 are:

- high degree of commonality of design worldwide;
- compatibility of services within IMT-2000 and with the fixed networks;
- high quality;
- small terminal for worldwide use;
- worldwide roaming capability;
- capability for multimedia applications, and a wide range of services and terminals.

IMT-2000 are defined by a set of interdependent Recommendations of which this one is part of.

Recommendation ITU-R M.1457 forms part of the process of specifying the terrestrial radio interfaces of IMT-2000, as defined in Recommendation ITU-R M.1225. It identifies the detailed specifications for the IMT-2000 terrestrial radio interfaces.

This Recommendation forms the final part of the process of specifying the radio interfaces of IMT-2000, as defined in Recommendation ITU-R M.1225. It identifies the detailed specifications for the IMT-2000 satellite radio interfaces.

Updates and enhancements to the satellite radio interfaces incorporated in this Recommendation have undergone a defined process of development and review to ensure consistency with the original goals and objectives established for IMT-2000 while acknowledging the obligation to accommodate the changing requirements of the global marketplace.

By updating the existing technologies, harmonizing existing interfaces, and entertaining new mechanisms, IMT-2000 remains at the forefront of mobile radio technology.

2 Related Recommendations

The existing IMT-2000 Recommendations that are considered to be of importance in the development of this particular Recommendation are as follows:

Recommendation ITU-R M.687:	International Mobile Telecommunications-2000 (IMT-2000)
Recommendation ITU-R M.816:	Framework for services supported on International Mobile Telecommunications-2000 (IMT-2000)
Recommendation ITU-R M.817:	International Mobile Telecommunications-2000 (IMT-2000). Network architectures
Recommendation ITU-R M.818:	Satellite operation within International Mobile Telecommunications-2000 (IMT-2000)
Recommendation ITU-R M.819:	International Mobile Telecommunications-2000 (IMT-2000) for developing countries

¹ Abbreviations used in this Recommendation are listed in Annex 1.

- Recommendation ITU-R M.1034: Requirements for the radio interface(s) for International Mobile Telecommunications-2000 (IMT-2000)
- Recommendation ITU-R M.1035: Framework for the radio interface(s) and radio sub-system functionality for International Mobile Telecommunications-2000 (IMT-2000)
- Recommendation ITU-R M.1036: Frequency arrangements for implementation of the terrestrial component of International Mobile Telecommunications (IMT) in the bands identified for IMT in the Radio Regulations (RR)
- Recommendation ITU-R M.1167: Framework for the satellite component of International Mobile Telecommunications-2000 (IMT-2000)
- Recommendation ITU-R M.1224: Vocabulary of terms for International Mobile Telecommunications (IMT)
- Recommendation ITU-R M.1225: Guidelines for evaluation of radio transmission technologies for IMT-2000
- Recommendation ITU-R M.1308: Evolution of land mobile systems towards IMT-2000
- Recommendation ITU-R M.1311: Framework for modularity and radio commonality within IMT-2000
- Recommendation ITU-R M.1343: Essential technical requirements of mobile earth stations for global non-geostationary mobile-satellite service systems in the bands 1-3 GHz
- Recommendation ITU-R M.1457: Detailed specifications of the radio interfaces of International Mobile Telecommunications-2000 (IMT-2000)
- Recommendation ITU-R M.1480: Essential technical requirements of mobile earth stations of geostationary mobile-satellite systems that are implementing the Global mobile personal communications by satellite (GMPCS) – Memorandum of understanding arrangements in parts of the frequency band 1-3 GHz
- Recommendation ITU-R SM.329: Unwanted emissions in the spurious domain
- Recommendation ITU-T Q.1701: Framework of IMT-2000 networks
- Recommendation ITU-T Q.1711: Network functional model for IMT-2000
- Recommendation ITU-T Q.1721: Information flows for IMT-2000 capability set 1
- Recommendation ITU-T Q.1731: Radio-technology independent requirements for IMT-2000 layer 2 radio interface
- Handbook on Land Mobile (including Wireless Access), Volume 2 – Principles and Approaches on Evolution to IMT-2000/FPLMTS.

3 Considerations

3.1 Radio interfaces for the satellite component of IMT-2000

IMT-2000 consists of both terrestrial component and satellite component radio interfaces. All of the satellite radio interfaces for IMT-2000 are encompassed and defined by information supplied with this Recommendation.

Due to the constraints on satellite system design and deployment, several satellite radio interfaces will be required for IMT-2000 (see Recommendation ITU-R M.1167 for further considerations).

Because a satellite system is resource limited (e.g. power and spectrum limited), its radio interfaces are therefore specified primarily based on a whole system optimization process, driven by the market needs and business objectives. It is generally not technically feasible or viable from a business point-of-view to have a radio interface common to satellite and terrestrial IMT-2000 components. Nevertheless, it is desirable to achieve as much commonality as possible with the terrestrial component when designing and developing an IMT-2000 satellite system.

The strong dependency between technical design and business objectives of an IMT-2000 satellite system requires a large scope of flexibility in the satellite radio interface specifications. Future modifications and updates of these specifications may nevertheless be needed in order to adapt to changes in market demands, business objectives, technology developments, and operational needs, as well as to maximize the commonality with terrestrial IMT-2000 systems as appropriate.

The radio interfaces for the terrestrial components are described in detail in § 5 of Recommendation ITU-R M.1457. The radio interfaces for the satellite components are described in detail in § 4 of this Recommendation.

3.2 Incorporation of externally developed specification material

IMT-2000 is a system with global development activity and the IMT-2000 radio interface specifications identified in this Recommendation have been developed by the ITU in collaboration with the radio interface technology proponent organizations, global partnership projects and regional standards development organizations (SDOs). The ITU has provided the global and overall framework and requirements, and has developed the core global specifications jointly with these organizations. The detailed standardization has been undertaken within the recognized external organization (see Note 1), which operate in concert with the radio interface technology proponent organizations and global partnership projects. This Recommendation therefore makes extensive use of references to externally developed specifications.

NOTE 1 – A “recognized organization” in this context is defined to be a recognized SDO that has legal capacity, a permanent secretariat, a designated representative, and open, fair, and well-documented working methods.

This approach was considered to be the most appropriate solution to enable completion of this Recommendation within the aggressive schedules set by the ITU and by the needs of administrations, operators and manufacturers.

This Recommendation has therefore been constructed to take full advantage of this method of work and to allow the global standardization time-scales to be maintained. The main body of this Recommendation has been developed by the ITU, with references within each radio interface pointing to the location of the more detailed information. The sub-sections containing this detailed information have been developed by the ITU and the recognized external organizations. Such use of referencing has enabled timely completion of the high-level elements of this Recommendation, with change control procedures, transposition (conversion of the core specifications into SDO deliverables) and public enquiry procedures being undertaken within the recognized external organization.

The structure of the detailed specifications received from the recognized external organization has generally been adopted unchanged, recognizing the need to minimize duplication of work, and the need to facilitate and support an on-going maintenance and update process.

This general agreement, that the detailed specifications of the radio interface should to a large extent be achieved by reference to the work of recognized external organizations, highlights not only the ITU’s significant role as a catalyst in stimulating, coordinating and facilitating the development of advanced telecommunications technologies, but also its forward-looking and flexible approach to the development of this and other telecommunications standards for the 21st century.

3.3 Satellite component interfaces

The terrestrial and satellite components are complementary, with the terrestrial component providing coverage over areas of land mass with population density considered to be large enough for economic provision of terrestrially-based systems, and the satellite component providing service elsewhere by a virtually global coverage. The ubiquitous coverage of IMT-2000 can only therefore be realized using a combination of satellite and terrestrial radio interfaces.

To fulfill the scope, this Recommendation describes those elements needed for worldwide compatibility of operation noting that international use is inherently ensured through the global coverage of a satellite system. This description includes consideration of all the satellite component interfaces.

Figure 1, which has been developed from Fig. 1 of Recommendation ITU-R M.818, shows the various interfaces in the IMT-2000 satellite component.

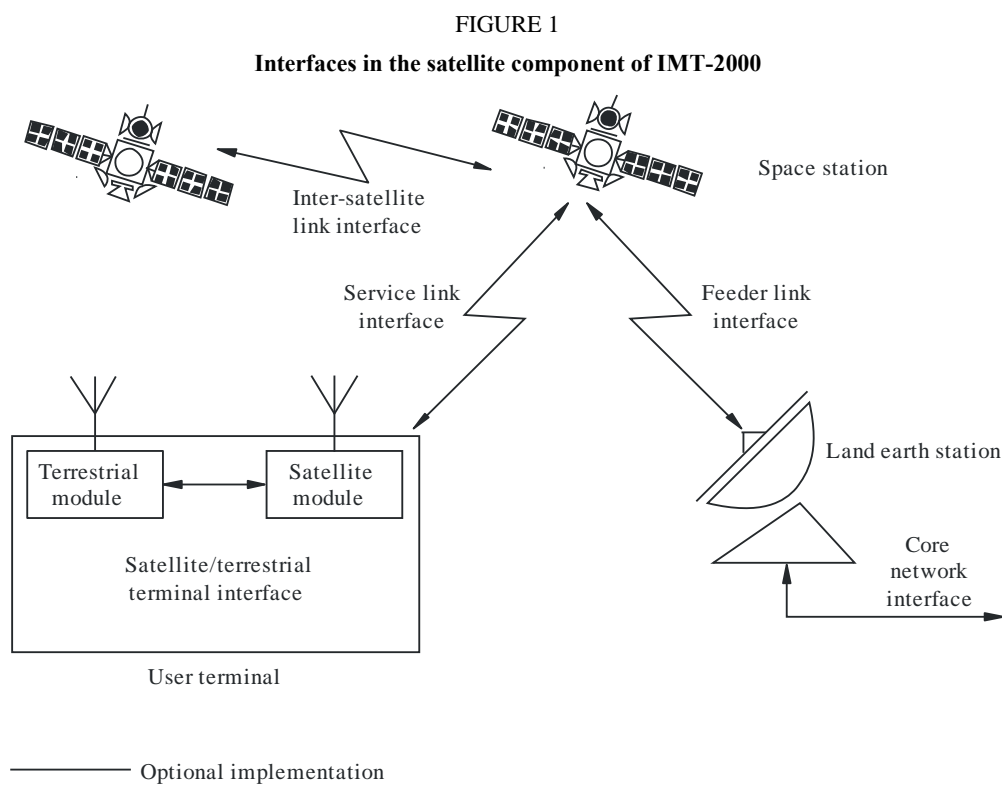

3.3.1 Radio interfaces

3.3.1.1 Service link interface

The service link interface is the radio interface between a mobile earth station (MES) (the satellite module of a user terminal (UT)) and a space station.

3.3.1.2 Feeder-link interface

The feeder-link interface is the radio interface between space stations and land earth stations (LESs). Feeder links are analogous to the radio interfaces used on back-haul fixed links to carry traffic to/from terrestrial base stations (BSs). When designing a satellite system, system specific implementations for feeder links result since:

- feeder links can operate in any of a number of frequency bands, which are outside those bands identified for IMT-2000;

- each individual feeder link presents its own issues, some of which are related to satellite system architecture, while others are related to the frequency band of operation.

The feeder-link interface is therefore largely an intra-system specification, and can be viewed as an implementation issue. This has been addressed in Recommendation ITU-R M.1167, which states that “The radio interfaces between the satellites and the LESs (i.e. the feeder links) are not subject to IMT-2000 standardization”. The specification of this interface is therefore outside the scope of this Recommendation.

3.3.1.3 Inter-satellite link interface

The inter-satellite link interface is the interface between two space stations, noting that some systems may not implement this interface. The issues discussed above under feeder-link interface are also applicable here, and the inter-satellite link interface is therefore largely an intra-system specification, and can be viewed as an implementation issue. The specification of this interface is therefore outside the scope of this Recommendation.

3.3.2 Other interfaces

It is recognized that the core network (CN) and satellite/terrestrial terminal interfaces described below are not radio interfaces. However, it is also recognized that they have a direct impact on the design and specification of satellite radio interfaces and on the worldwide compatibility of operation. Other IMT-2000 Recommendations also make reference to these interfaces.

3.3.2.1 CN interface

The CN interface is the interface between the radio access part of a LES and the CN.

The following describes one possible architecture for the satellite component to interface to the CN, as shown in Fig. 2. This architecture would provide some compatibility with the terrestrial component. In this example, the CN interface for the satellite component is called the Ius. The Ius interface performs similar functions as the Iu interface described in §§ 5.1 and 5.3 of Recommendation ITU-R M.1457, and will be designed to achieve as much commonality as possible with the Iu interface, so as to be compatible with the Iu interface.

The satellite radio access network (SRAN) consists of the LES and the satellite, together with the feeder link and inter-satellite links (if any). The SRAN uses the Ius interface for communicating with the CN and Uus interface for communicating with the UT for satellite service provision. The Uus interface is the satellite service link radio interface which is specified in § 4.3.

Since the satellite component of IMT-2000 is generally global in nature, it is not necessary to provide an interface from the SRAN of one satellite network to the SRAN of another satellite network. Also, the interface between LESs of the same satellite network is an internal implementation issue of the satellite network, thus there is no need for standardization of this interface.

FIGURE 2

Example of a satellite network interface architecture

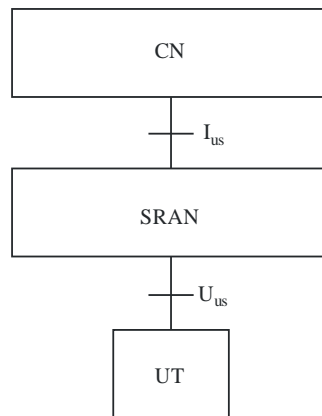

M.1850-02

3.3.2.2 Satellite/terrestrial terminal interface

The satellite/terrestrial terminal interface is the interface between the satellite and terrestrial modules within a user terminal. For terminals incorporating both the satellite and terrestrial components of IMT-2000, there is a requirement to identify both how the two components operate together and any interfacing necessary between them.

For example, Recommendation ITU-R M.818 highlights “that a protocol be developed to establish whether a terrestrial or satellite component should be used for a given call”. Recommendation ITU-R M.1167 also recognizes that “An IMT-2000 user should not necessarily need to request the terminal to access the satellite or the terrestrial component” and also that “In order to facilitate roaming, it is important that the user can be reached by dialling a single number, regardless of whether the mobile terminal is accessing the terrestrial or the satellite component at the time”.

4 Recommendations (satellite component)

The ITU Radiocommunication Assembly recommends that the principles described in §§ 4.1 and 4.2 should be applied by satellite systems providing the satellite component of IMT-2000. These sections describe the basic functions and features of the core network interface and the satellite/ terrestrial terminal interface.

The ITU Radiocommunication Assembly recommends that the radio interfaces described in § 4.3 should be those of the satellite component of IMT-2000.

4.1 Core network interface

The satellite component should interface to the core network in a similar manner to the terrestrial component. Key IMT-2000 requirements, such as appropriate call routing, automatic network roaming, common billing, etc. can therefore be supported, subject to technical and market considerations. However some differences may be required to support a specific satellite radio interface.

4.2 Satellite/terrestrial terminal interface

The IMT-2000 satellite user terminals will offer one or more modes of operation: one satellite mode and possibly one or more terrestrial modes. If a terrestrial mode is implemented, terminals should be able to select either satellite or terrestrial modes of operation automatically or under user control.

The satellite/terrestrial terminal interface performs the following functions:

- provide the bearer service negotiation capabilities in both terrestrial and satellite networks;
- support roaming between terrestrial and satellite networks;
- align the service management and provisioning with IMT-2000 Recommendations.

Handover between terrestrial and satellite components is not a requirement of IMT-2000. It is up to the network operator to determine whether to implement handover between the terrestrial and satellite component. If handover is not implemented, roaming between terrestrial and satellite component may be just a switching function, i.e. if a user terminal loses its connection to a terrestrial network, it could look for a satellite network.

Terminal locations are registered and updated between the terrestrial and satellite databases by using the standard location updating procedures for updating locations between different public land mobile networks (PLMNs).

For roaming between a terrestrial and a satellite network, standard location update procedures employed by PLMNs can be applied, since both networks can be viewed as separate PLMNs. For example, when a user roams out of the terrestrial network coverage and into satellite coverage, standard procedures for detecting and initiating location updates for roaming among PLMNs is applied. When a user roams into terrestrial network coverage from satellite network coverage and the terminal has the terrestrial network provisioned as the preferred network, the terminal will register into the terrestrial network by initiating procedures for detecting and initiating location updates similar to those used for roaming among PLMNs.

It should be possible to address an IMT-2000 terminal using a single number, regardless of which component (terrestrial or satellite) the terminal is currently using.

4.3 Satellite radio interface specifications²

The specification of each satellite radio interface is given in the following subsections. These include only elements related to the service link interface; the feeder-link and inter-satellite link interfaces are not specified in this Recommendation.

Because of the strong dependency between the radio interface design and overall satellite system optimization, this section includes the architectural and system descriptions as well as the RF and baseband specifications of radio interfaces.

4.3.1 Satellite radio interface A (SRI-A) specifications

Satellite wideband code division multiple access (SW-CDMA) is a satellite radio interface designed to meet the requirements of the satellite component of the third generation (3G) wireless communication systems. The SW-CDMA radio interface has been examined by the ETSI SES Technical Committee among the family of IMT-2000 satellite radio interfaces as a voluntary standard.

SW-CDMA is based on the adaptation to the satellite environment of the IMT-2000 CDMA Direct Spread terrestrial radio interface (Universal Terrestrial Radio Access (UTRA) Frequency Division Duplex (FDD) or Wideband CDMA (WCDMA)) (see § 5.1 of Recommendation ITU-R M.1457). The intention is to reuse the same core network and reuse the radio interface specifications for the Iu and Cu interface. Only the Uu interface will be adapted to the satellite environment.

² The satellite radio interface C is harmonized with SRI-G specifications and all of its features are now embedded in the SRI-G specifications (enhanced version).

SW-CDMA operates in FDD mode with RF channel bandwidth of either 2.350 or 4.700 MHz for each transmission direction. The half rate 2.350 MHz option provides finer spectrum granularity yielding an easier spectrum sharing among different systems.

SW-CDMA provides a wide range of bearer services from 1.2 up to 144 kbit/s. High-quality telecommunication service can be supported including voice quality telephony and data services in a global coverage satellite environment. SW-CDMA deviations from the above-mentioned terrestrial radio interface are summarized hereafter:

- Maximum bit rate supported limited to 144 kbit/s.
- Permanent softer handover forward link operations for constellations providing satellite diversity.
- Permanent reverse link satellite diversity combining for constellations providing satellite diversity.
- Feeder link (gateway-satellite) and satellite to user link beam centre Doppler pre-compensation.
- Two-steps (instead of three-steps as terrestrial) forward link acquisition procedure.
- Optional half chip-rate mode for improved frequency granularity.
- Introduction of a high-power paging channel for in-building penetration.
- Optional (not standard) use of pilot symbols in the communication channels.
- Reduced power control rate with multi-level predictive power control loop to cope with longer propagation delay.
- Shorter scrambling sequence length (2 560 chips) in the forward link.
- Optional use in the forward link of a short scrambling sequence (256 chips) to allow CDMA interference mitigation at single user terminal level.
- Longer random access preamble sequence.

SW-CDMA offers a great degree of commonality with the terrestrial radio interface making the interoperability between the IMT-2000 terrestrial and the satellite components easier.

4.3.1.1 Architectural description

4.3.1.1.1 Channels structure

This radio interface specification is relevant just to the service link, the feeder link not being a part of it.

The service link consists of a forward link, between the satellite station and the MES and a return link in the opposite direction.

At the physical layer, the information flow to and from the MES is conveyed through logical channels as defined in Recommendation ITU-R M.1035. Those logical channels make use of physical channels as bearer medium, as shown in Table 1.

TABLE 1
Physical to logical channel mapping

Logical channels	Physical channels	Direction
BCCH	Primary CCPCH	Forward
FACH PCH	Secondary CCPCH	Forward
DSCH	PDSCH PDSCH	Forward Forward
RACH RTCH	PRACH	Reverse
DCCH	DPDCH	Bidirectional
DTCH	DPDCH	Bidirectional
Layer 1 signalling	DPCCH	Bidirectional

Two broadcast physical channels are foreseen in the forward direction, primary and secondary common control physical channel (CCPCH). The primary CCPCH supports the broadcast control channel (BCCH) used to broadcast system and beam specific information. The secondary CCPCH supports two logical channels namely the forward access channel (FACH), carrying control information to an identified MES when its position is known and a paging channel (PCH), used as high penetration paging channel.

The physical random access channel (PRACH) supports the random access channel (RACH), carrying control information and the random traffic channel (RTCH), carrying short user packets.

The dedicated physical control channel (DPCCH) is used for carrying Layer 1 signalling data.

The dedicated physical data channel (DPDCH) either control information such as higher layers signalling, conveyed through the dedicated control channel (DCCH) and bidirectional user data conveyed through the dedicated traffic channel (DTCH).

The above bearer services can be utilized to provide circuit-switched and packet data services. On the forward link, packet traffic is supported either on the FACH channel, a downlink shared channel (DSCH) where multiple user services can be supported on the same connection using a time-multiplexed structure or on a dedicated channel for higher throughput requirements. On the reverse link the RACH channel may be utilized for the transmission of occasional short user packets. For a non-occasional, but still moderate throughput and/or low-duty cycle packet traffic, ad hoc codes will be assigned by the LES to the user in order to avoid code collision with other users of the RACH channel. In this case the RTCH is still mapped on a RACH-like physical channel. The data part, however, may be of variable length (in any case a multiple of the physical layer frame length). For higher throughput packet channels on the reverse link, a couple DPCCH/DPDCH can be assigned. The DPDCH is only transmitted when the packet queue is not empty. Also in this case a packet may span multiple physical layer frames. Rate agility is also supported in this case.

A high penetration messaging service is foreseen as unidirectional service (in the forward direction, i.e. between the satellite station and the MES) supporting low data rates with messages containing some tens of bytes. Its primary scope is a paging service or ring alert for MESs localized inside buildings.

In addition to the channels defined in Recommendation ITU-R M.1035, a dedicated physical channel has been introduced for Layer 1 signalling. This carries reference symbols for channel estimation and synchronization purposes.

4.3.1.1.2 Constellation

SW-CDMA does not compel to any particular constellation. It has been designed to be supported by LEO, MEO, GEO or HEO constellations.

Even though multiple satellite diversity will ensure the best system performances, this shall not be regarded as a mandatory system requirement.

4.3.1.1.3 Satellites

SW-CDMA does not compel to any particular satellite architecture. It can be operated either over a bent-pipe transparent satellite transponder or by regenerative transponder architecture. For the reverse link, satellite path diversity exploitation requires bent-pipe transponder as demodulation takes place on the ground.

4.3.1.2 System description

4.3.1.2.1 Service features

Depending on the MES class, SW-CDMA supports bearer services ranging from 1.2 kbit/s up to 144 kbit/s with associated maximum bit error ratio (BER) between 1×10^{-3} to 1×10^{-6} .

The maximum tolerated delay is up to 400 ms, compatible with any of the above-mentioned satellite constellations.

4.3.1.2.2 System features

Both in the forward and in the return link two spreading rates are supported, either 3.840 Mchip/s (full chip rate) and 1.920 Mchip/s (half chip rate).

The transmission is organized in frames. The frame period is 10 ms for the 3.840 Mchip/s option and 20 ms for the 1.920 Mchip/s. Frames are organized in hierarchical structure. A multiframe (MF) consists of 8 frames (full rate option) or 4 frames (half rate option). The MF period is 80 ms. MF are organized in super-frames. One super-frame consists of 9 MFs and has a period equal to 720 ms.

Closed-loop power control is implemented for both the forward and return link. The loop is driven in order to set the measured SNIR value after RAKE fingers combining to a target value. The target value is itself adaptively modified by means of slower outer control loop based on frame error ratio (FER) measurements. To support FER measurements 8 bit CRC (4 bits for 2 400 bit/s) are appended to data in each frame.

An open loop power control is provided for packet transmission and initial setting of power during the call set-up phase.

Three basic service classes are supported by a concatenation of coding and interleaving:

- standard services with inner coding (rate 1/3 convolutional, polynomials 557, 663, 711) and interleaving only, with a target BER equal to 1×10^{-3} ;
- high quality services with inner coding and interleaving plus outer RS coding and interleaving (or optional Turbo coding). The target BER is 1×10^{-6} ;
- services with service specific coding. For these services no specific forward error correction (FEC) coding technique is applied by the radio interface. Possible FEC coding is entirely managed at higher layer.

These classes allow to match the various quality of service (QoS) requirements of the selected satellite services and permit QoS enhancements if required through the choice of a service specific coding.

The interleaving scheme is negotiated at call set-up, depending on the actual data rate. The interleaving depth spans over an integer multiple of the frame period. The interleaving block is written

per rows over a number of columns which is a power of two, the exponent depending on the actual data rate. In reception, the interleaving block is read per columns in a shuffled sequence, i.e. by reading the binary column index in the reverse order.

Access Description – Forward Link

DPDCH/DPCCH – The DPDCH/DPCCH frame structure is shown in Fig. 3. Each frame is divided in 15 time slots and each time slot carries in time-division multiplexing DPDCH and the corresponding DPCCH.

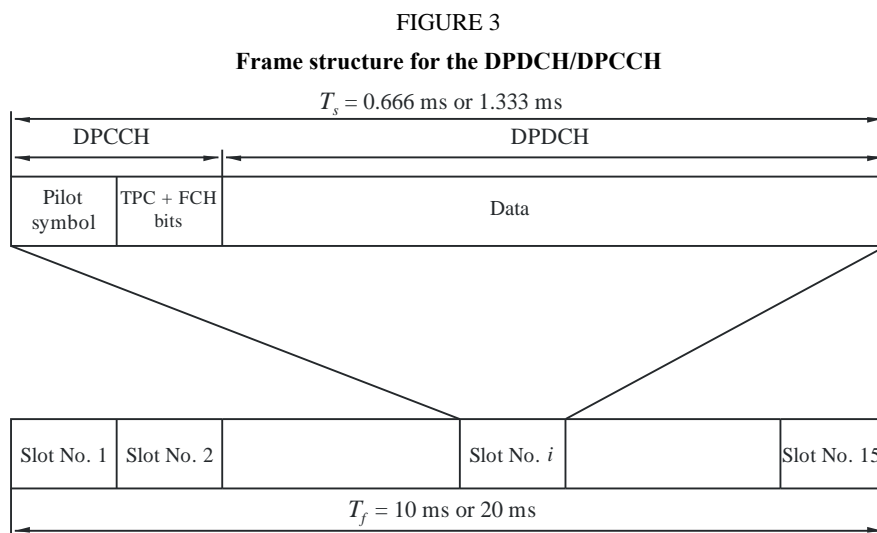

M.1850-03

The DPCCH carries the optional (see Note 1) reference (pilot) symbols, the power control field (transmit power control (TPC)) and the frame control header (FCH), which indicates the actual DPDCH format and speed. The reference pilot symbols are optional.

The format and the data rate of the DPDCH may change during the communication session frame by frame: the MES can detect the format and speed of the current frame from the FCH. The DPDCH may even be absent in some frames. As the data rate on the DPDCH changes also the relative power level of DPDCH and DPCCH changes.

The TCP field consists of two bits. For the TPC function only one increase/decrease command per frames is sufficient due to the large loop delay. However, a multi-level loop allows faster reaction to changes into the channel conditions. Hence, an additional bit per frame is allocated for that purpose.

The FCH field consists of three bits. These 3 bits can address eight different DPDCH formats: because the possible DPDCH formats are more than eight, the FCH will actually select a data format in a subset of the available formats which is defined during call set-up negotiation.

The TPC and FCH bits are coded together by mapping the resulting 5-bit word to one 15-bit long sequence (codeword) belonging to a family of 32 sequences. The proposed, length 15 bits, family of sequences is obtained by all the 15 cyclic shift of an ML sequence of length $2^4 - 1$ plus the all zero sequence plus the antipodal of all the previous sequences. The total number of available sequence is thus 32. The cross-correlation between sequences is either -1 or -15 . The sequences are either almost orthogonal or antipodal.

NOTE 1 – Typically channel estimation is performed by means of the CCPCH thus no pilot symbols are required in the individual DPCCH.

CCPCH – The frame structure of the primary and secondary CCPCH is shown in Fig. 4.

The primary CCPCH is continuously transmitted at a fixed transmission rate (15 kbit/s in the full chip rate option and 7.5 kbit/s in the half chip rate option). It is used to carry the BCH and a frame synchronization word (FSW).

FIGURE 4
Frame structure for the CCPCH

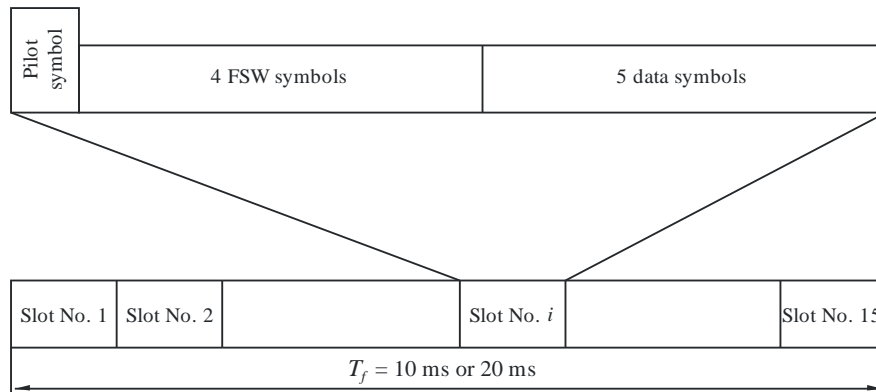

M.1850-04

The primary CCPCH channel code for this channel is the same on all beams and satellite and is known to all MES. Two different FSWs are used. One FSW is used on all frames except the first frame of each MF where the other FSW is utilized. It shall be observed that no pilot symbols are used on the CCPCH. The hypothesis is to use the common pilot for such purposes.

The secondary CCPCH carries the paging channel (PCH) and the forward access channel (FACH). This channel is also a constant rate and it is transmitted only when user traffic is present. On the secondary CCPCH, the FACH and PCH are time multiplexed on a frame-by-frame basis within the super frame structure. The set of frames allocated to FACH and PCH respectively is broadcast on the BCCH. No power control strategy is implemented in the primary and secondary CCPCH.

PDSCH/PDSCCH – The physical downlink shared channel (PDSCH) carries packet data to MESs without the need to allocate a permanent DCH to each user, which may potentially bring to downlink code shortage. The PDSCH channels use a branch of the OVSF code tree. A single MES per frame is served in case the lowest super frame node of the code branch (i.e. the branch root) is used. Multiple MESs per frame may instead be served via code multiplexing in case a higher super frame factor is used (i.e. lower nodes in the branch tree). All PDSCH channels share a single PDSCCH which is transmitted in code multiplexing and carries code assignment, FCH and TPC information to all users.

Modulation and spreading

The modulation scheme (see Fig. 5) is Quadrature Phase-Shift Keying (QPSK) where each bit pair is mapped to the I and Q branches. Those are then spread to the chip rate with the same channel code, cch, and subsequently scrambled by the same beam specific complex scrambling code, cscramb.

For the lower user data rates ($\leq 4\ 800 \text{ bit/s}$), Binary Phase-Shift Keying (BPSK) modulation is used, instead of QPSK modulation, to reduce the sensitivity to phase errors.

The choice of short spreading codes allows the implementation of a linear minimum output energy (MOE) adaptive CDMA demodulator in the MES. The optional use of CDMA MOE detectors is intended to increase system capacity and or/quality of service with no space segment impact.

FIGURE 5
QPSK modulation/BPSK spreading for the forward link physical channels

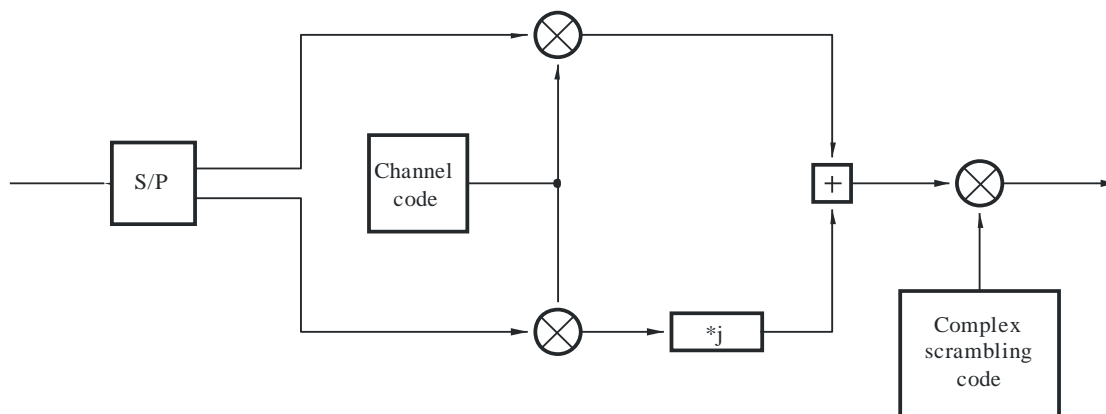

M.1850-05

Codes allocation and synchronization

Scrambling codes – The scrambling code is a complex quaternary sequence of length 2 560 chips. Optionally, in case of MOE-based CDMA interference mitigation at the MES, the use of a shorter (256 chips) real scrambling code is envisaged.

The same scrambling code (staggered by a fixed amount of chips) can be reused in each beam of a given satellite. Different sets of scrambling codes are assigned to each spacecraft. If a given spacecraft is accessed by different LES on the same frequency slot, they must be either mutually synchronized or they shall use different scrambling codes. Depending on orbital parameters, scrambling sequences may be reused among satellites not in simultaneous visibility of the same region. Scrambling code allocation can be done according to several strategies also depending on the constellation and payload (transparent or regenerative) types as well as the degree of synchronization accuracy of LES stations.

The CCPCH common pilot is necessary to support the initial code and frequency acquisition and support satellite diversity operations. The optional use of reference symbols in addition to the common pilot may be required for supporting adaptive antennas.

Channel codes – The channel codes belong to the orthogonal variable spreading factor (OVSF) family. These codes preserve the orthogonality between forward link channels of different rates and spreading factors. Note that as the CCPCH differs from the DPDCH only by the channel code (see Note 1) thus differently from the corresponding terrestrial radio interface the CCPCH is orthogonal to the DPDCH.

The OVSF codes can be defined using the code tree of Fig. 6.

Each level in the code tree defines channel codes of length SF_i . All codes within the code tree cannot be used simultaneously within the same beam. A code can be used in a beam if and only if no other code on the path from the specific code to the root or in the underlying sub-tree is in use. This means that the number of available channel codes is not fixed but depends on the rate and spreading factor of each physical channel.

NOTE 1 – The CCPCH shares the same DPDCH scrambling sequence.

FIGURE 6
Code tree generation for OVSF codes

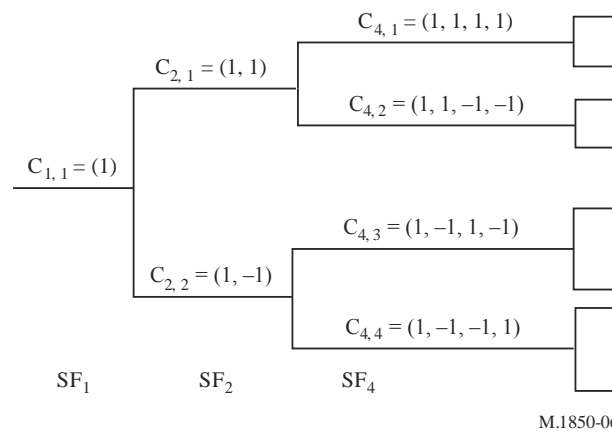

Acquisition and synchronization

In the MES, the initial acquisition is performed by means of the common pilot. The pilot is modulated with a low rate known pattern and its channelization code is known (typically the all zero sequence code). The known pattern modulating the common pilot has the scope to extend the period of the overall signal in order to support satellite diversity operation. After power on, the MES searches for the scrambling code of the common pilot.

The efficiency of that search and therefore the speed of convergence of the initial acquisition, depends on the number of codes to be searched and possible MES knowledge of candidate satellites. The suggested use of staggered scrambling sequence for the different satellite beams will help in reducing the initial acquisition time. Scrambling sequence reuse among different satellites is also a way to reduce the initial search space dimensions.

Once a pilot has been acquired, the primary CCPCH can be de-spread and the BCCH recovered. This maintains specific information on the list of candidate satellites with the associated scrambling codes in order to accelerate the acquisition of other satellites.

Hand-off

Four possible hand-off situations are envisaged: beam hand-off, satellite hand-off, LES hand-off and frequency hand-off.

Beam hand-off – The MES always measures the de-spread pilot $C/(N + I)$ received from adjacent beams and reports measurement results to the LES. When the beam pilot quality is approaching a system threshold level, the LES typically initiates a beam hand-off procedure. According to the MES pilot reports, the LES will decide to transmit the same channel through two different beams (soft beam hand-off) and command the MES to add a finger to demodulate the additional signal. As soon as the LES receives confirmation that the new signal is received, it drops the old beam connection.

Inter-satellite hand-off – The procedure is analogous to that of inter-beam hand-off. The only difference is that the MES has also to search for different pilot scrambling codes. If a new pilot scrambling code is detected, the measure is reported back to the LES, which may decide to exploit satellite diversity by transmitting the same signal through different satellites.

When the satellite constellation provides multiple path diversity, it is useful to operate mobile users in permanent softer hand-off mode. In this case the LES associate the same channel to the strongest satellite diversity paths. The MES exploits path diversity through maximal ratio combining.

Inter-LES hand-off – Inter-LES hand-off may be needed in some cases depending on the constellation characteristics. The inter-LES hand-off shall be negotiated between the LESs. In particular, the new LES starts transmitting its carrier towards the mobile that is simultaneously commanded by the old

LES to search for the new LES signal. When the MES confirms to the old LES that it is also receiving from the new one, the old LES stops transmitting towards the MS.

Inter-frequency hand-off – Only hard inter-frequency hand-off is supported. This hand-off can be either intra-gateway or inter-gateway.

Access description – return link

DPDCH/DPCCH frame structure – The DPDCH/DPCCH frame structure in the return link (see Fig. 7) is the same as that in the forward link. However, differently from the forward link, the DPDCH and DPCCH are code and not time-division multiplexed.

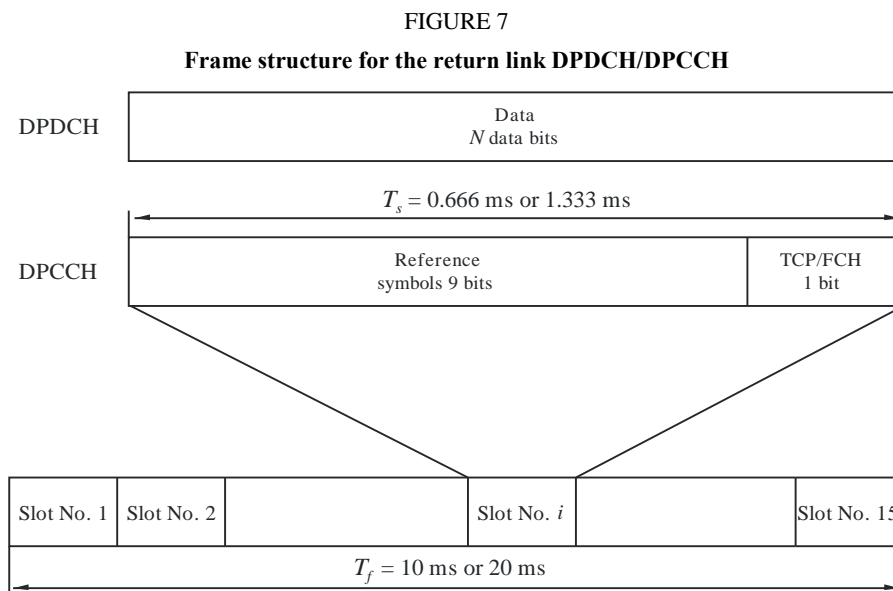

M.1850-07

In the DPCCH, the TCP/FCH field has the same function as that in the forward link. As in the forward link, these bits are mapped to a sequence belonging to a family of 32 sequences. The proposed, length 15 bits, family of sequences is obtained by all the 15 cyclic shift of an ML sequence of length 2^4-1 plus the all zero sequence plus the antipodal of all the previous sequences. The sequences are either almost orthogonal or antipodal.

The reference bit pattern is described in Table 2. The shadowed part can be used as frame synchronization words. The value of the pilot bit other than the frame synchronization word shall be 1. The frame synchronization word is inverted to mark the beginning of a MF.

The rate at which reference symbols, TPC/FCH bits are transmitted is fixed and equal to 15 kbit/s for the full chip rate option and 7.5 kbit/s for the half chip rate option.

Similarly to the forward link, 2 and 3 bits will be transmitted per frame respectively for the TPC and the FCH functions.

- The number of bits per DPDCH slot is related to the spreading factor SF of the physical channel as $SF = 256/2^k$ with $k = 0, \dots, 4$. The spreading factor may thus range from 256 down to 16.

TABLE 2
Reference bit pattern for uplink DPCCH

Bit No. Slot No.	0	1	2	3	4	5	6	7	8
1	1	1	1	0	1	0	1	1	1
2	1	1	1	0	1	1	1	0	1
3	1	0	1	0	1	1	1	0	1
4	1	0	1	1	1	1	1	1	1
5	1	1	1	1	1	0	1	0	1
6	1	0	1	1	1	0	1	1	1
7	1	0	1	1	1	1	1	0	1
8	1	1	1	0	1	1	1	1	1
9	1	0	1	1	1	1	1	0	1
10	1	1	1	0	1	0	1	0	1
11	1	0	1	0	1	0	1	0	1
12	1	0	1	1	1	0	1	0	1
13	1	0	1	0	1	1	1	1	1
14	1	1	1	0	1	1	1	0	1
15	1	0	1	0	1	1	1	1	1

PRACH frame structure – The PRACH frame structure is shown in Fig. 8.

FIGURE 8
PRACH frame structure



M.1850-08

The preamble part is formed by modulating a 48 symbols codeword over a spreading code of period 256 chips.

The 48 symbols codeword preamble is randomly selected by the MES in a small set of quaternary codewords. The spreading code is randomly selected between the spreading codes available for random access. Information about the available spreading codes is given on the BCCH channel.

The data part of the RACH burst is actually composed of a data channel on the I transmission arm and an associated control channel on the Q transmission arm carrying the reference symbols for coherent demodulation and a FCH informing about the data rate and format of the I arm. The data rate of the preamble part is instead fixed and equal to 15 ksymbol/s or 7.5 ksymbol/s according to the chip rate option. The length of the data part of the RACH burst is equal to a frame (i.e. 10 or 20 ms, according to the chip rate option).

No diversity combining is supported on the RACH channel.

Modulation and spreading – The modulation/spreading code used in the return link is shown in Fig. 9. Data modulation is BPSK, where the DPDCH and DPCCH are mapped to the carrier I and Q branches respectively. The I and Q branches are then spread to the chip rate with two different channel codes c_D/c_C and subsequently complex scrambled by a MS specific complex quadri-phase scrambling code.

FIGURE 9

Reverse link spreading modulation scheme for dedicated physical channels a) and its complex representation b)

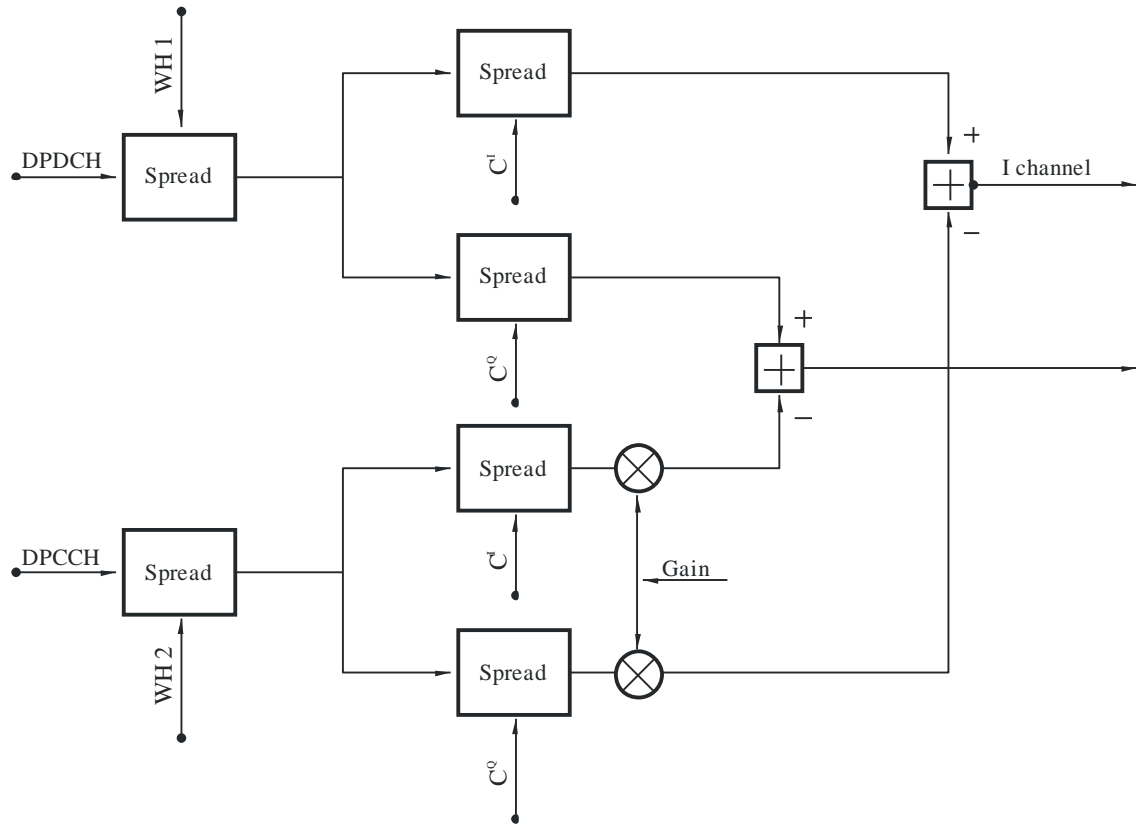

a)

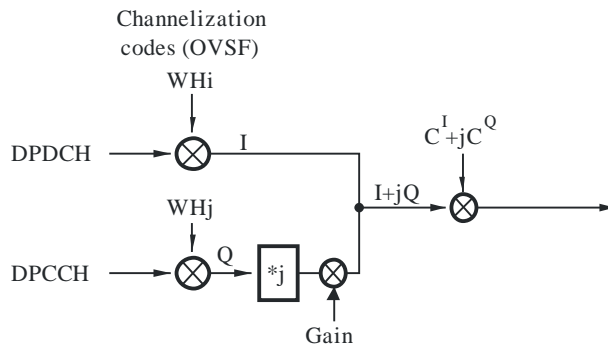

b)

M.1850-09

Scrambling code length is one frame (38 400 chips). An option with a short code (256) is being evaluated for use in conjunction with an MMSE-based interference mitigation technique. The scrambling sequences are the same as defined in specification TS25.213 (prepared by 3GPP).

Scrambling codes are assigned to the MES by the LES on a semi-permanent basis.

The channel codes are the same OVSF codes as for the forward link.

4.3.1.2.3 Terminal features

SW-CDMA supports four MES classes: hand-held (H), vehicular (V), transportable (T) and fixed (F). In Table 3 the terminal feature to terminal classes are mapped.

TABLE 3
Bearer services

Bearer data rate (kbit/s)	Supported QoS	MES class
1.2	10^{-6}	H,V,T,F
2.4	$10^{-3}, 10^{-5}, 10^{-6}$	H,V,T,F
4.8	$10^{-3}, 10^{-5}, 10^{-6}$	H,V,T,F
9.6	$10^{-3}, 10^{-5}, 10^{-6}$	H,V,T,F
16	$10^{-3}, 10^{-5}, 10^{-6}$	H,V,T,F
32	$10^{-3}, 10^{-5}, 10^{-6}$	V,T,F
64	$10^{-5}, 10^{-6}$	V,T,F
144	$10^{-5}, 10^{-6}$	T,F

4.3.1.2.4 RF specifications

4.3.1.2.5 Satellite station

The satellite station RF specifications depend on the actual space segment architecture.

4.3.1.2.6 MES

In Table 4 the RF specifications for the different MES classes are reported.

TABLE 4
MES RF specification

RF parameter	MES class		
	H	V	T
Channel bandwidth (kHz)	2 350 ⁽¹⁾ , 4 700 ⁽²⁾	2 350 ⁽¹⁾ , 4 700 ⁽²⁾	2 350 ⁽¹⁾ , 4 700 ⁽²⁾
Uplink frequency stability (ppm)	3	3	3
Downlink frequency stability (ppm)	0.5	0.5	0.5
Maximum e.i.r.p. (dBW)	3.0	16.0	16.0
Average e.i.r.p. per channel (dBW)	⁽³⁾	⁽³⁾	⁽³⁾
Antenna gain (dBi)	-1.0	2.0 ⁽⁴⁾ , 8.0 ⁽⁵⁾	4.0 ⁽⁴⁾ , 25.0 ⁽⁵⁾
Power control range (dB)	20.0	20.0	20.0
Power control step (dB)	0.2-1	0.2-1	0.2-1
Power control rate (Hz)	50 ÷ 100	50 ÷ 100	50 ÷ 100
Transmit/receive isolation (dB)	> 169	> 169	> 169
G/T (dB/K)	-23.0 ⁽⁴⁾ , -23.0 ⁽⁵⁾	-23.5 ⁽⁴⁾ , -20.0 ⁽⁵⁾	-23.5 ⁽⁴⁾ , -20.0 ⁽⁵⁾
Doppler shift compensation	Yes	Yes	Not applicable

TABLE 4 (end)

RF parameter	MES class		
	H	V	T
Mobility restriction (maximum speed) (km/h)	250 ⁽¹⁾ , 500 ⁽²⁾	250 ⁽¹⁾ , 500 ⁽²⁾	Not applicable

(1) Half rate option (1.920 Mchip/s).

(2) Full rate option (3.840 Mchip/s).

(3) Depending on the satellite station characteristics.

(4) Typical value for LEO constellation.

(5) Typical value for GEO constellation.

Baseband specifications

The baseband specifications are provided in Table 5.

TABLE 5

Baseband characteristics

BB-1	Multiple access	
BB-1.1	Technique	Direct sequence CDMA
BB-1.2	Chip rate (where appropriate)	1.920 Mchip/s or 3.840 Mchip/s
BB-1.3	Time slots (where appropriate)	15 time slots per frame
BB-2	Modulation type	– Dual-code BPSK in the uplink – QPSK or BPSK in the downlink
BB-3	Dynamic channel allocation (yes/no)	No
BB-4	Duplex method (e.g. FDD, TDD)	FDD
BB-5	FEC	– Standard quality: convolutional coding with code rate 1/3 or 1/2 constraint length $k = 9$. Variable puncturing repetition to match the required info rate. – High quality concatenated RS code over GF(2 ⁸), concatenated with inner convolutional code with rate 1/3 or 1/2, constraint length $k = 9$. Turbo coder as option
BB-6	Interleaving	– Interleaving on a single frame basis (default). – Interleaving on a multiple frame basis (optional)
BB-7	Synchronization between satellites required (y/n)	– Synchronization between BSs working on different satellites is not required. – Synchronization between BSs working on the same satellite is required

Detailed specifications

The SW-CDMA radio interface detailed specification is based on the following set of documents:

- *Physical layer*: the most recent version of the SW-CDMA documents derived from the 25.200 series (see Note 1).
- *Protocols*: most recent versions of the 25.300 draft specifications (see Note 2).

NOTE 1 – This set of detailed specifications is presently being elaborated inside the ETSI TC-SES S-UMTS working group among the family of the voluntary standards for IMT-2000 satellite radio interface. This specification will also provide a general description of the physical layer of the SW-CDMA air interface.

NOTE 2 – As developed within the 3GPP RAN TSG. These documents can be found on: <http://www.3gpp.org/RAN> and <http://www.3gpp.org/RAN4-Radio-performance-and>. This specification describes the documents being produced by the 3GPP TSG RAN WG 4.

4.3.2 Satellite radio interface B (SRI-B) specifications

Wideband code/Time division multiple access (W-C/TDMA) is a satellite radio interface designed to meet the requirements of the satellite component of the third generation (3G) wireless communication systems (see Note 1).

The W-C/TDMA radio interface is supposed to be compliant with the radio interface CN and related specifications for the Iu and Cu interface.

W-C/TDMA is based on a hybrid code and time-division multiple access (C/TDMA) technique with RF channel bandwidth of either 2.350 or 4.700 MHz for each transmission direction.

W-C/TDMA is characterized by a slotted structure, a quasi-synchronous operation of the uplink resulting in a quasi-orthogonal partitioning of most radio resources of a single, multibeam satellite system.

According to the relevant IMT-2000 satellite band regulations, the baseline duplexing scheme is FDD: however a TDD/FDD scheme is supported in which the transmission takes place in a different time slot with respect to reception and in different frequency bands. The half rate option provides finer spectrum granularity and robustness with respect to chip synchronization and tracking in channel with high Doppler shift.

W-C/TDMA provides a wide range of bearer services from 1.2 up to 144 kbit/s. High quality telecommunication service can be supported including voice quality telephony and data services in a global coverage satellite environment. W-C/TDMA supports additional features specific of the satellite environment such as the provision of a high penetration paging channel.

The main attractive features of W-C/TDMA are hereafter summarized:

- W-C/TDMA provides superior system capacity over a narrow-band TDMA or FDMA system.
- Supports FDD/TDD mode operation requiring terminals with less demanding antenna duplexers.
- Provides more resources allocation flexibility thanks to orthogonal partitioning (TDM/TDMA) of a high percentage of radio resources on top of CDM/CDMA.
- Allows full frequency re-use simplifying frequency planning.
- Provision of finer granularity of user data rates compared to narrow-band systems avoiding high peak-to-mean power.
- Provision of accurate user positioning without external means.
- Support of high penetration messaging service.

NOTE 1 – The W-C/TDMA radio interface is currently being examined by the (ETSI) SES Technical Committee among the family of IMT-2000 satellite radio interfaces as a voluntary standard.

4.3.2.1 Architectural description

4.3.2.1.1 Channels structure

This radio interface specification is relevant just to the service link, the feeder link not being part of it.

The service link consists of a forward link, between the satellite station and the MES and a return link in the opposite direction.

At the physical layer, the information flow to and from the MES is conveyed through logical channels as defined in Recommendation ITU-R M.1035.

Those logical channels make use of physical channels as bearer medium.

W-C/TDMA adopts the same physical channel structure as the terrestrial radio interface. The mapping between physical and logical channels is shown in Table 6.

Two broadcast physical channels are foreseen in the forward direction, primary and secondary common control physical channel, P/S-CCPCH.

The primary CCPCH supports the broadcast control channel (BCCH) used to broadcast system and beam specific information.

The secondary CCPCH supports two logical channels namely the forward access channel (FACH), carrying control information to an identified MES when its position is known.

The PRACH supports the RACH, carrying control information and the RTCH, carrying short user packets.

TABLE 6
Physical to logical channel mapping

Logical channels	Physical channels	Direction
BCCH	Primary CCPCH	Forward
FACH	Secondary CCPCH	Forward
Pilot	PI-CCPCH	Forward
PCH	HP-CCPCH	Forward
RACH RTCH	PRACH	Reverse
DCCH	DDPCH	Bidirectional
DTCH	DDPCH	Bidirectional
Layer 1 signalling and pilot symbols	DCPCH	Bidirectional

The dedicated physical control channel (DCPCH) is used for Layer 1 signalling.

The DDPCH is used for carrying either control information such as higher layer signalling, conveyed through the dedicated control channel (DCCH) and bidirectional user data conveyed through the dedicated traffic channel (DTCH).

The above bearer services can be utilized to provide circuit-switched and packet data services.

Multiple user services can be supported on the same connection using a time-multiplexed structure.

With respect to that a specific physical control channel has been introduced, HP-CCPCH, supporting, in the forward link the high penetration paging channel, a low data rate service, whose primary scope is as a paging service or ring alert for MESs localized inside buildings.

4.3.2.1.2 Constellation

W-C/TDMA does not compel to any particular constellation. It has been designed to be supported by low, medium, geostationary or high Earth orbit (LEO, MEO, GEO or HEO) constellations.

Even though multiple spot-beam coverage will ensure the best system performances, this shall not be regarded as a mandatory system requirement.

4.3.2.1.3 Satellites

W-C/TDMA does not compel to any particular satellite architecture. It can be operated either over a bent-pipe transparent satellite transponder or by regenerative transponder architecture.

4.3.2.2 System description

4.3.2.2.1 Service features

Depending on the MES class, W-C/TDMA supports bearer services ranging from 1.2 kbit/s up to 144 kbit/s with associated maximum BER between 1×10^{-3} to 1×10^{-6} .

The maximum tolerated delay is up to 400 ms, compatible with any of the above-mentioned satellite constellations.

4.3.2.2.2 System features

Both in the forward and in the return link two spreading rates are supported, both 3.840 Mchip/s (full chip rate) and 1.920 Mchip/s (half chip rate).

Closed-loop power control is implemented for both the forward and return link. The loop is driven in order to set the measured SNIR value after RAKE combining to a target value. The target value is itself adaptively modified by means of slower outer control loop based on FER measurements. To support FER measurements 8 bit CRC (4 bit for 2 400 bit/s) are appended to data in each frame.

An open loop power control is provided for packet transmission and initial setting of power during the call set-up phase.

Three basic service classes are supported by a concatenation of coding and interleaving:

- standard services with inner coding (rate 1/3 convolutional, polynomials 557, 663, 711) and interleaving only, with a target BER equal to 1×10^{-3} ;
- high quality services with inner coding and interleaving plus outer RS coding and interleaving. The target BER after the inner decoding is 1×10^{-6} ;
- services with service specific coding. For these services no specific FEC coding technique is applied by the radio interface. Possible FEC coding is entirely managed at higher layer.

These classes allow matching of the various QoS requirements of the selected satellite services and permitting QoS enhancements, if required, through the choice of a service specific coding.

The interleaving scheme is negotiated at call set-up, depending on the actual data rate. The interleaving depth spans over an integer multiple of the frame period. The interleaving block is written per rows over a number of columns, which is a power of two, the exponent depending on the actual data rate. In reception, the interleaving block is read per columns in a shuffled sequence, i.e. by reading the binary column index in the reverse order.

Satellite diversity

In a multiple satellite coverage scenario, the LES may decide to combine return link signals of co-coverage satellites with the return link signal received via the primary satellite to improve the SNIR and to reduce shadowing probability. Since quasi-synchronous operation is restricted to the primary satellite, the resulting SIR at a secondary satellite demodulator where the user is received asynchronously is generally lower. In spite of these SIR inequities, it can be shown that there is a substantial gain from maximal ratio combining techniques which may be used to increase return link power efficiency and capacity.

Access description

In the forward link from the satellite station to the MES an orthogonal CTDM is adopted. In the return link, from the MES to the satellite station quasi-synchronous W-C/TDMA is adopted.

The transmission is organized in frames, as shown in Fig. 10. The frame period is 20 ms and is subdivided in 8 time slots. Frames are organized in multiframes (MF, period 180 ms) consisting of 8 ordinary frames plus one extra frame.

The coexistence between synchronous and asynchronous traffic (initial access) is handled with a segregated approach, in which the available resources are partitioned in time in two frames each one reserved to its specific use.

In the forward link frame 0 is dedicated to broadcast common functions (paging, high penetration messaging channel, synchronization, etc.).

The first frame in each MF (frame 0) is reserved to the asynchronous traffic: in the return link, packets are sent asynchronously by MESs in frame 0 of each multiframe, as shown in Fig. 11.

Bursts – Transmission takes place in bursts which can have the duration of a single time slot or may span over an integer number of time slots.

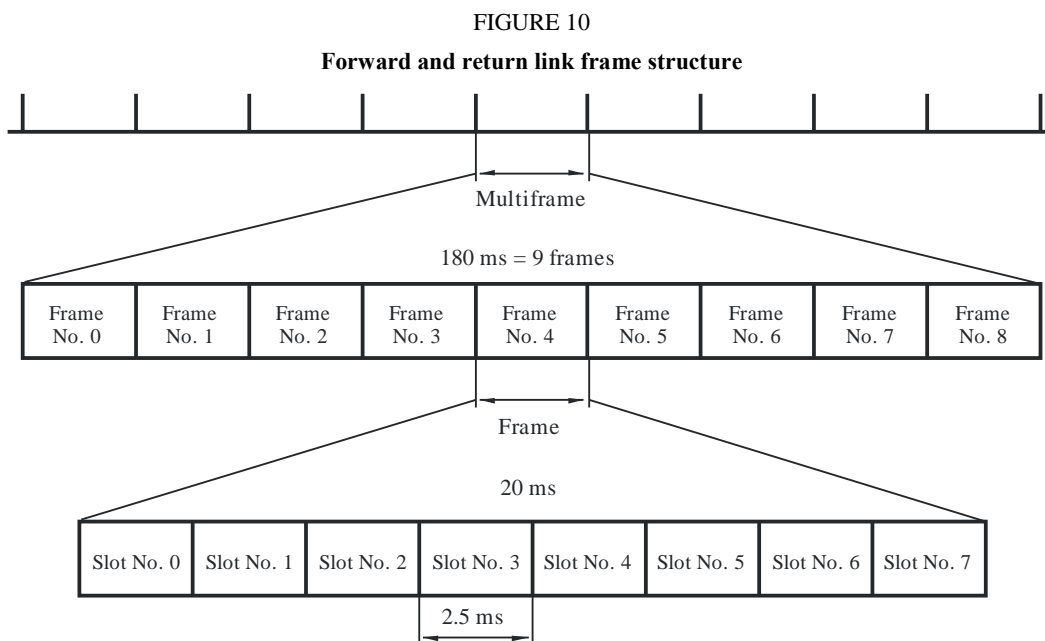
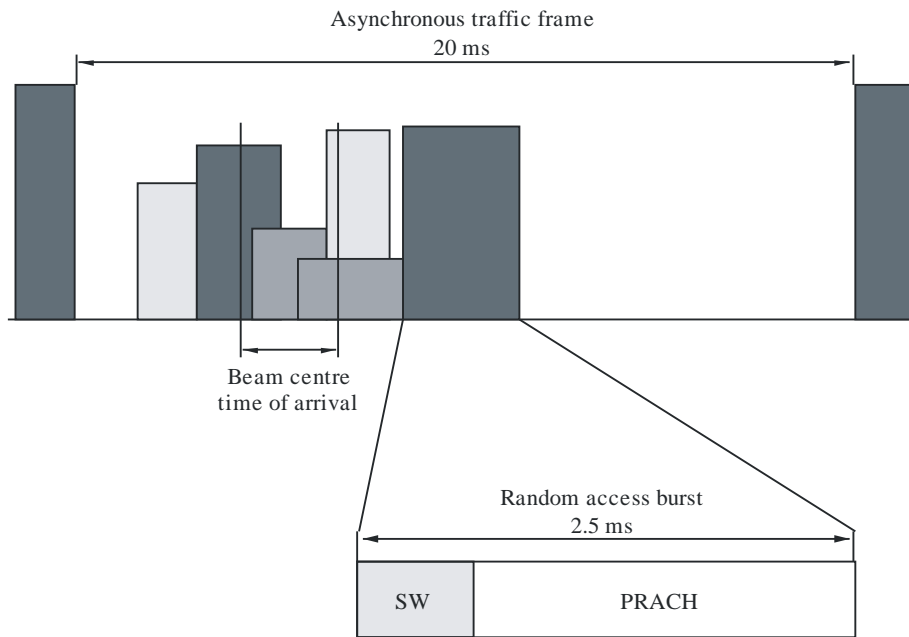

FIGURE 11
Asynchronous traffic in the return link, frame 0



M.1850-11

In case of synchronous traffic, burst can span over an integer number of time slots, not necessarily contiguous.

In case of asynchronous traffic, bursts are transmitted, in a non-slotted frame, at random times taking care not to invade the adjacent frames.

Two bursts size are envisaged: short, containing 160 bytes and long containing 320 bytes.

The duration of a burst depends on the selected chip rate and spreading factor.

The burst size and the spreading factor are controlled by the LES and cannot be modified during a session. The information rate can be varied on a burst-to-burst basis.

Forward link

DCPCH/DDPCH – In the forward link DCPCH and DDPCH are multiplexed on the same burst (forward link dedicated burst). The burst structure is shown as in Fig. 12.

The DPCCH carries the reference (pilot) symbols, the power control field (TPC), the frame control header (FCH), which indicates the actual code rate, and the time and frequency control field (TFC), required for quasi-synchronous operation.

FIGURE 12

Forward link dedicated burst

DCPCH				DDPCH
FCH	TPC	TFC	Pilot	User data
n_{FFD}	n_{TPD}	n_{TFD}	(n_{PFD})	n_{DFD}
n_{OFD}				
Control and user data interleaved, pilot symbols equally spaced				
1, 2 or 4 slots				

M.1850-12

The forward link common burst carries the CCPCH. Its structure is shown in Fig. 13.

FIGURE 13

Forward link common burst

CCPCH	
FCH	Data
n_{FFC}	n_{DFC}
n_{OFC}	
Control and user data interleaved	
1, 2 or 4 slots	

M.1850-13

The forward link synchronization burst carries the high penetration paging channel (HP-CCPCH). Its structure is shown in Fig. 14.

FIGURE 14
Forward link synchronization burst

HP-CCPCH		
SW	Pilot	Data
n_{SWS}	n_{PFS}	n_{DFS}
n_{OFS}		
SW	Pilot symbols equally spaced	
1 slot		

M.1850-14

Return link

Two burst structure are foreseen in the return link: random access burst and return link dedicated burst. Their structure is shown in Figs 15 and 16, respectively.

FIGURE 15
Return link random access burst

PRACH		
SW	Pilot	Data
n_{SRR}	n_{PRR}	n_{DRR}
n_{ORR}		
SW	Pilot symbols equally spaced	
1 slot		

M.1850-15

FIGURE 16
Return link dedicated burst

DCPCH			DDPCH
FCH	TPC	Pilot	User data
n_{FRD}	n_{TRD}	(n_{PRD})	n_{DRD}
n_{ORD}			
Control and user data interleaved, pilot symbols equally spaced			
1, 2 or 4 slots			

M.1850-16

Definition of the burst parameters

The burst parameters are defined in Tables 7 to 11.

TABLE 7
Forward link dedicated burst

		Short burst		Long burst	
		Symbols	Percentage	Symbols	Percentage
Total	N_{OFD}	160	100	320	100
Data	N_{DFD}	112	70	256	80
(Pilot)	(N_{PFD})	(16)	(10)	(32)	(10)
FCH	N_{FFD}	16	10	16	5
TPC	N_{TPD}	8	5	8	2.5
TFC	N_{TFD}	8	5	8	2.5
Total overhead		48	30	64	20

TABLE 8
Forward link common control burst

		Short burst		Long burst	
		Symbols	Percentage	Symbols	Percentage
Total	N_{OFC}	160	100	320	100
Data	N_{DFC}	144	90	304	95
FCH	N_{FFC}	16	10	16	5
Total overhead		16	10	16	5

TABLE 9

Forward link synchronization burst

		Short burst	
		Symbols	Percentage
Total	N_{OFS}	160	100
Data	N_{DFS}	112	70
SW	N_{SWS}	32	20
Pilot	N_{PFS}	16	10
Total overhead		48	30

TABLE 10

Random access burst

		Short burst	
		Symbols	Percentage
Total	N_{ORR}	160	100
Data	N_{DRR}	112	70
SW	N_{SRR}	32	20
Pilot	N_{PRR}	16	10
Total overhead		48	30

TABLE 11

Return link dedicated burst

		Short burst		Long burst	
		Symbols	Percentage	Symbols	Percentage
Total	N_{ORD}	160	100	320	100
Data	N_{DRD}	120	75	264	82.5
Pilot	N_{PRD}	16	10	32	10
FCH	N_{FRD}	16	10	16	5
TPC	N_{TRD}	8	5	8	2.5
Total overhead		40	25	56	17.5

Channel assignment and transmission mode

The combination of an assignment of a number of spreading code and time slots in a multi-frame constitutes a virtual channel assignment. The number of codes will likely be equal to one, but might be greater than one if MESs capable of multi-code reception and/or transmission are considered. The assignment of slots for dedicated channels is restricted to frames No. 1 to No. 8 (No. 5 in the five frames per multi-frame option). A channel assignment is valid for the duration of a session.

The principle of OVSF codes permits orthogonal or quasi-orthogonal channels with codes associated to different spreading factors to coexist. Spreading code, slots, burst type, and other link parameters for the forward and return link are assigned by the LES during the set-up of a session. It is proposed not to change the spreading code (spreading factor) during a session. Variable rate transmission is realized solely by changing the code rate.

Different transmission modes are considered:

- Two-way stream mode transmission: a communication channel is assigned on the forward and the return link.
- Forward link stream mode one-way transmission: a communication channel is assigned only on the forward link.
- Return link stream mode one-way transmission: this mode is prohibited since there is no possibility to send TFC commands on the forward link.
- Packet data transfer: If the frequency of packets to the same destination is low, no channel will be assigned and packets are transferred in frame No. 0. This is valid for both directions. (Zones at the edges of frame No. 0 where congestion is assumed to be lower will preferably be used for packet transfer in the return direction.) If the frequency of packets to the same destination is sufficiently high to justify a session, a dedicated channel may be assigned in frames No. 1 to No. 8.

An optimum choice of the justification threshold for an assignment of a dedicated channel for packet data transfer is crucial. It should prevent overloading of frame No. 0 in particular of the return link and save satellite power. Connectionless packet data transfer does not allow power control. Thus, higher link margins have to be provided for packet transmission requiring more satellite power. On the other hand, channel assignments require signalling overhead which also requires additional satellite energy and reduces capacity.

Channel coding, rate adapter and service multiplexing

The channel coding and service multiplexing scheme is shown in Fig. 17 and is applicable to the forward and return link dedicated physical channel. The diagram is generic and applies in the simple case where only one service with specified quality and rate is transmitted on a single burst in a single code channel as well as in the more general case where multiple services requiring different rates and qualities are simultaneously transmitted on a single burst in a single code channel.

FIGURE 17

Coding and multiplexing scheme

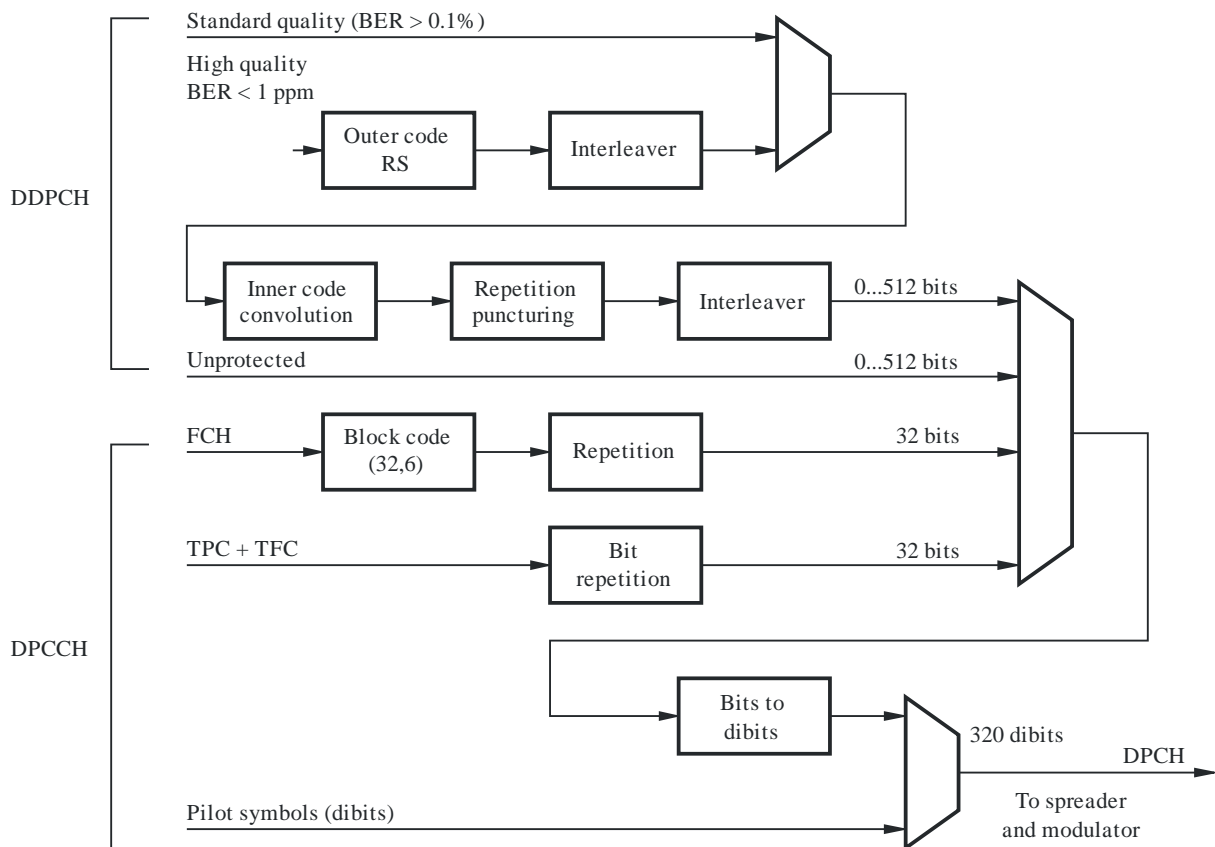

M.1850-17

The de-multiplexing and decoding schemes to be applied at the receiving side are indicated in the FCH.

Modulation and spreading

Figure 18 represents the proposed generic spreader and modulator for the forward and return link, respectively. The principle of the proposed spreading and modulation scheme for the forward and return link is described in the following: After insertion (multiplexing) of pilot symbols (dibits) (if required), the dibit stream is split into two bi-polar data streams, called the I- and the Q-streams. These data, clocked at symbol rate, are multiplied with the bi-polar components of the spreading code vector denoted $c_{s,m}$, clocked at chip rate, such that one bi-polar data sample is a scalar factor of the code vector. This operation is called spreading or channelization.

FIGURE 18

Forward link generic spreader and modulator
 (rates indicated refer to the 1.920 Mchip/s option and a spreading factor of 32)

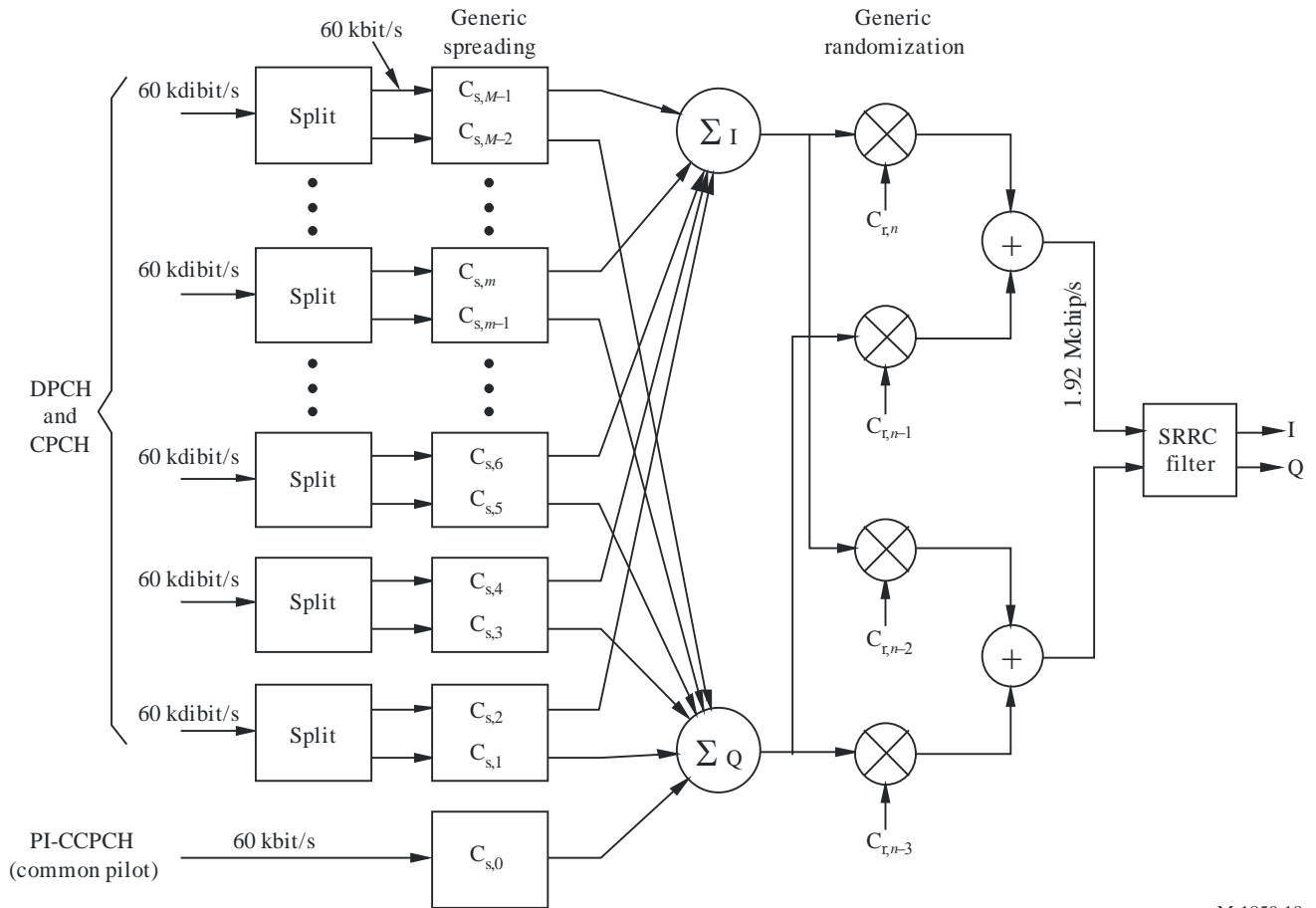

M.1850-18

The resulting I- and Q-spread transmit sequences are additionally randomized using bi-polar PN-sequences, called randomization codes, denoted $c_{r,n}$, such that the transmit signal appears noise like in a receiver which is not synchronized or which reuses the same spreading code. There are three different ways to randomize:

- real randomization using a single randomization code;
- complex randomization using a pair of randomization codes and full complex multiplication;
- I/Q independent randomization using a pair of randomization codes such that one code is multiplied with the I-branch signal and the other code with the Q-branch signal.

Possible code configurations for QPSK and dual BPSK using either real or complex randomization are listed in Table 12.

TABLE 12

Spreading and randomization code configurations

Data modulation	Spreading codes	Randomization codes	Remarks
QPSK	$c_{s,m} = c_{s,m-1}$	$c_{r,n} = c_{r,n-3}, c_{r,n-1} = c_{r,n-2} = 0$	Real randomization
QPSK	$c_{s,m} = c_{s,m-1}$	$c_{r,n} = c_{r,n-2} \neq c_{r,n-1} = c_{r,n-3}$	Complex randomization
Dual BPSK	$c_{s,m} = c_{s,m-1}$	$c_{r,n} = c_{r,n-3}, c_{r,n-1} = c_{r,n-2} = 0$	Different randomization on I- and Q-branch
Dual BPSK	$c_{s,m} \neq c_{s,m-1}$	$c_{r,n} = c_{r,n-3}, c_{r,n-1} = c_{r,n-2} = 0$	Real randomization
Dual BPSK	$c_{s,m} \neq c_{s,m-1}$	$c_{r,n} = c_{r,n-2} \neq c_{r,n-1} = c_{r,n-3}$	Complex randomization

In line with the scheme applicable for the corresponding terrestrial radio interface, orthogonal variable spreading factor (OVSF) codes based on a length 128 bits Walsh-Hadamard code set for the 1.920 Mchip/s option and on a length 256 bits Walsh-Hadamard code set for the 3.840 Mchip/s option are proposed.

Forward link

The generic form of the forward link spreader and modulator is shown in Fig. 18. Except for the common pilot channel (PI-CCPCH), different configurations of spreading and randomization codes may be applied. Since the same randomization is applied to all simultaneously transmitted forward link channels, summation is prior to randomization.

It is proposed to use either QPSK or dual BPSK and real randomization for all DPCH and CPCH. Normally, a multitude of code channels is simultaneously transmitted on the forward link that results in a circular I/Q amplitude distribution in any case. Thus, real randomization is adequate requiring minimum complexity.

The use of dual BPSK would reduce the number of orthogonal code channels to one half, since different spreading codes are applied to the I- and Q-branches. Single spreading code dual BPSK with I/Q independent randomization represents a way to avoid the above code-book limitation at the expenses of an increased sensitivity to carrier phase errors.

Dual BPSK with real randomization is used for the synchronization burst (HP-CCPCH). The PI-CCPCH is mapped on spreading code No. 0 which is the all 1-sequence. The PI-CCPCH data is simply an endless sequence of 1 s, interrupted in those slots where the synchronization burst is transmitted. Thus, the PI-CCPCH is the randomization code itself.

Return link

The generic form of the return link spreader and modulator is shown in Fig. 19. Different configurations of spreading and randomization codes may be applied as on the forward link.

It is proposed to use either QPSK or dual BPSK data modulation both with complex randomization for DPCH. The use of orthogonal dual BPSK would reduce the number of code channels to one half. Dual BPSK with I/Q independent spreading (without code channel reduction) can be considered when code-book size is an issue. The more robust dual BPSK with complex randomization is proposed for the random access burst (PRACH).

In contrast to the forward link, $\pi/4$ -QPSK spreading modulation is proposed in order to reduce envelope fluctuations. Optionally, pre-compensated frequency modulation (PFM) can be envisaged. PFM is a constant envelope modulation technique which can be designed to work with a standard

Nyquist-filtered $\pi/4$ -QPSK receiver. PFM represents a trade-off between adjacent channel (frequency band) interference (ACI), code channel cross talk and BER-performance in AWGN conditions.

FIGURE 19
Return link generic spreader and modulator
(rates indicated refer to the 1.920 Mchip/s option and a spreading factor of 32)

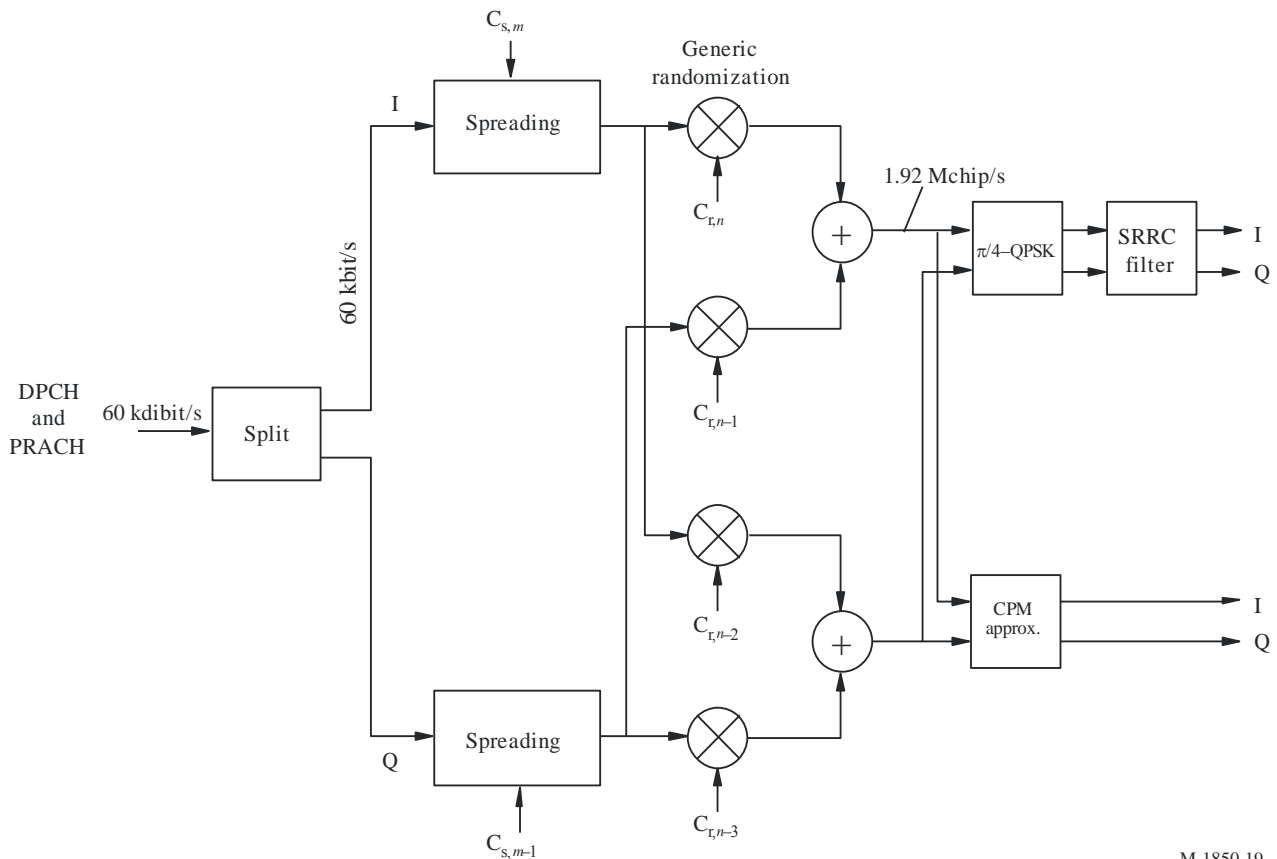

M.1850-19

System time and frequency reference

It is assumed that system time and frequency reference is virtually located in the satellite. This means, that the signals emitted by the satellite correspond to the nominal frequencies and timing. In case of a transparent transponder, the LES offsets the transmit times, frequencies, chip rates, etc. of its feeder uplink so that the signals arrive at the intended satellite in synchronism with the nominal system time and frequency. Beam specific time shifts and Doppler pre-compensation may be additionally applied for the service links. For the return link it is assumed that the LES controls timing of the individual MTs such that the return link signals arrive at the intended satellite in quasi-synchronism with the nominal system time and frequency. Beam specific time shifts and frequency offsets may be applied additionally for the service return links.

The feeder downlink needs no specification in this context, since feeder propagation time varies for all beams exactly in the same manner.

Intra-satellite inter-beam synchronization

It is proposed to keep transmit times (frame structure) in all beams of the same satellite aligned. There will be small intentional and fixed time offsets in the order of a few chip periods in order to permit reuse of the same randomization code in all beams of the same satellite.

Time offsets will also be required for the return link frame structure of signals arriving at the satellite from different beams, if the same randomization code shall be used for all beams of a satellite. The

same time offsets are proposed for the return link frame structure. The LES controls the MTs in a manner such that the above offsets occur at the LES receiver.

In general, there will be a fixed offset between the forward and return link frame structure.

System-wide inter-satellite synchronization

It is proposed to maintain time synchronism between all satellites belonging to the same SRAN. This means transmissions from different satellites are aligned to one another with respect to the frame structure within an accuracy in the order of a MS. In case of transparent payloads and no inter-satellite links, the system-wide synchronization may be maintained by the LESs interconnected via a terrestrial network. Time alignment limits frame timing differences between pairs of satellites to the minimum possible. It is believed that this is advantageous for satellite path diversity and handover.

Randomization codes assignment

The purpose of the overlaid randomization of the spreading code is to make adjacent beam and inter-satellite interference appear more noise like in any situation at any time. The following generic randomization codes assignment approach is proposed:

- One specific and one common randomization code sequence (real randomization) is assigned to each satellite belonging to the same SRAN to be used on the forward link.
- A specific pair of randomization codes (complex randomization) is assigned to each satellite belonging to the same SRAN to be used on the return link.
- The specific forward link randomization code is unique in the SRAN and is applied to all forward link transmissions (except the synchronization burst) of all beams of the same satellite.
- The specific pair of return link codes is unique in the SRAN and is applied to all quasi-synchronous and asynchronous return link transmissions of all beams of the same satellite.
- The common code is applied to the forward link synchronization bursts (HP-CCPCH) of all beams of all satellites belonging to the same SRAN.
- The start of the specific and common randomization code refers to the first chip in slot No. 1 of frame No. 0 for both forward link synchronous and return link quasi-synchronous traffic. Clocking of the randomization code is continued through any period of HP-CCPCH transmission on the forward link or asynchronous traffic frame on the return link where quasi-synchronous traffic is interrupted.
- In case of asynchronous traffic, the start of the randomization code sequences of the specific pair refers to the first chip of the random access burst.

The use of a common randomization code for the synchronization bursts simplifies forward link acquisition and allows decoding of the HP-CCPCH with minimum system information. Accidental interference de-randomization in case of HP-CCPCH reception is unavoidable with this approach. In order to lower the probability of acquisition failures or message losses in the delay co-incidence zones of a multiple satellite scenario, it is proposed to artificially vary the power of the synchronization bursts transmitted by the different satellites by approximately 6 dB in a manner such that only one of the serving satellites transmits at full power at a time. Power variation would be applied only in those beams covering the delay co-incidence zones.

Forward link acquisition and synchronization

The following forward link acquisition and synchronization procedure is proposed:

- The MES initially acquires the forward link synchronization (time and frequency) by using the periodic SWs transmitted in slot No. 1 of frame No. 0. The spread SW has a length of $32 \times 30 = 960$ chips referred to the half rate option) and is common to all beams and satellites.

- If several SWs from different beams or satellites are detected, it chooses the one associated with the largest correlation peak to establish frequency, frame, symbol and chip synchronization.
- The MES uses the common pilot channel (PI-CCPCH) to extract the randomization code unique to the particular satellite by correlating the receive signal against all possible randomization sequences used in the SRAN.
- The MES attempts to further improve time and frequency synchronization using the PI-CCPCH.
- The MES reads the BCCH transmitted on a primary CCPCH in frame No. 0 to acquire all relevant high level synchronization and system information.

Return link synchronization acquisition

The following procedure is proposed for initial access and the return link synchronization acquisition and tracking:

- The MES is allowed to access the LES only after having successfully established forward link synchronization.
- The MES reads the information about the instantaneous Doppler and time delay at the beam centre point broadcast by the LES in frame No. 0.
- The MES applies Doppler pre-compensation and timing advance, such that the random access burst is received with minimum Doppler shift and timing error at the satellite. The MES therefore computes frequency pre-compensation and burst timing to be applied on the return link using information gathered on the forward link.
- The MES transmits the pre-compensated random access burst in frame No. 0 at the computed time instance. (The computed timing of the random access bursts may be additionally slightly randomized to avoid interference hot spots in the asynchronous traffic frame. However, these offsets would have to be indicated in the content of the random access burst.)
- If the LES has successfully captured the random access burst, it estimates time and frequency (measures residual timing and Doppler errors) and sends a channel assignment, as well as timing and frequency corrections to the MES using a CCPCH.
- Upon successful reception of the forward link message, the MES corrects its Doppler pre-compensation and chip timing and starts to transmit bursts in the assigned time slots within the quasi-synchronous traffic frames. The return link transmission may now be considered as quasi-synchronous to other traffic arriving at the LES. The return link may be considered as fully Doppler precompensated with respect to carrier frequency and chip clock.
- The MES continuously tracks the forward link carrier frequency and chip timing and corrects return link carrier frequency and chip timing upon reception of TFC commands continuously sent by the LES.

Recognizing that the precise synchronization required may occasionally be lost (e.g. caused by shadowing), a reacquisition procedure is also defined in order to quickly restore synchronization.

A loss of synchronization may be indicated at the LES or the MES by the fact that the BER measured over a number of received bursts exceeds a certain threshold. In case of synchronization loss the LES may initiate a reacquisition procedure. The reacquisition procedure is similar to the forward and return link acquisition procedure and is proposed as follows:

- The LES requests a reacquisition using the dedicated logical control channel soon after it has lost return link synchronization.

- On reception of the reacquisition request or on local synchronization loss indication, the MES immediately stops transmitting traffic and, if necessary, tries to reacquire forward link synchronization (the use of the common pilot may be sufficient for this purpose).
- In any case, the MES sends a reacquisition message only upon request by the LES using the random access burst. (Since timing uncertainty may be assumed to be smaller compared to the initial access case, special portions close to the edges of the asynchronous traffic frame having lower congestion may be used for this purpose.)
- After having restored full synchronization, traffic transmission is continued. The LES continues to send TFC commands to track the return link synchronization.

The quasi-synchronous W-C/TDMA return link

The advantage of a quasi-synchronous return link is that intra-beam interference is kept at a minimum, thus, allowing more inter-beam or inter-satellite interference. Its drawback is the need for precise timing control by the LES. Considering multi-satellite path diversity, only a portion of the MES population will be synchronized to one satellite (those which are assigned to that satellite by the SRAN). The return link signals of the remaining MESs, assigned to different satellites, would have to be received asynchronously.

FDD/TDD mode operation

The W-C/TDMA scheme proposed intends to support terminals operating in frequency/time division duplex mode. A pure TDD mode using the same carrier frequency in both transmit directions as proposed by ETSI for the terrestrial component is not considered here.

A MES operating in frequency/time division transmits and receives signals in separate time periods and on separate carrier frequencies but never at the same time. Such MESs require simpler diplexers at the antenna port.

In contrast to terrestrial networks, for satellites in non-geostationary orbit, the propagation time may significantly vary inside the footprint of a beam during a connection. The LES controls return link timing such that the frame timing of the signals arriving at the satellite is maintained at a beam specific offset.

In general, there will also be an unknown but fixed offset between the forward and return link frame structure of the same beam. While a fixed return link timing is maintained at the satellite (LES), the timing of the return link frames continuously drifts against the forward link for an observer at the MES when the path length changes. During the time a MES dwells in the footprint of the same beam, the frame offset may vary up to approximately 12 ms, depending on the satellite system. The relative frame drift in a MES operating in FDD/TDD implies the requirement of slot reassignments from time to time, in order to prevent a transmit/receive conflict. The FDD/TDD mode is mainly suited for hand-held terminals.

4.3.2.2.3 Terminal features

W-C/TDMA supports four MES classes: hand-held (H), vehicular (V), transportable (T) and fixed (F). In Table 13 the terminal feature to terminal classes are mapped.

TABLE 13
Bearer services

Bearer data rate (kbit/s)	Supported QoS	MES class
1.2	10^{-6}	H,V,T,F
2.4	$10^{-3}, 10^{-5}, 10^{-6}$	H,V,T,F
4.8	$10^{-3}, 10^{-5}, 10^{-6}$	H,V,T,F
9.6	$10^{-3}, 10^{-5}, 10^{-6}$	H,V,T,F
16	$10^{-3}, 10^{-5}, 10^{-6}$	H,V,T,F
32	$10^{-3}, 10^{-5}, 10^{-6}$	V,T,F
64	$10^{-5}, 10^{-6}$	V,T,F
144	$10^{-5}, 10^{-6}$	T,F

4.3.2.3 RF specifications

4.3.2.3.1 Satellite station

The satellite station RF specifications depend on the actual space segment architecture.

4.3.2.3.2 MES

In Table 14 the RF specifications for the different MES classes are reported.

TABLE 14
MES RF specifications

RF parameter	MES class		
	H	V	T
Channel bandwidth (kHz)	2 350 ⁽¹⁾ , 4 700 ⁽²⁾	2 350 ⁽¹⁾ , 4 700 ⁽²⁾	2 350 ⁽¹⁾ , 4 700 ⁽²⁾
Uplink frequency stability (ppm)	3	3	3
Downlink frequency stability (ppm)	0.5	0.5	0.5
Maximum e.i.r.p. (dBW)	8.0 ⁽³⁾ , 12.0 ⁽⁴⁾	11.0 ⁽³⁾ , 18.0 ⁽⁴⁾	20.0 ⁽³⁾ , 20.0 ⁽⁴⁾
Average e.i.r.p. per channel (dBW)	⁽⁵⁾	⁽⁵⁾	⁽⁵⁾
Antenna gain (dBi)	2.0	2.0 ⁽⁶⁾ , 8.0 ⁽⁷⁾	4.0 ⁽⁶⁾ , 25.0 ⁽⁷⁾
Power control range (dB)	20.0	20.0	20.0
Power control step (dB)	0.2/1	0.2/1	0.2/1
Power control rate (Hz)	50 ÷ 100	50 ÷ 100	50 ÷ 100
Transmit/receive isolation (dB)	> 169	> 169	> 169
G/T (dB/K)	-23.0 ⁽⁶⁾ , -22.0 ⁽⁷⁾	-23.5 ⁽⁶⁾ , -20.0 ⁽⁷⁾	-23.5 ⁽⁶⁾ , -20.0 ⁽⁷⁾

TABLE 14 (*end*)

RF parameter	MES class		
	H	V	T
Doppler shift compensation	Yes	Yes	Not applicable
Mobility restriction (maximum speed (km/h))	250 ⁽¹⁾ , 500 ⁽²⁾	250 ⁽¹⁾ , 500 ⁽²⁾	Not applicable

(1) At 1.920 Mchip/s.

(2) At 3.840 Mchip/s.

(3) FDD/TDD mode.

(4) FDD mode.

(5) Depending on the satellite station characteristics.

(6) Typical value for LEO constellation.

(7) Typical value for GEO constellation

4.3.2.4 Baseband specifications

In Table 15 the overall W-C/TDMA baseband characteristics are summarized.

TABLE 15

Baseband characteristics

BB-1	Multiple access	
BB-1.1	Technique	Forward link: Hybrid wideband Orthogonal CDM/TDM (W-O-C/TDM) Return link: Hybrid wideband Quasi-synchronous quasi-orthogonal CDMA/TDMA (W-QS-QO-C/TDMA)
BB-1.2	Chip rate	3.840 Mchip/s or 1.920 Mchip/s
BB-1.3	Time slots	8 time slots per frame
BB-2	Modulation type	– QPSK or dual-code BPSK in the uplink – QPSK or BPSK (low data rate) in the downlink
BB-3	Dynamic channel allocation (yes/no)	No
BB-4	Duplex method (e.g. FDD, TDD)	FDD or FDD/TDD

TABLE 15 (*end*)

BB-5	Forward error correction	<ul style="list-style-type: none"> – Standard quality: convolutional coding with code rate 1/3 or 1/2 constraint length $k = 9$. Variable puncturing repetition to match the required info rate. – High quality concatenated RS code over $GF(2^8)$, concatenated with inner convolutional code with rate 1/3 or 1/2, constraint length $k = 9$. Turbo coder as option
BB-6	Interleaving	<ul style="list-style-type: none"> – Interleaving on a single burst basis (default). – Interleaving on a multiple burst basis (optional)
BB-7	Synchronization between satellites required	<ul style="list-style-type: none"> – Synchronization between LESs working on the same channel of different satellites is required. – Synchronization between LESs working on different channels of the same satellite is not required

4.3.2.5 Detailed specifications

The W-C/TDMA radio interface detailed specification is based on the following set of documents:

- *Physical layer*: the most recent version of the W-C/TDMA documents derived from the 25.200 series (see Note 1).
- *Protocols*: most recent versions of the 25.300 draft specifications (see Note 2).

NOTE 1 – This set of detailed specifications is presently being elaborated inside the ETSI TC-SES S-UMTS Working Group among the family of the voluntary standards for IMT-2000 satellite radio interface. This specification will also provide a general description of the physical layer of the W-C/TDMA air interface.

NOTE 2 – As developed within the 3GPP RAN TSG. These documents can be found on: <http://www.3gpp.org/RAN> and <http://www.3gpp.org/RAN4-Radio-performance-and>. This specification describes the documents being produced by the 3GPP TSG RAN WG 4.

4.3.3 Satellite radio interface D (SRI-D) specifications

SRI-D has been optimized for operation with a specific satellite system. This system consists of a constellation of satellites in MEO working with 12 LESs, which are located around the world and interconnected by a ground network. The configuration has been designed to provide coverage of the entire surface of the Earth at all times. The system will route traffic from terrestrial networks through a LES, which will select a satellite through which the call will be connected to a user. Traffic from a UT will be routed via the satellite constellation to the appropriate fixed or mobile network. The system will provide users anywhere on the Earth with access to telecommunications services. SRI-D supports robust and flexible communications, both voice and data, with rates up to 38.4 kbit/s, in a spectral and power efficient manner. The large majority of UTs used with the system are expected to be truly hand-portable and capable of dual-mode (terrestrial and satellite) operation. A wide range of other UTs will be supported including vehicular, aeronautical and maritime mobile, and semi-fixed terminals.

The following sub-sections specify only those elements relevant to this Recommendation, dealing therefore primarily with worldwide compatibility and international use.

4.3.3.1 Architectural description

The ground segment employs many standard components that allow conformance of the system to terrestrial telecommunications standards. The architecture (illustrated in Fig. 20) comprises:

- 12 interconnected LESs located around the world;
- duplicated network management centres;
- duplicated billing and administration centres.

Each LES comprises:

- five antennas and associated equipment to communicate with the satellites;
- mobile switching centres and registers, including HLRs and VLRs;
- interconnections with terrestrial networks.

The LESs are interconnected with each other via terrestrial links, thereby building the basic platform that provides the system's global mobile telecommunications services. Interfaces will be provided to PSTN, PLMN and data networks. However, handover is only supported within a single network. Interworking functions (IWFs) will deliver automatic roaming with other terrestrial (second and third generation) mobile networks.

4.3.3.1.1 Constellation

Table 16 summarizes the satellite constellation configuration.

Worldwide use is a key feature of IMT-2000 and the constellation described provides true global coverage whilst maintaining a high minimum elevation angle to the visible satellites, as shown in Figs 21 and 22.

Each satellite provides radio coverage down to an elevation angle of 0° for both UTs and LESs. Figure 21 shows the percentage of time for which a number of satellites are visible as a function of latitude. For all areas of the Earth there will be two or more satellites visible for at least 90% of the time.

The system is very robust to individual failures of satellite and/or LES since:

- full global coverage can be maintained while there are at least four satellites in each orbit plane;
- individual LES failure will not normally result in loss of service around the LES.

Figure 22 shows the minimum and average elevation angles of the nearest satellite that gives the highest elevation amongst the visible satellites as a function of latitude. The minimum and average elevation angles exceed 20° and 40° , respectively, in most areas. For regions between 20° and 50° in latitude, the constellation provides a minimum elevation angle of better than 25° and an average elevation angle of more than 50° .

FIGURE 20
The ground network

Interconnection with other networks

–PoI between system and interconnecting networks PSTN, PLMN and PSDN

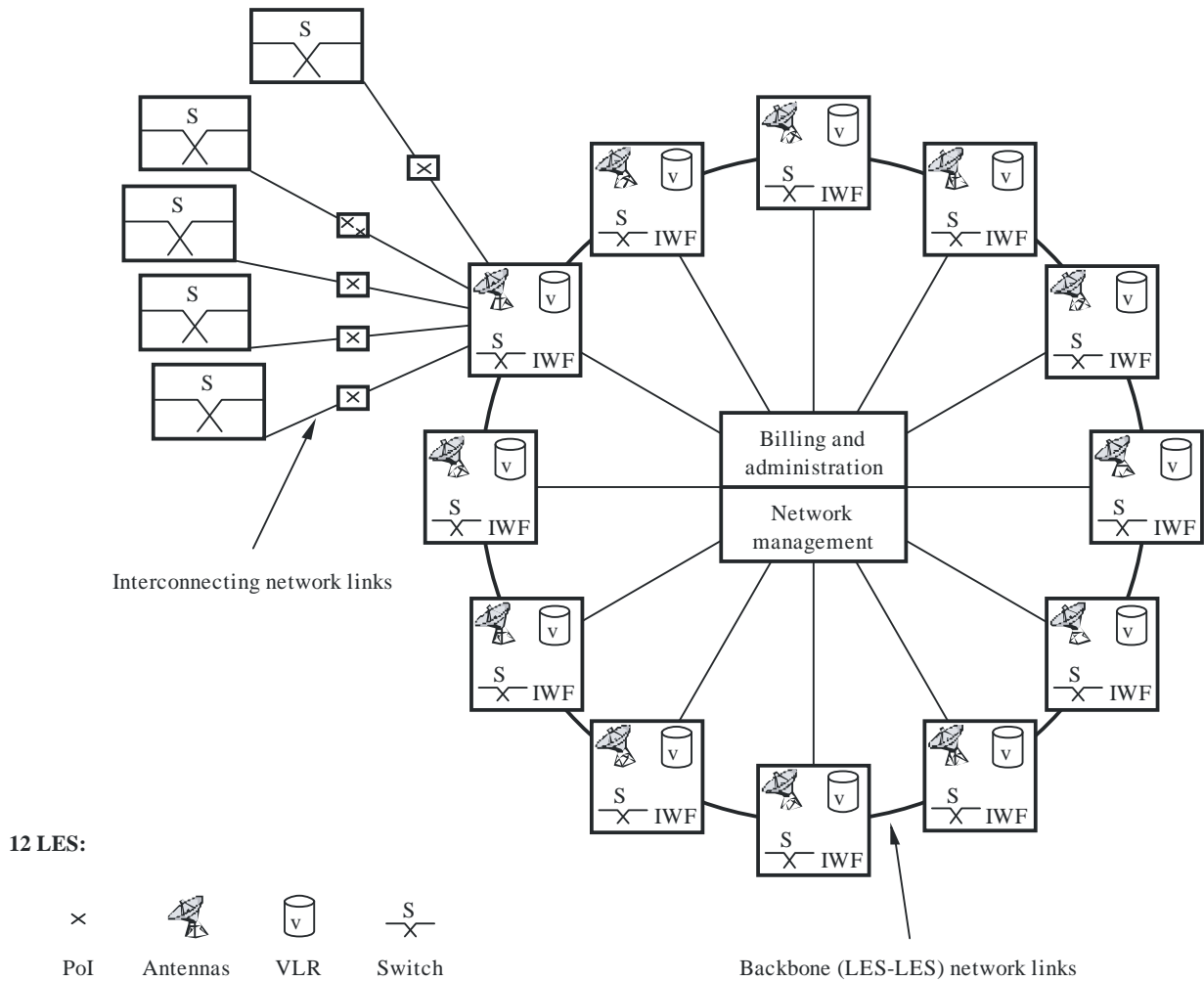

PoI: Point of interconnection

M.1850-20

TABLE 16

Satellite constellation configuration

Orbit type	MEO
Orbit altitude	Nominally 10 390 km
Orbit inclination angle	45°
Number of orbit planes	2
Plane phasing	180°
Number of satellites per orbit plane	5-6
In-plane satellite phasing	The in-plane satellite phasing for a constellation of 10 satellites (5 satellites in each of 2 planes) is 72°. If all 12 satellites are launched successfully (6 satellites in each of 2 planes) the in-plane satellite phasing is 60°

FIGURE 21

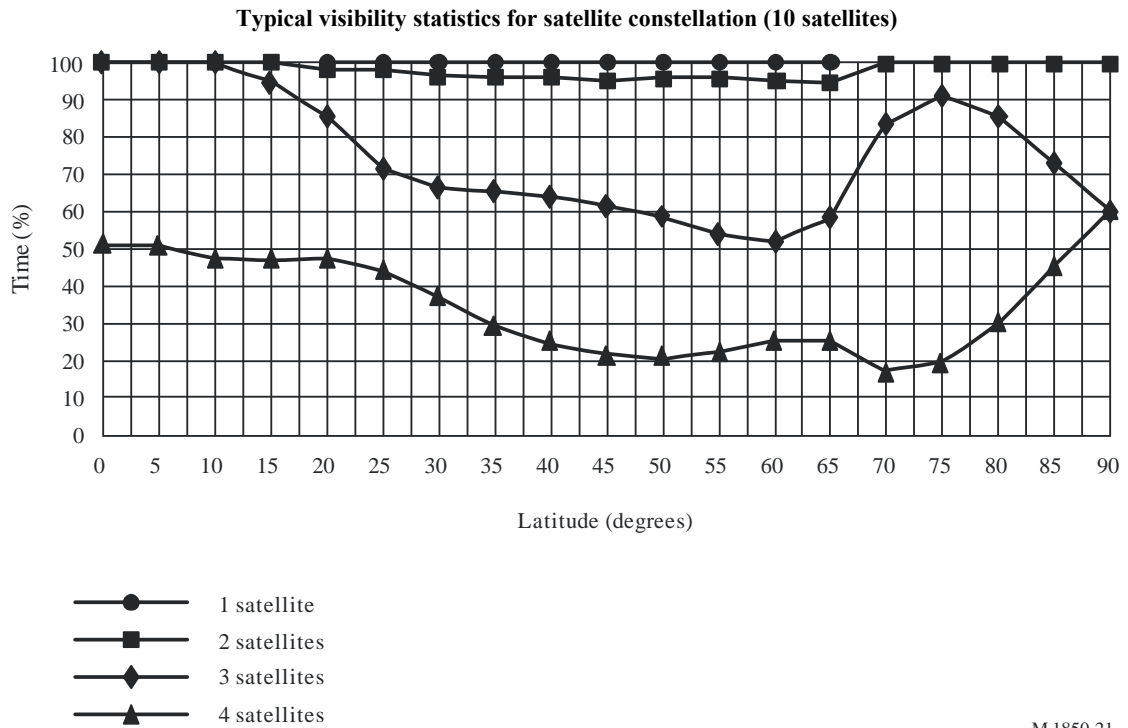
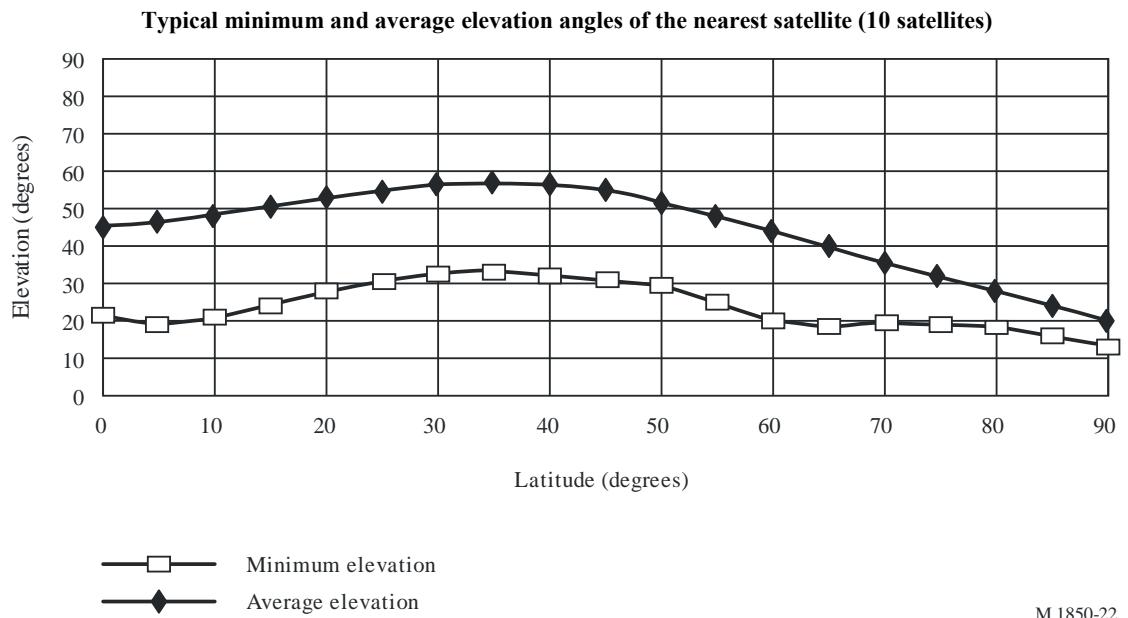

FIGURE 22



4.3.3.1.2 Satellites

Spacecraft

Specific features have been introduced to the satellites to meet the unique mission requirements in MEO, including:

- 163 beams providing full field-of-view coverage on the service link to mobile users, realized with separate 127 element transmit and receive direct radiating array (DRA) antennas.
- Beam forming and channelization of the transponders realized with digital technology that enables 490 satellite filter channels to be switched between the 163 actively generated beams.

This enables the satellites to respond to traffic and interference requirements as they change through the orbit.

- An on-board self-calibration facility that monitors and, if required, corrects the service link antenna performance on-orbit. This will maintain the antenna gain and frequency reuse performance throughout the life of the spacecraft.

Communications subsystem

The payload is a fully digital design using narrow-band beam-forming, digital beam-forming and digital channelization. In the service link, the payload generates a fixed grid of 163 spot beams covering the full field-of-view from a combined transmit/receive DRA antenna fixed on the spacecraft earth panel.

The on-board digital processor is transparent in that it channelizes and routes the signals to the 163 service link spot beams and does not demodulate and regenerate the signals. 490 filter channels of 170 kHz are created in the processor and each channel can be routed to any of the 163 beams at any frequency on a 150 kHz grid within the service link 30 MHz bandwidth. Each of the 490 channels can be considered equivalent to a conventional transponder.

Channel to beam routing can be changed continuously through the orbit to enable the satellites to respond to traffic and interference demands on a preplanned, predicted basis. This also enables flexible use to be made of the available spectrum.

In addition, the digital processor forms all 163 service link spot beams by generating amplitude and phase coefficients for each of the 127 elements for each beam. The integrity of the element excitation coefficients can be verified using the on-board satellite self-calibration system, whereby an external feed on a boom senses the excitation coefficient within each element. This enables spot beam performance, both main lobe and sidelobe, to be maintained through the life of the satellite, thereby ensuring that frequency reuse between the spot beams is maintained.

Spot beams

The 163 congruent transmit and receive mobile beams per satellite are arranged in a radial circular cell pattern around the sub-satellite cell as shown in Fig. 23. The beams are electronically de-yawed to maintain the pattern relative to the spacecraft velocity vector. Beam directivity changes by about 2 dB between nadir and the edge of coverage.

FIGURE 23

Hexagonal lattice showing the 19 beam types

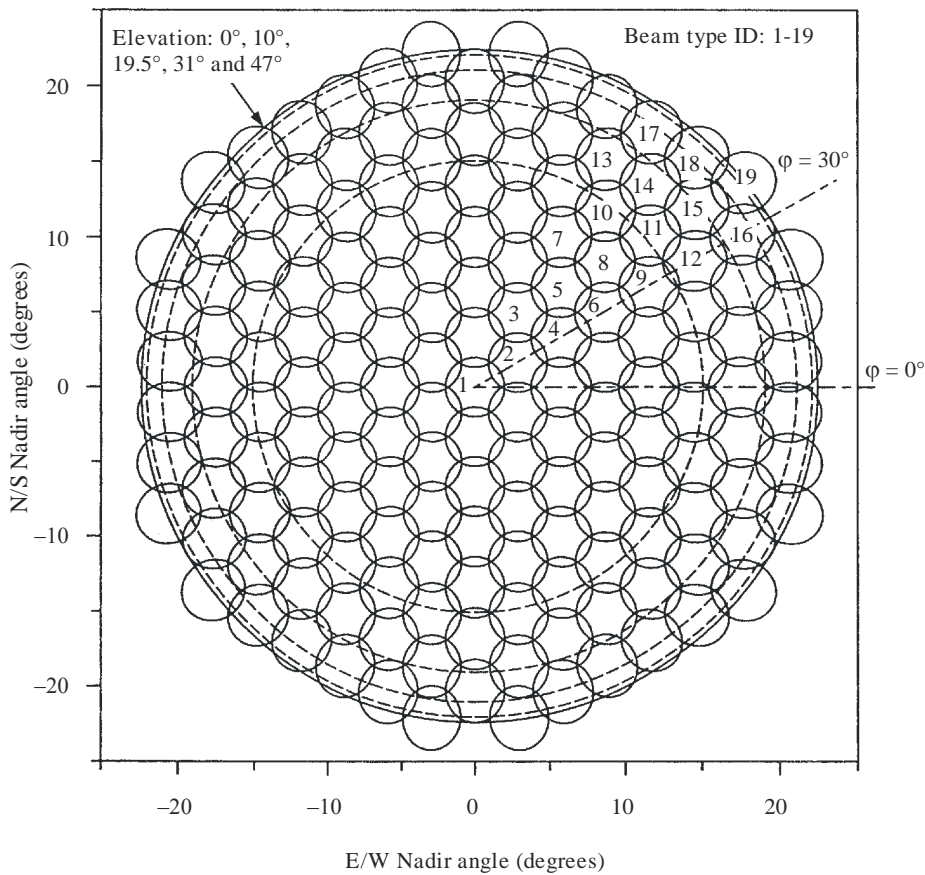

M.1850-23

The centres of the cells are defined as the centroids of the -3 dB contours of the individual beams. There are 19 beam types, numbered in order of their increasing angular distance from nadir. Each beam type has the same range of path delay and (within $\pm 10\%$) the same range of Doppler.

Table 17 summarizes the nominal cell parameters.

TABLE 17

Nominal cell parameters

Cell size	3.343°
Beamwidth	3.860°
Cell reuse	4
Cell area	9.678°
Reuse cell area	38.714°
Reuse centre to centre spacing	6.686°
Reuse sidelobe spacing	5.015°

Frequency reuse

The function of the frequency plan is to maximize the use of the mobile link spectrum while ensuring that no harmful intra-system interference occurs. The frequency plan for the whole satellite constellation is performed centrally at the network management centre.

The frequency plan defines the spectrum allocated to each beam in the constellation as a function of time in such a way that a given frequency is never available simultaneously to two beams with insufficient isolation. Beam side lobes are controlled to allow 4-cell frequency reuse within the 163-spot beam pattern. The frequency plan is adaptive to the traffic variation and the evolution of the constellation.

The frequency plan is a satellite oriented frequency assignment plan. The frequencies used in each beam remain fairly constant in the beams as the satellite moves in orbit. The mobile terminals are generally required to change frequency at beam handover.

The example frequency plan presented here has been developed for a constellation of 10 satellites in two orbital planes, each satellite having 163 fixed spot beams covering the full field-of-view with a 4-cell frequency reuse pattern as the one shown in Fig. 24. A similar frequency plan would be applicable for the 12-satellite constellation.

The mobile link spectrum is partitioned into 16 frequency blocks, as shown in Fig. 25. Eight blocks are allocated to each satellite plane: blocks 1 through 8 to plane 1 and blocks 9 through 16 to plane 2.

FIGURE 24

Typical 4-cell frequency reuse pattern

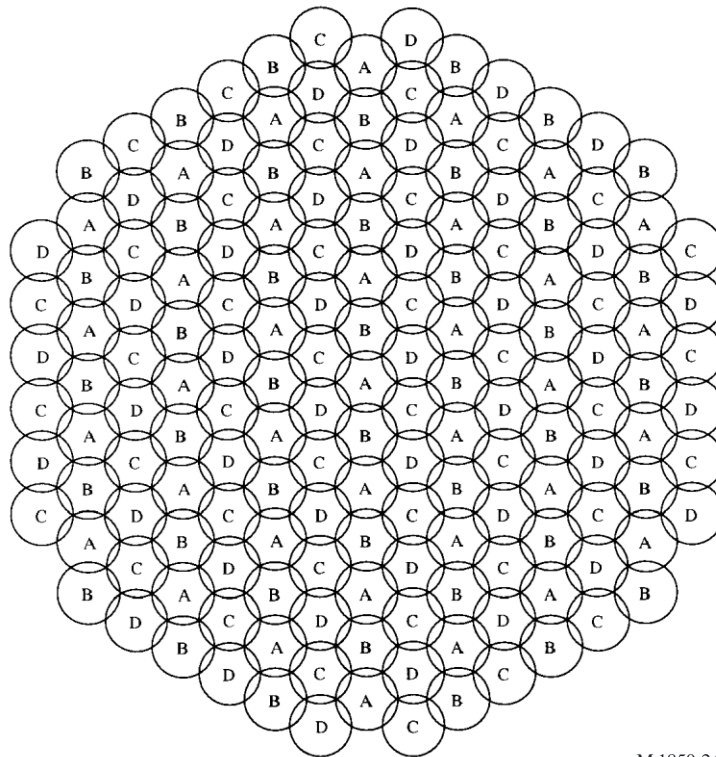

M.1850-24

Within a plane of satellites, the relative position of all five satellites remains constant. The 163 beams of each satellite are divided into two groups corresponding to the leading and trailing edges of the field-of-view. As shown in Fig. 26, the leading edges of all five satellite coverages do not overlap, and the same applies to all five trailing edges. Therefore, the eight blocks nominally allocated to plane 1 are arranged into two separate 4-block sub-plans: one for the leading beams of all five satellites (blocks 1, 2, 3 and 4), the other for the trailing beams (blocks 5, 6, 7 and 8). A similar partition is done in plane 2. The frequency plan for the satellites in plane 1 is shown in Fig. 27. The leading and trailing sub-plans overlap over the central beams, as the sub-plans are designed to comprise as many beams as allowed by the beam isolation constraints.

FIGURE 25
Example partitioning of the service link spectrum into frequency blocks

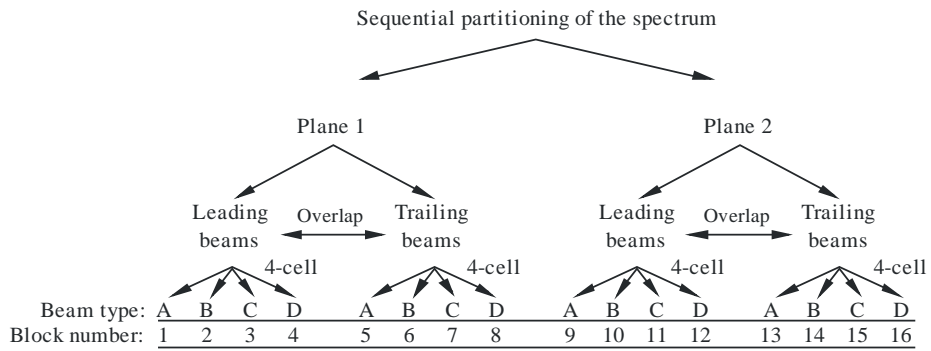

M.1850-25

FIGURE 26
Example leading and trailing beam sub-plans

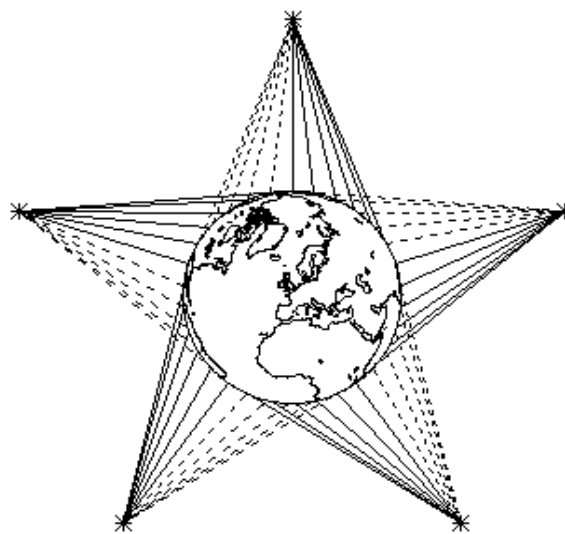

— Leading beams
 - - - Trailing beams

M.1850-26

FIGURE 27

Example frequency plan for satellites in plane 1

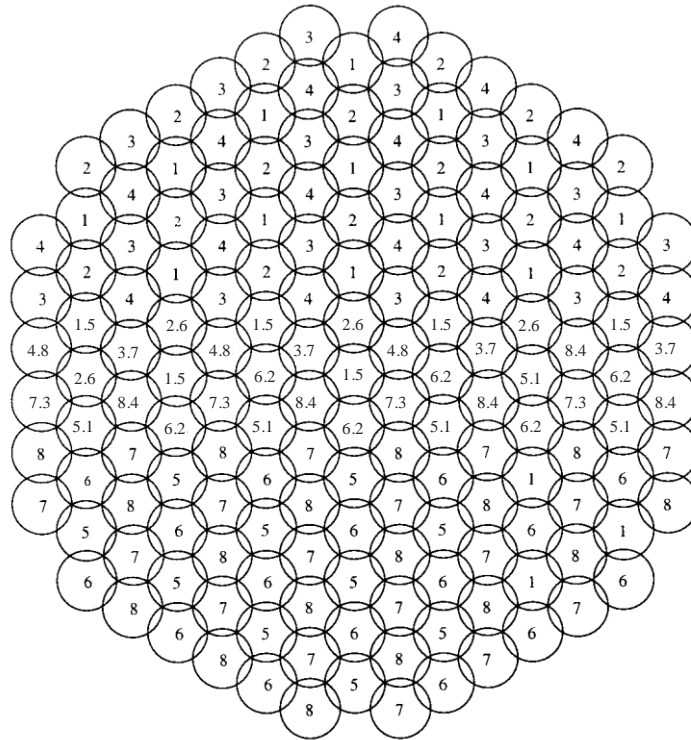

M.1850-27

4.3.3.2 System description

4.3.3.2.1 Service features

The system supports UPT through, inter alia, service portability, which facilitates access to services expected on a home network from within a visited network, and service transparency, by which the user experiences the same look and feel, irrespective of location, through transparent service delivery.

The system can support a range of teleservices, bearer services, alternate services, supplementary services and messaging services:

- Teleservices; include telephony, emergency calls, Group 3 fax (with rates up to 14.4 kbit/s).
The nominal voice coding scheme has been optimized for SRI-D. The coded rate is 4.8 kbit/s. The nominal voice codec also supports transparent DTMF sending in both forward and return directions. The radio interface can support other codecs.
- Bearer services: various data rates are supported and can be utilized depending on the application type. The channel speed can be varied according to system resources and user requirements. This functionality is not employed to compensate for transmission medium impairments. Variable rate source coding is not employed. Asymmetric transmission can be employed for data services by asymmetric allocation of TDMA slots on forward and return links. Medium data rates (up to 38.4 kbit/s using time-slot aggregation) including the following, non-exhaustive list of data rates are supported (note that multiple time slots and/or multiple RF channels are used to realize data rates higher than that available from a single time slot (2.4 kbit/s before coding)):
 - Asynchronous transparent and non-transparent circuit-switched data: 0.3, 1.2, 2.4, 4.8, 9.6, 14.4, 19.2, 28.8 and 38.4 kbit/s.
 - Synchronous transparent and non-transparent circuit-switched data: 1.2, 2.4, 4.8, 9.6, 14.4, 19.2, 28.8 and 38.4 kbit/s.

- Packet-switched data: The system and its radio interface are capable of supporting packet-switched services; implementation is currently under review.
- Supplementary services; include line identification services, forwarding services, call waiting services, multi-party services, call restriction services, advice of charge services and location services.
- Messaging services; include voice messaging, fax messaging and mobile originated and mobile terminated SMS.

4.3.3.2.2 System features

Handover

Handover is supported within the system between beams of the same satellite, between beams of different satellites and between land earth stations.

UTs may be required to change frequency at handover. UT assisted handover is employed using UT measurements and controlled switching. Hard and soft handover are supported. Soft handover, implying no break on handover, is preferred whereby the handover decision is made by the UT. When soft handover is not possible, a make-before-break procedure is used.

Doppler compensation

Knowledge of the satellite's motion and the UT's location provides the information to permit Doppler compensation. Pre-compensation limits Doppler shift to less than 1.1 kHz in the forward link and 40 Hz in the return link.

Channel allocation

On-board digital channelization enables the 490 satellite filter channels to be switched between the 163 actively generated beams. Predictive channel allocation is therefore employed to enable satellites to respond to traffic and interference requirements as practicable as they change through the orbit. It also enables flexible use to be made of the available spectrum.

Diversity

Time, space and frequency diversity are supported:

- Time diversity is supported for data traffic using RLP, signalling by Layer 2 retransmission and paging/notification/broadcast/RACH by repetition.
- Space diversity is supported for traffic and signalling by allowing a UT to communicate with the network through any of the satellites that are visible (satellite path diversity). Most of the time the system constellation provides coverage to an area via two or more diverse paths from two or more satellites, as shown in Fig. 21. The system has been designed to increase the probability of a direct line-of-sight to a satellite by fully exploiting the satellite path diversity capability of the constellation for all services.
- Frequency diversity is supported for BCCH and common control channels.

The minimum number of RF receivers/antennas per UT to permit satellite path diversity is 1. The degree of improvement achieved is dependent on the underlying conditions, however, since the paths are uncorrelated typically about 5 dB to 8 dB, improvement is expected.

Voice activation

Voice-activated transmission is required on the forward and return links to allow satellite power savings for increased capacity on the forward link and to allow satellite and UT power savings on the return link. Voice activation is used to maximize the available return link margin and maximize the UT talk time, respectively. The voice activity factor is typically 40%.

4.3.3.2.3 Terminal features

The provision of IMT-2000 services via satellite, particularly to truly hand-portable terminals, is very demanding. Significant source coding must be employed with higher transmission powers and lower level (2- or 4-state) modulation schemes in order to attain, over the satellite link, a BER comparable to terrestrial networks. Particularly for hand-portable terminals, these requirements (coding, power and modulation which all directly impact on spectrum usage) must be balanced against the need for terminals to be similar to terrestrial terminals in terms of size, weight and battery performance.

Service will be provided to a wide range of terminal types. The large majority of UTs are expected to be capable of both satellite and terrestrial operation and, as appropriate, will support service portability, which facilitates access to services expected on a home network from within a visited network, and service transparency, by which the user experiences the same look and feel, irrespective of location, through transparent service delivery. Examples of the terminals, with their technical characteristics and services are summarized in Table 18.

TABLE 18

Examples of terminal types

Terminal	Service	Bit rate (kbit/s)	BER ⁽¹⁾
Hand-held	Voice	4.8	4%
	Data	2.4-9.6	10 ⁻⁵
Ruggedized transportable	Voice	4.8	4%
	Data	2.4-9.6	10 ⁻⁵
Private vehicle	Voice	4.8	4%
	Data	8.0-38.4	10 ⁻⁵
Commercial vehicle	Voice	4.8	4%
	Data	8.0-38.4	10 ⁻⁵
Semi-fixed	Voice	4.8	4%
	Data	8.0-38.4	10 ⁻⁵

⁽¹⁾ The BER for voice services is before error correction.

The technology used in these terminals is also expected to be incorporated in a wide range of other UT types including vehicular, aeronautical, and maritime mobile terminals and semi-fixed terminals, such as rural telephone booths and community telephones.

4.3.3.3 RF specifications

Power control

A UT will control its output as required by the network and the network will control the output power of the land earth station for each individual channel. The objective of the power control is to enable the minimum transmit power to be used by the LES, UT and satellite for each radio channel that is

sufficient to maintain an acceptable received signal quality. Closed-loop power control is used for traffic channels in both the forward and reverse direction. Open-loop power control can also be used. Power control results in:

- an increase in system capacity;
- an increase in UT battery life;
- a reduction in interference.

A power control step size of 1 dB is used, with a dynamic range of 16 dB. The number of power control cycles per second is 2 cycles. The power control bit rate is variable from 2 to 10 bits per 0.5 s per 2 paths.

Channel bandwidth, bit rate and symbol rate

The RF channel spacing is 25 kHz. The RF channel bit rate and symbol rate are dependant on the channel type and its associated modulation. Table 33 provides further information on channel types and associated modulations.

For channels employing QPSK or GMSK modulation, the RF channel bit rate is 36 kbit/s. For channels employing BPSK modulation, the RF channel bit rate is 18 kbit/s.

For channels employing QPSK or BPSK modulation, the channel symbol rate (after modulation) is 18 ksymbol/s. For channels employing GMSK modulation, the channel symbol rate (after modulation) is 36 ksymbol/s.

UT e.i.r.p. and G/T

Nominal values for UT e.i.r.p. and G/T for each example terminal type are given in Table 19.

TABLE 19
Nominal UT e.i.r.p. and G/T

Terminal	Gain (dBi)	G/T (dB/K)	Peak e.i.r.p. (dBW)	Minimum peak e.i.r.p. ⁽¹⁾ (dBW)	Time average e.i.r.p. ⁽²⁾ (dBW)
Hand-held	2	-23.8	≤ 7	-9	≤ -4
Ruggedized transportable	3.5	-21.5	≤ 7	-9	≤ -4
Private vehicle	3.5	-21.5	≤ 10	-6	≤ -1
Commercial vehicle	6.5	-18.0	≤ 10	-6	≤ -1
Semi-fixed	10.5	-14.0	≤ 10	-6	≤ -1

⁽¹⁾ Takes into account power control.

⁽²⁾ Time averages have been calculated assuming single slot voice use at peak e.i.r.p. with discontinuous transmission. Power control has not been taken into account.

Satellite e.i.r.p. and G/T

To aid description of the satellite e.i.r.p. and G/T performance, Fig. 28 defines various ranges of satellite nadir angle (corresponding to equal surface areas on the Earth).

The service link e.i.r.p. resource can be flexibly allocated to any of the 163 spot beams by appropriate selection of the uplink (feeder link) frequency corresponding to the satellite filter channel routed to the desired spot beam. Table 20 indicates the nominal maximum e.i.r.p. in each ring if all the e.i.r.p.

were directed to that ring only to the exclusion of the beams in the other rings. In realistic traffic applications, e.i.r.p. will be distributed in all rings with less e.i.r.p. than the peak for each ring.

The nominal service link G/T allocation is given in Table 21 for each ring of spot beams.

FIGURE 28

Definition of e.i.r.p. specification areas from a satellite

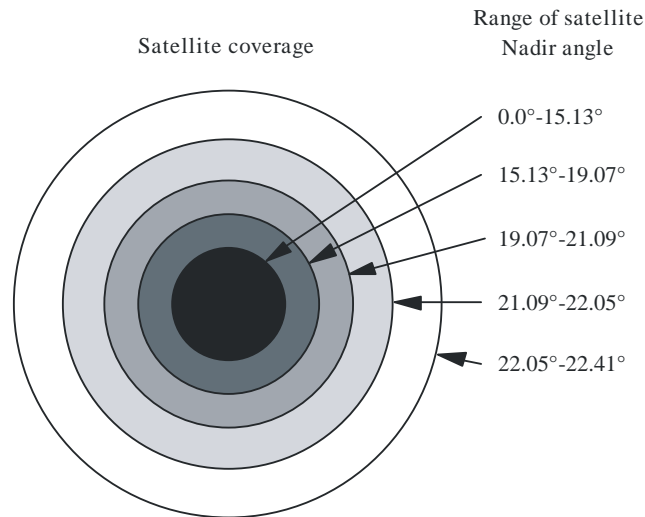

M.1850-28

TABLE 20

Nominal service link maximum e.i.r.p. for each ring

	Ring 1	Ring 2	Ring 3	Ring 4	Ring 5
SSPA combined output power (dBW)	28.5	28.5	28.5	28.5	28.5
Output losses (dB)	0.7	0.7	0.7	0.7	0.7
Antenna average gain (dB)	30.6	29.6	28.9	28.7	28.2
e.i.r.p. (dBW)	58.2	57.4	56.7	56.6	56.1
Power robbing at worst gain setting (dB)	0.4	0.5	0.6	0.7	0.7
Useful e.i.r.p. (dBW)	58.1	56.9	56.1	55.9	55.4

TABLE 21

Nominal service link worst-case G/T for each ring

	Ring 1	Ring 2	Ring 3	Ring 4	Ring 5
Average antenna gain (dB)	30.4	29.4	28.7	28.5	28.1
System noise temperature (dB/K)	25.5	25.0	24.3	23.9	23.8
G/T without losses (dB/K)	4.9	4.4	4.4	4.6	4.3
Losses at low processor gain (dB)	2.3	2.4	2.6	2.8	2.8
G/T at low processor gain (dB/K)	2.6	2.0	1.8	1.9	1.5

Synchronization and frequency stability

LES-LES synchronization of the bit clock is required. The 2σ timing accuracy is $1\ \mu\text{s}$ and the external system reference is GPS.

The network controls the UT burst timing. The UT synchronizes to the forward link timing, the LES measures the offset from the expected value and any correction to be applied is sent to the UT via a control channel. The UT timing reference clock accuracy is typically 3 ppm.

The frequency stability of the satellite transmit signal is 0.5 ppm.

The UT transmit frequency is controlled by the network. The UT synchronizes to the forward link frequency, the SAN measures the offset from the expected value and any correction to be applied is sent to the UT via a control channel. The frequency stability of the UT transmission is 3 ppm (unlocked) and 0.1 ppm (locked).

Polarization

The polarization on the uplink (Earth-to-space) and downlink (space-to-Earth) is RHCP.

Frequency reuse

Typically a 4-cell frequency reuse pattern is used as the basis for the frequency plan. See § 4.3.3.1.2 for further details.

4.3.3.4 Baseband specifications

Multiple access

The system operates in an FDD mode, however there is not generally a fixed frequency relationship (duplex spacing) between the Earth-to-space and space-to-Earth frequencies used for communications to and from the UTs. A combination of FDMA and TDMA is used. Each 25 kHz RF carrier supports frames of length 40 ms. Each frame supports 6 TDMA time slots, with each time slot therefore of duration $\sim 6.67\ \text{ms}$ (40/6 ms). Each time slot contains 2 guard symbols at both its start and end.

Modulation

The modulation scheme employed depends on the channel type. Table 22 provides information on carrier types and their associated modulations.

TABLE 22

Carrier types and their associated modulations

Carrier type	Modulation
Voice (TCH)	QPSK (GMSK on return uplink)
Data (TCH)	QPSK (GMSK on return uplink)
BCCH	BPSK
RACH	BPSK (S-BPSK on return uplink)
SDCCH	BPSK

Coding

The convolutional coding rate used depends on carrier type. Table 23 provides information on the coding rates employed.

TABLE 23
Coding rates

Carrier type	Coding rate
Voice (TCH)	1/3
Data (TCH)	1/2
BCCH	1/2
RACH	1/6
SDCCH	1/4

Soft decision decoding is used.

Carrier bit rates

Each time slot supports a bit rate of 6 kbit/s (a channel bit rate of 36 kbit/s with 6 time slots per frame). This provides for 4.8 kbit/s of data and 1.2 kbit/s of framing and in-band signalling.

For TCH, each time slot supports nominal user information bit rates of 2.4 kbit/s for data (before coding) and 4.8 kbit/s for voice (after coding).

For BCCH and RACH, a coded bit rate of 18 kbit/s is supported.

For associated control channels, maximum bit rates of 160 bit/s (SACCH) and 80 bit/40 ms (FACCH) are supported.

Interleaving

For voice (TCH), intra-burst interleaving is used. For data (TCH), intra-burst interleaving and interleaving over 4 bursts are used.

4.3.4 Satellite radio interface E (SRI-E) specifications

The Satellite radio interface E (SRI-E) was optimized for use with a constellation of geostationary satellites to provide worldwide coverage for multimedia terminals, in line with the objectives of IMT-2000. Although SRI-E has been optimized for the satellite component, account has also been taken of the need for broader compatibility within the spirit and objectives of IMT-2000. The primary terminal type foreseen for use with SRI-E is a laptop or palmtop computer connected to a small, portable communications unit incorporating a directional antenna. With such terminals SRI-E can achieve transmission rates of up to 512 kbit/s. SRI-E caters for all terminal environments ranging from stationary (including FWA) up to aircraft speeds.

The primary traffic objective is data, particularly for connectivity to the public Internet and to private Intranets, in support of typical applications used over these networks such as e-mail and information browsers. Traditional telecommunications services, such as voice and fax, are also supported. Although the bit rate per carrier is 512 kbit/s, higher bit rates are also possible through specialized terminals with multiple transceivers, through the aggregation of carriers. The satellites used to support SRI-E should use state-of-the-art geostationary technology, where each satellite deploys a large number of spot beams, which together cover continental sized areas and achieve frequency re-use in a manner analogous to that of terrestrial cellular systems.

A key objective in the design of SRI-E has been to make it fully independent of the services and traffic types that it carries. This is viewed as an essential characteristic for a multimedia system.

Shared access bearers is the terminology used to refer to the specific satellite channels which support the transfer of data between the radio network subsystem (RNS) and the user terminal (UE). Shared

access bearers, by definition, support more than one connection at a time. The mechanisms for sharing of the resource involve a combination of techniques, where each individual packet transferred over a shared access bearer has an address which identifies the connection.

The resource management system helps to support the operation of multiple bearer types in the system. The Air Interface protocols use one signalling system. The physical bearers are sufficiently independent of the upper layers to support almost any signalling system.

The optimum resource management approach for this configuration is to utilize the channels on a time-division-multiplex/time-division-multiple-access basis (TDM/TDMA) basis.

4.3.4.1 Architectural description

4.3.4.1.1 Constellation

As mentioned above, SRI-E is optimized for implementation with a geostationary-satellite system. The constellation parameters are summarized in Table 24.

TABLE 24

Satellite constellation characteristics for SRI-E

Satellite altitude	36 000 km
Orbit inclination angle	$\leq 3^\circ$
Number of orbit planes	1
Number of satellites per orbit plane	3 for global coverage
Satellite diversity method	No satellite diversity is used

Satellites

The complexity of the satellite-borne equipment expected to be used with SRI-E is at the limit of currently deployable technology. It allows the use of multiple spot beams, and it provides the RF power needed to enable the high rate information services to be delivered to small mobile terminals.

The satellite characteristics ideal for use with SRI-E are shown in Table 25.

TABLE 25

Satellite constellation characteristics for SRI-E

Number of spot beams per satellite	Up to 300, depending on desired coverage
Configuration of spot beams	Spot beams are assumed to be simple cones. The configuration should be flexible and reconfigurable during system lifetime in response to evolving traffic patterns
Spot beam size	Approximately 1° beam width, i.e. 800 km diameter at the sub-satellite point
Frequency reuse	Frequency reuse plan is based on 7-beam clusters. In the satellite environment, frequency allocation to spot beams follows a simple, regular pattern. Frequency planning does not affect other aspects of the system, e.g. signalling, synchronization, inter-working with terrestrial networks

TABLE 25 (end)

Service link G/T of satellite beam	Average: 10 dB/K Minimum: 9.5 dB/K
Service link saturation e.i.r.p. of each beam	Minimum: 38 dBW Maximum: 53 dBW
Service link total saturation e.i.r.p. per satellite	67 dBW
Satellite e.i.r.p. per RF carrier: 43 dBW	Maximum e.i.r.p.: 43 dBW Average e.i.r.p.: 42 dBW
Required frequency stability	1 ppm
Power control	Allows an average saving of around 3 dB in satellite power; this enables a virtual doubling of traffic capacity
Power control step size	0.5 dB
Number of power control cycles per second	1
Power control dynamic range	8 dB
Minimum transmit power level with power control	7 dBW

4.3.4.2 System description

4.3.4.2.1 Service features

The baseline SRI-E satellite system has been designed to deliver, support and provide interoperability with UMTS type applications.

The air interface is a packet data system which implies that bearers are shared access bearers and therefore the user data rate during a connection varies depending on the traffic load. Circuit switched type applications (voice, ISDN) can be supported through defined quality of service parameters set to guarantee the user data rate.

4.3.4.2.1.1 Capability for multimedia services

Multimedia services are different from traditional telecommunication services in a number of ways, as described in the following sections. SRI-E has been designed for this traffic, as explained under each of the topics.

Independence between transport and applications

Second-generation mobile networks have a close association between the radio transport and the characteristics of the principal application, i.e. voice traffic. For a multimedia network such a coupling is highly undesirable. Rather, a radio interface should be designed to be as general as possible and to support a wide variety of traffic, including those which have not been foreseen at present. This principle underlies the design of ATM.

SRI-E fully supports this objective. It makes no assumption about the protocols or services to be used above it. Compatibility with terrestrial ATM ensures that any traffic which can be carried by ATM can also be carried by SRI-E (as long as bandwidth is adequate).

Support of IP-based services

In the coming decade the Internet will assume an importance equal to that of the international telephone network, as the global backbone for information sharing and exchange as well as for real-time distribution of data. Indeed, there are those who claim that it will even usurp the role of the

telephone network for carrying voice, although this claim remains contentious. In addition to the shared Internet, companies and other organizations now base their internal information sharing around Internet technology, leading to so-called Intranets and, for closed groups of users, Extranets.

Any communications technology designed to integrate with the real world of the twenty-first century must incorporate the Internet and its associated protocols as a primary mode of operation. The ability to handle this traffic with maximum efficiency will be the distinguishing criterion of successfully deployed communications technologies.

One of the primary characteristics of Internet traffic, compared with traditional telecommunications, is its bursty nature. A user will typically require information in relatively concentrated bursts, for example when loading a web page or a form, and will then have low bandwidth requirements for a period afterwards. This is a well-known characteristic of today's network, allowing for statistical multiplexing of, typically, five times the number of users that the static bandwidth would appear to permit. Traditional networks, with their emphasis on fixed bandwidth for the duration of a call, are ill-equipped to deal with such traffic. Another characteristic of this traffic is its asymmetry. Typically the amount of data flowing in one direction (normally towards the user) exceeds that in the other direction by an order of magnitude.

SRI-E has been designed with Internet support as its primary goal. Its variable bandwidth service provides instantaneous response to changing traffic, especially towards the remote user. No renegotiation or other delay is imposed between the arrival of traffic and the assignment of corresponding bandwidth, assuming that the latter is available. Where there is contention for bandwidth (i.e. there is not enough to meet the instantaneous demand) it automatically shares what is available in an equitable fashion. Although not included in the current proposal, allowance is also made for more elaborate schemes where, for example, some calls might receive a greater share of bandwidth when contention occurs, based on a commercially priced quality of service.

The dynamic bandwidth assignment also naturally allows for asymmetrical traffic. A mixture of typical Internet users together with reverse-direction traffic, such as uploading of transaction histories or telemetry data, will automatically optimize the use of bandwidth.

Another characteristic of Internet use (including Internet-like services such as Intranets) is that users expect full-time connection, without active intervention on their part for example to make or break a call in relation to their activities. (This mode of operation is reluctantly supported by domestic dial-up users but does not occur in the corporate environment and is really an artefact of the unsuitability of the PSTN for this kind of traffic.) It is therefore desirable for an access technology to provide a low-cost mode of connection on a full-time basis, with actual bandwidth being engaged only when required in response to the traffic.

SRI-E provides such an option, corresponding to unassured bit rate (UBR) in ATM networks. When such a user is inactive (as determined by traffic monitoring) no radio resources are used. When they become active, i.e. when traffic is received at the base station or from the user's terminal, radio resources are allocated through a call restoration procedure.

Support for multiple concurrent calls

Multimedia traffic will frequently demand multiple calls, to the different or the same destinations and with differing quality requirements. For example, Recommendation ITU-T H.323 standard for multimedia conferencing assumes this capability.

SRI-E supports any mixture of calls, each with its own destination and QoS, within the overall capacity limit of a channel (512 kbit/s). SRI-E automatically multiplexes calls for different terminals within a channel, but can dedicate a whole channel to a single terminal if required.

The handover capability is used not only to support geographic mobility but also to optimize channel usage. A terminal may start its activity with a single low-bandwidth call (e.g. voice) then add further

calls until the shared capacity of the channel is no longer adequate. At this point the handover mechanism is invoked to move the terminal (or indeed another terminal) into another channel, having the required capacity. Similarly, as calls are terminated, effective use of bandwidth may require that terminals operating in different channels be compacted into a single channel, freeing resources for use elsewhere.

Support of location determination

It is increasingly a legal requirement on mobile systems that they be able to inform security and emergency services of the physical location of a terminal. Provision of this capability will therefore be a requirement in order to obtain an operating licence in many countries. Moreover other regulatory differences between countries, which could impact on the use of the terminal or services, require location information.

A system using SRI-E should use an independent GPS receiver to obtain accurate (100 m) position information. The signalling protocol includes the means to transmit this to the base station. If SRI-E were used in a terrestrial environment then the GPS receiver could be replaced by radio-location means.

4.3.4.2.1.2 Quality aspects

SRI-E does not intrinsically impose any particular voice quality. It is envisaged that ITU-T Recommendation ITU-T G.729 will be used and quality will be as specified therein. Lower or higher qualities (with corresponding impact on bandwidth requirement) are possible without impact to the radio interface.

Transmission quality is one of the strengths of SRI-E. The error rate is specified in FEC-block error rates. The link adaption will seek to provide a steady error rate below 1×10^{-3} . This is adequate for all multimedia applications, without further enhancement at the radio interface or interface layers. (Applications requiring higher integrity than this invariably operate their own higher-layer data integrity protocols).

SRI-E uses adaptive turbo coding, whereby the coding rate (and hence the user data rate) is adjusted in real time as channel conditions change to maintain a fixed block error rate of 10^{-3} .

In addition, the SRI-E includes a high-level data link control (HDLC) based protocol on the satellite hop which is optimized for the satellite environment. Packet switched connections (interactive or background class) operate in acknowledged mode and lost packets are retransmitted. Circuit switched and streaming class packet switched connections use unacknowledged/transparent mode and are subject to potential loss.

SRI-E does not impose constraints on the service protocols used, SRI-E will adopt the new 4 kbit/s adaptive multi-band excitation (AMBE+2TM) codec for which measurements have achieved a subjective voice quality in excess of the toll-quality voice transmission quoted in Recommendation ITU-T G.729. This meets IMT-2000 requirements.

In some modes of operation, e.g. acknowledged mode, no packet loss is expected during handover since all traffic is stopped up. For unacknowledged mode traffic may be stopped, but this may have some noticeable impact on say a video streaming application only. Transparent mode, most noticeably voice, would lead to a loss of frames, this may affect the voice quality. For non real-time services, such as Internet access, the cell loss will be recovered by the Recommendation ITU-T V.42 integrity enhancement protocol, and will therefore be transparent to the application. It will appear in the same way as a transmission error, which will be statistically more common.

Variations in signal quality are dealt with primarily using active coding rate management, therefore the end data rate seen by the user is driven by the link quality although the error rate is constrained.

This is more appropriate to a multimedia environment, where applications are typically more sensitive to data errors or to the effects of error recovery than is the case for traditional services such as voice.

4.3.4.2.2 System features

Gateways

Calls are directed to the satellite gateways responsible for the spot beam in which the terminal is located. Multiple RNS stations may serve a single spot beam. The mobility management is handled using a GSM/UMTS core network. Each spot-beam acts as a mobility management routing area/location area and mobiles are tracked on that basis. All satellites in the system have to be visible from at least one gateway each. Thus, only a small number of gateways are required in the geostationary satellite environment – a minimum of one per satellite or three for a global system.

Network interface

SRI-E does not impose any constraints on the network interface. No additional PSTN functionality is required for ISDN or PSTN inter-working. Similarly, no constraints are placed on Internet routers. However, SRI-E can take advantage of emerging Internet features such as bandwidth reservation.

Conventional network interfaces can be used, following established standards such as Recommendations ITU-T Q.761, ITU-T Q.931 and ITU-T Q.2931. Satellite and mobile specific features such as handover and mobility management are not visible at the network interface.

No modifications are required to the landline network for SRI-E to pass the standard set of ISDN bearer services. All landline ISDN and other services and features are passed in the SRI-E. SRI-E only provides a pipe for UMTS signalling protocols and does not interpret these messages.

Handover/automatic radio link transfer (ALT)

Users are required to be managed efficiently, this may lead to users being moved from one beam to another. Several scenarios are possible:

- The move to a different beam of the same type on the same satellite, controlled by the same radio network controller (RNC).
- The move to a different beam of the same type on the same satellite, controlled by a different RNC.
- The move to a different beam of the same type on another satellite.

Handover is handled entirely within different layers of SRI-E. Handover is initiated by a radio resource management (RRM) event, the bearer control layer configures the target bearer control process but leaves the source bearer control process intact. A signalling process via the UE helps the target bearer control process to reconfigure and communicate with the RNC. After reattachment and signalling of acknowledgment, the old connection is detached.

Handover may result in the loss of some data. For voice, this means a short duration, with no audible impact, when using Recommendation ITU-T G.729. For data, ARQ mechanisms guarantee data integrity.

Handover affects system complexity in two ways:

- the need for additional protocol mechanisms – these affect only software and therefore do not impact the unit terminal cost;
- the need for BS channel units to be able to split and combine traffic from the old and new radio channels during the handover – this has no impact on terminals.

Dynamic channel allocation

Frequencies can be dynamically assigned to spot beams according to traffic load. The satellite component is subject to an environment where there are not substantial variations in propagation conditions. Hence, SRI-E is more spectrally efficient (and more efficient in the use of critical satellite power) than is the case where wider variations need to be accommodated.

Power consumption

SRI-E has been designed for use in situations where access to mains power may be impossible. It therefore optimizes power consumption, allowing the greatest possible economy in both standby and operational modes. Both transmission and reception operate intermittently, as required by the traffic. Even when variable bandwidth calls (e.g. for Internet traffic) are in use, intermittent reception is used except when a burst of traffic is being received.

Due to the variance in geographical locations of UEs relative to the centre of the spot-beam, power supply variations and manufacturer tolerances, transmissions from a UE may be received at a considerable range of signal to noise ratios at the RNS. To limit interference, to ensure that the receiver is operating in its optimum range, and to conserve battery power at the mobile, the RNS performs a correction of the transmissions by each UE as necessary. This may occur at any time during communications.

Timing correction

The nature of satellite communications is that the propagation path for the radio signals differs in length considerably, owing to the variance in geographical locations of the mobiles communicating. This is not normally a problem in a pure FDMA single-channel-per-carrier (SCPC) system, but in a shared access system, when multiple mobile transmitters are using the same physical resource, it is important to ensure that mobiles do not interfere with each other. This is achieved either by the use of satellite position and GPS position or through a combination of providing a guard time between mobile transmissions and by providing timing correction information to each mobile transmitter, relative to a reference at the RNS receiver. The bearer control sub-layer is responsible for monitoring and correcting timing errors.

The accuracy of the timing measurement and correction requirements is dependent upon the particular physical layer in operation.

Once the initial timing offsets have been corrected, the timing of transmissions from each individual mobile is continuously monitored, and, when necessary, a differential correction mechanism is provided.

Frequency correction

The UE will lock on to the forward bearer and correct its own long-term frequency stability.

4.3.4.3 RF specifications

Frequency band

SRI-E imposes no frequency band constraints. In principle it could be used at any frequency band, although propagation conditions and constraints on antenna technology makes it most suitable for use at frequencies between 1 and 3 GHz.

Multiple access

SRI-E generally builds upon well understood and proven techniques. This includes the use of TDM/TDMA/FDMA.

The multiple access system consists of forward and return channels that are shared by several users. By allowing several users to share the same channel, one user's inactivity will be balanced against another user's activity. Together users will be transferring data in both directions, so forward and return channels will be busy.

Duplex method

SRI-E is designed for FDD. The minimum up/down frequency separation is a cost dependent function of implementation.

Modulation and coding

SRI-E supports a wide range of mobile terminal antenna apertures and e.i.r.p. capabilities therefore it is not possible to provide a single solution which optimizes the transmission rate whilst maintaining communication across all the types of terminals. The problem is solved in this case by introducing a range of bearer types, operating both 16-QAM and 4-ary modulations in the return direction. In the forward direction 16-QAM bearer and QPSK for signalling is employed. To maximize the efficiency and the bit rate obtainable by each terminal a technology described as variable coding is used. This is essential in order to achieve the high spectrum efficiency.

Variable coding techniques involve the puncturing of the turbo-code generated parity streams using one of a number of pre-defined puncturing matrices, such that the level of redundancy provided by the code is variable. This allows the information to be transmitted to or from a mobile over a single channel to be increased when the mobile is operating in good channel conditions, and correspondingly reduced to allow the communications link to be maintained when the mobile is operating in poor channel conditions.

C/N requirement

The system has been designed such that steps in the coding rate provide nominally 1 dB steps in C/N_0 requirements to achieve the requisite burst error rate performance of 10^{-3} . This approach can also be used to counter the effect of slow fading. The satellite gateway controls the coding rate depending on the reported C/N_0 values of the link.

Carrier spacing and channelling

The SRI-E forward bearers are capable of carrying nominal data rates in the range between 4.5 kbit/s and 512 kbit/s and are based upon the continuous transmission of time-division-multiplexed (TDM) carriers. The forward bearer is transmitted with a constant mean power level.

The return bearers are capable of carrying nominal data rates in the range between 8.4 kbit/s and 492.8 kbit/s and are based upon burst transmissions using a time-division-multiple access scheme (TDMA). The bursts are transmitted in slots of either 5 ms or 20 ms duration, which are described in a return schedule transmitted on a forward bearer. These return schedules also describe the symbol rate and modulation that shall be used for the transmission.

Spectrum efficiency

SRI-E achieves the highest spectrum efficiency possible with today's technology, for a geostationary satellite system. The basic modulation efficiency provided by the advanced modulation and coding technology is 1.4 bit/s/Hz. The use of traffic-sensitive statistical multiplexing further increases spectrum efficiency. In the case of data and Internet traffic, because of the highly flexible variable bandwidth mechanism, the effective rate taking into account probable statistically multiplexing gains is in the range 3-7 bit/s/Hz. In the case of voice traffic, voice activation can be expected to double the basic raw channel efficiency.

Mobile earth station characteristics

SRI-E will support multiple ranges of user terminals. However, only data for three types are included here, each of these have antenna gains in the range from 7.7 dBi to 14 dBi. The e.i.r.p. of these mobile terminals will range from 10 dBW to 20 dBW.

UEs frequency synthesizer

The requirements for the UE frequency synthesizer are listed in Table 26.

TABLE 26

Frequency synthesizer requirements

Step size	1.25 kHz
Switched speed	80 ms (including protocol processing)
Frequency range	Depends on spectrum allocation only
Frequency stability	1 ppm

Doppler compensation method

No explicit Doppler compensation is required as SRI-E is designed for a geostationary system. Receiver AFC is adequate for all mobile terminal speeds including those on airliners. Residual frequency offset will be determined at baseband using DSP techniques.

Propagation factors

Multipath interference has only limited impact in the target environment. It is accounted for in the link budget.

The fading rate is much slower than the symbol rate, so the intersymbol interference caused by changing delay spread profile is negligible.

4.3.4.4 Baseband specifications

Bit rates

Forward link

The forward link data can deliver from 21.6 kbit/s up to 512 kbit/s depending on the bearer type supported by the mobile and the channel conditions. The user data rate can be varied in response to variations in the channel C/N_0 as the user moves in the centre of the spot beam. The data rate can be dynamically adjusted on a burst by burst basis by the RNS and this is signalled by the unique word and an attribute value pair (AVP) in the first FEC block if the coding rate is not the same as the full frame.

Return link

Similarly in the return direction the data rates supported depend on the mobile capabilities and the channel conditions. The return bearers are able to deliver from 19.2 kbit/s up to 512 kbit/s. Again the data rate can be adjusted on a burst by burst basis and this is controlled by the RNS and partially by the UE itself.

Frame structure

Forward frame structures

The forward frame structure and combination of initial unique word and distributed pilot symbols have been adopted for the forward direction. The frame duration is 80 ms. Three types of forward bearers have been designed:

- The first operates at 8.4 ksymbol/s and is primarily used in the global beam, the bearer uses QPSK. Each frame occupies 10.5 kHz.
- The second operates at 33.6 ksymbol/s (occupying 42 kHz) and is used for signalling and for servicing small aperture terminals. Each frame is divided in four 20 ms FEC blocks. The bearer uses QPSK and 16-QAM.
- The third type is a “wide” bearer operating at 151.2 ksymbol/s (189 kHz). This bearer carries traffic data. Each frame is subdivided in eight 10 ms FEC blocks. This results in reducing delays in the forward direction from 20 ms to 10 ms. This is of prime importance for latency sensitive applications such as voice.

Return burst structures

In the return direction, two bursts duration have been chosen: 5 ms and 20 ms. For the highest rate bearer the number of blocks in a burst has been increased from one to two, to avoid excessive increase in turbo-encoder memory requirements. Again the 5 ms burst duration has been chosen for minimizing latency.

The smallest viable payload for turbo-coded blocks is around 20 octets, and this places a lower bound on the use of the 5 ms slot size – it can only be used for bearers with a symbol rate of at least 33.6 ksymbol/s when using the 16-QAM modulation or a symbol rate of 67.2 ksymbol/s when using a 4-ary modulation.

Nomenclature

TABLE 27A

Bearer names definition

Direction	Frame/burst duration (ms)	Symbol rate (multiplier) (ksymbol/s)	Modulation	FEC blocks per frame
F: Forward	80	0.25×33.6	X: 16-QAM Q: QPSK	1B
		1×33.6		4B
		4.5×33.6		8B
R: Return	20 5	0.5×33.6	X: 16-QAM Q: $\pi/4$ QPSK	1B
		1×33.6		2B
		2×33.6		
		4.5×33.6		

TABLE 27B

Overview of forward bearer types

Identifier	Frame duration (ms)	Symbol rate (ksymbol/s)	Modulation	FEC blocks per frame
F80T0.25Q1B	80	0.25×33.6	QPSK	1
F80T1X4B	80	33.6	16-QAM	4
F80T4.5X8B	80	4.5×33.6	16-QAM	8
F80T1Q4B	80	33.6	QPSK	4

TABLE 27C

Summary of return bearer types

Identifier	Burst duration (ms)	Symbol rate (ksymbol/s)	Modulation	FEC blocks per burst
R5T1X	5	33.6	16-QAM	1
R5T2X	5	2×33.6	16-QAM	1
R5T4.5X	5	4.5×33.6	16-QAM	1
R20T1X	20	33.6	16-QAM	1
R20T2X	20	2×33.6	16-QAM	1

TABLE 27D

Identifier	Burst duration (ms)	Symbol rate (ksymbol/s)	Modulation	FEC blocks per burst
R20T4.5X	20	4.5×33.6	16-QAM	2
R5T2Q	5	2×33.6	$\pi/4$ QPSK	1
R5T4.5Q	5	4.5×33.6	$\pi/4$ QPSK	1
R20T0.5Q	20	0.5×33.6	$\pi/4$ QPSK	1
R20T1Q	20	33.6	$\pi/4$ QPSK	1
R20T2Q	20	2×33.6	$\pi/4$ QPSK	1
R20T4.5Q	20	4.5×33.6	$\pi/4$ QPSK	1

Coding

To maximize the efficiency and the bit rate obtainable by each mobile, a technology described as variable coding is employed. This involves the puncturing of the turbo-code generated parity streams using one of a number of pre-defined puncturing matrices, such that the level of redundancy provided by the code is variable.

This allows the information rate to or from a mobile over a single channel to be increased when the mobile is operating in good channel conditions, and correspondingly reduced to allow the communications link to be maintained when the mobile is operating in poor channel conditions.

The steps in the coding rate provide nominally 1 dB steps in C/N_0 requirements to achieve the requisite burst error rate performance of 10^{-3} . This approach is also be used to counter the effect of slow fading. The satellite gateway controls the coding rate depending on the reported C/N_0 values of the link.

TABLE 28

Air interface variables

Modulation	Symbol rate (ksymbol/s)	Coding rate
QPSK, $\pi/4$ QPSK, 16-QAM	8.4, 16.8, 33.6, 67.2, 151.2	0.34, 0.4, 0.5, 0.6, 0.7, 0.8, 0.84

Parametric algorithmic design

There are a large number of coding rates required to achieve the full operational range, but the memory requirements for the mobiles are kept to a minimum. The functions for control encoder and decoder, the puncturing matrices and the channel interleaver matrices are described algorithmically, rather than in table form. This methodology ensures that there is a minimizing of the potential for specification and implementation errors.

Unique words

The encoding rate is signalled by the unique word used for the burst, this minimizes the constraints on system design and ensures that each frame or burst can be correctly demodulated and decoded without *a priori* knowledge of the coding rate that the transmitter is applying to a specific burst or frame transmission.

Turbo-synchronization

Signalling using the unique words and operating at low E_s/N_0 creates problems with the performance of the burst detection and synchronization mechanisms if classic techniques are utilized. The SRI-E incorporates a new technique to dramatically improve the performance.

The radio transmission processing delay due to the overall process of channel coding, bit interleaving, framing, etc., not including source coding, given as transmitter delay from the input of the channel coder to the antenna plus the receiver delay from the antenna to the output of the channel decoder is 55 ms for voice at 8 kbit/s and 10 ms for data at 144 kbit/s.

Echo control

SRI-E round trip delay is 100 ms for an 8 kbit/s connection, not including propagation delay. Clearly for a geostationary satellite system the latter predominates, adding approximately 600 ms and making echo control indispensable.

Linear transmitter requirements

Operation of the UE will conform to ETSI and other spectrum masks.

Receiver requirements

The dynamic range of the receiver is specified at 10 dB. Since the peak-to-average power ratio after baseband filtering is 3 dB, this is entirely adequate to cater for the variations of signal levels expected.

Required transmit/receive isolation

40 dB.

4.3.5 Satellite radio interface F (SRI-F) specifications

The Satcom2000 satellite radio interface F provides the air interface specifications for a personal mobile satellite system that uses advanced architecture and technologies to support a variety of service applications in diverse user environments.

A personal mobile satellite system employing the Satcom2000 radio interface will serve as a global extension of and complement to terrestrial networks, offering the quality and diversity of services envisioned for IMT-2000 systems. In coordination with terrestrial network operators, this system can provide subscribers with one phone and one number for almost all their communications needs. This system will offer a range of voice and data services, including a combination of voice, data, facsimile transfer, Internet access, e-mail, voice-mail, paging and messaging applications.

4.3.5.1 Architectural description

With smart antennae, hybrid multiple access schemes, on-board processing and switching, and other advanced technologies, a personal mobile satellite system employing the Satcom2000 radio interface is designed to optimize spectral, spatial and power resources. The ability to select alternative multiple access schemes allows the method best suited for the service and environment to be selected. Baseband switching provides a high level of control on the path for specific user data. Baseband processing and coding allow a lower BER on the user channels.

A block diagram of the architecture of Satcom2000 radio interface is shown in Fig. 29. In this figure, the gateway equipment (gateway controller and antenna subsystem) and the satellite constellation are grouped together as the SRAN. The feeder link and inter-satellite links are internal implementation details of the SRAN. The interface with the CN is called the Ius interface, and the interface with the user terminals is called the U_{us} interface. The physical implementation of this system includes a constellation of switched digital communications satellites with large number of high gain spot beams for each satellite.

The SRAN performs the following functions:

- Control message distribution – The SRAN will determine the appropriate routing destination of messages received from the constellation. This function includes routing of messages to the CN as well as to other access networks.
- Admission negotiation for the CN.
- Paging – The SRAN will provide paging distribution for a page request.
- Satellite network resource management functions. These functions include:
 - coordination of access network functions, including resource allocation and assignment, to handle call set-up and release,
 - handover management, including handover between beams in one satellite, handover between different satellites in the constellation and handover between satellite and terrestrial,
 - QoS negotiations (may require interaction with CN),
 - collection of statistics for satellite resource utilization.

FIGURE 29

Architecture of Satcom2000

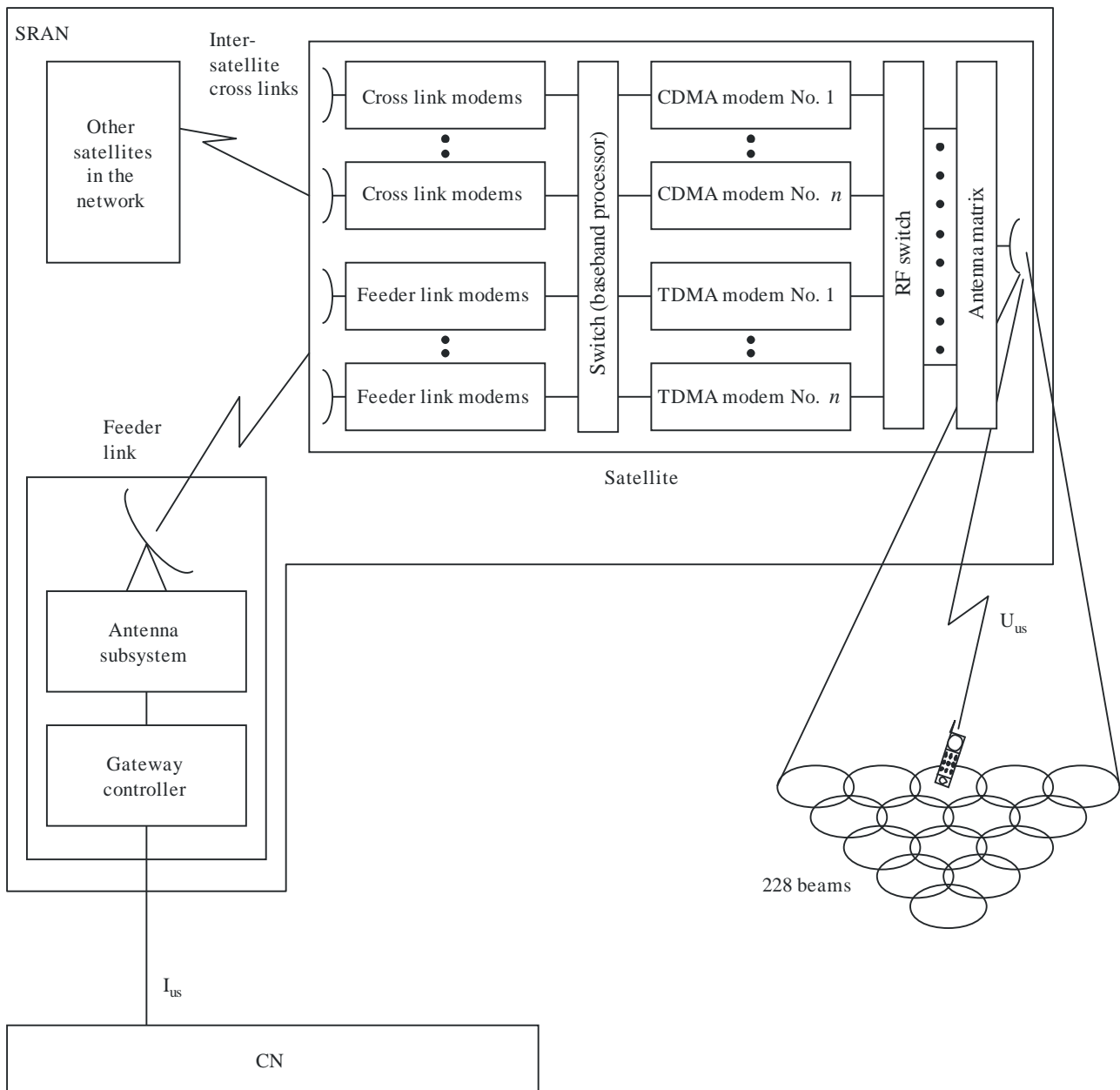

M.1850-29

4.3.5.1.1 Constellation

The personal mobile satellite system of Satcom2000 consists of a constellation of 96 LEO satellites in eight near-polar orbits, with twelve satellites equally spaced in each orbital plane (excluding spares). The orbit selection criteria, each of which is vital to the commercial service provision and technological feasibility of the system, are as follows:

- the need to provide global coverage over the entire surface of the Earth at all times;
- the requirement that the relative spacing and LoS relationships to neighbouring satellites are fixed or slowly changing, thus allowing simplification of the on-board subsystems that control inter-satellite links;
- the desire to minimize the cost of the entire constellation; and

- the effects of altitude on hardware costs (i.e. trade-offs considering a high-altitude radiation environment significantly increases costs, whereas low altitudes require more fuel and station-keeping manoeuvres).

This satellite constellation, which is illustrated in Fig. 30, provides coverage over the entire surface of the Earth. This selected orbit may be adjusted to optimize the system design.

The major constellation parameters of this satellite system are shown in Table 29.

FIGURE 30
Satellite constellation

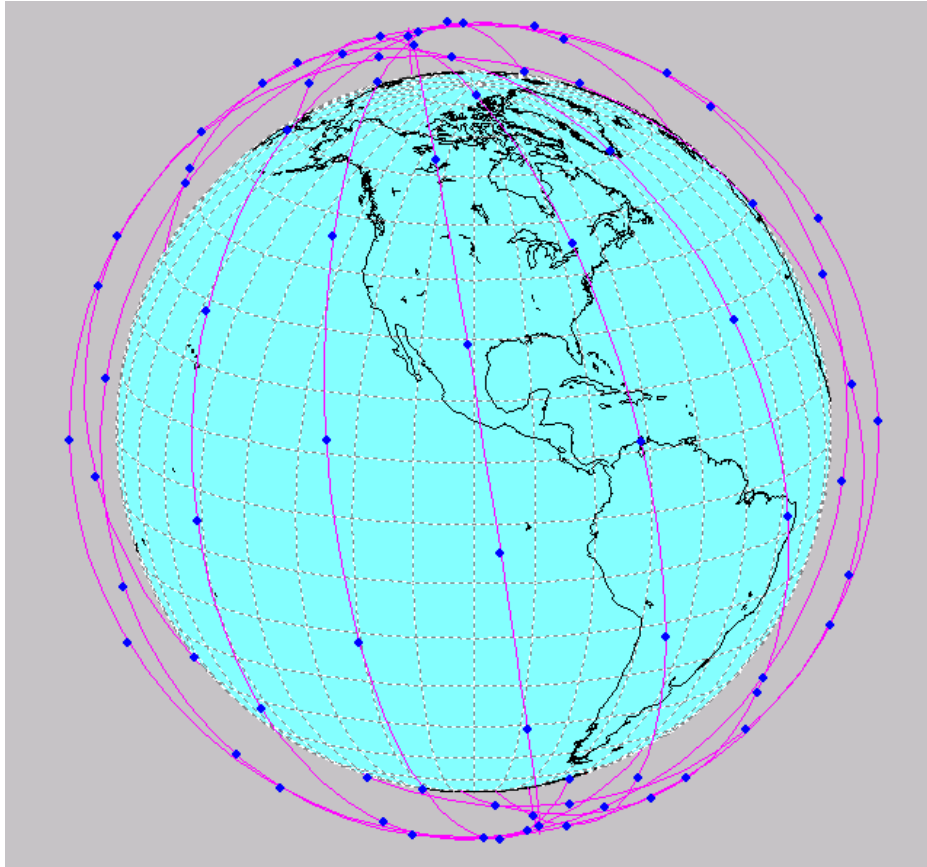

M.1850-30

TABLE 29

Constellation parameters

Orbit type	LEO
Number of satellites	96
Number of orbital planes	8
Number of satellites per plane	12
Inclination type	Polar
Inclination	98.8°
Orbital period	6 119.6 s
Apogee altitude	862.4 km

TABLE 29 (*end*)

Perigee altitude	843.5 km
Arguments of perigee	270°
Active service arc(s)	Not applicable – global coverage area
Right ascension of ascending nodes	160°, 183.5°, 207°, 230.5°, 254°, 277.5°, 301°, 324.5°

4.3.5.1.2 Satellites

The 96 satellites of the system space segment will provide universal service provision through global coverage from space.

All the satellites in the constellation are linked together as a switched digital communications network in the sky and use the principles of terrestrial cellular network to provide maximum frequency reuse. Each satellite uses spot beams to form cells on the surface of the Earth. Multiple and relatively small beams provide high satellite antenna gains and thus reduce the RF power required from the satellite and the user subscriber equipment. The number of spot beams can be adjusted for the system performance optimization even when the satellite is in orbit.

The major characteristics of each satellite communications payload are shown in Table 30.

TABLE 30

Major satellite communications payload characteristics

Number of spot beams per satellite	228 (may be adjusted for performance improvement)
Minimum elevation angle for user	15°
Inter-satellite links (yes/no)	Yes
On-board baseband processing (yes/no)	Yes
Geographical coverage (e.g. global, near global, below xx degrees latitude, regional)	Global
Dynamic beam traffic distribution (yes/no)	Yes

The spatial separation enabled by satellite spot beams allows increased spectral efficiency via time and frequency reuse within multiple cells. The frequency reuse pattern can be re-configured based on actual traffic conditions even when the satellites are in orbit.

Each satellite has the capability to allocate its power and bandwidth resources from one beam to another dynamically in response to actual traffic needs. For example, due to a disaster relief event, if the traffic demand in one beam increases above its nominal traffic, the satellite can re-allocate power and bandwidth that were originally allocated to other beams to this hot spot so that more traffic can be accommodated.

The requirement for communicating with subscriber units is supported by a satellite antenna complex, which forms cellular-like beams. A set of two phased-array antennas on the spacecraft, one for transmit and one for receive, support the uplink and downlink. Transmit and receive phased-array antenna pairs produce nearly identical and congruent uplink and downlink beams. The footprint of each satellite is divided into clusters of beams in order to facilitate channel reuse. Any of the beam ports of the transmitting antenna can be simultaneously activated by exciting it with one or more carrier signals. Each beam is dynamically assigned a set of channels corresponding to specific

frequency and time slot assignments in the frequency band commensurate with the number and usage of subscriber units being served. To efficiently accommodate variations in traffic, hardware allows the number of connections per beam to adapt automatically to the demand.

Beams also can be turned on or off, as appropriate, to accommodate traffic conditions and changing overlap of coverage. For example, to minimize possible interference from overlapping satellite footprints and to conserve satellite power, the system will employ a cell management architecture that turns beams off as each satellite traverses from the Equator toward the Polar regions.

The service link antenna subsystem is fixed to the satellite body and its pointing accuracy is dependent upon the satellite attitude control stabilization system.

Inter-satellite links connect the satellites in orbit to create a global telecommunications network in the sky. These links provide connectivity within and across orbital planes.

Each satellite has the capability, via feeder links, to establish links with the gateways on the Earth. The system will accommodate various numbers of gateways. The actual number of gateways to be deployed will be based on technical as well as business considerations.

In addition to the above communications links, the satellite has the capability to establish telemetry, tracking and command links with telemetry, telecommand and control (TT&C) stations located around the world.

Figure 31 shows a representative in-orbit coverage of a single satellite over the United States of America, at an altitude of 853 km.

4.3.5.2 System description

This Satcom2000 personal mobile satellite system is designed to satisfy the projected growth in overall demand for global mobile telecommunications, provide access to services requiring higher and variable data rate capabilities, and enable greater expansion and integration of satellite services with the terrestrial fixed and mobile networks.

This system will be capable of providing two-way voice, data, messaging, and multimedia communications services between a variety of user equipment anywhere in the world, and interconnecting any such user equipment to the PSTN, PSDN, PLMN, and other terrestrial networks, including global roaming and interoperability with the terrestrial component of IMT-2000 networks.

In order to provide this range of services, Satcom2000 will employ both TDMA and CDMA radio access technologies, comprising FDMA/TDMA and FDMA/CDMA channels operating on every satellite. This hybrid multiple radio access scheme incorporated into a single satellite system meets the diverse personal communications needs for wireless users in the twenty-first century and provides efficient spectrum utilization for such a variety of service offerings.

FIGURE 31
Single satellite coverage region, 853 km, 15° elevation angle



M.1850-31

There are five segments comprising this Satcom2000 personal mobile satellite system:

- space segment consisting of a constellation of 96 operational satellites in LEO of 854 km altitude, with 8 orbital planes and 12 satellites in each plane;
- system control segment that provides centralized TT&C for the entire satellite constellation;
- ground segment consisting of gateway stations and associated facilities including infrastructure for interfacing with terrestrial networks and service distribution;
- subscriber segment that features dual mode (satellite/terrestrial services compatible) multi-standard and multi-band user terminals; and
- business and customer support segment consisting of billing system and customer care centre, etc.

It will be possible for a satellite system employing Satcom2000 to interwork with the terrestrial component of IMT-2000 described in § 5 of Recommendation ITU-R M.1457. Roaming between the terrestrial network and the satellite network is supported. In most cases, automatic handover between the terrestrial and the satellite network will also be supported.

4.3.5.2.1 Service features

This personal mobile satellite system provides voice, data and messaging services in full-duplex communications. Bandwidth on demand, bit rate on demand, paging (alerting) service via satellites are supported. In order to accommodate the inherent nature of asymmetric Internet traffic, the system has provision for asymmetric data transmission. Asynchronous data transmission is also supported.

Table 31 summarizes the key service features supported by this personal mobile satellite system.

TABLE 31

Key service features

Bandwidth on demand (yes/no)	Yes
Bit rate on demand (yes/no)	Yes
Asynchronous data (yes/no)	Yes
Asymmetric data (yes/no)	Yes

4.3.5.2.2 System features

The key features of this personal mobile satellite system are summarized in Table 32.

TABLE 32

Key system features

Multiple access schemes	FDMA/TDMA and FDMA/CDMA
Handover technique (e.g. intra- and inter-satellite, soft or hard or hybrid)	Intra- and inter-satellite, using soft/hard handover
Diversity (e.g. time, frequency, space)	Time, space, etc.
Minimum satellite channelization	TDMA: 27.17 kHz CDMA: 1.25 MHz
Operation in satellite radio operating environments of Recommendation ITU-R M.1034	Urban satellite environment Rural satellite environment Satellite fixed-mounted environment Indoor satellite environment

Satcom2000 provides two separate satellite service link radio air interfaces: one is based on TDMA multiple access technology, and the other is based on CDMA multiple access technology. Both interfaces use a frequency plan with individual carriers separated in a basic FDMA scheme. Partitioning between the TDMA and CDMA operations will be optimized to match the service type and user environment, meet the traffic demand and maximize the system effectiveness.

The CDMA sub-system can achieve high spectral efficiency where power control techniques are effective at keeping all users at similar power levels. However, satellite systems suffer from relatively long path delays that impede the effectiveness of power control feedback loops. Where power control is ineffective, CDMA's spectral efficiency will be reduced.

For applications in which the user environment and hence the signal level change rapidly, e.g. mobile voice services, a TDMA scheme will achieve better performance in terms of both spectral efficiency and service quality. For applications such as high-speed data services in which the user environment may change slowly and thus the power control can be effective, a CDMA scheme will be more appropriate. This hybrid implementation allows all service types to be supported with an optimal use of the satellite resources.

The TDMA links provide large fade margins for various user environments in order to meet or exceed availability requirements. The CDMA links encompass a wide range of data rates, with link margins appropriate to specific services.

Satcom2000 supports handover between beams on a satellite, handover between beams on different satellites, as well as handover between a terrestrial IMT-2000 network and this satellite network. Management of handovers including call maintenance is handled by the SRAN.

4.3.5.2.2.1 FDMA/TDMA radio interface

The basic FDMA/TDMA individual voice channels are each transmitted at a 34.545 kbit/s burst rate, each occupying a bandwidth of 27.17 kHz using QPSK modulation. This permits a peak density per beam of 147 voice channels per 1 MHz, and 184 voice channels per 1.25 MHz.

Satcom2000 employs state-of-the-art voice coding technology in its vocoder design in order to get the best voice quality out of the least number of bits. A rate 2/3 FEC is incorporated into the vocoder.

The key parameters for the FDMA/TDMA scheme are summarized in Table 33.

TABLE 33

FDMA/TDMA voice channel characteristics

Number of voice time slots/frame	4
Burst rate	34.545 kbit/s
Channel spacing	27.17 kHz
Information rate	2.4-4 kbit/s
FEC (integrated with vocoder)	Rate = 2/3
Modulation type	QPSK

4.3.5.2.2.2 FDMA/CDMA radio interface

The CDMA portion of the allocated frequency band will be divided into 1.25 MHz sub-bands. The CDMA access scheme used within each sub-band allows multiple users to share the spectrum simultaneously. The spectrum can be reused on each satellite beam, resulting in a large frequency reuse factor for this CDMA subsystem. The CDMA links will provide variable user data rates up to 144 kbit/s.

The CDMA radio interface is based on a terrestrial IMT-2000 compatible standard. It has a 1.25 MHz bandwidth, and uses a direct-sequence spread spectrum access scheme. The peak channel bit rate is 9.6 kbit/s. The radio interface uses rate 1/3 convolutional encoding for the uplink, and rate 1/2 encoding for the downlink. A power control channel is added to each link using a punctured convolutional code.

The key parameters for the FDMA/CDMA scheme are summarized in Table 34.

TABLE 34

FDMA/CDMA data channel characteristics

Subframes/frame	2
Spreading rate	1.228 to 4.096 Mbit/s
Channel spacing	1.25 MHz
Information rate	to 9.6 kbit/s (up to 144 kbit/s using multiple channels)
FEC	Rate = 1/2 down; 1/3 up
Modulation type	16-QAM/QPSK

A data link using multiple channels will be able to provide data services at up to 144 kbit/s.

4.3.5.2.3 Terminal features

The user equipment for the satellite portion of the system will provide service for a variety of applications. The types of user equipment that will be supported include fixed, nomadic, portables, mobiles, maritime and aeronautical terminals. Most of these terminals will be equipped with multiple service capability (e.g. combined phone, message and data terminal). The actual user equipment types to be developed and the multiple service capability to be included would be based on market demand.

Some user equipment will handle only single channel, while others may be equipped with the capability to handle multi-channels. For example, a hand-held terminal will use only a single channel, but a fixed terminal may handle either single or multiple channels, which are multiplexed together through a multiplexer. High-speed data terminals operate using multiple basic data channels to provide high-speed services.

The key terminal features are shown in Table 35.

TABLE 35
Terminal features

Terminal types	<ul style="list-style-type: none"> – Hand-held – Portable – Nomadic – Fixed – Aeronautical – Maritime – Others
Multiple service capability (e.g. combined phone, pager, data terminal)	Yes
Mobility restrictions for each terminal type (e.g. up to xx km/h or yy m/s)	Up to 500 km/h for hand-held Up to 5 000 km/h for aero

4.3.5.3 RF specifications

The Satcom2000 personal mobile satellite system will operate in the 2 GHz band and generate cellular-like beams with each beam covering a relatively small area on the Earth to provide a large satellite service link margin. The RF parameters specified in this section are values at 2 GHz. They can also be modified to operate in other frequency bands allocated to IMT-2000 satellite component.

Satcom2000 requires that the TDMA and CDMA radio access subsystems operate on separate segments of spectrum. Thus any spectrum allocated to the satellite system will be segmented to the TDMA and the CDMA portion.

Satcom2000 provides both voice and data services. The basic voice services provide a high link margin and diversity to support operation in fading environments. In clear line of sight (CLOs) areas a lower link margin is traded for more efficient usage of bandwidth. The services provide higher data rates in areas with low fade margin. In areas with higher fade margin the data services operate at lower rates. An overlay of TDMA and CDMA multiple access channels within an FDMA structure provides the most appropriate access scheme based on the required type and quality of user services along with the operating environments.

Due to path delays of about 20 ms, the maximum power control rate for CDMA in this LEO satellite system is 50 Hz. This limits the effectiveness of CDMA technology except in slow fading user environment such as data applications or fixed services with CLOs signal paths to the satellites. These applications will be able to take advantage of both the data handling capability of IMT-2000 terrestrial

protocols along with their capacity gains. In order to minimize interference, the power control step size is determined to be 0.5 dB. The CDMA handset will use FDD mode to transmit and receive simultaneously, requiring approximately 63 dB isolation between transmission and receive. The modulation type will be selected to achieve as much commonality as possible with an appropriate technology used by IMT-2000 terrestrial systems. Because these applications are usually used in an environment with CLoS, some higher order modulation schemes, such as 16-QAM may be used for further improvement of the spectrum efficiency.

The capacity for the TDMA subsystem is less affected by high fading applications and therefore is reserved for mobile voice communications in rapidly changing environments. Power control is used solely to reduce power consumption at both user equipment and satellites. A coarser power control step size can be used in the TDMA subsystem. The power control rate is a function of both path delay and frame size. The TDMA user terminals can operate TDD mode to reduce the isolation requirements between transmission and receive.

The antenna gains and power levels on both user equipment and satellites are designed to optimize the service performance and system implementation. The initial values of these design parameters are given in Table 60. The satellites will be able to handle several different categories of user terminals. These terminals will have different e.i.r.p. levels based on their applications and size and therefore are able to support services in different fade margins. These decisions will be driven by the market demand.

The RF parameters of Satcom2000 are shown in Table 36.

TABLE 36
RF specifications

User terminal transmitter e.i.r.p. – Maximum e.i.r.p. for each terminal type – Average e.i.r.p. for each terminal type	–2 to 4 dBW for hand-held Market driven for other terminal types –8 to –2 dBW for hand-held Market driven for other terminal types
User terminal <i>G/T</i> for each terminal	–24.8 dB/K for hand-held Market driven for other terminal types
Antenna gain for each terminal type	2 dBi for hand-held Market driven for other terminal types
Maximum satellite e.i.r.p.	29.6 dBW
Maximum satellite <i>G/T</i>	0.1 dB/K
Channel bandwidth	TDMA: 27.17 kHz CDMA: 1.25 to 5 MHz
Multiple channel capability (yes/no)	Yes
Power control: Range Step size Rate	25 dB TDMA: 2 dB CDMA: 0.5 dB 50 Hz

TABLE 36 (end)

Frequency stability	
Uplink	0.375 ppm (AFC)
Downlink	1.5 ppm (thermal)
Doppler compensation (yes/no)	Yes
Terminal transmitter/receiver isolation	63 dB
Maximum fade margins for each service type	Voice: 15 to 25 dB Messaging/paging: 45 dB

4.3.5.4 Baseband specifications

Multiple access scheme

The multiple access schemes for the Satcom2000 radio interface include both FDMA/TDMA and FDMA/CDMA, as explained in § 4.3.6.2.2. Both TDD and FDD modes are available.

Frame length

The frame length is 40 ms. Each frame consist of 4 time slots of 8.88 ms, plus a guard band of 4.48 ms.

Channel coding

The channel coding used for the traffic channel will be a concatenated code consisting of a RS outer code and a convolutional inner code punctured to allow for variable rate bit protection. The purpose of the outer code is to provide burst error detection capability which is not provided by the convolutional code. A variety of different convolutional codes will be used depending on the required quality of service.

ARQ

In addition to FEC, some non-real services will include ARQ as well. ARQ schemes are not implemented for real-time services such as video teleconferencing due to the requirement for real-time performance and an allowable higher BER. However, applications such as file transfer protocol (FTP) may require a higher degree of transmission integrity depending upon the types of files being transferred and it may be necessary to implement an ARQ scheme. Executable files for obvious reasons require absolutely no errors in the transferred data, thus it is essential to have an ARQ scheme. ARQ schemes included in Satcom2000 include the selective-to-repeat scheme and the go-back-*N* scheme, and the choice of either one will depend on the actual application.

Interleaving

Interleaving is incorporated in Satcom2000 to spread the effect of bursty errors into several data segments so that in each data segment the resulting errors within a given data segment are independent. The interleaving structure is chosen such that there will be no effect on total system delay.

The baseband parameters of Satcom2000 are shown in Table 37.

TABLE 37

Baseband specifications

Multiple access techniques	FDMA/TDMA and FDMA/CDMA
Duplex method	TDD/FDD
Burst rate (TDMA mode)	34.545 kbit/s
Time slots (TDMA mode)	4 time slots/frame
Frame length	40 ms
Information rate	TDMA: 2.4-4 kbit/s CDMA: 0.048 to 9.6 kbit/s Information rate of up to 144 kbit/s can be achieved using multichannel configuration.
Chip rate (CDMA mode)	1.228 to 4.096 Mchip/s
Modulation type	TDMA: QPSK CDMA: 16-QAM/QPSK
FEC	TDMA: rate 2/3 CDMA: rate 1/2 down, rate 1/3 up
Dynamic channel allocation (yes/no)	Yes
Interleaving (yes/no)	Yes
Synchronization between satellites required (yes/no)	Yes

4.3.6 Satellite radio interface G (SRI-G) specifications (enhanced version)

This radio interface is a harmonized result of previous SRI-C and G families. It is also noted that a few satellite-specific features of SRI-A family are also incorporated. The selected enhancing features from SRI-A and C specifications are added into this radio interface as optional modes A and C, respectively, in order to optimize the radio interface over satellite.

This satellite radio interface is based on the IMT-2000 CDMA DS radio interface as described in § 5.1 of Recommendation ITU-R M.1457. Mobile Satellite systems intending to use this interface will address User Equipment (UE) fully compatible with IMT-2000 CDMA DS, with adaptation for agility to a neighbouring mobile-satellite service (MSS) frequency band.

The use of a standardized technology as well as a satellite IMT-2000 frequency band adjacent to a terrestrial IMT-2000 frequency band allows to accommodate these MSS system's features in 3G handsets with no waveform modification and consequently low cost impact. This optimizes considerably the market entry and penetration.

The key service and operational features of this radio-interface are the following:

- Support for low data rate services (e.g. 1.2 kbit/s) up to high-data-rate transmission (384 kbit/s) with wide-area coverage.
- High service flexibility with support of multiple parallel variable-rate services on each connection.
- Efficient packet access.
- Built-in support for future capacity/coverage-enhancing technologies, such as adaptive antennas, advanced receiver structures, and transmitter diversity.

- Support of inter-frequency handover for operation with hierarchical cell structures and handover to other systems, including handover to GSM.

This radio interface supports two optional modes of A and C. These optional modes include various satellite-specific features for performance enhancement. User terminals can be operated in multiple modes depending on their capabilities. In order for the multiple modes to keep backward compatibility with a normal mode, a satellite system supporting multiple modes should support the terminal supporting only the normal mode and the terminal supporting multiple modes should be operated in a satellite system supporting only the normal mode. For this, the following terminal types are considered.

- Terminal type 1: It can be operated for only normal mode.
- Terminal type 2: It can be operated for normal as well as optional mode A.
- Terminal type 3: It can be operated for normal as well as optional mode C.
- Terminal type 4: It can be operated for normal as well as optional modes A and C.

The information on which types of terminals are supported in the targeted frame and/or the considered Base Station is sent via broadcasting channel.

4.3.6.1 Architectural description

The system architecture is shown in Fig. 32.

The system may provide either single or multiple satellite constellation, each satellite may provide either mono or multi-spot coverage.

A location area may be either a spot or a group of spots for roaming users.

User Equipments (Ues) are connected to the network via one or several satellites which redirect the radio signal to/from gateways. The system allows for either a centralized gateway or a group of geographically distributed gateways, depending on the operators requirements. The Gateway connects the signal to the Radio Network Subsystem (RNS), i.e. Node Bs and RNC. The decision to integrate Node Bs and/or RNC inside or outside the Gateway is under manufacturers implementation choice.

In a satellite environment, signal transmission is subject to degradation due to buildings, mountains, etc. Coverage continuity in highly shadowed areas can possibly be complemented with Intermediate Module Repeaters (IMRs), reusing the same frequency as the satellite, to amplify and repeat the signal to and from the satellite. IMRs are a system deployment and implementation issue and are therefore not part of this Satellite Radio Interface. Technical, operational and regulatory issues related to IMRs have not been assessed.

FIGURE 32
System architecture

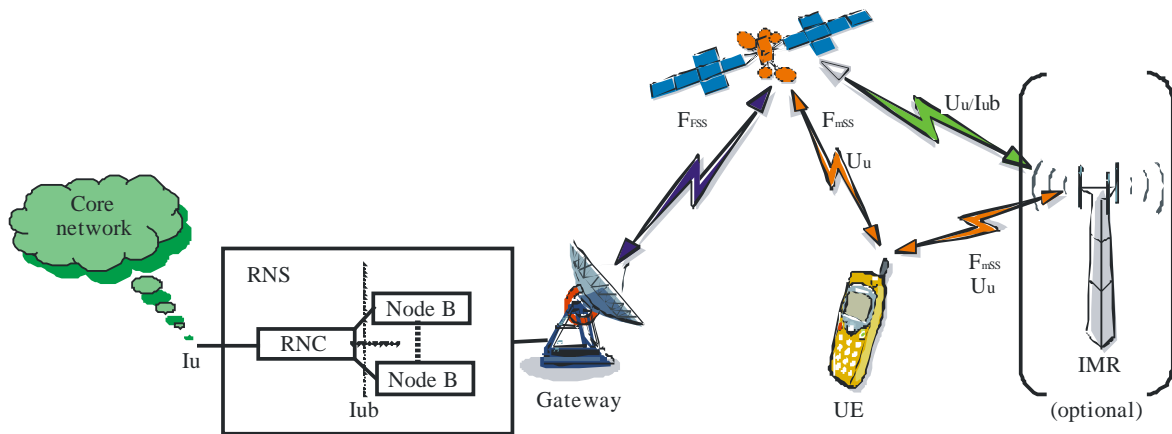

M.1850-32

4.3.6.1.1 Constellation

This interface is able to cope with several satellite constellation types, i.e. LEO, HEO, MEO or GSO. This section however presents the detailed architecture and performances of the GSO constellation type.

4.3.6.1.2 Satellites

Several architectures are envisaged depending on throughput requirements. The examples below assume European coverage. Global beam configuration means there is a unique spot covering the entire Europe area.

Multi-beam configuration means a satellite serves several spots, for instance 1 spot per linguistic area (7 multi-beam configuration) or 1 spot per regional area (extended multi-beam configuration).

Another possible configuration is a system built with several satellites, each satellite serving several spots.

FIGURE 33

Global beam and 7 multi-beam satellite configuration

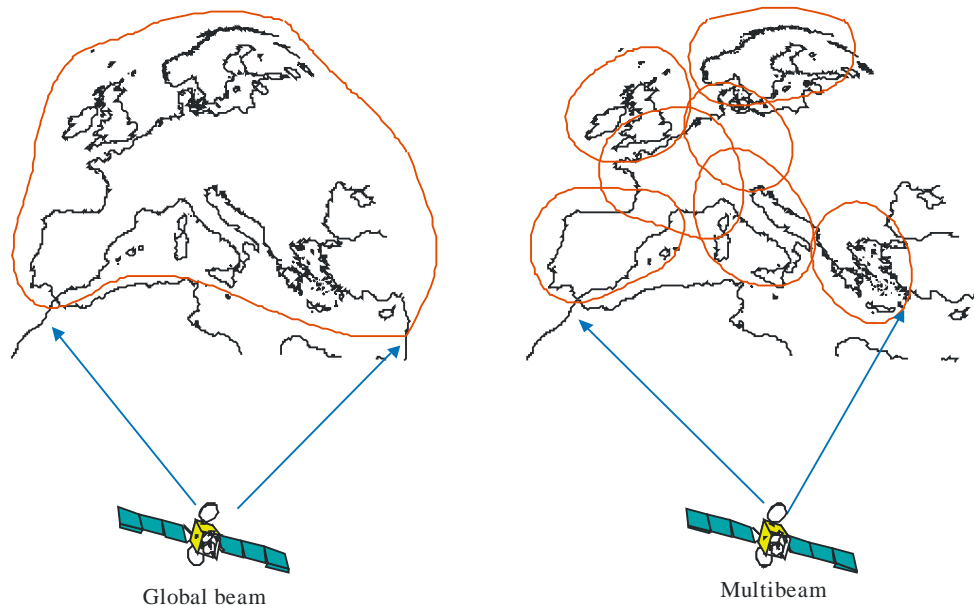

M.1850-33

FIGURE 34

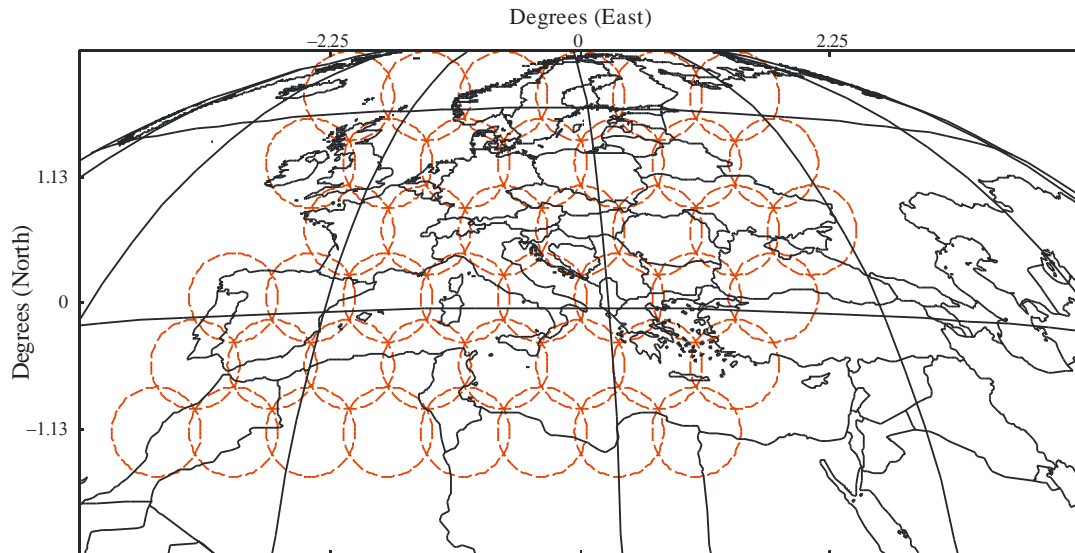
Extended multi-beam configuration

Satellite 16.00 0.00 35786.
Centre Map 18.00 40.40 0.

M.1850-34

FIGURE 35

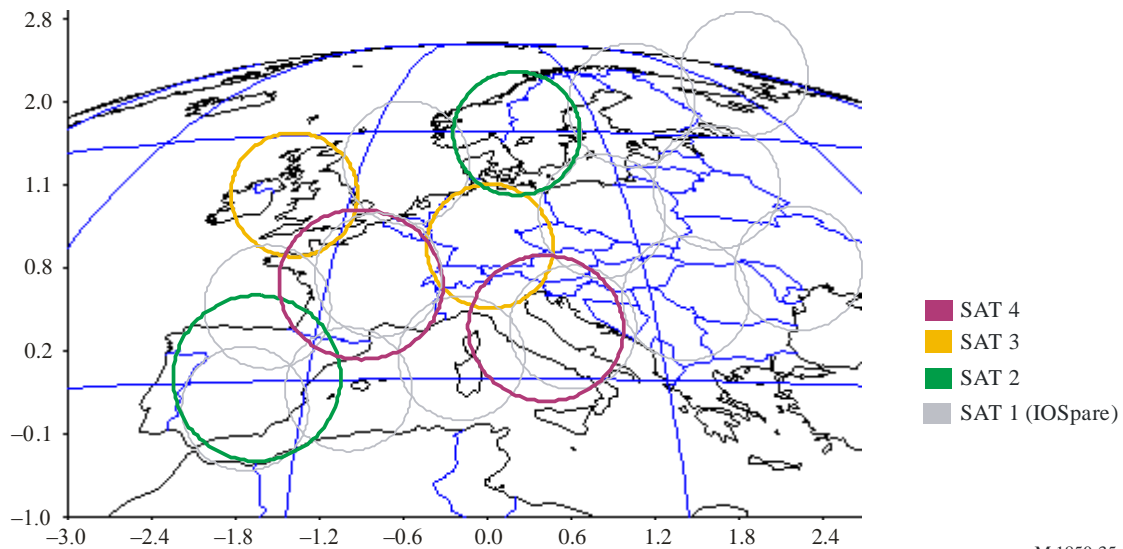
Multi-satellite and multi-beam configuration

M.1850-35

4.3.6.2 System description**4.3.6.2.1 Service features****4.3.6.2.1.1 Basic bearer services**

Basic bearer services to be supported by this radio interface include voice in which data rates are from 2.4 kbit/s to 12.2 kbit/s data from and 1.2 kbit/s to 384 kbit/s.

4.3.6.2.1.2 Packet data services

Packet data services will be provided at the data rates which are from 1.2 kbit/s to 384 kbit/s.

4.3.6.2.1.3 Teleservices

Teleservices include speech transmission such as emergency calls, short message service, facsimile transmission, video telephony service, paging service, etc.

4.3.6.2.1.4 Deep paging service

Deep paging service will be provided for contacting the mobile terminal user located in areas such as deep penetration in buildings where normal services cannot be provided.

4.3.6.2.1.5 Multicasting

Multicasting services will be provided to the UE local cache through a direct satellite distribution link exploiting the push service over MBMS (Multicast Broadcast Multimedia Services, described in § 5.1 of Recommendation ITU-R M.1457). The bit rate of multicasting services is from 1.2 kbit/s to $n \times 384$ kbit/s ($n = 2, 3$ or more according to the configurations).

4.3.6.2.2 System features

This radio interface is based on the key technical characteristics listed in Table 38.

TABLE 38

Key technical characteristics of SRI-G

Multiple-access scheme	DS-CDMA
Duplex scheme	FDD
Chip rate	3.840 Mchip/s
Carrier spacing	5 MHz (200 kHz carrier raster)
Frame length	10 ms
Inter-spot synchronization	No accurate synchronization needed
Multi-rate/Variable-rate scheme	Variable-spreading factor + Multi-code
Channel coding scheme	Convolutional coding (rate 1/2 – 1/3) Turbo coding 1/3
Packet access	Dual mode (common and dedicated channel)

4.3.6.2.3 Terminal features

The user equipment may be of various types: hand-held, portable, vehicular, transportable or aeronautical. The data rate and mobility restriction for each type of terminal are described in Table 39. For the maximum capacity assessment it is necessary to distinguish between the forward link and the return link.

TABLE 39

Mobility restrictions for each terminal type

Terminal type	Applied service data rate (return link) (kbit/s)	Applied service data rate (forward link) (kbit/s)	Nominal mobility restriction (km/h)
Hand-held	1.2-12.2	1.2-384	500
Portable	1.2-384	1.2-384	500
Vehicular	1.2-384	1.2-384	500 (maximum 1 000)
Transportable	1.2-384	1.2-384	Static
Aeronautical	1.2-384	1.2-384	5 000

4.3.6.2.4 Handover

This radio interface will support handover of communications from one satellite radio channel to another. The handover strategy is mobile-assisted network-decided handover.

Soft and softer handover is supported.

The following handoff types are the most common in the system.

Beam hand-off

The UE always measures the level of the pilot $C/(N+I)$ coming from adjacent beams and report such information to the LES. The LES may then decide to transmit the same channel through two different beams (soft beam hand-off) and command the UE to add a finger to demodulate the additional signal. As soon as the LES receives a confirmation that the new signal is received, it drops the old connection. There is in fact no scope to have a prolonged inter-beam soft handoff because no path diversity is actually introduced.

Inter-satellite handoff

The procedure is analogous to that of inter-beam hand-off. The only difference is that the UE has also to search for different satellite specific pilot scrambling codes. If a new, strong enough, pilot scrambling code is detected, the measure is reported back to the LES, which may decide to exploit satellite diversity by transmitting the same signal through different satellites.

Differently from the previous case, there is now a path diversity advantage and it is useful that all strong enough diversity paths are exploited.

Maximal ratio combining can then be performed (time ambiguity resolution is done through the primary CCPCHs MF synchronization).

Inter-frequency handoff

Only hard inter-frequency, handoff is supported. This hand-off can be either intra-gateway or inter-gateway.

Inter-frequency handoff is generally not needed. This hand-off is decided by the LES without any support by the UE (i.e. this hand-off type is not a mobile-assisted handoff).

On the reverse link, the LES will instead combine all signals received from the same UE through different beams and/or satellites.

4.3.6.2.5 Satellite diversity

Satellite diversity can be provided when the system is built with several satellites. Advantages are:

- solve path blockage problem inherent to satellite systems;
- reduce required link margin for situations where satellite signal is strongly attenuated (but not completely obstructed);
- ease UE handover when moving through coverage areas.

The method is also applicable to spots belonging to a given satellite (spot diversity).

In the following, it is assumed that the number of satellites offering diversity is limited to 2.

FIGURE 36
Satellite diversity

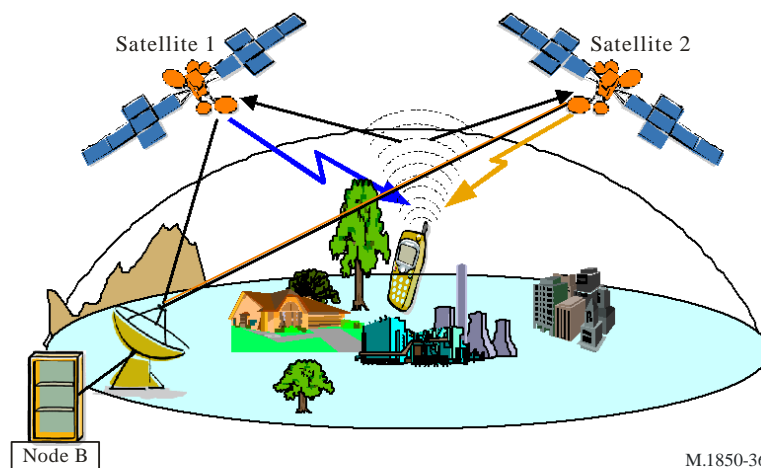

When switched to satellite diversity mode, UE is simultaneously radio connected to both satellites over the same carrier frequency.

In the return link, UE transmits a unique signal (one unique scrambling code). This uplink signal is received by both satellites, redirected to the gateway and combined at Node B rake receiver.

In the forward link, each satellite transmits with a distinct scrambling code, UE rake receivers combine both signals.

Simulations were driven for several UE situations in view of both satellites:

- One satellite LoS, the other satellite NLoS: LoS component is such predominant that performances are equivalent to 1 single satellite with LoS. Spot Selection Diversity Transmission (SSDT) mechanism allows to switch off 2nd satellite in order not to waste scarce satellite transmit power.
- Both satellites LoS.
- None of the satellites LoS.

Simulation results presented hereafter highlight Tx E_b/N_0 gain due to satellite diversity, i.e. the difference versus the path loss difference of Tx E_b/N_0 obtained with and without satellite diversity for reaching a target BLER of 1%. Results are given as a function of the 2nd satellite path loss difference, i.e. path loss between UE and 1st satellite is taken as a reference. ITU channels models A, B, C (as in Recommendation ITU-R M.1225) are tested.

4.3.6.2.5.1 Both satellites LoS

Path loss difference is to be understood as distinct satellite Rx antenna gain (uplink)/Tx satellite power capability (downlink).

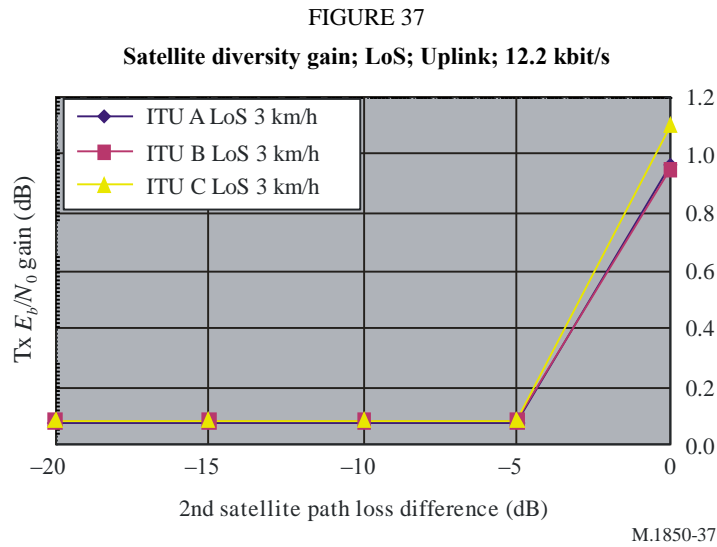

Diversity gain is practically identical for UE speed from 0 km/h to 50 km/h. It is limited to a maximum of ~1 dB (12,2 kbit/s).

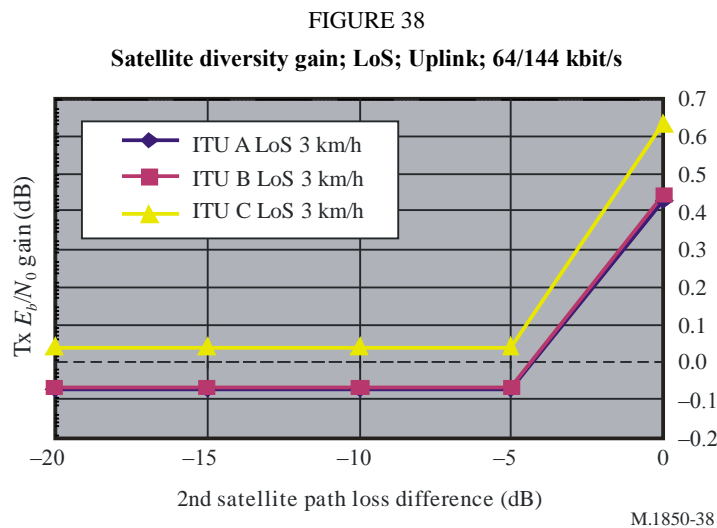

In the downlink direction, Tx E_b/N_0 gain is negative and almost identical whatever service data rate. Tx power gain is counteracted by increase of interference, due to non orthogonality of both satellites scrambling codes. Nevertheless, satellite diversity can still be envisaged for allowing dynamic power distribution among satellites in high traffic load conditions.

FIGURE 39

Satellite diversity gain; LoS; Downlink

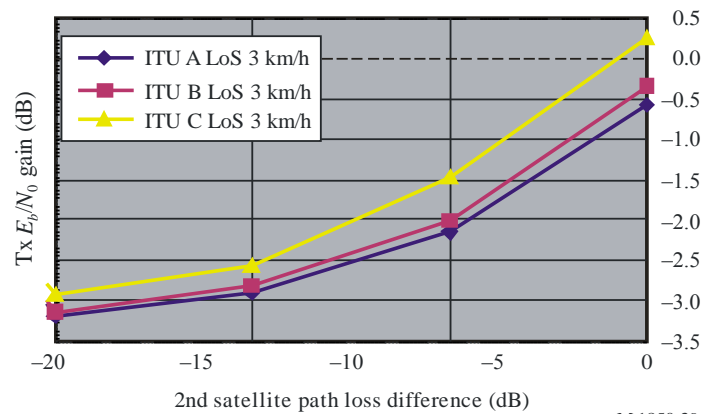

M.1850-39

4.3.6.2.5.2 None of the satellite LoS

Satellite diversity gain is significant when UE is suffering NLoS with none of the satellites. Furthermore, the case when 2nd satellite path loss difference is 0 dB looks a highly probable assumption. Maximum Tx E_b/N_0 gain is reached for low speed UEs. In the downlink direction, it is almost independent of the service data rate.

FIGURE 40

Satellite diversity gain; NLoS; Uplink; 12.2 kbit/s; 3 km/h

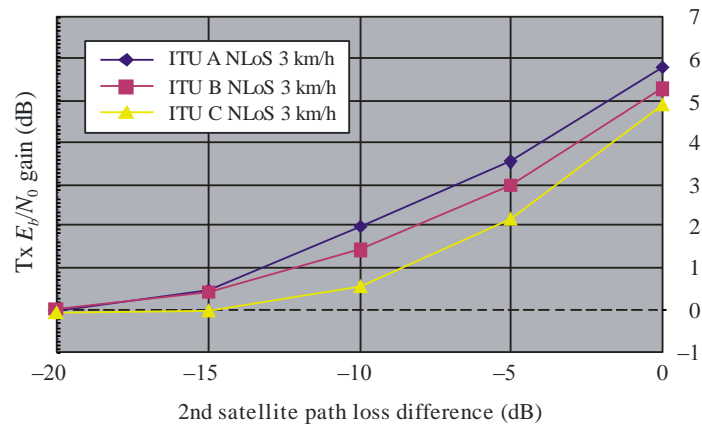

M.1850-40

FIGURE 41

Satellite diversity gain; NLoS; Uplink; 64/144 kbit/s; 3 km/h

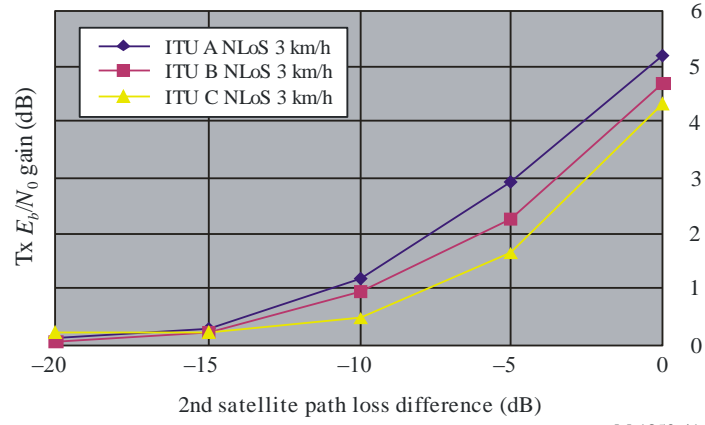

FIGURE 42

Satellite diversity gain; NLoS; Uplink; 12.2 kbit/s; 50 km/h

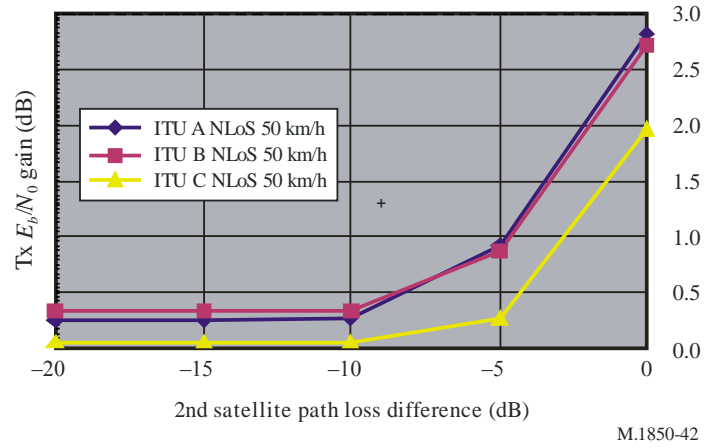

FIGURE 43

Satellite diversity gain; NLoS; Uplink; 64/144 kbit/s; 50 km/h

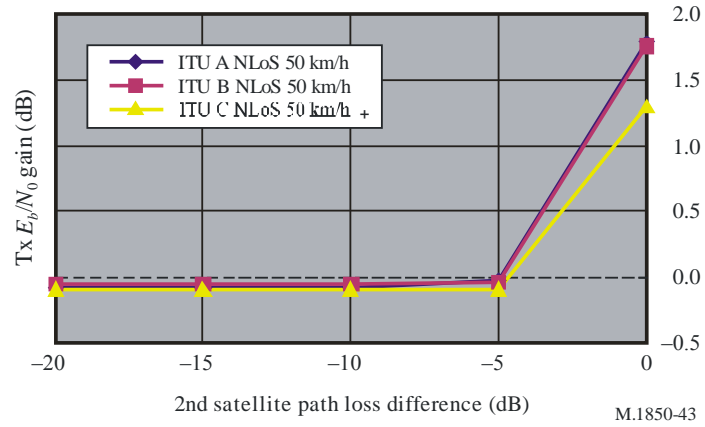

FIGURE 44

Satellite diversity gain; NLoS; Downlink; 3 km/h

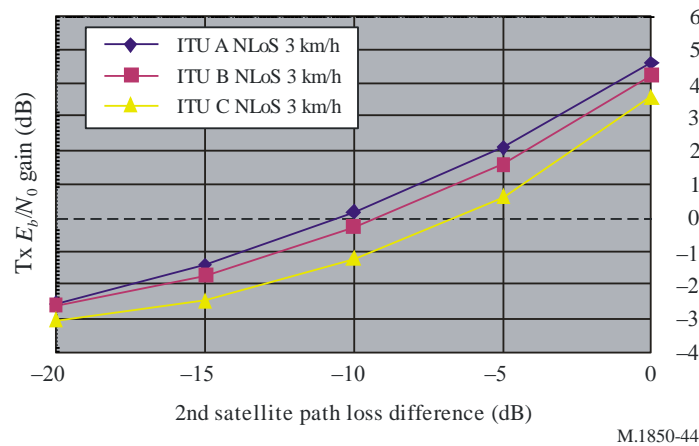
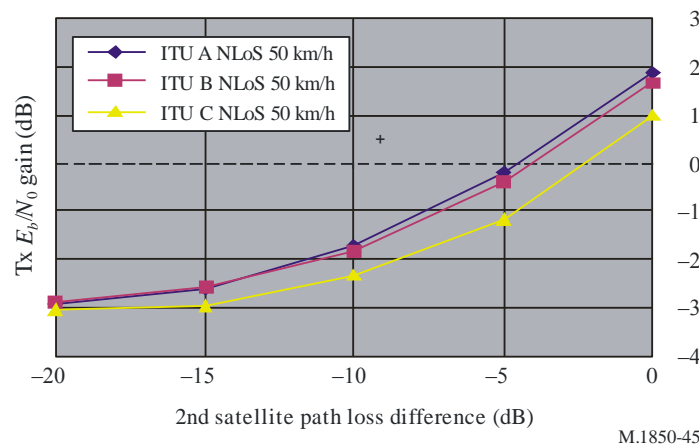

FIGURE 45

Satellite diversity gain; NLoS; Downlink; 50 km/h



4.3.6.3 RF specifications

4.3.6.3.1 Satellite station

a) Global beam architecture

The global beam architecture provides an overall throughput of 3.84 Mbit/s over Europe shared among 2 FDM. For instance, if 384 kbit/s service is provided, each FDM carries a maximum of 5 channel codes.

Each FDM occupies 5 MHz bandwidth among MSS frequency band.

Satellite performances are summarized in Table 40.

TABLE 40

Satellite global beam architecture

	Global beam
Number of spot beams	1
Downlink (satellite to UE) Frequency (satellite to UE) (MHz) Polarisation On board e.i.r.p. per carrier (dBW)	2 170-2 200 LHCP or RHCP 64
Uplink Frequency (UE to satellite) (MHz) Polarisation Rx Antenna gain (dB)	1 980-2 010 LHCP or RHCP ~30

b) Multi-beam architecture

Satellite performances are summarized in Table 41.

TABLE 41

Satellite 7 multi-beam architecture

	7 multibeam
Number of spot beams	7
Downlink (satellite to UE) Frequency (satellite to UE) (MHz) Polarisation On board e.i.r.p. per carrier (dBW)	2 170-2 200 LHCP or RHCP From 64 to 74 (see Note 1)
Uplink Frequency (UE to satellite) (MHz) Polarisation Rx Antenna gain (dB)	1 980-2 010 LHCP or RHCP 36 -39

NOTE 1 – Depending on considered spot beam and frequency reuse pattern.

c) Extended multi-beam architecture

Satellite performances are summarized in Table 42.

TABLE 42
Satellite extended multi-beam architecture

	Extended multibeam
Number of spot beams	30
Downlink (satellite to UE) Frequency (satellite to UE) (MHz) Polarisation On board e.i.r.p. per carrier (dBW)	2 170-2 200 LHCP or RHCP 74
Uplink Frequency (UE to satellite) (MHz) Polarisation Rx Antenna gain (dB)	1 980-2 010 LHCP or RHCP 42-47

4.3.6.3.2 MES

The mobile earth station is also named User Equipment (UE). The UE may be of several types:

3G standardized handset: the use in satellite environment requires adaptation for frequency agility to the MSS band. The basic assumption is UE power class 1, 2 and 3, equipped with standard omnidirectional antenna.

Portable: the portable configuration is built with a notebook PC to which an external antenna is appended.

Vehicular: the vehicular configuration is obtained by mounting an RF module on car roof connected to the UE in the cockpit.

Transportable: the transportable configuration is built with a notebook which cover contains flat patch antennas (manually pointed towards the satellite).

Aeronautical: aeronautical configuration is built by mounting an antenna on top of the fuselage.

FIGURE 46
UE configuration

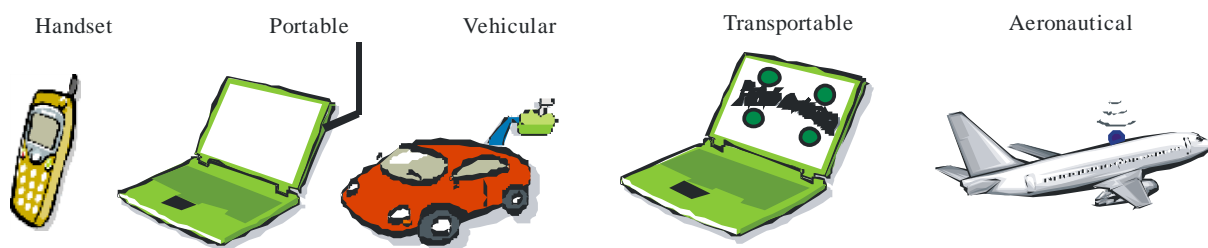

M.1850-46

The power and gain characteristics for the four UE configurations are summarized in Table 43.

TABLE 43

UE maximum transmit power, antenna gain and EIRP

UE type	Maximum transmit power	Reference antenna gain (see Note 1)	Maximum EIRP	Antenna temp.	G/T
3G Handset					
Class 1	2W (33 dBm)	0 dBi	3 dBW	290 K	-33,6 dB/K
Class 2	500 mW (27 dBm)		-3 dBW		
Class 3	250 mW (24 dBm)		-6 dBW		
Portable	2 W (33 dBm)	2 dBi	5 dBW	200 K	-26 dB/K
Vehicular	8 W (39 dBm)	4 dBi	13 dBW	250 K	-25 dB/K
Transportable	2 W (33 dBm)	14 dBi	17 dBW	200 K	-14 dB/K
Aeronautical	2 W (33 dBm)	3 dBi	6 dBW		

NOTE 1 – Typical values.

4.3.6.4 Baseband specifications

4.3.6.4.1 Channel structure

4.3.6.4.1.1 Transport channel

4.3.6.4.1.1.1 Common channel

Broadcast Channel (BCH)

BCH is a downlink channel for broadcasting system control information for each beam to MES.

Paging Channel (PCH)

PCH is a downlink channel used to carry control information to MES when the system does not know which beam the MES belongs to. The PCH is associated with physical-layer generated paging indicators, to support efficient sleep-mode procedures.

Forward Access Channel (FACH)

FACH is a downlink channel used to carry user or control information to MES. This channel is used when the system knows which beam the MES belongs to.

Downlink Shared Channel (DSCH)

DSCH is a downlink channel shared by several MESs carrying dedicated control or traffic data, and associated with one or several downlink DCH.

Random Access Channel (RACH)

RACH is an uplink channel used to carry user or control information from MES to LES.

Common Packet Channel (CPCH)

CPCH is an uplink channel used to carry user information from MES to LES. CPCH is associated with a downlink common control channel that provides power control and CPCH control commands.

4.3.6.4.1.1.2 Dedicated channel (DCH)

The DCH is a downlink or uplink channel transmitted over the entire beam or over only a part of the beam, dedicated to one MES.

4.3.6.4.1.2 Physical channel

4.3.6.4.1.2.1 Downlink physical channel

4.3.6.4.1.2.1.1 Common pilot channel (CPICH)

The CPICH is a fixed rate (30 kbit/s, SF = 256) downlink physical channel that carries a pre-defined bit/symbol sequence.

Two types of CPICH are defined, the Primary and Secondary CPICH. They differ in their use and the limitations placed on their physical features:

- Primary common pilot channel (P-CPICH):
 - the same channelization code is always used for the P-CPICH;
 - the P-CPICH is scrambled by the primary scrambling code;
 - there is one and only one P-CPICH per spot;
 - the P-CPICH is broadcast over the entire spot;
 - the Primary CPICH is a phase reference for the downlink physical channels.
- Secondary common pilot channel (S-CPICH):
 - an arbitrary channelization code of SF = 256 is used for the S-CPICH;
 - a S-CPICH is scrambled by either the primary or a secondary scrambling code;
 - there may be zero, one, or several S-CPICH per spot;
 - a S-CPICH may be transmitted over the entire spot or only over a part of the spot;
 - a Secondary CPICH may be a phase reference for a downlink DPCH.

FIGURE 47

Frame structure of CPICH

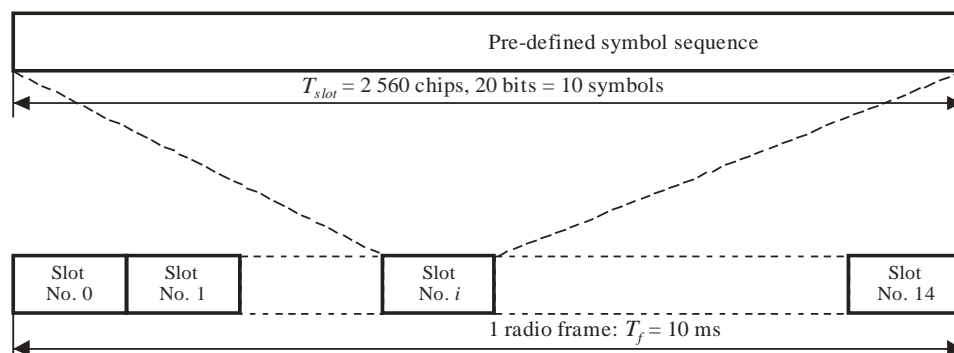

M.1850-47

4.3.6.4.1.2.1.2 Primary common control physical channel (P-CCPCH)

The Primary CCPCH is a fixed rate (30 kbit/s, SF = 256) downlink physical channels used to carry the BCH transport channel.

The Primary CCPCH is not transmitted during the first 256 chips of each slot. Instead, Primary SCH and Secondary SCH are transmitted during this period.

FIGURE 48

Frame structure of P-CCPCH

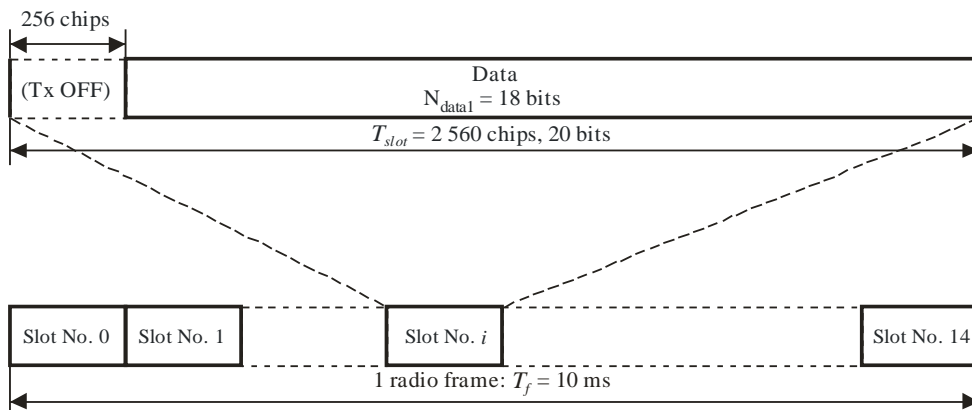

M.1850-48

4.3.6.4.1.2.1.3 Secondary common control physical channel (S-CCPCH)

The Secondary CCPCH is used to carry the FACH and PCH. There are two types of Secondary CCPCH: those that include TFCI and those that do not include TFCI. The set of possible rates for the Secondary CCPCH is the same as for the downlink DPCH.

FIGURE 49

Frame structure of S-CCPCH

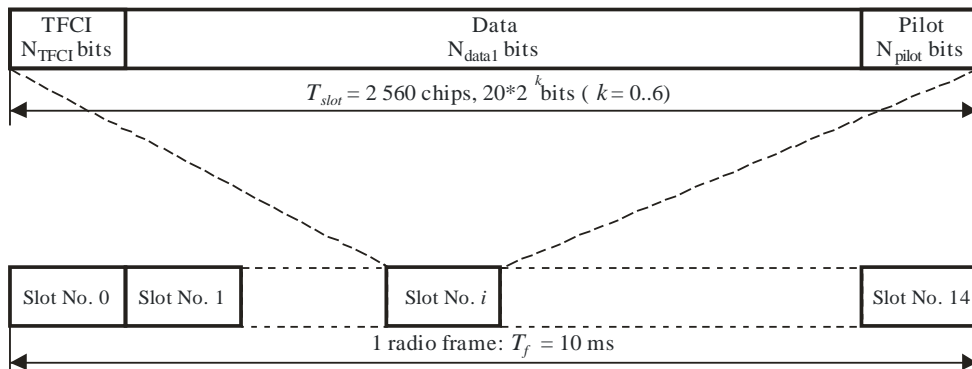

M.1850-49

The parameter k in Fig. 49 determines the total number of bits per downlink Secondary CCPCH slot. It is related to the spreading factor SF of the physical channel as $SF = 256 / 2^k$. The spreading factor range is from 256 down to 4.

The FACH and PCH can be mapped to the same or to separate Secondary CCPCHs. If FACH and PCH are mapped to the same Secondary CCPCH, they can be mapped to the same frame. The main difference between a CCPCH and a downlink dedicated physical channel is that a CCPCH is not inner-loop power controlled. The main difference between the Primary and Secondary CCPCH is that the transport channel mapped to the Primary CCPCH (BCH) can only have a fixed predefined transport format combination, while the Secondary CCPCH support multiple transport format combinations using TFCI.

4.3.6.4.1.2.1.4 Synchronization channel (SCH)

The synchronization channel (SCH) is a downlink signal used for spot search. The SCH consists of two sub-channels, the Primary and Secondary SCH. The 10 ms radio frames of the Primary and Secondary SCH are divided into 15 slots, each of length 2 560 chips.

FIGURE 50
Structure of SCH

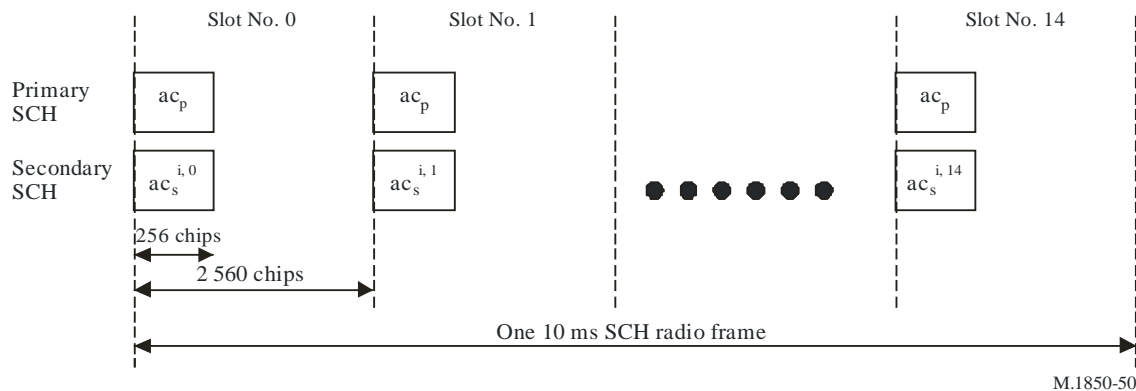

The Primary SCH consists of a modulated code of length 256 chips, the Primary Synchronization Code (PSC) denoted c_p in Fig. 50, transmitted once every slot. The PSC is the same for every spot in the system.

The Secondary SCH consists of repeatedly transmitting a length 15 sequence of modulated codes of length 256 chips, the Secondary Synchronization Codes (SSC), transmitted in parallel with the Primary SCH. The SSC is denoted $c_s^{i,k}$ in Fig. 50, where $i = 0, 1, \dots, 63$ is the number of the scrambling code group, and $k = 0, 1, \dots, 14$ is the slot number. Each SSC is chosen from a set of 16 different codes of length 256. This sequence on the Secondary SCH indicates which of the code groups the spot's downlink scrambling code belongs to.

4.3.6.4.1.2.1.5 Physical downlink shared channel (PDSCH)

The PDSCH is used to carry the downlink shared channel (DSCH).

FIGURE 51
Frame structure of PDSCH

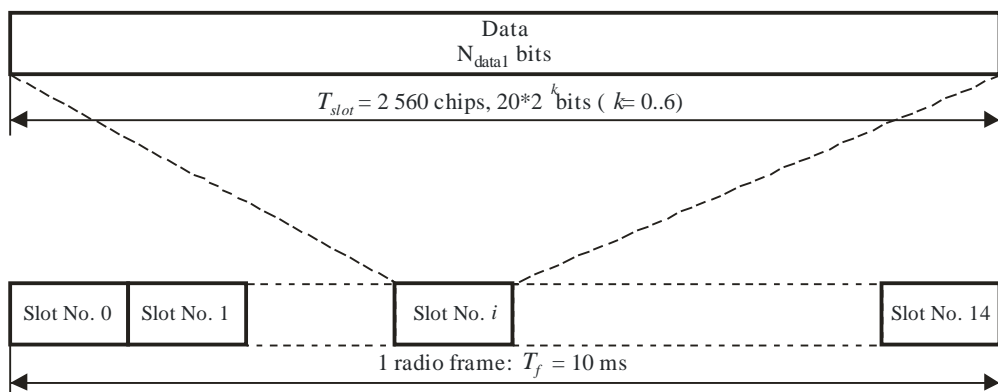

M.1850-51

A PDSCH is allocated on a radio frame basis to a single UE. Within one radio frame, UTRAN may allocate different PDSCHs under the same PDSCH root channelization code to different UEs based on code multiplexing. Within the same radio frame, multiple parallel PDSCHs, with the same spreading factor, may be allocated to a single UE. This is a special case of multicode transmission. All the PDSCHs are operated with radio frame synchronization.

PDSCHs allocated to the same UE on different radio frames may have different spreading factors.

For each radio frame, each PDSCH is associated with one downlink DPCH. The PDSCH and associated DPCH do not necessarily have the same spreading factors and are not necessarily frame aligned.

All relevant Layer 1 control information is transmitted on the DPCH part of the associated DPCH, i.e. the PDSCH does not carry Layer 1 information. To indicate for UE that there is data to decode on the DSCH, the TFCI field of the associated DPCH shall be used.

The TFCI informs the UE of the instantaneous transport format parameters related to the PDSCH as well as the channelization code of the PDSCH.

For PDSCH the allowed spreading factors may vary from 256 to 4.

4.3.6.4.1.2.1.6 Acquisition indicator channel (AICH)

The AICH is a fixed rate (SF = 256) physical channel used to carry Acquisition Indicators (AI). Acquisition Indicator AIs corresponds to signature s on the PRACH.

The AICH consists of a repeated sequence of 15 consecutive access slots (AS), each of length 5 120 chips. Each access slot consists of two parts, an *Acquisition-Indicator* (AI) part consisting of 32 real-valued symbols a_0, \dots, a_{31} and a part of duration 1 024 chips with no transmission that is not formally part of the AICH. The part of the slot with no transmission is reserved for possible use by CSICH or possible future use by other physical channels.

The spreading factor (SF) used for channelization of the AICH is 256.

The phase reference for the AICH is the Primary CPICH.

FIGURE 52

Structure of AICH

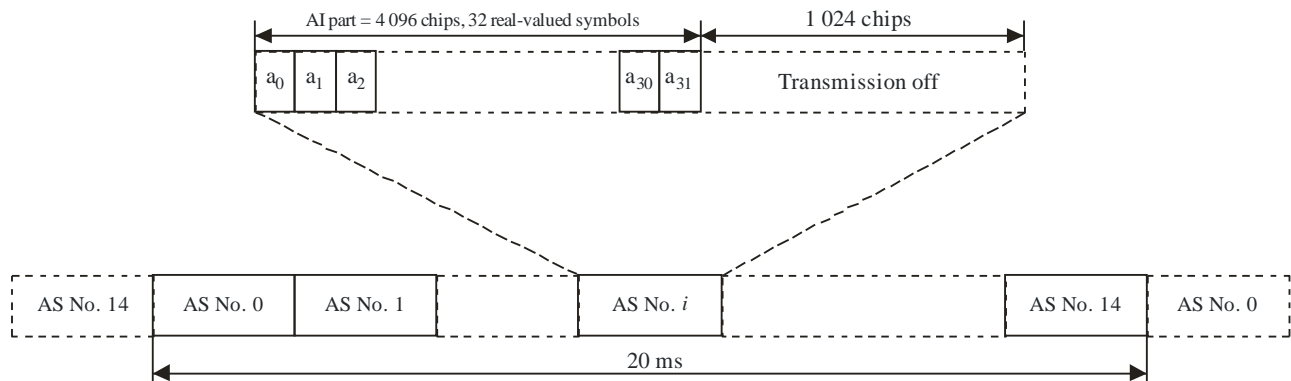

M.1850-52

4.3.6.4.1.2.1.6.2 Operation in optional mode C

When sub-access frames are not used for the PRACH, the Acquisition Indicator part for the PRACH is transmitted only on the first access slot (AS No. 0). The AICH is not transmitted during the remaining 14 access slots. When sub-access frames are used for the PRACH, the AI part is transmitted only on the first access slot (AS No. 0) and the ninth access slot (AS No. 8). The AI part of the first access slot carries the AI corresponding to the signature of PRACH preamble transmitted at the even sub-access frame. The AI part of the ninth access slot carries the AI corresponding to the signature of PRACH preamble transmitted at the odd sub-access frame.

4.3.6.4.1.2.1.7 Paging indicator channel (PICH)

The PICH is a fixed rate (SF = 256) physical channel used to carry the paging indicators. The PICH is always associated with an S-CCPCH to which a PCH transport channel is mapped.

One PICH radio frame of length 10 ms consists of 300 bits. Of these, 288 bits are used to carry paging indicators. The remaining 12 bits are not formally part of the PICH and shall not be transmitted. The part of the frame with no transmission is reserved for possible future use.

FIGURE 53
Structure of PICH

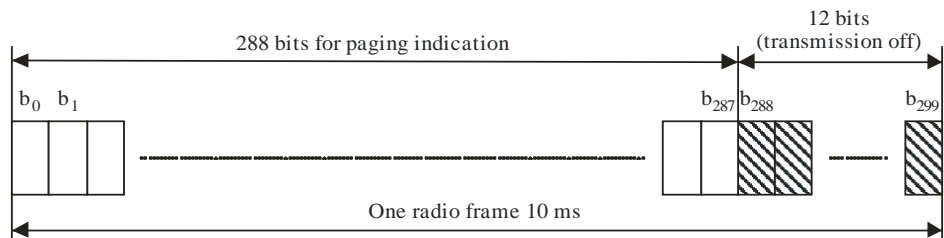

M.1850-53

4.3.6.4.1.2.1.8 High penetration paging indicator channel (HPPICH)

In optional mode A, the following new paging indication channel is applied.

The high penetration page indication channel (HPPICH) is a physical channel used to carry page indicator (PI). Normal paging operation makes use of both PICH and S-CCPCH (onto which the transport PCH is mapped). However, the system can decide to use this physical HPPICH in case paging was not successful. In this case, the transport PCH is not sent until a new trial in the PICH has been made.

Information is transmitted in short packets of length 10 ms. Transmission timing of this HPPICH does not depend on the general timing relationships described in § 4.3.6.4.1.3, i.e. it is independent of the transmission of other channels.

Information is transmitted at a rate of 15 kbit/s, making a total of 150 bits. Frame structure is shown in Fig. 54. It is made of an unmodulated preamble of 24 bits (all bits set to zero), an UW of 12 bits (the sequence 1100001001011) and a data field of 114 bits.

FIGURE 54
Packet structure for HPPICH

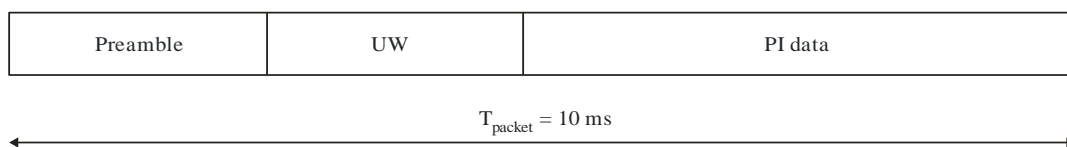

M.1850-54

The data field carries a 24-bit word user identifier and an 8-bit CRC part. They are encoded with the convolutional code rate 1/3, and punctured to 114 bits.

Differently from the rest of the physical channels, HPPICH is not spread. It is modulated onto a BPSK signal.

4.3.6.4.1.2.1.9 Downlink dedicated physical channel (downlink DPCH)

There are two types of dedicated physical channels, the DPDCH and the Dedicated Physical Control Channel (DPCCH).

DPDCH is used to carry dedicated data generated at Layer 2 and above, i.e. the dedicated transport channels.

DPCCH is used to carry control information generated at Layer 1. Control information consists of known pilot bits to support channel estimation for coherent detection, transmit power-control (TPC) commands, Transport Format Combination Indicator (TFCI).

The transport format combination indicator informs the receiver about the instantaneous rate of the different services multiplexed on the dedicated physical data channels. It is also possible, in the absence of TFCI, to use Blind Detection.

FIGURE 55

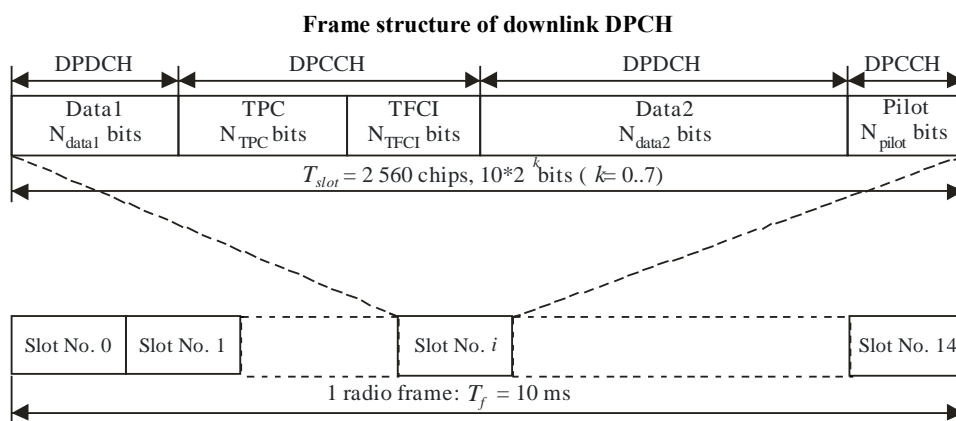

M.1850-55

For the downlink, DPDCH and DPCCH are time multiplexed within each radio frame and transmitted with QPSK modulation.

Each frame of length 10 ms is split into 15 slots, each of length $T_{slot} = 0,666\ \text{ms}$ (2 560 chips). Within each slot, DPDCH and DPCCH are time multiplexed. Power control periods do not match fast fading correction due to satellite propagation time. Nevertheless, slot structure is kept unchanged in normal operation in order to reduce modification requirements of terrestrial UE and Node B modems. However, in optional mode C, power control period corresponds to a frame and slot structure is slightly changed in order to optimize in satellite environment.

The parameter k in Fig. 55 determines the total number of bits per downlink DPCH slot. It is related to the spreading factor SF of the physical channel as $SF = 512 / 2^k$. The spreading factor may thus range from 512 down to 4.

The exact number of bits for the different downlink DPCH fields (N_{pilot} , N_{TPC} , N_{TFCI} , N_{data1} and N_{data2}) is given in Table 44. A slot format to be used is configured by higher layers and can also be reconfigured by higher layers.

There are basically two types of downlink dedicated physical channels; those that include TFCI (e.g. for several simultaneous services) and those that do not include TFCI (e.g. for fixed-rate services). These types are reflected by the duplicated rows of Table 44. It is the satellite RAN that determines if a TFCI should be transmitted and it is mandatory for all UEs to support the use of TFCI in the downlink.

TABLE 44

PDDCH and DPCCH fields

Slot format #i	Channel bit rate (kbit/s)	Channel symbol rate (ksymbol/s)	SF	Bits/slot	DPDCH Bits/Slot		DPCCH Bits/Slot			Transmitted slots per radio frame N_{Tr}
					N_{Data1}	N_{Data2}	N_{TPC}	N_{TFCI}	N_{Pilot}	
0	15	7,5	512	10	0	4 (5)	2 (1)	0	4	15
0A	15	7,5	512	10	0	4 (5)	2 (1)	0	4	8 to 14
0B	30	15	256	20	0	8 (10)	4 (2)	0	8	8 to 14
1	15	7,5	512	10	0	2 (3)	2 (1)	2	4	15
1B	30	15	256	20	0	4 (6)	4 (2)	4	8	8 to 14
2	30	15	256	20	2	14 (15)	2 (1)	0	2	15
2A	30	15	256	20	2	14 (15)	2 (1)	0	2	8 to 14
2B	60	30	128	40	4	28 (30)	4 (2)	0	4	8 to 14
3	30	15	256	20	2	12 (13)	2 (1)	2	2	15
3A	30	15	256	20	2	10 (11)	2 (1)	4	2	8 to 14
3B	60	30	128	40	4	24 (26)	4 (2)	4	4	8 to 14
4	30	15	256	20	2	12 (13)	2 (1)	0	4	15
4A	30	15	256	20	2	12 (13)	2 (1)	0	4	8 to 14
4B	60	30	128	40	4	24 (26)	4 (2)	0	8	8 to 14
5	30	15	256	20	2	10 (11)	2 (1)	2	4	15
5A	30	15	256	20	2	8 (9)	2 (1)	4	4	8 to 14
5B	60	30	128	40	4	20 (22)	4 (2)	4	8	8 to 14
6	30	15	256	20	2	8 (9)	2 (1)	0	8	15
6A	30	15	256	20	2	8 (9)	2 (1)	0	8	8 to 14
6B	60	30	128	40	4	16 (18)	4 (2)	0	16	8 to 14
7	30	15	256	20	2	6 (7)	2 (1)	2	8	15

TABLE 44 (continued)

Slot format #i	Channel bit rate (kbit/s)	Channel symbol rate (ksymbol/s)	SF	Bits/slot	DPDCH Bits/Slot		DPCCH Bits/Slot			Transmitted slots per radio frame N_{Tr}
					NData1	NData2	NTPC	NTFCI	NPilot	
7A	30	15	256	20	2	4 (5)	2 (1)	4	8	8 to 14
7B	60	30	128	40	4	12 (14)	4 (2)	4	16	8 to 14
8	60	30	128	40	6	28 (29)	2 (1)	0	4	15
8A	60	30	128	40	6	28 (29)	2 (1)	0	4	8 to 14
8B	120	60	64	80	12	56 (58)	4 (2)	0	8	8 to 14
9	60	30	128	40	6	26 (27)	2 (1)	2	4	15
9A	60	30	128	40	6	24 (25)	2 (1)	4	4	8 to 14
9B	120	60	64	80	12	52 (54)	4 (2)	4	8	8 to 14
10	60	30	128	40	6	24 (25)	2 (1)	0	8	15
10A	60	30	128	40	6	24 (25)	2 (1)	0	8	8 to 14
10B	120	60	64	80	12	48 (50)	4 (2)	0	16	8 to 14
11	60	30	128	40	6	22 (23)	2 (1)	2	8	15
11A	60	30	128	40	6	20 (21)	2 (1)	4	8	8 to 14
11B	120	60	64	80	12	44 (46)	4 (2)	4	16	8 to 14
12	120	60	64	80	12	48 (50)	4 (2)	8 (see Note 4)	8	15
12A	120	60	64	80	12	40 (42)	4 (2)	16 (see Note 4)	8	8 to 14
12B	240	120	32	160	24	96 (100)	8 (4)	16 (see Note 4)	16	8 to 14
13	240	120	32	160	28	112 (114)	4 (2)	8 (see Note 4)	8	15
13A	240	120	32	160	28	104 (106)	4 (2)	16 (see Note 4)	8	8 to 14
13B	480	240	16	320	56	224 (228)	8 (4)	16 (see Note 4)	16	8 to 14
14	480	240	16	320	56	232 (236)	8 (4)	8 (see Note 4)	16	15
14A	480	240	16	320	56	224 (228)	8 (4)	16 (see Note 4)	16	8 to 14

TABLE 44 (end)

Slot format #i	Channel bit rate (kbit/s)	Channel symbol rate (ksymbol/s)	SF	Bits/slot	DPDCH Bits/Slot		DPCCH Bits/Slot			Transmitted slots per radio frame N_{Tr}
					N_{Data1}	N_{Data2}	N_{TPC}	N_{TFCI}	N_{Pilot}	
14B	960	480	8	640	112	464 (472)	16 (8)	16 (see Note 4)	32	8 to 14
15	960	480	8	640	120	488 (492)	8 (4)	8 (see Note 4)	16	15
15A	960	480	8	640	120	480 (484)	8 (4)	16 (see Note 4)	16	8 to 14
15B	1 920	960	4	1 280	240	976 (984)	16 (8)	16 (see Note 4)	32	8 to 14
16	1 920	960	4	1 280	248	1000 (1004)	8 (4)	8 (see Note 4)	16	15
16A	1 920	960	4	1 280	248	992 (996)	8 (4)	16 (see Note 4)	16	8 to 14

NOTE 1 – Compressed mode is only supported through spreading factor reduction for SF = 512 with TFCI.
NOTE 2 – Compressed mode by spreading factor reduction is not supported for SF = 4.
NOTE 3 – If the satellite gateway receives an invalid combination of data frames for downlink transmission, the procedure specified in TS 125 427, § 5.1.2, may require the use of DTX in both the DPDCH and the TFCI field of the DPCCH.
NOTE 4 – If TFCI bits are not used, then DTX shall be used in TFCI field.
NOTE 5 – () in N_{Data2} and N_{TPC} indicate the values for optional mode C.

The pilot bit patterns are described in Table 45. The shadowed column part of pilot bit pattern is defined as FSW and FSWs can be used to confirm frame synchronization. (The value of the pilot bit pattern other than FSWs shall be “11”.) In Table 45, the transmission order is from left to right.

In downlink compressed mode through spreading factor reduction, the number of bits in the TPC and pilot fields is doubled. Symbol repetition is used to fill up the fields.

TABLE 45

Pilot bit patterns for downlink DPCCH with $N_{\text{pilot}} = 2, 4, 8$ and 16

Symbol #	$N_{\text{pilot}} = 2$	$N_{\text{pilot}} = 4$ (see Note 1)		$N_{\text{pilot}} = 8$ (see Note 2)				$N_{\text{pilot}} = 16$ (see Note 3)							
	0	0	1	0	1	2	3	0	1	2	3	4	5	6	7
Slot #0	11	11	11	11	11	11	10	11	11	11	10	11	11	11	10
1	00	11	00	11	00	11	10	11	00	11	10	11	11	11	00
2	01	11	01	11	01	11	01	11	01	11	01	11	10	11	00
3	00	11	00	11	00	11	00	11	00	11	00	11	01	11	10
4	10	11	10	11	10	11	01	11	10	11	01	11	11	11	11
5	11	11	11	11	11	11	10	11	11	11	10	11	01	11	01
6	11	11	11	11	11	11	00	11	11	11	00	11	10	11	11
7	10	11	10	11	10	11	00	11	10	11	00	11	10	11	00
8	01	11	01	11	01	11	10	11	01	11	10	11	00	11	11
9	11	11	11	11	11	11	11	11	11	11	11	11	00	11	11
10	01	11	01	11	01	11	01	11	01	11	01	11	11	11	10
11	10	11	10	11	10	11	11	11	10	11	11	11	00	11	10
12	10	11	10	11	10	11	00	11	10	11	00	11	01	11	01
13	00	11	00	11	00	11	11	11	00	11	11	11	00	11	00
14	00	11	00	11	00	11	11	11	00	11	11	11	10	11	01

NOTE 1 – This pattern is used except slot formats 2B and 3B.
NOTE 2 – This pattern is used except slot formats 0B, 1B, 4B, 5B, 8B, and 9B.
NOTE 3 – This pattern is used except slot formats 6B, 7B, 10B, 11B, 12B, and 13B.
NOTE 4 – For slot format nB where $n = 0, \dots, 15$, the pilot bit pattern corresponding to $N_{\text{pilot}}/2$ is to be used and symbol repetition shall be applied.

The relationship between the TPC symbol and the transmitter power control command is presented in Table 46.

TABLE 46

TPC bit pattern

TPC Bit Pattern			Transmitter power control command
$N_{\text{TPC}} = 2$	$N_{\text{TPC}} = 4$	$N_{\text{TPC}} = 8$	
11	1111	11111111	1
00	0000	00000000	0

4.3.6.4.1.2.2 Uplink physical channel

4.3.6.4.1.2.2.1 Physical random access channel (PRACH)

4.3.6.4.1.2.2.1.1 Operation in normal mode

The random-access transmission is based on a Slotted ALOHA approach with fast acquisition indication. The UE can start the random-access transmission at the beginning of a number of well-defined time intervals, denoted *access slots*. There are 15 access slots per two frames and they are spaced 5 120 chips apart.

FIGURE 56
RACH access slot numbers and their spacing

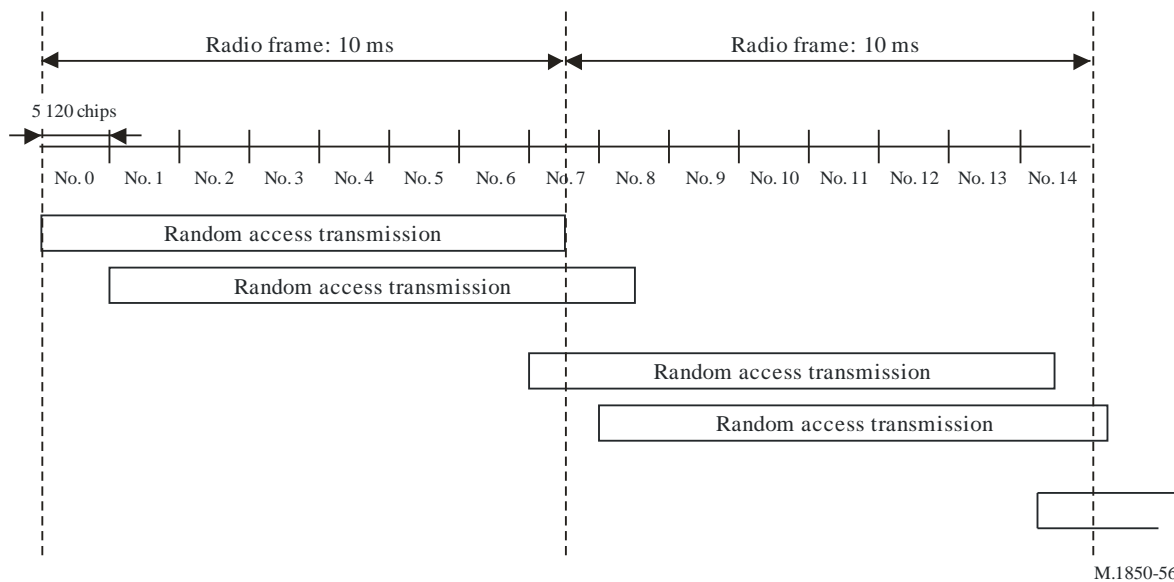

M.1850-56

The random-access transmission consists of one or several *preambles* of length 4 096 chips and a message of length 10 ms or 20 ms.

FIGURE 57
Structure of random-access transmission

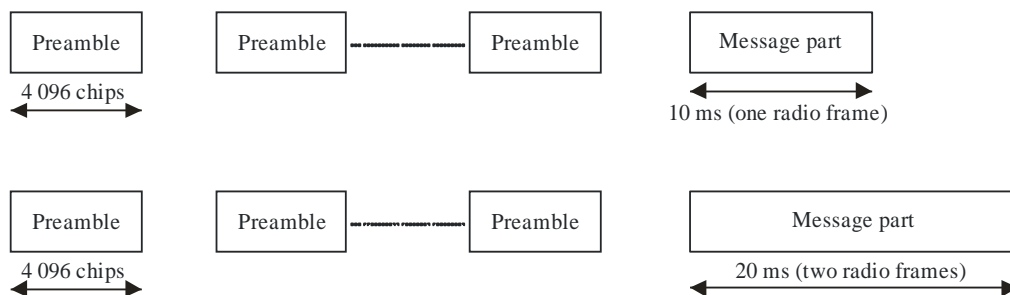

M.1850-57

Each preamble is of length 4 096 chips and consists of 256 repetitions of a signature of length 16 chips.

The 10 ms message part radio frame is split into 15 slots, each of length $T_{slot} = 2\,560$ chips. Each slot consists of two parts, a data part to which the RACH transport channel is mapped and a control part that carries Layer 1 control information. The data and control parts are transmitted in parallel. A 10 ms message part consists of one message part radio frame, while a 20 ms message part consists of two consecutive 10 ms message part radio frames. The message part length is equal to the Transmission Time Interval of the RACH Transport channel in use.

The data part consists of 10×2^k bits, where $k = 0, 1, 2, 3$. This corresponds to a spreading factor of 256, 128, 64 and 32 respectively for the message data part.

The control part consists of 8 known pilot bits to support channel estimation for coherent detection and 2 TFCI bits. This corresponds to a spreading factor of 256 for the message control part. The total number of TFCI bits in the random-access message is $15 \times 2 = 30$. The TFCI of a radio frame indicates the transport format of the RACH transport channel mapped to the simultaneously transmitted message part radio frame. In case of a 20 ms PRACH message part, the TFCI is repeated in the second radio frame.

FIGURE 58
Structure of the random-access message part radio frame

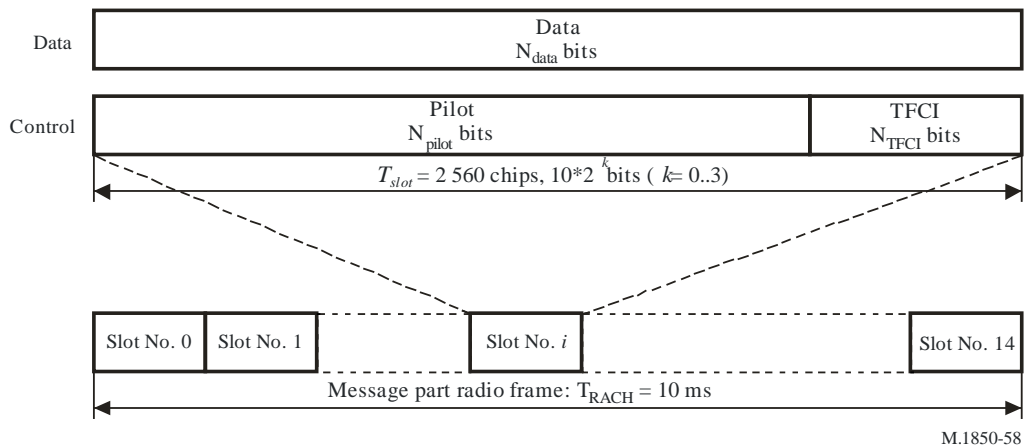

M.1850-58

4.3.6.4.1.2.2.1.2 Operation in optional mode C

The random access transmission is based on an ALOHA approach with fast acquisition indication. The UE can start the random access transmission at the beginning of a number of well-defined time intervals, denoted *access frame*. Each access frame has a length of two radio frames. Each access frame can consist of two sub-access frames, even sub-access frame and odd sub-access frame, see Fig. 59. Information on available access slots for random access transmission is given by high layers.

FIGURE 59
Structure of the random access transmission in optional mode C

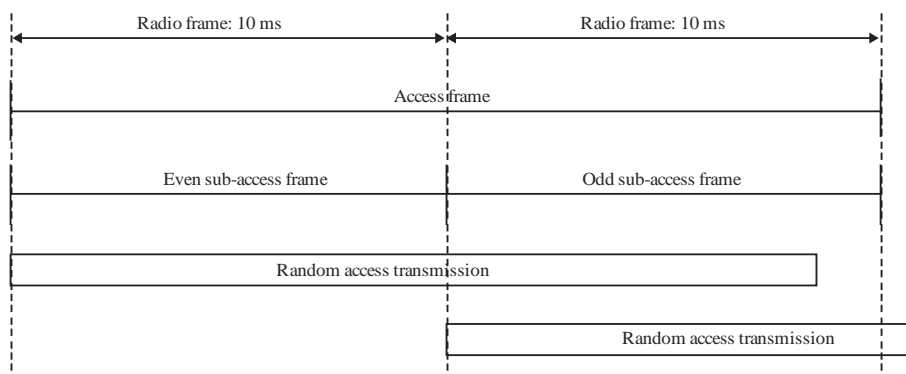

M.1850-59

The structure of the random access transmission is shown in Fig. 60. The random access transmission consists of one preamble of N_{sp} sub-preambles and a message of length 10 ms or 20 ms.

FIGURE 60

Structure of the random access transmission in optional mode C

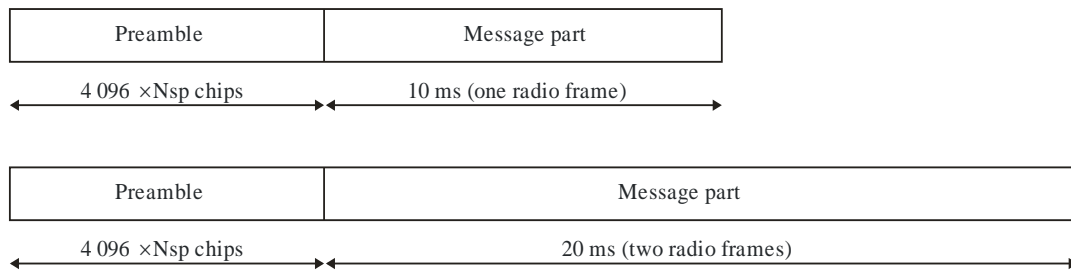

M.1850-60

The 10 ms message part radio frame is split into 15 slots, each of length $T_{slot} = 2\,560$ chips as shown in Fig. 58. Each slot consists of two parts, a data part to which the RACH transport channel is mapped and a control part that carries Layer 1 control information. The data and control parts are transmitted in parallel. A 10 ms message part consists of one message part radio frame, while a 20 ms message part consists of two consecutive 10 ms message part radio frames. The message part length is equal to the Transmission Time Interval of the RACH Transport channel in use.

The data part consists of 10×2^k bits, where $k = 0, 1, 2, 3$. This corresponds to a spreading factor of 256, 128, 64 and 32 respectively for the message data part.

The control part consists of 8 known pilot bits to support channel estimation for coherent detection and 2 TFCI bits. This corresponds to a spreading factor of 256 for the message control part. The total number of TFCI bits in the random-access message is $15 \times 2 = 30$. The TFCI of a radio frame indicates the transport format of the RACH transport channel mapped to the simultaneously transmitted message part radio frame. In case of a 20 ms PRACH message part, the TFCI is repeated in the second radio frame.

4.3.6.4.1.2.2.2 Uplink dedicated physical channel (uplink DPCH)

For the uplink, the DPDCH and the DPCCH are I/Q code multiplexed within each radio frame and transmitted with dual-channel QPSK modulation. Each additional DPDCHs is code multiplexed on either the I- or the Q-branch with this first channel pair.

Figure 61 shows the principle of frame structure of the uplink dedicated physical channels. Each frame of length 10 ms is split into 15 slots, each of length $T_{slot} = 0,666$ ms (2 560 chips), corresponding to one power-control period. Within each slot, the DPDCH and the DPCCH are transmitted in parallel. In optional mode C, a radio frame corresponds to one power control period.

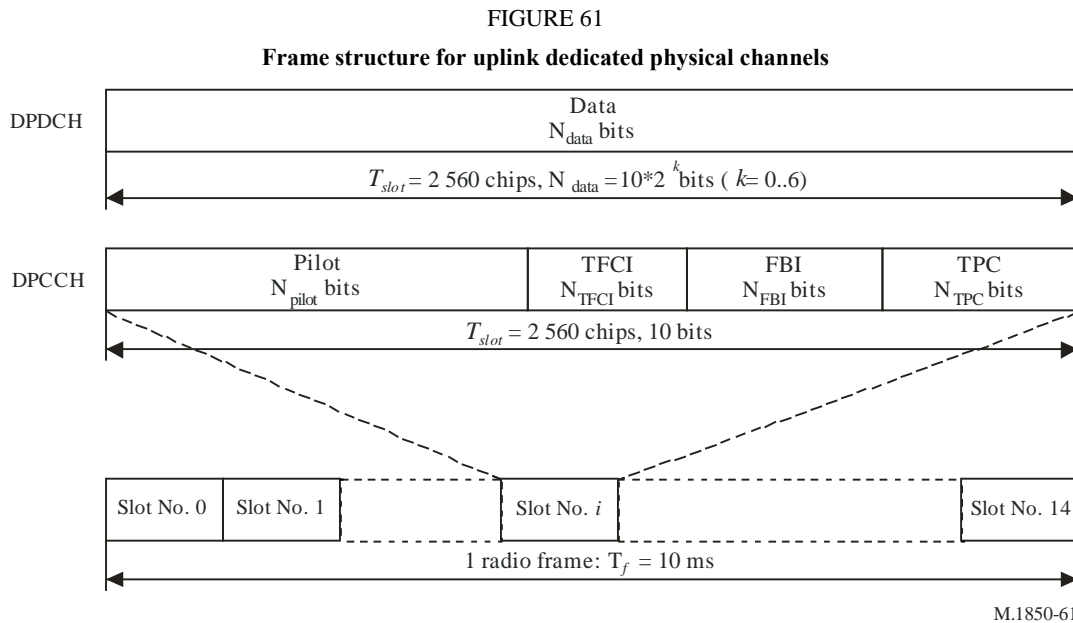

The parameter k in Fig. 61 determines the number of bits per DPDCH slot. It is related to the spreading factor SF of the physical channel as $SF = 256/2^k$. The spreading factor may range from 256 down to 4. The spreading factor of the uplink DPCCH is always equal to 256, i.e. there are 10 bits per uplink DPCCH slot.

The FBI bits are used to support techniques requiring feedback from the UE to the Satellite RAN Access Point, including closed loop mode transmit diversity and Spot Selection Diversity Transmission (SSDT).

72 consecutive uplink frames constitute one super frame of length 720 ms.

The exact number of bits of the uplink DPDCH and the different uplink DPCCH fields (N_{pilot} , N_{TFCI} , N_{FBI} and N_{TPC}) is given by Tables 47 and 48. Information on slot format is configured by higher layers and can also be reconfigured by higher layers.

The channel bit and symbol rates given in Tables 47 and 48 are the rates immediately before spreading. The pilot patterns are given in Tables 50 and 51, and the TPC bit pattern is given in Table 53.

In optional mode C, Tables 49 and 52 are applied instead of Tables 48 and 51, respectively.

TABLE 47
DPDCH fields

Slot format #i	Channel bit rate (kbit/s)	Channel symbol rate (ksymbol/s)	SF	Bits/Frame	Bits/Slot	N _{data}
0	15	15	256	150	10	10
1	30	30	128	300	20	20
2	60	60	64	600	40	40
3	120	120	32	1 200	80	80
4	240	240	16	2 400	160	160
5	480	480	8	4 800	320	320
6	960	960	4	9 600	640	640

There are two types of uplink dedicated physical channels; those that include TFCI (e.g. for several simultaneous services) and those that do not include TFCI (e.g. for fixed-rate services). These types are reflected by the duplicated rows of Table 48. It is the satellite RAN that determines if a TFCI should be transmitted and it is mandatory for all UEs to support the use of TFCI in the uplink.

In compressed mode, DPCCH slot formats with TFCI fields are changed. There are two possible compressed slot formats for each normal slot format. They are labelled A and B and the selection between them is dependent on the number of slots that are transmitted in each frame in compressed mode.

TABLE 48
DPCCH fields

Slot format #i	Channel bit rate (kbit/s)	Channel symbol rate (ksymbol/s)	SF	Bits/Frame	Bits/Slot	N _{pilot}	N _{TPC}	N _{TFCI}	N _{FBI}	Transmitted slots per radio frame
0	15	15	256	150	10	6	2	2	0	15
0A	15	15	256	150	10	5	2	3	0	10 to 14
0B	15	15	256	150	10	4	2	4	0	8 to 9
1	15	15	256	150	10	8	2	0	0	8 to 15
2	15	15	256	150	10	5	2	2	1	15
2A	15	15	256	150	10	4	2	3	1	10 to 14
2B	15	15	256	150	10	3	2	4	1	8 to 9
3	15	15	256	150	10	7	2	0	1	8 to 15
4	15	15	256	150	10	6	2	0	2	8 to 15
5	15	15	256	150	10	5	1	2	2	15
5A	15	15	256	150	10	4	1	3	2	10 to 14
5B	15	15	256	150	10	3	1	4	2	8 to 9

TABLE 49

DPDCH fields (optional mode C)

Slot format #i	Channel bit rate (kbit/s)	Channel symbol rate (ksymbol/s)	SF	Bits/Frame	Bits/Slot	N_{pilot}	N_{TPC}	N_{TFCI}	N_{FB}	Transmitted slots per radio frame
0	15	15	256	150	10	7	1	2	0	15
0A	15	15	256	150	10	6	1	3	0	10 to 14
0B	15	15	256	150	10	7	1	4	0	8 to 9
1	15	15	256	150	10	9	1	0	0	8 to 15
2	15	15	256	150	10	6	1	2	1	15
2A	15	15	256	150	10	5	1	3	1	10 to 14
2B	15	15	256	150	10	4	1	4	1	8 to 9
3	15	15	256	150	10	8	1	0	1	8 to 15

The pilot bit patterns are described in Tables 50, 51 and 52. The shadowed column part of pilot bit pattern is defined as FSW and FSWs can be used to confirm frame synchronization. (The value of the pilot bit pattern other than FSWs shall be "1".)

TABLE 50

TPC bit pattern

Bit #	$N_{\text{pilot}} = 3$			$N_{\text{pilot}} = 4$				$N_{\text{pilot}} = 5$					$N_{\text{pilot}} = 6$					
	0	1	2	0	1	2	3	0	1	2	3	4	0	1	2	3	4	5
Slot #0	1	1	1	1	1	1	1	1	1	1	1	0	1	1	1	1	1	0
1	0	0	1	1	0	0	1	0	0	1	1	0	1	0	0	1	1	0
2	0	1	1	1	0	1	1	0	1	1	0	1	1	0	1	1	0	1
3	0	0	1	1	0	0	1	0	0	1	0	0	1	0	0	1	0	0
4	1	0	1	1	1	0	1	1	0	1	0	1	1	1	0	1	0	1
5	1	1	1	1	1	1	1	1	1	1	1	0	1	1	1	1	1	0
6	1	1	1	1	1	1	1	1	1	1	0	0	1	1	1	1	0	0
7	1	0	1	1	1	0	1	1	0	1	0	0	1	1	0	1	0	0
8	0	1	1	1	0	1	1	0	1	1	1	0	1	0	1	1	1	0
9	1	1	1	1	1	1	1	1	1	1	1	1	1	1	1	1	1	1
10	0	1	1	1	0	1	1	0	1	1	0	1	1	0	1	1	0	1
11	1	0	1	1	1	0	1	1	0	1	1	1	1	1	0	1	1	1
12	1	0	1	1	1	0	1	1	0	1	0	0	1	1	0	1	0	0
13	0	0	1	1	0	0	1	0	0	1	1	1	1	0	0	1	1	1
14	0	0	1	1	0	0	1	0	0	1	1	1	1	0	0	1	1	1

TABLE 51
TPC bit pattern

Bit #	$N_{\text{pilot}} = 7$							$N_{\text{pilot}} = 8$							
	0	1	2	3	4	5	6	0	1	2	3	4	5	6	7
Slot #0	1	1	1	1	1	0	1	1	1	1	1	1	1	1	0
1	1	0	0	1	1	0	1	1	0	1	0	1	1	1	0
2	1	0	1	1	0	1	1	1	0	1	1	1	0	1	1
3	1	0	0	1	0	0	1	1	0	1	0	1	0	1	0
4	1	1	0	1	0	1	1	1	1	1	0	1	0	1	1
5	1	1	1	1	1	0	1	1	1	1	1	1	1	1	0
6	1	1	1	1	0	0	1	1	1	1	1	1	0	1	0
7	1	1	0	1	0	0	1	1	1	1	0	1	0	1	0
8	1	0	1	1	1	0	1	1	0	1	1	1	1	1	0
9	1	1	1	1	1	1	1	1	1	1	1	1	1	1	1
10	1	0	1	1	0	1	1	1	0	1	1	1	0	1	1
11	1	1	0	1	1	1	1	1	1	1	0	1	1	1	1
12	1	1	0	1	0	0	1	1	1	1	0	1	0	1	0
13	1	0	0	1	1	1	1	1	0	1	0	1	1	1	1
14	1	0	0	1	1	1	1	1	0	1	0	1	1	1	1

TABLE 52
TPC bit pattern

Bit #	$N_{\text{pilot}} = 9$								
	0	1	2	3	4	5	6	7	8
Slot #0	1	1	1	1	1	1	1	0	1
1	1	0	1	0	1	1	1	0	1
2	1	0	1	1	1	0	1	1	1
3	1	0	1	0	1	0	1	0	1
4	1	1	1	0	1	0	1	1	1
5	1	1	1	1	1	1	1	0	1
6	1	1	1	1	1	0	1	0	1
7	1	1	1	0	1	0	1	0	1
8	1	0	1	1	1	1	1	0	1
9	1	1	1	1	1	1	1	1	1
10	1	0	1	1	1	0	1	1	1
11	1	1	1	0	1	1	1	1	1
12	1	1	1	0	1	0	1	0	1
13	1	0	1	0	1	1	1	1	1
14	1	0	1	0	1	1	1	1	1

The relationship between the TPC bit pattern and transmitter power control command is presented in Table 53.

TABLE 53
TPC bit pattern

TPC Bit Pattern		Transmitter power control command
$N_{\text{TPC}} = 1$	$N_{\text{TPC}} = 2$	
1	11	1
0	00	0

4.3.6.4.1.3 Timing relationship between physical channels

The P-CCPCH, on which the spot SFN is transmitted, is used as timing reference for all the physical channels, directly for downlink and indirectly for uplink.

Figure 62 describes the frame timing of the downlink physical channels. For the AICH the access slot timing is included. Transmission timing for uplink physical channels is given by the received timing of downlink physical channels.

The SCH (primary and secondary), CPICH (primary and secondary), P-CCPCH, CPCH-CCPCH and PDSCH have identical frame timings. The S-CCPCH timing may be different for different S-CCPCHs, but the offset from the P-CCPCH frame timing is a multiple of 256 chips. The PICH timing is 7 680 chips prior to its corresponding S-CCPCH frame timing, i.e. the timing of the S-CCPCH carrying the PCH transport channel with the corresponding paging information. The AICH even sub-access frame has the identical timing to P-CCPCH frames with $(\text{SFN modulo } 2) = 0$, and the AICH odd sub-access frame has the identical timing to P-CCPCH frames with $(\text{SFN modulo } 2) = 1$. AICH access slots No. 0 starts the same time as P-CCPCH frames with $(\text{SFN modulo } 2) = 0$. The DPCH timing may be different for different DPCHs, but the offset from the P-CCPCH frame timing is a multiple of 256 chips.

FIGURE 62

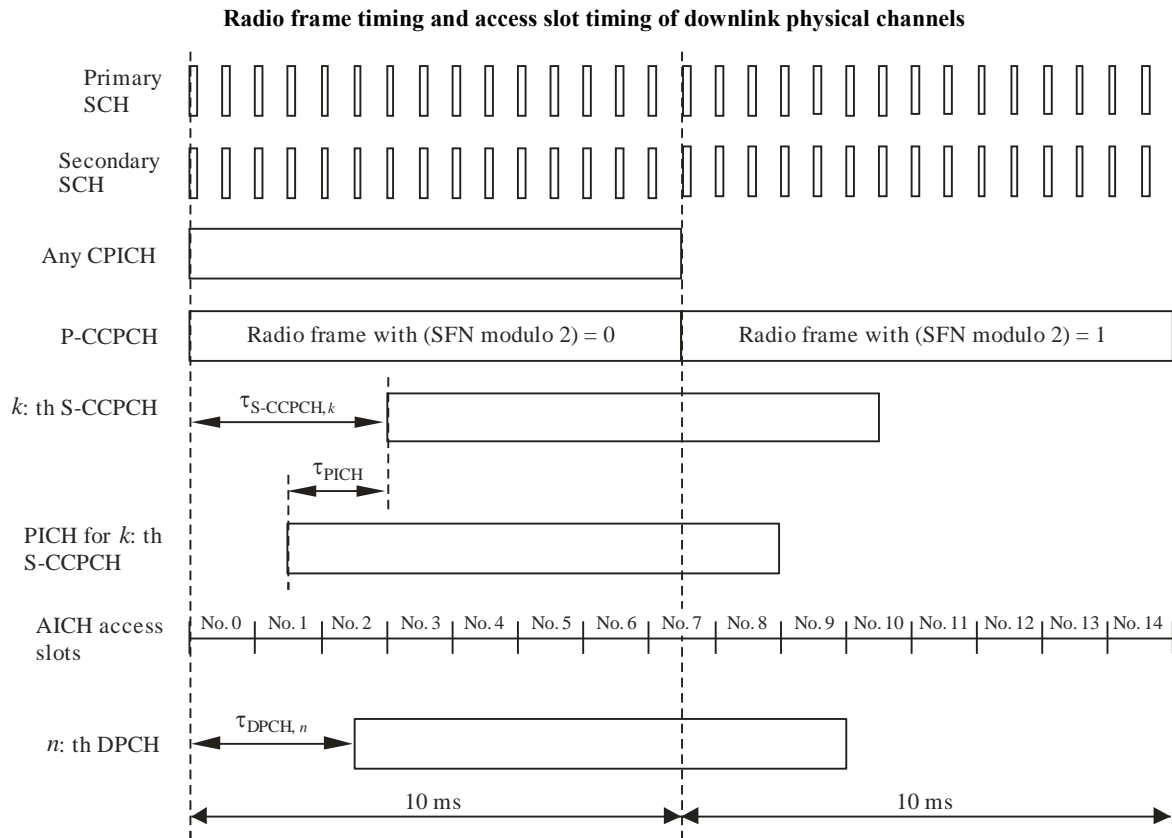

M.1850-62

4.3.6.4.1.3.1 PRACH/AICH timing relation

The downlink AICH is divided into downlink access slots, each access slot is of length 5 120 chips. The downlink access slots are time aligned with the P-CCPCH.

The uplink PRACH is divided into uplink access slots, each access slot is of length 5 120 chips. Uplink access slot number n is transmitted from the UE τ_{p-a} chips prior to the reception of downlink access slot number n , $n = 0, 1, \dots, 14$.

Transmission of downlink acquisition indicators may only start at the beginning of a downlink access slot. Similarly, transmission of uplink RACH preambles and RACH message parts may only start at the beginning of an uplink access slot.

The PRACH/AICH timing relation is shown in Fig. 63.

FIGURE 63

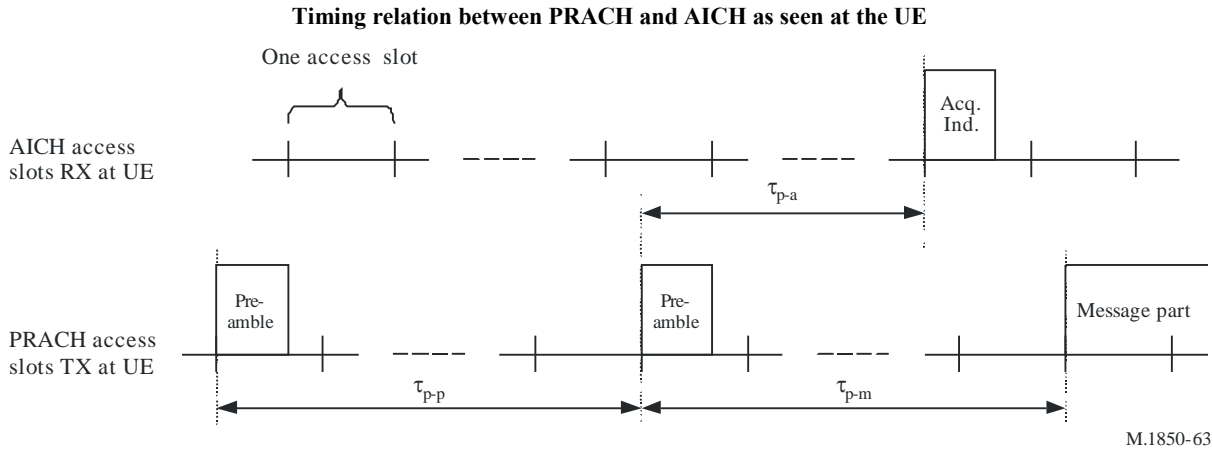

In optional mode C, the following is applied:

The downlink AICH access frames and sub-access frames are time-aligned with the P-CCPCH. The uplink PRACH access frame and sub-access frame are time-aligned with the reception of downlink AICH access frame and sub-access frame. The PRACH/AICH timing relation is shown in Fig. 64. Uplink access frame number n is transmitted from the UE τ_{p-a} chips prior to the reception of downlink access frame number n , $n=0, 1, \dots, 15$.

FIGURE 64

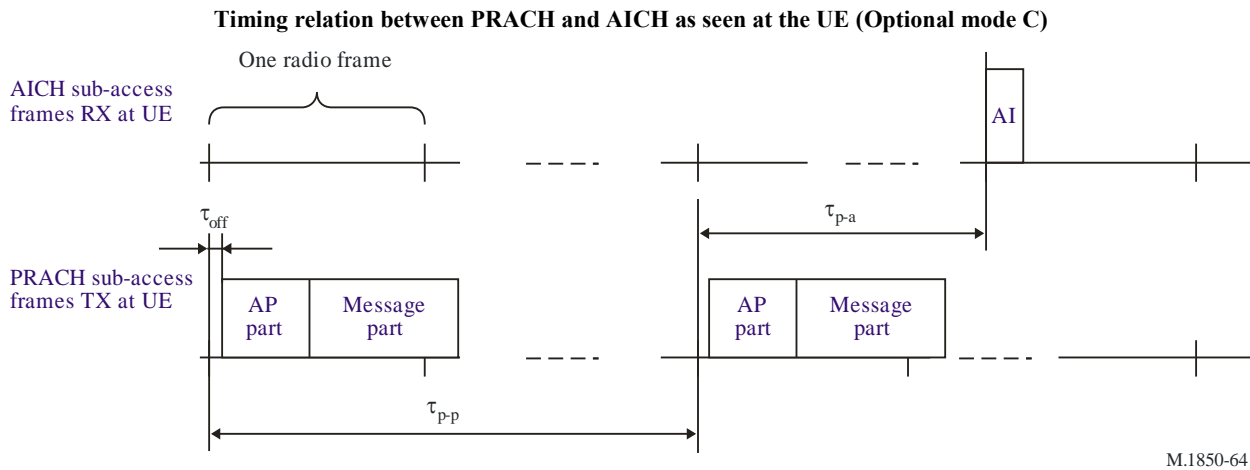

The transmission offset τ_{off} shall be a value between the range of $[-\tau_{off,max}, +\tau_{off,max}]$, defined by the Maximum Transmission Offset $\tau_{off,max}$. The parameter Maximum Transmission Offset is signalled by higher layers.

The preamble-to-preamble distance τ_{p-p} shall be larger than or equal to the minimum preamble-to-preamble distance $\tau_{p-p,min}$, i.e. $\tau_{p-p} \geq \tau_{p-p,min}$. In addition to $\tau_{p-p,min}$, the preamble-to-AI distance τ_{p-a} is defined as follows:

For systems based on LEO satellites,

- when AICH Transmission Timing is set to 0, then
 - $\tau_{p-p,min} = 230\ 400$ chips (6 radio frames)
 - $\tau_{p-a} = 153\ 600$ chips (4 radio frames)
- when AICH Transmission Timing is set to 1, then

$$\tau_{p-p,\min} = 307\,200 \text{ chips (8 radio frames)}$$

$$\tau_{p-a} = 230\,400 \text{ chips (6 radio frames).}$$

For systems based on GEO satellite,

- when AICH Transmission Timing is set to 0, then

$$\tau_{p-p,\min} = 1\,152\,000 \text{ chips (30 radio frames)}$$

$$\tau_{p-a} = 1\,075\,200 \text{ chips (28 radio frames)}$$

- when AICH Transmission Timing is set to 1, then

$$\tau_{p-p,\min} = 2\,150\,400 \text{ chips (56 radio frames)}$$

$$\tau_{p-a} = 2\,073\,600 \text{ chips (54 radio frames).}$$

4.3.6.4.1.3.2 DPCCH/DPDCH timing relations

In uplink the DPCCH and all the DPDCHs transmitted from one UE have the same frame timing.

In downlink, the DPCCH and all the DPDCHs of dedicated type to one UE have the same frame timing.

At the UE, the uplink DPCCH/DPDCH frame transmission takes place approximately T_0 chips after the reception of the first detected path (in time) of the corresponding downlink DPCCH/DPDCH frame. T_0 is a constant defined to be 1 024 chips.

4.3.6.4.2 Channel coding and service multiplexing

4.3.6.4.2.1 Processing step

The coding and multiplexing steps are shown in Figs 65 and 66 for normal mode and Figs 65 and 67 for optional mode A, where TrBk denotes transport block and DTX denotes discontinuous transmission.

4.3.6.4.2.2 Error detection

Error detection is provided on transport channel blocks through a CRC. The CRC is 24, 16, 12, 8 or 0 bits and it is signalled from higher layers which CRC length that should be used for each transport channel.

The entire transport block is used to calculate the CRC parity bits for each transport block. The parity bits are generated by one of the following cyclic generator polynomials:

- $G_{CRC24}(X) = X^{24} + X^{23} + X^6 + X^5 + X + 1$

- $G_{CRC16}(X) = X^{16} + X^{12} + X^5 + 1$

- $G_{CRC12}(X) = X^{12} + X^{11} + X^3 + X^2 + X + 1$

- $G_{CRC8}(X) = X^8 + X^7 + X^4 + X^3 + X + 1.$

FIGURE 65

Coding and multiplexing step in uplink

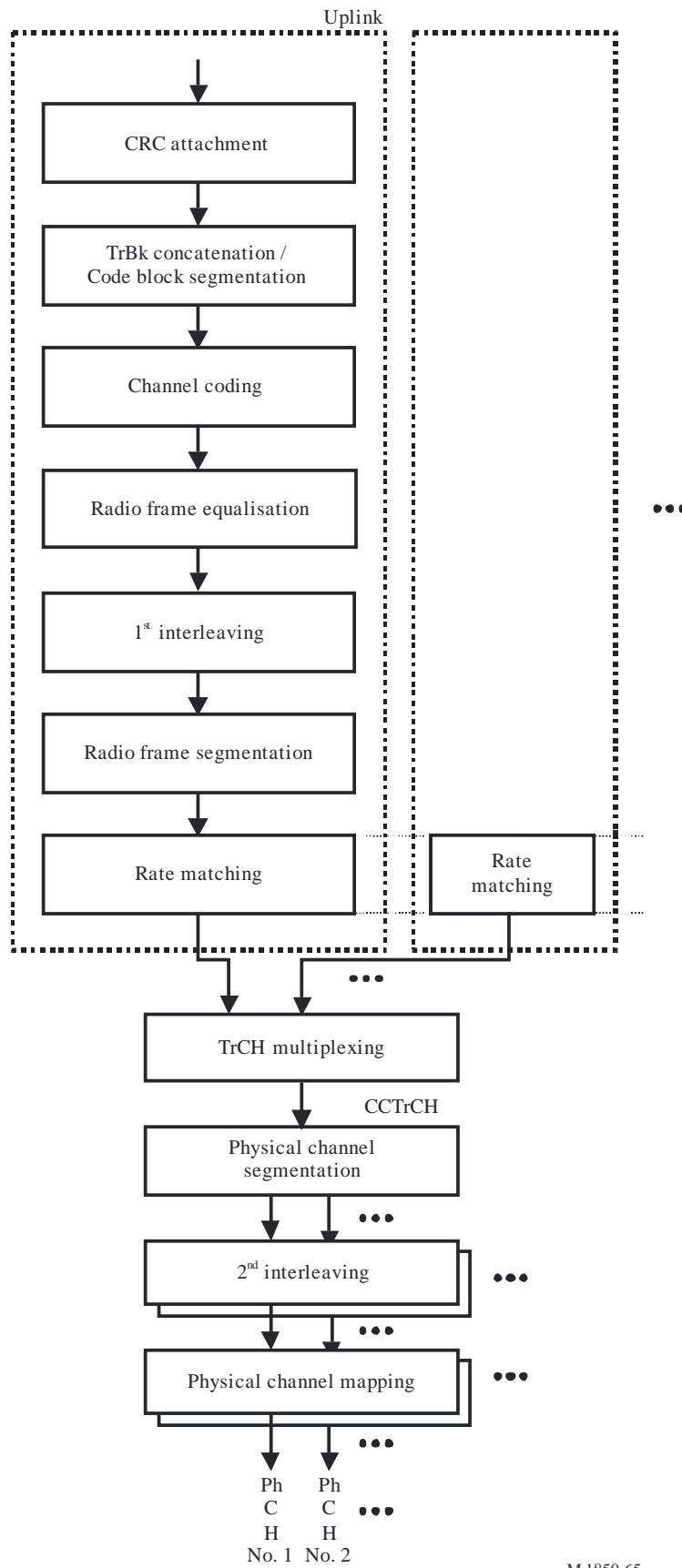

FIGURE 66

Coding and multiplexing step in downlink

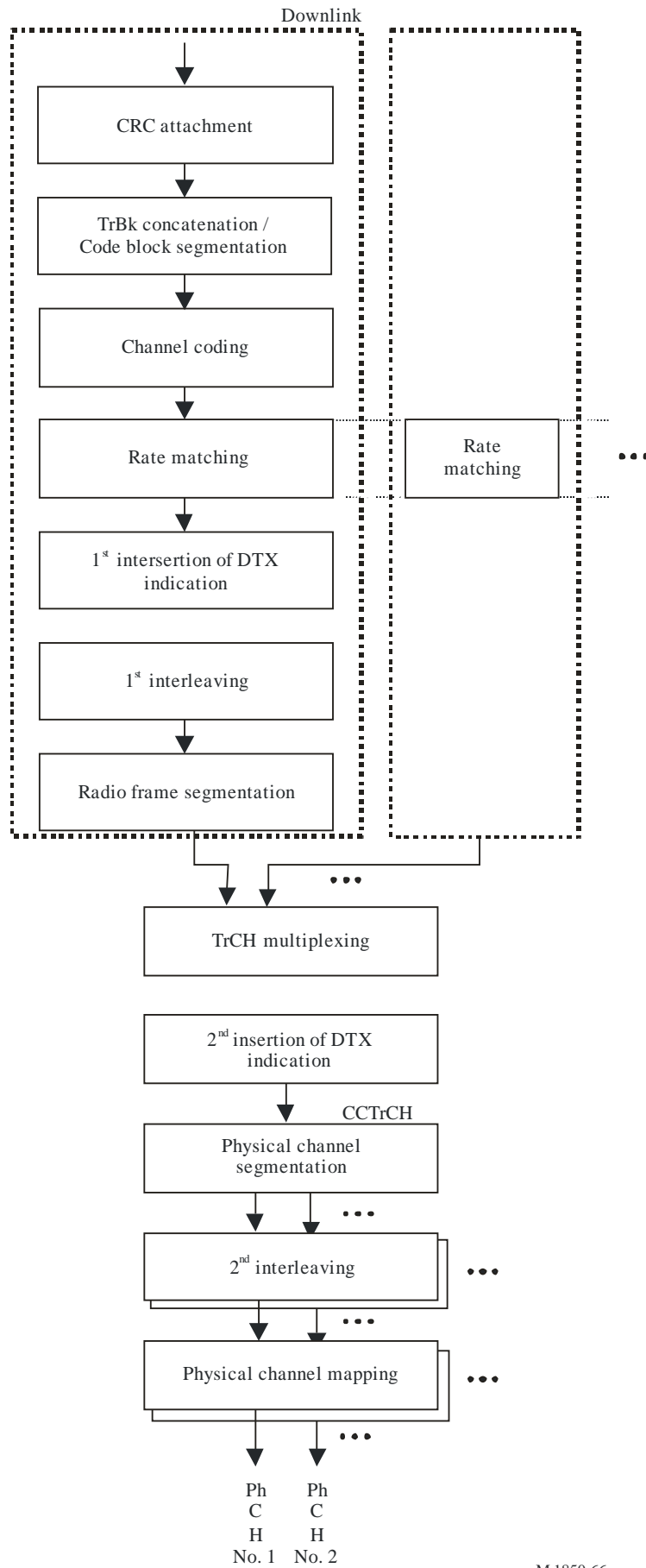
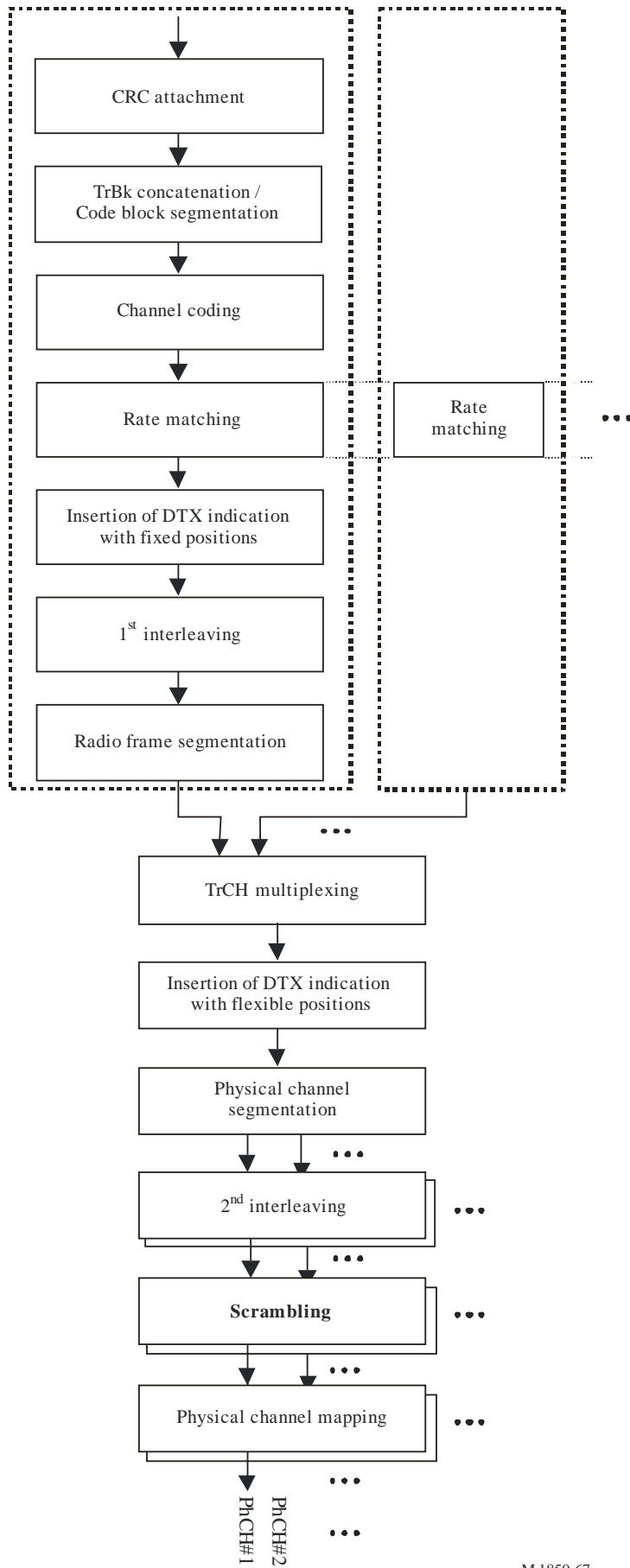

FIGURE 67

Coding and multiplexing step in downlink for optional mode A



4.3.6.4.2.3 Channel coding

For the channel coding, two schemes can be applied:

- Convolutional coding;
- Turbo coding.

Channel coding selection is indicated by upper layers. In order to randomize transmission errors, symbol interleaving is performed further.

The scheme of turbo coder is a parallel concatenated convolutional code (PCCC) with two 8-state constituent encoders and one turbo code internal interleaver.

TABLE 54

Channel coding scheme and coding rate

Type of TrCH	Coding scheme	Coding rate
BCH	Convolutional coding (constraint length 9)	1/2
PCH		
RACH		1/3, 1/2
CPCH, DCH, DSCH, FACH	Turbo coding	1/3
	No coding	

4.3.6.4.2.3.1 Convolutional coding

Convolutional codes with constraint length 9 and coding rates 1/3 and 1/2 are defined.

The generator functions for the rate 1/3 code are $G_0 = 557$ (OCT), $G_1 = 663$ (OCT) and $G_2 = 711$ (OCT).

The generator functions for the rate 1/2 code are $G_0 = 561$ (OCT) and $G_1 = 753$ (OCT).

FIGURE 68

Rate 1/2 and 1/3 convolutional code generator

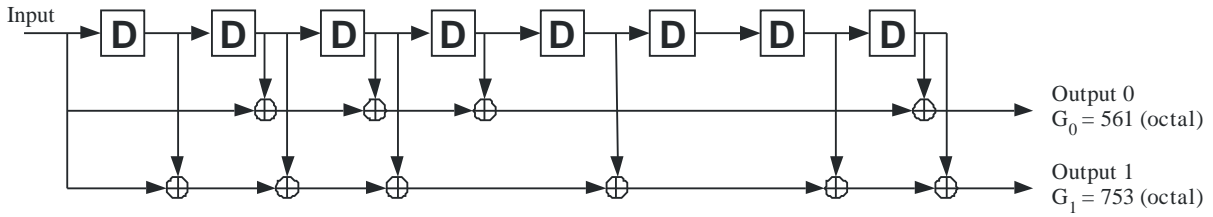

a) Rate 1/2 convolutional coder

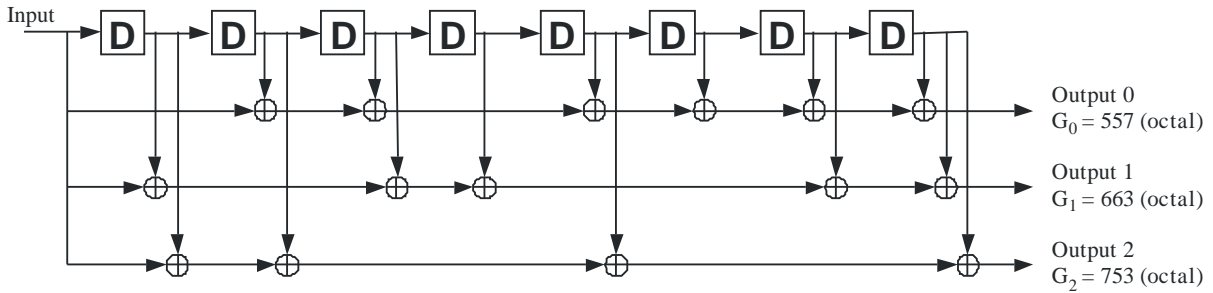

b) Rate 1/3 convolutional coder

M.1850-68

4.3.6.4.2.3.2 Turbo coding

The scheme of turbo coder is a parallel concatenated convolutional code (PCCC) with two 8-state constituent encoders and one turbo code internal interleaver. The coding rate of turbo coder is 1/3.

FIGURE 69

Rate 1/3 turbo coder generator (dotted lines apply for trellis termination only)

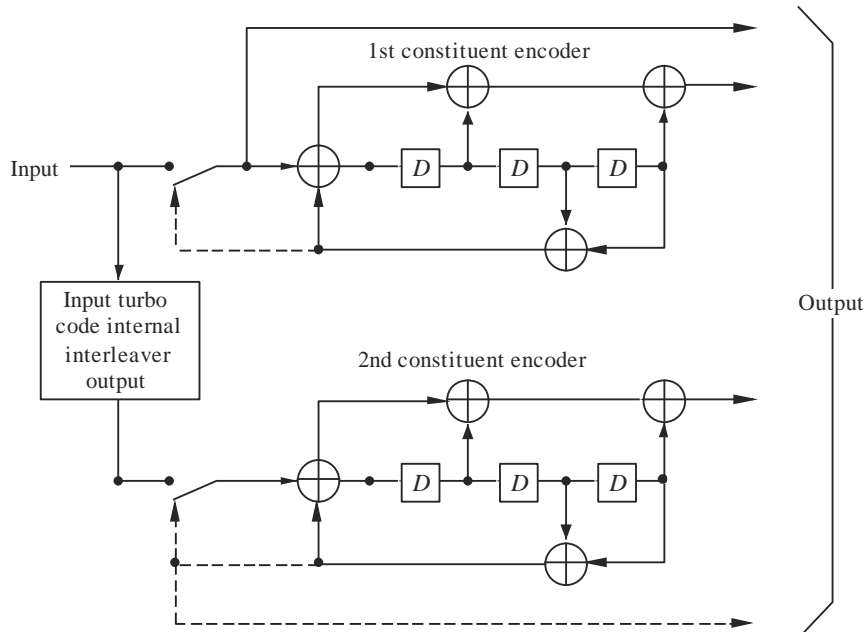

M.1850-69

The transfer function of the 8-state constituent code for PCCC is:

$$G(D) = \begin{bmatrix} 1, \frac{g_1(D)}{g_0(D)} \end{bmatrix}$$

where:

$$\begin{aligned} g_0(D) &= 1 + D^2 + D^3 \\ g_1(D) &= 1 + D + D^3. \end{aligned}$$

4.3.6.4.2.4 Interleaving

The 1st interleaver is a (M -row by N -column) block interleaver with inter-column permutations. The size of the 1st interleaver, $M \times N$ is an integer multiple of transmission time interval (TTI).

The 2nd interleaver is a (M -row by N -column) block interleaver with inter-column permutations. The size of the 2nd interleaver, $M \times N$ is the number of bits in one radio frame for one physical channel and the number of columns, N is 30. The inter-column permutation pattern is $\langle 0, 20, 10, 5, 15, 25, 3, 13, 23, 8, 18, 28, 1, 11, 21, 6, 16, 26, 4, 14, 24, 19, 9, 29, 12, 2, 7, 22, 27, 17 \rangle$.

4.3.6.4.2.5 Rate matching

The number of bits on a transport channel can vary between different transmission time intervals. In uplink, bits on a transport channel are repeated or punctured to ensure that the total bit rate after transport channel multiplexing is identical to the total channel bit rate of the allocated DPCH. In downlink, the total bit rate after the transport channel multiplexing is less than or equal to the total channel bit rate given by the channelization code(s) assigned by higher layers. The transmission is interrupted if the number of bits is lower than maximum.

4.3.6.4.2.6 Transport channel multiplexing

Every 10 ms, one radio frame from each transport channel is delivered to the transport channel multiplexing. These radio frames are serially multiplexed into a coded composite transport channel.

4.3.6.4.2.7 TFCI coding

The TFCI is encoded using a (32, 10) sub-code of the second order Reed-Muller code. The code words are linear combination of 10 basis sequences. The TFCI information bits shall correspond to the TFC index defined by the RRC layer to refer the TFC of the associated DPCH radio frame.

If one of the DCH is associated with a DSCH, the TFCI code word may be split in such a way that the code word relevant for TFCI activity indication is not transmitted from every beam. The use of such a functionality shall be indicated by higher layer signalling. The TFCI is encoded using a (16, 5) bi-orthogonal (or first order Reed-Muller) code. The code words of the (16, 5) bi-orthogonal code are linear combinations of 5 basis sequences. The first set of TFCI information bits shall correspond to the TFC index defined by the RRC layer to refer the TFC of the DCH CCTrCH in the associated DPCH radio frame. The second set of TFCI information bits shall correspond to the TFC index defined by the RRC layer to refer the TFC of the associated DSCH in the corresponding PDSCH radio frame.

The bits of the code word are directly mapped to the slots of the radio frame. The coded bits b_k , are mapped to the transmitted TFCI bits d_k , according to $d_k = b_{k \bmod 32}$, where $k = 0, \dots, K - 1$. The number of bits available in TFCI fields of a radio frame, K , depends on the slot format used for the frame.

4.3.6.4.2.8 TPC command coding

In optional mode C, the following is applied to generate the 2-bit TPC command:

The 2-bit TPC command is encoded by repetition. The set of TPC command bits (a_0, a_1) shall correspond to the TPC command defined by the power control procedure. The output code word bits b_k are given by $b_k = a_{k \bmod 2}$, where $k = 0, \dots, 15$.

For both uplink and downlink channels, the bits of the code word are mapped to 15 slots of a radio frame. The coded bits b_k , are mapped to the transmitted TPC bits d_k , according to $d_k = b_{k \bmod 15}$, where $k = 0, \dots, K - 1$. The number of bits available in TPC fields of a radio frame, K , depends on the slot format used for the frame.

4.3.6.4.2.9 Downlink data randomization

In optional mode A, the following data scrambling is applied:

For a downlink transport DCH, the bits output by the 2nd interleaver can be randomized, prior to mapping to the corresponding physical channel(s). This option is enabled by higher layers.

The scrambling sequence is a segment of a Maximum Length (ML) sequence. The polynomial for the pseudo-random binary sequence generator is:

$$G(D) = D^{20} + D^9 + D^5 + D^3 + 1.$$

The shift register generating the sequence is loaded with the sequence 00000100101010000000 every 720 ms, that is, every 72 radio frames. The first bit at the output of the generator is applied to the first bit of the radio frame for which $(SFN \bmod 72) = 0$ in the corresponding BCH.

The randomizer/de-randomizer operation is shown in Fig. 70, where Input Data can stand both for clear and randomized data, yielding respectively randomized and de-randomized data at the output.

FIGURE 70
Scrambler operation (optional mode A)

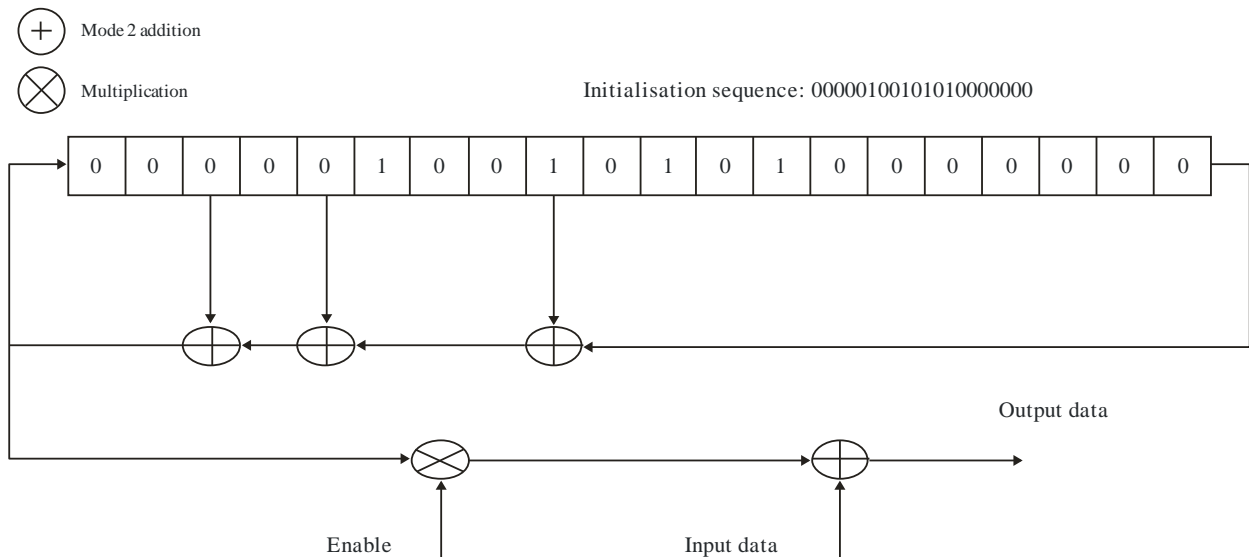

M.1850-70

4.3.6.4.3 Modulation and spreading

4.3.6.4.3.1 Uplink spreading

The spreading modulation uses orthogonal complex QPSK (OCQPSK) for uplink channels.

Spreading is applied to the physical channels. It consists of two operations. The first is the channelization operation, which transforms every data symbol into a number of chips, thus increasing the bandwidth of the signal. The number of chips per data symbol is called the Spreading Factor (SF).

The second operation is the scrambling operation, where a scrambling code is applied to the spread signal.

With the channelization, data symbols on so-called I- and Q-branches are independently multiplied with an OVVSF code. With the scrambling operation, the resultant signals on the I- and Q-branches are further multiplied by complex-valued scrambling code, where I and Q denote real and imaginary parts, respectively.

Figure 71 shows the configuration of the uplink-spreading. Channelization codes, C_{chi} , $i = 1, 2, \dots, N$, first spread one DPCCH channel and the DPDCH channels. Then the signals are adjusted by power gain factors, G_i , are added together both in I and Q branches, and are multiplied by a complex scrambling code $S_{up,n}$.

If only one DPDCH is needed, only the DPDCH₁ and the DPCCH are transmitted. In multi-code transmission, several DPDCHs are transmitted using I and Q branches.

The long scrambling code is built from constituent long sequences $c_{long,1,n}$ and $c_{long,2,n}$. The two sequences are obtained from position wise modulo 2 sum of 38 400 chip segments of two binary m -sequences x_n and y . The x_n sequence, which depends on the chosen scrambling sequence number n , is obtained from the m -sequence generator polynomial $X^{25} + X^3 + 1$ and the y sequence is obtained from the generator polynomial $X^{25} + X^3 + X^2 + X + 1$.

The configuration of long code generator for uplink is presented in Fig. 72.

Define the binary Gold sequence z_n by:

$$z_n(i) = x_n(i) + y(i) \text{ modulo } 2, i = 0, 1, 2, \dots, 2^{25} - 2.$$

These binary sequences are converted to real valued sequences Z_n . The real-valued long scrambling sequences $c_{long,1,n}$ and $c_{long,2,n}$ are defined as follows:

$$c_{long,1,n}(i) = Z_n(i), i = 0, 1, 2, \dots, 2^{25} - 2 \text{ and}$$

$$c_{long,2,n}(i) = Z_n((i + 16\,777\,232) \text{ modulo } (2^{25} - 1)), i = 0, 1, 2, \dots, 2^{25} - 2.$$

Finally, the complex-valued long scrambling sequence $C_{long, n}$, is defined as:

$$C_{long,n}(i) = c_{long,1,n}(i) + j(-1)^i c_{long,2,n}(2\lfloor i/2 \rfloor)$$

where $i = 0, 1, \dots, 2^{25} - 2$ and $\lfloor \cdot \rfloor$ denotes rounding to nearest lower integer.

FIGURE 71
Uplink spreading

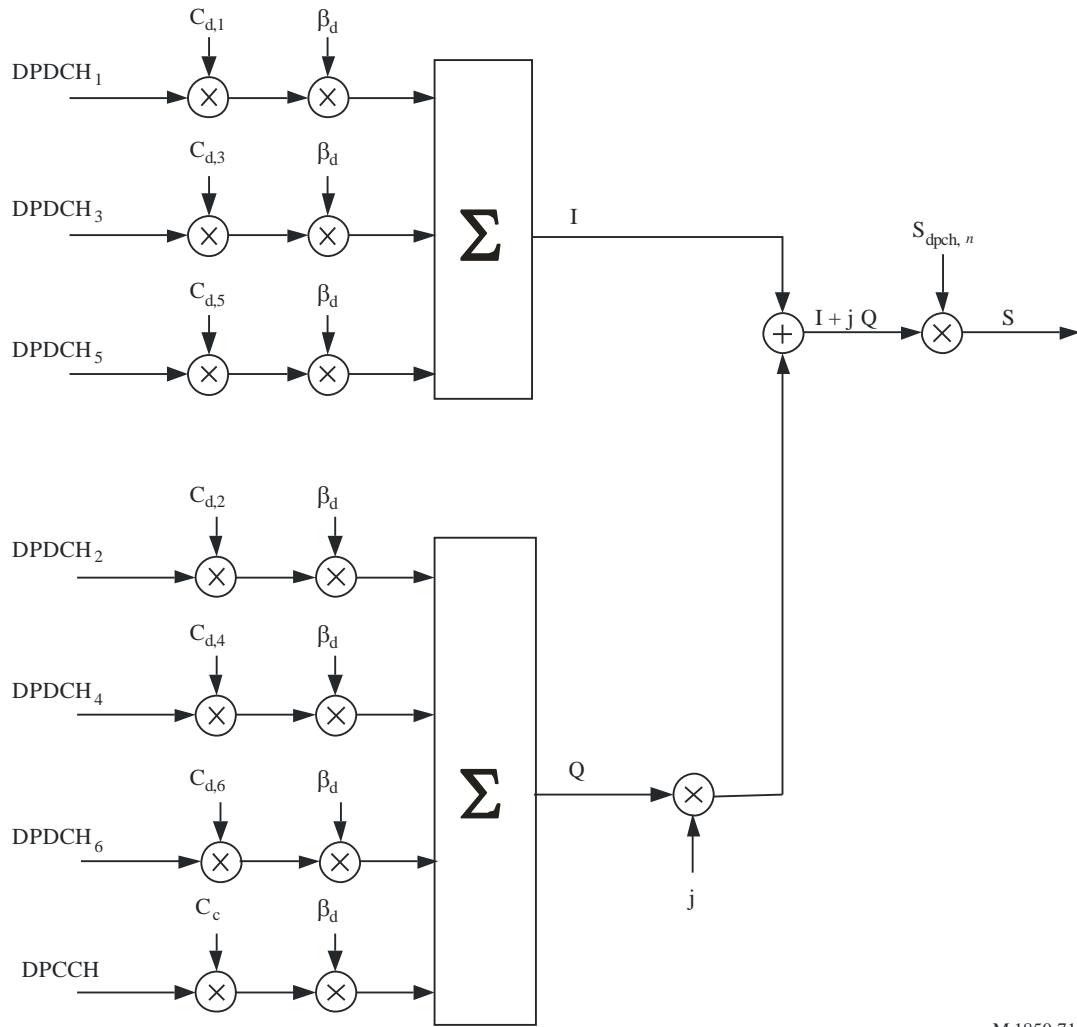

M.1850-71

FIGURE 72
Long code generator for uplink

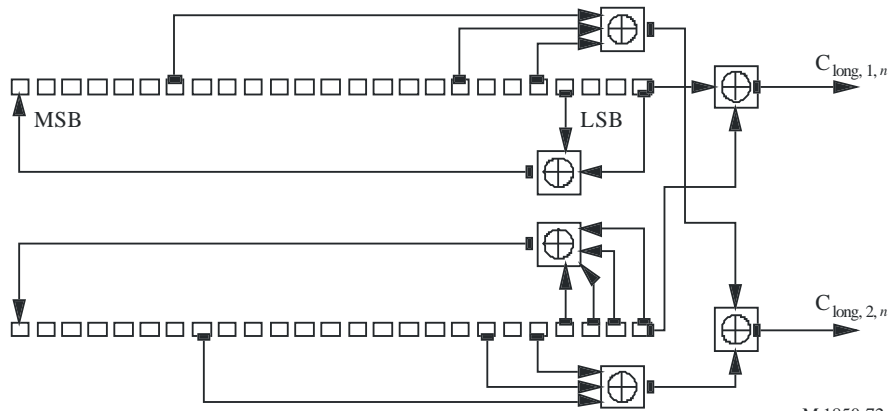

M.1850-72

4.3.6.4.3.1.1 PRACH codes

4.3.6.4.3.1.1.1 Operation in normal mode

The random access preamble code $C_{\text{pre},n}$ is a complex valued sequence. It is built from a preamble scrambling code $S_{\text{r-pre},n}$ and a preamble signature $C_{\text{sig},s}$ as follows:

$$C_{\text{pre},n,s}(k) = S_{\text{r-pre},n}(k) \times C_{\text{sig},s}(k) \times e^{j\left(\frac{\pi}{4} + \frac{\pi}{2}k\right)}, k = 0, 1, 2, 3, \dots, 4\,095$$

where $k = 0$ corresponds to the chip transmitted first in time.

The scrambling code for the PRACH preamble part is constructed from the long scrambling sequences. There are 8 192 PRACH preamble scrambling codes in total.

The n :th preamble scrambling code, $n = 0, 1, \dots, 8\,191$, is defined as:

$$S_{\text{r-pre},n}(i) = c_{\text{long},1,n}(i), i = 0, 1, \dots, 4\,095$$

where the sequence $c_{\text{long},1,n}$ is defined in § 4.3.2.2.

The 8 192 PRACH preamble scrambling codes are divided into 512 groups with 16 codes in each group. There is a one-to-one correspondence between the group of PRACH preamble scrambling codes in a cell and the primary scrambling code used in the downlink of the cell. The k :th PRACH preamble scrambling code within the cell with downlink primary scrambling code m , $k = 0, 1, 2, \dots, 15$ and $m = 0, 1, 2, \dots, 511$, is $S_{\text{r-pre},n}(i)$ as defined above with $n = 16 \times m + k$.

4.3.6.4.3.1.1.2 Operation in optional mode C

The access preamble code is of length $N_p \times 4\,096$ chips and consists of N_p sub-preamble codes. The sub-preamble code $C_{\text{pre},n,s,i}$ is a complex valued sequence. It is built from a preamble scrambling code $S_{\text{r-pre},n}$ and a preamble signature $C_{\text{sig},s}$ as follows:

– when N_p is set to 1, then:

$$C_{\text{pre},n,s,0}(k) = S_{\text{pre},n}(k) \times C_{\text{sig},s}(k) \times e^{j\left(\frac{\pi}{4} + \frac{\pi}{2}k\right)}, k = 0, 1, 2, 3, \dots, 4\,095$$

– when N_p is greater than 1, then:

$$C_{\text{pre},n,s,i}(k) = S_{\text{pre},n}(k) \times C_{\text{sig},s}(k) \times e^{j\left(\frac{\pi}{4} + \frac{\pi}{2}k\right)}, k = 0, 1, 2, 3, \dots, 4\,095, i = 0, 1, \dots, N_p - 2$$

$$C_{\text{pre},n,s,N_p-1}(k) = S_{\text{pre},n}(k) \times C_{\text{sig},s}(k) \times e^{j\left(\frac{\pi}{4} + \frac{\pi}{2}k\right)}, k = 0, 1, 2, 3, \dots, 4\,095$$

where $k = 0$ corresponds to the chip transmitted first in time.

The preamble signature corresponding to a signature s consists of 256 repetitions of a length 16 signature. The signature is from the set of 16 Hadamard codes of length 16.

The scrambling code for the preamble part is constructed from the long scrambling sequences. The n -th preamble scrambling code is defined as:

$$S_{\text{pre},n}(i) = c_{\text{long},1,n}(i)$$

where $i = 0, 1, \dots, 4\,095$. When sub-access frames are used for the PRACH, the n -th preamble scrambling code where n is an even number is used for the preamble transmitted at the even sub-access frame. The n -th preamble scrambling code where n is an odd number is used for the preamble transmitted at the odd sub-access frame.

The n -th PRACH message part scrambling code, denoted $S_{r\text{-msg},n}$, where $n = 0, 1, \dots, 8\ 191$, is based on the long scrambling sequence and is defined as:

$$S_{r\text{-msg},n}(i) = C_{\text{long},n}(i + 4\ 096), i = 0, 1, \dots, 38\ 399$$

In the case when the long scrambling codes are used:

$$S_{c\text{-msg},n}(i) = C_{\text{long},n}(i), i = 0, 1, \dots, 38\ 399$$

4.3.6.4.3.2 Uplink modulation

The modulating chip rate is 3.84 Mchip/s.

In the uplink, the modulation is dual-channel QPSK.

The modulated DPCCH is mapped to the Q-channel, while the first DPDCH is mapped to the I channel.

Subsequently added DPDCHs are mapped alternatively to the I or Q channels.

Figure 73 shows the configuration of the uplink modulation. The baseband filter (pulse shaping filter) is a root-raised cosine filter with roll-off $\alpha = 0.22$ in the frequency domain.

FIGURE 73
Uplink modulation

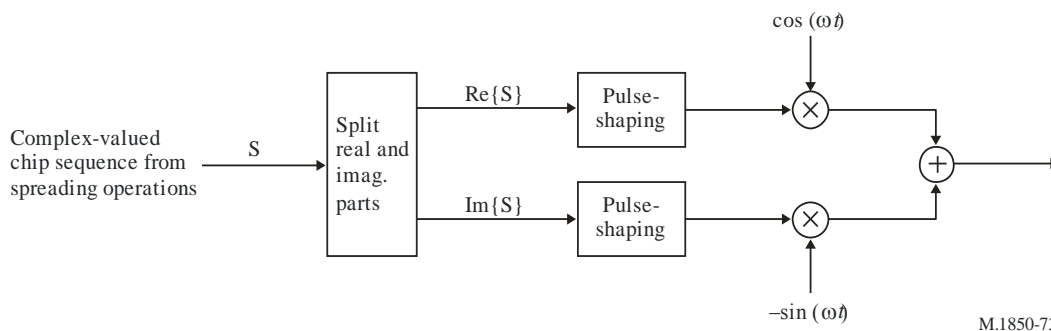

M.1850-73

4.3.6.4.3.3 Downlink spreading

Each pair of two consecutive real-valued symbols is first serial-to-parallel converted and mapped to an I and Q branch. The definition of the modulation mapper is such that even and odd numbered symbols are mapped to the I and Q branch respectively. For all channels except the indicator channels using signatures, symbol number zero is defined as the first symbol in each frame. For the indicator channels using signatures, symbol number zero is defined as the first symbol in each access slot. The I and Q branches are then both spread to the chip rate by the same real-valued channelization code $C_{\text{ch},\text{SF},m}$. The channelization code sequence shall be aligned in time with the symbol boundary. The sequences of real-valued chips on the I and Q branch are then treated as a single complex-valued sequence of chips. This sequence of chips is scrambled (complex chip-wise multiplication) by a complex-valued scrambling code $S_{\text{dl},n}$.

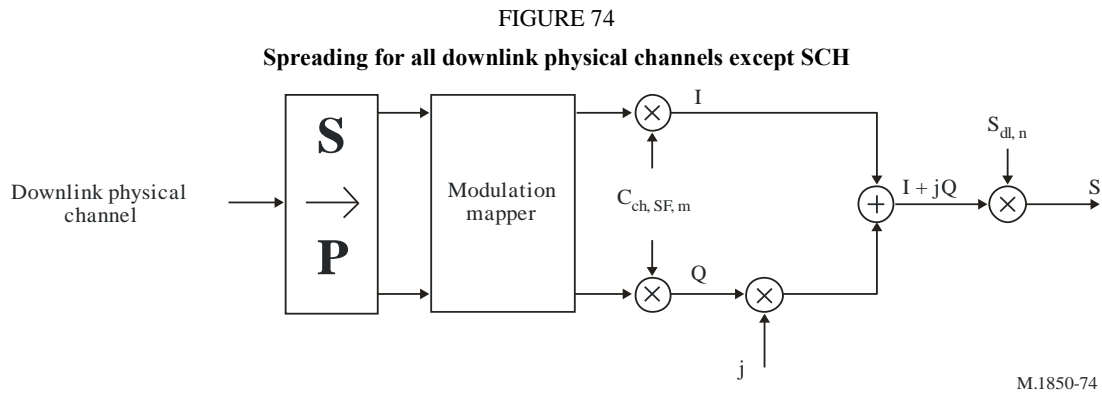
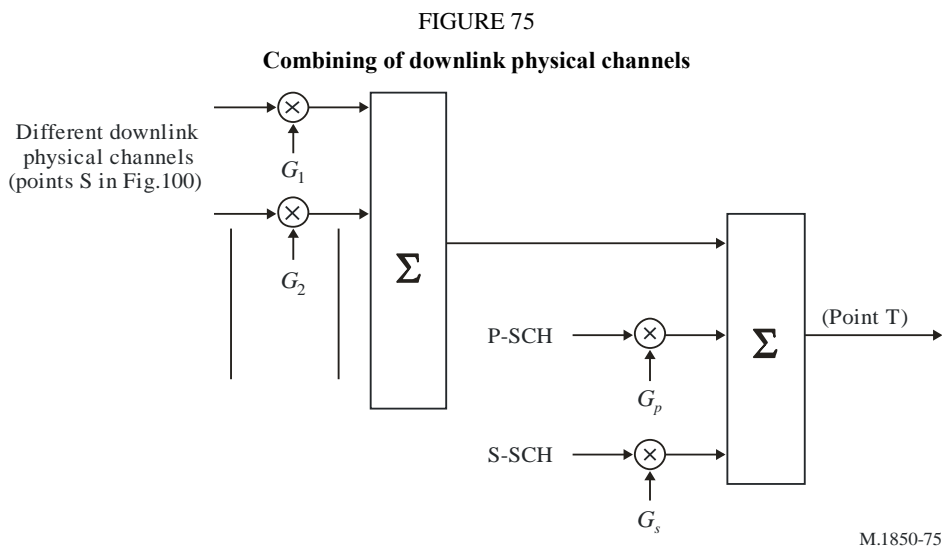

Figure 75 illustrates how different downlink channels are combined. Each complex-valued spread channel, corresponding to point S in Fig. 74, is separately weighted by a weight factor G_i . The complex-valued P-SCH and S-SCH, are separately weighted by weight factors G_p and G_s . All downlink physical channels are then combined using complex addition.



The channelization codes of Fig. 75 are the same codes as used in the uplink, namely orthogonal variable spreading factor (OVSF) codes that preserve the orthogonality between downlink channels of different rates and spreading factors.

The scrambling code is constructed by combining two real sequences into a complex sequence. Each of the two real sequences is obtained from position wise modulo 2 sum of 38 400 chip segments of two binary m -sequences x and y . The x sequence is obtained from the generator polynomial $X^{18} + X^7 + 1$. The y sequence is obtained from the generator polynomial $X^{18} + X^{10} + X^7 + X^5 + 1$. The initial condition for the x sequence is (00...1), where 1 is the LSB. The initial condition for the y sequence is (11...1).

The n -th Gold code sequence z_n , is then defined as:

$$z_n(i) = x((i + n) \text{ modulo } (2^{18} - 1)) + y(i) \text{ modulo } 2, i = 0, \dots, 218 - 2.$$

These binary sequences are converted to real valued sequences Z_n . Finally, the n :th complex scrambling code sequence $S_{dl,n}$ is defined as:

$$S_{dl,n}(i) = Z_n(i) + j Z_n((i + 131\ 072) \text{ modulo } (2^{18} - 1)), i = 0, 1, \dots, 38\ 399.$$

Note that the pattern from phase 0 up to the phase of 38 399 is repeated.

The scrambling codes are divided into 512 sets, and each set consists of a primary scrambling code and 15 secondary scrambling codes. The primary scrambling codes consist of scrambling codes $n = 16*i$ where $i = 0 \dots 511$. The i :th set of secondary scrambling codes consists of scrambling codes $16*i + k$, where $k = 1 \dots 15$. There is a one-to-one mapping between each primary scrambling code and 15 secondary scrambling codes in a set such that i -th primary scrambling code corresponds to i :th set of secondary scrambling codes. Hence scrambling codes $n = 0, 1, \dots, 8191$ are used.

The set of primary scrambling codes is further divided into 64 scrambling code groups, each consisting of eight primary scrambling codes. The j -th scrambling code group consists of primary scrambling codes $16*8*j + 16*k$, where $j = 0 \dots 63$ and $k = 0 \dots 7$.

4.3.6.4.3.3.1 Synchronization codes

4.3.6.4.3.3.1.1 Operation in normal mode

The primary synchronization code (PSC), C_{psc} is constructed as two generalized hierarchical Golay sequences.

Define:

$$- \quad a_1 = \langle x_1, x_2, x_3, \dots, x_{16} \rangle = \langle 1, -1, 1, -1, -1, -1, -1, -1, 1, 1, -1, -1, -1, 1, 1, -1 \rangle$$

$$- \quad a_2 = \langle y_1, y_2, y_3, \dots, y_{16} \rangle = \langle 1, -1, 1, -1, -1, -1, 1, 1, 1, -1, -1, 1, -1, -1, -1, -1 \rangle.$$

The PSC is generated by repeating the sequences a_1 and a_2 modulated by a Golay complementary sequence, and creating a complex-valued sequence with identical real and imaginary components. The PSC C_{psc} is defined as:

$$C_{psc} = (1 + j) \times \langle a_1, -a_1, -a_1, -a_1, -a_1, a_1, -a_1, -a_1, a_2, a_2, -a_2, a_2, -a_2, a_2, a_2, a_2 \rangle.$$

The 16 secondary synchronization codes (SSCs), $\{C_{ssc,1}, \dots, C_{ssc,16}\}$, are complex-valued with identical real and imaginary components, and are constructed from position wise multiplication of a Hadamard sequence and a sequence z , defined as:

$$z = \langle b_1, b_1, b_1, b_1, b_1, b_1, -b_1, -b_1, b_2, -b_2, -b_2, b_2, b_2, -b_2, b_2, -b_2 \rangle,$$

where:

$$- \quad b_1 = \langle x_1, x_2, x_3, x_4, x_5, x_6, x_7, x_8, -x_9, -x_{10}, -x_{11}, -x_{12}, -x_{13}, -x_{14}, -x_{15}, -x_{16} \rangle \text{ and } x_1, x_2, \dots, x_{15}, x_{16}, \text{ are the same as in the definition of the sequence } a_1 \text{ above.}$$

$$- \quad b_2 = \langle y_1, y_2, y_3, y_4, y_5, y_6, y_7, y_8, -y_9, -y_{10}, -y_{11}, -y_{12}, -y_{13}, -y_{14}, -y_{15}, -y_{16} \rangle \text{ and } y_1, y_2, \dots, y_{15}, y_{16}, \text{ are the same as in the definition of the sequence } a_2 \text{ above.}$$

The Hadamard sequences are obtained as the rows in a matrix H_8 constructed recursively. Denote the n :th Hadamard sequence as a row of H_8 numbered from the top, $n = 0, 1, 2, \dots, 255$, in the sequel. Furthermore, let $h_n(i)$ and $z(i)$ denote the i :th symbol of the sequence h_n and z , respectively where $i = 0, 1, 2, \dots, 255$.

The k -th SSC, $C_{ssc,k}$, $k = 1, 2, 3, \dots, 16$ is then defined as:

$$C_{ssc,k} = (1 + j) \times \langle h_m(0) \times z(0), h_m(1) \times z(1), h_m(2) \times z(2), \dots, h_m(255) \times z(255) \rangle$$

where $m = 8 \times (k - 1)$.

There are 64 secondary SCH sequences and each sequence consists of 15 SSCs. The 64 secondary SCH sequences are constructed such that their cyclic-shifts are unique, i.e. a non-zero cyclic shift less than 15 of any of the 64 sequences is not equivalent to any cyclic shift of any other of the 64 sequences. Also, a non-zero cyclic shift less than 15 of any of the sequences is not equivalent to itself with any other cyclic shift less than 15.

4.3.6.4.3.1.2 Operation in optional mode C

The primary synchronization code (PSC), C_{psc} is constructed as two so-called generalized hierarchical Golay sequences. The PSC is furthermore chosen to have good aperiodic autocorrelation properties.

Define:

$$- \quad a_1 = \langle x_1, x_2, x_3, \dots, x_{16} \rangle = \langle 1, -1, 1, -1, -1, -1, -1, -1, 1, 1, -1, -1, -1, 1, 1, -1 \rangle$$

$$- \quad a_2 = \langle y_1, y_2, y_3, \dots, y_{16} \rangle = \langle 1, -1, 1, -1, -1, -1, 1, 1, 1, -1, -1, 1, -1, -1, -1, -1 \rangle$$

The PSC is generated by repeating the sequences a_1 and a_2 modulated by a Golay complementary sequence, and creating a complex-valued sequence with identical real and imaginary components. The PSC C_{psc} is defined as:

$$C_{\text{psc}} = (1 + j) \times \langle a_1, -a_1, -a_1, -a_1, -a_1, a_1, -a_1, -a_1, a_2, a_2, -a_2, a_2, -a_2, a_2, a_2, a_2 \rangle;$$

where the leftmost chip in the sequence corresponds to the chip transmitted first in time.

The 16 secondary synchronization codes (SSCs), $\{C_{\text{ssc},1}, \dots, C_{\text{ssc},16}\}$, are complex-valued with identical real and imaginary components, and are constructed from position wise multiplication of a Hadamard sequence and a sequence z , defined as:

$$z = \langle b_1, b_1, b_1, b_1, b_1, b_1, -b_1, -b_1, b_2, -b_2, -b_2, b_2, b_2, -b_2, b_2, -b_2 \rangle, \text{ where}$$

$$b_1 = \langle x_1, x_2, x_3, x_4, x_5, x_6, x_7, x_8, -x_9, -x_{10}, -x_{11}, -x_{12}, -x_{13}, -x_{14}, -x_{15}, -x_{16} \rangle \text{ and } x_1, x_2, \dots, x_{15}, x_{16} \text{ are the same as in the definition of the sequence } a_1 \text{ above.}$$

$$b_2 = \langle y_1, y_2, y_3, y_4, y_5, y_6, y_7, y_8, -y_9, -y_{10}, -y_{11}, -y_{12}, -y_{13}, -y_{14}, -y_{15}, -y_{16} \rangle \text{ and } y_1, y_2, \dots, y_{15}, y_{16} \text{ are the same as in the definition of the sequence } a_2 \text{ above.}$$

The Hadamard sequences are obtained as the rows in a matrix H_8 constructed recursively by:

$$H_0 = (1)$$

$$H_k = \begin{pmatrix} H_{k-1} & H_{k-1} \\ H_{k-1} & -H_{k-1} \end{pmatrix}, \quad k \geq 1$$

The rows are numbered from the top starting with row 0 (the all ones sequence).

Denote the n :th Hadamard sequence as a row of H_8 numbered from the top, $n = 0, 1, 2, \dots, 255$, in the sequel.

Furthermore, let $h_n(i)$ and $z(i)$ denote the i :th symbol of the sequence h_n and z , respectively where $i = 0, 1, 2, \dots, 255$ and $i = 0$ corresponds to the leftmost symbol.

The k :th SSC, $C_{\text{ssc},k}$, $k = 1, 2, 3, \dots, 16$ is then defined as:

$$C_{\text{ssc},k} = (1 + j) \times \langle h_m(0) \times z(0), h_m(1) \times z(1), h_m(2) \times z(2), \dots, h_m(255) \times z(255) \rangle;$$

where $m = 8 \times (k - 1)$ and the leftmost chip in the sequence corresponds to the chip transmitted first in time.

4.3.6.4.3.4 Downlink modulation

The modulating chip rate is 3.84 Mchip/s.

Modulation of the complex-valued chip sequence generated by the spreading process is shown in Fig. 76.

The modulated DPDCH and DPCCH are time-multiplexed.

The baseband filter (pulse shaping filter) is a root-raised cosine filter with roll-off $\alpha = 0.22$ in the frequency domain.

FIGURE 76

Downlink modulation

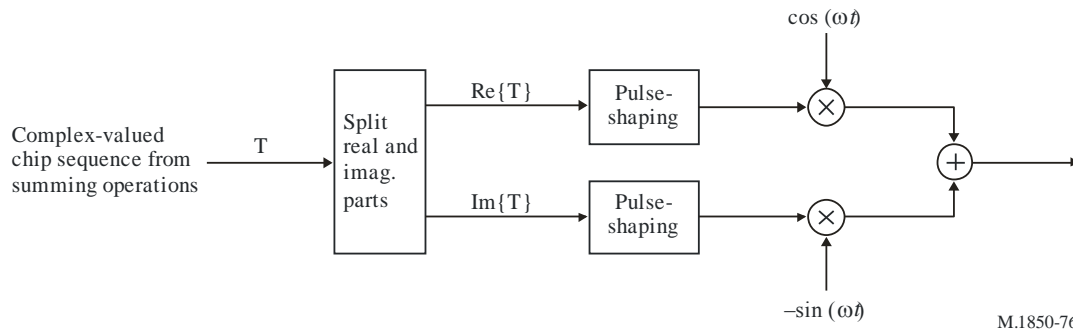

M.1850-76

4.3.6.4.4 Procedures

4.3.6.4.4.1 Spot search

During the spot search, the UE searches for a satellite beam and determines the downlink scrambling code and common channel frame synchronization of that satellite beam.

During the spot search, the MES searches for a spot and determines the downlink scrambling code and frame synchronization of that spot. The spot search is typically carried out in three steps:

Step 1: Slot synchronization

During the first step of the spot search procedure the MES uses the SCH's primary synchronization code to acquire slot synchronization to a spot. This is typically done with a single matched filter (or any similar device) matched to the primary synchronization code which is common to all spots. The slot timing of the spot can be obtained by detecting peaks in the matched filter output.

Step 2: Frame synchronization and code-group identification

During the second step of the spot search procedure, the MES uses the SCH's secondary synchronization code to find frame synchronization and identify the code group of the spot found in the first step. This is done by correlating the received signal with all possible secondary synchronization code sequences, and identifying the maximum correlation value. Since the cyclic shifts of the sequences are unique the code group as well as the frame synchronization is determined.

Step 3: Scrambling-code identification

During the third and last step of the spot search procedure, the MES determines the exact primary scrambling code used by the found spot. The primary scrambling code is typically identified through symbol-by-symbol correlation over the CPICH with all codes within the code group identified in the second step. After the primary scrambling code has been identified, the Primary CCPCH can be detected and the system- and spot specific BCH information can be read.

During the first and the second steps, a coarse frequency search and/or a differential detection technique may be required because of the carrier frequency error due to the Doppler shift.

During the second and the third steps, the MES can use locally stored information on satellite constellation and its position. This can reduce the beam search time.

4.3.6.4.4.2 Random access**4.3.6.4.4.2.1 RACH procedure****4.3.6.4.4.2.1.1 Operation in normal mode**

In the MAC layer, when there is data to be transmitted, MES selects the RACH class and starts on a retransmission cycle. If the number of retransmission cycles is larger than the maximum retransmission cycles, MES stops the procedure and reports to the higher layer.

At the beginning of each retransmission cycle, MES refreshes the parameters related to RACH procedure with the up-to-date values, included in system information messages broadcast over BCH. MES then decides whether to start the RACH transmission in the current frame, based on the persistence value. If the transmission is not allowed, MES repeats from the persistence check in the next frame. If the transmission is allowed, MES starts on a ramping-up retransmission period. If the number of the repeated periods is larger than the maximum ramping-up retransmissions, MES restarts on the retransmission cycle in the next frame.

During the ramping-up retransmission period, the MES shall perform the physical random-access procedure as follows:

Step 1: Derive the available uplink access slots, in the next full access slot set, for the set of available RACH sub-channels within the given ASC. Randomly select one access slot among the ones previously determined. If there is no access slot available in the selected set, randomly select one uplink access slot corresponding to the set of available RACH sub-channels within the given ASC from the next access slot set.

Step 2: Randomly select a signature from the set of available signatures within the given ASC.

Step 3: Set the Preamble Retransmission Counter to Preamble Retrans Max.

Step 4: Set the parameter Commanded Preamble Power to Preamble_Initial_Power.

Step 5: In the case that the Commanded Preamble Power exceeds the maximum allowed value, set the preamble transmission power to the maximum allowed power. Otherwise set the preamble transmission power to the Commanded Preamble Power. Transmit a preamble using the selected uplink access slot, signature, and preamble transmission power.

Step 6: If no positive or negative acquisition indicator corresponding to the selected signature is detected in the downlink access slot corresponding to the selected uplink access slot :

Step 6.1: Select the next available access slot in the set of available RACH sub-channels within the given ASC.

Step 6.2: Randomly select a new signature from the set of available signatures within the given ASC.

Step 6.3: Increase the Commanded Preamble Power by $\Delta P_0 = \text{Power Ramp Step (dB)}$. If the Commanded Preamble Power exceeds the maximum allowed power by 6 dB, the MES may pass L1 status (“No ack on AICH”) to the higher layers (MAC) and exit the physical random access procedure.

Step 6.4: Decrease the Preamble Retransmission Counter by one.

Step 6.5: If the Preamble Retransmission Counter > 0 then repeat from Step 5. Otherwise pass L1 status (“No ack on AICH”) to the higher layers (MAC) and exit the physical random access procedure.

Step 7: If a negative acquisition indicator corresponding to the selected signature is detected in the downlink access slot corresponding to the selected uplink access slot, pass L1 status (“Nack on AICH received”) to the higher layers (MAC) and exit the physical random access procedure.

Step 8: Transmit the random access message three or four uplink access slots after the uplink access slot of the last transmitted preamble depending on the AICH transmission timing parameter. Transmission power of the control part of the random access message should be P_{p-m} (dB) higher than the power of the last transmitted preamble.

Step 9: Pass L1 status “RACH message transmitted” to the higher layers and exit the physical random access procedure.

In the transmission of the RACH preamble and message, MES may use a Doppler pre-compensation technique, based on the Doppler shift estimation on the downlink carrier.

If the response message corresponding to the transmitted RACH message is received in the higher layer (RLC or RRC) at any time during the random access procedure, MES should stop the RACH procedure.

4.3.6.4.4.2.1.2 Operation in optional mode C

In the MAC layer, when there is data to be transmitted, MES selects the RACH class and starts on a retransmission cycle. If the number of retransmission cycles is larger than the maximum retransmission cycles, MES stops the procedure and reports to the higher layer RLC or RRC.

At the beginning of each retransmission cycle, MES refreshes the parameters related to RACH procedure with the up-to-date values, included in system information messages within BCH. MES then decides whether to start the RACH transmission in the current frame, based on the persistence value. If the transmission is not allowed, MES repeats from the persistence check in the next frame. If the transmission is allowed, MES starts on a ramping-up retransmission period. If the number of the repeated periods is larger than the maximum ramping-up retransmissions, MES restarts on the retransmission cycle in the next frame.

During the ramping-up retransmission period, the MES shall perform the physical random-access procedure as follows:

Step 1: Derive the available uplink access frame, in the next full access frame set, by using the set of available RACH sub-channels within the given RACH Class. Randomly select one access frame among the ones previously determined. When sub-access frames are used for the PRACH, the MES randomly selects a sub-access frame from the even and odd sub-access frames within the selected access frame.

Step 2: Randomly select a signature from the set of available signatures within the given RACH Class.

Step 3: Set the Preamble Retransmission Counter to Preamble Retrans Max.

Step 4: Set the preamble power to Preamble_Initial_Power.

Step 5: Randomly select a transmission offset time, τ_{off} , in range of $-\tau_{off,max}$ to $\tau_{off,max}$ chips.

Step 6: Transmit a preamble part and a message part using the selected access frame (or sub-access frame), transmission offset time, signature, and preamble transmission power. Transmission power of the control part of the random access message should be P_{p-m} (dB) higher than the power of the preamble.

Step 7: If neither positive nor negative acquisition indicator corresponding to the selected signature is detected in the downlink AICH access frame (or sub-access frame) corresponding to the transmitted uplink access frame (or sub-access frame), then:

Step 7.1: Select the next available access frame in the set of available RACH sub-channels within the given RACH Class. When sub-access frames are used for the PRACH, the MES randomly selects a sub-access frame from the even and odd sub-access frames within the selected access frame.

Step 7.2: Randomly select a new signature from the available signatures.

Step 7.3: Increase the preamble power by $\Delta P_0 = \text{Power Ramp Step}$.

Step 7.4: Decrease the Preamble Retransmission Counter by one.

Step 7.5: If the Preamble Retransmission Counter > 0 then repeat from Step 5. Otherwise report L1 status “No ack on AICH” to the higher layer (MAC) and exit the physical random access procedure.

Step 8: If a negative acquisition indicator corresponding to the selected signature is detected in the downlink access frame (or sub-access frame) corresponding to the selected uplink access frame (or sub-access frame) frame, report L1 status “Nack on AICH received” to the higher layer (MAC) and exit the physical random access procedure.

Step 9: Report L1 status “Ack on AICH received” to the higher layer (MAC) and exit the physical random access procedure.

A RACH sub-channel defines a set of uplink access frames that are time-aligned with P-CCPCH frames. There are a total of eight RACH sub-channels.

In the transmission of the RACH preamble and message, MES may use a Doppler pre-compensation technique, based on the Doppler shift estimation on the downlink carrier.

In the MAC layer, when L1 indicates that an acknowledgement on AICH is received, the successful completion of the MAC transmission control procedure shall be indicated to higher layer. When L1 indicates that no acknowledgement on AICH is received, a new retransmission cycle is performed. When L1 indicates that a negative acknowledgement is received, the MES derives a backoff time. After the backoff time, a new retransmission cycle is started.

If the response message corresponding to the transmitted RACH message is received in the higher layer (RLC or RRC) at any time during the random access procedure, MES should stop the RACH procedure.

4.3.6.4.4.3 Power control

4.3.6.4.4.3.1 Operation in normal mode

4.3.6.4.4.3.1.1 Open loop power control

Open-loop power control is used to adjust the transmit power of the physical Random-Access channel. Before the transmission of a Random-Access frame, MES measures the received power of the downlink Primary Common Control Physical Channel over a sufficiently long time to remove any effect of the non-reciprocal multi-path fading. From the power estimate and knowledge of the Primary CCPCH transmit power (broadcast on the BCCH) the downlink path-loss including shadow fading can be found. From this path loss estimate and knowledge of the uplink interference level and the required received SIR, the transmit power of the physical Random-Access channel can be determined. The uplink interference level as well as the required received SIR is broadcast on the BCCH.

Open loop power control is also used at dedicated traffic channel establishment and can optionally be continuously activated until dedicated traffic channel release.

4.3.6.4.4.3.1.2 Closed loop power control

Slow closed loop power control is processed by Layer 3 (RRC) based on MES measurement reports for downlink and on MES signal measurements for uplink.

Additionally Layer 1 closed loop power control, with a rhythm of one Transmit Power Control command (TPC) per frame.

4.3.6.4.4.3.2 Operation in optional mode C

4.3.6.4.4.3.2.1 Uplink power control

The power control aims to overcome the near-far problem. There are open loop power control and closed loop power control depending on the existence of feedback information.

4.3.6.4.4.3.2.1.1 Open loop power control

The open loop power control is used to adjust the transmit power of the DPCH. It can reduce H/W complexity compared with closed loop power control. The MES should measure the received power of the downlink P-CCPCH before the transmission of a DPCH. The transmit power of DPCH is determined by the CSI and uplink SIR.

The MES shall perform continuously the OLPC procedure as follows:

Step 1: If the MES receives the data from Satellite-RAN in idle state, then it checks the pilot field of DPCCCH and/or CPICH and/or S-CCPCH.

Step 2: The MES takes CSI from channel estimation.

Step 3: The MES estimates the received SIR of downlink DPCCCH/DPDCH.

Step 4: The MES compares the target SIR with the received SIR.

Step 5: The MES determines transmit power of DPCH as follows:

$$P_{DPCH}(i) = P_{DPCH}(i-1) \pm \Delta_{\varepsilon}(i-1) \quad \text{dBm}$$

where:

$$\Delta_{\varepsilon}(i) \square = SIR_{est}(i) - SIR_{target}(i)$$

4.3.6.4.4.3.2.1.2 Closed loop power control

The uplink closed loop power control procedure simultaneously controls the power of a DPCCCH and its corresponding DPDCHs (if present). The relative transmit power offset between DPCCCH and DPDCHs is determined by the network and is signalled to the MES using higher layer signalling.

The uplink inner-loop power control adjusts the MES transmit power in order to keep the received uplink signal-to-interference ratio (SIR) at a given SIR target, SIR_{target} . The uplink power control shall be performed while the MES transmit power is below the maximum allowed output power.

Any change in the uplink DPCCCH transmit power shall take place immediately before the start of the frame on the DPCCCH. The change in DPCCCH power with respect to its previous value is derived by the MES and is denoted by Δ_{DPCCCH} (dB).

The satellite-RAN should estimate signal-to-interference ratio SIR_{est} of the received uplink DPCH, generate TPC commands, and transmit the commands once per radio frame according to the following rule:

Define the variable:

$$\Delta_{\varepsilon} = SIR_{est} - SIR_{target};$$

$$\Delta_p(i) = \text{power control step whose value is determined to be one of } \{-\Delta_L, -\Delta_S, \Delta_S, \Delta_L\} \text{ according to the } i\text{-th frame's TPC_cmd, where the step sizes } \Delta_S, \Delta_L \text{ are under the control of the Satellite-RAN;}$$

$$N_{frame} = \text{loop delay expressed in frames.}$$

And then, $\Delta_p(i)$ is generated by using Δ_{ε} and the past N_{frame} power control steps $\Delta_p(k)$, $k = i - N_{frame} - 1, \dots, i - 1$ as follows:

Compute:

$$\Delta_{\varepsilon,c} = \Delta_{\varepsilon} + \chi \sum_{k=i-N_{frame}}^{i-1} \{\Delta_p(k) - \alpha\Delta_p(k-1)\}$$

where the loop delay compensation indicator χ is set to “1” when an MES is in soft handover and “0” when an MES is not in soft handover. The accumulation reduction factor, $\alpha(0 < \alpha < 1)$ is the higher layer parameter and is identical for all MESs in the same beam.

- if $|\Delta_{\varepsilon,c}| < \varepsilon_T$ and $\Delta_{\varepsilon,c} < 0$, $\Delta_p(i) = \Delta_S$;
- if $|\Delta_{\varepsilon,c}| < \varepsilon_T$ and $\Delta_{\varepsilon,c} > 0$, $\Delta_p(i) = -\Delta_S$;
- if $|\Delta_{\varepsilon,c}| < \varepsilon_T$ and $\Delta_{\varepsilon,c} < 0$, $\Delta_p(i) = \Delta_L$;
- if $|\Delta_{\varepsilon,c}| < \varepsilon_T$ and $\Delta_{\varepsilon,c} > 0$, $\Delta_p(i) = -\Delta_L$.

The MES adjusts the transmit power of the uplink DPCCH with a step of Δ_{DPCCH} (dB) using two most recently received power control steps, $\Delta_p(i)$ and $\Delta_p(i - 1)$ as follows:

- When an MES is not in soft handover:

$$\Delta_{DPCCH} = \Delta_p(i)\alpha\Delta_p(i - 1)$$

Where α is identical to that used in the serving beam and is signalled by the higher layer.

- When an MES is in soft handover:

$$\Delta_{DPCCH} = \kappa\Delta_p(i)$$

Where κ is the power control step reduction factor signalled by the higher layer.

The relationship between $\Delta_p(i)$ and the transmitter power control command TPC_cmd is presented in Table 55.

TABLE 55

Channel coding scheme and coding rate

TPC_cmd	$\Delta_p(i)$
–2	$-\Delta_L$
–1	$-\Delta_S$
1	Δ_S
2	Δ_L

When the MES is not in soft handover, only one TPC command will be received in each radio frame. In this case, the value of TPC_cmd shall be derived as follows:

- If the received TPC command is equal to 00, then TPC_cmd for that frame is –2.
- If the received TPC command is equal to 01, then TPC_cmd for that frame is –1.
- If the received TPC command is equal to 10, then TPC_cmd for that frame is 1.
- If the received TPC command is equal to 11, then TPC_cmd for that frame is 2.

When the MES is in soft handover, multiple TPC commands may be received in each radio frame from different beams in the active set. In the case when more than one radio links are in the same radio link set, the TPC commands from the same radio link set shall be combined into one TPC

command, to be further combined with TPC commands from other radio link sets. The MES shall conduct a soft symbol decision W_i on each of the power control commands TPC_i , where $i = 1, 2, \dots, N$, where N is greater than 1 and is the number of TPC commands from radio links of different radio link sets. The MES derives a combined TPC command, TPC_cmd , as a function γ of all the N soft symbol decisions W_i : $TPC_cmd = \gamma(W_1, W_2, \dots, W_N)$, where TPC_cmd can take the values 2, 1, -1 or -2. The function γ shall fulfil the following criteria:

if the N TPC commands are random and uncorrelated, with equal probability of being transmitted as “00”, “01”, “10” or “11”, the probability that the output of γ is greater than or equal to 1 shall be greater than or equal to $1/(2N)$, and the probability that the output of γ is smaller than or equal to -1 shall be greater than or equal to 0.5. Further, the output of γ shall equal to 2 if the TPC commands from all the radio link sets are reliably “11”, and the output of γ shall equal to -2 if a TPC command from any of the radio link sets is reliably “00”.

For the uplink power control of PCPCH, any change of the PCPCH transmit power shall take place immediately before the start of the frame on the message part. The network should estimate the signal-to-interference ratio SIR_{est} of the received PCPCH. The network should then generate TPC commands and transmit the commands once per frame according to the same rule as described for DPDCH/DPCCH. The MES derives a TPC command, TPC_cmd , for each radio frame according to the same rule as described for DPDCH/DPCCH. After deriving the TPC command TPC_cmd , the MES shall adjust the transmit power of the uplink PCPCH control part with a step of $\Delta_{PCPCH-CP}$ (dB) determined by the same rule as described for DPDCH/DPCCH.

4.3.6.4.3.2.2 Downlink power control

The downlink transmit power control procedure controls simultaneously the power of a DPCCH and its corresponding DPDCHs. The power control loop adjusts the power of the DPCCH and DPDCHs with the same amount. The relative transmit power offset between DPCCH fields and DPDCHs is determined by the network.

The downlink inner-loop power control adjusts the network transmit power in order to keep the received downlink SIR at a given SIR target, SIR_{target} . The MES should estimate the received signal-to-interference ratio of downlink DPCCH/DPDCH, SIR_{est} . The obtained SIR estimate SIR_{est} is then used by the MES to generate TPC commands according to the following rule:

- if $|SIR_{est} - SIR_{target}| > \epsilon_T$ and $SIR_{est} > SIR_{target}$, then the TPC command to transmit is “00”;
- if $|SIR_{est} - SIR_{target}| > \epsilon_T$ and $SIR_{est} < SIR_{target}$, then the TPC command to transmit is “01”;
- if $|SIR_{est} - SIR_{target}| > \epsilon_T$ and $SIR_{est} < SIR_{target}$, then the TPC command to transmit is “10”;
- if $|SIR_{est} - SIR_{target}| > \epsilon_T$ and $SIR_{est} > SIR_{target}$, then the TPC command to transmit is “11”.

When the MES is in soft handover and BSDT is not activated, the MES should estimate SIR_{est} from the downlink signals of all beams in the active set.

The MES may employ prediction algorithm which estimates the future SIR value after the round trip delay. Prediction for the SIR variation can be implemented by observing the trace of the past SIR variations of the CPICH/S-CCPCH/DPCHs in the active set. In order to support MESs which employ the prediction algorithm, a nominal round trip delay of the beam to which the MES belongs is signalled by higher layers. The predicted SIR variation after round trip delay, Δ_{pred} , is used by the MES to generate TPC commands according to the following rule:

Define $SIR_{est,pred} = SIR_{est} + \Delta_{pred}$, then:

- if $|SIR_{est,pred} - SIR_{target}| > \epsilon_T$ and $SIR_{est,pred} > SIR_{target}$, then the TPC command to transmit is “00”;
- if $|SIR_{est,pred} - SIR_{target}| > \epsilon_T$ and $SIR_{est,pred} < SIR_{target}$, then the TPC command to transmit is “01”;

- if $|SIR_{est.pred} - SIR_{target}| > \varepsilon_T$ and $SIR_{est.pred} < SIR_{target}$, then the TPC command to transmit is “10”;
- if $|SIR_{est.pred} - SIR_{target}| > \varepsilon_T$ and $SIR_{est.pred} > SIR_{target}$, then the TPC command to transmit is “11”.

Upon receiving the TPC commands satellite-RAN shall adjust its downlink DPCCH/DPDCH power accordingly. Satellite-RAN shall estimate the transmitted TPC command TPC_{est} , and shall update the power every frame. After estimating the k -th TPC command, satellite-RAN shall adjust the current downlink power $P(k-1)$ (dB) to power $P(k)$ (dB) according to the following formula:

$$P(k) = P(k-1) + P_{TPC}(k) + P_{bal}(k)$$

where $P_{TPC}(k)$ is the k -th power adjustment due to the inner loop power control, and $P_{bal}(k)$ (dB) is a correction according to the downlink power control procedure for balancing radio link powers towards a common reference power. $P_{TPC}(k)$ is calculated as follows:

$$P_{TPC}(k) = \begin{cases} -\Delta_L & \text{if } TPC_{est}(k) = 00 \\ -\Delta_S & \text{if } TPC_{est}(k) = 01 \\ +\Delta_S & \text{if } TPC_{est}(k) = 10 \\ +\Delta_L & \text{if } TPC_{est}(k) = 11 \end{cases}$$

4.3.6.4.4 Spot selection transmit diversity

Beam selection transmit diversity (SSTD) is a macro diversity method in soft handover mode. This method is optional in satellite-RAN. The MES periodically selects one of the beams from its active set to be “primary”, all other beams are classed as “non-primary” by measuring the received signal power of CPICHs transmitted by the active beams. The beam with the highest CPICH power is detected as a primary beam. The downlink DPDCH is transmitted from the primary beam while the downlink DPDCH is not transmitted from non-primary beams.

In order to select a primary beam, each beam is assigned a temporary identification (ID) and MES periodically informs a primary beam ID to the connecting beams. The primary beam ID is delivered by MES to the active beams via the FBI field on the uplink DPCCH.

Each beam is given a temporary ID during SSTD and the ID is utilized as beam selection signal. One 15-bit ID code is transmitted within a radio frame.

A beam recognizes its state as non-primary if the following conditions are fulfilled simultaneously:

- the received ID code does not match to the own ID code;
- the received uplink signal quality satisfies the quality threshold defined by the network.

The state of the beams (primary or non-primary) in the active set is updated synchronously. If a beam receives the coded ID in uplink frame j , the state of beam is updated in downlink frame $(j + 1 + T_{os})$, where T_{os} is provided by higher layers (the value of T_{os} is determined by the network according to the round trip delay in the beam).

4.3.6.5 Description of optional modes

4.3.6.5.1 Definition of the optional modes A and C

The following two optional modes are defined in this radio interface.

- Optional mode A: Operation with ETSI S-UMTS G-family features and ETSI S-UMTS A-family optional features which are identified in § 4.3.6.5.2 for performance enhancement.
- Optional mode C: Operation with ETSI S-UMTS G-family features and TTA SAT-CDMA optional features which are identified in § 4.3.6.5.3 for performance enhancement. They are based on harmonization of previous versions of SRI-C and G families.

4.3.6.5.2 Description of optional mode A

The following new features are added for performance enhancement.

TABLE 56

Description of features of optional mode A

Features	Description
HPPICH	<ul style="list-style-type: none"> – Additional paging channel – Unspread BPSK signal packet of length 10 ms – Channel rate = 15 ksymbol/s – Packet = preamble (24bits) +UW (12 bits) + data (114 bits)
Downlink data scrambling	<ul style="list-style-type: none"> – For downlink when interference mitigation is used – Prior to physical channel mapping – By a ML sequence with polynomial $1+X^{14}+X^{15}$ – Rate: 30 kbit/s

4.3.6.5.3 Description of optional mode C

The following new features of are added for performance enhancement.

TABLE 57

Description of features of optional mode C

Features	Description
Uplink random access	<ul style="list-style-type: none"> – Transmission of both preamble and message, together – Access frame: 2 radio frames
FBI/TPC bits generation and transmission	<ul style="list-style-type: none"> – TPC field: the reduction of the half of TPC field – FBI field: removal of 2 bits FBI filed
Power control	<ul style="list-style-type: none"> – CLPC: a delay compensation power control scheme + prediction algorithm – SIR estimation from CPICH and S-CCPCH – 2-bit TPC command – OLPC algorithm using pilot diversity in option
Synchronization codes for downlink SCH in LEO constellation	<ul style="list-style-type: none"> – One so-called generalized hierarchical Golay sequence

4.3.7 Satellite radio interface H specifications

SRI-H air interface is an evolutionary third generation (3G) mobile satellite system air interface that was first published as the GMR-1 (Geo-Mobile Radio-1) mobile satellite air interface specification by both ETSI (ETSI TS 101 376) and TIA (S-J-STD-782) in 2001. The ETSI version has been updated several times with improvements, additional features and routine maintenance including a Release 2 and Release 3. The latest version of Release 3, version 3.3.1 has been published by ETSI in December, 2012. This section is a brief summary of the air interface. For a fuller description, please see the published specification.

The GMR-1 development and standardization path follows the evolution of GSM/EDGE Radio Access Network or GERAN as shown in Fig. 77.

GMR-1 air interface specifications based on TDMA were first standardized in ETSI in 2001 (GMR-1 Release 1) based on GSM protocol architecture with satellite specific optimizations and use of A interface with core Network (see Fig. 78). GMR-1 Release 1 radio interface supports compatible services to GSM and reuses the GSM network infrastructure. It is designed to be used with dual-mode terminals (satellite/terrestrial) allowing the user to roam between GMR-1 satellite networks and GSM terrestrial networks. Features include spectrally efficient voice, delay tolerant fax, reliable non-transparent data services up to 9.6 kbit/s, Short Message Service (SMS), cell broadcast services, position-based services, subscriber identity module (SIM) roaming, high penetration alerting and single-satellite hop terminal-to-terminal calls. Systems based on GMR-1 Release 1 are being used today in Europe, Africa, Asia and Middle East.

FIGURE 77

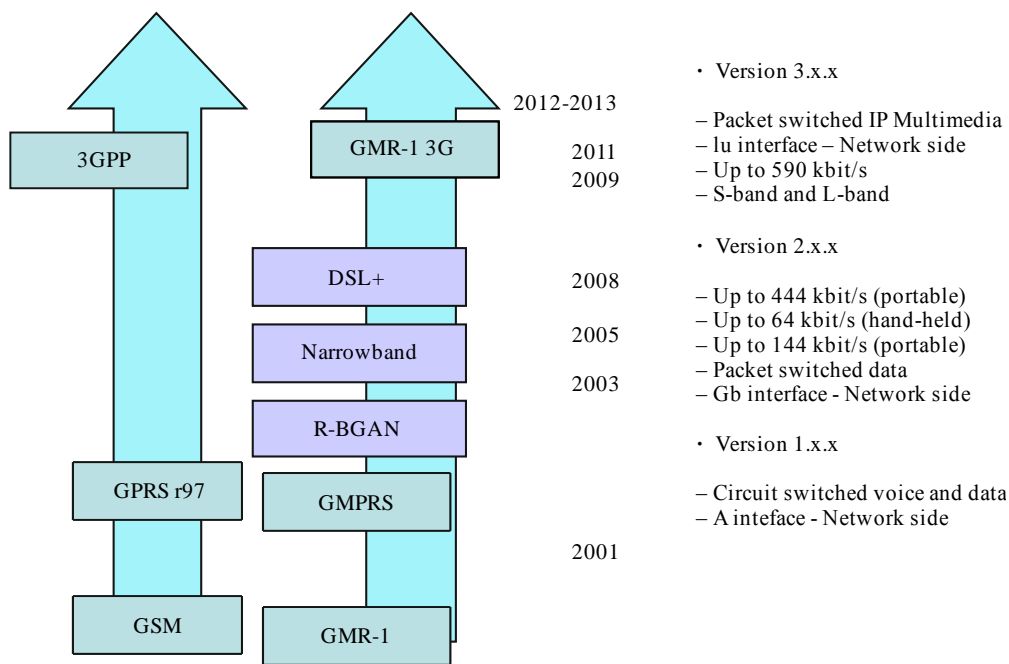
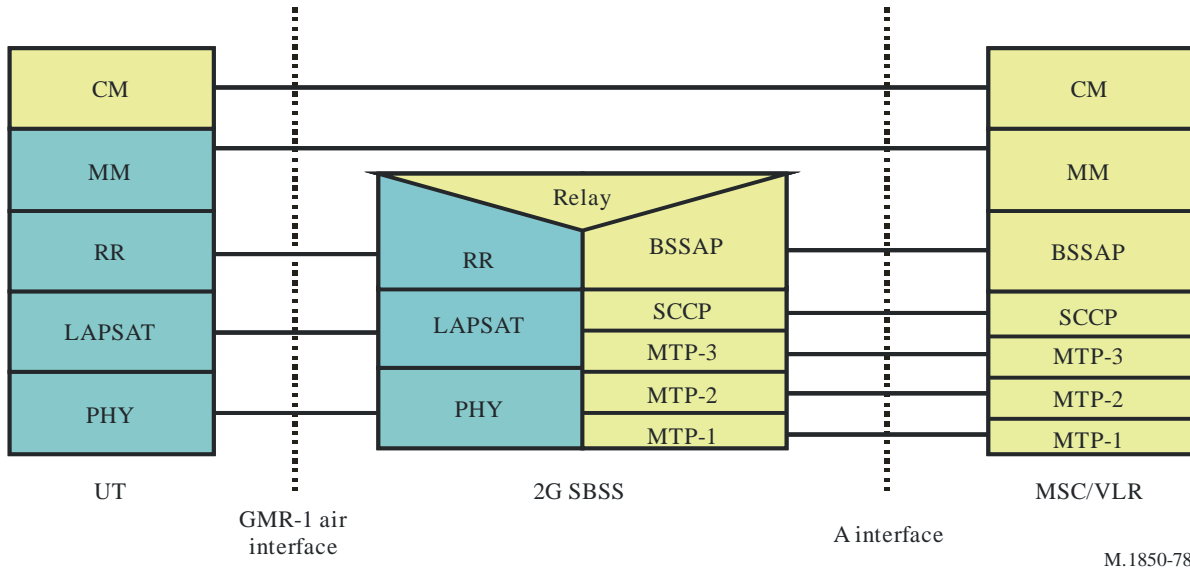

FIGURE 78



M.1850-78

The circuit switched specification (Release 1) has been updated two additional times in the ETSI satellite earth stations (SES) and systems technical committee, in 2002 (Version 1.2.1) and again in 2005 (Version 1.3.1).

GMR-1 uses time division multiplex on the forward link and time division multiple access on the return link.

In 2003, GMR-1 was enhanced with the addition of a packet switched data capability and published as GMPRS-1 (Geo-Mobile Packet Radio System) or GMR-1 Release 2. GMPRS-1 provides IP data services to transportable terminals using GPRS technology with a Gb interface to core network. Figures 79 and 80 illustrate protocol architecture of GMR-1 air interface for user plane and control plane using Gb interface towards core network. A number of satellite specific enhancements were introduced at PHY and MAC layers of the protocol stack to provide improved throughputs and better spectral efficiencies.

FIGURE 79

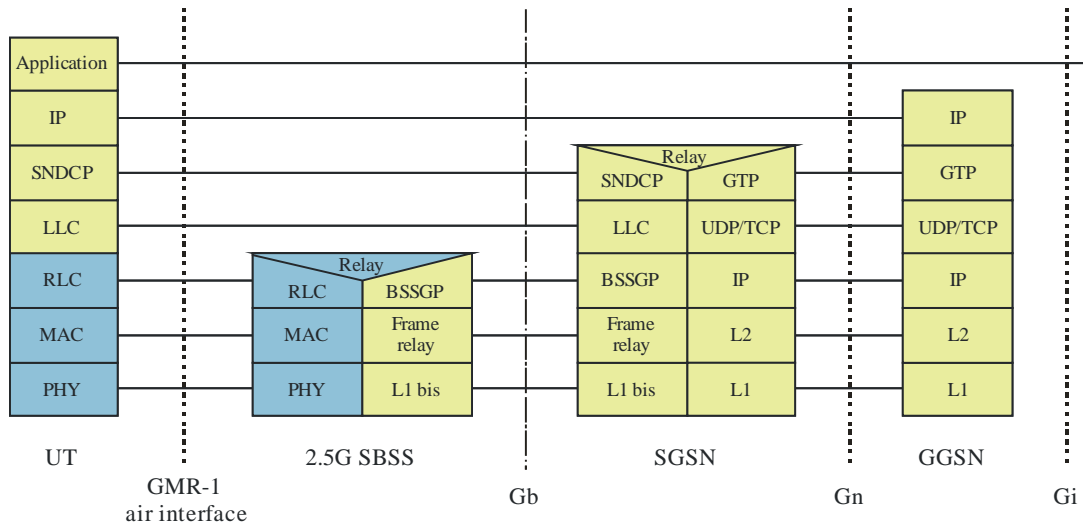

M.1850-79

FIGURE 80

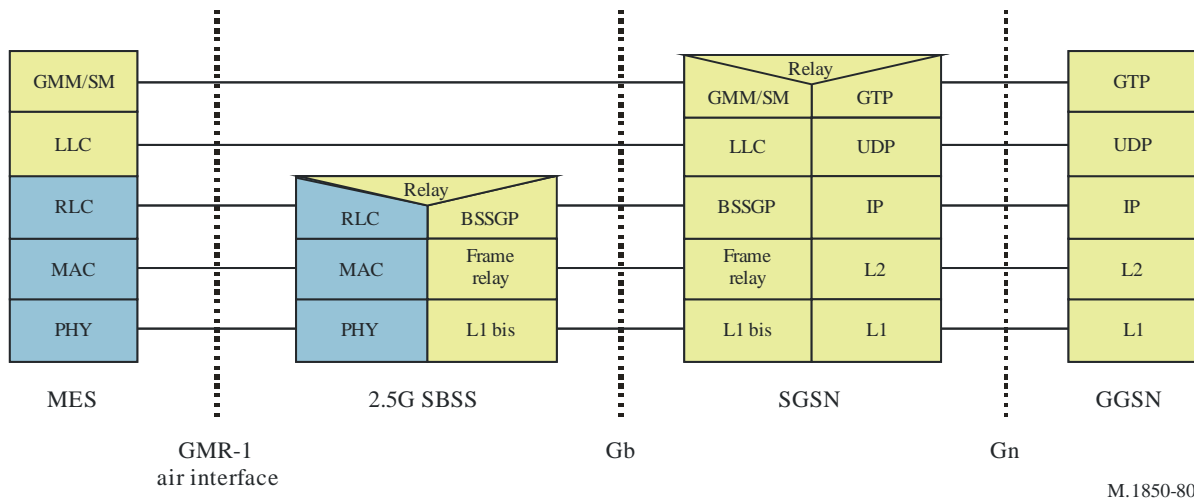

GMPRS-1 Version 2.1.1 supports bidirectional packet data rates up to 144 kbit/s, QoS differentiation across users, and dynamic link adaptation. GMPRS-1 Version 2.2.1, published in 2005, supports narrowband packet data services to handheld terminals that permit up to 28.8 kbit/s in uplink and 64 kbit/s in downlink. Wideband packet service is expanded to 444 kbit/s on the forward link and 202 kbit/s on the return link for A5 size transportable terminals in Version 2.3.1 published in 2008. The system also permits achieving up to 400 kbit/s in uplink with an external antenna. This latest set of specifications uses the state-of-the-art techniques in the physical layer such as LDPC codes and 32-APSK modulation and can provide bidirectional streaming services.

A system, using GMR-1, Release 2 specifications, has been successfully deployed in the field and is being used in Europe, Africa, Asia and Middle East.

GMR-1 3G Release 3.1.1 was first published by ETSI in July, 2009. It has been updated twice since as Release 3.2.1 (in February, 2011) and Release 3.3.1 (in December, 2012). GMR-1 3G is based on the adaptation to the satellite environment of the ETSI TDMA EDGE radio air interface (see Recommendation ITU-R M.1457-6, IMT-2000 TDMA Single-Carrier). GMR-1 3G is therefore the satellite equivalent to EDGE. The protocol architecture is based on 3GPP Release 6 and beyond, but the air interface is TDMA. In line with ETSI 3GPP specifications, the satellite base-station is therefore equivalent to a GERAN. GMR-1 3G is designed to meet the requirements of the satellite component of the third generation (3G) wireless communication systems.

Systems based on GMR-1 3G air interface specifications are currently being developed for MSS operators around the world operating in the MSS bands at both L-band and S-band frequencies as defined in ETSI TS 101 376-5-5.

4.3.7.1 Key features of GMR-1 3G

The GMR-1 3G specification uses the Iu-PS interface between radio network and core network. The objective is to allow MSS operators to provide forward-looking IP Multimedia System (IMS) based services. Key features included in this air interface are:

- Spectrally efficient multi-rate VoIP with zero byte header compression.
- V.44 data compression.
- TCP/IP, UDP/IP and RTP/UDP/IP header compression.

- Robust waveforms for link closure with terrestrial form-factor MESs.
- Up to 590 kbit/s throughput.
- Multiple carrier bandwidth operation.
- Multiple terminal types – Hand-held terminals, PDA, vehicular, portable, fixed, maritime and aeronautical.
- IP multimedia services.
- Differentiated QoS across users and applications.
- Dynamic link adaptation.
- IPv6 compatibility.
- Terrestrial/Satellite handovers.
- Beam-to-beam handovers.
- Unmodified non-access stratum (NAS) protocols and core network.
- High penetration alerting.
- GPS assist including either Earth-Centered Earth-Fixed coordinates or Keplerian coordinates.
- Cell broadcast.
- Capability to multiplex support multiple VOIP sessions for one MES.
- Resource efficient multicast.
- Resource and delay efficient push-to-talk.
- Regional beams and spot beam operation with or without overlay.
- Flexible traffic-only beam support.

Figures 81 and 82 illustrate protocol architecture of GMR-1 3G air interface for user plane and control plane using Iu-PS interface towards core network.

FIGURE 81

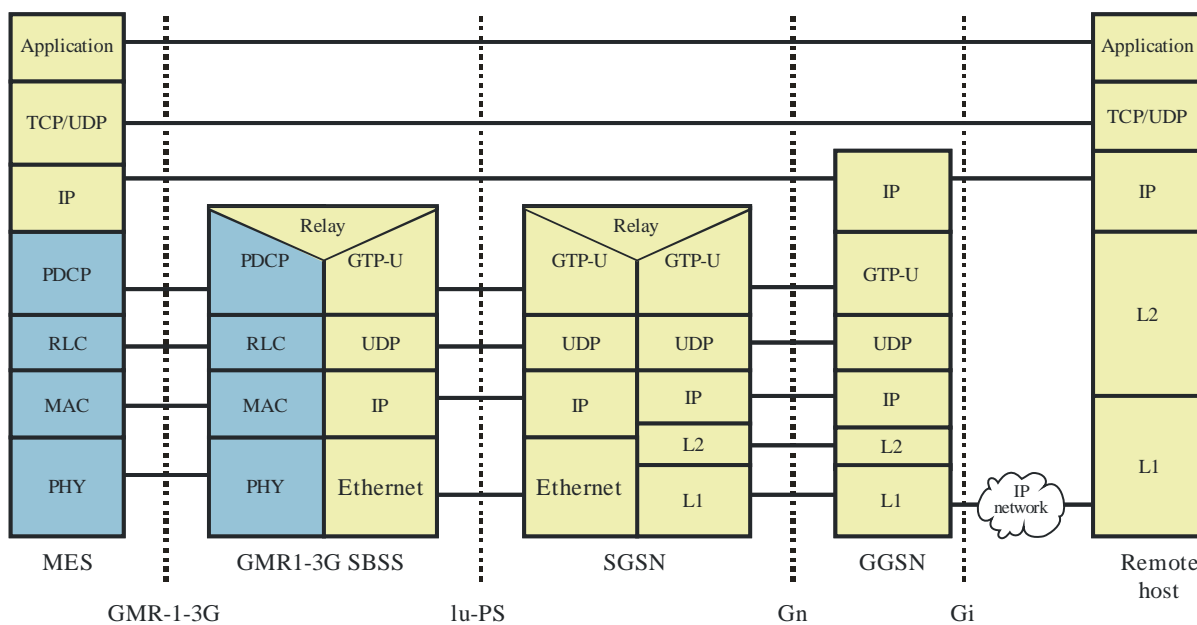
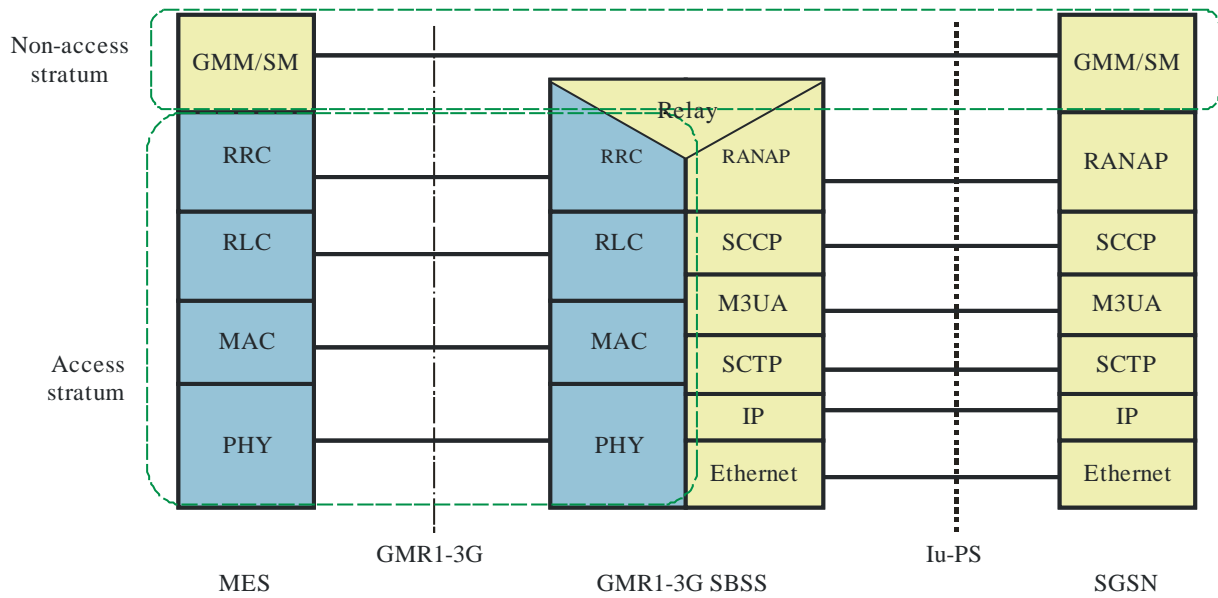

FIGURE 82



M.1850-82

End-to-end architectures depicting the use of GMR-1 3G air interface with different core network interfaces are depicted in Fig. 83. A given operator may choose an individual architecture option (A, Gb, Iu-PS) or a combination thereof.

In this description, the term “GMR-1” is used to refer to attributes of the air interface and system that uses A interface and Gb interface. Where a particular attribute is only applicable to A-interface or Gb-interface, it will be referred to as GMR-1 (A mode) or GMR-1 (Gb mode), respectively. The term GMR-1 3G is used to refer to attributes of the air interface and system that uses the Iu-PS interface, and will be referred to as GMR-1 3G (Iu mode). If no interface is referenced the attribute is common to all interfaces.

FIGURE 83

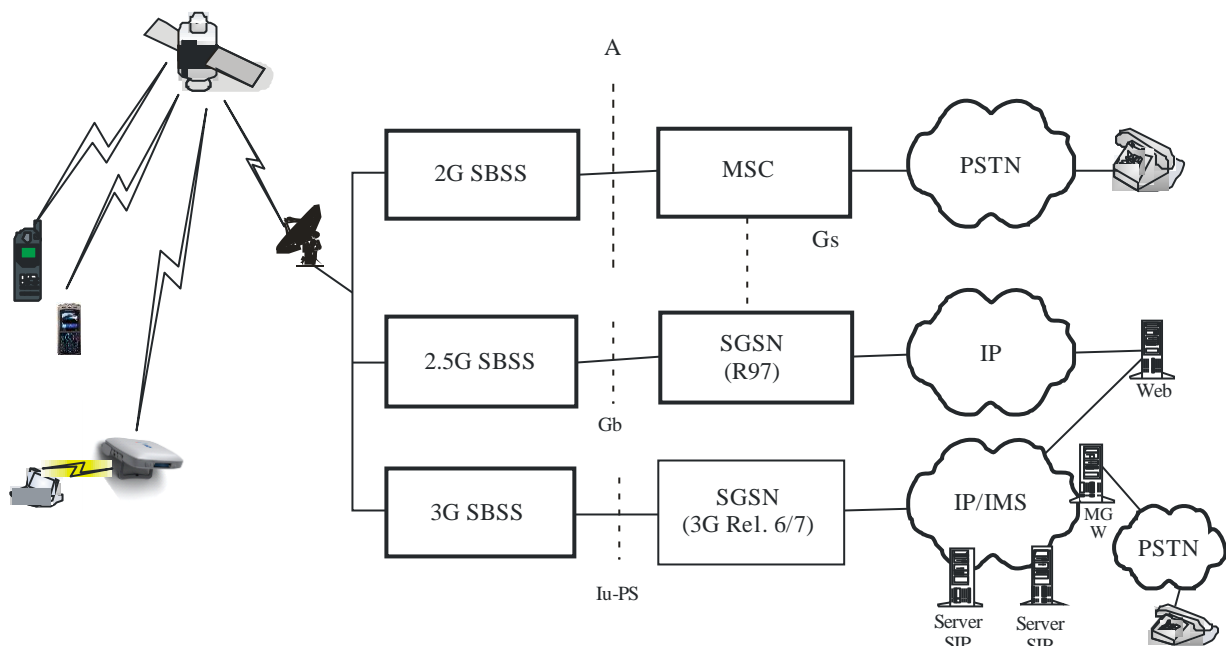

M.1850-83

GMR-1 3G operates in FDD mode with RF channel bandwidths from 31.25 kHz up to 312.5 kHz. Provides finer spectrum granularity yielding an easier spectrum sharing among different systems.

GMR-1 3G provides a wide range of bearer services from 1.2 up to 592 kbit/s. High-quality telecommunication service can be supported including voice quality telephony and data services in a global coverage satellite environment.

The implementation of efficient multicast is shown in Fig. 84. Terminals use Internet Group Management Protocol (IGMPv2) (see IETF RFC 2236) to join multicast sessions. The core network functions as defined in 3GPP specifications. The SBSS merges the multiple streams onto a single multicast TFI stream per beam. Details are provided in ETSI TS 101 376-4-14 and ETSI TS 101 376-4-12.

FIGURE 84

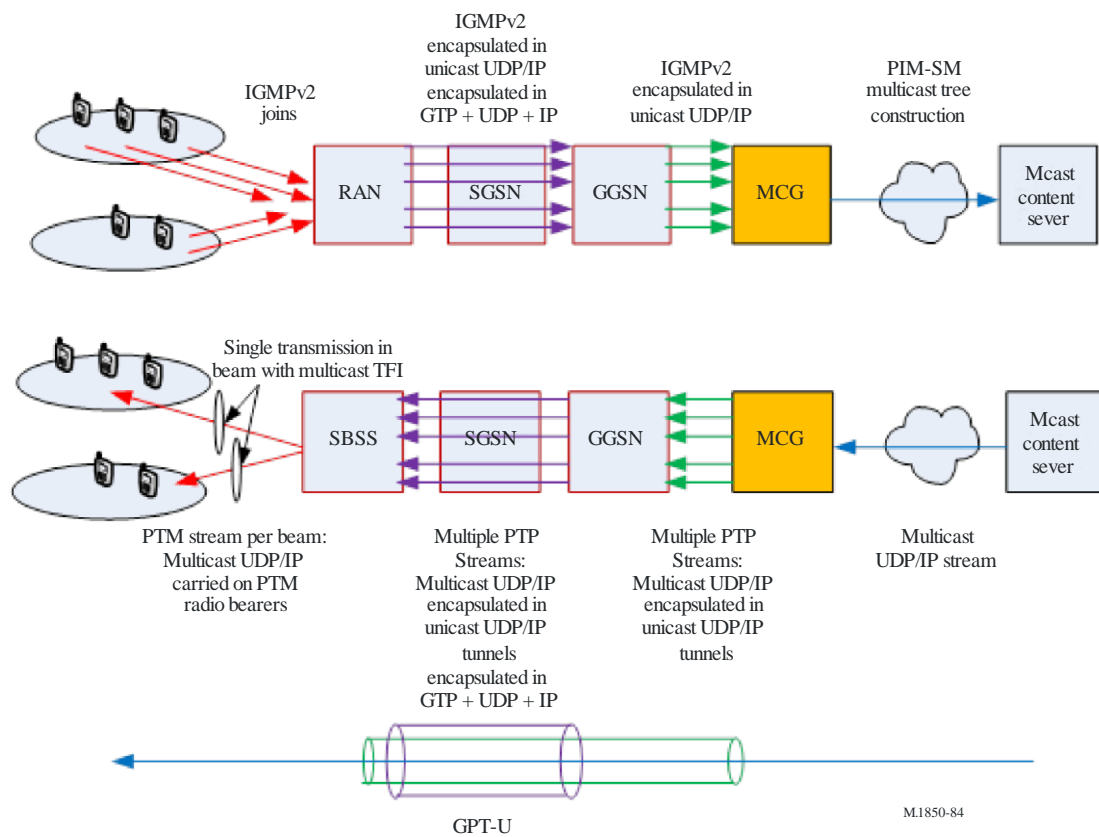

An example of flexible beam coverage support is shown in Fig. 85. GMR-1 3G is deployed in systems which use a variety of beam types in the same system. Figure 85 shows a regional beam overlay, a spot beam overlay and flexible traffic-only beams superimposed on the same coverage area. In this example, regional beams might be large with relatively low G/T and e.i.r.p. properties suitable for support of aeronautical terminals with high-gain antennas. Spot beam might be very small with much higher G/T and e.i.r.p. designed to support high capacity and very small handheld terminals with electrically small, low gain antennas. Traffic-only beams might be stationary or steerable and configured to support spot traffic needs. With the advances in satellite/ground technology including ground based beam formers, steerable antennas and array architectures, the GMR-1 3G air interface does not constrain satellite or system design.

FIGURE 85

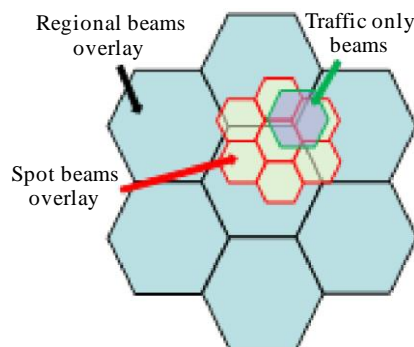

M.1850-85

4.3.7.2 Frame structure

The time reference structure (ETSI TS 101 376-5-2 and ETSI TS 101 376-5-7) is shown in Fig. 86.

GMR-1 uses Frequency Division Duplex (FDD) of the forward and return links, with time division multiplex (TDM) on the forward link and Time Division Multiple Access (TDMA) on the return link.

The air interface frame structure is shown in Fig. 86. The same frame structure is used on both the forward link and the return link: in this description all references to “TDMA Frames” apply equally to TDM frames on the forward link and TDMA frames on the return link.

The timeslots within a TDMA frame are numbered from 0 to 23 and a particular timeslot is referred to by its Timeslot Number (TN). TDMA frames are numbered by a Frame Number (FN). The frame number is cyclic and has a range of 0 to $FN_MAX = (16 \times 4 \times 4\ 896) - 1 = 313\ 343$. The frame number is incremented at the end of each TDMA frame. The complete cycle of TDMA frame numbers from 0 to FN_MAX is defined as a hyperframe. Other combinations of frames include:

- Multiframes: A multiframe consists of 16 TDMA frames. Multiframes are aligned so that the FN of the first frame in a multiframe, modulo 16, is always 0.
- Superframes: A superframe consists of four multiframes. Superframes are aligned so that the FN of the first frame in a superframe, modulo 64, is always 0.
- System information cycle: The system information cycle has the same duration as a superframe. However, the first frame of the system information cycle is delayed an integer number of frames (0 to 15) from the start of a superframe. The actual delay is intentionally varied from spot beam to spot beam to reduce the satellite’s peak power requirements. The FCCH and BCCH are used to achieve system information cycle synchronization at the MES.

FIGURE 86

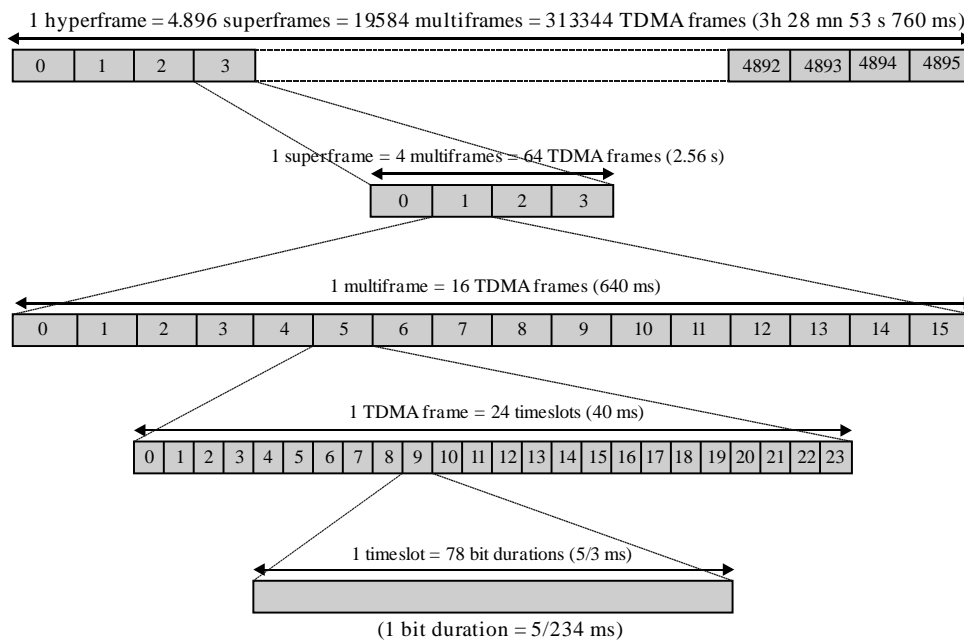

M.185086

4.3.7.3 Channels

The radio subsystem is required to support a certain number of logical channels described in ETSI TS 101 376-5-2 that can be separated into two overall categories:

- traffic channels (TCHs);
- control channels (CCHs).

4.3.7.3.1 Traffic channels

Circuit switched or A-mode traffic channels include those listed in Table 58. These traffic channels are bidirectional.

TABLE 58

Channel type	User information capability	Gross data transmission rate	Modulation	Channel coding
TCH3	Encoded speech	5.85 kbit/s	$\pi/4$ CQPSK	Convolutional code
TCH6	User data: 4.8 kbit/s Fax: 2.4 or 4.8 kbit/s	11.70 kbit/s	$\pi/4$ CQPSK	Convolutional code
TCH9	User data: 9.6 kbit/s Fax: 2 kbit/s; 4 kbit/s; 4.8 kbit/s or 9.6 kbit/s	17.55 kbit/s	$\pi/4$ CQPSK	Convolutional code

Packet channels are defined which provide data rates between 8.8 kbit/s and 587.2 kbit/s.

A packet data traffic channel (PDTCH) corresponds to the resource allocated to a single MES on one physical channel for user data transmission. Different logical channels may be dynamically multiplexed on to the same PDTCH. The PDTCH uses $\pi/2$ BPSK, $\pi/4$ QPSK, 16 APSK, or 32 APSK

modulation. All packet data traffic channels are unidirectional, either uplink (PDTCH/U), for a mobile-originated packet transfer or downlink (PDTCH/D) for a mobile-terminated packet transfer.

PDTCHs are used to carry packet data traffic in either Gb or Iu mode. Those applicable to Gb mode are listed in Table 59 and those applicable to Iu mode are listed in Table 3. Different PDTCHs are defined by the suffix (m, n) where m indicates the bandwidth of the physical channel in which the PDTCH is mapped, $m \times 31.25$ kHz, and n defines the number of timeslots allocated to this physical channel. Tables 59 and 60 summarize different types of packet traffic data channels, PDTCH $(m, 3)$, $(m = 1, 4, 5$ and $10)$, where the burst duration is 5 ms, PDTCH $(m, 6)$, $(m = 1, 2)$, where the burst duration is 10 ms, and PDTCH $(m, 12)$, $(m = 5)$, where the burst duration is 20 ms.

A dedicated traffic channel (DTCH) is used to carry user traffic when a dedicated channel (DCH) is allocated to the mobile earth station (MES) in packet dedicated mode. A DTCH is unidirectional. DTCH/U is used for the uplink and a DTCH/D is used for the downlink. A DTCH may support either 2.45 or 4.0 kbit/s encoded speech. Table 60 summarizes different types of packet traffic data channels, DTCH $(m, 3)$, $(m = 1, 4, 5$ and $10)$, where the burst duration is 5 ms, DTCH $(m, 6)$, $(m = 1, 2)$, where the burst duration is 10 ms, and DTCH $(m, 8)$, $(m = 1)$, where the burst duration is 13.333 ms.

TABLE 59

Channels	Direction (U: uplink, D: downlink)	Transmission symbol rate (ksymbol/s)	Channel coding	Modulation	Transmission bandwidth (kHz)	Peak payload transmission rate (without CRC) (kbit/s)	Peak payload transmission rate (with CRC) (kbit/s)
PDTCH(4,3)	U/D	93.6	Conv.	$\pi/4$ -QPSK	125.0	113.6	116.8
PDTCH(5,3)	U/D	117.0	Conv.	$\pi/4$ -QPSK	156.25	145.6	148.8
PDTCH(1,6)	U/D	23.4	Conv.	$\pi/4$ -QPSK	31.25	27.2	28.8
PDTCH(2,6)	D/D	46.8	Conv.	$\pi/4$ -QPSK	62.5	62.4	64.0
PDTCH2(5,12)	D	117.0	LDPC	$\pi/4$ -QPSK	156.25	199.2	199.6
PDTCH2(5,12)	D	117.0	LDPC	16-APSK	156.25	354.8	355.2
PDTCH2(5,12)	D	117.0	LDPC	32-APSK	156.25	443.6	444.0
PDTCH2(5,12)	U	117.0	LDPC	$\pi/4$ -QPSK	156.25	199.2	199.6
PDTCH2(5,12)	U	117.0	LDPC	16-APSK	156.25	399.2	399.6
PDTCH2(5,3)	U/D	117.0	LDPC	$\pi/4$ -QPSK	156.25	169.6	171.2
PDTCH2(5,3)	U/D	117.0	LDPC	16-APSK	156.25	342.4	344.0
PDTCH2(5,3)	U/D	117.0	LDPC	32-APSK	156.25	380.8	382.4

TABLE 60

Channels	Direction (U: uplink, D: downlink)	Transmission symbol rate (ksymbol/s)	Channel coding	Modulation	Transmissio n bandwidth (kHz)	Peak payload transmission rate (without CRC) (kbit/s)	Peak payload transmission rate (with CRC) (kbit/s)
DTCH(1,3)	U/D	23.4	Conv.	$\pi/4$ -QPSK	31.25	28.8	32.0
DTCH(1,6)	U/D	23.4	Conv.	$\pi/2$ -BPSK	31.25	14.4	16.0
DTCH(1,6)	U/D	23.4	Conv.	$\pi/4$ -QPSK	31.25	8.8	10.4
DTCH(1,8)	U/D	23.4	Conv.	$\pi/2$ -BPSK	31.25	10.8	12.0
PDTCH(1,6)	U/D	23.4	Conv.	$\pi/4$ -QPSK	31.25	27.2	28.8
PDTCH3(2,6)	U/D	46.8	Conv.	$\pi/4$ -QPSK	62.5	62.4	64.0
PDTCH3(2,6)	U/D	46.8	Turbo	$\pi/4$ -QPSK	62.5	62.4	64.0
PDTCH3(5,3)	U/D	117.0	Turbo	$\pi/4$ -QPSK	156.25	156.80	160.00
PDTCH3(5,3)	D	117.0	Turbo	16-APSK	156.25	252.80	256.0
PDTCH3(5,12)	U/D	117.0	Turbo	$\pi/4$ -QPSK	156.25	185.2	186.0
PDTCH3(5,12)	U/D	117.0	Turbo	16-APSK	156.25	257.6	259.2
PDTCH3(5,12)	D	117.0	Turbo	16-APSK	156.25	295.2	296.0
PDTCH3(10,3)	D	234.0	Turbo	$\pi/4$ -QPSK	312.50	344.0	347.20
PDTCH3(10,3)	D	234.0	Turbo	16-APSK	312.50	587.20	590.40

A complete list of supported modulation and coding schemes is found in ETSI TS 101 376-4-12.

4.3.7.3.1.1 Cell broadcast channels

Traffic can be broadcast on a per spot beam basis using the cell broadcast channel (CBCH). This channel is downlink only and used to broadcast Short Message Service Cell Broadcast (SMSCB) information to MESs. When the FCCH is used the CBCH is broadcast using a DC6 burst structure and when the FCCH3 is used the CBCH is broadcast using a DC12 burst structure.

4.3.7.3.2 PUI and PRI

A MAC/RLC block consists of PUI (Public User Information) and PRI (Private User Information) as shown in Fig. 87. Downlink blocks may include an extended PUI which contains an uplink allocation mapping or ULMAP. This field allows multiple uplink assignments to different MES using the same downlink burst. See ETSI TS 101 376-4-12 and ETSI TS 101 376-5-2 for more detailed information.

FIGURE 87



M.1850-87

The payload is the Private Information (PRI) delivered to the physical layer by the link layer. The PRI includes the MAC header and the other higher layer overhead. The peak payload transmission rate (without CRC) is defined as the maximum attainable PRI data rate with continuous transmission, i.e. using all 24 timeslots in a frame. The above peak-rates are achieved with rate 3/4 coding for PDTCH (4,3) and PDTCH (5,3) and are achieved with rate 4/5 for PDTCH (1,6) and PDTCH (2,6). The peak rates of LDPC coded PDTCH2 (5,12) and LDPC coded PDTCH2 (5,3) are achieved for different modulation schemes with the following coding rate combinations:

- Downlink: 32 APSK Rate 4/5, 16 APSK Rate 4/5, $\pi/4$ QPSK Rate 9/10.
- Uplink: 16 APSK Rate 9/10, $\pi/4$ QPSK Rate 9/10.

The peak rates of Turbo coded PDTCH3 (5,12) and PDTCH3 (5,3) are achieved for different modulation schemes with the following coding rate combinations:

- Downlink: 16 APSK Rate 2/3, $\pi/4$ QPSK Rate 5/6.
- Uplink: $\pi/4$ QPSK Rate 5/6, for PDTCH3 (5,3), and
- Uplink: 16 APSK Rate 4/7 for PDTCH3 (5,12).

The peak rates of Turbo coded PDTCH3 (10,3) are achieved for different modulation schemes with the following coding rate combinations:

- Downlink: 16 APSK Rate 2/3, $\pi/4$ QPSK Rate 5/6.

4.3.7.3.3 Control channels

Control channels (ETSI TS 101 376-5-2) are intended to carry signalling or synchronization data. Three categories of control channels are defined: broadcast, common and dedicated. Specific channels within these categories are defined. As with traffic channels, some control channels are applicable to A, Gb and Iu modes and some are specific to a subset of modes. Where no mode is indicated, the control channel is applicable to both. Two sets of control channels are defined. Depending on available satellite e.i.r.p. one set may be preferred over the other. All broadcast and common control channels are transmitted on a 31.25 kHz carrier.

4.3.7.3.3.1 Broadcast control channels

4.3.7.3.3.1.1 FCCH or FCCH3

The frequency correction channel (FCCH or FCCH3) carries information for frequency correction of the MES. This frequency correction is only required for operation of the radio subsystem. The FCCH is also used for system information cycle synchronization of the MES. The FCCH is downlink only.

The FCCH burst is a real chirp signal spanning three slots. The complex envelope of the transmitted burst is defined as follows (ETSI TS 101 376-5-4):

$$x(t) = p(t) \left[e^{j\varphi_0} \sqrt{2} \cos(0.64\pi(t - 58.5T)^2) \right]$$

where φ_0 is a random phase and $p(t)$ is the ramp function as defined in the published specification. This signal defines the chirp sweeping range as $(-7.488 \text{ kHz}, 7.488 \text{ kHz})$.

The FCCH3 burst is a real chirp signal spanning twelve slots. The complex envelope of the transmitted burst is defined as follows:

$$x(t) = p(t) \left[e^{j\varphi_0} \sqrt{2} \cos(0.32\pi(t - 234T)^2) \right]$$

where φ_0 is a random phase and $p(t)$ is the ramp function as defined in the specification. This signal defines the chirp sweeping range as $(-3.744 \text{ kHz to } 3.744 \text{ kHz})$.

4.3.7.3.3.1.2 GBCH or GBCH3

The GPS broadcast control channel (GBCH or GBCH3) carries global positioning system (GPS) time information and GPS satellite ephemeris information to the MESS. (The PCH described below may also contain almanac data). The GBCH is downlink only.

Each GBCH burst contains 108 bits of information and is broadcast using the two-slot DC2 burst. The DC2 burst uses $\pi/4$ CQPSK modulation is encoded using a convolutional code. The GBCH3 contains the same information as the GBCH but is formatted to fit a DC12 burst structure. The DC12 burst structure uses $\pi/2$ BPSK modulation and convolutional coding. Each GBCH3 burst contains 192 bits of information.

4.3.7.3.3.1.3 BCCH

The broadcast control channel (BCCH) broadcasts system information to the MESS and is downlink only. The BCCH system information parameters are described in (ETSI TS 101 376-4-8). Each BCCH burst contains 192 bit of information. The BCCH is broadcast using either the BCCH burst structure or the DC12 burst structure. The BCCH burst structure is six-slot long and is broadcast using $\pi/4$ CQPSK modulation is encoded using a convolutional code.

4.3.7.3.3.2 Common control channels

The common control channel (CCCH) includes the following common control-type channels.

4.3.7.3.3.2.1 PCH

The paging channel (PCH): downlink only, used to page MESS. Each PCH burst contains 192 bits of information and is broadcast using either the six-slot DC6 burst or the DC12 burst. The DC6 burst is broadcast using $\pi/4$ CQPSK modulation is encoded using a convolutional code.

4.3.7.3.3.2.2 RACH or RACH3

The random access channel (RACH): uplink only, used to request the allocation of traffic channel resources.

4.3.7.3.3.2.3 AGCH

The access grant channel (AGCH): downlink only, used to allocate traffic channel resources to the user terminal or MES. Each AGCH burst contains 192 bits of information and is broadcast using either the six-slot DC6 burst or the DC12 burst.

4.3.7.3.3.2.4 BACH

The basic alerting channel (BACH): downlink only, used to alert MESs. The BCCH system information parameters are described in ETSI TS 101 376-4-8. Each BCCH burst contains 192 bit of information. The BCCH is broadcast using either the BCCH burst structure or the DC12 burst structure. The BCCH burst structure is six-slot long and is broadcast using $\pi/4$ CQPSK modulation is encoded using a convolutional code.

4.3.7.4 FEC

GMR-1 3G adopts various state-of-the-art FEC schemes (ETSI TS 101 376-5-3). Table 61 lists the FEC schemes supported by GMR-1 3G.

TABLE 61

FEC Code	FEC block size (Information bits)	Comments
Convolutional Code	Between 20-1 000 bits	Constraint length $K = 5, 6, 7,$ and 9 . Mother code of rate $1/4, 1/3,$ and $1/2$. Various rates by puncturing. Tail biting for small FEC block
Turbo Code	Between 200-6 000 bits	Turbo code. Various Rates by puncturing
Reed Solomon Code	Blocks of 9 information symbols of 4 bits	Systematic (15,9) Reed-Solomon
Extended Golay Code	12 bit information bits	(12,24) extended Golay code
LDPC (low density parity check) Code	Between 500-9 000 bits	Optimized for small FEC block size
CRC (cyclic redundancy check) Code	Between 20-9 000 bits	3, 5, 8, 12, 16 bit CRC for error detection

The FEC coded bits are additionally punctured, interleaved and scrambled before modulation. Details can be found in ETSI TS 101 376-5-3.

4.3.7.5 Modulation

GMR-1 3G adopts power and spectrally efficient modulations as specified in ETSI TS 101 376-5-4. The specified modulation schemes are:

- Dual Chirp
- $\pi/2$ -BPSK, $\pi/4$ -QPSK, 16 APSK and 32 APSK.

Dual chirp is a constant envelope frequency modulated signal that is used for MES initial timing and frequency acquisition of frequency correction channel (FCCH). The dual chirp waveform is shown in Fig. 88.

FIGURE 88

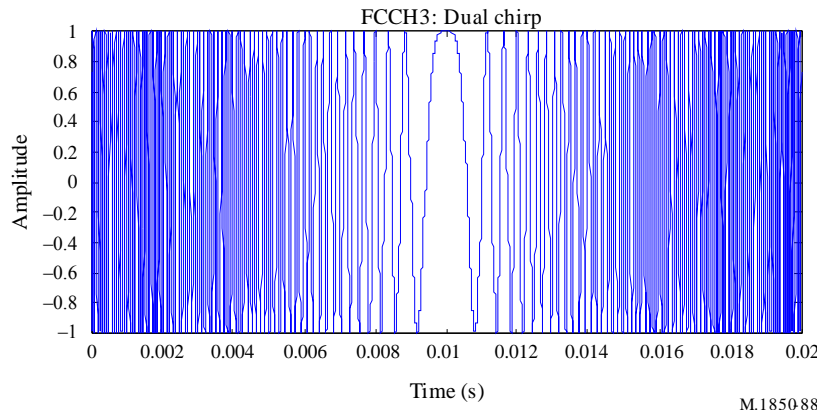

Control channels use either $\pi/2$ -BPSK or $\pi/4$ -QPSK, and traffic channels use $\pi/2$ -BPSK, $\pi/4$ -QPSK, 16 APSK or 32 APSK depending on data rate. The signal constellations for $\pi/2$ -BPSK and $\pi/4$ -QPSK are shown in Fig. 89 and for 16 APSK and 32 APSK in Fig. 90.

FIGURE 89

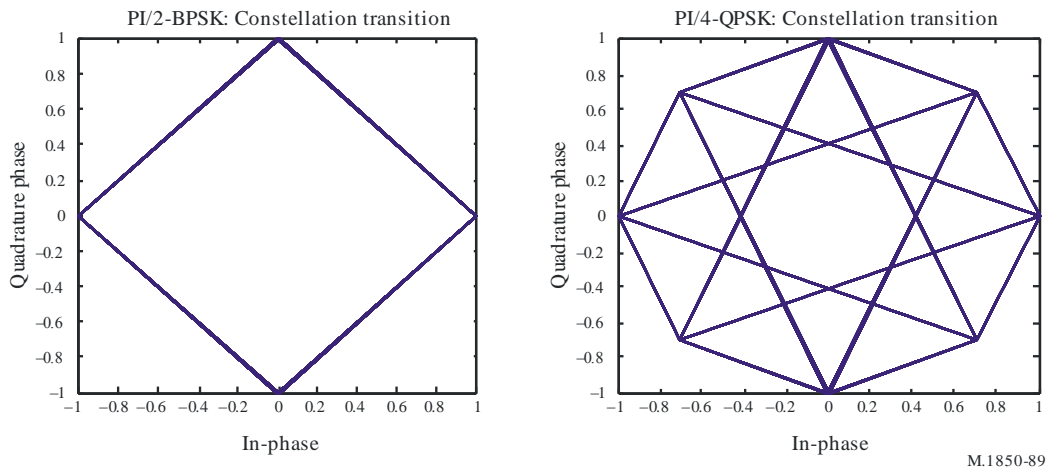
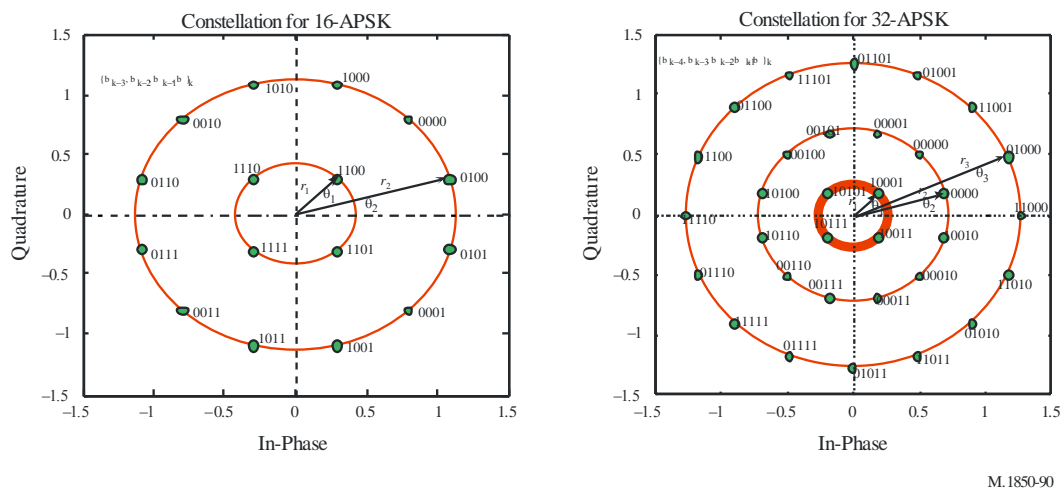

FIGURE 90



The modulated signal is pulse-shaped by the square root raised cosine (SQRC) filter with a roll-off factor 0.35. As an example, the power spectral density (PSD) of $\pi/4$ -QPSK modulated PNB3(5,3) is shown in Fig. 91.

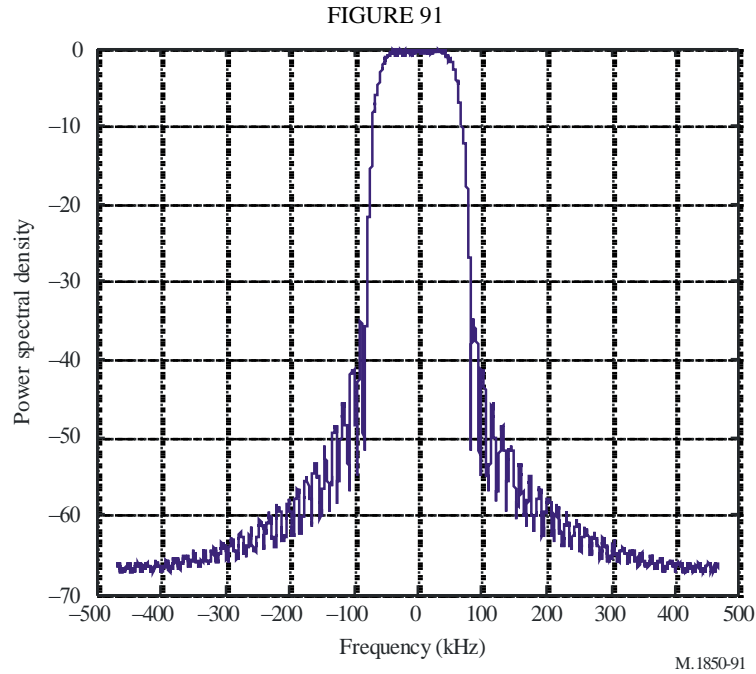

Table 62 lists the peak-to-average-power-ratio (PAPR) for different modulation schemes. The adopted GMR-1 3G modulation schemes such as $\pi/2$ -BPSK, $\pi/4$ -QPSK, or 16-APSK have much smaller PAPR than conventional BPSK, QPSK and 16-QAM.

TABLE 62

Modulation	$\pi/2$ -BPSK	BPSK	QPSK	$\pi/4$ - QPSK	16-QAM	16-APSK	32-APSK
PAPR (dB)	1.84	3.86	3.86	3.17	6.17	4.72	5.91

4.3.7.6 Power control and link adaptation

4.3.7.6.1 General

GMR-1 3G supports power control and link adaptation, as specified in ETSI TS 101 376-5-6. The power control and link adaptation allows the system to manage the radio resources optimally according to the MES receive and transmit channel quality.

The objective of the modulation-code rate adaptation is:

- to adjust the transmission throughput according to each user’s unique channel environment while maintaining a reliable transmission.

For the mobile return link, the objectives of power control are to:

- reduce co-channel interference at the satellite receiver by ensuring that all signals from different UTs are received at approximately the same level at the satellite;
- minimize MES power drain by using the minimum equivalent isotropically radiated power (e.i.r.p.) necessary to close the link for a given channel condition.

4.3.7.6.2 Link adaptation

Packet data services use coding rate and modulation scheme control procedures both over the forward and return link (ETSI TS 101 376-5-6).

The network selects the coding rate/modulation scheme for both the forward and return directions based on the signal quality and power level information available at the network or reported by the terminals.

The terminal identifies the coding rate and modulation selected by the network by reading the Physical Layer Header (PUI) on each forward burst.

4.3.7.6.3 Power control

Dedicated channels utilize power control for both return and forward link (ETSI TS 101 376-5-6). In packet data service, power control is used in the return direction. The transmit power at the MES is regulated so as to achieve expected, but not excessive, signal quality at the network end. The power transmitted by the terminal can be changed over a range of 24 dB below the maximum power with 0.4 dB resolution.

Both closed loop and open loop power control are supported.

In the closed-loop power control, the MES's transmit power is controlled based upon measurements of the received signal quality made at the network. Due to the round trip time, for the closed-loop, the reaction speed to channel variation is slow. Closed-loop control is intended to mitigate shadowing events. The network makes the selection of the terminal power control based on signal quality measurement made by the network physical layer over the transmitted bursts from MES.

In the open loop power control, the measurements of received signal quality at the MES are processed and are used to quickly adjust the MES's transmit power should the signal quality suddenly deteriorate. This approach assumes that there is some degree of statistical correlation between the receive and transmit shadowing. This approach is used at the UTs to speed the power control response to abrupt shadowing events.

4.3.7.7 Control channel organization

A mobile satellite system may use either the three-slot FCCH or the twelve-slot FCCH3 burst for synchronization (ETSI TS 101 376-5-2). The choice would depend on the available e.i.r.p. for the satellite. Table 63 lists the burst types used for the broadcast and common control channels for the cases where the FCCH is used and Table 64 lists the burst types used for the broadcast and common control channels for the case where the FCCH3 is used.

An MES would scan for either the FCCH or the FCCH3 and would be able to receive the other control channels depending on which version of the frequency correction channel it received.

TABLE 63

Control channel	Burst type
FCCH	FCCH
BCCH	BCCH
GBCH	DC2
PCH	DC6
AGCH	DC6
BACH	BACH

TABLE 64

Control channel	Burst type
FCCH3	FCCH3
BCCH	DC12
GBCH3	DC12
PCH	DC12
AGCH	DC12
BACH	BACH

The organization of control channel broadcast on the 31.25 kHz BCCH/CCCH channel when the FCCH is used is shown in Fig. 92. Note that the FCCH is a three-slot burst and the BCCH and PCH are six-slot bursts. When the FCCH is used 6 out of the 24 time slots in each frame are dedicated to broadcast of the control channels. The twenty four-slot frame is shown in Fig. 93. Note the GBCH is broadcast two time slots later than the BCCH/CCCH within each frame. The unused time slots from time slot 12 to time slot 23 within the frame may be used for traffic. The Physical Channel Relative Timeslot Number (PCRTN) and the System Information relative frame number are described in ETSI TS 101 376-5-2. The number after PCH and BACH refer to the paging and alerting groups. This is described in ETSI TS 101 376-5-2.

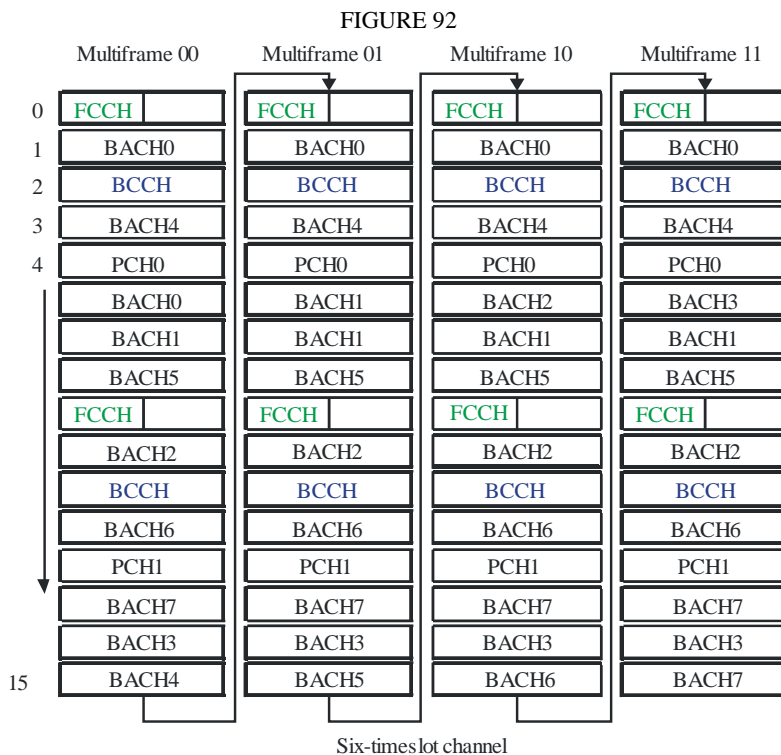

- Selecting logical channels for signalling radio bearer.
- Selecting logical channels for user radio bearer.
- Assignment, reconfiguration and release of shared resources for a TBF.
- MES measurement reporting and control of reporting.
- Broadcasting/listening of BCCH and CCCH.
- Ciphering and deciphering for Transparent Mode in Iu Mode.
- Identification of different traffic flows of one or more MESs on the shared channel.
- Multiplexing/demultiplexing of higher layer PDUs.
- Multiplexing/demultiplexing of multiple TBFs on the same PDTCH.
- Scheduling of RLC/MAC data and control PDUs delivered to the physical channel on a shared channel.
- Splitting/recombining RLC/MAC PDUs onto/from several shared logical channels.
- Mapping multicast bearers to shared TFIs.

The RLC operates in Acknowledge mode (AM) or UnAcknowledged mode (UM). Functions include:

- Segmentation of upper layer PDUs into RLC data blocks.
- Concatenation of upper layer PDUs into RLC data blocks.
- Padding to fill out RLC data block.
- Reassembly of RLC data blocks into upper layer PDU.
- In-sequence delivery of upper layer PDUs.
- Link Adaptation.
- Ciphering and deciphering in Iu Mode.
- Sequence number check to detect lost RLC blocks.

For Iu mode of operation, RLC can also operate in Transparent Mode for carrying spectrally efficient VoIP.

In addition to the above, RLC provides the following functions when operating in ACK mode:

- Backward error correction (BEC) procedure enabling the selective retransmission of RLC data blocks.
- Discard of RLC SDUs not yet segmented into RLC PDUs, according to the delay requirements of the associated radio bearers.

4.3.7.9 RRC layer design

Radio resource control (RRC) layer design for SRI-H is based on ETSI GERAN Iu mode RRC specifications (ETSI TS 101 376-4-13) specifications with satellite specific optimizations to cater to long delay environments and achieve better spectral efficiency.

RRC state model is based on RRC states defined in ETSI TS 101 376-4-13 and is illustrated in Fig. 98.

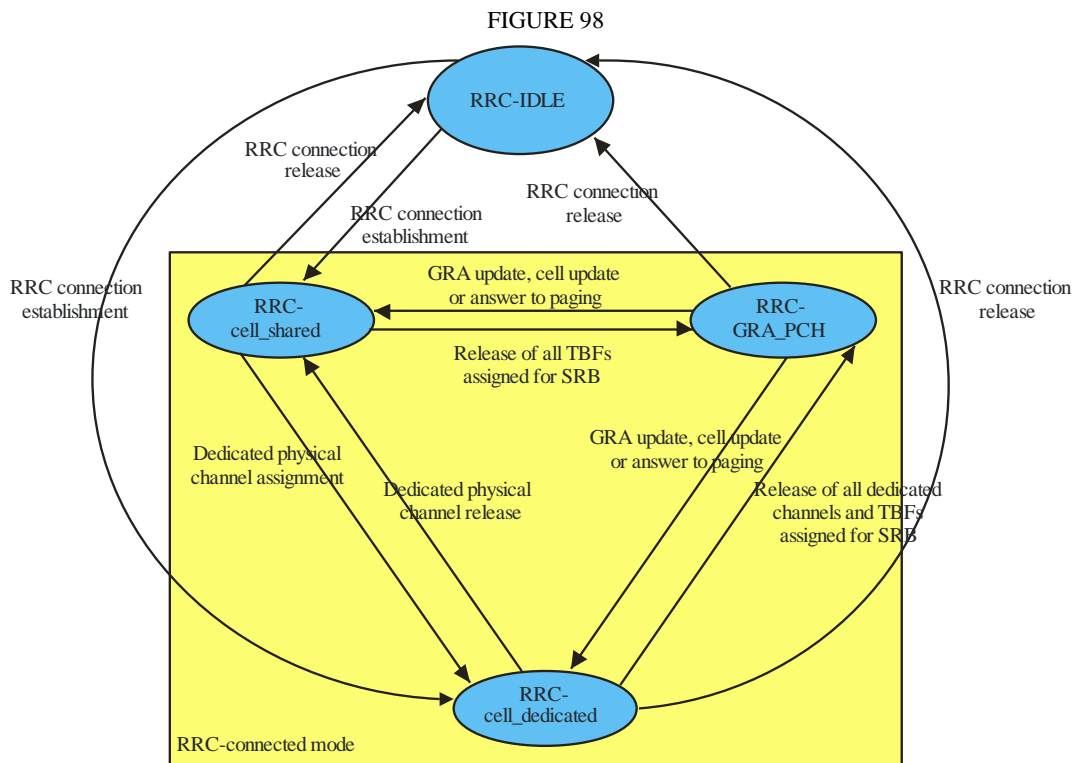

M.1850-98

RRC functions include:

- Assignment, reconfiguration, and release of radio resources for the RRC connection.
- Establishment, reconfiguration, and release of radio bearers.
- Release of signalling connections.
- Paging.
- Routing of higher layer PDUs.
- Control of requested QoS.
- Control of ciphering.
- Integrity protection.
- Support for location services.
- Timing advance control.

Satellite specific enhancements in RRC layer includes:

- Enhancements to cell update procedure to reduce number of round-trips.
- Fast RRC connection setup using RACH.
- Fast GRA update using RACH/PRACH.
- Fast RRC connection reject/connection release using AGCH.
- RAB Binding procedure to identify PTT bearers.
- RAB Binding procedure to identify multicast bearer.
- RB Reconfiguration procedure for intra-beam carrier relocation.

4.3.7.10 PDCP layer design

Packet data convergence protocol (PDCP) layer design is defined in ETSI TS 101 376-4-15 with satellite specific enhancements. The PDCP structure is shown in Fig. 99.

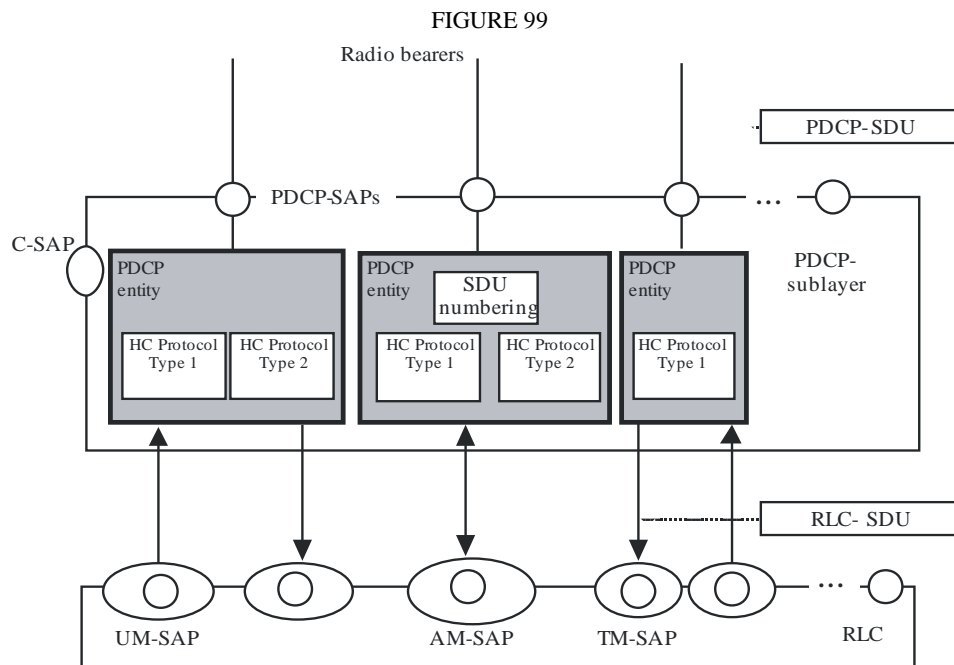

M.1850-99

The PDCP performs the following functions:

- Header compression and decompression of IP data streams (e.g. TCP/IP and RTP/UDP/IP headers for IPv4 and IPv6) at the transmitting and receiving entity, respectively.
- Transfer of user data. This function is used for conveyance of data between users of PDCP services.
- Maintenance of PDCP sequence numbers.
- Data compression using V.44.

PDCP uses the services provided by the radio link control (RLC) sublayer.

Satellite specific optimizations include:

- Early context establishment procedures.
- Zero byte header compression.
- Efficient handling of RTCP packets.
- Efficient handling of IPv6 RTP/UDP/IP headers.
- Interaction with TCP performance enhancing proxy.

Benefits of PDCP layer functions include:

- Improve spectral efficiency and decrease satellite power usage.
- Improve capacity.
- Improve MES battery life.
- Improve interactive response time.
- Reduce packet loss rate.

4.3.7.11 Terminal types

GMR-1 3G supports a wide range of terminal types from small handheld terminals to large high gain fixed or transportable terminals. Both 2.45 kbit/s and 4 kbit/s voice rates are supported using zero-byte header compression, as well as IP data traffic with bandwidths dependent on terminal type. The following terminal characteristics are supported.

- GMR-1 3G terminal type identifier (signalling code point). See ETSI TS 101 376-5-2.
- Multislot class (limitations on burst transmissions for small terminals). See ETSI TS 101 376-5-2.
- Power class. See ETSI TS 101 376-5-5.
- Supported channel types (FCCH and/or FCCH3). See ETSI TS 101 376-5-2.
- Supported traffic channel types based on terminal capability.
- Transmission capability (half or full duplex).
- Mode of use (handheld, fixed, etc.).
- Antenna type (internal or external, linearly or circularly polarized, etc.).
- Network interfaces supported (A, Gb or Iu mode).
- Operating band (S-band, L-band). See ETSI TS 101 376-5-5.

4.3.7.12 Conclusion

GMR-1 3G comprises three releases of an ETSI and TIA standard for mobile satellite communications to support IMT-2000 services. GMR-1 is currently used in mobile satellite systems covering Europe, Africa, Asia and Middle East. GMR-1 3G is currently being deployed in North America.

GMR-1 3G provides IMT-2000 services to a wide variety of terminals and supports packet data throughputs from 2.45 to 592 kbit/s.

GMR-1 3G supports spectrally efficient zero-byte header compressed voice.

GMR-1 3G is currently available as a published air interface specification from ETSI (ETSI TS 101 376) and TIA (S-J-STD-782).

5 Recommendations on unwanted emission limits from the terminals of IMT-2000 satellite systems

Unwanted emissions from the terminals of IMT-2000 satellite systems should comply with limits set in the relevant ITU-R Recommendations (e.g. for non-GSO and GSO satellite systems operating in certain bands in the range 1-3 GHz, all terminals should comply with the levels specified in Recommendations ITU-R M.1343 and ITU-R M.1480, respectively).

Annex 1

Abbreviations

3GPP	3rd Generation Partnership Project
AI	Acquisition indicator
AICH	Acquisition indicator channel
ALT	Automatic radio link transfer
AP	Access preamble
ARQ	Automatic repeat request
AS	Access slot

AVP	Attribute value pair
BCH	Broadcast channel
BCCH	Broadcast control channel
BEC	Backward error correction
BER	Bit error ratio
BPSK	Binary phase shift keying
BS	Base station
BSDT	Beam selection diversity transmission technique
CCCH	Common control channel
CCPCH	Common control physical channel
CDMA	Code division multiple access
CDP	Collision detection preamble
CLoS	Clear line of sight
CN	Core network
CPCH	Common packet channel
CPICH	Common pilot channel
CSICH	CPCH status indicator channel
CTCH	Common traffic channel
DCCH	Dedicated control channel
DPCCH	Dedicated physical control channel
DPDCH	Dedicated physical data channel
DRA	Direct radiating array
DS-CDMA	Direct spread CDMA
DSCH	Downlink shared channel
DTCH	Dedicated traffic channel
DTMF	Dual-tone multiple frequency
FACH	Forward access channel
FBI	Feedback information
FCH	Frame control header
FCCH	Frequency correction channel
FDD	Frequency division duplex
FDMA	Frequency division multiple access
FEC	Forward error correction
FER	Frame error ratio
FFT	Fast Fourier transform
FSW	Frame synchronization word

FTP	File transfer protocol
GBCH	GPS broadcast channel
GCC	Ground control centre
GERAN	GSM EDGE Radio access network
GMR-1	Geo-Mobile Radio -1
GPS	Global positioning system
HDLC	High-level data link control
HP-CCPCH	High penetrating common control physical channel
IMS	IP multimedia subsystems
IMR	Intermediate module repeater
IP	Internet protocol
IWF	Interworking functions
LDPC	Low density parity check code
LES	Land earth stations
MAC	Medium access control
MBMS	Multimedia broadcast/multicast service
MC	Multi-carrier
MES	Mobile earth station
MF	Multiframe
MOE	Minimum output energy
MRC	Maximum ratio combining
MTCH	MBMS traffic channel
MTs	Mobile terminals
NCCH	Notifications control channel
OCQPSK	Orthogonal complex QPSK
OVSF	Orthogonal variable spreading factor
PBX	Private branch exchange
PCCC	Parallel concatenated convolution code
PCH	Paging channel
PC-P	Power control preamble
PCPCH	Physical common packet channel
P-CPICH	Primary common pilot channel
PDCP	Packet data convergence protocol
PDSCH	Physical downlink shared channel
PDSCH	Physical downlink shared channel
PDSCH	Physical downlink shared control channel
PDTCH	Packet data traffic channel

PDU	Protocol data unit
PFM	Pre-compensated frequency modulation
PI-CCPCH	Pilot common control physical channel
PLMN	Public land mobile network
PRACH	Physical random access channel
PRI	Private user information
PSC	Primary sync code
PSDN	Public switched data network
PSTN	Public switched telephone network
PUI	Public user information
QoS	Quality of service
QPSK	Quadrature phase shift keying
RACH	Random access channel
RF	Radio frequency
RLC	Radio link control
RNC	Radio network controller
RNS	Radio network sub-systems
RRC	Radio resource control
RRM	Radio resource management
RTCH	Random traffic channel
S-CCPCH	Secondary common control physical channel
S-CPICH	Secondary common pilot channel
SC	Single-carrier
SCC	Satellite control centre
SCH	Synchronization channel
SCPC	Single-channel-per-carrier
SDO(s)	Standards development organization(s)
SDU	Service data unit
SF	Spreading factor
SFN	System frame number
SI	Status indicator
SIR	Signal-to-interference ratio
SIM	Subscriber identity module
SMS	Short message service
SRAN	Satellite radio access network
SRI-E	Satellite radio interface E

SS	Subscriber station
SSC	Secondary sync code
SSDT	Spot selection diversity transmission
SSTD	Beam selection transmit diversity
SW-CDMA	Satellite wideband CDMA
TDD	Time division duplex
TDMA	Time division multiple access
TFCI	Transport-format combination indicator
TPC	Transmit power control
TT&C	Telemetry, telecommand, and control
TTI	Transmission time interval
UBR	Unassured bit rate
UE	User equipment
URL	Uniform resource locator
UT	User terminal
UTRA	Universal terrestrial radio access
WCDMA	Wideband CDMA
W-C/TDMA	Wideband (hybrid) code and time-division multiple access
W-O-C/TDM	(Hybrid) wideband orthogonal CDM/TDM
W-QS-QO-C/TDMA	(Hybrid) wideband quasi-synchronous quasi-orthogonal CDMA/TDMA
