

## RECOMMENDATION ITU-R M.1457-4

**Detailed specifications of the radio interfaces of International  
Mobile Telecommunications-2000 (IMT-2000)\***

(2000-2001-2004-2005)

## CONTENTS

	<i>Page</i>
1 Introduction .....	3
2 Scope .....	3
3 Related Recommendations .....	4
4 Considerations .....	5
4.1 Radio interfaces for IMT-2000 .....	5
4.2 Incorporation of externally developed specification material .....	6
4.3 Satellite component interfaces .....	6
4.3.1 Radio interfaces .....	7
4.3.2 Other interfaces.....	8
5 Recommendations (terrestrial component) .....	9
5.1 IMT-2000 CDMA Direct Spread .....	9
5.1.1 Overview of the radio interface .....	9
5.1.2 Detailed specification of the radio interface .....	25
5.2 IMT-2000 CDMA Multi-Carrier .....	120
5.2.1 Overview of the radio interface .....	120

---

\* The recommended detailed specifications of the radio interfaces of IMT-2000 are contained in the core global specifications which form part of this Recommendation by means of references to uniform resource locators (URLs) at the ITU Web site. For those cases where recognized external organizations have converted these core global specifications or parts thereof into their own approved standards, a reference to the corresponding external text is included in this Recommendation by means of URLs at their Web sites. Such references do not give the external texts the status, as stand-alone texts, of ITU Recommendations. Any reference to an external text is accurate at the time of approval of this Recommendation. Since the external text may be revised, users of this Recommendation are advised to contact the source of the external text to determine whether the reference is still current. This Recommendation will be subject to periodic updates that will be coordinated with the appropriate recognized external organizations responsible for the external texts that are referenced.

	<i>Page</i>
5.2.2 Detailed specification of the radio interface .....	135
5.3 IMT-2000 CDMA TDD .....	156
5.3.1 Overview of the radio interface .....	156
5.3.2 Detailed specification of the radio interface .....	175
5.4 IMT-2000 TDMA Single-Carrier .....	258
5.4.1 Overview of the radio interface .....	258
5.4.2 Detailed specifications of the radio interface .....	268
5.5 IMT-2000 FDMA/TDMA .....	342
5.5.1 Overview of the radio interface .....	342
5.5.2 Detailed specification of the radio interface .....	354
6 Recommendations (satellite component) .....	358
6.1 Core network interface .....	358
6.2 Satellite/terrestrial terminal interface .....	358
6.3 Satellite radio interface specifications .....	358
6.3.1 Satellite radio interface A specifications .....	359
6.3.2 Satellite radio interface B specifications .....	371
6.3.3 Satellite radio interface C specifications .....	391
6.3.4 Satellite radio interface D (SRI-D) specifications .....	430
6.3.5 Satellite radio interface E specifications .....	444
6.3.6 Satellite radio interface F specifications .....	455
7 Recommendations on unwanted emission limits .....	467
7.1 Terrestrial radio interfaces .....	467
7.2 Satellite radio interfaces .....	467

## 1 Introduction

IMT-2000's are third generation mobile systems which are scheduled to start service around the year 2000, subject to market considerations. They will provide access, by means of one or more radio links, to a wide range of telecommunications services supported by the fixed telecommunication networks (e.g. PSTN/ISDN/Internet protocol (IP)), and to other services which are specific to mobile users.

A range of mobile terminal types is encompassed, linking to terrestrial and/or satellite-based networks, and the terminals may be designed for mobile or fixed use.

Key features of IMT-2000 are:

- high degree of commonality of design worldwide;
- compatibility of services within IMT-2000 and with the fixed networks;
- high quality;
- small terminal for worldwide use;
- worldwide roaming capability;
- capability for multimedia applications, and a wide range of services and terminals.

IMT-2000 are defined by a set of interdependent Recommendations of which this one is part of.

Recommendation ITU-R M.1455 defines the original key characteristics of the IMT-2000 radio interfaces, and represents the results of the evaluation process by the ITU-R on IMT-2000 radio interface proposals submitted to the ITU to a set of defined requirements.

This Recommendation forms the final part of the process of specifying the radio interfaces of IMT-2000, as defined in Recommendation ITU-R M.1225. It identifies the detailed specifications for the IMT-2000 radio interfaces.

This Recommendation has been developed based on consideration of the evaluation results and consensus building, continuing from the IMT-2000 key characteristics defined in Recommendation ITU-R M.1455 and recognizing the need to minimize the number of different radio interfaces and maximize their commonality, while incorporating the best possible performance capabilities in the various IMT-2000 radio operating environments.

Revisions to this Recommendation have been developed jointly by the ITU and the radio interface technology proponent organizations, global partnership projects and regional standards development organizations. Updates and enhancements to the radio interfaces incorporated in this Recommendation have undergone a defined process of development and review to ensure consistency with the original goals and objectives established for IMT-2000 while acknowledging the obligation to accommodate the changing requirements of the global marketplace.

By updating the existing technologies, harmonizing existing interfaces, and entertaining new mechanisms, IMT-2000 remains at the forefront of mobile radio technology.

## 2 Scope

This Recommendation identifies the IMT-2000 terrestrial and satellite radio interface specifications, originally based on the key characteristics identified in Recommendation ITU-R M.1455 and output of activities outside ITU.

These radio interfaces support the features and design parameters of IMT-2000, including the capability to ensure worldwide compatibility, international roaming, and access to high-speed data services.

### 3 Related Recommendations

The existing IMT-2000 Recommendations that are considered to be of importance in the development of this particular Recommendation are as follows:

- Recommendation ITU-R M.687: International Mobile Telecommunications-2000 (IMT-2000)
- Recommendation ITU-R M.816: Framework for services supported on International Mobile Telecommunications-2000 (IMT-2000)
- Recommendation ITU-R M.817: International Mobile Telecommunications-2000 (IMT-2000) – *Network architectures*
- Recommendation ITU-R M.818: Satellite operation within International Mobile Telecommunications-2000 (IMT-2000)
- Recommendation ITU-R M.819: International Mobile Telecommunications-2000 (IMT-2000) for developing countries
- Recommendation ITU-R M.1034: Requirements for the radio interface(s) for International Mobile Telecommunications-2000 (IMT-2000)
- Recommendation ITU-R M.1035: Framework for the radio interface(s) and radio sub-system functionality for International Mobile Telecommunications-2000 (IMT-2000)
- Recommendation ITU-R M.1036: Spectrum considerations for implementation of International Mobile Telecommunications-2000 (IMT-2000) in the bands 1 885-2 025 MHz and 2 110-2 200 MHz
- Recommendation ITU-R M.1167: Framework for the satellite component of International Mobile Telecommunications-2000 (IMT-2000)
- Recommendation ITU-R M.1224: Vocabulary of terms for International Mobile Telecommunications-2000 (IMT-2000)
- Recommendation ITU-R M.1225: Guidelines for evaluation of radio transmission technologies for IMT-2000
- Recommendation ITU-R M.1308: Evolution of land mobile systems towards IMT-2000
- Recommendation ITU-R M.1311: Framework for modularity and radio commonality within IMT-2000
- Recommendation ITU-R M.1343: Essential technical requirements of mobile earth stations for global non-geostationary mobile-satellite service systems in the bands 1-3 GHz
- Recommendation ITU-R M.1455: Key characteristics for the International Mobile Telecommunications (IMT-2000) radio interfaces
- Recommendation ITU-R M.1480: Essential technical requirements of mobile earth stations of geostationary mobile-satellite systems that are implementing the global mobile personal communications by satellite (GMPCS) – Memorandum of Understanding arrangements in parts of the frequency band 1-3 GHz
- Recommendation ITU-R SM.329: Spurious emissions

- ITU-T Recommendation Q.1701: Framework of IMT-2000 networks
- ITU-T Recommendation Q.1711: Network functional model for IMT-2000
- ITU-T Recommendation Q.1721: Information flows for IMT-2000 capability set 1
- ITU-T Recommendation Q.1731: Radio-technology independent requirements for IMT-2000 layer 2 radio interface
- Handbook on Land Mobile (including Wireless Access), Volume 2: Principles and Approaches on Evolution to IMT-2000/FPLMTS.

## 4 Considerations

### 4.1 Radio interfaces for IMT-2000

IMT-2000 consists of both terrestrial component and satellite component radio interfaces. All of the radio interfaces for IMT-2000 both terrestrial and satellite are fully encompassed by this Recommendation. In particular, the terrestrial radio interfaces are fully defined by information supplied within this Recommendation and by information incorporated by reference to external materials. The satellite radio interfaces are fully defined by information supplied with this Recommendation.

Recommendation ITU-R M.1455 lists the original key characteristics of all radio interface for the terrestrial component of IMT-2000. The organization of terrestrial radio interfaces within that Recommendation continues the philosophy that IMT-2000 should comprise a single terrestrial standard encompassing two high-level groupings: code division multiple access (CDMA), time division multiple access (TDMA), or a combination thereof. The CDMA grouping accommodates frequency division duplex (FDD) direct spread, FDD multi-carrier and time division duplex (TDD). The TDMA grouping accommodates FDD and TDD, single carrier and multi-carrier. These groupings satisfy the needs expressed by the global community.

Recommendation ITU-R M.1455 also lists the key characteristics of six radio interfaces for the satellite component of IMT-2000. As highlighted in that Recommendation, due to the constraints on satellite system design and deployment, several satellite radio interfaces will be required for IMT-2000 (see Recommendation ITU-R M.1167 for further considerations).

A satellite system is severely resource limited (e.g. power and spectrum limited), its radio interfaces are therefore specified primarily based on a whole system optimization process, driven by the market needs and business objectives. It is generally not technically feasible or viable from a business point-of-view to have a radio interface common to satellite and terrestrial IMT-2000 components. Nevertheless, it is desirable to achieve as much commonality as possible with the terrestrial component when designing and developing an IMT-2000 satellite system.

The strong dependency between technical design and business objectives of an IMT-2000 satellite system requires a large scope of flexibility in the satellite radio interface specifications. Future modifications and updates of these specifications may nevertheless be needed in order to adapt to changes in market demands, business objectives, technology developments, and operational needs, as well as to maximize the commonality with terrestrial IMT-2000 systems as appropriate.

The radio interfaces for the terrestrial and satellite components are described in detail in § 5 and 6, respectively.

## 4.2 Incorporation of externally developed specification material

IMT-2000 is a system with global development activity and the IMT-2000 radio interface specifications identified in this Recommendation have been developed by the ITU in collaboration with the radio interface technology proponent organizations, global partnership projects and regional standards development organizations (SDOs). The ITU has provided the global and overall framework and requirements, and has developed the core global specifications jointly with these organizations. The detailed standardization has been undertaken within the recognized external organization (see Note 1), which operate in concert with the radio interface technology proponent organizations and global partnership projects. This Recommendation therefore makes extensive use of references to externally developed specifications.

NOTE 1 – A “recognized organization” in this context is defined to be a recognized SDO that has legal capacity, a permanent secretariat, a designated representative, and open, fair, and well-documented working methods.

This approach was considered to be the most appropriate solution to enable completion of this Recommendation within the aggressive schedules set by the ITU and by the needs of administrations, operators and manufacturers.

This Recommendation has therefore been constructed to take full advantage of this method of work and to allow the global standardization time-scales to be maintained. The main body of this Recommendation has been developed by the ITU, with references within each radio interface pointing to the location of the more detailed information. The sub-sections containing this detailed information have been developed by the ITU and the recognized external organizations. Such use of referencing has enabled timely completion of the high-level elements of this Recommendation, with change control procedures, transposition (conversion of the core specifications into SDO deliverables) and public enquiry procedures being undertaken within the recognized external organization.

The structure of the detailed specifications received from the recognized external organization has generally been adopted unchanged, recognizing the need to minimize duplication of work, and the need to facilitate and support an on-going maintenance and update process.

This general agreement, that the detailed specifications of the radio interface should to a large extent be achieved by reference to the work of recognized external organizations, highlights not only the ITU's significant role as a catalyst in stimulating, coordinating and facilitating the development of advanced telecommunications technologies, but also its forward-looking and flexible approach to the development of this and other telecommunications standards for the 21st century.

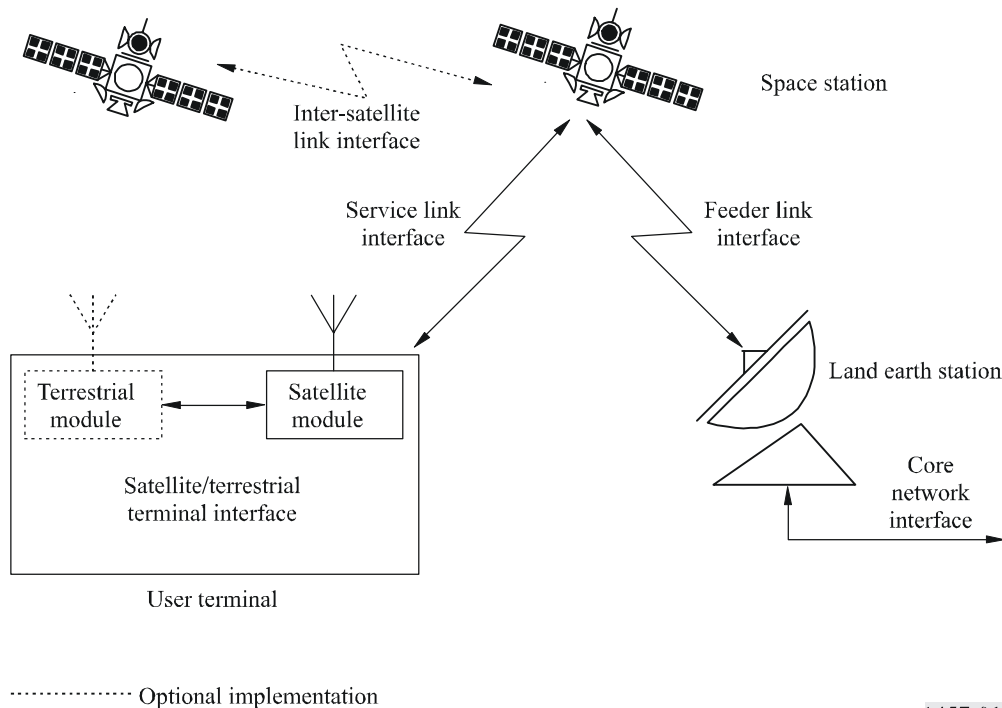
## 4.3 Satellite component interfaces

The terrestrial and satellite components are complementary, with the terrestrial component providing coverage over areas of land mass with population density considered to be large enough for economic provision of terrestrially-based systems, and the satellite component providing service elsewhere by a virtually global coverage. The ubiquitous coverage of IMT-2000 can only therefore be realized using a combination of satellite and terrestrial radio interfaces.

To fulfil the scope given in § 2, this Recommendation describes those elements needed for worldwide compatibility of operation noting that international use is inherently ensured through the global coverage of a satellite system. This description includes consideration of all the satellite component interfaces.

Figure 1, which has been developed from Fig. 1 of Recommendation ITU-R M.818, shows the various interfaces in the IMT-2000 satellite component.

FIGURE 1  
Interfaces in the satellite component of IMT-2000



1457-01

### 4.3.1 Radio interfaces

#### 4.3.1.1 Service link interface

The service link interface is the radio interface between a mobile earth station (MES) (the satellite module of a user terminal (UT)) and a space station.

#### 4.3.1.2 Feeder link interface

The feeder link interface is the radio interface between space stations and land earth stations (LESs). Feeder links are analogous to the radio interfaces used on back-haul fixed links to carry traffic to/from terrestrial base stations (BSs). When designing a satellite system, system specific implementations for feeder links result since:

- feeder links can operate in any of a number of frequency bands, which are outside those bands identified for IMT-2000;
- each individual feeder link presents its own issues, some of which are related to satellite system architecture, while others are related to the frequency band of operation.

The feeder link interface is therefore largely an intra-system specification, and can be viewed as an implementation issue. This has been addressed in Recommendation ITU-R M.1167, which states that “The radio interfaces between the satellites and the LESs (i.e. the feeder links) are not subject to IMT-2000 standardization”. The specification of this interface is therefore outside the scope of this Recommendation.

#### 4.3.1.3 Inter-satellite link interface

The inter-satellite link interface is the interface between two space stations, noting that some systems may not implement this interface. The issues discussed above under feeder link interface are also applicable here, and the inter-satellite link interface is therefore largely an intra-system

specification, and can be viewed as an implementation issue. The specification of this interface is therefore outside the scope of this Recommendation.

### 4.3.2 Other interfaces

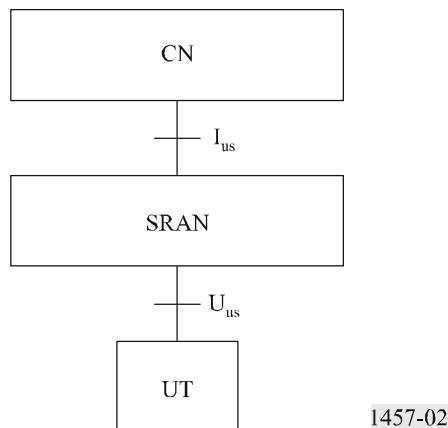
It is recognized that the core network (CN) and satellite/terrestrial terminal interfaces described below are not radio interfaces. However, it is also recognized that they have a direct impact on the design and specification of satellite radio interfaces and on the worldwide compatibility of operation. Other IMT-2000 Recommendations also make reference to these interfaces.

#### 4.3.2.1 CN interface

The CN interface is the interface between the radio access part of a LES and the CN.

The following describes one possible architecture for the satellite component to interface to the CN, as shown in Fig. 2. This architecture would provide some compatibility with the terrestrial component. In this example, the CN interface for the satellite component is called the  $I_{us}$ . The  $I_{us}$  interface performs similar functions as the  $I_u$  interface described in § 5.1 and 5.3, and will be designed to achieve as much commonality as possible with the  $I_u$  interface, so as to be compatible with the  $I_u$  interface.

FIGURE 2  
Example of a satellite network interface architecture



The satellite radio access network (SRAN) consists of the LES and the satellite, together with the feeder link and inter-satellite links (if any). The SRAN uses the  $I_{us}$  interface for communicating with the CN and  $U_{us}$  interface for communicating with the UT for satellite service provision. The  $U_{us}$  interface is the satellite service link radio interface which is specified in § 6.3.

Since the satellite component of IMT-2000 is generally global in nature, it is not necessary to provide an interface from the SRAN of one satellite network to the SRAN of another satellite network. Also, the interface between LESs of the same satellite network is an internal implementation issue of the satellite network, thus there is no need for standardization of this interface.

#### 4.3.2.2 Satellite/terrestrial terminal interface

The satellite/terrestrial terminal interface is the interface between the satellite and terrestrial modules within a user terminal. For terminals incorporating both the satellite and terrestrial components of IMT-2000, there is a requirement to identify both how the two components operate together and any interfacing necessary between them.



For example, Recommendation ITU-R M.818 highlights “that a protocol be developed to establish whether a terrestrial or satellite component should be used for a given call”. Recommendation ITU-R M.1167 also recognizes that “An IMT-2000 user should not necessarily need to request the terminal to access the satellite or the terrestrial component” and also that “In order to facilitate roaming, it is important that the user can be reached by dialling a single number, regardless of whether the mobile terminal is accessing the terrestrial or the satellite component at the time”.

## **5 Recommendations (terrestrial component)**

The Radiocommunication Assembly recommends that the radio interfaces given in § 5.1 to 5.5 should be those of the terrestrial component of IMT-2000.

The organization of terrestrial radio interfaces within this Recommendation continues the philosophy that IMT-2000 should comprise a single terrestrial standard encompassing two high-level groupings: CDMA, TDMA, or a combination thereof. The CDMA grouping accommodates FDD direct spread, FDD multi-carrier and TDD. The TDMA grouping accommodates FDD and TDD, single carrier and multi-carrier. These groupings satisfy the needs expressed by the global community.

The terrestrial radio interface sections are identified as:

- IMT-2000 CDMA Direct Spread
- IMT-2000 CDMA Multi-Carrier
- IMT-2000 CDMA TDD
- IMT-2000 TDMA Single-Carrier
- IMT-2000 FDMA/TDMA.

An overview of each radio interface is provided in § 5.1.1, 5.2.1, 5.3.1, 5.4.1, and 5.5.1.

The detailed information provided and/or referenced in § 5.1.2, 5.2.2, 5.3.2, 5.4.2, and 5.5.2 is recommended as the complete definition of the radio interfaces of the terrestrial component of IMT-2000.

### **5.1 IMT-2000 CDMA Direct Spread**

#### **5.1.1 Overview of the radio interface**

##### **5.1.1.1 Introduction**

The IMT-2000 radio-interface specifications for CDMA Direct Spread technology are developed by a partnership of SDOs (see Note 1). This radio interface is called Universal Terrestrial Radio Access (UTRA) FDD or Wideband CDMA (WCDMA).

NOTE 1 – Currently, these specifications are developed within the third generation partnership project (3GPP) where the participating SDOs are the Association of Radio Industries and Businesses (ARIB), China Communications Standards Association (CCSA), the European Telecommunications Standards Institute (ETSI), T1 (Alliance for Telecommunications Industry Solutions (ATIS) Standards Committee T1), Telecommunications Technology Association (TTA) and Telecommunication Technology Committee (TTC).

These radio-interface specifications have been developed with the strong objective of harmonization with the TDD component (see § 5.3) to achieve maximum commonality. This was achieved by harmonization of important parameters of the physical layer. Furthermore, a common set of protocols in the higher layers is specified for both FDD and TDD.

In the development of this radio interface the CN specifications are based on an evolved GSM-MAP. However, the specifications include the necessary capabilities for operation with an evolved ANSI-41-based CN.

The radio-access scheme is Direct-Sequence CDMA (DS-SS) with information spread over approximately 5 MHz bandwidth using a chip rate of 3.84 Mchip/s. The radio interface is defined to carry a wide range of services to efficiently support both circuit-switched services (e.g. PSTN- and ISDN-based networks) as well as packet-switched services (e.g. IP-based networks). A flexible radio protocol has been designed where several different services such as speech, data and multimedia can simultaneously be used by a user and multiplexed on a single carrier. The defined radio-bearer services provide support for both real-time and non-real-time services by employing transparent and/or non-transparent data transport. The quality of service (QoS) can be adjusted in terms such as delay, bit error probability, and frame error ratio (FER).

The radio-interface specification includes enhanced features for High-Speed Downlink Packet Access (HSDPA), allowing for downlink packet-data transmission with peak data rates exceeding 8 Mbit/s and simultaneous high-speed packet data and other services such as speech on the single carrier.

CDMA Direct Spread was originally specified for the IMT-2000 core bands identified in WARC-92 and using 1 920-1 980 MHz as uplink and 2 110-2 170 MHz as downlink. At WRC-2000 additional spectrum for IMT-2000 was identified and subsequently as a complement to 3GPP Release 99 the relevant specifications have been updated to also include the 1 900 MHz, 1 800 MHz, 850 MHz, and 800 MHz bands as well as a pairing of parts, or whole, of 1 710-1 770 MHz as uplink with whole, or parts, of 2 110-2 170 MHz as downlink. In addition a more general study has been performed considering the viable deployment of CDMA Direct Spread in additional and diverse spectrum arrangements.

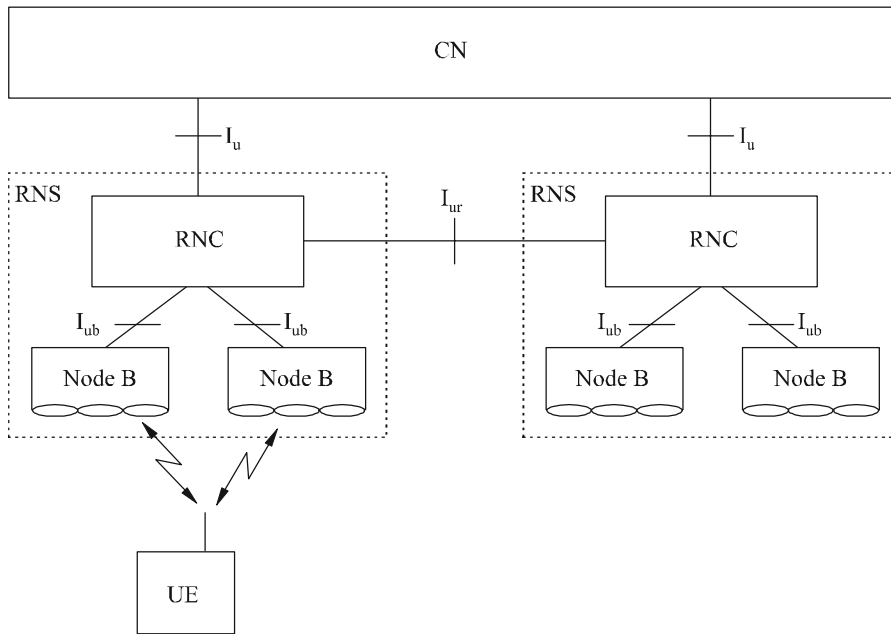
### 5.1.1.2 Radio access network architecture

The overall architecture of the radio access network is shown in Fig. 3.

The architecture of this radio interface consists of a set of radio network subsystems (RNS) connected to the CN through the  $I_u$  interface. An RNS consists of a radio network controller (RNC) and one or more entities called Node B. Node B is connected to the RNC through the  $I_{ub}$  interface. Each Node B can handle one or more cells. The RNC is responsible for the handover decisions that require signalling to the user equipment (UE). In case macro diversity between different Node Bs is to be supported, the RNC comprises a combining/splitting function to support this. Node B can comprise an optional combining/splitting function to support macro diversity within a Node B. The RNCs of the RNS can be interconnected through the  $I_{ur}$  interface.  $I_u$  and  $I_{ur}$  are logical interfaces, i.e. the  $I_{ur}$  interface can be conveyed over a direct physical connection between RNCs or via any suitable transport network.

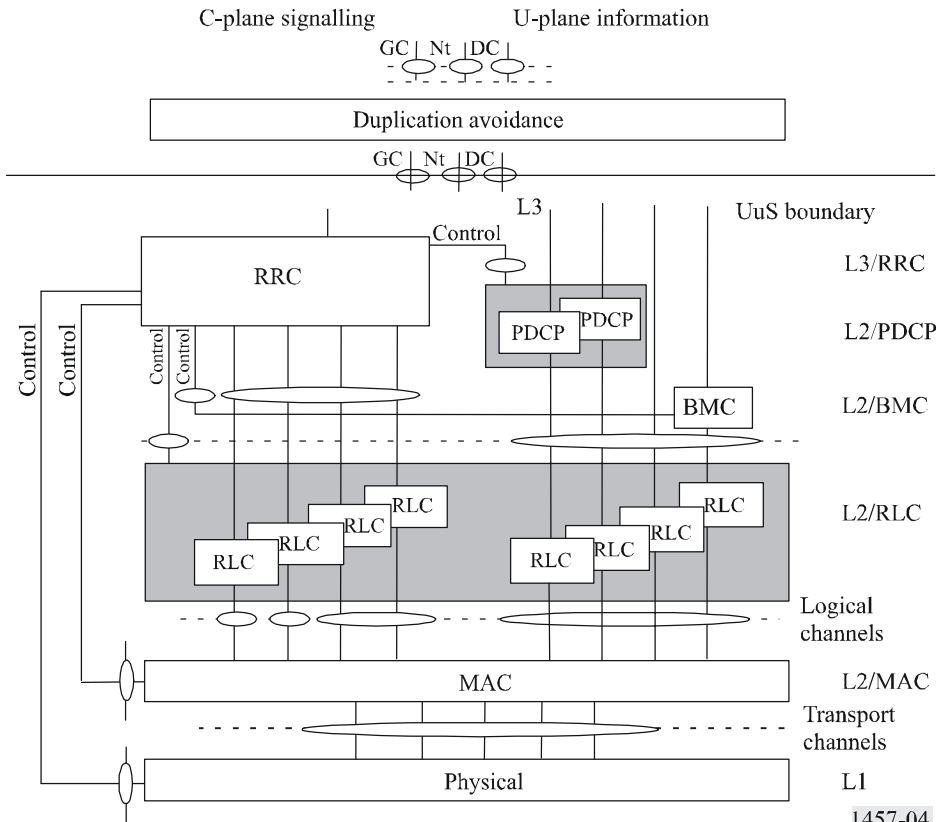
Figure 4 shows the radio interface protocol architecture for the radio access network. On a general level, the protocol architecture is similar to the current ITU-R protocol architecture as described in Recommendation ITU-R M.1035. Layer 2 (L2) is split into the following sub-layers; radio link control (RLC), medium access control (MAC), Packet Data Convergence Protocol (PDCP) and Broadcast/Multicast Control (BMC). Layer 3 (L3) and RLC are divided into control (C-plane) and user (U-plane) planes. In the C-plane, L3 is partitioned into sub-layers where the lowest sub-layer, denoted as radio resource control (RRC), interfaces with L2. The higher-layer signalling such as mobility management (MM) and call control (CC) are assumed to belong to the CN. There are no L3 elements in this radio interface for the U-plane.

FIGURE 3  
Radio access network architecture  
(Cells are indicated by ellipses)



1457-03

FIGURE 4  
Radio interface protocol architecture of the RRC sublayer (L2 and L1)



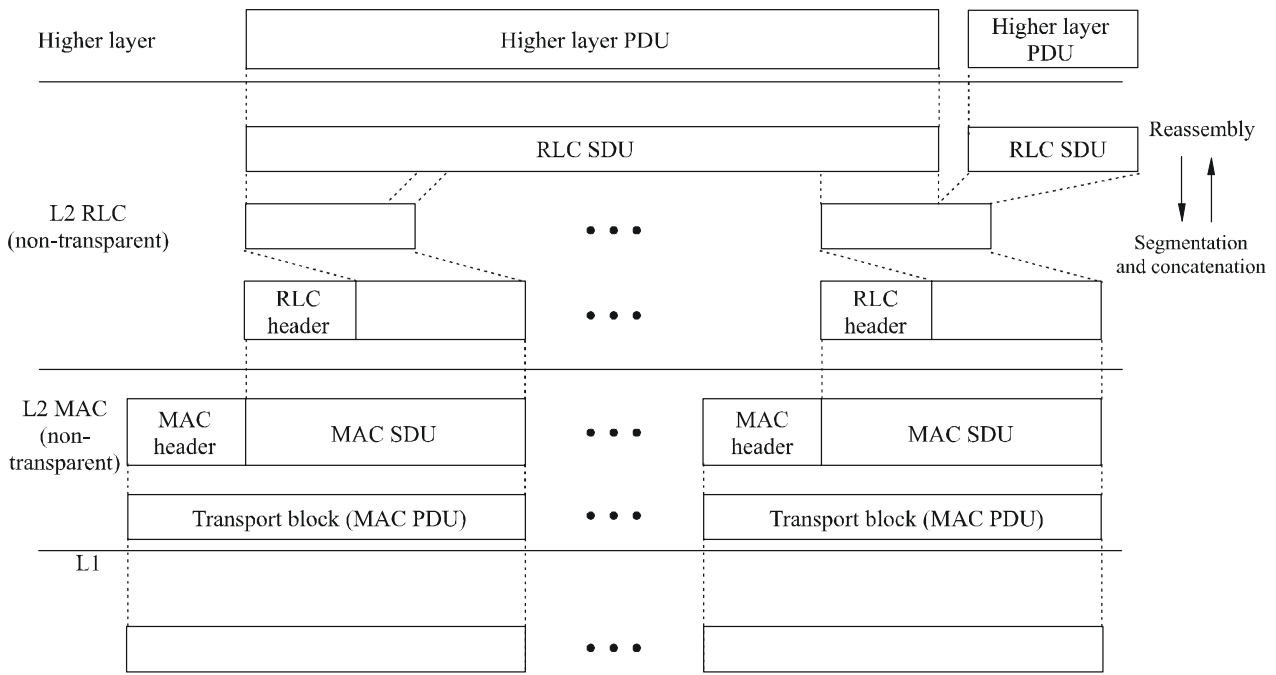
1457-04

Each block in Fig. 4 represents an instance of the respective protocol. Service access points (SAPs) for peer-to-peer communication are marked with circles at the interface between sub-layers. The SAP between MAC and the physical layer provides the transport channels. A transport channel is characterized by how the information is transferred over the radio interface (see § 5.1.1.3.1 for an overview of the types of transport channels defined). The SAPs between RLC and the MAC sub-layer provide the logical channels. A logical channel is characterized by the type of information that is transferred over the radio interface. The logical channels are divided into control channels and traffic channels. The different types of logical channels are not further described in this overview. In the C-plane, the interface between RRC and higher L3 sub-layers (CC, MM) is defined by the general control (GC), notification (Nt) and dedicated control (DC) SAPs. These SAPs are not further discussed in this overview.

Also shown in Fig. 4 are connections between RRC and MAC as well as RRC and L1 providing local inter-layer control services (including measurement results). An equivalent control interface exists between RRC and the RLC sub-layer. These interfaces allow the RRC to control the configuration of the lower layers. For this purpose separate control SAPs are defined between RRC and each lower layer (RLC, MAC, and L1).

Figure 5 shows the general structure and some additional terminology definitions of the channel formats at the various sub-layer interfaces indicated in Fig. 4. The Figure indicates how higher layer service data units (SDUs) and protocol data units (PDUs) are segmented and multiplexed to transport blocks to be further treated by the physical layer (e.g. CRC handling). The transmission chain of the physical layer is exemplified in the next section.

FIGURE 5  
**Data flow for a service using a non-transparent RLC and non-transparent MAC**  
 (see § 5.1.1.4.1 and 5.1.1.4.2 for further definitions of the MAC and RLC services and functionality)



### 5.1.1.3 Physical layer

#### 5.1.1.3.1 Transport Channels

Transport channels are the services offered by the physical layer to MAC and higher layers. The general classification of transport channels is into two groups:

- Common transport channels where there is a need for explicit UE identification when a particular UE is addressed or a particular group of UEs are addressed.
- Dedicated transport channels where a UE is implicitly identified by the physical channel, i.e. code and frequency.

Common transport channel types are:

- **Random Access Channel (RACH)**  
A contention based uplink channel used for transmission of relatively small amounts of data, e.g. for initial access or non-real-time dedicated control or traffic data.
- **Common Packet Channel (CPCH)**  
A contention based uplink channel used for transmission of bursty data traffic. The common packet channel is shared by the UEs in a cell and therefore, it is a common resource. The CPCH is fast power controlled.
- **Forward Access Channel (FACH)**  
A common downlink channel without closed-loop power control used for transmission of relatively small amount of data.
- **Downlink Shared Channel (DSCH)**  
A downlink channel shared by several UEs carrying dedicated control or traffic data.
- **High-speed Downlink Shared Channel (HS-DSCH)**  
A downlink channel served by several UEs carrying dedicated control or traffic data. HS-DSCH offers the possibility for high-speed downlink packet access through the support of higher-order modulation, adaptive modulation and coding, fast channel-dependent scheduling, and hybrid ARQ with soft combining.
- **Broadcast Channel (BCH)**  
A downlink channel used for broadcast of system information into an entire cell.
- **Paging Channel (PCH)**  
A downlink channel used for broadcast of control information into an entire cell allowing efficient UE sleep mode procedures. Currently identified information types are paging and notification. Another use could be UTRAN notification of change of BCCH information.

Dedicated transport channel types are:

- **Dedicated Channel (DCH)**  
A channel dedicated to one UE used in uplink or downlink.

On each transport channel, a number of *Transport Blocks* are delivered to/from the physical layer once every *Transmission Time Interval* (TTI). To each transport channel, there is an associated *Transport Format* or set of transport formats. The transport format describes the physical properties of the transport channel, such as the TTI, the number of transport blocks per TTI, the number of bits per transport blocks, the coding scheme and coding rate, and the modulation scheme.

### 5.1.1.3.2 Physical layer functionality and building blocks

The physical layer includes the following functionality:

- error detection on transport channels and indication to higher layers;
- forward error correction (FEC) encoding/decoding of transport channels;
- multiplexing of transport channels and demultiplexing of coded composite transport channels;
- rate matching;
- mapping of coded composite transport channels on physical channels;
- data modulation and demodulation of physical channels;
- spreading and de-spreading of physical channels;
- radio characteristics measurements including FER, Signal-to-Interference (SIR), Interference Power Level, etc., and indication to higher layers;
- frequency and time (chip, bit, slot, frame) synchronization;
- power weighting and combining of physical channels;
- closed-loop power control;
- RF processing;
- support of UE positioning methods;
- beamforming;
- macro-diversity distribution/combining and soft handover execution.

Figure 6 gives the physical layer transmission chain for the DCH transport channel. The Figure shows how several transport channels can be multiplexed onto one or more dedicated physical data channels (DPDCH).

The cyclic redundancy check (CRC) provides for error detection of the transport blocks for the particular transport channel. The CRC can take the length zero (no CRC), 8, 12, 16 or 24 bits depending on the service requirements.

The transport block concatenation and code block segmentation functionality performs serial concatenation of those transport blocks that will be sent in one transmission time interval and any code block segmentation if necessary.

The types of channel coding defined are convolutional coding, turbo coding and no coding. Real-time services use only FEC encoding while non-real-time services uses a combination of FEC and ARQ. The ARQ functionality resides in the RLC sub-layer of Layer 2. The convolutional coding rates are 1/2 or 1/3 while the rate is 1/3 for turbo codes. The possible interleaving depths are 10, 20, 40 or 80 ms.

The radio frame segmentation performs padding of bits. The rate matching adapts any remaining differences of the bit rate so the number of outgoing bits fit to the available bit rates of the physical channels. Repetition coding and/or puncturing is used for this purpose.

The transport channel multiplexing stage combines transport channels in a serial fashion. This is done every 10 ms. The output of this operation is also called coded composite transport channels.

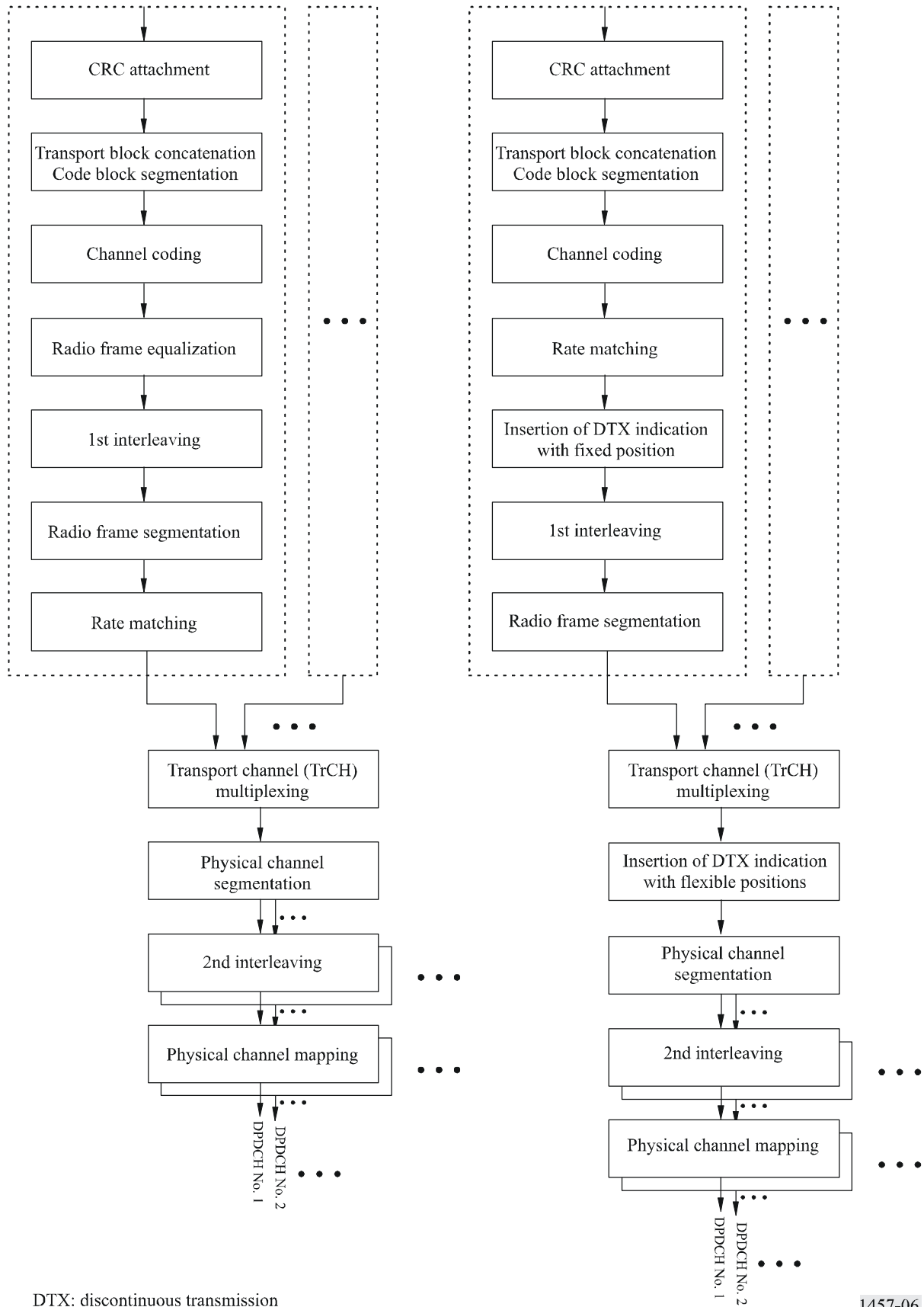
If several physical channels will be used to transmit the data, the split is made in the physical channel segmentation unit.

The downlink can use DTX on a slot-to-slot basis for variable rate transmission. The insertions could either be at fixed or at flexible positions.

For other transport-channel types, the physical-layer transmission chain is similar although not necessarily identical to that of DCH in Fig. 6.

FIGURE 6

DCH transport channel multiplexing structure (left: uplink; right: downlink)

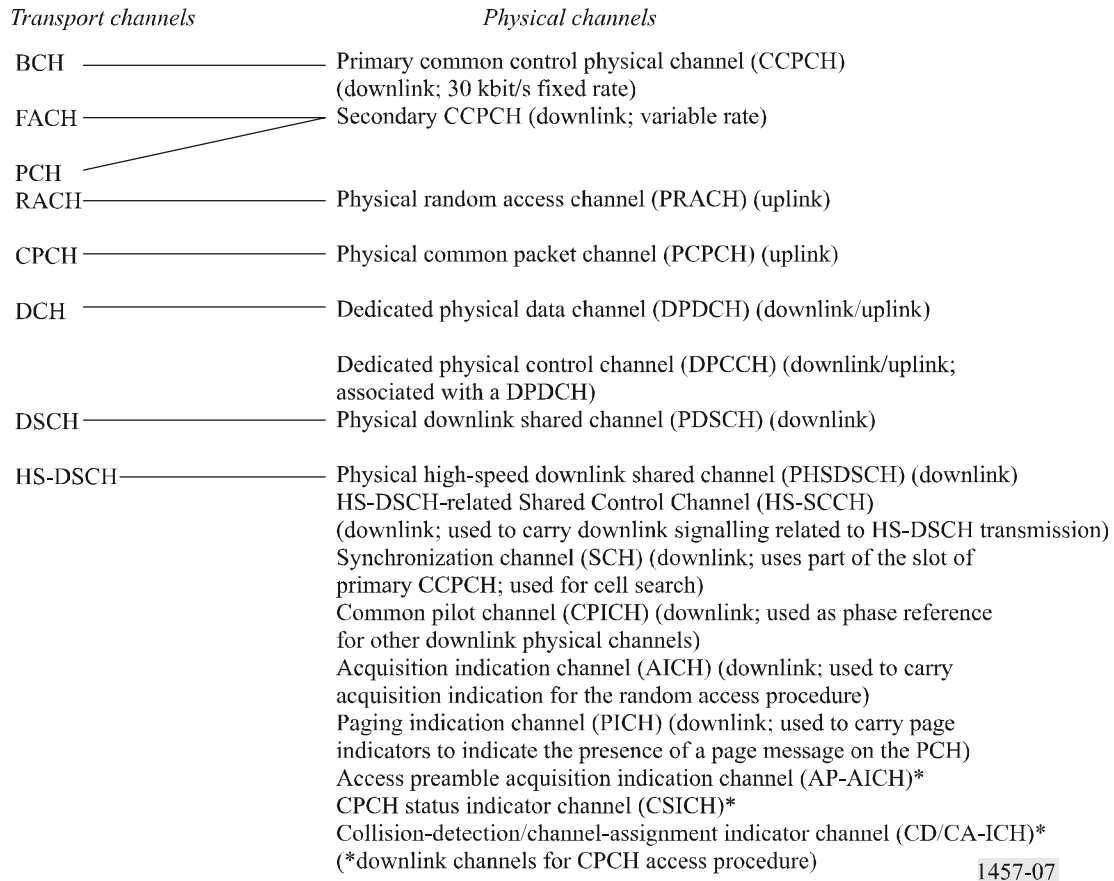


DTX: discontinuous transmission

**5.1.1.3.3 Transport channels to physical channel mapping**

The transport channels are mapped onto the physical channels. Figure 7 shows the different physical channels and summarizes the mapping of transport channels onto physical channels. Each physical channel has its tailored slot content. The slot content for the uplink and downlink DPDCH/DPCCH, on to which the uplink and downlink DCH is mapped, is shown in § 5.1.1.3.4.

FIGURE 7  
**Transport channels, physical channels and their mapping**

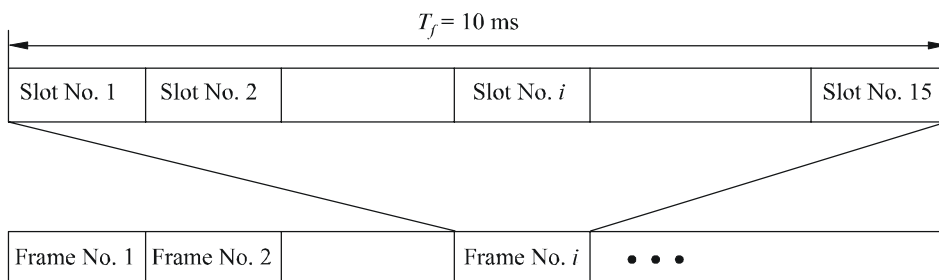


1457-07

**5.1.1.3.4 Physical frame structure**

The basic physical frame rate is 10 ms with 15 slots. Figure 8 shows the frame structure.

FIGURE 8  
**Basic frame structure**

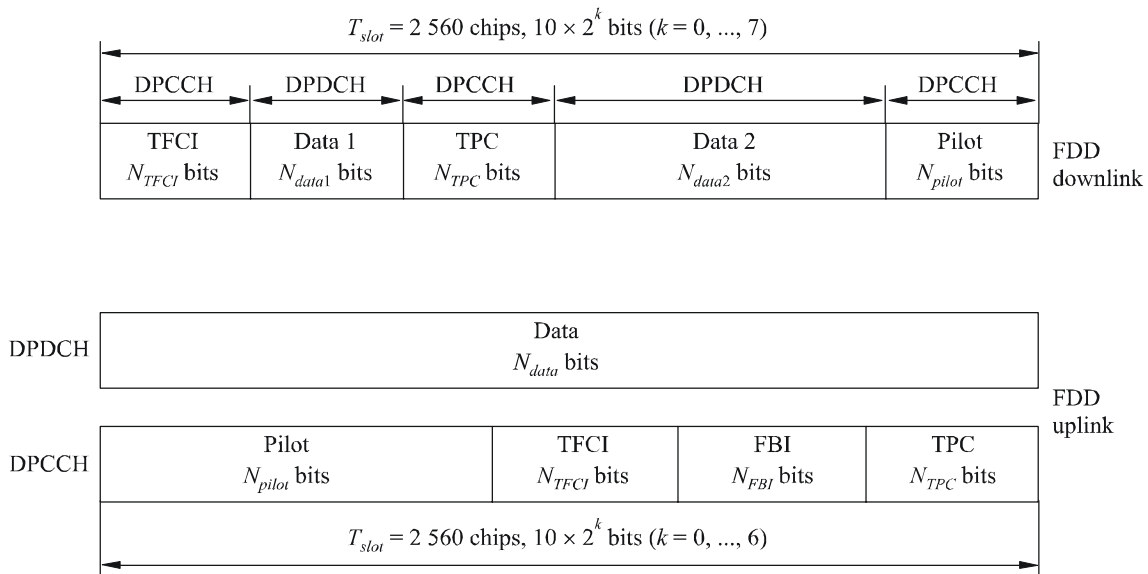


1457-08



Figure 9 shows the content for a slot used by the DCH. The uplink physical channels DPDCH and DPCCH are I/Q multiplexed while the downlink channels are time multiplexed. The DPDCH, the channel where the user data is transmitted on, is always associated with a DPCCH containing Layer 1 control information. The transport format combination indicator (TFCI) field is used for indicating the demultiplexing scheme of the data stream. The TFCI field does not exist for combinations that are static (i.e. fixed bit rate allocations) or blind transport format detection is employed. The feedback information (FBI) field is used for transmit and site diversity functions. The transmit power control (TPC) bits are used for power control.

FIGURE 9  
Slot content for the DPDCH/DPCCH



1457-09

For the uplink, the DPDCH bit rate can vary between 15 up to 960 kbit/s using spreading factors (SFs) (256 down to 4). To obtain higher bit rates for a user several physical channels can be used. The bit rate of the DPCCH is fixed to 15 kbit/s. For the downlink the DPDCH bit rate is variable between 15 up to 1 920 kbit/s with a SF ranging from 512 down to 4. Note that the symbol bit rate is equal to the channel bit rate for the uplink while it is half of the channel bit rate for the downlink.

A CPICH is defined. It is an unmodulated downlink channel, that is the phase reference for other downlink physical channels. There is always one primary CPICH in each cell. There may also be additional secondary CPICHs in a cell.

To be able to support inter-frequency handover as well as measurements on other carrier frequencies or carriers of other systems, like GSM, a compressed mode of operation is defined. The function is implemented by having some slots empty, but without deleting any user data. Instead the user data is transmitted in the remaining slots. The number of slots that is not used can be variable with a minimum of three slots (giving minimum idle lengths of at least 1.73 ms). The slots can be empty either in the middle of a frame or at the end and in the beginning of the consecutive frame. If and how often is controlled by the RRC functionality in Layer 3.

### 5.1.1.3.5 Spreading, modulation and pulse shaping

#### Uplink

Spreading consists of two operations. The first is the channelization operation, which transforms every data symbol into a number of chips, thus increasing the bandwidth of the signal. The number of chips per data symbol is called the SF. The second operation is the scrambling operation, where a scrambling code is applied to the spread signal.

In the channelization operation, data symbol on so-called I- and Q-branches are independently multiplied with a code. The channelization codes are orthogonal variable spreading factor (OVSF) codes that preserve the orthogonality between a user's different physical channels. With the scrambling operation, the resultant signals on the I and Q branches are further multiplied by complex-valued scrambling code, where I and Q denote real and imaginary parts, respectively. Note that before complex multiplication binary values 0 and 1 are mapped to +1 and -1, respectively. Figure 10 illustrates the spreading and modulation for the case of multiple uplink DPDCHs. Note that this Figure only shows the principle, and does not necessarily describe an actual implementation. Modulation is dual-channel QPSK (i.e. separate BPSK on I and Q channels), where the uplink DPDCH and DPCCH are mapped to the I and Q branches respectively. The I and Q branches are then spread to the chip rate with two different channelization codes and subsequently complex scrambled by a UE specific complex scrambling code  $C_{\text{scramb}}$ . There are  $2^{24}$  uplink-scrambling codes. Either short (256 chips from the family of S(2) codes) or long (38 400 chips equal to one frame length, gold code-based) scrambling codes is used on the uplink. The short scrambling code is typically used in cells where the BS is equipped with an advanced receiver, such as a multi-user detector or interference canceller whereas the long codes gives better interference averaging properties.

The pulse-shaping filters are root-raised cosine with roll-off  $\alpha = 0.22$  in the frequency domain.

The modulation of both DPCCH and DPDCH is BPSK. The modulated DPCCH is mapped to the Q branch, while the first DPDCH is mapped to the I branch. Subsequently added DPDCHs are mapped alternatively to the I- or Q-branches.

#### Downlink

Figure 11 illustrates the spreading and modulation for the downlink DPDCH/DPCCH. Data modulation is QPSK where each pair of two bits are serial-to-parallel (S/P) converted and mapped to the I and Q branches respectively. The I and Q branches are then spread to the chip rate with the same channelization code  $C_{\text{ch}}$  (real spreading) and subsequently scrambled by the scrambling code  $C_{\text{scramb}}$  (complex scrambling).

The channelization codes are the same codes as used in the uplink that preserve the orthogonality between downlink channels of different rates and SFs. There are a total of  $512 \times 512 = 262\,144$  scrambling codes, numbered 0 to 262 143. The scrambling codes are divided into 512 sets each of a primary scrambling code and 511 secondary scrambling codes. Each cell is allocated one and only one primary scrambling code. The primary CCPCH is always transmitted using the primary scrambling code. The other downlink physical channels can be transmitted with either the primary scrambling code or a secondary scrambling code from the set associated with the primary scrambling code of the cell.

The pulse-shaping filters are root-raised cosine with roll-off  $\alpha = 0.22$  in the frequency domain.

Downlink spreading for downlink physical channels other than the downlink DPCH is very similar. For the physical channel to which HS-DSCH is mapped, higher-order data modulation can be used in addition to QPSK.

FIGURE 10  
Spreading/modulation for uplink DPDCH/DPCCH

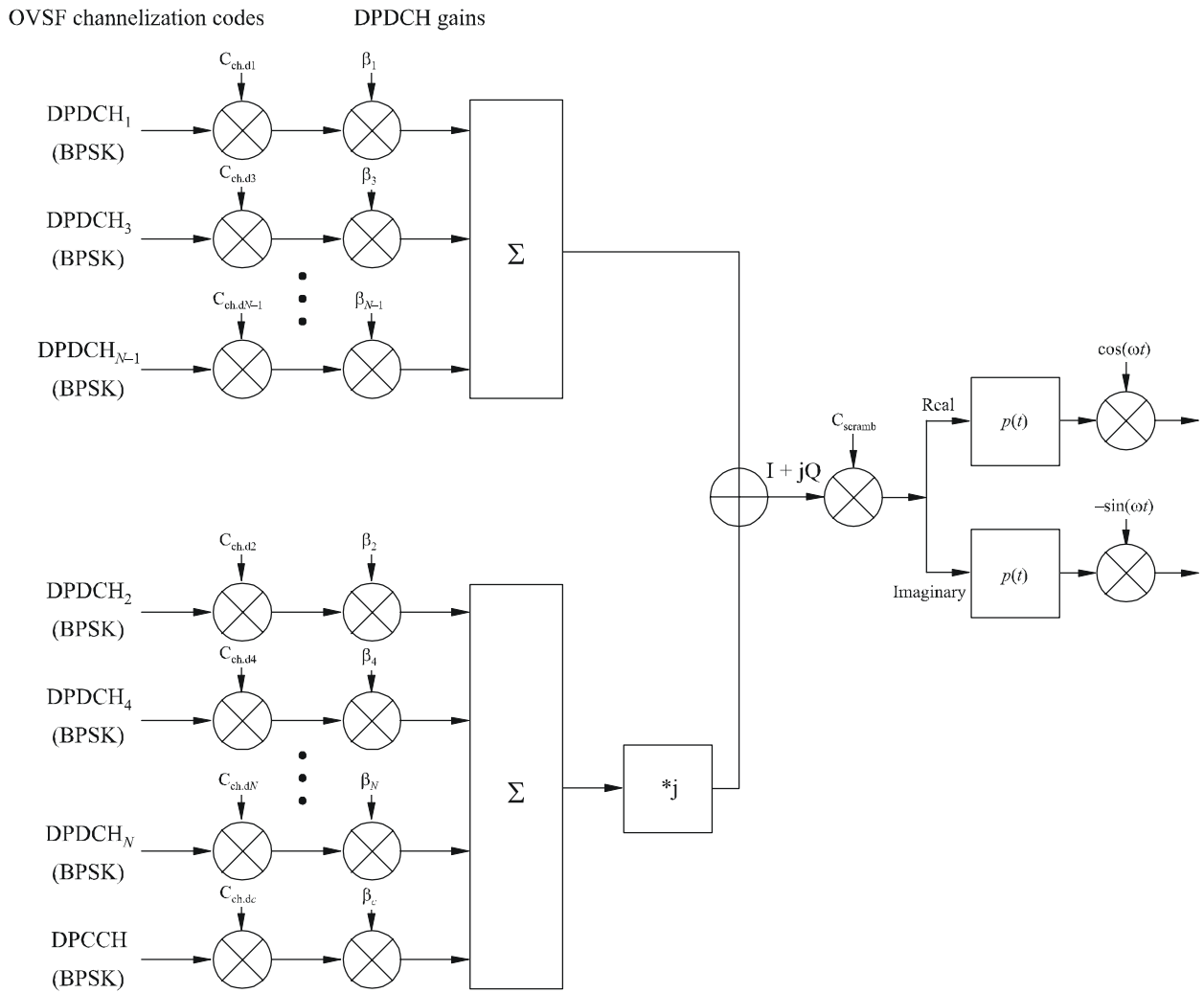
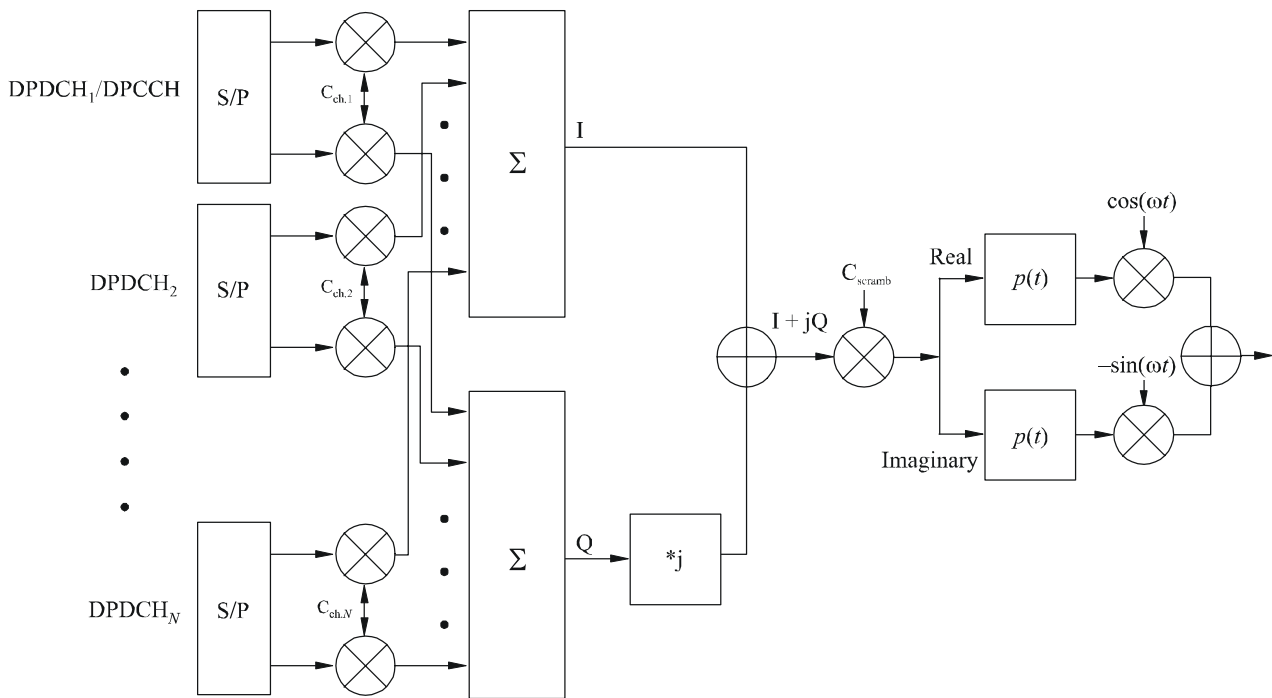


FIGURE 11  
Spreading/modulation for downlink DPDCH/DPCCH



1457-11

#### 5.1.1.4 Layer 2

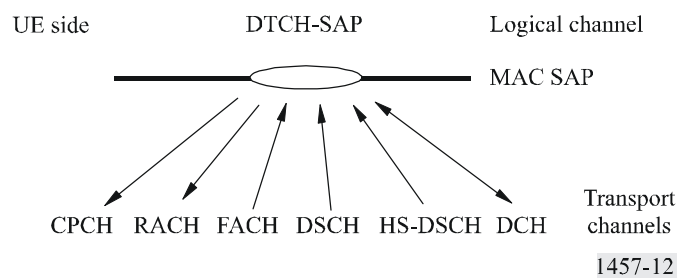
##### 5.1.1.4.1 MAC sub-layer

The MAC sub-layer is responsible for the handling of the data streams coming from the RLC and RRC sub-layers. It provides an unacknowledged transfer mode service to the upper layers. The interface to the RLC sub-layer is through logical channel service access points. It also re-allocates radio resources on request by the RRC sub-layer as well as provides measurements to the upper layers. The logical channels are divided into control channels and traffic channels. Thus, the functionality handles issues like:

- mapping of the different logical channels to the appropriate transport channels and selection of appropriate transport format for the transport channels based on the instantaneous source bit rate, and optimization of the HS-DSCH transport channel;
- multiplexing/demultiplexing of the PDUs to/from transport blocks which are thereafter further treated by the physical layer;
- dynamic switching between common and dedicated transport channels based on information from the RRC sub-layer;
- priority issues for services to one UE according to information from higher layers and physical layer (e.g. available transmit power level) as well as priority handling between UEs by means of dynamic scheduling in order to increase spectrum efficiency;
- monitoring of traffic volume that can be used by the RRC sub-layer;
- hybrid ARQ with soft combining in case of the HS-DSCH transport channel.

Figure 12 shows the possibilities of mapping the logical dedicated traffic channel (DTCH) onto transport channels. There are possibilities to map onto common transport channels as well as dedicated transport channels. The choice of mapping could be determined on e.g. the DTCH traffic intensity.

FIGURE 12  
Possible transport channel mappings of the dedicated traffic channel (DTCH)  
(The arrows show the direction of the channel (UE side).  
The directions are reversed from the network side)



#### 5.1.1.4.2 RLC sub-layer

The RLC sub-layer provides three different types of data transfer modes:

- *Transparent data transfer.* This service transmits higher layer PDUs without adding any protocol information, possibly including segmentation/reassemble functionality.
- *Unacknowledged data transfer.* This service transmits higher layer PDUs without guaranteeing delivery to the peer entity. The unacknowledged data transfer mode has the following characteristics:
  - a) detection of erroneous data: The RLC sub-layer shall deliver only those SDUs to the receiving higher layer that are free of transmission errors by using the sequence-number check function;
  - b) unique delivery: The RLC sub-layer shall deliver each SDU only once to the receiving upper layer using duplication detection function;
  - c) immediate delivery: The receiving RLC sub-layer entity shall deliver a SDU to the higher layer receiving entity as soon as it arrives at the receiver.
- *Acknowledged data transfer.* This service transmits higher layer PDUs and guarantees delivery to the peer entity. In case RLC is unable to deliver the data correctly, the user of RLC at the transmitting side is notified. For this service, both in-sequence and out-of-sequence delivery are supported. In many cases a higher layer protocol can restore the order of its PDUs. As long as the out-of-sequence properties of the lower layer are known and controlled (i.e. the higher layer protocol will not immediately request retransmission of a missing PDU) allowing out-of-sequence delivery can save memory space in the receiving RLC. The acknowledged data transfer mode has the following characteristics:
  - a) error-free delivery: error-free delivery is ensured by means of retransmission. The receiving RLC entity delivers only error-free SDUs to the higher layer;

- b) unique delivery: the RLC sub-layer shall deliver each SDU only once to the receiving upper layer using duplication detection function;
- c) in-sequence delivery: RLC sub-layer shall provide support for in-order delivery of SDUs, i.e. RLC sub-layer should deliver SDUs to the receiving higher layer entity in the same order as the transmitting higher layer entity submits them to the RLC sub-layer;
- d) out-of-sequence delivery: alternatively to in-sequence delivery, it shall also be possible to allow that the receiving RLC entity delivers SDUs to higher layer in different order than submitted to RLC sub-layer at the transmitting side.

It also provides for RLC connection establishment/release. As well as QoS setting and notification to higher layers in case of unrecoverable errors.

An example of the data flow for non-transparent (acknowledged/unacknowledged) data transfer is shown in Fig. 5.

#### 5.1.1.4.3 PDCP sub-layer

PDCP provides transmission and reception of Network PDUs in acknowledged, unacknowledged and transparent RLC mode.

It is responsible for the mapping of Network PDUs from one network protocol to one RLC entity and it provides compression in the transmitting entity and decompression in the receiving entity of redundant Network PDU control information (header compression/decompression).

#### 5.1.1.4.4 BMC sub-layer

The BMC provides a broadcast/multicast transmission service in the user plane on the radio interface for common user data in transparent or unacknowledged mode.

It can handle functionalities such as storage, scheduling and transmission of BMC messages.

#### 5.1.1.5 Layer 3 (RRC sub-layer)

The RRC sub-layer handles the control plane signalling of Layer 3 between the UEs and the radio interface. In addition to the relation with the upper layers (such as CN) the following main functions are performed:

- *Broadcast of information provided by the non-access stratum (CN)* – The RRC layer performs system information broadcasting from the network to all UEs. The system information is normally repeated on a regular basis. This function supports broadcast of higher layer (above RRC) information. This information may be cell specific or not. As an example RRC may broadcast CN location service area information related to some specific cells.
- *Broadcast of information related to the access stratum* – The RRC layer performs system information broadcasting from the network to all UEs. This function supports broadcast of typically cell-specific information.
- *Establishment, maintenance and release of an RRC connection between the UE and the radio access network* – The establishment of an RRC connection is initiated by a request from higher layers at the UE side to establish the first signalling connection for the UE. The establishment of an RRC connection includes an optional cell re-selection, an admission control, and a Layer 2 signalling link establishment.

- *Establishment, reconfiguration and release of radio access bearers* – The RRC layer will, on request from higher layers, perform the establishment, reconfiguration and release of radio access bearers in the user plane. A number of radio access bearers can be established to an UE at the same time. At establishment and reconfiguration, the RRC layer performs admission control and selects parameters describing the radio access bearer processing in Layer 2 and Layer 1, based on information from higher layers.
- *Assignment, reconfiguration and release of radio resources for the RRC connection* – The RRC layer handles the assignment of radio resources (e.g. codes) needed for the RRC connection including needs from both the control and user plane. The RRC layer may reconfigure radio resources during an established RRC connection. This function includes coordination of the radio resource allocation between multiple radio bearers related to the same RRC connection. RRC controls the radio resources in the uplink and downlink such that UE and the radio access network can communicate using unbalanced radio resources (asymmetric uplink and downlink). RRC signals to the UE to indicate resource allocations for purposes of handover to GSM or other radio systems.
- *RRC connection mobility functions* – The RRC layer performs evaluation, decision and execution related to RRC connection mobility during an established RRC connection, such as handover, preparation of handover to GSM or other systems, cell re-selection and cell/paging area update procedures, based on e.g. measurements done by the UE.
- *Paging/notification* – The RRC layer can broadcast paging information from the network to selected UEs. The RRC layer can also initiate paging during an established RRC connection.
- *Control of requested QoS* – This function ensures that the QoS requested for the radio access bearers can be met. This includes the allocation of a sufficient number of radio resources.
- *UE measurement reporting and control of the reporting* – The measurements performed by the UE are controlled by the RRC layer, in terms of what to measure, when to measure and how to report, including both this radio interface and other systems. The RRC layer also performs the reporting of the measurements from the UE to the network.
- *Outer loop power control* – The RRC layer controls setting of the target of the closed-loop power control.
- *Control of ciphering* – The RRC layer provides procedures for setting of ciphering (on/off) between the UE and the radio access network.
- *Initial cell selection and re-selection in idle mode* – Selection of the most suitable cell based on idle mode measurements and cell selection criteria.
- *Arbitration of the radio resource allocation between the cells* – This function shall ensure optimal performance of the overall radio access network capacity.

## 5.1.1.6 Summary of major technical parameters

Parameter	Value	Reference to § 5.1.2
Multiple access technique and duplexing scheme	Multiple access: DS-CDMA Duplexing: FDD	5.1.2.1.1
Chip rate (Mchip/s)	3.84	5.1.2.1.4
Frame length and structure	Frame length: 10 ms Slot length: 10/15 ms. TTI: 10 ms, 20 ms, 40 ms, 80 ms, 2 ms (HS-DSCH only)	5.1.2.1.2
Occupied bandwidth	Less than 5 MHz	5.1.2.4.1, 5.1.2.4.3
Adjacent channel leakage power ratio (ACLR) (transmitter side)	UE (UE power class: +21 dBm and +24 dBm): ACLR (5 MHz) = 33 dB ACLR (10 MHz) = 43 dB BS: ACLR (5 MHz) = 45 dB ACLR (10 MHz) = 50 dB	5.1.2.4.1 5.1.2.4.3
Adjacent channel selectivity (ACS) (receiver side)	UE: ACS (5 MHz) = 33 dB BS: ACS (5 MHz) = 45 dB	5.1.2.4.1 5.1.2.4.3
Random access mechanism	Acquisition indication based random-access mechanism with power ramping on preamble followed by message	5.1.2.1.2 5.1.2.1.5
Pilot structure	Uplink: dedicated pilots Downlink: common and/or dedicated pilots	5.1.2.1.2
Inter-base station asynchronous/synchronous operation	Asynchronous; synchronous	5.1.2.1.5 5.1.2.4.3



## 5.1.2 Detailed specification of the radio interface

The standards contained in this section are derived from the global core specifications for IMT 2000 contained at <http://ties.itu.int/u/itu-r/ede/rsg8/wp8f/wp8f-tech/GCSrev4/5-1/>. The following notes apply to the sections below, where indicated: (1) The relevant SDOs should make their reference material available from their Web site. (2) This information was supplied by the recognized external organizations and relates to their own deliverables of the transposed global core specification.

### 5.1.2.1

#### 25.200 series

##### 5.1.2.1.1 25.201

#### Physical layer - General description

This specification gives a general description of the physical layer of the UTRA radio interface.

SDO (2)	Document No.	Version	Status	Issued date	Location (1)
<b>Release 99</b>					
ARIB	ARIB STD-T63-25.201	3.4.0	Approved	25/05/2004	<a href="http://www.arib.or.jp/IMT-2000/ARIB-STD/ITU-R/R99/A25201-340.pdf">http://www.arib.or.jp/IMT-2000/ARIB-STD/ITU-R/R99/A25201-340.pdf</a>
CCSA	CCSA-TSD-DS-25.201	340	Approved	01/07/2003	<a href="http://www.ccsa.org.cn/english/tc/files.php?docpath=/ITU-R/M.1457/M.1457-4/DS/">http://www.ccsa.org.cn/english/tc/files.php?docpath=/ITU-R/M.1457/M.1457-4/DS/</a>
ETSI	ETSI TS 125 201	3.4.0	Published	05/07/2002	<a href="http://pda.etsi.org/pda/home.asp?wkr=RTS/TSGR-0125201v340">http://pda.etsi.org/pda/home.asp?wkr=RTS/TSGR-0125201v340</a>
T1 (ATIS)	T1.3GPP.25.201V340-2003	3.4.0	Approved	27/03/2003	<a href="https://www.atis.org/atis/docstore/search.asp?committee=S24">https://www.atis.org/atis/docstore/search.asp?committee=S24</a>
TTA	TTAT.3G-25.201(R99-3.4.0)	3.4.0	Approved	21/03/2003	<a href="http://www.tta.or.kr/standardDB/stnfile/TTAT.3G-25.201(R99-3.4.0).zip">http://www.tta.or.kr/standardDB/stnfile/TTAT.3G-25.201(R99-3.4.0).zip</a>
<b>Release 4</b>					
ARIB	ARIB STD-T63-25.201	4.3.0	Approved	25/05/2004	<a href="http://www.arib.or.jp/IMT-2000/ARIB-STD/ITU-R/Rel4/A25201-430.pdf">http://www.arib.or.jp/IMT-2000/ARIB-STD/ITU-R/Rel4/A25201-430.pdf</a>
CCSA	CCSA-TSD-DS-25.201	430	Approved	01/07/2003	<a href="http://www.ccsa.org.cn/english/tc/files.php?docpath=/ITU-R/M.1457/M.1457-4/DS/">http://www.ccsa.org.cn/english/tc/files.php?docpath=/ITU-R/M.1457/M.1457-4/DS/</a>
ETSI	ETSI TS 125 201	4.3.0	Published	05/07/2002	<a href="http://pda.etsi.org/pda/home.asp?wkr=RTS/TSGR-0125201v430">http://pda.etsi.org/pda/home.asp?wkr=RTS/TSGR-0125201v430</a>
T1 (ATIS)	T1.3GPP.25.201V430-2003	4.3.0	Approved	27/03/2003	<a href="https://www.atis.org/atis/docstore/search.asp?committee=S24">https://www.atis.org/atis/docstore/search.asp?committee=S24</a>
TTA	TTAT.3G-25.201(R4-4.3.0)	4.3.0	Approved	21/03/2003	<a href="http://www.tta.or.kr/standardDB/stnfile/TTAT.3G-25.201(R4-4.3.0).zip">http://www.tta.or.kr/standardDB/stnfile/TTAT.3G-25.201(R4-4.3.0).zip</a>
<b>Release 5</b>					
ARIB	ARIB STD-T63-25.201	5.2.0	Approved	25/05/2004	<a href="http://www.arib.or.jp/IMT-2000/ARIB-STD/ITU-R/Rel5/A25201-520.pdf">http://www.arib.or.jp/IMT-2000/ARIB-STD/ITU-R/Rel5/A25201-520.pdf</a>
CCSA	CCSA-TSD-DS-25.201	520	Approved	01/07/2003	<a href="http://www.ccsa.org.cn/english/tc/files.php?docpath=/ITU-R/M.1457/M.1457-4/DS/">http://www.ccsa.org.cn/english/tc/files.php?docpath=/ITU-R/M.1457/M.1457-4/DS/</a>
ETSI	ETSI TS 125 201	5.2.0	Published	04/10/2002	<a href="http://pda.etsi.org/pda/home.asp?wkr=RTS/TSGR-0125201v520">http://pda.etsi.org/pda/home.asp?wkr=RTS/TSGR-0125201v520</a>
T1 (ATIS)	T1.3GPP.25.201V520-2003	5.2.0	Approved	27/03/2003	<a href="https://www.atis.org/atis/docstore/search.asp?committee=S24">https://www.atis.org/atis/docstore/search.asp?committee=S24</a>
TTA	TTAT.3G-25.201(R5-5.2.0)	5.2.0	Approved	21/03/2003	<a href="http://www.tta.or.kr/standardDB/stnfile/TTAT.3G-25.201(R5-5.2.0).zip">http://www.tta.or.kr/standardDB/stnfile/TTAT.3G-25.201(R5-5.2.0).zip</a>
<b>Release 6</b>					
ARIB	ARIB STD-T63-25.211	6.0.0	Approved	25/05/2004	<a href="http://www.arib.or.jp/IMT-2000/ARIB-STD/ITU-R/Rel6/A25211-600.pdf">http://www.arib.or.jp/IMT-2000/ARIB-STD/ITU-R/Rel6/A25211-600.pdf</a>
ETSI	ETSI TS 125 201	6.0.0	Published	21/01/2004	<a href="http://pda.etsi.org/pda/home.asp?wkr=RTS/TSGR-0125201v600">http://pda.etsi.org/pda/home.asp?wkr=RTS/TSGR-0125201v600</a>
T1 (ATIS)	T1.3GPP.25.201V600-2004	6.0.0	Approved	21/05/2004	<a href="https://www.atis.org/atis/docstore/search.asp?committee=S24">https://www.atis.org/atis/docstore/search.asp?committee=S24</a>
TTA	TTAT.3G-25.201(R6-6.0.0)	6.0.0	Approved	25/05/2004	<a href="http://www.tta.or.kr/standardDB/stnfile/TTAT.3G-25.201(R6-6.0.0).zip">http://www.tta.or.kr/standardDB/stnfile/TTAT.3G-25.201(R6-6.0.0).zip</a>

## 5.1.2.1.2 25.211

**Physical channels and mapping of transport channels onto physical channels (FDD)**

This specification describes the characteristics of the Layer 1 transport channels and physical channels in the FDD mode of UTRA. The main objectives of the specification are to be a part of the full description of the UTRA Layer 1, and to serve as a basis for the drafting of the actual technical specification (TS).

SDO (2)	Document No.	Version	Status	Issued date	Location (1)
<b>Release 99</b>					
ARIB	ARIB STD-T63-25.211	3.12.0	Approved	25/05/2004	<a href="http://www.arib.or.jp/IMT-2000/ARIB-STD/ITU-R/R99/A25211-3c0.pdf">http://www.arib.or.jp/IMT-2000/ARIB-STD/ITU-R/R99/A25211-3c0.pdf</a>
CCSA	CCSA-TSD-DS-25.211	3C0	Approved	01/07/2003	<a href="http://www.ccsa.org.cn/english/tc/files.php?docpath=/ITU-R/M.1457/M.1457-4/DS/">http://www.ccsa.org.cn/english/tc/files.php?docpath=/ITU-R/M.1457/M.1457-4/DS/</a>
ETSI	ETSI TS 125 211	3.12.0	Published	04/10/2002	<a href="http://pda.etsi.org/pda/home.asp?wkr=RTS/TSGR-0125211v3c0">http://pda.etsi.org/pda/home.asp?wkr=RTS/TSGR-0125211v3c0</a>
T1 (ATIS)	T1.3GPP.25.211V3120-2003	3.12.0	Approved	27/03/2003	<a href="https://www.atis.org/atis/docstore/search.asp?committee=S24">https://www.atis.org/atis/docstore/search.asp?committee=S24</a>
TTA	TTAT.3G-25.211(R99F-3120)	3.12.0	Approved	21/03/2003	<a href="http://www.tta.or.kr/standardDB/stnfile/TTAT.3G-25.211(R99F-3120).zip">http://www.tta.or.kr/standardDB/stnfile/TTAT.3G-25.211(R99F-3120).zip</a>
<b>Release 4</b>					
ARIB	ARIB STD-T63-25.211	4.6.0	Approved	25/05/2004	<a href="http://www.arib.or.jp/IMT-2000/ARIB-STD/ITU-R/Rel4/A25211-460.pdf">http://www.arib.or.jp/IMT-2000/ARIB-STD/ITU-R/Rel4/A25211-460.pdf</a>
CCSA	CCSA-TSD-DS-25.211	460	Approved	01/07/2003	<a href="http://www.ccsa.org.cn/english/tc/files.php?docpath=/ITU-R/M.1457/M.1457-4/DS/">http://www.ccsa.org.cn/english/tc/files.php?docpath=/ITU-R/M.1457/M.1457-4/DS/</a>
ETSI	ETSI TS 125 211	4.6.0	Published	04/10/2002	<a href="http://pda.etsi.org/pda/home.asp?wkr=RTS/TSGR-0125211v460">http://pda.etsi.org/pda/home.asp?wkr=RTS/TSGR-0125211v460</a>
T1 (ATIS)	T1.3GPP.25.211V460-2003	4.6.0	Approved	27/03/2003	<a href="https://www.atis.org/atis/docstore/search.asp?committee=S24">https://www.atis.org/atis/docstore/search.asp?committee=S24</a>
TTA	TTAT.3G-25.211(R4F-4.6.0)	4.6.0	Approved	21/03/2003	<a href="http://www.tta.or.kr/standardDB/stnfile/TTAT.3G-25.211(R4F-4.6.0).zip">http://www.tta.or.kr/standardDB/stnfile/TTAT.3G-25.211(R4F-4.6.0).zip</a>
<b>Release 5</b>					
ARIB	ARIB STD-T63-25.211	5.5.0	Approved	25/05/2004	<a href="http://www.arib.or.jp/IMT-2000/ARIB-STD/ITU-R/Rel5/A25211-550.pdf">http://www.arib.or.jp/IMT-2000/ARIB-STD/ITU-R/Rel5/A25211-550.pdf</a>
CCSA	CCSA-TSD-DS-25.211	540	Approved	01/07/2003	<a href="http://www.ccsa.org.cn/english/tc/files.php?docpath=/ITU-R/M.1457/M.1457-4/DS/">http://www.ccsa.org.cn/english/tc/files.php?docpath=/ITU-R/M.1457/M.1457-4/DS/</a>
ETSI	ETSI TS 125 211	5.5.0	Published	01/10/2003	<a href="http://pda.etsi.org/pda/home.asp?wkr=RTS/TSGR-0125211v550">http://pda.etsi.org/pda/home.asp?wkr=RTS/TSGR-0125211v550</a>
T1 (ATIS)	T1.3GPP.25.211V550-2004	5.5.0	Approved	21/05/2004	<a href="https://www.atis.org/atis/docstore/search.asp?committee=S24">https://www.atis.org/atis/docstore/search.asp?committee=S24</a>
TTA	TTAT.3G-25.211(R5F-5.5.0)	5.5.0	Approved	25/05/2004	<a href="http://www.tta.or.kr/standardDB/stnfile/TTAT.3G-25.211(R5F-5.5.0).zip">http://www.tta.or.kr/standardDB/stnfile/TTAT.3G-25.211(R5F-5.5.0).zip</a>
<b>Release 6</b>					
ARIB	ARIB STD-T63-25.211	6.0.0	Approved	25/05/2004	<a href="http://www.arib.or.jp/IMT-2000/ARIB-STD/ITU-R/Rel6/A25211-600.pdf">http://www.arib.or.jp/IMT-2000/ARIB-STD/ITU-R/Rel6/A25211-600.pdf</a>
ETSI	ETSI TS 125 211	6.0.0	Published	21/01/2004	<a href="http://pda.etsi.org/pda/home.asp?wkr=RTS/TSGR-0125211v600">http://pda.etsi.org/pda/home.asp?wkr=RTS/TSGR-0125211v600</a>
T1 (ATIS)	T1.3GPP.25.211V600-2004	6.0.0	Approved	21/05/2004	<a href="https://www.atis.org/atis/docstore/search.asp?committee=S24">https://www.atis.org/atis/docstore/search.asp?committee=S24</a>
TTA	TTAT.3G-25.211(R6F-6.0.0)	6.0.0	Approved	25/05/2004	<a href="http://www.tta.or.kr/standardDB/stnfile/TTAT.3G-25.211(R6F-6.0.0).zip">http://www.tta.or.kr/standardDB/stnfile/TTAT.3G-25.211(R6F-6.0.0).zip</a>

## 5.1.2.1.3 25.212

**Multiplexing and channel coding (FDD)**

This specification describes the characteristics of the Layer 1 multiplexing and channel coding in the FDD mode of UTRA.

SDO (2)	Document No.	Version	Status	Issued date	Location (1)
<b>Release 99</b>					
ARIB	ARIB STD-T63-25.212	3.11.0	Approved	25/05/2004	<a href="http://www.arib.or.jp/IMT-2000/ARIB-STD/ITU-R/R99/A25212-3b0.pdf">http://www.arib.or.jp/IMT-2000/ARIB-STD/ITU-R/R99/A25212-3b0.pdf</a>
CCSA	CCSA-TSD-DS-25.212	3B0	Approved	01/07/2003	<a href="http://www.ccsa.org.cn/english/tc/files.php?docpath=/ITU-R/M.1457/M.1457-4/DS/">http://www.ccsa.org.cn/english/tc/files.php?docpath=/ITU-R/M.1457/M.1457-4/DS/</a>
ETSI	ETSI TS 125 212	3.11.0	Published	07/10/2002	<a href="http://pda.etsi.org/pda/home.asp?wkr=RTS/TSGR-0125212v3b0">http://pda.etsi.org/pda/home.asp?wkr=RTS/TSGR-0125212v3b0</a>
T1 (ATIS)	T1.3GPP.25.212V3110-2003	3.11.0	Approved	27/03/2003	<a href="https://www.atis.org/atis/docstore/search.asp?committee=S24">https://www.atis.org/atis/docstore/search.asp?committee=S24</a>
TTA	TTAT.3G-25.212(R99F-3110)	3.11.0	Approved	21/03/2003	<a href="http://www.tta.or.kr/standardDB/stnfile/TTAT.3G-25.212(R99F-3110).zip">http://www.tta.or.kr/standardDB/stnfile/TTAT.3G-25.212(R99F-3110).zip</a>
<b>Release 4</b>					
ARIB	ARIB STD-T63-25.212	4.6.0	Approved	25/05/2004	<a href="http://www.arib.or.jp/IMT-2000/ARIB-STD/ITU-R/Rel4/A25212-460.pdf">http://www.arib.or.jp/IMT-2000/ARIB-STD/ITU-R/Rel4/A25212-460.pdf</a>
CCSA	CCSA-TSD-DS-25.212	460	Approved	01/07/2003	<a href="http://www.ccsa.org.cn/english/tc/files.php?docpath=/ITU-R/M.1457/M.1457-4/DS/">http://www.ccsa.org.cn/english/tc/files.php?docpath=/ITU-R/M.1457/M.1457-4/DS/</a>
ETSI	ETSI TS 125 212	4.6.0	Published	07/10/2002	<a href="http://pda.etsi.org/pda/home.asp?wkr=RTS/TSGR-0125212v460">http://pda.etsi.org/pda/home.asp?wkr=RTS/TSGR-0125212v460</a>
T1 (ATIS)	T1.3GPP.25.212V460-2003	4.6.0	Approved	27/03/2003	<a href="https://www.atis.org/atis/docstore/search.asp?committee=S24">https://www.atis.org/atis/docstore/search.asp?committee=S24</a>
TTA	TTAT.3G-25.212(R4F-4.6.0)	4.6.0	Approved	21/03/2003	<a href="http://www.tta.or.kr/standardDB/stnfile/TTAT.3G-25.212(R4F-4.6.0).zip">http://www.tta.or.kr/standardDB/stnfile/TTAT.3G-25.212(R4F-4.6.0).zip</a>
<b>Release 5</b>					
ARIB	ARIB STD-T63-25.212	5.7.0	Approved	25/05/2004	<a href="http://www.arib.or.jp/IMT-2000/ARIB-STD/ITU-R/Rel5/A25212-570.pdf">http://www.arib.or.jp/IMT-2000/ARIB-STD/ITU-R/Rel5/A25212-570.pdf</a>
CCSA	CCSA-TSD-DS-25.212	550	Approved	01/07/2003	<a href="http://www.ccsa.org.cn/english/tc/files.php?docpath=/ITU-R/M.1457/M.1457-4/DS/">http://www.ccsa.org.cn/english/tc/files.php?docpath=/ITU-R/M.1457/M.1457-4/DS/</a>
ETSI	ETSI TS 125 212	5.7.0	Published	21/01/2004	<a href="http://pda.etsi.org/pda/home.asp?wkr=RTS/TSGR-0125212v570">http://pda.etsi.org/pda/home.asp?wkr=RTS/TSGR-0125212v570</a>
T1 (ATIS)	T1.3GPP.25.212V570-2004	5.7.0	Approved	21/05/2004	<a href="https://www.atis.org/atis/docstore/search.asp?committee=S24">https://www.atis.org/atis/docstore/search.asp?committee=S24</a>
TTA	TTAT.3G-25.212(R5F-5.7.0)	5.7.0	Approved	25/05/2004	<a href="http://www.tta.or.kr/standardDB/stnfile/TTAT.3G-25.212(R5F-5.7.0).zip">http://www.tta.or.kr/standardDB/stnfile/TTAT.3G-25.212(R5F-5.7.0).zip</a>
<b>Release 6</b>					
ARIB	ARIB STD-T63-25.212	6.0.0	Approved	25/05/2004	<a href="http://www.arib.or.jp/IMT-2000/ARIB-STD/ITU-R/Rel6/A25212-600.pdf">http://www.arib.or.jp/IMT-2000/ARIB-STD/ITU-R/Rel6/A25212-600.pdf</a>
ETSI	ETSI TS 125 212	6.0.0	Published	22/01/2004	<a href="http://pda.etsi.org/pda/home.asp?wkr=RTS/TSGR-0125212v600">http://pda.etsi.org/pda/home.asp?wkr=RTS/TSGR-0125212v600</a>
T1 (ATIS)	T1.3GPP.25.212V600-2004	6.0.0	Approved	21/05/2004	<a href="https://www.atis.org/atis/docstore/search.asp?committee=S24">https://www.atis.org/atis/docstore/search.asp?committee=S24</a>
TTA	TTAT.3G-25.212(R6F-6.0.0)	6.0.0	Approved	25/05/2004	<a href="http://www.tta.or.kr/standardDB/stnfile/TTAT.3G-25.212(R6F-6.0.0).zip">http://www.tta.or.kr/standardDB/stnfile/TTAT.3G-25.212(R6F-6.0.0).zip</a>

#### 5.1.2.1.4 25.213

#### Spreading and modulation (FDD)

This specification describes spreading and modulation for UTRA physical layer FDD mode.

SDO (2)	Document No.	Version	Status	Issued date	Location (1)
<b>Release 99</b>					
ARIB	ARIB STD-T63-25.213	3.9.0	Approved	25/05/2004	<a href="http://www.arib.or.jp/IMT-2000/ARIB-STD/ITU-R/R99/A25213-390.pdf">http://www.arib.or.jp/IMT-2000/ARIB-STD/ITU-R/R99/A25213-390.pdf</a>
CCSA	CCSA-TSD-DS-25.213	380	Approved	01/07/2003	<a href="http://www.ccsa.org.cn/english/tc/files.php?docpath=/ITU-R/M.1457/M.1457-4/DS/">http://www.ccsa.org.cn/english/tc/files.php?docpath=/ITU-R/M.1457/M.1457-4/DS/</a>
ETSI	ETSI TS 125 213	3.9.0	Published	22/01/2004	<a href="http://pda.etsi.org/pda/home.asp?wkr=RTS/TSGR-0125213v390">http://pda.etsi.org/pda/home.asp?wkr=RTS/TSGR-0125213v390</a>
T1 (ATIS)	T1.3GPP.25.213V390-2004	3.9.0	Approved	21/05/2004	<a href="https://www.atis.org/atis/docstore/search.asp?committee=S24">https://www.atis.org/atis/docstore/search.asp?committee=S24</a>
TTA	TTAT.3G-25.213(R99F-3.9.0)	3.9.0	Approved	25/05/2004	<a href="http://www.tta.or.kr/standardDB/stnfile/TTAT.3G-25.213(R99F-3.9.0).zip">http://www.tta.or.kr/standardDB/stnfile/TTAT.3G-25.213(R99F-3.9.0).zip</a>

**Release 4**

ARIB	ARIB STD-T63-25.213	4.4.0	Approved	25/05/2004	<a href="http://www.arib.or.jp/IMT-2000/ARIB-STD/ITU-R/Rel4/A25213-440.pdf">http://www.arib.or.jp/IMT-2000/ARIB-STD/ITU-R/Rel4/A25213-440.pdf</a>
CCSA	CCSA-TSD-DS-25.213	430	Approved	01/07/2003	<a href="http://www.ccsa.org.cn/english/tc/files.php?docpath=/ITU-R/M.1457/M.1457-4/DS/">http://www.ccsa.org.cn/english/tc/files.php?docpath=/ITU-R/M.1457/M.1457-4/DS/</a>
ETSI	ETSI TS 125 213	4.4.0	Published	22/01/2004	<a href="http://pda.etsi.org/pda/home.asp?wkr=RTS/TSGR-0125213v440">http://pda.etsi.org/pda/home.asp?wkr=RTS/TSGR-0125213v440</a>
T1 (ATIS)	T1.3GPP.25.213V440-2004	4.4.0	Approved	21/05/2004	<a href="https://www.atis.org/atis/docstore/search.asp?committee=S24">https://www.atis.org/atis/docstore/search.asp?committee=S24</a>
TTA	TTAT.3G-25.213(R4F-4.4.0)	4.4.0	Approved	25/05/2004	<a href="http://www.tta.or.kr/standardDB/stnfile/TTAT.3G-25.213(R4F-4.4.0).zip">http://www.tta.or.kr/standardDB/stnfile/TTAT.3G-25.213(R4F-4.4.0).zip</a>

**Release 5**

ARIB	ARIB STD-T63-25.213	5.5.0	Approved	25/05/2004	<a href="http://www.arib.or.jp/IMT-2000/ARIB-STD/ITU-R/Rel5/A25213-550.pdf">http://www.arib.or.jp/IMT-2000/ARIB-STD/ITU-R/Rel5/A25213-550.pdf</a>
CCSA	CCSA-TSD-DS-25.213	530	Approved	01/07/2003	<a href="http://www.ccsa.org.cn/english/tc/files.php?docpath=/ITU-R/M.1457/M.1457-4/DS/">http://www.ccsa.org.cn/english/tc/files.php?docpath=/ITU-R/M.1457/M.1457-4/DS/</a>
ETSI	ETSI TS 125 213	5.5.0	Published	22/01/2004	<a href="http://pda.etsi.org/pda/home.asp?wkr=RTS/TSGR-0125213v550">http://pda.etsi.org/pda/home.asp?wkr=RTS/TSGR-0125213v550</a>
T1 (ATIS)	T1.3GPP.25.213V550-2004	5.5.0	Approved	21/05/2004	<a href="https://www.atis.org/atis/docstore/search.asp?committee=S24">https://www.atis.org/atis/docstore/search.asp?committee=S24</a>
TTA	TTAT.3G-25.213(R5F-5.5.0)	5.5.0	Approved	25/05/2004	<a href="http://www.tta.or.kr/standardDB/stnfile/TTAT.3G-25.213(R5F-5.5.0).zip">http://www.tta.or.kr/standardDB/stnfile/TTAT.3G-25.213(R5F-5.5.0).zip</a>

**Release 6**

ARIB	ARIB STD-T63-25.213	6.0.0	Approved	25/05/2004	<a href="http://www.arib.or.jp/IMT-2000/ARIB-STD/ITU-R/Rel6/A25213-600.pdf">http://www.arib.or.jp/IMT-2000/ARIB-STD/ITU-R/Rel6/A25213-600.pdf</a>
ETSI	ETSI TS 125 213	6.0.0	Published	22/01/2004	<a href="http://pda.etsi.org/pda/home.asp?wkr=RTS/TSGR-0125213v600">http://pda.etsi.org/pda/home.asp?wkr=RTS/TSGR-0125213v600</a>
T1 (ATIS)	T1.3GPP.25.213V600-2004	6.0.0	Approved	21/05/2004	<a href="https://www.atis.org/atis/docstore/search.asp?committee=S24">https://www.atis.org/atis/docstore/search.asp?committee=S24</a>
TTA	TTAT.3G-25.213(R6F-6.0.0)	6.0.0	Approved	25/05/2004	<a href="http://www.tta.or.kr/standardDB/stnfile/TTAT.3G-25.213(R6F-6.0.0).zip">http://www.tta.or.kr/standardDB/stnfile/TTAT.3G-25.213(R6F-6.0.0).zip</a>

**5.1.2.1.5 25.214****Physical layer procedures (FDD)**

This specification describes and establishes the characteristics of the physical layer procedures in the FDD mode of UTRA.

SDO (2)	Document No.	Version	Status	Issued date	Location (1)
<b>Release 99</b>					
ARIB	ARIB STD-T63-25.214	3.12.0	Approved	25/05/2004	<a href="http://www.arib.or.jp/IMT-2000/ARIB-STD/ITU-R/R99/A25214-3c0.pdf">http://www.arib.or.jp/IMT-2000/ARIB-STD/ITU-R/R99/A25214-3c0.pdf</a>
CCSA	CCSA-TSD-DS-25.214	3C0	Approved	01/07/2003	<a href="http://www.ccsa.org.cn/english/tc/files.php?docpath=/ITU-R/M.1457/M.1457-4/DS/">http://www.ccsa.org.cn/english/tc/files.php?docpath=/ITU-R/M.1457/M.1457-4/DS/</a>
ETSI	ETSI TS 125 214	3.12.0	Published	10/04/2003	<a href="http://pda.etsi.org/pda/home.asp?wkr=RTS/TSGR-0125214v3c0">http://pda.etsi.org/pda/home.asp?wkr=RTS/TSGR-0125214v3c0</a>
T1 (ATIS)	T1.3GPP.25.214V3120-2004	3.12.0	Approved	21/05/2004	<a href="https://www.atis.org/atis/docstore/search.asp?committee=S24">https://www.atis.org/atis/docstore/search.asp?committee=S24</a>
TTA	TTAT.3G-25.214(R99F-3.12.0)	3.12.0	Approved	25/05/2004	<a href="http://www.tta.or.kr/standardDB/stnfile/TTAT.3G-25.214(R99F-3.12.0).zip">http://www.tta.or.kr/standardDB/stnfile/TTAT.3G-25.214(R99F-3.12.0).zip</a>
<b>Release 4</b>					
ARIB	ARIB STD-T63-25.214	4.6.0	Approved	25/05/2004	<a href="http://www.arib.or.jp/IMT-2000/ARIB-STD/ITU-R/Rel4/A25214-460.pdf">http://www.arib.or.jp/IMT-2000/ARIB-STD/ITU-R/Rel4/A25214-460.pdf</a>
CCSA	CCSA-TSD-DS-25.214	460	Approved	01/07/2003	<a href="http://www.ccsa.org.cn/english/tc/files.php?docpath=/ITU-R/M.1457/M.1457-4/DS/">http://www.ccsa.org.cn/english/tc/files.php?docpath=/ITU-R/M.1457/M.1457-4/DS/</a>
ETSI	ETSI TS 125 214	4.6.0	Published	10/04/2003	<a href="http://pda.etsi.org/pda/home.asp?wkr=RTS/TSGR-0125214v460">http://pda.etsi.org/pda/home.asp?wkr=RTS/TSGR-0125214v460</a>
T1 (ATIS)	T1.3GPP.25.214V460-2004	4.6.0	Approved	21/05/2004	<a href="https://www.atis.org/atis/docstore/search.asp?committee=S24">https://www.atis.org/atis/docstore/search.asp?committee=S24</a>
TTA	TTAT.3G-25.214(R4F-4.6.0)	4.6.0	Approved	25/05/2004	<a href="http://www.tta.or.kr/standardDB/stnfile/TTAT.3G-25.214(R4F-4.6.0).zip">http://www.tta.or.kr/standardDB/stnfile/TTAT.3G-25.214(R4F-4.6.0).zip</a>

**Release 5**

ARIB	ARIB STD-T63-25.214	5.7.0	Approved	25/05/2004	<a href="http://www.arib.or.jp/IMT-2000/ARIB-STD/ITU-R/Rel5/A25214-570.pdf">http://www.arib.or.jp/IMT-2000/ARIB-STD/ITU-R/Rel5/A25214-570.pdf</a>
CCSA	CCSA-TSD-DS-25.214	550	Approved	01/07/2003	<a href="http://www.ccsa.org.cn/english/tc/files.php?docpath=/ITU-R/M.1457/M.1457-4/DS/">http://www.ccsa.org.cn/english/tc/files.php?docpath=/ITU-R/M.1457/M.1457-4/DS/</a>
ETSI	ETSI TS 125 214	5.7.0	Published	22/01/2004	<a href="http://pda.etsi.org/pda/home.asp?wkr=RTS/TSGR-0125214v570">http://pda.etsi.org/pda/home.asp?wkr=RTS/TSGR-0125214v570</a>
T1 (ATIS)	T1.3GPP.25.214V570-2004	5.7.0	Approved	21/05/2004	<a href="https://www.atis.org/atis/docstore/search.asp?committee=S24">https://www.atis.org/atis/docstore/search.asp?committee=S24</a>
TTA	TTAT.3G-25.214(R5F-5.7.0)	5.7.0	Approved	25/05/2004	<a href="http://www.tta.or.kr/standardDB/stnfile/TTAT.3G-25.214(R5F-5.7.0).zip">http://www.tta.or.kr/standardDB/stnfile/TTAT.3G-25.214(R5F-5.7.0).zip</a>

**Release 6**

ARIB	ARIB STD-T63-25.214	6.0.0	Approved	25/05/2004	<a href="http://www.arib.or.jp/IMT-2000/ARIB-STD/ITU-R/Rel6/A25214-600.pdf">http://www.arib.or.jp/IMT-2000/ARIB-STD/ITU-R/Rel6/A25214-600.pdf</a>
ETSI	ETSI TS 125 214	6.0.0	Published	22/01/2004	<a href="http://pda.etsi.org/pda/home.asp?wkr=RTS/TSGR-0125214v600">http://pda.etsi.org/pda/home.asp?wkr=RTS/TSGR-0125214v600</a>
T1 (ATIS)	T1.3GPP.25.214V600-2004	6.0.0	Approved	21/05/2004	<a href="https://www.atis.org/atis/docstore/search.asp?committee=S24">https://www.atis.org/atis/docstore/search.asp?committee=S24</a>
TTA	TTAT.3G-25.214(R6F-6.0.0)	6.0.0	Approved	25/05/2004	<a href="http://www.tta.or.kr/standardDB/stnfile/TTAT.3G-25.214(R6F-6.0.0).zip">http://www.tta.or.kr/standardDB/stnfile/TTAT.3G-25.214(R6F-6.0.0).zip</a>

**5.1.2.1.6 25.215****Physical layer - Measurements (FDD)**

This specification describes the measurements done at the UE and network in order to support operation in idle mode and connected mode for FDD mode.

SDO (2)	Document No.	Version	Status	Issued date	Location (1)
<b>Release 99</b>					
ARIB	ARIB STD-T63-25.215	3.12.0	Approved	25/05/2004	<a href="http://www.arib.or.jp/IMT-2000/ARIB-STD/ITU-R/R99/A25215-3c0.pdf">http://www.arib.or.jp/IMT-2000/ARIB-STD/ITU-R/R99/A25215-3c0.pdf</a>
CCSA	CCSA-TSD-DS-25.215	3C0	Approved	01/07/2003	<a href="http://www.ccsa.org.cn/english/tc/files.php?docpath=/ITU-R/M.1457/M.1457-4/DS/">http://www.ccsa.org.cn/english/tc/files.php?docpath=/ITU-R/M.1457/M.1457-4/DS/</a>
ETSI	ETSI TS 125 215	3.12.0	Published	08/07/2003	<a href="http://pda.etsi.org/pda/home.asp?wkr=RTS/TSGR-0125215v3c0">http://pda.etsi.org/pda/home.asp?wkr=RTS/TSGR-0125215v3c0</a>
T1 (ATIS)	T1.3GPP.25.215V3120-2004	3.12.0	Approved	21/05/2004	<a href="https://www.atis.org/atis/docstore/search.asp?committee=S24">https://www.atis.org/atis/docstore/search.asp?committee=S24</a>
TTA	TTAT.3G-25.215(R99F-3.12.0)	3.12.0	Approved	25/05/2004	<a href="http://www.tta.or.kr/standardDB/stnfile/TTAT.3G-25.215(R99F-3.12.0).zip">http://www.tta.or.kr/standardDB/stnfile/TTAT.3G-25.215(R99F-3.12.0).zip</a>
<b>Release 4</b>					
ARIB	ARIB STD-T63-25.215	4.7.0	Approved	25/05/2004	<a href="http://www.arib.or.jp/IMT-2000/ARIB-STD/ITU-R/Rel4/A25215-470.pdf">http://www.arib.or.jp/IMT-2000/ARIB-STD/ITU-R/Rel4/A25215-470.pdf</a>
CCSA	CCSA-TSD-DS-25.215	470	Approved	01/07/2003	<a href="http://www.ccsa.org.cn/english/tc/files.php?docpath=/ITU-R/M.1457/M.1457-4/DS/">http://www.ccsa.org.cn/english/tc/files.php?docpath=/ITU-R/M.1457/M.1457-4/DS/</a>
ETSI	ETSI TS 125 215	4.7.0	Published	08/07/2003	<a href="http://pda.etsi.org/pda/home.asp?wkr=RTS/TSGR-0125215v470">http://pda.etsi.org/pda/home.asp?wkr=RTS/TSGR-0125215v470</a>
T1 (ATIS)	T1.3GPP.25.215V470-2004	4.7.0	Approved	21/05/2004	<a href="https://www.atis.org/atis/docstore/search.asp?committee=S24">https://www.atis.org/atis/docstore/search.asp?committee=S24</a>
TTA	TTAT.3G-25.215(R4F-4.7.0)	4.7.0	Approved	25/05/2004	<a href="http://www.tta.or.kr/standardDB/stnfile/TTAT.3G-25.215(R4F-4.7.0).zip">http://www.tta.or.kr/standardDB/stnfile/TTAT.3G-25.215(R4F-4.7.0).zip</a>
<b>Release 5</b>					
ARIB	ARIB STD-T63-25.215	5.5.0	Approved	25/05/2004	<a href="http://www.arib.or.jp/IMT-2000/ARIB-STD/ITU-R/Rel5/A25215-550.pdf">http://www.arib.or.jp/IMT-2000/ARIB-STD/ITU-R/Rel5/A25215-550.pdf</a>
CCSA	CCSA-TSD-DS-25.215	540	Approved	01/07/2003	<a href="http://www.ccsa.org.cn/english/tc/files.php?docpath=/ITU-R/M.1457/M.1457-4/DS/">http://www.ccsa.org.cn/english/tc/files.php?docpath=/ITU-R/M.1457/M.1457-4/DS/</a>
ETSI	ETSI TS 125 215	5.5.0	Published	01/10/2003	<a href="http://pda.etsi.org/pda/home.asp?wkr=RTS/TSGR-0125215v550">http://pda.etsi.org/pda/home.asp?wkr=RTS/TSGR-0125215v550</a>
T1 (ATIS)	T1.3GPP.25.215V550-2004	5.5.0	Approved	21/05/2004	<a href="https://www.atis.org/atis/docstore/search.asp?committee=S24">https://www.atis.org/atis/docstore/search.asp?committee=S24</a>
TTA	TTAT.3G-25.215(R5F-5.5.0)	5.5.0	Approved	25/05/2004	<a href="http://www.tta.or.kr/standardDB/stnfile/TTAT.3G-25.215(R5F-5.5.0).zip">http://www.tta.or.kr/standardDB/stnfile/TTAT.3G-25.215(R5F-5.5.0).zip</a>

**Release 6**

ARIB	ARIB STD-T63-25.215	6.0.0	Approved	25/05/2004	<a href="http://www.arib.or.jp/IMT-2000/ARIB-STD/ITU-R/Rel6/A25215-600.pdf">http://www.arib.or.jp/IMT-2000/ARIB-STD/ITU-R/Rel6/A25215-600.pdf</a>
ETSI	ETSI TS 125 215	6.0.0	Published	26/01/2004	<a href="http://pda.etsi.org/pda/home.asp?wkr=RTS/TSGR-0125215v600">http://pda.etsi.org/pda/home.asp?wkr=RTS/TSGR-0125215v600</a>
T1 (ATIS)	T1.3GPP.25.215V600-2004	6.0.0	Approved	21/05/2004	<a href="https://www.atis.org/atis/docstore/search.asp?committee=S24">https://www.atis.org/atis/docstore/search.asp?committee=S24</a>
TTA	TTAT.3G-25.215(R6F-6.0.0)	6.0.0	Approved	25/05/2004	<a href="http://www.tta.or.kr/standardDB/stnfile/TTAT.3G-25.215(R6F-6.0.0).zip">http://www.tta.or.kr/standardDB/stnfile/TTAT.3G-25.215(R6F-6.0.0).zip</a>

**5.1.2.2****25.300 series****5.1.2.2.1 25.301****Radio interface protocol architecture**

This specification describes an overview and overall description of the UE-UTRAN radio interface protocol architecture. Details of the radio protocols will be specified in companion documents.

SDO (2)	Document No.	Version	Status	Issued date	Location (1)
<b>Release 99</b>					
ARIB	ARIB STD-T63-25.301	3.11.0	Approved	25/05/2004	<a href="http://www.arib.or.jp/IMT-2000/ARIB-STD/ITU-R/R99/A25301-3b0.pdf">http://www.arib.or.jp/IMT-2000/ARIB-STD/ITU-R/R99/A25301-3b0.pdf</a>
CCSA	CCSA-TSD-DS-25.301	3B0	Approved	01/07/2003	<a href="http://www.ccsa.org.cn/english/tc/files.php?docpath=/ITU-R/M.1457/M.1457-4/DS/">http://www.ccsa.org.cn/english/tc/files.php?docpath=/ITU-R/M.1457/M.1457-4/DS/</a>
ETSI	ETSI TS 125 301	3.11.0	Published	07/10/2002	<a href="http://pda.etsi.org/pda/home.asp?wkr=RTS/TSGR-0225301v3b0">http://pda.etsi.org/pda/home.asp?wkr=RTS/TSGR-0225301v3b0</a>
T1 (ATIS)	T1.3GPP.25.301V3110-2003	3.11.0	Approved	27/03/2003	<a href="https://www.atis.org/atis/docstore/search.asp?committee=S24">https://www.atis.org/atis/docstore/search.asp?committee=S24</a>
TTA	TTAT.3G-25.301(R99-3.11.0)	3.11.0	Approved	21/03/2003	<a href="http://www.tta.or.kr/standardDB/stnfile/TTAT.3G-25.301(R99-3.11.0).zip">http://www.tta.or.kr/standardDB/stnfile/TTAT.3G-25.301(R99-3.11.0).zip</a>
<b>Release 4</b>					
ARIB	ARIB STD-T63-25.301	4.4.0	Approved	25/05/2004	<a href="http://www.arib.or.jp/IMT-2000/ARIB-STD/ITU-R/Rel4/A25301-440.pdf">http://www.arib.or.jp/IMT-2000/ARIB-STD/ITU-R/Rel4/A25301-440.pdf</a>
CCSA	CCSA-TSD-DS-25.301	440	Approved	01/07/2003	<a href="http://www.ccsa.org.cn/english/tc/files.php?docpath=/ITU-R/M.1457/M.1457-4/DS/">http://www.ccsa.org.cn/english/tc/files.php?docpath=/ITU-R/M.1457/M.1457-4/DS/</a>
ETSI	ETSI TS 125 301	4.4.0	Published	07/10/2002	<a href="http://pda.etsi.org/pda/home.asp?wkr=RTS/TSGR-0225301v440">http://pda.etsi.org/pda/home.asp?wkr=RTS/TSGR-0225301v440</a>
T1 (ATIS)	T1.3GPP.25.301V440-2003	4.4.0	Approved	27/03/2003	<a href="https://www.atis.org/atis/docstore/search.asp?committee=S24">https://www.atis.org/atis/docstore/search.asp?committee=S24</a>
TTA	TTAT.3G-25.301(R4-4.4.0)	4.4.0	Approved	21/03/2003	<a href="http://www.tta.or.kr/standardDB/stnfile/TTAT.3G-25.301(R4-4.4.0).zip">http://www.tta.or.kr/standardDB/stnfile/TTAT.3G-25.301(R4-4.4.0).zip</a>
<b>Release 5</b>					
ARIB	ARIB STD-T63-25.301	5.2.0	Approved	25/05/2004	<a href="http://www.arib.or.jp/IMT-2000/ARIB-STD/ITU-R/Rel5/A25301-520.pdf">http://www.arib.or.jp/IMT-2000/ARIB-STD/ITU-R/Rel5/A25301-520.pdf</a>
CCSA	CCSA-TSD-DS-25.301	520	Approved	01/07/2003	<a href="http://www.ccsa.org.cn/english/tc/files.php?docpath=/ITU-R/M.1457/M.1457-4/DS/">http://www.ccsa.org.cn/english/tc/files.php?docpath=/ITU-R/M.1457/M.1457-4/DS/</a>
ETSI	ETSI TS 125 301	5.2.0	Published	07/10/2002	<a href="http://pda.etsi.org/pda/home.asp?wkr=RTS/TSGR-0225301v520">http://pda.etsi.org/pda/home.asp?wkr=RTS/TSGR-0225301v520</a>
T1 (ATIS)	T1.3GPP.25.301V520-2003	5.2.0	Approved	27/03/2003	<a href="https://www.atis.org/atis/docstore/search.asp?committee=S24">https://www.atis.org/atis/docstore/search.asp?committee=S24</a>
TTA	TTAT.3G-25.301(R5-5.2.0)	5.2.0	Approved	21/03/2003	<a href="http://www.tta.or.kr/standardDB/stnfile/TTAT.3G-25.301(R5-5.2.0).zip">http://www.tta.or.kr/standardDB/stnfile/TTAT.3G-25.301(R5-5.2.0).zip</a>
<b>Release 6</b>					
ARIB	ARIB STD-T63-25.301	6.0.0	Approved	25/05/2004	<a href="http://www.arib.or.jp/IMT-2000/ARIB-STD/ITU-R/Rel6/A25301-600.pdf">http://www.arib.or.jp/IMT-2000/ARIB-STD/ITU-R/Rel6/A25301-600.pdf</a>
ETSI	ETSI TS 125 301	6.0.0	Published	14/01/2004	<a href="http://pda.etsi.org/pda/home.asp?wkr=RTS/TSGR-0225301v600">http://pda.etsi.org/pda/home.asp?wkr=RTS/TSGR-0225301v600</a>
T1 (ATIS)	T1.3GPP.25.301V600-2004	6.0.0	Approved	21/05/2004	<a href="https://www.atis.org/atis/docstore/search.asp?committee=S24">https://www.atis.org/atis/docstore/search.asp?committee=S24</a>
TTA	TTAT.3G-25.301(R6-6.0.0)	6.0.0	Approved	25/05/2004	<a href="http://www.tta.or.kr/standardDB/stnfile/TTAT.3G-25.301(R6-6.0.0).zip">http://www.tta.or.kr/standardDB/stnfile/TTAT.3G-25.301(R6-6.0.0).zip</a>

**5.1.2.2.2 25.302****Services provided by the physical layer**

This specification describes a technical specification of the services provided by the physical layer of UTRA to upper layers.

SDO (2)	Document No.	Version	Status	Issued date	Location (1)
<b>Release 99</b>					
ARIB	ARIB STD-T63-25.302	3.16.0	Approved	25/05/2004	<a href="http://www.arib.or.jp/IMT-2000/ARIB-STD/ITU-R/R99/A25302-3g0.pdf">http://www.arib.or.jp/IMT-2000/ARIB-STD/ITU-R/R99/A25302-3g0.pdf</a>
CCSA	CCSA-TSD-DS-25.302	3F0	Approved	01/07/2003	<a href="http://www.ccsa.org.cn/english/tc/files.php?docpath=/ITU-R/M.1457/M.1457-4/DS/">http://www.ccsa.org.cn/english/tc/files.php?docpath=/ITU-R/M.1457/M.1457-4/DS/</a>
ETSI	ETSI TS 125 302	3.16.0	Published	07/10/2003	<a href="http://pda.etsi.org/pda/home.asp?wkr=RTS/TSGR-0225302v3g0">http://pda.etsi.org/pda/home.asp?wkr=RTS/TSGR-0225302v3g0</a>
T1 (ATIS)	T1.3GPP.25.302V3160-2004	3.16.0	Approved	21/05/2004	<a href="https://www.atis.org/atis/docstore/search.asp?committee=S24">https://www.atis.org/atis/docstore/search.asp?committee=S24</a>
TTA	TTAT.3G-25.302(R99-3.16.0)	3.16.0	Approved	25/05/2004	<a href="http://www.tta.or.kr/standardDB/stnfile/TTAT.3G-25.302(R99-3.16.0).zip">http://www.tta.or.kr/standardDB/stnfile/TTAT.3G-25.302(R99-3.16.0).zip</a>
<b>Release 4</b>					
ARIB	ARIB STD-T63-25.302	4.8.0	Approved	25/05/2004	<a href="http://www.arib.or.jp/IMT-2000/ARIB-STD/ITU-R/Rel4/A25302-480.pdf">http://www.arib.or.jp/IMT-2000/ARIB-STD/ITU-R/Rel4/A25302-480.pdf</a>
CCSA	CCSA-TSD-DS-25.302	470	Approved	01/07/2003	<a href="http://www.ccsa.org.cn/english/tc/files.php?docpath=/ITU-R/M.1457/M.1457-4/DS/">http://www.ccsa.org.cn/english/tc/files.php?docpath=/ITU-R/M.1457/M.1457-4/DS/</a>
ETSI	ETSI TS 125 302	4.8.0	Published	07/10/2003	<a href="http://pda.etsi.org/pda/home.asp?wkr=RTS/TSGR-0225302v480">http://pda.etsi.org/pda/home.asp?wkr=RTS/TSGR-0225302v480</a>
T1 (ATIS)	T1.3GPP.25.302V480-2004	4.8.0	Approved	21/05/2004	<a href="https://www.atis.org/atis/docstore/search.asp?committee=S24">https://www.atis.org/atis/docstore/search.asp?committee=S24</a>
TTA	TTAT.3G-25.302(R4-4.8.0)	4.8.0	Approved	25/05/2004	<a href="http://www.tta.or.kr/standardDB/stnfile/TTAT.3G-25.302(R4-4.8.0).zip">http://www.tta.or.kr/standardDB/stnfile/TTAT.3G-25.302(R4-4.8.0).zip</a>
<b>Release 5</b>					
ARIB	ARIB STD-T63-25.302	5.6.0	Approved	25/05/2004	<a href="http://www.arib.or.jp/IMT-2000/ARIB-STD/ITU-R/Rel5/A25302-560.pdf">http://www.arib.or.jp/IMT-2000/ARIB-STD/ITU-R/Rel5/A25302-560.pdf</a>
CCSA	CCSA-TSD-DS-25.302	550	Approved	01/07/2003	<a href="http://www.ccsa.org.cn/english/tc/files.php?docpath=/ITU-R/M.1457/M.1457-4/DS/">http://www.ccsa.org.cn/english/tc/files.php?docpath=/ITU-R/M.1457/M.1457-4/DS/</a>
ETSI	ETSI TS 125 302	5.7.0	Published	13/01/2004	<a href="http://pda.etsi.org/pda/home.asp?wkr=RTS/TSGR-0225302v570">http://pda.etsi.org/pda/home.asp?wkr=RTS/TSGR-0225302v570</a>
T1 (ATIS)	T1.3GPP.25.302V570-2004	5.7.0	Approved	21/05/2004	<a href="https://www.atis.org/atis/docstore/search.asp?committee=S24">https://www.atis.org/atis/docstore/search.asp?committee=S24</a>
TTA	TTAT.3G-25.302(R5-5.7.0)	5.7.0	Approved	25/05/2004	<a href="http://www.tta.or.kr/standardDB/stnfile/TTAT.3G-25.302(R5-5.7.0).zip">http://www.tta.or.kr/standardDB/stnfile/TTAT.3G-25.302(R5-5.7.0).zip</a>
<b>Release 6</b>					
ARIB	ARIB STD-T63-25.302	6.0.0	Approved	25/05/2004	<a href="http://www.arib.or.jp/IMT-2000/ARIB-STD/ITU-R/Rel6/A25302-600.pdf">http://www.arib.or.jp/IMT-2000/ARIB-STD/ITU-R/Rel6/A25302-600.pdf</a>
ETSI	ETSI TS 125 302	6.0.0	Published	14/01/2004	<a href="http://pda.etsi.org/pda/home.asp?wkr=RTS/TSGR-0225302v600">http://pda.etsi.org/pda/home.asp?wkr=RTS/TSGR-0225302v600</a>
T1 (ATIS)	T1.3GPP.25.302V600-2004	6.0.0	Approved	21/05/2004	<a href="https://www.atis.org/atis/docstore/search.asp?committee=S24">https://www.atis.org/atis/docstore/search.asp?committee=S24</a>
TTA	TTAT.3G-25.302(R6-6.0.0)	6.0.0	Approved	25/05/2004	<a href="http://www.tta.or.kr/standardDB/stnfile/TTAT.3G-25.302(R6-6.0.0).zip">http://www.tta.or.kr/standardDB/stnfile/TTAT.3G-25.302(R6-6.0.0).zip</a>

**5.1.2.2.3 25.303****Interlayer procedures in connected mode**

This specification describes informative interlayer procedures to perform the required tasks. This specification attempts to provide a comprehensive overview of the different states and transitions within the connected mode of universal mobile telecommunications system (UMTS) terminal.

SDO (2)	Document No.	Version	Status	Issued date	Location (1)
<b>Release 99</b>					
ARIB	ARIB STD-T63-25.303	3.12.0	Approved	25/05/2004	<a href="http://www.arib.or.jp/IMT-2000/ARIB-STD/ITU-R/R99/A25303-3c0.pdf">http://www.arib.or.jp/IMT-2000/ARIB-STD/ITU-R/R99/A25303-3c0.pdf</a>
CCSA	CCSA-TSD-DS-25.303	3C0	Approved	01/07/2003	<a href="http://www.ccsa.org.cn/english/tc/files.php?docpath=/ITU-R/M.1457/M.1457-4/DS/">http://www.ccsa.org.cn/english/tc/files.php?docpath=/ITU-R/M.1457/M.1457-4/DS/</a>



ETSI	ETSI TS 125 303	3.12.0	Published	24/06/2002	<a href="http://pda.etsi.org/pda/home.asp?wkr=RTS/TSGR-0225303v3c0">http://pda.etsi.org/pda/home.asp?wkr=RTS/TSGR-0225303v3c0</a>
T1 (ATIS)	T1.3GPP.25.303V3120-2003	3.12.0	Approved	27/03/2003	<a href="https://www.atis.org/atis/docstore/search.asp?committee=S24">https://www.atis.org/atis/docstore/search.asp?committee=S24</a>
TTA	TTAT.3G-25.303(R99-3.12.0)	3.12.0	Approved	21/03/2003	<a href="http://www.tta.or.kr/standardDB/stnfile/TTAT.3G-25.303(R99-3.12.0).zip">http://www.tta.or.kr/standardDB/stnfile/TTAT.3G-25.303(R99-3.12.0).zip</a>
<b>Release 4</b>					
ARIB	ARIB STD-T63-25.303	4.5.0	Approved	25/05/2004	<a href="http://www.arib.or.jp/IMT-2000/ARIB-STD/ITU-R/Rel4/A25303-450.pdf">http://www.arib.or.jp/IMT-2000/ARIB-STD/ITU-R/Rel4/A25303-450.pdf</a>
CCSA	CCSA-TSD-DS-25.303	450	Approved	01/07/2003	<a href="http://www.ccsa.org.cn/english/tc/files.php?docpath=/ITU-R/M.1457/M.1457-4/DS/">http://www.ccsa.org.cn/english/tc/files.php?docpath=/ITU-R/M.1457/M.1457-4/DS/</a>
ETSI	ETSI TS 125 303	4.5.0	Published	24/06/2002	<a href="http://pda.etsi.org/pda/home.asp?wkr=RTS/TSGR-0225303v450">http://pda.etsi.org/pda/home.asp?wkr=RTS/TSGR-0225303v450</a>
T1 (ATIS)	T1.3GPP.25.303V450-2003	4.5.0	Approved	27/03/2003	<a href="https://www.atis.org/atis/docstore/search.asp?committee=S24">https://www.atis.org/atis/docstore/search.asp?committee=S24</a>
TTA	TTAT.3G-25.303(R4-4.5.0)	4.5.0	Approved	21/03/2003	<a href="http://www.tta.or.kr/standardDB/stnfile/TTAT.3G-25.303(R4-4.5.0).zip">http://www.tta.or.kr/standardDB/stnfile/TTAT.3G-25.303(R4-4.5.0).zip</a>
<b>Release 5</b>					
ARIB	ARIB STD-T63-25.303	5.1.0	Approved	25/05/2004	<a href="http://www.arib.or.jp/IMT-2000/ARIB-STD/ITU-R/Rel5/A25303-510.pdf">http://www.arib.or.jp/IMT-2000/ARIB-STD/ITU-R/Rel5/A25303-510.pdf</a>
CCSA	CCSA-TSD-DS-25.303	510	Approved	01/07/2003	<a href="http://www.ccsa.org.cn/english/tc/files.php?docpath=/ITU-R/M.1457/M.1457-4/DS/">http://www.ccsa.org.cn/english/tc/files.php?docpath=/ITU-R/M.1457/M.1457-4/DS/</a>
ETSI	ETSI TS 125 303	5.1.0	Published	24/06/2002	<a href="http://pda.etsi.org/pda/home.asp?wkr=RTS/TSGR-0225303v510">http://pda.etsi.org/pda/home.asp?wkr=RTS/TSGR-0225303v510</a>
T1 (ATIS)	T1.3GPP.25.303V510-2003	5.1.0	Approved	27/03/2003	<a href="https://www.atis.org/atis/docstore/search.asp?committee=S24">https://www.atis.org/atis/docstore/search.asp?committee=S24</a>
TTA	TTAT.3G-25.303(R5-5.1.0)	5.1.0	Approved	21/03/2003	<a href="http://www.tta.or.kr/standardDB/stnfile/TTAT.3G-25.303(R5-5.1.0).zip">http://www.tta.or.kr/standardDB/stnfile/TTAT.3G-25.303(R5-5.1.0).zip</a>
<b>Release 6</b>					
ARIB	ARIB STD-T63-25.303	6.0.0	Approved	25/05/2004	<a href="http://www.arib.or.jp/IMT-2000/ARIB-STD/ITU-R/Rel6/A25303-600.pdf">http://www.arib.or.jp/IMT-2000/ARIB-STD/ITU-R/Rel6/A25303-600.pdf</a>
ETSI	ETSI TS 125 303	6.0.0	Published	14/01/2004	<a href="http://pda.etsi.org/pda/home.asp?wkr=RTS/TSGR-0225303v600">http://pda.etsi.org/pda/home.asp?wkr=RTS/TSGR-0225303v600</a>
T1 (ATIS)	T1.3GPP.25.303V600-2004	6.0.0	Approved	21/05/2004	<a href="https://www.atis.org/atis/docstore/search.asp?committee=S24">https://www.atis.org/atis/docstore/search.asp?committee=S24</a>
TTA	TTAT.3G-25.303(R6-6.0.0)	6.0.0	Approved	25/05/2004	<a href="http://www.tta.or.kr/standardDB/stnfile/TTAT.3G-25.303(R6-6.0.0).zip">http://www.tta.or.kr/standardDB/stnfile/TTAT.3G-25.303(R6-6.0.0).zip</a>

#### 5.1.2.2.4 25.304

#### UE procedures in idle mode and procedures for cell reselection in connected mode

This specification describes the overall idle mode process for the UE and the functional division between the non-access stratum and access stratum in the UE. The UE is in idle mode when the connection of the UE is closed on all layers, e.g. there is neither an MM connection nor an RRC connection. This specification presents also examples of inter-layer procedures related to the idle mode processes and describes idle mode functionality of a dual mode UMTS/GSM UE.

SDO (2)	Document No.	Version	Status	Issued date	Location (1)
<b>Release 99</b>					
ARIB	ARIB STD-T63-25.304	3.13.0	Approved	25/05/2004	<a href="http://www.arib.or.jp/IMT-2000/ARIB-STD/ITU-R/R99/A25304-3d0.pdf">http://www.arib.or.jp/IMT-2000/ARIB-STD/ITU-R/R99/A25304-3d0.pdf</a>
CCSA	CCSA-TSD-DS-25.304	3D0	Approved	01/07/2003	<a href="http://www.ccsa.org.cn/english/tc/files.php?docpath=/ITU-R/M.1457/M.1457-4/DS/">http://www.ccsa.org.cn/english/tc/files.php?docpath=/ITU-R/M.1457/M.1457-4/DS/</a>
ETSI	ETSI TS 125 304	3.13.0	Published	03/07/2003	<a href="http://pda.etsi.org/pda/home.asp?wkr=RTS/TSGR-0225304v3d0">http://pda.etsi.org/pda/home.asp?wkr=RTS/TSGR-0225304v3d0</a>
T1 (ATIS)	T1.3GPP.25.304V3130-2004	3.13.0	Approved	21/05/2004	<a href="https://www.atis.org/atis/docstore/search.asp?committee=S24">https://www.atis.org/atis/docstore/search.asp?committee=S24</a>
TTA	TTAT.3G-25.304(R99-3.13.0)	3.13.0	Approved	25/05/2004	<a href="http://www.tta.or.kr/standardDB/stnfile/TTAT.3G-25.304(R99-3.13.0).zip">http://www.tta.or.kr/standardDB/stnfile/TTAT.3G-25.304(R99-3.13.0).zip</a>
<b>Release 4</b>					
ARIB	ARIB STD-T63-25.304	4.7.0	Approved	25/05/2004	<a href="http://www.arib.or.jp/IMT-2000/ARIB-STD/ITU-R/Rel4/A25304-470.pdf">http://www.arib.or.jp/IMT-2000/ARIB-STD/ITU-R/Rel4/A25304-470.pdf</a>
CCSA	CCSA-TSD-DS-25.304	470	Approved	01/07/2003	<a href="http://www.ccsa.org.cn/english/tc/files.php?docpath=/ITU-R/M.1457/M.1457-4/DS/">http://www.ccsa.org.cn/english/tc/files.php?docpath=/ITU-R/M.1457/M.1457-4/DS/</a>



ETSI	ETSI TS 125 304	4.7.0	Published	03/07/2003	<a href="http://pda.etsi.org/pda/home.asp?wkr=RTS/TSGR-0225304v470">http://pda.etsi.org/pda/home.asp?wkr=RTS/TSGR-0225304v470</a>
T1 (ATIS)	T1.3GPP.25.304V470-2004	4.7.0	Approved	21/05/2004	<a href="https://www.atis.org/atis/docstore/search.asp?committee=S24">https://www.atis.org/atis/docstore/search.asp?committee=S24</a>
TTA	TTAT.3G-25.304(R4-4.7.0)	4.7.0	Approved	25/05/2004	<a href="http://www.tta.or.kr/standardDB/stnfile/TTAT.3G-25.304(R4-4.7.0).zip">http://www.tta.or.kr/standardDB/stnfile/TTAT.3G-25.304(R4-4.7.0).zip</a>
<b>Release 5</b>					
ARIB	ARIB STD-T63-25.304	5.3.0	Approved	25/05/2004	<a href="http://www.arib.or.jp/IMT-2000/ARIB-STD/ITU-R/Rel5/A25304-530.pdf">http://www.arib.or.jp/IMT-2000/ARIB-STD/ITU-R/Rel5/A25304-530.pdf</a>
CCSA	CCSA-TSD-DS-25.304	530	Approved	01/07/2003	<a href="http://www.ccsa.org.cn/english/tc/files.php?docpath=/ITU-R/M.1457/M.1457-4/DS/">http://www.ccsa.org.cn/english/tc/files.php?docpath=/ITU-R/M.1457/M.1457-4/DS/</a>
ETSI	ETSI TS 125 304	5.3.0	Published	03/07/2003	<a href="http://pda.etsi.org/pda/home.asp?wkr=RTS/TSGR-0225304v530">http://pda.etsi.org/pda/home.asp?wkr=RTS/TSGR-0225304v530</a>
T1 (ATIS)	T1.3GPP.25.304V530-2004	5.3.0	Approved	21/05/2004	<a href="https://www.atis.org/atis/docstore/search.asp?committee=S24">https://www.atis.org/atis/docstore/search.asp?committee=S24</a>
TTA	TTAT.3G-25.304(R5-5.3.0)	5.3.0	Approved	25/05/2004	<a href="http://www.tta.or.kr/standardDB/stnfile/TTAT.3G-25.304(R5-5.3.0).zip">http://www.tta.or.kr/standardDB/stnfile/TTAT.3G-25.304(R5-5.3.0).zip</a>
<b>Release 6</b>					
ARIB	ARIB STD-T63-25.304	6.0.0	Approved	25/05/2004	<a href="http://www.arib.or.jp/IMT-2000/ARIB-STD/ITU-R/Rel6/A25304-600.pdf">http://www.arib.or.jp/IMT-2000/ARIB-STD/ITU-R/Rel6/A25304-600.pdf</a>
ETSI	ETSI TS 125 304	6.0.0	Published	14/01/2004	<a href="http://pda.etsi.org/pda/home.asp?wkr=RTS/TSGR-0225304v600">http://pda.etsi.org/pda/home.asp?wkr=RTS/TSGR-0225304v600</a>
T1 (ATIS)	T1.3GPP.25.304V600-2004	6.0.0	Approved	21/05/2004	<a href="https://www.atis.org/atis/docstore/search.asp?committee=S24">https://www.atis.org/atis/docstore/search.asp?committee=S24</a>
TTA	TTAT.3G-25.304(R6-6.0.0)	6.0.0	Approved	25/05/2004	<a href="http://www.tta.or.kr/standardDB/stnfile/TTAT.3G-25.304(R6-6.0.0).zip">http://www.tta.or.kr/standardDB/stnfile/TTAT.3G-25.304(R6-6.0.0).zip</a>

### 5.1.2.2.5 25.305

#### Stage 2 Functional Specification of UE positioning in UTRAN (LCS)

This document specifies the stage 2 of the UE Positioning function of UTRAN, which provides the mechanisms to support the calculation of the geographical position of a UE.

SDO (2)	Document No.	Version	Status	Issued date	Location (1)
<b>Release 99</b>					
ARIB	ARIB STD-T63-25.305	3.11.0	Approved	25/05/2004	<a href="http://www.arib.or.jp/IMT-2000/ARIB-STD/ITU-R/R99/A25305-3b0.pdf">http://www.arib.or.jp/IMT-2000/ARIB-STD/ITU-R/R99/A25305-3b0.pdf</a>
CCSA	CCSA-TSD-DS-25.305	390	Approved	01/07/2003	<a href="http://www.ccsa.org.cn/english/tc/files.php?docpath=/ITU-R/M.1457/M.1457-4/DS/">http://www.ccsa.org.cn/english/tc/files.php?docpath=/ITU-R/M.1457/M.1457-4/DS/</a>
ETSI	ETSI TS 125 305	3.11.0	Published	13/01/2004	<a href="http://pda.etsi.org/pda/home.asp?wkr=RTS/TSGR-0225305v3b0">http://pda.etsi.org/pda/home.asp?wkr=RTS/TSGR-0225305v3b0</a>
T1 (ATIS)	T1.3GPP.25.305V3110-2004	3.11.0	Approved	21/05/2004	<a href="https://www.atis.org/atis/docstore/search.asp?committee=S24">https://www.atis.org/atis/docstore/search.asp?committee=S24</a>
TTA	TTAT.3G-25.305(R99-3.11.0)	3.11.0	Approved	25/05/2004	<a href="http://www.tta.or.kr/standardDB/stnfile/TTAT.3G-25.305(R99-3.11.0).zip">http://www.tta.or.kr/standardDB/stnfile/TTAT.3G-25.305(R99-3.11.0).zip</a>
<b>Release 4</b>					
ARIB	ARIB STD-T63-25.305	4.7.0	Approved	25/05/2004	<a href="http://www.arib.or.jp/IMT-2000/ARIB-STD/ITU-R/Rel4/A25305-470.pdf">http://www.arib.or.jp/IMT-2000/ARIB-STD/ITU-R/Rel4/A25305-470.pdf</a>
CCSA	CCSA-TSD-DS-25.305	450	Approved	01/07/2003	<a href="http://www.ccsa.org.cn/english/tc/files.php?docpath=/ITU-R/M.1457/M.1457-4/DS/">http://www.ccsa.org.cn/english/tc/files.php?docpath=/ITU-R/M.1457/M.1457-4/DS/</a>
ETSI	ETSI TS 125 305	4.7.0	Published	13/01/2004	<a href="http://pda.etsi.org/pda/home.asp?wkr=RTS/TSGR-0225305v470">http://pda.etsi.org/pda/home.asp?wkr=RTS/TSGR-0225305v470</a>
T1 (ATIS)	T1.3GPP.25.305V470-2004	4.7.0	Approved	21/05/2004	<a href="https://www.atis.org/atis/docstore/search.asp?committee=S24">https://www.atis.org/atis/docstore/search.asp?committee=S24</a>
TTA	TTAT.3G-25.305(R4-4.7.0)	4.7.0	Approved	25/05/2004	<a href="http://www.tta.or.kr/standardDB/stnfile/TTAT.3G-25.305(R4-4.7.0).zip">http://www.tta.or.kr/standardDB/stnfile/TTAT.3G-25.305(R4-4.7.0).zip</a>
<b>Release 5</b>					
ARIB	ARIB STD-T63-25.305	5.8.0	Approved	25/05/2004	<a href="http://www.arib.or.jp/IMT-2000/ARIB-STD/ITU-R/Rel5/A25305-580.pdf">http://www.arib.or.jp/IMT-2000/ARIB-STD/ITU-R/Rel5/A25305-580.pdf</a>
CCSA	CCSA-TSD-DS-25.305	560	Approved	01/07/2003	<a href="http://www.ccsa.org.cn/english/tc/files.php?docpath=/ITU-R/M.1457/M.1457-4/DS/">http://www.ccsa.org.cn/english/tc/files.php?docpath=/ITU-R/M.1457/M.1457-4/DS/</a>
ETSI	ETSI TS 125 305	5.8.0	Published	14/01/2004	<a href="http://pda.etsi.org/pda/home.asp?wkr=RTS/TSGR-0225305v580">http://pda.etsi.org/pda/home.asp?wkr=RTS/TSGR-0225305v580</a>
T1 (ATIS)	T1.3GPP.25.305V580-2004	5.8.0	Approved	21/05/2004	<a href="https://www.atis.org/atis/docstore/search.asp?committee=S24">https://www.atis.org/atis/docstore/search.asp?committee=S24</a>

TTA	TTAT.3G-25.305(R5-5.8.0)	5.8.0	Approved	25/05/2004	<a href="http://www.tta.or.kr/standardDB/stnfile/TTAT.3G-25.305(R5-5.8.0).zip">http://www.tta.or.kr/standardDB/stnfile/TTAT.3G-25.305(R5-5.8.0).zip</a>
<b>Release 6</b>					
ARIB	ARIB STD-T63-25.305	6.0.0	Approved	25/05/2004	<a href="http://www.arib.or.jp/IMT-2000/ARIB-STD/ITU-R/Rel6/A25305-600.pdf">http://www.arib.or.jp/IMT-2000/ARIB-STD/ITU-R/Rel6/A25305-600.pdf</a>
ETSI	ETSI TS 125 305	6.0.0	Published	14/01/2004	<a href="http://pda.etsi.org/pda/home.asp?wkr=RTS/TSGR-0225305v600">http://pda.etsi.org/pda/home.asp?wkr=RTS/TSGR-0225305v600</a>
T1 (ATIS)	T1.3GPP.25.305V600-2004	6.0.0	Approved	21/05/2004	<a href="https://www.atis.org/atis/docstore/search.asp?committee=S24">https://www.atis.org/atis/docstore/search.asp?committee=S24</a>
TTA	TTAT.3G-25.305(R6-6.0.0)	6.0.0	Approved	25/05/2004	<a href="http://www.tta.or.kr/standardDB/stnfile/TTAT.3G-25.305(R6-6.0.0).zip">http://www.tta.or.kr/standardDB/stnfile/TTAT.3G-25.305(R6-6.0.0).zip</a>

### 5.1.2.2.6 25.306

#### UE Radio Access capabilities definition

This document identifies the parameters of the access stratum part of the UE radio access capabilities. Furthermore, some reference configurations of these values are defined. The intention is that these configurations will be used for test specifications.

SDO (2)	Document No.	Version	Status	Issued date	Location (1)
<b>Release 99</b>					
ARIB	ARIB STD-T63-25.306	3.10.0	Approved	25/05/2004	<a href="http://www.arib.or.jp/IMT-2000/ARIB-STD/ITU-R/R99/A25306-3a0.pdf">http://www.arib.or.jp/IMT-2000/ARIB-STD/ITU-R/R99/A25306-3a0.pdf</a>
CCSA	CCSA-TSD-DS-25.306	380	Approved	01/07/2003	<a href="http://www.ccsa.org.cn/english/tc/files.php?docpath=/ITU-R/M.1457/M.1457-4/DS/">http://www.ccsa.org.cn/english/tc/files.php?docpath=/ITU-R/M.1457/M.1457-4/DS/</a>
ETSI	ETSI TS 125 306	3.10.0	Published	14/01/2004	<a href="http://pda.etsi.org/pda/home.asp?wkr=RTS/TSGR-0225306v3a0">http://pda.etsi.org/pda/home.asp?wkr=RTS/TSGR-0225306v3a0</a>
T1 (ATIS)	T1.3GPP.25.306V3100-2004	3.10.0	Approved	21/05/2004	<a href="https://www.atis.org/atis/docstore/search.asp?committee=S24">https://www.atis.org/atis/docstore/search.asp?committee=S24</a>
TTA	TTAT.3G-25.306(R99-3.10.0)	3.10.0	Approved	25/05/2004	<a href="http://www.tta.or.kr/standardDB/stnfile/TTAT.3G-25.306(R99-3.10.0).zip">http://www.tta.or.kr/standardDB/stnfile/TTAT.3G-25.306(R99-3.10.0).zip</a>
<b>Release 4</b>					
ARIB	ARIB STD-T63-25.306	4.9.0	Approved	25/05/2004	<a href="http://www.arib.or.jp/IMT-2000/ARIB-STD/ITU-R/Rel4/A25306-490.pdf">http://www.arib.or.jp/IMT-2000/ARIB-STD/ITU-R/Rel4/A25306-490.pdf</a>
CCSA	CCSA-TSD-DS-25.306	470	Approved	01/07/2003	<a href="http://www.ccsa.org.cn/english/tc/files.php?docpath=/ITU-R/M.1457/M.1457-4/DS/">http://www.ccsa.org.cn/english/tc/files.php?docpath=/ITU-R/M.1457/M.1457-4/DS/</a>
ETSI	ETSI TS 125 306	4.9.0	Published	14/01/2004	<a href="http://pda.etsi.org/pda/home.asp?wkr=RTS/TSGR-0225306v490">http://pda.etsi.org/pda/home.asp?wkr=RTS/TSGR-0225306v490</a>
T1 (ATIS)	T1.3GPP.25.306V490-2004	4.9.0	Approved	21/05/2004	<a href="https://www.atis.org/atis/docstore/search.asp?committee=S24">https://www.atis.org/atis/docstore/search.asp?committee=S24</a>
TTA	TTAT.3G-25.306(R4-4.9.0)	4.9.0	Approved	25/05/2004	<a href="http://www.tta.or.kr/standardDB/stnfile/TTAT.3G-25.306(R4-4.9.0).zip">http://www.tta.or.kr/standardDB/stnfile/TTAT.3G-25.306(R4-4.9.0).zip</a>
<b>Release 5</b>					
ARIB	ARIB STD-T63-25.306	5.7.0	Approved	25/05/2004	<a href="http://www.arib.or.jp/IMT-2000/ARIB-STD/ITU-R/Rel5/A25306-570.pdf">http://www.arib.or.jp/IMT-2000/ARIB-STD/ITU-R/Rel5/A25306-570.pdf</a>
CCSA	CCSA-TSD-DS-25.306	550	Approved	01/07/2003	<a href="http://www.ccsa.org.cn/english/tc/files.php?docpath=/ITU-R/M.1457/M.1457-4/DS/">http://www.ccsa.org.cn/english/tc/files.php?docpath=/ITU-R/M.1457/M.1457-4/DS/</a>
ETSI	ETSI TS 125 306	5.7.0	Published	14/01/2004	<a href="http://pda.etsi.org/pda/home.asp?wkr=RTS/TSGR-0225306v570">http://pda.etsi.org/pda/home.asp?wkr=RTS/TSGR-0225306v570</a>
T1 (ATIS)	T1.3GPP.25.306V570-2004	5.7.0	Approved	21/05/2004	<a href="https://www.atis.org/atis/docstore/search.asp?committee=S24">https://www.atis.org/atis/docstore/search.asp?committee=S24</a>
TTA	TTAT.3G-25.306(R5-5.7.0)	5.7.0	Approved	25/05/2004	<a href="http://www.tta.or.kr/standardDB/stnfile/TTAT.3G-25.306(R5-5.7.0).zip">http://www.tta.or.kr/standardDB/stnfile/TTAT.3G-25.306(R5-5.7.0).zip</a>
<b>Release 6</b>					
ARIB	ARIB STD-T63-25.306	6.0.0	Approved	25/05/2004	<a href="http://www.arib.or.jp/IMT-2000/ARIB-STD/ITU-R/Rel6/A25306-600.pdf">http://www.arib.or.jp/IMT-2000/ARIB-STD/ITU-R/Rel6/A25306-600.pdf</a>
ETSI	ETSI TS 125 306	6.0.0	Published	14/01/2004	<a href="http://pda.etsi.org/pda/home.asp?wkr=RTS/TSGR-0225306v600">http://pda.etsi.org/pda/home.asp?wkr=RTS/TSGR-0225306v600</a>
T1 (ATIS)	T1.3GPP.25.306V600-2004	6.0.0	Approved	21/05/2004	<a href="https://www.atis.org/atis/docstore/search.asp?committee=S24">https://www.atis.org/atis/docstore/search.asp?committee=S24</a>
TTA	TTAT.3G-25.306(R6-6.0.0)	6.0.0	Approved	25/05/2004	<a href="http://www.tta.or.kr/standardDB/stnfile/TTAT.3G-25.306(R6-6.0.0).zip">http://www.tta.or.kr/standardDB/stnfile/TTAT.3G-25.306(R6-6.0.0).zip</a>

**5.1.2.2.7 25.307****Requirements on UE supporting a release-independent frequency band**

This document specifies requirements on UEs supporting a frequency band that is independent of release.

SDO (2)	Document No.	Version	Status	Issued date	Location (1)
<b>Release 99</b>					
ARIB	ARIB STD-T63-25.307	3.2.0	Approved	25/05/2004	<a href="http://www.arib.or.jp/IMT-2000/ARIB-STD/ITU-R/R99/A25307-320.pdf">http://www.arib.or.jp/IMT-2000/ARIB-STD/ITU-R/R99/A25307-320.pdf</a>
CCSA	CCSA-TSD-DS-25.307	310	Approved	01/07/2003	<a href="http://www.ccsa.org.cn/english/tc/files.php?docpath=/ITU-R/M.1457/M.1457-4/DS/">http://www.ccsa.org.cn/english/tc/files.php?docpath=/ITU-R/M.1457/M.1457-4/DS/</a>
ETSI	ETSI TS 125 307	3.2.0	Published	14/01/2004	<a href="http://pda.etsi.org/pda/home.asp?wkr=RTS/TSGR-0225307v320">http://pda.etsi.org/pda/home.asp?wkr=RTS/TSGR-0225307v320</a>
T1 (ATIS)	T1.3GPP.25.307V320-2004	3.2.0	Approved	21/05/2004	<a href="https://www.atis.org/atis/docstore/search.asp?committee=S24">https://www.atis.org/atis/docstore/search.asp?committee=S24</a>
TTA	TTAT.3G-25.307(R99-3.2.0)	3.2.0	Approved	25/05/2004	<a href="http://www.tta.or.kr/standardDB/stnfile/TTAT.3G-25.307(R99-3.2.0).zip">http://www.tta.or.kr/standardDB/stnfile/TTAT.3G-25.307(R99-3.2.0).zip</a>
<b>Release 4</b>					
ARIB	ARIB STD-T63-25.307	4.2.0	Approved	25/05/2004	<a href="http://www.arib.or.jp/IMT-2000/ARIB-STD/ITU-R/Rel4/A25307-420.pdf">http://www.arib.or.jp/IMT-2000/ARIB-STD/ITU-R/Rel4/A25307-420.pdf</a>
CCSA	CCSA-TSD-DS-25.307	410	Approved	01/07/2003	<a href="http://www.ccsa.org.cn/english/tc/files.php?docpath=/ITU-R/M.1457/M.1457-4/DS/">http://www.ccsa.org.cn/english/tc/files.php?docpath=/ITU-R/M.1457/M.1457-4/DS/</a>
ETSI	ETSI TS 125 307	4.2.0	Published	14/01/2004	<a href="http://pda.etsi.org/pda/home.asp?wkr=RTS/TSGR-0225307v420">http://pda.etsi.org/pda/home.asp?wkr=RTS/TSGR-0225307v420</a>
T1 (ATIS)	T1.3GPP.25.307V420-2004	4.2.0	Approved	21/05/2004	<a href="https://www.atis.org/atis/docstore/search.asp?committee=S24">https://www.atis.org/atis/docstore/search.asp?committee=S24</a>
TTA	TTAT.3G-25.307(R4-4.2.0)	4.2.0	Approved	25/05/2004	<a href="http://www.tta.or.kr/standardDB/stnfile/TTAT.3G-25.307(R4-4.2.0).zip">http://www.tta.or.kr/standardDB/stnfile/TTAT.3G-25.307(R4-4.2.0).zip</a>
<b>Release 5</b>					
ARIB	ARIB STD-T63-25.307	5.1.0	Approved	25/05/2004	<a href="http://www.arib.or.jp/IMT-2000/ARIB-STD/ITU-R/Rel5/A25307-510.pdf">http://www.arib.or.jp/IMT-2000/ARIB-STD/ITU-R/Rel5/A25307-510.pdf</a>
CCSA	CCSA-TSD-DS-25.307	500	Approved	01/07/2003	<a href="http://www.ccsa.org.cn/english/tc/files.php?docpath=/ITU-R/M.1457/M.1457-4/DS/">http://www.ccsa.org.cn/english/tc/files.php?docpath=/ITU-R/M.1457/M.1457-4/DS/</a>
ETSI	ETSI TS 125 307	5.1.0	Published	14/01/2004	<a href="http://pda.etsi.org/pda/home.asp?wkr=RTS/TSGR-0225307v510">http://pda.etsi.org/pda/home.asp?wkr=RTS/TSGR-0225307v510</a>
T1 (ATIS)	T1.3GPP.25.307V510-2004	5.1.0	Approved	21/05/2004	<a href="https://www.atis.org/atis/docstore/search.asp?committee=S24">https://www.atis.org/atis/docstore/search.asp?committee=S24</a>
TTA	TTAT.3G-25.307(R5-5.1.0)	5.1.0	Approved	25/05/2004	<a href="http://www.tta.or.kr/standardDB/stnfile/TTAT.3G-25.307(R5-5.1.0).zip">http://www.tta.or.kr/standardDB/stnfile/TTAT.3G-25.307(R5-5.1.0).zip</a>
<b>Release 6</b>					
ARIB	ARIB STD-T63-25.307	6.0.0	Approved	25/05/2004	<a href="http://www.arib.or.jp/IMT-2000/ARIB-STD/ITU-R/Rel6/A25307-600.pdf">http://www.arib.or.jp/IMT-2000/ARIB-STD/ITU-R/Rel6/A25307-600.pdf</a>
ETSI	ETSI TS 125 307	6.0.0	Published	14/01/2004	<a href="http://pda.etsi.org/pda/home.asp?wkr=RTS/TSGR-0225307v600">http://pda.etsi.org/pda/home.asp?wkr=RTS/TSGR-0225307v600</a>
T1 (ATIS)	T1.3GPP.25.307V600-2004	6.0.0	Approved	21/05/2004	<a href="https://www.atis.org/atis/docstore/search.asp?committee=S24">https://www.atis.org/atis/docstore/search.asp?committee=S24</a>
TTA	TTAT.3G-25.307(R6-6.0.0)	6.0.0	Approved	25/05/2004	<a href="http://www.tta.or.kr/standardDB/stnfile/TTAT.3G-25.307(R6-6.0.0).zip">http://www.tta.or.kr/standardDB/stnfile/TTAT.3G-25.307(R6-6.0.0).zip</a>

**5.1.2.2.8 25.308****UTRA High Speed Downlink Packet Access - Overall Description (Stage 2)**

This document is a technical specification of the overall support of High Speed Downlink Packet Access in UTRA.

SDO (2)	Document No.	Version	Status	Issued date	Location (1)
<b>Release 5</b>					
CCSA	CCSA-TSD-DS-25.308	540	Approved	01/07/2003	<a href="http://www.ccsa.org.cn/english/tc/files.php?docpath=/ITU-R/M.1457/M.1457-4/DS/">http://www.ccsa.org.cn/english/tc/files.php?docpath=/ITU-R/M.1457/M.1457-4/DS/</a>
ETSI	ETSI TS 125 308	5.4.0	Published	03/04/2003	<a href="http://pda.etsi.org/pda/home.asp?wkr=RTS/TSGR-0225308v540">http://pda.etsi.org/pda/home.asp?wkr=RTS/TSGR-0225308v540</a>
T1 (ATIS)	T1.3GPP.25.308V540-2004	5.4.0	Approved	21/05/2004	<a href="https://www.atis.org/atis/docstore/search.asp?committee=S24">https://www.atis.org/atis/docstore/search.asp?committee=S24</a>

## 36

TTA	TTAT.3G-25.308(R5-5.4.0)	5.4.0	Approved
<b>Release 6</b>			
ETSI	ETSI TS 125 308	6.0.0	Published
T1 (ATIS)	T1.3GPP.25.308V600-2004	6.0.0	Approved
TTA	TTAT.3G-25.308(R6-6.0.0)	6.0.0	Approved

## Rec. ITU-R M.1457-4

25/05/2004	<a href="http://www.tta.or.kr/standardDB/stnfile/TTAT.3G-25.308(R5-5.4.0).zip">http://www.tta.or.kr/standardDB/stnfile/TTAT.3G-25.308(R5-5.4.0).zip</a>
14/01/2004	<a href="http://pda.etsi.org/pda/home.asp?wkr=RTS/TSGR-0225308v600">http://pda.etsi.org/pda/home.asp?wkr=RTS/TSGR-0225308v600</a>
21/05/2004	<a href="https://www.atis.org/atis/docstore/search.asp?committee=S24">https://www.atis.org/atis/docstore/search.asp?committee=S24</a>
25/05/2004	<a href="http://www.tta.or.kr/standardDB/stnfile/TTAT.3G-25.308(R6-6.0.0).zip">http://www.tta.or.kr/standardDB/stnfile/TTAT.3G-25.308(R6-6.0.0).zip</a>

### 5.1.2.2.9 25.321

#### Medium access control (MAC) protocol specification

This specification describes the MAC protocol.

SDO (2)	Document No.	Version	Status	Issued date	Location (1)
<b>Release 99</b>					
ARIB	ARIB STD-T63-25.321	3.16.0	Approved	25/05/2004	<a href="http://www.arib.or.jp/IMT-2000/ARIB-STD/ITU-R/R99/A25321-3g0.pdf">http://www.arib.or.jp/IMT-2000/ARIB-STD/ITU-R/R99/A25321-3g0.pdf</a>
CCSA	CCSA-TSD-DS-25.321	3F0	Approved	01/07/2003	<a href="http://www.ccsa.org.cn/english/tc/files.php?docpath=/ITU-R/M.1457/M.1457-4/DS/">http://www.ccsa.org.cn/english/tc/files.php?docpath=/ITU-R/M.1457/M.1457-4/DS/</a>
ETSI	ETSI TS 125 321	3.16.0	Published	09/10/2003	<a href="http://pda.etsi.org/pda/home.asp?wkr=RTS/TSGR-0225321v3g0">http://pda.etsi.org/pda/home.asp?wkr=RTS/TSGR-0225321v3g0</a>
T1 (ATIS)	T1.3GPP.25.321V3160-2004	3.16.0	Approved	21/05/2004	<a href="https://www.atis.org/atis/docstore/search.asp?committee=S24">https://www.atis.org/atis/docstore/search.asp?committee=S24</a>
TTA	TTAT.3G-25.321(R99-3.16.0)	3.16.0	Approved	25/05/2004	<a href="http://www.tta.or.kr/standardDB/stnfile/TTAT.3G-25.321(R99-3.16.0).zip">http://www.tta.or.kr/standardDB/stnfile/TTAT.3G-25.321(R99-3.16.0).zip</a>
<b>Release 4</b>					
ARIB	ARIB STD-T63-25.321	4.9.0	Approved	25/05/2004	<a href="http://www.arib.or.jp/IMT-2000/ARIB-STD/ITU-R/Rel4/A25321-490.pdf">http://www.arib.or.jp/IMT-2000/ARIB-STD/ITU-R/Rel4/A25321-490.pdf</a>
CCSA	CCSA-TSD-DS-25.321	480	Approved	01/07/2003	<a href="http://www.ccsa.org.cn/english/tc/files.php?docpath=/ITU-R/M.1457/M.1457-4/DS/">http://www.ccsa.org.cn/english/tc/files.php?docpath=/ITU-R/M.1457/M.1457-4/DS/</a>
ETSI	ETSI TS 125 321	4.9.0	Published	09/10/2003	<a href="http://pda.etsi.org/pda/home.asp?wkr=RTS/TSGR-0225321v490">http://pda.etsi.org/pda/home.asp?wkr=RTS/TSGR-0225321v490</a>
T1 (ATIS)	T1.3GPP.25.321V490-2004	4.9.0	Approved	21/05/2004	<a href="https://www.atis.org/atis/docstore/search.asp?committee=S24">https://www.atis.org/atis/docstore/search.asp?committee=S24</a>
TTA	TTAT.3G-25.321(R4-4.9.0)	4.9.0	Approved	25/05/2004	<a href="http://www.tta.or.kr/standardDB/stnfile/TTAT.3G-25.321(R4-4.9.0).zip">http://www.tta.or.kr/standardDB/stnfile/TTAT.3G-25.321(R4-4.9.0).zip</a>
<b>Release 5</b>					
ARIB	ARIB STD-T63-25.321	5.7.0	Approved	25/05/2004	<a href="http://www.arib.or.jp/IMT-2000/ARIB-STD/ITU-R/Rel5/A25321-570.pdf">http://www.arib.or.jp/IMT-2000/ARIB-STD/ITU-R/Rel5/A25321-570.pdf</a>
CCSA	CCSA-TSD-DS-25.321	550	Approved	01/07/2003	<a href="http://www.ccsa.org.cn/english/tc/files.php?docpath=/ITU-R/M.1457/M.1457-4/DS/">http://www.ccsa.org.cn/english/tc/files.php?docpath=/ITU-R/M.1457/M.1457-4/DS/</a>
ETSI	ETSI TS 125 321	5.7.0	Published	14/01/2004	<a href="http://pda.etsi.org/pda/home.asp?wkr=RTS/TSGR-0225321v570">http://pda.etsi.org/pda/home.asp?wkr=RTS/TSGR-0225321v570</a>
T1 (ATIS)	T1.3GPP.25.321V570-2004	5.7.0	Approved	21/05/2004	<a href="https://www.atis.org/atis/docstore/search.asp?committee=S24">https://www.atis.org/atis/docstore/search.asp?committee=S24</a>
TTA	TTAT.3G-25.321(R5-5.7.0)	5.7.0	Approved	25/05/2004	<a href="http://www.tta.or.kr/standardDB/stnfile/TTAT.3G-25.321(R5-5.7.0).zip">http://www.tta.or.kr/standardDB/stnfile/TTAT.3G-25.321(R5-5.7.0).zip</a>
<b>Release 6</b>					
ARIB	ARIB STD-T63-25.321	6.0.0	Approved	25/05/2004	<a href="http://www.arib.or.jp/IMT-2000/ARIB-STD/ITU-R/Rel6/A25321-600.pdf">http://www.arib.or.jp/IMT-2000/ARIB-STD/ITU-R/Rel6/A25321-600.pdf</a>
ETSI	ETSI TS 125 321	6.0.0	Published	14/01/2004	<a href="http://pda.etsi.org/pda/home.asp?wkr=RTS/TSGR-0225321v600">http://pda.etsi.org/pda/home.asp?wkr=RTS/TSGR-0225321v600</a>
T1 (ATIS)	T1.3GPP.25.321V600-2004	6.0.0	Approved	21/05/2004	<a href="https://www.atis.org/atis/docstore/search.asp?committee=S24">https://www.atis.org/atis/docstore/search.asp?committee=S24</a>
TTA	TTAT.3G-25.321(R6-6.0.0)	6.0.0	Approved	25/05/2004	<a href="http://www.tta.or.kr/standardDB/stnfile/TTAT.3G-25.321(R6-6.0.0).zip">http://www.tta.or.kr/standardDB/stnfile/TTAT.3G-25.321(R6-6.0.0).zip</a>

**5.1.2.2.10 25.322****Radio link control (RLC) protocol specification**

This specification describes the RLC protocol.

SDO (2)	Document No.	Version	Status	Issued date	Location (1)
<b>Release 99</b>					
CCSA	CCSA-TSD-DS-25.322	3F0	Approved	01/07/2003	<a href="http://www.ccsa.org.cn/english/tc/files.php?docpath=/ITU-R/M.1457/M.1457-4/DS/">http://www.ccsa.org.cn/english/tc/files.php?docpath=/ITU-R/M.1457/M.1457-4/DS/</a>
ETSI	ETSI TS 125 322	3.17.0	Published	16/01/2004	<a href="http://pda.etsi.org/pda/home.asp?wkr=RTS/TSGR-0225322v3h0">http://pda.etsi.org/pda/home.asp?wkr=RTS/TSGR-0225322v3h0</a>
T1 (ATIS)	T1.3GPP.25.322V31720-2004	3.17.0	Approved	21/05/2004	<a href="https://www.atis.org/atis/docstore/search.asp?committee=S24">https://www.atis.org/atis/docstore/search.asp?committee=S24</a>
TTA	TTAT.3G-25.322(R99-3.17.0)	3.17.0	Approved	25/05/2004	<a href="http://www.tta.or.kr/standardDB/stnfile/TTAT.3G-25.322(R99-3.17.0).zip">http://www.tta.or.kr/standardDB/stnfile/TTAT.3G-25.322(R99-3.17.0).zip</a>
TTC	TS-3GA-25.322(R99)v3.17.0	1	Approved	01/02/2004	<a href="http://www.ttc.or.jp/imt/ts/ts25322r99v3h0.pdf">http://www.ttc.or.jp/imt/ts/ts25322r99v3h0.pdf</a>
<b>Release 4</b>					
CCSA	CCSA-TSD-DS-25.322	490	Approved	01/07/2003	<a href="http://www.ccsa.org.cn/english/tc/files.php?docpath=/ITU-R/M.1457/M.1457-4/DS/">http://www.ccsa.org.cn/english/tc/files.php?docpath=/ITU-R/M.1457/M.1457-4/DS/</a>
ETSI	ETSI TS 125 322	4.11.0	Published	16/01/2004	<a href="http://pda.etsi.org/pda/home.asp?wkr=RTS/TSGR-0225322v4b0">http://pda.etsi.org/pda/home.asp?wkr=RTS/TSGR-0225322v4b0</a>
T1 (ATIS)	T1.3GPP.25.322V4110-2004	4.11.0	Approved	21/05/2004	<a href="https://www.atis.org/atis/docstore/search.asp?committee=S24">https://www.atis.org/atis/docstore/search.asp?committee=S24</a>
TTA	TTAT.3G-25.322(R4-4.11.0)	4.11.0	Approved	25/05/2004	<a href="http://www.tta.or.kr/standardDB/stnfile/TTAT.3G-25.322(R4-4.11.0).zip">http://www.tta.or.kr/standardDB/stnfile/TTAT.3G-25.322(R4-4.11.0).zip</a>
TTC	TS-3GA-25.322(Rel4)v4.11.0	1	Approved	01/02/2004	<a href="http://www.ttc.or.jp/imt/ts/ts25322rel4v4b0.pdf">http://www.ttc.or.jp/imt/ts/ts25322rel4v4b0.pdf</a>
<b>Release 5</b>					
CCSA	CCSA-TSD-DS-25.322	550	Approved	01/07/2003	<a href="http://www.ccsa.org.cn/english/tc/files.php?docpath=/ITU-R/M.1457/M.1457-4/DS/">http://www.ccsa.org.cn/english/tc/files.php?docpath=/ITU-R/M.1457/M.1457-4/DS/</a>
ETSI	ETSI TS 125 322	5.7.0	Published	16/01/2004	<a href="http://pda.etsi.org/pda/home.asp?wkr=RTS/TSGR-0225322v570">http://pda.etsi.org/pda/home.asp?wkr=RTS/TSGR-0225322v570</a>
T1 (ATIS)	T1.3GPP.25.322V570-2004	5.7.0	Approved	21/05/2004	<a href="https://www.atis.org/atis/docstore/search.asp?committee=S24">https://www.atis.org/atis/docstore/search.asp?committee=S24</a>
TTA	TTAT.3G-25.322(R5-5.7.0)	5.7.0	Approved	25/05/2004	<a href="http://www.tta.or.kr/standardDB/stnfile/TTAT.3G-25.322(R5-5.7.0).zip">http://www.tta.or.kr/standardDB/stnfile/TTAT.3G-25.322(R5-5.7.0).zip</a>
TTC	TS-3GA-25.322(Rel5)v5.7.0	1	Approved	01/02/2004	<a href="http://www.ttc.or.jp/imt/ts/ts25322rel5v570.pdf">http://www.ttc.or.jp/imt/ts/ts25322rel5v570.pdf</a>
<b>Release 6</b>					
ETSI	ETSI TS 125 322	6.0.0	Published	16/01/2004	<a href="http://pda.etsi.org/pda/home.asp?wkr=RTS/TSGR-0225322v600">http://pda.etsi.org/pda/home.asp?wkr=RTS/TSGR-0225322v600</a>
T1 (ATIS)	T1.3GPP.25.322V600-2004	6.0.0	Approved	21/05/2004	<a href="https://www.atis.org/atis/docstore/search.asp?committee=S24">https://www.atis.org/atis/docstore/search.asp?committee=S24</a>
TTA	TTAT.3G-25.322(R6-6.0.0)	6.0.0	Approved	25/05/2004	<a href="http://www.tta.or.kr/standardDB/stnfile/TTAT.3G-25.322(R6-6.0.0).zip">http://www.tta.or.kr/standardDB/stnfile/TTAT.3G-25.322(R6-6.0.0).zip</a>
TTC	TS-3GA-25.322(Rel6)v6.0.0	1	Approved	01/02/2004	<a href="http://www.ttc.or.jp/imt/ts/ts25322rel6v600.pdf">http://www.ttc.or.jp/imt/ts/ts25322rel6v600.pdf</a>

**5.1.2.2.11 25.323****Packet Data Convergence Protocol (PDCP) protocol**

This document provides the description of the Packet Data Convergence Protocol (PDCP). PDCP provides its services to the NAS at the UE or the relay at the Radio Network Controller (RNC). PDCP uses the services provided by the Radio Link Control (RLC) sublayer.

SDO (2)	Document No.	Version	Status	Issued date	Location (1)
<b>Release 99</b>					
CCSA	CCSA-TSD-DS-25.323	3A0	Approved	01/07/2003	<a href="http://www.ccsa.org.cn/english/tc/files.php?docpath=/ITU-R/M.1457/M.1457-4/DS/">http://www.ccsa.org.cn/english/tc/files.php?docpath=/ITU-R/M.1457/M.1457-4/DS/</a>
ETSI	ETSI TS 125 323	3.10.0	Published	07/10/2002	<a href="http://pda.etsi.org/pda/home.asp?wkr=RTS/TSGR-0225323v3a0">http://pda.etsi.org/pda/home.asp?wkr=RTS/TSGR-0225323v3a0</a>
T1 (ATIS)	T1.3GPP.25.323V3100-2003	3.10.0	Approved	27/03/2003	<a href="https://www.atis.org/atis/docstore/search.asp?committee=S24">https://www.atis.org/atis/docstore/search.asp?committee=S24</a>
TTA	TTAT.3G-25.323(R99-3.10.0)	3.10.0	Approved	21/03/2003	<a href="http://www.tta.or.kr/standardDB/stnfile/TTAT.3G-25.323(R99-3.10.0).zip">http://www.tta.or.kr/standardDB/stnfile/TTAT.3G-25.323(R99-3.10.0).zip</a>
TTC	TS-3GA-25.323(R99)v3.10.0	1	Approved	01/11/2002	<a href="http://www.ttc.or.jp/imt/ts/ts25323r99v3a0.pdf">http://www.ttc.or.jp/imt/ts/ts25323r99v3a0.pdf</a>
<b>Release 4</b>					
CCSA	CCSA-TSD-DS-25.323	460	Approved	01/07/2003	<a href="http://www.ccsa.org.cn/english/tc/files.php?docpath=/ITU-R/M.1457/M.1457-4/DS/">http://www.ccsa.org.cn/english/tc/files.php?docpath=/ITU-R/M.1457/M.1457-4/DS/</a>
ETSI	ETSI TS 125 323	4.6.0	Published	07/10/2002	<a href="http://pda.etsi.org/pda/home.asp?wkr=RTS/TSGR-0225323v460">http://pda.etsi.org/pda/home.asp?wkr=RTS/TSGR-0225323v460</a>
T1 (ATIS)	T1.3GPP.25.323V460-2003	4.6.0	Approved	27/03/2003	<a href="https://www.atis.org/atis/docstore/search.asp?committee=S24">https://www.atis.org/atis/docstore/search.asp?committee=S24</a>
TTA	TTAT.3G-25.323(R4-4.6.0)	4.6.0	Approved	21/03/2003	<a href="http://www.tta.or.kr/standardDB/stnfile/TTAT.3G-25.323(R4-4.6.0).zip">http://www.tta.or.kr/standardDB/stnfile/TTAT.3G-25.323(R4-4.6.0).zip</a>
TTC	TS-3GA-25.323(Rel4)v4.6.0	1	Approved	01/11/2002	<a href="http://www.ttc.or.jp/imt/ts/ts25323rel4v460.pdf">http://www.ttc.or.jp/imt/ts/ts25323rel4v460.pdf</a>
<b>Release 5</b>					
CCSA	CCSA-TSD-DS-25.323	520	Approved	01/07/2003	<a href="http://www.ccsa.org.cn/english/tc/files.php?docpath=/ITU-R/M.1457/M.1457-4/DS/">http://www.ccsa.org.cn/english/tc/files.php?docpath=/ITU-R/M.1457/M.1457-4/DS/</a>
ETSI	ETSI TS 125 323	5.2.0	Published	07/10/2002	<a href="http://pda.etsi.org/pda/home.asp?wkr=RTS/TSGR-0225323v520">http://pda.etsi.org/pda/home.asp?wkr=RTS/TSGR-0225323v520</a>
T1 (ATIS)	T1.3GPP.25.323V520-2003	5.2.0	Approved	27/03/2003	<a href="https://www.atis.org/atis/docstore/search.asp?committee=S24">https://www.atis.org/atis/docstore/search.asp?committee=S24</a>
TTA	TTAT.3G-25.323(R5-5.2.0)	5.2.0	Approved	21/03/2003	<a href="http://www.tta.or.kr/standardDB/stnfile/TTAT.3G-25.323(R5-5.2.0).zip">http://www.tta.or.kr/standardDB/stnfile/TTAT.3G-25.323(R5-5.2.0).zip</a>
TTC	TS-3GA-25.323(Rel5)v5.2.0	1	Approved	01/11/2002	<a href="http://www.ttc.or.jp/imt/ts/ts25323rel5v520.pdf">http://www.ttc.or.jp/imt/ts/ts25323rel5v520.pdf</a>
<b>Release 6</b>					
ETSI	ETSI TS 125 323	6.0.0	Published	16/01/2004	<a href="http://pda.etsi.org/pda/home.asp?wkr=RTS/TSGR-0225323v600">http://pda.etsi.org/pda/home.asp?wkr=RTS/TSGR-0225323v600</a>
T1 (ATIS)	T1.3GPP.25.323V600-2004	6.0.0	Approved	21/05/2004	<a href="https://www.atis.org/atis/docstore/search.asp?committee=S24">https://www.atis.org/atis/docstore/search.asp?committee=S24</a>
TTA	TTAT.3G-25.323(R6-6.0.0)	6.0.0	Approved	25/05/2004	<a href="http://www.tta.or.kr/standardDB/stnfile/TTAT.3G-25.323(R6-6.0.0).zip">http://www.tta.or.kr/standardDB/stnfile/TTAT.3G-25.323(R6-6.0.0).zip</a>
TTC	TS-3GA-25.323(Rel6)v6.0.0	1	Approved	01/02/2004	<a href="http://www.ttc.or.jp/imt/ts/ts25323rel6v600.pdf">http://www.ttc.or.jp/imt/ts/ts25323rel6v600.pdf</a>

### 5.1.2.2.12 25.324

#### Broadcast/Multicast Control (BMC) Services

This document provides the description of the Broadcast/Multicast Control Protocol (BMC). This protocol adapts broadcast and multicast services on the radio interface.

SDO (2)	Document No.	Version	Status	Issued date	Location (1)
<b>Release 99</b>					
CCSA	CCSA-TSD-DS-25.324	370	Approved	01/07/2003	<a href="http://www.ccsa.org.cn/english/tc/files.php?docpath=/ITU-R/M.1457/M.1457-4/DS/">http://www.ccsa.org.cn/english/tc/files.php?docpath=/ITU-R/M.1457/M.1457-4/DS/</a>
ETSI	ETSI TS 125 324	3.7.0	Published	03/04/2003	<a href="http://pda.etsi.org/pda/home.asp?wkr=RTS/TSGR-0225324v370">http://pda.etsi.org/pda/home.asp?wkr=RTS/TSGR-0225324v370</a>
T1 (ATIS)	T1.3GPP.25.324V370-2004	3.7.0	Approved	21/05/2004	<a href="https://www.atis.org/atis/docstore/search.asp?committee=S24">https://www.atis.org/atis/docstore/search.asp?committee=S24</a>
TTA	TTAT.3G-25.324(R99-3.7.0)	3.7.0	Approved	25/05/2004	<a href="http://www.tta.or.kr/standardDB/stnfile/TTAT.3G-25.324(R99-3.7.0).zip">http://www.tta.or.kr/standardDB/stnfile/TTAT.3G-25.324(R99-3.7.0).zip</a>
TTC	TS-3GA-25.324(R99)v3.7.0	1	Approved	01/05/2003	<a href="http://www.ttc.or.jp/imt/ts/ts25324r99v370.pdf">http://www.ttc.or.jp/imt/ts/ts25324r99v370.pdf</a>



**Release 4**

CCSA	CCSA-TSD-DS-25.324	430	Approved	01/07/2003	<a href="http://www.ccsa.org.cn/english/tc/files.php?docpath=/ITU-R/M.1457/M.1457-4/DS/">http://www.ccsa.org.cn/english/tc/files.php?docpath=/ITU-R/M.1457/M.1457-4/DS/</a>
ETSI	ETSI TS 125 324	4.3.0	Published	03/04/2003	<a href="http://pda.etsi.org/pda/home.asp?wkr=RTS/TSGR-0225324v430">http://pda.etsi.org/pda/home.asp?wkr=RTS/TSGR-0225324v430</a>
T1 (ATIS)	T1.3GPP.25.324V430-2004	4.3.0	Approved	21/05/2004	<a href="https://www.atis.org/atis/docstore/search.asp?committee=S24">https://www.atis.org/atis/docstore/search.asp?committee=S24</a>
TTA	TTAT.3G-25.324(R4-4.3.0)	4.3.0	Approved	25/05/2004	<a href="http://www.tta.or.kr/standardDB/stnfile/TTAT.3G-25.324(R4-4.3.0).zip">http://www.tta.or.kr/standardDB/stnfile/TTAT.3G-25.324(R4-4.3.0).zip</a>
TTC	TS-3GA-25.324(Rel4)v4.3.0	1	Approved	01/05/2003	<a href="http://www.ttc.or.jp/imt/ts/ts25324rel4v430.pdf">http://www.ttc.or.jp/imt/ts/ts25324rel4v430.pdf</a>

**Release 5**

CCSA	CCSA-TSD-DS-25.324	530	Approved	01/07/2003	<a href="http://www.ccsa.org.cn/english/tc/files.php?docpath=/ITU-R/M.1457/M.1457-4/DS/">http://www.ccsa.org.cn/english/tc/files.php?docpath=/ITU-R/M.1457/M.1457-4/DS/</a>
ETSI	ETSI TS 125 324	5.3.0	Published	03/04/2003	<a href="http://pda.etsi.org/pda/home.asp?wkr=RTS/TSGR-0225324v530">http://pda.etsi.org/pda/home.asp?wkr=RTS/TSGR-0225324v530</a>
T1 (ATIS)	T1.3GPP.25.324V530-2004	5.3.0	Approved	21/05/2004	<a href="https://www.atis.org/atis/docstore/search.asp?committee=S24">https://www.atis.org/atis/docstore/search.asp?committee=S24</a>
TTA	TTAT.3G-25.324(R5-5.3.0)	5.3.0	Approved	25/05/2004	<a href="http://www.tta.or.kr/standardDB/stnfile/TTAT.3G-25.324(R5-5.3.0).zip">http://www.tta.or.kr/standardDB/stnfile/TTAT.3G-25.324(R5-5.3.0).zip</a>
TTC	TS-3GA-25.324(Rel5)v5.3.0	1	Approved	01/05/2003	<a href="http://www.ttc.or.jp/imt/ts/ts25324rel5v530.pdf">http://www.ttc.or.jp/imt/ts/ts25324rel5v530.pdf</a>

**Release 6**

ETSI	ETSI TS 125 324	6.0.0	Published	16/01/2004	<a href="http://pda.etsi.org/pda/home.asp?wkr=RTS/TSGR-0225324v600">http://pda.etsi.org/pda/home.asp?wkr=RTS/TSGR-0225324v600</a>
T1 (ATIS)	T1.3GPP.25.324V600-2004	6.0.0	Approved	21/05/2004	<a href="https://www.atis.org/atis/docstore/search.asp?committee=S24">https://www.atis.org/atis/docstore/search.asp?committee=S24</a>
TTA	TTAT.3G-25.324(R6-6.0.0)	6.0.0	Approved	25/05/2004	<a href="http://www.tta.or.kr/standardDB/stnfile/TTAT.3G-25.324(R6-6.0.0).zip">http://www.tta.or.kr/standardDB/stnfile/TTAT.3G-25.324(R6-6.0.0).zip</a>
TTC	TS-3GA-25.324(Rel6)v6.0.0	1	Approved	01/02/2004	<a href="http://www.ttc.or.jp/imt/ts/ts25324rel6v600.pdf">http://www.ttc.or.jp/imt/ts/ts25324rel6v600.pdf</a>

**5.1.2.2.13 25.331****Radio resource control (RRC) protocol specification**

This specification describes the RRC protocol for the radio system. The scope of this specification contains also the information to be transported in a transparent container between source RNC and target RNC in connection to SRNC relocation.

SDO (2)	Document No.	Version	Status	Issued date	Location (1)
<b>Release 99</b>					
CCSA	CCSA-TSD-DS-25.331	3F0	Approved	01/07/2003	<a href="http://www.ccsa.org.cn/english/tc/files.php?docpath=/ITU-R/M.1457/M.1457-4/DS/">http://www.ccsa.org.cn/english/tc/files.php?docpath=/ITU-R/M.1457/M.1457-4/DS/</a>
ETSI	ETSI TS 125 331	3.17.0	Published	16/01/2004	<a href="http://pda.etsi.org/pda/home.asp?wkr=RTS/TSGR-0225331v3h0">http://pda.etsi.org/pda/home.asp?wkr=RTS/TSGR-0225331v3h0</a>
T1 (ATIS)	T1.3GPP.25.331V3170-2004	3.17.0	Approved	21/05/2004	<a href="https://www.atis.org/atis/docstore/search.asp?committee=S24">https://www.atis.org/atis/docstore/search.asp?committee=S24</a>
TTA	TTAT.3G-25.331(R99-3.17.0)	3.17.0	Approved	25/05/2004	<a href="http://www.tta.or.kr/standardDB/stnfile/TTAT.3G-25.331(R99-3.17.0).zip">http://www.tta.or.kr/standardDB/stnfile/TTAT.3G-25.331(R99-3.17.0).zip</a>
TTC	TS-3GA-25.331(R99)v3.17.0	1	Approved	01/02/2004	<a href="http://www.ttc.or.jp/imt/ts/ts25331r99v3h0.pdf">http://www.ttc.or.jp/imt/ts/ts25331r99v3h0.pdf</a>
<b>Release 4</b>					
CCSA	CCSA-TSD-DS-25.331	4A0	Approved	01/07/2003	<a href="http://www.ccsa.org.cn/english/tc/files.php?docpath=/ITU-R/M.1457/M.1457-4/DS/">http://www.ccsa.org.cn/english/tc/files.php?docpath=/ITU-R/M.1457/M.1457-4/DS/</a>
ETSI	ETSI TS 125 331	4.12.0	Published	19/01/2004	<a href="http://pda.etsi.org/pda/home.asp?wkr=RTS/TSGR-0225331v4c0">http://pda.etsi.org/pda/home.asp?wkr=RTS/TSGR-0225331v4c0</a>
T1 (ATIS)	T1.3GPP.25.331V4120-2004	4.12.0	Approved	21/05/2004	<a href="https://www.atis.org/atis/docstore/search.asp?committee=S24">https://www.atis.org/atis/docstore/search.asp?committee=S24</a>
TTA	TTAT.3G-25.331(R4-4.12.0)	4.12.0	Approved	25/05/2004	<a href="http://www.tta.or.kr/standardDB/stnfile/TTAT.3G-25.331(R4-4.12.0).zip">http://www.tta.or.kr/standardDB/stnfile/TTAT.3G-25.331(R4-4.12.0).zip</a>
TTC	TS-3GA-25.331(Rel4)v4.12.0	1	Approved	01/02/2004	<a href="http://www.ttc.or.jp/imt/ts/ts25331rel4v4c0.pdf">http://www.ttc.or.jp/imt/ts/ts25331rel4v4c0.pdf</a>

**Release 5**

CCSA	CCSA-TSD-DS-25.331	550	Approved	01/07/2003	<a href="http://www.ccsa.org.cn/english/tc/files.php?docpath=/ITU-R/M.1457/M.1457-4/DS/">http://www.ccsa.org.cn/english/tc/files.php?docpath=/ITU-R/M.1457/M.1457-4/DS/</a>
ETSI	ETSI TS 125 331	5.7.1	Published	26/01/2004	<a href="http://pda.etsi.org/pda/home.asp?wkr=RTS/TSGR-0225331v571">http://pda.etsi.org/pda/home.asp?wkr=RTS/TSGR-0225331v571</a>
T1 (ATIS)	T1.3GPP.25.331V571-2004	5.7.1	Approved	21/05/2004	<a href="https://www.atis.org/atis/docstore/search.asp?committee=S24">https://www.atis.org/atis/docstore/search.asp?committee=S24</a>
TTA	TTAT.3G-25.331(R5-5.7.1)	5.7.1	Approved	25/05/2004	<a href="http://www.tta.or.kr/standardDB/stnfile/TTAT.3G-25.331(R5-5.7.1).zip">http://www.tta.or.kr/standardDB/stnfile/TTAT.3G-25.331(R5-5.7.1).zip</a>
TTC	TS-3GA-25.331(Rel5)v5.7.1	1	Approved	01/02/2004	<a href="http://www.ttc.or.jp/imt/ts/25331rel5v571.pdf">http://www.ttc.or.jp/imt/ts/25331rel5v571.pdf</a>

**Release 6**

ETSI	ETSI TS 125 331	6.0.1	Published	26/01/2004	<a href="http://pda.etsi.org/pda/home.asp?wkr=RTS/TSGR-0225331v601">http://pda.etsi.org/pda/home.asp?wkr=RTS/TSGR-0225331v601</a>
T1 (ATIS)	T1.3GPP.25.331V601-2004	6.0.1	Approved	21/05/2004	<a href="https://www.atis.org/atis/docstore/search.asp?committee=S24">https://www.atis.org/atis/docstore/search.asp?committee=S24</a>
TTA	TTAT.3G-25.331(R6-6.0.1)	6.0.1	Approved	25/05/2004	<a href="http://www.tta.or.kr/standardDB/stnfile/TTAT.3G-25.331(R6-6.0.1).zip">http://www.tta.or.kr/standardDB/stnfile/TTAT.3G-25.331(R6-6.0.1).zip</a>

**5.1.2.3****25.400 series****5.1.2.3.1 25.401****UTRAN overall description**

This specification describes the overall architecture of the UTRAN, including internal interfaces and assumptions on the radio and Iu interfaces.

SDO (2)	Document No.	Version	Status	Issued date	Location (1)
<b>Release 99</b>					
ARIB	ARIB STD-T63-25.401	3.10.0	Approved	25/05/2004	<a href="http://www.arib.or.jp/IMT-2000/ARIB-STD/ITU-R/R99/A25401-3a0.pdf">http://www.arib.or.jp/IMT-2000/ARIB-STD/ITU-R/R99/A25401-3a0.pdf</a>
CCSA	CCSA-TSD-DS-25.401	3A0	Approved	01/07/2003	<a href="http://www.ccsa.org.cn/english/tc/files.php?docpath=/ITU-R/M.1457/M.1457-4/DS/">http://www.ccsa.org.cn/english/tc/files.php?docpath=/ITU-R/M.1457/M.1457-4/DS/</a>
ETSI	ETSI TS 125 401	3.10.0	Published	10/07/2002	<a href="http://pda.etsi.org/pda/home.asp?wkr=RTS/TSGR-0325401v3a0">http://pda.etsi.org/pda/home.asp?wkr=RTS/TSGR-0325401v3a0</a>
T1 (ATIS)	T1.3GPP.25.401V3100-2003	3.10.0	Approved	27/03/2003	<a href="https://www.atis.org/atis/docstore/search.asp?committee=S24">https://www.atis.org/atis/docstore/search.asp?committee=S24</a>
TTA	TTAT.3G-25.401(R99-3.10.0)	3.10.0	Approved	21/03/2003	<a href="http://www.tta.or.kr/standardDB/stnfile/TTAT.3G-25.401(R99-3.10.0).zip">http://www.tta.or.kr/standardDB/stnfile/TTAT.3G-25.401(R99-3.10.0).zip</a>
<b>Release 4</b>					
ARIB	ARIB STD-T63-25.401	4.6.0	Approved	25/05/2004	<a href="http://www.arib.or.jp/IMT-2000/ARIB-STD/ITU-R/Rel4/A25401-460.pdf">http://www.arib.or.jp/IMT-2000/ARIB-STD/ITU-R/Rel4/A25401-460.pdf</a>
CCSA	CCSA-TSD-DS-25.401	460	Approved	01/07/2003	<a href="http://www.ccsa.org.cn/english/tc/files.php?docpath=/ITU-R/M.1457/M.1457-4/DS/">http://www.ccsa.org.cn/english/tc/files.php?docpath=/ITU-R/M.1457/M.1457-4/DS/</a>
ETSI	ETSI TS 125 401	4.6.0	Published	08/01/2003	<a href="http://pda.etsi.org/pda/home.asp?wkr=RTS/TSGR-0325401v460">http://pda.etsi.org/pda/home.asp?wkr=RTS/TSGR-0325401v460</a>
T1 (ATIS)	T1.3GPP.25.401V460-2003	4.6.0	Approved	27/03/2003	<a href="https://www.atis.org/atis/docstore/search.asp?committee=S24">https://www.atis.org/atis/docstore/search.asp?committee=S24</a>
TTA	TTAT.3G-25.401(R4-4.6.0)	4.6.0	Approved	21/03/2003	<a href="http://www.tta.or.kr/standardDB/stnfile/TTAT.3G-25.401(R4-4.6.0).zip">http://www.tta.or.kr/standardDB/stnfile/TTAT.3G-25.401(R4-4.6.0).zip</a>
<b>Release 5</b>					
ARIB	ARIB STD-T63-25.401	5.7.0	Approved	25/05/2004	<a href="http://www.arib.or.jp/IMT-2000/ARIB-STD/ITU-R/Rel5/A25401-570.pdf">http://www.arib.or.jp/IMT-2000/ARIB-STD/ITU-R/Rel5/A25401-570.pdf</a>
CCSA	CCSA-TSD-DS-25.401	560	Approved	01/07/2003	<a href="http://www.ccsa.org.cn/english/tc/files.php?docpath=/ITU-R/M.1457/M.1457-4/DS/">http://www.ccsa.org.cn/english/tc/files.php?docpath=/ITU-R/M.1457/M.1457-4/DS/</a>
ETSI	ETSI TS 125 401	5.7.0	Published	19/01/2004	<a href="http://pda.etsi.org/pda/home.asp?wkr=RTS/TSGR-0325401v570">http://pda.etsi.org/pda/home.asp?wkr=RTS/TSGR-0325401v570</a>
T1 (ATIS)	T1.3GPP.25.401V570-2004	5.7.0	Approved	21/05/2004	<a href="https://www.atis.org/atis/docstore/search.asp?committee=S24">https://www.atis.org/atis/docstore/search.asp?committee=S24</a>
TTA	TTAT.3G-25.401(R5-5.7.0)	5.7.0	Approved	25/05/2004	<a href="http://www.tta.or.kr/standardDB/stnfile/TTAT.3G-25.401(R5-5.7.0).zip">http://www.tta.or.kr/standardDB/stnfile/TTAT.3G-25.401(R5-5.7.0).zip</a>



**Release 6**

ARIB	ARIB STD-T63-25.401	6.2.0	Approved	25/05/2004	<a href="http://www.arib.or.jp/IMT-2000/ARIB-STD/ITU-R/Rel6/A25401-620.pdf">http://www.arib.or.jp/IMT-2000/ARIB-STD/ITU-R/Rel6/A25401-620.pdf</a>
CCSA	CCSA-TSD-DS-25.401	610	Approved	01/07/2003	<a href="http://www.ccsa.org.cn/english/tc/files.php?docpath=/ITU-R/M.1457/M.1457-4/DS/">http://www.ccsa.org.cn/english/tc/files.php?docpath=/ITU-R/M.1457/M.1457-4/DS/</a>
ETSI	ETSI TS 125 401	6.2.0	Published	19/01/2004	<a href="http://pda.etsi.org/pda/home.asp?wkr=RTS/TSGR-0325401v620">http://pda.etsi.org/pda/home.asp?wkr=RTS/TSGR-0325401v620</a>
T1 (ATIS)	T1.3GPP.25.401V620-2004	6.2.0	Approved	21/05/2004	<a href="https://www.atis.org/atis/docstore/search.asp?committee=S24">https://www.atis.org/atis/docstore/search.asp?committee=S24</a>
TTA	TTAT.3G-25.401(R6-6.2.0)	6.2.0	Approved	25/05/2004	<a href="http://www.tta.or.kr/standardDB/stnfile/TTAT.3G-25.401(R6-6.2.0).zip">http://www.tta.or.kr/standardDB/stnfile/TTAT.3G-25.401(R6-6.2.0).zip</a>

**5.1.2.3.2 25.402****Synchronization in UTRAN Stage 2**

This document constitutes the stage 2 specification of different synchronisation mechanisms in UTRAN and on Uu.

SDO (2)	Document No.	Version	Status	Issued date	Location (1)
<b>Release 99</b>					
ARIB	ARIB STD-T63-25.402	3.10.0	Approved	25/05/2004	<a href="http://www.arib.or.jp/IMT-2000/ARIB-STD/ITU-R/R99/A25402-3a0.pdf">http://www.arib.or.jp/IMT-2000/ARIB-STD/ITU-R/R99/A25402-3a0.pdf</a>
CCSA	CCSA-TSD-DS-25.402	3A0	Approved	01/07/2003	<a href="http://www.ccsa.org.cn/english/tc/files.php?docpath=/ITU-R/M.1457/M.1457-4/DS/">http://www.ccsa.org.cn/english/tc/files.php?docpath=/ITU-R/M.1457/M.1457-4/DS/</a>
ETSI	ETSI TS 125 402	3.10.0	Published	10/07/2002	<a href="http://pda.etsi.org/pda/home.asp?wkr=RTS/TSGR-0325402v3a0">http://pda.etsi.org/pda/home.asp?wkr=RTS/TSGR-0325402v3a0</a>
T1 (ATIS)	T1.3GPP.25.402V3100-2003	3.10.0	Approved	27/03/2003	<a href="https://www.atis.org/atis/docstore/search.asp?committee=S24">https://www.atis.org/atis/docstore/search.asp?committee=S24</a>
TTA	TTAT.3G-25.402(R99-3.10.0)	3.10.0	Approved	21/03/2003	<a href="http://www.tta.or.kr/standardDB/stnfile/TTAT.3G-25.402(R99-3.10.0).zip">http://www.tta.or.kr/standardDB/stnfile/TTAT.3G-25.402(R99-3.10.0).zip</a>
<b>Release 4</b>					
ARIB	ARIB STD-T63-25.402	4.6.0	Approved	25/05/2004	<a href="http://www.arib.or.jp/IMT-2000/ARIB-STD/ITU-R/Rel4/A25402-460.pdf">http://www.arib.or.jp/IMT-2000/ARIB-STD/ITU-R/Rel4/A25402-460.pdf</a>
CCSA	CCSA-TSD-DS-25.402	460	Approved	01/07/2003	<a href="http://www.ccsa.org.cn/english/tc/files.php?docpath=/ITU-R/M.1457/M.1457-4/DS/">http://www.ccsa.org.cn/english/tc/files.php?docpath=/ITU-R/M.1457/M.1457-4/DS/</a>
ETSI	ETSI TS 125 402	4.6.0	Published	08/01/2003	<a href="http://pda.etsi.org/pda/home.asp?wkr=RTS/TSGR-0325402v460">http://pda.etsi.org/pda/home.asp?wkr=RTS/TSGR-0325402v460</a>
T1 (ATIS)	T1.3GPP.25.402V460-2003	4.6.0	Approved	27/03/2003	<a href="https://www.atis.org/atis/docstore/search.asp?committee=S24">https://www.atis.org/atis/docstore/search.asp?committee=S24</a>
TTA	TTAT.3G-25.402(R4-4.6.0)	4.6.0	Approved	21/03/2003	<a href="http://www.tta.or.kr/standardDB/stnfile/TTAT.3G-25.402(R4-4.6.0).zip">http://www.tta.or.kr/standardDB/stnfile/TTAT.3G-25.402(R4-4.6.0).zip</a>
<b>Release 5</b>					
ARIB	ARIB STD-T63-25.402	5.3.0	Approved	25/05/2004	<a href="http://www.arib.or.jp/IMT-2000/ARIB-STD/ITU-R/Rel5/A25402-530.pdf">http://www.arib.or.jp/IMT-2000/ARIB-STD/ITU-R/Rel5/A25402-530.pdf</a>
CCSA	CCSA-TSD-DS-25.402	520	Approved	01/07/2003	<a href="http://www.ccsa.org.cn/english/tc/files.php?docpath=/ITU-R/M.1457/M.1457-4/DS/">http://www.ccsa.org.cn/english/tc/files.php?docpath=/ITU-R/M.1457/M.1457-4/DS/</a>
ETSI	ETSI TS 125 402	5.3.0	Published	19/01/2004	<a href="http://pda.etsi.org/pda/home.asp?wkr=RTS/TSGR-0325402v530">http://pda.etsi.org/pda/home.asp?wkr=RTS/TSGR-0325402v530</a>
T1 (ATIS)	T1.3GPP.25.402V530-2004	5.3.0	Approved	21/05/2004	<a href="https://www.atis.org/atis/docstore/search.asp?committee=S24">https://www.atis.org/atis/docstore/search.asp?committee=S24</a>
TTA	TTAT.3G-25.402(R5-5.3.0)	5.3.0	Approved	25/05/2004	<a href="http://www.tta.or.kr/standardDB/stnfile/TTAT.3G-25.402(R5-5.3.0).zip">http://www.tta.or.kr/standardDB/stnfile/TTAT.3G-25.402(R5-5.3.0).zip</a>
<b>Release 6</b>					
ARIB	ARIB STD-T63-25.402	6.0.0	Approved	25/05/2004	<a href="http://www.arib.or.jp/IMT-2000/ARIB-STD/ITU-R/Rel6/A25402-600.pdf">http://www.arib.or.jp/IMT-2000/ARIB-STD/ITU-R/Rel6/A25402-600.pdf</a>
ETSI	ETSI TS 125 402	6.0.0	Published	19/01/2004	<a href="http://pda.etsi.org/pda/home.asp?wkr=RTS/TSGR-0325402v600">http://pda.etsi.org/pda/home.asp?wkr=RTS/TSGR-0325402v600</a>
T1 (ATIS)	T1.3GPP.25.402V600-2004	6.0.0	Approved	21/05/2004	<a href="https://www.atis.org/atis/docstore/search.asp?committee=S24">https://www.atis.org/atis/docstore/search.asp?committee=S24</a>
TTA	TTAT.3G-25.402(R6-6.0.0)	6.0.0	Approved	25/05/2004	<a href="http://www.tta.or.kr/standardDB/stnfile/TTAT.3G-25.402(R6-6.0.0).zip">http://www.tta.or.kr/standardDB/stnfile/TTAT.3G-25.402(R6-6.0.0).zip</a>

**5.1.2.3.3** 25.410**UTRAN Iu interface: general aspects and principles**

This specification describes an introduction to the 25.41x series of technical specifications that define the Iu interface for the interconnection of RNC component of the UTRAN to the CN.

SDO (2)	Document No.	Version	Status	Issued date	Location (1)
<b>Release 99</b>					
CCSA	CCSA-TSD-DS-25.410	380	Approved	01/07/2003	<a href="http://www.ccsa.org.cn/english/tc/files.php?docpath=/ITU-R/M.1457/M.1457-4/DS/">http://www.ccsa.org.cn/english/tc/files.php?docpath=/ITU-R/M.1457/M.1457-4/DS/</a>
ETSI	ETSI TS 125 410	3.8.0	Published	14/10/2002	<a href="http://pda.etsi.org/pda/home.asp?wkr=RTS/TSGR-0325410v380">http://pda.etsi.org/pda/home.asp?wkr=RTS/TSGR-0325410v380</a>
T1 (ATIS)	T1.3GPP.25.410V380-2003	3.8.0	Approved	27/03/2003	<a href="https://www.atis.org/atis/docstore/search.asp?committee=S24">https://www.atis.org/atis/docstore/search.asp?committee=S24</a>
TTA	TTAT.3G-25.410(R99-3.8.0)	3.8.0	Approved	21/03/2003	<a href="http://www.tta.or.kr/standardDB/stnfile/TTAT.3G-25.410(R99-3.8.0).zip">http://www.tta.or.kr/standardDB/stnfile/TTAT.3G-25.410(R99-3.8.0).zip</a>
TTC	TS-3GA-25.410(R99)v3.8.0	1	Approved	01/11/2002	<a href="http://www.ttc.or.jp/imt/ts/ts25410r99v380.pdf">http://www.ttc.or.jp/imt/ts/ts25410r99v380.pdf</a>
<b>Release 4</b>					
CCSA	CCSA-TSD-DS-25.410	450	Approved	01/07/2003	<a href="http://www.ccsa.org.cn/english/tc/files.php?docpath=/ITU-R/M.1457/M.1457-4/DS/">http://www.ccsa.org.cn/english/tc/files.php?docpath=/ITU-R/M.1457/M.1457-4/DS/</a>
ETSI	ETSI TS 125 410	4.5.0	Published	14/10/2002	<a href="http://pda.etsi.org/pda/home.asp?wkr=RTS/TSGR-0325410v450">http://pda.etsi.org/pda/home.asp?wkr=RTS/TSGR-0325410v450</a>
T1 (ATIS)	T1.3GPP.25.410V450-2003	4.5.0	Approved	27/03/2003	<a href="https://www.atis.org/atis/docstore/search.asp?committee=S24">https://www.atis.org/atis/docstore/search.asp?committee=S24</a>
TTA	TTAT.3G-25.410(R4-4.5.0)	4.5.0	Approved	21/03/2003	<a href="http://www.tta.or.kr/standardDB/stnfile/TTAT.3G-25.410(R4-4.5.0).zip">http://www.tta.or.kr/standardDB/stnfile/TTAT.3G-25.410(R4-4.5.0).zip</a>
TTC	TS-3GA-25.410(Rel4)v4.5.0	1	Approved	01/11/2002	<a href="http://www.ttc.or.jp/imt/ts/ts25410rel4v450.pdf">http://www.ttc.or.jp/imt/ts/ts25410rel4v450.pdf</a>
<b>Release 5</b>					
CCSA	CCSA-TSD-DS-25.410	520	Approved	01/07/2003	<a href="http://www.ccsa.org.cn/english/tc/files.php?docpath=/ITU-R/M.1457/M.1457-4/DS/">http://www.ccsa.org.cn/english/tc/files.php?docpath=/ITU-R/M.1457/M.1457-4/DS/</a>
ETSI	ETSI TS 125 410	5.3.0	Published	08/01/2003	<a href="http://pda.etsi.org/pda/home.asp?wkr=RTS/TSGR-0325410v530">http://pda.etsi.org/pda/home.asp?wkr=RTS/TSGR-0325410v530</a>
T1 (ATIS)	T1.3GPP.25.410V530-2003	5.3.0	Approved	27/03/2003	<a href="https://www.atis.org/atis/docstore/search.asp?committee=S24">https://www.atis.org/atis/docstore/search.asp?committee=S24</a>
TTA	TTAT.3G-25.410(R5-5.3.0)	5.3.0	Approved	21/03/2003	<a href="http://www.tta.or.kr/standardDB/stnfile/TTAT.3G-25.410(R5-5.3.0).zip">http://www.tta.or.kr/standardDB/stnfile/TTAT.3G-25.410(R5-5.3.0).zip</a>
TTC	TS-3GA-25.410(Rel5)v5.3.0	1	Approved	01/05/2003	<a href="http://www.ttc.or.jp/imt/ts/ts25410rel5v530.pdf">http://www.ttc.or.jp/imt/ts/ts25410rel5v530.pdf</a>
<b>Release 6</b>					
ETSI	ETSI TS 125 410	6.0.0	Published	19/01/2004	<a href="http://pda.etsi.org/pda/home.asp?wkr=RTS/TSGR-0325410v600">http://pda.etsi.org/pda/home.asp?wkr=RTS/TSGR-0325410v600</a>
T1 (ATIS)	T1.3GPP.25.410V600-2004	6.0.0	Approved	21/05/2004	<a href="https://www.atis.org/atis/docstore/search.asp?committee=S24">https://www.atis.org/atis/docstore/search.asp?committee=S24</a>
TTA	TTAT.3G-25.410(R6-6.0.0)	6.0.0	Approved	25/05/2004	<a href="http://www.tta.or.kr/standardDB/stnfile/TTAT.3G-25.410(R6-6.0.0).zip">http://www.tta.or.kr/standardDB/stnfile/TTAT.3G-25.410(R6-6.0.0).zip</a>
TTC	TS-3GA-25.410(Rel6)v6.0.0	1	Approved	01/02/2004	<a href="http://www.ttc.or.jp/imt/ts/ts25410rel6v600.pdf">http://www.ttc.or.jp/imt/ts/ts25410rel6v600.pdf</a>

**5.1.2.3.4** 25.411**UTRAN Iu interface Layer 1**

This specification describes the standards allowed to implement Layer 1 on the Iu interface. The specification of transmission delay requirements and O&M requirements are not in the scope of this specification.

SDO (2)	Document No.	Version	Status	Issued date	Location (1)
<b>Release 99</b>					
CCSA	CCSA-TSD-DS-25.411	350	Approved	01/07/2003	<a href="http://www.ccsa.org.cn/english/tc/files.php?docpath=/ITU-R/M.1457/M.1457-4/DS/">http://www.ccsa.org.cn/english/tc/files.php?docpath=/ITU-R/M.1457/M.1457-4/DS/</a>
ETSI	ETSI TS 125 411	3.5.0	Published	06/08/2001	<a href="http://pda.etsi.org/pda/home.asp?wkr=RTS/TSGR-0325411UR4">http://pda.etsi.org/pda/home.asp?wkr=RTS/TSGR-0325411UR4</a>
T1 (ATIS)	T1.3GPP.25.411V350-2002	3.5.0	Approved	03/05/2002	<a href="https://www.atis.org/atis/docstore/search.asp?committee=S24">https://www.atis.org/atis/docstore/search.asp?committee=S24</a>
TTA	TTAE.3G-25.411(R99-3.5.0)	3.5.0	Approved	29/05/2002	<a href="http://www.tta.or.kr/standardDB/stnfile/TTAE.3G-25.411(R99-3.5.0).zip">http://www.tta.or.kr/standardDB/stnfile/TTAE.3G-25.411(R99-3.5.0).zip</a>
TTC	TS-3GA-25.411(R99)v3.5.0	1	Approved	01/08/2001	<a href="http://www.ttc.or.jp/imt/ts/ts25411r99.pdf">http://www.ttc.or.jp/imt/ts/ts25411r99.pdf</a>
<b>Release 4</b>					
CCSA	CCSA-TSD-DS-25.411	410	Approved	01/07/2003	<a href="http://www.ccsa.org.cn/english/tc/files.php?docpath=/ITU-R/M.1457/M.1457-4/DS/">http://www.ccsa.org.cn/english/tc/files.php?docpath=/ITU-R/M.1457/M.1457-4/DS/</a>
ETSI	ETSI TS 125 411	4.1.0	Published	06/08/2001	<a href="http://pda.etsi.org/pda/home.asp?wkr=RTS/TSGR-0325411Uv4R1">http://pda.etsi.org/pda/home.asp?wkr=RTS/TSGR-0325411Uv4R1</a>
T1 (ATIS)	T1.3GPP.25.411V410-2002	4.1.0	Approved	03/05/2002	<a href="https://www.atis.org/atis/docstore/search.asp?committee=S24">https://www.atis.org/atis/docstore/search.asp?committee=S24</a>
TTA	TTAE.3G-25.411(R4-4.1.0)	4.1.0	Approved	29/05/2002	<a href="http://www.tta.or.kr/standardDB/stnfile/TTAE.3G-25.411(R4-4.1.0).zip">http://www.tta.or.kr/standardDB/stnfile/TTAE.3G-25.411(R4-4.1.0).zip</a>
TTC	TS-3GA-25.411(Rel4)v4.1.0	1	Approved	01/08/2001	<a href="http://www.ttc.or.jp/imt/ts/ts25411rel4.pdf">http://www.ttc.or.jp/imt/ts/ts25411rel4.pdf</a>
<b>Release 5</b>					
CCSA	CCSA-TSD-DS-25.411	500	Approved	01/07/2003	<a href="http://www.ccsa.org.cn/english/tc/files.php?docpath=/ITU-R/M.1457/M.1457-4/DS/">http://www.ccsa.org.cn/english/tc/files.php?docpath=/ITU-R/M.1457/M.1457-4/DS/</a>
ETSI	ETSI TS 125 411	5.0.0	Published	23/04/2002	<a href="http://pda.etsi.org/pda/home.asp?wkr=RTS/TSGR-0325411Uv5">http://pda.etsi.org/pda/home.asp?wkr=RTS/TSGR-0325411Uv5</a>
T1 (ATIS)	T1.3GPP.25.411V500-2002	5.0.0	Approved	03/05/2002	<a href="https://www.atis.org/atis/docstore/search.asp?committee=S24">https://www.atis.org/atis/docstore/search.asp?committee=S24</a>
TTA	TTAE.3G-25.411(R5-5.0.0)	5.0.0	Approved	29/05/2002	<a href="http://www.tta.or.kr/standardDB/stnfile/TTAE.3G-25.411(R5-5.0.0).zip">http://www.tta.or.kr/standardDB/stnfile/TTAE.3G-25.411(R5-5.0.0).zip</a>
TTC	TS-3GA-25.411(Rel5)v5.0.0	1	Approved	01/05/2002	<a href="http://www.ttc.or.jp/imt/ts/ts25411rel5.pdf">http://www.ttc.or.jp/imt/ts/ts25411rel5.pdf</a>
<b>Release 6</b>					
ETSI	ETSI TS 125 411	6.0.0	Published	19/01/2004	<a href="http://pda.etsi.org/pda/home.asp?wkr=RTS/TSGR-0325411v600">http://pda.etsi.org/pda/home.asp?wkr=RTS/TSGR-0325411v600</a>
T1 (ATIS)	T1.3GPP.25.411V600-2004	6.0.0	Approved	21/05/2004	<a href="https://www.atis.org/atis/docstore/search.asp?committee=S24">https://www.atis.org/atis/docstore/search.asp?committee=S24</a>
TTA	TTAT.3G-25.411(R6-6.0.0)	6.0.0	Approved	25/05/2004	<a href="http://www.tta.or.kr/standardDB/stnfile/TTAT.3G-25.411(R6-6.0.0).zip">http://www.tta.or.kr/standardDB/stnfile/TTAT.3G-25.411(R6-6.0.0).zip</a>
TTC	TS-3GA-25.411(Rel6)v6.0.0	1	Approved	01/02/2004	<a href="http://www.ttc.or.jp/imt/ts/ts25411rel6v600.pdf">http://www.ttc.or.jp/imt/ts/ts25411rel6v600.pdf</a>

### 5.1.2.3.5 25.412

#### UTRAN Iu interface signalling transport

This specification describes the standards for Signalling Transport to be used across Iu Interface.

SDO (2)	Document No.	Version	Status	Issued date	Location (1)
<b>Release 99</b>					
CCSA	CCSA-TSD-DS-25.412	360	Approved	01/07/2003	<a href="http://www.ccsa.org.cn/english/tc/files.php?docpath=/ITU-R/M.1457/M.1457-4/DS/">http://www.ccsa.org.cn/english/tc/files.php?docpath=/ITU-R/M.1457/M.1457-4/DS/</a>
ETSI	ETSI TS 125 412	3.6.0	Published	13/02/2001	<a href="http://pda.etsi.org/pda/home.asp?wkr=RTS/TSGR-0325412UR4">http://pda.etsi.org/pda/home.asp?wkr=RTS/TSGR-0325412UR4</a>
T1 (ATIS)	T1.3GPP.25.412V360-2002	3.6.0	Approved	03/05/2002	<a href="https://www.atis.org/atis/docstore/search.asp?committee=S24">https://www.atis.org/atis/docstore/search.asp?committee=S24</a>
TTA	TTAE.3G-25.412(R99-3.6.0)	3.6.0	Approved	29/05/2002	<a href="http://www.tta.or.kr/standardDB/stnfile/TTAE.3G-25.412(R99-3.6.0).zip">http://www.tta.or.kr/standardDB/stnfile/TTAE.3G-25.412(R99-3.6.0).zip</a>
TTC	JP-3GA-25.412(R99)	3	Approved	01/05/2001	<a href="http://www.ttc.or.jp/imt/std/jp25412r99.pdf">http://www.ttc.or.jp/imt/std/jp25412r99.pdf</a>

**Release 4**

CCSA	CCSA-TSD-DS-25.412	410	Approved	01/07/2003	<a href="http://www.ccsa.org.cn/english/tc/files.php?docpath=/ITU-R/M.1457/M.1457-4/DS/">http://www.ccsa.org.cn/english/tc/files.php?docpath=/ITU-R/M.1457/M.1457-4/DS/</a>
ETSI	ETSI TS 125 412	4.1.0	Published	16/10/2002	<a href="http://pda.etsi.org/pda/home.asp?wkr=RTS/TSGR-0325412v410">http://pda.etsi.org/pda/home.asp?wkr=RTS/TSGR-0325412v410</a>
T1 (ATIS)	T1.3GPP.25.412V410-2003	4.1.0	Approved	27/03/2003	<a href="https://www.atis.org/atis/docstore/search.asp?committee=S24">https://www.atis.org/atis/docstore/search.asp?committee=S24</a>
TTA	TTAT.3G-25.412(R4-4.1.0)	4.1.0	Approved	21/03/2003	<a href="http://www.tta.or.kr/standardDB/stnfile/TTAT.3G-25.412(R4-4.1.0).zip">http://www.tta.or.kr/standardDB/stnfile/TTAT.3G-25.412(R4-4.1.0).zip</a>
TTC	TS-3GA-25.412(Rel4)v4.1.0	1	Approved	01/11/2002	<a href="http://www.ttc.or.jp/imt/ts/ts25412rel4v410.pdf">http://www.ttc.or.jp/imt/ts/ts25412rel4v410.pdf</a>

**Release 5**

CCSA	CCSA-TSD-DS-25.412	510	Approved	01/07/2003	<a href="http://www.ccsa.org.cn/english/tc/files.php?docpath=/ITU-R/M.1457/M.1457-4/DS/">http://www.ccsa.org.cn/english/tc/files.php?docpath=/ITU-R/M.1457/M.1457-4/DS/</a>
ETSI	ETSI TS 125 412	5.1.0	Published	16/10/2002	<a href="http://pda.etsi.org/pda/home.asp?wkr=RTS/TSGR-0325412v510">http://pda.etsi.org/pda/home.asp?wkr=RTS/TSGR-0325412v510</a>
T1 (ATIS)	T1.3GPP.25.412V510-2003	5.1.0	Approved	27/03/2003	<a href="https://www.atis.org/atis/docstore/search.asp?committee=S24">https://www.atis.org/atis/docstore/search.asp?committee=S24</a>
TTA	TTAT.3G-25.412(R5-5.1.0)	5.1.0	Approved	21/03/2003	<a href="http://www.tta.or.kr/standardDB/stnfile/TTAT.3G-25.412(R5-5.1.0).zip">http://www.tta.or.kr/standardDB/stnfile/TTAT.3G-25.412(R5-5.1.0).zip</a>
TTC	TS-3GA-25.412(Rel5)v5.1.0	1	Approved	01/11/2002	<a href="http://www.ttc.or.jp/imt/ts/ts25412rel5v510.pdf">http://www.ttc.or.jp/imt/ts/ts25412rel5v510.pdf</a>

**Release 6**

ETSI	ETSI TS 125 412	6.0.0	Published	19/01/2004	<a href="http://pda.etsi.org/pda/home.asp?wkr=RTS/TSGR-0325412v600">http://pda.etsi.org/pda/home.asp?wkr=RTS/TSGR-0325412v600</a>
T1 (ATIS)	T1.3GPP.25.412V600-2004	6.0.0	Approved	21/05/2004	<a href="https://www.atis.org/atis/docstore/search.asp?committee=S24">https://www.atis.org/atis/docstore/search.asp?committee=S24</a>
TTA	TTAT.3G-25.412(R6-6.0.0)	6.0.0	Approved	25/05/2004	<a href="http://www.tta.or.kr/standardDB/stnfile/TTAT.3G-25.412(R6-6.0.0).zip">http://www.tta.or.kr/standardDB/stnfile/TTAT.3G-25.412(R6-6.0.0).zip</a>
TTC	TS-3GA-25.412(Rel6)v6.0.0	1	Approved	01/02/2004	<a href="http://www.ttc.or.jp/imt/ts/ts25412rel6v600.pdf">http://www.ttc.or.jp/imt/ts/ts25412rel6v600.pdf</a>

**5.1.2.3.6 25.413****UTRAN Iu interface RANAP signalling**

This specification describes the signalling between the CN and the UTRAN over the Iu interface. This specification describes the standards for user data transport protocols and related signalling protocols to establish user plane transport bearers over the Iu interface.

SDO (2)	Document No.	Version	Status	Issued date	Location (1)
<b>Release 99</b>					
CCSA	CCSA-TSD-DS-25.413	3D0	Approved	01/07/2003	<a href="http://www.ccsa.org.cn/english/tc/files.php?docpath=/ITU-R/M.1457/M.1457-4/DS/">http://www.ccsa.org.cn/english/tc/files.php?docpath=/ITU-R/M.1457/M.1457-4/DS/</a>
ETSI	ETSI TS 125 413	3.14.0	Published	03/10/2003	<a href="http://pda.etsi.org/pda/home.asp?wkr=RTS/TSGR-0325413v3e0">http://pda.etsi.org/pda/home.asp?wkr=RTS/TSGR-0325413v3e0</a>
T1 (ATIS)	T1.3GPP.25.413V3140-2004	3.14.0	Approved	21/05/2004	<a href="https://www.atis.org/atis/docstore/search.asp?committee=S24">https://www.atis.org/atis/docstore/search.asp?committee=S24</a>
TTA	TTAT.3G-25.413(R99-3.14.0)	3.14.0	Approved	25/05/2004	<a href="http://www.tta.or.kr/standardDB/stnfile/TTAT.3G-25.413(R99-3.14.0).zip">http://www.tta.or.kr/standardDB/stnfile/TTAT.3G-25.413(R99-3.14.0).zip</a>
TTC	TS-3GA-25.413(R99)v3.14.0	1	Approved	01/11/2003	<a href="http://www.ttc.or.jp/imt/ts/ts25413r99v3e0.pdf">http://www.ttc.or.jp/imt/ts/ts25413r99v3e0.pdf</a>
<b>Release 4</b>					
CCSA	CCSA-TSD-DS-25.413	490	Approved	01/07/2003	<a href="http://www.ccsa.org.cn/english/tc/files.php?docpath=/ITU-R/M.1457/M.1457-4/DS/">http://www.ccsa.org.cn/english/tc/files.php?docpath=/ITU-R/M.1457/M.1457-4/DS/</a>
ETSI	ETSI TS 125 413	4.11.0	Published	20/01/2004	<a href="http://pda.etsi.org/pda/home.asp?wkr=RTS/TSGR-0325413v4b0">http://pda.etsi.org/pda/home.asp?wkr=RTS/TSGR-0325413v4b0</a>
T1 (ATIS)	T1.3GPP.25.413V4110-2004	4.11.0	Approved	21/05/2004	<a href="https://www.atis.org/atis/docstore/search.asp?committee=S24">https://www.atis.org/atis/docstore/search.asp?committee=S24</a>
TTA	TTAT.3G-25.413(R4-4.11.0)	4.11.0	Approved	25/05/2004	<a href="http://www.tta.or.kr/standardDB/stnfile/TTAT.3G-25.413(R4-4.11.0).zip">http://www.tta.or.kr/standardDB/stnfile/TTAT.3G-25.413(R4-4.11.0).zip</a>
TTC	TS-3GA-25.413(Rel4)v4.11.0	1	Approved	01/02/2004	<a href="http://www.ttc.or.jp/imt/ts/ts25413rel4v4b0.pdf">http://www.ttc.or.jp/imt/ts/ts25413rel4v4b0.pdf</a>

**Release 5**

CCSA	CCSA-TSD-DS-25.413	550	Approved	01/07/2003	<a href="http://www.ccsa.org.cn/english/tc/files.php?docpath=/ITU-R/M.1457/M.1457-4/DS/">http://www.ccsa.org.cn/english/tc/files.php?docpath=/ITU-R/M.1457/M.1457-4/DS/</a>
ETSI	ETSI TS 125 413	5.7.0	Published	20/01/2004	<a href="http://pda.etsi.org/pda/home.asp?wkr=RTS/TSGR-0325413v570">http://pda.etsi.org/pda/home.asp?wkr=RTS/TSGR-0325413v570</a>
T1 (ATIS)	T1.3GPP.25.413V570-2004	5.7.0	Approved	21/05/2004	<a href="https://www.atis.org/atis/docstore/search.asp?committee=S24">https://www.atis.org/atis/docstore/search.asp?committee=S24</a>
TTA	TTAT.3G-25.413(R5-5.7.0)	5.7.0	Approved	25/05/2004	<a href="http://www.tta.or.kr/standardDB/stnfile/TTAT.3G-25.413(R5-5.7.0).zip">http://www.tta.or.kr/standardDB/stnfile/TTAT.3G-25.413(R5-5.7.0).zip</a>
TTC	TS-3GA-25.413(Rel5)v5.7.0	1	Approved	01/02/2004	<a href="http://www.ttc.or.jp/imt/ts/ts25413rel5v570.pdf">http://www.ttc.or.jp/imt/ts/ts25413rel5v570.pdf</a>

**Release 6**

ETSI	ETSI TS 125 413	6.0.0	Published	20/01/2004	<a href="http://pda.etsi.org/pda/home.asp?wkr=RTS/TSGR-0325413v600">http://pda.etsi.org/pda/home.asp?wkr=RTS/TSGR-0325413v600</a>
T1 (ATIS)	T1.3GPP.25.413V600-2004	6.0.0	Approved	21/05/2004	<a href="https://www.atis.org/atis/docstore/search.asp?committee=S24">https://www.atis.org/atis/docstore/search.asp?committee=S24</a>
TTA	TTAT.3G-25.413(R6-6.0.0)	6.0.0	Approved	25/05/2004	<a href="http://www.tta.or.kr/standardDB/stnfile/TTAT.3G-25.413(R6-6.0.0).zip">http://www.tta.or.kr/standardDB/stnfile/TTAT.3G-25.413(R6-6.0.0).zip</a>
TTC	TS-3GA-25.413(Rel6)v6.0.0	1	Approved	01/02/2004	<a href="http://www.ttc.or.jp/imt/ts/ts25413rel6v600.pdf">http://www.ttc.or.jp/imt/ts/ts25413rel6v600.pdf</a>

**5.1.2.3.7 TS 25.414****UTRAN Iu interface data transport and transport signaling**

This specification describes the standards for user data transport protocols and related signalling protocols to establish user plane transport bearers over the Iu interface.

SDO (2)	Document No.	Version	Status	Issued date	Location (1)
<b>Release 99</b>					
CCSA	CCSA-TSD-DS-25.414	3D0	Approved	01/07/2003	<a href="http://www.ccsa.org.cn/english/tc/files.php?docpath=/ITU-R/M.1457/M.1457-4/DS/">http://www.ccsa.org.cn/english/tc/files.php?docpath=/ITU-R/M.1457/M.1457-4/DS/</a>
ETSI	ETSI TS 125 414	3.13.0	Published	04/04/2003	<a href="http://pda.etsi.org/pda/home.asp?wkr=RTS/TSGR-0325414v3d0">http://pda.etsi.org/pda/home.asp?wkr=RTS/TSGR-0325414v3d0</a>
T1 (ATIS)	T1.3GPP.25.414V3130-2004	3.13.0	Approved	21/05/2004	<a href="https://www.atis.org/atis/docstore/search.asp?committee=S24">https://www.atis.org/atis/docstore/search.asp?committee=S24</a>
TTA	TTAT.3G-25.414(R99-3.13.0)	3.13.0	Approved	25/05/2004	<a href="http://www.tta.or.kr/standardDB/stnfile/TTAT.3G-25.414(R99-3.13.0).zip">http://www.tta.or.kr/standardDB/stnfile/TTAT.3G-25.414(R99-3.13.0).zip</a>
TTC	TS-3GA-25.414(R99)v3.13.0	1	Approved	01/05/2003	<a href="http://www.ttc.or.jp/imt/ts/ts25414r99v3d0.pdf">http://www.ttc.or.jp/imt/ts/ts25414r99v3d0.pdf</a>
<b>Release 4</b>					
CCSA	CCSA-TSD-DS-25.414	460	Approved	01/07/2003	<a href="http://www.ccsa.org.cn/english/tc/files.php?docpath=/ITU-R/M.1457/M.1457-4/DS/">http://www.ccsa.org.cn/english/tc/files.php?docpath=/ITU-R/M.1457/M.1457-4/DS/</a>
ETSI	ETSI TS 125 414	4.7.0	Published	20/01/2004	<a href="http://pda.etsi.org/pda/home.asp?wkr=RTS/TSGR-0325414v470">http://pda.etsi.org/pda/home.asp?wkr=RTS/TSGR-0325414v470</a>
T1 (ATIS)	T1.3GPP.25.414V470-2004	4.7.0	Approved	21/05/2004	<a href="https://www.atis.org/atis/docstore/search.asp?committee=S24">https://www.atis.org/atis/docstore/search.asp?committee=S24</a>
TTA	TTAT.3G-25.414(R4-4.7.0)	4.7.0	Approved	25/05/2004	<a href="http://www.tta.or.kr/standardDB/stnfile/TTAT.3G-25.414(R4-4.7.0).zip">http://www.tta.or.kr/standardDB/stnfile/TTAT.3G-25.414(R4-4.7.0).zip</a>
TTC	TS-3GA-25.414(Rel4)v4.7.0	1	Approved	01/02/2004	<a href="http://www.ttc.or.jp/imt/ts/ts25414rel4v470.pdf">http://www.ttc.or.jp/imt/ts/ts25414rel4v470.pdf</a>
<b>Release 5</b>					
CCSA	CCSA-TSD-DS-25.414	540	Approved	01/07/2003	<a href="http://www.ccsa.org.cn/english/tc/files.php?docpath=/ITU-R/M.1457/M.1457-4/DS/">http://www.ccsa.org.cn/english/tc/files.php?docpath=/ITU-R/M.1457/M.1457-4/DS/</a>
ETSI	ETSI TS 125 414	5.5.0	Published	20/01/2004	<a href="http://pda.etsi.org/pda/home.asp?wkr=RTS/TSGR-0325414v550">http://pda.etsi.org/pda/home.asp?wkr=RTS/TSGR-0325414v550</a>
T1 (ATIS)	T1.3GPP.25.414V550-2004	5.5.0	Approved	21/05/2004	<a href="https://www.atis.org/atis/docstore/search.asp?committee=S24">https://www.atis.org/atis/docstore/search.asp?committee=S24</a>
TTA	TTAT.3G-25.414(R5-5.5.0)	5.5.0	Approved	25/05/2004	<a href="http://www.tta.or.kr/standardDB/stnfile/TTAT.3G-25.414(R5-5.5.0).zip">http://www.tta.or.kr/standardDB/stnfile/TTAT.3G-25.414(R5-5.5.0).zip</a>
TTC	TS-3GA-25.414(Rel5)v5.5.0	1	Approved	01/02/2004	<a href="http://www.ttc.or.jp/imt/ts/ts25414rel5v550.pdf">http://www.ttc.or.jp/imt/ts/ts25414rel5v550.pdf</a>

**Release 6**

ETSI	ETSI TS 125 414	6.0.0	Published	20/01/2004	<a href="http://pda.etsi.org/pda/home.asp?wkr=RTS/TSGR-0325414v600">http://pda.etsi.org/pda/home.asp?wkr=RTS/TSGR-0325414v600</a>
T1 (ATIS)	T1.3GPP.25.414V600-2004	6.0.0	Approved	21/05/2004	<a href="https://www.atis.org/atis/docstore/search.asp?committee=S24">https://www.atis.org/atis/docstore/search.asp?committee=S24</a>
TTA	TTAT.3G-25.414(R6-6.0.0)	6.0.0	Approved	25/05/2004	<a href="http://www.tta.or.kr/standardDB/stnfile/TTAT.3G-25.414(R6-6.0.0).zip">http://www.tta.or.kr/standardDB/stnfile/TTAT.3G-25.414(R6-6.0.0).zip</a>
TTC	TS-3GA-25.414(Rel6)v6.0.0	1	Approved	01/02/2004	<a href="http://www.ttc.or.jp/imt/ts/ts25414rel6v600.pdf">http://www.ttc.or.jp/imt/ts/ts25414rel6v600.pdf</a>

**5.1.2.3.8 25.415****UTRAN Iu interface user plane protocols**

This specification describes the protocols being used to transport and control over the Iu interface, the Iu user data streams.

SDO (2)	Document No.	Version	Status	Issued date	Location (1)
<b>Release 99</b>					
CCSA	CCSA-TSD-DS-25.415	3C0	Approved	01/07/2003	<a href="http://www.ccsa.org.cn/english/tc/files.php?docpath=/ITU-R/M.1457/M.1457-4/DS/">http://www.ccsa.org.cn/english/tc/files.php?docpath=/ITU-R/M.1457/M.1457-4/DS/</a>
ETSI	ETSI TS 125 415	3.12.0	Published	17/10/2002	<a href="http://pda.etsi.org/pda/home.asp?wkr=RTS/TSGR-0325415v3c0">http://pda.etsi.org/pda/home.asp?wkr=RTS/TSGR-0325415v3c0</a>
T1 (ATIS)	T1.3GPP.25.415V3120-2003	3.12.0	Approved	27/03/2003	<a href="https://www.atis.org/atis/docstore/search.asp?committee=S24">https://www.atis.org/atis/docstore/search.asp?committee=S24</a>
TTA	TTAT.3G-25.415(R99-3.12.0)	3.12.0	Approved	21/03/2003	<a href="http://www.tta.or.kr/standardDB/stnfile/TTAT.3G-25.415(R99-3.12.0).zip">http://www.tta.or.kr/standardDB/stnfile/TTAT.3G-25.415(R99-3.12.0).zip</a>
TTC	TS-3GA-25.415(R99)v3.12.0	1	Approved	01/11/2002	<a href="http://www.ttc.or.jp/imt/ts/ts25415r99v3c0.pdf">http://www.ttc.or.jp/imt/ts/ts25415r99v3c0.pdf</a>
<b>Release 4</b>					
CCSA	CCSA-TSD-DS-25.415	470	Approved	01/07/2003	<a href="http://www.ccsa.org.cn/english/tc/files.php?docpath=/ITU-R/M.1457/M.1457-4/DS/">http://www.ccsa.org.cn/english/tc/files.php?docpath=/ITU-R/M.1457/M.1457-4/DS/</a>
ETSI	ETSI TS 125 415	4.7.0	Published	09/01/2003	<a href="http://pda.etsi.org/pda/home.asp?wkr=RTS/TSGR-0325415v470">http://pda.etsi.org/pda/home.asp?wkr=RTS/TSGR-0325415v470</a>
T1 (ATIS)	T1.3GPP.25.415V470-2003	4.7.0	Approved	27/03/2003	<a href="https://www.atis.org/atis/docstore/search.asp?committee=S24">https://www.atis.org/atis/docstore/search.asp?committee=S24</a>
TTA	TTAT.3G-25.415(R4-4.7.0)	4.7.0	Approved	21/03/2003	<a href="http://www.tta.or.kr/standardDB/stnfile/TTAT.3G-25.415(R4-4.7.0).zip">http://www.tta.or.kr/standardDB/stnfile/TTAT.3G-25.415(R4-4.7.0).zip</a>
TTC	TS-3GA-25.415(Rel4)v4.7.0	1	Approved	01/02/2003	<a href="http://www.ttc.or.jp/imt/ts/ts25415rel4v470.pdf">http://www.ttc.or.jp/imt/ts/ts25415rel4v470.pdf</a>
<b>Release 5</b>					
CCSA	CCSA-TSD-DS-25.415	530	Approved	01/07/2003	<a href="http://www.ccsa.org.cn/english/tc/files.php?docpath=/ITU-R/M.1457/M.1457-4/DS/">http://www.ccsa.org.cn/english/tc/files.php?docpath=/ITU-R/M.1457/M.1457-4/DS/</a>
ETSI	ETSI TS 125 415	5.3.0	Published	09/01/2003	<a href="http://pda.etsi.org/pda/home.asp?wkr=RTS/TSGR-0325415v530">http://pda.etsi.org/pda/home.asp?wkr=RTS/TSGR-0325415v530</a>
T1 (ATIS)	T1.3GPP.25.415V530-2003	5.3.0	Approved	27/03/2003	<a href="https://www.atis.org/atis/docstore/search.asp?committee=S24">https://www.atis.org/atis/docstore/search.asp?committee=S24</a>
TTA	TTAT.3G-25.415(R5-5.3.0)	5.3.0	Approved	21/03/2003	<a href="http://www.tta.or.kr/standardDB/stnfile/TTAT.3G-25.415(R5-5.3.0).zip">http://www.tta.or.kr/standardDB/stnfile/TTAT.3G-25.415(R5-5.3.0).zip</a>
TTC	TS-3GA-25.415(Rel5)v5.3.0	1	Approved	01/02/2003	<a href="http://www.ttc.or.jp/imt/ts/ts25415rel5v530.pdf">http://www.ttc.or.jp/imt/ts/ts25415rel5v530.pdf</a>
<b>Release 6</b>					
ETSI	ETSI TS 125 415	6.0.0	Published	20/01/2004	<a href="http://pda.etsi.org/pda/home.asp?wkr=RTS/TSGR-0325415v600">http://pda.etsi.org/pda/home.asp?wkr=RTS/TSGR-0325415v600</a>
T1 (ATIS)	T1.3GPP.25.415V600-2004	6.0.0	Approved	21/05/2004	<a href="https://www.atis.org/atis/docstore/search.asp?committee=S24">https://www.atis.org/atis/docstore/search.asp?committee=S24</a>
TTA	TTAT.3G-25.415(R6-6.0.0)	6.0.0	Approved	25/05/2004	<a href="http://www.tta.or.kr/standardDB/stnfile/TTAT.3G-25.415(R6-6.0.0).zip">http://www.tta.or.kr/standardDB/stnfile/TTAT.3G-25.415(R6-6.0.0).zip</a>
TTC	TS-3GA-25.415(Rel6)v6.0.0	1	Approved	01/02/2004	<a href="http://www.ttc.or.jp/imt/ts/ts25415rel6v600.pdf">http://www.ttc.or.jp/imt/ts/ts25415rel6v600.pdf</a>

**5.1.2.3.9** 25.419**UTRAN Iu-bc interface: Cell broadcast protocols between CBC and RNC**

This document specifies the Service Area Broadcast Protocol (SABP) between the Cell Broadcast Centre (CBC) and the Radio Network Controller (RNC).

SDO (2)	Document No.	Version	Status	Issued date	Location (1)
<b>Release 99</b>					
CCSA	CCSA-TSD-DS-25.419	3B0	Approved	01/07/2003	<a href="http://www.ccsa.org.cn/english/tc/files.php?docpath=/ITU-R/M.1457/M.1457-4/DS/">http://www.ccsa.org.cn/english/tc/files.php?docpath=/ITU-R/M.1457/M.1457-4/DS/</a>
ETSI	ETSI TS 125 419	3.11.0	Published	20/06/2003	<a href="http://pda.etsi.org/pda/home.asp?wkr=RTS/TSGR-0325419v3b0">http://pda.etsi.org/pda/home.asp?wkr=RTS/TSGR-0325419v3b0</a>
T1 (ATIS)	T1.3GPP.25.419V3110-2004	3.11.0	Approved	21/05/2004	<a href="https://www.atis.org/atis/docstore/search.asp?committee=S24">https://www.atis.org/atis/docstore/search.asp?committee=S24</a>
TTA	TTAT.3G-25.419(R99-3.11.0)	3.11.0	Approved	25/05/2004	<a href="http://www.tta.or.kr/standardDB/stnfile/TTAT.3G-25.419(R99-3.11.0).zip">http://www.tta.or.kr/standardDB/stnfile/TTAT.3G-25.419(R99-3.11.0).zip</a>
TTC	TS-3GA-25.419(R99)v3.11.0	1	Approved	01/08/2003	<a href="http://www.ttc.or.jp/imt/ts/ts25419r99v3b0.pdf">http://www.ttc.or.jp/imt/ts/ts25419r99v3b0.pdf</a>
<b>Release 4</b>					
CCSA	CCSA-TSD-DS-25.419	480	Approved	01/07/2003	<a href="http://www.ccsa.org.cn/english/tc/files.php?docpath=/ITU-R/M.1457/M.1457-4/DS/">http://www.ccsa.org.cn/english/tc/files.php?docpath=/ITU-R/M.1457/M.1457-4/DS/</a>
ETSI	ETSI TS 125 419	4.10.0	Published	20/01/2004	<a href="http://pda.etsi.org/pda/home.asp?wkr=RTS/TSGR-0325419v4a0">http://pda.etsi.org/pda/home.asp?wkr=RTS/TSGR-0325419v4a0</a>
T1 (ATIS)	T1.3GPP.25.419V4100-2004	4.10.0	Approved	21/05/2004	<a href="https://www.atis.org/atis/docstore/search.asp?committee=S24">https://www.atis.org/atis/docstore/search.asp?committee=S24</a>
TTA	TTAT.3G-25.419(R4-4.10.0)	4.10.0	Approved	25/05/2004	<a href="http://www.tta.or.kr/standardDB/stnfile/TTAT.3G-25.419(R4-4.10.0).zip">http://www.tta.or.kr/standardDB/stnfile/TTAT.3G-25.419(R4-4.10.0).zip</a>
TTC	TS-3GA-25.419(Rel4)v4.10.0	1	Approved	01/02/2004	<a href="http://www.ttc.or.jp/imt/ts/ts25419rel4v4a0.pdf">http://www.ttc.or.jp/imt/ts/ts25419rel4v4a0.pdf</a>
<b>Release 5</b>					
CCSA	CCSA-TSD-DS-25.419	540	Approved	01/07/2003	<a href="http://www.ccsa.org.cn/english/tc/files.php?docpath=/ITU-R/M.1457/M.1457-4/DS/">http://www.ccsa.org.cn/english/tc/files.php?docpath=/ITU-R/M.1457/M.1457-4/DS/</a>
ETSI	ETSI TS 125 419	5.6.0	Published	20/01/2004	<a href="http://pda.etsi.org/pda/home.asp?wkr=RTS/TSGR-0325419v560">http://pda.etsi.org/pda/home.asp?wkr=RTS/TSGR-0325419v560</a>
T1 (ATIS)	T1.3GPP.25.419V560-2004	5.6.0	Approved	21/05/2004	<a href="https://www.atis.org/atis/docstore/search.asp?committee=S24">https://www.atis.org/atis/docstore/search.asp?committee=S24</a>
TTA	TTAT.3G-25.419(R5-5.6.0)	5.6.0	Approved	25/05/2004	<a href="http://www.tta.or.kr/standardDB/stnfile/TTAT.3G-25.419(R5-5.6.0).zip">http://www.tta.or.kr/standardDB/stnfile/TTAT.3G-25.419(R5-5.6.0).zip</a>
TTC	TS-3GA-25.419(Rel5)v5.6.0	1	Approved	01/02/2004	<a href="http://www.ttc.or.jp/imt/ts/ts25419rel5v560.pdf">http://www.ttc.or.jp/imt/ts/ts25419rel5v560.pdf</a>
<b>Release 6</b>					
ETSI	ETSI TS 125 419	6.0.0	Published	20/01/2004	<a href="http://pda.etsi.org/pda/home.asp?wkr=RTS/TSGR-0325419v600">http://pda.etsi.org/pda/home.asp?wkr=RTS/TSGR-0325419v600</a>
T1 (ATIS)	T1.3GPP.25.419V600-2004	6.0.0	Approved	21/05/2004	<a href="https://www.atis.org/atis/docstore/search.asp?committee=S24">https://www.atis.org/atis/docstore/search.asp?committee=S24</a>
TTA	TTAT.3G-25.419(R6-6.0.0)	6.0.0	Approved	25/05/2004	<a href="http://www.tta.or.kr/standardDB/stnfile/TTAT.3G-25.419(R6-6.0.0).zip">http://www.tta.or.kr/standardDB/stnfile/TTAT.3G-25.419(R6-6.0.0).zip</a>
TTC	TS-3GA-25.419(Rel6)v6.0.0	1	Approved	01/02/2004	<a href="http://www.ttc.or.jp/imt/ts/ts25419rel6v600.pdf">http://www.ttc.or.jp/imt/ts/ts25419rel6v600.pdf</a>

**5.1.2.3.10** 25.420**UTRAN Iur interface: general aspects and principles**

This specification describes an introduction to the TSG RAN TS 25.42x series of technical specifications that define the Iur interface. It is a logical interface for the interconnection of two RNC components of the UTRAN.



SDO (2)	Document No.	Version	Status	Issued date	Location (1)
<b>Release 99</b>					
ARIB	ARIB STD-T63-25.420	3.5.0	Approved	25/05/2004	<a href="http://www.arib.or.jp/IMT-2000/ARIB-STD/ITU-R/R99/A25420-350.pdf">http://www.arib.or.jp/IMT-2000/ARIB-STD/ITU-R/R99/A25420-350.pdf</a>
CCSA	CCSA-TSD-DS-25.420	350	Approved	01/07/2003	<a href="http://www.ccsa.org.cn/english/tc/files.php?docpath=/ITU-R/M.1457/M.1457-4/DS/">http://www.ccsa.org.cn/english/tc/files.php?docpath=/ITU-R/M.1457/M.1457-4/DS/</a>
ETSI	ETSI TS 125 420	3.5.0	Published	15/04/2002	<a href="http://pda.etsi.org/pda/home.asp?wkr=RTS/TSGR-0325420UR5">http://pda.etsi.org/pda/home.asp?wkr=RTS/TSGR-0325420UR5</a>
T1 (ATIS)	T1.3GPP.25.420V350-2002	3.5.0	Approved	03/05/2002	<a href="https://www.atis.org/atis/docstore/search.asp?committee=S24">https://www.atis.org/atis/docstore/search.asp?committee=S24</a>
TTA	TTAE.3G-25.420(R99-3.5.0)	3.5.0	Approved	29/05/2002	<a href="http://www.tta.or.kr/standardDB/stnfile/TTAE.3G-25.420(R99-3.5.0).zip">http://www.tta.or.kr/standardDB/stnfile/TTAE.3G-25.420(R99-3.5.0).zip</a>
<b>Release 4</b>					
ARIB	ARIB STD-T63-25.420	4.2.0	Approved	25/05/2004	<a href="http://www.arib.or.jp/IMT-2000/ARIB-STD/ITU-R/Rel4/A25420-420.pdf">http://www.arib.or.jp/IMT-2000/ARIB-STD/ITU-R/Rel4/A25420-420.pdf</a>
CCSA	CCSA-TSD-DS-25.420	420	Approved	01/07/2003	<a href="http://www.ccsa.org.cn/english/tc/files.php?docpath=/ITU-R/M.1457/M.1457-4/DS/">http://www.ccsa.org.cn/english/tc/files.php?docpath=/ITU-R/M.1457/M.1457-4/DS/</a>
ETSI	ETSI TS 125 420	4.2.0	Published	15/04/2002	<a href="http://pda.etsi.org/pda/home.asp?wkr=RTS/TSGR-0325420Uv4R2">http://pda.etsi.org/pda/home.asp?wkr=RTS/TSGR-0325420Uv4R2</a>
T1 (ATIS)	T1.3GPP.25.420V420-2002	4.2.0	Approved	03/05/2002	<a href="https://www.atis.org/atis/docstore/search.asp?committee=S24">https://www.atis.org/atis/docstore/search.asp?committee=S24</a>
TTA	TTAE.3G-25.420(R4-4.2.0)	4.2.0	Approved	29/05/2002	<a href="http://www.tta.or.kr/standardDB/stnfile/TTAE.3G-25.420(R4-4.2.0).zip">http://www.tta.or.kr/standardDB/stnfile/TTAE.3G-25.420(R4-4.2.0).zip</a>
<b>Release 5</b>					
ARIB	ARIB STD-T63-25.420	5.1.0	Approved	25/05/2004	<a href="http://www.arib.or.jp/IMT-2000/ARIB-STD/ITU-R/Rel5/A25420-510.pdf">http://www.arib.or.jp/IMT-2000/ARIB-STD/ITU-R/Rel5/A25420-510.pdf</a>
CCSA	CCSA-TSD-DS-25.420	510	Approved	01/07/2003	<a href="http://www.ccsa.org.cn/english/tc/files.php?docpath=/ITU-R/M.1457/M.1457-4/DS/">http://www.ccsa.org.cn/english/tc/files.php?docpath=/ITU-R/M.1457/M.1457-4/DS/</a>
ETSI	ETSI TS 125 420	5.1.0	Published	15/10/2002	<a href="http://pda.etsi.org/pda/home.asp?wkr=RTS/TSGR-0325420v510">http://pda.etsi.org/pda/home.asp?wkr=RTS/TSGR-0325420v510</a>
T1 (ATIS)	T1.3GPP.25.420V510-2003	5.1.0	Approved	27/03/2003	<a href="https://www.atis.org/atis/docstore/search.asp?committee=S24">https://www.atis.org/atis/docstore/search.asp?committee=S24</a>
TTA	TTAT.3G-25.420(R5-5.1.0)	5.1.0	Approved	21/03/2003	<a href="http://www.tta.or.kr/standardDB/stnfile/TTAT.3G-25.420(R5-5.1.0).zip">http://www.tta.or.kr/standardDB/stnfile/TTAT.3G-25.420(R5-5.1.0).zip</a>
<b>Release 6</b>					
ARIB	ARIB STD-T63-25.420	6.0.0	Approved	25/05/2004	<a href="http://www.arib.or.jp/IMT-2000/ARIB-STD/ITU-R/Rel6/A25420-600.pdf">http://www.arib.or.jp/IMT-2000/ARIB-STD/ITU-R/Rel6/A25420-600.pdf</a>
ETSI	ETSI TS 125 420	6.0.0	Published	20/01/2004	<a href="http://pda.etsi.org/pda/home.asp?wkr=RTS/TSGR-0325420v600">http://pda.etsi.org/pda/home.asp?wkr=RTS/TSGR-0325420v600</a>
T1 (ATIS)	T1.3GPP.25.420V600-2004	6.0.0	Approved	21/05/2004	<a href="https://www.atis.org/atis/docstore/search.asp?committee=S24">https://www.atis.org/atis/docstore/search.asp?committee=S24</a>
TTA	TTAT.3G-25.420(R6-6.0.0)	6.0.0	Approved	25/05/2004	<a href="http://www.tta.or.kr/standardDB/stnfile/TTAT.3G-25.420(R6-6.0.0).zip">http://www.tta.or.kr/standardDB/stnfile/TTAT.3G-25.420(R6-6.0.0).zip</a>

### 5.1.2.3.11 25.421

#### UTRAN Iur interface Layer 1

This specification describes the standards allowed to implement Layer 1 on the Iur interface. The specification of transmission delay requirements and O&M requirements are not in the scope of this specification.

SDO (2)	Document No.	Version	Status	Issued date	Location (1)
<b>Release 99</b>					
ARIB	ARIB STD-T63-25.421	3.1.0	Approved	25/05/2004	<a href="http://www.arib.or.jp/IMT-2000/ARIB-STD/ITU-R/R99/A25421-310.pdf">http://www.arib.or.jp/IMT-2000/ARIB-STD/ITU-R/R99/A25421-310.pdf</a>
CCSA	CCSA-TSD-DS-25.421	310	Approved	01/07/2003	<a href="http://www.ccsa.org.cn/english/tc/files.php?docpath=/ITU-R/M.1457/M.1457-4/DS/">http://www.ccsa.org.cn/english/tc/files.php?docpath=/ITU-R/M.1457/M.1457-4/DS/</a>
ETSI	ETSI TS 125 421	3.1.0	Published	27/04/2001	<a href="http://pda.etsi.org/pda/home.asp?wkr=RTS/TSGR-0325421UR1">http://pda.etsi.org/pda/home.asp?wkr=RTS/TSGR-0325421UR1</a>
T1 (ATIS)	T1.3GPP.25.421V310-2002	3.1.0	Approved	03/05/2002	<a href="https://www.atis.org/atis/docstore/search.asp?committee=S24">https://www.atis.org/atis/docstore/search.asp?committee=S24</a>
TTA	TTAE.3G-25.421(R99-3.1.0)	3.1.0	Approved	29/05/2002	<a href="http://www.tta.or.kr/standardDB/stnfile/TTAE.3G-25.421(R99-3.1.0).zip">http://www.tta.or.kr/standardDB/stnfile/TTAE.3G-25.421(R99-3.1.0).zip</a>



**Release 4**

ARIB	ARIB STD-T63-25.421	4.0.0	Approved	25/05/2004	<a href="http://www.arib.or.jp/IMT-2000/ARIB-STD/ITU-R/Rel4/A25421-400.pdf">http://www.arib.or.jp/IMT-2000/ARIB-STD/ITU-R/Rel4/A25421-400.pdf</a>
CCSA	CCSA-TSD-DS-25.421	400	Approved	01/07/2003	<a href="http://www.ccsa.org.cn/english/tc/files.php?docpath=/ITU-R/M.1457/M.1457-4/DS/">http://www.ccsa.org.cn/english/tc/files.php?docpath=/ITU-R/M.1457/M.1457-4/DS/</a>
ETSI	ETSI TS 125 421	4.0.0	Published	27/04/2001	<a href="http://pda.etsi.org/pda/home.asp?wkr=RTS/TSGR-0325421Uv4">http://pda.etsi.org/pda/home.asp?wkr=RTS/TSGR-0325421Uv4</a>
T1 (ATIS)	T1.3GPP.25.421V400-2002	4.0.0	Approved	03/05/2002	<a href="https://www.atis.org/atis/docstore/search.asp?committee=S24">https://www.atis.org/atis/docstore/search.asp?committee=S24</a>
TTA	TTAE.3G-25.421(R4-4.0.0)	4.0.0	Approved	29/05/2002	<a href="http://www.tta.or.kr/standardDB/stnfile/TTAE.3G-25.421(R4-4.0.0).zip">http://www.tta.or.kr/standardDB/stnfile/TTAE.3G-25.421(R4-4.0.0).zip</a>

**Release 5**

ARIB	ARIB STD-T63-25.421	5.0.0	Approved	25/05/2004	<a href="http://www.arib.or.jp/IMT-2000/ARIB-STD/ITU-R/Rel5/A25421-500.pdf">http://www.arib.or.jp/IMT-2000/ARIB-STD/ITU-R/Rel5/A25421-500.pdf</a>
CCSA	CCSA-TSD-DS-25.421	500	Approved	01/07/2003	<a href="http://www.ccsa.org.cn/english/tc/files.php?docpath=/ITU-R/M.1457/M.1457-4/DS/">http://www.ccsa.org.cn/english/tc/files.php?docpath=/ITU-R/M.1457/M.1457-4/DS/</a>
ETSI	ETSI TS 125 421	5.0.0	Published	15/04/2002	<a href="http://pda.etsi.org/pda/home.asp?wkr=RTS/TSGR-0325421Uv5">http://pda.etsi.org/pda/home.asp?wkr=RTS/TSGR-0325421Uv5</a>
T1 (ATIS)	T1.3GPP.25.421V500-2002	5.0.0	Approved	03/05/2002	<a href="https://www.atis.org/atis/docstore/search.asp?committee=S24">https://www.atis.org/atis/docstore/search.asp?committee=S24</a>
TTA	TTAE.3G-25.421(R5-5.0.0)	5.0.0	Approved	29/05/2002	<a href="http://www.tta.or.kr/standardDB/stnfile/TTAE.3G-25.421(R5-5.0.0).zip">http://www.tta.or.kr/standardDB/stnfile/TTAE.3G-25.421(R5-5.0.0).zip</a>

**Release 6**

ARIB	ARIB STD-T63-25.421	6.0.0	Approved	25/05/2004	<a href="http://www.arib.or.jp/IMT-2000/ARIB-STD/ITU-R/Rel6/A25421-600.pdf">http://www.arib.or.jp/IMT-2000/ARIB-STD/ITU-R/Rel6/A25421-600.pdf</a>
ETSI	ETSI TS 125 421	6.0.0	Published	20/01/2004	<a href="http://pda.etsi.org/pda/home.asp?wkr=RTS/TSGR-0325421v600">http://pda.etsi.org/pda/home.asp?wkr=RTS/TSGR-0325421v600</a>
T1 (ATIS)	T1.3GPP.25.421V600-2004	6.0.0	Approved	21/05/2004	<a href="https://www.atis.org/atis/docstore/search.asp?committee=S24">https://www.atis.org/atis/docstore/search.asp?committee=S24</a>
TTA	TTAT.3G-25.421(R6-6.0.0)	6.0.0	Approved	25/05/2004	<a href="http://www.tta.or.kr/standardDB/stnfile/TTAT.3G-25.421(R6-6.0.0).zip">http://www.tta.or.kr/standardDB/stnfile/TTAT.3G-25.421(R6-6.0.0).zip</a>

**5.1.2.3.12 25.422****UTRAN Iur interface signalling transport**

This specification describes the standards for Signalling Transport to be used across Iur Interface.

SDO (2)	Document No.	Version	Status	Issued date	Location (1)
<b>Release 99</b>					
ARIB	ARIB STD-T63-25.422	3.6.1	Approved	25/05/2004	<a href="http://www.arib.or.jp/IMT-2000/ARIB-STD/ITU-R/R99/A25422-361.pdf">http://www.arib.or.jp/IMT-2000/ARIB-STD/ITU-R/R99/A25422-361.pdf</a>
CCSA	CCSA-TSD-DS-25.422	361	Approved	01/07/2003	<a href="http://www.ccsa.org.cn/english/tc/files.php?docpath=/ITU-R/M.1457/M.1457-4/DS/">http://www.ccsa.org.cn/english/tc/files.php?docpath=/ITU-R/M.1457/M.1457-4/DS/</a>
ETSI	ETSI TS 125 422	3.6.1	Published	15/04/2002	<a href="http://pda.etsi.org/pda/home.asp?wkr=RTS/TSGR-0325422UR6">http://pda.etsi.org/pda/home.asp?wkr=RTS/TSGR-0325422UR6</a>
T1 (ATIS)	T1.3GPP.25.422V361-2002	3.6.1	Approved	03/05/2002	<a href="https://www.atis.org/atis/docstore/search.asp?committee=S24">https://www.atis.org/atis/docstore/search.asp?committee=S24</a>
TTA	TTAT.3G-25.422(R99-3.6.1)	3.6.1	Approved	21/03/2003	<a href="http://www.tta.or.kr/standardDB/stnfile/TTAT.3G-25.422(R99-3.6.1).zip">http://www.tta.or.kr/standardDB/stnfile/TTAT.3G-25.422(R99-3.6.1).zip</a>
<b>Release 4</b>					
ARIB	ARIB STD-T63-25.422	4.2.0	Approved	25/05/2004	<a href="http://www.arib.or.jp/IMT-2000/ARIB-STD/ITU-R/Rel4/A25422-420.pdf">http://www.arib.or.jp/IMT-2000/ARIB-STD/ITU-R/Rel4/A25422-420.pdf</a>
CCSA	CCSA-TSD-DS-25.422	420	Approved	01/07/2003	<a href="http://www.ccsa.org.cn/english/tc/files.php?docpath=/ITU-R/M.1457/M.1457-4/DS/">http://www.ccsa.org.cn/english/tc/files.php?docpath=/ITU-R/M.1457/M.1457-4/DS/</a>
ETSI	ETSI TS 125 422	4.2.0	Published	15/10/2002	<a href="http://pda.etsi.org/pda/home.asp?wkr=RTS/TSGR-0325422v420">http://pda.etsi.org/pda/home.asp?wkr=RTS/TSGR-0325422v420</a>
T1 (ATIS)	T1.3GPP.25.422V420-2003	4.2.0	Approved	27/03/2003	<a href="https://www.atis.org/atis/docstore/search.asp?committee=S24">https://www.atis.org/atis/docstore/search.asp?committee=S24</a>
TTA	TTAT.3G-25.422(R4-4.2.0)	4.2.0	Approved	21/03/2003	<a href="http://www.tta.or.kr/standardDB/stnfile/TTAT.3G-25.422(R4-4.2.0).zip">http://www.tta.or.kr/standardDB/stnfile/TTAT.3G-25.422(R4-4.2.0).zip</a>
<b>Release 5</b>					
ARIB	ARIB STD-T63-25.422	5.1.0	Approved	25/05/2004	<a href="http://www.arib.or.jp/IMT-2000/ARIB-STD/ITU-R/Rel5/A25422-510.pdf">http://www.arib.or.jp/IMT-2000/ARIB-STD/ITU-R/Rel5/A25422-510.pdf</a>
CCSA	CCSA-TSD-DS-25.422	510	Approved	01/07/2003	<a href="http://www.ccsa.org.cn/english/tc/files.php?docpath=/ITU-R/M.1457/M.1457-4/DS/">http://www.ccsa.org.cn/english/tc/files.php?docpath=/ITU-R/M.1457/M.1457-4/DS/</a>
ETSI	ETSI TS 125 422	5.1.0	Published	15/10/2002	<a href="http://pda.etsi.org/pda/home.asp?wkr=RTS/TSGR-0325422v510">http://pda.etsi.org/pda/home.asp?wkr=RTS/TSGR-0325422v510</a>

T1 (ATIS) T1.3GPP.25.422V510-2003	5.1.0	Approved	27/03/2003	<a href="https://www.atis.org/atis/docstore/search.asp?committee=S24">https://www.atis.org/atis/docstore/search.asp?committee=S24</a>
TTA TTAT.3G-25.422(R5-5.1.0)	5.1.0	Approved	21/03/2003	<a href="http://www.tta.or.kr/standardDB/stnfile/TTAT.3G-25.422(R5-5.1.0).zip">http://www.tta.or.kr/standardDB/stnfile/TTAT.3G-25.422(R5-5.1.0).zip</a>
<b>Release 6</b>				
ARIB ARIB STD-T63-25.422	6.0.0	Approved	25/05/2004	<a href="http://www.arib.or.jp/IMT-2000/ARIB-STD/ITU-R/Rel6/A25422-600.pdf">http://www.arib.or.jp/IMT-2000/ARIB-STD/ITU-R/Rel6/A25422-600.pdf</a>
ETSI ETSI TS 125 422	6.0.0	Published	20/01/2004	<a href="http://pda.etsi.org/pda/home.asp?wkr=RTS/TSGR-0325422v600">http://pda.etsi.org/pda/home.asp?wkr=RTS/TSGR-0325422v600</a>
T1 (ATIS) T1.3GPP.25.422V600-2004	6.0.0	Approved	21/05/2004	<a href="https://www.atis.org/atis/docstore/search.asp?committee=S24">https://www.atis.org/atis/docstore/search.asp?committee=S24</a>
TTA TTAT.3G-25.422(R6-6.0.0)	6.0.0	Approved	25/05/2004	<a href="http://www.tta.or.kr/standardDB/stnfile/TTAT.3G-25.422(R6-6.0.0).zip">http://www.tta.or.kr/standardDB/stnfile/TTAT.3G-25.422(R6-6.0.0).zip</a>

### 5.1.2.3.13 25.423

#### UTRAN Iur interface RNSAP signalling

This specification describes the radio network layer signalling procedures between RNCs in UTRAN.

SDO (2)	Document No.	Version	Status	Issued date	Location (1)
<b>Release 99</b>					
ARIB	ARIB STD-T63-25.423	3.14.0	Approved	25/05/2004	<a href="http://www.arib.or.jp/IMT-2000/ARIB-STD/ITU-R/R99/A25423-3e0.pdf">http://www.arib.or.jp/IMT-2000/ARIB-STD/ITU-R/R99/A25423-3e0.pdf</a>
CCSA	CCSA-TSD-DS-25.423	3D0	Approved	01/07/2003	<a href="http://www.ccsa.org.cn/english/tc/files.php?docpath=/ITU-R/M.1457/M.1457-4/DS/">http://www.ccsa.org.cn/english/tc/files.php?docpath=/ITU-R/M.1457/M.1457-4/DS/</a>
ETSI	ETSI TS 125 423	3.14.0	Published	03/10/2003	<a href="http://pda.etsi.org/pda/home.asp?wkr=RTS/TSGR-0325423v3e0">http://pda.etsi.org/pda/home.asp?wkr=RTS/TSGR-0325423v3e0</a>
T1 (ATIS)	T1.3GPP.25.423V3140-2004	3.14.0	Approved	21/05/2004	<a href="https://www.atis.org/atis/docstore/search.asp?committee=S24">https://www.atis.org/atis/docstore/search.asp?committee=S24</a>
TTA	TTAT.3G-25.423(R99-3.14.0)	3.14.0	Approved	25/05/2004	<a href="http://www.tta.or.kr/standardDB/stnfile/TTAT.3G-25.423(R99-3.14.0).zip">http://www.tta.or.kr/standardDB/stnfile/TTAT.3G-25.423(R99-3.14.0).zip</a>
<b>Release 4</b>					
ARIB	ARIB STD-T63-25.423	4.11.0	Approved	25/05/2004	<a href="http://www.arib.or.jp/IMT-2000/ARIB-STD/ITU-R/Rel4/A25423-4b0.pdf">http://www.arib.or.jp/IMT-2000/ARIB-STD/ITU-R/Rel4/A25423-4b0.pdf</a>
CCSA	CCSA-TSD-DS-25.423	490	Approved	01/07/2003	<a href="http://www.ccsa.org.cn/english/tc/files.php?docpath=/ITU-R/M.1457/M.1457-4/DS/">http://www.ccsa.org.cn/english/tc/files.php?docpath=/ITU-R/M.1457/M.1457-4/DS/</a>
ETSI	ETSI TS 125 423	4.11.0	Published	21/01/2004	<a href="http://pda.etsi.org/pda/home.asp?wkr=RTS/TSGR-0325423v4b0">http://pda.etsi.org/pda/home.asp?wkr=RTS/TSGR-0325423v4b0</a>
T1 (ATIS)	T1.3GPP.25.423V4110-2004	4.11.0	Approved	21/05/2004	<a href="https://www.atis.org/atis/docstore/search.asp?committee=S24">https://www.atis.org/atis/docstore/search.asp?committee=S24</a>
TTA	TTAT.3G-25.423(R4-4.11.0)	4.11.0	Approved	25/05/2004	<a href="http://www.tta.or.kr/standardDB/stnfile/TTAT.3G-25.423(R4-4.11.0).zip">http://www.tta.or.kr/standardDB/stnfile/TTAT.3G-25.423(R4-4.11.0).zip</a>
<b>Release 5</b>					
ARIB	ARIB STD-T63-25.423	5.8.0	Approved	25/05/2004	<a href="http://www.arib.or.jp/IMT-2000/ARIB-STD/ITU-R/Rel5/A25423-580.pdf">http://www.arib.or.jp/IMT-2000/ARIB-STD/ITU-R/Rel5/A25423-580.pdf</a>
CCSA	CCSA-TSD-DS-25.423	560	Approved	01/07/2003	<a href="http://www.ccsa.org.cn/english/tc/files.php?docpath=/ITU-R/M.1457/M.1457-4/DS/">http://www.ccsa.org.cn/english/tc/files.php?docpath=/ITU-R/M.1457/M.1457-4/DS/</a>
ETSI	ETSI TS 125 423	5.8.0	Published	30/01/2004	<a href="http://pda.etsi.org/pda/home.asp?wkr=RTS/TSGR-0325423v580">http://pda.etsi.org/pda/home.asp?wkr=RTS/TSGR-0325423v580</a>
T1 (ATIS)	T1.3GPP.25.423V580-2004	5.8.0	Approved	21/05/2004	<a href="https://www.atis.org/atis/docstore/search.asp?committee=S24">https://www.atis.org/atis/docstore/search.asp?committee=S24</a>
TTA	TTAT.3G-25.423(R5-5.8.0)	5.8.0	Approved	25/05/2004	<a href="http://www.tta.or.kr/standardDB/stnfile/TTAT.3G-25.423(R5-5.8.0).zip">http://www.tta.or.kr/standardDB/stnfile/TTAT.3G-25.423(R5-5.8.0).zip</a>
<b>Release 6</b>					
ARIB	ARIB STD-T63-25.423	6.0.0	Approved	25/05/2004	<a href="http://www.arib.or.jp/IMT-2000/ARIB-STD/ITU-R/Rel6/A25423-600.pdf">http://www.arib.or.jp/IMT-2000/ARIB-STD/ITU-R/Rel6/A25423-600.pdf</a>
ETSI	ETSI TS 125 423	6.0.0	Published	30/01/2004	<a href="http://pda.etsi.org/pda/home.asp?wkr=RTS/TSGR-0325423v600">http://pda.etsi.org/pda/home.asp?wkr=RTS/TSGR-0325423v600</a>
T1 (ATIS)	T1.3GPP.25.423V600-2004	6.0.0	Approved	21/05/2004	<a href="https://www.atis.org/atis/docstore/search.asp?committee=S24">https://www.atis.org/atis/docstore/search.asp?committee=S24</a>
TTA	TTAT.3G-25.423(R6-6.0.0)	6.0.0	Approved	25/05/2004	<a href="http://www.tta.or.kr/standardDB/stnfile/TTAT.3G-25.423(R6-6.0.0).zip">http://www.tta.or.kr/standardDB/stnfile/TTAT.3G-25.423(R6-6.0.0).zip</a>

**5.1.2.3.14** 25.424**UTRAN Iur interface data transport and transport signalling for common transport channel data streams**

This specification describes the UTRAN RNS-RNS (Iur) interface data transport and transport signalling for common transport channel data streams.

SDO (2)	Document No.	Version	Status	Issued date	Location (1)
<b>Release 99</b>					
ARIB	ARIB STD-T63-25.424	3.9.0	Approved	25/05/2004	<a href="http://www.arib.or.jp/IMT-2000/ARIB-STD/ITU-R/R99/A25424-390.pdf">http://www.arib.or.jp/IMT-2000/ARIB-STD/ITU-R/R99/A25424-390.pdf</a>
CCSA	CCSA-TSD-DS-25.424	390	Approved	01/07/2003	<a href="http://www.ccsa.org.cn/english/tc/files.php?docpath=/ITU-R/M.1457/M.1457-4/DS/">http://www.ccsa.org.cn/english/tc/files.php?docpath=/ITU-R/M.1457/M.1457-4/DS/</a>
ETSI	ETSI TS 125 424	3.9.0	Published	11/07/2002	<a href="http://pda.etsi.org/pda/home.asp?wkr=RTS/TSGR-0325424v390">http://pda.etsi.org/pda/home.asp?wkr=RTS/TSGR-0325424v390</a>
T1 (ATIS)	T1.3GPP.25.424V390-2003	3.9.0	Approved	27/03/2003	<a href="https://www.atis.org/atis/docstore/search.asp?committee=S24">https://www.atis.org/atis/docstore/search.asp?committee=S24</a>
TTA	TTAT.3G-25.424(R99-3.9.0)	3.9.0	Approved	21/03/2003	<a href="http://www.tta.or.kr/standardDB/stnfile/TTAT.3G-25.424(R99-3.9.0).zip">http://www.tta.or.kr/standardDB/stnfile/TTAT.3G-25.424(R99-3.9.0).zip</a>
<b>Release 4</b>					
ARIB	ARIB STD-T63-25.424	4.3.0	Approved	25/05/2004	<a href="http://www.arib.or.jp/IMT-2000/ARIB-STD/ITU-R/Rel4/A25424-430.pdf">http://www.arib.or.jp/IMT-2000/ARIB-STD/ITU-R/Rel4/A25424-430.pdf</a>
CCSA	CCSA-TSD-DS-25.424	430	Approved	01/07/2003	<a href="http://www.ccsa.org.cn/english/tc/files.php?docpath=/ITU-R/M.1457/M.1457-4/DS/">http://www.ccsa.org.cn/english/tc/files.php?docpath=/ITU-R/M.1457/M.1457-4/DS/</a>
ETSI	ETSI TS 125 424	4.3.0	Published	11/07/2002	<a href="http://pda.etsi.org/pda/home.asp?wkr=RTS/TSGR-0325424v430">http://pda.etsi.org/pda/home.asp?wkr=RTS/TSGR-0325424v430</a>
T1 (ATIS)	T1.3GPP.25.424V430-2003	4.3.0	Approved	27/03/2003	<a href="https://www.atis.org/atis/docstore/search.asp?committee=S24">https://www.atis.org/atis/docstore/search.asp?committee=S24</a>
TTA	TTAT.3G-25.424(R4-4.3.0)	4.3.0	Approved	21/03/2003	<a href="http://www.tta.or.kr/standardDB/stnfile/TTAT.3G-25.424(R4-4.3.0).zip">http://www.tta.or.kr/standardDB/stnfile/TTAT.3G-25.424(R4-4.3.0).zip</a>
<b>Release 5</b>					
ARIB	ARIB STD-T63-25.424	5.3.0	Approved	25/05/2004	<a href="http://www.arib.or.jp/IMT-2000/ARIB-STD/ITU-R/Rel5/A25424-530.pdf">http://www.arib.or.jp/IMT-2000/ARIB-STD/ITU-R/Rel5/A25424-530.pdf</a>
CCSA	CCSA-TSD-DS-25.424	510	Approved	01/07/2003	<a href="http://www.ccsa.org.cn/english/tc/files.php?docpath=/ITU-R/M.1457/M.1457-4/DS/">http://www.ccsa.org.cn/english/tc/files.php?docpath=/ITU-R/M.1457/M.1457-4/DS/</a>
ETSI	ETSI TS 125 424	5.3.0	Published	20/01/2004	<a href="http://pda.etsi.org/pda/home.asp?wkr=RTS/TSGR-0325424v530">http://pda.etsi.org/pda/home.asp?wkr=RTS/TSGR-0325424v530</a>
T1 (ATIS)	T1.3GPP.25.424V530-2004	5.3.0	Approved	21/05/2004	<a href="https://www.atis.org/atis/docstore/search.asp?committee=S24">https://www.atis.org/atis/docstore/search.asp?committee=S24</a>
TTA	TTAT.3G-25.424(R5-5.3.0)	5.3.0	Approved	25/05/2004	<a href="http://www.tta.or.kr/standardDB/stnfile/TTAT.3G-25.424(R5-5.3.0).zip">http://www.tta.or.kr/standardDB/stnfile/TTAT.3G-25.424(R5-5.3.0).zip</a>
<b>Release 6</b>					
ARIB	ARIB STD-T63-25.424	6.0.0	Approved	25/05/2004	<a href="http://www.arib.or.jp/IMT-2000/ARIB-STD/ITU-R/Rel6/A25424-600.pdf">http://www.arib.or.jp/IMT-2000/ARIB-STD/ITU-R/Rel6/A25424-600.pdf</a>
ETSI	ETSI TS 125 424	6.0.0	Published	20/01/2004	<a href="http://pda.etsi.org/pda/home.asp?wkr=RTS/TSGR-0325424v600">http://pda.etsi.org/pda/home.asp?wkr=RTS/TSGR-0325424v600</a>
T1 (ATIS)	T1.3GPP.25.424V600-2004	6.0.0	Approved	21/05/2004	<a href="https://www.atis.org/atis/docstore/search.asp?committee=S24">https://www.atis.org/atis/docstore/search.asp?committee=S24</a>
TTA	TTAT.3G-25.424(R6-6.0.0)	6.0.0	Approved	25/05/2004	<a href="http://www.tta.or.kr/standardDB/stnfile/TTAT.3G-25.424(R6-6.0.0).zip">http://www.tta.or.kr/standardDB/stnfile/TTAT.3G-25.424(R6-6.0.0).zip</a>

**5.1.2.3.15** 25.425**UTRAN Iur interface user plane protocols for common transport channel data streams**

This specification describes the UTRAN RNS-RNS (Iur) interface user plane protocols for common transport channel data streams.

SDO (2)	Document No.	Version	Status	Issued date	Location (1)
<b>Release 99</b>					
ARIB	ARIB STD-T63-25.425	3.8.0	Approved	25/05/2004	<a href="http://www.arib.or.jp/IMT-2000/ARIB-STD/ITU-R/R99/A25425-380.pdf">http://www.arib.or.jp/IMT-2000/ARIB-STD/ITU-R/R99/A25425-380.pdf</a>
CCSA	CCSA-TSD-DS-25.425	370	Approved	01/07/2003	<a href="http://www.ccsa.org.cn/english/tc/files.php?docpath=/ITU-R/M.1457/M.1457-4/DS/">http://www.ccsa.org.cn/english/tc/files.php?docpath=/ITU-R/M.1457/M.1457-4/DS/</a>

ETSI	ETSI TS 125 425	3.8.0	Published	20/01/2004	<a href="http://pda.etsi.org/pda/home.asp?wkr=RTS/TSGR-0325425v380">http://pda.etsi.org/pda/home.asp?wkr=RTS/TSGR-0325425v380</a>
T1 (ATIS)	T1.3GPP.25.425V380-2004	3.8.0	Approved	21/05/2004	<a href="https://www.atis.org/atis/docstore/search.asp?committee=S24">https://www.atis.org/atis/docstore/search.asp?committee=S24</a>
TTA	TTAT.3G-25.425(R99-3.8.0)	3.8.0	Approved	25/05/2004	<a href="http://www.tta.or.kr/standardDB/stnfile/TTAT.3G-25.425(R99-3.8.0).zip">http://www.tta.or.kr/standardDB/stnfile/TTAT.3G-25.425(R99-3.8.0).zip</a>
<b>Release 4</b>					
ARIB	ARIB STD-T63-25.425	4.4.0	Approved	25/05/2004	<a href="http://www.arib.or.jp/IMT-2000/ARIB-STD/ITU-R/Rel4/A25425-440.pdf">http://www.arib.or.jp/IMT-2000/ARIB-STD/ITU-R/Rel4/A25425-440.pdf</a>
CCSA	CCSA-TSD-DS-25.425	430	Approved	01/07/2003	<a href="http://www.ccsa.org.cn/english/tc/files.php?docpath=/ITU-R/M.1457/M.1457-4/DS/">http://www.ccsa.org.cn/english/tc/files.php?docpath=/ITU-R/M.1457/M.1457-4/DS/</a>
ETSI	ETSI TS 125 425	4.4.0	Published	20/01/2004	<a href="http://pda.etsi.org/pda/home.asp?wkr=RTS/TSGR-0325425v440">http://pda.etsi.org/pda/home.asp?wkr=RTS/TSGR-0325425v440</a>
T1 (ATIS)	T1.3GPP.25.425V440-2004	4.4.0	Approved	21/05/2004	<a href="https://www.atis.org/atis/docstore/search.asp?committee=S24">https://www.atis.org/atis/docstore/search.asp?committee=S24</a>
TTA	TTAT.3G-25.425(R4-4.4.0)	4.4.0	Approved	25/05/2004	<a href="http://www.tta.or.kr/standardDB/stnfile/TTAT.3G-25.425(R4-4.4.0).zip">http://www.tta.or.kr/standardDB/stnfile/TTAT.3G-25.425(R4-4.4.0).zip</a>
<b>Release 5</b>					
ARIB	ARIB STD-T63-25.425	5.5.0	Approved	25/05/2004	<a href="http://www.arib.or.jp/IMT-2000/ARIB-STD/ITU-R/Rel5/A25425-550.pdf">http://www.arib.or.jp/IMT-2000/ARIB-STD/ITU-R/Rel5/A25425-550.pdf</a>
CCSA	CCSA-TSD-DS-25.425	550	Approved	01/07/2003	<a href="http://www.ccsa.org.cn/english/tc/files.php?docpath=/ITU-R/M.1457/M.1457-4/DS/">http://www.ccsa.org.cn/english/tc/files.php?docpath=/ITU-R/M.1457/M.1457-4/DS/</a>
ETSI	ETSI TS 125 425	5.6.0	Published	20/01/2004	<a href="http://pda.etsi.org/pda/home.asp?wkr=RTS/TSGR-0325425v560">http://pda.etsi.org/pda/home.asp?wkr=RTS/TSGR-0325425v560</a>
T1 (ATIS)	T1.3GPP.25.425V560-2004	5.6.0	Approved	21/05/2004	<a href="https://www.atis.org/atis/docstore/search.asp?committee=S24">https://www.atis.org/atis/docstore/search.asp?committee=S24</a>
TTA	TTAT.3G-25.425(R5-5.6.0)	5.6.0	Approved	25/05/2004	<a href="http://www.tta.or.kr/standardDB/stnfile/TTAT.3G-25.425(R5-5.6.0).zip">http://www.tta.or.kr/standardDB/stnfile/TTAT.3G-25.425(R5-5.6.0).zip</a>
<b>Release 6</b>					
ARIB	ARIB STD-T63-25.425	6.0.0	Approved	25/05/2004	<a href="http://www.arib.or.jp/IMT-2000/ARIB-STD/ITU-R/Rel6/A25425-600.pdf">http://www.arib.or.jp/IMT-2000/ARIB-STD/ITU-R/Rel6/A25425-600.pdf</a>
ETSI	ETSI TS 125 425	6.0.0	Published	20/01/2004	<a href="http://pda.etsi.org/pda/home.asp?wkr=RTS/TSGR-0325425v600">http://pda.etsi.org/pda/home.asp?wkr=RTS/TSGR-0325425v600</a>
T1 (ATIS)	T1.3GPP.25.425V600-2004	6.0.0	Approved	21/05/2004	<a href="https://www.atis.org/atis/docstore/search.asp?committee=S24">https://www.atis.org/atis/docstore/search.asp?committee=S24</a>
TTA	TTAT.3G-25.425(R6-6.0.0)	6.0.0	Approved	25/05/2004	<a href="http://www.tta.or.kr/standardDB/stnfile/TTAT.3G-25.425(R6-6.0.0).zip">http://www.tta.or.kr/standardDB/stnfile/TTAT.3G-25.425(R6-6.0.0).zip</a>

### 5.1.2.3.16 25.426

#### UTRAN Iur and Iub interface data transport and transport signalling for DCH data streams

This specification describes the transport bearers for the DCH data streams on UTRAN Iur and Iub interfaces. The corresponding transport network control plane is also specified. The physical layer for the transport bearers is outside the scope of this TS.

SDO (2)	Document No.	Version	Status	Issued date	Location (1)
<b>Release 99</b>					
ARIB	ARIB STD-T63-25.426	3.9.0	Approved	25/05/2004	<a href="http://www.arib.or.jp/IMT-2000/ARIB-STD/ITU-R/R99/A25426-390.pdf">http://www.arib.or.jp/IMT-2000/ARIB-STD/ITU-R/R99/A25426-390.pdf</a>
CCSA	CCSA-TSD-DS-25.426	390	Approved	01/07/2003	<a href="http://www.ccsa.org.cn/english/tc/files.php?docpath=/ITU-R/M.1457/M.1457-4/DS/">http://www.ccsa.org.cn/english/tc/files.php?docpath=/ITU-R/M.1457/M.1457-4/DS/</a>
ETSI	ETSI TS 125 426	3.9.0	Published	11/07/2002	<a href="http://pda.etsi.org/pda/home.asp?wkr=RTS/TSGR-0325426v390">http://pda.etsi.org/pda/home.asp?wkr=RTS/TSGR-0325426v390</a>
T1 (ATIS)	T1.3GPP.25.426V390-2003	3.9.0	Approved	27/03/2003	<a href="https://www.atis.org/atis/docstore/search.asp?committee=S24">https://www.atis.org/atis/docstore/search.asp?committee=S24</a>
TTA	TTAT.3G-25.426(R99-3.9.0)	3.9.0	Approved	21/03/2003	<a href="http://www.tta.or.kr/standardDB/stnfile/TTAT.3G-25.426(R99-3.9.0).zip">http://www.tta.or.kr/standardDB/stnfile/TTAT.3G-25.426(R99-3.9.0).zip</a>
<b>Release 4</b>					
ARIB	ARIB STD-T63-25.426	4.4.0	Approved	25/05/2004	<a href="http://www.arib.or.jp/IMT-2000/ARIB-STD/ITU-R/Rel4/A25426-440.pdf">http://www.arib.or.jp/IMT-2000/ARIB-STD/ITU-R/Rel4/A25426-440.pdf</a>
CCSA	CCSA-TSD-DS-25.426	440	Approved	01/07/2003	<a href="http://www.ccsa.org.cn/english/tc/files.php?docpath=/ITU-R/M.1457/M.1457-4/DS/">http://www.ccsa.org.cn/english/tc/files.php?docpath=/ITU-R/M.1457/M.1457-4/DS/</a>
ETSI	ETSI TS 125 426	4.4.0	Published	15/10/2002	<a href="http://pda.etsi.org/pda/home.asp?wkr=RTS/TSGR-0325426v440">http://pda.etsi.org/pda/home.asp?wkr=RTS/TSGR-0325426v440</a>
T1 (ATIS)	T1.3GPP.25.426V440-2003	4.4.0	Approved	27/03/2003	<a href="https://www.atis.org/atis/docstore/search.asp?committee=S24">https://www.atis.org/atis/docstore/search.asp?committee=S24</a>

TTA	TTAT.3G-25.426(R4-4.4.0)	4.4.0	Approved	21/03/2003	<a href="http://www.tta.or.kr/standardDB/stnfile/TTAT.3G-25.426(R4-4.4.0).zip">http://www.tta.or.kr/standardDB/stnfile/TTAT.3G-25.426(R4-4.4.0).zip</a>
<b>Release 5</b>					
ARIB	ARIB STD-T63-25.426	5.3.0	Approved	25/05/2004	<a href="http://www.arib.or.jp/IMT-2000/ARIB-STD/ITU-R/Rel5/A25426-530.pdf">http://www.arib.or.jp/IMT-2000/ARIB-STD/ITU-R/Rel5/A25426-530.pdf</a>
CCSA	CCSA-TSD-DS-25.426	520	Approved	01/07/2003	<a href="http://www.ccsa.org.cn/english/tc/files.php?docpath=/ITU-R/M.1457/M.1457-4/DS/">http://www.ccsa.org.cn/english/tc/files.php?docpath=/ITU-R/M.1457/M.1457-4/DS/</a>
ETSI	ETSI TS 125 426	5.3.0	Published	03/10/2003	<a href="http://pda.etsi.org/pda/home.asp?wkr=RTS/TSGR-0325426v530">http://pda.etsi.org/pda/home.asp?wkr=RTS/TSGR-0325426v530</a>
T1 (ATIS)	T1.3GPP.25.426V530-2004	5.3.0	Approved	21/05/2004	<a href="https://www.atis.org/atis/docstore/search.asp?committee=S24">https://www.atis.org/atis/docstore/search.asp?committee=S24</a>
TTA	TTAT.3G-25.426(R5-5.3.0)	5.3.0	Approved	25/05/2004	<a href="http://www.tta.or.kr/standardDB/stnfile/TTAT.3G-25.426(R5-5.3.0).zip">http://www.tta.or.kr/standardDB/stnfile/TTAT.3G-25.426(R5-5.3.0).zip</a>
<b>Release 6</b>					
ARIB	ARIB STD-T63-25.426	6.0.0	Approved	25/05/2004	<a href="http://www.arib.or.jp/IMT-2000/ARIB-STD/ITU-R/Rel6/A25426-600.pdf">http://www.arib.or.jp/IMT-2000/ARIB-STD/ITU-R/Rel6/A25426-600.pdf</a>
ETSI	ETSI TS 125 426	6.0.0	Published	20/01/2004	<a href="http://pda.etsi.org/pda/home.asp?wkr=RTS/TSGR-0325426v600">http://pda.etsi.org/pda/home.asp?wkr=RTS/TSGR-0325426v600</a>
T1 (ATIS)	T1.3GPP.25.426V600-2004	6.0.0	Approved	21/05/2004	<a href="https://www.atis.org/atis/docstore/search.asp?committee=S24">https://www.atis.org/atis/docstore/search.asp?committee=S24</a>
TTA	TTAT.3G-25.426(R6-6.0.0)	6.0.0	Approved	25/05/2004	<a href="http://www.tta.or.kr/standardDB/stnfile/TTAT.3G-25.426(R6-6.0.0).zip">http://www.tta.or.kr/standardDB/stnfile/TTAT.3G-25.426(R6-6.0.0).zip</a>

### 5.1.2.3.17 25.427

#### UTRAN Iur and Iub interface user plane protocols for DCH data streams

This specification describes the UTRAN Iur and Iub interfaces user plane protocols for dedicated transport channel data streams.

SDO (2)	Document No.	Version	Status	Issued date	Location (1)
<b>Release 99</b>					
ARIB	ARIB STD-T63-25.427	3.11.0	Approved	25/05/2004	<a href="http://www.arib.or.jp/IMT-2000/ARIB-STD/ITU-R/R99/A25427-3b0.pdf">http://www.arib.or.jp/IMT-2000/ARIB-STD/ITU-R/R99/A25427-3b0.pdf</a>
CCSA	CCSA-TSD-DS-25.427	3A0	Approved	01/07/2003	<a href="http://www.ccsa.org.cn/english/tc/files.php?docpath=/ITU-R/M.1457/M.1457-4/DS/">http://www.ccsa.org.cn/english/tc/files.php?docpath=/ITU-R/M.1457/M.1457-4/DS/</a>
ETSI	ETSI TS 125 427	3.11.0	Published	20/01/2004	<a href="http://pda.etsi.org/pda/home.asp?wkr=RTS/TSGR-0325427v3b0">http://pda.etsi.org/pda/home.asp?wkr=RTS/TSGR-0325427v3b0</a>
T1 (ATIS)	T1.3GPP.25.427V3110-2004	3.11.0	Approved	21/05/2004	<a href="https://www.atis.org/atis/docstore/search.asp?committee=S24">https://www.atis.org/atis/docstore/search.asp?committee=S24</a>
TTA	TTAT.3G-25.427(R99-3.11.0)	3.11.0	Approved	25/05/2004	<a href="http://www.tta.or.kr/standardDB/stnfile/TTAT.3G-25.427(R99-3.11.0).zip">http://www.tta.or.kr/standardDB/stnfile/TTAT.3G-25.427(R99-3.11.0).zip</a>
<b>Release 4</b>					
ARIB	ARIB STD-T63-25.427	4.5.0	Approved	25/05/2004	<a href="http://www.arib.or.jp/IMT-2000/ARIB-STD/ITU-R/Rel4/A25427-450.pdf">http://www.arib.or.jp/IMT-2000/ARIB-STD/ITU-R/Rel4/A25427-450.pdf</a>
CCSA	CCSA-TSD-DS-25.427	440	Approved	01/07/2003	<a href="http://www.ccsa.org.cn/english/tc/files.php?docpath=/ITU-R/M.1457/M.1457-4/DS/">http://www.ccsa.org.cn/english/tc/files.php?docpath=/ITU-R/M.1457/M.1457-4/DS/</a>
ETSI	ETSI TS 125 427	4.5.0	Published	20/01/2004	<a href="http://pda.etsi.org/pda/home.asp?wkr=RTS/TSGR-0325427v450">http://pda.etsi.org/pda/home.asp?wkr=RTS/TSGR-0325427v450</a>
T1 (ATIS)	T1.3GPP.25.427V450-2004	4.5.0	Approved	21/05/2004	<a href="https://www.atis.org/atis/docstore/search.asp?committee=S24">https://www.atis.org/atis/docstore/search.asp?committee=S24</a>
TTA	TTAT.3G-25.427(R4-4.5.0)	4.5.0	Approved	25/05/2004	<a href="http://www.tta.or.kr/standardDB/stnfile/TTAT.3G-25.427(R4-4.5.0).zip">http://www.tta.or.kr/standardDB/stnfile/TTAT.3G-25.427(R4-4.5.0).zip</a>
<b>Release 5</b>					
ARIB	ARIB STD-T63-25.427	5.3.0	Approved	25/05/2004	<a href="http://www.arib.or.jp/IMT-2000/ARIB-STD/ITU-R/Rel5/A25427-530.pdf">http://www.arib.or.jp/IMT-2000/ARIB-STD/ITU-R/Rel5/A25427-530.pdf</a>
CCSA	CCSA-TSD-DS-25.427	510	Approved	01/07/2003	<a href="http://www.ccsa.org.cn/english/tc/files.php?docpath=/ITU-R/M.1457/M.1457-4/DS/">http://www.ccsa.org.cn/english/tc/files.php?docpath=/ITU-R/M.1457/M.1457-4/DS/</a>
ETSI	ETSI TS 125 427	5.3.0	Published	20/01/2004	<a href="http://pda.etsi.org/pda/home.asp?wkr=RTS/TSGR-0325427v530">http://pda.etsi.org/pda/home.asp?wkr=RTS/TSGR-0325427v530</a>
T1 (ATIS)	T1.3GPP.25.427V530-2004	5.3.0	Approved	21/05/2004	<a href="https://www.atis.org/atis/docstore/search.asp?committee=S24">https://www.atis.org/atis/docstore/search.asp?committee=S24</a>
TTA	TTAT.3G-25.427(R5-5.3.0)	5.3.0	Approved	25/05/2004	<a href="http://www.tta.or.kr/standardDB/stnfile/TTAT.3G-25.427(R5-5.3.0).zip">http://www.tta.or.kr/standardDB/stnfile/TTAT.3G-25.427(R5-5.3.0).zip</a>

**Release 6**

ARIB	ARIB STD-T63-25.427	6.0.0	Approved	25/05/2004	<a href="http://www.arib.or.jp/IMT-2000/ARIB-STD/ITU-R/Rel6/A25427-600.pdf">http://www.arib.or.jp/IMT-2000/ARIB-STD/ITU-R/Rel6/A25427-600.pdf</a>
ETSI	ETSI TS 125 427	6.0.0	Published	20/01/2004	<a href="http://pda.etsi.org/pda/home.asp?wkr=RTS/TSGR-0325427v600">http://pda.etsi.org/pda/home.asp?wkr=RTS/TSGR-0325427v600</a>
T1 (ATIS)	T1.3GPP.25.427V600-2004	6.0.0	Approved	21/05/2004	<a href="https://www.atis.org/atis/docstore/search.asp?committee=S24">https://www.atis.org/atis/docstore/search.asp?committee=S24</a>
TTA	TTAT.3G-25.427(R6-6.0.0)	6.0.0	Approved	25/05/2004	<a href="http://www.tta.or.kr/standardDB/stnfile/TTAT.3G-25.427(R6-6.0.0).zip">http://www.tta.or.kr/standardDB/stnfile/TTAT.3G-25.427(R6-6.0.0).zip</a>

**5.1.2.3.18 25.430****UTRAN Iub interface: general aspects and principles**

This specification describes the TSG RAN TS 25.43x series of UMTS technical specifications that define the Iub interface. The Iub interface is a logical interface for the interconnection of Node B and RNC components of the UTRAN.

<b>SDO (2)</b>	<b>Document No.</b>	<b>Version</b>	<b>Status</b>	<b>Issued date</b>	<b>Location (1)</b>
<b>Release 99</b>					
ARIB	ARIB STD-T63-25.430	3.8.0	Approved	25/05/2004	<a href="http://www.arib.or.jp/IMT-2000/ARIB-STD/ITU-R/R99/A25430-380.pdf">http://www.arib.or.jp/IMT-2000/ARIB-STD/ITU-R/R99/A25430-380.pdf</a>
CCSA	CCSA-TSD-DS-25.430	380	Approved	01/07/2003	<a href="http://www.ccsa.org.cn/english/tc/files.php?docpath=/ITU-R/M.1457/M.1457-4/DS/">http://www.ccsa.org.cn/english/tc/files.php?docpath=/ITU-R/M.1457/M.1457-4/DS/</a>
ETSI	ETSI TS 125 430	3.8.0	Published	11/07/2002	<a href="http://pda.etsi.org/pda/home.asp?wkr=RTS/TSGR-0325430v380">http://pda.etsi.org/pda/home.asp?wkr=RTS/TSGR-0325430v380</a>
T1 (ATIS)	T1.3GPP.25.430V380-2003	3.8.0	Approved	27/03/2003	<a href="https://www.atis.org/atis/docstore/search.asp?committee=S24">https://www.atis.org/atis/docstore/search.asp?committee=S24</a>
TTA	TTAT.3G-25.430(R99-3.8.0)	3.8.0	Approved	21/03/2003	<a href="http://www.tta.or.kr/standardDB/stnfile/TTAT.3G-25.430(R99-3.8.0).zip">http://www.tta.or.kr/standardDB/stnfile/TTAT.3G-25.430(R99-3.8.0).zip</a>
<b>Release 4</b>					
ARIB	ARIB STD-T63-25.430	4.4.0	Approved	25/05/2004	<a href="http://www.arib.or.jp/IMT-2000/ARIB-STD/ITU-R/Rel4/A25430-440.pdf">http://www.arib.or.jp/IMT-2000/ARIB-STD/ITU-R/Rel4/A25430-440.pdf</a>
CCSA	CCSA-TSD-DS-25.430	440	Approved	01/07/2003	<a href="http://www.ccsa.org.cn/english/tc/files.php?docpath=/ITU-R/M.1457/M.1457-4/DS/">http://www.ccsa.org.cn/english/tc/files.php?docpath=/ITU-R/M.1457/M.1457-4/DS/</a>
ETSI	ETSI TS 125 430	4.4.0	Published	16/10/2002	<a href="http://pda.etsi.org/pda/home.asp?wkr=RTS/TSGR-0325430v440">http://pda.etsi.org/pda/home.asp?wkr=RTS/TSGR-0325430v440</a>
T1 (ATIS)	T1.3GPP.25.430V440-2003	4.4.0	Approved	27/03/2003	<a href="https://www.atis.org/atis/docstore/search.asp?committee=S24">https://www.atis.org/atis/docstore/search.asp?committee=S24</a>
TTA	TTAT.3G-25.430(R4-4.4.0)	4.4.0	Approved	21/03/2003	<a href="http://www.tta.or.kr/standardDB/stnfile/TTAT.3G-25.430(R4-4.4.0).zip">http://www.tta.or.kr/standardDB/stnfile/TTAT.3G-25.430(R4-4.4.0).zip</a>
<b>Release 5</b>					
ARIB	ARIB STD-T63-25.430	5.2.0	Approved	25/05/2004	<a href="http://www.arib.or.jp/IMT-2000/ARIB-STD/ITU-R/Rel5/A25430-520.pdf">http://www.arib.or.jp/IMT-2000/ARIB-STD/ITU-R/Rel5/A25430-520.pdf</a>
CCSA	CCSA-TSD-DS-25.430	520	Approved	01/07/2003	<a href="http://www.ccsa.org.cn/english/tc/files.php?docpath=/ITU-R/M.1457/M.1457-4/DS/">http://www.ccsa.org.cn/english/tc/files.php?docpath=/ITU-R/M.1457/M.1457-4/DS/</a>
ETSI	ETSI TS 125 430	5.2.0	Published	16/10/2002	<a href="http://pda.etsi.org/pda/home.asp?wkr=RTS/TSGR-0325430v520">http://pda.etsi.org/pda/home.asp?wkr=RTS/TSGR-0325430v520</a>
T1 (ATIS)	T1.3GPP.25.430V520-2003	5.2.0	Approved	27/03/2003	<a href="https://www.atis.org/atis/docstore/search.asp?committee=S24">https://www.atis.org/atis/docstore/search.asp?committee=S24</a>
TTA	TTAT.3G-25.430(R5-5.2.0)	5.2.0	Approved	21/03/2003	<a href="http://www.tta.or.kr/standardDB/stnfile/TTAT.3G-25.430(R5-5.2.0).zip">http://www.tta.or.kr/standardDB/stnfile/TTAT.3G-25.430(R5-5.2.0).zip</a>
<b>Release 6</b>					
ARIB	ARIB STD-T63-25.430	6.0.0	Approved	25/05/2004	<a href="http://www.arib.or.jp/IMT-2000/ARIB-STD/ITU-R/Rel5/A25430-600.pdf">http://www.arib.or.jp/IMT-2000/ARIB-STD/ITU-R/Rel5/A25430-600.pdf</a>
ETSI	ETSI TS 125 430	6.0.0	Published	20/01/2004	<a href="http://pda.etsi.org/pda/home.asp?wkr=RTS/TSGR-0325430v600">http://pda.etsi.org/pda/home.asp?wkr=RTS/TSGR-0325430v600</a>
T1 (ATIS)	T1.3GPP.25.430V600-2003	6.0.0	Approved	21/05/2004	<a href="https://www.atis.org/atis/docstore/search.asp?committee=S24">https://www.atis.org/atis/docstore/search.asp?committee=S24</a>
TTA	TTAT.3G-25.430(R6-6.0.0)	6.0.0	Approved	25/05/2004	<a href="http://www.tta.or.kr/standardDB/stnfile/TTAT.3G-25.430(R6-6.0.0).zip">http://www.tta.or.kr/standardDB/stnfile/TTAT.3G-25.430(R6-6.0.0).zip</a>



**5.1.2.3.19** 25.431**UTRAN Iub interface: Layer 1**

This specification describes the standards allowed to implement Layer 1 on the Iub interface. The specification of transmission delay requirements and O&M requirements is not in the scope of this specification.

SDO (2)	Document No.	Version	Status	Issued date	Location (1)
<b>Release 99</b>					
ARIB	ARIB STD-T63-25.431	3.1.0	Approved	25/05/2004	<a href="http://www.arib.or.jp/IMT-2000/ARIB-STD/ITU-R/R99/A25431-310.pdf">http://www.arib.or.jp/IMT-2000/ARIB-STD/ITU-R/R99/A25431-310.pdf</a>
CCSA	CCSA-TSD-DS-25.431	310	Approved	01/07/2003	<a href="http://www.ccsa.org.cn/english/tc/files.php?docpath=/ITU-R/M.1457/M.1457-4/DS/">http://www.ccsa.org.cn/english/tc/files.php?docpath=/ITU-R/M.1457/M.1457-4/DS/</a>
ETSI	ETSI TS 125 431	3.1.0	Published	27/04/2001	<a href="http://pda.etsi.org/pda/home.asp?wkr=RTS/TSGR-0325431UR1">http://pda.etsi.org/pda/home.asp?wkr=RTS/TSGR-0325431UR1</a>
T1 (ATIS)	T1.3GPP.25.431V310-2002	3.1.0	Approved	03/05/2002	<a href="https://www.atis.org/atis/docstore/search.asp?committee=S24">https://www.atis.org/atis/docstore/search.asp?committee=S24</a>
TTA	TTAE.3G-25.431(R99-3.1.0)	3.1.0	Approved	29/05/2002	<a href="http://www.tta.or.kr/standardDB/stnfile/TTAE.3G-25.431(R99-3.1.0).zip">http://www.tta.or.kr/standardDB/stnfile/TTAE.3G-25.431(R99-3.1.0).zip</a>
<b>Release 4</b>					
ARIB	ARIB STD-T63-25.431	4.0.0	Approved	25/05/2004	<a href="http://www.arib.or.jp/IMT-2000/ARIB-STD/ITU-R/Rel4/A25431-400.pdf">http://www.arib.or.jp/IMT-2000/ARIB-STD/ITU-R/Rel4/A25431-400.pdf</a>
CCSA	CCSA-TSD-DS-25.431	400	Approved	01/07/2003	<a href="http://www.ccsa.org.cn/english/tc/files.php?docpath=/ITU-R/M.1457/M.1457-4/DS/">http://www.ccsa.org.cn/english/tc/files.php?docpath=/ITU-R/M.1457/M.1457-4/DS/</a>
ETSI	ETSI TS 125 431	4.0.0	Published	27/04/2001	<a href="http://pda.etsi.org/pda/home.asp?wkr=RTS/TSGR-0325431Uv4">http://pda.etsi.org/pda/home.asp?wkr=RTS/TSGR-0325431Uv4</a>
T1 (ATIS)	T1.3GPP.25.431V400-2002	4.0.0	Approved	03/05/2002	<a href="https://www.atis.org/atis/docstore/search.asp?committee=S24">https://www.atis.org/atis/docstore/search.asp?committee=S24</a>
TTA	TTAE.3G-25.431(R4-4.0.0)	4.0.0	Approved	29/05/2002	<a href="http://www.tta.or.kr/standardDB/stnfile/TTAE.3G-25.431(R4-4.0.0).zip">http://www.tta.or.kr/standardDB/stnfile/TTAE.3G-25.431(R4-4.0.0).zip</a>
<b>Release 5</b>					
ARIB	ARIB STD-T63-25.431	5.0.0	Approved	25/05/2004	<a href="http://www.arib.or.jp/IMT-2000/ARIB-STD/ITU-R/Rel5/A25431-500.pdf">http://www.arib.or.jp/IMT-2000/ARIB-STD/ITU-R/Rel5/A25431-500.pdf</a>
CCSA	CCSA-TSD-DS-25.431	500	Approved	01/07/2003	<a href="http://www.ccsa.org.cn/english/tc/files.php?docpath=/ITU-R/M.1457/M.1457-4/DS/">http://www.ccsa.org.cn/english/tc/files.php?docpath=/ITU-R/M.1457/M.1457-4/DS/</a>
ETSI	ETSI TS 125 431	5.0.0	Published	15/04/2002	<a href="http://pda.etsi.org/pda/home.asp?wkr=RTS/TSGR-0325431Uv5">http://pda.etsi.org/pda/home.asp?wkr=RTS/TSGR-0325431Uv5</a>
T1 (ATIS)	T1.3GPP.25.431V500-2002	5.0.0	Approved	03/05/2002	<a href="https://www.atis.org/atis/docstore/search.asp?committee=S24">https://www.atis.org/atis/docstore/search.asp?committee=S24</a>
TTA	TTAE.3G-25.431(R5-5.0.0)	5.0.0	Approved	29/05/2002	<a href="http://www.tta.or.kr/standardDB/stnfile/TTAE.3G-25.431(R5-5.0.0).zip">http://www.tta.or.kr/standardDB/stnfile/TTAE.3G-25.431(R5-5.0.0).zip</a>
<b>Release 6</b>					
ARIB	ARIB STD-T63-25.431	6.0.0	Approved	25/05/2004	<a href="http://www.arib.or.jp/IMT-2000/ARIB-STD/ITU-R/Rel6/A25431-600.pdf">http://www.arib.or.jp/IMT-2000/ARIB-STD/ITU-R/Rel6/A25431-600.pdf</a>
ETSI	ETSI TS 125 431	6.0.0	Published	20/01/2004	<a href="http://pda.etsi.org/pda/home.asp?wkr=RTS/TSGR-0325431v600">http://pda.etsi.org/pda/home.asp?wkr=RTS/TSGR-0325431v600</a>
T1 (ATIS)	T1.3GPP.25.431V600-2004	6.0.0	Approved	21/05/2004	<a href="https://www.atis.org/atis/docstore/search.asp?committee=S24">https://www.atis.org/atis/docstore/search.asp?committee=S24</a>
TTA	TTAT.3G-25.431(R6-6.0.0)	6.0.0	Approved	25/05/2004	<a href="http://www.tta.or.kr/standardDB/stnfile/TTAT.3G-25.431(R6-6.0.0).zip">http://www.tta.or.kr/standardDB/stnfile/TTAT.3G-25.431(R6-6.0.0).zip</a>

**5.1.2.3.20** 25.432**UTRAN Iub interface: signalling transport**

This specification describes the signalling transport related to the Node B application part (NBAP) signalling to be used across the Iub interface. The Iub interface is a logical interface for the interconnection of Node B and RNC components of the UTRAN. The RNC signalling between these nodes is based on NBAP.

SDO (2)	Document No.	Version	Status	Issued date	Location (1)
<b>Release 99</b>					
ARIB	ARIB STD-T63-25.432	3.1.0	Approved	25/05/2004	<a href="http://www.arib.or.jp/IMT-2000/ARIB-STD/ITU-R/R99/A25432-310.pdf">http://www.arib.or.jp/IMT-2000/ARIB-STD/ITU-R/R99/A25432-310.pdf</a>
CCSA	CCSA-TSD-DS-25.432	310	Approved	01/07/2003	<a href="http://www.ccsa.org.cn/english/tc/files.php?docpath=/ITU-R/M.1457/M.1457-4/DS/">http://www.ccsa.org.cn/english/tc/files.php?docpath=/ITU-R/M.1457/M.1457-4/DS/</a>
ETSI	ETSI TS 125 432	3.1.0	Published	01/02/2000	<a href="http://pda.etsi.org/pda/home.asp?wkr=DTS/TSGR-0325432U">http://pda.etsi.org/pda/home.asp?wkr=DTS/TSGR-0325432U</a>
T1 (ATIS)	T1.3GPP.25.432V310-2002	3.1.0	Approved	03/05/2002	<a href="https://www.atis.org/atis/docstore/search.asp?committee=S24">https://www.atis.org/atis/docstore/search.asp?committee=S24</a>
TTA	TTAE.3G-25.432(F)	3.1.0	Approved	28/03/2000	<a href="http://www.tta.or.kr/standardDB/stnfile/TTAE_3G-25_432F.zip">http://www.tta.or.kr/standardDB/stnfile/TTAE_3G-25_432F.zip</a>
<b>Release 4</b>					
ARIB	ARIB STD-T63-25.432	4.0.0	Approved	25/05/2004	<a href="http://www.arib.or.jp/IMT-2000/ARIB-STD/ITU-R/Rel4/A25432-400.pdf">http://www.arib.or.jp/IMT-2000/ARIB-STD/ITU-R/Rel4/A25432-400.pdf</a>
CCSA	CCSA-TSD-DS-25.432	400	Approved	01/07/2003	<a href="http://www.ccsa.org.cn/english/tc/files.php?docpath=/ITU-R/M.1457/M.1457-4/DS/">http://www.ccsa.org.cn/english/tc/files.php?docpath=/ITU-R/M.1457/M.1457-4/DS/</a>
ETSI	ETSI TS 125 432	4.0.0	Published	27/04/2001	<a href="http://pda.etsi.org/pda/home.asp?wkr=RTS/TSGR-0325432Uv4">http://pda.etsi.org/pda/home.asp?wkr=RTS/TSGR-0325432Uv4</a>
T1 (ATIS)	T1.3GPP.25.432V400-2002	4.0.0	Approved	03/05/2002	<a href="https://www.atis.org/atis/docstore/search.asp?committee=S24">https://www.atis.org/atis/docstore/search.asp?committee=S24</a>
TTA	TTAE.3G-25.432(R4-4.0.0)	4.0.0	Approved	29/05/2002	<a href="http://www.tta.or.kr/standardDB/stnfile/TTAE.3G-25.432(R4-4.0.0).zip">http://www.tta.or.kr/standardDB/stnfile/TTAE.3G-25.432(R4-4.0.0).zip</a>
<b>Release 5</b>					
ARIB	ARIB STD-T63-25.432	5.1.0	Approved	25/05/2004	<a href="http://www.arib.or.jp/IMT-2000/ARIB-STD/ITU-R/Rel5/A25432-510.pdf">http://www.arib.or.jp/IMT-2000/ARIB-STD/ITU-R/Rel5/A25432-510.pdf</a>
CCSA	CCSA-TSD-DS-25.432	510	Approved	01/07/2003	<a href="http://www.ccsa.org.cn/english/tc/files.php?docpath=/ITU-R/M.1457/M.1457-4/DS/">http://www.ccsa.org.cn/english/tc/files.php?docpath=/ITU-R/M.1457/M.1457-4/DS/</a>
ETSI	ETSI TS 125 432	5.1.0	Published	10/10/2002	<a href="http://pda.etsi.org/pda/home.asp?wkr=RTS/TSGR-0325432v510">http://pda.etsi.org/pda/home.asp?wkr=RTS/TSGR-0325432v510</a>
T1 (ATIS)	T1.3GPP.25.432V510-2003	5.1.0	Approved	27/03/2003	<a href="https://www.atis.org/atis/docstore/search.asp?committee=S24">https://www.atis.org/atis/docstore/search.asp?committee=S24</a>
TTA	TTAT.3G-25.432(R5-5.1.0)	5.1.0	Approved	21/03/2003	<a href="http://www.tta.or.kr/standardDB/stnfile/TTAT.3G-25.432(R5-5.1.0).zip">http://www.tta.or.kr/standardDB/stnfile/TTAT.3G-25.432(R5-5.1.0).zip</a>
<b>Release 6</b>					
ARIB	ARIB STD-T63-25.432	6.0.0	Approved	25/05/2004	<a href="http://www.arib.or.jp/IMT-2000/ARIB-STD/ITU-R/Rel6/A25432-600.pdf">http://www.arib.or.jp/IMT-2000/ARIB-STD/ITU-R/Rel6/A25432-600.pdf</a>
ETSI	ETSI TS 125 432	6.0.0	Published	20/01/2004	<a href="http://pda.etsi.org/pda/home.asp?wkr=RTS/TSGR-0325432v600">http://pda.etsi.org/pda/home.asp?wkr=RTS/TSGR-0325432v600</a>
T1 (ATIS)	T1.3GPP.25.432V600-2004	6.0.0	Approved	21/05/2004	<a href="https://www.atis.org/atis/docstore/search.asp?committee=S24">https://www.atis.org/atis/docstore/search.asp?committee=S24</a>
TTA	TTAT.3G-25.432(R6-6.0.0)	6.0.0	Approved	25/05/2004	<a href="http://www.tta.or.kr/standardDB/stnfile/TTAT.3G-25.432(R6-6.0.0).zip">http://www.tta.or.kr/standardDB/stnfile/TTAT.3G-25.432(R6-6.0.0).zip</a>

### 5.1.2.3.21 25.433

#### UTRAN Iub interface: NBAP signalling

This specification describes the standards for NBAP specification to be used over Iub interface.

SDO (2)	Document No.	Version	Status	Issued date	Location (1)
<b>Release 99</b>					
ARIB	ARIB STD-T63-25.433	3.14.0	Approved	25/05/2004	<a href="http://www.arib.or.jp/IMT-2000/ARIB-STD/ITU-R/R99/A25433-3e0.pdf">http://www.arib.or.jp/IMT-2000/ARIB-STD/ITU-R/R99/A25433-3e0.pdf</a>
CCSA	CCSA-TSD-DS-25.433	3D0	Approved	01/07/2003	<a href="http://www.ccsa.org.cn/english/tc/files.php?docpath=/ITU-R/M.1457/M.1457-4/DS/">http://www.ccsa.org.cn/english/tc/files.php?docpath=/ITU-R/M.1457/M.1457-4/DS/</a>
ETSI	ETSI TS 125 433	3.14.0	Published	06/10/2003	<a href="http://pda.etsi.org/pda/home.asp?wkr=RTS/TSGR-0325433v3e0">http://pda.etsi.org/pda/home.asp?wkr=RTS/TSGR-0325433v3e0</a>
T1 (ATIS)	T1.3GPP.25.433V3140-2004	3.14.0	Approved	21/05/2004	<a href="https://www.atis.org/atis/docstore/search.asp?committee=S24">https://www.atis.org/atis/docstore/search.asp?committee=S24</a>
TTA	TTAT.3G-25.433(R99-3.14.0)	3.14.0	Approved	25/05/2004	<a href="http://www.tta.or.kr/standardDB/stnfile/TTAT.3G-25.433(R99-3.14.0).zip">http://www.tta.or.kr/standardDB/stnfile/TTAT.3G-25.433(R99-3.14.0).zip</a>
<b>Release 4</b>					
ARIB	ARIB STD-T63-25.433	4.11.0	Approved	25/05/2004	<a href="http://www.arib.or.jp/IMT-2000/ARIB-STD/ITU-R/Rel4/A25433-4b0.pdf">http://www.arib.or.jp/IMT-2000/ARIB-STD/ITU-R/Rel4/A25433-4b0.pdf</a>
CCSA	CCSA-TSD-DS-25.433	490	Approved	01/07/2003	<a href="http://www.ccsa.org.cn/english/tc/files.php?docpath=/ITU-R/M.1457/M.1457-4/DS/">http://www.ccsa.org.cn/english/tc/files.php?docpath=/ITU-R/M.1457/M.1457-4/DS/</a>



ETSI	ETSI TS 125 433	4.11.0	Published	21/01/2004	<a href="http://pda.etsi.org/pda/home.asp?wkr=RTS/TSGR-0325433v4b0">http://pda.etsi.org/pda/home.asp?wkr=RTS/TSGR-0325433v4b0</a>
T1 (ATIS)	T1.3GPP.25.433V4110-2004	4.11.0	Approved	21/05/2004	<a href="https://www.atis.org/atis/docstore/search.asp?committee=S24">https://www.atis.org/atis/docstore/search.asp?committee=S24</a>
TTA	TTAT.3G-25.433(R4-4.11.0)	4.11.0	Approved	25/05/2004	<a href="http://www.tta.or.kr/standardDB/stnfile/TTAT.3G-25.433(R4-4.11.0).zip">http://www.tta.or.kr/standardDB/stnfile/TTAT.3G-25.433(R4-4.11.0).zip</a>
<b>Release 5</b>					
ARIB	ARIB STD-T63-25.433	5.8.0	Approved	25/05/2004	<a href="http://www.arib.or.jp/IMT-2000/ARIB-STD/ITU-R/Rel5/A25433-570.pdf">http://www.arib.or.jp/IMT-2000/ARIB-STD/ITU-R/Rel5/A25433-570.pdf</a>
CCSA	CCSA-TSD-DS-25.433	550	Approved	01/07/2003	<a href="http://www.ccsa.org.cn/english/tc/files.php?docpath=/ITU-R/M.1457/M.1457-4/DS/">http://www.ccsa.org.cn/english/tc/files.php?docpath=/ITU-R/M.1457/M.1457-4/DS/</a>
ETSI	ETSI TS 125 433	5.7.0	Published	30/01/2004	<a href="http://pda.etsi.org/pda/home.asp?wkr=RTS/TSGR-0325433v570">http://pda.etsi.org/pda/home.asp?wkr=RTS/TSGR-0325433v570</a>
T1 (ATIS)	T1.3GPP.25.433V570-2004	5.7.0	Approved	21/05/2004	<a href="https://www.atis.org/atis/docstore/search.asp?committee=S24">https://www.atis.org/atis/docstore/search.asp?committee=S24</a>
TTA	TTAT.3G-25.433(R5-5.7.0)	5.7.0	Approved	25/05/2004	<a href="http://www.tta.or.kr/standardDB/stnfile/TTAT.3G-25.433(R5-5.7.0).zip">http://www.tta.or.kr/standardDB/stnfile/TTAT.3G-25.433(R5-5.7.0).zip</a>
<b>Release 6</b>					
ARIB	ARIB STD-T63-25.433	6.0.0	Approved	25/05/2004	<a href="http://www.arib.or.jp/IMT-2000/ARIB-STD/ITU-R/Rel6/A25433-600.pdf">http://www.arib.or.jp/IMT-2000/ARIB-STD/ITU-R/Rel6/A25433-600.pdf</a>
ETSI	ETSI TS 125 433	6.0.0	Published	30/01/2004	<a href="http://pda.etsi.org/pda/home.asp?wkr=RTS/TSGR-0325433v600">http://pda.etsi.org/pda/home.asp?wkr=RTS/TSGR-0325433v600</a>
T1 (ATIS)	T1.3GPP.25.433V600-2004	6.0.0	Approved	21/05/2004	<a href="https://www.atis.org/atis/docstore/search.asp?committee=S24">https://www.atis.org/atis/docstore/search.asp?committee=S24</a>
TTA	TTAT.3G-25.433(R6-6.0.0)	6.0.0	Approved	25/05/2004	<a href="http://www.tta.or.kr/standardDB/stnfile/TTAT.3G-25.433(R6-6.0.0).zip">http://www.tta.or.kr/standardDB/stnfile/TTAT.3G-25.433(R6-6.0.0).zip</a>

### 5.1.2.3.22 25.434

#### UTRAN Iub interface data transport and transport signalling for common transport channel data streams

This specification describes the UTRAN RNC-Node B (Iub) interface data transport and transport signalling for CCH data streams.

SDO (2)	Document No.	Version	Status	Issued date	Location (1)
<b>Release 99</b>					
ARIB	ARIB STD-T63-25.434	3.8.0	Approved	25/05/2004	<a href="http://www.arib.or.jp/IMT-2000/ARIB-STD/ITU-R/R99/A25434-380.pdf">http://www.arib.or.jp/IMT-2000/ARIB-STD/ITU-R/R99/A25434-380.pdf</a>
CCSA	CCSA-TSD-DS-25.434	380	Approved	01/07/2003	<a href="http://www.ccsa.org.cn/english/tc/files.php?docpath=/ITU-R/M.1457/M.1457-4/DS/">http://www.ccsa.org.cn/english/tc/files.php?docpath=/ITU-R/M.1457/M.1457-4/DS/</a>
ETSI	ETSI TS 125 434	3.8.0	Published	11/07/2002	<a href="http://pda.etsi.org/pda/home.asp?wkr=RTS/TSGR-0325434v380">http://pda.etsi.org/pda/home.asp?wkr=RTS/TSGR-0325434v380</a>
T1 (ATIS)	T1.3GPP.25.434V380-2003	3.8.0	Approved	27/03/2003	<a href="https://www.atis.org/atis/docstore/search.asp?committee=S24">https://www.atis.org/atis/docstore/search.asp?committee=S24</a>
TTA	TTAT.3G-25.434(R99-3.8.0)	3.8.0	Approved	21/03/2003	<a href="http://www.tta.or.kr/standardDB/stnfile/TTAT.3G-25.434(R99-3.8.0).zip">http://www.tta.or.kr/standardDB/stnfile/TTAT.3G-25.434(R99-3.8.0).zip</a>
<b>Release 4</b>					
ARIB	ARIB STD-T63-25.434	4.4.0	Approved	25/05/2004	<a href="http://www.arib.or.jp/IMT-2000/ARIB-STD/ITU-R/Rel4/A25434-440.pdf">http://www.arib.or.jp/IMT-2000/ARIB-STD/ITU-R/Rel4/A25434-440.pdf</a>
CCSA	CCSA-TSD-DS-25.434	440	Approved	01/07/2003	<a href="http://www.ccsa.org.cn/english/tc/files.php?docpath=/ITU-R/M.1457/M.1457-4/DS/">http://www.ccsa.org.cn/english/tc/files.php?docpath=/ITU-R/M.1457/M.1457-4/DS/</a>
ETSI	ETSI TS 125 434	4.4.0	Published	11/07/2002	<a href="http://pda.etsi.org/pda/home.asp?wkr=RTS/TSGR-0325434v440">http://pda.etsi.org/pda/home.asp?wkr=RTS/TSGR-0325434v440</a>
T1 (ATIS)	T1.3GPP.25.434V440-2003	4.4.0	Approved	27/03/2003	<a href="https://www.atis.org/atis/docstore/search.asp?committee=S24">https://www.atis.org/atis/docstore/search.asp?committee=S24</a>
TTA	TTAT.3G-25.434(R4-4.4.0)	4.4.0	Approved	21/03/2003	<a href="http://www.tta.or.kr/standardDB/stnfile/TTAT.3G-25.434(R4-4.4.0).zip">http://www.tta.or.kr/standardDB/stnfile/TTAT.3G-25.434(R4-4.4.0).zip</a>
<b>Release 5</b>					
ARIB	ARIB STD-T63-25.434	5.3.0	Approved	25/05/2004	<a href="http://www.arib.or.jp/IMT-2000/ARIB-STD/ITU-R/Rel5/A25434-530.pdf">http://www.arib.or.jp/IMT-2000/ARIB-STD/ITU-R/Rel5/A25434-530.pdf</a>
CCSA	CCSA-TSD-DS-25.434	510	Approved	01/07/2003	<a href="http://www.ccsa.org.cn/english/tc/files.php?docpath=/ITU-R/M.1457/M.1457-4/DS/">http://www.ccsa.org.cn/english/tc/files.php?docpath=/ITU-R/M.1457/M.1457-4/DS/</a>
ETSI	ETSI TS 125 434	5.3.0	Published	21/01/2004	<a href="http://pda.etsi.org/pda/home.asp?wkr=RTS/TSGR-0325434v530">http://pda.etsi.org/pda/home.asp?wkr=RTS/TSGR-0325434v530</a>
T1 (ATIS)	T1.3GPP.25.434V530-2004	5.3.0	Approved	21/05/2004	<a href="https://www.atis.org/atis/docstore/search.asp?committee=S24">https://www.atis.org/atis/docstore/search.asp?committee=S24</a>
TTA	TTAT.3G-25.434(R5-5.3.0)	5.3.0	Approved	25/05/2004	<a href="http://www.tta.or.kr/standardDB/stnfile/TTAT.3G-25.434(R5-5.3.0).zip">http://www.tta.or.kr/standardDB/stnfile/TTAT.3G-25.434(R5-5.3.0).zip</a>

**Release 6**

ARIB	ARIB STD-T63-25.434	6.0.0	Approved	25/05/2004	<a href="http://www.arib.or.jp/IMT-2000/ARIB-STD/ITU-R/Rel6/A25434-600.pdf">http://www.arib.or.jp/IMT-2000/ARIB-STD/ITU-R/Rel6/A25434-600.pdf</a>
ETSI	ETSI TS 125 434	6.0.0	Published	21/01/2004	<a href="http://pda.etsi.org/pda/home.asp?wkr=RTS/TSGR-0325434v600">http://pda.etsi.org/pda/home.asp?wkr=RTS/TSGR-0325434v600</a>
T1 (ATIS)	T1.3GPP.25.434V600-2004	6.0.0	Approved	21/05/2004	<a href="https://www.atis.org/atis/docstore/search.asp?committee=S24">https://www.atis.org/atis/docstore/search.asp?committee=S24</a>
TTA	TTAT.3G-25.434(R6-6.0.0)	6.0.0	Approved	25/05/2004	<a href="http://www.tta.or.kr/standardDB/stnfile/TTAT.3G-25.434(R6-6.0.0).zip">http://www.tta.or.kr/standardDB/stnfile/TTAT.3G-25.434(R6-6.0.0).zip</a>

**5.1.2.3.23 25.435****UTRAN Iub interface user plane protocols for common transport channel data streams**

This specification describes the UTRAN RNC-Node B (Iub) interface user plane protocols for common transport channel data streams.

SDO (2)	Document No.	Version	Status	Issued date	Location (1)
<b>Release 99</b>					
ARIB	ARIB STD-T63-25.435	3.11.0	Approved	25/05/2004	<a href="http://www.arib.or.jp/IMT-2000/ARIB-STD/ITU-R/R99/A25435-3b0.pdf">http://www.arib.or.jp/IMT-2000/ARIB-STD/ITU-R/R99/A25435-3b0.pdf</a>
CCSA	CCSA-TSD-DS-25.435	3A0	Approved	01/07/2003	<a href="http://www.ccsa.org.cn/english/tc/files.php?docpath=/ITU-R/M.1457/M.1457-4/DS/">http://www.ccsa.org.cn/english/tc/files.php?docpath=/ITU-R/M.1457/M.1457-4/DS/</a>
ETSI	ETSI TS 125 435	3.11.0	Published	21/01/2004	<a href="http://pda.etsi.org/pda/home.asp?wkr=RTS/TSGR-0325435v3b0">http://pda.etsi.org/pda/home.asp?wkr=RTS/TSGR-0325435v3b0</a>
T1 (ATIS)	T1.3GPP.25.435V3110-2004	3.11.0	Approved	21/05/2004	<a href="https://www.atis.org/atis/docstore/search.asp?committee=S24">https://www.atis.org/atis/docstore/search.asp?committee=S24</a>
TTA	TTAT.3G-25.435(R99-3.11.0)	3.11.0	Approved	25/05/2004	<a href="http://www.tta.or.kr/standardDB/stnfile/TTAT.3G-25.435(R99-3.11.0).zip">http://www.tta.or.kr/standardDB/stnfile/TTAT.3G-25.435(R99-3.11.0).zip</a>
<b>Release 4</b>					
ARIB	ARIB STD-T63-25.435	4.6.0	Approved	25/05/2004	<a href="http://www.arib.or.jp/IMT-2000/ARIB-STD/ITU-R/Rel4/A25435-460.pdf">http://www.arib.or.jp/IMT-2000/ARIB-STD/ITU-R/Rel4/A25435-460.pdf</a>
CCSA	CCSA-TSD-DS-25.435	450	Approved	01/07/2003	<a href="http://www.ccsa.org.cn/english/tc/files.php?docpath=/ITU-R/M.1457/M.1457-4/DS/">http://www.ccsa.org.cn/english/tc/files.php?docpath=/ITU-R/M.1457/M.1457-4/DS/</a>
ETSI	ETSI TS 125 435	4.6.0	Published	21/01/2004	<a href="http://pda.etsi.org/pda/home.asp?wkr=RTS/TSGR-0325435v460">http://pda.etsi.org/pda/home.asp?wkr=RTS/TSGR-0325435v460</a>
T1 (ATIS)	T1.3GPP.25.435V460-2004	4.6.0	Approved	21/05/2004	<a href="https://www.atis.org/atis/docstore/search.asp?committee=S24">https://www.atis.org/atis/docstore/search.asp?committee=S24</a>
TTA	TTAT.3G-25.435(R4-4.6.0)	4.6.0	Approved	25/05/2004	<a href="http://www.tta.or.kr/standardDB/stnfile/TTAT.3G-25.435(R4-4.6.0).zip">http://www.tta.or.kr/standardDB/stnfile/TTAT.3G-25.435(R4-4.6.0).zip</a>
<b>Release 5</b>					
ARIB	ARIB STD-T63-25.435	5.5.0	Approved	25/05/2004	<a href="http://www.arib.or.jp/IMT-2000/ARIB-STD/ITU-R/Rel5/A25435-550.pdf">http://www.arib.or.jp/IMT-2000/ARIB-STD/ITU-R/Rel5/A25435-550.pdf</a>
CCSA	CCSA-TSD-DS-25.435	550	Approved	01/07/2003	<a href="http://www.ccsa.org.cn/english/tc/files.php?docpath=/ITU-R/M.1457/M.1457-4/DS/">http://www.ccsa.org.cn/english/tc/files.php?docpath=/ITU-R/M.1457/M.1457-4/DS/</a>
ETSI	ETSI TS 125 435	5.6.0	Published	21/01/2004	<a href="http://pda.etsi.org/pda/home.asp?wkr=RTS/TSGR-0325435v560">http://pda.etsi.org/pda/home.asp?wkr=RTS/TSGR-0325435v560</a>
T1 (ATIS)	T1.3GPP.25.435V560-2004	5.6.0	Approved	21/05/2004	<a href="https://www.atis.org/atis/docstore/search.asp?committee=S24">https://www.atis.org/atis/docstore/search.asp?committee=S24</a>
TTA	TTAT.3G-25.435(R5-5.6.0)	5.6.0	Approved	25/05/2004	<a href="http://www.tta.or.kr/standardDB/stnfile/TTAT.3G-25.435(R5-5.6.0).zip">http://www.tta.or.kr/standardDB/stnfile/TTAT.3G-25.435(R5-5.6.0).zip</a>
<b>Release 6</b>					
ARIB	ARIB STD-T63-25.435	6.0.0	Approved	25/05/2004	<a href="http://www.arib.or.jp/IMT-2000/ARIB-STD/ITU-R/Rel6/A25435-600.pdf">http://www.arib.or.jp/IMT-2000/ARIB-STD/ITU-R/Rel6/A25435-600.pdf</a>
ETSI	ETSI TS 125 435	6.0.0	Published	21/01/2004	<a href="http://pda.etsi.org/pda/home.asp?wkr=RTS/TSGR-0325435v600">http://pda.etsi.org/pda/home.asp?wkr=RTS/TSGR-0325435v600</a>
T1 (ATIS)	T1.3GPP.25.435V600-2004	6.0.0	Approved	21/05/2004	<a href="https://www.atis.org/atis/docstore/search.asp?committee=S24">https://www.atis.org/atis/docstore/search.asp?committee=S24</a>
TTA	TTAT.3G-25.435(R6-6.0.0)	6.0.0	Approved	25/05/2004	<a href="http://www.tta.or.kr/standardDB/stnfile/TTAT.3G-25.435(R6-6.0.0).zip">http://www.tta.or.kr/standardDB/stnfile/TTAT.3G-25.435(R6-6.0.0).zip</a>

**5.1.2.3.24** 25.442**UTRAN implementation specific O&M transport**

This specification describes the transport of implementation specific O&M signalling between Node B and the management platform in case that the transport is routed via the RNC.

SDO (2)	Document No.	Version	Status	Issued date	Location (1)
<b>Release 99</b>					
ARIB	ARIB STD-T63-25.442	3.1.0	Approved	25/05/2004	<a href="http://www.arib.or.jp/IMT-2000/ARIB-STD/ITU-R/R99/A25442-310.pdf">http://www.arib.or.jp/IMT-2000/ARIB-STD/ITU-R/R99/A25442-310.pdf</a>
CCSA	CCSA-TSD-DS-25.442	310	Approved	01/07/2003	<a href="http://www.ccsa.org.cn/english/tc/files.php?docpath=/ITU-R/M.1457/M.1457-4/DS/">http://www.ccsa.org.cn/english/tc/files.php?docpath=/ITU-R/M.1457/M.1457-4/DS/</a>
ETSI	ETSI TS 125 442	3.1.0	Published	17/05/2000	<a href="http://pda.etsi.org/pda/home.asp?wkr=RTS/TSGR-0325442UR1">http://pda.etsi.org/pda/home.asp?wkr=RTS/TSGR-0325442UR1</a>
T1 (ATIS)	T1.3GPP.25.442V310-2002	3.1.0	Approved	03/05/2002	<a href="https://www.atis.org/atis/docstore/search.asp?committee=S24">https://www.atis.org/atis/docstore/search.asp?committee=S24</a>
TTA	TTAE.3G-25.442(R99-3.1.0)	3.1.0	Approved	29/05/2002	<a href="http://www.tta.or.kr/standardDB/stnfile/TTAE.3G-25.442(R99-3.1.0).zip">http://www.tta.or.kr/standardDB/stnfile/TTAE.3G-25.442(R99-3.1.0).zip</a>
<b>Release 4</b>					
ARIB	ARIB STD-T63-25.442	4.0.0	Approved	25/05/2004	<a href="http://www.arib.or.jp/IMT-2000/ARIB-STD/ITU-R/Rel4/A25442-400.pdf">http://www.arib.or.jp/IMT-2000/ARIB-STD/ITU-R/Rel4/A25442-400.pdf</a>
CCSA	CCSA-TSD-DS-25.442	400	Approved	01/07/2003	<a href="http://www.ccsa.org.cn/english/tc/files.php?docpath=/ITU-R/M.1457/M.1457-4/DS/">http://www.ccsa.org.cn/english/tc/files.php?docpath=/ITU-R/M.1457/M.1457-4/DS/</a>
ETSI	ETSI TS 125 442	4.0.0	Published	27/04/2001	<a href="http://pda.etsi.org/pda/home.asp?wkr=RTS/TSGR-0325442Uv4">http://pda.etsi.org/pda/home.asp?wkr=RTS/TSGR-0325442Uv4</a>
T1 (ATIS)	T1.3GPP.25.442V400-2002	4.0.0	Approved	03/05/2002	<a href="https://www.atis.org/atis/docstore/search.asp?committee=S24">https://www.atis.org/atis/docstore/search.asp?committee=S24</a>
TTA	TTAE.3G-25.442(R4-4.0.0)	4.0.0	Approved	29/05/2002	<a href="http://www.tta.or.kr/standardDB/stnfile/TTAE.3G-25.442(R4-4.0.0).zip">http://www.tta.or.kr/standardDB/stnfile/TTAE.3G-25.442(R4-4.0.0).zip</a>
<b>Release 5</b>					
ARIB	ARIB STD-T63-25.442	5.1.0	Approved	25/05/2004	<a href="http://www.arib.or.jp/IMT-2000/ARIB-STD/ITU-R/Rel5/A25442-510.pdf">http://www.arib.or.jp/IMT-2000/ARIB-STD/ITU-R/Rel5/A25442-510.pdf</a>
CCSA	CCSA-TSD-DS-25.442	510	Approved	01/07/2003	<a href="http://www.ccsa.org.cn/english/tc/files.php?docpath=/ITU-R/M.1457/M.1457-4/DS/">http://www.ccsa.org.cn/english/tc/files.php?docpath=/ITU-R/M.1457/M.1457-4/DS/</a>
ETSI	ETSI TS 125 442	5.1.0	Published	10/10/2002	<a href="http://pda.etsi.org/pda/home.asp?wkr=RTS/TSGR-0325442v510">http://pda.etsi.org/pda/home.asp?wkr=RTS/TSGR-0325442v510</a>
T1 (ATIS)	T1.3GPP.25.442V510-2003	5.1.0	Approved	27/03/2003	<a href="https://www.atis.org/atis/docstore/search.asp?committee=S24">https://www.atis.org/atis/docstore/search.asp?committee=S24</a>
TTA	TTAT.3G-25.442(R5-5.1.0)	5.1.0	Approved	21/03/2003	<a href="http://www.tta.or.kr/standardDB/stnfile/TTAT.3G-25.442(R5-5.1.0).zip">http://www.tta.or.kr/standardDB/stnfile/TTAT.3G-25.442(R5-5.1.0).zip</a>
<b>Release 6</b>					
ARIB	ARIB STD-T63-25.442	6.0.0	Approved	25/05/2004	<a href="http://www.arib.or.jp/IMT-2000/ARIB-STD/ITU-R/Rel6/A25442-600.pdf">http://www.arib.or.jp/IMT-2000/ARIB-STD/ITU-R/Rel6/A25442-600.pdf</a>
ETSI	ETSI TS 125 442	6.0.0	Published	21/01/2004	<a href="http://pda.etsi.org/pda/home.asp?wkr=RTS/TSGR-0325442v600">http://pda.etsi.org/pda/home.asp?wkr=RTS/TSGR-0325442v600</a>
T1 (ATIS)	T1.3GPP.25.442V600-2004	6.0.0	Approved	21/05/2004	<a href="https://www.atis.org/atis/docstore/search.asp?committee=S24">https://www.atis.org/atis/docstore/search.asp?committee=S24</a>
TTA	TTAT.3G-25.442(R6-6.0.0)	6.0.0	Approved	25/05/2004	<a href="http://www.tta.or.kr/standardDB/stnfile/TTAT.3G-25.442(R6-6.0.0).zip">http://www.tta.or.kr/standardDB/stnfile/TTAT.3G-25.442(R6-6.0.0).zip</a>

**5.1.2.3.25** 25.450**UTRAN Iupc interface general aspects and principles**

The present document is an introduction to the TSG RAN TS 25.45z series of UMTS Technical Specifications that define the Iupc Interface. The Iupc interface is a logical interface for the interconnection of Standalone SMLC (SAS) and Radio Network Controller (RNC) components of the Universal Terrestrial Radio Access Network (UTRAN) for the UMTS system.

SDO (2)	Document No.	Version	Status	Issued date	Location (1)
<b>Release 5</b>					
ARIB	ARIB STD-T63-25.450	5.1.0	Approved	25/05/2004	<a href="http://www.arib.or.jp/IMT-2000/ARIB-STD/ITU-R/Rel5/A25450-510.pdf">http://www.arib.or.jp/IMT-2000/ARIB-STD/ITU-R/Rel5/A25450-510.pdf</a>
CCSA	CCSA-TSD-DS-25.450	510	Approved	01/07/2003	<a href="http://www.ccsa.org.cn/english/tc/files.php?docpath=/ITU-R/M.1457/M.1457-4/DS/">http://www.ccsa.org.cn/english/tc/files.php?docpath=/ITU-R/M.1457/M.1457-4/DS/</a>
ETSI	ETSI TS 125 450	5.1.0	Published	23/04/2002	<a href="http://pda.etsi.org/pda/home.asp?wkr=DTS/TSGR-0325450Uv5">http://pda.etsi.org/pda/home.asp?wkr=DTS/TSGR-0325450Uv5</a>
T1 (ATIS)	T1.3GPP.25.450V510-2002	5.1.0	Approved	03/05/2002	<a href="https://www.atis.org/atis/docstore/search.asp?committee=S24">https://www.atis.org/atis/docstore/search.asp?committee=S24</a>
TTA	TTAE.3G-25.450(R5-5.1.0)	5.1.0	Approved	29/05/2002	<a href="http://www.tta.or.kr/standardDB/stnfile/TTAE.3G-25.450(R5-5.1.0).zip">http://www.tta.or.kr/standardDB/stnfile/TTAE.3G-25.450(R5-5.1.0).zip</a>
<b>Release 6</b>					
ARIB	ARIB STD-T63-25.450	6.0.0	Approved	25/05/2004	<a href="http://www.arib.or.jp/IMT-2000/ARIB-STD/ITU-R/Rel6/A25450-600.pdf">http://www.arib.or.jp/IMT-2000/ARIB-STD/ITU-R/Rel6/A25450-600.pdf</a>
CCSA	CCSA-TSD-DS-25.450	600	Approved	01/07/2003	<a href="http://www.ccsa.org.cn/english/tc/files.php?docpath=/ITU-R/M.1457/M.1457-4/DS/">http://www.ccsa.org.cn/english/tc/files.php?docpath=/ITU-R/M.1457/M.1457-4/DS/</a>
ETSI	ETSI TS 125 450	6.0.0	Published	27/01/2004	<a href="http://pda.etsi.org/pda/home.asp?wkr=RTS/TSGR-0325450v600">http://pda.etsi.org/pda/home.asp?wkr=RTS/TSGR-0325450v600</a>
T1 (ATIS)	T1.3GPP.25.450V600-2004	6.0.0	Approved	21/05/2004	<a href="https://www.atis.org/atis/docstore/search.asp?committee=S24">https://www.atis.org/atis/docstore/search.asp?committee=S24</a>
TTA	TTAT.3G-25.450(R6-6.0.0)	6.0.0	Approved	25/05/2004	<a href="http://www.tta.or.kr/standardDB/stnfile/TTAT.3G-25.450(R6-6.0.0).zip">http://www.tta.or.kr/standardDB/stnfile/TTAT.3G-25.450(R6-6.0.0).zip</a>

### 5.1.2.3.26 25.451

#### UTRAN Iupc Interface Layer 1

The present document specifies the standards allowed to implement Layer 1 on the Iupc interface.

SDO (2)	Document No.	Version	Status	Issued date	Location (1)
<b>Release 5</b>					
ARIB	ARIB STD-T63-25.451	5.0.1	Approved	25/05/2004	<a href="http://www.arib.or.jp/IMT-2000/ARIB-STD/ITU-R/Rel5/A25451-501.pdf">http://www.arib.or.jp/IMT-2000/ARIB-STD/ITU-R/Rel5/A25451-501.pdf</a>
CCSA	CCSA-TSD-DS-25.451	501	Approved	01/07/2003	<a href="http://www.ccsa.org.cn/english/tc/files.php?docpath=/ITU-R/M.1457/M.1457-4/DS/">http://www.ccsa.org.cn/english/tc/files.php?docpath=/ITU-R/M.1457/M.1457-4/DS/</a>
ETSI	ETSI TS 125 451	5.0.1	Published	24/04/2002	<a href="http://pda.etsi.org/pda/home.asp?wkr=DTS/TSGR-0325451Uv5">http://pda.etsi.org/pda/home.asp?wkr=DTS/TSGR-0325451Uv5</a>
T1 (ATIS)	T1.3GPP.25.451V501-2002	5.0.1	Approved	03/05/2002	<a href="https://www.atis.org/atis/docstore/search.asp?committee=S24">https://www.atis.org/atis/docstore/search.asp?committee=S24</a>
TTA	TTAT.3G-25.451(R5-5.0.1)	5.0.1	Approved	21/03/2003	<a href="http://www.tta.or.kr/standardDB/stnfile/TTAT.3G-25.451(R5-5.0.1).zip">http://www.tta.or.kr/standardDB/stnfile/TTAT.3G-25.451(R5-5.0.1).zip</a>
<b>Release 6</b>					
ETSI	ETSI TS 125 451	6.0.0	Published	21/01/2004	<a href="http://pda.etsi.org/pda/home.asp?wkr=RTS/TSGR-0325451v600">http://pda.etsi.org/pda/home.asp?wkr=RTS/TSGR-0325451v600</a>
T1 (ATIS)	T1.3GPP.25.451V600-2004	6.0.0	Approved	21/05/2004	<a href="https://www.atis.org/atis/docstore/search.asp?committee=S24">https://www.atis.org/atis/docstore/search.asp?committee=S24</a>

### 5.1.2.3.27 25.452

#### UTRAN Iupc Interface: Signalling Transport

The present document specifies the signalling transport related to PCAP signalling to be used across the Iupc interface.

SDO (2)	Document No.	Version	Status	Issued date	Location (1)
<b>Release 5</b>					
ARIB	ARIB STD-T63-25.452	5.0.0	Approved	25/05/2004	<a href="http://www.arib.or.jp/IMT-2000/ARIB-STD/ITU-R/Rel5/A25452-500.pdf">http://www.arib.or.jp/IMT-2000/ARIB-STD/ITU-R/Rel5/A25452-500.pdf</a>
CCSA	CCSA-TSD-DS-25.452	500	Approved	01/07/2003	<a href="http://www.ccsa.org.cn/english/tc/files.php?docpath=/ITU-R/M.1457/M.1457-4/DS/">http://www.ccsa.org.cn/english/tc/files.php?docpath=/ITU-R/M.1457/M.1457-4/DS/</a>
ETSI	ETSI TS 125 452	5.0.0	Published	23/04/2002	<a href="http://pda.etsi.org/pda/home.asp?wkr=DTS/TSGR-0325452Uv5">http://pda.etsi.org/pda/home.asp?wkr=DTS/TSGR-0325452Uv5</a>

T1 (ATIS) T1.3GPP.25.452V500-2002	5.0.0	Approved	03/05/2002	<a href="https://www.atis.org/atis/docstore/search.asp?committee=S24">https://www.atis.org/atis/docstore/search.asp?committee=S24</a>
TTA TTAE.3G-25.452(R5-5.0.0)	5.0.0	Approved	29/05/2002	<a href="http://www.tta.or.kr/standardDB/stnfile/TTAE.3G-25.452(R5-5.0.0).zip">http://www.tta.or.kr/standardDB/stnfile/TTAE.3G-25.452(R5-5.0.0).zip</a>
<b>Release 6</b>				
ARIB ARIB STD-T63-25.452	6.0.0	Approved	25/05/2004	<a href="http://www.arib.or.jp/IMT-2000/ARIB-STD/ITU-R/Rel6/A25452-600.pdf">http://www.arib.or.jp/IMT-2000/ARIB-STD/ITU-R/Rel6/A25452-600.pdf</a>
CCSA CCSA-TSD-DS-25.452	600	Approved	01/07/2003	<a href="http://www.ccsa.org.cn/english/tc/files.php?docpath=/ITU-R/M.1457/M.1457-4/DS/">http://www.ccsa.org.cn/english/tc/files.php?docpath=/ITU-R/M.1457/M.1457-4/DS/</a>
ETSI ETSI TS 125 452	6.0.0	Published	27/01/2004	<a href="http://pda.etsi.org/pda/home.asp?wkr=RTS/TSGR-0325452v600">http://pda.etsi.org/pda/home.asp?wkr=RTS/TSGR-0325452v600</a>
T1 (ATIS) T1.3GPP.25.452V600-2004	6.0.0	Approved	21/05/2004	<a href="https://www.atis.org/atis/docstore/search.asp?committee=S24">https://www.atis.org/atis/docstore/search.asp?committee=S24</a>
TTA TTAT.3G-25.452(R6-6.0.0)	6.0.0	Approved	25/05/2004	<a href="http://www.tta.or.kr/standardDB/stnfile/TTAT.3G-25.452(R6-6.0.0).zip">http://www.tta.or.kr/standardDB/stnfile/TTAT.3G-25.452(R6-6.0.0).zip</a>

### 5.1.2.3.28 25.453

#### UTRAN Iupc interface PCAP signalling

The present document specifies the Positioning Calculation Application Part (PCAP) between the Radio Network Controller (RNC) and the Stand-alone SMLC (SAS).

SDO (2)	Document No.	Version	Status	Issued date	Location (1)
<b>Release 5</b>					
ARIB	ARIB STD-T63-25.453	5.7.0	Approved	25/05/2004	<a href="http://www.arib.or.jp/IMT-2000/ARIB-STD/ITU-R/Rel5/A25453-570.pdf">http://www.arib.or.jp/IMT-2000/ARIB-STD/ITU-R/Rel5/A25453-570.pdf</a>
CCSA	CCSA-TSD-DS-25.453	560	Approved	01/07/2003	<a href="http://www.ccsa.org.cn/english/tc/files.php?docpath=/ITU-R/M.1457/M.1457-4/DS/">http://www.ccsa.org.cn/english/tc/files.php?docpath=/ITU-R/M.1457/M.1457-4/DS/</a>
ETSI	ETSI TS 125 453	5.8.0	Published	21/01/2004	<a href="http://pda.etsi.org/pda/home.asp?wkr=RTS/TSGR-0325453v580">http://pda.etsi.org/pda/home.asp?wkr=RTS/TSGR-0325453v580</a>
T1 (ATIS)	T1.3GPP.25.453V580-2004	5.8.0	Approved	21/05/2004	<a href="https://www.atis.org/atis/docstore/search.asp?committee=S24">https://www.atis.org/atis/docstore/search.asp?committee=S24</a>
TTA	TTAT.3G-25.453(R5-5.8.0)	5.8.0	Approved	25/05/2004	<a href="http://www.tta.or.kr/standardDB/stnfile/TTAT.3G-25.453(R5-5.8.0).zip">http://www.tta.or.kr/standardDB/stnfile/TTAT.3G-25.453(R5-5.8.0).zip</a>
<b>Release 6</b>					
ARIB	ARIB STD-T63-25.453	6.3.0	Approved	25/05/2004	<a href="http://www.arib.or.jp/IMT-2000/ARIB-STD/ITU-R/Rel6/A25453-630.pdf">http://www.arib.or.jp/IMT-2000/ARIB-STD/ITU-R/Rel6/A25453-630.pdf</a>
CCSA	CCSA-TSD-DS-25.453	610	Approved	01/07/2003	<a href="http://www.ccsa.org.cn/english/tc/files.php?docpath=/ITU-R/M.1457/M.1457-4/DS/">http://www.ccsa.org.cn/english/tc/files.php?docpath=/ITU-R/M.1457/M.1457-4/DS/</a>
ETSI	ETSI TS 125 453	6.3.0	Published	21/01/2004	<a href="http://pda.etsi.org/pda/home.asp?wkr=RTS/TSGR-0325453v630">http://pda.etsi.org/pda/home.asp?wkr=RTS/TSGR-0325453v630</a>
T1 (ATIS)	T1.3GPP.25.453V600-2004	6.0.0	Approved	21/05/2004	<a href="https://www.atis.org/atis/docstore/search.asp?committee=S24">https://www.atis.org/atis/docstore/search.asp?committee=S24</a>
TTA	TTAT.3G-25.453(R6-6.3.0)	6.3.0	Approved	25/05/2004	<a href="http://www.tta.or.kr/standardDB/stnfile/TTAT.3G-25.453(R6-6.3.0).zip">http://www.tta.or.kr/standardDB/stnfile/TTAT.3G-25.453(R6-6.3.0).zip</a>

### 5.1.2.4

#### 25.100 series

##### 5.1.2.4.1 25.101

#### UE radio transmission and reception (FDD)

This document establishes the minimum RF characteristics of the UTRA User Equipment (UE) operating in the FDD mode. The values in the TS make no allowance for measurement uncertainty in conformance testing. Test limits to be used for conformance testing are specified separately in the UE conformance test specifications TS 34.121.

SDO (2)	Document No.	Version	Status	Issued date	Location (1)
<b>Release 99</b>					
ARIB	ARIB STD-T63-25.101	3.16.0	Approved	25/05/2004	<a href="http://www.arib.or.jp/IMT-2000/ARIB-STD/ITU-R/R99/A25101-3g0.pdf">http://www.arib.or.jp/IMT-2000/ARIB-STD/ITU-R/R99/A25101-3g0.pdf</a>
CCSA	CCSA-TSD-DS-25.101	3E0	Approved	01/07/2003	<a href="http://www.ccsa.org.cn/english/tc/files.php?docpath=/ITU-R/M.1457/M.1457-4/DS/">http://www.ccsa.org.cn/english/tc/files.php?docpath=/ITU-R/M.1457/M.1457-4/DS/</a>
ETSI	ETSI TS 125 101	3.16.0	Published	26/01/2004	<a href="http://pda.etsi.org/pda/home.asp?wkr=RTS/TSGR-0425101v3g0">http://pda.etsi.org/pda/home.asp?wkr=RTS/TSGR-0425101v3g0</a>
T1 (ATIS)	T1.3GPP.25.101V3160-2004	3.16.0	Approved	21/05/2004	<a href="https://www.atis.org/atis/docstore/search.asp?committee=S24">https://www.atis.org/atis/docstore/search.asp?committee=S24</a>
TTA	TTAT.3G-25.101(R99F-3.16.0)	3.16.0	Approved	25/05/2004	<a href="http://www.tta.or.kr/standardDB/stnfile/TTAT.3G-25.101(R99F-3.16.0).zip">http://www.tta.or.kr/standardDB/stnfile/TTAT.3G-25.101(R99F-3.16.0).zip</a>
<b>Release 4</b>					
ARIB	ARIB STD-T63-25.101	4.10.0	Approved	25/05/2004	<a href="http://www.arib.or.jp/IMT-2000/ARIB-STD/ITU-R/Rel4/A25101-4a0.pdf">http://www.arib.or.jp/IMT-2000/ARIB-STD/ITU-R/Rel4/A25101-4a0.pdf</a>
CCSA	CCSA-TSD-DS-25.101	480	Approved	01/07/2003	<a href="http://www.ccsa.org.cn/english/tc/files.php?docpath=/ITU-R/M.1457/M.1457-4/DS/">http://www.ccsa.org.cn/english/tc/files.php?docpath=/ITU-R/M.1457/M.1457-4/DS/</a>
ETSI	ETSI TS 125 101	4.10.0	Published	26/01/2004	<a href="http://pda.etsi.org/pda/home.asp?wkr=RTS/TSGR-0425101v4a0">http://pda.etsi.org/pda/home.asp?wkr=RTS/TSGR-0425101v4a0</a>
T1 (ATIS)	T1.3GPP.25.101V4100-2004	4.10.0	Approved	21/05/2004	<a href="https://www.atis.org/atis/docstore/search.asp?committee=S24">https://www.atis.org/atis/docstore/search.asp?committee=S24</a>
TTA	TTAT.3G-25.101(R4F-4.10.0)	4.10.0	Approved	25/05/2004	<a href="http://www.tta.or.kr/standardDB/stnfile/TTAT.3G-25.101(R4F-4.10.0).zip">http://www.tta.or.kr/standardDB/stnfile/TTAT.3G-25.101(R4F-4.10.0).zip</a>
<b>Release 5</b>					
ARIB	ARIB STD-T63-25.101	5.9.0	Approved	25/05/2004	<a href="http://www.arib.or.jp/IMT-2000/ARIB-STD/ITU-R/Rel5/A25101-590.pdf">http://www.arib.or.jp/IMT-2000/ARIB-STD/ITU-R/Rel5/A25101-590.pdf</a>
CCSA	CCSA-TSD-DS-25.101	570	Approved	01/07/2003	<a href="http://www.ccsa.org.cn/english/tc/files.php?docpath=/ITU-R/M.1457/M.1457-4/DS/">http://www.ccsa.org.cn/english/tc/files.php?docpath=/ITU-R/M.1457/M.1457-4/DS/</a>
ETSI	ETSI TS 125 101	5.9.0	Published	30/01/2004	<a href="http://pda.etsi.org/pda/home.asp?wkr=RTS/TSGR-0425101v590">http://pda.etsi.org/pda/home.asp?wkr=RTS/TSGR-0425101v590</a>
T1 (ATIS)	T1.3GPP.25.101V590-2004	5.9.0	Approved	21/05/2004	<a href="https://www.atis.org/atis/docstore/search.asp?committee=S24">https://www.atis.org/atis/docstore/search.asp?committee=S24</a>
TTA	TTAT.3G-25.101(R5F-5.9.0)	5.9.0	Approved	25/05/2004	<a href="http://www.tta.or.kr/standardDB/stnfile/TTAT.3G-25.101(R5F-5.9.0).zip">http://www.tta.or.kr/standardDB/stnfile/TTAT.3G-25.101(R5F-5.9.0).zip</a>
<b>Release 6</b>					
ARIB	ARIB STD-T63-25.101	6.3.0	Approved	25/05/2004	<a href="http://www.arib.or.jp/IMT-2000/ARIB-STD/ITU-R/Rel6/A25101-630.pdf">http://www.arib.or.jp/IMT-2000/ARIB-STD/ITU-R/Rel6/A25101-630.pdf</a>
CCSA	CCSA-TSD-DS-25.101	610	Approved	01/07/2003	<a href="http://www.ccsa.org.cn/english/tc/files.php?docpath=/ITU-R/M.1457/M.1457-4/DS/">http://www.ccsa.org.cn/english/tc/files.php?docpath=/ITU-R/M.1457/M.1457-4/DS/</a>
ETSI	ETSI TS 125 101	6.3.0	Published	30/01/2004	<a href="http://pda.etsi.org/pda/home.asp?wkr=RTS/TSGR-0425101v630">http://pda.etsi.org/pda/home.asp?wkr=RTS/TSGR-0425101v630</a>
T1 (ATIS)	T1.3GPP.25.101V630-2004	6.3.0	Approved	21/05/2004	<a href="https://www.atis.org/atis/docstore/search.asp?committee=S24">https://www.atis.org/atis/docstore/search.asp?committee=S24</a>
TTA	TTAT.3G-25.101(R6F-6.3.0)	6.3.0	Approved	25/05/2004	<a href="http://www.tta.or.kr/standardDB/stnfile/TTAT.3G-25.101(R6F-6.3.0).zip">http://www.tta.or.kr/standardDB/stnfile/TTAT.3G-25.101(R6F-6.3.0).zip</a>

#### 5.1.2.4.2 25.106

### UTRA Repeater; Radio Transmission and Reception

The present document establishes the minimum radio frequency performance of UTRA repeaters.

SDO (2)	Document No.	Version	Status	Issued date	Location (1)
<b>Release 4</b>					
CCSA	CCSA-TSD-DS-25.106	460	Approved	01/07/2003	<a href="http://www.ccsa.org.cn/english/tc/files.php?docpath=/ITU-R/M.1457/M.1457-4/DS/">http://www.ccsa.org.cn/english/tc/files.php?docpath=/ITU-R/M.1457/M.1457-4/DS/</a>
ETSI	ETSI TS 125 106	4.7.0	Published	27/01/2004	<a href="http://pda.etsi.org/pda/home.asp?wkr=RTS/TSGR-0425106v470">http://pda.etsi.org/pda/home.asp?wkr=RTS/TSGR-0425106v470</a>
T1 (ATIS)	T1.3GPP.25.106V470-2004	4.7.0	Approved	21/05/2004	<a href="https://www.atis.org/atis/docstore/search.asp?committee=s24">https://www.atis.org/atis/docstore/search.asp?committee=s24</a>
TTA	TTAT.3G-25.106(R4-4.7.0)	4.7.0	Approved	25/05/2004	<a href="http://www.tta.or.kr/standardDB/stnfile/TTAT.3G-25.106(R4-4.7.0).zip">http://www.tta.or.kr/standardDB/stnfile/TTAT.3G-25.106(R4-4.7.0).zip</a>



**Release 5**

CCSA	CCSA-TSD-DS-25.106	550	Approved	01/07/2003	<a href="http://www.ccsa.org.cn/english/tc/files.php?docpath=/ITU-R/M.1457/M.1457-4/DS/">http://www.ccsa.org.cn/english/tc/files.php?docpath=/ITU-R/M.1457/M.1457-4/DS/</a>
ETSI	ETSI TS 125 106	5.7.0	Published	27/01/2004	<a href="http://pda.etsi.org/pda/home.asp?wkr=RTS/TSGR-0425106v570">http://pda.etsi.org/pda/home.asp?wkr=RTS/TSGR-0425106v570</a>
T1 (ATIS)	T1.3GPP.25.106V570-2004	5.7.0	Approved	21/05/2004	<a href="https://www.atis.org/atis/docstore/search.asp?committee=s24">https://www.atis.org/atis/docstore/search.asp?committee=s24</a>
TTA	TTAT.3G-25.106(R5-5.7.0)	5.7.0	Approved	25/05/2004	<a href="http://www.tta.or.kr/standardDB/stnfile/TTAT.3G-25.106(R5-5.7.0).zip">http://www.tta.or.kr/standardDB/stnfile/TTAT.3G-25.106(R5-5.7.0).zip</a>

**Release 6**

ETSI	ETSI TS 125 106	6.0.0	Published	27/01/2004	<a href="http://pda.etsi.org/pda/home.asp?wkr=RTS/TSGR-0425106v600">http://pda.etsi.org/pda/home.asp?wkr=RTS/TSGR-0425106v600</a>
T1 (ATIS)	T1.3GPP.25.106V600-2004	6.0.0	Approved	21/05/2004	<a href="https://www.atis.org/atis/docstore/search.asp?committee=s24">https://www.atis.org/atis/docstore/search.asp?committee=s24</a>
TTA	TTAT.3G-25.106(R6-6.0.0)	6.0.0	Approved	25/05/2004	<a href="http://www.tta.or.kr/standardDB/stnfile/TTAT.3G-25.106(R6-6.0.0).zip">http://www.tta.or.kr/standardDB/stnfile/TTAT.3G-25.106(R6-6.0.0).zip</a>

**5.1.2.4.3 25.133****Requirements for support of radio resource management (FDD)**

This specification describes the requirements for support of radio resource management for FDD including requirements on measurements in UTRAN and the UE as well as on node dynamic behaviour and interaction, in terms of delay and response characteristics.

SDO (2)	Document No.	Version	Status	Issued date	Location (1)
<b>Release 99</b>					
ARIB	ARIB STD-T63-25.133	3.16.0	Approved	25/05/2004	<a href="http://www.arib.or.jp/IMT-2000/ARIB-STD/ITU-R/R99/A25133-3g0.pdf">http://www.arib.or.jp/IMT-2000/ARIB-STD/ITU-R/R99/A25133-3g0.pdf</a>
CCSA	CCSA-TSD-DS-25.133	3E0	Approved	01/07/2003	<a href="http://www.ccsa.org.cn/english/tc/files.php?docpath=/ITU-R/M.1457/M.1457-4/DS/">http://www.ccsa.org.cn/english/tc/files.php?docpath=/ITU-R/M.1457/M.1457-4/DS/</a>
ETSI	ETSI TS 125 133	3.16.0	Published	02/02/2004	<a href="http://pda.etsi.org/pda/home.asp?wkr=RTS/TSGR-0425133v3g0">http://pda.etsi.org/pda/home.asp?wkr=RTS/TSGR-0425133v3g0</a>
T1 (ATIS)	T1.3GPP.25.133V3160-2004	3.16.0	Approved	21/05/2004	<a href="https://www.atis.org/atis/docstore/search.asp?committee=S24">https://www.atis.org/atis/docstore/search.asp?committee=S24</a>
TTA	TTAT.3G-25.133(R99F-3.16.0)	3.16.0	Approved	25/05/2004	<a href="http://www.tta.or.kr/standardDB/stnfile/TTAT.3G-25.133(R99F-3.16.0).zip">http://www.tta.or.kr/standardDB/stnfile/TTAT.3G-25.133(R99F-3.16.0).zip</a>
<b>Release 4</b>					
ARIB	ARIB STD-T63-25.133	4.11.0	Approved	25/05/2004	<a href="http://www.arib.or.jp/IMT-2000/ARIB-STD/ITU-R/Rel4/A25133-4b0.pdf">http://www.arib.or.jp/IMT-2000/ARIB-STD/ITU-R/Rel4/A25133-4b0.pdf</a>
CCSA	CCSA-TSD-DS-25.133	490	Approved	01/07/2003	<a href="http://www.ccsa.org.cn/english/tc/files.php?docpath=/ITU-R/M.1457/M.1457-4/DS/">http://www.ccsa.org.cn/english/tc/files.php?docpath=/ITU-R/M.1457/M.1457-4/DS/</a>
ETSI	ETSI TS 125 133	4.11.0	Published	02/02/2004	<a href="http://pda.etsi.org/pda/home.asp?wkr=RTS/TSGR-0425133v4b0">http://pda.etsi.org/pda/home.asp?wkr=RTS/TSGR-0425133v4b0</a>
T1 (ATIS)	T1.3GPP.25.133V4110-2004	4.11.0	Approved	21/05/2004	<a href="https://www.atis.org/atis/docstore/search.asp?committee=S24">https://www.atis.org/atis/docstore/search.asp?committee=S24</a>
TTA	TTAT.3G-25.133(R4F-4.11.0)	4.11.0	Approved	25/05/2004	<a href="http://www.tta.or.kr/standardDB/stnfile/TTAT.3G-25.133(R4F-4.11.0).zip">http://www.tta.or.kr/standardDB/stnfile/TTAT.3G-25.133(R4F-4.11.0).zip</a>
<b>Release 5</b>					
ARIB	ARIB STD-T63-25.133	5.9.0	Approved	25/05/2004	<a href="http://www.arib.or.jp/IMT-2000/ARIB-STD/ITU-R/Rel5/A25133-590.pdf">http://www.arib.or.jp/IMT-2000/ARIB-STD/ITU-R/Rel5/A25133-590.pdf</a>
CCSA	CCSA-TSD-DS-25.133	570	Approved	01/07/2003	<a href="http://www.ccsa.org.cn/english/tc/files.php?docpath=/ITU-R/M.1457/M.1457-4/DS/">http://www.ccsa.org.cn/english/tc/files.php?docpath=/ITU-R/M.1457/M.1457-4/DS/</a>
ETSI	ETSI TS 125 133	5.9.0	Published	02/02/2004	<a href="http://pda.etsi.org/pda/home.asp?wkr=RTS/TSGR-0425133v590">http://pda.etsi.org/pda/home.asp?wkr=RTS/TSGR-0425133v590</a>
T1 (ATIS)	T1.3GPP.25.133V590-2004	5.9.0	Approved	21/05/2004	<a href="https://www.atis.org/atis/docstore/search.asp?committee=S24">https://www.atis.org/atis/docstore/search.asp?committee=S24</a>
TTA	TTAT.3G-25.133(R5F-5.9.0)	5.9.0	Approved	25/05/2004	<a href="http://www.tta.or.kr/standardDB/stnfile/TTAT.3G-25.133(R5F-5.9.0).zip">http://www.tta.or.kr/standardDB/stnfile/TTAT.3G-25.133(R5F-5.9.0).zip</a>
<b>Release 6</b>					
ARIB	ARIB STD-T63-25.133	6.4.0	Approved	25/05/2004	<a href="http://www.arib.or.jp/IMT-2000/ARIB-STD/ITU-R/Rel6/A25133-640.pdf">http://www.arib.or.jp/IMT-2000/ARIB-STD/ITU-R/Rel6/A25133-640.pdf</a>
CCSA	CCSA-TSD-DS-25.133	620	Approved	01/07/2003	<a href="http://www.ccsa.org.cn/english/tc/files.php?docpath=/ITU-R/M.1457/M.1457-4/DS/">http://www.ccsa.org.cn/english/tc/files.php?docpath=/ITU-R/M.1457/M.1457-4/DS/</a>
ETSI	ETSI TS 125 133	6.4.0	Published	02/02/2004	<a href="http://pda.etsi.org/pda/home.asp?wkr=RTS/TSGR-0425133v640">http://pda.etsi.org/pda/home.asp?wkr=RTS/TSGR-0425133v640</a>

T1 (ATIS) T1.3GPP.25.133V640-2004	6.4.0	Approved	21/05/2004	<a href="https://www.atis.org/atis/docstore/search.asp?committee=S24">https://www.atis.org/atis/docstore/search.asp?committee=S24</a>
TTA TTAT.3G-25.133(R6F-6.4.0)	6.4.0	Approved	25/05/2004	<a href="http://www.tta.or.kr/standardDB/stnfile/TTAT.3G-25.133(R6F-6.4.0).zip">http://www.tta.or.kr/standardDB/stnfile/TTAT.3G-25.133(R6F-6.4.0).zip</a>

#### 5.1.2.4.4 25.104

### BTS radio transmission and reception (FDD)

This specification describes the base station minimum RF characteristics of the FDD mode of UTRA. The values in the TS make no allowance for measurements uncertainties in conformance testing. Test limit to be used for conformance testing are specified separately in the BS conformance test Specification TS 25.141.

SDO (2)	Document No.	Version	Status	Issued date	Location (1)
<b>Release 99</b>					
ARIB	ARIB STD-T63-25.104	3.12.0	Approved	25/05/2004	<a href="http://www.arib.or.jp/IMT-2000/ARIB-STD/ITU-R/R99/A25104-3c0.pdf">http://www.arib.or.jp/IMT-2000/ARIB-STD/ITU-R/R99/A25104-3c0.pdf</a>
CCSA	CCSA-TSD-DS-25.104	3C0	Approved	01/07/2003	<a href="http://www.ccsa.org.cn/english/tc/files.php?docpath=/ITU-R/M.1457/M.1457-4/DS/">http://www.ccsa.org.cn/english/tc/files.php?docpath=/ITU-R/M.1457/M.1457-4/DS/</a>
ETSI	ETSI TS 125 104	3.12.0	Published	10/04/2003	<a href="http://pda.etsi.org/pda/home.asp?wkr=RTS/TSGR-0425104v3c0">http://pda.etsi.org/pda/home.asp?wkr=RTS/TSGR-0425104v3c0</a>
T1 (ATIS)	T1.3GPP.25.104V3120-2004	3.12.0	Approved	21/05/2004	<a href="https://www.atis.org/atis/docstore/search.asp?committee=S24">https://www.atis.org/atis/docstore/search.asp?committee=S24</a>
TTA	TTAT.3G-25.104(R99F-3.12.0)	3.12.0	Approved	25/05/2004	<a href="http://www.tta.or.kr/standardDB/stnfile/TTAT.3G-25.104(R99F-3.12.0).zip">http://www.tta.or.kr/standardDB/stnfile/TTAT.3G-25.104(R99F-3.12.0).zip</a>
<b>Release 4</b>					
ARIB	ARIB STD-T63-25.104	4.7.0	Approved	25/05/2004	<a href="http://www.arib.or.jp/IMT-2000/ARIB-STD/ITU-R/Rel4/A25104-470.pdf">http://www.arib.or.jp/IMT-2000/ARIB-STD/ITU-R/Rel4/A25104-470.pdf</a>
CCSA	CCSA-TSD-DS-25.104	470	Approved	01/07/2003	<a href="http://www.ccsa.org.cn/english/tc/files.php?docpath=/ITU-R/M.1457/M.1457-4/DS/">http://www.ccsa.org.cn/english/tc/files.php?docpath=/ITU-R/M.1457/M.1457-4/DS/</a>
ETSI	ETSI TS 125 104	4.7.0	Published	10/04/2003	<a href="http://pda.etsi.org/pda/home.asp?wkr=RTS/TSGR-0425104v470">http://pda.etsi.org/pda/home.asp?wkr=RTS/TSGR-0425104v470</a>
T1 (ATIS)	T1.3GPP.25.104V470-2004	4.7.0	Approved	21/05/2004	<a href="https://www.atis.org/atis/docstore/search.asp?committee=S24">https://www.atis.org/atis/docstore/search.asp?committee=S24</a>
TTA	TTAT.3G-25.104(R4F-4.7.0)	4.7.0	Approved	25/05/2004	<a href="http://www.tta.or.kr/standardDB/stnfile/TTAT.3G-25.104(R4F-4.7.0).zip">http://www.tta.or.kr/standardDB/stnfile/TTAT.3G-25.104(R4F-4.7.0).zip</a>
<b>Release 5</b>					
ARIB	ARIB STD-T63-25.104	5.8.0	Approved	25/05/2004	<a href="http://www.arib.or.jp/IMT-2000/ARIB-STD/ITU-R/Rel5/A25104-580.pdf">http://www.arib.or.jp/IMT-2000/ARIB-STD/ITU-R/Rel5/A25104-580.pdf</a>
CCSA	CCSA-TSD-DS-25.104	570	Approved	01/07/2003	<a href="http://www.ccsa.org.cn/english/tc/files.php?docpath=/ITU-R/M.1457/M.1457-4/DS/">http://www.ccsa.org.cn/english/tc/files.php?docpath=/ITU-R/M.1457/M.1457-4/DS/</a>
ETSI	ETSI TS 125 104	5.8.0	Published	30/01/2004	<a href="http://pda.etsi.org/pda/home.asp?wkr=RTS/TSGR-0425104v580">http://pda.etsi.org/pda/home.asp?wkr=RTS/TSGR-0425104v580</a>
T1 (ATIS)	T1.3GPP.25.104V580-2004	5.8.0	Approved	21/05/2004	<a href="https://www.atis.org/atis/docstore/search.asp?committee=S24">https://www.atis.org/atis/docstore/search.asp?committee=S24</a>
TTA	TTAT.3G-25.104(R5F-5.8.0)	5.8.0	Approved	25/05/2004	<a href="http://www.tta.or.kr/standardDB/stnfile/TTAT.3G-25.104(R5F-5.8.0).zip">http://www.tta.or.kr/standardDB/stnfile/TTAT.3G-25.104(R5F-5.8.0).zip</a>
<b>Release 6</b>					
ARIB	ARIB STD-T63-25.104	6.4.0	Approved	25/05/2004	<a href="http://www.arib.or.jp/IMT-2000/ARIB-STD/ITU-R/Rel6/A25104-640.pdf">http://www.arib.or.jp/IMT-2000/ARIB-STD/ITU-R/Rel6/A25104-640.pdf</a>
CCSA	CCSA-TSD-DS-25.104	620	Approved	01/07/2003	<a href="http://www.ccsa.org.cn/english/tc/files.php?docpath=/ITU-R/M.1457/M.1457-4/DS/">http://www.ccsa.org.cn/english/tc/files.php?docpath=/ITU-R/M.1457/M.1457-4/DS/</a>
ETSI	ETSI TS 125 104	6.4.0	Published	30/01/2004	<a href="http://pda.etsi.org/pda/home.asp?wkr=RTS/TSGR-0425104v640">http://pda.etsi.org/pda/home.asp?wkr=RTS/TSGR-0425104v640</a>
T1 (ATIS)	T1.3GPP.25.104V640-2004	6.4.0	Approved	21/05/2004	<a href="https://www.atis.org/atis/docstore/search.asp?committee=S24">https://www.atis.org/atis/docstore/search.asp?committee=S24</a>
TTA	TTAT.3G-25.104(R6F-6.4.0)	6.4.0	Approved	25/05/2004	<a href="http://www.tta.or.kr/standardDB/stnfile/TTAT.3G-25.104(R6F-6.4.0).zip">http://www.tta.or.kr/standardDB/stnfile/TTAT.3G-25.104(R6F-6.4.0).zip</a>



**5.1.2.4.5** 25.141**Base station conformance testing (FDD)**

This specification describes the RF test methods and conformance requirements for UTRA base transceiver stations (BTS) operating in the FDD mode. These have been derived from, and are consistent with, the core UTRA specifications specified in the requirements reference subclause of each test. The maximum acceptable measurement uncertainty is specified in the TS for each test, where appropriate.

SDO (2)	Document No.	Version	Status	Issued date	Location (1)
<b>Release 99</b>					
ARIB	ARIB STD-T63-25.141	3.13.0	Approved	25/05/2004	<a href="http://www.arib.or.jp/IMT-2000/ARIB-STD/ITU-R/R99/A25141-3d0.pdf">http://www.arib.or.jp/IMT-2000/ARIB-STD/ITU-R/R99/A25141-3d0.pdf</a>
CCSA	CCSA-TSD-DS-25.141	3D0	Approved	01/07/2003	<a href="http://www.ccsa.org.cn/english/tc/files.php?docpath=/ITU-R/M.1457/M.1457-4/DS/">http://www.ccsa.org.cn/english/tc/files.php?docpath=/ITU-R/M.1457/M.1457-4/DS/</a>
ETSI	ETSI TS 125 141	3.13.0	Published	10/04/2003	<a href="http://pda.etsi.org/pda/home.asp?wkr=RTS/TSGR-0425141v3d0">http://pda.etsi.org/pda/home.asp?wkr=RTS/TSGR-0425141v3d0</a>
T1 (ATIS)	T1.3GPP.25.141V3130-2004	3.13.0	Approved	21/05/2004	<a href="https://www.atis.org/atis/docstore/search.asp?committee=S24">https://www.atis.org/atis/docstore/search.asp?committee=S24</a>
TTA	TTAT.3G-25.141(R99F-3.13.0)	3.13.0	Approved	25/05/2004	<a href="http://www.tta.or.kr/standardDB/stnfile/TTAT.3G-25.141(R99F-3.13.0).zip">http://www.tta.or.kr/standardDB/stnfile/TTAT.3G-25.141(R99F-3.13.0).zip</a>
<b>Release 4</b>					
ARIB	ARIB STD-T63-25.141	4.8.0	Approved	25/05/2004	<a href="http://www.arib.or.jp/IMT-2000/ARIB-STD/ITU-R/Rel4/A25141-480.pdf">http://www.arib.or.jp/IMT-2000/ARIB-STD/ITU-R/Rel4/A25141-480.pdf</a>
CCSA	CCSA-TSD-DS-25.141	480	Approved	01/07/2003	<a href="http://www.ccsa.org.cn/english/tc/files.php?docpath=/ITU-R/M.1457/M.1457-4/DS/">http://www.ccsa.org.cn/english/tc/files.php?docpath=/ITU-R/M.1457/M.1457-4/DS/</a>
ETSI	ETSI TS 125 141	4.8.0	Published	10/04/2003	<a href="http://pda.etsi.org/pda/home.asp?wkr=RTS/TSGR-0425141v480">http://pda.etsi.org/pda/home.asp?wkr=RTS/TSGR-0425141v480</a>
T1 (ATIS)	T1.3GPP.25.141V480-2004	4.8.0	Approved	21/05/2004	<a href="https://www.atis.org/atis/docstore/search.asp?committee=S24">https://www.atis.org/atis/docstore/search.asp?committee=S24</a>
TTA	TTAT.3G-25.141(R4F-4.8.0)	4.8.0	Approved	25/05/2004	<a href="http://www.tta.or.kr/standardDB/stnfile/TTAT.3G-25.141(R4F-4.8.0).zip">http://www.tta.or.kr/standardDB/stnfile/TTAT.3G-25.141(R4F-4.8.0).zip</a>
<b>Release 5</b>					
ARIB	ARIB STD-T63-25.141	5.8.0	Approved	25/05/2004	<a href="http://www.arib.or.jp/IMT-2000/ARIB-STD/ITU-R/Rel5/A25141-580.pdf">http://www.arib.or.jp/IMT-2000/ARIB-STD/ITU-R/Rel5/A25141-580.pdf</a>
CCSA	CCSA-TSD-DS-25.141	570	Approved	01/07/2003	<a href="http://www.ccsa.org.cn/english/tc/files.php?docpath=/ITU-R/M.1457/M.1457-4/DS/">http://www.ccsa.org.cn/english/tc/files.php?docpath=/ITU-R/M.1457/M.1457-4/DS/</a>
ETSI	ETSI TS 125 141	5.8.0	Published	02/02/2004	<a href="http://pda.etsi.org/pda/home.asp?wkr=RTS/TSGR-0425141v580">http://pda.etsi.org/pda/home.asp?wkr=RTS/TSGR-0425141v580</a>
T1 (ATIS)	T1.3GPP.25.141V580-2004	5.8.0	Approved	21/05/2004	<a href="https://www.atis.org/atis/docstore/search.asp?committee=S24">https://www.atis.org/atis/docstore/search.asp?committee=S24</a>
TTA	TTAT.3G-25.141(R5F-5.8.0)	5.8.0	Approved	25/05/2004	<a href="http://www.tta.or.kr/standardDB/stnfile/TTAT.3G-25.141(R5F-5.8.0).zip">http://www.tta.or.kr/standardDB/stnfile/TTAT.3G-25.141(R5F-5.8.0).zip</a>
<b>Release 6</b>					
ARIB	ARIB STD-T63-25.141	6.4.0	Approved	25/05/2004	<a href="http://www.arib.or.jp/IMT-2000/ARIB-STD/ITU-R/Rel6/A25141-640.pdf">http://www.arib.or.jp/IMT-2000/ARIB-STD/ITU-R/Rel6/A25141-640.pdf</a>
CCSA	CCSA-TSD-DS-25.141	620	Approved	01/07/2003	<a href="http://www.ccsa.org.cn/english/tc/files.php?docpath=/ITU-R/M.1457/M.1457-4/DS/">http://www.ccsa.org.cn/english/tc/files.php?docpath=/ITU-R/M.1457/M.1457-4/DS/</a>
ETSI	ETSI TS 125 141	6.4.0	Published	02/02/2004	<a href="http://pda.etsi.org/pda/home.asp?wkr=RTS/TSGR-0425141v640">http://pda.etsi.org/pda/home.asp?wkr=RTS/TSGR-0425141v640</a>
T1 (ATIS)	T1.3GPP.25.141V640-2004	6.4.0	Approved	21/05/2004	<a href="https://www.atis.org/atis/docstore/search.asp?committee=S24">https://www.atis.org/atis/docstore/search.asp?committee=S24</a>
TTA	TTAT.3G-25.141(R6F-6.4.0)	6.4.0	Approved	25/05/2004	<a href="http://www.tta.or.kr/standardDB/stnfile/TTAT.3G-25.141(R6F-6.4.0).zip">http://www.tta.or.kr/standardDB/stnfile/TTAT.3G-25.141(R6F-6.4.0).zip</a>

**5.1.2.4.6** 25.113**Base station EMC (see Note 1)**

This specification describes the assessment of base stations and associated ancillary equipment in respect of EMC. NOTE 1 - This specification does not include the antenna port immunity and emissions.

SDO (2)	Document No.	Version	Status	Issued date	Location (1)
<b>Release 99</b>					
ARIB	ARIB STD-T63-25.113	3.5.0	Approved	25/05/2004	<a href="http://www.arib.or.jp/IMT-2000/ARIB-STD/ITU-R/R99/A25113-350.pdf">http://www.arib.or.jp/IMT-2000/ARIB-STD/ITU-R/R99/A25113-350.pdf</a>
CCSA	CCSA-TSD-DS-25.113	350	Approved	01/07/2003	<a href="http://www.ccsa.org.cn/english/tc/files.php?docpath=/ITU-R/M.1457/M.1457-4/DS/">http://www.ccsa.org.cn/english/tc/files.php?docpath=/ITU-R/M.1457/M.1457-4/DS/</a>
ETSI	ETSI TS 125 113	3.5.0	Published	11/05/2001	<a href="http://pda.etsi.org/pda/home.asp?wkr=RTS/TSGR-0425113UR5">http://pda.etsi.org/pda/home.asp?wkr=RTS/TSGR-0425113UR5</a>
T1 (ATIS)	T1.3GPP.25.113V350-2002	3.5.0	Approved	03/05/2002	<a href="https://www.atis.org/atis/docstore/search.asp?committee=S24">https://www.atis.org/atis/docstore/search.asp?committee=S24</a>
TTA	TTAE.3G-25.113(R99-3.5.0)	3.5.0	Approved	29/05/2002	<a href="http://www.tta.or.kr/standardDB/stnfile/TTAE.3G-25.113(R99-3.5.0).zip">http://www.tta.or.kr/standardDB/stnfile/TTAE.3G-25.113(R99-3.5.0).zip</a>
<b>Release 4</b>					
ARIB	ARIB STD-T63-25.113	4.4.0	Approved	25/05/2004	<a href="http://www.arib.or.jp/IMT-2000/ARIB-STD/ITU-R/Rel4/A25113-440.pdf">http://www.arib.or.jp/IMT-2000/ARIB-STD/ITU-R/Rel4/A25113-440.pdf</a>
CCSA	CCSA-TSD-DS-25.113	440	Approved	01/07/2003	<a href="http://www.ccsa.org.cn/english/tc/files.php?docpath=/ITU-R/M.1457/M.1457-4/DS/">http://www.ccsa.org.cn/english/tc/files.php?docpath=/ITU-R/M.1457/M.1457-4/DS/</a>
ETSI	ETSI TS 125 113	4.4.0	Published	16/01/2003	<a href="http://pda.etsi.org/pda/home.asp?wkr=RTS/TSGR-0425113v440">http://pda.etsi.org/pda/home.asp?wkr=RTS/TSGR-0425113v440</a>
T1 (ATIS)	T1.3GPP.25.113V440-2003	4.4.0	Approved	27/03/2003	<a href="https://www.atis.org/atis/docstore/search.asp?committee=S24">https://www.atis.org/atis/docstore/search.asp?committee=S24</a>
TTA	TTAT.3G-25.113(R4-4.4.0)	4.4.0	Approved	21/03/2003	<a href="http://www.tta.or.kr/standardDB/stnfile/TTAT.3G-25.113(R4-4.4.0).zip">http://www.tta.or.kr/standardDB/stnfile/TTAT.3G-25.113(R4-4.4.0).zip</a>
<b>Release 5</b>					
ARIB	ARIB STD-T63-25.113	5.4.0	Approved	25/05/2004	<a href="http://www.arib.or.jp/IMT-2000/ARIB-STD/ITU-R/Rel5/A25113-540.pdf">http://www.arib.or.jp/IMT-2000/ARIB-STD/ITU-R/Rel5/A25113-540.pdf</a>
CCSA	CCSA-TSD-DS-25.113	540	Approved	01/07/2003	<a href="http://www.ccsa.org.cn/english/tc/files.php?docpath=/ITU-R/M.1457/M.1457-4/DS/">http://www.ccsa.org.cn/english/tc/files.php?docpath=/ITU-R/M.1457/M.1457-4/DS/</a>
ETSI	ETSI TS 125 113	5.5.0	Published	30/01/2004	<a href="http://pda.etsi.org/pda/home.asp?wkr=RTS/TSGR-0425113v550">http://pda.etsi.org/pda/home.asp?wkr=RTS/TSGR-0425113v550</a>
T1 (ATIS)	T1.3GPP.25.113V550-2004	5.5.0	Approved	21/05/2004	<a href="https://www.atis.org/atis/docstore/search.asp?committee=S24">https://www.atis.org/atis/docstore/search.asp?committee=S24</a>
TTA	TTAT.3G-25.113(R5-5.5.0)	5.5.0	Approved	25/05/2004	<a href="http://www.tta.or.kr/standardDB/stnfile/TTAT.3G-25.113(R5-5.5.0).zip">http://www.tta.or.kr/standardDB/stnfile/TTAT.3G-25.113(R5-5.5.0).zip</a>
<b>Release 6</b>					
ARIB	ARIB STD-T63-25.113	6.0.0	Approved	25/05/2004	<a href="http://www.arib.or.jp/IMT-2000/ARIB-STD/ITU-R/Rel6/A25113-600.pdf">http://www.arib.or.jp/IMT-2000/ARIB-STD/ITU-R/Rel6/A25113-600.pdf</a>
ETSI	ETSI TS 125 113	6.0.0	Published	30/01/2004	<a href="http://pda.etsi.org/pda/home.asp?wkr=RTS/TSGR-0425113v600">http://pda.etsi.org/pda/home.asp?wkr=RTS/TSGR-0425113v600</a>
T1 (ATIS)	T1.3GPP.25.113V600-2004	6.0.0	Approved	21/05/2004	<a href="https://www.atis.org/atis/docstore/search.asp?committee=S24">https://www.atis.org/atis/docstore/search.asp?committee=S24</a>
TTA	TTAT.3G-25.113(R6-6.0.0)	6.0.0	Approved	25/05/2004	<a href="http://www.tta.or.kr/standardDB/stnfile/TTAT.3G-25.113(R6-6.0.0).zip">http://www.tta.or.kr/standardDB/stnfile/TTAT.3G-25.113(R6-6.0.0).zip</a>

#### 5.1.2.4.7 25.143

### UTRA Repeater; Conformance Testing

The present document specifies the Radio Frequency (RF) test methods and Minimum Requirements for UTRA Repeaters. These have been derived from, and are consistent with the UTRA Repeater specifications defined in TS 25.106.

SDO (2)	Document No.	Version	Status	Issued date	Location (1)
<b>Release 4</b>					
CCSA	CCSA-TSD-DS-25.143	480	Approved	01/07/2003	<a href="http://www.ccsa.org.cn/english/tc/files.php?docpath=/ITU-R/M.1457/M.1457-4/DS/">http://www.ccsa.org.cn/english/tc/files.php?docpath=/ITU-R/M.1457/M.1457-4/DS/</a>
ETSI	ETSI TS 125 143	4.9.0	Published	27/01/2004	<a href="http://pda.etsi.org/pda/home.asp?wkr=RTS/TSGR-0425143v490">http://pda.etsi.org/pda/home.asp?wkr=RTS/TSGR-0425143v490</a>
T1 (ATIS)	T1.3GPP.25.143V490-2004	4.9.0	Approved	21/05/2004	<a href="https://www.atis.org/atis/docstore/search.asp?committee=s24">https://www.atis.org/atis/docstore/search.asp?committee=s24</a>
TTA	TTAT.3G-25.143(R4-4.9.0)	4.9.0	Approved	25/05/2004	<a href="http://www.tta.or.kr/standardDB/stnfile/TTAT.3G-25.143(R4-4.9.0).zip">http://www.tta.or.kr/standardDB/stnfile/TTAT.3G-25.143(R4-4.9.0).zip</a>

**Release 5**

CCSA	CCSA-TSD-DS-25.143	550	Approved	01/07/2003	<a href="http://www.ccsa.org.cn/english/tc/files.php?docpath=/ITU-R/M.1457/M.1457-4/DS/">http://www.ccsa.org.cn/english/tc/files.php?docpath=/ITU-R/M.1457/M.1457-4/DS/</a>
ETSI	ETSI TS 125 143	5.7.0	Published	27/01/2004	<a href="http://pda.etsi.org/pda/home.asp?wkr=RTS/TSGR-0425143v570">http://pda.etsi.org/pda/home.asp?wkr=RTS/TSGR-0425143v570</a>
T1 (ATIS)	T1.3GPP.25.143V570-2004	5.7.0	Approved	21/05/2004	<a href="https://www.atis.org/atis/docstore/search.asp?committee=s24">https://www.atis.org/atis/docstore/search.asp?committee=s24</a>
TTA	TTAT.3G-25.143(R5-5.7.0)	5.7.0	Approved	25/05/2004	<a href="http://www.tta.or.kr/standardDB/stnfile/TTAT.3G-25.143(R5-5.7.0).zip">http://www.tta.or.kr/standardDB/stnfile/TTAT.3G-25.143(R5-5.7.0).zip</a>

**Release 6**

ETSI	ETSI TS 125 143	6.0.0	Published	27/01/2004	<a href="http://pda.etsi.org/pda/home.asp?wkr=RTS/TSGR-0425143v600">http://pda.etsi.org/pda/home.asp?wkr=RTS/TSGR-0425143v600</a>
T1 (ATIS)	T1.3GPP.25.143V600-2004	6.0.0	Approved	21/05/2004	<a href="https://www.atis.org/atis/docstore/search.asp?committee=s24">https://www.atis.org/atis/docstore/search.asp?committee=s24</a>
TTA	TTAT.3G-25.143(R6-6.0.0)	6.0.0	Approved	25/05/2004	<a href="http://www.tta.or.kr/standardDB/stnfile/TTAT.3G-25.143(R6-6.0.0).zip">http://www.tta.or.kr/standardDB/stnfile/TTAT.3G-25.143(R6-6.0.0).zip</a>

**5.1.2.5****34.100 series****5.1.2.5.1 34.108****Common Test Environments for User Equipment (UE) Conformance Testing**

This document contains definitions of reference conditions and test signals, default parameters, reference Radio Bearer configurations, common requirements for test equipment and generic set-up procedures for use in UE conformance tests.

SDO (2)	Document No.	Version	Status	Issued date	Location (1)
<b>Release 99</b>					
ARIB	ARIB STD-T63-34.108	3.14.0	Approved	25/05/2004	<a href="http://www.arib.or.jp/IMT-2000/ARIB-STD/ITU-R/R99/A34108-3e0.pdf">http://www.arib.or.jp/IMT-2000/ARIB-STD/ITU-R/R99/A34108-3e0.pdf</a>
CCSA	CCSA-TSD-DS-34.108	3C0	Approved	01/07/2003	<a href="http://www.ccsa.org.cn/english/tc/files.php?docpath=/ITU-R/M.1457/M.1457-4/DS/">http://www.ccsa.org.cn/english/tc/files.php?docpath=/ITU-R/M.1457/M.1457-4/DS/</a>
ETSI	ETSI TS 134 108	3.14.0	Published	26/01/2004	<a href="http://pda.etsi.org/pda/home.asp?wkr=RTS/TSGT-0134108v3e0">http://pda.etsi.org/pda/home.asp?wkr=RTS/TSGT-0134108v3e0</a>
T1 (ATIS)	T1.3GPP.34.108V3140-2004	3.14.0	Approved	21/05/2004	<a href="https://www.atis.org/atis/docstore/search.asp?committee=S24">https://www.atis.org/atis/docstore/search.asp?committee=S24</a>
TTA	TTAT.3G-34.108(R99-3.14.0)	3.14.0	Approved	25/05/2004	<a href="http://www.tta.or.kr/standardDB/stnfile/TTAT.3G-34.108(R99-3.14.0).zip">http://www.tta.or.kr/standardDB/stnfile/TTAT.3G-34.108(R99-3.14.0).zip</a>
<b>Release 4</b>					
ARIB	ARIB STD-T63-34.108	4.9.0	Approved	25/05/2004	<a href="http://www.arib.or.jp/IMT-2000/ARIB-STD/ITU-R/Rel4/A34108-490.pdf">http://www.arib.or.jp/IMT-2000/ARIB-STD/ITU-R/Rel4/A34108-490.pdf</a>
CCSA	CCSA-TSD-DS-34.108	470	Approved	01/07/2003	<a href="http://www.ccsa.org.cn/english/tc/files.php?docpath=/ITU-R/M.1457/M.1457-4/DS/">http://www.ccsa.org.cn/english/tc/files.php?docpath=/ITU-R/M.1457/M.1457-4/DS/</a>
ETSI	ETSI TS 134 108	4.9.0	Published	27/01/2004	<a href="http://pda.etsi.org/pda/home.asp?wkr=RTS/TSGT-0134108v490">http://pda.etsi.org/pda/home.asp?wkr=RTS/TSGT-0134108v490</a>
T1 (ATIS)	T1.3GPP.34.108V490-2004	4.9.0	Approved	21/05/2004	<a href="https://www.atis.org/atis/docstore/search.asp?committee=S24">https://www.atis.org/atis/docstore/search.asp?committee=S24</a>
TTA	TTAT.3G-34.108(R4-4.9.0)	4.9.0	Approved	25/05/2004	<a href="http://www.tta.or.kr/standardDB/stnfile/TTAT.3G-34.108(R4-4.9.0).zip">http://www.tta.or.kr/standardDB/stnfile/TTAT.3G-34.108(R4-4.9.0).zip</a>
<b>Release 5</b>					
T1 (ATIS)	T1.3GPP.34.108V500-2004	5.0.0	Approved	21/05/2004	<a href="https://www.atis.org/atis/docstore/search.asp?committee=S24">https://www.atis.org/atis/docstore/search.asp?committee=S24</a>

## 5.1.2.5.2 34.109

**Logical Test Interface (TDD and FDD)**

This document specifies for User Equipment (UE), in UMTS system, for FDD and TDD modes, those UE functions that are required for conformance testing purposes.

SDO (2)	Document No.	Version	Status	Issued date	Location (1)
<b>Release 99</b>					
ARIB	ARIB STD-T63-34.109	3.9.0	Approved	25/05/2004	<a href="http://www.arib.or.jp/IMT-2000/ARIB-STD/ITU-R/R99/A34109-390.pdf">http://www.arib.or.jp/IMT-2000/ARIB-STD/ITU-R/R99/A34109-390.pdf</a>
CCSA	CCSA-TSD-DS-34.109	390	Approved	01/07/2003	<a href="http://www.ccsa.org.cn/english/tc/files.php?docpath=/ITU-R/M.1457/M.1457-4/DS/">http://www.ccsa.org.cn/english/tc/files.php?docpath=/ITU-R/M.1457/M.1457-4/DS/</a>
ETSI	ETSI TS 134 109	3.9.0	Published	04/04/2003	<a href="http://pda.etsi.org/pda/home.asp?wkr=RTS/TSGR-0234109v390">http://pda.etsi.org/pda/home.asp?wkr=RTS/TSGR-0234109v390</a>
T1 (ATIS)	T1.3GPP.34.109V390-2004	3.9.0	Approved	21/05/2004	<a href="https://www.atis.org/atis/docstore/search.asp?committee=S24">https://www.atis.org/atis/docstore/search.asp?committee=S24</a>
TTA	TTAT.3G-34.109(R99-3.9.0)	3.9.0	Approved	25/05/2004	<a href="http://www.tta.or.kr/standardDB/stnfile/TTAT.3G-34.109(R99-3.9.0).zip">http://www.tta.or.kr/standardDB/stnfile/TTAT.3G-34.109(R99-3.9.0).zip</a>
<b>Release 4</b>					
ARIB	ARIB STD-T63-34.109	4.5.0	Approved	25/05/2004	<a href="http://www.arib.or.jp/IMT-2000/ARIB-STD/ITU-R/Rel4/A34109-450.pdf">http://www.arib.or.jp/IMT-2000/ARIB-STD/ITU-R/Rel4/A34109-450.pdf</a>
CCSA	CCSA-TSD-DS-34.109	450	Approved	01/07/2003	<a href="http://www.ccsa.org.cn/english/tc/files.php?docpath=/ITU-R/M.1457/M.1457-4/DS/">http://www.ccsa.org.cn/english/tc/files.php?docpath=/ITU-R/M.1457/M.1457-4/DS/</a>
ETSI	ETSI TS 134 109	4.5.0	Published	04/04/2003	<a href="http://pda.etsi.org/pda/home.asp?wkr=RTS/TSGR-0234109v450">http://pda.etsi.org/pda/home.asp?wkr=RTS/TSGR-0234109v450</a>
T1 (ATIS)	T1.3GPP.34.109V450-2004	4.5.0	Approved	21/05/2004	<a href="https://www.atis.org/atis/docstore/search.asp?committee=S24">https://www.atis.org/atis/docstore/search.asp?committee=S24</a>
TTA	TTAT.3G-34.109(R4-4.5.0)	4.5.0	Approved	25/05/2004	<a href="http://www.tta.or.kr/standardDB/stnfile/TTAT.3G-34.109(R4-4.5.0).zip">http://www.tta.or.kr/standardDB/stnfile/TTAT.3G-34.109(R4-4.5.0).zip</a>
<b>Release 5</b>					
ARIB	ARIB STD-T63-34.109	5.3.0	Approved	25/05/2004	<a href="http://www.arib.or.jp/IMT-2000/ARIB-STD/ITU-R/Rel5/A34109-530.pdf">http://www.arib.or.jp/IMT-2000/ARIB-STD/ITU-R/Rel5/A34109-530.pdf</a>
CCSA	CCSA-TSD-DS-34.109	530	Approved	01/07/2003	<a href="http://www.ccsa.org.cn/english/tc/files.php?docpath=/ITU-R/M.1457/M.1457-4/DS/">http://www.ccsa.org.cn/english/tc/files.php?docpath=/ITU-R/M.1457/M.1457-4/DS/</a>
ETSI	ETSI TS 134 109	5.3.0	Published	04/04/2003	<a href="http://pda.etsi.org/pda/home.asp?wkr=RTS/TSGR-0234109v530">http://pda.etsi.org/pda/home.asp?wkr=RTS/TSGR-0234109v530</a>
T1 (ATIS)	T1.3GPP.34.109V530-2004	5.3.0	Approved	21/05/2004	<a href="https://www.atis.org/atis/docstore/search.asp?committee=S24">https://www.atis.org/atis/docstore/search.asp?committee=S24</a>
TTA	TTAT.3G-34.109(R5-5.3.0)	5.3.0	Approved	25/05/2004	<a href="http://www.tta.or.kr/standardDB/stnfile/TTAT.3G-34.109(R5-5.3.0).zip">http://www.tta.or.kr/standardDB/stnfile/TTAT.3G-34.109(R5-5.3.0).zip</a>

## 5.1.2.5.3 34.121

**Terminal Conformance Specification, Radio Transmission and Reception (FDD)**

This document specifies the Radio Frequency (RF) test methods and conformance requirements for UTRA User Equipment (UE) operating in the FDD mode. These have been derived from, and are consistent with, the core UTRA specifications. The maximum acceptable measurement uncertainty is specified in the TS for each test, where appropriate.

SDO (2)	Document No.	Version	Status	Issued date	Location (1)
<b>Release 99</b>					
ARIB	ARIB STD-T63-34.121	3.14.0	Approved	25/05/2004	<a href="http://www.arib.or.jp/IMT-2000/ARIB-STD/ITU-R/R99/A34121-3e0.pdf">http://www.arib.or.jp/IMT-2000/ARIB-STD/ITU-R/R99/A34121-3e0.pdf</a>
CCSA	CCSA-TSD-DS-34.121	3D0	Approved	01/07/2003	<a href="http://www.ccsa.org.cn/english/tc/files.php?docpath=/ITU-R/M.1457/M.1457-4/DS/">http://www.ccsa.org.cn/english/tc/files.php?docpath=/ITU-R/M.1457/M.1457-4/DS/</a>
ETSI	ETSI TS 134 121	3.14.0	Published	17/10/2003	<a href="http://pda.etsi.org/pda/home.asp?wkr=RTS/TSGT-0134121v3e0">http://pda.etsi.org/pda/home.asp?wkr=RTS/TSGT-0134121v3e0</a>
T1 (ATIS)	T1.3GPP.34.121V3140-2004	3.14.0	Approved	21/05/2004	<a href="https://www.atis.org/atis/docstore/search.asp?committee=S24">https://www.atis.org/atis/docstore/search.asp?committee=S24</a>
TTA	TTAT.3G-34.121(R99F-3.14.0)	3.14.0	Approved	25/05/2004	<a href="http://www.tta.or.kr/standardDB/stnfile/TTAT.3G-34.121(R99F-3.14.0).zip">http://www.tta.or.kr/standardDB/stnfile/TTAT.3G-34.121(R99F-3.14.0).zip</a>

**Release 4**

ARIB	ARIB STD-T63-34.121	4.1.0	Approved	25/05/2004	<a href="http://www.arib.or.jp/IMT-2000/ARIB-STD/ITU-R/Rel4/A34121-410.pdf">http://www.arib.or.jp/IMT-2000/ARIB-STD/ITU-R/Rel4/A34121-410.pdf</a>
CCSA	CCSA-TSD-DS-34.121	400	Approved	01/07/2003	<a href="http://www.ccsa.org.cn/english/tc/files.php?docpath=/ITU-R/M.1457/M.1457-4/DS/">http://www.ccsa.org.cn/english/tc/files.php?docpath=/ITU-R/M.1457/M.1457-4/DS/</a>
ETSI	ETSI TS 134 121	4.1.0	Published	17/10/2003	<a href="http://pda.etsi.org/pda/home.asp?wkr=RTS/TSGT-0134121v410">http://pda.etsi.org/pda/home.asp?wkr=RTS/TSGT-0134121v410</a>
T1 (ATIS)	T1.3GPP.34.121V410-2004	4.1.0	Approved	21/05/2004	<a href="https://www.atis.org/atis/docstore/search.asp?committee=S24">https://www.atis.org/atis/docstore/search.asp?committee=S24</a>
TTA	TTAT.3G-34.121(R4F-4.1.0)	4.1.0	Approved	25/05/2004	<a href="http://www.tta.or.kr/standardDB/stnfile/TTAT.3G-34.121(R4F-4.1.0).zip">http://www.tta.or.kr/standardDB/stnfile/TTAT.3G-34.121(R4F-4.1.0).zip</a>

**Release 5**

ARIB	ARIB STD-T63-34.121	5.2.0	Approved	25/05/2004	<a href="http://www.arib.or.jp/IMT-2000/ARIB-STD/ITU-R/Rel5/A34121-520.pdf">http://www.arib.or.jp/IMT-2000/ARIB-STD/ITU-R/Rel5/A34121-520.pdf</a>
CCSA	CCSA-TSD-DS-34.121	500	Approved	01/07/2003	<a href="http://www.ccsa.org.cn/english/tc/files.php?docpath=/ITU-R/M.1457/M.1457-4/DS/">http://www.ccsa.org.cn/english/tc/files.php?docpath=/ITU-R/M.1457/M.1457-4/DS/</a>
ETSI	ETSI TS 134 121	5.2.0	Published	30/01/2004	<a href="http://pda.etsi.org/pda/home.asp?wkr=RTS/TSGT-0134121v520">http://pda.etsi.org/pda/home.asp?wkr=RTS/TSGT-0134121v520</a>
T1 (ATIS)	T1.3GPP.34.121V520-2004	5.2.0	Approved	21/05/2004	<a href="https://www.atis.org/atis/docstore/search.asp?committee=S24">https://www.atis.org/atis/docstore/search.asp?committee=S24</a>
TTA	TTAT.3G-34.121(R5F-5.2.0)	5.2.0	Approved	25/05/2004	<a href="http://www.tta.or.kr/standardDB/stnfile/TTAT.3G-34.121(R5F-5.2.0).zip">http://www.tta.or.kr/standardDB/stnfile/TTAT.3G-34.121(R5F-5.2.0).zip</a>

**5.1.2.5.4 34.123-1**

**UE Conformance Specification, Part 1- Conformance specification**

This document specifies the protocol conformance testing for the 3rd Generation User Equipment (UE). This is the first part of a multi-part test specification.

SDO (2)	Document No.	Version	Status	Issued date	Location (1)
<b>Release 99</b>					
ARIB	ARIB STD-T63-34.123-1	3.5.0	Approved	25/05/2004	<a href="http://www.arib.or.jp/IMT-2000/ARIB-STD/ITU-R/R99/A34123-1-350.pdf">http://www.arib.or.jp/IMT-2000/ARIB-STD/ITU-R/R99/A34123-1-350.pdf</a>
CCSA	CCSA-TSD-DS-34.123-1	350	Approved	01/07/2003	<a href="http://www.ccsa.org.cn/english/tc/files.php?docpath=/ITU-R/M.1457/M.1457-4/DS/">http://www.ccsa.org.cn/english/tc/files.php?docpath=/ITU-R/M.1457/M.1457-4/DS/</a>
ETSI	ETSI TS 134 123-1	3.5.0	Published	19/10/2001	<a href="http://pda.etsi.org/pda/home.asp?wkr=RTS/TSGT-0134123-1UR6">http://pda.etsi.org/pda/home.asp?wkr=RTS/TSGT-0134123-1UR6</a>
T1 (ATIS)	T1.3GPP.34.123-1V350-2002	3.5.0	Approved	03/05/2002	<a href="https://www.atis.org/atis/docstore/search.asp?committee=S24">https://www.atis.org/atis/docstore/search.asp?committee=S24</a>
TTA	TTAE.3G-34.123-1(R99350)	3.5.0	Approved	29/05/2002	<a href="http://www.tta.or.kr/standardDB/stnfile/TTAE.3G-34.123-1(R99350).zip">http://www.tta.or.kr/standardDB/stnfile/TTAE.3G-34.123-1(R99350).zip</a>
<b>Release 4</b>					
ARIB	ARIB STD-T63-34.123-1	4.3.0	Approved	25/05/2004	<a href="http://www.arib.or.jp/IMT-2000/ARIB-STD/ITU-R/Rel4/A34123-1-430.pdf">http://www.arib.or.jp/IMT-2000/ARIB-STD/ITU-R/Rel4/A34123-1-430.pdf</a>
CCSA	CCSA-TSD-DS-34.123-1	430	Approved	01/07/2003	<a href="http://www.ccsa.org.cn/english/tc/files.php?docpath=/ITU-R/M.1457/M.1457-4/DS/">http://www.ccsa.org.cn/english/tc/files.php?docpath=/ITU-R/M.1457/M.1457-4/DS/</a>
ETSI	ETSI TS 134 123-1	4.3.0	Published	02/07/2002	<a href="http://pda.etsi.org/pda/home.asp?wkr=RTS/TSGT-0134123-1v430">http://pda.etsi.org/pda/home.asp?wkr=RTS/TSGT-0134123-1v430</a>
T1 (ATIS)	T1.3GPP.34.123-1V430-2003	4.3.0	Approved	27/03/2003	<a href="https://www.atis.org/atis/docstore/search.asp?committee=S24">https://www.atis.org/atis/docstore/search.asp?committee=S24</a>
TTA	TTAT.3G-34.123-1(R4-4.3.0)	4.3.0	Approved	21/03/2003	<a href="http://www.tta.or.kr/standardDB/stnfile/TTAT.3G-34.123-1(R4-4.3.0).zip">http://www.tta.or.kr/standardDB/stnfile/TTAT.3G-34.123-1(R4-4.3.0).zip</a>
<b>Release 5</b>					
ARIB	ARIB STD-T63-34.123-1	5.6.0	Approved	25/05/2004	<a href="http://www.arib.or.jp/IMT-2000/ARIB-STD/ITU-R/Rel5/A34123-1-560.zip">http://www.arib.or.jp/IMT-2000/ARIB-STD/ITU-R/Rel5/A34123-1-560.zip</a>
CCSA	CCSA-TSD-DS-34.123-1	540	Approved	01/07/2003	<a href="http://www.ccsa.org.cn/english/tc/files.php?docpath=/ITU-R/M.1457/M.1457-4/DS/">http://www.ccsa.org.cn/english/tc/files.php?docpath=/ITU-R/M.1457/M.1457-4/DS/</a>
ETSI	ETSI TS 134 123-1	5.6.0	Published	27/01/2004	<a href="http://pda.etsi.org/pda/home.asp?wkr=RTS/TSGT-0134123-1v560">http://pda.etsi.org/pda/home.asp?wkr=RTS/TSGT-0134123-1v560</a>
T1 (ATIS)	T1.3GPP.34.123-1V560-2004	5.6.0	Approved	21/05/2004	<a href="https://www.atis.org/atis/docstore/search.asp?committee=S24">https://www.atis.org/atis/docstore/search.asp?committee=S24</a>
TTA	TTAT.3G-34.123-1(R5-5.6.0)	5.6.0	Approved	25/05/2004	<a href="http://www.tta.or.kr/standardDB/stnfile/TTAT.3G-34.123-1(R5-5.6.0).zip">http://www.tta.or.kr/standardDB/stnfile/TTAT.3G-34.123-1(R5-5.6.0).zip</a>

**5.1.2.5.5** 34.123-2**UE Conformance Specification, Part 2- ICS**

This document provides the Implementation Conformance Statement (ICS) proforma for 3rd Generation User Equipment (UE), in compliance with the relevant requirements, and in accordance with the relevant guidance given in ISO/IEC 9646-7 and ETS 300 406. This document also specifies a recommended applicability statement for the test cases included in TS 34.123-1. These applicability statements are based on the features implemented in the UE.

SDO (2)	Document No.	Version	Status	Issued date	Location (1)
<b>Release 99</b>					
ARIB	ARIB STD-T63-34.123-2	3.5.0	Approved	25/05/2004	<a href="http://www.arib.or.jp/IMT-2000/ARIB-STD/ITU-R/R99/A34123-2-350.pdf">http://www.arib.or.jp/IMT-2000/ARIB-STD/ITU-R/R99/A34123-2-350.pdf</a>
CCSA	CCSA-TSD-DS-34.123-2	350	Approved	01/07/2003	<a href="http://www.ccsa.org.cn/english/tc/files.php?docpath=/ITU-R/M.1457/M.1457-4/DS/">http://www.ccsa.org.cn/english/tc/files.php?docpath=/ITU-R/M.1457/M.1457-4/DS/</a>
ETSI	ETSI TS 134 123-2	3.5.0	Published	19/10/2001	<a href="http://pda.etsi.org/pda/home.asp?wkr=RTS/TSGT-0134123-2UR4">http://pda.etsi.org/pda/home.asp?wkr=RTS/TSGT-0134123-2UR4</a>
T1 (ATIS)	T1.3GPP.34.123-2V350-2002	3.5.0	Approved	03/05/2002	<a href="https://www.atis.org/atis/docstore/search.asp?committee=S24">https://www.atis.org/atis/docstore/search.asp?committee=S24</a>
TTA	TTAE.3G-34.123-2(R99350)	3.5.0	Approved	29/05/2002	<a href="http://www.tta.or.kr/standardDB/stnfile/TTAE.3G-34.123-2(R99350).zip">http://www.tta.or.kr/standardDB/stnfile/TTAE.3G-34.123-2(R99350).zip</a>
<b>Release 4</b>					
ARIB	ARIB STD-T63-34.123-2	4.3.0	Approved	25/05/2004	<a href="http://www.arib.or.jp/IMT-2000/ARIB-STD/ITU-R/Rel4/A34123-2-430.pdf">http://www.arib.or.jp/IMT-2000/ARIB-STD/ITU-R/Rel4/A34123-2-430.pdf</a>
CCSA	CCSA-TSD-DS-34.123-2	430	Approved	01/07/2003	<a href="http://www.ccsa.org.cn/english/tc/files.php?docpath=/ITU-R/M.1457/M.1457-4/DS/">http://www.ccsa.org.cn/english/tc/files.php?docpath=/ITU-R/M.1457/M.1457-4/DS/</a>
ETSI	ETSI TS 134 123-2	4.3.0	Published	27/06/2002	<a href="http://pda.etsi.org/pda/home.asp?wkr=RTS/TSGT-0134123-2v430">http://pda.etsi.org/pda/home.asp?wkr=RTS/TSGT-0134123-2v430</a>
T1 (ATIS)	T1.3GPP.34.123-2V430-2003	4.3.0	Approved	27/03/2003	<a href="https://www.atis.org/atis/docstore/search.asp?committee=S24">https://www.atis.org/atis/docstore/search.asp?committee=S24</a>
TTA	TTAT.3G-34.123-2(R4-4.3.0)	4.3.0	Approved	21/03/2003	<a href="http://www.tta.or.kr/standardDB/stnfile/TTAT.3G-34.123-2(R4-4.3.0).zip">http://www.tta.or.kr/standardDB/stnfile/TTAT.3G-34.123-2(R4-4.3.0).zip</a>
<b>Release 5</b>					
ARIB	ARIB STD-T63-34.123-2	5.6.0	Approved	25/05/2004	<a href="http://www.arib.or.jp/IMT-2000/ARIB-STD/ITU-R/Rel5/A34123-2-560.pdf">http://www.arib.or.jp/IMT-2000/ARIB-STD/ITU-R/Rel5/A34123-2-560.pdf</a>
CCSA	CCSA-TSD-DS-34.123-2	540	Approved	01/07/2003	<a href="http://www.ccsa.org.cn/english/tc/files.php?docpath=/ITU-R/M.1457/M.1457-4/DS/">http://www.ccsa.org.cn/english/tc/files.php?docpath=/ITU-R/M.1457/M.1457-4/DS/</a>
ETSI	ETSI TS 134 123-2	5.6.0	Published	26/01/2004	<a href="http://pda.etsi.org/pda/home.asp?wkr=RTS/TSGT-0134123-2v560">http://pda.etsi.org/pda/home.asp?wkr=RTS/TSGT-0134123-2v560</a>
T1 (ATIS)	T1.3GPP.34.123-2V560-2004	5.6.0	Approved	21/05/2004	<a href="https://www.atis.org/atis/docstore/search.asp?committee=S24">https://www.atis.org/atis/docstore/search.asp?committee=S24</a>
TTA	TTAT.3G-34.123-2(R5-5.6.0)	5.6.0	Approved	25/05/2004	<a href="http://www.tta.or.kr/standardDB/stnfile/TTAT.3G-34.123-2(R5-5.6.0).zip">http://www.tta.or.kr/standardDB/stnfile/TTAT.3G-34.123-2(R5-5.6.0).zip</a>

**5.1.2.5.6** 34.124**Electromagnetic compatibility (EMC) requirements for Mobile terminals and ancillary equipment**

This document establishes the essential EMC requirements for 3rd generation digital cellular mobile terminal equipment and ancillary accessories in combination with a 3GPP user equipment (UE).

SDO (2)	Document No.	Version	Status	Issued date	Location (1)
<b>Release 99</b>					
ARIB	ARIB STD-T63-34.124	3.4.0	Approved	25/05/2004	<a href="http://www.arib.or.jp/IMT-2000/ARIB-STD/ITU-R/R99/A34124-340.pdf">http://www.arib.or.jp/IMT-2000/ARIB-STD/ITU-R/R99/A34124-340.pdf</a>
CCSA	CCSA-TSD-DS-34.124	340	Approved	01/07/2003	<a href="http://www.ccsa.org.cn/english/tc/files.php?docpath=/ITU-R/M.1457/M.1457-4/DS/">http://www.ccsa.org.cn/english/tc/files.php?docpath=/ITU-R/M.1457/M.1457-4/DS/</a>
ETSI	ETSI TS 134 124	3.4.0	Published	14/04/2003	<a href="http://pda.etsi.org/pda/home.asp?wkr=RTS/TSGR-0434124v340">http://pda.etsi.org/pda/home.asp?wkr=RTS/TSGR-0434124v340</a>
T1 (ATIS)	T1.3GPP.34.124V340-2004	3.4.0	Approved	21/05/2004	<a href="https://www.atis.org/atis/docstore/search.asp?committee=S24">https://www.atis.org/atis/docstore/search.asp?committee=S24</a>

TTA	TTAT.3G-34.124(R99-3.4.0)	3.4.0	Approved	28/05/2003	<a href="http://www.tta.or.kr/standardDB/stnfile/TTAT.3G-34.124(R99-3.4.0).zip">http://www.tta.or.kr/standardDB/stnfile/TTAT.3G-34.124(R99-3.4.0).zip</a>
<b>Release 4</b>					
ARIB	ARIB STD-T63-34.124	4.2.0	Approved	25/05/2004	<a href="http://www.arib.or.jp/IMT-2000/ARIB-STD/ITU-R/Rel4/A34124-410.pdf">http://www.arib.or.jp/IMT-2000/ARIB-STD/ITU-R/Rel4/A34124-410.pdf</a>
CCSA	CCSA-TSD-DS-34.124	420	Approved	01/07/2003	<a href="http://www.ccsa.org.cn/english/tc/files.php?docpath=/ITU-R/M.1457/M.1457-4/DS/">http://www.ccsa.org.cn/english/tc/files.php?docpath=/ITU-R/M.1457/M.1457-4/DS/</a>
ETSI	ETSI TS 134 124	4.2.0	Published	14/04/2003	<a href="http://pda.etsi.org/pda/home.asp?wkr=RTS/TSGR-0434124v420">http://pda.etsi.org/pda/home.asp?wkr=RTS/TSGR-0434124v420</a>
T1 (ATIS)	T1.3GPP.34.124V420-2004	4.2.0	Approved	21/05/2004	<a href="https://www.atis.org/atis/docstore/search.asp?committee=S24">https://www.atis.org/atis/docstore/search.asp?committee=S24</a>
TTA	TTAT.3G-34.124(R4-4.2.0)	4.2.0	Approved	25/05/2004	<a href="http://www.tta.or.kr/standardDB/stnfile/TTAT.3G-34.124(R4-4.2.0).zip">http://www.tta.or.kr/standardDB/stnfile/TTAT.3G-34.124(R4-4.2.0).zip</a>
<b>Release 5</b>					
ARIB	ARIB STD-T63-34.124	5.3.0	Approved	25/05/2004	<a href="http://www.arib.or.jp/IMT-2000/ARIB-STD/ITU-R/Rel5/A34124-530.pdf">http://www.arib.or.jp/IMT-2000/ARIB-STD/ITU-R/Rel5/A34124-530.pdf</a>
CCSA	CCSA-TSD-DS-34.124	530	Approved	01/07/2003	<a href="http://www.ccsa.org.cn/english/tc/files.php?docpath=/ITU-R/M.1457/M.1457-4/DS/">http://www.ccsa.org.cn/english/tc/files.php?docpath=/ITU-R/M.1457/M.1457-4/DS/</a>
ETSI	ETSI TS 134 124	5.3.0	Published	14/04/2003	<a href="http://pda.etsi.org/pda/home.asp?wkr=RTS/TSGR-0434124v530">http://pda.etsi.org/pda/home.asp?wkr=RTS/TSGR-0434124v530</a>
T1 (ATIS)	T1.3GPP.34.124V530-2004	5.3.0	Approved	21/05/2004	<a href="https://www.atis.org/atis/docstore/search.asp?committee=S24">https://www.atis.org/atis/docstore/search.asp?committee=S24</a>
TTA	TTAT.3G-34.124(R5-5.3.0)	5.3.0	Approved	25/05/2004	<a href="http://www.tta.or.kr/standardDB/stnfile/TTAT.3G-34.124(R5-5.3.0).zip">http://www.tta.or.kr/standardDB/stnfile/TTAT.3G-34.124(R5-5.3.0).zip</a>

### 5.1.2.6

#### Core network aspects

##### 5.1.2.6.1 23.108

#### Mobile radio interface Layer 3 specification core network protocols - Stage 2

This specification describes the procedures used at the radio interface for call control (CC), mobility management (MM) and session management (SM). It shall hold examples of the structured procedures.

SDO (2)	Document No.	Version	Status	Issued date	Location (1)
<b>Release 99</b>					
CCSA	CCSA-TSD-DS-23.108	320	Approved	01/07/2003	<a href="http://www.ccsa.org.cn/english/tc/files.php?docpath=/ITU-R/M.1457/M.1457-4/DS/">http://www.ccsa.org.cn/english/tc/files.php?docpath=/ITU-R/M.1457/M.1457-4/DS/</a>
ETSI	ETSI TS 123 108	3.2.0	Published	17/05/2000	<a href="http://pda.etsi.org/pda/home.asp?wkr=RTS/TSGN-0123108UR1">http://pda.etsi.org/pda/home.asp?wkr=RTS/TSGN-0123108UR1</a>
T1 (ATIS)	T1.3GPP.23.108V320-2002	3.2.0	Approved	03/05/2002	<a href="https://www.atis.org/atis/docstore/search.asp?committee=S24">https://www.atis.org/atis/docstore/search.asp?committee=S24</a>
TTA	TTAE.3G-23.108(R99)	3.2.0	Approved	19/12/2001	<a href="http://www.tta.or.kr/standardDB/stnfile/TTAE_3G-23_108_R99_.zip">http://www.tta.or.kr/standardDB/stnfile/TTAE_3G-23_108_R99_.zip</a>
TTC	JP-3GA-23.108(R99)	2	Approved	01/10/2000	<a href="http://www.ttc.or.jp/imt/std/jp23108r99.pdf">http://www.ttc.or.jp/imt/std/jp23108r99.pdf</a>
<b>Release 4</b>					
CCSA	CCSA-TSD-DS-23.108	401	Approved	01/07/2003	<a href="http://www.ccsa.org.cn/english/tc/files.php?docpath=/ITU-R/M.1457/M.1457-4/DS/">http://www.ccsa.org.cn/english/tc/files.php?docpath=/ITU-R/M.1457/M.1457-4/DS/</a>
ETSI	ETSI TS 123 108	4.0.1	Published	17/07/2002	<a href="http://pda.etsi.org/pda/home.asp?wkr=RTS/TSGN-0123108v401">http://pda.etsi.org/pda/home.asp?wkr=RTS/TSGN-0123108v401</a>
T1 (ATIS)	T1.3GPP.23.108V401-2004	4.0.1	Approved	21/05/2004	<a href="https://www.atis.org/atis/docstore/search.asp?committee=S24">https://www.atis.org/atis/docstore/search.asp?committee=S24</a>
TTA	TTAT.3G-23.108(R4-4.0.1)	4.0.1	Approved	25/05/2004	<a href="http://www.tta.or.kr/standardDB/stnfile/TTAT.3G-23.108(R4-4.0.1).zip">http://www.tta.or.kr/standardDB/stnfile/TTAT.3G-23.108(R4-4.0.1).zip</a>
TTC	TS-3GA-23.108(Rel4)v4.0.0	1	Approved	01/05/2001	<a href="http://www.ttc.or.jp/imt/ts/23108rel4v400.pdf">http://www.ttc.or.jp/imt/ts/23108rel4v400.pdf</a>



**Release 5**

CCSA	CCSA-TSD-DS-23.108	500	Approved	01/07/2003	<a href="http://www.ccsa.org.cn/english/tc/files.php?docpath=/ITU-R/M.1457/M.1457-4/DS/">http://www.ccsa.org.cn/english/tc/files.php?docpath=/ITU-R/M.1457/M.1457-4/DS/</a>
ETSI	ETSI TS 123 108	5.0.0	Published	04/07/2002	<a href="http://pda.etsi.org/pda/home.asp?wkr=RTS/TSGN-0123108v500">http://pda.etsi.org/pda/home.asp?wkr=RTS/TSGN-0123108v500</a>
T1 (ATIS)	T1.3GPP.23.108V500-2003	5.0.0	Approved	27/03/2003	<a href="https://www.atis.org/atis/docstore/search.asp?committee=S24">https://www.atis.org/atis/docstore/search.asp?committee=S24</a>
TTA	TTAT.3G-23.108(R5-5.0.0)	5.0.0	Approved	21/03/2003	<a href="http://www.tta.or.kr/standardDB/stnfile/TTAT.3G-23.108(R5-5.0.0).zip">http://www.tta.or.kr/standardDB/stnfile/TTAT.3G-23.108(R5-5.0.0).zip</a>
TTC	TS-3GA-23.108(Rel5)v5.0.0	1	Approved	01/08/2002	<a href="http://www.ttc.or.jp/imt/ts/ts23108rel5v500.pdf">http://www.ttc.or.jp/imt/ts/ts23108rel5v500.pdf</a>

**5.1.2.6.2 23.110****UMTS access stratum services and functions**

This specification describes the detailed specifications of the protocols which rule the information flows, both control and user data, between the access stratum and the parts of UMTS outside the access stratum, and of the detailed specifications of the UTRAN. These detailed specifications are to be found in other technical specifications.

SDO (2)	Document No.	Version	Status	Issued date	Location (1)
<b>Release 99</b>					
CCSA	CCSA-TSD-DS-23.110	340	Approved	01/07/2003	<a href="http://www.ccsa.org.cn/english/tc/files.php?docpath=/ITU-R/M.1457/M.1457-4/DS/">http://www.ccsa.org.cn/english/tc/files.php?docpath=/ITU-R/M.1457/M.1457-4/DS/</a>
ETSI	ETSI TS 123 110	3.4.0	Published	17/05/2000	<a href="http://pda.etsi.org/pda/home.asp?wkr=RTS/TSGS-0223110UR1">http://pda.etsi.org/pda/home.asp?wkr=RTS/TSGS-0223110UR1</a>
T1 (ATIS)	T1.3GPP.23.110V340-2002	3.4.0	Approved	03/05/2002	<a href="https://www.atis.org/atis/docstore/search.asp?committee=S24">https://www.atis.org/atis/docstore/search.asp?committee=S24</a>
TTA	TTAE.3G-23.110(R99)	3.4.0	Approved	19/12/2001	<a href="http://www.tta.or.kr/standardDB/stnfile/TTAE_3G-23_110_R99_.zip">http://www.tta.or.kr/standardDB/stnfile/TTAE_3G-23_110_R99_.zip</a>
TTC	JP-3GA-23.110(R99)	2	Approved	01/10/2000	<a href="http://www.ttc.or.jp/imt/std/jp23110r99.pdf">http://www.ttc.or.jp/imt/std/jp23110r99.pdf</a>
<b>Release 4</b>					
CCSA	CCSA-TSD-DS-23.110	400	Approved	01/07/2003	<a href="http://www.ccsa.org.cn/english/tc/files.php?docpath=/ITU-R/M.1457/M.1457-4/DS/">http://www.ccsa.org.cn/english/tc/files.php?docpath=/ITU-R/M.1457/M.1457-4/DS/</a>
ETSI	ETSI TS 123 110	4.0.0	Published	17/04/2001	<a href="http://pda.etsi.org/pda/home.asp?wkr=RTS/TSGS-0223110Uv4">http://pda.etsi.org/pda/home.asp?wkr=RTS/TSGS-0223110Uv4</a>
T1 (ATIS)	T1.3GPP.23.110V400-2002	4.0.0	Approved	03/05/2002	<a href="https://www.atis.org/atis/docstore/search.asp?committee=S24">https://www.atis.org/atis/docstore/search.asp?committee=S24</a>
TTA	TTAE.3G-23.110(R4)	4.0.0	Approved	19/12/2001	<a href="http://www.tta.or.kr/standardDB/stnfile/TTAE_3G-23_110_R4_.zip">http://www.tta.or.kr/standardDB/stnfile/TTAE_3G-23_110_R4_.zip</a>
TTC	TS-3GA-23.110(Rel4)v4.0.0	1	Approved	01/05/2001	<a href="http://www.ttc.or.jp/imt/ts/ts23110rel4.pdf">http://www.ttc.or.jp/imt/ts/ts23110rel4.pdf</a>
<b>Release 5</b>					
ETSI	ETSI TS 123 110	5.0.0	Published	18/12/2003	<a href="http://pda.etsi.org/pda/home.asp?wkr=RTS/TSGS-0223110v500">http://pda.etsi.org/pda/home.asp?wkr=RTS/TSGS-0223110v500</a>
T1 (ATIS)	T1.3GPP.23.110V500-2004	5.0.0	Approved	21/05/2004	<a href="https://www.atis.org/atis/docstore/search.asp?committee=S24">https://www.atis.org/atis/docstore/search.asp?committee=S24</a>
TTA	TTAT.3G-23.110(R5-5.0.0)	5.0.0	Approved	25/05/2004	<a href="http://www.tta.or.kr/standardDB/stnfile/TTAT.3G-23.110(R5-5.0.0).zip">http://www.tta.or.kr/standardDB/stnfile/TTAT.3G-23.110(R5-5.0.0).zip</a>
TTC	TS-3GA-23.110(Rel5)v5.0.0	1	Approved	01/02/2004	<a href="http://www.ttc.or.jp/imt/ts/ts23110rel5v500.pdf">http://www.ttc.or.jp/imt/ts/ts23110rel5v500.pdf</a>

**5.1.2.6.3 23.122****Functions related to Mobile Stations (MS) in idle mode and group receive mode**

This specification shall give an overview of the tasks undertaken by a Mobile Station (MS) when in idle mode, that is, switched on but not having a dedicated channel allocated, e.g. not making or receiving a call, or when in group receive mode, that is, receiving a group call or broadcast call but not having a dedicated connection. It also describes the corresponding network functions.



SDO (2)	Document No.	Version	Status	Issued date	Location (1)
<b>Release 99</b>					
CCSA	CCSA-TSD-DS-23.122	390	Approved	01/07/2003	<a href="http://www.ccsa.org.cn/english/tc/files.php?docpath=/ITU-R/M.1457/M.1457-4/DS/">http://www.ccsa.org.cn/english/tc/files.php?docpath=/ITU-R/M.1457/M.1457-4/DS/</a>
ETSI	ETSI TS 123 122	3.10.0	Published	14/10/2003	<a href="http://pda.etsi.org/pda/home.asp?wkr=RTS/TSGN-0123122v3a0">http://pda.etsi.org/pda/home.asp?wkr=RTS/TSGN-0123122v3a0</a>
T1 (ATIS)	T1.3GPP.23.122V3100-2004	3.10.0	Approved	21/05/2004	<a href="https://www.atis.org/atis/docstore/search.asp?committee=S24">https://www.atis.org/atis/docstore/search.asp?committee=S24</a>
TTA	TTAT.3G-23.122(R99-3.10.0)	3.10.0	Approved	25/05/2004	<a href="http://www.tta.or.kr/standardDB/stnfile/TTAT.3G-23.122(R99-3.10.0).zip">http://www.tta.or.kr/standardDB/stnfile/TTAT.3G-23.122(R99-3.10.0).zip</a>
TTC	TS-3GA-23.122(R99)v3.10.0	1	Approved	01/11/2003	<a href="http://www.ttc.or.jp/imt/ts/ts23122r99v3a0.pdf">http://www.ttc.or.jp/imt/ts/ts23122r99v3a0.pdf</a>
<b>Release 4</b>					
CCSA	CCSA-TSD-DS-23.122	430	Approved	01/07/2003	<a href="http://www.ccsa.org.cn/english/tc/files.php?docpath=/ITU-R/M.1457/M.1457-4/DS/">http://www.ccsa.org.cn/english/tc/files.php?docpath=/ITU-R/M.1457/M.1457-4/DS/</a>
ETSI	ETSI TS 123 122	4.4.0	Published	14/10/2003	<a href="http://pda.etsi.org/pda/home.asp?wkr=RTS/TSGN-0123122v440">http://pda.etsi.org/pda/home.asp?wkr=RTS/TSGN-0123122v440</a>
T1 (ATIS)	T1.3GPP.23.122V440-2004	4.4.0	Approved	21/05/2004	<a href="https://www.atis.org/atis/docstore/search.asp?committee=S24">https://www.atis.org/atis/docstore/search.asp?committee=S24</a>
TTA	TTAT.3G-23.122(R4-4.4.0)	4.4.0	Approved	25/05/2004	<a href="http://www.tta.or.kr/standardDB/stnfile/TTAT.3G-23.122(R4-4.4.0).zip">http://www.tta.or.kr/standardDB/stnfile/TTAT.3G-23.122(R4-4.4.0).zip</a>
TTC	TS-3GA-23.122(Rel4)v4.4.0	1	Approved	01/11/2003	<a href="http://www.ttc.or.jp/imt/ts/ts23122rel4v440.pdf">http://www.ttc.or.jp/imt/ts/ts23122rel4v440.pdf</a>
<b>Release 5</b>					
CCSA	CCSA-TSD-DS-23.122	520	Approved	01/07/2003	<a href="http://www.ccsa.org.cn/english/tc/files.php?docpath=/ITU-R/M.1457/M.1457-4/DS/">http://www.ccsa.org.cn/english/tc/files.php?docpath=/ITU-R/M.1457/M.1457-4/DS/</a>
ETSI	ETSI TS 123 122	5.3.0	Published	14/10/2003	<a href="http://pda.etsi.org/pda/home.asp?wkr=RTS/TSGN-0123122v530">http://pda.etsi.org/pda/home.asp?wkr=RTS/TSGN-0123122v530</a>
T1 (ATIS)	T1.3GPP.23.122V530-2004	5.3.0	Approved	21/05/2004	<a href="https://www.atis.org/atis/docstore/search.asp?committee=S24">https://www.atis.org/atis/docstore/search.asp?committee=S24</a>
TTA	TTAT.3G-23.122(R5-5.3.0)	5.3.0	Approved	25/05/2004	<a href="http://www.tta.or.kr/standardDB/stnfile/TTAT.3G-23.122(R5-5.3.0).zip">http://www.tta.or.kr/standardDB/stnfile/TTAT.3G-23.122(R5-5.3.0).zip</a>
TTC	TS-3GA-23.122(Rel5)v5.3.0	1	Approved	01/11/2003	<a href="http://www.ttc.or.jp/imt/ts/ts23122rel5v530.pdf">http://www.ttc.or.jp/imt/ts/ts23122rel5v530.pdf</a>
<b>Release 6</b>					
T1 (ATIS)	T1.3GPP.23.122V600-2004	6.0.0	Approved	21/05/2004	<a href="https://www.atis.org/atis/docstore/search.asp?committee=S24">https://www.atis.org/atis/docstore/search.asp?committee=S24</a>

### 5.1.2.6.4 24.007

#### Mobile radio interface signalling Layer 3 - general aspects

This specification describes the principal architecture of Layer 3 and its sub-layers on the GSM Um interface, i.e. the interface between mobile station (MS) and network; for the CM sub-layer, the description is restricted to paradigmatic examples, CC, supplementary services, and short message services for non-general packet radio service (GPRS) services. It also defines the basic message format and error handling applied by the Layer 3 protocols.

SDO (2)	Document No.	Version	Status	Issued date	Location (1)
<b>Release 99</b>					
CCSA	CCSA-TSD-DS-24.007	390	Approved	01/07/2003	<a href="http://www.ccsa.org.cn/english/tc/files.php?docpath=/ITU-R/M.1457/M.1457-4/DS/">http://www.ccsa.org.cn/english/tc/files.php?docpath=/ITU-R/M.1457/M.1457-4/DS/</a>
ETSI	ETSI TS 124 007	3.9.0	Published	01/07/2002	<a href="http://pda.etsi.org/pda/home.asp?wkr=RTS/TSGN-0124007v390">http://pda.etsi.org/pda/home.asp?wkr=RTS/TSGN-0124007v390</a>
T1 (ATIS)	T1.3GPP.24.007V390-2003	3.9.0	Approved	27/03/2003	<a href="https://www.atis.org/atis/docstore/search.asp?committee=S24">https://www.atis.org/atis/docstore/search.asp?committee=S24</a>
TTA	TTAT.3G-24.007(R99-3.9.0)	3.9.0	Approved	21/03/2003	<a href="http://www.tta.or.kr/standardDB/stnfile/TTAT.3G-24.007(R99-3.9.0).zip">http://www.tta.or.kr/standardDB/stnfile/TTAT.3G-24.007(R99-3.9.0).zip</a>
TTC	TS-3GA-24.007(R99)v3.9.0	1	Approved	01/08/2002	<a href="http://www.ttc.or.jp/imt/ts/ts24007r99v390.pdf">http://www.ttc.or.jp/imt/ts/ts24007r99v390.pdf</a>

**Release 4**

CCSA	CCSA-TSD-DS-24.007	420	Approved	01/07/2003	<a href="http://www.ccsa.org.cn/english/tc/files.php?docpath=/ITU-R/M.1457/M.1457-4/DS/">http://www.ccsa.org.cn/english/tc/files.php?docpath=/ITU-R/M.1457/M.1457-4/DS/</a>
ETSI	ETSI TS 124 007	4.2.0	Published	01/07/2002	<a href="http://pda.etsi.org/pda/home.asp?wkr=RTS/TSGN-0124007v420">http://pda.etsi.org/pda/home.asp?wkr=RTS/TSGN-0124007v420</a>
T1 (ATIS)	T1.3GPP.24.007V420-2003	4.2.0	Approved	27/03/2003	<a href="https://www.atis.org/atis/docstore/search.asp?committee=S24">https://www.atis.org/atis/docstore/search.asp?committee=S24</a>
TTA	TTAT.3G-24.007(R4-4.2.0)	4.2.0	Approved	21/03/2003	<a href="http://www.tta.or.kr/standardDB/stnfile/TTAT.3G-24.007(R4-4.2.0).zip">http://www.tta.or.kr/standardDB/stnfile/TTAT.3G-24.007(R4-4.2.0).zip</a>
TTC	TS-3GA-24.007(Rel4)v4.2.0	1	Approved	01/08/2002	<a href="http://www.ttc.or.jp/imt/ts/ts24007rel4v420.pdf">http://www.ttc.or.jp/imt/ts/ts24007rel4v420.pdf</a>

**Release 5**

CCSA	CCSA-TSD-DS-24.007	510	Approved	01/07/2003	<a href="http://www.ccsa.org.cn/english/tc/files.php?docpath=/ITU-R/M.1457/M.1457-4/DS/">http://www.ccsa.org.cn/english/tc/files.php?docpath=/ITU-R/M.1457/M.1457-4/DS/</a>
ETSI	ETSI TS 124 007	5.1.0	Published	20/09/2002	<a href="http://pda.etsi.org/pda/home.asp?wkr=RTS/TSGN-0124007v510">http://pda.etsi.org/pda/home.asp?wkr=RTS/TSGN-0124007v510</a>
T1 (ATIS)	T1.3GPP.24.007V510-2003	5.1.0	Approved	27/03/2003	<a href="https://www.atis.org/atis/docstore/search.asp?committee=S24">https://www.atis.org/atis/docstore/search.asp?committee=S24</a>
TTA	TTAT.3G-24.007(R5-5.1.0)	5.1.0	Approved	21/03/2003	<a href="http://www.tta.or.kr/standardDB/stnfile/TTAT.3G-24.007(R5-5.1.0).zip">http://www.tta.or.kr/standardDB/stnfile/TTAT.3G-24.007(R5-5.1.0).zip</a>
TTC	TS-3GA-24.007(Rel5)v5.1.0	1	Approved	01/11/2002	<a href="http://www.ttc.or.jp/imt/ts/ts24007rel5v510.pdf">http://www.ttc.or.jp/imt/ts/ts24007rel5v510.pdf</a>

**Release 6**

T1 (ATIS)	T1.3GPP.24.007V600-2004	6.0.0	Approved	21/05/2004	<a href="https://www.atis.org/atis/docstore/search.asp?committee=S24">https://www.atis.org/atis/docstore/search.asp?committee=S24</a>
TTA	TTAT.3G-24.007(R6-6.0.0)	6.0.0	Approved	25/05/2004	<a href="http://www.tta.or.kr/standardDB/stnfile/TTAT.3G-24.007(R6-6.0.0).zip">http://www.tta.or.kr/standardDB/stnfile/TTAT.3G-24.007(R6-6.0.0).zip</a>
TTC	TS-3GA-24.007(Rel6)v6.0.0	1	Approved	01/02/2004	<a href="http://www.ttc.or.jp/imt/ts/ts24007rel6v600.pdf">http://www.ttc.or.jp/imt/ts/ts24007rel6v600.pdf</a>

**5.1.2.6.5 24.008****Mobile radio interface Layer 3 specification; core network protocols - Stage 3**

This specification describes the procedures used at the radio interface for CC, MM and SM. The procedures currently described are for the CC of circuit-switched connections, SM for GPRS services, MM and radio resource management for circuit-switched and GPRS services.

SDO (2)	Document No.	Version	Status	Issued date	Location (1)
<b>Release 99</b>					
CCSA	CCSA-TSD-DS-24.008	3G0	Approved	01/07/2003	<a href="http://www.ccsa.org.cn/english/tc/files.php?docpath=/ITU-R/M.1457/M.1457-4/DS/">http://www.ccsa.org.cn/english/tc/files.php?docpath=/ITU-R/M.1457/M.1457-4/DS/</a>
ETSI	ETSI TS 124 008	3.17.0	Published	16/10/2003	<a href="http://pda.etsi.org/pda/home.asp?wkr=RTS/TSGN-0124008v3h0">http://pda.etsi.org/pda/home.asp?wkr=RTS/TSGN-0124008v3h0</a>
T1 (ATIS)	T1.3GPP.24.008V3170-2004	3.17.0	Approved	21/05/2004	<a href="https://www.atis.org/atis/docstore/search.asp?committee=S24">https://www.atis.org/atis/docstore/search.asp?committee=S24</a>
TTA	TTAT.3G-24.008(R99-3.17.0)	3.17.0	Approved	25/05/2004	<a href="http://www.tta.or.kr/standardDB/stnfile/TTAT.3G-24.008(R99-3.17.0).zip">http://www.tta.or.kr/standardDB/stnfile/TTAT.3G-24.008(R99-3.17.0).zip</a>
TTC	TS-3GA-24.008(R99)v3.17.0	1	Approved	01/11/2003	<a href="http://www.ttc.or.jp/imt/ts/ts24008r99v3h0.pdf">http://www.ttc.or.jp/imt/ts/ts24008r99v3h0.pdf</a>
<b>Release 4</b>					
CCSA	CCSA-TSD-DS-24.008	4B0	Approved	01/07/2003	<a href="http://www.ccsa.org.cn/english/tc/files.php?docpath=/ITU-R/M.1457/M.1457-4/DS/">http://www.ccsa.org.cn/english/tc/files.php?docpath=/ITU-R/M.1457/M.1457-4/DS/</a>
ETSI	ETSI TS 124 008	4.12.0	Published	16/10/2003	<a href="http://pda.etsi.org/pda/home.asp?wkr=RTS/TSGN-0124008v4c0">http://pda.etsi.org/pda/home.asp?wkr=RTS/TSGN-0124008v4c0</a>
T1 (ATIS)	T1.3GPP.24.008V4120-2004	4.12.0	Approved	21/05/2004	<a href="https://www.atis.org/atis/docstore/search.asp?committee=S24">https://www.atis.org/atis/docstore/search.asp?committee=S24</a>
TTA	TTAT.3G-24.008(R4-4.12.0)	4.12.0	Approved	25/05/2004	<a href="http://www.tta.or.kr/standardDB/stnfile/TTAT.3G-24.008(R4-4.12.0).zip">http://www.tta.or.kr/standardDB/stnfile/TTAT.3G-24.008(R4-4.12.0).zip</a>
TTC	TS-3GA-24.008(Rel4)v4.12.0	1	Approved	01/11/2003	<a href="http://www.ttc.or.jp/imt/ts/ts24008rel4v4c0.pdf">http://www.ttc.or.jp/imt/ts/ts24008rel4v4c0.pdf</a>
<b>Release 5</b>					
CCSA	CCSA-TSD-DS-24.008	580	Approved	01/07/2003	<a href="http://www.ccsa.org.cn/english/tc/files.php?docpath=/ITU-R/M.1457/M.1457-4/DS/">http://www.ccsa.org.cn/english/tc/files.php?docpath=/ITU-R/M.1457/M.1457-4/DS/</a>
ETSI	ETSI TS 124 008	5.10.0	Published	14/01/2004	<a href="http://pda.etsi.org/pda/home.asp?wkr=RTS/TSGN-0124008v5a0">http://pda.etsi.org/pda/home.asp?wkr=RTS/TSGN-0124008v5a0</a>

T1 (ATIS) T1.3GPP.24.008V5100-2004	5.10.0	Approved	21/05/2004	<a href="https://www.atis.org/atis/docstore/search.asp?committee=S24">https://www.atis.org/atis/docstore/search.asp?committee=S24</a>
TTA TTAT.3G-24.008(R5-5.10.0)	5.10.0	Approved	25/05/2004	<a href="http://www.tta.or.kr/standardDB/stnfile/TTAT.3G-24.008(R5-5.10.0).zip">http://www.tta.or.kr/standardDB/stnfile/TTAT.3G-24.008(R5-5.10.0).zip</a>
TTC TS-3GA-24.008(Rel5)v5.10.0	1	Approved	01/02/2004	<a href="http://www.ttc.or.jp/imt/ts/ts24008rel5v5a0.pdf">http://www.ttc.or.jp/imt/ts/ts24008rel5v5a0.pdf</a>
<b>Release 6</b>				
CCSA CCSA-TSD-DS-24.008	610	Approved	01/07/2003	<a href="http://www.ccsa.org.cn/english/tc/files.php?docpath=/ITU-R/M.1457/M.1457-4/DS/">http://www.ccsa.org.cn/english/tc/files.php?docpath=/ITU-R/M.1457/M.1457-4/DS/</a>
T1 (ATIS) T1.3GPP.24.008V630-2004	6.3.0	Approved	21/05/2004	<a href="https://www.atis.org/atis/docstore/search.asp?committee=S24">https://www.atis.org/atis/docstore/search.asp?committee=S24</a>
TTA TTAT.3G-24.008(R6-6.3.0)	6.3.0	Approved	25/05/2004	<a href="http://www.tta.or.kr/standardDB/stnfile/TTAT.3G-24.008(R6-6.3.0).zip">http://www.tta.or.kr/standardDB/stnfile/TTAT.3G-24.008(R6-6.3.0).zip</a>
TTC TS-3GA-24.008(Rel6)v6.3.0	1	Approved	01/02/2004	<a href="http://www.ttc.or.jp/imt/ts/ts24008rel6v630.pdf">http://www.ttc.or.jp/imt/ts/ts24008rel6v630.pdf</a>

### 5.1.2.6.6 24.011

#### Point-to-point short message service (SMS) support on mobile radio interface

This specification describes the procedures used across the mobile radio interface by the signalling Layer 3 function short message control (SMC) and short message relay (SM-RL) function for both circuit-switched GSM and GPRS.

SDO (2)	Document No.	Version	Status	Issued date	Location (1)
<b>Release 99</b>					
CCSA	CCSA-TSD-DS-24.011	360	Approved	01/07/2003	<a href="http://www.ccsa.org.cn/english/tc/files.php?docpath=/ITU-R/M.1457/M.1457-4/DS/">http://www.ccsa.org.cn/english/tc/files.php?docpath=/ITU-R/M.1457/M.1457-4/DS/</a>
ETSI	ETSI TS 124 011	3.6.0	Published	25/04/2001	<a href="http://pda.etsi.org/pda/home.asp?wkr=RTS/TSGN-0124011UR5">http://pda.etsi.org/pda/home.asp?wkr=RTS/TSGN-0124011UR5</a>
T1 (ATIS)	T1.3GPP.24.011V360-2002	3.6.0	Approved	03/05/2002	<a href="https://www.atis.org/atis/docstore/search.asp?committee=S24">https://www.atis.org/atis/docstore/search.asp?committee=S24</a>
TTA	TTAE.3G-24.011(R99F)	3.6.0	Approved	19/12/2001	<a href="http://www.tta.or.kr/standardDB/stnfile/TTAE_3G-24_011_R99F_.zip">http://www.tta.or.kr/standardDB/stnfile/TTAE_3G-24_011_R99F_.zip</a>
TTC	TS-3GA-24.011(R99)v3.6.0	1	Approved	01/05/2001	<a href="http://www.ttc.or.jp/imt/ts/ts24011r99.pdf">http://www.ttc.or.jp/imt/ts/ts24011r99.pdf</a>
<b>Release 4</b>					
CCSA	CCSA-TSD-DS-24.011	410	Approved	01/07/2003	<a href="http://www.ccsa.org.cn/english/tc/files.php?docpath=/ITU-R/M.1457/M.1457-4/DS/">http://www.ccsa.org.cn/english/tc/files.php?docpath=/ITU-R/M.1457/M.1457-4/DS/</a>
ETSI	ETSI TS 124 011	4.1.1	Published	17/07/2002	<a href="http://pda.etsi.org/pda/home.asp?wkr=RTS/TSGN-0124011v411">http://pda.etsi.org/pda/home.asp?wkr=RTS/TSGN-0124011v411</a>
T1 (ATIS)	T1.3GPP.24.011V411-2003	4.1.1	Approved	27/03/2003	<a href="https://www.atis.org/atis/docstore/search.asp?committee=S24">https://www.atis.org/atis/docstore/search.asp?committee=S24</a>
TTA	TTAT.3G-24.011(R4-4.1.1)	4.1.1	Approved	21/03/2003	<a href="http://www.tta.or.kr/standardDB/stnfile/TTAT.3G-24.011(R4-4.1.1).zip">http://www.tta.or.kr/standardDB/stnfile/TTAT.3G-24.011(R4-4.1.1).zip</a>
TTC	TS-3GA-24.011(Rel4)v4.1.0	1	Approved	01/05/2002	<a href="http://www.ttc.or.jp/imt/ts/ts24011rel4.pdf">http://www.ttc.or.jp/imt/ts/ts24011rel4.pdf</a>
<b>Release 5</b>					
CCSA	CCSA-TSD-DS-24.011	520	Approved	01/07/2003	<a href="http://www.ccsa.org.cn/english/tc/files.php?docpath=/ITU-R/M.1457/M.1457-4/DS/">http://www.ccsa.org.cn/english/tc/files.php?docpath=/ITU-R/M.1457/M.1457-4/DS/</a>
ETSI	ETSI TS 124 011	5.2.0	Published	10/07/2003	<a href="http://pda.etsi.org/pda/home.asp?wkr=RTS/TSGN-0124011v520">http://pda.etsi.org/pda/home.asp?wkr=RTS/TSGN-0124011v520</a>
T1 (ATIS)	T1.3GPP.24.011V520-2004	5.2.0	Approved	21/05/2004	<a href="https://www.atis.org/atis/docstore/search.asp?committee=S24">https://www.atis.org/atis/docstore/search.asp?committee=S24</a>
TTA	TTAT.3G-24.011(R5-5.2.0)	5.2.0	Approved	25/05/2004	<a href="http://www.tta.or.kr/standardDB/stnfile/TTAT.3G-24.011(R5-5.2.0).zip">http://www.tta.or.kr/standardDB/stnfile/TTAT.3G-24.011(R5-5.2.0).zip</a>
TTC	TS-3GA-24.011(Rel5)v5.2.0	1	Approved	01/08/2003	<a href="http://www.ttc.or.jp/imt/ts/ts24011rel5v520.pdf">http://www.ttc.or.jp/imt/ts/ts24011rel5v520.pdf</a>
<b>Release 6</b>					
T1 (ATIS)	T1.3GPP.24.011V600-2004	6.0.0	Approved	21/05/2004	<a href="https://www.atis.org/atis/docstore/search.asp?committee=S24">https://www.atis.org/atis/docstore/search.asp?committee=S24</a>
TTA	TTAT.3G-24.011(R6-6.0.0)	6.0.0	Approved	25/05/2004	<a href="http://www.tta.or.kr/standardDB/stnfile/TTAT.3G-24.011(R6-6.0.0).zip">http://www.tta.or.kr/standardDB/stnfile/TTAT.3G-24.011(R6-6.0.0).zip</a>
TTC	TS-3GA-24.011(Rel6)v6.0.0	1	Approved	01/02/2004	<a href="http://www.ttc.or.jp/imt/ts/ts24011rel6v600.pdf">http://www.ttc.or.jp/imt/ts/ts24011rel6v600.pdf</a>

## 5.1.2.6.7 23.060

**General packet radio service (GPRS) service description - Stage 2**

This specification describes a general overview over the GPRS architecture as well as a more detailed overview of the MS - CN protocol architecture. Details of the protocols will be specified in companion documents.

SDO (2)	Document No.	Version	Status	Issued date	Location (1)
<b>Release 99</b>					
CCSA	CCSA-TSD-DS-23.060	3F0	Approved	01/07/2003	<a href="http://www.ccsa.org.cn/english/tc/files.php?docpath=/ITU-R/M.1457/M.1457-4/DS/">http://www.ccsa.org.cn/english/tc/files.php?docpath=/ITU-R/M.1457/M.1457-4/DS/</a>
ETSI	ETSI TS 123 060	3.16.0	Published	13/01/2004	<a href="http://pda.etsi.org/pda/home.asp?wkr=RTS/TSGS-0223060v3g0">http://pda.etsi.org/pda/home.asp?wkr=RTS/TSGS-0223060v3g0</a>
T1 (ATIS)	T1.3GPP.23.060V3160-2004	3.16.0	Approved	21/05/2004	<a href="https://www.atis.org/atis/docstore/search.asp?committee=S24">https://www.atis.org/atis/docstore/search.asp?committee=S24</a>
TTA	TTAT.3G-23.060(R99-3.16.0)	3.16.0	Approved	25/05/2004	<a href="http://www.tta.or.kr/standardDB/stnfile/TTAT.3G-23.060(R99-3.16.0).zip">http://www.tta.or.kr/standardDB/stnfile/TTAT.3G-23.060(R99-3.16.0).zip</a>
TTC	TS-3GA-23.060(R99)v3.16.0	1	Approved	01/02/2004	<a href="http://www.ttc.or.jp/imt/ts/ts23060r99v3g0.pdf">http://www.ttc.or.jp/imt/ts/ts23060r99v3g0.pdf</a>
<b>Release 4</b>					
CCSA	CCSA-TSD-DS-23.060	480	Approved	01/07/2003	<a href="http://www.ccsa.org.cn/english/tc/files.php?docpath=/ITU-R/M.1457/M.1457-4/DS/">http://www.ccsa.org.cn/english/tc/files.php?docpath=/ITU-R/M.1457/M.1457-4/DS/</a>
ETSI	ETSI TS 123 060	4.9.0	Published	13/01/2004	<a href="http://pda.etsi.org/pda/home.asp?wkr=RTS/TSGS-0223060v490">http://pda.etsi.org/pda/home.asp?wkr=RTS/TSGS-0223060v490</a>
T1 (ATIS)	T1.3GPP.23.060V490-2004	4.9.0	Approved	21/05/2004	<a href="https://www.atis.org/atis/docstore/search.asp?committee=S24">https://www.atis.org/atis/docstore/search.asp?committee=S24</a>
TTA	TTAT.3G-23.060(R4-4.9.0)	4.9.0	Approved	25/05/2004	<a href="http://www.tta.or.kr/standardDB/stnfile/TTAT.3G-23.060(R4-4.9.0).zip">http://www.tta.or.kr/standardDB/stnfile/TTAT.3G-23.060(R4-4.9.0).zip</a>
TTC	TS-3GA-23.060(Rel4)v4.9.0	1	Approved	01/02/2004	<a href="http://www.ttc.or.jp/imt/ts/ts23060rel4v490.pdf">http://www.ttc.or.jp/imt/ts/ts23060rel4v490.pdf</a>
<b>Release 5</b>					
CCSA	CCSA-TSD-DS-23.060	560	Approved	01/07/2003	<a href="http://www.ccsa.org.cn/english/tc/files.php?docpath=/ITU-R/M.1457/M.1457-4/DS/">http://www.ccsa.org.cn/english/tc/files.php?docpath=/ITU-R/M.1457/M.1457-4/DS/</a>
ETSI	ETSI TS 123 060	5.7.0	Published	13/01/2004	<a href="http://pda.etsi.org/pda/home.asp?wkr=RTS/TSGS-0223060v570">http://pda.etsi.org/pda/home.asp?wkr=RTS/TSGS-0223060v570</a>
T1 (ATIS)	T1.3GPP.23.060V570-2004	5.7.0	Approved	21/05/2004	<a href="https://www.atis.org/atis/docstore/search.asp?committee=S24">https://www.atis.org/atis/docstore/search.asp?committee=S24</a>
TTA	TTAT.3G-23.060(R5-5.7.0)	5.7.0	Approved	25/05/2004	<a href="http://www.tta.or.kr/standardDB/stnfile/TTAT.3G-23.060(R5-5.7.0).zip">http://www.tta.or.kr/standardDB/stnfile/TTAT.3G-23.060(R5-5.7.0).zip</a>
TTC	TS-3GA-23.060(Rel5)v5.7.0	1	Approved	01/02/2004	<a href="http://www.ttc.or.jp/imt/ts/ts23060rel5v570.pdf">http://www.ttc.or.jp/imt/ts/ts23060rel5v570.pdf</a>
<b>Release 6</b>					
CCSA	CCSA-TSD-DS-23.060	610	Approved	01/07/2003	<a href="http://www.ccsa.org.cn/english/tc/files.php?docpath=/ITU-R/M.1457/M.1457-4/DS/">http://www.ccsa.org.cn/english/tc/files.php?docpath=/ITU-R/M.1457/M.1457-4/DS/</a>
T1 (ATIS)	T1.3GPP.23.060V630-2004	6.3.0	Approved	21/05/2004	<a href="https://www.atis.org/atis/docstore/search.asp?committee=S24">https://www.atis.org/atis/docstore/search.asp?committee=S24</a>
TTA	TTAT.3G-23.060(R6-6.3.0)	6.3.0	Approved	25/05/2004	<a href="http://www.tta.or.kr/standardDB/stnfile/TTAT.3G-23.060(R6-6.3.0).zip">http://www.tta.or.kr/standardDB/stnfile/TTAT.3G-23.060(R6-6.3.0).zip</a>
TTC	TS-3GA-23.060(Rel6)v6.3.0	1	Approved	01/02/2004	<a href="http://www.ttc.or.jp/imt/ts/ts23060rel6v630.pdf">http://www.ttc.or.jp/imt/ts/ts23060rel6v630.pdf</a>

## 5.1.2.6.8 24.022

**Radio link protocol (RLP) for circuit switched bearer and teleservices**

This specification describes the RLP for data transmission over the UMTS public land mobile network (PLMN). RLP covers the Layer 2 functionality of the ISO OSI reference model (IS 7498). It is based on ideas contained in IS 3309, IS 4335 and IS 7809 (HDLC of ISO) as well as ITU-T Recommendations X.25, Q.921 and Q.922 (LAP-B and LAP-D, respectively). RLP has been tailored to the special needs of digital radio transmission. RLP provides to its users the OSI data link service (IS 8886).

SDO (2)	Document No.	Version	Status	Issued date	Location (1)
<b>Release 99</b>					
CCSA	CCSA-TSD-DS-24.022	350	Approved	01/07/2003	<a href="http://www.ccsa.org.cn/english/tc/files.php?docpath=/ITU-R/M.1457/M.1457-4/DS/">http://www.ccsa.org.cn/english/tc/files.php?docpath=/ITU-R/M.1457/M.1457-4/DS/</a>
ETSI	ETSI TS 124 022	3.5.0	Published	02/07/2003	<a href="http://pda.etsi.org/pda/home.asp?wkr=RTS/TSGN-0324022v350">http://pda.etsi.org/pda/home.asp?wkr=RTS/TSGN-0324022v350</a>
T1 (ATIS)	T1.3GPP.24.022V350-2004	3.5.0	Approved	21/05/2004	<a href="https://www.atis.org/atis/docstore/search.asp?committee=s24">https://www.atis.org/atis/docstore/search.asp?committee=s24</a>
TTA	TTAT.3G-24.022(R99-3.5.0)	3.5.0	Approved	25/05/2004	<a href="http://www.tta.or.kr/standardDB/stnfile/TTAT.3G-24.022(R99-3.5.0).zip">http://www.tta.or.kr/standardDB/stnfile/TTAT.3G-24.022(R99-3.5.0).zip</a>
TTC	TS-3GA-24.022(R99)v3.5.0	1	Approved	01/08/2003	<a href="http://www.ttc.or.jp/imt/ts/ts24022r99v350.pdf">http://www.ttc.or.jp/imt/ts/ts24022r99v350.pdf</a>
<b>Release 4</b>					
CCSA	CCSA-TSD-DS-24.022	410	Approved	01/07/2003	<a href="http://www.ccsa.org.cn/english/tc/files.php?docpath=/ITU-R/M.1457/M.1457-4/DS/">http://www.ccsa.org.cn/english/tc/files.php?docpath=/ITU-R/M.1457/M.1457-4/DS/</a>
ETSI	ETSI TS 124 022	4.1.0	Published	02/07/2003	<a href="http://pda.etsi.org/pda/home.asp?wkr=RTS/TSGN-0324022v410">http://pda.etsi.org/pda/home.asp?wkr=RTS/TSGN-0324022v410</a>
T1 (ATIS)	T1.3GPP.24.022V410-2004	4.1.0	Approved	21/05/2004	<a href="https://www.atis.org/atis/docstore/search.asp?committee=s24">https://www.atis.org/atis/docstore/search.asp?committee=s24</a>
TTA	TTAT.3G-24.022(R4-4.1.0)	4.1.0	Approved	25/05/2004	<a href="http://www.tta.or.kr/standardDB/stnfile/TTAT.3G-24.022(R4-4.1.0).zip">http://www.tta.or.kr/standardDB/stnfile/TTAT.3G-24.022(R4-4.1.0).zip</a>
TTC	TS-3GA-24.022(Rel4)v4.1.0	1	Approved	01/08/2003	<a href="http://www.ttc.or.jp/imt/ts/ts24022rel4v410.pdf">http://www.ttc.or.jp/imt/ts/ts24022rel4v410.pdf</a>
<b>Release 5</b>					
CCSA	CCSA-TSD-DS-24.022	530	Approved	01/07/2003	<a href="http://www.ccsa.org.cn/english/tc/files.php?docpath=/ITU-R/M.1457/M.1457-4/DS/">http://www.ccsa.org.cn/english/tc/files.php?docpath=/ITU-R/M.1457/M.1457-4/DS/</a>
ETSI	ETSI TS 124 022	5.5.0	Published	19/01/2004	<a href="http://pda.etsi.org/pda/home.asp?wkr=RTS/TSGN-0324022v550">http://pda.etsi.org/pda/home.asp?wkr=RTS/TSGN-0324022v550</a>
T1 (ATIS)	T1.3GPP.24.022V550-2004	5.5.0	Approved	21/05/2004	<a href="https://www.atis.org/atis/docstore/search.asp?committee=s24">https://www.atis.org/atis/docstore/search.asp?committee=s24</a>
TTA	TTAT.3G-24.022(R5-5.5.0)	5.5.0	Approved	25/05/2004	<a href="http://www.tta.or.kr/standardDB/stnfile/TTAT.3G-24.022(R5-5.5.0).zip">http://www.tta.or.kr/standardDB/stnfile/TTAT.3G-24.022(R5-5.5.0).zip</a>
TTC	TS-3GA-24.022(Rel5)v5.5.0	1	Approved	01/11/2003	<a href="http://www.ttc.or.jp/imt/ts/ts24022rel5v550.pdf">http://www.ttc.or.jp/imt/ts/ts24022rel5v550.pdf</a>

### 5.1.2.6.9 24.010

#### Mobile radio interface Layer 3 - supplementary services specification - general aspects

This specification describes the general aspects of the specification of supplementary services at the Layer 3 radio interface. Details will be specified in other documents.

SDO (2)	Document No.	Version	Status	Issued date	Location (1)
<b>Release 99</b>					
CCSA	CCSA-TSD-DS-24.010	320	Approved	01/07/2003	<a href="http://www.ccsa.org.cn/english/tc/files.php?docpath=/ITU-R/M.1457/M.1457-4/DS/">http://www.ccsa.org.cn/english/tc/files.php?docpath=/ITU-R/M.1457/M.1457-4/DS/</a>
ETSI	ETSI TS 124 010	3.2.0	Published	15/01/2002	<a href="http://pda.etsi.org/pda/home.asp?wkr=RTS/TSGN-0424010UR2">http://pda.etsi.org/pda/home.asp?wkr=RTS/TSGN-0424010UR2</a>
T1 (ATIS)	T1.3GPP.24.010V320-2002	3.2.0	Approved	03/05/2002	<a href="https://www.atis.org/atis/docstore/search.asp?committee=S24">https://www.atis.org/atis/docstore/search.asp?committee=S24</a>
TTA	TTAE.3G-24.010(R99-3.2.0)	3.2.0	Approved	29/05/2002	<a href="http://www.tta.or.kr/standardDB/stnfile/TTAE.3G-24.010(R99-3.2.0).zip">http://www.tta.or.kr/standardDB/stnfile/TTAE.3G-24.010(R99-3.2.0).zip</a>
TTC	TS-3GA-24.010(R99)v3.2.0	1	Approved	01/02/2002	<a href="http://www.ttc.or.jp/imt/ts/ts24010r99.pdf">http://www.ttc.or.jp/imt/ts/ts24010r99.pdf</a>
<b>Release 4</b>					
CCSA	CCSA-TSD-DS-24.010	420	Approved	01/07/2003	<a href="http://www.ccsa.org.cn/english/tc/files.php?docpath=/ITU-R/M.1457/M.1457-4/DS/">http://www.ccsa.org.cn/english/tc/files.php?docpath=/ITU-R/M.1457/M.1457-4/DS/</a>
ETSI	ETSI TS 124 010	4.2.0	Published	15/01/2002	<a href="http://pda.etsi.org/pda/home.asp?wkr=RTS/TSGN-0424010Uv4R2">http://pda.etsi.org/pda/home.asp?wkr=RTS/TSGN-0424010Uv4R2</a>
T1 (ATIS)	T1.3GPP.24.010V420-2002	4.2.0	Approved	03/05/2002	<a href="https://www.atis.org/atis/docstore/search.asp?committee=S24">https://www.atis.org/atis/docstore/search.asp?committee=S24</a>
TTA	TTAE.3G-24.010(R4-4.2.0)	4.2.0	Approved	29/05/2002	<a href="http://www.tta.or.kr/standardDB/stnfile/TTAE.3G-24.010(R4-4.2.0).zip">http://www.tta.or.kr/standardDB/stnfile/TTAE.3G-24.010(R4-4.2.0).zip</a>
TTC	TS-3GA-24.010(Rel4)v4.2.0	1	Approved	01/02/2002	<a href="http://www.ttc.or.jp/imt/ts/ts24010rel4.pdf">http://www.ttc.or.jp/imt/ts/ts24010rel4.pdf</a>

**Release 5**

CCSA	CCSA-TSD-DS-24.010	500	Approved	01/07/2003	<a href="http://www.ccsa.org.cn/english/tc/files.php?docpath=/ITU-R/M.1457/M.1457-4/DS/">http://www.ccsa.org.cn/english/tc/files.php?docpath=/ITU-R/M.1457/M.1457-4/DS/</a>
ETSI	ETSI TS 124 010	5.0.0	Published	02/07/2002	<a href="http://pda.etsi.org/pda/home.asp?wkr=RTS/TSGN-0424010v500">http://pda.etsi.org/pda/home.asp?wkr=RTS/TSGN-0424010v500</a>
T1 (ATIS)	T1.3GPP.24.010V500-2003	5.0.0	Approved	27/03/2003	<a href="https://www.atis.org/atis/docstore/search.asp?committee=S24">https://www.atis.org/atis/docstore/search.asp?committee=S24</a>
TTA	TTAT.3G-24.010(R5-5.0.0)	5.0.0	Approved	21/03/2003	<a href="http://www.tta.or.kr/standardDB/stnfile/TTAT.3G-24.010(R5-5.0.0).zip">http://www.tta.or.kr/standardDB/stnfile/TTAT.3G-24.010(R5-5.0.0).zip</a>
TTC	TS-3GA-24.010(Rel5)v5.0.0	1	Approved	01/08/2002	<a href="http://www.ttc.or.jp/imt/ts/24010rel5v500.pdf">http://www.ttc.or.jp/imt/ts/24010rel5v500.pdf</a>

**5.1.2.6.10 24.080****Mobile radio interface Layer 3 - supplementary services specification - formats and coding**

This specification describes the coding of information necessary for support of supplementary service operation on the mobile radio interface L3. Details will be specified in other documents.

SDO (2)	Document No.	Version	Status	Issued date	Location (1)
<b>Release 99</b>					
CCSA	CCSA-TSD-DS-24.080	370	Approved	01/07/2003	<a href="http://www.ccsa.org.cn/english/tc/files.php?docpath=/ITU-R/M.1457/M.1457-4/DS/">http://www.ccsa.org.cn/english/tc/files.php?docpath=/ITU-R/M.1457/M.1457-4/DS/</a>
ETSI	ETSI TS 124 080	3.7.1	Published	14/10/2003	<a href="http://pda.etsi.org/pda/home.asp?wkr=RTS/TSGN-0424080v371">http://pda.etsi.org/pda/home.asp?wkr=RTS/TSGN-0424080v371</a>
T1 (ATIS)	T1.3GPP.24.080V371-2004	3.7.1	Approved	21/05/2004	<a href="https://www.atis.org/atis/docstore/search.asp?committee=S24">https://www.atis.org/atis/docstore/search.asp?committee=S24</a>
TTA	TTAT.3G-24.080(R99-3.7.1)	3.7.1	Approved	25/05/2004	<a href="http://www.tta.or.kr/standardDB/stnfile/TTAT.3G-24.080(R99-3.7.1).zip">http://www.tta.or.kr/standardDB/stnfile/TTAT.3G-24.080(R99-3.7.1).zip</a>
TTC	TS-3GA-24.080(R99)v3.7.0	1	Approved	01/08/2002	<a href="http://www.ttc.or.jp/imt/ts/24080r99v370.pdf">http://www.ttc.or.jp/imt/ts/24080r99v370.pdf</a>
<b>Release 4</b>					
CCSA	CCSA-TSD-DS-24.080	430	Approved	01/07/2003	<a href="http://www.ccsa.org.cn/english/tc/files.php?docpath=/ITU-R/M.1457/M.1457-4/DS/">http://www.ccsa.org.cn/english/tc/files.php?docpath=/ITU-R/M.1457/M.1457-4/DS/</a>
ETSI	ETSI TS 124 080	4.3.1	Published	14/10/2003	<a href="http://pda.etsi.org/pda/home.asp?wkr=RTS/TSGN-0424080v431">http://pda.etsi.org/pda/home.asp?wkr=RTS/TSGN-0424080v431</a>
T1 (ATIS)	T1.3GPP.24.080V431-2004	4.3.1	Approved	21/05/2004	<a href="https://www.atis.org/atis/docstore/search.asp?committee=S24">https://www.atis.org/atis/docstore/search.asp?committee=S24</a>
TTA	TTAT.3G-24.080(R4-4.3.1)	4.3.1	Approved	25/05/2004	<a href="http://www.tta.or.kr/standardDB/stnfile/TTAT.3G-24.080(R4-4.3.1).zip">http://www.tta.or.kr/standardDB/stnfile/TTAT.3G-24.080(R4-4.3.1).zip</a>
TTC	TS-3GA-24.080(Rel4)v4.3.0	1	Approved	01/08/2002	<a href="http://www.ttc.or.jp/imt/ts/24080rel4v430.pdf">http://www.ttc.or.jp/imt/ts/24080rel4v430.pdf</a>
<b>Release 5</b>					
CCSA	CCSA-TSD-DS-24.080	530	Approved	01/07/2003	<a href="http://www.ccsa.org.cn/english/tc/files.php?docpath=/ITU-R/M.1457/M.1457-4/DS/">http://www.ccsa.org.cn/english/tc/files.php?docpath=/ITU-R/M.1457/M.1457-4/DS/</a>
ETSI	ETSI TS 124 080	5.4.0	Published	14/10/2003	<a href="http://pda.etsi.org/pda/home.asp?wkr=RTS/TSGN-0424080v540">http://pda.etsi.org/pda/home.asp?wkr=RTS/TSGN-0424080v540</a>
T1 (ATIS)	T1.3GPP.24.080V540-2004	5.4.0	Approved	21/05/2004	<a href="https://www.atis.org/atis/docstore/search.asp?committee=S24">https://www.atis.org/atis/docstore/search.asp?committee=S24</a>
TTA	TTAT.3G-24.080(R5-5.4.0)	5.4.0	Approved	25/05/2004	<a href="http://www.tta.or.kr/standardDB/stnfile/TTAT.3G-24.080(R5-5.4.0).zip">http://www.tta.or.kr/standardDB/stnfile/TTAT.3G-24.080(R5-5.4.0).zip</a>
TTC	TS-3GA-24.080(Rel5)v5.4.0	1	Approved	01/11/2003	<a href="http://www.ttc.or.jp/imt/ts/24080rel5v540.pdf">http://www.ttc.or.jp/imt/ts/24080rel5v540.pdf</a>
<b>Release 6</b>					
T1 (ATIS)	T1.3GPP.24.080V600-2004	6.0.0	Approved	21/05/2004	<a href="https://www.atis.org/atis/docstore/search.asp?committee=S24">https://www.atis.org/atis/docstore/search.asp?committee=S24</a>
TTA	TTAT.3G-24.080(R6-6.0.0)	6.0.0	Approved	25/05/2004	<a href="http://www.tta.or.kr/standardDB/stnfile/TTAT.3G-24.080(R6-6.0.0).zip">http://www.tta.or.kr/standardDB/stnfile/TTAT.3G-24.080(R6-6.0.0).zip</a>
TTC	TS-3GA-24.080(Rel6)v6.0.0	1	Approved	01/02/2004	<a href="http://www.ttc.or.jp/imt/ts/24080rel6v600.pdf">http://www.ttc.or.jp/imt/ts/24080rel6v600.pdf</a>

**5.1.2.7****Terminal aspects****5.1.2.7.1 21.111****USIM and IC card requirements**

This specification describes the requirements of the USIM and the USIM IC card (UICC). These are derived from the service and security requirements defined in the respective specifications. The document is the basis for the detailed specification of the USIM and the UICC, and the interface to the terminal.

<b>SDO (2)</b>	<b>Document No.</b>	<b>Version</b>	<b>Status</b>	<b>Issued date</b>	<b>Location (1)</b>
<b>Release 99</b>					
ARIB	ARIB STD-T63-21.111	3.4.0	Approved	25/05/2004	<a href="http://www.arib.or.jp/IMT-2000/ARIB-STD/ITU-R/R99/A21111-340.pdf">http://www.arib.or.jp/IMT-2000/ARIB-STD/ITU-R/R99/A21111-340.pdf</a>
CCSA	CCSA-TSD-DS-21.111	340	Approved	01/07/2003	<a href="http://www.ccsa.org.cn/english/tc/files.php?docpath=/ITU-R/M.1457/M.1457-4/DS/">http://www.ccsa.org.cn/english/tc/files.php?docpath=/ITU-R/M.1457/M.1457-4/DS/</a>
ETSI	ETSI TS 121 111	3.4.0	Published	02/10/2002	<a href="http://pda.etsi.org/pda/home.asp?wkr=RTS/TSGT-0321111v340">http://pda.etsi.org/pda/home.asp?wkr=RTS/TSGT-0321111v340</a>
T1 (ATIS)	T1.3GPP.21.111V340-2003	3.4.0	Approved	27/03/2003	<a href="https://www.atis.org/atis/docstore/search.asp?committee=S24">https://www.atis.org/atis/docstore/search.asp?committee=S24</a>
TTA	TTAT.3G-21.111(R99-3.4.0)	3.4.0	Approved	21/03/2003	<a href="http://www.tta.or.kr/standardDB/stnfile/TTAT.3G-21.111(R99-3.4.0).zip">http://www.tta.or.kr/standardDB/stnfile/TTAT.3G-21.111(R99-3.4.0).zip</a>
<b>Release 4</b>					
ARIB	ARIB STD-T63-21.111	4.1.0	Approved	25/05/2004	<a href="http://www.arib.or.jp/IMT-2000/ARIB-STD/ITU-R/Rel4/A21111-410.pdf">http://www.arib.or.jp/IMT-2000/ARIB-STD/ITU-R/Rel4/A21111-410.pdf</a>
CCSA	CCSA-TSD-DS-21.111	410	Approved	01/07/2003	<a href="http://www.ccsa.org.cn/english/tc/files.php?docpath=/ITU-R/M.1457/M.1457-4/DS/">http://www.ccsa.org.cn/english/tc/files.php?docpath=/ITU-R/M.1457/M.1457-4/DS/</a>
ETSI	ETSI TS 121 111	4.1.0	Published	02/10/2002	<a href="http://pda.etsi.org/pda/home.asp?wkr=RTS/TSGT-0321111v410">http://pda.etsi.org/pda/home.asp?wkr=RTS/TSGT-0321111v410</a>
T1 (ATIS)	T1.3GPP.21.111V410-2003	4.1.0	Approved	27/03/2003	<a href="https://www.atis.org/atis/docstore/search.asp?committee=S24">https://www.atis.org/atis/docstore/search.asp?committee=S24</a>
TTA	TTAT.3G-21.111(R4-4.1.0)	4.1.0	Approved	21/03/2003	<a href="http://www.tta.or.kr/standardDB/stnfile/TTAT.3G-21.111(R4-4.1.0).zip">http://www.tta.or.kr/standardDB/stnfile/TTAT.3G-21.111(R4-4.1.0).zip</a>
<b>Release 5</b>					
ARIB	ARIB STD-T63-21.111	5.1.0	Approved	25/05/2004	<a href="http://www.arib.or.jp/IMT-2000/ARIB-STD/ITU-R/Rel5/A21111-510.pdf">http://www.arib.or.jp/IMT-2000/ARIB-STD/ITU-R/Rel5/A21111-510.pdf</a>
CCSA	CCSA-TSD-DS-21.111	510	Approved	01/07/2003	<a href="http://www.ccsa.org.cn/english/tc/files.php?docpath=/ITU-R/M.1457/M.1457-4/DS/">http://www.ccsa.org.cn/english/tc/files.php?docpath=/ITU-R/M.1457/M.1457-4/DS/</a>
ETSI	ETSI TS 121 111	5.1.0	Published	02/10/2002	<a href="http://pda.etsi.org/pda/home.asp?wkr=RTS/TSGT-0321111v510">http://pda.etsi.org/pda/home.asp?wkr=RTS/TSGT-0321111v510</a>
T1 (ATIS)	T1.3GPP.21.111V510-2003	5.1.0	Approved	27/03/2003	<a href="https://www.atis.org/atis/docstore/search.asp?committee=S24">https://www.atis.org/atis/docstore/search.asp?committee=S24</a>
TTA	TTAT.3G-21.111(R5-5.1.0)	5.1.0	Approved	21/03/2003	<a href="http://www.tta.or.kr/standardDB/stnfile/TTAT.3G-21.111(R5-5.1.0).zip">http://www.tta.or.kr/standardDB/stnfile/TTAT.3G-21.111(R5-5.1.0).zip</a>
<b>Release 6</b>					
T1 (ATIS)	T1.3GPP.21.111V600-2004	6.0.0	Approved	21/05/2004	<a href="https://www.atis.org/atis/docstore/search.asp?committee=S24">https://www.atis.org/atis/docstore/search.asp?committee=S24</a>

**5.1.2.7.2 22.112****USAT-Interpreter - Stage 1**

This document specifies a system to make Mobile Operator services, based on USAT functionality and USIM based security functionality, available to an internet environment. This is achieved by specifying the necessary components and protocols for a secure narrow band channel between the internet application and an USAT Interpreter on the USIM.



SDO (2)	Document No.	Version	Status	Issued date	Location (1)
<b>Release 5</b>					
ARIB	ARIB STD-T63-22.112	5.0.0	Approved	25/05/2004	<a href="http://www.arib.or.jp/IMT-2000/ARIB-STD/ITU-R/Rel5/A22112-500.pdf">http://www.arib.or.jp/IMT-2000/ARIB-STD/ITU-R/Rel5/A22112-500.pdf</a>
CCSA	CCSA-TSD-DS-21.112	500	Approved	01/07/2003	<a href="http://www.ccsa.org.cn/english/tc/files.php?docpath=/ITU-R/M.1457/M.1457-4/DS/">http://www.ccsa.org.cn/english/tc/files.php?docpath=/ITU-R/M.1457/M.1457-4/DS/</a>
ETSI	ETSI TS 122 112	5.0.0	Published	05/08/2002	<a href="http://pda.etsi.org/pda/home.asp?wkr=RTS/TSGT-0322112v500">http://pda.etsi.org/pda/home.asp?wkr=RTS/TSGT-0322112v500</a>
T1 (ATIS)	T1.3GPP.22.112V500-2004	5.0.0	Approved	21/05/2004	<a href="https://www.atis.org/atis/docstore/search.asp?committee=S24">https://www.atis.org/atis/docstore/search.asp?committee=S24</a>
TTA	TTAT.3G-22.112(R5-5.0.0)	5.0.0	Approved	28/05/2003	<a href="http://www.tta.or.kr/standardDB/stnfile/TTAT.3G-22.112(R5-5.0.0).zip">http://www.tta.or.kr/standardDB/stnfile/TTAT.3G-22.112(R5-5.0.0).zip</a>

### 5.1.2.7.3 31.101

#### UICC-Terminal Interface; Physical and Logical Characteristics

This document specifies the interface between the UICC and the Terminal for 3G telecom network operation. This includes the requirements for the physical characteristics of the UICC, the electrical interface between the UICC and the Terminal, the initial communication establishment and the transport protocols, the communication commands and the procedures and the application independent files and protocols.

SDO (2)	Document No.	Version	Status	Issued date	Location (1)
<b>Release 99</b>					
ARIB	ARIB STD-T63-31.101	3.3.0	Approved	25/05/2004	<a href="http://www.arib.or.jp/IMT-2000/ARIB-STD/ITU-R/R99/A31101-330.pdf">http://www.arib.or.jp/IMT-2000/ARIB-STD/ITU-R/R99/A31101-330.pdf</a>
CCSA	CCSA-TSD-DS-31.101	330	Approved	01/07/2003	<a href="http://www.ccsa.org.cn/english/tc/files.php?docpath=/ITU-R/M.1457/M.1457-4/DS/">http://www.ccsa.org.cn/english/tc/files.php?docpath=/ITU-R/M.1457/M.1457-4/DS/</a>
ETSI	ETSI TS 131 101	3.3.0	Published	07/11/2000	<a href="http://pda.etsi.org/pda/home.asp?wkr=RTS/TSGT-0331101UR3">http://pda.etsi.org/pda/home.asp?wkr=RTS/TSGT-0331101UR3</a>
T1 (ATIS)	T1.3GPP.31.101V330-2002	3.3.0	Approved	03/05/2002	<a href="https://www.atis.org/atis/docstore/search.asp?committee=S24">https://www.atis.org/atis/docstore/search.asp?committee=S24</a>
TTA	TTAE.3G-31.101(R99-3.3.0)	3.3.0	Approved	29/05/2002	<a href="http://www.tta.or.kr/standardDB/stnfile/TTAE.3G-31.101(R99-3.3.0).zip">http://www.tta.or.kr/standardDB/stnfile/TTAE.3G-31.101(R99-3.3.0).zip</a>
<b>Release 4</b>					
ARIB	ARIB STD-T63-31.101	4.1.0	Approved	25/05/2004	<a href="http://www.arib.or.jp/IMT-2000/ARIB-STD/ITU-R/Rel4/A31101-410.pdf">http://www.arib.or.jp/IMT-2000/ARIB-STD/ITU-R/Rel4/A31101-410.pdf</a>
CCSA	CCSA-TSD-DS-31.101	410	Approved	01/07/2003	<a href="http://www.ccsa.org.cn/english/tc/files.php?docpath=/ITU-R/M.1457/M.1457-4/DS/">http://www.ccsa.org.cn/english/tc/files.php?docpath=/ITU-R/M.1457/M.1457-4/DS/</a>
ETSI	ETSI TS 131 101	4.1.0	Published	08/01/2003	<a href="http://pda.etsi.org/pda/home.asp?wkr=RTS/TSGT-0331101v410">http://pda.etsi.org/pda/home.asp?wkr=RTS/TSGT-0331101v410</a>
T1 (ATIS)	T1.3GPP.31.101V410-2003	4.1.0	Approved	27/03/2003	<a href="https://www.atis.org/atis/docstore/search.asp?committee=S24">https://www.atis.org/atis/docstore/search.asp?committee=S24</a>
TTA	TTAT.3G-31.101(R4-4.1.0)	4.1.0	Approved	21/03/2003	<a href="http://www.tta.or.kr/standardDB/stnfile/TTAT.3G-31.101(R4-4.1.0).zip">http://www.tta.or.kr/standardDB/stnfile/TTAT.3G-31.101(R4-4.1.0).zip</a>
<b>Release 5</b>					
ARIB	ARIB STD-T63-31.101	5.1.0	Approved	25/05/2004	<a href="http://www.arib.or.jp/IMT-2000/ARIB-STD/ITU-R/Rel5/A31101-510.pdf">http://www.arib.or.jp/IMT-2000/ARIB-STD/ITU-R/Rel5/A31101-510.pdf</a>
CCSA	CCSA-TSD-DS-31.101	510	Approved	01/07/2003	<a href="http://www.ccsa.org.cn/english/tc/files.php?docpath=/ITU-R/M.1457/M.1457-4/DS/">http://www.ccsa.org.cn/english/tc/files.php?docpath=/ITU-R/M.1457/M.1457-4/DS/</a>
ETSI	ETSI TS 131 101	5.1.0	Published	08/01/2003	<a href="http://pda.etsi.org/pda/home.asp?wkr=RTS/TSGT-0331101v510">http://pda.etsi.org/pda/home.asp?wkr=RTS/TSGT-0331101v510</a>
T1 (ATIS)	T1.3GPP.31.101V510-2003	5.1.0	Approved	27/03/2003	<a href="https://www.atis.org/atis/docstore/search.asp?committee=S24">https://www.atis.org/atis/docstore/search.asp?committee=S24</a>
TTA	TTAT.3G-31.101(R5-5.1.0)	5.1.0	Approved	21/03/2003	<a href="http://www.tta.or.kr/standardDB/stnfile/TTAT.3G-31.101(R5-5.1.0).zip">http://www.tta.or.kr/standardDB/stnfile/TTAT.3G-31.101(R5-5.1.0).zip</a>
<b>Release 6</b>					
ARIB	ARIB STD-T63-31.101	6.2.0	Approved	25/05/2004	<a href="http://www.arib.or.jp/IMT-2000/ARIB-STD/ITU-R/Rel6/A31101-620.pdf">http://www.arib.or.jp/IMT-2000/ARIB-STD/ITU-R/Rel6/A31101-620.pdf</a>
CCSA	CCSA-TSD-DS-31.101	620	Approved	01/07/2003	<a href="http://www.ccsa.org.cn/english/tc/files.php?docpath=/ITU-R/M.1457/M.1457-4/DS/">http://www.ccsa.org.cn/english/tc/files.php?docpath=/ITU-R/M.1457/M.1457-4/DS/</a>
T1 (ATIS)	T1.3GPP.31.101V620-2004	6.2.0	Approved	21/05/2004	<a href="https://www.atis.org/atis/docstore/search.asp?committee=S24">https://www.atis.org/atis/docstore/search.asp?committee=S24</a>
TTA	TTAT.3G-31.101(R6-6.2.0)	6.2.0	Approved	25/05/2004	<a href="http://www.tta.or.kr/standardDB/stnfile/TTAT.3G-31.101(R6-6.2.0).zip">http://www.tta.or.kr/standardDB/stnfile/TTAT.3G-31.101(R6-6.2.0).zip</a>



**5.1.2.7.4** 31.102**Characteristics of the USIM Application**

This document defines the USIM application for 3G telecom network operation. The present document specifies, command parameters, file structures and content, security functions and the application protocol to be used on the interface between UICC (USIM) and ME.

SDO (2)	Document No.	Version	Status	Issued date	Location (1)
<b>Release 99</b>					
ARIB	ARIB STD-T63-31.102	3.15.0	Approved	25/05/2004	<a href="http://www.arib.or.jp/IMT-2000/ARIB-STD/ITU-R/R99/A31102-3e0.pdf">http://www.arib.or.jp/IMT-2000/ARIB-STD/ITU-R/R99/A31102-3e0.pdf</a>
CCSA	CCSA-TSD-DS-31.102	3D0	Approved	01/07/2003	<a href="http://www.ccsa.org.cn/english/tc/files.php?docpath=/ITU-R/M.1457/M.1457-4/DS/">http://www.ccsa.org.cn/english/tc/files.php?docpath=/ITU-R/M.1457/M.1457-4/DS/</a>
ETSI	ETSI TS 131 102	3.15.0	Published	19/01/2004	<a href="http://pda.etsi.org/pda/home.asp?wkr=RTS/TSGT-0331102v3f0">http://pda.etsi.org/pda/home.asp?wkr=RTS/TSGT-0331102v3f0</a>
T1 (ATIS)	T1.3GPP.31.102V3150-2004	3.15.0	Approved	21/05/2004	<a href="https://www.atis.org/atis/docstore/search.asp?committee=S24">https://www.atis.org/atis/docstore/search.asp?committee=S24</a>
TTA	TTAT.3G-31.102(R99-3.15.0)	3.15.0	Approved	25/05/2004	<a href="http://www.tta.or.kr/standardDB/stnfile/TTAT.3G-31.102(R99-3.15.0).zip">http://www.tta.or.kr/standardDB/stnfile/TTAT.3G-31.102(R99-3.15.0).zip</a>
<b>Release 4</b>					
ARIB	ARIB STD-T63-31.102	4.11.0	Approved	25/05/2004	<a href="http://www.arib.or.jp/IMT-2000/ARIB-STD/ITU-R/Rel4/A31102-4b0.pdf">http://www.arib.or.jp/IMT-2000/ARIB-STD/ITU-R/Rel4/A31102-4b0.pdf</a>
CCSA	CCSA-TSD-DS-31.102	490	Approved	01/07/2003	<a href="http://www.ccsa.org.cn/english/tc/files.php?docpath=/ITU-R/M.1457/M.1457-4/DS/">http://www.ccsa.org.cn/english/tc/files.php?docpath=/ITU-R/M.1457/M.1457-4/DS/</a>
ETSI	ETSI TS 131 102	4.11.0	Published	19/01/2004	<a href="http://pda.etsi.org/pda/home.asp?wkr=RTS/TSGT-0331102v4b0">http://pda.etsi.org/pda/home.asp?wkr=RTS/TSGT-0331102v4b0</a>
T1 (ATIS)	T1.3GPP.31.102V4110-2004	4.11.0	Approved	21/05/2004	<a href="https://www.atis.org/atis/docstore/search.asp?committee=S24">https://www.atis.org/atis/docstore/search.asp?committee=S24</a>
TTA	TTAT.3G-31.102(R4-4.11.0)	4.11.0	Approved	25/05/2004	<a href="http://www.tta.or.kr/standardDB/stnfile/TTAT.3G-31.102(R4-4.11.0).zip">http://www.tta.or.kr/standardDB/stnfile/TTAT.3G-31.102(R4-4.11.0).zip</a>
<b>Release 5</b>					
ARIB	ARIB STD-T63-31.102	5.7.0	Approved	25/05/2004	<a href="http://www.arib.or.jp/IMT-2000/ARIB-STD/ITU-R/Rel5/A31102-570.pdf">http://www.arib.or.jp/IMT-2000/ARIB-STD/ITU-R/Rel5/A31102-570.pdf</a>
CCSA	CCSA-TSD-DS-31.102	550	Approved	01/07/2003	<a href="http://www.ccsa.org.cn/english/tc/files.php?docpath=/ITU-R/M.1457/M.1457-4/DS/">http://www.ccsa.org.cn/english/tc/files.php?docpath=/ITU-R/M.1457/M.1457-4/DS/</a>
ETSI	ETSI TS 131 102	5.7.0	Published	19/01/2004	<a href="http://pda.etsi.org/pda/home.asp?wkr=RTS/TSGT-0331102v570">http://pda.etsi.org/pda/home.asp?wkr=RTS/TSGT-0331102v570</a>
T1 (ATIS)	T1.3GPP.31.102V570-2004	5.7.0	Approved	21/05/2004	<a href="https://www.atis.org/atis/docstore/search.asp?committee=S24">https://www.atis.org/atis/docstore/search.asp?committee=S24</a>
TTA	TTAT.3G-31.102(R5-5.7.0)	5.7.0	Approved	25/05/2004	<a href="http://www.tta.or.kr/standardDB/stnfile/TTAT.3G-31.102(R5-5.7.0).zip">http://www.tta.or.kr/standardDB/stnfile/TTAT.3G-31.102(R5-5.7.0).zip</a>
<b>Release 6</b>					
ARIB	ARIB STD-T63-31.102	6.4.0	Approved	25/05/2004	<a href="http://www.arib.or.jp/IMT-2000/ARIB-STD/ITU-R/Rel6/A31102-640.pdf">http://www.arib.or.jp/IMT-2000/ARIB-STD/ITU-R/Rel6/A31102-640.pdf</a>
CCSA	CCSA-TSD-DS-31.102	620	Approved	01/07/2003	<a href="http://www.ccsa.org.cn/english/tc/files.php?docpath=/ITU-R/M.1457/M.1457-4/DS/">http://www.ccsa.org.cn/english/tc/files.php?docpath=/ITU-R/M.1457/M.1457-4/DS/</a>
ETSI	ETSI TS 131 102	6.4.0	Awaiting		<a href="http://pda.etsi.org/pda/home.asp?wkr=RTS/TSGT-0331102v640">http://pda.etsi.org/pda/home.asp?wkr=RTS/TSGT-0331102v640</a>
T1 (ATIS)	T1.3GPP.31.102V640-2004	6.4.0	Approved	21/05/2004	<a href="https://www.atis.org/atis/docstore/search.asp?committee=S24">https://www.atis.org/atis/docstore/search.asp?committee=S24</a>
TTA	TTAT.3G-31.102(R6-6.4.0)	6.4.0	Approved	25/05/2004	<a href="http://www.tta.or.kr/standardDB/stnfile/TTAT.3G-31.102(R6-6.4.0).zip">http://www.tta.or.kr/standardDB/stnfile/TTAT.3G-31.102(R6-6.4.0).zip</a>

**5.1.2.7.5** 31.103**Characteristics of the ISIM Application**

This document defines the ISIM application for 3G telecom network operation. The present document specifies, command parameters, file structures and content, security functions and the application protocol to be used on the interface between UICC (ISIM) and ME.

SDO (2)	Document No.	Version	Status	Issued date	Location (1)
<b>Release 5</b>					
ARIB	ARIB STD-T63-31.103	5.5.0	Approved	25/05/2004	<a href="http://www.arib.or.jp/IMT-2000/ARIB-STD/ITU-R/Rel5/A31103-550.pdf">http://www.arib.or.jp/IMT-2000/ARIB-STD/ITU-R/Rel5/A31103-550.pdf</a>
CCSA	CCSA-TSD-DS-31.103	540	Approved	01/07/2003	<a href="http://www.ccsa.org.cn/english/tc/files.php?docpath=/ITU-R/M.1457/M.1457-4/DS/">http://www.ccsa.org.cn/english/tc/files.php?docpath=/ITU-R/M.1457/M.1457-4/DS/</a>
ETSI	ETSI TS 131 103	5.5.0	Published	19/01/2004	<a href="http://pda.etsi.org/pda/home.asp?wkr=RTS/TSGT-0331103v550">http://pda.etsi.org/pda/home.asp?wkr=RTS/TSGT-0331103v550</a>
T1 (ATIS)	T1.3GPP.31.103V550-2004	5.5.0	Approved	21/05/2004	<a href="https://www.atis.org/atis/docstore/search.asp?committee=S24">https://www.atis.org/atis/docstore/search.asp?committee=S24</a>
TTA	TTAT.3G-31.103(R5-5.5.0)	5.5.0	Approved	25/05/2004	<a href="http://www.tta.or.kr/standardDB/stnfile/TTAT.3G-31.103(R5-5.5.0).zip">http://www.tta.or.kr/standardDB/stnfile/TTAT.3G-31.103(R5-5.5.0).zip</a>
<b>Release 6</b>					
ARIB	ARIB STD-T63-31.103	6.2.0	Approved	25/05/2004	<a href="http://www.arib.or.jp/IMT-2000/ARIB-STD/ITU-R/Rel6/A31103-620.pdf">http://www.arib.or.jp/IMT-2000/ARIB-STD/ITU-R/Rel6/A31103-620.pdf</a>
T1 (ATIS)	T1.3GPP.31.103V620-2004	6.2.0	Approved	21/05/2004	<a href="https://www.atis.org/atis/docstore/search.asp?committee=S24">https://www.atis.org/atis/docstore/search.asp?committee=S24</a>
TTA	TTAT.3G-31.103(R6-6.2.0)	6.2.0	Approved	25/05/2004	<a href="http://www.tta.or.kr/standardDB/stnfile/TTAT.3G-31.103(R6-6.2.0).zip">http://www.tta.or.kr/standardDB/stnfile/TTAT.3G-31.103(R6-6.2.0).zip</a>

### 5.1.2.7.6 31.110

#### Numbering system for telecommunication IC card applications

This document describes the numbering system for Application IDentifiers (AID) for 3G telecommunication Integrated Circuits (IC) card applications. The numbering system provides a means for an application and related services offered by a provider to identify if a given card contains the elements required by its application and related services.

SDO (2)	Document No.	Version	Status	Issued date	Location (1)
<b>Release 99</b>					
ARIB	ARIB STD-T63-31.110	3.2.0	Approved	25/05/2004	<a href="http://www.arib.or.jp/IMT-2000/ARIB-STD/ITU-R/R99/A31110-320.pdf">http://www.arib.or.jp/IMT-2000/ARIB-STD/ITU-R/R99/A31110-320.pdf</a>
CCSA	CCSA-TSD-DS-31.110	320	Approved	01/07/2003	<a href="http://www.ccsa.org.cn/english/tc/files.php?docpath=/ITU-R/M.1457/M.1457-4/DS/">http://www.ccsa.org.cn/english/tc/files.php?docpath=/ITU-R/M.1457/M.1457-4/DS/</a>
ETSI	ETSI TS 131 110	3.2.0	Published	07/11/2000	<a href="http://pda.etsi.org/pda/home.asp?wkr=RTS/TSGT-0331110UR2">http://pda.etsi.org/pda/home.asp?wkr=RTS/TSGT-0331110UR2</a>
T1 (ATIS)	T1.3GPP.31.110V320-2002	3.2.0	Approved	03/05/2002	<a href="https://www.atis.org/atis/docstore/search.asp?committee=S24">https://www.atis.org/atis/docstore/search.asp?committee=S24</a>
TTA	TTAE.3G-31.110(R99)	3.2.0	Approved	19/12/2001	<a href="http://www.tta.or.kr/standardDB/stnfile/TTAE_3G-31_110_R99_.zip">http://www.tta.or.kr/standardDB/stnfile/TTAE_3G-31_110_R99_.zip</a>
<b>Release 4</b>					
ARIB	ARIB STD-T63-31.110	4.1.0	Approved	25/05/2004	<a href="http://www.arib.or.jp/IMT-2000/ARIB-STD/ITU-R/Rel4/A31110-410.pdf">http://www.arib.or.jp/IMT-2000/ARIB-STD/ITU-R/Rel4/A31110-410.pdf</a>
CCSA	CCSA-TSD-DS-31.110	410	Approved	01/07/2003	<a href="http://www.ccsa.org.cn/english/tc/files.php?docpath=/ITU-R/M.1457/M.1457-4/DS/">http://www.ccsa.org.cn/english/tc/files.php?docpath=/ITU-R/M.1457/M.1457-4/DS/</a>
ETSI	ETSI TS 131 110	4.1.0	Published	25/01/2002	<a href="http://pda.etsi.org/pda/home.asp?wkr=RTS/TSGT-0331110Uv4R1">http://pda.etsi.org/pda/home.asp?wkr=RTS/TSGT-0331110Uv4R1</a>
T1 (ATIS)	T1.3GPP.31.110V410-2002	4.1.0	Approved	03/05/2002	<a href="https://www.atis.org/atis/docstore/search.asp?committee=S24">https://www.atis.org/atis/docstore/search.asp?committee=S24</a>
TTA	TTAE.3G-31.110(R4-4.1.0)	4.1.0	Approved	29/05/2002	<a href="http://www.tta.or.kr/standardDB/stnfile/TTAE.3G-31.110(R4-4.1.0).zip">http://www.tta.or.kr/standardDB/stnfile/TTAE.3G-31.110(R4-4.1.0).zip</a>

### 5.1.2.7.7 31.111

#### USIM application toolkit (USAT)

This document defines the interface between the UICC and the Mobile Equipment (ME), and mandatory ME procedures, specifically for “USIM Application Toolkit”. USAT is a set of commands and procedures for use during the network operation phase of 3G, in addition to those defined in TS 31.101.

SDO (2)	Document No.	Version	Status	Issued date	Location (1)
<b>Release 99</b>					
ARIB	ARIB STD-T63-31.111	3.11.0	Approved	25/05/2004	<a href="http://www.arib.or.jp/IMT-2000/ARIB-STD/ITU-R/R99/A31111-3b0.pdf">http://www.arib.or.jp/IMT-2000/ARIB-STD/ITU-R/R99/A31111-3b0.pdf</a>
CCSA	CCSA-TSD-DS-31.111	3A0	Approved	01/07/2003	<a href="http://www.ccsa.org.cn/english/tc/files.php?docpath=/ITU-R/M.1457/M.1457-4/DS/">http://www.ccsa.org.cn/english/tc/files.php?docpath=/ITU-R/M.1457/M.1457-4/DS/</a>
ETSI	ETSI TS 131 111	3.11.0	Published	19/01/2004	<a href="http://pda.etsi.org/pda/home.asp?wkr=RTS/TSGT-0331111v3b0">http://pda.etsi.org/pda/home.asp?wkr=RTS/TSGT-0331111v3b0</a>
T1 (ATIS)	T1.3GPP.31.111V3110-2004	3.11.0	Approved	21/05/2004	<a href="https://www.atis.org/atis/docstore/search.asp?committee=S24">https://www.atis.org/atis/docstore/search.asp?committee=S24</a>
TTA	TTAT.3G-31.111(R99-3.11.0)	3.11.0	Approved	25/05/2004	<a href="http://www.tta.or.kr/standardDB/stnfile/TTAT.3G-31.111(R99-3.11.0).zip">http://www.tta.or.kr/standardDB/stnfile/TTAT.3G-31.111(R99-3.11.0).zip</a>
<b>Release 4</b>					
ARIB	ARIB STD-T63-31.111	4.11.0	Approved	25/05/2004	<a href="http://www.arib.or.jp/IMT-2000/ARIB-STD/ITU-R/Rel4/A31111-4b0.pdf">http://www.arib.or.jp/IMT-2000/ARIB-STD/ITU-R/Rel4/A31111-4b0.pdf</a>
CCSA	CCSA-TSD-DS-31.111	4A0	Approved	01/07/2003	<a href="http://www.ccsa.org.cn/english/tc/files.php?docpath=/ITU-R/M.1457/M.1457-4/DS/">http://www.ccsa.org.cn/english/tc/files.php?docpath=/ITU-R/M.1457/M.1457-4/DS/</a>
ETSI	ETSI TS 131 111	4.11.0	Published	01/10/2003	<a href="http://pda.etsi.org/pda/home.asp?wkr=RTS/TSGT-0331111v4b0">http://pda.etsi.org/pda/home.asp?wkr=RTS/TSGT-0331111v4b0</a>
T1 (ATIS)	T1.3GPP.31.111V4110-2004	4.11.0	Approved	21/05/2004	<a href="https://www.atis.org/atis/docstore/search.asp?committee=S24">https://www.atis.org/atis/docstore/search.asp?committee=S24</a>
TTA	TTAT.3G-31.111(R4-4.11.0)	4.11.0	Approved	25/05/2004	<a href="http://www.tta.or.kr/standardDB/stnfile/TTAT.3G-31.111(R4-4.11.0).zip">http://www.tta.or.kr/standardDB/stnfile/TTAT.3G-31.111(R4-4.11.0).zip</a>
<b>Release 5</b>					
ARIB	ARIB STD-T63-31.111	5.6.0	Approved	25/05/2004	<a href="http://www.arib.or.jp/IMT-2000/ARIB-STD/ITU-R/Rel5/A31111-560.pdf">http://www.arib.or.jp/IMT-2000/ARIB-STD/ITU-R/Rel5/A31111-560.pdf</a>
CCSA	CCSA-TSD-DS-31.111	540	Approved	01/07/2003	<a href="http://www.ccsa.org.cn/english/tc/files.php?docpath=/ITU-R/M.1457/M.1457-4/DS/">http://www.ccsa.org.cn/english/tc/files.php?docpath=/ITU-R/M.1457/M.1457-4/DS/</a>
ETSI	ETSI TS 131 111	5.6.0	Published	19/01/2004	<a href="http://pda.etsi.org/pda/home.asp?wkr=RTS/TSGT-0331111v560">http://pda.etsi.org/pda/home.asp?wkr=RTS/TSGT-0331111v560</a>
T1 (ATIS)	T1.3GPP.31.111V560-2004	5.6.0	Approved	21/05/2004	<a href="https://www.atis.org/atis/docstore/search.asp?committee=S24">https://www.atis.org/atis/docstore/search.asp?committee=S24</a>
TTA	TTAT.3G-31.111(R5-5.6.0)	5.6.0	Approved	25/05/2004	<a href="http://www.tta.or.kr/standardDB/stnfile/TTAT.3G-31.111(R5-5.6.0).zip">http://www.tta.or.kr/standardDB/stnfile/TTAT.3G-31.111(R5-5.6.0).zip</a>
<b>Release 6</b>					
ARIB	ARIB STD-T63-31.111	6.0.0	Approved	25/05/2004	<a href="http://www.arib.or.jp/IMT-2000/ARIB-STD/ITU-R/Rel6/A31111-600.pdf">http://www.arib.or.jp/IMT-2000/ARIB-STD/ITU-R/Rel6/A31111-600.pdf</a>
T1 (ATIS)	T1.3GPP.31.111V600-2004	6.0.0	Approved	21/05/2004	<a href="https://www.atis.org/atis/docstore/search.asp?committee=S24">https://www.atis.org/atis/docstore/search.asp?committee=S24</a>
TTA	TTAT.3G-31.111(R6-6.0.0)	6.0.0	Approved	25/05/2004	<a href="http://www.tta.or.kr/standardDB/stnfile/TTAT.3G-31.111(R6-6.0.0).zip">http://www.tta.or.kr/standardDB/stnfile/TTAT.3G-31.111(R6-6.0.0).zip</a>

**5.1.2.7.8 31.112**

**USIM Application Toolkit (USAT) interpreter architecture**

This document defines the overall architecture for the USAT Interpreter system including the role models, system architecture and information flow.

SDO (2)	Document No.	Version	Status	Issued date	Location (1)
<b>Release 5</b>					
ARIB	ARIB STD-T63-31.112	5.2.0	Approved	25/05/2004	<a href="http://www.arib.or.jp/IMT-2000/ARIB-STD/ITU-R/Rel5/A31112-520.pdf">http://www.arib.or.jp/IMT-2000/ARIB-STD/ITU-R/Rel5/A31112-520.pdf</a>
CCSA	CCSA-TSD-DS-31.112	520	Approved	01/07/2003	<a href="http://www.ccsa.org.cn/english/tc/files.php?docpath=/ITU-R/M.1457/M.1457-4/DS/">http://www.ccsa.org.cn/english/tc/files.php?docpath=/ITU-R/M.1457/M.1457-4/DS/</a>
ETSI	ETSI TS 131 112	5.2.0	Published	24/06/2002	<a href="http://pda.etsi.org/pda/home.asp?wkr=RTS/TSGT-0331112v520">http://pda.etsi.org/pda/home.asp?wkr=RTS/TSGT-0331112v520</a>
T1 (ATIS)	T1.3GPP.31.112V520-2003	5.2.0	Approved	27/03/2003	<a href="https://www.atis.org/atis/docstore/search.asp?committee=S24">https://www.atis.org/atis/docstore/search.asp?committee=S24</a>
TTA	TTAT.3G-31.112(R5-5.2.0)	5.2.0	Approved	21/03/2003	<a href="http://www.tta.or.kr/standardDB/stnfile/TTAT.3G-31.112(R5-5.2.0).zip">http://www.tta.or.kr/standardDB/stnfile/TTAT.3G-31.112(R5-5.2.0).zip</a>

**5.1.2.7.9** 31.113**USAT Interpreter Byte Codes**

This document specifies the byte codes that are recognised by an USAT Interpreter. The primary purpose of the byte codes is to provide efficient programmatic access to the SIM Application Toolkit commands.

SDO (2)	Document No.	Version	Status	Issued date	Location (1)
<b>Release 5</b>					
ARIB	ARIB STD-T63-31.113	5.5.0	Approved	25/05/2004	<a href="http://www.arib.or.jp/IMT-2000/ARIB-STD/ITU-R/Rel5/A31113-550.pdf">http://www.arib.or.jp/IMT-2000/ARIB-STD/ITU-R/Rel5/A31113-550.pdf</a>
CCSA	CCSA-TSD-DS-31.113	550	Approved	01/07/2003	<a href="http://www.ccsa.org.cn/english/tc/files.php?docpath=/ITU-R/M.1457/M.1457-4/DS/">http://www.ccsa.org.cn/english/tc/files.php?docpath=/ITU-R/M.1457/M.1457-4/DS/</a>
ETSI	ETSI TS 131 113	5.5.0	Published	04/04/2003	<a href="http://pda.etsi.org/pda/home.asp?wkr=RTS/TSGT-0331113v550">http://pda.etsi.org/pda/home.asp?wkr=RTS/TSGT-0331113v550</a>
T1 (ATIS)	T1.3GPP.31.113V550-2004	5.5.0	Approved	21/05/2004	<a href="https://www.atis.org/atis/docstore/search.asp?committee=S24">https://www.atis.org/atis/docstore/search.asp?committee=S24</a>
TTA	TTAT.3G-31.113(R5-5.5.0)	5.5.0	Approved	25/05/2004	<a href="http://www.tta.or.kr/standardDB/stnfile/TTAT.3G-31.113(R5-5.5.0).zip">http://www.tta.or.kr/standardDB/stnfile/TTAT.3G-31.113(R5-5.5.0).zip</a>
<b>Release 6</b>					
CCSA	CCSA-TSD-DS-31.113	620	Approved	01/07/2003	<a href="http://www.ccsa.org.cn/english/tc/files.php?docpath=/ITU-R/M.1457/M.1457-4/DS/">http://www.ccsa.org.cn/english/tc/files.php?docpath=/ITU-R/M.1457/M.1457-4/DS/</a>
T1 (ATIS)	T1.3GPP.31.113V620-2004	6.2.0	Approved	21/05/2004	<a href="https://www.atis.org/atis/docstore/search.asp?committee=S24">https://www.atis.org/atis/docstore/search.asp?committee=S24</a>
TTA	TTAT.3G-31.113(R6-6.2.0)	6.2.0	Approved	25/05/2004	<a href="http://www.tta.or.kr/standardDB/stnfile/TTAT.3G-31.113(R6-6.2.0).zip">http://www.tta.or.kr/standardDB/stnfile/TTAT.3G-31.113(R6-6.2.0).zip</a>

**5.1.2.7.10** 31.120**Physical, Electrical and Logical Test Specification**

This document tests the physical, electrical and logical requirements as specified in TS 31.01.

SDO (2)	Document No.	Version	Status	Issued date	Location (1)
<b>Release 99</b>					
ARIB	ARIB STD-T63-31.120	3.0.0	Approved	25/05/2004	<a href="http://www.arib.or.jp/IMT-2000/ARIB-STD/ITU-R/R99/A31120-300.pdf">http://www.arib.or.jp/IMT-2000/ARIB-STD/ITU-R/R99/A31120-300.pdf</a>
CCSA	CCSA-TSD-DS-31.120	300	Approved	01/07/2003	<a href="http://www.ccsa.org.cn/english/tc/files.php?docpath=/ITU-R/M.1457/M.1457-4/DS/">http://www.ccsa.org.cn/english/tc/files.php?docpath=/ITU-R/M.1457/M.1457-4/DS/</a>
ETSI	ETSI TS 131 120	3.0.0	Published	13/02/2001	<a href="http://pda.etsi.org/pda/home.asp?wkr=DTS/TSGT-0331120U">http://pda.etsi.org/pda/home.asp?wkr=DTS/TSGT-0331120U</a>
T1 (ATIS)	T1.3GPP.31.120V300-2002	3.0.0	Approved	03/05/2002	<a href="https://www.atis.org/atis/docstore/search.asp?committee=S24">https://www.atis.org/atis/docstore/search.asp?committee=S24</a>
TTA	TTAE.3G-31.120(R99-3.0.0)	3.0.0	Approved	29/05/2002	<a href="http://www.tta.or.kr/standardDB/stnfile/TTAE.3G-31.120(R99-3.0.0).zip">http://www.tta.or.kr/standardDB/stnfile/TTAE.3G-31.120(R99-3.0.0).zip</a>

**5.1.2.7.11** 31.121**UICC-Terminal Interface; USIM Application Test specification**

This document provides the UICC-Terminal Interface Conformance Test Specification between the 3G Terminal and USIM (Universal Subscriber Identity Module) as an application on the UICC and the Terminal for 3G telecom network operation.

SDO (2)	Document No.	Version	Status	Issued date	Location (1)
<b>Release 99</b>					
ARIB	ARIB STD-T63-31.121	3.7.0	Approved	25/05/2004	<a href="http://www.arib.or.jp/IMT-2000/ARIB-STD/ITU-R/R99/A31121-370.pdf">http://www.arib.or.jp/IMT-2000/ARIB-STD/ITU-R/R99/A31121-370.pdf</a>
CCSA	CCSA-TSD-DS-31.121	360	Approved	01/07/2003	<a href="http://www.ccsa.org.cn/english/tc/files.php?docpath=/ITU-R/M.1457/M.1457-4/DS/">http://www.ccsa.org.cn/english/tc/files.php?docpath=/ITU-R/M.1457/M.1457-4/DS/</a>
ETSI	ETSI TS 131 121	3.7.0	Published	01/10/2003	<a href="http://pda.etsi.org/pda/home.asp?wkr=RTS/TSGT-0331121v370">http://pda.etsi.org/pda/home.asp?wkr=RTS/TSGT-0331121v370</a>
T1 (ATIS)	T1.3GPP.31.121V370-2004	3.7.0	Approved	21/05/2004	<a href="https://www.atis.org/atis/docstore/search.asp?committee=S24">https://www.atis.org/atis/docstore/search.asp?committee=S24</a>
TTA	TTAT.3G-31.121(R99-3.7.0)	3.7.0	Approved	25/05/2004	<a href="http://www.tta.or.kr/standardDB/stnfile/TTAT.3G-31.121(R99-3.7.0).zip">http://www.tta.or.kr/standardDB/stnfile/TTAT.3G-31.121(R99-3.7.0).zip</a>
<b>Release 4</b>					
ARIB	ARIB STD-T63-31.121	4.6.0	Approved	25/05/2004	<a href="http://www.arib.or.jp/IMT-2000/ARIB-STD/ITU-R/Rel4/A31121-460.pdf">http://www.arib.or.jp/IMT-2000/ARIB-STD/ITU-R/Rel4/A31121-460.pdf</a>
CCSA	CCSA-TSD-DS-31.121	450	Approved	01/07/2003	<a href="http://www.ccsa.org.cn/english/tc/files.php?docpath=/ITU-R/M.1457/M.1457-4/DS/">http://www.ccsa.org.cn/english/tc/files.php?docpath=/ITU-R/M.1457/M.1457-4/DS/</a>
ETSI	ETSI TS 131 121	4.6.0	Published	01/10/2003	<a href="http://pda.etsi.org/pda/home.asp?wkr=RTS/TSGT-0331121v460">http://pda.etsi.org/pda/home.asp?wkr=RTS/TSGT-0331121v460</a>
T1 (ATIS)	T1.3GPP.31.121V460-2004	4.6.0	Approved	21/05/2004	<a href="https://www.atis.org/atis/docstore/search.asp?committee=S24">https://www.atis.org/atis/docstore/search.asp?committee=S24</a>
TTA	TTAT.3G-31.121(R4-4.6.0)	4.6.0	Approved	25/05/2004	<a href="http://www.tta.or.kr/standardDB/stnfile/TTAT.3G-31.121(R4-4.6.0).zip">http://www.tta.or.kr/standardDB/stnfile/TTAT.3G-31.121(R4-4.6.0).zip</a>

### 5.1.2.7.12 31.122

#### USIM Conformance Test Specification

The present document provides the Conformance Test Specification for a UICC defined in TS 31.101 with Universal Subscriber Identity Module (USIM) defined in 3G TS 31.102.

SDO (2)	Document No.	Version	Status	Issued date	Location (1)
<b>Release 99</b>					
ARIB	ARIB STD-T63-31.122	3.7.0	Approved	25/05/2004	<a href="http://www.arib.or.jp/IMT-2000/ARIB-STD/ITU-R/R99/A31122-370.pdf">http://www.arib.or.jp/IMT-2000/ARIB-STD/ITU-R/R99/A31122-370.pdf</a>
CCSA	CCSA-TSD-DS-31.122	360	Approved	01/07/2003	<a href="http://www.ccsa.org.cn/english/tc/files.php?docpath=/ITU-R/M.1457/M.1457-4/DS/">http://www.ccsa.org.cn/english/tc/files.php?docpath=/ITU-R/M.1457/M.1457-4/DS/</a>
ETSI	ETSI TS 131 122	3.7.0	Published	19/01/2004	<a href="http://pda.etsi.org/pda/home.asp?wkr=RTS/TSGT-0331122v370">http://pda.etsi.org/pda/home.asp?wkr=RTS/TSGT-0331122v370</a>
T1 (ATIS)	T1.3GPP.31.122V370-2004	3.7.0	Approved	21/05/2004	<a href="https://www.atis.org/atis/docstore/search.asp?committee=S24">https://www.atis.org/atis/docstore/search.asp?committee=S24</a>
TTA	TTAT.3G-31.122(R99-3.7.0)	3.7.0	Approved	25/05/2004	<a href="http://www.tta.or.kr/standardDB/stnfile/TTAT.3G-31.122(R99-3.7.0).zip">http://www.tta.or.kr/standardDB/stnfile/TTAT.3G-31.122(R99-3.7.0).zip</a>

### 5.1.2.7.13 31.131

#### 'C' Language Binding to USIM API

This document includes information applicable to (U)SIM toolkit application developers creating applications using the C programming language ISO/IEC 9899 [7]. The present document describes an interface between toolkit applications written in the C programming language and the (U)SIM in order to realize the co-operation set forth in TS 42.019 [4]. In particular, the API described herein provides the service of assembling proactive commands and disassembling the responses to these commands for the application programmer.

SDO (2)	Document No.	Version	Status	Issued date	Location (1)
<b>Release 6</b>					
ARIB	ARIB STD-T63-31.131	6.1.0	Approved	25/05/2004	<a href="http://www.arib.or.jp/IMT-2000/ARIB-STD/ITU-R/Rel6/A31131-610.pdf">http://www.arib.or.jp/IMT-2000/ARIB-STD/ITU-R/Rel6/A31131-610.pdf</a>
CCSA	CCSA-TSD-DS-31.131	610	Approved	01/07/2003	<a href="http://www.ccsa.org.cn/english/tc/files.php?docpath=/ITU-R/M.1457/M.1457-4/DS/">http://www.ccsa.org.cn/english/tc/files.php?docpath=/ITU-R/M.1457/M.1457-4/DS/</a>

T1 (ATIS) T1.3GPP.31.131V610-2004	6.1.0	Approved	21/05/2004	<a href="https://www.atis.org/atis/docstore/search.asp?committee=S24">https://www.atis.org/atis/docstore/search.asp?committee=S24</a>
TTA TTAT.3G-31.131(R6-6.1.0)	6.1.0	Approved	25/05/2004	<a href="http://www.tta.or.kr/standardDB/stnfile/TTAT.3G-31.131(R6-6.1.0).zip">http://www.tta.or.kr/standardDB/stnfile/TTAT.3G-31.131(R6-6.1.0).zip</a>

#### 5.1.2.7.14 22.048

### Security mechanisms for (U)SIM application toolkit - stage 1

This document provides standardised security mechanisms in conjunction with the SIM Application Toolkit for the interface between a 3G or GSM PLMN Entity and a UICC at the functional level.

SDO (2)	Document No.	Version	Status	Issued date	Location (1)
<b>Release 4</b>					
ARIB	ARIB STD-T63-22.048	4.0.0	Approved	25/05/2004	<a href="http://www.arib.or.jp/IMT-2000/ARIB-STD/ITU-R/Rel4/A22048-400.pdf">http://www.arib.or.jp/IMT-2000/ARIB-STD/ITU-R/Rel4/A22048-400.pdf</a>
CCSA	CCSA-TSD-DS-22.048-4	400	Approved	01/07/2003	<a href="http://www.ccsa.org.cn/english/tc/files.php?docpath=/ITU-R/M.1457/M.1457-4/DS/">http://www.ccsa.org.cn/english/tc/files.php?docpath=/ITU-R/M.1457/M.1457-4/DS/</a>
ETSI	ETSI TS 122 048	4.0.0	Published	26/07/2001	<a href="http://pda.etsi.org/pda/home.asp?wkr=DTS/TSGT-0322048Uv4">http://pda.etsi.org/pda/home.asp?wkr=DTS/TSGT-0322048Uv4</a>
T1 (ATIS) T1.3GPP.22.048V400-2002		4.0.0	Approved	03/05/2002	<a href="https://www.atis.org/atis/docstore/search.asp?committee=S24">https://www.atis.org/atis/docstore/search.asp?committee=S24</a>
TTA	TTAE.3G-22.048(R4)	4.0.0	Approved	19/12/2001	<a href="http://www.tta.or.kr/standardDB/stnfile/TTAE_3G-22_048_R4_.zip">http://www.tta.or.kr/standardDB/stnfile/TTAE_3G-22_048_R4_.zip</a>
<b>Release 5</b>					
CCSA	CCSA-TSD-DS-22.048-4	500	Approved	01/07/2003	<a href="http://www.ccsa.org.cn/english/tc/files.php?docpath=/ITU-R/M.1457/M.1457-4/DS/">http://www.ccsa.org.cn/english/tc/files.php?docpath=/ITU-R/M.1457/M.1457-4/DS/</a>
ETSI	ETSI TS 122 048	5.0.0	Published	01/07/2003	<a href="http://pda.etsi.org/pda/home.asp?wkr=RTS/TSGT-0322048v500">http://pda.etsi.org/pda/home.asp?wkr=RTS/TSGT-0322048v500</a>
T1 (ATIS) T1.3GPP.22.048V500-2004		5.0.0	Approved	21/05/2004	<a href="https://www.atis.org/atis/docstore/search.asp?committee=S24">https://www.atis.org/atis/docstore/search.asp?committee=S24</a>
TTA	TTAT.3G-22.048(R5-5.0.0)	5.0.0	Approved	25/05/2004	<a href="http://www.tta.or.kr/standardDB/stnfile/TTAT.3G-22.048(R5-5.0.0).zip">http://www.tta.or.kr/standardDB/stnfile/TTAT.3G-22.048(R5-5.0.0).zip</a>

#### 5.1.2.7.15 23.048

### Security mechanisms for (U)SIM application toolkit - stage 2

This document specifies the structure of the Secured Packets in a general format and in implementations using Short Message Service Point to Point (SMS-PP) and Short Message Service Cell Broadcast (SMS-CB).

SDO (2)	Document No.	Version	Status	Issued date	Location (1)
<b>Release 4</b>					
ARIB	ARIB STD-T63-23.048	4.4.0	Approved	25/05/2004	<a href="http://www.arib.or.jp/IMT-2000/ARIB-STD/ITU-R/Rel4/A23048-440.pdf">http://www.arib.or.jp/IMT-2000/ARIB-STD/ITU-R/Rel4/A23048-440.pdf</a>
CCSA	CCSA-TSD-DS-23.048-4	440	Approved	01/07/2003	<a href="http://www.ccsa.org.cn/english/tc/files.php?docpath=/ITU-R/M.1457/M.1457-4/DS/">http://www.ccsa.org.cn/english/tc/files.php?docpath=/ITU-R/M.1457/M.1457-4/DS/</a>
ETSI	ETSI TS 123 048	4.4.0	Published	04/04/2003	<a href="http://pda.etsi.org/pda/home.asp?wkr=RTS/TSGT-0323048v440">http://pda.etsi.org/pda/home.asp?wkr=RTS/TSGT-0323048v440</a>
T1 (ATIS) T1.3GPP.23.048V440-2004		4.4.0	Approved	21/05/2004	<a href="https://www.atis.org/atis/docstore/search.asp?committee=S24">https://www.atis.org/atis/docstore/search.asp?committee=S24</a>
TTA	TTAT.3G-23.048(R4-4.4.0)	4.4.0	Approved	28/05/2003	<a href="http://www.tta.or.kr/standardDB/stnfile/TTAT.3G-23.048(R4-4.4.0).zip">http://www.tta.or.kr/standardDB/stnfile/TTAT.3G-23.048(R4-4.4.0).zip</a>
<b>Release 5</b>					
CCSA	CCSA-TSD-DS-23.048-4	570	Approved	01/07/2003	<a href="http://www.ccsa.org.cn/english/tc/files.php?docpath=/ITU-R/M.1457/M.1457-4/DS/">http://www.ccsa.org.cn/english/tc/files.php?docpath=/ITU-R/M.1457/M.1457-4/DS/</a>
ETSI	ETSI TS 123 048	5.8.0	Published	13/01/2004	<a href="http://pda.etsi.org/pda/home.asp?wkr=RTS/TSGT-0323048v580">http://pda.etsi.org/pda/home.asp?wkr=RTS/TSGT-0323048v580</a>
T1 (ATIS) T1.3GPP.23.048V580-2004		5.8.0	Approved	21/05/2004	<a href="https://www.atis.org/atis/docstore/search.asp?committee=S24">https://www.atis.org/atis/docstore/search.asp?committee=S24</a>
TTA	TTAT.3G-23.048(R5-5.8.0)	5.8.0	Approved	25/05/2004	<a href="http://www.tta.or.kr/standardDB/stnfile/TTAT.3G-23.048(R5-5.8.0).zip">http://www.tta.or.kr/standardDB/stnfile/TTAT.3G-23.048(R5-5.8.0).zip</a>

**5.1.2.7.16 23.038****Alphabets and language specific information**

This specification describes the language specific requirements for the terminals including character coding.

SDO (2)	Document No.	Version	Status	Issued date	Location (1)
<b>Release 99</b>					
ARIB	ARIB STD-T63-23.038	3.3.0	Approved	25/05/2004	<a href="http://www.arib.or.jp/IMT-2000/ARIB-STD/ITU-R/R99/A23038-330.pdf">http://www.arib.or.jp/IMT-2000/ARIB-STD/ITU-R/R99/A23038-330.pdf</a>
CCSA	CCSA-TSD-DS-23.038-4	330	Approved	01/07/2003	<a href="http://www.ccsa.org.cn/english/tc/files.php?docpath=/ITU-R/M.1457/M.1457-4/DS/">http://www.ccsa.org.cn/english/tc/files.php?docpath=/ITU-R/M.1457/M.1457-4/DS/</a>
ETSI	ETSI TS 123 038	3.3.0	Published	01/02/2000	<a href="http://pda.etsi.org/pda/home.asp?wkr=DTS/TSGT-0223038U">http://pda.etsi.org/pda/home.asp?wkr=DTS/TSGT-0223038U</a>
T1 (ATIS)	T1.3GPP.23.038V330-2002	3.3.0	Approved	03/05/2002	<a href="https://www.atis.org/atis/docstore/search.asp?committee=S24">https://www.atis.org/atis/docstore/search.asp?committee=S24</a>
TTA	TTAE.3G-23.038(R99)	3.3.0	Approved	19/12/2001	<a href="http://www.tta.or.kr/standardDB/stnfile/TTAE_3G-23_038_R99_.zip">http://www.tta.or.kr/standardDB/stnfile/TTAE_3G-23_038_R99_.zip</a>
<b>Release 4</b>					
ARIB	ARIB STD-T63-23.038	4.4.0	Approved	25/05/2004	<a href="http://www.arib.or.jp/IMT-2000/ARIB-STD/ITU-R/Rel4/A23038-440.pdf">http://www.arib.or.jp/IMT-2000/ARIB-STD/ITU-R/Rel4/A23038-440.pdf</a>
CCSA	CCSA-TSD-DS-23.038-4	440	Approved	01/07/2003	<a href="http://www.ccsa.org.cn/english/tc/files.php?docpath=/ITU-R/M.1457/M.1457-4/DS/">http://www.ccsa.org.cn/english/tc/files.php?docpath=/ITU-R/M.1457/M.1457-4/DS/</a>
ETSI	ETSI TS 123 038	4.4.0	Published	15/01/2002	<a href="http://pda.etsi.org/pda/home.asp?wkr=RTS/TSGT-0223038Uv4R2">http://pda.etsi.org/pda/home.asp?wkr=RTS/TSGT-0223038Uv4R2</a>
T1 (ATIS)	T1.3GPP.23.038V440-2002	4.4.0	Approved	03/05/2002	<a href="https://www.atis.org/atis/docstore/search.asp?committee=S24">https://www.atis.org/atis/docstore/search.asp?committee=S24</a>
TTA	TTAE.3G-23.038(R4-4.4.0)	4.4.0	Approved	29/05/2002	<a href="http://www.tta.or.kr/standardDB/stnfile/TTAE.3G-23.038(R4-4.4.0).zip">http://www.tta.or.kr/standardDB/stnfile/TTAE.3G-23.038(R4-4.4.0).zip</a>
<b>Release 5</b>					
ARIB	ARIB STD-T63-23.038	5.0.0	Approved	25/05/2004	<a href="http://www.arib.or.jp/IMT-2000/ARIB-STD/ITU-R/Rel5/A23038-500.pdf">http://www.arib.or.jp/IMT-2000/ARIB-STD/ITU-R/Rel5/A23038-500.pdf</a>
CCSA	CCSA-TSD-DS-23.038-4	500	Approved	01/07/2003	<a href="http://www.ccsa.org.cn/english/tc/files.php?docpath=/ITU-R/M.1457/M.1457-4/DS/">http://www.ccsa.org.cn/english/tc/files.php?docpath=/ITU-R/M.1457/M.1457-4/DS/</a>
ETSI	ETSI TS 123 038	5.0.0	Published	03/04/2002	<a href="http://pda.etsi.org/pda/home.asp?wkr=RTS/TSGT-0223038Uv5">http://pda.etsi.org/pda/home.asp?wkr=RTS/TSGT-0223038Uv5</a>
T1 (ATIS)	T1.3GPP.23.038V500-2002	5.0.0	Approved	03/05/2002	<a href="https://www.atis.org/atis/docstore/search.asp?committee=S24">https://www.atis.org/atis/docstore/search.asp?committee=S24</a>
TTA	TTAE.3G-23.038(R5-5.0.0)	5.0.0	Approved	29/05/2002	<a href="http://www.tta.or.kr/standardDB/stnfile/TTAE.3G-23.038(R5-5.0.0).zip">http://www.tta.or.kr/standardDB/stnfile/TTAE.3G-23.038(R5-5.0.0).zip</a>
<b>Release 6</b>					
ARIB	ARIB STD-T63-23.038	6.0.0	Approved	25/05/2004	<a href="http://www.arib.or.jp/IMT-2000/ARIB-STD/ITU-R/Rel6/A23038-600.pdf">http://www.arib.or.jp/IMT-2000/ARIB-STD/ITU-R/Rel6/A23038-600.pdf</a>
T1 (ATIS)	T1.3GPP.23.038V600-2004	6.0.0	Approved	21/05/2004	<a href="https://www.atis.org/atis/docstore/search.asp?committee=S24">https://www.atis.org/atis/docstore/search.asp?committee=S24</a>
TTA	TTAT.3G-23.038(R6-6.0.0)	6.0.0	Approved	25/05/2004	<a href="http://www.tta.or.kr/standardDB/stnfile/TTAT.3G-23.038(R6-6.0.0).zip">http://www.tta.or.kr/standardDB/stnfile/TTAT.3G-23.038(R6-6.0.0).zip</a>

**5.1.2.7.17 23.040****Technical realization of SMS point-to-point**

This specification describes the point-to-point SMS.

SDO (2)	Document No.	Version	Status	Issued date	Location (1)
<b>Release 99</b>					
ARIB	ARIB STD-T63-23.040	3.10.0	Approved	25/05/2004	<a href="http://www.arib.or.jp/IMT-2000/ARIB-STD/ITU-R/R99/A23040-3a0.pdf">http://www.arib.or.jp/IMT-2000/ARIB-STD/ITU-R/R99/A23040-3a0.pdf</a>
CCSA	CCSA-TSD-DS-23.040	3A0	Approved	01/07/2003	<a href="http://www.ccsa.org.cn/english/tc/files.php?docpath=/ITU-R/M.1457/M.1457-4/DS/">http://www.ccsa.org.cn/english/tc/files.php?docpath=/ITU-R/M.1457/M.1457-4/DS/</a>
ETSI	ETSI TS 123 040	3.10.0	Published	03/07/2003	<a href="http://pda.etsi.org/pda/home.asp?wkr=RTS/TSGT-0223040v3a0">http://pda.etsi.org/pda/home.asp?wkr=RTS/TSGT-0223040v3a0</a>
T1 (ATIS)	T1.3GPP.23.040V3100-2004	3.10.0	Approved	21/05/2004	<a href="https://www.atis.org/atis/docstore/search.asp?committee=S24">https://www.atis.org/atis/docstore/search.asp?committee=S24</a>



## 88

SDO (2)	Document No.	Version	Status	Issued date	Location (1)
TTA	TTAT.3G-23.040(R99-3.10.0)	3.10.0	Approved	25/05/2004	<a href="http://www.tta.or.kr/standardDB/stnfile/TTAT.3G-23.040(R99-3.10.0).zip">http://www.tta.or.kr/standardDB/stnfile/TTAT.3G-23.040(R99-3.10.0).zip</a>
<b>Release 4</b>					
ARIB	ARIB STD-T63-23.040	4.7.0	Approved	25/05/2004	<a href="http://www.arib.or.jp/IMT-2000/ARIB-STD/ITU-R/Rel4/A23040-470.pdf">http://www.arib.or.jp/IMT-2000/ARIB-STD/ITU-R/Rel4/A23040-470.pdf</a>
CCSA	CCSA-TSD-DS-23.040	480	Approved	01/07/2003	<a href="http://www.ccsa.org.cn/english/tc/files.php?docpath=/ITU-R/M.1457/M.1457-4/DS/">http://www.ccsa.org.cn/english/tc/files.php?docpath=/ITU-R/M.1457/M.1457-4/DS/</a>
ETSI	ETSI TS 123 040	4.8.0	Published	07/07/2003	<a href="http://pda.etsi.org/pda/home.asp?wkr=RTS/TSGT-0223040v480">http://pda.etsi.org/pda/home.asp?wkr=RTS/TSGT-0223040v480</a>
T1 (ATIS)	T1.3GPP.23.040V480-2004	4.8.0	Approved	21/05/2004	<a href="https://www.atis.org/atis/docstore/search.asp?committee=S24">https://www.atis.org/atis/docstore/search.asp?committee=S24</a>
TTA	TTAT.3G-23.040(R4-4.8.0)	4.8.0	Approved	25/05/2004	<a href="http://www.tta.or.kr/standardDB/stnfile/TTAT.3G-23.040(R4-4.8.0).zip">http://www.tta.or.kr/standardDB/stnfile/TTAT.3G-23.040(R4-4.8.0).zip</a>
<b>Release 5</b>					
ARIB	ARIB STD-T63-23.040	5.6.1	Approved	25/05/2004	<a href="http://www.arib.or.jp/IMT-2000/ARIB-STD/ITU-R/Rel5/A23040-561.pdf">http://www.arib.or.jp/IMT-2000/ARIB-STD/ITU-R/Rel5/A23040-561.pdf</a>
CCSA	CCSA-TSD-DS-23.040	560	Approved	01/07/2003	<a href="http://www.ccsa.org.cn/english/tc/files.php?docpath=/ITU-R/M.1457/M.1457-4/DS/">http://www.ccsa.org.cn/english/tc/files.php?docpath=/ITU-R/M.1457/M.1457-4/DS/</a>
ETSI	ETSI TS 123 040	5.6.1	Published	09/10/2003	<a href="http://pda.etsi.org/pda/home.asp?wkr=RTS/TSGT-0223040v561">http://pda.etsi.org/pda/home.asp?wkr=RTS/TSGT-0223040v561</a>
T1 (ATIS)	T1.3GPP.23.040V561-2004	5.6.1	Approved	21/05/2004	<a href="https://www.atis.org/atis/docstore/search.asp?committee=S24">https://www.atis.org/atis/docstore/search.asp?committee=S24</a>
TTA	TTAT.3G-23.040(R5-5.6.1)	5.6.1	Approved	25/05/2004	<a href="http://www.tta.or.kr/standardDB/stnfile/TTAT.3G-23.040(R5-5.6.1).zip">http://www.tta.or.kr/standardDB/stnfile/TTAT.3G-23.040(R5-5.6.1).zip</a>
<b>Release 6</b>					
ARIB	ARIB STD-T63-23.040	6.2.0	Approved	25/05/2004	<a href="http://www.arib.or.jp/IMT-2000/ARIB-STD/ITU-R/Rel6/A23040-620.pdf">http://www.arib.or.jp/IMT-2000/ARIB-STD/ITU-R/Rel6/A23040-620.pdf</a>
CCSA	CCSA-TSD-DS-23.040	610	Approved	01/07/2003	<a href="http://www.ccsa.org.cn/english/tc/files.php?docpath=/ITU-R/M.1457/M.1457-4/DS/">http://www.ccsa.org.cn/english/tc/files.php?docpath=/ITU-R/M.1457/M.1457-4/DS/</a>
ETSI	ETSI TS 123 040	6.2.0	Awaiting		<a href="http://pda.etsi.org/pda/home.asp?wkr=RTS/TSGT-0223040v620">http://pda.etsi.org/pda/home.asp?wkr=RTS/TSGT-0223040v620</a>
T1 (ATIS)	T1.3GPP.23.040V620-2004	6.2.0	Approved	21/05/2004	<a href="https://www.atis.org/atis/docstore/search.asp?committee=S24">https://www.atis.org/atis/docstore/search.asp?committee=S24</a>
TTA	TTAT.3G-23.040(R6-6.2.0)	6.2.0	Approved	25/05/2004	<a href="http://www.tta.or.kr/standardDB/stnfile/TTAT.3G-23.040(R6-6.2.0).zip">http://www.tta.or.kr/standardDB/stnfile/TTAT.3G-23.040(R6-6.2.0).zip</a>

## 5.1.2.7.18 23.041

## Technical realization of cell broadcast service (CBS)

This specification describes the point-to-multipoint CBS.

SDO (2)	Document No.	Version	Status	Issued date	Location (1)
<b>Release 99</b>					
ARIB	ARIB STD-T63-23.041	3.5.0	Approved	25/05/2004	<a href="http://www.arib.or.jp/IMT-2000/ARIB-STD/ITU-R/R99/A23041-350.pdf">http://www.arib.or.jp/IMT-2000/ARIB-STD/ITU-R/R99/A23041-350.pdf</a>
CCSA	CCSA-TSD-DS-23.041	350	Approved	01/07/2003	<a href="http://www.ccsa.org.cn/english/tc/files.php?docpath=/ITU-R/M.1457/M.1457-4/DS/">http://www.ccsa.org.cn/english/tc/files.php?docpath=/ITU-R/M.1457/M.1457-4/DS/</a>
ETSI	ETSI TS 123 041	3.5.0	Published	04/07/2002	<a href="http://pda.etsi.org/pda/home.asp?wkr=RTS/TSGT-0223041v350">http://pda.etsi.org/pda/home.asp?wkr=RTS/TSGT-0223041v350</a>
T1 (ATIS)	T1.3GPP.23.041V350-2003	3.5.0	Approved	27/03/2003	<a href="https://www.atis.org/atis/docstore/search.asp?committee=S24">https://www.atis.org/atis/docstore/search.asp?committee=S24</a>
TTA	TTAT.3G-23.041(R99-3.5.0)	3.5.0	Approved	21/03/2003	<a href="http://www.tta.or.kr/standardDB/stnfile/TTAT.3G-23.041(R99-3.5.0).zip">http://www.tta.or.kr/standardDB/stnfile/TTAT.3G-23.041(R99-3.5.0).zip</a>
<b>Release 4</b>					
ARIB	ARIB STD-T63-23.041	4.4.0	Approved	25/05/2004	<a href="http://www.arib.or.jp/IMT-2000/ARIB-STD/ITU-R/Rel4/A23041-440.pdf">http://www.arib.or.jp/IMT-2000/ARIB-STD/ITU-R/Rel4/A23041-440.pdf</a>
CCSA	CCSA-TSD-DS-23.041	441	Approved	01/07/2003	<a href="http://www.ccsa.org.cn/english/tc/files.php?docpath=/ITU-R/M.1457/M.1457-4/DS/">http://www.ccsa.org.cn/english/tc/files.php?docpath=/ITU-R/M.1457/M.1457-4/DS/</a>
ETSI	ETSI TS 123 041	4.4.0	Published	01/04/2003	<a href="http://pda.etsi.org/pda/home.asp?wkr=RTS/TSGT-0223041v440">http://pda.etsi.org/pda/home.asp?wkr=RTS/TSGT-0223041v440</a>
T1 (ATIS)	T1.3GPP.23.041V440-2004	4.4.0	Approved	21/05/2004	<a href="https://www.atis.org/atis/docstore/search.asp?committee=S24">https://www.atis.org/atis/docstore/search.asp?committee=S24</a>
TTA	TTAT.3G-23.041(R4-4.4.0)	4.4.0	Approved	25/05/2004	<a href="http://www.tta.or.kr/standardDB/stnfile/TTAT.3G-23.041(R4-4.4.0).zip">http://www.tta.or.kr/standardDB/stnfile/TTAT.3G-23.041(R4-4.4.0).zip</a>
<b>Release 5</b>					
ARIB	ARIB STD-T63-23.041	5.2.0	Approved	25/05/2004	<a href="http://www.arib.or.jp/IMT-2000/ARIB-STD/ITU-R/Rel5/A23041-520.pdf">http://www.arib.or.jp/IMT-2000/ARIB-STD/ITU-R/Rel5/A23041-520.pdf</a>

## Rec. ITU-R M.1457-4



CCSA	CCSA-TSD-DS-23.041	510	Approved	01/07/2003	<a href="http://www.ccsa.org.cn/english/tc/files.php?docpath=/ITU-R/M.1457/M.1457-4/DS/">http://www.ccsa.org.cn/english/tc/files.php?docpath=/ITU-R/M.1457/M.1457-4/DS/</a>
ETSI	ETSI TS 123 041	5.2.0	Published	13/01/2004	<a href="http://pda.etsi.org/pda/home.asp?wkr=RTS/TSGT-0223041v520">http://pda.etsi.org/pda/home.asp?wkr=RTS/TSGT-0223041v520</a>
T1 (ATIS)	T1.3GPP.23.041V520-2004	5.2.0	Approved	21/05/2004	<a href="https://www.atis.org/atis/docstore/search.asp?committee=S24">https://www.atis.org/atis/docstore/search.asp?committee=S24</a>
TTA	TTAT.3G-23.041(R5-5.2.0)	5.2.0	Approved	25/05/2004	<a href="http://www.tta.or.kr/standardDB/stnfile/TTAT.3G-23.041(R5-5.2.0).zip">http://www.tta.or.kr/standardDB/stnfile/TTAT.3G-23.041(R5-5.2.0).zip</a>
<b>Release 6</b>					
ARIB	ARIB STD-T63-23.041	6.2.0	Approved	25/05/2004	<a href="http://www.arib.or.jp/IMT-2000/ARIB-STD/ITU-R/Rel6/A23041-620.pdf">http://www.arib.or.jp/IMT-2000/ARIB-STD/ITU-R/Rel6/A23041-620.pdf</a>
CCSA	CCSA-TSD-DS-23.041	610	Approved	01/07/2003	<a href="http://www.ccsa.org.cn/english/tc/files.php?docpath=/ITU-R/M.1457/M.1457-4/DS/">http://www.ccsa.org.cn/english/tc/files.php?docpath=/ITU-R/M.1457/M.1457-4/DS/</a>
ETSI	ETSI TS 123 041	6.2.0	Awaiting		<a href="http://pda.etsi.org/pda/home.asp?wkr=RTS/TSGT-0223041v620">http://pda.etsi.org/pda/home.asp?wkr=RTS/TSGT-0223041v620</a>
T1 (ATIS)	T1.3GPP.23.041V620-2004	6.2.0	Approved	21/05/2004	<a href="https://www.atis.org/atis/docstore/search.asp?committee=S24">https://www.atis.org/atis/docstore/search.asp?committee=S24</a>
TTA	TTAT.3G-23.041(R6-6.2.0)	6.2.0	Approved	25/05/2004	<a href="http://www.tta.or.kr/standardDB/stnfile/TTAT.3G-23.041(R6-6.2.0).zip">http://www.tta.or.kr/standardDB/stnfile/TTAT.3G-23.041(R6-6.2.0).zip</a>

### 5.1.2.7.19 23.042

#### Compression algorithm for text messaging services

This specification describes the compression algorithm for text messaging services.

SDO (2)	Document No.	Version	Status	Issued date	Location (1)
<b>Release 99</b>					
ARIB	ARIB STD-T63-23.042	3.1.0	Approved	25/05/2004	<a href="http://www.arib.or.jp/IMT-2000/ARIB-STD/ITU-R/R99/A23042-310.pdf">http://www.arib.or.jp/IMT-2000/ARIB-STD/ITU-R/R99/A23042-310.pdf</a>
CCSA	CCSA-TSD-DS-23.042	31	Approved	01/07/2003	<a href="http://www.ccsa.org.cn/english/tc/files.php?docpath=/ITU-R/M.1457/M.1457-4/DS/">http://www.ccsa.org.cn/english/tc/files.php?docpath=/ITU-R/M.1457/M.1457-4/DS/</a>
ETSI	ETSI TS 123 042	3.1.0	Published	01/02/2000	<a href="http://pda.etsi.org/pda/home.asp?wkr=DTS/TSGT-0223042U">http://pda.etsi.org/pda/home.asp?wkr=DTS/TSGT-0223042U</a>
T1 (ATIS)	T1.3GPP.23.042V310-2002	3.1.0	Approved	03/05/2002	<a href="https://www.atis.org/atis/docstore/search.asp?committee=S24">https://www.atis.org/atis/docstore/search.asp?committee=S24</a>
TTA	TTAE.3G-23.042(F)	3.1.0	Approved	28/03/2000	<a href="http://www.tta.or.kr/standardDB/stnfile/TTAE_3G-23_042F.zip">http://www.tta.or.kr/standardDB/stnfile/TTAE_3G-23_042F.zip</a>
<b>Release 4</b>					
ARIB	ARIB STD-T63-23.042	4.0.1	Approved	25/05/2004	<a href="http://www.arib.or.jp/IMT-2000/ARIB-STD/ITU-R/Rel4/A23042-401.zip">http://www.arib.or.jp/IMT-2000/ARIB-STD/ITU-R/Rel4/A23042-401.zip</a>
CCSA	CCSA-TSD-DS-23.042	401	Approved	01/07/2003	<a href="http://www.ccsa.org.cn/english/tc/files.php?docpath=/ITU-R/M.1457/M.1457-4/DS/">http://www.ccsa.org.cn/english/tc/files.php?docpath=/ITU-R/M.1457/M.1457-4/DS/</a>
ETSI	ETSI TS 123 042	4.0.1	Published	19/10/2001	<a href="http://pda.etsi.org/pda/home.asp?wkr=RTS/TSGT-0223042Uv4R1">http://pda.etsi.org/pda/home.asp?wkr=RTS/TSGT-0223042Uv4R1</a>
T1 (ATIS)	T1.3GPP.23.042V401-2002	4.0.1	Approved	03/05/2002	<a href="https://www.atis.org/atis/docstore/search.asp?committee=S24">https://www.atis.org/atis/docstore/search.asp?committee=S24</a>
TTA	TTAE.3G-23.042(R4-4.0.1)	4.0.1	Approved	29/05/2002	<a href="http://www.tta.or.kr/standardDB/stnfile/TTAE.3G-23.042(R4-4.0.1).zip">http://www.tta.or.kr/standardDB/stnfile/TTAE.3G-23.042(R4-4.0.1).zip</a>
<b>Release 5</b>					
ARIB	ARIB STD-T63-23.042	5.0.0	Approved	25/05/2004	<a href="http://www.arib.or.jp/IMT-2000/ARIB-STD/ITU-R/Rel5/A23042-500.pdf">http://www.arib.or.jp/IMT-2000/ARIB-STD/ITU-R/Rel5/A23042-500.pdf</a>
CCSA	CCSA-TSD-DS-23.042	500	Approved	01/07/2003	<a href="http://www.ccsa.org.cn/english/tc/files.php?docpath=/ITU-R/M.1457/M.1457-4/DS/">http://www.ccsa.org.cn/english/tc/files.php?docpath=/ITU-R/M.1457/M.1457-4/DS/</a>
ETSI	ETSI TS 123 042	5.0.0	Published	04/07/2002	<a href="http://pda.etsi.org/pda/home.asp?wkr=RTS/TSGT-0223042v500">http://pda.etsi.org/pda/home.asp?wkr=RTS/TSGT-0223042v500</a>
T1 (ATIS)	T1.3GPP.23.042V500-2003	5.0.0	Approved	27/03/2003	<a href="https://www.atis.org/atis/docstore/search.asp?committee=S24">https://www.atis.org/atis/docstore/search.asp?committee=S24</a>
TTA	TTAT.3G-23.042(R5-5.0.0)	5.0.0	Approved	21/03/2003	<a href="http://www.tta.or.kr/standardDB/stnfile/TTAT.3G-23.042(R5-5.0.0).zip">http://www.tta.or.kr/standardDB/stnfile/TTAT.3G-23.042(R5-5.0.0).zip</a>

## 5.1.2.7.20 23.057

**Mobile Execution Environment (MExE) - stage 2**

This TS describes the functional capabilities and the security architecture of the Mobile Execution Environment.

SDO (2)	Document No.	Version	Status	Issued date	Location (1)
<b>Release 99</b>					
ARIB	ARIB STD-T63-23.057	3.4.0	Approved	25/05/2004	<a href="http://www.arib.or.jp/IMT-2000/ARIB-STD/ITU-R/R99/A23057-340.pdf">http://www.arib.or.jp/IMT-2000/ARIB-STD/ITU-R/R99/A23057-340.pdf</a>
CCSA	CCSA-TSD-DS-23.057	340	Approved	01/07/2003	<a href="http://www.ccsa.org.cn/english/tc/files.php?docpath=/ITU-R/M.1457/M.1457-4/DS/">http://www.ccsa.org.cn/english/tc/files.php?docpath=/ITU-R/M.1457/M.1457-4/DS/</a>
ETSI	ETSI TS 123 057	3.4.0	Published	12/04/2001	<a href="http://pda.etsi.org/pda/home.asp?wkr=RTS/TSGT-0223057UR4">http://pda.etsi.org/pda/home.asp?wkr=RTS/TSGT-0223057UR4</a>
T1 (ATIS)	T1.3GPP.23.057V340-2002	3.4.0	Approved	03/05/2002	<a href="https://www.atis.org/atis/docstore/search.asp?committee=s24">https://www.atis.org/atis/docstore/search.asp?committee=s24</a>
TTA	TTAE.3G-23.057(R99)	3.4.0	Approved	19/12/2001	<a href="http://www.tta.or.kr/standardDB/stnfile/TTAE_3G-23_057_R99_.zip">http://www.tta.or.kr/standardDB/stnfile/TTAE_3G-23_057_R99_.zip</a>
<b>Release 4</b>					
ARIB	ARIB STD-T63-23.057	4.5.0	Approved	25/05/2004	<a href="http://www.arib.or.jp/IMT-2000/ARIB-STD/ITU-R/Rel4/A23057-450.pdf">http://www.arib.or.jp/IMT-2000/ARIB-STD/ITU-R/Rel4/A23057-450.pdf</a>
CCSA	CCSA-TSD-DS-23.057	450	Approved	01/07/2003	<a href="http://www.ccsa.org.cn/english/tc/files.php?docpath=/ITU-R/M.1457/M.1457-4/DS/">http://www.ccsa.org.cn/english/tc/files.php?docpath=/ITU-R/M.1457/M.1457-4/DS/</a>
ETSI	ETSI TS 123 057	4.5.0	Published	08/04/2002	<a href="http://pda.etsi.org/pda/home.asp?wkr=RTS/TSGT-0223057Uv4R4">http://pda.etsi.org/pda/home.asp?wkr=RTS/TSGT-0223057Uv4R4</a>
T1 (ATIS)	T1.3GPP.23.057V450-2002	4.5.0	Approved	03/05/2002	<a href="https://www.atis.org/atis/docstore/search.asp?committee=s24">https://www.atis.org/atis/docstore/search.asp?committee=s24</a>
TTA	TTAE.3G-23.057(R4-4.5.0)	4.5.0	Approved	29/05/2002	<a href="http://www.tta.or.kr/standardDB/stnfile/TTAE.3G-23.057(R4-4.5.0).zip">http://www.tta.or.kr/standardDB/stnfile/TTAE.3G-23.057(R4-4.5.0).zip</a>
<b>Release 5</b>					
ARIB	ARIB STD-T63-23.057	5.1.0	Approved	25/05/2004	<a href="http://www.arib.or.jp/IMT-2000/ARIB-STD/ITU-R/Rel5/A23057-510.pdf">http://www.arib.or.jp/IMT-2000/ARIB-STD/ITU-R/Rel5/A23057-510.pdf</a>
CCSA	CCSA-TSD-DS-23.057	510	Approved	01/07/2003	<a href="http://www.ccsa.org.cn/english/tc/files.php?docpath=/ITU-R/M.1457/M.1457-4/DS/">http://www.ccsa.org.cn/english/tc/files.php?docpath=/ITU-R/M.1457/M.1457-4/DS/</a>
ETSI	ETSI TS 123 057	5.1.0	Published	18/10/2002	<a href="http://pda.etsi.org/pda/home.asp?wkr=RTS/TSGT-0223057v510">http://pda.etsi.org/pda/home.asp?wkr=RTS/TSGT-0223057v510</a>
T1 (ATIS)	T1.3GPP.23.057V510-2003	5.1.0	Approved	27/03/2003	<a href="https://www.atis.org/atis/docstore/search.asp?committee=s24">https://www.atis.org/atis/docstore/search.asp?committee=s24</a>
TTA	TTAT.3G-23.057(R5-5.1.0)	5.1.0	Approved	21/03/2003	<a href="http://www.tta.or.kr/standardDB/stnfile/TTAT.3G-23.057(R5-5.1.0).zip">http://www.tta.or.kr/standardDB/stnfile/TTAT.3G-23.057(R5-5.1.0).zip</a>
<b>Release 6</b>					
ARIB	ARIB STD-T63-23.057	6.2.0	Approved	25/05/2004	<a href="http://www.arib.or.jp/IMT-2000/ARIB-STD/ITU-R/Rel6/A23057-620.pdf">http://www.arib.or.jp/IMT-2000/ARIB-STD/ITU-R/Rel6/A23057-620.pdf</a>
CCSA	CCSA-TSD-DS-23.057	610	Approved	01/07/2003	<a href="http://www.ccsa.org.cn/english/tc/files.php?docpath=/ITU-R/M.1457/M.1457-4/DS/">http://www.ccsa.org.cn/english/tc/files.php?docpath=/ITU-R/M.1457/M.1457-4/DS/</a>
ETSI	ETSI TS 123 057	6.2.0	Awaiting		<a href="http://pda.etsi.org/pda/home.asp?wkr=RTS/TSGT-0223057v620">http://pda.etsi.org/pda/home.asp?wkr=RTS/TSGT-0223057v620</a>
T1 (ATIS)	T1.3GPP.23.057V620-2004	6.2.0	Approved	21/05/2004	<a href="https://www.atis.org/atis/docstore/search.asp?committee=s24">https://www.atis.org/atis/docstore/search.asp?committee=s24</a>
TTA	TTAT.3G-23.057(R6-6.2.0)	6.2.0	Approved	25/05/2004	<a href="http://www.tta.or.kr/standardDB/stnfile/TTAT.3G-23.057(R6-6.2.0).zip">http://www.tta.or.kr/standardDB/stnfile/TTAT.3G-23.057(R6-6.2.0).zip</a>

## 5.1.2.7.21 23.140

**Multimedia Messaging Service - stage 2**

This TS describes the MMS network architecture, the application protocol framework and the technical realization of service features needed to support the non-realtime Multimedia Messaging Service.

SDO (2)	Document No.	Version	Status	Issued date	Location (1)
<b>Release 99</b>					
ARIB	ARIB STD-T63-23.140	3.1.0	Approved	25/05/2004	<a href="http://www.arib.or.jp/IMT-2000/ARIB-STD/ITU-R/R99/A23140-310.pdf">http://www.arib.or.jp/IMT-2000/ARIB-STD/ITU-R/R99/A23140-310.pdf</a>

CCSA	CCSA-TSD-DS-23.140	310	Approved	01/07/2003	<a href="http://www.ccsa.org.cn/english/tc/files.php?docpath=/ITU-R/M.1457/M.1457-4/DS/">http://www.ccsa.org.cn/english/tc/files.php?docpath=/ITU-R/M.1457/M.1457-4/DS/</a>
ETSI	ETSI TS 123 140	3.1.0	Published	01/07/2002	<a href="http://pda.etsi.org/pda/home.asp?wkr=RTS/TSGT-0223140v310">http://pda.etsi.org/pda/home.asp?wkr=RTS/TSGT-0223140v310</a>
T1 (ATIS)	T1.3GPP.23.140V310-2003	3.1.0	Approved	27/03/2003	<a href="https://www.atis.org/atis/docstore/search.asp?committee=s24">https://www.atis.org/atis/docstore/search.asp?committee=s24</a>
TTA	TTAT.3G-23.140(R99-3.1.0)	3.1.0	Approved	21/03/2003	<a href="http://www.tta.or.kr/standardDB/stnfile/TTAT.3G-23.140(R99-3.1.0).zip">http://www.tta.or.kr/standardDB/stnfile/TTAT.3G-23.140(R99-3.1.0).zip</a>
<b>Release 4</b>					
ARIB	ARIB STD-T63-23.140	4.10.0	Approved	25/05/2004	<a href="http://www.arib.or.jp/IMT-2000/ARIB-STD/ITU-R/Rel4/A23140-4a0.pdf">http://www.arib.or.jp/IMT-2000/ARIB-STD/ITU-R/Rel4/A23140-4a0.pdf</a>
CCSA	CCSA-TSD-DS-23.140	4A0	Approved	01/07/2003	<a href="http://www.ccsa.org.cn/english/tc/files.php?docpath=/ITU-R/M.1457/M.1457-4/DS/">http://www.ccsa.org.cn/english/tc/files.php?docpath=/ITU-R/M.1457/M.1457-4/DS/</a>
ETSI	ETSI TS 123 140	4.10.0	Published	02/07/2003	<a href="http://pda.etsi.org/pda/home.asp?wkr=RTS/TSGT-0223140v4a0">http://pda.etsi.org/pda/home.asp?wkr=RTS/TSGT-0223140v4a0</a>
T1 (ATIS)	T1.3GPP.23.140V4100-2004	4.10.0	Approved	21/05/2004	<a href="https://www.atis.org/atis/docstore/search.asp?committee=s24">https://www.atis.org/atis/docstore/search.asp?committee=s24</a>
TTA	TTAT.3G-23.140(R4-4.10.0)	4.10.0	Approved	25/05/2004	<a href="http://www.tta.or.kr/standardDB/stnfile/TTAT.3G-23.140(R4-4.10.0).zip">http://www.tta.or.kr/standardDB/stnfile/TTAT.3G-23.140(R4-4.10.0).zip</a>
<b>Release 5</b>					
ARIB	ARIB STD-T63-23.140	5.9.0	Approved	25/05/2004	<a href="http://www.arib.or.jp/IMT-2000/ARIB-STD/ITU-R/Rel5/A23140-590.pdf">http://www.arib.or.jp/IMT-2000/ARIB-STD/ITU-R/Rel5/A23140-590.pdf</a>
CCSA	CCSA-TSD-DS-23.140	570	Approved	01/07/2003	<a href="http://www.ccsa.org.cn/english/tc/files.php?docpath=/ITU-R/M.1457/M.1457-4/DS/">http://www.ccsa.org.cn/english/tc/files.php?docpath=/ITU-R/M.1457/M.1457-4/DS/</a>
ETSI	ETSI TS 123 140	5.9.0	Published	14/01/2004	<a href="http://pda.etsi.org/pda/home.asp?wkr=RTS/TSGT-0223140v590">http://pda.etsi.org/pda/home.asp?wkr=RTS/TSGT-0223140v590</a>
T1 (ATIS)	T1.3GPP.23.140V590-2004	5.9.0	Approved	21/05/2004	<a href="https://www.atis.org/atis/docstore/search.asp?committee=s24">https://www.atis.org/atis/docstore/search.asp?committee=s24</a>
TTA	TTAT.3G-23.140(R5-5.9.0)	5.9.0	Approved	25/05/2004	<a href="http://www.tta.or.kr/standardDB/stnfile/TTAT.3G-23.140(R5-5.9.0).zip">http://www.tta.or.kr/standardDB/stnfile/TTAT.3G-23.140(R5-5.9.0).zip</a>
<b>Release 6</b>					
ARIB	ARIB STD-T63-23.140	6.4.0	Approved	25/05/2004	<a href="http://www.arib.or.jp/IMT-2000/ARIB-STD/ITU-R/Rel6/A23140-640.pdf">http://www.arib.or.jp/IMT-2000/ARIB-STD/ITU-R/Rel6/A23140-640.pdf</a>
CCSA	CCSA-TSD-DS-23.140	620	Approved	01/07/2003	<a href="http://www.ccsa.org.cn/english/tc/files.php?docpath=/ITU-R/M.1457/M.1457-4/DS/">http://www.ccsa.org.cn/english/tc/files.php?docpath=/ITU-R/M.1457/M.1457-4/DS/</a>
ETSI	ETSI TS 123 140	6.4.0	Awaiting		<a href="http://pda.etsi.org/pda/home.asp?wkr=RTS/TSGT-0223140v640">http://pda.etsi.org/pda/home.asp?wkr=RTS/TSGT-0223140v640</a>
T1 (ATIS)	T1.3GPP.23.140V640-2004	6.4.0	Approved	21/05/2004	<a href="https://www.atis.org/atis/docstore/search.asp?committee=s24">https://www.atis.org/atis/docstore/search.asp?committee=s24</a>
TTA	TTAT.3G-23.140(R6-6.4.0)	6.4.0	Approved	25/05/2004	<a href="http://www.tta.or.kr/standardDB/stnfile/TTAT.3G-23.140(R6-6.4.0).zip">http://www.tta.or.kr/standardDB/stnfile/TTAT.3G-23.140(R6-6.4.0).zip</a>

### 5.1.2.7.22 27.005

#### Use of data terminal equipment - data circuit terminating equipment (DTE - DCE) interface for cell broadcast service (CBS)

This specification describes three interface protocols for control of SMS functions within a GSM mobile telephone from a remote terminal via an asynchronous interface.

SDO (2)	Document No.	Version	Status	Issued date	Location (1)
<b>Release 99</b>					
ARIB	ARIB STD-T63-27.005	3.2.0	Approved	25/05/2004	<a href="http://www.arib.or.jp/IMT-2000/ARIB-STD/ITU-R/R99/A27005-320.pdf">http://www.arib.or.jp/IMT-2000/ARIB-STD/ITU-R/R99/A27005-320.pdf</a>
CCSA	CCSA-TSD-DS-27.005	320	Approved	01/07/2003	<a href="http://www.ccsa.org.cn/english/tc/files.php?docpath=/ITU-R/M.1457/M.1457-4/DS/">http://www.ccsa.org.cn/english/tc/files.php?docpath=/ITU-R/M.1457/M.1457-4/DS/</a>
ETSI	ETSI TS 127 005	3.2.0	Published	05/07/2002	<a href="http://pda.etsi.org/pda/home.asp?wkr=RTS/TSGT-0227005v320">http://pda.etsi.org/pda/home.asp?wkr=RTS/TSGT-0227005v320</a>
T1 (ATIS)	T1.3GPP.27.005V320-2003	3.2.0	Approved	27/03/2003	<a href="https://www.atis.org/atis/docstore/search.asp?committee=S24">https://www.atis.org/atis/docstore/search.asp?committee=S24</a>
TTA	TTAT.3G-27.005(R99-3.2.0)	3.2.0	Approved	21/03/2003	<a href="http://www.tta.or.kr/standardDB/stnfile/TTAT.3G-27.005(R99-3.2.0).zip">http://www.tta.or.kr/standardDB/stnfile/TTAT.3G-27.005(R99-3.2.0).zip</a>
<b>Release 4</b>					
ARIB	ARIB STD-T63-27.005	4.2.0	Approved	25/05/2004	<a href="http://www.arib.or.jp/IMT-2000/ARIB-STD/ITU-R/Rel4/A27005-420.pdf">http://www.arib.or.jp/IMT-2000/ARIB-STD/ITU-R/Rel4/A27005-420.pdf</a>
CCSA	CCSA-TSD-DS-27.005	420	Approved	01/07/2003	<a href="http://www.ccsa.org.cn/english/tc/files.php?docpath=/ITU-R/M.1457/M.1457-4/DS/">http://www.ccsa.org.cn/english/tc/files.php?docpath=/ITU-R/M.1457/M.1457-4/DS/</a>

ETSI	ETSI TS 127 005	4.2.0	Published	05/07/2002	<a href="http://pda.etsi.org/pda/home.asp?wkr=RTS/TSGT-0227005v420">http://pda.etsi.org/pda/home.asp?wkr=RTS/TSGT-0227005v420</a>
T1 (ATIS)	T1.3GPP.27.005V420-2003	4.2.0	Approved	27/03/2003	<a href="https://www.atis.org/atis/docstore/search.asp?committee=S24">https://www.atis.org/atis/docstore/search.asp?committee=S24</a>
TTA	TTAT.3G-27.005(R4-4.2.0)	4.2.0	Approved	21/03/2003	<a href="http://www.tta.or.kr/standardDB/stnfile/TTAT.3G-27.005(R4-4.2.0).zip">http://www.tta.or.kr/standardDB/stnfile/TTAT.3G-27.005(R4-4.2.0).zip</a>
<b>Release 5</b>					
ARIB	ARIB STD-T63-27.005	5.0.0	Approved	25/05/2004	<a href="http://www.arib.or.jp/IMT-2000/ARIB-STD/ITU-R/Rel5/A27005-500.pdf">http://www.arib.or.jp/IMT-2000/ARIB-STD/ITU-R/Rel5/A27005-500.pdf</a>
CCSA	CCSA-TSD-DS-27.005	500	Approved	01/07/2003	<a href="http://www.ccsa.org.cn/english/tc/files.php?docpath=/ITU-R/M.1457/M.1457-4/DS/">http://www.ccsa.org.cn/english/tc/files.php?docpath=/ITU-R/M.1457/M.1457-4/DS/</a>
ETSI	ETSI TS 127 005	5.0.0	Published	05/07/2002	<a href="http://pda.etsi.org/pda/home.asp?wkr=RTS/TSGT-0227005v500">http://pda.etsi.org/pda/home.asp?wkr=RTS/TSGT-0227005v500</a>
T1 (ATIS)	T1.3GPP.27.005V500-2003	5.0.0	Approved	27/03/2003	<a href="https://www.atis.org/atis/docstore/search.asp?committee=S24">https://www.atis.org/atis/docstore/search.asp?committee=S24</a>
TTA	TTAT.3G-27.005(R5-5.0.0)	5.0.0	Approved	21/03/2003	<a href="http://www.tta.or.kr/standardDB/stnfile/TTAT.3G-27.005(R5-5.0.0).zip">http://www.tta.or.kr/standardDB/stnfile/TTAT.3G-27.005(R5-5.0.0).zip</a>

### 5.1.2.7.23 27.007

#### AT command set for the user equipment (UE)

This specification describes a profile of AT commands and recommends that this profile be used for controlling mobile equipment (ME) functions and GSM network services from a terminal equipment (TE) through terminal adaptor (TA).

SDO (2)	Document No.	Version	Status	Issued date	Location (1)
<b>Release 99</b>					
ARIB	ARIB STD-T63-27.007	3.13.0	Approved	25/05/2004	<a href="http://www.arib.or.jp/IMT-2000/ARIB-STD/ITU-R/R99/A27007-3d0.pdf">http://www.arib.or.jp/IMT-2000/ARIB-STD/ITU-R/R99/A27007-3d0.pdf</a>
CCSA	CCSA-TSD-DS-27.007	310	Approved	01/07/2003	<a href="http://www.ccsa.org.cn/english/tc/files.php?docpath=/ITU-R/M.1457/M.1457-4/DS/">http://www.ccsa.org.cn/english/tc/files.php?docpath=/ITU-R/M.1457/M.1457-4/DS/</a>
ETSI	ETSI TS 127 007	3.13.0	Published	08/04/2003	<a href="http://pda.etsi.org/pda/home.asp?wkr=RTS/TSGT-0227007v3d0">http://pda.etsi.org/pda/home.asp?wkr=RTS/TSGT-0227007v3d0</a>
T1 (ATIS)	T1.3GPP.27.007V3130-2004	3.13.0	Approved	21/05/2004	<a href="https://www.atis.org/atis/docstore/search.asp?committee=S24">https://www.atis.org/atis/docstore/search.asp?committee=S24</a>
TTA	TTAT.3G-27.007(R99-3.13.0)	3.13.0	Approved	25/05/2004	<a href="http://www.tta.or.kr/standardDB/stnfile/TTAT.3G-27.007(R99-3.13.0).zip">http://www.tta.or.kr/standardDB/stnfile/TTAT.3G-27.007(R99-3.13.0).zip</a>
<b>Release 4</b>					
ARIB	ARIB STD-T63-27.007	4.6.0	Approved	25/05/2004	<a href="http://www.arib.or.jp/IMT-2000/ARIB-STD/ITU-R/Rel4/A27007-460.pdf">http://www.arib.or.jp/IMT-2000/ARIB-STD/ITU-R/Rel4/A27007-460.pdf</a>
CCSA	CCSA-TSD-DS-27.007	400	Approved	01/07/2003	<a href="http://www.ccsa.org.cn/english/tc/files.php?docpath=/ITU-R/M.1457/M.1457-4/DS/">http://www.ccsa.org.cn/english/tc/files.php?docpath=/ITU-R/M.1457/M.1457-4/DS/</a>
ETSI	ETSI TS 127 007	4.6.0	Published	08/04/2003	<a href="http://pda.etsi.org/pda/home.asp?wkr=RTS/TSGT-0227007v460">http://pda.etsi.org/pda/home.asp?wkr=RTS/TSGT-0227007v460</a>
T1 (ATIS)	T1.3GPP.27.007V460-2004	4.6.0	Approved	21/05/2004	<a href="https://www.atis.org/atis/docstore/search.asp?committee=S24">https://www.atis.org/atis/docstore/search.asp?committee=S24</a>
TTA	TTAT.3G-27.007(R4-4.6.0)	4.6.0	Approved	25/05/2004	<a href="http://www.tta.or.kr/standardDB/stnfile/TTAT.3G-27.007(R4-4.6.0).zip">http://www.tta.or.kr/standardDB/stnfile/TTAT.3G-27.007(R4-4.6.0).zip</a>
<b>Release 5</b>					
ARIB	ARIB STD-T63-27.007	5.4.0	Approved	25/05/2004	<a href="http://www.arib.or.jp/IMT-2000/ARIB-STD/ITU-R/Rel5/A27007-540.pdf">http://www.arib.or.jp/IMT-2000/ARIB-STD/ITU-R/Rel5/A27007-540.pdf</a>
CCSA	CCSA-TSD-DS-27.007	500	Approved	01/07/2003	<a href="http://www.ccsa.org.cn/english/tc/files.php?docpath=/ITU-R/M.1457/M.1457-4/DS/">http://www.ccsa.org.cn/english/tc/files.php?docpath=/ITU-R/M.1457/M.1457-4/DS/</a>
ETSI	ETSI TS 127 007	5.4.0	Published	09/10/2003	<a href="http://pda.etsi.org/pda/home.asp?wkr=RTS/TSGT-0227007v540">http://pda.etsi.org/pda/home.asp?wkr=RTS/TSGT-0227007v540</a>
T1 (ATIS)	T1.3GPP.27.007V540-2004	5.4.0	Approved	21/05/2004	<a href="https://www.atis.org/atis/docstore/search.asp?committee=S24">https://www.atis.org/atis/docstore/search.asp?committee=S24</a>
TTA	TTAT.3G-27.007(R5-5.4.0)	5.4.0	Approved	25/05/2004	<a href="http://www.tta.or.kr/standardDB/stnfile/TTAT.3G-27.007(R5-5.4.0).zip">http://www.tta.or.kr/standardDB/stnfile/TTAT.3G-27.007(R5-5.4.0).zip</a>
<b>Release 6</b>					
ARIB	ARIB STD-T63-27.007	6.4.0	Approved	25/05/2004	<a href="http://www.arib.or.jp/IMT-2000/ARIB-STD/ITU-R/Rel6/A27007-640.pdf">http://www.arib.or.jp/IMT-2000/ARIB-STD/ITU-R/Rel6/A27007-640.pdf</a>
CCSA	CCSA-TSD-DS-27.007	V4	Approved	01/07/2003	<a href="http://www.ccsa.org.cn/english/tc/files.php?docpath=/ITU-R/M.1457/M.1457-4/DS/">http://www.ccsa.org.cn/english/tc/files.php?docpath=/ITU-R/M.1457/M.1457-4/DS/</a>
ETSI	ETSI TS 127 007	6.4.0	Awaiting		<a href="http://pda.etsi.org/pda/home.asp?wkr=RTS/TSGT-0227007v640">http://pda.etsi.org/pda/home.asp?wkr=RTS/TSGT-0227007v640</a>

T1 (ATIS) T1.3GPP.27.007V640-2004	6.4.0	Approved	21/05/2004	<a href="https://www.atis.org/atis/docstore/search.asp?committee=S24">https://www.atis.org/atis/docstore/search.asp?committee=S24</a>
TTA TTAT.3G-27.007(R6-6.4.0)	6.4.0	Approved	25/05/2004	<a href="http://www.tta.or.kr/standardDB/stnfile/TTAT.3G-27.007(R6-6.4.0).zip">http://www.tta.or.kr/standardDB/stnfile/TTAT.3G-27.007(R6-6.4.0).zip</a>

### 5.1.2.7.24 27.010

#### Terminal equipment to mobile station (TE-MS) multiplexer protocol

This specification describes a multiplexing protocol between a mobile station and an external data terminal for the purposes of enabling multiple channels to be established for different purposes (e.g. simultaneous SMS and data call).

SDO (2)	Document No.	Version	Status	Issued date	Location (1)
<b>Release 99</b>					
ARIB	ARIB STD-T63-27.010	3.4.0	Approved	25/05/2004	<a href="http://www.arib.or.jp/IMT-2000/ARIB-STD/ITU-R/R99/A27010-340.pdf">http://www.arib.or.jp/IMT-2000/ARIB-STD/ITU-R/R99/A27010-340.pdf</a>
CCSA	CCSA-TSD-DS-27.010	340	Approved	01/07/2003	<a href="http://www.ccsa.org.cn/english/tc/files.php?docpath=/ITU-R/M.1457/M.1457-4/DS/">http://www.ccsa.org.cn/english/tc/files.php?docpath=/ITU-R/M.1457/M.1457-4/DS/</a>
ETSI	ETSI TS 127 010	3.4.0	Published	18/04/2002	<a href="http://pda.etsi.org/pda/home.asp?wkr=RTS/TSGT-0227010UR2">http://pda.etsi.org/pda/home.asp?wkr=RTS/TSGT-0227010UR2</a>
T1 (ATIS)	T1.3GPP.27.010V340-2002	3.4.0	Approved	03/05/2002	<a href="https://www.atis.org/atis/docstore/search.asp?committee=S24">https://www.atis.org/atis/docstore/search.asp?committee=S24</a>
TTA	TTAE.3G-27.010(R99-3.4.0)	3.4.0	Approved	29/05/2002	<a href="http://www.tta.or.kr/standardDB/stnfile/TTAE.3G-27.010(R99-3.4.0).zip">http://www.tta.or.kr/standardDB/stnfile/TTAE.3G-27.010(R99-3.4.0).zip</a>
<b>Release 4</b>					
ARIB	ARIB STD-T63-27.010	4.6.0	Approved	25/05/2004	<a href="http://www.arib.or.jp/IMT-2000/ARIB-STD/ITU-R/Rel4/A27010-460.pdf">http://www.arib.or.jp/IMT-2000/ARIB-STD/ITU-R/Rel4/A27010-460.pdf</a>
CCSA	CCSA-TSD-DS-27.010	420	Approved	01/07/2003	<a href="http://www.ccsa.org.cn/english/tc/files.php?docpath=/ITU-R/M.1457/M.1457-4/DS/">http://www.ccsa.org.cn/english/tc/files.php?docpath=/ITU-R/M.1457/M.1457-4/DS/</a>
ETSI	ETSI TS 127 010	4.2.0	Published	18/04/2002	<a href="http://pda.etsi.org/pda/home.asp?wkr=RTS/TSGT-0227010Uv4R2">http://pda.etsi.org/pda/home.asp?wkr=RTS/TSGT-0227010Uv4R2</a>
T1 (ATIS)	T1.3GPP.27.010V420-2002	4.2.0	Approved	03/05/2002	<a href="https://www.atis.org/atis/docstore/search.asp?committee=S24">https://www.atis.org/atis/docstore/search.asp?committee=S24</a>
TTA	TTAE.3G-27.010(R4-4.2.0)	4.2.0	Approved	29/05/2002	<a href="http://www.tta.or.kr/standardDB/stnfile/TTAE.3G-27.010(R4-4.2.0).zip">http://www.tta.or.kr/standardDB/stnfile/TTAE.3G-27.010(R4-4.2.0).zip</a>
<b>Release 5</b>					
ARIB	ARIB STD-T63-27.010	5.0.0	Approved	25/05/2004	<a href="http://www.arib.or.jp/IMT-2000/ARIB-STD/ITU-R/Rel5/A27010-500.pdf">http://www.arib.or.jp/IMT-2000/ARIB-STD/ITU-R/Rel5/A27010-500.pdf</a>
CCSA	CCSA-TSD-DS-27.010	500	Approved	01/07/2003	<a href="http://www.ccsa.org.cn/english/tc/files.php?docpath=/ITU-R/M.1457/M.1457-4/DS/">http://www.ccsa.org.cn/english/tc/files.php?docpath=/ITU-R/M.1457/M.1457-4/DS/</a>
ETSI	ETSI TS 127 010	5.0.0	Published	05/07/2002	<a href="http://pda.etsi.org/pda/home.asp?wkr=RTS/TSGT-0227010v500">http://pda.etsi.org/pda/home.asp?wkr=RTS/TSGT-0227010v500</a>
T1 (ATIS)	T1.3GPP.27.010V500-2003	5.0.0	Approved	27/03/2003	<a href="https://www.atis.org/atis/docstore/search.asp?committee=S24">https://www.atis.org/atis/docstore/search.asp?committee=S24</a>
TTA	TTAT.3G-27.010(R5-5.0.0)	5.0.0	Approved	21/03/2003	<a href="http://www.tta.or.kr/standardDB/stnfile/TTAT.3G-27.010(R5-5.0.0).zip">http://www.tta.or.kr/standardDB/stnfile/TTAT.3G-27.010(R5-5.0.0).zip</a>
<b>Release 6</b>					
CCSA	CCSA-TSD-DS-27.010	V4	Approved	01/07/2003	<a href="http://www.ccsa.org.cn/english/tc/files.php?docpath=/ITU-R/M.1457/M.1457-4/DS/">http://www.ccsa.org.cn/english/tc/files.php?docpath=/ITU-R/M.1457/M.1457-4/DS/</a>

### 5.1.2.7.25 27.103

#### Wide area network synchronization standard

This specification describes a definition of a wide area synchronization protocol. The synchronization protocol is based upon infrared mobile communication (IrMC) Level 4 for Release 99. The synchronization protocol is based upon SyncML from Release 4 onwards.

SDO (2)	Document No.	Version	Status	Issued date	Location (1)
<b>Release 99</b>					
ARIB	ARIB STD-T63-27.103	3.1.0	Approved	25/05/2004	<a href="http://www.arib.or.jp/IMT-2000/ARIB-STD/ITU-R/R99/A27103-310.pdf">http://www.arib.or.jp/IMT-2000/ARIB-STD/ITU-R/R99/A27103-310.pdf</a>

CCSA	CCSA-TSD-DS-27.103	310	Approved	01/07/2003	<a href="http://www.ccsa.org.cn/english/tc/files.php?docpath=/ITU-R/M.1457/M.1457-4/DS/">http://www.ccsa.org.cn/english/tc/files.php?docpath=/ITU-R/M.1457/M.1457-4/DS/</a>
ETSI	ETSI TS 127 103	3.1.0	Published	07/11/2000	<a href="http://pda.etsi.org/pda/home.asp?wkr=RTS/TSGT-0227103UR1">http://pda.etsi.org/pda/home.asp?wkr=RTS/TSGT-0227103UR1</a>
T1 (ATIS)	T1.3GPP.27.103V310-2002	3.1.0	Approved	03/05/2002	<a href="https://www.atis.org/atis/docstore/search.asp?committee=S24">https://www.atis.org/atis/docstore/search.asp?committee=S24</a>
TTA	TTAE.3G-27.103(R99F)	3.1.0	Approved	19/12/2001	<a href="http://www.tta.or.kr/standardDB/stnfile/TTAE_3G-27_103_R99F_.zip">http://www.tta.or.kr/standardDB/stnfile/TTAE_3G-27_103_R99F_.zip</a>
<b>Release 4</b>					
ARIB	ARIB STD-T63-27.103	4.0.0	Approved	25/05/2004	<a href="http://www.arib.or.jp/IMT-2000/ARIB-STD/ITU-R/Rel4/A27103-400.pdf">http://www.arib.or.jp/IMT-2000/ARIB-STD/ITU-R/Rel4/A27103-400.pdf</a>
CCSA	CCSA-TSD-DS-27.103	400	Approved	01/07/2003	<a href="http://www.ccsa.org.cn/english/tc/files.php?docpath=/ITU-R/M.1457/M.1457-4/DS/">http://www.ccsa.org.cn/english/tc/files.php?docpath=/ITU-R/M.1457/M.1457-4/DS/</a>
ETSI	ETSI TS 127 103	4.0.0	Published	25/04/2001	<a href="http://pda.etsi.org/pda/home.asp?wkr=RTS/TSGT-0227103Uv4">http://pda.etsi.org/pda/home.asp?wkr=RTS/TSGT-0227103Uv4</a>
T1 (ATIS)	T1.3GPP.27.103V400-2002	4.0.0	Approved	03/05/2002	<a href="https://www.atis.org/atis/docstore/search.asp?committee=S24">https://www.atis.org/atis/docstore/search.asp?committee=S24</a>
TTA	TTAE.3G-27.103(R4-4.0.0)	4.0.0	Approved	29/05/2002	<a href="http://www.tta.or.kr/standardDB/stnfile/TTAE.3G-27.103(R4-4.0.0).zip">http://www.tta.or.kr/standardDB/stnfile/TTAE.3G-27.103(R4-4.0.0).zip</a>
<b>Release 5</b>					
ARIB	ARIB STD-T63-27.103	5.0.0	Approved	25/05/2004	<a href="http://www.arib.or.jp/IMT-2000/ARIB-STD/ITU-R/Rel5/A27103-500.pdf">http://www.arib.or.jp/IMT-2000/ARIB-STD/ITU-R/Rel5/A27103-500.pdf</a>
CCSA	CCSA-TSD-DS-27.103	500	Approved	01/07/2003	<a href="http://www.ccsa.org.cn/english/tc/files.php?docpath=/ITU-R/M.1457/M.1457-4/DS/">http://www.ccsa.org.cn/english/tc/files.php?docpath=/ITU-R/M.1457/M.1457-4/DS/</a>
ETSI	ETSI TS 127 103	5.0.0	Published	05/07/2002	<a href="http://pda.etsi.org/pda/home.asp?wkr=RTS/TSGT-0227103v500">http://pda.etsi.org/pda/home.asp?wkr=RTS/TSGT-0227103v500</a>
T1 (ATIS)	T1.3GPP.27.103V500-2003	5.0.0	Approved	27/03/2003	<a href="https://www.atis.org/atis/docstore/search.asp?committee=S24">https://www.atis.org/atis/docstore/search.asp?committee=S24</a>
TTA	TTAT.3G-27.103(R5-5.0.0)	5.0.0	Approved	21/03/2003	<a href="http://www.tta.or.kr/standardDB/stnfile/TTAT.3G-27.103(R5-5.0.0).zip">http://www.tta.or.kr/standardDB/stnfile/TTAT.3G-27.103(R5-5.0.0).zip</a>

### 5.1.2.7.26 23.227

#### Application and user interaction in the UE; Principles and specific requirements

This Technical Specification defines the principles for scheduling resources between applications in different application execution environment (e.g. MExE, USAT etc.) and internal and external peripherals (e.g. infra-red, Bluetooth, USIM, radio interface, MMI, memory etc.).

SDO (2)	Document No.	Version	Status	Issued date	Location (1)
<b>Release 4</b>					
ARIB	ARIB STD-T63-23.227	4.2.0	Approved	25/05/2004	<a href="http://www.arib.or.jp/IMT-2000/ARIB-STD/ITU-R/Rel4/A23227-420.pdf">http://www.arib.or.jp/IMT-2000/ARIB-STD/ITU-R/Rel4/A23227-420.pdf</a>
CCSA	CCSA-TSD-DS-27.227	420	Approved	01/07/2003	<a href="http://www.ccsa.org.cn/english/tc/files.php?docpath=/ITU-R/M.1457/M.1457-4/DS/">http://www.ccsa.org.cn/english/tc/files.php?docpath=/ITU-R/M.1457/M.1457-4/DS/</a>
ETSI	ETSI TS 123 227	4.2.0	Published	09/04/2002	<a href="http://pda.etsi.org/pda/home.asp?wkr=RTS/TSGT-0223227Uv4R2">http://pda.etsi.org/pda/home.asp?wkr=RTS/TSGT-0223227Uv4R2</a>
T1 (ATIS)	T1.3GPP.23.227V420-2002	4.2.0	Approved	03/05/2002	<a href="https://www.atis.org/atis/docstore/search.asp?committee=S24">https://www.atis.org/atis/docstore/search.asp?committee=S24</a>
TTA	TTAE.3G-23.227(R4-4.2.0)	4.2.0	Approved	29/05/2002	<a href="http://www.tta.or.kr/standardDB/stnfile/TTAE.3G-23.227(R4-4.2.0).zip">http://www.tta.or.kr/standardDB/stnfile/TTAE.3G-23.227(R4-4.2.0).zip</a>
<b>Release 5</b>					
ARIB	ARIB STD-T63-23.227	5.1.0	Approved	25/05/2004	<a href="http://www.arib.or.jp/IMT-2000/ARIB-STD/ITU-R/Rel5/A23227-510.pdf">http://www.arib.or.jp/IMT-2000/ARIB-STD/ITU-R/Rel5/A23227-510.pdf</a>
CCSA	CCSA-TSD-DS-27.227	510	Approved	01/07/2003	<a href="http://www.ccsa.org.cn/english/tc/files.php?docpath=/ITU-R/M.1457/M.1457-4/DS/">http://www.ccsa.org.cn/english/tc/files.php?docpath=/ITU-R/M.1457/M.1457-4/DS/</a>
ETSI	ETSI TS 123 227	5.1.0	Published	09/04/2002	<a href="http://pda.etsi.org/pda/home.asp?wkr=RTS/TSGT-0223227Uv5">http://pda.etsi.org/pda/home.asp?wkr=RTS/TSGT-0223227Uv5</a>
T1 (ATIS)	T1.3GPP.23.227V510-2002	5.1.0	Approved	03/05/2002	<a href="https://www.atis.org/atis/docstore/search.asp?committee=S24">https://www.atis.org/atis/docstore/search.asp?committee=S24</a>
TTA	TTAE.3G-23.227(R5-5.1.0)	5.1.0	Approved	29/05/2002	<a href="http://www.tta.or.kr/standardDB/stnfile/TTAE.3G-23.227(R5-5.1.0).zip">http://www.tta.or.kr/standardDB/stnfile/TTAE.3G-23.227(R5-5.1.0).zip</a>

**5.1.2.8****System aspects****5.1.2.8.1 TS 23.002****UMTS release 1999 network architecture**

This specification describes the possible architectures of the mobile system.

SDO (2)	Document No.	Version	Status	Issued date	Location (1)
<b>Release 99</b>					
ETSI	ETSI TS 123 002	3.6.0	Published	03/10/2002	<a href="http://pda.etsi.org/pda/home.asp?wkr=RTS/TSGS-0223002v360">http://pda.etsi.org/pda/home.asp?wkr=RTS/TSGS-0223002v360</a>
<b>Release 4</b>					
ETSI	ETSI TS 123 002	4.8.0	Published	01/07/2003	<a href="http://pda.etsi.org/pda/home.asp?wkr=RTS/TSGS-0223002v480">http://pda.etsi.org/pda/home.asp?wkr=RTS/TSGS-0223002v480</a>
<b>Release 5</b>					
ETSI	ETSI TS 123 002	5.12.0	Published	06/10/2003	<a href="http://pda.etsi.org/pda/home.asp?wkr=RTS/TSGS-0223002v5c0">http://pda.etsi.org/pda/home.asp?wkr=RTS/TSGS-0223002v5c0</a>

**5.1.2.8.2 TS 23.101****General UMTS architecture**

This specification describes the basic physical and functional separation of UMTS. The content of this specification is limited to those features that are common to all UMTS networks independent of their origin. It identifies and names the reference points and functional groupings appearing at this level.

SDO (2)	Document No.	Version	Status	Issued date	Location (1)
<b>Release 99</b>					
ETSI	ETSI TS 123 101	3.1.0	Published	13/02/2001	<a href="http://pda.etsi.org/pda/home.asp?wkr=RTS/TSGS-0223101UR1">http://pda.etsi.org/pda/home.asp?wkr=RTS/TSGS-0223101UR1</a>
<b>Release 4</b>					
ETSI	ETSI TS 123 101	4.0.0	Published	17/04/2001	<a href="http://pda.etsi.org/pda/home.asp?wkr=RTS/TSGS-0223101Uv4">http://pda.etsi.org/pda/home.asp?wkr=RTS/TSGS-0223101Uv4</a>
<b>Release 5</b>					
ETSI	ETSI TS 123 101	5.0.1	Published	30/01/2004	<a href="http://pda.etsi.org/pda/home.asp?wkr=RTS/TSGS-0223101v501">http://pda.etsi.org/pda/home.asp?wkr=RTS/TSGS-0223101v501</a>

**5.1.2.8.3 TS 23.107****QoS concept and architecture**

This specification describes the framework for QoS in UMTS. The document shall be used as a living document which will cover all issues related QoS in UMTS.

SDO (2)	Document No.	Version	Status	Issued date	Location (1)
<b>Release 99</b>					
ETSI	ETSI TS 123 107	3.9.0	Published	03/10/2002	<a href="http://pda.etsi.org/pda/home.asp?wkr=RTS/TSGS-0223107v390">http://pda.etsi.org/pda/home.asp?wkr=RTS/TSGS-0223107v390</a>



**Release 4**

ETSI	ETSI TS 123 107	4.6.0	Published	13/01/2003	<a href="http://pda.etsi.org/pda/home.asp?wkr=RTS/TSGS-0223107v460">http://pda.etsi.org/pda/home.asp?wkr=RTS/TSGS-0223107v460</a>
------	-----------------	-------	-----------	------------	-----------------------------------------------------------------------------------------------------------------------------------

**Release 5**

ETSI	ETSI TS 123 107	5.11.0	Published	08/01/2004	<a href="http://pda.etsi.org/pda/home.asp?wkr=RTS/TSGS-0223107v5b0">http://pda.etsi.org/pda/home.asp?wkr=RTS/TSGS-0223107v5b0</a>
------	-----------------	--------	-----------	------------	-----------------------------------------------------------------------------------------------------------------------------------

**5.1.2.8.4** TS 23.121**Architectural requirements for release 1999**

This specification describes architectural requirements for release 1999 related to the evolution of the GSM platform towards UMTS with the overall goal of fulfilling the UMTS service requirements, support of roaming and support of new functionality, signalling systems and interfaces.

SDO (2)	Document No.	Version	Status	Issued date	Location (1)
<b>Release 99</b>					
ETSI	ETSI TS 123 121	3.6.0	Published	24/06/2002	<a href="http://pda.etsi.org/pda/home.asp?wkr=RTS/TSGS-0223121v360">http://pda.etsi.org/pda/home.asp?wkr=RTS/TSGS-0223121v360</a>

**5.1.2.8.5** TR 23.930**Iu principles**

This specification describes the requirements on the Iu and studies relevant principles to guide further standardization of the related interface(s).

SDO (2)	Document No.	Version	Status	Issued date	Location (1)
<b>Release 99</b>					
ETSI	ETSI TR 123 930	3.0.0	Published	01/02/2000	<a href="http://pda.etsi.org/pda/home.asp?wkr=DTR/TSGS-0223930U">http://pda.etsi.org/pda/home.asp?wkr=DTR/TSGS-0223930U</a>
<b>Release 4</b>					
ETSI	ETSI TR 123 930	4.0.0	Published	19/04/2001	<a href="http://pda.etsi.org/pda/home.asp?wkr=RTR/TSGS-0223930Uv4">http://pda.etsi.org/pda/home.asp?wkr=RTR/TSGS-0223930Uv4</a>

**5.1.2.8.6** TS 22.002**Bearer services supported by a GSM PLMN**

This 3G specification describes a set of bearer services to be provided to 3G subscribers by a 3G network itself and in connection with other networks. This document is also be used as a reference for defining the corresponding required mobile network capabilities which are specified by means of the connection type concept.

SDO (2)	Document No.	Version	Status	Issued date	Location (1)
<b>Release 99</b>					
ETSI	ETSI TS 122 002	3.6.0	Published	19/04/2001	<a href="http://pda.etsi.org/pda/home.asp?wkr=RTS/TSGS-0122002UR4">http://pda.etsi.org/pda/home.asp?wkr=RTS/TSGS-0122002UR4</a>
<b>Release 4</b>					
ETSI	ETSI TS 122 002	4.2.0	Published	16/07/2001	<a href="http://pda.etsi.org/pda/home.asp?wkr=RTS/TSGS-0122002Uv4R1">http://pda.etsi.org/pda/home.asp?wkr=RTS/TSGS-0122002Uv4R1</a>
<b>Release 5</b>					
ETSI	ETSI TS 122 002	5.0.0	Published	16/07/2002	<a href="http://pda.etsi.org/pda/home.asp?wkr=RTS/TSGS-0122002v500">http://pda.etsi.org/pda/home.asp?wkr=RTS/TSGS-0122002v500</a>



**5.1.2.8.7** TS 22.004**General on supplementary services**

This specification describes a recommended set of supplementary services to the teleservices and bearer services which will be supported by a 3G network in connection with other networks as a basis for the definition of the network capabilities required.

SDO (2)	Document No.	Version	Status	Issued date	Location (1)
<b>Release 99</b>					
ETSI	ETSI TS 122 004	3.3.0	Published	25/07/2002	<a href="http://pda.etsi.org/pda/home.asp?wkr=RTS/TSGS-0122004v330">http://pda.etsi.org/pda/home.asp?wkr=RTS/TSGS-0122004v330</a>
<b>Release 4</b>					
ETSI	ETSI TS 122 004	4.2.0	Published	25/07/2002	<a href="http://pda.etsi.org/pda/home.asp?wkr=RTS/TSGS-0122004v420">http://pda.etsi.org/pda/home.asp?wkr=RTS/TSGS-0122004v420</a>
<b>Release 5</b>					
ETSI	ETSI TS 122 004	5.0.0	Published	25/07/2002	<a href="http://pda.etsi.org/pda/home.asp?wkr=RTS/TSGS-0122004v500">http://pda.etsi.org/pda/home.asp?wkr=RTS/TSGS-0122004v500</a>

**5.1.2.8.8** TS 22.011**Service accessibility**

This specification describes the service access procedures as presented to the user. The document contains definitions and procedures are provided for international roaming, national roaming and regionally provided service. These are mandatory in relation to the technical realization of the UE.

SDO (2)	Document No.	Version	Status	Issued date	Location (1)
<b>Release 99</b>					
ETSI	ETSI TS 122 011	3.8.0	Published	20/09/2002	<a href="http://pda.etsi.org/pda/home.asp?wkr=RTS/TSGS-0122011v380">http://pda.etsi.org/pda/home.asp?wkr=RTS/TSGS-0122011v380</a>
<b>Release 4</b>					
ETSI	ETSI TS 122 011	4.8.0	Published	20/09/2002	<a href="http://pda.etsi.org/pda/home.asp?wkr=RTS/TSGS-0122011v480">http://pda.etsi.org/pda/home.asp?wkr=RTS/TSGS-0122011v480</a>
<b>Release 5</b>					
ETSI	ETSI TS 122 011	5.1.0	Published	20/09/2002	<a href="http://pda.etsi.org/pda/home.asp?wkr=RTS/TSGS-0122011v510">http://pda.etsi.org/pda/home.asp?wkr=RTS/TSGS-0122011v510</a>

**5.1.2.8.9** TS 22.016**International mobile equipment identities (IMEI)**

This specification describes the principal purpose and use of unique equipment identities.

SDO (2)	Document No.	Version	Status	Issued date	Location (1)
<b>Release 99</b>					
ETSI	ETSI TS 122 016	3.3.0	Published	16/07/2002	<a href="http://pda.etsi.org/pda/home.asp?wkr=RTS/TSGS-0122016v330">http://pda.etsi.org/pda/home.asp?wkr=RTS/TSGS-0122016v330</a>
<b>Release 4</b>					
ETSI	ETSI TS 122 016	4.2.1	Published	16/07/2002	<a href="http://pda.etsi.org/pda/home.asp?wkr=RTS/TSGS-0122016v421">http://pda.etsi.org/pda/home.asp?wkr=RTS/TSGS-0122016v421</a>
<b>Release 5</b>					
ETSI	ETSI TS 122 016	5.0.0	Published	25/07/2002	<a href="http://pda.etsi.org/pda/home.asp?wkr=RTS/TSGS-0122016v500">http://pda.etsi.org/pda/home.asp?wkr=RTS/TSGS-0122016v500</a>

**5.1.2.8.10** TS 22.022**Personalization of GSM ME mobile functionality specification - Stage 1**

This specification describes functional specifications of five features to personalize UE. These features are called: - network personalization; - network subset personalization; - service provider (SP) personalization; - corporate personalization; - UMTS subscriber identity module (USIM) personalization. This specification describes requirements for UE, which provide these personalization features.

SDO (2)	Document No.	Version	Status	Issued date	Location (1)
<b>Release 99</b>					
ETSI	ETSI TS 122 022	3.2.1	Published	27/06/2002	<a href="http://pda.etsi.org/pda/home.asp?wkr=RTS/TSGS-0322022v321">http://pda.etsi.org/pda/home.asp?wkr=RTS/TSGS-0322022v321</a>
<b>Release 4</b>					
ETSI	ETSI TS 122 022	4.1.0	Published	24/06/2002	<a href="http://pda.etsi.org/pda/home.asp?wkr=RTS/TSGS-0322022v410">http://pda.etsi.org/pda/home.asp?wkr=RTS/TSGS-0322022v410</a>
<b>Release 5</b>					
ETSI	ETSI TS 122 022	5.0.0	Published	02/10/2002	<a href="http://pda.etsi.org/pda/home.asp?wkr=RTS/TSGS-0322022v500">http://pda.etsi.org/pda/home.asp?wkr=RTS/TSGS-0322022v500</a>

**5.1.2.8.11** TS 22.024**Description of charge advice information (CAI)**

This specification describes an overall view of how the charging advice supplementary service shall operate both in the network and within the UE. The charging supplementary service is described in TS 22.086.

SDO (2)	Document No.	Version	Status	Issued date	Location (1)
<b>Release 99</b>					
ETSI	ETSI TS 122 024	3.0.1	Published	01/02/2000	<a href="http://pda.etsi.org/pda/home.asp?wkr=DTS/TSGS-0122024U">http://pda.etsi.org/pda/home.asp?wkr=DTS/TSGS-0122024U</a>
<b>Release 4</b>					
ETSI	ETSI TS 122 024	4.0.0	Published	25/04/2001	<a href="http://pda.etsi.org/pda/home.asp?wkr=RTS/TSGS-0122024Uv4">http://pda.etsi.org/pda/home.asp?wkr=RTS/TSGS-0122024Uv4</a>
<b>Release 5</b>					
ETSI	ETSI TS 122 024	5.0.0	Published	25/07/2002	<a href="http://pda.etsi.org/pda/home.asp?wkr=RTS/TSGS-0122024v500">http://pda.etsi.org/pda/home.asp?wkr=RTS/TSGS-0122024v500</a>

**5.1.2.8.12** TS 22.030**Man-machine interface (MMI) of the mobile station**

This specification describes the requirements for and gives guidelines on the MMI for calls on the 3G UE. This includes the requirements of the user procedures for call control and supplementary service control, the requirements on the physical input media and the output, such as indications and displayed information.

SDO (2)	Document No.	Version	Status	Issued date	Location (1)
<b>Release 99</b>					
ETSI	ETSI TS 122 030	3.4.0	Published	07/11/2000	<a href="http://pda.etsi.org/pda/home.asp?wkr=RTS/TSGS-0122030UR2">http://pda.etsi.org/pda/home.asp?wkr=RTS/TSGS-0122030UR2</a>

**Release 4**

ETSI	ETSI TS 122 030	4.1.0	Published	08/04/2002	<a href="http://pda.etsi.org/pda/home.asp?wkr=RTS/TSGS-0122030Uv4R1">http://pda.etsi.org/pda/home.asp?wkr=RTS/TSGS-0122030Uv4R1</a>
------	-----------------	-------	-----------	------------	-------------------------------------------------------------------------------------------------------------------------------------

**Release 5**

ETSI	ETSI TS 122 030	5.0.0	Published	25/07/2002	<a href="http://pda.etsi.org/pda/home.asp?wkr=RTS/TSGS-0122030v500">http://pda.etsi.org/pda/home.asp?wkr=RTS/TSGS-0122030v500</a>
------	-----------------	-------	-----------	------------	-----------------------------------------------------------------------------------------------------------------------------------

**5.1.2.8.13 TS 22.034****High speed circuit switched data (HSCSD) - Stage 1**

This specification describes the Stage 1 description of HSCSD. HSCSD is a feature that allows users subscribing to the general bearer services to access user rates that can be achieved with one or more traffic channel. HSCSD also defines a flexible use of air interface resources, which makes efficient and flexible use of higher user rates feasible.

SDO (2)	Document No.	Version	Status	Issued date	Location (1)
<b>Release 99</b>					
ETSI	ETSI TS 122 034	3.2.1	Published	17/05/2000	<a href="http://pda.etsi.org/pda/home.asp?wkr=RTS/TSGS-0122034UR1">http://pda.etsi.org/pda/home.asp?wkr=RTS/TSGS-0122034UR1</a>
<b>Release 4</b>					
ETSI	ETSI TS 122 034	4.1.0	Published	25/07/2002	<a href="http://pda.etsi.org/pda/home.asp?wkr=RTS/TSGS-0122034v410">http://pda.etsi.org/pda/home.asp?wkr=RTS/TSGS-0122034v410</a>
<b>Release 5</b>					
ETSI	ETSI TS 122 034	5.0.0	Published	25/07/2002	<a href="http://pda.etsi.org/pda/home.asp?wkr=RTS/TSGS-0122034v500">http://pda.etsi.org/pda/home.asp?wkr=RTS/TSGS-0122034v500</a>

**5.1.2.8.14 TS 22.038****SIM application toolkit (SAT) - Stage 1**

This specification describes the Stage 1 description of the SAT primarily from the subscriber's and serving environment's points of view, and does not deal with the details of the human interface itself. It includes information applicable to network operators, serving environments and terminal, switch and database manufacturers and contains the core requirements for a SAT which are sufficient to provide a complete service.

SDO (2)	Document No.	Version	Status	Issued date	Location (1)
<b>Release 99</b>					
ETSI	ETSI TS 122 038	3.4.0	Published	08/01/2004	<a href="http://pda.etsi.org/pda/home.asp?wkr=RTS/TSGS-0122038v340">http://pda.etsi.org/pda/home.asp?wkr=RTS/TSGS-0122038v340</a>
<b>Release 4</b>					
ETSI	ETSI TS 122 038	4.3.0	Published	08/01/2004	<a href="http://pda.etsi.org/pda/home.asp?wkr=RTS/TSGS-0122038v430">http://pda.etsi.org/pda/home.asp?wkr=RTS/TSGS-0122038v430</a>
<b>Release 5</b>					
ETSI	ETSI TS 122 038	5.4.0	Published	08/01/2004	<a href="http://pda.etsi.org/pda/home.asp?wkr=RTS/TSGS-0122038v540">http://pda.etsi.org/pda/home.asp?wkr=RTS/TSGS-0122038v540</a>
<b>Release 6</b>					
ETSI	ETSI TS 122 038	6.2.0	Awaiting		<a href="http://pda.etsi.org/pda/home.asp?wkr=RTS/TSGS-0122038v620">http://pda.etsi.org/pda/home.asp?wkr=RTS/TSGS-0122038v620</a>

**5.1.2.8.15** TS 22.041**Operator determined call barring**

The feature operator determined barring (ODB) allows the network operator or service provider to regulate, by means of an exceptional procedure, access by the subscribers to 3G services, by the barring of certain categories of outgoing or incoming calls or of roaming. ODB shall take effect immediately and shall terminate ongoing calls and bar future calls. The purpose of this network feature is to be able to limit the service provider's financial exposure to new subscribers, or to those who have not promptly paid their bills. It may only be applied to the service provider's own subscribers.

SDO (2)	Document No.	Version	Status	Issued date	Location (1)
<b>Release 99</b>					
ETSI	ETSI TS 122 041	3.3.1	Published	25/06/2001	<a href="http://pda.etsi.org/pda/home.asp?wkr=RTS/TSGS-0122041UR2">http://pda.etsi.org/pda/home.asp?wkr=RTS/TSGS-0122041UR2</a>
<b>Release 4</b>					
ETSI	ETSI TS 122 041	4.1.0	Published	25/04/2001	<a href="http://pda.etsi.org/pda/home.asp?wkr=RTS/TSGS-0122041Uv4">http://pda.etsi.org/pda/home.asp?wkr=RTS/TSGS-0122041Uv4</a>
<b>Release 5</b>					
ETSI	ETSI TS 122 041	5.0.0	Published	25/07/2002	<a href="http://pda.etsi.org/pda/home.asp?wkr=RTS/TSGS-0122041v500">http://pda.etsi.org/pda/home.asp?wkr=RTS/TSGS-0122041v500</a>

**5.1.2.8.16** TS 22.042**Network identity and time zone (NITZ) - Stage 1**

The feature NITZ provides the means for serving networks to transfer current identity, time, daylight saving time and the local time zone to user equipment storage and use.

SDO (2)	Document No.	Version	Status	Issued date	Location (1)
<b>Release 99</b>					
ETSI	ETSI TS 122 042	3.0.1	Published	01/02/2000	<a href="http://pda.etsi.org/pda/home.asp?wkr=DTS/TSGS-0122042U">http://pda.etsi.org/pda/home.asp?wkr=DTS/TSGS-0122042U</a>
<b>Release 4</b>					
ETSI	ETSI TS 122 042	4.2.1	Published	03/07/2003	<a href="http://pda.etsi.org/pda/home.asp?wkr=RTS/TSGS-0122042v421">http://pda.etsi.org/pda/home.asp?wkr=RTS/TSGS-0122042v421</a>
<b>Release 5</b>					
ETSI	ETSI TS 122 042	5.1.0	Published	01/07/2003	<a href="http://pda.etsi.org/pda/home.asp?wkr=RTS/TSGS-0122042v510">http://pda.etsi.org/pda/home.asp?wkr=RTS/TSGS-0122042v510</a>

**5.1.2.8.17** TS 22.057**Mobile station application execution environment (MExE) - Stage 1**

This specification describes the Stage 1 description of the MExE.

SDO (2)	Document No.	Version	Status	Issued date	Location (1)
<b>Release 99</b>					
ETSI	ETSI TS 122 057	3.0.1	Published	01/02/2000	<a href="http://pda.etsi.org/pda/home.asp?wkr=DTS/TSGS-0122057U">http://pda.etsi.org/pda/home.asp?wkr=DTS/TSGS-0122057U</a>

**Release 4**

ETSI	ETSI TS 122 057	4.1.0	Published	08/04/2002	<a href="http://pda.etsi.org/pda/home.asp?wkr=RTS/TSGS-0122057Uv4R1">http://pda.etsi.org/pda/home.asp?wkr=RTS/TSGS-0122057Uv4R1</a>
------	-----------------	-------	-----------	------------	-------------------------------------------------------------------------------------------------------------------------------------

**Release 5**

ETSI	ETSI TS 122 057	5.4.0	Published	16/07/2002	<a href="http://pda.etsi.org/pda/home.asp?wkr=RTS/TSGS-0122057v540">http://pda.etsi.org/pda/home.asp?wkr=RTS/TSGS-0122057v540</a>
------	-----------------	-------	-----------	------------	-----------------------------------------------------------------------------------------------------------------------------------

**5.1.2.8.18 TS 22.060****General packet radio service (GPRS) - Stage 1**

This specification describes the Stage 1 description of the GPRS.

SDO (2)	Document No.	Version	Status	Issued date	Location (1)
<b>Release 99</b>					
ETSI	ETSI TS 122 060	3.5.0	Published	07/11/2000	<a href="http://pda.etsi.org/pda/home.asp?wkr=RTS/TSGS-0122060UR3">http://pda.etsi.org/pda/home.asp?wkr=RTS/TSGS-0122060UR3</a>
<b>Release 4</b>					
ETSI	ETSI TS 122 060	4.4.0	Published	16/07/2002	<a href="http://pda.etsi.org/pda/home.asp?wkr=RTS/TSGS-0122060v440">http://pda.etsi.org/pda/home.asp?wkr=RTS/TSGS-0122060v440</a>
<b>Release 5</b>					
ETSI	ETSI TS 122 060	5.3.0	Published	01/04/2003	<a href="http://pda.etsi.org/pda/home.asp?wkr=RTS/TSGS-0122060v530">http://pda.etsi.org/pda/home.asp?wkr=RTS/TSGS-0122060v530</a>

**5.1.2.8.19 TS 22.066****Support of mobile number portability (MNP) - Stage 1**

This specification describes the Stage 1 description of the support of MNP between networks in the same country. It is in response to a study mandate agreed between the European Commission and ETSI under order voucher ETSI/97/M-251.

SDO (2)	Document No.	Version	Status	Issued date	Location (1)
<b>Release 99</b>					
ETSI	ETSI TS 122 066	3.2.0	Published	22/08/2000	<a href="http://pda.etsi.org/pda/home.asp?wkr=RTS/TSGS-0122066UR2">http://pda.etsi.org/pda/home.asp?wkr=RTS/TSGS-0122066UR2</a>
<b>Release 4</b>					
ETSI	ETSI TS 122 066	4.0.0	Published	25/04/2001	<a href="http://pda.etsi.org/pda/home.asp?wkr=RTS/TSGS-0122066Uv4">http://pda.etsi.org/pda/home.asp?wkr=RTS/TSGS-0122066Uv4</a>
<b>Release 5</b>					
ETSI	ETSI TS 122 066	5.1.0	Published	01/07/2003	<a href="http://pda.etsi.org/pda/home.asp?wkr=RTS/TSGS-0122066v510">http://pda.etsi.org/pda/home.asp?wkr=RTS/TSGS-0122066v510</a>

**5.1.2.8.20 TS 22.067****Priority set-up service - Stage 1 (ASCI spec)**

This specification describes the Stage 1 description of the enhanced multi-level precedence and pre-emption (eMLPP) service. This service has two parts: precedence and pre-emption. Precedence involves assigning a priority level to a call in combination with fast call set-up. Pre-emption involves the seizing of resources, which are in use by a call of a lower precedence, by a higher level precedence call in the absence of idle resources. Pre-emption can also involve the disconnection of an on-going call of lower precedence to accept an incoming call of higher precedence.

## 102

## Rec. ITU-R M.1457-4

SDO (2)	Document No.	Version	Status	Issued date	Location (1)
<b>Release 99</b>					
ETSI	ETSI TS 122 067	3.0.1	Published	01/02/2000	<a href="http://pda.etsi.org/pda/home.asp?wkr=DTS/TSGS-0122067U">http://pda.etsi.org/pda/home.asp?wkr=DTS/TSGS-0122067U</a>
<b>Release 4</b>					
ETSI	ETSI TS 122 067	4.1.0	Published	08/04/2002	<a href="http://pda.etsi.org/pda/home.asp?wkr=RTS/TSGS-0122067Uv4R1">http://pda.etsi.org/pda/home.asp?wkr=RTS/TSGS-0122067Uv4R1</a>
<b>Release 5</b>					
ETSI	ETSI TS 122 067	5.0.0	Published	30/07/2002	<a href="http://pda.etsi.org/pda/home.asp?wkr=RTS/TSGS-0122067v500">http://pda.etsi.org/pda/home.asp?wkr=RTS/TSGS-0122067v500</a>

### 5.1.2.8.21 TS 22.071

#### Location services (LCS) - Stage 1

LCS is a network provided enabling technology consisting of standardized service capabilities which enables the provision of location applications. This application may be service provider specific. The description of the numerous and varied possible location applications which are enabled by this technology are outside the scope of this specification. However, clarifying examples of how the functionality being specified may be used to provide specific LCS is included in various sections of the specification.

SDO (2)	Document No.	Version	Status	Issued date	Location (1)
<b>Release 99</b>					
ETSI	ETSI TS 122 071	3.4.0	Published	08/04/2002	<a href="http://pda.etsi.org/pda/home.asp?wkr=RTS/TSGS-0122071UR2">http://pda.etsi.org/pda/home.asp?wkr=RTS/TSGS-0122071UR2</a>
<b>Release 4</b>					
ETSI	ETSI TS 122 071	4.5.0	Published	03/10/2003	<a href="http://pda.etsi.org/pda/home.asp?wkr=RTS/TSGS-0122071v450">http://pda.etsi.org/pda/home.asp?wkr=RTS/TSGS-0122071v450</a>
<b>Release 5</b>					
ETSI	ETSI TS 122 071	5.3.0	Published	08/01/2004	<a href="http://pda.etsi.org/pda/home.asp?wkr=RTS/TSGS-0122071v530">http://pda.etsi.org/pda/home.asp?wkr=RTS/TSGS-0122071v530</a>
<b>Release 6</b>					
ETSI	ETSI TS 122 071	6.6.0	Awaiting		<a href="http://pda.etsi.org/pda/home.asp?wkr=RTS/TSGS-0122071v660">http://pda.etsi.org/pda/home.asp?wkr=RTS/TSGS-0122071v660</a>

### 5.1.2.8.22 TS 22.072

#### Call deflection (CD) - Stage 1

CD enables the served mobile subscriber to respond to an incoming call offered by the network by requesting redirection of this call to another number specified in the response. The CD supplementary service can only be invoked before the connection is established by the served mobile subscriber, i.e. in response to the offered call, or during the period that the served subscriber is being informed of the call. The served subscriber's ability to originate calls is unaffected by the CD supplementary service.

SDO (2)	Document No.	Version	Status	Issued date	Location (1)
<b>Release 99</b>					
ETSI	ETSI TS 122 072	3.0.1	Published	01/02/2000	<a href="http://pda.etsi.org/pda/home.asp?wkr=DTS/TSGS-0122072U">http://pda.etsi.org/pda/home.asp?wkr=DTS/TSGS-0122072U</a>
<b>Release 4</b>					
ETSI	ETSI TS 122 072	4.0.0	Published	03/05/2001	<a href="http://pda.etsi.org/pda/home.asp?wkr=RTS/TSGS-0122072Uv4">http://pda.etsi.org/pda/home.asp?wkr=RTS/TSGS-0122072Uv4</a>

**Release 5**

SDO (2)	Document No.	Version	Status	Issued date	Location (1)
ETSI	ETSI TS 122 072	5.0.0	Published	25/07/2002	<a href="http://pda.etsi.org/pda/home.asp?wkr=RTS/TSGS-0122072v500">http://pda.etsi.org/pda/home.asp?wkr=RTS/TSGS-0122072v500</a>

**5.1.2.8.23 TS 22.078****Customized applications for mobile network enhanced logic (CAMEL) - Stage 1**

This specification describes the Stage 1 description for CAMEL feature which provides the mechanisms to support services consistently independently of the serving network. The CAMEL features shall facilitate service control of operator specific services external from the serving network. The CAMEL feature is a network feature and not a supplementary service. It is a tool to help the network operator to provide the subscribers with the operator specific services even when roaming outside the home network.

SDO (2)	Document No.	Version	Status	Issued date	Location (1)
<b>Release 99</b>					
ETSI	ETSI TS 122 078	3.9.0	Published	09/04/2002	<a href="http://pda.etsi.org/pda/home.asp?wkr=RTS/TSGS-0122078UR7">http://pda.etsi.org/pda/home.asp?wkr=RTS/TSGS-0122078UR7</a>
<b>Release 4</b>					
ETSI	ETSI TS 122 078	4.5.0	Published	09/04/2002	<a href="http://pda.etsi.org/pda/home.asp?wkr=RTS/TSGS-0122078Uv4R3">http://pda.etsi.org/pda/home.asp?wkr=RTS/TSGS-0122078Uv4R3</a>
<b>Release 5</b>					
ETSI	ETSI TS 122 078	5.12.0	Published	13/01/2004	<a href="http://pda.etsi.org/pda/home.asp?wkr=RTS/TSGS-0122078v5c0">http://pda.etsi.org/pda/home.asp?wkr=RTS/TSGS-0122078v5c0</a>

**5.1.2.8.24 TS 22.079****Support of optimal routing - Stage 1**

Support of optimal routing is a network feature to reduce the number of unnecessary inter-network call legs when the subscriber is roaming.

SDO (2)	Document No.	Version	Status	Issued date	Location (1)
<b>Release 99</b>					
ETSI	ETSI TS 122 079	3.0.1	Published	01/02/2000	<a href="http://pda.etsi.org/pda/home.asp?wkr=DTS/TSGS-0122079U">http://pda.etsi.org/pda/home.asp?wkr=DTS/TSGS-0122079U</a>
<b>Release 4</b>					
ETSI	ETSI TS 122 079	4.0.0	Published	25/04/2001	<a href="http://pda.etsi.org/pda/home.asp?wkr=RTS/TSGS-0122079Uv4">http://pda.etsi.org/pda/home.asp?wkr=RTS/TSGS-0122079Uv4</a>
<b>Release 5</b>					
ETSI	ETSI TS 122 079	5.0.0	Published	26/07/2002	<a href="http://pda.etsi.org/pda/home.asp?wkr=RTS/TSGS-0122079v500">http://pda.etsi.org/pda/home.asp?wkr=RTS/TSGS-0122079v500</a>

**5.1.2.8.25 TS 22.081****Line identification supplementary services - Stage 1**

This specification describes the supplementary services belonging to the group line identification supplementary services. The group of line identification supplementary services is divided into the following four supplementary services: CLIP: calling line identification presentation (clause 1); CLIR: calling line identification restriction (clause 2); COLP: connected line identification presentation (clause 3); COLR: connected line identification restriction (clause 4).

## 104

## Rec. ITU-R M.1457-4

SDO (2)	Document No.	Version	Status	Issued date	Location (1)
<b>Release 99</b>					
ETSI	ETSI TS 122 081	3.2.0	Published	22/08/2000	<a href="http://pda.etsi.org/pda/home.asp?wkr=RTS/TSGS-0122081UR1">http://pda.etsi.org/pda/home.asp?wkr=RTS/TSGS-0122081UR1</a>
<b>Release 4</b>					
ETSI	ETSI TS 122 081	4.1.0	Published	08/04/2002	<a href="http://pda.etsi.org/pda/home.asp?wkr=RTS/TSGS-0122081Uv4R1">http://pda.etsi.org/pda/home.asp?wkr=RTS/TSGS-0122081Uv4R1</a>
<b>Release 5</b>					
ETSI	ETSI TS 122 081	5.0.0	Published	25/07/2002	<a href="http://pda.etsi.org/pda/home.asp?wkr=RTS/TSGS-0122081v500">http://pda.etsi.org/pda/home.asp?wkr=RTS/TSGS-0122081v500</a>

### 5.1.2.8.26 TS 22.082

#### Call forwarding (CF) supplementary services - Stage 1

This specification describes the supplementary services belonging to the group call offering supplementary services. The group of supplementary services call offering supplementary services is divided into four different supplementary services: - call forwarding unconditional (clause 1); - call forwarding on mobile subscriber busy (clause 2); - call forwarding on no reply (clause 3); - call forwarding on mobile subscriber not reachable (clause 4).

SDO (2)	Document No.	Version	Status	Issued date	Location (1)
<b>Release 99</b>					
ETSI	ETSI TS 122 082	3.0.1	Published		<a href="http://pda.etsi.org/pda/home.asp?wkr=DTS/TSGS-0122082U">http://pda.etsi.org/pda/home.asp?wkr=DTS/TSGS-0122082U</a>
<b>Release 4</b>					
ETSI	ETSI TS 122 082	4.2.0	Published	08/04/2002	<a href="http://pda.etsi.org/pda/home.asp?wkr=RTS/TSGS-0122082Uv4R2">http://pda.etsi.org/pda/home.asp?wkr=RTS/TSGS-0122082Uv4R2</a>
<b>Release 5</b>					
ETSI	ETSI TS 122 082	5.0.0	Published	30/07/2002	<a href="http://pda.etsi.org/pda/home.asp?wkr=RTS/TSGS-0122082v500">http://pda.etsi.org/pda/home.asp?wkr=RTS/TSGS-0122082v500</a>

### 5.1.2.8.27 TS 2.083

#### Call waiting (CW) and call hold (HOLD) supplementary services - Stage 1

This specification describes the supplementary services belonging to the group call completion supplementary services which are divided into the following two supplementary services: - call waiting (clause 1); - call hold (clause 2).

SDO (2)	Document No.	Version	Status	Issued date	Location (1)
<b>Release 99</b>					
ETSI	ETSI TS 122 083	3.0.1	Published	01/02/2000	<a href="http://pda.etsi.org/pda/home.asp?wkr=DTS/TSGS-0122083U">http://pda.etsi.org/pda/home.asp?wkr=DTS/TSGS-0122083U</a>
<b>Release 4</b>					
ETSI	ETSI TS 122 083	4.1.0	Published	08/04/2002	<a href="http://pda.etsi.org/pda/home.asp?wkr=RTS/TSGS-0122083Uv4R1">http://pda.etsi.org/pda/home.asp?wkr=RTS/TSGS-0122083Uv4R1</a>
<b>Release 5</b>					
ETSI	ETSI TS 122 083	5.0.0	Published	25/07/2002	<a href="http://pda.etsi.org/pda/home.asp?wkr=RTS/TSGS-0122083v500">http://pda.etsi.org/pda/home.asp?wkr=RTS/TSGS-0122083v500</a>



**5.1.2.8.28** TS 22.084**Multiparty (MPTY) supplementary service - Stage 1**

This supplementary service provides a mobile subscriber with the ability to have a multi-connection call, i.e. a simultaneous communication with more than one party.

SDO (2)	Document No.	Version	Status	Issued date	Location (1)
<b>Release 99</b>					
ETSI	ETSI TS 122 084	3.0.1	Published	01/02/2000	<a href="http://pda.etsi.org/pda/home.asp?wkr=DTS/TSGS-0122084U">http://pda.etsi.org/pda/home.asp?wkr=DTS/TSGS-0122084U</a>
<b>Release 4</b>					
ETSI	ETSI TS 122 084	4.1.0	Published	08/04/2002	<a href="http://pda.etsi.org/pda/home.asp?wkr=RTS/TSGS-0122084Uv4R1">http://pda.etsi.org/pda/home.asp?wkr=RTS/TSGS-0122084Uv4R1</a>
<b>Release 5</b>					
ETSI	ETSI TS 122 084	5.0.0	Published	26/07/2002	<a href="http://pda.etsi.org/pda/home.asp?wkr=RTS/TSGS-0122084v500">http://pda.etsi.org/pda/home.asp?wkr=RTS/TSGS-0122084v500</a>

**5.1.2.8.29** TS 22.085**Closed user group (CUG) supplementary services - Stage 1**

The CUG supplementary service enables subscribers, connected to a network and possibly also other networks, to form CUGs to and from which access is restricted. A specific user may be a member of one or more CUGs. Members of a specific CUG can communicate among each other but not, in general, with users outside the group.

SDO (2)	Document No.	Version	Status	Issued date	Location (1)
<b>Release 99</b>					
ETSI	ETSI TS 122 085	3.1.0	Published	01/02/2000	<a href="http://pda.etsi.org/pda/home.asp?wkr=DTS/TSGS-0122085U">http://pda.etsi.org/pda/home.asp?wkr=DTS/TSGS-0122085U</a>
<b>Release 4</b>					
ETSI	ETSI TS 122 085	4.1.0	Published	08/04/2002	<a href="http://pda.etsi.org/pda/home.asp?wkr=RTS/TSGS-0122085Uv4R1">http://pda.etsi.org/pda/home.asp?wkr=RTS/TSGS-0122085Uv4R1</a>
<b>Release 5</b>					
ETSI	ETSI TS 122 085	5.0.0	Published	26/07/2002	<a href="http://pda.etsi.org/pda/home.asp?wkr=RTS/TSGS-0122085v500">http://pda.etsi.org/pda/home.asp?wkr=RTS/TSGS-0122085v500</a>

**5.1.2.8.30** TS 22.086**Advice of charge (AoC) supplementary services - Stage 1**

These services are designed to supply to a mobile user sufficient information to allow a real-time estimate to be made of the bill which will eventually be levied in the home public land mobile network (PLMN) on the mobile station subscriber.

SDO (2)	Document No.	Version	Status	Issued date	Location (1)
<b>Release 99</b>					
ETSI	ETSI TS 122 086	3.1.0	Published	17/05/2000	<a href="http://pda.etsi.org/pda/home.asp?wkr=DTS/TSGS-0122086U">http://pda.etsi.org/pda/home.asp?wkr=DTS/TSGS-0122086U</a>
<b>Release 4</b>					
ETSI	ETSI TS 122 086	4.0.0	Published	25/04/2001	<a href="http://pda.etsi.org/pda/home.asp?wkr=RTS/TSGS-0122086Uv4">http://pda.etsi.org/pda/home.asp?wkr=RTS/TSGS-0122086Uv4</a>

**Release 5**

ETSI	ETSI TS 122 086	5.0.0	Published	26/07/2002	<a href="http://pda.etsi.org/pda/home.asp?wkr=RTS/TSGS-0122086v500">http://pda.etsi.org/pda/home.asp?wkr=RTS/TSGS-0122086v500</a>
------	-----------------	-------	-----------	------------	-----------------------------------------------------------------------------------------------------------------------------------

**5.1.2.8.31 TS 22.087****User-to-user signalling (UUS) - Stage 1**

The UUS supplementary service allows a mobile subscriber to send/receive a limited amount of information to/from another network or ISDN subscriber over the signalling channel in association with a call to the other subscriber.

SDO (2)	Document No.	Version	Status	Issued date	Location (1)
<b>Release 99</b>					
ETSI	ETSI TS 122 087	3.1.0	Published	17/05/2000	<a href="http://pda.etsi.org/pda/home.asp?wkr=RTS/TSGS-0122087UR1">http://pda.etsi.org/pda/home.asp?wkr=RTS/TSGS-0122087UR1</a>
<b>Release 4</b>					
ETSI	ETSI TS 122 087	4.0.0	Published	25/04/2001	<a href="http://pda.etsi.org/pda/home.asp?wkr=RTS/TSGS-0122087Uv4">http://pda.etsi.org/pda/home.asp?wkr=RTS/TSGS-0122087Uv4</a>
<b>Release 5</b>					
ETSI	ETSI TS 122 087	5.0.0	Published	26/07/2002	<a href="http://pda.etsi.org/pda/home.asp?wkr=RTS/TSGS-0122087v500">http://pda.etsi.org/pda/home.asp?wkr=RTS/TSGS-0122087v500</a>

**5.1.2.8.32 TS 22.088****Call barring (CB) supplementary services - Stage 1**

The call restriction supplementary services allow the possibility for a mobile subscriber to have barring of certain categories of outgoing or incoming calls at the mobile subscribers access. The group of call restriction services includes two supplementary services: - barring of outgoing calls; - barring of incoming calls. By use of subscription options, the mobile subscriber can at provision time select a set of one or more barring programs to determine the categories of calls to be barred. The following categories are defined: - all outgoing calls; - outgoing international calls; - outgoing international calls except those directed to the home PLMN country; - all incoming calls; - incoming calls when roaming outside the home PLMN country.

SDO (2)	Document No.	Version	Status	Issued date	Location (1)
<b>Release 99</b>					
ETSI	ETSI TS 122 088	3.0.2	Published	25/04/2001	<a href="http://pda.etsi.org/pda/home.asp?wkr=RTS/TSGS-0122088UR1">http://pda.etsi.org/pda/home.asp?wkr=RTS/TSGS-0122088UR1</a>
<b>Release 4</b>					
ETSI	ETSI TS 122 088	4.1.0	Published	08/04/2002	<a href="http://pda.etsi.org/pda/home.asp?wkr=RTS/TSGS-0122088Uv4R1">http://pda.etsi.org/pda/home.asp?wkr=RTS/TSGS-0122088Uv4R1</a>
<b>Release 5</b>					
ETSI	ETSI TS 122 088	5.0.0	Published	26/07/2002	<a href="http://pda.etsi.org/pda/home.asp?wkr=RTS/TSGS-0122088v500">http://pda.etsi.org/pda/home.asp?wkr=RTS/TSGS-0122088v500</a>

**5.1.2.8.33** TS 22.090**Unstructured supplementary service data (USSD) - Stage 1**

There are two modes of USSD: MMI-mode and application mode. MMI-mode USSD is for the transparent transport of MMI strings entered by the user to the network and for the transparent transport of text strings from the network that are displayed by the mobile for user information. Application mode USSD is for the transparent transport of data between the network and the mobile station. Application mode USSD is intended to be used by applications in the network and their peer applications in the UE. The communication over the radio interface takes place on the signalling channels using short dialogues with peak data throughput rate capabilities of up to approximately 600 bit/s outside of a call and 1 000 bit/s during a call.

SDO (2)	Document No.	Version	Status	Issued date	Location (1)
<b>Release 99</b>					
ETSI	ETSI TS 122 090	3.1.0	Published	17/05/2000	<a href="http://pda.etsi.org/pda/home.asp?wkr=RTS/TSGS-0122090UR1">http://pda.etsi.org/pda/home.asp?wkr=RTS/TSGS-0122090UR1</a>
<b>Release 4</b>					
ETSI	ETSI TS 122 090	4.0.0	Published	25/04/2001	<a href="http://pda.etsi.org/pda/home.asp?wkr=RTS/TSGS-0122090Uv4">http://pda.etsi.org/pda/home.asp?wkr=RTS/TSGS-0122090Uv4</a>
<b>Release 5</b>					
ETSI	ETSI TS 122 090	5.0.0	Published	30/07/2002	<a href="http://pda.etsi.org/pda/home.asp?wkr=RTS/TSGS-0122090v500">http://pda.etsi.org/pda/home.asp?wkr=RTS/TSGS-0122090v500</a>

**5.1.2.8.34** TS 22.091**Explicit call transfer (ECT) supplementary service - Stage 1**

The ECT supplementary service enables the served mobile subscriber (subscriber A) who has two calls, each of which can be an incoming or outgoing call, to connect the other parties in the two calls and release the served mobile subscribers own connection.

SDO (2)	Document No.	Version	Status	Issued date	Location (1)
<b>Release 99</b>					
ETSI	ETSI TS 122 091	3.1.0	Published	07/11/2000	<a href="http://pda.etsi.org/pda/home.asp?wkr=RTS/TSGS-0122091UR1">http://pda.etsi.org/pda/home.asp?wkr=RTS/TSGS-0122091UR1</a>
<b>Release 4</b>					
ETSI	ETSI TS 122 091	4.0.0	Published	25/04/2001	<a href="http://pda.etsi.org/pda/home.asp?wkr=RTS/TSGS-0122091Uv4">http://pda.etsi.org/pda/home.asp?wkr=RTS/TSGS-0122091Uv4</a>
<b>Release 5</b>					
ETSI	ETSI TS 122 091	5.0.0	Published	30/07/2002	<a href="http://pda.etsi.org/pda/home.asp?wkr=RTS/TSGS-0122091v500">http://pda.etsi.org/pda/home.asp?wkr=RTS/TSGS-0122091v500</a>

**5.1.2.8.35** TS 22.093**Call completion to busy subscriber (CCBS) - Stage 1**

In the situation when subscriber A encounters a network determined user busy (NDUB) destination B, the subscriber A can request the CCBS supplementary service (i.e. activate a CCBS request against destination B). The network will then monitor the wanted destination B for becoming idle. When the wanted destination B becomes idle, then the network will wait a short time in order to allow destination B to make an outgoing call.

If destination B does not make any outgoing call within this time, then the network shall automatically recall subscriber A.

SDO (2)	Document No.	Version	Status	Issued date	Location (1)
<b>Release 99</b>					
ETSI	ETSI TS 122 093	3.0.1	Published	01/02/2000	<a href="http://pda.etsi.org/pda/home.asp?wkr=DTS/TSGS-0122093U">http://pda.etsi.org/pda/home.asp?wkr=DTS/TSGS-0122093U</a>
<b>Release 4</b>					
ETSI	ETSI TS 122 093	4.0.0	Published	25/04/2001	<a href="http://pda.etsi.org/pda/home.asp?wkr=RTS/TSGS-0122093Uv4">http://pda.etsi.org/pda/home.asp?wkr=RTS/TSGS-0122093Uv4</a>
<b>Release 5</b>					
ETSI	ETSI TS 122 093	5.0.0	Published	30/07/2002	<a href="http://pda.etsi.org/pda/home.asp?wkr=RTS/TSGS-0122093v500">http://pda.etsi.org/pda/home.asp?wkr=RTS/TSGS-0122093v500</a>

### 5.1.2.8.36 TS 22.096

#### Calling name presentation (CNAP) - Stage 1

The CNAP supplementary service enables the called party to receive the calling name information of the calling party.

SDO (2)	Document No.	Version	Status	Issued date	Location (1)
<b>Release 99</b>					
ETSI	ETSI TS 122 096	3.0.1	Published	01/02/2000	<a href="http://pda.etsi.org/pda/home.asp?wkr=DTS/TSGS-0122096U">http://pda.etsi.org/pda/home.asp?wkr=DTS/TSGS-0122096U</a>
<b>Release 4</b>					
ETSI	ETSI TS 122 096	4.0.0	Published	25/04/2001	<a href="http://pda.etsi.org/pda/home.asp?wkr=RTS/TSGS-0122096Uv4">http://pda.etsi.org/pda/home.asp?wkr=RTS/TSGS-0122096Uv4</a>
<b>Release 5</b>					
ETSI	ETSI TS 122 096	5.0.0	Published	30/07/2002	<a href="http://pda.etsi.org/pda/home.asp?wkr=RTS/TSGS-0122096v500">http://pda.etsi.org/pda/home.asp?wkr=RTS/TSGS-0122096v500</a>

### 5.1.2.8.37 TS 22.097

#### Multiple subscriber profile (MSP) - Stage 1

MSP is an optional service to enable mobile subscribers to have several profiles associated with a single subscriber identity (SIM) and a single international mobile subscriber identity (IMSI), with each profile being a subscription option. Each profile may be used for mobile originated and mobile terminated calls. Up to four different profiles can be provisioned against a subscriber using the MSP feature. This will allow the subscriber to separate her telecommunication service needs into different identities (e.g. business and home).

SDO (2)	Document No.	Version	Status	Issued date	Location (1)
<b>Release 99</b>					
ETSI	ETSI TS 122 097	3.2.0	Published	07/11/2000	<a href="http://pda.etsi.org/pda/home.asp?wkr=RTS/TSGS-0122097UR1">http://pda.etsi.org/pda/home.asp?wkr=RTS/TSGS-0122097UR1</a>
<b>Release 4</b>					
ETSI	ETSI TS 122 097	4.1.0	Published	08/04/2002	<a href="http://pda.etsi.org/pda/home.asp?wkr=RTS/TSGS-0122097Uv4R1">http://pda.etsi.org/pda/home.asp?wkr=RTS/TSGS-0122097Uv4R1</a>
<b>Release 5</b>					
ETSI	ETSI TS 122 097	5.0.0	Published	25/07/2002	<a href="http://pda.etsi.org/pda/home.asp?wkr=RTS/TSGS-0122097v500">http://pda.etsi.org/pda/home.asp?wkr=RTS/TSGS-0122097v500</a>

**5.1.2.8.38 TS 22.100****UMTS phase 1 capabilities**

This specification describes contains how the definition of the UMTS system will be achieved in a phased approach. This document also specifies the requirements for release 99 of UMTS. Some requirements which are necessary to ensure a smooth transition to later releases are also indicated. This document should, however, be read in conjunction with the other 22.000 series documents which provide a complete description of the requirements for UMTS release 1999 and beyond.

SDO (2)	Document No.	Version	Status	Issued date	Location (1)
<b>Release 99</b>					
ETSI	ETSI TS 122 100	3.7.0	Published	10/10/2001	<a href="http://pda.etsi.org/pda/home.asp?wkr=RTS/TSGS-0122100UR2">http://pda.etsi.org/pda/home.asp?wkr=RTS/TSGS-0122100UR2</a>

**5.1.2.8.39 TS 22.101****UMTS service principles**

This specification describes the service principles of the UMTS.

SDO (2)	Document No.	Version	Status	Issued date	Location (1)
<b>Release 99</b>					
ETSI	ETSI TS 122 101	3.16.0	Published	08/01/2004	<a href="http://pda.etsi.org/pda/home.asp?wkr=RTS/TSGS-0122101v3g0">http://pda.etsi.org/pda/home.asp?wkr=RTS/TSGS-0122101v3g0</a>
<b>Release 4</b>					
ETSI	ETSI TS 122 101	4.9.0	Published	08/01/2004	<a href="http://pda.etsi.org/pda/home.asp?wkr=RTS/TSGS-0122101v490">http://pda.etsi.org/pda/home.asp?wkr=RTS/TSGS-0122101v490</a>
<b>Release 5</b>					
ETSI	ETSI TS 122 101	5.12.0	Published	08/01/2004	<a href="http://pda.etsi.org/pda/home.asp?wkr=RTS/TSGS-0122101v5c0">http://pda.etsi.org/pda/home.asp?wkr=RTS/TSGS-0122101v5c0</a>
<b>Release 6</b>					
ETSI	ETSI TS 122 101	6.6.0	Awaiting		<a href="http://pda.etsi.org/pda/home.asp?wkr=RTS/TSGS-0122101v660">http://pda.etsi.org/pda/home.asp?wkr=RTS/TSGS-0122101v660</a>

**5.1.2.8.40 TS 22.105****Services and service capabilities**

Pre-UMTS systems have largely standardized the complete sets of bearer services, teleservices and supplementary services which they provide. One major difference between UMTS and pre-UMTS systems is that service capabilities rather than services are standardized for UMTS, allowing service differentiation and system continuity. This document describes how and what kind of services the UMTS user has access to.

SDO (2)	Document No.	Version	Status	Issued date	Location (1)
<b>Release 99</b>					
ETSI	ETSI TS 122 105	3.10.0	Published	13/02/2001	<a href="http://pda.etsi.org/pda/home.asp?wkr=RTS/TSGS-0122105UR3">http://pda.etsi.org/pda/home.asp?wkr=RTS/TSGS-0122105UR3</a>
<b>Release 4</b>					
ETSI	ETSI TS 122 105	4.3.0	Published	09/04/2002	<a href="http://pda.etsi.org/pda/home.asp?wkr=RTS/TSGS-0122105Uv4R1">http://pda.etsi.org/pda/home.asp?wkr=RTS/TSGS-0122105Uv4R1</a>

**Release 5**

ETSI	ETSI TS 122 105	5.2.0	Published	16/07/2002	<a href="http://pda.etsi.org/pda/home.asp?wkr=RTS/TSGS-0122105v520">http://pda.etsi.org/pda/home.asp?wkr=RTS/TSGS-0122105v520</a>
------	-----------------	-------	-----------	------------	-----------------------------------------------------------------------------------------------------------------------------------

**5.1.2.8.41 TS 22.115****Service aspects: charging and billing**

This specification describes the service aspects of charging and billing of the UMTS. This standard is not intended to duplicate existing standards or standards being developed by other groups on these topics, and will reference these where appropriate. This standard will elaborate on the charging requirements described in the charging principles in TS 22.101 UMTS service principles. It will allow the generation of accurate charging information to be used in the commercial and contractual relationships between the parties concerned.

<b>SDO (2)</b>	<b>Document No.</b>	<b>Version</b>	<b>Status</b>	<b>Issued date</b>	<b>Location (1)</b>
<b>Release 99</b>					
ETSI	ETSI TS 122 115	3.4.0	Published	08/01/2004	<a href="http://pda.etsi.org/pda/home.asp?wkr=RTS/TSGS-0122115v340">http://pda.etsi.org/pda/home.asp?wkr=RTS/TSGS-0122115v340</a>
<b>Release 4</b>					
ETSI	ETSI TS 122 115	4.1.0	Published	08/01/2004	<a href="http://pda.etsi.org/pda/home.asp?wkr=RTS/TSGS-0122115v410">http://pda.etsi.org/pda/home.asp?wkr=RTS/TSGS-0122115v410</a>
<b>Release 5</b>					
ETSI	ETSI TS 122 115	5.4.0	Published	08/01/2004	<a href="http://pda.etsi.org/pda/home.asp?wkr=RTS/TSGS-0122115v540">http://pda.etsi.org/pda/home.asp?wkr=RTS/TSGS-0122115v540</a>

**5.1.2.8.42 TS 22.121****Virtual home environment (VHE)**

This specification describes the content of the Stage 1 requirement for realization of VHE. VHE is defined as a concept for personal service environment (PSE) portability across network boundaries and between terminals. The concept of the VHE is such that users are consistently presented with the same personalized features, user interface customization and services in whatever network and whatever terminal (within the capabilities of the terminal and the network), wherever the user may be located. A key feature to support VHE is the ability to build services using a standardized application interface.

<b>SDO (2)</b>	<b>Document No.</b>	<b>Version</b>	<b>Status</b>	<b>Issued date</b>	<b>Location (1)</b>
<b>Release 99</b>					
ETSI	ETSI TR 122 121	3.3.1	Published	30/07/2002	<a href="http://pda.etsi.org/pda/home.asp?wkr=RTR/TSGS-0122121v331">http://pda.etsi.org/pda/home.asp?wkr=RTR/TSGS-0122121v331</a>
<b>Release 4</b>					
ETSI	ETSI TR 122 121	4.1.1	Published	30/07/2002	<a href="http://pda.etsi.org/pda/home.asp?wkr=RTR/TSGS-0122121v411">http://pda.etsi.org/pda/home.asp?wkr=RTR/TSGS-0122121v411</a>
<b>Release 5</b>					
ETSI	ETSI TR 122 121	5.3.1	Published	30/07/2002	<a href="http://pda.etsi.org/pda/home.asp?wkr=RTR/TSGS-0122121v531">http://pda.etsi.org/pda/home.asp?wkr=RTR/TSGS-0122121v531</a>

**5.1.2.8.43 TS 22.129****Handover requirements between UMTS and GSM or other radio systems**

This specification describes service requirements for handover (terms are defined below) within UMTS systems and between UMTS, other IMT-2000 family members and second generation systems. Particular emphasis has been placed on the description of requirements for handover between UMTS and GSM but requirements specific to other systems are incorporated as required.

SDO (2)	Document No.	Version	Status	Issued date	Location (1)
<b>Release 99</b>					
ETSI	ETSI TS 122 129	3.6.0	Published	15/01/2002	<a href="http://pda.etsi.org/pda/home.asp?wkr=RTS/TSGS-0122129UR4">http://pda.etsi.org/pda/home.asp?wkr=RTS/TSGS-0122129UR4</a>
<b>Release 4</b>					
ETSI	ETSI TS 122 129	4.4.0	Published	15/01/2002	<a href="http://pda.etsi.org/pda/home.asp?wkr=RTS/TSGS-0122129Uv4R2">http://pda.etsi.org/pda/home.asp?wkr=RTS/TSGS-0122129Uv4R2</a>
<b>Release 5</b>					
ETSI	ETSI TS 122 129	5.2.0	Published	16/07/2002	<a href="http://pda.etsi.org/pda/home.asp?wkr=RTS/TSGS-0122129v520">http://pda.etsi.org/pda/home.asp?wkr=RTS/TSGS-0122129v520</a>

**5.1.2.8.44 TS 22.135****Multicall**

This specification describes multicall scenarios and requirements for UMTS phase 1 release 1999. Multicall feature specifies functionality and interactions related to usage of several simultaneous bearers between a terminal and a network. Multicall features allows both circuit-switched call(s) and packet session(s) to exist simultaneously.

SDO (2)	Document No.	Version	Status	Issued date	Location (1)
<b>Release 99</b>					
ETSI	ETSI TS 122 135	3.4.0	Published	07/11/2000	<a href="http://pda.etsi.org/pda/home.asp?wkr=RTS/TSGS-0122135UR3">http://pda.etsi.org/pda/home.asp?wkr=RTS/TSGS-0122135UR3</a>
<b>Release 4</b>					
ETSI	ETSI TS 122 135	4.2.0	Published	19/12/2002	<a href="http://pda.etsi.org/pda/home.asp?wkr=RTS/TSGS-0122135v420">http://pda.etsi.org/pda/home.asp?wkr=RTS/TSGS-0122135v420</a>
<b>Release 5</b>					
ETSI	ETSI TS 122 135	5.0.0	Published	25/07/2002	<a href="http://pda.etsi.org/pda/home.asp?wkr=RTS/TSGS-0122135v500">http://pda.etsi.org/pda/home.asp?wkr=RTS/TSGS-0122135v500</a>

**5.1.2.8.45 TR 22.971****Automatic establishment of roaming relations**

This report describes a proposed framework for commercial and technical interworking between UMTS home environments and serving networks who have no direct prior commercial agreements with each other. This text is applicable to UMTS standardization within ETSI, and is produced with the intent to clarify the concepts involved, and identify those areas which require standardization.



SDO (2)	Document No.	Version	Status	Issued date	Location (1)
<b>Release 99</b>					
ETSI	ETSI TR 122 971	3.1.1	Published	01/02/2000	<a href="http://pda.etsi.org/pda/home.asp?wkr=DTR/TSGS-0122971U">http://pda.etsi.org/pda/home.asp?wkr=DTR/TSGS-0122971U</a>

#### 5.1.2.8.46 TR 22.975

##### Advanced addressing

This report describes the requirements for numbering and addressing for UMTS. This technical report is aimed at generating discussion and should be agreed with ETSI WG NA2. The responsibility for developing of numbering and addressing schemes for all networks being in ETSI NA2.

SDO (2)	Document No.	Version	Status	Issued date	Location (1)
<b>Release 99</b>					
ETSI	ETSI TR 122 975	3.1.0	Published	01/02/2000	<a href="http://pda.etsi.org/pda/home.asp?wkr=DTR/TSGS-0122975U">http://pda.etsi.org/pda/home.asp?wkr=DTR/TSGS-0122975U</a>

#### 5.1.2.8.47 TS 21.133

##### Security threats and requirements

Detailed security requirements.

SDO (2)	Document No.	Version	Status	Issued date	Location (1)
<b>Release 99</b>					
ETSI	ETSI TS 121 133	3.2.0	Published	14/01/2002	<a href="http://pda.etsi.org/pda/home.asp?wkr=RTS/TSGS-0321133UR1">http://pda.etsi.org/pda/home.asp?wkr=RTS/TSGS-0321133UR1</a>
<b>Release 4</b>					
ETSI	ETSI TS 121 133	4.1.0	Published	14/01/2002	<a href="http://pda.etsi.org/pda/home.asp?wkr=RTS/TSGS-0321133Uv4R1">http://pda.etsi.org/pda/home.asp?wkr=RTS/TSGS-0321133Uv4R1</a>

#### 5.1.2.8.48 TS 33.102

##### Security architecture

Provides a specification of all security mechanisms and protocols, except algorithms.

SDO (2)	Document No.	Version	Status	Issued date	Location (1)
<b>Release 99</b>					
ETSI	ETSI TS 133 102	3.13.0	Published	03/01/2003	<a href="http://pda.etsi.org/pda/home.asp?wkr=RTS/TSGS-0333102v3d0">http://pda.etsi.org/pda/home.asp?wkr=RTS/TSGS-0333102v3d0</a>
<b>Release 4</b>					
ETSI	ETSI TS 133 102	4.5.0	Published	03/01/2003	<a href="http://pda.etsi.org/pda/home.asp?wkr=RTS/TSGS-0333102v450">http://pda.etsi.org/pda/home.asp?wkr=RTS/TSGS-0333102v450</a>
<b>Release 5</b>					
ETSI	ETSI TS 133 102	5.3.0	Published	03/10/2003	<a href="http://pda.etsi.org/pda/home.asp?wkr=RTS/TSGS-0333102v530">http://pda.etsi.org/pda/home.asp?wkr=RTS/TSGS-0333102v530</a>

#### 5.1.2.8.49 TS 33.103

##### Security integration guidelines

SDO (2)	Document No.	Version	Status	Issued date	Location (1)
<b>Release 99</b>					
ETSI	ETSI TS 133 103	3.7.0	Published	19/10/2001	<a href="http://pda.etsi.org/pda/home.asp?wkr=RTS/TSGS-0333103UR6">http://pda.etsi.org/pda/home.asp?wkr=RTS/TSGS-0333103UR6</a>
<b>Release 4</b>					
ETSI	ETSI TS 133 103	4.2.0	Published	19/10/2001	<a href="http://pda.etsi.org/pda/home.asp?wkr=RTS/TSGS-0333103Uv4R2">http://pda.etsi.org/pda/home.asp?wkr=RTS/TSGS-0333103Uv4R2</a>

#### 5.1.2.8.50 TS 33.105

##### Cryptographic algorithm requirements

Defines requirements for standard cipher and integrity algorithm.

SDO (2)	Document No.	Version	Status	Issued date	Location (1)
<b>Release 99</b>					
ETSI	ETSI TS 133 105	3.8.0	Published	31/07/2001	<a href="http://pda.etsi.org/pda/home.asp?wkr=RTS/TSGS-0333105UR6">http://pda.etsi.org/pda/home.asp?wkr=RTS/TSGS-0333105UR6</a>
<b>Release 4</b>					
ETSI	ETSI TS 133 105	4.1.0	Published	31/07/2001	<a href="http://pda.etsi.org/pda/home.asp?wkr=RTS/TSGS-0333105Uv4R1">http://pda.etsi.org/pda/home.asp?wkr=RTS/TSGS-0333105Uv4R1</a>

#### 5.1.2.8.51 TS 33.106

##### Lawful interception requirements

Defines all requirements for network based lawful interception.

SDO (2)	Document No.	Version	Status	Issued date	Location (1)
<b>Release 99</b>					
ETSI	ETSI TS 133 106	3.1.0	Published	01/02/2000	<a href="http://pda.etsi.org/pda/home.asp?wkr=DTS/TSGS-0333106U">http://pda.etsi.org/pda/home.asp?wkr=DTS/TSGS-0333106U</a>
<b>Release 4</b>					
ETSI	ETSI TS 133 106	4.0.0	Published	27/04/2001	<a href="http://pda.etsi.org/pda/home.asp?wkr=RTS/TSGS-0333106Uv4">http://pda.etsi.org/pda/home.asp?wkr=RTS/TSGS-0333106Uv4</a>
<b>Release 5</b>					
ETSI	ETSI TS 133 106	5.1.0	Published	15/10/2002	<a href="http://pda.etsi.org/pda/home.asp?wkr=RTS/TSGS-0333106v510">http://pda.etsi.org/pda/home.asp?wkr=RTS/TSGS-0333106v510</a>

#### 5.1.2.8.52 TS 33.120

##### Security objectives and principles

Elaborates on the basic principles underlying the security.

SDO (2)	Document No.	Version	Status	Issued date	Location (1)
<b>Release 99</b>					
ETSI	ETSI TS 133 120	3.0.0	Published	01/02/2000	<a href="http://pda.etsi.org/pda/home.asp?wkr=DTS/TSGS-0333120U">http://pda.etsi.org/pda/home.asp?wkr=DTS/TSGS-0333120U</a>
<b>Release 4</b>					
ETSI	ETSI TS 133 120	4.0.0	Published	27/04/2001	<a href="http://pda.etsi.org/pda/home.asp?wkr=RTS/TSGS-0333120Uv4">http://pda.etsi.org/pda/home.asp?wkr=RTS/TSGS-0333120Uv4</a>

**5.1.2.8.53** TR 33.901**Criteria for cryptographic algorithm design process**

This report describes the process used to design cipher and integrity algorithm.

SDO (2)	Document No.	Version	Status	Issued date	Location (1)
<b>Release 99</b>					
ETSI	ETSI TR 133 901	3.0.0	Published	01/02/2000	<a href="http://pda.etsi.org/pda/home.asp?wkr=DTR/TSGS-0333901U">http://pda.etsi.org/pda/home.asp?wkr=DTR/TSGS-0333901U</a>
<b>Release 4</b>					
ETSI	ETSI TR 133 901	4.0.0	Published	19/10/2001	<a href="http://pda.etsi.org/pda/home.asp?wkr=RTR/TSGS-0333901Uv4">http://pda.etsi.org/pda/home.asp?wkr=RTR/TSGS-0333901Uv4</a>

**5.1.2.8.54** TR 33.902**Formal analysis of the 3G authentication protocol with modified sequence number management**

Formal analysis using BAN and temporal logic of authentication mechanism.

SDO (2)	Document No.	Version	Status	Issued date	Location (1)
<b>Release 99</b>					
ETSI	ETSI TR 133 902	3.1.0	Published	01/02/2000	<a href="http://pda.etsi.org/pda/home.asp?wkr=DTR/TSGS-0333902U">http://pda.etsi.org/pda/home.asp?wkr=DTR/TSGS-0333902U</a>
<b>Release 4</b>					
ETSI	ETSI TR 133 902	4.0.0	Published	23/10/2001	<a href="http://pda.etsi.org/pda/home.asp?wkr=RTR/TSGS-0333902Uv4">http://pda.etsi.org/pda/home.asp?wkr=RTR/TSGS-0333902Uv4</a>

**5.1.2.8.55** TS 26.071**AMR speech codec: general description**

This specification describes an introduction to the set of the adaptive multi-rate (AMR) specifications.

SDO (2)	Document No.	Version	Status	Issued date	Location (1)
<b>Release 99</b>					
ETSI	ETSI TS 126 071	3.0.1	Published	01/02/2000	<a href="http://pda.etsi.org/pda/home.asp?wkr=DTS/TSGS-0426071U">http://pda.etsi.org/pda/home.asp?wkr=DTS/TSGS-0426071U</a>
<b>Release 4</b>					
ETSI	ETSI TS 126 071	4.0.0	Published	25/04/2001	<a href="http://pda.etsi.org/pda/home.asp?wkr=RTS/TSGS-0426071Uv4">http://pda.etsi.org/pda/home.asp?wkr=RTS/TSGS-0426071Uv4</a>
<b>Release 5</b>					
ETSI	ETSI TS 126 071	5.0.0	Published	16/07/2002	<a href="http://pda.etsi.org/pda/home.asp?wkr=RTS/TSGS-0426071v500">http://pda.etsi.org/pda/home.asp?wkr=RTS/TSGS-0426071v500</a>

**5.1.2.8.56** TS 26.090**AMR speech codec: transcoding functions**

This specification describes a detailed description of the AMR speech codec transcoding functions.

SDO (2)	Document No.	Version	Status	Issued date	Location (1)
<b>Release 99</b>					
ETSI	ETSI TS 126 090	3.1.0	Published	01/02/2000	<a href="http://pda.etsi.org/pda/home.asp?wkr=DTS/TSGS-0426090U">http://pda.etsi.org/pda/home.asp?wkr=DTS/TSGS-0426090U</a>
<b>Release 4</b>					
ETSI	ETSI TS 126 090	4.0.0	Published	25/04/2001	<a href="http://pda.etsi.org/pda/home.asp?wkr=RTS/TSGS-0426090Uv4">http://pda.etsi.org/pda/home.asp?wkr=RTS/TSGS-0426090Uv4</a>
<b>Release 5</b>					
ETSI	ETSI TS 126 090	5.0.0	Published	11/07/2002	<a href="http://pda.etsi.org/pda/home.asp?wkr=RTS/TSGS-0426090v500">http://pda.etsi.org/pda/home.asp?wkr=RTS/TSGS-0426090v500</a>

#### 5.1.2.8.57 TS 26.091

##### AMR speech codec: error concealment of lost frames

This specification describes example procedures for the error concealment, also called frame substitution or muting procedure, of lost speech or silence indicator frames.

SDO (2)	Document No.	Version	Status	Issued date	Location (1)
<b>Release 99</b>					
ETSI	ETSI TS 126 091	3.1.0	Published	01/02/2000	<a href="http://pda.etsi.org/pda/home.asp?wkr=DTS/TSGS-0426091U">http://pda.etsi.org/pda/home.asp?wkr=DTS/TSGS-0426091U</a>
<b>Release 4</b>					
ETSI	ETSI TS 126 091	4.0.0	Published	25/04/2001	<a href="http://pda.etsi.org/pda/home.asp?wkr=RTS/TSGS-0426091Uv4">http://pda.etsi.org/pda/home.asp?wkr=RTS/TSGS-0426091Uv4</a>
<b>Release 5</b>					
ETSI	ETSI TS 126 091	5.0.0	Published	11/07/2002	<a href="http://pda.etsi.org/pda/home.asp?wkr=RTS/TSGS-0426091v500">http://pda.etsi.org/pda/home.asp?wkr=RTS/TSGS-0426091v500</a>

#### 5.1.2.8.58 TS 26.092

##### AMR speech codec: comfort noise aspects

This specification describes the detailed requirements for the correct operation of the background acoustic noise evaluation, noise parameter encoding/decoding and comfort noise generation for the AMR speech codec during source controlled rate (SCR) operation.

SDO (2)	Document No.	Version	Status	Issued date	Location (1)
<b>Release 99</b>					
ETSI	ETSI TS 126 092	3.0.1	Published	01/02/2000	<a href="http://pda.etsi.org/pda/home.asp?wkr=DTS/TSGS-0426092U">http://pda.etsi.org/pda/home.asp?wkr=DTS/TSGS-0426092U</a>
<b>Release 4</b>					
ETSI	ETSI TS 126 092	4.0.0	Published	25/04/2001	<a href="http://pda.etsi.org/pda/home.asp?wkr=RTS/TSGS-0426092Uv4">http://pda.etsi.org/pda/home.asp?wkr=RTS/TSGS-0426092Uv4</a>
<b>Release 5</b>					
ETSI	ETSI TS 126 092	5.0.0	Published	11/07/2002	<a href="http://pda.etsi.org/pda/home.asp?wkr=RTS/TSGS-0426092v500">http://pda.etsi.org/pda/home.asp?wkr=RTS/TSGS-0426092v500</a>

#### 5.1.2.8.59 TS 26.093

##### AMR speech codec: source controlled rate (SCR) operation

This specification describes the operation of the AMR speech codec during SCR operation.

## 116

## Rec. ITU-R M.1457-4

SDO (2)	Document No.	Version	Status	Issued date	Location (1)
<b>Release 99</b>					
ETSI	ETSI TS 126 093	3.3.0	Published	13/02/2001	<a href="http://pda.etsi.org/pda/home.asp?wkr=RTS/TSGS-0426093UR2">http://pda.etsi.org/pda/home.asp?wkr=RTS/TSGS-0426093UR2</a>
<b>Release 4</b>					
ETSI	ETSI TS 126 093	4.0.0	Published	05/08/2002	<a href="http://pda.etsi.org/pda/home.asp?wkr=RTS/TSGS-0426093v400">http://pda.etsi.org/pda/home.asp?wkr=RTS/TSGS-0426093v400</a>
<b>Release 5</b>					
ETSI	ETSI TS 126 093	5.2.0	Published	08/01/2003	<a href="http://pda.etsi.org/pda/home.asp?wkr=RTS/TSGS-0426093v520">http://pda.etsi.org/pda/home.asp?wkr=RTS/TSGS-0426093v520</a>

### 5.1.2.8.60 TS 26.094

#### AMR speech codec: voice activity detector (VAD)

This specification describes two alternatives for the VAD to be used during SCR operation in conjunction with the AMR codec.

SDO (2)	Document No.	Version	Status	Issued date	Location (1)
<b>Release 99</b>					
ETSI	ETSI TS 126 094	3.0.0	Published	01/02/2000	<a href="http://pda.etsi.org/pda/home.asp?wkr=DTS/TSGS-0426094U">http://pda.etsi.org/pda/home.asp?wkr=DTS/TSGS-0426094U</a>
<b>Release 4</b>					
ETSI	ETSI TS 126 094	4.0.0	Published	25/04/2001	<a href="http://pda.etsi.org/pda/home.asp?wkr=RTS/TSGS-0426094Uv4">http://pda.etsi.org/pda/home.asp?wkr=RTS/TSGS-0426094Uv4</a>
<b>Release 5</b>					
ETSI	ETSI TS 126 094	5.0.0	Published	11/07/2002	<a href="http://pda.etsi.org/pda/home.asp?wkr=RTS/TSGS-0426094v500">http://pda.etsi.org/pda/home.asp?wkr=RTS/TSGS-0426094v500</a>

### 5.1.2.8.61 TS 26.110

#### Codec for circuit-switched multimedia telephony service: general description

This specification describes an introduction to the set of specifications for the support of circuit-switched 3G-324M multimedia telephony service.

SDO (2)	Document No.	Version	Status	Issued date	Location (1)
<b>Release 99</b>					
ETSI	ETSI TS 126 110	3.1.0	Published	25/04/2001	<a href="http://pda.etsi.org/pda/home.asp?wkr=RTS/TSGS-0426110UR1">http://pda.etsi.org/pda/home.asp?wkr=RTS/TSGS-0426110UR1</a>
<b>Release 4</b>					
ETSI	ETSI TS 126 110	4.1.0	Published	25/04/2001	<a href="http://pda.etsi.org/pda/home.asp?wkr=RTS/TSGS-0426110Uv4">http://pda.etsi.org/pda/home.asp?wkr=RTS/TSGS-0426110Uv4</a>
<b>Release 5</b>					
ETSI	ETSI TS 126 110	5.0.0	Published	11/07/2002	<a href="http://pda.etsi.org/pda/home.asp?wkr=RTS/TSGS-0426110v500">http://pda.etsi.org/pda/home.asp?wkr=RTS/TSGS-0426110v500</a>

### 5.1.2.8.62 TS 26.111

#### Codec for circuit-switched multimedia telephony service: modifications to ITU-T Recommendation H.324

This specification describes the modifications applicable to the ITU-T Recommendation H.324, Annex C for the support of circuit-switched 3G-324M multimedia telephony service.

SDO (2)	Document No.	Version	Status	Issued date	Location (1)
<b>Release 99</b>					
ETSI	ETSI TS 126 111	3.4.0	Published	13/02/2001	<a href="http://pda.etsi.org/pda/home.asp?wkr=RTS/TSGS-0426111UR3">http://pda.etsi.org/pda/home.asp?wkr=RTS/TSGS-0426111UR3</a>
<b>Release 4</b>					
ETSI	ETSI TS 126 111	4.0.0	Published	25/04/2001	<a href="http://pda.etsi.org/pda/home.asp?wkr=RTS/TSGS-0426111Uv4">http://pda.etsi.org/pda/home.asp?wkr=RTS/TSGS-0426111Uv4</a>
<b>Release 5</b>					
ETSI	ETSI TS 126 111	5.1.0	Published	03/07/2003	<a href="http://pda.etsi.org/pda/home.asp?wkr=RTS/TSGS-0426111v510">http://pda.etsi.org/pda/home.asp?wkr=RTS/TSGS-0426111v510</a>

### 5.1.2.8.63 TR 26.911

#### Codec for circuit-switched multimedia telephony service: terminal implementor's guide

This report describes non-mandatory Recommendations for the use of the different codec implementation options for the circuit-switched 3G-324M multimedia telephony service based on ITU-T Recommendation H.324, Annex C. These Recommendations address issues specific to the third generation operating environment, including guaranteeing sufficient error resilience and inter-working between terminals.

SDO (2)	Document No.	Version	Status	Issued date	Location (1)
<b>Release 99</b>					
ETSI	ETSI TR 126 911	3.4.0	Published	11/04/2003	<a href="http://pda.etsi.org/pda/home.asp?wkr=RTR/TSGS-0426911v340">http://pda.etsi.org/pda/home.asp?wkr=RTR/TSGS-0426911v340</a>
<b>Release 4</b>					
ETSI	ETSI TR 126 911	4.2.0	Published	11/04/2003	<a href="http://pda.etsi.org/pda/home.asp?wkr=RTR/TSGS-0426911v420">http://pda.etsi.org/pda/home.asp?wkr=RTR/TSGS-0426911v420</a>
<b>Release 5</b>					
ETSI	ETSI TR 126 911	5.1.0	Published	11/04/2003	<a href="http://pda.etsi.org/pda/home.asp?wkr=RTR/TSGS-0426911v510">http://pda.etsi.org/pda/home.asp?wkr=RTR/TSGS-0426911v510</a>

### 5.1.2.9 TR 21.905

#### Vocabulary

Document 21.905 is a collection of terms, definitions and abbreviations related to the baseline documents defining the objectives and systems framework. This document provides a tool for further work on the technical documentation and facilitates their understanding.

SDO (2)	Document No.	Version	Status	Issued date	Location (1)
<b>Release 99</b>					
ARIB	ARIB TR-T12-21.905	3.3.0	Approved	25/05/2004	<a href="http://www.arib.or.jp/IMT-2000/ARIB-STD/ITU-R/R99/A21905-330.pdf">http://www.arib.or.jp/IMT-2000/ARIB-STD/ITU-R/R99/A21905-330.pdf</a>
CCSA	CCSA-TSD-DS-21.905	330	Approved	01/07/2003	<a href="http://www.ccsa.org.cn/english/tc/files.php?docpath=/ITU-R/M.1457/M.1457-4/DS/">http://www.ccsa.org.cn/english/tc/files.php?docpath=/ITU-R/M.1457/M.1457-4/DS/</a>
ETSI	ETSI TR 121 905	3.3.0	Published	10/10/2001	<a href="http://pda.etsi.org/pda/home.asp?wkr=RTR/TSGS-0121905UR3">http://pda.etsi.org/pda/home.asp?wkr=RTR/TSGS-0121905UR3</a>
T1 (ATIS)	T1.3GPP.21.905V330-2002	3.3.0	Approved	03/05/2002	<a href="https://www.atis.org/atis/docstore/search.asp?committee=S24">https://www.atis.org/atis/docstore/search.asp?committee=S24</a>
TTA	TTAE.3G-21.905(R99-3.3.0)	3.3.0	Approved	29/05/2002	<a href="http://www.tta.or.kr/standardDB/stnfile/TTAE.3G-21.905(R99-3.3.0).zip">http://www.tta.or.kr/standardDB/stnfile/TTAE.3G-21.905(R99-3.3.0).zip</a>
<b>Release 4</b>					
ARIB	ARIB TR-T12-21.905	4.5.0	Approved	25/05/2004	<a href="http://www.arib.or.jp/IMT-2000/ARIB-STD/ITU-R/Rel4/A21905-450.pdf">http://www.arib.or.jp/IMT-2000/ARIB-STD/ITU-R/Rel4/A21905-450.pdf</a>
CCSA	CCSA-TSD-DS-21.905	450	Approved	01/07/2003	<a href="http://www.ccsa.org.cn/english/tc/files.php?docpath=/ITU-R/M.1457/M.1457-4/DS/">http://www.ccsa.org.cn/english/tc/files.php?docpath=/ITU-R/M.1457/M.1457-4/DS/</a>
ETSI	ETSI TR 121 905	4.5.0	Published	01/07/2003	<a href="http://pda.etsi.org/pda/home.asp?wkr=RTR/TSGS-0121905v450">http://pda.etsi.org/pda/home.asp?wkr=RTR/TSGS-0121905v450</a>

**118****Rec. ITU-R M.1457-4**

T1 (ATIS)	T1.3GPP.21.905V450-2004	4.5.0	Approved	21/05/2004	<a href="https://www.atis.org/atis/docstore/search.asp?committee=S24">https://www.atis.org/atis/docstore/search.asp?committee=S24</a>
TTA	TTAT.3G-21.905(R4-4.5.0)	4.5.0	Approved	25/05/2004	<a href="http://www.tta.or.kr/standardDB/stnfile/TTAT.3G-21.905(R4-4.5.0).zip">http://www.tta.or.kr/standardDB/stnfile/TTAT.3G-21.905(R4-4.5.0).zip</a>
<b>Release 5</b>					
ARIB	ARIB TR-T12-21.905	5.8.0	Approved	25/05/2004	<a href="http://www.arib.or.jp/IMT-2000/ARIB-STD/ITU-R/Rel5/A21905-580.pdf">http://www.arib.or.jp/IMT-2000/ARIB-STD/ITU-R/Rel5/A21905-580.pdf</a>
CCSA	CCSA-TSD-DS-21.905	570	Approved	01/07/2003	<a href="http://www.ccsa.org.cn/english/tc/files.php?docpath=/ITU-R/M.1457/M.1457-4/DS/">http://www.ccsa.org.cn/english/tc/files.php?docpath=/ITU-R/M.1457/M.1457-4/DS/</a>
ETSI	ETSI TR 121 905	5.8.0	Published	03/10/2003	<a href="http://pda.etsi.org/pda/home.asp?wkr=RTR/TSGS-0121905v580">http://pda.etsi.org/pda/home.asp?wkr=RTR/TSGS-0121905v580</a>
T1 (ATIS)	T1.3GPP.21.905V580-2004	5.8.0	Approved	21/05/2004	<a href="https://www.atis.org/atis/docstore/search.asp?committee=S24">https://www.atis.org/atis/docstore/search.asp?committee=S24</a>
TTA	TTAT.3G-21.905(R5-5.8.0)	5.8.0	Approved	25/05/2004	<a href="http://www.tta.or.kr/standardDB/stnfile/TTAT.3G-21.905(R5-5.8.0).zip">http://www.tta.or.kr/standardDB/stnfile/TTAT.3G-21.905(R5-5.8.0).zip</a>
<b>Release 6</b>					
CCSA	CCSA-TSD-DS-21.905	630	Approved	01/07/2003	<a href="http://www.ccsa.org.cn/english/tc/files.php?docpath=/ITU-R/M.1457/M.1457-4/DS/">http://www.ccsa.org.cn/english/tc/files.php?docpath=/ITU-R/M.1457/M.1457-4/DS/</a>
ETSI	ETSI TR 121 905	6.5.0	Awaiting		<a href="http://pda.etsi.org/pda/home.asp?wkr=RTR/TSGS-0121905v650">http://pda.etsi.org/pda/home.asp?wkr=RTR/TSGS-0121905v650</a>
T1 (ATIS)	T1.3GPP.21.905V650-2004	6.5.0	Approved	21/05/2004	<a href="https://www.atis.org/atis/docstore/search.asp?committee=S24">https://www.atis.org/atis/docstore/search.asp?committee=S24</a>
TTA	TTAT.3G-21.905(R6-6.5.0)	6.5.0	Approved	25/05/2004	<a href="http://www.tta.or.kr/standardDB/stnfile/TTAT.3G-21.905(R6-6.5.0).zip">http://www.tta.or.kr/standardDB/stnfile/TTAT.3G-21.905(R6-6.5.0).zip</a>

**5.1.2.10****SDO's complete system standard**

<b>SDO</b>	<b>Location</b>
<b>Release 99</b>	
ARIB	<a href="http://www.arib.or.jp/IMT-2000/ARIB-STD/STD-T63/R99dot4.html">http://www.arib.or.jp/IMT-2000/ARIB-STD/STD-T63/R99dot4.html</a>
CCSA	<a href="http://www.ccsa.org.cn/english/tc/files.php?docpath=/ITU-R/M.1457/M.1457-4/DS/">http://www.ccsa.org.cn/english/tc/files.php?docpath=/ITU-R/M.1457/M.1457-4/DS/</a>
ETSI	<a href="http://www.etsi.org/getastandard/home.htm">http://www.etsi.org/getastandard/home.htm</a>
T1 (ATIS)	<a href="https://www.atis.org/atis/docstore/search.asp?committee=S24">https://www.atis.org/atis/docstore/search.asp?committee=S24</a>
TTA	<a href="http://www.tta.or.kr/Home2003/standards/Imt2000List.jsp">http://www.tta.or.kr/Home2003/standards/Imt2000List.jsp</a>
TTC	<a href="http://www.ttc.or.jp">http://www.ttc.or.jp</a>
<b>Release 4</b>	
ARIB	<a href="http://www.arib.or.jp/IMT-2000/ARIB-STD/STD-T63/Rel4dot4.html">http://www.arib.or.jp/IMT-2000/ARIB-STD/STD-T63/Rel4dot4.html</a>
CCSA	<a href="http://www.ccsa.org.cn/english">http://www.ccsa.org.cn/english</a>
ETSI	<a href="http://www.etsi.org/getastandard/home.htm">http://www.etsi.org/getastandard/home.htm</a>
T1 (ATIS)	<a href="https://www.atis.org/atis/docstore/search.asp?committee=S24">https://www.atis.org/atis/docstore/search.asp?committee=S24</a>
TTA	<a href="http://www.tta.or.kr/Home2003/standards/Imt2000List.jsp">http://www.tta.or.kr/Home2003/standards/Imt2000List.jsp</a>
TTC	<a href="http://www.ttc.or.jp">http://www.ttc.or.jp</a>
<b>Release 5</b>	
ARIB	<a href="http://www.arib.or.jp/IMT-2000/ARIB-STD/STD-T63/Rel5dot4.html">http://www.arib.or.jp/IMT-2000/ARIB-STD/STD-T63/Rel5dot4.html</a>
CCSA	<a href="http://www.ccsa.org.cn/english">http://www.ccsa.org.cn/english</a>
ETSI	<a href="http://www.etsi.org/getastandard/home.htm">http://www.etsi.org/getastandard/home.htm</a>
T1 (ATIS)	<a href="https://www.atis.org/atis/docstore/search.asp?committee=S24">https://www.atis.org/atis/docstore/search.asp?committee=S24</a>
TTA	<a href="http://www.tta.or.kr/Home2003/standards/Imt2000List.jsp">http://www.tta.or.kr/Home2003/standards/Imt2000List.jsp</a>
TTC	<a href="http://www.ttc.or.jp">http://www.ttc.or.jp</a>



**Release 6**

ARIB <http://www.arib.or.jp/IMT-2000/ARIB-STD/STD-T63/Rel6dot4.html>  
CCSA <http://www.ccsa.org.cn/english>  
ETSI <http://www.etsi.org/getastandard/home.htm>  
T1 (ATIS) <https://www.atis.org/atis/docstore/search.asp?committee=S24>  
TTA <http://www.tta.or.kr/Home2003/standards/Imt2000List.jsp>  
TTC <http://www.ttc.or.jp>

## 5.2 IMT-2000 CDMA Multi-Carrier

### 5.2.1 Overview of the radio interface

#### 5.2.1.1 Introduction

The IMT-2000 radio interface specifications for CDMA multi-carrier (MC) technology are developed by a partnership of SDOs (see Note 1). This radio interface is called cdma2000, which consists of the 1X and 3X components. The 1X component includes enhancements for high rate packet data access.

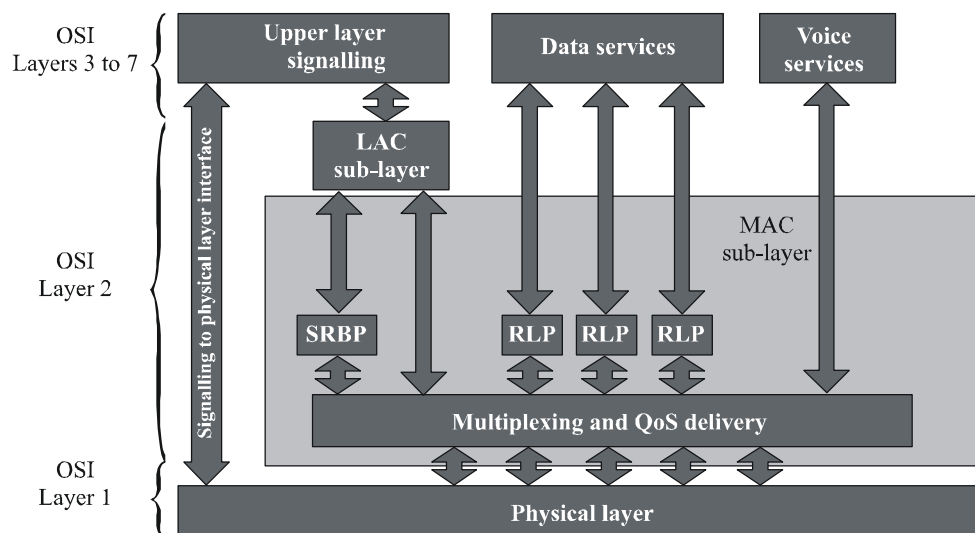
NOTE 1 – Currently, these specifications are developed within the third generation partnership project 2 (3GPP2), where the participating SDOs are ARIB, CCSA, TIA, TTA and TTC.

In the development of this radio interface the CN specifications are based on an evolved ANSI-41 and IP network, but the specifications include the necessary capabilities for operation with an evolved GSM-MAP-based CN.

This radio interface is a wideband spread spectrum radio interface that utilizes CDMA technology in order to meet the needs of the 3G wireless communication systems and to meet the requirements for the 3G evolution of the current 2G TIA/EIA-95-B family of standards.

As shown in Fig. 13, this radio interface has a layered structure that provides a combination of voice, packet data, and circuit data services, according to the ISO/OSI reference model (i.e. Layer 1 – the physical layer, and Layer 2 – the link layer). Layer 2 is further subdivided into the link access control (LAC) sub-layer and the MAC sub-layer. Applications and upper layer protocols corresponding to OSI Layers 3 through 7 utilize the services provided by the LAC services, e.g. signalling services, voice services, data services (packet data and circuit data).

FIGURE 13  
General radio interface architecture



1457-13

In this radio interface a generalized multimedia service model is supported. This allows any combination of voice, packet data, and circuit data services to be operated. The radio interface also includes a QoS control mechanism to balance the varying QoS requirements of multiple concurrent services (e.g. to support ISDN or RSVP network layer QoS capabilities).

The physical layer supports RF channel bandwidths of  $N \times 1.25$  MHz, where  $N$  is the spreading rate number. Currently  $N = 1$  and 3 is specified, and  $N$  can be easily extended to  $N = 6, 9, 12$ . The data rates, channel encoding, and modulation parameters supported on the traffic channels are specified by radio configurations. For Spreading rates 1 and 3, there are seven radio configurations for the reverse link and there are ten radio configurations for the forward link. Collectively, these radio configurations form the radio interface, which consists of the 1X and 3X components. Spreading rate 1 corresponds to 1X. Spreading rate 3 corresponds to 3X. Radio configurations 1 and 2 are specified to be backward compatible with TIA/EIA-95-B systems. The radio interface also supports a class of operational band plans as specified in the TIA/EIA/IS-2000 standard.

This specification includes a flexible and efficient MAC sub-layer that supports multiple data service state machine instances, one for each active packet or circuit data service instance. Along with the multiplexing QoS control entity, the MAC realizes the complex multimedia, multi-service capabilities of 3G wireless systems with QoS management capabilities for each active service.

This specification also introduces a LAC sub-layer to provide reliable transmission over the air for signalling services. To provide flexible voice services, this radio interface provides the framework and the services to transport encoded voice data in the form of packet data or circuit data traffic, as well as in a manner that is backward compatible with the TIA/EIA-95-B family of standards (i.e. the encoded voice data is transported directly by the physical layer). In the latter case, the LAC and MAC services are null. The LAC sub-layer provides an ARQ (retransmission) protocol.

## 5.2.1.2 Physical layer

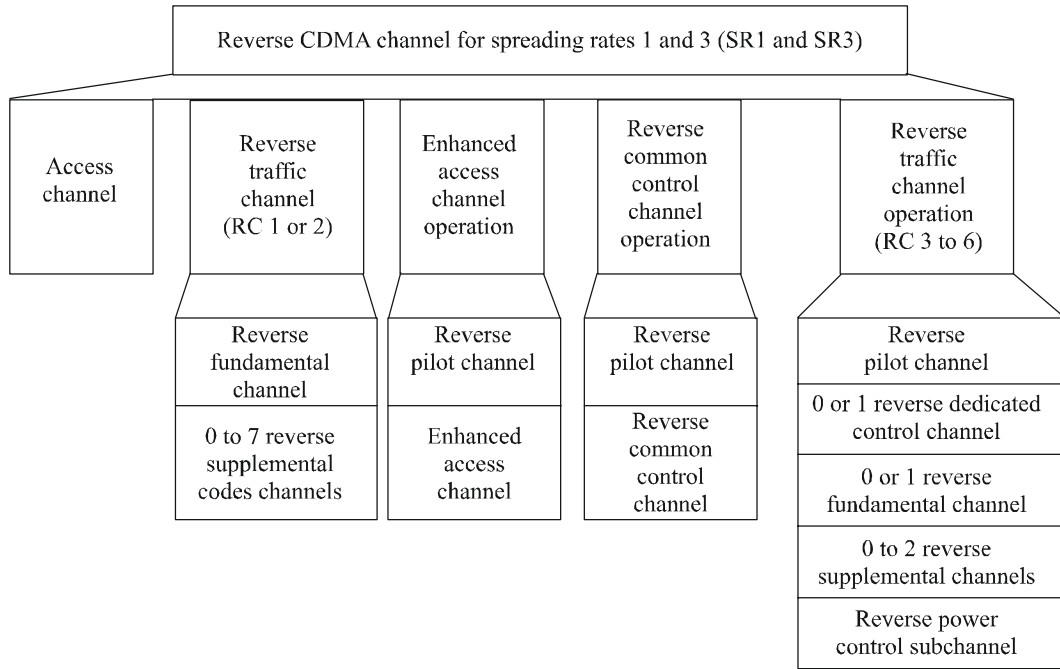
### 5.2.1.2.1 Reverse link (uplink)

#### 5.2.1.2.1.1 Radio configurations 1 through 6

Figure 14 shows the reverse CDMA Channels received at the BS. The reverse pilot channel is an unmodulated spread spectrum signal used to assist the BS in detecting the mobile station transmission. The mobile station also inserts a reverse power control subchannel in the reverse pilot channel. The reverse power control subchannel is used to transmit forward power control commands. The access channel is used by the mobile station to initiate communication with the BS and to respond to paging channel messages. The enhanced access channel is used by the mobile station to initiate communication with the BS or to respond to a mobile station directed message. The reverse common control channel is used for the transmission of user and signalling information to the BS when reverse traffic channels are not in use. The reverse traffic channels with radio configurations 1 and 2 include the reverse fundamental channel and reverse supplemental code channel. The reverse traffic channels with radio configurations 3 through 6 include the reverse dedicated control channel, reverse fundamental channel, and reverse supplemental channel. The reverse dedicated control channel and reverse fundamental channel are used for the transmission of user and signalling information to the BS during a call. The reverse supplemental channel and reverse supplemental code channel are used for the transmission of user information to the BS during a call.

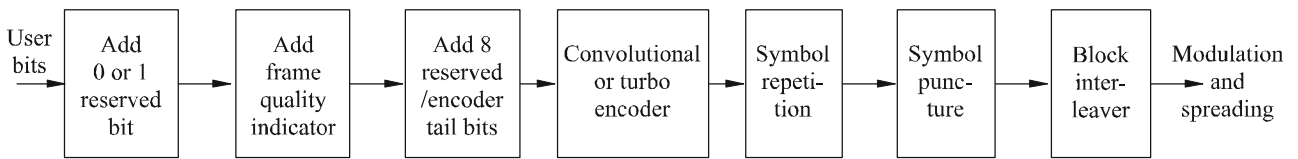
Figure 15 shows the reverse channel structure (except the pilot channel). Channel encoded symbols are repeated and punctured to match a nominal value of data rate. Block interleaving is used on the access channel, the enhanced access channel, the reverse common control channel, and the reverse traffic channels. The channel encoded and interleaved symbols are modulated and are direct spread prior to transmission. The spreading chip rate is  $N \times 1.2288$  Mchip/s ( $N$  is the spreading rate number described above). Figure 16 shows the uplink spreading and the modulation operation for radio configurations 3 through 6.

FIGURE 14  
Reverse CDMA channels received at the BS



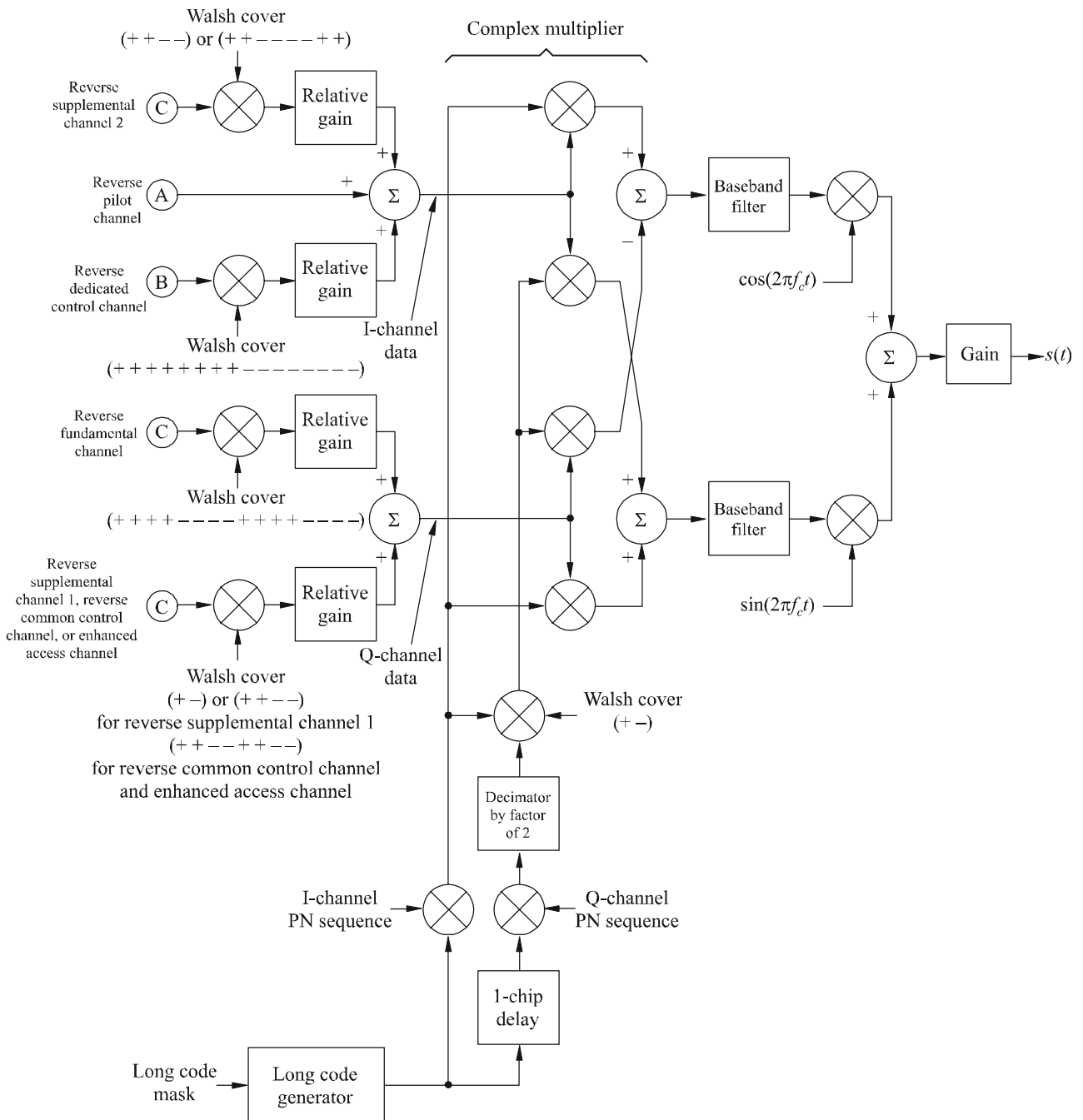
1457-14

FIGURE 15  
Reverse channels structure (except the pilot channel)



1457-15

FIGURE 16  
Uplink spreading and modulation for radio configurations 3 through 6



1457-16

The mobile station supports three types of forward link power control based upon: 800 Hz feedback; the erasure indicator bits (EIB); and the quality indicator bits (QIB). The feedback is on the reverse power control subchannel. For the 800 Hz feedback mode, the outer loop estimates the setpoint value based on  $E_b/N_t$  to achieve the target FER on each assigned forward traffic channel. The inner loop compares the  $E_b/N_t$  of the received forward traffic channel with the corresponding outer loop setpoint to determine the value of the power control bit to be sent on the reverse power control subchannel every 1.25 ms.

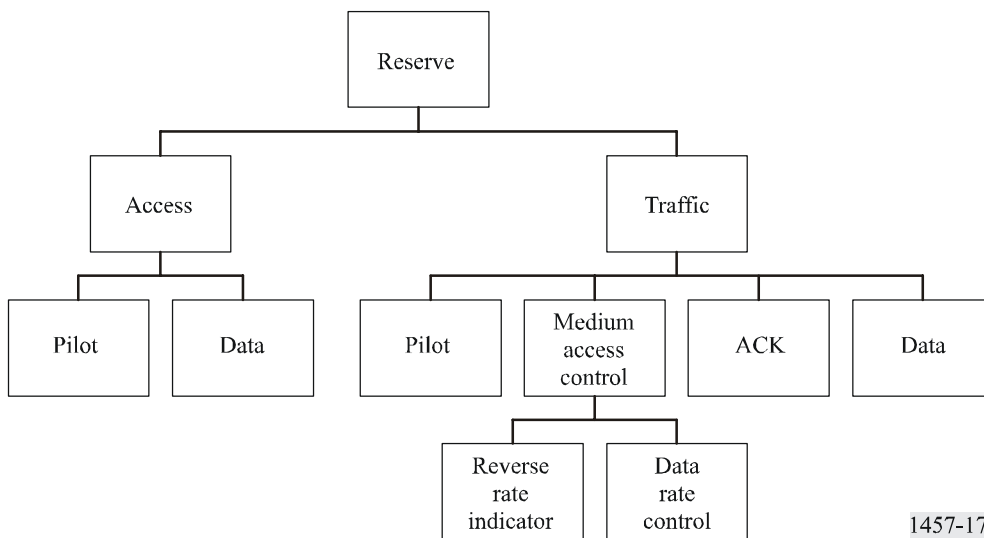
Uplink soft handoff is achieved by performing diversity or selection combining at the BS.

### 5.2.1.2.1.2 High Rate Packet Data (HRPD) Access

The Reverse CDMA Channel, deployed on a dedicated 1X RF Channel, consists of the Access Channel and the Reverse Traffic Channel as shown in Fig. 17. The Access Channel is used by the access terminal to initiate communication with the access network or to respond to an access terminal directed message. The Access Channel consists of a Pilot Channel and a Data Channel. The Reverse Traffic Channel is used by the mobile station to transmit user-specific traffic or signalling information to the access network. The Reverse Traffic Channel comprises a Pilot Channel, a Reverse Rate Indicator (RRI) Channel, a Data Rate Control (DRC) Channel, an Acknowledgement (ACK) Channel, and a Data Channel. The RRI Channel is used to indicate the data rate transmitted on the Reverse Traffic Channel. The RRI Channel is time-multiplexed with the Pilot Channel. The DRC Channel is used by the mobile station to indicate to the access network the supportable Forward Traffic Channel data rate and the best serving sector on the Forward CDMA Channel. The ACK Channel is used by the access terminal to inform the access network whether or not the data packet transmitted on the Forward Traffic Channel has been received successfully.

For the enhanced HRPD access, physical layer H-ARQ (Hybrid Automatic Repeat Request), shorter frame sizes, fast scheduling/rate-control, and adaptive modulation and coding are implemented to increase the peak data rate and system throughput of the reverse link.

FIGURE 17  
Reverse CDMA channel for high rate packet data access



1457-17

### 5.2.1.2.1.3 High Rate Packet Data with Voice

The High Rate Packet Data with Voice (1xEV-DV) includes enhanced features allowing for high-speed packet data transmission, higher spectral efficiency, and simultaneous high-speed packet data and real-time services, such as voice, on a single 1.25 MHz RF carrier. The high data rates are achieved with the support of key features, such as adaptive modulation and coding, higher-order modulation, fast scheduling, and hybrid Automatic Repeat Request (ARQ).

For the enhanced 1xEV-DV access, physical layer hybrid ARQ, shorter frames, fast scheduling/rate-control, and adaptive modulation and coding are also used to increase the peak data rate and system throughput of the reverse link.

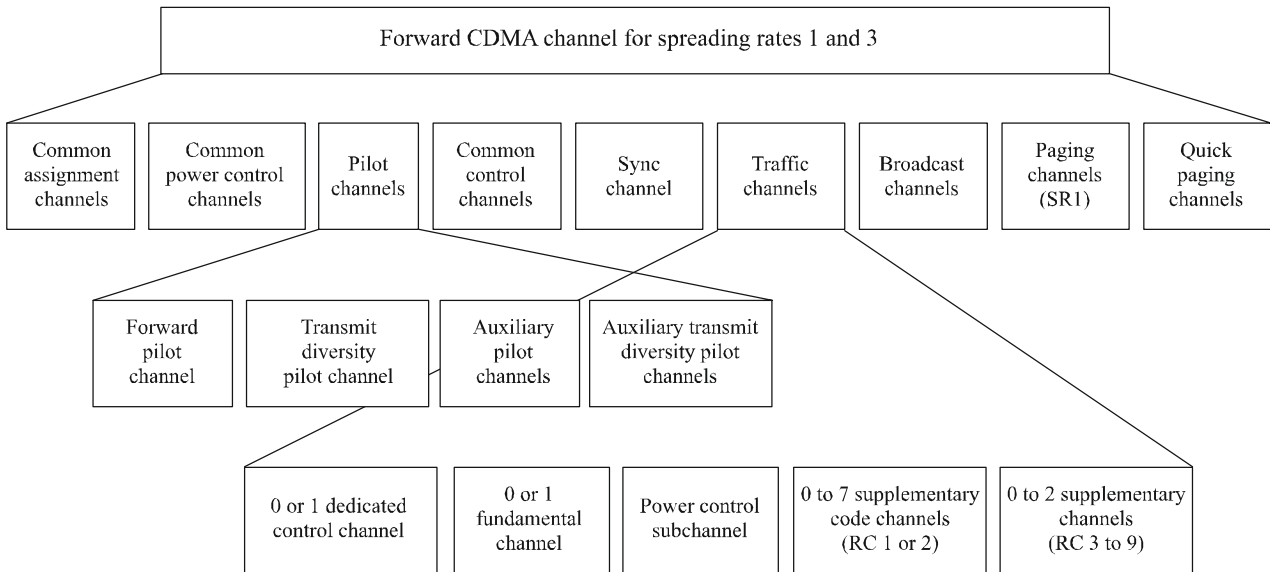
### 5.2.1.2.2 Forward Link (Downlink)

#### 5.2.1.2.2.1 Radio configurations 1 through 9

Figure 18 shows the forward CDMA channels received at the mobile station. The forward pilot channel, the transmit diversity pilot channel, the auxiliary pilot channels, and the auxiliary transmit diversity pilot channels are unmodulated spread spectrum signals used for synchronization by a mobile station operating within the coverage area of the BS. The forward pilot channel is transmitted at all times by the BS on each active forward CDMA channel. The auxiliary pilot channel is transmitted in a beamforming application. The transmit diversity pilot channel and the auxiliary transmit diversity pilot channel are transmitted when transmit diversity is used. The sync channel is used by mobile stations operating within the coverage area of the BS to acquire initial time synchronization. The paging channel is used by the BS to transmit system overhead information and mobile station specific messages. The broadcast channel is used by the BS to transmit system overhead information. The quick paging channel is used by the BS to inform mobile stations, operating in the slotted mode while in the idle state, whether or not to receive the forward common control channel, the broadcast channel, or the paging channel. The common power control channel is used by the BS for transmitting common power control subchannels (one bit per subchannel) for the power control of multiple reverse common control channels and enhanced access channels. The common power control subchannels are time multiplexed on the common power control channel. Each common power control subchannel controls a reverse common control channel or an enhanced access channel. The common assignment channel is used by the BS to provide quick assignment of the reverse common control channel. The forward common control channel is used by the BS to transmit mobile station-specific messages. For radio configurations 1 and 2, the forward traffic channels include the forward fundamental channel and forward supplemental code channel. For radio configurations 3 through 9, the forward traffic channels include the forward dedicated control channel, forward fundamental channel, and forward supplemental channel. Similar to the corresponding reverse traffic channels, these channels are used for transmission of user and/or signalling information to a specific mobile station during a call. The forward traffic channels also include the forward power control subchannel. It is used to transmit reverse power control commands and is transmitted either on the forward fundamental channel or on the forward dedicated control channel.

The channel structure of the forward link is similar to that of the reverse link shown in Fig. 15, except that the sync channel and the paging channel do not use the frame quality indicator, and that the quick paging channel and the common power control channel do not use channel coding or interleaving. Block interleaving is used on the sync channel, the paging channels, the broadcast channel, the common assignment channel, the forward common control channel, and the forward traffic channels.

FIGURE 18  
Forward CDMA channels received at the mobile station



1457-18

Figure 19 shows an example of scrambling, power control symbol puncturing, and demultiplexer structure for the forward traffic channels with radio configurations 3 through 9. The channel encoded and interleaved output symbols are scrambled by the long code. The power control symbols are punctured on the forward fundamental channel and forward dedicated control channel only. The DEMUX functions distribute the scrambled and punctured symbols sequentially from the top to the bottom, forming pairs of quadrature modulation symbols. When operating in SR 1 (1X) without transmit diversity (TD), each modulation symbol in a quadrature pair is spread by the appropriate Walsh or quasi-orthogonal function and is then spread by a quadrature pair of PN sequences at a fixed chip rate of 1.2288 Mchip/s. When operating in SR 1 (1X) with transmit diversity, each modulation symbol in two quadrature pairs is spread by the appropriate Walsh or quasi-orthogonal function and a quadrature pair of PN sequences to a chip rate of 1.2288 Mchip/s. Then the two quadrature pairs are transmitted on two separate antennas. When operating in the SR  $N$  multi-carrier mode, each modulation symbol in  $N$  quadrature pairs is spread by the appropriate Walsh or quasi-orthogonal function and a quadrature pair of PN sequences to a chip rate of 1.2288 Mchip/s. Then the  $N$  quadrature pairs are transmitted on  $N$  adjacent 1.25 MHz carriers. Figure 20 shows the downlink spreading and modulation for SR 1 (1X) without transmit diversity as an example, which also shows each downlink modulation carrier for SR  $N$  multi-carrier operation. The system described in this sub-section can be deployed as an overlay on up to  $N$  carriers of TIA/EIA-95-B family of systems. This system can also be deployed in clear spectrum.

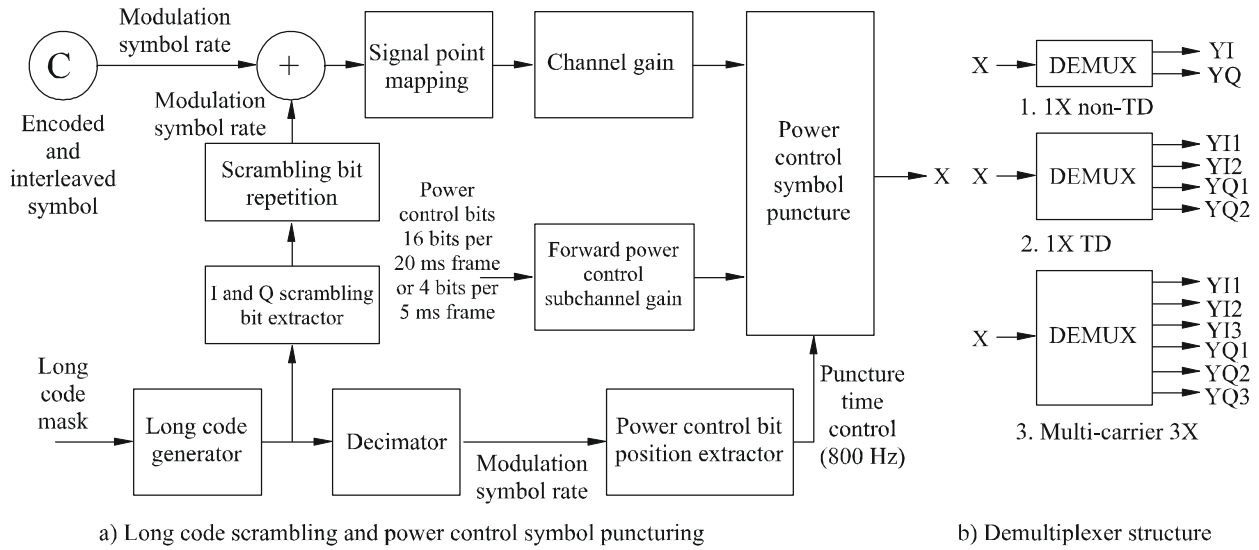
The reverse traffic channels utilize an 800 Hz feedback power control mechanism similar to that for the forward traffic channel. In addition, the mobile station supports open loop power control.

Downlink soft handoff is achieved by performing diversity combining at the mobile station. Transmit diversity is achieved by transmitting modulation symbols on separate transmit antennas or by transmitting separate carriers on separate antennas.



FIGURE 19

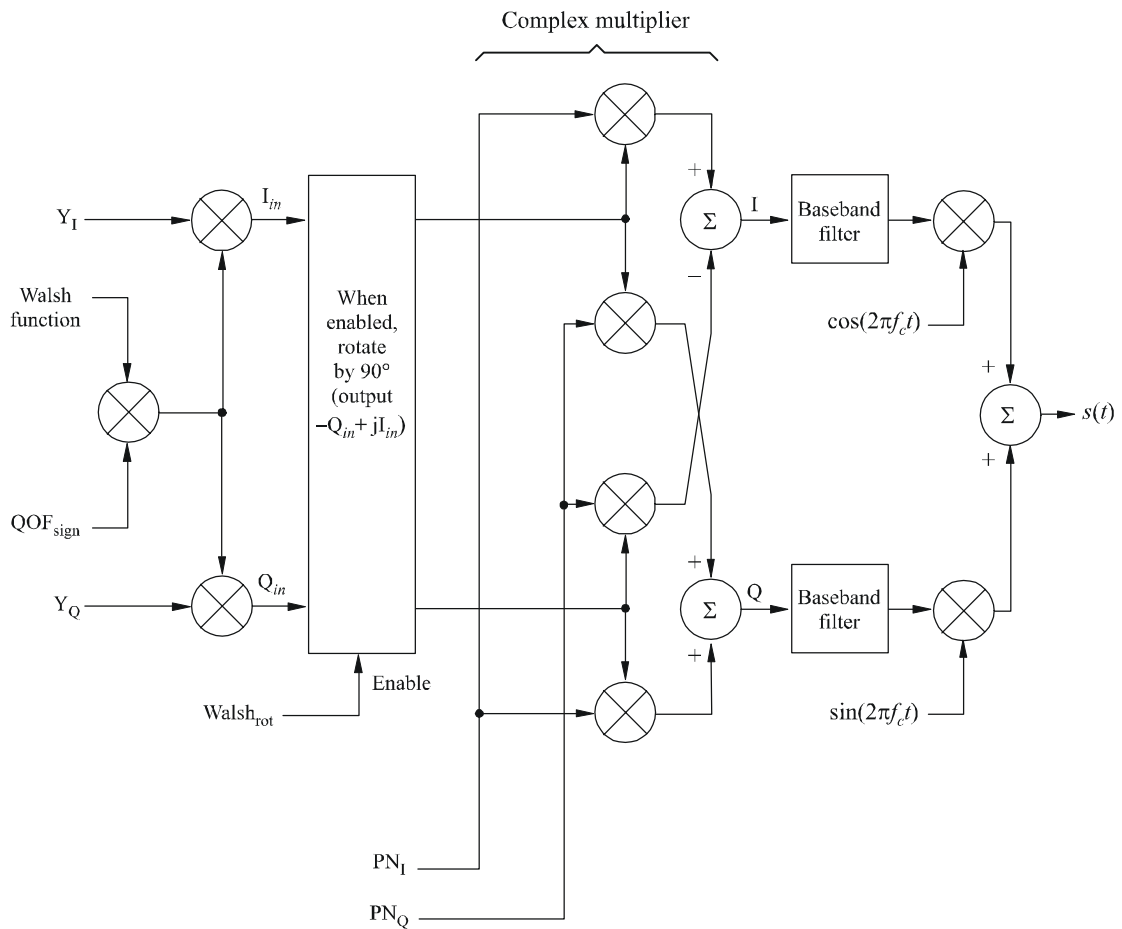
Example of scrambling, power control symbol puncturing and demultiplexing



1457-19

FIGURE 20

Downlink spreading and modulation for 1X without transmit diversity

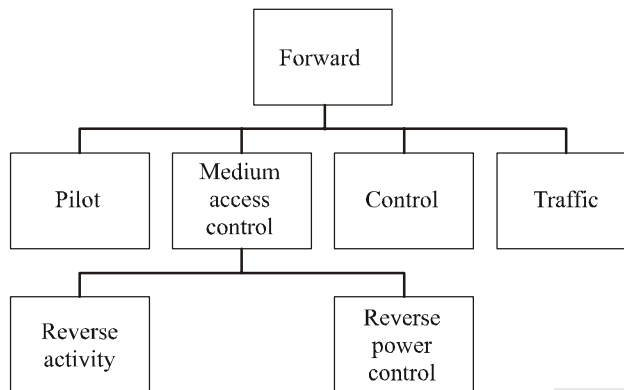


1457-20

### 5.2.1.2.2 High Rate Packet Data Access

The Forward CDMA Channel, deployed on a dedicated 1X RF Channel, consists of the following time-multiplexed channels: the Pilot Channel, the Forward Medium Access Control (MAC) Channel, the Control Channel and the Forward Traffic Channel as shown in Fig. 21. The Forward Traffic Channel carries user data packets. The Control Channel carries control messages, and it may also carry user traffic. Each channel is further decomposed into code-division-multiplexed quadrature Walsh channels.

FIGURE 21  
Forward CDMA channel for high rate packet data access



The MAC Channel consists of two subchannels: the Reverse Power Control (RPC) Channel and the Reverse Activity (RA) Channel. The RA Channel transmits a reverse link activity bit (RAB) stream. Each MAC Channel symbol is BPSK modulated on one of sixty-four 64-ary Walsh codewords.

The Forward Traffic Channel is a packet-based, variable-rate channel. The user data for an access terminal is transmitted at a data rate that varies from 38.4 kbit/s to 2.4576 Mbit/s.

The Forward Traffic Channel and Control Channel data are encoded, scrambled and interleaved. The output of the channel interleaver are fed into a QPSK/8-PSK/16-QAM modulator. The modulated symbol sequences are repeated and punctured, as necessary. Then, the resulting sequences of modulation symbols are demultiplexed to form 16 pairs (in-phase and quadrature) of parallel streams. Each of the parallel streams are covered with a distinct 16-ary Walsh function at a chip rate to yield Walsh symbols at 76.8 ksymbol/s. The Walsh-coded symbols of all the streams are summed together to form a single in-phase stream and a single quadrature stream at a chip rate of 1.2288 Mchip/s. The resulting chips are time-division multiplexed with the preamble, Pilot Channel, and MAC Channel chips to form the resultant sequence of chips for the quadrature spreading operation.

Forward Traffic Channel physical layer packets can be transmitted in 1 to 16 slots. When more than one slot is allocated, the transmitted slots use a 4-slot interlacing. That is, the transmitted slots of a packet are separated by three intervening slots, and slots of other packets are transmitted in the slots between those transmit slots. If a positive acknowledgement is received on the reverse link ACK Channel that the physical layer packet has been received on the Forward Traffic Channel before all of the allocated slots have been transmitted, the remaining untransmitted slots are not transmitted and the next allocated slot is used for the first slot of the next physical layer packet transmission.

The Control Channel is transmitted at a data rate of 76.8 kbit/s or 38.4 kbit/s. The modulation characteristics for the Control Channel are the same as those of the Forward Traffic Channel transmitted at the corresponding rate.

### 5.2.1.2.3 High Rate Packet Data with Voice

The High Rate Packet Data with Voice (1xEV-DV) includes enhanced features allowing for high-speed packet data transmission with peak data rates exceeding 2.4 Mbit/s, higher spectral efficiency, and simultaneous high-speed packet data and real-time services, such as voice, on a single 1.25 MHz RF carrier. The high data rates are achieved with the support of key features such as adaptive modulation and coding, higher-order modulation, fast scheduling, and hybrid Automatic Repeat Request (ARQ).

### 5.2.1.3 Layer 2 – MAC

#### 5.2.1.3.1 Introduction

The MAC sub-layer provides the following important functions:

- Best effort delivery – reasonably reliable transmission over the radio link with a RLP that provides a “best effort” level of reliability.
- Rules governing access terminal transmission timing, power characteristics, and rate selection on the Access Channel.
- Rate control on both uplink and downlink traffic channels.
- Multiplexing and QoS control – enforcement of negotiated QoS levels by mediating conflicting requests from competing services and the appropriate prioritization of access requests.

#### 5.2.1.3.2 Layering structure and entities

The layering structure of this radio interface is shown in Fig. 22.

### 5.2.1.4 Layer 2 – LAC

The LAC sub-layer performs the following important functions:

- Delivery of SDUs to Layer 3 entity using ARQ techniques, when needed, to provide reliability.
- Building and validating well-formed PDUs appropriate for carrying the SDUs.
- Segmentation of encapsulated PDUs into LAC PDU fragments of sizes suitable for transfer by the MAC Sub-layer and re-assembly of LAC PDU fragments into encapsulated PDUs.
- Access control through global challenge authentication. Conceptually, some messages failing authentication on a common channel should not be delivered to the upper layers for processing.
- Address control for delivery of PDUs based on addresses that identify particular mobile stations.

As a generated or received data unit traverses the protocol stack, it is processed by various protocol sub-layers in sequence. Each sub-layer processes only specific fields of the data unit that are associated with the sub-layer-defined functionality. The general processing of data units by the LAC sub-layer and its sub-layers is shown in Fig. 23. The LAC sub-layer provides services to Layer 3 in the data plane. SDUs are passed between Layer 3 and the LAC sub-layer. The LAC sub-layer provides the proper encapsulation of the SDUs into LAC PDUs, which are subject to segmentation and re-assembly and are transferred as LAC PDU fragments to the MAC sub-layer.

FIGURE 22  
Layering structure and service interfaces (MS)

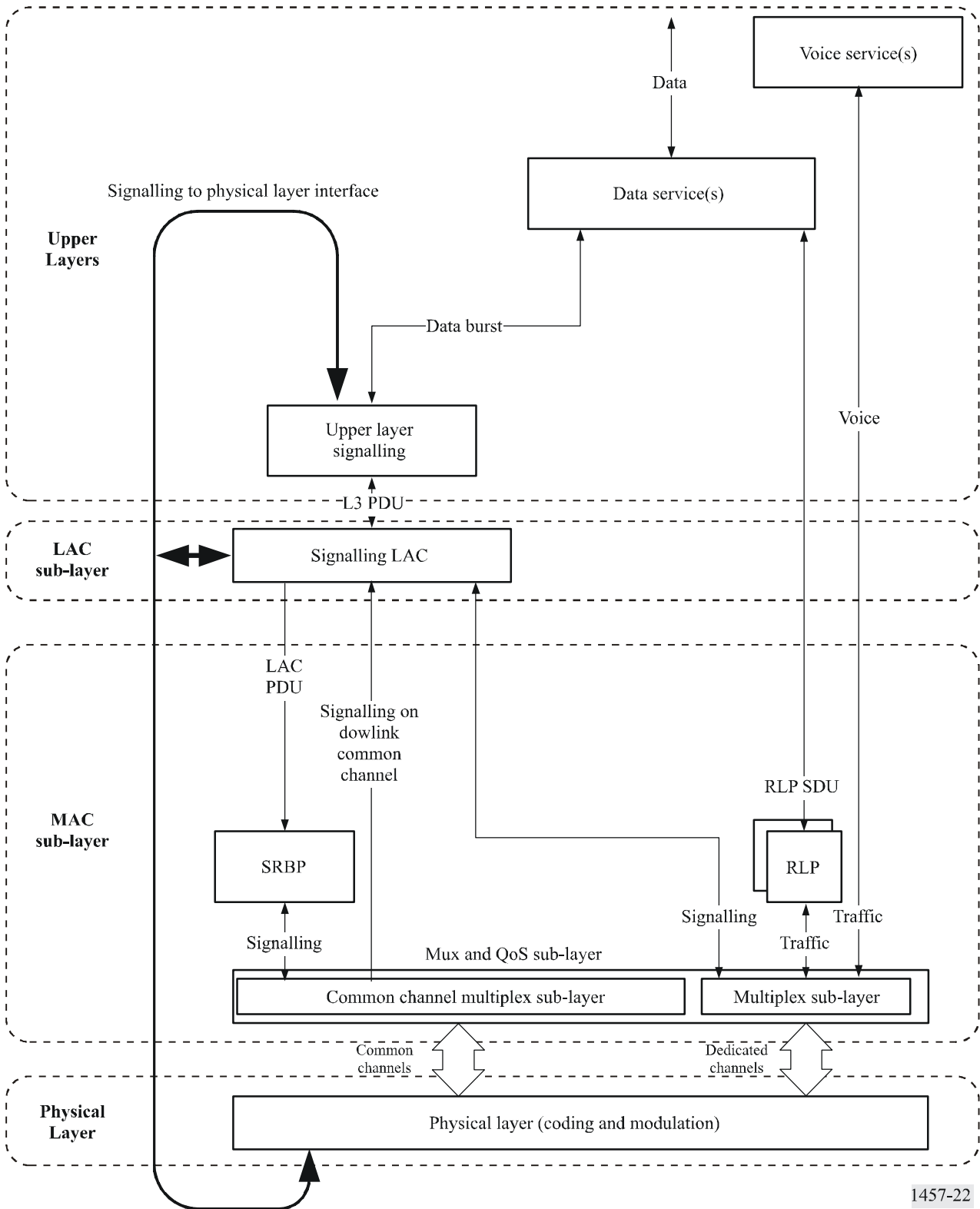
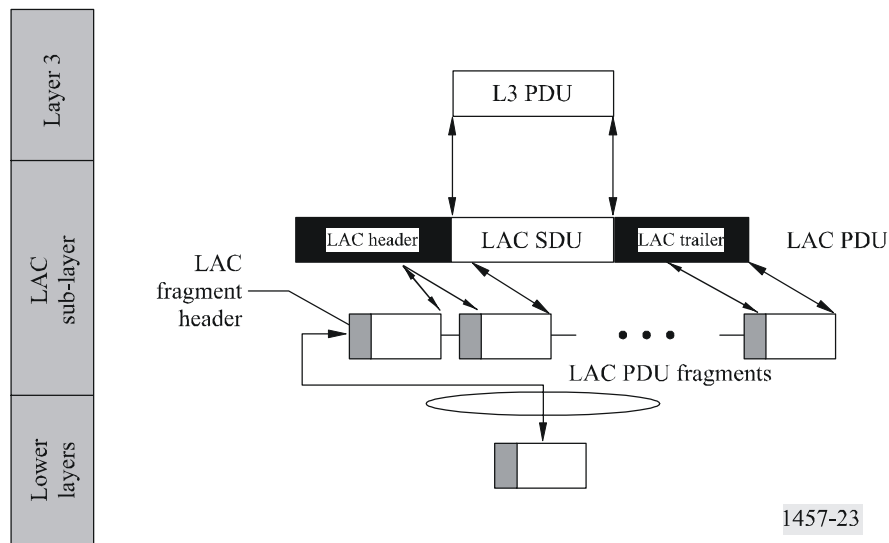


FIGURE 23  
LAC data unit processing



1457-23

In the data plane, Layer 3 and the LAC sub-layer send and receive signalling information on *logical channels*, thus avoiding the need to be sensitive to the radio characteristics of the physical channels. The system described in this sub-section uses the following types of logical channel to carry signalling information:

- f-csch/r-csch (forward and reverse common signalling channel, respectively),
- f-dsch/r-dsch (forward and reverse dedicated signalling channel, respectively).

Logical channels are defined for the purposes of synchronization, broadcast, general signalling, access, and dedicated signalling. Multiple instances of the same logical channel may be deployed. Figures 24 and 25 show the logical channels on the forward and reverse links, respectively.

### 5.2.1.5 Layer 3 signalling

Layer 3 signalling provides a flexible structure designed to support a wide range of radio interface signalling alternatives:

- backward compatible to TIA/EIA-95-B Layer 3 signalling in the IS-2000 mode;
- the native upper layer signalling for this radio interface; and
- other existing or future upper layer signalling entities.

In addition to supporting the standard cellular and PCS features, Layer 3 signalling also supports the following radio related features and capabilities:

- Radio configuration negotiation
- Quick paging operation (to improve battery life)
- Handoff capabilities (i.e. soft handoff, hard handoff, idle handoff, access probe handoff, and access handoff)
- Power control
- High-speed data
- Enhanced access
- Broadcast control operation
- Auxiliary pilot support, and
- MAC state transitions.

FIGURE 24  
Downlink logical channel architecture

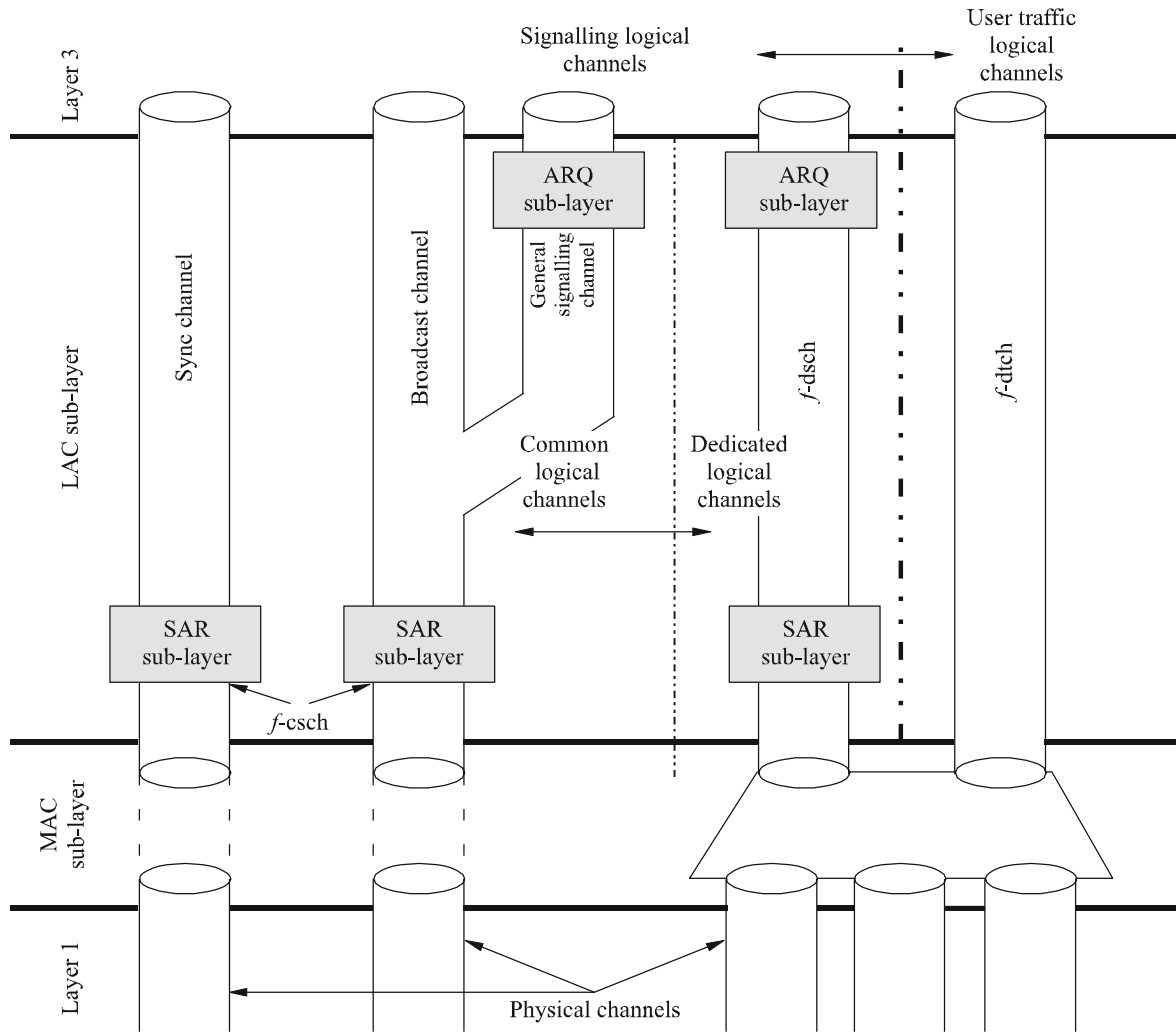
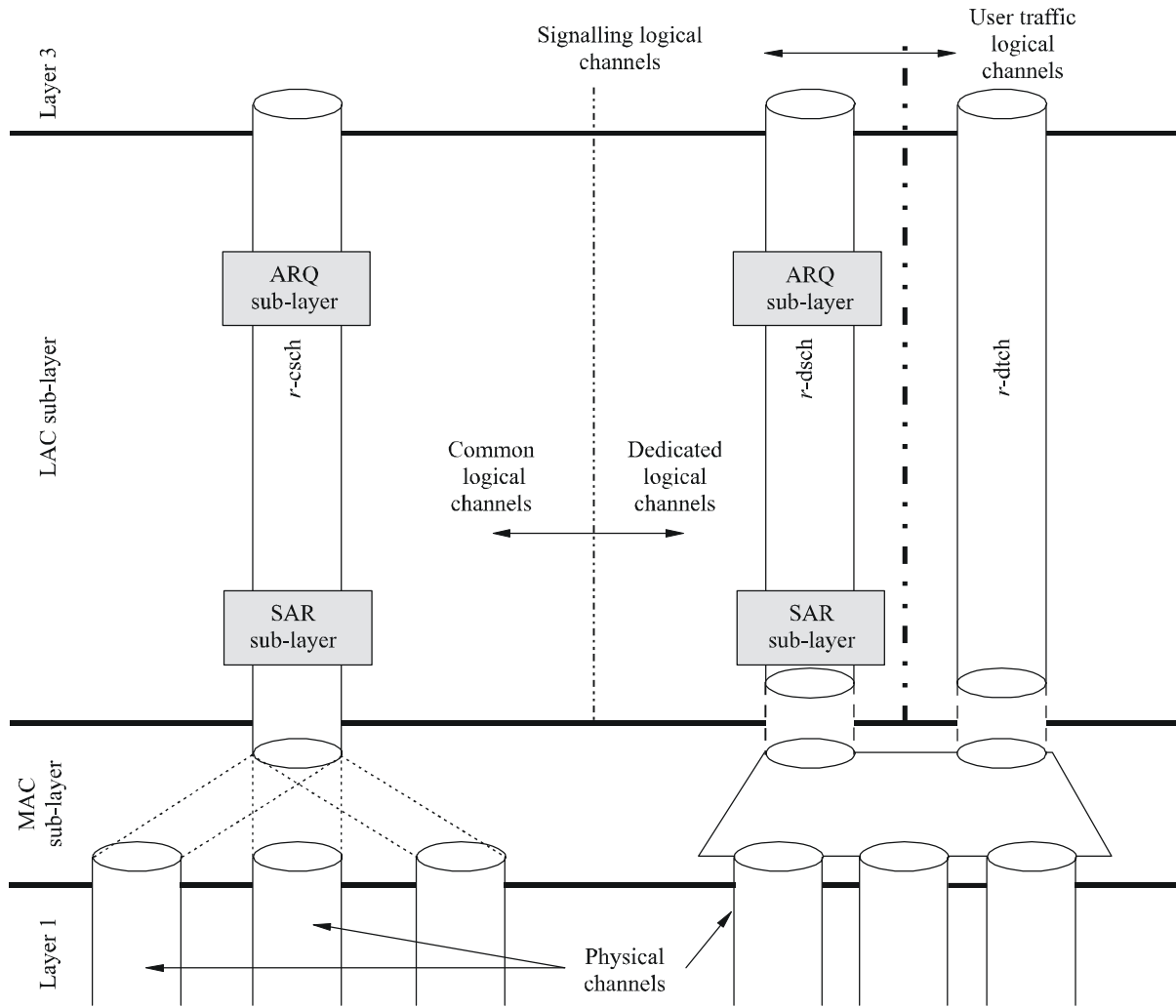


FIGURE 25  
Uplink logical channel architecture



## 5.2.1.6 Summary of major technical parameters

Parameter	Value	Reference to § 5.2.2
Multiple access technique and duplexing scheme	Multiple access technique: CDMA Duplexing scheme: FDD	5.2.2.1.2 and 5.2.2.1.23
Chip rate	$N \times 1.2288$ Mchip/s (currently $N = 1$ and 3 is specified, and $N$ can be easily extended to $N = 6, 9, 12$ )	5.2.2.1.2 and 5.2.2.1.23
Inter-BS asynchronous/synchronous operation	Synchronous operation is required	5.2.2.1.2 and 5.2.2.1.23
Pilot structure	Code division dedicated pilot (UL); code division common pilot (DL); and code division common or dedicated auxiliary pilot (DL); and time division common pilot	5.2.2.1.2 and 5.2.2.1.23
Frame length and interleaving	5, 10, 20, 26.666, 40, 80 ms frame and channel interleaving	5.2.2.1.2 and 5.2.2.1.23
Modulation and detection	Data modulation: BPSK; QPSK, 8PSK, and 16QAM Spreading modulation: HPSK (UL); QPSK (DL) Detection: Pilot aided coherent detection	5.2.2.1.2 and 5.2.2.1.23
Channelization code	Walsh codes and long codes (UL) Walsh codes or quasi-orthogonal codes (DL)	5.2.2.1.2 and 5.2.2.1.23
Scrambling (spreading) code	Long code and short PN code	5.2.2.1.2 and 5.2.2.1.23
Channel coding	Convolutional code with $K = 9$ , $R = 1/2, 1/3, 1/4$ , or $1/6$ ; Turbo code with $K = 4$ , $R = 2/3, 1/2, 1/3, 1/4$ , or $1/5$	5.2.2.1.2 and 5.2.2.1.23
Access scheme (uplink)	Basic access; power controlled access; reservation access; or designated access	5.2.2.1.2 and 5.2.2.1.23
Power control	Open loop Closed loop (800 Hz or 50 Hz update rate) Power control steps: 1.0, 0.5, 0.25 dB	5.2.2.1.2 and 5.2.2.1.23



## 5.2.2 Detailed specification of the radio interface

The standards contained in this section are derived from the global core specifications for IMT 2000 contained at <http://ties.itu.int/u/itu-r/ede/rsg8/wp8f/wp8f-tech/GCSrev4/5-2/>. The following notes apply to the sections below, where indicated: (1) The relevant SDOs should make their reference material available from their Web site. (2) This information was supplied by the recognized external organizations and relates to their own deliverables of the transposed global core specification.

### 5.2.2.1 cdma2000 radio aspects specifications

#### 5.2.2.1.1 C.S0001

##### Introduction to cdma2000 spread spectrum systems

This volume provides an overview of cdma2000 standards. The general architecture of cdma2000 and its relation to TIA/EIA-95-B family of standards is described. This volume also defines some common aspects such as channel naming convention used in the standard.

SDO (2)	Document No.	Version	Status	Issued date	Location (1)
<b>Revision A</b>					
ARIB	ARIB_STD-T64-C.S0001-A	A V5.0	Approved	25/05/2004	<a href="http://www.arib.or.jp/IMT-2000/ARIB-STD/ITU-R-4/ARIB_STD-T64-C.S0001-AV5.PDF">http://www.arib.or.jp/IMT-2000/ARIB-STD/ITU-R-4/ARIB_STD-T64-C.S0001-AV5.PDF</a>
CCSA	CCSA-TSD-MC-C.S0001-A	v5.0	Approved	01/02/2002	<a href="http://www.ccsa.org.cn/english/tc/files.php?docpath=/ITU-R/M.1457/M.1457-4">http://www.ccsa.org.cn/english/tc/files.php?docpath=/ITU-R/M.1457/M.1457-4</a>
TIA	TIA/EIA/IS-2000.1-A-2	A	Published	01/04/2002	<a href="http://www.tiaonline.org/standards/sfg/imt2k/cdma2000">http://www.tiaonline.org/standards/sfg/imt2k/cdma2000</a>
TTA	TTAE.3G-C.S0001-A v5.0	5.0	Approved	29/05/2002	<a href="http://www.tta.or.kr/standardDB/stnfile/TTAE.3G-C.S0001-A v5.0.zip">http://www.tta.or.kr/standardDB/stnfile/TTAE.3G-C.S0001-A v5.0.zip</a>
<b>Revision B</b>					
ARIB	ARIB_STD-T64-C.S0001-B	B V1.0	Approved	25/05/2004	<a href="http://www.arib.or.jp/IMT-2000/ARIB-STD/ITU-R-4/ARIB_STD-T64-C.S0001-BV1.PDF">http://www.arib.or.jp/IMT-2000/ARIB-STD/ITU-R-4/ARIB_STD-T64-C.S0001-BV1.PDF</a>
CCSA	CCSA-TSD-MC-C.S0001-B	1.0	Approved	01/08/2002	<a href="http://www.ccsa.org.cn/english/tc/files.php?docpath=/ITU-R/M.1457/M.1457-4">http://www.ccsa.org.cn/english/tc/files.php?docpath=/ITU-R/M.1457/M.1457-4</a>
TIA	TIA/EIA/IS-2000.1-B	B	Published	01/05/2002	<a href="http://www.tiaonline.org/standards/sfg/imt2k/cdma2000">http://www.tiaonline.org/standards/sfg/imt2k/cdma2000</a>
TTA	TTAE.3G-C.S0001-B	1.0	Approved	29/05/2002	<a href="http://www.tta.or.kr/standardDB/stnfile/TTAE.3G-C.S0001-B v1.0.zip">http://www.tta.or.kr/standardDB/stnfile/TTAE.3G-C.S0001-B v1.0.zip</a>
<b>Revision C</b>					
ARIB	ARIB_STD-T64-C.S0001-C	C V1.0	Approved	25/05/2004	<a href="http://www.arib.or.jp/IMT-2000/ARIB-STD/ITU-R-4/ARIB_STD-T64-C.S0001-C_v1.0.pdf">http://www.arib.or.jp/IMT-2000/ARIB-STD/ITU-R-4/ARIB_STD-T64-C.S0001-C_v1.0.pdf</a>
CCSA	CCSA-TSD-MC-C.S0001-C	1.0	Approved	01/08/2002	<a href="http://www.ccsa.org.cn/english/tc/files.php?docpath=/ITU-R/M.1457/M.1457-4">http://www.ccsa.org.cn/english/tc/files.php?docpath=/ITU-R/M.1457/M.1457-4</a>
TIA	TIA/EIA/IS-2000.1-C	C	Published	01/05/2002	<a href="http://www.tiaonline.org/standards/sfg/imt2k/cdma2000">http://www.tiaonline.org/standards/sfg/imt2k/cdma2000</a>
TTA	TTAT.3G-C.S0001-C v1.0	1.0	Approved	21/03/2003	<a href="http://www.tta.or.kr/standardDB/stnfile/TTAT.3G-C.S0001-C v1.0.zip">http://www.tta.or.kr/standardDB/stnfile/TTAT.3G-C.S0001-C v1.0.zip</a>
<b>Revision D</b>					
ARIB	ARIB_STD-T64-C.S0001-D	D V1.0	Approved	25/05/2004	<a href="http://www.arib.or.jp/IMT-2000/ARIB-STD/ITU-R-4/ARIB_STD-T64-C.S0001-D_v1.0.pdf">http://www.arib.or.jp/IMT-2000/ARIB-STD/ITU-R-4/ARIB_STD-T64-C.S0001-D_v1.0.pdf</a>
TIA	TIA-2000.1-D D		Published	01/03/2004	<a href="http://www.tiaonline.org/standards/sfg/imt2k/cdma2000">http://www.tiaonline.org/standards/sfg/imt2k/cdma2000</a>
TTA	TTAT.3G-C.S0001-D v1.0	1.0	Approved	25/05/2004	<a href="http://www.tta.or.kr/standardDB/stnfile/TTAT.3G-C.S0001-D v1.0.zip">http://www.tta.or.kr/standardDB/stnfile/TTAT.3G-C.S0001-D v1.0.zip</a>

### 5.2.2.1.2 C.S0002

#### Physical layer standard for cdma2000 spread spectrum systems

This volume defines the physical layer of the cdma2000 standard, including the requirements for the mobile station and the BS CDMA operation. Section 1 defines the terms and numeric indications used in this document. This section also describes the time reference used in the CDMA system and the tolerances used throughout the document. Section 2 describes the physical layer requirements for mobile stations operating in the CDMA mode. Section 3 describes the requirements for CDMA base stations.

SDO (2)	Document No.	Version	Status	Issued date	Location (1)
<b>Revision A</b>					
ARIB	ARIB STD-T64-C.S0002-A	A V6	Approved	25/05/2004	<a href="http://www.arib.or.jp/IMT-2000/ARIB-STD/ITU-R-4/ARIB_STD-T64-C.S0002-AV6.PDF">http://www.arib.or.jp/IMT-2000/ARIB-STD/ITU-R-4/ARIB_STD-T64-C.S0002-AV6.PDF</a>
CCSA	CCSA-TSD-MC-C.S0002-A	V6.0	Approved	01/02/2002	<a href="http://www.ccsa.org.cn/english/tc/files.php?docpath=/ITU-R/M.1457/M.1457-4">http://www.ccsa.org.cn/english/tc/files.php?docpath=/ITU-R/M.1457/M.1457-4</a>
TIA	TIA/EIA/IS-2000.2-A-2	A	Published	01/04/2002	<a href="http://www.tiaonline.org/standards/sfg/imt2k/cdma2000">http://www.tiaonline.org/standards/sfg/imt2k/cdma2000</a>
TTA	TTAE.3G-C.S0002-A v6.0	6.0	Approved	29/05/2002	<a href="http://www.tta.or.kr/standardDB/stnfile/TTAE.3G-C.S0002-A v6.0.zip">http://www.tta.or.kr/standardDB/stnfile/TTAE.3G-C.S0002-A v6.0.zip</a>
<b>Revision B</b>					
ARIB	ARIB STD-T64-C.S0002-B	B V1	Approved	25/05/2004	<a href="http://www.arib.or.jp/IMT-2000/ARIB-STD/ITU-R-4/ARIB_STD-T64-C.S0002-BV1.PDF">http://www.arib.or.jp/IMT-2000/ARIB-STD/ITU-R-4/ARIB_STD-T64-C.S0002-BV1.PDF</a>
CCSA	CCSA-TSD-MC-C.S0002-B	1.0	Approved	01/08/2002	<a href="http://www.ccsa.org.cn/english/tc/files.php?docpath=/ITU-R/M.1457/M.1457-4">http://www.ccsa.org.cn/english/tc/files.php?docpath=/ITU-R/M.1457/M.1457-4</a>
TIA	TIA/EIA/IS-2000.2-B	B	Published	01/05/2002	<a href="http://www.tiaonline.org/standards/sfg/imt2k/cdma2000">http://www.tiaonline.org/standards/sfg/imt2k/cdma2000</a>
TTA	TTAE.3G-C.S0002-B v1.0	1.0	Approved	29/05/2002	<a href="http://www.tta.or.kr/standardDB/stnfile/TTAE.3G-C.S0002-B v1.0.zip">http://www.tta.or.kr/standardDB/stnfile/TTAE.3G-C.S0002-B v1.0.zip</a>
<b>Revision C</b>					
ARIB	ARIB STD-T64-C.S0002-C	C V1.0	Approved	25/05/2004	<a href="http://www.arib.or.jp/IMT-2000/ARIB-STD/ITU-R-4/ARIB_STD-T64-C.S0002-C v1.0.pdf">http://www.arib.or.jp/IMT-2000/ARIB-STD/ITU-R-4/ARIB_STD-T64-C.S0002-C v1.0.pdf</a>
CCSA	CCSA-TSD-MC-C.S0002-C	1.0	Approved	01/08/2002	<a href="http://www.ccsa.org.cn/english/tc/files.php?docpath=/ITU-R/M.1457/M.1457-4">http://www.ccsa.org.cn/english/tc/files.php?docpath=/ITU-R/M.1457/M.1457-4</a>
TIA	TIA/EIA/IS-2000.2-C	C	Published	01/05/2002	<a href="http://www.tiaonline.org/standards/sfg/imt2k/cdma2000">http://www.tiaonline.org/standards/sfg/imt2k/cdma2000</a>
TTA	TTAT.3G-C.S0002-C v1.0	1.0	Approved	21/03/2003	<a href="http://www.tta.or.kr/standardDB/stnfile/TTAT.3G-C.S0002-C v1.0.zip">http://www.tta.or.kr/standardDB/stnfile/TTAT.3G-C.S0002-C v1.0.zip</a>
<b>Revision D</b>					
ARIB	ARIB STD-T64-C.S0002-D	D V1.0	Approved	25/05/2004	<a href="http://www.arib.or.jp/IMT-2000/ARIB-STD/ITU-R-4/ARIB_STD-T64-C.S0002-D v1.0.pdf">http://www.arib.or.jp/IMT-2000/ARIB-STD/ITU-R-4/ARIB_STD-T64-C.S0002-D v1.0.pdf</a>
TIA	TIA-2000.2-D	D	Published	01/03/2004	<a href="http://www.tiaonline.org/standards/sfg/imt2k/cdma2000">http://www.tiaonline.org/standards/sfg/imt2k/cdma2000</a>
TTA	TTAT.3G-C.S0002-D v1.0	1.0	Approved	25/05/2004	<a href="http://www.tta.or.kr/standardDB/stnfile/TTAT.3G-C.S0002-D v1.0.zip">http://www.tta.or.kr/standardDB/stnfile/TTAT.3G-C.S0002-D v1.0.zip</a>

### 5.2.2.1.3 C.S0003

#### Medium access control (MAC) standard for cdma2000 spread spectrum systems

This volume provides the detailed definitions of all component entities within the cdma2000 MAC layer, the service interfaces and primitives exchanged between entities within the MAC layer, and the service interfaces and primitives exchanged between the MAC layer and other cdma2000 layers. Section 1 contains the definitions of terms and an overview of this standard. Section 2 defines the normative behavior of the cdma2000 MAC sub-layer by describing the precise processing rules for each of the MAC sub-layer entities. Section 3 describes the service

interfaces between the MAC sub-layer and other entities that are defined outside of this standards document (i.e. upper layer signalling and the physical layer). Section 4 contains a set of informative flow diagrams, which demonstrate the steps that the mobile station and the BS have to follow to make certain state transitions.

SDO (2)	Document No.	Version	Status	Issued date	Location (1)
<b>Revision A</b>					
ARIB	ARIB STD-T64-C.S0003-A	A V6.0	Approved	25/05/2004	<a href="http://www.arib.or.jp/IMT-2000/ARIB-STD/ITU-R-4/ARIB_STD-T64-C.S0003-AV6.PDF">http://www.arib.or.jp/IMT-2000/ARIB-STD/ITU-R-4/ARIB_STD-T64-C.S0003-AV6.PDF</a>
CCSA	CCSA-TSD-MC-C.S0003-A	v6.0	Approved	01/02/2002	<a href="http://www.ccsa.org.cn/english/tc/files.php?docpath=/ITU-R/M.1457/M.1457-4">http://www.ccsa.org.cn/english/tc/files.php?docpath=/ITU-R/M.1457/M.1457-4</a>
TIA	TIA/EIA/IS-2000.3-A-2	A	Published	01/04/2002	<a href="http://www.tiaonline.org/standards/sfg/imt2k/cdma2000">http://www.tiaonline.org/standards/sfg/imt2k/cdma2000</a>
TTA	TTAE.3G-C.S0003-A v6.0	6.0	Approved	29/05/2002	<a href="http://www.tta.or.kr/standardDB/stnfile/TTAE.3G-C.S0003-A v6.0.zip">http://www.tta.or.kr/standardDB/stnfile/TTAE.3G-C.S0003-A v6.0.zip</a>
<b>Revision B</b>					
ARIB	ARIB STD-T64-C.S0003-B	B V1.0	Approved	25/05/2004	<a href="http://www.arib.or.jp/IMT-2000/ARIB-STD/ITU-R-4/ARIB_STD-T64-C.S0003-BV1.PDF">http://www.arib.or.jp/IMT-2000/ARIB-STD/ITU-R-4/ARIB_STD-T64-C.S0003-BV1.PDF</a>
CCSA	CCSA-TSD-MC-C.S0003-B	1.0	Approved	01/08/2002	<a href="http://www.ccsa.org.cn/english/tc/files.php?docpath=/ITU-R/M.1457/M.1457-4">http://www.ccsa.org.cn/english/tc/files.php?docpath=/ITU-R/M.1457/M.1457-4</a>
TIA	TIA/EIA/IS-2000.3-B	B	Published	01/05/2002	<a href="http://www.tiaonline.org/standards/sfg/imt2k/cdma2000">http://www.tiaonline.org/standards/sfg/imt2k/cdma2000</a>
TTA	TTAE.3G-C.S0003-B v1.0	1.0	Approved	29/05/2002	<a href="http://www.tta.or.kr/standardDB/stnfile/TTAE.3G-C.S0003-B v1.0.zip">http://www.tta.or.kr/standardDB/stnfile/TTAE.3G-C.S0003-B v1.0.zip</a>
<b>Revision C</b>					
ARIB	ARIB STD-T64-C.S0003-C	C V1.0	Approved	25/05/2004	<a href="http://www.arib.or.jp/IMT-2000/ARIB-STD/ITU-R-4/ARIB_STD-T64-C.S0003-C_v1.0.pdf">http://www.arib.or.jp/IMT-2000/ARIB-STD/ITU-R-4/ARIB_STD-T64-C.S0003-C_v1.0.pdf</a>
CCSA	CCSA-TSD-MC-C.S0003-C	1.0	Approved	01/08/2002	<a href="http://www.ccsa.org.cn/english/tc/files.php?docpath=/ITU-R/M.1457/M.1457-4">http://www.ccsa.org.cn/english/tc/files.php?docpath=/ITU-R/M.1457/M.1457-4</a>
TIA	TIA/EIA/IS-2000.3-C	C	Published	01/05/2002	<a href="http://www.tiaonline.org/standards/sfg/imt2k/cdma2000">http://www.tiaonline.org/standards/sfg/imt2k/cdma2000</a>
TTA	TTAT.3G-C.S0003-C v1.0	1.0	Approved	21/03/2003	<a href="http://www.tta.or.kr/standardDB/stnfile/TTAT.3G-C.S0003-C v1.0.zip">http://www.tta.or.kr/standardDB/stnfile/TTAT.3G-C.S0003-C v1.0.zip</a>
<b>Revision D</b>					
ARIB	ARIB STD-T64-C.S0003-D	D V1.0	Approved	25/05/2004	<a href="http://www.arib.or.jp/IMT-2000/ARIB-STD/ITU-R-4/ARIB_STD-T64-C.S0003-D_v1.0.pdf">http://www.arib.or.jp/IMT-2000/ARIB-STD/ITU-R-4/ARIB_STD-T64-C.S0003-D_v1.0.pdf</a>
TIA	TIA-2000.3-D	D	Published	01/03/2004	<a href="http://www.tiaonline.org/standards/sfg/imt2k/cdma2000">http://www.tiaonline.org/standards/sfg/imt2k/cdma2000</a>
TTA	TTAT.3G-C.S0003-D v1.0	1.0	Approved	25/05/2004	<a href="http://www.tta.or.kr/standardDB/stnfile/TTAT.3G-C.S0003-D v1.0.zip">http://www.tta.or.kr/standardDB/stnfile/TTAT.3G-C.S0003-D v1.0.zip</a>

#### 5.2.2.1.4 C.S0004

##### Signalling link access control (LAC) standard for cdma2000 spread spectrum systems

This volume describes the LAC signalling protocol architecture and functionality used to provide the transport and delivery of Layer 3 signalling messages over cdma2000 radio channels. Section 1 defines the terms and numeric information used in this standard. Section 2 describes the requirements for cdma2000 mobile stations. Section 3 describes the requirements for cdma2000 BSs. Annex A describes the architectural and functional model used to develop cdma2000 LAC signalling. Annex B contains tables that give specific values for the constant identifiers found in Section 2 and Section 3.

SDO (2)	Document No.	Version	Status	Issued date	Location (1)
<b>Revision A</b>					
ARIB	ARIB STD-T64-C.S0004 -A	A V6.0	Approved	25/05/2004	<a href="http://www.arib.or.jp/IMT-2000/ARIB-STD/ITU-R-4/ARIB_STD-T64-C.S0004-A_v6.0.pdf">http://www.arib.or.jp/IMT-2000/ARIB-STD/ITU-R-4/ARIB_STD-T64-C.S0004-A_v6.0.pdf</a>
CCSA	CCSA-TSD-MC-C.S0004-A	v6.0	Approved	01/02/2002	<a href="http://www.ccsa.org.cn/english/tc/files.php?docpath=/ITU-R/M.1457/M.1457-4">http://www.ccsa.org.cn/english/tc/files.php?docpath=/ITU-R/M.1457/M.1457-4</a>
TIA	TIA/EIA/IS-2000.4-A-2	A	Published	01/04/2002	<a href="http://www.tiaonline.org/standards/sfg/imt2k/cdma2000">http://www.tiaonline.org/standards/sfg/imt2k/cdma2000</a>

TTA	TTAE.3G-C.S0004-A v6.0	6.0	Approved	29/05/2002	<a href="http://www.tta.or.kr/standardDB/stnfile/TTAE.3G-C.S0004-A v6.0.zip">http://www.tta.or.kr/standardDB/stnfile/TTAE.3G-C.S0004-A v6.0.zip</a>
<b>Revision B</b>					
ARIB	ARIB_STD-T64-C.S0004-B	B V1.0	Approved	25/05/2004	<a href="http://www.arib.or.jp/IMT-2000/ARIB-STD/ITU-R-4/ARIB_STD-T64-C.S0004-B_v1.0.pdf">http://www.arib.or.jp/IMT-2000/ARIB-STD/ITU-R-4/ARIB_STD-T64-C.S0004-B_v1.0.pdf</a>
CCSA	CCSA-TSD-MC-C.S0004-B	1.0	Approved	01/08/2002	<a href="http://www.ccsa.org.cn/english/tc/files.php?docpath=/ITU-R/M.1457/M.1457-4">http://www.ccsa.org.cn/english/tc/files.php?docpath=/ITU-R/M.1457/M.1457-4</a>
TIA	TIA/EIA/IS-2000.4-B	B	Published	01/05/2002	<a href="http://www.tiaonline.org/standards/sfg/imt2k/cdma2000">http://www.tiaonline.org/standards/sfg/imt2k/cdma2000</a>
TTA	TTAE.3G-C.S0004-B v1.0	1.0	Approved	29/05/2002	<a href="http://www.tta.or.kr/standardDB/stnfile/TTAE.3G-C.S0004-B v1.0.zip">http://www.tta.or.kr/standardDB/stnfile/TTAE.3G-C.S0004-B v1.0.zip</a>
<b>Revision C</b>					
ARIB	ARIB_STD-T64-C.S0004-C	C V1.0	Approved	25/05/2004	<a href="http://www.arib.or.jp/IMT-2000/ARIB-STD/ITU-R-4/ARIB_STD-T64-C.S0004-C_v1.0.pdf">http://www.arib.or.jp/IMT-2000/ARIB-STD/ITU-R-4/ARIB_STD-T64-C.S0004-C_v1.0.pdf</a>
CCSA	CCSA-TSD-MC-C.S0004-C	1.0	Approved	01/08/2002	<a href="http://www.ccsa.org.cn/english/tc/files.php?docpath=/ITU-R/M.1457/M.1457-4">http://www.ccsa.org.cn/english/tc/files.php?docpath=/ITU-R/M.1457/M.1457-4</a>
TIA	TIA/EIA/IS-2000.4-C	C	Published	01/05/2002	<a href="http://www.tiaonline.org/standards/sfg/imt2k/cdma2000">http://www.tiaonline.org/standards/sfg/imt2k/cdma2000</a>
TTA	TTAT.3G-C.S0004-C v1.0	1.0	Approved	21/03/2003	<a href="http://www.tta.or.kr/standardDB/stnfile/TTAT.3G-C.S0004-C v1.0.zip">http://www.tta.or.kr/standardDB/stnfile/TTAT.3G-C.S0004-C v1.0.zip</a>
<b>Revision D</b>					
ARIB	ARIB_STD-T64-C.S0004-D	D V1.0	Approved	25/05/2004	<a href="http://www.arib.or.jp/IMT-2000/ARIB-STD/ITU-R-4/ARIB_STD-T64-C.S0004-D_v1.0.pdf">http://www.arib.or.jp/IMT-2000/ARIB-STD/ITU-R-4/ARIB_STD-T64-C.S0004-D_v1.0.pdf</a>
TIA	TIA-2000.4-D	D	Published	01/03/2004	<a href="http://www.tiaonline.org/standards/sfg/imt2k/cdma2000">http://www.tiaonline.org/standards/sfg/imt2k/cdma2000</a>
TTA	TTAT.3G-C.S0004-D v1.0	1.0	Approved	25/05/2004	<a href="http://www.tta.or.kr/standardDB/stnfile/TTAT.3G-C.S0004-D v1.0.zip">http://www.tta.or.kr/standardDB/stnfile/TTAT.3G-C.S0004-D v1.0.zip</a>

### 5.2.2.1.5 C.S0005

#### Upper layer (Layer 3) signalling standard for cdma2000 spread spectrum systems

This volume details the Layer 3 call processing and procedures, including the requirements for the mobile station and the BS CDMA operation. Section 1 defines the terms and numeric indications used in this document. Section 2 defines requirements that are specific to CDMA mobile station equipment and operation. Section 3 defines requirements that are specific to CDMA BS equipment and operation.

SDO (2)	Document No.	Version	Status	Issued date	Location (1)
<b>Revision A</b>					
ARIB	ARIB_STD-T64-C.S0005-A	A V6.0	Approved	25/05/2004	<a href="http://www.arib.or.jp/IMT-2000/ARIB-STD/ITU-R-4/ARIB_STD-T64-C.S0005-A_v6.0.pdf">http://www.arib.or.jp/IMT-2000/ARIB-STD/ITU-R-4/ARIB_STD-T64-C.S0005-A_v6.0.pdf</a>
CCSA	CCSA-TSD-MC-C.S0005-A	v6.0	Approved	01/02/2002	<a href="http://www.ccsa.org.cn/english/tc/files.php?docpath=/ITU-R/M.1457/M.1457-4">http://www.ccsa.org.cn/english/tc/files.php?docpath=/ITU-R/M.1457/M.1457-4</a>
TIA	TIA/EIA/IS-2000.5-A-2	A	Published	01/04/2002	<a href="http://www.tiaonline.org/standards/sfg/imt2k/cdma2000">http://www.tiaonline.org/standards/sfg/imt2k/cdma2000</a>
TTA	TTAE.3G-C.S0005-A v6.0	6.0	Approved	29/05/2002	<a href="http://www.tta.or.kr/standardDB/stnfile/TTAE.3G-C.S0005-A v6.0.zip">http://www.tta.or.kr/standardDB/stnfile/TTAE.3G-C.S0005-A v6.0.zip</a>
<b>Revision B</b>					
ARIB	ARIB_STD-T64-C.S0005-B	B V1.0	Approved	25/05/2004	<a href="http://www.arib.or.jp/IMT-2000/ARIB-STD/ITU-R-4/ARIB_STD-T64-C.S0005-B_v1.0.pdf">http://www.arib.or.jp/IMT-2000/ARIB-STD/ITU-R-4/ARIB_STD-T64-C.S0005-B_v1.0.pdf</a>
CCSA	CCSA-TSD-MC-C.S0005-B	1.0	Approved	01/08/2002	<a href="http://www.ccsa.org.cn/english/tc/files.php?docpath=/ITU-R/M.1457/M.1457-4">http://www.ccsa.org.cn/english/tc/files.php?docpath=/ITU-R/M.1457/M.1457-4</a>
TIA	TIA/EIA/IS-2000.5-B	B	Published	01/05/2002	<a href="http://www.tiaonline.org/standards/sfg/imt2k/cdma2000">http://www.tiaonline.org/standards/sfg/imt2k/cdma2000</a>
TTA	TTAE.3G-C.S0005-B v1.0	1.0	Approved	29/05/2002	<a href="http://www.tta.or.kr/standardDB/stnfile/TTAE.3G-C.S0005-B v1.0.zip">http://www.tta.or.kr/standardDB/stnfile/TTAE.3G-C.S0005-B v1.0.zip</a>
<b>Revision C</b>					
ARIB	ARIB_STD-T64-C.S0005-C	C V1.0	Approved	25/05/2004	<a href="http://www.arib.or.jp/IMT-2000/ARIB-STD/ITU-R-4/ARIB_STD-T64-C.S0005-C_v1.0.pdf">http://www.arib.or.jp/IMT-2000/ARIB-STD/ITU-R-4/ARIB_STD-T64-C.S0005-C_v1.0.pdf</a>
CCSA	CCSA-TSD-MC-C.S0005-C	1.0	Approved	01/08/2002	<a href="http://www.ccsa.org.cn/english/tc/files.php?docpath=/ITU-R/M.1457/M.1457-4">http://www.ccsa.org.cn/english/tc/files.php?docpath=/ITU-R/M.1457/M.1457-4</a>
TIA	TIA/EIA/IS-2000.5-C	C	Published	01/05/2002	<a href="http://www.tiaonline.org/standards/sfg/imt2k/cdma2000">http://www.tiaonline.org/standards/sfg/imt2k/cdma2000</a>
TTA	TTAT.3G-C.S0005-C v1.0	1.0	Approved	21/03/2003	<a href="http://www.tta.or.kr/standardDB/stnfile/TTAT.3G-C.S0005-C v1.0.zip">http://www.tta.or.kr/standardDB/stnfile/TTAT.3G-C.S0005-C v1.0.zip</a>

**Revision D**

TIA	TIA-2000.5-D	D	Published	01/03/2004	<a href="http://www.tiaonline.org/standards/sfg/imt2k/cdma2000">http://www.tiaonline.org/standards/sfg/imt2k/cdma2000</a>
TTA	TTAT.3G-C.S0005-D v1.0	1.0	Approved	25/05/2004	<a href="http://www.tta.or.kr/standardDB/stnfile/TTAT.3G-C.S0005-D v1.0.zip">http://www.tta.or.kr/standardDB/stnfile/TTAT.3G-C.S0005-D v1.0.zip</a>

**5.2.2.1.6 C.S0006****Analogue Signaling standard for cdma2000 spread spectrum systems**

This volume specifies analogue operation at 800 MHz based upon the standard TIA/EIA-553-A. This standard provides the differences within TIA/EIA-553-A, which are used by dual-mode mobile stations. Section 1 defines the terms and numeric indications used in this document. Section 2 describes the requirements for CDMA-analogue dual-mode mobile stations operating in the analogue mode. Section 3 describes the requirements for analogue BSs. Section 4 describes the requirements for CDMA-analogue dual-mode mobile stations, which use the 32-digit dialing option on the reverse analogue control channel. In addition, this section describes mobile station requirements for use of the optional extended protocol. Section 5 describes the BS requirements for using the 32-digit dialing option on the reverse analogue control channel. In addition, this section describes BS requirements for use of the optional extended protocol.

SDO (2)	Document No.	Version	Status	Issued date	Location (1)
<b>Revision A</b>					
CCSA	CCSA-TSD-MC-C.S0006-A	v6.0	Approved	01/02/2002	<a href="http://www.ccsa.org.cn/english/tc/files.php?docpath=/ITU-R/M.1457/M.1457-4">http://www.ccsa.org.cn/english/tc/files.php?docpath=/ITU-R/M.1457/M.1457-4</a>
TIA	TIA/EIA/IS-2000.6-A-2	A	Published	01/04/2002	<a href="http://www.tiaonline.org/standards/sfg/imt2k/cdma2000">http://www.tiaonline.org/standards/sfg/imt2k/cdma2000</a>
TTA	TTAE.3G-C.S0006-A v6.0	6.0	Approved	29/05/2002	<a href="http://www.tta.or.kr/standardDB/stnfile/TTAE.3G-C.S0006-A v6.0.zip">http://www.tta.or.kr/standardDB/stnfile/TTAE.3G-C.S0006-A v6.0.zip</a>
<b>Revision B</b>					
CCSA	CCSA-TSD-MC-C.S0006-B	1.0	Approved	01/08/2002	<a href="http://www.ccsa.org.cn/english/tc/files.php?docpath=/ITU-R/M.1457/M.1457-4">http://www.ccsa.org.cn/english/tc/files.php?docpath=/ITU-R/M.1457/M.1457-4</a>
TIA	TIA/EIA/IS-2000.6-B	B	Published	01/05/2002	<a href="http://www.tiaonline.org/standards/sfg/imt2k/cdma2000">http://www.tiaonline.org/standards/sfg/imt2k/cdma2000</a>
TTA	TTAE.3G-C.S0006-B v1.0	1.0	Approved	29/05/2002	<a href="http://www.tta.or.kr/standardDB/stnfile/TTAE.3G-C.S0006-B v1.0.zip">http://www.tta.or.kr/standardDB/stnfile/TTAE.3G-C.S0006-B v1.0.zip</a>
<b>Revision C</b>					
CCSA	CCSA-TSD-MC-C.S0006-C	1.0	Approved	01/08/2002	<a href="http://www.ccsa.org.cn/english/tc/files.php?docpath=/ITU-R/M.1457/M.1457-4">http://www.ccsa.org.cn/english/tc/files.php?docpath=/ITU-R/M.1457/M.1457-4</a>
TIA	TIA/EIA/IS-2000.6-C	C	Published	01/05/2002	<a href="http://www.tiaonline.org/standards/sfg/imt2k/cdma2000">http://www.tiaonline.org/standards/sfg/imt2k/cdma2000</a>
TTA	TTAT.3G-C.S0006-C v1.0	1.0	Approved	28/05/2003	<a href="http://www.tta.or.kr/standardDB/stnfile/TTAT.3G-C.S0006-C v1.0.zip">http://www.tta.or.kr/standardDB/stnfile/TTAT.3G-C.S0006-C v1.0.zip</a>
<b>Revision D</b>					
TIA	TIA-2000.6-D	D	Published	01/03/2004	<a href="http://www.tiaonline.org/standards/sfg/imt2k/cdma2000">http://www.tiaonline.org/standards/sfg/imt2k/cdma2000</a>
TTA	TTAT.3G-C.S0006-D v1.0	1.0	Approved	25/05/2004	<a href="http://www.tta.or.kr/standardDB/stnfile/TTAT.3G-C.S0006-D v1.0.zip">http://www.tta.or.kr/standardDB/stnfile/TTAT.3G-C.S0006-D v1.0.zip</a>

**5.2.2.1.7 C.S0007****Direct Spread Specification for Spread Spectrum Systems on ANSI-41 (DS-41) (Upper Layers Air Interface)**

This specification covers upper layers signalling protocols and procedures for the DS-41 (IMT-2000 CDMA-DS on ANSI-41) radio interface which support functionality customarily classified as pertaining to CC and MM.

SDO (2)	Document No.	Version	Status	Issued date	Location (1)
CCSA	CCSA-TSD-MC-C.S0007-0	1.0	Approved	01/02/2002	<a href="http://www.ccsa.org.cn/english/tc/files.php?docpath=/ITU-R/M.1457/M.1457-4">http://www.ccsa.org.cn/english/tc/files.php?docpath=/ITU-R/M.1457/M.1457-4</a>
TIA	TIA/EIA/IS-834		Published	01/03/2000	<a href="http://www.tiaonline.org/standards/sfg/imt2k/cdma2000">http://www.tiaonline.org/standards/sfg/imt2k/cdma2000</a>
TTA	TTAE.3G-C.S0007	1.0	Approved	28/03/2000	<a href="http://www.tta.or.kr/standardDB/stnfile/TTAE_3G-C_S0007.zip">http://www.tta.or.kr/standardDB/stnfile/TTAE_3G-C_S0007.zip</a>

#### 5.2.2.1.8 C.S0008

### Multi-Carrier Specification for Spread Spectrum Systems on GSM MAP (MC-MAP)

This specification covers lower layers (Layer 3 RRC, Layer 2, Layer 1) protocols and procedures for the MC-MAP (IMT-2000 CDMA-MC on GSM-MAP) radio interface.

SDO (2)	Document No.	Version	Status	Issued date	Location (1)
CCSA	CCSA-TSD-MC-C.S0008-0	1.0	Approved	01/02/2002	<a href="http://www.ccsa.org.cn/english/tc/files.php?docpath=/ITU-R/M.1457/M.1457-4">http://www.ccsa.org.cn/english/tc/files.php?docpath=/ITU-R/M.1457/M.1457-4</a>
TIA	TIA/EIA/IS-833		Published	01/03/2000	<a href="http://www.tiaonline.org/standards/sfg/imt2k/cdma2000">http://www.tiaonline.org/standards/sfg/imt2k/cdma2000</a>
TTA	TTAE.3G-C.S0008	1.0	Approved	28/03/2000	<a href="http://www.tta.or.kr/standardDB/stnfile/TTAE_3G-C_S0008.zip">http://www.tta.or.kr/standardDB/stnfile/TTAE_3G-C_S0008.zip</a>

#### 5.2.2.1.9 C.S0009

### Standard for Wideband Spread Spectrum Systems

This Specification defines the original variable rate speech codec which has a full rate of 8 kbps.

SDO (2)	Document No.	Version	Status	Issued date	Location (1)
ARIB	ARIB STD-T64-C.S0009-0	0	Approved	25/05/2004	<a href="http://www.arib.or.jp/IMT-2000/ARIB-STD/ITU-R-4/ARIB_STD-T64-C.S0009-0.PDF">http://www.arib.or.jp/IMT-2000/ARIB-STD/ITU-R-4/ARIB_STD-T64-C.S0009-0.PDF</a>
CCSA	CCSA-TSD-MC-C.S0009-0	1.0	Approved	01/02/2002	<a href="http://www.ccsa.org.cn/english/tc/files.php?docpath=/ITU-R/M.1457/M.1457-4">http://www.ccsa.org.cn/english/tc/files.php?docpath=/ITU-R/M.1457/M.1457-4</a>
TTA	TTAE.3G-C.S0009	1.0	Approved	13/07/2000	<a href="http://www.tta.or.kr/standardDB/stnfile/TTAE_3G-C_S0009.zip">http://www.tta.or.kr/standardDB/stnfile/TTAE_3G-C_S0009.zip</a>
<b>Revision C</b>					
TIA	TIA/EIA-96-C C		Published	01/08/1998	<a href="http://www.tiaonline.org/standards/sfg/imt2k/cdma2000">http://www.tiaonline.org/standards/sfg/imt2k/cdma2000</a>

#### 5.2.2.1.10 C.S0010

### Recommended Minimum Performance Standards for Base Stations Supporting Dual Mode Spread Spectrum Systems

This Specification provides definitions, methods of measurement, and minimum performance requirements for CDMA base stations.

SDO (2)	Document No.	Version	Status	Issued date	Location (1)
ARIB	ARIB STD-T64-C.S0010	A / B / B V2.0	Approved	25/05/2004	<a href="http://www.arib.or.jp/IMT-2000/ARIB-STD/ITU-R-4/ARIB_STD-T64-C.S0010.zip">http://www.arib.or.jp/IMT-2000/ARIB-STD/ITU-R-4/ARIB_STD-T64-C.S0010.zip</a>
CCSA	CCSA-TSD-MC-C.S0010-A	1.0	Approved	01/02/2002	<a href="http://www.ccsa.org.cn/english/tc/files.php?docpath=/ITU-R/M.1457/M.1457-4">http://www.ccsa.org.cn/english/tc/files.php?docpath=/ITU-R/M.1457/M.1457-4</a>
TTA	TTAE-3G-C.S0010	1.0	Approved	13/07/2000	<a href="http://www.tta.or.kr/standardDB/stnfile/TTAE_3G-C_S0010.zip">http://www.tta.or.kr/standardDB/stnfile/TTAE_3G-C_S0010.zip</a>

**Revision D**

TIA	TIA/EIA-97-D	D	Published	01/06/2001	<a href="http://www.tiaonline.org/standards/sfg/imt2k/cdma2000">http://www.tiaonline.org/standards/sfg/imt2k/cdma2000</a>
-----	--------------	---	-----------	------------	---------------------------------------------------------------------------------------------------------------------------

**Revision E**

TIA	TIA-97-E	E	Published	01/02/2003	<a href="http://www.tiaonline.org/standards/sfg/imt2k/cdma2000">http://www.tiaonline.org/standards/sfg/imt2k/cdma2000</a>
-----	----------	---	-----------	------------	---------------------------------------------------------------------------------------------------------------------------

**5.2.2.1.11 C.S0011****Recommended Minimum Performance Standards for cdma2000 Spread Spectrum Mobile Stations**

This Specification provides definitions, methods of measurement, and minimum performance requirements for CDMA mobile stations.

SDO (2)	Document No.	Version	Status	Issued date	Location (1)
ARIB	ARIB STD-T64-C.S0011	A / B	Approved	25/05/2004	<a href="http://www.arib.or.jp/IMT-2000/ARIB-STD/ITU-R-4/ARIB_STD-T64-C.S0011.zip">http://www.arib.or.jp/IMT-2000/ARIB-STD/ITU-R-4/ARIB_STD-T64-C.S0011.zip</a>
CCSA	CCSA-TSD-MC-C.S0011-A	1.0	Approved	01/02/2002	<a href="http://www.ccsa.org.cn/english/tc/files.php?docpath=/ITU-R/M.1457/M.1457-4">http://www.ccsa.org.cn/english/tc/files.php?docpath=/ITU-R/M.1457/M.1457-4</a>
TTA	TTAE-3G-C.S0011	1.0	Approved	13/07/2000	<a href="http://www.tta.or.kr/standardDB/stnfile/TTAE_3G-C_S0011.zip">http://www.tta.or.kr/standardDB/stnfile/TTAE_3G-C_S0011.zip</a>

**Revision D**

TIA	TIA/EIA-98-D	D	Published	01/06/2001	<a href="http://www.tiaonline.org/standards/sfg/imt2k/cdma2000">http://www.tiaonline.org/standards/sfg/imt2k/cdma2000</a>
-----	--------------	---	-----------	------------	---------------------------------------------------------------------------------------------------------------------------

**Revision E**

TIA	TIA-98-E	E	Published	01/02/2003	<a href="http://www.tiaonline.org/standards/sfg/imt2k/cdma2000">http://www.tiaonline.org/standards/sfg/imt2k/cdma2000</a>
-----	----------	---	-----------	------------	---------------------------------------------------------------------------------------------------------------------------

**5.2.2.1.12 C.S0012****Minimum Performance Standard for Speech Service Option 1**

This Specification provides definitions, methods of measurement, and minimum performance requirements for the 8 kbps speech codec, C.S0009 (see 5.2.2.1.9).

SDO (2)	Document No.	Version	Status	Issued date	Location (1)
ARIB	ARIB STD-T64-C.S0012-0	0	Approved	25/05/2004	<a href="http://www.arib.or.jp/IMT-2000/ARIB-STD/ITU-R-4/ARIB_STD-T64-C.S0012-0.PDF">http://www.arib.or.jp/IMT-2000/ARIB-STD/ITU-R-4/ARIB_STD-T64-C.S0012-0.PDF</a>
CCSA	CCSA-TSD-MC-C.S0012-0	1.0	Approved	01/02/2002	<a href="http://www.ccsa.org.cn/english/tc/files.php?docpath=/ITU-R/M.1457/M.1457-4">http://www.ccsa.org.cn/english/tc/files.php?docpath=/ITU-R/M.1457/M.1457-4</a>
TTA	TTAE-3G-C.S0012	1.0	Approved	13/07/2000	<a href="http://www.tta.or.kr/standardDB/stnfile/TTAE_3G-C_S0012.zip">http://www.tta.or.kr/standardDB/stnfile/TTAE_3G-C_S0012.zip</a>

**Revision A**

TIA	TIA/EIA-125-AA		Published	01/08/2000	<a href="http://www.tiaonline.org/standards/sfg/imt2k/cdma2000">http://www.tiaonline.org/standards/sfg/imt2k/cdma2000</a>
-----	----------------	--	-----------	------------	---------------------------------------------------------------------------------------------------------------------------

**5.2.2.1.13 C.S0013****Loopback Service Options (LSO) for cdma2000 Spread Spectrum System**

This Specification defines loopback mechanism used for testing CDMA mobile stations and base stations.

SDO (2)	Document No.	Version	Status	Issued date	Location (1)
ARIB	ARIB STD-T64-C.S0013-A	A VBR	Approved	25/05/2004	<a href="http://www.arib.or.jp/IMT-2000/ARIB-STD/ITU-R-4/ARIB_STD-T64-C.S0013-A.PDF">http://www.arib.or.jp/IMT-2000/ARIB-STD/ITU-R-4/ARIB_STD-T64-C.S0013-A.PDF</a>
CCSA	CCSA-TSD-MC-C.S0013-A	1.0	Approved	01/02/2002	<a href="http://www.ccsa.org.cn/english/tc/files.php?docpath=/ITU-R/M.1457/M.1457-4">http://www.ccsa.org.cn/english/tc/files.php?docpath=/ITU-R/M.1457/M.1457-4</a>
TTA	TTAE-3G-C.S0013	1.0	Approved	13/07/2000	<a href="http://www.tta.or.kr/standardDB/stnfile/TTAE_3G-C_S0013.zip">http://www.tta.or.kr/standardDB/stnfile/TTAE_3G-C_S0013.zip</a>



**Revision D**

TIA	TIA/EIA-126-D	D	Published	01/06/2001	<a href="http://www.tiaonline.org/standards/sfg/imt2k/cdma2000">http://www.tiaonline.org/standards/sfg/imt2k/cdma2000</a>
-----	---------------	---	-----------	------------	---------------------------------------------------------------------------------------------------------------------------

**5.2.2.1.14 C.S0014****Enhanced Variable Rate Codec Speech Service Option 3 for Wideband Speech Digital Systems - Addendum 3**

This Specification defines the Enhanced Variable Rate Speech codec (EVRC) which has a full rate of 8 kbps.

SDO (2)	Document No.	Version	Status	Issued date	Location (1)
ARIB	ARIB STD-T64-C.S0014	0 / 0 V1.0	Approved	25/05/2004	<a href="http://www.arib.or.jp/IMT-2000/ARIB-STD/ITU-R-4/ARIB_STD-T64-C.S0014.zip">http://www.arib.or.jp/IMT-2000/ARIB-STD/ITU-R-4/ARIB_STD-T64-C.S0014.zip</a>
CCSA	CCSA-TSD-MC-C.S0014-0-3	3.0	Approved	01/02/2002	<a href="http://www.ccsa.org.cn/english/tc/files.php?docpath=/ITU-R/M.1457/M.1457-4">http://www.ccsa.org.cn/english/tc/files.php?docpath=/ITU-R/M.1457/M.1457-4</a>
TIA	TIA/EIA/IS-127-1		Published	01/08/1998	<a href="http://www.tiaonline.org/standards/sfg/imt2k/cdma2000">http://www.tiaonline.org/standards/sfg/imt2k/cdma2000</a>
TIA	TIA/EIA/IS-127-2		Published	01/09/1999	<a href="http://www.tiaonline.org/standards/sfg/imt2k/cdma2000">http://www.tiaonline.org/standards/sfg/imt2k/cdma2000</a>
TIA	TIA/EIA/IS-127-3		Published	01/09/2001	<a href="http://www.tiaonline.org/standards/sfg/imt2k/cdma2000">http://www.tiaonline.org/standards/sfg/imt2k/cdma2000</a>
TIA	TIA/EIA/IS-127		Published	01/01/1997	<a href="http://www.tiaonline.org/standards/sfg/imt2k/cdma2000">http://www.tiaonline.org/standards/sfg/imt2k/cdma2000</a>
TTA	TTAT.3G-C.S0014-0-3 V1.0	1.0	Approved	28/05/2003	<a href="http://www.tta.or.kr/standardDB/stnfile/TTAT.3G-C.S0014-0-3 V1.0.zip">http://www.tta.or.kr/standardDB/stnfile/TTAT.3G-C.S0014-0-3 V1.0.zip</a>

**5.2.2.1.15 C.S0015****Short Message Services for Wideband Spread Spectrum Systems**

This Specification defines the short message service feature and related procedures.

SDO (2)	Document No.	Version	Status	Issued date	Location (1)
CCSA	CCSA-TSD-MC-C.S0015-A	1.0	Approved	01/02/2002	<a href="http://www.ccsa.org.cn/english/tc/files.php?docpath=/ITU-R/M.1457/M.1457-4">http://www.ccsa.org.cn/english/tc/files.php?docpath=/ITU-R/M.1457/M.1457-4</a>
TTA	TTAE-3G-C.S0015	1.0	Approved	13/07/2000	<a href="http://www.tta.or.kr/standardDB/stnfile/TTAE_3G-C_S0015.zip">http://www.tta.or.kr/standardDB/stnfile/TTAE_3G-C_S0015.zip</a>

**Revision A**

ARIB	ARIB STD-T64-C.S0015-A	A	Approved	25/05/2004	<a href="http://www.arib.or.jp/IMT-2000/ARIB-STD/ITU-R-4/ARIB_STD-T64-C.S0015-A.PDF">http://www.arib.or.jp/IMT-2000/ARIB-STD/ITU-R-4/ARIB_STD-T64-C.S0015-A.PDF</a>
------	------------------------	---	----------	------------	---------------------------------------------------------------------------------------------------------------------------------------------------------------------

**Revision B**

TIA	TIA/EIA-637-B	B	Published	01/01/2002	<a href="http://www.tiaonline.org/standards/sfg/imt2k/cdma2000">http://www.tiaonline.org/standards/sfg/imt2k/cdma2000</a>
-----	---------------	---	-----------	------------	---------------------------------------------------------------------------------------------------------------------------

**5.2.2.1.16 C.S0016****Over-the Air Provisioning of Mobile Stations in Spread Spectrum Systems**

This Specification defines the over-the-air service provisioning (OTASP) feature and related procedures. This includes over-the-air provisioning of operational parameters, system selection for preferred roaming, and service programming locks.

SDO (2)	Document No.	Version	Status	Issued date	Location (1)
ARIB	ARIB STD-T64-C.S0016	A V2.0 / B	Approved	25/05/2004	<a href="http://www.arib.or.jp/IMT-2000/ARIB-STD/ITU-R-4/ARIB_STD-T64-C.S0016.zip">http://www.arib.or.jp/IMT-2000/ARIB-STD/ITU-R-4/ARIB_STD-T64-C.S0016.zip</a>
CCSA	CCSA-TSD-MC-C.S0016-A	v2.0	Approved	01/02/2002	<a href="http://www.ccsa.org.cn/english/tc/files.php?docpath=/ITU-R/M.1457/M.1457-4">http://www.ccsa.org.cn/english/tc/files.php?docpath=/ITU-R/M.1457/M.1457-4</a>
TTA	TTAE.3G-C.S0016		Approved	13/07/2000	<a href="http://www.tta.or.kr/standardDB/stnfile/TTAE_3G-C_S0016.zip">http://www.tta.or.kr/standardDB/stnfile/TTAE_3G-C_S0016.zip</a>



**Revision B**

TIA	TIA/EIA-683-B	B	Published	01/12/2001	<a href="http://www.tiaonline.org/standards/sfg/imt2k/cdma2000">http://www.tiaonline.org/standards/sfg/imt2k/cdma2000</a>
-----	---------------	---	-----------	------------	---------------------------------------------------------------------------------------------------------------------------

**Revision C**

TIA	TIA-683-C	C	Published	01/03/2003	<a href="http://www.tiaonline.org/standards/sfg/imt2k/cdma2000">http://www.tiaonline.org/standards/sfg/imt2k/cdma2000</a>
-----	-----------	---	-----------	------------	---------------------------------------------------------------------------------------------------------------------------

**5.2.2.1.17 C.S0017****Data Service Options for Spread Spectrum Systems**

This Specification defines the CDMA data services, which include asynchronous and synchronous circuit switched data, packet data, and analog fax. This Specification includes the definition of the protocol stack, and specifications for the various protocol layers.

<b>SDO (2)</b>	<b>Document No.</b>	<b>Version</b>	<b>Status</b>	<b>Issued date</b>	<b>Location (1)</b>
ARIB	ARIB STD-T64-C.S0017	0 / 0 V1.0 / 0 V2.0 / 0 V3.0	Approved	25/05/2004	<a href="http://www.arib.or.jp/IMT-2000/ARIB-STD/ITU-R-4/ARIB_STD-T64-C.S0017.zip">http://www.arib.or.jp/IMT-2000/ARIB-STD/ITU-R-4/ARIB_STD-T64-C.S0017.zip</a>
CCSA	CCSA-TSD-MC-C.S0017-0-2	v2.0	Approved	01/02/2002	<a href="http://www.ccsa.org.cn/english/tc/files.php?docpath=/ITU-R/M.1457/M.1457-4">http://www.ccsa.org.cn/english/tc/files.php?docpath=/ITU-R/M.1457/M.1457-4</a>
TTA	TTAT.3G-C.S0017-0 v5.0	5.0	Approved	25/05/2004	<a href="http://www.tta.or.kr/standardDB/stnfile/TTAT.3G-C.S0017-0 v5.0.zip">http://www.tta.or.kr/standardDB/stnfile/TTAT.3G-C.S0017-0 v5.0.zip</a>
<b>Revision A</b>					
TIA	TIA/EIA/IS-707-A-1	A	Published	01/12/1999	<a href="http://www.tiaonline.org/standards/sfg/imt2k/cdma2000">http://www.tiaonline.org/standards/sfg/imt2k/cdma2000</a>
TIA	TIA/EIA/IS-707	A	Published	01/02/1998	<a href="http://www.tiaonline.org/standards/sfg/imt2k/cdma2000">http://www.tiaonline.org/standards/sfg/imt2k/cdma2000</a>
TIA	TIA/EIA/IS-707-A	A	Published	01/04/1999	<a href="http://www.tiaonline.org/standards/sfg/imt2k/cdma2000">http://www.tiaonline.org/standards/sfg/imt2k/cdma2000</a>
TIA	TIA/EIA/IS-707-A-2	A	Published	01/02/2003	<a href="http://www.tiaonline.org/standards/sfg/imt2k/cdma2000">http://www.tiaonline.org/standards/sfg/imt2k/cdma2000</a>
TIA	TIA/IS-707-A-3	A	Published	01/02/2003	<a href="http://www.tiaonline.org/standards/sfg/imt2k/cdma2000">http://www.tiaonline.org/standards/sfg/imt2k/cdma2000</a>

**5.2.2.1.18 C.S0018****Minimum Performance Specification for Enhanced Variable Rate Codec (EVRC) Speech Option 3 for Spread Spectrum Systems**

This Specification provides definitions, methods of measurement, and minimum performance requirements for the EVRC speech codec, C.S0014 (see 5.2.2.1.14).

<b>SDO (2)</b>	<b>Document No.</b>	<b>Version</b>	<b>Status</b>	<b>Issued date</b>	<b>Location (1)</b>
ARIB	ARIB STD-T64-C.S0018-0	0	Approved	25/05/2004	<a href="http://www.arib.or.jp/IMT-2000/ARIB-STD/ITU-R-4/ARIB_STD-T64-C.S0018-0.PDF">http://www.arib.or.jp/IMT-2000/ARIB-STD/ITU-R-4/ARIB_STD-T64-C.S0018-0.PDF</a>
CCSA	CCSA-TSD-MC-C.S0018-0	1.0	Approved	01/02/2002	<a href="http://www.ccsa.org.cn/english/tc/files.php?docpath=/ITU-R/M.1457/M.1457-4">http://www.ccsa.org.cn/english/tc/files.php?docpath=/ITU-R/M.1457/M.1457-4</a>
TIA	TIA/EIA/IS-718		Published	01/07/1998	<a href="http://www.tiaonline.org/standards/sfg/imt2k/cdma2000">http://www.tiaonline.org/standards/sfg/imt2k/cdma2000</a>
TTA	TTAE-3G-C.S0018	1.0	Approved	13/07/2000	<a href="http://www.tta.or.kr/standardDB/stnfile/TTAE_3G-C_S0018.zip">http://www.tta.or.kr/standardDB/stnfile/TTAE_3G-C_S0018.zip</a>

**5.2.2.1.19 C.S0020****High Rate Speech Service Option 17 for Wideband Spread Spectrum Communication Systems - Addendum 2**

This Specification defines the high rate variable rate speech codec which has a full rate of 13 kbps.

SDO (2)	Document No.	Version	Status	Issued date	Location (1)
ARIB	ARIB STD-T64-C.S0020-0	0	Approved	25/05/2004	<a href="http://www.arib.or.jp/IMT-2000/ARIB-STD/ITU-R-4/ARIB_STD-T64-C.S0020-0.PDF">http://www.arib.or.jp/IMT-2000/ARIB-STD/ITU-R-4/ARIB_STD-T64-C.S0020-0.PDF</a>
CCSA	CCSA-TSD-MC-C.S0020-0-2	2.0	Approved	01/02/2002	<a href="http://www.ccsa.org.cn/english/tc/files.php?docpath=/ITU-R/M.1457/M.1457-4">http://www.ccsa.org.cn/english/tc/files.php?docpath=/ITU-R/M.1457/M.1457-4</a>
TIA	TIA/EIA/IS-733		Published	01/03/1998	<a href="http://www.tiaonline.org/standards/sfg/imt2k/cdma2000">http://www.tiaonline.org/standards/sfg/imt2k/cdma2000</a>
TIA	TIA/EIA/IS-733-1		Published	01/09/1999	<a href="http://www.tiaonline.org/standards/sfg/imt2k/cdma2000">http://www.tiaonline.org/standards/sfg/imt2k/cdma2000</a>
TIA	TIA/EIA/IS-733-2		Published	01/09/2001	<a href="http://www.tiaonline.org/standards/sfg/imt2k/cdma2000">http://www.tiaonline.org/standards/sfg/imt2k/cdma2000</a>
TTA	TTAT.3G-C.S0020-0-2 V1.0	1.0	Approved	28/05/2003	<a href="http://www.tta.or.kr/standardDB/stnfile/TTAT.3G-C.S0020-0-2 V1.0.zip">http://www.tta.or.kr/standardDB/stnfile/TTAT.3G-C.S0020-0-2 V1.0.zip</a>

**5.2.2.1.20 C.S0021****Recommended Minimum Performance Standard for the High Rate Speech Option 17 for Wideband Spread Spectrum Communication Systems**

This Specification provides definitions, methods of measurement, and minimum performance requirements for the 13 kbps variable-rate speech codec, C.S0020 (see 5.2.2.1.19).

SDO (2)	Document No.	Version	Status	Issued date	Location (1)
ARIB	ARIB STD-T64-C.S0021-0	0	Approved	25/05/2004	<a href="http://www.arib.or.jp/IMT-2000/ARIB-STD/ITU-R-4/ARIB_STD-T64-C.S0021-0.PDF">http://www.arib.or.jp/IMT-2000/ARIB-STD/ITU-R-4/ARIB_STD-T64-C.S0021-0.PDF</a>
CCSA	CCSA-TSD-MC-C.S0021-0	1.0	Approved	01/02/2002	<a href="http://www.ccsa.org.cn/english/tc/files.php?docpath=/ITU-R/M.1457/M.1457-4">http://www.ccsa.org.cn/english/tc/files.php?docpath=/ITU-R/M.1457/M.1457-4</a>
TTA	TTAE.3G-C.S0021	1.0	Approved	13/07/2000	<a href="http://www.tta.or.kr/standardDB/stnfile/TTAE_3G-C_S0021.zip">http://www.tta.or.kr/standardDB/stnfile/TTAE_3G-C_S0021.zip</a>
<b>Revision A</b>					
TIA	TIA/EIA-736-AA		Published	01/08/2000	<a href="http://www.tiaonline.org/standards/sfg/imt2k/cdma2000">http://www.tiaonline.org/standards/sfg/imt2k/cdma2000</a>

**5.2.2.1.21 C.S0022****Position Determination Service Standard for Dual Mode Spread Spectrum Systems**

This Specification defines the position location feature which provides the capability to locate the mobile station. This specification supports automatic forward link triangulation and GPS position location mechanisms.

SDO (2)	Document No.	Version	Status	Issued date	Location (1)
ARIB	ARIB STD-T64-C.S0022	0 / 0 V2.0	Approved	25/05/2004	<a href="http://www.arib.or.jp/IMT-2000/ARIB-STD/ITU-R-4/ARIB_STD-T64-C.S0022.zip">http://www.arib.or.jp/IMT-2000/ARIB-STD/ITU-R-4/ARIB_STD-T64-C.S0022.zip</a>
CCSA	CCSA-TSD-MC-C.S0022-0-1	1.0	Approved	01/02/2002	<a href="http://www.ccsa.org.cn/english/tc/files.php?docpath=/ITU-R/M.1457/M.1457-4">http://www.ccsa.org.cn/english/tc/files.php?docpath=/ITU-R/M.1457/M.1457-4</a>
TIA	TIA/EIA/IS-801		Published	01/11/1999	<a href="http://www.tiaonline.org/standards/sfg/imt2k/cdma2000">http://www.tiaonline.org/standards/sfg/imt2k/cdma2000</a>
TIA	TIA/EIA/IS-801-1		Published	01/03/2001	<a href="http://www.tiaonline.org/standards/sfg/imt2k/cdma2000">http://www.tiaonline.org/standards/sfg/imt2k/cdma2000</a>
TTA	TTAT.3G-C.S0022-0 v3.0	3.0	Approved	25/05/2004	<a href="http://www.tta.or.kr/standardDB/stnfile/TTAT.3G-C.S0022-0 v3.0.zip">http://www.tta.or.kr/standardDB/stnfile/TTAT.3G-C.S0022-0 v3.0.zip</a>

**5.2.2.1.22 C.S0023****Removable User Identity Module (R-UIM) for cdma2000 Spread Spectrum Systems**

This Specification provides requirements for removable user identity modules (R-UIM).

SDO (2)	Document No.	Version	Status	Issued date	Location (1)
ARIB	ARIB STD-T64-C.S0023	0 V4.0 / A V1.0 / A V2.0	Approved	25/05/2004	<a href="http://www.arib.or.jp/IMT-2000/ARIB-STD/ITU-R-4/ARIB_STD-T64-C.S0023.zip">http://www.arib.or.jp/IMT-2000/ARIB-STD/ITU-R-4/ARIB_STD-T64-C.S0023.zip</a>
CCSA	CCSA-TSD-MC-C.S0023-A	V1.0	Approved	01/03/2003	<a href="http://www.ccsa.org.cn/english/tc/files.php?docpath=/ITU-R/M.1457/M.1457-4">http://www.ccsa.org.cn/english/tc/files.php?docpath=/ITU-R/M.1457/M.1457-4</a>
TIA	TIA-820-A-1[E]		Published	01/04/2004	<a href="http://www.tiaonline.org/standards/sfg/imt2k/cdma2000">http://www.tiaonline.org/standards/sfg/imt2k/cdma2000</a>
TIA	TIA/IS-820-A		Published	01/09/2002	<a href="http://www.tiaonline.org/standards/sfg/imt2k/cdma2000">http://www.tiaonline.org/standards/sfg/imt2k/cdma2000</a>
TIA	TIA/EIA/IS-820-1		Published	01/06/2001	<a href="http://www.tiaonline.org/standards/sfg/imt2k/cdma2000">http://www.tiaonline.org/standards/sfg/imt2k/cdma2000</a>
TIA	TIA/EIA/IS-820		Published	01/05/2000	<a href="http://www.tiaonline.org/standards/sfg/imt2k/cdma2000">http://www.tiaonline.org/standards/sfg/imt2k/cdma2000</a>
TTA	TTAE-3G-C.S0023-0(V4.0)	4.0	Approved	19/12/2001	<a href="http://www.tta.or.kr/standardDB/stnfile/TTAE_3G-C_S0023-0_v4.0.zip">http://www.tta.or.kr/standardDB/stnfile/TTAE_3G-C_S0023-0_v4.0.zip</a>

**5.2.2.1.23 C.S0024****cdma2000 High Rate Packet Data Air Interface Specification**

This Specification provides description for high speech packet access.

SDO (2)	Document No.	Version	Status	Issued date	Location (1)
ARIB	ARIB STD-T64-C.S0024-0	0 V4.0	Approved	25/05/2004	<a href="http://www.arib.or.jp/IMT-2000/ARIB-STD/ITU-R-4/ARIB_STD-T64-C.S0024-0_v4.pdf">http://www.arib.or.jp/IMT-2000/ARIB-STD/ITU-R-4/ARIB_STD-T64-C.S0024-0_v4.pdf</a>
CCSA	CCSA-TSD-MC-C.S0024-0	v 4.0	Approved	01/03/2003	<a href="http://www.ccsa.org.cn/english/tc/files.php?docpath=/ITU-R/M.1457/M.1457-4">http://www.ccsa.org.cn/english/tc/files.php?docpath=/ITU-R/M.1457/M.1457-4</a>
TTA	TTAT.3G-C.S0024-0 V4.0	4.0	Approved	28/05/2003	<a href="http://www.tta.or.kr/standardDB/stnfile/TTAT.3G-C.S0024-0 V4.0.zip">http://www.tta.or.kr/standardDB/stnfile/TTAT.3G-C.S0024-0 V4.0.zip</a>
<b>Revision 0</b>					
TIA	TIA/EIA/IS-856-1		Published	01/01/2002	<a href="http://www.tiaonline.org/standards/sfg/imt2k/cdma2000">http://www.tiaonline.org/standards/sfg/imt2k/cdma2000</a>
TIA	TIA/EIA/IS-856		Published	01/11/2000	<a href="http://www.tiaonline.org/standards/sfg/imt2k/cdma2000">http://www.tiaonline.org/standards/sfg/imt2k/cdma2000</a>
TIA	TIA-856-2[E]		Published	01/03/2004	<a href="http://www.tiaonline.org/standards/sfg/imt2k/cdma2000">http://www.tiaonline.org/standards/sfg/imt2k/cdma2000</a>
<b>Revision A</b>					
ARIB	ARIB STD-T64-C.S0024-A	A V1.0	Approved	25/05/2004	<a href="http://www.arib.or.jp/IMT-2000/ARIB-STD/ITU-R-4/ARIB_STD-T64-C.S0024-A.pdf">http://www.arib.or.jp/IMT-2000/ARIB-STD/ITU-R-4/ARIB_STD-T64-C.S0024-A.pdf</a>
TIA	TIA-856-A A		Published	01/04/2004	<a href="http://www.tiaonline.org/standards/sfg/imt2k/cdma2000">http://www.tiaonline.org/standards/sfg/imt2k/cdma2000</a>

**5.2.2.1.24 C.S0025****Markov Service Option (MSO) for cdma2000 Spread Spectrum Systems**

This document specifies procedures for the Markov Service Option (MSO).

SDO (2)	Document No.	Version	Status	Issued date	Location (1)
ARIB	ARIB STD-T64-C.S0025	VBR	Approved	25/05/2004	<a href="http://www.arib.or.jp/IMT-2000/ARIB-STD/ITU-R-4/ARIB_STD-T64-C.S0025_VBR.PDF">http://www.arib.or.jp/IMT-2000/ARIB-STD/ITU-R-4/ARIB_STD-T64-C.S0025_VBR.PDF</a>
CCSA	CCSA-TSD-MC-C.S0025	V1.0	Approved	01/02/2002	<a href="http://www.ccsa.org.cn/english/tc/files.php?docpath=/ITU-R/M.1457/M.1457-4">http://www.ccsa.org.cn/english/tc/files.php?docpath=/ITU-R/M.1457/M.1457-4</a>

TIA	TIA/EIA/IS-871	Published	01/04/2001	<a href="http://www.tiaonline.org/standards/sfg/imt2k/cdma2000">http://www.tiaonline.org/standards/sfg/imt2k/cdma2000</a>
TTA	TTAT.3G-C.S0025-0	Approved	21/03/2003	<a href="http://www.tta.or.kr/standardDB/stnfile/TTAT.3G-C.S0025-0.zip">http://www.tta.or.kr/standardDB/stnfile/TTAT.3G-C.S0025-0.zip</a>

### 5.2.2.1.25 C.S0026

#### Test Data Service Option (TDSO) for cdma2000 Spread Spectrum Systems

This document specifies procedures for the Test Data Service Option (TDSO).

SDO (2)	Document No.	Version	Status	Issued date	Location (1)
ARIB	ARIB_STD-T64-C.S0026	1 / VBR	Approved	25/05/2004	<a href="http://www.arib.or.jp/IMT-2000/ARIB-STD/ITU-R-4/ARIB_STD-T64-C.S0026.zip">http://www.arib.or.jp/IMT-2000/ARIB-STD/ITU-R-4/ARIB_STD-T64-C.S0026.zip</a>
CCSA	CCSA-TSD-MC-C.S0026-0	V2.0	Approved	01/03/2003	<a href="http://www.ccsa.org.cn/english/tc/files.php?docpath=/ITU-R/M.1457/M.1457-4">http://www.ccsa.org.cn/english/tc/files.php?docpath=/ITU-R/M.1457/M.1457-4</a>
TIA	TIA/EIA/IS-870		Published	01/04/2001	<a href="http://www.tiaonline.org/standards/sfg/imt2k/cdma2000">http://www.tiaonline.org/standards/sfg/imt2k/cdma2000</a>
TTA	TTAT.3G-C.S0026-0 v2.0	2.0	Approved	21/03/2003	<a href="http://www.tta.or.kr/standardDB/stnfile/TTAT.3G-C.S0026-0 v2.0.zip">http://www.tta.or.kr/standardDB/stnfile/TTAT.3G-C.S0026-0 v2.0.zip</a>

### 5.2.2.1.26 C.S0028

#### CDMA TTY/TDD Minimum Performance Specification

This Specification defines the CDMA TTY/TDD Minimum Performance Specification.

SDO (2)	Document No.	Version	Status	Issued date	Location (1)
CCSA	CCSA-TSD-MC-C.S0028-0	V2.0	Approved	01/02/2002	<a href="http://www.ccsa.org.cn/english/tc/files.php?docpath=/ITU-R/M.1457/M.1457-4">http://www.ccsa.org.cn/english/tc/files.php?docpath=/ITU-R/M.1457/M.1457-4</a>
TIA	TIA/IS-889		Published	01/09/2002	<a href="http://www.tiaonline.org/standards/sfg/imt2k/cdma2000">http://www.tiaonline.org/standards/sfg/imt2k/cdma2000</a>
TTA	TTAT.3G-C.S0028-0 v2.0	2.0	Approved	21/03/2003	<a href="http://www.tta.or.kr/standardDB/stnfile/TTAT.3G-C.S0028-0 v2.0.zip">http://www.tta.or.kr/standardDB/stnfile/TTAT.3G-C.S0028-0 v2.0.zip</a>

### 5.2.2.1.27 C.S0029

#### Test Application Specification (TAS) for High Rate Packet Data Air Interface

These technical requirements form a compatibility standard for test applications in cdma2000 high rate packet data systems.

SDO (2)	Document No.	Version	Status	Issued date	Location (1)
ARIB	ARIB_STD-T64-C.S0029	0 V2.0 / 0 V3.0	Approved	25/05/2004	<a href="http://www.arib.or.jp/IMT-2000/ARIB-STD/ITU-R-4/ARIB_STD-T64-C.S0029.zip">http://www.arib.or.jp/IMT-2000/ARIB-STD/ITU-R-4/ARIB_STD-T64-C.S0029.zip</a>
CCSA	CCSA-TSD-MC-C.S0029-0	2.0	Approved	01/02/2002	<a href="http://www.ccsa.org.cn/english/tc/files.php?docpath=/ITU-R/M.1457/M.1457-4">http://www.ccsa.org.cn/english/tc/files.php?docpath=/ITU-R/M.1457/M.1457-4</a>
TIA	TIA-890-1[E]		Published	01/01/2004	<a href="http://www.tiaonline.org/standards/sfg/imt2k/cdma2000">http://www.tiaonline.org/standards/sfg/imt2k/cdma2000</a>
TIA	TIA/EIA/IS-890		Published	01/07/2001	<a href="http://www.tiaonline.org/standards/sfg/imt2k/cdma2000">http://www.tiaonline.org/standards/sfg/imt2k/cdma2000</a>
TTA	TTAT.3G-C.S0029-0 v3.0	3.0	Approved	25/05/2004	<a href="http://www.tta.or.kr/standardDB/stnfile/TTAT.3G-C.S0029-0 v3.0.zip">http://www.tta.or.kr/standardDB/stnfile/TTAT.3G-C.S0029-0 v3.0.zip</a>

### 5.2.2.1.28 C.S0030

#### Selectable Mode Vocoder Service Option for Wideband Spread Spectrum Communication Systems

This Specification defines the Selectable Mode Vocoder Service Option for Wideband Spread Spectrum Communication Systems.

SDO (2)	Document No.	Version	Status	Issued date	Location (1)
ARIB	ARIB_STD-T64-C.S0030	0 V2.0 / 0 V3.0	Approved	25/05/2004	<a href="http://www.arib.or.jp/IMT-2000/ARIB-STD/ITU-R-4/ARIB_STD-T64-C.S0030.zip">http://www.arib.or.jp/IMT-2000/ARIB-STD/ITU-R-4/ARIB_STD-T64-C.S0030.zip</a>
CCSA	CCSA-TSD-MC-C.S0030-0	2.0	Approved	01/02/2002	<a href="http://www.ccsa.org.cn/english/tc/files.php?docpath=/ITU-R/M.1457/M.1457-4">http://www.ccsa.org.cn/english/tc/files.php?docpath=/ITU-R/M.1457/M.1457-4</a>
TIA	TIA-893		Published	01/05/2004	<a href="http://www.tiaonline.org/standards/sfg/imt2k/cdma2000">http://www.tiaonline.org/standards/sfg/imt2k/cdma2000</a>
TTA	TTAT.3G-C.S0030-0 v3.0	3.0	Approved	25/05/2004	<a href="http://www.tta.or.kr/standardDB/stnfile/TTAT.3G-C.S0030-0 v3.0.zip">http://www.tta.or.kr/standardDB/stnfile/TTAT.3G-C.S0030-0 v3.0.zip</a>

### 5.2.2.1.29 C.S0031

#### Signalling Conformance Tests for cdma2000 Spread Spectrum Systems

This document facilitates interoperability testing between CDMA infrastructure and CDMA mobile station manufacturers.

SDO (2)	Document No.	Version	Status	Issued date	Location (1)
ARIB	ARIB_STD-T64-C.S0031-0	0	Approved	25/05/2004	<a href="http://www.arib.or.jp/IMT-2000/ARIB-STD/ITU-R-4/ARIB_STD-T64-C.S0031-0.PDF">http://www.arib.or.jp/IMT-2000/ARIB-STD/ITU-R-4/ARIB_STD-T64-C.S0031-0.PDF</a>
CCSA	CCSA-TSD-MC-C.S0031-0	2.0	Approved	01/02/2002	<a href="http://www.ccsa.org.cn/english/tc/files.php?docpath=/ITU-R/M.1457/M.1457-4">http://www.ccsa.org.cn/english/tc/files.php?docpath=/ITU-R/M.1457/M.1457-4</a>
TIA	TIA/EIA-898		Published	01/12/2001	<a href="http://www.tiaonline.org/standards/sfg/imt2k/cdma2000">http://www.tiaonline.org/standards/sfg/imt2k/cdma2000</a>
TTA	TTAT.3G-C.S0031-0 v2.0	2.0	Approved	21/03/2003	<a href="http://www.tta.or.kr/standardDB/stnfile/TTAT.3G-C.S0031-0 v2.0.zip">http://www.tta.or.kr/standardDB/stnfile/TTAT.3G-C.S0031-0 v2.0.zip</a>

### 5.2.2.1.30 C.S0032

#### Recommended Minimum Performance Standards for cmda2000 High Rate Packet Data Access Network

This document details definitions, methods of measurement, and minimum performance requirements for access networks.

SDO (2)	Document No.	Version	Status	Issued date	Location (1)
ARIB	ARIB_STD-T64-C.S0032-0	0 V2.0	Approved	25/05/2004	<a href="http://www.arib.or.jp/IMT-2000/ARIB-STD/ITU-R-4/ARIB_STD-T64-C.S0032-0_v2.pdf">http://www.arib.or.jp/IMT-2000/ARIB-STD/ITU-R-4/ARIB_STD-T64-C.S0032-0_v2.pdf</a>
CCSA	CCSA-TSD-MC-C.S0032-0	1.0	Approved	01/02/2002	<a href="http://www.ccsa.org.cn/english/tc/files.php?docpath=/ITU-R/M.1457/M.1457-4">http://www.ccsa.org.cn/english/tc/files.php?docpath=/ITU-R/M.1457/M.1457-4</a>
TIA	TIA-864		Published	01/02/2002	<a href="http://www.tiaonline.org/standards/sfg/imt2k/cdma2000">http://www.tiaonline.org/standards/sfg/imt2k/cdma2000</a>
TTA	TTAT.3G-C.S0032-0 v2.0	2.0	Approved	25/05/2004	<a href="http://www.tta.or.kr/standardDB/stnfile/TTAT.3G-C.S0032-0 v2.0.zip">http://www.tta.or.kr/standardDB/stnfile/TTAT.3G-C.S0032-0 v2.0.zip</a>

### 5.2.2.1.31 C.S0033

#### Recommended Minimum Performance Standards for cmda2000 High Rate Packet Data Access Terminal

This document details definitions, methods of measurement, and minimum performance characteristics for access terminals.

SDO (2)	Document No.	Version	Status	Issued date	Location (1)
ARIB	ARIB_STD-T64-C.S0033-0	0 V2.0	Approved	25/05/2004	<a href="http://www.arib.or.jp/IMT-2000/ARIB-STD/ITU-R-4/ARIB_STD-T64-C.S0033-0_v2.pdf">http://www.arib.or.jp/IMT-2000/ARIB-STD/ITU-R-4/ARIB_STD-T64-C.S0033-0_v2.pdf</a>
CCSA	CCSA-TSD-MC-C.S0033	1.0	Approved	01/02/2002	<a href="http://www.ccsa.org.cn/english/tc/files.php?docpath=/ITU-R/M.1457/M.1457-4">http://www.ccsa.org.cn/english/tc/files.php?docpath=/ITU-R/M.1457/M.1457-4</a>
TIA	TIA-866		Published	01/02/2002	<a href="http://www.tiaonline.org/standards/sfg/imt2k/cdma2000">http://www.tiaonline.org/standards/sfg/imt2k/cdma2000</a>
TTA	TTAT.3G-C.S0033-0 v2.0	2.0	Approved	25/05/2004	<a href="http://www.tta.or.kr/standardDB/stnfile/TTAT.3G-C.S0033-0 v2.0.zip">http://www.tta.or.kr/standardDB/stnfile/TTAT.3G-C.S0033-0 v2.0.zip</a>

**5.2.2.1.32 C.S0035****CDMA Card Application Toolkit (CCAT)**

This document contains the requirements for CDMA Card Application Toolkit (CCAT). CCAT is a set of commands and procedures for use during the network operation phase of CDMA. Specifying the interface is to ensure interoperability between an R-UIM and an ME independently of the respective manufacturers and operators. CCAT will allow Service Providers to offer unique services to their subscribers by placing applications they have designed (or third party applications) on the R-UIM that would function on any particular manufacture's ME that supports the Toolkit features.

SDO (2)	Document No.	Version	Status	Issued date	Location (1)
ARIB	ARIB_STD-T64-C.S0035-0	0 V1.0	Approved	25/05/2004	<a href="http://www.arib.or.jp/IMT-2000/ARIB-STD/ITU-R-4/ARIB_STD-T64-C.S0035-0_v1.pdf">http://www.arib.or.jp/IMT-2000/ARIB-STD/ITU-R-4/ARIB_STD-T64-C.S0035-0_v1.pdf</a>
CCSA	CCSA-TSD-MC-C.S0035-0	1.0	Approved	01/09/2003	<a href="http://www.ccsa.org.cn/english/tc/files.php?docpath=/ITU-R/M.1457/M.1457-4">http://www.ccsa.org.cn/english/tc/files.php?docpath=/ITU-R/M.1457/M.1457-4</a>
TIA	TIA-915		Published	01/02/2003	<a href="http://www.tiaonline.org/standards/sfg/imt2k/cdma2000">http://www.tiaonline.org/standards/sfg/imt2k/cdma2000</a>
TTA	TTAT.3G-C.S0035-0 v1.0	1.0	Approved	25/05/2004	<a href="http://www.tta.or.kr/standardDB/stnfile/TTAT.3G-C.S0035-0 v1.0.zip">http://www.tta.or.kr/standardDB/stnfile/TTAT.3G-C.S0035-0 v1.0.zip</a>

**5.2.2.1.33 C.S0036****Recommended Minimum Performance Specification for C.S0022-0 Spread Spectrum Mobile Stations**

This document details definitions, methods of measurement, and minimum performance characteristics for Position Location Capable Code Division Multiple Access (CDMA) mobile stations.

SDO (2)	Document No.	Version	Status	Issued date	Location (1)
ARIB	ARIB_STD-T64-C.S0036-0	0 V1.0	Approved	25/05/2004	<a href="http://www.arib.or.jp/IMT-2000/ARIB-STD/ITU-R-4/ARIB_STD-T64-C.S0036-0_V1.0.PDF">http://www.arib.or.jp/IMT-2000/ARIB-STD/ITU-R-4/ARIB_STD-T64-C.S0036-0_V1.0.PDF</a>
CCSA	CCSA-TSD-MC-C.S0036-0	1.0	Approved	01/06/2002	<a href="http://www.ccsa.org.cn/english/tc/files.php?docpath=/ITU-R/M.1457/M.1457-4">http://www.ccsa.org.cn/english/tc/files.php?docpath=/ITU-R/M.1457/M.1457-4</a>
TIA	TIA-916		Published	01/04/2002	<a href="http://www.tiaonline.org/standards/sfg/imt2k/cdma2000">http://www.tiaonline.org/standards/sfg/imt2k/cdma2000</a>
TTA	TTAT.3G-C.S0036-0 v1.0	1.0	Approved	21/03/2003	<a href="http://www.tta.or.kr/standardDB/stnfile/TTAT.3G-C.S0036-0 v1.0.zip">http://www.tta.or.kr/standardDB/stnfile/TTAT.3G-C.S0036-0 v1.0.zip</a>

**5.2.2.1.34 C.S0037****Signalling Conformance Specification for cdma2000 Wireless IP Networks**

This document is designed to facilitate the interoperability testing between mobile stations and infrastructure, as well as provide network specific test cases. Definitions, recommended methods of measurement, and minimum standards are provided.

SDO (2)	Document No.	Version	Status	Issued date	Location (1)
ARIB	ARIB_STD-T64-C.S0037-0	0 V1.0	Approved	25/05/2004	<a href="http://www.arib.or.jp/IMT-2000/ARIB-STD/ITU-R-4/ARIB_STD-T64-C.S0037-0_V1.0.PDF">http://www.arib.or.jp/IMT-2000/ARIB-STD/ITU-R-4/ARIB_STD-T64-C.S0037-0_V1.0.PDF</a>
CCSA	CCSA-TSD-MC-C.S0037-0	1.0	Approved	01/06/2002	<a href="http://www.ccsa.org.cn/english/tc/files.php?docpath=/ITU-R/M.1457/M.1457-4">http://www.ccsa.org.cn/english/tc/files.php?docpath=/ITU-R/M.1457/M.1457-4</a>
TIA	TIA-918		Published	01/05/2002	<a href="http://www.tiaonline.org/standards/sfg/imt2k/cdma2000">http://www.tiaonline.org/standards/sfg/imt2k/cdma2000</a>
TTA	TTAT.3G-C.S0037-0 v1.0	1.0	Approved	21/03/2003	<a href="http://www.tta.or.kr/standardDB/stnfile/TTAT.3G-C.S0037-0 v1.0.zip">http://www.tta.or.kr/standardDB/stnfile/TTAT.3G-C.S0037-0 v1.0.zip</a>

**5.2.2.1.35 C.S0038****Signalling Conformance Specification for High Rate Packet Data Air Interface**

These technical requirements form a document for signalling conformance in cdma2000 high rate packet data systems. These requirements ensure that compliant access terminals and compliant access networks can execute tests in meeting the objectives.

SDO (2)	Document No.	Version	Status	Issued date	Location (1)
ARIB	ARIB_STD-T64-C.S0038-0	0 V1.0	Approved	25/05/2004	<a href="http://www.arib.or.jp/IMT-2000/ARIB-STD/ITU-R-4/ARIB_STD-T64-C.S0038-0_V1.0.PDF">http://www.arib.or.jp/IMT-2000/ARIB-STD/ITU-R-4/ARIB_STD-T64-C.S0038-0_V1.0.PDF</a>
CCSA	CCSA-TSD-MC-C.S0038-0	1.0	Approved	01/06/2002	<a href="http://www.ccsa.org.cn/english/tc/files.php?docpath=/ITU-R/M.1457/M.1457-4">http://www.ccsa.org.cn/english/tc/files.php?docpath=/ITU-R/M.1457/M.1457-4</a>
TIA	TIA-919		Published	01/05/2002	<a href="http://www.tiaonline.org/standards/sfg/imt2k/cdma2000">http://www.tiaonline.org/standards/sfg/imt2k/cdma2000</a>
TTA	TTAT.3G-C.S0038-0 v1.0	1.0	Approved	21/03/2003	<a href="http://www.tta.or.kr/standardDB/stnfile/TTAT.3G-C.S0038-0_v1.0.zip">http://www.tta.or.kr/standardDB/stnfile/TTAT.3G-C.S0038-0_v1.0.zip</a>

**5.2.2.1.36 C.S0039****Enhanced Subscriber Privacy for cdma2000 High Rate Packet Data**

Enhanced Subscriber Privacy for HRPD is provided by the use of Advance Encryption Algorithm (AES) by encrypting the air interface to protect subscriber traffic and certain signalling messages from unauthorized disclosure.

SDO (2)	Document No.	Version	Status	Issued date	Location (1)
ARIB	ARIB_STD-T64-C.S0039	V1.0	Approved	25/05/2004	<a href="http://www.arib.or.jp/IMT-2000/ARIB-STD/ITU-R-4/ARIB_STD-T64-C.S0039.PDF">http://www.arib.or.jp/IMT-2000/ARIB-STD/ITU-R-4/ARIB_STD-T64-C.S0039.PDF</a>
CCSA	CCSA-TSD-MC-C.S0039-0	1.0	Approved	01/09/2003	<a href="http://www.ccsa.org.cn/english/tc/files.php?docpath=/ITU-R/M.1457/M.1457-4">http://www.ccsa.org.cn/english/tc/files.php?docpath=/ITU-R/M.1457/M.1457-4</a>
TIA	TIA-925		Published	01/09/2002	<a href="http://www.tiaonline.org/standards/sfg/imt2k/cdma2000">http://www.tiaonline.org/standards/sfg/imt2k/cdma2000</a>
TTA	TTAT.3G-C.S0039-0 v1.0	1.0	Approved	30/10/2003	<a href="http://www.tta.or.kr/standardDB/stnfile/TTAT.3G-C.S0039-0_v1.0.zip">http://www.tta.or.kr/standardDB/stnfile/TTAT.3G-C.S0039-0_v1.0.zip</a>

**5.2.2.1.37 C.S0040****IP Based Over-the-Air Handset Configuration Management (IOTA-HCM)**

These technical requirements form a standard for Over-the-Air Service Provisioning of mobile stations using Internet Protocol (IP).

SDO (2)	Document No.	Version	Status	Issued date	Location (1)
ARIB	ARIB_STD-T64-C.S0040-0	0 V1.0	Approved	25/05/2004	<a href="http://www.arib.or.jp/IMT-2000/ARIB-STD/ITU-R-4/ARIB_STD-T64-C.S0040-0_v1.pdf">http://www.arib.or.jp/IMT-2000/ARIB-STD/ITU-R-4/ARIB_STD-T64-C.S0040-0_v1.pdf</a>
CCSA	CCSA-TSD-MC-C.S0040-0	1.0	Approved	01/09/2003	<a href="http://www.ccsa.org.cn/english/tc/files.php?docpath=/ITU-R/M.1457/M.1457-4">http://www.ccsa.org.cn/english/tc/files.php?docpath=/ITU-R/M.1457/M.1457-4</a>
TIA	TIA-1010		Published	01/08/2003	<a href="http://www.tiaonline.org/standards/sfg/imt2k/cdma2000">http://www.tiaonline.org/standards/sfg/imt2k/cdma2000</a>
TTA	TTAT.3G-C.S0040-0 v1.0	1.0	Approved	25/05/2004	<a href="http://www.tta.or.kr/standardDB/stnfile/TTAT.3G-C.S0040-0_v1.0.zip">http://www.tta.or.kr/standardDB/stnfile/TTAT.3G-C.S0040-0_v1.0.zip</a>

**5.2.2.1.38 C.S0042****Circuit-Switched Video Conferencing Services**

This specification defines the functional characteristics and requirements of the circuit-switched video conferencing services. The service features and system requirements are defined to provide video conferencing services in 3GPP2 wireless telecommunications networks.



SDO (2)	Document No.	Version	Status	Issued date	Location (1)
ARIB	ARIB_STD-T64-C.S0042-0	0 V1.0	Approved	25/05/2004	<a href="http://www.arib.or.jp/IMT-2000/ARIB-STD/ITU-R-4/ARIB_STD-T64-C.S0042-0_v1.pdf">http://www.arib.or.jp/IMT-2000/ARIB-STD/ITU-R-4/ARIB_STD-T64-C.S0042-0_v1.pdf</a>
CCSA	CCSA-TSD-MC-C.S0042-0	1.0	Approved	01/12/2002	<a href="http://www.ccsa.org.cn/english/tc/files.php?docpath=/ITU-R/M.1457/M.1457-4">http://www.ccsa.org.cn/english/tc/files.php?docpath=/ITU-R/M.1457/M.1457-4</a>
TIA	TIA-926		Published	01/12/2002	<a href="http://www.tiaonline.org/standards/sfg/imt2k/cdma2000">http://www.tiaonline.org/standards/sfg/imt2k/cdma2000</a>
TTA	TTAT.3G-C.S0042-0 v1.0	1.0	Approved	21/03/2003	<a href="http://www.tta.or.kr/standardDB/stnfile/TTAT.3G-C.S0042-0 v1.0.zip">http://www.tta.or.kr/standardDB/stnfile/TTAT.3G-C.S0042-0 v1.0.zip</a>

### 5.2.2.1.39 C.S0047

#### Link-Layer Assisted Service Options for Voice-Over-IP: Header Removal (SO60) and Robust Header Compression (SO61)

These technical requirements form a standard for the Link-Layer Assisted (LLA) Service Options. Service Option 60 (SO60) defines a variable rate Voice-over-IP (VoIP) service option for transport of header-removed IP/UDP/RTP packets carrying speech frames. Service Option 61 (SO61) defines a variable rate Voice-over-IP (VoIP) service option for transport of header- compressed IP/UDP/RTP packets carrying speech frames.

SDO (2)	Document No.	Version	Status	Issued date	Location (1)
ARIB	ARIB_STD-T64-C.S0047-0	0 V1.0	Approved	25/05/2004	<a href="http://www.arib.or.jp/IMT-2000/ARIB-STD/ITU-R-4/ARIB_STD-T64-C.S0047_0_v1.pdf">http://www.arib.or.jp/IMT-2000/ARIB-STD/ITU-R-4/ARIB_STD-T64-C.S0047_0_v1.pdf</a>
CCSA	CCSA-TSD-MC-C.S0047-0	1.0	Approved	01/09/2003	<a href="http://www.ccsa.org.cn/english/tc/files.php?docpath=/ITU-R/M.1457/M.1457-4">http://www.ccsa.org.cn/english/tc/files.php?docpath=/ITU-R/M.1457/M.1457-4</a>
TIA	TIA-923		Published	01/05/2003	<a href="http://www.tiaonline.org/standards/sfg/imt2k/cdma2000">http://www.tiaonline.org/standards/sfg/imt2k/cdma2000</a>
TTA	TTAT.3G-C.S0047-0 v1.0	1.0	Approved	25/05/2004	<a href="http://www.tta.or.kr/standardDB/stnfile/TTAT.3G-C.S0047-0 v1.0.zip">http://www.tta.or.kr/standardDB/stnfile/TTAT.3G-C.S0047-0 v1.0.zip</a>

### 5.2.2.1.40 A.S0001

#### 3GPP2 Access Network Interfaces Interoperability Specification (3G-IOS V4.0.0)

This Specification defines the interfaces within the radio access network and the interfaces from the radio access network to the core network and the packet network. This includes the “A” interface.

SDO (2)	Document No.	Version	Status	Issued date	Location (1)
<b>Revision A</b>					
CCSA	CCSA-TSD-MC-A.S0001-A	2.0	Approved	01/02/2002	<a href="http://www.ccsa.org.cn/english/tc/files.php?docpath=/ITU-R/M.1457/M.1457-4">http://www.ccsa.org.cn/english/tc/files.php?docpath=/ITU-R/M.1457/M.1457-4</a>
TIA	TIA/EIA/IS-2001-A	A	Published	01/08/2001	<a href="http://www.tiaonline.org/standards/sfg/imt2k/cdma2000">http://www.tiaonline.org/standards/sfg/imt2k/cdma2000</a>
TTA	TTAT.3G-A.S0001-A v2.0	2.0	Approved	21/03/2003	<a href="http://www.tta.or.kr/standardDB/stnfile/TTAT.3G-A.S0001-A v2.0.zip">http://www.tta.or.kr/standardDB/stnfile/TTAT.3G-A.S0001-A v2.0.zip</a>
TTC	JP-3GB-A.S0001	2	Approved	01/05/2001	<a href="http://www.ttc.or.jp/imt/std/jpas0001v20.pdf">http://www.ttc.or.jp/imt/std/jpas0001v20.pdf</a>

### 5.2.2.1.41 A.S0003-A

#### BTS-BSC Inter-operability (Abis Interface)

This Specification defines the BTS-BSC Inter-operability (Abis Interface).

SDO (2)	Document No.	Version	Status	Issued date	Location (1)
CCSA	CCSA-TSD-MC-A.S0003-A	2.0	Approved	01/02/2002	<a href="http://www.ccsa.org.cn/english/tc/files.php?docpath=/ITU-R/M.1457/M.1457-4">http://www.ccsa.org.cn/english/tc/files.php?docpath=/ITU-R/M.1457/M.1457-4</a>
TTA	TTAT.3G-A.S0003-A v2.0	2.0	Approved	21/03/2003	<a href="http://www.tta.or.kr/standardDB/stnfile/TTAT.3G-A.S0003-A v2.0.zip">http://www.tta.or.kr/standardDB/stnfile/TTAT.3G-A.S0003-A v2.0.zip</a>



TTC	TS-3GB-A.S0011-0v2.0	1	Approved	01/08/2002	<a href="http://www.ttc.or.jp/imt/ts/tsas0011-0v20.pdf">http://www.ttc.or.jp/imt/ts/tsas0011-0v20.pdf</a>
<b>Revision B</b>					
TIA	TIA/EIA/IS-2001.1-B	B	Published	01/05/2002	<a href="http://www.tiaonline.org/standards/sfg/imt2k/cdma2000">http://www.tiaonline.org/standards/sfg/imt2k/cdma2000</a>
<b>Revision C</b>					
TIA	TIA-2001-C	C	Published	01/09/2003	<a href="http://www.tiaonline.org/standards/sfg/imt2k/cdma2000">http://www.tiaonline.org/standards/sfg/imt2k/cdma2000</a>

#### 5.2.2.1.42 A.S0004-A

##### CDMA Tandem Free Operation

This Specification defines the CDMA Tandem Free Operation.

SDO (2)	Document No.	Version	Status	Issued date	Location (1)
CCSA	CCSA-TSD-MC-A.S0004-A	2.0	Approved	01/06/2002	<a href="http://www.ccsa.org.cn/english/tc/files.php?docpath=/ITU-R/M.1457/M.1457-4">http://www.ccsa.org.cn/english/tc/files.php?docpath=/ITU-R/M.1457/M.1457-4</a>
TTA	TTAT.3G-A.S0004-A v2.0	2.0	Approved	21/03/2003	<a href="http://www.tta.or.kr/standardDB/stnfile/TTAT.3G-A.S0004-A v2.0.zip">http://www.tta.or.kr/standardDB/stnfile/TTAT.3G-A.S0004-A v2.0.zip</a>
TTC	TS-3GB-A.S0012-0v2.0	1	Approved	01/08/2002	<a href="http://www.ttc.or.jp/imt/ts/tsas0012-0v20.pdf">http://www.ttc.or.jp/imt/ts/tsas0012-0v20.pdf</a>
<b>Revision B</b>					
TIA	TIA/EIA/IS-2001.2-B	B	Published	01/05/2002	<a href="http://www.tiaonline.org/standards/sfg/imt2k/cdma2000">http://www.tiaonline.org/standards/sfg/imt2k/cdma2000</a>
<b>Revision C</b>					
TIA	TIA-2001-C	C	Published	01/09/2003	<a href="http://www.tiaonline.org/standards/sfg/imt2k/cdma2000">http://www.tiaonline.org/standards/sfg/imt2k/cdma2000</a>

#### 5.2.2.1.43 A.S0007-0

##### Inter-Operability Specification (IOS) for HRPD

This Specification defines the Inter-Operability Specification (IOS) for High Rate Packet Data (HRPD) Access Network Interfaces.

SDO (2)	Document No.	Version	Status	Issued date	Location (1)
CCSA	CCSA-TSD-MC-A.S0007-0	2.0	Approved	01/02/2002	<a href="http://www.ccsa.org.cn/english/tc/files.php?docpath=/ITU-R/M.1457/M.1457-4">http://www.ccsa.org.cn/english/tc/files.php?docpath=/ITU-R/M.1457/M.1457-4</a>
TTA	TTAT.3G-A.S0007-0 v2.0	2.0	Approved	25/05/2004	<a href="http://www.tta.or.kr/standardDB/stnfile/TTAT.3G-A.S0007-0 v2.0.zip">http://www.tta.or.kr/standardDB/stnfile/TTAT.3G-A.S0007-0 v2.0.zip</a>
TTC	TS-3GB-A.S0013-0v2.0	1	Approved	01/08/2002	<a href="http://www.ttc.or.jp/imt/ts/tsas0013-0v20.pdf">http://www.ttc.or.jp/imt/ts/tsas0013-0v20.pdf</a>
<b>Revision B</b>					
TIA	TIA/EIA/IS-2001.3-B	B	Published	01/05/2002	<a href="http://www.tiaonline.org/standards/sfg/imt2k/cdma2000">http://www.tiaonline.org/standards/sfg/imt2k/cdma2000</a>
<b>Revision C</b>					
TIA	TIA-2001-C	C	Published	01/09/2003	<a href="http://www.tiaonline.org/standards/sfg/imt2k/cdma2000">http://www.tiaonline.org/standards/sfg/imt2k/cdma2000</a>

#### 5.2.2.1.44 A.S0011

##### Access Network Interfaces (3G-IOS)

This Specification defines the Interoperability Specification (IOS) for cdma2000 Access Network Interfaces - Part 1 Overview.

SDO (2)	Document No.	Version	Status	Issued date	Location (1)
CCSA	CCSA-TSD-MC-A.S0011-A	1.0	Approved	01/03/2003	<a href="http://www.ccsa.org.cn/english/tc/files.php?docpath=/ITU-R/M.1457/M.1457-4">http://www.ccsa.org.cn/english/tc/files.php?docpath=/ITU-R/M.1457/M.1457-4</a>

**152****Rec. ITU-R M.1457-4**

TTA	TTAT.3G-A.S0011-0 v2.0	2.0	Approved	21/03/2003	<a href="http://www.tta.or.kr/standardDB/stnfile/TTAT.3G-A.S0011-0 v2.0.zip">http://www.tta.or.kr/standardDB/stnfile/TTAT.3G-A.S0011-0 v2.0.zip</a>
TTC	TS-3GB-A.S0014-0v2.0	1	Approved	01/08/2002	<a href="http://www.ttc.or.jp/imt/ts/tsas0014-0v20.pdf">http://www.ttc.or.jp/imt/ts/tsas0014-0v20.pdf</a>
<b>Revision B</b>					
TIA	TIA/EIA/IS-2001.4-B	B	Published	01/05/2002	<a href="http://www.tiaonline.org/standards/sfg/imt2k/cdma2000">http://www.tiaonline.org/standards/sfg/imt2k/cdma2000</a>
<b>Revision C</b>					
TIA	TIA-2001-C	C	Published	01/09/2003	<a href="http://www.tiaonline.org/standards/sfg/imt2k/cdma2000">http://www.tiaonline.org/standards/sfg/imt2k/cdma2000</a>

**5.2.2.1.45 A.S0012****Access Network Interfaces (3G-IOS)**

This Specification defines the Interoperability Specification (IOS) for cdma2000 Access Network Interfaces - Part 2 Transport.

SDO (2)	Document No.	Version	Status	Issued date	Location (1)
CCSA	CCSA-TSD-MC-A.S0012-A	1.0	Approved	01/03/2003	<a href="http://www.ccsa.org.cn/english/tc/files.php?docpath=/ITU-R/M.1457/M.1457-4">http://www.ccsa.org.cn/english/tc/files.php?docpath=/ITU-R/M.1457/M.1457-4</a>
TTA	TTAT.3G-A.S0012-0 v2.0	2.0	Approved	21/03/2003	<a href="http://www.tta.or.kr/standardDB/stnfile/TTAT.3G-A.S0012-0 v2.0.zip">http://www.tta.or.kr/standardDB/stnfile/TTAT.3G-A.S0012-0 v2.0.zip</a>
TTC	TS-3GB-A.S0015-0v2.0	1	Approved	01/08/2002	<a href="http://www.ttc.or.jp/imt/ts/tsas0015-0v20.pdf">http://www.ttc.or.jp/imt/ts/tsas0015-0v20.pdf</a>
<b>Revision B</b>					
TIA	TIA/EIA/IS-2001.5-B	B	Published	01/05/2002	<a href="http://www.tiaonline.org/standards/sfg/imt2k/cdma2000">http://www.tiaonline.org/standards/sfg/imt2k/cdma2000</a>
<b>Revision C</b>					
TIA	TIA-2001-C	C	Published	01/09/2003	<a href="http://www.tiaonline.org/standards/sfg/imt2k/cdma2000">http://www.tiaonline.org/standards/sfg/imt2k/cdma2000</a>

**5.2.2.1.46 A.S0013****Access Network Interfaces (3G-IOS)**

This Specification defines the Interoperability Specification (IOS) for cdma2000 Access Network Interfaces - Part 3 Features.

SDO (2)	Document No.	Version	Status	Issued date	Location (1)
CCSA	CCSA-TSD-MC-A.S0013-A	1.0	Approved	01/03/2003	<a href="http://www.ccsa.org.cn/english/tc/files.php?docpath=/ITU-R/M.1457/M.1457-4">http://www.ccsa.org.cn/english/tc/files.php?docpath=/ITU-R/M.1457/M.1457-4</a>
TTA	TTAT.3G-A.S0013-0 v2.0	2.0	Approved	21/03/2003	<a href="http://www.tta.or.kr/standardDB/stnfile/TTAT.3G-A.S0013-0 v2.0.zip">http://www.tta.or.kr/standardDB/stnfile/TTAT.3G-A.S0013-0 v2.0.zip</a>
TTC	TS-3GB-A.S0016-0v2.0	1	Approved	01/08/2002	<a href="http://www.ttc.or.jp/imt/ts/tsas0016-0v20.pdf">http://www.ttc.or.jp/imt/ts/tsas0016-0v20.pdf</a>
<b>Revision B</b>					
TIA	TIA/EIA/IS-2001.6-B	B	Published	01/05/2002	<a href="http://www.tiaonline.org/standards/sfg/imt2k/cdma2000">http://www.tiaonline.org/standards/sfg/imt2k/cdma2000</a>
<b>Revision C</b>					
TIA	TIA-2001-C	C	Published	01/09/2003	<a href="http://www.tiaonline.org/standards/sfg/imt2k/cdma2000">http://www.tiaonline.org/standards/sfg/imt2k/cdma2000</a>

**5.2.2.1.47 A.S0014****Access Network Interfaces (3G-IOS)**

This Specification defines the Interoperability Specification (IOS) for cdma2000 Access Network Interfaces - Part 4 (A1, A2 and A5 Interfaces).

SDO (2)	Document No.	Version	Status	Issued date	Location (1)
CCSA	CCSA-TSD-MC-A.S0014-A	1.0	Approved	01/03/2003	<a href="http://www.ccsa.org.cn/english/tc/files.php?docpath=/ITU-R/M.1457/M.1457-4">http://www.ccsa.org.cn/english/tc/files.php?docpath=/ITU-R/M.1457/M.1457-4</a>
TTA	TTAT.3G-A.S0014-0 v2.0	2.0	Approved	21/03/2003	<a href="http://www.tta.or.kr/standardDB/stnfile/TTAT.3G-A.S0014-0 v2.0.zip">http://www.tta.or.kr/standardDB/stnfile/TTAT.3G-A.S0014-0 v2.0.zip</a>
TTC	TS-3GB-A.S0017-0v2.0	1	Approved	01/08/2002	<a href="http://www.ttc.or.jp/imt/ts/tsas0017-0v20.pdf">http://www.ttc.or.jp/imt/ts/tsas0017-0v20.pdf</a>
<b>Revision B</b>					
TIA	TIA/EIA/IS-2001.7-B	B	Published	01/05/2002	<a href="http://www.tiaonline.org/standards/sfg/imt2k/cdma2000">http://www.tiaonline.org/standards/sfg/imt2k/cdma2000</a>
<b>Revision C</b>					
TIA	TIA-2001-C	C	Published	01/09/2003	<a href="http://www.tiaonline.org/standards/sfg/imt2k/cdma2000">http://www.tiaonline.org/standards/sfg/imt2k/cdma2000</a>

**5.2.2.1.48 A.S0015****Access Network Interfaces (3G-IOS)**

This Specification defines the Interoperability Specification (IOS) for cdma2000 Access Network Interfaces - Part 5 (A3 and A7 Interfaces).

SDO (2)	Document No.	Version	Status	Issued date	Location (1)
CCSA	CCSA-TSD-MC-A.S0015-A	1.0	Approved	01/03/2003	<a href="http://www.ccsa.org.cn/english/tc/files.php?docpath=/ITU-R/M.1457/M.1457-4">http://www.ccsa.org.cn/english/tc/files.php?docpath=/ITU-R/M.1457/M.1457-4</a>
TIA	TIA/EIA-828		Published	01/12/2001	<a href="http://www.tiaonline.org/standards/sfg/imt2k/cdma2000">http://www.tiaonline.org/standards/sfg/imt2k/cdma2000</a>
TTA	TTAT.3G-A.S0015-0 v2.0	2.0	Approved	21/03/2003	<a href="http://www.tta.or.kr/standardDB/stnfile/TTAT.3G-A.S0015-0 v2.0.zip">http://www.tta.or.kr/standardDB/stnfile/TTAT.3G-A.S0015-0 v2.0.zip</a>

**5.2.2.1.49 A.S0016****Access Network Interfaces (3G-IOS)**

This Specification defines the Interoperability Specification (IOS) for cdma2000 Access Network Interfaces - Part 6 (A8 and A9 Interfaces).

SDO (2)	Document No.	Version	Status	Issued date	Location (1)
CCSA	CCSA-TSD-MC-A.S0016-A	1.0	Approved	01/03/2003	<a href="http://www.ccsa.org.cn/english/tc/files.php?docpath=/ITU-R/M.1457/M.1457-4">http://www.ccsa.org.cn/english/tc/files.php?docpath=/ITU-R/M.1457/M.1457-4</a>
TTA	TTAT.3G-A.S0016-0 v2.0	2.0	Approved	21/03/2003	<a href="http://www.tta.or.kr/standardDB/stnfile/TTAT.3G-A.S0016-0 v2.0.zip">http://www.tta.or.kr/standardDB/stnfile/TTAT.3G-A.S0016-0 v2.0.zip</a>
<b>Revision 0</b>					
TIA	TIA/EIA-895 0		Published	01/03/2002	<a href="http://www.tiaonline.org/standards/sfg/imt2k/cdma2000">http://www.tiaonline.org/standards/sfg/imt2k/cdma2000</a>
<b>Revision A</b>					
TIA	TIA-895-A	A	Published	01/10/2002	<a href="http://www.tiaonline.org/standards/sfg/imt2k/cdma2000">http://www.tiaonline.org/standards/sfg/imt2k/cdma2000</a>

**5.2.2.1.50** A.S0017**Access Network Interfaces (3G-IOS)**

This Specification defines the Interoperability Specification (IOS) for cdma2000 Access Network Interfaces - Part 7 (A10 and A11 Interfaces).

SDO (2)	Document No.	Version	Status	Issued date	Location (1)
CCSA	CCSA-TSD-MC-A.S0017-A	1.0	Approved	01/03/2003	<a href="http://www.ccsa.org.cn/english/tc/files.php?docpath=/ITU-R/M.1457/M.1457-4">http://www.ccsa.org.cn/english/tc/files.php?docpath=/ITU-R/M.1457/M.1457-4</a>
TIA	TIA-878		Published	01/12/2001	<a href="http://www.tiaonline.org/standards/sfg/imt2k/cdma2000">http://www.tiaonline.org/standards/sfg/imt2k/cdma2000</a>
TIA	TIA-878-1		Published	01/05/2003	<b>Error! Hyperlink reference not valid.</b>
TTA	TTAT.3G-A.S0017-0 v2.0	2.0	Approved	21/03/2003	<a href="http://www.tta.or.kr/standardDB/stnfile/TTAT.3G-A.S0017-0 v2.0.zip">http://www.tta.or.kr/standardDB/stnfile/TTAT.3G-A.S0017-0 v2.0.zip</a>

**5.2.2.2****cdma2000 System and Service Aspects Specifications****5.2.2.2.1** S.R0005**3GPP2 Network Reference Model**

This document describes the network entities and associated reference points that comprise a wireless network.

SDO (2)	Document No.	Version	Status	Issued date	Location (1)
<b>Revision A</b>					
TIA	TSB100-AA	Published		01/03/2001	<a href="http://www.tiaonline.org/standards/sfg/imt2k/cdma2000">http://www.tiaonline.org/standards/sfg/imt2k/cdma2000</a>

**5.2.2.2.2** N.S0003**User Identity Module**

This Specification defines the enhancements required to support mobile stations equipped with UIMs.

SDO (2)	Document No.	Version	Status	Issued date	Location (1)
TIA	TIA/EIA/IS-808		Published	01/11/2000	<a href="http://www.tiaonline.org/standards/sfg/imt2k/cdma2000">http://www.tiaonline.org/standards/sfg/imt2k/cdma2000</a>
TTC	TS-3GB-N.S0003v1.0	1	Approved	01/05/2001	<a href="http://www.ttc.or.jp/imt/ts/tsns0003v10.pdf">http://www.ttc.or.jp/imt/ts/tsns0003v10.pdf</a>

**5.2.2.2.3** N.S0004**WIN Phase 2**

This Specification defines the enhancements for wireless intelligent network (WIN) which includes trigger for preferred language, advice of charge, rejection of undesired annoying calls, premium rate charging, and freephone service.

SDO (2)	Document No.	Version	Status	Issued date	Location (1)
TIA	TIA/EIA/IS-848		Published	01/11/2000	<a href="http://www.tiaonline.org/standards/sfg/imt2k/cdma2000">http://www.tiaonline.org/standards/sfg/imt2k/cdma2000</a>
TTC	TS-3GB-N.S0004-0v1.0	1	Approved	01/05/2001	<a href="http://www.ttc.or.jp/imt/ts/tsns0004-0v10.pdf">http://www.ttc.or.jp/imt/ts/tsns0004-0v10.pdf</a>

**5.2.2.2.4** N.S0005**Cellular Radiotelecommunications Intersystem Operations**

This Specification defines the TIA/EIA-41 core network.

SDO (2)	Document No.	Version	Status	Issued date	Location (1)
<b>Revision D</b>					
TIA	TIA/EIA-41-D		Published	01/12/1997	<a href="http://www.tiaonline.org/standards/sfg/imt2k/cdma2000">http://www.tiaonline.org/standards/sfg/imt2k/cdma2000</a>
TIA	TIA/EIA-41-D-1	D	Published	01/04/2002	<a href="http://www.tiaonline.org/standards/sfg/imt2k/cdma2000">http://www.tiaonline.org/standards/sfg/imt2k/cdma2000</a>

**5.2.2.3****SDO's complete system standard**

SDO	Location
ARIB	<a href="http://www.arib.or.jp/IMT-2000/ARIB-STD-4/STD-T64v3.0.html">http://www.arib.or.jp/IMT-2000/ARIB-STD-4/STD-T64v3.0.html</a>
CCSA	<a href="http://www.ccsa.org.cn/english/tc/files.php?docpath=/ITU-R/M.1457/M.1457-4">http://www.ccsa.org.cn/english/tc/files.php?docpath=/ITU-R/M.1457/M.1457-4</a>
TIA	<a href="http://www.tiaonline.org/standards/sfg/imt2k/cdma2000">http://www.tiaonline.org/standards/sfg/imt2k/cdma2000</a>
TTA	<a href="http://www.tta.or.kr/Home2003/standards/Imt2000List.jsp?gubun=3GPP2">http://www.tta.or.kr/Home2003/standards/Imt2000List.jsp?gubun=3GPP2</a>
TTC	<a href="http://www.ttc.or.jp/">http://www.ttc.or.jp/</a>

### 5.3 IMT-2000 CDMA TDD

#### 5.3.1 Overview of the radio interface

##### 5.3.1.1 Introduction

The IMT-2000 radio interface specifications for CDMA TDD technology are developed by a partnership of standards development organizations (SDOs) (see Note 1) and CCSA. This radio interface is called the Universal Terrestrial Radio Access (UTRA) time division duplex (TDD), where two options, called 1.28 Mchip/s TDD (TD-SCDMA - see Note 2) and 3.84 Mchip/s TDD can be distinguished.

The UTRA TDD specifications have been developed with the strong objective of harmonization with the FDD component (see § 5.1) to achieve maximum commonality. This was achieved by harmonization of important parameters of the physical layer and a common set of protocols in the higher layers are specified for both FDD and TDD, where 1.28 Mchip/s TDD has significant commonality with 3.84 Mchip/s TDD. UTRA TDD with the two options accommodates the various needs of the different Regions in a flexible way and is specified in a common set of specifications.

In the development of this radio interface the core network specifications are based on an evolved GSM-MAP. However, the specifications include the necessary capabilities for operation with an evolved ANSI-41-based core network.

The radio access scheme is direct-sequence code division multiple access. There are two chip rate options: the 3.84 Mchip/s TDD option, with information spread over approximately 5 MHz bandwidth and a chip rate of 3.84 Mchip/s and the 1.28 Mchip/s TDD option, with information spread over approximately 1.6 MHz bandwidth and a chip rate of 1.28 Mchip/s. The radio interface is defined to carry a wide range of services to efficiently support both circuit-switched services (e.g. PSTN- and ISDN-based networks) as well as packet-switched services (e.g. IP-based networks). A flexible radio protocol has been designed where several different services such as speech, data and multimedia can simultaneously be used by a user and multiplexed on a single carrier. The defined radio bearer services provide support for both real-time and non-real-time services by employing transparent and/or non-transparent data transport. The QoS can be adjusted in terms such as delay, BER and FER.

The radio-interface specification includes enhanced features for High-Speed Downlink Packet Access (HSDPA), allowing for downlink packet-data transmission with peak data rates exceeding 8 Mbit/s and simultaneous high-speed packet data and other services such as speech on the single carrier.

NOTE 1 – Currently, these specifications are developed within the third generation partnership project (3GPP) where the participating SDOs are ARIB, CCSA, ETSI, T1, TTA and TTC.

NOTE 2 – The same name TD-SCDMA was previously used for one of the original proposals that was further refined following the harmonisation process.

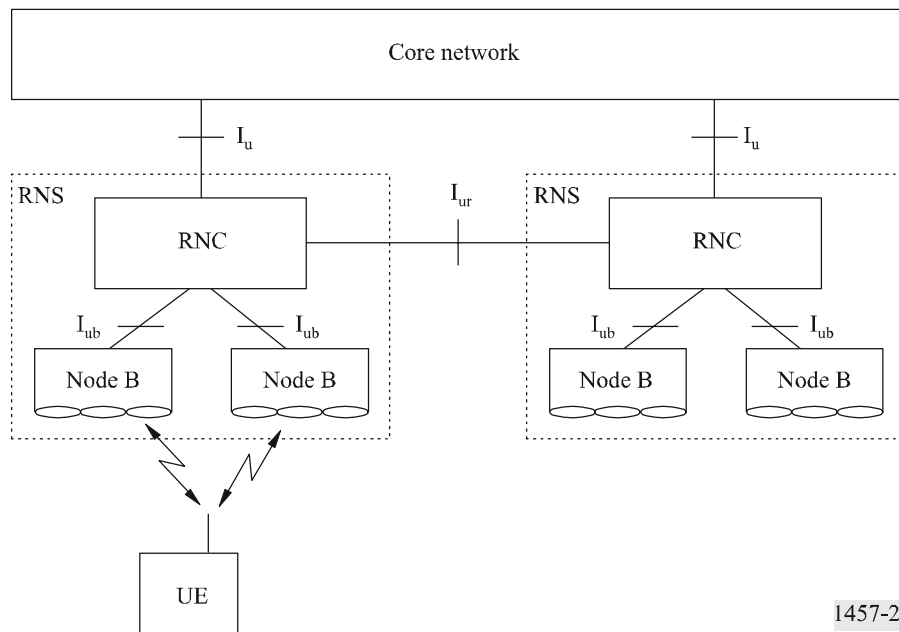
##### 5.3.1.2 Radio access network architecture

The overall architecture of the radio access network is shown in Fig. 26.

The architecture of the radio access network consists of a set of radio network subsystems (RNS) connected to the core network through the  $I_{u}$  interface.

An RNS consists of a radio network controller (RNC) and one or more entities called Node B. The Node B is connected to the RNC through the  $I_{ub}$  interface. Node B can handle one or more cells.

FIGURE 26  
Radio access network architecture  
(Cells are indicated by ellipses)



1457-26

The RNC is responsible for the handover decisions that require signalling to the user equipment (UE).

The RNCs of the RNS can be interconnected together through the  $I_{ur}$  interface.  $I_u$  and  $I_{ur}$  are logical interfaces, i.e. the  $I_{ur}$  interface can be conveyed over a direct physical connection between RNCs or via any suitable transport network.

Figure 27 shows the radio interface protocol architecture for the radio access network. On a general level, the protocol architecture is similar to the current ITU-R protocol architecture as described in Recommendation ITU-R M.1035. Layer 2 (L2) is split into the following sub-layers; RLC, MAC, Packet Data Convergence Protocol (PDCP) and Broadcast/Multicast Control (BMC). Layer 3 (L3) and RLC are divided into Control (C-) and User (U-) planes.

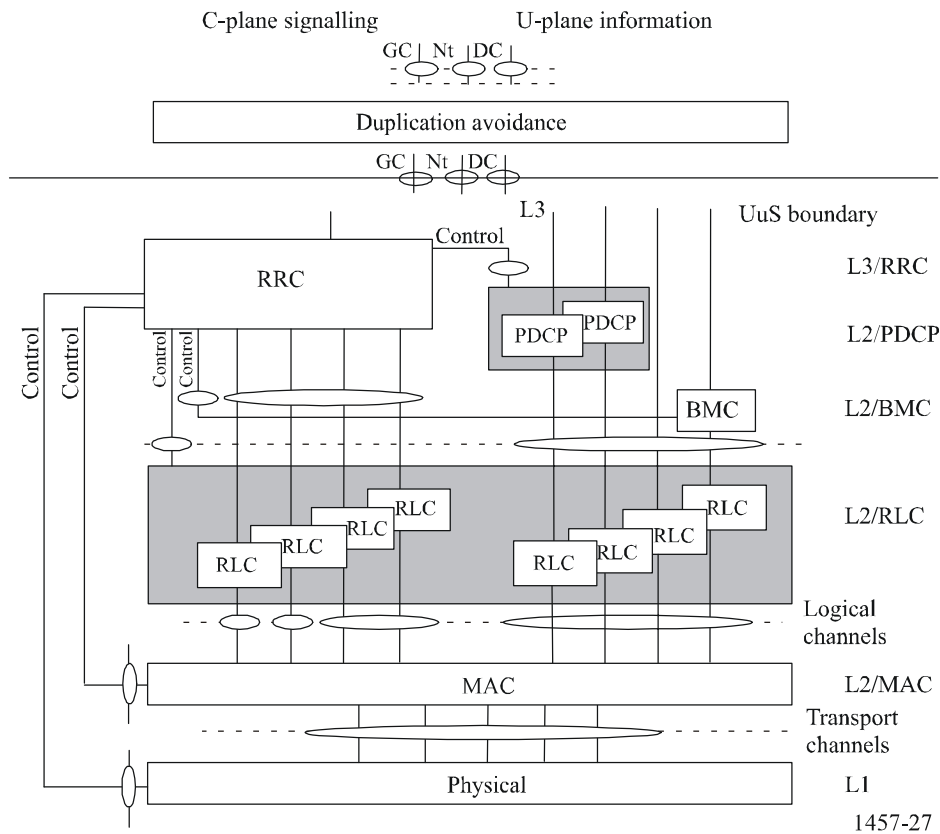
In the C-plane, L3 is partitioned into sub-layers where the lowest sub-layer, denoted as RRC, interfaces with L2. The higher layer signalling such as MM and CC are assumed to belong to the core network. There are no L3 elements in UTRAN for the U-plane.

Each block in Fig. 27 represents an instance of the respective protocol. Service access points (SAPs) for peer-to-peer communication are marked with circles at the interface between sub-layers.

The SAP between MAC and the physical layer provides the transport channels. A transport channel is characterized by how the information is transferred over the radio interface (see § 5.3.1.3.1.2 and 5.3.1.3.2.2 for an overview of the types of transport channels defined).

The SAPs between RLC and the MAC sub-layer provide the logical channels. A logical channel is characterized by the type of information that is transferred over the radio interface. The logical channels are divided into control channels and traffic channels. The different types of logical channels are not further described in this overview. The physical layer generates the physical channels that will be transmitted over the air. The physical channel in each TDD option (1.28 Mchip/s, 3.84 Mchip/s) is defined by carrier frequency, code, time slot and multi-frame information. In the C-plane, the interface between RRC and higher L3 sub-layers (CC, MM) is defined by the GC, Nt and DC SAPs. These SAPs are not further discussed in this overview.

FIGURE 27  
Radio interface protocol architecture of the RRC sub-layers (L2 and L1)



Also shown in the Figure are connections between RRC and MAC as well as RRC and L1 providing local inter-layer control services (including measurement results). An equivalent control interface exists between RRC and the RLC sub-layer. These interfaces allow the RRC to control the configuration of the lower layers. For this purpose separate control SAPs are defined between RRC and each lower layer (RLC, MAC, and L1).

Figure 28 shows the general structure and some additional terminology definitions of the channel formats at the various sub-layer interfaces indicated in Fig. 27. The Figure indicates how higher layer SDUs and PDUs are segmented and multiplexed to transport blocks to be further treated by the physical layer (e.g. CRC handling). The transmission chain of the physical layer is exemplified in the next section.

### 5.3.1.3 Physical layer

#### 5.3.1.3.1 UTRA TDD (3.84 Mchip/s TDD option)

##### 5.3.1.3.1.1 Physical layer functionality and building blocks

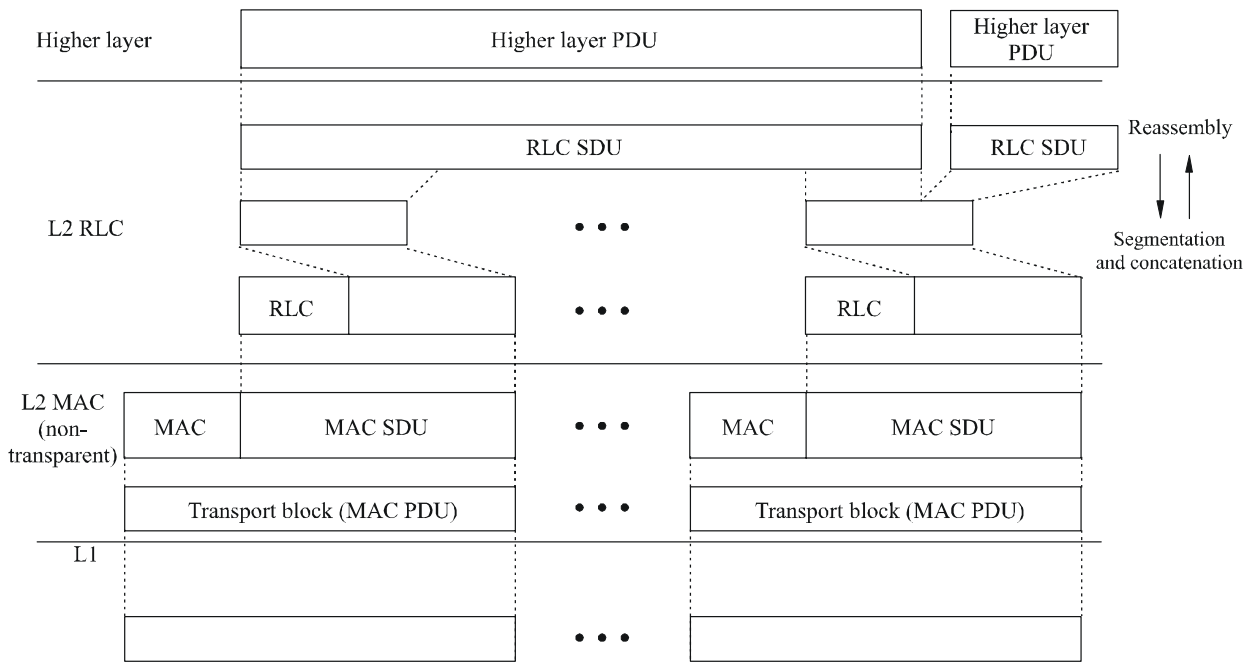
The physical layer includes the following functionality:

- Error detection on transport channels and indication to higher layers.
- FEC encoding/decoding of transport channels.
- Multiplexing of transport channels and demultiplexing of coded composite transport channels.
- Rate matching (data multiplexed on dedicated and shared channels).
- Mapping of coded composite transport channels on physical channels.



- Modulation and demodulation of physical channels.
- Spreading and despreading of physical channels.
- Radio characteristics measurements including FER, Signal-to-Interference (SIR), Interference Power Level etc., and indication to higher layers.
- Frequency and time (chip, bit, slot, frame) synchronization.
- Power weighting and combining of physical channels.
- Closed-loop power control for downlink.
- RF processing.
- Support of UE positioning methods.
- Beamforming.
- Support of timing advance on uplink channels.
- Support of a Node B synchronization method over the air.

FIGURE 28  
**Data flow for a service using a non-transparent RLC and non-transparent MAC**  
 (see § 5.3.1.4.1 and 5.3.1.4.2 for further definitions of the MAC and RLC services and functionality)



1457-28

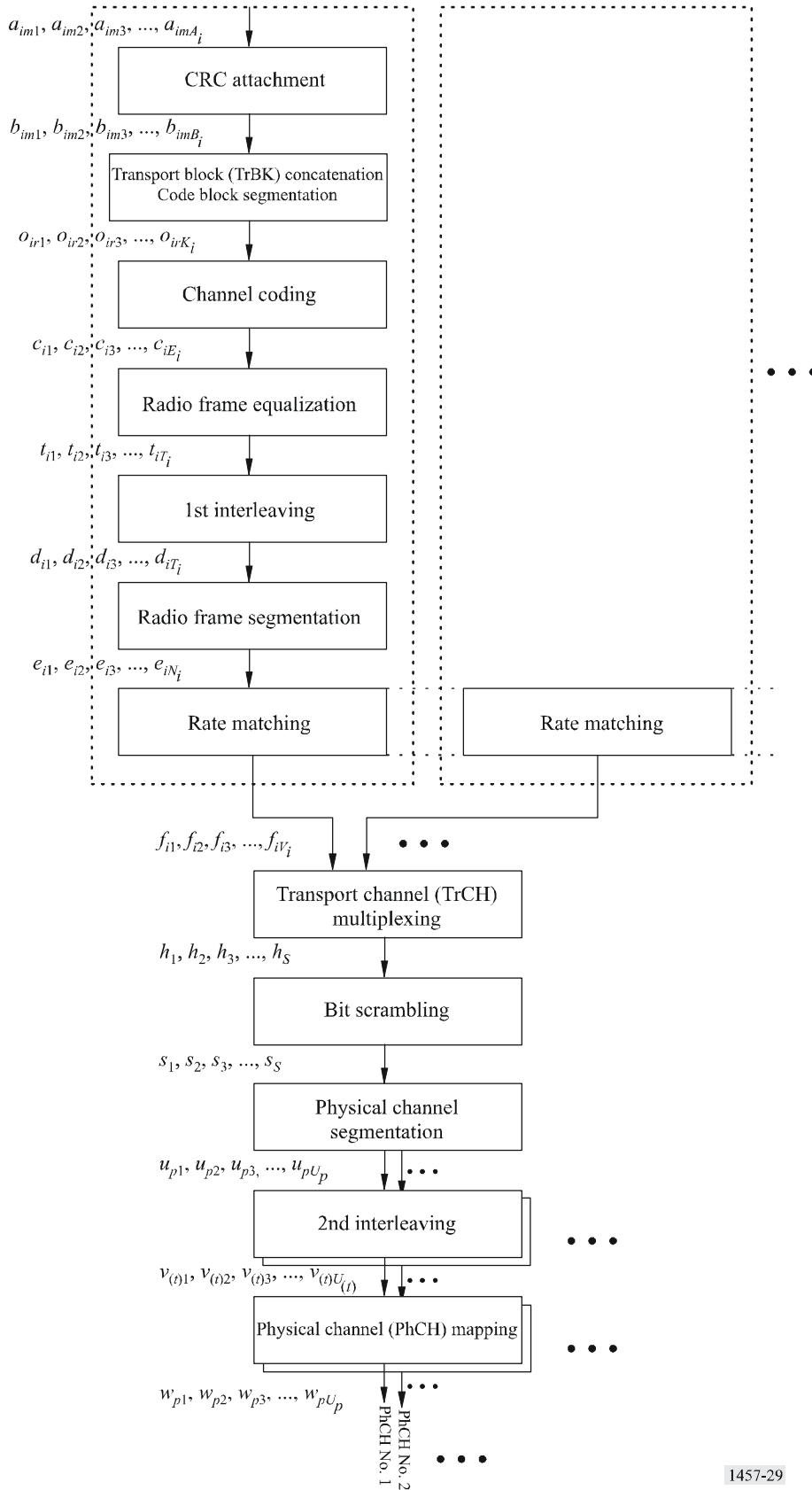
Figure 29 gives the physical layer transmission chain for the user plane data, i.e. from the level of transport channels down to the level of physical channel. The Figure shows how several transport channels can be multiplexed onto one or more DPDCH.

The CRC provides for error detection of the transport blocks for the particular transport channel. The CRC can take the length zero (no CRC), 8, 12, 16 or 24 bits depending on the service requirements.

The transport block concatenation and code block segmentation functionality performs serial concatenation of those transport blocks that will be sent in one transmission time interval and any code block segmentation if necessary.

FIGURE 29

Transport channel multiplexing structure



The types of channel coding defined are convolutional coding, turbo coding and no coding. Real-time services use only FEC encoding while non-real-time services uses a combination of FEC and ARQ. The ARQ functionality resides in the RLC sub-layer of Layer 2. The convolutional coding rates are 1/2 or 1/3 while the rate is 1/3 for turbo codes.

The possible interleaving depths are 10, 20, 40 or 80 ms.

The radio frame segmentation performs padding of bits. The rate matching adapts any remaining differences of the bit rate so the number of outgoing bits fit to the available bit rates of the physical channels. Repetition coding and/or puncturing is used for this purpose.

The TrCH multiplexing stage combines transport channels in a serial fashion. This is done every 10 ms. The output of this operation is also called coded composite transport channels.

If several physical channels will be used to transmit the data, the split is made in the physical channel segmentation unit.

### 5.3.1.3.1.2 Transport channels

The interface to the MAC sub-layer is the transport channels, see Fig. 27. The transport channels define how and with which type of characteristics the data is transferred by the physical layer. They are categorized into dedicated channels or common channels where many UEs are sharing the latter type. Introducing an information field containing the address then does the address resolution, if needed. The physical channel itself defines a dedicated channel. Thus no specific address is needed for the UE. Table 1 summarizes the different types of available transport channels.

TABLE 1  
The defined transport channels

Transport channel	Type and direction	Used for
DCH (Dedicated channel)	Dedicated; uplink and downlink	User or control information to a UE (entire cell or part of cell (lobe-forming))
BCH (Broadcast channel)	Common; downlink	Broadcast system and cell specific information
FACH (Forward access channel)	Common; downlink	Control information when system knows UE location or short user packets to a UE
PCH (Paging channel)	Common; downlink	Control information to UEs when good sleep mode properties are needed, e.g. idle mode operation
RACH (Random access channel)	Common; uplink	Control information or short user packets from an UE
USCH (Uplink shared channel)	Common; uplink	Carries dedicated user data and control information using a shared channel
DSCH (Downlink shared channel)	Common; downlink	Carries dedicated user data and control information using a shared channel.
HS-DSCH (High Speed Downlink shared channel)	Common; downlink	A downlink channel serving several UEs carrying dedicated control or traffic data. HS-DSCH offers the possibility for high-speed downlink packet access through the support of higher-order modulation, adaptive modulation and coding, fast channel-dependent scheduling, and hybrid ARQ with soft combining

The RACH on the uplink is contention-based while the DCH is reservation-based.

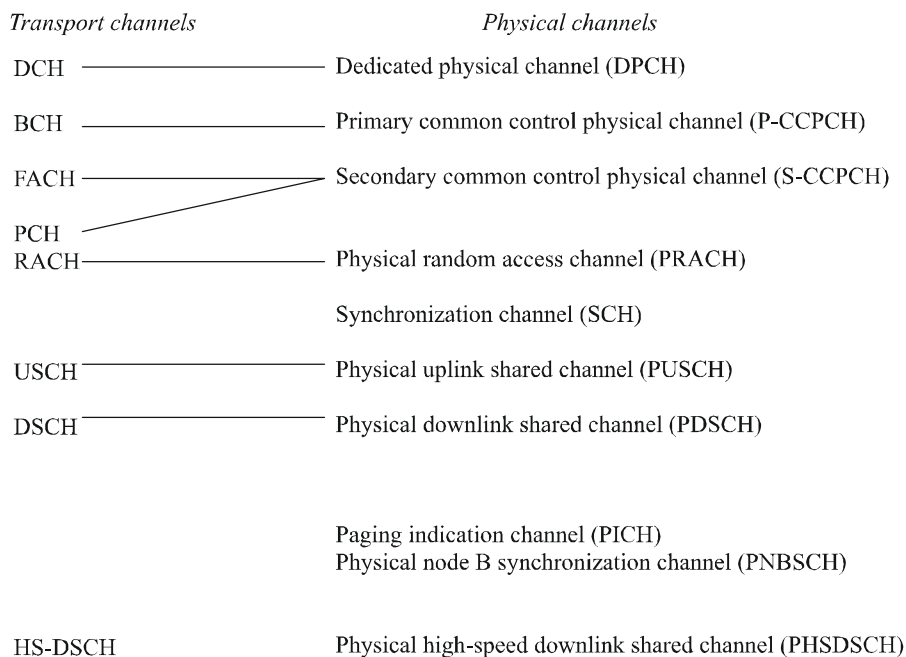
On each transport channel, a number of *Transport Blocks* are delivered to/from the physical layer once every *Transmission Time Interval* (TTI). To each transport channel, there is an associated *Transport Format* or set of transport formats. The transport format describes the physical properties of the transport channel, such as the TTI, the number of transport blocks per TTI, the number of bits per transport blocks, the coding scheme and coding rate, and the modulation scheme.

### 5.3.1.3.1.3 Transport channels to physical channel mapping

The transport channels are mapped onto the physical channels and Fig. 30 shows the different physical channels and summarizes the mapping of transport channels onto physical channels. Each physical channel has its tailored slot content. The DCH is shown in § 5.3.1.3.1.4.

FIGURE 30

Transport channels, physical channels and their mapping



1457-30

### 5.3.1.3.1.4 Physical frame structure

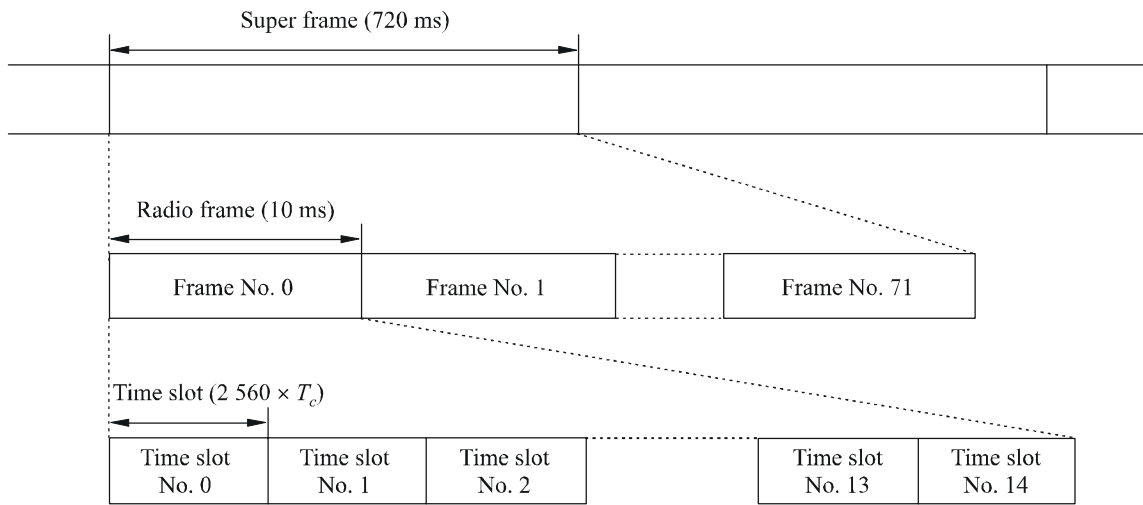
The basic physical frame rate is 10 ms with 15 slots. Figure 31 shows the frame structure.

Each 10 ms frame consists of 15 time slots, each allocated to either the uplink or the downlink. With such a flexibility, this radio interface can be adapted to different environments and deployment scenarios. In any configuration at least one time slot has to be allocated for the downlink and at least one time slot has to be allocated for the uplink.

Figures 32, 33 and 34 show the three burst formats stating the content for a slot used by a DCH. The usage of either burst format 1, 2 or 3 is depending on the application for UL or DL (type 3 for uplink only) and the number of allocated users per time slot.

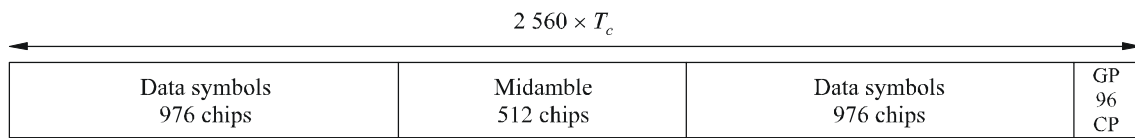
In both cases data bits on the DPCH are QPSK modulated and the resulting symbols are spread with a channelization code of length 1 to 16 (for the DL, only 1 and 16 apply). Due to this variable spreading factor, each burst provides the number of symbols as shown in Table 2.

FIGURE 31  
Basic frame structure



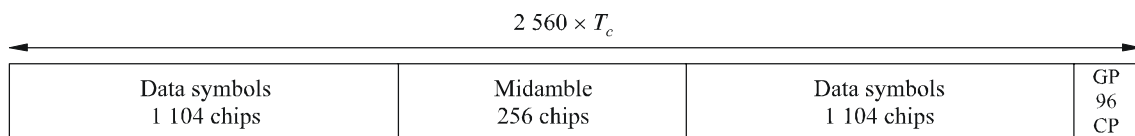
1457-31

FIGURE 32  
Burst structure of the burst type 1  
(GP denotes the guard period and CP the chip periods)



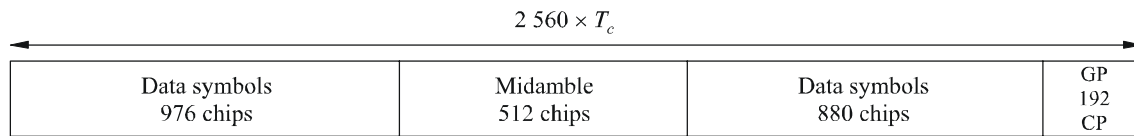
1457-32

FIGURE 33  
Burst structure of the burst type 2  
(GP denotes the guard period and CP the chip periods)



1457-33

FIGURE 34  
**Burst structure of the burst type 3**  
 (GP denotes the guard period and CP the chip periods)



1457-34

TABLE 2  
**Number of data symbols in TDD bursts in 3.84 Mchip/s TDD option**

Spreading factor, $Q$	Number of symbols, $N$ , for burst type 1	Number of symbols, $N$ , for burst type 2	Number of symbols, $N$ , for burst type 3
1	1952	2208	1856
2	976	1104	928
4	488	552	464
8	244	276	232
16	122	138	116

Thus, the number of bits per TDD burst in 3.84 Mchip/s TDD option is two times the number shown in Table 2. Usage of multicode and multiple time slots can be applied.

#### 5.3.1.3.1.5 Spreading, modulation and pulse shaping

Spreading is applied after modulation and before pulse shaping. It consists of two operations. The first is the channelization operation, which transforms every data symbol into a number of chips, thus increasing the bandwidth of the signal. The number of chips per data symbol is called the spreading factor (SF) and is in the range of 1 to 16. The second operation is the scrambling operation, where a scrambling code is applied to the spread signal. This procedure is similar to the radio interface specified in § 5.1, but it should be noted that the midamble part in TDD bursts (see Figs. 32 and 33, and 34) is not spread.

The applied channelization codes are OVVSF-codes that preserve the distinguishability of different users. The applied scrambling code is cell-specific and 128 different scrambling codes are available.

In the uplink, the applied midamble is user specific and derived from a cell-specific basic midamble sequence. In the downlink, the applied midamble is either user specific, code specific (default) or common for the whole cell. In each case 128 different basic midamble sequences are available.

After spreading the same pulse-shaping is applied as in FDD mode, i.e. the filters are root-raised cosine with roll-off  $\alpha = 0.22$  in the frequency domain.

Downlink spreading for downlink physical channels other than the downlink DPCH is very similar. For the physical channel to which HS-DSCH is mapped, higher-order data modulation can be used in addition to QPSK.

### 5.3.1.3.2 UTRA TDD (1.28 Mcchip/s TDD option)

#### 5.3.1.3.2.1 Physical layer functionality and building blocks

The physical layer includes the following functionality:

- Error detection on transport channels and indication to higher layers
- Forward Error Control (FEC) encoding/decoding of transport channels
- Multiplexing of transport channels and demultiplexing of coded composite transport channels
- Rate matching (data multiplexed on Dedicated and Shared Channels)
- Mapping of coded composite transport channels on physical channels
- Modulation and demodulation of physical channels
- Spreading and despreading of physical channels
- Radio characteristics measurements including FER, SIR, DOA, timing advance, handover measurements, etc.
- Frequency and time (chip, bit, time slot, subframe) synchronization
- Power weighting and combining of physical channels
- Power control
- Radio Frequency (RF) processing
- UE location/positioning (Smart antenna)
- Beamforming for both uplink and downlink (Smart antenna)
- Macrodiversity distribution/combining and handover execution
- Uplink synchronization
- Random access process
- Subframe segmentation.

Figure 35 gives the physical layer transmission chain for the user plane data, i.e. from the level of transport channels down to the level of physical channel. Figure 35 shows how several transport channels can be multiplexed onto one or more dedicated physical channels (DPCH).

The CRC provides for error detection of the transport blocks for the particular transport channel. The CRC can take the length 0 (no CRC), 8, 12, 16 or 24 bits depending on the service requirements.

The transport block concatenation and code block segmentation functionality performs serial concatenation of those transport blocks that will be sent in one transmission time interval and any code block segmentation if necessary.

The types of channel coding defined are convolutional coding, turbo coding and no coding. Real-time services use only FEC encoding while non-real-time services uses a combination of FEC and ARQ. The ARQ functionality resides in the RLC sub-layer of Layer 2. The convolutional coding rates are 1/2 or 1/3 while the rate is 1/3 for turbo codes.

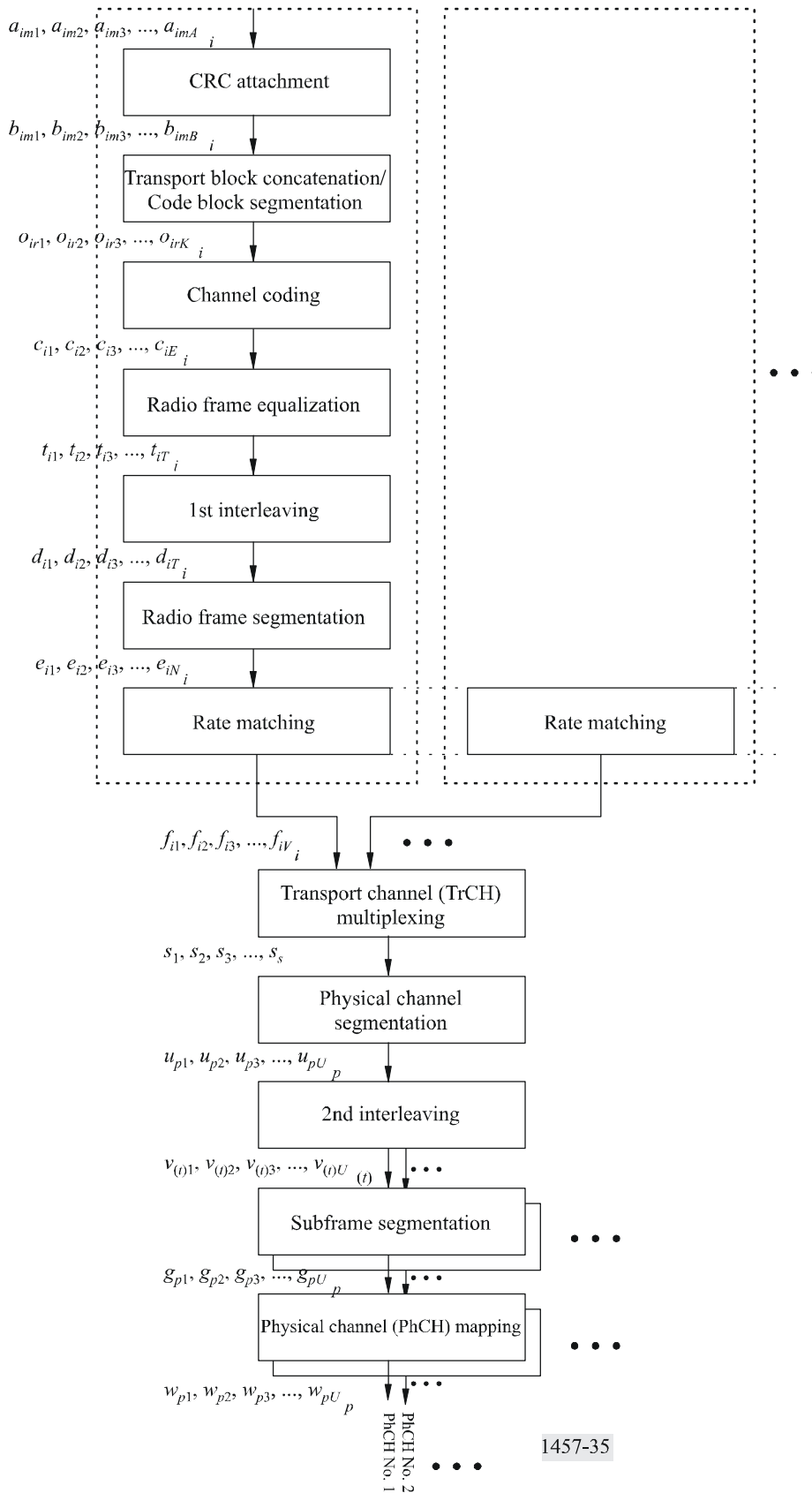
The possible interleaving depths are 10, 20, 40 or 80 ms, for the RACH also 5 ms may apply.

The radio frame equalization performs padding of bits. The rate matching adapts any remaining differences of the bit rate so the number of outgoing bits fit to the available bit rates of the physical channels. Repetition coding and/or puncturing is used for this purpose.

The TrCH multiplexing stage combines transport channels in a serial fashion. This is done every 10 ms. The output of this operation is also called coded composite transport channels.

FIGURE 35

Transport channel multiplexing structure





If several physical channels will be used to transmit the data, the split is made in the physical channel segmentation unit.

### 5.3.1.3.2.2 Transport channels

The interface to the MAC sub-layer is the transport channels, see Fig. 27. The transport channels define how and with which type of characteristics the data is transferred by the physical layer. They are categorized into DCH or common channels where many UEs are sharing the latter type. Introducing an information field containing the address then does the address resolution, if needed. The physical channel itself defines a DCH. Thus no specific address is needed for the UE. Table 3 summarizes the different types of available transport channels.

TABLE 3  
The defined transport channels

Transport channel	Type and direction	Used for
DCH (dedicated channel)	Dedicated; uplink and downlink	User or control information to a UE (entire cell or part of cell (lobe-forming))
BCH (broadcast channel)	Common; downlink	Broadcast system and cell specific information
FACH (forward access channel)	Common; downlink	Control information when system knows UE location or short user packets to a UE
PCH (paging channel)	Common; downlink	Control information to UEs when good sleep mode properties are needed, e.g. idle mode operation
RACH (random access channel)	Common; uplink	Control information or short user packets from an UE
DSCH (downlink shared channel)	Common; downlink	Carries dedicated user data and control information using a shared channel
HS-DSCH (high speed downlink shared channel)	Common; downlink	A downlink channel serving several UEs carrying dedicated control or traffic data. HS-DSCH offers the possibility for high-speed downlink packet access through the support of higher-order modulation, adaptive modulation and coding, fast channel-dependent scheduling, and hybrid ARQ with soft combining.
USCH (uplink shared channel)	Common; uplink	Carries dedicated user data and control information using a shared channel

The RACH on the uplink is contention-based while the DCH is reservation-based.

On each transport channel, a number of *Transport Blocks* are delivered to/from the physical layer once every *Transmission Time Interval* (TTI). To each transport channel, there is an associated *Transport Format* or set of transport formats. The transport format describes the physical properties of the transport channel, such as the TTI, the number of transport blocks per TTI, the number of bits per transport blocks, the coding scheme and coding rate, and the modulation scheme.

### 5.3.1.3.2.3 Transport channels to physical channel mapping

The transport channels are mapped onto the physical channels and Fig. 36 shows the different physical channels and summarizes the mapping of transport channels onto physical channels. Each physical channel has its tailored slot content. The DCH is shown in § 5.3.1.3.2.4.

FIGURE 36

Transport channel, physical channel and their mapping

Transport channels	Physical channels
DCH	Dedicated physical channel (DPCH)
BCH	Primary common control physical channels (P-CCPCH)
PCH	Secondary common control physical channels (S-CCPCH)
FACH	Secondary common control physical channels (S-CCPCH)
RACH	Physical random access channel (PRACH)
USCH	Physical uplink shared channel (PUSCH)
DSCH	Physical downlink shared channel (PDSCH)
HS-DSCH	Physical high-speed-downlink shared channel (PHSDSCH)
	Downlink pilot channel (DwPCH)
	Uplink pilot channel (UpPCH)
	Fast physical access channel (FPACH)
	Paging indication channel (PICH)

1457-36

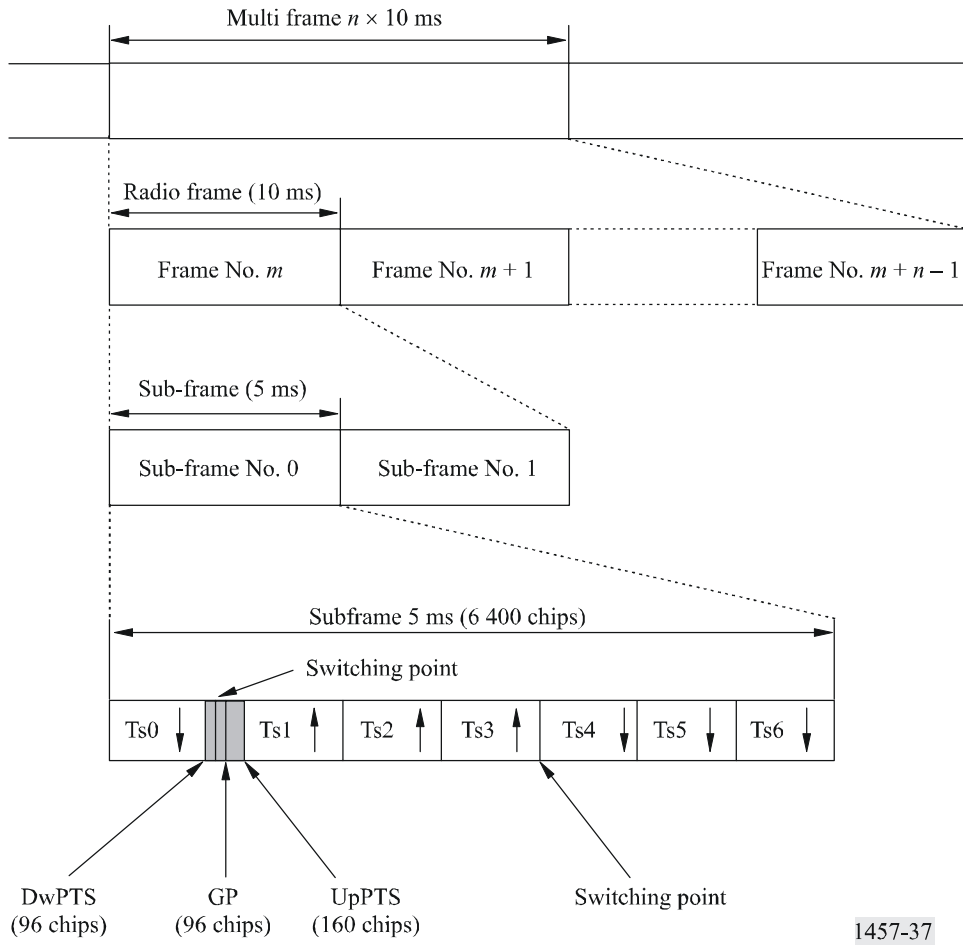
### 5.3.1.3.2.4 Frame structure

Physical channels take four-layer structure of multi-frames, radio frames, sub-frames and time slots/codes as shown in Fig. 37. The radio frame has a duration of 10 ms and is subdivided into 2 sub-frames of 5 ms each, and each sub-frame is then subdivided into 7 traffic time slots of 675  $\mu$ s duration each and 3 special time slots: DwPTS (downlink pilot timeslot), GP (guard period) and UpPTS (uplink pilot timeslot).

The burst structure is shown in Fig. 38. The burst type consist of two data symbol fields, a mid-amble of 144 chips and a guard period of 16 chips. The data fields of the burst type are 704 chips long. The data bits in the burst are QPSK modulated and are spread by the spreading factor of 1 to 16 in the UL and with the spreading factors 1 or 16 in the DL. The guard period is 16 chips long. 8-PSK modulation may optionally be applied.

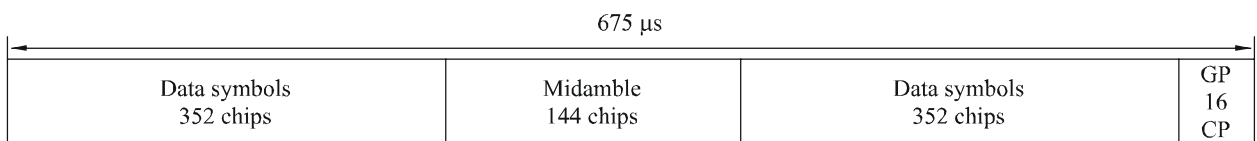
The corresponding number of symbols depends on the spreading factor as indicated in Table 4.

FIGURE 37  
Frame and burst structure



1457-37

FIGURE 38  
Burst structure



1457-38

TABLE 4

**Number of data symbols in one burst with different SF in the 1.28 Mchip/s TDD option**

Spreading factor, $Q$	Number of symbols, $N$ , per data field in the burst
1	352
2	176
4	88
8	44
16	22

### 5.3.1.3.2.5 Spreading, modulation and pulse shaping

Spreading is applied after modulation and before pulse shaping. It consists of two operations. The first is the channelization operation, which transforms every data symbol into a number of chips, thus increasing the bandwidth of the signal. The number of chips per data symbol is called the SF and is in the range of 1 to 16. The second operation is the scrambling operation, where a scrambling code is applied to the spread signal. It should be noted that the midamble part in TDD bursts is not spread.

The applied channelization codes are OVSF-codes that preserve the distinguishability of different users. The applied scrambling code is cell-specific.

In the uplink, the applied midamble is user specific and derived from a cell-specific basic midamble sequence. In the downlink, the applied midamble is either user specific, code specific (default) or common for the whole cell.

After spreading, pulse-shaping is applied, i.e. the filters are root-raised cosine with roll-off  $\alpha = 0.22$  in the frequency domain.

Downlink spreading for downlink physical channels other than the downlink DPCH is very similar. For the physical channel to which HS-DSCH is mapped, higher-order data modulation can be used in addition to QPSK.

### 5.3.1.3.2.6 Transmission and reception

The frequency bands assumed for operation are unpaired frequency bands at 2 GHz. Also the system can work in other frequency bands available. Several Tx power classes for UE are being defined currently.

## 5.3.1.4 Layer 2

### 5.3.1.4.1 MAC layer

The MAC sub-layer is responsible for the handling of the data streams coming from the RLC and RRC sub-layers. It provides an unacknowledged transfer mode service to the upper layers. The interface to the RLC sub-layer is through logical channel service access points. It also re-allocates radio resources on request by the RRC sub-layer as well as provides measurements to the upper layers. The logical channels are divided into control channels and traffic channels. Thus, the functionality handles issues like:

- mapping of the different logical channels to the appropriate transport channels, selection of appropriate transport format for the transport channels based on the instantaneous source bit rate, and optimization of the HS-DSCH transport channel.
- Multiplexing/ demultiplexing of the PDUs to/from transport blocks which are thereafter further treated by the physical layer;
- Dynamic switching between common and dedicated transport channels based on information from the RRC sub-layer;
- Priority issues for services to one UE according to information from higher layers and physical layer (e.g. available transmit power level) as well as priority handling between UEs by means of dynamic scheduling in order to increase spectrum efficiency;
- Monitoring of traffic volume that can be used by the RRC sub-layer;
- Hybrid ARQ with soft combining in case of the HS-DSCH transport channel.

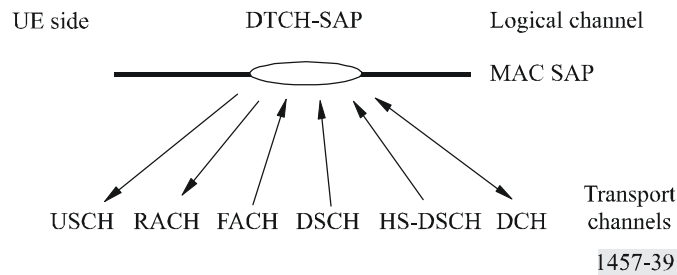
Figure 39 shows the possibilities of mapping the logical channel DTCH onto transport channels. There are possibilities to map onto common transport channels as well as dedicated transport channels. The choice of mapping could be determined on e.g. amount of traffic a user creates.

FIGURE 39

**The possible transport channel mappings of the dedicated traffic channel (DTCH)**

(The arrows show the direction of the channel (UE side).

The directions are reversed from the network side)

**5.3.1.4.2 RLC sub-layer**

The RLC sub-layer provides three different types of data transfer modes:

- *Transparent data transfer* – This service transmits higher layer PDUs without adding any protocol information, possibly including segmentation/reassemble functionality.
- *Unacknowledged data transfer* – This service transmits higher layer PDUs without guaranteeing delivery to the peer entity. The unacknowledged data transfer mode has the following characteristics:
  - Detection of erroneous data: The RLC sub-layer shall deliver only those SDUs to the receiving higher layer that are free of transmission errors by using the sequence-number check function.
  - Unique delivery: The RLC sub-layer shall deliver each SDU only once to the receiving upper layer using duplication detection function.
  - Immediate delivery: The receiving RLC sub-layer entity shall deliver a SDU to the higher layer receiving entity as soon as it arrives at the receiver.
- *Acknowledged data transfer* – This service transmits higher layer PDUs and guarantees delivery to the peer entity. In case RLC is unable to deliver the data correctly, the user of RLC at the transmitting side is notified. For this service, both in-sequence and out-of-sequence delivery are supported. In many cases a higher layer protocol can restore the order of its PDUs. As long as the out-of-sequence properties of the lower layer are known and controlled (i.e. the higher layer protocol will not immediately request retransmission of a missing PDU) allowing out-of-sequence delivery can save memory space in the receiving RLC. The acknowledged data transfer mode has the following characteristics:
  - Error-free delivery: Error-free delivery is ensured by means of retransmission. The receiving RLC entity delivers only error-free SDUs to the higher layer.
  - Unique delivery: The RLC sub-layer shall deliver each SDU only once to the receiving upper layer using duplication detection function.
  - In-sequence delivery: RLC sub-layer shall provide support for in-order delivery of SDUs, i.e. RLC sub-layer should deliver SDUs to the receiving higher layer entity in the same order as the transmitting higher layer entity submits them to the RLC sub-layer.
  - Out-of-sequence delivery: Alternatively to in-sequence delivery, it shall also be possible to allow that the receiving RLC entity delivers SDUs to higher layer in different order than submitted to RLC sub-layer at the transmitting side.

It also provides for RLC connection establishment/release. As well as QoS setting and notification to higher layers in case of unrecoverable errors.

An example of the data flow for non-transparent (acknowledged/unacknowledged) data transfer is shown in Fig. 28.

#### 5.3.1.4.3 PDCP sub-layer

PDCP provides transmission and reception of Network PDUs in acknowledged, unacknowledged and transparent RLC mode.

It is responsible for the mapping of Network PDUs from one network protocol to one RLC entity and it provides compression in the transmitting entity and decompression in the receiving entity of redundant Network PDU control information (header compression/decompression).

#### 5.3.1.4.4 BMC sub-layer

The BMC provides a broadcast/multicast transmission service in the user plane on the radio interface for common user data in transparent or unacknowledged mode.

It can handle functionalities such as storage, scheduling and transmission of BMC messages.

#### 5.3.1.5 Layer 3 (radio resource control sub-layer)

The radio resource control (RRC) sub-layer handles the control plane signalling of Layer 3 between the UEs and the radio access network. In addition to the relation with the upper layers (such as core network) the following main functions are performed:

- *Broadcast of information provided by the non-access stratum (core network)* – The RRC layer performs system information broadcasting from the network to all UEs. The system information is normally repeated on a regular basis. This function supports broadcast of higher layer (above RRC) information. This information may be cell specific or not. As an example RRC may broadcast core network location service area information related to some specific cells.
- *Broadcast of information related to the access stratum* – The RRC layer performs system information broadcasting from the network to all UEs. This function supports broadcast of typically cell-specific information.
- *Establishment, maintenance and release of an RRC connection between the UE and this radio interface* – The establishment of an RRC connection is initiated by a request from higher layers at the UE side to establish the first signalling connection for the UE. The establishment of an RRC connection includes an optional cell re-selection, an admission control, and a Layer 2 signalling link establishment.
- *Establishment, reconfiguration and release of radio access bearers* – The RRC layer will, on request from higher layers, perform the establishment, reconfiguration and release of radio access bearers in the user plane. A number of radio access bearers can be established to an UE at the same time. At establishment and reconfiguration, the RRC layer performs admission control and selects parameters describing the radio access bearer processing in Layer 2 and Layer 1, based on information from higher layers.
- *Assignment, reconfiguration and release of radio resources for the RRC connection* – The RRC layer handles the assignment of radio resources (e.g. codes and, for TDD only, time slots) needed for the RRC connection including needs from both the control and user plane. The RRC layer may reconfigure radio resources during an established RRC connection. This function includes coordination of the radio resource allocation between multiple radio bearers related to the same RRC connection. RRC controls the radio resources in the uplink and downlink such that UE and the radio access network can communicate using

unbalanced radio resources (asymmetric uplink and downlink). RRC signals to the UE to indicate resource allocations for purposes of handover to GSM or other radio systems.

- *RRC connection mobility functions* – The RRC layer performs evaluation, decision and execution related to RRC connection mobility during an established RRC connection, such as handover, preparation of handover to GSM or other systems, cell re-selection and cell/paging area update procedures, based on e.g. measurements done by the UE.
- *Paging/notification* – The RRC layer can broadcast paging information from the network to selected UEs. The RRC layer can also initiate paging during an established RRC connection.
- *Control of requested QoS* – This function ensures that the QoS requested for the radio access bearers can be met. This includes the allocation of a sufficient number of radio resources.
- *UE measurement reporting and control of the reporting* – The measurements performed by the UE are controlled by the RRC layer, in terms of what to measure, when to measure and how to report, including both this radio interface and other systems. The RRC layer also performs the reporting of the measurements from the UE to the network.
- *Outer loop power control* – The RRC layer controls setting of the target of the closed-loop power control.
- *Control of ciphering* – The RRC layer provides procedures for setting of ciphering (on/off) between the UE and the radio access network.
- *Initial cell selection and re-selection in idle mode* – Selection of the most suitable cell based on idle mode measurements and cell selection criteria.
- *Arbitration of the radio resource allocation between the cells* – This function shall ensure optimal performance of the overall radio access network capacity.
- *Slow DCA* – Allocation of preferred radio resources based on long-term decision criteria.
- *Timing advance control* – The RRC controls the operation of timing advance.

### 5.3.1.6 Summary of major technical parameters

Parameter	Value	Reference to § 5.3.2
Multiple access technique and duplexing scheme	Multiple access: TDMA/CDMA Duplexing: TDD	5.3.2.1.1
Chip rate (Mchip/s)	3.84 Mchip/s TDD option: 3.84 1.28 Mchip/s TDD option: 1.28	5.3.2.1.4
Frame length and structure	3.84 Mchip/s TDD option: Frame length: 10 ms 15 slots per frame, each 666.666 $\mu$ s 1.28 Mchip/s TDD option: Frame length: 10 ms Sub-frame length: 5 ms 7 main slots per sub-frame, each 675 $\mu$ s TTI: 10 ms, 20 ms, 40 ms, 80 ms, 5 ms (HS-DSCH and PRACH, 1.28 Mchip/s option only)	5.3.2.1.2
Occupied bandwidth (MHz)	3.84 Mchip/s TDD option: Less than 5 1.28 Mchip/s TDD option: Less than 1.6	5.3.2.4.1 5.3.2.4.3
Adjacent channel leakage power ratio (ACLR) (transmitter side)	3.84 Mchip/s TDD option: UE (UE power class: 21 dBm, 24 dBm) ACLR (5 MHz) = 33 dB ACLR (10 MHz) = 43 dB BS: ACLR (5 MHz) = 45 dB ACLR (10 MHz) = 55 dB 1.28 Mchip/s TDD option: UE (UE power class: 21 dBm, 24 dBm) ACLR (1.6 MHz) = 33 dB ACLR (3.2 MHz) = 43 dB BS: ACLR (1.6 MHz) = 40 dB ACLR (3.2 MHz) = 50 dB	5.3.2.4.1 5.3.2.4.3
Adjacent channel selectivity (ACS) (receiver side)	3.84 Mchip/s TDD option: UE: (UE power class: 21 dBm, 24 dBm) ACS (5 MHz) = 33 dB BS: ACS (5 MHz) = 45 dB 1.28 Mchip/s TDD option: UE: (UE power class: 21 dBm, 24 dBm) ACS (1.6 MHz) = 33 dB BS: ACS (1.6 MHz) = 45 dB	5.3.2.4.1 5.3.2.4.3
Random access mechanism	3.84 Mchip/s TDD option: RACH burst on dedicated uplink slot(s) 1.28 Mchip/s TDD option: Two step random-access with fast physical layer signalling	5.3.2.1.2, 5.3.2.1.5
Channel estimation	Midambles are used for channel estimation	5.3.2.1.2
Inter-base station asynchronous/ synchronous operation	Synchronous operation	5.3.2.1.5 5.3.2.4.3



### 5.3.2

#### Detailed specification of the radio interface

The standards contained in this section are derived from the global core specifications for IMT 2000 contained at <http://ties.itu.int/u/itu-r/ede/rsg8/wp8f/wp8f-tech/GCSrev4/5-3/>. The following notes apply to the sections below, where indicated: (1) The relevant SDOs should make their reference material available from their Web site. (2) This information was supplied by the recognized external organizations and relates to their own deliverables of the transposed global core specification.

#### 5.3.2.1

##### 25.200 series

##### 5.3.2.1.1 25.201

#### Physical layer - General description

This specification gives a general description of the physical layer of the UTRA radio interface.

SDO (2)	Document No.	Version	Status	Issued date	Location (1)
<b>Release 99</b>					
CCSA	CCSA-TSD-DS-25.201	340	Approved	01/07/2003	<a href="http://www.ccsa.org.cn/english/tc/files.php?docpath=/ITU-R/M.1457/M.1457-4/DS/">http://www.ccsa.org.cn/english/tc/files.php?docpath=/ITU-R/M.1457/M.1457-4/DS/</a>
ETSI	ETSI TS 125 201	3.4.0	Published	05/07/2002	<a href="http://pda.etsi.org/pda/home.asp?wkr=RTS/TSGR-0125201v340">http://pda.etsi.org/pda/home.asp?wkr=RTS/TSGR-0125201v340</a>
T1 (ATIS)	T1.3GPP.25.201V340-2003	3.4.0	Approved	27/03/2003	<a href="https://www.atis.org/atis/docstore/search.asp?committee=S24">https://www.atis.org/atis/docstore/search.asp?committee=S24</a>
TTA	TTAT.3G-25.201(R99-3.4.0)	3.4.0	Approved	21/03/2003	<a href="http://www.tta.or.kr/standardDB/stnfile/TTAT.3G-25.201(R99-3.4.0).zip">http://www.tta.or.kr/standardDB/stnfile/TTAT.3G-25.201(R99-3.4.0).zip</a>
<b>Release 4</b>					
CCSA	CCSA-TSD-DS-25.201	430	Approved	01/07/2003	<a href="http://www.ccsa.org.cn/english/tc/files.php?docpath=/ITU-R/M.1457/M.1457-4/DS/">http://www.ccsa.org.cn/english/tc/files.php?docpath=/ITU-R/M.1457/M.1457-4/DS/</a>
ETSI	ETSI TS 125 201	4.3.0	Published	05/07/2002	<a href="http://pda.etsi.org/pda/home.asp?wkr=RTS/TSGR-0125201v430">http://pda.etsi.org/pda/home.asp?wkr=RTS/TSGR-0125201v430</a>
T1 (ATIS)	T1.3GPP.25.201V430-2003	4.3.0	Approved	27/03/2003	<a href="https://www.atis.org/atis/docstore/search.asp?committee=S24">https://www.atis.org/atis/docstore/search.asp?committee=S24</a>
TTA	TTAT.3G-25.201(R4-4.3.0)	4.3.0	Approved	21/03/2003	<a href="http://www.tta.or.kr/standardDB/stnfile/TTAT.3G-25.201(R4-4.3.0).zip">http://www.tta.or.kr/standardDB/stnfile/TTAT.3G-25.201(R4-4.3.0).zip</a>
<b>Release 5</b>					
CCSA	CCSA-TSD-DS-25.201	520	Approved	01/07/2003	<a href="http://www.ccsa.org.cn/english/tc/files.php?docpath=/ITU-R/M.1457/M.1457-4/DS/">http://www.ccsa.org.cn/english/tc/files.php?docpath=/ITU-R/M.1457/M.1457-4/DS/</a>
ETSI	ETSI TS 125 201	5.2.0	Published	04/10/2002	<a href="http://pda.etsi.org/pda/home.asp?wkr=RTS/TSGR-0125201v520">http://pda.etsi.org/pda/home.asp?wkr=RTS/TSGR-0125201v520</a>
T1 (ATIS)	T1.3GPP.25.201V520-2003	5.2.0	Approved	27/03/2003	<a href="https://www.atis.org/atis/docstore/search.asp?committee=S24">https://www.atis.org/atis/docstore/search.asp?committee=S24</a>
TTA	TTAT.3G-25.201(R5-5.2.0)	5.2.0	Approved	21/03/2003	<a href="http://www.tta.or.kr/standardDB/stnfile/TTAT.3G-25.201(R5-5.2.0).zip">http://www.tta.or.kr/standardDB/stnfile/TTAT.3G-25.201(R5-5.2.0).zip</a>
<b>Release 6</b>					
ETSI	ETSI TS 125 201	6.0.0	Published	21/01/2004	<a href="http://pda.etsi.org/pda/home.asp?wkr=RTS/TSGR-0125201v600">http://pda.etsi.org/pda/home.asp?wkr=RTS/TSGR-0125201v600</a>
T1 (ATIS)	T1.3GPP.25.201V600-2004	6.0.0	Approved	21/05/2004	<a href="https://www.atis.org/atis/docstore/search.asp?committee=S24">https://www.atis.org/atis/docstore/search.asp?committee=S24</a>
TTA	TTAT.3G-25.201(R6-6.0.0)	6.0.0	Approved	25/05/2004	<a href="http://www.tta.or.kr/standardDB/stnfile/TTAT.3G-25.201(R6-6.0.0).zip">http://www.tta.or.kr/standardDB/stnfile/TTAT.3G-25.201(R6-6.0.0).zip</a>

**5.3.2.1.2 25.221****Physical channels and mapping of transport channels onto physical channels (TDD)**

This specification describes the characteristics of the Layer 1 transport channels and physical channel in the TDD mode of UTRA. The main objectives of the document are to be a part of the full description of the UTRA Layer 1, and to serve as a basis for the drafting of the actual technical specification (TS).

SDO (2)	Document No.	Version	Status	Issued date	Location (1)
<b>Release 99</b>					
ETSI	ETSI TS 125 221	3.11.0	Published	15/10/2002	<a href="http://pda.etsi.org/pda/home.asp?wkr=RTS/TSGR-0125221v3b0">http://pda.etsi.org/pda/home.asp?wkr=RTS/TSGR-0125221v3b0</a>
T1 (ATIS)	T1.3GPP.25.221V3110-2003	3.11.0	Approved	27/03/2003	<a href="https://www.atis.org/atis/docstore/search.asp?committee=S24">https://www.atis.org/atis/docstore/search.asp?committee=S24</a>
<b>Release 4</b>					
CCSA	CCSA-TSD-TDD-25.221	470	Approved	01/07/2003	<a href="http://www.ccsa.org.cn/english/tc/files.php?docpath=/ITU-R/M.1457/M.1457-4/TDD/">http://www.ccsa.org.cn/english/tc/files.php?docpath=/ITU-R/M.1457/M.1457-4/TDD/</a>
ETSI	ETSI TS 125 221	4.7.0	Published	13/01/2003	<a href="http://pda.etsi.org/pda/home.asp?wkr=RTS/TSGR-0125221v470">http://pda.etsi.org/pda/home.asp?wkr=RTS/TSGR-0125221v470</a>
T1 (ATIS)	T1.3GPP.25.221V470-2003	4.7.0	Approved	27/03/2003	<a href="https://www.atis.org/atis/docstore/search.asp?committee=S24">https://www.atis.org/atis/docstore/search.asp?committee=S24</a>
<b>Release 5</b>					
ETSI	ETSI TS 125 221	5.5.0	Published	08/07/2003	<a href="http://pda.etsi.org/pda/home.asp?wkr=RTS/TSGR-0125221v550">http://pda.etsi.org/pda/home.asp?wkr=RTS/TSGR-0125221v550</a>
T1 (ATIS)	T1.3GPP.25.221V550-2003	5.5.0	Approved	27/03/2003	<a href="https://www.atis.org/atis/docstore/search.asp?committee=S24">https://www.atis.org/atis/docstore/search.asp?committee=S24</a>
<b>Release 6</b>					
ETSI	ETSI TS 125 221	6.0.0	Published	22/01/2004	<a href="http://pda.etsi.org/pda/home.asp?wkr=RTS/TSGR-0125221v600">http://pda.etsi.org/pda/home.asp?wkr=RTS/TSGR-0125221v600</a>
T1 (ATIS)	T1.3GPP.25.221V600-2003	6.0.0	Approved	21/05/2004	<a href="https://www.atis.org/atis/docstore/search.asp?committee=S24">https://www.atis.org/atis/docstore/search.asp?committee=S24</a>

**5.3.2.1.3 25.222****Multiplexing and channel coding (TDD)**

This specification describes multiplexing, channel coding and interleaving for UTRA physical layer TDD mode.

SDO (2)	Document No.	Version	Status	Issued date	Location (1)
<b>Release 99</b>					
ETSI	ETSI TS 125 222	3.10.0	Published	15/10/2002	<a href="http://pda.etsi.org/pda/home.asp?wkr=RTS/TSGR-0125222v3a0">http://pda.etsi.org/pda/home.asp?wkr=RTS/TSGR-0125222v3a0</a>
T1 (ATIS)	T1.3GPP.25.222V3100-2003	3.10.0	Approved	27/03/2003	<a href="https://www.atis.org/atis/docstore/search.asp?committee=S24">https://www.atis.org/atis/docstore/search.asp?committee=S24</a>
<b>Release 4</b>					
CCSA	CCSA-TSD-TDD-25.222	460	Approved	01/07/2003	<a href="http://www.ccsa.org.cn/english/tc/files.php?docpath=/ITU-R/M.1457/M.1457-4/TDD/">http://www.ccsa.org.cn/english/tc/files.php?docpath=/ITU-R/M.1457/M.1457-4/TDD/</a>
ETSI	ETSI TS 125 222	4.7.0	Published	26/01/2004	<a href="http://pda.etsi.org/pda/home.asp?wkr=RTS/TSGR-0125222v470">http://pda.etsi.org/pda/home.asp?wkr=RTS/TSGR-0125222v470</a>
T1 (ATIS)	T1.3GPP.25.222V470-2004	4.7.0	Approved	21/05/2004	<a href="https://www.atis.org/atis/docstore/search.asp?committee=S24">https://www.atis.org/atis/docstore/search.asp?committee=S24</a>
<b>Release 5</b>					
ETSI	ETSI TS 125 222	5.6.0	Published	26/01/2004	<a href="http://pda.etsi.org/pda/home.asp?wkr=RTS/TSGR-0125222v560">http://pda.etsi.org/pda/home.asp?wkr=RTS/TSGR-0125222v560</a>
T1 (ATIS)	T1.3GPP.25.222V560-2004	5.6.0	Approved	21/05/2004	<a href="https://www.atis.org/atis/docstore/search.asp?committee=S24">https://www.atis.org/atis/docstore/search.asp?committee=S24</a>

**Release 6**

ETSI	ETSI TS 125 222	6.0.0	Published	26/01/2004	<a href="http://pda.etsi.org/pda/home.asp?wkr=RTS/TSGR-0125222v600">http://pda.etsi.org/pda/home.asp?wkr=RTS/TSGR-0125222v600</a>
T1 (ATIS)	T1.3GPP.25.222V600-2004	6.0.0	Approved	21/05/2004	<a href="https://www.atis.org/atis/docstore/search.asp?committee=S24">https://www.atis.org/atis/docstore/search.asp?committee=S24</a>

**5.3.2.1.4 25.223****Spreading and modulation (TDD)**

This specification describes the characteristics of the spreading and modulation in the TDD mode. The main objectives of the document are to be a part of the full description of the Layer 1, and to serve as a basis for the drafting of the actual technical specification (TS).

SDO (2)	Document No.	Version	Status	Issued date	Location (1)
<b>Release 99</b>					
ETSI	ETSI TS 125 223	3.8.0	Published	23/04/2002	<a href="http://pda.etsi.org/pda/home.asp?wkr=RTS/TSGR-0125223UR7">http://pda.etsi.org/pda/home.asp?wkr=RTS/TSGR-0125223UR7</a>
T1 (ATIS)	T1.3GPP.25.223V380-2002	3.8.0	Approved	03/05/2002	<a href="https://www.atis.org/atis/docstore/search.asp?committee=S24">https://www.atis.org/atis/docstore/search.asp?committee=S24</a>
<b>Release 4</b>					
CCSA	CCSA-TSD-TDD-25.223	450	Approved	01/07/2003	<a href="http://www.ccsa.org.cn/english/tc/files.php?docpath=/ITU-R/M.1457/M.1457-4/TDD/">http://www.ccsa.org.cn/english/tc/files.php?docpath=/ITU-R/M.1457/M.1457-4/TDD/</a>
ETSI	ETSI TS 125 223	4.5.0	Published	13/01/2003	<a href="http://pda.etsi.org/pda/home.asp?wkr=RTS/TSGR-0125223v450">http://pda.etsi.org/pda/home.asp?wkr=RTS/TSGR-0125223v450</a>
T1 (ATIS)	T1.3GPP.25.223V450-2003	4.5.0	Approved	27/03/2003	<a href="https://www.atis.org/atis/docstore/search.asp?committee=S24">https://www.atis.org/atis/docstore/search.asp?committee=S24</a>
<b>Release 5</b>					
ETSI	ETSI TS 125 223	5.3.0	Published	10/04/2003	<a href="http://pda.etsi.org/pda/home.asp?wkr=RTS/TSGR-0125223v530">http://pda.etsi.org/pda/home.asp?wkr=RTS/TSGR-0125223v530</a>
T1 (ATIS)	T1.3GPP.25.223V530-2004	5.3.0	Approved	21/05/2004	<a href="https://www.atis.org/atis/docstore/search.asp?committee=S24">https://www.atis.org/atis/docstore/search.asp?committee=S24</a>
<b>Release 6</b>					
ETSI	ETSI TS 125 223	6.0.0	Published	26/01/2004	<a href="http://pda.etsi.org/pda/home.asp?wkr=RTS/TSGR-0125223v600">http://pda.etsi.org/pda/home.asp?wkr=RTS/TSGR-0125223v600</a>
T1 (ATIS)	T1.3GPP.25.223V600-2004	6.0.0	Approved	21/05/2004	<a href="https://www.atis.org/atis/docstore/search.asp?committee=S24">https://www.atis.org/atis/docstore/search.asp?committee=S24</a>

**5.3.2.1.5 25.224****Physical layer procedures (TDD)**

This specification describes the physical layer procedures in the TDD mode of UTRA.

SDO (2)	Document No.	Version	Status	Issued date	Location (1)
<b>Release 99</b>					
ETSI	ETSI TS 125 224	3.13.0	Published	01/10/2003	<a href="http://pda.etsi.org/pda/home.asp?wkr=RTS/TSGR-0125224v3d0">http://pda.etsi.org/pda/home.asp?wkr=RTS/TSGR-0125224v3d0</a>
ETSI	ETSI TS 125 225	3.12.0	Published	08/07/2003	<a href="http://pda.etsi.org/pda/home.asp?wkr=RTS/TSGR-0125225v3c0">http://pda.etsi.org/pda/home.asp?wkr=RTS/TSGR-0125225v3c0</a>
T1 (ATIS)	T1.3GPP.25.224V3130-2004	3.13.0	Approved	21/05/2004	<a href="https://www.atis.org/atis/docstore/search.asp?committee=S24">https://www.atis.org/atis/docstore/search.asp?committee=S24</a>
<b>Release 4</b>					
CCSA	CCSA-TSD-TDD-25.224	480	Approved	01/07/2003	<a href="http://www.ccsa.org.cn/english/tc/files.php?docpath=/ITU-R/M.1457/M.1457-4/TDD/">http://www.ccsa.org.cn/english/tc/files.php?docpath=/ITU-R/M.1457/M.1457-4/TDD/</a>
ETSI	ETSI TS 125 224	4.10.0	Published	26/01/2004	<a href="http://pda.etsi.org/pda/home.asp?wkr=RTS/TSGR-0125224v4a0">http://pda.etsi.org/pda/home.asp?wkr=RTS/TSGR-0125224v4a0</a>
ETSI	ETSI TS 125 225	4.7.0	Published	08/07/2003	<a href="http://pda.etsi.org/pda/home.asp?wkr=RTS/TSGR-0125225v470">http://pda.etsi.org/pda/home.asp?wkr=RTS/TSGR-0125225v470</a>
T1 (ATIS)	T1.3GPP.25.224V4100-2004	4.10.0	Approved	21/05/2004	<a href="https://www.atis.org/atis/docstore/search.asp?committee=S24">https://www.atis.org/atis/docstore/search.asp?committee=S24</a>

**Release 5**

ETSI	ETSI TS 125 225	5.6.0	Published	26/01/2004	<a href="http://pda.etsi.org/pda/home.asp?wkr=RTS/TSGR-0125225v560">http://pda.etsi.org/pda/home.asp?wkr=RTS/TSGR-0125225v560</a>
ETSI	ETSI TS 125 224	5.7.0	Published	26/01/2004	<a href="http://pda.etsi.org/pda/home.asp?wkr=RTS/TSGR-0125224v570">http://pda.etsi.org/pda/home.asp?wkr=RTS/TSGR-0125224v570</a>
T1 (ATIS)	T1.3GPP.25.224V570-2004	5.7.0	Approved	21/05/2004	<a href="https://www.atis.org/atis/docstore/search.asp?committee=S24">https://www.atis.org/atis/docstore/search.asp?committee=S24</a>

**Release 6**

ETSI	ETSI TS 125 224	6.0.0	Published	26/01/2004	<a href="http://pda.etsi.org/pda/home.asp?wkr=RTS/TSGR-0125224v600">http://pda.etsi.org/pda/home.asp?wkr=RTS/TSGR-0125224v600</a>
ETSI	ETSI TS 125 225	6.0.0	Published	26/01/2004	<a href="http://pda.etsi.org/pda/home.asp?wkr=RTS/TSGR-0125225v600">http://pda.etsi.org/pda/home.asp?wkr=RTS/TSGR-0125225v600</a>
T1 (ATIS)	T1.3GPP.25.224V600-2004	6.0.0	Approved	21/05/2004	<a href="https://www.atis.org/atis/docstore/search.asp?committee=S24">https://www.atis.org/atis/docstore/search.asp?committee=S24</a>

**5.3.2.1.6 25.225****Physical layer - Measurements (TDD)**

This specification describes the description of the measurements done at the UE and network in order to support operation in idle mode and connected mode for TDD mode.

SDO (2)	Document No.	Version	Status	Issued date	Location (1)
<b>Release 99</b>					
T1 (ATIS)	T1.3GPP.25.225V3120-2004	3.12.0	Approved	21/05/2004	<a href="https://www.atis.org/atis/docstore/search.asp?committee=S24">https://www.atis.org/atis/docstore/search.asp?committee=S24</a>
<b>Release 4</b>					
T1 (ATIS)	T1.3GPP.25.225V470-2004	4.7.0	Approved	21/05/2004	<a href="https://www.atis.org/atis/docstore/search.asp?committee=S24">https://www.atis.org/atis/docstore/search.asp?committee=S24</a>
<b>Release 5</b>					
T1 (ATIS)	T1.3GPP.25.225V560-2004	5.6.0	Approved	21/05/2004	<a href="https://www.atis.org/atis/docstore/search.asp?committee=S24">https://www.atis.org/atis/docstore/search.asp?committee=S24</a>
<b>Release 6</b>					
T1 (ATIS)	T1.3GPP.25.225V600-2004	6.0.0	Approved	21/05/2004	<a href="https://www.atis.org/atis/docstore/search.asp?committee=S24">https://www.atis.org/atis/docstore/search.asp?committee=S24</a>

**5.3.2.2****25.300 series****5.3.2.2.1 25.301****Radio interface protocol architecture**

This specification describes an overview and overall description of the UE-UTRAN radio interface protocol architecture. Details of the radio protocols will be specified in companion documents.

SDO (2)	Document No.	Version	Status	Issued date	Location (1)
<b>Release 99</b>					
CCSA	CCSA-TSD-DS-25.301	3B0	Approved	01/07/2003	<a href="http://www.ccsa.org.cn/english/tc/files.php?docpath=/ITU-R/M.1457/M.1457-4/DS/">http://www.ccsa.org.cn/english/tc/files.php?docpath=/ITU-R/M.1457/M.1457-4/DS/</a>
ETSI	ETSI TS 125 301	3.11.0	Published	07/10/2002	<a href="http://pda.etsi.org/pda/home.asp?wkr=RTS/TSGR-0225301v3b0">http://pda.etsi.org/pda/home.asp?wkr=RTS/TSGR-0225301v3b0</a>
T1 (ATIS)	T1.3GPP.25.301V3110-2003	3.11.0	Approved	27/03/2003	<a href="https://www.atis.org/atis/docstore/search.asp?committee=S24">https://www.atis.org/atis/docstore/search.asp?committee=S24</a>
TTA	TTAT.3G-25.301(R99-3.11.0)	3.11.0	Approved	21/03/2003	<a href="http://www.tta.or.kr/standardDB/stnfile/TTAT.3G-25.301(R99-3.11.0).zip">http://www.tta.or.kr/standardDB/stnfile/TTAT.3G-25.301(R99-3.11.0).zip</a>

**Release 4**

CCSA	CCSA-TSD-DS-25.301	440	Approved	01/07/2003	<a href="http://www.ccsa.org.cn/english/tc/files.php?docpath=/ITU-R/M.1457/M.1457-4/DS/">http://www.ccsa.org.cn/english/tc/files.php?docpath=/ITU-R/M.1457/M.1457-4/DS/</a>
ETSI	ETSI TS 125 301	4.4.0	Published	07/10/2002	<a href="http://pda.etsi.org/pda/home.asp?wkr=RTS/TSGR-0225301v440">http://pda.etsi.org/pda/home.asp?wkr=RTS/TSGR-0225301v440</a>
T1 (ATIS)	T1.3GPP.25.301V440-2003	4.4.0	Approved	27/03/2003	<a href="https://www.atis.org/atis/docstore/search.asp?committee=S24">https://www.atis.org/atis/docstore/search.asp?committee=S24</a>
TTA	TTAT.3G-25.301(R4-4.4.0)	4.4.0	Approved	21/03/2003	<a href="http://www.tta.or.kr/standardDB/stnfile/TTAT.3G-25.301(R4-4.4.0).zip">http://www.tta.or.kr/standardDB/stnfile/TTAT.3G-25.301(R4-4.4.0).zip</a>

**Release 5**

CCSA	CCSA-TSD-DS-25.301	520	Approved	01/07/2003	<a href="http://www.ccsa.org.cn/english/tc/files.php?docpath=/ITU-R/M.1457/M.1457-4/DS/">http://www.ccsa.org.cn/english/tc/files.php?docpath=/ITU-R/M.1457/M.1457-4/DS/</a>
ETSI	ETSI TS 125 301	5.2.0	Published	07/10/2002	<a href="http://pda.etsi.org/pda/home.asp?wkr=RTS/TSGR-0225301v520">http://pda.etsi.org/pda/home.asp?wkr=RTS/TSGR-0225301v520</a>
T1 (ATIS)	T1.3GPP.25.301V520-2003	5.2.0	Approved	27/03/2003	<a href="https://www.atis.org/atis/docstore/search.asp?committee=S24">https://www.atis.org/atis/docstore/search.asp?committee=S24</a>
TTA	TTAT.3G-25.301(R5-5.2.0)	5.2.0	Approved	21/03/2003	<a href="http://www.tta.or.kr/standardDB/stnfile/TTAT.3G-25.301(R5-5.2.0).zip">http://www.tta.or.kr/standardDB/stnfile/TTAT.3G-25.301(R5-5.2.0).zip</a>

**Release 6**

ETSI	ETSI TS 125 301	6.0.0	Published	14/01/2004	<a href="http://pda.etsi.org/pda/home.asp?wkr=RTS/TSGR-0225301v600">http://pda.etsi.org/pda/home.asp?wkr=RTS/TSGR-0225301v600</a>
T1 (ATIS)	T1.3GPP.25.301V600-2004	6.0.0	Approved	21/05/2004	<a href="https://www.atis.org/atis/docstore/search.asp?committee=S24">https://www.atis.org/atis/docstore/search.asp?committee=S24</a>
TTA	TTAT.3G-25.301(R6-6.0.0)	6.0.0	Approved	25/05/2004	<a href="http://www.tta.or.kr/standardDB/stnfile/TTAT.3G-25.301(R6-6.0.0).zip">http://www.tta.or.kr/standardDB/stnfile/TTAT.3G-25.301(R6-6.0.0).zip</a>

**5.3.2.2.2 25.302****Services provided by the physical layer**

This specification describes a technical specification of the services provided by the physical layer of UTRA to upper layers.

SDO (2)	Document No.	Version	Status	Issued date	Location (1)
<b>Release 99</b>					
CCSA	CCSA-TSD-DS-25.302	3F0	Approved	01/07/2003	<a href="http://www.ccsa.org.cn/english/tc/files.php?docpath=/ITU-R/M.1457/M.1457-4/DS/">http://www.ccsa.org.cn/english/tc/files.php?docpath=/ITU-R/M.1457/M.1457-4/DS/</a>
ETSI	ETSI TS 125 302	3.16.0	Published	07/10/2003	<a href="http://pda.etsi.org/pda/home.asp?wkr=RTS/TSGR-0225302v3g0">http://pda.etsi.org/pda/home.asp?wkr=RTS/TSGR-0225302v3g0</a>
T1 (ATIS)	T1.3GPP.25.302V3160-2004	3.16.0	Approved	21/05/2004	<a href="https://www.atis.org/atis/docstore/search.asp?committee=S24">https://www.atis.org/atis/docstore/search.asp?committee=S24</a>
TTA	TTAT.3G-25.302(R99-3.16.0)	3.16.0	Approved	25/05/2004	<a href="http://www.tta.or.kr/standardDB/stnfile/TTAT.3G-25.302(R99-3.16.0).zip">http://www.tta.or.kr/standardDB/stnfile/TTAT.3G-25.302(R99-3.16.0).zip</a>
<b>Release 4</b>					
CCSA	CCSA-TSD-DS-25.302	470	Approved	01/07/2003	<a href="http://www.ccsa.org.cn/english/tc/files.php?docpath=/ITU-R/M.1457/M.1457-4/DS/">http://www.ccsa.org.cn/english/tc/files.php?docpath=/ITU-R/M.1457/M.1457-4/DS/</a>
ETSI	ETSI TS 125 302	4.8.0	Published	07/10/2003	<a href="http://pda.etsi.org/pda/home.asp?wkr=RTS/TSGR-0225302v480">http://pda.etsi.org/pda/home.asp?wkr=RTS/TSGR-0225302v480</a>
T1 (ATIS)	T1.3GPP.25.302V480-2004	4.8.0	Approved	21/05/2004	<a href="https://www.atis.org/atis/docstore/search.asp?committee=S24">https://www.atis.org/atis/docstore/search.asp?committee=S24</a>
TTA	TTAT.3G-25.302(R4-4.8.0)	4.8.0	Approved	25/05/2004	<a href="http://www.tta.or.kr/standardDB/stnfile/TTAT.3G-25.302(R4-4.8.0).zip">http://www.tta.or.kr/standardDB/stnfile/TTAT.3G-25.302(R4-4.8.0).zip</a>
<b>Release 5</b>					
CCSA	CCSA-TSD-DS-25.302	550	Approved	01/07/2003	<a href="http://www.ccsa.org.cn/english/tc/files.php?docpath=/ITU-R/M.1457/M.1457-4/DS/">http://www.ccsa.org.cn/english/tc/files.php?docpath=/ITU-R/M.1457/M.1457-4/DS/</a>
ETSI	ETSI TS 125 302	5.7.0	Published	13/01/2004	<a href="http://pda.etsi.org/pda/home.asp?wkr=RTS/TSGR-0225302v570">http://pda.etsi.org/pda/home.asp?wkr=RTS/TSGR-0225302v570</a>
T1 (ATIS)	T1.3GPP.25.302V570-2004	5.7.0	Approved	21/05/2004	<a href="https://www.atis.org/atis/docstore/search.asp?committee=S24">https://www.atis.org/atis/docstore/search.asp?committee=S24</a>
TTA	TTAT.3G-25.302(R5-5.7.0)	5.7.0	Approved	25/05/2004	<a href="http://www.tta.or.kr/standardDB/stnfile/TTAT.3G-25.302(R5-5.7.0).zip">http://www.tta.or.kr/standardDB/stnfile/TTAT.3G-25.302(R5-5.7.0).zip</a>

**Release 6**

ETSI	ETSI TS 125 302	6.0.0	Published	14/01/2004	<a href="http://pda.etsi.org/pda/home.asp?wkr=RTS/TSGR-0225302v600">http://pda.etsi.org/pda/home.asp?wkr=RTS/TSGR-0225302v600</a>
T1 (ATIS)	T1.3GPP.25.302V600-2004	6.0.0	Approved	21/05/2004	<a href="https://www.atis.org/atis/docstore/search.asp?committee=S24">https://www.atis.org/atis/docstore/search.asp?committee=S24</a>
TTA	TTAT.3G-25.302(R6-6.0.0)	6.0.0	Approved	25/05/2004	<a href="http://www.tta.or.kr/standardDB/stnfile/TTAT.3G-25.302(R6-6.0.0).zip">http://www.tta.or.kr/standardDB/stnfile/TTAT.3G-25.302(R6-6.0.0).zip</a>

**5.3.2.2.3 25.303****Interlayer procedures in connected mode**

This specification describes informative interlayer procedures to perform the required tasks. This specification attempts to provide a comprehensive overview of the different states and transitions within the connected mode of universal mobile telecommunications system (UMTS) terminal.

<b>SDO (2)</b>	<b>Document No.</b>	<b>Version</b>	<b>Status</b>	<b>Issued date</b>	<b>Location (1)</b>
<b>Release 99</b>					
CCSA	CCSA-TSD-DS-25.303	3C0	Approved	01/07/2003	<a href="http://www.ccsa.org.cn/english/tc/files.php?docpath=/ITU-R/M.1457/M.1457-4/DS/">http://www.ccsa.org.cn/english/tc/files.php?docpath=/ITU-R/M.1457/M.1457-4/DS/</a>
ETSI	ETSI TS 125 303	3.12.0	Published	24/06/2002	<a href="http://pda.etsi.org/pda/home.asp?wkr=RTS/TSGR-0225303v3c0">http://pda.etsi.org/pda/home.asp?wkr=RTS/TSGR-0225303v3c0</a>
T1 (ATIS)	T1.3GPP.25.303V3120-2003	3.12.0	Approved	27/03/2003	<a href="https://www.atis.org/atis/docstore/search.asp?committee=S24">https://www.atis.org/atis/docstore/search.asp?committee=S24</a>
TTA	TTAT.3G-25.303(R99-3.12.0)	3.12.0	Approved	21/03/2003	<a href="http://www.tta.or.kr/standardDB/stnfile/TTAT.3G-25.303(R99-3.12.0).zip">http://www.tta.or.kr/standardDB/stnfile/TTAT.3G-25.303(R99-3.12.0).zip</a>
<b>Release 4</b>					
CCSA	CCSA-TSD-DS-25.303	450	Approved	01/07/2003	<a href="http://www.ccsa.org.cn/english/tc/files.php?docpath=/ITU-R/M.1457/M.1457-4/DS/">http://www.ccsa.org.cn/english/tc/files.php?docpath=/ITU-R/M.1457/M.1457-4/DS/</a>
ETSI	ETSI TS 125 303	4.5.0	Published	24/06/2002	<a href="http://pda.etsi.org/pda/home.asp?wkr=RTS/TSGR-0225303v450">http://pda.etsi.org/pda/home.asp?wkr=RTS/TSGR-0225303v450</a>
T1 (ATIS)	T1.3GPP.25.303V450-2003	4.5.0	Approved	27/03/2003	<a href="https://www.atis.org/atis/docstore/search.asp?committee=S24">https://www.atis.org/atis/docstore/search.asp?committee=S24</a>
TTA	TTAT.3G-25.303(R4-4.5.0)	4.5.0	Approved	21/03/2003	<a href="http://www.tta.or.kr/standardDB/stnfile/TTAT.3G-25.303(R4-4.5.0).zip">http://www.tta.or.kr/standardDB/stnfile/TTAT.3G-25.303(R4-4.5.0).zip</a>
<b>Release 5</b>					
CCSA	CCSA-TSD-DS-25.303	510	Approved	01/07/2003	<a href="http://www.ccsa.org.cn/english/tc/files.php?docpath=/ITU-R/M.1457/M.1457-4/DS/">http://www.ccsa.org.cn/english/tc/files.php?docpath=/ITU-R/M.1457/M.1457-4/DS/</a>
ETSI	ETSI TS 125 303	5.1.0	Published	24/06/2002	<a href="http://pda.etsi.org/pda/home.asp?wkr=RTS/TSGR-0225303v510">http://pda.etsi.org/pda/home.asp?wkr=RTS/TSGR-0225303v510</a>
T1 (ATIS)	T1.3GPP.25.303V510-2003	5.1.0	Approved	27/03/2003	<a href="https://www.atis.org/atis/docstore/search.asp?committee=S24">https://www.atis.org/atis/docstore/search.asp?committee=S24</a>
TTA	TTAT.3G-25.303(R5-5.1.0)	5.1.0	Approved	21/03/2003	<a href="http://www.tta.or.kr/standardDB/stnfile/TTAT.3G-25.303(R5-5.1.0).zip">http://www.tta.or.kr/standardDB/stnfile/TTAT.3G-25.303(R5-5.1.0).zip</a>
<b>Release 6</b>					
ETSI	ETSI TS 125 303	6.0.0	Published	14/01/2004	<a href="http://pda.etsi.org/pda/home.asp?wkr=RTS/TSGR-0225303v600">http://pda.etsi.org/pda/home.asp?wkr=RTS/TSGR-0225303v600</a>
T1 (ATIS)	T1.3GPP.25.303V600-2004	6.0.0	Approved	21/05/2004	<a href="https://www.atis.org/atis/docstore/search.asp?committee=S24">https://www.atis.org/atis/docstore/search.asp?committee=S24</a>
TTA	TTAT.3G-25.303(R6-6.0.0)	6.0.0	Approved	25/05/2004	<a href="http://www.tta.or.kr/standardDB/stnfile/TTAT.3G-25.303(R6-6.0.0).zip">http://www.tta.or.kr/standardDB/stnfile/TTAT.3G-25.303(R6-6.0.0).zip</a>

**5.3.2.2.4 25.304****UE procedures in idle mode and procedures for cell reselection in connected mode**

This specification describes the overall idle mode process for the UE and the functional division between the non-access stratum and access stratum in the UE. The UE is in idle mode when the connection of the UE is closed on all layers, e.g. there is neither an MM connection nor an RRC connection. This specification presents also examples of inter-layer procedures related to the idle mode processes and describes idle mode functionality of a dual mode UMTS/GSM UE.

SDO (2)	Document No.	Version	Status	Issued date	Location (1)
<b>Release 99</b>					
CCSA	CCSA-TSD-DS-25.304	3D0	Approved	01/07/2003	<a href="http://www.ccsa.org.cn/english/tc/files.php?docpath=/ITU-R/M.1457/M.1457-4/DS/">http://www.ccsa.org.cn/english/tc/files.php?docpath=/ITU-R/M.1457/M.1457-4/DS/</a>
ETSI	ETSI TS 125 304	3.13.0	Published	03/07/2003	<a href="http://pda.etsi.org/pda/home.asp?wkr=RTS/TSGR-0225304v3d0">http://pda.etsi.org/pda/home.asp?wkr=RTS/TSGR-0225304v3d0</a>
T1 (ATIS)	T1.3GPP.25.304V3130-2004	3.13.0	Approved	21/05/2004	<a href="https://www.atis.org/atis/docstore/search.asp?committee=S24">https://www.atis.org/atis/docstore/search.asp?committee=S24</a>
TTA	TTAT.3G-25.304(R99-3.13.0)	3.13.0	Approved	25/05/2004	<a href="http://www.tta.or.kr/standardDB/stnfile/TTAT.3G-25.304(R99-3.13.0).zip">http://www.tta.or.kr/standardDB/stnfile/TTAT.3G-25.304(R99-3.13.0).zip</a>
<b>Release 4</b>					
CCSA	CCSA-TSD-DS-25.304	470	Approved	01/07/2003	<a href="http://www.ccsa.org.cn/english/tc/files.php?docpath=/ITU-R/M.1457/M.1457-4/DS/">http://www.ccsa.org.cn/english/tc/files.php?docpath=/ITU-R/M.1457/M.1457-4/DS/</a>
ETSI	ETSI TS 125 304	4.7.0	Published	03/07/2003	<a href="http://pda.etsi.org/pda/home.asp?wkr=RTS/TSGR-0225304v470">http://pda.etsi.org/pda/home.asp?wkr=RTS/TSGR-0225304v470</a>
T1 (ATIS)	T1.3GPP.25.304V470-2004	4.7.0	Approved	21/05/2004	<a href="https://www.atis.org/atis/docstore/search.asp?committee=S24">https://www.atis.org/atis/docstore/search.asp?committee=S24</a>
TTA	TTAT.3G-25.304(R4-4.7.0)	4.7.0	Approved	25/05/2004	<a href="http://www.tta.or.kr/standardDB/stnfile/TTAT.3G-25.304(R4-4.7.0).zip">http://www.tta.or.kr/standardDB/stnfile/TTAT.3G-25.304(R4-4.7.0).zip</a>
<b>Release 5</b>					
CCSA	CCSA-TSD-DS-25.304	530	Approved	01/07/2003	<a href="http://www.ccsa.org.cn/english/tc/files.php?docpath=/ITU-R/M.1457/M.1457-4/DS/">http://www.ccsa.org.cn/english/tc/files.php?docpath=/ITU-R/M.1457/M.1457-4/DS/</a>
ETSI	ETSI TS 125 304	5.3.0	Published	03/07/2003	<a href="http://pda.etsi.org/pda/home.asp?wkr=RTS/TSGR-0225304v530">http://pda.etsi.org/pda/home.asp?wkr=RTS/TSGR-0225304v530</a>
T1 (ATIS)	T1.3GPP.25.304V530-2004	5.3.0	Approved	21/05/2004	<a href="https://www.atis.org/atis/docstore/search.asp?committee=S24">https://www.atis.org/atis/docstore/search.asp?committee=S24</a>
TTA	TTAT.3G-25.304(R5-5.3.0)	5.3.0	Approved	25/05/2004	<a href="http://www.tta.or.kr/standardDB/stnfile/TTAT.3G-25.304(R5-5.3.0).zip">http://www.tta.or.kr/standardDB/stnfile/TTAT.3G-25.304(R5-5.3.0).zip</a>
<b>Release 6</b>					
ETSI	ETSI TS 125 304	6.0.0	Published	14/01/2004	<a href="http://pda.etsi.org/pda/home.asp?wkr=RTS/TSGR-0225304v600">http://pda.etsi.org/pda/home.asp?wkr=RTS/TSGR-0225304v600</a>
T1 (ATIS)	T1.3GPP.25.304V600-2004	6.0.0	Approved	21/05/2004	<a href="https://www.atis.org/atis/docstore/search.asp?committee=S24">https://www.atis.org/atis/docstore/search.asp?committee=S24</a>
TTA	TTAT.3G-25.304(R6-6.0.0)	6.0.0	Approved	25/05/2004	<a href="http://www.tta.or.kr/standardDB/stnfile/TTAT.3G-25.304(R6-6.0.0).zip">http://www.tta.or.kr/standardDB/stnfile/TTAT.3G-25.304(R6-6.0.0).zip</a>

### 5.3.2.2.5 25.305

#### Stage 2 Functional Specification of UE positioning in UTRAN (LCS)

This document specifies the stage 2 of the UE Positioning function of UTRAN, which provides the mechanisms to support the calculation of the geographical position of a UE.

SDO (2)	Document No.	Version	Status	Issued date	Location (1)
<b>Release 99</b>					
CCSA	CCSA-TSD-DS-25.305	390	Approved	01/07/2003	<a href="http://www.ccsa.org.cn/english/tc/files.php?docpath=/ITU-R/M.1457/M.1457-4/DS/">http://www.ccsa.org.cn/english/tc/files.php?docpath=/ITU-R/M.1457/M.1457-4/DS/</a>
ETSI	ETSI TS 125 305	3.11.0	Published	13/01/2004	<a href="http://pda.etsi.org/pda/home.asp?wkr=RTS/TSGR-0225305v3b0">http://pda.etsi.org/pda/home.asp?wkr=RTS/TSGR-0225305v3b0</a>
T1 (ATIS)	T1.3GPP.25.305V3110-2004	3.11.0	Approved	21/05/2004	<a href="https://www.atis.org/atis/docstore/search.asp?committee=S24">https://www.atis.org/atis/docstore/search.asp?committee=S24</a>
TTA	TTAT.3G-25.305(R99-3.11.0)	3.11.0	Approved	25/05/2004	<a href="http://www.tta.or.kr/standardDB/stnfile/TTAT.3G-25.305(R99-3.11.0).zip">http://www.tta.or.kr/standardDB/stnfile/TTAT.3G-25.305(R99-3.11.0).zip</a>
<b>Release 4</b>					
CCSA	CCSA-TSD-DS-25.305	450	Approved	01/07/2003	<a href="http://www.ccsa.org.cn/english/tc/files.php?docpath=/ITU-R/M.1457/M.1457-4/DS/">http://www.ccsa.org.cn/english/tc/files.php?docpath=/ITU-R/M.1457/M.1457-4/DS/</a>
ETSI	ETSI TS 125 305	4.7.0	Published	13/01/2004	<a href="http://pda.etsi.org/pda/home.asp?wkr=RTS/TSGR-0225305v470">http://pda.etsi.org/pda/home.asp?wkr=RTS/TSGR-0225305v470</a>
T1 (ATIS)	T1.3GPP.25.305V470-2004	4.7.0	Approved	21/05/2004	<a href="https://www.atis.org/atis/docstore/search.asp?committee=S24">https://www.atis.org/atis/docstore/search.asp?committee=S24</a>
TTA	TTAT.3G-25.305(R4-4.7.0)	4.7.0	Approved	25/05/2004	<a href="http://www.tta.or.kr/standardDB/stnfile/TTAT.3G-25.305(R4-4.7.0).zip">http://www.tta.or.kr/standardDB/stnfile/TTAT.3G-25.305(R4-4.7.0).zip</a>



**Release 5**

CCSA	CCSA-TSD-DS-25.305	560	Approved	01/07/2003	<a href="http://www.ccsa.org.cn/english/tc/files.php?docpath=/ITU-R/M.1457/M.1457-4/DS/">http://www.ccsa.org.cn/english/tc/files.php?docpath=/ITU-R/M.1457/M.1457-4/DS/</a>
ETSI	ETSI TS 125 305	5.8.0	Published	14/01/2004	<a href="http://pda.etsi.org/pda/home.asp?wkr=RTS/TSGR-0225305v580">http://pda.etsi.org/pda/home.asp?wkr=RTS/TSGR-0225305v580</a>
T1 (ATIS)	T1.3GPP.25.305V580-2004	5.8.0	Approved	21/05/2004	<a href="https://www.atis.org/atis/docstore/search.asp?committee=S24">https://www.atis.org/atis/docstore/search.asp?committee=S24</a>
TTA	TTAT.3G-25.305(R5-5.8.0)	5.8.0	Approved	25/05/2004	<a href="http://www.tta.or.kr/standardDB/stnfile/TTAT.3G-25.305(R5-5.8.0).zip">http://www.tta.or.kr/standardDB/stnfile/TTAT.3G-25.305(R5-5.8.0).zip</a>

**Release 6**

ETSI	ETSI TS 125 305	6.0.0	Published	14/01/2004	<a href="http://pda.etsi.org/pda/home.asp?wkr=RTS/TSGR-0225305v600">http://pda.etsi.org/pda/home.asp?wkr=RTS/TSGR-0225305v600</a>
T1 (ATIS)	T1.3GPP.25.305V600-2004	6.0.0	Approved	21/05/2004	<a href="https://www.atis.org/atis/docstore/search.asp?committee=S24">https://www.atis.org/atis/docstore/search.asp?committee=S24</a>
TTA	TTAT.3G-25.305(R6-6.0.0)	6.0.0	Approved	25/05/2004	<a href="http://www.tta.or.kr/standardDB/stnfile/TTAT.3G-25.305(R6-6.0.0).zip">http://www.tta.or.kr/standardDB/stnfile/TTAT.3G-25.305(R6-6.0.0).zip</a>

**5.3.2.2.6 25.306****UE Radio Access capabilities definition**

This document identifies the parameters of the access stratum part of the UE radio access capabilities. Furthermore, some reference configurations of these values are defined. The intention is that these configurations will be used for test specifications.

SDO (2)	Document No.	Version	Status	Issued date	Location (1)
<b>Release 99</b>					
CCSA	CCSA-TSD-DS-25.306	380	Approved	01/07/2003	<a href="http://www.ccsa.org.cn/english/tc/files.php?docpath=/ITU-R/M.1457/M.1457-4/DS/">http://www.ccsa.org.cn/english/tc/files.php?docpath=/ITU-R/M.1457/M.1457-4/DS/</a>
ETSI	ETSI TS 125 306	3.10.0	Published	14/01/2004	<a href="http://pda.etsi.org/pda/home.asp?wkr=RTS/TSGR-0225306v3a0">http://pda.etsi.org/pda/home.asp?wkr=RTS/TSGR-0225306v3a0</a>
T1 (ATIS)	T1.3GPP.25.306V3100-2004	3.10.0	Approved	21/05/2004	<a href="https://www.atis.org/atis/docstore/search.asp?committee=S24">https://www.atis.org/atis/docstore/search.asp?committee=S24</a>
TTA	TTAT.3G-25.306(R99-3.10.0)	3.10.0	Approved	25/05/2004	<a href="http://www.tta.or.kr/standardDB/stnfile/TTAT.3G-25.306(R99-3.10.0).zip">http://www.tta.or.kr/standardDB/stnfile/TTAT.3G-25.306(R99-3.10.0).zip</a>
<b>Release 4</b>					
CCSA	CCSA-TSD-DS-25.306	470	Approved	01/07/2003	<a href="http://www.ccsa.org.cn/english/tc/files.php?docpath=/ITU-R/M.1457/M.1457-4/DS/">http://www.ccsa.org.cn/english/tc/files.php?docpath=/ITU-R/M.1457/M.1457-4/DS/</a>
ETSI	ETSI TS 125 306	4.9.0	Published	14/01/2004	<a href="http://pda.etsi.org/pda/home.asp?wkr=RTS/TSGR-0225306v490">http://pda.etsi.org/pda/home.asp?wkr=RTS/TSGR-0225306v490</a>
T1 (ATIS)	T1.3GPP.25.306V490-2004	4.9.0	Approved	21/05/2004	<a href="https://www.atis.org/atis/docstore/search.asp?committee=S24">https://www.atis.org/atis/docstore/search.asp?committee=S24</a>
TTA	TTAT.3G-25.306(R4-4.9.0)	4.9.0	Approved	25/05/2004	<a href="http://www.tta.or.kr/standardDB/stnfile/TTAT.3G-25.306(R4-4.9.0).zip">http://www.tta.or.kr/standardDB/stnfile/TTAT.3G-25.306(R4-4.9.0).zip</a>
<b>Release 5</b>					
CCSA	CCSA-TSD-DS-25.306	550	Approved	01/07/2003	<a href="http://www.ccsa.org.cn/english/tc/files.php?docpath=/ITU-R/M.1457/M.1457-4/DS/">http://www.ccsa.org.cn/english/tc/files.php?docpath=/ITU-R/M.1457/M.1457-4/DS/</a>
ETSI	ETSI TS 125 306	5.7.0	Published	14/01/2004	<a href="http://pda.etsi.org/pda/home.asp?wkr=RTS/TSGR-0225306v570">http://pda.etsi.org/pda/home.asp?wkr=RTS/TSGR-0225306v570</a>
T1 (ATIS)	T1.3GPP.25.306V570-2004	5.7.0	Approved	21/05/2004	<a href="https://www.atis.org/atis/docstore/search.asp?committee=S24">https://www.atis.org/atis/docstore/search.asp?committee=S24</a>
TTA	TTAT.3G-25.306(R5-5.7.0)	5.7.0	Approved	25/05/2004	<a href="http://www.tta.or.kr/standardDB/stnfile/TTAT.3G-25.306(R5-5.7.0).zip">http://www.tta.or.kr/standardDB/stnfile/TTAT.3G-25.306(R5-5.7.0).zip</a>
<b>Release 6</b>					
ETSI	ETSI TS 125 306	6.0.0	Published	14/01/2004	<a href="http://pda.etsi.org/pda/home.asp?wkr=RTS/TSGR-0225306v600">http://pda.etsi.org/pda/home.asp?wkr=RTS/TSGR-0225306v600</a>
T1 (ATIS)	T1.3GPP.25.306V600-2004	6.0.0	Approved	21/05/2004	<a href="https://www.atis.org/atis/docstore/search.asp?committee=S24">https://www.atis.org/atis/docstore/search.asp?committee=S24</a>
TTA	TTAT.3G-25.306(R6-6.0.0)	6.0.0	Approved	25/05/2004	<a href="http://www.tta.or.kr/standardDB/stnfile/TTAT.3G-25.306(R6-6.0.0).zip">http://www.tta.or.kr/standardDB/stnfile/TTAT.3G-25.306(R6-6.0.0).zip</a>



**5.3.2.2.7 25.307****Requirements on UE supporting a release-independent frequency band**

This document specifies requirements on UEs supporting a frequency band that is independent of release.

SDO (2)	Document No.	Version	Status	Issued date	Location (1)
<b>Release 99</b>					
CCSA	CCSA-TSD-DS-25.307	310	Approved	01/07/2003	<a href="http://www.ccsa.org.cn/english/tc/files.php?docpath=/ITU-R/M.1457/M.1457-4/DS/">http://www.ccsa.org.cn/english/tc/files.php?docpath=/ITU-R/M.1457/M.1457-4/DS/</a>
ETSI	ETSI TS 125 307	3.2.0	Published	14/01/2004	<a href="http://pda.etsi.org/pda/home.asp?wkr=RTS/TSGR-0225307v320">http://pda.etsi.org/pda/home.asp?wkr=RTS/TSGR-0225307v320</a>
T1 (ATIS)	T1.3GPP.25.307V320-2004	3.2.0	Approved	21/05/2004	<a href="https://www.atis.org/atis/docstore/search.asp?committee=S24">https://www.atis.org/atis/docstore/search.asp?committee=S24</a>
TTA	TTAT.3G-25.307(R99-3.2.0)	3.2.0	Approved	25/05/2004	<a href="http://www.tta.or.kr/standardDB/stnfile/TTAT.3G-25.307(R99-3.2.0).zip">http://www.tta.or.kr/standardDB/stnfile/TTAT.3G-25.307(R99-3.2.0).zip</a>
<b>Release 4</b>					
CCSA	CCSA-TSD-DS-25.307	410	Approved	01/07/2003	<a href="http://www.ccsa.org.cn/english/tc/files.php?docpath=/ITU-R/M.1457/M.1457-4/DS/">http://www.ccsa.org.cn/english/tc/files.php?docpath=/ITU-R/M.1457/M.1457-4/DS/</a>
ETSI	ETSI TS 125 307	4.2.0	Published	14/01/2004	<a href="http://pda.etsi.org/pda/home.asp?wkr=RTS/TSGR-0225307v420">http://pda.etsi.org/pda/home.asp?wkr=RTS/TSGR-0225307v420</a>
T1 (ATIS)	T1.3GPP.25.307V420-2004	4.2.0	Approved	21/05/2004	<a href="https://www.atis.org/atis/docstore/search.asp?committee=S24">https://www.atis.org/atis/docstore/search.asp?committee=S24</a>
TTA	TTAT.3G-25.307(R4-4.2.0)	4.2.0	Approved	25/05/2004	<a href="http://www.tta.or.kr/standardDB/stnfile/TTAT.3G-25.307(R4-4.2.0).zip">http://www.tta.or.kr/standardDB/stnfile/TTAT.3G-25.307(R4-4.2.0).zip</a>
<b>Release 5</b>					
CCSA	CCSA-TSD-DS-25.307	500	Approved	01/07/2003	<a href="http://www.ccsa.org.cn/english/tc/files.php?docpath=/ITU-R/M.1457/M.1457-4/DS/">http://www.ccsa.org.cn/english/tc/files.php?docpath=/ITU-R/M.1457/M.1457-4/DS/</a>
ETSI	ETSI TS 125 307	5.1.0	Published	14/01/2004	<a href="http://pda.etsi.org/pda/home.asp?wkr=RTS/TSGR-0225307v510">http://pda.etsi.org/pda/home.asp?wkr=RTS/TSGR-0225307v510</a>
T1 (ATIS)	T1.3GPP.25.307V510-2004	5.1.0	Approved	21/05/2004	<a href="https://www.atis.org/atis/docstore/search.asp?committee=S24">https://www.atis.org/atis/docstore/search.asp?committee=S24</a>
TTA	TTAT.3G-25.307(R5-5.1.0)	5.1.0	Approved	25/05/2004	<a href="http://www.tta.or.kr/standardDB/stnfile/TTAT.3G-25.307(R5-5.1.0).zip">http://www.tta.or.kr/standardDB/stnfile/TTAT.3G-25.307(R5-5.1.0).zip</a>
<b>Release 6</b>					
ETSI	ETSI TS 125 307	6.0.0	Published	14/01/2004	<a href="http://pda.etsi.org/pda/home.asp?wkr=RTS/TSGR-0225307v600">http://pda.etsi.org/pda/home.asp?wkr=RTS/TSGR-0225307v600</a>
T1 (ATIS)	T1.3GPP.25.307V600-2004	6.0.0	Approved	21/05/2004	<a href="https://www.atis.org/atis/docstore/search.asp?committee=S24">https://www.atis.org/atis/docstore/search.asp?committee=S24</a>
TTA	TTAT.3G-25.307(R6-6.0.0)	6.0.0	Approved	25/05/2004	<a href="http://www.tta.or.kr/standardDB/stnfile/TTAT.3G-25.307(R6-6.0.0).zip">http://www.tta.or.kr/standardDB/stnfile/TTAT.3G-25.307(R6-6.0.0).zip</a>

**5.3.2.2.8 25.308****UTRA High Speed Downlink Packet Access - Overall Description (Stage 2)**

This document is a technical specification of the overall support of High Speed Downlink Packet Access in UTRA.

SDO (2)	Document No.	Version	Status	Issued date	Location (1)
<b>Release 5</b>					
CCSA	CCSA-TSD-DS-25.308	540	Approved	01/07/2003	<a href="http://www.ccsa.org.cn/english/tc/files.php?docpath=/ITU-R/M.1457/M.1457-4/DS/">http://www.ccsa.org.cn/english/tc/files.php?docpath=/ITU-R/M.1457/M.1457-4/DS/</a>
ETSI	ETSI TS 125 308	5.4.0	Published	03/04/2003	<a href="http://pda.etsi.org/pda/home.asp?wkr=RTS/TSGR-0225308v540">http://pda.etsi.org/pda/home.asp?wkr=RTS/TSGR-0225308v540</a>
T1 (ATIS)	T1.3GPP.25.308V540-2004	5.4.0	Approved	21/05/2004	<a href="https://www.atis.org/atis/docstore/search.asp?committee=S24">https://www.atis.org/atis/docstore/search.asp?committee=S24</a>
TTA	TTAT.3G-25.308(R5-5.4.0)	5.4.0	Approved	25/05/2004	<a href="http://www.tta.or.kr/standardDB/stnfile/TTAT.3G-25.308(R5-5.4.0).zip">http://www.tta.or.kr/standardDB/stnfile/TTAT.3G-25.308(R5-5.4.0).zip</a>

**Release 6**

ETSI	ETSI TS 125 308	6.0.0	Published	14/01/2004	<a href="http://pda.etsi.org/pda/home.asp?wkr=RTS/TSGR-0225308v600">http://pda.etsi.org/pda/home.asp?wkr=RTS/TSGR-0225308v600</a>
T1 (ATIS)	T1.3GPP.25.308V600-2004	6.0.0	Approved	21/05/2004	<a href="https://www.atis.org/atis/docstore/search.asp?committee=S24">https://www.atis.org/atis/docstore/search.asp?committee=S24</a>
TTA	TTAT.3G-25.308(R6-6.0.0)	6.0.0	Approved	25/05/2004	<a href="http://www.tta.or.kr/standardDB/stnfile/TTAT.3G-25.308(R6-6.0.0).zip">http://www.tta.or.kr/standardDB/stnfile/TTAT.3G-25.308(R6-6.0.0).zip</a>

**5.3.2.2.9 25.321****Medium access control (MAC) protocol specification**

This specification describes the MAC protocol.

SDO (2)	Document No.	Version	Status	Issued date	Location (1)
<b>Release 99</b>					
CCSA	CCSA-TSD-DS-25.321	3F0	Approved	01/07/2003	<a href="http://www.ccsa.org.cn/english/tc/files.php?docpath=/ITU-R/M.1457/M.1457-4/DS/">http://www.ccsa.org.cn/english/tc/files.php?docpath=/ITU-R/M.1457/M.1457-4/DS/</a>
ETSI	ETSI TS 125 321	3.16.0	Published	09/10/2003	<a href="http://pda.etsi.org/pda/home.asp?wkr=RTS/TSGR-0225321v3g0">http://pda.etsi.org/pda/home.asp?wkr=RTS/TSGR-0225321v3g0</a>
T1 (ATIS)	T1.3GPP.25.321V3160-2004	3.16.0	Approved	21/05/2004	<a href="https://www.atis.org/atis/docstore/search.asp?committee=S24">https://www.atis.org/atis/docstore/search.asp?committee=S24</a>
TTA	TTAT.3G-25.321(R99-3.16.0)	3.16.0	Approved	25/05/2004	<a href="http://www.tta.or.kr/standardDB/stnfile/TTAT.3G-25.321(R99-3.16.0).zip">http://www.tta.or.kr/standardDB/stnfile/TTAT.3G-25.321(R99-3.16.0).zip</a>
<b>Release 4</b>					
CCSA	CCSA-TSD-DS-25.321	480	Approved	01/07/2003	<a href="http://www.ccsa.org.cn/english/tc/files.php?docpath=/ITU-R/M.1457/M.1457-4/DS/">http://www.ccsa.org.cn/english/tc/files.php?docpath=/ITU-R/M.1457/M.1457-4/DS/</a>
ETSI	ETSI TS 125 321	4.9.0	Published	09/10/2003	<a href="http://pda.etsi.org/pda/home.asp?wkr=RTS/TSGR-0225321v490">http://pda.etsi.org/pda/home.asp?wkr=RTS/TSGR-0225321v490</a>
T1 (ATIS)	T1.3GPP.25.321V490-2004	4.9.0	Approved	21/05/2004	<a href="https://www.atis.org/atis/docstore/search.asp?committee=S24">https://www.atis.org/atis/docstore/search.asp?committee=S24</a>
TTA	TTAT.3G-25.321(R4-4.9.0)	4.9.0	Approved	25/05/2004	<a href="http://www.tta.or.kr/standardDB/stnfile/TTAT.3G-25.321(R4-4.9.0).zip">http://www.tta.or.kr/standardDB/stnfile/TTAT.3G-25.321(R4-4.9.0).zip</a>
<b>Release 5</b>					
CCSA	CCSA-TSD-DS-25.321	550	Approved	01/07/2003	<a href="http://www.ccsa.org.cn/english/tc/files.php?docpath=/ITU-R/M.1457/M.1457-4/DS/">http://www.ccsa.org.cn/english/tc/files.php?docpath=/ITU-R/M.1457/M.1457-4/DS/</a>
ETSI	ETSI TS 125 321	5.7.0	Published	14/01/2004	<a href="http://pda.etsi.org/pda/home.asp?wkr=RTS/TSGR-0225321v570">http://pda.etsi.org/pda/home.asp?wkr=RTS/TSGR-0225321v570</a>
T1 (ATIS)	T1.3GPP.25.321V570-2004	5.7.0	Approved	21/05/2004	<a href="https://www.atis.org/atis/docstore/search.asp?committee=S24">https://www.atis.org/atis/docstore/search.asp?committee=S24</a>
TTA	TTAT.3G-25.321(R5-5.7.0)	5.7.0	Approved	25/05/2004	<a href="http://www.tta.or.kr/standardDB/stnfile/TTAT.3G-25.321(R5-5.7.0).zip">http://www.tta.or.kr/standardDB/stnfile/TTAT.3G-25.321(R5-5.7.0).zip</a>
<b>Release 6</b>					
ETSI	ETSI TS 125 321	6.0.0	Published	14/01/2004	<a href="http://pda.etsi.org/pda/home.asp?wkr=RTS/TSGR-0225321v600">http://pda.etsi.org/pda/home.asp?wkr=RTS/TSGR-0225321v600</a>
T1 (ATIS)	T1.3GPP.25.321V600-2004	6.0.0	Approved	21/05/2004	<a href="https://www.atis.org/atis/docstore/search.asp?committee=S24">https://www.atis.org/atis/docstore/search.asp?committee=S24</a>
TTA	TTAT.3G-25.321(R6-6.0.0)	6.0.0	Approved	25/05/2004	<a href="http://www.tta.or.kr/standardDB/stnfile/TTAT.3G-25.321(R6-6.0.0).zip">http://www.tta.or.kr/standardDB/stnfile/TTAT.3G-25.321(R6-6.0.0).zip</a>

**5.3.2.2.10 25.322****Radio link control (RLC) protocol specification**

This specification describes the RLC protocol.

SDO (2)	Document No.	Version	Status	Issued date	Location (1)
<b>Release 99</b>					
CCSA	CCSA-TSD-DS-25.322	3F0	Approved	01/07/2003	<a href="http://www.ccsa.org.cn/english/tc/files.php?docpath=/ITU-R/M.1457/M.1457-4/DS/">http://www.ccsa.org.cn/english/tc/files.php?docpath=/ITU-R/M.1457/M.1457-4/DS/</a>
ETSI	ETSI TS 125 322	3.17.0	Published	16/01/2004	<a href="http://pda.etsi.org/pda/home.asp?wkr=RTS/TSGR-0225322v3h0">http://pda.etsi.org/pda/home.asp?wkr=RTS/TSGR-0225322v3h0</a>
T1 (ATIS)	T1.3GPP.25.322V31720-2004	3.17.0	Approved	21/05/2004	<a href="https://www.atis.org/atis/docstore/search.asp?committee=S24">https://www.atis.org/atis/docstore/search.asp?committee=S24</a>
TTA	TTAT.3G-25.322(R99-3.17.0)	3.17.0	Approved	25/05/2004	<a href="http://www.tta.or.kr/standardDB/stnfile/TTAT.3G-25.322(R99-3.17.0).zip">http://www.tta.or.kr/standardDB/stnfile/TTAT.3G-25.322(R99-3.17.0).zip</a>
<b>Release 4</b>					
CCSA	CCSA-TSD-DS-25.322	490	Approved	01/07/2003	<a href="http://www.ccsa.org.cn/english/tc/files.php?docpath=/ITU-R/M.1457/M.1457-4/DS/">http://www.ccsa.org.cn/english/tc/files.php?docpath=/ITU-R/M.1457/M.1457-4/DS/</a>
ETSI	ETSI TS 125 322	4.11.0	Published	16/01/2004	<a href="http://pda.etsi.org/pda/home.asp?wkr=RTS/TSGR-0225322v4b0">http://pda.etsi.org/pda/home.asp?wkr=RTS/TSGR-0225322v4b0</a>
T1 (ATIS)	T1.3GPP.25.322V4110-2004	4.11.0	Approved	21/05/2004	<a href="https://www.atis.org/atis/docstore/search.asp?committee=S24">https://www.atis.org/atis/docstore/search.asp?committee=S24</a>
TTA	TTAT.3G-25.322(R4-4.11.0)	4.11.0	Approved	25/05/2004	<a href="http://www.tta.or.kr/standardDB/stnfile/TTAT.3G-25.322(R4-4.11.0).zip">http://www.tta.or.kr/standardDB/stnfile/TTAT.3G-25.322(R4-4.11.0).zip</a>
<b>Release 5</b>					
CCSA	CCSA-TSD-DS-25.322	550	Approved	01/07/2003	<a href="http://www.ccsa.org.cn/english/tc/files.php?docpath=/ITU-R/M.1457/M.1457-4/DS/">http://www.ccsa.org.cn/english/tc/files.php?docpath=/ITU-R/M.1457/M.1457-4/DS/</a>
ETSI	ETSI TS 125 322	5.7.0	Published	16/01/2004	<a href="http://pda.etsi.org/pda/home.asp?wkr=RTS/TSGR-0225322v570">http://pda.etsi.org/pda/home.asp?wkr=RTS/TSGR-0225322v570</a>
T1 (ATIS)	T1.3GPP.25.322V570-2004	5.7.0	Approved	21/05/2004	<a href="https://www.atis.org/atis/docstore/search.asp?committee=S24">https://www.atis.org/atis/docstore/search.asp?committee=S24</a>
TTA	TTAT.3G-25.322(R5-5.7.0)	5.7.0	Approved	25/05/2004	<a href="http://www.tta.or.kr/standardDB/stnfile/TTAT.3G-25.322(R5-5.7.0).zip">http://www.tta.or.kr/standardDB/stnfile/TTAT.3G-25.322(R5-5.7.0).zip</a>
<b>Release 6</b>					
ETSI	ETSI TS 125 322	6.0.0	Published	16/01/2004	<a href="http://pda.etsi.org/pda/home.asp?wkr=RTS/TSGR-0225322v600">http://pda.etsi.org/pda/home.asp?wkr=RTS/TSGR-0225322v600</a>
T1 (ATIS)	T1.3GPP.25.322V600-2004	6.0.0	Approved	21/05/2004	<a href="https://www.atis.org/atis/docstore/search.asp?committee=S24">https://www.atis.org/atis/docstore/search.asp?committee=S24</a>
TTA	TTAT.3G-25.322(R6-6.0.0)	6.0.0	Approved	25/05/2004	<a href="http://www.tta.or.kr/standardDB/stnfile/TTAT.3G-25.322(R6-6.0.0).zip">http://www.tta.or.kr/standardDB/stnfile/TTAT.3G-25.322(R6-6.0.0).zip</a>

### 5.3.2.2.11 25.323

#### Packet Data Convergence Protocol (PDCP) protocol

This document provides the description of the Packet Data Convergence Protocol (PDCP). PDCP provides its services to the NAS at the UE or the relay at the Radio Network Controller (RNC). PDCP uses the services provided by the Radio Link Control (RLC) sublayer.

SDO (2)	Document No.	Version	Status	Issued date	Location (1)
<b>Release 99</b>					
CCSA	CCSA-TSD-DS-25.323	3A0	Approved	01/07/2003	<a href="http://www.ccsa.org.cn/english/tc/files.php?docpath=/ITU-R/M.1457/M.1457-4/DS/">http://www.ccsa.org.cn/english/tc/files.php?docpath=/ITU-R/M.1457/M.1457-4/DS/</a>
ETSI	ETSI TS 125 323	3.10.0	Published	07/10/2002	<a href="http://pda.etsi.org/pda/home.asp?wkr=RTS/TSGR-0225323v3a0">http://pda.etsi.org/pda/home.asp?wkr=RTS/TSGR-0225323v3a0</a>
T1 (ATIS)	T1.3GPP.25.323V3100-2003	3.10.0	Approved	27/03/2003	<a href="https://www.atis.org/atis/docstore/search.asp?committee=S24">https://www.atis.org/atis/docstore/search.asp?committee=S24</a>
TTA	TTAT.3G-25.323(R99-3.10.0)	3.10.0	Approved	21/03/2003	<a href="http://www.tta.or.kr/standardDB/stnfile/TTAT.3G-25.323(R99-3.10.0).zip">http://www.tta.or.kr/standardDB/stnfile/TTAT.3G-25.323(R99-3.10.0).zip</a>
<b>Release 4</b>					
CCSA	CCSA-TSD-DS-25.323	460	Approved	01/07/2003	<a href="http://www.ccsa.org.cn/english/tc/files.php?docpath=/ITU-R/M.1457/M.1457-4/DS/">http://www.ccsa.org.cn/english/tc/files.php?docpath=/ITU-R/M.1457/M.1457-4/DS/</a>
ETSI	ETSI TS 125 323	4.6.0	Published	07/10/2002	<a href="http://pda.etsi.org/pda/home.asp?wkr=RTS/TSGR-0225323v460">http://pda.etsi.org/pda/home.asp?wkr=RTS/TSGR-0225323v460</a>
T1 (ATIS)	T1.3GPP.25.323V460-2003	4.6.0	Approved	27/03/2003	<a href="https://www.atis.org/atis/docstore/search.asp?committee=S24">https://www.atis.org/atis/docstore/search.asp?committee=S24</a>
TTA	TTAT.3G-25.323(R4-4.6.0)	4.6.0	Approved	21/03/2003	<a href="http://www.tta.or.kr/standardDB/stnfile/TTAT.3G-25.323(R4-4.6.0).zip">http://www.tta.or.kr/standardDB/stnfile/TTAT.3G-25.323(R4-4.6.0).zip</a>

**Release 5**

CCSA	CCSA-TSD-DS-25.323	520	Approved	01/07/2003	<a href="http://www.ccsa.org.cn/english/tc/files.php?docpath=/ITU-R/M.1457/M.1457-4/DS/">http://www.ccsa.org.cn/english/tc/files.php?docpath=/ITU-R/M.1457/M.1457-4/DS/</a>
ETSI	ETSI TS 125 323	5.2.0	Published	07/10/2002	<a href="http://pda.etsi.org/pda/home.asp?wkr=RTS/TSGR-0225323v520">http://pda.etsi.org/pda/home.asp?wkr=RTS/TSGR-0225323v520</a>
T1 (ATIS)	T1.3GPP.25.323V520-2003	5.2.0	Approved	27/03/2003	<a href="https://www.atis.org/atis/docstore/search.asp?committee=S24">https://www.atis.org/atis/docstore/search.asp?committee=S24</a>
TTA	TTAT.3G-25.323(R5-5.2.0)	5.2.0	Approved	21/03/2003	<a href="http://www.tta.or.kr/standardDB/stnfile/TTAT.3G-25.323(R5-5.2.0).zip">http://www.tta.or.kr/standardDB/stnfile/TTAT.3G-25.323(R5-5.2.0).zip</a>

**Release 6**

ETSI	ETSI TS 125 323	6.0.0	Published	16/01/2004	<a href="http://pda.etsi.org/pda/home.asp?wkr=RTS/TSGR-0225323v600">http://pda.etsi.org/pda/home.asp?wkr=RTS/TSGR-0225323v600</a>
T1 (ATIS)	T1.3GPP.25.323V600-2004	6.0.0	Approved	21/05/2004	<a href="https://www.atis.org/atis/docstore/search.asp?committee=S24">https://www.atis.org/atis/docstore/search.asp?committee=S24</a>
TTA	TTAT.3G-25.323(R6-6.0.0)	6.0.0	Approved	25/05/2004	<a href="http://www.tta.or.kr/standardDB/stnfile/TTAT.3G-25.323(R6-6.0.0).zip">http://www.tta.or.kr/standardDB/stnfile/TTAT.3G-25.323(R6-6.0.0).zip</a>

**5.3.2.2.12 25.324****Broadcast/Multicast Control (BMC) Services**

This document provides the description of the Broadcast/Multicast Control Protocol (BMC). This protocol adapts broadcast and multicast services on the radio interface.

SDO (2)	Document No.	Version	Status	Issued date	Location (1)
<b>Release 99</b>					
CCSA	CCSA-TSD-DS-25.324	370	Approved	01/07/2003	<a href="http://www.ccsa.org.cn/english/tc/files.php?docpath=/ITU-R/M.1457/M.1457-4/DS/">http://www.ccsa.org.cn/english/tc/files.php?docpath=/ITU-R/M.1457/M.1457-4/DS/</a>
ETSI	ETSI TS 125 324	3.7.0	Published	03/04/2003	<a href="http://pda.etsi.org/pda/home.asp?wkr=RTS/TSGR-0225324v370">http://pda.etsi.org/pda/home.asp?wkr=RTS/TSGR-0225324v370</a>
T1 (ATIS)	T1.3GPP.25.324V370-2004	3.7.0	Approved	21/05/2004	<a href="https://www.atis.org/atis/docstore/search.asp?committee=S24">https://www.atis.org/atis/docstore/search.asp?committee=S24</a>
TTA	TTAT.3G-25.324(R99-3.7.0)	3.7.0	Approved	25/05/2004	<a href="http://www.tta.or.kr/standardDB/stnfile/TTAT.3G-25.324(R99-3.7.0).zip">http://www.tta.or.kr/standardDB/stnfile/TTAT.3G-25.324(R99-3.7.0).zip</a>
<b>Release 4</b>					
CCSA	CCSA-TSD-DS-25.324	430	Approved	01/07/2003	<a href="http://www.ccsa.org.cn/english/tc/files.php?docpath=/ITU-R/M.1457/M.1457-4/DS/">http://www.ccsa.org.cn/english/tc/files.php?docpath=/ITU-R/M.1457/M.1457-4/DS/</a>
ETSI	ETSI TS 125 324	4.3.0	Published	03/04/2003	<a href="http://pda.etsi.org/pda/home.asp?wkr=RTS/TSGR-0225324v430">http://pda.etsi.org/pda/home.asp?wkr=RTS/TSGR-0225324v430</a>
T1 (ATIS)	T1.3GPP.25.324V430-2004	4.3.0	Approved	21/05/2004	<a href="https://www.atis.org/atis/docstore/search.asp?committee=S24">https://www.atis.org/atis/docstore/search.asp?committee=S24</a>
TTA	TTAT.3G-25.324(R4-4.3.0)	4.3.0	Approved	25/05/2004	<a href="http://www.tta.or.kr/standardDB/stnfile/TTAT.3G-25.324(R4-4.3.0).zip">http://www.tta.or.kr/standardDB/stnfile/TTAT.3G-25.324(R4-4.3.0).zip</a>
<b>Release 5</b>					
CCSA	CCSA-TSD-DS-25.324	530	Approved	01/07/2003	<a href="http://www.ccsa.org.cn/english/tc/files.php?docpath=/ITU-R/M.1457/M.1457-4/DS/">http://www.ccsa.org.cn/english/tc/files.php?docpath=/ITU-R/M.1457/M.1457-4/DS/</a>
ETSI	ETSI TS 125 324	5.3.0	Published	03/04/2003	<a href="http://pda.etsi.org/pda/home.asp?wkr=RTS/TSGR-0225324v530">http://pda.etsi.org/pda/home.asp?wkr=RTS/TSGR-0225324v530</a>
T1 (ATIS)	T1.3GPP.25.324V530-2004	5.3.0	Approved	21/05/2004	<a href="https://www.atis.org/atis/docstore/search.asp?committee=S24">https://www.atis.org/atis/docstore/search.asp?committee=S24</a>
TTA	TTAT.3G-25.324(R5-5.3.0)	5.3.0	Approved	25/05/2004	<a href="http://www.tta.or.kr/standardDB/stnfile/TTAT.3G-25.324(R5-5.3.0).zip">http://www.tta.or.kr/standardDB/stnfile/TTAT.3G-25.324(R5-5.3.0).zip</a>
<b>Release 6</b>					
ETSI	ETSI TS 125 324	6.0.0	Published	16/01/2004	<a href="http://pda.etsi.org/pda/home.asp?wkr=RTS/TSGR-0225324v600">http://pda.etsi.org/pda/home.asp?wkr=RTS/TSGR-0225324v600</a>
T1 (ATIS)	T1.3GPP.25.324V600-2004	6.0.0	Approved	21/05/2004	<a href="https://www.atis.org/atis/docstore/search.asp?committee=S24">https://www.atis.org/atis/docstore/search.asp?committee=S24</a>
TTA	TTAT.3G-25.324(R6-6.0.0)	6.0.0	Approved	25/05/2004	<a href="http://www.tta.or.kr/standardDB/stnfile/TTAT.3G-25.324(R6-6.0.0).zip">http://www.tta.or.kr/standardDB/stnfile/TTAT.3G-25.324(R6-6.0.0).zip</a>

**5.3.2.2.13** 25.331**Radio resource control (RRC) protocol specification**

This specification describes the RRC protocol for the radio system. The scope of this specification contains also the information to be transported in a transparent container between source RNC and target RNC in connection to SRNC relocation.

SDO (2)	Document No.	Version	Status	Issued date	Location (1)
<b>Release 99</b>					
CCSA	CCSA-TSD-DS-25.331	3F0	Approved	01/07/2003	<a href="http://www.ccsa.org.cn/english/tc/files.php?docpath=/ITU-R/M.1457/M.1457-4/DS/">http://www.ccsa.org.cn/english/tc/files.php?docpath=/ITU-R/M.1457/M.1457-4/DS/</a>
ETSI	ETSI TS 125 331	3.17.0	Published	16/01/2004	<a href="http://pda.etsi.org/pda/home.asp?wkr=RTS/TSGR-0225331v3h0">http://pda.etsi.org/pda/home.asp?wkr=RTS/TSGR-0225331v3h0</a>
T1 (ATIS)	T1.3GPP.25.331V3170-2004	3.17.0	Approved	21/05/2004	<a href="https://www.atis.org/atis/docstore/search.asp?committee=S24">https://www.atis.org/atis/docstore/search.asp?committee=S24</a>
TTA	TTAT.3G-25.331(R99-3.17.0)	3.17.0	Approved	25/05/2004	<a href="http://www.tta.or.kr/standardDB/stnfile/TTAT.3G-25.331(R99-3.17.0).zip">http://www.tta.or.kr/standardDB/stnfile/TTAT.3G-25.331(R99-3.17.0).zip</a>
<b>Release 4</b>					
CCSA	CCSA-TSD-DS-25.331	4A0	Approved	01/07/2003	<a href="http://www.ccsa.org.cn/english/tc/files.php?docpath=/ITU-R/M.1457/M.1457-4/DS/">http://www.ccsa.org.cn/english/tc/files.php?docpath=/ITU-R/M.1457/M.1457-4/DS/</a>
ETSI	ETSI TS 125 331	4.12.0	Published	19/01/2004	<a href="http://pda.etsi.org/pda/home.asp?wkr=RTS/TSGR-0225331v4c0">http://pda.etsi.org/pda/home.asp?wkr=RTS/TSGR-0225331v4c0</a>
T1 (ATIS)	T1.3GPP.25.331V4120-2004	4.12.0	Approved	21/05/2004	<a href="https://www.atis.org/atis/docstore/search.asp?committee=S24">https://www.atis.org/atis/docstore/search.asp?committee=S24</a>
TTA	TTAT.3G-25.331(R4-4.12.0)	4.12.0	Approved	25/05/2004	<a href="http://www.tta.or.kr/standardDB/stnfile/TTAT.3G-25.331(R4-4.12.0).zip">http://www.tta.or.kr/standardDB/stnfile/TTAT.3G-25.331(R4-4.12.0).zip</a>
<b>Release 5</b>					
CCSA	CCSA-TSD-DS-25.331	550	Approved	01/07/2003	<a href="http://www.ccsa.org.cn/english/tc/files.php?docpath=/ITU-R/M.1457/M.1457-4/DS/">http://www.ccsa.org.cn/english/tc/files.php?docpath=/ITU-R/M.1457/M.1457-4/DS/</a>
ETSI	ETSI TS 125 331	5.7.1	Published	26/01/2004	<a href="http://pda.etsi.org/pda/home.asp?wkr=RTS/TSGR-0225331v571">http://pda.etsi.org/pda/home.asp?wkr=RTS/TSGR-0225331v571</a>
T1 (ATIS)	T1.3GPP.25.331V571-2004	5.7.1	Approved	21/05/2004	<a href="https://www.atis.org/atis/docstore/search.asp?committee=S24">https://www.atis.org/atis/docstore/search.asp?committee=S24</a>
TTA	TTAT.3G-25.331(R5-5.7.1)	5.7.1	Approved	25/05/2004	<a href="http://www.tta.or.kr/standardDB/stnfile/TTAT.3G-25.331(R5-5.7.1).zip">http://www.tta.or.kr/standardDB/stnfile/TTAT.3G-25.331(R5-5.7.1).zip</a>
<b>Release 6</b>					
ETSI	ETSI TS 125 331	6.0.1	Published	26/01/2004	<a href="http://pda.etsi.org/pda/home.asp?wkr=RTS/TSGR-0225331v601">http://pda.etsi.org/pda/home.asp?wkr=RTS/TSGR-0225331v601</a>
T1 (ATIS)	T1.3GPP.25.331V601-2004	6.0.1	Approved	21/05/2004	<a href="https://www.atis.org/atis/docstore/search.asp?committee=S24">https://www.atis.org/atis/docstore/search.asp?committee=S24</a>
TTA	TTAT.3G-25.331(R6-6.0.1)	6.0.1	Approved	25/05/2004	<a href="http://www.tta.or.kr/standardDB/stnfile/TTAT.3G-25.331(R6-6.0.1).zip">http://www.tta.or.kr/standardDB/stnfile/TTAT.3G-25.331(R6-6.0.1).zip</a>

**5.3.2.3****25.400 series****5.3.2.3.1** 25.401**UTRAN overall description**

This specification describes the overall architecture of the UTRAN, including internal interfaces and assumptions on the radio and Iu interfaces.

SDO (2)	Document No.	Version	Status	Issued date	Location (1)
<b>Release 99</b>					
CCSA	CCSA-TSD-DS-25.401	3A0	Approved	01/07/2003	<a href="http://www.ccsa.org.cn/english/tc/files.php?docpath=/ITU-R/M.1457/M.1457-4/DS/">http://www.ccsa.org.cn/english/tc/files.php?docpath=/ITU-R/M.1457/M.1457-4/DS/</a>
ETSI	ETSI TS 125 401	3.10.0	Published	10/07/2002	<a href="http://pda.etsi.org/pda/home.asp?wkr=RTS/TSGR-0325401v3a0">http://pda.etsi.org/pda/home.asp?wkr=RTS/TSGR-0325401v3a0</a>
T1 (ATIS)	T1.3GPP.25.401V3100-2003	3.10.0	Approved	27/03/2003	<a href="https://www.atis.org/atis/docstore/search.asp?committee=S24">https://www.atis.org/atis/docstore/search.asp?committee=S24</a>

TTA	TTAT.3G-25.401(R99-3.10.0)	3.10.0	Approved	21/03/2003	<a href="http://www.tta.or.kr/standardDB/stnfile/TTAT.3G-25.401(R99-3.10.0).zip">http://www.tta.or.kr/standardDB/stnfile/TTAT.3G-25.401(R99-3.10.0).zip</a>
<b>Release 4</b>					
CCSA	CCSA-TSD-DS-25.401	460	Approved	01/07/2003	<a href="http://www.ccsa.org.cn/english/tc/files.php?docpath=/ITU-R/M.1457/M.1457-4/DS/">http://www.ccsa.org.cn/english/tc/files.php?docpath=/ITU-R/M.1457/M.1457-4/DS/</a>
ETSI	ETSI TS 125 401	4.6.0	Published	08/01/2003	<a href="http://pda.etsi.org/pda/home.asp?wkr=RTS/TSGR-0325401v460">http://pda.etsi.org/pda/home.asp?wkr=RTS/TSGR-0325401v460</a>
T1 (ATIS)	T1.3GPP.25.401V460-2003	4.6.0	Approved	27/03/2003	<a href="https://www.atis.org/atis/docstore/search.asp?committee=S24">https://www.atis.org/atis/docstore/search.asp?committee=S24</a>
TTA	TTAT.3G-25.401(R4-4.6.0)	4.6.0	Approved	21/03/2003	<a href="http://www.tta.or.kr/standardDB/stnfile/TTAT.3G-25.401(R4-4.6.0).zip">http://www.tta.or.kr/standardDB/stnfile/TTAT.3G-25.401(R4-4.6.0).zip</a>
<b>Release 5</b>					
CCSA	CCSA-TSD-DS-25.401	560	Approved	01/07/2003	<a href="http://www.ccsa.org.cn/english/tc/files.php?docpath=/ITU-R/M.1457/M.1457-4/DS/">http://www.ccsa.org.cn/english/tc/files.php?docpath=/ITU-R/M.1457/M.1457-4/DS/</a>
ETSI	ETSI TS 125 401	5.7.0	Published	19/01/2004	<a href="http://pda.etsi.org/pda/home.asp?wkr=RTS/TSGR-0325401v570">http://pda.etsi.org/pda/home.asp?wkr=RTS/TSGR-0325401v570</a>
T1 (ATIS)	T1.3GPP.25.401V570-2004	5.7.0	Approved	21/05/2004	<a href="https://www.atis.org/atis/docstore/search.asp?committee=S24">https://www.atis.org/atis/docstore/search.asp?committee=S24</a>
TTA	TTAT.3G-25.401(R5-5.7.0)	5.7.0	Approved	25/05/2004	<a href="http://www.tta.or.kr/standardDB/stnfile/TTAT.3G-25.401(R5-5.7.0).zip">http://www.tta.or.kr/standardDB/stnfile/TTAT.3G-25.401(R5-5.7.0).zip</a>
<b>Release 6</b>					
CCSA	CCSA-TSD-DS-25.401	610	Approved	01/07/2003	<a href="http://www.ccsa.org.cn/english/tc/files.php?docpath=/ITU-R/M.1457/M.1457-4/DS/">http://www.ccsa.org.cn/english/tc/files.php?docpath=/ITU-R/M.1457/M.1457-4/DS/</a>
ETSI	ETSI TS 125 401	6.2.0	Published	19/01/2004	<a href="http://pda.etsi.org/pda/home.asp?wkr=RTS/TSGR-0325401v620">http://pda.etsi.org/pda/home.asp?wkr=RTS/TSGR-0325401v620</a>
T1 (ATIS)	T1.3GPP.25.401V620-2004	6.2.0	Approved	21/05/2004	<a href="https://www.atis.org/atis/docstore/search.asp?committee=S24">https://www.atis.org/atis/docstore/search.asp?committee=S24</a>
TTA	TTAT.3G-25.401(R6-6.2.0)	6.2.0	Approved	25/05/2004	<a href="http://www.tta.or.kr/standardDB/stnfile/TTAT.3G-25.401(R6-6.2.0).zip">http://www.tta.or.kr/standardDB/stnfile/TTAT.3G-25.401(R6-6.2.0).zip</a>

### 5.3.2.3.2 25.402

#### Synchronization in UTRAN Stage 2

This document constitutes the stage 2 specification of different synchronisation mechanisms in UTRAN and on Uu.

SDO (2)	Document No.	Version	Status	Issued date	Location (1)
<b>Release 99</b>					
CCSA	CCSA-TSD-DS-25.402	3A0	Approved	01/07/2003	<a href="http://www.ccsa.org.cn/english/tc/files.php?docpath=/ITU-R/M.1457/M.1457-4/DS/">http://www.ccsa.org.cn/english/tc/files.php?docpath=/ITU-R/M.1457/M.1457-4/DS/</a>
ETSI	ETSI TS 125 402	3.10.0	Published	10/07/2002	<a href="http://pda.etsi.org/pda/home.asp?wkr=RTS/TSGR-0325402v3a0">http://pda.etsi.org/pda/home.asp?wkr=RTS/TSGR-0325402v3a0</a>
T1 (ATIS)	T1.3GPP.25.402V3100-2003	3.10.0	Approved	27/03/2003	<a href="https://www.atis.org/atis/docstore/search.asp?committee=S24">https://www.atis.org/atis/docstore/search.asp?committee=S24</a>
TTA	TTAT.3G-25.402(R99-3.10.0)	3.10.0	Approved	21/03/2003	<a href="http://www.tta.or.kr/standardDB/stnfile/TTAT.3G-25.402(R99-3.10.0).zip">http://www.tta.or.kr/standardDB/stnfile/TTAT.3G-25.402(R99-3.10.0).zip</a>
<b>Release 4</b>					
CCSA	CCSA-TSD-DS-25.402	460	Approved	01/07/2003	<a href="http://www.ccsa.org.cn/english/tc/files.php?docpath=/ITU-R/M.1457/M.1457-4/DS/">http://www.ccsa.org.cn/english/tc/files.php?docpath=/ITU-R/M.1457/M.1457-4/DS/</a>
ETSI	ETSI TS 125 402	4.6.0	Published	08/01/2003	<a href="http://pda.etsi.org/pda/home.asp?wkr=RTS/TSGR-0325402v460">http://pda.etsi.org/pda/home.asp?wkr=RTS/TSGR-0325402v460</a>
T1 (ATIS)	T1.3GPP.25.402V460-2003	4.6.0	Approved	27/03/2003	<a href="https://www.atis.org/atis/docstore/search.asp?committee=S24">https://www.atis.org/atis/docstore/search.asp?committee=S24</a>
TTA	TTAT.3G-25.402(R4-4.6.0)	4.6.0	Approved	21/03/2003	<a href="http://www.tta.or.kr/standardDB/stnfile/TTAT.3G-25.402(R4-4.6.0).zip">http://www.tta.or.kr/standardDB/stnfile/TTAT.3G-25.402(R4-4.6.0).zip</a>
<b>Release 5</b>					
CCSA	CCSA-TSD-DS-25.402	520	Approved	01/07/2003	<a href="http://www.ccsa.org.cn/english/tc/files.php?docpath=/ITU-R/M.1457/M.1457-4/DS/">http://www.ccsa.org.cn/english/tc/files.php?docpath=/ITU-R/M.1457/M.1457-4/DS/</a>
ETSI	ETSI TS 125 402	5.3.0	Published	19/01/2004	<a href="http://pda.etsi.org/pda/home.asp?wkr=RTS/TSGR-0325402v530">http://pda.etsi.org/pda/home.asp?wkr=RTS/TSGR-0325402v530</a>
T1 (ATIS)	T1.3GPP.25.402V530-2004	5.3.0	Approved	21/05/2004	<a href="https://www.atis.org/atis/docstore/search.asp?committee=S24">https://www.atis.org/atis/docstore/search.asp?committee=S24</a>
TTA	TTAT.3G-25.402(R5-5.3.0)	5.3.0	Approved	25/05/2004	<a href="http://www.tta.or.kr/standardDB/stnfile/TTAT.3G-25.402(R5-5.3.0).zip">http://www.tta.or.kr/standardDB/stnfile/TTAT.3G-25.402(R5-5.3.0).zip</a>

**Release 6**

ETSI	ETSI TS 125 402	6.0.0	Published	19/01/2004	<a href="http://pda.etsi.org/pda/home.asp?wkr=RTS/TSGR-0325402v600">http://pda.etsi.org/pda/home.asp?wkr=RTS/TSGR-0325402v600</a>
T1 (ATIS)	T1.3GPP.25.402V600-2004	6.0.0	Approved	21/05/2004	<a href="https://www.atis.org/atis/docstore/search.asp?committee=S24">https://www.atis.org/atis/docstore/search.asp?committee=S24</a>
TTA	TTAT.3G-25.402(R6-6.0.0)	6.0.0	Approved	25/05/2004	<a href="http://www.tta.or.kr/standardDB/stnfile/TTAT.3G-25.402(R6-6.0.0).zip">http://www.tta.or.kr/standardDB/stnfile/TTAT.3G-25.402(R6-6.0.0).zip</a>

**5.3.2.3.3 25.410****UTRAN Iu interface: general aspects and principles**

This specification describes an introduction to the 25.41x series of technical specifications that define the Iu interface for the interconnection of RNC component of the UTRAN to the CN.

SDO (2)	Document No.	Version	Status	Issued date	Location (1)
<b>Release 99</b>					
CCSA	CCSA-TSD-DS-25.410	380	Approved	01/07/2003	<a href="http://www.ccsa.org.cn/english/tc/files.php?docpath=/ITU-R/M.1457/M.1457-4/DS/">http://www.ccsa.org.cn/english/tc/files.php?docpath=/ITU-R/M.1457/M.1457-4/DS/</a>
ETSI	ETSI TS 125 410	3.8.0	Published	14/10/2002	<a href="http://pda.etsi.org/pda/home.asp?wkr=RTS/TSGR-0325410v380">http://pda.etsi.org/pda/home.asp?wkr=RTS/TSGR-0325410v380</a>
T1 (ATIS)	T1.3GPP.25.410V380-2003	3.8.0	Approved	27/03/2003	<a href="https://www.atis.org/atis/docstore/search.asp?committee=S24">https://www.atis.org/atis/docstore/search.asp?committee=S24</a>
TTA	TTAT.3G-25.410(R99-3.8.0)	3.8.0	Approved	21/03/2003	<a href="http://www.tta.or.kr/standardDB/stnfile/TTAT.3G-25.410(R99-3.8.0).zip">http://www.tta.or.kr/standardDB/stnfile/TTAT.3G-25.410(R99-3.8.0).zip</a>
<b>Release 4</b>					
CCSA	CCSA-TSD-DS-25.410	450	Approved	01/07/2003	<a href="http://www.ccsa.org.cn/english/tc/files.php?docpath=/ITU-R/M.1457/M.1457-4/DS/">http://www.ccsa.org.cn/english/tc/files.php?docpath=/ITU-R/M.1457/M.1457-4/DS/</a>
ETSI	ETSI TS 125 410	4.5.0	Published	14/10/2002	<a href="http://pda.etsi.org/pda/home.asp?wkr=RTS/TSGR-0325410v450">http://pda.etsi.org/pda/home.asp?wkr=RTS/TSGR-0325410v450</a>
T1 (ATIS)	T1.3GPP.25.410V450-2003	4.5.0	Approved	27/03/2003	<a href="https://www.atis.org/atis/docstore/search.asp?committee=S24">https://www.atis.org/atis/docstore/search.asp?committee=S24</a>
TTA	TTAT.3G-25.410(R4-4.5.0)	4.5.0	Approved	21/03/2003	<a href="http://www.tta.or.kr/standardDB/stnfile/TTAT.3G-25.410(R4-4.5.0).zip">http://www.tta.or.kr/standardDB/stnfile/TTAT.3G-25.410(R4-4.5.0).zip</a>
<b>Release 5</b>					
CCSA	CCSA-TSD-DS-25.410	520	Approved	01/07/2003	<a href="http://www.ccsa.org.cn/english/tc/files.php?docpath=/ITU-R/M.1457/M.1457-4/DS/">http://www.ccsa.org.cn/english/tc/files.php?docpath=/ITU-R/M.1457/M.1457-4/DS/</a>
ETSI	ETSI TS 125 410	5.3.0	Published	08/01/2003	<a href="http://pda.etsi.org/pda/home.asp?wkr=RTS/TSGR-0325410v530">http://pda.etsi.org/pda/home.asp?wkr=RTS/TSGR-0325410v530</a>
T1 (ATIS)	T1.3GPP.25.410V530-2003	5.3.0	Approved	27/03/2003	<a href="https://www.atis.org/atis/docstore/search.asp?committee=S24">https://www.atis.org/atis/docstore/search.asp?committee=S24</a>
TTA	TTAT.3G-25.410(R5-5.3.0)	5.3.0	Approved	21/03/2003	<a href="http://www.tta.or.kr/standardDB/stnfile/TTAT.3G-25.410(R5-5.3.0).zip">http://www.tta.or.kr/standardDB/stnfile/TTAT.3G-25.410(R5-5.3.0).zip</a>
<b>Release 6</b>					
ETSI	ETSI TS 125 410	6.0.0	Published	19/01/2004	<a href="http://pda.etsi.org/pda/home.asp?wkr=RTS/TSGR-0325410v600">http://pda.etsi.org/pda/home.asp?wkr=RTS/TSGR-0325410v600</a>
T1 (ATIS)	T1.3GPP.25.410V600-2004	6.0.0	Approved	21/05/2004	<a href="https://www.atis.org/atis/docstore/search.asp?committee=S24">https://www.atis.org/atis/docstore/search.asp?committee=S24</a>
TTA	TTAT.3G-25.410(R6-6.0.0)	6.0.0	Approved	25/05/2004	<a href="http://www.tta.or.kr/standardDB/stnfile/TTAT.3G-25.410(R6-6.0.0).zip">http://www.tta.or.kr/standardDB/stnfile/TTAT.3G-25.410(R6-6.0.0).zip</a>

**5.3.2.3.4 25.411****UTRAN Iu interface Layer 1**

This specification describes the standards allowed to implement Layer 1 on the Iu interface. The specification of transmission delay requirements and O&M requirements are not in the scope of this specification.



SDO (2)	Document No.	Version	Status	Issued date	Location (1)
<b>Release 99</b>					
CCSA	CCSA-TSD-DS-25.411	350	Approved	01/07/2003	<a href="http://www.ccsa.org.cn/english/tc/files.php?docpath=/ITU-R/M.1457/M.1457-4/DS/">http://www.ccsa.org.cn/english/tc/files.php?docpath=/ITU-R/M.1457/M.1457-4/DS/</a>
ETSI	ETSI TS 125 411	3.5.0	Published	06/08/2001	<a href="http://pda.etsi.org/pda/home.asp?wkr=RTS/TSGR-0325411UR4">http://pda.etsi.org/pda/home.asp?wkr=RTS/TSGR-0325411UR4</a>
T1 (ATIS)	T1.3GPP.25.411V350-2002	3.5.0	Approved	03/05/2002	<a href="https://www.atis.org/atis/docstore/search.asp?committee=S24">https://www.atis.org/atis/docstore/search.asp?committee=S24</a>
TTA	TTAE.3G-25.411(R99-3.5.0)	3.5.0	Approved	29/05/2002	<a href="http://www.tta.or.kr/standardDB/stnfile/TTAE.3G-25.411(R99-3.5.0).zip">http://www.tta.or.kr/standardDB/stnfile/TTAE.3G-25.411(R99-3.5.0).zip</a>
<b>Release 4</b>					
CCSA	CCSA-TSD-DS-25.411	410	Approved	01/07/2003	<a href="http://www.ccsa.org.cn/english/tc/files.php?docpath=/ITU-R/M.1457/M.1457-4/DS/">http://www.ccsa.org.cn/english/tc/files.php?docpath=/ITU-R/M.1457/M.1457-4/DS/</a>
ETSI	ETSI TS 125 411	4.1.0	Published	06/08/2001	<a href="http://pda.etsi.org/pda/home.asp?wkr=RTS/TSGR-0325411Uv4R1">http://pda.etsi.org/pda/home.asp?wkr=RTS/TSGR-0325411Uv4R1</a>
T1 (ATIS)	T1.3GPP.25.411V410-2002	4.1.0	Approved	03/05/2002	<a href="https://www.atis.org/atis/docstore/search.asp?committee=S24">https://www.atis.org/atis/docstore/search.asp?committee=S24</a>
TTA	TTAE.3G-25.411(R4-4.1.0)	4.1.0	Approved	29/05/2002	<a href="http://www.tta.or.kr/standardDB/stnfile/TTAE.3G-25.411(R4-4.1.0).zip">http://www.tta.or.kr/standardDB/stnfile/TTAE.3G-25.411(R4-4.1.0).zip</a>
<b>Release 5</b>					
CCSA	CCSA-TSD-DS-25.411	500	Approved	01/07/2003	<a href="http://www.ccsa.org.cn/english/tc/files.php?docpath=/ITU-R/M.1457/M.1457-4/DS/">http://www.ccsa.org.cn/english/tc/files.php?docpath=/ITU-R/M.1457/M.1457-4/DS/</a>
ETSI	ETSI TS 125 411	5.0.0	Published	23/04/2002	<a href="http://pda.etsi.org/pda/home.asp?wkr=RTS/TSGR-0325411Uv5">http://pda.etsi.org/pda/home.asp?wkr=RTS/TSGR-0325411Uv5</a>
T1 (ATIS)	T1.3GPP.25.411V500-2002	5.0.0	Approved	03/05/2002	<a href="https://www.atis.org/atis/docstore/search.asp?committee=S24">https://www.atis.org/atis/docstore/search.asp?committee=S24</a>
TTA	TTAE.3G-25.411(R5-5.0.0)	5.0.0	Approved	29/05/2002	<a href="http://www.tta.or.kr/standardDB/stnfile/TTAE.3G-25.411(R5-5.0.0).zip">http://www.tta.or.kr/standardDB/stnfile/TTAE.3G-25.411(R5-5.0.0).zip</a>
<b>Release 6</b>					
ETSI	ETSI TS 125 411	6.0.0	Published	19/01/2004	<a href="http://pda.etsi.org/pda/home.asp?wkr=RTS/TSGR-0325411v600">http://pda.etsi.org/pda/home.asp?wkr=RTS/TSGR-0325411v600</a>
T1 (ATIS)	T1.3GPP.25.411V600-2004	6.0.0	Approved	21/05/2004	<a href="https://www.atis.org/atis/docstore/search.asp?committee=S24">https://www.atis.org/atis/docstore/search.asp?committee=S24</a>
TTA	TTAT.3G-25.411(R6-6.0.0)	6.0.0	Approved	25/05/2004	<a href="http://www.tta.or.kr/standardDB/stnfile/TTAT.3G-25.411(R6-6.0.0).zip">http://www.tta.or.kr/standardDB/stnfile/TTAT.3G-25.411(R6-6.0.0).zip</a>

### 5.3.2.3.5 25.412

#### UTRAN Iu interface signalling transport

This specification describes the standards for Signalling Transport to be used across Iu Interface.

SDO (2)	Document No.	Version	Status	Issued date	Location (1)
<b>Release 99</b>					
CCSA	CCSA-TSD-DS-25.412	360	Approved	01/07/2003	<a href="http://www.ccsa.org.cn/english/tc/files.php?docpath=/ITU-R/M.1457/M.1457-4/DS/">http://www.ccsa.org.cn/english/tc/files.php?docpath=/ITU-R/M.1457/M.1457-4/DS/</a>
ETSI	ETSI TS 125 412	3.6.0	Published	13/02/2001	<a href="http://pda.etsi.org/pda/home.asp?wkr=RTS/TSGR-0325412UR4">http://pda.etsi.org/pda/home.asp?wkr=RTS/TSGR-0325412UR4</a>
T1 (ATIS)	T1.3GPP.25.412V360-2002	3.6.0	Approved	03/05/2002	<a href="https://www.atis.org/atis/docstore/search.asp?committee=S24">https://www.atis.org/atis/docstore/search.asp?committee=S24</a>
TTA	TTAE.3G-25.412(R99-3.6.0)	3.6.0	Approved	29/05/2002	<a href="http://www.tta.or.kr/standardDB/stnfile/TTAE.3G-25.412(R99-3.6.0).zip">http://www.tta.or.kr/standardDB/stnfile/TTAE.3G-25.412(R99-3.6.0).zip</a>
<b>Release 4</b>					
CCSA	CCSA-TSD-DS-25.412	410	Approved	01/07/2003	<a href="http://www.ccsa.org.cn/english/tc/files.php?docpath=/ITU-R/M.1457/M.1457-4/DS/">http://www.ccsa.org.cn/english/tc/files.php?docpath=/ITU-R/M.1457/M.1457-4/DS/</a>
ETSI	ETSI TS 125 412	4.1.0	Published	16/10/2002	<a href="http://pda.etsi.org/pda/home.asp?wkr=RTS/TSGR-0325412v410">http://pda.etsi.org/pda/home.asp?wkr=RTS/TSGR-0325412v410</a>
T1 (ATIS)	T1.3GPP.25.412V410-2003	4.1.0	Approved	27/03/2003	<a href="https://www.atis.org/atis/docstore/search.asp?committee=S24">https://www.atis.org/atis/docstore/search.asp?committee=S24</a>
TTA	TTAT.3G-25.412(R4-4.1.0)	4.1.0	Approved	21/03/2003	<a href="http://www.tta.or.kr/standardDB/stnfile/TTAT.3G-25.412(R4-4.1.0).zip">http://www.tta.or.kr/standardDB/stnfile/TTAT.3G-25.412(R4-4.1.0).zip</a>
<b>Release 5</b>					
CCSA	CCSA-TSD-DS-25.412	510	Approved	01/07/2003	<a href="http://www.ccsa.org.cn/english/tc/files.php?docpath=/ITU-R/M.1457/M.1457-4/DS/">http://www.ccsa.org.cn/english/tc/files.php?docpath=/ITU-R/M.1457/M.1457-4/DS/</a>
ETSI	ETSI TS 125 412	5.1.0	Published	16/10/2002	<a href="http://pda.etsi.org/pda/home.asp?wkr=RTS/TSGR-0325412v510">http://pda.etsi.org/pda/home.asp?wkr=RTS/TSGR-0325412v510</a>



T1 (ATIS) T1.3GPP.25.412V510-2003	5.1.0	Approved	27/03/2003	<a href="https://www.atis.org/atis/docstore/search.asp?committee=S24">https://www.atis.org/atis/docstore/search.asp?committee=S24</a>
TTA TTAT.3G-25.412(R5-5.1.0)	5.1.0	Approved	21/03/2003	<a href="http://www.tta.or.kr/standardDB/stnfile/TTAT.3G-25.412(R5-5.1.0).zip">http://www.tta.or.kr/standardDB/stnfile/TTAT.3G-25.412(R5-5.1.0).zip</a>
<b>Release 6</b>				
ETSI ETSI TS 125 412	6.0.0	Published	19/01/2004	<a href="http://pda.etsi.org/pda/home.asp?wkr=RTS/TSGR-0325412v600">http://pda.etsi.org/pda/home.asp?wkr=RTS/TSGR-0325412v600</a>
T1 (ATIS) T1.3GPP.25.412V600-2004	6.0.0	Approved	21/05/2004	<a href="https://www.atis.org/atis/docstore/search.asp?committee=S24">https://www.atis.org/atis/docstore/search.asp?committee=S24</a>
TTA TTAT.3G-25.412(R6-6.0.0)	6.0.0	Approved	25/05/2004	<a href="http://www.tta.or.kr/standardDB/stnfile/TTAT.3G-25.412(R6-6.0.0).zip">http://www.tta.or.kr/standardDB/stnfile/TTAT.3G-25.412(R6-6.0.0).zip</a>

### 5.3.2.3.6 25.413

#### UTRAN Iu interface RANAP signalling

This specification describes the signalling between the CN and the UTRAN over the Iu interface. This specification describes the standards for user data transport protocols and related signalling protocols to establish user plane transport bearers over the Iu interface.

SDO (2)	Document No.	Version	Status	Issued date	Location (1)
<b>Release 99</b>					
CCSA	CCSA-TSD-DS-25.413	3D0	Approved	01/07/2003	<a href="http://www.ccsa.org.cn/english/tc/files.php?docpath=/ITU-R/M.1457/M.1457-4/DS/">http://www.ccsa.org.cn/english/tc/files.php?docpath=/ITU-R/M.1457/M.1457-4/DS/</a>
ETSI	ETSI TS 125 413	3.14.0	Published	03/10/2003	<a href="http://pda.etsi.org/pda/home.asp?wkr=RTS/TSGR-0325413v3e0">http://pda.etsi.org/pda/home.asp?wkr=RTS/TSGR-0325413v3e0</a>
T1 (ATIS)	T1.3GPP.25.413V3140-2004	3.14.0	Approved	21/05/2004	<a href="https://www.atis.org/atis/docstore/search.asp?committee=S24">https://www.atis.org/atis/docstore/search.asp?committee=S24</a>
TTA	TTAT.3G-25.413(R99-3.14.0)	3.14.0	Approved	25/05/2004	<a href="http://www.tta.or.kr/standardDB/stnfile/TTAT.3G-25.413(R99-3.14.0).zip">http://www.tta.or.kr/standardDB/stnfile/TTAT.3G-25.413(R99-3.14.0).zip</a>
<b>Release 4</b>					
CCSA	CCSA-TSD-DS-25.413	490	Approved	01/07/2003	<a href="http://www.ccsa.org.cn/english/tc/files.php?docpath=/ITU-R/M.1457/M.1457-4/DS/">http://www.ccsa.org.cn/english/tc/files.php?docpath=/ITU-R/M.1457/M.1457-4/DS/</a>
ETSI	ETSI TS 125 413	4.11.0	Published	20/01/2004	<a href="http://pda.etsi.org/pda/home.asp?wkr=RTS/TSGR-0325413v4b0">http://pda.etsi.org/pda/home.asp?wkr=RTS/TSGR-0325413v4b0</a>
T1 (ATIS)	T1.3GPP.25.413V4110-2004	4.11.0	Approved	21/05/2004	<a href="https://www.atis.org/atis/docstore/search.asp?committee=S24">https://www.atis.org/atis/docstore/search.asp?committee=S24</a>
TTA	TTAT.3G-25.413(R4-4.11.0)	4.11.0	Approved	25/05/2004	<a href="http://www.tta.or.kr/standardDB/stnfile/TTAT.3G-25.413(R4-4.11.0).zip">http://www.tta.or.kr/standardDB/stnfile/TTAT.3G-25.413(R4-4.11.0).zip</a>
<b>Release 5</b>					
CCSA	CCSA-TSD-DS-25.413	550	Approved	01/07/2003	<a href="http://www.ccsa.org.cn/english/tc/files.php?docpath=/ITU-R/M.1457/M.1457-4/DS/">http://www.ccsa.org.cn/english/tc/files.php?docpath=/ITU-R/M.1457/M.1457-4/DS/</a>
ETSI	ETSI TS 125 413	5.7.0	Published	20/01/2004	<a href="http://pda.etsi.org/pda/home.asp?wkr=RTS/TSGR-0325413v570">http://pda.etsi.org/pda/home.asp?wkr=RTS/TSGR-0325413v570</a>
T1 (ATIS)	T1.3GPP.25.413V570-2004	5.7.0	Approved	21/05/2004	<a href="https://www.atis.org/atis/docstore/search.asp?committee=S24">https://www.atis.org/atis/docstore/search.asp?committee=S24</a>
TTA	TTAT.3G-25.413(R5-5.7.0)	5.7.0	Approved	25/05/2004	<a href="http://www.tta.or.kr/standardDB/stnfile/TTAT.3G-25.413(R5-5.7.0).zip">http://www.tta.or.kr/standardDB/stnfile/TTAT.3G-25.413(R5-5.7.0).zip</a>
<b>Release 6</b>					
ETSI	ETSI TS 125 413	6.0.0	Published	20/01/2004	<a href="http://pda.etsi.org/pda/home.asp?wkr=RTS/TSGR-0325413v600">http://pda.etsi.org/pda/home.asp?wkr=RTS/TSGR-0325413v600</a>
T1 (ATIS)	T1.3GPP.25.413V600-2004	6.0.0	Approved	21/05/2004	<a href="https://www.atis.org/atis/docstore/search.asp?committee=S24">https://www.atis.org/atis/docstore/search.asp?committee=S24</a>
TTA	TTAT.3G-25.413(R6-6.0.0)	6.0.0	Approved	25/05/2004	<a href="http://www.tta.or.kr/standardDB/stnfile/TTAT.3G-25.413(R6-6.0.0).zip">http://www.tta.or.kr/standardDB/stnfile/TTAT.3G-25.413(R6-6.0.0).zip</a>

### 5.3.2.3.7 25.414

#### UTRAN Iu interface data transport and transport signaling

This specification describes the standards for user data transport protocols and related signalling protocols to establish user plane transport bearers over the Iu interface.

SDO (2)	Document No.	Version	Status	Issued date	Location (1)
<b>Release 99</b>					
CCSA	CCSA-TSD-DS-25.414	3D0	Approved	01/07/2003	<a href="http://www.ccsa.org.cn/english/tc/files.php?docpath=/ITU-R/M.1457/M.1457-4/DS/">http://www.ccsa.org.cn/english/tc/files.php?docpath=/ITU-R/M.1457/M.1457-4/DS/</a>
ETSI	ETSI TS 125 414	3.13.0	Published	04/04/2003	<a href="http://pda.etsi.org/pda/home.asp?wkr=RTS/TSGR-0325414v3d0">http://pda.etsi.org/pda/home.asp?wkr=RTS/TSGR-0325414v3d0</a>
T1 (ATIS)	T1.3GPP.25.414V3130-2004	3.13.0	Approved	21/05/2004	<a href="https://www.atis.org/atis/docstore/search.asp?committee=S24">https://www.atis.org/atis/docstore/search.asp?committee=S24</a>
TTA	TTAT.3G-25.414(R99-3.13.0)	3.13.0	Approved	25/05/2004	<a href="http://www.tta.or.kr/standardDB/stnfile/TTAT.3G-25.414(R99-3.13.0).zip">http://www.tta.or.kr/standardDB/stnfile/TTAT.3G-25.414(R99-3.13.0).zip</a>
<b>Release 4</b>					
CCSA	CCSA-TSD-DS-25.414	460	Approved	01/07/2003	<a href="http://www.ccsa.org.cn/english/tc/files.php?docpath=/ITU-R/M.1457/M.1457-4/DS/">http://www.ccsa.org.cn/english/tc/files.php?docpath=/ITU-R/M.1457/M.1457-4/DS/</a>
ETSI	ETSI TS 125 414	4.7.0	Published	20/01/2004	<a href="http://pda.etsi.org/pda/home.asp?wkr=RTS/TSGR-0325414v470">http://pda.etsi.org/pda/home.asp?wkr=RTS/TSGR-0325414v470</a>
T1 (ATIS)	T1.3GPP.25.414V470-2004	4.7.0	Approved	21/05/2004	<a href="https://www.atis.org/atis/docstore/search.asp?committee=S24">https://www.atis.org/atis/docstore/search.asp?committee=S24</a>
TTA	TTAT.3G-25.414(R4-4.7.0)	4.7.0	Approved	25/05/2004	<a href="http://www.tta.or.kr/standardDB/stnfile/TTAT.3G-25.414(R4-4.7.0).zip">http://www.tta.or.kr/standardDB/stnfile/TTAT.3G-25.414(R4-4.7.0).zip</a>
<b>Release 5</b>					
CCSA	CCSA-TSD-DS-25.414	540	Approved	01/07/2003	<a href="http://www.ccsa.org.cn/english/tc/files.php?docpath=/ITU-R/M.1457/M.1457-4/DS/">http://www.ccsa.org.cn/english/tc/files.php?docpath=/ITU-R/M.1457/M.1457-4/DS/</a>
ETSI	ETSI TS 125 414	5.5.0	Published	20/01/2004	<a href="http://pda.etsi.org/pda/home.asp?wkr=RTS/TSGR-0325414v550">http://pda.etsi.org/pda/home.asp?wkr=RTS/TSGR-0325414v550</a>
T1 (ATIS)	T1.3GPP.25.414V550-2004	5.5.0	Approved	21/05/2004	<a href="https://www.atis.org/atis/docstore/search.asp?committee=S24">https://www.atis.org/atis/docstore/search.asp?committee=S24</a>
TTA	TTAT.3G-25.414(R5-5.5.0)	5.5.0	Approved	25/05/2004	<a href="http://www.tta.or.kr/standardDB/stnfile/TTAT.3G-25.414(R5-5.5.0).zip">http://www.tta.or.kr/standardDB/stnfile/TTAT.3G-25.414(R5-5.5.0).zip</a>
<b>Release 6</b>					
ETSI	ETSI TS 125 414	6.0.0	Published	20/01/2004	<a href="http://pda.etsi.org/pda/home.asp?wkr=RTS/TSGR-0325414v600">http://pda.etsi.org/pda/home.asp?wkr=RTS/TSGR-0325414v600</a>
T1 (ATIS)	T1.3GPP.25.414V600-2004	6.0.0	Approved	21/05/2004	<a href="https://www.atis.org/atis/docstore/search.asp?committee=S24">https://www.atis.org/atis/docstore/search.asp?committee=S24</a>
TTA	TTAT.3G-25.414(R6-6.0.0)	6.0.0	Approved	25/05/2004	<a href="http://www.tta.or.kr/standardDB/stnfile/TTAT.3G-25.414(R6-6.0.0).zip">http://www.tta.or.kr/standardDB/stnfile/TTAT.3G-25.414(R6-6.0.0).zip</a>

### 5.3.2.3.8 25.415

#### UTRAN Iu interface user plane protocols

This specification describes the protocols being used to transport and control over the Iu interface, the Iu user data streams.

SDO (2)	Document No.	Version	Status	Issued date	Location (1)
<b>Release 99</b>					
CCSA	CCSA-TSD-DS-25.415	3C0	Approved	01/07/2003	<a href="http://www.ccsa.org.cn/english/tc/files.php?docpath=/ITU-R/M.1457/M.1457-4/DS/">http://www.ccsa.org.cn/english/tc/files.php?docpath=/ITU-R/M.1457/M.1457-4/DS/</a>
ETSI	ETSI TS 125 415	3.12.0	Published	17/10/2002	<a href="http://pda.etsi.org/pda/home.asp?wkr=RTS/TSGR-0325415v3c0">http://pda.etsi.org/pda/home.asp?wkr=RTS/TSGR-0325415v3c0</a>
T1 (ATIS)	T1.3GPP.25.415V3120-2003	3.12.0	Approved	27/03/2003	<a href="https://www.atis.org/atis/docstore/search.asp?committee=S24">https://www.atis.org/atis/docstore/search.asp?committee=S24</a>
TTA	TTAT.3G-25.415(R99-3.12.0)	3.12.0	Approved	21/03/2003	<a href="http://www.tta.or.kr/standardDB/stnfile/TTAT.3G-25.415(R99-3.12.0).zip">http://www.tta.or.kr/standardDB/stnfile/TTAT.3G-25.415(R99-3.12.0).zip</a>
<b>Release 4</b>					
CCSA	CCSA-TSD-DS-25.415	470	Approved	01/07/2003	<a href="http://www.ccsa.org.cn/english/tc/files.php?docpath=/ITU-R/M.1457/M.1457-4/DS/">http://www.ccsa.org.cn/english/tc/files.php?docpath=/ITU-R/M.1457/M.1457-4/DS/</a>
ETSI	ETSI TS 125 415	4.7.0	Published	09/01/2003	<a href="http://pda.etsi.org/pda/home.asp?wkr=RTS/TSGR-0325415v470">http://pda.etsi.org/pda/home.asp?wkr=RTS/TSGR-0325415v470</a>
T1 (ATIS)	T1.3GPP.25.415V470-2003	4.7.0	Approved	27/03/2003	<a href="https://www.atis.org/atis/docstore/search.asp?committee=S24">https://www.atis.org/atis/docstore/search.asp?committee=S24</a>
TTA	TTAT.3G-25.415(R4-4.7.0)	4.7.0	Approved	21/03/2003	<a href="http://www.tta.or.kr/standardDB/stnfile/TTAT.3G-25.415(R4-4.7.0).zip">http://www.tta.or.kr/standardDB/stnfile/TTAT.3G-25.415(R4-4.7.0).zip</a>

**Release 5**

CCSA	CCSA-TSD-DS-25.415	530	Approved	01/07/2003	<a href="http://www.ccsa.org.cn/english/tc/files.php?docpath=/ITU-R/M.1457/M.1457-4/DS/">http://www.ccsa.org.cn/english/tc/files.php?docpath=/ITU-R/M.1457/M.1457-4/DS/</a>
ETSI	ETSI TS 125 415	5.3.0	Published	09/01/2003	<a href="http://pda.etsi.org/pda/home.asp?wkr=RTS/TSGR-0325415v530">http://pda.etsi.org/pda/home.asp?wkr=RTS/TSGR-0325415v530</a>
T1 (ATIS)	T1.3GPP.25.415V530-2003	5.3.0	Approved	27/03/2003	<a href="https://www.atis.org/atis/docstore/search.asp?committee=S24">https://www.atis.org/atis/docstore/search.asp?committee=S24</a>
TTA	TTAT.3G-25.415(R5-5.3.0)	5.3.0	Approved	21/03/2003	<a href="http://www.tta.or.kr/standardDB/stnfile/TTAT.3G-25.415(R5-5.3.0).zip">http://www.tta.or.kr/standardDB/stnfile/TTAT.3G-25.415(R5-5.3.0).zip</a>

**Release 6**

ETSI	ETSI TS 125 415	6.0.0	Published	20/01/2004	<a href="http://pda.etsi.org/pda/home.asp?wkr=RTS/TSGR-0325415v600">http://pda.etsi.org/pda/home.asp?wkr=RTS/TSGR-0325415v600</a>
T1 (ATIS)	T1.3GPP.25.415V600-2004	6.0.0	Approved	21/05/2004	<a href="https://www.atis.org/atis/docstore/search.asp?committee=S24">https://www.atis.org/atis/docstore/search.asp?committee=S24</a>
TTA	TTAT.3G-25.415(R6-6.0.0)	6.0.0	Approved	25/05/2004	<a href="http://www.tta.or.kr/standardDB/stnfile/TTAT.3G-25.415(R6-6.0.0).zip">http://www.tta.or.kr/standardDB/stnfile/TTAT.3G-25.415(R6-6.0.0).zip</a>

**5.3.2.3.9 25.419****UTRAN Iu-bc interface: Cell broadcast protocols between CBC and RNC**

This document specifies the Service Area Broadcast Protocol (SABP) between the Cell Broadcast Centre (CBC) and the Radio Network Controller (RNC).

SDO (2)	Document No.	Version	Status	Issued date	Location (1)
<b>Release 99</b>					
CCSA	CCSA-TSD-DS-25.419	3B0	Approved	01/07/2003	<a href="http://www.ccsa.org.cn/english/tc/files.php?docpath=/ITU-R/M.1457/M.1457-4/DS/">http://www.ccsa.org.cn/english/tc/files.php?docpath=/ITU-R/M.1457/M.1457-4/DS/</a>
ETSI	ETSI TS 125 419	3.11.0	Published	20/06/2003	<a href="http://pda.etsi.org/pda/home.asp?wkr=RTS/TSGR-0325419v3b0">http://pda.etsi.org/pda/home.asp?wkr=RTS/TSGR-0325419v3b0</a>
T1 (ATIS)	T1.3GPP.25.419V3110-2004	3.11.0	Approved	21/05/2004	<a href="https://www.atis.org/atis/docstore/search.asp?committee=S24">https://www.atis.org/atis/docstore/search.asp?committee=S24</a>
TTA	TTAT.3G-25.419(R99-3.11.0)	3.11.0	Approved	25/05/2004	<a href="http://www.tta.or.kr/standardDB/stnfile/TTAT.3G-25.419(R99-3.11.0).zip">http://www.tta.or.kr/standardDB/stnfile/TTAT.3G-25.419(R99-3.11.0).zip</a>
<b>Release 4</b>					
CCSA	CCSA-TSD-DS-25.419	480	Approved	01/07/2003	<a href="http://www.ccsa.org.cn/english/tc/files.php?docpath=/ITU-R/M.1457/M.1457-4/DS/">http://www.ccsa.org.cn/english/tc/files.php?docpath=/ITU-R/M.1457/M.1457-4/DS/</a>
ETSI	ETSI TS 125 419	4.10.0	Published	20/01/2004	<a href="http://pda.etsi.org/pda/home.asp?wkr=RTS/TSGR-0325419v4a0">http://pda.etsi.org/pda/home.asp?wkr=RTS/TSGR-0325419v4a0</a>
T1 (ATIS)	T1.3GPP.25.419V4100-2004	4.10.0	Approved	21/05/2004	<a href="https://www.atis.org/atis/docstore/search.asp?committee=S24">https://www.atis.org/atis/docstore/search.asp?committee=S24</a>
TTA	TTAT.3G-25.419(R4-4.10.0)	4.10.0	Approved	25/05/2004	<a href="http://www.tta.or.kr/standardDB/stnfile/TTAT.3G-25.419(R4-4.10.0).zip">http://www.tta.or.kr/standardDB/stnfile/TTAT.3G-25.419(R4-4.10.0).zip</a>
<b>Release 5</b>					
CCSA	CCSA-TSD-DS-25.419	540	Approved	01/07/2003	<a href="http://www.ccsa.org.cn/english/tc/files.php?docpath=/ITU-R/M.1457/M.1457-4/DS/">http://www.ccsa.org.cn/english/tc/files.php?docpath=/ITU-R/M.1457/M.1457-4/DS/</a>
ETSI	ETSI TS 125 419	5.6.0	Published	20/01/2004	<a href="http://pda.etsi.org/pda/home.asp?wkr=RTS/TSGR-0325419v560">http://pda.etsi.org/pda/home.asp?wkr=RTS/TSGR-0325419v560</a>
T1 (ATIS)	T1.3GPP.25.419V560-2004	5.6.0	Approved	21/05/2004	<a href="https://www.atis.org/atis/docstore/search.asp?committee=S24">https://www.atis.org/atis/docstore/search.asp?committee=S24</a>
TTA	TTAT.3G-25.419(R5-5.6.0)	5.6.0	Approved	25/05/2004	<a href="http://www.tta.or.kr/standardDB/stnfile/TTAT.3G-25.419(R5-5.6.0).zip">http://www.tta.or.kr/standardDB/stnfile/TTAT.3G-25.419(R5-5.6.0).zip</a>
<b>Release 6</b>					
ETSI	ETSI TS 125 419	6.0.0	Published	20/01/2004	<a href="http://pda.etsi.org/pda/home.asp?wkr=RTS/TSGR-0325419v600">http://pda.etsi.org/pda/home.asp?wkr=RTS/TSGR-0325419v600</a>
T1 (ATIS)	T1.3GPP.25.419V600-2004	6.0.0	Approved	21/05/2004	<a href="https://www.atis.org/atis/docstore/search.asp?committee=S24">https://www.atis.org/atis/docstore/search.asp?committee=S24</a>
TTA	TTAT.3G-25.419(R6-6.0.0)	6.0.0	Approved	25/05/2004	<a href="http://www.tta.or.kr/standardDB/stnfile/TTAT.3G-25.419(R6-6.0.0).zip">http://www.tta.or.kr/standardDB/stnfile/TTAT.3G-25.419(R6-6.0.0).zip</a>

## 5.3.2.3.10 25.420

**UTRAN Iur interface: general aspects and principles**

This specification describes an introduction to the TSG RAN TS 25.42x series of technical specifications that define the Iur interface. It is a logical interface for the interconnection of two RNC components of the UTRAN.

SDO (2)	Document No.	Version	Status	Issued date	Location (1)
<b>Release 99</b>					
CCSA	CCSA-TSD-DS-25.420	350	Approved	01/07/2003	<a href="http://www.ccsa.org.cn/english/tc/files.php?docpath=/ITU-R/M.1457/M.1457-4/DS/">http://www.ccsa.org.cn/english/tc/files.php?docpath=/ITU-R/M.1457/M.1457-4/DS/</a>
ETSI	ETSI TS 125 420	3.5.0	Published	15/04/2002	<a href="http://pda.etsi.org/pda/home.asp?wkr=RTS/TSGR-0325420UR5">http://pda.etsi.org/pda/home.asp?wkr=RTS/TSGR-0325420UR5</a>
T1 (ATIS)	T1.3GPP.25.420V350-2002	3.5.0	Approved	03/05/2002	<a href="https://www.atis.org/atis/docstore/search.asp?committee=S24">https://www.atis.org/atis/docstore/search.asp?committee=S24</a>
TTA	TTAE.3G-25.420(R99-3.5.0)	3.5.0	Approved	29/05/2002	<a href="http://www.tta.or.kr/standardDB/stnfile/TTAE.3G-25.420(R99-3.5.0).zip">http://www.tta.or.kr/standardDB/stnfile/TTAE.3G-25.420(R99-3.5.0).zip</a>
<b>Release 4</b>					
CCSA	CCSA-TSD-DS-25.420	420	Approved	01/07/2003	<a href="http://www.ccsa.org.cn/english/tc/files.php?docpath=/ITU-R/M.1457/M.1457-4/DS/">http://www.ccsa.org.cn/english/tc/files.php?docpath=/ITU-R/M.1457/M.1457-4/DS/</a>
ETSI	ETSI TS 125 420	4.2.0	Published	15/04/2002	<a href="http://pda.etsi.org/pda/home.asp?wkr=RTS/TSGR-0325420Uv4R2">http://pda.etsi.org/pda/home.asp?wkr=RTS/TSGR-0325420Uv4R2</a>
T1 (ATIS)	T1.3GPP.25.420V420-2002	4.2.0	Approved	03/05/2002	<a href="https://www.atis.org/atis/docstore/search.asp?committee=S24">https://www.atis.org/atis/docstore/search.asp?committee=S24</a>
TTA	TTAE.3G-25.420(R4-4.2.0)	4.2.0	Approved	29/05/2002	<a href="http://www.tta.or.kr/standardDB/stnfile/TTAE.3G-25.420(R4-4.2.0).zip">http://www.tta.or.kr/standardDB/stnfile/TTAE.3G-25.420(R4-4.2.0).zip</a>
<b>Release 5</b>					
CCSA	CCSA-TSD-DS-25.420	510	Approved	01/07/2003	<a href="http://www.ccsa.org.cn/english/tc/files.php?docpath=/ITU-R/M.1457/M.1457-4/DS/">http://www.ccsa.org.cn/english/tc/files.php?docpath=/ITU-R/M.1457/M.1457-4/DS/</a>
ETSI	ETSI TS 125 420	5.1.0	Published	15/10/2002	<a href="http://pda.etsi.org/pda/home.asp?wkr=RTS/TSGR-0325420v510">http://pda.etsi.org/pda/home.asp?wkr=RTS/TSGR-0325420v510</a>
T1 (ATIS)	T1.3GPP.25.420V510-2003	5.1.0	Approved	27/03/2003	<a href="https://www.atis.org/atis/docstore/search.asp?committee=S24">https://www.atis.org/atis/docstore/search.asp?committee=S24</a>
TTA	TTAT.3G-25.420(R5-5.1.0)	5.1.0	Approved	21/03/2003	<a href="http://www.tta.or.kr/standardDB/stnfile/TTAT.3G-25.420(R5-5.1.0).zip">http://www.tta.or.kr/standardDB/stnfile/TTAT.3G-25.420(R5-5.1.0).zip</a>
<b>Release 6</b>					
ETSI	ETSI TS 125 420	6.0.0	Published	20/01/2004	<a href="http://pda.etsi.org/pda/home.asp?wkr=RTS/TSGR-0325420v600">http://pda.etsi.org/pda/home.asp?wkr=RTS/TSGR-0325420v600</a>
T1 (ATIS)	T1.3GPP.25.420V600-2004	6.0.0	Approved	21/05/2004	<a href="https://www.atis.org/atis/docstore/search.asp?committee=S24">https://www.atis.org/atis/docstore/search.asp?committee=S24</a>
TTA	TTAT.3G-25.420(R6-6.0.0)	6.0.0	Approved	25/05/2004	<a href="http://www.tta.or.kr/standardDB/stnfile/TTAT.3G-25.420(R6-6.0.0).zip">http://www.tta.or.kr/standardDB/stnfile/TTAT.3G-25.420(R6-6.0.0).zip</a>

## 5.3.2.3.11 25.421

**UTRAN Iur interface Layer 1**

This specification describes the standards allowed to implement Layer 1 on the Iur interface. The specification of transmission delay requirements and O&M requirements are not in the scope of this specification.

SDO (2)	Document No.	Version	Status	Issued date	Location (1)
<b>Release 99</b>					
CCSA	CCSA-TSD-DS-25.421	310	Approved	01/07/2003	<a href="http://www.ccsa.org.cn/english/tc/files.php?docpath=/ITU-R/M.1457/M.1457-4/DS/">http://www.ccsa.org.cn/english/tc/files.php?docpath=/ITU-R/M.1457/M.1457-4/DS/</a>
ETSI	ETSI TS 125 421	3.1.0	Published	27/04/2001	<a href="http://pda.etsi.org/pda/home.asp?wkr=RTS/TSGR-0325421UR1">http://pda.etsi.org/pda/home.asp?wkr=RTS/TSGR-0325421UR1</a>
T1 (ATIS)	T1.3GPP.25.421V310-2002	3.1.0	Approved	03/05/2002	<a href="https://www.atis.org/atis/docstore/search.asp?committee=S24">https://www.atis.org/atis/docstore/search.asp?committee=S24</a>
TTA	TTAE.3G-25.421(R99-3.1.0)	3.1.0	Approved	29/05/2002	<a href="http://www.tta.or.kr/standardDB/stnfile/TTAE.3G-25.421(R99-3.1.0).zip">http://www.tta.or.kr/standardDB/stnfile/TTAE.3G-25.421(R99-3.1.0).zip</a>

**Release 4**

CCSA	CCSA-TSD-DS-25.421	400	Approved	01/07/2003	<a href="http://www.ccsa.org.cn/english/tc/files.php?docpath=/ITU-R/M.1457/M.1457-4/DS/">http://www.ccsa.org.cn/english/tc/files.php?docpath=/ITU-R/M.1457/M.1457-4/DS/</a>
ETSI	ETSI TS 125 421	4.0.0	Published	27/04/2001	<a href="http://pda.etsi.org/pda/home.asp?wkr=RTS/TSGR-0325421Uv4">http://pda.etsi.org/pda/home.asp?wkr=RTS/TSGR-0325421Uv4</a>
T1 (ATIS)	T1.3GPP.25.421V400-2002	4.0.0	Approved	03/05/2002	<a href="https://www.atis.org/atis/docstore/search.asp?committee=S24">https://www.atis.org/atis/docstore/search.asp?committee=S24</a>
TTA	TTAE.3G-25.421(R4-4.0.0)	4.0.0	Approved	29/05/2002	<a href="http://www.tta.or.kr/standardDB/stnfile/TTAE.3G-25.421(R4-4.0.0).zip">http://www.tta.or.kr/standardDB/stnfile/TTAE.3G-25.421(R4-4.0.0).zip</a>

**Release 5**

CCSA	CCSA-TSD-DS-25.421	500	Approved	01/07/2003	<a href="http://www.ccsa.org.cn/english/tc/files.php?docpath=/ITU-R/M.1457/M.1457-4/DS/">http://www.ccsa.org.cn/english/tc/files.php?docpath=/ITU-R/M.1457/M.1457-4/DS/</a>
ETSI	ETSI TS 125 421	5.0.0	Published	15/04/2002	<a href="http://pda.etsi.org/pda/home.asp?wkr=RTS/TSGR-0325421Uv5">http://pda.etsi.org/pda/home.asp?wkr=RTS/TSGR-0325421Uv5</a>
T1 (ATIS)	T1.3GPP.25.421V500-2002	5.0.0	Approved	03/05/2002	<a href="https://www.atis.org/atis/docstore/search.asp?committee=S24">https://www.atis.org/atis/docstore/search.asp?committee=S24</a>
TTA	TTAE.3G-25.421(R5-5.0.0)	5.0.0	Approved	29/05/2002	<a href="http://www.tta.or.kr/standardDB/stnfile/TTAE.3G-25.421(R5-5.0.0).zip">http://www.tta.or.kr/standardDB/stnfile/TTAE.3G-25.421(R5-5.0.0).zip</a>

**Release 6**

ETSI	ETSI TS 125 421	6.0.0	Published	20/01/2004	<a href="http://pda.etsi.org/pda/home.asp?wkr=RTS/TSGR-0325421v600">http://pda.etsi.org/pda/home.asp?wkr=RTS/TSGR-0325421v600</a>
T1 (ATIS)	T1.3GPP.25.421V600-2004	6.0.0	Approved	21/05/2004	<a href="https://www.atis.org/atis/docstore/search.asp?committee=S24">https://www.atis.org/atis/docstore/search.asp?committee=S24</a>
TTA	TTAT.3G-25.421(R6-6.0.0)	6.0.0	Approved	25/05/2004	<a href="http://www.tta.or.kr/standardDB/stnfile/TTAT.3G-25.421(R6-6.0.0).zip">http://www.tta.or.kr/standardDB/stnfile/TTAT.3G-25.421(R6-6.0.0).zip</a>

**5.3.2.3.12 25.422****UTRAN Iur interface signalling transport**

This specification describes the standards for Signalling Transport to be used across Iur Interface.

SDO (2)	Document No.	Version	Status	Issued date	Location (1)
<b>Release 99</b>					
CCSA	CCSA-TSD-DS-25.422	361	Approved	01/07/2003	<a href="http://www.ccsa.org.cn/english/tc/files.php?docpath=/ITU-R/M.1457/M.1457-4/DS/">http://www.ccsa.org.cn/english/tc/files.php?docpath=/ITU-R/M.1457/M.1457-4/DS/</a>
ETSI	ETSI TS 125 422	3.6.1	Published	15/04/2002	<a href="http://pda.etsi.org/pda/home.asp?wkr=RTS/TSGR-0325422UR6">http://pda.etsi.org/pda/home.asp?wkr=RTS/TSGR-0325422UR6</a>
T1 (ATIS)	T1.3GPP.25.422V361-2002	3.6.1	Approved	03/05/2002	<a href="https://www.atis.org/atis/docstore/search.asp?committee=S24">https://www.atis.org/atis/docstore/search.asp?committee=S24</a>
TTA	TTAT.3G-25.422(R99-3.6.1)	3.6.1	Approved	21/03/2003	<a href="http://www.tta.or.kr/standardDB/stnfile/TTAT.3G-25.422(R99-3.6.1).zip">http://www.tta.or.kr/standardDB/stnfile/TTAT.3G-25.422(R99-3.6.1).zip</a>
<b>Release 4</b>					
CCSA	CCSA-TSD-DS-25.422	420	Approved	01/07/2003	<a href="http://www.ccsa.org.cn/english/tc/files.php?docpath=/ITU-R/M.1457/M.1457-4/DS/">http://www.ccsa.org.cn/english/tc/files.php?docpath=/ITU-R/M.1457/M.1457-4/DS/</a>
ETSI	ETSI TS 125 422	4.2.0	Published	15/10/2002	<a href="http://pda.etsi.org/pda/home.asp?wkr=RTS/TSGR-0325422v420">http://pda.etsi.org/pda/home.asp?wkr=RTS/TSGR-0325422v420</a>
T1 (ATIS)	T1.3GPP.25.422V420-2003	4.2.0	Approved	27/03/2003	<a href="https://www.atis.org/atis/docstore/search.asp?committee=S24">https://www.atis.org/atis/docstore/search.asp?committee=S24</a>
TTA	TTAT.3G-25.422(R4-4.2.0)	4.2.0	Approved	21/03/2003	<a href="http://www.tta.or.kr/standardDB/stnfile/TTAT.3G-25.422(R4-4.2.0).zip">http://www.tta.or.kr/standardDB/stnfile/TTAT.3G-25.422(R4-4.2.0).zip</a>
<b>Release 5</b>					
CCSA	CCSA-TSD-DS-25.422	510	Approved	01/07/2003	<a href="http://www.ccsa.org.cn/english/tc/files.php?docpath=/ITU-R/M.1457/M.1457-4/DS/">http://www.ccsa.org.cn/english/tc/files.php?docpath=/ITU-R/M.1457/M.1457-4/DS/</a>
ETSI	ETSI TS 125 422	5.1.0	Published	15/10/2002	<a href="http://pda.etsi.org/pda/home.asp?wkr=RTS/TSGR-0325422v510">http://pda.etsi.org/pda/home.asp?wkr=RTS/TSGR-0325422v510</a>
T1 (ATIS)	T1.3GPP.25.422V510-2003	5.1.0	Approved	27/03/2003	<a href="https://www.atis.org/atis/docstore/search.asp?committee=S24">https://www.atis.org/atis/docstore/search.asp?committee=S24</a>
TTA	TTAT.3G-25.422(R5-5.1.0)	5.1.0	Approved	21/03/2003	<a href="http://www.tta.or.kr/standardDB/stnfile/TTAT.3G-25.422(R5-5.1.0).zip">http://www.tta.or.kr/standardDB/stnfile/TTAT.3G-25.422(R5-5.1.0).zip</a>
<b>Release 6</b>					
ETSI	ETSI TS 125 422	6.0.0	Published	20/01/2004	<a href="http://pda.etsi.org/pda/home.asp?wkr=RTS/TSGR-0325422v600">http://pda.etsi.org/pda/home.asp?wkr=RTS/TSGR-0325422v600</a>
T1 (ATIS)	T1.3GPP.25.422V600-2004	6.0.0	Approved	21/05/2004	<a href="https://www.atis.org/atis/docstore/search.asp?committee=S24">https://www.atis.org/atis/docstore/search.asp?committee=S24</a>
TTA	TTAT.3G-25.422(R6-6.0.0)	6.0.0	Approved	25/05/2004	<a href="http://www.tta.or.kr/standardDB/stnfile/TTAT.3G-25.422(R6-6.0.0).zip">http://www.tta.or.kr/standardDB/stnfile/TTAT.3G-25.422(R6-6.0.0).zip</a>

**5.3.2.3.13** 25.423**UTRAN Iur interface RNSAP signalling**

This specification describes the radio network layer signalling procedures between RNCs in UTRAN.

SDO (2)	Document No.	Version	Status	Issued date	Location (1)
<b>Release 99</b>					
CCSA	CCSA-TSD-DS-25.423	3D0	Approved	01/07/2003	<a href="http://www.ccsa.org.cn/english/tc/files.php?docpath=/ITU-R/M.1457/M.1457-4/DS/">http://www.ccsa.org.cn/english/tc/files.php?docpath=/ITU-R/M.1457/M.1457-4/DS/</a>
ETSI	ETSI TS 125 423	3.14.0	Published	03/10/2003	<a href="http://pda.etsi.org/pda/home.asp?wkr=RTS/TSGR-0325423v3e0">http://pda.etsi.org/pda/home.asp?wkr=RTS/TSGR-0325423v3e0</a>
T1 (ATIS)	T1.3GPP.25.423V3140-2004	3.14.0	Approved	21/05/2004	<a href="https://www.atis.org/atis/docstore/search.asp?committee=S24">https://www.atis.org/atis/docstore/search.asp?committee=S24</a>
TTA	TTAT.3G-25.423(R99-3.14.0)	3.14.0	Approved	25/05/2004	<a href="http://www.tta.or.kr/standardDB/stnfile/TTAT.3G-25.423(R99-3.14.0).zip">http://www.tta.or.kr/standardDB/stnfile/TTAT.3G-25.423(R99-3.14.0).zip</a>
<b>Release 4</b>					
CCSA	CCSA-TSD-DS-25.423	490	Approved	01/07/2003	<a href="http://www.ccsa.org.cn/english/tc/files.php?docpath=/ITU-R/M.1457/M.1457-4/DS/">http://www.ccsa.org.cn/english/tc/files.php?docpath=/ITU-R/M.1457/M.1457-4/DS/</a>
ETSI	ETSI TS 125 423	4.11.0	Published	21/01/2004	<a href="http://pda.etsi.org/pda/home.asp?wkr=RTS/TSGR-0325423v4b0">http://pda.etsi.org/pda/home.asp?wkr=RTS/TSGR-0325423v4b0</a>
T1 (ATIS)	T1.3GPP.25.423V4110-2004	4.11.0	Approved	21/05/2004	<a href="https://www.atis.org/atis/docstore/search.asp?committee=S24">https://www.atis.org/atis/docstore/search.asp?committee=S24</a>
TTA	TTAT.3G-25.423(R4-4.11.0)	4.11.0	Approved	25/05/2004	<a href="http://www.tta.or.kr/standardDB/stnfile/TTAT.3G-25.423(R4-4.11.0).zip">http://www.tta.or.kr/standardDB/stnfile/TTAT.3G-25.423(R4-4.11.0).zip</a>
<b>Release 5</b>					
CCSA	CCSA-TSD-DS-25.423	560	Approved	01/07/2003	<a href="http://www.ccsa.org.cn/english/tc/files.php?docpath=/ITU-R/M.1457/M.1457-4/DS/">http://www.ccsa.org.cn/english/tc/files.php?docpath=/ITU-R/M.1457/M.1457-4/DS/</a>
ETSI	ETSI TS 125 423	5.8.0	Published	30/01/2004	<a href="http://pda.etsi.org/pda/home.asp?wkr=RTS/TSGR-0325423v580">http://pda.etsi.org/pda/home.asp?wkr=RTS/TSGR-0325423v580</a>
T1 (ATIS)	T1.3GPP.25.423V580-2004	5.8.0	Approved	21/05/2004	<a href="https://www.atis.org/atis/docstore/search.asp?committee=S24">https://www.atis.org/atis/docstore/search.asp?committee=S24</a>
TTA	TTAT.3G-25.423(R5-5.8.0)	5.8.0	Approved	25/05/2004	<a href="http://www.tta.or.kr/standardDB/stnfile/TTAT.3G-25.423(R5-5.8.0).zip">http://www.tta.or.kr/standardDB/stnfile/TTAT.3G-25.423(R5-5.8.0).zip</a>
<b>Release 6</b>					
ETSI	ETSI TS 125 423	6.0.0	Published	30/01/2004	<a href="http://pda.etsi.org/pda/home.asp?wkr=RTS/TSGR-0325423v600">http://pda.etsi.org/pda/home.asp?wkr=RTS/TSGR-0325423v600</a>
T1 (ATIS)	T1.3GPP.25.423V600-2004	6.0.0	Approved	21/05/2004	<a href="https://www.atis.org/atis/docstore/search.asp?committee=S24">https://www.atis.org/atis/docstore/search.asp?committee=S24</a>
TTA	TTAT.3G-25.423(R6-6.0.0)	6.0.0	Approved	25/05/2004	<a href="http://www.tta.or.kr/standardDB/stnfile/TTAT.3G-25.423(R6-6.0.0).zip">http://www.tta.or.kr/standardDB/stnfile/TTAT.3G-25.423(R6-6.0.0).zip</a>

**5.3.2.3.14** 25.424**UTRAN Iur interface data transport and transport signalling for common transport channel data streams**

This specification describes the UTRAN RNS-RNS (Iur) interface data transport and transport signalling for common transport channel data streams.

SDO (2)	Document No.	Version	Status	Issued date	Location (1)
<b>Release 99</b>					
CCSA	CCSA-TSD-DS-25.424	390	Approved	01/07/2003	<a href="http://www.ccsa.org.cn/english/tc/files.php?docpath=/ITU-R/M.1457/M.1457-4/DS/">http://www.ccsa.org.cn/english/tc/files.php?docpath=/ITU-R/M.1457/M.1457-4/DS/</a>
ETSI	ETSI TS 125 424	3.9.0	Published	11/07/2002	<a href="http://pda.etsi.org/pda/home.asp?wkr=RTS/TSGR-0325424v390">http://pda.etsi.org/pda/home.asp?wkr=RTS/TSGR-0325424v390</a>
T1 (ATIS)	T1.3GPP.25.424V390-2003	3.9.0	Approved	27/03/2003	<a href="https://www.atis.org/atis/docstore/search.asp?committee=S24">https://www.atis.org/atis/docstore/search.asp?committee=S24</a>
TTA	TTAT.3G-25.424(R99-3.9.0)	3.9.0	Approved	21/03/2003	<a href="http://www.tta.or.kr/standardDB/stnfile/TTAT.3G-25.424(R99-3.9.0).zip">http://www.tta.or.kr/standardDB/stnfile/TTAT.3G-25.424(R99-3.9.0).zip</a>



**Release 4**

CCSA	CCSA-TSD-DS-25.424	430	Approved	01/07/2003	<a href="http://www.ccsa.org.cn/english/tc/files.php?docpath=/ITU-R/M.1457/M.1457-4/DS/">http://www.ccsa.org.cn/english/tc/files.php?docpath=/ITU-R/M.1457/M.1457-4/DS/</a>
ETSI	ETSI TS 125 424	4.3.0	Published	11/07/2002	<a href="http://pda.etsi.org/pda/home.asp?wkr=RTS/TSGR-0325424v430">http://pda.etsi.org/pda/home.asp?wkr=RTS/TSGR-0325424v430</a>
T1 (ATIS)	T1.3GPP.25.424V430-2003	4.3.0	Approved	27/03/2003	<a href="https://www.atis.org/atis/docstore/search.asp?committee=S24">https://www.atis.org/atis/docstore/search.asp?committee=S24</a>
TTA	TTAT.3G-25.424(R4-4.3.0)	4.3.0	Approved	21/03/2003	<a href="http://www.tta.or.kr/standardDB/stnfile/TTAT.3G-25.424(R4-4.3.0).zip">http://www.tta.or.kr/standardDB/stnfile/TTAT.3G-25.424(R4-4.3.0).zip</a>

**Release 5**

CCSA	CCSA-TSD-DS-25.424	510	Approved	01/07/2003	<a href="http://www.ccsa.org.cn/english/tc/files.php?docpath=/ITU-R/M.1457/M.1457-4/DS/">http://www.ccsa.org.cn/english/tc/files.php?docpath=/ITU-R/M.1457/M.1457-4/DS/</a>
ETSI	ETSI TS 125 424	5.3.0	Published	20/01/2004	<a href="http://pda.etsi.org/pda/home.asp?wkr=RTS/TSGR-0325424v530">http://pda.etsi.org/pda/home.asp?wkr=RTS/TSGR-0325424v530</a>
T1 (ATIS)	T1.3GPP.25.424V530-2004	5.3.0	Approved	21/05/2004	<a href="https://www.atis.org/atis/docstore/search.asp?committee=S24">https://www.atis.org/atis/docstore/search.asp?committee=S24</a>
TTA	TTAT.3G-25.424(R5-5.3.0)	5.3.0	Approved	25/05/2004	<a href="http://www.tta.or.kr/standardDB/stnfile/TTAT.3G-25.424(R5-5.3.0).zip">http://www.tta.or.kr/standardDB/stnfile/TTAT.3G-25.424(R5-5.3.0).zip</a>

**Release 6**

ETSI	ETSI TS 125 424	6.0.0	Published	20/01/2004	<a href="http://pda.etsi.org/pda/home.asp?wkr=RTS/TSGR-0325424v600">http://pda.etsi.org/pda/home.asp?wkr=RTS/TSGR-0325424v600</a>
T1 (ATIS)	T1.3GPP.25.424V600-2004	6.0.0	Approved	21/05/2004	<a href="https://www.atis.org/atis/docstore/search.asp?committee=S24">https://www.atis.org/atis/docstore/search.asp?committee=S24</a>
TTA	TTAT.3G-25.424(R6-6.0.0)	6.0.0	Approved	25/05/2004	<a href="http://www.tta.or.kr/standardDB/stnfile/TTAT.3G-25.424(R6-6.0.0).zip">http://www.tta.or.kr/standardDB/stnfile/TTAT.3G-25.424(R6-6.0.0).zip</a>

**5.3.2.3.15 25.425****UTRAN Iur interface user plane protocols for common transport channel data streams**

This specification describes the UTRAN RNS-RNS (Iur) interface user plane protocols for common transport channel data streams.

SDO (2)	Document No.	Version	Status	Issued date	Location (1)
<b>Release 99</b>					
CCSA	CCSA-TSD-DS-25.425	370	Approved	01/07/2003	<a href="http://www.ccsa.org.cn/english/tc/files.php?docpath=/ITU-R/M.1457/M.1457-4/DS/">http://www.ccsa.org.cn/english/tc/files.php?docpath=/ITU-R/M.1457/M.1457-4/DS/</a>
ETSI	ETSI TS 125 425	3.8.0	Published	20/01/2004	<a href="http://pda.etsi.org/pda/home.asp?wkr=RTS/TSGR-0325425v380">http://pda.etsi.org/pda/home.asp?wkr=RTS/TSGR-0325425v380</a>
T1 (ATIS)	T1.3GPP.25.425V380-2004	3.8.0	Approved	21/05/2004	<a href="https://www.atis.org/atis/docstore/search.asp?committee=S24">https://www.atis.org/atis/docstore/search.asp?committee=S24</a>
TTA	TTAT.3G-25.425(R99-3.8.0)	3.8.0	Approved	25/05/2004	<a href="http://www.tta.or.kr/standardDB/stnfile/TTAT.3G-25.425(R99-3.8.0).zip">http://www.tta.or.kr/standardDB/stnfile/TTAT.3G-25.425(R99-3.8.0).zip</a>
<b>Release 4</b>					
CCSA	CCSA-TSD-DS-25.425	430	Approved	01/07/2003	<a href="http://www.ccsa.org.cn/english/tc/files.php?docpath=/ITU-R/M.1457/M.1457-4/DS/">http://www.ccsa.org.cn/english/tc/files.php?docpath=/ITU-R/M.1457/M.1457-4/DS/</a>
ETSI	ETSI TS 125 425	4.4.0	Published	20/01/2004	<a href="http://pda.etsi.org/pda/home.asp?wkr=RTS/TSGR-0325425v440">http://pda.etsi.org/pda/home.asp?wkr=RTS/TSGR-0325425v440</a>
T1 (ATIS)	T1.3GPP.25.425V440-2004	4.4.0	Approved	21/05/2004	<a href="https://www.atis.org/atis/docstore/search.asp?committee=S24">https://www.atis.org/atis/docstore/search.asp?committee=S24</a>
TTA	TTAT.3G-25.425(R4-4.4.0)	4.4.0	Approved	25/05/2004	<a href="http://www.tta.or.kr/standardDB/stnfile/TTAT.3G-25.425(R4-4.4.0).zip">http://www.tta.or.kr/standardDB/stnfile/TTAT.3G-25.425(R4-4.4.0).zip</a>
<b>Release 5</b>					
CCSA	CCSA-TSD-DS-25.425	550	Approved	01/07/2003	<a href="http://www.ccsa.org.cn/english/tc/files.php?docpath=/ITU-R/M.1457/M.1457-4/DS/">http://www.ccsa.org.cn/english/tc/files.php?docpath=/ITU-R/M.1457/M.1457-4/DS/</a>
ETSI	ETSI TS 125 425	5.6.0	Published	20/01/2004	<a href="http://pda.etsi.org/pda/home.asp?wkr=RTS/TSGR-0325425v560">http://pda.etsi.org/pda/home.asp?wkr=RTS/TSGR-0325425v560</a>
T1 (ATIS)	T1.3GPP.25.425V560-2004	5.6.0	Approved	21/05/2004	<a href="https://www.atis.org/atis/docstore/search.asp?committee=S24">https://www.atis.org/atis/docstore/search.asp?committee=S24</a>
TTA	TTAT.3G-25.425(R5-5.6.0)	5.6.0	Approved	25/05/2004	<a href="http://www.tta.or.kr/standardDB/stnfile/TTAT.3G-25.425(R5-5.6.0).zip">http://www.tta.or.kr/standardDB/stnfile/TTAT.3G-25.425(R5-5.6.0).zip</a>
<b>Release 6</b>					
ETSI	ETSI TS 125 425	6.0.0	Published	20/01/2004	<a href="http://pda.etsi.org/pda/home.asp?wkr=RTS/TSGR-0325425v600">http://pda.etsi.org/pda/home.asp?wkr=RTS/TSGR-0325425v600</a>
T1 (ATIS)	T1.3GPP.25.425V600-2004	6.0.0	Approved	21/05/2004	<a href="https://www.atis.org/atis/docstore/search.asp?committee=S24">https://www.atis.org/atis/docstore/search.asp?committee=S24</a>
TTA	TTAT.3G-25.425(R6-6.0.0)	6.0.0	Approved	25/05/2004	<a href="http://www.tta.or.kr/standardDB/stnfile/TTAT.3G-25.425(R6-6.0.0).zip">http://www.tta.or.kr/standardDB/stnfile/TTAT.3G-25.425(R6-6.0.0).zip</a>

**5.3.2.3.16** 25.426**UTRAN Iur and Iub interface data transport and transport signalling for DCH data streams**

This specification describes the transport bearers for the DCH data streams on UTRAN Iur and Iub interfaces. The corresponding transport network control plane is also specified. The physical layer for the transport bearers is outside the scope of this TS.

SDO (2)	Document No.	Version	Status	Issued date	Location (1)
<b>Release 99</b>					
CCSA	CCSA-TSD-DS-25.426	390	Approved	01/07/2003	<a href="http://www.ccsa.org.cn/english/tc/files.php?docpath=/ITU-R/M.1457/M.1457-4/DS/">http://www.ccsa.org.cn/english/tc/files.php?docpath=/ITU-R/M.1457/M.1457-4/DS/</a>
ETSI	ETSI TS 125 426	3.9.0	Published	11/07/2002	<a href="http://pda.etsi.org/pda/home.asp?wkr=RTS/TSGR-0325426v390">http://pda.etsi.org/pda/home.asp?wkr=RTS/TSGR-0325426v390</a>
T1 (ATIS)	T1.3GPP.25.426V390-2003	3.9.0	Approved	27/03/2003	<a href="https://www.atis.org/atis/docstore/search.asp?committee=S24">https://www.atis.org/atis/docstore/search.asp?committee=S24</a>
TTA	TTAT.3G-25.426(R99-3.9.0)	3.9.0	Approved	21/03/2003	<a href="http://www.tta.or.kr/standardDB/stnfile/TTAT.3G-25.426(R99-3.9.0).zip">http://www.tta.or.kr/standardDB/stnfile/TTAT.3G-25.426(R99-3.9.0).zip</a>
<b>Release 4</b>					
CCSA	CCSA-TSD-DS-25.426	440	Approved	01/07/2003	<a href="http://www.ccsa.org.cn/english/tc/files.php?docpath=/ITU-R/M.1457/M.1457-4/DS/">http://www.ccsa.org.cn/english/tc/files.php?docpath=/ITU-R/M.1457/M.1457-4/DS/</a>
ETSI	ETSI TS 125 426	4.4.0	Published	15/10/2002	<a href="http://pda.etsi.org/pda/home.asp?wkr=RTS/TSGR-0325426v440">http://pda.etsi.org/pda/home.asp?wkr=RTS/TSGR-0325426v440</a>
T1 (ATIS)	T1.3GPP.25.426V440-2003	4.4.0	Approved	27/03/2003	<a href="https://www.atis.org/atis/docstore/search.asp?committee=S24">https://www.atis.org/atis/docstore/search.asp?committee=S24</a>
TTA	TTAT.3G-25.426(R4-4.4.0)	4.4.0	Approved	21/03/2003	<a href="http://www.tta.or.kr/standardDB/stnfile/TTAT.3G-25.426(R4-4.4.0).zip">http://www.tta.or.kr/standardDB/stnfile/TTAT.3G-25.426(R4-4.4.0).zip</a>
<b>Release 5</b>					
CCSA	CCSA-TSD-DS-25.426	520	Approved	01/07/2003	<a href="http://www.ccsa.org.cn/english/tc/files.php?docpath=/ITU-R/M.1457/M.1457-4/DS/">http://www.ccsa.org.cn/english/tc/files.php?docpath=/ITU-R/M.1457/M.1457-4/DS/</a>
ETSI	ETSI TS 125 426	5.3.0	Published	03/10/2003	<a href="http://pda.etsi.org/pda/home.asp?wkr=RTS/TSGR-0325426v530">http://pda.etsi.org/pda/home.asp?wkr=RTS/TSGR-0325426v530</a>
T1 (ATIS)	T1.3GPP.25.426V530-2004	5.3.0	Approved	21/05/2004	<a href="https://www.atis.org/atis/docstore/search.asp?committee=S24">https://www.atis.org/atis/docstore/search.asp?committee=S24</a>
TTA	TTAT.3G-25.426(R5-5.3.0)	5.3.0	Approved	25/05/2004	<a href="http://www.tta.or.kr/standardDB/stnfile/TTAT.3G-25.426(R5-5.3.0).zip">http://www.tta.or.kr/standardDB/stnfile/TTAT.3G-25.426(R5-5.3.0).zip</a>
<b>Release 6</b>					
ETSI	ETSI TS 125 426	6.0.0	Published	20/01/2004	<a href="http://pda.etsi.org/pda/home.asp?wkr=RTS/TSGR-0325426v600">http://pda.etsi.org/pda/home.asp?wkr=RTS/TSGR-0325426v600</a>
T1 (ATIS)	T1.3GPP.25.426V600-2004	6.0.0	Approved	21/05/2004	<a href="https://www.atis.org/atis/docstore/search.asp?committee=S24">https://www.atis.org/atis/docstore/search.asp?committee=S24</a>
TTA	TTAT.3G-25.426(R6-6.0.0)	6.0.0	Approved	25/05/2004	<a href="http://www.tta.or.kr/standardDB/stnfile/TTAT.3G-25.426(R6-6.0.0).zip">http://www.tta.or.kr/standardDB/stnfile/TTAT.3G-25.426(R6-6.0.0).zip</a>

**5.3.2.3.17** 25.427**UTRAN Iur and Iub interface user plane protocols for DCH data streams**

This specification describes the UTRAN Iur and Iub interfaces user plane protocols for dedicated transport channel data streams.

SDO (2)	Document No.	Version	Status	Issued date	Location (1)
<b>Release 99</b>					
CCSA	CCSA-TSD-DS-25.427	3A0	Approved	01/07/2003	<a href="http://www.ccsa.org.cn/english/tc/files.php?docpath=/ITU-R/M.1457/M.1457-4/DS/">http://www.ccsa.org.cn/english/tc/files.php?docpath=/ITU-R/M.1457/M.1457-4/DS/</a>
ETSI	ETSI TS 125 427	3.11.0	Published	20/01/2004	<a href="http://pda.etsi.org/pda/home.asp?wkr=RTS/TSGR-0325427v3b0">http://pda.etsi.org/pda/home.asp?wkr=RTS/TSGR-0325427v3b0</a>
T1 (ATIS)	T1.3GPP.25.427V3110-2004	3.11.0	Approved	21/05/2004	<a href="https://www.atis.org/atis/docstore/search.asp?committee=S24">https://www.atis.org/atis/docstore/search.asp?committee=S24</a>
TTA	TTAT.3G-25.427(R99-3.11.0)	3.11.0	Approved	25/05/2004	<a href="http://www.tta.or.kr/standardDB/stnfile/TTAT.3G-25.427(R99-3.11.0).zip">http://www.tta.or.kr/standardDB/stnfile/TTAT.3G-25.427(R99-3.11.0).zip</a>



**Release 4**

CCSA	CCSA-TSD-DS-25.427	440	Approved	01/07/2003	<a href="http://www.ccsa.org.cn/english/tc/files.php?docpath=/ITU-R/M.1457/M.1457-4/DS/">http://www.ccsa.org.cn/english/tc/files.php?docpath=/ITU-R/M.1457/M.1457-4/DS/</a>
ETSI	ETSI TS 125 427	4.5.0	Published	20/01/2004	<a href="http://pda.etsi.org/pda/home.asp?wkr=RTS/TSGR-0325427v450">http://pda.etsi.org/pda/home.asp?wkr=RTS/TSGR-0325427v450</a>
T1 (ATIS)	T1.3GPP.25.427V450-2004	4.5.0	Approved	21/05/2004	<a href="https://www.atis.org/atis/docstore/search.asp?committee=S24">https://www.atis.org/atis/docstore/search.asp?committee=S24</a>
TTA	TTAT.3G-25.427(R4-4.5.0)	4.5.0	Approved	25/05/2004	<a href="http://www.tta.or.kr/standardDB/stnfile/TTAT.3G-25.427(R4-4.5.0).zip">http://www.tta.or.kr/standardDB/stnfile/TTAT.3G-25.427(R4-4.5.0).zip</a>

**Release 5**

CCSA	CCSA-TSD-DS-25.427	510	Approved	01/07/2003	<a href="http://www.ccsa.org.cn/english/tc/files.php?docpath=/ITU-R/M.1457/M.1457-4/DS/">http://www.ccsa.org.cn/english/tc/files.php?docpath=/ITU-R/M.1457/M.1457-4/DS/</a>
ETSI	ETSI TS 125 427	5.3.0	Published	20/01/2004	<a href="http://pda.etsi.org/pda/home.asp?wkr=RTS/TSGR-0325427v530">http://pda.etsi.org/pda/home.asp?wkr=RTS/TSGR-0325427v530</a>
T1 (ATIS)	T1.3GPP.25.427V530-2004	5.3.0	Approved	21/05/2004	<a href="https://www.atis.org/atis/docstore/search.asp?committee=S24">https://www.atis.org/atis/docstore/search.asp?committee=S24</a>
TTA	TTAT.3G-25.427(R5-5.3.0)	5.3.0	Approved	25/05/2004	<a href="http://www.tta.or.kr/standardDB/stnfile/TTAT.3G-25.427(R5-5.3.0).zip">http://www.tta.or.kr/standardDB/stnfile/TTAT.3G-25.427(R5-5.3.0).zip</a>

**Release 6**

ETSI	ETSI TS 125 427	6.0.0	Published	20/01/2004	<a href="http://pda.etsi.org/pda/home.asp?wkr=RTS/TSGR-0325427v600">http://pda.etsi.org/pda/home.asp?wkr=RTS/TSGR-0325427v600</a>
T1 (ATIS)	T1.3GPP.25.427V600-2004	6.0.0	Approved	21/05/2004	<a href="https://www.atis.org/atis/docstore/search.asp?committee=S24">https://www.atis.org/atis/docstore/search.asp?committee=S24</a>
TTA	TTAT.3G-25.427(R6-6.0.0)	6.0.0	Approved	25/05/2004	<a href="http://www.tta.or.kr/standardDB/stnfile/TTAT.3G-25.427(R6-6.0.0).zip">http://www.tta.or.kr/standardDB/stnfile/TTAT.3G-25.427(R6-6.0.0).zip</a>

**5.3.2.3.18 25.430****UTRAN Iub interface: general aspects and principles**

This specification describes the TSG RAN TS 25.43x series of UMTS technical specifications that define the Iub interface. The Iub interface is a logical interface for the interconnection of Node B and RNC components of the UTRAN.

SDO (2)	Document No.	Version	Status	Issued date	Location (1)
<b>Release 99</b>					
CCSA	CCSA-TSD-DS-25.430	380	Approved	01/07/2003	<a href="http://www.ccsa.org.cn/english/tc/files.php?docpath=/ITU-R/M.1457/M.1457-4/DS/">http://www.ccsa.org.cn/english/tc/files.php?docpath=/ITU-R/M.1457/M.1457-4/DS/</a>
ETSI	ETSI TS 125 430	3.8.0	Published	11/07/2002	<a href="http://pda.etsi.org/pda/home.asp?wkr=RTS/TSGR-0325430v380">http://pda.etsi.org/pda/home.asp?wkr=RTS/TSGR-0325430v380</a>
T1 (ATIS)	T1.3GPP.25.430V380-2003	3.8.0	Approved	27/03/2003	<a href="https://www.atis.org/atis/docstore/search.asp?committee=S24">https://www.atis.org/atis/docstore/search.asp?committee=S24</a>
TTA	TTAT.3G-25.430(R99-3.8.0)	3.8.0	Approved	21/03/2003	<a href="http://www.tta.or.kr/standardDB/stnfile/TTAT.3G-25.430(R99-3.8.0).zip">http://www.tta.or.kr/standardDB/stnfile/TTAT.3G-25.430(R99-3.8.0).zip</a>
<b>Release 4</b>					
CCSA	CCSA-TSD-DS-25.430	440	Approved	01/07/2003	<a href="http://www.ccsa.org.cn/english/tc/files.php?docpath=/ITU-R/M.1457/M.1457-4/DS/">http://www.ccsa.org.cn/english/tc/files.php?docpath=/ITU-R/M.1457/M.1457-4/DS/</a>
ETSI	ETSI TS 125 430	4.4.0	Published	16/10/2002	<a href="http://pda.etsi.org/pda/home.asp?wkr=RTS/TSGR-0325430v440">http://pda.etsi.org/pda/home.asp?wkr=RTS/TSGR-0325430v440</a>
T1 (ATIS)	T1.3GPP.25.430V440-2003	4.4.0	Approved	27/03/2003	<a href="https://www.atis.org/atis/docstore/search.asp?committee=S24">https://www.atis.org/atis/docstore/search.asp?committee=S24</a>
TTA	TTAT.3G-25.430(R4-4.4.0)	4.4.0	Approved	21/03/2003	<a href="http://www.tta.or.kr/standardDB/stnfile/TTAT.3G-25.430(R4-4.4.0).zip">http://www.tta.or.kr/standardDB/stnfile/TTAT.3G-25.430(R4-4.4.0).zip</a>
<b>Release 5</b>					
CCSA	CCSA-TSD-DS-25.430	520	Approved	01/07/2003	<a href="http://www.ccsa.org.cn/english/tc/files.php?docpath=/ITU-R/M.1457/M.1457-4/DS/">http://www.ccsa.org.cn/english/tc/files.php?docpath=/ITU-R/M.1457/M.1457-4/DS/</a>
ETSI	ETSI TS 125 430	5.2.0	Published	16/10/2002	<a href="http://pda.etsi.org/pda/home.asp?wkr=RTS/TSGR-0325430v520">http://pda.etsi.org/pda/home.asp?wkr=RTS/TSGR-0325430v520</a>
T1 (ATIS)	T1.3GPP.25.430V520-2003	5.2.0	Approved	27/03/2003	<a href="https://www.atis.org/atis/docstore/search.asp?committee=S24">https://www.atis.org/atis/docstore/search.asp?committee=S24</a>
TTA	TTAT.3G-25.430(R5-5.2.0)	5.2.0	Approved	21/03/2003	<a href="http://www.tta.or.kr/standardDB/stnfile/TTAT.3G-25.430(R5-5.2.0).zip">http://www.tta.or.kr/standardDB/stnfile/TTAT.3G-25.430(R5-5.2.0).zip</a>

**Release 6**

ETSI	ETSI TS 125 430	6.0.0	Published	20/01/2004	<a href="http://pda.etsi.org/pda/home.asp?wkr=RTS/TSGR-0325430v600">http://pda.etsi.org/pda/home.asp?wkr=RTS/TSGR-0325430v600</a>
T1 (ATIS)	T1.3GPP.25.430V600-2003	6.0.0	Approved	21/05/2004	<a href="https://www.atis.org/atis/docstore/search.asp?committee=S24">https://www.atis.org/atis/docstore/search.asp?committee=S24</a>
TTA	TTAT.3G-25.430(R6-6.0.0)	6.0.0	Approved	25/05/2004	<a href="http://www.tta.or.kr/standardDB/stnfile/TTAT.3G-25.430(R6-6.0.0).zip">http://www.tta.or.kr/standardDB/stnfile/TTAT.3G-25.430(R6-6.0.0).zip</a>

**5.3.2.3.19** 25.431**UTRAN Iub interface: Layer 1**

This specification describes the standards allowed to implement Layer 1 on the Iub interface. The specification of transmission delay requirements and O&M requirements is not in the scope of this specification.

SDO (2)	Document No.	Version	Status	Issued date	Location (1)
<b>Release 99</b>					
CCSA	CCSA-TSD-DS-25.431	310	Approved	01/07/2003	<a href="http://www.ccsa.org.cn/english/tc/files.php?docpath=/ITU-R/M.1457/M.1457-4/DS/">http://www.ccsa.org.cn/english/tc/files.php?docpath=/ITU-R/M.1457/M.1457-4/DS/</a>
ETSI	ETSI TS 125 431	3.1.0	Published	27/04/2001	<a href="http://pda.etsi.org/pda/home.asp?wkr=RTS/TSGR-0325431UR1">http://pda.etsi.org/pda/home.asp?wkr=RTS/TSGR-0325431UR1</a>
T1 (ATIS)	T1.3GPP.25.431V310-2002	3.1.0	Approved	03/05/2002	<a href="https://www.atis.org/atis/docstore/search.asp?committee=S24">https://www.atis.org/atis/docstore/search.asp?committee=S24</a>
TTA	TTAE.3G-25.431(R99-3.1.0)	3.1.0	Approved	29/05/2002	<a href="http://www.tta.or.kr/standardDB/stnfile/TTAE.3G-25.431(R99-3.1.0).zip">http://www.tta.or.kr/standardDB/stnfile/TTAE.3G-25.431(R99-3.1.0).zip</a>
<b>Release 4</b>					
CCSA	CCSA-TSD-DS-25.431	400	Approved	01/07/2003	<a href="http://www.ccsa.org.cn/english/tc/files.php?docpath=/ITU-R/M.1457/M.1457-4/DS/">http://www.ccsa.org.cn/english/tc/files.php?docpath=/ITU-R/M.1457/M.1457-4/DS/</a>
ETSI	ETSI TS 125 431	4.0.0	Published	27/04/2001	<a href="http://pda.etsi.org/pda/home.asp?wkr=RTS/TSGR-0325431Uv4">http://pda.etsi.org/pda/home.asp?wkr=RTS/TSGR-0325431Uv4</a>
T1 (ATIS)	T1.3GPP.25.431V400-2002	4.0.0	Approved	03/05/2002	<a href="https://www.atis.org/atis/docstore/search.asp?committee=S24">https://www.atis.org/atis/docstore/search.asp?committee=S24</a>
TTA	TTAE.3G-25.431(R4-4.0.0)	4.0.0	Approved	29/05/2002	<a href="http://www.tta.or.kr/standardDB/stnfile/TTAE.3G-25.431(R4-4.0.0).zip">http://www.tta.or.kr/standardDB/stnfile/TTAE.3G-25.431(R4-4.0.0).zip</a>
<b>Release 5</b>					
CCSA	CCSA-TSD-DS-25.431	500	Approved	01/07/2003	<a href="http://www.ccsa.org.cn/english/tc/files.php?docpath=/ITU-R/M.1457/M.1457-4/DS/">http://www.ccsa.org.cn/english/tc/files.php?docpath=/ITU-R/M.1457/M.1457-4/DS/</a>
ETSI	ETSI TS 125 431	5.0.0	Published	15/04/2002	<a href="http://pda.etsi.org/pda/home.asp?wkr=RTS/TSGR-0325431Uv5">http://pda.etsi.org/pda/home.asp?wkr=RTS/TSGR-0325431Uv5</a>
T1 (ATIS)	T1.3GPP.25.431V500-2002	5.0.0	Approved	03/05/2002	<a href="https://www.atis.org/atis/docstore/search.asp?committee=S24">https://www.atis.org/atis/docstore/search.asp?committee=S24</a>
TTA	TTAE.3G-25.431(R5-5.0.0)	5.0.0	Approved	29/05/2002	<a href="http://www.tta.or.kr/standardDB/stnfile/TTAE.3G-25.431(R5-5.0.0).zip">http://www.tta.or.kr/standardDB/stnfile/TTAE.3G-25.431(R5-5.0.0).zip</a>
<b>Release 6</b>					
ETSI	ETSI TS 125 431	6.0.0	Published	20/01/2004	<a href="http://pda.etsi.org/pda/home.asp?wkr=RTS/TSGR-0325431v600">http://pda.etsi.org/pda/home.asp?wkr=RTS/TSGR-0325431v600</a>
T1 (ATIS)	T1.3GPP.25.431V600-2004	6.0.0	Approved	21/05/2004	<a href="https://www.atis.org/atis/docstore/search.asp?committee=S24">https://www.atis.org/atis/docstore/search.asp?committee=S24</a>
TTA	TTAT.3G-25.431(R6-6.0.0)	6.0.0	Approved	25/05/2004	<a href="http://www.tta.or.kr/standardDB/stnfile/TTAT.3G-25.431(R6-6.0.0).zip">http://www.tta.or.kr/standardDB/stnfile/TTAT.3G-25.431(R6-6.0.0).zip</a>

**5.3.2.3.20** 25.432**UTRAN Iub interface: signalling transport**

This specification describes the signalling transport related to the Node B application part (NBAP) signalling to be used across the Iub interface. The Iub interface is a logical interface for the interconnection of Node B and RNC components of the UTRAN. The RNC signalling between these nodes is based on NBAP.

SDO (2)	Document No.	Version	Status	Issued date	Location (1)
<b>Release 99</b>					
CCSA	CCSA-TSD-DS-25.432	310	Approved	01/07/2003	<a href="http://www.ccsa.org.cn/english/tc/files.php?docpath=/ITU-R/M.1457/M.1457-4/DS/">http://www.ccsa.org.cn/english/tc/files.php?docpath=/ITU-R/M.1457/M.1457-4/DS/</a>
ETSI	ETSI TS 125 432	3.1.0	Published	01/02/2000	<a href="http://pda.etsi.org/pda/home.asp?wkr=DTS/TSGR-0325432U">http://pda.etsi.org/pda/home.asp?wkr=DTS/TSGR-0325432U</a>
T1 (ATIS)	T1.3GPP.25.432V310-2002	3.1.0	Approved	03/05/2002	<a href="https://www.atis.org/atis/docstore/search.asp?committee=S24">https://www.atis.org/atis/docstore/search.asp?committee=S24</a>
TTA	TTAE.3G-25.432(F)	3.1.0	Approved	28/03/2000	<a href="http://www.tta.or.kr/standardDB/stnfile/TTAE_3G-25_432F.zip">http://www.tta.or.kr/standardDB/stnfile/TTAE_3G-25_432F.zip</a>
<b>Release 4</b>					
CCSA	CCSA-TSD-DS-25.432	400	Approved	01/07/2003	<a href="http://www.ccsa.org.cn/english/tc/files.php?docpath=/ITU-R/M.1457/M.1457-4/DS/">http://www.ccsa.org.cn/english/tc/files.php?docpath=/ITU-R/M.1457/M.1457-4/DS/</a>
ETSI	ETSI TS 125 432	4.0.0	Published	27/04/2001	<a href="http://pda.etsi.org/pda/home.asp?wkr=RTS/TSGR-0325432Uv4">http://pda.etsi.org/pda/home.asp?wkr=RTS/TSGR-0325432Uv4</a>
T1 (ATIS)	T1.3GPP.25.432V400-2002	4.0.0	Approved	03/05/2002	<a href="https://www.atis.org/atis/docstore/search.asp?committee=S24">https://www.atis.org/atis/docstore/search.asp?committee=S24</a>
TTA	TTAE.3G-25.432(R4-4.0.0)	4.0.0	Approved	29/05/2002	<a href="http://www.tta.or.kr/standardDB/stnfile/TTAE.3G-25.432(R4-4.0.0).zip">http://www.tta.or.kr/standardDB/stnfile/TTAE.3G-25.432(R4-4.0.0).zip</a>
<b>Release 5</b>					
CCSA	CCSA-TSD-DS-25.432	510	Approved	01/07/2003	<a href="http://www.ccsa.org.cn/english/tc/files.php?docpath=/ITU-R/M.1457/M.1457-4/DS/">http://www.ccsa.org.cn/english/tc/files.php?docpath=/ITU-R/M.1457/M.1457-4/DS/</a>
ETSI	ETSI TS 125 432	5.1.0	Published	10/10/2002	<a href="http://pda.etsi.org/pda/home.asp?wkr=RTS/TSGR-0325432v510">http://pda.etsi.org/pda/home.asp?wkr=RTS/TSGR-0325432v510</a>
T1 (ATIS)	T1.3GPP.25.432V510-2003	5.1.0	Approved	27/03/2003	<a href="https://www.atis.org/atis/docstore/search.asp?committee=S24">https://www.atis.org/atis/docstore/search.asp?committee=S24</a>
TTA	TTAT.3G-25.432(R5-5.1.0)	5.1.0	Approved	21/03/2003	<a href="http://www.tta.or.kr/standardDB/stnfile/TTAT.3G-25.432(R5-5.1.0).zip">http://www.tta.or.kr/standardDB/stnfile/TTAT.3G-25.432(R5-5.1.0).zip</a>
<b>Release 6</b>					
ETSI	ETSI TS 125 432	6.0.0	Published	20/01/2004	<a href="http://pda.etsi.org/pda/home.asp?wkr=RTS/TSGR-0325432v600">http://pda.etsi.org/pda/home.asp?wkr=RTS/TSGR-0325432v600</a>
T1 (ATIS)	T1.3GPP.25.432V600-2004	6.0.0	Approved	21/05/2004	<a href="https://www.atis.org/atis/docstore/search.asp?committee=S24">https://www.atis.org/atis/docstore/search.asp?committee=S24</a>
TTA	TTAT.3G-25.432(R6-6.0.0)	6.0.0	Approved	25/05/2004	<a href="http://www.tta.or.kr/standardDB/stnfile/TTAT.3G-25.432(R6-6.0.0).zip">http://www.tta.or.kr/standardDB/stnfile/TTAT.3G-25.432(R6-6.0.0).zip</a>

### 5.3.2.3.21 25.433

#### UTRAN Iub interface: NBAP signalling

This specification describes the standards for NBAP specification to be used over Iub interface.

SDO (2)	Document No.	Version	Status	Issued date	Location (1)
<b>Release 99</b>					
CCSA	CCSA-TSD-DS-25.433	3D0	Approved	01/07/2003	<a href="http://www.ccsa.org.cn/english/tc/files.php?docpath=/ITU-R/M.1457/M.1457-4/DS/">http://www.ccsa.org.cn/english/tc/files.php?docpath=/ITU-R/M.1457/M.1457-4/DS/</a>
ETSI	ETSI TS 125 433	3.14.0	Published	06/10/2003	<a href="http://pda.etsi.org/pda/home.asp?wkr=RTS/TSGR-0325433v3e0">http://pda.etsi.org/pda/home.asp?wkr=RTS/TSGR-0325433v3e0</a>
T1 (ATIS)	T1.3GPP.25.433V3140-2004	3.14.0	Approved	21/05/2004	<a href="https://www.atis.org/atis/docstore/search.asp?committee=S24">https://www.atis.org/atis/docstore/search.asp?committee=S24</a>
TTA	TTAT.3G-25.433(R99-3.14.0)	3.14.0	Approved	25/05/2004	<a href="http://www.tta.or.kr/standardDB/stnfile/TTAT.3G-25.433(R99-3.14.0).zip">http://www.tta.or.kr/standardDB/stnfile/TTAT.3G-25.433(R99-3.14.0).zip</a>
<b>Release 4</b>					
CCSA	CCSA-TSD-DS-25.433	490	Approved	01/07/2003	<a href="http://www.ccsa.org.cn/english/tc/files.php?docpath=/ITU-R/M.1457/M.1457-4/DS/">http://www.ccsa.org.cn/english/tc/files.php?docpath=/ITU-R/M.1457/M.1457-4/DS/</a>
ETSI	ETSI TS 125 433	4.11.0	Published	21/01/2004	<a href="http://pda.etsi.org/pda/home.asp?wkr=RTS/TSGR-0325433v4b0">http://pda.etsi.org/pda/home.asp?wkr=RTS/TSGR-0325433v4b0</a>
T1 (ATIS)	T1.3GPP.25.433V4110-2004	4.11.0	Approved	21/05/2004	<a href="https://www.atis.org/atis/docstore/search.asp?committee=S24">https://www.atis.org/atis/docstore/search.asp?committee=S24</a>
TTA	TTAT.3G-25.433(R4-4.11.0)	4.11.0	Approved	25/05/2004	<a href="http://www.tta.or.kr/standardDB/stnfile/TTAT.3G-25.433(R4-4.11.0).zip">http://www.tta.or.kr/standardDB/stnfile/TTAT.3G-25.433(R4-4.11.0).zip</a>

**Release 5**

CCSA	CCSA-TSD-DS-25.433	550	Approved	01/07/2003	<a href="http://www.ccsa.org.cn/english/tc/files.php?docpath=/ITU-R/M.1457/M.1457-4/DS/">http://www.ccsa.org.cn/english/tc/files.php?docpath=/ITU-R/M.1457/M.1457-4/DS/</a>
ETSI	ETSI TS 125 433	5.7.0	Published	30/01/2004	<a href="http://pda.etsi.org/pda/home.asp?wkr=RTS/TSGR-0325433v570">http://pda.etsi.org/pda/home.asp?wkr=RTS/TSGR-0325433v570</a>
T1 (ATIS)	T1.3GPP.25.433V570-2004	5.7.0	Approved	21/05/2004	<a href="https://www.atis.org/atis/docstore/search.asp?committee=S24">https://www.atis.org/atis/docstore/search.asp?committee=S24</a>
TTA	TTAT.3G-25.433(R5-5.7.0)	5.7.0	Approved	25/05/2004	<a href="http://www.tta.or.kr/standardDB/stnfile/TTAT.3G-25.433(R5-5.7.0).zip">http://www.tta.or.kr/standardDB/stnfile/TTAT.3G-25.433(R5-5.7.0).zip</a>

**Release 6**

ETSI	ETSI TS 125 433	6.0.0	Published	30/01/2004	<a href="http://pda.etsi.org/pda/home.asp?wkr=RTS/TSGR-0325433v600">http://pda.etsi.org/pda/home.asp?wkr=RTS/TSGR-0325433v600</a>
T1 (ATIS)	T1.3GPP.25.433V600-2004	6.0.0	Approved	21/05/2004	<a href="https://www.atis.org/atis/docstore/search.asp?committee=S24">https://www.atis.org/atis/docstore/search.asp?committee=S24</a>
TTA	TTAT.3G-25.433(R6-6.0.0)	6.0.0	Approved	25/05/2004	<a href="http://www.tta.or.kr/standardDB/stnfile/TTAT.3G-25.433(R6-6.0.0).zip">http://www.tta.or.kr/standardDB/stnfile/TTAT.3G-25.433(R6-6.0.0).zip</a>

**5.3.2.3.22 25.434****UTRAN Iub interface data transport and transport signalling for common transport channel data streams**

This specification describes the UTRAN RNC-Node B (Iub) interface data transport and transport signalling for CCH data streams.

SDO (2)	Document No.	Version	Status	Issued date	Location (1)
<b>Release 99</b>					
CCSA	CCSA-TSD-DS-25.434	380	Approved	01/07/2003	<a href="http://www.ccsa.org.cn/english/tc/files.php?docpath=/ITU-R/M.1457/M.1457-4/DS/">http://www.ccsa.org.cn/english/tc/files.php?docpath=/ITU-R/M.1457/M.1457-4/DS/</a>
ETSI	ETSI TS 125 434	3.8.0	Published	11/07/2002	<a href="http://pda.etsi.org/pda/home.asp?wkr=RTS/TSGR-0325434v380">http://pda.etsi.org/pda/home.asp?wkr=RTS/TSGR-0325434v380</a>
T1 (ATIS)	T1.3GPP.25.434V380-2003	3.8.0	Approved	27/03/2003	<a href="https://www.atis.org/atis/docstore/search.asp?committee=S24">https://www.atis.org/atis/docstore/search.asp?committee=S24</a>
TTA	TTAT.3G-25.434(R99-3.8.0)	3.8.0	Approved	21/03/2003	<a href="http://www.tta.or.kr/standardDB/stnfile/TTAT.3G-25.434(R99-3.8.0).zip">http://www.tta.or.kr/standardDB/stnfile/TTAT.3G-25.434(R99-3.8.0).zip</a>
<b>Release 4</b>					
CCSA	CCSA-TSD-DS-25.434	440	Approved	01/07/2003	<a href="http://www.ccsa.org.cn/english/tc/files.php?docpath=/ITU-R/M.1457/M.1457-4/DS/">http://www.ccsa.org.cn/english/tc/files.php?docpath=/ITU-R/M.1457/M.1457-4/DS/</a>
ETSI	ETSI TS 125 434	4.4.0	Published	11/07/2002	<a href="http://pda.etsi.org/pda/home.asp?wkr=RTS/TSGR-0325434v440">http://pda.etsi.org/pda/home.asp?wkr=RTS/TSGR-0325434v440</a>
T1 (ATIS)	T1.3GPP.25.434V440-2003	4.4.0	Approved	27/03/2003	<a href="https://www.atis.org/atis/docstore/search.asp?committee=S24">https://www.atis.org/atis/docstore/search.asp?committee=S24</a>
TTA	TTAT.3G-25.434(R4-4.4.0)	4.4.0	Approved	21/03/2003	<a href="http://www.tta.or.kr/standardDB/stnfile/TTAT.3G-25.434(R4-4.4.0).zip">http://www.tta.or.kr/standardDB/stnfile/TTAT.3G-25.434(R4-4.4.0).zip</a>
<b>Release 5</b>					
CCSA	CCSA-TSD-DS-25.434	510	Approved	01/07/2003	<a href="http://www.ccsa.org.cn/english/tc/files.php?docpath=/ITU-R/M.1457/M.1457-4/DS/">http://www.ccsa.org.cn/english/tc/files.php?docpath=/ITU-R/M.1457/M.1457-4/DS/</a>
ETSI	ETSI TS 125 434	5.3.0	Published	21/01/2004	<a href="http://pda.etsi.org/pda/home.asp?wkr=RTS/TSGR-0325434v530">http://pda.etsi.org/pda/home.asp?wkr=RTS/TSGR-0325434v530</a>
T1 (ATIS)	T1.3GPP.25.434V530-2004	5.3.0	Approved	21/05/2004	<a href="https://www.atis.org/atis/docstore/search.asp?committee=S24">https://www.atis.org/atis/docstore/search.asp?committee=S24</a>
TTA	TTAT.3G-25.434(R5-5.3.0)	5.3.0	Approved	25/05/2004	<a href="http://www.tta.or.kr/standardDB/stnfile/TTAT.3G-25.434(R5-5.3.0).zip">http://www.tta.or.kr/standardDB/stnfile/TTAT.3G-25.434(R5-5.3.0).zip</a>
<b>Release 6</b>					
ETSI	ETSI TS 125 434	6.0.0	Published	21/01/2004	<a href="http://pda.etsi.org/pda/home.asp?wkr=RTS/TSGR-0325434v600">http://pda.etsi.org/pda/home.asp?wkr=RTS/TSGR-0325434v600</a>
T1 (ATIS)	T1.3GPP.25.434V600-2004	6.0.0	Approved	21/05/2004	<a href="https://www.atis.org/atis/docstore/search.asp?committee=S24">https://www.atis.org/atis/docstore/search.asp?committee=S24</a>
TTA	TTAT.3G-25.434(R6-6.0.0)	6.0.0	Approved	25/05/2004	<a href="http://www.tta.or.kr/standardDB/stnfile/TTAT.3G-25.434(R6-6.0.0).zip">http://www.tta.or.kr/standardDB/stnfile/TTAT.3G-25.434(R6-6.0.0).zip</a>

**5.3.2.3.23** 25.435**UTRAN Iub interface user plane protocols for common transport channel data streams**

This specification describes the UTRAN RNC-Node B (Iub) interface user plane protocols for common transport channel data streams.

SDO (2)	Document No.	Version	Status	Issued date	Location (1)
<b>Release 99</b>					
CCSA	CCSA-TSD-DS-25.435	3A0	Approved	01/07/2003	<a href="http://www.ccsa.org.cn/english/tc/files.php?docpath=/ITU-R/M.1457/M.1457-4/DS/">http://www.ccsa.org.cn/english/tc/files.php?docpath=/ITU-R/M.1457/M.1457-4/DS/</a>
ETSI	ETSI TS 125 435	3.11.0	Published	21/01/2004	<a href="http://pda.etsi.org/pda/home.asp?wkr=RTS/TSGR-0325435v3b0">http://pda.etsi.org/pda/home.asp?wkr=RTS/TSGR-0325435v3b0</a>
T1 (ATIS)	T1.3GPP.25.435V3110-2004	3.11.0	Approved	21/05/2004	<a href="https://www.atis.org/atis/docstore/search.asp?committee=S24">https://www.atis.org/atis/docstore/search.asp?committee=S24</a>
TTA	TTAT.3G-25.435(R99-3.11.0)	3.11.0	Approved	25/05/2004	<a href="http://www.tta.or.kr/standardDB/stnfile/TTAT.3G-25.435(R99-3.11.0).zip">http://www.tta.or.kr/standardDB/stnfile/TTAT.3G-25.435(R99-3.11.0).zip</a>
<b>Release 4</b>					
CCSA	CCSA-TSD-DS-25.435	450	Approved	01/07/2003	<a href="http://www.ccsa.org.cn/english/tc/files.php?docpath=/ITU-R/M.1457/M.1457-4/DS/">http://www.ccsa.org.cn/english/tc/files.php?docpath=/ITU-R/M.1457/M.1457-4/DS/</a>
ETSI	ETSI TS 125 435	4.6.0	Published	21/01/2004	<a href="http://pda.etsi.org/pda/home.asp?wkr=RTS/TSGR-0325435v460">http://pda.etsi.org/pda/home.asp?wkr=RTS/TSGR-0325435v460</a>
T1 (ATIS)	T1.3GPP.25.435V460-2004	4.6.0	Approved	21/05/2004	<a href="https://www.atis.org/atis/docstore/search.asp?committee=S24">https://www.atis.org/atis/docstore/search.asp?committee=S24</a>
TTA	TTAT.3G-25.435(R4-4.6.0)	4.6.0	Approved	25/05/2004	<a href="http://www.tta.or.kr/standardDB/stnfile/TTAT.3G-25.435(R4-4.6.0).zip">http://www.tta.or.kr/standardDB/stnfile/TTAT.3G-25.435(R4-4.6.0).zip</a>
<b>Release 5</b>					
CCSA	CCSA-TSD-DS-25.435	550	Approved	01/07/2003	<a href="http://www.ccsa.org.cn/english/tc/files.php?docpath=/ITU-R/M.1457/M.1457-4/DS/">http://www.ccsa.org.cn/english/tc/files.php?docpath=/ITU-R/M.1457/M.1457-4/DS/</a>
ETSI	ETSI TS 125 435	5.6.0	Published	21/01/2004	<a href="http://pda.etsi.org/pda/home.asp?wkr=RTS/TSGR-0325435v560">http://pda.etsi.org/pda/home.asp?wkr=RTS/TSGR-0325435v560</a>
T1 (ATIS)	T1.3GPP.25.435V560-2004	5.6.0	Approved	21/05/2004	<a href="https://www.atis.org/atis/docstore/search.asp?committee=S24">https://www.atis.org/atis/docstore/search.asp?committee=S24</a>
TTA	TTAT.3G-25.435(R5-5.6.0)	5.6.0	Approved	25/05/2004	<a href="http://www.tta.or.kr/standardDB/stnfile/TTAT.3G-25.435(R5-5.6.0).zip">http://www.tta.or.kr/standardDB/stnfile/TTAT.3G-25.435(R5-5.6.0).zip</a>
<b>Release 6</b>					
ETSI	ETSI TS 125 435	6.0.0	Published	21/01/2004	<a href="http://pda.etsi.org/pda/home.asp?wkr=RTS/TSGR-0325435v600">http://pda.etsi.org/pda/home.asp?wkr=RTS/TSGR-0325435v600</a>
T1 (ATIS)	T1.3GPP.25.435V600-2004	6.0.0	Approved	21/05/2004	<a href="https://www.atis.org/atis/docstore/search.asp?committee=S24">https://www.atis.org/atis/docstore/search.asp?committee=S24</a>
TTA	TTAT.3G-25.435(R6-6.0.0)	6.0.0	Approved	25/05/2004	<a href="http://www.tta.or.kr/standardDB/stnfile/TTAT.3G-25.435(R6-6.0.0).zip">http://www.tta.or.kr/standardDB/stnfile/TTAT.3G-25.435(R6-6.0.0).zip</a>

**5.3.2.3.24** 25.442**UTRAN implementation specific O&M transport**

This specification describes the transport of implementation specific O&M signalling between Node B and the management platform in case that the transport is routed via the RNC.

SDO (2)	Document No.	Version	Status	Issued date	Location (1)
<b>Release 99</b>					
CCSA	CCSA-TSD-DS-25.442	310	Approved	01/07/2003	<a href="http://www.ccsa.org.cn/english/tc/files.php?docpath=/ITU-R/M.1457/M.1457-4/DS/">http://www.ccsa.org.cn/english/tc/files.php?docpath=/ITU-R/M.1457/M.1457-4/DS/</a>
ETSI	ETSI TS 125 442	3.1.0	Published	17/05/2000	<a href="http://pda.etsi.org/pda/home.asp?wkr=RTS/TSGR-0325442UR1">http://pda.etsi.org/pda/home.asp?wkr=RTS/TSGR-0325442UR1</a>
T1 (ATIS)	T1.3GPP.25.442V310-2002	3.1.0	Approved	03/05/2002	<a href="https://www.atis.org/atis/docstore/search.asp?committee=S24">https://www.atis.org/atis/docstore/search.asp?committee=S24</a>
TTA	TTAE.3G-25.442(R99-3.1.0)	3.1.0	Approved	29/05/2002	<a href="http://www.tta.or.kr/standardDB/stnfile/TTAE.3G-25.442(R99-3.1.0).zip">http://www.tta.or.kr/standardDB/stnfile/TTAE.3G-25.442(R99-3.1.0).zip</a>

**Release 4**

CCSA	CCSA-TSD-DS-25.442	400	Approved	01/07/2003	<a href="http://www.ccsa.org.cn/english/tc/files.php?docpath=/ITU-R/M.1457/M.1457-4/DS/">http://www.ccsa.org.cn/english/tc/files.php?docpath=/ITU-R/M.1457/M.1457-4/DS/</a>
ETSI	ETSI TS 125 442	4.0.0	Published	27/04/2001	<a href="http://pda.etsi.org/pda/home.asp?wkr=RTS/TSGR-0325442Uv4">http://pda.etsi.org/pda/home.asp?wkr=RTS/TSGR-0325442Uv4</a>
T1 (ATIS)	T1.3GPP.25.442V400-2002	4.0.0	Approved	03/05/2002	<a href="https://www.atis.org/atis/docstore/search.asp?committee=S24">https://www.atis.org/atis/docstore/search.asp?committee=S24</a>
TTA	TTAE.3G-25.442(R4-4.0.0)	4.0.0	Approved	29/05/2002	<a href="http://www.tta.or.kr/standardDB/stnfile/TTAE.3G-25.442(R4-4.0.0).zip">http://www.tta.or.kr/standardDB/stnfile/TTAE.3G-25.442(R4-4.0.0).zip</a>

**Release 5**

CCSA	CCSA-TSD-DS-25.442	510	Approved	01/07/2003	<a href="http://www.ccsa.org.cn/english/tc/files.php?docpath=/ITU-R/M.1457/M.1457-4/DS/">http://www.ccsa.org.cn/english/tc/files.php?docpath=/ITU-R/M.1457/M.1457-4/DS/</a>
ETSI	ETSI TS 125 442	5.1.0	Published	10/10/2002	<a href="http://pda.etsi.org/pda/home.asp?wkr=RTS/TSGR-0325442v510">http://pda.etsi.org/pda/home.asp?wkr=RTS/TSGR-0325442v510</a>
T1 (ATIS)	T1.3GPP.25.442V510-2003	5.1.0	Approved	27/03/2003	<a href="https://www.atis.org/atis/docstore/search.asp?committee=S24">https://www.atis.org/atis/docstore/search.asp?committee=S24</a>
TTA	TTAT.3G-25.442(R5-5.1.0)	5.1.0	Approved	21/03/2003	<a href="http://www.tta.or.kr/standardDB/stnfile/TTAT.3G-25.442(R5-5.1.0).zip">http://www.tta.or.kr/standardDB/stnfile/TTAT.3G-25.442(R5-5.1.0).zip</a>

**Release 6**

ETSI	ETSI TS 125 442	6.0.0	Published	21/01/2004	<a href="http://pda.etsi.org/pda/home.asp?wkr=RTS/TSGR-0325442v600">http://pda.etsi.org/pda/home.asp?wkr=RTS/TSGR-0325442v600</a>
T1 (ATIS)	T1.3GPP.25.442V600-2004	6.0.0	Approved	21/05/2004	<a href="https://www.atis.org/atis/docstore/search.asp?committee=S24">https://www.atis.org/atis/docstore/search.asp?committee=S24</a>
TTA	TTAT.3G-25.442(R6-6.0.0)	6.0.0	Approved	25/05/2004	<a href="http://www.tta.or.kr/standardDB/stnfile/TTAT.3G-25.442(R6-6.0.0).zip">http://www.tta.or.kr/standardDB/stnfile/TTAT.3G-25.442(R6-6.0.0).zip</a>

**5.3.2.3.25 25.450****UTRAN Iupc interface general aspects and principles**

The present document is an introduction to the TSG RAN TS 25.45z series of UMTS Technical Specifications that define the Iupc Interface. The Iupc interface is a logical interface for the interconnection of Standalone SMLC (SAS) and Radio Network Controller (RNC) components of the Universal Terrestrial Radio Access Network (UTRAN) for the UMTS system.

SDO (2)	Document No.	Version	Status	Issued date	Location (1)
<b>Release 5</b>					
CCSA	CCSA-TSD-DS-25.450	510	Approved	01/07/2003	<a href="http://www.ccsa.org.cn/english/tc/files.php?docpath=/ITU-R/M.1457/M.1457-4/DS/">http://www.ccsa.org.cn/english/tc/files.php?docpath=/ITU-R/M.1457/M.1457-4/DS/</a>
ETSI	ETSI TS 125 450	5.1.0	Published	23/04/2002	<a href="http://pda.etsi.org/pda/home.asp?wkr=DTS/TSGR-0325450Uv5">http://pda.etsi.org/pda/home.asp?wkr=DTS/TSGR-0325450Uv5</a>
T1 (ATIS)	T1.3GPP.25.450V510-2002	5.1.0	Approved	03/05/2002	<a href="https://www.atis.org/atis/docstore/search.asp?committee=S24">https://www.atis.org/atis/docstore/search.asp?committee=S24</a>
TTA	TTAE.3G-25.450(R5-5.1.0)	5.1.0	Approved	29/05/2002	<a href="http://www.tta.or.kr/standardDB/stnfile/TTAE.3G-25.450(R5-5.1.0).zip">http://www.tta.or.kr/standardDB/stnfile/TTAE.3G-25.450(R5-5.1.0).zip</a>
<b>Release 6</b>					
CCSA	CCSA-TSD-DS-25.450	600	Approved	01/07/2003	<a href="http://www.ccsa.org.cn/english/tc/files.php?docpath=/ITU-R/M.1457/M.1457-4/DS/">http://www.ccsa.org.cn/english/tc/files.php?docpath=/ITU-R/M.1457/M.1457-4/DS/</a>
ETSI	ETSI TS 125 450	6.0.0	Published	27/01/2004	<a href="http://pda.etsi.org/pda/home.asp?wkr=RTS/TSGR-0325450v600">http://pda.etsi.org/pda/home.asp?wkr=RTS/TSGR-0325450v600</a>
T1 (ATIS)	T1.3GPP.25.450V600-2004	6.0.0	Approved	21/05/2004	<a href="https://www.atis.org/atis/docstore/search.asp?committee=S24">https://www.atis.org/atis/docstore/search.asp?committee=S24</a>
TTA	TTAT.3G-25.450(R6-6.0.0)	6.0.0	Approved	25/05/2004	<a href="http://www.tta.or.kr/standardDB/stnfile/TTAT.3G-25.450(R6-6.0.0).zip">http://www.tta.or.kr/standardDB/stnfile/TTAT.3G-25.450(R6-6.0.0).zip</a>

**5.3.2.3.26 25.451****UTRAN Iupc Interface Layer 1**

The present document specifies the standards allowed to implement Layer 1 on the Iupc interface.

SDO (2)	Document No.	Version	Status	Issued date	Location (1)
<b>Release 5</b>					
CCSA	CCSA-TSD-DS-25.451	501	Approved	01/07/2003	<a href="http://www.ccsa.org.cn/english/tc/files.php?docpath=/ITU-R/M.1457/M.1457-4/DS/">http://www.ccsa.org.cn/english/tc/files.php?docpath=/ITU-R/M.1457/M.1457-4/DS/</a>
ETSI	ETSI TS 125 451	5.0.1	Published	24/04/2002	<a href="http://pda.etsi.org/pda/home.asp?wkr=DTS/TSGR-0325451Uv5">http://pda.etsi.org/pda/home.asp?wkr=DTS/TSGR-0325451Uv5</a>
T1 (ATIS)	T1.3GPP.25.451V501-2002	5.0.1	Approved	03/05/2002	<a href="https://www.atis.org/atis/docstore/search.asp?committee=S24">https://www.atis.org/atis/docstore/search.asp?committee=S24</a>
TTA	TTAT.3G-25.451(R5-5.0.1)	5.0.1	Approved	21/03/2003	<a href="http://www.tta.or.kr/standardDB/stnfile/TTAT.3G-25.451(R5-5.0.1).zip">http://www.tta.or.kr/standardDB/stnfile/TTAT.3G-25.451(R5-5.0.1).zip</a>
<b>Release 6</b>					
ETSI	ETSI TS 125 451	6.0.0	Published	21/01/2004	<a href="http://pda.etsi.org/pda/home.asp?wkr=RTS/TSGR-0325451v600">http://pda.etsi.org/pda/home.asp?wkr=RTS/TSGR-0325451v600</a>
T1 (ATIS)	T1.3GPP.25.451V600-2004	6.0.0	Approved	21/05/2004	<a href="https://www.atis.org/atis/docstore/search.asp?committee=S24">https://www.atis.org/atis/docstore/search.asp?committee=S24</a>

### 5.3.2.3.27 25.452

#### UTRAN Iupc Interface: Signalling Transport

The present document specifies the signalling transport related to PCAP signalling to be used across the Iupc interface.

SDO (2)	Document No.	Version	Status	Issued date	Location (1)
<b>Release 5</b>					
CCSA	CCSA-TSD-DS-25.452	500	Approved	01/07/2003	<a href="http://www.ccsa.org.cn/english/tc/files.php?docpath=/ITU-R/M.1457/M.1457-4/DS/">http://www.ccsa.org.cn/english/tc/files.php?docpath=/ITU-R/M.1457/M.1457-4/DS/</a>
ETSI	ETSI TS 125 452	5.0.0	Published	23/04/2002	<a href="http://pda.etsi.org/pda/home.asp?wkr=DTS/TSGR-0325452Uv5">http://pda.etsi.org/pda/home.asp?wkr=DTS/TSGR-0325452Uv5</a>
T1 (ATIS)	T1.3GPP.25.452V500-2002	5.0.0	Approved	03/05/2002	<a href="https://www.atis.org/atis/docstore/search.asp?committee=S24">https://www.atis.org/atis/docstore/search.asp?committee=S24</a>
TTA	TTAE.3G-25.452(R5-5.0.0)	5.0.0	Approved	29/05/2002	<a href="http://www.tta.or.kr/standardDB/stnfile/TTAE.3G-25.452(R5-5.0.0).zip">http://www.tta.or.kr/standardDB/stnfile/TTAE.3G-25.452(R5-5.0.0).zip</a>
<b>Release 6</b>					
CCSA	CCSA-TSD-DS-25.452	600	Approved	01/07/2003	<a href="http://www.ccsa.org.cn/english/tc/files.php?docpath=/ITU-R/M.1457/M.1457-4/DS/">http://www.ccsa.org.cn/english/tc/files.php?docpath=/ITU-R/M.1457/M.1457-4/DS/</a>
ETSI	ETSI TS 125 452	6.0.0	Published	27/01/2004	<a href="http://pda.etsi.org/pda/home.asp?wkr=RTS/TSGR-0325452v600">http://pda.etsi.org/pda/home.asp?wkr=RTS/TSGR-0325452v600</a>
T1 (ATIS)	T1.3GPP.25.452V600-2004	6.0.0	Approved	21/05/2004	<a href="https://www.atis.org/atis/docstore/search.asp?committee=S24">https://www.atis.org/atis/docstore/search.asp?committee=S24</a>
TTA	TTAT.3G-25.452(R6-6.0.0)	6.0.0	Approved	25/05/2004	<a href="http://www.tta.or.kr/standardDB/stnfile/TTAT.3G-25.452(R6-6.0.0).zip">http://www.tta.or.kr/standardDB/stnfile/TTAT.3G-25.452(R6-6.0.0).zip</a>

### 5.3.2.3.28 25.453

#### UTRAN Iupc interface PCAP signalling

The present document specifies the Positioning Calculation Application Part (PCAP) between the Radio Network Controller (RNC) and the Stand-alone SMLC (SAS).

SDO (2)	Document No.	Version	Status	Issued date	Location (1)
<b>Release 5</b>					
CCSA	CCSA-TSD-DS-25.453	560	Approved	01/07/2003	<a href="http://www.ccsa.org.cn/english/tc/files.php?docpath=/ITU-R/M.1457/M.1457-4/DS/">http://www.ccsa.org.cn/english/tc/files.php?docpath=/ITU-R/M.1457/M.1457-4/DS/</a>
ETSI	ETSI TS 125 453	5.8.0	Published	21/01/2004	<a href="http://pda.etsi.org/pda/home.asp?wkr=RTS/TSGR-0325453v580">http://pda.etsi.org/pda/home.asp?wkr=RTS/TSGR-0325453v580</a>
T1 (ATIS)	T1.3GPP.25.453V580-2004	5.8.0	Approved	21/05/2004	<a href="https://www.atis.org/atis/docstore/search.asp?committee=S24">https://www.atis.org/atis/docstore/search.asp?committee=S24</a>
TTA	TTAT.3G-25.453(R5-5.8.0)	5.8.0	Approved	25/05/2004	<a href="http://www.tta.or.kr/standardDB/stnfile/TTAT.3G-25.453(R5-5.8.0).zip">http://www.tta.or.kr/standardDB/stnfile/TTAT.3G-25.453(R5-5.8.0).zip</a>



**Release 6**

CCSA	CCSA-TSD-DS-25.453	610	Approved	01/07/2003	<a href="http://www.ccsa.org.cn/english/tc/files.php?docpath=/ITU-R/M.1457/M.1457-4/DS/">http://www.ccsa.org.cn/english/tc/files.php?docpath=/ITU-R/M.1457/M.1457-4/DS/</a>
ETSI	ETSI TS 125 453	6.3.0	Published	21/01/2004	<a href="http://pda.etsi.org/pda/home.asp?wkr=RTS/TSGR-0325453v630">http://pda.etsi.org/pda/home.asp?wkr=RTS/TSGR-0325453v630</a>
T1 (ATIS)	T1.3GPP.25.453V600-2004	6.0.0	Approved	21/05/2004	<a href="https://www.atis.org/atis/docstore/search.asp?committee=S24">https://www.atis.org/atis/docstore/search.asp?committee=S24</a>
TTA	TTAT.3G-25.453(R6-6.3.0)	6.3.0	Approved	25/05/2004	<a href="http://www.tta.or.kr/standardDB/stnfile/TTAT.3G-25.453(R6-6.3.0).zip">http://www.tta.or.kr/standardDB/stnfile/TTAT.3G-25.453(R6-6.3.0).zip</a>

**5.3.2.4****25.100 series****5.3.2.4.1 25.102****UE radio transmission and reception (TDD)**

This document establishes the minimum RF characteristics of the UTRA User Equipment (UE) operating in the TDD mode. The values in the TS make no allowance for measurement uncertainty in conformance testing. Test limits to be used for conformance testing are specified separately in the UE conformance test specifications TS 34.122.

SDO (2)	Document No.	Version	Status	Issued date	Location (1)
<b>Release 99</b>					
ETSI	ETSI TS 125 102	3.12.0	Published	10/10/2002	<a href="http://pda.etsi.org/pda/home.asp?wkr=RTS/TSGR-0425102v3c0">http://pda.etsi.org/pda/home.asp?wkr=RTS/TSGR-0425102v3c0</a>
T1 (ATIS)	T1.3GPP.25.102V3120-2003	3.12.0	Approved	27/03/2003	<a href="https://www.atis.org/atis/docstore/search.asp?committee=S24">https://www.atis.org/atis/docstore/search.asp?committee=S24</a>
<b>Release 4</b>					
CCSA	CCSA-TSD-TDD-25.102	470	Approved	01/07/2003	<a href="http://www.ccsa.org.cn/english/tc/files.php?docpath=/ITU-R/M.1457/M.1457-4/TDD/">http://www.ccsa.org.cn/english/tc/files.php?docpath=/ITU-R/M.1457/M.1457-4/TDD/</a>
ETSI	ETSI TS 125 102	4.7.0	Published	16/01/2003	<a href="http://pda.etsi.org/pda/home.asp?wkr=RTS/TSGR-0425102v470">http://pda.etsi.org/pda/home.asp?wkr=RTS/TSGR-0425102v470</a>
T1 (ATIS)	T1.3GPP.25.102V470-2003	4.7.0	Approved	27/03/2003	<a href="https://www.atis.org/atis/docstore/search.asp?committee=S24">https://www.atis.org/atis/docstore/search.asp?committee=S24</a>
<b>Release 5</b>					
ETSI	ETSI TS 125 102	5.6.0	Published	26/01/2004	<a href="http://pda.etsi.org/pda/home.asp?wkr=RTS/TSGR-0425102v560">http://pda.etsi.org/pda/home.asp?wkr=RTS/TSGR-0425102v560</a>
T1 (ATIS)	T1.3GPP.25.102V560-2004	5.6.0	Approved	21/05/2004	<a href="https://www.atis.org/atis/docstore/search.asp?committee=S24">https://www.atis.org/atis/docstore/search.asp?committee=S24</a>
<b>Release 6</b>					
ETSI	ETSI TS 125 102	6.0.0	Published	26/01/2004	<a href="http://pda.etsi.org/pda/home.asp?wkr=RTS/TSGR-0425102v600">http://pda.etsi.org/pda/home.asp?wkr=RTS/TSGR-0425102v600</a>
T1 (ATIS)	T1.3GPP.25.102V600-2004	6.0.0	Approved	21/05/2004	<a href="https://www.atis.org/atis/docstore/search.asp?committee=S24">https://www.atis.org/atis/docstore/search.asp?committee=S24</a>

**5.3.2.4.2 25.123****Requirements for support of radio resource management (TDD)**

This specification describes the requirements for support of radio resource management for TDD including requirements on measurements in UTRAN and the UE as well as on node dynamic behaviour and interaction, in terms of delay and response characteristics.



SDO (2)	Document No.	Version	Status	Issued date	Location (1)
<b>Release 99</b>					
ETSI	ETSI TS 125 123	3.14.0	Published	27/01/2004	<a href="http://pda.etsi.org/pda/home.asp?wkr=RTS/TSGR-0425123v3e0">http://pda.etsi.org/pda/home.asp?wkr=RTS/TSGR-0425123v3e0</a>
T1 (ATIS)	T1.3GPP.25.123V3140-2004	3.14.0	Approved	21/05/2004	<a href="https://www.atis.org/atis/docstore/search.asp?committee=S24">https://www.atis.org/atis/docstore/search.asp?committee=S24</a>
<b>Release 4</b>					
CCSA	CCSA-TSD-TDD-25.123	490	Approved	01/07/2003	<a href="http://www.ccsa.org.cn/english/tc/files.php?docpath=/ITU-R/M.1457/M.1457-4/TDD/">http://www.ccsa.org.cn/english/tc/files.php?docpath=/ITU-R/M.1457/M.1457-4/TDD/</a>
ETSI	ETSI TS 125 123	4.11.0	Published	02/02/2004	<a href="http://pda.etsi.org/pda/home.asp?wkr=RTS/TSGR-0425123v4b0">http://pda.etsi.org/pda/home.asp?wkr=RTS/TSGR-0425123v4b0</a>
T1 (ATIS)	T1.3GPP.25.123V4110-2004	4.11.0	Approved	21/05/2004	<a href="https://www.atis.org/atis/docstore/search.asp?committee=S24">https://www.atis.org/atis/docstore/search.asp?committee=S24</a>
<b>Release 5</b>					
ETSI	ETSI TS 125 123	5.7.0	Published	02/02/2004	<a href="http://pda.etsi.org/pda/home.asp?wkr=RTS/TSGR-0425123v570">http://pda.etsi.org/pda/home.asp?wkr=RTS/TSGR-0425123v570</a>
T1 (ATIS)	T1.3GPP.25.123V570-2004	5.7.0	Approved	21/05/2004	<a href="https://www.atis.org/atis/docstore/search.asp?committee=S24">https://www.atis.org/atis/docstore/search.asp?committee=S24</a>
<b>Release 6</b>					
ETSI	ETSI TS 125 123	6.0.0	Published	02/02/2004	<a href="http://pda.etsi.org/pda/home.asp?wkr=RTS/TSGR-0425123v600">http://pda.etsi.org/pda/home.asp?wkr=RTS/TSGR-0425123v600</a>
T1 (ATIS)	T1.3GPP.25.123V600-2004	6.0.0	Approved	21/05/2004	<a href="https://www.atis.org/atis/docstore/search.asp?committee=S24">https://www.atis.org/atis/docstore/search.asp?committee=S24</a>

5.3.2.4.3 25.105

**BTS radio transmission and reception (TDD)**

This specification describes the minimum RF characteristics of the TDD mode of UTRA. The values in the TS make no allowance for measurements uncertainties in conformance testing. Test limit to be used for conformance testing are specified separately in the base station conformance test Specification TS 25.142.

SDO (2)	Document No.	Version	Status	Issued date	Location (1)
<b>Release 99</b>					
ETSI	ETSI TS 125 105	3.13.0	Published	10/04/2003	<a href="http://pda.etsi.org/pda/home.asp?wkr=RTS/TSGR-0425105v3d0">http://pda.etsi.org/pda/home.asp?wkr=RTS/TSGR-0425105v3d0</a>
T1 (ATIS)	T1.3GPP.25.105V3130-2004	3.13.0	Approved	21/05/2004	<a href="https://www.atis.org/atis/docstore/search.asp?committee=S24">https://www.atis.org/atis/docstore/search.asp?committee=S24</a>
<b>Release 4</b>					
CCSA	CCSA-TSD-TDD-25.105	470	Approved	01/07/2003	<a href="http://www.ccsa.org.cn/english/tc/files.php?docpath=/ITU-R/M.1457/M.1457-4/TDD/">http://www.ccsa.org.cn/english/tc/files.php?docpath=/ITU-R/M.1457/M.1457-4/TDD/</a>
ETSI	ETSI TS 125 105	4.7.0	Published	10/04/2003	<a href="http://pda.etsi.org/pda/home.asp?wkr=RTS/TSGR-0425105v470">http://pda.etsi.org/pda/home.asp?wkr=RTS/TSGR-0425105v470</a>
T1 (ATIS)	T1.3GPP.25.105V470-2004	4.7.0	Approved	21/05/2004	<a href="https://www.atis.org/atis/docstore/search.asp?committee=S24">https://www.atis.org/atis/docstore/search.asp?committee=S24</a>
<b>Release 5</b>					
ETSI	ETSI TS 125 105	5.5.0	Published	26/01/2004	<a href="http://pda.etsi.org/pda/home.asp?wkr=RTS/TSGR-0425105v550">http://pda.etsi.org/pda/home.asp?wkr=RTS/TSGR-0425105v550</a>
T1 (ATIS)	T1.3GPP.25.105V550-2004	5.5.0	Approved	21/05/2004	<a href="https://www.atis.org/atis/docstore/search.asp?committee=S24">https://www.atis.org/atis/docstore/search.asp?committee=S24</a>
<b>Release 6</b>					
ETSI	ETSI TS 125 105	6.0.0	Published	26/01/2004	<a href="http://pda.etsi.org/pda/home.asp?wkr=RTS/TSGR-0425105v600">http://pda.etsi.org/pda/home.asp?wkr=RTS/TSGR-0425105v600</a>
T1 (ATIS)	T1.3GPP.25.105V600-2004	6.0.0	Approved	21/05/2004	<a href="https://www.atis.org/atis/docstore/search.asp?committee=S24">https://www.atis.org/atis/docstore/search.asp?committee=S24</a>

## 5.3.2.4.4 25.142

**Base station conformance testing (TDD)**

This specification describes the radio frequency (RF) test methods and conformance requirements for UTRA base transceiver stations (BTS) operating in the TDD mode. These have been derived from, and are consistent with, the core UTRA specifications specified in the requirements reference sub-clause of each test. The maximum acceptable measurement uncertainty is specified in the TS for each test, where appropriate.

SDO (2)	Document No.	Version	Status	Issued date	Location (1)
<b>Release 99</b>					
ETSI	ETSI TS 125 142	3.13.0	Published	10/04/2003	<a href="http://pda.etsi.org/pda/home.asp?wkr=RTS/TSGR-0425142v3d0">http://pda.etsi.org/pda/home.asp?wkr=RTS/TSGR-0425142v3d0</a>
T1 (ATIS)	T1.3GPP.25.142V3130-2004	3.13.0	Approved	21/05/2004	<a href="https://www.atis.org/atis/docstore/search.asp?committee=S24">https://www.atis.org/atis/docstore/search.asp?committee=S24</a>
<b>Release 4</b>					
CCSA	CCSA-TSD-TDD-25.142	480	Approved	01/07/2003	<a href="http://www.ccsa.org.cn/english/tc/files.php?docpath=/ITU-R/M.1457/M.1457-4/TDD/">http://www.ccsa.org.cn/english/tc/files.php?docpath=/ITU-R/M.1457/M.1457-4/TDD/</a>
ETSI	ETSI TS 125 142	4.8.0	Published	10/04/2003	<a href="http://pda.etsi.org/pda/home.asp?wkr=RTS/TSGR-0425142v480">http://pda.etsi.org/pda/home.asp?wkr=RTS/TSGR-0425142v480</a>
T1 (ATIS)	T1.3GPP.25.142V480-2004	4.8.0	Approved	21/05/2004	<a href="https://www.atis.org/atis/docstore/search.asp?committee=S24">https://www.atis.org/atis/docstore/search.asp?committee=S24</a>
<b>Release 5</b>					
ETSI	ETSI TS 125 142	5.6.0	Published	27/01/2004	<a href="http://pda.etsi.org/pda/home.asp?wkr=RTS/TSGR-0425142v560">http://pda.etsi.org/pda/home.asp?wkr=RTS/TSGR-0425142v560</a>
T1 (ATIS)	T1.3GPP.25.142V560-2004	5.6.0	Approved	21/05/2004	<a href="https://www.atis.org/atis/docstore/search.asp?committee=S24">https://www.atis.org/atis/docstore/search.asp?committee=S24</a>
<b>Release 6</b>					
ETSI	ETSI TS 125 142	6.0.0	Published	27/01/2004	<a href="http://pda.etsi.org/pda/home.asp?wkr=RTS/TSGR-0425142v600">http://pda.etsi.org/pda/home.asp?wkr=RTS/TSGR-0425142v600</a>
T1 (ATIS)	T1.3GPP.25.142V600-2004	6.0.0	Approved	21/05/2004	<a href="https://www.atis.org/atis/docstore/search.asp?committee=S24">https://www.atis.org/atis/docstore/search.asp?committee=S24</a>

## 5.3.2.4.5 25.113

**Base station EMC (see Note 1)**

This specification describes the assessment of base stations and associated ancillary equipment in respect of EMC. NOTE 1 - This specification does not include the antenna port immunity and emissions.

SDO (2)	Document No.	Version	Status	Issued date	Location (1)
<b>Release 99</b>					
CCSA	CCSA-TSD-DS-25.113	350	Approved	01/07/2003	<a href="http://www.ccsa.org.cn/english/tc/files.php?docpath=/ITU-R/M.1457/M.1457-4/DS/">http://www.ccsa.org.cn/english/tc/files.php?docpath=/ITU-R/M.1457/M.1457-4/DS/</a>
ETSI	ETSI TS 125 113	3.5.0	Published	11/05/2001	<a href="http://pda.etsi.org/pda/home.asp?wkr=RTS/TSGR-0425113UR5">http://pda.etsi.org/pda/home.asp?wkr=RTS/TSGR-0425113UR5</a>
T1 (ATIS)	T1.3GPP.25.113V350-2002	3.5.0	Approved	03/05/2002	<a href="https://www.atis.org/atis/docstore/search.asp?committee=S24">https://www.atis.org/atis/docstore/search.asp?committee=S24</a>
TTA	TTAE.3G-25.113(R99-3.5.0)	3.5.0	Approved	29/05/2002	<a href="http://www.tta.or.kr/standardDB/stnfile/TTAE.3G-25.113(R99-3.5.0).zip">http://www.tta.or.kr/standardDB/stnfile/TTAE.3G-25.113(R99-3.5.0).zip</a>
<b>Release 4</b>					
CCSA	CCSA-TSD-DS-25.113	440	Approved	01/07/2003	<a href="http://www.ccsa.org.cn/english/tc/files.php?docpath=/ITU-R/M.1457/M.1457-4/DS/">http://www.ccsa.org.cn/english/tc/files.php?docpath=/ITU-R/M.1457/M.1457-4/DS/</a>
ETSI	ETSI TS 125 113	4.4.0	Published	16/01/2003	<a href="http://pda.etsi.org/pda/home.asp?wkr=RTS/TSGR-0425113v440">http://pda.etsi.org/pda/home.asp?wkr=RTS/TSGR-0425113v440</a>
T1 (ATIS)	T1.3GPP.25.113V440-2003	4.4.0	Approved	27/03/2003	<a href="https://www.atis.org/atis/docstore/search.asp?committee=S24">https://www.atis.org/atis/docstore/search.asp?committee=S24</a>
TTA	TTAT.3G-25.113(R4-4.4.0)	4.4.0	Approved	21/03/2003	<a href="http://www.tta.or.kr/standardDB/stnfile/TTAT.3G-25.113(R4-4.4.0).zip">http://www.tta.or.kr/standardDB/stnfile/TTAT.3G-25.113(R4-4.4.0).zip</a>

**Release 5**

CCSA	CCSA-TSD-DS-25.113	540	Approved	01/07/2003	<a href="http://www.ccsa.org.cn/english/tc/files.php?docpath=/ITU-R/M.1457/M.1457-4/DS/">http://www.ccsa.org.cn/english/tc/files.php?docpath=/ITU-R/M.1457/M.1457-4/DS/</a>
ETSI	ETSI TS 125 113	5.5.0	Published	30/01/2004	<a href="http://pda.etsi.org/pda/home.asp?wkr=RTS/TSGR-0425113v550">http://pda.etsi.org/pda/home.asp?wkr=RTS/TSGR-0425113v550</a>
T1 (ATIS)	T1.3GPP.25.113V550-2004	5.5.0	Approved	21/05/2004	<a href="https://www.atis.org/atis/docstore/search.asp?committee=S24">https://www.atis.org/atis/docstore/search.asp?committee=S24</a>
TTA	TTAT.3G-25.113(R5-5.5.0)	5.5.0	Approved	25/05/2004	<a href="http://www.tta.or.kr/standardDB/stnfile/TTAT.3G-25.113(R5-5.5.0).zip">http://www.tta.or.kr/standardDB/stnfile/TTAT.3G-25.113(R5-5.5.0).zip</a>

**Release 6**

ETSI	ETSI TS 125 113	6.0.0	Published	30/01/2004	<a href="http://pda.etsi.org/pda/home.asp?wkr=RTS/TSGR-0425113v600">http://pda.etsi.org/pda/home.asp?wkr=RTS/TSGR-0425113v600</a>
T1 (ATIS)	T1.3GPP.25.113V600-2004	6.0.0	Approved	21/05/2004	<a href="https://www.atis.org/atis/docstore/search.asp?committee=S24">https://www.atis.org/atis/docstore/search.asp?committee=S24</a>
TTA	TTAT.3G-25.113(R6-6.0.0)	6.0.0	Approved	25/05/2004	<a href="http://www.tta.or.kr/standardDB/stnfile/TTAT.3G-25.113(R6-6.0.0).zip">http://www.tta.or.kr/standardDB/stnfile/TTAT.3G-25.113(R6-6.0.0).zip</a>

**5.3.2.5****34.100 series****5.3.2.5.1 34.108****Common Test Environments for User Equipment (UE) Conformance Testing**

This document contains definitions of reference conditions and test signals, default parameters, reference Radio Bearer configurations, common requirements for test equipment and generic set-up procedures for use in UE conformance tests.

SDO (2)	Document No.	Version	Status	Issued date	Location (1)
<b>Release 99</b>					
CCSA	CCSA-TSD-DS-34.108	3C0	Approved	01/07/2003	<a href="http://www.ccsa.org.cn/english/tc/files.php?docpath=/ITU-R/M.1457/M.1457-4/DS/">http://www.ccsa.org.cn/english/tc/files.php?docpath=/ITU-R/M.1457/M.1457-4/DS/</a>
ETSI	ETSI TS 134 108	3.14.0	Published	26/01/2004	<a href="http://pda.etsi.org/pda/home.asp?wkr=RTS/TSGT-0134108v3e0">http://pda.etsi.org/pda/home.asp?wkr=RTS/TSGT-0134108v3e0</a>
T1 (ATIS)	T1.3GPP.34.108V3140-2004	3.14.0	Approved	21/05/2004	<a href="https://www.atis.org/atis/docstore/search.asp?committee=S24">https://www.atis.org/atis/docstore/search.asp?committee=S24</a>
TTA	TTAT.3G-34.108(R99-3.14.0)	3.14.0	Approved	25/05/2004	<a href="http://www.tta.or.kr/standardDB/stnfile/TTAT.3G-34.108(R99-3.14.0).zip">http://www.tta.or.kr/standardDB/stnfile/TTAT.3G-34.108(R99-3.14.0).zip</a>
<b>Release 4</b>					
CCSA	CCSA-TSD-DS-34.108	470	Approved	01/07/2003	<a href="http://www.ccsa.org.cn/english/tc/files.php?docpath=/ITU-R/M.1457/M.1457-4/DS/">http://www.ccsa.org.cn/english/tc/files.php?docpath=/ITU-R/M.1457/M.1457-4/DS/</a>
ETSI	ETSI TS 134 108	4.9.0	Published	27/01/2004	<a href="http://pda.etsi.org/pda/home.asp?wkr=RTS/TSGT-0134108v490">http://pda.etsi.org/pda/home.asp?wkr=RTS/TSGT-0134108v490</a>
T1 (ATIS)	T1.3GPP.34.108V490-2004	4.9.0	Approved	21/05/2004	<a href="https://www.atis.org/atis/docstore/search.asp?committee=S24">https://www.atis.org/atis/docstore/search.asp?committee=S24</a>
TTA	TTAT.3G-34.108(R4-4.9.0)	4.9.0	Approved	25/05/2004	<a href="http://www.tta.or.kr/standardDB/stnfile/TTAT.3G-34.108(R4-4.9.0).zip">http://www.tta.or.kr/standardDB/stnfile/TTAT.3G-34.108(R4-4.9.0).zip</a>
<b>Release 5</b>					
T1 (ATIS)	T1.3GPP.34.108V500-2004	5.0.0	Approved	21/05/2004	<a href="https://www.atis.org/atis/docstore/search.asp?committee=S24">https://www.atis.org/atis/docstore/search.asp?committee=S24</a>

**5.3.2.5.2 34.109****Logical Test Interface (TDD and FDD)**

This document specifies for User Equipment (UE), in UMTS system, for FDD and TDD modes, those UE functions that are required for conformance testing purposes.

SDO (2)	Document No.	Version	Status	Issued date	Location (1)
<b>Release 99</b>					
CCSA	CCSA-TSD-DS-34.109	390	Approved	01/07/2003	<a href="http://www.ccsa.org.cn/english/tc/files.php?docpath=/ITU-R/M.1457/M.1457-4/DS/">http://www.ccsa.org.cn/english/tc/files.php?docpath=/ITU-R/M.1457/M.1457-4/DS/</a>
ETSI	ETSI TS 134 109	3.9.0	Published	04/04/2003	<a href="http://pda.etsi.org/pda/home.asp?wkr=RTS/TSGR-0234109v390">http://pda.etsi.org/pda/home.asp?wkr=RTS/TSGR-0234109v390</a>
T1 (ATIS)	T1.3GPP.34.109V390-2004	3.9.0	Approved	21/05/2004	<a href="https://www.atis.org/atis/docstore/search.asp?committee=S24">https://www.atis.org/atis/docstore/search.asp?committee=S24</a>
TTA	TTAT.3G-34.109(R99-3.9.0)	3.9.0	Approved	25/05/2004	<a href="http://www.tta.or.kr/standardDB/stnfile/TTAT.3G-34.109(R99-3.9.0).zip">http://www.tta.or.kr/standardDB/stnfile/TTAT.3G-34.109(R99-3.9.0).zip</a>
<b>Release 4</b>					
CCSA	CCSA-TSD-DS-34.109	450	Approved	01/07/2003	<a href="http://www.ccsa.org.cn/english/tc/files.php?docpath=/ITU-R/M.1457/M.1457-4/DS/">http://www.ccsa.org.cn/english/tc/files.php?docpath=/ITU-R/M.1457/M.1457-4/DS/</a>
ETSI	ETSI TS 134 109	4.5.0	Published	04/04/2003	<a href="http://pda.etsi.org/pda/home.asp?wkr=RTS/TSGR-0234109v450">http://pda.etsi.org/pda/home.asp?wkr=RTS/TSGR-0234109v450</a>
T1 (ATIS)	T1.3GPP.34.109V450-2004	4.5.0	Approved	21/05/2004	<a href="https://www.atis.org/atis/docstore/search.asp?committee=S24">https://www.atis.org/atis/docstore/search.asp?committee=S24</a>
TTA	TTAT.3G-34.109(R4-4.5.0)	4.5.0	Approved	25/05/2004	<a href="http://www.tta.or.kr/standardDB/stnfile/TTAT.3G-34.109(R4-4.5.0).zip">http://www.tta.or.kr/standardDB/stnfile/TTAT.3G-34.109(R4-4.5.0).zip</a>
<b>Release 5</b>					
CCSA	CCSA-TSD-DS-34.109	530	Approved	01/07/2003	<a href="http://www.ccsa.org.cn/english/tc/files.php?docpath=/ITU-R/M.1457/M.1457-4/DS/">http://www.ccsa.org.cn/english/tc/files.php?docpath=/ITU-R/M.1457/M.1457-4/DS/</a>
ETSI	ETSI TS 134 109	5.3.0	Published	04/04/2003	<a href="http://pda.etsi.org/pda/home.asp?wkr=RTS/TSGR-0234109v530">http://pda.etsi.org/pda/home.asp?wkr=RTS/TSGR-0234109v530</a>
T1 (ATIS)	T1.3GPP.34.109V530-2004	5.3.0	Approved	21/05/2004	<a href="https://www.atis.org/atis/docstore/search.asp?committee=S24">https://www.atis.org/atis/docstore/search.asp?committee=S24</a>
TTA	TTAT.3G-34.109(R5-5.3.0)	5.3.0	Approved	25/05/2004	<a href="http://www.tta.or.kr/standardDB/stnfile/TTAT.3G-34.109(R5-5.3.0).zip">http://www.tta.or.kr/standardDB/stnfile/TTAT.3G-34.109(R5-5.3.0).zip</a>

### 5.3.2.5.3 34.122

#### Terminal Conformance Specification, Radio Transmission and Reception (TDD)

This document specifies the Radio Frequency (RF) test methods and conformance requirements for UTRA User Equipment (UE) operating in the TDD mode. These have been derived from, and are consistent with, the core UTRA specifications. The maximum acceptable measurement uncertainty is specified in the TS for each test, where appropriate.

SDO (2)	Document No.	Version	Status	Issued date	Location (1)
<b>Release 99</b>					
CCSA	CCSA-TSD-DS-34.121	3D0	Approved	01/07/2003	<a href="http://www.ccsa.org.cn/english/tc/files.php?docpath=/ITU-R/M.1457/M.1457-4/DS/">http://www.ccsa.org.cn/english/tc/files.php?docpath=/ITU-R/M.1457/M.1457-4/DS/</a>
ETSI	ETSI TS 134 122	3.12.0	Published	26/01/2004	<a href="http://pda.etsi.org/pda/home.asp?wkr=RTS/TSGT-0134122v3c0">http://pda.etsi.org/pda/home.asp?wkr=RTS/TSGT-0134122v3c0</a>
T1 (ATIS)	T1.3GPP.34.122V3120-2004	3.12.0	Approved	21/05/2004	<a href="https://www.atis.org/atis/docstore/search.asp?committee=S24">https://www.atis.org/atis/docstore/search.asp?committee=S24</a>
T1 (ATIS)	T1.3GPP.34.121V3140-2004	3.14.0	Approved	21/05/2004	<a href="https://www.atis.org/atis/docstore/search.asp?committee=S24">https://www.atis.org/atis/docstore/search.asp?committee=S24</a>
TTA	TTAT.3G-34.121(R99F-3.14.0)	3.14.0	Approved	25/05/2004	<a href="http://www.tta.or.kr/standardDB/stnfile/TTAT.3G-34.121(R99F-3.14.0).zip">http://www.tta.or.kr/standardDB/stnfile/TTAT.3G-34.121(R99F-3.14.0).zip</a>
<b>Release 4</b>					
CCSA	CCSA-TSD-DS-34.121	400	Approved	01/07/2003	<a href="http://www.ccsa.org.cn/english/tc/files.php?docpath=/ITU-R/M.1457/M.1457-4/DS/">http://www.ccsa.org.cn/english/tc/files.php?docpath=/ITU-R/M.1457/M.1457-4/DS/</a>
ETSI	ETSI TS 134 122	4.10.0	Published	26/01/2004	<a href="http://pda.etsi.org/pda/home.asp?wkr=RTS/TSGT-0134122v4a0">http://pda.etsi.org/pda/home.asp?wkr=RTS/TSGT-0134122v4a0</a>
T1 (ATIS)	T1.3GPP.34.121V410-2004	4.1.0	Approved	21/05/2004	<a href="https://www.atis.org/atis/docstore/search.asp?committee=S24">https://www.atis.org/atis/docstore/search.asp?committee=S24</a>
T1 (ATIS)	T1.3GPP.34.122V4100-2004	4.10.0	Approved	21/05/2004	<a href="https://www.atis.org/atis/docstore/search.asp?committee=S24">https://www.atis.org/atis/docstore/search.asp?committee=S24</a>
TTA	TTAT.3G-34.121(R4F-4.1.0)	4.1.0	Approved	25/05/2004	<a href="http://www.tta.or.kr/standardDB/stnfile/TTAT.3G-34.121(R4F-4.1.0).zip">http://www.tta.or.kr/standardDB/stnfile/TTAT.3G-34.121(R4F-4.1.0).zip</a>

**Release 5**

CCSA	CCSA-TSD-DS-34.121	500	Approved	01/07/2003	<a href="http://www.ccsa.org.cn/english/tc/files.php?docpath=/ITU-R/M.1457/M.1457-4/DS/">http://www.ccsa.org.cn/english/tc/files.php?docpath=/ITU-R/M.1457/M.1457-4/DS/</a>
ETSI	ETSI TS 134 122	5.0.0	Published	30/01/2004	<a href="http://pda.etsi.org/pda/home.asp?wkr=RTS/TSGT-0134122v500">http://pda.etsi.org/pda/home.asp?wkr=RTS/TSGT-0134122v500</a>
T1 (ATIS)	T1.3GPP.34.122V500-2004	5.0.0	Approved	21/05/2004	<a href="https://www.atis.org/atis/docstore/search.asp?committee=S24">https://www.atis.org/atis/docstore/search.asp?committee=S24</a>
T1 (ATIS)	T1.3GPP.34.121V520-2004	5.2.0	Approved	21/05/2004	<a href="https://www.atis.org/atis/docstore/search.asp?committee=S24">https://www.atis.org/atis/docstore/search.asp?committee=S24</a>
TTA	TTAT.3G-34.121(R5F-5.2.0)	5.2.0	Approved	25/05/2004	<a href="http://www.tta.or.kr/standardDB/stnfile/TTAT.3G-34.121(R5F-5.2.0).zip">http://www.tta.or.kr/standardDB/stnfile/TTAT.3G-34.121(R5F-5.2.0).zip</a>

**5.3.2.5.4** 34.123-1**UE Conformance Specification, Part 1 – Conformance specification**

This document specifies the protocol conformance testing for the 3rd Generation User Equipment (UE). This is the first part of a multi-part test specification.

SDO (2)	Document No.	Version	Status	Issued date	Location (1)
<b>Release 99</b>					
CCSA	CCSA-TSD-DS-34.123-1	350	Approved	01/07/2003	<a href="http://www.ccsa.org.cn/english/tc/files.php?docpath=/ITU-R/M.1457/M.1457-4/DS/">http://www.ccsa.org.cn/english/tc/files.php?docpath=/ITU-R/M.1457/M.1457-4/DS/</a>
ETSI	ETSI TS 134 123-1	3.5.0	Published	19/10/2001	<a href="http://pda.etsi.org/pda/home.asp?wkr=RTS/TSGT-0134123-1UR6">http://pda.etsi.org/pda/home.asp?wkr=RTS/TSGT-0134123-1UR6</a>
T1 (ATIS)	T1.3GPP.34.123-1V350-2002	3.5.0	Approved	03/05/2002	<a href="https://www.atis.org/atis/docstore/search.asp?committee=S24">https://www.atis.org/atis/docstore/search.asp?committee=S24</a>
TTA	TTAE.3G-34.123-1(R99350)	3.5.0	Approved	29/05/2002	<a href="http://www.tta.or.kr/standardDB/stnfile/TTAE.3G-34.123-1(R99350).zip">http://www.tta.or.kr/standardDB/stnfile/TTAE.3G-34.123-1(R99350).zip</a>
<b>Release 4</b>					
CCSA	CCSA-TSD-DS-34.123-1	430	Approved	01/07/2003	<a href="http://www.ccsa.org.cn/english/tc/files.php?docpath=/ITU-R/M.1457/M.1457-4/DS/">http://www.ccsa.org.cn/english/tc/files.php?docpath=/ITU-R/M.1457/M.1457-4/DS/</a>
ETSI	ETSI TS 134 123-1	4.3.0	Published	02/07/2002	<a href="http://pda.etsi.org/pda/home.asp?wkr=RTS/TSGT-0134123-1v430">http://pda.etsi.org/pda/home.asp?wkr=RTS/TSGT-0134123-1v430</a>
T1 (ATIS)	T1.3GPP.34.123-1V430-2003	4.3.0	Approved	27/03/2003	<a href="https://www.atis.org/atis/docstore/search.asp?committee=S24">https://www.atis.org/atis/docstore/search.asp?committee=S24</a>
TTA	TTAT.3G-34.123-1(R4-4.3.0)	4.3.0	Approved	21/03/2003	<a href="http://www.tta.or.kr/standardDB/stnfile/TTAT.3G-34.123-1(R4-4.3.0).zip">http://www.tta.or.kr/standardDB/stnfile/TTAT.3G-34.123-1(R4-4.3.0).zip</a>
<b>Release 5</b>					
CCSA	CCSA-TSD-DS-34.123-1	540	Approved	01/07/2003	<a href="http://www.ccsa.org.cn/english/tc/files.php?docpath=/ITU-R/M.1457/M.1457-4/DS/">http://www.ccsa.org.cn/english/tc/files.php?docpath=/ITU-R/M.1457/M.1457-4/DS/</a>
ETSI	ETSI TS 134 123-1	5.6.0	Published	27/01/2004	<a href="http://pda.etsi.org/pda/home.asp?wkr=RTS/TSGT-0134123-1v560">http://pda.etsi.org/pda/home.asp?wkr=RTS/TSGT-0134123-1v560</a>
T1 (ATIS)	T1.3GPP.34.123-1V560-2004	5.6.0	Approved	21/05/2004	<a href="https://www.atis.org/atis/docstore/search.asp?committee=S24">https://www.atis.org/atis/docstore/search.asp?committee=S24</a>
TTA	TTAT.3G-34.123-1(R5-5.6.0)	5.6.0	Approved	25/05/2004	<a href="http://www.tta.or.kr/standardDB/stnfile/TTAT.3G-34.123-1(R5-5.6.0).zip">http://www.tta.or.kr/standardDB/stnfile/TTAT.3G-34.123-1(R5-5.6.0).zip</a>

**5.3.2.5.5** 34.123-2**UE Conformance Specification, Part 2 – ICS**

This document provides the Implementation Conformance Statement (ICS) proforma for 3rd Generation User Equipment (UE), in compliance with the relevant requirements, and in accordance with the relevant guidance given in ISO/IEC 9646-7 and ETS 300 406. This document also specifies a recommended applicability statement for the test cases included in TS 34.123-1. These applicability statements are based on the features implemented in the UE.

SDO (2)	Document No.	Version	Status	Issued date	Location (1)
<b>Release 99</b>					
CCSA	CCSA-TSD-DS-34.123-2	350	Approved	01/07/2003	<a href="http://www.ccsa.org.cn/english/tc/files.php?docpath=/ITU-R/M.1457/M.1457-4/DS/">http://www.ccsa.org.cn/english/tc/files.php?docpath=/ITU-R/M.1457/M.1457-4/DS/</a>
ETSI	ETSI TS 134 123-2	3.5.0	Published	19/10/2001	<a href="http://pda.etsi.org/pda/home.asp?wkr=RTS/TSGT-0134123-2UR4">http://pda.etsi.org/pda/home.asp?wkr=RTS/TSGT-0134123-2UR4</a>
T1 (ATIS)	T1.3GPP.34.123-2V350-2002	3.5.0	Approved	03/05/2002	<a href="https://www.atis.org/atis/docstore/search.asp?committee=S24">https://www.atis.org/atis/docstore/search.asp?committee=S24</a>
TTA	TTAE.3G-34.123-2(R99350)	3.5.0	Approved	29/05/2002	<a href="http://www.tta.or.kr/standardDB/stnfile/TTAE.3G-34.123-2(R99350).zip">http://www.tta.or.kr/standardDB/stnfile/TTAE.3G-34.123-2(R99350).zip</a>
<b>Release 4</b>					
CCSA	CCSA-TSD-DS-34.123-2	430	Approved	01/07/2003	<a href="http://www.ccsa.org.cn/english/tc/files.php?docpath=/ITU-R/M.1457/M.1457-4/DS/">http://www.ccsa.org.cn/english/tc/files.php?docpath=/ITU-R/M.1457/M.1457-4/DS/</a>
ETSI	ETSI TS 134 123-2	4.3.0	Published	27/06/2002	<a href="http://pda.etsi.org/pda/home.asp?wkr=RTS/TSGT-0134123-2v430">http://pda.etsi.org/pda/home.asp?wkr=RTS/TSGT-0134123-2v430</a>
T1 (ATIS)	T1.3GPP.34.123-2V430-2003	4.3.0	Approved	27/03/2003	<a href="https://www.atis.org/atis/docstore/search.asp?committee=S24">https://www.atis.org/atis/docstore/search.asp?committee=S24</a>
TTA	TTAT.3G-34.123-2(R4-4.3.0)	4.3.0	Approved	21/03/2003	<a href="http://www.tta.or.kr/standardDB/stnfile/TTAT.3G-34.123-2(R4-4.3.0).zip">http://www.tta.or.kr/standardDB/stnfile/TTAT.3G-34.123-2(R4-4.3.0).zip</a>
<b>Release 5</b>					
CCSA	CCSA-TSD-DS-34.123-2	540	Approved	01/07/2003	<a href="http://www.ccsa.org.cn/english/tc/files.php?docpath=/ITU-R/M.1457/M.1457-4/DS/">http://www.ccsa.org.cn/english/tc/files.php?docpath=/ITU-R/M.1457/M.1457-4/DS/</a>
ETSI	ETSI TS 134 123-2	5.6.0	Published	26/01/2004	<a href="http://pda.etsi.org/pda/home.asp?wkr=RTS/TSGT-0134123-2v560">http://pda.etsi.org/pda/home.asp?wkr=RTS/TSGT-0134123-2v560</a>
T1 (ATIS)	T1.3GPP.34.123-2V560-2004	5.6.0	Approved	21/05/2004	<a href="https://www.atis.org/atis/docstore/search.asp?committee=S24">https://www.atis.org/atis/docstore/search.asp?committee=S24</a>
TTA	TTAT.3G-34.123-2(R5-5.6.0)	5.6.0	Approved	25/05/2004	<a href="http://www.tta.or.kr/standardDB/stnfile/TTAT.3G-34.123-2(R5-5.6.0).zip">http://www.tta.or.kr/standardDB/stnfile/TTAT.3G-34.123-2(R5-5.6.0).zip</a>

### 5.3.2.5.6 34.124

#### Electromagnetic compatibility (EMC) requirements for Mobile terminals and ancillary equipment

This document establishes the essential EMC requirements for 3rd generation digital cellular mobile terminal equipment and ancillary accessories in combination with a 3GPP user equipment (UE).

SDO (2)	Document No.	Version	Status	Issued date	Location (1)
<b>Release 99</b>					
CCSA	CCSA-TSD-DS-34.124	340	Approved	01/07/2003	<a href="http://www.ccsa.org.cn/english/tc/files.php?docpath=/ITU-R/M.1457/M.1457-4/DS/">http://www.ccsa.org.cn/english/tc/files.php?docpath=/ITU-R/M.1457/M.1457-4/DS/</a>
ETSI	ETSI TS 134 124	3.4.0	Published	14/04/2003	<a href="http://pda.etsi.org/pda/home.asp?wkr=RTS/TSGR-0434124v340">http://pda.etsi.org/pda/home.asp?wkr=RTS/TSGR-0434124v340</a>
T1 (ATIS)	T1.3GPP.34.124V340-2004	3.4.0	Approved	21/05/2004	<a href="https://www.atis.org/atis/docstore/search.asp?committee=S24">https://www.atis.org/atis/docstore/search.asp?committee=S24</a>
TTA	TTAT.3G-34.124(R99-3.4.0)	3.4.0	Approved	28/05/2003	<a href="http://www.tta.or.kr/standardDB/stnfile/TTAT.3G-34.124(R99-3.4.0).zip">http://www.tta.or.kr/standardDB/stnfile/TTAT.3G-34.124(R99-3.4.0).zip</a>
<b>Release 4</b>					
CCSA	CCSA-TSD-DS-34.124	420	Approved	01/07/2003	<a href="http://www.ccsa.org.cn/english/tc/files.php?docpath=/ITU-R/M.1457/M.1457-4/DS/">http://www.ccsa.org.cn/english/tc/files.php?docpath=/ITU-R/M.1457/M.1457-4/DS/</a>
ETSI	ETSI TS 134 124	4.2.0	Published	14/04/2003	<a href="http://pda.etsi.org/pda/home.asp?wkr=RTS/TSGR-0434124v420">http://pda.etsi.org/pda/home.asp?wkr=RTS/TSGR-0434124v420</a>
T1 (ATIS)	T1.3GPP.34.124V420-2004	4.2.0	Approved	21/05/2004	<a href="https://www.atis.org/atis/docstore/search.asp?committee=S24">https://www.atis.org/atis/docstore/search.asp?committee=S24</a>
TTA	TTAT.3G-34.124(R4-4.2.0)	4.2.0	Approved	25/05/2004	<a href="http://www.tta.or.kr/standardDB/stnfile/TTAT.3G-34.124(R4-4.2.0).zip">http://www.tta.or.kr/standardDB/stnfile/TTAT.3G-34.124(R4-4.2.0).zip</a>
<b>Release 5</b>					
CCSA	CCSA-TSD-DS-34.124	530	Approved	01/07/2003	<a href="http://www.ccsa.org.cn/english/tc/files.php?docpath=/ITU-R/M.1457/M.1457-4/DS/">http://www.ccsa.org.cn/english/tc/files.php?docpath=/ITU-R/M.1457/M.1457-4/DS/</a>
ETSI	ETSI TS 134 124	5.3.0	Published	14/04/2003	<a href="http://pda.etsi.org/pda/home.asp?wkr=RTS/TSGR-0434124v530">http://pda.etsi.org/pda/home.asp?wkr=RTS/TSGR-0434124v530</a>
T1 (ATIS)	T1.3GPP.34.124V530-2004	5.3.0	Approved	21/05/2004	<a href="https://www.atis.org/atis/docstore/search.asp?committee=S24">https://www.atis.org/atis/docstore/search.asp?committee=S24</a>
TTA	TTAT.3G-34.124(R5-5.3.0)	5.3.0	Approved	25/05/2004	<a href="http://www.tta.or.kr/standardDB/stnfile/TTAT.3G-34.124(R5-5.3.0).zip">http://www.tta.or.kr/standardDB/stnfile/TTAT.3G-34.124(R5-5.3.0).zip</a>

**5.3.2.6****Core network aspects****5.3.2.6.1 23.108****Mobile radio interface Layer 3 specification core network protocols - Stage 2**

This specification describes the procedures used at the radio interface for call control (CC), mobility management (MM) and session management (SM). It shall hold examples of the structured procedures.

SDO (2)	Document No.	Version	Status	Issued date	Location (1)
<b>Release 99</b>					
CCSA	CCSA-TSD-DS-23.108	320	Approved	01/07/2003	<a href="http://www.ccsa.org.cn/english/tc/files.php?docpath=/ITU-R/M.1457/M.1457-4/DS/">http://www.ccsa.org.cn/english/tc/files.php?docpath=/ITU-R/M.1457/M.1457-4/DS/</a>
ETSI	ETSI TS 123 108	3.2.0	Published	17/05/2000	<a href="http://pda.etsi.org/pda/home.asp?wkr=RTS/TSGN-0123108UR1">http://pda.etsi.org/pda/home.asp?wkr=RTS/TSGN-0123108UR1</a>
T1 (ATIS)	T1.3GPP.23.108V320-2002	3.2.0	Approved	03/05/2002	<a href="https://www.atis.org/atis/docstore/search.asp?committee=S24">https://www.atis.org/atis/docstore/search.asp?committee=S24</a>
TTA	TTAE.3G-23.108(R99)	3.2.0	Approved	19/12/2001	<a href="http://www.tta.or.kr/standardDB/stnfile/TTAE_3G-23_108_R99_.zip">http://www.tta.or.kr/standardDB/stnfile/TTAE_3G-23_108_R99_.zip</a>
<b>Release 4</b>					
CCSA	CCSA-TSD-DS-23.108	401	Approved	01/07/2003	<a href="http://www.ccsa.org.cn/english/tc/files.php?docpath=/ITU-R/M.1457/M.1457-4/DS/">http://www.ccsa.org.cn/english/tc/files.php?docpath=/ITU-R/M.1457/M.1457-4/DS/</a>
ETSI	ETSI TS 123 108	4.0.1	Published	17/07/2002	<a href="http://pda.etsi.org/pda/home.asp?wkr=RTS/TSGN-0123108v401">http://pda.etsi.org/pda/home.asp?wkr=RTS/TSGN-0123108v401</a>
T1 (ATIS)	T1.3GPP.23.108V401-2004	4.0.1	Approved	21/05/2004	<a href="https://www.atis.org/atis/docstore/search.asp?committee=S24">https://www.atis.org/atis/docstore/search.asp?committee=S24</a>
TTA	TTAT.3G-23.108(R4-4.0.1)	4.0.1	Approved	25/05/2004	<a href="http://www.tta.or.kr/standardDB/stnfile/TTAT.3G-23.108(R4-4.0.1).zip">http://www.tta.or.kr/standardDB/stnfile/TTAT.3G-23.108(R4-4.0.1).zip</a>
<b>Release 5</b>					
CCSA	CCSA-TSD-DS-23.108	500	Approved	01/07/2003	<a href="http://www.ccsa.org.cn/english/tc/files.php?docpath=/ITU-R/M.1457/M.1457-4/DS/">http://www.ccsa.org.cn/english/tc/files.php?docpath=/ITU-R/M.1457/M.1457-4/DS/</a>
ETSI	ETSI TS 123 108	5.0.0	Published	04/07/2002	<a href="http://pda.etsi.org/pda/home.asp?wkr=RTS/TSGN-0123108v500">http://pda.etsi.org/pda/home.asp?wkr=RTS/TSGN-0123108v500</a>
T1 (ATIS)	T1.3GPP.23.108V500-2003	5.0.0	Approved	27/03/2003	<a href="https://www.atis.org/atis/docstore/search.asp?committee=S24">https://www.atis.org/atis/docstore/search.asp?committee=S24</a>
TTA	TTAT.3G-23.108(R5-5.0.0)	5.0.0	Approved	21/03/2003	<a href="http://www.tta.or.kr/standardDB/stnfile/TTAT.3G-23.108(R5-5.0.0).zip">http://www.tta.or.kr/standardDB/stnfile/TTAT.3G-23.108(R5-5.0.0).zip</a>

**5.3.2.6.2 23.110****UMTS access stratum services and functions**

This specification describes the detailed specifications of the protocols which rule the information flows, both control and user data, between the access stratum and the parts of UMTS outside the access stratum, and of the detailed specifications of the UTRAN. These detailed specifications are to be found in other technical specifications.

SDO (2)	Document No.	Version	Status	Issued date	Location (1)
<b>Release 99</b>					
CCSA	CCSA-TSD-DS-23.110	340	Approved	01/07/2003	<a href="http://www.ccsa.org.cn/english/tc/files.php?docpath=/ITU-R/M.1457/M.1457-4/DS/">http://www.ccsa.org.cn/english/tc/files.php?docpath=/ITU-R/M.1457/M.1457-4/DS/</a>
ETSI	ETSI TS 123 110	3.4.0	Published	17/05/2000	<a href="http://pda.etsi.org/pda/home.asp?wkr=RTS/TSGS-0223110UR1">http://pda.etsi.org/pda/home.asp?wkr=RTS/TSGS-0223110UR1</a>
T1 (ATIS)	T1.3GPP.23.110V340-2002	3.4.0	Approved	03/05/2002	<a href="https://www.atis.org/atis/docstore/search.asp?committee=S24">https://www.atis.org/atis/docstore/search.asp?committee=S24</a>
TTA	TTAE.3G-23.110(R99)	3.4.0	Approved	19/12/2001	<a href="http://www.tta.or.kr/standardDB/stnfile/TTAE_3G-23_110_R99_.zip">http://www.tta.or.kr/standardDB/stnfile/TTAE_3G-23_110_R99_.zip</a>



**Release 4**

CCSA	CCSA-TSD-DS-23.110	400	Approved	01/07/2003	<a href="http://www.ccsa.org.cn/english/tc/files.php?docpath=/ITU-R/M.1457/M.1457-4/DS/">http://www.ccsa.org.cn/english/tc/files.php?docpath=/ITU-R/M.1457/M.1457-4/DS/</a>
ETSI	ETSI TS 123 110	4.0.0	Published	17/04/2001	<a href="http://pda.etsi.org/pda/home.asp?wkr=RTS/TSGS-0223110Uv4">http://pda.etsi.org/pda/home.asp?wkr=RTS/TSGS-0223110Uv4</a>
T1 (ATIS)	T1.3GPP.23.110V400-2002	4.0.0	Approved	03/05/2002	<a href="https://www.atis.org/atis/docstore/search.asp?committee=S24">https://www.atis.org/atis/docstore/search.asp?committee=S24</a>
TTA	TTAE.3G-23.110(R4)	4.0.0	Approved	19/12/2001	<a href="http://www.tta.or.kr/standardDB/stnfile/TTAE_3G-23_110_R4_.zip">http://www.tta.or.kr/standardDB/stnfile/TTAE_3G-23_110_R4_.zip</a>

**Release 5**

ETSI	ETSI TS 123 110	5.0.0	Published	18/12/2003	<a href="http://pda.etsi.org/pda/home.asp?wkr=RTS/TSGS-0223110v500">http://pda.etsi.org/pda/home.asp?wkr=RTS/TSGS-0223110v500</a>
T1 (ATIS)	T1.3GPP.23.110V500-2004	5.0.0	Approved	21/05/2004	<a href="https://www.atis.org/atis/docstore/search.asp?committee=S24">https://www.atis.org/atis/docstore/search.asp?committee=S24</a>
TTA	TTAT.3G-23.110(R5-5.0.0)	5.0.0	Approved	25/05/2004	<a href="http://www.tta.or.kr/standardDB/stnfile/TTAT.3G-23.110(R5-5.0.0).zip">http://www.tta.or.kr/standardDB/stnfile/TTAT.3G-23.110(R5-5.0.0).zip</a>

**5.3.2.6.3 23.122****Functions related to Mobile Stations (MS) in idle mode and group receive mode**

This specification shall give an overview of the tasks undertaken by a Mobile Station (MS) when in idle mode, that is, switched on but not having a dedicated channel allocated, e.g. not making or receiving a call, or when in group receive mode, that is, receiving a group call or broadcast call but not having a dedicated connection. It also describes the corresponding network functions.

SDO (2)	Document No.	Version	Status	Issued date	Location (1)
<b>Release 99</b>					
CCSA	CCSA-TSD-DS-23.122	390	Approved	01/07/2003	<a href="http://www.ccsa.org.cn/english/tc/files.php?docpath=/ITU-R/M.1457/M.1457-4/DS/">http://www.ccsa.org.cn/english/tc/files.php?docpath=/ITU-R/M.1457/M.1457-4/DS/</a>
ETSI	ETSI TS 123 122	3.10.0	Published	14/10/2003	<a href="http://pda.etsi.org/pda/home.asp?wkr=RTS/TSGN-0123122v3a0">http://pda.etsi.org/pda/home.asp?wkr=RTS/TSGN-0123122v3a0</a>
T1 (ATIS)	T1.3GPP.23.122V3100-2004	3.10.0	Approved	21/05/2004	<a href="https://www.atis.org/atis/docstore/search.asp?committee=S24">https://www.atis.org/atis/docstore/search.asp?committee=S24</a>
TTA	TTAT.3G-23.122(R99-3.10.0)	3.10.0	Approved	25/05/2004	<a href="http://www.tta.or.kr/standardDB/stnfile/TTAT.3G-23.122(R99-3.10.0).zip">http://www.tta.or.kr/standardDB/stnfile/TTAT.3G-23.122(R99-3.10.0).zip</a>
<b>Release 4</b>					
CCSA	CCSA-TSD-DS-23.122	430	Approved	01/07/2003	<a href="http://www.ccsa.org.cn/english/tc/files.php?docpath=/ITU-R/M.1457/M.1457-4/DS/">http://www.ccsa.org.cn/english/tc/files.php?docpath=/ITU-R/M.1457/M.1457-4/DS/</a>
ETSI	ETSI TS 123 122	4.4.0	Published	14/10/2003	<a href="http://pda.etsi.org/pda/home.asp?wkr=RTS/TSGN-0123122v440">http://pda.etsi.org/pda/home.asp?wkr=RTS/TSGN-0123122v440</a>
T1 (ATIS)	T1.3GPP.23.122V440-2004	4.4.0	Approved	21/05/2004	<a href="https://www.atis.org/atis/docstore/search.asp?committee=S24">https://www.atis.org/atis/docstore/search.asp?committee=S24</a>
TTA	TTAT.3G-23.122(R4-4.4.0)	4.4.0	Approved	25/05/2004	<a href="http://www.tta.or.kr/standardDB/stnfile/TTAT.3G-23.122(R4-4.4.0).zip">http://www.tta.or.kr/standardDB/stnfile/TTAT.3G-23.122(R4-4.4.0).zip</a>
<b>Release 5</b>					
CCSA	CCSA-TSD-DS-23.122	520	Approved	01/07/2003	<a href="http://www.ccsa.org.cn/english/tc/files.php?docpath=/ITU-R/M.1457/M.1457-4/DS/">http://www.ccsa.org.cn/english/tc/files.php?docpath=/ITU-R/M.1457/M.1457-4/DS/</a>
ETSI	ETSI TS 123 122	5.3.0	Published	14/10/2003	<a href="http://pda.etsi.org/pda/home.asp?wkr=RTS/TSGN-0123122v530">http://pda.etsi.org/pda/home.asp?wkr=RTS/TSGN-0123122v530</a>
T1 (ATIS)	T1.3GPP.23.122V530-2004	5.3.0	Approved	21/05/2004	<a href="https://www.atis.org/atis/docstore/search.asp?committee=S24">https://www.atis.org/atis/docstore/search.asp?committee=S24</a>
TTA	TTAT.3G-23.122(R5-5.3.0)	5.3.0	Approved	25/05/2004	<a href="http://www.tta.or.kr/standardDB/stnfile/TTAT.3G-23.122(R5-5.3.0).zip">http://www.tta.or.kr/standardDB/stnfile/TTAT.3G-23.122(R5-5.3.0).zip</a>
<b>Release 6</b>					
T1 (ATIS)	T1.3GPP.23.122V600-2004	6.0.0	Approved	21/05/2004	<a href="https://www.atis.org/atis/docstore/search.asp?committee=S24">https://www.atis.org/atis/docstore/search.asp?committee=S24</a>



**5.3.2.6.4** 24.007**Mobile radio interface signalling Layer 3 - general aspects**

This specification describes the principal architecture of Layer 3 and its sub-layers on the GSM Um interface, i.e. the interface between mobile station (MS) and network; for the CM sub-layer, the description is restricted to paradigmatic examples, CC, supplementary services, and short message services for non-general packet radio service (GPRS) services. It also defines the basic message format and error handling applied by the Layer 3 protocols.

SDO (2)	Document No.	Version	Status	Issued date	Location (1)
<b>Release 99</b>					
CCSA	CCSA-TSD-DS-24.007	390	Approved	01/07/2003	<a href="http://www.ccsa.org.cn/english/tc/files.php?docpath=/ITU-R/M.1457/M.1457-4/DS/">http://www.ccsa.org.cn/english/tc/files.php?docpath=/ITU-R/M.1457/M.1457-4/DS/</a>
ETSI	ETSI TS 124 007	3.9.0	Published	01/07/2002	<a href="http://pda.etsi.org/pda/home.asp?wkr=RTS/TSGN-0124007v390">http://pda.etsi.org/pda/home.asp?wkr=RTS/TSGN-0124007v390</a>
T1 (ATIS)	T1.3GPP.24.007V390-2003	3.9.0	Approved	27/03/2003	<a href="https://www.atis.org/atis/docstore/search.asp?committee=S24">https://www.atis.org/atis/docstore/search.asp?committee=S24</a>
TTA	TTAT.3G-24.007(R99-3.9.0)	3.9.0	Approved	21/03/2003	<a href="http://www.tta.or.kr/standardDB/stnfile/TTAT.3G-24.007(R99-3.9.0).zip">http://www.tta.or.kr/standardDB/stnfile/TTAT.3G-24.007(R99-3.9.0).zip</a>
<b>Release 4</b>					
CCSA	CCSA-TSD-DS-24.007	420	Approved	01/07/2003	<a href="http://www.ccsa.org.cn/english/tc/files.php?docpath=/ITU-R/M.1457/M.1457-4/DS/">http://www.ccsa.org.cn/english/tc/files.php?docpath=/ITU-R/M.1457/M.1457-4/DS/</a>
ETSI	ETSI TS 124 007	4.2.0	Published	01/07/2002	<a href="http://pda.etsi.org/pda/home.asp?wkr=RTS/TSGN-0124007v420">http://pda.etsi.org/pda/home.asp?wkr=RTS/TSGN-0124007v420</a>
T1 (ATIS)	T1.3GPP.24.007V420-2003	4.2.0	Approved	27/03/2003	<a href="https://www.atis.org/atis/docstore/search.asp?committee=S24">https://www.atis.org/atis/docstore/search.asp?committee=S24</a>
TTA	TTAT.3G-24.007(R4-4.2.0)	4.2.0	Approved	21/03/2003	<a href="http://www.tta.or.kr/standardDB/stnfile/TTAT.3G-24.007(R4-4.2.0).zip">http://www.tta.or.kr/standardDB/stnfile/TTAT.3G-24.007(R4-4.2.0).zip</a>
<b>Release 5</b>					
CCSA	CCSA-TSD-DS-24.007	510	Approved	01/07/2003	<a href="http://www.ccsa.org.cn/english/tc/files.php?docpath=/ITU-R/M.1457/M.1457-4/DS/">http://www.ccsa.org.cn/english/tc/files.php?docpath=/ITU-R/M.1457/M.1457-4/DS/</a>
ETSI	ETSI TS 124 007	5.1.0	Published	20/09/2002	<a href="http://pda.etsi.org/pda/home.asp?wkr=RTS/TSGN-0124007v510">http://pda.etsi.org/pda/home.asp?wkr=RTS/TSGN-0124007v510</a>
T1 (ATIS)	T1.3GPP.24.007V510-2003	5.1.0	Approved	27/03/2003	<a href="https://www.atis.org/atis/docstore/search.asp?committee=S24">https://www.atis.org/atis/docstore/search.asp?committee=S24</a>
TTA	TTAT.3G-24.007(R5-5.1.0)	5.1.0	Approved	21/03/2003	<a href="http://www.tta.or.kr/standardDB/stnfile/TTAT.3G-24.007(R5-5.1.0).zip">http://www.tta.or.kr/standardDB/stnfile/TTAT.3G-24.007(R5-5.1.0).zip</a>
<b>Release 6</b>					
T1 (ATIS)	T1.3GPP.24.007V600-2004	6.0.0	Approved	21/05/2004	<a href="https://www.atis.org/atis/docstore/search.asp?committee=S24">https://www.atis.org/atis/docstore/search.asp?committee=S24</a>
TTA	TTAT.3G-24.007(R6-6.0.0)	6.0.0	Approved	25/05/2004	<a href="http://www.tta.or.kr/standardDB/stnfile/TTAT.3G-24.007(R6-6.0.0).zip">http://www.tta.or.kr/standardDB/stnfile/TTAT.3G-24.007(R6-6.0.0).zip</a>

**5.3.2.6.5** 24.008**Mobile radio interface Layer 3 specification; core network protocols - Stage 3**

This specification describes the procedures used at the radio interface for CC, MM and SM. The procedures currently described are for the CC of circuit-switched connections, SM for GPRS services, MM and radio resource management for circuit-switched and GPRS services.

SDO (2)	Document No.	Version	Status	Issued date	Location (1)
<b>Release 99</b>					
CCSA	CCSA-TSD-DS-24.008	3G0	Approved	01/07/2003	<a href="http://www.ccsa.org.cn/english/tc/files.php?docpath=/ITU-R/M.1457/M.1457-4/DS/">http://www.ccsa.org.cn/english/tc/files.php?docpath=/ITU-R/M.1457/M.1457-4/DS/</a>
ETSI	ETSI TS 124 008	3.17.0	Published	16/10/2003	<a href="http://pda.etsi.org/pda/home.asp?wkr=RTS/TSGN-0124008v3h0">http://pda.etsi.org/pda/home.asp?wkr=RTS/TSGN-0124008v3h0</a>
T1 (ATIS)	T1.3GPP.24.008V3170-2004	3.17.0	Approved	21/05/2004	<a href="https://www.atis.org/atis/docstore/search.asp?committee=S24">https://www.atis.org/atis/docstore/search.asp?committee=S24</a>
TTA	TTAT.3G-24.008(R99-3.17.0)	3.17.0	Approved	25/05/2004	<a href="http://www.tta.or.kr/standardDB/stnfile/TTAT.3G-24.008(R99-3.17.0).zip">http://www.tta.or.kr/standardDB/stnfile/TTAT.3G-24.008(R99-3.17.0).zip</a>

**Release 4**

CCSA	CCSA-TSD-DS-24.008	4B0	Approved	01/07/2003	<a href="http://www.ccsa.org.cn/english/tc/files.php?docpath=/ITU-R/M.1457/M.1457-4/DS/">http://www.ccsa.org.cn/english/tc/files.php?docpath=/ITU-R/M.1457/M.1457-4/DS/</a>
ETSI	ETSI TS 124 008	4.12.0	Published	16/10/2003	<a href="http://pda.etsi.org/pda/home.asp?wkr=RTS/TSGN-0124008v4c0">http://pda.etsi.org/pda/home.asp?wkr=RTS/TSGN-0124008v4c0</a>
T1 (ATIS)	T1.3GPP.24.008V4120-2004	4.12.0	Approved	21/05/2004	<a href="https://www.atis.org/atis/docstore/search.asp?committee=S24">https://www.atis.org/atis/docstore/search.asp?committee=S24</a>
TTA	TTAT.3G-24.008(R4-4.12.0)	4.12.0	Approved	25/05/2004	<a href="http://www.tta.or.kr/standardDB/stnfile/TTAT.3G-24.008(R4-4.12.0).zip">http://www.tta.or.kr/standardDB/stnfile/TTAT.3G-24.008(R4-4.12.0).zip</a>

**Release 5**

CCSA	CCSA-TSD-DS-24.008	580	Approved	01/07/2003	<a href="http://www.ccsa.org.cn/english/tc/files.php?docpath=/ITU-R/M.1457/M.1457-4/DS/">http://www.ccsa.org.cn/english/tc/files.php?docpath=/ITU-R/M.1457/M.1457-4/DS/</a>
ETSI	ETSI TS 124 008	5.10.0	Published	14/01/2004	<a href="http://pda.etsi.org/pda/home.asp?wkr=RTS/TSGN-0124008v5a0">http://pda.etsi.org/pda/home.asp?wkr=RTS/TSGN-0124008v5a0</a>
T1 (ATIS)	T1.3GPP.24.008V5100-2004	5.10.0	Approved	21/05/2004	<a href="https://www.atis.org/atis/docstore/search.asp?committee=S24">https://www.atis.org/atis/docstore/search.asp?committee=S24</a>
TTA	TTAT.3G-24.008(R5-5.10.0)	5.10.0	Approved	25/05/2004	<a href="http://www.tta.or.kr/standardDB/stnfile/TTAT.3G-24.008(R5-5.10.0).zip">http://www.tta.or.kr/standardDB/stnfile/TTAT.3G-24.008(R5-5.10.0).zip</a>

**Release 6**

CCSA	CCSA-TSD-DS-24.008	610	Approved	01/07/2003	<a href="http://www.ccsa.org.cn/english/tc/files.php?docpath=/ITU-R/M.1457/M.1457-4/DS/">http://www.ccsa.org.cn/english/tc/files.php?docpath=/ITU-R/M.1457/M.1457-4/DS/</a>
T1 (ATIS)	T1.3GPP.24.008V630-2004	6.3.0	Approved	21/05/2004	<a href="https://www.atis.org/atis/docstore/search.asp?committee=S24">https://www.atis.org/atis/docstore/search.asp?committee=S24</a>
TTA	TTAT.3G-24.008(R6-6.3.0)	6.3.0	Approved	25/05/2004	<a href="http://www.tta.or.kr/standardDB/stnfile/TTAT.3G-24.008(R6-6.3.0).zip">http://www.tta.or.kr/standardDB/stnfile/TTAT.3G-24.008(R6-6.3.0).zip</a>

**5.3.2.6.6 24.011****Point-to-point short message service (SMS) support on mobile radio interface**

This specification describes the procedures used across the mobile radio interface by the signalling Layer 3 function short message control (SMC) and short message relay (SM-RL) function for both circuit-switched GSM and GPRS.

SDO (2)	Document No.	Version	Status	Issued date	Location (1)
<b>Release 99</b>					
CCSA	CCSA-TSD-DS-24.011	360	Approved	01/07/2003	<a href="http://www.ccsa.org.cn/english/tc/files.php?docpath=/ITU-R/M.1457/M.1457-4/DS/">http://www.ccsa.org.cn/english/tc/files.php?docpath=/ITU-R/M.1457/M.1457-4/DS/</a>
ETSI	ETSI TS 124 011	3.6.0	Published	25/04/2001	<a href="http://pda.etsi.org/pda/home.asp?wkr=RTS/TSGN-0124011UR5">http://pda.etsi.org/pda/home.asp?wkr=RTS/TSGN-0124011UR5</a>
T1 (ATIS)	T1.3GPP.24.011V360-2002	3.6.0	Approved	03/05/2002	<a href="https://www.atis.org/atis/docstore/search.asp?committee=S24">https://www.atis.org/atis/docstore/search.asp?committee=S24</a>
TTA	TTAE.3G-24.011(R99F)	3.6.0	Approved	19/12/2001	<a href="http://www.tta.or.kr/standardDB/stnfile/TTAE_3G-24_011_R99F_.zip">http://www.tta.or.kr/standardDB/stnfile/TTAE_3G-24_011_R99F_.zip</a>
<b>Release 4</b>					
CCSA	CCSA-TSD-DS-24.011	410	Approved	01/07/2003	<a href="http://www.ccsa.org.cn/english/tc/files.php?docpath=/ITU-R/M.1457/M.1457-4/DS/">http://www.ccsa.org.cn/english/tc/files.php?docpath=/ITU-R/M.1457/M.1457-4/DS/</a>
ETSI	ETSI TS 124 011	4.1.1	Published	17/07/2002	<a href="http://pda.etsi.org/pda/home.asp?wkr=RTS/TSGN-0124011v411">http://pda.etsi.org/pda/home.asp?wkr=RTS/TSGN-0124011v411</a>
T1 (ATIS)	T1.3GPP.24.011V411-2003	4.1.1	Approved	27/03/2003	<a href="https://www.atis.org/atis/docstore/search.asp?committee=S24">https://www.atis.org/atis/docstore/search.asp?committee=S24</a>
TTA	TTAT.3G-24.011(R4-4.1.1)	4.1.1	Approved	21/03/2003	<a href="http://www.tta.or.kr/standardDB/stnfile/TTAT.3G-24.011(R4-4.1.1).zip">http://www.tta.or.kr/standardDB/stnfile/TTAT.3G-24.011(R4-4.1.1).zip</a>
<b>Release 5</b>					
CCSA	CCSA-TSD-DS-24.011	520	Approved	01/07/2003	<a href="http://www.ccsa.org.cn/english/tc/files.php?docpath=/ITU-R/M.1457/M.1457-4/DS/">http://www.ccsa.org.cn/english/tc/files.php?docpath=/ITU-R/M.1457/M.1457-4/DS/</a>
ETSI	ETSI TS 124 011	5.2.0	Published	10/07/2003	<a href="http://pda.etsi.org/pda/home.asp?wkr=RTS/TSGN-0124011v520">http://pda.etsi.org/pda/home.asp?wkr=RTS/TSGN-0124011v520</a>
T1 (ATIS)	T1.3GPP.24.011V520-2004	5.2.0	Approved	21/05/2004	<a href="https://www.atis.org/atis/docstore/search.asp?committee=S24">https://www.atis.org/atis/docstore/search.asp?committee=S24</a>
TTA	TTAT.3G-24.011(R5-5.2.0)	5.2.0	Approved	25/05/2004	<a href="http://www.tta.or.kr/standardDB/stnfile/TTAT.3G-24.011(R5-5.2.0).zip">http://www.tta.or.kr/standardDB/stnfile/TTAT.3G-24.011(R5-5.2.0).zip</a>
<b>Release 6</b>					
T1 (ATIS)	T1.3GPP.24.011V600-2004	6.0.0	Approved	21/05/2004	<a href="https://www.atis.org/atis/docstore/search.asp?committee=S24">https://www.atis.org/atis/docstore/search.asp?committee=S24</a>

TTA TTAT.3G-24.011(R6-6.0.0) 6.0.0 Approved 25/05/2004 [http://www.tta.or.kr/standardDB/stnfile/TTAT.3G-24.011\(R6-6.0.0\).zip](http://www.tta.or.kr/standardDB/stnfile/TTAT.3G-24.011(R6-6.0.0).zip)

### 5.3.2.6.7 23.060

#### General packet radio service (GPRS) service description - Stage 2

This specification describes a general overview over the GPRS architecture as well as a more detailed overview of the MS - CN protocol architecture. Details of the protocols will be specified in companion documents.

SDO (2)	Document No.	Version	Status	Issued date	Location (1)
<b>Release 99</b>					
CCSA	CCSA-TSD-DS-23.060	3F0	Approved	01/07/2003	<a href="http://www.ccsa.org.cn/english/tc/files.php?docpath=/ITU-R/M.1457/M.1457-4/DS/">http://www.ccsa.org.cn/english/tc/files.php?docpath=/ITU-R/M.1457/M.1457-4/DS/</a>
ETSI	ETSI TS 123 060	3.16.0	Published	13/01/2004	<a href="http://pda.etsi.org/pda/home.asp?wkr=RTS/TSGS-0223060v3g0">http://pda.etsi.org/pda/home.asp?wkr=RTS/TSGS-0223060v3g0</a>
T1 (ATIS)	T1.3GPP.23.060V3160-2004	3.16.0	Approved	21/05/2004	<a href="https://www.atis.org/atis/docstore/search.asp?committee=S24">https://www.atis.org/atis/docstore/search.asp?committee=S24</a>
TTA	TTAT.3G-23.060(R99-3.16.0)	3.16.0	Approved	25/05/2004	<a href="http://www.tta.or.kr/standardDB/stnfile/TTAT.3G-23.060(R99-3.16.0).zip">http://www.tta.or.kr/standardDB/stnfile/TTAT.3G-23.060(R99-3.16.0).zip</a>
<b>Release 4</b>					
CCSA	CCSA-TSD-DS-23.060	480	Approved	01/07/2003	<a href="http://www.ccsa.org.cn/english/tc/files.php?docpath=/ITU-R/M.1457/M.1457-4/DS/">http://www.ccsa.org.cn/english/tc/files.php?docpath=/ITU-R/M.1457/M.1457-4/DS/</a>
ETSI	ETSI TS 123 060	4.9.0	Published	13/01/2004	<a href="http://pda.etsi.org/pda/home.asp?wkr=RTS/TSGS-0223060v490">http://pda.etsi.org/pda/home.asp?wkr=RTS/TSGS-0223060v490</a>
T1 (ATIS)	T1.3GPP.23.060V490-2004	4.9.0	Approved	21/05/2004	<a href="https://www.atis.org/atis/docstore/search.asp?committee=S24">https://www.atis.org/atis/docstore/search.asp?committee=S24</a>
TTA	TTAT.3G-23.060(R4-4.9.0)	4.9.0	Approved	25/05/2004	<a href="http://www.tta.or.kr/standardDB/stnfile/TTAT.3G-23.060(R4-4.9.0).zip">http://www.tta.or.kr/standardDB/stnfile/TTAT.3G-23.060(R4-4.9.0).zip</a>
<b>Release 5</b>					
CCSA	CCSA-TSD-DS-23.060	560	Approved	01/07/2003	<a href="http://www.ccsa.org.cn/english/tc/files.php?docpath=/ITU-R/M.1457/M.1457-4/DS/">http://www.ccsa.org.cn/english/tc/files.php?docpath=/ITU-R/M.1457/M.1457-4/DS/</a>
ETSI	ETSI TS 123 060	5.7.0	Published	13/01/2004	<a href="http://pda.etsi.org/pda/home.asp?wkr=RTS/TSGS-0223060v570">http://pda.etsi.org/pda/home.asp?wkr=RTS/TSGS-0223060v570</a>
T1 (ATIS)	T1.3GPP.23.060V570-2004	5.7.0	Approved	21/05/2004	<a href="https://www.atis.org/atis/docstore/search.asp?committee=S24">https://www.atis.org/atis/docstore/search.asp?committee=S24</a>
TTA	TTAT.3G-23.060(R5-5.7.0)	5.7.0	Approved	25/05/2004	<a href="http://www.tta.or.kr/standardDB/stnfile/TTAT.3G-23.060(R5-5.7.0).zip">http://www.tta.or.kr/standardDB/stnfile/TTAT.3G-23.060(R5-5.7.0).zip</a>
<b>Release 6</b>					
CCSA	CCSA-TSD-DS-23.060	610	Approved	01/07/2003	<a href="http://www.ccsa.org.cn/english/tc/files.php?docpath=/ITU-R/M.1457/M.1457-4/DS/">http://www.ccsa.org.cn/english/tc/files.php?docpath=/ITU-R/M.1457/M.1457-4/DS/</a>
T1 (ATIS)	T1.3GPP.23.060V630-2004	6.3.0	Approved	21/05/2004	<a href="https://www.atis.org/atis/docstore/search.asp?committee=S24">https://www.atis.org/atis/docstore/search.asp?committee=S24</a>
TTA	TTAT.3G-23.060(R6-6.3.0)	6.3.0	Approved	25/05/2004	<a href="http://www.tta.or.kr/standardDB/stnfile/TTAT.3G-23.060(R6-6.3.0).zip">http://www.tta.or.kr/standardDB/stnfile/TTAT.3G-23.060(R6-6.3.0).zip</a>

### 5.3.2.6.8 24.022

#### Radio link protocol (RLP) for circuit switched bearer and teleservices

This specification describes the RLP for data transmission over the UMTS public land mobile network (PLMN). RLP covers the Layer 2 functionality of the ISO OSI reference model (IS 7498). It is based on ideas contained in IS 3309, IS 4335 and IS 7809 (HDLC of ISO) as well as ITU-T Recommendations X.25, Q.921 and Q.922 (LAP-B and LAP-D, respectively). RLP has been tailored to the special needs of digital radio transmission. RLP provides to its users the OSI data link service (IS 8886).

SDO (2)	Document No.	Version	Status	Issued date	Location (1)
<b>Release 99</b>					
CCSA	CCSA-TSD-DS-24.022	350	Approved	01/07/2003	<a href="http://www.ccsa.org.cn/english/tc/files.php?docpath=/ITU-R/M.1457/M.1457-4/DS/">http://www.ccsa.org.cn/english/tc/files.php?docpath=/ITU-R/M.1457/M.1457-4/DS/</a>

ETSI	ETSI TS 124 022	3.5.0	Published	02/07/2003	<a href="http://pda.etsi.org/pda/home.asp?wkr=RTS/TSGN-0324022v350">http://pda.etsi.org/pda/home.asp?wkr=RTS/TSGN-0324022v350</a>
T1 (ATIS)	T1.3GPP.24.022V350-2004	3.5.0	Approved	21/05/2004	<a href="https://www.atis.org/atis/docstore/search.asp?committee=s24">https://www.atis.org/atis/docstore/search.asp?committee=s24</a>
TTA	TTAT.3G-24.022(R99-3.5.0)	3.5.0	Approved	25/05/2004	<a href="http://www.tta.or.kr/standardDB/stnfile/TTAT.3G-24.022(R99-3.5.0).zip">http://www.tta.or.kr/standardDB/stnfile/TTAT.3G-24.022(R99-3.5.0).zip</a>
<b>Release 4</b>					
CCSA	CCSA-TSD-DS-24.022	410	Approved	01/07/2003	<a href="http://www.ccsa.org.cn/english/tc/files.php?docpath=/ITU-R/M.1457/M.1457-4/DS/">http://www.ccsa.org.cn/english/tc/files.php?docpath=/ITU-R/M.1457/M.1457-4/DS/</a>
ETSI	ETSI TS 124 022	4.1.0	Published	02/07/2003	<a href="http://pda.etsi.org/pda/home.asp?wkr=RTS/TSGN-0324022v410">http://pda.etsi.org/pda/home.asp?wkr=RTS/TSGN-0324022v410</a>
T1 (ATIS)	T1.3GPP.24.022V410-2004	4.1.0	Approved	21/05/2004	<a href="https://www.atis.org/atis/docstore/search.asp?committee=s24">https://www.atis.org/atis/docstore/search.asp?committee=s24</a>
TTA	TTAT.3G-24.022(R4-4.1.0)	4.1.0	Approved	25/05/2004	<a href="http://www.tta.or.kr/standardDB/stnfile/TTAT.3G-24.022(R4-4.1.0).zip">http://www.tta.or.kr/standardDB/stnfile/TTAT.3G-24.022(R4-4.1.0).zip</a>
<b>Release 5</b>					
CCSA	CCSA-TSD-DS-24.022	530	Approved	01/07/2003	<a href="http://www.ccsa.org.cn/english/tc/files.php?docpath=/ITU-R/M.1457/M.1457-4/DS/">http://www.ccsa.org.cn/english/tc/files.php?docpath=/ITU-R/M.1457/M.1457-4/DS/</a>
ETSI	ETSI TS 124 022	5.5.0	Published	19/01/2004	<a href="http://pda.etsi.org/pda/home.asp?wkr=RTS/TSGN-0324022v550">http://pda.etsi.org/pda/home.asp?wkr=RTS/TSGN-0324022v550</a>
T1 (ATIS)	T1.3GPP.24.022V550-2004	5.5.0	Approved	21/05/2004	<a href="https://www.atis.org/atis/docstore/search.asp?committee=s24">https://www.atis.org/atis/docstore/search.asp?committee=s24</a>
TTA	TTAT.3G-24.022(R5-5.5.0)	5.5.0	Approved	25/05/2004	<a href="http://www.tta.or.kr/standardDB/stnfile/TTAT.3G-24.022(R5-5.5.0).zip">http://www.tta.or.kr/standardDB/stnfile/TTAT.3G-24.022(R5-5.5.0).zip</a>

### 5.3.2.6.9 24.010

#### Mobile radio interface Layer 3 - supplementary services specification - general aspects

This specification describes the general aspects of the specification of supplementary services at the Layer 3 radio interface. Details will be specified in other documents.

SDO (2)	Document No.	Version	Status	Issued date	Location (1)
<b>Release 99</b>					
CCSA	CCSA-TSD-DS-24.010	320	Approved	01/07/2003	<a href="http://www.ccsa.org.cn/english/tc/files.php?docpath=/ITU-R/M.1457/M.1457-4/DS/">http://www.ccsa.org.cn/english/tc/files.php?docpath=/ITU-R/M.1457/M.1457-4/DS/</a>
ETSI	ETSI TS 124 010	3.2.0	Published	15/01/2002	<a href="http://pda.etsi.org/pda/home.asp?wkr=RTS/TSGN-0424010UR2">http://pda.etsi.org/pda/home.asp?wkr=RTS/TSGN-0424010UR2</a>
T1 (ATIS)	T1.3GPP.24.010V320-2002	3.2.0	Approved	03/05/2002	<a href="https://www.atis.org/atis/docstore/search.asp?committee=S24">https://www.atis.org/atis/docstore/search.asp?committee=S24</a>
TTA	TTAE.3G-24.010(R99-3.2.0)	3.2.0	Approved	29/05/2002	<a href="http://www.tta.or.kr/standardDB/stnfile/TTAE.3G-24.010(R99-3.2.0).zip">http://www.tta.or.kr/standardDB/stnfile/TTAE.3G-24.010(R99-3.2.0).zip</a>
<b>Release 4</b>					
CCSA	CCSA-TSD-DS-24.010	420	Approved	01/07/2003	<a href="http://www.ccsa.org.cn/english/tc/files.php?docpath=/ITU-R/M.1457/M.1457-4/DS/">http://www.ccsa.org.cn/english/tc/files.php?docpath=/ITU-R/M.1457/M.1457-4/DS/</a>
ETSI	ETSI TS 124 010	4.2.0	Published	15/01/2002	<a href="http://pda.etsi.org/pda/home.asp?wkr=RTS/TSGN-0424010Uv4R2">http://pda.etsi.org/pda/home.asp?wkr=RTS/TSGN-0424010Uv4R2</a>
T1 (ATIS)	T1.3GPP.24.010V420-2002	4.2.0	Approved	03/05/2002	<a href="https://www.atis.org/atis/docstore/search.asp?committee=S24">https://www.atis.org/atis/docstore/search.asp?committee=S24</a>
TTA	TTAE.3G-24.010(R4-4.2.0)	4.2.0	Approved	29/05/2002	<a href="http://www.tta.or.kr/standardDB/stnfile/TTAE.3G-24.010(R4-4.2.0).zip">http://www.tta.or.kr/standardDB/stnfile/TTAE.3G-24.010(R4-4.2.0).zip</a>
<b>Release 5</b>					
CCSA	CCSA-TSD-DS-24.010	500	Approved	01/07/2003	<a href="http://www.ccsa.org.cn/english/tc/files.php?docpath=/ITU-R/M.1457/M.1457-4/DS/">http://www.ccsa.org.cn/english/tc/files.php?docpath=/ITU-R/M.1457/M.1457-4/DS/</a>
ETSI	ETSI TS 124 010	5.0.0	Published	02/07/2002	<a href="http://pda.etsi.org/pda/home.asp?wkr=RTS/TSGN-0424010v500">http://pda.etsi.org/pda/home.asp?wkr=RTS/TSGN-0424010v500</a>
T1 (ATIS)	T1.3GPP.24.010V500-2003	5.0.0	Approved	27/03/2003	<a href="https://www.atis.org/atis/docstore/search.asp?committee=S24">https://www.atis.org/atis/docstore/search.asp?committee=S24</a>
TTA	TTAT.3G-24.010(R5-5.0.0)	5.0.0	Approved	21/03/2003	<a href="http://www.tta.or.kr/standardDB/stnfile/TTAT.3G-24.010(R5-5.0.0).zip">http://www.tta.or.kr/standardDB/stnfile/TTAT.3G-24.010(R5-5.0.0).zip</a>

**5.3.2.6.10** 24.080**Mobile radio interface Layer 3 - supplementary services specification - formats and coding**

This specification describes the coding of information necessary for support of supplementary service operation on the mobile radio interface L3. Details will be specified in other documents.

SDO (2)	Document No.	Version	Status	Issued date	Location (1)
<b>Release 99</b>					
CCSA	CCSA-TSD-DS-24.080	370	Approved	01/07/2003	<a href="http://www.ccsa.org.cn/english/tc/files.php?docpath=/ITU-R/M.1457/M.1457-4/DS/">http://www.ccsa.org.cn/english/tc/files.php?docpath=/ITU-R/M.1457/M.1457-4/DS/</a>
ETSI	ETSI TS 124 080	3.7.1	Published	14/10/2003	<a href="http://pda.etsi.org/pda/home.asp?wkr=RTS/TSGN-0424080v371">http://pda.etsi.org/pda/home.asp?wkr=RTS/TSGN-0424080v371</a>
T1 (ATIS)	T1.3GPP.24.080V371-2004	3.7.1	Approved	21/05/2004	<a href="https://www.atis.org/atis/docstore/search.asp?committee=S24">https://www.atis.org/atis/docstore/search.asp?committee=S24</a>
TTA	TTAT.3G-24.080(R99-3.7.1)	3.7.1	Approved	25/05/2004	<a href="http://www.tta.or.kr/standardDB/stnfile/TTAT.3G-24.080(R99-3.7.1).zip">http://www.tta.or.kr/standardDB/stnfile/TTAT.3G-24.080(R99-3.7.1).zip</a>
<b>Release 4</b>					
CCSA	CCSA-TSD-DS-24.080	430	Approved	01/07/2003	<a href="http://www.ccsa.org.cn/english/tc/files.php?docpath=/ITU-R/M.1457/M.1457-4/DS/">http://www.ccsa.org.cn/english/tc/files.php?docpath=/ITU-R/M.1457/M.1457-4/DS/</a>
ETSI	ETSI TS 124 080	4.3.1	Published	14/10/2003	<a href="http://pda.etsi.org/pda/home.asp?wkr=RTS/TSGN-0424080v431">http://pda.etsi.org/pda/home.asp?wkr=RTS/TSGN-0424080v431</a>
T1 (ATIS)	T1.3GPP.24.080V431-2004	4.3.1	Approved	21/05/2004	<a href="https://www.atis.org/atis/docstore/search.asp?committee=S24">https://www.atis.org/atis/docstore/search.asp?committee=S24</a>
TTA	TTAT.3G-24.080(R4-4.3.1)	4.3.1	Approved	25/05/2004	<a href="http://www.tta.or.kr/standardDB/stnfile/TTAT.3G-24.080(R4-4.3.1).zip">http://www.tta.or.kr/standardDB/stnfile/TTAT.3G-24.080(R4-4.3.1).zip</a>
<b>Release 5</b>					
CCSA	CCSA-TSD-DS-24.080	530	Approved	01/07/2003	<a href="http://www.ccsa.org.cn/english/tc/files.php?docpath=/ITU-R/M.1457/M.1457-4/DS/">http://www.ccsa.org.cn/english/tc/files.php?docpath=/ITU-R/M.1457/M.1457-4/DS/</a>
ETSI	ETSI TS 124 080	5.4.0	Published	14/10/2003	<a href="http://pda.etsi.org/pda/home.asp?wkr=RTS/TSGN-0424080v540">http://pda.etsi.org/pda/home.asp?wkr=RTS/TSGN-0424080v540</a>
T1 (ATIS)	T1.3GPP.24.080V540-2004	5.4.0	Approved	21/05/2004	<a href="https://www.atis.org/atis/docstore/search.asp?committee=S24">https://www.atis.org/atis/docstore/search.asp?committee=S24</a>
TTA	TTAT.3G-24.080(R5-5.4.0)	5.4.0	Approved	25/05/2004	<a href="http://www.tta.or.kr/standardDB/stnfile/TTAT.3G-24.080(R5-5.4.0).zip">http://www.tta.or.kr/standardDB/stnfile/TTAT.3G-24.080(R5-5.4.0).zip</a>
<b>Release 6</b>					
T1 (ATIS)	T1.3GPP.24.080V600-2004	6.0.0	Approved	21/05/2004	<a href="https://www.atis.org/atis/docstore/search.asp?committee=S24">https://www.atis.org/atis/docstore/search.asp?committee=S24</a>
TTA	TTAT.3G-24.080(R6-6.0.0)	6.0.0	Approved	25/05/2004	<a href="http://www.tta.or.kr/standardDB/stnfile/TTAT.3G-24.080(R6-6.0.0).zip">http://www.tta.or.kr/standardDB/stnfile/TTAT.3G-24.080(R6-6.0.0).zip</a>

**5.3.2.7****Terminal aspects****5.3.2.7.1** 21.111**USIM and IC card requirements**

This specification describes the requirements of the USIM and the USIM IC card (UICC). These are derived from the service and security requirements defined in the respective specifications. The document is the basis for the detailed specification of the USIM and the UICC, and the interface to the terminal.

SDO (2)	Document No.	Version	Status	Issued date	Location (1)
<b>Release 99</b>					
CCSA	CCSA-TSD-DS-21.111	340	Approved	01/07/2003	<a href="http://www.ccsa.org.cn/english/tc/files.php?docpath=/ITU-R/M.1457/M.1457-4/DS/">http://www.ccsa.org.cn/english/tc/files.php?docpath=/ITU-R/M.1457/M.1457-4/DS/</a>

## 220

ETSI	ETSI TS 121 111	3.4.0	Published	02/10/2002	<a href="http://pda.etsi.org/pda/home.asp?wkr=RTS/TSGT-0321111v340">http://pda.etsi.org/pda/home.asp?wkr=RTS/TSGT-0321111v340</a>
T1 (ATIS)	T1.3GPP.21.111V340-2003	3.4.0	Approved	27/03/2003	<a href="https://www.atis.org/atis/docstore/search.asp?committee=S24">https://www.atis.org/atis/docstore/search.asp?committee=S24</a>
TTA	TTAT.3G-21.111(R99-3.4.0)	3.4.0	Approved	21/03/2003	<a href="http://www.tta.or.kr/standardDB/stnfile/TTAT.3G-21.111(R99-3.4.0).zip">http://www.tta.or.kr/standardDB/stnfile/TTAT.3G-21.111(R99-3.4.0).zip</a>

### Release 4

CCSA	CCSA-TSD-DS-21.111	410	Approved	01/07/2003	<a href="http://www.ccsa.org.cn/english/tc/files.php?docpath=/ITU-R/M.1457/M.1457-4/DS/">http://www.ccsa.org.cn/english/tc/files.php?docpath=/ITU-R/M.1457/M.1457-4/DS/</a>
ETSI	ETSI TS 121 111	4.1.0	Published	02/10/2002	<a href="http://pda.etsi.org/pda/home.asp?wkr=RTS/TSGT-0321111v410">http://pda.etsi.org/pda/home.asp?wkr=RTS/TSGT-0321111v410</a>
T1 (ATIS)	T1.3GPP.21.111V410-2003	4.1.0	Approved	27/03/2003	<a href="https://www.atis.org/atis/docstore/search.asp?committee=S24">https://www.atis.org/atis/docstore/search.asp?committee=S24</a>
TTA	TTAT.3G-21.111(R4-4.1.0)	4.1.0	Approved	21/03/2003	<a href="http://www.tta.or.kr/standardDB/stnfile/TTAT.3G-21.111(R4-4.1.0).zip">http://www.tta.or.kr/standardDB/stnfile/TTAT.3G-21.111(R4-4.1.0).zip</a>

### Release 5

CCSA	CCSA-TSD-DS-21.111	510	Approved	01/07/2003	<a href="http://www.ccsa.org.cn/english/tc/files.php?docpath=/ITU-R/M.1457/M.1457-4/DS/">http://www.ccsa.org.cn/english/tc/files.php?docpath=/ITU-R/M.1457/M.1457-4/DS/</a>
ETSI	ETSI TS 121 111	5.1.0	Published	02/10/2002	<a href="http://pda.etsi.org/pda/home.asp?wkr=RTS/TSGT-0321111v510">http://pda.etsi.org/pda/home.asp?wkr=RTS/TSGT-0321111v510</a>
T1 (ATIS)	T1.3GPP.21.111V510-2003	5.1.0	Approved	27/03/2003	<a href="https://www.atis.org/atis/docstore/search.asp?committee=S24">https://www.atis.org/atis/docstore/search.asp?committee=S24</a>
TTA	TTAT.3G-21.111(R5-5.1.0)	5.1.0	Approved	21/03/2003	<a href="http://www.tta.or.kr/standardDB/stnfile/TTAT.3G-21.111(R5-5.1.0).zip">http://www.tta.or.kr/standardDB/stnfile/TTAT.3G-21.111(R5-5.1.0).zip</a>

### Release 6

T1 (ATIS)	T1.3GPP.21.111V600-2004	6.0.0	Approved	21/05/2004	<a href="https://www.atis.org/atis/docstore/search.asp?committee=S24">https://www.atis.org/atis/docstore/search.asp?committee=S24</a>
-----------	-------------------------	-------	----------	------------	---------------------------------------------------------------------------------------------------------------------------------------

## 5.3.2.7.2 22.112

### USAT-Interpreter - Stage 1

This document specifies a system to make Mobile Operator services, based on USAT functionality and USIM based security functionality, available to an internet environment. This is achieved by specifying the necessary components and protocols for a secure narrow band channel between the internet application and an USAT Interpreter on the USIM.

SDO (2)	Document No.	Version	Status	Issued date	Location (1)
---------	--------------	---------	--------	-------------	--------------

### Release 5

CCSA	CCSA-TSD-DS-21.112	500	Approved	01/07/2003	<a href="http://www.ccsa.org.cn/english/tc/files.php?docpath=/ITU-R/M.1457/M.1457-4/DS/">http://www.ccsa.org.cn/english/tc/files.php?docpath=/ITU-R/M.1457/M.1457-4/DS/</a>
ETSI	ETSI TS 122 112	5.0.0	Published	05/08/2002	<a href="http://pda.etsi.org/pda/home.asp?wkr=RTS/TSGT-0322112v500">http://pda.etsi.org/pda/home.asp?wkr=RTS/TSGT-0322112v500</a>
T1 (ATIS)	T1.3GPP.22.112V500-2004	5.0.0	Approved	21/05/2004	<a href="https://www.atis.org/atis/docstore/search.asp?committee=S24">https://www.atis.org/atis/docstore/search.asp?committee=S24</a>
TTA	TTAT.3G-22.112(R5-5.0.0)	5.0.0	Approved	28/05/2003	<a href="http://www.tta.or.kr/standardDB/stnfile/TTAT.3G-22.112(R5-5.0.0).zip">http://www.tta.or.kr/standardDB/stnfile/TTAT.3G-22.112(R5-5.0.0).zip</a>

## 5.3.2.7.3 31.101

### UICC-Terminal Interface; Physical and Logical Characteristics

This document specifies the interface between the UICC and the Terminal for 3G telecom network operation. This includes the requirements for the physical characteristics of the UICC, the electrical interface between the UICC and the Terminal, the initial communication establishment and the transport protocols, the communication commands and the procedures and the application independent files and protocols.

SDO (2)	Document No.	Version	Status	Issued date	Location (1)
---------	--------------	---------	--------	-------------	--------------

### Release 99

CCSA	CCSA-TSD-DS-31.101	330	Approved	01/07/2003	<a href="http://www.ccsa.org.cn/english/tc/files.php?docpath=/ITU-R/M.1457/M.1457-4/DS/">http://www.ccsa.org.cn/english/tc/files.php?docpath=/ITU-R/M.1457/M.1457-4/DS/</a>
------	--------------------	-----	----------	------------	-----------------------------------------------------------------------------------------------------------------------------------------------------------------------------

## Rec. ITU-R M.1457-4

ETSI	ETSI TS 131 101	3.3.0	Published	07/11/2000	<a href="http://pda.etsi.org/pda/home.asp?wkr=RTS/TSGT-0331101UR3">http://pda.etsi.org/pda/home.asp?wkr=RTS/TSGT-0331101UR3</a>
T1 (ATIS)	T1.3GPP.31.101V330-2002	3.3.0	Approved	03/05/2002	<a href="https://www.atis.org/atis/docstore/search.asp?committee=S24">https://www.atis.org/atis/docstore/search.asp?committee=S24</a>
TTA	TTAE.3G-31.101(R99-3.3.0)	3.3.0	Approved	29/05/2002	<a href="http://www.tta.or.kr/standardDB/stnfile/TTAE.3G-31.101(R99-3.3.0).zip">http://www.tta.or.kr/standardDB/stnfile/TTAE.3G-31.101(R99-3.3.0).zip</a>
<b>Release 4</b>					
CCSA	CCSA-TSD-DS-31.101	410	Approved	01/07/2003	<a href="http://www.ccsa.org.cn/english/tc/files.php?docpath=/ITU-R/M.1457/M.1457-4/DS/">http://www.ccsa.org.cn/english/tc/files.php?docpath=/ITU-R/M.1457/M.1457-4/DS/</a>
ETSI	ETSI TS 131 101	4.1.0	Published	08/01/2003	<a href="http://pda.etsi.org/pda/home.asp?wkr=RTS/TSGT-0331101v410">http://pda.etsi.org/pda/home.asp?wkr=RTS/TSGT-0331101v410</a>
T1 (ATIS)	T1.3GPP.31.101V410-2003	4.1.0	Approved	27/03/2003	<a href="https://www.atis.org/atis/docstore/search.asp?committee=S24">https://www.atis.org/atis/docstore/search.asp?committee=S24</a>
TTA	TTAT.3G-31.101(R4-4.1.0)	4.1.0	Approved	21/03/2003	<a href="http://www.tta.or.kr/standardDB/stnfile/TTAT.3G-31.101(R4-4.1.0).zip">http://www.tta.or.kr/standardDB/stnfile/TTAT.3G-31.101(R4-4.1.0).zip</a>
<b>Release 5</b>					
CCSA	CCSA-TSD-DS-31.101	510	Approved	01/07/2003	<a href="http://www.ccsa.org.cn/english/tc/files.php?docpath=/ITU-R/M.1457/M.1457-4/DS/">http://www.ccsa.org.cn/english/tc/files.php?docpath=/ITU-R/M.1457/M.1457-4/DS/</a>
ETSI	ETSI TS 131 101	5.1.0	Published	08/01/2003	<a href="http://pda.etsi.org/pda/home.asp?wkr=RTS/TSGT-0331101v510">http://pda.etsi.org/pda/home.asp?wkr=RTS/TSGT-0331101v510</a>
T1 (ATIS)	T1.3GPP.31.101V510-2003	5.1.0	Approved	27/03/2003	<a href="https://www.atis.org/atis/docstore/search.asp?committee=S24">https://www.atis.org/atis/docstore/search.asp?committee=S24</a>
TTA	TTAT.3G-31.101(R5-5.1.0)	5.1.0	Approved	21/03/2003	<a href="http://www.tta.or.kr/standardDB/stnfile/TTAT.3G-31.101(R5-5.1.0).zip">http://www.tta.or.kr/standardDB/stnfile/TTAT.3G-31.101(R5-5.1.0).zip</a>
<b>Release 6</b>					
CCSA	CCSA-TSD-DS-31.101	620	Approved	01/07/2003	<a href="http://www.ccsa.org.cn/english/tc/files.php?docpath=/ITU-R/M.1457/M.1457-4/DS/">http://www.ccsa.org.cn/english/tc/files.php?docpath=/ITU-R/M.1457/M.1457-4/DS/</a>
T1 (ATIS)	T1.3GPP.31.101V620-2004	6.2.0	Approved	21/05/2004	<a href="https://www.atis.org/atis/docstore/search.asp?committee=S24">https://www.atis.org/atis/docstore/search.asp?committee=S24</a>
TTA	TTAT.3G-31.101(R6-6.2.0)	6.2.0	Approved	25/05/2004	<a href="http://www.tta.or.kr/standardDB/stnfile/TTAT.3G-31.101(R6-6.2.0).zip">http://www.tta.or.kr/standardDB/stnfile/TTAT.3G-31.101(R6-6.2.0).zip</a>

### 5.3.2.7.4 31.102

#### Characteristics of the USIM Application

This document defines the USIM application for 3G telecom network operation. The present document specifies, command parameters, file structures and content, security functions and the application protocol to be used on the interface between UICC (USIM) and ME.

SDO (2)	Document No.	Version	Status	Issued date	Location (1)
<b>Release 99</b>					
CCSA	CCSA-TSD-DS-31.102	3D0	Approved	01/07/2003	<a href="http://www.ccsa.org.cn/english/tc/files.php?docpath=/ITU-R/M.1457/M.1457-4/DS/">http://www.ccsa.org.cn/english/tc/files.php?docpath=/ITU-R/M.1457/M.1457-4/DS/</a>
ETSI	ETSI TS 131 102	3.15.0	Published	19/01/2004	<a href="http://pda.etsi.org/pda/home.asp?wkr=RTS/TSGT-0331102v3f0">http://pda.etsi.org/pda/home.asp?wkr=RTS/TSGT-0331102v3f0</a>
T1 (ATIS)	T1.3GPP.31.102V3150-2004	3.15.0	Approved	21/05/2004	<a href="https://www.atis.org/atis/docstore/search.asp?committee=S24">https://www.atis.org/atis/docstore/search.asp?committee=S24</a>
TTA	TTAT.3G-31.102(R99-3.15.0)	3.15.0	Approved	25/05/2004	<a href="http://www.tta.or.kr/standardDB/stnfile/TTAT.3G-31.102(R99-3.15.0).zip">http://www.tta.or.kr/standardDB/stnfile/TTAT.3G-31.102(R99-3.15.0).zip</a>
<b>Release 4</b>					
CCSA	CCSA-TSD-DS-31.102	490	Approved	01/07/2003	<a href="http://www.ccsa.org.cn/english/tc/files.php?docpath=/ITU-R/M.1457/M.1457-4/DS/">http://www.ccsa.org.cn/english/tc/files.php?docpath=/ITU-R/M.1457/M.1457-4/DS/</a>
ETSI	ETSI TS 131 102	4.11.0	Published	19/01/2004	<a href="http://pda.etsi.org/pda/home.asp?wkr=RTS/TSGT-0331102v4b0">http://pda.etsi.org/pda/home.asp?wkr=RTS/TSGT-0331102v4b0</a>
T1 (ATIS)	T1.3GPP.31.102V4110-2004	4.11.0	Approved	21/05/2004	<a href="https://www.atis.org/atis/docstore/search.asp?committee=S24">https://www.atis.org/atis/docstore/search.asp?committee=S24</a>
TTA	TTAT.3G-31.102(R4-4.11.0)	4.11.0	Approved	25/05/2004	<a href="http://www.tta.or.kr/standardDB/stnfile/TTAT.3G-31.102(R4-4.11.0).zip">http://www.tta.or.kr/standardDB/stnfile/TTAT.3G-31.102(R4-4.11.0).zip</a>
<b>Release 5</b>					
CCSA	CCSA-TSD-DS-31.102	550	Approved	01/07/2003	<a href="http://www.ccsa.org.cn/english/tc/files.php?docpath=/ITU-R/M.1457/M.1457-4/DS/">http://www.ccsa.org.cn/english/tc/files.php?docpath=/ITU-R/M.1457/M.1457-4/DS/</a>
ETSI	ETSI TS 131 102	5.7.0	Published	19/01/2004	<a href="http://pda.etsi.org/pda/home.asp?wkr=RTS/TSGT-0331102v570">http://pda.etsi.org/pda/home.asp?wkr=RTS/TSGT-0331102v570</a>
T1 (ATIS)	T1.3GPP.31.102V570-2004	5.7.0	Approved	21/05/2004	<a href="https://www.atis.org/atis/docstore/search.asp?committee=S24">https://www.atis.org/atis/docstore/search.asp?committee=S24</a>



## 222

## Rec. ITU-R M.1457-4

TTA	TTAT.3G-31.102(R5-5.7.0)	5.7.0	Approved	25/05/2004	<a href="http://www.tta.or.kr/standardDB/stnfile/TTAT.3G-31.102(R5-5.7.0).zip">http://www.tta.or.kr/standardDB/stnfile/TTAT.3G-31.102(R5-5.7.0).zip</a>
<b>Release 6</b>					
CCSA	CCSA-TSD-DS-31.102	620	Approved	01/07/2003	<a href="http://www.ccsa.org.cn/english/tc/files.php?docpath=/ITU-R/M.1457/M.1457-4/DS/">http://www.ccsa.org.cn/english/tc/files.php?docpath=/ITU-R/M.1457/M.1457-4/DS/</a>
ETSI	ETSI TS 131 102	6.4.0	Awaiting		<a href="http://pda.etsi.org/pda/home.asp?wkr=RTS/TSGT-0331102v640">http://pda.etsi.org/pda/home.asp?wkr=RTS/TSGT-0331102v640</a>
T1 (ATIS)	T1.3GPP.31.102V640-2004	6.4.0	Approved	21/05/2004	<a href="https://www.atis.org/atis/docstore/search.asp?committee=S24">https://www.atis.org/atis/docstore/search.asp?committee=S24</a>
TTA	TTAT.3G-31.102(R6-6.4.0)	6.4.0	Approved	25/05/2004	<a href="http://www.tta.or.kr/standardDB/stnfile/TTAT.3G-31.102(R6-6.4.0).zip">http://www.tta.or.kr/standardDB/stnfile/TTAT.3G-31.102(R6-6.4.0).zip</a>

### 5.3.2.7.5 31.103

#### Characteristics of the ISIM Application

This document defines the ISIM application for 3G telecom network operation. The present document specifies, command parameters, file structures and content, security functions and the application protocol to be used on the interface between UICC (ISIM) and ME.

SDO (2)	Document No.	Version	Status	Issued date	Location (1)
<b>Release 5</b>					
CCSA	CCSA-TSD-DS-31.103	540	Approved	01/07/2003	<a href="http://www.ccsa.org.cn/english/tc/files.php?docpath=/ITU-R/M.1457/M.1457-4/DS/">http://www.ccsa.org.cn/english/tc/files.php?docpath=/ITU-R/M.1457/M.1457-4/DS/</a>
ETSI	ETSI TS 131 103	5.5.0	Published	19/01/2004	<a href="http://pda.etsi.org/pda/home.asp?wkr=RTS/TSGT-0331103v550">http://pda.etsi.org/pda/home.asp?wkr=RTS/TSGT-0331103v550</a>
T1 (ATIS)	T1.3GPP.31.103V550-2004	5.5.0	Approved	21/05/2004	<a href="https://www.atis.org/atis/docstore/search.asp?committee=S24">https://www.atis.org/atis/docstore/search.asp?committee=S24</a>
TTA	TTAT.3G-31.103(R5-5.5.0)	5.5.0	Approved	25/05/2004	<a href="http://www.tta.or.kr/standardDB/stnfile/TTAT.3G-31.103(R5-5.5.0).zip">http://www.tta.or.kr/standardDB/stnfile/TTAT.3G-31.103(R5-5.5.0).zip</a>
<b>Release 6</b>					
T1 (ATIS)	T1.3GPP.31.103V620-2004	6.2.0	Approved	21/05/2004	<a href="https://www.atis.org/atis/docstore/search.asp?committee=S24">https://www.atis.org/atis/docstore/search.asp?committee=S24</a>
TTA	TTAT.3G-31.103(R6-6.2.0)	6.2.0	Approved	25/05/2004	<a href="http://www.tta.or.kr/standardDB/stnfile/TTAT.3G-31.103(R6-6.2.0).zip">http://www.tta.or.kr/standardDB/stnfile/TTAT.3G-31.103(R6-6.2.0).zip</a>

### 5.3.2.7.6 31.110

#### Numbering system for telecommunication IC card applications

This document describes the numbering system for Application IDentifiers (AID) for 3G telecommunication Integrated Circuits (IC) card applications. The numbering system provides a means for an application and related services offered by a provider to identify if a given card contains the elements required by its application and related services.

SDO (2)	Document No.	Version	Status	Issued date	Location (1)
<b>Release 99</b>					
CCSA	CCSA-TSD-DS-31.110	320	Approved	01/07/2003	<a href="http://www.ccsa.org.cn/english/tc/files.php?docpath=/ITU-R/M.1457/M.1457-4/DS/">http://www.ccsa.org.cn/english/tc/files.php?docpath=/ITU-R/M.1457/M.1457-4/DS/</a>
ETSI	ETSI TS 131 110	3.2.0	Published	07/11/2000	<a href="http://pda.etsi.org/pda/home.asp?wkr=RTS/TSGT-0331110UR2">http://pda.etsi.org/pda/home.asp?wkr=RTS/TSGT-0331110UR2</a>
T1 (ATIS)	T1.3GPP.31.110V320-2002	3.2.0	Approved	03/05/2002	<a href="https://www.atis.org/atis/docstore/search.asp?committee=S24">https://www.atis.org/atis/docstore/search.asp?committee=S24</a>
TTA	TTAE.3G-31.110(R99)	3.2.0	Approved	19/12/2001	<a href="http://www.tta.or.kr/standardDB/stnfile/TTAE_3G-31_110_R99_.zip">http://www.tta.or.kr/standardDB/stnfile/TTAE_3G-31_110_R99_.zip</a>
<b>Release 4</b>					
CCSA	CCSA-TSD-DS-31.110	410	Approved	01/07/2003	<a href="http://www.ccsa.org.cn/english/tc/files.php?docpath=/ITU-R/M.1457/M.1457-4/DS/">http://www.ccsa.org.cn/english/tc/files.php?docpath=/ITU-R/M.1457/M.1457-4/DS/</a>
ETSI	ETSI TS 131 110	4.1.0	Published	25/01/2002	<a href="http://pda.etsi.org/pda/home.asp?wkr=RTS/TSGT-0331110Uv4R1">http://pda.etsi.org/pda/home.asp?wkr=RTS/TSGT-0331110Uv4R1</a>



T1 (ATIS) T1.3GPP.31.110V410-2002	4.1.0	Approved	03/05/2002	<a href="https://www.atis.org/atis/docstore/search.asp?committee=S24">https://www.atis.org/atis/docstore/search.asp?committee=S24</a>
TTA TTAE.3G-31.110(R4-4.1.0)	4.1.0	Approved	29/05/2002	<a href="http://www.tta.or.kr/standardDB/stnfile/TTAE.3G-31.110(R4-4.1.0).zip">http://www.tta.or.kr/standardDB/stnfile/TTAE.3G-31.110(R4-4.1.0).zip</a>

### 5.3.2.7.7 31.111

#### USIM application toolkit (USAT)

This document defines the interface between the UICC and the Mobile Equipment (ME), and mandatory ME procedures, specifically for “USIM Application Toolkit”. USAT is a set of commands and procedures for use during the network operation phase of 3G, in addition to those defined in TS 31.101.

SDO (2)	Document No.	Version	Status	Issued date	Location (1)
<b>Release 99</b>					
CCSA	CCSA-TSD-DS-31.111	3A0	Approved	01/07/2003	<a href="http://www.ccsa.org.cn/english/tc/files.php?docpath=/ITU-R/M.1457/M.1457-4/DS/">http://www.ccsa.org.cn/english/tc/files.php?docpath=/ITU-R/M.1457/M.1457-4/DS/</a>
ETSI	ETSI TS 131 111	3.11.0	Published	19/01/2004	<a href="http://pda.etsi.org/pda/home.asp?wkr=RTS/TSGT-0331111v3b0">http://pda.etsi.org/pda/home.asp?wkr=RTS/TSGT-0331111v3b0</a>
T1 (ATIS)	T1.3GPP.31.111V3110-2004	3.11.0	Approved	21/05/2004	<a href="https://www.atis.org/atis/docstore/search.asp?committee=S24">https://www.atis.org/atis/docstore/search.asp?committee=S24</a>
TTA	TTAT.3G-31.111(R99-3.11.0)	3.11.0	Approved	25/05/2004	<a href="http://www.tta.or.kr/standardDB/stnfile/TTAT.3G-31.111(R99-3.11.0).zip">http://www.tta.or.kr/standardDB/stnfile/TTAT.3G-31.111(R99-3.11.0).zip</a>
<b>Release 4</b>					
CCSA	CCSA-TSD-DS-31.111	4A0	Approved	01/07/2003	<a href="http://www.ccsa.org.cn/english/tc/files.php?docpath=/ITU-R/M.1457/M.1457-4/DS/">http://www.ccsa.org.cn/english/tc/files.php?docpath=/ITU-R/M.1457/M.1457-4/DS/</a>
ETSI	ETSI TS 131 111	4.11.0	Published	01/10/2003	<a href="http://pda.etsi.org/pda/home.asp?wkr=RTS/TSGT-0331111v4b0">http://pda.etsi.org/pda/home.asp?wkr=RTS/TSGT-0331111v4b0</a>
T1 (ATIS)	T1.3GPP.31.111V4110-2004	4.11.0	Approved	21/05/2004	<a href="https://www.atis.org/atis/docstore/search.asp?committee=S24">https://www.atis.org/atis/docstore/search.asp?committee=S24</a>
TTA	TTAT.3G-31.111(R4-4.11.0)	4.11.0	Approved	25/05/2004	<a href="http://www.tta.or.kr/standardDB/stnfile/TTAT.3G-31.111(R4-4.11.0).zip">http://www.tta.or.kr/standardDB/stnfile/TTAT.3G-31.111(R4-4.11.0).zip</a>
<b>Release 5</b>					
CCSA	CCSA-TSD-DS-31.111	540	Approved	01/07/2003	<a href="http://www.ccsa.org.cn/english/tc/files.php?docpath=/ITU-R/M.1457/M.1457-4/DS/">http://www.ccsa.org.cn/english/tc/files.php?docpath=/ITU-R/M.1457/M.1457-4/DS/</a>
ETSI	ETSI TS 131 111	5.6.0	Published	19/01/2004	<a href="http://pda.etsi.org/pda/home.asp?wkr=RTS/TSGT-0331111v560">http://pda.etsi.org/pda/home.asp?wkr=RTS/TSGT-0331111v560</a>
T1 (ATIS)	T1.3GPP.31.111V560-2004	5.6.0	Approved	21/05/2004	<a href="https://www.atis.org/atis/docstore/search.asp?committee=S24">https://www.atis.org/atis/docstore/search.asp?committee=S24</a>
TTA	TTAT.3G-31.111(R5-5.6.0)	5.6.0	Approved	25/05/2004	<a href="http://www.tta.or.kr/standardDB/stnfile/TTAT.3G-31.111(R5-5.6.0).zip">http://www.tta.or.kr/standardDB/stnfile/TTAT.3G-31.111(R5-5.6.0).zip</a>
<b>Release 6</b>					
T1 (ATIS)	T1.3GPP.31.111V600-2004	6.0.0	Approved	21/05/2004	<a href="https://www.atis.org/atis/docstore/search.asp?committee=S24">https://www.atis.org/atis/docstore/search.asp?committee=S24</a>
TTA	TTAT.3G-31.111(R6-6.0.0)	6.0.0	Approved	25/05/2004	<a href="http://www.tta.or.kr/standardDB/stnfile/TTAT.3G-31.111(R6-6.0.0).zip">http://www.tta.or.kr/standardDB/stnfile/TTAT.3G-31.111(R6-6.0.0).zip</a>

### 5.3.2.7.8 31.112

#### USIM Application Toolkit (USAT) interpreter architecture

This document defines the overall architecture for the USAT Interpreter system including the role models, system architecture and information flow.

SDO (2)	Document No.	Version	Status	Issued date	Location (1)
<b>Release 5</b>					
CCSA	CCSA-TSD-DS-31.112	520	Approved	01/07/2003	<a href="http://www.ccsa.org.cn/english/tc/files.php?docpath=/ITU-R/M.1457/M.1457-4/DS/">http://www.ccsa.org.cn/english/tc/files.php?docpath=/ITU-R/M.1457/M.1457-4/DS/</a>
ETSI	ETSI TS 131 112	5.2.0	Published	24/06/2002	<a href="http://pda.etsi.org/pda/home.asp?wkr=RTS/TSGT-0331112v520">http://pda.etsi.org/pda/home.asp?wkr=RTS/TSGT-0331112v520</a>

T1 (ATIS) T1.3GPP.31.112V520-2003	5.2.0	Approved	27/03/2003	<a href="https://www.atis.org/atis/docstore/search.asp?committee=S24">https://www.atis.org/atis/docstore/search.asp?committee=S24</a>
TTA TTAT.3G-31.112(R5-5.2.0)	5.2.0	Approved	21/03/2003	<a href="http://www.tta.or.kr/standardDB/stnfile/TTAT.3G-31.112(R5-5.2.0).zip">http://www.tta.or.kr/standardDB/stnfile/TTAT.3G-31.112(R5-5.2.0).zip</a>

### 5.3.2.7.9 31.113

#### USAT Interpreter Byte Codes

This document specifies the byte codes that are recognised by an USAT Interpreter. The primary purpose of the byte codes is to provide efficient programmatic access to the SIM Application Toolkit commands.

SDO (2)	Document No.	Version	Status	Issued date	Location (1)
<b>Release 5</b>					
CCSA	CCSA-TSD-DS-31.113	550	Approved	01/07/2003	<a href="http://www.ccsa.org.cn/english/tc/files.php?docpath=/ITU-R/M.1457/M.1457-4/DS/">http://www.ccsa.org.cn/english/tc/files.php?docpath=/ITU-R/M.1457/M.1457-4/DS/</a>
ETSI	ETSI TS 131 113	5.5.0	Published	04/04/2003	<a href="http://pda.etsi.org/pda/home.asp?wkr=RTS/TSGT-0331113v550">http://pda.etsi.org/pda/home.asp?wkr=RTS/TSGT-0331113v550</a>
T1 (ATIS)	T1.3GPP.31.113V550-2004	5.5.0	Approved	21/05/2004	<a href="https://www.atis.org/atis/docstore/search.asp?committee=S24">https://www.atis.org/atis/docstore/search.asp?committee=S24</a>
TTA	TTAT.3G-31.113(R5-5.5.0)	5.5.0	Approved	25/05/2004	<a href="http://www.tta.or.kr/standardDB/stnfile/TTAT.3G-31.113(R5-5.5.0).zip">http://www.tta.or.kr/standardDB/stnfile/TTAT.3G-31.113(R5-5.5.0).zip</a>
<b>Release 6</b>					
CCSA	CCSA-TSD-DS-31.113	620	Approved	01/07/2003	<a href="http://www.ccsa.org.cn/english/tc/files.php?docpath=/ITU-R/M.1457/M.1457-4/DS/">http://www.ccsa.org.cn/english/tc/files.php?docpath=/ITU-R/M.1457/M.1457-4/DS/</a>
T1 (ATIS)	T1.3GPP.31.113V620-2004	6.2.0	Approved	21/05/2004	<a href="https://www.atis.org/atis/docstore/search.asp?committee=S24">https://www.atis.org/atis/docstore/search.asp?committee=S24</a>
TTA	TTAT.3G-31.113(R6-6.2.0)	6.2.0	Approved	25/05/2004	<a href="http://www.tta.or.kr/standardDB/stnfile/TTAT.3G-31.113(R6-6.2.0).zip">http://www.tta.or.kr/standardDB/stnfile/TTAT.3G-31.113(R6-6.2.0).zip</a>

### 5.3.2.7.10 31.120

#### Physical, Electrical and Logical Test Specification

This document tests the physical, electrical and logical requirements as specified in TS 31.101.

SDO (2)	Document No.	Version	Status	Issued date	Location (1)
<b>Release 99</b>					
CCSA	CCSA-TSD-DS-31.120	300	Approved	01/07/2003	<a href="http://www.ccsa.org.cn/english/tc/files.php?docpath=/ITU-R/M.1457/M.1457-4/DS/">http://www.ccsa.org.cn/english/tc/files.php?docpath=/ITU-R/M.1457/M.1457-4/DS/</a>
ETSI	ETSI TS 131 120	3.0.0	Published	13/02/2001	<a href="http://pda.etsi.org/pda/home.asp?wkr=DTS/TSGT-0331120U">http://pda.etsi.org/pda/home.asp?wkr=DTS/TSGT-0331120U</a>
T1 (ATIS)	T1.3GPP.31.120V300-2002	3.0.0	Approved	03/05/2002	<a href="https://www.atis.org/atis/docstore/search.asp?committee=S24">https://www.atis.org/atis/docstore/search.asp?committee=S24</a>
TTA	TTAE.3G-31.120(R99-3.0.0)	3.0.0	Approved	29/05/2002	<a href="http://www.tta.or.kr/standardDB/stnfile/TTAE.3G-31.120(R99-3.0.0).zip">http://www.tta.or.kr/standardDB/stnfile/TTAE.3G-31.120(R99-3.0.0).zip</a>

### 5.3.2.7.11 31.121

#### UICC-Terminal Interface; USIM Application Test specification

This document provides the UICC-Terminal Interface Conformance Test Specification between the 3G Terminal and USIM (Universal Subscriber Identity Module) as an application on the UICC and the Terminal for 3G telecom network operation.

SDO (2)	Document No.	Version	Status	Issued date	Location (1)
<b>Release 99</b>					
CCSA	CCSA-TSD-DS-31.121	360	Approved	01/07/2003	<a href="http://www.ccsa.org.cn/english/tc/files.php?docpath=/ITU-R/M.1457/M.1457-4/DS/">http://www.ccsa.org.cn/english/tc/files.php?docpath=/ITU-R/M.1457/M.1457-4/DS/</a>

ETSI	ETSI TS 131 121	3.7.0	Published	01/10/2003	<a href="http://pda.etsi.org/pda/home.asp?wkr=RTS/TSGT-0331121v370">http://pda.etsi.org/pda/home.asp?wkr=RTS/TSGT-0331121v370</a>
T1 (ATIS)	T1.3GPP.31.121V370-2004	3.7.0	Approved	21/05/2004	<a href="https://www.atis.org/atis/docstore/search.asp?committee=S24">https://www.atis.org/atis/docstore/search.asp?committee=S24</a>
TTA	TTAT.3G-31.121(R99-3.7.0)	3.7.0	Approved	25/05/2004	<a href="http://www.tta.or.kr/standardDB/stnfile/TTAT.3G-31.121(R99-3.7.0).zip">http://www.tta.or.kr/standardDB/stnfile/TTAT.3G-31.121(R99-3.7.0).zip</a>

**Release 4**

CCSA	CCSA-TSD-DS-31.121	450	Approved	01/07/2003	<a href="http://www.ccsa.org.cn/english/tc/files.php?docpath=/ITU-R/M.1457/M.1457-4/DS/">http://www.ccsa.org.cn/english/tc/files.php?docpath=/ITU-R/M.1457/M.1457-4/DS/</a>
ETSI	ETSI TS 131 121	4.6.0	Published	01/10/2003	<a href="http://pda.etsi.org/pda/home.asp?wkr=RTS/TSGT-0331121v460">http://pda.etsi.org/pda/home.asp?wkr=RTS/TSGT-0331121v460</a>
T1 (ATIS)	T1.3GPP.31.121V460-2004	4.6.0	Approved	21/05/2004	<a href="https://www.atis.org/atis/docstore/search.asp?committee=S24">https://www.atis.org/atis/docstore/search.asp?committee=S24</a>
TTA	TTAT.3G-31.121(R4-4.6.0)	4.6.0	Approved	25/05/2004	<a href="http://www.tta.or.kr/standardDB/stnfile/TTAT.3G-31.121(R4-4.6.0).zip">http://www.tta.or.kr/standardDB/stnfile/TTAT.3G-31.121(R4-4.6.0).zip</a>

**5.3.2.7.12 31.122**

**USIM Conformance Test Specification**

The present document provides the Conformance Test Specification for a UICC defined in TS 31.101 with Universal Subscriber Identity Module (USIM) defined in 3G TS 31.102.

SDO (2)	Document No.	Version	Status	Issued date	Location (1)
<b>Release 99</b>					
CCSA	CCSA-TSD-DS-31.122	360	Approved	01/07/2003	<a href="http://www.ccsa.org.cn/english/tc/files.php?docpath=/ITU-R/M.1457/M.1457-4/DS/">http://www.ccsa.org.cn/english/tc/files.php?docpath=/ITU-R/M.1457/M.1457-4/DS/</a>
ETSI	ETSI TS 131 122	3.7.0	Published	19/01/2004	<a href="http://pda.etsi.org/pda/home.asp?wkr=RTS/TSGT-0331122v370">http://pda.etsi.org/pda/home.asp?wkr=RTS/TSGT-0331122v370</a>
T1 (ATIS)	T1.3GPP.31.122V370-2004	3.7.0	Approved	21/05/2004	<a href="https://www.atis.org/atis/docstore/search.asp?committee=S24">https://www.atis.org/atis/docstore/search.asp?committee=S24</a>
TTA	TTAT.3G-31.122(R99-3.7.0)	3.7.0	Approved	25/05/2004	<a href="http://www.tta.or.kr/standardDB/stnfile/TTAT.3G-31.122(R99-3.7.0).zip">http://www.tta.or.kr/standardDB/stnfile/TTAT.3G-31.122(R99-3.7.0).zip</a>

**5.3.2.7.13 31.131**

**'C' Language Binding to USIM API**

This document includes information applicable to (U)SIM toolkit application developers creating applications using the C programming language ISO/IEC 9899 [7]. The present document describes an interface between toolkit applications written in the C programming language and the (U)SIM in order to realize the co-operation set forth in TS 42.019 [4]. In particular, the API described herein provides the service of assembling proactive commands and disassembling the responses to these commands for the application programmer.

SDO (2)	Document No.	Version	Status	Issued date	Location (1)
<b>Release 6</b>					
CCSA	CCSA-TSD-DS-31.131	610	Approved	01/07/2003	<a href="http://www.ccsa.org.cn/english/tc/files.php?docpath=/ITU-R/M.1457/M.1457-4/DS/">http://www.ccsa.org.cn/english/tc/files.php?docpath=/ITU-R/M.1457/M.1457-4/DS/</a>
T1 (ATIS)	T1.3GPP.31.131V610-2004	6.1.0	Approved	21/05/2004	<a href="https://www.atis.org/atis/docstore/search.asp?committee=S24">https://www.atis.org/atis/docstore/search.asp?committee=S24</a>
TTA	TTAT.3G-31.131(R6-6.1.0)	6.1.0	Approved	25/05/2004	<a href="http://www.tta.or.kr/standardDB/stnfile/TTAT.3G-31.131(R6-6.1.0).zip">http://www.tta.or.kr/standardDB/stnfile/TTAT.3G-31.131(R6-6.1.0).zip</a>

**5.3.2.7.14** 22.048**Security mechanisms for (U)SIM application toolkit - stage 1**

This document provides standardised security mechanisms in conjunction with the SIM Application Toolkit for the interface between a 3G or GSM PLMN Entity and a UICC at the functional level.

SDO (2)	Document No.	Version	Status	Issued date	Location (1)
<b>Release 4</b>					
CCSA	CCSA-TSD-DS-22.048-4	400	Approved	01/07/2003	<a href="http://www.ccsa.org.cn/english/tc/files.php?docpath=/ITU-R/M.1457/M.1457-4/DS/">http://www.ccsa.org.cn/english/tc/files.php?docpath=/ITU-R/M.1457/M.1457-4/DS/</a>
ETSI	ETSI TS 122 048	4.0.0	Published	26/07/2001	<a href="http://pda.etsi.org/pda/home.asp?wkr=DTS/TSGT-0322048Uv4">http://pda.etsi.org/pda/home.asp?wkr=DTS/TSGT-0322048Uv4</a>
T1 (ATIS)	T1.3GPP.22.048V400-2002	4.0.0	Approved	03/05/2002	<a href="https://www.atis.org/atis/docstore/search.asp?committee=S24">https://www.atis.org/atis/docstore/search.asp?committee=S24</a>
TTA	TTAE.3G-22.048(R4)	4.0.0	Approved	19/12/2001	<a href="http://www.tta.or.kr/standardDB/stnfile/TTAE_3G-22_048_R4_.zip">http://www.tta.or.kr/standardDB/stnfile/TTAE_3G-22_048_R4_.zip</a>
<b>Release 5</b>					
CCSA	CCSA-TSD-DS-22.048-4	500	Approved	01/07/2003	<a href="http://www.ccsa.org.cn/english/tc/files.php?docpath=/ITU-R/M.1457/M.1457-4/DS/">http://www.ccsa.org.cn/english/tc/files.php?docpath=/ITU-R/M.1457/M.1457-4/DS/</a>
ETSI	ETSI TS 122 048	5.0.0	Published	01/07/2003	<a href="http://pda.etsi.org/pda/home.asp?wkr=RTS/TSGT-0322048v500">http://pda.etsi.org/pda/home.asp?wkr=RTS/TSGT-0322048v500</a>
T1 (ATIS)	T1.3GPP.22.048V500-2004	5.0.0	Approved	21/05/2004	<a href="https://www.atis.org/atis/docstore/search.asp?committee=S24">https://www.atis.org/atis/docstore/search.asp?committee=S24</a>
TTA	TTAT.3G-22.048(R5-5.0.0)	5.0.0	Approved	25/05/2004	<a href="http://www.tta.or.kr/standardDB/stnfile/TTAT.3G-22.048(R5-5.0.0).zip">http://www.tta.or.kr/standardDB/stnfile/TTAT.3G-22.048(R5-5.0.0).zip</a>

**5.3.2.7.15** 23.048**Security mechanisms for (U)SIM application toolkit - stage 2**

This document specifies the structure of the Secured Packets in a general format and in implementations using Short Message Service Point to Point (SMS-PP) and Short Message Service Cell Broadcast (SMS-CB).

SDO (2)	Document No.	Version	Status	Issued date	Location (1)
<b>Release 4</b>					
CCSA	CCSA-TSD-DS-23.048-4	440	Approved	01/07/2003	<a href="http://www.ccsa.org.cn/english/tc/files.php?docpath=/ITU-R/M.1457/M.1457-4/DS/">http://www.ccsa.org.cn/english/tc/files.php?docpath=/ITU-R/M.1457/M.1457-4/DS/</a>
ETSI	ETSI TS 123 048	4.4.0	Published	04/04/2003	<a href="http://pda.etsi.org/pda/home.asp?wkr=RTS/TSGT-0323048v440">http://pda.etsi.org/pda/home.asp?wkr=RTS/TSGT-0323048v440</a>
T1 (ATIS)	T1.3GPP.23.048V440-2004	4.4.0	Approved	21/05/2004	<a href="https://www.atis.org/atis/docstore/search.asp?committee=S24">https://www.atis.org/atis/docstore/search.asp?committee=S24</a>
TTA	TTAT.3G-23.048(R4-4.4.0)	4.4.0	Approved	28/05/2003	<a href="http://www.tta.or.kr/standardDB/stnfile/TTAT.3G-23.048(R4-4.4.0).zip">http://www.tta.or.kr/standardDB/stnfile/TTAT.3G-23.048(R4-4.4.0).zip</a>
<b>Release 5</b>					
CCSA	CCSA-TSD-DS-23.048-4	570	Approved	01/07/2003	<a href="http://www.ccsa.org.cn/english/tc/files.php?docpath=/ITU-R/M.1457/M.1457-4/DS/">http://www.ccsa.org.cn/english/tc/files.php?docpath=/ITU-R/M.1457/M.1457-4/DS/</a>
ETSI	ETSI TS 123 048	5.8.0	Published	13/01/2004	<a href="http://pda.etsi.org/pda/home.asp?wkr=RTS/TSGT-0323048v580">http://pda.etsi.org/pda/home.asp?wkr=RTS/TSGT-0323048v580</a>
T1 (ATIS)	T1.3GPP.23.048V580-2004	5.8.0	Approved	21/05/2004	<a href="https://www.atis.org/atis/docstore/search.asp?committee=S24">https://www.atis.org/atis/docstore/search.asp?committee=S24</a>
TTA	TTAT.3G-23.048(R5-5.8.0)	5.8.0	Approved	25/05/2004	<a href="http://www.tta.or.kr/standardDB/stnfile/TTAT.3G-23.048(R5-5.8.0).zip">http://www.tta.or.kr/standardDB/stnfile/TTAT.3G-23.048(R5-5.8.0).zip</a>

**5.3.2.7.16** 23.038**Alphabets and language specific information**

This specification describes the language specific requirements for the terminals including character coding.

SDO (2)	Document No.	Version	Status	Issued date	Location (1)
<b>Release 99</b>					
CCSA	CCSA-TSD-DS-23.038-4	330	Approved	01/07/2003	<a href="http://www.ccsa.org.cn/english/tc/files.php?docpath=/ITU-R/M.1457/M.1457-4/DS/">http://www.ccsa.org.cn/english/tc/files.php?docpath=/ITU-R/M.1457/M.1457-4/DS/</a>
ETSI	ETSI TS 123 038	3.3.0	Published	01/02/2000	<a href="http://pda.etsi.org/pda/home.asp?wkr=DTS/TSGT-0223038U">http://pda.etsi.org/pda/home.asp?wkr=DTS/TSGT-0223038U</a>
T1 (ATIS)	T1.3GPP.23.038V330-2002	3.3.0	Approved	03/05/2002	<a href="https://www.atis.org/atis/docstore/search.asp?committee=S24">https://www.atis.org/atis/docstore/search.asp?committee=S24</a>
TTA	TTAE.3G-23.038(R99)	3.3.0	Approved	19/12/2001	<a href="http://www.tta.or.kr/standardDB/stnfile/TTAE_3G-23_038_R99_.zip">http://www.tta.or.kr/standardDB/stnfile/TTAE_3G-23_038_R99_.zip</a>
<b>Release 4</b>					
CCSA	CCSA-TSD-DS-23.038-4	440	Approved	01/07/2003	<a href="http://www.ccsa.org.cn/english/tc/files.php?docpath=/ITU-R/M.1457/M.1457-4/DS/">http://www.ccsa.org.cn/english/tc/files.php?docpath=/ITU-R/M.1457/M.1457-4/DS/</a>
ETSI	ETSI TS 123 038	4.4.0	Published	15/01/2002	<a href="http://pda.etsi.org/pda/home.asp?wkr=RTS/TSGT-0223038Uv4R2">http://pda.etsi.org/pda/home.asp?wkr=RTS/TSGT-0223038Uv4R2</a>
T1 (ATIS)	T1.3GPP.23.038V440-2002	4.4.0	Approved	03/05/2002	<a href="https://www.atis.org/atis/docstore/search.asp?committee=S24">https://www.atis.org/atis/docstore/search.asp?committee=S24</a>
TTA	TTAE.3G-23.038(R4-4.4.0)	4.4.0	Approved	29/05/2002	<a href="http://www.tta.or.kr/standardDB/stnfile/TTAE.3G-23.038(R4-4.4.0).zip">http://www.tta.or.kr/standardDB/stnfile/TTAE.3G-23.038(R4-4.4.0).zip</a>
<b>Release 5</b>					
CCSA	CCSA-TSD-DS-23.038-4	500	Approved	01/07/2003	<a href="http://www.ccsa.org.cn/english/tc/files.php?docpath=/ITU-R/M.1457/M.1457-4/DS/">http://www.ccsa.org.cn/english/tc/files.php?docpath=/ITU-R/M.1457/M.1457-4/DS/</a>
ETSI	ETSI TS 123 038	5.0.0	Published	03/04/2002	<a href="http://pda.etsi.org/pda/home.asp?wkr=RTS/TSGT-0223038Uv5">http://pda.etsi.org/pda/home.asp?wkr=RTS/TSGT-0223038Uv5</a>
T1 (ATIS)	T1.3GPP.23.038V500-2002	5.0.0	Approved	03/05/2002	<a href="https://www.atis.org/atis/docstore/search.asp?committee=S24">https://www.atis.org/atis/docstore/search.asp?committee=S24</a>
TTA	TTAE.3G-23.038(R5-5.0.0)	5.0.0	Approved	29/05/2002	<a href="http://www.tta.or.kr/standardDB/stnfile/TTAE.3G-23.038(R5-5.0.0).zip">http://www.tta.or.kr/standardDB/stnfile/TTAE.3G-23.038(R5-5.0.0).zip</a>
<b>Release 6</b>					
T1 (ATIS)	T1.3GPP.23.038V600-2004	6.0.0	Approved	21/05/2004	<a href="https://www.atis.org/atis/docstore/search.asp?committee=S24">https://www.atis.org/atis/docstore/search.asp?committee=S24</a>
TTA	TTAT.3G-23.038(R6-6.0.0)	6.0.0	Approved	25/05/2004	<a href="http://www.tta.or.kr/standardDB/stnfile/TTAT.3G-23.038(R6-6.0.0).zip">http://www.tta.or.kr/standardDB/stnfile/TTAT.3G-23.038(R6-6.0.0).zip</a>

### 5.3.2.7.17 23.040

#### Technical realization of SMS point-to-point

This specification describes the point-to-point SMS.

SDO (2)	Document No.	Version	Status	Issued date	Location (1)
<b>Release 99</b>					
CCSA	CCSA-TSD-DS-23.040	3A0	Approved	01/07/2003	<a href="http://www.ccsa.org.cn/english/tc/files.php?docpath=/ITU-R/M.1457/M.1457-4/DS/">http://www.ccsa.org.cn/english/tc/files.php?docpath=/ITU-R/M.1457/M.1457-4/DS/</a>
ETSI	ETSI TS 123 040	3.10.0	Published	03/07/2003	<a href="http://pda.etsi.org/pda/home.asp?wkr=RTS/TSGT-0223040v3a0">http://pda.etsi.org/pda/home.asp?wkr=RTS/TSGT-0223040v3a0</a>
T1 (ATIS)	T1.3GPP.23.040V3100-2004	3.10.0	Approved	21/05/2004	<a href="https://www.atis.org/atis/docstore/search.asp?committee=S24">https://www.atis.org/atis/docstore/search.asp?committee=S24</a>
TTA	TTAT.3G-23.040(R99-3.10.0)	3.10.0	Approved	25/05/2004	<a href="http://www.tta.or.kr/standardDB/stnfile/TTAT.3G-23.040(R99-3.10.0).zip">http://www.tta.or.kr/standardDB/stnfile/TTAT.3G-23.040(R99-3.10.0).zip</a>
<b>Release 4</b>					
CCSA	CCSA-TSD-DS-23.040	480	Approved	01/07/2003	<a href="http://www.ccsa.org.cn/english/tc/files.php?docpath=/ITU-R/M.1457/M.1457-4/DS/">http://www.ccsa.org.cn/english/tc/files.php?docpath=/ITU-R/M.1457/M.1457-4/DS/</a>
ETSI	ETSI TS 123 040	4.8.0	Published	07/07/2003	<a href="http://pda.etsi.org/pda/home.asp?wkr=RTS/TSGT-0223040v480">http://pda.etsi.org/pda/home.asp?wkr=RTS/TSGT-0223040v480</a>
T1 (ATIS)	T1.3GPP.23.040V480-2004	4.8.0	Approved	21/05/2004	<a href="https://www.atis.org/atis/docstore/search.asp?committee=S24">https://www.atis.org/atis/docstore/search.asp?committee=S24</a>
TTA	TTAT.3G-23.040(R4-4.8.0)	4.8.0	Approved	25/05/2004	<a href="http://www.tta.or.kr/standardDB/stnfile/TTAT.3G-23.040(R4-4.8.0).zip">http://www.tta.or.kr/standardDB/stnfile/TTAT.3G-23.040(R4-4.8.0).zip</a>
<b>Release 5</b>					
CCSA	CCSA-TSD-DS-23.040	560	Approved	01/07/2003	<a href="http://www.ccsa.org.cn/english/tc/files.php?docpath=/ITU-R/M.1457/M.1457-4/DS/">http://www.ccsa.org.cn/english/tc/files.php?docpath=/ITU-R/M.1457/M.1457-4/DS/</a>
ETSI	ETSI TS 123 040	5.6.1	Published	09/10/2003	<a href="http://pda.etsi.org/pda/home.asp?wkr=RTS/TSGT-0223040v561">http://pda.etsi.org/pda/home.asp?wkr=RTS/TSGT-0223040v561</a>
T1 (ATIS)	T1.3GPP.23.040V561-2004	5.6.1	Approved	21/05/2004	<a href="https://www.atis.org/atis/docstore/search.asp?committee=S24">https://www.atis.org/atis/docstore/search.asp?committee=S24</a>

## 228

TTA	TTAT.3G-23.040(R5-5.6.1)	5.6.1	Approved
<b>Release 6</b>			
CCSA	CCSA-TSD-DS-23.040	610	Approved
ETSI	ETSI TS 123 040	6.2.0	Awaiting
T1 (ATIS)	T1.3GPP.23.040V620-2004	6.2.0	Approved
TTA	TTAT.3G-23.040(R6-6.2.0)	6.2.0	Approved

## Rec. ITU-R M.1457-4

25/05/2004	<a href="http://www.tta.or.kr/standardDB/stnfile/TTAT.3G-23.040(R5-5.6.1).zip">http://www.tta.or.kr/standardDB/stnfile/TTAT.3G-23.040(R5-5.6.1).zip</a>
01/07/2003	<a href="http://www.ccsa.org.cn/english/tc/files.php?docpath=/ITU-R/M.1457/M.1457-4/DS/">http://www.ccsa.org.cn/english/tc/files.php?docpath=/ITU-R/M.1457/M.1457-4/DS/</a> <a href="http://pda.etsi.org/pda/home.asp?wkr=RTS/TSGT-0223040v620">http://pda.etsi.org/pda/home.asp?wkr=RTS/TSGT-0223040v620</a>
21/05/2004	<a href="https://www.atis.org/atis/docstore/search.asp?committee=S24">https://www.atis.org/atis/docstore/search.asp?committee=S24</a>
25/05/2004	<a href="http://www.tta.or.kr/standardDB/stnfile/TTAT.3G-23.040(R6-6.2.0).zip">http://www.tta.or.kr/standardDB/stnfile/TTAT.3G-23.040(R6-6.2.0).zip</a>

### 5.3.2.7.18 23.041

#### Technical realization of cell broadcast service (CBS)

This specification describes the point-to-multipoint CBS.

SDO (2)	Document No.	Version	Status	Issued date	Location (1)
<b>Release 99</b>					
CCSA	CCSA-TSD-DS-23.041	350	Approved	01/07/2003	<a href="http://www.ccsa.org.cn/english/tc/files.php?docpath=/ITU-R/M.1457/M.1457-4/DS/">http://www.ccsa.org.cn/english/tc/files.php?docpath=/ITU-R/M.1457/M.1457-4/DS/</a>
ETSI	ETSI TS 123 041	3.5.0	Published	04/07/2002	<a href="http://pda.etsi.org/pda/home.asp?wkr=RTS/TSGT-0223041v350">http://pda.etsi.org/pda/home.asp?wkr=RTS/TSGT-0223041v350</a>
T1 (ATIS)	T1.3GPP.23.041V350-2003	3.5.0	Approved	27/03/2003	<a href="https://www.atis.org/atis/docstore/search.asp?committee=S24">https://www.atis.org/atis/docstore/search.asp?committee=S24</a>
TTA	TTAT.3G-23.041(R99-3.5.0)	3.5.0	Approved	21/03/2003	<a href="http://www.tta.or.kr/standardDB/stnfile/TTAT.3G-23.041(R99-3.5.0).zip">http://www.tta.or.kr/standardDB/stnfile/TTAT.3G-23.041(R99-3.5.0).zip</a>
<b>Release 4</b>					
CCSA	CCSA-TSD-DS-23.041	441	Approved	01/07/2003	<a href="http://www.ccsa.org.cn/english/tc/files.php?docpath=/ITU-R/M.1457/M.1457-4/DS/">http://www.ccsa.org.cn/english/tc/files.php?docpath=/ITU-R/M.1457/M.1457-4/DS/</a>
ETSI	ETSI TS 123 041	4.4.0	Published	01/04/2003	<a href="http://pda.etsi.org/pda/home.asp?wkr=RTS/TSGT-0223041v440">http://pda.etsi.org/pda/home.asp?wkr=RTS/TSGT-0223041v440</a>
T1 (ATIS)	T1.3GPP.23.041V440-2004	4.4.0	Approved	21/05/2004	<a href="https://www.atis.org/atis/docstore/search.asp?committee=S24">https://www.atis.org/atis/docstore/search.asp?committee=S24</a>
TTA	TTAT.3G-23.041(R4-4.4.0)	4.4.0	Approved	25/05/2004	<a href="http://www.tta.or.kr/standardDB/stnfile/TTAT.3G-23.041(R4-4.4.0).zip">http://www.tta.or.kr/standardDB/stnfile/TTAT.3G-23.041(R4-4.4.0).zip</a>
<b>Release 5</b>					
CCSA	CCSA-TSD-DS-23.041	510	Approved	01/07/2003	<a href="http://www.ccsa.org.cn/english/tc/files.php?docpath=/ITU-R/M.1457/M.1457-4/DS/">http://www.ccsa.org.cn/english/tc/files.php?docpath=/ITU-R/M.1457/M.1457-4/DS/</a>
ETSI	ETSI TS 123 041	5.2.0	Published	13/01/2004	<a href="http://pda.etsi.org/pda/home.asp?wkr=RTS/TSGT-0223041v520">http://pda.etsi.org/pda/home.asp?wkr=RTS/TSGT-0223041v520</a>
T1 (ATIS)	T1.3GPP.23.041V520-2004	5.2.0	Approved	21/05/2004	<a href="https://www.atis.org/atis/docstore/search.asp?committee=S24">https://www.atis.org/atis/docstore/search.asp?committee=S24</a>
TTA	TTAT.3G-23.041(R5-5.2.0)	5.2.0	Approved	25/05/2004	<a href="http://www.tta.or.kr/standardDB/stnfile/TTAT.3G-23.041(R5-5.2.0).zip">http://www.tta.or.kr/standardDB/stnfile/TTAT.3G-23.041(R5-5.2.0).zip</a>
<b>Release 6</b>					
CCSA	CCSA-TSD-DS-23.041	610	Approved	01/07/2003	<a href="http://www.ccsa.org.cn/english/tc/files.php?docpath=/ITU-R/M.1457/M.1457-4/DS/">http://www.ccsa.org.cn/english/tc/files.php?docpath=/ITU-R/M.1457/M.1457-4/DS/</a>
ETSI	ETSI TS 123 041	6.2.0	Awaiting		<a href="http://pda.etsi.org/pda/home.asp?wkr=RTS/TSGT-0223041v620">http://pda.etsi.org/pda/home.asp?wkr=RTS/TSGT-0223041v620</a>
T1 (ATIS)	T1.3GPP.23.041V620-2004	6.2.0	Approved	21/05/2004	<a href="https://www.atis.org/atis/docstore/search.asp?committee=S24">https://www.atis.org/atis/docstore/search.asp?committee=S24</a>
TTA	TTAT.3G-23.041(R6-6.2.0)	6.2.0	Approved	25/05/2004	<a href="http://www.tta.or.kr/standardDB/stnfile/TTAT.3G-23.041(R6-6.2.0).zip">http://www.tta.or.kr/standardDB/stnfile/TTAT.3G-23.041(R6-6.2.0).zip</a>

### 5.3.2.7.19 23.042

#### Compression algorithm for text messaging services

This specification describes the compression algorithm for text messaging services.

SDO (2)	Document No.	Version	Status	Issued date	Location (1)
<b>Release 99</b>					
CCSA	CCSA-TSD-DS-23.042	31	Approved	01/07/2003	<a href="http://www.ccsa.org.cn/english/tc/files.php?docpath=/ITU-R/M.1457/M.1457-4/DS/">http://www.ccsa.org.cn/english/tc/files.php?docpath=/ITU-R/M.1457/M.1457-4/DS/</a>
ETSI	ETSI TS 123 042	3.1.0	Published	01/02/2000	<a href="http://pda.etsi.org/pda/home.asp?wkr=DTS/TSGT-0223042U">http://pda.etsi.org/pda/home.asp?wkr=DTS/TSGT-0223042U</a>
T1 (ATIS)	T1.3GPP.23.042V310-2002	3.1.0	Approved	03/05/2002	<a href="https://www.atis.org/atis/docstore/search.asp?committee=S24">https://www.atis.org/atis/docstore/search.asp?committee=S24</a>
TTA	TTAE.3G-23.042(F)	3.1.0	Approved	28/03/2000	<a href="http://www.tta.or.kr/standardDB/stnfile/TTAE_3G-23_042F.zip">http://www.tta.or.kr/standardDB/stnfile/TTAE_3G-23_042F.zip</a>
<b>Release 4</b>					
CCSA	CCSA-TSD-DS-23.042	401	Approved	01/07/2003	<a href="http://www.ccsa.org.cn/english/tc/files.php?docpath=/ITU-R/M.1457/M.1457-4/DS/">http://www.ccsa.org.cn/english/tc/files.php?docpath=/ITU-R/M.1457/M.1457-4/DS/</a>
ETSI	ETSI TS 123 042	4.0.1	Published	19/10/2001	<a href="http://pda.etsi.org/pda/home.asp?wkr=RTS/TSGT-0223042Uv4R1">http://pda.etsi.org/pda/home.asp?wkr=RTS/TSGT-0223042Uv4R1</a>
T1 (ATIS)	T1.3GPP.23.042V401-2002	4.0.1	Approved	03/05/2002	<a href="https://www.atis.org/atis/docstore/search.asp?committee=S24">https://www.atis.org/atis/docstore/search.asp?committee=S24</a>
TTA	TTAE.3G-23.042(R4-4.0.1)	4.0.1	Approved	29/05/2002	<a href="http://www.tta.or.kr/standardDB/stnfile/TTAE.3G-23.042(R4-4.0.1).zip">http://www.tta.or.kr/standardDB/stnfile/TTAE.3G-23.042(R4-4.0.1).zip</a>
<b>Release 5</b>					
CCSA	CCSA-TSD-DS-23.042	500	Approved	01/07/2003	<a href="http://www.ccsa.org.cn/english/tc/files.php?docpath=/ITU-R/M.1457/M.1457-4/DS/">http://www.ccsa.org.cn/english/tc/files.php?docpath=/ITU-R/M.1457/M.1457-4/DS/</a>
ETSI	ETSI TS 123 042	5.0.0	Published	04/07/2002	<a href="http://pda.etsi.org/pda/home.asp?wkr=RTS/TSGT-0223042v500">http://pda.etsi.org/pda/home.asp?wkr=RTS/TSGT-0223042v500</a>
T1 (ATIS)	T1.3GPP.23.042V500-2003	5.0.0	Approved	27/03/2003	<a href="https://www.atis.org/atis/docstore/search.asp?committee=S24">https://www.atis.org/atis/docstore/search.asp?committee=S24</a>
TTA	TTAT.3G-23.042(R5-5.0.0)	5.0.0	Approved	21/03/2003	<a href="http://www.tta.or.kr/standardDB/stnfile/TTAT.3G-23.042(R5-5.0.0).zip">http://www.tta.or.kr/standardDB/stnfile/TTAT.3G-23.042(R5-5.0.0).zip</a>

### 5.3.2.7.20 23.057

#### Mobile Execution Environment (MExE) - stage 2

This TS describes the functional capabilities and the security architecture of the Mobile Execution Environment.

SDO (2)	Document No.	Version	Status	Issued date	Location (1)
<b>Release 99</b>					
CCSA	CCSA-TSD-DS-23.057	340	Approved	01/07/2003	<a href="http://www.ccsa.org.cn/english/tc/files.php?docpath=/ITU-R/M.1457/M.1457-4/DS/">http://www.ccsa.org.cn/english/tc/files.php?docpath=/ITU-R/M.1457/M.1457-4/DS/</a>
ETSI	ETSI TS 123 057	3.4.0	Published	12/04/2001	<a href="http://pda.etsi.org/pda/home.asp?wkr=RTS/TSGT-0223057UR4">http://pda.etsi.org/pda/home.asp?wkr=RTS/TSGT-0223057UR4</a>
T1 (ATIS)	T1.3GPP.23.057V340-2002	3.4.0	Approved	03/05/2002	<a href="https://www.atis.org/atis/docstore/search.asp?committee=s24">https://www.atis.org/atis/docstore/search.asp?committee=s24</a>
TTA	TTAE.3G-23.057(R99)	3.4.0	Approved	19/12/2001	<a href="http://www.tta.or.kr/standardDB/stnfile/TTAE_3G-23_057_R99_.zip">http://www.tta.or.kr/standardDB/stnfile/TTAE_3G-23_057_R99_.zip</a>
<b>Release 4</b>					
CCSA	CCSA-TSD-DS-23.057	450	Approved	01/07/2003	<a href="http://www.ccsa.org.cn/english/tc/files.php?docpath=/ITU-R/M.1457/M.1457-4/DS/">http://www.ccsa.org.cn/english/tc/files.php?docpath=/ITU-R/M.1457/M.1457-4/DS/</a>
ETSI	ETSI TS 123 057	4.5.0	Published	08/04/2002	<a href="http://pda.etsi.org/pda/home.asp?wkr=RTS/TSGT-0223057Uv4R4">http://pda.etsi.org/pda/home.asp?wkr=RTS/TSGT-0223057Uv4R4</a>
T1 (ATIS)	T1.3GPP.23.057V450-2002	4.5.0	Approved	03/05/2002	<a href="https://www.atis.org/atis/docstore/search.asp?committee=s24">https://www.atis.org/atis/docstore/search.asp?committee=s24</a>
TTA	TTAE.3G-23.057(R4-4.5.0)	4.5.0	Approved	29/05/2002	<a href="http://www.tta.or.kr/standardDB/stnfile/TTAE.3G-23.057(R4-4.5.0).zip">http://www.tta.or.kr/standardDB/stnfile/TTAE.3G-23.057(R4-4.5.0).zip</a>
<b>Release 5</b>					
CCSA	CCSA-TSD-DS-23.057	510	Approved	01/07/2003	<a href="http://www.ccsa.org.cn/english/tc/files.php?docpath=/ITU-R/M.1457/M.1457-4/DS/">http://www.ccsa.org.cn/english/tc/files.php?docpath=/ITU-R/M.1457/M.1457-4/DS/</a>
ETSI	ETSI TS 123 057	5.1.0	Published	18/10/2002	<a href="http://pda.etsi.org/pda/home.asp?wkr=RTS/TSGT-0223057v510">http://pda.etsi.org/pda/home.asp?wkr=RTS/TSGT-0223057v510</a>
T1 (ATIS)	T1.3GPP.23.057V510-2003	5.1.0	Approved	27/03/2003	<a href="https://www.atis.org/atis/docstore/search.asp?committee=s24">https://www.atis.org/atis/docstore/search.asp?committee=s24</a>
TTA	TTAT.3G-23.057(R5-5.1.0)	5.1.0	Approved	21/03/2003	<a href="http://www.tta.or.kr/standardDB/stnfile/TTAT.3G-23.057(R5-5.1.0).zip">http://www.tta.or.kr/standardDB/stnfile/TTAT.3G-23.057(R5-5.1.0).zip</a>
<b>Release 6</b>					
CCSA	CCSA-TSD-DS-23.057	610	Approved	01/07/2003	<a href="http://www.ccsa.org.cn/english/tc/files.php?docpath=/ITU-R/M.1457/M.1457-4/DS/">http://www.ccsa.org.cn/english/tc/files.php?docpath=/ITU-R/M.1457/M.1457-4/DS/</a>



ETSI	ETSI TS 123 057	6.2.0	Awaiting		<a href="http://pda.etsi.org/pda/home.asp?wkr=RTS/TSGT-0223057v620">http://pda.etsi.org/pda/home.asp?wkr=RTS/TSGT-0223057v620</a>
T1 (ATIS)	T1.3GPP.23.057V620-2004	6.2.0	Approved	21/05/2004	<a href="https://www.atis.org/atis/docstore/search.asp?committee=s24">https://www.atis.org/atis/docstore/search.asp?committee=s24</a>
TTA	TTAT.3G-23.057(R6-6.2.0)	6.2.0	Approved	25/05/2004	<a href="http://www.tta.or.kr/standardDB/stnfile/TTAT.3G-23.057(R6-6.2.0).zip">http://www.tta.or.kr/standardDB/stnfile/TTAT.3G-23.057(R6-6.2.0).zip</a>

### 5.3.2.7.21 23.140

#### Multimedia Messaging Service - stage 2

This TS describes the MMS network architecture, the application protocol framework and the technical realization of service features needed to support the non-realtime Multimedia Messaging Service.

SDO (2)	Document No.	Version	Status	Issued date	Location (1)
<b>Release 99</b>					
CCSA	CCSA-TSD-DS-23.140	310	Approved	01/07/2003	<a href="http://www.ccsa.org.cn/english/tc/files.php?docpath=/ITU-R/M.1457/M.1457-4/DS/">http://www.ccsa.org.cn/english/tc/files.php?docpath=/ITU-R/M.1457/M.1457-4/DS/</a>
ETSI	ETSI TS 123 140	3.1.0	Published	01/07/2002	<a href="http://pda.etsi.org/pda/home.asp?wkr=RTS/TSGT-0223140v310">http://pda.etsi.org/pda/home.asp?wkr=RTS/TSGT-0223140v310</a>
T1 (ATIS)	T1.3GPP.23.140V310-2003	3.1.0	Approved	27/03/2003	<a href="https://www.atis.org/atis/docstore/search.asp?committee=s24">https://www.atis.org/atis/docstore/search.asp?committee=s24</a>
TTA	TTAT.3G-23.140(R99-3.1.0)	3.1.0	Approved	21/03/2003	<a href="http://www.tta.or.kr/standardDB/stnfile/TTAT.3G-23.140(R99-3.1.0).zip">http://www.tta.or.kr/standardDB/stnfile/TTAT.3G-23.140(R99-3.1.0).zip</a>
<b>Release 4</b>					
CCSA	CCSA-TSD-DS-23.140	4A0	Approved	01/07/2003	<a href="http://www.ccsa.org.cn/english/tc/files.php?docpath=/ITU-R/M.1457/M.1457-4/DS/">http://www.ccsa.org.cn/english/tc/files.php?docpath=/ITU-R/M.1457/M.1457-4/DS/</a>
ETSI	ETSI TS 123 140	4.10.0	Published	02/07/2003	<a href="http://pda.etsi.org/pda/home.asp?wkr=RTS/TSGT-0223140v4a0">http://pda.etsi.org/pda/home.asp?wkr=RTS/TSGT-0223140v4a0</a>
T1 (ATIS)	T1.3GPP.23.140V4100-2004	4.10.0	Approved	21/05/2004	<a href="https://www.atis.org/atis/docstore/search.asp?committee=s24">https://www.atis.org/atis/docstore/search.asp?committee=s24</a>
TTA	TTAT.3G-23.140(R4-4.10.0)	4.10.0	Approved	25/05/2004	<a href="http://www.tta.or.kr/standardDB/stnfile/TTAT.3G-23.140(R4-4.10.0).zip">http://www.tta.or.kr/standardDB/stnfile/TTAT.3G-23.140(R4-4.10.0).zip</a>
<b>Release 5</b>					
CCSA	CCSA-TSD-DS-23.140	570	Approved	01/07/2003	<a href="http://www.ccsa.org.cn/english/tc/files.php?docpath=/ITU-R/M.1457/M.1457-4/DS/">http://www.ccsa.org.cn/english/tc/files.php?docpath=/ITU-R/M.1457/M.1457-4/DS/</a>
ETSI	ETSI TS 123 140	5.9.0	Published	14/01/2004	<a href="http://pda.etsi.org/pda/home.asp?wkr=RTS/TSGT-0223140v590">http://pda.etsi.org/pda/home.asp?wkr=RTS/TSGT-0223140v590</a>
T1 (ATIS)	T1.3GPP.23.140V590-2004	5.9.0	Approved	21/05/2004	<a href="https://www.atis.org/atis/docstore/search.asp?committee=s24">https://www.atis.org/atis/docstore/search.asp?committee=s24</a>
TTA	TTAT.3G-23.140(R5-5.9.0)	5.9.0	Approved	25/05/2004	<a href="http://www.tta.or.kr/standardDB/stnfile/TTAT.3G-23.140(R5-5.9.0).zip">http://www.tta.or.kr/standardDB/stnfile/TTAT.3G-23.140(R5-5.9.0).zip</a>
<b>Release 6</b>					
CCSA	CCSA-TSD-DS-23.140	620	Approved	01/07/2003	<a href="http://www.ccsa.org.cn/english/tc/files.php?docpath=/ITU-R/M.1457/M.1457-4/DS/">http://www.ccsa.org.cn/english/tc/files.php?docpath=/ITU-R/M.1457/M.1457-4/DS/</a>
ETSI	ETSI TS 123 140	6.4.0	Awaiting		<a href="http://pda.etsi.org/pda/home.asp?wkr=RTS/TSGT-0223140v640">http://pda.etsi.org/pda/home.asp?wkr=RTS/TSGT-0223140v640</a>
T1 (ATIS)	T1.3GPP.23.140V640-2004	6.4.0	Approved	21/05/2004	<a href="https://www.atis.org/atis/docstore/search.asp?committee=s24">https://www.atis.org/atis/docstore/search.asp?committee=s24</a>
TTA	TTAT.3G-23.140(R6-6.4.0)	6.4.0	Approved	25/05/2004	<a href="http://www.tta.or.kr/standardDB/stnfile/TTAT.3G-23.140(R6-6.4.0).zip">http://www.tta.or.kr/standardDB/stnfile/TTAT.3G-23.140(R6-6.4.0).zip</a>

### 5.3.2.7.22 27.005

#### Use of data terminal equipment - data circuit terminating equipment (DTE - DCE) interface for cell broadcast service (CBS)

This specification describes three interface protocols for control of SMS functions within a GSM mobile telephone from a remote terminal via an asynchronous interface.



SDO (2)	Document No.	Version	Status	Issued date	Location (1)
<b>Release 99</b>					
CCSA	CCSA-TSD-DS-27.005	320	Approved	01/07/2003	<a href="http://www.ccsa.org.cn/english/tc/files.php?docpath=/ITU-R/M.1457/M.1457-4/DS/">http://www.ccsa.org.cn/english/tc/files.php?docpath=/ITU-R/M.1457/M.1457-4/DS/</a>
ETSI	ETSI TS 127 005	3.2.0	Published	05/07/2002	<a href="http://pda.etsi.org/pda/home.asp?wkr=RTS/TSGT-0227005v320">http://pda.etsi.org/pda/home.asp?wkr=RTS/TSGT-0227005v320</a>
T1 (ATIS)	T1.3GPP.27.005V320-2003	3.2.0	Approved	27/03/2003	<a href="https://www.atis.org/atis/docstore/search.asp?committee=S24">https://www.atis.org/atis/docstore/search.asp?committee=S24</a>
TTA	TTAT.3G-27.005(R99-3.2.0)	3.2.0	Approved	21/03/2003	<a href="http://www.tta.or.kr/standardDB/stnfile/TTAT.3G-27.005(R99-3.2.0).zip">http://www.tta.or.kr/standardDB/stnfile/TTAT.3G-27.005(R99-3.2.0).zip</a>
<b>Release 4</b>					
CCSA	CCSA-TSD-DS-27.005	420	Approved	01/07/2003	<a href="http://www.ccsa.org.cn/english/tc/files.php?docpath=/ITU-R/M.1457/M.1457-4/DS/">http://www.ccsa.org.cn/english/tc/files.php?docpath=/ITU-R/M.1457/M.1457-4/DS/</a>
ETSI	ETSI TS 127 005	4.2.0	Published	05/07/2002	<a href="http://pda.etsi.org/pda/home.asp?wkr=RTS/TSGT-0227005v420">http://pda.etsi.org/pda/home.asp?wkr=RTS/TSGT-0227005v420</a>
T1 (ATIS)	T1.3GPP.27.005V420-2003	4.2.0	Approved	27/03/2003	<a href="https://www.atis.org/atis/docstore/search.asp?committee=S24">https://www.atis.org/atis/docstore/search.asp?committee=S24</a>
TTA	TTAT.3G-27.005(R4-4.2.0)	4.2.0	Approved	21/03/2003	<a href="http://www.tta.or.kr/standardDB/stnfile/TTAT.3G-27.005(R4-4.2.0).zip">http://www.tta.or.kr/standardDB/stnfile/TTAT.3G-27.005(R4-4.2.0).zip</a>
<b>Release 5</b>					
CCSA	CCSA-TSD-DS-27.005	500	Approved	01/07/2003	<a href="http://www.ccsa.org.cn/english/tc/files.php?docpath=/ITU-R/M.1457/M.1457-4/DS/">http://www.ccsa.org.cn/english/tc/files.php?docpath=/ITU-R/M.1457/M.1457-4/DS/</a>
ETSI	ETSI TS 127 005	5.0.0	Published	05/07/2002	<a href="http://pda.etsi.org/pda/home.asp?wkr=RTS/TSGT-0227005v500">http://pda.etsi.org/pda/home.asp?wkr=RTS/TSGT-0227005v500</a>
T1 (ATIS)	T1.3GPP.27.005V500-2003	5.0.0	Approved	27/03/2003	<a href="https://www.atis.org/atis/docstore/search.asp?committee=S24">https://www.atis.org/atis/docstore/search.asp?committee=S24</a>
TTA	TTAT.3G-27.005(R5-5.0.0)	5.0.0	Approved	21/03/2003	<a href="http://www.tta.or.kr/standardDB/stnfile/TTAT.3G-27.005(R5-5.0.0).zip">http://www.tta.or.kr/standardDB/stnfile/TTAT.3G-27.005(R5-5.0.0).zip</a>

### 5.3.2.7.23 27.007

#### AT command set for the user equipment (UE)

This specification describes a profile of AT commands and recommends that this profile be used for controlling mobile equipment (ME) functions and GSM network services from a terminal equipment (TE) through terminal adaptor (TA).

SDO (2)	Document No.	Version	Status	Issued date	Location (1)
<b>Release 99</b>					
CCSA	CCSA-TSD-DS-27.007	310	Approved	01/07/2003	<a href="http://www.ccsa.org.cn/english/tc/files.php?docpath=/ITU-R/M.1457/M.1457-4/DS/">http://www.ccsa.org.cn/english/tc/files.php?docpath=/ITU-R/M.1457/M.1457-4/DS/</a>
ETSI	ETSI TS 127 007	3.13.0	Published	08/04/2003	<a href="http://pda.etsi.org/pda/home.asp?wkr=RTS/TSGT-0227007v3d0">http://pda.etsi.org/pda/home.asp?wkr=RTS/TSGT-0227007v3d0</a>
T1 (ATIS)	T1.3GPP.27.007V3130-2004	3.13.0	Approved	21/05/2004	<a href="https://www.atis.org/atis/docstore/search.asp?committee=S24">https://www.atis.org/atis/docstore/search.asp?committee=S24</a>
TTA	TTAT.3G-27.007(R99-3.13.0)	3.13.0	Approved	25/05/2004	<a href="http://www.tta.or.kr/standardDB/stnfile/TTAT.3G-27.007(R99-3.13.0).zip">http://www.tta.or.kr/standardDB/stnfile/TTAT.3G-27.007(R99-3.13.0).zip</a>
<b>Release 4</b>					
CCSA	CCSA-TSD-DS-27.007	400	Approved	01/07/2003	<a href="http://www.ccsa.org.cn/english/tc/files.php?docpath=/ITU-R/M.1457/M.1457-4/DS/">http://www.ccsa.org.cn/english/tc/files.php?docpath=/ITU-R/M.1457/M.1457-4/DS/</a>
ETSI	ETSI TS 127 007	4.6.0	Published	08/04/2003	<a href="http://pda.etsi.org/pda/home.asp?wkr=RTS/TSGT-0227007v460">http://pda.etsi.org/pda/home.asp?wkr=RTS/TSGT-0227007v460</a>
T1 (ATIS)	T1.3GPP.27.007V460-2004	4.6.0	Approved	21/05/2004	<a href="https://www.atis.org/atis/docstore/search.asp?committee=S24">https://www.atis.org/atis/docstore/search.asp?committee=S24</a>
TTA	TTAT.3G-27.007(R4-4.6.0)	4.6.0	Approved	25/05/2004	<a href="http://www.tta.or.kr/standardDB/stnfile/TTAT.3G-27.007(R4-4.6.0).zip">http://www.tta.or.kr/standardDB/stnfile/TTAT.3G-27.007(R4-4.6.0).zip</a>
<b>Release 5</b>					
CCSA	CCSA-TSD-DS-27.007	500	Approved	01/07/2003	<a href="http://www.ccsa.org.cn/english/tc/files.php?docpath=/ITU-R/M.1457/M.1457-4/DS/">http://www.ccsa.org.cn/english/tc/files.php?docpath=/ITU-R/M.1457/M.1457-4/DS/</a>
ETSI	ETSI TS 127 007	5.4.0	Published	09/10/2003	<a href="http://pda.etsi.org/pda/home.asp?wkr=RTS/TSGT-0227007v540">http://pda.etsi.org/pda/home.asp?wkr=RTS/TSGT-0227007v540</a>
T1 (ATIS)	T1.3GPP.27.007V540-2004	5.4.0	Approved	21/05/2004	<a href="https://www.atis.org/atis/docstore/search.asp?committee=S24">https://www.atis.org/atis/docstore/search.asp?committee=S24</a>
TTA	TTAT.3G-27.007(R5-5.4.0)	5.4.0	Approved	25/05/2004	<a href="http://www.tta.or.kr/standardDB/stnfile/TTAT.3G-27.007(R5-5.4.0).zip">http://www.tta.or.kr/standardDB/stnfile/TTAT.3G-27.007(R5-5.4.0).zip</a>

**Release 6**

SDO (2)	Document No.	Version	Status	Issued date	Location (1)
CCSA	CCSA-TSD-DS-27.007	V4	Approved	01/07/2003	<a href="http://www.ccsa.org.cn/english/tc/files.php?docpath=/ITU-R/M.1457/M.1457-4/DS/">http://www.ccsa.org.cn/english/tc/files.php?docpath=/ITU-R/M.1457/M.1457-4/DS/</a>
ETSI	ETSI TS 127 007	6.4.0	Awaiting		<a href="http://pda.etsi.org/pda/home.asp?wkr=RTS/TSGT-0227007v640">http://pda.etsi.org/pda/home.asp?wkr=RTS/TSGT-0227007v640</a>
T1 (ATIS)	T1.3GPP.27.007V640-2004	6.4.0	Approved	21/05/2004	<a href="https://www.atis.org/atis/docstore/search.asp?committee=S24">https://www.atis.org/atis/docstore/search.asp?committee=S24</a>
TTA	TTAT.3G-27.007(R6-6.4.0)	6.4.0	Approved	25/05/2004	<a href="http://www.tta.or.kr/standardDB/stnfile/TTAT.3G-27.007(R6-6.4.0).zip">http://www.tta.or.kr/standardDB/stnfile/TTAT.3G-27.007(R6-6.4.0).zip</a>

**5.3.2.7.24 27.010****Terminal equipment to mobile station (TE-MS) multiplexer protocol**

This specification describes a multiplexing protocol between a mobile station and an external data terminal for the purposes of enabling multiple channels to be established for different purposes (e.g. simultaneous SMS and data call).

SDO (2)	Document No.	Version	Status	Issued date	Location (1)
<b>Release 99</b>					
CCSA	CCSA-TSD-DS-27.010	340	Approved	01/07/2003	<a href="http://www.ccsa.org.cn/english/tc/files.php?docpath=/ITU-R/M.1457/M.1457-4/DS/">http://www.ccsa.org.cn/english/tc/files.php?docpath=/ITU-R/M.1457/M.1457-4/DS/</a>
ETSI	ETSI TS 127 010	3.4.0	Published	18/04/2002	<a href="http://pda.etsi.org/pda/home.asp?wkr=RTS/TSGT-0227010UR2">http://pda.etsi.org/pda/home.asp?wkr=RTS/TSGT-0227010UR2</a>
T1 (ATIS)	T1.3GPP.27.010V340-2002	3.4.0	Approved	03/05/2002	<a href="https://www.atis.org/atis/docstore/search.asp?committee=S24">https://www.atis.org/atis/docstore/search.asp?committee=S24</a>
TTA	TTAE.3G-27.010(R99-3.4.0)	3.4.0	Approved	29/05/2002	<a href="http://www.tta.or.kr/standardDB/stnfile/TTAE.3G-27.010(R99-3.4.0).zip">http://www.tta.or.kr/standardDB/stnfile/TTAE.3G-27.010(R99-3.4.0).zip</a>
<b>Release 4</b>					
CCSA	CCSA-TSD-DS-27.010	420	Approved	01/07/2003	<a href="http://www.ccsa.org.cn/english/tc/files.php?docpath=/ITU-R/M.1457/M.1457-4/DS/">http://www.ccsa.org.cn/english/tc/files.php?docpath=/ITU-R/M.1457/M.1457-4/DS/</a>
ETSI	ETSI TS 127 010	4.2.0	Published	18/04/2002	<a href="http://pda.etsi.org/pda/home.asp?wkr=RTS/TSGT-0227010Uv4R2">http://pda.etsi.org/pda/home.asp?wkr=RTS/TSGT-0227010Uv4R2</a>
T1 (ATIS)	T1.3GPP.27.010V420-2002	4.2.0	Approved	03/05/2002	<a href="https://www.atis.org/atis/docstore/search.asp?committee=S24">https://www.atis.org/atis/docstore/search.asp?committee=S24</a>
TTA	TTAE.3G-27.010(R4-4.2.0)	4.2.0	Approved	29/05/2002	<a href="http://www.tta.or.kr/standardDB/stnfile/TTAE.3G-27.010(R4-4.2.0).zip">http://www.tta.or.kr/standardDB/stnfile/TTAE.3G-27.010(R4-4.2.0).zip</a>
<b>Release 5</b>					
CCSA	CCSA-TSD-DS-27.010	500	Approved	01/07/2003	<a href="http://www.ccsa.org.cn/english/tc/files.php?docpath=/ITU-R/M.1457/M.1457-4/DS/">http://www.ccsa.org.cn/english/tc/files.php?docpath=/ITU-R/M.1457/M.1457-4/DS/</a>
ETSI	ETSI TS 127 010	5.0.0	Published	05/07/2002	<a href="http://pda.etsi.org/pda/home.asp?wkr=RTS/TSGT-0227010v500">http://pda.etsi.org/pda/home.asp?wkr=RTS/TSGT-0227010v500</a>
T1 (ATIS)	T1.3GPP.27.010V500-2003	5.0.0	Approved	27/03/2003	<a href="https://www.atis.org/atis/docstore/search.asp?committee=S24">https://www.atis.org/atis/docstore/search.asp?committee=S24</a>
TTA	TTAT.3G-27.010(R5-5.0.0)	5.0.0	Approved	21/03/2003	<a href="http://www.tta.or.kr/standardDB/stnfile/TTAT.3G-27.010(R5-5.0.0).zip">http://www.tta.or.kr/standardDB/stnfile/TTAT.3G-27.010(R5-5.0.0).zip</a>
<b>Release 6</b>					
CCSA	CCSA-TSD-DS-27.010	V4	Approved	01/07/2003	<a href="http://www.ccsa.org.cn/english/tc/files.php?docpath=/ITU-R/M.1457/M.1457-4/DS/">http://www.ccsa.org.cn/english/tc/files.php?docpath=/ITU-R/M.1457/M.1457-4/DS/</a>

**5.3.2.7.25 27.103****Wide area network synchronization standard**

This specification describes a definition of a wide area synchronization protocol. The synchronization protocol is based upon infrared mobile communication (IrMC) Level 4 for Release 99. The synchronization protocol is based upon SyncML from Release 4 onwards.

SDO (2)	Document No.	Version	Status	Issued date	Location (1)
<b>Release 99</b>					
CCSA	CCSA-TSD-DS-27.103	310	Approved	01/07/2003	<a href="http://www.ccsa.org.cn/english/tc/files.php?docpath=/ITU-R/M.1457/M.1457-4/DS/">http://www.ccsa.org.cn/english/tc/files.php?docpath=/ITU-R/M.1457/M.1457-4/DS/</a>

ETSI	ETSI TS 127 103	3.1.0	Published	07/11/2000	<a href="http://pda.etsi.org/pda/home.asp?wkr=RTS/TSGT-0227103UR1">http://pda.etsi.org/pda/home.asp?wkr=RTS/TSGT-0227103UR1</a>
T1 (ATIS)	T1.3GPP.27.103V310-2002	3.1.0	Approved	03/05/2002	<a href="https://www.atis.org/atis/docstore/search.asp?committee=S24">https://www.atis.org/atis/docstore/search.asp?committee=S24</a>
TTA	TTAE.3G-27.103(R99F)	3.1.0	Approved	19/12/2001	<a href="http://www.tta.or.kr/standardDB/stnfile/TTAE_3G-27_103_R99F_.zip">http://www.tta.or.kr/standardDB/stnfile/TTAE_3G-27_103_R99F_.zip</a>
<b>Release 4</b>					
CCSA	CCSA-TSD-DS-27.103	400	Approved	01/07/2003	<a href="http://www.ccsa.org.cn/english/tc/files.php?docpath=/ITU-R/M.1457/M.1457-4/DS/">http://www.ccsa.org.cn/english/tc/files.php?docpath=/ITU-R/M.1457/M.1457-4/DS/</a>
ETSI	ETSI TS 127 103	4.0.0	Published	25/04/2001	<a href="http://pda.etsi.org/pda/home.asp?wkr=RTS/TSGT-0227103Uv4">http://pda.etsi.org/pda/home.asp?wkr=RTS/TSGT-0227103Uv4</a>
T1 (ATIS)	T1.3GPP.27.103V400-2002	4.0.0	Approved	03/05/2002	<a href="https://www.atis.org/atis/docstore/search.asp?committee=S24">https://www.atis.org/atis/docstore/search.asp?committee=S24</a>
TTA	TTAE.3G-27.103(R4-4.0.0)	4.0.0	Approved	29/05/2002	<a href="http://www.tta.or.kr/standardDB/stnfile/TTAE.3G-27.103(R4-4.0.0).zip">http://www.tta.or.kr/standardDB/stnfile/TTAE.3G-27.103(R4-4.0.0).zip</a>
<b>Release 5</b>					
CCSA	CCSA-TSD-DS-27.103	500	Approved	01/07/2003	<a href="http://www.ccsa.org.cn/english/tc/files.php?docpath=/ITU-R/M.1457/M.1457-4/DS/">http://www.ccsa.org.cn/english/tc/files.php?docpath=/ITU-R/M.1457/M.1457-4/DS/</a>
ETSI	ETSI TS 127 103	5.0.0	Published	05/07/2002	<a href="http://pda.etsi.org/pda/home.asp?wkr=RTS/TSGT-0227103v500">http://pda.etsi.org/pda/home.asp?wkr=RTS/TSGT-0227103v500</a>
T1 (ATIS)	T1.3GPP.27.103V500-2003	5.0.0	Approved	27/03/2003	<a href="https://www.atis.org/atis/docstore/search.asp?committee=S24">https://www.atis.org/atis/docstore/search.asp?committee=S24</a>
TTA	TTAT.3G-27.103(R5-5.0.0)	5.0.0	Approved	21/03/2003	<a href="http://www.tta.or.kr/standardDB/stnfile/TTAT.3G-27.103(R5-5.0.0).zip">http://www.tta.or.kr/standardDB/stnfile/TTAT.3G-27.103(R5-5.0.0).zip</a>

### 5.3.2.7.26 23.227

#### Application and user interaction in the UE; Principles and specific requirements

This Technical Specification defines the principles for scheduling resources between applications in different application execution environment (e.g. MExE, USAT etc.) and internal and external peripherals (e.g. infra-red, Bluetooth, USIM, radio interface, MMI, memory etc.).

SDO (2)	Document No.	Version	Status	Issued date	Location (1)
<b>Release 4</b>					
CCSA	CCSA-TSD-DS-27.227	420	Approved	01/07/2003	<a href="http://www.ccsa.org.cn/english/tc/files.php?docpath=/ITU-R/M.1457/M.1457-4/DS/">http://www.ccsa.org.cn/english/tc/files.php?docpath=/ITU-R/M.1457/M.1457-4/DS/</a>
ETSI	ETSI TS 123 227	4.2.0	Published	09/04/2002	<a href="http://pda.etsi.org/pda/home.asp?wkr=RTS/TSGT-0223227Uv4R2">http://pda.etsi.org/pda/home.asp?wkr=RTS/TSGT-0223227Uv4R2</a>
T1 (ATIS)	T1.3GPP.23.227V420-2002	4.2.0	Approved	03/05/2002	<a href="https://www.atis.org/atis/docstore/search.asp?committee=S24">https://www.atis.org/atis/docstore/search.asp?committee=S24</a>
TTA	TTAE.3G-23.227(R4-4.2.0)	4.2.0	Approved	29/05/2002	<a href="http://www.tta.or.kr/standardDB/stnfile/TTAE.3G-23.227(R4-4.2.0).zip">http://www.tta.or.kr/standardDB/stnfile/TTAE.3G-23.227(R4-4.2.0).zip</a>
<b>Release 5</b>					
CCSA	CCSA-TSD-DS-27.227	510	Approved	01/07/2003	<a href="http://www.ccsa.org.cn/english/tc/files.php?docpath=/ITU-R/M.1457/M.1457-4/DS/">http://www.ccsa.org.cn/english/tc/files.php?docpath=/ITU-R/M.1457/M.1457-4/DS/</a>
ETSI	ETSI TS 123 227	5.1.0	Published	09/04/2002	<a href="http://pda.etsi.org/pda/home.asp?wkr=RTS/TSGT-0223227Uv5">http://pda.etsi.org/pda/home.asp?wkr=RTS/TSGT-0223227Uv5</a>
T1 (ATIS)	T1.3GPP.23.227V510-2002	5.1.0	Approved	03/05/2002	<a href="https://www.atis.org/atis/docstore/search.asp?committee=S24">https://www.atis.org/atis/docstore/search.asp?committee=S24</a>
TTA	TTAE.3G-23.227(R5-5.1.0)	5.1.0	Approved	29/05/2002	<a href="http://www.tta.or.kr/standardDB/stnfile/TTAE.3G-23.227(R5-5.1.0).zip">http://www.tta.or.kr/standardDB/stnfile/TTAE.3G-23.227(R5-5.1.0).zip</a>

### 5.3.2.8

#### System aspects

##### 5.3.2.8.1 TS 23.002

#### UMTS release 1999 network architecture

This specification describes the possible architectures of the mobile system.

SDO (2)	Document No.	Version	Status	Issued date	Location (1)
<b>Release 99</b>					
ETSI	ETSI TS 123 002	3.6.0	Published	03/10/2002	<a href="http://pda.etsi.org/pda/home.asp?wkr=RTS/TSGS-0223002v360">http://pda.etsi.org/pda/home.asp?wkr=RTS/TSGS-0223002v360</a>
<b>Release 4</b>					
ETSI	ETSI TS 123 002	4.8.0	Published	01/07/2003	<a href="http://pda.etsi.org/pda/home.asp?wkr=RTS/TSGS-0223002v480">http://pda.etsi.org/pda/home.asp?wkr=RTS/TSGS-0223002v480</a>
<b>Release 5</b>					
ETSI	ETSI TS 123 002	5.12.0	Published	06/10/2003	<a href="http://pda.etsi.org/pda/home.asp?wkr=RTS/TSGS-0223002v5c0">http://pda.etsi.org/pda/home.asp?wkr=RTS/TSGS-0223002v5c0</a>

### 5.3.2.8.2 TS 23.101

#### General UMTS architecture

This specification describes the basic physical and functional separation of UMTS. The content of this specification is limited to those features that are common to all UMTS networks independent of their origin. It identifies and names the reference points and functional groupings appearing at this level.

SDO (2)	Document No.	Version	Status	Issued date	Location (1)
<b>Release 99</b>					
ETSI	ETSI TS 123 101	3.1.0	Published	13/02/2001	<a href="http://pda.etsi.org/pda/home.asp?wkr=RTS/TSGS-0223101UR1">http://pda.etsi.org/pda/home.asp?wkr=RTS/TSGS-0223101UR1</a>
<b>Release 4</b>					
ETSI	ETSI TS 123 101	4.0.0	Published	17/04/2001	<a href="http://pda.etsi.org/pda/home.asp?wkr=RTS/TSGS-0223101Uv4">http://pda.etsi.org/pda/home.asp?wkr=RTS/TSGS-0223101Uv4</a>
<b>Release 5</b>					
ETSI	ETSI TS 123 101	5.0.1	Published	30/01/2004	<a href="http://pda.etsi.org/pda/home.asp?wkr=RTS/TSGS-0223101v501">http://pda.etsi.org/pda/home.asp?wkr=RTS/TSGS-0223101v501</a>

### 5.3.2.8.3 TS 23.107

#### QoS concept and architecture

This specification describes the framework for QoS in UMTS. The document shall be used as a living document which will cover all issues related QoS in UMTS.

SDO (2)	Document No.	Version	Status	Issued date	Location (1)
<b>Release 99</b>					
ETSI	ETSI TS 123 107	3.9.0	Published	03/10/2002	<a href="http://pda.etsi.org/pda/home.asp?wkr=RTS/TSGS-0223107v390">http://pda.etsi.org/pda/home.asp?wkr=RTS/TSGS-0223107v390</a>
<b>Release 4</b>					
ETSI	ETSI TS 123 107	4.6.0	Published	13/01/2003	<a href="http://pda.etsi.org/pda/home.asp?wkr=RTS/TSGS-0223107v460">http://pda.etsi.org/pda/home.asp?wkr=RTS/TSGS-0223107v460</a>
<b>Release 5</b>					
ETSI	ETSI TS 123 107	5.11.0	Published	08/01/2004	<a href="http://pda.etsi.org/pda/home.asp?wkr=RTS/TSGS-0223107v5b0">http://pda.etsi.org/pda/home.asp?wkr=RTS/TSGS-0223107v5b0</a>

**5.3.2.8.4** TS 23.121**Architectural requirements for release 1999**

This specification describes architectural requirements for release 1999 related to the evolution of the GSM platform towards UMTS with the overall goal of fulfilling the UMTS service requirements, support of roaming and support of new functionality, signalling systems and interfaces.

SDO (2)	Document No.	Version	Status	Issued date	Location (1)
<b>Release 99</b>					
ETSI	ETSI TS 123 121	3.6.0	Published	24/06/2002	<a href="http://pda.etsi.org/pda/home.asp?wkr=RTS/TSGS-0223121v360">http://pda.etsi.org/pda/home.asp?wkr=RTS/TSGS-0223121v360</a>

**5.3.2.8.5** TR 23.930**Iu principles**

This specification describes the requirements on the Iu and studies relevant principles to guide further standardization of the related interface(s).

SDO (2)	Document No.	Version	Status	Issued date	Location (1)
<b>Release 99</b>					
ETSI	ETSI TR 123 930	3.0.0	Published	01/02/2000	<a href="http://pda.etsi.org/pda/home.asp?wkr=DTR/TSGS-0223930U">http://pda.etsi.org/pda/home.asp?wkr=DTR/TSGS-0223930U</a>
<b>Release 4</b>					
ETSI	ETSI TR 123 930	4.0.0	Published	19/04/2001	<a href="http://pda.etsi.org/pda/home.asp?wkr=RTR/TSGS-0223930Uv4">http://pda.etsi.org/pda/home.asp?wkr=RTR/TSGS-0223930Uv4</a>

**5.3.2.8.6** TS 22.002**Bearer services supported by a GSM PLMN**

This 3G specification describes a set of bearer services to be provided to 3G subscribers by a 3G network itself and in connection with other networks. This document is also be used as a reference for defining the corresponding required mobile network capabilities which are specified by means of the connection type concept.

SDO (2)	Document No.	Version	Status	Issued date	Location (1)
<b>Release 99</b>					
ETSI	ETSI TS 122 002	3.6.0	Published	19/04/2001	<a href="http://pda.etsi.org/pda/home.asp?wkr=RTS/TSGS-0122002UR4">http://pda.etsi.org/pda/home.asp?wkr=RTS/TSGS-0122002UR4</a>
<b>Release 4</b>					
ETSI	ETSI TS 122 002	4.2.0	Published	16/07/2001	<a href="http://pda.etsi.org/pda/home.asp?wkr=RTS/TSGS-0122002Uv4R1">http://pda.etsi.org/pda/home.asp?wkr=RTS/TSGS-0122002Uv4R1</a>
<b>Release 5</b>					
ETSI	ETSI TS 122 002	5.0.0	Published	16/07/2002	<a href="http://pda.etsi.org/pda/home.asp?wkr=RTS/TSGS-0122002v500">http://pda.etsi.org/pda/home.asp?wkr=RTS/TSGS-0122002v500</a>

**5.3.2.8.7** TS 22.004**General on supplementary services**

This specification describes a recommended set of supplementary services to the teleservices and bearer services which will be supported by a 3G network in connection with other networks as a basis for the definition of the network capabilities required.

SDO (2)	Document No.	Version	Status	Issued date	Location (1)
<b>Release 99</b>					
ETSI	ETSI TS 122 004	3.3.0	Published	25/07/2002	<a href="http://pda.etsi.org/pda/home.asp?wkr=RTS/TSGS-0122004v330">http://pda.etsi.org/pda/home.asp?wkr=RTS/TSGS-0122004v330</a>
<b>Release 4</b>					
ETSI	ETSI TS 122 004	4.2.0	Published	25/07/2002	<a href="http://pda.etsi.org/pda/home.asp?wkr=RTS/TSGS-0122004v420">http://pda.etsi.org/pda/home.asp?wkr=RTS/TSGS-0122004v420</a>
<b>Release 5</b>					
ETSI	ETSI TS 122 004	5.0.0	Published	25/07/2002	<a href="http://pda.etsi.org/pda/home.asp?wkr=RTS/TSGS-0122004v500">http://pda.etsi.org/pda/home.asp?wkr=RTS/TSGS-0122004v500</a>

**5.3.2.8.8** TS 22.011**Service accessibility**

This specification describes the service access procedures as presented to the user. The document contains definitions and procedures are provided for international roaming, national roaming and regionally provided service. These are mandatory in relation to the technical realization of the UE.

SDO (2)	Document No.	Version	Status	Issued date	Location (1)
<b>Release 99</b>					
ETSI	ETSI TS 122 011	3.8.0	Published	20/09/2002	<a href="http://pda.etsi.org/pda/home.asp?wkr=RTS/TSGS-0122011v380">http://pda.etsi.org/pda/home.asp?wkr=RTS/TSGS-0122011v380</a>
<b>Release 4</b>					
ETSI	ETSI TS 122 011	4.8.0	Published	20/09/2002	<a href="http://pda.etsi.org/pda/home.asp?wkr=RTS/TSGS-0122011v480">http://pda.etsi.org/pda/home.asp?wkr=RTS/TSGS-0122011v480</a>
<b>Release 5</b>					
ETSI	ETSI TS 122 011	5.1.0	Published	20/09/2002	<a href="http://pda.etsi.org/pda/home.asp?wkr=RTS/TSGS-0122011v510">http://pda.etsi.org/pda/home.asp?wkr=RTS/TSGS-0122011v510</a>

**5.3.2.8.9** TS 22.016**International mobile equipment identities (IMEI)**

This specification describes the principal purpose and use of unique equipment identities.

SDO (2)	Document No.	Version	Status	Issued date	Location (1)
<b>Release 99</b>					
ETSI	ETSI TS 122 016	3.3.0	Published	16/07/2002	<a href="http://pda.etsi.org/pda/home.asp?wkr=RTS/TSGS-0122016v330">http://pda.etsi.org/pda/home.asp?wkr=RTS/TSGS-0122016v330</a>
<b>Release 4</b>					
ETSI	ETSI TS 122 016	4.2.1	Published	16/07/2002	<a href="http://pda.etsi.org/pda/home.asp?wkr=RTS/TSGS-0122016v421">http://pda.etsi.org/pda/home.asp?wkr=RTS/TSGS-0122016v421</a>
<b>Release 5</b>					
ETSI	ETSI TS 122 016	5.0.0	Published	25/07/2002	<a href="http://pda.etsi.org/pda/home.asp?wkr=RTS/TSGS-0122016v500">http://pda.etsi.org/pda/home.asp?wkr=RTS/TSGS-0122016v500</a>

**5.3.2.8.10** TS 22.022**Personalization of GSM ME mobile functionality specification - Stage 1**

This specification describes functional specifications of five features to personalize UE. These features are called: - network personalization; - network subset personalization; - service provider (SP) personalization; - corporate personalization; - UMTS subscriber identity module (USIM) personalization. This specification describes requirements for UE, which provide these personalization features.

SDO (2)	Document No.	Version	Status	Issued date	Location (1)
<b>Release 99</b>					
ETSI	ETSI TS 122 022	3.2.1	Published	27/06/2002	<a href="http://pda.etsi.org/pda/home.asp?wkr=RTS/TSGS-0322022v321">http://pda.etsi.org/pda/home.asp?wkr=RTS/TSGS-0322022v321</a>
<b>Release 4</b>					
ETSI	ETSI TS 122 022	4.1.0	Published	24/06/2002	<a href="http://pda.etsi.org/pda/home.asp?wkr=RTS/TSGS-0322022v410">http://pda.etsi.org/pda/home.asp?wkr=RTS/TSGS-0322022v410</a>
<b>Release 5</b>					
ETSI	ETSI TS 122 022	5.0.0	Published	02/10/2002	<a href="http://pda.etsi.org/pda/home.asp?wkr=RTS/TSGS-0322022v500">http://pda.etsi.org/pda/home.asp?wkr=RTS/TSGS-0322022v500</a>

**5.3.2.8.11** TS 22.024**Description of charge advice information (CAI)**

This specification describes an overall view of how the charging advice supplementary service shall operate both in the network and within the UE. The charging supplementary service is described in TS 22.086.

SDO (2)	Document No.	Version	Status	Issued date	Location (1)
<b>Release 99</b>					
ETSI	ETSI TS 122 024	3.0.1	Published	01/02/2000	<a href="http://pda.etsi.org/pda/home.asp?wkr=DTS/TSGS-0122024U">http://pda.etsi.org/pda/home.asp?wkr=DTS/TSGS-0122024U</a>
<b>Release 4</b>					
ETSI	ETSI TS 122 024	4.0.0	Published	25/04/2001	<a href="http://pda.etsi.org/pda/home.asp?wkr=RTS/TSGS-0122024Uv4">http://pda.etsi.org/pda/home.asp?wkr=RTS/TSGS-0122024Uv4</a>
<b>Release 5</b>					
ETSI	ETSI TS 122 024	5.0.0	Published	25/07/2002	<a href="http://pda.etsi.org/pda/home.asp?wkr=RTS/TSGS-0122024v500">http://pda.etsi.org/pda/home.asp?wkr=RTS/TSGS-0122024v500</a>

**5.3.2.8.12** TS 22.030**Man-machine interface (MMI) of the mobile station**

This specification describes the requirements for and gives guidelines on the MMI for calls on the 3G UE. This includes the requirements of the user procedures for call control and supplementary service control, the requirements on the physical input media and the output, such as indications and displayed information.

SDO (2)	Document No.	Version	Status	Issued date	Location (1)
<b>Release 99</b>					
ETSI	ETSI TS 122 030	3.4.0	Published	07/11/2000	<a href="http://pda.etsi.org/pda/home.asp?wkr=RTS/TSGS-0122030UR2">http://pda.etsi.org/pda/home.asp?wkr=RTS/TSGS-0122030UR2</a>

**Release 4**

ETSI	ETSI TS 122 030	4.1.0	Published	08/04/2002	<a href="http://pda.etsi.org/pda/home.asp?wkr=RTS/TSGS-0122030Uv4R1">http://pda.etsi.org/pda/home.asp?wkr=RTS/TSGS-0122030Uv4R1</a>
------	-----------------	-------	-----------	------------	-------------------------------------------------------------------------------------------------------------------------------------

**Release 5**

ETSI	ETSI TS 122 030	5.0.0	Published	25/07/2002	<a href="http://pda.etsi.org/pda/home.asp?wkr=RTS/TSGS-0122030v500">http://pda.etsi.org/pda/home.asp?wkr=RTS/TSGS-0122030v500</a>
------	-----------------	-------	-----------	------------	-----------------------------------------------------------------------------------------------------------------------------------

**5.3.2.8.13 TS 22.034****High speed circuit switched data (HSCSD) - Stage 1**

This specification describes the Stage 1 description of HSCSD. HSCSD is a feature that allows users subscribing to the general bearer services to access user rates that can be achieved with one or more traffic channel. HSCSD also defines a flexible use of air interface resources, which makes efficient and flexible use of higher user rates feasible.

SDO (2)	Document No.	Version	Status	Issued date	Location (1)
<b>Release 99</b>					
ETSI	ETSI TS 122 034	3.2.1	Published	17/05/2000	<a href="http://pda.etsi.org/pda/home.asp?wkr=RTS/TSGS-0122034UR1">http://pda.etsi.org/pda/home.asp?wkr=RTS/TSGS-0122034UR1</a>
<b>Release 4</b>					
ETSI	ETSI TS 122 034	4.1.0	Published	25/07/2002	<a href="http://pda.etsi.org/pda/home.asp?wkr=RTS/TSGS-0122034v410">http://pda.etsi.org/pda/home.asp?wkr=RTS/TSGS-0122034v410</a>
<b>Release 5</b>					
ETSI	ETSI TS 122 034	5.0.0	Published	25/07/2002	<a href="http://pda.etsi.org/pda/home.asp?wkr=RTS/TSGS-0122034v500">http://pda.etsi.org/pda/home.asp?wkr=RTS/TSGS-0122034v500</a>

**5.3.2.8.14 TS 22.038****SIM application toolkit (SAT) - Stage 1**

This specification describes the Stage 1 description of the SAT primarily from the subscriber's and serving environment's points of view, and does not deal with the details of the human interface itself. It includes information applicable to network operators, serving environments and terminal, switch and database manufacturers and contains the core requirements for a SAT which are sufficient to provide a complete service.

SDO (2)	Document No.	Version	Status	Issued date	Location (1)
<b>Release 99</b>					
ETSI	ETSI TS 122 038	3.4.0	Published	08/01/2004	<a href="http://pda.etsi.org/pda/home.asp?wkr=RTS/TSGS-0122038v340">http://pda.etsi.org/pda/home.asp?wkr=RTS/TSGS-0122038v340</a>
<b>Release 4</b>					
ETSI	ETSI TS 122 038	4.3.0	Published	08/01/2004	<a href="http://pda.etsi.org/pda/home.asp?wkr=RTS/TSGS-0122038v430">http://pda.etsi.org/pda/home.asp?wkr=RTS/TSGS-0122038v430</a>
<b>Release 5</b>					
ETSI	ETSI TS 122 038	5.4.0	Published	08/01/2004	<a href="http://pda.etsi.org/pda/home.asp?wkr=RTS/TSGS-0122038v540">http://pda.etsi.org/pda/home.asp?wkr=RTS/TSGS-0122038v540</a>
<b>Release 6</b>					
ETSI	ETSI TS 122 038	6.2.0	Awaiting		<a href="http://pda.etsi.org/pda/home.asp?wkr=RTS/TSGS-0122038v620">http://pda.etsi.org/pda/home.asp?wkr=RTS/TSGS-0122038v620</a>



**5.3.2.8.15** TS 22.041**Operator determined call barring**

The feature operator determined barring (ODB) allows the network operator or service provider to regulate, by means of an exceptional procedure, access by the subscribers to 3G services, by the barring of certain categories of outgoing or incoming calls or of roaming. ODB shall take effect immediately and shall terminate ongoing calls and bar future calls. The purpose of this network feature is to be able to limit the service provider's financial exposure to new subscribers, or to those who have not promptly paid their bills. It may only be applied to the service provider's own subscribers.

SDO (2)	Document No.	Version	Status	Issued date	Location (1)
<b>Release 99</b>					
ETSI	ETSI TS 122 041	3.3.1	Published	25/06/2001	<a href="http://pda.etsi.org/pda/home.asp?wkr=RTS/TSGS-0122041UR2">http://pda.etsi.org/pda/home.asp?wkr=RTS/TSGS-0122041UR2</a>
<b>Release 4</b>					
ETSI	ETSI TS 122 041	4.1.0	Published	25/04/2001	<a href="http://pda.etsi.org/pda/home.asp?wkr=RTS/TSGS-0122041Uv4">http://pda.etsi.org/pda/home.asp?wkr=RTS/TSGS-0122041Uv4</a>
<b>Release 5</b>					
ETSI	ETSI TS 122 041	5.0.0	Published	25/07/2002	<a href="http://pda.etsi.org/pda/home.asp?wkr=RTS/TSGS-0122041v500">http://pda.etsi.org/pda/home.asp?wkr=RTS/TSGS-0122041v500</a>

**5.3.2.8.16** TS 22.042**Network identity and time zone (NITZ) - Stage 1**

The feature NITZ provides the means for serving networks to transfer current identity, time, daylight saving time and the local time zone to user equipment storage and use.

SDO (2)	Document No.	Version	Status	Issued date	Location (1)
<b>Release 99</b>					
ETSI	ETSI TS 122 042	3.0.1	Published	01/02/2000	<a href="http://pda.etsi.org/pda/home.asp?wkr=DTS/TSGS-0122042U">http://pda.etsi.org/pda/home.asp?wkr=DTS/TSGS-0122042U</a>
<b>Release 4</b>					
ETSI	ETSI TS 122 042	4.2.1	Published	03/07/2003	<a href="http://pda.etsi.org/pda/home.asp?wkr=RTS/TSGS-0122042v421">http://pda.etsi.org/pda/home.asp?wkr=RTS/TSGS-0122042v421</a>
<b>Release 5</b>					
ETSI	ETSI TS 122 042	5.1.0	Published	01/07/2003	<a href="http://pda.etsi.org/pda/home.asp?wkr=RTS/TSGS-0122042v510">http://pda.etsi.org/pda/home.asp?wkr=RTS/TSGS-0122042v510</a>

**5.3.2.8.17** TS 22.057**Mobile station application execution environment (MExE) - Stage 1**

This specification describes the Stage 1 description of the MExE.

SDO (2)	Document No.	Version	Status	Issued date	Location (1)
<b>Release 99</b>					
ETSI	ETSI TS 122 057	3.0.1	Published	01/02/2000	<a href="http://pda.etsi.org/pda/home.asp?wkr=DTS/TSGS-0122057U">http://pda.etsi.org/pda/home.asp?wkr=DTS/TSGS-0122057U</a>

## 240

## Rec. ITU-R M.1457-4

### Release 4

ETSI	ETSI TS 122 057	4.1.0	Published	08/04/2002	<a href="http://pda.etsi.org/pda/home.asp?wkr=RTS/TSGS-0122057Uv4R1">http://pda.etsi.org/pda/home.asp?wkr=RTS/TSGS-0122057Uv4R1</a>
------	-----------------	-------	-----------	------------	-------------------------------------------------------------------------------------------------------------------------------------

### Release 5

ETSI	ETSI TS 122 057	5.4.0	Published	16/07/2002	<a href="http://pda.etsi.org/pda/home.asp?wkr=RTS/TSGS-0122057v540">http://pda.etsi.org/pda/home.asp?wkr=RTS/TSGS-0122057v540</a>
------	-----------------	-------	-----------	------------	-----------------------------------------------------------------------------------------------------------------------------------

### 5.3.2.8.18 TS 22.060

#### General packet radio service (GPRS) - Stage 1

This specification describes the Stage 1 description of the GPRS.

SDO (2)	Document No.	Version	Status	Issued date	Location (1)
<b>Release 99</b>					
ETSI	ETSI TS 122 060	3.5.0	Published	07/11/2000	<a href="http://pda.etsi.org/pda/home.asp?wkr=RTS/TSGS-0122060UR3">http://pda.etsi.org/pda/home.asp?wkr=RTS/TSGS-0122060UR3</a>
<b>Release 4</b>					
ETSI	ETSI TS 122 060	4.4.0	Published	16/07/2002	<a href="http://pda.etsi.org/pda/home.asp?wkr=RTS/TSGS-0122060v440">http://pda.etsi.org/pda/home.asp?wkr=RTS/TSGS-0122060v440</a>
<b>Release 5</b>					
ETSI	ETSI TS 122 060	5.3.0	Published	01/04/2003	<a href="http://pda.etsi.org/pda/home.asp?wkr=RTS/TSGS-0122060v530">http://pda.etsi.org/pda/home.asp?wkr=RTS/TSGS-0122060v530</a>

### 5.3.2.8.19 TS 22.066

#### Support of mobile number portability (MNP) - Stage 1

This specification describes the Stage 1 description of the support of MNP between networks in the same country. It is in response to a study mandate agreed between the European Commission and ETSI under order voucher ETSI/97/M-251.

SDO (2)	Document No.	Version	Status	Issued date	Location (1)
<b>Release 99</b>					
ETSI	ETSI TS 122 066	3.2.0	Published	22/08/2000	<a href="http://pda.etsi.org/pda/home.asp?wkr=RTS/TSGS-0122066UR2">http://pda.etsi.org/pda/home.asp?wkr=RTS/TSGS-0122066UR2</a>
<b>Release 4</b>					
ETSI	ETSI TS 122 066	4.0.0	Published	25/04/2001	<a href="http://pda.etsi.org/pda/home.asp?wkr=RTS/TSGS-0122066Uv4">http://pda.etsi.org/pda/home.asp?wkr=RTS/TSGS-0122066Uv4</a>
<b>Release 5</b>					
ETSI	ETSI TS 122 066	5.1.0	Published	01/07/2003	<a href="http://pda.etsi.org/pda/home.asp?wkr=RTS/TSGS-0122066v510">http://pda.etsi.org/pda/home.asp?wkr=RTS/TSGS-0122066v510</a>

### 5.3.2.8.20 TS 22.067

#### Priority set-up service - Stage 1 (ASCI spec)

This specification describes the Stage 1 description of the enhanced multi-level precedence and pre-emption (eMLPP) service. This service has two parts: precedence and pre-emption. Precedence involves assigning a priority level to a call in combination with fast call set-up. Pre-emption involves the seizing of resources, which are in use by a call of a lower precedence, by a higher level precedence call in the absence of idle resources. Pre-emption can also involve the disconnection of an on-going call of lower precedence to accept an incoming call of higher precedence.

SDO (2)	Document No.	Version	Status	Issued date	Location (1)
<b>Release 99</b>					
ETSI	ETSI TS 122 067	3.0.1	Published	01/02/2000	<a href="http://pda.etsi.org/pda/home.asp?wkr=DTS/TSGS-0122067U">http://pda.etsi.org/pda/home.asp?wkr=DTS/TSGS-0122067U</a>
<b>Release 4</b>					
ETSI	ETSI TS 122 067	4.1.0	Published	08/04/2002	<a href="http://pda.etsi.org/pda/home.asp?wkr=RTS/TSGS-0122067Uv4R1">http://pda.etsi.org/pda/home.asp?wkr=RTS/TSGS-0122067Uv4R1</a>
<b>Release 5</b>					
ETSI	ETSI TS 122 067	5.0.0	Published	30/07/2002	<a href="http://pda.etsi.org/pda/home.asp?wkr=RTS/TSGS-0122067v500">http://pda.etsi.org/pda/home.asp?wkr=RTS/TSGS-0122067v500</a>

### 5.3.2.8.21 TS 22.071

#### Location services (LCS) - Stage 1

LCS is a network provided enabling technology consisting of standardized service capabilities which enables the provision of location applications. This application may be service provider specific. The description of the numerous and varied possible location applications which are enabled by this technology are outside the scope of this specification. However, clarifying examples of how the functionality being specified may be used to provide specific LCS is included in various sections of the specification.

SDO (2)	Document No.	Version	Status	Issued date	Location (1)
<b>Release 99</b>					
ETSI	ETSI TS 122 071	3.4.0	Published	08/04/2002	<a href="http://pda.etsi.org/pda/home.asp?wkr=RTS/TSGS-0122071UR2">http://pda.etsi.org/pda/home.asp?wkr=RTS/TSGS-0122071UR2</a>
<b>Release 4</b>					
ETSI	ETSI TS 122 071	4.5.0	Published	03/10/2003	<a href="http://pda.etsi.org/pda/home.asp?wkr=RTS/TSGS-0122071v450">http://pda.etsi.org/pda/home.asp?wkr=RTS/TSGS-0122071v450</a>
<b>Release 5</b>					
ETSI	ETSI TS 122 071	5.3.0	Published	08/01/2004	<a href="http://pda.etsi.org/pda/home.asp?wkr=RTS/TSGS-0122071v530">http://pda.etsi.org/pda/home.asp?wkr=RTS/TSGS-0122071v530</a>
<b>Release 6</b>					
ETSI	ETSI TS 122 071	6.6.0	Awaiting		<a href="http://pda.etsi.org/pda/home.asp?wkr=RTS/TSGS-0122071v660">http://pda.etsi.org/pda/home.asp?wkr=RTS/TSGS-0122071v660</a>

### 5.3.2.8.22 TS 22.072

#### Call deflection (CD) - Stage 1

CD enables the served mobile subscriber to respond to an incoming call offered by the network by requesting redirection of this call to another number specified in the response. The CD supplementary service can only be invoked before the connection is established by the served mobile subscriber, i.e. in response to the offered call, or during the period that the served subscriber is being informed of the call. The served subscriber's ability to originate calls is unaffected by the CD supplementary service.

SDO (2)	Document No.	Version	Status	Issued date	Location (1)
<b>Release 99</b>					
ETSI	ETSI TS 122 072	3.0.1	Published	01/02/2000	<a href="http://pda.etsi.org/pda/home.asp?wkr=DTS/TSGS-0122072U">http://pda.etsi.org/pda/home.asp?wkr=DTS/TSGS-0122072U</a>
<b>Release 4</b>					
ETSI	ETSI TS 122 072	4.0.0	Published	03/05/2001	<a href="http://pda.etsi.org/pda/home.asp?wkr=RTS/TSGS-0122072Uv4">http://pda.etsi.org/pda/home.asp?wkr=RTS/TSGS-0122072Uv4</a>

**Release 5**

ETSI	ETSI TS 122 072	5.0.0	Published	25/07/2002	<a href="http://pda.etsi.org/pda/home.asp?wkr=RTS/TSGS-0122072v500">http://pda.etsi.org/pda/home.asp?wkr=RTS/TSGS-0122072v500</a>
------	-----------------	-------	-----------	------------	-----------------------------------------------------------------------------------------------------------------------------------

**5.3.2.8.23 TS 22.078****Customized applications for mobile network enhanced logic (CAMEL) - Stage 1**

This specification describes the Stage 1 description for CAMEL feature which provides the mechanisms to support services consistently independently of the serving network. The CAMEL features shall facilitate service control of operator specific services external from the serving network. The CAMEL feature is a network feature and not a supplementary service. It is a tool to help the network operator to provide the subscribers with the operator specific services even when roaming outside the home network.

SDO (2)	Document No.	Version	Status	Issued date	Location (1)
<b>Release 99</b>					
ETSI	ETSI TS 122 078	3.9.0	Published	09/04/2002	<a href="http://pda.etsi.org/pda/home.asp?wkr=RTS/TSGS-0122078UR7">http://pda.etsi.org/pda/home.asp?wkr=RTS/TSGS-0122078UR7</a>
<b>Release 4</b>					
ETSI	ETSI TS 122 078	4.5.0	Published	09/04/2002	<a href="http://pda.etsi.org/pda/home.asp?wkr=RTS/TSGS-0122078Uv4R3">http://pda.etsi.org/pda/home.asp?wkr=RTS/TSGS-0122078Uv4R3</a>
<b>Release 5</b>					
ETSI	ETSI TS 122 078	5.12.0	Published	13/01/2004	<a href="http://pda.etsi.org/pda/home.asp?wkr=RTS/TSGS-0122078v5c0">http://pda.etsi.org/pda/home.asp?wkr=RTS/TSGS-0122078v5c0</a>

**5.3.2.8.24 TS 22.079****Support of optimal routing - Stage 1**

Support of optimal routing is a network feature to reduce the number of unnecessary inter-network call legs when the subscriber is roaming.

SDO (2)	Document No.	Version	Status	Issued date	Location (1)
<b>Release 99</b>					
ETSI	ETSI TS 122 079	3.0.1	Published	01/02/2000	<a href="http://pda.etsi.org/pda/home.asp?wkr=DTS/TSGS-0122079U">http://pda.etsi.org/pda/home.asp?wkr=DTS/TSGS-0122079U</a>
<b>Release 4</b>					
ETSI	ETSI TS 122 079	4.0.0	Published	25/04/2001	<a href="http://pda.etsi.org/pda/home.asp?wkr=RTS/TSGS-0122079Uv4">http://pda.etsi.org/pda/home.asp?wkr=RTS/TSGS-0122079Uv4</a>
<b>Release 5</b>					
ETSI	ETSI TS 122 079	5.0.0	Published	26/07/2002	<a href="http://pda.etsi.org/pda/home.asp?wkr=RTS/TSGS-0122079v500">http://pda.etsi.org/pda/home.asp?wkr=RTS/TSGS-0122079v500</a>

**5.3.2.8.25 TS 22.081****Line identification supplementary services - Stage 1**

This specification describes the supplementary services belonging to the group line identification supplementary services. The group of line identification supplementary services is divided into the following four supplementary services: CLIP: calling line identification presentation (clause 1); CLIR: calling line identification restriction (clause 2); COLP: connected line identification presentation (clause 3); COLR: connected line identification restriction (clause 4).

SDO (2)	Document No.	Version	Status	Issued date	Location (1)
<b>Release 99</b>					
ETSI	ETSI TS 122 081	3.2.0	Published	22/08/2000	<a href="http://pda.etsi.org/pda/home.asp?wkr=RTS/TSGS-0122081UR1">http://pda.etsi.org/pda/home.asp?wkr=RTS/TSGS-0122081UR1</a>
<b>Release 4</b>					
ETSI	ETSI TS 122 081	4.1.0	Published	08/04/2002	<a href="http://pda.etsi.org/pda/home.asp?wkr=RTS/TSGS-0122081Uv4R1">http://pda.etsi.org/pda/home.asp?wkr=RTS/TSGS-0122081Uv4R1</a>
<b>Release 5</b>					
ETSI	ETSI TS 122 081	5.0.0	Published	25/07/2002	<a href="http://pda.etsi.org/pda/home.asp?wkr=RTS/TSGS-0122081v500">http://pda.etsi.org/pda/home.asp?wkr=RTS/TSGS-0122081v500</a>

### 5.3.2.8.26 TS 22.082

#### Call forwarding (CF) supplementary services - Stage 1

This specification describes the supplementary services belonging to the group call offering supplementary services. The group of supplementary services call offering supplementary services is divided into four different supplementary services: - call forwarding unconditional (clause 1); - call forwarding on mobile subscriber busy (clause 2); - call forwarding on no reply (clause 3); - call forwarding on mobile subscriber not reachable (clause 4).

SDO (2)	Document No.	Version	Status	Issued date	Location (1)
<b>Release 99</b>					
ETSI	ETSI TS 122 082	3.0.1	Published		<a href="http://pda.etsi.org/pda/home.asp?wkr=DTS/TSGS-0122082U">http://pda.etsi.org/pda/home.asp?wkr=DTS/TSGS-0122082U</a>
<b>Release 4</b>					
ETSI	ETSI TS 122 082	4.2.0	Published	08/04/2002	<a href="http://pda.etsi.org/pda/home.asp?wkr=RTS/TSGS-0122082Uv4R2">http://pda.etsi.org/pda/home.asp?wkr=RTS/TSGS-0122082Uv4R2</a>
<b>Release 5</b>					
ETSI	ETSI TS 122 082	5.0.0	Published	30/07/2002	<a href="http://pda.etsi.org/pda/home.asp?wkr=RTS/TSGS-0122082v500">http://pda.etsi.org/pda/home.asp?wkr=RTS/TSGS-0122082v500</a>

### 5.3.2.8.27 TS 2.083

#### Call waiting (CW) and call hold (HOLD) supplementary services - Stage 1

This specification describes the supplementary services belonging to the group call completion supplementary services which are divided into the following two supplementary services: - call waiting (clause 1); - call hold (clause 2).

SDO (2)	Document No.	Version	Status	Issued date	Location (1)
<b>Release 99</b>					
ETSI	ETSI TS 122 083	3.0.1	Published	01/02/2000	<a href="http://pda.etsi.org/pda/home.asp?wkr=DTS/TSGS-0122083U">http://pda.etsi.org/pda/home.asp?wkr=DTS/TSGS-0122083U</a>
<b>Release 4</b>					
ETSI	ETSI TS 122 083	4.1.0	Published	08/04/2002	<a href="http://pda.etsi.org/pda/home.asp?wkr=RTS/TSGS-0122083Uv4R1">http://pda.etsi.org/pda/home.asp?wkr=RTS/TSGS-0122083Uv4R1</a>
<b>Release 5</b>					
ETSI	ETSI TS 122 083	5.0.0	Published	25/07/2002	<a href="http://pda.etsi.org/pda/home.asp?wkr=RTS/TSGS-0122083v500">http://pda.etsi.org/pda/home.asp?wkr=RTS/TSGS-0122083v500</a>

**5.3.2.8.28** TS 22.084**Multiparty (MPTY) supplementary service - Stage 1**

This supplementary service provides a mobile subscriber with the ability to have a multi-connection call, i.e. a simultaneous communication with more than one party.

SDO (2)	Document No.	Version	Status	Issued date	Location (1)
<b>Release 99</b>					
ETSI	ETSI TS 122 084	3.0.1	Published	01/02/2000	<a href="http://pda.etsi.org/pda/home.asp?wkr=DTS/TSGS-0122084U">http://pda.etsi.org/pda/home.asp?wkr=DTS/TSGS-0122084U</a>
<b>Release 4</b>					
ETSI	ETSI TS 122 084	4.1.0	Published	08/04/2002	<a href="http://pda.etsi.org/pda/home.asp?wkr=RTS/TSGS-0122084Uv4R1">http://pda.etsi.org/pda/home.asp?wkr=RTS/TSGS-0122084Uv4R1</a>
<b>Release 5</b>					
ETSI	ETSI TS 122 084	5.0.0	Published	26/07/2002	<a href="http://pda.etsi.org/pda/home.asp?wkr=RTS/TSGS-0122084v500">http://pda.etsi.org/pda/home.asp?wkr=RTS/TSGS-0122084v500</a>

**5.3.2.8.29** TS 22.085**Closed user group (CUG) supplementary services - Stage 1**

The CUG supplementary service enables subscribers, connected to a network and possibly also other networks, to form CUGs to and from which access is restricted. A specific user may be a member of one or more CUGs. Members of a specific CUG can communicate among each other but not, in general, with users outside the group.

SDO (2)	Document No.	Version	Status	Issued date	Location (1)
<b>Release 99</b>					
ETSI	ETSI TS 122 085	3.1.0	Published	01/02/2000	<a href="http://pda.etsi.org/pda/home.asp?wkr=DTS/TSGS-0122085U">http://pda.etsi.org/pda/home.asp?wkr=DTS/TSGS-0122085U</a>
<b>Release 4</b>					
ETSI	ETSI TS 122 085	4.1.0	Published	08/04/2002	<a href="http://pda.etsi.org/pda/home.asp?wkr=RTS/TSGS-0122085Uv4R1">http://pda.etsi.org/pda/home.asp?wkr=RTS/TSGS-0122085Uv4R1</a>
<b>Release 5</b>					
ETSI	ETSI TS 122 085	5.0.0	Published	26/07/2002	<a href="http://pda.etsi.org/pda/home.asp?wkr=RTS/TSGS-0122085v500">http://pda.etsi.org/pda/home.asp?wkr=RTS/TSGS-0122085v500</a>

**5.3.2.8.30** TS 22.086**Advice of charge (AoC) supplementary services - Stage 1**

These services are designed to supply to a mobile user sufficient information to allow a real-time estimate to be made of the bill which will eventually be levied in the home public land mobile network (PLMN) on the mobile station subscriber.

SDO (2)	Document No.	Version	Status	Issued date	Location (1)
<b>Release 99</b>					
ETSI	ETSI TS 122 086	3.1.0	Published	17/05/2000	<a href="http://pda.etsi.org/pda/home.asp?wkr=DTS/TSGS-0122086U">http://pda.etsi.org/pda/home.asp?wkr=DTS/TSGS-0122086U</a>
<b>Release 4</b>					
ETSI	ETSI TS 122 086	4.0.0	Published	25/04/2001	<a href="http://pda.etsi.org/pda/home.asp?wkr=RTS/TSGS-0122086Uv4">http://pda.etsi.org/pda/home.asp?wkr=RTS/TSGS-0122086Uv4</a>

**Release 5**

ETSI	ETSI TS 122 086	5.0.0	Published	26/07/2002	<a href="http://pda.etsi.org/pda/home.asp?wkr=RTS/TSGS-0122086v500">http://pda.etsi.org/pda/home.asp?wkr=RTS/TSGS-0122086v500</a>
------	-----------------	-------	-----------	------------	-----------------------------------------------------------------------------------------------------------------------------------

**5.3.2.8.31 TS 22.087****User-to-user signalling (UUS) - Stage 1**

The UUS supplementary service allows a mobile subscriber to send/receive a limited amount of information to/from another network or ISDN subscriber over the signalling channel in association with a call to the other subscriber.

<b>SDO (2)</b>	<b>Document No.</b>	<b>Version</b>	<b>Status</b>	<b>Issued date</b>	<b>Location (1)</b>
<b>Release 99</b>					
ETSI	ETSI TS 122 087	3.1.0	Published	17/05/2000	<a href="http://pda.etsi.org/pda/home.asp?wkr=RTS/TSGS-0122087UR1">http://pda.etsi.org/pda/home.asp?wkr=RTS/TSGS-0122087UR1</a>
<b>Release 4</b>					
ETSI	ETSI TS 122 087	4.0.0	Published	25/04/2001	<a href="http://pda.etsi.org/pda/home.asp?wkr=RTS/TSGS-0122087Uv4">http://pda.etsi.org/pda/home.asp?wkr=RTS/TSGS-0122087Uv4</a>
<b>Release 5</b>					
ETSI	ETSI TS 122 087	5.0.0	Published	26/07/2002	<a href="http://pda.etsi.org/pda/home.asp?wkr=RTS/TSGS-0122087v500">http://pda.etsi.org/pda/home.asp?wkr=RTS/TSGS-0122087v500</a>

**5.3.2.8.32 TS 22.088****Call barring (CB) supplementary services - Stage 1**

The call restriction supplementary services allow the possibility for a mobile subscriber to have barring of certain categories of outgoing or incoming calls at the mobile subscribers access. The group of call restriction services includes two supplementary services: - barring of outgoing calls; - barring of incoming calls. By use of subscription options, the mobile subscriber can at provision time select a set of one or more barring programs to determine the categories of calls to be barred. The following categories are defined: - all outgoing calls; - outgoing international calls; - outgoing international calls except those directed to the home PLMN country; - all incoming calls; - incoming calls when roaming outside the home PLMN country.

<b>SDO (2)</b>	<b>Document No.</b>	<b>Version</b>	<b>Status</b>	<b>Issued date</b>	<b>Location (1)</b>
<b>Release 99</b>					
ETSI	ETSI TS 122 088	3.0.2	Published	25/04/2001	<a href="http://pda.etsi.org/pda/home.asp?wkr=RTS/TSGS-0122088UR1">http://pda.etsi.org/pda/home.asp?wkr=RTS/TSGS-0122088UR1</a>
<b>Release 4</b>					
ETSI	ETSI TS 122 088	4.1.0	Published	08/04/2002	<a href="http://pda.etsi.org/pda/home.asp?wkr=RTS/TSGS-0122088Uv4R1">http://pda.etsi.org/pda/home.asp?wkr=RTS/TSGS-0122088Uv4R1</a>
<b>Release 5</b>					
ETSI	ETSI TS 122 088	5.0.0	Published	26/07/2002	<a href="http://pda.etsi.org/pda/home.asp?wkr=RTS/TSGS-0122088v500">http://pda.etsi.org/pda/home.asp?wkr=RTS/TSGS-0122088v500</a>

**5.3.2.8.33** TS 22.090**Unstructured supplementary service data (USSD) - Stage 1**

There are two modes of USSD: MMI-mode and application mode. MMI-mode USSD is for the transparent transport of MMI strings entered by the user to the network and for the transparent transport of text strings from the network that are displayed by the mobile for user information. Application mode USSD is for the transparent transport of data between the network and the mobile station. Application mode USSD is intended to be used by applications in the network and their peer applications in the UE. The communication over the radio interface takes place on the signalling channels using short dialogues with peak data throughput rate capabilities of up to approximately 600 bit/s outside of a call and 1 000 bit/s during a call.

SDO (2)	Document No.	Version	Status	Issued date	Location (1)
<b>Release 99</b>					
ETSI	ETSI TS 122 090	3.1.0	Published	17/05/2000	<a href="http://pda.etsi.org/pda/home.asp?wkr=RTS/TSGS-0122090UR1">http://pda.etsi.org/pda/home.asp?wkr=RTS/TSGS-0122090UR1</a>
<b>Release 4</b>					
ETSI	ETSI TS 122 090	4.0.0	Published	25/04/2001	<a href="http://pda.etsi.org/pda/home.asp?wkr=RTS/TSGS-0122090Uv4">http://pda.etsi.org/pda/home.asp?wkr=RTS/TSGS-0122090Uv4</a>
<b>Release 5</b>					
ETSI	ETSI TS 122 090	5.0.0	Published	30/07/2002	<a href="http://pda.etsi.org/pda/home.asp?wkr=RTS/TSGS-0122090v500">http://pda.etsi.org/pda/home.asp?wkr=RTS/TSGS-0122090v500</a>

**5.3.2.8.34** TS 22.091**Explicit call transfer (ECT) supplementary service - Stage 1**

The ECT supplementary service enables the served mobile subscriber (subscriber A) who has two calls, each of which can be an incoming or outgoing call, to connect the other parties in the two calls and release the served mobile subscribers own connection.

SDO (2)	Document No.	Version	Status	Issued date	Location (1)
<b>Release 99</b>					
ETSI	ETSI TS 122 091	3.1.0	Published	07/11/2000	<a href="http://pda.etsi.org/pda/home.asp?wkr=RTS/TSGS-0122091UR1">http://pda.etsi.org/pda/home.asp?wkr=RTS/TSGS-0122091UR1</a>
<b>Release 4</b>					
ETSI	ETSI TS 122 091	4.0.0	Published	25/04/2001	<a href="http://pda.etsi.org/pda/home.asp?wkr=RTS/TSGS-0122091Uv4">http://pda.etsi.org/pda/home.asp?wkr=RTS/TSGS-0122091Uv4</a>
<b>Release 5</b>					
ETSI	ETSI TS 122 091	5.0.0	Published	30/07/2002	<a href="http://pda.etsi.org/pda/home.asp?wkr=RTS/TSGS-0122091v500">http://pda.etsi.org/pda/home.asp?wkr=RTS/TSGS-0122091v500</a>

**5.3.2.8.35** TS 22.093**Call completion to busy subscriber (CCBS) - Stage 1**

In the situation when subscriber A encounters a network determined user busy (NDUB) destination B, the subscriber A can request the CCBS supplementary service (i.e. activate a CCBS request against destination B). The network will then monitor the wanted destination B for becoming idle. When the wanted destination B becomes idle, then the network will wait a short time in order to allow destination B to make an outgoing call. If destination B does not make any outgoing call within this time, then the network shall automatically recall subscriber A.



SDO (2)	Document No.	Version	Status	Issued date	Location (1)
<b>Release 99</b>					
ETSI	ETSI TS 122 093	3.0.1	Published	01/02/2000	<a href="http://pda.etsi.org/pda/home.asp?wkr=DTS/TSGS-0122093U">http://pda.etsi.org/pda/home.asp?wkr=DTS/TSGS-0122093U</a>
<b>Release 4</b>					
ETSI	ETSI TS 122 093	4.0.0	Published	25/04/2001	<a href="http://pda.etsi.org/pda/home.asp?wkr=RTS/TSGS-0122093Uv4">http://pda.etsi.org/pda/home.asp?wkr=RTS/TSGS-0122093Uv4</a>
<b>Release 5</b>					
ETSI	ETSI TS 122 093	5.0.0	Published	30/07/2002	<a href="http://pda.etsi.org/pda/home.asp?wkr=RTS/TSGS-0122093v500">http://pda.etsi.org/pda/home.asp?wkr=RTS/TSGS-0122093v500</a>

### 5.3.2.8.36 TS 22.096

#### Calling name presentation (CNAP) - Stage 1

The CNAP supplementary service enables the called party to receive the calling name information of the calling party.

SDO (2)	Document No.	Version	Status	Issued date	Location (1)
<b>Release 99</b>					
ETSI	ETSI TS 122 096	3.0.1	Published	01/02/2000	<a href="http://pda.etsi.org/pda/home.asp?wkr=DTS/TSGS-0122096U">http://pda.etsi.org/pda/home.asp?wkr=DTS/TSGS-0122096U</a>
<b>Release 4</b>					
ETSI	ETSI TS 122 096	4.0.0	Published	25/04/2001	<a href="http://pda.etsi.org/pda/home.asp?wkr=RTS/TSGS-0122096Uv4">http://pda.etsi.org/pda/home.asp?wkr=RTS/TSGS-0122096Uv4</a>
<b>Release 5</b>					
ETSI	ETSI TS 122 096	5.0.0	Published	30/07/2002	<a href="http://pda.etsi.org/pda/home.asp?wkr=RTS/TSGS-0122096v500">http://pda.etsi.org/pda/home.asp?wkr=RTS/TSGS-0122096v500</a>

### 5.3.2.8.37 TS 22.097

#### Multiple subscriber profile (MSP) - Stage 1

MSP is an optional service to enable mobile subscribers to have several profiles associated with a single subscriber identity (SIM) and a single international mobile subscriber identity (IMSI), with each profile being a subscription option. Each profile may be used for mobile originated and mobile terminated calls. Up to four different profiles can be provisioned against a subscriber using the MSP feature. This will allow the subscriber to separate her telecommunication service needs into different identities (e.g. business and home).

SDO (2)	Document No.	Version	Status	Issued date	Location (1)
<b>Release 99</b>					
ETSI	ETSI TS 122 097	3.2.0	Published	07/11/2000	<a href="http://pda.etsi.org/pda/home.asp?wkr=RTS/TSGS-0122097UR1">http://pda.etsi.org/pda/home.asp?wkr=RTS/TSGS-0122097UR1</a>
<b>Release 4</b>					
ETSI	ETSI TS 122 097	4.1.0	Published	08/04/2002	<a href="http://pda.etsi.org/pda/home.asp?wkr=RTS/TSGS-0122097Uv4R1">http://pda.etsi.org/pda/home.asp?wkr=RTS/TSGS-0122097Uv4R1</a>
<b>Release 5</b>					
ETSI	ETSI TS 122 097	5.0.0	Published	25/07/2002	<a href="http://pda.etsi.org/pda/home.asp?wkr=RTS/TSGS-0122097v500">http://pda.etsi.org/pda/home.asp?wkr=RTS/TSGS-0122097v500</a>

**5.3.2.8.38** TS 22.100**UMTS phase 1 capabilities**

This specification describes contains how the definition of the UMTS system will be achieved in a phased approach. This document also specifies the requirements for release 99 of UMTS. Some requirements which are necessary to ensure a smooth transition to later releases are also indicated. This document should, however, be read in conjunction with the other 22.000 series documents which provide a complete description of the requirements for UMTS release 1999 and beyond.

SDO (2)	Document No.	Version	Status	Issued date	Location (1)
<b>Release 99</b>					
ETSI	ETSI TS 122 100	3.7.0	Published	10/10/2001	<a href="http://pda.etsi.org/pda/home.asp?wkr=RTS/TSGS-0122100UR2">http://pda.etsi.org/pda/home.asp?wkr=RTS/TSGS-0122100UR2</a>

**5.3.2.8.39** TS 22.101**UMTS service principles**

This specification describes the service principles of the UMTS.

SDO (2)	Document No.	Version	Status	Issued date	Location (1)
<b>Release 99</b>					
ETSI	ETSI TS 122 101	3.16.0	Published	08/01/2004	<a href="http://pda.etsi.org/pda/home.asp?wkr=RTS/TSGS-0122101v3g0">http://pda.etsi.org/pda/home.asp?wkr=RTS/TSGS-0122101v3g0</a>
<b>Release 4</b>					
ETSI	ETSI TS 122 101	4.9.0	Published	08/01/2004	<a href="http://pda.etsi.org/pda/home.asp?wkr=RTS/TSGS-0122101v490">http://pda.etsi.org/pda/home.asp?wkr=RTS/TSGS-0122101v490</a>
<b>Release 5</b>					
ETSI	ETSI TS 122 101	5.12.0	Published	08/01/2004	<a href="http://pda.etsi.org/pda/home.asp?wkr=RTS/TSGS-0122101v5c0">http://pda.etsi.org/pda/home.asp?wkr=RTS/TSGS-0122101v5c0</a>
<b>Release 6</b>					
ETSI	ETSI TS 122 101	6.6.0	Awaiting		<a href="http://pda.etsi.org/pda/home.asp?wkr=RTS/TSGS-0122101v660">http://pda.etsi.org/pda/home.asp?wkr=RTS/TSGS-0122101v660</a>

**5.3.2.8.40** TS 22.105**Services and service capabilities**

Pre-UMTS systems have largely standardized the complete sets of bearer services, teleservices and supplementary services which they provide. One major difference between UMTS and pre-UMTS systems is that service capabilities rather than services are standardized for UMTS, allowing service differentiation and system continuity. This document describes how and what kind of services the UMTS user has access to.

SDO (2)	Document No.	Version	Status	Issued date	Location (1)
<b>Release 99</b>					
ETSI	ETSI TS 122 105	3.10.0	Published	13/02/2001	<a href="http://pda.etsi.org/pda/home.asp?wkr=RTS/TSGS-0122105UR3">http://pda.etsi.org/pda/home.asp?wkr=RTS/TSGS-0122105UR3</a>
<b>Release 4</b>					
ETSI	ETSI TS 122 105	4.3.0	Published	09/04/2002	<a href="http://pda.etsi.org/pda/home.asp?wkr=RTS/TSGS-0122105Uv4R1">http://pda.etsi.org/pda/home.asp?wkr=RTS/TSGS-0122105Uv4R1</a>
<b>Release 5</b>					
ETSI	ETSI TS 122 105	5.2.0	Published	16/07/2002	<a href="http://pda.etsi.org/pda/home.asp?wkr=RTS/TSGS-0122105v520">http://pda.etsi.org/pda/home.asp?wkr=RTS/TSGS-0122105v520</a>

**5.3.2.8.41** TS 22.115**Service aspects: charging and billing**

This specification describes the service aspects of charging and billing of the UMTS. This standard is not intended to duplicate existing standards or standards being developed by other groups on these topics, and will reference these where appropriate. This standard will elaborate on the charging requirements described in the charging principles in TS 22.101 UMTS service principles. It will allow the generation of accurate charging information to be used in the commercial and contractual relationships between the parties concerned.

SDO (2)	Document No.	Version	Status	Issued date	Location (1)
<b>Release 99</b>					
ETSI	ETSI TS 122 115	3.4.0	Published	08/01/2004	<a href="http://pda.etsi.org/pda/home.asp?wkr=RTS/TSGS-0122115v340">http://pda.etsi.org/pda/home.asp?wkr=RTS/TSGS-0122115v340</a>
<b>Release 4</b>					
ETSI	ETSI TS 122 115	4.1.0	Published	08/01/2004	<a href="http://pda.etsi.org/pda/home.asp?wkr=RTS/TSGS-0122115v410">http://pda.etsi.org/pda/home.asp?wkr=RTS/TSGS-0122115v410</a>
<b>Release 5</b>					
ETSI	ETSI TS 122 115	5.4.0	Published	08/01/2004	<a href="http://pda.etsi.org/pda/home.asp?wkr=RTS/TSGS-0122115v540">http://pda.etsi.org/pda/home.asp?wkr=RTS/TSGS-0122115v540</a>

**5.3.2.8.42** TS 22.121**Virtual home environment (VHE)**

This specification describes the content of the Stage 1 requirement for realization of VHE. VHE is defined as a concept for personal service environment (PSE) portability across network boundaries and between terminals. The concept of the VHE is such that users are consistently presented with the same personalized features, user interface customization and services in whatever network and whatever terminal (within the capabilities of the terminal and the network), wherever the user may be located. A key feature to support VHE is the ability to build services using a standardized application interface.

SDO (2)	Document No.	Version	Status	Issued date	Location (1)
<b>Release 99</b>					
ETSI	ETSI TR 122 121	3.3.1	Published	30/07/2002	<a href="http://pda.etsi.org/pda/home.asp?wkr=RTR/TSGS-0122121v331">http://pda.etsi.org/pda/home.asp?wkr=RTR/TSGS-0122121v331</a>
<b>Release 4</b>					
ETSI	ETSI TR 122 121	4.1.1	Published	30/07/2002	<a href="http://pda.etsi.org/pda/home.asp?wkr=RTR/TSGS-0122121v411">http://pda.etsi.org/pda/home.asp?wkr=RTR/TSGS-0122121v411</a>
<b>Release 5</b>					
ETSI	ETSI TR 122 121	5.3.1	Published	30/07/2002	<a href="http://pda.etsi.org/pda/home.asp?wkr=RTR/TSGS-0122121v531">http://pda.etsi.org/pda/home.asp?wkr=RTR/TSGS-0122121v531</a>

**5.3.2.8.43** TS 22.129**Handover requirements between UMTS and GSM or other radio systems**

This specification describes service requirements for handover (terms are defined below) within UMTS systems and between UMTS, other IMT-2000 family members and second generation systems. Particular emphasis has been placed on the description of requirements for handover between UMTS and GSM but requirements specific to other systems are incorporated as required.

## 250

## Rec. ITU-R M.1457-4

SDO (2)	Document No.	Version	Status	Issued date	Location (1)
<b>Release 99</b>					
ETSI	ETSI TS 122 129	3.6.0	Published	15/01/2002	<a href="http://pda.etsi.org/pda/home.asp?wkr=RTS/TSGS-0122129UR4">http://pda.etsi.org/pda/home.asp?wkr=RTS/TSGS-0122129UR4</a>
<b>Release 4</b>					
ETSI	ETSI TS 122 129	4.4.0	Published	15/01/2002	<a href="http://pda.etsi.org/pda/home.asp?wkr=RTS/TSGS-0122129Uv4R2">http://pda.etsi.org/pda/home.asp?wkr=RTS/TSGS-0122129Uv4R2</a>
<b>Release 5</b>					
ETSI	ETSI TS 122 129	5.2.0	Published	16/07/2002	<a href="http://pda.etsi.org/pda/home.asp?wkr=RTS/TSGS-0122129v520">http://pda.etsi.org/pda/home.asp?wkr=RTS/TSGS-0122129v520</a>

### 5.3.2.8.44 TS 22.135

#### Multicall

This specification describes multicall scenarios and requirements for UMTS phase 1 release 1999. Multicall feature specifies functionality and interactions related to usage of several simultaneous bearers between a terminal and a network. Multicall features allows both circuit-switched call(s) and packet session(s) to exist simultaneously.

SDO (2)	Document No.	Version	Status	Issued date	Location (1)
<b>Release 99</b>					
ETSI	ETSI TS 122 135	3.4.0	Published	07/11/2000	<a href="http://pda.etsi.org/pda/home.asp?wkr=RTS/TSGS-0122135UR3">http://pda.etsi.org/pda/home.asp?wkr=RTS/TSGS-0122135UR3</a>
<b>Release 4</b>					
ETSI	ETSI TS 122 135	4.2.0	Published	19/12/2002	<a href="http://pda.etsi.org/pda/home.asp?wkr=RTS/TSGS-0122135v420">http://pda.etsi.org/pda/home.asp?wkr=RTS/TSGS-0122135v420</a>
<b>Release 5</b>					
ETSI	ETSI TS 122 135	5.0.0	Published	25/07/2002	<a href="http://pda.etsi.org/pda/home.asp?wkr=RTS/TSGS-0122135v500">http://pda.etsi.org/pda/home.asp?wkr=RTS/TSGS-0122135v500</a>

### 5.3.2.8.45 TR 22.971

#### Automatic establishment of roaming relations

This report describes a proposed framework for commercial and technical interworking between UMTS home environments and serving networks who have no direct prior commercial agreements with each other. This text is applicable to UMTS standardization within ETSI, and is produced with the intent to clarify the concepts involved, and identify those areas which require standardization.

SDO (2)	Document No.	Version	Status	Issued date	Location (1)
<b>Release 99</b>					
ETSI	ETSI TR 122 971	3.1.1	Published	01/02/2000	<a href="http://pda.etsi.org/pda/home.asp?wkr=DTR/TSGS-0122971U">http://pda.etsi.org/pda/home.asp?wkr=DTR/TSGS-0122971U</a>

### 5.3.2.8.46 TR 22.975

#### Advanced addressing

This report describes the requirements for numbering and addressing for UMTS. This technical report is aimed at generating discussion and should be agreed with ETSI WG NA2. The responsibility for developing of numbering and addressing schemes for all networks being in ETSI NA2.

SDO (2)	Document No.	Version	Status	Issued date	Location (1)
<b>Release 99</b>					
ETSI	ETSI TR 122 975	3.1.0	Published	01/02/2000	<a href="http://pda.etsi.org/pda/home.asp?wkr=DTR/TSGS-0122975U">http://pda.etsi.org/pda/home.asp?wkr=DTR/TSGS-0122975U</a>

### 5.3.2.8.47 TS 21.133

#### Security threats and requirements

Detailed security requirements.

SDO (2)	Document No.	Version	Status	Issued date	Location (1)
<b>Release 99</b>					
ETSI	ETSI TS 121 133	3.2.0	Published	14/01/2002	<a href="http://pda.etsi.org/pda/home.asp?wkr=RTS/TSGS-0321133UR1">http://pda.etsi.org/pda/home.asp?wkr=RTS/TSGS-0321133UR1</a>
<b>Release 4</b>					
ETSI	ETSI TS 121 133	4.1.0	Published	14/01/2002	<a href="http://pda.etsi.org/pda/home.asp?wkr=RTS/TSGS-0321133Uv4R1">http://pda.etsi.org/pda/home.asp?wkr=RTS/TSGS-0321133Uv4R1</a>

### 5.3.2.8.48 TS 33.102

#### Security architecture

Provides a specification of all security mechanisms and protocols, except algorithms.

SDO (2)	Document No.	Version	Status	Issued date	Location (1)
<b>Release 99</b>					
ETSI	ETSI TS 133 102	3.13.0	Published	03/01/2003	<a href="http://pda.etsi.org/pda/home.asp?wkr=RTS/TSGS-0333102v3d0">http://pda.etsi.org/pda/home.asp?wkr=RTS/TSGS-0333102v3d0</a>
<b>Release 4</b>					
ETSI	ETSI TS 133 102	4.5.0	Published	03/01/2003	<a href="http://pda.etsi.org/pda/home.asp?wkr=RTS/TSGS-0333102v450">http://pda.etsi.org/pda/home.asp?wkr=RTS/TSGS-0333102v450</a>
<b>Release 5</b>					
ETSI	ETSI TS 133 102	5.3.0	Published	03/10/2003	<a href="http://pda.etsi.org/pda/home.asp?wkr=RTS/TSGS-0333102v530">http://pda.etsi.org/pda/home.asp?wkr=RTS/TSGS-0333102v530</a>

### 5.3.2.8.49 TS 33.103

#### Security integration guidelines

SDO (2)	Document No.	Version	Status	Issued date	Location (1)
<b>Release 99</b>					
ETSI	ETSI TS 133 103	3.7.0	Published	19/10/2001	<a href="http://pda.etsi.org/pda/home.asp?wkr=RTS/TSGS-0333103UR6">http://pda.etsi.org/pda/home.asp?wkr=RTS/TSGS-0333103UR6</a>
<b>Release 4</b>					
ETSI	ETSI TS 133 103	4.2.0	Published	19/10/2001	<a href="http://pda.etsi.org/pda/home.asp?wkr=RTS/TSGS-0333103Uv4R2">http://pda.etsi.org/pda/home.asp?wkr=RTS/TSGS-0333103Uv4R2</a>

**5.3.2.8.50** TS 33.105**Cryptographic algorithm requirements**

Defines requirements for standard cipher and integrity algorithm.

SDO (2)	Document No.	Version	Status	Issued date	Location (1)
<b>Release 99</b>					
ETSI	ETSI TS 133 105	3.8.0	Published	31/07/2001	<a href="http://pda.etsi.org/pda/home.asp?wkr=RTS/TSGS-0333105UR6">http://pda.etsi.org/pda/home.asp?wkr=RTS/TSGS-0333105UR6</a>
<b>Release 4</b>					
ETSI	ETSI TS 133 105	4.1.0	Published	31/07/2001	<a href="http://pda.etsi.org/pda/home.asp?wkr=RTS/TSGS-0333105Uv4R1">http://pda.etsi.org/pda/home.asp?wkr=RTS/TSGS-0333105Uv4R1</a>

**5.3.2.8.51** TS 33.106**Lawful interception requirements**

Defines all requirements for network based lawful interception.

SDO (2)	Document No.	Version	Status	Issued date	Location (1)
<b>Release 99</b>					
ETSI	ETSI TS 133 106	3.1.0	Published	01/02/2000	<a href="http://pda.etsi.org/pda/home.asp?wkr=DTS/TSGS-0333106U">http://pda.etsi.org/pda/home.asp?wkr=DTS/TSGS-0333106U</a>
<b>Release 4</b>					
ETSI	ETSI TS 133 106	4.0.0	Published	27/04/2001	<a href="http://pda.etsi.org/pda/home.asp?wkr=RTS/TSGS-0333106Uv4">http://pda.etsi.org/pda/home.asp?wkr=RTS/TSGS-0333106Uv4</a>
<b>Release 5</b>					
ETSI	ETSI TS 133 106	5.1.0	Published	15/10/2002	<a href="http://pda.etsi.org/pda/home.asp?wkr=RTS/TSGS-0333106v510">http://pda.etsi.org/pda/home.asp?wkr=RTS/TSGS-0333106v510</a>

**5.3.2.8.52** TS 33.120**Security objectives and principles**

Elaborates on the basic principles underlying the security.

SDO (2)	Document No.	Version	Status	Issued date	Location (1)
<b>Release 99</b>					
ETSI	ETSI TS 133 120	3.0.0	Published	01/02/2000	<a href="http://pda.etsi.org/pda/home.asp?wkr=DTS/TSGS-0333120U">http://pda.etsi.org/pda/home.asp?wkr=DTS/TSGS-0333120U</a>
<b>Release 4</b>					
ETSI	ETSI TS 133 120	4.0.0	Published	27/04/2001	<a href="http://pda.etsi.org/pda/home.asp?wkr=RTS/TSGS-0333120Uv4">http://pda.etsi.org/pda/home.asp?wkr=RTS/TSGS-0333120Uv4</a>

**5.3.2.8.53** TR 33.901**Criteria for cryptographic algorithm design process**

This report describes the process used to design cipher and integrity algorithm.

SDO (2)	Document No.	Version	Status	Issued date	Location (1)
<b>Release 99</b>					
ETSI	ETSI TR 133 901	3.0.0	Published	01/02/2000	<a href="http://pda.etsi.org/pda/home.asp?wkr=DTR/TSGS-0333901U">http://pda.etsi.org/pda/home.asp?wkr=DTR/TSGS-0333901U</a>
<b>Release 4</b>					
ETSI	ETSI TR 133 901	4.0.0	Published	19/10/2001	<a href="http://pda.etsi.org/pda/home.asp?wkr=RTR/TSGS-0333901Uv4">http://pda.etsi.org/pda/home.asp?wkr=RTR/TSGS-0333901Uv4</a>

### 5.3.2.8.54 TR 33.902

#### Formal analysis of the 3G authentication protocol with modified sequence number management

Formal analysis using BAN and temporal logic of authentication mechanism.

SDO (2)	Document No.	Version	Status	Issued date	Location (1)
<b>Release 99</b>					
ETSI	ETSI TR 133 902	3.1.0	Published	01/02/2000	<a href="http://pda.etsi.org/pda/home.asp?wkr=DTR/TSGS-0333902U">http://pda.etsi.org/pda/home.asp?wkr=DTR/TSGS-0333902U</a>
<b>Release 4</b>					
ETSI	ETSI TR 133 902	4.0.0	Published	23/10/2001	<a href="http://pda.etsi.org/pda/home.asp?wkr=RTR/TSGS-0333902Uv4">http://pda.etsi.org/pda/home.asp?wkr=RTR/TSGS-0333902Uv4</a>

### 5.3.2.8.55 TS 26.071

#### AMR speech codec: general description

This specification describes an introduction to the set of the adaptive multi-rate (AMR) specifications.

SDO (2)	Document No.	Version	Status	Issued date	Location (1)
<b>Release 99</b>					
ETSI	ETSI TS 126 071	3.0.1	Published	01/02/2000	<a href="http://pda.etsi.org/pda/home.asp?wkr=DTS/TSGS-0426071U">http://pda.etsi.org/pda/home.asp?wkr=DTS/TSGS-0426071U</a>
<b>Release 4</b>					
ETSI	ETSI TS 126 071	4.0.0	Published	25/04/2001	<a href="http://pda.etsi.org/pda/home.asp?wkr=RTS/TSGS-0426071Uv4">http://pda.etsi.org/pda/home.asp?wkr=RTS/TSGS-0426071Uv4</a>
<b>Release 5</b>					
ETSI	ETSI TS 126 071	5.0.0	Published	16/07/2002	<a href="http://pda.etsi.org/pda/home.asp?wkr=RTS/TSGS-0426071v500">http://pda.etsi.org/pda/home.asp?wkr=RTS/TSGS-0426071v500</a>

### 5.3.2.8.56 TS 26.090

#### AMR speech codec: transcoding functions

This specification describes a detailed description of the AMR speech codec transcoding functions.

SDO (2)	Document No.	Version	Status	Issued date	Location (1)
<b>Release 99</b>					
ETSI	ETSI TS 126 090	3.1.0	Published	01/02/2000	<a href="http://pda.etsi.org/pda/home.asp?wkr=DTS/TSGS-0426090U">http://pda.etsi.org/pda/home.asp?wkr=DTS/TSGS-0426090U</a>
<b>Release 4</b>					
ETSI	ETSI TS 126 090	4.0.0	Published	25/04/2001	<a href="http://pda.etsi.org/pda/home.asp?wkr=RTS/TSGS-0426090Uv4">http://pda.etsi.org/pda/home.asp?wkr=RTS/TSGS-0426090Uv4</a>

**Release 5**

ETSI	ETSI TS 126 090	5.0.0	Published	11/07/2002	<a href="http://pda.etsi.org/pda/home.asp?wkr=RTS/TSGS-0426090v500">http://pda.etsi.org/pda/home.asp?wkr=RTS/TSGS-0426090v500</a>
------	-----------------	-------	-----------	------------	-----------------------------------------------------------------------------------------------------------------------------------

**5.3.2.8.57** TS 26.091**AMR speech codec: error concealment of lost frames**

This specification describes example procedures for the error concealment, also called frame substitution or muting procedure, of lost speech or silence indicator frames.

SDO (2)	Document No.	Version	Status	Issued date	Location (1)
<b>Release 99</b>					
ETSI	ETSI TS 126 091	3.1.0	Published	01/02/2000	<a href="http://pda.etsi.org/pda/home.asp?wkr=DTS/TSGS-0426091U">http://pda.etsi.org/pda/home.asp?wkr=DTS/TSGS-0426091U</a>
<b>Release 4</b>					
ETSI	ETSI TS 126 091	4.0.0	Published	25/04/2001	<a href="http://pda.etsi.org/pda/home.asp?wkr=RTS/TSGS-0426091Uv4">http://pda.etsi.org/pda/home.asp?wkr=RTS/TSGS-0426091Uv4</a>
<b>Release 5</b>					
ETSI	ETSI TS 126 091	5.0.0	Published	11/07/2002	<a href="http://pda.etsi.org/pda/home.asp?wkr=RTS/TSGS-0426091v500">http://pda.etsi.org/pda/home.asp?wkr=RTS/TSGS-0426091v500</a>

**5.3.2.8.58** TS 26.092**AMR speech codec: comfort noise aspects**

This specification describes the detailed requirements for the correct operation of the background acoustic noise evaluation, noise parameter encoding/decoding and comfort noise generation for the AMR speech codec during source controlled rate (SCR) operation.

SDO (2)	Document No.	Version	Status	Issued date	Location (1)
<b>Release 99</b>					
ETSI	ETSI TS 126 092	3.0.1	Published	01/02/2000	<a href="http://pda.etsi.org/pda/home.asp?wkr=DTS/TSGS-0426092U">http://pda.etsi.org/pda/home.asp?wkr=DTS/TSGS-0426092U</a>
<b>Release 4</b>					
ETSI	ETSI TS 126 092	4.0.0	Published	25/04/2001	<a href="http://pda.etsi.org/pda/home.asp?wkr=RTS/TSGS-0426092Uv4">http://pda.etsi.org/pda/home.asp?wkr=RTS/TSGS-0426092Uv4</a>
<b>Release 5</b>					
ETSI	ETSI TS 126 092	5.0.0	Published	11/07/2002	<a href="http://pda.etsi.org/pda/home.asp?wkr=RTS/TSGS-0426092v500">http://pda.etsi.org/pda/home.asp?wkr=RTS/TSGS-0426092v500</a>

**5.3.2.8.59** TS 26.093**AMR speech codec: source controlled rate (SCR) operation**

This specification describes the operation of the AMR speech codec during SCR operation.

SDO (2)	Document No.	Version	Status	Issued date	Location (1)
<b>Release 99</b>					
ETSI	ETSI TS 126 093	3.3.0	Published	13/02/2001	<a href="http://pda.etsi.org/pda/home.asp?wkr=RTS/TSGS-0426093UR2">http://pda.etsi.org/pda/home.asp?wkr=RTS/TSGS-0426093UR2</a>
<b>Release 4</b>					
ETSI	ETSI TS 126 093	4.0.0	Published	05/08/2002	<a href="http://pda.etsi.org/pda/home.asp?wkr=RTS/TSGS-0426093v400">http://pda.etsi.org/pda/home.asp?wkr=RTS/TSGS-0426093v400</a>



**Release 5**

ETSI	ETSI TS 126 093	5.2.0	Published	08/01/2003	<a href="http://pda.etsi.org/pda/home.asp?wkr=RTS/TSGS-0426093v520">http://pda.etsi.org/pda/home.asp?wkr=RTS/TSGS-0426093v520</a>
------	-----------------	-------	-----------	------------	-----------------------------------------------------------------------------------------------------------------------------------

**5.3.2.8.60 TS 26.094****AMR speech codec: voice activity detector (VAD)**

This specification describes two alternatives for the VAD to be used during SCR operation in conjunction with the AMR codec.

SDO (2)	Document No.	Version	Status	Issued date	Location (1)
<b>Release 99</b>					
ETSI	ETSI TS 126 094	3.0.0	Published	01/02/2000	<a href="http://pda.etsi.org/pda/home.asp?wkr=DTS/TSGS-0426094U">http://pda.etsi.org/pda/home.asp?wkr=DTS/TSGS-0426094U</a>
<b>Release 4</b>					
ETSI	ETSI TS 126 094	4.0.0	Published	25/04/2001	<a href="http://pda.etsi.org/pda/home.asp?wkr=RTS/TSGS-0426094Uv4">http://pda.etsi.org/pda/home.asp?wkr=RTS/TSGS-0426094Uv4</a>
<b>Release 5</b>					
ETSI	ETSI TS 126 094	5.0.0	Published	11/07/2002	<a href="http://pda.etsi.org/pda/home.asp?wkr=RTS/TSGS-0426094v500">http://pda.etsi.org/pda/home.asp?wkr=RTS/TSGS-0426094v500</a>

**5.3.2.8.61 TS 26.110****Codec for circuit-switched multimedia telephony service: general description**

This specification describes an introduction to the set of specifications for the support of circuit-switched 3G-324M multimedia telephony service.

SDO (2)	Document No.	Version	Status	Issued date	Location (1)
<b>Release 99</b>					
ETSI	ETSI TS 126 110	3.1.0	Published	25/04/2001	<a href="http://pda.etsi.org/pda/home.asp?wkr=RTS/TSGS-0426110UR1">http://pda.etsi.org/pda/home.asp?wkr=RTS/TSGS-0426110UR1</a>
<b>Release 4</b>					
ETSI	ETSI TS 126 110	4.1.0	Published	25/04/2001	<a href="http://pda.etsi.org/pda/home.asp?wkr=RTS/TSGS-0426110Uv4">http://pda.etsi.org/pda/home.asp?wkr=RTS/TSGS-0426110Uv4</a>
<b>Release 5</b>					
ETSI	ETSI TS 126 110	5.0.0	Published	11/07/2002	<a href="http://pda.etsi.org/pda/home.asp?wkr=RTS/TSGS-0426110v500">http://pda.etsi.org/pda/home.asp?wkr=RTS/TSGS-0426110v500</a>

**5.3.2.8.62 TS 26.111****Codec for circuit-switched multimedia telephony service: modifications to ITU-T Recommendation H.324**

This specification describes the modifications applicable to the ITU-T Recommendation H.324, Annex C for the support of circuit-switched 3G-324M multimedia telephony service.

SDO (2)	Document No.	Version	Status	Issued date	Location (1)
<b>Release 99</b>					
ETSI	ETSI TS 126 111	3.4.0	Published	13/02/2001	<a href="http://pda.etsi.org/pda/home.asp?wkr=RTS/TSGS-0426111UR3">http://pda.etsi.org/pda/home.asp?wkr=RTS/TSGS-0426111UR3</a>
<b>Release 4</b>					
ETSI	ETSI TS 126 111	4.0.0	Published	25/04/2001	<a href="http://pda.etsi.org/pda/home.asp?wkr=RTS/TSGS-0426111Uv4">http://pda.etsi.org/pda/home.asp?wkr=RTS/TSGS-0426111Uv4</a>
<b>Release 5</b>					
ETSI	ETSI TS 126 111	5.1.0	Published	03/07/2003	<a href="http://pda.etsi.org/pda/home.asp?wkr=RTS/TSGS-0426111v510">http://pda.etsi.org/pda/home.asp?wkr=RTS/TSGS-0426111v510</a>

**5.3.2.8.63** TR 26.911**Codec for circuit-switched multimedia telephony service: terminal implementor's guide**

This report describes non-mandatory Recommendations for the use of the different codec implementation options for the circuit-switched 3G-324M multimedia telephony service based on ITU-T Recommendation H.324, Annex C. These Recommendations address issues specific to the third generation operating environment, including guaranteeing sufficient error resilience and inter-working between terminals.

SDO (2)	Document No.	Version	Status	Issued date	Location (1)
<b>Release 99</b>					
ETSI	ETSI TR 126 911	3.4.0	Published	11/04/2003	<a href="http://pda.etsi.org/pda/home.asp?wkr=RTR/TSGS-0426911v340">http://pda.etsi.org/pda/home.asp?wkr=RTR/TSGS-0426911v340</a>
<b>Release 4</b>					
ETSI	ETSI TR 126 911	4.2.0	Published	11/04/2003	<a href="http://pda.etsi.org/pda/home.asp?wkr=RTR/TSGS-0426911v420">http://pda.etsi.org/pda/home.asp?wkr=RTR/TSGS-0426911v420</a>
<b>Release 5</b>					
ETSI	ETSI TR 126 911	5.1.0	Published	11/04/2003	<a href="http://pda.etsi.org/pda/home.asp?wkr=RTR/TSGS-0426911v510">http://pda.etsi.org/pda/home.asp?wkr=RTR/TSGS-0426911v510</a>

**5.3.2.9****Vocabulary****5.3.2.9.1** TR 21.905**Vocabulary**

Document 21.905 is a collection of terms, definitions and abbreviations related to the baseline documents defining the objectives and systems framework. This document provides a tool for further work on the technical documentation and facilitates their understanding.

SDO (2)	Document No.	Version	Status	Issued date	Location (1)
<b>Release 99</b>					
CCSA	CCSA-TSD-DS-21.905	330	Approved	01/07/2003	<a href="http://www.ccsa.org.cn/english/tc/files.php?docpath=/ITU-R/M.1457/M.1457-4/DS/">http://www.ccsa.org.cn/english/tc/files.php?docpath=/ITU-R/M.1457/M.1457-4/DS/</a>
ETSI	ETSI TR 121 905	3.3.0	Published	10/10/2001	<a href="http://pda.etsi.org/pda/home.asp?wkr=RTR/TSGS-0121905UR3">http://pda.etsi.org/pda/home.asp?wkr=RTR/TSGS-0121905UR3</a>
T1 (ATIS)	T1.3GPP.21.905V330-2002	3.3.0	Approved	03/05/2002	<a href="https://www.atis.org/atis/docstore/search.asp?committee=S24">https://www.atis.org/atis/docstore/search.asp?committee=S24</a>
TTA	TTAE.3G-21.905(R99-3.3.0)	3.3.0	Approved	29/05/2002	<a href="http://www.tta.or.kr/standardDB/stnfile/TTAE.3G-21.905(R99-3.3.0).zip">http://www.tta.or.kr/standardDB/stnfile/TTAE.3G-21.905(R99-3.3.0).zip</a>
<b>Release 4</b>					
CCSA	CCSA-TSD-DS-21.905	450	Approved	01/07/2003	<a href="http://www.ccsa.org.cn/english/tc/files.php?docpath=/ITU-R/M.1457/M.1457-4/DS/">http://www.ccsa.org.cn/english/tc/files.php?docpath=/ITU-R/M.1457/M.1457-4/DS/</a>
ETSI	ETSI TR 121 905	4.5.0	Published	01/07/2003	<a href="http://pda.etsi.org/pda/home.asp?wkr=RTR/TSGS-0121905v450">http://pda.etsi.org/pda/home.asp?wkr=RTR/TSGS-0121905v450</a>
T1 (ATIS)	T1.3GPP.21.905V450-2004	4.5.0	Approved	21/05/2004	<a href="https://www.atis.org/atis/docstore/search.asp?committee=S24">https://www.atis.org/atis/docstore/search.asp?committee=S24</a>
TTA	TTAT.3G-21.905(R4-4.5.0)	4.5.0	Approved	25/05/2004	<a href="http://www.tta.or.kr/standardDB/stnfile/TTAT.3G-21.905(R4-4.5.0).zip">http://www.tta.or.kr/standardDB/stnfile/TTAT.3G-21.905(R4-4.5.0).zip</a>
<b>Release 5</b>					
CCSA	CCSA-TSD-DS-21.905	570	Approved	01/07/2003	<a href="http://www.ccsa.org.cn/english/tc/files.php?docpath=/ITU-R/M.1457/M.1457-4/DS/">http://www.ccsa.org.cn/english/tc/files.php?docpath=/ITU-R/M.1457/M.1457-4/DS/</a>
ETSI	ETSI TR 121 905	5.8.0	Published	03/10/2003	<a href="http://pda.etsi.org/pda/home.asp?wkr=RTR/TSGS-0121905v580">http://pda.etsi.org/pda/home.asp?wkr=RTR/TSGS-0121905v580</a>
T1 (ATIS)	T1.3GPP.21.905V580-2004	5.8.0	Approved	21/05/2004	<a href="https://www.atis.org/atis/docstore/search.asp?committee=S24">https://www.atis.org/atis/docstore/search.asp?committee=S24</a>

TTA	TTAT.3G-21.905(R5-5.8.0)	5.8.0	Approved	25/05/2004	<a href="http://www.tta.or.kr/standardDB/stnfile/TTAT.3G-21.905(R5-5.8.0).zip">http://www.tta.or.kr/standardDB/stnfile/TTAT.3G-21.905(R5-5.8.0).zip</a>
<b>Release 6</b>					
CCSA	CCSA-TSD-DS-21.905	630	Approved	01/07/2003	<a href="http://www.ccsa.org.cn/english/tc/files.php?docpath=/ITU-R/M.1457/M.1457-4/DS/">http://www.ccsa.org.cn/english/tc/files.php?docpath=/ITU-R/M.1457/M.1457-4/DS/</a>
ETSI	ETSI TR 121 905	6.5.0	Awaiting		<a href="http://pda.etsi.org/pda/home.asp?wkr=RTR/TSGS-0121905v650">http://pda.etsi.org/pda/home.asp?wkr=RTR/TSGS-0121905v650</a>
T1 (ATIS)	T1.3GPP.21.905V650-2004	6.5.0	Approved	21/05/2004	<a href="https://www.atis.org/atis/docstore/search.asp?committee=S24">https://www.atis.org/atis/docstore/search.asp?committee=S24</a>
TTA	TTAT.3G-21.905(R6-6.5.0)	6.5.0	Approved	25/05/2004	<a href="http://www.tta.or.kr/standardDB/stnfile/TTAT.3G-21.905(R6-6.5.0).zip">http://www.tta.or.kr/standardDB/stnfile/TTAT.3G-21.905(R6-6.5.0).zip</a>

**5.3.2.10**

**SDO's complete system standard**

SDO	Location
<b>Release 99</b>	
CCSA	<a href="http://www.ccsa.org.cn/english/tc/files.php?docpath=/ITU-R/M.1457/M.1457-4/DS">http://www.ccsa.org.cn/english/tc/files.php?docpath=/ITU-R/M.1457/M.1457-4/DS</a>
ETSI	<a href="http://www.etsi.org/getastandard/home.htm">http://www.etsi.org/getastandard/home.htm</a>
T1 (ATIS)	<a href="https://www.atis.org/atis/docstore/search.asp?committee=S24">https://www.atis.org/atis/docstore/search.asp?committee=S24</a>
TTA	<a href="http://www.tta.or.kr/Home2003/standards/Imt2000List.jsp">http://www.tta.or.kr/Home2003/standards/Imt2000List.jsp</a>
<b>Release 4</b>	
CCSA	<a href="http://www.ccsa.org.cn/english">http://www.ccsa.org.cn/english</a>
ETSI	<a href="http://www.etsi.org/getastandard/home.htm">http://www.etsi.org/getastandard/home.htm</a>
T1 (ATIS)	<a href="https://www.atis.org/atis/docstore/search.asp?committee=S24">https://www.atis.org/atis/docstore/search.asp?committee=S24</a>
TTA	<a href="http://www.tta.or.kr/Home2003/standards/Imt2000List.jsp">http://www.tta.or.kr/Home2003/standards/Imt2000List.jsp</a>
<b>Release 5</b>	
CCSA	<a href="http://www.ccsa.org.cn/english">http://www.ccsa.org.cn/english</a>
ETSI	<a href="http://www.etsi.org/getastandard/home.htm">http://www.etsi.org/getastandard/home.htm</a>
T1 (ATIS)	<a href="https://www.atis.org/atis/docstore/search.asp?committee=S24">https://www.atis.org/atis/docstore/search.asp?committee=S24</a>
TTA	<a href="http://www.tta.or.kr/Home2003/standards/Imt2000List.jsp">http://www.tta.or.kr/Home2003/standards/Imt2000List.jsp</a>
<b>Release 6</b>	
CCSA	<a href="http://www.ccsa.org.cn/english">http://www.ccsa.org.cn/english</a>
ETSI	<a href="http://www.etsi.org/getastandard/home.htm">http://www.etsi.org/getastandard/home.htm</a>
T1 (ATIS)	<a href="https://www.atis.org/atis/docstore/search.asp?committee=S24">https://www.atis.org/atis/docstore/search.asp?committee=S24</a>
TTA	<a href="http://www.tta.or.kr/Home2003/standards/Imt2000List.jsp">http://www.tta.or.kr/Home2003/standards/Imt2000List.jsp</a>

## 5.4 IMT-2000 TDMA Single-Carrier

### 5.4.1 Overview of the radio interface

#### 5.4.1.1 Introduction

The IMT-2000 TDMA Single-Carrier radio interface specifications contain two variations depending on whether a TIA/EIA-41 circuit switched network component or a GSM evolved UMTS circuit switched network component is used. In either case, a common enhanced GSM General Packet Radio Service (GPRS) packet switched network component is used. The initial focus of the following sections has been to provide an evolution path for the TIA/EIA-136 pre-IMT-2000 radio interface to evolve to IMT-2000. As WRC 2000 identified additional frequency bands for IMT-2000, another pre-IMT-2000 radio interface (GSM/GPRS) is provided with an evolution path to TDMA Single-Carrier by incorporating common components of the IMT-2000 TDMA Single-Carrier radio interface. This application furthers the objective of maximum commonality between TIA/EIA-136 and GSM/EDGE GPRS.

##### 5.4.1.1.1 Radio interface used with TIA/EIA-41 Circuit Switched Network Component

The IMT-2000 radio interface specifications for TDMA Single-Carrier technology utilizing the TIA/EIA-41 circuit switched network component are developed by TIA TR45.3 with input from the Universal Wireless Communications Consortium. This radio interface is called Universal Wireless Communication-136 (UWC-136), which is specified by American National Standard TIA/EIA-136. It has been developed with the objective of maximum commonality between TIA/EIA-136 and GSM EDGE GPRS.

This radio interface was designed to provide a TIA/EIA-136 (designated as 136) based radio transmission technology that meets ITU-R's requirements for IMT-2000. It maintains the TDMA community's philosophy of evolution from 1st to 3rd generation systems while addressing the specific desires and goals of the TDMA community for a 3rd generation system.

This radio interface is an attractive and powerful evolutionary step for 136. The technology presented provides for future IMT-2000 services to existing operators, as well as providing new operators competitive features, services and technology. Additionally, the technology provides these same features and services in other bands around the world where regulatory approval has been granted to offer such services.

UWC-136 used a three component strategy for evolving the 136 technology to 3rd generation. The initial strategy consisted of enhancing the voice and data capabilities of the 30 kHz channels (designated as 136+), adding a 200 kHz carrier (EDGE) component for high speed data (384 kbit/s) accommodating high mobility (designated as 136HS Outdoor), and adding a 1.6 MHz carrier component for very high speed data (2 Mbit/s) in low mobility applications (designated as 136HS Indoor). The second phase update further enhanced the voice capabilities of the 30 kHz channel (designated as 136+), and added an additional alternative 200 kHz carrier EDGE component for high speed data (384 kbit/s) (designated as 136EHS).

This third phase update adds support for GSM EDGE Release 5 services and the IP multimedia subsystem (IMS) as well as incorporation of the harmonised Mobile Equipment Identifier (MEID). Additionally, an alternative for the circuit switched network component is added. The combined result constitutes this radio interface specification.

The 136HS Outdoor and Indoor components were developed to satisfy the requirements for an IMT-2000 radio transmission technology, with the additional requirement for the consideration of commercially effective evolution and deployment in current 136 networks. Such considerations include flexible spectrum allocation, spectrum efficiency, compatibility with 136 and 136+, and support of macrocellular performance at higher mobile speeds. 136EHS provided compatibility

with GSM EGPRS, while this update provides a common EDGE enhanced GPRS packet switched component with GSM EDGE Release 5 functionality thus providing commercially effective evolution and global roaming.

The TDMA community continues to enhance UWC-136, regularly providing revisions to the standards.

#### **5.4.1.1.2 Radio interface used with GSM evolved UMTS circuit switched network component**

This radio interface provides an evolution path for an additional pre-IMT-2000 technology (GSM/GPRS) to IMT-2000 TDMA Single-Carrier. The IMT-2000 radio interface specifications for TDMA Single-Carrier technology utilizing the GSM evolved UMTS circuit switched network component are developed by 3GPP and transposed by Committee T1. The circuit switched component uses a common 200 kHz carrier as does the GSM EDGE enhanced GPRS packet switched component, as used by 136EHS, to provide high speed data (384 kbit/s).

#### **5.4.1.2 Services**

UWC-136 builds on the mature and powerful TIA/EIA-136 standard, which has evolved over many years. Thus, all TIA/EIA-136 services are included, and the capabilities of 384 kbit/s, and 2 Mbit/s high speed data are added. Through TIA/EIA-136, this technology supports both full-rate (3 users/30 kHz) and half-rate (6 users/30 kHz) voice services. Utilizing the GSM evolved UMTS circuit switched network component, all the circuit switched services of the GSM system are provided by TDMA Single-Carrier. Additionally, the GAIT interoperability function provides interoperability between the two circuit switched networks.

#### **5.4.1.2.1 Voice Services**

##### **5.4.1.2.1.1 TIA/EIA-41 circuit switched network component**

Four full-rate voice coders are presently defined: VSELP, ACELP, US1, and AMR. Additionally, one half-rate voice coder is presently defined: AMR. Enhancements to voice services entail a more robust full-rate voice service using DQPSK modulation, and a low delay and improved tandeming codec for wireless office applications using 8-PSK modulation. An additional slot format for DQPSK results in a link budget improvement of 4 dB in robustness for ACELP.

The AMR voice coder supports 3 users per RF carrier (Full Rate) and 6 users per RF carrier (Half-Rate), utilizing slot sharing and enhanced interleaving to achieve diversity gains and lower delay. RF carriers support both DQPSK and 8-PSK modulation formats so that mobiles supporting either modulation can exist on the same carrier to maximize trunking efficiency.

Voice services are supported with robust error correction coding and link quality improvement techniques such as per slot power control. Enhanced reporting mechanisms for Frame Error Rate, real-time C/I, and BER are also defined to aid in RF system engineering.

##### **5.4.1.2.1.2 GSM evolved UMTS circuit switched network component**

The AMR voice coder supports 8 users per 200 kHz RF carrier (Full Rate) and 16 users per RF carrier (Half-Rate), utilizing the common coding and adaptation technology used in the UWC-136 AMR.

#### **5.4.1.2.2 Data Services**

A scalable packet data service having data rates from 11.2 kbit/s to greater than 2 Mbit/s is supported. For 136+, 136HS Outdoor, and 136HS Indoor, this packet data service is referred to as GPRS-136. For 136EHS this packet data service is referred to as EGPRS-136. Both use the GPRS

backbone network. Packet switched services are integrated with existing circuit switched services while maintaining TIA/EIA-136 capabilities. A Mobile Station in operation on the packet network may automatically move to the circuit network to place and receive calls, then return to the packet network upon completion of a circuit call. Mobile Stations in operation on the packet network are also able to support services such as Short Message Service (SMS) and message waiting indications.

The user can access two forms of data network; X.25 and Internet Protocol (IP) based. For IP based networks the user may have dynamic or static IP allocation. Differing Quality of Service requirements are supported for any data session and multiple simultaneous data sessions are supported. Only the user's subscription and system engineering limit the number of data sessions that are open for a user. The general approach of this integrated data model is to overlay the circuit switched network nodes with packet data network nodes for service provisioning, registration, mobility management, and accounting. Interworking is provided between the circuit switched and packet data networks for mobiles capable of both services. This allows a user engaged in an active data transfer to pause/resume operation should they wish to make or receive a circuit call.

#### 5.4.1.2.3 Ancillary Services

A host of services are offered, some of which are: portable subscriptions through Removable User Identity Modules (R-UIM), short messaging, message waiting indication, calling name indication, extended standby time via "sleep mode", wireless office (private systems), circuit switched data, over-the-air activation, over-the-air programming, encryption, broadcast teleservice transport, general UDP transport, and authentication.

The second update also provided location services capabilities through System Assisted Mobile Positioning through Satellite (SAMPS).

#### 5.4.1.3 Layer 1

The basic premise of operation is spectrum on demand. The amount of spectrum allocated at a given time is a function of the service mix that is required. It allows for incremental channels to be allocated and de-allocated as required. The bandwidth associated with each service is tailored to that service. By aggressively managing the spectrum, high spectral efficiency performance is supported as well as underlay cells which can "steal" spectrum from the overlay network to provide even more capacity in a given geographical region.

The 136+ bearer supports both voice and data service on a 30 kHz RF channel. Two modulation types are specified: mandatory  $\pi/4$ -DQPSK and optional 8-PSK at a common channel symbol rate of 24.3 ksymbols/s. Channels are spaced 30 kHz apart, centre to centre. Both the voice and data services can operate on either modulation to allow for service differentiation and channel robustness.

The 136HS Outdoor bearer and the 136EHS bearer use a 200 kHz RF carrier, known as EDGE, to enable the deployment of the high speed data services. Two mandatory modulations are specified: GMSK and 8-PSK at a common channel symbol rate of 270.833 ksymbols/s. The channel coding and modulation can be varied to provide an optimal adaptation of throughput versus channel robustness. Channels are spaced 200 kHz apart, centre to centre.

Finally, the 136HS Indoor bearer uses a 1.6 MHz RF carrier to enable the deployment of high-speed indoor data services at greater than 2 Mbit/s. Two mandatory modulations are specified: B-O-QAM and Q-O-QAM at a common channel symbol rate of 2.6 Msymbols/s. The channel modulation can be varied to provide an optimal adaptation of throughput versus channel robustness. Channels are spaced 1 600 kHz apart, centre to centre. Additionally, 136HS Indoor has an optional TDD mode.

#### 5.4.1.4 Layer 2

Layer 2 provides two different types of functionalities: those to support circuit based operation and those that support packet based operation.

##### 5.4.1.4.1 Circuit

The modulated/encoded voice is carried over the Digital Traffic Channel (DTC). The connection of the traffic channel is supervised using the Coded Digital Verification Colour Code (CDVCC) on Layer 2. The Mobile Station (MS) decodes the CDVCC (either explicitly or implicitly) received from the Base Station in every DTC time slot, and compares it with the colour code received from the original connection messages or the hand-off message (DVCCs). The MS transmits the coded DVCCs to the Base Station in each burst. The DTC also contains Fast and Slow Associated Control Channels (FACCH and SACCH) which carry control and supervising messages.

Layer 2 of the Digital Control Channel (DCCH) services requests from and provides indications to Layer 3. On the MS side, Layer 2 services the Layer 3 Reverse DCCH (RDCCH) Request Primitive to initiate a mobile station access attempt on the Random Access Channel (RACH) which is controlled by Layer 2. Layer 2 then performs Random or Reserve access procedures, and decoding of the Shared Channel Feedback (SCF) status information. Layer 2 issues a Forward DCCH (FDCCH) Indication Primitive to Layer 3 when the MS receives a complete layer 3 message broadcast or addressed on various FDCCH channels.

On the Base Station side, Layer 2 services the Layer 3 F-BCCH, E-BCCH, S-BCCH, and SPACH Request Primitives containing the Layer 3 messages to be sent to the MS. Layer 2 issues an RDCCH Indication Primitive to deliver to Layer 3 messages received from the MS.

Various Layer 2 protocols can be used to carry RDCCH and FDCCH information in support of layer 3 messages such as Frame Segmentation and Re-assembly, and Automatic Retransmission Request (ARQ) mode of operation. Other functions of the DCCH layer 2 are: Message Concatenation of layer 3 Messages, MSID Management, Header Formatting, and Monitoring Radio Link Quality (MRLQ).

##### 5.4.1.4.2 Packet

The overall function Layer 2 provides is to realize radio bearers for Layer 3, taking into consideration the requested QoS objectives. Layer 2 is structured into Logical Link Control (LLC), Radio Link Control (RLC), and Medium Access Control (MAC), (RLC and MAC may be combined into one function referred to as MAC).

The LLC is independent of the radio interface. The LLC provides acknowledged or unacknowledged data transfer, and provides support to the Tunneling Of Message sub layer allowing for TIA/EIA-41 signalling over the packet bearer.

Three separate MAC entities may be included in a single Layer 2 MAC, one entity to support each type of bearer: 136+ bearer, 136HS Outdoor bearer or 136EHS bearer and 136HS Indoor bearer. The main task of the MAC is to dynamically multiplex the radio resource so that the RF resources can be efficiently utilized among multiple users with minimal packet collisions. The MAC supports both an unacknowledged and an acknowledged mode. In acknowledged mode, the MAC is responsible for sequenced delivery of packets to the higher layers, and an error recovery method using a sliding window automatic repeat request is utilized. The MAC also supports transactions with different priorities, and provides quality of service (QoS) information with four levels of priority. This radio interface also supports several unique design features such as implicit addressing and active mobile identity management which provide link quality robustness, and resource efficiency.

The reason why RLC and MAC are considered as belonging to the same sublayer is that both entities have direct access to the physical layer and the LLC sublayer. Furthermore, the LLC protocol does not depend on the radio interface, whereas the RLC/MAC protocol is radio specific.

#### 5.4.1.5 Layer 3

Layer 3 provides two different types of mobility and resource management functionalities: those to support circuit based operation and those that support packet based operation.

136 Mobility Management and Radio Resource Management entities at Layer 3 provide circuit switched services. Layer 3 procedures (known as Intelligent Roaming) are defined to provide the user access to the optimum circuit switched service provider. Once the initial control channel selection has been accomplished, cell reselection and handoff algorithms provide continuity of service. The cell reselection algorithms include several trigger conditions and selection criteria to provide versatile management capability.

The GSM based GPRS mobility management function and the 136 mobility management function, operating in parallel, comprise the GPRS-136 Mobility Manager for GPRS-136. The GSM based EGPRS mobility management function and the 136 mobility management function, operating in parallel, comprise the EGPRS-136 Mobility Manager for EGPRS-136. The packet mobility management function provides packet data mobility management, while the 136 mobility management function provides circuit switched service mobility management. Together they ensure that the network knows the current location of Mobile Stations.

The packet Radio Resource Management (RRM) entity is similar to the Digital Control Channel Procedures that control voice resources. The main task of the RRM is to dynamically allocate the radio resource among the bearers so that the RF resources can be efficiently utilized among multiple users. Procedures are defined which will spread the load across multiple packet channels in a given cell. Techniques are outlined that allow for rapid finding of packet resources. Continuity of service is supported via cell reselection as a mobile traverses multiple cells. The packet Radio Resource Management (RRM) supports all three packet data bearers defined in this radio interface.

In addition to the Management functions Layer 3 provides other capabilities. Layer 3 Message construction rules provides backwards compatibility so that a Mobile Station or Base Station can process a message to the extent it understands it. This capability also allows new functions to be easily added for extensibility.

Layer 3 provides a generic R-DATA transport that can function in point-to-point or broadcast mode. This R-DATA transport can carry various Teleservice messages without regard to the exact using entity. This generic capability allows various value-added services such as Short Message Services and Over-the-Air programming to be defined or added to using the common transport.

#### 5.4.1.6 Network

A system is realized by uniquely combining a TDMA Single-Carrier Radio Interface with an EDGE enhanced GPRS packet switched network component combined with either a TIA/EIA-41 circuit switched network component or a GSM evolved UMTS circuit switched network component.

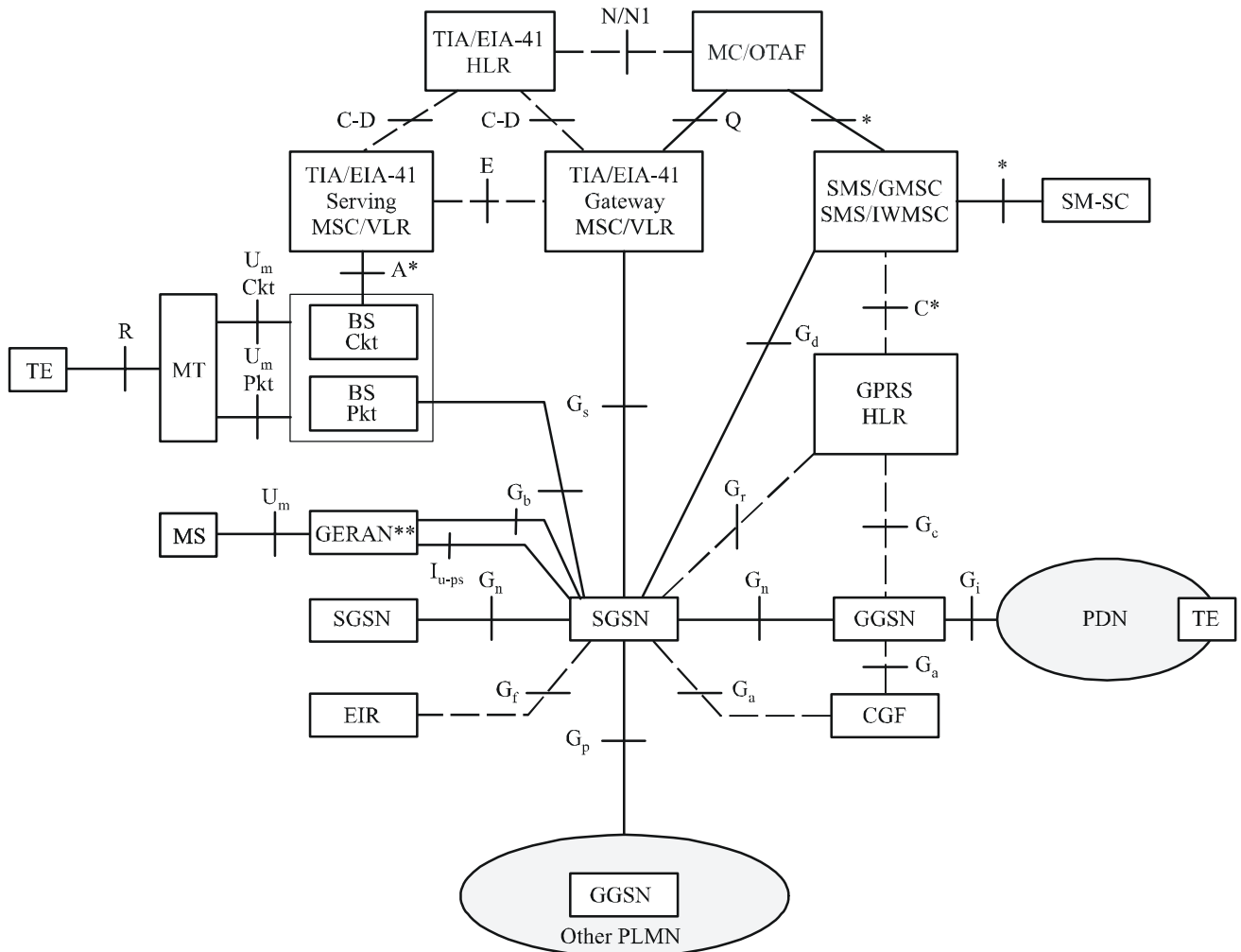
Figure 40a presents the network elements and the associated reference points that comprise a system utilizing the TIA/EIA-41 circuit switched network component. The primary TIA/EIA-41 network node visible to the SGSN is the Gateway MSC/VLR. The interface between the TIA/EIA-41 Gateway MSC/VLR and the SGSN is the Gs interface, which allows the tunnelling of TIA/EIA-136 signalling messages between the Mobile Station and the Gateway MSC/VLR. The tunnelling of these signalling messages is performed transparently through the SGSN. Between the Mobile



Station and the SGSN, the signalling messages are transported using the Tunnelling of Messages (TOM) protocol layer. TOM uses the LLC unacknowledged mode procedures to transport the signalling messages. Between the SGSN and the Gateway MSC/VLR, the messages are transported using the BSSAP+ protocol.

FIGURE 40a

Network elements and associated reference points



--- Signalling

— Signalling and data transfer interface

\*\* GERAN in this context is the union of GSM, GPRS, and EDGE

Notes:

- For simplicity, not all network elements of TIA/EIA-41 and ETSI GPRS are shown.
- Interfaces labeled with \* are implementation specific.
- Interface C\* is as defined in ETSI TS 129 002 (35).

Upon receiving a TIA/EIA-136 signalling message from a Mobile Station via the TOM protocol, the SGSN forwards the message to the appropriate Gateway MSC/VLR using the BSSAP+ protocol. Upon receiving a TIA/EIA-136 signalling message from a Gateway MSC/VLR via the BSSAP+ protocol, the SGSN forwards the message to the indicated Mobile Station using the TOM protocol.

Mobile Stations supporting both the TIA/EIA-41 circuit switched network component and packet services (Class B136 Mobile Stations) perform location updates with the circuit system by tunnelling the Registration message to the Gateway MSC/VLR. When an incoming call arrives for a given Mobile Station, the Gateway MSC/VLR associated with the latest Registration pages the Mobile Station through the SGSN. The page can be a Hard Page (no Layer 3 information included in the message), in which case, the Gs interface paging procedures are used by the MSC/VLR and the SGSN. If the circuit page is not for a voice call or, if additional parameters are associated with the page, a Layer 3 Page message is tunnelled to the Mobile Station by the MSC/VLR. Upon receiving a page, the Mobile Station pauses the packet data session and leaves the packet data channel for a suitable Digital Control Channel (DCCH). Broadcast information is provided on the packet control channel to assist the Mobile Station with a list of candidate DCCHs. Once on a DCCH, the Mobile Station sends a Page Response. The remaining call setup procedures, such as traffic channel designation, proceed as in a normal page response situation.

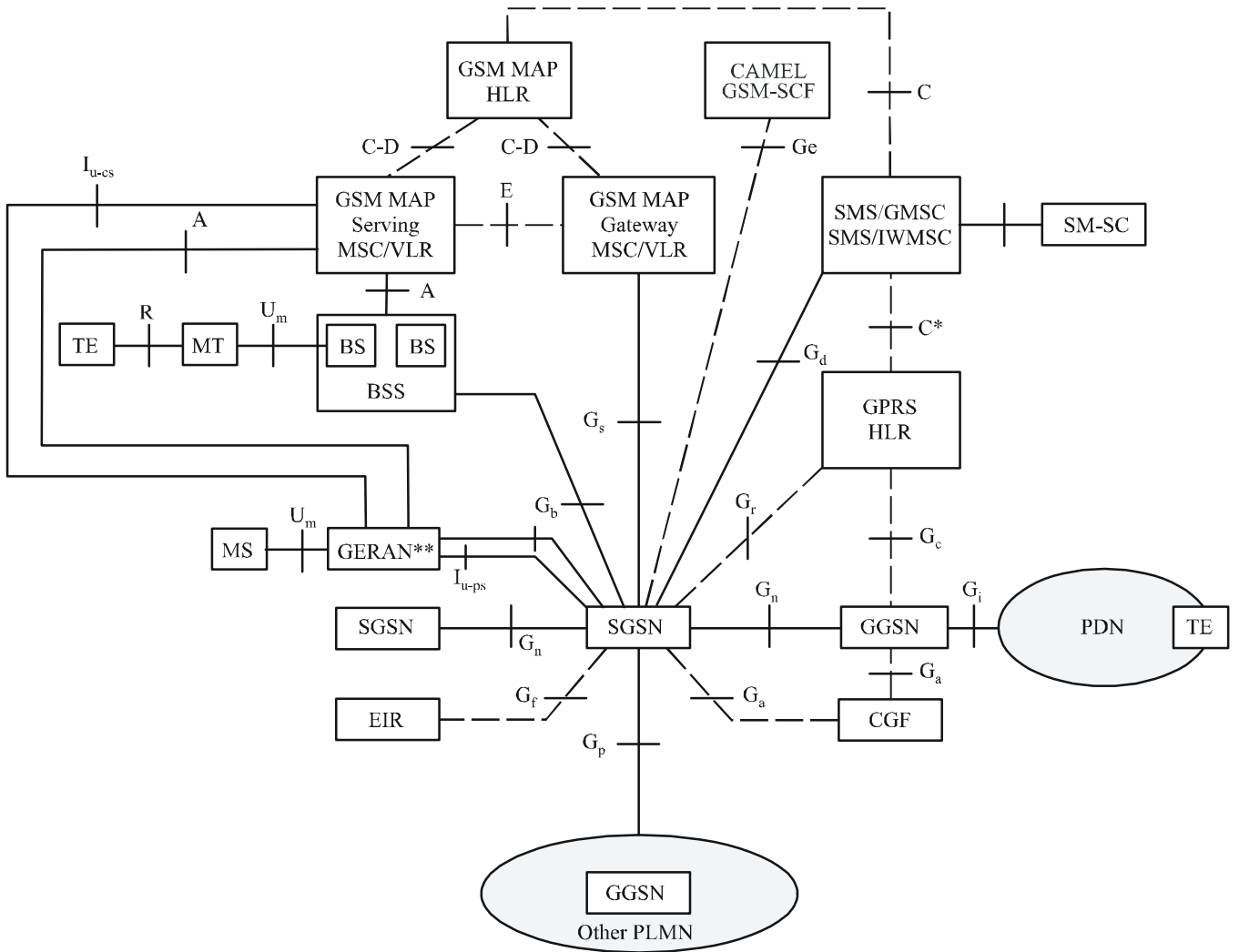
Figure 40b presents the network elements and the associated reference points that comprise a system utilizing the GSM evolved UMTS circuit switched network component along with the common GSM EDGE enhanced GPRS packet switched component.

Since the TDMA SC network supports a common EDGE 136EHS bearer connected to a core enhanced GPRS backbone network or a GSM EDGE radio access network, along with either circuit switched component, GSM EDGE Release 5 mobile stations and functions are supported. In addition to the Gs interface, GSM SMS functionality is also supported through the Gd interface.

The signalling plane between a Mobile Station and the Gateway MSC/VLR for the TIA/EIA-41 circuit switched network component is shown in Fig. 41.

FIGURE 40b

Network elements and associated reference points



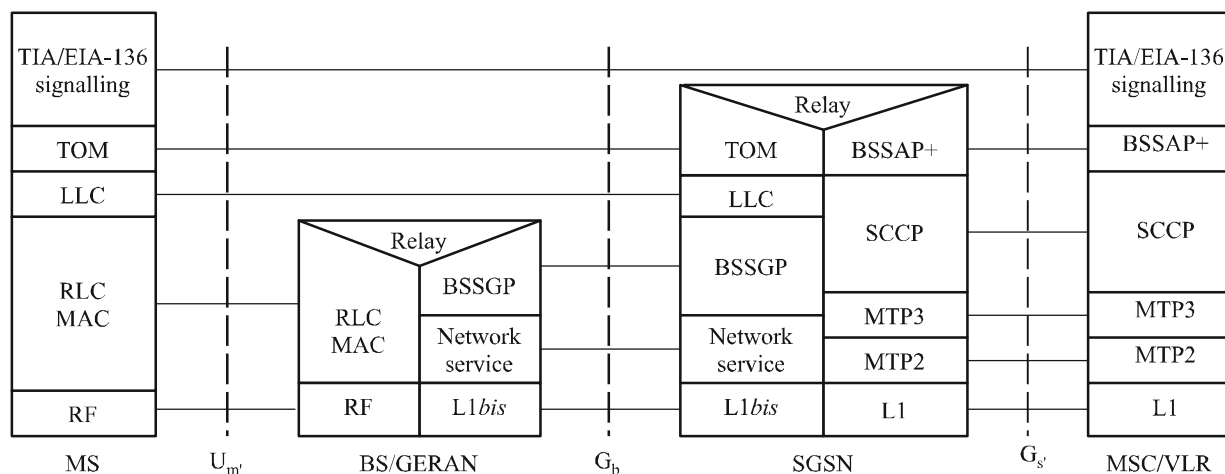
- Signalling
- Signalling and data transfer interface
- \*\*\* GERAN in this context is the union of GSM, GPRS and EDGE

*Notes:*

- For simplicity, not all network elements of TIA/EIA-41 and ETSI GPRS are shown.
- Interfaces labeled with \* are implementation specific.
- Interface C\* is as defined in ETSI TS 129 002 (35).

FIGURE 41

## Signalling plane between a mobile station and the Gateway MSC/VLR



1457-41

## 5.4.1.7 Summary of major technical parameters

The following Table lists the major technical parameters of this radio interface.

Parameter	Value	Reference to § 5.4.2
Multiple access technique	TDMA	5.4.2.5.4 5.4.2.5.12 5.4.2.5.17 5.4.2.3.12 5.4.2.3.3 5.4.2.3.6
Carrier spacing: 136+ bearer EDGE bearer 136HS indoor bearer	30 kHz 200 kHz 1.6 MHz	5.4.2.3.2
Carrier symbol rate: 136+ bearer EDGE bearer 136HS indoor bearer	24.3 ksymbols/s 270.833 ksymbols/s 2.6 Msymbols/s	5.4.2.5.4 5.4.2.3.6 5.4.2.5.12 5.4.2.3.14 5.4.2.5.17
Data modulation: 136+ bearer EDGE bearer 136HS Indoor bearer	$\pi/4$ DQPSK, 8-PSK GMSK, 8-PSK Binary offset QAM, Quaternary offset QAM	5.4.2.5.4 5.4.2.3.6 5.4.2.5.12 5.4.2.3.14 5.4.2.5.17
Channel coding: 136+ bearer EDGE bearer 136HS indoor bearer	Punctured convolutional codes Punctured convolutional codes Incremental redundancy Punctured convolutional codes, Type II hybrid ARQ	5.4.2.5.5 5.4.2.3.6 5.4.2.5.1 5.4.2.5.2 5.4.2.5.12 5.4.2.3.13 5.4.2.5.17

Parameter	Value	Reference to § 5.4.2
Frame structure: Frame length 136+ bearer	40 ms	5.4.2.5.4 5.4.2.3.3 5.4.2.3.6
EDGE bearer	4.615 (120/26) ms	5.4.2.5.12 5.4.2.3.12
136HS indoor bearer	4.615 (120/26) ms	5.4.2.5.17
Number of slots per frame 136+ bearer EDGE bearer	6 8	5.4.2.5.4 5.4.2.5.12 5.4.2.3.12
136HS indoor bearer	16-64	5.4.2.5.17
Minimum operating bandwidth: 136HS outdoor bearer 136EHS COMPACT bearer 136EHS classic bearer 136HS indoor bearer	2 × 600 kHz 2 × 600 kHz 2 × 2.4 MHz 2 × 1.6 MHz FDD 1 × 1.6 MHz TDD	5.4.2.10.6 5.4.2.5.19 5.4.2.5.19 5.4.2.10.6
Spectrum efficiency 136+ bearer (voice) EDGE bearer  136HS indoor bearer	58.8 E/MHz/cell (3 sectors) 0.9495 Mbit/s/MHz/cell (pedestrian A) 1.1760 Mbit/s/MHz/cell (vehicle A50) 1.0380 Mbit/s/MHz/cell (vehicle A120) 0.332 Mbit/s/MHz/cell (indoor A)	5.4.2.10.6
Receiver sensitivity 136+ bearer  EDGE bearer  136HS indoor bearer	-103 dBm (8 km/h) at 3% BER (DQPSK) -101 dBm (8 km/h) at 3% BER (8-PSK) -94 dBm (pedestrian B) at 10% BLER -100 dBm (vehicle A120) at 10% BLER -95 dBm (indoor A) at 10% BLER	5.4.2.4.6/7/8 5.4.2.4.6/7/8 5.4.2.4.9 5.4.2.4.9 5.4.2.4.9
Standby RF output power	-117 dBm	5.4.2.4.9
Power control	Per slot and per carrier	5.4.2.3.6 5.4.2.5.4
Variable data rate	Supported with slot aggregation and link adaptation	5.4.2.5.4 5.4.2.5.12 5.4.2.5.19 5.4.2.5.17
Dynamic channel allocation	Supported to increase capacity	5.4.2.10.6
Duplexing scheme	FDD TDD optional for 136HS indoor	5.4.2.3.2 5.4.2.5.17
Frequency stability	Base station: 0.05 ppm Mobile station: 0.1 ppm	5.4.2.4.9

### 5.4.2 Detailed specification of the radio interface

The standards contained in this section are derived from the global core specifications for IMT 2000 contained at <http://ties.itu.int/u/itu-r/ede/rsg8/wp8f/wp8f-tech/GCSrev4/5-4/>. The following notes apply to the sections below, where indicated: (1) The relevant SDOs should make their reference material available from their Web site. (2) This information was supplied by the recognized external organizations and relates to their own deliverables of the transposed global core specification.

#### 5.4.2.1

##### TIA/EIA-136/UWC-136

##### 5.4.2.1.1 136-000

##### List of parts

This part outlines the intended scope of the TIA/EIA-136 standard and details the list of parts comprising the current revision. The parts are organized into subgroups denoted by “nXX”. For example, group TIA/EIA-136-4XX contains parts 410, 420, 430 and 440.

SDO (2)	Document No.	Version	Status	Issued date	Location (1)
TIA	TIA-136-000	E	Published ANS	14/01/2004	<a href="http://www.tiaonline.org/standards/sfg/imt2k/uwc136">http://www.tiaonline.org/standards/sfg/imt2k/uwc136</a>

#### 5.4.2.2

##### Identities, Code Assignments, and UIM Information

##### 5.4.2.2.1 136-005

##### Introduction, identification and semi-permanent memory

This part contains explanations of terms along with identity definition and selection as used in all of the parts.

SDO (2)	Document No.	Version	Status	Issued date	Location (1)
TIA	TIA-136-005	C	Published ANS	14/01/2004	<a href="http://www.tiaonline.org/standards/sfg/imt2k/uwc136">http://www.tiaonline.org/standards/sfg/imt2k/uwc136</a>

##### 5.4.2.2.2 136-010

##### Optional mobile station facilities

This part outlines optional mobile station facilities.

SDO (2)	Document No.	Version	Status	Issued date	Location (1)
TIA	TIA/EIA-136-010	C	Published ANS	23/04/2001	<a href="http://www.tiaonline.org/standards/sfg/imt2k/uwc136">http://www.tiaonline.org/standards/sfg/imt2k/uwc136</a>

**5.4.2.2.3** 136-020**SOC, BSMC, and other code assignments**

This part provides a list of the system operator codes (SOC), base station manufacturer codes (BSMC), carrier specific higher layer protocol identifiers, and broadcast air-interface transport service category assignments.

SDO (2)	Document No.	Version	Status	Issued date	Location (1)
TIA	TIA-136-020	E	Published ANS	20/01/2004	<a href="http://www.tiaonline.org/standards/sfg/imt2k/uwc136">http://www.tiaonline.org/standards/sfg/imt2k/uwc136</a>

**5.4.2.2.4** 136-030**R-UIM Overview and Operations**

This part provides an overview of the operation of the Removable User Identity Module as supported in TIA/EIA-136.

SDO (2)	Document No.	Version	Status	Issued date	Location (1)
<b>Release 99</b>					
TIA	TIA/EIA-136-030	A	Published ANS	15/04/2002	<a href="http://www.tiaonline.org/standards/sfg/imt2k/uwc136">http://www.tiaonline.org/standards/sfg/imt2k/uwc136</a>
<b>Release 5</b>					
TIA	TIA-136-030	B	Published ANS	13/01/2004	<a href="http://www.tiaonline.org/standards/sfg/imt2k/uwc136">http://www.tiaonline.org/standards/sfg/imt2k/uwc136</a>

**5.4.2.2.5** 136-033**R-UIM File Structure**

This part describes the file structures contained on the Removable User Identity Module.

SDO (2)	Document No.	Version	Status	Issued date	Location (1)
TIA	TIA/EIA-136-033	A	Published ANS	15/04/2002	<a href="http://www.tiaonline.org/standards/sfg/imt2k/uwc136">http://www.tiaonline.org/standards/sfg/imt2k/uwc136</a>

**5.4.2.2.6** 136-034**R-UIM - ME Interface Procedures**

This part describes the interface procedures between the Removable User Identity Module and the mobile equipment.

SDO (2)	Document No.	Version	Status	Issued date	Location (1)
TIA	TIA/EIA-136-034	A	Published ANS	15/04/2002	<a href="http://www.tiaonline.org/standards/sfg/imt2k/uwc136">http://www.tiaonline.org/standards/sfg/imt2k/uwc136</a>

**5.4.2.2.7** 136-036**Personalization of Mobile Equipment**

This part includes the personalization of mobile equipment.

SDO (2)	Document No.	Version	Status	Issued date	Location (1)
TIA	TIA/EIA-136-036	0	Published ANS	23/04/2001	<a href="http://www.tiaonline.org/standards/sfg/imt2k/uwc136">http://www.tiaonline.org/standards/sfg/imt2k/uwc136</a>

**5.4.2.2.8** 136-037**R-UIM Application Toolkit**

This part describes an application toolkit for use with the Removable User Identity Module.

SDO (2)	Document No.	Version	Status	Issued date	Location (1)
TIA	TIA/EIA-136-037	A	Published ANS	15/04/2002	<a href="http://www.tiaonline.org/standards/sfg/imt2k/uwc136">http://www.tiaonline.org/standards/sfg/imt2k/uwc136</a>

**5.4.2.2.9** 3GPP TS 01.01**GSM/EDGE Release 99 specifications**

This document lists the documents that make up the GSM/EDGE Release 99 specifications.

SDO (2)	Document No.	Version	Status	Issued date	Location (1)
<b>Release 99</b>					
T1	T1.3GPP.01.01V880-2003	8.8.0	Approved	09/12/2003	<a href="https://www.atis.org/atis/docstore/search.asp?committee=S24">https://www.atis.org/atis/docstore/search.asp?committee=S24</a>

**5.4.2.2.10** 3GPP TR 21.905**Abbreviations and acronyms**

This document defines the abbreviations and acronyms used in the GSM/EDGE specifications.

SDO (2)	Document No.	Version	Status	Issued date	Location (1)
<b>Release 99</b>					
T1	T1.3GPP.01.04V800-2003	8.0.0	Approved	09/12/2003	<a href="https://www.atis.org/atis/docstore/search.asp?committee=S24">https://www.atis.org/atis/docstore/search.asp?committee=S24</a>
TIA	Included in TIA/EIA-136-290 as GSM 01.04 (ETSI TR 101 748 v8.0.0)	A	Published ANS	23/04/2001	<a href="http://www.tiaonline.org/standards/sfg/imt2k/uwc136">http://www.tiaonline.org/standards/sfg/imt2k/uwc136</a>
<b>Release 5</b>					
T1	T1.3GPP.21.905V550-2003	5.5.0	Approved	27/03/2003	<a href="https://www.atis.org/atis/docstore/search.asp?committee=S24">https://www.atis.org/atis/docstore/search.asp?committee=S24</a>

**5.4.2.2.11** 3GPP TS 22.016**International Mobile Station Equipment Identities**

This document describes the principal purpose and use of unique Equipment Identities.

SDO (2)	Document No.	Version	Status	Issued date	Location (1)
<b>Release 99</b>					
T1	T1.3GPP.22.016V330-2003	3.3.0	Approved	09/12/2003	<a href="https://www.atis.org/atis/docstore/search.asp?committee=S24">https://www.atis.org/atis/docstore/search.asp?committee=S24</a>
TIA	Included in TIA/EIA-136-370 as ETSI TS 122 016 v3.1.0	0	Published ANS	23/04/2001	<a href="http://www.tiaonline.org/standards/sfg/imt2k/uwc136">http://www.tiaonline.org/standards/sfg/imt2k/uwc136</a>



**Release 5**

T1	T1.3GPP.22.016V500-2003	5.0.0	Approved	27/03/2003	<a href="https://www.atis.org/atis/docstore/search.asp?committee=S24">https://www.atis.org/atis/docstore/search.asp?committee=S24</a>
TIA	Included in TIA-136-370 as ETSI TS 122 016 v5.0.0	A	Published ANS	13/01/2004	<a href="http://www.tiaonline.org/standards/sfg/imt2k/uwc136">http://www.tiaonline.org/standards/sfg/imt2k/uwc136</a>

**5.4.2.2.12 3GPP TS 22.022****Personalisation of Mobile Equipment Stage 1**

This document provides the functionality specification for the personalisation of mobile equipment.

SDO (2)	Document No.	Version	Status	Issued date	Location (1)
<b>Release 99</b>					
T1	T1.3GPP.22.022V321-2003	3.2.1	Approved	09/12/2003	<a href="https://www.atis.org/atis/docstore/search.asp?committee=S24">https://www.atis.org/atis/docstore/search.asp?committee=S24</a>
TIA	Included in TIA/EIA-136-030 as ETSI TS 122 022 v3.1.0	A	Published ANS	15/04/2002	<a href="http://www.tiaonline.org/standards/sfg/imt2k/uwc136">http://www.tiaonline.org/standards/sfg/imt2k/uwc136</a>
<b>Release 5</b>					
T1	T1.3GPP.22.022V500-2003	5.0.0	Approved	27/03/2003	<a href="https://www.atis.org/atis/docstore/search.asp?committee=S24">https://www.atis.org/atis/docstore/search.asp?committee=S24</a>
TIA	Included in TIA-136-030 as ETSI TS 122 022 v5.0.0	B	Published ANS	13/01/2004	<a href="http://www.tiaonline.org/standards/sfg/imt2k/uwc136">http://www.tiaonline.org/standards/sfg/imt2k/uwc136</a>

**5.4.2.2.13 3GPP TS 22.038****SIM Application Toolkit; Stage 1**

This part provides a service description for an application toolkit for use with the Subscriber Identity Module.

SDO (2)	Document No.	Version	Status	Issued date	Location (1)
<b>Release 99</b>					
T1	T1.3GPP.22.038V320-2000	3.2.0	Approved	01/06/2000	<a href="https://www.atis.org/atis/docstore/search.asp?committee=S24">https://www.atis.org/atis/docstore/search.asp?committee=S24</a>
<b>Release 5</b>					
T1	T1.3GPP.22.038V520-2003	5.2.0	Approved	27/03/2003	<a href="https://www.atis.org/atis/docstore/search.asp?committee=S24">https://www.atis.org/atis/docstore/search.asp?committee=S24</a>

**5.4.2.2.14 3GPP TS 23.003****Numbering, addressing and identification**

This document describes the principles of numbering and addressing.

SDO (2)	Document No.	Version	Status	Issued date	Location (1)
<b>Release 99</b>					
T1	T1.3GPP.23.003V3110-2003	3.11.0	Approved	09/12/2003	<a href="https://www.atis.org/atis/docstore/search.asp?committee=S24">https://www.atis.org/atis/docstore/search.asp?committee=S24</a>
TIA	Included in TIA/EIA-136-376 as ETSI TS 123 003 v3.4.0	0	Published ANS	23/04/2001	<a href="http://www.tiaonline.org/standards/sfg/imt2k/uwc136">http://www.tiaonline.org/standards/sfg/imt2k/uwc136</a>

**Release 5**

T1	T1.3GPP.23.003V540-2003	5.4.0	Approved	09/12/2003	<a href="https://www.atis.org/atis/docstore/search.asp?committee=S24">https://www.atis.org/atis/docstore/search.asp?committee=S24</a>
TIA	Included in TIA-136-376 as ETSI TS 123 003 v5.4.0	A	Published ANS	13/01/2004	<a href="http://www.tiaonline.org/standards/sfg/imt2k/uwc136">http://www.tiaonline.org/standards/sfg/imt2k/uwc136</a>

**5.4.2.2.15 3GPP TS 23.038****Alphabets and language-specific information**

This document describes alphabets and language-specific information used.

SDO (2)	Document No.	Version	Status	Issued date	Location (1)
---------	--------------	---------	--------	-------------	--------------

**Release 99**

T1	T1.3GPP.23.038V330-2000	3.3.0	Approved	01/01/2000	<a href="https://www.atis.org/atis/docstore/search.asp?committee=S24">https://www.atis.org/atis/docstore/search.asp?committee=S24</a>
TIA	Included in TIA/EIA-136-030 as ETSI TS 123 038 v3.3.0	A	Published ANS	15/04/2002	<a href="http://www.tiaonline.org/standards/sfg/imt2k/uwc136">http://www.tiaonline.org/standards/sfg/imt2k/uwc136</a>

**Release 5**

T1	T1.3GPP.23.038V500-2003	5.0.0	Approved	27/03/2003	<a href="https://www.atis.org/atis/docstore/search.asp?committee=S24">https://www.atis.org/atis/docstore/search.asp?committee=S24</a>
TIA	Included in TIA-136-030 as ETSI TS 123 038 v5.0.0	B	Published ANS	13/01/2004	<a href="http://www.tiaonline.org/standards/sfg/imt2k/uwc136">http://www.tiaonline.org/standards/sfg/imt2k/uwc136</a>

**5.4.2.2.16 3GPP TS 41.103****GSM/EDGE Release 5 specifications**

This document lists the documents that make up the GSM/EDGE Release 5 specifications.

SDO (2)	Document No.	Version	Status	Issued date	Location (1)
---------	--------------	---------	--------	-------------	--------------

**Release 5**

T1	T1.3GPP.41.103V510-2003	5.1.0	Approved	09/12/2003	<a href="https://www.atis.org/atis/docstore/search.asp?committee=S24">https://www.atis.org/atis/docstore/search.asp?committee=S24</a>
----	-------------------------	-------	----------	------------	---------------------------------------------------------------------------------------------------------------------------------------

**5.4.2.2.17 3GPP TS 02.17****Subscriber Identity Modules, Functional characteristics**

This document defines the functional characteristics for the SIM used in the GSM/EDGE specifications. Standalone SIM functionality is not specified beyond Release 4. For the latest available information see section 5.4.2.13.41.

SDO (2)	Document No.	Version	Status	Issued date	Location (1)
---------	--------------	---------	--------	-------------	--------------

**Release 99**

T1	T1.3GPP.02.17V800-2003	8.0.0	Approved	09/12/2003	<a href="https://www.atis.org/atis/docstore/search.asp?committee=S24">https://www.atis.org/atis/docstore/search.asp?committee=S24</a>
----	------------------------	-------	----------	------------	---------------------------------------------------------------------------------------------------------------------------------------

**5.4.2.2.18 3GPP TS 31.111****(U)SIM Application Toolkit**

This part describes an application toolkit for use with the Subscriber Identity Module.

SDO (2)	Document No.	Version	Status	Issued date	Location (1)
<b>Release 99</b>					
T1	T1.3GPP.11.14V8110-2003	8.11.0	Approved	09/12/2003	<a href="https://www.atis.org/atis/docstore/search.asp?committee=S24">https://www.atis.org/atis/docstore/search.asp?committee=S24</a>
TIA	Included in TIA/EIA-136-030 as GSM 11.14 (ETSI TS 101 267 v8.8.0)	A	Published ANS	15/04/2002	<a href="http://www.tiaonline.org/standards/sfg/imt2k/uwc136">http://www.tiaonline.org/standards/sfg/imt2k/uwc136</a>
<b>Release 5</b>					
T1	T1.3GPP.31.111V520-2003	5.2.0	Approved	09/12/2003	<a href="https://www.atis.org/atis/docstore/search.asp?committee=S24">https://www.atis.org/atis/docstore/search.asp?committee=S24</a>
TIA	Included in TIA-136-030 as ETSI TS 131 111 v5.2.0	B	Published ANS	13/01/2004	<a href="http://www.tiaonline.org/standards/sfg/imt2k/uwc136">http://www.tiaonline.org/standards/sfg/imt2k/uwc136</a>

**5.4.2.2.19 3GPP TS 11.11****Specification of SIM - ME Interface**

This document describes the interface between the mobile equipment and the subscriber identity module. Standalone SIM functionality is not specified beyond Release 4. For the latest available information see section 5.4.2.13.43.

SDO (2)	Document No.	Version	Status	Issued date	Location (1)
<b>Release 99</b>					
T1	T1.3GPP.11.11V880-2003	8.8.0	Approved	09/12/2003	<a href="https://www.atis.org/atis/docstore/search.asp?committee=S24">https://www.atis.org/atis/docstore/search.asp?committee=S24</a>
TIA	Included in TIA/EIA-136-370 as GSM 11.11 (ETSI TS 100 977 v8.3.0)	0	Published ANS	23/04/2001	<a href="http://www.tiaonline.org/standards/sfg/imt2k/uwc136">http://www.tiaonline.org/standards/sfg/imt2k/uwc136</a>

**5.4.2.3****Channels****5.4.2.3.1 136-100****Introduction to channels**

This part provides the protocol reference model, the logical channel definitions, and the Layer 3 message mapping through Layer 2 to the physical layer.

SDO (2)	Document No.	Version	Status	Issued date	Location (1)
TIA	TIA/EIA-136-100	B	Published ANS	31/03/2000	<a href="http://www.tiaonline.org/standards/sfg/imt2k/uwc136">http://www.tiaonline.org/standards/sfg/imt2k/uwc136</a>

**5.4.2.3.2** 136-110**RF channel assignments**

This part provides RF channel assignments for MS and BS.

SDO (2)	Document No.	Version	Status	Issued date	Location (1)
TIA	TIA/EIA-136-110	B	Published ANS	23/04/2001	<a href="http://www.tiaonline.org/standards/sfg/imt2k/uwc136">http://www.tiaonline.org/standards/sfg/imt2k/uwc136</a>

**5.4.2.3.3** 136-121**Digital control channel layer 1**

This part describes the digital control channel (DCCH) Layer 1 including the frame structures and channel/subchannel descriptions.

SDO (2)	Document No.	Version	Status	Issued date	Location (1)
TIA	TIA/EIA-136-121	A	Published ANS	29/11/1999	<a href="http://www.tiaonline.org/standards/sfg/imt2k/uwc136">http://www.tiaonline.org/standards/sfg/imt2k/uwc136</a>

**5.4.2.3.4** 136-122**Digital control channel layer 2**

This part provides the digital control channel (DCCH) Layer 2 service access points, protocols, and ARQ procedures, as well as requirements on the monitoring of radio link quality.

SDO (2)	Document No.	Version	Status	Issued date	Location (1)
TIA	TIA/EIA-136-122	B	Published ANS	31/03/2000	<a href="http://www.tiaonline.org/standards/sfg/imt2k/uwc136">http://www.tiaonline.org/standards/sfg/imt2k/uwc136</a>

**5.4.2.3.5** 136-123**Digital control channel layer 3**

This part provides the digital control channel (DCCH) Layer 3 description, including the mobile station state diagram, detailed procedures (e.g. intelligent roaming), the Layer 3 message set, information element descriptions, and timer descriptions.

SDO (2)	Document No.	Version	Status	Issued date	Location (1)
TIA	TIA-136-123	E	Published ANS	13/01/2004	<a href="http://www.tiaonline.org/standards/sfg/imt2k/uwc136">http://www.tiaonline.org/standards/sfg/imt2k/uwc136</a>

**5.4.2.3.6** 136-131**Digital traffic channel layer 1**

This part describes the digital traffic channel (DTC) Layer 1 including the channel structure, digital voice and data slot formats, modulation, and channel coding for the MS and BS.

SDO (2)	Document No.	Version	Status	Issued date	Location (1)
TIA	TIA/EIA-136-131	C	Published ANS	23/04/2001	<a href="http://www.tiaonline.org/standards/sfg/imt2k/uwc136">http://www.tiaonline.org/standards/sfg/imt2k/uwc136</a>

**5.4.2.3.7** 136-132**Digital traffic channel layer 2**

This part describes Layer 2 for the digital traffic channel (DTC), which consists primarily of supervision information.

SDO (2)	Document No.	Version	Status	Issued date	Location (1)
TIA	TIA/EIA-136-132	0	Published ANS	03/03/1999	<a href="http://www.tiaonline.org/standards/sfg/imt2k/uwc136">http://www.tiaonline.org/standards/sfg/imt2k/uwc136</a>

**5.4.2.3.8** 136-133**Digital traffic channel layer 3**

This part describes digital traffic channel (DTC) Layer 3, including discontinuous transmission, mobile assisted handoff, charging rate and total charge indication, MS control signalling and formats, smart antenna support, and per-slot power control.

SDO (2)	Document No.	Version	Status	Issued date	Location (1)
TIA	TIA-136-133	E	Published ANS	13/01/2004	<a href="http://www.tiaonline.org/standards/sfg/imt2k/uwc136">http://www.tiaonline.org/standards/sfg/imt2k/uwc136</a>

**5.4.2.3.9** 136-140**Analogue control channel**

This part describes the identification call processing, signalling formats, MS and BS requirements for the analogue control channel.

SDO (2)	Document No.	Version	Status	Issued date	Location (1)
TIA	TIA/EIA-136-140	B	Published ANS	31/03/2000	<a href="http://www.tiaonline.org/standards/sfg/imt2k/uwc136">http://www.tiaonline.org/standards/sfg/imt2k/uwc136</a>

**5.4.2.3.10** 136-150**Analogue voice channel**

This part includes descriptions of the modulation characteristics, charging indication, MS control, and signalling formats for the analogue voice channel.

SDO (2)	Document No.	Version	Status	Issued date	Location (1)
TIA	TIA/EIA-136-150	B	Published ANS	31/03/2000	<a href="http://www.tiaonline.org/standards/sfg/imt2k/uwc136">http://www.tiaonline.org/standards/sfg/imt2k/uwc136</a>

**5.4.2.3.11** 3GPP TS 45.001**Physical layer on the radio path**

This document provides a general description of the organization of the physical layer for the 200 kHz channel.

SDO (2)	Document No.	Version	Status	Issued date	Location (1)
<b>Release 99</b>					
T1	T1.3GPP.05.01V860-2003	8.6.0	Approved	09/12/2003	<a href="https://www.atis.org/atis/docstore/search.asp?committee=S24">https://www.atis.org/atis/docstore/search.asp?committee=S24</a>
TIA	Included in TIA/EIA-136-370 as GSM 05.01 (ETSI TS 100 573 v8.4.0)	0	Published ANS	23/04/2001	<a href="http://www.tiaonline.org/standards/sfg/imt2k/uwc136">http://www.tiaonline.org/standards/sfg/imt2k/uwc136</a>
<b>Release 5</b>					
T1	T1.3GPP.45.001V540-2003	5.4.0	Approved	09/12/2003	<a href="https://www.atis.org/atis/docstore/search.asp?committee=S24">https://www.atis.org/atis/docstore/search.asp?committee=S24</a>
TIA	Included in TIA-136-370 as ETSI TS 145 001 v5.4.0	A	Published ANS	13/01/2004	<a href="http://www.tiaonline.org/standards/sfg/imt2k/uwc136">http://www.tiaonline.org/standards/sfg/imt2k/uwc136</a>

#### 5.4.2.3.12 3GPP TS 45.002

##### Multiplexing and multiple access on the radio path

This document provides a description of multiplexing and multiple access techniques for the 200 kHz channel.

SDO (2)	Document No.	Version	Status	Issued date	Location (1)
<b>Release 99</b>					
T1	T1.3GPP.05.02V8100-2003	8.10.0	Approved	09/12/2003	<a href="https://www.atis.org/atis/docstore/search.asp?committee=S24">https://www.atis.org/atis/docstore/search.asp?committee=S24</a>
TIA	Included in TIA/EIA-136-370 as GSM 05.02 (ETSI EN 100 908 v8.7.0)	0	Published ANS	23/04/2001	<a href="http://www.tiaonline.org/standards/sfg/imt2k/uwc136">http://www.tiaonline.org/standards/sfg/imt2k/uwc136</a>
<b>Release 5</b>					
T1	T1.3GPP.45.002V560	5.6.0	Approved	09/12/2003	<a href="https://www.atis.org/atis/docstore/search.asp?committee=S24">https://www.atis.org/atis/docstore/search.asp?committee=S24</a>
TIA	Included in TIA-136-370 as ETSI TS 145 002 v5.6.0	A	Published ANS	13/01/2004	<a href="http://www.tiaonline.org/standards/sfg/imt2k/uwc136">http://www.tiaonline.org/standards/sfg/imt2k/uwc136</a>

#### 5.4.2.3.13 3GPP TS 45.003

##### Channel coding

This document provides a description of the channel coding for the physical layer for the 200 kHz channel.

SDO (2)	Document No.	Version	Status	Issued date	Location (1)
<b>Release 99</b>					
T1	T1.3GPP.05.03V861-2003	8.6.1	Approved	09/12/2003	<a href="https://www.atis.org/atis/docstore/search.asp?committee=S24">https://www.atis.org/atis/docstore/search.asp?committee=S24</a>
TIA	Included in TIA/EIA-136-370 as GSM 05.03 (ETSI EN 300 909 v8.5.1)	0	Published ANS	23/04/2001	<a href="http://www.tiaonline.org/standards/sfg/imt2k/uwc136">http://www.tiaonline.org/standards/sfg/imt2k/uwc136</a>
<b>Release 5</b>					
T1	T1.3GPP.45.003V560-2003	5.6.0	Approved	09/12/2003	<a href="https://www.atis.org/atis/docstore/search.asp?committee=S24">https://www.atis.org/atis/docstore/search.asp?committee=S24</a>
TIA	Included in TIA-136-370 as ETSI TS 145 003 v5.6.0	A	Published ANS	13/01/2004	<a href="http://www.tiaonline.org/standards/sfg/imt2k/uwc136">http://www.tiaonline.org/standards/sfg/imt2k/uwc136</a>

**5.4.2.3.14 3GPP TS 45.004****Modulation**

This document provides a description of the modulation techniques for the 200 kHz channel.

SDO (2)	Document No.	Version	Status	Issued date	Location (1)
<b>Release 99</b>					
T1	T1.3GPP.05.04V840-2003	8.4.0	Approved	09/12/2003	<a href="https://www.atis.org/atis/docstore/search.asp?committee=S24">https://www.atis.org/atis/docstore/search.asp?committee=S24</a>
TIA	Included in TIA/EIA-136-370 as GSM 05.04 (ETSI EN 300 959 v8.1.2)	0	Published ANS	23/04/2001	<a href="http://www.tiaonline.org/standards/sfg/imt2k/uwc136">http://www.tiaonline.org/standards/sfg/imt2k/uwc136</a>
<b>Release 5</b>					
T1	T1.3GPP.45.004V510-2003	5.1.0	Approved	09/12/2003	<a href="https://www.atis.org/atis/docstore/search.asp?committee=S24">https://www.atis.org/atis/docstore/search.asp?committee=S24</a>
TIA	Included in TIA-136-370 as ETSI TS 145 004 v5.1.0	A	Published ANS	13/01/2004	<a href="http://www.tiaonline.org/standards/sfg/imt2k/uwc136">http://www.tiaonline.org/standards/sfg/imt2k/uwc136</a>

**5.4.2.3.15 3GPP TS 45.005****Radio transmission and reception**

This document provides a general description of the radio transmission and reception for the 200 kHz channel.

SDO (2)	Document No.	Version	Status	Issued date	Location (1)
<b>Release 99</b>					
T1	T1.3GPP.05.05V8140-2003	8.14.0	Approved	09/12/2003	<a href="https://www.atis.org/atis/docstore/search.asp?committee=S24">https://www.atis.org/atis/docstore/search.asp?committee=S24</a>
TIA	Included in TIA/EIA-136-370 as GSM 05.05 (ETSI EN 300 910 v8.5.1)	0	Published ANS	23/04/2001	<a href="http://www.tiaonline.org/standards/sfg/imt2k/uwc136">http://www.tiaonline.org/standards/sfg/imt2k/uwc136</a>
<b>Release 5</b>					
T1	T1.3GPP.45.005V550-2003	5.5.0	Approved	09/12/2003	<a href="https://www.atis.org/atis/docstore/search.asp?committee=S24">https://www.atis.org/atis/docstore/search.asp?committee=S24</a>
TIA	Included in TIA-136-370 as ETSI TS 145 005 v5.5.0	A	Published ANS	13/01/2004	<a href="http://www.tiaonline.org/standards/sfg/imt2k/uwc136">http://www.tiaonline.org/standards/sfg/imt2k/uwc136</a>

**5.4.2.3.16 3GPP TS 45.008****Radio Subsystem Link Control**

This document provides a general description of the radio link control for the 200 kHz channel.

SDO (2)	Document No.	Version	Status	Issued date	Location (1)
<b>Release 99</b>					
T1	T1.3GPP.05.08V8150-2003	8.15.0	Approved	09/12/2003	<a href="https://www.atis.org/atis/docstore/search.asp?committee=S24">https://www.atis.org/atis/docstore/search.asp?committee=S24</a>
TIA	Included in TIA/EIA-136-370 as GSM 05.08 (ETSI TS 100 911 v8.5.0)	0	Published ANS	23/04/2001	<a href="http://www.tiaonline.org/standards/sfg/imt2k/uwc136">http://www.tiaonline.org/standards/sfg/imt2k/uwc136</a>

**Release 5**

T1	T1.3GPP.45.008V580-2003	5.8.0	Approved	09/12/2003	<a href="https://www.atis.org/atis/docstore/search.asp?committee=S24">https://www.atis.org/atis/docstore/search.asp?committee=S24</a>
TIA	Included in TIA-136-370 as ETSI TS 145 008 v5.8.0	A	Published ANS	13/01/2004	<a href="http://www.tiaonline.org/standards/sfg/imt2k/uwc136">http://www.tiaonline.org/standards/sfg/imt2k/uwc136</a>

**5.4.2.3.17 3GPP TS 45.009****Link Adaptation**

This document provides a general description of the link adaptation for the 200 kHz channel.

SDO (2)	Document No.	Version	Status	Issued date	Location (1)
<b>Release 98</b>					
TIA	Included in TIA/EIA-136-440 as GSM 05.09 (ETSI TS 101 709 v7.3.0)	0	Published ANS	23/04/2001	<a href="http://www.tiaonline.org/standards/sfg/imt2k/uwc136">http://www.tiaonline.org/standards/sfg/imt2k/uwc136</a>
<b>Release 99</b>					
T1	T1.3GPP.05.09V850-2003	8.5.0	Approved	09/12/2003	<a href="https://www.atis.org/atis/docstore/search.asp?committee=S24">https://www.atis.org/atis/docstore/search.asp?committee=S24</a>
<b>Release 5</b>					
T1	T1.3GPP.45.009V550-2003	5.5.0	Approved	09/12/2003	<a href="https://www.atis.org/atis/docstore/search.asp?committee=S24">https://www.atis.org/atis/docstore/search.asp?committee=S24</a>
TIA	Included in TIA-136-440 as ETSI TS 145 009 v5.5.0)	A	Published ANS	13/01/2004	<a href="http://www.tiaonline.org/standards/sfg/imt2k/uwc136">http://www.tiaonline.org/standards/sfg/imt2k/uwc136</a>

**5.4.2.3.18 3GPP TS 45.010****Radio Subsystem Synchronization**

This document provides a description of the synchronization of the radio link for the 200 kHz channel.

SDO (2)	Document No.	Version	Status	Issued date	Location (1)
<b>Release 99</b>					
T1	T1.3GPP.05.10V8100-2003	8.10.0	Approved	09/12/2003	<a href="https://www.atis.org/atis/docstore/search.asp?committee=S24">https://www.atis.org/atis/docstore/search.asp?committee=S24</a>
TIA	Included in TIA/EIA-136-370 as GSM 05.10 (ETSI TS 100 912 v8.4.0)	0	Published ANS	23/04/2001	<a href="http://www.tiaonline.org/standards/sfg/imt2k/uwc136">http://www.tiaonline.org/standards/sfg/imt2k/uwc136</a>
<b>Release 5</b>					
T1	T1.3GPP.45.010V510-2003	5.1.0	Approved	09/12/2003	<a href="https://www.atis.org/atis/docstore/search.asp?committee=S24">https://www.atis.org/atis/docstore/search.asp?committee=S24</a>
TIA	Included in TIA-136-370 as ETSI TS 145 010 v5.1.0	A	Published ANS	13/01/2004	<a href="http://www.tiaonline.org/standards/sfg/imt2k/uwc136">http://www.tiaonline.org/standards/sfg/imt2k/uwc136</a>



**5.4.2.3.19 3GPP TS 45.022****Radio Link management in hierarchical networks**

This document describes the radio link management for hierarchical networks.

SDO (2)	Document No.	Version	Status	Issued date	Location (1)
<b>Release 99</b>					
T1	T1.3GPP.05.22V800-2003	8.0.0	Approved	09/12/2003	<a href="https://www.atis.org/atis/docstore/search.asp?committee=S24">https://www.atis.org/atis/docstore/search.asp?committee=S24</a>
T1	T1.3GPP.45.022V500-2003	5.0.0	Approved	09/12/2003	<a href="https://www.atis.org/atis/docstore/search.asp?committee=S24">https://www.atis.org/atis/docstore/search.asp?committee=S24</a>

**5.4.2.3.20 3GPP TS 44.001****Mobile Station - Base station system interface general aspects**

This document provides a general description of the mobile station - Base station system (MS-BSS) interface for the 200 kHz channel.

SDO (2)	Document No.	Version	Status	Issued date	Location (1)
<b>Release 99</b>					
T1	T1.3GPP.44.001V500-2003	5.0.0	Approved	09/12/2003	<a href="https://www.atis.org/atis/docstore/search.asp?committee=S24">https://www.atis.org/atis/docstore/search.asp?committee=S24</a>
T1	T1.3GPP. 04.01V800-2003	8.0.0	Approved	09/12/2003	<a href="https://www.atis.org/atis/docstore/search.asp?committee=S24">https://www.atis.org/atis/docstore/search.asp?committee=S24</a>

**5.4.2.3.21 3GPP TS 44.003****Mobile Station - Base station system interface channel structures and access capabilities**

This document provides a description of the channel structures and access capabilities for the mobile station - Base station system (MS-BSS) interface for the 200 kHz channel.

SDO (2)	Document No.	Version	Status	Issued date	Location (1)
<b>Release 99</b>					
T1	T1.3GPP.04.03V802-2003	8.0.2	Approved	09/12/2003	<a href="https://www.atis.org/atis/docstore/search.asp?committee=S24">https://www.atis.org/atis/docstore/search.asp?committee=S24</a>
T1	T1.3GPP.44.003V500-2003	5.0.0	Approved	09/12/2003	<a href="https://www.atis.org/atis/docstore/search.asp?committee=S24">https://www.atis.org/atis/docstore/search.asp?committee=S24</a>

**5.4.2.3.22 3GPP TS 44.004****Layer 1 General requirements**

This document provides a general description of the requirements for Layer 1 for the 200 kHz channel.

SDO (2)	Document No.	Version	Status	Issued date	Location (1)
<b>Release 99</b>					
T1	T1.3GPP. 44.004V520-2003	5.2.0	Approved	09/12/2003	<a href="https://www.atis.org/atis/docstore/search.asp?committee=S24">https://www.atis.org/atis/docstore/search.asp?committee=S24</a>
T1	T1.3GPP.04.04V812-2003	8.1.2	Approved	09/12/2003	<a href="https://www.atis.org/atis/docstore/search.asp?committee=S24">https://www.atis.org/atis/docstore/search.asp?committee=S24</a>

### 5.4.2.3.23 3GPP TS 44.005

#### Data Link (DL) layer general aspects

This document provides a general description of the Data Link layer for the 200 kHz channel.

SDO (2)	Document No.	Version	Status	Issued date	Location (1)
<b>Release 99</b>					
T1	T1.3GPP.04.05V802-2003	8.0.2	Approved	09/12/2003	<a href="https://www.atis.org/atis/docstore/search.asp?committee=S24">https://www.atis.org/atis/docstore/search.asp?committee=S24</a>
TIA	Included in TIA/EIA-136-370 as GSM 04.05 (ETSI EN 300 937 v8.0.1)	0	Published ANS	23/04/2001	<a href="http://www.tiaonline.org/standards/sfg/imt2k/uwc136">http://www.tiaonline.org/standards/sfg/imt2k/uwc136</a>
<b>Release 5</b>					
T1	T1.3GPP.44.005V500-2003	5.0.0	Approved	09/12/2003	<a href="https://www.atis.org/atis/docstore/search.asp?committee=S24">https://www.atis.org/atis/docstore/search.asp?committee=S24</a>
TIA	Included in TIA-136-370 as ETSI TS 144 005 v5.0.0	A	Published ANS	13/01/2004	<a href="http://www.tiaonline.org/standards/sfg/imt2k/uwc136">http://www.tiaonline.org/standards/sfg/imt2k/uwc136</a>

### 5.4.2.3.24 3GPP TS 44.006

#### Mobile Station - Base station system interface Data link layer specification

This document provides the specification of the data link layer for the mobile station -Base station system (MS-BSS) interface for the 200 kHz channel.

SDO (2)	Document No.	Version	Status	Issued date	Location (1)
<b>Release 99</b>					
T1	T1.3GPP.04.06V821-2003	8.2.1	Approved	09/12/2003	<a href="https://www.atis.org/atis/docstore/search.asp?committee=S24">https://www.atis.org/atis/docstore/search.asp?committee=S24</a>
<b>Release 5</b>					
T1	T1.3GPP.44.006V500-2003	5.0.0	Approved	09/12/2003	<a href="https://www.atis.org/atis/docstore/search.asp?committee=S24">https://www.atis.org/atis/docstore/search.asp?committee=S24</a>

### 5.4.2.3.25 3GPP TS 44.018

#### Mobile Radio interface Layer 3 specification, RRC protocol

This document provides a description of the Radio Resource Control protocol of the layer 3 Mobile Radio interface for the 200 kHz channel.

SDO (2)	Document No.	Version	Status	Issued date	Location (1)
<b>Release 99</b>					
T1	T1.3GPP.04.18V8160-2003	8.16.0	Approved	09/12/2003	<a href="https://www.atis.org/atis/docstore/search.asp?committee=S24">https://www.atis.org/atis/docstore/search.asp?committee=S24</a>
TIA	Included in TIA/EIA-136-370 as GSM 04.18 (ETSI TS 101 503 v8.5.0)	0	Published ANS	23/04/2001	<a href="http://www.tiaonline.org/standards/sfg/imt2k/uwc136">http://www.tiaonline.org/standards/sfg/imt2k/uwc136</a>
<b>Release 5</b>					
T1	T1.3GPP.44.018V570-2003	5.7.0	Approved	09/12/2003	<a href="https://www.atis.org/atis/docstore/search.asp?committee=S24">https://www.atis.org/atis/docstore/search.asp?committee=S24</a>
TIA	Included in TIA-136-370 as ETSI TS 144 018 v5.7.0	A	Published ANS	13/01/2004	<a href="http://www.tiaonline.org/standards/sfg/imt2k/uwc136">http://www.tiaonline.org/standards/sfg/imt2k/uwc136</a>

**5.4.2.3.26 3GPP TS 44.021****Rate Adaption on the Mobile Station - Base station system (MS-BSS) interface**

This document provides the specification of rate adaption on the mobile station - Base station system (MS-BSS) interface for the 200 kHz channel.

SDO (2)	Document No.	Version	Status	Issued date	Location (1)
<b>Release 99</b>					
T1	T1.3GPP.04.21V830-2003	8.3.0	Approved	09/12/2003	<a href="https://www.atis.org/atis/docstore/search.asp?committee=S24">https://www.atis.org/atis/docstore/search.asp?committee=S24</a>
<b>Release 5</b>					
T1	T1.3GPP.44.021V511-2003	5.1.1	Approved	09/12/2003	<a href="https://www.atis.org/atis/docstore/search.asp?committee=S24">https://www.atis.org/atis/docstore/search.asp?committee=S24</a>

**5.4.2.3.27 3GPP TS 44.031****Location Services (LCS); Mobile station - Serving mobile location centre (SMLC) radio resource LCS protocol**

This document provides the specification of the radio resource LCS protocol for the 200 kHz channel.

SDO (2)	Document No.	Version	Status	Issued date	Location (1)
<b>Release 99</b>					
T1	T1.3GPP.04.31V8100-2003	8.10.0	Approved	09/12/2003	<a href="https://www.atis.org/atis/docstore/search.asp?committee=S24">https://www.atis.org/atis/docstore/search.asp?committee=S24</a>
TIA	Included in TIA/EIA-136-740 as GSM 04.31 (ETSI TS 101 527 v8.1.0)	0	Published ANS	23/04/2001	<a href="http://www.tiaonline.org/standards/sfg/imt2k/uwc136">http://www.tiaonline.org/standards/sfg/imt2k/uwc136</a>
<b>Release 5</b>					
T1	T1.3GPP.44.031V550-2003	5.5.0	Approved	09/12/2003	<a href="https://www.atis.org/atis/docstore/search.asp?committee=S24">https://www.atis.org/atis/docstore/search.asp?committee=S24</a>

**5.4.2.3.28 3GPP TS 44.035****Broadcast network assistance for E-OTD and GPS positioning methods**

This document provides the specification of broadcast assistance data for location services.

SDO (2)	Document No.	Version	Status	Issued date	Location (1)
<b>Release 99</b>					
T1	T1.3GPP.04.35V841-2003	8.4.1	Approved	09/12/2003	<a href="https://www.atis.org/atis/docstore/search.asp?committee=S24">https://www.atis.org/atis/docstore/search.asp?committee=S24</a>
TIA	Included in TIA/EIA-136-740 as GSM 04.35 (ETSI TS 101 528 v8.1.0)	0	Published ANS	23/04/2001	<a href="http://www.tiaonline.org/standards/sfg/imt2k/uwc136">http://www.tiaonline.org/standards/sfg/imt2k/uwc136</a>
<b>Release 5</b>					
T1	T1.3GPP.44.035V500-2003	5.0.0	Approved	09/12/2003	<a href="https://www.atis.org/atis/docstore/search.asp?committee=S24">https://www.atis.org/atis/docstore/search.asp?committee=S24</a>

**5.4.2.3.29 3GPP TS 44.068****Group Call control (GCC) protocol**

This document defines the protocol for the group call function.

282

## Rec. ITU-R M.1457-4

SDO (2)	Document No.	Version	Status	Issued date	Location (1)
<b>Release 99</b>					
T1	T1.3GPP.04.68V810-2003	8.1.0	Approved	09/12/2003	<a href="https://www.atis.org/atis/docstore/search.asp?committee=S24">https://www.atis.org/atis/docstore/search.asp?committee=S24</a>
<b>Release 5</b>					
T1	T1.3GPP.44.068V501-2003	5.0.1	Approved	09/12/2003	<a href="https://www.atis.org/atis/docstore/search.asp?committee=S24">https://www.atis.org/atis/docstore/search.asp?committee=S24</a>

### 5.4.2.3.30 3GPP TS 44.069

#### Broadcast Call control (GCC) protocol

This document defines the protocol for the broadcast call function.

SDO (2)	Document No.	Version	Status	Issued date	Location (1)
<b>Release 99</b>					
T1	T1.3GPP.04.69V810-2003	8.1.0	Approved	09/12/2003	<a href="https://www.atis.org/atis/docstore/search.asp?committee=S24">https://www.atis.org/atis/docstore/search.asp?committee=S24</a>
<b>Release 5</b>					
T1	T1.3GPP.44.069V500-2003	5.0.0	Approved	09/12/2003	<a href="https://www.atis.org/atis/docstore/search.asp?committee=S24">https://www.atis.org/atis/docstore/search.asp?committee=S24</a>

### 5.4.2.3.31 3GPP TS 44.071

#### Location Services (LCS); Mobile radio interface layer 3 specification

This document provides the location services layer 3 specification for the 200 kHz channel.

SDO (2)	Document No.	Version	Status	Issued date	Location (1)
<b>Release 99</b>					
T1	T1.3GPP.04.71V840-2003	8.4.0	Approved	09/12/2003	<a href="https://www.atis.org/atis/docstore/search.asp?committee=S24">https://www.atis.org/atis/docstore/search.asp?committee=S24</a>
<b>Release 5</b>					
T1	T1.3GPP.44.071V500-2003	5.0.0	Approved	09/12/2003	<a href="https://www.atis.org/atis/docstore/search.asp?committee=S24">https://www.atis.org/atis/docstore/search.asp?committee=S24</a>

### 5.4.2.3.32 3GPP TS 43.010

#### GSM Public Land Mobile Network (PLMN) Connection types

This document describes the connection types for the alternate circuit switched component.

SDO (2)	Document No.	Version	Status	Issued date	Location (1)
<b>Release 99</b>					
T1	T1.3GPP. 03.10V830-2003	8.3.0	Approved	09/12/2003	<a href="https://www.atis.org/atis/docstore/search.asp?committee=S24">https://www.atis.org/atis/docstore/search.asp?committee=S24</a>
<b>Release 5</b>					
T1	T1.3GPP. 43.010V510-2003	5.1.0	Approved	09/12/2003	<a href="https://www.atis.org/atis/docstore/search.asp?committee=S24">https://www.atis.org/atis/docstore/search.asp?committee=S24</a>

**5.4.2.3.33 3GPP TS 43.013****Discontinuous Reception (DRX) in the GSM system**

This document describes the discontinuous reception function for the alternate circuit switched component.

SDO (2)	Document No.	Version	Status	Issued date	Location (1)
<b>Release 99</b>					
T1	T1.3GPP.03.13V800-2003	8.0.0	Approved	09/12/2003	<a href="https://www.atis.org/atis/docstore/search.asp?committee=S24">https://www.atis.org/atis/docstore/search.asp?committee=S24</a>
<b>Release 5</b>					
T1	T1.3GPP.43.013V500-2003	5.0.0	Approved	09/12/2003	<a href="https://www.atis.org/atis/docstore/search.asp?committee=S24">https://www.atis.org/atis/docstore/search.asp?committee=S24</a>

**5.4.2.3.34 3GPP TS 43.022****Functions related to Mobile Station in idle mode and group receive mode**

This document describes the mobile station functions during idle or group receive mode for the alternate circuit switched component.

SDO (2)	Document No.	Version	Status	Issued date	Location (1)
<b>Release 99</b>					
T1	T1.3GPP.03.22V870-2003	8.7.0	Approved	09/12/2003	<a href="https://www.atis.org/atis/docstore/search.asp?committee=S24">https://www.atis.org/atis/docstore/search.asp?committee=S24</a>
<b>Release 5</b>					
T1	T1.3GPP.43.022V510-2003	5.1.0	Approved	09/12/2003	<a href="https://www.atis.org/atis/docstore/search.asp?committee=S24">https://www.atis.org/atis/docstore/search.asp?committee=S24</a>

**5.4.2.3.35 3GPP TR 43.055****Dual Transfer Mode (DTM)**

This document describes the dual mode operation of a mobile station in both packet and circuit mode.

SDO (2)	Document No.	Version	Status	Issued date	Location (1)
<b>Release 99</b>					
T1	T1.3GPP.03.55V800-2003	8.0.0	Approved	09/12/2003	<a href="https://www.atis.org/atis/docstore/search.asp?committee=S24">https://www.atis.org/atis/docstore/search.asp?committee=S24</a>
T1	T1.3GPP.43.055V500-2003	5.0.0	Approved	09/12/2003	<a href="https://www.atis.org/atis/docstore/search.asp?committee=S24">https://www.atis.org/atis/docstore/search.asp?committee=S24</a>

**5.4.2.3.36 3GPP TS 24.007****Mobile Radio interface Signalling Layer 3, General Aspects**

This document provides a description of the signalling aspects of the layer 3 Mobile Radio interface for the 200 kHz channel.

SDO (2)	Document No.	Version	Status	Issued date	Location (1)
<b>Release 99</b>					
T1	T1.3GPP.24.007V390-2003	3.9.0	Approved	09/12/2003	<a href="https://www.atis.org/atis/docstore/search.asp?committee=S24">https://www.atis.org/atis/docstore/search.asp?committee=S24</a>
TIA	Included in TIA/EIA-136-376 as ETSI TS 124 007 v3.3.1	0	Published ANS	23/04/2001	<a href="http://www.tiaonline.org/standards/sfg/imt2k/uwc136">http://www.tiaonline.org/standards/sfg/imt2k/uwc136</a>

**Release 5**

T1	T1.3GPP.24.007V510-2003	5.1.0	Approved	27/03/2003	<a href="https://www.atis.org/atis/docstore/search.asp?committee=S24">https://www.atis.org/atis/docstore/search.asp?committee=S24</a>
TIA	Included in TIA-136-376 as ETSI TS 124 007 v5.1.0	A	Published ANS	13/01/2004	<a href="http://www.tiaonline.org/standards/sfg/imt2k/uwc136">http://www.tiaonline.org/standards/sfg/imt2k/uwc136</a>

**5.4.2.3.37 3GPP TS 24.008****Mobile Radio interface Layer 3, Core Network protocols - Stage 3**

This document provides a description of the Core network protocols of the layer 3 Mobile Radio interface for the 200 kHz channel.

SDO (2)	Document No.	Version	Status	Issued date	Location (1)
---------	--------------	---------	--------	-------------	--------------

**Release 99**

T1	T1.3GPP.24.008V3130-2003	3.13.0	Approved	09/12/2003	<a href="https://www.atis.org/atis/docstore/search.asp?committee=S24">https://www.atis.org/atis/docstore/search.asp?committee=S24</a>
TIA	Included in TIA/EIA-136-376 as ETSI TS 124 008 v3.3.1	0	Published ANS	23/04/2001	<a href="http://www.tiaonline.org/standards/sfg/imt2k/uwc136">http://www.tiaonline.org/standards/sfg/imt2k/uwc136</a>

**Release 5**

T1	T1.3GPP.24.008V550-2003	5.5.0	Approved	09/12/2003	<a href="https://www.atis.org/atis/docstore/search.asp?committee=S24">https://www.atis.org/atis/docstore/search.asp?committee=S24</a>
TIA	Included in TIA-136-376 as ETSI TS 124 008 v5.5.0	A	Published ANS	13/01/2004	<a href="http://www.tiaonline.org/standards/sfg/imt2k/uwc136">http://www.tiaonline.org/standards/sfg/imt2k/uwc136</a>

**5.4.2.3.38 3GPP TS 24.010****Mobile Radio interface Layer 3, Supplementary services -General**

This document provides a general description of the supplementary services of the layer 3 Mobile Radio interface for the 200 kHz channel.

SDO (2)	Document No.	Version	Status	Issued date	Location (1)
---------	--------------	---------	--------	-------------	--------------

**Release 99**

T1	T1.3GPP.24.010V320-2002	3.2.0	Approved	03/05/2002	<a href="https://www.atis.org/atis/docstore/search.asp?committee=S24">https://www.atis.org/atis/docstore/search.asp?committee=S24</a>
----	-------------------------	-------	----------	------------	---------------------------------------------------------------------------------------------------------------------------------------

**Release 5**

T1	T1.3GPP.24.010V500-2003	5.0.0	Approved	27/03/2003	<a href="https://www.atis.org/atis/docstore/search.asp?committee=S24">https://www.atis.org/atis/docstore/search.asp?committee=S24</a>
----	-------------------------	-------	----------	------------	---------------------------------------------------------------------------------------------------------------------------------------

**5.4.2.3.39 3GPP TS 24.022****Radio Link Protocol (RLP) for circuit switched bearer and teleservices**

This document provides a general description of the radio link protocol for the circuit switched bearer and teleservices for the 200 kHz channel.

SDO (2)	Document No.	Version	Status	Issued date	Location (1)
---------	--------------	---------	--------	-------------	--------------

**Release 99**

T1	T1.3GPP.24.022V340-2002	3.4.0	Approved	03/05/2002	<a href="https://www.atis.org/atis/docstore/search.asp?committee=S24">https://www.atis.org/atis/docstore/search.asp?committee=S24</a>
----	-------------------------	-------	----------	------------	---------------------------------------------------------------------------------------------------------------------------------------

**Release 5**

T1	T1.3GPP.24.022V500-2003	5.0.0	Approved	09/12/2003	<a href="https://www.atis.org/atis/docstore/search.asp?committee=S24">https://www.atis.org/atis/docstore/search.asp?committee=S24</a>
----	-------------------------	-------	----------	------------	---------------------------------------------------------------------------------------------------------------------------------------

**5.4.2.4****Minimum performance****5.4.2.4.1 136-210****ACELP minimum performance**

This part details the BS minimum performance requirements for the ACELP vocoder.

SDO (2)	Document No.	Version	Status	Issued date	Location (1)
TIA	TIA/EIA-136-210	A	Published ANS	23/04/2001	<a href="http://www.tiaonline.org/standards/sfg/imt2k/uwc136">http://www.tiaonline.org/standards/sfg/imt2k/uwc136</a>

**5.4.2.4.2 136-220****VSELP minimum performance**

This part details the minimum performance requirements for the VSELP vocoder. This standard includes a software distribution.

SDO (2)	Document No.	Version	Status	Issued date	Location (1)
TIA	TIA/EIA-136-220	0	Published ANS	31/03/2000	<a href="http://www.tiaonline.org/standards/sfg/imt2k/uwc136">http://www.tiaonline.org/standards/sfg/imt2k/uwc136</a>

**5.4.2.4.3 136-230****US1 minimum performance**

This part details the BS minimum performance requirements for the US1 vocoder. This standard includes a software distribution.

SDO (2)	Document No.	Version	Status	Issued date	Location (1)
TIA	TIA/EIA-136-230	0	Published ANS	31/03/2000	<a href="http://www.tiaonline.org/standards/sfg/imt2k/uwc136">http://www.tiaonline.org/standards/sfg/imt2k/uwc136</a>

**5.4.2.4.4 136-240****Minimum Performance for Adaptive Multi-rate Codec**

This part details the minimum performance requirements for the Adaptive Multi-Rate voice coder. This standard includes a software distribution.

SDO (2)	Document No.	Version	Status	Issued date	Location (1)
TIA	TIA/EIA-136-240	0	Published ANS	23/04/2001	<a href="http://www.tiaonline.org/standards/sfg/imt2k/uwc136">http://www.tiaonline.org/standards/sfg/imt2k/uwc136</a>

**5.4.2.4.5 136-250****VAD Minimum Performance**

This part details the minimum performance requirements for the Voice Activity Detection feature. This standard includes a software distribution.

SDO (2)	Document No.	Version	Status	Issued date	Location (1)
TIA	TIA/EIA-136-250	0	Published ANS	23/04/2001	<a href="http://www.tiaonline.org/standards/sfg/imt2k/uwc136">http://www.tiaonline.org/standards/sfg/imt2k/uwc136</a>

**5.4.2.4.6** 136-270**Mobile stations minimum performance**

This part details definitions, methods of measurement, and MS minimum performance requirements operating 136? bearers.

SDO (2)	Document No.	Version	Status	Issued date	Location (1)
TIA	TIA/EIA-136-270	C	Published ANS	23/04/2001	<a href="http://www.tiaonline.org/standards/sfg/imt2k/uwc136">http://www.tiaonline.org/standards/sfg/imt2k/uwc136</a>

**5.4.2.4.7** 136-271**Mobile stations minimum performance for Global Circulation**

This part details definitions, methods of measurement, and minimum performance requirements for 2 GHz Wireless1 mobile stations. Unless otherwise stated, these requirements apply only to digital operation, within the regulatory mandates of the European Union “Electromagnetic compatibility and Radio spectrum Matters (ERM); Base stations (BS) and user equipment (UE) for IMT-2000 Third Generation cellular networks; Part 8: Harmonized EN for IMT-2000 TDMA Single Carrier (UWC 136) (UE)” covering essential requirements of article 3.2 of the R&TTE Directive.

SDO (2)	Document No.	Version	Status	Issued date	Location (1)
TIA	TIA/EIA-136-271	0	Published ANS	15/04/2002	<a href="http://www.tiaonline.org/standards/sfg/imt2k/uwc136">http://www.tiaonline.org/standards/sfg/imt2k/uwc136</a>

**5.4.2.4.8** 136-280**Base stations minimum performance**

This part details definitions, methods of measurement, and BS minimum performance requirements operating 136? bearers.

SDO (2)	Document No.	Version	Status	Issued date	Location (1)
TIA	TIA/EIA-136-280	D	Published ANS	29/04/2002	<a href="http://www.tiaonline.org/standards/sfg/imt2k/uwc136">http://www.tiaonline.org/standards/sfg/imt2k/uwc136</a>

**5.4.2.4.9** 136-290**RF Minimum performance requirements for 136HS Outdoor and 136HS Indoor bearers**

This part details the RF minimum performance requirements for BS and MS operating 136HS/136EHS Outdoor and 136HS Indoor bearers.

SDO (2)	Document No.	Version	Status	Issued date	Location (1)
TIA	TIA/EIA-136-290	A	Published ANS	23/04/2001	<a href="http://www.tiaonline.org/standards/sfg/imt2k/uwc136">http://www.tiaonline.org/standards/sfg/imt2k/uwc136</a>

**5.4.2.4.10** 3GPP TS 23.122**NAS Functions related to Mobile Station in idle mode**

This part details the Non-Access Stratum functional requirements of the Mobile station in idle mode.



SDO (2)	Document No.	Version	Status	Issued date	Location (1)
<b>Release 99</b>					
T1	T1.3GPP.23.122V380-2003	3.8.0	Approved	09/12/2003	<a href="https://www.atis.org/atis/docstore/search.asp?committee=S24">https://www.atis.org/atis/docstore/search.asp?committee=S24</a>
TIA	Included in TIA/EIA-136-370 as ETSI TS 123 122 v3.2.0	0	Published ANS	23/04/2001	<a href="http://www.tiaonline.org/standards/sfg/imt2k/uwc136">http://www.tiaonline.org/standards/sfg/imt2k/uwc136</a>
<b>Release 5</b>					
T1	T1.3GPP.23.122V510-2003	5.1.0	Approved	09/12/2003	<a href="https://www.atis.org/atis/docstore/search.asp?committee=S24">https://www.atis.org/atis/docstore/search.asp?committee=S24</a>
TIA	Included in TIA-136-370 as ETSI TS 123 122 v5.1.0	A	Published ANS	13/01/2004	<a href="http://www.tiaonline.org/standards/sfg/imt2k/uwc136">http://www.tiaonline.org/standards/sfg/imt2k/uwc136</a>

#### 5.4.2.4.11 3GPP TS 27.060

##### Packet Domain; MS supporting packet switched services

This part details the packet domain functional requirements of the Mobile station.

SDO (2)	Document No.	Version	Status	Issued date	Location (1)
<b>Release 99</b>					
T1	T1.3GPP.27.060V370-2003	3.7.0	Approved	09/12/2003	<a href="https://www.atis.org/atis/docstore/search.asp?committee=S24">https://www.atis.org/atis/docstore/search.asp?committee=S24</a>
TIA	Included in TIA/EIA-136-370 as ETSI TS 127 060 v3.4.0	0	Published ANS	23/04/2001	<a href="http://www.tiaonline.org/standards/sfg/imt2k/uwc136">http://www.tiaonline.org/standards/sfg/imt2k/uwc136</a>
<b>Release 5</b>					
T1	T1.3GPP.27.060V520-2003	5.2.0	Approved	09/12/2003	<a href="https://www.atis.org/atis/docstore/search.asp?committee=S24">https://www.atis.org/atis/docstore/search.asp?committee=S24</a>
TIA	Included in TIA-136-370 as ETSI TS 127 060 v5.2.0	A	Published ANS	13/01/2004	<a href="http://www.tiaonline.org/standards/sfg/imt2k/uwc136">http://www.tiaonline.org/standards/sfg/imt2k/uwc136</a>

#### 5.4.2.4.12 3GPP TS 11.17

##### SIM conformance test specification

This part details the conformance test requirements of the Subscriber Identity Module. Standalone SIM functionality is not specified beyond Release 4. For the latest available information see section 5.4.2.13.44.

SDO (2)	Document No.	Version	Status	Issued date	Location (1)
<b>Release 98</b>					
TIA	Included in TIA/EIA-136-030 as GSM 11.17 (ETSI TS 301 086 v7.0.2)	A	Published ANS	15/04/2002	<a href="http://www.tiaonline.org/standards/sfg/imt2k/uwc136">http://www.tiaonline.org/standards/sfg/imt2k/uwc136</a>
<b>Release 99</b>					
T1	T1.3GPP.11.17V810-2003	8.1.0	Approved	09/12/2003	<a href="https://www.atis.org/atis/docstore/search.asp?committee=S24">https://www.atis.org/atis/docstore/search.asp?committee=S24</a>

**5.4.2.4.13 3GPP TS 43.058****Characterization, test methods, and quality assessment for handsfree Mobile Stations**

This document describes the testing and characterization of handsfree devices for MSs.

SDO (2)	Document No.	Version	Status	Issued date	Location (1)
<b>Release 99</b>					
T1	T1.3GPP.03.58V800-2003	8.0.0	Approved	09/12/2003	<a href="https://www.atis.org/atis/docstore/search.asp?committee=S24">https://www.atis.org/atis/docstore/search.asp?committee=S24</a>
<b>Release 5</b>					
T1	T1.3GPP.43.058V500-2003	5.0.0	Approved	09/12/2003	<a href="https://www.atis.org/atis/docstore/search.asp?committee=S24">https://www.atis.org/atis/docstore/search.asp?committee=S24</a>

**5.4.2.4.14 3GPP TS 44.013****Performance requirements on mobile radio interface**

This part details the performance requirements of the Mobile station radio interface.

SDO (2)	Document No.	Version	Status	Issued date	Location (1)
<b>Release 99</b>					
T1	T1.3GPP.04.13V801-2003	8.0.1	Approved	09/12/2003	<a href="https://www.atis.org/atis/docstore/search.asp?committee=S24">https://www.atis.org/atis/docstore/search.asp?committee=S24</a>
<b>Release 5</b>					
T1	T1.3GPP.44.013V500-2003	5.0.0	Approved	09/12/2003	<a href="https://www.atis.org/atis/docstore/search.asp?committee=S24">https://www.atis.org/atis/docstore/search.asp?committee=S24</a>

**5.4.2.4.15 3GPP TS 44.014****Individual equipment type requirements and interworking; Special conformance testing**

This part details the packet domain functional requirements of the Mobile station.

SDO (2)	Document No.	Version	Status	Issued date	Location (1)
<b>Release 99</b>					
T1	T1.3GPP.04.14V840-2003	8.4.0	Approved	09/12/2003	<a href="https://www.atis.org/atis/docstore/search.asp?committee=S24">https://www.atis.org/atis/docstore/search.asp?committee=S24</a>
TIA	Included in TIA/EIA-136-290 as GSM 04.14 (ETSI TS 101 293 v8.1.0)	A	Published ANS	23/04/2001	<a href="http://www.tiaonline.org/standards/sfg/imt2k/uwc136">http://www.tiaonline.org/standards/sfg/imt2k/uwc136</a>
<b>Release 5</b>					
T1	T1.3GPP.44.014V500-2003	5.0.0	Approved	09/12/2003	<a href="https://www.atis.org/atis/docstore/search.asp?committee=S24">https://www.atis.org/atis/docstore/search.asp?committee=S24</a>

**5.4.2.4.16 3GPP TR 45.050****Background for Radio Frequency requirements**

This part gives the background information for the specification of the radio frequency requirements in 45.005.

SDO (2)	Document No.	Version	Status	Issued date	Location (1)
<b>Release 99</b>					
T1	T1.3GPP.05.50V820-2003	8.2.0	Approved	09/12/2003	<a href="https://www.atis.org/atis/docstore/search.asp?committee=S24">https://www.atis.org/atis/docstore/search.asp?committee=S24</a>
TIA	Included in TIA/EIA-136-290 as GSM 05.50 (ETSI TR 101 115 v8.1.0)	A	Published ANS	23/04/2001	<a href="http://www.tiaonline.org/standards/sfg/imt2k/uwc136">http://www.tiaonline.org/standards/sfg/imt2k/uwc136</a>
<b>Release 5</b>					
T1	T1.3GPP.45.050V501-2003	5.0.1	Approved	09/12/2003	<a href="https://www.atis.org/atis/docstore/search.asp?committee=S24">https://www.atis.org/atis/docstore/search.asp?committee=S24</a>

#### 5.4.2.4.17 3GPP TS 51.010-1

##### Mobile Station conformance specification; Part 1

This document provides a general description of the radio transmission and reception for the 200 kHz channel.

SDO (2)	Document No.	Version	Status	Issued date	Location (1)
<b>Release 99</b>					
T1	T1.3GPP.11.10-1V830-2003	8.3.0	Approved	09/12/2003	<a href="https://www.atis.org/atis/docstore/search.asp?committee=S24">https://www.atis.org/atis/docstore/search.asp?committee=S24</a>
TIA	Included in TIA/EIA-136-290 as GSM 11.10-1 (ETSI EN 300 607-1 v8.1.1)	A	Published ANS	23/04/2001	<a href="http://www.tiaonline.org/standards/sfg/imt2k/uwc136">http://www.tiaonline.org/standards/sfg/imt2k/uwc136</a>
<b>Release 5</b>					
T1	T1.3GPP.51.010-1V500-2003	5.0.0	Approved	09/12/2003	<a href="https://www.atis.org/atis/docstore/search.asp?committee=S24">https://www.atis.org/atis/docstore/search.asp?committee=S24</a>

#### 5.4.2.4.18 3GPP TS 51.010-2

##### Mobile Station conformance specification; Part 2; Protocol Implementation Conformance Statement (PICS) proforma specification

This document provides mobile station protocol implementation conformance statement (PICS) proforma.

SDO (2)	Document No.	Version	Status	Issued date	Location (1)
<b>Release 5</b>					
T1	T1.3GPP.51.010-2V500-2003	5.0.0	Approved	09/12/2003	<a href="https://www.atis.org/atis/docstore/search.asp?committee=S24">https://www.atis.org/atis/docstore/search.asp?committee=S24</a>

#### 5.4.2.4.19 3GPP TS 11.10-4

##### Mobile Station conformance specification; Part 4; SIM Application Toolkit conformance specification

This document provides a conformance specification for the SIM Application toolkit. Standalone SIM functionality is not specified beyond Release 4. For the latest available information see section 5.4.2.13.42

SDO (2)	Document No.	Version	Status	Issued date	Location (1)
<b>Release 99</b>					
T1	T1.3GPP.11.10-4V810-2003	8.1.0	Approved	09/12/2003	<a href="https://www.atis.org/atis/docstore/search.asp?committee=S24">https://www.atis.org/atis/docstore/search.asp?committee=S24</a>

**5.4.2.4.20** 3GPP TS 51.021**Base Station System equipment specification; radio aspects**

This part details the radio aspects of the BSS equipment specification.

SDO (2)	Document No.	Version	Status	Issued date	Location (1)
<b>Release 99</b>					
T1	T1.3GPP.11.21V860-2003	8.6.0	Approved	09/12/2003	<a href="https://www.atis.org/atis/docstore/search.asp?committee=S24">https://www.atis.org/atis/docstore/search.asp?committee=S24</a>
TIA	Included in TIA/EIA-136-290 as GSM 11.21 (ETSI EN 301 087 v8.1.1)	A	Published ANS	23/04/2001	<a href="http://www.tiaonline.org/standards/sfg/imt2k/uwc136">http://www.tiaonline.org/standards/sfg/imt2k/uwc136</a>
<b>Release 5</b>					
T1	T1.3GPP.51.021V500-2003	5.0.0	Approved	09/12/2003	<a href="https://www.atis.org/atis/docstore/search.asp?committee=S24">https://www.atis.org/atis/docstore/search.asp?committee=S24</a>

**5.4.2.5****Data services****5.4.2.5.1** 136-310**Radio link Protocol 1**

This part specifies a radio link protocol (RLP1) that provides error recovery functions allowing Layer 3 functions to asynchronously transport data octets across a TDMA radio interface utilizing an underlying half-rate, full-rate, double-rate, or triple-rate digital traffic channel as specified in TIA-136-131, 132, and 133.

SDO (2)	Document No.	Version	Status	Issued date	Location (1)
TIA	TIA/EIA-136-310	A	Published ANS	31/03/2000	<a href="http://www.tiaonline.org/standards/sfg/imt2k/uwc136">http://www.tiaonline.org/standards/sfg/imt2k/uwc136</a>

**5.4.2.5.2** 136-320**Radio link Protocol 2**

This part specifies a radio link protocol (RLP2) that allows Layer 3 functions to isochronously transport data octets across a TDMA radio interface utilizing an underlying half-rate, full-rate, double-rate, or triple-rate digital traffic channel as specified in TIA-136-131, 132, and 133.

SDO (2)	Document No.	Version	Status	Issued date	Location (1)
TIA	TIA/EIA-136-320	0	Published ANS	31/03/2000	<a href="http://www.tiaonline.org/standards/sfg/imt2k/uwc136">http://www.tiaonline.org/standards/sfg/imt2k/uwc136</a>

**5.4.2.5.3** 136-330**Packet-data service - Overview**

This part provides an overview of the GPRS-136 packet data service. An overview of the network reference model, BS and MS protocols, channel types, and options are provided. In addition, an overview of the 30 kHz 136? bearer is provided.

SDO (2)	Document No.	Version	Status	Issued date	Location (1)
TIA	TIA/EIA-136-330	0	Published ANS	31/03/2000	<a href="http://www.tiaonline.org/standards/sfg/imt2k/uwc136">http://www.tiaonline.org/standards/sfg/imt2k/uwc136</a>

#### 5.4.2.5.4 136-331

##### Packet-data service - 136+ physical layer

This part provides the 30 kHz 136? physical layer specification including slot formats, frame structure, modulation, and channel coding.

SDO (2)	Document No.	Version	Status	Issued date	Location (1)
TIA	TIA/EIA-136-331	0	Published ANS	31/03/2000	<a href="http://www.tiaonline.org/standards/sfg/imt2k/uwc136">http://www.tiaonline.org/standards/sfg/imt2k/uwc136</a>

#### 5.4.2.5.5 136-332

##### Packet-data service - 136+ medium access control

This part provides the 30 kHz 136? packet data MAC layer specification including MAC PDUs, transaction management, error recovery, and random access control.

SDO (2)	Document No.	Version	Status	Issued date	Location (1)
TIA	TIA/EIA-136-332	0	Published ANS	31/03/2000	<a href="http://www.tiaonline.org/standards/sfg/imt2k/uwc136">http://www.tiaonline.org/standards/sfg/imt2k/uwc136</a>

#### 5.4.2.5.6 136-333

##### Packet-data service - Logical-link control

This part defines the logical link control (LLC) layer protocol to be used for packet data transfer between the MS and serving GPRS support node (SGSN).

SDO (2)	Document No.	Version	Status	Issued date	Location (1)
TIA	TIA/EIA-136-333	0	Published ANS	31/03/2000	<a href="http://www.tiaonline.org/standards/sfg/imt2k/uwc136">http://www.tiaonline.org/standards/sfg/imt2k/uwc136</a>

#### 5.4.2.5.7 136-334

##### Packet-data service - Subnetwork dependent convergence protocol

This part provides the description of the subnetwork dependent convergence protocol (SNDCP). The user of the services provided by SNDCP is a packet data protocol (PDP) at the MS or the relay at the serving GPRS support node (SGSN).

SDO (2)	Document No.	Version	Status	Issued date	Location (1)
TIA	TIA/EIA-136-334	0	Published ANS	31/03/2000	<a href="http://www.tiaonline.org/standards/sfg/imt2k/uwc136">http://www.tiaonline.org/standards/sfg/imt2k/uwc136</a>

#### 5.4.2.5.8 136-335

##### Packet-data service - Radio resource management

This part specifies the radio resource management in a GPRS-136 packet data system. The entities in a GPRS-136 MS and BS that are used to achieve the goals of radio resource management are the radio resource management entity (RRME) and the broadcast management entity (BME) and are both described in this part.

SDO (2)	Document No.	Version	Status	Issued date	Location (1)
TIA	TIA/EIA-136-335	0	Published ANS	31/03/2000	<a href="http://www.tiaonline.org/standards/sfg/imt2k/uwc136">http://www.tiaonline.org/standards/sfg/imt2k/uwc136</a>

#### 5.4.2.5.9 136-336

##### Packet-data service - Mobility management

This part describes GPRS-136 mobility management and functions such as location tracking and user-identity confidentiality. The GPRS-136 packet data network combines TIA/EIA-41 circuit switched network elements with GPRS network elements.

SDO (2)	Document No.	Version	Status	Issued date	Location (1)
TIA	TIA/EIA-136-336	0	Published ANS	31/03/2000	<a href="http://www.tiaonline.org/standards/sfg/imt2k/uwc136">http://www.tiaonline.org/standards/sfg/imt2k/uwc136</a>

#### 5.4.2.5.10 136-337

##### Packet-data service - Tunnelling of signalling messages

This part specifies procedures to provide coordination between the TIA/EIA-136 circuit switched services controlled at the mobile switching centre (MSC)/visitors location register (VLR) and the GPRS-136 packet switched services controlled at the serving GPRS support node (SGSN).

SDO (2)	Document No.	Version	Status	Issued date	Location (1)
TIA	TIA/EIA-136-337	0	Published ANS	31/03/2000	<a href="http://www.tiaonline.org/standards/sfg/imt2k/uwc136">http://www.tiaonline.org/standards/sfg/imt2k/uwc136</a>

#### 5.4.2.5.11 136-340

##### Packet-data service - 136HS Outdoor overview

This part provides an overview of the 200 kHz 136HS outdoor bearer.

SDO (2)	Document No.	Version	Status	Issued date	Location (1)
TIA	TIA/EIA-136-340	0	Published ANS	31/03/2000	<a href="http://www.tiaonline.org/standards/sfg/imt2k/uwc136">http://www.tiaonline.org/standards/sfg/imt2k/uwc136</a>

**5.4.2.5.12** 136-341**Packet-data service - 136HS Outdoor physical layer**

This part provides the 200 kHz 136HS Outdoor bearer physical layer specification including slot formats, frame structure, modulation, and channel coding.

SDO (2)	Document No.	Version	Status	Issued date	Location (1)
TIA	TIA/EIA-136-341	0	Published ANS	31/03/2000	<a href="http://www.tiaonline.org/standards/sfg/imt2k/uwc136">http://www.tiaonline.org/standards/sfg/imt2k/uwc136</a>

**5.4.2.5.13** 136-342**Packet-data service - 136HS Outdoor RLC/MAC**

This part provides the 200 kHz 136HS Outdoor bearer RLC/MAC layer specification including RLC blocks, MAC protocol data units (PDUs), transaction management, error recovery, and random access control.

SDO (2)	Document No.	Version	Status	Issued date	Location (1)
TIA	TIA/EIA-136-342	0	Published ANS	31/03/2000	<a href="http://www.tiaonline.org/standards/sfg/imt2k/uwc136">http://www.tiaonline.org/standards/sfg/imt2k/uwc136</a>

**5.4.2.5.14** 136-350**Data-service control**

This part provides a description of the user-network commands and responses used to access async data service, fax data service, and other services running over radio link protocol 1.

SDO (2)	Document No.	Version	Status	Issued date	Location (1)
TIA	TIA/EIA-136-350	C	Published ANS	15/04/2002	<a href="http://www.tiaonline.org/standards/sfg/imt2k/uwc136">http://www.tiaonline.org/standards/sfg/imt2k/uwc136</a>

**5.4.2.5.15** 136-351**EGPRS-136 AT Command Set**

This part describes of the user-network commands and responses used to access the EGPRS-136 packet data service.

SDO (2)	Document No.	Version	Status	Issued date	Location (1)
TIA	TIA/EIA-136-351	0	Published ANS	23/04/2001	<a href="http://www.tiaonline.org/standards/sfg/imt2k/uwc136">http://www.tiaonline.org/standards/sfg/imt2k/uwc136</a>

**5.4.2.5.16** 136-360**Packet-data service - 136HS Indoor overview**

This part provides an overview of the 1.6 MHz 136HS indoor bearer.

SDO (2)	Document No.	Version	Status	Issued date	Location (1)
TIA	TIA/EIA-136-360	0	Published ANS	31/03/2000	<a href="http://www.tiaonline.org/standards/sfg/imt2k/uwc136">http://www.tiaonline.org/standards/sfg/imt2k/uwc136</a>

**5.4.2.5.17** 136-361**Packet-data service - 136HS Indoor physical layer**

This part provides the 1.6 MHz 136HS Indoor bearer physical layer specification including slot formats, frame structure, modulation, and channel coding.

SDO (2)	Document No.	Version	Status	Issued date	Location (1)
TIA	TIA/EIA-136-361	0	Published ANS	31/03/2000	<a href="http://www.tiaonline.org/standards/sfg/imt2k/uwc136">http://www.tiaonline.org/standards/sfg/imt2k/uwc136</a>

**5.4.2.5.18** 136-362**Packet-data service - 136HS Indoor RLC/MAC**

This part provides the 1.6 MHz 136HS indoor bearer RLC/MAC layer specification including RLC blocks, MAC PDUs, transaction management, error recovery, and random access control.

SDO (2)	Document No.	Version	Status	Issued date	Location (1)
TIA	TIA/EIA-136-362	0	Published ANS	31/03/2000	<a href="http://www.tiaonline.org/standards/sfg/imt2k/uwc136">http://www.tiaonline.org/standards/sfg/imt2k/uwc136</a>

**5.4.2.5.19** 136-370**Enhanced General Packet Data Service (EGPRS-136) Overview**

This part provides an overview of the Enhanced General Packet Data Service (EGPRS-136).

SDO (2)	Document No.	Version	Status	Issued date	Location (1)
<b>Release 99</b>					
TIA	TIA/EIA-136-370	0	Published ANS	23/04/2001	<a href="http://www.tiaonline.org/standards/sfg/imt2k/uwc136">http://www.tiaonline.org/standards/sfg/imt2k/uwc136</a>
<b>Release 5</b>					
TIA	TIA-136-370	A	Published ANS	13/01/2004	<a href="http://www.tiaonline.org/standards/sfg/imt2k/uwc136">http://www.tiaonline.org/standards/sfg/imt2k/uwc136</a>

**5.4.2.5.20** 136-376**Enhanced General Packet Data Service (EGPRS-136) Mobility Management (MM)**

This part describes the mobility management aspects of Enhanced General Packet Data Service (EGPRS-136).

SDO (2)	Document No.	Version	Status	Issued date	Location (1)
<b>Release 99</b>					
TIA	TIA/EIA-136-376	0	Published ANS	23/04/2001	<a href="http://www.tiaonline.org/standards/sfg/imt2k/uwc136">http://www.tiaonline.org/standards/sfg/imt2k/uwc136</a>
<b>Release 5</b>					
TIA	TIA-136-376	A	Published ANS	13/01/2004	<a href="http://www.tiaonline.org/standards/sfg/imt2k/uwc136">http://www.tiaonline.org/standards/sfg/imt2k/uwc136</a>



**5.4.2.5.21 136-377****EGPRS-136 Gs interface Specification**

This part describes operation of the interface between the MSC in the ANSI-41 network, and the SGSN in the EGPRS-136 network, in support of packet data operation.

SDO (2)	Document No.	Version	Status	Issued date	Location (1)
<b>Release 99</b>					
TIA	TIA/EIA-136-377	0	Published ANS	23/04/2001	<a href="http://www.tiaonline.org/standards/sfg/imt2k/uwc136">http://www.tiaonline.org/standards/sfg/imt2k/uwc136</a>
<b>Release 5</b>					
TIA	TIA-136-377	A	Published ANS	13/01/2004	<a href="http://www.tiaonline.org/standards/sfg/imt2k/uwc136">http://www.tiaonline.org/standards/sfg/imt2k/uwc136</a>

**5.4.2.5.22 3GPP TS 03.46****Technical realization of Facsimile Group 3 Service-non transparent**

This document specifies the Group 3 Facsimile function for non transparent operation.

SDO (2)	Document No.	Version	Status	Issued date	Location (1)
<b>Release 99</b>					
T1	T1.3GPP.03.46V800-2003	8.0.0	Approved	09/12/2003	<a href="https://www.atis.org/atis/docstore/search.asp?committee=S24">https://www.atis.org/atis/docstore/search.asp?committee=S24</a>

**5.4.2.5.23 3GPP TS 22.034****High Speed circuit switched data (HSCSD); Stage 1**

This document provides the stage 1 service description for High speed circuit switched data.

SDO (2)	Document No.	Version	Status	Issued date	Location (1)
<b>Release 99</b>					
T1	T1.3GPP.22.034V321-2000	3.2.1	Approved	01/04/2000	<a href="https://www.atis.org/atis/docstore/search.asp?committee=S24">https://www.atis.org/atis/docstore/search.asp?committee=S24</a>
<b>Release 5</b>					
T1	T1.3GPP. 22.034V500-2003	5.0.0	Approved	27/03/2003	<a href="https://www.atis.org/atis/docstore/search.asp?committee=S24">https://www.atis.org/atis/docstore/search.asp?committee=S24</a>

**5.4.2.5.24 3GPP TS 22.060****GPRS Service Description; Stage 1**

This document provides an overall service description for the General Packet Radio Service.

SDO (2)	Document No.	Version	Status	Issued date	Location (1)
<b>Release 99</b>					
T1	T1.3GPP.22.060V350-2000	3.5.0	Approved	01/10/2000	<a href="https://www.atis.org/atis/docstore/search.asp?committee=S24">https://www.atis.org/atis/docstore/search.asp?committee=S24</a>
TIA	Included in TIA/EIA-136-370 as ETSI TS 122 060 v3.3.0	0	Published ANS	23/04/2001	<a href="http://www.tiaonline.org/standards/sfg/imt2k/uwc136">http://www.tiaonline.org/standards/sfg/imt2k/uwc136</a>

**Release 5**

T1	T1.3GPP.22.060V520-2003	5.2.0	Approved	27/03/2003	<a href="https://www.atis.org/atis/docstore/search.asp?committee=S24">https://www.atis.org/atis/docstore/search.asp?committee=S24</a>
TIA	Included in TIA-136-370 as ETSI TS 122 060 v5.2.0	A	Published ANS	13/01/2004	<a href="http://www.tiaonline.org/standards/sfg/imt2k/uwc136">http://www.tiaonline.org/standards/sfg/imt2k/uwc136</a>

**5.4.2.5.25 3GPP TS 23.034****High Speed circuit switched data (HSCSD); Stage 2**

This document provides the stage 2 description for High speed circuit switched data.

SDO (2)	Document No.	Version	Status	Issued date	Location (1)
<b>Release 99</b>					
T1	T1.3GPP.23.034V330-2000	3.3.0	Approved	01/12/2000	<a href="https://www.atis.org/atis/docstore/search.asp?committee=S24">https://www.atis.org/atis/docstore/search.asp?committee=S24</a>
<b>Release 5</b>					
T1	T1.3GPP.23.034V500-2003	5.0.0	Approved	09/12/2003	<a href="https://www.atis.org/atis/docstore/search.asp?committee=S24">https://www.atis.org/atis/docstore/search.asp?committee=S24</a>

**5.4.2.5.26 3GPP TS 23.060****GPRS Service Description; Stage 2**

This document provides an overall stage 2 service description for the General Packet Radio Service.

SDO (2)	Document No.	Version	Status	Issued date	Location (1)
<b>Release 99</b>					
T1	T1.3GPP.23.060V3130	3.13.0	Approved	09/12/2003	<a href="https://www.atis.org/atis/docstore/search.asp?committee=S24">https://www.atis.org/atis/docstore/search.asp?committee=S24</a>
TIA	Included in TIA/EIA-136-376 as ETSI TS 123 060 v3.3.0	0	Published ANS	23/04/2001	<a href="http://www.tiaonline.org/standards/sfg/imt2k/uwc136">http://www.tiaonline.org/standards/sfg/imt2k/uwc136</a>
<b>Release 5</b>					
T1	T1.3GPP.23.060V530-2003	5.3.0	Approved	09/12/2003	<a href="https://www.atis.org/atis/docstore/search.asp?committee=S24">https://www.atis.org/atis/docstore/search.asp?committee=S24</a>
TIA	Included in TIA-136-376 as ETSI TS 123 060 v5.3.0	A	Published ANS	13/01/2004	<a href="http://www.tiaonline.org/standards/sfg/imt2k/uwc136">http://www.tiaonline.org/standards/sfg/imt2k/uwc136</a>

**5.4.2.5.27 3GPP TS 29.002****Mobile Application Part (MAP) specification**

This document provides the specification for the GSM/EDGE/UMTS MAP.

SDO (2)	Document No.	Version	Status	Issued date	Location (1)
<b>Release 99</b>					
T1	T1.3GPP.29.002V3140-2003	3.14.0	Approved	09/12/2003	<a href="https://www.atis.org/atis/docstore/search.asp?committee=S24">https://www.atis.org/atis/docstore/search.asp?committee=S24</a>
TIA	Included in TIA/EIA-136-370 as ETSI TS 129 002 v3.4.0	0	Published ANS	23/04/2001	<a href="http://www.tiaonline.org/standards/sfg/imt2k/uwc136">http://www.tiaonline.org/standards/sfg/imt2k/uwc136</a>

**Release 5**

T1	T1.3GPP.29.002V530-2003	5.3.0	Approved	09/12/2003	<a href="https://www.atis.org/atis/docstore/search.asp?committee=S24">https://www.atis.org/atis/docstore/search.asp?committee=S24</a>
TIA	Included in TIA-136-370 as ETSI TS 129 002 v5.3.0	A	Published ANS	13/01/2004	<a href="http://www.tiaonline.org/standards/sfg/imt2k/uwc136">http://www.tiaonline.org/standards/sfg/imt2k/uwc136</a>

**5.4.2.5.28 3GPP TS 29.016****GPRS SGSN - VLR; Gs interface Network Service specification**

This document provides the specification for the General Packet Radio Service Serving GPRS Support Node (SGSN) - Visitors Location Register (VLR) Gs Interface network service specification.

SDO (2)	Document No.	Version	Status	Issued date	Location (1)
<b>Release 99</b>					
T1	T1.3GPP.29.016V310-2000	3.1.0	Approved	01/09/2000	<a href="https://www.atis.org/atis/docstore/search.asp?committee=S24">https://www.atis.org/atis/docstore/search.asp?committee=S24</a>
TIA	Included in TIA/EIA-136-370 as ETSI TS 129 016 v3.0.0	0	Published ANS	23/04/2001	<a href="http://www.tiaonline.org/standards/sfg/imt2k/uwc136">http://www.tiaonline.org/standards/sfg/imt2k/uwc136</a>
<b>Release 5</b>					
T1	T1.3GPP.29.016V500-2003	5.0.0	Approved	27/03/2003	<a href="https://www.atis.org/atis/docstore/search.asp?committee=S24">https://www.atis.org/atis/docstore/search.asp?committee=S24</a>
TIA	Included in TIA-136-370 as ETSI TS 129 016 v5.0.0	A	Published ANS	13/01/2004	<a href="http://www.tiaonline.org/standards/sfg/imt2k/uwc136">http://www.tiaonline.org/standards/sfg/imt2k/uwc136</a>

**5.4.2.5.29 3GPP TS 29.018****GPRS SGSN - VLR; Gs interface Layer 3 specification**

This document provides the specification for the General Packet Radio Service Serving GPRS Support Node (SGSN) - Visitors Location Register (VLR) Gs Interface layer 3 specification.

SDO (2)	Document No.	Version	Status	Issued date	Location (1)
<b>Release 99</b>					
T1	T1.3GPP.29.018V3100-2003	3.10.0	Approved	09/12/2003	<a href="https://www.atis.org/atis/docstore/search.asp?committee=S24">https://www.atis.org/atis/docstore/search.asp?committee=S24</a>
TIA	Included in TIA/EIA-136-370 as ETSI TS 129 018 v3.3.0	0	Published ANS	23/04/2001	<a href="http://www.tiaonline.org/standards/sfg/imt2k/uwc136">http://www.tiaonline.org/standards/sfg/imt2k/uwc136</a>
<b>Release 5</b>					
T1	T1.3GPP.29.018V520-2003	5.2.0	Approved	09/12/2003	<a href="https://www.atis.org/atis/docstore/search.asp?committee=S24">https://www.atis.org/atis/docstore/search.asp?committee=S24</a>
TIA	Included in TIA-136-370 as ETSI TS 129 018 v5.2.0	A	Published ANS	13/01/2004	<a href="http://www.tiaonline.org/standards/sfg/imt2k/uwc136">http://www.tiaonline.org/standards/sfg/imt2k/uwc136</a>

**5.4.2.5.30 3GPP TS 29.060****GPRS Tunnelling Protocol (GTP) across Gn and Gp Interface**

This document provides the specification for the General Packet Radio Service Tunnelling Protocol (GTP).

SDO (2)	Document No.	Version	Status	Issued date	Location (1)
<b>Release 99</b>					
T1	T1.3GPP.29.060V3140-2003	3.14.0	Approved	09/12/2003	<a href="https://www.atis.org/atis/docstore/search.asp?committee=S24">https://www.atis.org/atis/docstore/search.asp?committee=S24</a>
TIA	Included in TIA/EIA-136-370 as ETSI TS 129 060 v3.4.0	0	Published ANS	23/04/2001	<a href="http://www.tiaonline.org/standards/sfg/imt2k/uwc136">http://www.tiaonline.org/standards/sfg/imt2k/uwc136</a>
<b>Release 5</b>					
T1	T1.3GPP.29.060V530-2003	5.3.0	Approved	09/12/2003	<a href="https://www.atis.org/atis/docstore/search.asp?committee=S24">https://www.atis.org/atis/docstore/search.asp?committee=S24</a>
TIA	Included in TIA-136-370 as ETSI TS 129 060 v5.3.0	A	Published ANS	13/01/2004	<a href="http://www.tiaonline.org/standards/sfg/imt2k/uwc136">http://www.tiaonline.org/standards/sfg/imt2k/uwc136</a>

**5.4.2.5.31 3GPP TS 01.61****GPRS ciphering algorithm requirements**

This document provides the requirements for the General Packet Radio ciphering algorithms. Standalone ciphering aspects for GSM GPRS are not specified beyond Release 4. For the latest available information see section 5.4.2.13.39

SDO (2)	Document No.	Version	Status	Issued date	Location (1)
<b>Release 99</b>					
T1	T1.3GPP.01.61V800-2003	8.0.0	Approved	09/12/2003	<a href="https://www.atis.org/atis/docstore/search.asp?committee=S24">https://www.atis.org/atis/docstore/search.asp?committee=S24</a>

**5.4.2.5.32 3GPP TS 43.045****Technical realization of Facsimile Group 3 Service-transparent**

This document specifies the Group 3 Facsimile function for transparent operation

SDO (2)	Document No.	Version	Status	Issued date	Location (1)
<b>Release 99</b>					
T1	T1.3GPP.03.45V801-2003	8.0.1	Approved	09/12/2003	<a href="https://www.atis.org/atis/docstore/search.asp?committee=S24">https://www.atis.org/atis/docstore/search.asp?committee=S24</a>
<b>Release 5</b>					
T1	T1.3GPP.43.045V500-2003	5.0.0	Approved	09/12/2003	<a href="https://www.atis.org/atis/docstore/search.asp?committee=S24">https://www.atis.org/atis/docstore/search.asp?committee=S24</a>

**5.4.2.5.33 3GPP TS 43.064****Overall description of the GPRS radio interface; Stage 2**

This document provides an overall stage 2 description of the General Packet Radio Service radio interface.

SDO (2)	Document No.	Version	Status	Issued date	Location (1)
<b>Release 99</b>					
T1	T1.3GPP.03.64V8100-2003	8.10.0	Approved	09/12/2003	<a href="https://www.atis.org/atis/docstore/search.asp?committee=S24">https://www.atis.org/atis/docstore/search.asp?committee=S24</a>
TIA	Included in TIA/EIA-136-370 as GSM 03.64 (ETSI TS 101 350 v8.5.0)	0	Published ANS	23/04/2001	<a href="http://www.tiaonline.org/standards/sfg/imt2k/uwc136">http://www.tiaonline.org/standards/sfg/imt2k/uwc136</a>
<b>Release 5</b>					
T1	T1.3GPP.43.064V500-2003	5.0.0	Approved	09/12/2003	<a href="https://www.atis.org/atis/docstore/search.asp?committee=S24">https://www.atis.org/atis/docstore/search.asp?committee=S24</a>
TIA	Included in TIA-136-370 as ETSI TS 143 064 v5.0.0	A	Published ANS	13/01/2004	<a href="http://www.tiaonline.org/standards/sfg/imt2k/uwc136">http://www.tiaonline.org/standards/sfg/imt2k/uwc136</a>

#### 5.4.2.5.34 3GPP TS 44.060

##### GPRS MS-BSS interface; RLC/MAC

This document provides the detailed specification for the General Packet Radio Service Mobile Station - Base Station System interface Radio Link Control and Medium Access Control.

SDO (2)	Document No.	Version	Status	Issued date	Location (1)
<b>Release 99</b>					
T1	T1.3GPP.04.60V8160-2003	8.16.0	Approved	09/12/2003	<a href="https://www.atis.org/atis/docstore/search.asp?committee=S24">https://www.atis.org/atis/docstore/search.asp?committee=S24</a>
TIA	Included in TIA/EIA-136-370 as GSM 04.60 (ETSI TS 101 349 v8.5.0)	0	Published ANS	23/04/2001	<a href="http://www.tiaonline.org/standards/sfg/imt2k/uwc136">http://www.tiaonline.org/standards/sfg/imt2k/uwc136</a>
<b>Release 5</b>					
T1	T1.3GPP.44.060V530-2003	5.3.0	Approved	09/12/2003	<a href="https://www.atis.org/atis/docstore/search.asp?committee=S24">https://www.atis.org/atis/docstore/search.asp?committee=S24</a>
TIA	Included in TIA-136-370 as ETSI TS 144 060 v5.3.0	A	Published ANS	13/01/2004	<a href="http://www.tiaonline.org/standards/sfg/imt2k/uwc136">http://www.tiaonline.org/standards/sfg/imt2k/uwc136</a>

#### 5.4.2.5.35 3GPP TS 44.064

##### GPRS MS-SGSN; Logical Link Control layer

This document provides the detailed specification for the General Packet Radio Service Mobile Station - Serving GPRS Support Node interface Logical Link Control layer.

SDO (2)	Document No.	Version	Status	Issued date	Location (1)
<b>Release 99</b>					
T1	T1.3GPP.04.64V870-2003	8.7.0	Approved	09/12/2003	<a href="https://www.atis.org/atis/docstore/search.asp?committee=S24">https://www.atis.org/atis/docstore/search.asp?committee=S24</a>
TIA	Included in TIA/EIA-136-370 as GSM 04.64 (ETSI TS 101 351 v8.4.0)	0	Published ANS	23/04/2001	<a href="http://www.tiaonline.org/standards/sfg/imt2k/uwc136">http://www.tiaonline.org/standards/sfg/imt2k/uwc136</a>

**Release 5**

T1	T1.3GPP.44.064V510-2003	5.1.0	Approved	09/12/2003	<a href="https://www.atis.org/atis/docstore/search.asp?committee=S24">https://www.atis.org/atis/docstore/search.asp?committee=S24</a>
TIA	Included in TIA-136-370 as ETSI TS 144 064 v5.1.0	A	Published ANS	13/01/2004	<a href="http://www.tiaonline.org/standards/sfg/imt2k/uwc136">http://www.tiaonline.org/standards/sfg/imt2k/uwc136</a>

**5.4.2.5.36 3GPP TS 44.065****GPRS MS-SGSN; Subnetwork Dependent Convergence Protocol**

This document provides the detailed specification for the General Packet Radio Service Mobile Station - Serving GPRS Support Node interface Subnetwork Dependent Convergence Protocol.

SDO (2)	Document No.	Version	Status	Issued date	Location (1)
<b>Release 99</b>					
T1	T1.3GPP.04.65V820-2003	8.2.0	Approved	09/12/2003	<a href="https://www.atis.org/atis/docstore/search.asp?committee=S24">https://www.atis.org/atis/docstore/search.asp?committee=S24</a>
TIA	Included in TIA/EIA-136-370 as ETSI TS 124 065 v3.1.0	0	Published ANS	23/04/2001	<a href="http://www.tiaonline.org/standards/sfg/imt2k/uwc136">http://www.tiaonline.org/standards/sfg/imt2k/uwc136</a>
<b>Release 5</b>					
T1	T1.3GPP.44.065V500-2003	5.0.0	Approved	09/12/2003	<a href="https://www.atis.org/atis/docstore/search.asp?committee=S24">https://www.atis.org/atis/docstore/search.asp?committee=S24</a>
TIA	Included in TIA-136-370 as ETSI TS 144 065 v5.0.0	A	Published ANS	13/01/2004	<a href="http://www.tiaonline.org/standards/sfg/imt2k/uwc136">http://www.tiaonline.org/standards/sfg/imt2k/uwc136</a>

**5.4.2.5.37 3GPP TS 48.014****GPRS BSS-SGSN interface; Gb interface Layer 1**

This document provides the detailed specification for the General Packet Radio Service Base Station System - Serving GPRS Support Node Gb Interface Layer 1.

SDO (2)	Document No.	Version	Status	Issued date	Location (1)
<b>Release 99</b>					
T1	T1.3GPP.08.14V801-2003	8.0.1	Approved	09/12/2003	<a href="https://www.atis.org/atis/docstore/search.asp?committee=S24">https://www.atis.org/atis/docstore/search.asp?committee=S24</a>
TIA	Included in TIA/EIA-136-370 as GSM 08.14 (ETSI TS 101 298 v8.0.0)	0	Published ANS	23/04/2001	<a href="http://www.tiaonline.org/standards/sfg/imt2k/uwc136">http://www.tiaonline.org/standards/sfg/imt2k/uwc136</a>
<b>Release 5</b>					
T1	T1.3GPP.48.014V500-2003	5.0.0	Approved	09/12/2003	<a href="https://www.atis.org/atis/docstore/search.asp?committee=S24">https://www.atis.org/atis/docstore/search.asp?committee=S24</a>
TIA	Included in TIA-136-370 as ETSI TS 148 014 v5.0.0	A	Published ANS	13/01/2004	<a href="http://www.tiaonline.org/standards/sfg/imt2k/uwc136">http://www.tiaonline.org/standards/sfg/imt2k/uwc136</a>

**5.4.2.5.38 3GPP TS 48.016****GPRS BSS-SGSN interface; Network Service**

This document provides the detailed specification for the General Packet Radio Service Base Station System - Serving GPRS Support Node Network service.

SDO (2)	Document No.	Version	Status	Issued date	Location (1)
<b>Release 99</b>					
T1	T1.3GPP.08.16V801-2003	8.0.1	Approved	09/12/2003	<a href="https://www.atis.org/atis/docstore/search.asp?committee=S24">https://www.atis.org/atis/docstore/search.asp?committee=S24</a>
TIA	Included in TIA/EIA-136-370 as GSM 08.16 (ETSI TS 101 299 v8.0.0)	0	Published ANS	23/04/2001	<a href="http://www.tiaonline.org/standards/sfg/imt2k/uwc136">http://www.tiaonline.org/standards/sfg/imt2k/uwc136</a>
<b>Release 5</b>					
T1	T1.3GPP.48.016V510-2003	5.1.0	Approved	09/12/2003	<a href="https://www.atis.org/atis/docstore/search.asp?committee=S24">https://www.atis.org/atis/docstore/search.asp?committee=S24</a>
TIA	Included in TIA-136-370 as ETSI TS 148 016 v5.1.0	A	Published ANS	13/01/2004	<a href="http://www.tiaonline.org/standards/sfg/imt2k/uwc136">http://www.tiaonline.org/standards/sfg/imt2k/uwc136</a>

**5.4.2.5.39 3GPP TS 48.018****GPRS BSS-SGSN; BSSGP Protocol**

This document provides the detailed specification for the General Packet Radio Service Base Station System - Serving GPRS Support Node BSS GPRS protocol.

SDO (2)	Document No.	Version	Status	Issued date	Location (1)
<b>Release 99</b>					
T1	T1.3GPP.08.18V8100-2003	8.10.0	Approved	09/12/2003	<a href="https://www.atis.org/atis/docstore/search.asp?committee=S24">https://www.atis.org/atis/docstore/search.asp?committee=S24</a>
TIA	Included in TIA/EIA-136-370 as GSM 08.18 (ETSI TS 101 343 v8.3.0)	0	Published ANS	23/04/2001	<a href="http://www.tiaonline.org/standards/sfg/imt2k/uwc136">http://www.tiaonline.org/standards/sfg/imt2k/uwc136</a>
<b>Release 5</b>					
T1	T1.3GPP.48.018V551-2003	5.5.1	Approved	09/12/2003	<a href="https://www.atis.org/atis/docstore/search.asp?committee=S24">https://www.atis.org/atis/docstore/search.asp?committee=S24</a>
TIA	Included in TIA-136-370 as ETSI TS 148 018 v5.5.1	A	Published ANS	13/01/2004	<a href="http://www.tiaonline.org/standards/sfg/imt2k/uwc136">http://www.tiaonline.org/standards/sfg/imt2k/uwc136</a>

**5.4.2.5.40 3GPP TS 23.221****UMTS Architectural Requirements (Release 5)**

This document provides the specification for the architectural requirements for UMTS and GERAN release 5.

## 302

## Rec. ITU-R M.1457-4

SDO (2)	Document No.	Version	Status	Issued date	Location (1)
<b>Release 5</b>					
T1	T1.3GPP.23.221V560-2003	5.6.0	Approved	09/12/2003	<a href="https://www.atis.org/atis/docstore/search.asp?committee=S24">https://www.atis.org/atis/docstore/search.asp?committee=S24</a>
TIA	Included in TIA-136-370 as ETSI TS 123 221 v5.6.0	A	Published ANS	13/01/2004	<a href="http://www.tiaonline.org/standards/sfg/imt2k/uwc136">http://www.tiaonline.org/standards/sfg/imt2k/uwc136</a>

### 5.4.2.5.41 3GPP TS 23.228

#### IP Multimedia Subsystem (IMS); Stage 2

This document provides the Stage 2 description for the IP Multimedia Subsystem (IMS).

SDO (2)	Document No.	Version	Status	Issued date	Location (1)
<b>Release 5</b>					
T1	T1.3GPP.23.228V560-2003	5.6.0	Approved	09/12/2003	<a href="https://www.atis.org/atis/docstore/search.asp?committee=S24">https://www.atis.org/atis/docstore/search.asp?committee=S24</a>
TIA	Included in TIA-136-370 as ETSI TS 123 228 v5.6.0	A	Published ANS	13/01/2004	<a href="http://www.tiaonline.org/standards/sfg/imt2k/uwc136">http://www.tiaonline.org/standards/sfg/imt2k/uwc136</a>

### 5.4.2.5.42 3GPP TS 43.051

#### GSM/EDGE Radio Access Network (GERAN) overall description

This document provides the overall description specification for the GSM/EDGE Radio Access Network (GERAN).

SDO (2)	Document No.	Version	Status	Issued date	Location (1)
<b>Release 5</b>					
T1	T1.3GPP.43.051V570-2003	5.7.0	Approved	09/12/2003	<a href="https://www.atis.org/atis/docstore/search.asp?committee=S24">https://www.atis.org/atis/docstore/search.asp?committee=S24</a>
TIA	Included in TIA-136-370 as ETSI TS 143 051 v5.7.0	A	Published ANS	13/01/2004	<a href="http://www.tiaonline.org/standards/sfg/imt2k/uwc136">http://www.tiaonline.org/standards/sfg/imt2k/uwc136</a>

### 5.4.2.5.43 3GPP TS 44.118

#### Mobile radio interface layer 3 specification; Radio Resource Control (RRC) protocol for Iu mode

This document provides the layer 3 specification for the Radio Resource Control protocol for Iu mode.

SDO (2)	Document No.	Version	Status	Issued date	Location (1)
<b>Release 5</b>					
T1	T1.3GPP.44.118V510-2003	5.1.0	Approved	09/12/2003	<a href="https://www.atis.org/atis/docstore/search.asp?committee=S24">https://www.atis.org/atis/docstore/search.asp?committee=S24</a>



**5.4.2.5.44** 3GPP TS 44.160**GPRS Mobile station - Base station system (BSS) interface; Radio LinkControl/Medium Access Control (RLC/MAC) protocol for Iu mode**

This document provides the specification for the General Packet Data Service Radio Link Control/Medium Access Control (RLC/MAC) protocol for Iu mode.

SDO (2)	Document No.	Version	Status	Issued date	Location (1)
<b>Release 5</b>					
T1	T1.3GPP.44.160V510-2003	5.1.0	Approved	09/12/2003	<a href="https://www.atis.org/atis/docstore/search.asp?committee=S24">https://www.atis.org/atis/docstore/search.asp?committee=S24</a>

**5.4.2.6****Voice coders**

SDO (2)	Document No.	Version	Status	Issued date	Location (1)
TIA	TIA/EIA-136-410	0	Published ANS	29/11/1999	<a href="http://www.tiaonline.org/standards/sfg/imt2k/uwc136">http://www.tiaonline.org/standards/sfg/imt2k/uwc136</a>

**5.4.2.6.1** 136-410**ACELP**

This part gives a bit exact description of the ACELP speech and channel codec for a TIA enhanced full rate codec. The codec consists of a 7.4 kbit/s ACELP speech codec and two channel codecs (forward error correction): channel coding 1 (CC1) a 5.6 kbit/s channel codec and channel coding 2 (CC2), a 6.5 kbit/s channel codec. This standard includes a software distribution.

**5.4.2.6.2** 136-420**VSELP**

The speech coding algorithm described in this part is a member of a class of speech codecs known as code excited linear predictive coding (CELP), stochastic coding or vector excited speech coding. These techniques use codebooks to vector quantize the excitation (residual) signal. The speech coding algorithm is a variation on CELP called vector-sum excited linear predictive coding (VSELP).

SDO (2)	Document No.	Version	Status	Issued date	Location (1)
TIA	TIA/EIA-136-420	0	Published ANS	03/03/1999	<a href="http://www.tiaonline.org/standards/sfg/imt2k/uwc136">http://www.tiaonline.org/standards/sfg/imt2k/uwc136</a>

**5.4.2.6.3** 136-430**US1**

This part gives a bit exact description of an enhanced ACELP voice coder which runs over a 136? 8-PSK DTC. The codec consists of a 12.2 kbit/s ACELP speech codec and a 7.75 kbit/s channel codec.

SDO (2)	Document No.	Version	Status	Issued date	Location (1)
TIA	TIA/EIA-136-430	0	Published ANS	29/11/1999	<a href="http://www.tiaonline.org/standards/sfg/imt2k/uwc136">http://www.tiaonline.org/standards/sfg/imt2k/uwc136</a>

#### 5.4.2.6.4 136-440

##### Adaptive Multi-Rate Codec

This part gives a bit exact description of the Adaptive Multi-rate speech and channel codec that may be operated on a 30 kHz Digital Traffic Channel.

SDO (2)	Document No.	Version	Status	Issued date	Location (1)
<b>Release 98</b>					
TIA	TIA/EIA-136-440	0	Published ANS	23/04/2001	<a href="http://www.tiaonline.org/standards/sfg/imt2k/uwc136">http://www.tiaonline.org/standards/sfg/imt2k/uwc136</a>
<b>Release 5</b>					
TIA	TIA-136-440	A	Published ANS	13/01/2004	<a href="http://www.tiaonline.org/standards/sfg/imt2k/uwc136">http://www.tiaonline.org/standards/sfg/imt2k/uwc136</a>

#### 5.4.2.6.5 3GPP TS 26.071

##### AMR Speech Codec; General Description

This document provides an introduction to the set of AMR specifications.

SDO (2)	Document No.	Version	Status	Issued date	Location (1)
<b>Release 98</b>					
TIA	Included in TIA/EIA-136-440 as GSM 06.71 (ETSI EN 301 703 v7.0.2)	0	Published ANS	23/04/2001	<a href="http://www.tiaonline.org/standards/sfg/imt2k/uwc136">http://www.tiaonline.org/standards/sfg/imt2k/uwc136</a>
<b>Release 99</b>					
T1	T1.3GPP.26.071V301-2003	3.0.1	Approved	09/12/2003	<a href="https://www.atis.org/atis/docstore/search.asp?committee=S24">https://www.atis.org/atis/docstore/search.asp?committee=S24</a>
<b>Release 5</b>					
T1	T1.3GPP.26.071V500-2003	5.0.0	Approved	27/03/2003	<a href="https://www.atis.org/atis/docstore/search.asp?committee=S24">https://www.atis.org/atis/docstore/search.asp?committee=S24</a>
TIA	Included in TIA-136-440 as ETSI TS 126 071 v5.0.0)	A	Published ANS	13/01/2004	<a href="http://www.tiaonline.org/standards/sfg/imt2k/uwc136">http://www.tiaonline.org/standards/sfg/imt2k/uwc136</a>

#### 5.4.2.6.6 3GPP TS 26.073

##### ANSI-C code for AMR Speech Codec

This document provides the ANSI-C code for the AMR specifications.

SDO (2)	Document No.	Version	Status	Issued date	Location (1)
<b>Release 98</b>					
TIA	Included in TIA/EIA-136-440 as GSM 06.73 (ETSI EN 301 712 v7.4.1)	0	Published ANS	23/04/2001	<a href="http://www.tiaonline.org/standards/sfg/imt2k/uwc136">http://www.tiaonline.org/standards/sfg/imt2k/uwc136</a>

**Release 99**

T1	T1.3GPP.26.073V330-2003	3.3.0	Approved	09/12/2003	<a href="https://www.atis.org/atis/docstore/search.asp?committee=S24">https://www.atis.org/atis/docstore/search.asp?committee=S24</a>
----	-------------------------	-------	----------	------------	---------------------------------------------------------------------------------------------------------------------------------------

**Release 5**

T1	T1.3GPP.26.073V500-2003	5.0.0	Approved	27/03/2003	<a href="https://www.atis.org/atis/docstore/search.asp?committee=S24">https://www.atis.org/atis/docstore/search.asp?committee=S24</a>
TIA	Included in TIA-136-440 as ETSI TS 126 073 v5.0.0)	A	Published ANS	13/01/2004	<a href="http://www.tiaonline.org/standards/sfg/imt2k/uwc136">http://www.tiaonline.org/standards/sfg/imt2k/uwc136</a>

**5.4.2.6.7 3GPP TS 26.074****Test sequences for AMR Speech Codec**

This document provides the test sequences for the AMR specifications.

SDO (2)	Document No.	Version	Status	Issued date	Location (1)
---------	--------------	---------	--------	-------------	--------------

**Release 98**

TIA	Included in TIA/EIA-136-440 as GSM 06.74 (ETSI EN 301 713 v7.0.3)	0	Published ANS	23/04/2001	<a href="http://www.tiaonline.org/standards/sfg/imt2k/uwc136">http://www.tiaonline.org/standards/sfg/imt2k/uwc136</a>
-----	----------------------------------------------------------------------	---	---------------	------------	-----------------------------------------------------------------------------------------------------------------------

**Release 99**

T1	T1.3GPP.26.074V311-2003	3.1.1	Approved	09/12/2003	<a href="https://www.atis.org/atis/docstore/search.asp?committee=S24">https://www.atis.org/atis/docstore/search.asp?committee=S24</a>
----	-------------------------	-------	----------	------------	---------------------------------------------------------------------------------------------------------------------------------------

**Release 5**

T1	T1.3GPP.26.074V500-2003	5.0.0	Approved	27/03/2003	<a href="https://www.atis.org/atis/docstore/search.asp?committee=S24">https://www.atis.org/atis/docstore/search.asp?committee=S24</a>
TIA	Included in TIA-136-440 as ETSI TS 126 074 v5.0.0)	A	Published ANS	13/01/2004	<a href="http://www.tiaonline.org/standards/sfg/imt2k/uwc136">http://www.tiaonline.org/standards/sfg/imt2k/uwc136</a>

**5.4.2.6.8 3GPP TS 26.090****AMR Speech Transcoding**

This document provides the speech coding definition for the AMR specifications.

SDO (2)	Document No.	Version	Status	Issued date	Location (1)
---------	--------------	---------	--------	-------------	--------------

**Release 98**

TIA	Included in TIA/EIA-136-440 as GSM 06.90 (ETSI EN 301 704 v7.2.1)	0	Published ANS	23/04/2001	<a href="http://www.tiaonline.org/standards/sfg/imt2k/uwc136">http://www.tiaonline.org/standards/sfg/imt2k/uwc136</a>
-----	----------------------------------------------------------------------	---	---------------	------------	-----------------------------------------------------------------------------------------------------------------------

**Release 99**

T1	T1.3GPP.26.090V310-1999	3.1.0	Approved	01/12/1999	<a href="https://www.atis.org/atis/docstore/search.asp?committee=S24">https://www.atis.org/atis/docstore/search.asp?committee=S24</a>
----	-------------------------	-------	----------	------------	---------------------------------------------------------------------------------------------------------------------------------------

**Release 5**

T1	T1.3GPP.26.090V500-2003	5.0.0	Approved	27/03/2003	<a href="https://www.atis.org/atis/docstore/search.asp?committee=S24">https://www.atis.org/atis/docstore/search.asp?committee=S24</a>
TIA	Included in TIA-136-440 as ETSI TS 126 090 v5.0.0)	A	Published ANS	13/01/2004	<a href="http://www.tiaonline.org/standards/sfg/imt2k/uwc136">http://www.tiaonline.org/standards/sfg/imt2k/uwc136</a>

**5.4.2.6.9 3GPP TS 26.091****Error Concealment of lost frames for AMR speech codec**

This document provides the bad frame masking definition for the AMR speech codec.

SDO (2)	Document No.	Version	Status	Issued date	Location (1)
<b>Release 98</b>					
TIA	Included in TIA/EIA-136-440 as GSM 06.91 (ETSI EN 301 705 v7.1.1)	0	Published ANS	23/04/2001	<a href="http://www.tiaonline.org/standards/sfg/imt2k/uwc136">http://www.tiaonline.org/standards/sfg/imt2k/uwc136</a>
<b>Release 99</b>					
T1	T1.3GPP.26.091V310-1999	3.1.0	Approved	01/12/1999	<a href="https://www.atis.org/atis/docstore/search.asp?committee=S24">https://www.atis.org/atis/docstore/search.asp?committee=S24</a>
<b>Release 5</b>					
T1	T1.3GPP.26.091V500-2003	5.0.0	Approved	27/03/2003	<a href="https://www.atis.org/atis/docstore/search.asp?committee=S24">https://www.atis.org/atis/docstore/search.asp?committee=S24</a>
TIA	Included in TIA-136-440 as ETSI TS 126 091 v5.0.0)	A	Published ANS	13/01/2004	<a href="http://www.tiaonline.org/standards/sfg/imt2k/uwc136">http://www.tiaonline.org/standards/sfg/imt2k/uwc136</a>

**5.4.2.6.10 3GPP TS 26.092****Comfort noise for AMR speech traffic channels**

This document provides the comfort noise definition for the AMR speech codec.

SDO (2)	Document No.	Version	Status	Issued date	Location (1)
<b>Release 98</b>					
TIA	Included in TIA/EIA-136-440 as GSM 06.92 (ETSI EN 301 706 v7.1.1)	0	Published ANS	23/04/2001	<a href="http://www.tiaonline.org/standards/sfg/imt2k/uwc136">http://www.tiaonline.org/standards/sfg/imt2k/uwc136</a>
<b>Release 99</b>					
T1	T1.3GPP.26.092V301-1999	3.0.1	Approved	01/08/1999	<a href="https://www.atis.org/atis/docstore/search.asp?committee=S24">https://www.atis.org/atis/docstore/search.asp?committee=S24</a>
<b>Release 5</b>					
T1	T1.3GPP.26.092V500-2003	5.0.0	Approved	27/03/2003	<a href="https://www.atis.org/atis/docstore/search.asp?committee=S24">https://www.atis.org/atis/docstore/search.asp?committee=S24</a>
TIA	Included in TIA-136-440 as ETSI TS 126 092 v5.0.0)	A	Published ANS	13/01/2004	<a href="http://www.tiaonline.org/standards/sfg/imt2k/uwc136">http://www.tiaonline.org/standards/sfg/imt2k/uwc136</a>

**5.4.2.6.11 3GPP TS 26.093****Source rate controlled operation for AMR speech codec**

This document provides the DTX definition for the AMR speech codec.

SDO (2)	Document No.	Version	Status	Issued date	Location (1)
<b>Release 98</b>					
TIA	Included in TIA/EIA-136-440 as GSM 06.93 (ETSI EN 301 707 v7.3.1)	0	Published ANS	23/04/2001	<a href="http://www.tiaonline.org/standards/sfg/imt2k/uwc136">http://www.tiaonline.org/standards/sfg/imt2k/uwc136</a>

**Release 99**

T1	T1.3GPP.26.093V330-2000	3.3.0	Approved	01/12/2000	<a href="https://www.atis.org/atis/docstore/search.asp?committee=S24">https://www.atis.org/atis/docstore/search.asp?committee=S24</a>
----	-------------------------	-------	----------	------------	---------------------------------------------------------------------------------------------------------------------------------------

**Release 5**

T1	T1.3GPP.26.093V510-2003	5.1.0	Approved	09/12/2003	<a href="https://www.atis.org/atis/docstore/search.asp?committee=S24">https://www.atis.org/atis/docstore/search.asp?committee=S24</a>
TIA	Included in TIA-136-440 as ETSI TS 126 093 v5.1.0)	A	Published ANS	13/01/2004	<a href="http://www.tiaonline.org/standards/sfg/imt2k/uwc136">http://www.tiaonline.org/standards/sfg/imt2k/uwc136</a>

**5.4.2.6.12 3GPP TS 26.094****Voice Activity Detector for AMR speech codec**

This document provides the VAD definition for the AMR speech codec.

SDO (2)	Document No.	Version	Status	Issued date	Location (1)
---------	--------------	---------	--------	-------------	--------------

**Release 98**

TIA	Included in TIA/EIA-136-440 as GSM 06.94 (ETSI EN 301 708 v7.1.1)	0	Published ANS	23/04/2001	<a href="http://www.tiaonline.org/standards/sfg/imt2k/uwc136">http://www.tiaonline.org/standards/sfg/imt2k/uwc136</a>
-----	----------------------------------------------------------------------	---	---------------	------------	-----------------------------------------------------------------------------------------------------------------------

**Release 99**

T1	T1.3GPP.26.094V300-1999	3.0.0	Approved	01/10/1999	<a href="https://www.atis.org/atis/docstore/search.asp?committee=S24">https://www.atis.org/atis/docstore/search.asp?committee=S24</a>
----	-------------------------	-------	----------	------------	---------------------------------------------------------------------------------------------------------------------------------------

**Release 5**

T1	T1.3GPP.26.094V500-2003	5.0.0	Approved	27/03/2003	<a href="https://www.atis.org/atis/docstore/search.asp?committee=S24">https://www.atis.org/atis/docstore/search.asp?committee=S24</a>
TIA	Included in TIA-136-440 as ETSI TS 126 094 v5.0.0)	A	Published ANS	13/01/2004	<a href="http://www.tiaonline.org/standards/sfg/imt2k/uwc136">http://www.tiaonline.org/standards/sfg/imt2k/uwc136</a>

**5.4.2.6.13 3GPP TS 26.102****AMR speech codec; Interface to Iu and Uu**

This document provides the interface definition for the AMR speech codec to Iu and Uu interfaces.

SDO (2)	Document No.	Version	Status	Issued date	Location (1)
---------	--------------	---------	--------	-------------	--------------

**Release 99**

T1	T1.3GPP.26.102V330-2001	3.3.0	Approved	01/03/2001	<a href="https://www.atis.org/atis/docstore/search.asp?committee=S24">https://www.atis.org/atis/docstore/search.asp?committee=S24</a>
----	-------------------------	-------	----------	------------	---------------------------------------------------------------------------------------------------------------------------------------

**Release 5**

T1	T1.3GPP.26.102V500-2003	5.0.0	Approved	09/12/2003	<a href="https://www.atis.org/atis/docstore/search.asp?committee=S24">https://www.atis.org/atis/docstore/search.asp?committee=S24</a>
TIA	Included in TIA-136-440 as ETSI TS 126 102 v5.0.0)	A	Published ANS	13/01/2004	<a href="http://www.tiaonline.org/standards/sfg/imt2k/uwc136">http://www.tiaonline.org/standards/sfg/imt2k/uwc136</a>

**5.4.2.6.14 3GPP TS 26.103****Speech codec list for GSM and UMTS**

This document provides the list of speech codecs for GSM and UMTS.

308

## Rec. ITU-R M.1457-4

SDO (2)	Document No.	Version	Status	Issued date	Location (1)
<b>Release 99</b>					
T1	T1.3GPP.26.103V320-2003	3.2.0	Approved	09/12/2003	<a href="https://www.atis.org/atis/docstore/search.asp?committee=S24">https://www.atis.org/atis/docstore/search.asp?committee=S24</a>
<b>Release 5</b>					
T1	T1.3GPP.26.103V530-2003	5.3.0	Approved	09/12/2003	<a href="https://www.atis.org/atis/docstore/search.asp?committee=S24">https://www.atis.org/atis/docstore/search.asp?committee=S24</a>

### 5.4.2.6.15 3GPP TS 26.104

#### ANSI-C code for floating point AMR speech codec

This document provides the ANSI-C code definition for the floating point AMR speech codec.

SDO (2)	Document No.	Version	Status	Issued date	Location (1)
<b>Release 99</b>					
T1	T1.3GPP.26.104V340-2003	3.4.0	Approved	09/12/2003	<a href="https://www.atis.org/atis/docstore/search.asp?committee=S24">https://www.atis.org/atis/docstore/search.asp?committee=S24</a>
<b>Release 5</b>					
T1	T1.3GPP.26.104V500-2003	5.0.0	Approved	27/03/2003	<a href="https://www.atis.org/atis/docstore/search.asp?committee=S24">https://www.atis.org/atis/docstore/search.asp?committee=S24</a>
TIA	Included in TIA-136-440 as ETSI TS 126 104 v5.0.0)	A	Published ANS	13/01/2004	<a href="http://www.tiaonline.org/standards/sfg/imt2k/uwc136">http://www.tiaonline.org/standards/sfg/imt2k/uwc136</a>

### 5.4.2.6.16 3GPP TS 26.110

#### Codec for circuit switched multimedia telephony service; General description

This document provides the general description for the codec used for multimedia telephony service.

SDO (2)	Document No.	Version	Status	Issued date	Location (1)
<b>Release 99</b>					
T1	T1.3GPP.26.110V310-2001	3.1.0	Approved	01/03/2001	<a href="https://www.atis.org/atis/docstore/search.asp?committee=S24">https://www.atis.org/atis/docstore/search.asp?committee=S24</a>
<b>Release 5</b>					
T1	T1.3GPP.26.110V500-2003	5.0.0	Approved	27/03/2003	<a href="https://www.atis.org/atis/docstore/search.asp?committee=S24">https://www.atis.org/atis/docstore/search.asp?committee=S24</a>
TIA	Included in TIA-136-440 as ETSI TS 126 110 v5.0.0)	A	Published ANS	13/01/2004	<a href="http://www.tiaonline.org/standards/sfg/imt2k/uwc136">http://www.tiaonline.org/standards/sfg/imt2k/uwc136</a>

### 5.4.2.6.17 3GPP TS 26.111

#### Codec for circuit switched multimedia telephony service; Modifications to H.324

This document provides the description for the modifications to H.324 for multimedia telephony service.

SDO (2)	Document No.	Version	Status	Issued date	Location (1)
<b>Release 99</b>					
T1	T1.3GPP.26.111V340-2000	3.4.0	Approved	01/12/2000	<a href="https://www.atis.org/atis/docstore/search.asp?committee=S24">https://www.atis.org/atis/docstore/search.asp?committee=S24</a>

**Release 5**

T1	T1.3GPP.26.111V500-2003	5.0.0	Approved	27/03/2003	<a href="https://www.atis.org/atis/docstore/search.asp?committee=S24">https://www.atis.org/atis/docstore/search.asp?committee=S24</a>
TIA	Included in TIA-136-440 as ETSI TS 126 111 v5.0.0)	A	Published ANS	13/01/2004	<a href="http://www.tiaonline.org/standards/sfg/imt2k/uwc136">http://www.tiaonline.org/standards/sfg/imt2k/uwc136</a>

**5.4.2.6.18 3GPP TS 26.230****Global text telephony(GTT); Cellular text telephone modem transmitter C-code description**

This document provides the C-code description for the GTT modem transmitter.

SDO (2)	Document No.	Version	Status	Issued date	Location (1)
---------	--------------	---------	--------	-------------	--------------

**Release 5**

T1	T1.3GPP.26.230V501-2003	5.0.1	Approved	27/03/2003	<a href="https://www.atis.org/atis/docstore/search.asp?committee=S24">https://www.atis.org/atis/docstore/search.asp?committee=S24</a>
----	-------------------------	-------	----------	------------	---------------------------------------------------------------------------------------------------------------------------------------

**5.4.2.6.19 3GPP TS 26.231****Global text telephony(GTT); Cellular text telephone modem minimum performance requirements**

This document specifies the minimum performance requirements for the GTT cellular text telephone modem.

SDO (2)	Document No.	Version	Status	Issued date	Location (1)
---------	--------------	---------	--------	-------------	--------------

**Release 5**

T1	T1.3GPP.26.231V520-2003	5.2.0	Approved	27/03/2003	<a href="https://www.atis.org/atis/docstore/search.asp?committee=S24">https://www.atis.org/atis/docstore/search.asp?committee=S24</a>
----	-------------------------	-------	----------	------------	---------------------------------------------------------------------------------------------------------------------------------------

**5.4.2.6.20 3GPP TS 26.235****Packet switched conversational multimedia applications; Default codecs**

This document specifies the default codecs used for packet switched conversational multimedia applications.

SDO (2)	Document No.	Version	Status	Issued date	Location (1)
---------	--------------	---------	--------	-------------	--------------

**Release 5**

T1	T1.3GPP.26.235V510-2003	5.1.0	Approved	27/03/2003	<a href="https://www.atis.org/atis/docstore/search.asp?committee=S24">https://www.atis.org/atis/docstore/search.asp?committee=S24</a>
----	-------------------------	-------	----------	------------	---------------------------------------------------------------------------------------------------------------------------------------

**5.4.2.6.21 3GPP TR 26.911****Codec for circuit switched multimedia telephony service; Terminal implementor's guide**

This document provides a guide to terminal implementors for multimedia telephony service.

SDO (2)	Document No.	Version	Status	Issued date	Location (1)
---------	--------------	---------	--------	-------------	--------------

**Release 99**

T1	T1.3GPP.26.911V330-2003	3.3.0	Approved	09/12/2003	<a href="https://www.atis.org/atis/docstore/search.asp?committee=S24">https://www.atis.org/atis/docstore/search.asp?committee=S24</a>
----	-------------------------	-------	----------	------------	---------------------------------------------------------------------------------------------------------------------------------------

**Release 5**

T1	T1.3GPP.26.911V500-2003	5.0.0	Approved	27/03/2003	<a href="https://www.atis.org/atis/docstore/search.asp?committee=S24">https://www.atis.org/atis/docstore/search.asp?committee=S24</a>
----	-------------------------	-------	----------	------------	---------------------------------------------------------------------------------------------------------------------------------------

TIA Included in TIA-136-440 as ETSI A Published ANS 13/01/2004 <http://www.tiaonline.org/standards/sfg/imt2k/uwc136>  
TR126 911 v5.0.0)

#### 5.4.2.6.22 3GPP TR 26.975

##### Performance characterisation of the AMR codec

This document provides a performance characterization of the AMR codec.

SDO (2)	Document No.	Version	Status	Issued date	Location (1)
<b>Release 99</b>					
T1	T1.3GPP.26.975V310-2003	3.1.0	Approved	09/12/2003	<a href="https://www.atis.org/atis/docstore/search.asp?committee=S24">https://www.atis.org/atis/docstore/search.asp?committee=S24</a>
<b>Release 5</b>					
T1	T1.3GPP.26.975V500-2003	5.0.0	Approved	27/03/2003	<a href="https://www.atis.org/atis/docstore/search.asp?committee=S24">https://www.atis.org/atis/docstore/search.asp?committee=S24</a>
TIA	Included in TIA-136-440 as ETSI A TR126 975 v5.0.0)	A	Published ANS	13/01/2004	<a href="http://www.tiaonline.org/standards/sfg/imt2k/uwc136">http://www.tiaonline.org/standards/sfg/imt2k/uwc136</a>

#### 5.4.2.6.23 3GPP TS 28.062

##### Inband Tandem Free Operation (TFO); Stage 3

This document provides a stage 3 service description for inband vocoder tandem free operation.

SDO (2)	Document No.	Version	Status	Issued date	Location (1)
<b>Release 99</b>					
T1	T1.3GPP.08.62V801-2003	8.0.1	Approved	09/12/2003	<a href="https://www.atis.org/atis/docstore/search.asp?committee=S24">https://www.atis.org/atis/docstore/search.asp?committee=S24</a>
<b>Release 5</b>					
T1	T1.3GPP.28.062V520-2003	5.2.0	Approved	09/12/2003	<a href="https://www.atis.org/atis/docstore/search.asp?committee=S24">https://www.atis.org/atis/docstore/search.asp?committee=S24</a>

#### 5.4.2.6.24 3GPP TS 43.050

##### Transmission Planning aspects of the speech service in GSM Public Land Mobile Network (PLMN)

This document describes the transmission planning aspects for the speech service for the alternate circuit switched component.

SDO (2)	Document No.	Version	Status	Issued date	Location (1)
<b>Release 99</b>					
T1	T1.3GPP.03.50V811-2003	8.1.1	Approved	09/12/2003	<a href="https://www.atis.org/atis/docstore/search.asp?committee=S24">https://www.atis.org/atis/docstore/search.asp?committee=S24</a>
<b>Release 5</b>					
T1	T1.3GPP.43.050V500-2003	5.0.0	Approved	09/12/2003	<a href="https://www.atis.org/atis/docstore/search.asp?committee=S24">https://www.atis.org/atis/docstore/search.asp?committee=S24</a>



**5.4.2.6.25 3GPP TS 46.001****Full rate speech processing functions**

This document defines speech processing functions for the full rate vocoder.

SDO (2)	Document No.	Version	Status	Issued date	Location (1)
<b>Release 99</b>					
T1	T1.3GPP.06.01V801-2003	8.0.1	Approved	09/12/2003	<a href="https://www.atis.org/atis/docstore/search.asp?committee=S24">https://www.atis.org/atis/docstore/search.asp?committee=S24</a>
<b>Release 5</b>					
T1	T1.3GPP.46.001V500-2003	5.0.0	Approved	09/12/2003	<a href="https://www.atis.org/atis/docstore/search.asp?committee=S24">https://www.atis.org/atis/docstore/search.asp?committee=S24</a>

**5.4.2.6.26 3GPP TS 46.002****Half rate speech processing functions**

This document defines speech processing functions for the half rate vocoder.

SDO (2)	Document No.	Version	Status	Issued date	Location (1)
<b>Release 99</b>					
T1	T1.3GPP.06.02V800-2003	8.0.0	Approved	09/12/2003	<a href="https://www.atis.org/atis/docstore/search.asp?committee=S24">https://www.atis.org/atis/docstore/search.asp?committee=S24</a>
<b>Release 5</b>					
T1	T1.3GPP.46.002V500-2003	5.0.0	Approved	09/12/2003	<a href="https://www.atis.org/atis/docstore/search.asp?committee=S24">https://www.atis.org/atis/docstore/search.asp?committee=S24</a>

**5.4.2.6.27 3GPP TS 46.006****Half rate speech; ANSI-C code for half rate speech codec**

This document provides the ANSI-C code for the half rate vocoder.

SDO (2)	Document No.	Version	Status	Issued date	Location (1)
<b>Release 99</b>					
T1	T1.3GPP.06.06V801-2003	8.0.1	Approved	09/12/2003	<a href="https://www.atis.org/atis/docstore/search.asp?committee=S24">https://www.atis.org/atis/docstore/search.asp?committee=S24</a>
<b>Release 5</b>					
T1	T1.3GPP.46.006V500-2003	5.0.0	Approved	09/12/2003	<a href="https://www.atis.org/atis/docstore/search.asp?committee=S24">https://www.atis.org/atis/docstore/search.asp?committee=S24</a>

**5.4.2.6.28 3GPP TS 46.007****Half rate speech; test sequences for half rate speech codec**

This document provides the test sequences for the half rate vocoder.

SDO (2)	Document No.	Version	Status	Issued date	Location (1)
<b>Release 99</b>					
T1	T1.3GPP.06.07V801-2003	8.0.1	Approved	09/12/2003	<a href="https://www.atis.org/atis/docstore/search.asp?committee=S24">https://www.atis.org/atis/docstore/search.asp?committee=S24</a>

**Release 5**

T1	T1.3GPP.46.007V500-2003	5.0.0	Approved	09/12/2003	<a href="https://www.atis.org/atis/docstore/search.asp?committee=S24">https://www.atis.org/atis/docstore/search.asp?committee=S24</a>
----	-------------------------	-------	----------	------------	---------------------------------------------------------------------------------------------------------------------------------------

**5.4.2.6.29 3GPP TS 46.008****Half rate speech; performance characterization of half rate speech codec**

This document provides the performance characterization for the half rate vocoder.

SDO (2)	Document No.	Version	Status	Issued date	Location (1)
---------	--------------	---------	--------	-------------	--------------

**Release 99**

T1	T1.3GPP.06.08V800-2003	8.0.0	Approved	09/12/2003	<a href="https://www.atis.org/atis/docstore/search.asp?committee=S24">https://www.atis.org/atis/docstore/search.asp?committee=S24</a>
----	------------------------	-------	----------	------------	---------------------------------------------------------------------------------------------------------------------------------------

**Release 5**

T1	T1.3GPP.46.008V500-2003	5.0.0	Approved	09/12/2003	<a href="https://www.atis.org/atis/docstore/search.asp?committee=S24">https://www.atis.org/atis/docstore/search.asp?committee=S24</a>
----	-------------------------	-------	----------	------------	---------------------------------------------------------------------------------------------------------------------------------------

**5.4.2.6.30 3GPP TS 46.010****Full rate speech transcoding**

This document provides the definition for speech transcoding for the full rate vocoder.

SDO (2)	Document No.	Version	Status	Issued date	Location (1)
---------	--------------	---------	--------	-------------	--------------

**Release 99**

T1	T1.3GPP.06.10V820-2003	8.2.0	Approved	09/12/2003	<a href="https://www.atis.org/atis/docstore/search.asp?committee=S24">https://www.atis.org/atis/docstore/search.asp?committee=S24</a>
----	------------------------	-------	----------	------------	---------------------------------------------------------------------------------------------------------------------------------------

**Release 5**

T1	T1.3GPP.46.010V500-2003	5.0.0	Approved	09/12/2003	<a href="https://www.atis.org/atis/docstore/search.asp?committee=S24">https://www.atis.org/atis/docstore/search.asp?committee=S24</a>
----	-------------------------	-------	----------	------------	---------------------------------------------------------------------------------------------------------------------------------------

**5.4.2.6.31 3GPP TS 46.011****Substitution and muting of lost frames for Full Rate speech channels**

This document defines the error concealment functions for full rate vocoder.

SDO (2)	Document No.	Version	Status	Issued date	Location (1)
---------	--------------	---------	--------	-------------	--------------

**Release 99**

T1	T1.3GPP.06.11V801-2003	8.0.1	Approved	09/12/2003	<a href="https://www.atis.org/atis/docstore/search.asp?committee=S24">https://www.atis.org/atis/docstore/search.asp?committee=S24</a>
----	------------------------	-------	----------	------------	---------------------------------------------------------------------------------------------------------------------------------------

**Release 5**

T1	T1.3GPP.46.011V500-2003	5.0.0	Approved	09/12/2003	<a href="https://www.atis.org/atis/docstore/search.asp?committee=S24">https://www.atis.org/atis/docstore/search.asp?committee=S24</a>
----	-------------------------	-------	----------	------------	---------------------------------------------------------------------------------------------------------------------------------------

**5.4.2.6.32 3GPP TS 46.012****Comfort noise aspects for Full Rate speech traffic channels**

This document defines the comfort noise functions for the full rate vocoder.

SDO (2)	Document No.	Version	Status	Issued date	Location (1)
<b>Release 99</b>					
T1	T1.3GPP.06.12V810-2003	8.1.0	Approved	09/12/2003	<a href="https://www.atis.org/atis/docstore/search.asp?committee=S24">https://www.atis.org/atis/docstore/search.asp?committee=S24</a>
<b>Release 5</b>					
T1	T1.3GPP.46.012V500-2003	5.0.0	Approved	09/12/2003	<a href="https://www.atis.org/atis/docstore/search.asp?committee=S24">https://www.atis.org/atis/docstore/search.asp?committee=S24</a>

#### 5.4.2.6.33 3GPP TS 46.020

##### Half rate speech transcoding

This document provides the definition for speech transcoding for the half rate vocoder.

SDO (2)	Document No.	Version	Status	Issued date	Location (1)
<b>Release 99</b>					
T1	T1.3GPP.06.20V801-2003	8.0.1	Approved	09/12/2003	<a href="https://www.atis.org/atis/docstore/search.asp?committee=S24">https://www.atis.org/atis/docstore/search.asp?committee=S24</a>
<b>Release 5</b>					
T1	T1.3GPP.46.020V500-2003	5.0.0	Approved	09/12/2003	<a href="https://www.atis.org/atis/docstore/search.asp?committee=S24">https://www.atis.org/atis/docstore/search.asp?committee=S24</a>

#### 5.4.2.6.34 3GPP TS 46.021

##### Substitution and muting of lost frames for Half Rate speech channels

This document defines the error concealment functions for half rate vocoder.

SDO (2)	Document No.	Version	Status	Issued date	Location (1)
<b>Release 99</b>					
T1	T1.3GPP.06.21V801-2003	8.0.1	Approved	09/12/2003	<a href="https://www.atis.org/atis/docstore/search.asp?committee=S24">https://www.atis.org/atis/docstore/search.asp?committee=S24</a>
<b>Release 5</b>					
T1	T1.3GPP.46.021V500-2003	5.0.0	Approved	09/12/2003	<a href="https://www.atis.org/atis/docstore/search.asp?committee=S24">https://www.atis.org/atis/docstore/search.asp?committee=S24</a>

#### 5.4.2.6.35 3GPP TS 46.022

##### Comfort noise aspects for Half Rate speech traffic channels

This document defines the comfort noise functions for the half rate vocoder.

SDO (2)	Document No.	Version	Status	Issued date	Location (1)
<b>Release 99</b>					
T1	T1.3GPP.06.22V801-2003	8.0.1	Approved	09/12/2003	<a href="https://www.atis.org/atis/docstore/search.asp?committee=S24">https://www.atis.org/atis/docstore/search.asp?committee=S24</a>
<b>Release 5</b>					
T1	T1.3GPP.46.022V500-2003	5.0.0	Approved	09/12/2003	<a href="https://www.atis.org/atis/docstore/search.asp?committee=S24">https://www.atis.org/atis/docstore/search.asp?committee=S24</a>

**5.4.2.6.36** 3GPP TS 46.031**Discontinuous Transmission (DTX) for Full Rate speech traffic channels**

This document defines the discontinuous transmission function for the full rate vocoder.

SDO (2)	Document No.	Version	Status	Issued date	Location (1)
<b>Release 99</b>					
T1	T1.3GPP.06.31V801-2003	8.0.1	Approved	09/12/2003	<a href="https://www.atis.org/atis/docstore/search.asp?committee=S24">https://www.atis.org/atis/docstore/search.asp?committee=S24</a>
<b>Release 5</b>					
T1	T1.3GPP.46.031V500-2003	5.0.0	Approved	09/12/2003	<a href="https://www.atis.org/atis/docstore/search.asp?committee=S24">https://www.atis.org/atis/docstore/search.asp?committee=S24</a>

**5.4.2.6.37** 3GPP TS 46.032**Voice Activity Detection (VAD) for full rate speech traffic channels**

This document defines the voice activity detection function for the full rate vocoder.

SDO (2)	Document No.	Version	Status	Issued date	Location (1)
<b>Release 99</b>					
T1	T1.3GPP.06.32V801-2003	8.0.1	Approved	09/12/2003	<a href="https://www.atis.org/atis/docstore/search.asp?committee=S24">https://www.atis.org/atis/docstore/search.asp?committee=S24</a>
<b>Release 5</b>					
T1	T1.3GPP.46.032V500-2003	5.0.0	Approved	09/12/2003	<a href="https://www.atis.org/atis/docstore/search.asp?committee=S24">https://www.atis.org/atis/docstore/search.asp?committee=S24</a>

**5.4.2.6.38** 3GPP TS 46.041**Discontinuous Transmission (DTX) for Half Rate speech traffic channels**

This document defines the discontinuous transmission function for the half rate vocoder.

SDO (2)	Document No.	Version	Status	Issued date	Location (1)
<b>Release 99</b>					
T1	T1.3GPP.06.41V801-2003	8.0.1	Approved	09/12/2003	<a href="https://www.atis.org/atis/docstore/search.asp?committee=S24">https://www.atis.org/atis/docstore/search.asp?committee=S24</a>
<b>Release 5</b>					
T1	T1.3GPP.46.041V500-2003	5.0.0	Approved	09/12/2003	<a href="https://www.atis.org/atis/docstore/search.asp?committee=S24">https://www.atis.org/atis/docstore/search.asp?committee=S24</a>

**5.4.2.6.39** 3GPP TS 46.042**Voice Activity Detection (VAD) for half rate speech traffic channels**

This document defines the voice activity detection function for the half rate vocoder.

SDO (2)	Document No.	Version	Status	Issued date	Location (1)
<b>Release 99</b>					
T1	T1.3GPP.06.42V801-2003	8.0.1	Approved	09/12/2003	<a href="https://www.atis.org/atis/docstore/search.asp?committee=S24">https://www.atis.org/atis/docstore/search.asp?committee=S24</a>

**Release 5**

T1	T1.3GPP.46.042V500-2003	5.0.0	Approved	09/12/2003	<a href="https://www.atis.org/atis/docstore/search.asp?committee=S24">https://www.atis.org/atis/docstore/search.asp?committee=S24</a>
----	-------------------------	-------	----------	------------	---------------------------------------------------------------------------------------------------------------------------------------

**5.4.2.6.40 3GPP TS 46.051****Enhanced full rate speech processing functions**

This document defines speech processing functions for the enhanced full rate vocoder.

SDO (2)	Document No.	Version	Status	Issued date	Location (1)
---------	--------------	---------	--------	-------------	--------------

**Release 99**

T1	T1.3GPP.06.51V820-2003	8.2.0	Approved	09/12/2003	<a href="https://www.atis.org/atis/docstore/search.asp?committee=S24">https://www.atis.org/atis/docstore/search.asp?committee=S24</a>
----	------------------------	-------	----------	------------	---------------------------------------------------------------------------------------------------------------------------------------

**Release 5**

T1	T1.3GPP.46.051V500-2003	5.0.0	Approved	09/12/2003	<a href="https://www.atis.org/atis/docstore/search.asp?committee=S24">https://www.atis.org/atis/docstore/search.asp?committee=S24</a>
----	-------------------------	-------	----------	------------	---------------------------------------------------------------------------------------------------------------------------------------

**5.4.2.6.41 3GPP TS 46.053****Enhanced full rate speech; ANSI-C code for enhanced full rate speech codec**

This document provides the ANSI-C code for the enhanced full rate vocoder.

SDO (2)	Document No.	Version	Status	Issued date	Location (1)
---------	--------------	---------	--------	-------------	--------------

**Release 99**

T1	T1.3GPP.06.53V801-2003	8.0.1	Approved	09/12/2003	<a href="https://www.atis.org/atis/docstore/search.asp?committee=S24">https://www.atis.org/atis/docstore/search.asp?committee=S24</a>
----	------------------------	-------	----------	------------	---------------------------------------------------------------------------------------------------------------------------------------

**Release 5**

T1	T1.3GPP.46.053V500-2003	5.0.0	Approved	09/12/2003	<a href="https://www.atis.org/atis/docstore/search.asp?committee=S24">https://www.atis.org/atis/docstore/search.asp?committee=S24</a>
----	-------------------------	-------	----------	------------	---------------------------------------------------------------------------------------------------------------------------------------

**5.4.2.6.42 3GPP TS 46.054****Enhanced full rate speech; test sequences for enhanced full rate speech codec**

This document provides the test sequences for the enhanced full rate vocoder.

SDO (2)	Document No.	Version	Status	Issued date	Location (1)
---------	--------------	---------	--------	-------------	--------------

**Release 99**

T1	T1.3GPP.06.54V820-2003	8.2.0	Approved	09/12/2003	<a href="https://www.atis.org/atis/docstore/search.asp?committee=S24">https://www.atis.org/atis/docstore/search.asp?committee=S24</a>
----	------------------------	-------	----------	------------	---------------------------------------------------------------------------------------------------------------------------------------

**Release 5**

T1	T1.3GPP.46.054V500-2003	5.0.0	Approved	09/12/2003	<a href="https://www.atis.org/atis/docstore/search.asp?committee=S24">https://www.atis.org/atis/docstore/search.asp?committee=S24</a>
----	-------------------------	-------	----------	------------	---------------------------------------------------------------------------------------------------------------------------------------

**5.4.2.6.43 3GPP TS 46.055****Enhanced full rate speech; performance characterization of EFR speech codec**

This document provides the performance characterization for the enhanced full rate vocoder.

SDO (2)	Document No.	Version	Status	Issued date	Location (1)
<b>Release 99</b>					
T1	T1.3GPP.06.55V800-2003	8.0.0	Approved	09/12/2003	<a href="https://www.atis.org/atis/docstore/search.asp?committee=S24">https://www.atis.org/atis/docstore/search.asp?committee=S24</a>
<b>Release 5</b>					
T1	T1.3GPP.46.055V500-2003	5.0.0	Approved	09/12/2003	<a href="https://www.atis.org/atis/docstore/search.asp?committee=S24">https://www.atis.org/atis/docstore/search.asp?committee=S24</a>

#### 5.4.2.6.44 3GPP TS 46.060

##### Enhanced full rate speech transcoding

This document provides the definition for speech transcoding for the enhanced full rate vocoder.

SDO (2)	Document No.	Version	Status	Issued date	Location (1)
<b>Release 99</b>					
T1	T1.3GPP.06.60V801-2003	8.0.1	Approved	09/12/2003	<a href="https://www.atis.org/atis/docstore/search.asp?committee=S24">https://www.atis.org/atis/docstore/search.asp?committee=S24</a>
<b>Release 5</b>					
T1	T1.3GPP.46.060V500-2003	5.0.0	Approved	09/12/2003	<a href="https://www.atis.org/atis/docstore/search.asp?committee=S24">https://www.atis.org/atis/docstore/search.asp?committee=S24</a>

#### 5.4.2.6.45 3GPP TS 46.061

##### Substitution and muting of lost frames for Enhanced full Rate speech channels

This document defines the error concealment functions for the enhanced full rate vocoder.

SDO (2)	Document No.	Version	Status	Issued date	Location (1)
<b>Release 99</b>					
T1	T1.3GPP.06.61V801-2003	8.0.1	Approved	09/12/2003	<a href="https://www.atis.org/atis/docstore/search.asp?committee=S24">https://www.atis.org/atis/docstore/search.asp?committee=S24</a>
<b>Release 5</b>					
T1	T1.3GPP.46.061V500-2003	5.0.0	Approved	09/12/2003	<a href="https://www.atis.org/atis/docstore/search.asp?committee=S24">https://www.atis.org/atis/docstore/search.asp?committee=S24</a>

#### 5.4.2.6.46 3GPP TS 46.062

##### Comfort noise aspects for Enhanced full Rate speech traffic channels

This document defines the comfort noise functions for the half rate vocoder.

SDO (2)	Document No.	Version	Status	Issued date	Location (1)
<b>Release 99</b>					
T1	T1.3GPP.06.62V801-2003	8.0.1	Approved	09/12/2003	<a href="https://www.atis.org/atis/docstore/search.asp?committee=S24">https://www.atis.org/atis/docstore/search.asp?committee=S24</a>
<b>Release 5</b>					
T1	T1.3GPP.46.062V500-2003	5.0.0	Approved	09/12/2003	<a href="https://www.atis.org/atis/docstore/search.asp?committee=S24">https://www.atis.org/atis/docstore/search.asp?committee=S24</a>

**5.4.2.6.47 3GPP TS 46.081****Discontinuous Transmission (DTX) for Enhanced full Rate speech traffic channels**

This document defines the discontinuous transmission function for the enhanced full rate vocoder.

SDO (2)	Document No.	Version	Status	Issued date	Location (1)
<b>Release 99</b>					
T1	T1.3GPP.06.81V801-2003	8.0.1	Approved	09/12/2003	<a href="https://www.atis.org/atis/docstore/search.asp?committee=S24">https://www.atis.org/atis/docstore/search.asp?committee=S24</a>
<b>Release 5</b>					
T1	T1.3GPP.46.081V500-2003	5.0.0	Approved	09/12/2003	<a href="https://www.atis.org/atis/docstore/search.asp?committee=S24">https://www.atis.org/atis/docstore/search.asp?committee=S24</a>

**5.4.2.6.48 3GPP TS 46.082****Voice Activity Detection (VAD) for enhanced full rate speech traffic channels**

This document defines the voice activity detection function for the enhanced full rate vocoder.

SDO (2)	Document No.	Version	Status	Issued date	Location (1)
<b>Release 99</b>					
T1	T1.3GPP.06.82V801-2003	8.0.1	Approved	09/12/2003	<a href="https://www.atis.org/atis/docstore/search.asp?committee=S24">https://www.atis.org/atis/docstore/search.asp?committee=S24</a>
<b>Release 5</b>					
T1	T1.3GPP.46.082V500-2003	5.0.0	Approved	09/12/2003	<a href="https://www.atis.org/atis/docstore/search.asp?committee=S24">https://www.atis.org/atis/docstore/search.asp?committee=S24</a>

**5.4.2.6.49 3GPP TS 48.060****Inband control of remote transcoders and rate adaptors for EFR/FR**

This document defines inband control of remote transcoders and rate adaptors for enhanced full rate and full rate vocoders.

SDO (2)	Document No.	Version	Status	Issued date	Location (1)
<b>Release 99</b>					
T1	T1.3GPP.08.60V820-2003	8.2.0	Approved	09/12/2003	<a href="https://www.atis.org/atis/docstore/search.asp?committee=S24">https://www.atis.org/atis/docstore/search.asp?committee=S24</a>
<b>Release 5</b>					
T1	T1.3GPP.48.060V520-2003	5.2.0	Approved	09/12/2003	<a href="https://www.atis.org/atis/docstore/search.asp?committee=S24">https://www.atis.org/atis/docstore/search.asp?committee=S24</a>

**5.4.2.6.50 3GPP TS 48.061****Inband control of remote transcoders and rate adaptors; (half rate)**

This document defines inband control of remote transcoders and rate adaptors for half rate vocoders.

SDO (2)	Document No.	Version	Status	Issued date	Location (1)
<b>Release 99</b>					
T1	T1.3GPP.08.61V810-2003	8.1.0	Approved	09/12/2003	<a href="https://www.atis.org/atis/docstore/search.asp?committee=S24">https://www.atis.org/atis/docstore/search.asp?committee=S24</a>

**Release 5**

T1	T1.3GPP.48.061V500-2003	5.0.0	Approved	09/12/2003	<a href="https://www.atis.org/atis/docstore/search.asp?committee=S24">https://www.atis.org/atis/docstore/search.asp?committee=S24</a>
----	-------------------------	-------	----------	------------	---------------------------------------------------------------------------------------------------------------------------------------

**5.4.2.7****Security****5.4.2.7.1 136-510****Authentication, encryption of signalling information/user data, and Privacy**

This part provides information on authentication for the digital control channel, analogue voice channel, analogue control channel, and digital traffic channel. It also provides a description of signalling message encryption and voice privacy and data privacy for TIA/EIA-136 systems.

SDO (2)	Document No.	Version	Status	Issued date	Location (1)
TIA	TIA/EIA-136-510	B	Published ANS	31/03/2000	<a href="http://www.tiaonline.org/standards/sfg/imt2k/uwc136">http://www.tiaonline.org/standards/sfg/imt2k/uwc136</a>

**5.4.2.7.2 136-511****Messages subject to encryption**

This part describes the messages which are subject to the encryption techniques described in TIA/EIA-136-510.

SDO (2)	Document No.	Version	Status	Issued date	Location (1)
TIA	TIA/EIA-136-511	A	Published ANS	31/03/2000	<a href="http://www.tiaonline.org/standards/sfg/imt2k/uwc136">http://www.tiaonline.org/standards/sfg/imt2k/uwc136</a>

**5.4.2.7.3 3GPP TS 02.09****Security aspects**

This document provides a description of the security aspects for the GSM/EDGE system. Standalone security aspects for GSM GPRS are not specified beyond Release 4. For the latest available information see section 5.4.2.13.40.

SDO (2)	Document No.	Version	Status	Issued date	Location (1)
<b>Release 99</b>					
T1	T1.3GPP.02.09V801-2003	8.0.1	Approved	09/12/2003	<a href="https://www.atis.org/atis/docstore/search.asp?committee=S24">https://www.atis.org/atis/docstore/search.asp?committee=S24</a>

**5.4.2.7.4 3GPP TS 43.020****Security related network functions**

This document provides a description of the security functions employed for the GSM/EDGE system.

SDO (2)	Document No.	Version	Status	Issued date	Location (1)
<b>Release 99</b>					
T1	T1.3GPP.03.20V810-2003	8.1.0	Approved	09/12/2003	<a href="https://www.atis.org/atis/docstore/search.asp?committee=S24">https://www.atis.org/atis/docstore/search.asp?committee=S24</a>



**Release 5**

T1	T1.3GPP.43.020V500-2003	5.0.0	Approved	09/12/2003	<a href="https://www.atis.org/atis/docstore/search.asp?committee=S24">https://www.atis.org/atis/docstore/search.asp?committee=S24</a>
----	-------------------------	-------	----------	------------	---------------------------------------------------------------------------------------------------------------------------------------

**5.4.2.8****Teleservice transport****5.4.2.8.1 136-610****R-DATA/SMDPP transport**

This part describes the transport of TIA/EIA-136 teleservice messages using a combination of the R-DATA message air interface transport and the TIA/EIA-41 SMDPP transport.

SDO (2)	Document No.	Version	Status	Issued date	Location (1)
TIA	TIA/EIA-136-610	B	Published ANS	15/04/2002	<a href="http://www.tiaonline.org/standards/sfg/imt2k/uwc136">http://www.tiaonline.org/standards/sfg/imt2k/uwc136</a>

**5.4.2.8.2 136-620****Teleservice segmentation and reassembly (TSAR)**

This part describes teleservice segmentation and reassembly (TSAR). TSAR provides a mechanism to deliver TIA/EIA-136 teleservice messages that are not constrained by any message length limitations imposed by the air interface, or network layers supporting the teleservice. The service consists of the application of segmentation and reassembly, and retransmission of errored segments.

SDO (2)	Document No.	Version	Status	Issued date	Location (1)
TIA	TIA/EIA-136-620	A	Published ANS	04/05/2001	<a href="http://www.tiaonline.org/standards/sfg/imt2k/uwc136">http://www.tiaonline.org/standards/sfg/imt2k/uwc136</a>

**5.4.2.8.3 136-630****Broadcast teleservice transport - Broadcast air-interface transport service (BATS)**

This part describes a broadcast teleservice transport. The BATS teleservice transport operates between a teleservice server and MS using both TIA/EIA-136 and TIA/EIA-41 based protocol stacks along with relay functions in the BS, mobile switching centre and interworking function. BATS is a general-purpose broadcast transport mechanism that can be used by existing teleservices as well as other future teleservices/applications requiring broadcast transport support.

SDO (2)	Document No.	Version	Status	Issued date	Location (1)
TIA	TIA/EIA-136-630	0	Published ANS	29/11/1999	<a href="http://www.tiaonline.org/standards/sfg/imt2k/uwc136">http://www.tiaonline.org/standards/sfg/imt2k/uwc136</a>

**5.4.2.8.4 136-670****Teleservice over GSM SMS (TOGS)**

This part describes support of TIA/EIA-136 teleservices over a GSM Short Message Service delivery mechanism.

SDO (2)	Document No.	Version	Status	Issued date	Location (1)
TIA	TIA/EIA-136-670	0	Published ANS	23/05/2001	<a href="http://www.tiaonline.org/standards/sfg/imt2k/uwc136">http://www.tiaonline.org/standards/sfg/imt2k/uwc136</a>

### 5.4.2.9

#### Teleservices

##### 5.4.2.9.1 136-700

#### Introduction to teleservices

This part provides an introduction to TIA/EIA-136 based teleservices including the teleservice protocol stack, transport, and higher layer protocol identifiers.

SDO (2)	Document No.	Version	Status	Issued date	Location (1)
TIA	TIA/EIA-136-700	D	Published ANS	15/04/2002	<a href="http://www.tiaonline.org/standards/sfg/imt2k/uwc136">http://www.tiaonline.org/standards/sfg/imt2k/uwc136</a>

##### 5.4.2.9.2 136-710

#### Short message service - Cellular messaging teleservice

This part describes the procedures, message set, and information elements necessary to provide short message service in TIA/EIA-136 based systems.

SDO (2)	Document No.	Version	Status	Issued date	Location (1)
TIA	TIA/EIA-136-710	C	Published ANS	15/04/2002	<a href="http://www.tiaonline.org/standards/sfg/imt2k/uwc136">http://www.tiaonline.org/standards/sfg/imt2k/uwc136</a>

##### 5.4.2.9.3 136-711

#### GSM Hosted SMS Teleservice (GHOST)

This part describes the procedures, message set, and information elements necessary to deliver GSM SMS Protocol Data Units (PDUs) to and from a mobile station operating in a TIA/EIA-136 network.

SDO (2)	Document No.	Version	Status	Issued date	Location (1)
TIA	TIA/EIA-136-711	0	Published ANS	15/04/2002	<a href="http://www.tiaonline.org/standards/sfg/imt2k/uwc136">http://www.tiaonline.org/standards/sfg/imt2k/uwc136</a>

##### 5.4.2.9.4 136-720

#### Over-the-air activation teleservice (OATS)

This part describes a teleservice that is designed to support over-the-air activation (OTA). The over-the-air activation teleservice (OATS) supports data exchange between a MS and a customer service centre (CSC)/over-the-air activation function (OTAF) which enables downloading information to the MS number assignment module.

SDO (2)	Document No.	Version	Status	Issued date	Location (1)
TIA	TIA/EIA-136-720	C	Published ANS	15/04/2002	<a href="http://www.tiaonline.org/standards/sfg/imt2k/uwc136">http://www.tiaonline.org/standards/sfg/imt2k/uwc136</a>

#### 5.4.2.9.5 136-730

##### Over-the-air programming teleservice (OPTS)

This part describes a teleservice that is designed to support downloading of non-NAM programming information (e.g. intelligent roaming database or IRDB) to an MS. The over-the-air programming teleservice (OPTS) provides a sequence of messages exchanged between the over-the-air service provisioning function (OTASP) and the MS for the delivery of information.

SDO (2)	Document No.	Version	Status	Issued date	Location (1)
TIA	TIA/EIA-136-730	A	Published ANS	15/04/2002	<a href="http://www.tiaonline.org/standards/sfg/imt2k/uwc136">http://www.tiaonline.org/standards/sfg/imt2k/uwc136</a>

#### 5.4.2.9.6 136-740

##### System Assisted Mobile Positioning through Satellite (SAMPS)

This part describes a teleservice that facilitates the exchange of information between a network entity and a mobile station to provide geographic positioning.

SDO (2)	Document No.	Version	Status	Issued date	Location (1)
TIA	TIA/EIA-136-740	0	Published ANS	23/04/2001	<a href="http://www.tiaonline.org/standards/sfg/imt2k/uwc136">http://www.tiaonline.org/standards/sfg/imt2k/uwc136</a>

#### 5.4.2.9.7 136-741

##### System Assisted Mobile Positioning through Satellite (SAMPS) in Analog Systems

This part describes the procedures, signaling, and transport on analog channels (ACC, AVC) that facilitates the exchange of information between a network entity and a mobile station to provide geographic positioning.

SDO (2)	Document No.	Version	Status	Issued date	Location (1)
TIA	TIA/EIA-136-741	0	Published ANS	22/04/2002	<a href="http://www.tiaonline.org/standards/sfg/imt2k/uwc136">http://www.tiaonline.org/standards/sfg/imt2k/uwc136</a>

#### 5.4.2.9.8 136-750

##### General UDP transport service (GUTS)

This part describes the general UDP transport service (GUTS), which is a teleservice to support the transport of user datagram protocol (UDP) PDUs between a teleservice server and an MS.

SDO (2)	Document No.	Version	Status	Issued date	Location (1)
TIA	TIA/EIA-136-750	0	Published ANS	29/11/1999	<a href="http://www.tiaonline.org/standards/sfg/imt2k/uwc136">http://www.tiaonline.org/standards/sfg/imt2k/uwc136</a>

**5.4.2.9.9** 136-760**Charge indication teleservice (CIT)**

This part describes a teleservice that is designed to provide the MS user with charge information for a call.

SDO (2)	Document No.	Version	Status	Issued date	Location (1)
TIA	TIA/EIA-136-760	A	Published ANS	15/04/2002	<a href="http://www.tiaonline.org/standards/sfg/imt2k/uwc136">http://www.tiaonline.org/standards/sfg/imt2k/uwc136</a>

**5.4.2.9.10** 3GPP TS 22.011**Service Accessibility**

This document describes the service access procedures as presented to the user.

SDO (2)	Document No.	Version	Status	Issued date	Location (1)
<b>Release 99</b>					
T1	T1.3GPP.22.011V380-2003	3.8.0	Approved	09/12/2003	<a href="https://www.atis.org/atis/docstore/search.asp?committee=S24">https://www.atis.org/atis/docstore/search.asp?committee=S24</a>
<b>Release 5</b>					
T1	T1.3GPP.22.011V510-2003	5.1.0	Approved	27/03/2003	<a href="https://www.atis.org/atis/docstore/search.asp?committee=S24">https://www.atis.org/atis/docstore/search.asp?committee=S24</a>

**5.4.2.9.11** 3GPP TS 23.032**Universal Geographical Area Description (GAD)**

This document describes the data used by the location services positioning procedures.

SDO (2)	Document No.	Version	Status	Issued date	Location (1)
<b>Release 99</b>					
T1	T1.3GPP.23.032V310-2000	3.1.0	Approved	01/03/2000	<a href="https://www.atis.org/atis/docstore/search.asp?committee=S24">https://www.atis.org/atis/docstore/search.asp?committee=S24</a>
TIA	Included in TIA/EIA-136-740 as ETSI TS 123 032 v3.1.0)	0	Published ANS	23/04/2001	<a href="http://www.tiaonline.org/standards/sfg/imt2k/uwc136">http://www.tiaonline.org/standards/sfg/imt2k/uwc136</a>
<b>Release 5</b>					
T1	T1.3GPP.23.032V500-2003	5.0.0	Approved	09/12/2003	<a href="https://www.atis.org/atis/docstore/search.asp?committee=S24">https://www.atis.org/atis/docstore/search.asp?committee=S24</a>

**5.4.2.9.12** 3GPP TS 23.039**Interface protocols for connection of SMS service centers (SMSCs) to Short message entities (SMEs)**

This document provides the description of the protocols between the Short Message Service Centers and the SMS entities utilizing SMS.

SDO (2)	Document No.	Version	Status	Issued date	Location (1)
<b>Release 99</b>					
T1	T1.3GPP.23.039V320-2003	3.2.0	Approved	09/12/2003	<a href="https://www.atis.org/atis/docstore/search.asp?committee=S24">https://www.atis.org/atis/docstore/search.asp?committee=S24</a>
<b>Release 5</b>					
T1	T1.3GPP.23.039V500-2003	5.0.0	Approved	27/03/2003	<a href="https://www.atis.org/atis/docstore/search.asp?committee=S24">https://www.atis.org/atis/docstore/search.asp?committee=S24</a>

**5.4.2.9.13 3GPP TS 23.040****Technical realization of the Short Message Service (SMS)**

This document provides the overall description for the Short Message Service.

SDO (2)	Document No.	Version	Status	Issued date	Location (1)
<b>Release 99</b>					
T1	T1.3GPP.23.040V390-2003	3.9.0	Approved	27/03/2003	<a href="https://www.atis.org/atis/docstore/search.asp?committee=S24">https://www.atis.org/atis/docstore/search.asp?committee=S24</a>
TIA	Included in TIA/EIA-136-370 as ETSI TS 123 040 v3.4.1	0	Published ANS	23/04/2001	<a href="http://www.tiaonline.org/standards/sfg/imt2k/uwc136">http://www.tiaonline.org/standards/sfg/imt2k/uwc136</a>
<b>Release 5</b>					
T1	T1.3GPP.23.040V551-2003	5.5.1	Approved	27/03/2003	<a href="https://www.atis.org/atis/docstore/search.asp?committee=S24">https://www.atis.org/atis/docstore/search.asp?committee=S24</a>
TIA	Included in TIA-136-370 as ETSI TS 123 040 v5.5.1	A	Published ANS	13/01/2004	<a href="http://www.tiaonline.org/standards/sfg/imt2k/uwc136">http://www.tiaonline.org/standards/sfg/imt2k/uwc136</a>

**5.4.2.9.14 3GPP TS 23.041****Technical realization of the Cell Broadcast Service (CBS)**

This document provides the overall description for the cell broadcast Service.

SDO (2)	Document No.	Version	Status	Issued date	Location (1)
<b>Release 99</b>					
T1	T1.3GPP.23.041V350-2003	3.5.0	Approved	27/03/2003	<a href="https://www.atis.org/atis/docstore/search.asp?committee=S24">https://www.atis.org/atis/docstore/search.asp?committee=S24</a>
<b>Release 5</b>					
T1	T1.3GPP.23.041V500-2003	5.0.0	Approved	27/03/2003	<a href="https://www.atis.org/atis/docstore/search.asp?committee=S24">https://www.atis.org/atis/docstore/search.asp?committee=S24</a>

**5.4.2.9.15 3GPP TS 23.042****Compression algorithm for SMS**

This document provides the description of the compression algorithm used for the short message service.

SDO (2)	Document No.	Version	Status	Issued date	Location (1)
<b>Release 99</b>					
T1	T1.3GPP.23.042V310-2002	3.1.0	Approved	03/05/2002	<a href="https://www.atis.org/atis/docstore/search.asp?committee=S24">https://www.atis.org/atis/docstore/search.asp?committee=S24</a>
<b>Release 5</b>					
T1	T1.3GPP.23.042V500-2003	5.0.0	Approved	27/03/2003	<a href="https://www.atis.org/atis/docstore/search.asp?committee=S24">https://www.atis.org/atis/docstore/search.asp?committee=S24</a>

**5.4.2.9.16 3GPP TS 23.140****Multimedia Messaging Service (MMS); Functional description; Stage 2**

This document provides the functional description of the Multimedia Messaging Service.

324

## Rec. ITU-R M.1457-4

SDO (2)	Document No.	Version	Status	Issued date	Location (1)
<b>Release 99</b>					
T1	T1.3GPP.23.140V310-2003	3.1.0	Approved	09/12/2003	<a href="https://www.atis.org/atis/docstore/search.asp?committee=S24">https://www.atis.org/atis/docstore/search.asp?committee=S24</a>
<b>Release 5</b>					
T1	T1.3GPP.23.140V540-2003	5.4.0	Approved	09/12/2003	<a href="https://www.atis.org/atis/docstore/search.asp?committee=S24">https://www.atis.org/atis/docstore/search.asp?committee=S24</a>

### 5.4.2.9.17 3GPP TS 24.011

#### Point-to-Point Short Message Service (SMS) support on mobile radio interface

This document provides the specification for support for the Short Message Service on the 200 kHz mobile radio interface.

SDO (2)	Document No.	Version	Status	Issued date	Location (1)
<b>Release 99</b>					
T1	T1.3GPP.24.011V360-2001	3.6.0	Approved	01/03/2001	<a href="https://www.atis.org/atis/docstore/search.asp?committee=S24">https://www.atis.org/atis/docstore/search.asp?committee=S24</a>
TIA	Included in TIA/EIA-136-370 as ETSI TS 124 011 v3.2.0	0	Published ANS	23/04/2001	<a href="http://www.tiaonline.org/standards/sfg/imt2k/uwc136">http://www.tiaonline.org/standards/sfg/imt2k/uwc136</a>
<b>Release 5</b>					
T1	T1.3GPP.24.011V500-2003	5.0.0	Approved	09/12/2003	<a href="https://www.atis.org/atis/docstore/search.asp?committee=S24">https://www.atis.org/atis/docstore/search.asp?committee=S24</a>
TIA	Included in TIA-136-370 as ETSI TS 124 011 v5.0.0	A	Published ANS	13/01/2004	<a href="http://www.tiaonline.org/standards/sfg/imt2k/uwc136">http://www.tiaonline.org/standards/sfg/imt2k/uwc136</a>

### 5.4.2.9.18 3GPP TS 26.140

#### Multimedia Messaging Service (MMS); Media formats and codes

This document provides the specification of the media formats and codes for the Multimedia Messaging Service.

SDO (2)	Document No.	Version	Status	Issued date	Location (1)
<b>Release 5</b>					
T1	T1.3GPP.26.140V510-2003	5.1.0	Approved	09/12/2003	<a href="https://www.atis.org/atis/docstore/search.asp?committee=S24">https://www.atis.org/atis/docstore/search.asp?committee=S24</a>

### 5.4.2.9.19 3GPP TS 32.005

#### Call and Event data for circuit switched domain

This document provides the Release 99 description for the charging data for the circuit switched component.

SDO (2)	Document No.	Version	Status	Issued date	Location (1)
<b>Release 99</b>					
T1	T1.3GPP.32.005V360-2003	3.6.0	Approved	09/12/2003	<a href="https://www.atis.org/atis/docstore/search.asp?committee=S24">https://www.atis.org/atis/docstore/search.asp?committee=S24</a>

**5.4.2.9.20 3GPP TS 32.205****Charging data description for circuit switched domain**

This document provides the Release 5 description for the charging data for the circuit switched component.

SDO (2)	Document No.	Version	Status	Issued date	Location (1)
<b>Release 5</b>					
T1	T1.3GPP.32.205V510-2003	5.1.0	Approved	09/12/2003	<a href="https://www.atis.org/atis/docstore/search.asp?committee=S24">https://www.atis.org/atis/docstore/search.asp?committee=S24</a>

**5.4.2.9.21 3GPP TS 32.015****Call and Event data for packet switched domain**

This document provides the Release 99 description for the charging data for the packet switched component.

SDO (2)	Document No.	Version	Status	Issued date	Location (1)
<b>Release 99</b>					
T1	T1.3GPP.32.015V390-2003	3.9.0	Approved	09/12/2003	<a href="https://www.atis.org/atis/docstore/search.asp?committee=S24">https://www.atis.org/atis/docstore/search.asp?committee=S24</a>
TIA	Included in TIA/EIA-136-370 as ETSI TS 132 015 v3.1.1	0	Published ANS	23/04/2001	<a href="http://www.tiaonline.org/standards/sfg/imt2k/uwc136">http://www.tiaonline.org/standards/sfg/imt2k/uwc136</a>

**5.4.2.9.22 3GPP TS 32.215****Charging data description for packet switched domain**

This document provides the Release 5 description for the charging data for the packet switched component.

SDO (2)	Document No.	Version	Status	Issued date	Location (1)
<b>Release 5</b>					
T1	T1.3GPP.32.215V510-2003	5.1.0	Approved	09/12/2003	<a href="https://www.atis.org/atis/docstore/search.asp?committee=S24">https://www.atis.org/atis/docstore/search.asp?committee=S24</a>
TIA	Included in TIA-136-370 as ETSI TS 132 215 v5.1.0	A	Published ANS	13/01/2004	<a href="http://www.tiaonline.org/standards/sfg/imt2k/uwc136">http://www.tiaonline.org/standards/sfg/imt2k/uwc136</a>

**5.4.2.9.23 3GPP TS 44.012****Short Message Service Cell Broadcast (SMSCB) support on mobile radio interface**

This document provides the specification for support for the cell broadcast Short Message Service on the 200 kHz mobile radio interface.

SDO (2)	Document No.	Version	Status	Issued date	Location (1)
<b>Release 99</b>					
T1	T1.3GPP.04.12V800-2003	8.0.0	Approved	09/12/2003	<a href="https://www.atis.org/atis/docstore/search.asp?committee=S24">https://www.atis.org/atis/docstore/search.asp?committee=S24</a>
<b>Release 5</b>					
T1	T1.3GPP.44.012V500-2003	5.0.0	Approved	09/12/2003	<a href="https://www.atis.org/atis/docstore/search.asp?committee=S24">https://www.atis.org/atis/docstore/search.asp?committee=S24</a>

**5.4.2.10****Annexes/Appendices****5.4.2.10.1 136-900****Introduction to Annexes and Appendices**

This part contains information concerning the 900 series of parts which contain additional normative and informative information related to the TIA/EIA-136 standard.

SDO (2)	Document No.	Version	Status	Issued date	Location (1)
TIA	TIA/EIA-136-900	0	Published ANS	31/03/2000	<a href="http://www.tiaonline.org/standards/sfg/imt2k/uwc136">http://www.tiaonline.org/standards/sfg/imt2k/uwc136</a>

**5.4.2.10.2 136-905****Normative information**

This part contains additional normative information related to the TIA/EIA-136 standard.

SDO (2)	Document No.	Version	Status	Issued date	Location (1)
TIA	TIA-136-905	A	Published ANS	13/01/2004	<a href="http://www.tiaonline.org/standards/sfg/imt2k/uwc136">http://www.tiaonline.org/standards/sfg/imt2k/uwc136</a>

**5.4.2.10.3 136-910****Informative information**

This part provides additional informative information to aid the user to understand the use or application of the TIA/EIA-136 standard. Information such as frame formats, calculation of R-DATA message lengths and addressing is provided.

SDO (2)	Document No.	Version	Status	Issued date	Location (1)
TIA	TIA/EIA-136-910	C	Published ANS	15/04/2002	<a href="http://www.tiaonline.org/standards/sfg/imt2k/uwc136">http://www.tiaonline.org/standards/sfg/imt2k/uwc136</a>

**5.4.2.10.4 136-932****Packet-data service - Stage 2 description**

This informative part of TIA/EIA-136 contains stage 2 descriptions for the GPRS-136 packet data service. It describes the main traffic scenarios and the message flows between different network elements.

SDO (2)	Document No.	Version	Status	Issued date	Location (1)
TIA	TIA/EIA-136-932	0	Published ANS	31/03/2000	<a href="http://www.tiaonline.org/standards/sfg/imt2k/uwc136">http://www.tiaonline.org/standards/sfg/imt2k/uwc136</a>



**5.4.2.10.5** 136-933**Packet-data service - Fixed coding mode MAC**

This part describes the fixed-coding mode of the 136? medium access control (MAC) function specified in TIA/EIA-136-332. Higher layers may use the MAC to transport data across a GPRS-136 radio interface using the 136? bearer.

SDO (2)	Document No.	Version	Status	Issued date	Location (1)
TIA	TIA/EIA-136-933	0	Published ANS	31/03/2000	<a href="http://www.tiaonline.org/standards/sfg/imt2k/uwc136">http://www.tiaonline.org/standards/sfg/imt2k/uwc136</a>

**5.4.2.10.6** 136-940**Capacity and performance characteristics of UWC-136**

This informative part contains additional information concerning the voice capacity, spectrum efficiency, and throughput performance for the UWC-136 system.

SDO (2)	Document No.	Version	Status	Issued date	Location (1)
TIA	TIA/EIA-136-940	0	Published ANS	31/03/2000	<a href="http://www.tiaonline.org/standards/sfg/imt2k/uwc136">http://www.tiaonline.org/standards/sfg/imt2k/uwc136</a>

**5.4.2.10.7** 136-972**Enhanced General Packet Data Service (EGPRS-136) Stage 2 Description**

This informative part provides a Stage-2 description of the Enhanced General Packet Data Service (EGPRS-136).

SDO (2)	Document No.	Version	Status	Issued date	Location (1)
TIA	TIA/EIA-136-972	0	Published ANS	23/04/2001	<a href="http://www.tiaonline.org/standards/sfg/imt2k/uwc136">http://www.tiaonline.org/standards/sfg/imt2k/uwc136</a>

**5.4.2.11****Other Procedures and Signalling****5.4.2.11.1** 3GPP TS 23.007**Restoration procedures**

This document describes the restoration procedures for the Location Register (HLR or VLR) data.

SDO (2)	Document No.	Version	Status	Issued date	Location (1)
<b>Release 99</b>					
T1	T1.3GPP.23.007V350-2003	3.5.0	Approved	09/12/2003	<a href="https://www.atis.org/atis/docstore/search.asp?committee=S24">https://www.atis.org/atis/docstore/search.asp?committee=S24</a>
<b>Release 5</b>					
T1	T1.3GPP.23.007V500-2003	5.0.0	Approved	27/03/2003	<a href="https://www.atis.org/atis/docstore/search.asp?committee=S24">https://www.atis.org/atis/docstore/search.asp?committee=S24</a>

**5.4.2.11.2 3GPP TS 23.008****Organization of subscriber data**

This document describes the organization of the subscriber data stored in the HLR, VLR, or GSNs.

SDO (2)	Document No.	Version	Status	Issued date	Location (1)
<b>Release 99</b>					
T1	T1.3GPP.23.008V370-2003	3.7.0	Approved	09/12/2003	<a href="https://www.atis.org/atis/docstore/search.asp?committee=S24">https://www.atis.org/atis/docstore/search.asp?committee=S24</a>
<b>Release 5</b>					
T1	T1.3GPP.23.008V520-2003	5.2.0	Approved	09/12/2003	<a href="https://www.atis.org/atis/docstore/search.asp?committee=S24">https://www.atis.org/atis/docstore/search.asp?committee=S24</a>

**5.4.2.11.3 3GPP TS 23.009****Handover Procedures**

This document describes the procedures for handover from cell to cell.

SDO (2)	Document No.	Version	Status	Issued date	Location (1)
<b>Release 99</b>					
T1	T1.3GPP.23.009V3110-2003	3.11.0	Approved	09/12/2003	<a href="https://www.atis.org/atis/docstore/search.asp?committee=S24">https://www.atis.org/atis/docstore/search.asp?committee=S24</a>
<b>Release 5</b>					
T1	T1.3GPP.23.009V520-2003	5.2.0	Approved	09/12/2003	<a href="https://www.atis.org/atis/docstore/search.asp?committee=S24">https://www.atis.org/atis/docstore/search.asp?committee=S24</a>

**5.4.2.11.4 3GPP TS 23.012****Location Management Procedures**

This document describes the procedures involving HLR, VLR, and MSC location management.

SDO (2)	Document No.	Version	Status	Issued date	Location (1)
<b>Release 99</b>					
T1	T1.3GPP.23.012V330-2000	3.3.0	Approved	01/06/2000	<a href="https://www.atis.org/atis/docstore/search.asp?committee=S24">https://www.atis.org/atis/docstore/search.asp?committee=S24</a>
<b>Release 5</b>					
T1	T1.3GPP.23.012V500-2003	5.0.0	Approved	27/03/2003	<a href="https://www.atis.org/atis/docstore/search.asp?committee=S24">https://www.atis.org/atis/docstore/search.asp?committee=S24</a>

**5.4.2.11.5 3GPP TS 23.014****Support of DTMF signalling**

This document describes the support of Dual Tone Multi Frequency (DTMF) signalling.

SDO (2)	Document No.	Version	Status	Issued date	Location (1)
<b>Release 99</b>					
T1	T1.3GPP.23.014V320-2003	3.2.0	Approved	09/12/2003	<a href="https://www.atis.org/atis/docstore/search.asp?committee=S24">https://www.atis.org/atis/docstore/search.asp?committee=S24</a>

**Release 5**

T1	T1.3GPP.23.014V510-2003	5.1.0	Approved	09/12/2003	<a href="https://www.atis.org/atis/docstore/search.asp?committee=S24">https://www.atis.org/atis/docstore/search.asp?committee=S24</a>
----	-------------------------	-------	----------	------------	---------------------------------------------------------------------------------------------------------------------------------------

**5.4.2.11.6 3GPP TS 23.018****Basic Call handling; Technical realization**

This document describes technical realization of basic call handling.

SDO (2)	Document No.	Version	Status	Issued date	Location (1)
<b>Release 99</b>					
T1	T1.3GPP.23.018V3110-2003	3.11.0	Approved	09/12/2003	<a href="https://www.atis.org/atis/docstore/search.asp?committee=S24">https://www.atis.org/atis/docstore/search.asp?committee=S24</a>
<b>Release 5</b>					
T1	T1.3GPP.23.018V540-2003	5.4.0	Approved	09/12/2003	<a href="https://www.atis.org/atis/docstore/search.asp?committee=S24">https://www.atis.org/atis/docstore/search.asp?committee=S24</a>

**5.4.2.11.7 3GPP TS 23.108****Mobile radio interface layer 3 protocols; Stage 2**

This document provides a stage 2 functional description of the layer 3 protocols for call control, mobility management, and session management.

SDO (2)	Document No.	Version	Status	Issued date	Location (1)
<b>Release 99</b>					
T1	T1.3GPP.23.108V320-2000	3.2.0	Approved	01/03/2000	<a href="https://www.atis.org/atis/docstore/search.asp?committee=S24">https://www.atis.org/atis/docstore/search.asp?committee=S24</a>
<b>Release 5</b>					
T1	T1.3GPP.23.108V500-2003	5.0.0	Approved	27/03/2003	<a href="https://www.atis.org/atis/docstore/search.asp?committee=S24">https://www.atis.org/atis/docstore/search.asp?committee=S24</a>

**5.4.2.11.8 3GPP TS 27.005****Use of DTE-DCE interface for SMS and cell broadcast service**

This document provides specification of the DTE-DCE interface for use with SMS and cell broadcast services.

SDO (2)	Document No.	Version	Status	Issued date	Location (1)
<b>Release 99</b>					
T1	T1.3GPP.27.005V320-2003	3.2.0	Approved	27/03/2003	<a href="https://www.atis.org/atis/docstore/search.asp?committee=S24">https://www.atis.org/atis/docstore/search.asp?committee=S24</a>
<b>Release 5</b>					
T1	T1.3GPP.27.005V500-2003	5.0.0	Approved	27/03/2003	<a href="https://www.atis.org/atis/docstore/search.asp?committee=S24">https://www.atis.org/atis/docstore/search.asp?committee=S24</a>

**5.4.2.11.9 3GPP TS 27.007****At command set for User Equipment (UE)**

This document provides specification of the AT command set for user equipment.

### 330

### Rec. ITU-R M.1457-4

SDO (2)	Document No.	Version	Status	Issued date	Location (1)
<b>Release 99</b>					
T1	T1.3GPP.27.007V3110-2002	3.11.0	Approved	03/05/2002	<a href="https://www.atis.org/atis/docstore/search.asp?committee=S24">https://www.atis.org/atis/docstore/search.asp?committee=S24</a>
<b>Release 5</b>					
T1	T1.3GPP.27.007V510-2003	5.1.0	Approved	09/12/2003	<a href="https://www.atis.org/atis/docstore/search.asp?committee=S24">https://www.atis.org/atis/docstore/search.asp?committee=S24</a>

#### 5.4.2.11.10 3GPP TS 27.010

#### Terminal Equipment to User Equipment (TE-UE) Multiplexer protocol

This document provides specification of the multiplexer protocol for the TE to UE interface.

SDO (2)	Document No.	Version	Status	Issued date	Location (1)
<b>Release 99</b>					
T1	T1.3GPP.27.010V340-2002	3.4.0	Approved	03/05/2002	<a href="https://www.atis.org/atis/docstore/search.asp?committee=S24">https://www.atis.org/atis/docstore/search.asp?committee=S24</a>
<b>Release 5</b>					
T1	T1.3GPP.27.010V500-2003	5.0.0	Approved	27/03/2003	<a href="https://www.atis.org/atis/docstore/search.asp?committee=S24">https://www.atis.org/atis/docstore/search.asp?committee=S24</a>

#### 5.4.2.11.11 3GPP TS 27.103

#### Wide area network synchronization

This document provides specification of the wide area network synchronization.

SDO (2)	Document No.	Version	Status	Issued date	Location (1)
<b>Release 99</b>					
T1	T1.3GPP.27.103V310-2003	3.1.0	Approved	09/12/2003	<a href="https://www.atis.org/atis/docstore/search.asp?committee=S24">https://www.atis.org/atis/docstore/search.asp?committee=S24</a>
<b>Release 5</b>					
T1	T1.3GPP.27.103V500-2003	5.0.0	Approved	27/03/2003	<a href="https://www.atis.org/atis/docstore/search.asp?committee=S24">https://www.atis.org/atis/docstore/search.asp?committee=S24</a>

#### 5.4.2.12

#### Intra-RAN

SDO (2)	Document No.	Version	Status	Issued date	Location (1)
<b>Release 99</b>					
T1	T1.3GPP.29.010V390-2003	3.9.0	Approved	09/12/2003	<a href="https://www.atis.org/atis/docstore/search.asp?committee=S24">https://www.atis.org/atis/docstore/search.asp?committee=S24</a>
<b>Release 5</b>					
T1	T1.3GPP.29.010V510-2003	5.1.0	Approved	09/12/2003	<a href="https://www.atis.org/atis/docstore/search.asp?committee=S24">https://www.atis.org/atis/docstore/search.asp?committee=S24</a>

#### 5.4.2.12.1 3GPP TS 29.010

#### Information Element Mapping between MS-BSS and BSS-MSC signalling procedures and the mobile application part (MAP)

This document describes the mapping between information elements used for signalling between MS and BSS and signalling between BSS and MSC and the MAP.

#### 5.4.2.12.2 3GPP TS 29.078

##### **Customized Applications for Mobile network Enhanced Logic (CAMEL); CAMEL application part (CAP) specification**

This document contains the CAMEL application part (CAP) specification.

SDO (2)	Document No.	Version	Status	Issued date	Location (1)
<b>Release 99</b>					
T1	T1.3GPP.29.078V3130-2003	3.13.0	Approved	09/12/2003	<a href="https://www.atis.org/atis/docstore/search.asp?committee=S24">https://www.atis.org/atis/docstore/search.asp?committee=S24</a>
<b>Release 5</b>					
T1	T1.3GPP.29.078V510-2003	5.1.0	Approved	09/12/2003	<a href="https://www.atis.org/atis/docstore/search.asp?committee=S24">https://www.atis.org/atis/docstore/search.asp?committee=S24</a>

#### 5.4.2.12.3 3GPP TS 48.001

##### **General aspects on the BSS-MSC interface**

This document describes the general aspects of the BSS-MSC interface for the alternate circuit switched component.

SDO (2)	Document No.	Version	Status	Issued date	Location (1)
<b>Release 99</b>					
T1	T1.3GPP.08.01V801-2003	8.0.1	Approved	09/12/2003	<a href="https://www.atis.org/atis/docstore/search.asp?committee=S24">https://www.atis.org/atis/docstore/search.asp?committee=S24</a>
<b>Release 5</b>					
T1	T1.3GPP.48.001V500-2003	5.0.0	Approved	09/12/2003	<a href="https://www.atis.org/atis/docstore/search.asp?committee=S24">https://www.atis.org/atis/docstore/search.asp?committee=S24</a>

#### 5.4.2.12.4 3GPP TS 48.002

##### **Base Station System - Mobile Services Switching Centre (BSS-MSC) Interface - Interface principles**

This document describes the general principles of the BSS-MSC interface for the alternate circuit switched component.

SDO (2)	Document No.	Version	Status	Issued date	Location (1)
<b>Release 99</b>					
T1	T1.3GPP.08.02V801-2003	8.0.1	Approved	09/12/2003	<a href="https://www.atis.org/atis/docstore/search.asp?committee=S24">https://www.atis.org/atis/docstore/search.asp?committee=S24</a>
<b>Release 5</b>					
T1	T1.3GPP.48.002V510-2003	5.1.0	Approved	09/12/2003	<a href="https://www.atis.org/atis/docstore/search.asp?committee=S24">https://www.atis.org/atis/docstore/search.asp?committee=S24</a>

#### 5.4.2.12.5 3GPP TS 48.004

##### **Base Station System - Mobile Services Switching Centre (BSS-MSC) Interface Layer 1 specifications**

This document contains the BSS-MSC interface layer 1 specifications for the alternate circuit switched component.

332

## Rec. ITU-R M.1457-4

SDO (2)	Document No.	Version	Status	Issued date	Location (1)
<b>Release 99</b>					
T1	T1.3GPP.08.04V801-2003	8.0.1	Approved	09/12/2003	<a href="https://www.atis.org/atis/docstore/search.asp?committee=S24">https://www.atis.org/atis/docstore/search.asp?committee=S24</a>
<b>Release 5</b>					
T1	T1.3GPP.48.004V500-2003	5.0.0	Approved	09/12/2003	<a href="https://www.atis.org/atis/docstore/search.asp?committee=S24">https://www.atis.org/atis/docstore/search.asp?committee=S24</a>

### 5.4.2.12.6 3GPP TS 48.006

#### Signalling Transport mechanism specification for the BSS-MSC Interface

This document contains the BSS-MSC interface signalling transport specifications for the alternate circuit switched component.

SDO (2)	Document No.	Version	Status	Issued date	Location (1)
<b>Release 99</b>					
T1	T1.3GPP.08.06V801-2003	8.0.1	Approved	09/12/2003	<a href="https://www.atis.org/atis/docstore/search.asp?committee=S24">https://www.atis.org/atis/docstore/search.asp?committee=S24</a>
<b>Release 5</b>					
T1	T1.3GPP.48.006V500-2003	5.0.0	Approved	09/12/2003	<a href="https://www.atis.org/atis/docstore/search.asp?committee=S24">https://www.atis.org/atis/docstore/search.asp?committee=S24</a>

### 5.4.2.12.7 3GPP TS 48.008

#### Base Station System - Mobile Services Switching Centre (BSS-MSC) Interface Layer 3 specifications

This document contains the BSS-MSC interface layer 3 specifications for the alternate circuit switched component.

SDO (2)	Document No.	Version	Status	Issued date	Location (1)
<b>Release 99</b>					
T1	T1.3GPP.08.08V8130-2003	8.13.0	Approved	09/12/2003	<a href="https://www.atis.org/atis/docstore/search.asp?committee=S24">https://www.atis.org/atis/docstore/search.asp?committee=S24</a>
<b>Release 5</b>					
T1	T1.3GPP.48.008V570-2003	5.7.0	Approved	09/12/2003	<a href="https://www.atis.org/atis/docstore/search.asp?committee=S24">https://www.atis.org/atis/docstore/search.asp?committee=S24</a>

### 5.4.2.12.8 3GPP TS 48.020

#### Rate Adaption on the BSS-MSC Interface

This document specifies the rate adaption function on the BSS-MSC interface for the alternate circuit switched component.

SDO (2)	Document No.	Version	Status	Issued date	Location (1)
<b>Release 99</b>					
T1	T1.3GPP.08.20V840-2003	8.4.0	Approved	09/12/2003	<a href="https://www.atis.org/atis/docstore/search.asp?committee=S24">https://www.atis.org/atis/docstore/search.asp?committee=S24</a>
<b>Release 5</b>					
T1	T1.3GPP.48.020V510-2003	5.1.0	Approved	09/12/2003	<a href="https://www.atis.org/atis/docstore/search.asp?committee=S24">https://www.atis.org/atis/docstore/search.asp?committee=S24</a>

**5.4.2.12.9 3GPP TS 48.031****Location Services; SMLC - SMLC SMLCPP specification (BSS-MSC) Interface Layer 3 specifications**

This document contains the SMLC-SMLC protocol specification for location services.

SDO (2)	Document No.	Version	Status	Issued date	Location (1)
<b>Release 99</b>					
T1	T1.3GPP.08.31V811-2003	8.1.1	Approved	09/12/2003	<a href="https://www.atis.org/atis/docstore/search.asp?committee=S24">https://www.atis.org/atis/docstore/search.asp?committee=S24</a>
<b>Release 5</b>					
T1	T1.3GPP.48.031V500-2003	5.0.0	Approved	09/12/2003	<a href="https://www.atis.org/atis/docstore/search.asp?committee=S24">https://www.atis.org/atis/docstore/search.asp?committee=S24</a>

**5.4.2.12.10 3GPP TS 48.051****Base Station Controller - Base Transceiver Station (BSC-BTS) Interface General aspects**

This document describes the general aspects of the BSC-BTS interface.

SDO (2)	Document No.	Version	Status	Issued date	Location (1)
<b>Release 99</b>					
T1	T1.3GPP.08.51V801-2003	8.0.1	Approved	09/12/2003	<a href="https://www.atis.org/atis/docstore/search.asp?committee=S24">https://www.atis.org/atis/docstore/search.asp?committee=S24</a>
<b>Release 5</b>					
T1	T1.3GPP.48.051V500-2003	5.0.0	Approved	09/12/2003	<a href="https://www.atis.org/atis/docstore/search.asp?committee=S24">https://www.atis.org/atis/docstore/search.asp?committee=S24</a>

**5.4.2.12.11 3GPP TS 48.052****Base Station Controller - Base Transceiver Station (BSC-BTS) Interface; Interface principles**

This document describes the interface principles for the BSC-BTS interface.

SDO (2)	Document No.	Version	Status	Issued date	Location (1)
<b>Release 99</b>					
T1	T1.3GPP.08.52V801-2003	8.0.1	Approved	09/12/2003	<a href="https://www.atis.org/atis/docstore/search.asp?committee=S24">https://www.atis.org/atis/docstore/search.asp?committee=S24</a>
<b>Release 5</b>					
T1	T1.3GPP.48.052V500-2003	5.0.0	Approved	09/12/2003	<a href="https://www.atis.org/atis/docstore/search.asp?committee=S24">https://www.atis.org/atis/docstore/search.asp?committee=S24</a>

**5.4.2.12.12 3GPP TS 48.054****Base Station Controller - Base Transceiver Station (BSC-BTS) Interface; Layer 1 structure of physical circuits**

This document describes the layer 1 structure of physical circuits for the BSC-BTS interface.

SDO (2)	Document No.	Version	Status	Issued date	Location (1)
<b>Release 99</b>					
T1	T1.3GPP.08.54V801-2003	8.0.1	Approved	09/12/2003	<a href="https://www.atis.org/atis/docstore/search.asp?committee=S24">https://www.atis.org/atis/docstore/search.asp?committee=S24</a>

**Release 5**

T1	T1.3GPP.48.054V500-2003	5.0.0	Approved	09/12/2003	<a href="https://www.atis.org/atis/docstore/search.asp?committee=S24">https://www.atis.org/atis/docstore/search.asp?committee=S24</a>
----	-------------------------	-------	----------	------------	---------------------------------------------------------------------------------------------------------------------------------------

**5.4.2.12.13 3GPP TS 48.056****Base Station Controller - Base Transceiver Station (BSC-BTS) Interface; Layer 2 specification**

This document provides the layer 2 specification for the BSC-BTS interface.

SDO (2)	Document No.	Version	Status	Issued date	Location (1)
---------	--------------	---------	--------	-------------	--------------

**Release 99**

T1	T1.3GPP.08.56V801-2003	8.0.1	Approved	09/12/2003	<a href="https://www.atis.org/atis/docstore/search.asp?committee=S24">https://www.atis.org/atis/docstore/search.asp?committee=S24</a>
----	------------------------	-------	----------	------------	---------------------------------------------------------------------------------------------------------------------------------------

**Release 5**

T1	T1.3GPP.48.056V500-2003	5.0.0	Approved	09/12/2003	<a href="https://www.atis.org/atis/docstore/search.asp?committee=S24">https://www.atis.org/atis/docstore/search.asp?committee=S24</a>
----	-------------------------	-------	----------	------------	---------------------------------------------------------------------------------------------------------------------------------------

**5.4.2.12.14 3GPP TS 48.058****Base Station Controller - Base Transceiver Station (BSC-BTS) Interface; Layer 3 specification**

This document provides the layer 3 specification for the BSC-BTS interface.

SDO (2)	Document No.	Version	Status	Issued date	Location (1)
---------	--------------	---------	--------	-------------	--------------

**Release 99**

T1	T1.3GPP.08.58V860-2003	8.6.0	Approved	09/12/2003	<a href="https://www.atis.org/atis/docstore/search.asp?committee=S24">https://www.atis.org/atis/docstore/search.asp?committee=S24</a>
----	------------------------	-------	----------	------------	---------------------------------------------------------------------------------------------------------------------------------------

**Release 5**

T1	T1.3GPP.48.058V560-2003	5.6.0	Approved	09/12/2003	<a href="https://www.atis.org/atis/docstore/search.asp?committee=S24">https://www.atis.org/atis/docstore/search.asp?committee=S24</a>
----	-------------------------	-------	----------	------------	---------------------------------------------------------------------------------------------------------------------------------------

**5.4.2.12.15 3GPP TS 48.071****Location Services; SMLC - BSS Interface Layer 3 specifications**

This document contains the SMLC-BSS layer 3 specification for location services.

SDO (2)	Document No.	Version	Status	Issued date	Location (1)
---------	--------------	---------	--------	-------------	--------------

**Release 99**

T1	T1.3GPP.08.71V850-2003	8.5.0	Approved	09/12/2003	<a href="https://www.atis.org/atis/docstore/search.asp?committee=S24">https://www.atis.org/atis/docstore/search.asp?committee=S24</a>
----	------------------------	-------	----------	------------	---------------------------------------------------------------------------------------------------------------------------------------

**Release 5**

T1	T1.3GPP.48.071V500-2003	5.0.0	Approved	09/12/2003	<a href="https://www.atis.org/atis/docstore/search.asp?committee=S24">https://www.atis.org/atis/docstore/search.asp?committee=S24</a>
----	-------------------------	-------	----------	------------	---------------------------------------------------------------------------------------------------------------------------------------

**5.4.2.12.16 3GPP TS 49.008****Application of BSS application part (BSSAP) on E interface**

This document describe the BSSAP protocol on the E interface.



SDO (2)	Document No.	Version	Status	Issued date	Location (1)
<b>Release 99</b>					
T1	T1.3GPP.09.08V810-2003	8.1.0	Approved	09/12/2003	<a href="https://www.atis.org/atis/docstore/search.asp?committee=S24">https://www.atis.org/atis/docstore/search.asp?committee=S24</a>
<b>Release 5</b>					
T1	T1.3GPP.49.008V500-2003	5.0.0	Approved	09/12/2003	<a href="https://www.atis.org/atis/docstore/search.asp?committee=S24">https://www.atis.org/atis/docstore/search.asp?committee=S24</a>

#### 5.4.2.12.17 3GPP TS 49.031

##### Location Services LCS extension (BSSAP-LE)

This document describes the LCS extension to the BSS application part.

SDO (2)	Document No.	Version	Status	Issued date	Location (1)
<b>Release 99</b>					
T1	T1.3GPP.09.31V860-2003	8.6.0	Approved	09/12/2003	<a href="https://www.atis.org/atis/docstore/search.asp?committee=S24">https://www.atis.org/atis/docstore/search.asp?committee=S24</a>
<b>Release 5</b>					
T1	T1.3GPP.49.031V530-2003	5.3.0	Approved	09/12/2003	<a href="https://www.atis.org/atis/docstore/search.asp?committee=S24">https://www.atis.org/atis/docstore/search.asp?committee=S24</a>

#### 5.4.2.13

##### Other System aspects

The IMT-2000 TDMA-SC specification also includes the following documents which are useful and related to this Recommendation.

#### 5.4.2.13.1 3GPP TS 22.002

##### Circuit bearer services supported by a Public Land Mobile Network (PLMN)

This document describes the services supported by the circuit switched bearer on the 200 kHz channel.

#### 5.4.2.13.2 3GPP TS 22.048

##### Security mechanisms for the (U)SIM Application Toolkit; Stage 1

This document provides functional description for the security mechanisms employed for the SIM or USIM Application Toolkit.

#### 5.4.2.13.3 3GPP TS 22.053

##### Tandem Free Operation; Service Description; Stage 1

This document provides a stage 1 description for vocoder tandem free operation.

**5.4.2.13.4** 3GPP TS 22.057**Mobile Execution Environment (MexE); Stage 1 description**

This document provides a stage 1 functional description of the mobile execution environment.

**5.4.2.13.5** 3GPP TS 22.066**Support of Mobile Number portability; Stage 1**

This document provides a stage 1 description of mobile number portability.

**5.4.2.13.6** 3GPP TS 22.067**Enhanced Multi-level Precedence and Pre-emption (eMLPP) service; Stage 1**

This document provides a stage 1 description of the enhanced multi-level precedence and pre-emption (eMLPP) function, which provides different call priorities in combination with fast set-up and pre-emption.

**5.4.2.13.7** 3GPP TS 22.071**Location Services Supplementary service; Stage 1**

This document provides a stage 1 description of the location services supplementary service.

**5.4.2.13.8** 3GPP TS 22.072**Call deflection Supplementary service; Stage 1**

This document provides a stage 1 description of the call deflection supplementary service.

**5.4.2.13.9** 3GPP TS 22.078**Customised Applications for Mobile network Enhanced Logic (CAMEL); Stage 1**

This document provides a stage 1 description of the CAMEL functionality.

**5.4.2.13.10** 3GPP TS 22.079**Support of optimal routing; Stage 1**

This document provides a stage 1 of the optimal routing function.

**5.4.2.13.11** 3GPP TS 22.081**Line Identification Supplementary service; Stage 1**

This document provides a stage 1 description of the calling line identification supplementary service.

**5.4.2.13.12** 3GPP TS 22.082**Call Forwarding Supplementary service; Stage 1**

This document provides a stage 1 description of the call forwarding supplementary service.

**5.4.2.13.13** 3GPP TS 22.083**Call Waiting and Call Hold Supplementary service; Stage 1**

This document provides a stage 1 description of the call waiting and call hold supplementary service.

**5.4.2.13.14** 3GPP TS 22.084**Multi-party Supplementary service; Stage 1**

This document provides a stage 1 description of the multi-party supplementary service.

**5.4.2.13.15** 3GPP TS 22.085**Closed User Group (CUG) Supplementary service; Stage 1**

This document provides a stage 1 description of the multi-party supplementary service.

**5.4.2.13.16** 3GPP TS 22.086**Advice of Charge (AoC) Supplementary service; Stage 1**

This document provides a stage 1 description of the advice of charge supplementary service.

**5.4.2.13.17** 3GPP TS 22.087**User-to-User Signalling Supplementary service; Stage 1**

This document provides a stage 1 description of the user-to-user signalling supplementary service.

**5.4.2.13.18** 3GPP TS 22.088**Call Barring Supplementary service; Stage 1**

This document provides a stage 1 description of the call barring supplementary service.

**5.4.2.13.19** 3GPP TS 22.090**Unstructured Supplementary Service Data (USSD); Stage 1**

This document provides a stage 1 description of unstructured supplementary service data.

**5.4.2.13.20** 3GPP TS 22.091**Explicit call transfer Supplementary Service; Stage 1**

This document provides a stage 1 description of the explicit call transfer supplementary service.

**5.4.2.13.21** 3GPP TS 22.093**Completion of Calls to Busy Subscriber (CCBS); Stage 1**

This document provides a stage 1 service description of the explicit call transfer supplementary service.

**5.4.2.13.22** 3GPP TS 22.094**Follow me supplementary Service; Stage 1**

This document provides a stage 1 description of the follow me supplementary service.

**5.4.2.13.23** 3GPP TS 22.096**Name Identification Supplementary Service; Stage 1**

This document provides a stage 1 description of the name identification supplementary service.

**5.4.2.13.24** 3GPP TS 22.097**Multiple Subscriber Profile phase 1; Stage 1**

This document provides a stage 1 service description of the phase 1 multiple subscriber profile service.

**5.4.2.13.25** 3GPP TS 22.226**Global Text Telephony (GTT); Stage 1**

This document provides a stage 1 service description of the Global text telephony service.

**5.4.2.13.26** 3GPP TS 22.228**IP Multimedia Subsystem (IMS); Stage 1**

This document provides the stage 1 service requirements of the IP Multimedia Subsystem.

**5.4.2.13.27** 3GPP TS 23.002**Network Architecture**

This document describes the overall network architecture utilizing the alternate circuit switched component.

**5.4.2.13.28** 3GPP TS 23.121**Architectural requirements for Release 99**

This document provides architectural requirements for Release 99.

**5.4.2.13.29** 3GPP TS 23.207**End-to-end Quality of Service (QoS) concepts and architecture**

This document provides a description of the concepts and architecture for end-to-end QoS.

**5.4.2.13.30** 3GPP TS 23.221**Architectural requirements for Release 5**

This document provides architectural requirements for Release 5

**5.4.2.13.31** 3GPP TS 23.236**Intra-domain connection of RAN nodes to multiple CN nodes**

This document describes the connection of RAN nodes to multiple CN nodes such as MSCs.

**5.4.2.13.32** 3GPP TS 29.278**CAMEL Application part (CAP) specification for IMS**

This document describes the CAMEL application part for IP multimedia subsystems.

**5.4.2.13.33** 3GPP TS 41.031**Fraud information gathering system (FIGS);Service requirements; Stage 0**

This document provides a description of the fraud information gathering system for the GSM/EDGE system.

**5.4.2.13.34** 3GPP TS 41.033**Lawful interception requirements for GSM/EDGE**

This document provides a description of the lawful interception requirements the GSM/EDGE system.

**5.4.2.13.35** 3GPP TS 42.019**Subscriber Identity Modules, Application programming interface; Stage 1**

This document provides the functional description for the SIM Application Programming Interface (API) used in the GSM/EDGE specifications.

**5.4.2.13.36** 3GPP TS 42.031**Fraud information gathering system (FIGS);Service description; Stage 1**

This document provides a stage 1 description of the fraud information gathering system for the GSM/EDGE system.

**5.4.2.13.37** 3GPP TS 42.033**Lawful interception; Stage 1**

This document provides a stage 1 description of the lawful interception functions for the GSM/EDGE system.

**5.4.2.13.38** 3GPP TS 43.030**Radio network planning aspects**

This document describes the aspects of planning a radio network.

**5.4.2.13.39** 3GPP TS 41.061**GPRS ciphering algorithm requirements**

This document provides the requirements for the General Packet Radio ciphering algorithms.

**5.4.2.13.40** 3GPP TS 42.009**Security aspects**

This document provides a description of the security aspects for the GSM/EDGE system.

**5.4.2.13.41** 3GPP TS 42.017**Subscriber Identity Modules, Functional characteristics**

This document defines the functional characteristics for the SIM used in the GSM/EDGE specifications.

**5.4.2.13.42** 3GPP TS 51.010-4**Mobile Station conformance specification, Part 4- SIM Application Toolkit conformance specification**

This document provides a conformance specification for the SIM Application toolkit

**5.4.2.13.43** 3GPP TS 51.011

**Specification of SIM-ME interface**

This document describes the interface between the mobile equipment and the subscriber identity module.

**5.4.2.13.44** 3GPP TS 31.122

**USIM conformance test specification**

This document provides a conformance specification for the USIM.

## 5.5 IMT-2000 FDMA/TDMA

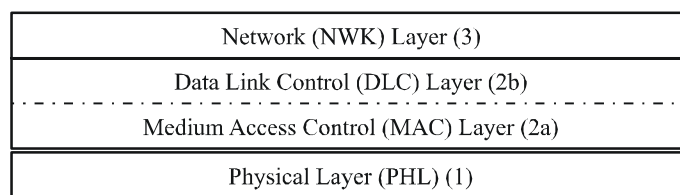
### 5.5.1 Overview of the radio interface

#### 5.5.1.1 Introduction

The IMT-2000 radio interface specifications for FDMA/TDMA technology are defined by a set of ETSI standards. This radio interface is called digital enhanced cordless telecommunications (DECT).

Figure 42 shows the layers of this radio interface.

FIGURE 42  
Protocol layered structure



1457-42

The individual layers are defined in different parts of the common interface (CI) standard. The standard specifies a TDMA radio interface with TDD. The radio frequency bit rates for the specified modulation schemes are 1.152 Mbit/s, 2.304 Mbit/s, 3.456 Mbit/s, 4.608 Mbit/s and 6.912 Mbit/s. The standard supports symmetric and asymmetric connections, connection oriented and connectionless data transport as well as variable user bit rates up to 5.76 Mbit/s per carrier. The network layer contains the protocols for call control, supplementary services, connection oriented message service, connectionless message service and mobility management, including the security and confidentiality services.

In addition to the CI standard, access profile standards define minimum requirements for accessing specific networks and the interworking to these networks. For example, the generic access profile (GAP) standard defines the requirements when using the speech service and the DECT packet radio service (DPRS) standard defines the requirements for packet data transport.

A high-level description of features and how the relevant ETSI standards interrelate to the different applications can be found in the ETSI Technical Report TR 101 178: "A high-level guide to the DECT standardization".

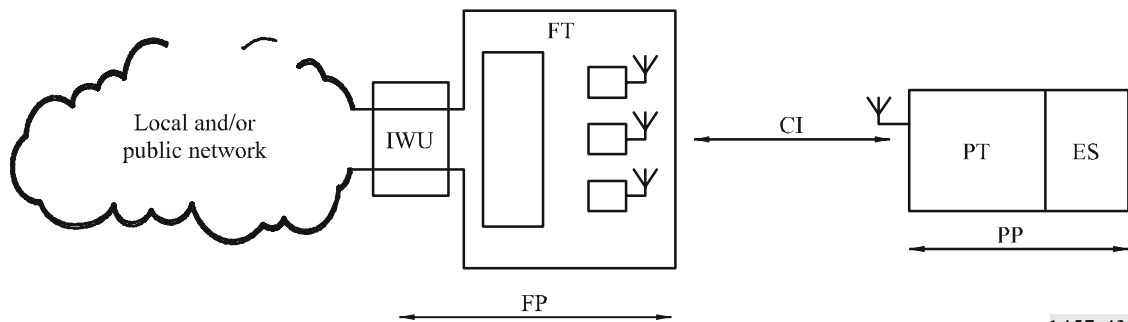
This radio interface is a general radio access technology for wireless telecommunications. It is a high capacity digital technology, for wide cell radii ranging from a few metres to several kilometres, depending on application and environment. It provides telephony quality voice services, and a broad range of data services, including ISDN and packet data. It can be effectively implemented in a range from simple residential cordless telephones up to large systems providing a wide range of telecommunications services, including fixed wireless access.

#### 5.5.1.2 General access technology

This technology provides a comprehensive set of protocols which provide the flexibility to interwork between numerous different applications and networks. Thus a local and/or public network is not part of this specification. Figure 43 illustrates this.



FIGURE 43  
The CI structure



1457-43

The radio interface covers, in principle, only the air interface between the fixed part (FP) and portable part (PP). The interworking unit (IWU) between a network and the fixed radio termination (FT) is network specific and is not part of the CI specification, but the profile specifications define IWUs for various networks. Similarly, the end system (ES), the application(s) in a PP is also excluded. The CI specification contains general end-to-end compatibility requirements e.g. on speech transmission. The IWU and ES are also subject to general attachment requirements for the relevant public network, e.g. the PSTN/ISDN.

NOTE 1 – An ES depends on the application supported in a PP. For a speech telephony application the ES may be a microphone, speaker, keyboard and display. The ES could equally well be a serial computer port, a fax machine or whatever the application requires.

For each specific network, local or global, the specific services and features of that network are made available via the air interface to the users of PPs/handsets. Except for cordless capability and mobility, this standard does not offer a specific service; it is transparent to the services provided by the connected network. Thus the CI standard is, and has to be, a tool box with protocols and messages from which a selection is made to access any specific network, and to provide means for market success for simple residential systems as well as for much more complex systems e.g. office ISDN services.

IMT-2000 FDMA/TDMA is very suitable to be used as radio access system to connect to mobile networks. Specifically the access to GSM/UMTS networks has been specified in detail, which allows the provision of GSM/UMTS services via DECT. The multipart TS 101 863 contains the UMTS interworking specification.

The detailed requirements that have governed the standardization efforts of this interface are provided by the ETR 043 – DECT Common Interface Services and Facilities Requirements Specification – where one requirement is flexibility for additions and evolutionary applications. The CI standard has a layered structure as indicated in § 5.5.2. It contains a complete set of requirements, procedures and messages. The messages also contain codes that are reserved for evolutionary applications and proprietary extensions. The authentication algorithm and the encryption algorithm are not part of the CI standard, but are obtained from ETSI through a special legal procedure. The administration of global unique identity codes for manufacturing, installation and public operation are also handled by ETSI.

**5.5.1.3 Summary of the physical layer**

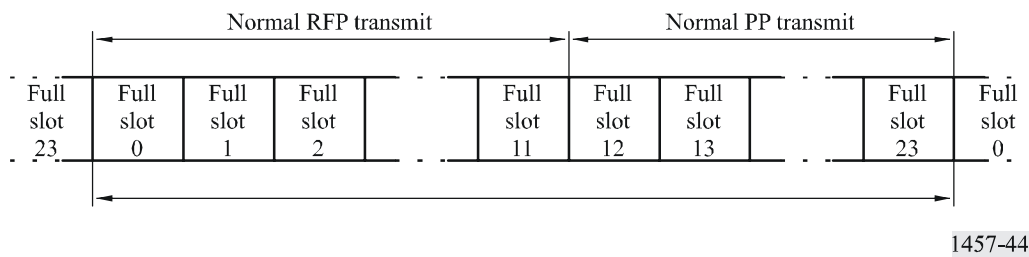
The specification for the physical layer is given in § 5.5.2.1. The tasks of the physical layer can be grouped into five categories:

- to modulate and demodulate radio carriers with a bit stream of a defined rate to create a radio frequency channel;
- to acquire and maintain bit and slot synchronization between transmitters and receivers;
- to transmit or receive a defined number of bits at a requested time and on a particular frequency;
- to add and remove the synchronization field and the Z-field used for rear end collision detection;
- to observe the radio environment to report signal strengths.

**5.5.1.3.1 The physical channels**

The radio access frequency channels as well as a time structure are defined. The carrier spacing is 1.728 MHz. To access the medium in time, a regular TDMA structure with a frame length of 10 ms is used. Within this frame 24 full-slots are created, each consisting of two half-slots. A double slot has a length of two full slots, and starts concurrently with an even numbered full slot.

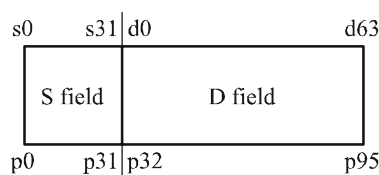
FIGURE 44  
Frame structure using full slot format



Data is transmitted within the frequency, time, and space dimensions using physical packets. Physical packets shall be of one of the following four types:

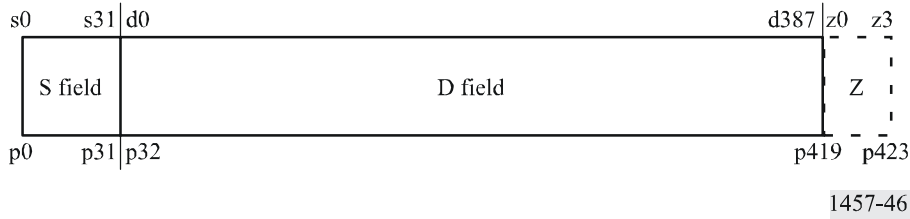
- short physical packet P00 (D-field contains 64 symbols):

FIGURE 45  
Packet P00



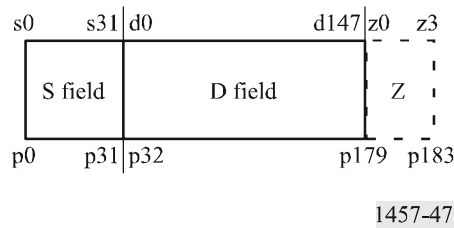
- basic physical packet P32 (the D-field contains 388 symbols):

FIGURE 46  
Packet P32



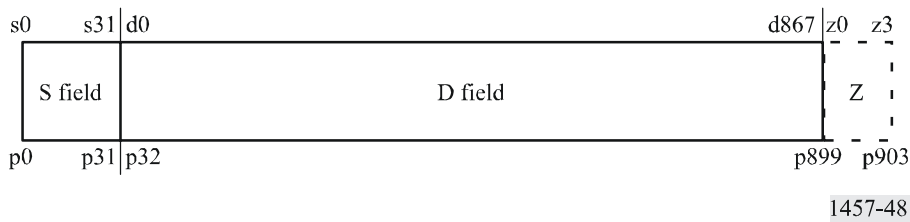
- low capacity physical packet P08 (the D-field contains 148 symbols):

FIGURE 47  
Packet P08



- high capacity physical packet P80 (the D-field contains 868 symbols):

FIGURE 48  
Packet P80



Each physical packet contains a synchronization field S and a data field D. The packets P80, P32 and P08 may contain an optional collision detection field, Z.

The synchronization field S may be used by the receiver for clock and packet synchronization of the radio link. The first 16 bits are a preamble, and the last 16 bits are the packet synchronization word. A prolonged preamble field which extends the preamble bit pattern by 16 bits is optional. This prolonged preamble field may be used by a receiver for implementation of an antenna selection diversity algorithm.

### 5.5.1.3.2 The RF carrier modulation

The modulation method is either gaussian frequency shift keying (GFSK), with a bandwidth-bit period product of nominally 0.5 or differential phase shift keying (DPSK) or phase amplitude modulation (QAM). Equipment is allowed to use 4-level and/or 8-level and/or 16-level and/or 64-level modulation in addition to 2-level modulation. This increases the bit rate of single radio equipment by a factor 2 or 3 or 4 or 6, which allows for 4 Mbit/s services. For example, the asymmetric double-slot service with modulation configuration 3 provides up to 5.76 Mbit/s B-field data rate per carrier. The 4-level modulation shall be  $\pi/4$ -DQPSK, the 8-level modulation  $\pi/8$ -D8PSK, the 16-level modulation 16-QAM and the 64-level modulation 64-QAM. It is only allowed to use 4-level and/or 8-level modulation in the B + Z or the A + B + Z fields, whereby the S + A or the S field respectively shall use the  $\pi/2$ -DBPSK 2-level modulation. It is only allowed to use 16-level and/or 64-level modulation in the B + Z fields, whereby the S + A field shall use the  $\pi/2$ -DBPSK 2-level modulation. The allowed combinations of modulation schemes are defined in Table 5.

TABLE 5

Allowed combinations of modulation schemes

Configuration	S-field	A-field	B + Z-field
1a	GFSK	GFSK	GFSK
1b	$\pi/2$ -DBPSK	$\pi/2$ -DBPSK	$\pi/2$ -DBPSK
2	$\pi/2$ -DBPSK	$\pi/2$ -DBPSK	$\pi/4$ -DQPSK
3	$\pi/2$ -DBPSK	$\pi/2$ -DBPSK	$\pi/8$ -D8PSK
4a	$\pi/2$ -DBPSK	$\pi/4$ -DQPSK	$\pi/4$ -DQPSK
4b	$\pi/2$ -DBPSK	$\pi/8$ -D8PSK	$\pi/8$ -D8PSK
5	$\pi/2$ -DBPSK	$\pi/2$ -DBPSK	16-QAM
6	$\pi/2$ -DBPSK	$\pi/2$ -DBPSK	64-QAM

Schemes 2, 3, 5 and 6 ensure that equipment with basic 2-level modulation, and equipment with a higher rate option, can efficiently share a common BS infrastructure. The GFSK modulation can be detected for instance in a non-coherent  $\pi/2$ -DPSK receiver, and the  $\pi/2$ -DPSK modulation can be detected in a GFSK receiver. Therefore all A-field information including broadcast system information, paging and call control can be received independently of whether configuration 1, 2, 3, 5 or 6 is used.

### 5.5.1.4 Summary of the MAC layer

The specification for the MAC layer is given in § 5.5.2.2. The MAC layer offers three groups of services to the upper layers and to the management entity:

- broadcast message control (BMC);
- connectionless message control (CMC);
- multi-bearer control (MBC).

The BMC provides a set of continuous point-to-multipoint connectionless services. These are used to carry internal logical channels, and are also offered to the higher layers. These services operate in the direction FT to PT, and are available to all PTs within range.

The CMC provides connectionless point-to-point or point-to-multipoint services to the higher layers. These services may operate in both directions between one specific FT and one or more PTs.

Each instance of MBC provides one of a set of connection oriented point-to-point services to the higher layers. An MBC service may use more than one bearer to provide a single service.

Four types of MAC bearer are defined:

- Simplex bearer: a simplex bearer is created by allocating one physical channel for transmissions in one direction.
- Duplex bearer: a duplex bearer is created by a pair of simplex bearers, operating in opposite directions on two physical channels.
- Double simplex: a double simplex bearer is created by a pair of long simplex bearers operating in the same direction on two physical channels.
- Double duplex bearer: a double duplex bearer is composed by a pair of duplex bearers referring to the same MAC connection.

A bearer can exist in one of three operational states:

- Dummy bearer: where there are normally continuous transmissions (i.e. one transmission in every frame).
- Traffic bearer: where there are continuous point-to-point transmissions. A traffic bearer is a duplex bearer or a double simplex bearer or a double duplex bearer.
- Connectionless bearer: where there are discontinuous transmissions. A connectionless bearer is either a simplex or a duplex bearer.

The MAC layer defines a logical structure for the physical channels. The user bit rate depends on the selected slot-type, modulation scheme, level of protection and number of slots. Table 6 gives the user bit rates for unprotected single slot operation.

TABLE 6  
Bit rates for single slot operation

	2-level modulation (kbit/s)	4-level modulation (kbit/s)	8-level modulation (kbit/s)	16-level modulation (kbit/s)	64-level modulation (kbit/s)
Half slot	8	16	24	32	48
Full slot	32	64	96	128	192
Double slot	80	160	240	320	480

### 5.5.1.5 Summary of the data link control (DLC) layer

The specification for the DLC layer is given in § 5.5.2.3. The DLC layer contains two independent planes of protocol, the C-plane and the U-plane. The C-plane is the control plane of the protocol stacks. The U-plane is the user plane of the protocol stacks.

#### 5.5.1.5.1 C-plane services

The C-plane data link service is provided by two protocol entities called LAPC and Lc. These two protocol entities separate the link access protocol functions from the lower link control functions. The upper LAPC entity uses a protocol derived from the ISDN LAPD protocol. The lower Lc entity buffers and fragments complete LAPC frames (LAPC protocol data units) to/from the MAC layer.

The Lb entity provides a broadcast service in the direction FP to PP. It operates on simple fixed length frames and uses the dedicated MAC layer broadcast service.

#### 5.5.1.5.2 U-plane services

The U-plane services are all optional, in the sense that each service corresponds to a particular requirement, and for any given application only selected services may be implemented. Each U-plane service is divided into two entities, an upper (LUx) entity and a lower (FBx) entity. The upper (LUx) entity contains all of the service dependent functions, and therefore defines the majority of the procedures. The lower (FBx) entity buffers and fragments the complete U-plane frames (LUx protocol data units) to/from the MAC layer. The following family members have been defined:

LU1:	transparent unprotected service (TRUP)
LU2:	frame relay service (FREL)
LU3:	frame switching service (FSWI)
LU4:	FEC service
LU5:	basic rate adaption service (BRAT)
LU6:	secondary rate adaption service (SRAT)
LU7:	64 kbit/s data bearer service with ARQ mechanism
LU8:	64 kbit/s data bearer service without ARQ mechanism
LU9:	unprotected rate adaption for V series equipment (RAVE) service
LU10:	enhanced data service
LU11:	64 kbit/s data bearer service when A and B fields are both modulated at 4 level
LU12 to LU15:	reserved for standard family member
LU16:	escape for non-standard family (ESC).

#### 5.5.1.6 Summary of the network (NWK) layer

The specification for the C-plane of the NWK layer is given in § 5.5.2.4. It contains no specification for the U-plane (user plane) because the U-plane is null for all services at the NWK layer.

The NWK layer (Layer 3) protocol contains the following groups of functions:

*Link control entity (LCE):* The establishment, operation and release of a C-plane link between the fixed termination and every active portable termination.

*Call control (CC) entity:* The establishment, maintenance and release of circuit-switched calls.

*Call independent supplementary services (CISS) entity:* The support of call independent supplementary services.

*Connection oriented message service (COMS) entity:* The support of connection-oriented messages.

*Connectionless message service (CLMS) entity:* The support of connectionless messages.

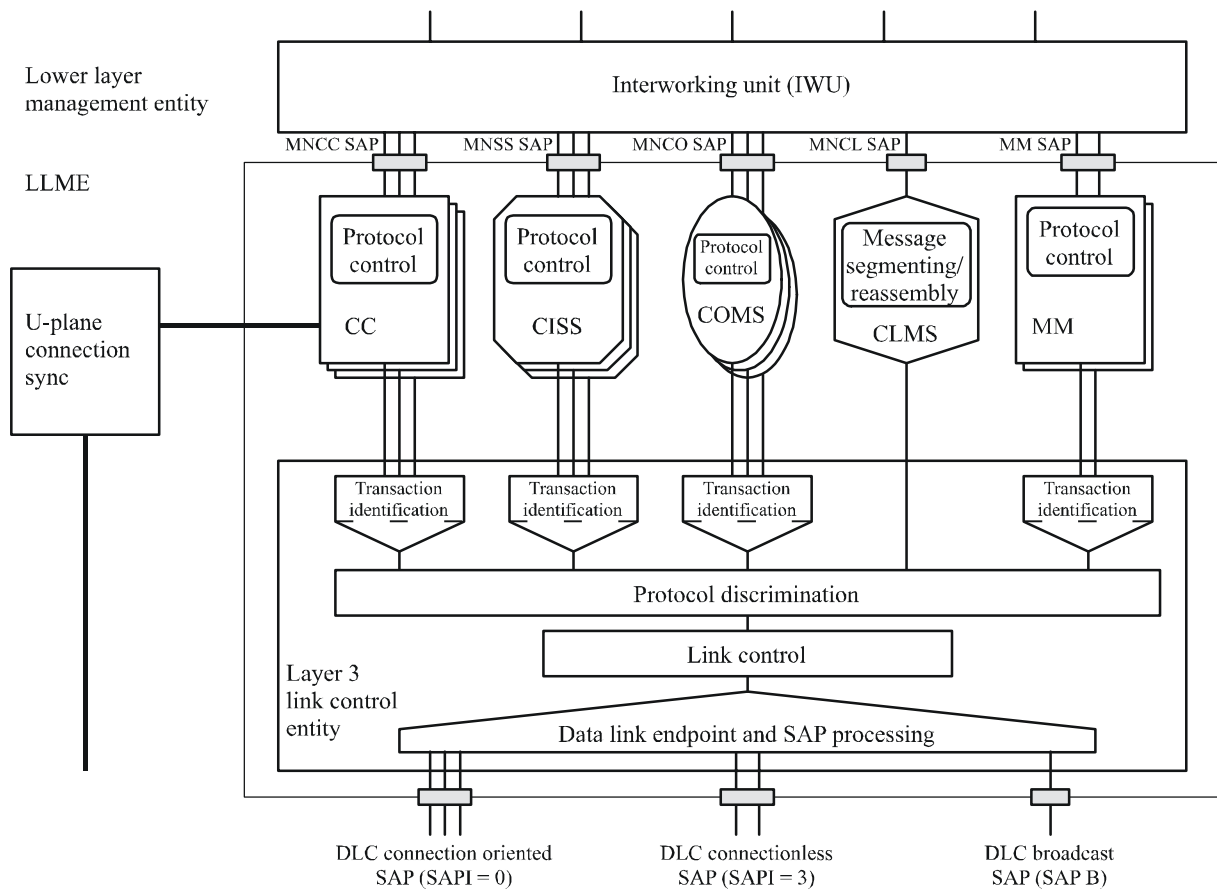
*Mobility management (MM) entity:* The management of identities, authentication, location updating, on-air subscription and key allocation.

In addition all of these C-plane entities interface to the lower layer management entity (LLME). This provides coordination of the operations between different NWK layer entities and also between the NWK layer and the lower layers.

5.5.1.7 Summary of identities and addressing

The specifications for the identities and addressing mechanisms are given in § 5.5.2.5. FP identities are used to inform PPs about the identity of a FP and the access rights to that FP and thereby reduce the number of access attempts from unauthorized portables. A FP broadcasts this information. A PP needs to be able to interpret necessary parts of this broadcast information to detect the access rights to a system or even access rights agreements between system operators, i.e. operators A and B have a bilateral agreement permitting their users to roam between their systems. These agreements can change and cannot therefore be stored in PPs without updating them frequently. Therefore the FP handles access rights information which is embedded in the identity structure. The identity structure provides solutions for residential, public and private environments. This can also be extended to combinations between these environments, e.g. private groups of users within a public network built using this standard, and e.g. public users access to private networks.

FIGURE 49  
Network layer



1457-49

PP identities have two main purposes, first to enable a PP to select a valid FP and second to uniquely identify the PP within that FP. For these purposes there are two identities defined. These identities are the portable access rights key (PARK) and the IPUI.

Connection related identities are associated with the peer-to-peer communication. That means that every layer-to-layer connection has an identity. These identities serve the purpose of handshake, protection against co-channel interference, avoiding loss of a connection during bearer and connection handover, etc.

#### **5.5.1.8 Summary of security features**

The specifications for the security architecture, the types of cryptographic algorithms required, the way in which they are to be used, and the requirements for integrating the security features provided by the architecture are given in § 5.5.2.6. It also describes how the features can be managed and how they relate to certain fixed systems and local network configurations. The security architecture is defined in terms of the security services which are to be supported at the CI, the mechanisms which are to be used to provide the services, and the cryptographic parameters, keys and processes which are associated with these mechanisms.

Two basic security services are specified, which are authentication and encryption. The authentication is used to verify the provided identity. There are four forms defined, which are portable authentication, fixed part authentication, mutual authentication and user authentication. Encryption is used to obtain confidentiality of the data which is transmitted over the air.

#### **5.5.1.9 Coexistence of uncoordinated installations on a common frequency band**

The mandatory instant dynamic channel selection messages and procedures provide effective coexistence of uncoordinated private and public systems on the common designated frequency band and avoid any need for traditional frequency planning. Each device has access to all channels (time/frequency combinations). When a connection is needed, the channel is selected, that at that instant and at that locality, is least interfered of all the common access channels. This avoids any need for traditional frequency planning, and greatly simplifies the installations. This procedure also provides higher and higher capacity by closer and closer BS installation, while maintaining a high radio link quality. Not needing to split the frequency resource between different services or users gives a very efficient use of the allocated spectrum. There is a large spectrum efficiency gain in sharing spectrum between applications and between operators.

Much unique knowledge and experience is available on the subject of sharing spectrum between uncoordinated installations. Information on this subject has been collected in an ETSI Technical Report, TR 101 310, which describes configurations for typical applications and relevant mixes of these, including residential, office, public and radio local loop (RLL) applications, and the traffic capacity is analysed, mainly by advanced simulations.

#### **5.5.1.10 Access to different systems by the same PP**

Each system, FP, has a broadcasted globally unique access rights identity (ARI). To each ARI are linked the available services, the related protocols and when required e.g. a cipher-key and/or authentication-key. For each service suitable protocols have been selected from the CI tool box to efficiently provide these services.

Similarly each PP (handset) has one or more portable access rights keys (PARKs). One PARK relates to one FP or a group of FPs belonging to the same operator. To each PARK are linked the corresponding FP ARIs, related services and protocols, and when required e.g. a ciphering-key and/or authentication-key.

Thus the same PP will have access to several different types of systems, if equipped with the relevant PARKs and associated protocols. Thus, it is basically not a common protocol for all systems that provide intersystem roaming, but it is that the PP is equipped with access rights and related protocols to the wanted systems. A detailed description of the flexible and powerful identity provisions are found in Part 6 of the CI standard.



### 5.5.1.11 Access to several applications through the same BS

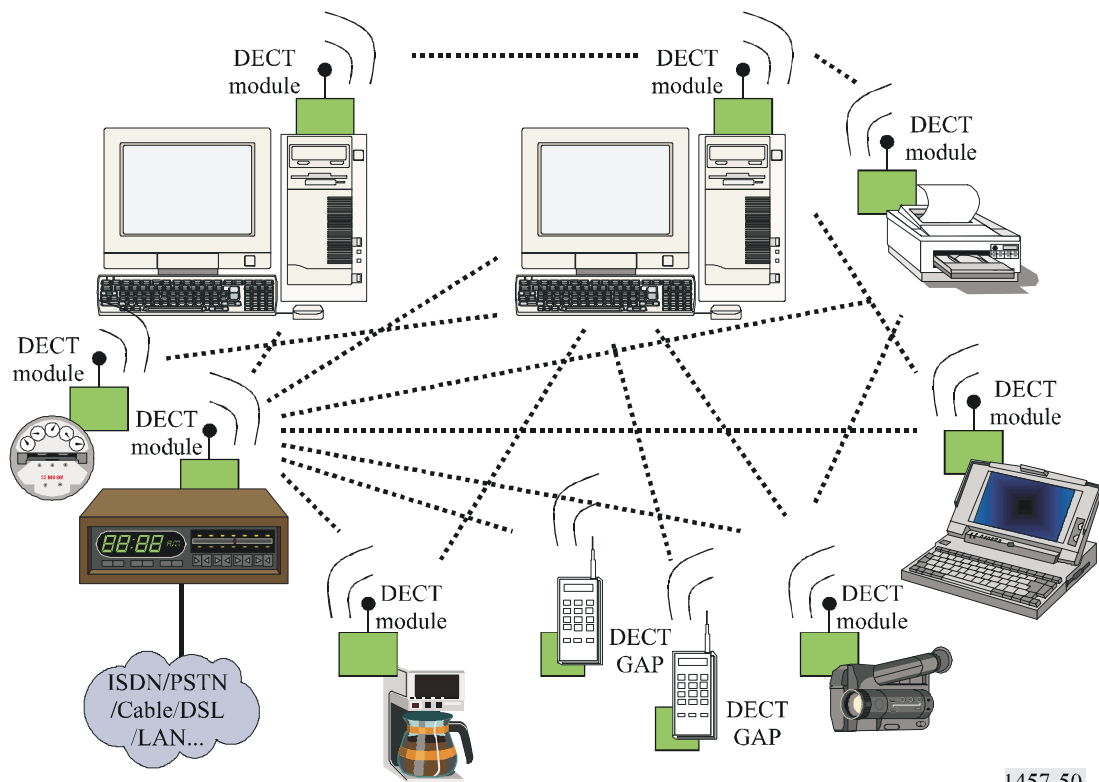
This radio interface also provides the means for sharing BS or systems between different operators or applications, e.g. hosting private user groups in a large public system, providing public access through a privately owned system, or hosting public access to several service providers in one system owned by one of the service providers.

### 5.5.1.12 DECT Packet Radio Service (DPRS)

This standard defines the requirements and procedures for packet data transport over the DECT air interface. It specifies the interworking to ISO/IEC 8802-3 (Ethernet), ISO/IEC 8802-5 (Token Ring), Internet Protocol (IP), Point-to-Point Protocol (PPP) and V.24. The Figure below gives an example of a DECT wireless Ethernet LAN with Distributed Communication and additional voice capability.

FIGURE 50

DECT wireless ethernet (LAN) with distributed communication including voice capability



### 5.5.1.13 DECT access to IP-networks

This technical specification defines how DECT can use mobile IP for roaming and how the DECT signalling can be interworked with the "Session Initiation Protocol" (SIP).

## 5.5.1.14 Summary of major technical parameters

Technical parameter	Value	Reference to § 5.5.2
Multiple access technique	TDMA	5.5.2.2
Duplexing scheme	TDD	5.5.2.2
Frame length	10 ms	5.5.2.2
Number of time slots in a frame	12 double slots 24 full slots 48 half slots	5.5.2.2
Modulation	GFSK, $\pi/2$ -DBPSK, $\pi/4$ -DQPSK, $\pi/8$ -D8PSK, 16-QAM, 64-QAM	5.5.2.2
RF bit rate	1 152 kbit/s for 2-level modulation 2 304 kbit/s for 4-level modulation 3 456 kbit/s for 8-level modulation 4 608 kbit/s for 16-level modulation 6 912 kbit/s for 64-level modulation	5.5.2.2
Channel spacing	1 728 kHz	5.5.2.2
Transmit power	Peak power Level 1: 2.5 mW (4 dBm) Level 2: 250 mW (24 dBm)	5.5.2.2
Frequency stability	For the portable part the centre frequency accuracy shall be within $\pm 50$ kHz at extreme conditions either relative to an absolute frequency reference or relative to the received carrier, except during the first one second after the transition from the idle-locked state to the active-locked state the centre frequency accuracy shall be within $\pm 100$ kHz at extreme conditions relative to the received carrier.  At an RFP the transmitted RF carrier frequency corresponding to RF channel $C$ shall be in the range $F_C \pm 50$ kHz at extreme conditions.  The maximum rate of change of the centre frequency at both the RFP and the PP while transmitting, shall not exceed 15 kHz per slot	5.5.2.2
Adjacent channel leakage power	1 channel: 160 $\mu$ W 2 channel: 1 $\mu$ W 3 channel: 80 nW >3 channel: 40 nW	5.5.2.2
Transmit linearity requirements	The power level of intermodulation products that are on any of this standard's physical channel when any combination of the transmitters at a radio end point are in calls on the same slot on different frequencies shall be less than 1 $\mu$ W. The power level is defined by integration over the 1 MHz centred on the nominal centre frequency of the afflicted channel and averaged over the time period	5.5.2.2
Reference sensitivity	better than $-83$ dBm $-86$ dBm for speech service according to Generic Access Profile (GAP) Sensitivity is measured at $1 \times 10^{-3}$ raw BER	5.5.2.2 5.5.2.11
Intermodulation sensitivity	The level of the interfering signals is $-48$ dBm, wanted signal is $-80$ dBm and $1 \times 10^{-3}$ raw BER	5.5.2.2

Technical parameter	Value			Reference to § 5.5.2
Spurious response and blocking	With the desired signal set at $-80$ dBm, the BER shall be maintained below $1 \times 10^{-3}$ in the presence of any one of the signals shown in the table below where: $F_L$ and $F_U$ : lower and the upper edges of the allocated frequency band $F_C$ : centre frequency of the allocated frequency band			5.5.2.2
	Frequency	Interferer level for radiated measurements (dB( $\mu$ V/m))	Interferer level for conducted measurements (dBm)	
	$25 \text{ MHz} < f < F_L - 100 \text{ MHz}$	120	-23	
	$F_L - 100 \text{ MHz} < f < F_L - 5 \text{ MHz}$	110	-33	
	$ f - F_C  > 6 \text{ MHz}$	100	-43	
	$F_U + 5 \text{ MHz} < f < F_U + 100 \text{ MHz}$	110	-33	
	$F_U + 100 \text{ MHz} < f < 12.75 \text{ GHz}$	120	-23	
Adjacent channel selectivity	With a received signal strength of $-73$ dBm (i.e. $70$ dB( $\mu$ V/m)) on RF channel M, the BER in the D-field shall be maintained better than $1 \times 10^{-3}$ when a modulated, reference interferer of the indicated strength is introduced on the RF channels shown below:			5.5.2.2
	Interferer on RF channel Y	Interferer signal strength		
		(dB( $\mu$ V/m))	(dBm)	
	Y = M	59	-84	
	Y = M $\pm$ 1	83	-60	
	Y = any other channel	110	-33	
Handover	Seamless handover, mobile controlled, triggered when another BS becomes stronger			5.5.2.3, 5.5.2.4, 5.5.2.5
Random access	Instant dynamic channel selection for every set-up using the least interfered channel measured at the mobile			5.5.2.3
Pilot structure	Broadcast system information available on each active downlink, at least one downlink is active on every BS			5.5.2.3
Dynamic channel allocation	Supported			5.5.2.3

## 5.5.2

### Detailed specification of the radio interface

The standards contained in this section are derived from the global core specifications for IMT 2000 contained at <http://ties.itu.int/u/itu-r/ede/rsg8/wp8f/wp8f-tech/GCSrev4/5-5/>.

#### 5.5.2.1 EN 300 175-1

##### Digital Enhanced Cordless Telecommunications (DECT); Common Interface (CI); Part 1: Overview

This standard gives an introduction and overview of the complete Digital Enhanced Cordless Telecommunications (DECT) Common Interface (CI). This part of the DECT CI contains an abstract of the other parts of the DECT standard together with a general description of the objectives of the present document; the DECT Common Interface and the protocol architecture of DECT. The present document also provides an extensive vocabulary, in particular it contains the common definitions of all the technical terms used in different parts of the present document.

SDO	Document No.	Version	Status	Issued date	Location
ETSI	EN 300 175 - 1	V1.7.1	Published	01/07/2003	<a href="http://webapp.etsi.org/workprogram/Report_WorkItem.asp?WKI_ID=14994">http://webapp.etsi.org/workprogram/Report_WorkItem.asp?WKI_ID=14994</a>

#### 5.5.2.2 EN 300 175-2

##### Digital Enhanced Cordless Telecommunications (DECT); Common Interface (CI); Part 2: Physical Layer (PHL)

This standard specifies the physical channel arrangements. The tasks of the PHL are to modulate and demodulate radio carriers with a bit stream of a defined rate to create a radio-frequency channel, to acquire and maintain bit and slot synchronization between transmitters and receivers, to transmit or receive a defined number of bits at a requested time and on a particular frequency, to add and remove the synchronization field and the Z-field used for rear end collision detection and to observe the radio environment to report signal strengths.

SDO	Document No.	Version	Status	Issued date	Location
ETSI	EN 300 175-2	V1.7.1	Published	01/07/2003	<a href="http://webapp.etsi.org/workprogram/Report_WorkItem.asp?WKI_ID=13301">http://webapp.etsi.org/workprogram/Report_WorkItem.asp?WKI_ID=13301</a>

#### 5.5.2.3 EN 300 175-3

##### Digital Enhanced Cordless Telecommunications (DECT); Common Interface (CI); Part 3: Medium Access Control (MAC) layer

This standard specifies the Layer 2a of the DECT protocol stack. It defines three groups of MAC services: the broadcast message control service, the connectionless message control service and the multi-bearer control service. It also specifies the logical channels that are used by the above-mentioned services, and how they are multiplexed and mapped into the Service Data Units that are exchanged with the Physical Layer.

SDO	Document No.	Version	Status	Issued date	Location
ETSI	EN 300 175-3	V1.7.1	Published	01/07/2003	<a href="http://webapp.etsi.org/workprogram/Report_WorkItem.asp?WKI_ID=14995">http://webapp.etsi.org/workprogram/Report_WorkItem.asp?WKI_ID=14995</a>

**5.5.2.4** EN 300 175-4**Digital Enhanced Cordless Telecommunications (DECT); Common Interface (CI); Part 4: Data Link Control (DLC) layer**

This standard specifies the Layer 2b of the DECT protocol stack. Two planes of operation are specified for this DLC (sub)layer. These planes are called the Control plane (C-plane) and the User plane (U-plane). The C-plane is mostly concerned with the DECT signalling aspects. It provides a reliable point-to-point service that uses a link access protocol to offer error protected transmission of network layer messages. The C-plane also provides a separate point-to-multipoint (broadcast) service. The U-plane is only concerned with end-to-end user information. This plane contains most of the application dependent procedures of DECT. Several alternative services (both circuit-mode and packet-mode) are defined as a family of independent entities. Each service provides one or more point-to-point U-plane data links, where the detailed characteristics of those links are determined by the particular needs of each service. The defined services cover a wide range of performance, from unprotected with low delay for speech applications to highly protected with variable delay, for local area network applications.

SDO	Document No.	Version	Status	Issued date	Location
ETSI	EN 300 175-4	V1.7.1	Published	01/07/2003	<a href="http://webapp.etsi.org/workprogram/Report_WorkItem.asp?WKI_ID=14996">http://webapp.etsi.org/workprogram/Report_WorkItem.asp?WKI_ID=14996</a>

**5.5.2.5** EN 300 175-5**Digital Enhanced Cordless Telecommunications (DECT); Common Interface (CI); Part 5: Network (NWK) layer**

This standard specifies the Layer 3 of the DECT protocol stack. It contains the following groups of functions: Link Control Entity (LCE), Call Control (CC) entity, Call Independent Supplementary Services (CISS) entity, Connection Oriented Message Service (COMS) entity, Connectionless Message Service (CLMS) entity and the Mobility Management (MM) entity.

SDO	Document No.	Version	Status	Issued date	Location
ETSI	EN 300 175-5	V1.7.1	Published	01/07/2003	<a href="http://webapp.etsi.org/workprogram/Report_WorkItem.asp?WKI_ID=14999">http://webapp.etsi.org/workprogram/Report_WorkItem.asp?WKI_ID=14999</a>

**5.5.2.6** EN 300 175-6**Digital Enhanced Cordless Telecommunications (DECT); Common Interface (CI); Part 6: Identities and addressing**

This standard specifies the identities and addressing structure of the DECT Common Interface. There are four categories of identities defined, which are Fixed Part (FP), Portable Part (PP), connection-related, and equipment-related identities.

SDO	Document No.	Version	Status	Issued date	Location
ETSI	EN 300 175-6	V1.7.1	Published	01/07/2003	<a href="http://webapp.etsi.org/workprogram/Report_WorkItem.asp?WKI_ID=15000">http://webapp.etsi.org/workprogram/Report_WorkItem.asp?WKI_ID=15000</a>

**5.5.2.7** EN 300 175-7**Digital Enhanced Cordless Telecommunications (DECT); Common Interface (CI); Part 7: Security features**

This part of the DECT CI specifies the security architecture, the types of cryptographic algorithms required, the way in which they are to be used, and the requirements for integrating the security features provided by the architecture into the DECT CI. It also describes how the features can be

managed and how they relate to certain DECT fixed systems and local network configurations. The security architecture is defined in terms of the security services which are to be supported at the CI, the mechanisms which are to be used to provide the services, and the cryptographic parameters, keys and processes which are associated with these mechanisms.

SDO	Document No.	Version	Status	Issued date	Location
ETSI	EN 300 175-7	V1.7.1	Published	01/07/2003	<a href="http://webapp.etsi.org/workprogram/Report_WorkItem.asp?WKI_ID=15001">http://webapp.etsi.org/workprogram/Report_WorkItem.asp?WKI_ID=15001</a>

#### 5.5.2.8 EN 300 175-8

##### **Digital Enhanced Cordless Telecommunications (DECT); Common Interface (CI); Part 8: Speech coding and transmission**

This part of the DECT CI specifies the speech coding and transmission requirements. In order to ensure satisfactory interworking of different portable and fixed units, it is necessary to specify the transmission performance of the analogue information over the digital link. This requires not only use of a common speech algorithm, but also standardization of frequency responses, reference speech levels (or loudness) at the air interface and various other parameters.

SDO	Document No.	Version	Status	Issued date	Location
ETSI	EN 300 175 - 8	V1.7.1	Published	01/07/2003	<a href="http://webapp.etsi.org/workprogram/Report_WorkItem.asp?WKI_ID=15003">http://webapp.etsi.org/workprogram/Report_WorkItem.asp?WKI_ID=15003</a>

#### 5.5.2.9 EN 300 176-1

##### **Digital Enhanced Cordless Telecommunications (DECT); Approval test specification; Part 1: Radio**

This standard specifies radio tests for DECT equipment. It covers testing of radio-frequency parameters, security elements and those DECT protocols that facilitate the radio-frequency tests and efficient use of frequency spectrum. The aims of this document are to ensure efficient use of frequency spectrum and that no harm is done to other radio networks and services.

SDO	Document No.	Version	Status	Issued date	Location
ETSI	EN 300 176-1	V1.5.1	Published	01/10/2003	<a href="http://webapp.etsi.org/workprogram/Report_WorkItem.asp?WKI_ID=14123">http://webapp.etsi.org/workprogram/Report_WorkItem.asp?WKI_ID=14123</a>

#### 5.5.2.10 EN 300 176-2

##### **Digital Enhanced Cordless Telecommunications (DECT); Approval test specification; Part 2: Speech**

This standard specifies tests applicable to DECT speech transmission.

SDO	Document No.	Version	Status	Issued date	Location
ETSI	EN 300 176 - 2	V1.5.1	Published	01/01/2004	<a href="http://webapp.etsi.org/workprogram/Report_WorkItem.asp?WKI_ID=18822">http://webapp.etsi.org/workprogram/Report_WorkItem.asp?WKI_ID=18822</a>

**5.5.2.11** EN 300 444**Digital Enhanced Cordless Telecommunications (DECT); Generic Access Profile**

The objective of the standard is to ensure inter-operability of DECT equipment capable of 3.1 kHz telephony applications. The profile consists of the minimum mandatory requirements that allow a 3.1 kHz teleservice connection to be established, maintained and released between a Fixed Termination (FT) and a Portable Termination (PT) with the appropriate access rights.

SDO	Document No.	Version	Status	Issued date	Location
ETSI	EN 300 444	V1.4.2	Published	01/02/2003	<a href="http://webapp.etsi.org/workprogram/Report_WorkItem.asp?WKI_ID=17823">http://webapp.etsi.org/workprogram/Report_WorkItem.asp?WKI_ID=17823</a>

**5.5.2.12** EN 301 649**Digital Enhanced Cordless Telecommunications (DECT); DECT Packet Radio Service**

The document defines the standard for packet data services for Digital Enhanced Cordless Telecommunications (DECT) systems conforming to EN 300 175 Parts 1 to 7. It is the basis of profiles which define more specific applications, aimed at the connection of terminals supporting packet data services to a fixed infrastructure, both private and public.

**5.5.2.13** TS 102 265**Digital Enhanced Cordless Telecommunications (DECT); DECT access to IP-networks**

The document specifies additional requirements for Digital Enhanced Cordless Telecommunications (DECT) Internet Protocol applications including networking aspects, voice over IP, SIP interworking, mobility and quality of service properties.

## **6 Recommendations (satellite component)**

The ITU Radiocommunication Assembly recommends that the principles described in § 6.1 and 6.2 should be applied by satellite systems providing the satellite component of IMT-2000. These sections describe the basic functions and features of the core network interface and the satellite/terrestrial terminal interface.

The ITU Radiocommunication Assembly recommends that the radio interfaces described in § 6.3 should be those of the satellite component of IMT-2000.

### **6.1 Core network interface**

The satellite component should interface to the core network in a similar manner to the terrestrial component. Key IMT-2000 requirements, such as appropriate call routing, automatic network roaming, common billing, etc. can therefore be supported, subject to technical and market considerations. However some differences may be required to support a specific satellite radio interface.

### **6.2 Satellite/terrestrial terminal interface**

The IMT-2000 satellite user terminals will offer one or more modes of operation: one satellite mode and possibly one or more terrestrial modes. If a terrestrial mode is implemented, terminals should be able to select either satellite or terrestrial modes of operation automatically or under user control.

The satellite/terrestrial terminal interface performs the following functions:

- provide the bearer service negotiation capabilities in both terrestrial and satellite networks;
- support roaming between terrestrial and satellite networks;
- align the service management and provisioning with IMT-2000 Recommendations.

Handover between terrestrial and satellite components is not a requirement of IMT-2000. It is up to the network operator to determine whether to implement handover between the terrestrial and satellite component. If handover is not implemented, roaming between terrestrial and satellite component may be just a switching function i.e. if a user terminal loses its connection to a terrestrial network, it could look for a satellite network.

Terminal locations are registered and updated between the terrestrial and satellite databases by using the standard location updating procedures for updating locations between different public land mobile networks (PLMNs).

For roaming between a terrestrial and a satellite network, standard location update procedures employed by PLMNs can be applied, since both networks can be viewed as separate PLMNs. For example, when a user roams out of the terrestrial network coverage and into satellite coverage, standard procedures for detecting and initiating location updates for roaming among PLMNs is applied. When a user roams into terrestrial network coverage from satellite network coverage and the terminal has the terrestrial network provisioned as the preferred network, the terminal will register into the terrestrial network by initiating procedures for detecting and initiating location updates similar to those used for roaming among PLMNs.

It should be possible to address an IMT-2000 terminal using a single number, regardless of which component (terrestrial or satellite) the terminal is currently using.

### **6.3 Satellite radio interface specifications**

The specification of each satellite radio interface is given in the following subsections. These include only elements related to the service link interface; the feeder link and intersatellite link interfaces are not specified in this Recommendation.



Because of the strong dependency between the radio interface design and overall satellite system optimization, this section includes the architectural and system descriptions as well as the RF and baseband specifications of radio interfaces.

### **6.3.1 Satellite radio interface A specifications**

SW-CDMA is a satellite radio interface designed to meet the requirements of the satellite component of the third generation (3G) wireless communication systems. The SW-CDMA radio interface is currently being examined by the ETSI SES Technical Committee among the family of IMT-2000 satellite radio interfaces as a voluntary standard.

SW-CDMA is based on the adaptation to the satellite environment of the IMT-2000 CDMA Direct Spread terrestrial radio interface (UTRA FDD or WCDMA) (see § 5.1). The intention is to reuse the same core network and reuse the radio interface specifications for the Iu and Cu interface. Only the Uu interface will be adapted to the satellite environment.

SW-CDMA operates in FDD mode with RF channel bandwidth of either 2.350 or 4.700 MHz for each transmission direction. The half rate 2.350 MHz option provides finer spectrum granularity yielding an easier spectrum sharing among different systems.

SW-CDMA provides a wide range of bearer services from 1.2 up to 144 kbit/s. High-quality telecommunication service can be supported including voice quality telephony and data services in a global coverage satellite environment. SW-CDMA deviations from the above-mentioned terrestrial radio interface are summarized hereafter:

- Maximum bit rate supported limited to 144 kbit/s
- Permanent softer handover forward link operations for constellations providing satellite diversity
- Permanent reverse link satellite diversity combining for constellations providing satellite diversity
- Feeder link (gateway-satellite) and satellite to user link beam centre Doppler pre-compensation
- Two-steps (instead of three-steps as terrestrial) forward link acquisition procedure
- Optional half chip-rate mode for improved frequency granularity
- Introduction of a high-power paging channel for in-building penetration
- Optional (not standard) use of pilot symbols in the communication channels
- Reduced power control rate with multi-level predictive power control loop to cope with longer propagation delay
- Shorter scrambling sequence length (2 560 chips) in the forward link
- Optional use in the forward link of a short scrambling sequence (256 chips) to allow CDMA interference mitigation at single user terminal level
- Longer random access preamble sequence.

SW-CDMA offers a great degree of commonality with the terrestrial radio interface making the interoperability between the IMT-2000 terrestrial and the satellite components easier.

#### **6.3.1.1 Architectural description**

##### **6.3.1.1.1 Channels structure**

This radio interface specification is relevant just to the service link, the feeder link not being a part of it.

The service link consists of a forward link, between the satellite station and the MES and a return link in the opposite direction.

At the physical layer, the information flow to and from the MES is conveyed through logical channels as defined in Recommendation ITU-R M.1035. Those logical channels make use of physical channels as bearer medium, as shown in Table 7.

TABLE 7  
Physical to logical channel mapping

Logical channels	Physical channels	Direction
BCCH	Primary CCPCH	Forward
FACH PCH	Secondary CCPCH	Forward
DSCH	PDSCH PDSCCH	Forward Forward
RACH RTCH	PRACH	Reverse
DCCH	DPDCH	Bidirectional
DTCH	DPDCH	Bidirectional
Layer 1 signalling	DPCCH	Bidirectional

Two broadcast physical channels are foreseen in the forward direction, primary and secondary common control physical channel, CCPCH. The primary CCPCH supports the broadcast control channel (BCCH) used to broadcast system and beam specific information. The secondary CCPCH supports two logical channels namely the forward access channel (FACH), carrying control information to an identified MES when its position is known and a paging channel (PCH), used as high penetration paging channel.

The physical random access channel (PRACH) supports the random access channel (RACH), carrying control information and the random traffic channel (RTCH), carrying short user packets.

The dedicated physical control channel (DPCCH) is used for carrying Layer 1 signalling data.

The dedicated physical data channel (DPDCH) either control information such as higher layers signalling, conveyed through the dedicated control channel (DCCH) and bidirectional user data conveyed through the dedicated traffic channel (DTCH).

The above bearer services can be utilized to provide circuit-switched and packet data services. On the forward link, packet traffic is supported either on the FACH channel, a downlink shared channel (DSCH) where multiple user services can be supported on the same connection using a time-multiplexed structure or on a dedicated channel for higher throughput requirements. On the reverse link the RACH channel may be utilized for the transmission of occasional short user packets. For a non-occasional, but still moderate throughput and/or low-duty cycle packet traffic, ad hoc codes will be assigned by the LES to the user in order to avoid code collision with other users of the RACH channel. In this case the RTCH is still mapped on a RACH-like physical channel. The data part, however, may be of variable length (in any case a multiple of the physical layer frame length). For higher throughput packet channels on the reverse link, a couple DPCCH/DPDCH can be assigned. The DPDCH is only transmitted when the packet queue is not empty. Also in this case a packet may span multiple physical layer frames. Rate agility is also supported in this case.

A high penetration messaging service is foreseen as unidirectional service (in the forward direction, i.e. between the satellite station and the MES) supporting low data rates with messages containing some tens of bytes. Its primary scope is a paging service or ring alert for MESs localized inside buildings.

In addition to Recommendation ITU-R M.1035, a dedicated physical channel has been introduced for Layer 1 signalling. This carries reference symbols for channel estimation and synchronization purposes.

#### **6.3.1.1.2 Constellation**

SW-CDMA does not compel to any particular constellation. It has been designed to be supported by LEO, MEO, GEO or HEO constellations.

Even though multiple satellite diversity will ensure the best system performances, this shall not be regarded as a mandatory system requirement.

#### **6.3.1.1.3 Satellites**

SW-CDMA does not compel to any particular satellite architecture. It can be operated either over a bent-pipe transparent satellite transponder or by regenerative transponder architecture. For the reverse link, satellite path diversity exploitation requires bent-pipe transponder as demodulation takes place on the ground.

### **6.3.1.2 System description**

#### **6.3.1.2.1 Service features**

Depending on the MES class, SW-CDMA supports bearer services ranging from 1.2 kbit/s up to 144 kbit/s with associated maximum BER between  $1 \times 10^{-3}$  to  $1 \times 10^{-6}$ .

The maximum tolerated delay is up to 400 ms, compatible with any of the above-mentioned satellite constellations.

#### **6.3.1.2.2 System features**

Both in the forward and in the return link two spreading rates are supported, either 3.840 Mchip/s (full chip rate) and 1.920 Mchip/s (half chip rate).

The transmission is organized in frames. The frame period is 10 ms for the 3.840 Mchip/s option and 20 ms for the 1.920 Mchip/s. Frames are organized in hierarchical structure. A multiframe (MF) consists of 8 frames (full rate option) or 4 frames (half rate option). The MF period is 80 ms. Multiframes are organized in super-frames. One super-frame consists of 9 MFs and has a period equal to 720 ms.

Closed-loop power control is implemented for both the forward and return link. The loop is driven in order to set the measured SNIR value after RAKE fingers combining to a target value. The target value is itself adaptively modified by means of slower outer control loop based on FER measurements. To support FER measurements 8 bit CRC (4 bits for 2400 bit/s) are appended to data in each frame.

An open loop power control is provided for packet transmission and initial setting of power during the call set-up phase.

Three basic service classes are supported by a concatenation of coding and interleaving:

- standard services with inner coding (rate 1/3 convolutional, polynomials 557, 663, 711) and interleaving only, with a target BER equal to  $1 \times 10^{-3}$ ;

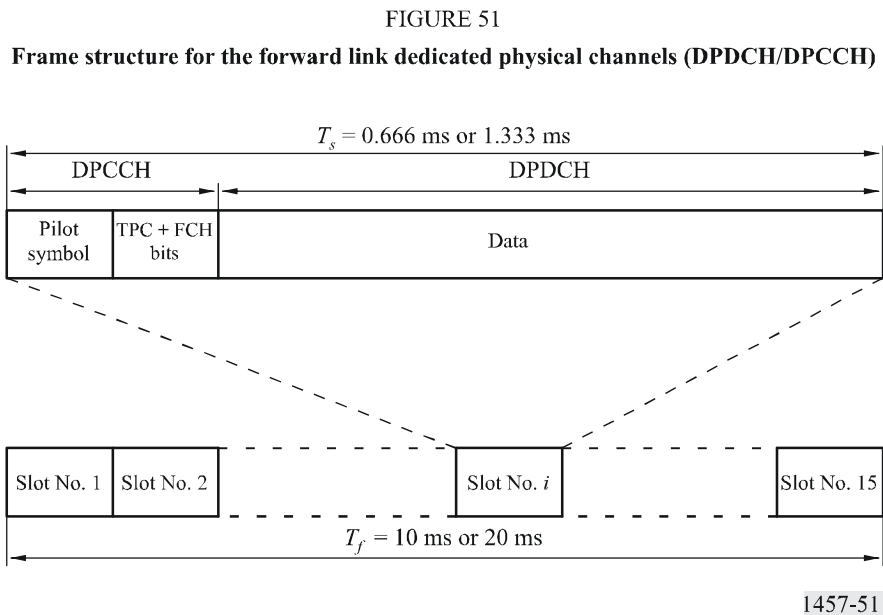
- high quality services with inner coding and interleaving plus outer RS coding and interleaving (or optional Turbo coding). The target BER is  $1 \times 10^{-6}$ ;
- services with service specific coding. For these services no specific FEC coding technique is applied by the radio interface. Possible FEC coding is entirely managed at higher layer.

These classes allow to match the various QoS requirements of the selected satellite services and permit QoS enhancements if required through the choice of a service specific coding.

The interleaving scheme is negotiated at call set-up, depending on the actual data rate. The interleaving depth spans over an integer multiple of the frame period. The interleaving block is written per rows over a number of columns which is a power of two, the exponent depending on the actual data rate. In reception, the interleaving block is read per columns in a shuffled sequence, i.e. by reading the binary column index in the reverse order.

### Access Description – Forward Link

**DPDCH/DPCCH** – The DPDCH/DPCCH frame structure is shown in Fig. 51. Each frame is divided in 15 time slots and each time slot carries in time-division multiplexing DPDCH and the corresponding DPCCH.



The DPCCH carries the *optional* (see Note 1) reference (pilot) symbols, the power control field (TPC) and the frame control header (FCH), which indicates the actual DPDCH format and speed. The reference pilot symbols are optional.

The format and the data rate of the DPDCH may change during the communication session frame by frame: the MES can detect the format and speed of the current frame from the FCH. The DPDCH may even be absent in some frames. As the data rate on the DPDCH changes also the relative power level of DPDCH and DPCCH changes.

The TCP field consists of two bits. For the TPC function only one increase/decrease command per frames is sufficient due to the large loop delay. However, a multi-level loop allows faster reaction to changes into the channel conditions. Hence, an additional bit per frame is allocated for that purpose.

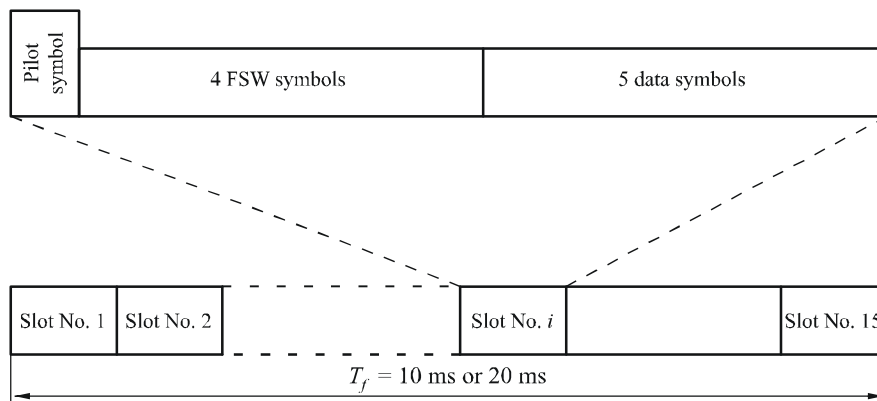
The FCH field consists of three bits. These 3 bits can address eight different DPDCH formats: because the possible DPDCH formats are more than eight, the FCH will actually select a data format in a subset of the available formats which is defined during call set-up negotiation.

The TPC and FCH bits are coded together by mapping the resulting 5-bit word to one 15-bit long sequence (codeword) belonging to a family of 32 sequences. The proposed, length 15 bits, family of sequences is obtained by all the 15 cyclic shift of an ML sequence of length  $2^4 - 1$  plus the all zero sequence plus the antipodal of all the previous sequences. The total number of available sequence is thus 32. The cross-correlation between sequences is either  $\pm 1$  or  $-15$ . The sequences are either almost orthogonal or antipodal.

NOTE 1 – Typically channel estimation is performed by means of the CCPCH thus no pilot symbols are required in the individual DPCCCH.

CCPCH – The frame structure of the primary and secondary CCPCH is shown in Fig. 52.

FIGURE 52  
**Frame structure for the common control physical channels (CCPCH)**



1457-52

The primary CCPCH is continuously transmitted at a fixed transmission rate (15 kbit/s in the full chip rate option and 7.5 kbit/s in the half chip rate option). It is used to carry the BCH and a frame synchronization word (FSW).

The primary CCPCH channel code for this channel is the same on all beams and satellite and is known to all MES. Two different FSWs are used. One FSW is used on all frames except the first frame of each MF where the other FSW is utilized. It shall be observed that no pilot symbols are used on the CCPCH. The hypothesis is to use the common pilot for such purposes.

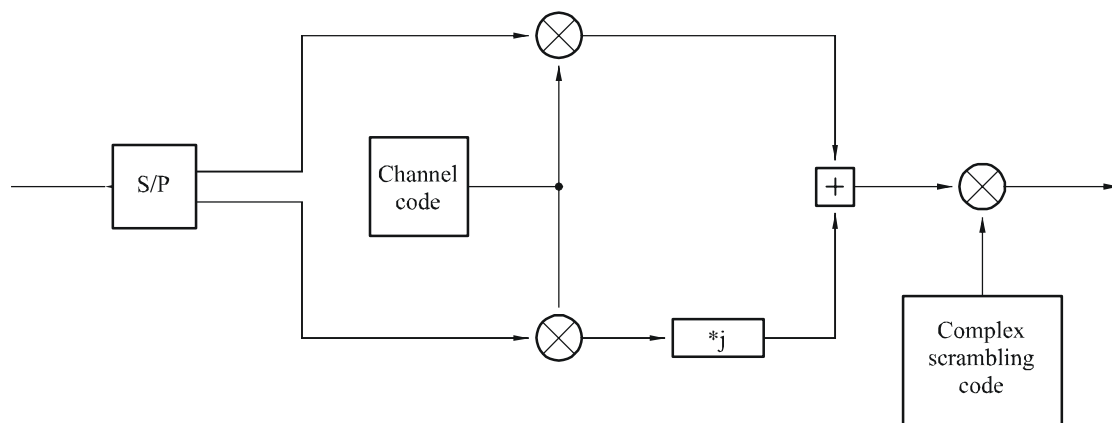
The secondary CCPCH carries the paging channel (PCH) and the forward access channel (FACH). This channel is also a constant rate channel and it is transmitted only when user traffic is present. On the secondary CCPCH, the FACH and PCH are time multiplexed on a frame-by-frame basis within the super frame structure. The set of frames allocated to FACH and PCH respectively is broadcast on the BCCH. No power control strategy is implemented in the primary and secondary CCPCH.

*PDSCH/PDSCCH* – The physical downlink shared channel (PDSCH) carries packet data to MESs without the need to allocate a permanent DCH to each user, which may potentially bring to downlink code shortage. The PDSCH channels use a branch of the OVSF code tree. A single MES per frame is served in case the lowest super frame node of the code branch (i.e. the branch root) is used. Multiple MESs per frame may instead be served via code multiplexing in case a higher super frame factor is used (i.e. lower nodes in the branch tree). All PDSCH channels share a single physical downlink shared control channel (PDSCCH) which is transmitted in code multiplexing and carries code assignment, FCH and TPC information to all users.

### Modulation and spreading

The modulation scheme (see Fig. 53) is QPSK where each bit pair is mapped to the I and Q branches. Those are then spread to the chip rate with the same channel code,  $c_{ch}$ , and subsequently scrambled by the same beam specific complex scrambling code,  $c_{scramb}$ .

FIGURE 53  
QPSK modulation/BPSK spreading for the forward link physical channels



1457-53

For the lower user data rates ( $\leq 4800$  bit/s), BPSK modulation is used, instead of QPSK modulation, to reduce the sensitivity to phase errors.

The choice of short spreading codes allows the implementation of a linear minimum output energy (MOE) adaptive CDMA demodulator in the MES. The optional use of CDMA MOE detectors is intended to increase system capacity and or/quality of service with no space segment impact.

### Codes allocation and synchronization

*Scrambling codes* – The scrambling code is a complex quaternary sequence of length 2 560 chips. Optionally, in case of MOE-based CDMA interference mitigation at the MES, the use of a shorter (256 chips) real scrambling code is envisaged.

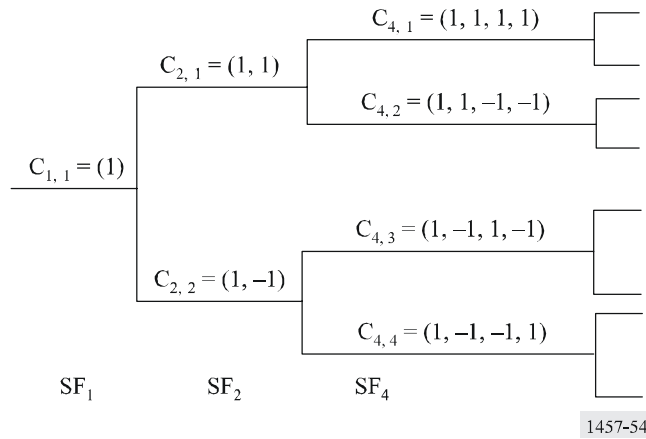
The same scrambling code (staggered by a fixed amount of chips) can be reused in each beam of a given satellite. Different sets of scrambling codes are assigned to each spacecraft. If a given spacecraft is accessed by different LES on the same frequency slot, they must be either mutually synchronized or they shall use different scrambling codes. Depending on orbital parameters, scrambling sequences may be reused among satellites not in simultaneous visibility of the same region. Scrambling code allocation can be done according to several strategies also depending on the constellation and payload (transparent or regenerative) types as well as the degree of synchronization accuracy of LES stations.

The CCPCH common pilot is necessary to support the initial code and frequency acquisition and support satellite diversity operations. The optional use of reference symbols in addition to the common pilot may be required for supporting adaptive antennas.

*Channel codes* – The channel codes belong to the orthogonal variable spreading factor (OVSF) family. These codes preserve the orthogonality between forward link channels of different rates and spreading factors. Note that as the CCPCH differs from the DPDCH only by the channel code (see Note 1) thus differently from the corresponding terrestrial radio interface the CCPCH is orthogonal to the DPDCH.

The OVSF codes can be defined using the code tree of Fig. 54.

FIGURE 54  
Code tree generation for OVSF codes



Each level in the code tree defines channel codes of length  $SF_j$ . All codes within the code tree cannot be used simultaneously within the same beam. A code can be used in a beam if and only if no other code on the path from the specific code to the root or in the underlying sub-tree is in use. This means that the number of available channel codes is not fixed but depends on the rate and spreading factor of each physical channel.

NOTE 1 – The CCPCH shares the same DPDCH scrambling sequence.

### Acquisition and synchronization

In the MES, the initial acquisition is performed by means of the common pilot. The pilot is modulated with a low rate known pattern and its channelization code is known (typically the all zero sequence code). The known pattern modulating the common pilot has the scope to extend the period of the overall signal in order to support satellite diversity operation. After power on, the MES searches for the scrambling code of the common pilot.

The efficiency of that search and therefore the speed of convergence of the initial acquisition, depends on the number of codes to be searched and possible MES knowledge of candidate satellites. The suggested use of staggered scrambling sequence for the different satellite beams will help in reducing the initial acquisition time. Scrambling sequence reuse among different satellites is also a way to reduce the initial search space dimensions.

Once a pilot has been acquired, the primary CCPCH can be de-spread and the BCCH recovered. This maintains specific information on the list of candidate satellites with the associated scrambling codes in order to accelerate the acquisition of other satellites.

### Hand-off

Four possible hand-off situations are envisaged: beam hand-off, satellite hand-off, LES hand-off and frequency hand-off.

*Beam hand-off* – The MES always measures the de-spread pilot  $C/(N + I)$  received from adjacent beams and reports measurement results to the LES. When the beam pilot quality is approaching a system threshold level, the LES typically initiates a beam hand-off procedure. According to the MES pilot reports, the LES will decide to transmit the same channel through two different beams (soft beam hand-off) and command the MES to add a finger to demodulate the additional signal. As

soon as the LES receives confirmation that the new signal is received, it drops the old beam connection.

*Inter-satellite hand-off* – The procedure is analogous to that of inter-beam hand-off. The only difference is that the MES has also to search for different pilot scrambling codes. If a new pilot scrambling code is detected, the measure is reported back to the LES, which may decide to exploit satellite diversity by transmitting the same signal through different satellites.

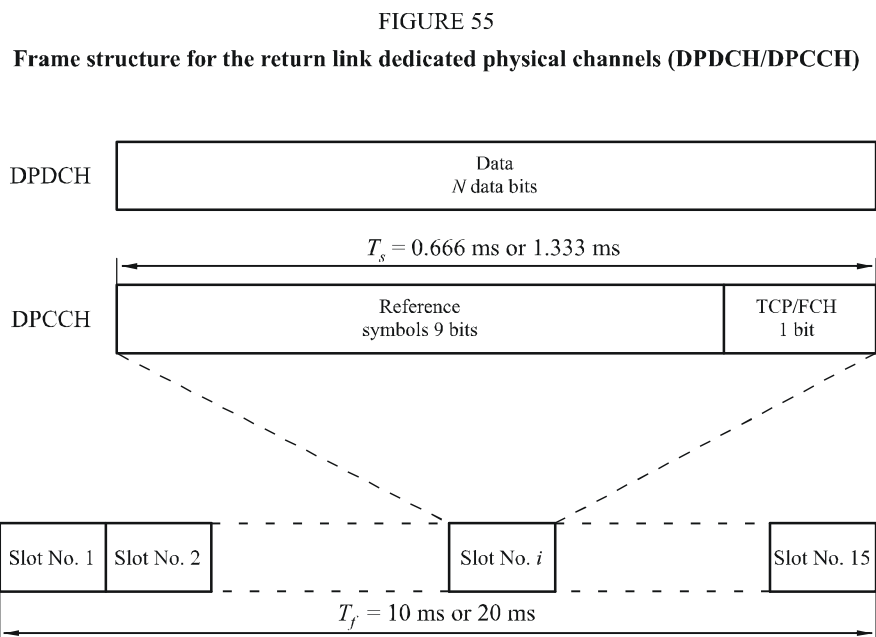
When the satellite constellation provides multiple path diversity, it is useful to operate mobile users in permanent softer hand-off mode. In this case the LES associate the same channel to the strongest satellite diversity paths. The MES exploits path diversity through maximal ratio combining.

*Inter-LES hand-off* – Inter-LES hand-off may be needed in some cases depending on the constellation characteristics. The inter-LES hand-off shall be negotiated between the LESs. In particular, the new LES starts transmitting its carrier towards the mobile that is simultaneously commanded by the old LES to search for the new LES signal. When the MES confirms to the old LES that it is also receiving from the new one, the old LES stops transmitting towards the MS.

*Inter-frequency hand-off* – Only hard inter-frequency hand-off is supported. This hand-off can be either intra-gateway or inter-gateway.

### Access description – return link

*DPDCH/DPCCH frame structure* – The DPDCH/DPCCH frame structure in the return link (see Fig. 55) is the same of that in the forward link. However, differently from the forward link, the DPDCH and DPCCH are code and not time-division multiplexed.



1457-55

In the DPCCH, the TCP/FCH field has the same function of that in the forward link. As in the forward link, these bits are mapped to a sequence belonging to a family of 32 sequences. The proposed, length 15 bits, family of sequences is obtained by all the 15 cyclic shift of an ML sequence of length  $2^4 - 1$  plus the all zero sequence plus the antipodal of all the previous sequences. The sequences are either almost orthogonal or antipodal.



The reference bit pattern is described in Table 8. The shadowed part can be used as frame synchronization words. The value of the pilot bit other than the frame synchronization word shall be 1. The frame synchronization word is inverted to mark the beginning of a MF.

TABLE 8  
Reference bit pattern for uplink DPCCH

Slot No. \ Bit No.	0	1	2	3	4	5	6	7	8
1	1	1	1	0	1	0	1	1	1
2	1	1	1	0	1	1	1	0	1
3	1	0	1	0	1	1	1	0	1
4	1	0	1	1	1	1	1	1	1
5	1	1	1	1	1	0	1	0	1
6	1	0	1	1	1	0	1	1	1
7	1	0	1	1	1	1	1	0	1
8	1	1	1	0	1	1	1	1	1
9	1	0	1	1	1	1	1	0	1
10	1	1	1	0	1	0	1	0	1
11	1	0	1	0	1	0	1	0	1
12	1	0	1	1	1	0	1	0	1
13	1	0	1	0	1	1	1	1	1
14	1	1	1	0	1	1	1	0	1
15	1	0	1	0	1	1	1	1	1

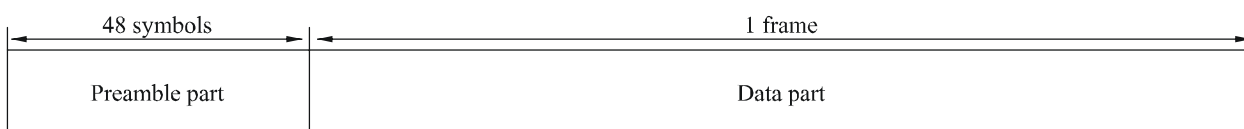
The rate at which reference symbols, TPC/FCH bits are transmitted is fixed and equal to 15 kbit/s for the full chip rate option and 7.5 kbit/s for the half chip rate option.

Similarly to the forward link, 2 and 3 bits will be transmitted per frame respectively for the TPC and the FCH functions.

- The number of bits per DPDCH slot is related to the spreading factor SF of the physical channel as  $SF = 256/2^k$  with  $k = 0, \dots, 4$ . The spreading factor may thus range from 256 down to 16.

*PRACH frame structure* – The PRACH frame structure is shown in Fig. 56.

FIGURE 56  
Physical random access channel (PRACH) frame structure



1457-56

The preamble part is formed by modulating a 48 symbols codeword over a spreading code of period 256 chips.

The 48 symbols codeword preamble is randomly selected by the MES in a small set of quaternary codewords. The spreading code is randomly selected between the spreading codes available for random access. Information about the available spreading codes is given on the BCCH channel.

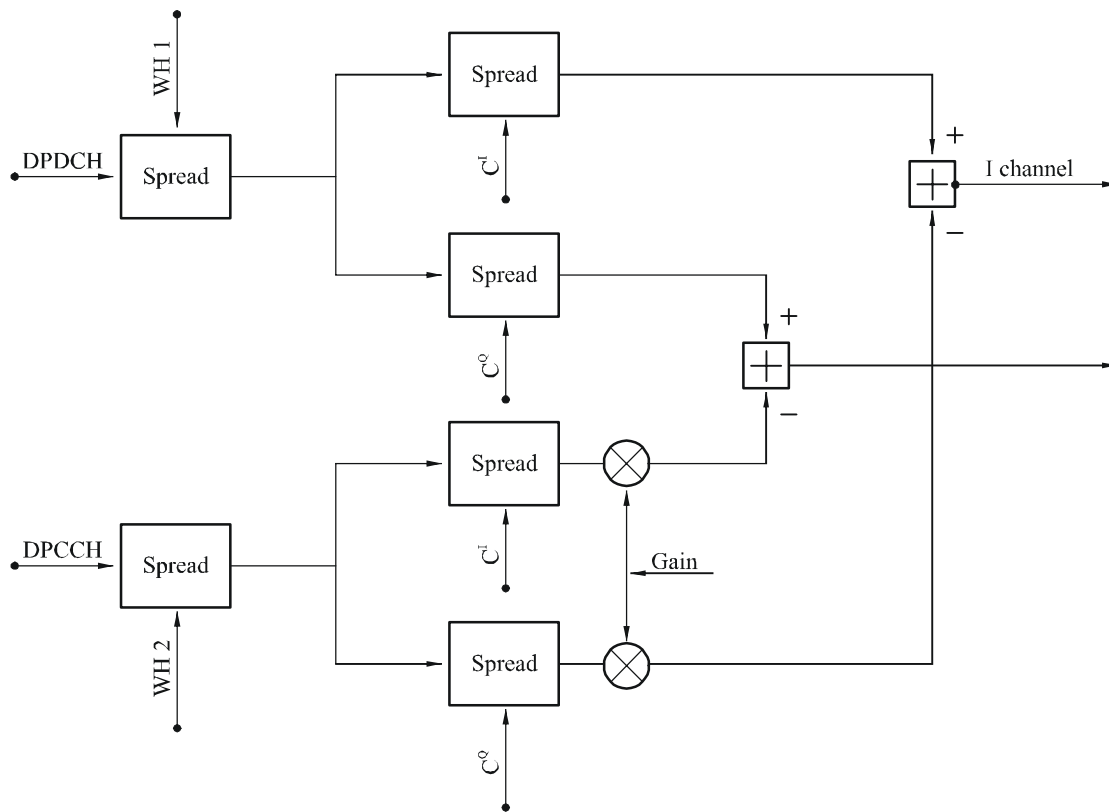
The data part of the RACH burst is actually composed of a data channel on the I transmission arm and an associated control channel on the Q transmission arm carrying the reference symbols for coherent demodulation and a FCH informing about the data rate and format of the I arm. The data rate of the preamble part is instead fixed and equal to 15 ksymbol/s or 7.5 ksymbol/s according to the chip rate option. The length of the data part of the RACH burst is equal to a frame (i.e. 10 or 20 ms, according to the chip rate option).

No diversity combining is supported on the RACH channel.

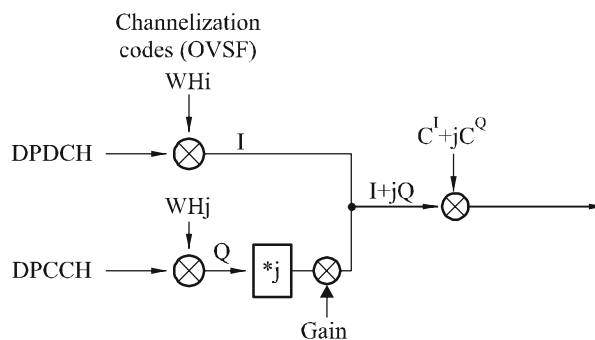
*Modulation and spreading* – The modulation/spreading code used in the return link is shown in Fig. 57. Data modulation is BPSK, where the DPDCH and DPCCH are mapped to the carrier I and Q branches respectively. The I and Q branches are then spread to the chip rate with two different channel codes  $c_D/c_C$  and subsequently complex scrambled by a MS specific complex quadri-phase scrambling code.

FIGURE 57

Reverse link spreading modulation scheme for dedicated physical channels a) and its complex representation b)



a)



b)

Scrambling code length is one frame (38400 chips). An option with a short code (256) is being evaluated for use in conjunction with an MMSE-based interference mitigation technique. The scrambling sequences are the same as defined in specification TS25.213 (prepared by 3GPP).

Scrambling codes are assigned to the MES by the LES on a semi-permanent basis.

The channel codes are the same OVSF codes as for the forward link.

### 6.3.1.2.3 Terminal features

SW-CDMA supports four MES classes: hand-held (H), vehicular (V), transportable (T) and fixed (F). In Table 9 the terminal feature to terminal classes are mapped.

TABLE 9  
Bearer services

Bearer data rate (kbit/s)	Supported QoS	MES class
1.2	$10^{-6}$	H,V,T,F
2.4	$10^{-3}$ , $10^{-5}$ , $10^{-6}$	H,V,T,F
4.8	$10^{-3}$ , $10^{-5}$ , $10^{-6}$	H,V,T,F
9.6	$10^{-3}$ , $10^{-5}$ , $10^{-6}$	H,V,T,F
16	$10^{-3}$ , $10^{-5}$ , $10^{-6}$	H,V,T,F
32	$10^{-3}$ , $10^{-5}$ , $10^{-6}$	V,T,F
64	$10^{-5}$ , $10^{-6}$	V,T,F
144	$10^{-5}$ , $10^{-6}$	T,F

### 6.3.1.2.4 RF specifications

### 6.3.1.2.5 Satellite station

The satellite station RF specifications depend on the actual space segment architecture.

### 6.3.1.2.6 MES

In Table 10 the RF specifications for the different MES classes are reported.

TABLE 10  
MES RF specification

RF parameter	MES class		
	H	V	T
Channel bandwidth (kHz)	2 350 <sup>(1)</sup> , 4 700 <sup>(2)</sup>	2 350 <sup>(1)</sup> , 4 700 <sup>(2)</sup>	2 350 <sup>(1)</sup> , 4 700 <sup>(2)</sup>
Uplink frequency stability (ppm)	3	3	3
Downlink frequency stability (ppm)	0.5	0.5	0.5
Maximum e.i.r.p. (dBW)	3.0	16.0	16.0
Average e.i.r.p. per channel (dBW)	(3)	(3)	(3)
Antenna gain (dBi)	-1.0	2.0 <sup>(4)</sup> , 8.0 <sup>(5)</sup>	4.0 <sup>(4)</sup> , 25.0 <sup>(5)</sup>
Power control range (dB)	20.0	20.0	20.0
Power control step (dB)	0.2-1	0.2-1	0.2-1
Power control rate (Hz)	50 ÷ 100	50 ÷ 100	50 ÷ 100
Transmit/receive isolation (dB)	> 169	> 169	> 169
G/T (dB/K)	-23.0 <sup>(4)</sup> , -23.0 <sup>(5)</sup>	-23.5 <sup>(4)</sup> , -20.0 <sup>(5)</sup>	-23.5 <sup>(4)</sup> , -20.0 <sup>(5)</sup>
Doppler shift compensation	Yes	Yes	Not applicable
Mobility restriction (maximum speed) (km/h)	250 <sup>(1)</sup> , 500 <sup>(2)</sup>	250 <sup>(1)</sup> , 500 <sup>(2)</sup>	Not applicable

- (1) Half rate option (1.920 Mchip/s).  
(2) Full rate option (3.840 Mchip/s).  
(3) Depending on the satellite station characteristics.  
(4) Typical value for LEO constellation.  
(5) Typical value for GEO constellation.

### Baseband specifications

The baseband specifications are provided in Table 11.

### Detailed specifications

The SW-CDMA radio interface detailed specification is based on the following set of documents:

- *Physical layer*: the most recent version of the SW-CDMA documents derived from the 25.200 series (see Note 1).
- *Protocols*: most recent versions of the 25.300 draft specifications (see Note 2).

NOTE 1 – This set of detailed specifications is presently being elaborated inside the ETSI TC-SES S-UMTS working group among the family of the voluntary standards for IMT-2000 satellite radio interface. This specification will also provide a general description of the physical layer of the SW-CDMA air interface.

NOTE 2 – As developed within the 3GPP RAN TSG. These documents can be found on: <http://www.3gpp.org/TSG/RAN.html>. This specification describes the documents being produced by the 3GPP TSG RAN WG 4.

TABLE 11

**Baseband characteristics**

BB-1	Multiple access	
BB-1.1	Technique	Direct sequence CDMA
BB-1.2	Chip rate (where appropriate)	1.920 Mchip/s or 3.840 Mchip/s
BB-1.3	Time slots (where appropriate)	15 time slots per frame
BB-2	Modulation type	– Dual-code BPSK in the uplink – QPSK or BPSK in the downlink
BB-3	Dynamic channel allocation (yes/no)	No
BB-4	Duplex method (e.g. FDD, TDD)	FDD
BB-5	FEC	– Standard quality: convolutional coding with code rate 1/3 or 1/2 constraint length $k = 9$ . Variable puncturing repetition to match the required info rate. – High quality concatenated RS code over $GF(2^8)$ , concatenated with inner convolutional code with rate 1/3 or 1/2, constraint length $k = 9$ . Turbo coder as option
BB-6	Interleaving	– Interleaving on a single frame basis (default). – Interleaving on a multiple frame basis (optional)
BB-7	Synchronization between satellites required (y/n)	– Synchronization between BSs working on different satellites is not required. – Synchronization between BSs working on the same satellite is required

**6.3.2 Satellite radio interface B specifications**

W-C/TDMA is a satellite radio interface designed to meet the requirements of the satellite component of the third generation (3G) wireless communication systems (see Note 1).

The W-C/TDMA radio interface is supposed to be compliant with the radio interface CN and related specifications for the Iu and Cu interface.

W-C/TDMA is based on a hybrid code and time-division multiple access (C/TDMA) technique with RF channel bandwidth of either 2.350 or 4.700 MHz for each transmission direction.

W-C/TDMA is characterized by a slotted structure, a quasi-synchronous operation of the uplink resulting in a quasi-orthogonal partitioning of most radio resources of a single, multibeam satellite system.

According to the relevant IMT-2000 satellite band regulations, the baseline duplexing scheme is FDD: however a TDD/FDD scheme is supported in which the transmission takes place in a different time slot with respect to reception and in different frequency bands. The half rate option provides finer spectrum granularity and robustness with respect to chip synchronization and tracking in channel with high Doppler shift.

W-C/TDMA provides a wide range of bearer services from 1.2 up to 144 kbit/s. High quality telecommunication service can be supported including voice quality telephony and data services in a global coverage satellite environment. W-C/TDMA supports additional features specific of the satellite environment such as the provision of a high penetration paging channel.

The main attractive features of W-C/TDMA are hereafter summarized:

- W-C/TDMA provides superior system capacity over a narrow-band TDMA or FDMA system.
- Supports FDD/TDD mode operation requiring terminals with less demanding antenna diplexers.
- Provides more resources allocation flexibility thanks to orthogonal partitioning (TDM/TDMA) of a high percentage of radio resources on top of CDM/CDMA.
- Allows full frequency re-use simplifying frequency planning.
- Provision of finer granularity of user data rates compared to narrow-band systems avoiding high peak-to-mean power.
- Provision of accurate user positioning without external means.
- Support of high penetration messaging service.

NOTE 1 – The W-C/TDMA radio interface is currently being examined by the (ETSI) SES Technical Committee among the family of IMT-2000 satellite radio interfaces as a voluntary standard.

### **6.3.2.1 Architectural description**

#### **6.3.2.1.1 Channels structure**

This radio interface specification is relevant just to the service link, the feeder link not being part of it.

The service link consists of a forward link, between the satellite station and the MES and a return link in the opposite direction.

At the physical layer, the information flow to and from the MES is conveyed through logical channels as defined in Recommendation ITU-R M.1035.

Those logical channels make use of physical channels as bearer medium.

W-C/TDMA adopts the same physical channel structure as the terrestrial radio interface. The mapping between physical and logical channels is shown in Table 12.

Two broadcast physical channels are foreseen in the forward direction, primary and secondary common control physical channel, P/S-CCPCH.

The primary CCPCH supports the broadcast control channel (BCCH) used to broadcast system and beam specific information.

The secondary CCPCH supports two logical channels namely the forward access channel (FACH), carrying control information to an identified MES when its position is known.

The physical random access channel (PRACH) supports the random access channel (RACH), carrying control information and the random traffic channel (RTCH), carrying short user packets.

TABLE 12  
Physical to logical channel mapping

Logical channels	Physical channels	Direction
BCCH	Primary CCPCH	Forward
FACH	Secondary CCPCH	Forward
Pilot	PI-CCPCH	Forward
PCH	HP-CCPCH	Forward
RACH RTCH	PRACH	Reverse
DCCH	DDPCH	Bidirectional
DTCH	DDPCH	Bidirectional
Layer 1 signalling and pilot symbols	DCPCH	Bidirectional

The dedicated physical control channel (DCPCH) is used for Layer 1 signalling.

The dedicated physical control channel (DDPCH) is used for carrying either control information such as higher layer signalling, conveyed through the dedicated control channel (DCCH) and bidirectional user data conveyed through the dedicated traffic channel (DTCH).

The above bearer services can be utilized to provide circuit-switched and packet data services.

Multiple user services can be supported on the same connection using a time-multiplexed structure.

With respect to that a specific physical control channel has been introduced, HP-CCPCH, supporting, in the forward link the high penetration paging channel, a low data rate service, whose primary scope is as a paging service or ring alert for MESs localized inside buildings.

#### 6.3.2.1.2 Constellation

W-C/TDMA does not compel to any particular constellation. It has been designed to be supported by low, medium, geostationary or high Earth orbit (LEO, MEO, GEO or HEO) constellations.

Even though multiple spot-beam coverage will ensure the best system performances, this shall not be regarded as a mandatory system requirement.

#### 6.3.2.1.3 Satellites

W-C/TDMA does not compel to any particular satellite architecture. It can be operated either over a bent-pipe transparent satellite transponder or by regenerative transponder architecture.

### 6.3.2.2 System description

#### 6.3.2.2.1 Service features

Depending on the MES class, W-C/TDMA supports bearer services ranging from 1.2 kbit/s up to 144 kbit/s with associated maximum BER between  $1 \times 10^{-3}$  to  $1 \times 10^{-6}$ .

The maximum tolerated delay is up to 400 ms, compatible with any of the above-mentioned satellite constellations.

#### 6.3.2.2.2 System features

Both in the forward and in the return link two spreading rates are supported, both 3.840 Mchip/s (full chip rate) and 1.920 Mchip/s (half chip rate).

Closed-loop power control is implemented for both the forward and return link. The loop is driven in order to set the measured SNIR value after RAKE combining to a target value. The target value is itself adaptively modified by means of slower outer control loop based on FER measurements. To support FER measurements 8 bit CRC (4 bit for 2 400 bit/s) are appended to data in each frame.

An open loop power control is provided for packet transmission and initial setting of power during the call set-up phase.

Three basic service classes are supported by a concatenation of coding and interleaving:

- standard services with inner coding (rate 1/3 convolutional, polynomials 557, 663, 711) and interleaving only, with a target BER equal to  $1 \times 10^{-3}$ ;
- high quality services with inner coding and interleaving plus outer RS coding and interleaving. The target BER after the inner decoding is  $1 \times 10^{-6}$ ;
- services with service specific coding. For these services no specific FEC coding technique is applied by the radio interface. Possible FEC coding is entirely managed at higher layer.

These classes allow matching of the various QoS requirements of the selected satellite services and permitting QoS enhancements, if required, through the choice of a service specific coding.

The interleaving scheme is negotiated at call set-up, depending on the actual data rate. The interleaving depth spans over an integer multiple of the frame period. The interleaving block is written per rows over a number of columns, which is a power of two, the exponent depending on the actual data rate. In reception, the interleaving block is read per columns in a shuffled sequence, i.e. by reading the binary column index in the reverse order.

### **Satellite diversity**

In a multiple satellite coverage scenario, the LES may decide to combine return link signals of co-coverage satellites with the return link signal received via the primary satellite to improve the SNIR and to reduce shadowing probability. Since quasi-synchronous operation is restricted to the primary satellite, the resulting SIR at a secondary satellite demodulator where the user is received asynchronously is generally lower. In spite of these SIR inequities, it can be shown that there is a substantial gain from maximal ratio combining techniques which may be used to increase return link power efficiency and capacity.

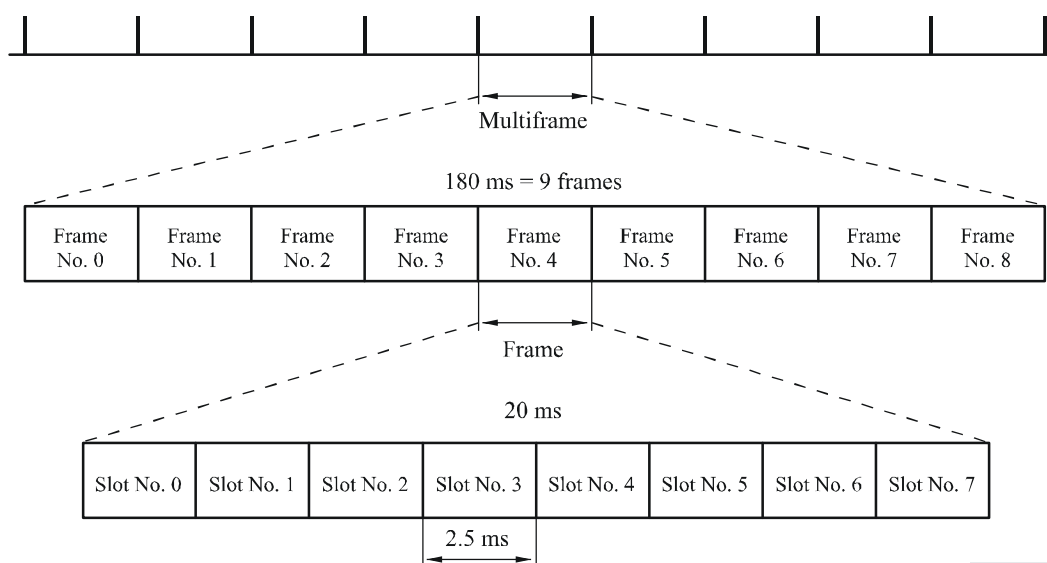
### **Access description**

In the forward link from the satellite station to the MES an orthogonal CTDM is adopted. In the return link, from the MES to the satellite station quasi-synchronous W-C/TDMA is adopted.

The transmission is organized in frames, as shown in Fig. 58. The frame period is 20 ms and is subdivided in 8 time slots. Frames are organized in multiframes (MF, period 180 ms) consisting of 8 ordinary frames plus one extra frame.



FIGURE 58  
Forward and return link frame structure



1457-58

The coexistence between synchronous and asynchronous traffic (initial access) is handled with a segregated approach, in which the available resources are partitioned in time in two frames each one reserved to its specific use.

In the forward link frame 0 is dedicated to broadcast common functions (paging, high penetration messaging channel, synchronization, etc.).

The first frame in each MF (frame 0) is reserved to the asynchronous traffic: in the return link, packets are sent asynchronously by MESs in frame 0 of each multiframe, as shown in Fig. 59.

*Bursts* – Transmission takes place in bursts which can have the duration of a single time slot or may span over an integer number of time slots.

In case of synchronous traffic, burst can span over an integer number of time slots, not necessarily contiguous.

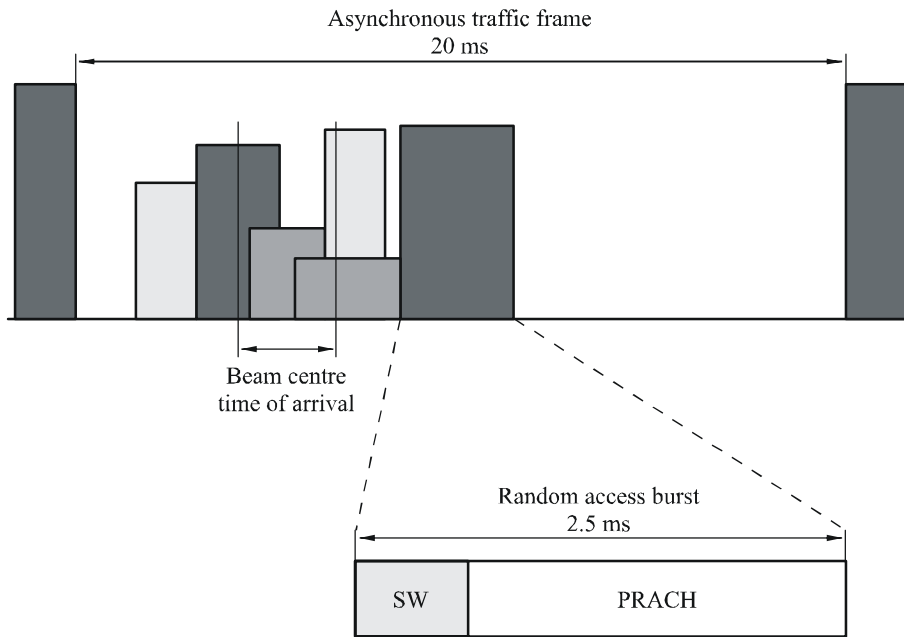
In case of asynchronous traffic, bursts are transmitted, in a non-slotted frame, at random times taking care not to invade the adjacent frames.

Two bursts size are envisaged: short, containing 160 bytes and long containing 320 bytes.

The duration of a burst depends on the selected chip rate and spreading factor.

The burst size and the spreading factor are controlled by the LES and cannot be modified during a session. The information rate can be varied on a burst-to-burst basis.

FIGURE 59  
Asynchronous traffic in the return link, frame 0



1457-59

**Forward link**

*DCPCH/DDPCH* – In the forward link DCPCH and DDPCH are multiplexed on the same burst (forward link dedicated burst). The burst structure is shown as for Fig. 60.

FIGURE 60  
Forward link dedicated burst

DCPCH				DDPCH
FCH	TPC	TFC	Pilot	User data
$n_{FFD}$	$n_{TPD}$	$n_{TFD}$	$(n_{PFD})$	$n_{DFD}$
$n_{OFD}$				
Control and user data interleaved, pilot symbols equally spaced				
1, 2 or 4 slots				

1457-60

The DPCCH carries the reference (pilot) symbols, the power control field (TPC), the frame control header (FCH), which indicates the actual code rate and the time and frequency control field (TFC), required for quasi-synchronous operation.

The forward link common burst carries the CCPCH. Its structure is shown in Fig. 61.

FIGURE 61  
Forward link common burst

CCPCH	
FCH	Data
$n_{FFC}$	$n_{DFC}$
$n_{OFC}$	
Control and user data interleaved	
1, 2 or 4 slots	

1457-61

The forward link synchronization burst carries the high penetration paging channel (HP-CCPCH). Its structure is shown in Fig. 62.

FIGURE 62  
Forward link synchronization burst

HP-CCPCH		
SW	Pilot	Data
$n_{SWS}$	$n_{PFS}$	$n_{DFS}$
$n_{OFS}$		
SW	Pilot symbols equally spaced	
1 slot		

1457-62

**Return link**

Two burst structure are foreseen in the return link: random access burst and return link dedicated burst. Their structure is shown in Fig. 63 and Fig. 64, respectively.

FIGURE 63  
Return link random access burst

PRACH		
SW	Pilot	Data
$n_{SRR}$	$n_{PRR}$	$n_{DRR}$
$n_{ORR}$		
SW	Pilot symbols equally spaced	
1 slot		

1457-63

FIGURE 64  
Return link dedicated burst

DCPCH			DDPCH
FCH	TPC	Pilot	User data
$n_{FRD}$	$n_{TRD}$	$(n_{PRD})$	$n_{DRD}$
$n_{ORD}$			
Control and user data interleaved, pilot symbols equally spaced			
1, 2 or 4 slots			

1457-64

**Definition of the burst parameters**

The burst parameters are defined as for Tables 13 to 17.

TABLE 13

**Forward link dedicated burst**

		Short burst		Long burst	
		Symbols	Percentage	Symbols	Percentage
Total	$N_{\text{OFD}}$	160	100	320	100
Data	$N_{\text{DFD}}$	112	70	256	80
(Pilot)	$(N_{\text{PFD}})$	(16)	(10)	(32)	(10)
FCH	$N_{\text{FFD}}$	16	10	16	5
TPC	$N_{\text{TPD}}$	8	5	8	2.5
TFC	$N_{\text{TFD}}$	8	5	8	2.5
Total overhead		48	30	64	20

TABLE 14

**Forward link common control burst**

		Short burst		Long burst	
		Symbols	Percentage	Symbols	Percentage
Total	$N_{\text{OFC}}$	160	100	320	100
Data	$N_{\text{DFC}}$	144	90	304	95
FCH	$N_{\text{FFC}}$	16	10	16	5
Total overhead		16	10	16	5

TABLE 15

**Forward link synchronization burst**

		Short burst	
		Symbols	Percentage
Total	$N_{\text{OFS}}$	160	100
Data	$N_{\text{DFS}}$	112	70
SW	$N_{\text{SWS}}$	32	20
Pilot	$N_{\text{PFS}}$	16	10
Total overhead		48	30

TABLE 16

**Random access burst**

		Short burst	
		Symbols	Percentage
Total	$N_{ORR}$	160	100
Data	$N_{DRR}$	112	70
SW	$N_{SRR}$	32	20
Pilot	$N_{PRR}$	16	10
Total overhead		48	30

TABLE 17

**Return link dedicated burst**

		Short burst		Long burst	
		Symbols	Percentage	Symbols	Percentage
Total	$N_{ORD}$	160	100	320	100
Data	$N_{DRD}$	120	75	264	82.5
Pilot	$N_{PRD}$	16	10	32	10
FCH	$N_{FRD}$	16	10	16	5
TPC	$N_{TRD}$	8	5	8	2.5
Total overhead		40	25	56	17.5

**Channel assignment and transmission mode**

The combination of an assignment of a number of spreading code and time slots in a multi-frame constitutes a virtual channel assignment. The number of codes will likely be equal to one, but might be greater than one if MESs capable of multi-code reception and/or transmission are considered. The assignment of slots for dedicated channels is restricted to frames No. 1 to No. 8 (No. 5 in the five frames per multi-frame option). A channel assignment is valid for the duration of a session.

The principle of OVSF codes permits orthogonal or quasi-orthogonal channels with codes associated to different spreading factors to coexist. Spreading code, slots, burst type, and other link parameters for the forward and return link are assigned by the LES during the set-up of a session. It is proposed not to change the spreading code (spreading factor) during a session. Variable rate transmission is realized solely by changing the code rate.

Different transmission modes are considered:

- Two-way stream mode transmission: a communication channel is assigned on the forward and the return link.
- Forward link stream mode one-way transmission: a communication channel is assigned only on the forward link.
- Return link stream mode one-way transmission: this mode is prohibited since there is no possibility to send TFC commands on the forward link.

- Packet data transfer: If the frequency of packets to the same destination is low, no channel will be assigned and packets are transferred in frame No. 0. This is valid for both directions. (Zones at the edges of frame No. 0 where congestion is assumed to be lower will preferably be used for packet transfer in the return direction.) If the frequency of packets to the same destination is sufficiently high to justify a session, a dedicated channel may be assigned in frames No. 1 to No. 8.

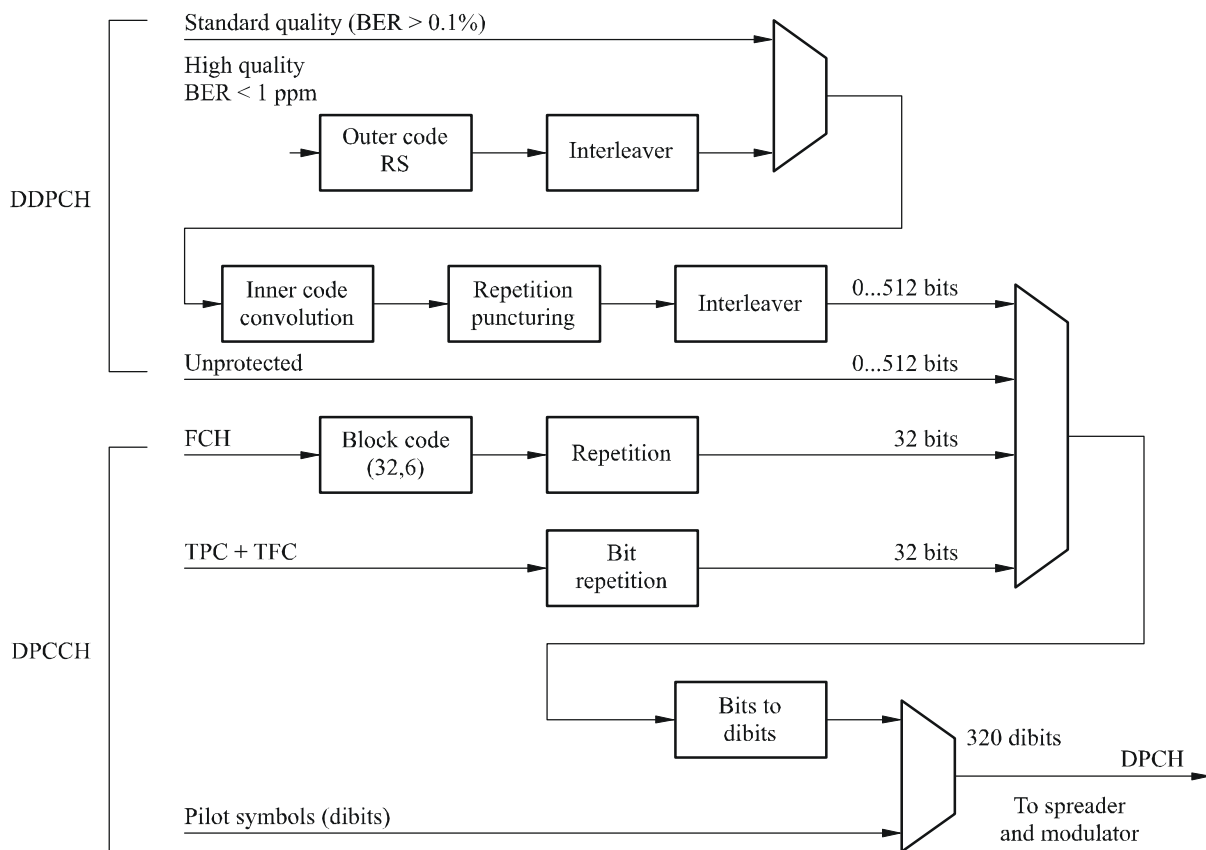
An optimum choice of the justification threshold for an assignment of a dedicated channel for packet data transfer is crucial. It should prevent overloading of frame No. 0 in particular of the return link and save satellite power. Connectionless packet data transfer does not allow power control. Thus, higher link margins have to be provided for packet transmission requiring more satellite power. On the other hand, channel assignments require signalling overhead which also requires additional satellite energy and reduces capacity.

**Channel coding, rate adapter and service multiplexing**

The channel coding and service multiplexing scheme is shown in Fig. 65 and is applicable to the forward and return link dedicated physical channel. The diagram is generic and applies in the simple case where only one service with specified quality and rate is transmitted on a single burst in a single code channel as well as in the more general case where multiple services requiring different rates and qualities are simultaneously transmitted on a single burst in a single code channel.

The de-multiplexing and decoding schemes to be applied at the receiving side are indicated in the FCH.

FIGURE 65  
Coding and multiplexing scheme

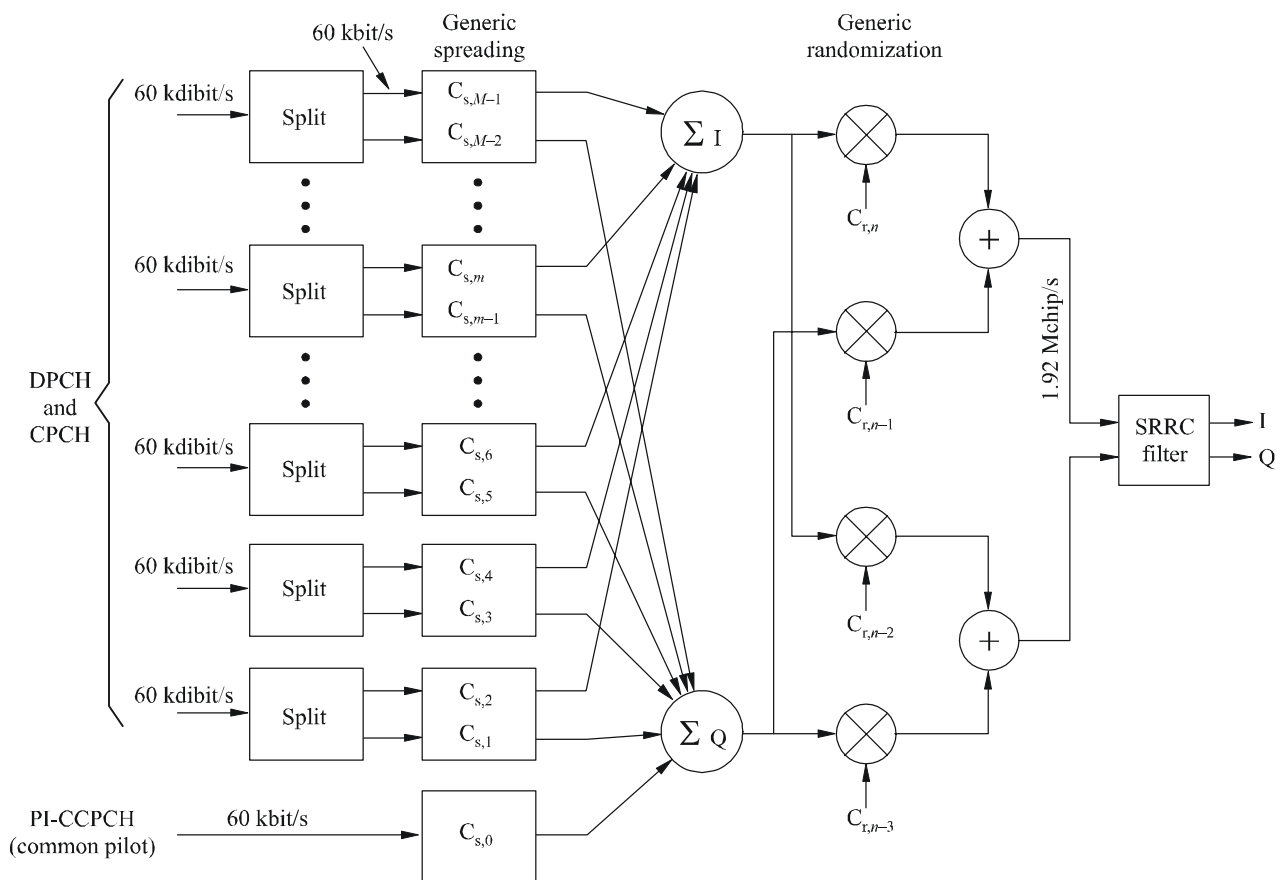


## Modulation and spreading

Figure 66 represents the proposed generic spreader and modulator for the forward and return link, respectively. The principle of the proposed spreading and modulation scheme for the forward and return link is described in the following: After insertion (multiplexing) of pilot symbols (dibits) (if required), the dibit stream is split into two bi-polar data streams, called the I- and the Q-streams. These data, clocked at symbol rate, are multiplied with the bi-polar components of the spreading code vector denoted  $c_{s,m}$ , clocked at chip rate, such that one bi-polar data sample is a scalar factor of the code vector. This operation is called spreading or channelization.

FIGURE 66

Forward link generic spreader and modulator  
(rates indicated refer to the 1.920 Mchip/s option and a spreading factor of 32)



1457-66

The resulting I- and Q-spread transmit sequences are additionally randomized using bi-polar PN-sequences, called randomization codes, denoted  $c_{r,n}$ , such that the transmit signal appears noise like in a receiver which is not synchronized or which reuses the same spreading code. There are three different ways to randomize:

- real randomization using a single randomization code;
- complex randomization using a pair of randomization codes and full complex multiplication;
- I/Q independent randomization using a pair of randomization codes such that one code is multiplied with the I-branch signal and the other code with the Q-branch signal.



Possible code configurations for QPSK and dual BPSK using either real or complex randomization are listed in Table 18.

TABLE 18  
Spreading and randomization code configurations

Data modulation	Spreading codes	Randomization codes	Remarks
QPSK	$c_{s,m} = c_{s,m-1}$	$c_{r,n} = c_{r,n-3}, c_{r,n-1} = c_{r,n-2} = 0$	Real randomization
QPSK	$c_{s,m} = c_{s,m-1}$	$c_{r,n} = c_{r,n-2} \neq c_{r,n-1} = c_{r,n-3}$	Complex randomization
Dual BPSK	$c_{s,m} = c_{s,m-1}$	$c_{r,n} = c_{r,n-3}, c_{r,n-1} = c_{r,n-2} = 0$	Different randomization on I- and Q-branch
Dual BPSK	$c_{s,m} \neq c_{s,m-1}$	$c_{r,n} = c_{r,n-3}, c_{r,n-1} = c_{r,n-2} = 0$	Real randomization
Dual BPSK	$c_{s,m} \neq c_{s,m-1}$	$c_{r,n} = c_{r,n-2} \neq c_{r,n-1} = c_{r,n-3}$	Complex randomization

In line with the scheme applicable for the corresponding terrestrial radio interface, orthogonal variable spreading factor (OVSF) codes based on a length 128 bits Walsh-Hadamard code set for the 1.920 Mchip/s option and on a length 256 bits Walsh-Hadamard code set for the 3.840 Mchip/s option are proposed.

#### Forward link

The generic form of the forward link spreader and modulator is shown in Fig. 66. Except for the common pilot channel (PI-CCPCH), different configurations of spreading and randomization codes may be applied. Since the same randomization is applied to all simultaneously transmitted forward link channels, summation is prior to randomization.

It is proposed to use either QPSK or dual BPSK and real randomization for all DPCH and CPCH. Normally, a multitude of code channels is simultaneously transmitted on the forward link that results in a circular I/Q amplitude distribution in any case. Thus, real randomization is adequate requiring minimum complexity.

The use of dual BPSK would reduce the number of orthogonal code channels to one half, since different spreading codes are applied to the I- and Q-branches. Single spreading code dual BPSK with I/Q independent randomization represents a way to avoid the above code-book limitation at the expenses of an increased sensitivity to carrier phase errors.

Dual BPSK with real randomization is used for the synchronization burst (HP-CCPCH). The PI-CCPCH is mapped on spreading code No. 0 which is the all 1-sequence. The PI-CCPCH data is simply an endless sequence of 1 s, interrupted in those slots where the synchronization burst is transmitted. Thus, the PI-CCPCH is the randomization code itself.

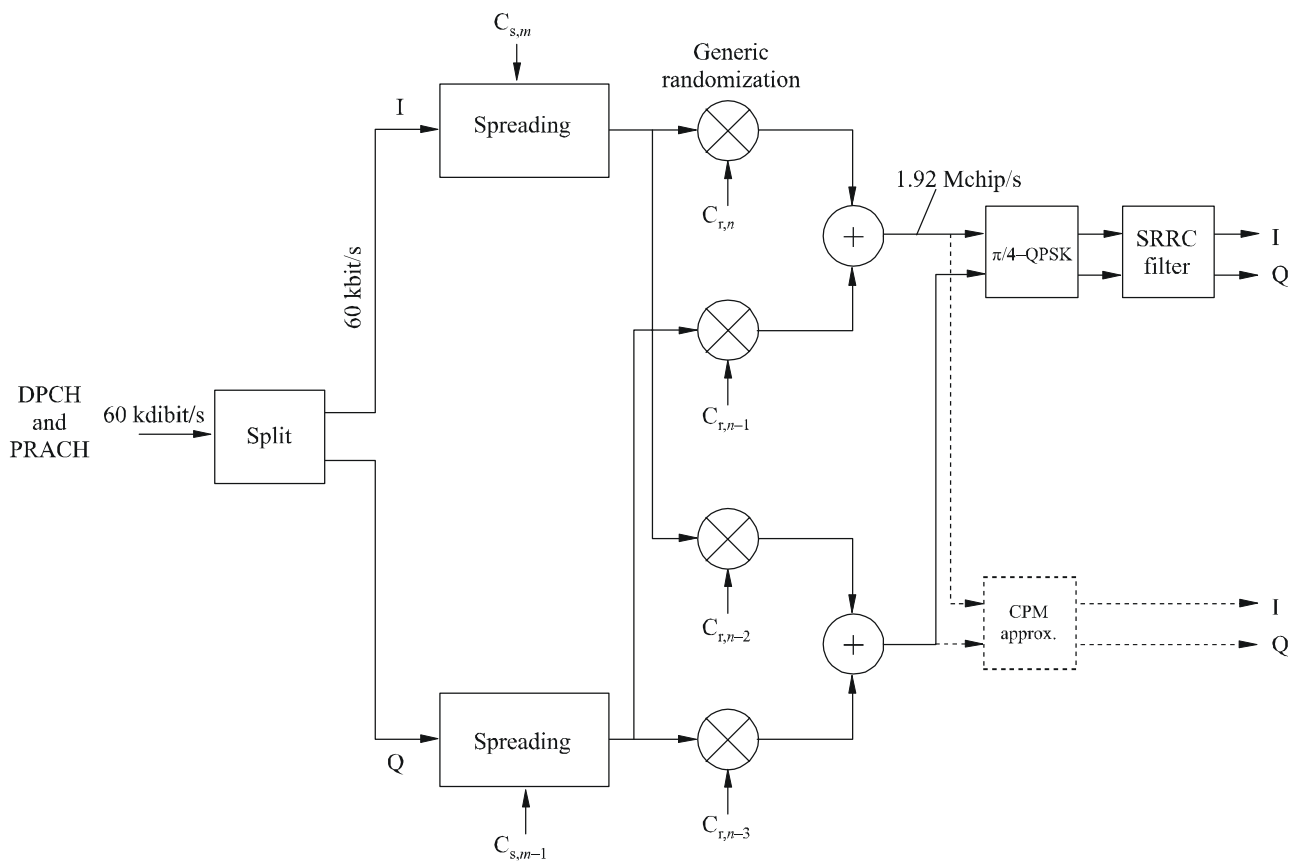
#### Return link

The generic form of the return link spreader and modulator is shown in Fig. 67. Different configurations of spreading and randomization codes may be applied as on the forward link.

It is proposed to use either QPSK or dual BPSK data modulation both with complex randomization for DPCH. The use of orthogonal dual BPSK would reduce the number of code channels to one half. Dual BPSK with I/Q independent spreading (without code channel reduction) can be considered when code-book size is an issue. The more robust dual BPSK with complex randomization is proposed for the random access burst (PRACH).

In contrast to the forward link,  $\pi/4$ -QPSK spreading modulation is proposed in order to reduce envelope fluctuations. Optionally, pre-compensated frequency modulation (PFM) can be envisaged. PFM is a constant envelope modulation technique which can be designed to work with a standard Nyquist-filtered  $\pi/4$ -QPSK receiver. PFM represents a trade-off between adjacent channel (frequency band) interference (ACI), code channel cross talk and BER-performance in AWGN conditions.

FIGURE 67  
Return link generic spreader and modulator  
(rates indicated refer to the 1.920 Mchip/s option and a spreading factor of 32)



1457-67

### System time and frequency reference

It is assumed that system time and frequency reference is virtually located in the satellite. This means, that the signals emitted by the satellite correspond to the nominal frequencies and timing. In case of a transparent transponder, the LES offsets the transmit times, frequencies, chip rates etc. of its feeder uplink so that the signals arrive at the intended satellite in synchronism with the nominal system time and frequency. Beam specific time shifts and Doppler pre-compensation may be additionally applied for the service links. For the return link it is assumed that the LES controls timing of the individual MTs such that the return link signals arrive at the intended satellite in quasi-synchronism with the nominal system time and frequency. Beam specific time shifts and frequency offsets may be applied additionally for the service return links.

The feeder downlink needs no specification in this context, since feeder propagation time varies for all beams exactly in the same manner.

### **Intra-satellite inter-beam synchronization**

It is proposed to keep transmit times (frame structure) in all beams of the same satellite aligned. There will be small intentional and fixed time offsets in the order of a few chip periods in order to permit reuse of the same randomization code in all beams of the same satellite.

Time offsets will also be required for the return link frame structure of signals arriving at the satellite from different beams, if the same randomization code shall be used for all beams of a satellite. The same time offsets are proposed for the return link frame structure. The LES controls the MTs in a manner such that the above offsets occur at the LES receiver.

In general, there will be a fixed offset between the forward and return link frame structure.

### **System-wide inter-satellite synchronization**

It is proposed to maintain time synchronism between all satellites belonging to the same SRAN. This means transmissions from different satellites are aligned to one another with respect to the frame structure within an accuracy in the order of a ms. In case of transparent payloads and no inter-satellite links, the system-wide synchronization may be maintained by the LESs inter-connected via a terrestrial network. Time alignment limits frame timing differences between pairs of satellites to the minimum possible. It is believed that this is advantageous for satellite path diversity and handover.

### **Randomization codes assignment**

The purpose of the overlaid randomization of the spreading code is to make adjacent beam and inter-satellite interference appear more noise like in any situation at any time. The following generic randomization codes assignment approach is proposed:

- One specific and one common randomization code sequence (real randomization) is assigned to each satellite belonging to the same SRAN to be used on the forward link.
- A specific pair of randomization codes (complex randomization) is assigned to each satellite belonging to the same SRAN to be used on the return link.
- The specific forward link randomization code is unique in the SRAN and is applied to all forward link transmissions (except the synchronization burst) of all beams of the same satellite.
- The specific pair of return link codes is unique in the SRAN and is applied to all quasi-synchronous and asynchronous return link transmissions of all beams of the same satellite.
- The common code is applied to the forward link synchronization bursts (HP-CCPCH) of all beams of all satellites belonging to the same SRAN.
- The start of the specific and common randomization code refers to the first chip in slot No. 1 of frame No. 0 for both forward link synchronous and return link quasi-synchronous traffic. Clocking of the randomization code is continued through any period of HP-CCPCH transmission on the forward link or asynchronous traffic frame on the return link where quasi-synchronous traffic is interrupted.
- In case of asynchronous traffic, the start of the randomization code sequences of the specific pair refers to the first chip of the random access burst.

The use of a common randomization code for the synchronization bursts simplifies forward link acquisition and allows decoding of the HP-CCPCH with minimum system information. Accidental interference de-randomization in case of HP-CCPCH reception is unavoidable with this approach. In order to lower the probability of acquisition failures or message losses in the delay co-incidence zones of a multiple satellite scenario, it is proposed to artificially vary the power of the synchronization bursts transmitted by the different satellites by approximately 6 dB in a manner

such that only one of the serving satellites transmits at full power at a time. Power variation would be applied only in those beams covering the delay co-incidence zones.

### **Forward link acquisition and synchronization**

The following forward link acquisition and synchronization procedure is proposed:

- The MES initially acquires the forward link synchronization (time and frequency) by using the periodic SWs transmitted in slot No. 1 of frame No. 0. The spread SW has a length of  $32 \times 30 = 960$  chips (referred to the half rate option) and is common to all beams and satellites.
- If several SWs from different beams or satellites are detected, it chooses the one associated with the largest correlation peak to establish frequency, frame, symbol and chip synchronization.
- The MES uses the common pilot channel (PI-CCPCH) to extract the randomization code unique to the particular satellite by correlating the receive signal against all possible randomization sequences used in the SRAN.
- The MES attempts to further improve time and frequency synchronization using the PI-CCPCH.
- The MES reads the BCCH transmitted on a primary CCPCH in frame No. 0 to acquire all relevant high level synchronization and system information.

### **Return link synchronization acquisition**

The following procedure is proposed for initial access and the return link synchronization acquisition and tracking:

- The MES is allowed to access the LES only after having successfully established forward link synchronization.
- The MES reads the information about the instantaneous Doppler and time delay at the beam centre point broadcast by the LES in frame No. 0.
- The MES applies Doppler pre-compensation and timing advance, such that the random access burst is received with minimum Doppler shift and timing error at the satellite. The MES therefore computes frequency pre-compensation and burst timing to be applied on the return link using information gathered on the forward link.
- The MES transmits the pre-compensated random access burst in frame No. 0 at the computed time instance. (The computed timing of the random access bursts may be additionally slightly randomized to avoid interference hot spots in the asynchronous traffic frame. However, these offsets would have to be indicated in the content of the random access burst.)
- If the LES has successfully captured the random access burst, it estimates time and frequency (measures residual timing and Doppler errors) and sends a channel assignment, as well as timing and frequency corrections to the MES using a CCPCH.
- Upon successful reception of the forward link message, the MES corrects its Doppler pre-compensation and chip timing and starts to transmit bursts in the assigned time slots within the quasi-synchronous traffic frames. The return link transmission may now be considered as quasi-synchronous to other traffic arriving at the LES. The return link may be considered as fully Doppler precompensated with respect to carrier frequency and chip clock.
- The MES continuously tracks the forward link carrier frequency and chip timing and corrects return link carrier frequency and chip timing upon reception of TFC commands continuously sent by the LES.

Recognizing that the precise synchronization required may occasionally be lost (e.g. caused by shadowing), a reacquisition procedure is also defined in order to quickly restore synchronization.

A loss of synchronization may be indicated at the LES or the MES by the fact that the BER measured over a number of received bursts exceeds a certain threshold. In case of synchronization loss the LES may initiate a reacquisition procedure. The reacquisition procedure is similar to the forward and return link acquisition procedure and is proposed as follows:

- The LES requests a reacquisition using the dedicated logical control channel soon after it has lost return link synchronization.
- On reception of the reacquisition request or on local synchronization loss indication, the MES immediately stops transmitting traffic and, if necessary, tries to reacquire forward link synchronization (the use of the common pilot may be sufficient for this purpose).
- In any case, the MES sends a reacquisition message only upon request by the LES using the random access burst. (Since timing uncertainty may be assumed to be smaller compared to the initial access case, special portions close to the edges of the asynchronous traffic frame having lower congestion may be used for this purpose.)
- After having restored full synchronization, traffic transmission is continued. The LES continues to send TFC commands to track the return link synchronization.

#### **The quasi-synchronous W-C/TDMA return link**

The advantage of a quasi-synchronous return link is that intra-beam interference is kept at a minimum, thus, allowing more inter-beam or inter-satellite interference. Its drawback is the need for precise timing control by the LES. Considering multi-satellite path diversity, only a portion of the MES population will be synchronized to one satellite (those which are assigned to that satellite by the SRAN). The return link signals of the remaining MESs, assigned to different satellites, would have to be received asynchronously.

#### **FDD/TDD mode operation**

The W-C/TDMA scheme proposed intends to support terminals operating in frequency/time division duplex mode. A pure TDD mode using the same carrier frequency in both transmit directions as proposed by ETSI for the terrestrial component is not considered here.

A MES operating in frequency/time division transmits and receives signals in separate time periods and on separate carrier frequencies but never at the same time. Such MESs require simpler diplexers at the antenna port.

In contrast to terrestrial networks, for satellites in non-geostationary orbit, the propagation time may significantly vary inside the footprint of a beam during a connection. The LES controls return link timing such that the frame timing of the signals arriving at the satellite is maintained at a beam specific offset.

In general, there will also be an unknown but fixed offset between the forward and return link frame structure of the same beam. While a fixed return link timing is maintained at the satellite (LES), the timing of the return link frames continuously drifts against the forward link for an observer at the MES when the path length changes. During the time a MES dwells in the footprint of the same beam, the frame offset may vary up to approximately 12 ms, depending on the satellite system. The relative frame drift in a MES operating in FDD/TDD implies the requirement of slot reassignments from time to time, in order to prevent a transmit/receive conflict. The FDD/TDD mode is mainly suited for hand-held terminals.

### 6.3.2.2.3 Terminal features

W-C/TDMA supports four MES classes: hand-held (H), vehicular (V), transportable (T) and fixed (F). In Table 19 the terminal feature to terminal classes are mapped.

TABLE 19  
Bearer services

Bearer data rate (kbit/s)	Supported QoS	MES class
1.2	$10^{-6}$	H,V,T,F
2.4	$10^{-3}, 10^{-5}, 10^{-6}$	H,V,T,F
4.8	$10^{-3}, 10^{-5}, 10^{-6}$	H,V,T,F
9.6	$10^{-3}, 10^{-5}, 10^{-6}$	H,V,T,F
16	$10^{-3}, 10^{-5}, 10^{-6}$	H,V,T,F
32	$10^{-3}, 10^{-5}, 10^{-6}$	V,T,F
64	$10^{-5}, 10^{-6}$	V,T,F
144	$10^{-5}, 10^{-6}$	T,F

### 6.3.2.3 RF specifications

#### 6.3.2.3.1 Satellite station

The satellite station RF specifications depend on the actual space segment architecture.

#### 6.3.2.3.2 MES

In Table 20 the RF specifications for the different MES classes are reported.

TABLE 20  
MES RF specifications

RF parameter	MES class		
	H	V	T
Channel bandwidth (kHz)	2 350 <sup>(1)</sup> , 4 700 <sup>(2)</sup>	2 350 <sup>(1)</sup> , 4 700 <sup>(2)</sup>	2 350 <sup>(1)</sup> , 4 700 <sup>(2)</sup>
Uplink frequency stability (ppm)	3	3	3
Downlink frequency stability (ppm)	0.5	0.5	0.5
Maximum e.i.r.p. (dBW)	8.0 <sup>(3)</sup> , 12.0 <sup>(4)</sup>	11.0 <sup>(3)</sup> , 18.0 <sup>(4)</sup>	20.0 <sup>(3)</sup> , 20.0 <sup>(4)</sup>
Average e.i.r.p. per channel (dBW)	(5)	(5)	(5)
Antenna gain (dBi)	2.0	2.0 <sup>(6)</sup> , 8.0 <sup>(7)</sup>	4.0 <sup>(6)</sup> , 25.0 <sup>(7)</sup>
Power control range (dB)	20.0	20.0	20.0
Power control step (dB)	0.2/1	0.2/1	0.2/1
Power control rate (Hz)	50 ÷ 100	50 ÷ 100	50 ÷ 100
Transmit/receive isolation (dB)	> 169	> 169	> 169
<i>G/T</i> (dB/K)	-23.0 <sup>(6)</sup> , -22.0 <sup>(7)</sup>	-23.5 <sup>(6)</sup> , -20.0 <sup>(7)</sup>	-23.5 <sup>(6)</sup> , -20.0 <sup>(7)</sup>
Doppler shift compensation	Yes	Yes	Not applicable
Mobility restriction (maximum speed (km/h))	250 <sup>(1)</sup> , 500 <sup>(2)</sup>	250 <sup>(1)</sup> , 500 <sup>(2)</sup>	Not applicable

(1) At 1.920 Mchip/s.

(2) At 3.840 Mchip/s.

(3) FDD/TDD mode.

(4) FDD mode.

(5) Depending on the satellite station characteristics.

(6) Typical value for LEO constellation.

(7) Typical value for GEO constellation

#### 6.3.2.4 Baseband specifications

In Table 21 the overall W-C/TDMA baseband characteristics are summarized.

TABLE 21

## Baseband characteristics

BB-1	Multiple access	
BB-1.1	Technique	Forward link: Hybrid wideband Orthogonal CDM/TDM (W-O-C/TDM) Return link: Hybrid wideband Quasi-synchronous quasi-orthogonal CDMA/TDMA (W-QS-QO-C/TDMA)
BB-1.2	Chip rate	3.840 Mchip/s or 1.920 Mchip/s
BB-1.3	Time slots	8 time slots per frame
BB-2	Modulation type	– QPSK or dual-code BPSK in the uplink – QPSK or BPSK (low data rate) in the downlink
BB-3	Dynamic channel allocation (yes/no)	No
BB-4	Duplex method (e.g. FDD, TDD)	FDD or FDD/TDD
BB-5	Forward error correction	– Standard quality: convolutional coding with code rate 1/3 or 1/2 constraint length $k = 9$ . Variable puncturing repetition to match the required info rate. – High quality concatenated RS code over $GF(2^8)$ , concatenated with inner convolutional code with rate 1/3 or 1/2, constraint length $k = 9$ . Turbo coder as option
BB-6	Interleaving	– Interleaving on a single burst basis (default). – Interleaving on a multiple burst basis (optional)
BB-7	Synchronization between satellites required	– Synchronization between LESs working on the same channel of different satellites is required. – Synchronization between LESs working on different channels of the same satellite is not required

## 6.3.2.5 Detailed specifications

The W-C/TDMA radio interface detailed specification is based on the following set of documents:

- *Physical layer*: the most recent version of the W-C/TDMA documents derived from the 25.200 series (see Note 1).
- *Protocols*: most recent versions of the 25.300 draft specifications (see Note 2).



NOTE 1 – This set of detailed specifications is presently being elaborated inside the ETSI TC-SES S-UMTS Working Group among the family of the voluntary standards for IMT-2000 satellite radio interface. This specification will also provide a general description of the physical layer of the W-C/TDMA air interface.

NOTE 2 – As developed within the 3GPP RAN TSG. These documents can be found on: <http://www.3gpp.org/TSG/RAN.htm>. This specification describes the documents being produced by the 3GPP TSG RAN WG 4.

### 6.3.3 Satellite radio interface C specifications

The SAT-CDMA is a satellite radio interface to provide the various advanced mobile telecommunications services defined for the IMT-2000 satellite environment with maximum data rate, 144 kbit/s.

This system includes the satellite constellation which comprises 48 satellites in LEO for the global international communications.

The major technical scheme in SAT-CDMA is wideband code division multiple access (W-CDMA) whose chip rate is 3.84 Mchip/s.

This system will be developed to obtain more commonality with the IMT-2000 terrestrial component.

#### 6.3.3.1 Architectural description

##### 6.3.3.1.1 Constellation

The SAT-CDMA satellite constellation comprises 48 satellites in 1 600 km LEO. In order to get high elevation angle, economical design of satellite constellation, high data rate services, low power of MESs and satellites, and reasonable radiation dose, LEO satellites with 1 600 km altitude is assumed to be reasonable. The satellites are arranged in 8 orbital planes with 54° inclination. Each orbital plane comprises 6 equally spaced satellites. Satellites complete an orbit every 118.2 min. The configuration of satellite constellation enables to cover service areas between 69° S latitude and 69° N latitude with 15° minimum elevation angle for user links. The minimum elevation angle for feeder links is 10°, and the links for inter-satellites are available. The summary of the parameters determined for the configuration is described in Table 22.

TABLE 22

**Configuration of satellite constellation**

Orbit configuration	LEO
Orbit altitude (km)	1 600
Orbit inclination (degrees)	54
Number of orbit planes	8
Number of satellites per orbit plane	6
Phase offset between adjacent orbit satellite (degrees)	7.5
Orbit period (min)	118.2

Figure 68 shows user link coverage for satellites when the minimum elevation angle is 15°. The minimum elevation angle sustained in the dense population area ranging 30° to 60° latitude is above 20° and the average elevation angle is above 40° in this area as shown in Fig. 69.

FIGURE 68  
The coverage area user link for satellites with  
minimum elevation angle of 15°

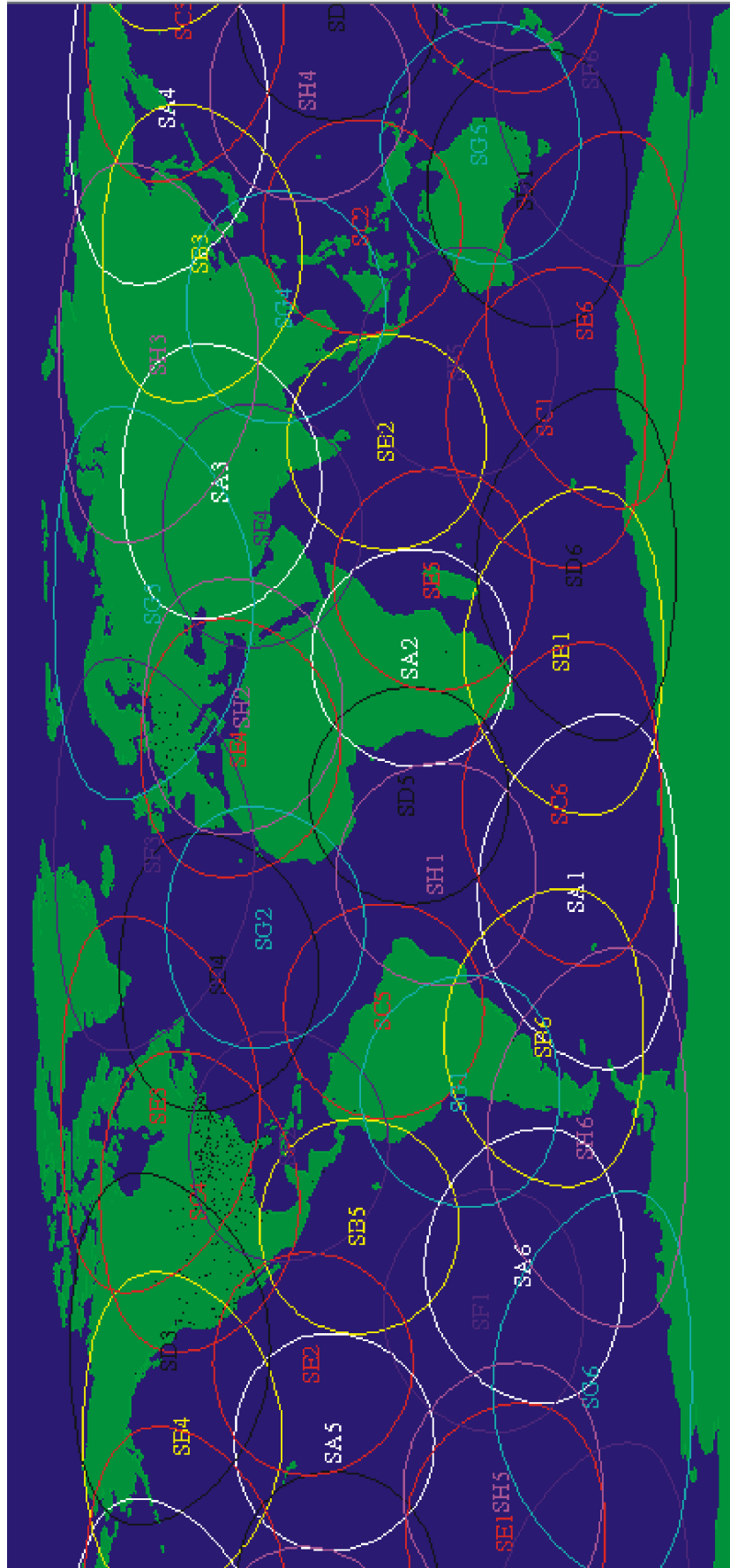
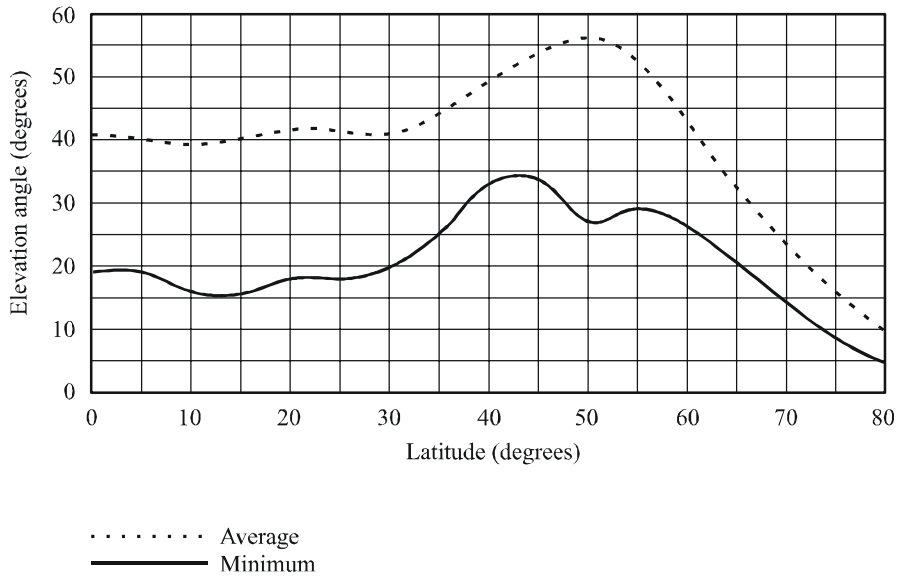


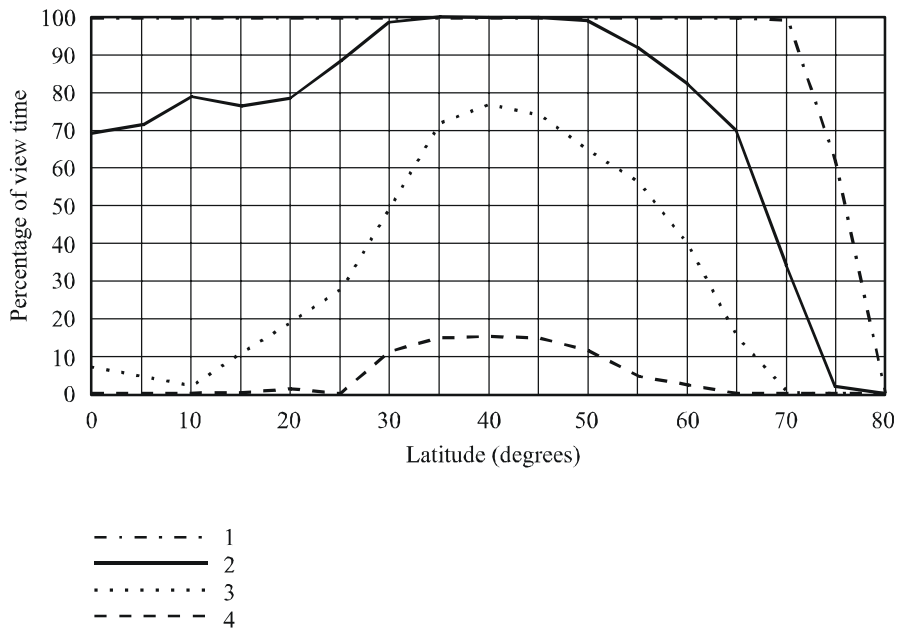
FIGURE 69  
**Minimum and average elevation angle distributions  
as a function of latitude**



1457-69

Figure 70 displays the percentage of the satellite-view time in terms of the number of satellites (1-4) as latitude increases, showing that the minimum elevation angle is 15°, the percentage of concurrent access to more than two satellites is more than 98% in the areas of latitude between 30° and 50°.

FIGURE 70  
**Percentage of time of visible satellites with  
minimum elevation angle above 15°**



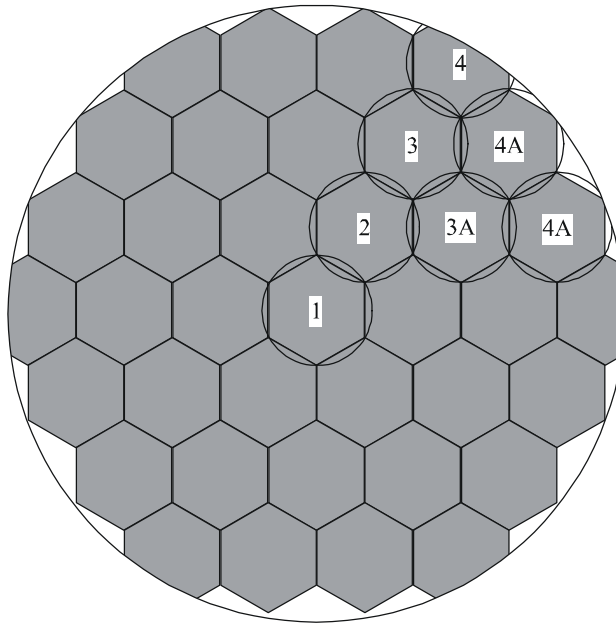
1457-70

### 6.3.3.1.2 Satellites

Each satellite provides the mobile link coverage for user terminal's through a set of 37 fixed spot beams with overlapping coverage. Figure 71 shows a set of spot-beam pattern obtained from a satellite whose radius is about 2 721.4 km. The diameter of each beam is described in Table 23. It takes about 16 min to path through a satellite coverage.

FIGURE 71

Spot-beam pattern of one satellite



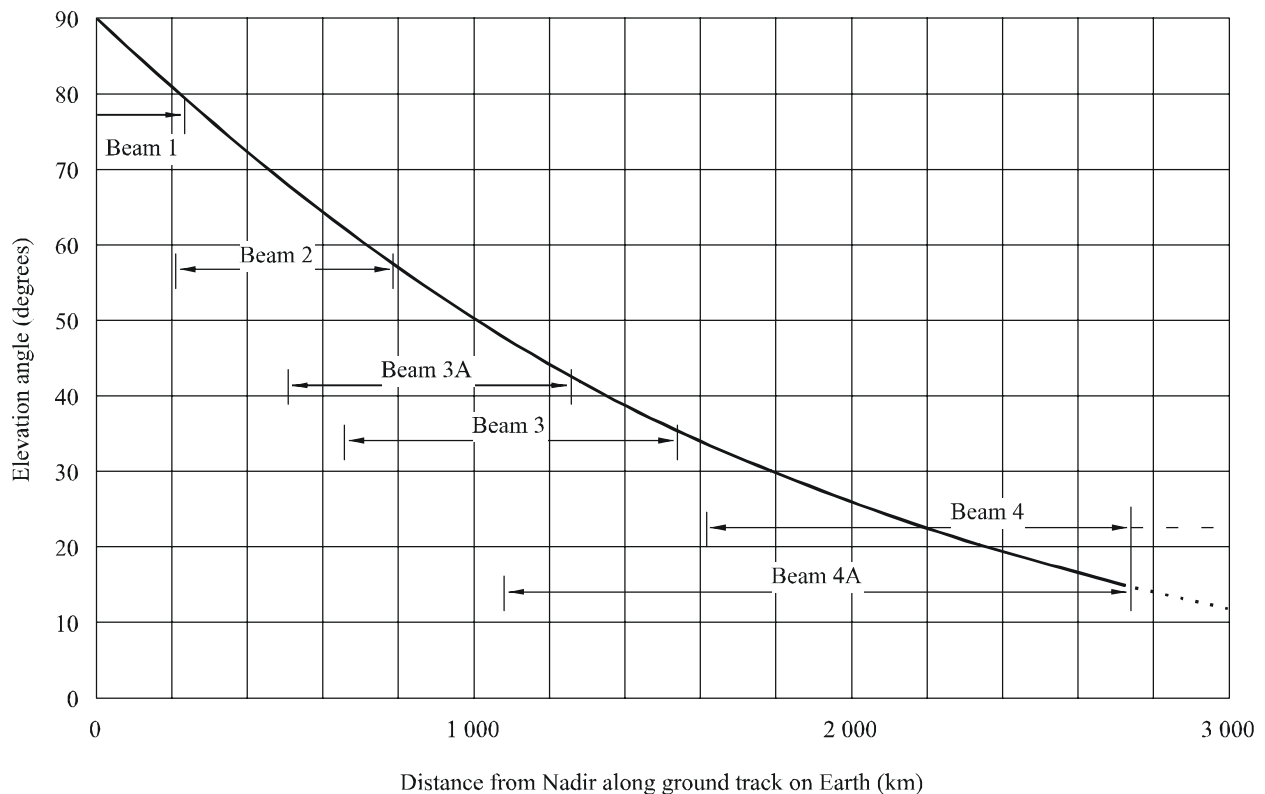
1457-71

TABLE 23

Spot beam size

Spot beam type	Spot beam size (km)
1	519.6
2	584.6
3A	763.8
3	893.1
4	1 310.1
4A	1 654.0

FIGURE 72  
Spot beam position from Nadir on Earth and provided elevation angle



1457-72

### 6.3.3.2 System description

#### 6.3.3.2.1 Service features

##### 6.3.3.2.1.1 Basic bearer services

Basic bearer services to be supported by SAT-CDMA include voice and data communications in which data rates are from 2.4 kbit/s to 64 kbit/s.

##### 6.3.3.2.1.2 Packet data services

Packet data services will be provided at the data rates which are from 2.4 kbit/s to 144 kbit/s.

##### 6.3.3.2.1.3 Teleservices

Teleservices include speech transmission such as emergency calls, short message service, facsimile transmission, video telephony service, paging service, etc.

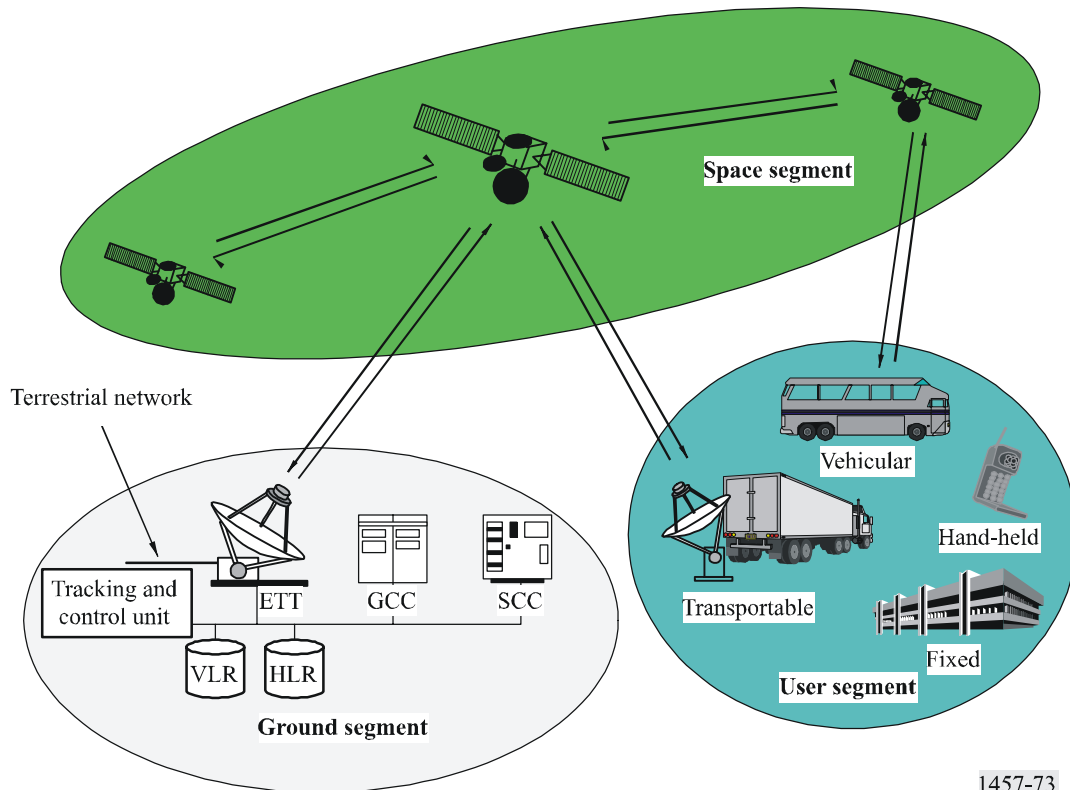
##### 6.3.3.2.1.4 Deep paging service

Deep paging service will be provided for contacting the mobile terminal user located in areas such as deep space in buildings where normal services cannot be provided.

#### 6.3.3.2.2 System features

The SAT-CDMA system comprises three elements: space segment, user segment, and ground segment. Figure 73 illustrates the system architecture.

FIGURE 73  
System architecture



1457-73

The space segment includes the satellite constellation which comprises 48 satellites in 1 600 km LEO. The satellites are arranged in 8 orbital planes with 54° inclination. Each orbital plane comprises 6 equally spaced satellites. Satellites complete an orbit every 118.2 min.

The satellite payload consists of transponders with on-board processing units and provides the mobile links for user terminals at 2.5 GHz band, the feeder links for gateways at 4/6 GHz band and the inter-satellite links at 60 GHz band.

The ground segment comprises LES, satellite control centres (SCC), and ground control centre (GCC).

### 6.3.3.2.3 Terminal features

In user terminal types, there are hand-held units, transportable units, vehicular units, and fixed units.

TABLE 24

#### Mobility restrictions for each terminal type

Terminal type	Applied service data rate (kbit/s)	Nominal mobility restriction (km/h)
Hand-held	2.4-16	500
Vehicular	2.4-32	500 (maximum 1 000)
Transportable	2.4-64	0
Fixed	2.4-144	0

#### **6.3.3.2.4 Handover**

The SAT-CDMA will support handover of communications from one satellite radio channel to another. The handover strategy is mobile-assisted network-decided handover.

##### **6.3.3.2.4.1 Inter-beam handover**

This is required when the MES moves from the coverage of one beam to another due to MES or satellite movement. MES monitors the pilot signal levels from adjacent beams and reports to the network pilots crossing or above a given set of thresholds. Based on this information and the knowledge of satellite ephemeris, the network may decide to transmit the same information through two different beams and orders the MES to demodulate the additional signals. Coherent combining of the different signal is performed in the MES by maximum ratio combining (MRC) technique. As soon as the network obtains confirmation from the MES that the new signal is received, it releases the old channel.

##### **6.3.3.2.4.2 Inter-satellite handover**

Inter-satellite handover is required when the MES and LES are both in the coverage overlap area of two more satellites and communication has to be transferred from one satellite to another to keep continuity of connection from MES to LES and to path diversity. MES has two more resources allocated on different satellites and monitors the pilot signal levels from adjacent satellites and reports to the network. Based on this information and the knowledge of satellite ephemeris, the network may decide to transmit the same information through two more different satellites and orders the MES to demodulate the additional signals. In this case satellite path diversity is exploited. When visibility of the first satellite is lost inter-satellite handover is required, and then the first channel may be released after the new satellite has been acquired.

##### **6.3.3.2.4.3 Inter-LES handover**

In the event that a satellite handover is required but the new satellite is not in contact with the same LES as the old satellite a simultaneous LES-to-LES handover is required.

The inter-LES handover shall be negotiated between the LES. The new LES start transmitting its carrier toward the MES that is simultaneously ordered by the old LES to search for the new LES signal. When the old LES obtains confirmation from the MES that the new signal is received from the new one, the old LES stops transmitting towards the MES.

##### **6.3.3.2.5 Satellite diversity**

In normal situations the MES has an unobstructed view of the satellite and gets a clear direct line-of-sight signal unlike typical terrestrial links. There is also a multi-path signal reflecting off the ground and nearby objects, which makes the resulting signal a direct plus diffuse reflection Rician signal. However, this multi-path is diffuse and all reflecting from a relatively short distance away. Such multi-path cannot be resolved in a well-known way of RAKE receiver link terrestrial cellular. Fortunately, this diffuse multi-path energy is usually quite small. Despite the fact that the RAKE receiver is not effective to combat multi-path, it is nonetheless invaluable.

From the fact that there exist coverage zones by beams of at least two different satellites in the SAT-CDMA system, each satellite may be assigned to an MES receiver in the forward direction and the power of the two satellites is effectively combined by the maximal ratio combining technique.

This multiple satellite diversity plays a two-fold role. First, it reduces the probability of shadowing by increasing the chance of having at least one satellite in a clear line-of-sight. In addition, it introduces artificial multi-path, which enable use of called artificial RAKE receiver in the MES's receiver. There is a classical diversity advantage, that is, not only the mean received power increased but also the fluctuations around the mean are decreased.

### 6.3.3.3 RF specifications

#### 6.3.3.3.1 User terminal

The hand-held user terminal (UT) will provide voice and low-rate data services to personal communications users.

The hand-held UT antenna has a near omnidirectional gain profile over a hemisphere. The maximum e.i.r.p. requirement is determined by user safety requirements. The  $G/T$  is determined by the need to have a near omnidirectional antenna. The maximum data bit rate to be supported by a hand-held terminal can be specified as 16 kbit/s.

Vehicle mounted terminals are physically mounted in a vehicle. The antenna is mounted outside the vehicle and where power to the terminal is supplied by physical connection to the vehicle. Hand-held and portable terminals could be used within vehicles and certain terminals may be designed to be dual mode (hand-held/vehicle mounted or portable/vehicle mounted). The vehicle can be a car, motorcycle, truck, bus, train, ship, aircraft.

The maximum data bit rate to be supported by a vehicular terminal can be specified as 32 kbit/s.

These are large heavy MS that cannot be hand carried and whose power is generally supplied from some external source. A moveable terminal may operate as a fixed terminal since it may be taken to a location and may be switched on in order to operate. The maximum data bit rate to be supported by a transportable terminal can be specified as 64 kbit/s.

These operate from a fixed location and power is usually provided by an external source. Fixed terminals may be used to allow the provision of services to fixed terminal equipment and to connect private branch exchanges (PBXs). Fixed terminals may also operate as docking station for laptop PCs.

TABLE 25  
UT characteristics

Terminal type	Hand-held	Vehicular	Transportable	Fixed
Maximum e.i.r.p. (dBW)	2.0	15.8	21.0	36.0
Maximum power (W)	1.0	14.8	17	20.0
Antenna gain (dBi)	2.0	2.0	4.0	23.0
Receiver temperature (K)	300	300	300	500
$G/T$ (dB/K)	-22.8	-22.8	-20.8	-4.0



**6.3.3.3.2 Satellite**

TABLE 26

**Satellite information**

Nominal e.i.r.p. (dBW)	9.6
Rx antenna gain (dBi)	20
Noise temperature (K)	500
$G/T$ (dB/K)	-7.0

**6.3.3.3.3 Channel bandwidth**

The channel bandwidth is approximately 5 MHz.

**6.3.3.3.4 Power control**

The pre-defined step size of power control is 0.25 dB and 1 dB. Because of the limitation of the hand-held terminal amplifier, the dynamic range of power control is expected to be less than 20 dB.

The long round trip delays (maximum 21.52 ms in the slant range of SAT-CDMA with 1 600 km altitude) could limit the action of fast closed-loop power control. However, it would be sufficient to provide one power control command (2-bit) per 10 ms frame.

**6.3.3.3.5 Frequency stability**

The uplink and downlink frequency stabilities are 1 and 0.1 ppm, respectively.

**6.3.3.3.6 Doppler compensation**

In SAT-CDMA, compensation for Doppler shift is performed simultaneously at the transmitter (pre-compensation) and at the receiver (post-compensation).

The pre-compensation is required due to the limitation of the post-compensation and mitigates the burden of the post-compensation. The Doppler shift is compensated for by controlling the transmit frequency according to the prediction from the knowledge of the positions of the transmitter and the receiver as well as the position and velocity of the satellite.

The post-compensation requires two stages of carrier frequency recovery procedures: coarse and fine compensation.

The coarse compensation is performed simultaneously with the PN code timing acquisition since one of the two is easily resolved after the other is achieved. It is recommended to employ a two-dimensional search algorithm for the acquisition of both PN code timing and Doppler shift. It computes the spectrum of the de-spread signal using FFT and coarsely estimates the Doppler shift by detecting the frequency of the maximum signal power at the FFT output. PN code timing acquisition is performed by searching for a PN code timing for which the maximum signal power exceeds a given threshold.

For fine Doppler shift compensation, a closed-loop structure is recommended and it is recommended to employ the FFT-based frequency domain frequency detection algorithm since it minimizes the circuit complexity and power consumption when incorporated with the aforementioned two-dimensional search algorithm.

**6.3.3.3.7 Terminal transmitter/receiver isolation**

The isolation level required to independently operate the transmitter part and receiver part of the terminal may be above 110 dB.

### 6.3.3.3.8 Fade margin

At low elevations the signal level generally varies between  $-7$  dB below and  $+4$  dB above the nominal level due to a combination of diffuse (arising from multiple reflections) and specular (arising from a single ground reflection) components. At higher elevations the variation is less. For a moving car, fade duration of 100-200 ms are typical. Occasionally fades of  $-10$  dB below the nominal level occur at very low elevation, ( $10^\circ$  to  $20^\circ$ ) particularly in a suburban environment, where specular multipath dominates. In such case an absolutely fixed user can experience fades of 10 to 20 s duration.

### 6.3.3.4 Baseband specifications

#### 6.3.3.4.1 Channel structure

##### 6.3.3.4.1.1 Transport channel

###### 6.3.3.4.1.1.1 Common channel

###### *Broadcast Channel (BCH)*

BCH is a downlink channel for broadcasting system control information for each beam to MES.

###### *Paging Channel (PCH)*

PCH is a downlink channel used to carry control information to MES when the system does not know which beam the MES belongs to. The PCH is associated with physical-layer generated paging indicators, to support efficient sleep-mode procedures.

###### *Forward Access Channel (FACH)*

FACH is a downlink channel used to carry user or control information to MES. This channel is used when the system knows which beam the MES belongs to.

###### *Downlink Shared Channel (DSCH)*

DSCH is a downlink channel shared by several MESs and associated with one or several downlink DCH.

###### *Random Access Channel (RACH)*

RACH is an uplink channel used to carry user or control information from MES to LES.

###### *Common Packet Channel (CPCH)*

CPCH is an uplink channel used to carry user information from MES to LES. CPCH is associated with a downlink common control channel that provides power control and CPCH control commands.

##### 6.3.3.4.1.1.2 Dedicated channel (DCH)

The DCH is a downlink or uplink channel transmitted over the entire beam or over only a part of the beam.

##### 6.3.3.4.1.2 Physical channel

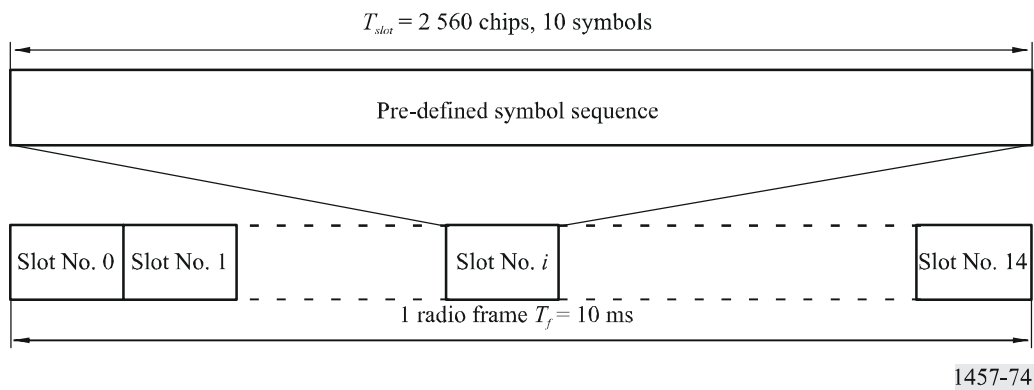
###### 6.3.3.4.1.2.1 Downlink physical channel

###### 6.3.3.4.1.2.1.1 Common pilot channel (CPICH)

The CPICH is a fixed rate (30 kbit/s, SF = 256) downlink physical channel that carries a predefined symbol sequence. Every symbol in the sequence is  $1+j$ . Figure 74 shows the frame structure of the CPICH. There are two types of common pilot channels, the primary and secondary CPICH

(S-CPICH). The primary CPICH is scrambled by the primary scrambling code and is the phase reference for the following downlink physical channels: SCH, P-CCPCH, AICH, PICH, APA/CD/CA-ICH, CSICH, and the S-CCPCH. The same channelization code of SF (Spreading Factor) = 256 is used for the P-CPICH. There is one and only one P-CPICH per beam. A secondary CPICH is scrambled by either the primary or a secondary scrambling code and may be the reference for the downlink DPCH. An arbitrary channelization code of SF = 256 is used for the S-CPICH. There may be zero, one, or several S-CPICH per beam.

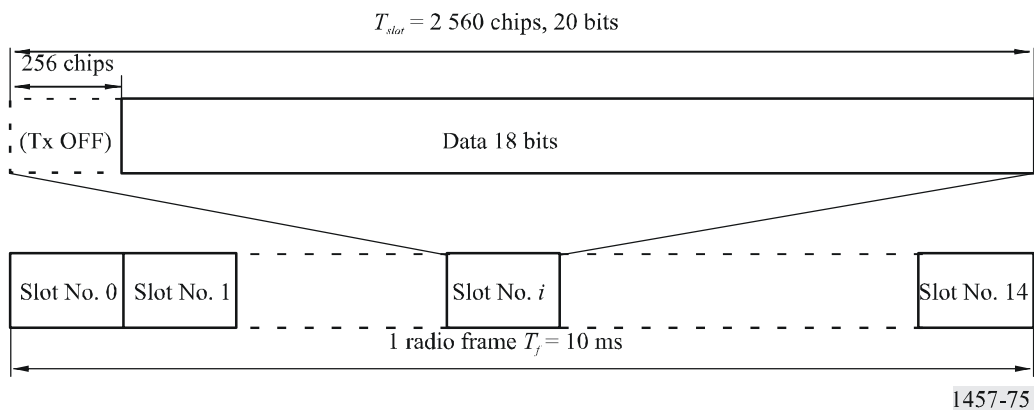
FIGURE 74  
 Frame structure for common pilot channel (CPICH)



**6.3.3.4.1.2.1.2 Primary common control physical channel (P-CCPCH)**

The P-CCPCH is a fixed rate (30 kbit/s) downlink channel used to carry the BCH. Figure 75 shows the frame structure of the Primary CCPCH. The P-CCPCH is not transmitted during the first 256 chips of each slot. Instead, Primary SCH and Secondary SCH are transmitted during this period.

FIGURE 75  
 Frame structure for primary common control physical channel (P-CCPCH)

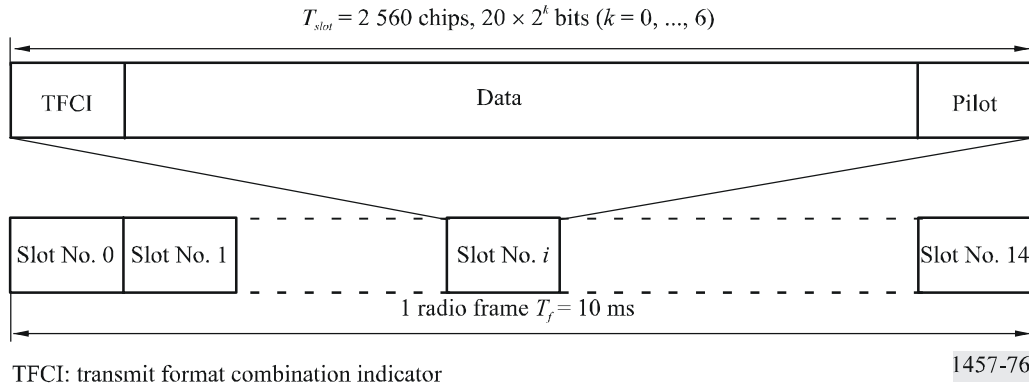


**6.3.3.4.1.2.1.3 Secondary common control physical channel (S-CCPCH)**

The S-CCPCH is used to carry the PCH and the FACH. The frame structure of the secondary CCPCH is shown in Fig. 76. The transport-format combination indicator (TFCI) informs the receiver of the instantaneous transport format combination of the transport channels mapped to the S-CCPCH radio frame. The parameter  $k$  in Fig. 76 determines the total number of bits per downlink secondary CCPCH slot. It is related to the spreading factor SF of the physical channel as

SF = 256/2<sup>k</sup>. The spreading factor ranges from 256 down to 4. The FACH and PCH can be mapped to the same or to separate secondary CCPCHs.

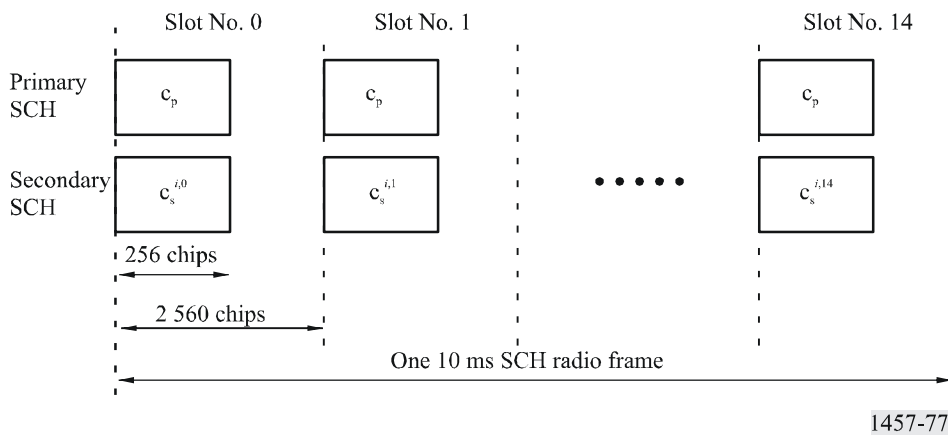
FIGURE 76  
 Frame structure for secondary common control physical channel (S-CCPCH)



**6.3.3.4.1.2.1.4 Synchronization channel (SCH)**

The SCH is a downlink signal used for beam search. The SCH consists of two sub-channels, the primary SCH and the secondary SCH. The 10 ms radio frames of the primary and secondary SCH are divided into 15 slots, each of length 2 560 chips. Figure 77 illustrates the structure of the SCH radio frame. The primary SCH consists of a modulated code of length 256 chips, the Primary Synchronization Code (PSC) denoted by  $c_p$  in Fig. 77, transmitted once every slot. The PSC is the same for every beam in the system. The secondary SCH consists of repeatedly transmitting a length 15 sequence of modulated codes of length 256 chips, the Secondary Synchronization Codes (SSC). The SSC is denoted by  $c_s^{i,k}$  in Fig. 77, where  $i = 0, 1, \dots, 63$  is the scrambling code group number, and  $k = 0, 1, \dots, 14$  is the slot number. Each SSC is chosen from a set of 16 different codes of length 256. This sequence on the secondary SCH indicates to which code group the downlink scrambling code of the beam belongs.

FIGURE 77  
 Structure of synchronization channel (SCH)



**6.3.3.4.1.2.1.5 Physical downlink shared channel (PDSCH)**

The PDSCH is used to carry the DSCH.

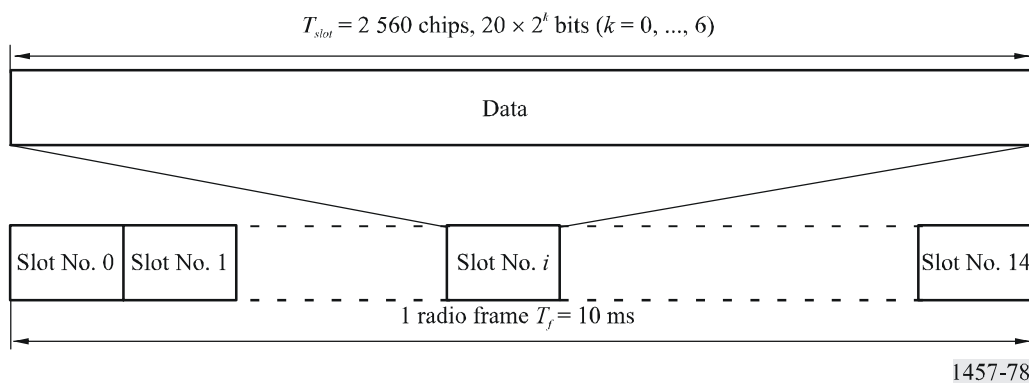
A PDSCH is allocated on a radio frame basis to a single MES. Within one radio frame, satellite-radio access network (SRAN) may allocate different PDSCHs under the same PDSCH root

channelization code to different MESs based on code multiplexing. Within the same radio frame, multiple parallel PDSCHs, with the same spreading factor, may be allocated to a single MES.

The frame and slot structure of the PDSCH are shown on Fig. 78. The spreading factors may vary from 4 to 256.

For each radio frame, each PDSCH is associated with one downlink DPCH. All relevant Layer 1 control information is transmitted on the DPCCH part of the associated DPCH.

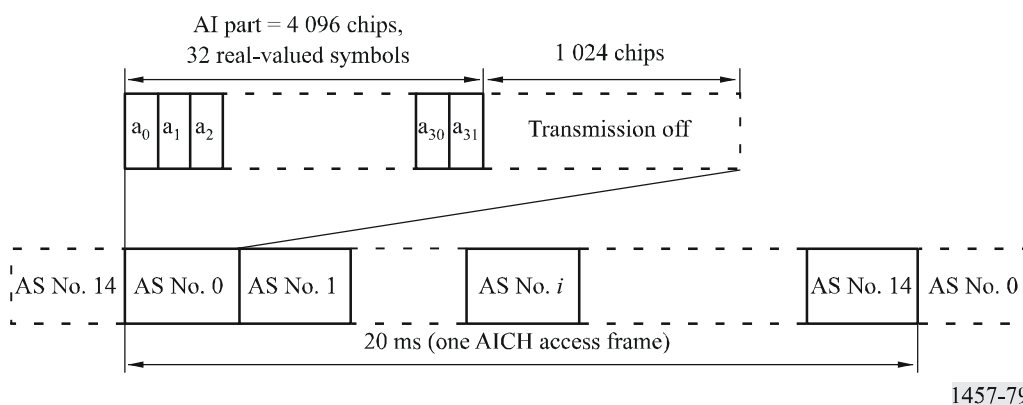
FIGURE 78  
Frame structure for physical downlink shared channel (PDSCH)



### 6.3.3.4.1.2.1.6 Acquisition indicator channel (AICH)

The AICH is a fixed rate (30 kbit/s) physical channel used to carry acquisition indicators (AIs). The AI corresponds to the signature on the PRACH. Figure 79 illustrates the structure of the AICH. The AICH consists of a repeated sequence of 15 consecutive access slots (ASs), each of length 5 120 chips. Each access slot consists of two parts, an AI part of duration 4 096 chips and a part of duration 1 024 chips with no transmission. When sub-access frames are not used for the PRACH, the Acquisition Indicator part for the PRACH is transmitted only on the first access slot (AS No. 0). The AICH is not transmitted during the remaining 14 access slots. When sub-access frames are used for the PRACH, the AI part is transmitted only on the first access slot (AS No. 0) and the ninth access slot (AS No. 8). The AI part of the first access slot carries the AI corresponding to the signature of PRACH preamble transmitted at the even sub-access frame. The AI part of the ninth access slot carries the AI corresponding to the signature of PRACH preamble transmitted at the odd sub-access frame.

FIGURE 79  
Structure of acquisition indicator channel (AICH)

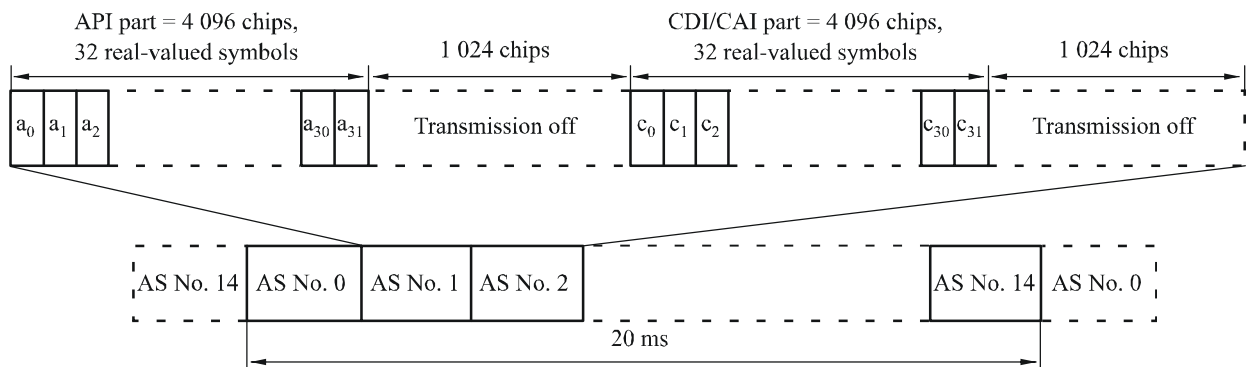


**6.3.3.4.1.2.1.7 CPCH Access Preamble Acquisition/Collision Detection/Channel Assignment Indicator Channel (APA/CD/CA-ICH)**

The APA/CD/CA-ICH is a fixed rate (30 kbit/s) physical channel used to carry AP Acquisition Indicators (API) and CD Indicator/CA Indicator (CDI/CAI) of CPCH. APA/CD/CA-ICH and AICH may use the same or different channelization codes. The structure of APA/CD/CA-ICH is shown in Figure 80. The APA/CD/CA-ICH has a part of duration 4 096 chips where either the API or the CDI/CAI is transmitted, followed by a part of duration 1 024 chips with no transmission. When sub-access frames are not used for the PRACH, the APA/CD/CA-ICH is not transmitted on the first access slot (AS No. 0). A pair of the API and the CDI/CAI is transmitted on the API/CDI/CAI part over two consecutive access slots after the first access slot. One or several (up to seven) pairs of the API and the CDI/CAI can be transmitted on each AICH frame. When sub-access frames are used for the PRACH, the APA/CD/CA-ICH is not transmitted on the first access slot (AS No. 0), the eighth access slot (AS No. 7) and the ninth access slot (AS No. 8). A pair of the API and the CDI/CAI is transmitted on the API/CDI/CAI part over two consecutive access slots. Three pairs of AS No. 1/AS No. 2, AS No. 3/AS No. 4, and AS No. 5/AS No. 6 carry the API and CDI/CAI corresponding to the PCPCH preamble transmitted at the even sub-access frame. Three pairs of AS No. 9/AS No. 10, AS No. 11/AS No. 12, and AS No. 13/AS No. 14 carry the API and CDI/CAI corresponding to the PCPCH preamble transmitted at the odd sub-access frame.

FIGURE 80

Structure of APA/CD/CA indicator channel (APA/CD/CA-ICH)

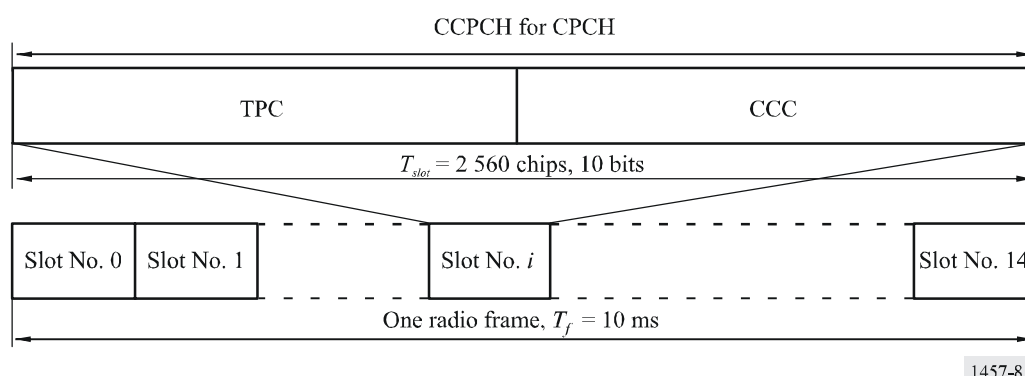


1457-80

**6.3.3.4.1.2.1.8 CPCH Common Control Physical Channel (CPCH-CCPCH)**

The CCPCH for CPCH is a fixed rate (30 kbit/s) downlink physical channel used to control the uplink PCPCH in a CPCH set. The spreading factor for downlink CPCH-CCPCH is 256. Figure 81 shows the frame structure of CPCH-CCPCH.

FIGURE 81  
Frame structure for downlink CPCH-CCPCH



1457-81

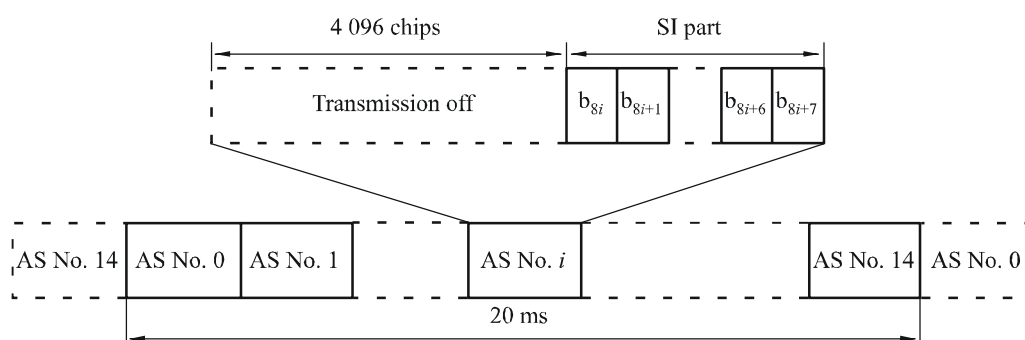
Each slot in the radio frame of the CPCH-CCPCH is associated to an uplink PCPCH in the CPCH set. There is a one-to-one mapping between slot No.  $i$  and  $i$ -th PCPCH in the CPCH set,  $i = 0, 1, \dots, 14$ . The slot is not transmitted if the associated PCPCH is not used on uplink.

Each slot of the CPCH-CCPCH consists of TPC command and CPCH Control Command (CCC). The CCC field and TPC field in each slot consists of 12 bits and 8 bits, respectively. The CCC pattern of 4-bit length used to support CPCH signalling to the associated PCPCH is bit-wisely repeated and mapped onto the CCC field. The TPC command of 2-bit length is bit-wisely repeated and mapped onto TPC field.

### 6.3.3.4.1.2.1.9 CPCH Status Indicator Channel (CSICH)

The CSICH is a fixed rate (30 kbit/s) physical channel used to carry CPCH status information. A CSICH is always associated with a physical channel used for transmission of APA/CD/CA-ICH and uses the same channelization and scrambling codes. Figure 82 illustrates the frame structure of the CSICH. The CSICH frame consists of 15 consecutive access slots (AS), each of length 40 bits. Each access slot consists of two parts, a part of duration 4 096 chips with no transmission and a Status Indicator (SI) part consisting of 8 bits.  $N$  Status Indicators shall be transmitted in each CSICH frame.

FIGURE 82  
Structure of CPCH status indicator channel (CSICH)



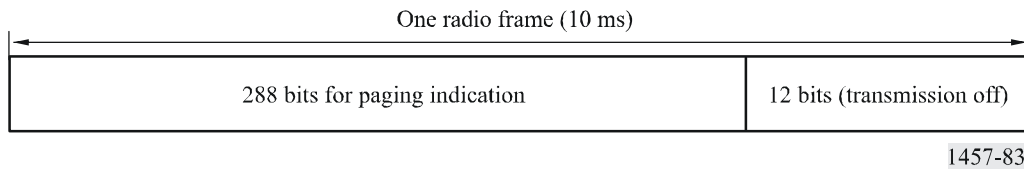
1457-82

### 6.3.3.4.1.2.1.10 Paging indicator channel (PICH)

The PICH is a fixed rate (30 kbit/s) physical channel used to carry the paging indicators (PIs). The PICH is always associated with an S-CCPCH to which a PCH transport channel is mapped.

Figure 83 illustrates the frame structure of the PICH. One PICH radio frame of length 10 ms consists of 300 bits. Of these, 288 bits are used to carry paging indicators. The remaining 12 bits are not formally part of the PICH and shall not be transmitted.

FIGURE 83  
Structure of paging indicator channel (PICH)



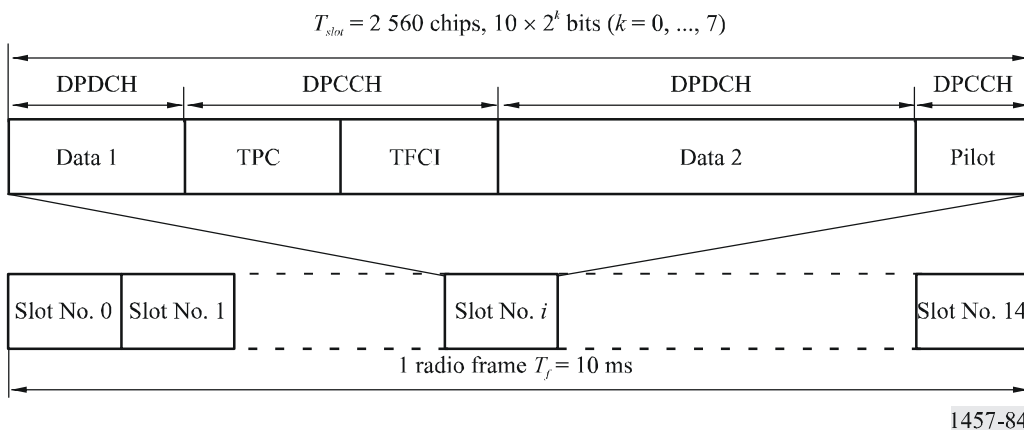
#### 6.3.3.4.1.2.1.11 Downlink dedicated physical channel (downlink DPCH)

Downlink DPCH is used to the dedicated transport channel (DCH). The spreading factor may range from 4 to 512.

Within one downlink DPCH, the DCH is transmitted in time-multiplex with control information generated at Layer 1 (known pilot bits and TFCI/TPC bits).

Figure 84 shows the frame structure of the downlink DPCH. Each frame of length 10 ms is split into 15 slots, each of length  $T_{slot} = 2\,560$  chips. Each radio frame corresponds to one power-control period.

FIGURE 84  
Frame structure of downlink DPCH



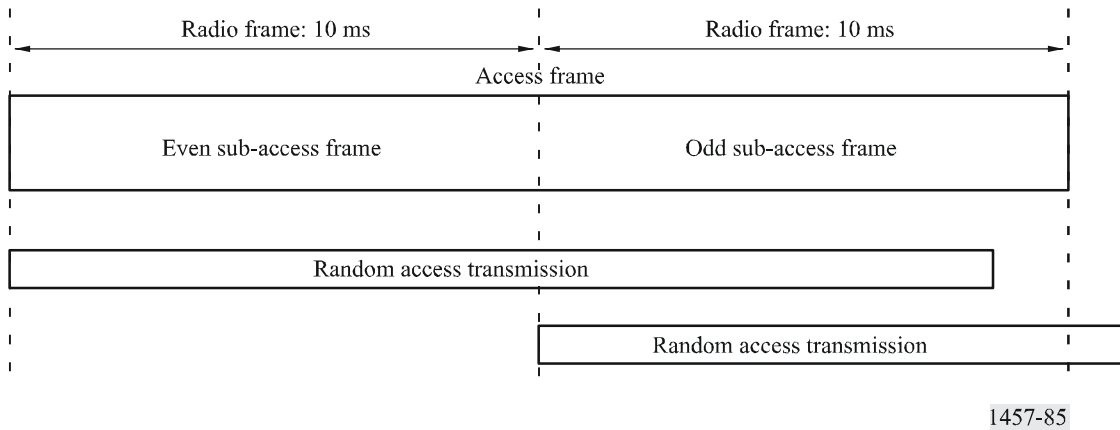
#### 6.3.3.4.1.2.2 Uplink physical channel

##### 6.3.3.4.1.2.2.1 Physical random access channel (PRACH)

The physical random access channel is used to carry the RACH. The random-access transmission is based on an ALOHA approach. The MES can start the random-access transmission at the beginning of a number of well-defined time intervals, denoted access frames. Each access frame has a length of two radio frames as shown in Fig. 85. Each access frame can consist of two sub-access frames, even sub-access frame and odd sub-access frame. The use of sub-access frames is optional. When the sub-access frames are used, the MES can start the random-access transmission at the beginning of either the even sub-access frame or the odd sub-access frame. The random access transmissions at the even sub-access frame and at the odd sub-access frame use different scrambling codes.

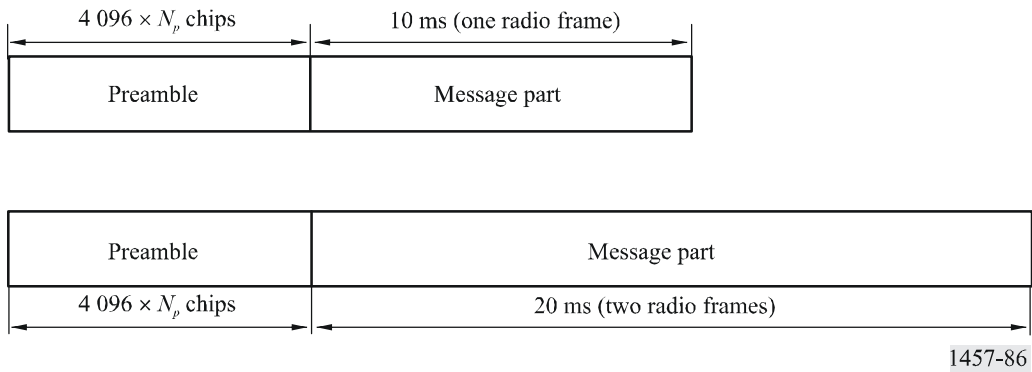


FIGURE 85  
Random access frame



The random access transmission consists of a preamble of length  $N_p \times 4\,096$  chips and a message of length 10 ms or 20 ms as illustrated in Fig. 86.

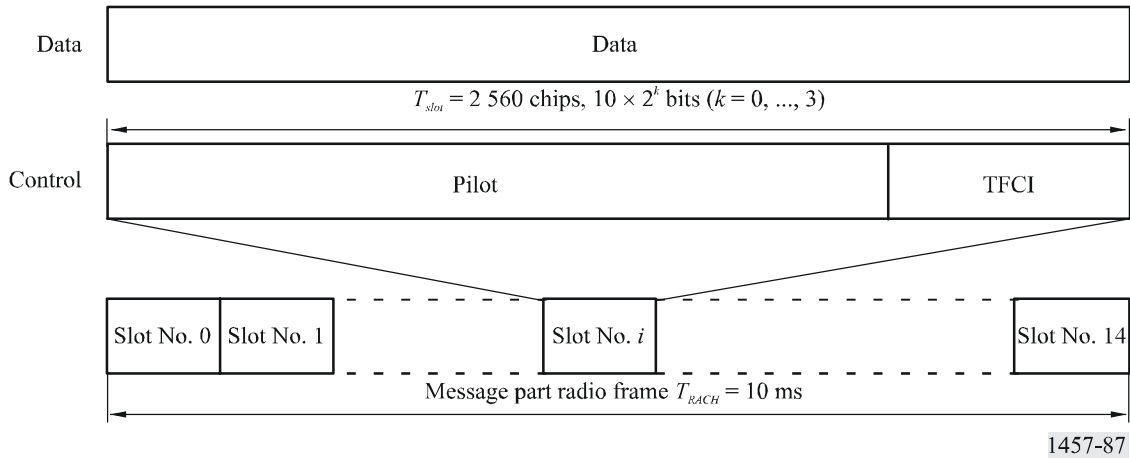
FIGURE 86  
Structure of the random access transmission



The preamble consists of  $N_p$  sub-preambles. The value of  $N_p$  is provided by high layers. The sub-preamble is of length 4 096 chips and consists of repetitions of a signature. Every sub-preamble has the identical length, signature and scrambling code. The last sub-preamble code is a conjugate of the code used in the previous sub-preambles.

Figure 87 shows the structure of the random-access message part. The message consists of 15 slots. Each slot is comprised of two parts, a Layer 2 information data part and a Layer 1 control part. The data part consists of  $10 \times 2^k$  bits, where  $k = 0, 1, 2, 3$ . This corresponds to a spreading factor of 256, 128, 64, and 32 respectively for the message data part. The control part consists of eight known pilot bits and two TFCI bits. The spreading factor for the control part of the CPCH message part shall be 256. The TFCI of a radio frame indicates the transport format of the RACH transport channel mapped to the simultaneously transmitted message part radio frame.

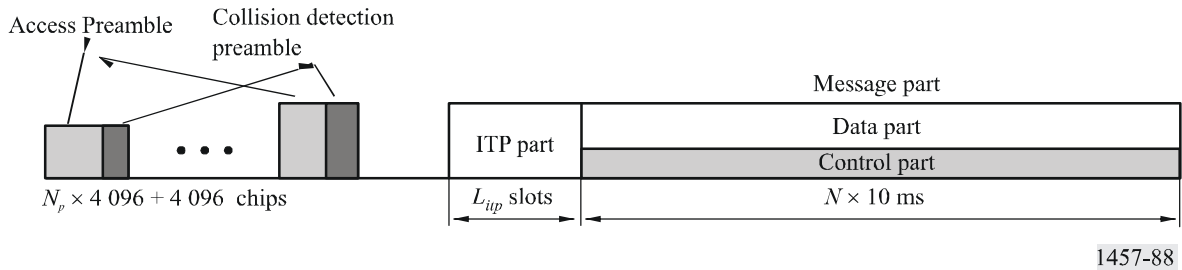
FIGURE 87  
Structure of the random access message part



6.3.3.4.1.2.2.2 Physical Common Packet Channel (PCPCH)

The PCPCH is used to carry the CPCH. The access frame timing and structure is identical to PRACH. The structure of the CPCH access transmission is shown in Fig. 88. The PCPCH access transmission consists of one or several pairs of Access Preambles (AP) of length  $N_p \times 4\,096$  chips, a Collision Detection Preamble (CDP) of length 4 096 chips, a Initial Transmission Preamble (ITP) of length  $L_{itp}$  slots, and a message of variable length  $N \times 10$  ms.

FIGURE 88  
Structure of the CPCH access transmission



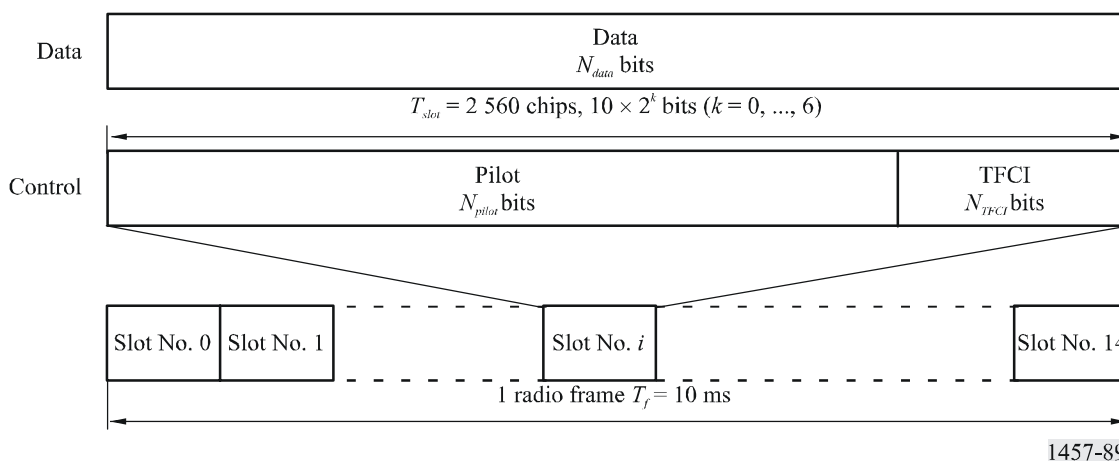
The structure of the AP part is identical to PRACH preamble part. The scrambling code could either be chosen to be a different scrambling code from the RACH preambles, or be the same scrambling code in case the signature set is shared.

The structure of the CDP part is identical to the PRACH sub-preamble. The scrambling code is the same code used for the CPCH access preamble part.

The ITP part consists of  $L_{itp}$  slots. The ITP length  $L_{itp}$  is a higher layer parameter. The slot format shall be the same as for the following message part.

Figure 89 shows the structure of the CPCH message part. Each message consists of up to  $N_{Max\_frames}$  frames where  $N_{Max\_frames}$  is a higher layer parameter. Each 10 ms frame is split into 15 slots, each of length  $T_{slot} = 2\,560$  chips. Each slot consists of two parts, a data part and a control part. The slot format of the control part of CPCH message part is identical to RACH message part. The data part consists of  $10 \times 2^k$  bits, where  $k = 0, 1, 2, 3, 4, 5, 6$ . This corresponds to spreading factors of 256, 128, 64, 32, 16, 8, 4 respectively.

FIGURE 89  
 Frame structure for uplink data and control parts associated with PCPCH



1457-89

### 6.3.3.4.1.2.2.3 Uplink dedicated physical channel (uplink DPCH)

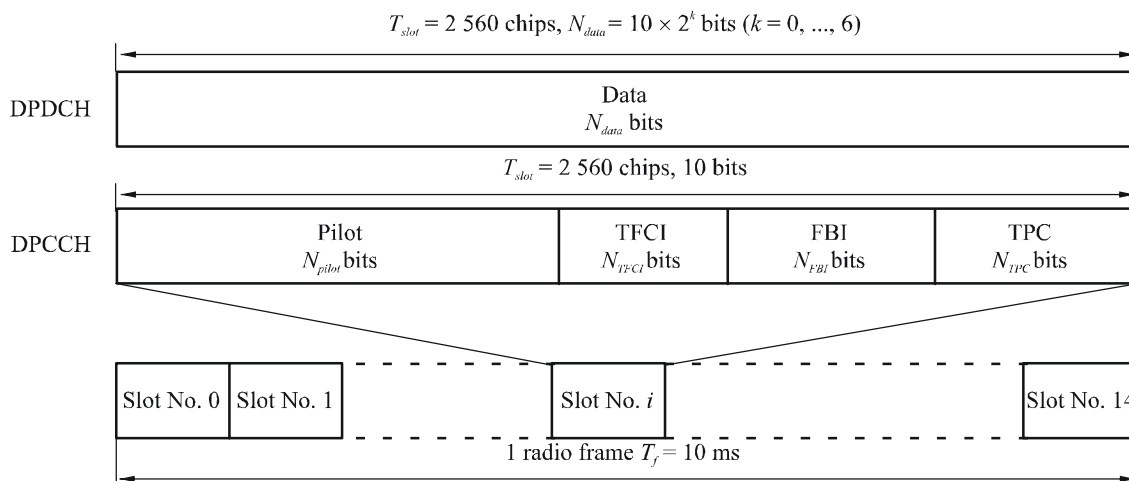
The uplink DPCH consists of the uplink dedicated physical data Channel (uplink DPDCH) and the uplink dedicated physical control channel (uplink DPCCH). The DPDCH and the DPCCH are I/Q code multiplexed within each radio frame.

The DPDCH is used to carry data generated at Layer 2 and above, and the DPCCH is used to carry dedicated control information generated at Layer 1. The DPDCH spreading factor may range from 256 down to 4. The spreading factor of the uplink DPCCH is always equal to 256.

Figure 90 shows the frame structure of the uplink DPCH. Each radio frame of length 10 ms is split into 15 slots, each of length 2 560 chips. Each radio frame corresponds to one power-control period. The parameter  $k$  in Fig. 90 determines the number of bits per uplink DPDCH slot. It is related to the spreading factor SF of the DPDCH as  $SF = 256/2^k$ .

The Layer 1 control information consists of known pilot bits to support channel estimation for coherent detection, transport-format combination indicator (TFCI), transmit power-control (TPC) commands, and an optional feedback information (FBI). The FBI bits are used to support the beam selection diversity transmission technique (BSDT) requiring feedback from the MES to the SRAN.

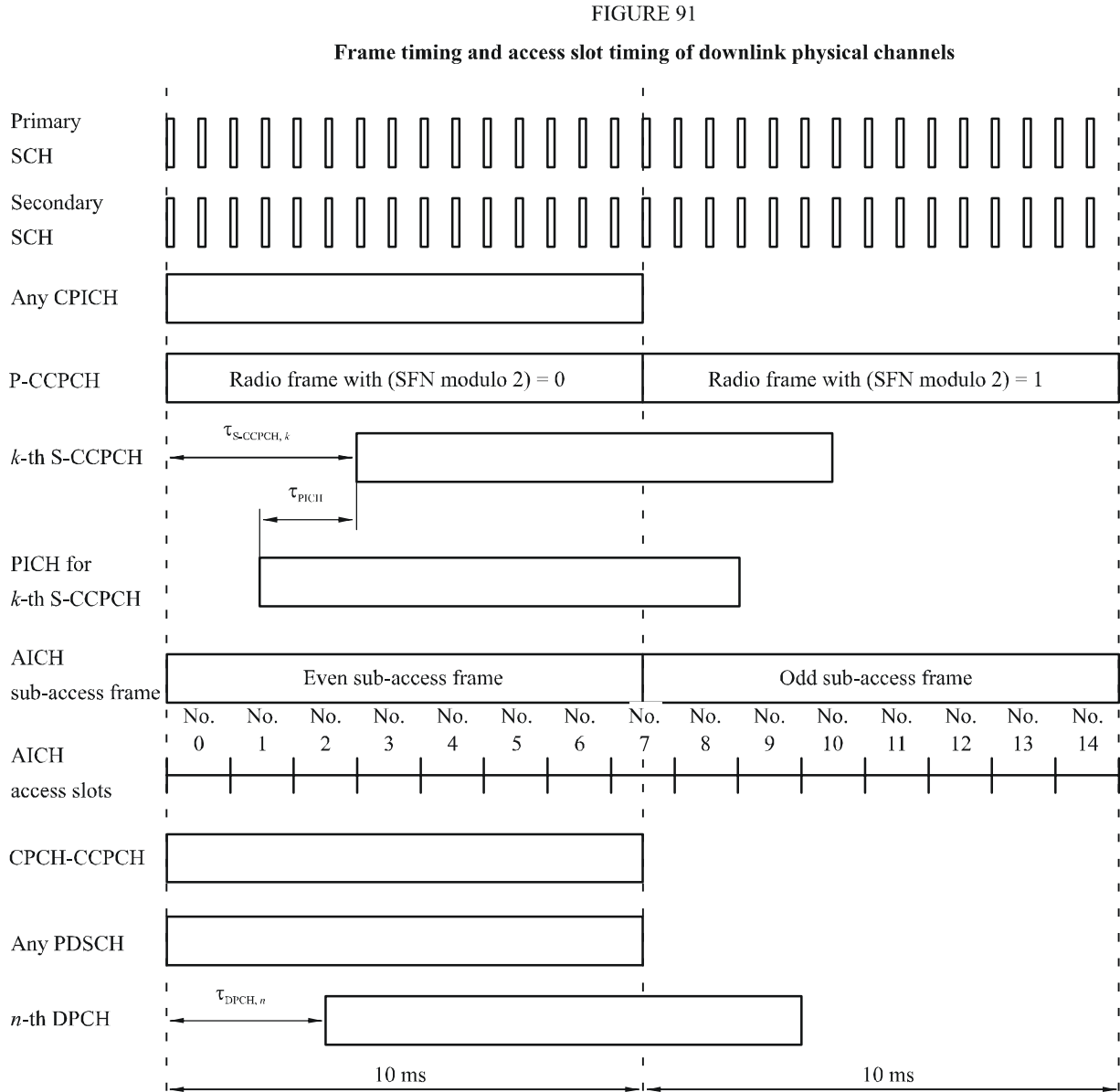
FIGURE 90  
 Frame structure of uplink DPCH



1457-90

6.3.3.4.1.3 Timing relationship between physical channels

The P-CCPCH, on which the beam SFN is transmitted, is used as timing reference for all the physical channels, directly for downlink and indirectly for uplink. Figure 91 describes the frame timing of the downlink physical channels.



1457-91

The SCH (primary and secondary), CPICH (primary and secondary), P-CCPCH, CPCH-CCPCH and PDSCH have identical frame timings. The S-CCPCH timing may be different for different S-CCPCHs, but the offset from the P-CCPCH frame timing is a multiple of 256 chips. The PICH timing is 7 680 chips prior to its corresponding S-CCPCH frame timing, i.e. the timing of the S-CCPCH carrying the PCH transport channel with the corresponding paging information. The AICH even sub-access frame has the identical timing to P-CCPCH frames with (SFN modulo 2) = 0, and the AICH odd sub-access frame has the identical timing to P-CCPCH frames with (SFN modulo 2) = 1. AICH access slots No. 0 starts the same time as P-CCPCH frames with (SFN modulo 2) = 0. The DPCH timing may be different for different DPCHs, but the offset from the P-CCPCH frame timing is a multiple of 256 chips.

### 6.3.3.4.1.3.1 PRACH/AICH timing relation

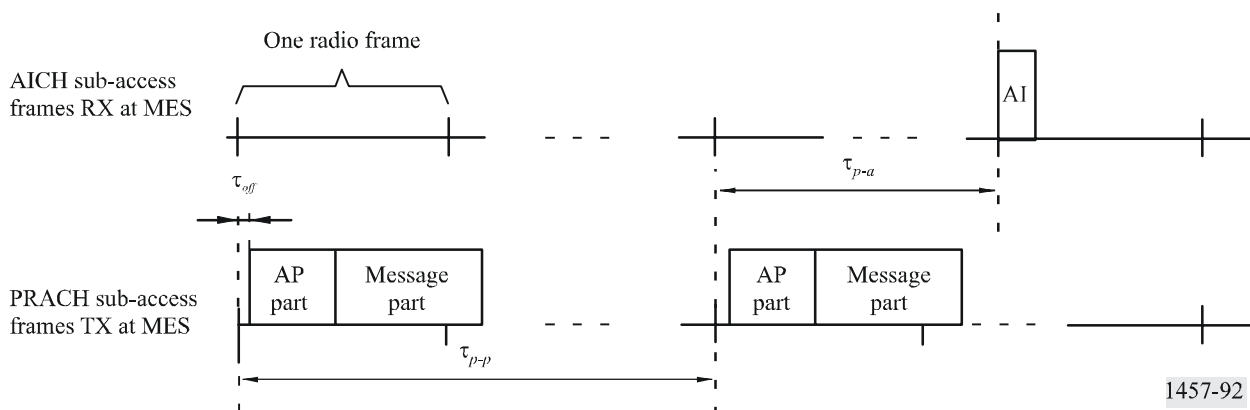
The downlink AICH access frames and sub-access frames are time-aligned with the P-CCPCH. The uplink PRACH access frame and sub-access frame are time-aligned with the reception of downlink AICH access frame and sub-access frame. Uplink access frame number  $n$  is transmitted from the MES  $\tau_{p-a}$  chips prior to the reception of downlink access frame number  $n$ ,  $n = 0, 1, \dots, 15$ . The PRACH/AICH timing relation is shown in Figure 92. The transmission offset  $\tau_{off}$  shall be a value between the range of  $-\tau_{off,max}$  to  $\tau_{off,max}$ , where  $\tau_{off,max}$  is Maximum Transmission Offset and is signalled by higher layers. The preamble-to-preamble distance  $\tau_{p-p}$  shall be larger than or equal to the minimum preamble-to-preamble distance  $\tau_{p-p,min}$ . In addition to  $\tau_{p-p,min}$ , the preamble-to-AI distance  $\tau_{p-a}$  is defined as follows:

- when AICH\_Transmission\_Timing is set to 0, then  $\tau_{p-p,min} = 230\ 400$  chips (six radio frames) and  $\tau_{p-a} = 153\ 600$  chips (four radio frames);
- when AICH\_Transmission\_Timing is set to 1, then  $\tau_{p-p,min} = 307\ 200$  chips (eight radio frames) and  $\tau_{p-a} = 230\ 400$  chips (six radio frames).

The parameter AICH\_Transmission\_Timing is signalled by higher layers.

FIGURE 92

Timing relation between PRACH and AICH as seen at the MES



### 6.3.3.4.1.3.2 PCPCH/AICH timing relation

The downlink APA/CD/CA-ICH access frames and sub-access frames are time aligned with the P-CCPCH. The uplink PCPCH access frame and sub-access frame are time aligned with the reception of downlink APA/CD/CA-ICH access frame and sub-access frame.

The timing relationships between AP/CDP and APA/CD/CA-ICH is identical to RACH Preamble and AICH. Note that the collision resolution preamble successively follows the access preamble without any gap. Figure 93 illustrates the PCPCH/AICH timing.

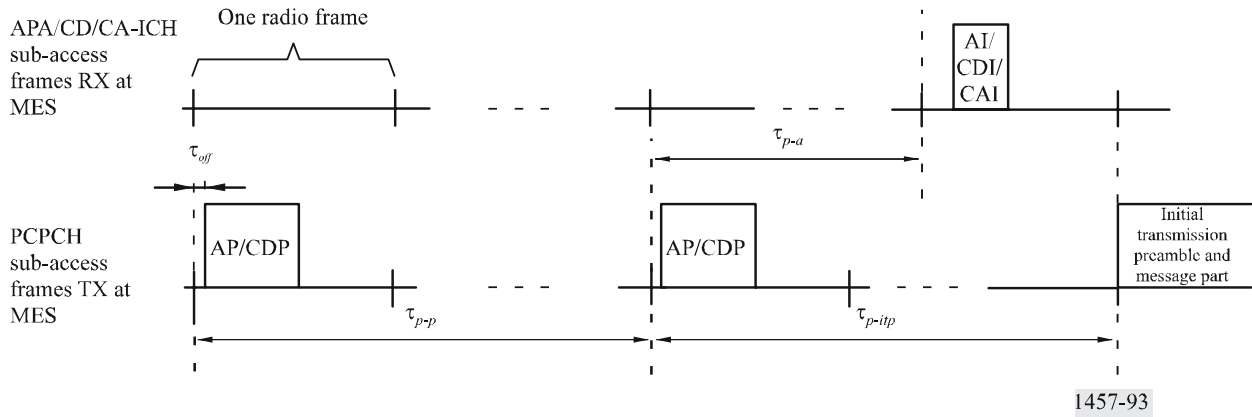
In addition to  $\tau_{p-p,min}$ , the preamble-to-AI distance  $\tau_{p-a}$  and preamble-to-ITP distance  $\tau_{p-itp}$  are defined as follows:

- when  $T_{cpch}$  is set to 0, then  $\tau_{p-p,min} = 230\ 400$  chips (six radio frames),  $\tau_{p-a} = 153\ 600$  chips (four radio frames) and  $\tau_{p-itp} = 230\ 400$  chips (six radio frames);
- when  $T_{cpch}$  is set to 1, then  $\tau_{p-p,min} = 307\ 200$  chips (eight radio frames),  $\tau_{p-a} = 230\ 400$  chips (six radio frames) and  $\tau_{p-itp} = 307\ 200$  chips (eight radio frames).

The  $T_{cpch}$  timing parameter is identical to the PRACH/AICH transmission timing parameter.

FIGURE 93

Timing relation between PCPCH and APA/CD/CA-ICH as seen at the MES



#### 6.3.3.4.1.3.3 PCPCH/CPCH-CCPCH timing relation

The start of the associated CPCH-CCPCH frame is received 38 400 chips prior to the transmission of PCPCH initial transmission preamble. The start of a CPCH-CCPCH frame is denoted  $T_{CPCH-CCPCH}$  and the start of the associated PCPCH message frame is denoted  $T_{PCPCH}$ . Any CPCH-CCPCH frame is associated to one PCPCH message frame through the relation,  $T_{PCPCH} - T_{CPCH-CCPCH} = 38\,400 + L_{itp} \times 2\,560$  chips.

#### 6.3.3.4.1.3.4 DPCH/PDSCH timing relation

The start of a DPCH frame is denoted  $T_{DPCH}$  and the start of the associated PDSCH frame is denoted  $T_{PDSCH}$ . Any DPCH frame is associated to one PDSCH frame through the relation  $46\,080 \text{ chips} \leq T_{PDSCH} - T_{DPCH} < 84\,480 \text{ chips}$ .

#### 6.3.3.4.1.3.5 DPCCH/DPDCH timing relations

At the MES, the uplink DPCCH/DPDCH frame transmission takes place approximately  $T_0$  chips after the reception of the first significant path of the corresponding downlink DPCCH/DPDCH frame.  $T_0$  is a constant defined to be  $38\,400 + 1\,024$  chips.

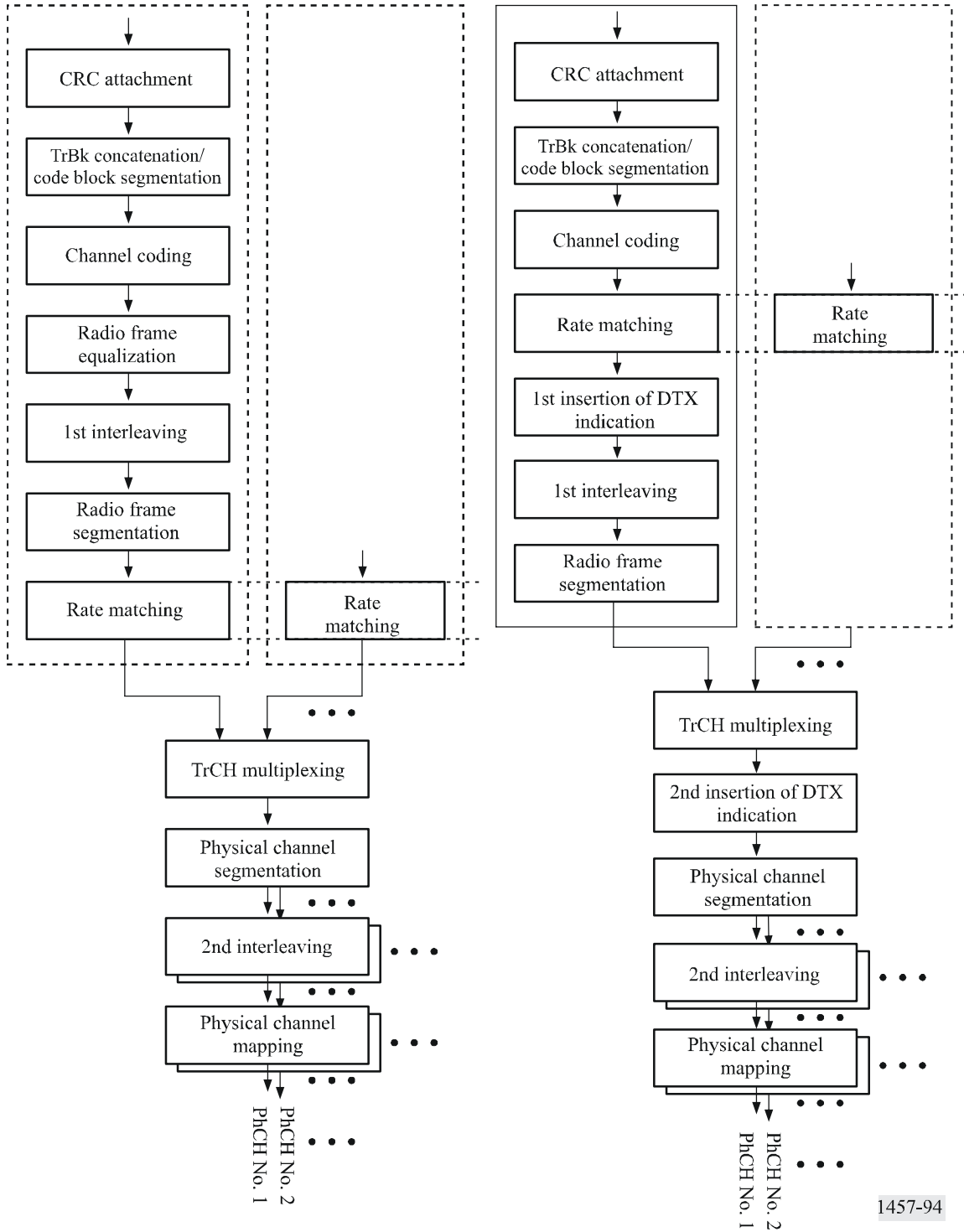
### 6.3.3.4.2 Channel coding and multiplexing

#### 6.3.3.4.2.1 Processing step

The coding and multiplexing steps are shown in Fig. 94, where TrBk denotes transport block and DTX denotes discontinuous transmission.

FIGURE 94

Processing steps for transport channel (TrCH) to physical channel (PhCH) (left: uplink, right: downlink)



### 6.3.3.4.2.2 Error detection

Error detection is provided on transport channel blocks through a CRC. The CRC is 24, 16, 12, 8 or 0 bits and it is signalled from higher layers which CRC length that should be used for each transport channel.

The entire transport block is used to calculate the CRC parity bits for each transport block. The parity bits are generated by one of the following cyclic generator polynomials:

- $G_{CRC24}(X) = X^{24} + X^{23} + X^6 + X^5 + X + 1$ ;
- $G_{CRC16}(X) = X^{16} + X^{12} + X^5 + 1$ ;
- $G_{CRC12}(X) = X^{12} + X^{11} + X^3 + X^2 + X + 1$ ;
- $G_{CRC8}(X) = X^8 + X^7 + X^4 + X^3 + X + 1$ .

### 6.3.3.4.2.3 Channel coding

For the channel coding in SAT-CDMA, two schemes can be applied:

- Convolutional coding;
- Turbo coding.

Channel coding selection is indicated by upper layers. In order to randomize transmission errors, symbol interleaving is performed further.

TABLE 27

Channel coding schemes for logical channels

Transport channel	Coding scheme	Coding rate
BCH	Convolutional coding	1/2
PCH		
RACH		1/3, 1/2
DCH, DSCH, FACH		
	Turbo coding	1/3

#### 6.3.3.4.2.3.1 Convolutional coding

Convolutional codes with constraint length 9 and coding rates 1/3 and 1/2 are defined.

The generator functions for the rate 1/3 code are  $G_0 = 557$  (OCT),  $G_1 = 663$  (OCT) and  $G_2 = 711$  (OCT).

The generator functions for the rate 1/2 code are  $G_0 = 561$  (OCT) and  $G_1 = 753$  (OCT).



FIGURE 95  
Rate 1/3, constraint length = 9 convolutional code generator

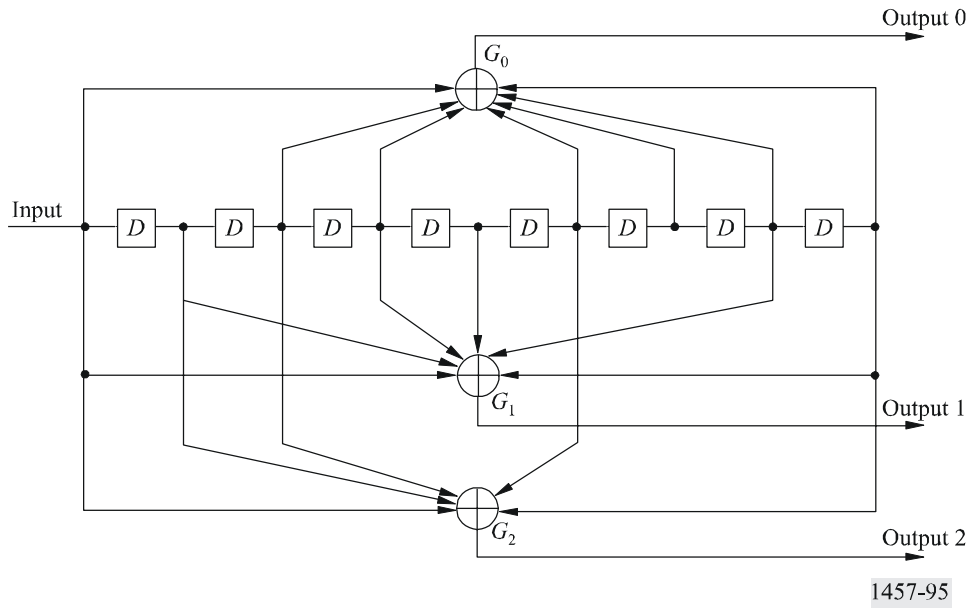
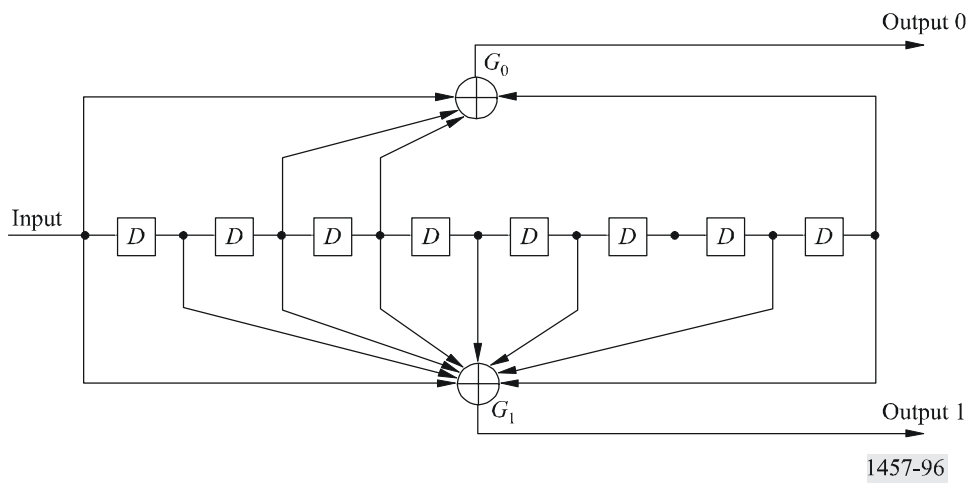


FIGURE 96  
Rate 1/2, constraint length = 9 convolutional code generator



**6.3.3.4.2.3.2 Turbo coding**

The scheme of turbo coder is a parallel concatenated convolutional code (PCCC) with two 8-state constituent encoders and one Turbo code internal interleaver. The coding rate of turbo coder is 1/3.

The transfer function of the 8-state constituent code for PCCC is:

$$G(D) = \left[ 1, \frac{g_1(D)}{g_0(D)} \right]$$

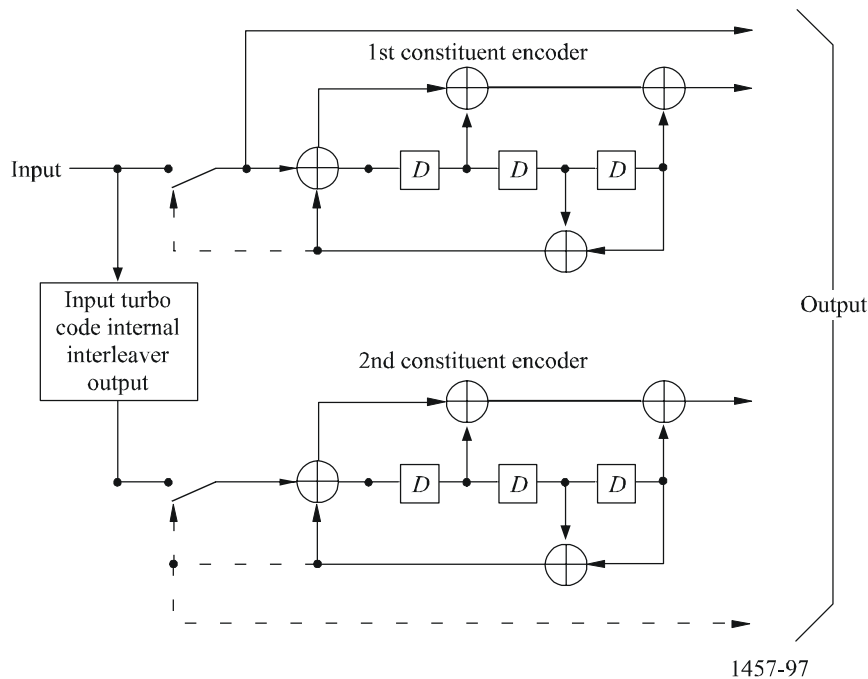
where:

$$g_0(D) = 1 + D^2 + D^3$$

$$g_1(D) = 1 + D + D^3.$$

FIGURE 97

Rate 1/3 turbo coder generator (dotted lines apply for trellis termination only)



#### 6.3.3.4.2.4 Interleaving

The 1st interleaver is a ( $M$ -row by  $N$ -column) block interleaver with inter-column permutations. The size of the 1st interleaver,  $M \times N$  is an integer multiple of transmission time interval (TTI).

The 2nd interleaver is a ( $M$ -row by  $N$ -column) block interleaver with inter-column permutations. The size of the 2nd interleaver,  $M \times N$  is the number of bits in one radio frame for one physical channel and the number of columns,  $N$  is 30. The inter-column permutation pattern is  $\langle 0, 20, 10, 5, 15, 25, 3, 13, 23, 8, 18, 28, 1, 11, 21, 6, 16, 26, 4, 14, 24, 19, 9, 29, 12, 2, 7, 22, 27, 17 \rangle$ .

#### 6.3.3.4.2.5 Rate matching

The number of bits on a transport channel can vary between different transmission time intervals. In uplink, bits on a transport channel are repeated or punctured to ensure that the total bit rate after transport channel multiplexing is identical to the total channel bit rate of the allocated DPCH. In downlink, the total bit rate after the transport channel multiplexing is less than or equal to the total channel bit rate given by the channelization code(s) assigned by higher layers. The transmission is interrupted if the number of bits is lower than maximum.

#### 6.3.3.4.2.6 Transport channel multiplexing

Every 10 ms, one radio frame from each transport channel is delivered to the transport channel multiplexing. These radio frames are serially multiplexed into a coded composite transport channel.

#### 6.3.3.4.2.7 TFCI coding

The TFCI is encoded using a (32, 10) sub-code of the second order Reed-Muller code. The code words are linear combination of 10 basis sequences. The TFCI information bits shall correspond to the TFC index defined by the RRC layer to refer the TFC of the associated DPCH radio frame.

If one of the DCH is associated with a DSCH, the TFCI code word may be split in such a way that the code word relevant for TFCI activity indication is not transmitted from every beam. The use of such a functionality shall be indicated by higher layer signalling. The TFCI is encoded using a (16, 5) bi-orthogonal (or first order Reed-Muller) code. The code words of the (16, 5) bi-orthogonal code are linear combinations of 5 basis sequences. The first set of TFCI information bits shall correspond to the TFC index defined by the RRC layer to refer the TFC of the DCH CCTrCH in the associated DPCH radio frame. The second set of TFCI information bits shall correspond to the TFC index defined by the RRC layer to refer the TFC of the associated DSCH in the corresponding PDSCH radio frame.

The bits of the code word are directly mapped to the slots of the radio frame. The coded bits  $b_k$ , are mapped to the transmitted TFCI bits  $d_k$ , according to  $d_k = b_{k \bmod 32}$ , where  $k = 0, \dots, K - 1$ . The number of bits available in TFCI fields of a radio frame,  $K$ , depends on the slot format used for the frame.

#### 6.3.3.4.2.8 TPC command coding

The 2-bit TPC command is encoded by repetition. The set of TPC command bits  $(a_0, a_1)$  shall correspond to the TPC command defined by the power control procedure. The output code word bits  $b_k$  are given by  $b_k = a_{k \bmod 2}$ , where  $k = 0, \dots, 15$ .

For both uplink and downlink channels, the bits of the code word are mapped to 15 slots of a radio frame. The coded bits  $b_k$ , are mapped to the transmitted TPC bits  $d_k$ , according to  $d_k = b_{k \bmod 15}$ , where  $k = 0, \dots, K - 1$ . The number of bits available in TPC fields of a radio frame,  $K$ , depends on the slot format used for the frame.

#### 6.3.3.4.3 Modulation and spreading

##### 6.3.3.4.3.1 Uplink spreading

The spreading modulation uses orthogonal complex QPSK (OCQPSK) for uplink channels.

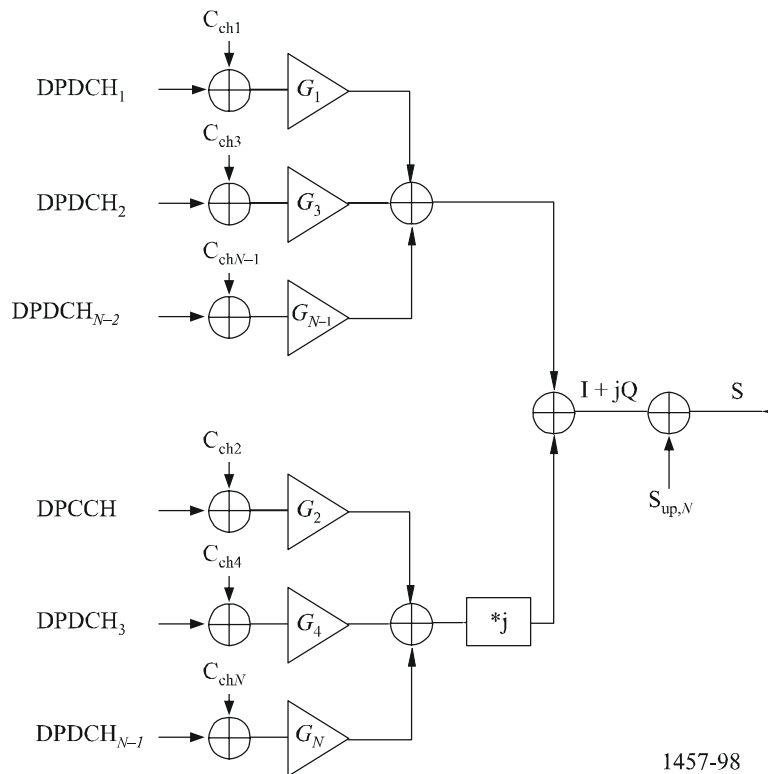
The spreading operation consists of two operations; short code spreading for channelization and long code spreading for scrambling.

Direct sequence spreading using the long code shall be applied to the uplink channel.

Figure 96 shows the configuration of the uplink-spreading. Channelization codes,  $C_{ch\ i}$ ,  $i = 1, 2, \dots, N$ , first spread one DPCCH channel and the DPDCH channels. Then the signals are adjusted by power gain factors,  $G_i$ , are added together both in I and Q branches, and are multiplied by a complex scrambling code  $S_{up,N}$ .

If only one DPDCH is needed, only the DPDCH<sub>1</sub> and the DPCCH are transmitted. In multi-code transmission, several DPDCHs are transmitted using I and Q branches.

FIGURE 98  
Spreading for uplink DPDCH/DPCCH



1457-98

The channelization codes for uplink DPCH are OVSF codes.

The long scrambling code is built from constituent long sequences  $c_{\text{long},1,n}$  and  $c_{\text{long},2,n}$ . The two sequences are obtained from position wise modulo 2 sum of 38 400 chip segments of two binary  $m$ -sequences  $x_n$  and  $y$ . The  $x_n$  sequence, which depends on the chosen scrambling sequence number  $n$ , is obtained from the  $m$ -sequence generator polynomial  $X^{25} + X^3 + 1$  and the  $y$  sequence is obtained from the generator polynomial  $X^{25} + X^3 + X^2 + X + 1$ .

The configuration of long code generator for uplink is presented in Fig. 99.

Define the binary Gold sequence  $z_n$  by:

$$z_n(i) = x_n(i) + y(i) \text{ modulo } 2, \quad i = 0, 1, 2, \dots, 2^{25} - 2.$$

These binary sequences are converted to real valued sequences  $Z_n$ . The real-valued long scrambling sequences  $c_{\text{long},1,n}$  and  $c_{\text{long},2,n}$  are defined as follows:

$$c_{\text{long},1,n}(i) = Z_n(i), \quad i = 0, 1, 2, \dots, 2^{25} - 2 \text{ and}$$

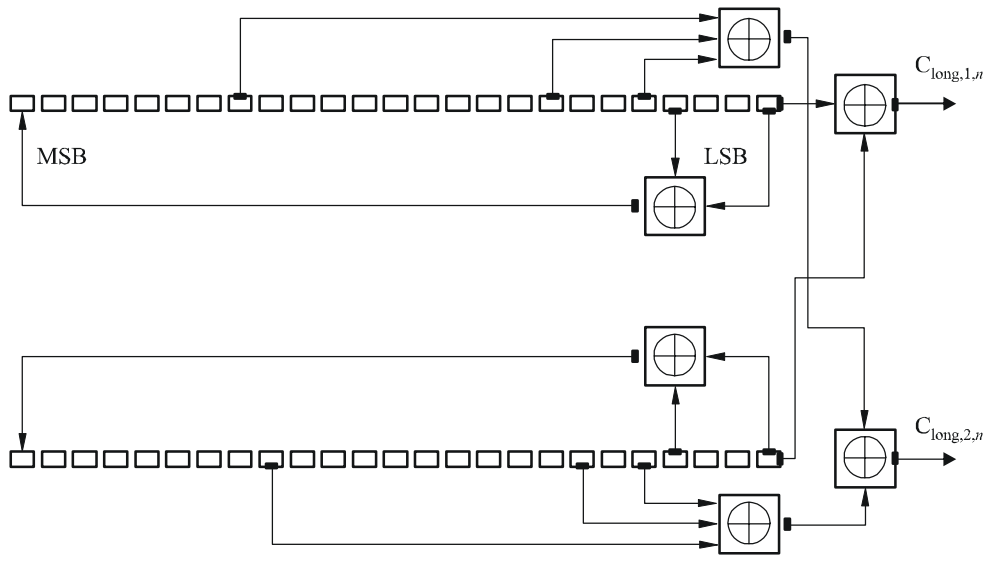
$$c_{\text{long},2,n}(i) = Z_n((i + 16\,777\,232) \text{ modulo } (2^{25} - 1)), \quad i = 0, 1, 2, \dots, 2^{25} - 2.$$

Finally, the complex-valued long scrambling sequence  $C_{\text{long},n}$ , is defined as:

$$C_{\text{long},n}(i) = c_{\text{long},1,n}(i) \left( 1 + j(-1)^i c_{\text{long},2,n}(2 \lfloor i/2 \rfloor) \right)$$

where  $i = 0, 1, \dots, 2^{25} - 2$  and  $\lfloor \cdot \rfloor$  denotes rounding to nearest lower integer.

FIGURE 99  
Uplink long code generator



1457-99

**6.3.3.4.3.1.1 PRACH and PCPCH codes**

The access preamble code is of length  $N_p \times 4\,096$  chips and consists of  $N_p$  sub-preamble codes. The sub-preamble code  $C_{pre,n,s,i}$  is a complex valued sequence. It is built from a preamble scrambling code  $S_{r-pre,n}$  and a preamble signature  $C_{sig,s}$  as follows:

- when  $N_p$  is set to 1, then

$$C_{pre,n,s,0}(k) = S_{pre,n,s}(k) \times e^{j\left(\frac{\pi}{4} + \frac{\pi}{2}k\right)}, k = 0, 1, 2, 3, \dots, 4\,095$$

- when  $N_p$  is greater than 1, then

$$C_{pre,n,s,i}(k) = S_{pre,n}(k) \times C_{sig,s}(k) \times e^{j\left(\frac{\pi}{4} + \frac{\pi}{2}k\right)}, k = 0, 1, 2, 3, \dots, 4\,095, i = 0, 1, \dots, N_p - 2$$

$$C_{pre,n,s,N_p-1}(k) = S_{pre,n}(k) \times C_{sig,s}(k) \times e^{-j\left(\frac{\pi}{4} + \frac{\pi}{2}k\right)}, k = 0, 1, 2, 3, \dots, 4\,095$$

where  $k = 0$  corresponds to the chip transmitted first in time.

The preamble signature corresponding to a signature  $s$  consists of 256 repetitions of a length 16 signature. The signature is from the set of 16 Hadamard codes of length 16.

The scrambling code for the preamble part is constructed from the long scrambling sequences. The  $n$ :th preamble scrambling code is defined as

$$S_{pre,n}(i) = c_{long,1,n}(i),$$

where  $i = 0, 1, \dots, 4\,095$ . When sub-access frames are used for the PRACH, the  $n$ -th preamble scrambling code where  $n$  is an even number is used for the preamble transmitted at the even sub-access frame. The  $n$ -th preamble scrambling code where  $n$  is an odd number is used for the preamble transmitted at the odd sub-access frame.

The  $n$ -th PRACH message part scrambling code, denoted  $S_{r-msg,n}$ , where  $n = 0, 1, \dots, 8\,191$ , is based on the long scrambling sequence and is defined as:

$$S_{r-msg,n}(i) = C_{long,n}(i + 4\,096), i = 0, 1, \dots, 38\,399$$

The  $n$ -th PCPCH message part scrambling code, denoted  $S_{c\text{-msg},n}$ , where  $n = 8\ 192, 8\ 193, \dots, 40\ 959$  is based on the scrambling sequence and is defined as:

In the case when the long scrambling codes are used:

$$S_{c\text{-msg},n}(i) = C_{\text{long},n}(i), \quad i = 0, 1, \dots, 38\ 399$$

### 6.3.3.4.3.2 Uplink modulation

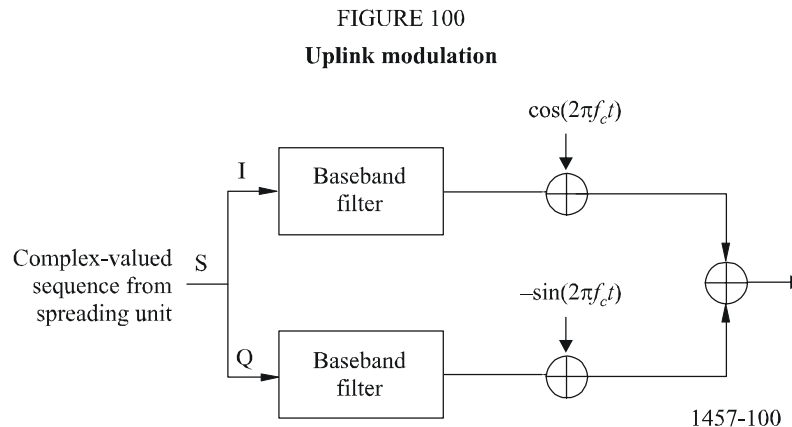
The modulating chip rate is 3.84 Mchip/s.

In the uplink, the modulation is dual-channel QPSK.

The modulated DPCCH is mapped to the Q-channel, while the first DPDCH is mapped to the I channel.

Subsequently added DPDCHs are mapped alternatively to the I or Q channels.

Figure 100 shows the configuration of the uplink modulation. The baseband filter (pulse shaping filter) is a root-raised cosine filter with roll-off  $\alpha = 0.22$  in the frequency domain.

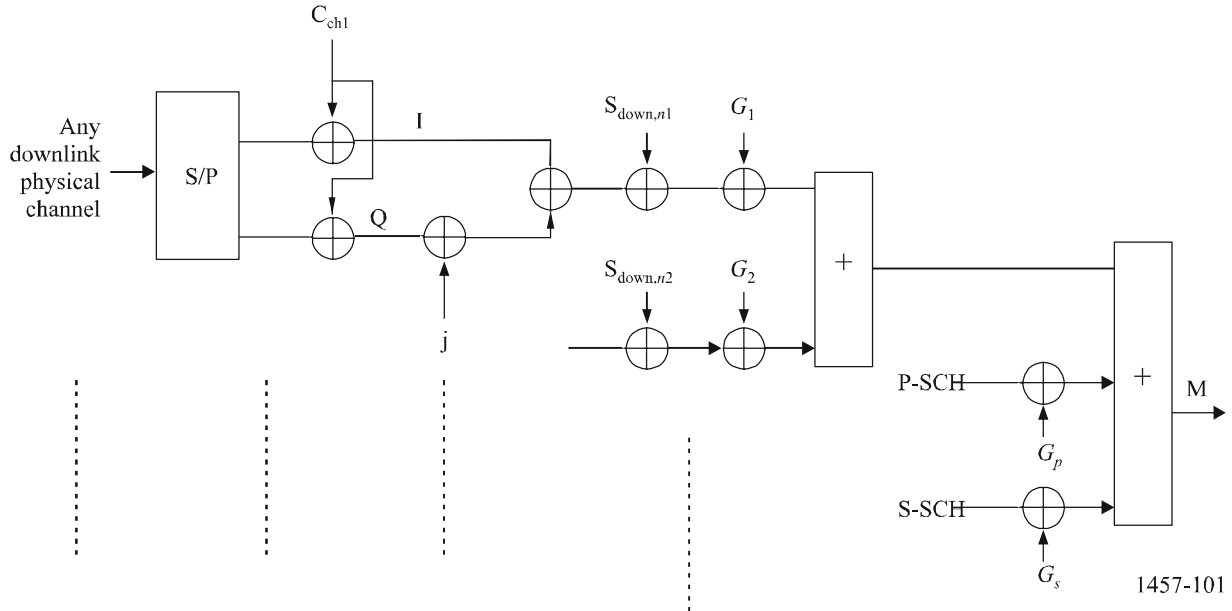


### 6.3.3.4.3.3 Downlink spreading

OCQPSK is not used in the downlink. The spreading operation consists of two operations; short code spreading for channelization and long code spreading for scrambling. Direct sequence spreading using the long code shall be applied to the downlink channel. For the downlink channel, this long code shall be periodic with a period of 38 400 chips. The long code length is equal to the frame length of 10 ms.

Figure 101 shows the configuration of the downlink-spreading.

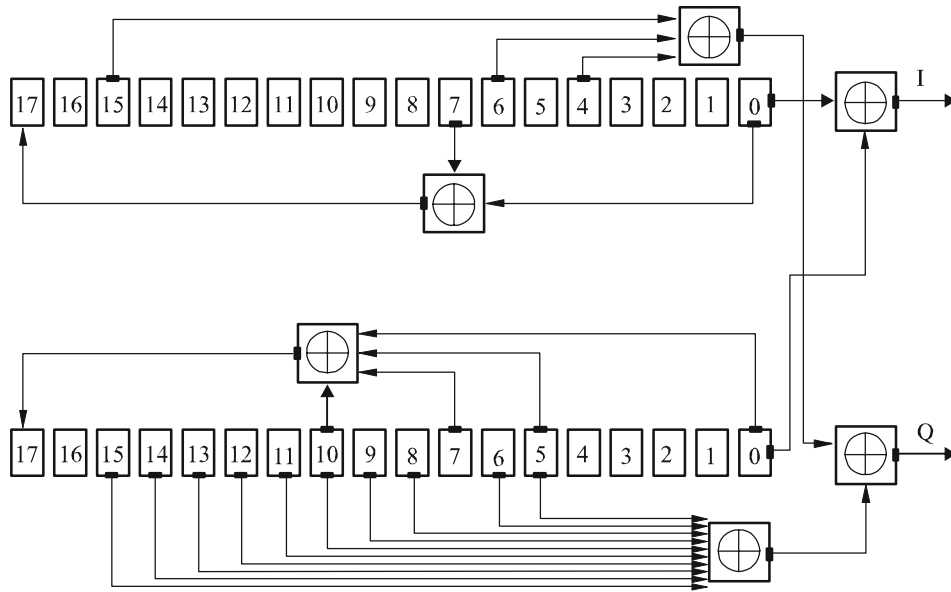
FIGURE 101  
Spreading for downlink physical channels



The channelization code for downlink physical channels is the same OVFSF codes as used in the uplink.

The scrambling code is constructed by combining two real sequences into a complex sequence. Each of the two real sequences is obtained from position wise modulo 2 sum of 38400 chip segments of two binary  $m$ -sequences  $x$  and  $y$ . The  $x$  sequence is obtained from the generator polynomial  $X^{18} + X^7 + 1$ . The  $y$  sequence is obtained from the generator polynomial  $X^{18} + X^{10} + X^7 + X^5 + 1$ . The initial condition for the  $x$  sequence is (00...1), where 1 is the LSB. The initial condition for the  $y$  sequence is (11...1). Figure 102 shows the configuration of the downlink scrambling code generator.

FIGURE 102  
Downlink scrambling code generator



1457-102

The  $n$ -th Gold code sequence  $z_n$ , is then defined as:

$$z_n(i) = x((i + n) \text{ modulo } (2^{18} - 1)) + y(i) \text{ modulo } 2, i = 0, \dots, 2^{18} - 2.$$

These binary sequences are converted to real valued sequences  $Z_n$ . Finally, the  $n$ -th complex scrambling code sequence  $S_{dl,n}$  is defined as:

$$S_{dl,n}(i) = Z_n(i) + j Z_n((i + 131\,072) \text{ modulo } (2^{18} - 1)), i = 0, 1, \dots, 38\,399.$$

Note that the pattern from phase 0 up to the phase of 38 399 is repeated.

The scrambling codes are divided into 512 sets, and each set consists of a primary scrambling code and 15 secondary scrambling codes. The primary scrambling codes consist of scrambling codes  $n = 16 \times i$  where  $i = 0 \dots 511$ . The  $i$ -th set of secondary scrambling codes consists of scrambling codes  $16 \times i + k$ , where  $k = 1 \dots 15$ . There is a one-to-one mapping between each primary scrambling code and 15 secondary scrambling codes in a set such that  $i$ -th primary scrambling code corresponds to  $i$ -th set of secondary scrambling codes. Hence scrambling codes  $n = 0, 1, \dots, 8\,191$  are used.

The set of primary scrambling codes is further divided into 64 scrambling code groups, each consisting of eight primary scrambling codes. The  $j$ -th scrambling code group consists of primary scrambling codes  $16 \times 8 \times j + 16 \times k$ , where  $j = 0 \dots 63$  and  $k = 0 \dots 7$ .

### 6.3.3.4.3.3.1 Synchronization codes

The primary synchronization code (PSC),  $C_{psc}$  is constructed as two generalized hierarchical Golay sequences.

Define:

$$a_1 = \langle x_1, x_2, x_3, \dots, x_{16} \rangle = \langle 1, -1, 1, -1, -1, -1, -1, -1, 1, 1, -1, -1, -1, 1, 1, -1 \rangle$$

$$a_2 = \langle y_1, y_2, y_3, \dots, y_{16} \rangle = \langle 1, -1, 1, -1, -1, -1, 1, 1, 1, -1, -1, 1, -1, -1, -1, -1 \rangle$$



The PSC is generated by repeating the sequences  $a_1$  and  $a_2$  modulated by a Golay complementary sequence, and creating a complex-valued sequence with identical real and imaginary components. The PSC  $C_{psc}$  is defined as:

$$C_{psc} = (1 + j) \times \langle a_1, -a_1, -a_1, -a_1, -a_1, a_1, -a_1, -a_1, a_2, a_2, -a_2, a_2, -a_2, a_2, a_2, a_2 \rangle$$

The 16 secondary synchronization codes (SSCs),  $\{C_{ssc,1}, \dots, C_{ssc,16}\}$ , are complex-valued with identical real and imaginary components, and are constructed from position wise multiplication of a Hadamard sequence and a sequence  $z$ , defined as:

- $z = \langle b_1, b_1, b_1, b_1, b_1, b_1, -b_1, -b_1, b_2, -b_2, -b_2, b_2, b_2, -b_2, b_2, -b_2 \rangle$ , where
- $b_1 = \langle x_1, x_2, x_3, x_4, x_5, x_6, x_7, x_8, -x_9, -x_{10}, -x_{11}, -x_{12}, -x_{13}, -x_{14}, -x_{15}, -x_{16} \rangle$  and  $x_1, x_2, \dots, x_{15}, x_{16}$ , are the same as in the definition of the sequence  $a_1$  above.
- $b_2 = \langle y_1, y_2, y_3, y_4, y_5, y_6, y_7, y_8, -y_9, -y_{10}, -y_{11}, -y_{12}, -y_{13}, -y_{14}, -y_{15}, -y_{16} \rangle$  and  $y_1, y_2, \dots, y_{15}, y_{16}$ , are the same as in the definition of the sequence  $a_2$  above.

The Hadamard sequences are obtained as the rows in a matrix  $H_8$  constructed recursively. Denote the  $n$ -th Hadamard sequence as a row of  $H_8$  numbered from the top,  $n = 0, 1, 2, \dots, 255$ , in the sequel. Furthermore, let  $h_n(i)$  and  $z(i)$  denote the  $i$ :th symbol of the sequence  $h_n$  and  $z$ , respectively where  $i = 0, 1, 2, \dots, 255$ .

The  $k$ -th SSC,  $C_{ssc,k}$ ,  $k = 1, 2, 3, \dots, 16$  is then defined as:

$$C_{ssc,k} = (1 + j) \times \langle h_m(0) \times z(0), h_m(1) \times z(1), h_m(2) \times z(2), \dots, h_m(255) \times z(255) \rangle$$

where  $m = 8 \times (k - 1)$ .

There are 64 secondary SCH sequences and each sequence consists of 15 SSCs. The 64 secondary SCH sequences are constructed such that their cyclic-shifts are unique, i.e. a non-zero cyclic shift less than 15 of any of the 64 sequences is not equivalent to any cyclic shift of any other of the 64 sequences. Also, a non-zero cyclic shift less than 15 of any of the sequences is not equivalent to itself with any other cyclic shift less than 15.

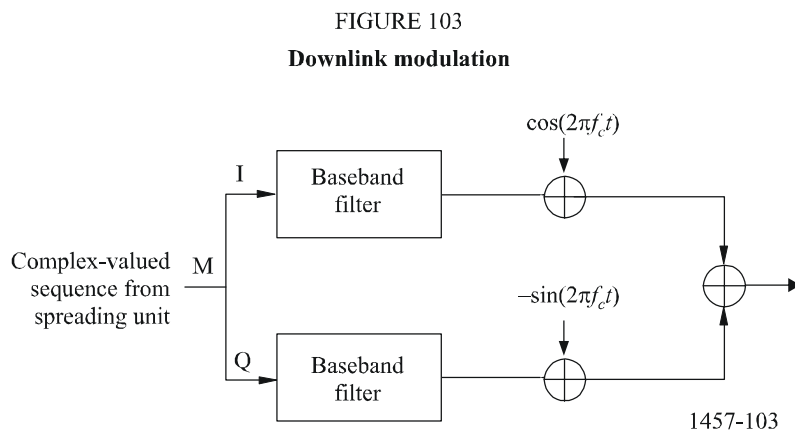
**6.3.3.4.3.4 Downlink modulation**

The modulating chip rate is 3.84 Mchip/s.

In the downlink, the data modulation of DPCH is QPSK.

The modulated DPDCH and DPCCH are time-multiplexed.

Figure 103 shows the configuration of the downlink modulation. The baseband filter (pulse shaping filter) is a root-raised cosine filter with roll-off  $\alpha = 0.22$  in the frequency domain.



### 6.3.3.4.4 Procedures

#### 6.3.3.4.4.1 Beam search

The beam search is carried out in three steps:

*Step 1:* MES uses the SCH's primary synchronization code to acquire slot synchronization to a beam.

*Step 2:* MES uses the SCH's secondary synchronization code sequences to find frame synchronization and identify the code group of the beam found in the first step.

*Step 3:* MES determines the exact primary scrambling code used by the found beam.

During the first and the second steps, a coarse frequency search and/or a differential detection technique may be required because of the carrier frequency error due to the Doppler shift.

During the second and the third steps, the MES can use locally stored information on satellite constellation and its position. This can reduce the beam search time.

#### 6.3.3.4.4.2 Random access

##### 6.3.3.4.4.2.1 RACH procedure

In the MAC layer, when there is data to be transmitted, MES selects the RACH class and starts on a retransmission cycle. If the number of retransmission cycles is larger than the maximum retransmission cycles, MES stops the procedure and reports to the higher layer (RLC or RRC).

At the beginning of each retransmission cycle, MES refreshes the parameters related to RACH procedure with the up-to-date values, included in system information messages within BCH. MES then decides whether to start the RACH transmission in the current frame, based on the persistence value. If the transmission is not allowed, MES repeats from the persistence check in the next frame. If the transmission is allowed, MES starts on a ramping-up retransmission period. If the number of the repeated periods is larger than the maximum ramping-up retransmissions, MES restarts on the retransmission cycle in the next frame.

During the ramping-up retransmission period, the MES shall perform the physical random-access procedure as follows:

- Step 1:* Derive the available uplink access frame, in the next full access frame set, by using the set of available RACH sub-channels within the given RACH Class. Randomly select one access frame among the ones previously determined. When sub-access frames are used for the PRACH, the MES randomly selects a sub-access frame from the even and odd sub-access frames within the selected access frame.
- Step 2:* Randomly select a signature from the set of available signatures within the given RACH Class.
- Step 3:* Set the Preamble Retransmission Counter to Preamble Retrans Max.
- Step 4:* Set the preamble power to Preamble\_Initial\_Power.
- Step 5:* Randomly select a transmission offset time,  $\tau_{off}$ , in range of  $-\tau_{off,max}$  to  $\tau_{off,max}$  chips.
- Step 6:* Transmit a preamble part and a message part using the selected access frame (or sub-access frame), transmission offset time, signature, and preamble transmission power. Transmission power of the control part of the random access message should be  $P_{p-m}$  [dB] higher than the power of the preamble.

- Step 7:* If neither positive nor negative acquisition indicator corresponding to the selected signature is detected in the downlink AICH access frame (or sub-access frame) corresponding to the transmitted uplink access frame (or sub-access frame), then:
- Sub-Step 7.1:* Select the next available access frame in the set of available RACH sub-channels within the given RACH Class. When sub-access frames are used for the PRACH, the MES randomly selects a sub-access frame from the even and odd sub-access frames within the selected access frame.
  - Sub-Step 7.2:* Randomly select a new signature from the available signatures.
  - Sub-Step 7.3:* Increase the preamble power by  $\Delta P_0 = \text{Power Ramp Step}$ .
  - Sub-Step 7.4:* Decrease the Preamble Retransmission Counter by one.
  - Sub-Step 7.5:* If the Preamble Retransmission Counter  $> 0$  then repeat from step 5. Otherwise report L1 status “No ack on AICH” to the higher layer (MAC) and exit the physical random access procedure.
- Step 8:* If a negative acquisition indicator corresponding to the selected signature is detected in the downlink access frame (or sub-access frame) corresponding to the selected uplink access frame (or sub-access frame) frame, report L1 status “Nack on AICH received” to the higher layer (MAC) and exit the physical random access procedure.
- Step 9:* Report L1 status “Ack on AICH received” to the higher layer (MAC) and exit the physical random access procedure.

A RACH sub-channel defines a set of uplink access frames that are time-aligned with P-CCPCH frames. There are a total of eight RACH sub-channels.

In the transmission of the RACH preamble and message, MES may use a Doppler pre-compensation technique, based on the Doppler shift estimation on the downlink carrier.

In the MAC layer, when L1 indicates that an acknowledgement on AICH is received, the successful completion of the MAC transmission control procedure shall be indicated to higher layer. When L1 indicates that no acknowledgement on AICH is received, a new retransmission cycle is performed. When L1 indicates that a negative acknowledgement is received, the MES derives a backoff time. After the backoff time, a new retransmission cycle is started.

If the response message corresponding to the transmitted RACH message is received in the higher layer (RLC or RRC) at any time during the random access procedure, MES should stop the RACH procedure.

#### **6.3.3.4.4.2.2 CPCH procedure**

For each CPCH physical channel in a CPCH set allocated to a beam the physical layer parameters are included in system information messages within BCH. The physical layer shall perform the CPCH procedure as follows:

- Step 1:* Upon receipt of the access request from the MAC layer, the MES shall test the SI values of the most recent transmission. If this indicates that the maximum available data rate is less than the requested data rate, the MES shall abort the access attempt.
- Step 2:* The MES sets the preamble transmit power to Preamble\_Initial\_Power.
- Step 3:* The MES sets the AP Retransmission Counter to  $N_{AP\_Retrans\_Max}$ .
- Step 4:* Using the access frame sub-channel group of the access resource combination corresponding to the required data rate, the MES derives the available access frames. The MES randomly selects one uplink access frame from the derived available ones. When sub-access frames are used for the PRACH, the MES randomly selects a sub-access frame from the even and odd sub-access frames within the selected access frame.

- Step 5:* The MES randomly selects an AP signature from the set of available signatures in the access resource combination corresponding to the required data rate.
- Step 6:* The MES randomly selects a CD signature from the CD signature set.
- Step 7:* Randomly select a transmission offset time  $\tau_{off}$  in the range of  $-\tau_{off,max}$  to  $\tau_{off,max}$ .
- Step 8:* The MES shall test the value of the Status Indicator. If this indicates that the maximum available data rate is less than the requested data rate, the MES shall abort the access attempt and send a failure message to the MAC layer. Otherwise, the MES transmits the AP using the selected uplink access frame (or sub-access frame), signature, transmission offset time, and initial preamble transmission power, and successively transmits a CD Preamble at the same power as with the AP.
- Step 9:* If the MES does not detect the AP positive or negative acquisition indicator and the CDI corresponding to the selected AP signature and CDP signature, respectively, from the APA/CD/CA-ICH in the downlink access frame (or sub-access frame) corresponding to the selected uplink access frame (or sub-access frame), the following steps shall be executed:
- Sub-Step 9a:* Select the next available access frame in the sub-channel group used. When sub-access frames are used for the PRACH, the MES randomly selects a sub-access frame between the even and odd sub-access frames within the selected access frame.
  - Sub-Step 9b:* Randomly select a new CD signature from the CD signature set.
  - Sub-Step 9c:* Increases the preamble transmission power with a specified offset  $\Delta P$ . Power offset  $\Delta P_0$  is used unless the negative AICH timer is running, in which case  $\Delta P_1$  is used instead.
  - Sub-Step 9d:* Decrease the AP Retransmission Counter by one.
  - Sub-Step 9e:* If the AP Retransmission Counter  $< 0$ , the MES aborts the access attempt and sends a failure message to the MAC layer. If the AP Retransmission Counter is equal to or larger than 0, the MES repeats from Step 7.
- Step 10:* If the MES detects the AP negative acquisition indicator corresponding to the selected AP signature from the APA/CD/CA-ICH in the downlink access frame (or sub-access frame) corresponding to the selected uplink access frame (or sub-access frame), the MES aborts the access attempt and sends a failure message to the MAC layer. The MES sets the negative AICH timer to indicate use of  $\Delta P_1$  as the preamble power offset until the timer expires.
- Step 11:* If the MES receives the AP positive acquisition indicator corresponding to the selected AP signature and a CDI with a signature that does not match the signature in the CD Preamble, the MES aborts the access attempt and sends a failure message to the MAC layer.
- Step 12:* If the MES receives an AP positive acquisition indicator and a CDI from the APC/CD/CA-ICH with matching signatures, and if CA message points out to one of the PCPCHs that were indicated to be free by the last received CSICH broadcast, the MES transmits the initial transmission preamble  $\tau_{p-ip}$  ms later as measured from initiation of the AP/CDP. The initial transmission power shall be  $\Delta P_{p-m}$  [dB] higher than that of the AP/CDP. The transmission of the message portion of the burst starts immediately after the initial transmission preamble. Power control in the message part is performed according to the TPC command in the downlink slot associated to the PCPCH on the CPCH-CCPCH.
- Step 13:* During CPCH Packet Data transmission, the MES and Satellite-RAN perform inner-loop power control on the PCPCH message part.

In the transmission of the preamble and message, MES may use a Doppler pre-compensation technique, based on the Doppler shift estimation on the downlink carrier.

### 6.3.3.4.4.3 Power control

#### 6.3.3.4.4.3.1 Uplink power control

The uplink transmit power control procedure simultaneously controls the power of a DPCCH and its corresponding DPDCHs (if present). The relative transmit power offset between DPCCH and DPDCHs is determined by the network and is signalled to the MES using higher layer signalling.

The uplink inner-loop power control adjusts the MES transmit power in order to keep the received uplink signal-to-interference ratio (SIR) at a given SIR target,  $SIR_{target}$ . The uplink power control shall be performed while the MES transmit power is below the maximum allowed output power.

Any change in the uplink DPCCH transmit power shall take place immediately before the start of the frame on the DPCCH. The change in DPCCH power with respect to its previous value is derived by the MES and is denoted by  $\Delta_{DPCCH}$  (in dB).

The satellite-RAN should estimate signal-to-interference ratio  $SIR_{est}$  of the received uplink DPCH, generate TPC commands, and transmit the commands once per radio frame according to the following rule:

Define the variable

$$\begin{aligned}\Delta_{\epsilon} &= SIR_{est} - SIR_{target} \\ \Delta_p(i) &= \text{power control step whose value is determined to be one of } \{-\Delta_L, -\Delta_S, \Delta_S, \Delta_L\} \\ &\quad \text{according to the } i\text{-th frame's TPC\_cmd, where the step sizes } \Delta_S, \Delta_L \text{ are under the} \\ &\quad \text{control of the Satellite-RAN,} \\ N_{frame} &= \text{loop delay expressed in frames.}\end{aligned}$$

And then,  $\Delta_p(i)$  is generated by using  $\Delta_{\epsilon}$  and the past  $N_{frame}$  power control steps  $\Delta_p(k)$ ,  $k = i - N_{frame} - 1, \dots, i - 1$  as follows:

Compute

$$\Delta_{\epsilon,c} = \Delta_{\epsilon} + \chi \sum_{k=i-N_{frame}}^{i-1} \{\Delta_p(k) - \alpha \Delta_p(k-1)\}$$

where the loop delay compensation indicator  $\chi$  is set to "1" when an MES is in soft handover and "0" when an MES is not in soft handover. The accumulation reduction factor,  $\alpha$  ( $0 < \alpha < 1$ ) is the higher layer parameter and is identical for all MESs in the same beam.

$$\begin{aligned}\text{if } |\Delta_{\epsilon,c}| < \epsilon_T \text{ and } \Delta_{\epsilon,c} < 0, \Delta_p(i) &= \Delta_S \\ \text{if } |\Delta_{\epsilon,c}| < \epsilon_T \text{ and } \Delta_{\epsilon,c} > 0, \Delta_p(i) &= -\Delta_S \\ \text{if } |\Delta_{\epsilon,c}| > \epsilon_T \text{ and } \Delta_{\epsilon,c} < 0, \Delta_p(i) &= \Delta_L \\ \text{if } |\Delta_{\epsilon,c}| > \epsilon_T \text{ and } \Delta_{\epsilon,c} > 0, \Delta_p(i) &= -\Delta_L\end{aligned}$$

The MES adjusts the transmit power of the uplink DPCCH with a step of  $\Delta_{DPCCH}$  (dB) using two most recently received power control steps,  $\Delta_p(i)$  and  $\Delta_p(i-1)$  as follows:

– When an MES is not in soft handover,

$$\Delta_{DPCCH} = \Delta_p(i) - \alpha \Delta_p(i-1)$$

where  $\alpha$  is identical to that used in the serving beam and is signalled by the higher layer.

- When an MES is in soft handover,

$$\Delta_{DPCCH} = \kappa \Delta_p(i)$$

where  $\kappa$  is the power control step reduction factor signalled by the higher layer.

The relationship between  $\Delta_p(i)$  and the transmitter power control command TPC\_cmd is presented in Table 28

TABLE 28

Relationship between  $\Delta_p(i)$  and TPC\_cmd

TPC_cmd	$\Delta_p(i)$
–2	$-\Delta_L$
–1	$-\Delta_S$
1	$\Delta_S$
2	$\Delta_L$

When the MES is not in soft handover, only one TPC command will be received in each radio frame. In this case, the value of TPC\_cmd shall be derived as follows:

- If the received TPC command is equal to 00, then TPC\_cmd for that frame is –2.
- If the received TPC command is equal to 01, then TPC\_cmd for that frame is –1.
- If the received TPC command is equal to 10, then TPC\_cmd for that frame is 1.
- If the received TPC command is equal to 11, then TPC\_cmd for that frame is 2.

When the MES is in soft handover, multiple TPC commands may be received in each radio frame from different beams in the active set. In the case when more than one radio links are in the same radio link set, the TPC commands from the same radio link set shall be combined into one TPC command, to be further combined with TPC commands from other radio link sets. The MES shall conduct a soft symbol decision  $W_i$  on each of the power control commands  $TPC_i$ , where  $i = 1, 2, \dots, N$ , where  $N$  is greater than 1 and is the number of TPC commands from radio links of different radio link sets. The MES derives a combined TPC command, TPC\_cmd, as a function  $\gamma$  of all the  $N$  soft symbol decisions  $W_i$ :  $TPC\_cmd = \gamma(W_1, W_2, \dots, W_N)$ , where TPC\_cmd can take the values 2, 1, –1 or –2. The function  $\gamma$  shall fulfil the following criteria:

If the  $N$  TPC commands are random and uncorrelated, with equal probability of being transmitted as “00”, “01”, “10” or “11”, the probability that the output of  $\gamma$  is greater than or equal to 1 shall be greater than or equal to  $1/(2^N)$ , and the probability that the output of  $\gamma$  is smaller than or equal to –1 shall be greater than or equal to 0.5. Further, the output of  $\gamma$  shall equal to 2 if the TPC commands from all the radio link sets are reliably “11”, and the output of  $\gamma$  shall equal to –2 if a TPC command from any of the radio link sets is reliably “00”.

For the uplink power control of PCPCH, any change of the PCPCH transmit power shall take place immediately before the start of the frame on the message part. The network should estimate the signal-to-interference ratio  $SIR_{est}$  of the received PCPCH. The network should then generate TPC commands and transmit the commands once per frame according to the same rule as described for DPDCH/DPCCH. The MES derives a TPC command, TPC\_cmd, for each radio frame according to the same rule as described for DPDCH/DPCCH. After deriving the TPC command TPC\_cmd, the MES shall adjust the transmit power of the uplink PCPCH control part with a step of  $\Delta_{PCPCH-CP}$  (dB) determined by the same rule as described for DPDCH/DPCCH.

### 6.3.3.4.4.3.2 Downlink power control

The downlink transmit power control procedure controls simultaneously the power of a DPCCH and its corresponding DPDCHs. The power control loop adjusts the power of the DPCCH and DPDCHs with the same amount. The relative transmit power offset between DPCCH fields and DPDCHs is determined by the network.

The downlink inner-loop power control adjusts the network transmit power in order to keep the received downlink SIR at a given SIR target,  $SIR_{target}$ . The MES should estimate the received signal-to-interference ratio of downlink DPCCH/DPDCH,  $SIR_{est}$ . The obtained SIR estimate  $SIR_{est}$  is then used by the MES to generate TPC commands according to the following rule:

- if  $|SIR_{est} - SIR_{target}| > \epsilon_T$  and  $SIR_{est} > SIR_{target}$ , then the TPC command to transmit is “00”
- if  $|SIR_{est} - SIR_{target}| < \epsilon_T$  and  $SIR_{est} > SIR_{target}$ , then the TPC command to transmit is “01”
- if  $|SIR_{est} - SIR_{target}| > \epsilon_T$  and  $SIR_{est} < SIR_{target}$ , then the TPC command to transmit is “10”
- if  $|SIR_{est} - SIR_{target}| < \epsilon_T$  and  $SIR_{est} < SIR_{target}$ , then the TPC command to transmit is “11”

When the MES is in soft handover and BSDT is not activated, the MES should estimate  $SIR_{est}$  from the downlink signals of all beams in the active set.

The MES may employ prediction algorithm which estimates the future SIR value after the round trip delay. Prediction for the SIR variation can be implemented by observing the trace of the past SIR variations of the CPICHs in the active set. In order to support MESs which employ the prediction algorithm, a nominal round trip delay of the beam to which the MES belongs is signalled by higher layers. The predicted SIR variation after round trip delay,  $\Delta_{pred}$ , is used by the MES to generate TPC commands according to the following rule:

Define  $SIR_{est,pred} = SIR_{est} + \Delta_{pred}$ , then

if  $|SIR_{est,pred} - SIR_{target}| > \epsilon_T$  and  $SIR_{est,pred} > SIR_{target}$ , then the TPC command to transmit is “00”

if  $|SIR_{est,pred} - SIR_{target}| < \epsilon_T$  and  $SIR_{est,pred} > SIR_{target}$ , then the TPC command to transmit is “01”

if  $|SIR_{est,pred} - SIR_{target}| > \epsilon_T$  and  $SIR_{est,pred} < SIR_{target}$ , then the TPC command to transmit is “10”

if  $|SIR_{est,pred} - SIR_{target}| < \epsilon_T$  and  $SIR_{est,pred} < SIR_{target}$ , then the TPC command to transmit is “11”

Upon receiving the TPC commands satellite-RAN shall adjust its downlink DPCCH/DPDCH power accordingly. Satellite-RAN shall estimate the transmitted TPC command  $TPC_{est}$ , and shall update the power every frame. After estimating the  $k$ -th TPC command, satellite-RAN shall adjust the current downlink power  $P(k-1)$  (dB) to power  $P(k)$  (dB) according to the following formula:

$$P(k) = P(k-1) + P_{TPC}(k) + P_{bal}(k)$$

where  $P_{TPC}(k)$  is the  $k$ -th power adjustment due to the inner loop power control, and  $P_{bal}(k)$  (dB) is a correction according to the downlink power control procedure for balancing radio link powers towards a common reference power.  $P_{TPC}(k)$  is calculated as follows:

$$P_{TPC}(k) = \begin{cases} -\Delta_L & \text{if } TPC_{est}(k) = 00 \\ -\Delta_S & \text{if } TPC_{est}(k) = 01 \\ +\Delta_S & \text{if } TPC_{est}(k) = 10 \\ +\Delta_L & \text{if } TPC_{est}(k) = 11 \end{cases}$$

### 6.3.3.4.4.4 Beam selection diversity transmission

Beam selection diversity transmission (BSDT) is a macro diversity method in soft handover mode. This method is optional in satellite-RAN. The MES selects one of the beams from its active set to

be “primary”, all other beams are classed as “non-primary”. The downlink DPDCH is transmitted from the primary beam while the downlink DPDCH is not transmitted from non-primary beams.

In order to select a primary beam, each beam is assigned a temporary identification (ID) and MES periodically informs a primary beam ID to the connecting beams. The primary beam ID is delivered by MES to the active beams via the FBI field on the uplink DPCCH.

Each beam is given a temporary ID during BSDT and the ID is utilized as beam selection signal. One 15-bit ID code is transmitted within a radio frame.

The MES shall generate TPC commands to control the network transmit power, in the TPC field of the uplink DPCCH based on the downlink signals from the primary beam only. The MES periodically selects a primary beam by measuring the received signal power of CPICHs transmitted by the active beams. The beam with the highest CPICH power is detected as a primary beam.

A beam recognizes its state as non-primary if the following conditions are fulfilled simultaneously:

- the received ID code does not match to the own ID code;
- the received uplink signal quality satisfies the quality threshold defined by the network.

The state of the beams (primary or non-primary) in the active set is updated synchronously. If a beam receives the coded ID in uplink frame  $j$ , the state of beam is updated in downlink frame  $(j + 1 + T_{os})$ , where  $T_{os}$  is provided by higher layers (the value of  $T_{os}$  is determined by the network according to the round trip delay in the beam).

### 6.3.4 Satellite radio interface D (SRI-D) specifications

SRI-D has been optimized for operation with a specific satellite system. This system consists of a constellation of satellites in MEO working with 12 LESs, which are located around the world and interconnected by a ground network. The configuration has been designed to provide coverage of the entire surface of the Earth at all times. The system will route traffic from terrestrial networks through a LES, which will select a satellite through which the call will be connected to a user. Traffic from a UT will be routed via the satellite constellation to the appropriate fixed or mobile network. The system will provide users anywhere on the Earth with access to telecommunications services. SRI-D supports robust and flexible communications, both voice and data, with rates up to 38.4 kbit/s, in a spectral and power efficient manner. The large majority of UTs used with the system are expected to be truly hand-portable and capable of dual-mode (terrestrial and satellite) operation. A wide range of other UTs will be supported including vehicular, aeronautical and maritime mobile, and semi-fixed terminals.

The following sub-sections specify only those elements relevant to this Recommendation, dealing therefore primarily with worldwide compatibility and international use.

#### 6.3.4.1 Architectural description

The ground segment employs many standard components that allow conformance of the system to terrestrial telecommunications standards. The architecture (illustrated in Fig. 104) comprises:

- 12 interconnected LESs located around the world;
- duplicated network management centres;
- duplicated billing and administration centres.

Each LES comprises:

- five antennas and associated equipment to communicate with the satellites;
- mobile switching centres and registers, including HLRs and VLRs;
- interconnections with terrestrial networks.

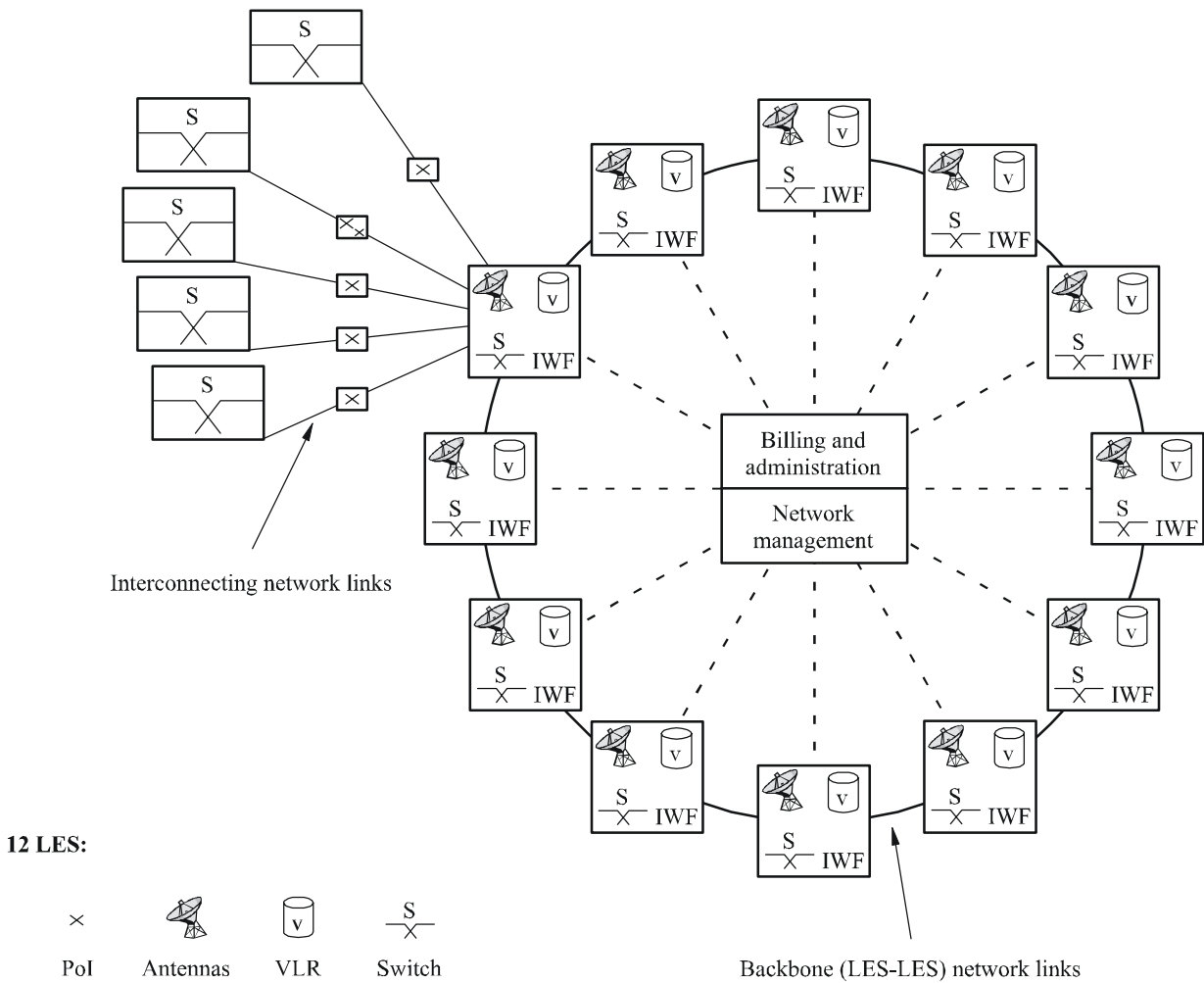


The LESs are interconnected with each other via terrestrial links, thereby building the basic platform that provides the system’s global mobile telecommunications services. Interfaces will be provided to PSTN, PLMN and data networks. However, handover is only supported within a single network. Interworking functions (IWFs) will deliver automatic roaming with other terrestrial (second and third generation) mobile networks.

FIGURE 104  
The ground network

**Interconnection with other networks**

–PoI between system and interconnecting networks PSTN, PLMN and PSDN



PoI: Point of interconnection

**6.3.4.1.1 Constellation**

Table 29 summarizes the satellite constellation configuration.

TABLE 20

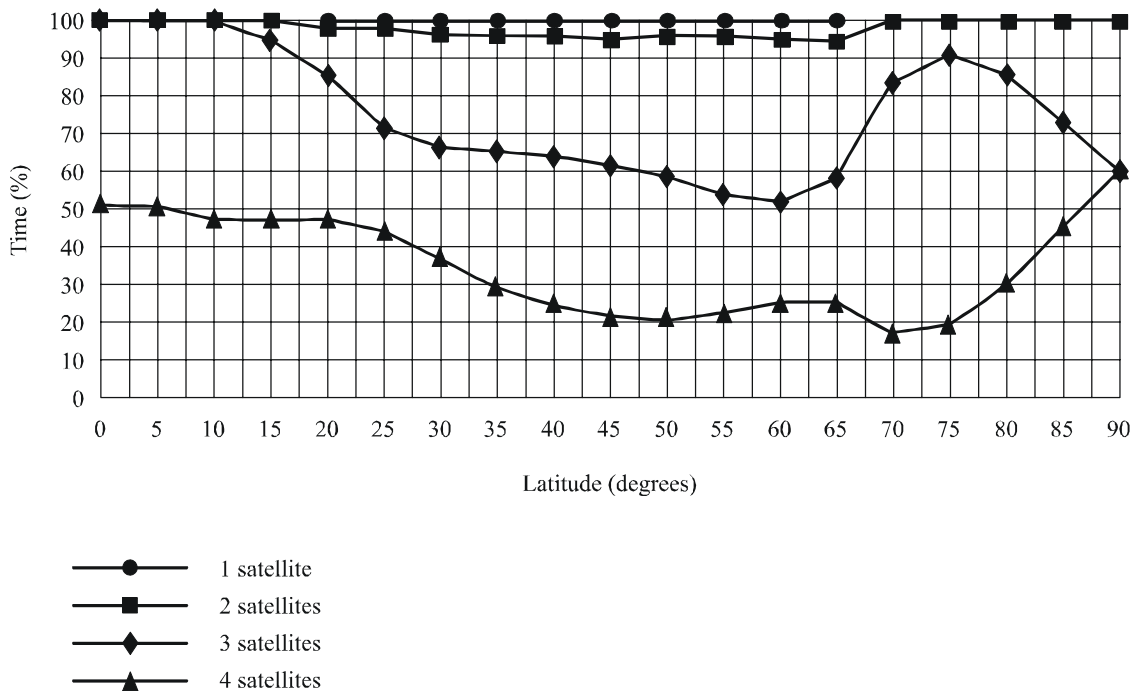
**Satellite constellation configuration**

Orbit type	MEO
Orbit altitude	Nominally 10 390 km
Orbit inclination angle	45°
Number of orbit planes	2
Plane phasing	180°
Number of satellites per orbit plane	5-6
In-plane satellite phasing	The in-plane satellite phasing for a constellation of 10 satellites (5 satellites in each of 2 planes) is 72°. If all 12 satellites are launched successfully (6 satellites in each of 2 planes) the in-plane satellite phasing is 60°

Worldwide use is a key feature of IMT-2000 and the constellation described provides true global coverage whilst maintaining a high minimum elevation angle to the visible satellites, as shown in Figs. 105 and 106.

Each satellite provides radio coverage down to an elevation angle of 0° for both UTs and LESs. Figure 105 shows the percentage of time for which a number of satellites are visible as a function of latitude. For all areas of the Earth there will be two or more satellites visible for at least 90% of the time.

FIGURE 105  
Typical visibility statistics for satellite constellation (10 satellites)

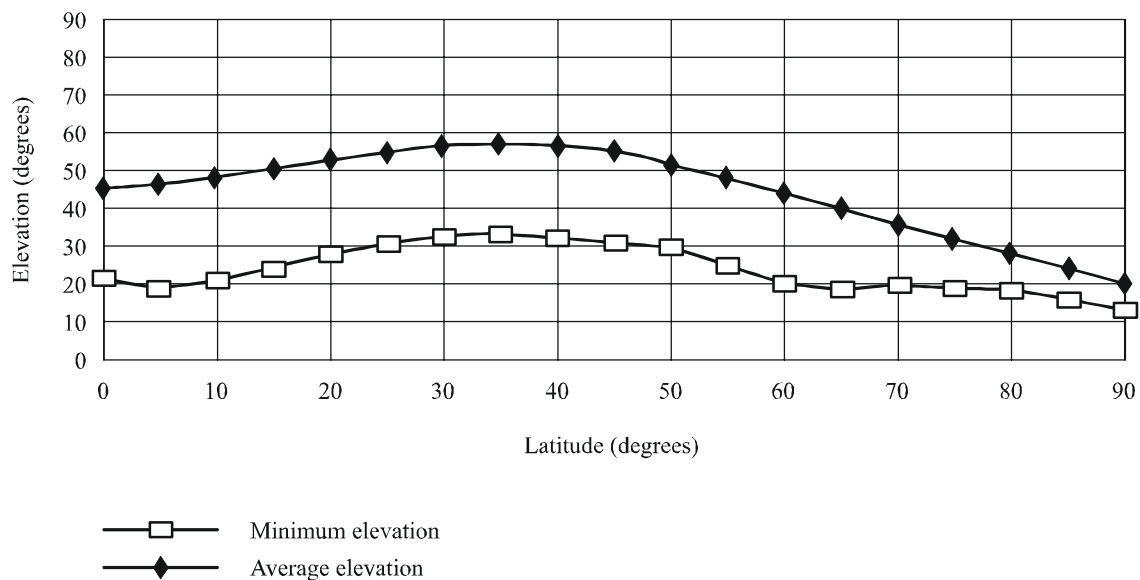


The system is very robust to individual failures of satellite and/or LES since:

- full global coverage can be maintained while there are at least four satellites in each orbit plane;
- individual LES failure will not normally result in loss of service around the LES.

Figure 106 shows the minimum and average elevation angles of the nearest satellite that gives the highest elevation amongst the visible satellites as a function of latitude. The minimum and average elevation angles exceed 20° and 40°, respectively, in most areas. For regions between 20° and 50° in latitude, the constellation provides a minimum elevation angle of better than 25° and an average elevation angle of more than 50°.

FIGURE 106  
Typical minimum and average elevation angles of the nearest satellite (10 satellites)



1457-106

### 6.3.4.1.2 Satellites

#### Spacecraft

Specific features have been introduced to the satellites to meet the unique mission requirements in MEO, including:

- 163 beams providing full field-of-view coverage on the service link to mobile users, realized with separate 127 element transmit and receive direct radiating array (DRA) antennas.
- Beam forming and channelization of the transponders realized with digital technology that enables 490 satellite filter channels to be switched between the 163 actively generated beams. This enables the satellites to respond to traffic and interference requirements as they change through the orbit.
- An on-board self-calibration facility that monitors and, if required, corrects the service link antenna performance on-orbit. This will maintain the antenna gain and frequency reuse performance throughout the life of the spacecraft.

### **Communications subsystem**

The payload is a fully digital design using narrow-band beam-forming, digital beam-forming and digital channelization. In the service link, the payload generates a fixed grid of 163 spot beams covering the full field-of-view from a combined transmit/receive DRA antenna fixed on the spacecraft earth panel.

The on-board digital processor is transparent in that it channelizes and routes the signals to the 163 service link spot beams and does not demodulate and regenerate the signals. 490 filter channels of 170 kHz are created in the processor and each channel can be routed to any of the 163 beams at any frequency on a 150 kHz grid within the service link 30 MHz bandwidth. Each of the 490 channels can be considered equivalent to a conventional transponder.

Channel to beam routing can be changed continuously through the orbit to enable the satellites to respond to traffic and interference demands on a preplanned, predicted basis. This also enables flexible use to be made of the available spectrum.

In addition, the digital processor forms all 163 service link spot beams by generating amplitude and phase coefficients for each of the 127 elements for each beam. The integrity of the element excitation coefficients can be verified using the on-board satellite self-calibration system, whereby an external feed on a boom senses the excitation coefficient within each element. This enables spot beam performance, both main lobe and sidelobe, to be maintained through the life of the satellite, thereby ensuring that frequency reuse between the spot beams is maintained.

### **Spot beams**

The 163 congruent transmit and receive mobile beams per satellite are arranged in a radial circular cell pattern around the sub-satellite cell as shown in Fig. 107. The beams are electronically de-ayed to maintain the pattern relative to the spacecraft velocity vector. Beam directivity changes by about 2 dB between nadir and the edge of coverage.

The centres of the cells are defined as the centroids of the  $-3$  dB contours of the individual beams. There are 19 beam types, numbered in order of their increasing angular distance from nadir. Each beam type has the same range of path delay, and (within  $\pm 10\%$ ) the same range of Doppler.

Table 30 summarizes the nominal cell parameters.

### **Frequency reuse**

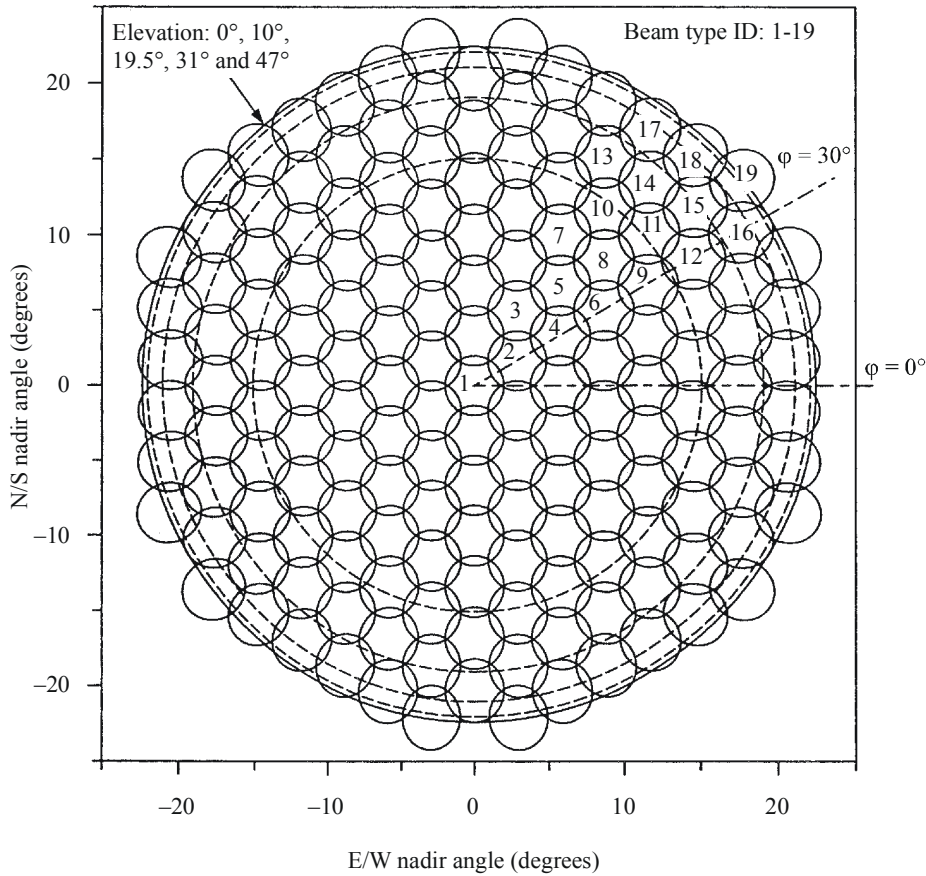
The function of the frequency plan is to maximize the use of the mobile link spectrum while ensuring that no harmful intra-system interference occurs. The frequency plan for the whole satellite constellation is performed centrally at the network management centre.

The frequency plan defines the spectrum allocated to each beam in the constellation as a function of time in such a way that a given frequency is never available simultaneously to two beams with insufficient isolation. Beam side lobes are controlled to allow 4-cell frequency re-use within the 163-spot beam pattern. The frequency plan is adaptive to the traffic variation and the evolution of the constellation.

The frequency plan is a satellite oriented frequency assignment plan. The frequencies used in each beam remain fairly constant in the beams as the satellite moves in orbit. The mobile terminals are generally required to change frequency at beam handover.

The example frequency plan presented here has been developed for a constellation of 10 satellites in two orbital planes, each satellite having 163 fixed spot beams covering the full field-of-view with a 4-cell frequency reuse pattern as the one shown in Fig. 108. A similar frequency plan would be applicable for the 12-satellite constellation.

FIGURE 107  
Hexagonal lattice showing the 19 beam types



1457-107

TABLE 30  
Nominal cell parameters

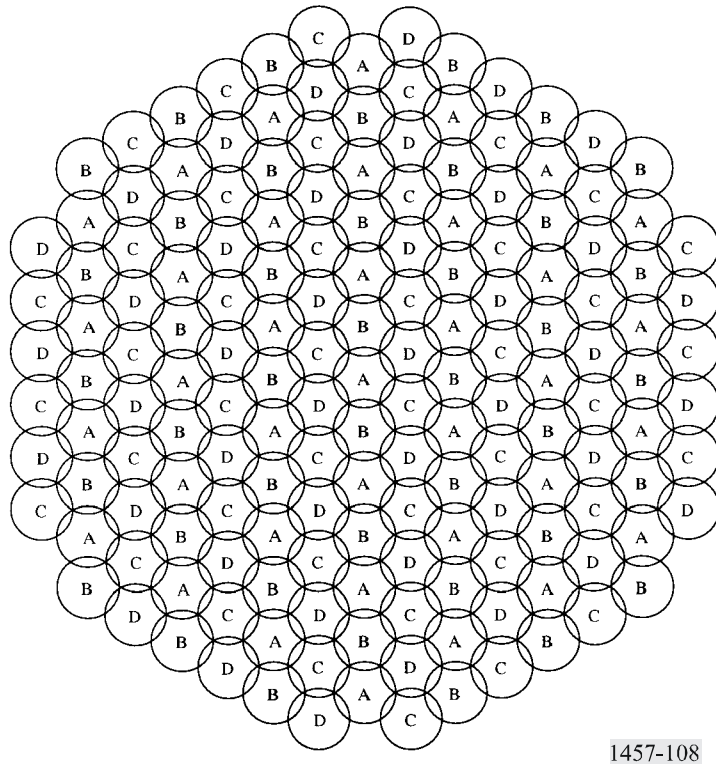
Cell size	3.343°
Beamwidth	3.860°
Cell reuse	4
Cell area	9.678°
Reuse cell area	38.714°
Reuse centre to centre spacing	6.686°
Reuse sidelobe spacing	5.015°

The mobile link spectrum is partitioned into 16 frequency blocks, as shown in Fig. 109. Eight blocks are allocated to each satellite plane: blocks 1 through 8 to plane 1 and blocks 9 through 16 to plane 2.

Within a plane of satellites, the relative position of all five satellites remains constant. The 163 beams of each satellite are divided into two groups corresponding to the leading and trailing edges of the field-of-view. As shown in Fig. 110, the leading edges of all five satellite coverages do not

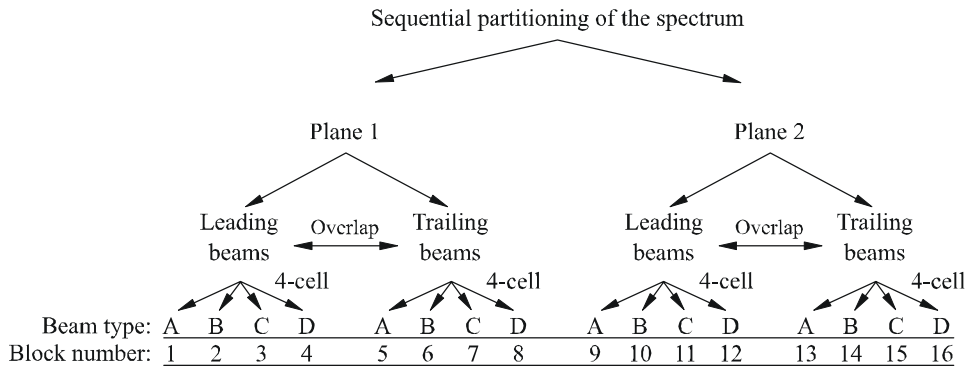
overlap, and the same applies to all five trailing edges. Therefore, the eight blocks nominally allocated to plane 1 are arranged into two separate 4-block sub-plans: one for the leading beams of all five satellites (blocks 1, 2, 3 and 4), the other for the trailing beams (blocks 5, 6, 7 and 8). A similar partitioning is done in plane 2. The frequency plan for the satellites in plane 1 is shown in Fig. 111. The leading and trailing sub-plans overlap over the central beams, as the sub-plans are designed to comprise as many beams as allowed by the beam isolation constraints.

FIGURE 108  
Typical 4-cell frequency reuse pattern



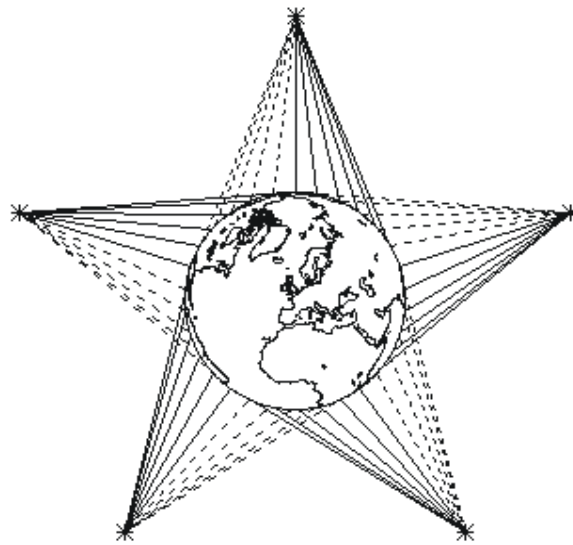
1457-108

FIGURE 109  
Example partitioning of the service link spectrum into frequency blocks



1457-109

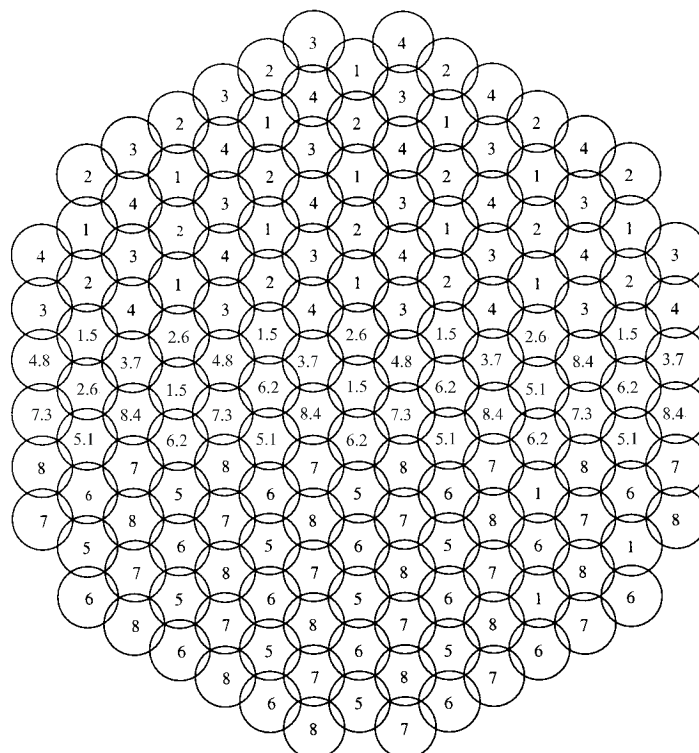
FIGURE 110  
 Example leading and trailing beam sub-planes



— Leading beams  
 - - Trailing beams

1457-110

FIGURE 111  
 Example frequency plan for satellites in plane 1



1457-111

### 6.3.4.2 System description

#### 6.3.4.2.1 Service features

The system supports UPT through, inter alia, service portability, which facilitates access to services expected on a home network from within a visited network, and service transparency, by which the user experiences the same look and feel, irrespective of location, through transparent service delivery.

The system can support a range of teleservices, bearer services, alternate services, supplementary services and messaging services:

- Teleservices; include telephony, emergency calls, Group 3 fax (with rates up to 14.4 kbit/s). The nominal voice coding scheme has been optimized for SRI-D. The coded rate is 4.8 kbit/s. The nominal voice codec also supports transparent DTMF sending in both forward and return directions. The radio interface can support other codecs.
- Bearer services: various data rates are supported and can be utilized dependant on application type. The channel speed can be varied according to system resources and user requirements. This functionality is not employed to compensate for transmission medium impairments. Variable rate source coding is not employed. Asymmetric transmission can be employed for data services by asymmetric allocation of TDMA slots on forward and return links. Medium data rates (up to 38.4 kbit/s using time-slot aggregation) including the following, non-exhaustive list of data rates are supported (note that multiple time slots and/or multiple RF channels are used to realize data rates higher than that available from a single time slot (2.4 kbit/s before coding)):
  - Asynchronous transparent and non-transparent circuit-switched data: 0.3, 1.2, 2.4, 4.8, 9.6, 14.4, 19.2, 28.8 and 38.4 kbit/s.
  - Synchronous transparent and non-transparent circuit-switched data: 1.2, 2.4, 4.8, 9.6, 14.4, 19.2, 28.8 and 38.4 kbit/s.
  - Packet-switched data: The system and its radio interface are capable of supporting packet-switched services; implementation is currently under review.
- Supplementary services; include line identification services, forwarding services, call waiting services, multi-party services, call restriction services, advice of charge services and location services.
- Messaging services; include voice messaging, fax messaging and mobile originated and mobile terminated SMS.

#### 6.3.4.2.2 System features

##### Handover

Handover is supported within the system between beams of the same satellite, between beams of different satellites and between land earth stations.

UTs may be required to change frequency at handover. UT assisted handover is employed using UT measurements and controlled switching. Hard and soft handover are supported. Soft handover, implying no break on handover, is preferred whereby the handover decision is made by the UT. When soft handover is not possible, a make-before-break procedure is used.

##### Doppler compensation

Knowledge of the satellite's motion and the UT's location provides the information to permit Doppler compensation. Pre-compensation limits Doppler shift to less than 1.1 kHz in the forward link and 40 Hz in the return link.



### Channel allocation

On-board digital channelization enables the 490 satellite filter channels to be switched between the 163 actively generated beams. Predictive channel allocation is therefore employed to enable satellites to respond to traffic and interference requirements as practicable as they change through the orbit. It also enables flexible use to be made of the available spectrum.

### Diversity

Time, space and frequency diversity are supported:

- Time diversity is supported for data traffic using RLP, signalling by Layer 2 retransmission and paging/notification/broadcast/RACH by repetition.
- Space diversity is supported for traffic and signalling by allowing a UT to communicate with the network through any of the satellites that are visible (satellite path diversity). Most of the time the system constellation provides coverage to an area via two or more diverse paths from two or more satellites, as shown in Fig. 105. The system has been designed to increase the probability of a direct line-of-sight to a satellite by fully exploiting the satellite path diversity capability of the constellation for all services.
- Frequency diversity is supported for BCCH and common control channels.

The minimum number of RF receivers/antennas per UT to permit satellite path diversity is 1. The degree of improvement achieved is dependent on the underlying conditions, however since the paths are uncorrelated typically about 5 dB to 8 dB improvement is expected.

### Voice activation

Voice-activated transmission is required on the forward and return links to allow satellite power savings for increased capacity on the forward link and to allow satellite and UT power savings on the return link. Voice activation is used to maximize the available return link margin and maximize the UT talk time, respectively. The voice activity factor is typically 40%.

#### 6.3.4.2.3 Terminal features

The provision of IMT-2000 services via satellite, particularly to truly hand-portable terminals, is very demanding. Significant source coding must be employed with higher transmission powers and lower level (2- or 4-state) modulation schemes in order to attain, over the satellite link, a BER comparable to terrestrial networks. Particularly for hand-portable terminals, these requirements (coding, power and modulation which all directly impact on spectrum usage) must be balanced against the need for terminals to be similar to terrestrial terminals in terms of size, weight and battery performance.

Service will be provided to a wide range of terminal types. The large majority of UTs are expected to be capable of both satellite and terrestrial operation and, as appropriate, will support service portability, which facilitates access to services expected on a home network from within a visited network, and service transparency, by which the user experiences the same look and feel, irrespective of location, through transparent service delivery. Examples of the terminals, with their technical characteristics and services are summarized in Table 31.

TABLE 31  
Examples of terminal types

Terminal	Service	Bit rate (kbit/s)	BER <sup>(1)</sup>
Hand-held	Voice	4.8	4%
	Data	2.4-9.6	10 <sup>-5</sup>
Ruggedized transportable	Voice	4.8	4%
	Data	2.4-9.6	10 <sup>-5</sup>
Private vehicle	Voice	4.8	4%
	Data	8.0-38.4	10 <sup>-5</sup>
Commercial vehicle	Voice	4.8	4%
	Data	8.0-38.4	10 <sup>-5</sup>
Semi-fixed	Voice	4.8	4%
	Data	8.0-38.4	10 <sup>-5</sup>

(1) The BER for voice services is before error correction.

The technology used in these terminals is also expected to be incorporated in a wide range of other UT types including vehicular, aeronautical, and maritime mobile terminals and semi-fixed terminals, such as rural telephone booths and community telephones.

### 6.3.4.3 RF specifications

#### Power control

A UT will control its output as required by the network and the network will control the output power of the land earth station for each individual channel. The objective of the power control is to enable the minimum transmit power to be used by the LES, UT and satellite for each radio channel that is sufficient to maintain an acceptable received signal quality. Closed-loop power control is used for traffic channels in both the forward and reverse direction. Open-loop power control can also be used. Power control results in:

- an increase in system capacity;
- an increase in UT battery life;
- a reduction in interference.

A power control step size of 1 dB is used, with a dynamic range of 16 dB. The number of power control cycles per second is 2 cycles. The power control bit rate is variable from 2 to 10 bits per 0.5 s per 2 paths.

#### Channel bandwidth, bit rate and symbol rate

The RF channel spacing is 25 kHz. The RF channel bit rate and symbol rate are dependant on the channel type and its associated modulation. Table 35 provides further information on channel types and associated modulations.

For channels employing QPSK or GMSK modulation, the RF channel bit rate is 36 kbit/s. For channels employing BPSK modulation, the RF channel bit rate is 18 kbit/s.

For channels employing QPSK or BPSK modulation, the channel symbol rate (after modulation) is 18 ksymbol/s. For channels employing GMSK modulation, the channel symbol rate (after modulation) is 36 ksymbol/s.

**UT e.i.r.p. and  $G/T$**

Nominal values for UT e.i.r.p. and  $G/T$  for each example terminal type are given in Table 32.

TABLE 32

**Nominal UT e.i.r.p. and  $G/T$**

Terminal	Gain (dBi)	$G/T$ (dB(K <sup>-1</sup> ))	Peak e.i.r.p. (dBW)	Minimum peak e.i.r.p. <sup>(1)</sup> (dBW)	Time average e.i.r.p. <sup>(2)</sup> (dBW)
Hand-held	2	-23.8	≤ 7	-9	≤ -4
Ruggedized transportable	3.5	-21.5	≤ 7	-9	≤ -4
Private vehicle	3.5	-21.5	≤ 10	-6	≤ -1
Commercial vehicle	6.5	-18.0	≤ 10	-6	≤ -1
Semi-fixed	10.5	-14.0	≤ 10	-6	≤ -1

(1) Takes into account power control.

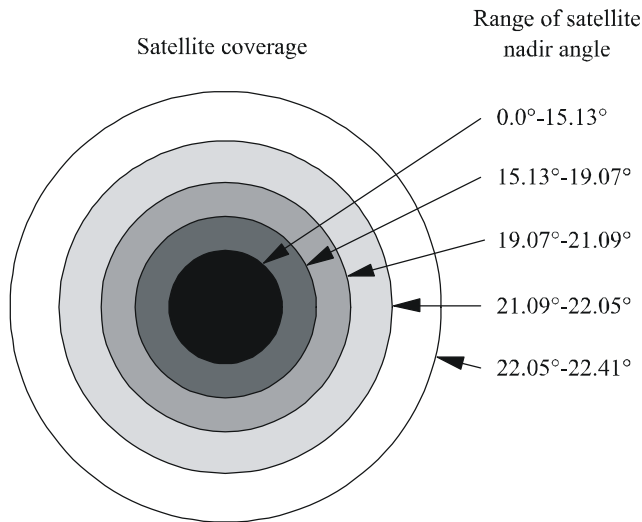
(2) Time averages have been calculated assuming single slot voice use at peak e.i.r.p. with discontinuous transmission. Power control has not been taken into account.

**Satellite e.i.r.p. and  $G/T$**

To aid description of the satellite e.i.r.p. and  $G/T$  performance, Fig. 112 defines various ranges of satellite nadir angle (corresponding to equal surface areas on the Earth).

FIGURE 112

**Definition of e.i.r.p. specification areas from a satellite**



1457-112

The service link e.i.r.p. resource can be flexibly allocated to any of the 163 spot beams by appropriate selection of the uplink (feeder link) frequency corresponding to the satellite filter channel routed to the desired spot beam. Table 33 indicates the nominal maximum e.i.r.p. in each ring if all the e.i.r.p. were directed to that ring only to the exclusion of the beams in the other rings. In realistic traffic applications, e.i.r.p. will be distributed in all rings with less e.i.r.p. than the peak for each ring.

TABLE 33

**Nominal service link maximum e.i.r.p. for each ring**

	<b>Ring 1</b>	<b>Ring 2</b>	<b>Ring 3</b>	<b>Ring 4</b>	<b>Ring 5</b>
SSPA combined output power (dBW)	28.5	28.5	28.5	28.5	28.5
Output losses (dB)	0.7	0.7	0.7	0.7	0.7
Antenna average gain (dB)	30.6	29.6	28.9	28.7	28.2
e.i.r.p. (dBW)	58.2	57.4	56.7	56.6	56.1
Power robbing at worst gain setting (dB)	0.4	0.5	0.6	0.7	0.7
Useful e.i.r.p. (dBW)	58.1	56.9	56.1	55.9	55.4

The nominal service link  $G/T$  allocation is given in Table 34 for each ring of spot beams.

TABLE 34

**Nominal service link worst-case  $G/T$  for each ring**

	<b>Ring 1</b>	<b>Ring 2</b>	<b>Ring 3</b>	<b>Ring 4</b>	<b>Ring 5</b>
Average antenna gain (dB)	30.4	29.4	28.7	28.5	28.1
System noise temperature (dB/K)	25.5	25.0	24.3	23.9	23.8
$G/T$ without losses (dB(K <sup>-1</sup> ))	4.9	4.4	4.4	4.6	4.3
Losses at low processor gain (dB)	2.3	2.4	2.6	2.8	2.8
$G/T$ at low processor gain (dB(K <sup>-1</sup> ))	2.6	2.0	1.8	1.9	1.5

**Synchronization and frequency stability**

LES-LES synchronization of the bit clock is required. The  $2\sigma$  timing accuracy is 1  $\mu$ s and the external system reference is GPS.

The network controls the UT burst timing. The UT synchronizes to the forward link timing, the LES measures the offset from the expected value and any correction to be applied is sent to the UT via a control channel. The UT timing reference clock accuracy is typically 3 ppm.

The frequency stability of the satellite transmit signal is 0.5 ppm.

The UT transmit frequency is controlled by the network. The UT synchronizes to the forward link frequency, the SAN measures the offset from the expected value and any correction to be applied is sent to the UT via a control channel. The frequency stability of the UT transmission is 3 ppm (unlocked) and 0.1 ppm (locked).

**Polarization**

The polarization on the uplink (Earth-to-space) and downlink (space-to-Earth) is RHCP.

**Frequency re-use**

Typically a 4-cell frequency reuse pattern is used as the basis for the frequency plan. See § 6.3.4.1.2 for further details.

### 6.3.4.4 Baseband specifications

#### Multiple access

The system operates in an FDD mode, however there is not generally a fixed frequency relationship (duplex spacing) between the Earth-to-space and space-to-Earth frequencies used for communications to and from the UTs. A combination of FDMA and TDMA is used. Each 25 kHz RF carrier supports frames of length 40 ms. Each frame supports 6 TDMA time slots, with each time slot therefore of duration  $\sim 6.67$  ms (40/6 ms). Each time slot contains 2 guard symbols at both its start and end.

#### Modulation

The modulation scheme employed depends on the channel type. Table 35 provides information on carrier types and their associated modulations.

TABLE 35

**Carrier types and their associated modulations**

Carrier type	Modulation
Voice (TCH)	QPSK (GMSK on return uplink)
Data (TCH)	QPSK (GMSK on return uplink)
BCCH	BPSK
RACH	BPSK (S-BPSK on return uplink)
SDCCH	BPSK

#### Coding

The convolutional coding rate used depends on carrier type. Table 36 provides information on the coding rates employed.

TABLE 36

**Coding rates**

Carrier type	Coding rate
Voice (TCH)	1/3
Data (TCH)	1/2
BCCH	1/2
RACH	1/6
SDCCH	1/4

Soft decision decoding is used.

#### Carrier bit rates

Each time slot supports a bit rate of 6 kbit/s (a channel bit rate of 36 kbit/s with 6 time slots per frame). This provides for 4.8 kbit/s of data and 1.2 kbit/s of framing and in-band signalling.

For TCH, each time slot supports nominal user information bit rates of 2.4 kbit/s for data (before coding) and 4.8 kbit/s for voice (after coding).

For BCCH and RACH, a coded bit rate of 18 kbit/s is supported.

For associated control channels, maximum bit rates of 160 bit/s (SACCH) and 80 bit/40 ms (FACCH) are supported.

### **Interleaving**

For voice (TCH), intra-burst interleaving is used. For data (TCH), intra-burst interleaving and interleaving over 4 bursts are used.

### **6.3.5 Satellite radio interface E specifications**

The Satellite radio interface E (SRI-E) was optimized for use with a constellation of geostationary satellites to provide worldwide coverage for multimedia terminals, in line with the objectives of IMT-2000. Although SRI-E has been optimized for the satellite component, account has also been taken of the need for broader compatibility within the spirit and objectives of IMT-2000. The primary terminal type foreseen for use with SRI-E is a laptop or palmtop computer connected to a small, portable communications unit incorporating a directional antenna. With such terminals SRI-E can achieve transmission rates of up to 512 kbit/s. SRI-E caters for all terminal environments ranging from stationary (including FWA) up to aircraft speeds.

The primary traffic objective is data, particularly for connectivity to the public Internet and to private Intranets, in support of typical applications used over these networks such as e-mail and information browsers. Traditional telecommunications services, such as voice and fax, are also supported. Although the bit rate per carrier is 512 kbit/s, higher bit rates are also possible through specialized terminals with multiple transceivers, through the aggregation of carriers. The satellites used to support SRI-E should use state-of-the-art geostationary technology, where each satellite deploys a large number of spot beams, which together cover continental sized areas and achieve frequency re-use in a manner analogous to that of terrestrial cellular systems.

A key objective in the design of SRI-E has been to make it fully independent of the services and traffic types that it carries. This is viewed as an essential characteristic for a multimedia system.

Shared access bearers is the terminology used to refer to the specific satellite channels which support the transfer of data between the radio network subsystem (RNS) and the user terminal (UE). Shared access bearers, by definition, support more than one connection at a time. The mechanisms for sharing of the resource involve a combination of techniques, where each individual packet transferred over a shared access bearer has an address which identifies the connection.

The resource management system helps to support the operation of multiple bearer types in the system. The Air Interface protocols use one signalling system. The physical bearers are sufficiently independent of the upper layers to support almost any signalling system.

The optimum resource management approach for this configuration is to utilize the channels on a time-division-multiplex/time-division-multiple-access basis (TDM/TDMA) basis.

#### **6.3.5.1 Architectural description**

##### **6.3.5.1.1 Constellation**

As mentioned above, SRI-E is optimized for implementation with a geostationary-satellite system. The constellation parameters are summarized in Table 37.

TABLE 37

**Satellite constellation characteristics for SRI-E**

Satellite altitude	36 000 km
Orbit inclination angle	$\leq 3^\circ$
Number of orbit planes	1
Number of satellites per orbit plane	3 for global coverage
Satellite diversity method	No satellite diversity is used

**Satellites**

The complexity of the satellite-borne equipment expected to be used with SRI-E is at the limit of currently deployable technology. It allows the use of multiple spot beams, and it provides the RF power needed to enable the high rate information services to be delivered to small mobile terminals.

The satellite characteristics ideal for use with SRI-E are shown in Table 38.

TABLE 38

**Satellite constellation characteristics for SRI-E**

Number of spot beams per satellite	Up to 300, depending on desired coverage
Configuration of spot beams	Spot beams are assumed to be simple cones. The configuration should be flexible and reconfigurable during system lifetime in response to evolving traffic patterns
Spot beam size	Approximately $1^\circ$ beam width, i.e. 800 km diameter at the sub-satellite point
Frequency reuse	Frequency reuse plan is based on 7-beam clusters. In the satellite environment, frequency allocation to spot beams follows a simple, regular pattern. Frequency planning does not affect other aspects of the system, e.g. signalling, synchronization, inter-working with terrestrial networks
Service link $G/T$ of satellite beam	Average: 10 dB/K Minimum: 9.5 dB/K
Service link saturation e.i.r.p. of each beam	Minimum: 38 dBW Maximum: 53 dBW
Service link total saturation e.i.r.p. per satellite	67 dBW
Satellite e.i.r.p. per RF carrier: 43 dBW	Maximum e.i.r.p.: 43 dBW Average e.i.r.p.: 42 dBW
Required frequency stability	1 ppm
Power control	Allows an average saving of around 3 dB in satellite power; this enables a virtual doubling of traffic capacity
Power control step size	0.5 dB
Number of power control cycles per second	1
Power control dynamic range	8 dB
Minimum transmit power level with power control	7 dBW

### **6.3.5.2 System description**

#### **6.3.5.2.1 Service features**

The baseline SRI-E satellite system has been designed to deliver, support and provide interoperability with UMTS type applications.

The air interface is a packet data system which implies that bearers are shared access bearers and therefore the user data rate during a connection varies depending on the traffic load. Circuit switched type applications (voice, ISDN) can be supported through defined quality of service parameters set to guarantee the user data rate.

##### **6.3.5.2.1.1 Capability for multimedia services**

Multimedia services are different from traditional telecommunication services in a number of ways, as described in the following sections. SRI-E has been designed for this traffic, as explained under each of the topics.

#### **Independence between transport and applications**

Second-generation mobile networks have a close association between the radio transport and the characteristics of the principal application, i.e. voice traffic. For a multimedia network such a coupling is highly undesirable. Rather, a radio interface should be designed to be as general as possible and to support a wide variety of traffic, including those which have not been foreseen at present. This principle underlies the design of ATM.

SRI-E fully supports this objective. It makes no assumption about the protocols or services to be used above it. Compatibility with terrestrial ATM ensures that any traffic which can be carried by ATM can also be carried by SRI-E (as long as bandwidth is adequate).

#### **Support of IP-based services**

In the coming decade the Internet will assume an importance equal to that of the international telephone network, as the global backbone for information sharing and exchange as well as for real-time distribution of data. Indeed, there are those who claim that it will even usurp the role of the telephone network for carrying voice, although this claim remains contentious. In addition to the shared Internet, companies and other organizations now base their internal information sharing around Internet technology, leading to so-called Intranets and, for closed groups of users, Extranets.

Any communications technology designed to integrate with the real world of the twenty-first century must incorporate the Internet and its associated protocols as a primary mode of operation. The ability to handle this traffic with maximum efficiency will be the distinguishing criterion of successfully deployed communications technologies.

One of the primary characteristics of Internet traffic, compared with traditional telecommunications, is its bursty nature. A user will typically require information in relatively concentrated bursts, for example when loading a web page or a form, and will then have low bandwidth requirements for a period afterwards. This is a well-known characteristic of today's network, allowing for statistical multiplexing of, typically, five times the number of users that the static bandwidth would appear to permit. Traditional networks, with their emphasis on fixed bandwidth for the duration of a call, are ill-equipped to deal with such traffic. Another characteristic of this traffic is its asymmetry. Typically the amount of data flowing in one direction (normally towards the user) exceeds that in the other direction by an order of magnitude.

SRI-E has been designed with Internet support as its primary goal. Its variable bandwidth service provides instantaneous response to changing traffic, especially towards the remote user. No renegotiation or other delay is imposed between the arrival of traffic and the assignment of



corresponding bandwidth, assuming that the latter is available. Where there is contention for bandwidth (i.e. there is not enough to meet the instantaneous demand) it automatically shares what is available in an equitable fashion. Although not included in the current proposal, allowance is also made for more elaborate schemes where, for example, some calls might receive a greater share of bandwidth when contention occurs, based on a commercially priced quality of service.

The dynamic bandwidth assignment also naturally allows for asymmetrical traffic. A mixture of typical Internet users together with reverse-direction traffic, such as uploading of transaction histories or telemetry data, will automatically optimize the use of bandwidth.

Another characteristic of Internet use (including Internet-like services such as Intranets) is that users expect full-time connection, without active intervention on their part for example to make or break a call in relation to their activities. (This mode of operation is reluctantly supported by domestic dial-up users but does not occur in the corporate environment and is really an artefact of the unsuitability of the PSTN for this kind of traffic.) It is therefore desirable for an access technology to provide a low-cost mode of connection on a full-time basis, with actual bandwidth being engaged only when required in response to the traffic.

SRI-E provides such an option, corresponding to unassured bit rate (UBR) in ATM networks. When such a user is inactive (as determined by traffic monitoring) no radio resources are used. When they become active, i.e. when traffic is received at the base station or from the user's terminal, radio resources are allocated through a call restoration procedure.

### **Support for multiple concurrent calls**

Multimedia traffic will frequently demand multiple calls, to the different or the same destinations and with differing quality requirements. For example, the ITU-T Recommendation H.323 standard for multimedia conferencing assumes this capability.

SRI-E supports any mixture of calls, each with its own destination and QoS, within the overall capacity limit of a channel (512 kbit/s). SRI-E automatically multiplexes calls for different terminals within a channel, but can dedicate a whole channel to a single terminal if required.

The handover capability is used not only to support geographic mobility but also to optimize channel usage. A terminal may start its activity with a single low-bandwidth call (e.g. voice) then add further calls until the shared capacity of the channel is no longer adequate. At this point the handover mechanism is invoked to move the terminal (or indeed another terminal) into another channel, having the required capacity. Similarly, as calls are terminated, effective use of bandwidth may require that terminals operating in different channels be compacted into a single channel, freeing resources for use elsewhere.

### **Support of location determination**

It is increasingly a legal requirement on mobile systems that they be able to inform security and emergency services of the physical location of a terminal. Provision of this capability will therefore be a requirement in order to obtain an operating licence in many countries. Moreover other regulatory differences between countries, which could impact on the use of the terminal or services, require location information.

A system using SRI-E should use an independent GPS receiver to obtain accurate (100 m) position information. The signalling protocol includes the means to transmit this to the base station. If SRI-E were used in a terrestrial environment then the GPS receiver could be replaced by radio-location means.

### 6.3.5.2.1.2 Quality aspects

SRI-E does not intrinsically impose any particular voice quality. It is envisaged that ITU-T Recommendation G.729 will be used and quality will be as specified therein. Lower or higher qualities (with corresponding impact on bandwidth requirement) are possible without impact to the radio interface.

Transmission quality is one of the strengths of SRI-E. The error rate is specified in FEC-block error rates. The link adaption will seek to provide a steady error rate below  $1 \times 10^{-3}$ . This is adequate for all multimedia applications, without further enhancement at the radio interface or interface layers. (Applications requiring higher integrity than this invariably operate their own higher-layer data integrity protocols).

SRI-E uses adaptive turbo coding, whereby the coding rate (and hence the user data rate) is adjusted in real time as channel conditions change to maintain a fixed block error rate of  $10^{-3}$ .

In addition, the SRI-E includes a high-level data link control (HDLC) based protocol on the satellite hop which is optimized for the satellite environment. Packet switched connections (interactive or background class) operate in acknowledged mode and lost packets are retransmitted. Circuit switched and streaming class packet switched connections use unacknowledged/transparent mode and are subject to potential loss.

SRI-E does not impose constraints on the service protocols used, SRI-E will adopt the new 4 kbit/s adaptive multi band excitation (AMBE+2<sup>TM</sup>) codec for which measurements have achieved a subjective voice quality in excess of the toll-quality voice transmission quoted in ITU-T Recommendation G.729. This meets IMT-2000 requirements.

In some modes of operation e.g. acknowledged mode, no packet loss is expected during handover since all traffic is stopped up. For unacknowledged mode traffic may be stopped, but this may have some noticeable impact on say a video streaming application only. Transparent mode, most noticeably voice, would lead to a loss of frames, this may affect the voice quality. For non real-time services, such as Internet access, the cell loss will be recovered by the ITU-T Recommendation V.42 integrity enhancement protocol, and will therefore be transparent to the application. It will appear in the same way as a transmission error, which will be statistically more common.

Variations in signal quality are dealt with primarily using active coding rate management, therefore the end data rate seen by the user is driven by the link quality although the error rate is constrained. This is more appropriate to a multimedia environment, where applications are typically more sensitive to data errors or to the effects of error recovery than is the case for traditional services such as voice.

### 6.3.5.2.2 System features

#### Gateways

Calls are directed to the satellite gateways responsible for the spot beam in which the terminal is located. Multiple RNS stations may serve a single spot beam. The mobility management is handled using a GSM/UMTS core network. Each spot-beam acts as a mobility management routing area/location area and mobiles are tracked on that basis. All satellites in the system have to be visible from at least one gateway each. Thus, only a small number of gateways are required in the geostationary satellite environment - a minimum of one per satellite or three for a global system.

### **Network interface**

SRI-E does not impose any constraints on the network interface. No additional PSTN functionality is required for ISDN or PSTN inter-working. Similarly, no constraints are placed on Internet routers. However, SRI-E can take advantage of emerging Internet features such as bandwidth reservation.

Conventional network interfaces can be used, following established standards such as ITU-T Recommendations Q.761, Q.931 and Q.2931. Satellite and mobile specific features such as handover and mobility management are not visible at the network interface.

No modifications are required to the landline network for SRI-E to pass the standard set of ISDN bearer services. All landline ISDN and other services and features are passed in the SRI-E. SRI-E only provides a pipe for UMTS signalling protocols and does not interpret these messages.

### **Handover/automatic radio link transfer (ALT)**

Users are required to be managed efficiently, this may lead to users being moved from one beam to another. Several scenarios are possible:

- The move to a different beam of the same type on the same satellite, controlled by the same radio network controller (RNC);
- The move to a different beam of the same type on the same satellite, controlled by a different RNC;
- The move to a different beam of the same type on another satellite.

Handover is handled entirely within different layers of SRI-E. Handover is initiated by a radio resource management (RRM) event, the bearer control layer configures the target bearer control process but leaves the source bearer control process intact. A signalling process via the UE helps the target bearer control process to reconfigure and communicate with the RNC. After reattachment and signalling of acknowledgment, the old connection is detached.

Handover may result in the loss of some data. For voice, this means a short duration, with no audible impact, when using ITU-T Recommendation G.729. For data, ARQ mechanisms guarantee data integrity.

Handover affects system complexity in two ways:

- the need for additional protocol mechanisms - these affect only software and therefore do not impact the unit terminal cost;
- the need for BS channel units to be able to split and combine traffic from the old and new radio channels during the handover - this has no impact on terminals.

### **Dynamic channel allocation**

Frequencies can be dynamically assigned to spot beams according to traffic load. The satellite component is subject to an environment where there are not substantial variations in propagation conditions. Hence, SRI-E is more spectrally efficient (and more efficient in the use of critical satellite power) than is the case where wider variations need to be accommodated.

### **Power consumption**

SRI-E has been designed for use in situations where access to mains power may be impossible. It therefore optimizes power consumption, allowing the greatest possible economy in both standby and operational modes. Both transmission and reception operate intermittently, as required by the traffic. Even when variable bandwidth calls (e.g. for Internet traffic) are in use, intermittent reception is used except when a burst of traffic is being received.

Due to the variance in geographical locations of UEs relative to the centre of the spot-beam, power supply variations and manufacturer tolerances, transmissions from a UE may be received at a considerable range of signal to noise ratios at the RNS. To limit interference, to ensure that the receiver is operating in its optimum range, and to conserve battery power at the mobile, the RNS performs a correction of the transmissions by each UE as necessary. This may occur at any time during communications.

### **Timing correction**

The nature of satellite communications is that the propagation path for the radio signals differs in length considerably, owing to the variance in geographical locations of the mobiles communicating. This is not normally a problem in a pure FDMA single-channel-per-carrier (SCPC) system, but in a shared access system, when multiple mobile transmitters are using the same physical resource, it is important to ensure that mobiles do not interfere with each other. This is achieved either by the use of satellite position and GPS position or through a combination of providing a guard time between mobile transmissions and by providing timing correction information to each mobile transmitter, relative to a reference at the RNS receiver. The bearer control sub-layer is responsible for monitoring and correcting timing errors.

The accuracy of the timing measurement and correction requirements is dependent upon the particular physical layer in operation.

Once the initial timing offsets have been corrected, the timing of transmissions from each individual mobile is continuously monitored, and, when necessary, a differential correction mechanism is provided.

### **Frequency correction**

The UE will lock on to the forward bearer and correct its own long-term frequency stability.

#### **6.3.5.3 RF specifications**

##### **Frequency band**

SRI-E imposes no frequency band constraints. In principle it could be used at any frequency band, although propagation conditions and constraints on antenna technology makes it most suitable for use at frequencies between 1 and 3 GHz.

##### **Multiple access**

SRI-E generally builds upon well understood and proven techniques. This includes the use of TDM/TDMA/FDMA.

The multiple access system consists of forward and return channels that are shared by several users. By allowing several users to share the same channel, one user's inactivity will be balanced against another user's activity. Together users will be transferring data in both directions, so forward and return channels will be busy.

##### **Duplex method**

SRI-E is designed for FDD. The minimum up/down frequency separation is a cost dependent function of implementation.

##### **Modulation and coding**

SRI-E supports a wide range of mobile terminal antenna apertures and e.i.r.p. capabilities therefore it is not possible to provide a single solution which optimizes the transmission rate whilst maintaining communication across all the types of terminals. The problem is solved in this case by introducing a range of bearer types, operating both 16-QAM and 4-ary modulations in the return

direction. In the forward direction 16-QAM bearer and QPSK for signalling is employed. To maximize the efficiency and the bit rate obtainable by each terminal a technology described as variable coding is used. This is essential in order to achieve the high spectrum efficiency.

Variable coding techniques involve the puncturing of the turbo-code generated parity streams using one of a number of pre-defined puncturing matrices, such that the level of redundancy provided by the code is variable. This allows the information to be transmitted to or from a mobile over a single channel to be increased when the mobile is operating in good channel conditions, and correspondingly reduced to allow the communications link to be maintained when the mobile is operating in poor channel conditions.

### **C/N requirement**

The system has been designed such that steps in the coding rate provide nominally 1 dB steps in C/No requirements to achieve the requisite burst error rate performance of  $10^{-3}$ . This approach can also be used to counter the effect of slow fading. The satellite gateway controls the coding rate depending on the reported C/No values of the link.

### **Carrier spacing and channelling**

The SRI-E forward bearers are capable of carrying nominal data rates in the range between 4.5 kbit/s and 512 kbit/s and are based upon the continuous transmission of time-division-multiplexed (TDM) carriers. The forward bearer is transmitted with a constant mean power level.

The return bearers are capable of carrying nominal data rates in the range between 8.4 kbit/s and 492.8 kbit/s and are based upon burst transmissions using a time-division-multiple access scheme (TDMA). The bursts are transmitted in slots of either 5 ms or 20 ms duration, which are described in a return schedule transmitted on a forward bearer. These return schedules also describe the symbol rate and modulation that shall be used for the transmission.

### **Spectrum efficiency**

SRI-E achieves the highest spectrum efficiency possible with today's technology, for a geostationary satellite system. The basic modulation efficiency provided by the advanced modulation and coding technology is 1.4 bit/s/Hz. The use of traffic-sensitive statistical multiplexing further increases spectrum efficiency. In the case of data and Internet traffic, because of the highly flexible variable bandwidth mechanism, the effective rate taking into account probable statistically multiplexing gains is in the range 3-7 bit/s/Hz. In the case of voice traffic, voice activation can be expected to double the basic raw channel efficiency.

### **Mobile earth station characteristics**

SRI-E will support multiple ranges of user terminals. However, only data for three types are included here, each of these have antenna gains in the range from 7.7 dBi to 14 dBi. The e.i.r.p. of these mobile terminals will range from 10 dBW to 20 dBW.

### **UEs frequency synthesizer**

The requirements for the UE frequency synthesizer are listed in Table 39.

TABLE 39

**Frequency synthesizer requirements**

Step size	1.25 kHz
Switched speed	80 ms (including protocol processing)
Frequency range	Depends on spectrum allocation only
Frequency stability	1 ppm

**Doppler compensation method**

No explicit Doppler compensation is required as SRI-E is designed for a geostationary system. Receiver AFC is adequate for all mobile terminal speeds including those on airliners. Residual frequency offset will be determined at baseband using DSP techniques.

**Propagation factors**

Multipath interference has only limited impact in the target environment. It is accounted for in the link budget.

The fading rate is much slower than the symbol rate, so the intersymbol interference caused by changing delay spread profile is negligible.

**6.3.5.4 Baseband specifications****Bit rates****Forward link**

The forward link data can deliver from 21.6 kbit/s up to the 512 kbit/s depending on the bearer type supported by the mobile and the channel conditions. The user data rate can be varied in response to variations in the channel  $C/N_0$  as the user moves in the centre of the spot beam. The data rate can be dynamically adjusted on a burst by burst basis by the RNS and this is signalled by the unique word and an attribute value pair (AVP) in the first FEC block if the coding rate is not the same as the full frame.

**Return link**

Similarly in the return direction the data rates supported depend on the mobile capabilities and the channel conditions. The return bearers are able to deliver from 19.2 kbit/s up to 512 kbit/s. Again the data rate can be adjusted on a burst by burst basis and this is controlled by the RNS and partially by the UE itself.

**Frame structure****Forward frame structures**

The forward frame structure and combination of initial unique word and distributed pilot symbols have been adopted for the forward direction. The frame duration is 80 ms. Three types of forward bearers have been designed:

- The first operates at 8.4 ksymbol/s and is primarily used in the global beam, the bearer uses QPSK. Each frame occupies 10.5 kHz.
- The second operates at 33.6 ksymbol/s (occupying 42 kHz) and is used for signalling and for servicing small aperture terminals. Each frame is divided in four 20 ms FEC blocks. The bearer uses QPSK and 16-QAM.

- The third type is a “wide” bearer operating at 151.2 ksymbol/s (189 kHz). This bearer carries traffic data. Each frame is subdivided in eight 10 ms FEC blocks. This results in reducing delays in the forward direction from 20 ms to 10 ms. This is of prime importance for latency sensitive applications such as voice.

### Return burst structures

In the return direction, two bursts duration have been chosen: 5 ms and 20 ms. For the highest rate bearer the number of blocks in a burst has been increased from one to two, to avoid excessive increase in turbo-encoder memory requirements. Again the 5 ms burst duration has been chosen for minimising latency.

The smallest viable payload for turbo-coded blocks is around 20 octets, and this places a lower bound on the use of the 5 ms slot size - it can only be used for bearers with a symbol rate of at least 33.6 ksymbol/s when using the 16-QAM modulation or a symbol rate of 67.2 ksymbol/s when using a 4-ary modulation.

### Nomenclature

TABLE 40a

Bearer names definition

Direction	Frame/burst duration (ms)	Symbol rate (multiplier) (ksymbol/s)	Modulation	FEC blocks per frame
F: Forward	80	$0.25 \times 33.6$	X: 16-QAM Q: QPSK	1B
		$1 \times 33.6$		4B
		$4.5 \times 33.6$		8B
R: Return	20 5	$0.5 \times 33.6$	X: 16-QAM Q: $\pi/4$ QPSK	1B
		$1 \times 33.6$		2B
		$2 \times 33.6$		
		$4.5 \times 33.6$		

TABLE 40b

Overview of Forward Bearer Types

Identifier	Frame duration (ms)	Symbol rate (ksymbol/s)	Modulation	FEC blocks per frame
F80T0.25Q1B	80	$0.25 \times 33.6$	QPSK	1
F80T1X4B	80	33.6	16-QAM	4
F80T4.5X8B	80	$4.5 \times 33.6$	16-QAM	8
F80T1Q4B	80	33.6	QPSK	4

TABLE 40c  
Summary of Return Bearer Types

Identifier	Burst duration (ms)	Symbol rate (ksymbol/s)	Modulation	FEC blocks per burst
R5T1X	5	33.6	16-QAM	1
R5T2X	5	$2 \times 33.6$	16-QAM	1
R5T4.5X	5	$4.5 \times 33.6$	16-QAM	1
R20T1X	20	33.6	16-QAM	1
R20T2X	20	$2 \times 33.6$	16-QAM	1
R20T4.5X	20	$4.5 \times 33.6$	16-QAM	2
R5T2Q	5	$2 \times 33.6$	$\pi/4$ QPSK	1
R5T4.5Q	5	$4.5 \times 33.6$	$\pi/4$ QPSK	1
R20T0.5Q	20	$0.5 \times 33.6$	$\pi/4$ QPSK	1
R20T1Q	20	33.6	$\pi/4$ QPSK	1
R20T2Q	20	$2 \times 33.6$	$\pi/4$ QPSK	1
R20T4.5Q	20	$4.5 \times 33.6$	$\pi/4$ QPSK	1

### Coding

To maximize the efficiency and the bit rate obtainable by each mobile, a technology described as variable coding is employed. This involves the puncturing of the turbo-code generated parity streams using one of a number of pre-defined puncturing matrices, such that the level of redundancy provided by the code is variable.

This allows the information rate to or from a mobile over a single channel to be increased when the mobile is operating in good channel conditions, and correspondingly reduced to allow the communications link to be maintained when the mobile is operating in poor channel conditions.

The steps in the coding rate provide nominally 1 dB steps in  $C/N_0$  requirements to achieve the requisite burst error rate performance of  $10^{-3}$ . This approach is also used to counter the effect of slow fading. The satellite gateway controls the coding rate depending on the reported  $C/N_0$  values of the link.

TABLE 41  
Air interface variables

Modulation	Symbol rate (ksymbol/s)	Coding rate
QPSK, $\pi/4$ QPSK, 16-QAM	8.4, 16.8, 33.6, 67.2, 151.2	0.34, 0.4, 0.5, 0.6, 0.7, 0.8, 0.84

### Parametric algorithmic design

There are a large number of coding rates required to achieve the full operational range, but the memory requirements for the mobiles are kept to a minimum. The functions for control encoder and decoder, the puncturing matrices and the channel interleaver matrices are described algorithmically, rather than in table form. This methodology ensures that there is a minimizing of the potential for specification and implementation errors.



### Unique words

The encoding rate is signalled by the unique word used for the burst, this minimizes the constraints on system design and ensures that each frame or burst can be correctly demodulated and decoded without *a priori* knowledge of the coding rate that the transmitter is applying to a specific burst or frame transmission.

### Turbo-synchronisation

Signalling using the unique words and operating at low  $E_s/N_0$  creates problems with the performance of the burst detection and synchronization mechanisms if classic techniques are utilized. The SRI-E incorporates a new technique to dramatically improve the performance.

The radio transmission processing delay due to the overall process of channel coding, bit interleaving, framing, etc., not including source coding, given as transmitter delay from the input of the channel coder to the antenna plus the receiver delay from the antenna to the output of the channel decoder is 55 ms for voice at 8 kbit/s and 10 ms for data at 144 kbit/s.

### Echo control

SRI-E round trip delay is 100 ms for an 8 kbit/s connection, not including propagation delay. Clearly for a geostationary satellite system the latter predominates, adding approximately 600 ms and making echo control indispensable.

### Linear transmitter requirements

Operation of the UE will conform to ETSI and other spectrum masks.

### Receiver requirements

The dynamic range of the receiver is specified at 10 dB. Since the peak-to-average power ratio after baseband filtering is 3 dB, this is entirely adequate to cater for the variations of signal levels expected.

### Required transmit/receive isolation

40 dB.

## 6.3.6 Satellite radio interface F specifications

The Satcom2000 satellite radio interface F provides the air interface specifications for a personal mobile satellite system that uses advanced architecture and technologies to support a variety of service applications in diverse user environments.

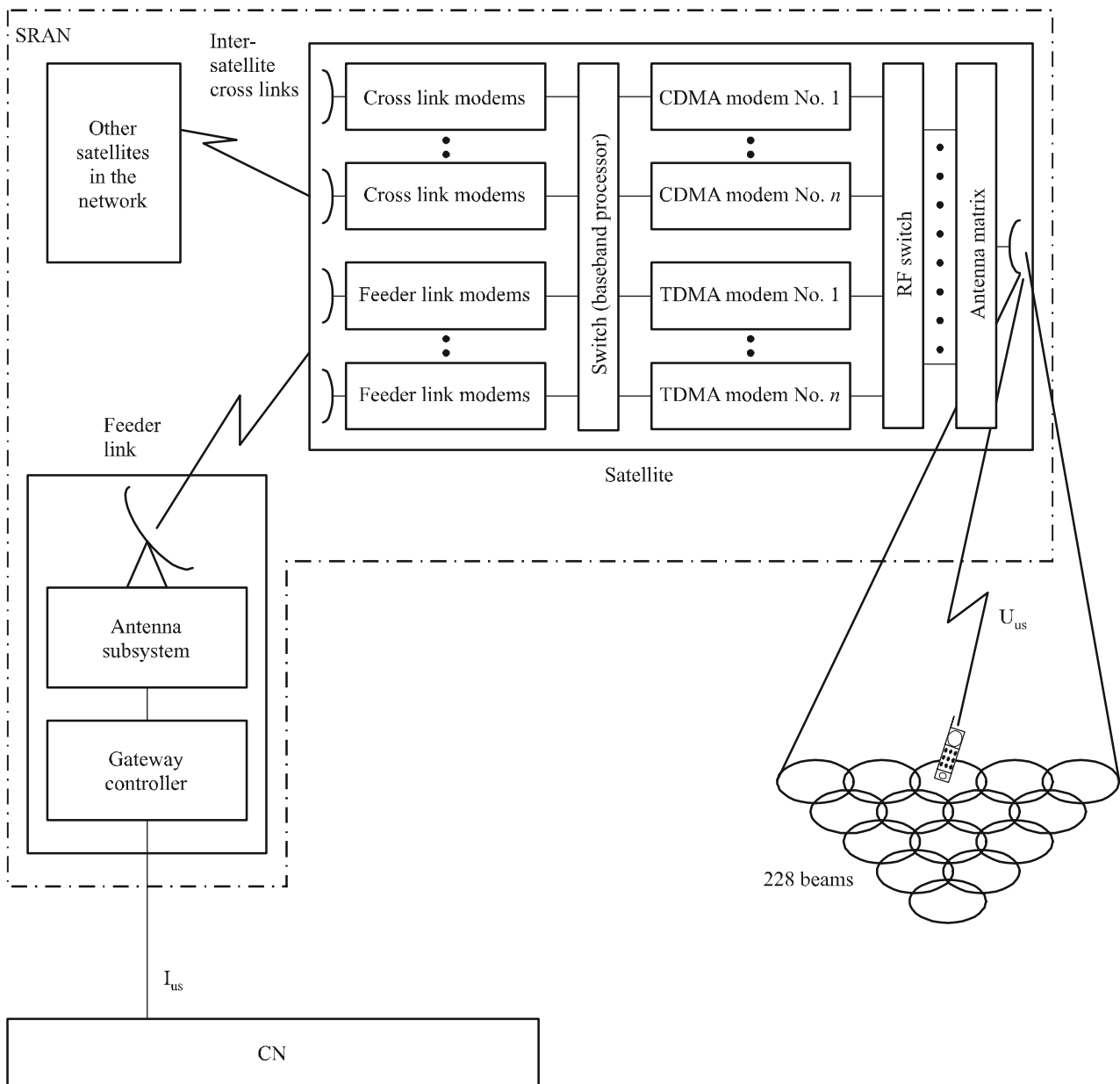
A personal mobile satellite system employing the Satcom2000 radio interface will serve as a global extension of and complement to terrestrial networks, offering the quality and diversity of services envisioned for IMT-2000 systems. In coordination with terrestrial network operators, this system can provide subscribers with one phone and one number for almost all their communications needs. This system will offer a range of voice and data services, including a combination of voice, data, facsimile transfer, Internet access, e-mail, voice-mail, paging and messaging applications.

### 6.3.6.1 Architectural description

With smart antennae, hybrid multiple access schemes, on-board processing and switching, and other advanced technologies, a personal mobile satellite system employing the Satcom2000 radio interface is designed to optimize spectral, spatial and power resources. The ability to select alternative multiple access schemes allows the method best suited for the service and environment to be selected. Baseband switching provides a high level of control on the path for specific user data. Baseband processing and coding allow a lower BER on the user channels.

A block diagram of the architecture of Satcom2000 radio interface is shown in Fig. 113. In this Figure, the gateway equipment (gateway controller and antenna subsystem) and the satellite constellation are grouped together as the SRAN. The feeder link and inter-satellite links are internal implementation details of the SRAN. The interface with the CN is called the  $I_{us}$  interface, and the interface with the user terminals is called the  $U_{us}$  interface. The physical implementation of this system includes a constellation of switched digital communications satellites with large number of high gain spot beams for each satellite.

FIGURE 113  
Architecture of Satcom2000



The SRAN performs the following functions:

- Control message distribution – The SRAN will determine the appropriate routing destination of messages received from the constellation. This function includes routing of messages to the CN as well as to other access networks.
- Admission negotiation for the CN.
- Paging – The SRAN will provide paging distribution for a page request.
- Satellite network resource management functions. These functions include:
  - coordination of access network functions, including resource allocation and assignment, to handle call set-up and release,
  - handover management, including handover between beams in one satellite, handover between different satellites in the constellation and handover between satellite and terrestrial,
  - QoS negotiations (may require interaction with CN),
  - collection of statistics for satellite resource utilization.

#### **6.3.6.1.1 Constellation**

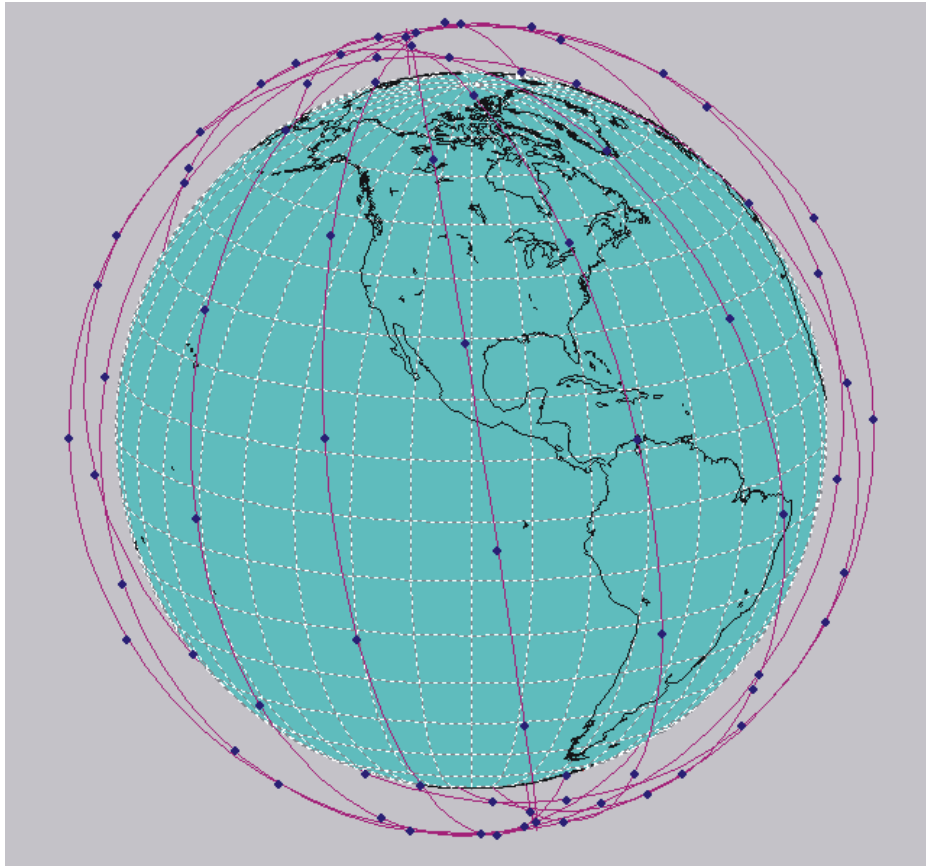
The personal mobile satellite system of Satcom2000 consists of a constellation of 96 LEO satellites in eight near-polar orbits, with twelve satellites equally spaced in each orbital plane (excluding spares). The orbit selection criteria, each of which is vital to the commercial service provision and technological feasibility of the system, are as follows:

- the need to provide global coverage over the entire surface of the Earth at all times;
- the requirement that the relative spacing and line-of-sight relationships to neighbouring satellites are fixed or slowly changing, thus allowing simplification of the on-board subsystems that control inter-satellite links;
- the desire to minimize the cost of the entire constellation; and
- the effects of altitude on hardware costs (i.e. trade-offs considering a high-altitude radiation environment significantly increases costs, whereas low altitudes require more fuel and station-keeping manoeuvres).

This satellite constellation, which is illustrated in Fig. 114, provides coverage over the entire surface of the Earth. This selected orbit may be adjusted to optimize the system design.

The major constellation parameters of this satellite system are shown in Table 42.

FIGURE 114  
Satellite constellation



1457-114

TABLE 42

**Constellation parameters**

Orbit type	LEO
Number of satellites	96
Number of orbital planes	8
Number of satellites per plane	12
Inclination type	Polar
Inclination	98.8°
Orbital period	6 119.6 s
Apogee altitude	862.4 km
Perigee altitude	843.5 km
Arguments of perigee	270°
Active service arc(s)	Not applicable – global coverage area
Right ascension of ascending nodes	160°, 183.5°, 207°, 230.5°, 254°, 277.5°, 301°, 324.5°

### 6.3.6.1.2 Satellites

The 96 satellites of the system space segment will provide universal service provision through global coverage from space.

All the satellites in the constellation are linked together as a switched digital communications network in the sky and use the principles of terrestrial cellular network to provide maximum frequency reuse. Each satellite uses spot beams to form cells on the surface of the Earth. Multiple and relatively small beams provide high satellite antenna gains and thus reduce the RF power required from the satellite and the user subscriber equipment. The number of spot beams can be adjusted for the system performance optimization even when the satellite is in orbit.

The major characteristics of each satellite communications payload are shown in Table 43.

TABLE 43

**Major satellite communications payload characteristics**

Number of spot beams per satellite	228 (may be adjusted for performance improvement)
Minimum elevation angle for user	15°
Inter-satellite links (yes/no)	Yes
On-board baseband processing (yes/no)	Yes
Geographical coverage (e.g. global, near global, below xx degrees latitude, regional)	Global
Dynamic beam traffic distribution (yes/no)	Yes

The spatial separation enabled by satellite spot beams allows increased spectral efficiency via time and frequency reuse within multiple cells. The frequency reuse pattern can be re-configured based on actual traffic conditions even when the satellites are in orbit.

Each satellite has the capability to allocate its power and bandwidth resources from one beam to another dynamically in response to actual traffic needs. For example, due to a disaster relief event, if the traffic demand in one beam increases above its nominal traffic, the satellite can re-allocate power and bandwidth that were originally allocated to other beams to this hot spot so that more traffic can be accommodated.

The requirement for communicating with subscriber units is supported by a satellite antenna complex, which forms cellular-like beams. A set of two phased-array antennas on the spacecraft, one for transmit and one for receive, support the uplink and downlink. Transmit and receive phased-array antenna pairs produce nearly identical and congruent uplink and downlink beams. The footprint of each satellite is divided into clusters of beams in order to facilitate channel reuse. Any of the beam ports of the transmitting antenna can be simultaneously activated by exciting it with one or more carrier signals. Each beam is dynamically assigned a set of channels corresponding to specific frequency and time slot assignments in the frequency band commensurate with the number and usage of subscriber units being served. To efficiently accommodate variations in traffic, hardware allows the number of connections per beam to adapt automatically to the demand.

Beams also can be turned on or off, as appropriate, to accommodate traffic conditions and changing overlap of coverage. For example, to minimize possible interference from overlapping satellite footprints and to conserve satellite power, the system will employ a cell management architecture that turns beams off as each satellite traverses from the Equator toward the Polar regions.

The service link antenna subsystem is fixed to the satellite body and its pointing accuracy is dependent upon the satellite attitude control stabilization system.

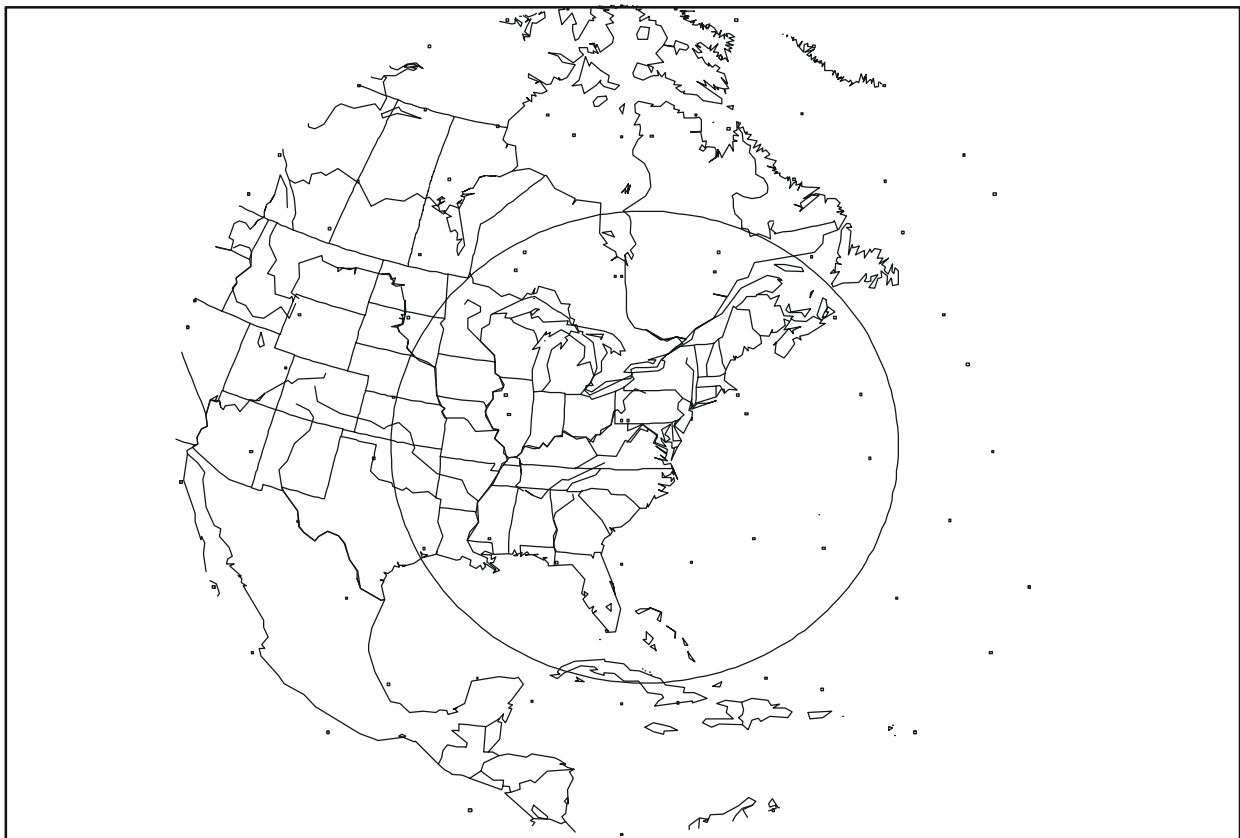
Inter-satellite links connect the satellites in orbit to create a global telecommunications network in the sky. These links provide connectivity within and across orbital planes.

Each satellite has the capability, via feeder links, to establish links with the gateways on the Earth. The system will accommodate various numbers of gateways. The actual number of gateways to be deployed will be based on technical as well as business considerations.

In addition to the above communications links, the satellite has the capability to establish telemetry, tracking and command links with telemetry, telecommand and control (TT&C) stations located around the world.

Figure 115 shows a representative in-orbit coverage of a single satellite over the United States of America, at an altitude of 853 km.

FIGURE 115  
Single satellite coverage region, 853 km, 15° elevation angle



1457-115

### 6.3.6.2 System description

This Satcom2000 personal mobile satellite system is designed to satisfy the projected growth in overall demand for global mobile telecommunications, provide access to services requiring higher and variable data rate capabilities, and enable greater expansion and integration of satellite services with the terrestrial fixed and mobile networks.

This system will be capable of providing two-way voice, data, messaging, and multimedia communications services between a variety of user equipment anywhere in the world, and interconnecting any such user equipment to the PSTN, PSDN, PLMN, and other terrestrial networks, including global roaming and interoperability with the terrestrial component of IMT-2000 networks.

In order to provide this range of services, Satcom2000 will employ both TDMA and CDMA radio access technologies, comprising FDMA/TDMA and FDMA/CDMA channels operating on every satellite. This hybrid multiple radio access scheme incorporated into a single satellite system meets the diverse personal communications needs for wireless users in the twenty-first century and provides efficient spectrum utilization for such a variety of service offerings.

There are five segments comprising this Satcom2000 personal mobile satellite system:

- space segment consisting of a constellation of 96 operational satellites in LEO of 854 km altitude, with 8 orbital planes and 12 satellites in each plane;
- system control segment that provides centralized TT&C for the entire satellite constellation;
- ground segment consisting of gateway stations and associated facilities including infrastructure for interfacing with terrestrial networks and service distribution;
- subscriber segment that features dual mode (satellite/terrestrial services compatible) multi-standard and multi-band user terminals; and
- business and customer support segment consisting of billing system and customer care centre, etc.

It will be possible for a satellite system employing Satcom2000 to interwork with the terrestrial component of IMT-2000 described in § 5. Roaming between the terrestrial network and the satellite network is supported. In most cases, automatic handover between the terrestrial and the satellite network will also be supported.

**6.3.6.2.1 Service features**

This personal mobile satellite system provides voice, data and messaging services in full-duplex communications. Bandwidth on demand, bit rate on demand, paging (alerting) service via satellites are supported. In order to accommodate the inherent nature of asymmetric Internet traffic, the system has provision for asymmetric data transmission. Asynchronous data transmission is also supported.

Table 44 below summarizes the key service features supported by this personal mobile satellite system.

TABLE 44

**Key service features**

Bandwidth on demand (yes/no)	Yes
Bit rate on demand (yes/no)	Yes
Asynchronous data (yes/no)	Yes
Asymmetric data (yes/no)	Yes

**6.3.6.2.2 System features**

The key features of this personal mobile satellite system are summarized in Table 45.

Satcom2000 provides two separate satellite service link radio air interfaces: one is based on TDMA multiple access technology, and the other is based on CDMA multiple access technology. Both interfaces use a frequency plan with individual carriers separated in a basic FDMA scheme. Partitioning between the TDMA and CDMA operations will be optimized to match the service type and user environment, meet the traffic demand and maximize the system effectiveness.

TABLE 45

**Key system features**

Multiple access schemes	FDMA/TDMA and FDMA/CDMA
Handover technique (e.g. intra- and inter-satellite, soft or hard or hybrid)	Intra- and inter-satellite, using soft/hard handover
Diversity (e.g. time, frequency, space)	Time, space, etc.
Minimum satellite channelization	TDMA: 27.17 kHz CDMA: 1.25 MHz
Operation in satellite radio operating environments of Recommendation ITU-R M.1034	Urban satellite environment Rural satellite environment Satellite fixed-mounted environment Indoor satellite environment

The CDMA sub-system can achieve high spectral efficiency where power control techniques are effective at keeping all users at similar power levels. However, satellite systems suffer from relatively long path delays that impede the effectiveness of power control feedback loops. Where power control is ineffective, CDMA's spectral efficiency will be reduced.

For applications in which the user environment and hence the signal level change rapidly, e.g. mobile voice services, a TDMA scheme will achieve better performance in terms of both spectral efficiency and service quality. For applications such as high-speed data services in which the user environment may change slowly and thus the power control can be effective, a CDMA scheme will be more appropriate. This hybrid implementation allows all service types to be supported with an optimal use of the satellite resources.

The TDMA links provide large fade margins for various user environments in order to meet or exceed availability requirements. The CDMA links encompass a wide range of data rates, with link margins appropriate to specific services.

Satcom2000 supports handover between beams on a satellite, handover between beams on different satellites, as well as handover between a terrestrial IMT-2000 network and this satellite network. Management of handovers including call maintenance is handled by the SRAN.

**6.3.6.2.2.1 FDMA/TDMA radio interface**

The basic FDMA/TDMA individual voice channels are each transmitted at a 34.545 kbit/s burst rate, each occupying a bandwidth of 27.17 kHz using QPSK modulation. This permits a peak density per beam of 147 voice channels per 1 MHz, and 184 voice channels per 1.25 MHz.

Satcom2000 employs state-of-the-art voice coding technology in its vocoder design in order to get the best voice quality out of the least number of bits. A rate 2/3 FEC is incorporated into the vocoder.

The key parameters for the FDMA/TDMA scheme are summarized in Table 46.



TABLE 46

**FDMA/TDMA voice channel characteristics**

Number of voice time slots/frame	4
Burst rate	34.545 kbit/s
Channel spacing	27.17 kHz
Information rate	2.4-4 kbit/s
FEC (integrated with vocoder)	Rate = 2/3
Modulation type	QPSK

**6.3.6.2.2 FDMA/CDMA radio interface**

The CDMA portion of the allocated frequency band will be divided into 1.25 MHz sub-bands. The CDMA access scheme used within each sub-band allows multiple users to share the spectrum simultaneously. The spectrum can be reused on each satellite beam, resulting in a large frequency reuse factor for this CDMA subsystem. The CDMA links will provide variable user data rates up to 144 kbit/s.

The CDMA radio interface is based on a terrestrial IMT-2000 compatible standard. It has a 1.25 MHz bandwidth, and uses a direct-sequence spread spectrum access scheme. The peak channel bit rate is 9.6 kbit/s. The radio interface uses rate 1/3 convolutional encoding for the uplink, and rate 1/2 encoding for the downlink. A power control channel is added to each link using a punctured convolutional code.

The key parameters for the FDMA/CDMA scheme are summarized in Table 47 .

TABLE 47

**FDMA/CDMA data channel characteristics**

Subframes/frame	2
Spreading rate	1.228 to 4.096 Mbit/s
Channel spacing	1.25 MHz
Information rate	to 9.6 kbit/s (up to 144 kbit/s using multiple channels)
FEC	Rate = 1/2 down; 1/3 up
Modulation type	16-QAM/QPSK

A data link using multiple channels will be able to provide data services at up to 144 kbit/s.

**6.3.6.2.3 Terminal features**

The user equipment for the satellite portion of the system will provide service for a variety of applications. The types of user equipment that will be supported include fixed, nomadic, portables, mobiles, maritime and aeronautical terminals. Most of these terminals will be equipped with multiple service capability (e.g. combined phone, message and data terminal). The actual user

equipment types to be developed and the multiple service capability to be included would be based on market demand.

Some user equipment will handle only single channel, while others may be equipped with the capability to handle multi-channels. For example, a hand-held terminal will use only a single channel, but a fixed terminal may handle either single or multiple channels, which are multiplexed together through a multiplexer. High-speed data terminals operate using multiple basic data channels to provide high-speed services.

The key terminal features are shown in Table 48.

TABLE 48  
Terminal features

Terminal types	<ul style="list-style-type: none"> <li>– Hand-held</li> <li>– Portable</li> <li>– Nomadic</li> <li>– Fixed</li> <li>– Aeronautical</li> <li>– Maritime</li> <li>Others</li> </ul>
Multiple service capability (e.g. combined phone, pager, data terminal)	Yes
Mobility restrictions for each terminal type (e.g. up to xx km/h or yy m/s)	Up to 500 km/h for hand-held Up to 5 000 km/h for aero

### 6.3.6.3 RF specifications

The Satcom2000 personal mobile satellite system will operate in the 2 GHz band and generate cellular-like beams with each beam covering a relatively small area on the Earth to provide a large satellite service link margin. The RF parameters specified in this section are values at 2 GHz. They can also be modified to operate in other frequency bands allocated to IMT-2000 satellite component.

Satcom2000 requires that the TDMA and CDMA radio access subsystems operate on separate segments of spectrum. Thus any spectrum allocated to the satellite system will be segmented to the TDMA and the CDMA portion.

Satcom2000 provides both voice and data services. The basic voice services provide a high link margin and diversity to support operation in fading environments. In clear line of sight (CLOS) areas a lower link margin is traded for more efficient usage of bandwidth. The services provide higher data rates in areas with low fade margin. In areas with higher fade margin the data services operate at lower rates. An overlay of TDMA and CDMA multiple access channels within an FDMA structure provides the most appropriate access scheme based on the required type and quality of user services along with the operating environments.

Due to path delays of about 20 ms, the maximum power control rate for CDMA in this LEO satellite system is 50 Hz. This limits the effectiveness of CDMA technology except in slow fading user environment such as data applications or fixed services with CLOS signal paths to the satellites. These applications will be able to take advantage of both the data handling capability of IMT-2000 terrestrial protocols along with their capacity gains. In order to minimize interference, the power control step size is determined to be 0.5 dB. The CDMA handset will use FDD mode to transmit

and receive simultaneously, requiring approximately 63 dB isolation between transmission and receive. The modulation type will be selected to achieve as much commonality as possible with an appropriate technology used by IMT-2000 terrestrial systems. Because these applications are usually used in an environment with CLoS, some higher order modulation schemes, such as 16-QAM may be used for further improvement of the spectrum efficiency.

The capacity for the TDMA subsystem is less affected by high fading applications and therefore is reserved for mobile voice communications in rapidly changing environments. Power control is used solely to reduce power consumption at both user equipment and satellites. A coarser power control step size can be used in the TDMA subsystem. The power control rate is a function of both path delay and frame size. The TDMA user terminals can operate TDD mode to reduce the isolation requirements between transmission and receive.

The antenna gains and power levels on both user equipment and satellites are designed to optimize the service performance and system implementation. The initial values of these design parameters are given in Table 50. The satellites will be able to handle several different categories of user terminals. These terminals will have different e.i.r.p. levels based on their applications and size and therefore are able to support services in different fade margins. These decisions will be driven by the market demand.

The RF parameters of Satcom2000 are shown in Table 49.

TABLE 49  
RF specifications

User terminal transmitter e.i.r.p. – Maximum e.i.r.p. for each terminal type – Average e.i.r.p. for each terminal type	–2 to 4 dBW for hand-held Market driven for other terminal types –8 to –2 dBW for hand-held Market driven for other terminal types
User terminal $G/T$ for each terminal	–24.8 dB/K for hand-held Market driven for other terminal types
Antenna gain for each terminal type	2 dBi for hand-held Market driven for other terminal types
Maximum satellite e.i.r.p.	29.6 dBW
Maximum satellite $G/T$	0.1 dB/K
Channel bandwidth	TDMA: 27.17 kHz CDMA: 1.25 to 5 MHz
Multiple channel capability (yes/no)	Yes
Power control: Range Step size Rate	25 dB TDMA: 2 dB CDMA: 0.5 dB 50 Hz
Frequency stability Uplink Downlink	0.375 ppm (AFC) 1.5 ppm (thermal)
Doppler compensation (yes/no)	Yes
Terminal transmitter/receiver isolation	63 dB
Maximum fade margins for each service type	Voice: 15 to 25 dB Messaging/paging: 45 dB

#### **6.3.6.4 Baseband specifications**

##### **Multiple access scheme**

The multiple access schemes for the Satcom2000 radio interface include both FDMA/TDMA and FDMA/CDMA, as explained in § 6.3.6.2.2. Both TDD and FDD modes are available.

##### **Frame length**

The frame length is 40 ms. Each frame consist of 4 time slots of 8.88 ms, plus a guard band of 4.48 ms.

##### **Channel coding**

The channel coding used for the traffic channel will be a concatenated code consisting of a RS outer code and a convolutional inner code punctured to allow for variable rate bit protection. The purpose of the outer code is to provide burst error detection capability which is not provided by the convolutional code. A variety of different convolutional codes will be used depending on the required quality of service.

##### **ARQ**

In addition to FEC, some non-real services will include ARQ as well. ARQ schemes are not implemented for real-time services such as video teleconferencing due to the requirement for real-time performance and an allowable higher BER. However, applications such as file transfer protocol (FTP) may require a higher degree of transmission integrity depending upon the types of files being transferred and it may be necessary to implement an ARQ scheme. Executable files for obvious reasons require absolutely no errors in the transferred data, thus it is essential to have an ARQ scheme. ARQ schemes included in Satcom2000 include the selective-to-repeat scheme and the go-back-*N* scheme, and the choice of either one will depend on the actual application.

##### **Interleaving**

Interleaving is incorporated in Satcom2000 to spread the effect of bursty errors into several data segments so that in each data segment the resulting errors within a given data segment are independent. The interleaving structure is chosen such that there will be no effect on total system delay.

The baseband parameters of Satcom2000 are shown in Table 50.

TABLE 50

**Baseband specifications**

Multiple access techniques	FDMA/TDMA and FDMA/CDMA
Duplex method	TDD/FDD
Burst rate (TDMA mode)	34.545 kbit/s
Time slots (TDMA mode)	4 time slots/frame
Frame length	40 ms
Information rate	TDMA: 2.4-4 kbit/s CDMA: 0.048 to 9.6 kbit/s Information rate of up to 144 kbit/s can be achieved using multichannel configuration.
Chip rate (CDMA mode)	1.228 to 4.096 Mchip/s
Modulation type	TDMA: QPSK CDMA: 16-QAM/QPSK
FEC	TDMA: rate 2/3 CDMA: rate 1/2 down, rate 1/3 up
Dynamic channel allocation (yes/no)	Yes
Interleaving (yes/no)	Yes
Synchronization between satellites required (yes/no)	Yes

**7 Recommendations on unwanted emission limits****7.1 Terrestrial radio interfaces**

The information on emissions limits is recommended in Recommendation ITU-R M.1581 “Generic unwanted emission characteristics of mobile stations using the terrestrial radio interfaces of IMT-2000” and in Recommendation ITU-R M.1580 “Generic unwanted emission characteristics of base stations using the terrestrial radio interfaces of IMT-2000”.

**7.2 Satellite radio interfaces**

Unwanted emissions from the terminals of IMT-2000 satellite systems should comply with limits set in the relevant ITU-R Recommendations (e.g. for non-GSO and GSO satellite systems operating in certain bands in the range 1-3 GHz, all terminals should comply with the levels specified in Recommendations ITU-R M.1343 and ITU-R M.1480, respectively).