

RECOMMENDATION ITU-R M.1371-1*

Technical characteristics for a universal shipborne automatic identification system using time division multiple access in the VHF maritime mobile band

(Question ITU-R 232/8)

(1998-2001)

The ITU Radiocommunication Assembly,

considering

- a) that the International Maritime Organization (IMO) has a requirement for a universal shipborne automatic identification system (AIS);
- b) that the use of a universal shipborne AIS would allow efficient exchange of navigational data between ships and between ships and shore stations, thereby improving safety of navigation;
- c) that a system using self-organized time division multiple access (SOTDMA) would accommodate all users and meet the likely future requirements for efficient use of the spectrum;
- d) that such a system should be used primarily for surveillance and safety of navigation purposes in ship to ship use, ship reporting and vessel traffic services (VTS) applications. It could also be used for other maritime safety related communications, provided that the primary functions were not impaired;
- e) that such a system would be autonomous, automatic, continuous and operate primarily in a broadcast, but also in an assigned and in an interrogation mode using time division multiple access (TDMA) techniques;
- f) that such a system would be capable of expansion to accommodate future expansion in the number of users and diversification of applications, including vessels which are not subject to IMO AIS carriage requirement, aids to navigation and search and rescue;
- g) that IALA is maintaining and publishing a record of the international application identifier branch and technical guidelines for the manufacturers of AIS and other interested parties,

recommends

- 1** that the AIS should be designed in accordance with the operational characteristics given in Annex 1 and the technical characteristics given in Annexes 2, 3, 4 and 6;
- 2** that applications of the AIS which make use of application specific messages of the AIS, as defined in Annex 2, should comply with the characteristics given in Annex 5;

* This Recommendation should be brought to the attention of the International Maritime Organization (IMO), the International Civil Aviation Organization (ICAO), the International Association of Marine Aids to Navigation and Lighthouse Authorities (IALA), the International Electrotechnical Commission (IEC) and the Comité International Radio Maritime (CIRM).

- 3 that the AIS applications should take into account the international application identifier branch, as specified in Annex 5, maintained and published by IALA;
- 4 that the AIS design should take into account technical guidelines maintained and published by IALA.

ANNEX 1

Operational characteristics of a universal shipborne AIS using TDMA techniques in the VHF maritime mobile band

1 General

- 1.1 The system should automatically broadcast ships dynamic and some other information to all other installations in a self-organized manner.
- 1.2 The system installation should be capable of receiving and processing specified interrogating calls.
- 1.3 The system should be capable of transmitting additional safety information on request.
- 1.4 The system installation should be able to operate continuously while under way or at anchor.
- 1.5 The system should use TDMA techniques synchronized to coordinated universal time (UTC) or, if not available, an alternative source.
- 1.6 The system should be capable of three modes of operation, autonomous, assigned and polled.

2 Shipborne mobile equipment classes

- 2.1 Class A shipborne mobile equipment will comply with relevant IMO AIS carriage requirement.
- 2.2 Class B shipborne mobile equipment will provide facilities not necessarily in full accordance with IMO AIS carriage requirement.

3 Identification

For the purpose of identification, the appropriate maritime mobile service identity (MMSI) should be used, (refer to Annex 2, § 3.3.7.2.1 and 3.3.7.3.1).

4 Information content

The system should provide static, dynamic and voyage related data.

In the case of Class A shipborne mobile equipment see Messages 1, 2, 3, 5, 6 and 8 in Annex 2. In the case of Class B shipborne mobile equipment see Messages 18 and 19 in Annex 2. See also Table 13.

4.1 Short safety related messages

Class A shipborne mobile equipment should be capable of receiving and transmitting short safety related messages containing important navigational or important meteorological warning.

Class B shipborne mobile equipment should be capable of receiving short safety related messages.

4.2 Information update rates for autonomous mode

4.2.1 Reporting rate

The different information types are valid for a different time period and thus need a different update rate.

Static information:	Every 6 min or, when data has been amended, on request.
Dynamic information:	Dependent on speed and course alteration according to Tables 1a and b.
Voyage related information:	Every 6 min or, when data has been amended, on request.
Safety related message:	As required.

TABLE 1a

Class A shipborne mobile equipment reporting intervals

Ship's dynamic conditions	Nominal reporting interval
Ship at anchor or moored and not moving faster than 3 knots	3 min ⁽¹⁾
Ship at anchor or moored and moving faster than 3 knots	10 s ⁽¹⁾
Ship 0-14 knots	10 s ⁽¹⁾
Ship 0-14 knots and changing course	3 1/3 s ⁽¹⁾
Ship 14-23 knots	6 s ⁽¹⁾
Ship 14-23 knots and changing course	2 s
Ship >23 knots	2 s
Ship >23 knots and changing course	2 s

⁽¹⁾ When a mobile station determines that it is the semaphore (see § 3.1.1.4, Annex 2), the reporting rate should increase to once per 2 s (see § 3.1.3.3.2, Annex 2).

NOTE 1 – These values have been chosen to minimize unnecessary loading of the radio channels while maintaining compliance within the IMO AIS performance standards.

TABLE 1b

Reporting intervals for equipment other than Class A shipborne mobile equipment

Platform's condition	Nominal reporting interval
Class B shipborne mobile equipment not moving faster than 2 knots	3 min
Class B shipborne mobile equipment moving 2-14 knots	30 s
Class B shipborne mobile equipment moving 14-23 knots	15 s
Class B shipborne mobile equipment moving >23 knots	5 s
Search and rescue aircraft (airborne mobile equipment)	10 s
Aids to navigation	3 min
AIS base station ⁽¹⁾	10 s

⁽¹⁾ The base station rate should increase to once per 3 1/3 s after the station detects that one or more stations are synchronizing to the base station (see § 3.1.3.3.1, Annex 2).

5 Frequency band

The AIS mobile station should be designed for operation in the VHF maritime mobile band, on either 25 kHz or 12.5 kHz simplex or duplex channels in half-duplex mode, in accordance with Radio Regulations (RR) Appendix 18 and Recommendation ITU-R M.1084, Annex 4.

A base station should use simplex channels or duplex channels in either full-duplex or half-duplex mode.

Two international channels have been allocated in RR Appendix 18 for AIS use.

The system should be able to operate on two parallel VHF channels. When the designated AIS channels are not available the system should be able to select alternative channels using channel management methods in accordance with this Recommendation.

ANNEX 2

Technical characteristics of a universal shipborne AIS using TDMA techniques in the maritime mobile band

1 Structure of this Annex

This standard covers layers 1 to 4 (physical layer, link layer, network layer, transport layer) of the open system interconnection (OSI) model.

The following Figure illustrates the layer model of an AIS station (physical layer to transport layer) and the layers of the applications (session layer to application layer):

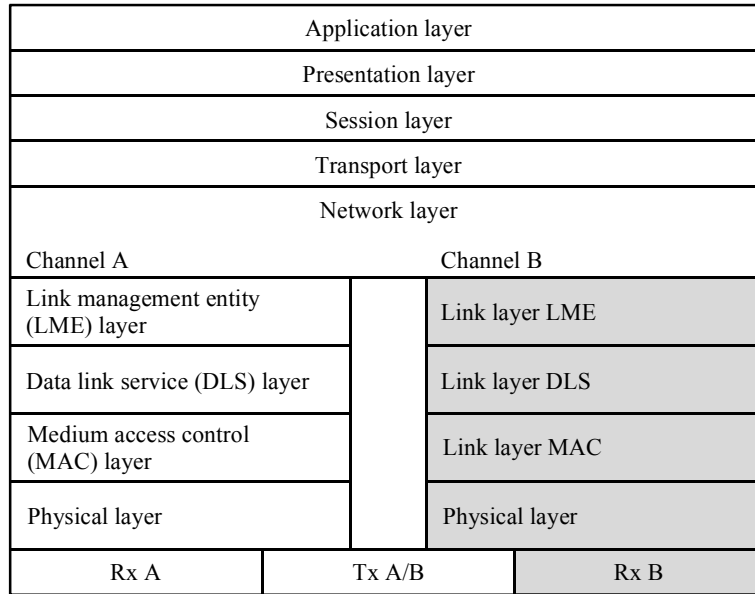

Rx: receiver
Tx: transmitter

1371-00

2 Physical layer

2.1 Parameters

2.1.1 General

The physical layer is responsible for the transfer of a bit-stream from an originator, out on to the data link. The performance requirements for the physical layer are summarized in Tables 2 to 4.

For transmit output power see also § 2.13.2.

The low setting and the high setting for each parameter is independent of the other parameters.

TABLE 2

Symbol	Parameter name	Low setting	High setting
PH.RFR	Regional frequencies (range of frequencies within RR Appendix 18) ⁽¹⁾ (MHz)	156.025	162.025
PH.CHS	Channel spacing (encoded according to RR Appendix 18 with footnotes) ⁽¹⁾ (kHz)	12.5	25
PH.AIS1	AIS 1 (default channel 1) (ch 87B), (2087) ⁽¹⁾ (see § 2.4.3) (MHz)	161.975	161.975
PH.AIS2	AIS 2 (default channel 2) (ch 88B), (2088) ⁽¹⁾ (see § 2.4.3) (MHz)	162.025	162.025
PH.CHB	Channel bandwidth: see § 2.1.3	Narrow	Wide
PH.BR	Bit rate (bit/s)	9 600	9 600
PH.TS	Training sequence (bits)	24	24
PH.TST	Transmitter settling time Transmit power within 20% of final value, Frequency stable to within ± 1.0 kHz of final value (ms)	≤ 1.0	≤ 1.0
PH.TXP	Transmit output power (W)	2	12.5

⁽¹⁾ See Recommendation ITU-R M.1084, Annex 4.

2.1.2 Constants

TABLE 3

Symbol	Parameter name	Value
PH.DE	Data encoding	NRZI
PH.FEC	Forward error correction	Not used
PH.IL	Interleaving	Not used
PH.BS	Bit scrambling	Not used
PH.MOD	Modulation	Bandwidth adapted GMSK/FM

GMSK/FM: see § 2.4.

NRZI: non-return to zero inverted.

2.1.3 Bandwidth dependent parameters

Table 4 below defines settings dependent on parameter PH.CHB.

TABLE 4

Symbol	Parameter name	PH.CHB narrow	PH.CHB wide
PH.TXBT	Transmit BT-product	0.3	0.4
PH.RXBT	Receive BT-product	0.3/0.5	0.5
PH.MI	Modulation index	0.25	0.50

BT-product: product of the bandwidth and the time.

2.1.4 Transmission media

Data transmissions are made in the VHF maritime mobile band. Data transmissions should default to AIS 1 and AIS 2 unless otherwise specified by a competent authority, as described in § 4.1 and Annex 3. See also Annex 4 concerning long range applications.

2.1.5 Dual channel operation

The transponder should be capable of operating on two parallel channels in accordance with § 4.1. Two separate TDMA receivers should be used to simultaneously receive information on two independent frequency channels. One TDMA transmitter should be used to alternate TDMA transmissions on two independent frequency channels.

2.2 Bandwidth

The AIS should be capable of operating on 25 kHz or 12.5 kHz channels according to Recommendation ITU-R M.1084 and RR Appendix 18. The channel bandwidth should be determined by the prescribed modulation scheme (see § 2.4). 25 kHz channel bandwidth should be used on the high seas whereas 25 kHz or 12.5 kHz channel bandwidth should be used as defined by the appropriate authority in territorial waters, as described in § 4.1 and Annex 3.

2.3 Transceiver characteristics

The transceiver should perform in accordance with the characteristics set forth herein.

2.4 Modulation scheme

The modulation scheme is bandwidth adapted frequency modulated Gaussian filtered minimum shift keying (GMSK/FM).

2.4.1 GMSK

2.4.1.1 The NRZI encoded data should be GMSK coded before frequency modulating the transmitter.

2.4.1.2 The GMSK modulator BT-product used for transmission of data should be 0.4 maximum when operating on a 25 kHz channel, and 0.3 when operating on a 12.5 kHz channel.

2.4.1.3 The GMSK demodulator used for receiving of data should be designed for a BT-product of maximum 0.5 when operating on a 25 kHz channel and 0.3 or 0.5 when operating on a 12.5 kHz channel.

2.4.2 Frequency modulation

The GMSK coded data should frequency modulate the VHF transmitter. The modulation index should be 0.5 when operating on a 25 kHz channel and 0.25 when operating on a 12.5 kHz channel.

2.4.3 Frequency stability

The frequency stability of the VHF radio transmitter/receiver should be better than ± 3 ppm.

2.5 Data transmission bit rate

The transmission bit rate should be 9 600 bit/s ± 50 ppm.

2.6 Training sequence

Data transmission should begin with a 24-bit demodulator training sequence (preamble) consisting of one segment synchronization. This segment should consist of alternating zeros and ones (0101....). This sequence may begin with a 1 or a 0 since NRZI encoding is used.

2.7 Data encoding

The NRZI waveform is used for data encoding. The waveform is specified as giving a change in the level when a zero (0) is encountered in the bit stream.

2.8 Forward error correction

Forward error correction is not used.

2.9 Interleaving

Interleaving is not used.

2.10 Bit scrambling

Bit scrambling is not used.

2.11 Data link sensing

Data link occupancy and data detection are entirely controlled by the link layer.

2.12 Transmitter settling time

The RF settling characteristics should comply with the requirements in § 3.1.5.

2.12.1 Transmitter RF attack time

The transmitter RF attack time should not exceed 1 ms after the Tx-ON signal according to the following definition: the RF attack time is the time from Tx-ON signal until the RF power has reached 80% of the nominal (steady state) level (see Fig. 3).

2.12.2 Transmitter frequency stabilization time

The transmitter frequency should be ± 1 kHz of its final value within 1 ms after start of transmission.

2.12.3 Transmitter RF release time

The transmitter RF power must be switched off within 1 ms from the termination of transmission.

2.12.4 Switching time

The channel switching time should be less than 25 ms (see Fig. 6).

The time taken to switch from transmit to receive conditions, and vice versa, should not exceed the transmit attack or release time. It should be possible to receive a message from the slot directly after or before own transmission.

The equipment should not be able to transmit during channel switching operation.

The equipment is not required to transmit on the other AIS channel in the adjacent time slot.

2.13 Transmitter power

The power level is determined by the LME of the link layer.

2.13.1 Provision should be made for two levels of nominal power (high power, low power) as required by some applications. The default operation of the transponder should be on the high nominal power level. Changes to the power level should only be by assignment by the approved channel management means (see § 4.1.1).

2.13.2 The nominal levels for the two power settings should be 2 W and 12.5 W. Tolerance should be within $\pm 20\%$.

2.14 Shutdown procedure

2.14.1 An automatic transmitter hardware shutdown procedure and indication should be provided in case a transmitter does not discontinue its transmission within 1 s of the end of its transmission slot.

2.15 Safety precautions

The AIS installation, when operating, should not be damaged by the effects of open circuited or short circuited antenna terminals.

3 Link layer

The link layer specifies how data is packaged in order to apply error detection and correction to the data transfer. The link layer is divided into three (3) sublayers.

3.1 Sublayer 1: medium access control (MAC)

The MAC sublayer provides a method for granting access to the data transfer medium, i.e. the VHF data link. The method used is a TDMA scheme using a common time reference.

3.1.1 TDMA synchronization

TDMA synchronization is achieved using an algorithm based on a synchronization state as described below. The sync state flag within SOTDMA communication state (see § 3.3.7.2.2) and within incremental TDMA (ITDMA) communication state (see § 3.3.7.3.2), indicates the synchronization state of a station. Refer to Fig. 1 and Fig. 2.

Parameters for TDMA synchronization:

Symbol	Parameter name/description	Nominal
MAC.SyncBaseRate	Sync support increased update rate (base station)	once per 3 1/3 s
MAC.SyncMobileRate	Sync support increased update rate (mobile station)	once per 2 s

3.1.1.1 UTC direct

A station, which has direct access to UTC timing with the required accuracy should indicate this by setting its synchronization state to UTC direct.

3.1.1.2 UTC indirect

A station, which is unable to get direct access to UTC, but can receive other stations that indicate UTC direct, should synchronize to those stations. It should then change its synchronization state to UTC indirect. Only one level of UTC indirect synchronization is allowed.

3.1.1.3 Synchronized to base station (direct or indirect)

Mobile stations, which are unable to attain direct or indirect UTC synchronization, but are able to receive transmissions from base stations, should synchronize to the base station which indicates the highest number of received stations, provided that two reports have been received from that station in the last 40 s. Once base station synchronization has been established, this synchronization shall be discontinued if fewer than two reports are received from the selected base station in the last 40 s. When the parameter SlotTimeOut of the SOTDMA communication state has one of the values three (3), five (5), or seven (7), the number of received stations should be contained within the SOTDMA communication state-submessage. The station which is thus synchronized to a base station should then change its synchronization state to “base station” to reflect this. Only one level of indirect access to the base station is allowed.

When a station is receiving several other base stations which indicate the same number of received stations, synchronization should be based on the station with the lowest MMSI.

3.1.1.4 Number of received stations

A station, which is unable to attain UTC direct or UTC indirect synchronization and is also unable to receive transmissions from a base station, should synchronize to the station indicating the highest number of other stations received during the last nine frames, provided that two reports have been received from that station in the last 40 s. This station should then change its synchronization state to “Number of received stations” (see § 3.3.7.2.2 for SOTDMA communication state and to § 3.3.7.3.2 for ITDMA communication state). When a station is receiving several other stations, which indicate the same number of received stations, synchronization should be based on the station with the lowest MMSI. That station becomes the *semaphore* on which synchronization should be performed.

3.1.2 Time division

The system uses the concept of a frame. A frame equals one (1) minute and is divided into 2250 slots. Access to the data link is, by default, given at the start of a slot. The frame start and stop coincide with the UTC minute, when UTC is available. When UTC is unavailable the procedure, described below should apply.

3.1.3 Slot phase and frame synchronization

3.1.3.1 Slot phase synchronization

Slot phase synchronization is the method whereby one station uses the messages from other stations or base stations to re-synchronize itself, thereby maintaining a high level of synchronization stability, and ensuring no message boundary overlapping or corruption of messages.

Decision to slot phase synchronize should be made after receipt of end flag and valid frame check sequence (FCS). (State T3, Fig. 6) At T5, the station resets its *Slot_Phase_Synchronization_Timer*, based on Ts, T3 and T5 (Fig. 6).

3.1.3.2 Frame synchronization

Frame synchronization is the method whereby one station uses the current slot number of another station or base station, adopting the received slot number as its own current slot number. When the parameter SlotTimeOut of the SOTDMA communication state has one of the values two (2), four (4), or six (6), the current slot number of a received station should be contained within the sub message of the SOTDMA communication state.

3.1.3.3 Synchronization – Transmitting stations (see Fig. 1)

FIGURE 1

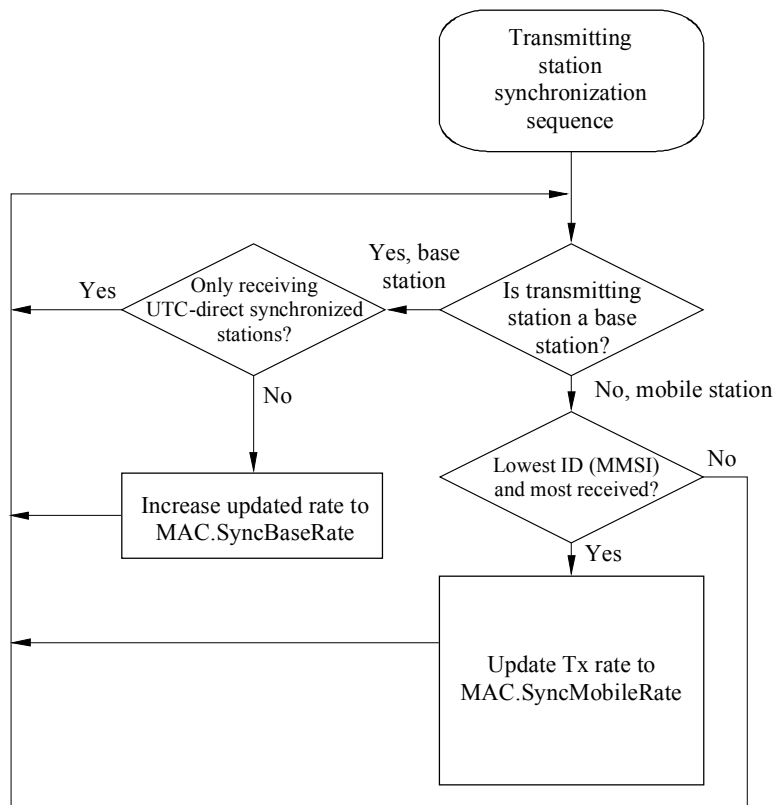

3.1.3.3.1 Base station operation

The base station should normally transmit the base station report (Message 4) with a minimum reporting rate of 10 s.

The base station should operate in this state until it detects one or more stations that are synchronizing to the base station. It should then increase its update rate of Message 4 to MAC.SyncBaseRate. It should remain in this state until no stations have indicated synchronizing to the base station for the last 3 min.

3.1.3.3.2 Mobile station operation as a semaphore

When a mobile station determines that it is the semaphore (see § 3.1.1.4), it should increase its update rate to MAC.SyncMobileRate.

3.1.3.4 Synchronization – Receiving stations (see Fig. 2)

FIGURE 2

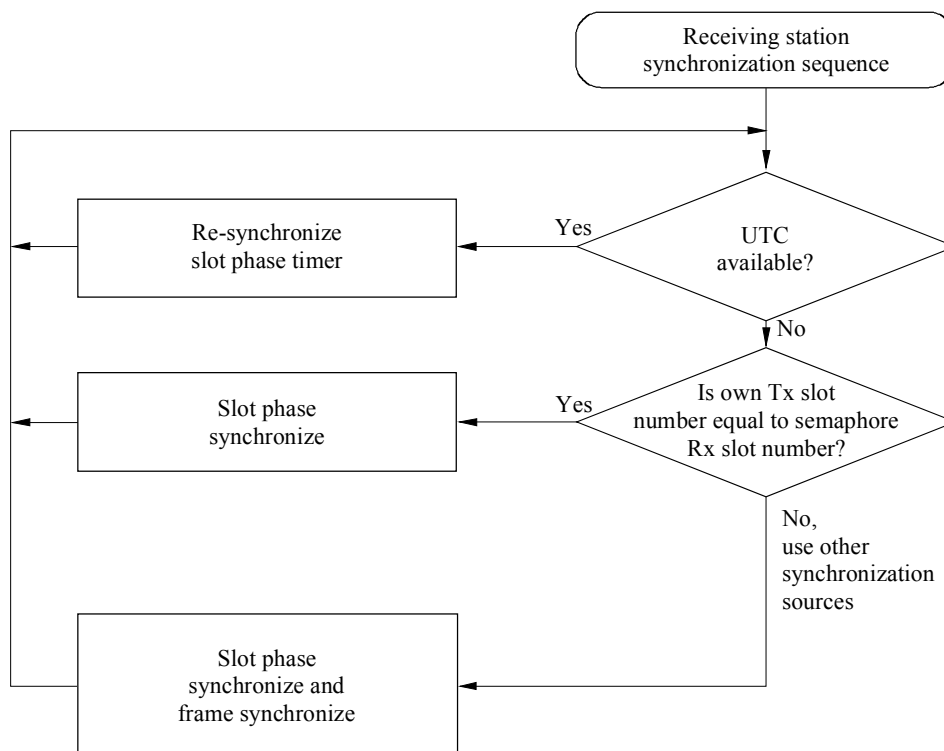

1371-02

3.1.3.4.1 UTC available

A station, which has direct or indirect access to UTC, should continuously re-synchronize its transmissions based on the UTC source.

3.1.3.4.2 Own transmission slot number equal to the received semaphore slot number

When the station determines that its own internal slot number is equal to the semaphore slot number, it is already in frame synchronization and it should continuously slot phase synchronize.

3.1.3.4.3 Other synchronization sources

Other possible synchronization sources, which can serve as the basis for slot phase and frame synchronizations, are listed below in the order of priority:

- a station which has UTC time;
- a base station which is semaphore qualified;
- other station(s) which are synchronized to a base station;
- a mobile station, which is semaphore qualified.

See § 3.1.1.4 for semaphore qualification. A station is semaphore qualified if it is indicating the most number of received stations. If more than one indicates the same amount, the one with the lowest identifier rules. The station with the highest sync state can also be semaphore qualified if that is the sole station with that sync state.

3.1.4 Slot identification

Each slot is identified by its index (0-2249). Slot zero (0) should be defined as the start of the frame.

3.1.5 Slot access

The transmitter should begin transmission by turning on the RF power at slot start.

The transmitter should be turned off after the last bit of the transmission packet has left the transmitting unit. This event must occur within the slots allocated for own transmission. The default length of a transmission occupies one (1) slot. The slot access is performed as shown in Fig. 3:

FIGURE 3

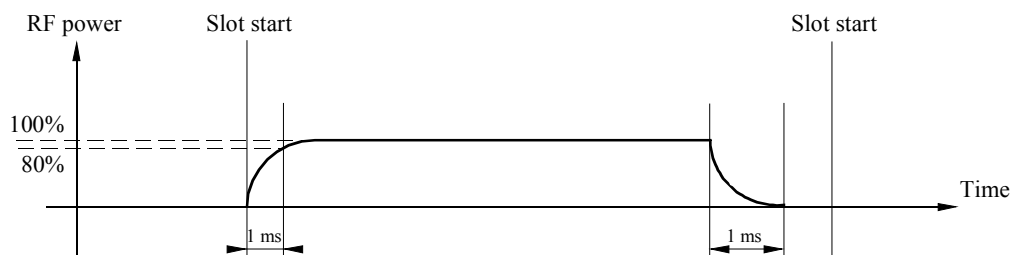

1371-03

3.1.6 Slot state

Each slot can be in one of the following states:

- FREE: meaning that the slot is unused within the receiving range of the own station. Externally allocated slots that have not been used during the preceding three frames are also FREE slots. This slot may be considered as a candidate slot for use by own station (see § 3.3.1.2);

- INTERNAL ALLOCATION: meaning that the slot is allocated by own station and can be used for transmission;
- EXTERNAL ALLOCATION: meaning that the slot is allocated for transmission by another station and cannot be used by own station;
- AVAILABLE: meaning that the slot is externally allocated by a distant station and is a possible candidate for slot reuse (see § 4.4.1).

3.2 Sublayer 2: data link service (DLS)

The DLS sublayer provides methods for:

- data link activation and release;
- data transfer; or
- error detection and control.

3.2.1 Data link activation and release

Based on the MAC sublayer the DLS will listen, activate or release the data link. Activation and release should be in accordance with § 3.1.5. A slot, marked as free or externally allocated, indicates that own equipment should be in receive mode and listen for other data link users. This should also be the case with slots, marked as available and not to be used by own station for transmission (see § 4.4.1).

3.2.2 Data transfer

Data transfer should use a bit-oriented protocol which is based on the high-level data link control (HDLC) as specified by ISO/IEC 3309: 1993 – Definition of packet structure. Information packets (I-Packets) should be used with the exception that the control field is omitted (see Fig. 4).

3.2.2.1 Bit stuffing

The bit stream should be subject to bit stuffing. This means that if five (5) consecutive ones (1's) are found in the output bit stream, a zero should be inserted. This applies to all bits except the data bits of HDLC flags (start flag and end flag, see Fig. 4).

3.2.2.2 Packet format

Data is transferred using a transmission packet as shown in Fig. 4:

FIGURE 4

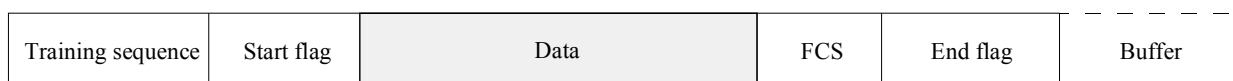

1371-04

The packet should be sent from left to right. This structure is identical to the general HDLC structure, except for the training sequence. The training sequence should be used in order to synchronize the VHF receiver and is discussed in § 3.2.2.3. The total length of the default packet is 256 bits. This is equivalent to one (1) slot.

3.2.2.3 Training sequence

The training sequence should be a bit pattern consisting of alternating 0's and 1's (010101010...). Twenty-four bits of preamble are transmitted prior to sending the flag. This bit pattern is modified due to the NRZI mode used by the communication circuit. See Fig. 5.

FIGURE 5

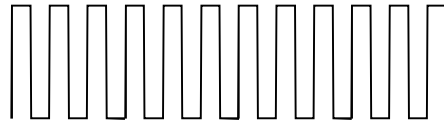

a) Unmodified bit pattern

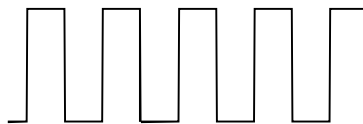

b) Modified bit pattern by NRZI

1371-05

The preamble should not be subject to bit stuffing.

3.2.2.4 Start flag

The start flag should be 8 bits long and consists of a standard HDLC flag. It is used in order to detect the start of a transmission packet. The start flag consists of a bit pattern, 8 bits long: 01111110 (7E_h). The flag should not be subject to bit stuffing, although it consists of 6 bits of consecutive ones (1's).

3.2.2.5 Data

The data portion is 168 bits long in the default transmission packet. The content of data is undefined at the DLS. Transmission of data, which occupy more than 168 bits, is described in § 3.2.2.11 below.

3.2.2.6 FCS

The FCS uses the cyclic redundancy check (CRC) 16-bit polynomial to calculate the checksum as defined in ISO/IEC 3309: 1993. The CRC bits should be pre-set to one (1) at the beginning of a CRC calculation. Only the data portion should be included in the CRC calculation (see Fig. 5).

3.2.2.7 End flag

The end flag is identical to the start flag as described in § 3.2.2.4.

3.2.2.8 Buffer

The buffer is normally 24 bits long and should be used as follows:

- bit stuffing: 4 bits (normally, for all messages except safety related messages and binary messages)
- distance delay: 12 bits
- repeater delay: 2 bits
- synchronization jitter: 6 bits

3.2.2.8.1 Bit stuffing

A statistical analysis of all possible bit combinations in the data field of the fixed length messages shows that 76% of combinations use 3 bits or less, for bit stuffing. Adding the logically possible bit combinations shows, that 4 bits are sufficient for these messages. Where variable length messages are used, additional bit stuffing could be required. For the case where additional bit stuffing is required, see § 5.3.1 and Table 36.

3.2.2.8.2 Distance delay

A buffer value of 12 bits is reserved for distance delay. This is equivalent to 202.16 nautical miles (nm). This distance delay provides protection for a propagation range of over 100 nm.

3.2.2.8.3 Repeater delay

The repeater delay provides for a turn-around time in a duplex repeater.

3.2.2.8.4 Synchronization jitter

The synchronization jitter bits preserve integrity on the TDMA data link, by allowing a jitter in each time slot, which is equivalent to ± 3 bits. Transmission timing error should be within $\pm 104 \mu\text{s}$ of the synchronization source. Since timing errors are additive, the accumulated timing error can be as much as $\pm 312 \mu\text{s}$.

3.2.2.9 Summary of the default transmission packet

The data packet is summarized as shown in Table 5:

TABLE 5

Ramp up	8 bits	T0 to T1 in Fig. 6
Training sequence	24 bits	Necessary for synchronization
Start flag	8 bits	In accordance with HDLC ($7E_H$)
Data	168 bits	Default
CRC	16 bits	In accordance with HDLC
End flag	8 bits	In accordance with HDLC ($7E_H$)
Buffer	24 bits	Bit stuffing distance delays, repeater delay and jitter
Total	256 bits	

3.2.2.10 Transmission timing

Figure 6 shows the timing events of the default transmission packet (one slot). At the situation where the ramp down of the RF power overshoots into the next slot, there should be no modulation of the RF after the termination of transmission. This prevents undesired interference, due to false locking of receiver modems, with the succeeding transmission in the next slot.

3.2.2.11 Long transmission packets

A station may occupy at maximum five consecutive slots for one (1) continuous transmission. Only a single application of the overhead (ramp up, training sequence, flags, FCS, buffer) is required for a long transmission packet. The length of a long transmission packet should not be longer than necessary to transfer the data; i.e. the AIS should not add filler.

3.2.3 Error detection and control

Error detection and control should be handled using the CRC polynomial as described in § 3.2.2.6. CRC errors should result in no further action by the AIS.

3.3 Sublayer 3 – link management entity (LME)

The LME controls the operation of the DLS, MAC and the physical layer.

3.3.1 Access to the data link

There should be four different access schemes for controlling access to the data transfer medium. The application and mode of operation determine the access scheme to be used. The access schemes are:

SOTDMA, ITDMA, random access TDMA (RATDMA) and fixed access TDMA (FATDMA). SOTDMA is the basic scheme used for scheduled repetitive transmissions from an autonomous station. When, for example, the update rate has to be changed, or a non-repetitive message is to be transmitted, other access schemes may be used.

3.3.1.1 Cooperation on the data link

The access schemes operate continuously, and in parallel, on the same physical data link. They all conform to the rules set up by the TDMA (as described in § 3.1).

3.3.1.2 Candidate slots

Slots, used for transmission, are selected from *candidate slots* in the selection interval (SI) (see Fig. 9). There should always be at minimum four candidate slots to choose from unless the number of candidate slots is otherwise restricted due to loss of position information (see § 4.4.1). When no candidate slot is available, the use of the current slot is allowed. The candidate slots are primarily selected from free slots (see § 3.1.6). When required, available slots are included in the candidate slot set. When selecting a slot from the candidates, any candidate has the same probability of being chosen, regardless of its slot state (see § 3.1.6).

FIGURE 6
Transmission timing

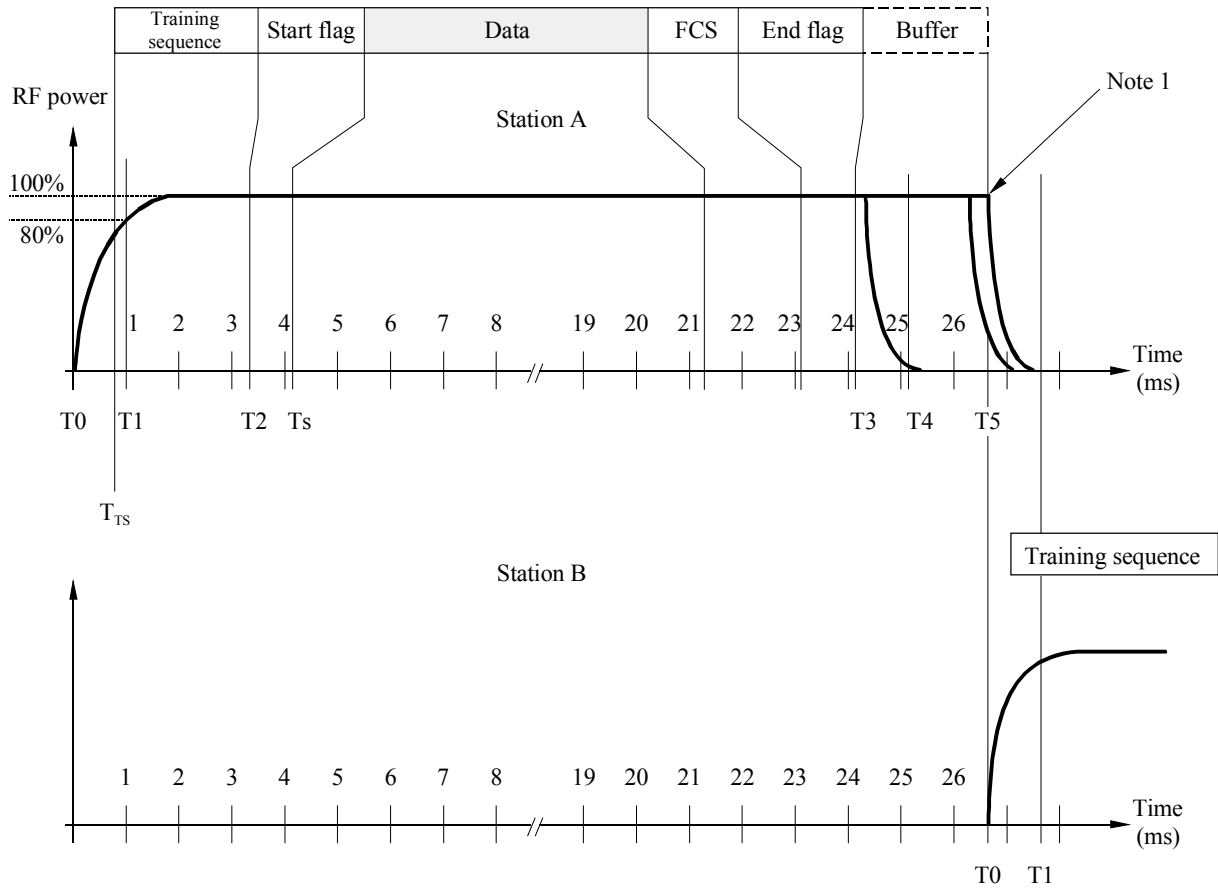

T(n)	Time (ms)	Description
T0	0.000	Slot start. RF power is applied
T _{TS}	0.832	Beginning of training sequence
T1	1.000	RF power and frequency stabilization time
T2	3.328	Start of transmission packet (start flag). This event can be used as a secondary synchronization source should the primary source (UTC) be lost
T _s	4.160	Slot phase synchronization marker. End of start flag, beginning of data
T3	24.128	End of transmission, assuming zero bit stuffing. No modulation is applied after termination of transmission. In case of a shorter data block, the transmission may end earlier
T4	T3 + 1.000	The time when RF power should have reached zero
T5	26.670	End of slot. Beginning of next slot

Note 1 – Should a transmission end exactly at the beginning of the next slot, the Tx-down period for station A will overlap into the next slot as shown in Fig. 6. Transmission of the training sequence is not impaired by this. This occasion would be extremely rare, and it would occur only in the event of a propagation anomaly. Even in this case, the operation of the AIS is not impaired due to the range discrimination characteristics of the receiver.

When selecting among candidate slots for transmission in one channel, the slot usage of other channels should be considered. If the candidate slot in the other channel is used by another station, the use of the slot should follow the same rules as for slot reuse (see § 4.4.1). If a slot in either channel is occupied by or allocated by other base or mobile station, that slot should be reused only in accordance with § 4.4.1.

The slots of another station, whose navigational status is not set to “at anchor” or “moored” and has not been received for 3 min, should be used as candidate slots for intentional slot reuse.

The own station is unable to transmit on an adjacent slot on the two parallel channels because of the necessary switching time (see § 2.12.4). Thus, the two adjacent slots on either side of a slot that is being used by the own station on one channel should not be considered as candidate slots on the other channel.

The purpose of intentionally reusing slots and maintaining a minimum of four candidate slots within the same probability of being used for transmission is to provide high probability of access to the link. To further provide high probability of access, time-out characteristics are applied to the use of the slots so that slots will continuously become available for new use.

Figure 7 illustrates the process of selecting among candidate slots for transmission on the link.

FIGURE 7

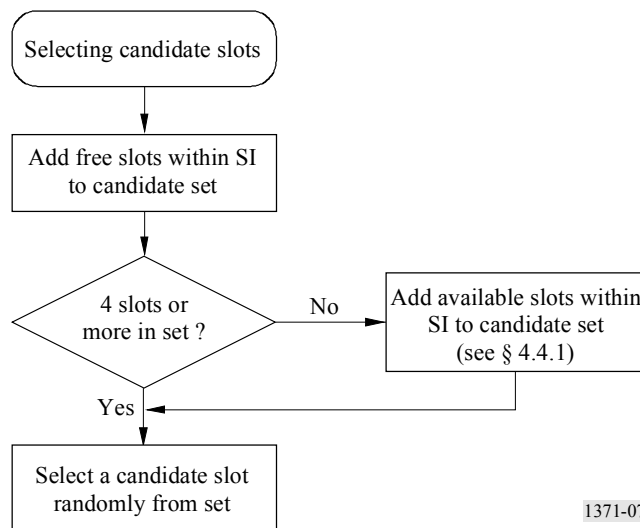

1371-07

3.3.2 Modes of operation

There should be three modes of operation. The default mode should be autonomous and may be switched to/from other modes as required by a competent authority.

3.3.2.1 Autonomous and continuous

A station operating autonomously should determine its own schedule for transmission of its position. The station should automatically resolve scheduling conflicts with other stations.

3.3.2.2 Assigned

A station operating in the assigned mode should use a transmission schedule assigned by a competent authority's base or repeater station.

3.3.2.3 Polled

A station operating in polled mode should automatically respond to interrogation messages (Message 15) from a ship or competent authority. Operation in the polled mode should not conflict with operation in the other two modes. The response should be transmitted on the channel where the interrogation message was received.

3.3.3 Initialization

At power on, a station should monitor the TDMA channels for one (1) min to determine channel activity, other participating member IDs, current slot assignments and reported positions of other users, and possible existence of shore stations. During this time period, a dynamic directory of all stations operating in the system should be established. A frame map should be constructed, which reflects TDMA channel activity. After one (1) min has elapsed, the station should enter the operational mode and start to transmit according to its own schedule.

3.3.4 Channel access schemes

The access schemes, as defined below, should coexist and operate simultaneously on the TDMA channel.

3.3.4.1 Incremental TDMA – ITDMA

The ITDMA access scheme allows a station to pre-announce transmission slots of non-repeatable character, with one exception: during data link network entry, ITDMA slots should be marked so that they are reserved for one additional frame. This allows a station to pre-announce its allocations for autonomous and continuous operation.

ITDMA should be used on three occasions:

- data link network entry,
- temporary changes and transitions in periodical report rates,
- pre-announcement of safety related messages.

3.3.4.1.1 ITDMA access algorithm

A station can begin its ITDMA transmission by either substituting a SOTDMA allocated slot or, by allocating a new, unannounced slot, using RATDMA. Either way, this becomes the first ITDMA slot.

The first transmission slot, during data link network entry, should be allocated using RATDMA. That slot should then be used as the first ITDMA transmission.

When higher layers dictate a temporary change of report rate or the need to transmit a safety related message, the next scheduled SOTDMA slot may pre-emptively be used for an ITDMA transmission.

Prior to transmitting in the first ITDMA slot, the station randomly selects the next following ITDMA slot and calculates the relative offset to that location. This offset should be inserted into the ITDMA communication state. Receiving stations will be able to mark the slot, indicated by this offset, as externally allocated (see § 3.3.7.3.2 and 3.1.5). The communication state is transmitted as a part of the ITDMA transmission. During network entry, the station also indicates that the ITDMA slots should be reserved for one additional frame. The process of allocating slots continues as long as required. In the last ITDMA slot, the relative offset is set to zero.

3.3.4.1.2 ITDMA parameters

The parameters of Table 6 control ITDMA scheduling:

TABLE 6

Symbol	Name	Description	Minimum	Maximum
LME.ITINC	Slot increment	The slot increment is used to allocate a slot ahead in the frame. It is a relative offset from the current transmission slot. If it is set to zero, no more ITDMA allocations should be done	0	8 191
LME.ITSL	Number of slots	Indicates the number of consecutive slots, which are allocated, starting at the slot increment	1	5
LME.ITKP	Keep flag	This flag should be set to TRUE when the present slot(s) should be reserved in the next frame also. The keep flag is set to FALSE when the allocated slot should be freed immediately after transmission	FALSE = 0	TRUE = 1

3.3.4.2 Random access TDMA – RATDMA

RATDMA is used when a station needs to allocate a slot, which has not been pre-announced. This is generally done for the first transmission slot during data link network entry, or for messages of a non-repeatable character.

3.3.4.2.1 RATDMA algorithm

The RATDMA access scheme should use a probability persistent (p-persistent) algorithm as described in this paragraph (see Table 7).

Messages, which use the RATDMA access scheme, are stored in a priority first-in first-out (FIFO). When a candidate slot (see § 3.3.1.2) is detected, the station randomly select a probability value (LME.RTP1) between 0 and 100. This value should be compared with the current probability for

transmission (LME.RTP2). If LME.RTP1 is equal to, or less than LME.RTP2, transmission should occur in the candidate slot. If not, LME.RTP2 should be incremented with a probability increment (LME.RTP1) and the station should wait for the next candidate slot in the frame.

The SI for RATDMA should be 150 time slots, which is equivalent to 4 s. The candidate slot set should be chosen within the SI, so that the transmission occurs within 4 s.

Each time that a candidate slot is entered, the p-persistent algorithm is applied. If the algorithm determines that a transmission shall be inhibited, then the parameter LME.RTCSC is decremented by one and LME.RTA is incremented by one.

LME.RTCSC can also be decremented as a result of another station allocating a slot in the candidate set. If $LME.RTCSC + LME.RTA < 4$ then the candidate set shall be complemented with a new slot within the range of the current slot and LME.RTES following the slot selection criteria.

3.3.4.2.2 RATDMA parameters

The parameters of Table 7 control RATDMA scheduling:

TABLE 7

Symbol	Name	Description	Minimum	Maximum
LME.RTCSC	Candidate slot counter	The number of slots currently available in the candidate set. NOTE – The initial value is always 4 or more (see § 3.3.1.2). However, during the cycle of the p-persistent algorithm the value may be reduced below 4	1	150
LME.RTES	End slot	Defined as the slot number of the last slot in the initial SI, which is 150 slots ahead	0	2 249
LME.RTPRI	Priority	The priority that the transmission has when queuing messages. The priority is highest when LME.RTPRI is lowest. Safety related messages should have highest service priority (refer to § 4.2.3)	1	0
LME.RTPS	Start probability	Each time a new message is due for transmission, LME.RTP2 should be set equal to LME.RTPS. LME.RTPS shall be equal to $100/LME.RTCSC$. NOTE – LME.RTCSC is set to 4 or more initially. Therefore LME.RTPS has a maximum value of $-25 (100/4)$	0	25
LME.RTP1	Derived probability	Calculated probability for transmission in the next candidate slot. It should be less than or equal to LME.RTP2 for transmission to occur, and it should be randomly selected for each transmission attempt	0	100

TABLE 7 (end)

Symbol	Name	Description	Minimum	Maximum
LME.RTP2	Current probability	The current probability that a transmission will occur in the next candidate slot	LME.RTPS	100
LME.RTA	Number of attempts	Initial value set to 0. This value is incremented by one each time the p-persistent algorithm determines that a transmission shall not occur	0	149
LME.RTPI	Probability increment	Each time the algorithm determines that transmission should not occur, LME.RTP2 should be incremented with LME.RTPI. LME.RTPI shall be equal to $(100 - \text{LME.RTP2})/\text{LME.RTCSC}$	1	25

3.3.4.3 Fixed access TDMA – FATDMA

FATDMA should be used by base stations only. FATDMA allocated slots should be used for repetitive messages. For base stations use of FATDMA refer to § 4.5 and 4.6.

3.3.4.3.1 FATDMA algorithm

Access to the data link should be achieved with reference to frame start. Each allocation should be pre-configured by the competent authority, and not changed for the duration of the operation of the station or, until re-configured. Except where the time-out value is otherwise determined, receivers of FATDMA messages should set a time-out value of 3 min in order to determine when the FATDMA slot will become free. The 3 min time-out should be reset with each reception of the message.

3.3.4.3.2 FATDMA parameters

The parameters of Table 8 control FATDMA scheduling:

TABLE 8

Symbol	Name	Description	Minimum	Maximum
LME.FTST	Start slot	The first slot (referenced to frame start) to be used by the station	0	2 249
LME.FTI	Increment	Increment to next block of allocated slots. An increment of zero indicates that the station transmits one time per frame, in the start slot	0	1 125
LME.FTBS	Block size	Default block size. Determines the default number of consecutive slots which are to be reserved at each increment	1	5

3.3.4.4 Self-organizing TDMA – SOTDMA

The SOTDMA access scheme should be used by mobile stations operating in autonomous and continuous mode. The purpose of the access scheme is to offer an access algorithm which quickly resolves conflicts without intervention from controlling stations. Messages which use the SOTDMA access scheme are of a repeatable character and are used in order to supply a continuously updated surveillance picture to other users of the data link.

3.3.4.4.1 SOTDMA algorithm

The access algorithm and continuous operation of SOTDMA is described in § 3.3.5.

3.3.4.4.2 SOTDMA parameters

The parameters of Table 9 control SOTDMA scheduling:

TABLE 9

Symbol	Name	Description	Minimum	Maximum
NSS	Nominal start slot	<p>This is the first slot used by a station to announce itself on the data link. Other repeatable transmissions are generally selected with the NSS as a reference.</p> <p>When transmissions with the same reporting rate (R_r) are made using two channels (A and B), the NSS for the second channel (B) is offset from the first channel's NSS by NI:</p> $NSS_B = NSS_A + NI$	0	2 249
NS	Nominal slot	<p>The nominal slot is used as the centre around which slots are selected for transmission of position reports. For the first transmission in a frame, the NSS and NS are equal. The NS when using only one channel is:</p> $NS = NSS + (n \times NI); (0 \leq n < R_r)$ <p>When transmissions are made using two channels (A and B), the slot separation between the nominal slots on each channel is doubled and offset by NI:</p> $NS_A = NSS_A + (n \times 2 \times NI);$ <p>where: $0 \leq n < 0.5 \times R_r$</p> $NS_B = NSS_A + NI + (n \times 2 \times NI);$ <p>where: $0 \leq n < 0.5 \times R_r$</p>	0	2 249

TABLE 9 (end)

Symbol	Name	Description	Minimum	Maximum
NI	Nominal increment	The nominal increment is given in number of slots and is derived using the equation below: $NI = 2\,250/Rr$	75	1 225
Rr	Report rate	This is the desired number of position reports per frame. When a station uses a report rate of less than one report per frame, ITDMA allocations are used. Otherwise, SOTDMA is used	1/3	30
SI	Selection interval	The SI is the collection of slots which can be candidates for position reports. The SI is derived using the equation below: $SI = \{NS - (0.1 \times NI) \text{ to } NS + (0.1 \times NI)\}$	$0.2 \times NI$	$0.2 \times NI$
NTS	Nominal transmission slot	The slot, within a selection interval, currently used for transmissions within that interval	0	2 249
TMO_MIN	Minimum time-out	The minimum number of frames that a SOTDMA allocation will occupy a specific slot	3	3
TMO_MAX	Maximum time-out	The maximum number of frames that a SOTDMA allocation will occupy a specific slot	TMO_MIN	8

3.3.5 Autonomous and continuous operation

This section describes how a station operates in the autonomous and continuous mode. Figure 8 shows the slot map accessed using SOTDMA.

FIGURE 8
Uniform reporting rate using two channels

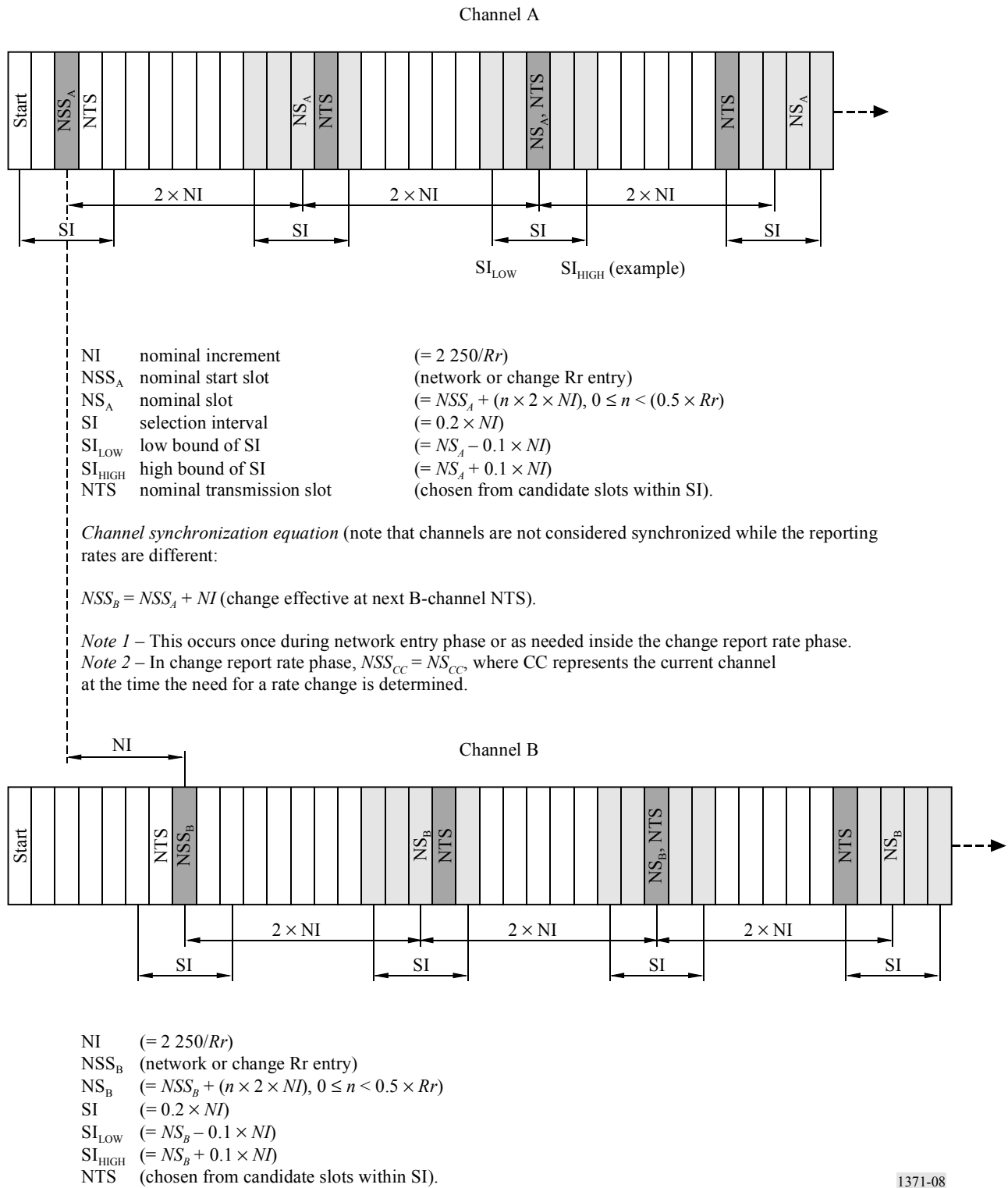

3.3.5.1 Initialization phase

The initialization phase is described using the flowchart shown in Fig. 9.

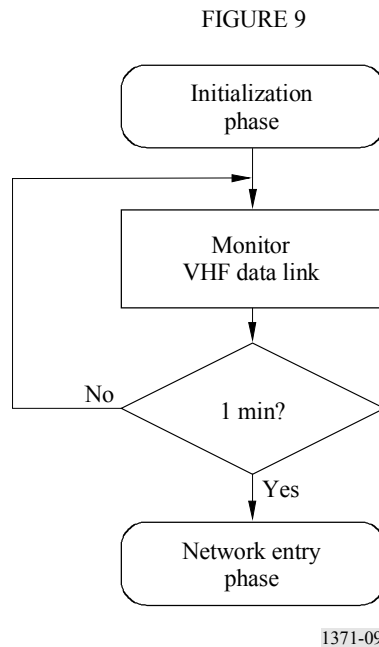

3.3.5.1.1 Monitor VHF data link (VDL)

At power on, a station should monitor the TDMA channel for one (1) min to determine channel activity, other participating member IDs, current slot assignments and reported positions of other users, and possible existence of base stations. During this time period, a dynamic directory of all members operating in the system should be established. A frame map should be constructed, which reflects TDMA channel activity.

3.3.5.1.2 Network entry after one min

After one (1) min has elapsed, the station should enter the network and start to transmit according to its own schedule, as described below.

3.3.5.2 Network entry phase

During the network entry phase, the station should select its first slot for transmission in order to make itself visible to other participating stations. The first transmission should always be the scheduled position report (see Fig. 10).

3.3.5.2.1 Select nominal start slot (NSS)

The NSS should be randomly selected between current slot and nominal increment (NI) slots forward. This slot should be the reference when selecting nominal slots (NS) during the first frame phase. The first NS should always be equal to NSS.

FIGURE 10

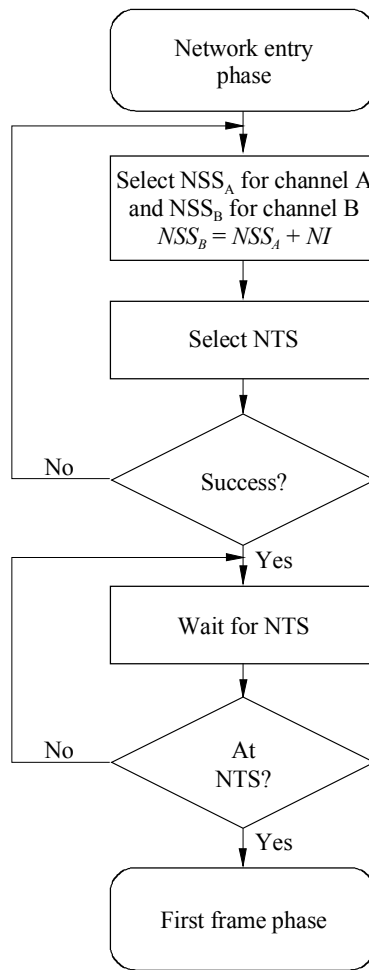

1371-10

3.3.5.2.2 Select nominal transmission slot (NTS)

Within the SOTDMA algorithm, the NTS should be randomly selected among candidate slots within the SI. This is the NTS, which should be marked as internally allocated and assigned a random time-out between TMO_MIN and TMO_MAX.

3.3.5.2.3 Wait for NTS

The station should wait until the NTS is approached.

3.3.5.2.4 At NTS

When the frame map indicates that the NTS is approaching, the station should enter the first frame phase.

3.3.5.3 First frame phase

During the first frame phase, the station should continuously allocate its transmission slots and transmit scheduled position reports using ITDMA (see Fig. 11).

FIGURE 11

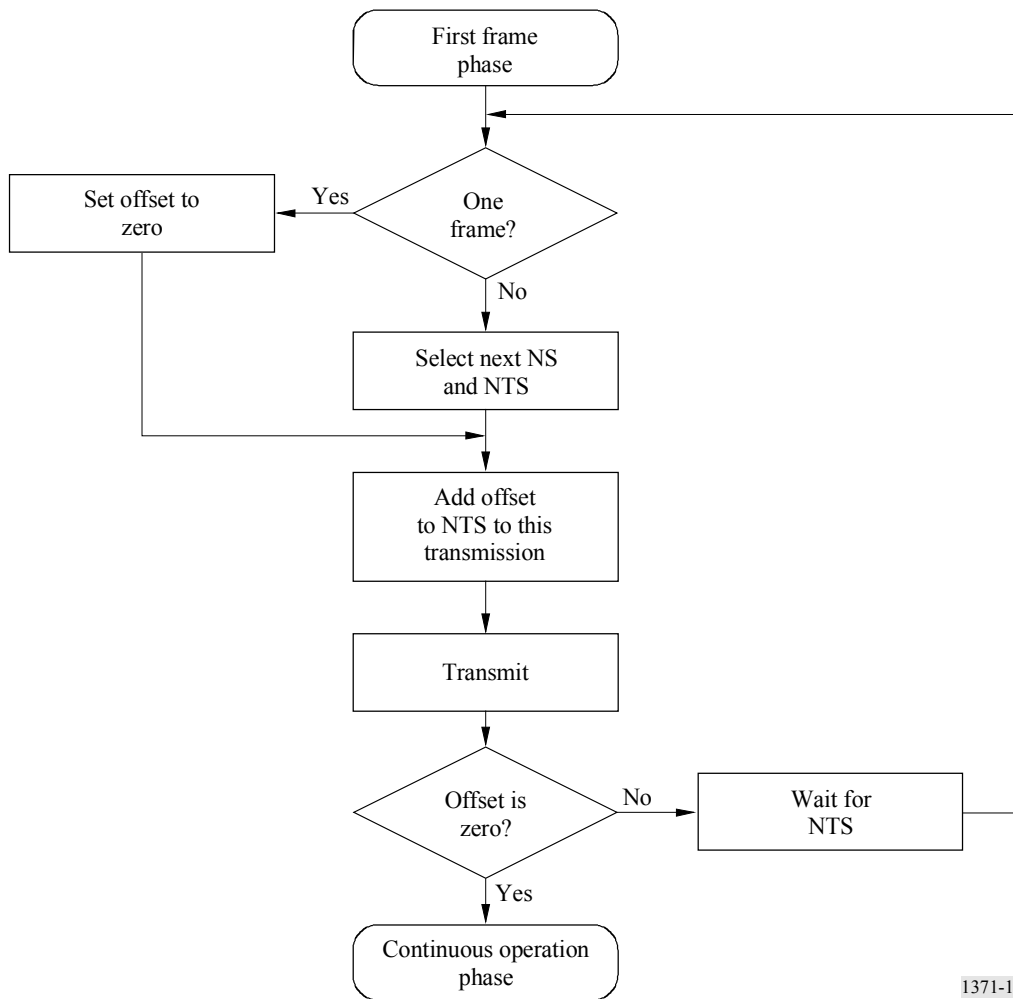

1371-11

3.3.5.3.1 Normal operation after one frame

When one frame has elapsed, the initial transmissions should have been allocated and normal operation should commence.

3.3.5.3.2 Set offset to zero

The offset should be used in the first frame when all transmissions use the ITDMA access scheme. The offset indicates the relative distance from the current transmission to next intended transmission. It is an incremental update of the intention of the station.

3.3.5.3.3 Select next NS and NTS

Prior to transmitting, the next NS should be selected. This should be done by keeping track of the number of transmissions performed so far on the channel (from n to $Rr - 1$). The NS should be selected using the equation described in Table 9.

Nominal transmission slot should be selected using the SOTDMA algorithm to select among candidate slots within SI. The NTS should then be marked as internally allocated. The offset to next NTS should be calculated and saved for the next step.

3.3.5.3.4 Add offset to this transmission

All transmissions in the first frame phase should use the ITDMA access scheme. This structure contains an offset from the current transmission to the next slot in which a transmission is due to occur. The transmission also sets the keep flag so that receiving stations will allocate the slot for one additional frame.

3.3.5.3.5 Transmit

A scheduled position report should be entered into the ITDMA packet and transmitted in the allocated slot. The slot time-out of this slot should be decremented by one.

3.3.5.3.6 Offset is zero

If the offset has been set to zero, the first frame phase should be considered to have ended. The station should now enter the continuous operation phase.

3.3.5.3.7 Wait for NTS

If the offset was non-zero, the station should wait for the next NTS and repeat the sequence.

3.3.5.4 Continuous operation phase

The station should remain in the continuous operation phase until it shuts down, enters assigned mode or is changing its report rate (see Fig. 12).

FIGURE 12

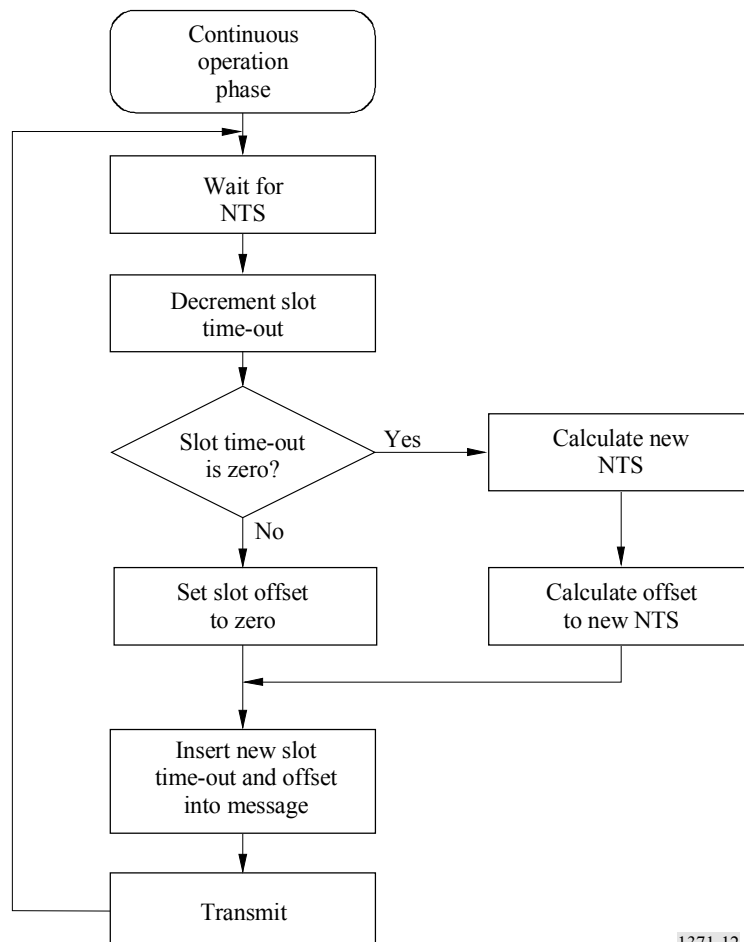

3.3.5.4.1 Wait for NTS

The station should now wait until this slot is approached.

3.3.5.4.2 Decrement slot time-out

Upon reaching the NTS, the SOTDMA time-out counter, for that slot, should be decremented. This slot time-out specifies how many frames the slot is allocated for. The slot time-out should always be included as part of the SOTDMA transmission.

3.3.5.4.3 Slot time-out is zero

If the slot time-out is zero, a new NTS should be selected. The SI around the NS should be searched for candidate slots and one of the candidates should be randomly selected. The offset from the current NTS and the new NTS should be calculated and assigned as a slot offset value. The new NTS should be assigned a time-out value with a randomly selected value between TMO_MIN and TMO_MAX.

If the slot time-out is more than zero, the slot offset value should be set to zero.

3.3.5.4.4 Assign time-out and offset to packet

The time-out and slot offset values are inserted into the SOTDMA communication state (see § 3.3.7.2.2).

3.3.5.4.5 Transmit

A scheduled position report is inserted into the SOTDMA packet and transmitted in the allocated slot. The slot time-out should be decremented by one. The station should then wait for the next NTS.

3.3.5.5 Changing report rate

When the nominal report rate is required to change, the station should enter change report rate phase (see Fig. 13). During this phase, it will reschedule its periodic transmissions to suit the new desired reporting rate.

The procedure, described in this section, should be used for changes which will persist for at least 2 frames. For temporary changes, ITDMA transmissions should be inserted between SOTDMA transmissions for the duration of the change.

3.3.5.5.1 Wait for next transmit slot

Prior to changing its report rate, the station should wait for the next slot, which has been allocated for own transmission. Upon reaching this slot, the associated NS is set to the new NSS. The slot, which was allocated for own transmission, should be checked to make sure that the slot time-out is non-zero. If it is zero, the slot time-out should be set to one.

FIGURE 13

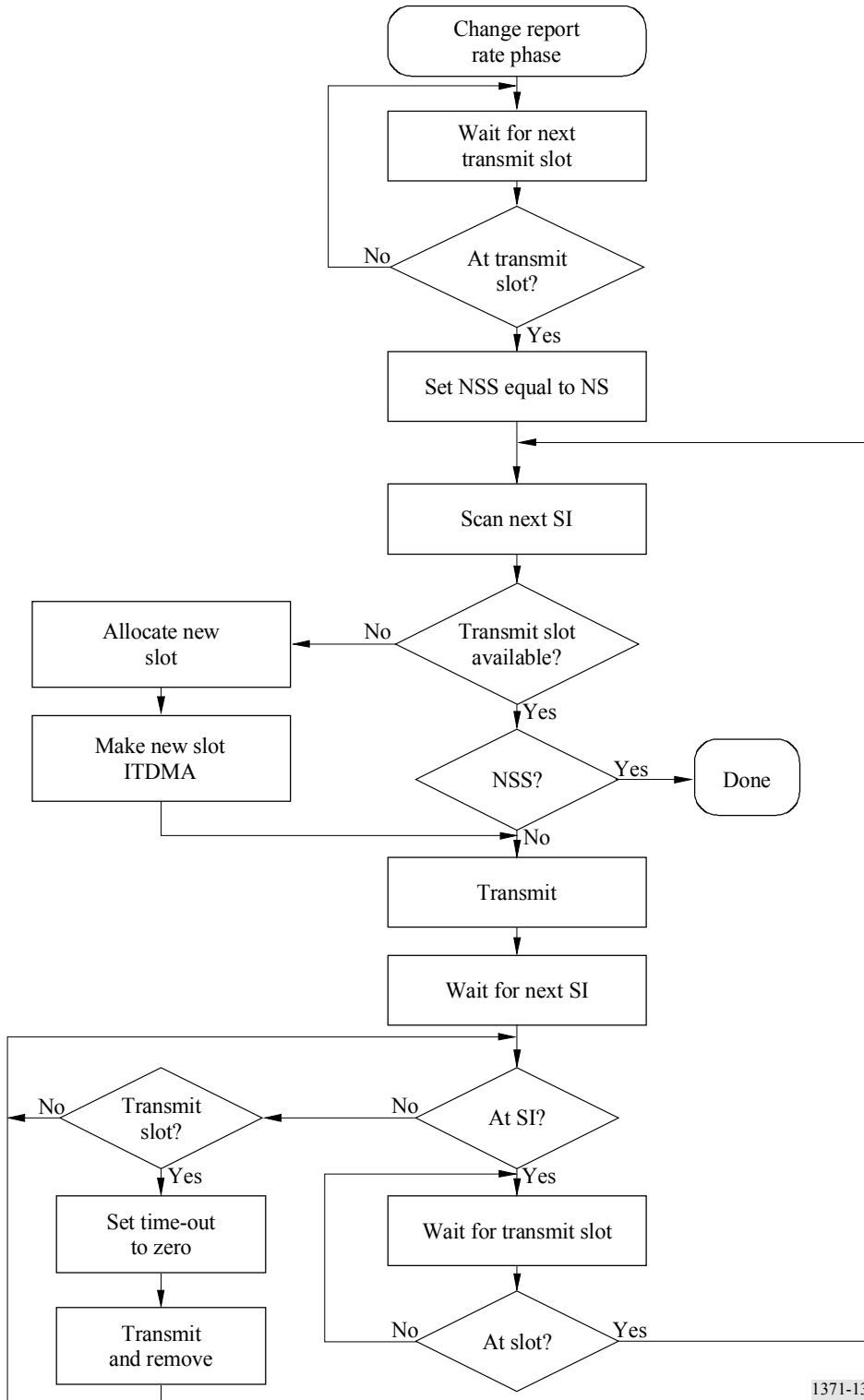

3.3.5.5.2 Scan next SI

When using the new report rate, a new NI should be derived. With the new NI, the station should examine the area which is covered by the next SI. If a slot is found, which is allocated for own transmission, it should be checked to see if it is associated with the NSS. If so, the phase is complete and the station should return to normal operation. If not, the slot should be kept with a time-out above zero.

If a slot was not found within the SI, a slot should be allocated. The offset, in slots, between the current transmit slot and the new allocated slot, should be calculated. The current transmit slot should be converted into an ITDMA transmission which should hold the offset with the keep flag set to TRUE.

The current slot should then be used for transmission of periodic messages such as a position report.

3.3.5.5.3 Wait for next SI

While waiting for the next SI, the station continuously scans the frame for slots which are allocated for own transmission. If a slot is found, the slot time-out should be set to zero. After transmission in that slot, the slot should be freed.

When the next SI is approached, the station should begin to search for the transmit slot allocated within the SI. When found, the process should be repeated.

3.3.6 Assigned operation

An autonomous station may be commanded to operate according to a specific transmission schedule, defined by a competent authority via a base or repeater station using Message 16, the assigned mode command. When operating in the assigned mode, the station should use Message 2, the position report, for its transmission of all of its position reports instead of Message 1. The assigned mode should affect only the station's transmission of position reports, and no other behaviour of the station should be affected. The transmission of position reports should be only as directed by Message 16, and the station should not change its reporting rate for changing course and speed. Assignments are limited in time and will be re-issued by the competent authority as needed. Two levels of assignments are possible:

3.3.6.1 Assignment of Rr

When assigned a new Rr, the mobile station should continue to autonomously schedule its transmissions using the assigned Rr as instructed by a competent authority. The process of changing Rr is the same as described in § 4.3.

3.3.6.2 Assignment of transmission slots

A station may be assigned the exact slots to be used for repeatable transmissions by a competent authority using the assigned mode command Message 16 (see § 4.5).

3.3.6.2.1 Entering assigned mode

Upon receipt of the assigned mode command Message 16, the station should allocate the specified slots and begin transmission in these. It should continue to transmit in the autonomously allocated slots with a zero slot time-out and a zero slot offset, until those slots have been removed from the transmission schedule. A transmission with a zero slot time-out and a zero slot offset indicates that this is the last transmission in that slot with no further allocation in that SI.

3.3.6.2.2 Operating in the assigned mode

The assigned slots should use the SOTDMA access scheme, with the time-out value set to the assigned slot time-out. The assigned slot time-out should be between 3 and 8 frames. For each frame, the slot time-out should be decremented.

3.3.6.2.3 Returning to autonomous and continuous mode

Unless a new assignment is received, the assignment should be terminated, when the slot time-out reaches zero of any assigned slot. At this stage, the station should return to autonomous and continuous mode.

The station should initiate the return to autonomous and continuous mode as soon as it detects an assigned slot with a zero slot time-out. This slot should be used to re-enter the network. The station should randomly select an available slot from candidate slots within a NI of the current slot and make this the NSS. It should then substitute the assigned slot for an ITDMA slot and should use this to transmit the relative offset to the new NSS. From this point on, the process should be identical to the network entry phase (see § 3.3.5.2).

3.3.7 Message structure

Messages, which are part of the access schemes, should have the following structure shown in Fig. 14 inside the data portion of a data packet:

FIGURE 14

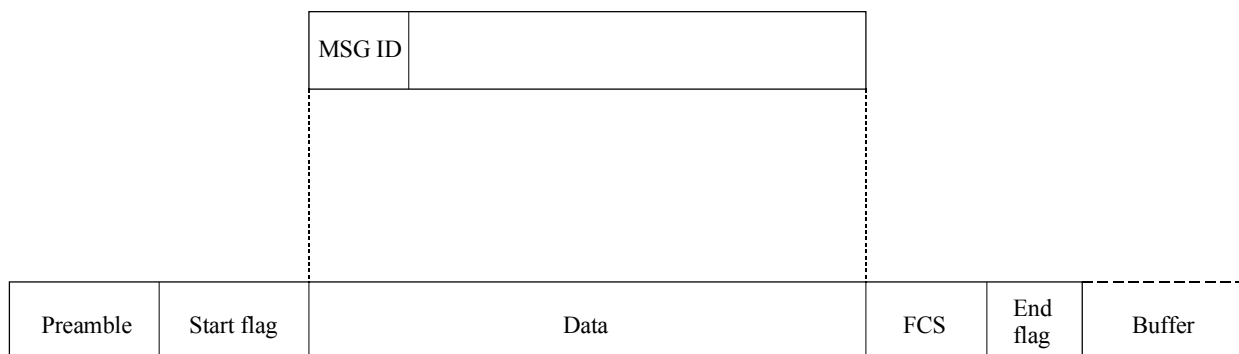

1371-14

Each message is described using a table with parameter fields listed from top to bottom. Each parameter field is defined with the most significant bit first.

Parameter fields containing sub-fields (e.g. communication state) are defined in separate tables with sub-fields listed top to bottom most significant bit first within each sub-field.

Character strings are presented left to right most significant bit first. All unused characters should be represented by the @ symbol, and they should be placed at the end of the string.

When data is output on the VHF data link it should be grouped in bytes of 8 bits from top to bottom of the table associated with each message in accordance with ISO/IEC 3309: 1993. Each byte should be output with least significant bit first. During the output process, data should be subject to bit-stuffing and NRZI coding as described in § 3.2.2.

Unused bits in the last byte should be set to zero in order to preserve byte boundary.

Generic example for a message table:

Parameter	Symbol	Number of bits	Description
P1	T	6	Parameter 1
P2	D	1	Parameter 2
P3	I	1	Parameter 3
P4	M	27	Parameter 4
P5	N	2	Parameter 5
Unused	0	3	Unused bits

Logical view of data as described in § 3.3.7:

Bit order	M----L--	M-----	-----	-----	--LML000
Symbol	TTTTTTDI	MMMMMMMM	MMMMMMMM	MMMMMMMM	MMMNNO00
Byte order	1	2	3	4	5

Output order to VHF data link (bit-stuffing is disregarded in the example):

Bit order	--L----M	-----M	-----	-----	000LML--
Symbol	IDTTTTTT	MMMMMMMM	MMMMMMMM	MMMMMMMM	000NNMMM
Byte order	1	2	3	4	5

3.3.7.1 Message ID (MSG ID)

The message ID should be 6 bits long and should range between 0 and 63. The message ID should identify the message type.

3.3.7.2 SOTDMA message structure

The SOTDMA message structure should supply the necessary information in order to operate in accordance with § 3.3.4.4. The message structure is shown in Fig. 15.

FIGURE 15

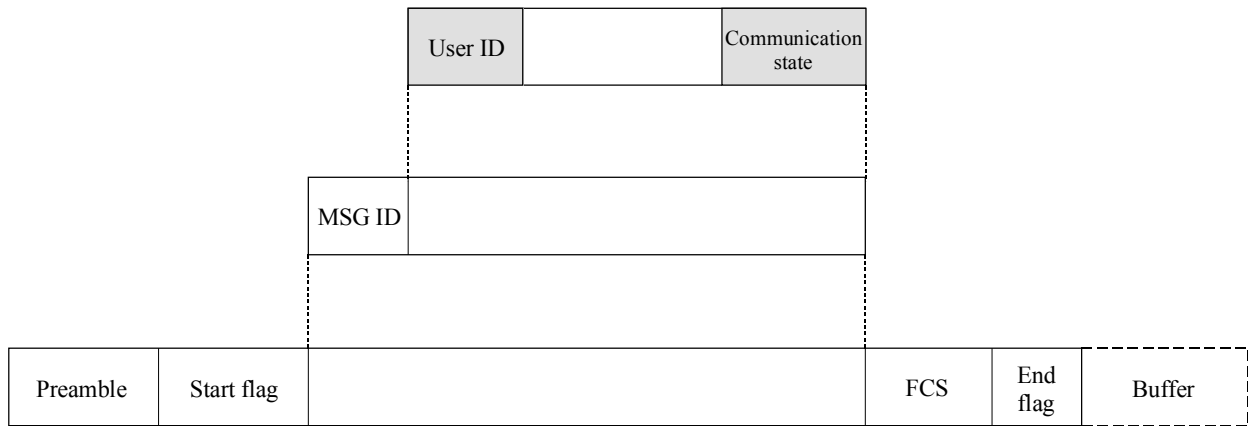

1371-15

3.3.7.2.1 User ID

The user ID should be the MMSI. The MMSI is 30 bits long. The first 9 digits (most significant digits) should be used only. Recommendation ITU-R M.1083 should not be applied with respect to the 10th digit (least significant digit).

3.3.7.2.2 SOTDMA communication state

The communication state provides the following functions:

- it contains information used by the slot allocation algorithm in the SOTDMA concept;
- it also indicates the synchronization state.

The SOTDMA communication state is structured as shown in Table 10:

TABLE 10

Parameter	Number of bits	Description
Sync state	2	0 UTC direct (see § 3.1.1.1) 1 UTC indirect (see § 3.1.1.2) 2 Station is synchronized to a base station (see § 3.1.1.3) 3 Station is synchronized to another station based on the highest number of received stations (see § 3.1.1.4)
Slot time-out	3	Specifies frames remaining until a new slot is selected 0 means that this was the last transmission in this slot 1-7 means that 1 to 7 frames respectively are left until slot change
Sub message	14	The sub message depends on the current value in slot time-out as described in Table 11

The SOTDMA communication state should apply only to the slot in the channel where the relevant transmission occurs.

3.3.7.2.3 Sub messages

TABLE 11

Slot time-out	Sub message	Description
3, 5, 7	Received stations	Number of other stations (not own station) which the station currently is receiving (between 0 and 16383)
2, 4, 6	Slot number	Slot number used for this transmission (between 0 and 2249)
1	UTC hour and minute	If the station has access to UTC, the hour and minute should be indicated in this sub message. Hour (0-23) should be coded in bits 13 to 9 of the sub message (bit 13 is MSB). Minute (0-59) should be coded in bit 8 to 2 (bit 8 is MSB)
0	Slot offset	If the slot time-out value is 0 (zero) then the slot offset should indicate the relative jump to the slot in which transmission will occur during next frame. If the slot offset is zero, the slot should be de-allocated after transmission.

3.3.7.3 ITDMA message structure

The ITDMA message structure supplies the necessary information in order to operate in accordance with § 3.3.4.1. The message structure is shown in Fig. 16:

FIGURE 16

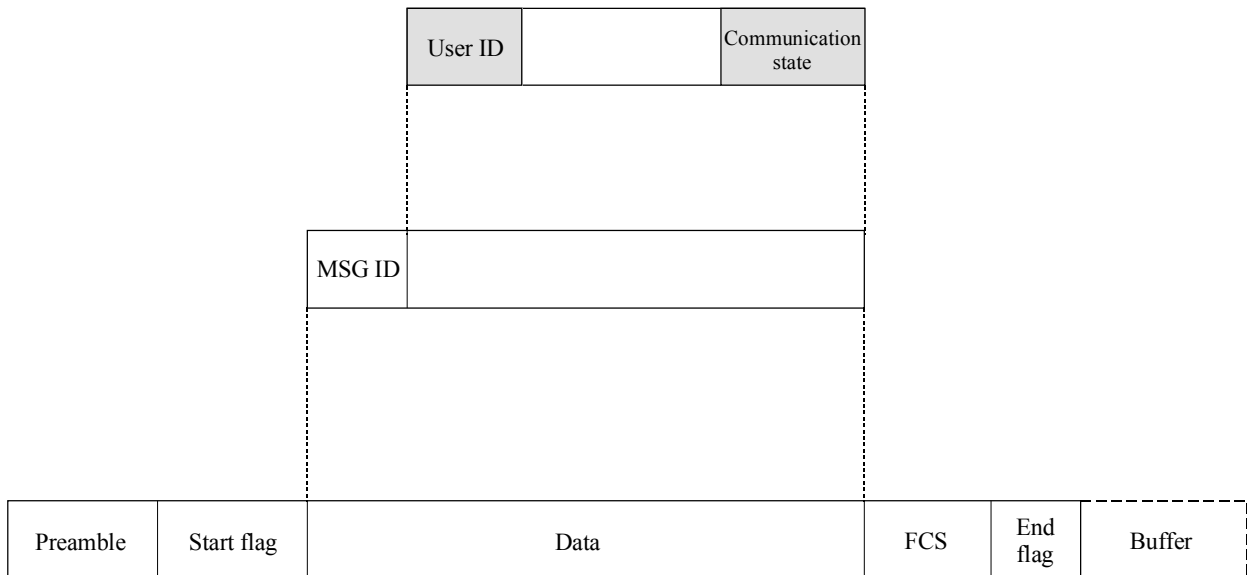

1371-16

3.3.7.3.1 User ID

The user ID should be the MMSI. The MMSI is 30 bits long. The first 9 digits (most significant digits) should be used only. Recommendation ITU-R M.1083 should not be applied with respect to the 10th digit (least significant digit).

3.3.7.3.2 ITDMA communication state

The communication state provides the following functions:

- it contains information used by the slot allocation algorithm in the ITDMA concept;
- it also indicates the synchronization state.

The ITDMA communication state is structured as shown in Table 12:

TABLE 12

Parameter	Number of Bits	Description
Sync state	2	0 UTC direct (see § 3.1.1.1) 1 UTC indirect (see § 3.1.1.2) 2 Station is synchronized to a base station (see § 3.1.1.3) 3 Station is synchronized to another station based on the highest number of received stations (see § 3.1.1.4)
Slot increment	13	Offset to next slot to be used, or zero (0) if no more transmissions
Number of slots	3	Number of consecutive slots to allocate. (0 = 1 slot, 1 = 2 slots, 2 = 3 slots, 3 = 4 slots, 4 = 5 slots)
Keep flag	1	Set to TRUE = 1 if the slot remains allocated for one additional frame (see Table 6)

The ITDMA communication state should apply only to the slot in the channel where the relevant transmission occurs.

3.3.7.4 RATDMA message structure

The RATDMA access scheme may use message structures determined by message ID and may thus lack a uniform structure.

A message with a communication state may be transmitted using RATDMA in the following situations:

- When initially entering the network (refer to § 3.3.4.1.1).
- When repeating a message.

3.3.7.4.1 The communication state when initially entering the network should be set in accordance with § 3.3.4.1.1 and 3.3.7.3.2.

3.3.7.4.2 The communication state when repeating a message should be set in accordance with § 4.6.2 and 4.6.3.

3.3.7.5 FATDMA message structure

The FATDMA access scheme may use message structures determined by message ID and may thus lack a uniform structure.

A message with a communication state may be transmitted using FATDMA, e.g. when repeated. In this situation, the communication state should be set in accordance with § 4.6.2 and 4.6.3.

3.3.8 Message types

This paragraph describes all messages on the TDMA data link. The message Table (Table 13) uses the following columns:

Message ID:	message identifier as defined in § 3.3.7.1.
Name:	name of the message. Can also be found in § 3.3.8.2.
Description:	Brief description of the message. See § 3.3.8.2 for detailed description of each message.
Category:	category. Specifies if the message has been included in order to fulfil a functional requirement as specified by the operational use of the AIS, or if the message is included for system management purposes. F: functional message S: system management message F/S: functional and system management message.
Priority:	priority as defined in § 4.2.3.
Operation mode:	operational mode. A station transmitting a specific message will also say something about its mode of operation as defined in § 3.3.2. A combination of modes indicates that the station can be in either of these. AU: autonomous AS: assigned IN: interrogation/poll mode.
Access scheme:	this column indicates how a station may select slots for transmission of this message. The access scheme used for the selection of slots does not determine the message type nor the communication state of the message transmissions in those slots.
Communication state:	specifies which communication state is used in the message. If a message does not contain a communication state, it is stated as not applicable, N/A. Communication state, where applicable, indicates an expected future use of that slot. Where no communication state is indicated the slot is immediately available for future use.
M/B:	M: transmitted by mobile station B: transmitted by base station.

3.3.8.1 Message summary

The defined messages are summarized in Table 13.

TABLE 13

Message ID	Name	Description	Category	Priority	Operation mode	Access scheme	Communication state	M/B
1	Position report	Scheduled position report; (Class A shipborne mobile equipment)	F/S	1	AU	SOTDMA, RATDMA, ITDMA ⁽¹⁾	SOTDMA	M
2	Position report	Assigned scheduled position report; (Class A shipborne mobile equipment)	F/S	1	AS	SOTDMA	SOTDMA	M
3	Position report	Special position report, response to interrogation; (Class A shipborne mobile equipment)	F/S	1	AU	RATDMA	ITDMA	M
4	Base station report	Position, UTC, date and current slot number of base station	F/S	1	AS ^{(3), (7)}	FATDMA, RATDMA, ITDMA ⁽²⁾	SOTDMA	B
5	Static and voyage related data	Scheduled static and voyage related vessel data report; (Class A shipborne mobile equipment)	F	4 ⁽⁵⁾	AU, AS	RATDMA, ITDMA ⁽²⁾	N/A	M
6	Binary addressed message	Binary data for addressed communication	F	4	AU, AS, IN	RATDMA, FATDMA, ITDMA ⁽²⁾	N/A	M/B
7	Binary acknowledgement	Acknowledgement of received addressed binary data	S	1	AU, AS, IN	RATDMA, FATDMA, ITDMA ⁽²⁾	N/A	M/B
8	Binary broadcast message	Binary data for broadcast communication	F	4	AU, AS, IN	RATDMA, FATDMA, ITDMA ⁽²⁾	N/A	M/B
9	Standard SAR aircraft position report	Position report for airborne stations involved in SAR operations, only	F/S	1	AU, AS	SOTDMA, RATDMA, ITDMA ⁽¹⁾	SOTDMA	M
10	UTC/date inquiry	Request UTC and date	F/S	3	AU, AS, IN	RATDMA, FATDMA, ITDMA ⁽²⁾	N/A	M/B
11	UTC/date response	Current UTC and date if available	F/S	3	AU, AS, IN	RATDMA, ITDMA ⁽²⁾	SOTDMA	M
12	Addressed safety related message	Safety related data for addressed communication	F	2	AU, AS, IN	RATDMA, FATDMA, ITDMA ⁽²⁾	N/A	M/B
13	Safety related acknowledgement	Acknowledgement of received addressed safety related message	S	1	AU, AS, IN	RATDMA, FATDMA, ITDMA ⁽²⁾	N/A	M/B
14	Safety related broadcast message	Safety related data for broadcast communication	F	2	AU, AS, IN	RATDMA, FATDMA, ITDMA ⁽²⁾	N/A	M/B
15	Interrogation	Request for a specific message type (can result in multiple responses from one or several stations) ⁽⁴⁾	F	3	AU, AS, IN	RATDMA, FATDMA, ITDMA ⁽²⁾	N/A	M/B
16	Assignment mode command	Assignment of a specific report behaviour by competent authority using a base station	F/S	1	AS	RATDMA, FATDMA, ITDMA ⁽²⁾	N/A	B

TABLE 13 (end)

Message ID	Name	Description	Category	Priority	Operation mode	Access scheme	Communication state	M/B
17	DGNSS broadcast binary message	DGNSS corrections provided by a base station	F	2	AS ⁽³⁾	FATDMA, RATDMA, ITDMA ⁽²⁾	N/A	B
18	Standard Class B equipment position report	Standard position report for Class B shipborne mobile equipment to be used instead of Messages 1, 2, 3 ⁽⁸⁾	F/S	1	AU, AS	SOTDMA, ITDMA ⁽¹⁾	SOTDMA, ITDMA	M
19	Extended Class B equipment position report	Extended position report for class B shipborne mobile equipment; contains additional static information ⁽⁸⁾	F/S	1	AU, AS	ITDMA	N/A	M
20	Data link management message	Reserve slots for base station(s)	S	1	AS ⁽³⁾	FATDMA, RATDMA, ITDMA	N/A	B
21	Aids-to-navigation report	Position and status report for aids-to-navigation	F/S	1	AU, AS, IN ⁽³⁾	FATDMA, RATDMA, ITDMA ⁽²⁾	N/A	M/B
22	Channel management	Management of channels and transceiver modes by a base station	S	1	AS ^{(3), (6)}	FATDMA, RATDMA, ITDMA ⁽²⁾	N/A	B

SAR: search and rescue

DGNSS: digital global navigation-satellite system

- (1) ITDMA is used during the first frame phase (see § 3.3.5.3) and during a change of Rr. SOTDMA is used during the continuous operation phase (see § 3.3.5.4). RATDMA can be used at any time to transmit additional position reports.
- (2) This message type should be broadcast within 4 s. The RATDMA access scheme is the default method (see § 3.3.4.2.1) for allocating the slot(s) for this message type. Alternatively, an existing SOTDMA allocated slot can use the ITDMA access scheme for allocating the slot(s) for this message. A base station may use an existing FATDMA allocated slot for allocating the slot(s) for transmission of this message type.
- (3) A base station is always operating in assigned mode using a fixed transmission schedule (FATDMA) for its periodic transmissions. The data link management message should be used to announce the base station's fixed allocation schedule (see Message 20). If necessary, either ITDMA or RATDMA may be used to transmit non-periodic broadcasts.
- (4) For interrogation of UTC and date, message identifier 10 should be used.
- (5) Priority 3, if in response to interrogation.
- (6) In order to satisfy the requirements for dual channel operation (reference § 2.1.5 and 4.1), the following should apply, unless otherwise specified by Message 22:
- For periodic repeated messages, including the initial link access, the transmissions should alternate between AIS 1 and AIS 2.
 - Transmissions following slot allocation announcements, responses to interrogations, responses to requests, and acknowledgements should be transmitted on the same channel as the initial message.
 - For addressed messages, transmissions should utilize the channel in which a message from the addressed station was last received.
 - For non-periodic messages other than those referenced above, the transmissions of each message, regardless of message type, should alternate between AIS 1 and AIS 2.
- (7) Recommendations for base stations (dual channel operations): Base stations should alternate their transmissions between AIS 1 and AIS 2 for the following reasons:
- to increase link capacity;
 - to balance channel loading between AIS 1 and AIS 2; and
 - to mitigate the harmful effects of RF interference.
- (8) – Equipment other than Class B shipborne mobile should not transmit Messages 18 and 19.
- Class B shipborne mobile equipment should only use Messages 18 and 19 for position reporting and static data.

3.3.8.2 Message descriptions

All positions should be to be transmitted in WGS 84 datum.

Some telegrams specify the inclusion of character data, such as ship's name, destination, call sign, and more. These fields should use a 6-bit ASCII as defined in Table 14.

TABLE 14

6-Bit ASCII				STANDARD ASCII			6-Bit ASCII				STANDARD ASCII		
Chr	Dec	Hex	Binary	Dec	Hex	Binary	Chr	Dec	Hex	Binary	Dec	Hex	Binary
@	0	0x00	00 0000	64	0x40	0100 0000	!	33	0x21	10 0001	33	0x21	0010 0001
A	1	0x01	00 0001	65	0x41	0100 0001	”	34	0x22	10 0010	34	0x22	0010 0010
B	2	0x02	00 0010	66	0x42	0100 0010	#	35	0x23	10 0011	35	0x23	0010 0011
C	3	0x03	00 0011	67	0x43	0100 0011	\$	36	0x24	10 0100	36	0x24	0010 0100
D	4	0x04	00 0100	68	0x44	0100 0100	%	37	0x25	10 0101	37	0x25	0010 0101
E	5	0x05	00 0101	69	0x45	0100 0101	&	38	0x26	10 0110	38	0x26	0010 0110
F	6	0x06	00 0110	70	0x46	0100 0110	`	39	0x27	10 0111	39	0x27	0010 0111
G	7	0x07	00 0111	71	0x47	0100 0111	(40	0x28	10 1000	40	0x28	0010 1000
H	8	0x08	00 1000	72	0x48	0100 1000)	41	0x29	10 1001	41	0x29	0010 1001
I	9	0x09	00 1001	73	0x49	0100 1001	*	42	0x2A	10 1010	42	0x2A	0010 1010
J	10	0x0A	00 1010	74	0x4A	0100 1010	+	43	0x2B	10 1011	43	0x2B	0010 1011
K	11	0x0B	00 1011	75	0x4B	0100 1011	,	44	0x2C	10 1100	44	0x2C	0010 1100
L	12	0x0C	00 1100	76	0x4C	0100 1100	-	45	0x2D	10 1101	45	0x2D	0010 1101
M	13	0x0D	00 1101	77	0x4D	0100 1101	.	46	0x2E	10 1110	46	0x2E	0010 1110
N	14	0x0E	00 1110	78	0x4E	0100 1110	/	47	0x2F	10 1111	47	0x2F	0010 1111
O	15	0x0F	00 1111	79	0x4F	0100 1111	0	48	0x30	11 0000	48	0x30	0011 0000
P	16	0x10	01 0000	80	0x50	0101 0000	1	49	0x31	11 0001	49	0x31	0011 0001
Q	17	0x11	01 0001	81	0x51	0101 0001	2	50	0x32	11 0010	50	0x32	0011 0010
R	18	0x12	01 0010	82	0x52	0101 0010	3	51	0x33	11 0011	51	0x33	0011 0011
S	19	0x13	01 0011	83	0x53	0101 0011	4	52	0x34	11 0100	52	0x34	0011 0100
T	20	0x14	01 0100	84	0x54	0101 0100	5	53	0x35	11 0101	53	0x35	0011 0101
U	21	0x15	01 0101	85	0x55	0101 0101	6	54	0x36	11 0110	54	0x36	0011 0110
V	22	0x16	01 0110	86	0x56	0101 0110	7	55	0x37	11 0111	55	0x37	0011 0111
W	23	0x17	01 0111	87	0x57	0101 0111	8	56	0x38	11 1000	56	0x38	0011 1000
X	24	0x18	01 1000	88	0x58	0101 1000	9	57	0x39	11 1001	57	0x39	0011 1001
Y	25	0x19	01 1001	89	0x59	0101 1001	:	58	0x3A	11 1010	58	0x3A	0011 1010
Z	26	0x1A	01 1010	90	0x5A	0101 1010	;	59	0x3B	11 1011	59	0x3B	0011 1011
[27	0x1B	01 1011	91	0x5B	0101 1011	<	60	0x3C	11 1100	60	0x3C	0011 1100
\	28	0x1C	01 1100	92	0x5C	0101 1100	=	61	0x3D	11 1101	61	0x3D	0011 1101
]	29	0x1D	01 1101	93	0x5D	0101 1101	>	62	0x3E	11 1110	62	0x3E	0011 1110
^	30	0x1E	01 1110	94	0x5E	0101 1110	?	63	0x3F	11 1111	63	0x3F	0011 1111
-	31	0x1F	01 1111	95	0x5F	0101 1111							
Space	32	0x20	10 0000	32	0x20	0010 0000							

Chr: character

Unless otherwise specified all fields are binary. All numbers expressed are in decimal notation. Negative numbers are expressed using 2's complement.

3.3.8.2.1 Messages 1, 2, 3: position reports

The position report should be output periodically by mobile stations.

TABLE 15a

Parameter	Number of bits	Description
Message ID	6	Identifier for this message 1, 2 or 3
Repeat indicator	2	Used by the repeater to indicate how many times a message has been repeated. Refer to § 4.6.1; 0-3; 0 = default; 3 = do not repeat any more
User ID	30	MMSI number
Navigational status	4	0 = under way using engine, 1 = at anchor, 2 = not under command, 3 = restricted manoeuvrability, 4 = constrained by her draught, 5 = moored, 6 = aground, 7 = engaged in fishing, 8 = under way sailing, 9 = reserved for future amendment of navigational status for ships carrying DG, HS, or MP, or IMO hazard or pollutant category C (HSC), 10 = reserved for future amendment of navigational status for ships carrying DG, HS or MP, or IMO hazard or pollutant category A (WIG); 11-14 = reserved for future use, 15 = not defined = default
Rate of turn ROT _{AIS}	8	±127 (–128 (80 _h) indicates not available, which should be the default). Coded by ROT _{AIS} = 4.733 SQRT(ROT _{INDICATED}) degrees/min ROT _{INDICATED} is the rate of turn (720°/min), as indicated by an external sensor. +127 = turning right at 720°/min or higher –127 = turning left at 720°/min or higher
SOG	10	Speed over ground in 1/10 knot steps (0-102.2 knots) 1 023 = not available, 1 022 = 102.2 knots or higher
Position accuracy	1	1 = high (<10 m; differential mode of e.g. DGNSS receiver) 0 = low (>10 m; autonomous mode of e.g. global navigation satellite system (GNSS) receiver or of other electronic position fixing device); 0 = default
Longitude	28	Longitude in 1/10 000 min (±180°, East = positive, West = negative. 181° (6791AC0 _h) = not available = default)
Latitude	27	Latitude in 1/10 000 min (±90°, North = positive, South = negative. 91° (3412140 _h) = not available = default)
COG	12	Course over ground in 1/10° (0-3599). 3600 (E10 _h) = not available = default. 3 601-4 095 should not be used
True heading	9	Degrees (0-359) (511 indicates not available = default)
Time stamp	6	UTC second when the report was generated (0-59 or 60 if time stamp is not available, which should also be the default value or 62 if electronic position fixing system operates in estimated (dead reckoning) mode or 61 if positioning system is in manual input mode or 63 if the positioning system is inoperative)
Reserved for regional applications	4	Reserved for definition by a competent regional authority. Should be set to zero, if not used for any regional application. Regional applications should not use zero
Spare	1	Not used. Should be set to zero
RAIM-flag	1	RAIM (Receiver autonomous integrity monitoring) flag of electronic position fixing device; 0 = RAIM not in use = default; 1 = RAIM in use
Communication state	19	See below
Total number of bits	168	

TABLE 15b

Message ID	Communication state
1	SOTDMA communication state as described in § 3.3.7.2.2
2	SOTDMA communication state as described in § 3.3.7.2.2
3	ITDMA communication state as described in § 3.3.7.3.2

3.3.8.2.2 Message 4: Base station report

Message 11: UTC and date response

Should be used for reporting UTC time and date and, at the same time, position. A base station should use Message 4 in its periodical transmissions. A mobile station should output Message 11 only in response to interrogation by Message 10.

Message 11 is only transmitted as a result of a UTC request message (Message 10). The UTC and date response should be transmitted on the channel, where the UTC request message was received.

TABLE 16

Parameter	Number of bits	Description
Message ID	6	Identifier for this message 4, 11 4 = UTC and position report from base station 11 = UTC and position response from mobile station
Repeat indicator	2	Used by the repeater to indicate how many times a message has been repeated. Refer to § 4.6.1; 0-3; 0 = default; 3 = do not repeat any more
User ID	30	MMSI number
UTC year	14	1-9999; 0 = UTC year not available = default
UTC month	4	1-12; 0 = UTC month not available = default; 13-15 not used
UTC day	5	1-31; 0 = UTC day not available = default
UTC hour	5	0-23; 24 = UTC hour not available = default; 25-31 not used
UTC minute	6	0-59; 60 = UTC minute not available = default; 61-63 not used
UTC second	6	0-59; 60 = UTC second not available = default; 61-63 not used
Position accuracy	1	1 = high (<10 m; differential mode of e.g. DGNSS receiver) 0 = low (>10 m; autonomous mode of e.g. GNSS receiver, or of other electronic position fixing device), 0 = default
Longitude	28	Longitude in 1/10 000 min ($\pm 180^\circ$, East = positive, West = negative); 181° (6791AC0 _h) = not available = default
Latitude	27	Latitude in 1/10 000 min ($\pm 90^\circ$, North = positive, South = negative); 91° (3412140 _h) = not available = default

TABLE 16 (end)

Parameter	Number of bits	Description
Type of electronic position fixing device	4	Use of differential corrections is defined by field position accuracy above: 0 = undefined (default) 1 = global positioning system (GPS) 2 = GNSS (GLONASS) 3 = combined GPS/GLONASS 4 = Loran-C 5 = Chayka 6 = integrated navigation system 7 = surveyed 8-15 = not used
Spare	10	Not used. Should be set to zero
RAIM-flag	1	RAIM flag of electronic position fixing device; 0 = RAIM not in use = default; 1 = RAIM in use
Communication state	19	SOTDMA communication state as described in § 3.3.7.2.2
Total number of bits	168	

3.3.8.2.3 Message 5: Ship static and voyage related data

Should only be used by Class A shipborne mobile equipment when reporting static or voyage related data.

TABLE 17

Parameter	Number of bits	Description
Message ID	6	Identifier for this message 5
Repeat indicator	2	Used by the repeater to indicate how many times a message has been repeated. Refer to § 4.6.1; 0-3; 0 = default; 3 = do not repeat any more
User ID	30	MMSI number
AIS version indicator	2	0 = station compliant with AIS edition 0; 1-3 = station compliant with future AIS editions 1, 2, and 3
IMO number	30	1-999999999; 0 = not available = default
Call sign	42	7 × 6 bit ASCII characters, @@@@@@@@ = not available = default
Name	120	Maximum 20 characters 6 bit ASCII, @@@@@@@@@@@@@@@@@@@@@@@@@@@@@@@@@ = not available = default
Type of ship and cargo type	8	0 = not available or no ship = default 1-99 = as defined in § 3.3.8.2.3.2 100-199 = preserved, for regional use 200-255 = preserved, for future use

TABLE 17 (*end*)

Parameter	Number of bits	Description
Dimension/ reference for position	30	Reference point for reported position. Also indicates the dimension of ship (m) (see Fig. 18 and § 3.3.8.2.3.3)
Type of electronic position fixing device	4	0 = undefined (default) 1 = GPS 2 = GLONASS 3 = combined GPS/GLONASS 4 = Loran-C 5 = Chayka 6 = integrated navigation system 7 = surveyed 8-15 = not used
ETA	20	Estimated time of arrival; MMDDHHMM UTC Bits 19-16: month; 1-12; 0 = not available = default Bits 15-11: day; 1-31; 0 = not available = default Bits 10-6: hour; 0-23; 24 = not available = default Bits 5-0: minute; 0-59; 60 = not available = default
Maximum present static draught	8	in 1/10 m, 255 = draught 25.5 m or greater, 0 = not available = default; in accordance with IMO Resolution A.851
Destination	120	Maximum 20 characters using 6-bit ASCII; @@@@@@@@@@@@@@@@@@@@ = not available
DTE	1	Data terminal ready (0 = available, 1 = not available = default)
Spare	1	Spare. Not used. Should be set to zero
Number of bits	424	Occupies 2 slots

This message should be transmitted immediately after any parameter value has been changed.

3.3.8.2.3.1 The data terminal equipment (DTE) indicator

The purpose of the DTE indicator is to indicate to an application on the receiving side that, if set to available, the transmitting station conforms at least to the minimum keyboard and display requirements. On the transmitting side, the DTE indicator may also be set by an external application via the Presentation Interface. On the receiving side, the DTE indicator is only used as information provided to the application layer, that the transmitting station is available for communications.

3.3.8.2.3.2 Type of ship

TABLE 18

Identifiers to be used by ships to report their type			
Identifier No.	Special craft		
50	Pilot vessel		
51	Search and rescue vessels		
52	Tugs		
53	Port tenders		
54	Vessels with anti-pollution facilities or equipment		
55	Law enforcement vessels		
56	Spare – for assignments to local vessels		
57	Spare – for assignments to local vessels		
58	Medical transports (as defined in the 1949 Geneva Conventions and Additional Protocols)		
59	Ships according to RR Resolution No. 18 (Mob-83)		
Other ships			
First digit⁽¹⁾	Second digit⁽¹⁾	First digit⁽¹⁾	Second digit⁽¹⁾
1 – reserved for future use	0 – All ships of this type	–	0 – Fishing
2 – WIG	1 – Carrying DG, HS, or MP, IMO hazard or pollutant category A	–	1 – Towing
3 – see right column	2 – Carrying DG, HS, or MP, IMO hazard or pollutant category B	3 – Vessel	2 – Towing and length of the tow exceeds 200 m or breadth exceeds 25 m
4 – HSC	3 – Carrying DG, HS, or MP, IMO hazard or pollutant category C	–	3 – Engaged in dredging or underwater operations
5 – See above	4 – Carrying DG, HS, or MP, IMO hazard or pollutant category D	–	4 – Engaged in diving operations
	5 – Reserved for future use	–	5 – Engaged in military operations

TABLE 18 (end)

Identifiers to be used by ships to report their type			
Other ships			
First digit ⁽¹⁾	Second digit ⁽¹⁾	First digit ⁽¹⁾	Second digit ⁽¹⁾
6 – Passenger ships	6 – Reserved for future use	–	6 – Sailing
7 – Cargo ships	7 – Reserved for future use	–	7 – Pleasure craft
8 – Tanker(s)	8 – Reserved for future use	–	8 – Reserved for future use
9 – Other types of ship	9 – No additional information	–	9 – Reserved for future use

DG: dangerous goods

HS: harmful substances

MP: marine pollutants

(1) The identifier should be constructed by selecting the appropriate first and second digits.

3.3.8.2.3.3 Reference point for reported position and dimensions of ship

FIGURE 17

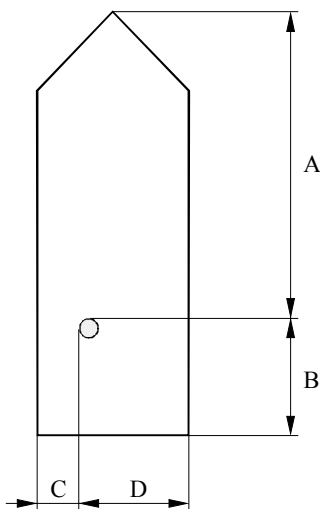

	Number of bits	Bit fields	Distance (m)
A	9	0-8	0-511
B	9	9-17	0-511
C	6	18-23	0-63; 63 = 63 or greater
D	6	24-29	0-63; 63 = 63 or greater

Reference point of reported position not available, but dimensions of ship are available: $A = C = 0$ and $B \neq 0$ and $D \neq 0$.
Neither reference point of reported position nor dimensions of ship available; $A = B = C = D = 0$ (= default).
For use in the message table, A = most significant field, D = least significant field.

3.3.8.2.4 Message 6: Addressed binary message

The addressed binary message should be variable in length, based on the amount of binary data. The length should vary between 1 and 5 slots. See application identifiers in § 3.3.8.2.4.1.

TABLE 19

Parameter	Number of bits	Description		
Message ID	6	Identifier for Message 6; always 6		
Repeat indicator	2	Used by the repeater to indicate how many times a message has been repeated. Refer to § 4.6.1; 0-3; default = 0; 3 = do not repeat any more		
Source ID	30	MMSI number of source station		
Sequence number	2	0-3; refer to § 5.3.1		
Destination ID	30	MMSI number of destination station		
Retransmit flag	1	Retransmit flag should be set upon retransmission: 0 = no retransmission = default; 1 = retransmitted		
Spare	1	Not used. Should be zero		
Binary data	Maximum 936	Application identifier	16 bits	Should be as described in § 3.3.8.2.4.1
		Application data	Maximum 920 bits	Application specific data
Maximum number of bits	Maximum 1 008	Occupies 1 to 5 slots subject to the length of sub-field message content		

Additional bit stuffing will be required for these message types. For details refer to transport layer, § 5.2.1.

The following Table gives the number of binary data bytes (including application ID and application data), so that the whole message fits into a given number of slots. It is recommended that any application minimizes the use of slots by limiting the number of binary data bytes to the numbers given, if possible:

Number of slots	Maximum binary data bytes
1	8
2	36
3	64
4	92
5	117

These numbers also take bit stuffing into account.

3.3.8.2.4.1 Application identifier

Addressed and broadcast binary messages should contain a 16-bit application identifier, structured as follows:

Bit	Description
15-6	Designated area code (DAC). This code should be identical to the maritime identification digits (MID), as defined by ITU-R, which are the leading three digits of the MMSI, with the exemptions for NULL and international application identifier given below. The length should be 10 bits. The DAC codes equal to or above 1000 are reserved for future AIS expansion
5-0	Function identifier. The meaning should be determined by the competent authority which is responsible for the area given in the designated area code. The length should be 6 bits

Whereas the application identifier allows for regional and local applications, the application identifier should have the following special values, which should apply to all stations in order to guarantee international compatibility.

3.3.8.2.4.1.1 NULL application identifier

The NULL application identifier should be used for local testing purposes. It should be identified by a DAC (bits 15-6 of application identifier) of 0 (zero). The function code should be arbitrary.

3.3.8.2.4.1.2 International application identifier

The international application identifier should be used for applications, which are of global relevance. See Table 20. Different international applications are separated by the use of function identifiers.

TABLE 20

DAC	Function identifier	Resulting application identifier (binary)	Resulting application identifier (hex)	Description
001	00	0000 0000 0100 0000	0040	Use of these messages, e.g. for aids-to-navigation, VTS, search and rescue, should be as defined in Annex 5
001	01	0000 0000 0100 0001	0041	
001	02	0000 0000 0100 0010	0042	
001	03	0000 0000 0100 0011	0043	
001	...	0000 0000 01XX XXXX	...	
001	63	0000 0000 0111 1111	007F	

3.3.8.2.4.1.3 Reserved AIS expansion identifiers

The DAC codes 1000 to 1023 should be reserved for a future expansion of the general capabilities of AIS.

3.3.8.2.5 Message 7: Binary acknowledge**Message 13: Safety related acknowledge**

Message 7 should be used as an acknowledgement of up to four Message 6 messages received (see § 5.3.1) and should be transmitted on the channel, where the addressed message to be acknowledged was received.

Message 13 should be used as an acknowledgement of up to four Message 12 messages received (see § 5.3.1) and should be transmitted on the channel, where the addressed message to be acknowledged was received.

These acknowledgements should be applicable only to the VHF data link (see § 5.3.1). Other means must be employed for acknowledging applications.

TABLE 21

Parameter	Number of bits	Description
Message ID	6	Identifier for Messages 7, 13 7 = binary acknowledge 13 = safety related acknowledge
Repeat indicator	2	Used by the repeater to indicate how many times a message has been repeated. See § 4.6.1; 0-3; 0 = default; 3 = do not repeat any more
Source ID	30	MMSI number of source of this ACK
Spare	2	Not used. Should be set to zero
Destination ID1	30	MMSI number of first destination of this ACK
Sequence number for ID1	2	Sequence number of message to be acknowledged; 0-3
Destination ID2	30	MMSI number of second destination of this ACK; should be omitted if no destination ID2
Sequence number for ID2	2	Sequence number of message to be acknowledged; 0-3; should be omitted if no destination ID2
Destination ID3	30	MMSI number of third destination of this ACK; should be omitted if no destination ID3
Sequence number for ID3	2	Sequence number of message to be acknowledged; 0-3; should be omitted if no destination ID3
Destination ID4	30	MMSI number of fourth destination of this ACK; should be omitted if no destination ID4
Sequence number for ID4	2	Sequence number of message to be acknowledged; 0-3. Should be omitted if there is no destination ID4
Total number of bits	72-168	

3.3.8.2.6 Message 8: Binary broadcast message

This message will be variable in length, based on the amount of binary data. The length should vary between 1 and 5 slots.

TABLE 22

Parameter	Number of bits	Description		
Message ID	6	Identifier for Message 8; always 8		
Repeat indicator	2	Used by the repeater to indicate how many times a message has been repeated. See § 3.3.8.2.1.1		
Source ID	30	MMSI number of source station		
Spare	2	Not used. Should be set to zero		
Binary data	Maximum 968	Application identifier	16 bits	Should be as described in § 3.3.8.2.4.1
		Application data	Maximum 952 bits	Application specific data
Total number of bits	Maximum 1 008	Occupies 1 to 5 slots		

The following Table gives the number of binary data bytes (including application ID and application data), so that the whole message fits into a given number of slots. It is recommended that any application minimizes the use of slots by limiting the number of binary data bytes to the numbers given, if possible:

Number of slots	Maximum binary data bytes
1	12
2	40
3	68
4	96
5	121

These numbers also take into account bit stuffing.

Additional bit stuffing will be required for this message type. For details refer to transport layer, § 5.2.1.

3.3.8.2.7 Message 9: Standard SAR aircraft position report

This message should be used as a standard position report for aircraft involved in SAR operations instead of Messages 1, 2 or 3. Stations other than aircraft involved in SAR operations should not use this message. The default reporting interval for this message should be 10 s.

TABLE 23

Parameter	Number of bits	Description
Message ID	6	Identifier for Message 9; always 9
Repeat indicator	2	Used by the repeater to indicate how many times a message has been repeated. See § 4.6.1; 0-3; 0 = default; 3 = do not repeat any more
User ID	30	MMSI number
Altitude (GNSS)	12	Altitude (derived from GNSS) (m) (0-4 094 m) 4 095 = not available, 4 094 = 4 094 m or higher
SOG	10	Speed over ground in knot steps (0-1 022 knots) 1 023 = not available, 1 022 = 1 022 knots or higher
Position accuracy	1	1 = high (<10 m; differential mode of e.g. DGNSS receiver) 0 = low (>10 m; autonomous mode of e.g. GNSS receiver or of other electronic position fixing device); 0 = default
Longitude	28	Longitude in 1/10 000 min ($\pm 180^\circ$, East = positive, West = negative; 181° (6791AC0 _h) = not available = default)
Latitude	27	Latitude in 1/10 000 min ($\pm 90^\circ$, North = positive, South = negative; 91° (3412140 _h) = not available = default)
COG	12	Course over ground in 1/10° (0-3 599). 3 600 (E10 _h) = not available = default; 3 601-4 095 should not be used
Time stamp	6	UTC second when the report was generated (0-59 or 60 if time stamp is not available, which should also be the default value or 62 if electronic position fixing system operates in estimated (dead reckoning) mode or 61 if positioning system is in manual input mode or 63 if the positioning system is inoperative)
Reserved for regional applications	8	Reserved for definition by a competent regional authority. Should be set to zero, if not used for any regional application. Regional applications should not use zero
DTE	1	Data terminal ready (0 = available 1 = not available = default) (see to § 3.3.8.2.3.1)
Spare	5	Not used. Should be set to zero
RAIM-flag	1	RAIM flag of electronic position fixing device; 0 = RAIM not in use = default; 1 = RAIM in use)
Communication state	19	SOTDMA (see § 3.3.7.2.2)
Total number of bits	168	

3.3.8.2.8 Message 10: UTC and date inquiry

This message should be used when a station is requesting UTC and date from another station.

TABLE 24

Parameter	Number of bits	Description
Message ID	6	Identifier for Message 10; always 10
Repeat indicator	2	Used by the repeater to indicate how many times a message has been repeated. See § 4.6.1; 0-3; 0 = default; 3 = do not repeat any more
Source ID	30	MMSI number of station which inquires UTC
Spare	2	Not used. Should be set to zero
Destination ID	30	MMSI number of station which is inquired
Spare	2	Not used. Should be set to zero
Total number of bits	72	

For Message 11 refer to description of Message 4.

3.3.8.2.9 Message 12: Addressed safety related message

The addressed safety related message could be variable in length, based on the amount of safety related text. The length should vary between 1 and 5 slots.

TABLE 25

Parameter	Number of bits	Description
Message ID	6	Identifier for Message 12; always 12
Repeat indicator	2	Used by the repeater to indicate how many times a message has been repeated. See § 4.6.1; 0-3; 0 = default; 3 = do not repeat any more
Source ID	30	MMSI number of station which is the source of the message
Sequence number	2	0-3; see § 5.3.1
Destination ID	30	MMSI number of station which is the destination of the message
Retransmit flag	1	Retransmit flag should be set upon retransmission: 0 = no retransmission = default; 1 = retransmitted
Spare	1	Not used. Should be zero
Safety related text	Maximum 936	6-bit ASCII
Total maximum number of bits	Maximum 1 008	Occupies 1 to 5 slots subject to the length of text

Additional bit stuffing will be required for this message type. For details refer to transport layer, § 5.2.1.

The following Table gives the number of 6-bit-ASCII characters, so that the whole message fits into a given number of slots. It is recommended that any application minimizes the use of slots by limiting the number of characters to the numbers given, if possible:

Number of slots	Maximum 6-bit ASCII characters
1	10
2	48
3	85
4	122
5	156

These numbers also take bit stuffing into account.

For Message 13 refer to description of Message 7.

3.3.8.2.10 Message 14: Safety related broadcast message

The safety related broadcast message could be variable in length, based on the amount of safety related text. The length should vary between 1 and 5 slots.

TABLE 26

Parameter	Number of bits	Description
Message ID	6	Identifier for Message 14; always 14.
Repeat indicator	2	Used by the repeater to indicate how many times a message has been repeated. See § 4.6.1; 0-3; 0 = default; 3 = do not repeat any more
Source ID	30	MMSI number of source station of message
Spare	2	Not used. Should be set to zero
Safety related text	Maximum 968	6-bit ASCII
Total number of bits	Maximum 1 008	Occupies 1 to 5 slots subject to the length of text

Additional bit stuffing will be required for this message type. For details refer to Transport Layer, § 5.2.1.

The following Table gives the number of 6-bit ASCII characters, so that the whole message fits into a given number of slots. It is recommended that any application minimizes the use of slots by limiting the number of characters to the numbers given, if possible:

Number of slots	Maximum 6-bit ASCII characters
1	16
2	53
3	90
4	128
5	161

These numbers also take bit stuffing into account.

3.3.8.2.11 Message 15: Interrogation

The interrogation message should be used for interrogations via the VHF TDMA link other than UTC and date requests. The response should be transmitted on the channel where the interrogation was received.

A Class A shipborne mobile station can be interrogated for message identifiers 3 and 5, by another station. A Class B shipborne mobile station can be interrogated for message identifiers 18 and 19, by another station. An airborne mobile station can be interrogated for message identifier 9, by another station. A mobile station mounted on an aids-to-navigation can be interrogated for message identifier 21, by another station. A base station can be interrogated for message identifiers 4, 17, 20 and 22.

The parameter slot offset should be set to zero, if slot should autonomously be allocated by the responding station. If a slot offset is given, it should be relative to the start slot of this transmission. There should be the following four (4) possibilities to use this message:

- One (1) station is interrogated one (1) message: The parameters destination ID1, message ID1.1 and slot offset 1.1 should be defined. All other parameters should be omitted.
- One (1) station is interrogated two (2) messages: The parameters destination ID1, message ID1.1, slot offset 1.1, message ID1.2, and slot offset 1.2 should be defined. The parameters destination ID2, message ID2.1, and slot offset 2.1 should be omitted.
- The first station and the second station are interrogated one (1) message each: The parameters destination ID1, message ID1.1, slot offset 1.1, destination ID2, message ID2.1, and slot offset 2.1 should be defined. The parameters message ID1.2 and slot offset 1.2 should be set to zero (0).
- The first station is interrogated two (2) messages, and the second station is interrogated one (1) message: All parameters should be defined.

TABLE 27

Parameter	Number of bits	Description
Message ID	6	Identifier for Message 15; always set to 15
Repeat indicator	2	Used by the repeater to indicate how many times a message has been repeated. See § 4.6.1; 0-3; 0 = default; 3 = do not repeat any more
Source ID	30	MMSI number of interrogating station
Spare	2	Not used. Should be set to zero
Destination ID1	30	MMSI number of first interrogated station
Message ID1.1	6	First requested message type from first interrogated station
Slot offset 1.1	12	Response slot offset for first requested message from first interrogated station

TABLE 27 (end)

Parameter	Number of bits	Description
Spare	2	Not used. Should be set to zero
Message ID 1.2	6	Second requested message type from first interrogated station
Slot offset 1.2	12	Response slot offset for second requested message from first interrogated station
Spare	2	Not used. Should be set to zero
Destination ID 2	30	MMSI number of second interrogated station
Message ID 2.1	6	Requested message type from second interrogated station
Slot offset 2.1	12	Response slot offset for requested message from second interrogated station
Spare	2	Not used. Should be set to zero
Total number of bits	88-160	Total number of bits depends upon number of messages requested

3.3.8.2.12 Message 16: Assigned mode command

Assignment should be transmitted by a base station when operating as a controlling entity. Other stations can be assigned a transmission schedule, other than the currently used one. If a station is assigned a schedule, it will also enter assigned mode.

Two stations can be assigned simultaneously.

When receiving an assignment schedule, the station should tag it with a time-out, randomly selected between 4 and 8 min after the first transmission.

NOTE 1 – A base station should monitor the mobile station's transmissions in order to determine when the mobile station will time-out.

TABLE 28

Parameter	Number of bits	Description
Message ID	6	Identifier for Message 16. Always 16
Repeat indicator	2	Used by the repeater to indicate how many times a message has been repeated. See § 4.6.1; 0-3; 0 = default; 3 = do not repeat any more
Source ID	30	MMSI of assigning station
Spare	2	Spare. Should be set to zero
Destination ID A	30	MMSI number. Destination identifier A
Offset A	12	Offset from current slot to first assigned slot ⁽¹⁾
Increment A	10	Increment to next assigned slot ⁽¹⁾

TABLE 28 (end)

Parameter	Number of bits	Description
Destination ID B	30	MMSI number. Destination identifier B. Should be omitted if there is assignment to station A, only
Offset B	12	Offset from current slot to first assigned slot. Should be omitted if there is assignment to station A, only ⁽¹⁾
Increment B	10	Increment to next assigned slot ⁽¹⁾ . Should be omitted, if there is assignment to station A, only
Spare	Maximum 4	Spare. Not used. Should be set to zero. The number of spare bits, which should be 0 or 4, should be adjusted in order to observe byte boundaries
Total	96 or 144	Should be 96 or 144 bits

⁽¹⁾ To assign a reporting rate for a station, the parameter increment should be set to zero. In order to facilitate low reporting rates, the parameter Offset should then be interpreted as the number of reports in a time interval of 10 min.

The base station making the assignment to the mobile station should consider the time-out behaviour of the mobile station when assigning this value.

3.3.8.2.13 Message 17: GNSS broadcast binary message

This message should be transmitted by a base station, which is connected to a DGNSS reference source, and configured to provide DGNSS data to receiving stations. The contents of the data should be in accordance with Recommendation ITU-R M.823, excluding preamble and parity formatting.

TABLE 29

Parameter	Number of bits	Description
Message ID	6	Identifier for Message 17; always 17
Repeat indicator	2	Used by the repeater to indicate how many times a message has been repeated. See § 4.6.1; 0-3; 0 = default; 3 = do not repeat any more
Source ID	30	MMSI of the base station
Spare	2	Spare. Should be set to zero
Longitude	18	Surveyed longitude of DGNSS reference station in 1/10 min ($\pm 180^\circ$, East = positive, West = negative). If interrogated and differential correction service not available, the longitude should be set to 181°
Latitude	17	Surveyed latitude of DGNSS reference station in 1/10 min ($\pm 90^\circ$, North = positive, South = negative). If interrogated and differential correction service not available, the latitude should be set to 91°
Spare	5	Not used. Should be set to zero
Data	0 - 736	Differential correction data (see below). If interrogated and differential correction service not available, the data field should remain empty (zero bits). This should be interpreted by the recipient as DGNSS data words set to zero
Total number of bits	80 - 816	80 bits: assumes $N = 0$; 816 bits: assumes $N = 29$ (maximum value); see Table 30

The differential correction data section should be organized as listed below:

TABLE 30

Parameter	Number of bits	Description
Message type	6	Recommendation ITU-R M.823
Station ID	10	Recommendation ITU-R M.823 station identifier
Z count	13	Time value in 0.6 s (0-3 599.4)
Sequence number	3	Message sequence number (cyclic 0-7)
N	5	Number of DGNSS data words following the two word header, up to a maximum of 29
Health	3	Reference station health (specified in Recommendation ITU-R M.823)
DGNSS data word	$N \times 24$	DGNSS message data words excluding parity
Total number of bits	736	Assuming $N = 29$ (the maximum value)

NOTE 1 – It is necessary to restore preamble and parity in accordance with Recommendation ITU-R M.823 before using this message to differentially correct GNSS positions to DGNSS positions.

NOTE 2 – Where DGNSS corrections are received from multiple sources, the DGNSS corrections from the nearest DGNSS reference station should be used taking into account the Z count, and the health of the DGNSS reference station.

NOTE 3 – Transmissions of Message 17 by base stations should take into account ageing, update rate and the resulting accuracy of the DGNSS service. Because of the resulting effects of VDL channel loading, the transmission of Message 17 should be no more than necessary to provide the necessary DGNSS service accuracy.

3.3.8.2.14 Message 18: Standard Class B equipment position report

The Standard Class B equipment position report should be output periodically and autonomously instead of Messages 1, 2, or 3 by Class B shipborne mobile equipment, only. The reporting interval should default to the values given in Table 1b, unless otherwise specified by the competent authority, depending on the current SOG, the current navigational status flag setting.

TABLE 31

Parameter	Number of bits	Description
Message ID	6	Identifier for Message 18; always 18
Repeat indicator	2	Used by the repeater to indicate how many times a message has been repeated. See § 4.6.1; 0-3; 0 = default; 3 = do not repeat any more
User ID	30	MMSI number
Reserved for regional or local applications	8	Reserved for definition by a competent regional or local authority. Should be set to zero, if not used for any regional or local application. Regional applications should not use zero

TABLE 31 (*end*)

Parameter	Number of bits	Description
SOG	10	Speed over ground in 1/10 knot steps (0-102.2 knots) 1 023 = not available, 1 022 = 102.2 knots or higher
Position accuracy	1	1 = high (<10 m; differential mode of e.g. DGNSS receiver) 0 = low (>10 m; autonomous mode of e.g. GNSS receiver or of other electronic position fixing device); default = 0
Longitude	28	Longitude in 1/10 000 min ($\pm 180^\circ$, East = positive, West = negative; 181° (6791AC0h) = not available = default)
Latitude	27	Latitude in 1/10 000 min ($\pm 90^\circ$, North = positive, South = negative; 91° (3412140h) = not available = default)
COG	12	Course over ground in $1/10^\circ$ (0-3 599). 3 600 (E10h) = not available = default; 3 601-4 095 should not be used
True heading	9	Degrees (0-359) (511 indicates not available = default)
Time stamp	6	UTC second when the report was generated (0-59 or 60 if time stamp is not available, which should also be the default value or 62 if electronic position fixing system operates in estimated (dead reckoning) mode or 61 if positioning system is in manual input mode or 63 if the positioning system is inoperative)
Reserved for regional applications	4	Reserved for definition by a competent regional authority. Should be set to zero, if not used for any regional application. Regional applications should not use zero
Spare	4	Not used, should be set to zero
RAIM-flag	1	RAIM flag of electronic position fixing device; 0 = RAIM not in use = default; 1 = RAIM in use
Communication state selector flag	1	0 = SOTDMA communication state follows 1 = ITDMA communication state follows
Communication state	19	SOTDMA communication state (see § 3.3.7.2.2), if communication state selector flag is set to 0, or ITDMA communication state (see § 3.3.7.2.3), if communication state selector flag is set to 1
Total number of bits	168	Occupies one slot

3.3.8.2.15 Message 19: Extended Class B equipment position report

This message should be used by Class B shipborne mobile equipment. This message should be transmitted once every 6 min in two slots allocated by the use of Message 18 in the ITDMA communication state. This message should be transmitted immediately after the following parameter values change: dimension of ship/reference for position or type of electronic position fixing device.

TABLE 32

Parameter	Number of bits	Description
Message ID	6	Identifier for Message 19; always 19
Repeat indicator	2	Used by the repeater to indicate how many times a message has been repeated. See § 4.6.1; 0-3; 0 = default; 3 = do not repeat any more
User ID	30	MMSI number
Reserved for regional or local applications	8	Reserved for definition by a competent regional or local authority. Should be set to zero, if not used for any regional or local application. Regional applications should not use zero
SOG	10	Speed over ground in 1/10 knot steps (0-102.2 knots) 1 023 = not available, 1 022 = 102.2 knots or higher
Position accuracy	1	1 = high (<10 m; differential mode of e.g. DGNSS receiver) 0 = low (>10 m; autonomous mode of e.g. GNSS receiver or of other electronic position fixing device); 0 = default
Longitude	28	Longitude in 1/10 000 min ($\pm 180^\circ$, East = positive, West = negative; 181° (6791AC0h) = not available = default)
Latitude	27	Latitude in 1/10 000 min ($\pm 90^\circ$, North = positive, South = negative; 91° (3412140h) = not available = default)
COG	12	Course over ground in 1/10° (0-3 599). 3 600 (E10h) = not available = default; 3 601-4 095 should not be used
True heading	9	Degrees (0-359) (511 indicates not available = default)
Time stamp	6	UTC second when the report was generated (0-59 or 60 if time stamp is not available, which should also be the default value or 62 if electronic position fixing system operates in estimated (dead reckoning) mode, or 61 if positioning system is in manual input mode or 63 if the positioning system is inoperative)
Reserved for regional applications	4	Reserved for definition by a competent regional authority. Should be set to zero, if not used for any regional application. Regional applications should not use zero
Name	120	Maximum 20 characters 6-bit ASCII, @@@@ = not available = default
Type of ship and cargo type	8	0 = not available or no ship = default 1-99 = as defined in § 3.3.8.2.3.2 100-199 = preserved, for regional use 200-255 = preserved, for future use
Dimension of ship/reference for position	30	Dimensions of ship in metres and reference point for reported position (see Fig. 17 and § 3.3.8.2.3.3)
Type of electronic position fixing device	4	0 = Undefined (default); 1 = GPS, 2 = GLONASS, 3 = combined GPS/GLONASS, 4 = Loran-C, 5 = Chayka, 6 = integrated navigation system, 7 = surveyed; 8-15 = not used
RAIM-flag	1	RAIM flag of electronic position fixing device; 0 = RAIM not in use = default; 1 = RAIM in use
DTE	1	Data terminal ready (0 = available 1 = not available = default) (see § 3.3.8.2.3.1)
Spare	5	Not used. Should be set to zero
Total number of bits	312	Occupies two slots

3.3.8.2.16 Message 20: Data link management message

This message should be used by base station(s) to pre-announce the fixed allocation schedule (FATDMA) for one or more base station(s) and it should be repeated as often as required. This way the system can provide a high level of integrity for base station(s). This is especially important in regions where several base stations are located adjacent to each other and mobile station(s) move between these different regions. These reserved slots cannot be autonomously allocated by mobile stations.

The mobile station should then reserve the slots for transmission by the base station(s) until time-out occurs. The base station should refresh the time-out value with each transmission of Message 20 in order to allow mobile stations to terminate their reservation for the use of the slots by the base stations (refer to § 3.3.1.2).

The parameters: offset number, number of slots, time-out, and increment should be treated as a unit, meaning that if one parameter is defined all other parameters should be defined within that unit. The parameter offset number should denote the offset from the slot in which Message 20 was received to the first slot to be reserved. The parameter number of slots should denote the number of consecutive slots to be reserved starting with the first reserved slot. This defines a reservation block. The parameter Increment should denote the number of slots between the starting slot of each reservation block. If Increment is set to zero, there should be no additional reservation blocks. This message applies only to the frequency channel in which it is transmitted.

If interrogated and no data link management information available, only offset number 1, number of slot offsets 1, time-out 1, and increment 1 should be sent. These fields should all be set to zero.

TABLE 33

Parameter	Number of bits	Description
Message ID	6	Identifier for Message 20; always 20
Repeat indicator	2	Used by the repeater to indicate how many times a message has been repeated. See § 4.6.1; 0-3; 0 = default; 3 = do not repeat any more
Source station ID	30	MMSI number of base station
Spare	2	Not used. Should be set to zero
Offset number 1	12	Reserved offset number; 0 = not available
Number of slots 1	4	Number of reserved consecutive slots: 1-15; 0 = not available
Time-out 1	3	Time-out value in minutes; 0 = not available
Increment 1	11	Increment to repeat reservation block 1; 0 = not available
Offset number 2	12	Reserved offset number (optional)
Number of slots 2	4	Number of reserved consecutive slots: 1-15; optional

TABLE 33 (*end*)

Parameter	Number of bits	Description
Time-out 2	3	Time-out value in minutes (optional)
Increment 2	11	Increment to repeat reservation block 2 (optional)
Offset number 3	12	Reserved offset number (optional)
Number of slots 3	4	Number of reserved consecutive slots: 1-15; optional
Time-out 3	3	Time-out value in minutes (optional)
Increment 3	11	Increment to repeat reservation block 3 (optional)
Offset number 4	12	Reserved offset number (optional)
Number of slots 4	4	Number of reserved consecutive slots: 1-15; optional
Time-out 4	3	Time-out value in minutes (optional)
Increment 4	11	Increment to repeat reservation block 4 (optional)
Spare	Maximum 6	Not used. Should be set to zero The number of spare bits which may be 0, 2, 4 or 6 should be adjusted in order to observe byte boundaries
Total number of bits	72-160	

3.3.8.2.17 Message 21: Aids-to-navigation report

This message should be used by a station mounted on an aid-to-navigation. This message should be transmitted autonomously at a Rr of once every three (3) min or it may be assigned by an assigned mode command (Message 16) via the VHF data link, or by an external command.

TABLE 34

Parameter	Number of bits	Description
Message ID	6	Identifier for Message 21
Repeat indicator	2	Used by the repeater to indicate how many times a message has been repeated. See § 4.6.1; 0-3; 0 = default; 3 = do not repeat any more
ID	30	MMSI number
Type of aids-to-navigation	5	0 = not available = default; 1-15 = fixed aid-to-navigation; 16-31 = floating aid-to-navigation; refer to appropriate definition set up by IALA
Name of Aids-to-Navigation	120	Maximum 20 characters 6-bit ASCII @@@@@@@@@@@@@@@@@@@@@@@@@@@@@ = not available = default
Position accuracy	1	1 = high (<10 m; differential mode of e.g. DGNSS receiver) 0 = low (>10 m; autonomous mode of e.g. GNSS receiver or of other electronic position fixing device); 0 = default

TABLE 34 (end)

Parameter	Number of bits	Description
Longitude	28	Longitude in 1/10 000 min of position of aids-to-navigation ($\pm 180^\circ$, East = positive, West = negative. 181° (6791AC0 _h) = not available = default)
Latitude	27	Latitude in 1/10 000 min of aids-to-navigation ($\pm 90^\circ$, North = positive, South = negative. 91° (3412140 _h) = not available = default)
Dimension/ reference for position	30	Reference point for reported position; also indicates the dimension of aids-to-navigation (m) (see Fig. 18 and § 3.3.8.2.3.3), if relevant
Type of electronic position fixing device	4	0 = Undefined (default); 1 = GPS 2 = GLONASS 3 = Combined GPS/GLONASS 4 = Loran-C 5 = Chayka 6 = Integrated Navigation System 7 = surveyed 8-15 = not used
Time stamp	6	UTC second when the report was generated (0-59 or 60 if time stamp is not available, which should also be the default value or 61 if positioning system is in manual input mode or 62 if electronic position fixing system operates in estimated (dead reckoning) mode or 63 if the positioning system is inoperative)
Off-position indicator	1	For floating aids-to-navigation, only: 0 = on position; 1 = off position; NOTE – This flag should only be considered valid by receiving station, if the aid-to-navigation is a floating aid, and if time stamp is equal to or below 59
Reserved for regional or local application	8	Reserved for definition by a competent regional or local authority. Should be set to zero, if not used for any regional or local application. Regional applications should not use zero
RAIM-flag	1	RAIM flag of electronic position fixing device; 0 = RAIM not in use = default; 1 = RAIM in use
Spare	3	Spare. Not used. Should be set to zero
Number of bits	272	Occupies two slots

This message should be transmitted immediately after any parameter value was changed.

Note on aids-to-navigation within AIS:

The competent international body for aids-to-navigation, IALA, defines an aid-to-navigation as: “a device or system external to vessels designed and operated to enhance safe and efficient navigation of vessels and/or vessel traffic.” (IALA Navguide, Edition 1997, Chapter 7).

The IALA Navguide stipulates: “A floating aid to navigation, which is out of position, adrift or during the night is unlighted, may itself become a danger to navigation. When a floating aid is out of position or malfunctioning, navigational warnings must be given.” Therefore, a station, which transmits Message 23, could also transmit safety related broadcast message (Message 14) upon detecting that the floating aid-to-navigation has gone out of position or is malfunctioning, at the competent authority’s discretion.

3.3.8.2.18 Message 22: Channel management

This message should be transmitted by a base station (as a broadcast message) to command the VHF data link parameters for the geographical area designated in this message. The geographical area designated by this message should be as defined in § 4.1. Alternatively, this message may be used by a base station (as an addressed message) to command individual AIS mobile stations to adopt the specified VHF data link parameters. When interrogated and no channel management performed by the interrogated base station, the not available and/or international default settings should be transmitted (see § 4.1).

TABLE 35

Parameter	Number of bits	Description
Message ID	6	Identifier for Message 22; always 22
Repeat indicator	2	Used by the repeater to indicate how many times a message has been repeated. See § 4.6.1; 0-3; 0 = default; 3 = do not repeat any more
Station ID	30	MMSI number of base station
Spare	2	Not used. Should be set to zero
Channel A	12	Channel number according to Recommendation ITU-R M.1084, Annex 4
Channel B	12	Channel number according to Recommendation ITU-R M.1084, Annex 4
Tx/Rx mode	4	0 = Tx A/Tx B, Rx A/Rx B (default) 1 = Tx A, Rx A/Rx B 2 = Tx B, Rx A/Rx B 3-15: not used
Power	1	0 = high (default), 1 = low
Longitude 1, (or 18 most significant bits (MSBs) of addressed station ID 1)	18	Longitude of area to which the assignment applies; upper right corner (north-east); in 1/10 min, or 18 MSBs of addressed station ID 1 ($\pm 180^\circ$, East = positive, West = negative). 181 = not available

TABLE 35 (end)

Parameter	Number of bits	Description
Latitude 1, (or 12 least significant bits (LSBs) of addressed station ID 1)	17	Latitude of area to which the assignment applies; upper right corner (north-east); in 1/10 min, or 12 LSBs of addressed station ID 1, followed by 5 zero bits ($\pm 90^\circ$, North = positive, South = negative). 91° = not available
Longitude 2, (or 18 MSBs of addressed station ID 2)	18	Longitude of area to which the assignment applies; lower left corner (south-west); in 1/10 min, or 18 MSBs of addressed station ID 2 ($\pm 180^\circ$, East = positive, West = negative)
Latitude 2, (or 12 LSBs of addressed station ID 2)	17	Latitude of area to which the assignment applies; lower left corner (south-west); in 1/10 min, or 12 LSBs of addressed station ID 2, followed by 5 zero bits ($\pm 90^\circ$, North = positive, South = negative)
Addressed or broadcast message indicator	1	0 = broadcast geographical area message = default; 1 = addressed message (to individual station(s))
Channel A bandwidth	1	0 = default (as specified by channel number); 1 = 12.5 kHz bandwidth
Channel B bandwidth	1	0 = default (as specified by channel number); 1 = 12.5 kHz bandwidth
Transitional zone size	3	The transitional zone size in nautical miles should be calculated by adding 1 to this parameter value. The default parameter value should be 4, which translates to 5 nautical miles; see § 4.1.5
Spare	23	Not used. Should be set to zero
Total number of bits	168	

4 Network layer

The network layer should be used for:

- establishing and maintaining channel connections;
- management of priority assignments of messages;
- distribution of transmission packets between channels;
- data link congestion resolution.

4.1 Dual channel operation and channel management

In order to satisfy the requirements for dual channel operation (see § 2.1.5), the following should apply, unless otherwise specified by Message 22.

4.1.1 Operating frequency channels

Two frequency channels have been designated in RR Appendix 18 for AIS use worldwide, on the high seas and in all other areas, unless other frequencies are designated on a regional basis for AIS purposes. The two designated frequencies are:

AIS 1 (Channel 87B, 161.975 MHz), (2087)*; and

AIS 2 (Channel 88B, 162.025 MHz) (2088)*.

The AIS should default to operation on these channels.

Operation on other channels should be accomplished by the following means: manual input commands (manual switching) from AIS input device, TDMA commands from a base station (automatic switching by TDMA telecommand), digital selective call (DSC) commands from a base station (automatic switching by DSC telecommand) or commands from shipborne systems, e.g. ECDIS or automatic switching by shipborne system command (ENC) via IEC 61162 command. The last eight (8) received regional operating settings including the region itself should be stored by the mobile station.

For channel management when position information is lost during normal operation, the current frequency channel use should be maintained until ordered by an addressed channel management message (addressed DSC command or addressed Message 22) or by manual input.

4.1.2 Normal default mode of dual channel operation

The normal default mode of operation should be a two-channel operating mode, where the AIS simultaneously receives on both channels in parallel. In order to accomplish this performance, the AIS transponder should contain two TDMA receivers.

Channel access is performed independently on each of the two parallel channels.

For periodic repeated messages, including the initial link access, the transmissions should alternate between AIS 1 and AIS 2. This alternating behaviour is on a transmission by transmission basis, without respect to time frames.

Transmissions following slot allocation announcements, responses to interrogations, responses to requests, and acknowledgements should be transmitted on the same channel as the initial message.

For addressed messages, transmissions should utilize the channel in which messages from the addressed station were last received.

For non-periodic messages other than those referenced above, the transmissions of each message, regardless of message type, should alternate between AIS 1 and AIS 2.

* See Recommendation ITU-R M.1084, Annex 4.

Base stations could alternate their transmissions between AIS 1 and AIS 2 for the following reasons:

- To increase link capacity.
- To balance channel loading between AIS 1 and AIS 2.
- To mitigate the harmful effects of RF interference.

When a base station is included in a channel management scenario, it should transmit addressed messages on the channel in which it last received a message from the addressed station.

4.1.3 Regional operating frequencies

Regional operating frequencies should be designated by the four-digit channel numbers specified in Recommendation ITU-R M.1084, Annex 4. This allows for simplex, duplex, 25 kHz and 12.5 kHz channels for regional options, subject to the provisions of RR Appendix 18.

4.1.4 Regional operating areas

Regional operating areas should be designated by a Mercator projection rectangle with two reference points (WGS-84). The first reference point should be the geographical coordinate address of the northeastern corner (to the nearest tenth of a minute) and the second reference point should be the geographical coordinate address of the southwestern corner (to the nearest tenth of a minute) of the rectangle.

The channel number designates the use of the channel (simplex, duplex, 25 kHz and 12.5 kHz).

When a station is subject to the regional boundaries, it should immediately set its operating frequency channel numbers, its transmitter/receiver mode and its power level to the values as commanded. When a station is not subject to the regional boundaries, the station should utilize the default settings, which are defined in the following paragraphs:

Power settings:	§ 2.13
Operating frequency channel numbers:	§ 4.1.1
Transmitter/receiver mode:	§ 4.1.2
Narrow-band mode:	§ 2.2
Transition zone size:	§ 4.1.5

If regional operating areas are used, the areas should be defined in such a way that these areas will be covered completely by transmissions of channel management commands (either TDMA or DSC) from at least one base station.

4.1.5 Transitional mode operations near regional boundaries

The AIS device should automatically switch to the two-channel transitional operating mode when it is located within five nautical miles, or the transition zone size (see Table 35), of a regional boundary. In this mode the AIS device should transmit and receive on the primary AIS frequency specified for the occupied region; it should also transmit and receive on the primary AIS frequency of the nearest adjacent region. Only one transmitter is required. Additionally, for dual channel operations as specified in § 4.1.2, except when the reporting rate has been assigned by Message 16, when operating in this mode, the reporting rate should be doubled and shared between the two

channels (alternate transmission mode). When the AIS is entering the transitional mode, it should continue to utilize the current channels for transmitting for a full one-minute frame while switching one of the receivers to the new channel. The TDMA access rules should be applied to vacating slots on the current channel and accessing slots on the new channel. This transitional behaviour is necessary only when the channels are changing.

Regional boundaries should be established by the competent authority in such a way that this two-channel transitional operating mode can be implemented as simply and safely as possible. For example, care should be taken to avoid having more than three adjacent regions at any regional boundary intersection. In this context the high seas area should be considered to be a region where default operating settings apply.

Regions should be as large as possible. For practical purposes, in order to provide safe transitions between regions, these should be no smaller than 20 nautical miles but not larger than 200 nautical miles on any boundary side. Examples of acceptable and unacceptable regional boundary definitions are illustrated in Figs. 18a and 18b.

FIGURE 18a

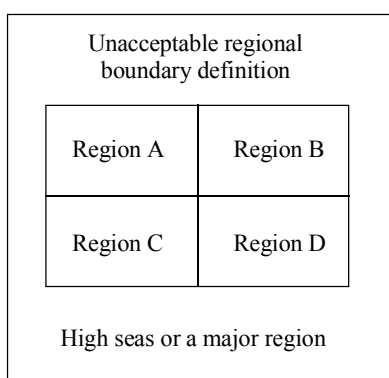
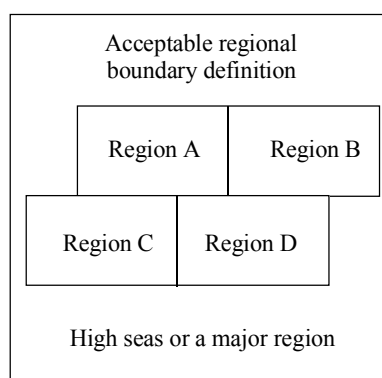

FIGURE 18b



1371-18ab

4.1.6 Channel management by manual input

Channel management by manual input should include the geographical area along with the designated AIS channel(s) for use in that area (refer to Message 22). Manual input should be subject to override by TDMA command, DSC command or shipborne system command.

4.1.7 Resumption of operation after power on

After power on, a mobile station should resume operation using the default settings, unless the own position is within any of the stored regions.

In this case, the mobile station should operate using the stored operating settings of that identified region.

4.1.8 Priority of channel management commands

The most current and applicable commands received should override previous channel management commands.

4.1.9 Conditions for changing both AIS operational frequency channels

When a competent authority needs to change both AIS operating frequency channels within a region, there should be a minimum time period of 9 min after the first AIS operating frequency channel is changed before the second AIS operating frequency channel is changed. This will ensure a safe frequency transition.

4.2 Distribution of transmission packets

4.2.1 The user directory

The user directory is internal to the AIS, and it is used to facilitate slot selection and synchronization. It is also used to select the proper channel for the transmission of an addressed message.

4.2.2 Routing of transmission packets

The following tasks are fulfilled with regard to packet routing:

- Position reports should be distributed to the presentation interface.
- Own position should be reported to the presentation interface and it should also be transmitted over the VDL.
- A priority is assigned to messages if message queuing is necessary.
- Received GNSS corrections are output to the presentation interface.

4.2.3 Management of priority assignments for messages

There are 4 (four) levels of message priority, namely:

Priority 1 (highest priority): Critical link management messages including position report messages in order to ensure the viability of the link;

Priority 2 (highest service priority): Safety related messages. These messages should be transmitted with a minimum of delay;

Priority 3: Assignment, interrogation and responses to interrogation messages;

Priority 4 (lowest priority): All other messages.

For details, refer to Table 13.

The above priorities are assigned to the relevant type of messages, thereby providing a mechanism for sequencing specific messages in order of priority. The messages are serviced in order of priority. This applies to both messages received and messages to be transmitted. Messages with the same priority are dealt with in an FIFO order.

4.3 Rr's

The parameter, Rr, is defined in § 3.3.4.4.2 (Table 9) and should be directly related to reporting interval as defined in Tables 1a and 1b in Annex 1. Rr should be determined by the network layer, either autonomously or as a result of an assignment by a competent authority (see § 3.3.6). The default value of the Rr should be as stated in Tables 1a and 1b of Annex 1. A mobile station should, when accessing the VDL for the first time, use the default value (refer to § 3.3.5.2). When a mobile station uses an Rr of less than one report per frame, it should use ITDMA for scheduling. Otherwise SOTDMA should be used.

4.3.1 Autonomously changed Rr (continuous and autonomous mode)

Paragraph 4.3.1, including subparagraphs, applies to Class A and Class B shipborne mobile equipment.

For Class A shipborne mobile equipment, the following should apply: If position, speed, or heading information is lost during normal operation, the current reporting schedule should be maintained, unless otherwise ordered by a change in navigation status or new transmission schedule is ordered by assigned mode command.

For Class B shipborne mobile equipment, the following should apply: If position and speed information is lost during normal operation, the current reporting schedule should be maintained, unless a new transmission schedule is ordered by assigned mode command.

4.3.1.1 Speed

The Rr should be affected by changes of speed as described in this paragraph. Speed should be determined by speed over ground (SOG). When an increase in speed results in a higher Rr (see Annex 1, Tables 1a and 1b) than the currently used Rr, the station should increase the Rr using the algorithm described in § 3.3.5. When a station has maintained a speed, which should result in an Rr lower than the currently used Rr, the station should reduce Rr when this state has persisted for three (3) min.

4.3.1.2 Changing course (applicable to Class A shipborne mobile equipment, only)

When a ship changes course, a higher update rate should be required according to Annex 1, Table 1a. Rr should be affected by changing course as described in this paragraph.

A change of course should be determined by calculating the mean value of the heading information (HDG) for the last 30 s and comparing the result with the present heading. When HDG is unavailable, the Rr should not be affected.

If the difference exceeds 5°, a higher Rr should be applied in accordance with Annex 1, Table 1a. The higher Rr should be maintained by using ITDMA to complement SOTDMA scheduled transmissions in order to derive the desired Rr.

The increased Rr should be maintained until the difference between the mean value of heading and present heading has been less than 5° for more than 20 s.

4.3.1.3 Navigational status (applicable to Class A shipborne mobile equipment, only)

Rr should be affected by navigational status (refer to Messages 1, 2, 3) as described in this paragraph when the vessel is not moving faster than 3 knots (to be determined by using SOG). When the vessel is at anchor, moored, not under command or aground, which is indicated by the navigational status, and not moving faster than 3 knots, Message 3 should be used with an Rr of 3 min. The navigational status should be set by the user via the appropriate user interface. The transmission of Message 3 should be interleaved three (3) min after Message 5. The Rr should be maintained until the navigational status is changed or SOG increases to more than 3 knots.

4.3.2 Assigned Rr

A competent authority may assign an Rr to any mobile station by transmitting assignment Message 16 from a base or repeater station. An assigned Rr should have precedence over all other reasons for changing Rr.

4.4 Data link congestion resolution

When the data link is loaded to such a level that the transmission of safety information is jeopardized, one of the following methods should be used to resolve the congestion.

4.4.1 Intentional slot reuse by the own station

A station should reuse time slots only in accordance with this paragraph and only when own position is available.

When selecting new slots for transmission, the station should select from its candidate slot set (see § 3.3.1.2) within the desired SI. When the candidate slot set has less than 4 slots, the station should intentionally reuse slots, used by other shipborne stations only, in order to make the candidate slot set equal to 4 slots. Slots may not be intentionally reused from stations that indicate no position available. This may result in fewer than 4 candidate slots. The intentionally reused slots should be taken from the most distant station(s) within the SI. Slots allocated or used by base stations should not be used unless the base station is located over 120 nautical miles from the own station. When a distant station has been subject to intentional slot reuse, that station should be excluded from further intentional slot reuse during a time period equal to one frame.

The intentional slot reuse should be performed as indicated in Fig. 19, which is an example, using an example status of slot use on both operating frequency channels:

4.4.2 Use of assignment for congestion resolution

A base station may assign Rr to shipborne stations and can thus protect the viability of the VDL.

4.5 Base station operation

A base station accomplishes the following tasks, additional to a mobile station:

- provide synchronization for stations not directly synchronized: emit base station reports (Message 4) with the default update rate;
- provide transmission slot assignment (see § 3.3.6.2 and 4.4.2);
- provide assignment of Rr to mobile station(s) (see § 3.3.6.1 and 4.3.1.4);
- use of channel management message;
- provide GNSS corrections via the VDL by Message 17 optionally.

FIGURE 19

		SI											
		1	2	3	4	5	6	7	8	9	10	11	12
Channel A		F	F	F	F	T	T	D	D	F	F	X	B
Channel B		F	T	D	E	F	T	F	I	X	O	X	X

It is intended to intentionally reuse one slot within the SI of frequency Channel A. The current status of the use of the slots within the SI on both frequency Channels A and B is given as follows:

- F: free
- I: internally allocated (allocated by own station, not in use)
- E: externally allocated (allocated by another station near own station)
- B: allocated by a base station within 120 nautical miles of own station
- T: another station under way that has not been received for 3 min or more
- D: allocated by the most distant station(s)
- O: internally allocated (allocated by own station, in use presently)
- X: should not be used

The slot for intentional slot reuse should then be selected by the following priority (indicated by the number of the slot combination as given in this Figure):

- Highest selection priority: No. 1
 No. 2
 No. 3
 No. 5
 No. 6
 No. 7

Lowest selection priority: No. 8

Combinations 4, 9, 10, 11 and 12 should not be used.

Rationale for not using slot combinations:

- No. 4 allocated by another near station
- No. 9 adjacent slot rule
- No. 10 opposite channel rule
- No. 11 adjacent slot rule
- No. 12 base station rule

1371-19

4.6 Repeater Operation

AIS base stations should consider repeater operations where it is necessary to provide extended environments for shipborne AIS transponders. The extended AIS environment may contain one or more repeaters.

In order to implement this function efficiently and safely, the relevant authority should perform a comprehensive analysis of the required coverage area and user traffic load, applying the relevant engineering standards and requirements.

A repeater may operate in the following modes:

- Duplex repeater mode.
- Simplex repeater mode.

4.6.1 Repeat indicator

4.6.1.1 Mobile station use of repeat indicator

When mobile station is transmitting a message, it should always set the repeat indicator to default = 0.

4.6.1.2 Base station/repeater station use of repeat indicator

The repeat indicator should be transmitted by base/repeater stations whenever the transmitted message is a repeat of a message already transmitted from another station.

4.6.1.2.1 Number of repeats

The number of repeats should be a repeater station configurable function, implemented by the competent authority.

The number of repeats should be set to either 1 or 2, indicating the number of further repeats required.

All repeaters within coverage of one another should be set to the same number of repeats, in order to ensure that “Binary acknowledgement” Message 7 and “Safety related acknowledgement” Message 13 are delivered to the originating station.

Each time a received message is processed by the repeater station, the repeat indicator value should be incremented by one (+1) before retransmitting the message. If the processed repeat indicator equals 3, the relevant message should not be retransmitted.

4.6.2 Duplex repeater mode

This is a real-time application – the same time slot is used for retransmission on the paired frequency.

The received message requires no additional processing before being retransmitted.

Repeat indicator is not relevant when being used in duplex repeater mode.

A duplex channel is required, which comprises a pair of frequencies, as described in Recommendation ITU-R M.1084.

4.6.3 Simplex repeater mode

This is a base station, which is specifically configured, in order to perform a repeater function.

This is not a real-time application – additional use of slots is required (store-and-forward).

Retransmission of messages should be performed as soon as possible after receiving the relevant messages which are required to be retransmitted.

Retransmission (repeat) should be performed on the same channel in which the original message was received by the repeater station.

4.6.3.1 Received messages

A received message requires additional processing before being retransmitted. The following processing is required:

- Select additional slot(s), required for re-transmitting message(s).
- Apply the same access scheme as in original slot use (received message).
- The communication state of relevant received messages should be changed, and is subject to parameters required by the slot(s) selected for retransmission by the repeater station.

4.6.3.2 Additional processing functionality

Filtering should be a function that is configurable by the repeater station, implemented by the competent authority.

Filtering of retransmissions should be applied, considering the following as parameters:

- Message types.
- Coverage area.
- Required message update rate (possibly reducing the update rate).

4.6.3.3 Synchronization and slot selection

When another station is synchronizing on a repeater station (base station), only positional information of the specific repeater station should be used. Positional information, included in any repeated message, should be disregarded for this purpose.

Intentional slot reuse (see § 4.4.1) should be performed when required. In order to assist in slot selection, measurement of received signal strength by the repeater station should be considered. The received signal strength indicator will indicate when two or more stations are transmitting in the same slot at approximately the same distance from the repeater station. A high level of received signal strength will indicate that the transmitting stations are close to the repeater, and a low level of received signal strength will indicate that the transmitting stations are farther away.

Congestion resolution on the VDL may be applied (see § 4.4.2).

4.7 Handling of errors related to packet sequencing and groups of packets

It should be possible to group transmission packets, which are addressed to another station (refer to addressed binary and addressed safety related messages) based on sequence number. Addressed packets should be assigned a sequence number by the transmitting station. The sequence number of a received packet should be forwarded together with the packet to the transport layer. Also, when errors related to packet sequencing and groups of packets are detected (see § 3.2.3), they should be handled by the transport layer as described in § 5.3.1.

5 Transport layer

The transport layer is responsible for:

- converting data into transmission packets of correct size;
- sequencing of data packets;
- interfacing protocol to upper layers.

The interface between the transport layer and higher layers should be performed by the presentation interface.

5.1 Definition of transmission packet

A transmission packet is an internal representation of some information which can ultimately be communicated to external systems. The transmission packet is dimensioned so that it conforms to the rules of data transfer.

5.2 Conversion of data into transmission packets

5.2.1 Conversion to transmission packets

The transport layer should convert data, received from the presentation interface, into transmission packets. If the length of the data requires a transmission that exceeds five (5) slots (see Table 36 for guidance) the AIS should not transmit the data, and it should respond with a negative acknowledgement to the presentation interface.

Table 36 is based on the assumption that the theoretical maximum of stuffing bits will be needed. A mechanism may be applied, which determines, prior to transmission, what the actually required bit stuffing will be with reference to § 3.2.2.1, depending on the actual content of the input for transmission from the presentation interface. If this mechanism determines that less stuffing bits than indicated in Table 36 would be needed, more data bits than indicated in Table 36 may be transmitted, applying the actually required number of stuffing bits. However, the total number of slots required for this transmission should not be increased by this optimization.

Taking into account that safety related and binary messages should be used, it is of importance that the variable messages are set on byte boundaries. In order to ensure that the required bit stuffing for the variable length messages is provided for in the worst-case condition, with reference to the packet format (see. § 3.2.2.2) the following parameters should be used as a guideline:

TABLE 36

Number of slots	Maximum data bits	Stuffing bits	Total buffer bits
1	136	36	56
2	360	68	88
3	584	100	120
4	808	132	152
5	1 032	164	184

5.3 Transmission packets

5.3.1 Addressed message

Addressed messages should have a destination user ID. The source station should anticipate an acknowledgement message (Message 7 or Message 13). If an acknowledgement is not received the station should retry the transmission. A time-out of 4 s is allowed before attempting retries. When a transmission is retried, the retransmit flag should be set to retransmitted. The number of retries should be 3, but it should be configurable between 0 and 3 retries by an external application via the presentation interface. When set to a different value by an external application, the number of retries should default to 3 retries after 8 min. The overall result of the data transfer should be forwarded to above layers. The acknowledgement should be between transport layers in two stations.

Each data transfer packet on the presentation interface should have a unique packet identifier consisting of the message type (binary or safety related messages), the source-ID, the destination-ID, and a sequence number.

The sequence number should be assigned in the appropriate presentation interface message which is input to the station.

The destination station should return the same sequence number in its acknowledgement message on the presentation interface.

The source station should not reuse a sequence number until it has been acknowledged or time-out has occurred.

The acknowledgement should be put first in the data transfer queue both on the presentation interface and on the VDL.

These acknowledgements are applicable only to the VDL. Other means must be employed for acknowledging applications.

See Fig. 20 and Annex 6.

FIGURE 20

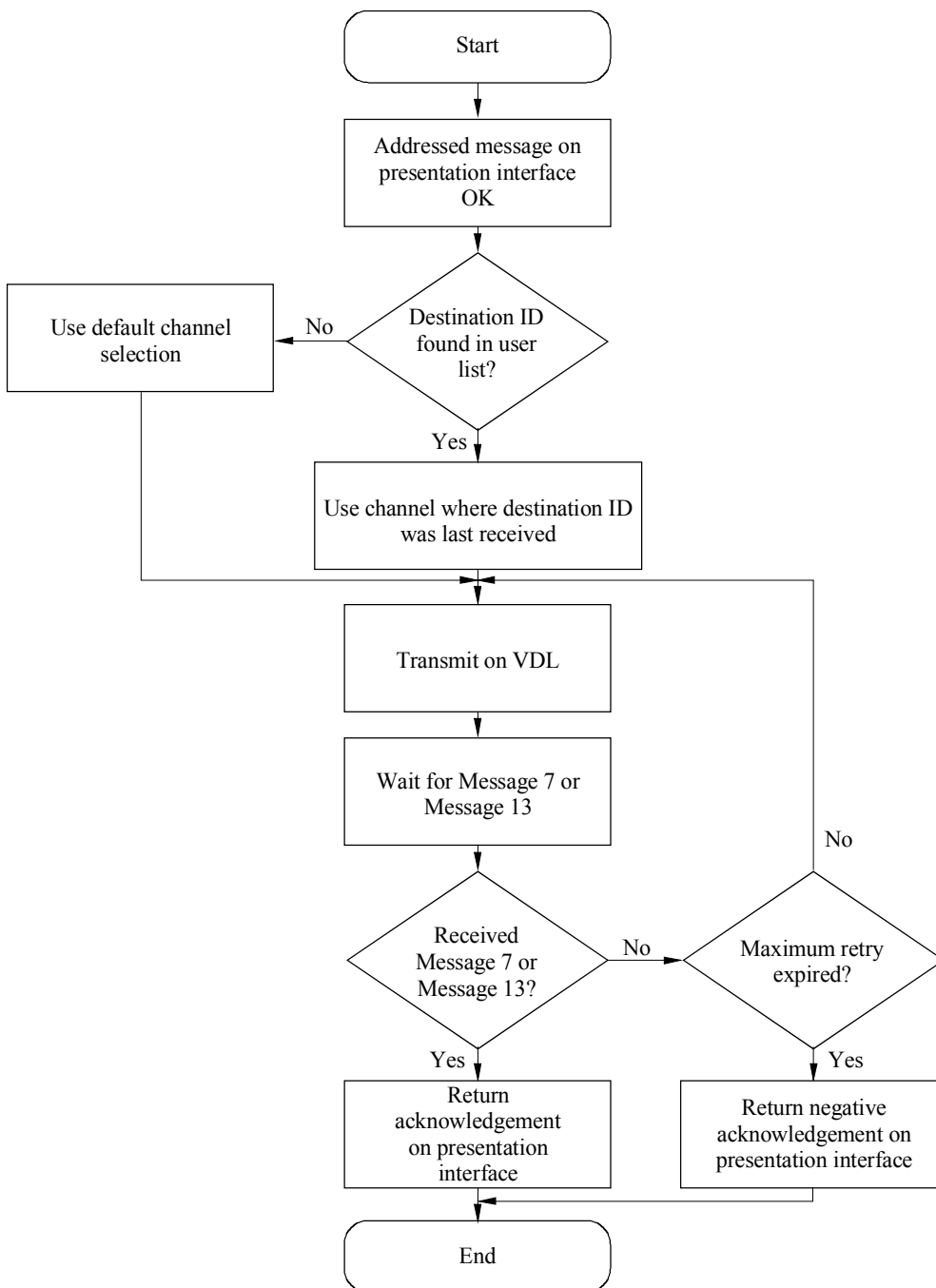

5.3.2 Broadcast messages

A broadcast message lacks a destination identifier ID. Therefore receiving stations should not acknowledge a broadcast message.

5.3.3 Conversion to presentation interface messages

Each received transmission packet should be converted to a corresponding presentation interface message and presented in the order they were received regardless of message category. Applications utilizing the presentation interface should be responsible for their own sequencing numbering scheme, as required. For a mobile station, addressed messages should not be output to the presentation interface, if destination User ID (destination MMSI) is different to the ID of own station (own MMSI).

5.4 Presentation interface protocol

Data, which is to be transmitted by the AIS device, should be input via the presentation interface; data, which is received by the AIS device, should be output through the presentation interface. The formats and protocol used for this data stream are defined by IEC 61162 series.

ANNEX 3

DSC compatibility*

1 General

1.1 The AIS should be capable of performing limited AIS-related DSC operations conforming to the provisions of Recommendations ITU-R M.493, ITU-R M.541 and ITU-R M.825. These operations should not include either Annex 2 of Recommendation ITU-R M.825 or distress-related features of Recommendation ITU-R M.493. In order to accomplish this performance, the AIS device should contain a dedicated DSC receiver that is tuned to channel 70. However, a dedicated DSC transmitter is not required.

1.2 DSC-equipped shore stations may transmit DSC all-ships calls or calls specifically addressed to individual stations on channel 70 to specify regional boundaries and regional frequency channels and transmitter power level to be used by the AIS in those specified regions. The AIS device should be capable of responding to expansion symbols No. 00, 01, 09, 10, 11, 12, and 13 of Table 5 of Recommendation ITU-R M.825 by performing operations in accordance with Annex 2, § 4.1 with the regional frequencies and regional boundaries specified by these calls. Calls addressed to individual stations that do not contain expansion symbols No. 12 and 13 should be used to command these stations to use the specified channels until further commands are transmitted to these stations. Primary and secondary regional channels (Recommendation ITU-R M.825-3, Table 5) correspond to Table 35 (Message 22) channel A and channel B, respectively.

* See Recommendation ITU-R M.1084, Annex 4.

1.3 The shore station should ensure that the total DSC traffic should be limited to 0.075 E in accordance with Recommendation ITU-R M.822.

2 Scheduling

Shore stations that transmit DSC all-ships calls to designate AIS regions and frequency channels should schedule their transmissions such that ships transiting these regions will receive sufficient notice to be able to perform the operations in Annex 2, § 4.1.1 to 4.1.5. A transmission interval of 15 min is recommended, and each transmission should be made twice, with a time separation of 500 ms between the two transmissions, in order to ensure that reception by AIS transponders is accomplished.

2.1 DSC operations performed by the AIS should be scheduled subject to the TDMA operations such that the TDMA operations are not impaired or delayed.

2.2 The automatic response to DSC calls addressed to a VTS area should be transmitted after a random delay, distributed over the range of 0 to 20 s, providing the DSC signalling channel is clear of other traffic and subject to the restrictions of § 2.1.

3 Polling

3.1 The AIS should be capable of automatically transmitting a DSC response to an interrogation request for information, as specified in Recommendation ITU-R M.825, Annex 1. An automatic response should be transmitted to any interrogation containing one or more of the symbols 101, 102, 103, 104, 108, 109, 111, 112 and 116 of Table 4 of Annex 1 of Recommendation ITU-R M.825-3. When an automatic response is required, but the requested information is not available, the relevant symbol in the response should be followed by the symbol 126.

3.2 Transmitted responses should be made on channel 70 unless instructed otherwise by symbol No. 101. However, the AIS should be inhibited from transmitting DSC responses on TDMA channels AIS 1 and AIS 2. If and when frequency channels other than channel 70 are used for DSC transmissions, the receive capability of TDMA operations should not be impaired more than it would be, if all DSC messages were transmitted on channel 70.

3.3 The AIS should not transmit DSC interrogation messages which request information.

4 Regional channel designation

4.1 For designation of regional AIS frequency channels, expansion symbols No. 09, 10 and 11 should be used in accordance with Table 5 of Recommendation ITU-R M.825. Each of these expansion symbols should be followed by two DSC symbols (4 digits) which specify the AIS regional channel(s), as defined by Recommendation ITU-R M.1084, Annex 4. This allows for simplex, duplex, 25 kHz and 12.5 kHz channels for regional options, subject to the provisions of RR Appendix 18. Expansion symbol No. 09 should designate the primary regional channel, and expansion symbol No. 10 or 11 should be used to designate the secondary regional channel.

4.2 When single-channel operation is required, expansion symbol No. 09 should be used, only. For two-channel operation, either expansion symbol No. 10 should be used to indicate that the secondary channel is to operate in both transmit and receive modes, or expansion symbol No. 11 should be used to indicate that the secondary channel is to operate only in receive mode.

5 Regional area designation

For designation of regional areas for utilizing AIS frequency channels, expansion symbols No. 12 and 13 should be in accordance with Table 5 of Recommendation ITU-R M.825. Expansion symbol No. 12 should be followed by the geographical coordinate address of the northeastern corner of the Mercator projection rectangle to the nearest tenth of a minute. Expansion symbol No. 13 should be followed by the geographical coordinate address of the southwestern corner of the Mercator projection rectangle to the nearest tenth of a minute. For calls addressed to individual stations, expansion symbols No. 12 and No. 13 may be omitted (see § 1.2 of this Annex).

ANNEX 4

Long-range applications

Class A shipborne mobile equipment should provide a two-way interface for equipment which provides for long-range communications. This interface should comply with IEC 61162 series.

Applications for long-range communications should consider that:

- The long-range application of AIS must operate in parallel with the VDL. Long-range operation will not be continuous. The system will not be designed for constructing and maintaining real-time traffic images for a large area. Position updates will be in the order of 2-4 times per hour (maximum). Some applications require an update of just twice a day. It can be stated that long-range application forms hardly any workload to the communication system or the transponder and will not interfere with the normal VDL operation.
- The long-range operational mode will be on interrogation basis only for geographical areas. Shore base stations shall interrogate AIS systems, initially by geographical area, followed by addressed interrogation. Only AIS information will be included in the reply; e.g. position and static and voyage-related data.
- The communication system for long-range AIS is not defined in this Recommendation. Inmarsat-C, as part of global maritime distress and safety system (GMDSS) on many vessels, can be a candidate to facilitate the long-range application, but this will not be mandatory. Most of the current Inmarsat-C, but also all other long-range communication systems, do not support the IEC 61162-2 interface. Because the IEC 61162 series will be standard on all future maritime on-board systems, the AIS will be supported by this interface only. This requires for long-range application an active interface box to translate

the long-range AIS 61162-2 messages to the required messages suitable for the chosen communication system and vice versa. This active interface can also gather the information which is not available as standard in the AIS. This can be another information system aboard (if installed).

Example configuration:

Operation with Inmarsat-C

The general set-up of the long-range configuration is in Fig. 21.

FIGURE 21

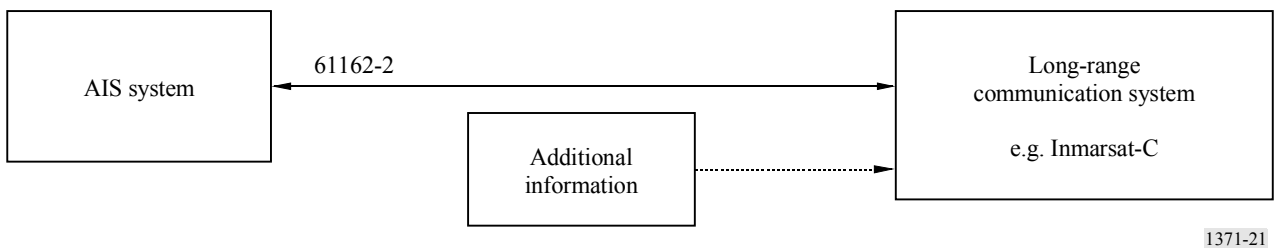

1371-21

Because of the lack of IEC 61162-2 interfaces on long-range communication systems, the configuration shown in Fig. 22 can be used as an interim solution.

FIGURE 22

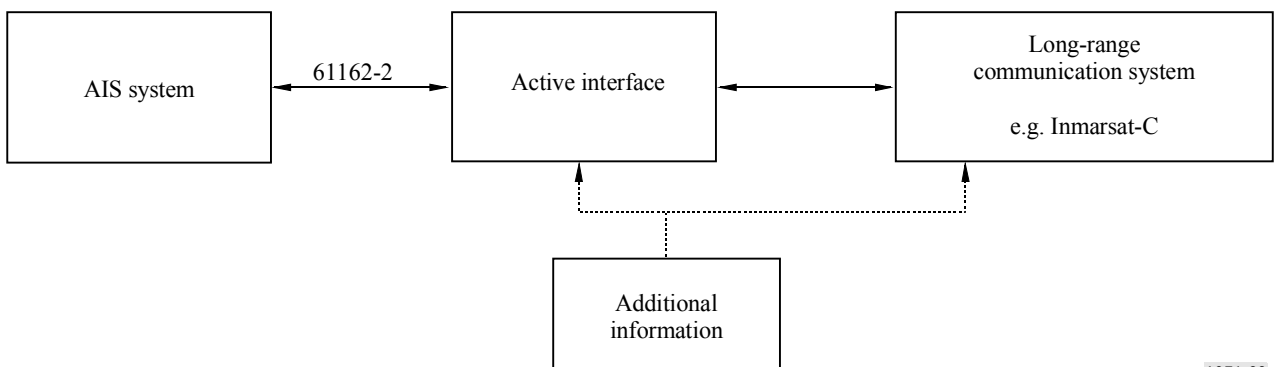

1371-22

ANNEX 5

Application specific messages**Use of application identifiers within binary messages by applications****1 General**

The general concept of application identifiers within broadcast or addressed binary messages is defined in Annex 2, § 3.3.8.2.4.1. To summarize that concept: Every binary message contains a binary data field of variable length up to a given maximum besides the standard VDL message header (message ID, repeat indicator, user ID of source, user ID of destination (addressed binary messages, only)). This binary data field is headed by an application identifier. Every application identifier consists of two parts:

- the designated area code (DAC); and
- the function identifier (FI).

The DAC defines the following different branches of application identifiers available:

- the international application identifier (IAI) branch; and
- branches of regional application identifiers (RAI), one branch available for every specified DAC. The DAC should be identical to the MID, as defined by ITU-R, which are the leading three digits of the MMSI, with the exemption for NULL (MID = 000) and the IAI (MID = 001).

Within every branch, as defined by the DAC, there are 64 FIs available. These FIs allow for the operation of several applications on the same VDL of the AIS.

Every FI is associated with a definition of a function message.

The definition of the technical characteristics, as defined in Annexes 2, 3, and 4, of any AIS station covers layers 1 to 4 of the OSI model, only (see Annex 2, § 1). Hence, any AIS station behaves transparent with regard to the content of binary data field within a binary message.

The layers 5 (session layer), 6 (presentation layer), 7 (application layer, which includes the human-machine-interface to the operator) should, however, be designed by manufacturers of equipment, which covers these layers of the AIS, in accordance with the definitions and guidelines given in this Annex in order to avoid mutual harmful interference of different applications operating on the same VDL of the AIS.

Therefore, this Annex allocates the FIs of the IAI branch to certain internationally recognized applications and defines the appropriate actual international function messages (IFM), leaning on the requirements of the relevant and competent international bodies.

In the future, there will be a need to amend the allocation of FIs of the IAI branch, and to amend the definitions of the IFMs. Therefore, this Annex additionally provides guidelines for maintenance of the allocation of FIs of the IAI branch and the actual IFMs.

Finally, this Annex also provides guidelines when allocating FIs of RAI branches to certain regional or local applications, and when composing the actual regional function messages (RFM).

2 Allocation of FIs within the IAI branch

The FIs within the IAI branch should be allocated and used as described in Table 37. Every FI within the IAI should be allocated to one of the following groups of application fields:

- general usage (Gen)
- VTS
- aids-to-navigation (A-to-N)
- search and rescue (SAR).

Some FIs within the IAI branch should be reserved for future use.

TABLE 37

FI	FIG	Name of IFM	Description	Broadcast	Addressed
0	Gen	Text telegram using 6-bit ASCII	As defined in § 3.1	✓ Reply request flag should not be set	✓
1	Gen	Application acknowledgement	As defined in § 3.2	Should not be used	✓
2	Gen	Interrogation for specified function messages within the IAI branch	As defined in § 3.3	Should not be used	✓
3	Gen	Capability interrogation	As defined in § 3.4	Should not be used	✓
4	Gen	Capability interrogation reply	As defined in § 3.5	Should not be used	✓
5	Gen	Reserved for future use	Reserved for future use		
6	Gen	Reserved for future use	Reserved for future use		
7	Gen	Reserved for future use	Reserved for future use		
8	Gen	Reserved for future use	Reserved for future use		
9	Gen	Reserved for future use	Reserved for future use		
10	Gen	Reserved for future use	Reserved for future use		
11	Gen	Reserved for future use	Reserved for future use		
12	Gen	Reserved for future use	Reserved for future use		

TABLE 37 (continued)

FI	FIG	Name of IFM	Description	Broadcast	Addressed
13	Gen	Reserved for future use	Reserved for future use		
14	Gen	Reserved for future use	Reserved for future use		
15	Gen	Reserved for future use	Reserved for future use		
16	VTS	VTS Targets (targets derived by other means than AIS)	As defined in § 3.6	✓ (Preferably)	✓
17	VTS	Ship waypoints and/or route plan report	As defined in § 3.7	✓	✓ (Preferably)
18	VTS	Advice of waypoints and/or route plan of VTS	As defined in § 3.8	✓	✓ (Preferably)
19	VTS	Extended ship static and voyage related data	As defined in § 3.9	✓	✓ (Preferably)
20	VTS	Reserved for future use	Reserved for future use		
21	VTS	Reserved for future use	Reserved for future use		
22	VTS	Reserved for future use	Reserved for future use		
23	VTS	Reserved for future use	Reserved for future use		
24	VTS	Reserved for future use	Reserved for future use		
25	VTS	Reserved for future use	Reserved for future use		
26	VTS	Reserved for future use	Reserved for future use		
27	VTS	Reserved for future use	Reserved for future use		
28	VTS	Reserved for future use	Reserved for future use		
29	VTS	Reserved for future use	Reserved for future use		
30	VTS	Reserved for future use	Reserved for future use		
31	VTS	Reserved for future use	Reserved for future use		
32	A-to-N	Reserved for future use	Reserved for future use		
33	A-to-N	Reserved for future use	Reserved for future use		
34	A-to-N	Reserved for future use	Reserved for future use		

TABLE 37 (continued)

FI	FIG	Name of IFM	Description	Broadcast	Addressed
35	A-to-N	Reserved for future use	Reserved for future use		
36	A-to-N	Reserved for future use	Reserved for future use		
37	A-to-N	Reserved for future use	Reserved for future use		
38	A-to-N	Reserved for future use	Reserved for future use		
39	A-to-N	Reserved for future use	Reserved for future use		
40	SAR	Number of persons on board	As defined in § 3.10	✓	✓ (preferably)
41	SAR	Reserved for future use	Reserved for future use		
42	SAR	Reserved for future use	Reserved for future use		
43	SAR	Reserved for future use	Reserved for future use		
44	SAR	Reserved for future use	Reserved for future use		
45	SAR	Reserved for future use	Reserved for future use		
46	SAR	Reserved for future use	Reserved for future use		
47	SAR	Reserved for future use	Reserved for future use		
48	Reserved	Reserved for future use	Reserved for future use		
49	Reserved	Reserved for future use	Reserved for future use		
50	Reserved	Reserved for future use	Reserved for future use		
51	Reserved	Reserved for future use	Reserved for future use		
52	Reserved	Reserved for future use	Reserved for future use		
53	Reserved	Reserved for future use	Reserved for future use		
54	Reserved	Reserved for future use	Reserved for future use		
55	Reserved	Reserved for future use	Reserved for future use		

TABLE 37 (end)

FI	FIG	Name of IFM	Description	Broadcast	Addressed
56	Reserved	Reserved for future use	Reserved for future use		
57	Reserved	Reserved for future use	Reserved for future use		
58	Reserved	Reserved for future use	Reserved for future use		
59	Reserved	Reserved for future use	Reserved for future use		
60	Reserved	Reserved for future use	Reserved for future use		
61	Reserved	Reserved for future use	Reserved for future use		
62	Reserved	Reserved for future use	Reserved for future use		
63	Reserved	Reserved for future use	Reserved for future use		

A-to-N: FI belongs to aids-to-navigation FIG

FI: FI within the IAI branch

FIG: FI Group.

3 Definitions of IFMs

3.1 IFM 0: Text telegram using 6-bit ASCII

This IFM should be used by a ship or base station to send 6-bit ASCII text telegram to other AIS stations. The text telegram can be sent with either binary message 6 or 8. The acknowledge required flag should not be set when using the broadcast message 8.

TABLE 38

Parameter	Number of bits	Description
Acknowledge required	1	1 = reply is required 0 = reply is not required
Message sequence number	11	Sequence number to be incremented by the application
Text message	924	6-bit ASCII as defined in Table 14. When using this IFM, the number of slots used for transmission should be minimized taking into account the table below
Spare bits	N	Formula for inserting for spare bits
Total number of bits	936	

The following table gives the number of 6-bit-ASCII characters, so that the whole message fits into a given number of slots. It is recommended that any application minimizes the use of slots by limiting the number of characters to the numbers given, if possible:

Number of slots	Maximum number of 6-bit ASCII characters	
	Addressed binary message, 06	Broadcast binary message
1	8	14
2	46	51
3	83	88
4	120	126
5	158	163

3.2 IFM 1: Application acknowledgement

This IFM should be used by a ship or base station to acknowledge a binary message.

This IFM should be returned to the interrogating station only.

TABLE 39

Parameter	Number of bits	Description
IAI/DAC code	10	See Annex 2, Table 20
Message sequence number	11	Sequence number in the message being acknowledged
Spare bits	3	Formula for inserting for spare bits
Total number of bits	24	

3.3 IFM 2: Interrogation for specified FMs within the IAI branch

This IFM allows a station to interrogate for a specified application within the IAI or DAC branch.

This IFM should be returned to the interrogating station only.

TABLE 40

Parameter	Number of bits	Description
IAI/DAC code	10	See Annex 2, Table 20
FI code	6	See Table 20
Total number of bits	16	

3.4 IFM 3: Capability interrogation

This IFM should be used by a ship or base station to request another station of its implemented application identifiers. The request is made for each IAI and DAC separately.

TABLE 41

Parameter	Number of bits	Description
IAI/DAC code	10	See Annex 2, Table 20
Spare	6	Spare. Should be set to zero
Total number of bits	16	

3.5 IFM 4: Capability reply

This IFM should be used by a ship or a base station to reply to a capability interrogation message. The reply contains a table of the implemented application identifiers.

This IFM should be returned to the interrogating station only.

TABLE 42

Parameter	Number of bits	Description
IAI/DAC code	10	See Annex 2, Table 20
Capability mask	128	IAI/DAC FI capability table, two consecutive bits should be used for every IAI/DAC FI as follows: first bit: IAI/DAC FI available if set to 1; IAI/DAC FI not available if set to 0 = default; second bit: reserved for future use, such as version indication; should be set to zero
Spare	6	Spare. Should be set to zero
Total number of bits	80	

3.6 IFM 16: VTS targets (targets derived by means other than AIS)

This IFM should be used to transmit VTS targets. This message should be variable in length, based on the amount of VTS targets. The maximum of VTS targets transmitted in one IFM 16 should be seven (7). Because of the resulting effects of VDL channel loading, the transmission of IFM 16 should be no more than necessary to provide the necessary level of safety.

TABLE 43

Parameter	Number of bits	Description
VTS target 1	120	See Table 44; occupies 2 slots
VTS target 2	120	Optional; see Table 44; occupies 2 slots
VTS target 3	120	Optional; see Table 44; occupies 3 slots
VTS target 4	120	Optional; see Table 44; occupies 3 slots
VTS target 5	120	Optional; see Table 44; occupies 4 slots
VTS target 6	120	Optional; see Table 44; occupies 4 slots
VTS target 7	120	Optional; see Table 44; occupies 5 slots
Total number of bits	Maximum 840	

Each VTS target should be structured as follows:

TABLE 44

Parameter	Bits	Description
Type of target identifier	2	Identifier type; 0 = The target identifier should be the MMSI number 1 = The target identifier should be the IMO number 2 = The target identifier should be the call sign 3 = Other (default)
Target ID	42	Target identifier. The target ID should depend on type of target identifier above. When call sign is used, it should be inserted using 6-bit ASCII. If target identifier is unknown, this field should be set to zero. When MMSI or IMO number is used, the least significant bit should equal bit zero of the target ID
Spare	4	Spare. Should be set to zero
Latitude	24	Latitude in 1/1 000 min
Longitude	25	Longitude in 1/1 000 min
COG	9	Course over ground (degrees) (0-359); 360 = not available = default
Time stamp	6	UTC second when the report was generated (0-59, or 60 if time stamp is not available, which should also be the default value)
SOG	8	Speed over ground in knots; 0-254; 255 = not available = default
Total	120	

A VTS target should only be used when the position of the target is known. However, the target identity and/or course and/or time stamp and/or speed over ground may be unknown.

3.7 IFM 17: Ship waypoints (WP) and/or route plan report

This IFM should be used by a ship to report its waypoints and/or its route plan. If the reporting ship uses this IFM 17 within an addressed binary message, then the waypoints and/or the route plan will be available to the addressed recipient, e.g. VTS or other ship, only. If the reporting ship uses this IFM 17 within a broadcast binary message, then the information will be available to all other AIS stations in its vicinity.

When transmitting a route plan the transmitting station should include up to 14 next waypoints (NWP), if available, and/or a route specified by a textual description, if available. The next waypoints should be transmitted in the order of the intended passage.

TABLE 45

Parameter	Number of bits		Description
NWP	4		Number of next waypoints available (1-14); 0 = no next waypoint available = default; 15 = not used
WP <i>i</i> .Lon	28		Longitude of next waypoint <i>i</i> in 1/10 000 min ($\pm 180^\circ$, East = positive, West = negative). Field required if and as often as $1 \leq i \leq NWP$, $i = 1, 2, 3, \dots, 14$; field not required if $NWP = 0$
WP <i>i</i> .Lat	27		Latitude of next waypoint <i>i</i> in 1/10 000 min ($\pm 90^\circ$, North = positive, South = negative). Field required if and as often as $1 \leq i \leq NWP$, $i = 1, 2, 3, \dots, 14$; field not required if $NWP = 0$
Route specified by textual description	120		Description of the route information in textual form, e.g. "West channel"; maximum 20 characters using 6-bit ASCII; @@@@@@@@@@@@@@@@@@ = not available (field must not be omitted)
Spare	NWP	Bits	Spare. Not used. Should be set to zero
	0, 8	4	
	1, 9	5	
	2, 10	6	
	3, 11	7	
	4, 12	0	
	5, 13	1	
	6, 14	2	
7	3		
Number of bits	128-896		The number of bits of the IFM 17 may be calculated as follows: $124 + (NWP \times 55) + \text{spare}$

The number of slots used for this message depends on the number of next waypoints transmitted as follows:

Number of next waypoints transmitted	0	1	2	3	4	5	6	7	8	9	10	11	12	13	14
Number of slots used for this message	2	2	2	3	3	3	3	4	4	4	4	5	5	5	5

3.8 IFM 18: Advice of waypoints (AWP) and/or route plan of VTS

This IFM should be used by a VTS to advise its waypoints and/or its route plan. If the VTS uses this IFM 18 within an addressed binary message, then the waypoints and/or the route plan will be available to the addressed recipient, one ship, only. If the VTS uses this IFM 18 within a broadcast binary message, then the information will be available to all other ships in the VTS's vicinity.

When transmitting, the VTS should include up to 12 advised waypoints and/or a route specified by a textual description, if available. If waypoints are transmitted, then a recommended turning radius may be transmitted for each waypoint.

TABLE 46

Parameter	Number of bits		Description
AWP	4		Number of advised waypoints (1-12); 0 = no waypoint = default; 12-15 = not used
WP <i>i</i> .Lon	28		Longitude of advised waypoint <i>i</i> in 1/10 000 min ($\pm 180^\circ$, East = positive, West = negative). Field required if and as often as $1 \leq i \leq AWP$, $i = 1, 2, 3, \dots, 12$; field not required if $AWP = 0$
WP <i>i</i> .Lat	27		Latitude of advised waypoint <i>i</i> in 1/10 000 min ($\pm 90^\circ$, North = positive, South = negative). Field required if and as often as $1 \leq i \leq AWP$, $i = 1, 2, 3, \dots, 12$; field not required if $AWP = 0$
Advised turning radius <i>i</i>	12		Advised turning radius at advised waypoint <i>i</i> in metres; 0 = not available = default; 1-4 095 m. Field required if and as often as $1 \leq i \leq AWP$, $i = 1, 2, 3, \dots, 12$; field not required if $AWP = 0$
Advised route specified by textual description	120		Description of the advised route in textual form, e.g. "west channel"; maximum 20 characters using 6-bit ASCII; @@@@@@@@@@@@@@@@@@@@ = not available (field must not be omitted)
Spare	AWP	Bits	Spare. Not used. Should be set to zero
	0, 8	4	
	1, 9	1	
	2, 10	6	
	3, 11	3	
	4, 12	0	
	5	5	
	6	2	
7	7		
Number of bits	128-928		The number of bits of the IFM 17 may be calculated as follows: $124 + (AWP \times 67) + \text{spare}$

The number of slots used for this message depends on the number of next waypoints transmitted as follows:

Number of next waypoints transmitted	0	1	2	3	4	5	6	7	8	9	10	11	12
Number of slots used for this message	2	2	2	3	3	3	4	4	4	4	5	5	5

3.9 IFM 19: Extended ship static and voyage related data

This IFM should be used by a ship to report the height over keel.

TABLE 47

Parameter	Number of bits	Description
Height over keel	11	In 1/10 m, 2 047 = height over keel 204, 7 m or greater, 0 = not available = default
Spare	5	Not used. Should be set to zero
Total number of bits	16	This IFM uses one slot

3.10 IFM 40: Number of persons on board

This IFM should be used by a ship to report the number of persons on board, e.g. on request by a competent authority.

TABLE 48

Parameter	Number of bits	Description
Number of persons	13	Current number of persons on board, including crew members: 0-8 191; 0 = default = not available; 8 191 = 8 191 or more
Spare	3	Not used. Should be set to zero
Total number of bits	16	This IFM uses one slot

4 Guidelines for maintaining the IAI branch

The currently allocated FIs within the IAI branch and the appropriate IFMs already cover a large variety of possible applications. However, a both flexible and also reliable method for maintaining the IAI branch is needed, when new applications are being developed in the future.

In both operational and technical terms, reliability should be considered as avoidance of mutual harmful interference between applications using FIs of the IAI branch and IFMs on the same VDL of the AIS, i.e. avoiding that different international applications, by accident, use the same FI of the IAI branch.

Reliability in formal terms should be considered as the ability of other international standardization organizations to rely on formally stated requirements of a recognized and competent international body.

This required ultimate reliability can be achieved within the framework of the ITU-R by maintaining a list of the allocated FIs within the IAI branch and the definitions of IFMs within this Recommendation. This calls for a revision of this Recommendation in certain time intervals. These time intervals should be reasonably long enough, i.e. at least four years.

In order to maintain a flexibility to allocate additional FIs in the IAI branch, the following method should be applied between revisions of this Recommendation: Sections 2 and 3 of this Annex should be maintained and published by IALA and should be submitted to IMO and ITU. When maintaining Sections 2 and 3 of this Annex, IALA should maintain backward compatibility with the present definition.

IALA should use its appropriate instruments to provide to the public an up-to-date list of all FIs of the IAI and of all IFMs in use at any time.

Existing FIs of the IAI and existing IFMs should only be deleted by a revision of this Recommendation, i.e. by ITU-R. The proposed deletion of an FI allocation within the IAI and the appropriate IFM should be announced at least two revision periods before the proposed date of deletion.

5 Guidelines for the allocation of FIs within RAI branches

The DAC identifies the regions or the countries to which the appropriate RAI branches apply. The competent authority of that region or that country should allocate the FIs within the appropriate RAI branch.

When allocating the FIs within its RAI branch, the competent authority should comply with the following:

- The available FIs should be partitioned into two parts: One part should be allocated for the use of the regional or national public; the other part should be allocated for the use of private organizations in that region or country. Both parts should have a sufficient size, i.e. not less than 24 FIs each, to satisfy the present and the future need of both, the public of that region or country and the private organizations.
- Organizations, which for reasons of security require encrypted messages, should be considered as private with regard to allocation of FIs within the RAI branch, and therefore should be assigned FI(s) within the part of the appropriate RAI branch, which was assigned to private use.
- The allocation of all FIs to the regional or national public or to private organizations should be published by an up-to-date list of all FIs.
- The definitions of the RFMs within the public part of the appropriate RAI branch in use should be published in sufficient detail by an up-to-date list, using the appropriate regional or national instrument.

- The definitions of the RFMs within the part of the appropriate RAI branch, which was assigned to private use, however, should not be published by the competent authority.
- The competent authority should establish and publish procedures to maintain the allocation of FIs within its RAI branch. These procedures should be informed by the procedures set up to maintain the FIs within the IAI branch.

6 Guidelines for the development of RFMs within RAI branches

When developing RFMs within the RAI branches, the following should be observed:

- Every region should provide a function message for test and evaluation purposes. This test/evaluation message should be used for test and evaluation purposes only. It should be used for that purpose to ensure system integrity in an operational system.
- In principle, RFMs and data fields should be developed in accordance with the rules given in Annex 2, § 3.3.7 (Message structure), and § 3.3.8.2 (Message descriptions).
- Values for not available and normal vs. malfunctioning should be defined for every data field, if appropriate.
- Default values should be defined for every data field.
- When there is position information included, it should comprise the following data fields in the following order as defined in e.g. Messages 1 and 5 (see Annex 2, § 3.3.8.2):
 - Position accuracy (1 bit): 1 = high (<10 m; differential mode of e.g. DGNSS receiver)
0 = low (>10 m; autonomous mode of e.g. GNSS receiver or of other electronic position fixing device); default = 0.
 - Longitude (28 bits): Longitude in 1/10 000 min ($\pm 180^\circ$, East = positive, West = negative. 181° (6791AC0h) = not available = default.
 - Latitude (27 bits): Latitude in 1/10 000 min ($\pm 90^\circ$, North = positive, South = negative, 91° (3412140h) = not available = default).
 - Type of electronic position fixing device (4 bits):
0 = undefined (default);
1 = GPS;
2 = GLONASS;
3 = combined GPS/GLONASS;
4 = Loran-C;
5 = Chayka;
6 = integrated navigation system;
7 = surveyed;
8-15 = not used.
 - Time stamp (UTC second) and integrity indicator of electronic position fixing device (6 bits):
UTC second when the report was generated (0-59;
or 60 if time stamp is not available, which should also be the default value;
or 61 if positioning system is in manual input mode;
or 62 if electronic position fixing system operates in estimated (dead reckoning) mode;
or 63 if the positioning system is inoperative).

- When transmitting time and/or date information, other than time stamp for position information, this information should be as defined as follows:
 - UTC year: 1-9999; 0 = UTC year not available = default (14 bits).
 - UTC month: 1-12; 0 = UTC month not available = default; 13-15 not used (4 bits).
 - UTC day: 1-31; 0 = UTC day not available = default (5 bits).
 - UTC hour: 0-23; 24 = UTC hour not available = default; 25-31 not used (5 bits).
 - UTC minute: 0-59; 60 = UTC minute not available = default; 61-63 not used (6 bits).
 - UTC second: 0-59; 60 = UTC second not available = default; 61-63 not used (6 bits).
- When transmitting information on direction of movement, this information should be defined as direction of movement over ground in $1/10^\circ$ (0-3 599); 3 600 (E10h) = not available = default; 3 601-4 095 should not be used.
- When transmitting information on rotation rate, this information should be defined as follows:
 - ± 127 (-128 (80_h) indicates not available, which should be the default).
 - Coded by $ROT_{AIS} = 4.733 \text{ SQRT}(ROT_{INDICATED})$ degrees/min
 - $ROT_{INDICATED}$ is the rotation rate ($\pm 720^\circ/\text{min}$), which is to be encoded.
 - +127 = turning right at $720^\circ/\text{min}$ or higher;
 - 127 = turning left at $720^\circ/\text{min}$ or higher.
- When transmitting text of variable length, the length of the transmitted text should be given in a numerical field of fixed length preceding the actual text field.
- All data fields of the FMs should observe byte boundaries. If needed to align with byte boundaries, spares should be inserted.
- If possible, applications should optimize their use of slots, taking into account the need for buffering, with regard to the number of data bits given in Annex 2 at the appropriate definition of the binary message itself.

ANNEX 6

Sequencing of transmission packets

This Annex describes the method by which information should be exchanged between stations' application layers (Application A and Application B) over the VDL through the presentation interface (PI).

The originating application assigns a sequence number to each transmission packet, using the addressed message. The sequence number can be 0, 1, 2 or 3. This number together with message type and destination gives the transmission a unique transaction identifier. This transaction identifier is communicated to the receiving application.

FIGURE 23

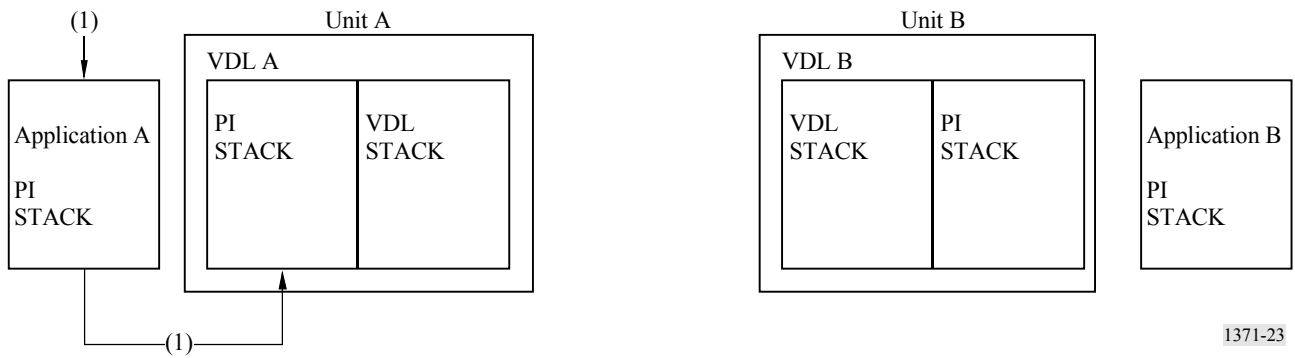

1371-23

Step 1: Application A delivers 4 addressed messages addressed to B with sequence numbers 0, 1, 2 and 3 via PI.

FIGURE 24

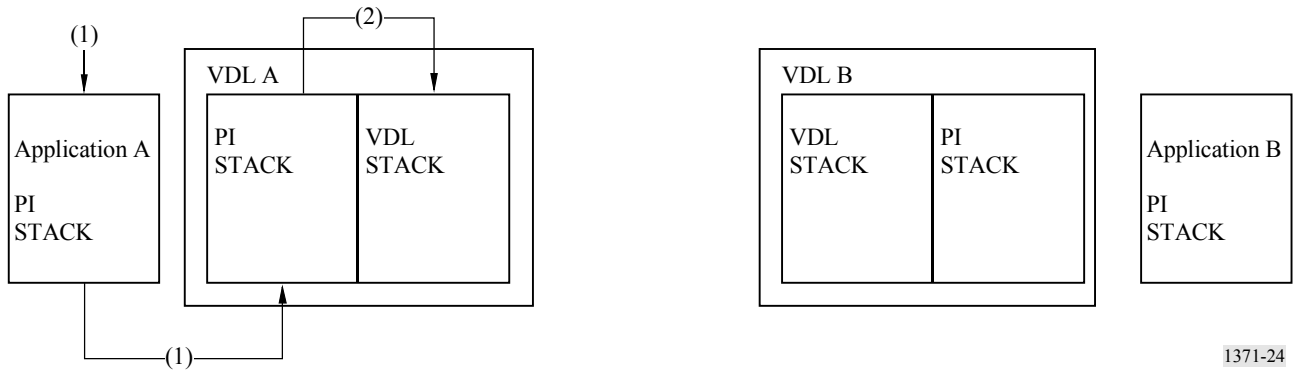

1371-24

Step 2: VDL A receives addressed messages and puts them in the transmit queue.

FIGURE 25

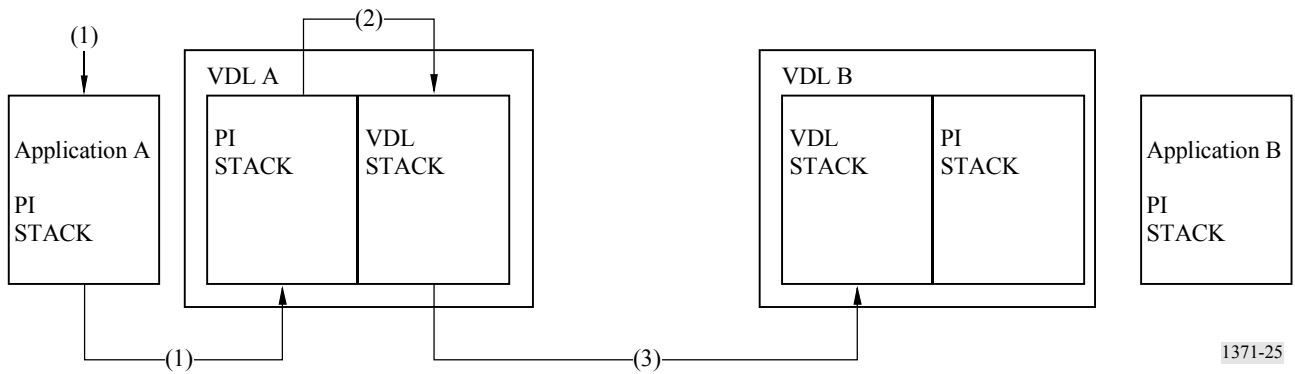

1371-25

Step 3: VDL A transmits the messages to VDL B, which only receives messages with sequence numbers 0 and 3.

FIGURE 26

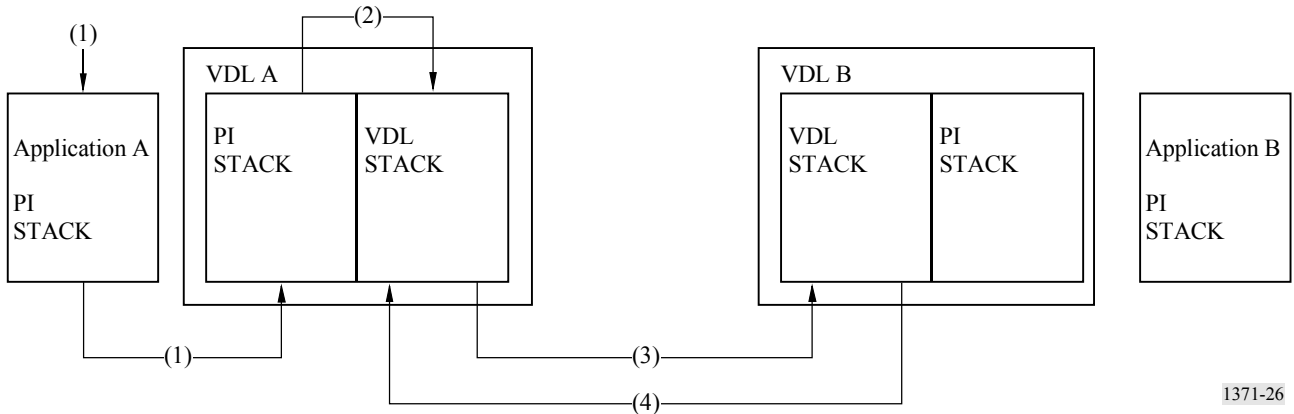

1371-26

Step 4: DL B returns VDL-ACK messages with sequence numbers 0 and 3 to VOL A.

FIGURE 27

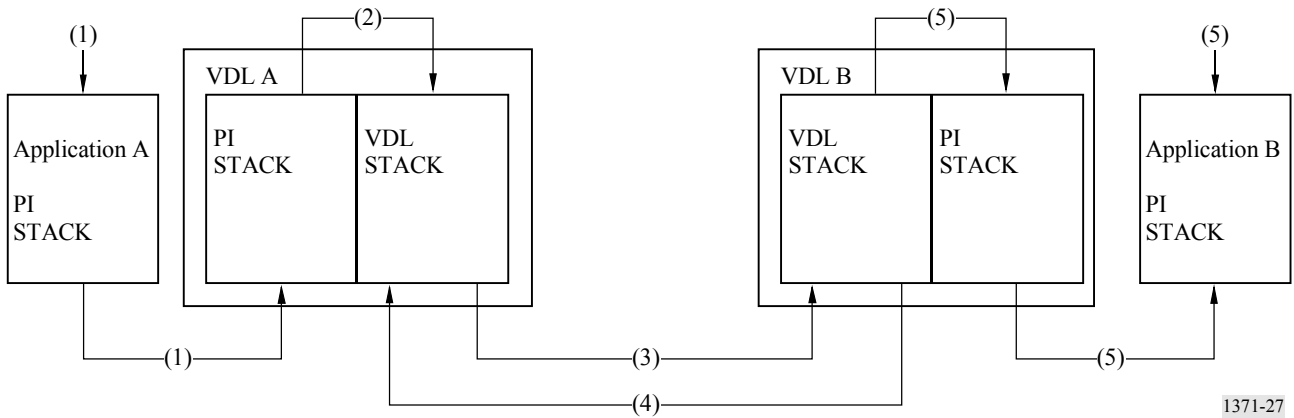

1371-27

Step 5: VDL B delivers addressed messages with sequence numbers 0 and 3 to Application B.

FIGURE 28

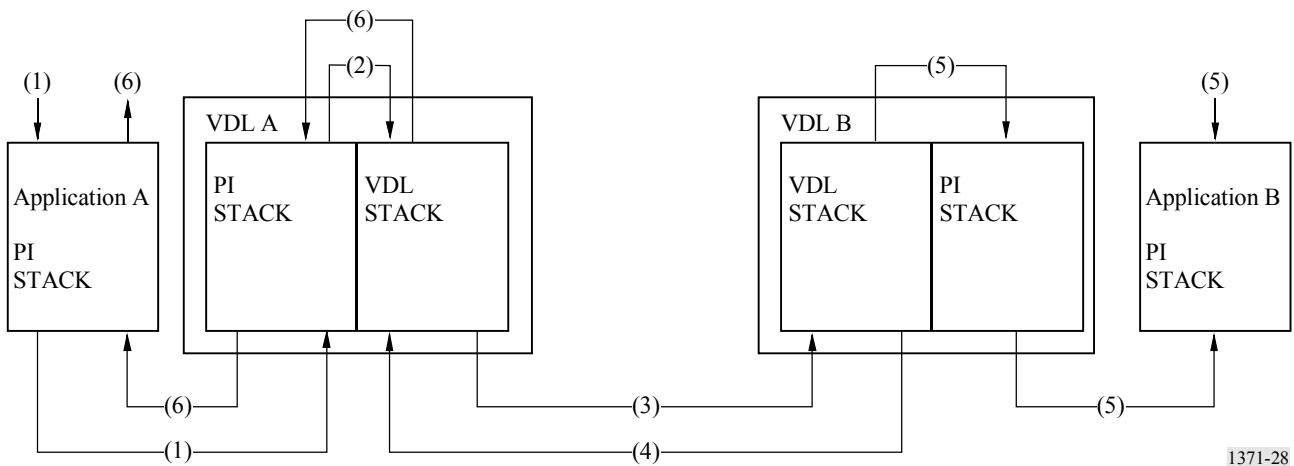

1371-28

Step 6: VDL A returns PI-ACK (OK) to Application A with sequence numbers 0 and 3.

FIGURE 29

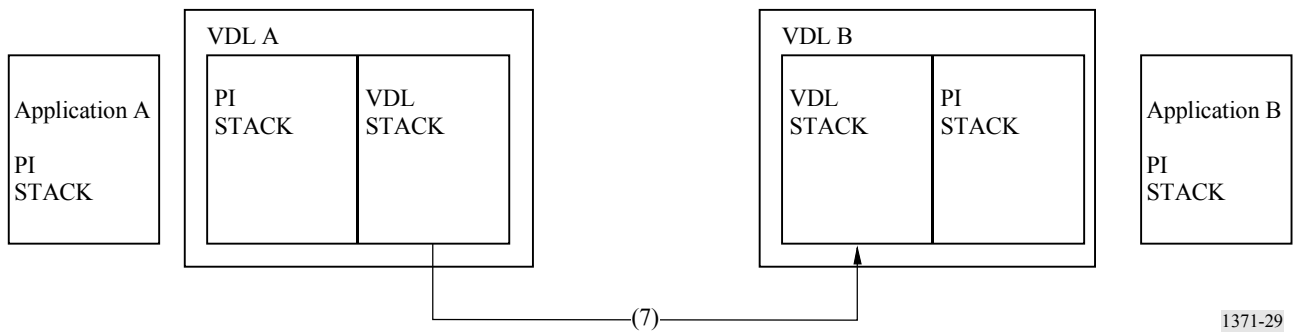

1371-29

Step 7: VDL A times out on sequence numbers 1 and 2 and retransmits the addressed messages to VDL B.

FIGURE 30

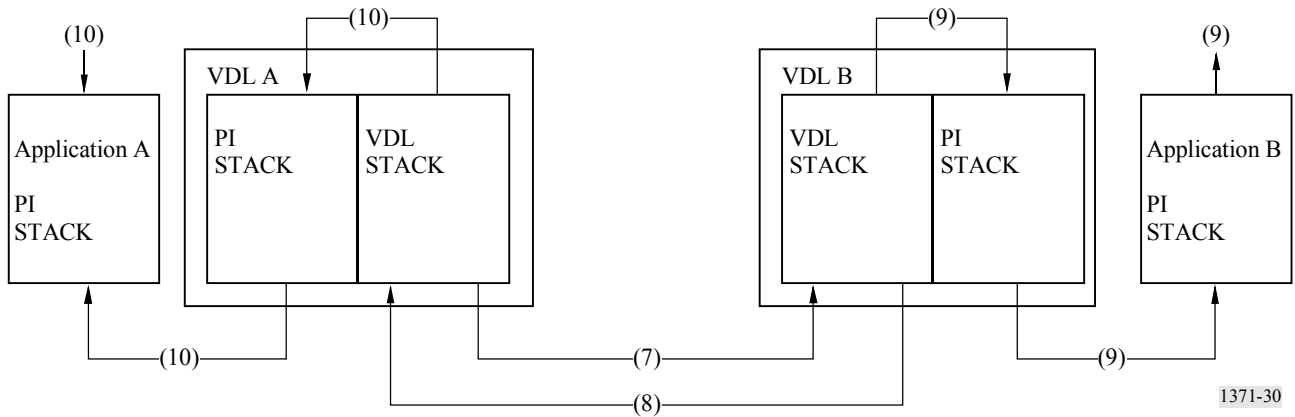

1371-30

Step 8: VDL B successfully receives Message 2 and returns a VDL-ACK with sequence number 2.

Step 9: VDL B delivers ABM (addressed binary message) message with sequence number 2 to Application B.

Step 10: VDL A delivers PI-ACK (OK) with sequence number 2 to Application A.

FIGURE 31

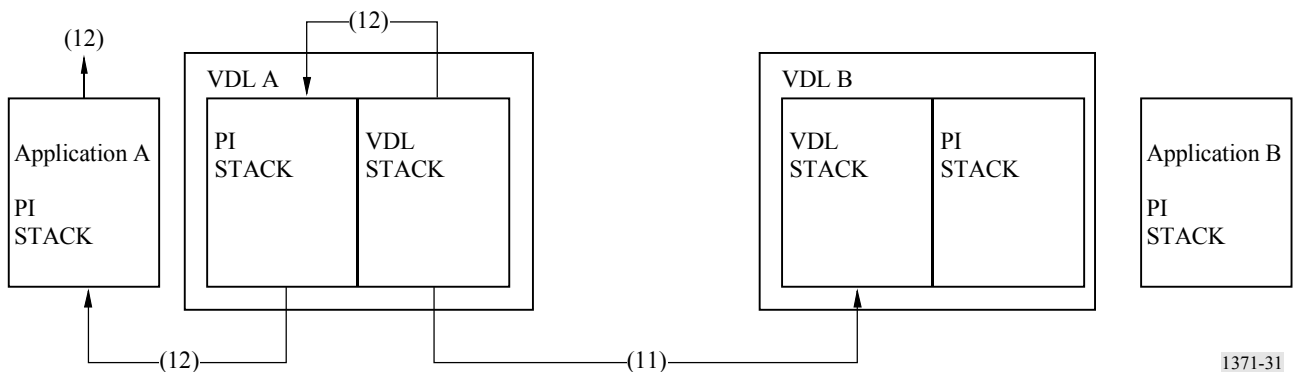

1371-31

Step 11: VDL A retransmits message, with sequence number 1, but does not receive a VDL-ACK from VDL B. It does this two times and is unsuccessful in delivering message.

Step 12: VDL A, upon failing the transmit transaction of message with sequence number 1, delivers a PI-ACK (FAIL) to Application A.