

RECOMMENDATION ITU-R F.387-9

**Radio-frequency channel arrangements for radio-relay systems
operating in the 11 GHz band***

(Question ITU-R 136/9)

(1963-1970-1974-1978-1986-1990-1992-1995-1999-2002)

The ITU Radiocommunication Assembly,

considering

- a) that, at 11 GHz, analogue radio-relay systems with a capacity of up to 1 800 telephone channels, or the equivalent, or digital systems with a capacity of up to 140 Mbit/s or synchronous digital hierarchy bit rates seem to be feasible, subject to rainfall conditions;
- b) that repeater spacing as well as other aspects of system design in this frequency range must take due cognizance of significant meteorological factors;
- c) that it is desirable to interconnect such systems at radio frequencies on international circuits;
- d) that for analogue systems a uniform radio-frequency (RF) channel arrangement for both smaller and larger capacities offers considerable advantages;
- e) that, in a frequency band 1 000 MHz wide, it may be desirable to interconnect up to twelve go and twelve return analogue channels;
- f) that economy may be achieved if up to 12 go and 12 return channels may be accommodated on a common antenna;
- g) that it may sometimes be desirable to interleave additional RF channels between those of the main pattern;
- h) that the channels should be so arranged as to enable an intermediate frequency of 70 MHz or 140 MHz to be used for analogue radio-relay system;
- j) that it is desirable to provide for operation of digital systems and analogue systems on the same path;
- k) that single- and multi-carrier digital radio-relay systems are both useful concepts to achieve the best technical and economic trade-off in system design,

* Subject to agreement between the administrations concerned, 2 700 telephone channel systems employing an intermediate frequency of 140 MHz and following the main pattern of the radio-frequency plan of this Recommendation, may be accommodated in the 11 GHz band when required for special cases.

recommends

1 that the preferred RF channel arrangement for analogue radio-relay systems with a maximum capacity of 1 800 telephone channels, or the equivalent, and operating in the 11 GHz band should be derived as follows:

Let f_0 be the frequency of the centre of the band of frequencies occupied (MHz),

f_n be the centre frequency of one RF channel in the lower half of the band (MHz),

f'_n be the centre frequency of one RF channel in the upper half of the band (MHz);

then the frequencies of individual channels are expressed by the following relationship:

$$\text{lower half of the band: } f_n = f_0 - 525 + 40 n \quad \text{MHz}$$

$$\text{upper half of the band: } f'_n = f_0 + 5 + 40 n \quad \text{MHz}$$

where:

$$n = 1, 2, 3, 4, 5, 6, 7, 8, 9, 10, 11 \text{ or } 12.$$

The frequency arrangement is illustrated in Fig. 1;

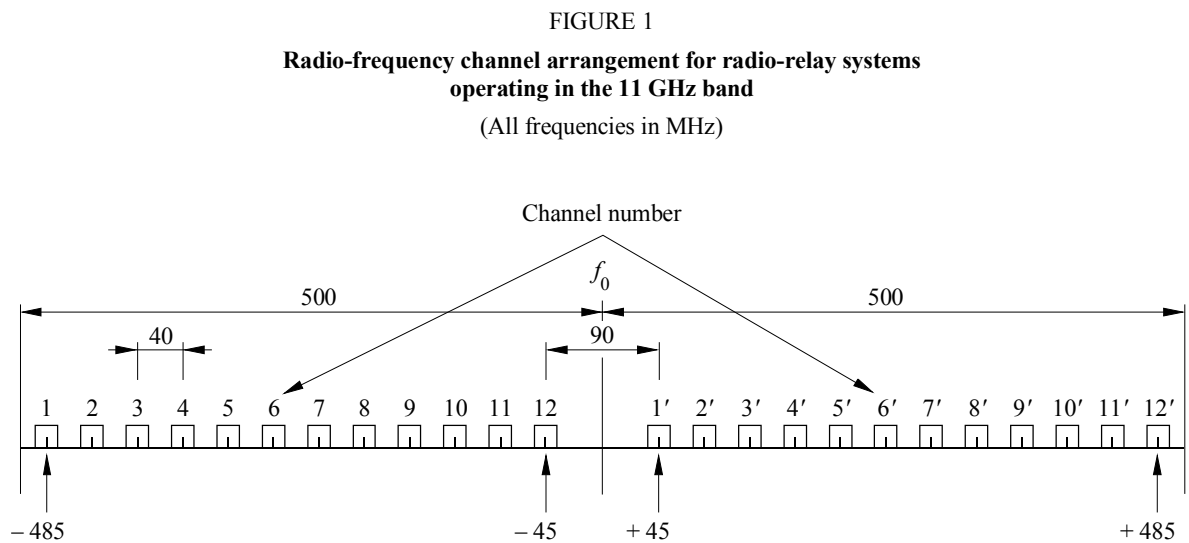

2 that, when additional analogue RF channels, interleaved between those of the main pattern are required, the values of the centre frequencies of these RF channels should be 20 MHz below those of the corresponding main channel frequencies.

NOTE 1 – Channel 1 of the interleaved pattern in the lower half of the band is beyond the lower extremity of a 1 000 MHz band and may therefore not be available for use.

NOTE 2 – The use of a single antenna working allows for twelve go and twelve return channels based on the channel arrangement of Fig. 1 and eleven go and eleven return channels based on the channel arrangement of Fig. 2a);

3 that, when analogue radio-frequency channels are also required for auxiliary radio-relay systems, the preferred frequencies for eleven go and eleven return channels, including two pairs of auxiliary channels in both the main and interleaved patterns should be derived by making:

$n = 2, 3, 4, \dots 12$ in the lower half of the band,

$n = 1, 2, 3, \dots 11$ in the upper half of the band.

The radio frequencies (MHz) for the auxiliary systems should be chosen as shown below:

	Main pattern	Interleaved pattern
lower half of the band	$f_0 - 485$	$f_0 - 95$
	$f_0 - 5$	$f_0 - 25$
upper half of the band	$f_0 + 15$	$f_0 + 2.5$
	$f_0 + 485$	$f_0 + 465$

The RF arrangement is illustrated in Fig. 2, which also shows a possible polarization arrangement;

FIGURE 2
Radio-frequency channel arrangement for main and auxiliary radio-relay systems operating in the 11 GHz band
 (All frequencies in MHz)

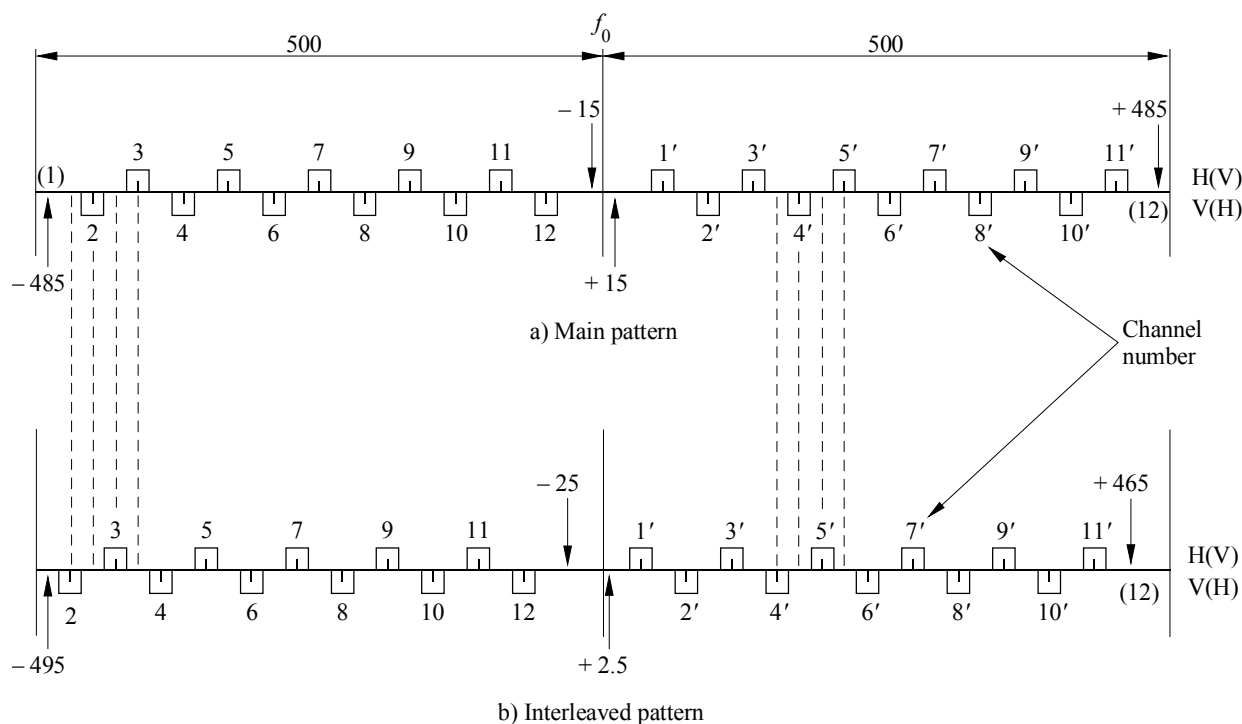

0387-02

4 that, in a section over which the international connection is arranged, all the go channels should be in one half of the band and all the return channels should be in the other half of the band;

5 that if, for example, only three go and three return channels are accommodated on a common transmit-receive antenna, it is preferable that the channel frequencies (MHz) be selected by making:

$$\left. \begin{array}{l} n = 1, 5, 9 \text{ or} \\ n = 2, 6, 10 \text{ or} \\ n = 3, 7, 11 \text{ or} \\ n = 4, 8, 12 \end{array} \right\} \text{ in both halves of the band}$$

6 that for adjacent analogue RF channels in the same half of the band different polarizations should preferably be used alternately;

7 that the preferred centre frequency is 11 200 MHz; other centre frequencies may be used by agreement between the administrations concerned;

8 that when low- or medium-capacity digital radio-relay systems are to be used in the 11 GHz band, the RF channel arrangement should be in accordance with *recommends* 1 and 2 (Note 7). A description of these channel arrangements is given in Annex 1;

9 that when high-capacity digital radio-relay systems with a bit rate of the order of plesiochronous, or synchronous digital hierarchy bit rates (Note 4), are to be used in the 11 GHz band, the RF channel arrangements should utilize the centre frequencies defined in *recommends* 1, 2 and 3. A description of these channel arrangements is given in Annex 2;

10 that a co-channel arrangement may also be used for digital radio-relay systems which can be derived from the arrangements given in Figs. 1 or 2 by supplementing each channel by its counterpart;

11 that if multi-carrier transmission (Note 5) is employed, the overall number of n carriers will be regarded as a single channel. The centre frequency of that channel should be derived from *recommends* 1 or *recommends* 2, disregarding the actual centre frequencies of the individual carriers, which may vary, for technical reasons, according to practical implementations. Operation of multi-carrier systems is addressed in greater detail in Annex 5.

NOTE 1 – Channel 1 of the interleaved pattern in the lower half of the band is beyond the lower extremity of a 1 000 MHz band and may therefore not be available for use.

NOTE 2 – The use of a single antenna working allows for 12 go and 12 return channels based on the channel arrangement of Fig. 1 and 11 go and 11 return channels based on the channel arrangement of Fig. 2a).

NOTE 3 – It is recognized that some administrations are using alternative 140 Mbit/s channel arrangements as described in Annexes 3 and 4.

NOTE 4 – Actual gross bit rates may be as much as 5% or more higher than net transmission bit rates.

NOTE 5 – A multi-carrier system is a system with n (where $n > 1$) digitally modulated carrier signals simultaneously transmitted (or received) by the same radio-frequency equipment. The centre frequency should be regarded as the arithmetic average of the n individual carrier frequencies of the multi-carrier system.

NOTE 6 – Due regard should be taken that in one country a channel arrangement based on 60 MHz channel separation is used. This arrangement is shown in Annex 6.

NOTE 7 – Due regard should be taken of the fact that, in some countries, other RF channel arrangements for medium- and small-capacity digital systems are used. A description of these RF channel arrangements is given in Annex 7.

ANNEX 1

Description of the radio-frequency channel arrangement referred to in *recommends 8*

1 Suitable channel arrangements for low- and medium-capacity digital radio-relay systems requiring channel spacings of 40 MHz can be provided by this Recommendation if co-channel assignments are made for both polarizations.

2 The preferred RF channel arrangement for digital radio-relay systems provides eleven go and eleven return channels derived as follows:

Let f_0 be the frequency of the centre of the band of frequencies occupied (MHz),

f_n be the centre frequency of one RF channel in the lower half of the band (MHz),

f'_n be the centre frequency of one RF channel in the upper half of the band (MHz);

then the frequencies of the co-channel pairs are expressed by the following relationship:

$$\text{lower half of the band: } f_n = f_0 - 545 + 40 n \quad \text{MHz}$$

$$\text{upper half of the band: } f'_n = f_0 - 15 + 40 n \quad \text{MHz}$$

where:

$$n = 2, 3, 4, 5, 6, 7, 8, 9, 10, 11 \text{ or } 12.$$

3 When digital radio channels are to be added to an existing analogue system that is not fully developed, the digital channels should preferably use the interleaved plan of *recommends 2* if the analogue channels are using the main pattern of § 1 and vice versa (Fig. 3 is included as an example).

However, it is recognized that in some cases it may be possible to add digital channels in the unused portions of an existing analogue plan.

3 The preferred RF channel arrangement providing 11 go and return channels based on the interleaved pattern shown in Fig. 2b) is defined by:

$n = 2, 3, 4, \dots 12$ in the lower half of the band,

$n = 1, 2, 3, \dots 11$ in the upper half of the band (see Fig. 2b)),

or:

$n = 2, 3, 4, \dots 12$ in the upper half of the band (see *recommends 2*).

4 The preferred RF channel arrangement providing 12 go and return channels is based on § 2 above with two additional channels as shown in Fig. 4 and defined by the following relationships:

lower half of the band: $f_n = f_0 - 505 + 40 n$ MHz

upper half of the band: $f'_n = f_0 - 15 + 40 n$ MHz

where:

$n = 1, 2, 3, \dots 12$.

NOTE 1 – Channels 1 and 12' in the main pattern with a guardband of 15 MHz are generally considered unsuitable for high-capacity digital radio systems with a symbol rate of more than 25 to 30 MBd.

NOTE 2 – Channels 12 and 1' in Fig. 4 with a separation of 50 MHz are generally considered to require separate antennas if operated on the same hop. Interference between channels 12 and 1' may increase during periods of high rain rate due to back-scatter from rain. This effect should be taken into consideration in areas of the world where high rain rates are encountered.

FIGURE 4
**Radio-frequency channel arrangement for high capacity digital radio-relay systems
operating in the 11 GHz band**
(All frequencies in MHz)

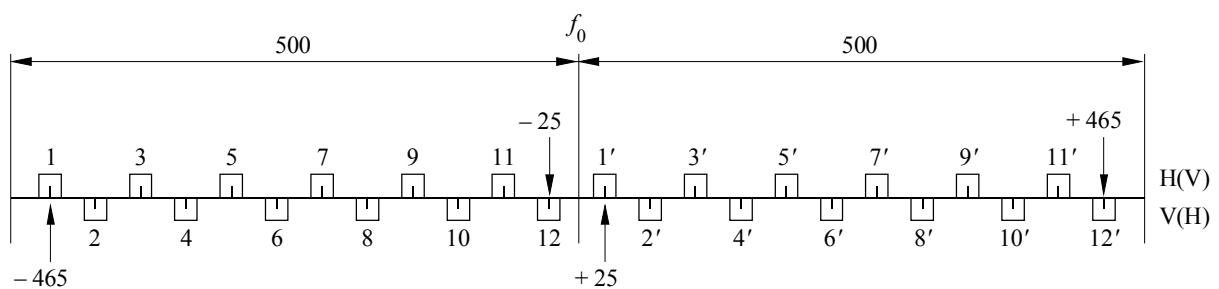

ANNEX 3

A practical RF channel arrangement using a system with 4-PSK modulation

The channel arrangement shown in Fig. 5 is used in the United Kingdom based on 4-PSK modulation, and is intended for use over existing radio-relay routes which incorporate hop lengths of up to 65 km.

FIGURE 5

**Radio-frequency channel arrangement for a 4-PSK
digital radio-relay system**
(All frequencies in MHz)

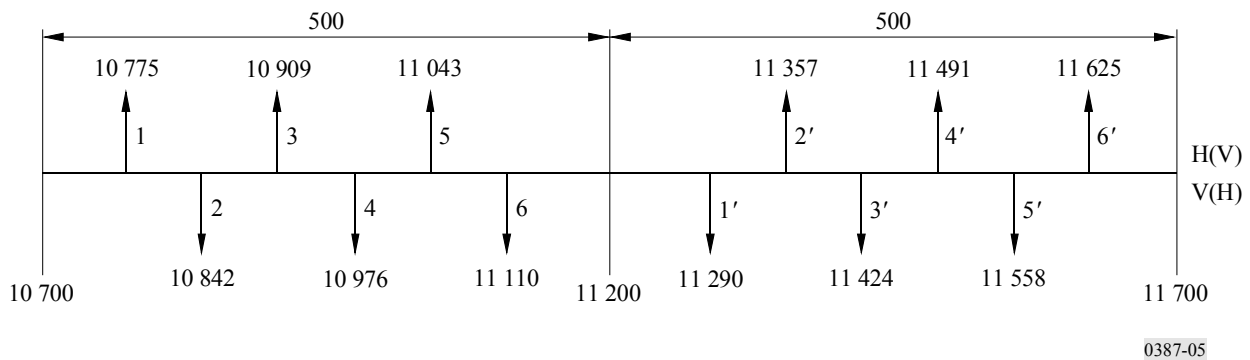

ANNEX 4

A practical RF channel arrangement using a system with 8-PSK modulation

The channel arrangement shown in Fig. 6 is used in France based on 8-PSK modulation.

The centre frequencies of this channel arrangement are defined on the basis of those referred to in this Recommendation, and the 60 MHz spacing between adjacent channels is obtained by choosing alternately a centre frequency from the interleaved plan (channels 1, 3, 5 and 7) and a centre frequency from the main plan (channels 2, 4, 6 and 8).

FIGURE 6

**Radio-frequency channel arrangement for a 140 Mbit/s radio-relay system
operating in the 10.7-11.7 GHz band**
(All frequencies in MHz)

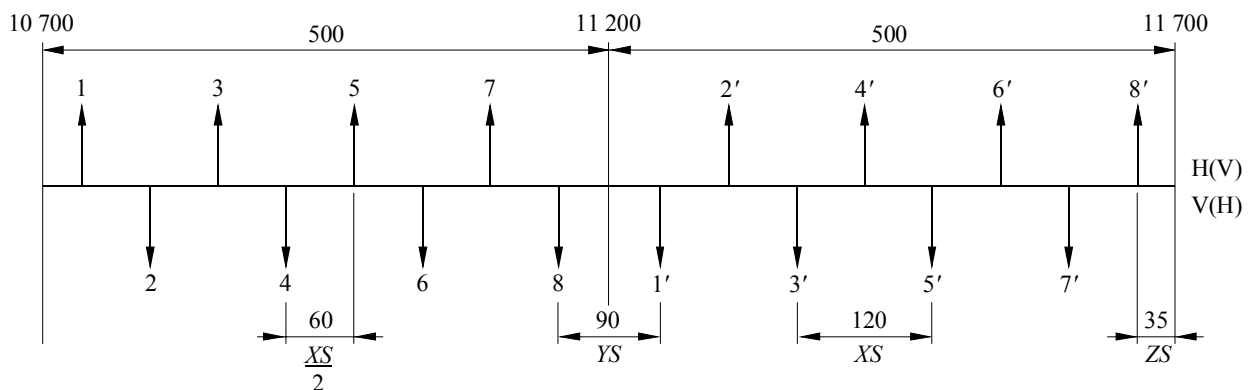

ANNEX 5

Description of a multi-carrier system

A multi-carrier system is a system with n (where $n > 1$) digitally modulated carrier signals simultaneously transmitted (or received) by the same radio frequency equipment.

For high capacity multi-carrier transmission, the centre frequency of the channel should coincide with one of the corresponding frequencies of the basic channel arrangements given in *recommends 1* or *recommends 2*. The channel spacing may be an integer multiple of the basic values defined by *recommends 1* or *recommends 2*. Compatibility with existing configurations has to be taken into account when choosing the appropriate alternative.

An example of a co-polar channel arrangement using a two carrier system with 64-QAM is shown below.

The channel arrangement depicted in Fig. 7 is based upon the use of a 2-carrier system transmitting $2 \times 2 \times 155.52$ Mbit/s ($4 \times$ STM-1) via two carrier pairs using both polarizations in the co-channel arrangement.

FIGURE 7

A radio-frequency channel arrangement for a $2 \times 2 \times 155.52$ Mbit/s ($4 \times$ STM-1) radio-relay system operating with 80 MHz channel spacing in the 10.7-11.7 GHz band, as used in Switzerland

(All frequencies in MHz)

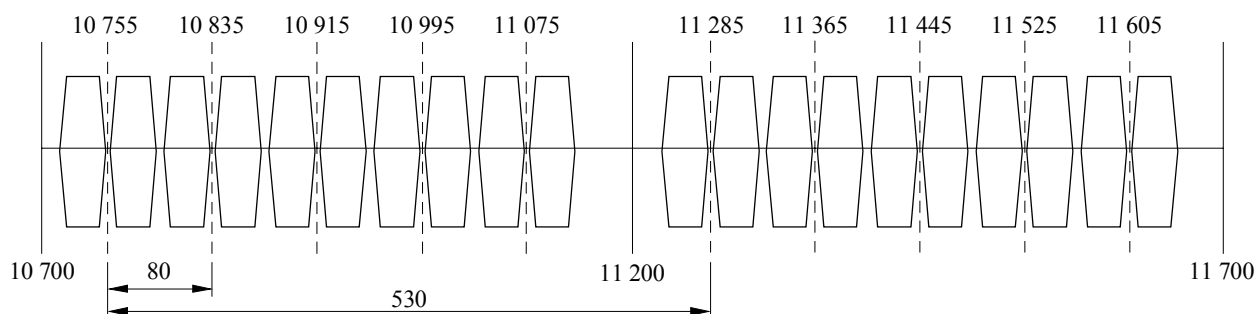

0387-07

ANNEX 6

Description of the 60 MHz RF channel arrangement

The RF channel arrangement referred to in Note 6 providing 16 go and return channels based on co-channel pattern is shown in Fig. 8 and defined as:

$$\text{lower half of the band: } f_n = f_0 - 470 + 60(n - 1) \quad \text{MHz}$$

$$\text{higher half of the band: } f'_n = f_0 + 50 + 60(n - 1) \quad \text{MHz}$$

where:

$$n = 1, 2, \dots, 8.$$

FIGURE 8
**Radio-frequency channel arrangement for high capacity digital radio-relay systems
operating in the 11 GHz band**
(All frequencies in MHz)

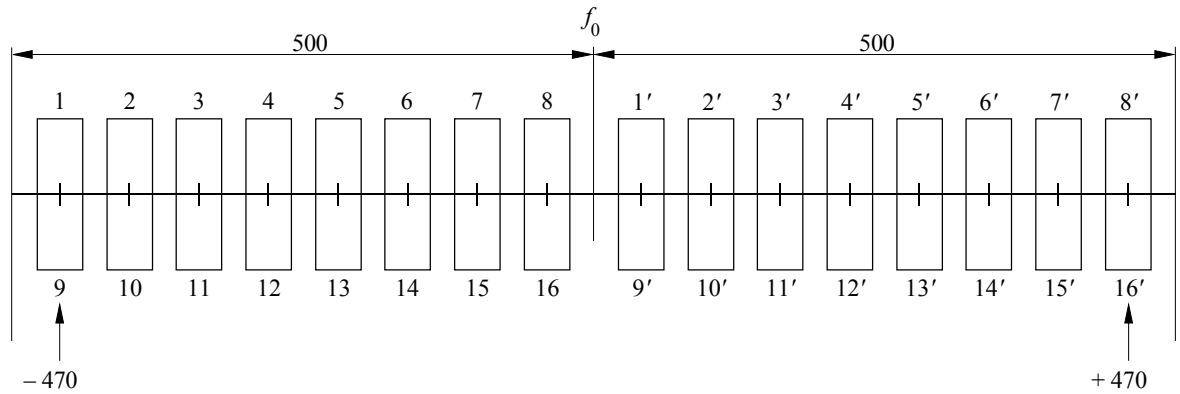

0387-08

ANNEX 7

**Radio-frequency channel arrangements for medium- and small-capacity digital
radio-relay systems operating in the band 10 700-11 700 MHz
with a channel spacing of 10 and 5 MHz**

The radio-frequency channel arrangements referred to in Note 7 of *recommends* 8 for carrier spacing of 10 MHz and 5 MHz are shown in Fig. 9 and shall be derived as follows:

- Let f_0 be the frequency of the centre of the band of frequencies occupied (MHz),
 f_n be the centre frequency of one radio-frequency channel in the lower half of the band (MHz),
 f'_n be the centre frequency of one radio-frequency channel in the upper half of the band (MHz);

- a) for systems with a carrier spacing of 10 MHz:
lower half of the band: $f_n = f_0 - 505 + 10n$
upper half of the band: $f'_n = f_0 + 25 + 10n$

where:

$$n = 1, 2, 3, \dots, 47;$$

- b) for systems with a carrier spacing of 5 MHz:
lower half of the band: $f_n = f_0 - 500 + 5n$
upper half of the band: $f'_n = f_0 + 30 + 5n$

where:

$$n = 1, 2, 3, \dots, 93.$$

The centre frequency f_0 is 11 200 MHz.

FIGURE 9
**Radio-frequency channel arrangements for radio-relay systems operating with
 10 MHz and 5 MHz channel spacing in the 10.7-11.7 GHz band**
 (All frequencies in MHz)

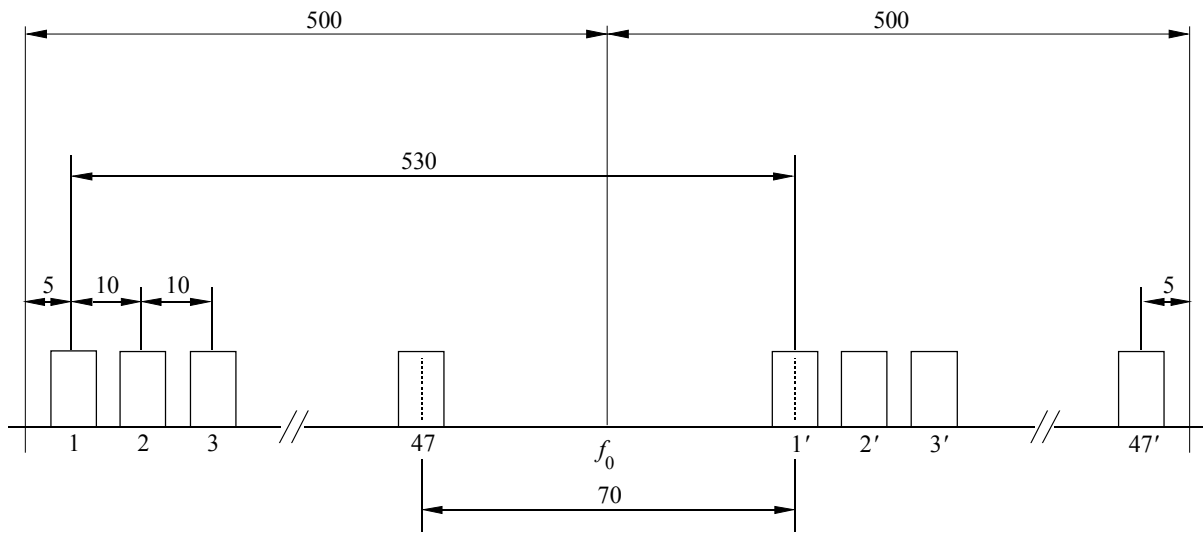

a) for systems with a carrier spacing of 10 MHz

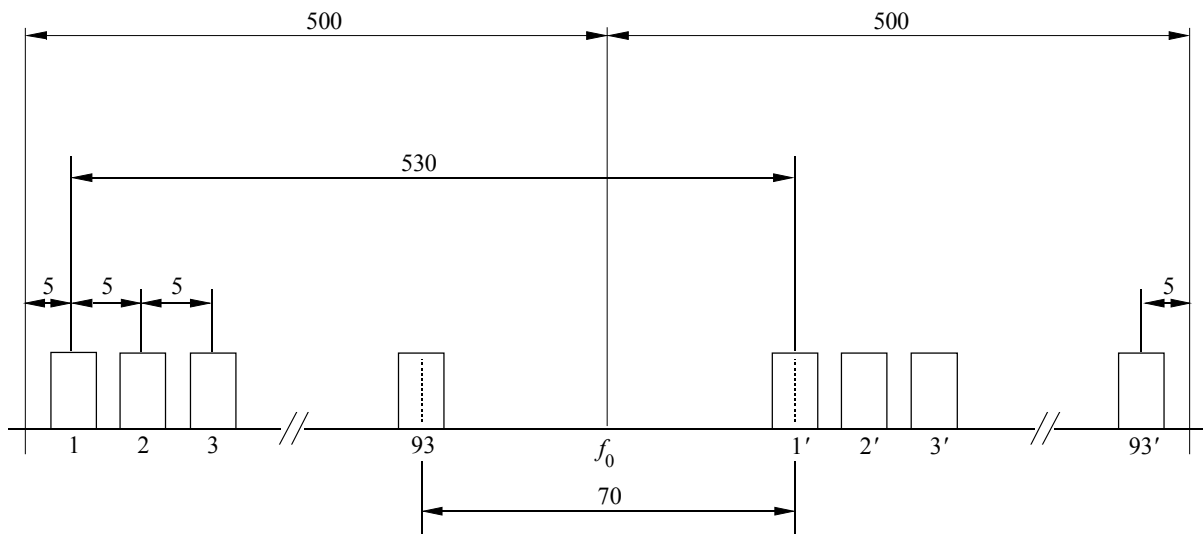

b) for systems with a carrier spacing of 5 MHz